

QUICK REFERENCE INDEX

Edition: October 2004
 Revision: October 2005
 Publication No. SM5E-1J60U1

A GENERAL INFORMATION	GI General Information
B ENGINE	EM Engine Mechanical
	LU Engine Lubrication System
	CO Engine Cooling System
	EC Engine Control System
	FL Fuel System
	EX Exhaust System
	ACC Accelerator Control System
	AT Automatic Transmission
C TRANSMISSION/ TRANSAXLE	
D DRIVELINE/AXLE	TF Transfer
	PR Propeller Shaft
	FFD Front Final Drive
	RFD Rear Final Drive
	FAX Front Axle
	RAX Rear Axle
E SUSPENSION	FSU Front Suspension
	RSU Rear Suspension
	WT Road Wheels & Tires
F BRAKES	BR Brake System
	PB Parking Brake System
	BRC Brake Control System
G STEERING	PS Power Steering System
H RESTRAINTS	SB Seat Belts
	SRS Supplemental Restraint System (SRS)
I BODY	BL Body, Lock & Security System
	GW Glasses, Window System & Mirrors
	RF Roof
	EI Exterior & Interior
	IP Instrument Panel
	SE Seat
	AP Adjustable Pedal
J AIR CONDITIONER	ATC Automatic Air Conditioner
K ELECTRICAL	SC Starting & Charging System
	LT Lighting System
	DI Driver Information System
	WW Wiper, Washer & Horn
	BCS Body Control System
	LAN LAN System
	AV Audio Visual, Navigation & Telephone System
	ACS Auto Cruise Control System
	PG Power Supply, Ground & Circuit Elements
	MA Maintenance
L MAINTENANCE	
M INDEX	IDX Alphabetical Index

A
B
C
D
E
F
G
H
I
J
K
L
M



FOREWORD

This manual contains maintenance and repair procedures for the 2005 INFINITI QX56.

In order to assure your safety and the efficient functioning of the vehicle, this manual should be read thoroughly. It is especially important that the PRECAUTIONS in the GI section be completely understood before starting any repair task.

All information in this manual is based on the latest product information at the time of publication. The right is reserved to make changes in specifications and methods at any time without notice.

IMPORTANT SAFETY NOTICE

The proper performance of service is essential for both the safety of the technician and the efficient functioning of the vehicle.

The service methods in this Service Manual are described in such a manner that the service may be performed safely and accurately. Service varies with the procedures used, the skills of the technician and the tools and parts available. Accordingly, anyone using service procedures, tools or parts which are not specifically recommended by NISSAN must first be completely satisfied that neither personal safety nor the vehicle's safety will be jeopardized by the service method selected.





PLEASE HELP MAKE THIS SERVICE MANUAL BETTER!

INFINITI®

Your comments are important to INFINITI and will help us to improve our Service Manuals.

Use this form to report any issues or comments you may have regarding our Service Manuals.

Please print this form and type or write your comments below. Mail or fax to:

Nissan North America, Inc.
Technical Service Information
39001 Sunrise Drive, P.O. Box 9200
Farmington Hills, MI USA 48331
FAX: (248) 488-3910

SERVICE MANUAL: Model: _____ **Year:** _____

PUBLICATION NO. (Refer to Quick Reference Index): _____

Please describe any Service Manual issues or problems in detail:

Page number(s) _____ *Note: Please include a copy of each page, marked with your comments.*

Are the trouble diagnosis procedures logical and easy to use? (circle your answer) YES NO

If no, what page number(s)? _____ *Note: Please include a copy of each page, marked with your comments.*

Please describe the issue or problem in detail: _____

Is the organization of the manual clear and easy to follow? (circle your answer) YES NO

Please comment: _____

What information should be included in INFINITI Service Manuals to better support you in servicing or repairing customer vehicles?

DATE: _____ YOUR NAME: _____ POSITION: _____

DEALER: _____ DEALER NO.: _____ ADDRESS: _____

CITY: _____ STATE/PROV./COUNTRY: _____ ZIP/POSTAL CODE: _____

QUICK REFERENCE CHART: QX56

PFP:00000

Engine Tune-Up Data

ELS001U4

Cylinder arrangement		V-8
Displacement		5,552 cm ³ (338.80 in ³)
Bore and stroke		98 x 92 mm (3.86 x 3.62 in)
Valve arrangement		DOHC
Firing order		1-8-7-3-6-5-4-2
Number of piston rings	Compression	2
	Oil	1
Number of main bearings		5
Compression ratio		9.8:1
Compression pressure	Standard	1,520 kPa (15.5 kg/cm ² , 220 psi) / 200 rpm
	Minimum	1,324 kPa (13.5 kg/cm ² , 192 psi) / 200 rpm
	Differential limit between cylinders	98 kPa (1.0 kg/cm ² , 14 psi) / 200 rpm

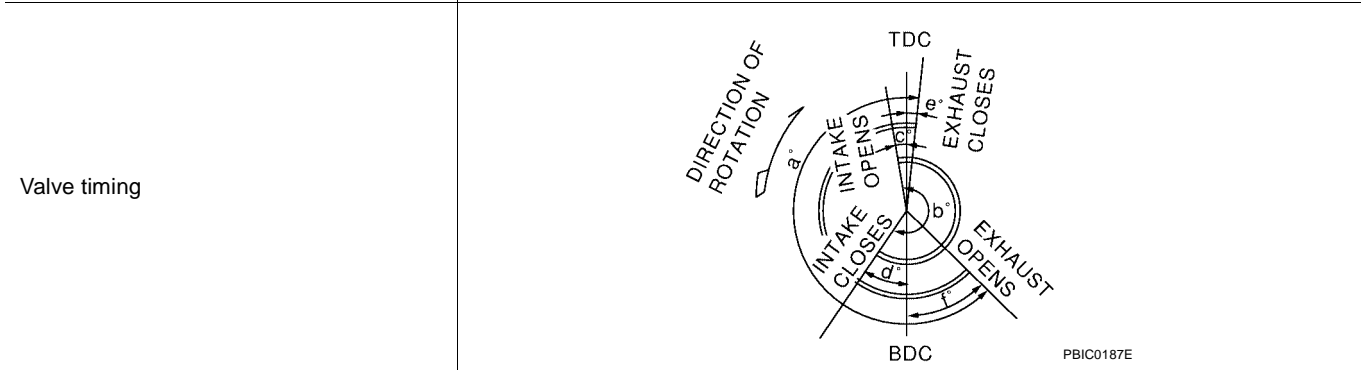
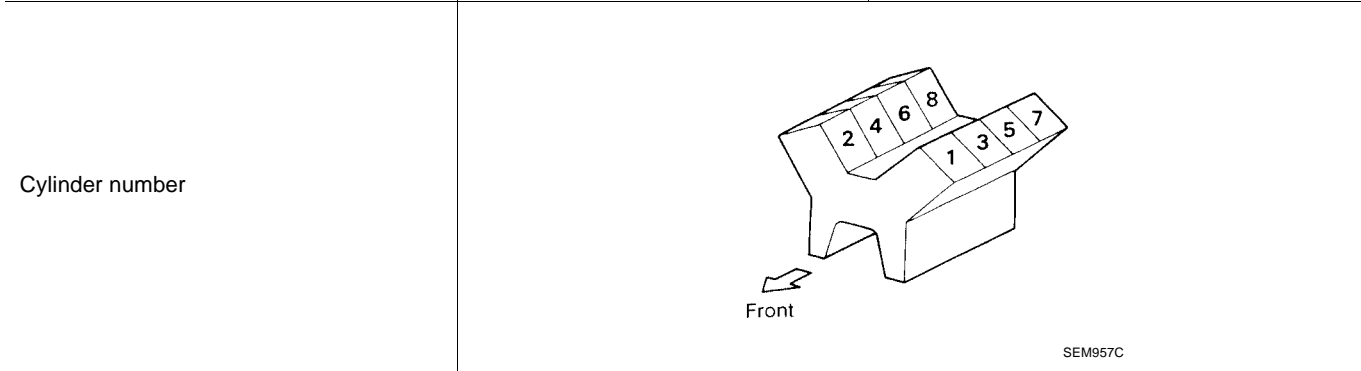

Unit: degree					
a	b	c	d	e	f
232°	230°	2°	48°	3°	49°

Drive Belt Deflection and Tension

Tension of drive belts	Auto adjustment by auto tensioner
------------------------	-----------------------------------

Spark Plugs (Double Platinum Tipped)

Make	NGK
Standard type	PLFR5A-11
Hot type	PLFR4A-11
Cold type	PLFR6A-11
Gap (nominal)	1.1 mm (0.043 in)

Front Wheel Alignment (Unladen*1)*6

ELS001U5

Drive type		4x2	4x4
Camber Degree minute (decimal degree)	Minimum	-0° 51' (-0.85°)	-0° 33' (-0.55°)
	Nominal	-0° 6' (-0.10°)	0° 12' (0.20°)
	Maximum	0° 39' (0.65°)	0° 57' (0.95°)
	Cross camber	0° 45' (0.75°) or less	0° 45' (0.75°) or less
Caster Degree minute (decimal degree)	Minimum	3° 15' (3.25°)	2° 45' (2.75°)
	Nominal	4° 0' (4.00°)	3° 30' (3.50°)
	Maximum	4° 45' (4.75°)	4° 15' (4.25°)
	Cross caster	0° 45' (0.75°) or less	0° 45' (0.75°) or less
Kingpin inclination Degree minute (decimal degree)		13° 32' (13.53°)	13° 13' (13.22°)

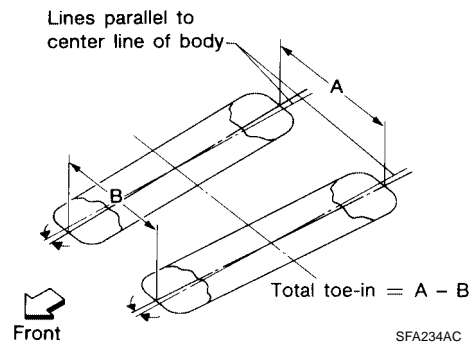

Total toe-in	Distance (A - B)	Minimum	1.8 mm (0.07 in)	1.8 mm (0.07 in)
		Nominal	2.8 mm (0.11 in)	2.8 mm (0.11 in)
		Maximum	3.8 mm (0.15 in)	3.8 mm (0.15 in)
	Angle (left side and right side) Degree minute (decimal degree)	Minimum	0° 3' (0.05°)	0° 3' (0.05°)
		Nominal	0° 5' (0.08°)	0° 5' (0.08°)
		Maximum	0° 7' (0.12°)	0° 7' (0.12°)
Wheel turning angle (full turn)	Inside Degree minute (decimal degree)	34° 31' - 38° 31' *2 (34.52° - 38.52°)	34° 44' - 38° 44' *4 (34.73° - 38.73°)	
	Outside Degree minute (decimal degree)	30° 59' - 34° 59' *3 (30.98° - 34.98°)	30° 29' - 34° 29' *5 (30.48° - 34.48°)	

*1: Fuel, radiator coolant and engine oil full. Spare tire, jack, hand tools and mats in designated positions.

*2: Target value 37° 31' (37.52°)

*3: Target value 33° 59' (33.98°)

*4: Target value 37° 44' (37.73°)

*5: Target value 33° 29' (33.48°)

*6: Some vehicles may be equipped with straight (non-adjustable) lower link bolts and washers. In order to adjust camber and caster on these vehicles, first replace the lower link bolts and washers with adjustable (cam) bolts and washers.

Rear Wheel Alignment

ELS001U6

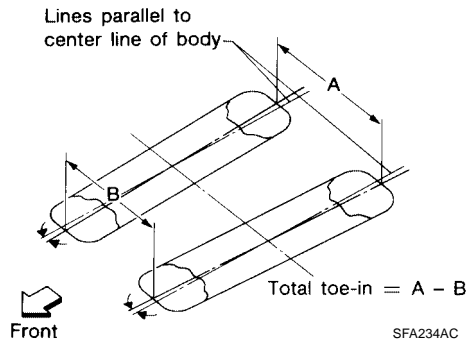

Camber Degree minute (decimal degree)	Minimum	0° 0' (0°)	
	Nominal	- 0° 30' (-0.5°)	
	Maximum	- 1° 0' (-1.0°)	
	Cross camber	0° 45' (0.75°)	
Toe-in	Distance (A - B)	Minimum	0 mm (0 in)
		Nominal	3.3 mm (0.130 in)
		Maximum	6.6 mm (0.260 in)
		Cross toe	2 mm (0.079 in)
	Angle (left, right) Degree minute (decimal degree)	Minimum	0° 0' (0°)
		Nominal	0° 7' (0.11°)
		Maximum	0° 14' (0.22°)
		Cross toe	0° 8' (0.14°)

Brake

ELS001U7

Unit: mm (in)

Front brake	Brake model	CLZ31VC
	Rotor outer diameter × thickness	320 × 26 (12.60 × 1.02)
	Pad Length × width × thickness	111.0 × 73.5 × 9.5 (4.73 × 2.894 × 0.374)
	Cylinder bore diameter	51 (2.01)
Rear brake	Brake model	AD14VE
	Rotor outer diameter × thickness	320 × 14 (12.60 × 0.55)
	Pad Length × width × thickness	83.0 × 33.0 × 8.5 (3.268 × 1.299 × 0.335)
	Cylinder bore diameter	48 (1.89)
Control valve	Valve model	Electric brake force distribution
Brake booster	Booster model	C215T
	Diaphragm diameter	215 (8.46)
Recommended brake fluid		Genuine NISSAN Super Heavy Duty Brake Fluid or equivalent, DOT 3 (US FMVSS No. 116)

QUICK REFERENCE CHART: QX56

2005

Disc Brake - Repair Limits

ELS001U8

Unit: mm (in)

Brake model		CLZ31VC (Front)	AD14VE (Rear)
Brake Pad	Standard thickness (new)	11.88 (0.468)	12.13 (0.478)
	Repair limit thickness	1.0 (0.039)	1.0 (0.039)
Disc rotor	Standard thickness (new)	26.0 (1.024)	14.0 (0.551)
	Repair limit thickness	24.5 (0.965)	12.0 (0.472)
	Maximum uneven wear (measured at 8 positions)	0.015 (0.0006)	0.015 (0.0006)
	Runout limit (with it attached to the vehicle)	0.04 (0.0016)	0.05 (0.0020)

Brake Pedal

ELS001U9

Unit: mm (in)

Brake pedal height (from dash panel top surface)	182.3 – 192.3 (7.18 – 7.57)
Depressed pedal height [under a force of 490 N (50 kg, 110 lb) with engine running]	More than 90.3 (3.55)
Clearance between stopper rubber and the threaded end of stop lamp switch	0.74 – 1.96 (0.029 – 0.077)
Pedal play	3 – 11 (0.12 – 0.43)

Refill Capacities

ELS001UA

Description	Capacity (Approximate)			
	Metric	US measure	Imp measure	
Fuel	105.8 ℓ	28 US gal	23 1/4 Imp gal	
Engine oil Drain and refill	With oil filter change	6 1/2 qt	5 1/2 qt	
	Without oil filter change	5.9 ℓ	6 1/4 qt	5 1/4 qt
Dry engine (engine overhaul)	7.6 ℓ	8 qt	6 3/4 qt	
Cooling system	With reservoir at MAX level	14.4 ℓ	3 3/4 gal	3 1/8 gal
Automatic transmission fluid (ATF)	10.6 ℓ	11 1/4 qt	9 3/8 qt	
Rear final drive oil	1.75 ℓ	3 3/4 pt	3 1/8 pt	
Transfer fluid	3.0 ℓ	3 1/8 qt	2 5/8 qt	
Front final drive oil	1.6 ℓ	3 3/8 pt	2 7/8 pt	
Power steering fluid (PSF)	1.0 ℓ	2 1/8 pt	1 3/4 pt	
Windshield washer fluid	4.5 ℓ	1 1/4 gal	1 gal	
Air conditioning system refrigerant	1.08 ± 0.05 kg	2.38 ± 0.11 lb	2.38 ± 0.11 lb	
Air conditioning system lubricants	290 m ℓ	9.8 fl oz	10.2 fl oz	