

WW

SECTION

WIPER, WASHER & HORN

A
B
C

D

E

CONTENTS

<p>PRECAUTION 3</p> <p> Precautions for Supplemental Restraint System (SRS) "AIR BAG" and "SEAT BELT PRE-TENSIONER" 3</p> <p> Wiring Diagrams and Trouble Diagnosis 3</p> <p>FRONT WIPER AND WASHER SYSTEM 4</p> <p> Components Parts and Harness Connector Location 4</p> <p> System Description 4</p> <p> LOW SPEED WIPER OPERATION 5</p> <p> HI SPEED WIPER OPERATION 5</p> <p> INTERMITTENT OPERATION 5</p> <p> AUTO STOP OPERATION 6</p> <p> FRONT WASHER OPERATION 6</p> <p> MIST OPERATION 6</p> <p> FAIL-SAFE FUNCTION 6</p> <p> COMBINATION SWITCH READING FUNCTION... 7</p> <p> CAN Communication System Description 9</p> <p> Schematic 10</p> <p> Wiring Diagram — WIPER — 11</p> <p> Terminals and Reference Values for BCM 14</p> <p> Terminals and Reference Values for IPDM E/R 15</p> <p> Work Flow 15</p> <p> Preliminary Inspection 15</p> <p> INSPECTION FOR POWER SUPPLY AND GROUND CIRCUIT 15</p> <p> CONSULT-II Function (BCM) 17</p> <p> CONSULT-II OPERATION 17</p> <p> WORK SUPPORT 18</p> <p> DATA MONITOR 18</p> <p> ACTIVE TEST 19</p> <p> CONSULT-II Function (IPDM E/R) 19</p> <p> CONSULT-II OPERATION 19</p> <p> DATA MONITOR 20</p> <p> ACTIVE TEST 21</p> <p> Trouble Diagnosis 21</p> <p> FRONT WIPER DOES NOT OPERATE 21</p> <p> FRONT WIPER STOP POSITION IS INCORRECT 24</p> <p> ONLY FRONT WIPER LOW DOES NOT OPER-</p>	<p>ATE 25</p> <p>ONLY FRONT WIPER HI DOES NOT OPERATE.. 27</p> <p>ONLY FRONT WIPER INT DOES NOT OPERATE 28</p> <p>FRONT WIPER INTERMITTENT OPERATION SWITCH POSITION CANNOT BE ADJUSTED.. 29</p> <p>WIPERS DO NOT WIPE WHEN FRONT WASHER OPERATES 29</p> <p>FRONT WIPERS OPERATE FOR 10 SECONDS, STOP FOR 20 SECONDS, AND AFTER REPEATING THIS OPERATION FIVE TIMES, THEY BECOME INOPERATIVE 29</p> <p>Removal and Installation of Front Wiper Arms, Adjustment of Wiper Arms Stop Location 31</p> <p> REMOVAL 31</p> <p> INSTALLATION 31</p> <p>Removal and Installation of Wiper Motor and Linkage 31</p> <p> REMOVAL 31</p> <p> INSTALLATION 32</p> <p>Washer Nozzle Adjustment 32</p> <p>Washer Tube Layout 33</p> <p>Removal and Installation of Wiper and Washer Switch 33</p> <p> REMOVAL 33</p> <p> INSTALLATION 33</p> <p>Removal and Installation of Washer Tank 33</p> <p> REMOVAL 33</p> <p> INSTALLATION 34</p> <p>Removal and Installation of Washer Motor 34</p> <p> REMOVAL 34</p> <p> INSTALLATION 34</p> <p>REAR WIPER AND WASHER SYSTEM 35</p> <p> Components Parts and Harness Connector Location 35</p> <p> System Description 35</p> <p> REAR WIPER OPERATION 36</p> <p> INTERMITTENT OPERATION 36</p> <p> AUTO STOP OPERATION 37</p> <p> REAR WASHER OPERATION 37</p>
---	---

F

G

H

I

J

WW

L

M

BCM WIPER SWITCH READING FUNCTION ...	38	INSTALLATION	53
Wiring Diagram — WIP/R —	39	Rear Washer Nozzle Adjustment	54
Terminals and Reference Values for BCM	41	Rear Washer Tube Layout	54
How to Proceed With Trouble Diagnosis	43	Removal and Installation of Rear Washer Nozzle...	54
Preliminary Inspection	43	REMOVAL	54
INSPECTION FOR POWER SUPPLY AND		INSTALLATION	54
GROUND CIRCUIT	43	Check Valve	55
CONSULT-II Function (BCM)	45	Removal and Installation of Rear Wiper and Washer	
CONSULT-II OPERATION	45	Switch	55
DATA MONITOR	46	Removal and Installation of Washer Tank	55
ACTIVE TEST	46	Removal and Installation of Washer Motor	55
Rear Wiper Does Not Operate	47	POWER SOCKET	56
Rear Wiper Stop Position Is Incorrect	49	Wiring Diagram — P/SCKT —	56
Only Rear Wiper Does Not Operate	50	Removal and Installation of Power Sockets	57
Only Rear Wiper Intermittent Does Not Operate ...	51	REMOVAL	57
Wiper Does Not Wipe When Rear Washer Operates..	51	INSTALLATION	57
Removal and Installation of Rear Wiper Arm, Adjust-		HORN	58
ment of Rear Wiper Arm Stop Location	52	Wiring Diagram — HORN —	58
REMOVAL	52	Removal and Installation	59
INSTALLATION	52	REMOVAL	59
Removal and Installation of Rear Wiper Motor	53	INSTALLATION	59
REMOVAL	53		

PRECAUTION

PRECAUTION

PFP:00011

Precautions for Supplemental Restraint System (SRS) “AIR BAG” and “SEAT BELT PRE-TENSIONER”

EKS00BDQ

The Supplemental Restraint System such as “AIR BAG” and “SEAT BELT PRE-TENSIONER”, used along with a front seat belt, helps to reduce the risk or severity of injury to the driver and front passenger for certain types of collision. This system includes seat belt switch inputs and dual stage front air bag modules. The SRS system uses the seat belt switches to determine the front air bag deployment, and may only deploy one front air bag, depending on the severity of a collision and whether the front occupants are belted or unbelted. Information necessary to service the system safely is included in the SRS and SB section of this Service Manual.

WARNING:

- To avoid rendering the SRS inoperative, which could increase the risk of personal injury or death in the event of a collision which would result in air bag inflation, all maintenance must be performed by an authorized NISSAN/INFINITI dealer.
- Improper maintenance, including incorrect removal and installation of the SRS, can lead to personal injury caused by unintentional activation of the system. For removal of Spiral Cable and Air Bag Module, see the SRS section.
- Do not use electrical test equipment on any circuit related to the SRS unless instructed to in this Service Manual. SRS wiring harnesses can be identified by yellow and/or orange harnesses or harness connectors.

Wiring Diagrams and Trouble Diagnosis

EKS00BDR

When you read wiring diagrams, refer to the following:

- Refer to [GI-15, "How to Read Wiring Diagrams"](#) .
- Refer to [PG-4, "POWER SUPPLY ROUTING CIRCUIT"](#) for power distribution circuit.

When you perform trouble diagnosis, refer to the following:

- Refer to [GI-11, "HOW TO FOLLOW TEST GROUPS IN TROUBLE DIAGNOSES"](#) .
- Refer to [GI-27, "How to Perform Efficient Diagnosis for an Electrical Incident"](#) .

A

B

C

D

E

F

G

H

I

J

WW

L

M

FRONT WIPER AND WASHER SYSTEM

- to combination switch terminal 14, and
- through 10A fuse (No. 59 located in the fuse and relay box)
- to BCM terminal 38.

Ground is supplied

- to BCM terminal 67 and
- to combination switch terminal 12
- through grounds M57, M61 and M79, and
- to IPDM E/R terminals 38 and 59 and
- to front wiper motor terminal 1
- through grounds E9, E15, and E24.

LOW SPEED WIPER OPERATION

When the ignition switch is in the ON or START position, and the front wiper switch is turned to the low position, the BCM detects a low speed wiper ON request through the combination switch (wiper switch) reading function. The BCM then sends a front wiper (low) request signal over CAN communication lines

- from BCM terminals 39 and 40
- to IPDM E/R terminals 39 and 40.

When IPDM E/R receives front wiper (low) request signal, it supplies ground to energize the front wiper relay. With the front wiper relay energized, power is supplied

- through front wiper relay
- to front wiper high relay
- through IPDM E/R terminal 32
- to front wiper motor terminal 3.

With power and ground supplied, the front wiper motor operates at low speed.

HI SPEED WIPER OPERATION

When the ignition switch is in the ON or START position, and the front wiper switch is turned to the high position, the BCM detects a high speed wiper ON request through the combination switch (wiper switch) reading function. The BCM then sends a front wiper (high) request signal over CAN communication lines

- from BCM terminals 39 and 40
- to IPDM E/R terminals 39 and 40.

When the IPDM E/R receives a front wiper (high) request signal, it supplies ground to energize the front wiper and the front wiper high relays.

With the front wiper and the front wiper high relays energized, power is supplied

- through front wiper relay
- to front wiper high relay
- through IPDM E/R terminal 35
- to front wiper motor terminal 2.

With power and ground supplied, the front wiper motor operates at high speed.

INTERMITTENT OPERATION

Wiper intermittent operation delay interval is determined from the combination of the intermittent wiper dial position inputs and vehicle speed. During each intermittent operation delay interval, the BCM sends a front wiper request signal to the IPDM E/R to operate the wipers.

When the ignition switch is in the ON or START position, and the front wiper switch is turned to an intermittent position, the BCM detects a front wiper (intermittent) ON request through the combination switch (wiper switch) reading function.

The BCM then sends a front wiper (intermittent) request signal over CAN communication lines

- from BCM terminals 39 and 40
- to IPDM E/R terminals 39 and 40.

When the BCM determines that combination switch status is front wiper intermittent ON, it performs the following operations.

- BCM detects ON/OFF status of intermittent wiper dial position.

A

B

C

D

E

F

G

H

I

J

WW

L

M

FRONT WIPER AND WASHER SYSTEM

- BCM calculates operation interval from wiper dial position and vehicle speed signal received through CAN communications.
- BCM sends front wiper request signal (INT) to IPDM E/R at calculated operation interval.

When the IPDM E/R receives a front wiper request signal (INT), it supplies ground to energize the front wiper relay. It then sends an auto-stop signal to the BCM, and conducts intermittent front wiper motor operation.

AUTO STOP OPERATION

When the wiper arms are not located at the base of the windshield, and the wiper switch is turned OFF, the wiper motor will continue to operate until the wiper arms reach the windshield base. When the wiper arms reach the base of windshield, front wiper motor terminals 6 and 1 are connected.

Ground is supplied

- to IPDM E/R terminal 43
- through front wiper motor terminal 6
- through front wiper motor terminal 1
- through grounds E9, E15, and E24.

The IPDM E/R sends an auto stop operation signal to the BCM through CAN communication lines.

When the BCM receives an auto stop operation signal, the BCM sends wiper stop signal to the IPDM E/R over CAN communication lines. The IPDM E/R then de-energizes the front wiper relay.

The wiper motor will then stop the wiper arms at the STOP position.

FRONT WASHER OPERATION

When the ignition switch is in the ON or START position, and the front and rear washer switches are OFF, the front and rear washer motor is supplied power

- through 10A fuse (No. 9, located in the fuse block J/B)
- through combination switch (wiper switch) terminal 14
- through combination switch (wiper switch) terminal 13
- to front and rear washer motor terminal 1, and
- through combination switch (wiper switch) terminal 11
- to front and rear washer motor terminal 2.

When the front wiper switch is in the front washer position, the BCM detects a front washer signal request through the combination switch (wiper switch) reading function.

Combination switch ground is supplied

- to front and rear washer motor terminal 2
- through combination switch (wiper switch) terminal 11
- through combination switch (wiper switch) terminal 12
- through grounds M57, M61 and M79.

With ground supplied, the front and rear washer motor is operated in the front direction.

When the BCM detects that front washer motor has operated for 0.4 seconds or longer, the BCM uses CAN communication and sends a wiper request signal to the IPDM E/R for low speed operation of wipers.

When the BCM detects that the washer switch is OFF, low speed operation cycles approximately 3 times and then stops.

MIST OPERATION

When the wiper switch is temporarily placed in the mist position, wiper low speed operation cycles once and then stops. For additional information about wiper operation under this condition, refer to [WW-5, "LOW SPEED WIPER OPERATION"](#).

If the switch is held in the mist position, low speed operation continues.

FAIL-SAFE FUNCTION

The BCM includes fail-safe function to prevent malfunction of electrical components controlled by CAN communications if a malfunction in CAN communications occurs.

The BCM uses CAN communications to stop output of electrical components it controls.

Until the ignition switch is turned off, the front wiper system remains in same status as just before fail-safe control was initiated. (If wiper was in low speed operation just before fail-safe, it continues low speed operation until ignition switch is turned OFF.)

When fail-safe status is initiated, the BCM remains in standby until normal signals are received.

When normal signals are received, fail-safe status is canceled.

FRONT WIPER AND WASHER SYSTEM

COMBINATION SWITCH READING FUNCTION

Description

- BCM reads combination switch status, and controls related systems such as headlamps and wipers, according to the results.
- BCM reads information for a maximum of 20 switches by combining five output terminals (OUTPUT 1-5) and five input terminals (INPUT 1-5).

Operation Description

- BCM activates transistors of output terminals (OUTPUT 1-5) periodically, and allows current to flow in turn.
- If any (1 or more) switches are turned ON, the circuit of output terminals (OUTPUT 1-5) and input terminals (INPUT 1-5) becomes active.
- At this time, transistors of output terminals (OUTPUT 1-5) are activated to allow current to flow. When voltage of the input terminal (INPUT 1-5) corresponding to that switch changes, the interface in the BCM detects a voltage change, and the BCM determines that the switch is ON.

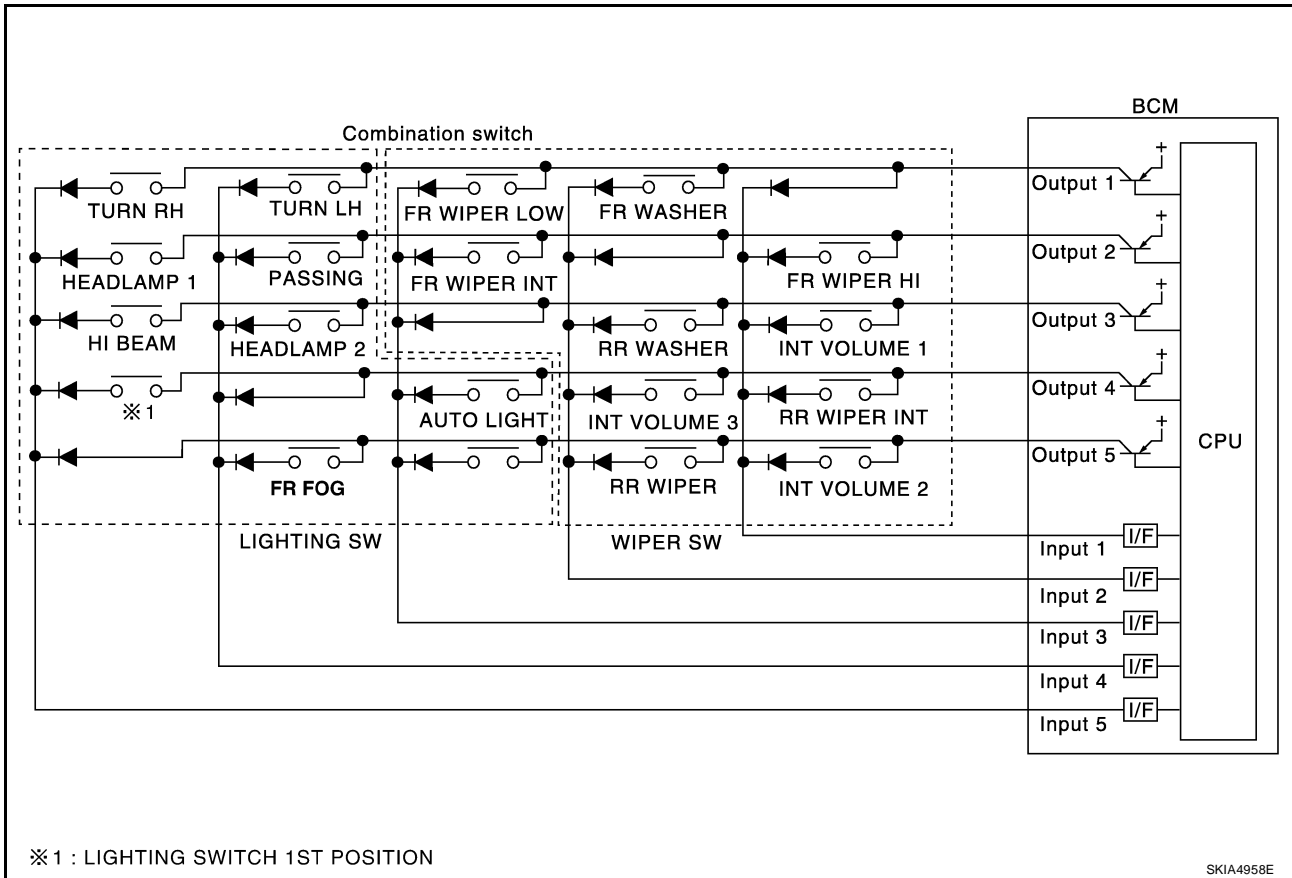

A
B
C
D
E
F
G
H
I
J
L
M

WW

FRONT WIPER AND WASHER SYSTEM

BCM - Operation Table of Combination Switches

- BCM reads operation status of the combination switch using combinations shown in the table below.

	COMB SW OUTPUT 1		COMB SW OUTPUT 2		COMB SW OUTPUT 3		COMB SW OUTPUT 4		COMB SW OUTPUT 5	
	ON	OFF	ON	OFF	ON	OFF	ON	OFF	ON	OFF
COMB SW INPUT 1	—	—	FR WIPER HI ON	FR WIPER HI OFF	INT VOLUME 1 ON	INT VOLUME 1 OFF	RR WIPER INT ON	RR WIPER INT OFF	INT VOLUME 2 ON	INT VOLUME 2 OFF
COMB SW INPUT 2	FR WASHER ON	FR WASHER OFF	—	—	RR WASHER ON	RR WASHER OFF	INT VOLUME 3 ON	INT VOLUME 3 OFF	RR WIPER ON	RR WIPER OFF
COMB SW INPUT 3	FR WIPER LOW ON	FR WIPER LOW OFF	FR WIPER INT ON	FR WIPER INT OFF	—	—	AUTO LIGHT ON	AUTO LIGHT OFF	—	—
COMB SW INPUT 4	TURN LH ON	TURN LH OFF	PASSING ON	PASSING OFF	HEAD-LAMP 2 ON	HEAD-LAMP 2 OFF	—	—	FR FOG ON	FR FOG OFF
COMB SW INPUT 5	TURN RH ON	TURN RH OFF	HEAD-LAMP 1 ON	HEAD-LAMP 1 OFF	HI BEAM ON	HI BEAM OFF	LIGHTING SW (1st) ON	LIGHTING SW (1st) OFF	—	—

SKIA4959E

Sample Operation: (When Wiper Switch is Turned ON)

- When the wiper switch is turned ON, contact in the combination switch turns ON. At this time if OUTPUT 1 transistor is activated, the BCM detects that voltage changes in INPUT 3.
- When the OUTPUT 1 transistor is ON, the BCM detects that voltage changes in INPUT 3, and judges that front wiper low is ON. Then the BCM sends a front wiper request signal (LO) to the IPDM E/R using CAN communication.
- When OUTPUT 1 transistor is activated again, BCM detects that voltage changes in INPUT 3, and recognizes that the wiper switch is continuously ON.

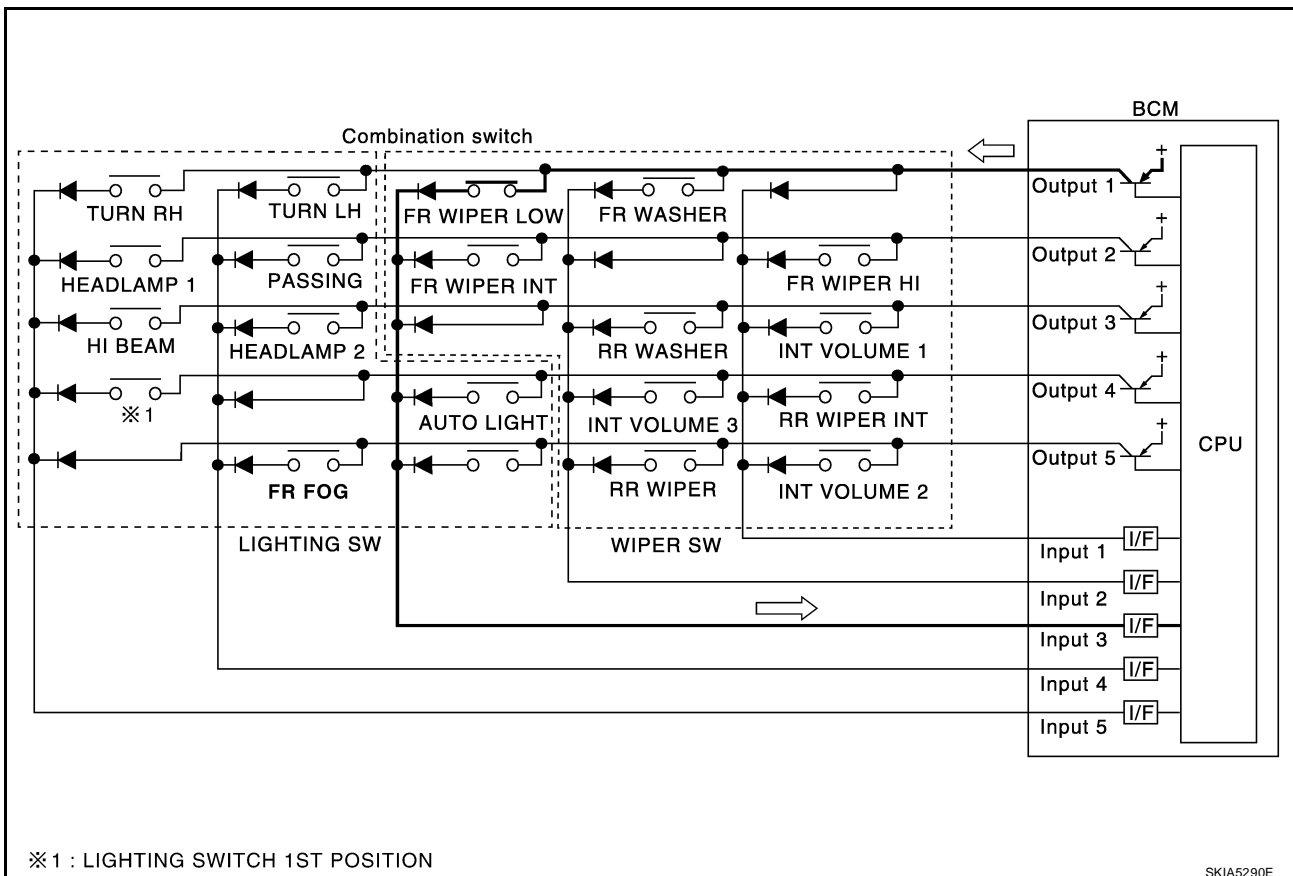

SKIA5290E

FRONT WIPER AND WASHER SYSTEM

NOTE:

Each OUTPUT terminal transistor is activated at 10 ms intervals. Therefore, after the switch is turned ON, electrical loads are activated with time delay. This time delay is so short that it cannot be detected by human senses.

Operation Mode

The combination switch reading function has the operation modes shown below.

1. Normal status
 - When BCM is not in sleep status, OUTPUT terminals (1-5) each turn ON-OFF every 10 ms.
2. Sleep status
 - When BCM is in sleep status, transistors of OUTPUT 1 stop the output, and BCM enters low current consumption mode. OUTPUT (2, 3, and 4) turn ON-OFF every 10 ms, and only input from light switch system is accepted.

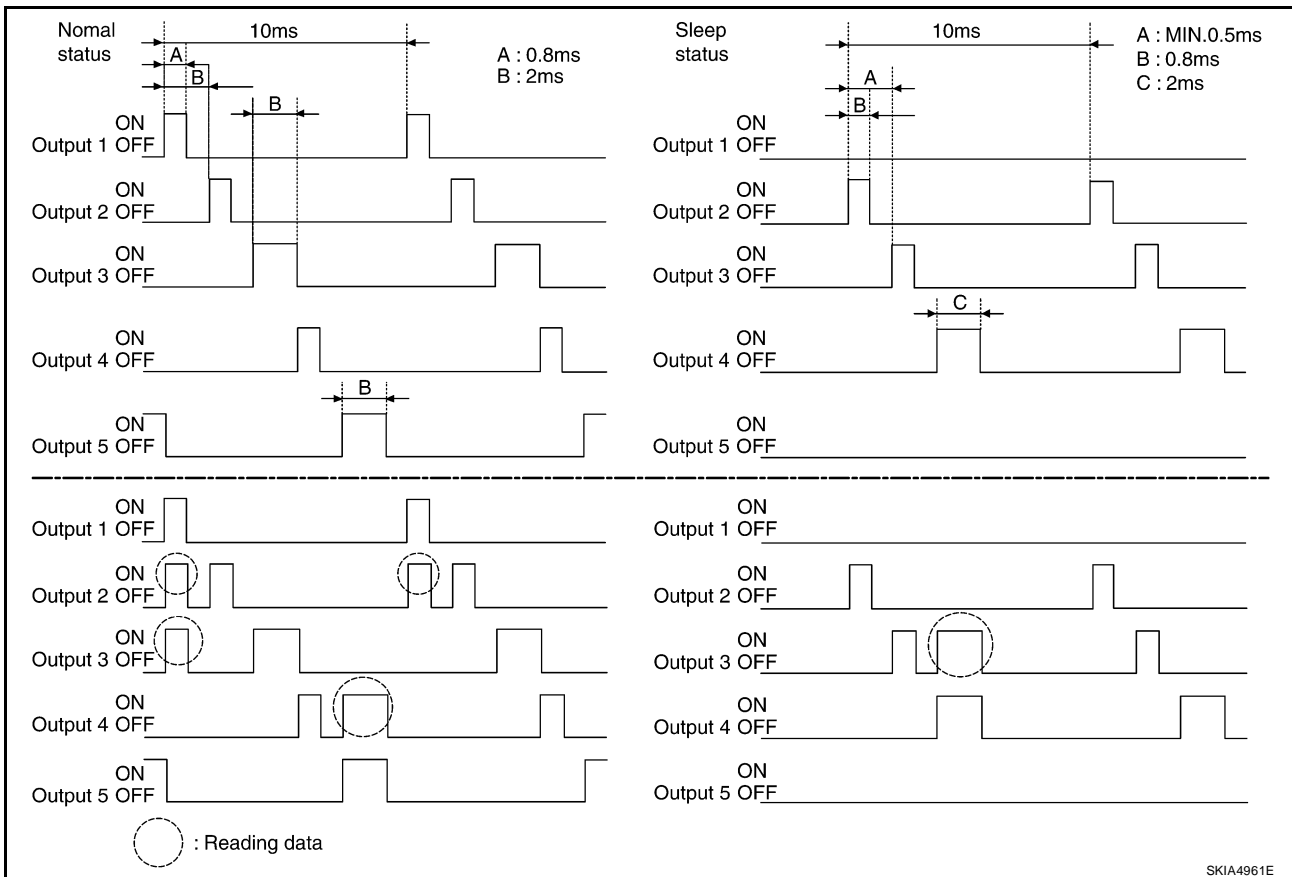

CAN Communication System Description

EKS00BDU

Refer to [LAN-5, "CAN COMMUNICATION"](#).

FRONT WIPER AND WASHER SYSTEM

Schematic

EKS00BDV

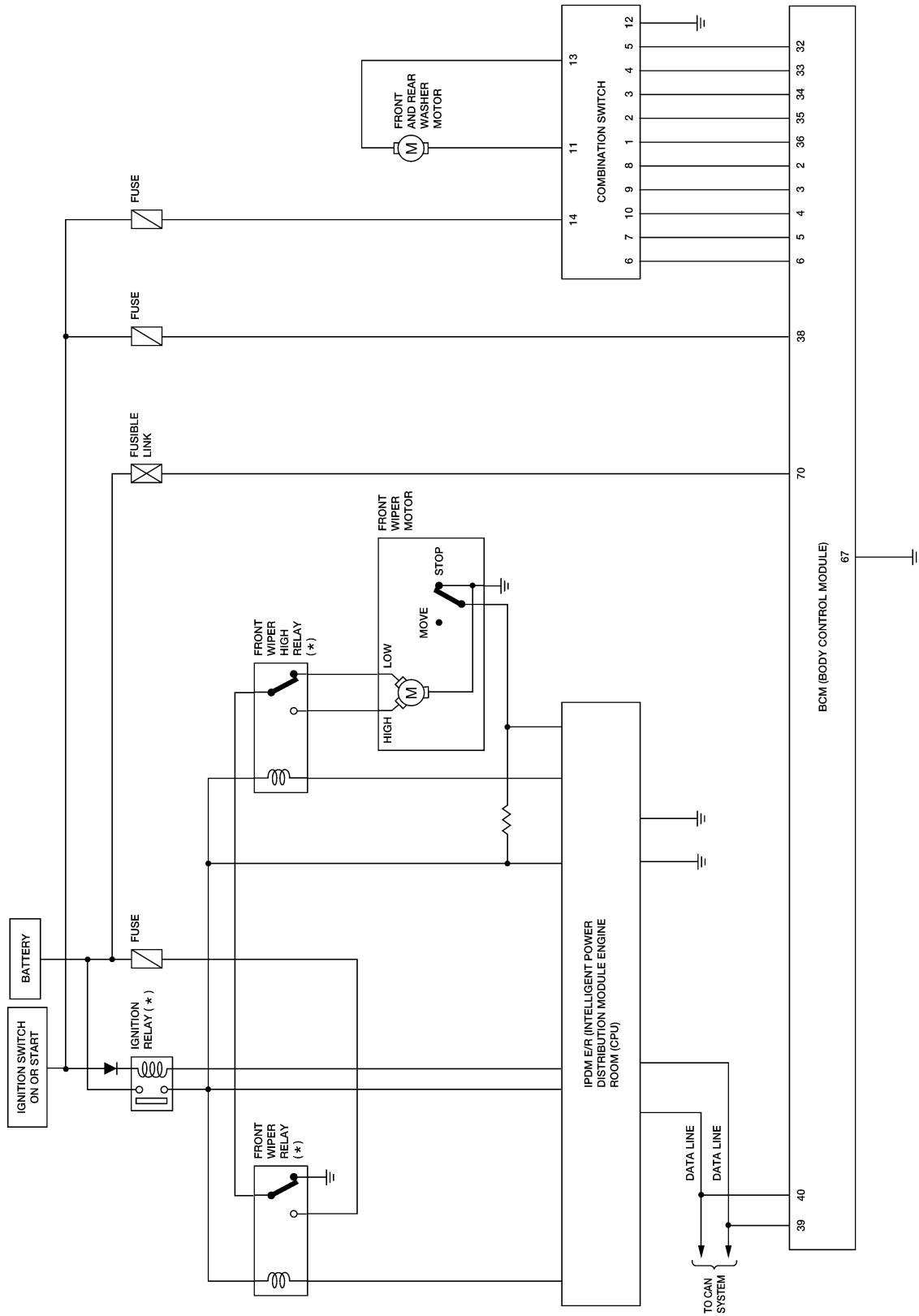

*: THIS RELAY IS BUILT INTO THE IPDM E/R (INTELLIGENT POWER DISTRIBUTION MODULE ENGINE ROOM).

FRONT WIPER AND WASHER SYSTEM

Wiring Diagram — WIPER —

EKS00BDW

WW-WIPER-01

— : DATA LINE

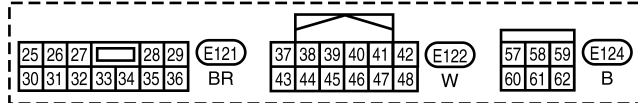
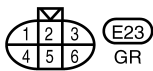
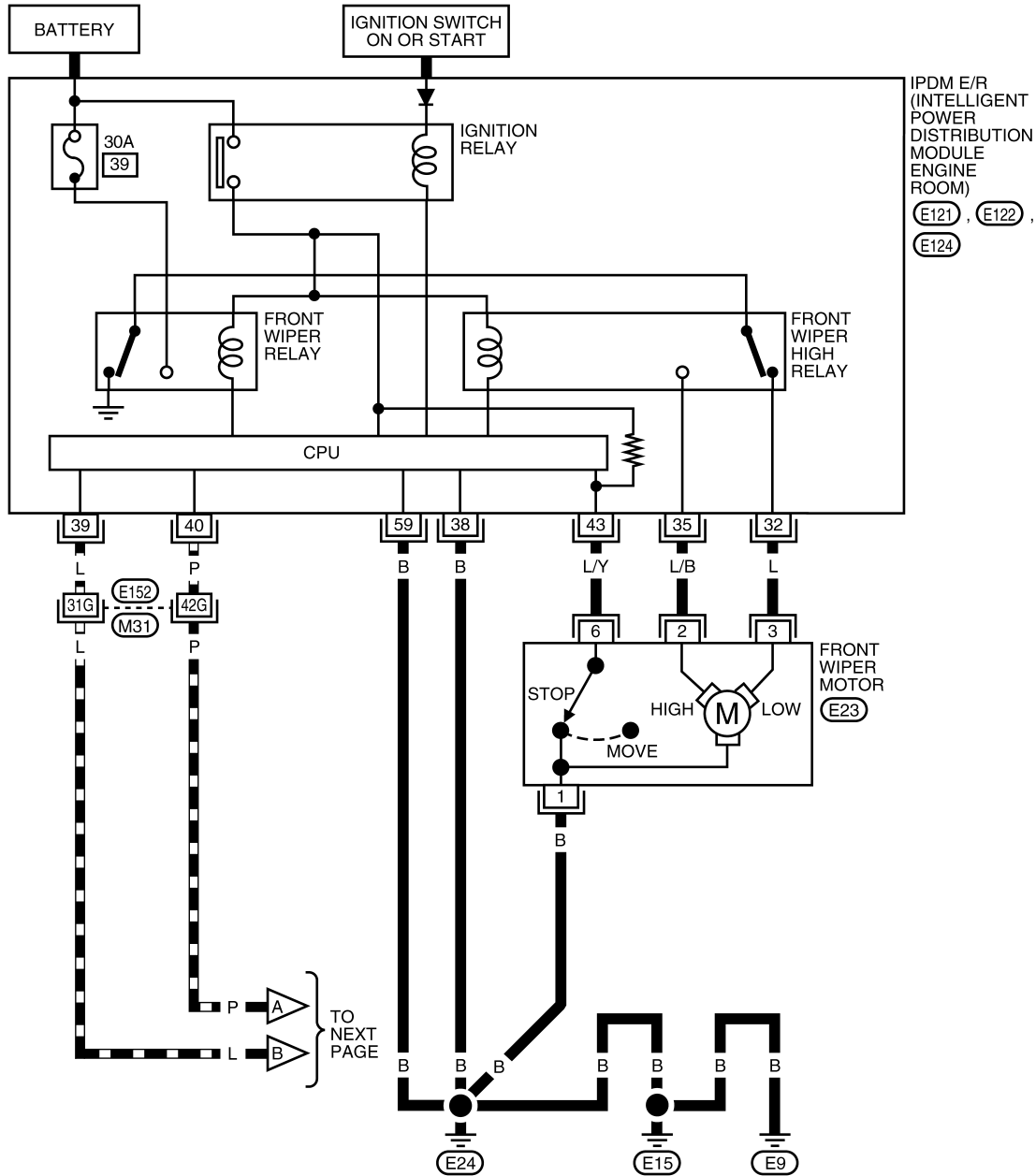

REFER TO THE FOLLOWING.

(M31) - SUPER MULTIPLE JUNCTION (SMJ)

WKWA4493E

FRONT WIPER AND WASHER SYSTEM

WW-WIPER-02

▬ : DATA LINE

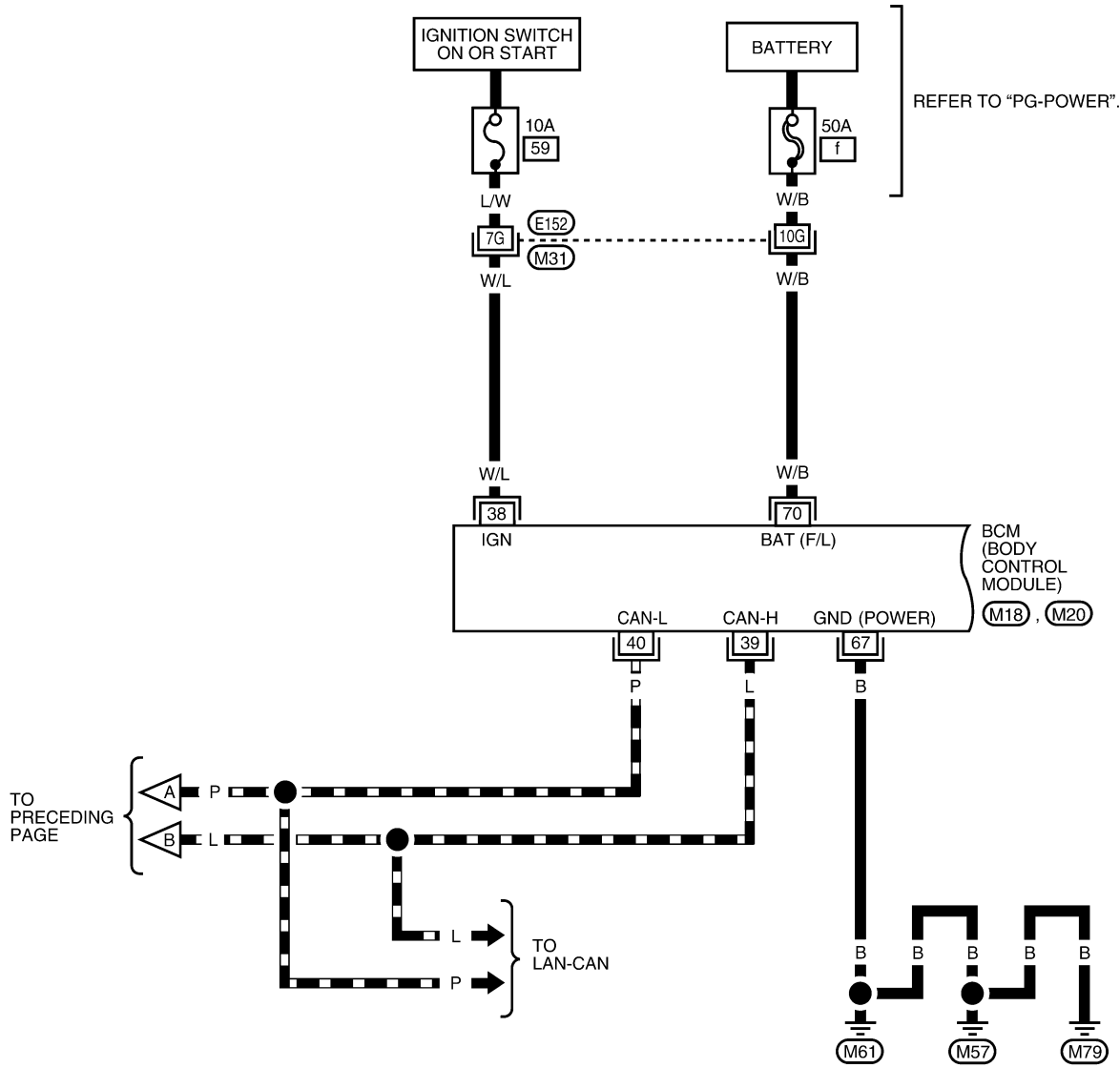

REFER TO "PG-POWER".

BCM
(BODY
CONTROL
MODULE)
M18 . M20

TO
PRECEDING
PAGE

TO
LAN-CAN

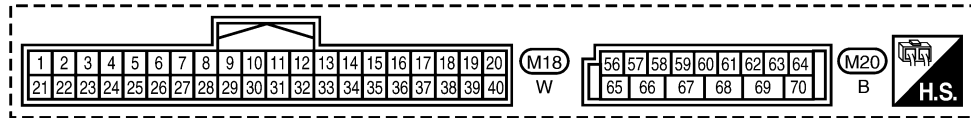

REFER TO THE FOLLOWING.
M31 - SUPER MULTIPLE
JUNCTION (SMJ)

WKWA2327E

FRONT WIPER AND WASHER SYSTEM

WW-WIPER-03

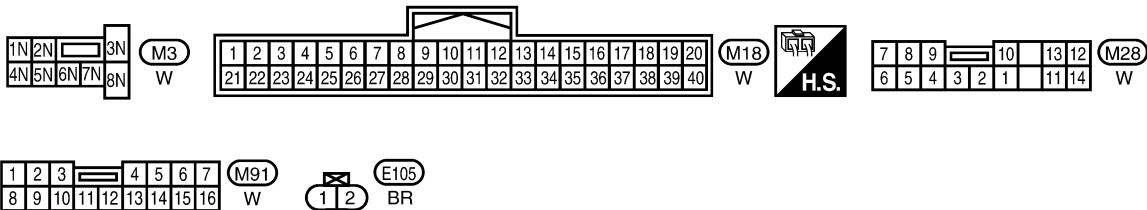
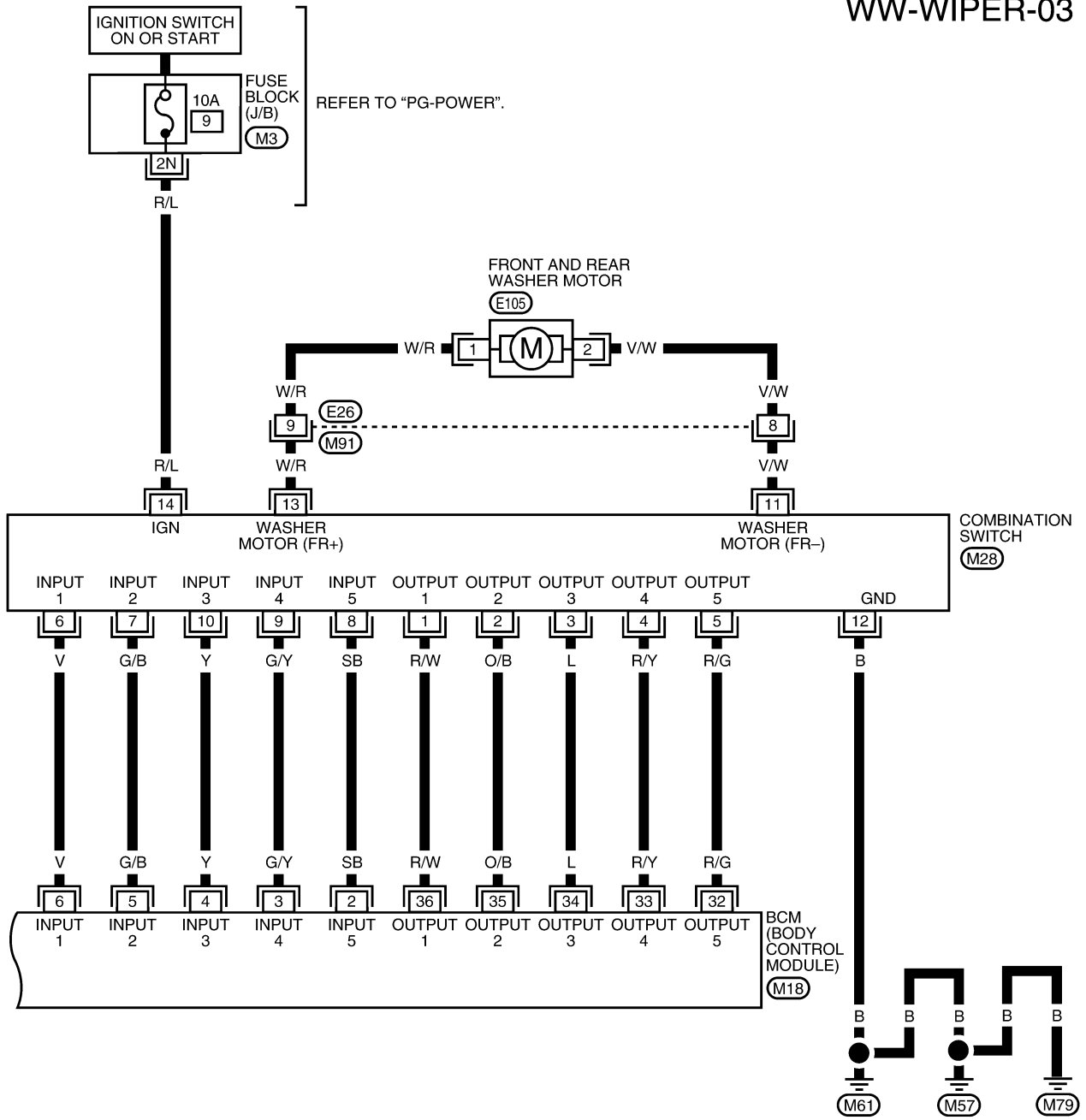



WKWA2265E

FRONT WIPER AND WASHER SYSTEM

Terminals and Reference Values for BCM

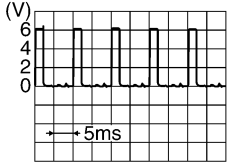
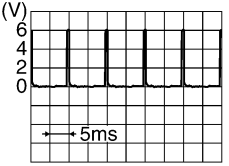
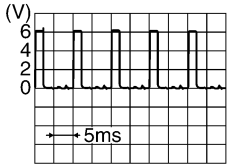
EKS00BDX

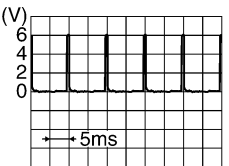
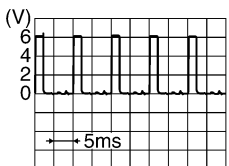
Terminal No.	Wire color	Signal name	Measuring condition		Reference Value (V) (Approx.)
			Ignition switch	Operation or condition	
2	SB	Combination switch input 5	ON	<ul style="list-style-type: none"> Light switch and wiper switch OFF Wiper dial position 4 	 <p style="text-align: right;">SKIA5291E</p>
3	G/Y	Combination switch input 4	ON	<ul style="list-style-type: none"> Light switch and wiper switch OFF Wiper dial position 4 	 <p style="text-align: right;">SKIA5292E</p>
4	Y	Combination switch input 3	ON	<ul style="list-style-type: none"> Light switch and wiper switch OFF Wiper dial position 4 	 <p style="text-align: right;">SKIA5291E</p>
5	G/B	Combination switch input 2	ON	<ul style="list-style-type: none"> Light switch and wiper switch OFF Wiper dial position 4 	 <p style="text-align: right;">SKIA5292E</p>
6	V	Combination switch input 1			
32	R/G	Combination switch output 5	ON	<ul style="list-style-type: none"> Light switch and wiper switch OFF Wiper dial position 4 	 <p style="text-align: right;">SKIA5291E</p>
33	R/Y	Combination switch output 4	ON	<ul style="list-style-type: none"> Light switch and wiper switch OFF Wiper dial position 4 	 <p style="text-align: right;">SKIA5292E</p>
34	L	Combination switch output 3	ON	<ul style="list-style-type: none"> Light switch and wiper switch OFF Wiper dial position 4 	 <p style="text-align: right;">SKIA5291E</p>

FRONT WIPER AND WASHER SYSTEM

Terminal No.	Wire color	Signal name	Measuring condition		Reference Value (V) (Approx.)
			Ignition switch	Operation or condition	
35	O/B	Combination switch output 2	ON	<ul style="list-style-type: none"> Light switch and wiper switch OFF Wiper dial position 4 	
36	R/W	Combination switch output 1			
38	W/L	Ignition switch (ON)	ON	—	Battery
39	L	CAN-H	ON	—	—
40	P	CAN-L	ON	—	—
67	B	Ground	—	—	0
70	W/B	Battery power	OFF	—	Battery

Terminals and Reference Values for IPDM E/R

EKS00BDY

Terminal No.	Wire color	Signal name	Measuring condition		Reference value (V) (Approx.)	
			Ignition switch	Operation or condition		
32	L	Low speed signal	ON	Wiper switch	OFF	0
					LO	Battery
35	L/B	High speed signal	ON	Wiper switch	OFF	0
					HI	Battery
38	B	Ground	—	—	0	
39	L	CAN-H	ON	—	—	
40	P	CAN-L	ON	—	—	
43	L/Y	Wiper auto stop signal	ON	Wiper operating	Battery	
				Wiper stopped	0	
59	B	Ground	—	—	0	

WW

Work Flow

EKS00BDZ

1. Confirm the trouble symptom or customer complaint.
2. Understand the system description, refer to [WW-4, "System Description"](#) .
3. Perform preliminary inspection, refer to [WW-15, "Preliminary Inspection"](#) .
4. Check symptom and repair or replace the cause of malfunction.
5. Does wiper function operate normally? If it operates normally, GO TO 6. If not, GO TO 4.
6. Inspection End.

Preliminary Inspection

EKS00BE0

INSPECTION FOR POWER SUPPLY AND GROUND CIRCUIT

Inspection procedure

1. CHECK FUSE

Check if wiper or washer fuse is blown.

Unit	Power source	Fuse No.
Front and rear washer motor	Ignition switch ON or START	9
Front wiper relay	Battery	39
BCM	Ignition switch ON or START	59
	Battery	f

FRONT WIPER AND WASHER SYSTEM

OK or NG

OK >> GO TO 2.

NG >> If fuse is blown, be sure to eliminate cause of problem before installing new fuse. Refer to [PG-4, "POWER SUPPLY ROUTING CIRCUIT"](#) .

2. CHECK POWER SUPPLY CIRCUIT

1. Disconnect BCM connectors.
2. Check voltage between BCM harness connector terminals and ground.

Terminals		Ignition switch position	
(+)		(-)	
Connector	Terminal (Wire color)	OFF	ON
M18	38 (W/L)	0V	Battery voltage
M20	70 (W/B)	Battery voltage	

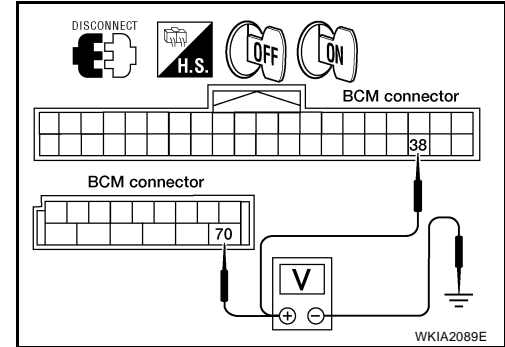

OK or NG

OK >> GO TO 3.

NG >> Check harness for open or short between BCM and fuse.

3. GROUND CIRCUIT INSPECTION (BCM)

Check for continuity between BCM terminal and ground.

Terminals		Ignition switch condition	Continuity
Connector	Terminal (wire color)		
M20	67 (B)	OFF	Yes

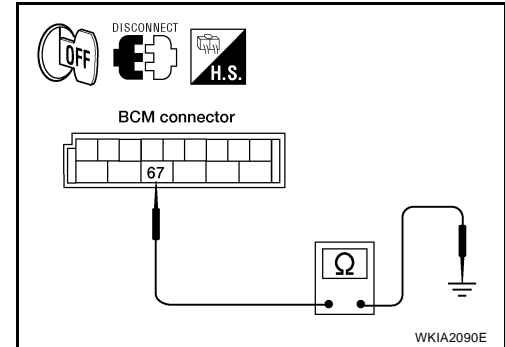

OK or NG

OK >> Inspection End.

NG >> Repair/replace BCM ground circuit.

FRONT WIPER AND WASHER SYSTEM

CONSULT-II Function (BCM)

EKS00BE1

CONSULT-II can display each diagnostic item using the diagnostic test modes shown following.

BCM diagnostic test item	Diagnostic mode	Description
Inspection by part	WORK SUPPORT	Supports inspections and adjustments. Commands are transmitted to the BCM for setting the status suitable for required operation, input/output signals are received from the BCM and received data is displayed.
	DATA MONITOR	Displays BCM input/output data in real time.
	ACTIVE TEST	Operation of electrical loads can be checked by sending drive signal to them.
	SELF-DIAG RESULTS	Displays BCM self-diagnosis results.
	CAN DIAG SUPPORT MNTR	The result of transmit/receive diagnosis of CAN communication can be read.
	ECU PART NUMBER	BCM part number can be read.
	CONFIGURATION	Performs BCM configuration read/write functions.

CONSULT-II OPERATION

CAUTION:

If CONSULT-II is used with no connection of CONSULT-II CONVERTER, malfunctions might be detected in self-diagnosis depending on control unit which carries out CAN communication.

1. With the ignition switch OFF, connect CONSULT-II and CONSULT-II CONVERTER to the data link connector, then turn the ignition switch ON.

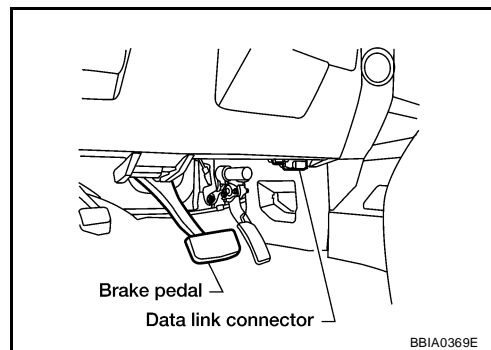

2. Touch "START (NISSAN BASED VHCL)".

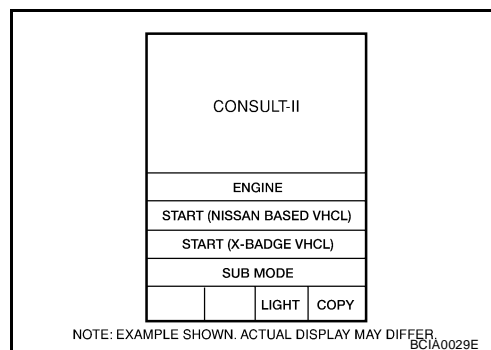

3. Touch "BCM" on the "SELECT SYSTEM" screen. If "BCM" is not indicated, go to [GI-39, "CONSULT-II Data Link Connector \(DLC\) Circuit"](#).

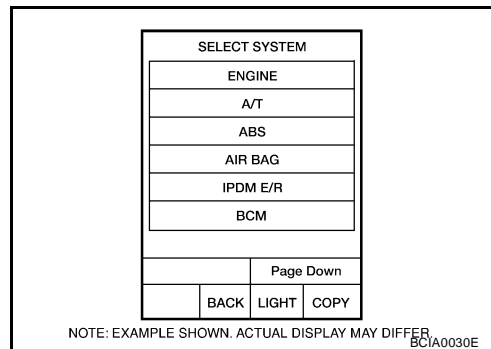

FRONT WIPER AND WASHER SYSTEM

4. Select the desired part to be diagnosed on the "SELECT TEST ITEM" screen.

SELECT TEST ITEM			
HEAD LAMP			
WIPER			
FLASHER			
AIR CONDITIONER			
COMB SW			
BCM			
Scroll Up		Page Down	
	BACK	LIGHT	COPY

LKIA0183E

WORK SUPPORT

Operation Procedure

1. Touch "WIPER" on the "SELECT TEST ITEM" screen.
2. Touch "WORK SUPPORT" on the "SELECT DIAG MODE" screen.
3. Touch "WIPER SPEED SETTING" on the "SELECT WORK ITEM" screen.
4. Touch "START".
5. Touch "CHANGE SETT".
6. The setting will be changed and "CURRENT SETTING" will be displayed.
7. Touch "END".

Work Support Setting Item

Item	Description	CONSULT-II
WIPER SPEED SETTING	When wiper switch is at INTERMITTENT, front wiper intermittent time can be selected according to vehicle speed. ● ON (Operated)/OFF ^{NOTE} (Not operated)	ON/OFF

NOTE:

Factory setting

DATA MONITOR

Operation Procedure

1. Touch "WIPER" on the "SELECT TEST ITEM" screen.
2. Touch "DATA MONITOR" on the "SELECT DIAG MODE" screen.
3. Touch either "ALL SIGNALS" or "SELECTION FROM MENU" on the "SELECT MONITOR ITEM" screen.

ALL SIGNALS	Monitors all the items.
SELECTION FROM MENU	Selects and monitors the individual item selected.

4. Touch "START".
5. When "SELECTION FROM MENU" is selected, touch items to be monitored. When "ALL SIGNALS" is selected, all the items will be monitored.
6. Touch "RECORD" while monitoring to record the status of the item being monitored. To stop recording, touch "STOP".

Display Item List

Monitor item name "OPERATION OR UNIT"	Contents
IGN ON SW "ON/OFF"	Displays "IGN Position (ON)/OFF, ACC Position (OFF)" status as judged from ignition switch signal.
IGN SW CAN "ON/OFF"	Displays "IGN switch ON (ON)/Other OFF or ACC (OFF)" status as judged from CAN communications.
FR WIPER HI "ON/OFF"	Displays "Front Wiper HI (ON)/Other (OFF)" status as judged from wiper switch signal.

FRONT WIPER AND WASHER SYSTEM

Monitor item name "OPERATION OR UNIT"		Contents
FR WIPER LOW	"ON/OFF"	Displays "Front Wiper LOW (ON)/Other (OFF)" status as judged from wiper switch signal.
FR WIPER INT	"ON/OFF"	Displays "Front Wiper INT (ON)/Other (OFF)" status as judged from wiper switch signal.
FR WASHER SW	"ON/OFF"	Displays "Front Washer Switch (ON)/Other (OFF)" status as judged from wiper switch signal.
INT VOLUME	(1 - 7)	Displays intermittent operation dial position setting (1 - 7) as judged from wiper switch signal.
FR WIPER STOP	"ON/OFF"	Displays "Stopped (ON)/Operating (OFF)" status as judged from the auto-stop signal.
VEHICLE SPEED	"0.0 km/h"	Displays vehicle speed as received from CAN communication.

ACTIVE TEST

Operation Procedure

1. Touch "WIPER" on the "SELECT TEST ITEM" screen.
2. Touch "ACTIVE TEST" on the "SELECT DIAG MODE" screen.
3. Touch item(s) to be tested and check operation of the selected item(s).
4. During the operation check, touching "BACK" deactivates the operation.

Display Item List

Test item	Display on CONSULT-II screen	Description
Front wiper HI output	FR WIPER (HI)	Front wiper HI can be operated by any ON-OFF operation.
Front wiper LO output	FR WIPER (LO)	Front wiper LO can be operated by any ON-OFF operation.
Front wiper INT output	FR WIPER (INT)	Front wiper INT can be operated by any ON-OFF operation.

CONSULT-II Function (IPDM E/R)

EKS00BE2

CONSULT-II can display each diagnostic item using the diagnostic test modes shown following.

IPDM E/R diagnostic Mode	Description
SELF-DIAG RESULTS	Displays IPDM E/R self-diagnosis results.
DATA MONITOR	Displays IPDM E/R input/output data in real time.
CAN DIAG SUPPORT MNTR	The result of transmit/receive diagnosis of CAN communication can be read.
ACTIVE TEST	Operation of electrical loads can be checked by sending drive signal to them.

CONSULT-II OPERATION

CAUTION:

If CONSULT-II is used with no connection of CONSULT-II CONVERTER, malfunctions might be detected in self-diagnosis depending on control unit which carries out CAN communication.

1. With the ignition switch OFF, connect CONSULT-II and CONSULT-II CONVERTER to the data link connector, then turn the ignition switch ON.

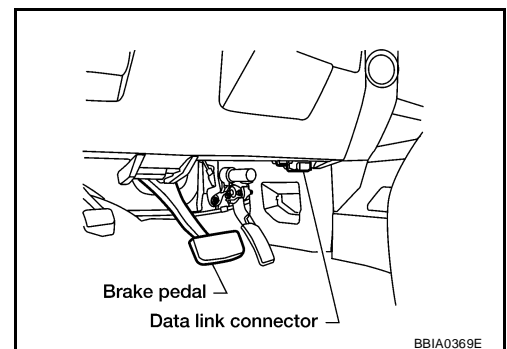

FRONT WIPER AND WASHER SYSTEM

2. Touch "START (NISSAN BASED VHCL)".

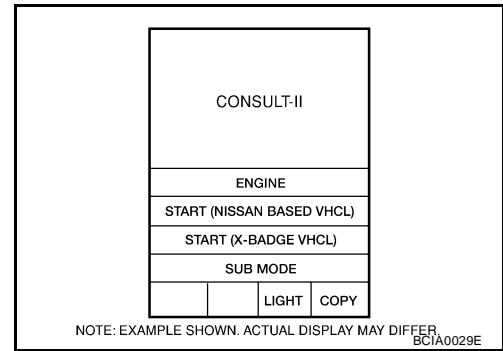

3. Touch "IPDM E/R" on "SELECT SYSTEM" screen.
If "IPDM E/R" is not displayed, go to [GI-39, "CONSULT-II Data Link Connector \(DLC\) Circuit"](#) .

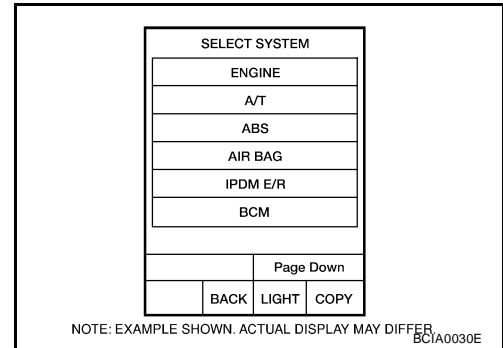

4. Select the desired part to be diagnosed on the "SELECT DIAG MODE" screen.

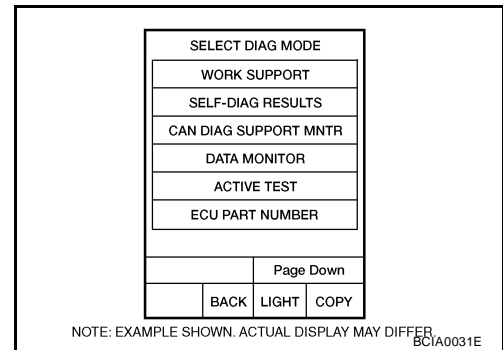

DATA MONITOR

Operation Procedure

1. Touch "WIPER" on the "SELECT TEST ITEM" screen.
2. Touch "DATA MONITOR" on the "SELECT DIAG MODE" screen.
3. Touch "ALL SIGNALS", "MAIN SIGNALS" or "SELECTION FROM MENU" on the "SELECT MONITOR ITEM" screen.

ALL SIGNALS	Monitors all the items.
MAIN SIGNALS	Monitors predetermined items.
SELECTION FROM MENU	Selects and monitors the individual item selected.

4. Touch "START".
5. When "SELECTION FROM MENU" is selected, touch items to be monitored. When "ALL SIGNALS" is selected, all the items will be monitored.
6. Touch "RECORD" while monitoring to record the status of the item being monitored. To stop recording, touch "STOP".

FRONT WIPER AND WASHER SYSTEM

All Signals, Main Signals, Selection From Menu

Item name	CONSULT-II screen display	Display or unit	Monitor item selection			Description
			ALL SIGNALS	MAIN SIGNALS	SELECTION FROM MENU	
Front wiper request	FR WIP REQ	STOP/1LO/LO/HI	x	x	x	Signal status input from BCM.
Wiper auto stop	WIP AUTO STOP	ACT P/STOP P	x	x	x	Output status of IPDM E/R.
Wiper protection	WIP PROT	OFF/LS/HS/BLOCK	x	x	x	Control status of IPDM E/R.

NOTE:

Perform monitoring of IPDM E/R data with the ignition switch ON. When the ignition switch is at ACC, the display may not be correct.

ACTIVE TEST

Operation Procedure

1. Touch "WIPER" on the "SELECT TEST ITEM" screen.
2. Touch "ACTIVE TEST" on the "SELECT DIAG MODE" screen.
3. Touch item(s) to be tested and check operation of the selected item(s).
4. During the operation check, touching "BACK" deactivates the operation.

Display Item List

Test item	CONSULT-II screen display	Description
Front wiper (HI, LO) output	FRONT WIPER	With a certain operation (OFF, HI, LO) front wiper relays can be operated.

Trouble Diagnosis

FRONT WIPER DOES NOT OPERATE

EKS00BE3

CAUTION:

During IPDM E/R fail-safe control, front wipers may not operate. Refer to [PG-17, "CAN COMMUNICATION LINE CONTROL"](#) to make sure that it is not in fail-safe status.

Inspection Procedure

1. CHECK IPDM E/R TO FRONT WIPERS (1)

① With CONSULT-II

1. Select "IPDM E/R" with CONSULT-II, and select "ACTIVE TEST" on "SELECT DIAG MODE" screen.
2. Select "FRONT WIPER" on "SELECT TEST ITEM" screen.

② Without CONSULT-II

1. Turn on front wipers using auto active test. Refer to [PG-22, "Auto Active Test"](#).
2. Confirm front wiper operation.

OK or NG

- OK >> GO TO 4.
 NG >> GO TO 2.

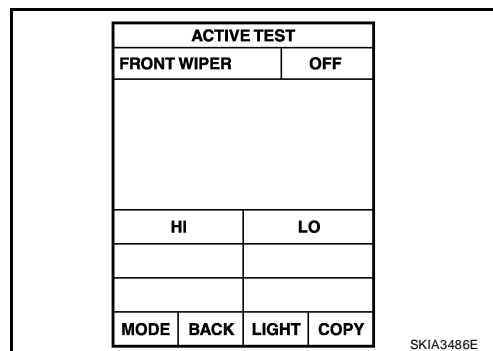

FRONT WIPER AND WASHER SYSTEM

2. IPDM E/R TO FRONT WIPERS (2) INSPECTION

1. Turn ignition switch OFF.
2. Disconnect IPDM E/R connectors and front wiper motor connector.
3. Check continuity between IPDM E/R harness connector terminals and front wiper motor harness connector terminals.

Terminals				Continuity
Connector	Terminal (wire color)	Connector	Terminal (wire color)	
E121	32 (L)	E23	3 (L)	Yes
	35 (L/B)		2 (L/B)	
E122	43 (L/Y)		6 (L/Y)	

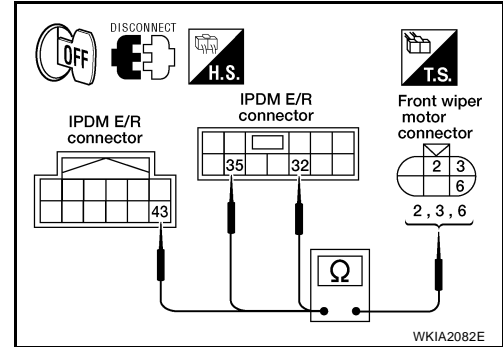

4. Check continuity between IPDM E/R harness connector terminals and ground.

Terminals				Continuity
Connector	Terminal (wire color)			
E121	32 (L)	Ground		No
	35 (L/B)			
E122	43 (L/Y)			

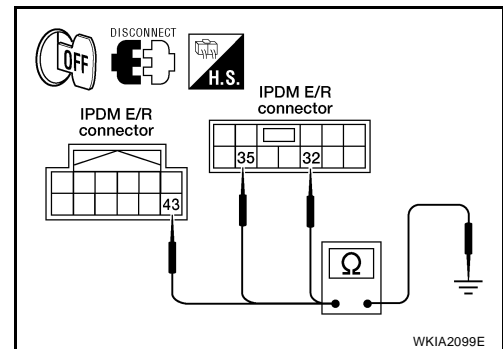

5. Check continuity between IPDM E/R harness connector terminal and ground.

Terminals				Continuity
Connector	Terminal (wire color)			
E122	38 (B)	Ground		Yes
E124	59 (B)			

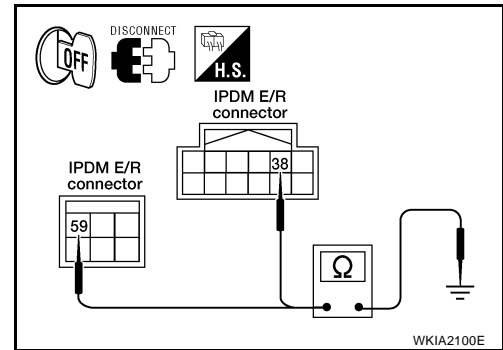

6. Check continuity between front wiper motor harness connector terminal 1 and ground.

Terminals				Continuity
Connector	Terminal (wire color)			
E23	1 (B)	Ground		Yes

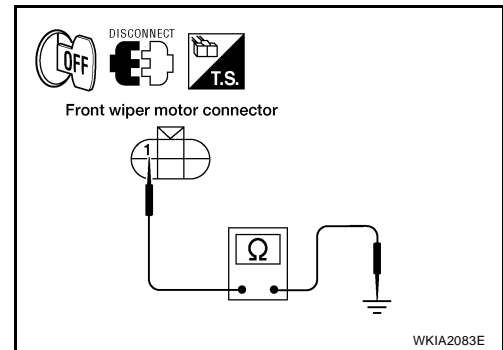

OK or NG

- OK >> Connect connectors. GO TO 3.
- NG >> Check for open circuit in harness between front wiper motor and ground.

FRONT WIPER AND WASHER SYSTEM

3. IPDM E/R INSPECTION

☑ With CONSULT-II

1. Select "HI" on "ACTIVE TEST" screen.
2. When front wiper relay, and front wiper high relay are operating, check voltage between IPDM E/R terminals and ground.

☒ Without CONSULT-II

1. Turn on front wipers using the auto active test. Refer to [PG-22, "Auto Active Test"](#).
2. When front wiper relay, and front wiper high relay are operating, check voltage between IPDM E/R terminals and ground.

Terminals		(-)	Condition	Voltage (Approx.)
(+) Connector Terminal (wire color)				
E121	32 (L)	Ground	Stopped	0
			LO operation	Battery voltage
	35 (L/B)		Stopped	0
			HI operation	Battery voltage

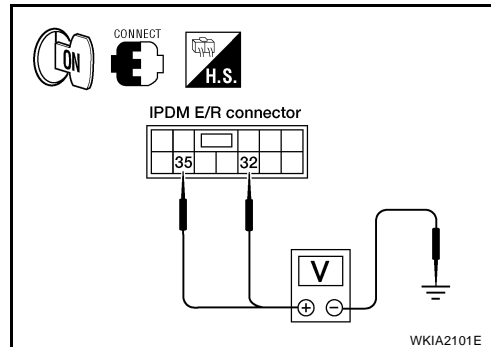

OK or NG

- OK >> Replace the front wiper motor. Refer to [WW-31, "Removal and Installation of Wiper Motor and Linkage"](#).
- NG >> Replace IPDM E/R. Refer to [PG-28, "Removal and Installation of IPDM E/R"](#).

4. COMBINATION SWITCH TO BCM (1) INSPECTION

Select "BCM" on CONSULT-II. With "WIPER" data monitor, check that "FR WIPER INT", "FR WIPER LOW" and "FR WIPER HI" turn ON-OFF according to operation of wiper switch.

OK or NG

- OK >> GO TO 5.
- NG >> Check wiper switch. Refer to [WW-7, "COMBINATION SWITCH READING FUNCTION"](#).

DATA MONITOR	
MONITOR	
IGN ON SW	OFF
IGN SW CAN	ON
FR WIPER HI	OFF
FR WIPER LOW	OFF
FR WIPER INT	OFF
FR WASHER SW	OFF
INT VOLUME	7
FR WIPER STOP	ON
VEHICLE SPEED	0.0 km/h
PAGE DOWN	
RECORD	
MODE	BACK
LIGHT	COPY

5. COMBINATION SWITCH TO BCM (2) INSPECTION

Select "BCM" on CONSULT-II. Carry out self-diagnosis of BCM.

Displayed self-diagnosis results

- NO DTC >> Replace the BCM. Refer to [BCS-20, "Removal and Installation of BCM"](#).
- CAN COMM CIRCUIT >> Check CAN communication line of BCM. GO TO [BCS-13, "CAN Communication Inspection Using CONSULT-II \(Self-Diagnosis\)"](#).

SELF-DIAG RESULTS			
DTC RESULTS		TIME	
CAN COMM CIRCUIT [U1000]		PAST	
ERASE		PRINT	
MODE	BACK	LIGHT	COPY

FRONT WIPER AND WASHER SYSTEM

FRONT WIPER STOP POSITION IS INCORRECT

Inspection Procedure

1. IPDM E/R TO FRONT WIPER MOTOR (1) INSPECTION

Ⓜ With CONSULT-II

Select "IPDM E/R" with CONSULT-II. With data monitor, confirm that "WIP AUTO STOP" changes from "ACT P" to "STOP P" according to wiper operation.

ⓧ Without CONSULT-II

GO TO 2.

OK or NG

OK >> Replace IPDM E/R. Refer to [PG-28, "Removal and Installation of IPDM E/R"](#).

NG >> GO TO 2.

DATA MONITOR	
MONITOR	
MOTOR FAN REQ	1
AC COMP REQ	OFF
TAIL&CLR REQ	OFF
HL LO REQ	OFF
HL HI REQ	OFF
FR FOG REQ	OFF
FR WIP REQ	STOP
WIP AUTO STOP	STOP P
WIP PROT	OFF
Page DOWN	
RECORD	
MODE	BACK
LIGHT	COPY

SKIA5301E

2. IPDM E/R TO FRONT WIPER MOTOR (2) INSPECTION

1. Turn ignition switch OFF.
2. Disconnect IPDM E/R connector and front wiper motor connector.
3. Check continuity between IPDM E/R harness connector and front wiper motor harness connector.

Terminals				Continuity
Connector	Terminal (wire color)	Connector	Terminal (wire color)	
E122	43 (L/Y)	E23	6 (L/Y)	Yes

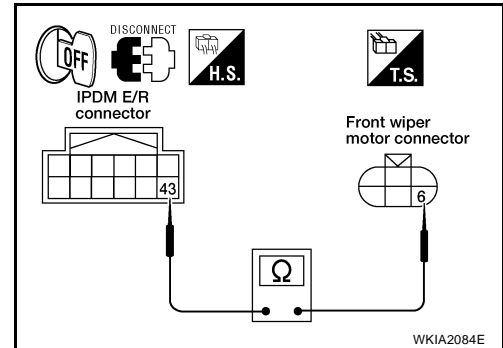

4. Check continuity between IPDM E/R harness connector terminal and ground.

Terminals			Continuity
Connector	Terminal (wire color)	Ground	
E122	43 (L/Y)	Ground	No

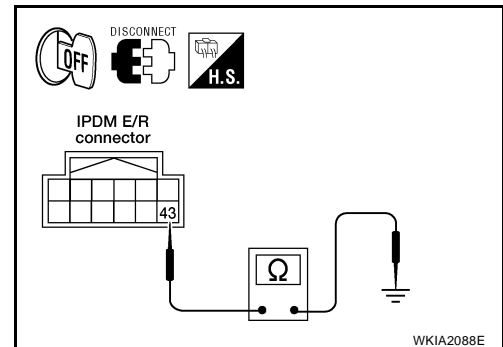

5. Check continuity between front wiper motor harness connector terminal 1 and ground.

Terminals			Continuity
Connector	Terminal (wire color)	Ground	
E23	1 (B)	Ground	Yes

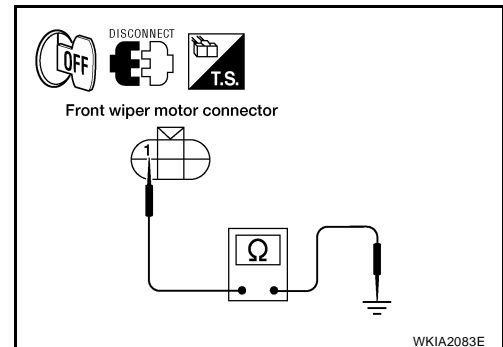

OK or NG

OK >> GO TO 3.

- NG >>
- Check for short circuit or open circuit in harness between IPDM E/R and front wiper motor.
 - Check for open circuit in harness between front wiper motor and ground.

FRONT WIPER AND WASHER SYSTEM

3. IPDM E/R INSPECTION

☑ With CONSULT-II

1. Connect IPDM E/R connector and front wiper motor connector.
2. Select "LO" on "ACTIVE TEST" screen.
3. When front wipers are operating and when stopped, measure voltage between IPDM E/R terminal 43 and ground.

☒ Without CONSULT-II

1. Connect IPDM E/R connector and front wiper motor connector.
2. Turn on front wipers using the auto active test. Refer to [PG-22, "Auto Active Test"](#) .
3. When front wipers are operating and when stopped, measure voltage between IPDM E/R terminal 43 and ground.

Terminals		(-)	Condition	Voltage (Approx.)
(+)				
Connector	Terminal (wire color)			
E122	43 (L/Y)	Ground	Wiper operating	Battery voltage
			Wiper stopped	0

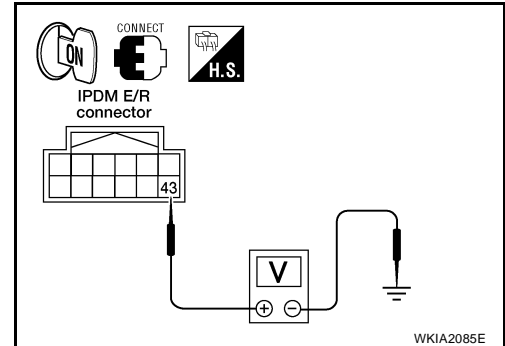

OK or NG

- OK >> Replace IPDM E/R. Refer to [PG-28, "Removal and Installation of IPDM E/R"](#) .
- NG >> Replace front wiper motor. Refer to [WW-31, "Removal and Installation of Wiper Motor and Linkage"](#) .

ONLY FRONT WIPER LOW DOES NOT OPERATE

Inspection Procedure

1. IPDM E/R TO FRONT WIPERS (1) INSPECTION

☑ With CONSULT-II

1. Select "IPDM E/R" with CONSULT-II, and select "ACTIVE TEST" on "SELECT DIAG MODE" screen.
2. Select "FRONT WIPER" on "SELECT TEST ITEM" screen.
3. Select "LO" on "ACTIVE TEST" screen.
4. Confirm front wiper low operation.

☒ Without CONSULT-II

1. Turn on front wipers using auto active test. Refer to [PG-22, "Auto Active Test"](#) .
2. Confirm front wiper low operation.

OK or NG

- OK >> GO TO 4.
- NG >> GO TO 2.

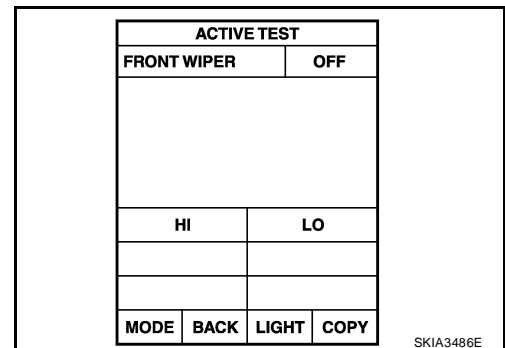

FRONT WIPER AND WASHER SYSTEM

2. IPDM E/R TO FRONT WIPERS (2) INSPECTION

1. Turn ignition switch OFF.
2. Disconnect IPDM E/R connector and front wiper motor connector.
3. Check continuity between IPDM E/R harness connector terminal and front wiper motor harness connector terminal.

Terminals				Continuity
Connector	Terminal (wire color)	Connector	Terminal (wire color)	
E121	32 (L)	E23	3 (L)	Yes

OK or NG

- OK >> GO TO 3.
 NG >> Check for short circuit or open circuit in harness between IPDM E/R and front wiper motor.

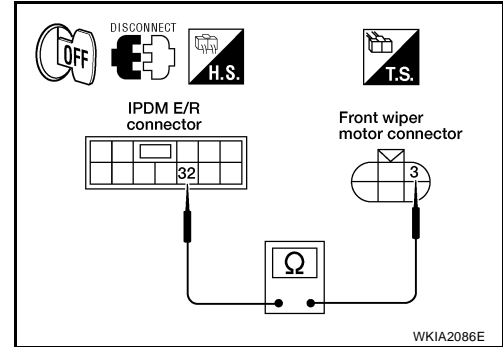

3. IPDM E/R INSPECTION

Ⓚ With CONSULT-II

1. Connect IPDM E/R connector and front wiper motor connector.
2. Select "LO" on "ACTIVE TEST" screen.
3. When front wiper relay is operating, check voltage between IPDM E/R terminals.

ⓧ Without CONSULT-II

1. Connect IPDM E/R connector and front wiper motor connector.
2. Turn on front wipers using the auto active test. Refer to [PG-22, "Auto Active Test"](#).
3. When front wiper relay is operating, check voltage between IPDM E/R terminals.

Terminals				Voltage (Approx.)
(-)		(+)		
Connector	Terminal (wire color)	Connector	Terminal (wire color)	
E122	38 (B)	E121	32 (L)	Battery voltage
E124	59 (B)			

OK or NG

- OK >> Replace the wiper motor. Refer to [WW-31, "Removal and Installation of Wiper Motor and Linkage"](#).
 NG >> Replace IPDM E/R. Refer to [PG-28, "Removal and Installation of IPDM E/R"](#).

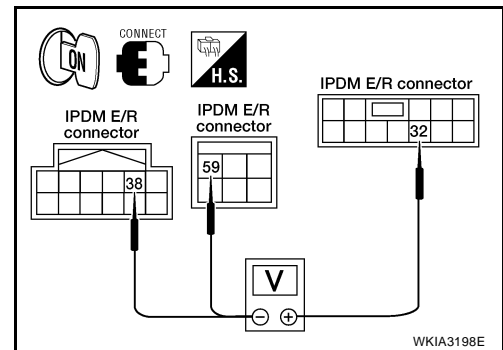

4. COMBINATION SWITCH TO BCM INSPECTION

Select "BCM" on CONSULT-II. With "WIPER" data monitor, check that "FR WIPER HI" turns ON-OFF according to operation of wiper switch.

OK or NG

- OK >> Replace BCM. Refer to [BCS-20, "Removal and Installation of BCM"](#).
 NG >> Replace wiper switch. Refer to [WW-33, "Removal and Installation of Wiper and Washer Switch"](#).

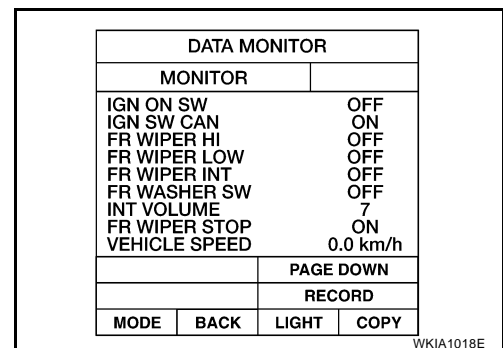

FRONT WIPER AND WASHER SYSTEM

ONLY FRONT WIPER HI DOES NOT OPERATE

Inspection Procedure

1. IPDM E/R TO FRONT WIPERS (1) INSPECTION

Ⓜ With CONSULT-II

1. Select "IPDM E/R" with CONSULT-II, and select "ACTIVE TEST" on "SELECT DIAG MODE" screen.
2. Select "FRONT WIPER" on "SELECT TEST ITEM" screen.
3. Select "HI" on "ACTIVE TEST" screen.
4. Confirm front wiper high operation.

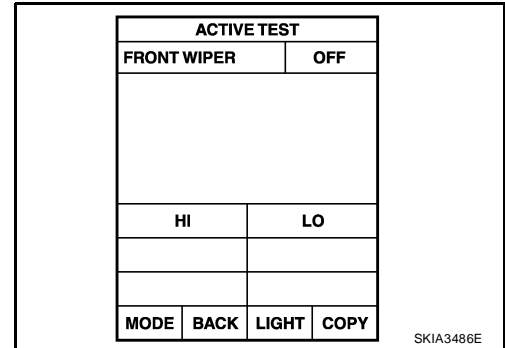

ⓧ Without CONSULT-II

1. Turn on front wipers using auto active test. Refer to [PG-22](#), "Auto Active Test".
2. Confirm front wiper operation.

OK or NG

- OK >> GO TO 4.
- NG >> GO TO 2.

2. IPDM E/R TO FRONT WIPERS (2) INSPECTION

1. Turn ignition switch OFF.
2. Disconnect IPDM E/R connector and front wiper motor connector.
3. Check continuity between IPDM E/R harness connector terminal and front wiper motor harness connector terminal.

Terminals				Continuity
Connector	Terminal (wire color)	Connector	Terminal (wire color)	
E121	35 (L/B)	E23	2 (L/B)	Yes

OK or NG

- OK >> GO TO 3.
- NG >> Check for short circuit or open circuit in harness between IPDM E/R and front wiper motor.

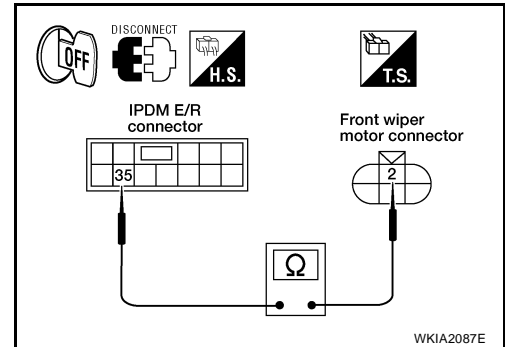

A
B
C
D
E
F
G
H
I
J
L
M

WW

FRONT WIPER AND WASHER SYSTEM

3. IPDM E/R INSPECTION

④ With CONSULT-II

1. Connect IPDM E/R connector and front wiper motor connector.
2. Select "HI" on "ACTIVE TEST" screen.
3. When front wiper high relay is operating, check voltage between IPDM E/R terminals.

⊗ Without CONSULT-II

1. Connect IPDM E/R connector and front wiper motor connector.
2. Turn on front wipers using the auto active test. Refer to [PG-22, "Auto Active Test"](#).
3. When front wiper high relay is operating, check voltage between IPDM E/R terminals.

Terminals				Voltage (Approx.)
(-)		(+)		
Connector	Terminal (wire color)	Connector	Terminal (wire color)	
E122	38 (B)	E121	35 (L/B)	Battery voltage
E124	59 (B)			

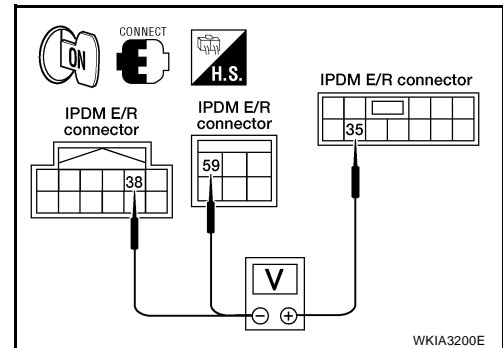

OK or NG

OK >> Replace the wiper motor. Refer to [WW-31, "Removal and Installation of Wiper Motor and Linkage"](#)

NG >> Replace IPDM E/R. Refer to [PG-28, "Removal and Installation of IPDM E/R"](#).

4. COMBINATION SWITCH TO BCM INSPECTION

Select "BCM" on CONSULT-II. With "WIPER" data monitor, check that "FR WIPER HI" turns ON-OFF according to operation of wiper switch.

OK or NG

OK >> Replace BCM. Refer to [BCS-20, "Removal and Installation of BCM"](#).

NG >> Replace wiper switch. Refer to [WW-33, "Removal and Installation of Wiper and Washer Switch"](#).

DATA MONITOR	
MONITOR	
IGN ON SW	OFF
IGN SW CAN	ON
FR WIPER HI	OFF
FR WIPER LOW	OFF
FR WIPER INT	OFF
FR WASHER SW	OFF
INT VOLUME	7
FR WIPER STOP	ON
VEHICLE SPEED	0.0 km/h
PAGE DOWN	
RECORD	
MODE	BACK LIGHT COPY

ONLY FRONT WIPER INT DOES NOT OPERATE

Inspection Procedure

1. COMBINATION SWITCH TO BCM INSPECTION

Select "BCM" on CONSULT-II. With "WIPER" data monitor, check that "FR WIPER INT" turns ON-OFF according to operation of wiper switch.

OK or NG

OK >> Replace BCM. Refer to [BCS-20, "Removal and Installation of BCM"](#).

NG >> Replace wiper switch. Refer to [WW-33, "Removal and Installation of Wiper and Washer Switch"](#).

DATA MONITOR	
MONITOR	
IGN ON SW	OFF
IGN SW CAN	ON
FR WIPER HI	OFF
FR WIPER LOW	OFF
FR WIPER INT	OFF
FR WASHER SW	OFF
INT VOLUME	7
FR WIPER STOP	ON
VEHICLE SPEED	0.0 km/h
PAGE DOWN	
RECORD	
MODE	BACK LIGHT COPY

FRONT WIPER AND WASHER SYSTEM

FRONT WIPER INTERMITTENT OPERATION SWITCH POSITION CANNOT BE ADJUSTED

Inspection Procedure

1. COMBINATION SWITCH TO BCM INSPECTION

Select "BCM" on CONSULT-II. With "WIPER" data monitor, check that "INT VOLUME" changes in order from 1 to 7 according to operation of the intermittent switch dial position.

OK or NG

- OK >> Replace BCM. Refer to [BCS-20, "Removal and Installation of BCM"](#).
- NG >> Replace wiper switch. Refer to [WW-33, "Removal and Installation of Wiper and Washer Switch"](#).

DATA MONITOR			
MONITOR			
IGN ON SW		OFF	
IGN SW CAN		ON	
FR WIPER HI		OFF	
FR WIPER LOW		OFF	
FR WIPER INT		OFF	
FR WASHER SW		OFF	
INT VOLUME		7	
FR WIPER STOP		ON	
VEHICLE SPEED		0.0 km/h	
		PAGE DOWN	
RECORD			
MODE	BACK	LIGHT	COPY

WKIA1018E

WIPERS DO NOT WIPE WHEN FRONT WASHER OPERATES

Inspection Procedure

1. COMBINATION SWITCH TO BCM INSPECTION

Select "BCM" on CONSULT-II. With "WIPER" data monitor, check that "FR WASHER SW" turns ON-OFF according to operation of front washer switch.

OK or NG

- OK >> Replace BCM. Refer to [BCS-20, "Removal and Installation of BCM"](#).
- NG >> Replace wiper switch. Refer to [WW-33, "Removal and Installation of Wiper and Washer Switch"](#).

DATA MONITOR			
MONITOR			
IGN ON SW		OFF	
IGN SW CAN		ON	
FR WIPER HI		OFF	
FR WIPER LOW		OFF	
FR WIPER INT		OFF	
FR WASHER SW		OFF	
INT VOLUME		7	
FR WIPER STOP		ON	
VEHICLE SPEED		0.0 km/h	
		PAGE DOWN	
RECORD			
MODE	BACK	LIGHT	COPY

WKIA1018E

FRONT WIPERS OPERATE FOR 10 SECONDS, STOP FOR 20 SECONDS, AND AFTER REPEATING THIS OPERATION FIVE TIMES, THEY BECOME INOPERATIVE

CAUTION:

- When auto stop signal has not varied for 10 seconds or longer while IPDM E/R is operating front wipers, IPDM E/R considers front wipers locked and stops wiper output, which causes this symptom.
- This status can be checked by using IPDM E/R "DATA MONITOR". Under this condition, "WIP PROT" reads "BLOCK".

Inspection Procedure

1. IPDM E/R TO FRONT WIPER MOTOR (1) INSPECTION

☑ With CONSULT-II

Select "IPDM E/R" with CONSULT-II. With data monitor, confirm that "WIP AUTO STOP" changes from "ACT P" to "STOP P" according to wiper operation.

☒ Without CONSULT-II

GO TO 2.

OK or NG

- OK >> Replace IPDM E/R. Refer to [PG-28, "Removal and Installation of IPDM E/R"](#).
- NG >> GO TO 2.

DATA MONITOR			
MONITOR			
MOTOR FAN REQ		1	
AC COMP REQ		OFF	
TAIL&CLR REQ		OFF	
HL LO REQ		OFF	
HL HI REQ		OFF	
FR FOG REQ		OFF	
FR WIP REQ		STOP	
WIP AUTO STOP		STOP P	
WIP PROT		OFF	
		Page DOWN	
RECORD			
MODE	BACK	LIGHT	COPY

SKIA5301E

FRONT WIPER AND WASHER SYSTEM

2. IPDM E/R TO FRONT WIPER MOTOR (2) INSPECTION

1. Turn ignition switch OFF.
2. Disconnect IPDM E/R connector and front wiper motor connector.
3. Check continuity between IPDM E/R harness connector terminal and front wiper motor harness connector terminal.

Terminals				Continuity
Connector	Terminal (wire color)	Connector	Terminal (wire color)	
E122	43 (L/Y)	E23	6 (L/Y)	Yes

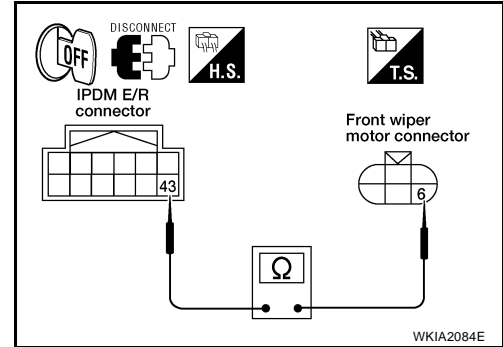

4. Check continuity between IPDM E/R harness connector terminal and ground.

Terminals			Continuity
Connector	Terminal (wire color)	Ground	
E122	43 (L/Y)	Ground	No

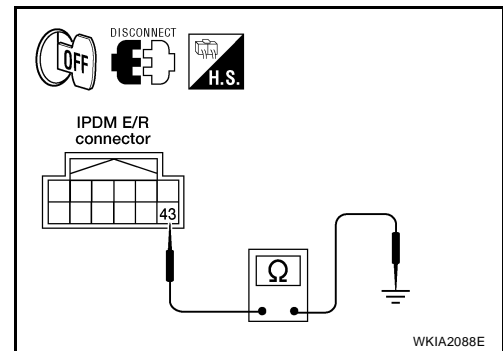

OK or NG

- OK >> Connect connectors. GO TO 3.
- NG >> Repair harness or connector.

3. IPDM E/R TO FRONT WIPER MOTOR (3) INSPECTION

While front wiper motor is stopped and while operating, measure voltage between IPDM E/R terminal 43 and ground.

Terminals				Voltage (Approx.)
(+)		(-)	Condition	
Connector	Terminal (wire color)	Ground	Wiper operating	
E122	43 (L/Y)	Ground	Wiper operating	Battery voltage
			Wiper stopped	0

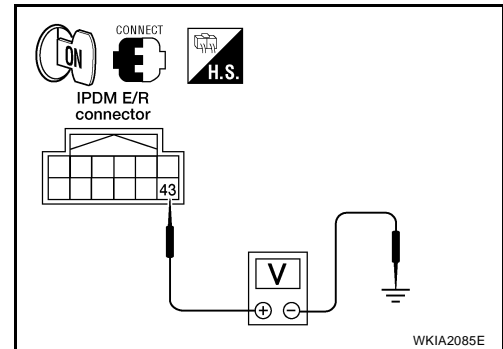

OK or NG

- OK >> Replace IPDM E/R. Refer to [PG-28, "Removal and Installation of IPDM E/R"](#).
- NG >> Replace front wiper motor. Refer to [WW-31, "Removal and Installation of Wiper Motor and Linkage"](#).

FRONT WIPER AND WASHER SYSTEM

Removal and Installation of Front Wiper Arms, Adjustment of Wiper Arms Stop Location

EKS00BE4

REMOVAL

1. Operate the wiper motor, and stop it at the auto stop position.
2. Remove the wiper arm mounting covers.
3. Remove the wiper arm mounting nuts, then remove the wiper arms.

INSTALLATION

1. Prior to wiper arm installation, turn on wiper switch to operate wiper motor and then turn it "OFF" (Auto Stop).
2. Lift the blade up and then set it down onto glass surface to set the blade center to clearance "L1" and "L2" immediately before tightening nut.
3. Eject washer fluid. Turn on wiper switch to operate wiper motor and then turn it "OFF".
4. Ensure that wiper blades stop within clearance "L1" and "L2".

Clearance "L1" : 41.5 - 56.5 mm (1.634 - 2.224 in)

Clearance "L2" : 52.5 - 67.5 mm (2.067 - 2.657 in)

- Before reinstalling wiper arm, clean up the pivot area as illustrated. This will reduce possibility of wiper arm looseness.
- Tighten wiper arm nuts to specified torque.

Front wiper arm nuts : 23.6 N·m (2.4 kg·m, 17 ft·lb)

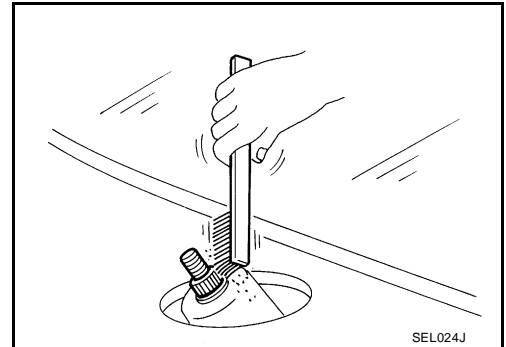
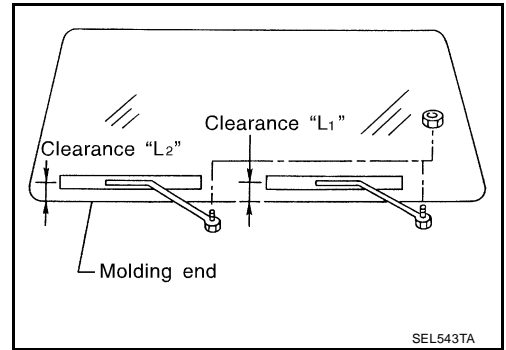

Removal and Installation of Wiper Motor and Linkage

EKS00BE5

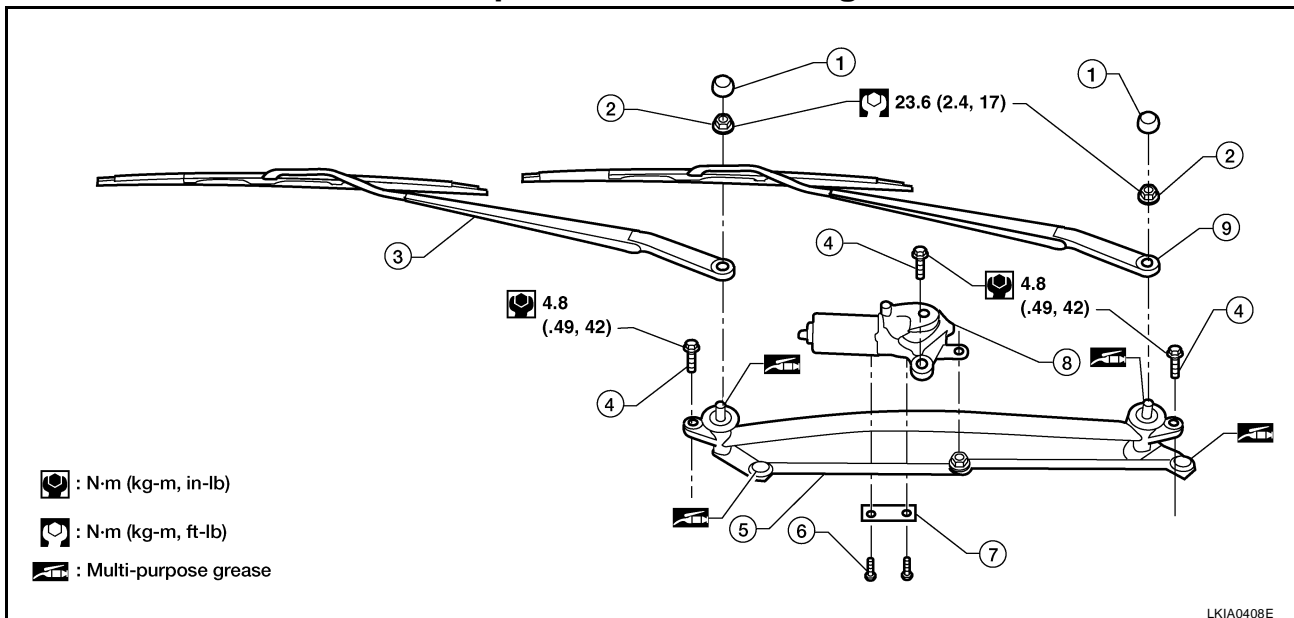

- | | | |
|--------------------------------|----------------------------|--|
| 1. Wiper arm mounting covers | 2. Wiper arm mounting nuts | 3. Front RH wiper arm and blade assembly |
| 4. Wiper frame mounting bolts | 5. Wiper frame assembly | 6. Wiper motor to frame mounting bolts |
| 7. Wiper motor mounting spacer | 8. Wiper motor | 9. Front LH wiper arm and blade assembly |

REMOVAL

1. Operate the wiper motor, and stop it at the auto stop position.

A
B
C
D
E
F
G
H
I
J

WW

L
M

FRONT WIPER AND WASHER SYSTEM

2. Remove wiper arms from the vehicle. Refer to [WW-31, "Removal and Installation of Front Wiper Arms, Adjustment of Wiper Arms Stop Location"](#).
3. Remove the cowl top extension. Refer to [EI-18, "COWL TOP"](#).
4. Disconnect wiper motor connector.
5. Remove cowl top extension bracket.
6. Remove wiper frame assembly mounting bolts, and remove wiper frame assembly.
7. Remove wiper motor from wiper frame assembly.

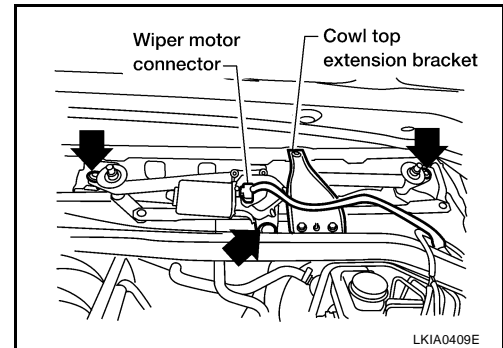

INSTALLATION

CAUTION:

- Do not drop the wiper motor or cause it to contact other parts.
 - Check the grease conditions of the motor arm and wiper link joint(s). Apply grease if necessary.
1. Connect wiper motor to connector. Turn the wiper switch ON to operate wiper motor, then turn the wiper switch OFF (auto stop).
 2. Disconnect wiper motor connector.
 3. Install wiper motor to wiper frame assembly, and install assembly into the vehicle.
 4. Install cowl top extension bracket.
 5. Connect wiper motor connector. Turn the wiper switch ON to operate the wiper motor, then turn wiper switch OFF (auto stop).
 6. Install cowl top extension. Refer to [EI-18, "COWL TOP"](#).
 7. Install wiper arms. Refer to [WW-31, "Removal and Installation of Front Wiper Arms, Adjustment of Wiper Arms Stop Location"](#).

Washer Nozzle Adjustment

- This vehicle is equipped with non-adjustable washer nozzles.
- If not satisfied with washer fluid spray coverage, confirm that the washer nozzle is installed correctly.
- If the washer nozzle is installed correctly, and the washer fluid spray coverage is not satisfactory, replace washer nozzle.

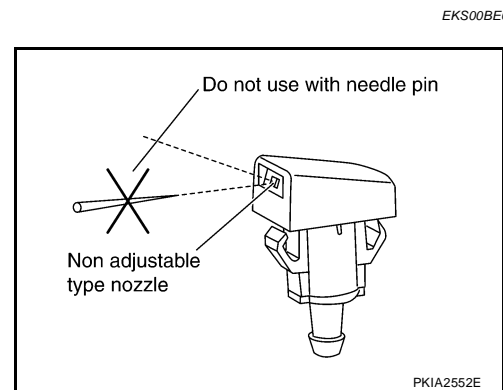

FRONT WIPER AND WASHER SYSTEM

Washer Tube Layout

EKS00BE7

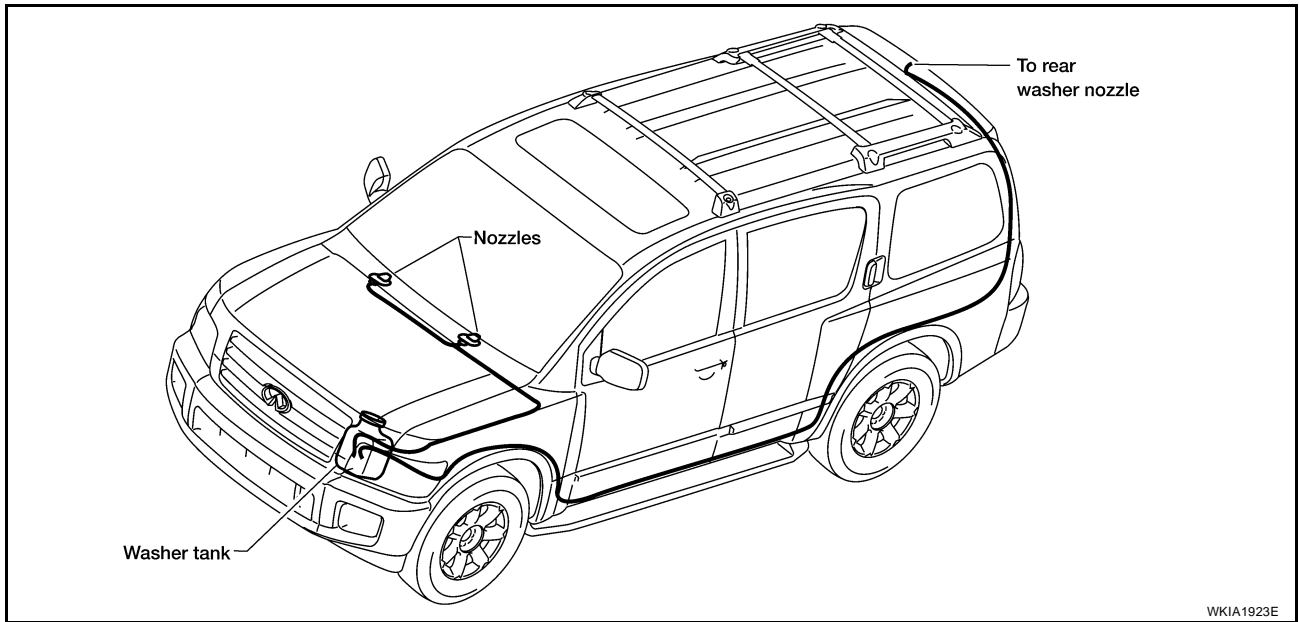

Removal and Installation of Wiper and Washer Switch

EKS00BE8

REMOVAL

1. Remove steering column covers.
2. Remove wiper washer switch connector.
3. Pinch tabs at wiper and washer switch base and slide switch away from steering column to remove.

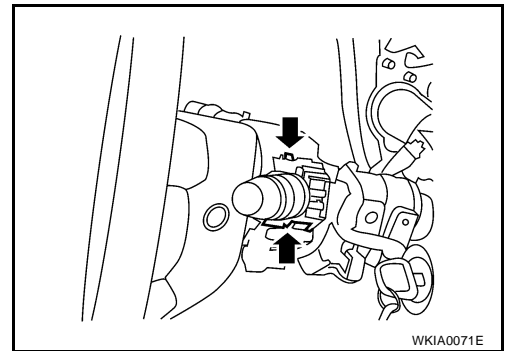

INSTALLATION

Installation is in the reverse order of removal.

Removal and Installation of Washer Tank

EKS00BE9

REMOVAL

1. Remove side washer tank screw.

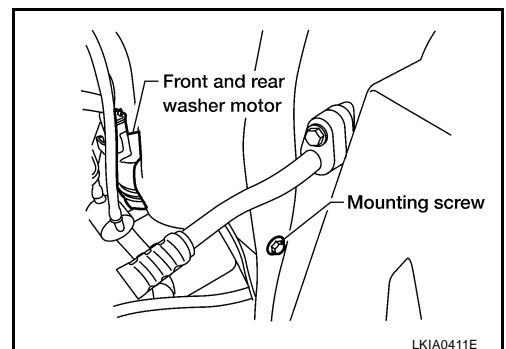

A
B
C
D
E
F
G
H
I
J
L
M

WW

FRONT WIPER AND WASHER SYSTEM

2. Remove front and rear washer motor connector, washer fluid level sensor connector, and front and rear washer hoses.

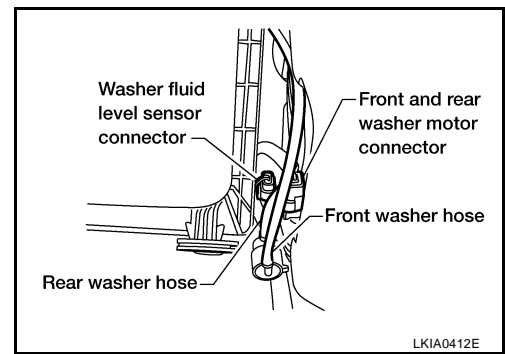

3. Remove front washer tank screw, then remove washer tank.

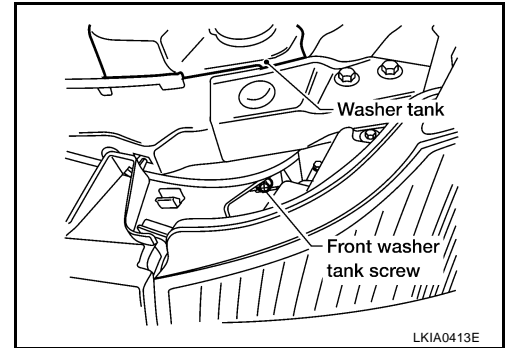

INSTALLATION

CAUTION:

After installation, add water up to the upper level of the washer tank inlet, and check for water leaks. Installation is in the reverse order of removal.

Washer tank installation screws: 5.5 N-m (0.56 kg-m, 49 in-lb)

Removal and Installation of Washer Motor

EKS00BEA

REMOVAL

1. Remove washer tank. Refer to [WW-33, "Removal and Installation of Washer Tank"](#).
2. Pull out front and rear washer motor in the direction of the arrow as shown, and remove the front and rear washer motor from the washer tank.

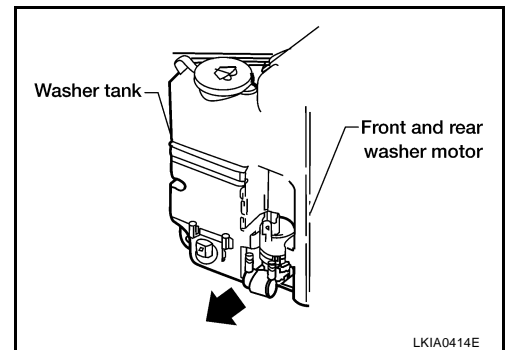

INSTALLATION

CAUTION:

When installing front and rear washer motor, there should be no packing twists, etc. Installation is in the reverse order of removal.

REAR WIPER AND WASHER SYSTEM

PF0:28710

EKS00BEB

REAR WIPER AND WASHER SYSTEM

Components Parts and Harness Connector Location

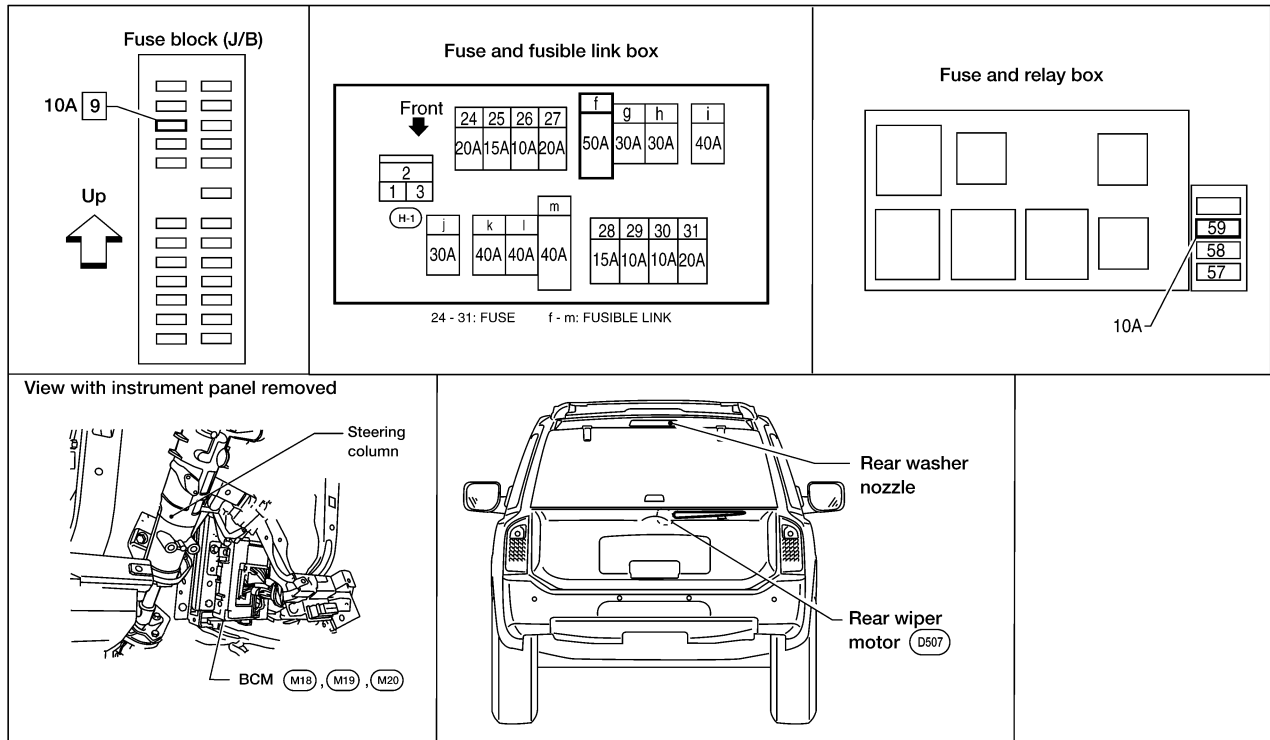

WKIA3462E

EKS00BEC

System Description

- The wiper switch (combination switch) is composed of a combination of 5 output terminals and 5 input terminals. Terminal combination status is read by the BCM (body control module) when switch is turned ON.
- The BCM controls rear wiper ON and INT (intermittent) operation.

Power is supplied at all times

- through 50A fusible link (letter f , located in fusible link box)
- to BCM terminal 70.

With the ignition switch in ON or START position, power is supplied

- through 10A fuse [No. 9, located in fuse block (J/B)]
- to combination switch terminal 14, and
- through 10A fuse (No. 59, located in the fuse and relay box)
- to BCM terminal 38.

Ground is supplied

- to BCM terminal 67 and
- to combination switch terminal 12
- through grounds M57, M61 and M79.

A
B
C
D
E
F
G
H
I
J

WW

L
M

REAR WIPER AND WASHER SYSTEM

REAR WIPER OPERATION

When the ignition switch is in the ON or START position, and the rear wiper switch is in the ON position, the BCM detects a rear wiper ON request through the combination switch (wiper switch) reading function.

The BCM will first check the status of the glass hatch ajar switch before supplying power to the rear wiper motor. If the glass hatch ajar switch is closed (ground) the BCM will not turn on the rear wiper motor. If the glass hatch ajar switch is open (not grounded) the BCM will control the rear wiper motor as follows.

The BCM controls rear wiper motor operation by switching direction of current flow between the two rear wiper motor output circuits.

Power is supplied to output circuit 1 for forward operation (counterclockwise sweep),

- through BCM terminal 55
- to rear wiper motor terminal 4.

Ground is supplied

- to rear wiper motor terminal 6
- through BCM terminal 54
- through BCM terminal 67
- through grounds M57, M61 and M79.

With output circuit 1 power and ground supplied, the rear wiper motor operates in a counterclockwise sweep direction until auto stop switch 1 closes (full sweep position). Auto stop switch 1 supplies ground

- to BCM terminal 44
- through rear wiper motor terminal 2
- through rear wiper motor terminal 5
- through grounds B117 and B132.

When the BCM receives this ground signal it turns off output circuit 1 and turns on output circuit 2.

Power is supplied to output circuit 2 for reverse operation (clockwise sweep),

- through BCM terminal 54
- to rear wiper motor terminal 6.

Ground is supplied

- to rear wiper motor terminal 4
- through BCM terminal 55
- through BCM terminal 67
- through grounds M57, M61 and M79.

With output circuit 2 power and ground supplied the rear wiper motor operates in a clockwise sweep direction until auto stop switch 2 closes (full sweep position). Auto stop switch 2 supplies ground

- to BCM terminal 26
- through rear wiper motor terminal 1
- through rear wiper motor terminal 3
- through grounds B117 and B132.

When the BCM receives this ground signal it turns off output circuit 2 and turns on output circuit 1. This process repeats until the rear wiper switch or ignition switch is turned off.

If the ignition switch is turned to OFF during operation, the rear wiper motor will immediately stop. If the ignition switch is turned ON after this condition, and the BCM does not receive a rear wiper switch ON or INT signal, the BCM will operate the rear wiper to the auto stop position.

If the BCM does not receive a change in status in either auto stop switch 1 or auto stop switch 2 within a 5 second period of output circuit 1 or output circuit 2 operation, the BCM will turn off output circuit 1 and output circuit 2.

If the BCM detects the rear door glass ajar signal during rear wiper motor operation, the BCM will operate the rear wiper motor to the auto stop position. Once the rear door glass ajar signal returns to open (not grounded) for 5 or more seconds, the BCM will resume rear wiper motor operation.

INTERMITTENT OPERATION

The rear wiper motor operates the wiper arm at low speed approximately every 7 seconds.

When the wiper switch is in the rear wiper INT position, the BCM detects a rear wiper INT request through the combination switch (wiper switch) reading function.

REAR WIPER AND WASHER SYSTEM

The BCM controls rear wiper motor operation by switching direction of current flow between the two rear wiper motor output circuits.

Power is supplied to output circuit 1 for forward operation (counterclockwise sweep),

- through BCM terminal 55
- to rear wiper motor terminal 4.

Ground is supplied

- to rear wiper motor terminal 6
- through BCM terminal 54
- through BCM terminal 67
- through grounds M57, M61 and M79.

With output circuit 1 power and ground supplied, the rear wiper motor operates in a counterclockwise sweep direction until auto stop switch 1 closes (full sweep position). Auto stop switch 1 supplies ground

- to BCM terminal 44
- through rear wiper motor terminal 2
- through rear wiper motor terminal 5
- through grounds B117 and B132.

When the BCM receives this ground signal it turns off output circuit 1 and turns on output circuit 2.

Power is supplied to output circuit 2 for reverse operation (clockwise sweep),

- through BCM terminal 54
- to rear wiper motor terminal 6.

Ground is supplied

- to rear wiper motor terminal 4
- through BCM terminal 55
- through BCM terminal 67
- through grounds M57, M61 and M79.

With output circuit 2 power and ground supplied the rear wiper motor operates in a clockwise sweep direction until auto stop switch 2 closes (full sweep position). Auto stop switch 2 supplies ground

- to BCM terminal 26
- through rear wiper motor terminal 1
- through rear wiper motor terminal 3
- through grounds B117 and B132.

When the BCM receives this ground signal it turns off output circuit 2 and starts the timing function of 7 seconds. After approximately 7 seconds the BCM turns on output circuit 1. This process repeats until the rear wiper switch or ignition switch is turned off.

AUTO STOP OPERATION

When the rear wiper switch is turned off, the BCM will continue the cycle of output circuit 1 or output circuit 2 until auto stop switch 1 and auto stop switch 2 are both in the closed position. When the BCM receives ground signals from auto stop switch 1 and auto stop switch 2 simultaneously, output circuit 1 and output circuit 2 are both turned off.

REAR WASHER OPERATION

When the ignition switch is in the ON or START position, and the front and rear washer switches are OFF, the front and rear washer motor is supplied power

- through 10A fuse (No. 9, located in the fuse block J/B)
- through combination switch (wiper switch) terminal 14
- through combination switch (wiper switch) terminal 11
- to front and rear washer motor terminal 2, and
- through combination switch (wiper switch) terminal 13
- to front and rear washer motor terminal 1.

When the rear wiper switch is in rear washer position, the BCM detects a rear washer signal by BCM wiper switch reading function. Combination switch ground is supplied

- to front and rear washer motor terminal 1

A
B
C
D
E
F
G
H
I
J

WW

L
M

REAR WIPER AND WASHER SYSTEM

- through combination switch (wiper switch) terminal 13
- through combination switch (wiper switch) terminal 12
- through grounds M57, M61 and M79.

With ground supplied, the front and rear washer motor is operated in the rear direction.

When the BCM detects that the rear washer motor has operated for 0.4 seconds or longer, BCM operates the rear wiper motor.

When the BCM detects that the rear washer switch is in OFF, the rear wiper motor cycles approximately 3 times and then stops.

If the rear washer is operated with the rear wiper switch in the INT position, normal rear wiper operation will take over. Once the rear washer switch is released the rear wiper will return to INT operation.

BCM WIPER SWITCH READING FUNCTION

Refer to [WW-7, "COMBINATION SWITCH READING FUNCTION"](#) .

REAR WIPER AND WASHER SYSTEM

Wiring Diagram — WIP/R —

EKS00BED

WW-WIP/R-01

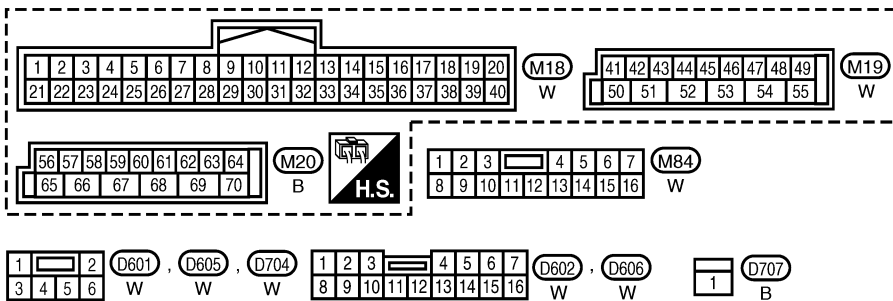
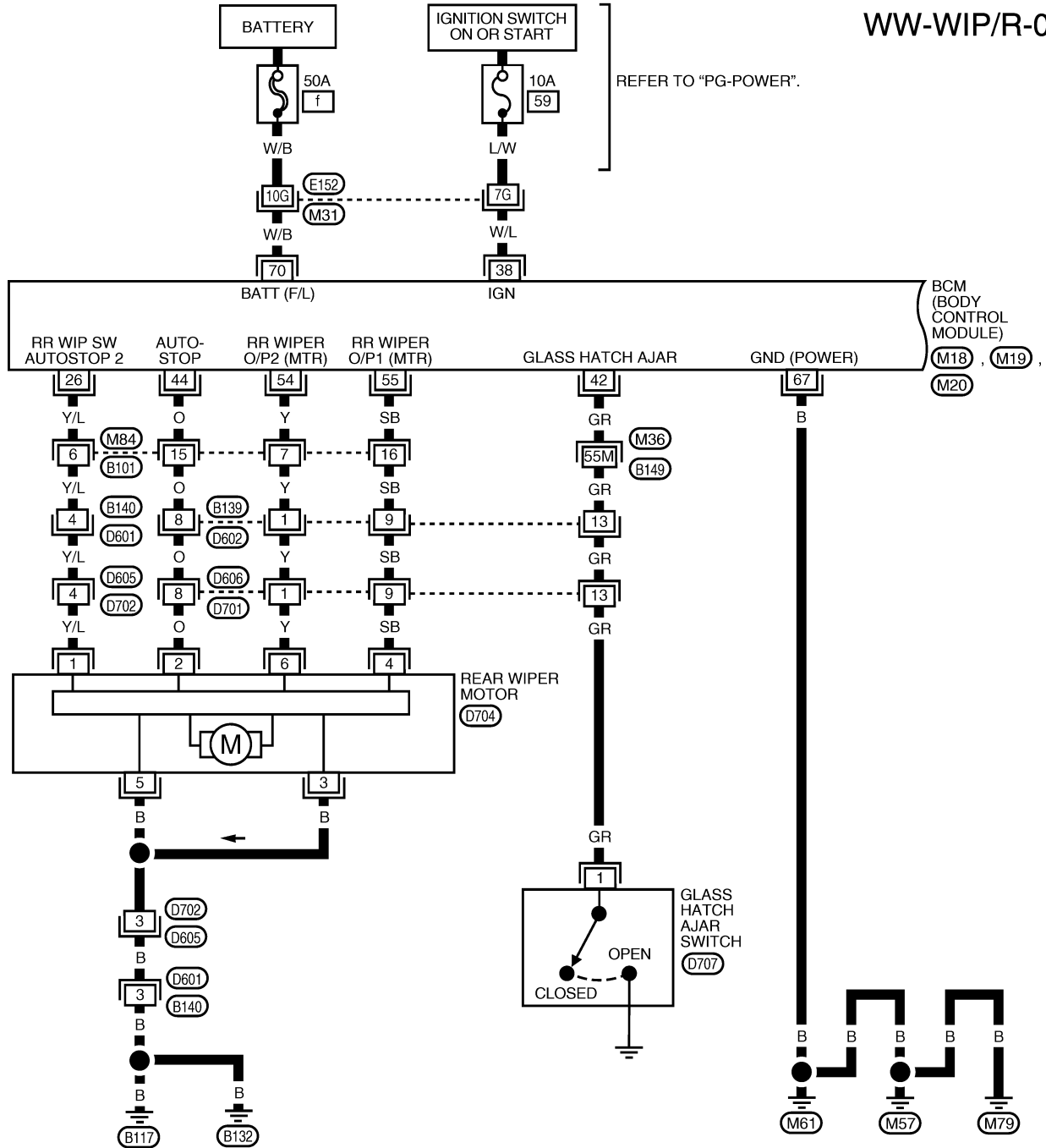

REFER TO THE FOLLOWING.
 (M31), (M36) - SUPER
 MULTIPLE JUNCTION (SMJ)

REAR WIPER AND WASHER SYSTEM

WW-WIP/R-02

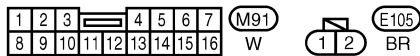
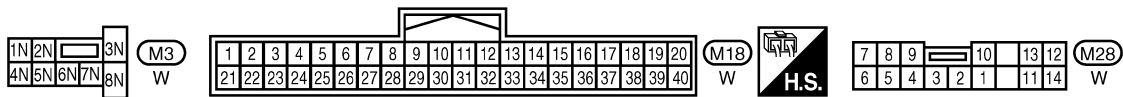
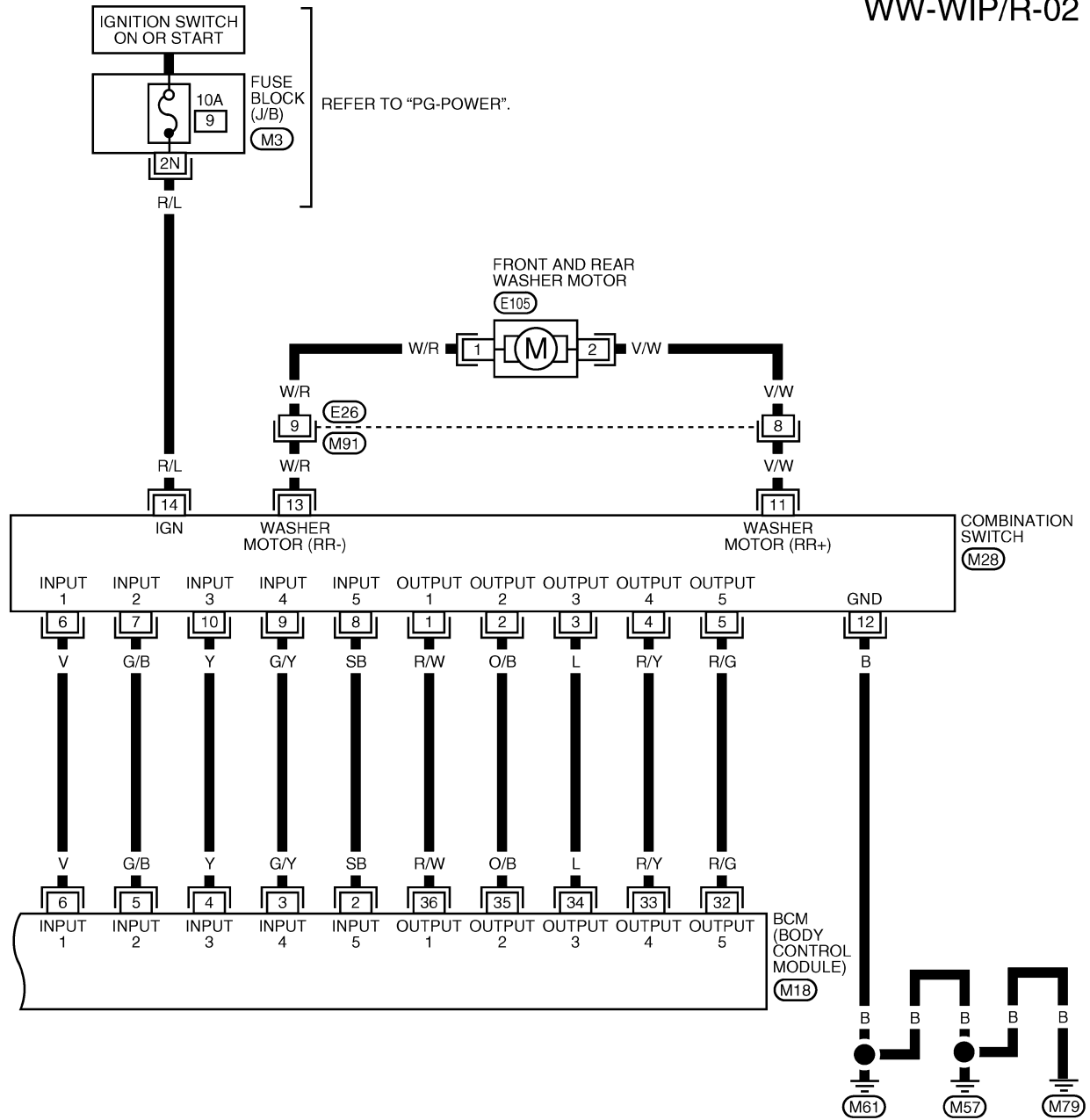





WKWA1390E

REAR WIPER AND WASHER SYSTEM

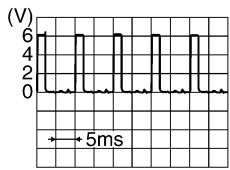
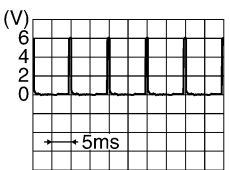
Terminals and Reference Values for BCM

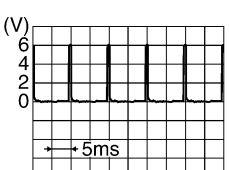
EKS00BEE

Terminal No.	Wire color	Signal name	Measuring condition		Reference Value (V) (Approx.)
			Ignition switch	Operation or condition	
2	SB	Combination switch input 5	ON	<ul style="list-style-type: none"> Light switch and wiper switch OFF Wiper dial position 4 	 <p style="text-align: right; font-size: small;">SKIA5291E</p>
3	G/Y	Combination switch input 4	ON	<ul style="list-style-type: none"> Light switch and wiper switch OFF Wiper dial position 4 	 <p style="text-align: right; font-size: small;">SKIA5292E</p>
4	Y	Combination switch input 3	ON	<ul style="list-style-type: none"> Light switch and wiper switch OFF Wiper dial position 4 	 <p style="text-align: right; font-size: small;">SKIA5291E</p>
5	G/B	Combination switch input 2	ON	<ul style="list-style-type: none"> Light switch and wiper switch OFF Wiper dial position 4 	 <p style="text-align: right; font-size: small;">SKIA5292E</p>
6	V	Combination switch input 1	ON		
26	Y/L	Rear wiper auto stop switch 2	ON	Rise up position (rear wiper arm on stopper)	0V
				A Position (full clockwise stop position)	0V
				Forward sweep (counterclockwise direction)	Fluctuating
				B Position (full counterclockwise stop position)	Battery voltage
				Reverse sweep (clockwise direction)	Fluctuating
32	R/G	Combination switch output 5	ON	<ul style="list-style-type: none"> Light switch and wiper switch OFF Wiper dial position 4 	 <p style="text-align: right; font-size: small;">SKIA5291E</p>

A
B
C
D
E
F
G
H
I
J
WW
L
M

REAR WIPER AND WASHER SYSTEM

Terminal No.	Wire color	Signal name	Measuring condition		Reference Value (V) (Approx.)
			Ignition switch	Operation or condition	
33	R/Y	Combination switch output 4	ON	<ul style="list-style-type: none"> ● Light switch and wiper switch OFF ● Wiper dial position 4 	<p style="text-align: right; font-size: small;">SKIA5292E</p>
34	L	Combination switch output 3	ON	<ul style="list-style-type: none"> ● Light switch and wiper switch OFF ● Wiper dial position 4 	<p style="text-align: right; font-size: small;">SKIA5291E</p>
35	O/B	Combination switch output 2	ON	<ul style="list-style-type: none"> ● Light switch and wiper switch OFF ● Wiper dial position 4 	<p style="text-align: right; font-size: small;">SKIA5292E</p>
36	R/W	Combination switch output 1	ON		
38	W/L	Ignition switch (ON)	ON	—	Battery voltage
42	GR	Glass hatch ajar switch signal	ON	Hatch glass closed	Battery voltage
				Hatch glass open	0V
44	O	Rear wiper auto stop switch 1	ON	Rise up position (rear wiper arm on stopper)	0V
				A Position (full clockwise stop position)	Battery voltage
				Forward sweep (counterclockwise direction)	Fluctuating
				B Position (full counterclockwise stop position)	0V
				Reverse sweep (clockwise direction)	Fluctuating
54	Y	Rear wiper output circuit 2	ON	Rise up position (rear wiper arm on stopper)	0V
				A Position (full clockwise stop position)	0V
				Forward sweep (counterclockwise direction)	0V
				B Position (full counterclockwise stop position)	Battery voltage
				Reverse sweep (clockwise direction)	Battery voltage

REAR WIPER AND WASHER SYSTEM

Terminal No.	Wire color	Signal name	Measuring condition		Reference Value (V) (Approx.)
			Ignition switch	Operation or condition	
55	SB	Rear wiper output circuit 1	ON	Rise up position (rear wiper arm on stopper)	0V (except battery voltage at initial rear wiper ON to lift arm off stop)
				A Position (full clockwise stop position)	Battery voltage
				Forward sweep (counterclockwise direction)	Battery voltage
				B Position (full counterclockwise stop position)	0V
				Reverse sweep (clockwise direction)	0V
67	B	Ground	ON	—	0V
70	W/B	Battery power	OFF	—	Battery voltage

How to Proceed With Trouble Diagnosis

EKS00BEF

1. Confirm the symptoms and customer complaint.
2. Understand operation description and function description. Refer to [WW-35, "System Description"](#).
3. Perform the Preliminary Check. Refer to [WW-43, "Preliminary Inspection"](#).
4. Check symptom and repair or replace the cause of malfunction.
5. Does the rear wiper operate normally? If YES: GO TO 6. If NO: GO TO 4.
6. Inspection End.

Preliminary Inspection INSPECTION FOR POWER SUPPLY AND GROUND CIRCUIT

EKS00BEG

Inspection procedure

1. CHECK FUSE

Check if wiper or washer fuse is blown.

Unit	Power source	Fuse No.
Front and rear washer motor	Ignition ON or START	9
BCM	Ignition ON or START	59
	Battery	f

OK or NG

- OK >> GO TO 2.
 NG >> If fuse is blown, be sure to eliminate cause of problem before installing new fuse. Refer to [PG-4, "POWER SUPPLY ROUTING CIRCUIT"](#).

REAR WIPER AND WASHER SYSTEM

2. CHECK POWER SUPPLY CIRCUIT

1. Disconnect BCM connectors.
2. Check voltage between BCM harness connector terminals and ground.

Terminals		(-)	Ignition switch position	
(+)			OFF	ON
Connector	Terminal (Wire color)	Ground	0V	Battery voltage
M18	38 (W/L)		Battery voltage	Battery voltage
M20	70 (W/B)			

OK or NG

OK >> GO TO 3.

NG >> Check harness for open or short between BCM and fuse.

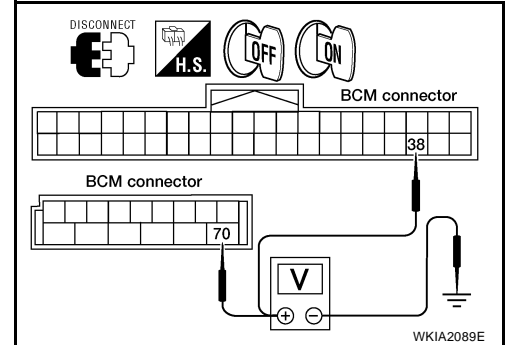

3. GROUND CIRCUIT INSPECTION (BCM)

Check for continuity between the BCM terminal and ground.

Terminals			Ignition switch condition	Continuity
Connector	Terminal (wire color)			
M20	67 (B)	Ground	OFF	Yes

OK or NG

OK >> Inspection End.

NG >> Repair/replace BCM ground circuit.

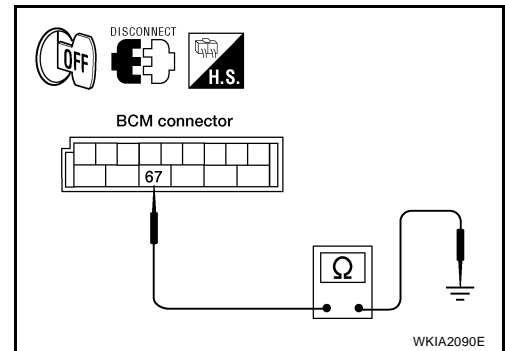

REAR WIPER AND WASHER SYSTEM

CONSULT-II Function (BCM)

EKS00BEH

CONSULT-II can display each diagnostic item using the diagnostic test modes shown following.

BCM diagnostic test item	Diagnostic mode	Description
Inspection by part	WORK SUPPORT	Supports inspections and adjustments. Commands are transmitted to the BCM for setting the status suitable for required operation, input/output signals are received from the BCM and received data is displayed.
	DATA MONITOR	Displays BCM input/output data in real time.
	ACTIVE TEST	Operation of electrical loads can be checked by sending drive signal to them.
	SELF-DIAG RESULTS	Displays BCM self-diagnosis results.
	CAN DIAG SUPPORT MNTR	The result of transmit/receive diagnosis of CAN communication can be read.
	ECU PART NUMBER	BCM part number can be read.
	CONFIGURATION	Performs BCM configuration read/write functions.

CONSULT-II OPERATION

CAUTION:

If CONSULT-II is used with no connection of CONSULT-II CONVERTER, malfunctions might be detected in self-diagnosis depending on control unit which carries out CAN communication.

1. With the ignition switch OFF, connect CONSULT-II and CONSULT-II CONVERTER to the data link connector, then turn the ignition switch ON.

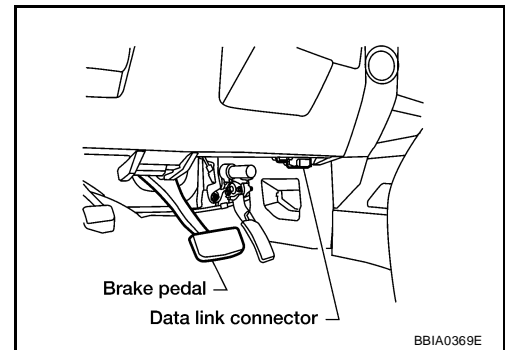

2. Touch "START (NISSAN BASED VHCL)".

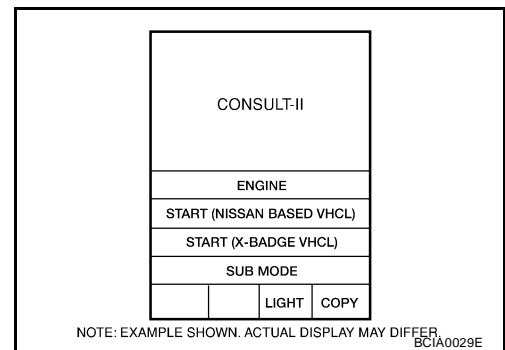

3. Touch "BCM" on the "SELECT SYSTEM" screen. If "BCM" is not indicated, go to [GI-39, "CONSULT-II Data Link Connector \(DLC\) Circuit"](#).

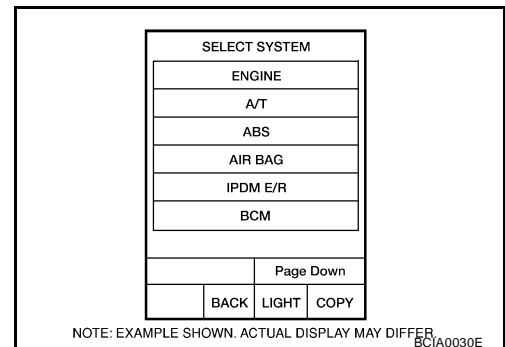

REAR WIPER AND WASHER SYSTEM

4. Select the desired part to be diagnosed on the "SELECT TEST ITEM" screen.

SELECT TEST ITEM			
HEAD LAMP			
WIPER			
FLASHER			
AIR CONDITIONER			
COMB SW			
BCM			
Scroll Up		Page Down	
BACK	LIGHT	COPY	

LKIA0183E

DATA MONITOR

Operation Procedure

1. Touch "WIPER" on "SELECT TEST ITEM" screen.
2. Touch "DATA MONITOR" on "SELECT DIAG MODE" screen.
3. Touch either "ALL SIGNALS" or "SELECTION FROM MENU" on "SELECT MONITOR ITEM" screen.

All signals	Monitors all the items.
Selection from menu	Selects and monitors the individual item selected.

4. Touch "START".
5. When "SELECTION FROM MENU" is selected, touch items to be monitored. When "ALL SIGNALS" is selected, all the items will be monitored.
6. Touch "RECORD" while monitoring, then the status of the monitored item can be recorded. To stop recording, touch "STOP".

Display Item List

Monitor item name "OPERATION OR UNIT"	Contents
IGN ON SW "ON/OFF"	Displays "IGN Position (ON)/OFF, ACC Position (OFF)" status as judged from ignition switch signal.
IGN SW CAN "ON/OFF"	Displays "IGN Position (ON)/OFF, ACC Position (OFF)" status as judged from CAN communications.
FR WIPER INT "ON/OFF"	Displays "Front Wiper INT (ON)/Other (OFF)" status as judged from wiper switch signal.
FR WIPER LOW "ON/OFF"	Displays "Front Wiper LOW (ON)/Other (OFF)" status as judged from wiper switch signal.
FR WIPER HI "ON/OFF"	Displays "Front Wiper HI (ON)/Other (OFF)" status as judged from wiper switch signal.
FR WASHER SW "ON/OFF"	Displays "Front Washer Switch (ON)/Other (OFF)" status as judged from wiper switch signal.
INT VOLUME (1 - 7)	Displays intermittent operation dial position setting (1 - 7) as judged from wiper switch signal.
VEHICLE SPEED "0.0 km/h"	Displays vehicle speed as received over CAN communication.
FR WIPER STOP "ON/OFF"	Displays "Stopped (ON)/Operating (OFF)" status as judged from the auto stop signal.
RR WIPER INT "ON/OFF"	Displays "Rear Wiper INT (ON)/Other (OFF)" status as judged from wiper switch signal.
RR WIPER ON "ON/OFF"	Displays "Rear Wiper (ON)/Other (OFF)" status as judged from wiper switch signal.
RR WASHER SW "ON/OFF"	Displays "Rear Washer Switch (ON)/Other (OFF)" status as judged from wiper switch signal.
RR WIPER STOP "ON/OFF"	Displays "Stopped (OFF)/Operating (ON)" status as judged from the auto stop switch 1.
RR AUTO STP 2 "ON/OFF"	Displays "Stopped (OFF)/Operating (ON)" status as judged from the auto stop switch 2.

ACTIVE TEST

Operation Procedure

1. Touch "WIPERS" on the "SELECT TEST ITEM" screen.
2. Touch "ACTIVE TEST" on the "SELECT DIAG MODE" screen.
3. Touch item to be tested and check operation of the selected item.
4. During the operation check, touching "BACK" deactivates the operation.

REAR WIPER AND WASHER SYSTEM

Display Item List

Test item	Display on CONSULT-II screen	Description
Front wiper HI output	FR WIPER (HI)	Front wiper HI can be operated by any ON-OFF operation.
Front wiper LO output	FR WIPER (LO)	Front wiper LO can be operated by any ON-OFF operation.
Front wiper INT output	FR WIPER (INT)	Front wiper INT can be operated by any ON-OFF operation.
Rear wiper output	RR WIPER	Rear wiper can be operated by any ON-OFF operation.

Rear Wiper Does Not Operate

EKS00BEI

1. REAR WIPER ACTIVE TEST

1. Turn on rear wiper using "ACTIVE TEST". Refer to [WW-46, "ACTIVE TEST"](#).
2. Make sure rear wiper operates.

Wiper should operate.

OK or NG

- OK >> GO TO 7.
NG >> GO TO 2.

2. CHECK REAR WIPER MOTOR CIRCUITS

1. Turn ignition switch OFF.
2. Disconnect BCM connector and rear wiper motor connector.
3. Check continuity between BCM harness connector terminals and rear wiper motor harness connector terminals.

Terminals				Continuity
Connector	Terminal (wire color)	Connector	Terminal (wire color)	
M19	55 (SB)	D704	4 (SB)	Yes
	54 (Y)		6 (Y)	

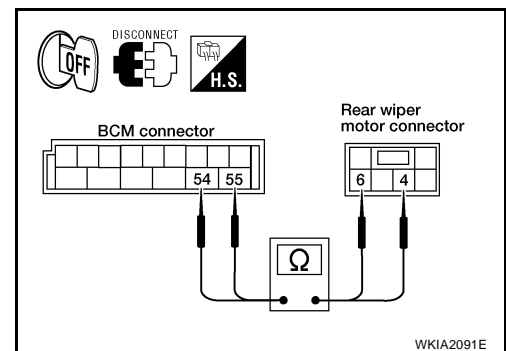

OK or NO

- OK >> GO TO 3.
NO >> Repair harness or connector.

3. CHECK GLASS HATCH AJAR SWITCH

1. Make sure hatch glass is closed.
2. Check continuity between BCM connector M19 terminal 42 (GR) and ground.

42 (GR) - Ground : Continuity should not exist.

OK or NG

- OK >> GO TO 4.
NG >> Repair harness if shorted. If not, refer to [BL-117, "GLASS HATCH AJAR SWITCH CHECK"](#) for further glass hatch ajar switch diagnosis.

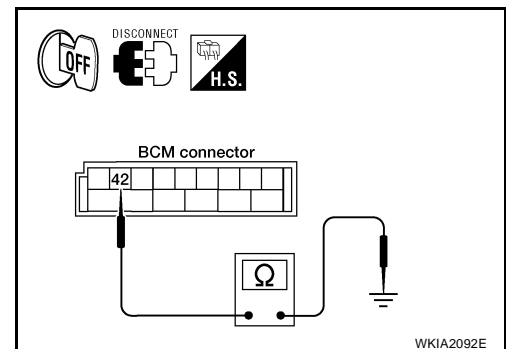

REAR WIPER AND WASHER SYSTEM

4. CHECK REAR WIPER MOTOR AUTO STOP CIRCUITS

1. Disconnect BCM connector M18.
2. Check continuity between BCM harness connector terminals and rear wiper motor harness connector terminals.

Terminals				Continuity
Connector	Terminal (wire color)	Connector	Terminal (wire color)	
M18	26 (Y/L)	D704	1 (Y/L)	Yes
M19	44 (O)		2 (O)	

OK or NO

OK >> GO TO 5.

NO >> Repair harness or connector.

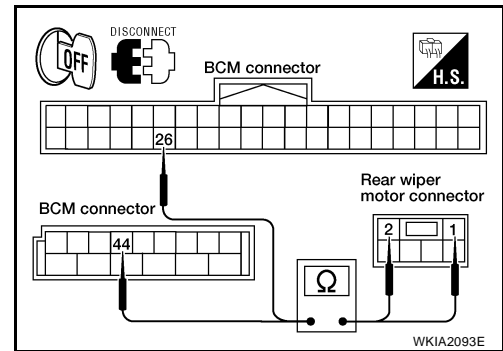

5. CHECK REAR WIPER MOTOR AUTO STOP SWITCH GROUNDS

Check continuity between rear wiper motor harness connector D704 terminals and ground.

Terminals			Continuity
Connector	Terminal (wire color)		
D704	3 (B)	Ground	Yes
	5 (B)		

OK or NG

OK >> GO TO 6.

NG >> Repair harness or connector.

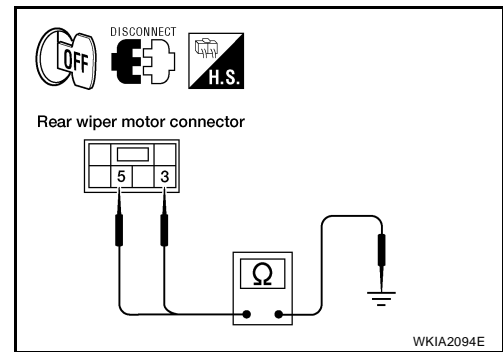

6. CHECK REAR WIPER OPERATING

1. Connect BCM connectors and rear wiper motor connector.
2. Select "RR WIPER" during "ACTIVE TEST". Refer to [WW-46, "ACTIVE TEST"](#). When rear wiper is operating, check voltage between BCM connector terminals.

Connector	Terminals		Condition	Voltage (Approx.)
	(+) Terminal (wire color)	(-)		
M19	54 (Y)	Ground	Operating	Fluctuating
	55 (SB)		End of travel (stopped)	0

OK or NG

OK >> Replace rear wiper motor. Refer to [WW-53, "Removal and Installation of Rear Wiper Motor"](#).

NG >> Replace BCM. Refer to [BCS-20, "Removal and Installation of BCM"](#).

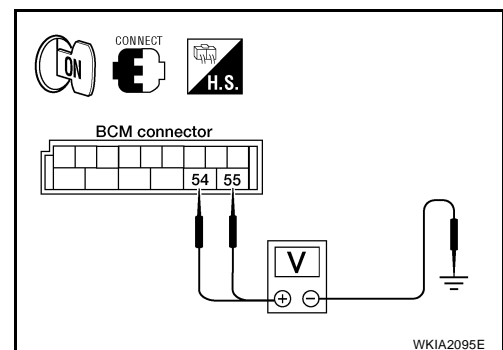

REAR WIPER AND WASHER SYSTEM

7. CHECK COMBINATION SWITCH INPUT SIGNAL

Select "BCM" on CONSULT-II. With "WIPER" data monitor, make sure "RR WIPER INT", "RR WIPER ON" turn ON-OFF according to operation of wiper switch.

When wiper switch is in INT position : RR WIPER INT ON

When wiper switch is in ON position : RR WIPER ON ON

OK or NG

OK >> Replace BCM. Refer to [BCS-20, "Removal and Installation of BCM"](#).

NG >> Check the wiper switch. Refer to [WW-7, "COMBINATION SWITCH READING FUNCTION"](#).

DATA MONITOR	
MONITOR	
RR WIPER INT	ON
RR WIPER ON	ON

SKIA4243E

Rear Wiper Stop Position Is Incorrect

EKS00BEJ

1. CHECK AUTO STOP SWITCH INPUT SIGNALS

Select "BCM" on CONSULT-II. With "WIPER" data monitor, make sure "RR WIPER STOP" and "RR AUTO STOP 2" turn ON-OFF according to wiper operation.

When wiper switch is OFF and arm on stop : RR WIPER STOP ON
: RR AUTO STOP 2 ON

When wiper switch is ON and arm in position A : RR WIPER STOP OFF
: RR AUTO STOP 2 ON

When wiper switch is ON counterclockwise sweep : RR WIPER STOP OFF
: RR AUTO STOP 2 OFF

When wiper switch is ON and arm in position B : RR WIPER STOP ON
: RR AUTO STOP 2 OFF

When wiper switch is ON clockwise sweep : RR WIPER STOP OFF
: RR AUTO STOP 2 OFF

When wiper switch is ON and arm in position A : RR WIPER STOP ON
: RR AUTO STOP 2 OFF

DATA MONITOR	
MONITOR	
RR WIPER STOP	OFF
RR AUTO STOP 2	OFF

MODE	BACK	LIGHT	COPY
------	------	-------	------

WKIA1418E

OK or NG

OK >> Replace BCM. Refer to [BCS-20, "Removal and Installation of BCM"](#).

NG >> GO TO 2.

2. CHECK AUTO STOP CIRCUITS FOR SHORT TO GROUND

- Turn ignition switch to OFF.
- Disconnect BCM and rear wiper motor connectors.
- Check continuity between BCM harness connector terminals and ground.

Terminals			Continuity
Connector	Terminal (wire color)		
M18	26 (Y/L)	Ground	No
M19	44 (O)		

OK or NO

OK >> GO TO 3.

NO >> Repair harness or connector.

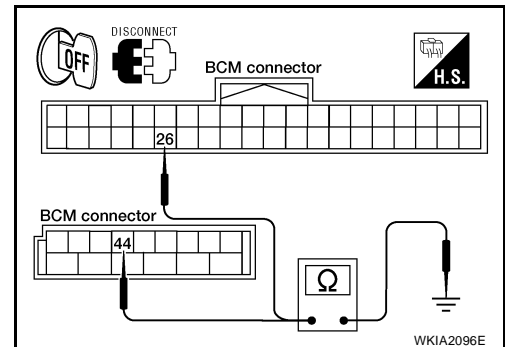

REAR WIPER AND WASHER SYSTEM

3. CHECK REAR WIPER MOTOR AUTO STOP SWITCH GROUNDS

Check continuity between rear wiper motor harness connector D704 terminals and ground.

Connector	Terminals		Continuity
	Terminal (wire color)		
D704	1 (Y/L)	Ground	No
	2 (O)		No
	3 (B)		Yes
	5 (B)		Yes

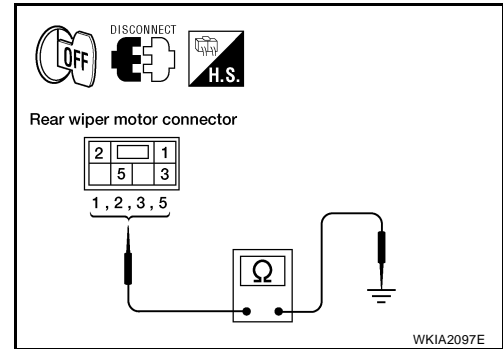

OK or NG

OK >> GO TO 4.

NG >> Repair harness or connector.

4. CHECK REAR WIPER OPERATING

1. Connect BCM connectors and rear wiper motor connector.
2. Turn ignition switch ON.
3. Turn rear wiper switch ON, then to OFF when wiper arm reaches mid sweep.
4. Check voltage between rear wiper motor connector D704 terminal 6 (Y) and ground.

Battery voltage should exist on the reverse wipe until arm is seated in the stop.

OK or NG

OK >> Replace rear wiper motor. Refer to [WW-53, "Removal and Installation of Rear Wiper Motor"](#).

NG >> Replace BCM. Refer to [BCS-20, "Removal and Installation of BCM"](#).

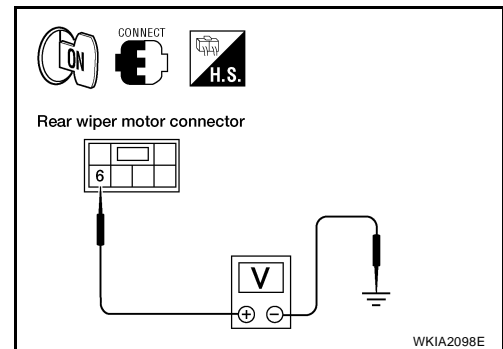

Only Rear Wiper Does Not Operate

EKS00BEK

1. CHECK COMBINATION SWITCH INPUT SIGNAL

Select "BCM" on CONSULT-II. With "WIPER" data monitor, make sure "RR WIPER ON" turns ON-OFF according to operation of wiper switch.

When rear wiper switch is in ON position : RR WIPER ON ON

OK or NG

OK >> Replace BCM. Refer to [BCS-20, "Removal and Installation of BCM"](#).

NG >> Check the wiper switch. Refer to [WW-7, "COMBINATION SWITCH READING FUNCTION"](#).

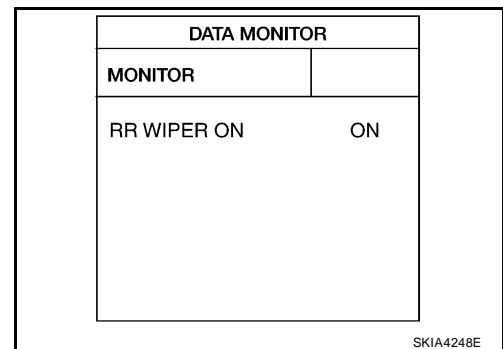

REAR WIPER AND WASHER SYSTEM

Only Rear Wiper Intermittent Does Not Operate

EKS00BEL

1. CHECK COMBINATION SWITCH INPUT SIGNAL

Select "BCM" on CONSULT-II. With "WIPER" data monitor, make sure "RR WIPER INT" turns ON-OFF according to operation of wiper switch.

When rear wiper switch is in INT position : RR WIPER INT ON

OK or NG

- OK >> Replace BCM. Refer to [BCS-20, "Removal and Installation of BCM"](#).
- NG >> Check the wiper switch. Refer to [WW-7, "COMBINATION SWITCH READING FUNCTION"](#).

DATA MONITOR	
MONITOR	
RR WIPER INT	ON

SKIA4249E

Wiper Does Not Wipe When Rear Washer Operates

EKS00BEM

1. CHECK COMBINATION SWITCH INPUT SIGNAL

Select "BCM" on CONSULT-II. With "WIPER" data monitor, make sure "RR WASHER SW" turns ON-OFF according to operation of rear washer switch.

When rear wiper switch is in WASHER position : RR WASHER SW ON

OK or NG

- OK >> Replace BCM. Refer to [BCS-20, "Removal and Installation of BCM"](#).
- NG >> Check the wiper switch. Refer to [WW-7, "COMBINATION SWITCH READING FUNCTION"](#).

DATA MONITOR	
MONITOR	
RR WASHER SW	ON

SKIA4250E

A
B
C
D
E
F
G
H
I
J
L
M

WW

REAR WIPER AND WASHER SYSTEM

Removal and Installation of Rear Wiper Arm, Adjustment of Rear Wiper Arm Stop Location

EKS00BEN

REMOVAL

1. Operate the rear wiper motor and stop it at the auto stop position.
2. Remove rear wiper arm cover by gripping bottom edge and rotating cover up. Remove mounting nut, and remove the wiper arm.

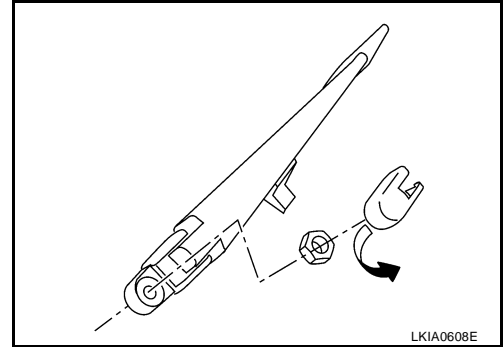

INSTALLATION

1. Prior to wiper arm installation, turn on wiper switch to operate wiper motor and then turn it "OFF" (Auto Stop).
2. Clean up the pivot area as illustrated. This will reduce the possibility of wiper arm looseness.
3. Install rear wiper arm so that the arm rests in the stopper and tighten wiper arm nut.

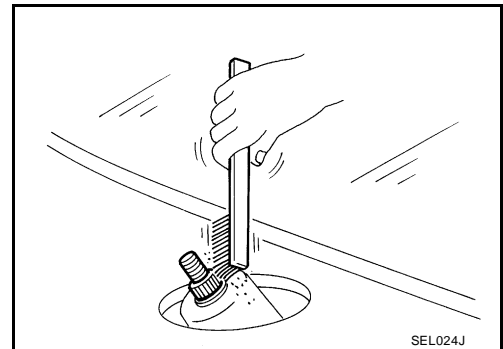

REAR WIPER AND WASHER SYSTEM

Removal and Installation of Rear Wiper Motor

EKS00BEO

SEC. 284

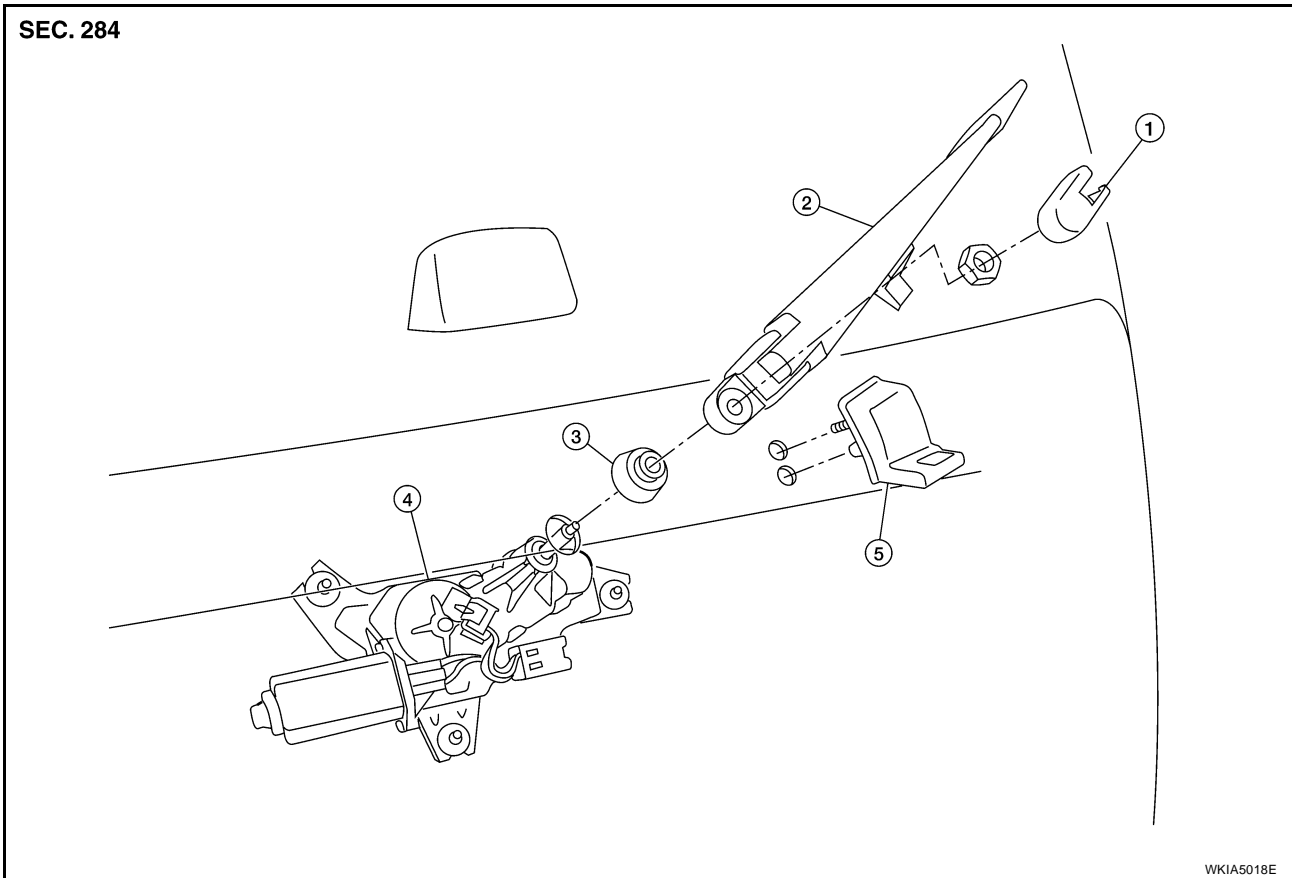

- | | | |
|---------------------|------------------------|--------------|
| 1. Wiper arm cover | 2. Wiper arm and blade | 3. Pivot cap |
| 4. Rear wiper motor | 5. Wiper arm stop | |

REMOVAL

1. Remove rear wiper arm. Refer to [WW-52, "Removal and Installation of Rear Wiper Arm, Adjustment of Rear Wiper Arm Stop Location"](#).
2. Remove pivot cap.
3. Remove back door finisher lower. Refer to [EI-42, "BACK DOOR TRIM"](#).
4. Remove the glass hatch latch assembly. Refer to [BL-135, "BACK DOOR LOCK"](#).
5. Disconnect rear wiper motor connector.
6. Remove rear wiper motor mounting bolts, and remove rear wiper motor.

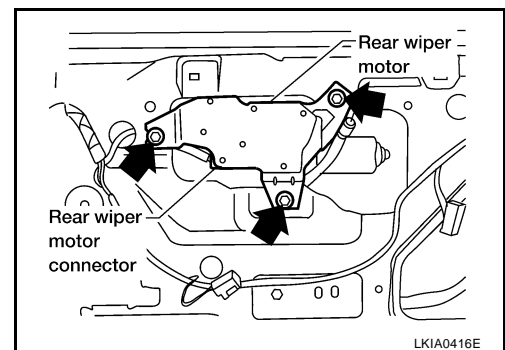

INSTALLATION

CAUTION:

- Do not drop the wiper motor or cause it to contact other parts.

A
B
C
D
E
F
G
H
I
J

WW
L
M

REAR WIPER AND WASHER SYSTEM

1. Clean up the pivot area as illustrated. This will reduce possibility of wiper arm looseness.
2. Install rear wiper motor to the vehicle.
3. Connect rear wiper motor connector.
4. Install glass hatch latch assembly and adjust as necessary. Refer to [BL-135, "BACK DOOR LOCK"](#) .
5. Install back door finisher lower. Refer to [EI-42, "BACK DOOR TRIM"](#) .
6. Attach pivot cap.
7. Attach wiper arm. Refer to [WW-52, "Removal and Installation of Rear Wiper Arm, Adjustment of Rear Wiper Arm Stop Location"](#) .

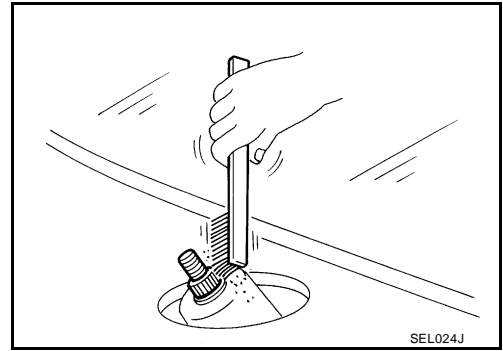

Rear Washer Nozzle Adjustment

EKS00BEP

- This vehicle is equipped with a non-adjustable rear washer nozzle.
- If not satisfied with washer fluid spray coverage, confirm that the washer nozzle is installed correctly.
- If the washer nozzle is installed correctly, and the washer fluid spray coverage is not satisfactory, replace the washer nozzle.

Rear Washer Tube Layout

EKS00BEO

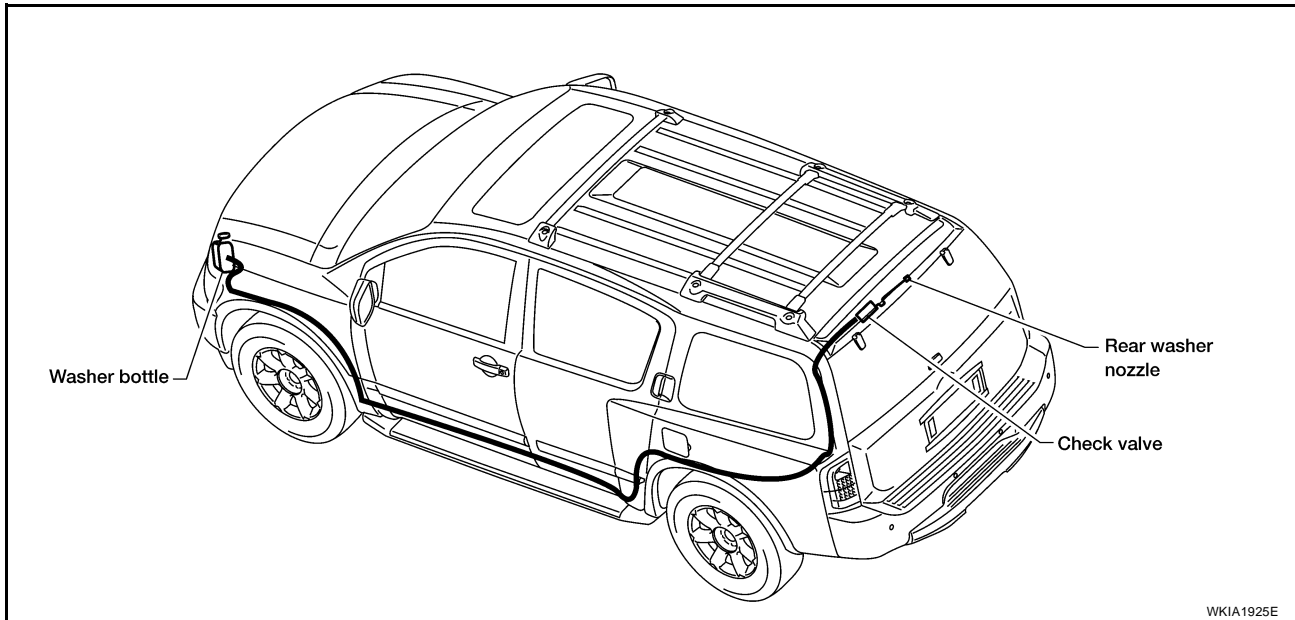

Removal and Installation of Rear Washer Nozzle

EKS00BER

- ### REMOVAL
1. Remove the rear spoiler. Refer to [EI-26, "REAR SPOILER"](#) .
 2. Remove rear washer tube from nozzle.
 3. Release retaining clips, and remove washer nozzle.

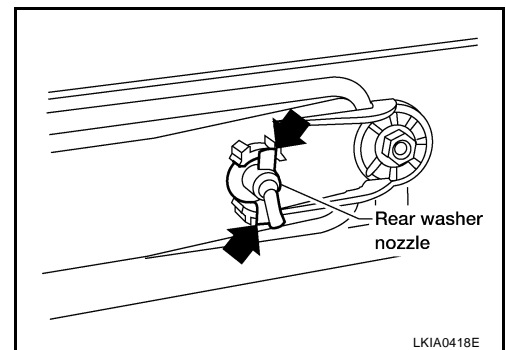

INSTALLATION

Installation is in the reverse order of removal.

REAR WIPER AND WASHER SYSTEM

Check Valve

EKS00BES

- A check valve is provided in the washer fluid line. Be careful not to connect check valve to washer tube in the wrong direction.

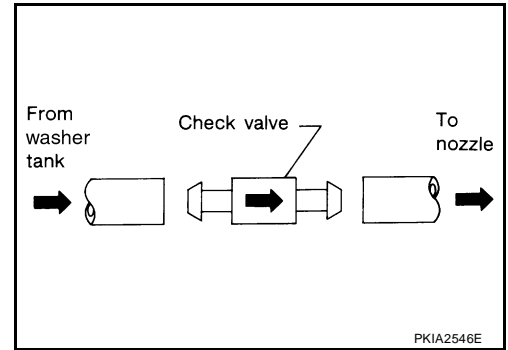

Removal and Installation of Rear Wiper and Washer Switch

EKS00BET

Refer to [WW-33, "Removal and Installation of Wiper and Washer Switch"](#) .

Removal and Installation of Washer Tank

EKS00BEU

Refer to [WW-33, "Removal and Installation of Washer Tank"](#) .

Removal and Installation of Washer Motor

EKS00BEV

Refer to [WW-34, "Removal and Installation of Washer Motor"](#) .

A
B
C
D
E
F
G
H
I
J
L
M

WW

POWER SOCKET

PPF:253A2

POWER SOCKET

Wiring Diagram — P/SCKT —

EKS00BEW

WW-P/SCKT-01

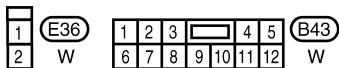
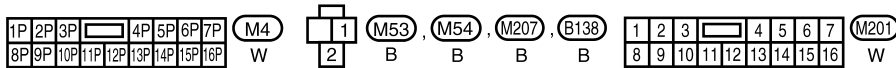
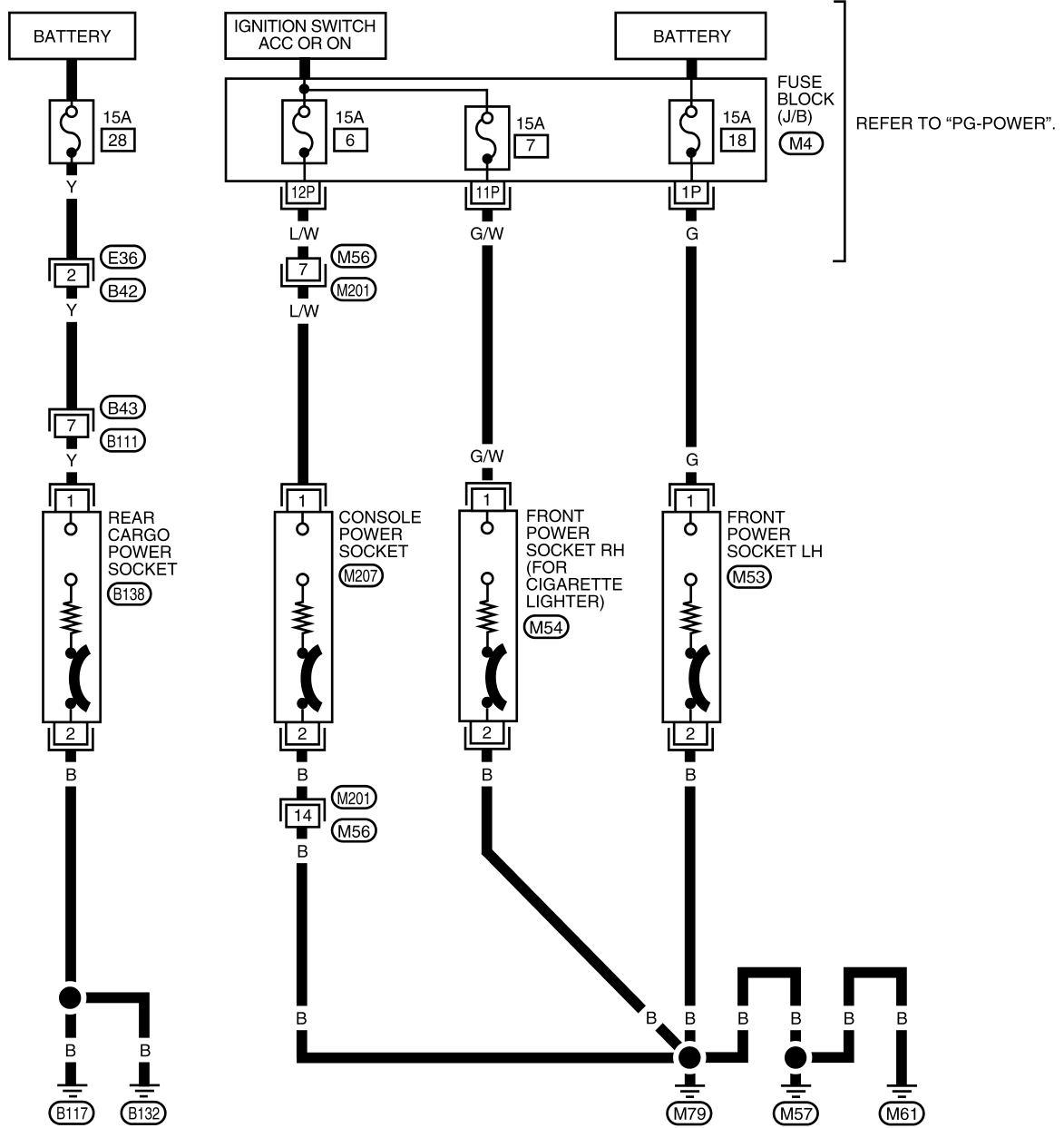

WKWA4494E

POWER SOCKET

Removal and Installation of Power Sockets

EKS00BEX

REMOVAL

1. Disconnect battery negative terminal before removing front power socket LH and rear cargo power socket. Remove inner socket from the ring, while pressing the hook on the ring out from square hole.
2. Disconnect power socket connector.
3. Remove ring from power socket finisher while pressing pawls.

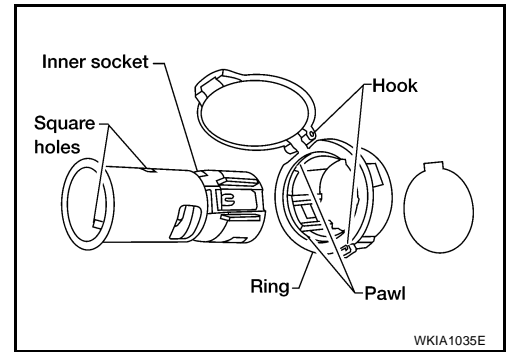

INSTALLATION

Installation is in the reverse order of removal.

A
B
C
D
E
F
G
H
I
J
L
M

WW

HORN

PFP:25610

HORN

Wiring Diagram — HORN —

EKS00BEY

WW-HORN-01

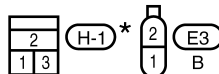
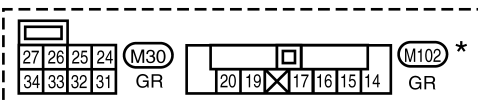
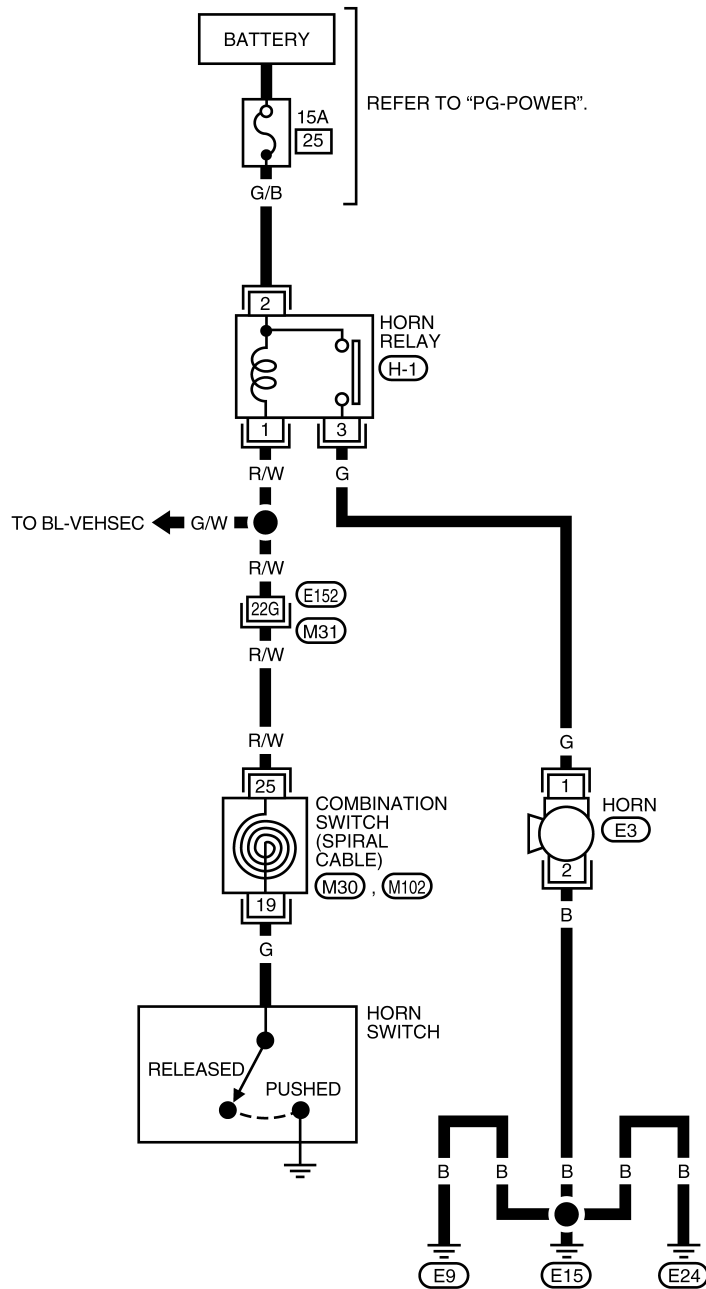

REFER TO THE FOLLOWING.

(M31) - SUPER MULTIPLE JUNCTION (SMJ)

* : THIS CONNECTOR IS NOT SHOWN IN "HARNESS LAYOUT" OF PG SECTION.

WKWA4495E

HORN

EKS00BEZ

Removal and Installation

REMOVAL

1. Remove the front grille. Refer to [EI-17, "FRONT GRILLE"](#) .
2. Disconnect horn connector.
3. Remove horn bolt and remove horn from vehicle.

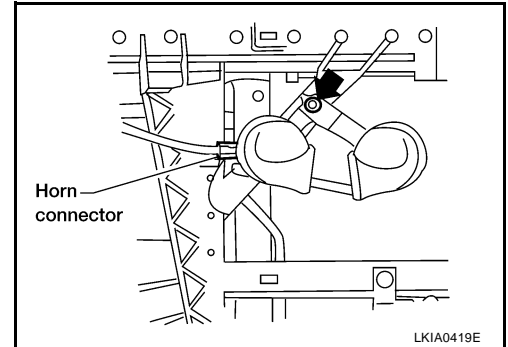

INSTALLATION

1. Tighten horn bolt to specified torque.
Horn bolt : 17 N·m (1.7 kg·m, 13 ft·lb)
2. Reconnect horn connector.
3. Install front grille. Refer to [EI-17, "FRONT GRILLE"](#) .

A
B
C
D
E
F
G
H
I
J
L
M

WW

HORN
