

SECTION **PG**

POWER SUPPLY, GROUND & CIRCUIT ELEMENTS

CONTENTS

BASIC INSPECTION	2	FUSE, FUSIBLE LINK AND RELAY BOX	65
BATTERY	2	Terminal Arrangement	65
How to Handle Battery	2	IPDM E/R (INTELLIGENT POWER DISTRI-	
Work Flow	4	BUTION MODULE ENGINE ROOM)	66
COMPONENT DIAGNOSIS	5	Fuse, Connector and Terminal Arrangement	66
POWER SUPPLY ROUTING CIRCUIT	5	PRECAUTION	67
Wiring Diagram — Battery Power Supply —	5	PRECAUTIONS	67
Wiring Diagram — Accessory Power Supply —	13	Supplemental Restraint System SRS "AIR BAG"	
Wiring Diagram — Ignition Power Supply —	16	and "SEAT BELT PRE-TENSIONER" Service	67
Fuse	23	Precautions For High-Voltage System	67
Fusible Link	23	PREPARATION	68
GROUND	24	PREPARATION	68
Ground Distribution	24	Special Service Tool	68
HARNESS	33	Commercial Service Tool	68
Harness Layout	33	ON-VEHICLE REPAIR	69
ELECTRICAL UNITS LOCATION	56	BATTERY	69
Electrical Units Location	56	Removal and Installation	69
HARNESS CONNECTOR	60	SERVICE DATA AND SPECIFICATIONS	
Description	60	(SDS)	70
STANDARDIZED RELAY	62	BATTERY	70
Description	62	Battery	70
FUSE BLOCK - JUNCTION BOX (J/B)	64		
Terminal Arrangement	64		

A
B
C
D
E
F
G
H
I
J
K
L
PG
N
O
P

BATTERY

< BASIC INSPECTION >

BASIC INSPECTION

BATTERY

How to Handle Battery

INFOID:000000001503504

CAUTION:

- If it becomes necessary to start the engine with a booster battery and jumper cables, use a 12-volt booster battery.
- After connecting battery cables, ensure that they are tightly clamped to battery terminals for good contact.
- Never add distilled water through the hole used to check specific gravity.

METHODS OF PREVENTING OVER-DISCHARGE

The following precautions must be taken to prevent over-discharging a battery.

- The battery surface (particularly its top) should always be kept clean and dry.
- The terminal connections should be clean and tight.
- At every routine maintenance, check the electrolyte level. This also applies to batteries designated as "low maintenance" and "maintenance-free".

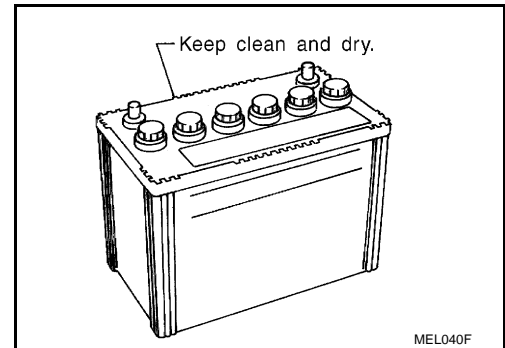

- When the vehicle is not going to be used over a long period of time, disconnect the battery cable from the negative terminal. (If the vehicle has an extended storage switch, turn it off.)

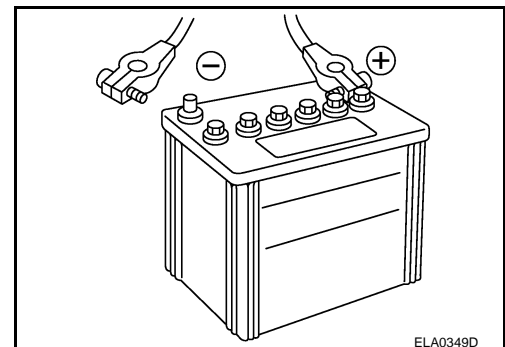

- Check the charge condition of the battery. Periodically check the specific gravity of the electrolyte. Keep a close check on charge condition to prevent over-discharge.

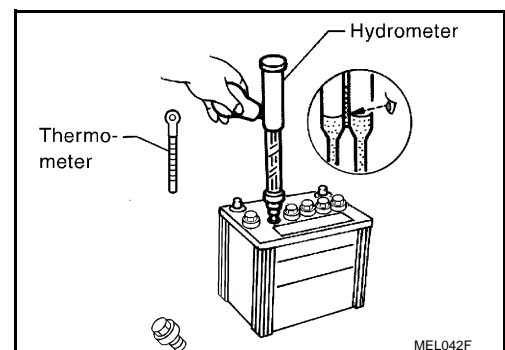

CHECKING ELECTROLYTE LEVEL

WARNING:

Never allow battery fluid to come in contact with skin, eyes, fabrics, or painted surfaces. After touching a battery, never touch or rub your eyes until you have thoroughly washed your hands. If acid contacts eyes, skin or clothing, immediately flush with water for 15 minutes and seek medical attention.

BATTERY

< BASIC INSPECTION >

- Remove the cell plug using a suitable tool.
- Add distilled water up to the MAX level.

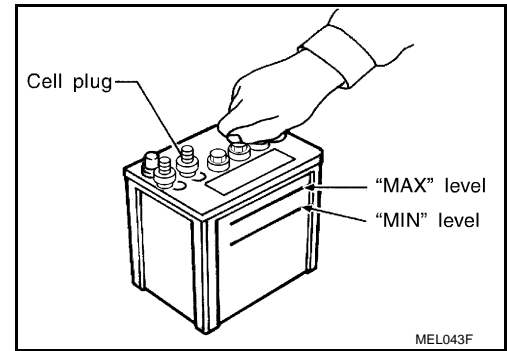

Sulphation

A battery will be completely discharged if it is left unattended for a long time and the specific gravity will become less than 1.100. This may result in sulphation on the cell plates.

To determine if a battery has been “sulphated”, note its voltage and current when charging it. As shown in the figure, less current and higher voltage are observed in the initial stage of charging sulphated batteries.

A sulphated battery may sometimes be brought back into service by means of a long, slow charge, 12 hours or more, followed by a battery capacity test.

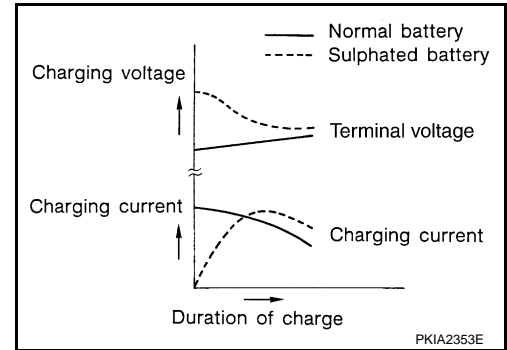

SPECIFIC GRAVITY CHECK

1. Read hydrometer and thermometer indications at eye level.
2. Use the chart below to correct your hydrometer reading according to electrolyte temperature.

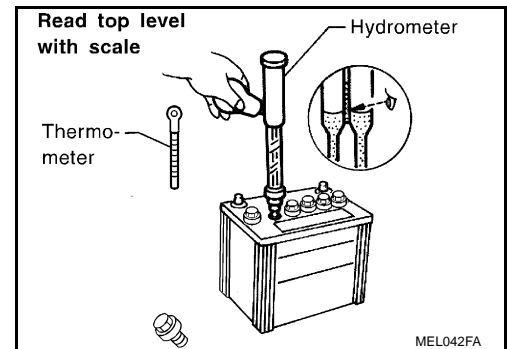

Hydrometer Temperature Correction

Battery electrolyte temperature [°C (°F)]	Add to specific gravity reading
71 (160)	0.032
66 (150)	0.028
60 (140)	0.024
54 (130)	0.020
49 (120)	0.016
43 (110)	0.012
38 (100)	0.008
32 (90)	0.004
27 (80)	0
21 (70)	-0.004
16 (60)	-0.008
10 (50)	-0.012
4 (40)	-0.016
-1 (30)	-0.020
-7 (20)	-0.024

A
B
C
D
E
F
G
H
I
J
K
L
N
O
P

BATTERY

< BASIC INSPECTION >

Battery electrolyte temperature [°C (°F)]	Add to specific gravity reading
-12 (10)	-0.028
-18 (0)	-0.032

Corrected specific gravity	Approximate charge condition
1.260 - 1.280	Fully charged
1.230 - 1.250	3/4 charged
1.200 - 1.220	1/2 charged
1.170 - 1.190	1/4 charged
1.140 - 1.160	Almost discharged
1.110 - 1.130	Completely discharged

CHARGING THE BATTERY

CAUTION:

- Never “quick charge” a fully discharged battery.
- Keep the battery away from open flame while it is being charged.
- When connecting the charger, connect the leads first, then turn on the charger. Never turn on the charger first, as this may cause a spark.
- If battery electrolyte temperature rises above 55 °C (131 °F), stop charging. Always charge battery at a temperature below 55 °C (131 °F).

Charging Rates

Amps	Time
50	1 hour
25	2 hours
10	5 hours
5	10 hours

Do not charge at more than 50 ampere rate.

NOTE:

The ammeter reading on your battery charger will automatically decrease as the battery charges. This indicates that the voltage of the battery is increasing normally as the state of charge improves. The charging amps indicated above refer to initial charge rate.

- If, after charging, the specific gravity of any two cells varies more than 0.050, the battery should be replaced.

Work Flow

INFOID:000000001503505

TROUBLE DIAGNOSIS WITH BATTERY SERVICE CENTER

For battery testing, use Battery Service Center (J-48087). For details and operating instructions, refer to Technical Service Bulletin and/or Battery Service Center User Guide.

POWER SUPPLY ROUTING CIRCUIT

< COMPONENT DIAGNOSIS >

COMPONENT DIAGNOSIS

POWER SUPPLY ROUTING CIRCUIT

Wiring Diagram —Battery Power Supply—

INFOID:000000001503506

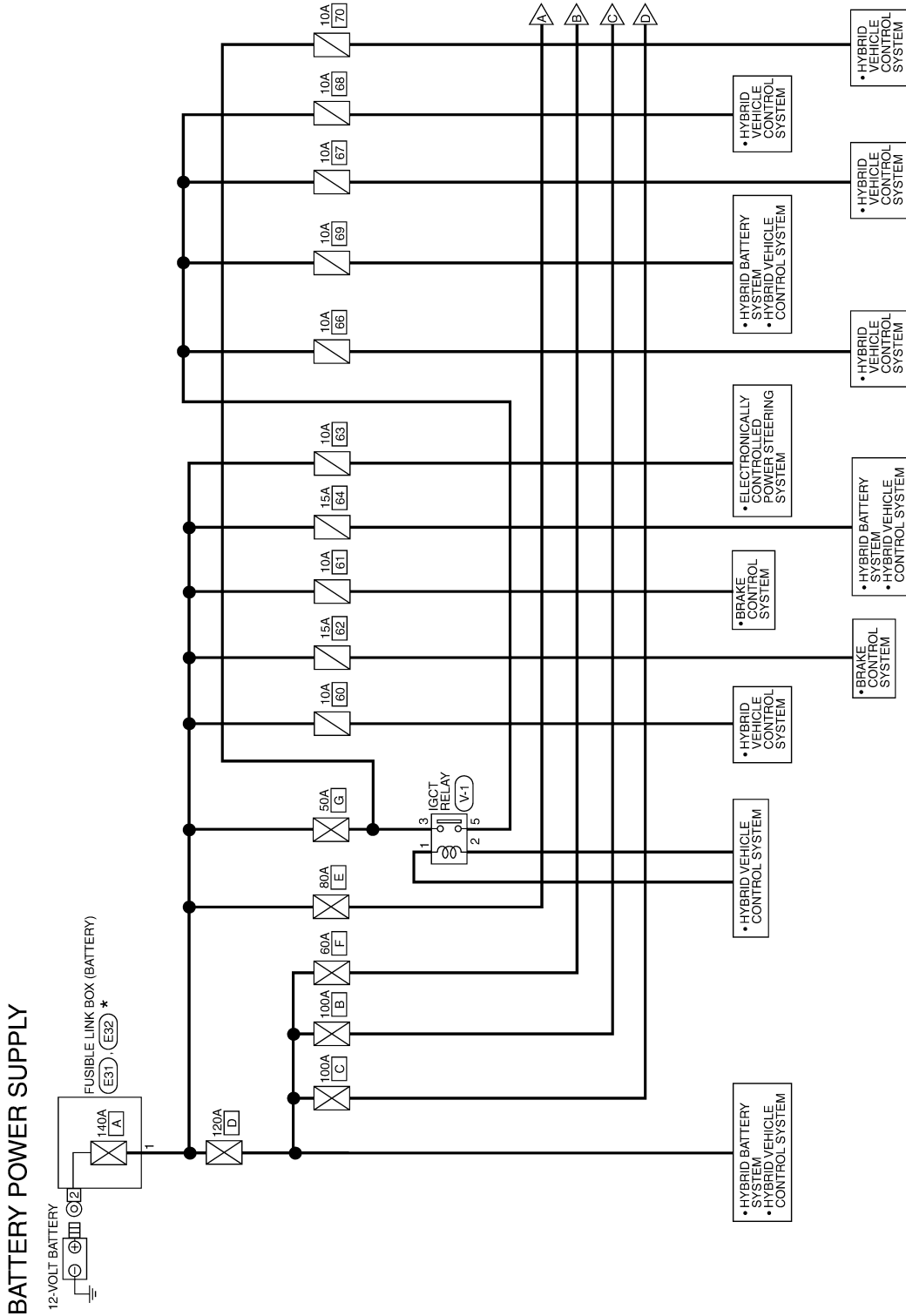

* (E32) IS AN INTEGRAL PART OF FUSIBLE LINK BOX (BATTERY) ASSEMBLY.

ALMWA0050GE

A
B
C
D
E
F
G
H
I
J
K
L
N
O
P

PG

POWER SUPPLY ROUTING CIRCUIT

< COMPONENT DIAGNOSIS >

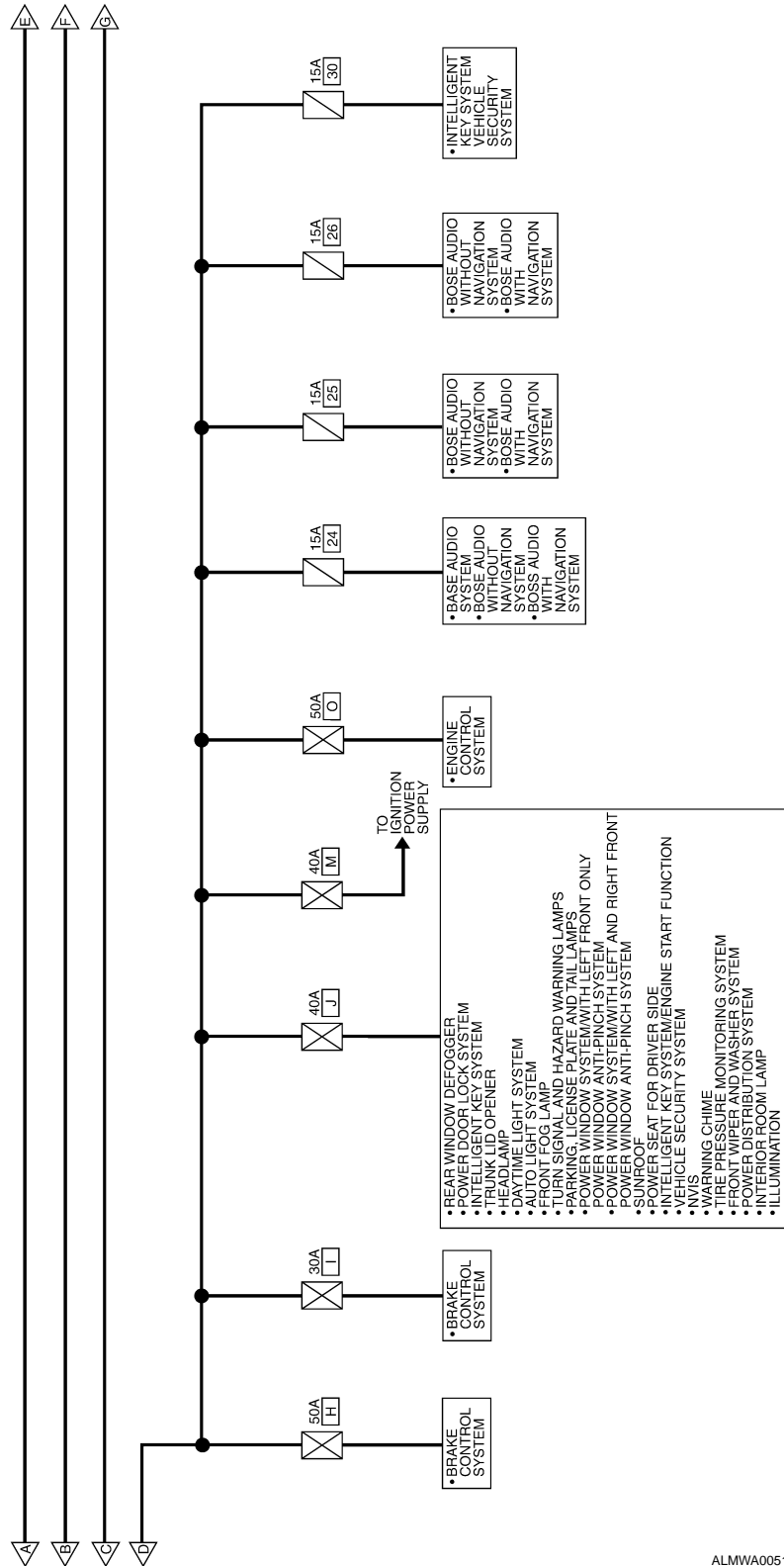

ALMWA0051GE

POWER SUPPLY ROUTING CIRCUIT

< COMPONENT DIAGNOSIS >

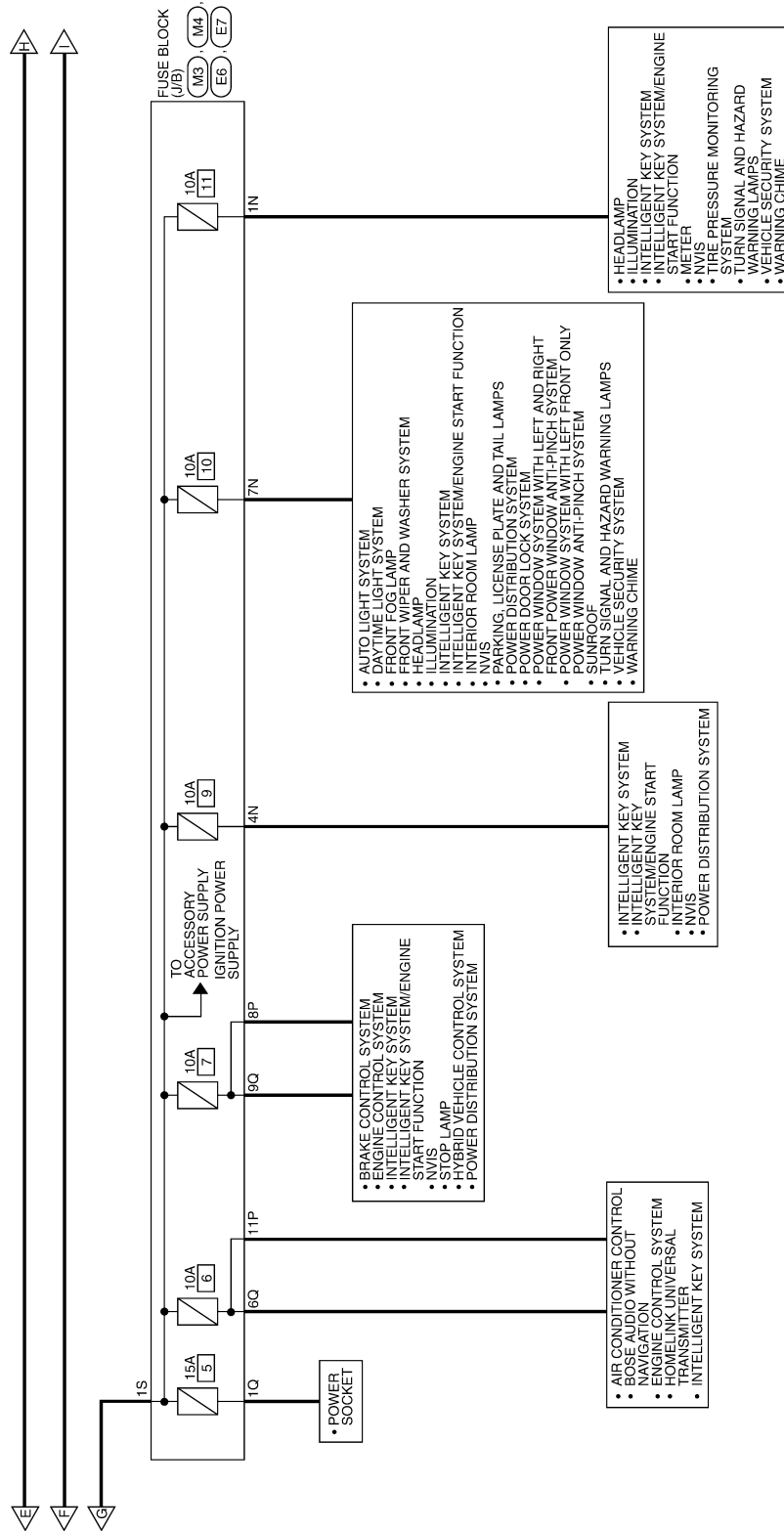

ALMWA0052GE

A
B
C
D
E
F
G
H
I
J
K
L
PG
N
O
P

POWER SUPPLY ROUTING CIRCUIT

< COMPONENT DIAGNOSIS >

FL : WITH FRONT FOG LAMPS
N : CANADA

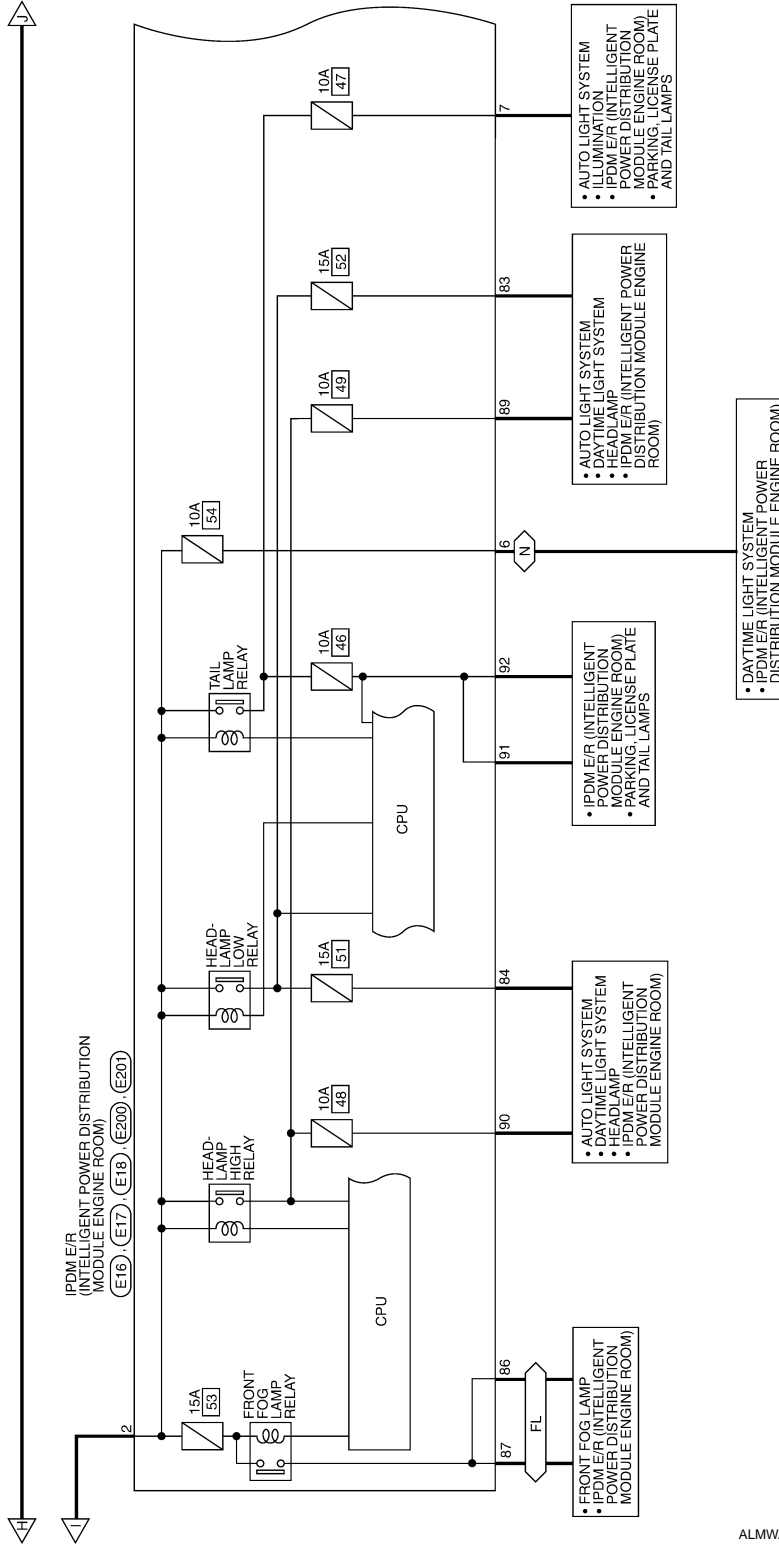

ALMWA0053GE

POWER SUPPLY ROUTING CIRCUIT

< COMPONENT DIAGNOSIS >

--- : DATA LINE

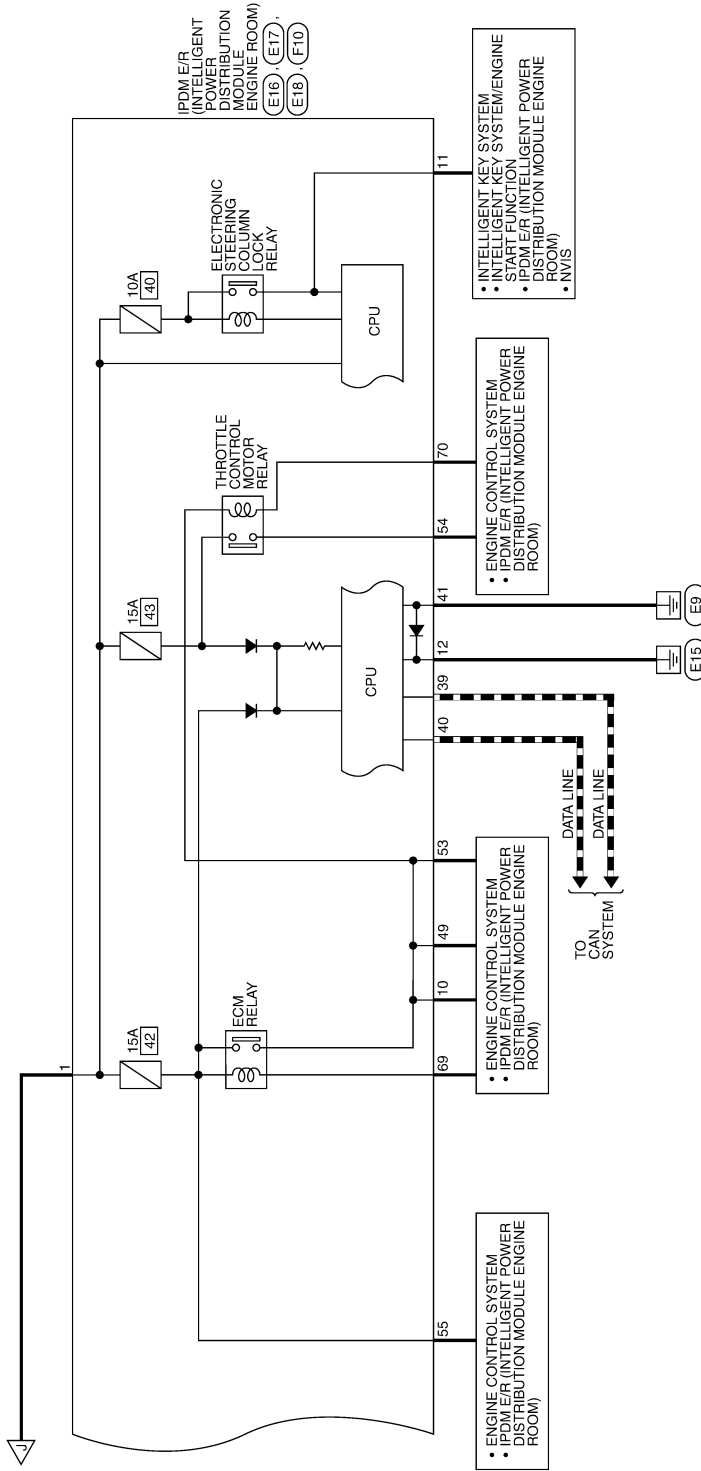

A
B
C
D
E
F
G
H
I
J
K
L
PG
N
O
P

ALMWA0054GE

POWER SUPPLY ROUTING CIRCUIT

< COMPONENT DIAGNOSIS >

BATTERY POWER SUPPLY CONNECTORS

Connector No.	M3
Connector Name	FUSE BLOCK (J/B)
Connector Color	WHITE

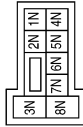

Terminal No.	Color of Wire	Signal Name
1N	W/L	—
4N	G/Y	—
7N	Y/R	—

Connector No.	M4
Connector Name	FUSE BLOCK (J/B)
Connector Color	WHITE

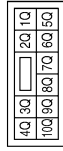

Terminal No.	Color of Wire	Signal Name
1Q	R/W	—
6Q	Y/R	—
9Q	R/W	—

Connector No.	E6
Connector Name	FUSE BLOCK (J/B)
Connector Color	WHITE



Terminal No.	Color of Wire	Signal Name
8P	Y/R	—
11P	Y/B	—

Connector No.	E7
Connector Name	FUSE BLOCK (J/B)
Connector Color	WHITE



Terminal No.	Color of Wire	Signal Name
1S	W	—

Connector No.	E16
Connector Name	IPDM E/R (INTELLIGENT POWER DISTRIBUTION MODULE ENGINE ROOM)
Connector Color	BLACK



Terminal No.	Color of Wire	Signal Name
1	R	F/L_MAIN
2	B/Y	F/L_USM

Connector No.	E17
Connector Name	IPDM E/R (INTELLIGENT POWER DISTRIBUTION MODULE ENGINE ROOM)
Connector Color	WHITE

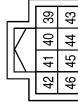

Terminal No.	Color of Wire	Signal Name
39	P	CAN-L
40	L	CAN-H
41	B/Y	S-GND

ALMIA0130GB

POWER SUPPLY ROUTING CIRCUIT

< COMPONENT DIAGNOSIS >

Connector No.	E200
Connector Name	IPDM E/R (INTELLIGENT POWER DISTRIBUTION MODULE ENGINE ROOM)
Connector Color	WHITE



85	84	83	
90	88	87	86

Terminal No.	Color of Wire	Signal Name
83	R/Y	HEAD_LAMP_LO_RH
84	L	HEAD_LAMP_LO_LH
86	W/R	FR_FOG_LAMP_RH
87	L/Y	FR_FOG_LAMP_LH
89	L/W	HEAD_LAMP_HI_RH
90	G	HEAD_LAMP_HI_LH

Connector No.	E31
Connector Name	FUSIBLE LINK BOX (BATTERY)
Connector Color	-



Terminal No.	Color of Wire	Signal Name
1	W/B	BATT

Connector No.	E18
Connector Name	IPDM E/R (INTELLIGENT POWER DISTRIBUTION MODULE ENGINE ROOM)
Connector Color	WHITE

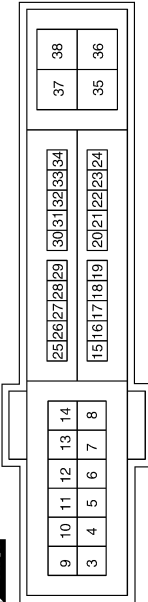

Terminal No.	Color of Wire	Signal Name
6	SB	DTRL
7	R/L	TAIL/ILLUMI
10	R/B	ECM_VB
11	P/L	ESCL
12	B	P-GND

Terminal No.	Color of Wire	Signal Name
49	B/R	ENG_SOL
53	R/W	IGN_COIL
54	G/W	ETC
55	W/L	ECM_BAT
69	W/B	SSOFF
70	O	MOTRLY

Connector No.	F10
Connector Name	IPDM E/R (INTELLIGENT POWER DISTRIBUTION MODULE ENGINE ROOM)
Connector Color	WHITE

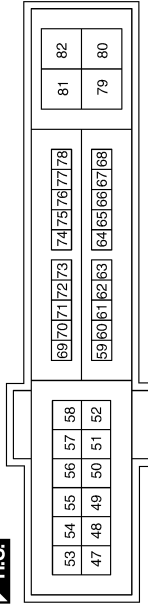

Connector No.	E201
Connector Name	IPDM E/R (INTELLIGENT POWER DISTRIBUTION MODULE ENGINE ROOM)
Connector Color	WHITE

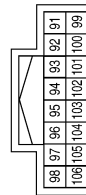

Terminal No.	Color of Wire	Signal Name
91	LG/R	CLEARANCE_RH
92	LG/B	CLEARANCE_LH

AWMIA0013GB

POWER SUPPLY ROUTING CIRCUIT

< COMPONENT DIAGNOSIS >

Connector No.	HIGH VOLTAGE FUSE AND FUSIBLE LINK BOX
Connector Name	V-1
Connector Color	—

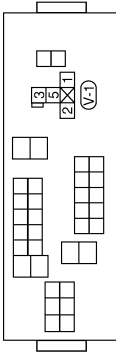

Terminal No.	Color of Wire	Signal Name
1	BR/Y	IGCT_CONT
2	B	GND
3	—	BATT
4	—	V_BATT

ALMIA0131GB

POWER SUPPLY ROUTING CIRCUIT

< COMPONENT DIAGNOSIS >

Wiring Diagram —Accessory Power Supply—

INFOID:000000001503507

ACCESSORY POWER SUPPLY

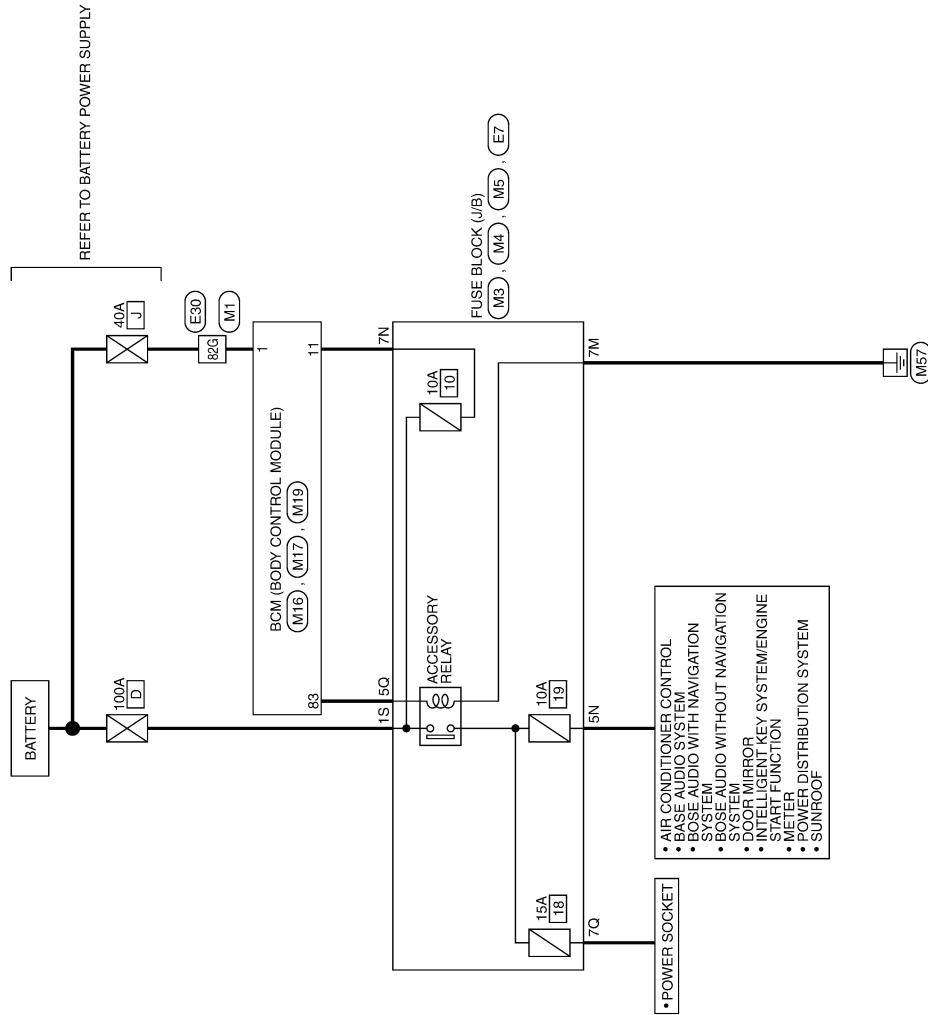

A
B
C
D
E
F
G
H
I
J
K
L
PG
N
O
P

AWMWA0001G

POWER SUPPLY ROUTING CIRCUIT

< COMPONENT DIAGNOSIS >

ACCESSORY POWER SUPPLY CONNECTORS

Connector No.	M1
Connector Name	WIRE TO WIRE
Connector Color	WHITE

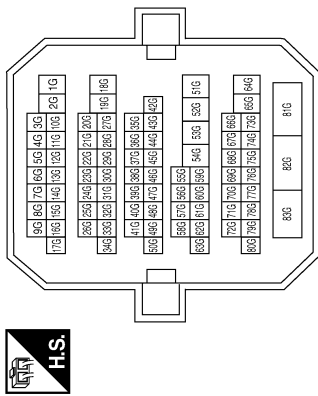

Terminal No.	Color of Wire	Signal Name
82G	W/B	—

Connector No.	M3
Connector Name	FUSE BLOCK (J/B)
Connector Color	WHITE

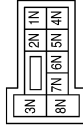

Terminal No.	Color of Wire	Signal Name
5N	V/Y	—
7N	Y/R	—

Connector No.	M4
Connector Name	FUSE BLOCK (J/B)
Connector Color	WHITE

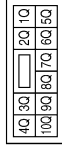

Terminal No.	Color of Wire	Signal Name
5Q	L	—
7Q	R/B	—

Connector No.	M5
Connector Name	FUSE BLOCK (J/B)
Connector Color	WHITE

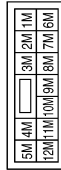

Terminal No.	Color of Wire	Signal Name
7M	B	—

Connector No.	M16
Connector Name	BCM (BODY CONTROL MODULE)
Connector Color	BLACK



Terminal No.	Color of Wire	Signal Name
1	W/B	BAT_POWER_F/L

Connector No.	M17
Connector Name	BCM (BODY CONTROL MODULE)
Connector Color	WHITE



Terminal No.	Color of Wire	Signal Name
11	Y/R	BAT_BCM_FUSE

POWER SUPPLY ROUTING CIRCUIT

< COMPONENT DIAGNOSIS >

Connector No.	E30
Connector Name	WIRE TO WIRE
Connector Color	WHITE

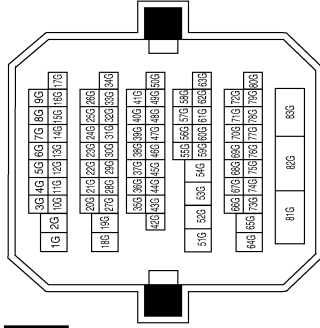

Terminal No.	82G	Color of Wire	W/B	Signal Name	—
--------------	-----	---------------	-----	-------------	---

Connector No.	E7
Connector Name	FUSE BLOCK (J/B)
Connector Color	WHITE



Terminal No.	1S	Color of Wire	W	Signal Name	—
--------------	----	---------------	---	-------------	---

Connector No.	M19
Connector Name	BCM (BODY CONTROL MODULE)
Connector Color	BLACK

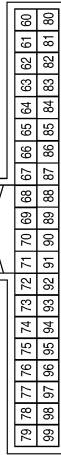

Terminal No.	83	Color of Wire	L	Signal Name	ACC_CONT
--------------	----	---------------	---	-------------	----------

AWMIA0015GB

A
B
C
D
E
F
G
H
I
J
K
L
N
O
P

PG

POWER SUPPLY ROUTING CIRCUIT

< COMPONENT DIAGNOSIS >

Wiring Diagram — Ignition Power Supply —

INFOID:000000001503508

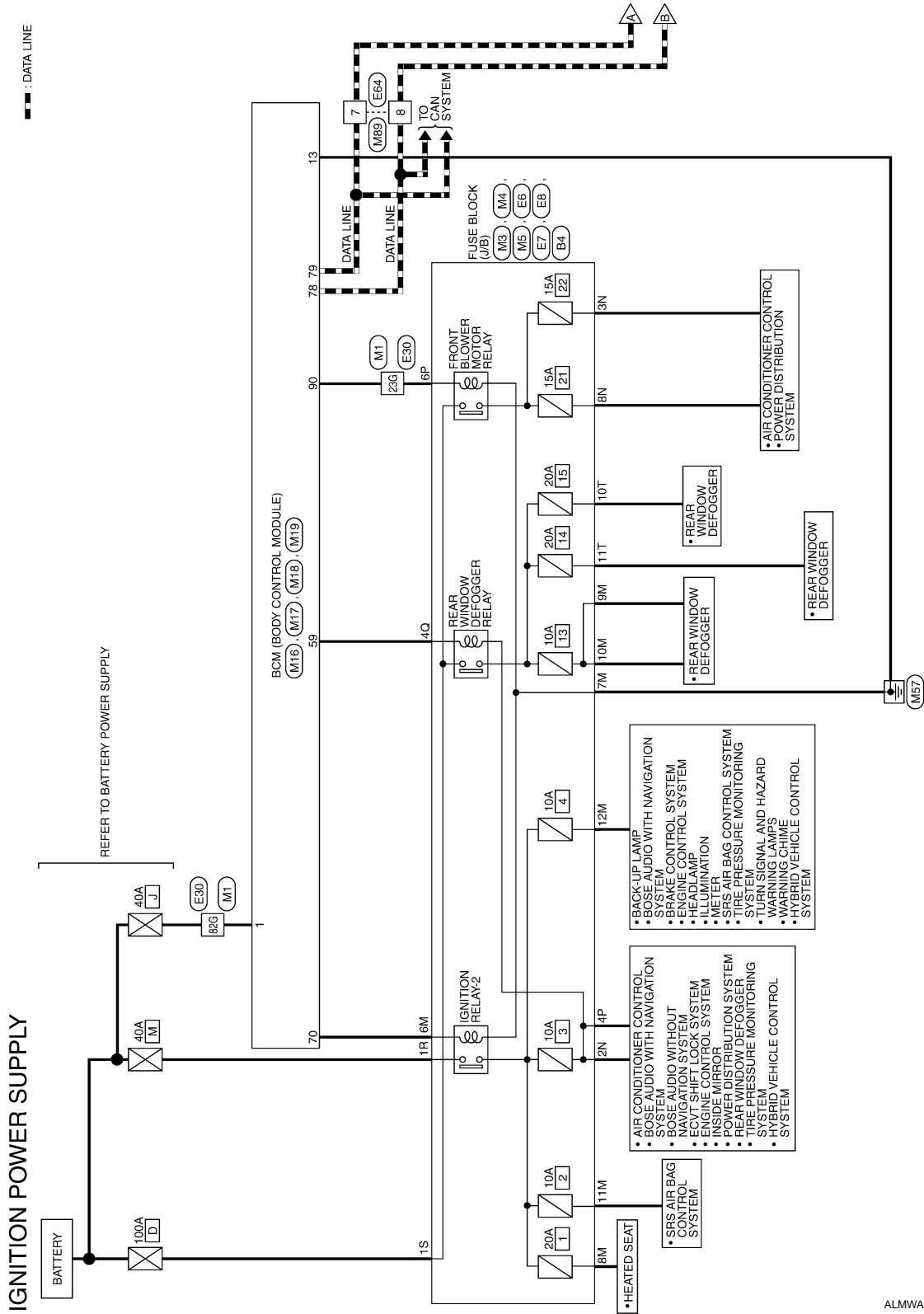

ALMWA0056Gf

POWER SUPPLY ROUTING CIRCUIT

< COMPONENT DIAGNOSIS >

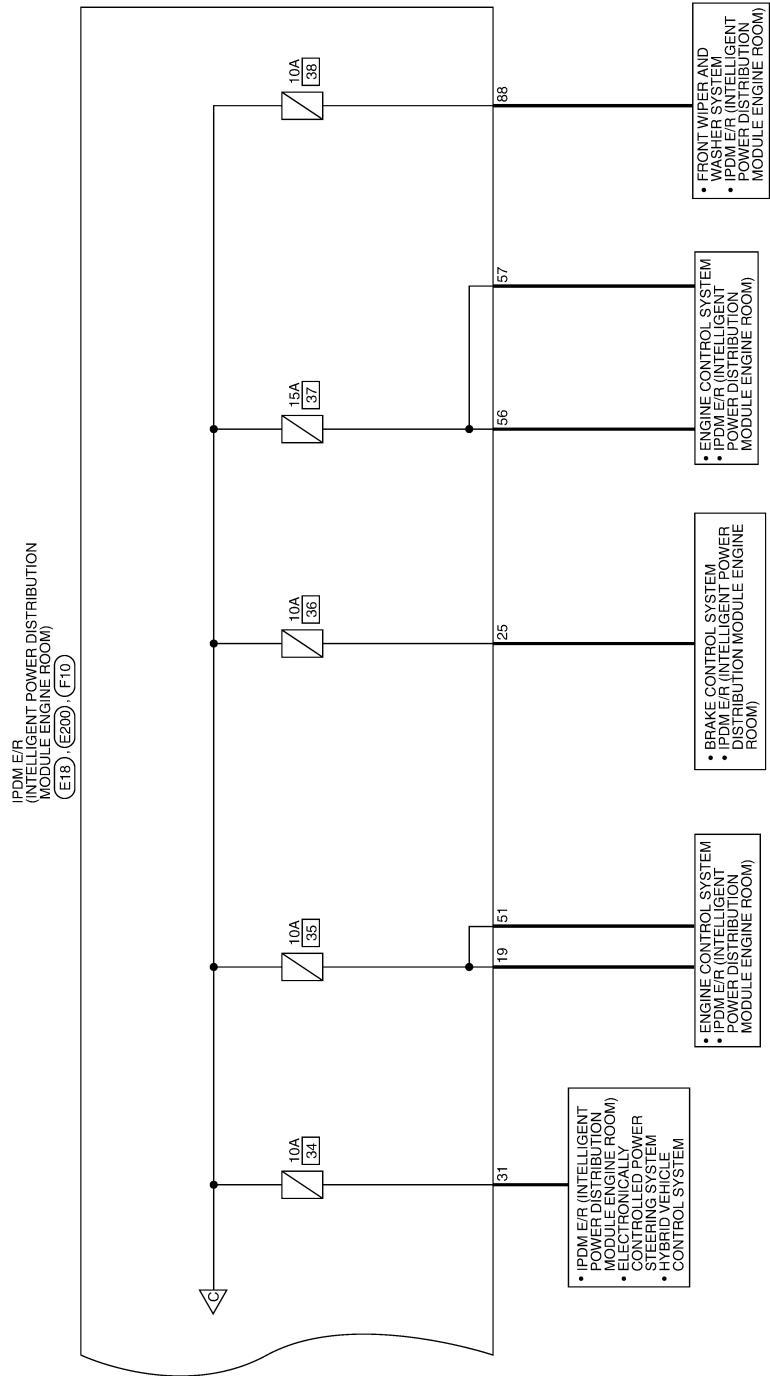

AWMWA0002G

POWER SUPPLY ROUTING CIRCUIT

< COMPONENT DIAGNOSIS >

IGNITION POWER SUPPLY CONNECTORS

Connector No.	M1
Connector Name	WIRE TO WIRE
Connector Color	WHITE

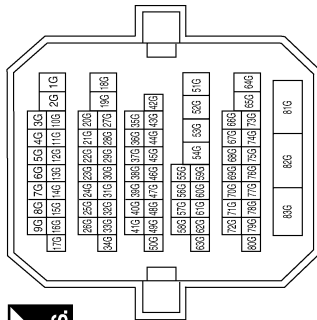

Terminal No.	Color of Wire	Signal Name
23G	Y	—
82G	W/B	—

Connector No.	M3
Connector Name	FUSE BLOCK (J/B)
Connector Color	WHITE

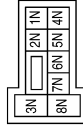

Terminal No.	Color of Wire	Signal Name
2N	G	—
3N	W/L	—
8N	W/L	—

Connector No.	M4
Connector Name	FUSE BLOCK (J/B)
Connector Color	WHITE

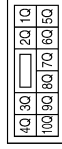

Terminal No.	Color of Wire	Signal Name
4Q	G/R	—

Connector No.	M5
Connector Name	FUSE BLOCK (J/B)
Connector Color	WHITE



Terminal No.	Color of Wire	Signal Name
6M	R/B	—
7M	B	—
8M	G/R	—
9M	GR	—
10M	L/Y	—
11M	R/L	—
12M	O	—

Connector No.	M16
Connector Name	BCM (BODY CONTROL MODULE)
Connector Color	BLACK



Terminal No.	Color of Wire	Signal Name
1	W/B	BAT_POWER_F/L

AWMIA0016GB

A
B
C
D
E
F
G
H
I
J
K
L
N
O
P

POWER SUPPLY ROUTING CIRCUIT

< COMPONENT DIAGNOSIS >

Connector No.	M17
Connector Name	BCM (BODY CONTROL MODULE)
Connector Color	WHITE



4	5	6	7	8	9	10		
11	12	13	14	15	16	17	18	19



39	38	37	36	35	34	33	32	31	30	29	28	27	26	25	24	23	22	21	20
59	58	57	56	55	54	53	52	51	50	49	48	47	46	45	44	43	42	41	40



Terminal No.	Color of Wire	Signal Name
13	B	GND1

Connector No.	M18
Connector Name	BCM (BODY CONTROL MODULE)
Connector Color	GREEN



79	78	77	76	75	74	73	72	71	70	69	68	67	66	65	64	63	62	61	60
99	98	97	96	95	94	93	92	91	90	89	88	87	86	85	84	83	82	81	80



Terminal No.	Color of Wire	Signal Name
59	G/R	REAR_DEFOGGER_RLY

Connector No.	M19
Connector Name	BCM (BODY CONTROL MODULE)
Connector Color	BLACK



79	78	77	76	75	74	73	72	71	70	69	68	67	66	65	64	63	62	61	60
99	98	97	96	95	94	93	92	91	90	89	88	87	86	85	84	83	82	81	80



Terminal No.	Color of Wire	Signal Name
70	R/B	IGN_ELEC_CONT
78	P	CAN-L
79	L	CAN-H
90	Y	IGN2_CONT

Connector No.	M89
Connector Name	WIRE TO WIRE
Connector Color	WHITE



5	4	3	2	1		
12	11	10	9	8	7	6



Terminal No.	Color of Wire	Signal Name
7	L	—
8	P	—

Connector No.	E6
Connector Name	FUSE BLOCK (J/B)
Connector Color	WHITE



7P	6P	5P	4P	3P	2P	1P		
16P	15P	14P	13P	12P	11P	10P	9P	8P



Terminal No.	Color of Wire	Signal Name
4P	G/R	—
6P	Y	—

Connector No.	E7
Connector Name	FUSE BLOCK (J/B)
Connector Color	WHITE



Terminal No.	Color of Wire	Signal Name
1S	W	—

POWER SUPPLY ROUTING CIRCUIT

< COMPONENT DIAGNOSIS >

Connector No.	E8
Connector Name	FUSE BLOCK (J/B)
Connector Color	BLACK



Terminal No.	Color of Wire	Signal Name
1R	G	—

Connector No.	E16
Connector Name	IPDM E/R (INTELLIGENT POWER DISTRIBUTION MODULE ENGINE ROOM)
Connector Color	BLACK



Terminal No.	Color of Wire	Signal Name
1	R	F/L MAIN
2	B/Y	F/L USM

Connector No.	E17
Connector Name	IPDM E/R (INTELLIGENT POWER DISTRIBUTION MODULE ENGINE ROOM)
Connector Color	WHITE

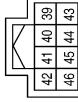

Terminal No.	Color of Wire	Signal Name
39	P	CAN-L
40	L	CAN-H
41	B/Y	S-GND

Connector No.	E18
Connector Name	IPDM E/R (INTELLIGENT POWER DISTRIBUTION MODULE ENGINE ROOM)
Connector Color	WHITE

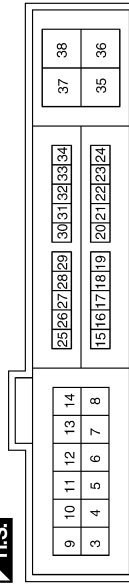

Terminal No.	Color of Wire	Signal Name
4	L/R	FR_WIPER_LO
5	L/B	FR_WIPER_HI
12	B	P-GND
13	W	FUEL_PUMP
15	BR	START_IG-E/R
16	L/Y	WIPER_AUTO_STOP
19	L/Y	BCM_IGN_SW
25	G/R	ABS_ECU
31	G/W	REC_RLY

Connector No.	E30
Connector Name	WIRE TO WIRE
Connector Color	WHITE

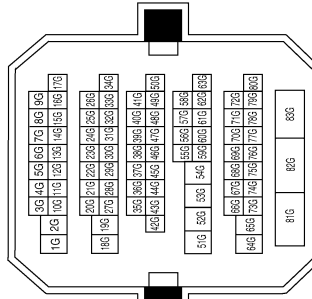

Terminal No.	Color of Wire	Signal Name
23G	Y	—
82G	W/B	—

Connector No.	E59
Connector Name	JOINT CONNECTOR-E07
Connector Color	BLUE

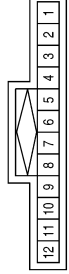

Terminal No.	Color of Wire	Signal Name
1	L	—
2	L	—
7	P	—
8	P	—

AWMIA0017GB

A B C D E F G H I J K L M N O P PG

POWER SUPPLY ROUTING CIRCUIT

< COMPONENT DIAGNOSIS >

Connector No.	E64
Connector Name	WIRE TO WIRE
Connector Color	WHITE



1	2	3	4	5
6	7	8	9	10
11	12			

Connector No.	E200
Connector Name	IPDM E/R (INTELLIGENT POWER DISTRIBUTION MODULE ENGINE ROOM)
Connector Color	WHITE



85	84	83
90	89	88
87	86	

Terminal No.	Color of Wire	Signal Name
7	L	—
8	P	—

Terminal No.	Color of Wire	Signal Name
88	R/W	WASHER_MTR

Connector No.	F10
Connector Name	IPDM E/R (INTELLIGENT POWER DISTRIBUTION MODULE ENGINE ROOM)
Connector Color	WHITE

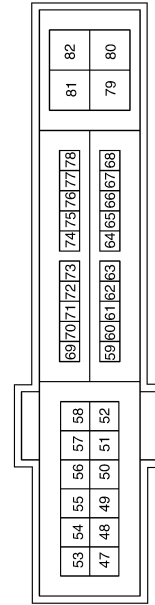

Terminal No.	Color of Wire	Signal Name
48	R	A/C COMP
51	LG	INJECTOR #1
56	R/Y	O2 SENS_#1
57	O	O2 SENS_#2
77	B/R	FPR

Connector No.	B4
Connector Name	FUSE BLOCK (J/B)
Connector Color	BROWN



51	4T	3T	2T	1T
12T	11T	10T	9T	8T
7T	6T			

Terminal No.	Color of Wire	Signal Name
10T	R	—
11T	R	—

ALMIA0135GB

POWER SUPPLY ROUTING CIRCUIT

< COMPONENT DIAGNOSIS >

Fuse

INFOID:000000001503509

- If fuse is blown, be sure to eliminate cause of malfunction before installing new fuse.
- Use fuse of specified rating. Never use fuse of more than specified rating.
- Do not partially install fuse; always insert it into fuse holder properly.
- Remove fuse for "ELECTRICAL PARTS (BAT)" if vehicle is not used for a long period of time.

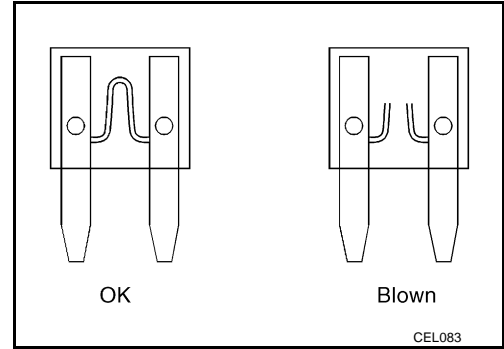

Fusible Link

INFOID:000000001503510

A melted fusible link can be detected either by visual inspection or by feeling with finger tip. If its condition is questionable, use circuit tester or test lamp.

1 : Fusible link

CAUTION:

- If fusible link should melt, it is possible that critical circuit (power supply or large current carrying circuit) is shorted. In such a case, carefully check and eliminate cause of malfunction.
- Never wrap outside of fusible link with vinyl tape. Important: Never let fusible link touch any other wiring harness, vinyl or rubber parts.

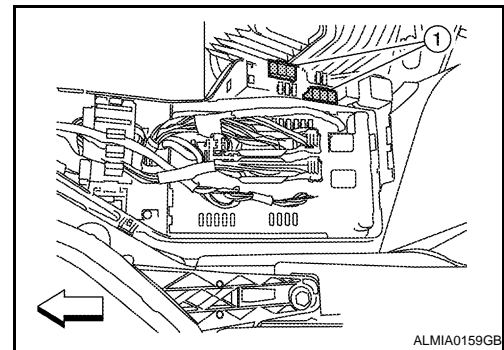

A
B
C
D
E
F
G
H
I
J
K
L
N
O
P

PG

GROUND

< COMPONENT DIAGNOSIS >

GROUND

Ground Distribution

INFOID:000000001503511

MAIN HARNESS

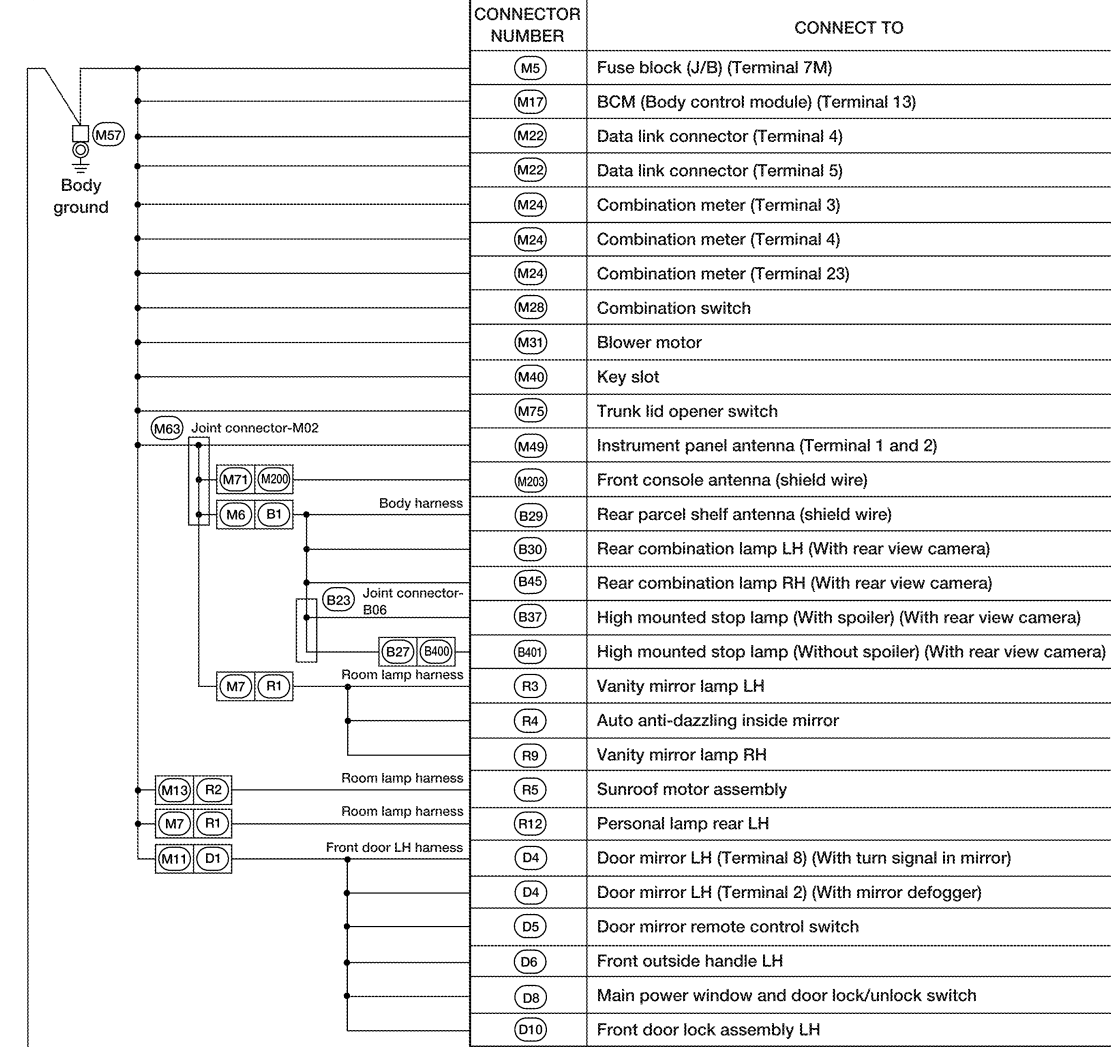
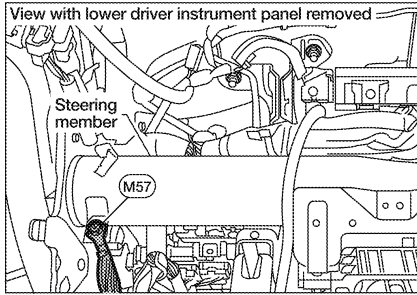

Next page

ALMIA0150GB

GROUND

< COMPONENT DIAGNOSIS >

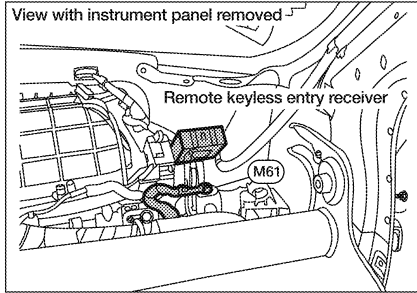

Preceding page

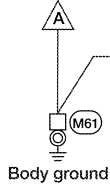

CONNECTOR NUMBER	CONNECT TO
(M23)	ECVT device (Terminal 7)
(M32)	Electronic steering column lock (Terminal 5)
(M32)	Electronic steering column lock (Terminal 6)
(M36)	Front passenger air bag off indicator
(M37)	Controller (Auto amp.) (Terminal 17)
(M37)	Controller (Auto amp.) (Terminal 37)
(M38)	Push-button ignition switch
(M55)	Yaw rate/side/decel G sensor
(M47)	AV control unit (Terminal 19)
(M49)	Instrument panel antenna (Terminal 1 and 2)
(M201)	Front heated seat switch LH
(M202)	Front heated seat switch RH
(M54)	Hazard switch
(M68)	Glove box lamp
(M74)	Trunk lid opener cancel switch
(M76)	Front power socket
(M126)	Intake door motor
(M127)	Mode door motor
(M128)	Air mix door motor LH
(M129)	Air mix door motor RH
(M203)	Front console antenna
(M351)	Front console power socket
(D105)	Power window and door lock/unlock switch RH
(D106)	Front outside handle RH
(D107)	Door mirror RH (Terminal 8) (With turn signal in mirror)
(D107)	Door mirror RH (Terminal 2) (With mirror defogger)

ALMIA0151GB

A
B
C
D
E
F
G
H
I
J
K
L
PG
N
O
P

GROUND

< COMPONENT DIAGNOSIS >

ENGINE ROOM HARNESS

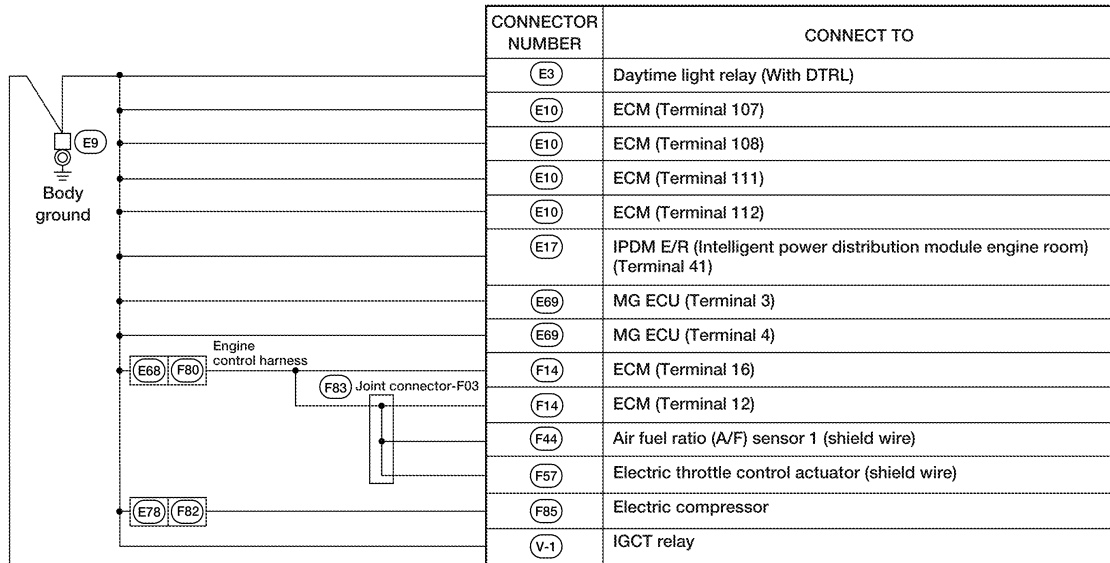
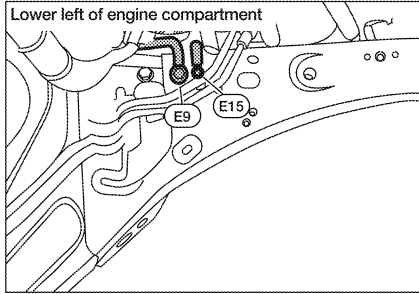

B
Next
page

ALMIA0152GB

GROUND

< COMPONENT DIAGNOSIS >

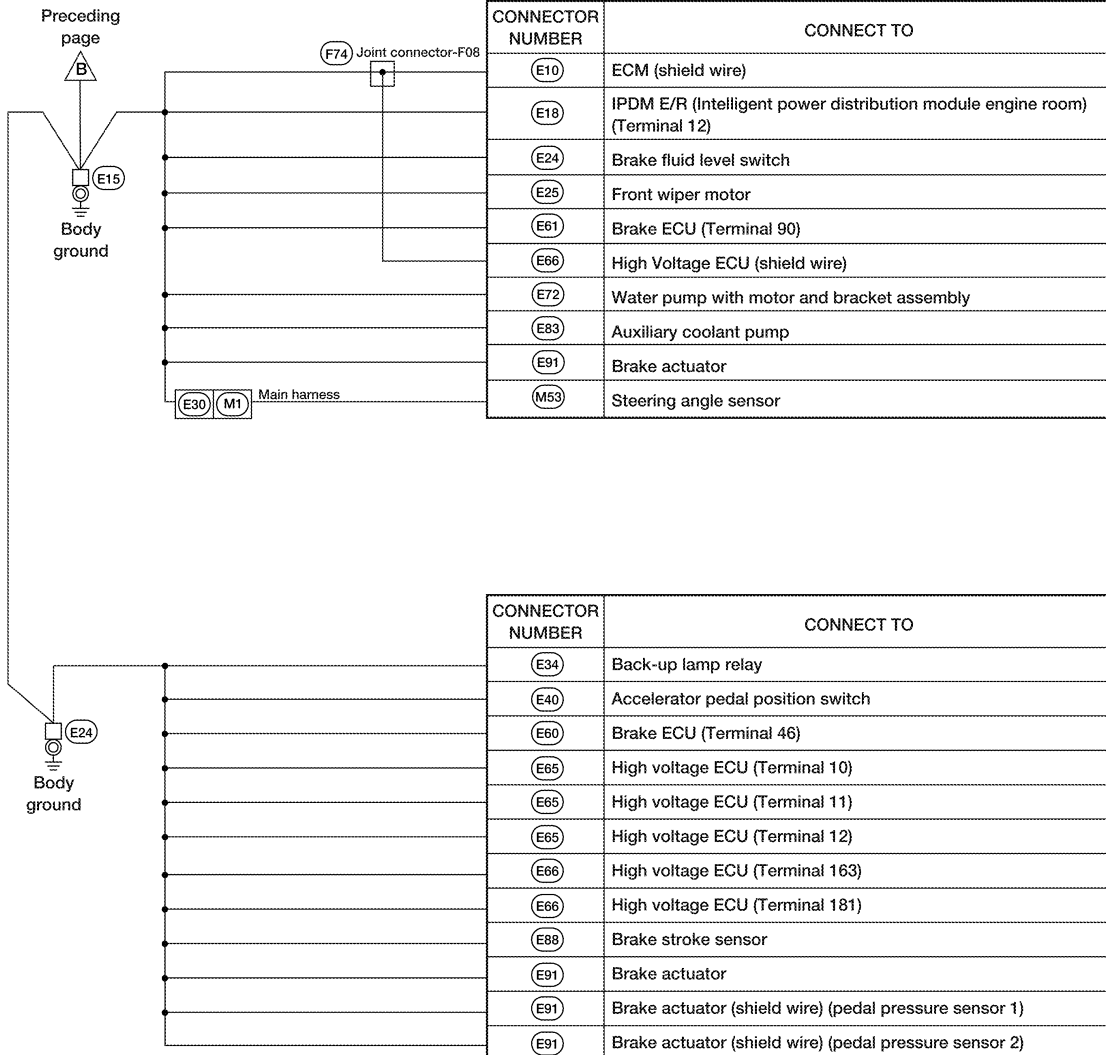
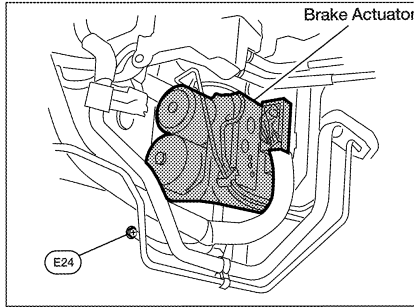
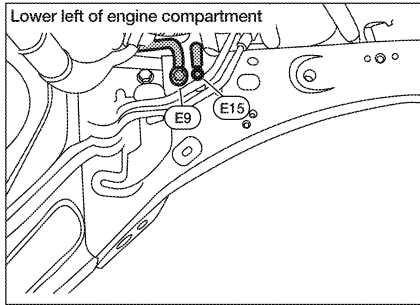

ALMIA0153GB

A
B
C
D
E
F
G
H
I
J
K
L
N
O
P

GROUND

< COMPONENT DIAGNOSIS > FRONT END MODULE HARNESS

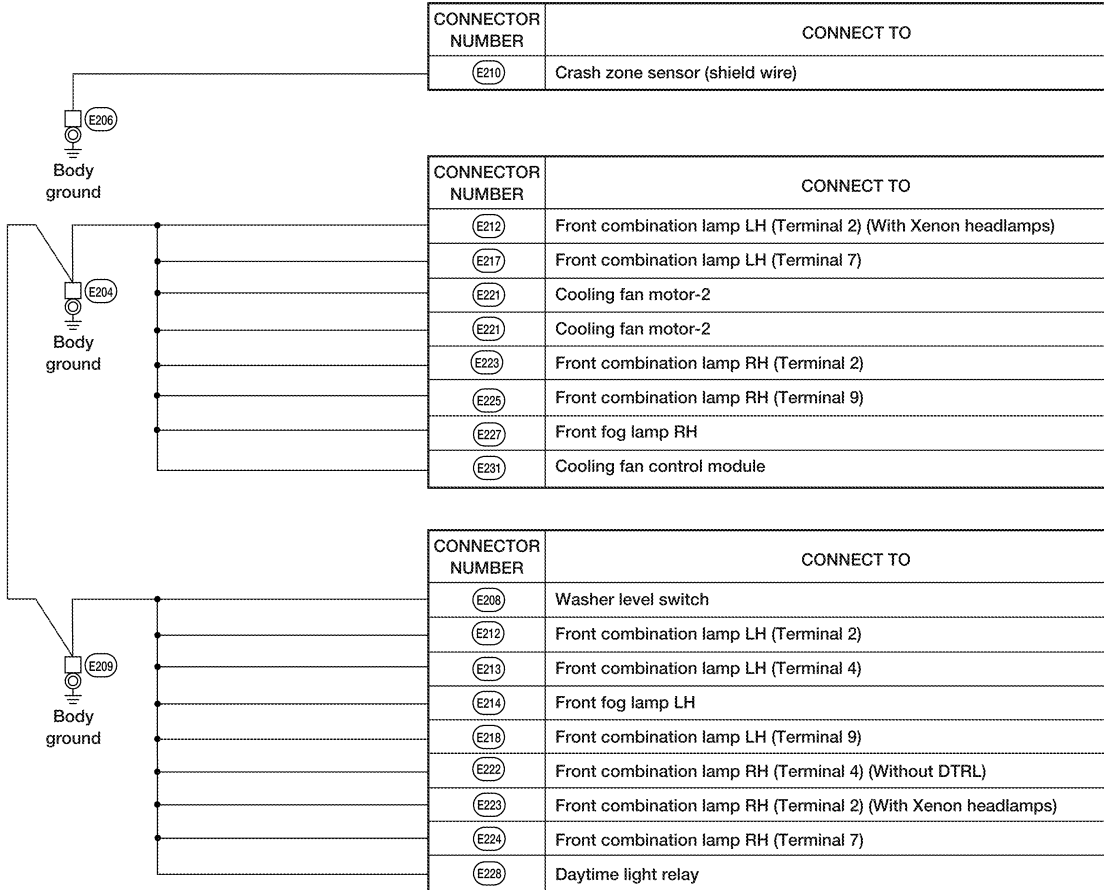
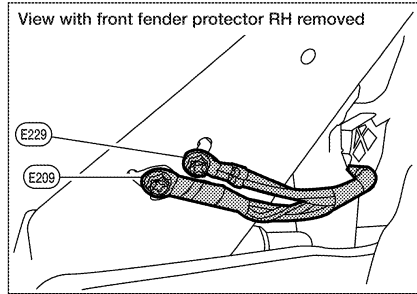
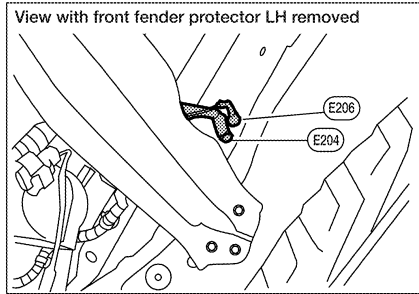

ALMIA0154GB

GROUND

< COMPONENT DIAGNOSIS >

HIGH VOLTAGE HARNESS

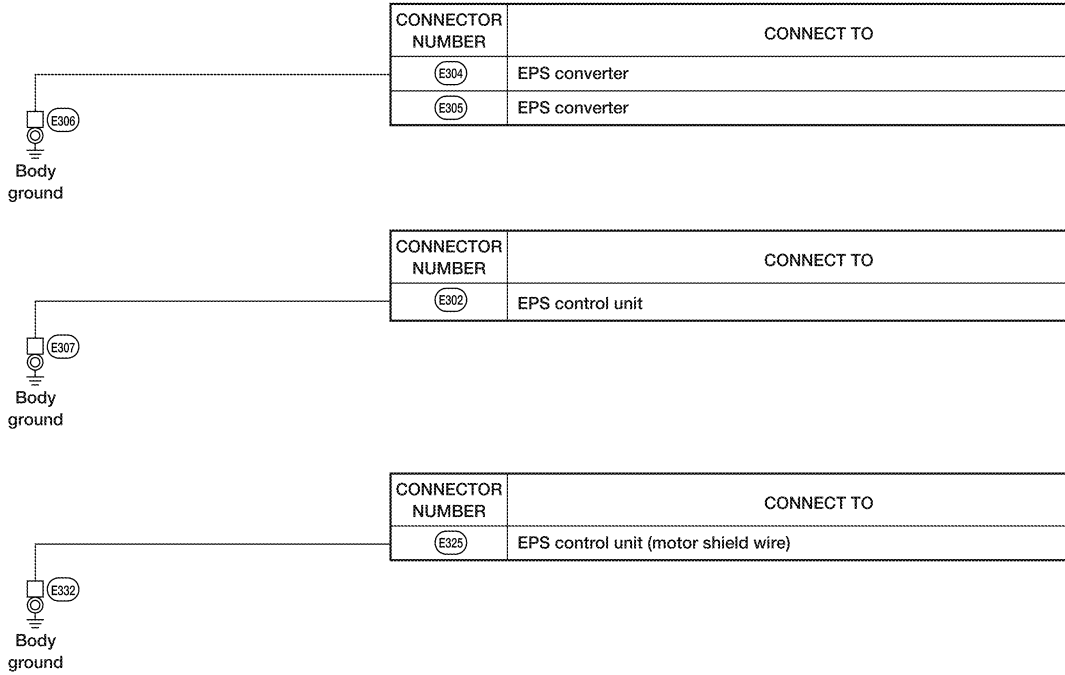
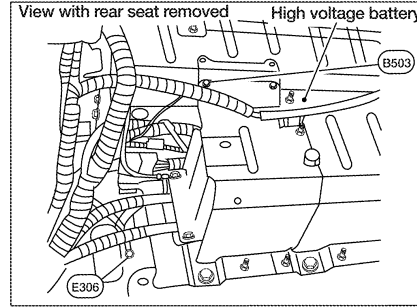
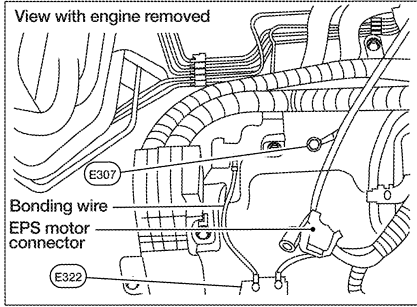

A
B
C
D
E
F
G
H
I
J
K
L
PG
N
O
P

ALMIA0155GB

GROUND

< COMPONENT DIAGNOSIS > ENGINE CONTROL HARNESS

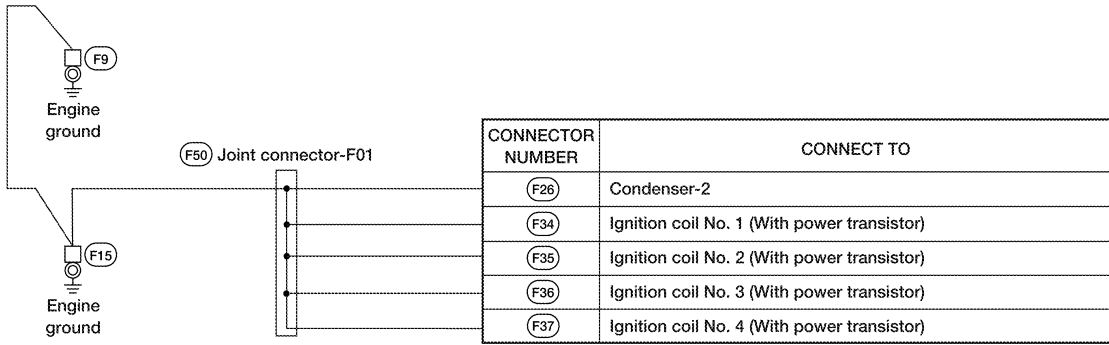
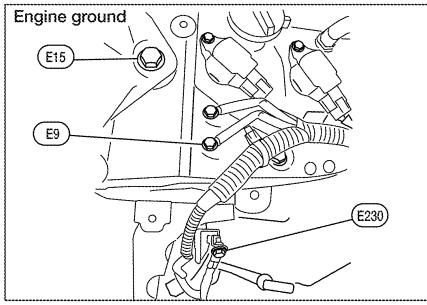

ALMIA0156GB

GROUND

< COMPONENT DIAGNOSIS >

BODY HARNESS

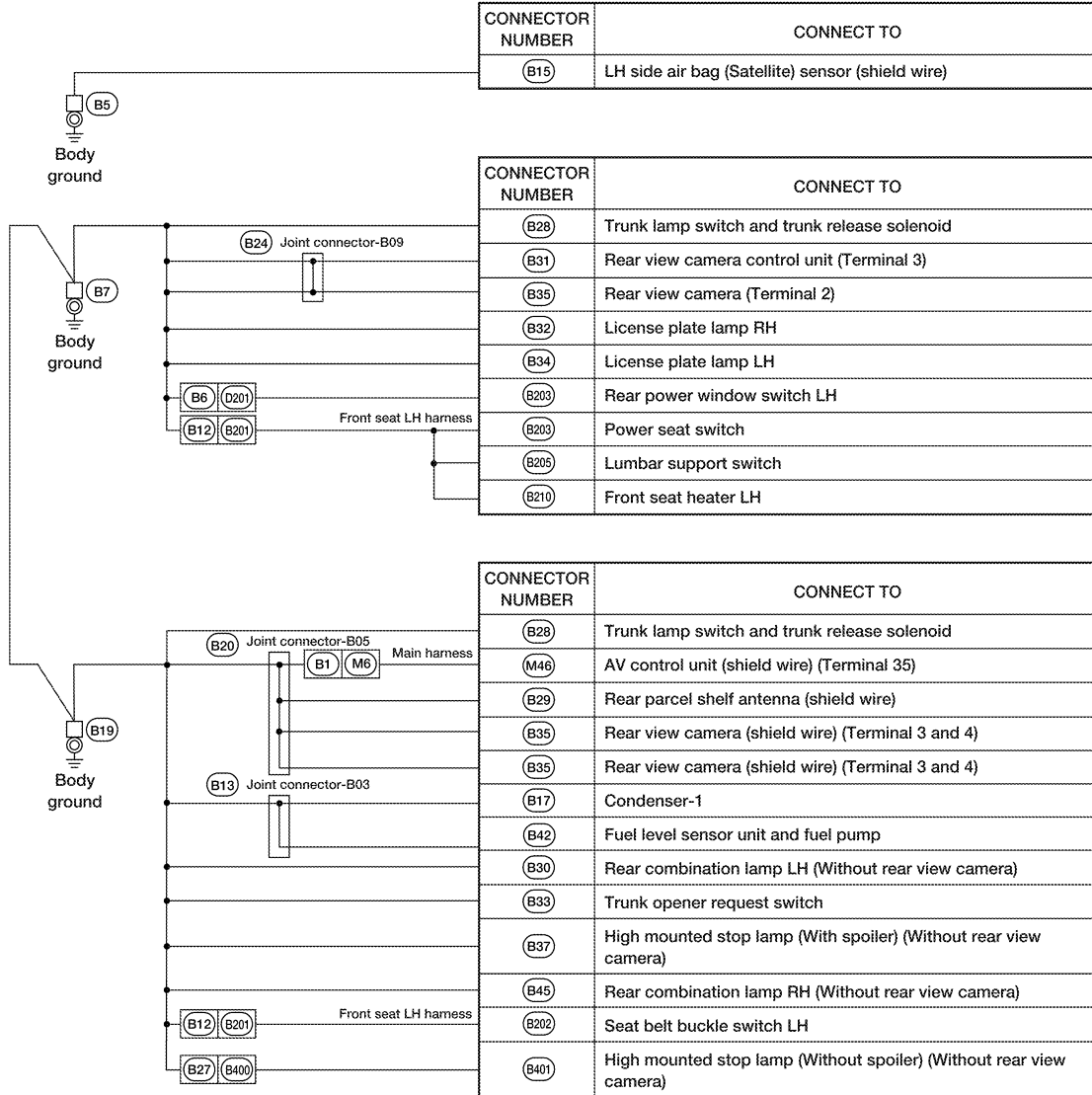
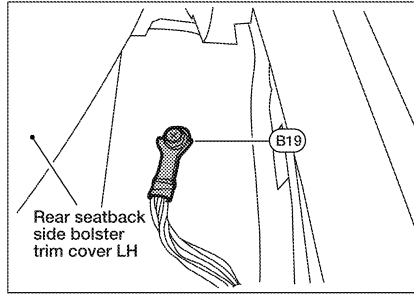
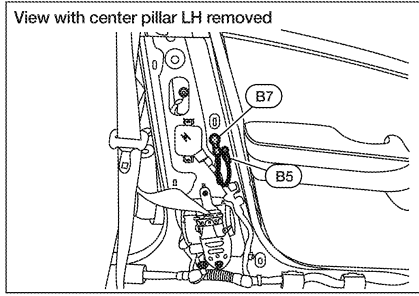

ALMIA0157GB

A
B
C
D
E
F
G
H
I
J
K
L
PG
N
O
P

GROUND

< COMPONENT DIAGNOSIS >

BODY NO. 2 HARNESS

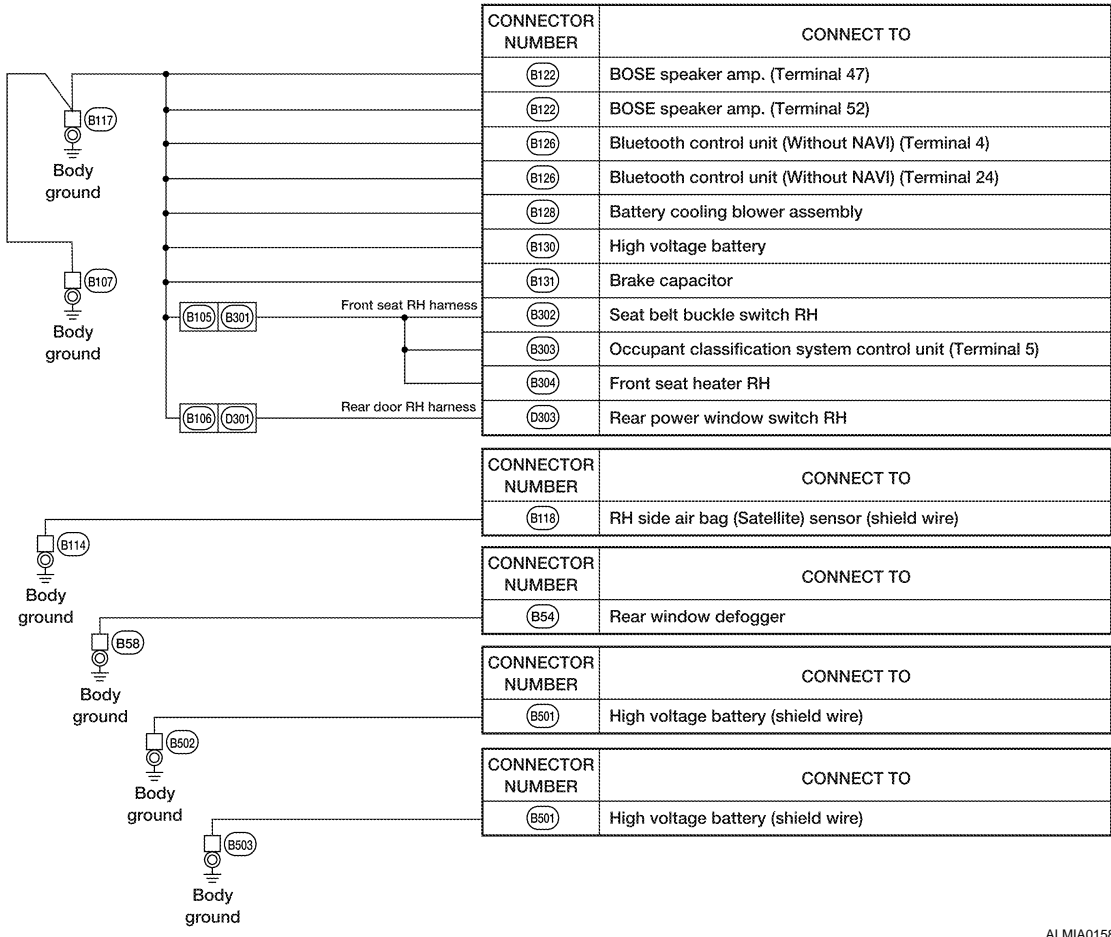
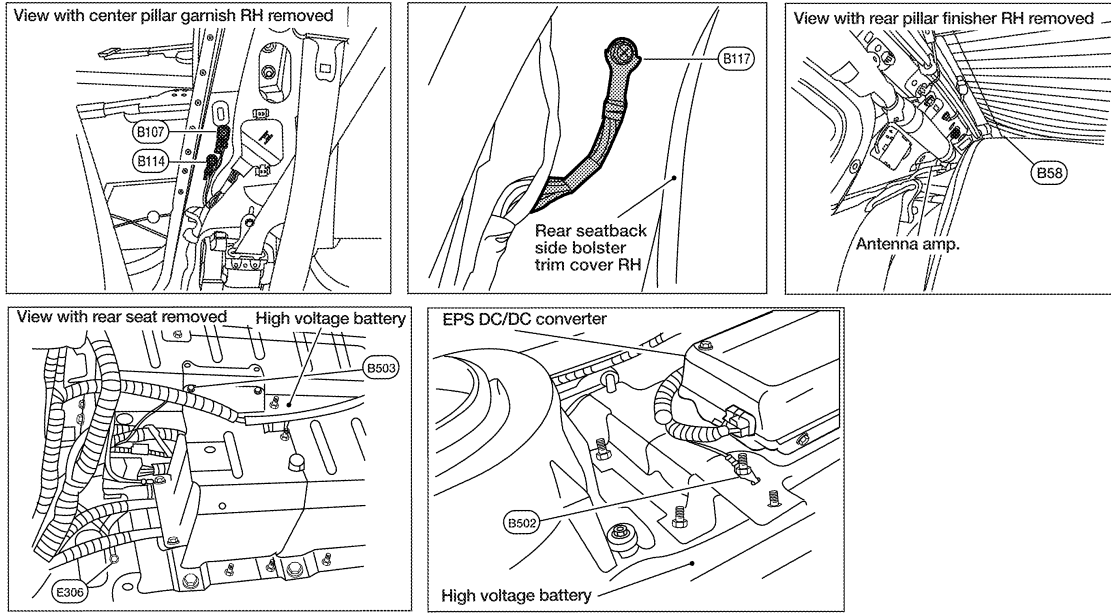

ALMIA0158GB

HARNESS

< COMPONENT DIAGNOSIS >

HARNESS

Harness Layout

INFOID:000000001503512

HOW TO READ HARNESS LAYOUT

The following Harness Layouts use a map style grid to help locate connectors on the drawings:

- Main Harness, Center Speaker Sub-harness and Console Sub-harness
- Engine Room Harness
- Engine Room Harness (Passenger Compartment)
- Front End Module Harness
- High Voltage Harness (Engine Room) and High Voltage Electric Compressor Sub-harness
- High Voltage Harness (Body)
- Engine Control Harness and Heated Oxygen Sensor Sub-harness
- Body Harness
- Body No. 2 Harness
- Room Lamp Harness

To use the grid reference

1. Find the desired connector number on the connector list.
2. Find the grid reference.
3. On the drawing, find the crossing of the grid reference letter column and number row.
4. Find the connector number in the crossing zone.
5. Follow the line (if used) to the connector.

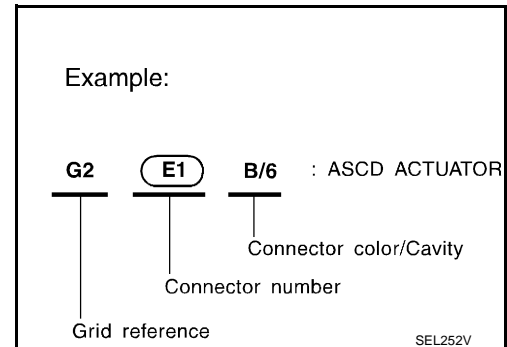

OUTLINE

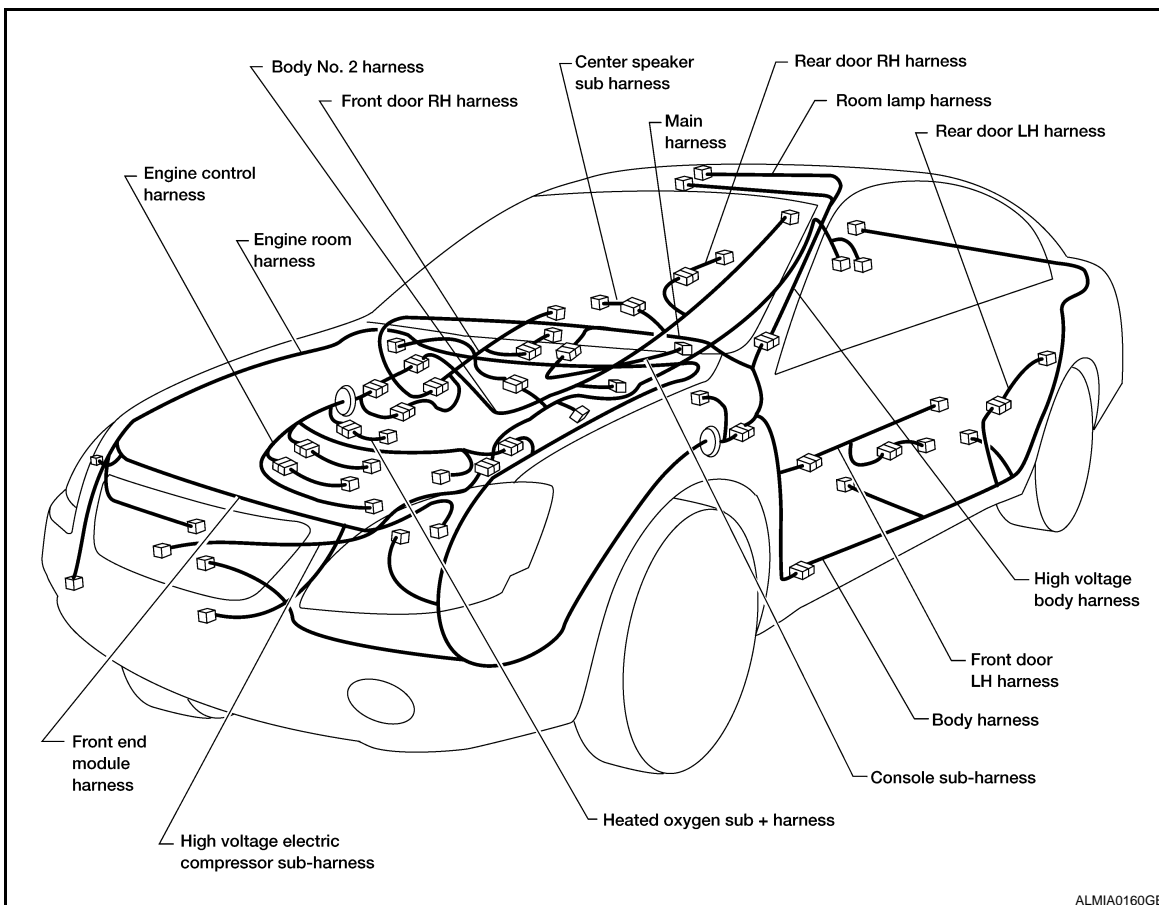

HARNESS

< COMPONENT DIAGNOSIS >

MAIN HARNESS

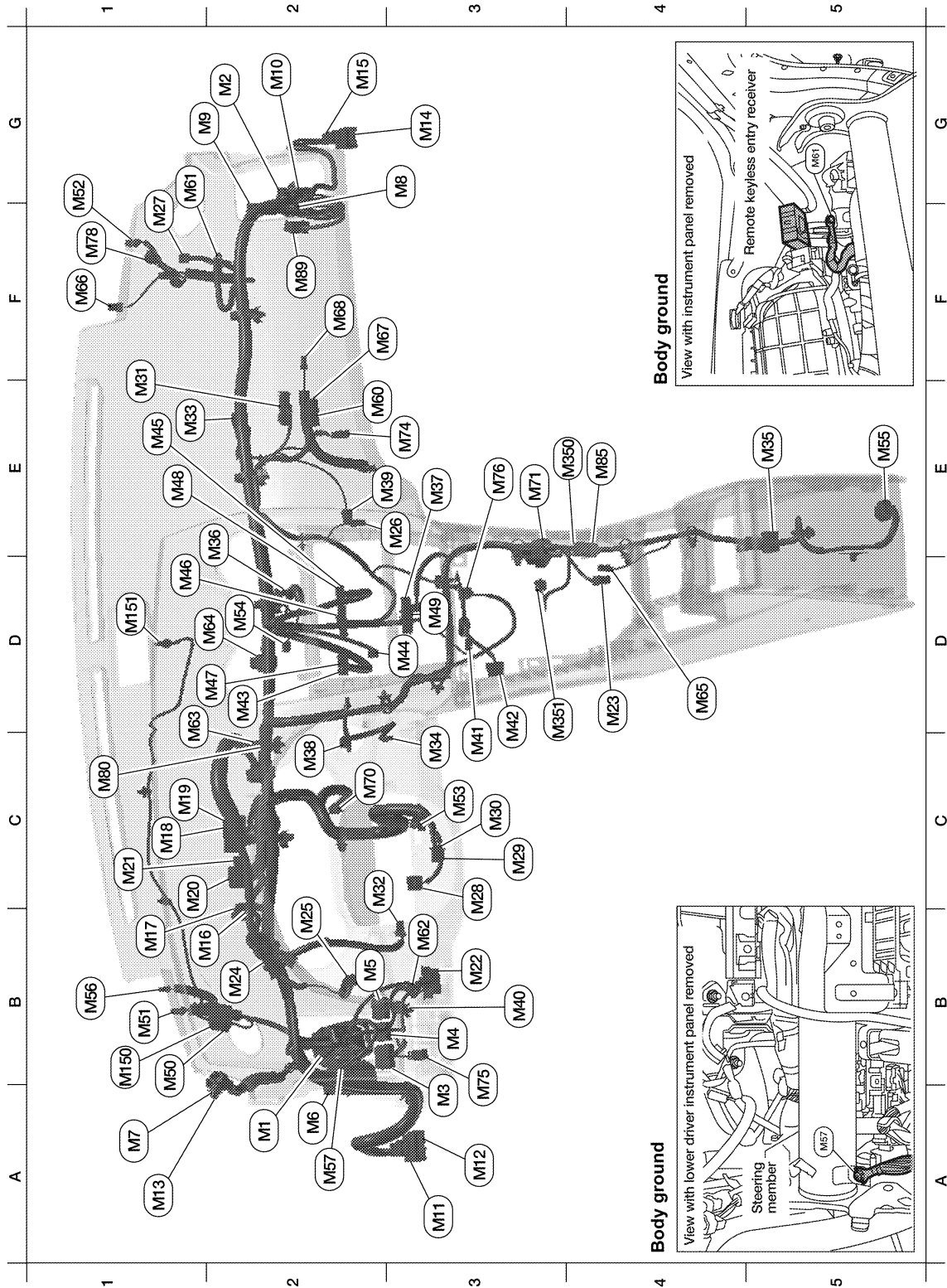

ALMIA0136GB

A2	M1	SMJ	: To E30	D3	M49	GR/2	: Instrument panel antenna
G2	M2	W/32	: To B101	B1	M50	W/2	: To M150
B3	M3	W/8	: Fuse block (J/B)	B1	M51	BR/2	: Tweeter LH
B3	M4	W/10	: Fuse block (J/B)	G1	M52	BR/2	: Tweeter RH

HARNESS

< COMPONENT DIAGNOSIS >

B2	M5	W/12	: Fuse block (J/B)	C3	M53	W/8	: Steering angle sensor	A	
A2	M6	SMJ	: To B1	D2	M54	W/4	: Hazard switch	B	
A1	M7	W/16	: To R1	E5	M55	B/5	: Yaw rate/side/decel G sensor	C	
G3	M8	W/24	: To B102	B1	M56	B/2	: Sunload sensor	D	
G1	M9	BR/16	: To B103	A2	M57	—	: Body ground	E	
G2	M10	BR/12	: To B104	E2	M60	Y/2	: Front passenger air bag module	F	
A3	M11	W/16	: To D1	G1	M61	—	: Body ground	G	
A3	M12	W/16	: To D2	B3	M62	W/2	: Tire pressure warning check connector	H	
A1	M13	W/4	: To R2	D1	M63	L/12	: Joint connector-M02	I	
G3	M14	W/10	: To D101	D1	M64	GR/6	: Joint connector-M01	J	
G2	M15	W/12	: To D102	D4	M65	BR/2	: ECVT device	K	
B1	M16	B/3	: BCM (body control module)	F1	M66	W/3	: Optical sensor	L	
B1	M17	W/16	: BCM (body control module)	F3	M67	O/2	: Front passenger air bag module	PG	
C1	M18	G/40	: BCM (body control module)	F2	M68	W/2	: Glove box lamp	N	
C1	M19	B/40	: BCM (body control module)	C2	M70	W/4	: Tire pressure receiver	O	
C1	M20	W/12	: BCM (body control module)	E3	M71	W/12	: To M200	P	
C1	M21	GR/40	: BCM (body control module)	E3	M74	W/2	: Trunk lid cancel switch		
B3	M22	W/16	: Data link connector	B3	M75	B/2	: Trunk lid opener switch		
D4	M23	W/10	: CVT device	E3	M76	B/3	: Front power socket		
B2	M24	W/40	: Combination meter	F1	M78	Y/4	: Front passenger air bag module (service replacement)		
B2	M25	B/10	: Meter mode switch	C1	M80	—	: Diode-3		
E3	M26	BR/2	: Brake warning buzzer	E4	M85	W/2	: To M350		
F1	M27	B/4	: Remote keyless entry receiver	F2	M89	W/12	: To E64		
C3	M28	W/16	: Combination switch	Center speaker sub-harness					
C3	M29	Y/6	: Combination switch (spiral cable)	D1	M150	W/2	: To M50		
C3	M30	GR/8	: Combination switch (spiral cable)	B1	M151	—	: Center speaker		
E1	M31	W/6	: Blower motor	Console sub-harness					
C2	M32	W/8	: Electronic steering column lock	D3	M350	W/2	: To M85		
E1	M33	W/3	: To M125	E3	M351	B/3	: Front console power socket		
C3	M34	W/2	: In-vehicle sensor						
E5	M35	Y/28	: Air bag diagnosis sensor unit						
E2	M36	W/3	: Front passenger air bag off indicator						
E3	M37	W/40	: Front air control						
C2	M38	BR/8	: Push-button ignition switch						
E2	M39	W/4	: Intake sensor						
D3	M40	W/12	: Card slot						
C3	M41	W/4	: Aux jack						
D3	M42	W/16	: CD changer						
D2	M43	W/20	: Audio unit						
D3	M44	W/8	: Audio unit						
E1	M45	W/12	: Audio unit						
D1	M46	W/40	: AV control unit						
D2	M47	W/20	: AV control unit						
E1	M48	GR/12	: AV control unit						

HARNESS

< COMPONENT DIAGNOSIS >

ENGINE ROOM HARNESS

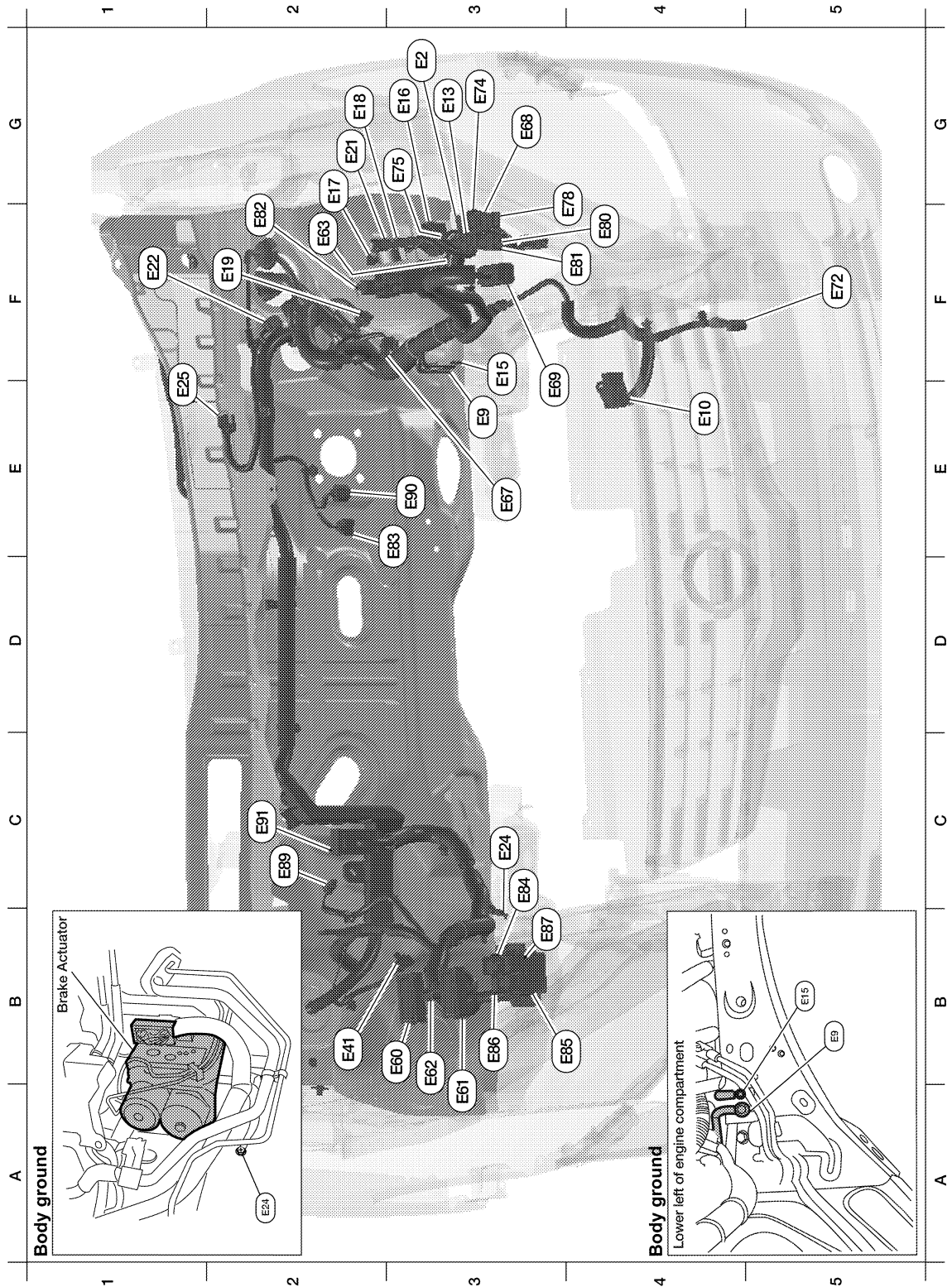

ALMIA0141GB

G3	E1	W/10	: To B109				
G3	E2	W/8	: To E202				
B5	E9	—	: Body ground				
E4	E10	B/32	: ECM				
G3	E13	B/3	: To E205				

HARNESS

< COMPONENT DIAGNOSIS >

E3	E15	—	: Body ground					
G3	E16	B/2	: IPDM E/R (intelligent power distribution module engine room)					
F2	E17	W/8	: IPDM E/R (intelligent power distribution module engine room)					
G2	E18	W/32	: IPDM E/R (intelligent power distribution module engine room)					
F2	E19	GR/2	: Front wheel sensor LH					
G2	E21	W/4	: Joint connector-E03					
F1	E22	B/10	: Joint connector-E04					
A2	E24	—	: Body ground					
E2	E25	GR/5	: Front wiper motor					
F4	E28	W/6	: Joint connector - E05					
B2	E41	GR/2	: Front wheel sensor RH					

A

B

C

D

E

F

G

H

I

J

K

L

PG

N

O

P

HARNESS

< COMPONENT DIAGNOSIS >

ENGINE ROOM HARNESS (PASSENGER COMPARTMENT)

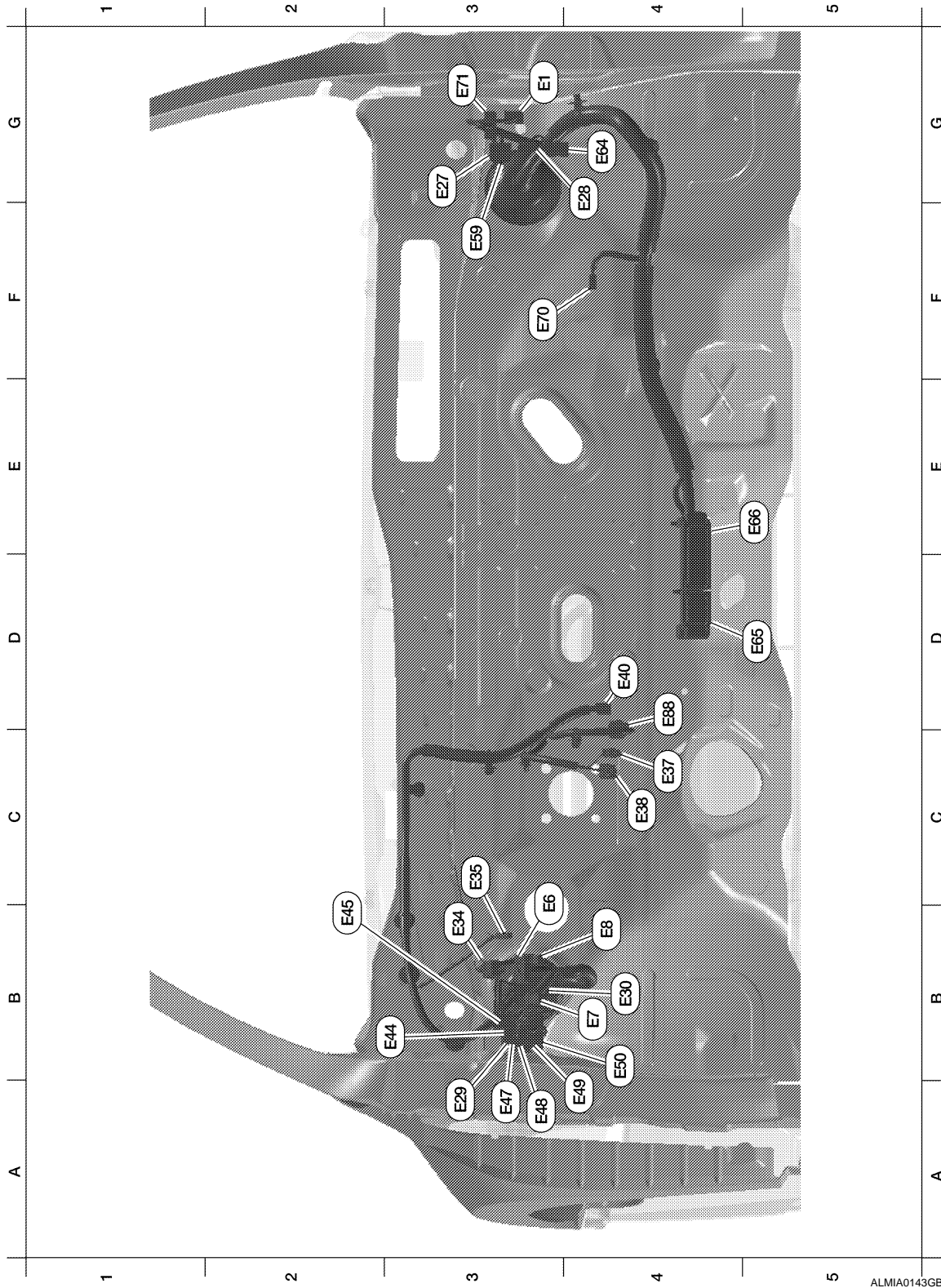

ALMIA0143GB

C3	E6	W/16	: Fuse block (J/B)			
B4	E7	W/1	: Fuse block (J/B)			
B4	E8	B/2	: Fuse block (J/B)			
G3	E27	W/4	: Joint connector-E06			
A3	E29	W/16	: To B10			

HARNESS

< COMPONENT DIAGNOSIS >

B4	E30	SMJ	: To M1							A
B3	E34	L/4	: Back-up lamp relay							B
C3	E35	B/1	: Park brake switch							B
C4	E37	BR/2	: ASCD brake switch							B
C4	E38	W/4	: Stop lamp switch							B
D4	E40	B/6	: Accelerator pedal position switch							C
B3	E44	BR/12	: Junction block							C
B2	E45	W/12	: Junction block							C
C3	E46	W/16	: Junction block							D
A3	E47	W/6	: Junction block							D
A3	E48	W/4	: Junction block							D
A4	E49	BR/4	: Junction block							E
B4	E50	W/2	: Junction block							E
F3	E59	L/12	: Joint connector - E07							F
B3	E60	B/46	: Brake ECU							F
B4	E61	B/40	: Brake ECU							G
B3	E62	B/5	: Brake ECU							G
F2	E63	W/4	: Joint connector - E09							H
G4	E64	W/12	: To M89							H
D5	E65	B/60	: High voltage ECU							H
E5	E66	B/126	: High voltage ECU							I
E3	E67	B/4	: To E301							I
G3	E68	W/20	: To F80							J
E3	E69	B/40	: MG ECU							J
F3	E70	W/8	: Data recorder							J
G3	E71	GR/24	: To B129							K
F5	E72	GR/4	: Water pump with motor and bracket assembly							K
G3	E74	W/4	: Joint connector - E08							L
G3	E75	W/6	: Joint connector - E01							L
F4	E78	W/12	: To F82							PG
F4	E80	BR/8	: To F84							PG
F4	E81	B/1	: To E207							PG
F2	E82	—	: Cooling fan relay - 1							N
D3	E83	B/2	: Auxiliary coolant pump							N
C4	E84	L/5	: ABS relay No. 1							O
B4	E85	L/5	: ABS relay No. 2							O
B3	E86	—	: ABS motor relay No. 2							O
B3	E87	—	: ABS motor relay No. 1							O
D4	E88	B/4	: Brake stroke sensor							P
C2	E89	B/2	: Brake fluid level switch							P
E3	E90	B/2	: Brake simulator							P
C2	E91	B/46	: Brake actuator							P

HARNESS

< COMPONENT DIAGNOSIS > FRONT END MODULE HARNESS

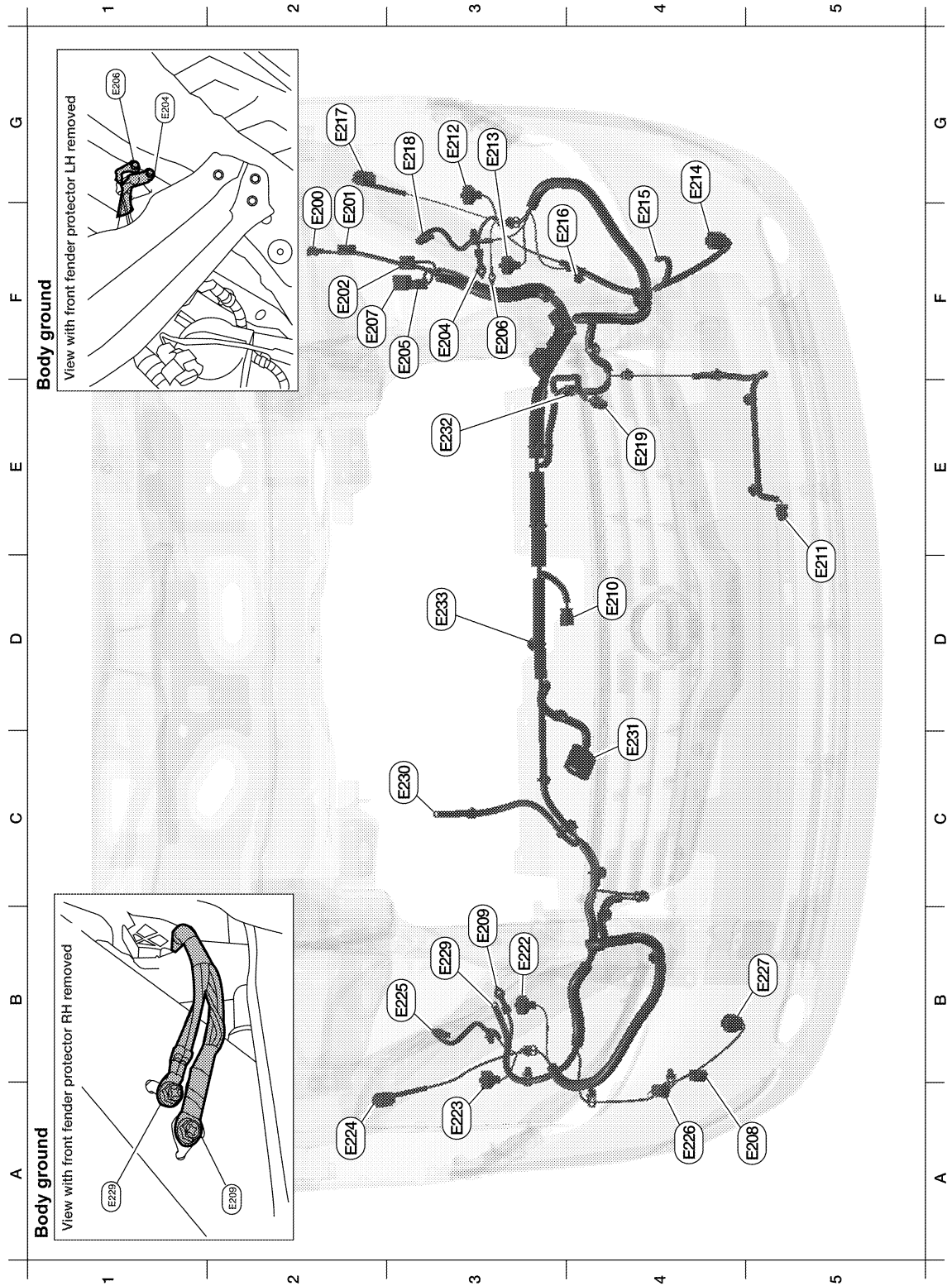

ALMIA0140GB

F2	E200	W/8	: IPDM E/R (intelligent power distribution module engine room)			
F2	E201	W/16	: IPDM E/R (intelligent power distribution module engine room)			
F2	E202	W/8	: To E2			
F3	E204	—	: Body ground			

HARNESS

< COMPONENT DIAGNOSIS >

F3	E205	B/3	: To E13							A
F3	E206	—	: Body ground							
F2	E207	B/1	: To E81							
A5	E208	W/2	: Washer fluid level switch							B
B3	E209	—	: Body ground							
D4	E210	Y/2	: Crash zone sensor							C
D5	E211	B/2	: Ambient sensor							
G3	E212	B/2	: Front headlamp LH (low)							
G3	E213	B/2	: Front headlamp LH (high)							D
G4	E214	B/2	: Front fog lamp LH							
F4	E215	B/1	: Horn (low)							
F3	E216	B/1	: Horn (high)							E
G2	E217	GR/3	: Front turn signal lamp LH							
G3	E218	B/2	: Front parking lamp LH							F
E4	E219	B/3	: Refrigerant pressure sensor							
B3	E222	B/2	: Front headlamp RH (high)							
A3	E223	B/2	: Front headlamp RH (low)							G
A2	E224	GR/3	: Front turn signal lamp RH							
B3	E225	B/2	: Front parking lamp RH							H
A4	E226	B/2	: Front washer motor							
B5	E227	B/2	: Front fog lamp RH							
B3	E229	—	: Bonding wire							I
C3	E230	—	: Body wire							
C4	E231	GR/3	: Cooling fan control module							J
E3	E232	B/2	: Cooling fan motor - 1							
D3	E233	B/2	: Cooling fan motor - 2							K

PG

N

O

P

HARNESS

< COMPONENT DIAGNOSIS >

HIGH VOLTAGE HARNESS (ENGINE ROOM)

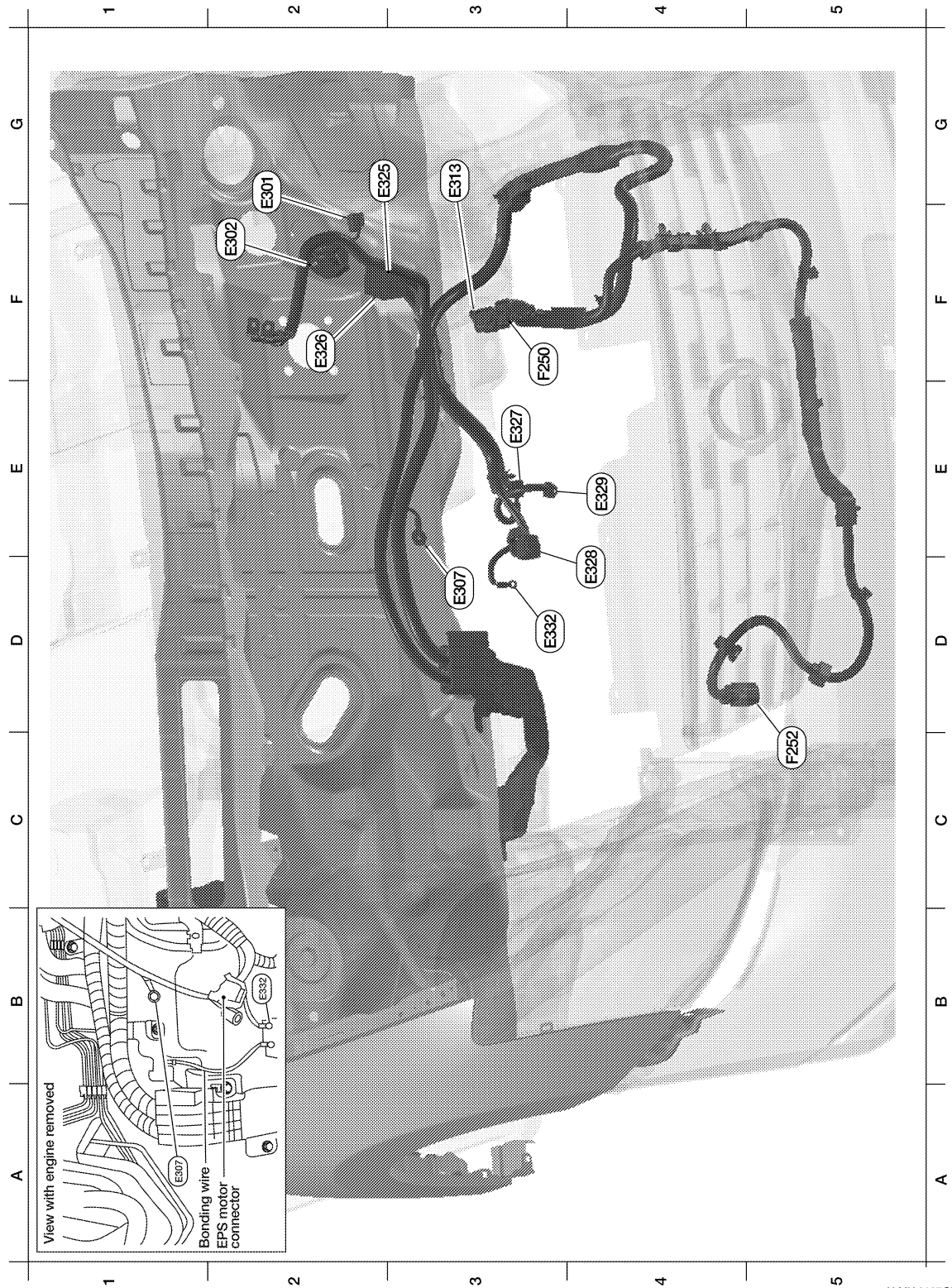

ALMIA0137GB

G2	E301	B/4	: To E67			
F2	E302	B/11	: EPS control unit			
D3	E307	—	: Body ground			
G2	E313	W/2	: Inverter			
G3	E325	GY/3	: EPS control unit			

HARNESS

< COMPONENT DIAGNOSIS >

F2	E326	GY/13	: EPS control unit				
E3	E327	—	: Torque sensor/EPS position sensor				
D4	E328	GY/3	: EPS motor				
E4	E329	GY/4	: EPS motor				
D3	E332	—	: Power steering motor ground				
High voltage electric compressor sub-harness							
F3	F250	W/2	: Inverter				
C5	F252	O/2	: A/C compressor				

A

B

C

D

E

F

G

H

I

J

K

L

PG

N

O

P

HARNESS

< COMPONENT DIAGNOSIS >

HIGH VOLTAGE HARNESS (BODY)

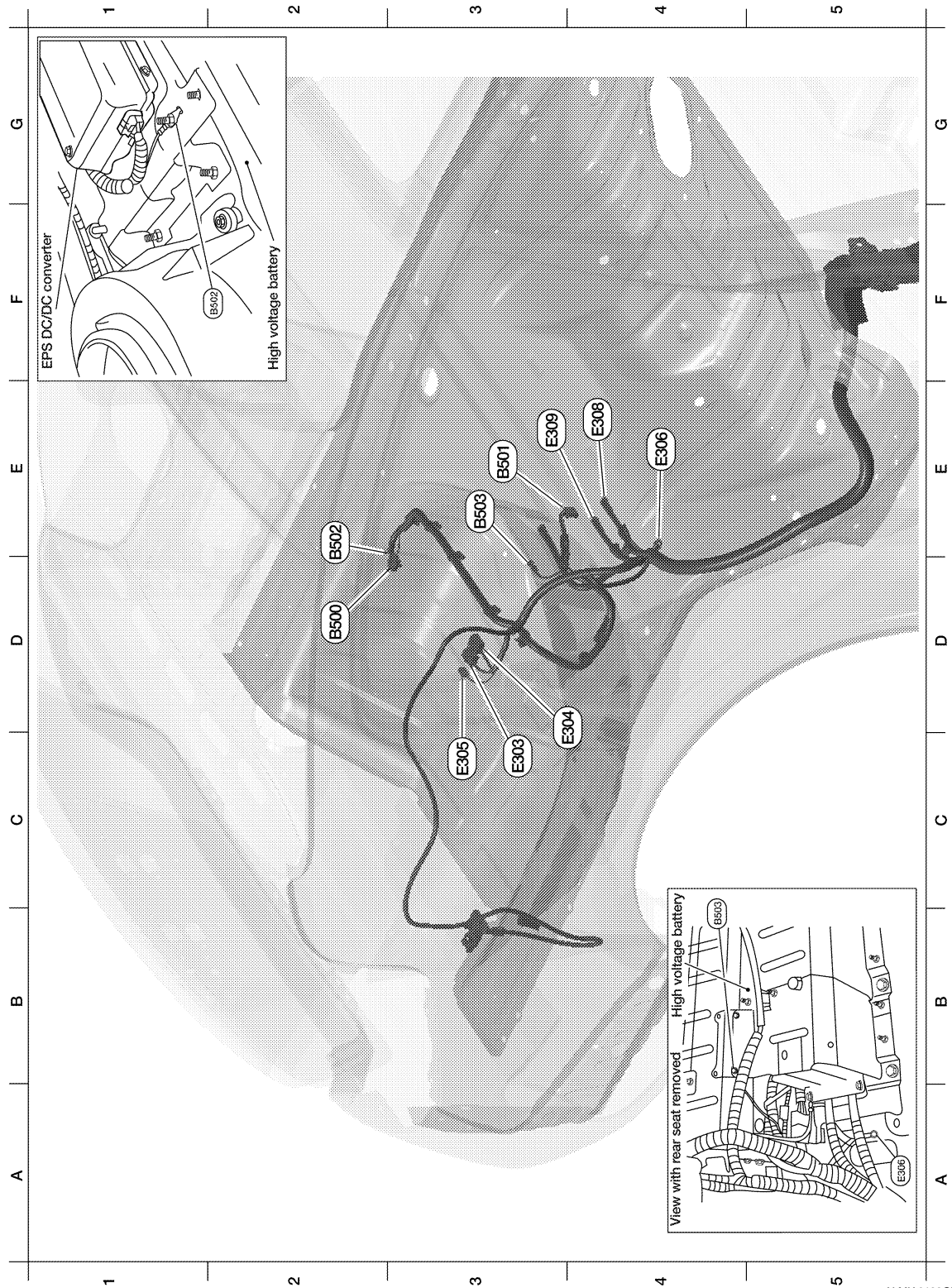

ALMIA0138GB

C3	E303	W/2	: EPS DC/DC convertor	E3	E309	—	: HV battery
D4	E304	GY/2	: EPS DC/DC convertor	D2	B500	O/5	: EPS DC/DC convertor
C3	E305	W/4	: EPS DC/DC convertor	E3	B501	W/4	: HV battery
E4	E306	—	: Body ground	E2	B502	—	: Body ground
E4	E308	—	: HV battery	E3	B503	—	: Body ground

HARNESS

< COMPONENT DIAGNOSIS > ENGINE CONTROL HARNESS

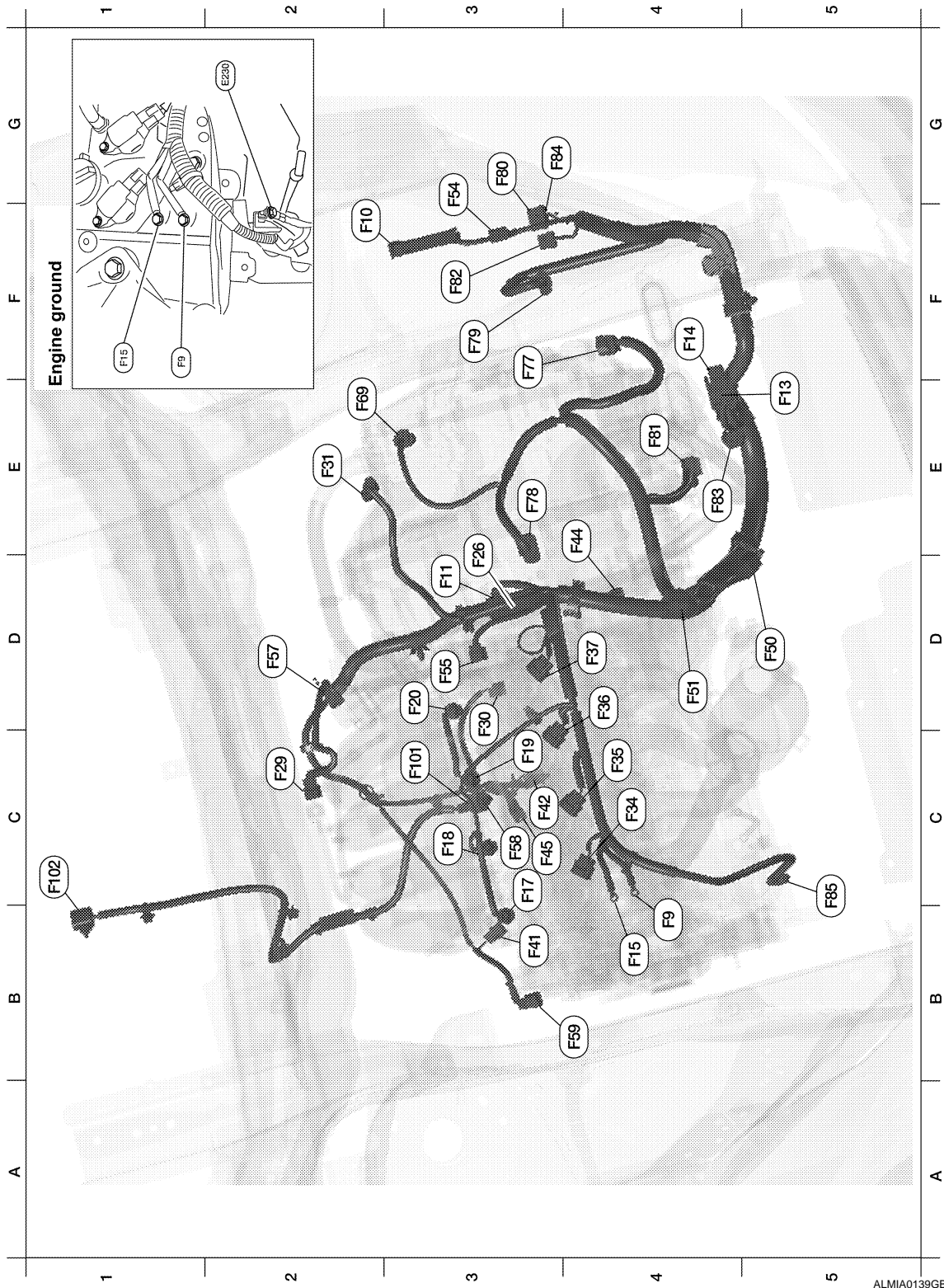

ALMIA0139GB

B4	F9	—	: Engine ground			
F2	F10	W/36	: IPDM E/R (intelligent power distribution module engine room)			
D3	F11	GR/2	: Engine coolant temperature sensor			
E5	F13	BR/48	: ECM			
F4	F14	GR/32	: ECM			

A
B
C
D
E
F
G
H
I
J
K
L
M
N
O
P

PG

HARNESS

< COMPONENT DIAGNOSIS >

B4	F15	—	: Engine ground			
C3	F17	GR/2	: Fuel injector No. 1			
C3	F18	GR/2	: Fuel injector No. 2			
C3	F19	GR/2	: Fuel injector No. 3			
D3	F20	GR/2	: Fuel injector No. 4			
E3	F26	GR/2	: Condenser-2			
C2	F29	L/2	: EVAP canister purge volume control solenoid valve			
D3	F30	B/3	: Crankshaft position sensor (POS)			
E2	F31	B/6	: Mass air flow sensor			
C4	F34	GR/3	: Ignition coil No. 1 (with power transistor)			
C4	F35	GR/3	: Ignition coil No. 2 (with power transistor)			
D4	F36	GR/3	: Ignition coil No. 3 (with power transistor)			
D4	F37	GR/3	: Ignition coil No. 4 (with power transistor)			
B3	F41	GR/1	: Oil pressure switch			
C3	F42	B/4	: Heated oxygen sensor 2			
E4	F44	GR/4	: Air fuel ratio (A/F) sensor 1			
C3	F45	GR/2	: Knock sensor			
D5	F50	B/10	: Joint connector - F01			
D4	F51	B/10	: Joint connector - F05			
G3	F54	W/4	: Joint connector - F08			
D3	F55	B/3	: Camshaft position sensor (phase)			
D2	F57	B/6	: Electric throttle control actuator			
C3	F58	B/4	: To F101			
B4	F59	G/2	: Intake valve timing control solenoid valve			
E2	F69	B/3	: Motor generator No. 2			
F3	F77	B/6	: Motor generator No. 2			
E3	F78	B/10	: Motor generator No. 1			
F3	F79	GR/13	: MG ECU			
G3	F80	W/20	: To E68			
E4	F81	GR/9	: Park/neutral (PNP) switch			
F3	F82	W/12	: To E78			
E4	F83	B/10	: Joint connector - F03			
F3	F84	BR/8	: To E80			
C5	F85	B/6	: A/C compressor			
Heated oxygen sensor sub-harness						
C3	F101	B/4	: To F58			
C1	F102	GR/4	: Heated oxygen sensor 3			

HARNESS

< COMPONENT DIAGNOSIS >

BODY HARNESS

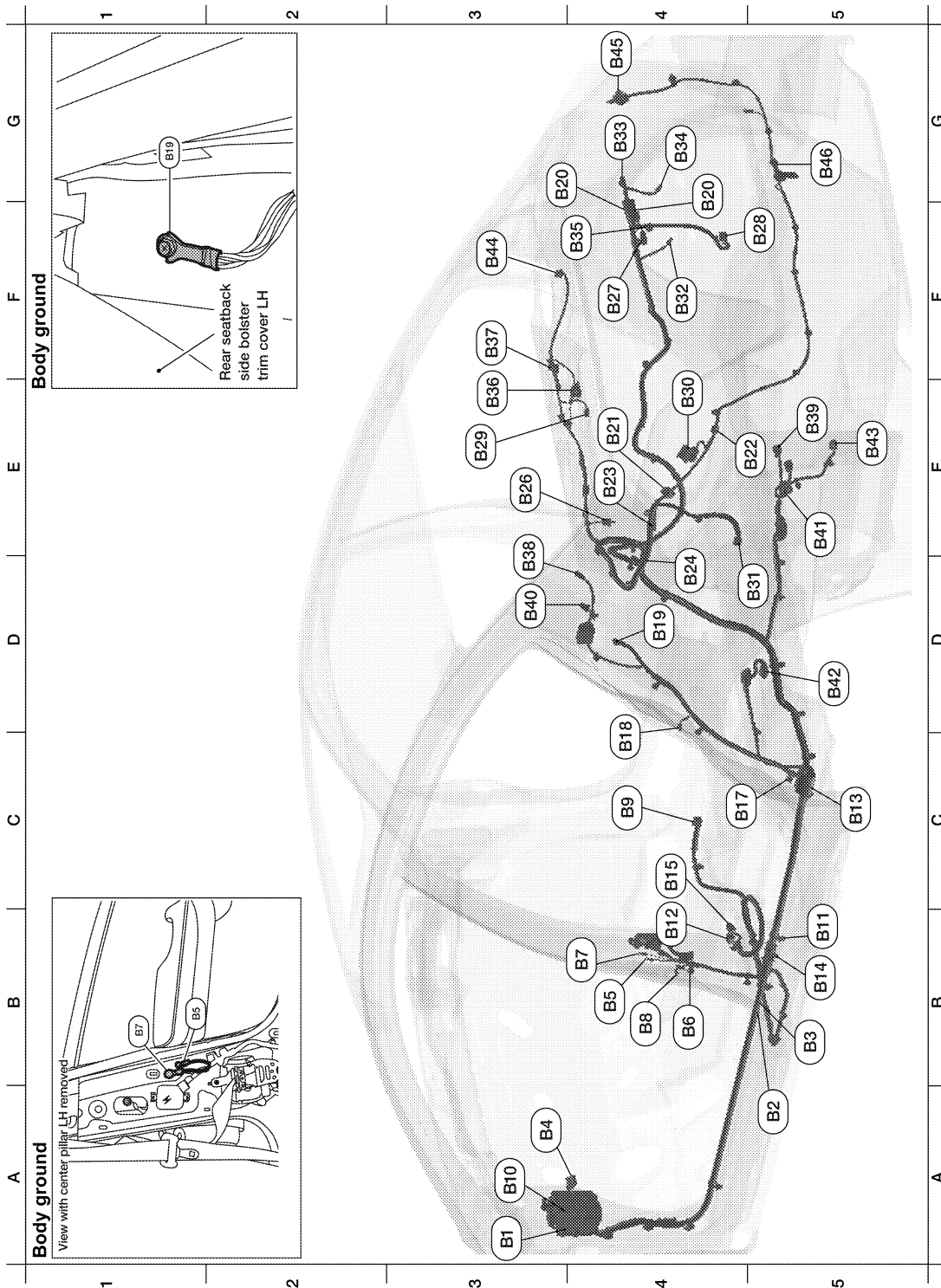

ALMIA0023GB

A3	B1	SMJ	: To M6			
A5	B2	W/4	: Joint connector-B01			
B5	B3	W/4	: Joint connector-B02			
A3	B4	BR/12	: Fuse block (J/B)			
B4	B5	—	: LH side air bag (satellite) sensor (sheild wire)			

A
B
C
D
E
F
G
H
I
J
K
L
M
N
O
P

PG

HARNESS

< COMPONENT DIAGNOSIS >

B4	B6	W/8	: To D201				
B4	B7	—	: Body ground				
B4	B8	W/3	: Front door switch LH				
C4	B9	Y/12	: Air bag diagnosis sensor unit				
A3	B10	W/16	: To E29				
B5	B11	Y/2	: Front LH side air bag module				
B4	B12	W/8	: To B201				
C5	B13	W/6	: Joint connector-B03				
B5	B14	Y/2	: Front LH seat belt pre-tensioner				
C4	B15	Y/2	: LH side air bag (satellite) sensor				
C4	B17	W/2	: Condenser-1				
C4	B18	W/3	: Rear door switch LH				
D4	B19	—	: Body ground				
G3	B20	GR/6	: Joint connector-B05				
E4	B21	L/12	: Joint connector-B06				
E5	B22	GR/6	: Joint connector-B07				
E4	B23	W/4	: Joint connector-B08				
D4	B24	W/4	: Joint connector-B09				
E3	B26	W/2	: Rear speaker LH				
F5	B28	W/4	: Trunk lamp switch and trunk release solenoid				
E3	B29	GR/2	: Rear parcel shelf antenna				
E4	B30	W/6	: Rear combination lamp LH				
D5	B31	W/16	: Rear view camera control unit				
F4	B32	BR/2	: License plate lamp RH				
G4	B33	BR/2	: Trunk opener request switch				
G4	B34	BR/2	: License plate lamp LH				
F4	B35	W/4	: Rear view camera control unit				
E3	B36	W/2	: Trunk room lamp				
F3	B37	W/2	: High mounted stop lamp				
D3	B38	Y/2	: LH side front curtain air bag module				
E5	B39	B/2	: EVAP canister vent control valve				
D3	B40	W/1	: Rear window defogger				
E5	B41	GR/3	: EVAP control system pressure sensor				
D5	B42	GR/5	: Fuel level sensor unit and fuel pump				
E5	B43	GR/4	: Rear wheel sensor				
F3	B44	W/2	: Rear speaker RH				
G4	B45	W/6	: Rear combination lamp RH				
G5	B46	GR/2	: Rear bumper antenna				

HARNESS

< COMPONENT DIAGNOSIS >

BODY NO. 2 HARNESS

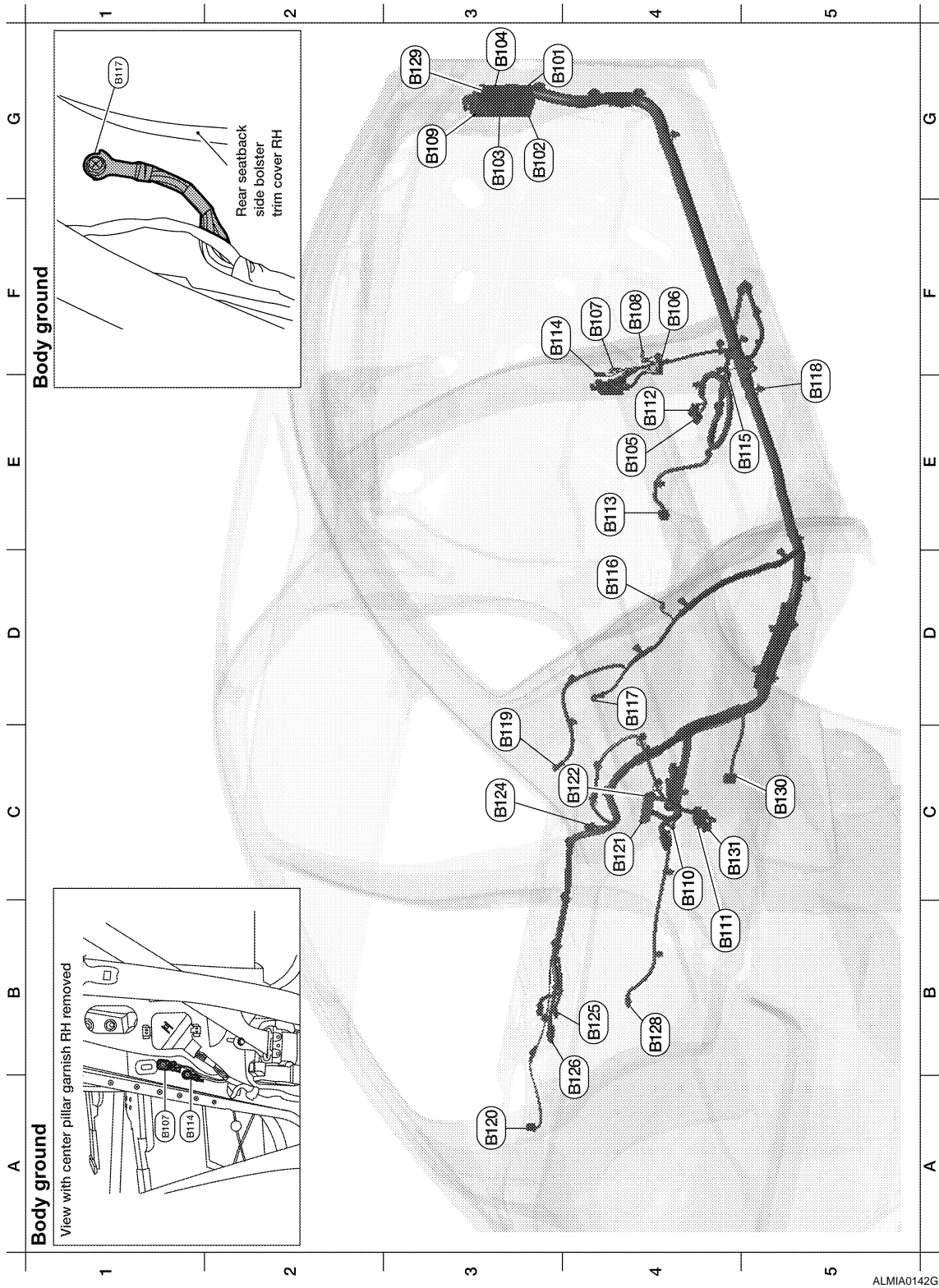

ALMIA0142GB

G3	B101	W/32	: To M2			
G3	B102	W/24	: To M8			
G3	B103	BR/16	: To M9			
G3	B104	BR/12	: To M10			
E4	B105	W/8	: To B301			

HARNESS

< COMPONENT DIAGNOSIS >

F4	B106	W/8	: To D301				
E4	B107	—	: Body ground				
F4	B108	W/3	: Front door switch RH				
G3	B109	W/10	: To E1				
C4	B110	W/6	: Joint connector - B01				
B4	B111	L/5	: High voltage battery fan relay				
E4	B112	Y/2	: Front RH side air bag module				
E4	B113	Y/12	: Air bag diagnosis sensor unit				
F3	B114	—	: RH side air bag (satellite) sensor (sheild wire)				
E5	B115	Y/2	: Front RH seat belt pre-tensioner				
D4	B116	W/3	: Rear door switch RH				
D4	B117	—	: Body ground				
E5	B118	Y/2	: RH side air bag (satellite) sensor				
C3	B119	Y/2	: RH side curtain air bag module				
A3	B120	W/2	: Rear speaker woofer LH				
C4	B121	BR/23	: BOSE speaker amp.				
C4	B122	BR/14	: BOSE speaker amp.				
C3	B124	W/2	: Rear subwoofer RH				
B4	B125	W/8	: Bluetooth control unit				
B4	B126	W/32	: Bluetooth control unit				
B4	B128	W/4	: Battery cooling blower assembly				
G3	B129	GR/24	: To E71				
C5	B130	W/20	: High Voltage Battery				
C4	B131	W/14	: Brake capacitor				

HARNESS

< COMPONENT DIAGNOSIS >

ROOM LAMP HARNESS

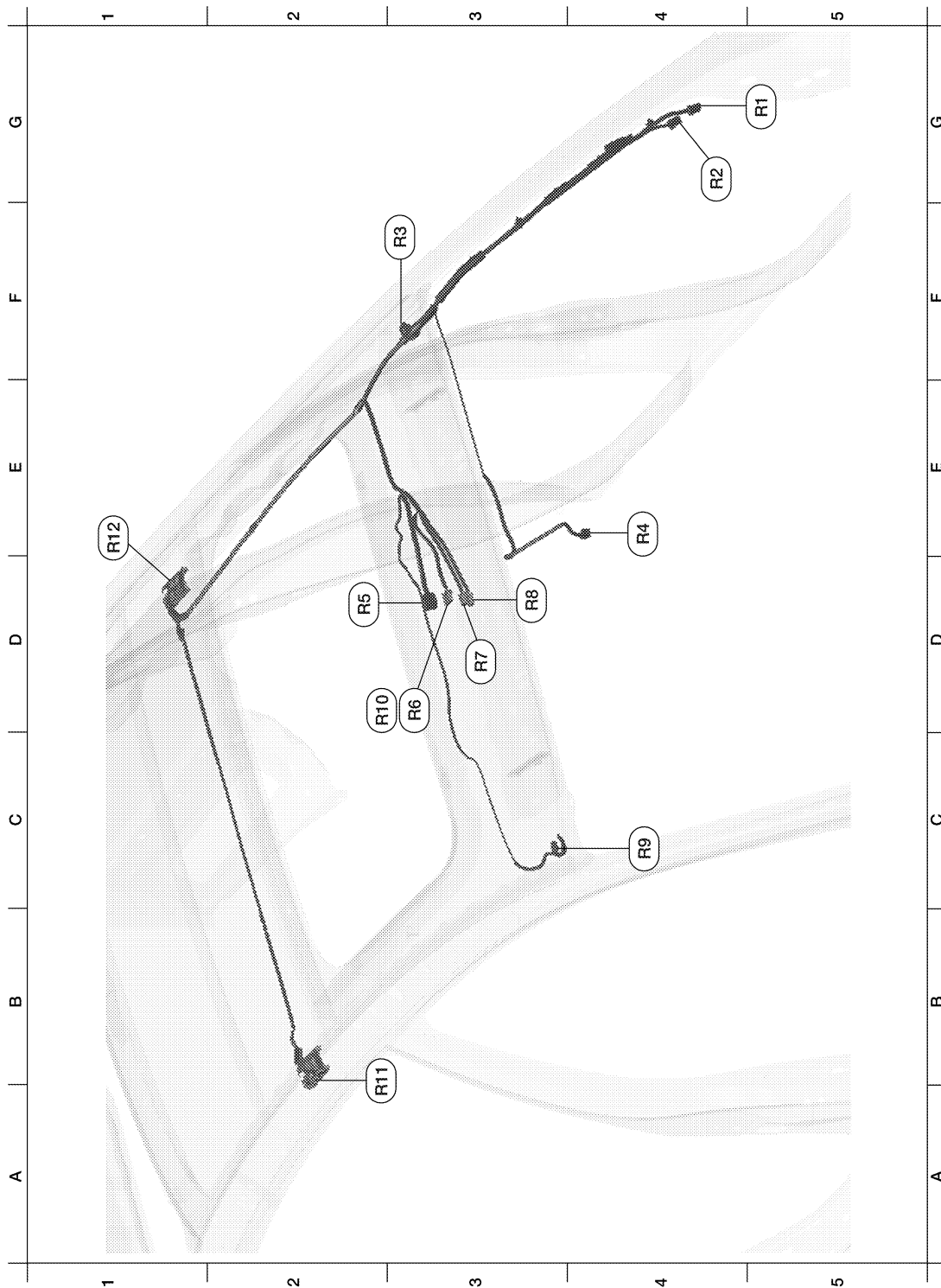

ALMIA0025GB

G5	R1	W/16	: To M7				
G4	R2	W/3	: To M13				
F3	R3	W/2	: Vanity mirror lamp LH				
E4	R4	B/10	: Auto anti-dazzling inside mirror				
D2	R5	W/10	: Sunroof motor assembly				

HARNESS

< COMPONENT DIAGNOSIS >

D3	R6	W/3	: Sunroof switch				
D3	R7	W/4	: Microphone				
D3	R8	W/4	: Bluetooth on indicator				
C4	R9	W/2	: Vanity mirror lamp RH				
D2	R10	GR/6	: Map lamp				
B2	R11	W/8	: Personal lamp rear RH				
E1	R12	W/8	: Personal lamp rear LH				

FRONT DOOR LH HARNESS

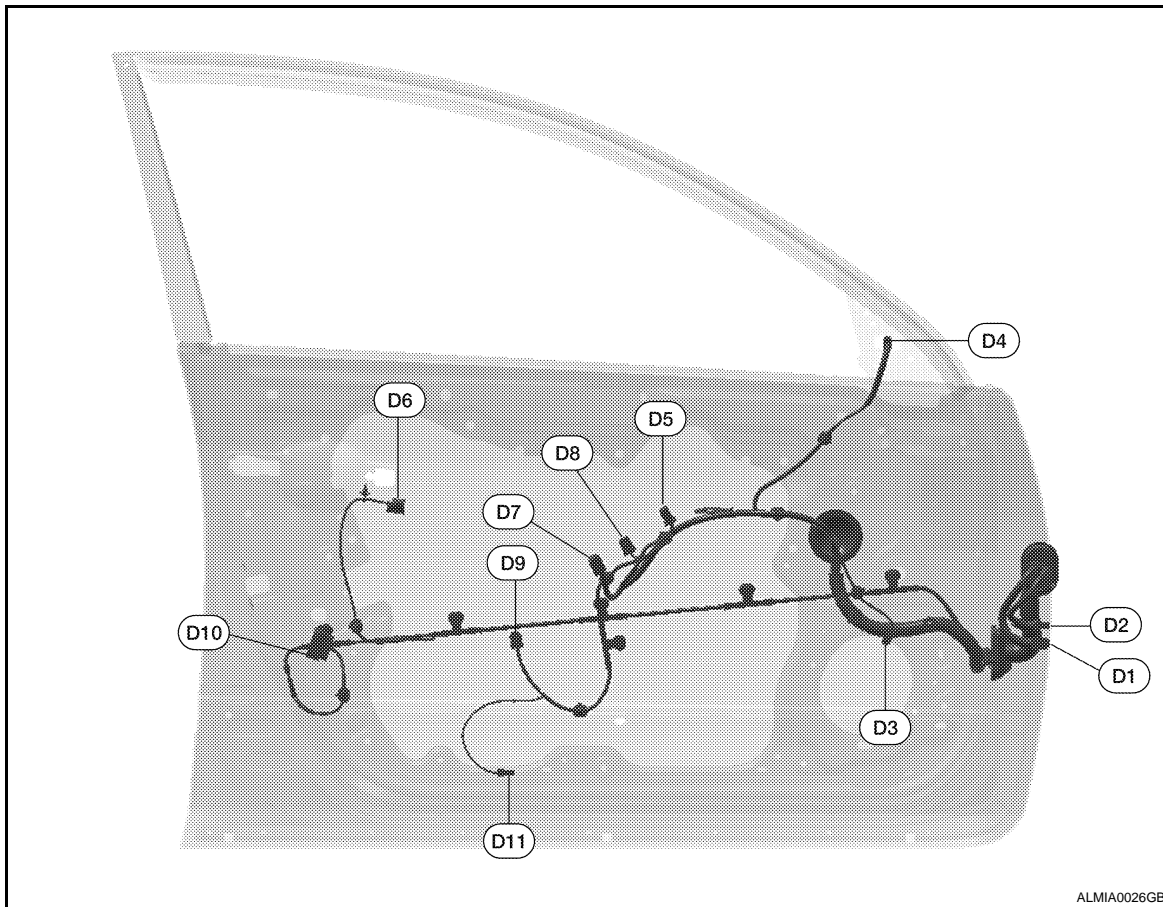

D1	W/16	: To M11	D6	B/4	: Front outside handle LH
D2	W/16	: To M12	D7	W/16	: Main power window and door lock/unlock switch
D3	BR/2	: Front door speaker LH (BOSE)	D8	W/3	: Main power window and door lock/unlock switch
D3	W/2	: Front door speaker LH (base)	D9	W/6	: Front power window motor LH
D4	W/8	: Door mirror LH	D10	GR/6	: Front door lock assembly LH
D5	W/16	: Door mirror remote control switch	D11	W/2	: Front step lamp LH

HARNESS

< COMPONENT DIAGNOSIS >

FRONT DOOR RH HARNESS

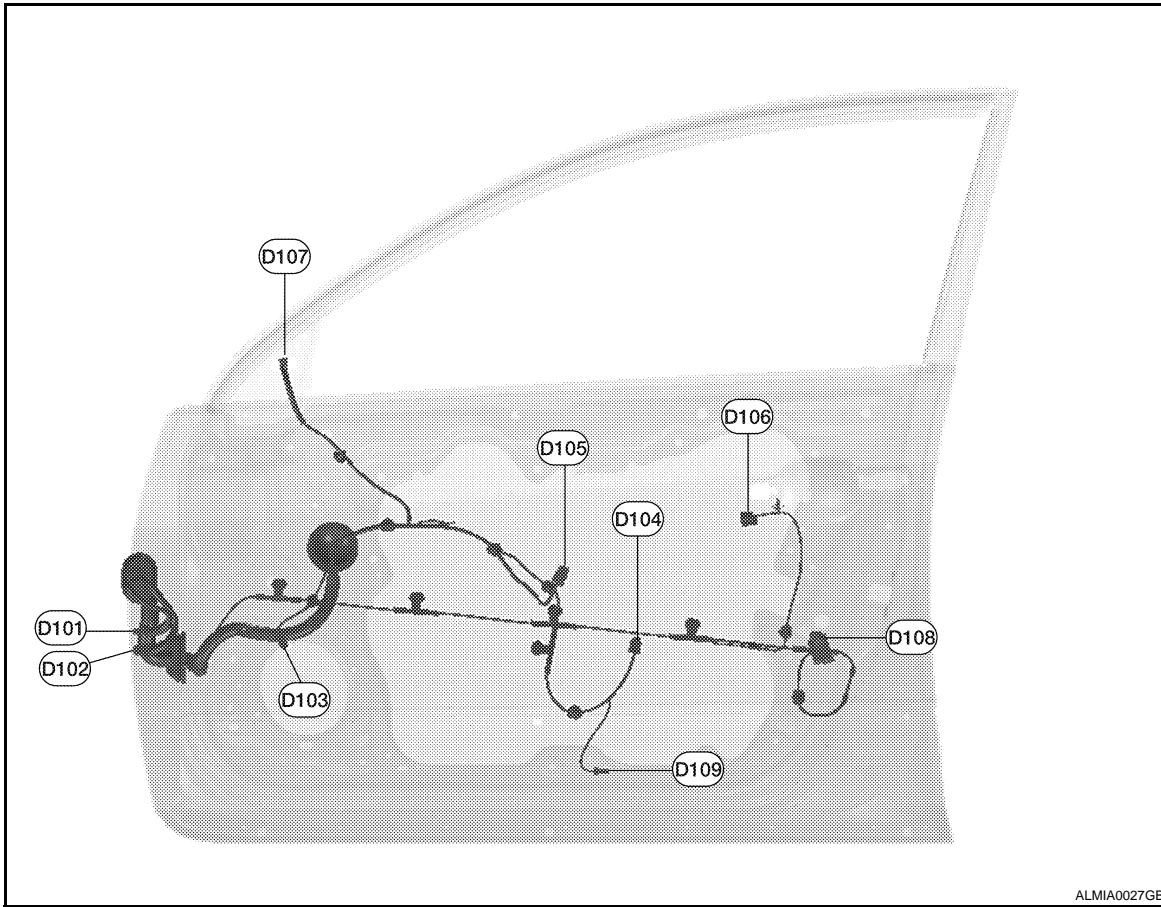

D101	W/10	: To M14	D105	W/16	: Power window and door lock/unlock switch RH (with left and right front power window anti -pinch system)
D102	W/16	: To M15	D106	B/4	: Front outside handle RH
D103	W/2	: Front door speaker RH (base)	D107	W/8	: Door mirror RH
D103	BR/2	: Front door speaker RH (BOSE)	D108	GR/8	: Front door lock actuator RH
D104	W/6	: Front power window motor RH	D109	W/2	: Front step lamp RH
D105	W/12	: Power window and door lock/unlock switch RH (with left front only power window anti -pinch system)			

A
B
C
D
E
F
G
H
I
J
K
L
PG
N
O
P

HARNESS

< COMPONENT DIAGNOSIS >

REAR DOOR LH HARNESS

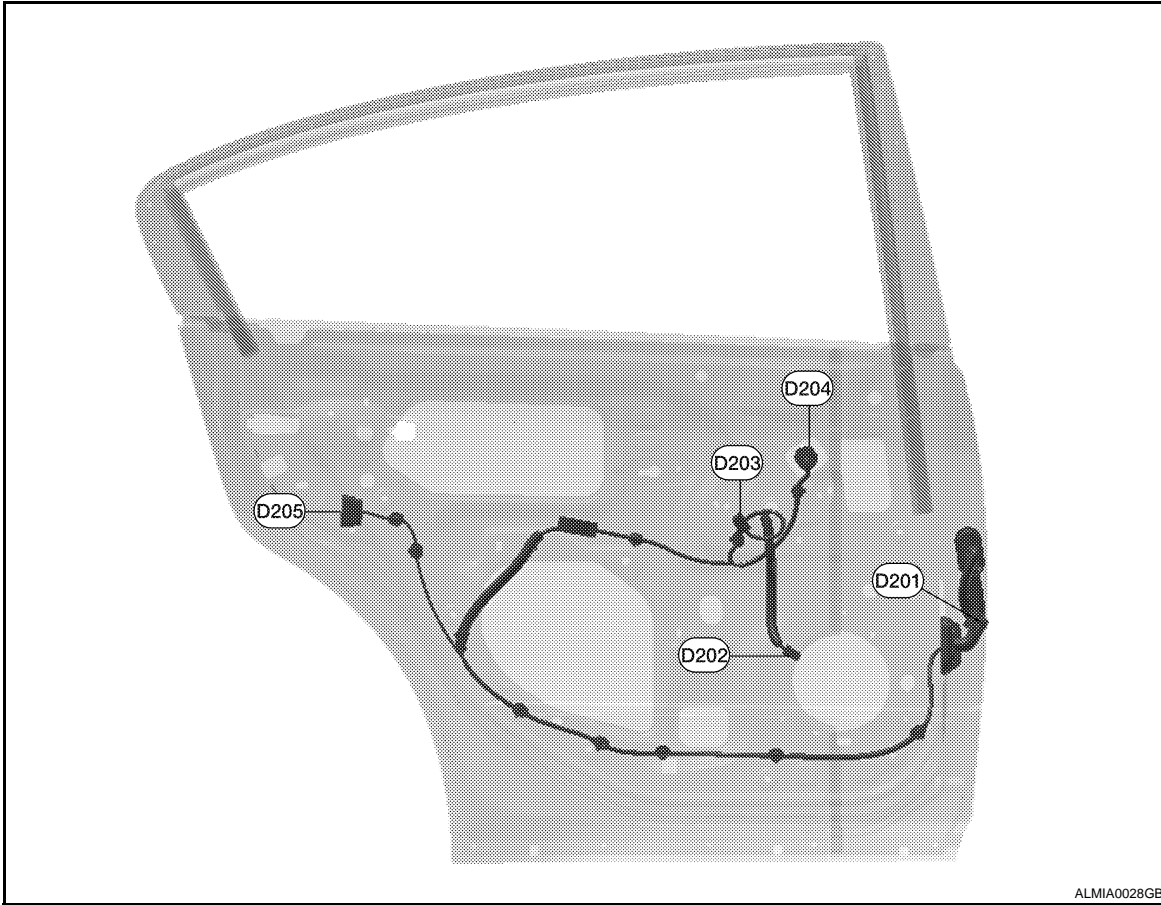

D201	W/8	: To B6			
D202	BR/2	: Rear door speaker LH			
D203	W/8	: Rear power window switch LH			
D204	G/6	: Rear power window motor LH			
D205	GR/6	: Rear door lock actuator LH			

HARNESS

< COMPONENT DIAGNOSIS >

REAR DOOR RH HARNESS

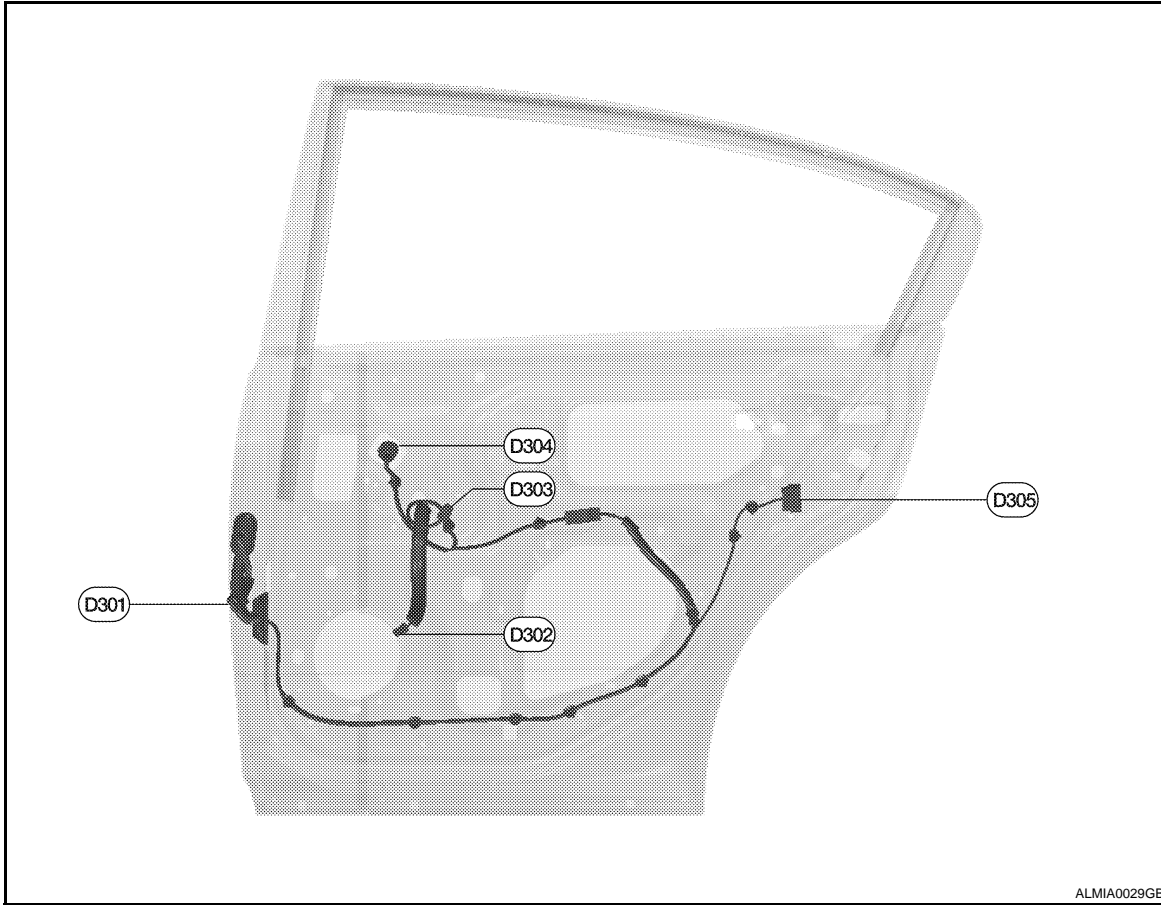

ALMIA0029GB

D301	W/8	: To B106			
D302	BR/2	: Rear door speaker RH			
D303	W/8	: Rear power window switch RH			
D304	G/6	: Rear power window motor RH			
D305	GR/6	: Rear door lock actuator RH			

A
B
C
D
E
F
G
H
I
J
K
L

PG

N
O
P

ELECTRICAL UNITS LOCATION

< COMPONENT DIAGNOSIS >

ELECTRICAL UNITS LOCATION

Electrical Units Location

INFOID:000000001503513

ENGINE COMPARTMENT

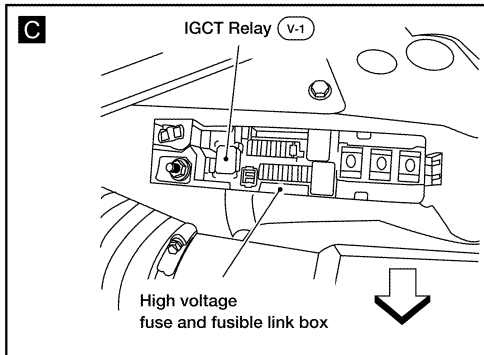
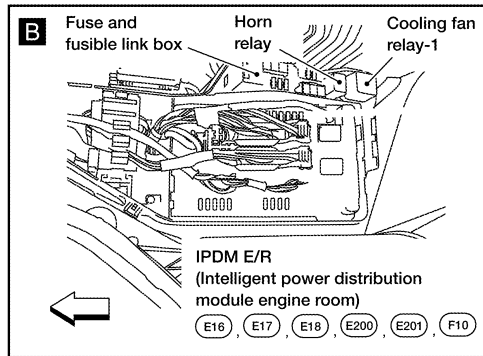
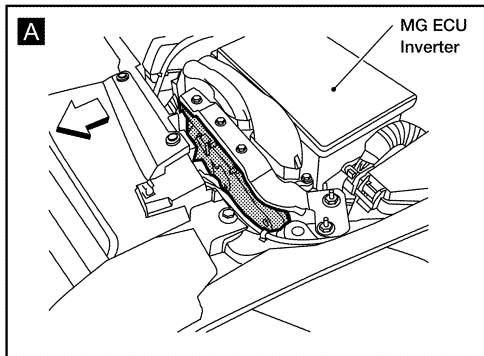
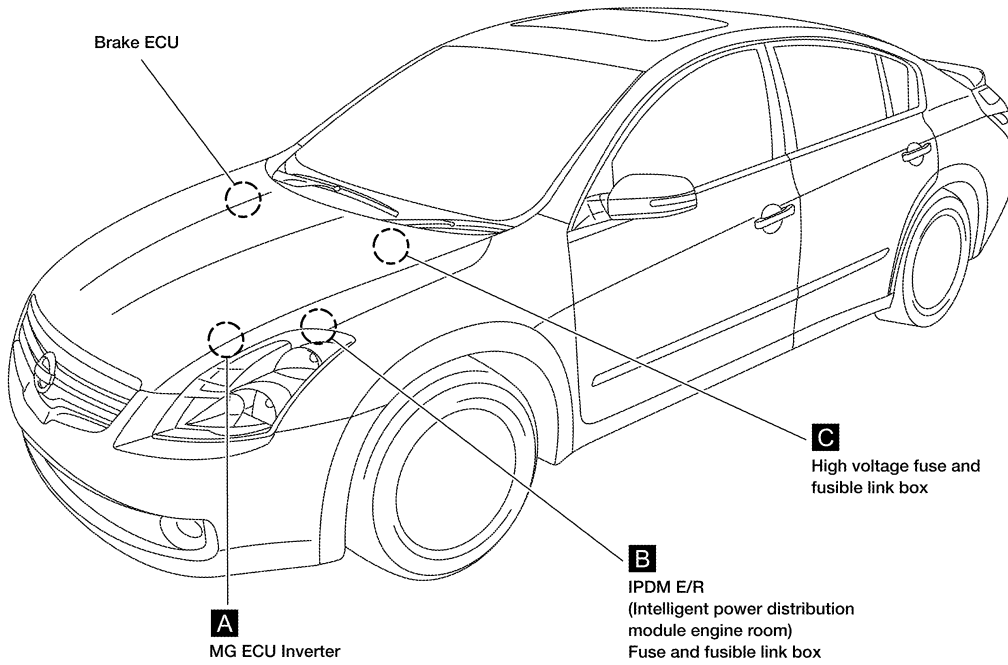

ALMIA0144GB

ELECTRICAL UNITS LOCATION

< COMPONENT DIAGNOSIS >
PASSENGER COMPARTMENT

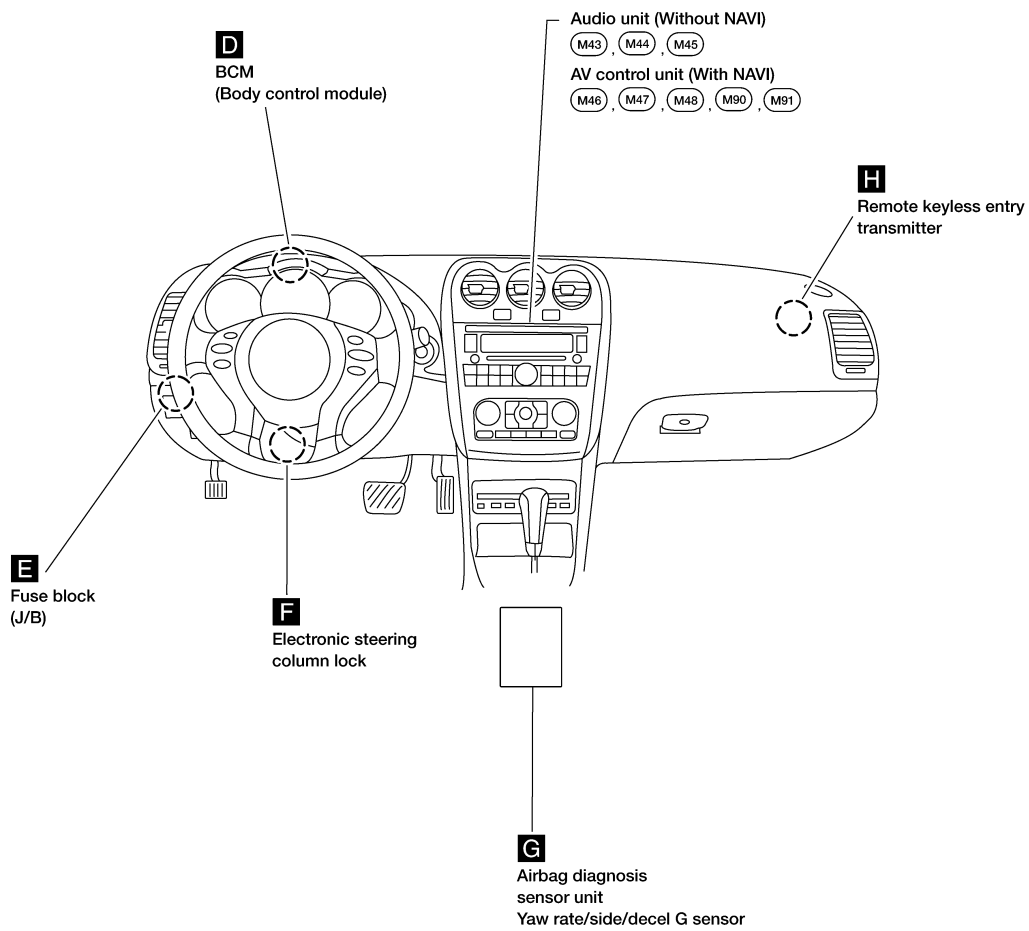

A
B
C
D
E
F
G
H
I
J
K
L
PG
N
O
P

ALMIA0145GB

ELECTRICAL UNITS LOCATION

< COMPONENT DIAGNOSIS >

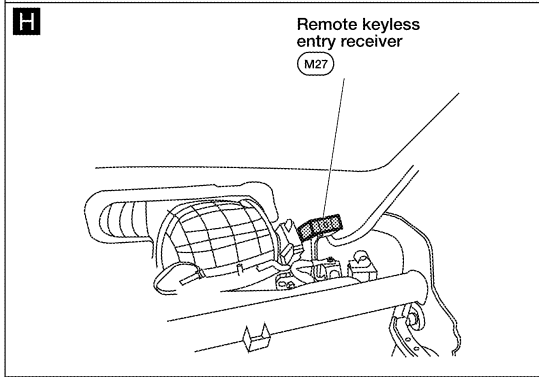
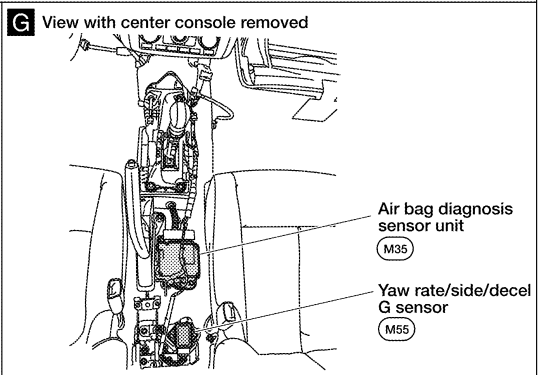
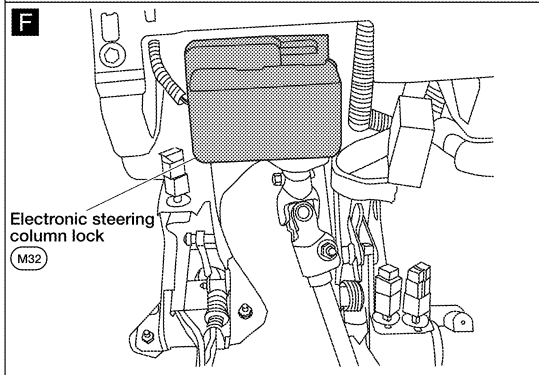
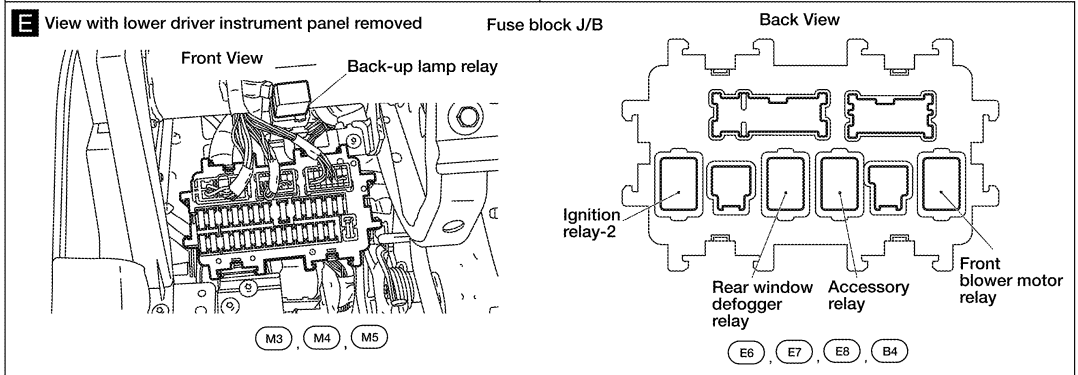
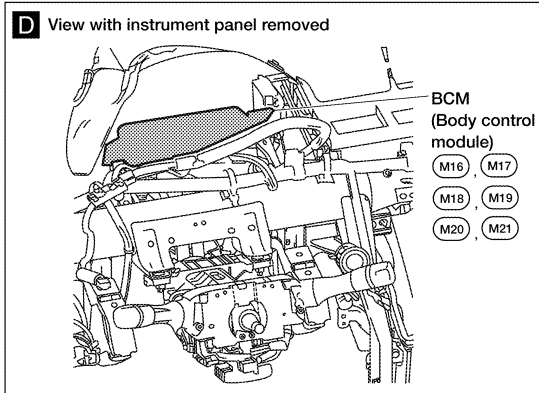

ALMIA0146GB

ELECTRICAL UNITS LOCATION

< COMPONENT DIAGNOSIS >

LUGGAGE COMPARTMENT

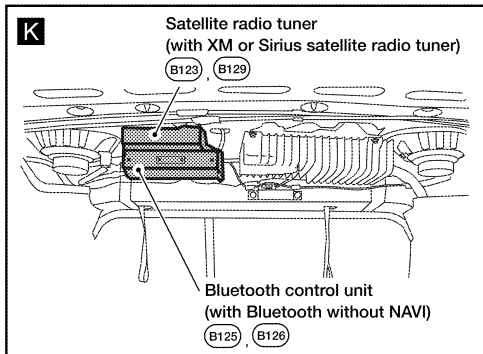
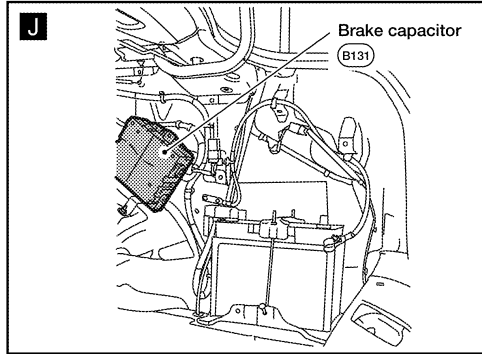
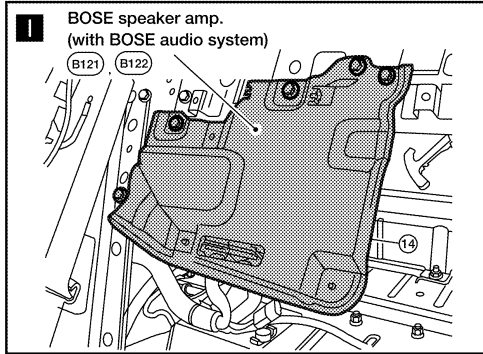
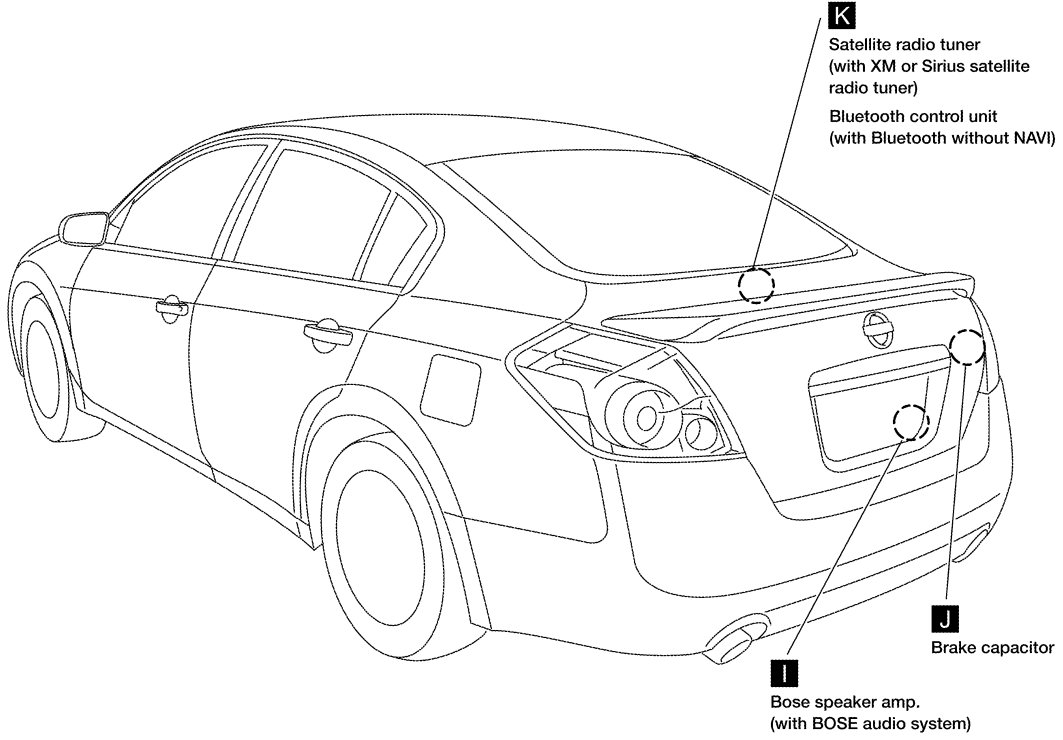

ALMIA0147GB

A
B
C
D
E
F
G
H
I
J
K
L
PG
N
O
P

HARNESS CONNECTOR

< COMPONENT DIAGNOSIS >

HARNESS CONNECTOR

Description

INFOID:000000001503514

HARNESS CONNECTOR (TAB-LOCKING TYPE)

- The tab-locking type connectors help prevent accidental looseness or disconnection.
- The tab-locking type connectors are disconnected by pushing or lifting the locking tab(s). Refer to the figure below.

Refer to the next page for description of the slide-locking type connector.

CAUTION:

Do not pull the harness or wires when disconnecting the connector.

[Example]

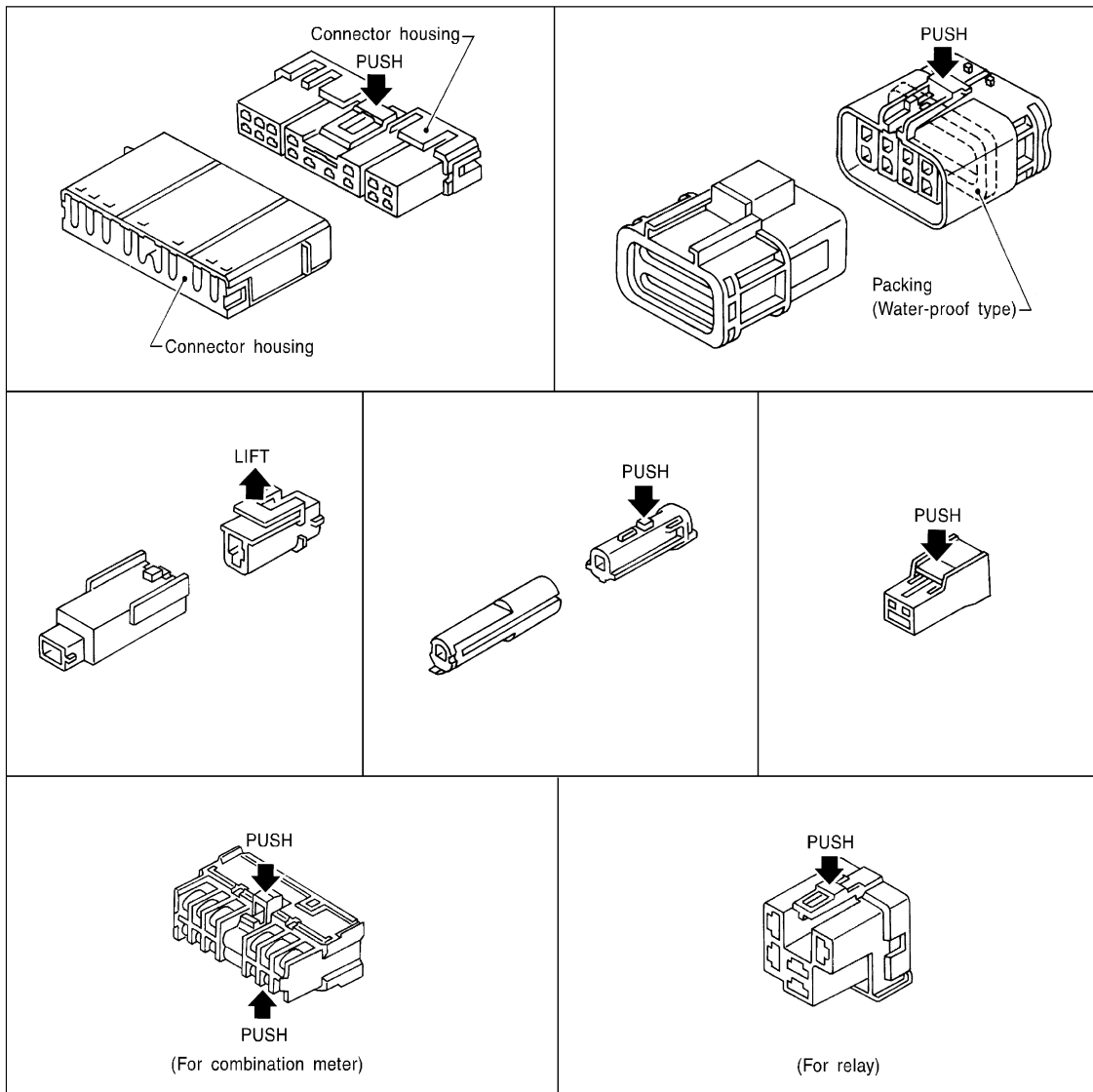

SEL769DA

HARNESS CONNECTOR (SLIDE-LOCKING TYPE)

- A new style slide-locking type connector is used on certain systems and components, especially those related to OBD.
- The slide-locking type connectors help prevent incomplete locking and accidental looseness or disconnection.

HARNESS CONNECTOR

< COMPONENT DIAGNOSIS >

- The slide-locking type connectors are disconnected by pushing or pulling the slider. Refer to the figure below.

CAUTION:

- Do not pull the harness or wires when disconnecting the connector.
- Be careful not to damage the connector support bracket when disconnecting the connector.

[Example]

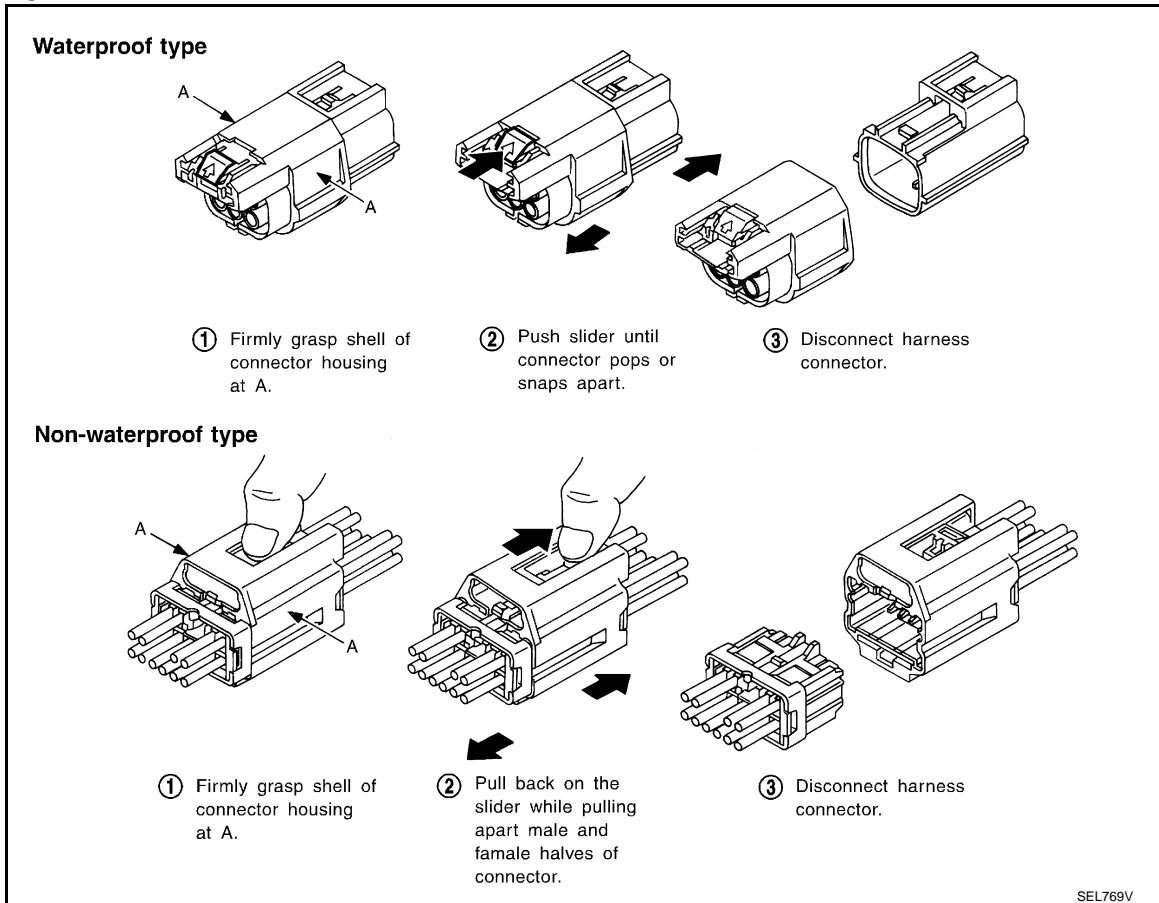

A
B
C
D
E
F
G
H
I
J
K
L
N
O
P

PG

STANDARDIZED RELAY

< COMPONENT DIAGNOSIS >

STANDARDIZED RELAY

Description

INFOID:000000001503515

NORMAL OPEN, NORMAL CLOSED AND MIXED TYPE RELAYS

Relays can mainly be divided into three types: normal open, normal closed and mixed type relays.

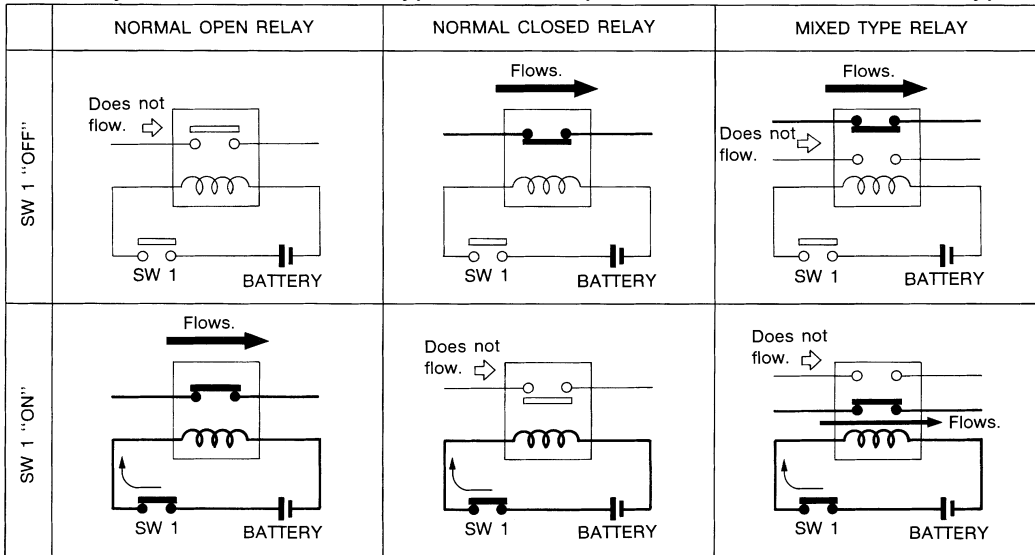

SEL881H

TYPE OF STANDARDIZED RELAYS

- 1M 1 Make
- 2M 2 Make
- 1T 1 Transfer
- 1M·1B 1 Make 1 Break

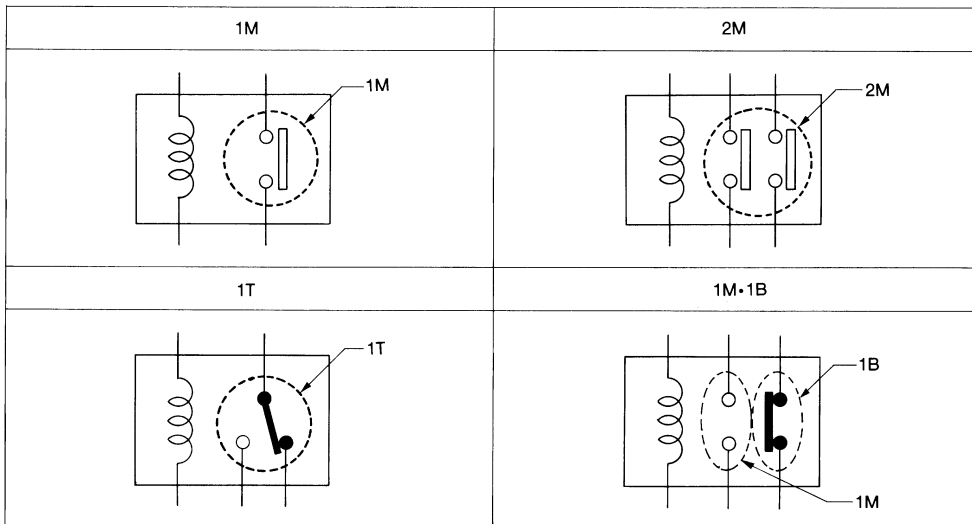

SEL882H

STANDARDIZED RELAY

< COMPONENT DIAGNOSIS >

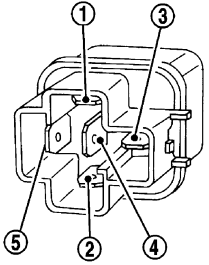
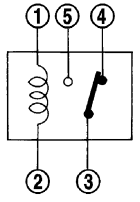
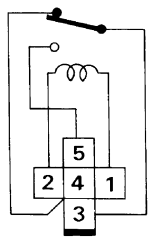
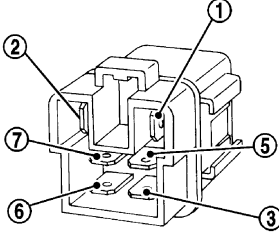
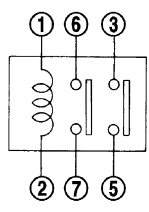
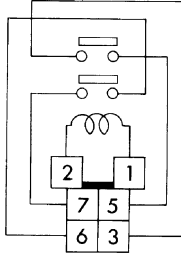
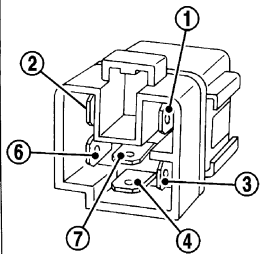
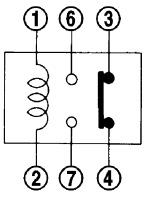
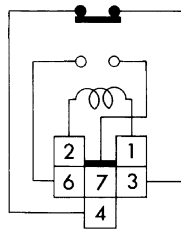
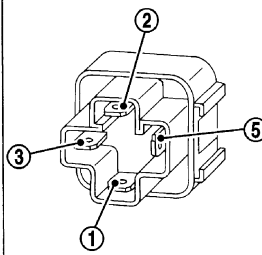
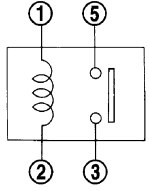
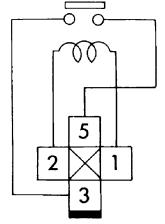
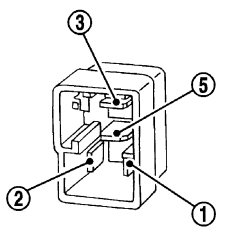
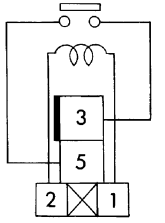
Type	Outer view	Circuit	Connector symbol and connection	Case color
1T				BLACK
2M				BROWN
1M•1B				GRAY
1M				BLUE
				

The arrangement of terminal numbers on the actual relays may differ from those shown above.

SEL188W

A
B
C
D
E
F
G
H
I
J
K
L
PG
N
O
P

FUSE BLOCK - JUNCTION BOX (J/B)

< COMPONENT DIAGNOSIS >

FUSE BLOCK - JUNCTION BOX (J/B)

Terminal Arrangement

INFOID:000000001503516

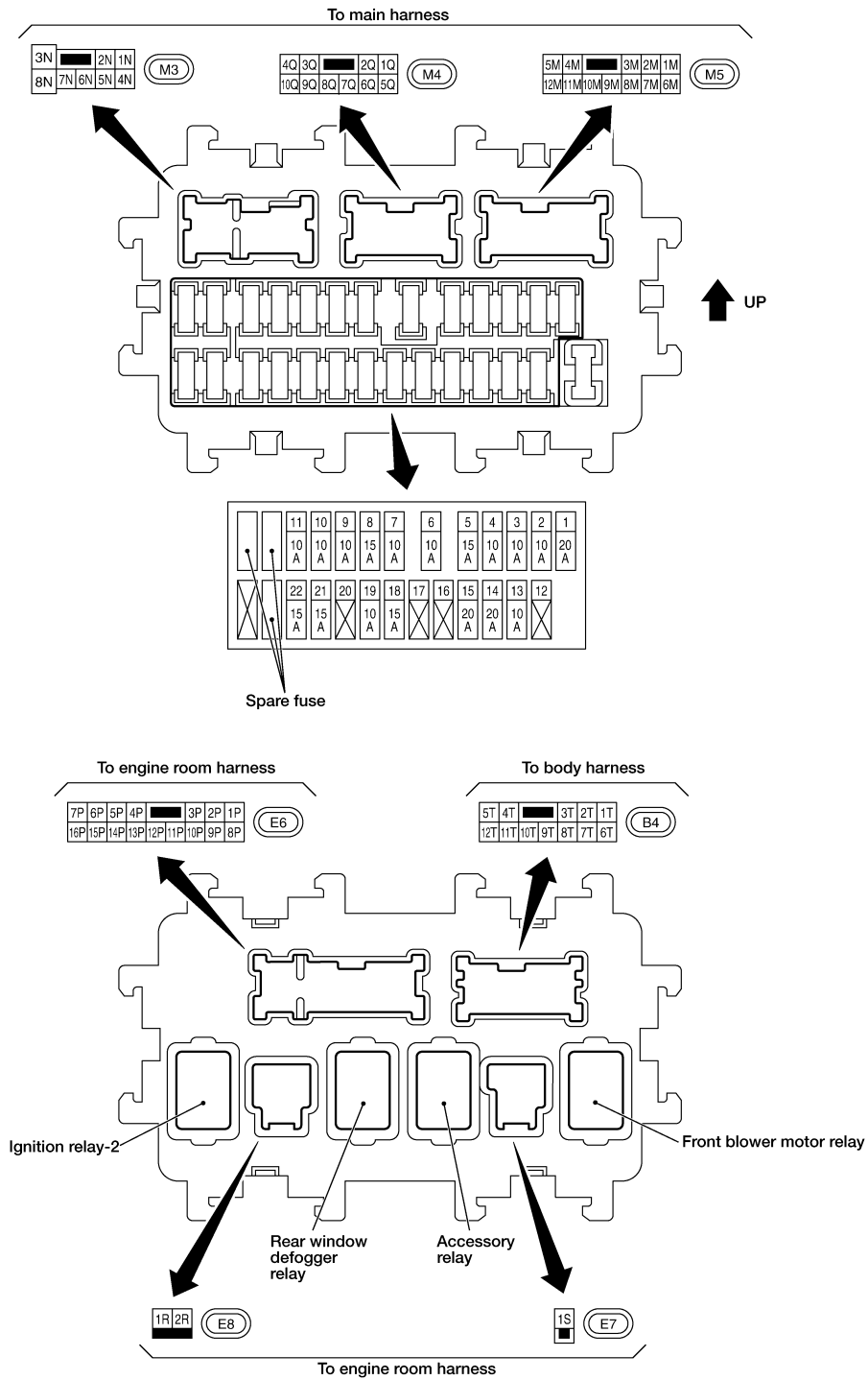

ALMIA0014GB

FUSE, FUSIBLE LINK AND RELAY BOX

< COMPONENT DIAGNOSIS >

FUSE, FUSIBLE LINK AND RELAY BOX

Terminal Arrangement

INFOID:000000001503517

A
B
C
D
E
F
G
H
I
J
K
L
PG
N
O
P

Fuse and fusible link box (Battery)

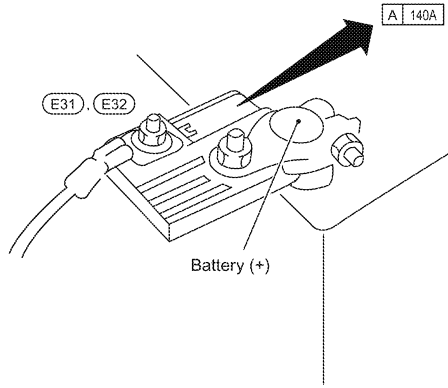

High voltage fuse and fusible link box

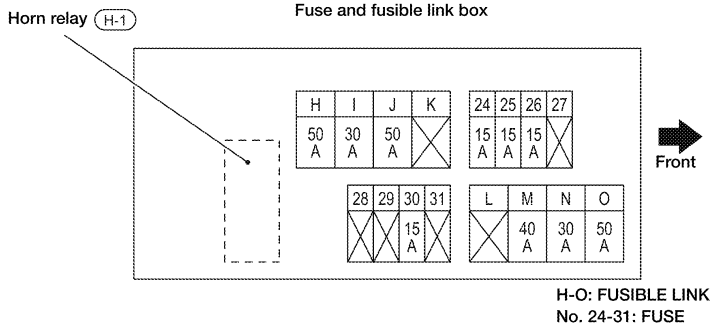
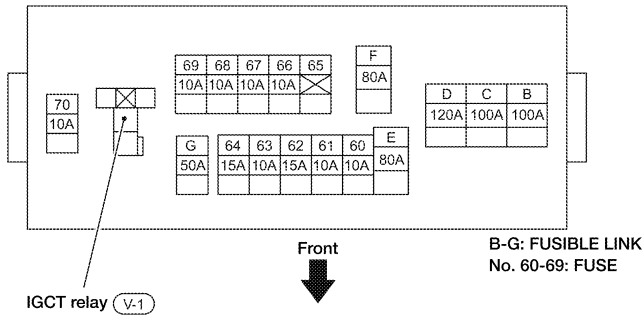

ALMIA0148GB

IPDM E/R (INTELLIGENT POWER DISTRIBUTION MODULE ENGINE ROOM)

< COMPONENT DIAGNOSIS >

IPDM E/R (INTELLIGENT POWER DISTRIBUTION MODULE ENGINE ROOM)

Fuse, Connector and Terminal Arrangement

INFOID:000000001503518

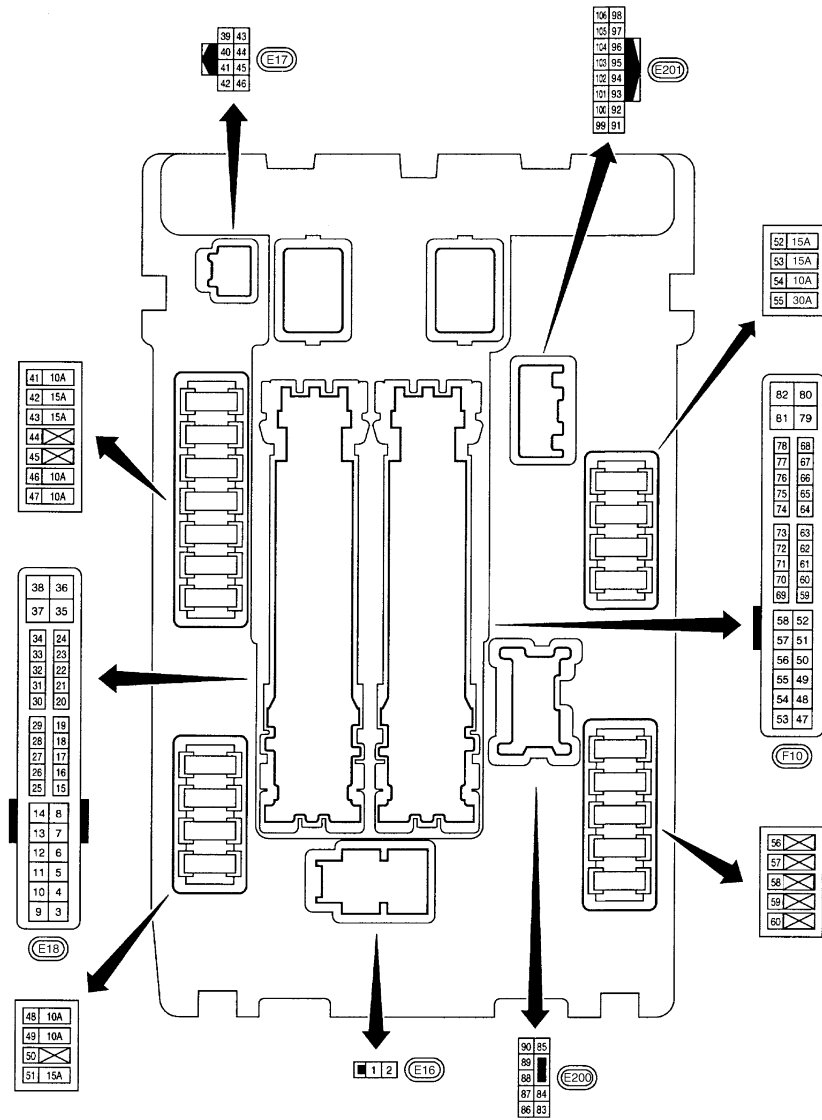

ALMIA0149GB

PRECAUTIONS

< PRECAUTION >

PRECAUTION

PRECAUTIONS

Supplemental Restraint System SRS "AIR BAG" and "SEAT BELT PRE-TENSIONER" Service

INFOID:000000001503519

The Supplemental Restraint System such as "AIR BAG" and "SEAT BELT PRE-TENSIONER", used along with a front seat belt, helps to reduce the risk or severity of injury to the driver and front passenger for certain types of collision. This system includes seat belt switch inputs and dual stage front air bag modules. The SRS system uses the seat belt switches to determine the front air bag deployment, and may only deploy one front air bag, depending on the severity of a collision and whether the front occupants are belted or unbelted. Information necessary to service the system safely is included in the SRS and SB section of this Service Manual.

WARNING:

- To avoid rendering the SRS inoperative, which could increase the risk of personal injury or death in the event of a collision which would result in air bag inflation, all maintenance must be performed by an authorized NISSAN/INFINITI dealer.
- Improper maintenance, including incorrect removal and installation of the SRS, can lead to personal injury caused by unintentional activation of the system. For removal of Spiral Cable and Air Bag Module, see the SRS section.
- Do not use electrical test equipment on any circuit related to the SRS unless instructed to in this Service Manual. SRS wiring harnesses can be identified by yellow and/or orange harnesses or harness connectors.

Precautions For High-Voltage System

INFOID:000000001503520

Refer to [GI-24. "Precautions For High-Voltage System"](#).

A
B
C
D
E
F
G
H
I
J
K
L
N
O
P

PG

PREPARATION

< PREPARATION >

PREPARATION

PREPARATION

Special Service Tool

INFOID:000000001503521

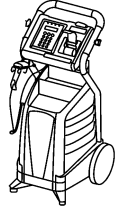
Tool number (Kent Moore No.) Tool name	Description
<p>(J-48087) Battery Service Center</p>  <p>WKIA5280E</p>	<p>Tests Battery. For operating instructions, refer to Technical Service Bulletin and Battery Service Center User Guide.</p>

Commercial Service Tool

INFOID:000000001503522

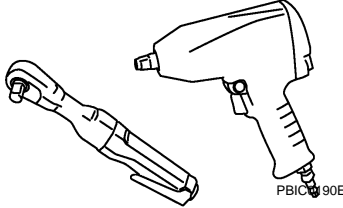
Tool name	Description
<p>Power tool</p>  <p>PBIC990E</p>	<p>Loosening bolts and nuts</p>

BATTERY

< ON-VEHICLE REPAIR >

ON-VEHICLE REPAIR

BATTERY

Removal and Installation

INFOID:000000001503523

REMOVAL

1. Verify if the high voltage system needs to be disabled. Refer to [HBB-92. "Precautions For High-Voltage System"](#).
2. Remove trunk side finisher (RH). Refer to [INT-21. "Exploded View"](#).
3. Loosen battery terminal nuts (A), and disconnect both battery cables from battery terminals.

CAUTION:

When disconnecting, disconnect the battery cable from the negative terminal first.

4. Remove the battery ventilation tube (D).
5. Remove battery fix frame nuts (B) and battery fix frame (C).
6. Remove battery.

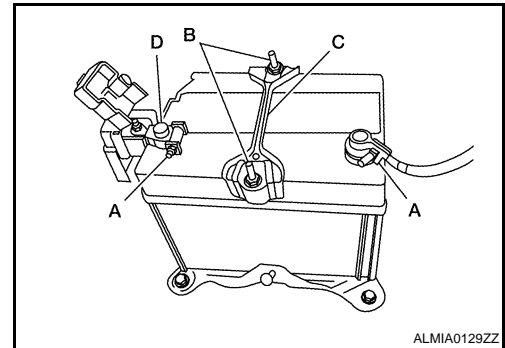

INSTALLATION

Installation is the reverse order of removal.

Battery fix frame nut : 3.92 N·m (0.4 kg-m, 35 in-lb)

Battery terminal nut : 5.4 N·m (0.55 kg-m, 48 in-lb)

CAUTION:

When connecting, connect the battery cable to the positive terminal first.

A
B
C
D
E
F
G
H
I
J
K
L
PG
N
O
P

BATTERY

< SERVICE DATA AND SPECIFICATIONS (SDS)

SERVICE DATA AND SPECIFICATIONS (SDS)

BATTERY

Battery

INFOID:000000001503524

Type	GR.35 (BCI)
Capacity (5 HR) minimum V-AH	52
Cold cranking current A (For reference value)	525