

A
EX
EXHAUST SYSTEM C

D
E
F
G
H
I
J
K
L
M
N
O
P

CONTENTS

QR25DE	VQ35DE
PREPARATION 2	PREPARATION 6
PREPARATION 2	PREPARATION 6
Special Service Tool2	Special Service Tool 6
Commercial Service Tool2	Commercial Service Tool 6
ON-VEHICLE MAINTENANCE 3	ON-VEHICLE MAINTENANCE 7
EXHAUST SYSTEM (QR25DE) 3	EXHAUST SYSTEM (VQ35DE) 7
Checking Exhaust System3	Checking Exhaust System 7
ON-VEHICLE REPAIR 4	ON-VEHICLE REPAIR 8
EXHAUST SYSTEM (QR25DE) 4	EXHAUST SYSTEM (VQ35DE) 8
Removal and Installation4	Removal and Installation 8
Inspection After Installation5	Inspection After Installation 9

PREPARATION

< PREPARATION >

[QR25DE]

PREPARATION

PREPARATION

Special Service Tool

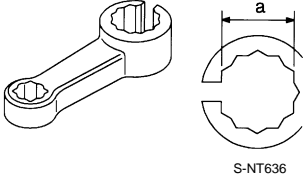

INFOID:000000000990430

The actual shapes of Kent-Moore tools may differ from those of special service tools illustrated here.

Tool number (Kent-Moore No.) Tool name	Description
KV10114400 (J-38365) Heated oxygen sensor wrench	Loosening or tightening heated oxygen sensors: a: 22 mm (0.87 in)
 <p style="text-align: center;">S-NT636</p>	

Commercial Service Tool

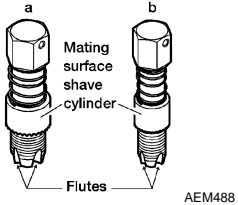
INFOID:000000000990431

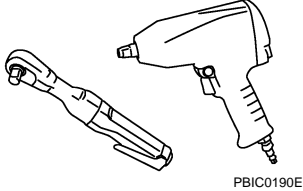
(Kent-Moore No.) Tool name	Description
(J-43897-18) (J-43897-12) Oxygen sensor thread cleaner	Reconditioning the exhaust system threads before installing a new oxygen sensor (Use with anti-seize lubricant shown below): a: J-43897-18 (18 mm dia.) for zirconia oxygen sensor b: J-43897-12 (12 mm dia.) for titania oxygen sensor
 <p style="text-align: center;">AEM488</p>	
Anti-seize lubricant (Permatex 133AR or equivalent meeting MIL specification MIL-A-907)	Lubricating oxygen sensor thread cleaning tool when reconditioning exhaust system threads
 <p style="text-align: center;">AEM489</p>	
Power tool	Loosening nuts and bolts
 <p style="text-align: center;">PBIC0190E</p>	

ON-VEHICLE MAINTENANCE

EXHAUST SYSTEM (QR25DE)

Checking Exhaust System

INFOID:000000000990432

Check the exhaust pipes, muffler, and mounting components for incorrect attachment, leaks, cracks, damage, or deterioration.

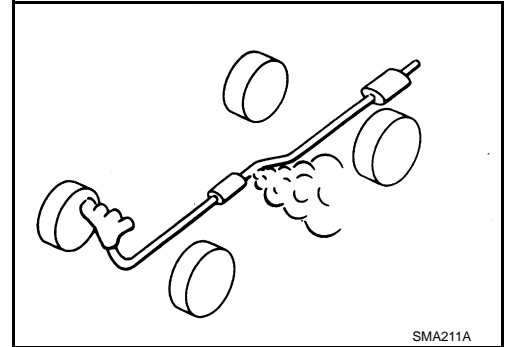

A

EX

C

D

E

F

G

H

I

J

K

L

M

N

O

P

EXHAUST SYSTEM (QR25DE)

< ON-VEHICLE REPAIR >

[QR25DE]

ON-VEHICLE REPAIR EXHAUST SYSTEM (QR25DE)

Removal and Installation

INFOID:000000000990433

SEC. 200

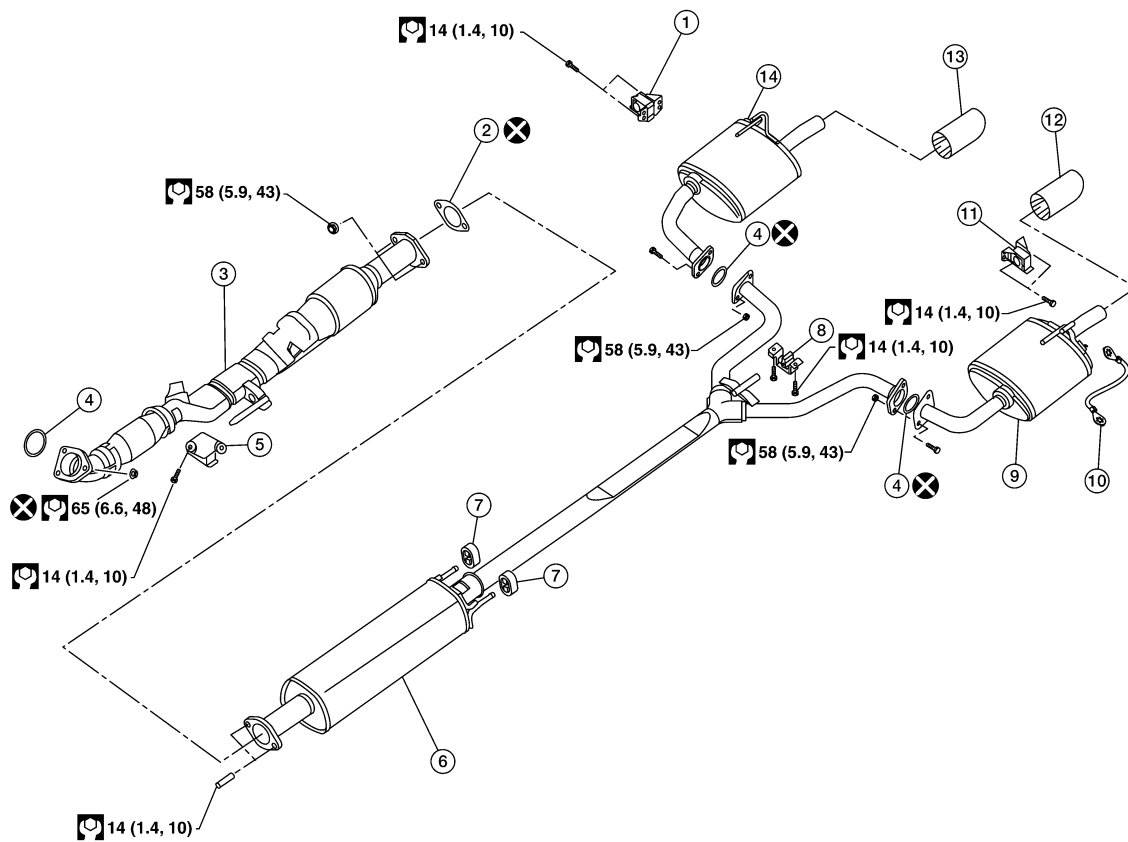

AWBIA0001GB

- | | | |
|----------------------------|-------------------------------|------------------------|
| 1. RH rear muffler bracket | 2. Gasket | 3. Front exhaust tube |
| 4. Ring gasket | 5. Front exhaust tube hanger | 6. Center exhaust tube |
| 7. Mounting rubber | 8. Center exhaust tube hanger | 9. LH rear muffler |
| 10. Ground strap | 11. LH rear muffler bracket | 12. LH muffler tip |
| 13. RH muffler tip | 14. RH rear muffler | |

EXHAUST SYSTEM (QR25DE)

< ON-VEHICLE REPAIR >

[QR25DE]

CAUTION:

- Use genuine NISSAN exhaust system parts or equivalent, which are specifically designed for heat resistance, corrosion resistance, and shape.
- Perform the procedure with the exhaust system fully cooled down because the system will be hot just after the engine is turned off.
- Be careful not to cut your hand on the insulator edges.
- If the insulator is badly deformed, repair or replace it. If deposits such as mud pile up on the insulator, clean and inspect the insulator.
- When installing the insulator avoid large gaps or interference between the insulator and each exhaust pipe.
- Remove deposits from the sealing surface of each connection. Connect them securely to avoid exhaust gas leaks.
- Temporarily tighten the exhaust manifold side nuts and the vehicle side bolts. Check each part for any interference, and then tighten the nuts and bolts to specification.
- When installing each mounting rubber, avoid twisting or excessive extension in up/down and right/left directions.
- Tighten the bolts without causing interference with the flange.
- Insert the seal bearing in the direction as shown. Tighten the bolt with the big end of the spring facing the flange as shown.

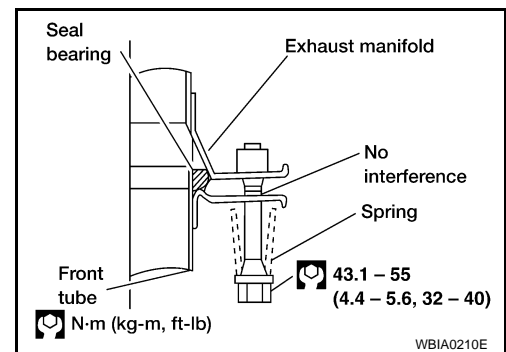

Inspection After Installation

INFOID:000000000990434

- With the engine running, check the exhaust tube joints for exhaust gas leaks and abnormal noise.
- Check that the mounting brackets and mounting insulators are installed properly and free from excessive stress. Improper installation could result in excessive noise, leaks, and vibration.

PREPARATION

< PREPARATION >

[VQ35DE]

PREPARATION

PREPARATION

Special Service Tool

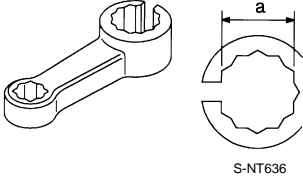

INFOID:000000000990435

The actual shapes of Kent-Moore tools may differ from those of special service tools illustrated here.

Tool number (Kent-Moore No.) Tool name	Description
KV10114400 (J-38365) Heated oxygen sensor wrench	Loosening or tightening heated oxygen sensors: a: 22 mm (0.87 in)
 <p style="text-align: center;"><small>S-NT636</small></p>	

Commercial Service Tool

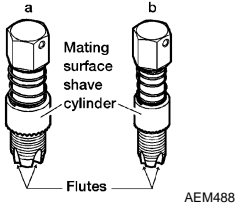
INFOID:000000000990436

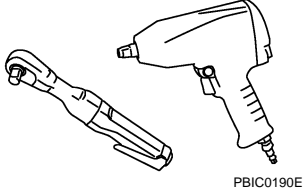
(Kent-Moore No.) Tool name	Description
(J-43897-18) (J-43897-12) Oxygen sensor thread cleaner	Reconditioning the exhaust system threads before installing a new oxygen sensor (Use with anti-seize lubricant shown below): a: J-43897-18 (18 mm dia.) for zirconia oxygen sensor b: J-43897-12 (12 mm dia.) for titania oxygen sensor
 <p style="text-align: center;"><small>AEM488</small></p>	
Anti-seize lubricant (Permatex 133AR or equivalent meeting MIL specification MIL-A-907)	Lubricating oxygen sensor thread cleaning tool when reconditioning exhaust system threads
 <p style="text-align: center;"><small>AEM489</small></p>	
Power tool	Loosening nuts and bolts
 <p style="text-align: center;"><small>PBIC0190E</small></p>	

ON-VEHICLE MAINTENANCE

EXHAUST SYSTEM (VQ35DE)

Checking Exhaust System

INFOID:000000000990437

Check the exhaust pipes, muffler, and mounting components for incorrect attachment, leaks, cracks, damage, or deterioration.

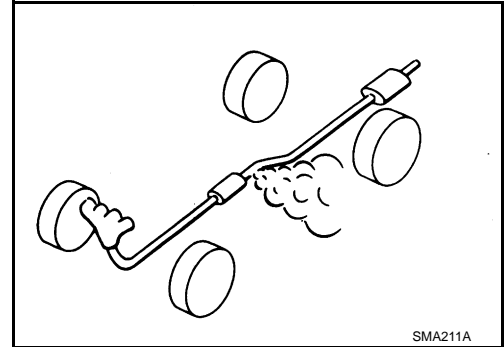

A

EX

C

D

E

F

G

H

I

J

K

L

M

N

O

P

EXHAUST SYSTEM (VQ35DE)

< ON-VEHICLE REPAIR >

[VQ35DE]

ON-VEHICLE REPAIR EXHAUST SYSTEM (VQ35DE)

Removal and Installation

INFOID:000000000990438

SEC. 200

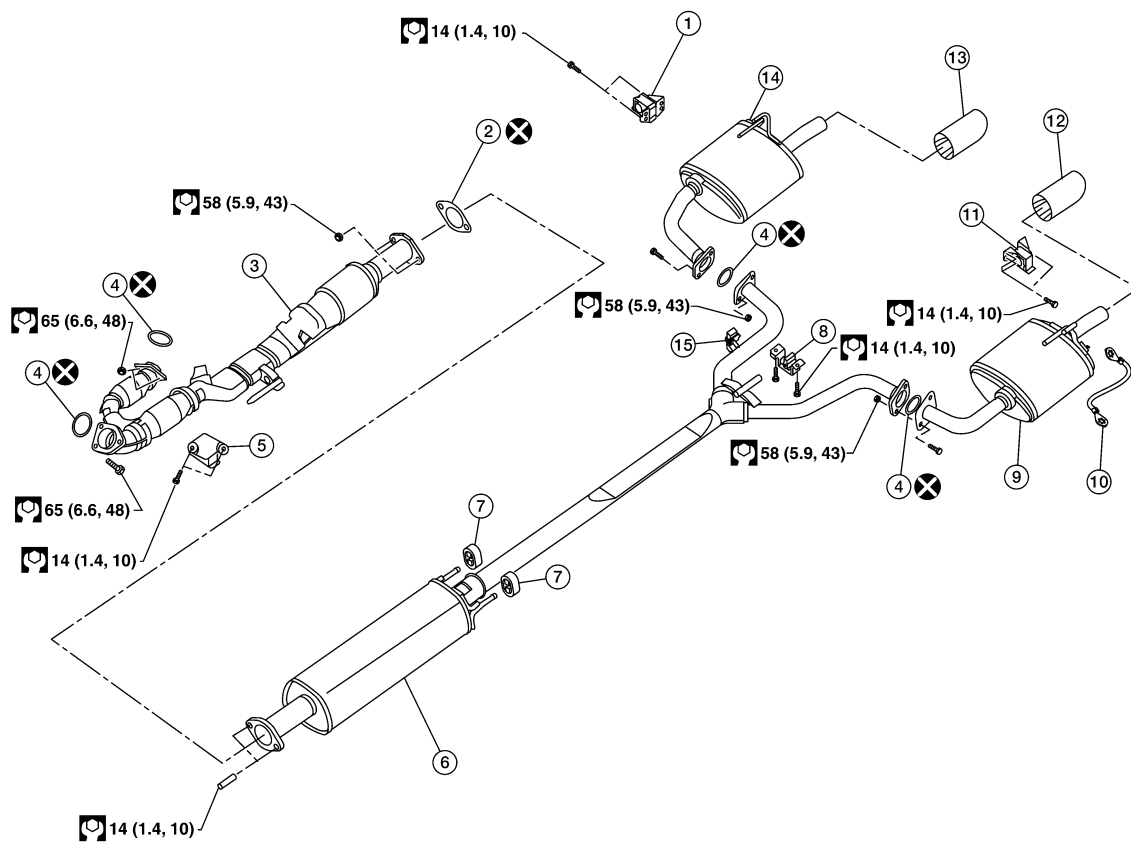

AWBIA0002GB

- | | | |
|----------------------------|-------------------------------|------------------------|
| 1. RH rear muffler bracket | 2. Gasket | 3. Front exhaust tube |
| 4. Ring gasket | 5. Front exhaust tube hanger | 6. Center exhaust tube |
| 7. Mounting rubber | 8. Center exhaust tube hanger | 9. LH rear muffler |
| 10. Ground strap | 11. LH rear muffler bracket | 12. LH muffler tip |
| 13. RH muffler tip | 14. RH rear muffler | 15. Dampner |

EXHAUST SYSTEM (VQ35DE)

< ON-VEHICLE REPAIR >

[VQ35DE]

CAUTION:

- Use genuine NISSAN exhaust system parts or equivalent, which are specifically designed for heat resistance, corrosion resistance, and shape.
- Perform the procedures with the exhaust system fully cooled down because the system will be hot just after the engine is turned off.
- Be careful not to cut your hand on the insulator edge.
- Always replace the exhaust gaskets with new ones for installation.
- If any insulator is badly deformed, repair or replace it. If deposits such as mud pile up on the insulator, clean and inspect them.
- When installing the insulator avoid large gaps or interference between the insulator and the exhaust pipe.
- Remove any deposits from the sealing surface of each connection. Connect them securely to avoid exhaust gas leakage.
- Temporarily tighten the mounting nuts on the exhaust manifold side and the mounting bolts on the vehicle side. Check each part for interference with other components, and then tighten the nuts and bolts to specification.
- When installing each mounting rubber, avoid twisting or any over extension in up/down and right/left directions.

Inspection After Installation

INFOID:000000000990439

- With the engine running, check the exhaust tube joints for exhaust gas leaks and unusual noises.
- Check that the mounting brackets and mounting insulators are installed properly and free from excessive stress. Improper installation could result in excessive noise, leaks, and vibration.

A

EX

C

D

E

F

G

H

I

J

K

L

M

N

O

P