

A
CO
C
D
E
F
G
H
I
J
K
L
M
N
O
P

SECTION CO

ENGINE COOLING SYSTEM

CONTENTS

QR25DE	
PRECAUTION	2
PRECAUTIONS	2
Precaution for Supplemental Restraint System (SRS) "AIR BAG" and "SEAT BELT PRE-TENSIONER"	2
Precautions For High-Voltage System	2
Precaution for Liquid Gasket	2
PREPARATION	4
PREPARATION	4
Special Service Tool	4
Commercial Service Tool	4
FUNCTION DIAGNOSIS	6
COOLING SYSTEM	6
Cooling Circuit	6
Schematic	7
OVERHEATING CAUSE ANALYSIS	8
Troubleshooting Chart	8
ON-VEHICLE MAINTENANCE	10
ENGINE COOLANT	10
System Inspection	10
Changing Engine Coolant	11
ON-VEHICLE REPAIR	14
RADIATOR	14
Removal and Installation	14
COOLING FAN	16
Removal and Installation	16
Disassembly and Assembly	16
WATER PUMP	18
Removal and Installation	18
THERMOSTAT AND THERMOSTAT HOUSING	20
Removal and Installation	20
WATER CONTROL VALVE	22
Removal and Installation	22
SERVICE DATA AND SPECIFICATIONS (SDS)	24
SERVICE DATA AND SPECIFICATIONS (SDS)	24
Capacity	24
Thermostat	24
Water Control Valve	24
Radiator	24

< PRECAUTION >

PRECAUTION

PRECAUTIONS

Precaution for Supplemental Restraint System (SRS) "AIR BAG" and "SEAT BELT PRE-TENSIONER"

INFOID:000000003069055

The Supplemental Restraint System such as "AIR BAG" and "SEAT BELT PRE-TENSIONER", used along with a front seat belt, helps to reduce the risk or severity of injury to the driver and front passenger for certain types of collision. This system includes seat belt switch inputs and dual stage front air bag modules. The SRS system uses the seat belt switches to determine the front air bag deployment, and may only deploy one front air bag, depending on the severity of a collision and whether the front occupants are belted or unbelted. Information necessary to service the system safely is included in the SR and SB section of this Service Manual.

WARNING:

- To avoid rendering the SRS inoperative, which could increase the risk of personal injury or death in the event of a collision which would result in air bag inflation, all maintenance must be performed by an authorized NISSAN/INFINITI dealer.
- Improper maintenance, including incorrect removal and installation of the SRS, can lead to personal injury caused by unintentional activation of the system. For removal of Spiral Cable and Air Bag Module, see the SR section.
- Do not use electrical test equipment on any circuit related to the SRS unless instructed to in this Service Manual. SRS wiring harnesses can be identified by yellow and/or orange harnesses or harness connectors.

Precautions For High-Voltage System

INFOID:000000003303903

Refer to [GI-24, "Precautions For High-Voltage System"](#).

Precaution for Liquid Gasket

INFOID:000000003069056

REMOVAL OF LIQUID GASKET SEALING

- After removing nuts and bolts, separate the mating surface, using Tool and remove old liquid gasket sealing.

Tool number : KV10111100 (J-37228)

CAUTION:

Be careful not to damage the mating surfaces.

- Tap (1) Tool to insert it, and then slide (2) it by tapping on the side as shown.
- In areas where Tool is difficult to use, use plastic hammer to lightly tap the parts, to remove it.

CAUTION:

If for some unavoidable reason suitable tool such as screwdriver is used, be careful not to damage the mating surfaces.

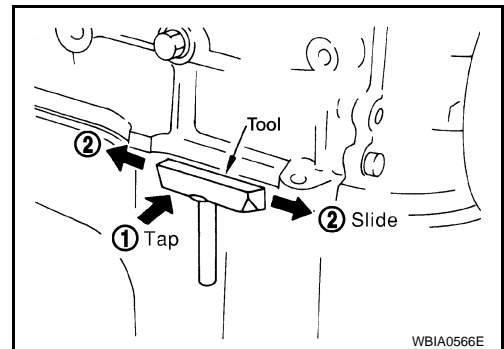

LIQUID GASKET APPLICATION PROCEDURE

1. Remove old liquid gasket adhering to the liquid gasket application surface and the mating surface, Using scraper.
 - Remove liquid gasket completely from the groove of the liquid gasket application surface, bolts, and bolt holes.
2. Thoroughly clean the mating surfaces and remove adhering moisture, grease and foreign materials.

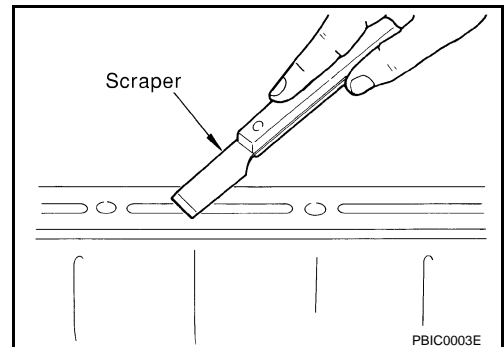

PRECAUTIONS

< PRECAUTION >

[QR25DE]

3. Attach liquid gasket tube to Tool.

Tool number : WS39930000 (—)

Use Genuine RTV Silicone Sealant or equivalent. Refer to GI-15, "Recommended Chemical Products and Sealants".

4. Apply liquid gasket without breaks to the specified location with the specified dimensions.

- If there is a groove for the liquid gasket application, apply liquid gasket to the groove.

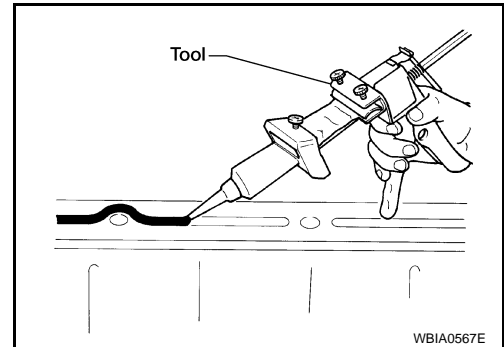

- As for the bolt holes, normally apply liquid gasket inside the holes. Occasionally, it should be applied outside the holes. Make sure to read the text of service manual.
- Within five minutes of liquid gasket application, install the mating component.
- If liquid gasket protrudes, wipe it off immediately.
- Do not retighten nuts or bolts after the installation.
- After 30 minutes or more have passed from the installation, fill engine oil and engine coolant.

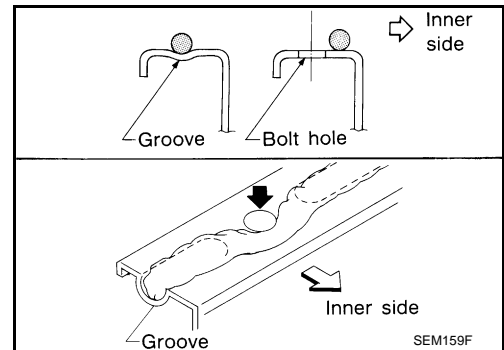

CAUTION:

If there are specific instructions in this manual, observe them.

A
CO
C
D
E
F
G
H
I
J
K
L
M
N
O
P

PREPARATION

< PREPARATION >

[QR25DE]

PREPARATION

PREPARATION

Special Service Tool

INFOID:000000003069058

The actual shape of the Kent-Moore tools may differ from those tools illustrated here.

Tool number (Kent-Moore No.) Tool name	Description
WS39930000 (—) Tube presser	Pressing the tube of liquid gasket
EG17650301 (J-33984-A) Radiator cap tester adapter	Adapting radiator cap tester to radiator filler neck: a: 28 (1.10) dia. b: 31.4 (1.236) dia. c: 41.3 (1.626) dia. Unit: mm (in)
KV10111100 (J-37228) Seal cutter	Removing chain tensioner cover and water pump cover
KV991J0070 (J-45695) Coolant Refill Tool	Refilling engine cooling system
— (J-23688) Engine coolant refractometer	Checking concentration of ethylene glycol in engine coolant

Commercial Service Tool

INFOID:000000003069058

PREPARATION

< PREPARATION >

[QR25DE]

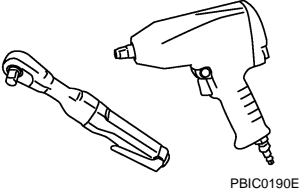
Tool name	Description
<p data-bbox="162 197 276 224">Power tool</p>  <p data-bbox="852 415 922 430">FBIC0190E</p>	<p data-bbox="1015 197 1266 224">Loosening bolts and nuts</p>

A

CO

C

D

E

F

G

H

I

J

K

L

M

N

O

P

COOLING SYSTEM

< FUNCTION DIAGNOSIS >

[QR25DE]

FUNCTION DIAGNOSIS

COOLING SYSTEM

Cooling Circuit

INFOID:000000003069060

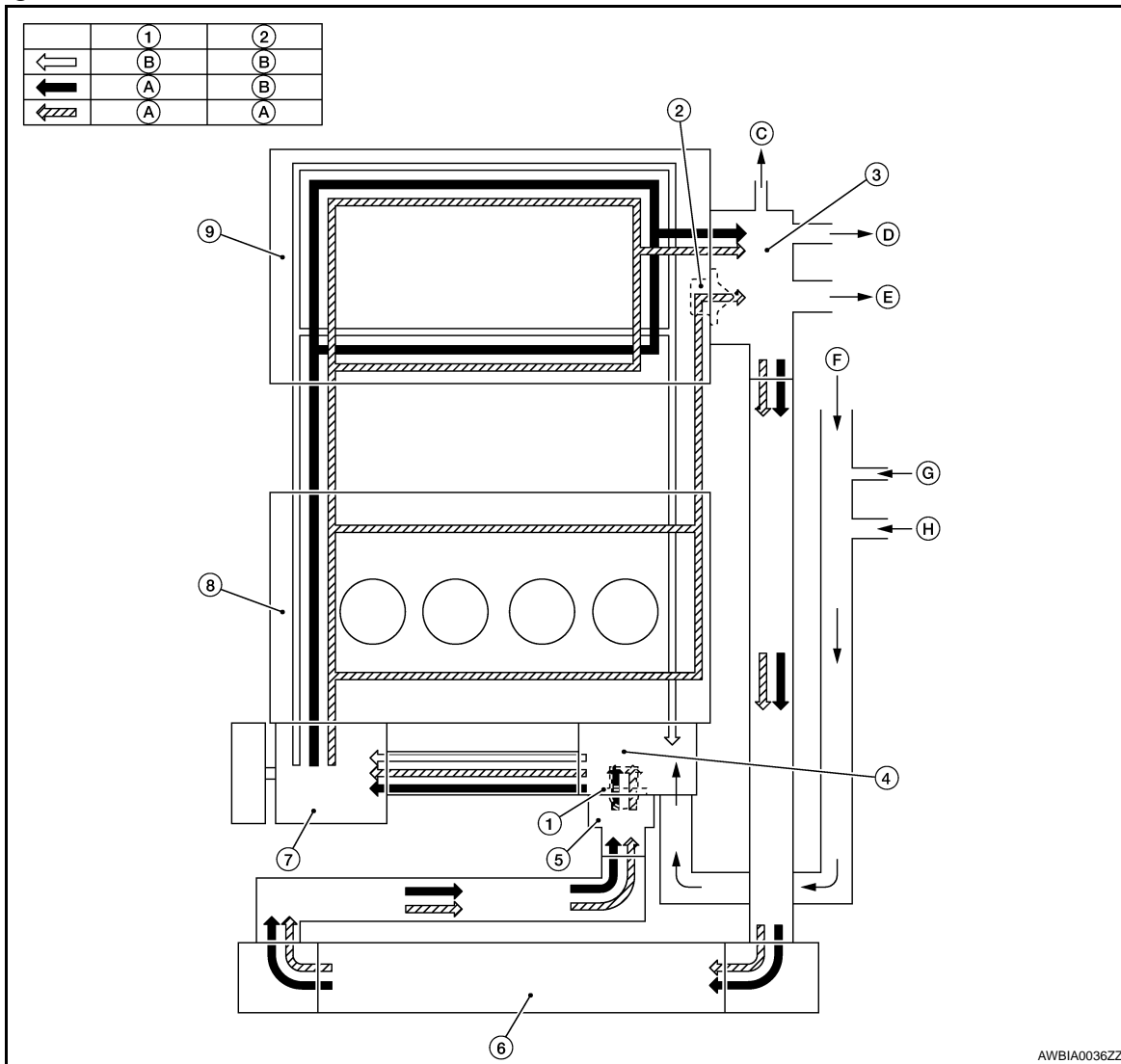

AWBIA0036ZZ

- | | | |
|----------------------------------------|-------------------------|-----------------------------------------------|
| 1. Thermostat | 2. Water control valve | 3. Water control valve housing (Water outlet) |
| 4. Cylinder block (Thermostat housing) | 5. Water inlet | 6. Radiator |
| 7. Water pump | 8. Cylinder block | 9. Cylinder head |
| A. Open | B. Closed | C. To electric throttle control |
| D. To oil cooler | E. To heater water pump | F. From heater core |
| G. From electric throttle control | H. From oil cooler | |

COOLING SYSTEM

< FUNCTION DIAGNOSIS >

[QR25DE]

Schematic

INFOID:000000003069061

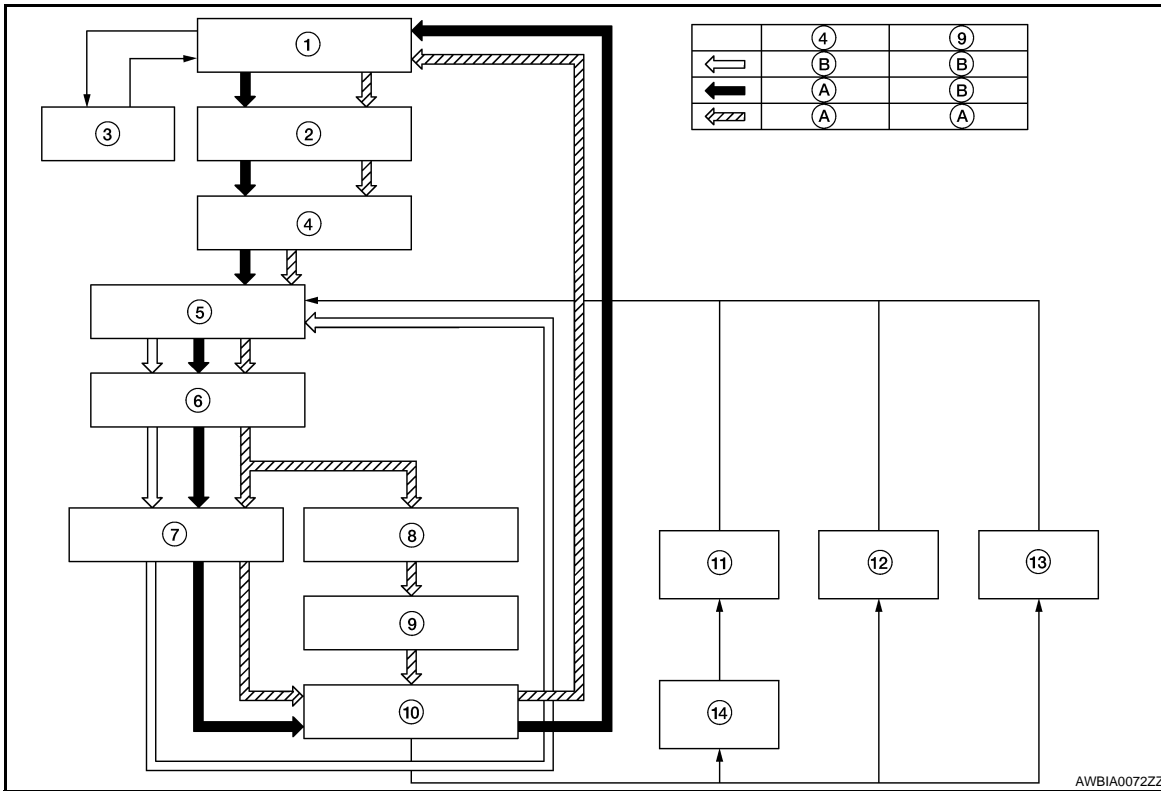

- | | | |
|---------------------------------|-----------------------|------------------------|
| 1. Radiator | 2. Water inlet | 3. Reservoir tank |
| 4. Thermostat | 5. Thermostat housing | 6. Water pump |
| 7. Cylinder head | 8. Cylinder block | 9. Water control valve |
| 10. Water control valve housing | 11. Heater | 12. Oil cooler |
| 13. Electric throttle control | 14. Heater water pump | A. Open |
| B. Closed | | |

A
CO
C
D
E
F
G
H
I
J
K
L
M
N
O
P

OVERHEATING CAUSE ANALYSIS

< FUNCTION DIAGNOSIS >

[QR25DE]

OVERHEATING CAUSE ANALYSIS

Troubleshooting Chart

INFOID:000000003069062

		Symptom	Check items		
Cooling system parts malfunction	Poor heat transfer	Water pump malfunction	Worn or loose drive belt	—	
		Thermostat stuck closed	Coolant circulation		
		Damaged fins	Dust contamination or rock clogging		
			Mechanical damage		
		Clogged radiator cooling tube	Excess foreign material (rust, dirt, sand, etc.)		
	Reduced air flow	Cooling fan does not operate	Engine cooling fans	—	
		High resistance to fan rotation			
		Damaged fan blades			
		Damaged radiator shroud	—	Radiator shroud	—
		Improper coolant mixture ratio	—	Coolant viscosity	—
		Poor coolant quality	—	Periodic maintenance	—
	Insufficient coolant	Coolant leaks	Cooling hose	Loose clamp	
				Cracked hose	
			Water pump	Poor sealing	
Radiator cap			Loose		
			Poor sealing		
Radiator			O-ring for damage, deterioration or improper fitting		
		Cracked radiator tank			
		Cracked radiator core			
	Reservoir tank	Cracked reservoir tank			
	Overflowing reservoir tank	Exhaust gas leaks into cooling system	Cylinder head deterioration		
			Cylinder head gasket deterioration		

OVERHEATING CAUSE ANALYSIS

< FUNCTION DIAGNOSIS >

[QR25DE]

	Symptom		Check items			
Except cooling system parts malfunction	—	Overload on engine	Abusive driving	High engine rpm under no load	A	
				—	CO	
			Powertrain system malfunction	—	Driving at extremely high speed	C
					Installed improper size wheels and tires	D
					Dragging brakes	E
					Improper ignition timing	F
	Blocked or restricted air flow	Blocked radiator grille	Blocked bumper	Installed car brassiere	G	
				Blocked radiator	Mud contamination or paper clogging	—
			Blocked condenser			—
				Installed large fog lamp	—	J

K
L
M
N
O
P

ON-VEHICLE MAINTENANCE

ENGINE COOLANT

System Inspection

INFOID:000000003069063

WARNING:

- Never remove the radiator cap when the engine and inverter are hot. Serious burns could occur from high pressure fluid escaping from the radiator.
- Wrap a thick cloth around the cap. Slowly push down and turn it a quarter turn to allow built-up pressure to escape. Carefully remove the cap by pushing down and turning it all the way.

CHECKING COOLING SYSTEM HOSES

Check hoses for the following:

- Improper attachment
- Leaks
- Cracks
- Damage
- Loose connections
- Chafing
- Deterioration

CHECKING RESERVOIR LEVEL

- Check if the reservoir tank coolant level is within MIN to MAX when the engine and inverter are cool.
- Adjust coolant level if it is too much or too little.

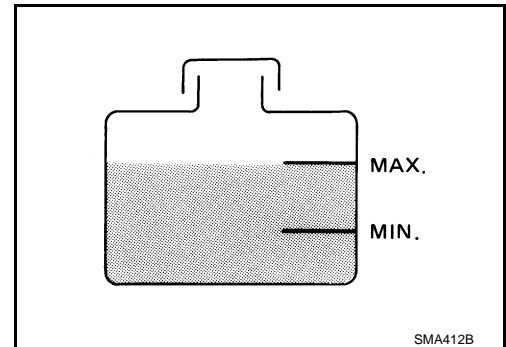

CHECKING COOLING SYSTEM FOR LEAKS

To check for leakage, apply pressure to the cooling system using Tool.

Tool number : EG17650301 (J-33984-A)

Testing pressure : 157 kPa (1.6 kg/cm², 23 psi)

WARNING:

Never remove the radiator cap when the engine and inverter are hot. Serious burns could occur from high pressure coolant escaping from the radiator.

CAUTION:

Higher pressure than specified may cause radiator damage.

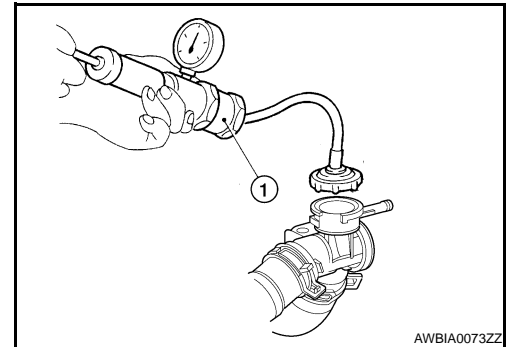

CHECKING RADIATOR CAP

CAUTION:

Use only specified radiator cap for L32. If radiator cap other than specified is used, engine overheating is likely occur.

1. Inspect the radiator cap.
 - Replace the cap if the metal plunger cannot be seen around the edge of the black rubber gasket.
 - Replace the cap if deposits of waxy residue or other foreign material are on the black rubber gasket or the metal retainer.

NOTE:

Thoroughly wipe out the radiator filler neck to remove any waxy residue or foreign material.

ENGINE COOLANT

< ON-VEHICLE MAINTENANCE >

[QR25DE]

2. Pull the negative-pressure valve to open it and check that it moves smoothly when released.
 - Check that there is no dirt or damage on the valve seat of the radiator cap negative-pressure valve.
 - Check that there are no abnormalities in the opening and closing conditions of the negative-pressure valve.

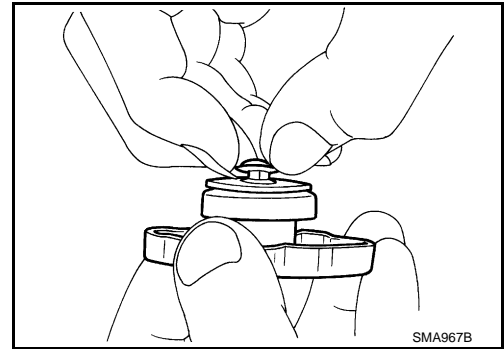

3. Check radiator cap relief pressure using Tool.

Tool number : EG17650301 (J-33984-A)

Standard: 122 - 152 kPa (1.2 - 1.5 kg/cm², 18 - 22 psi)

Limit: 107 kPa (1.1 kg/cm², 16 psi)

- When connecting the radiator cap to the tester, apply water or coolant to the cap seal surface.
- Replace the radiator cap if there is an abnormality in the negative-pressure valve, or if the open-valve pressure is outside of the standard values.

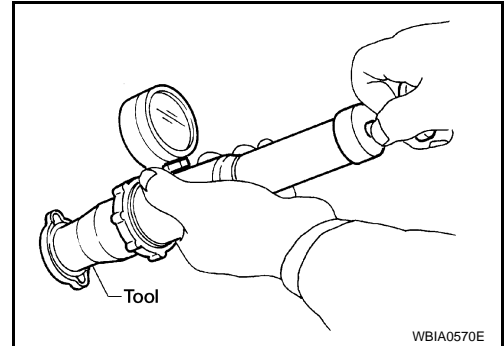

CHECKING RADIATOR

Check radiator for mud or clogging. If necessary, clean radiator as follows.

- Be careful not to bend or damage the radiator fins.
 - When radiator is cleaned without removal, remove all surrounding parts such as cooling fan shroud and horns. Then tape the harness and electrical connectors to prevent water from entering.
1. Apply water by hose to the back side of the radiator core, with the hose pointed vertically downward.
 2. Apply water again to all radiator core surfaces once per minute.
 3. Stop washing if any stains no longer flow out from the radiator.
 4. Blow air into the back side of radiator core, with the air hose pointed vertically downward.
 - Use compressed air lower than 490 kPa (5 kg/cm², 71 psi) and keep distance more than 30 cm (11.8 in).
 5. Blow air again into all the radiator core surfaces once per minute until no water sprays out.
 6. Check for leaks.

Changing Engine Coolant

INFOID:000000003069064

WARNING:

- **To avoid being scalded, never change the coolant when the engine and inverter are hot.**
- **Wrap a thick cloth around cap and carefully remove the cap. First, turn the cap a quarter of a turn to release built-up pressure. Then push down and turn the cap all the way to remove.**

DRAINING ENGINE COOLANT

1. Remove the engine undercover using power tool.
2. Open the radiator drain plug at the bottom of the radiator, and remove the radiator filler cap. This is the only step required when partially draining the cooling system (radiator only).

CAUTION:

Do not to allow the coolant to contact the drive belts.

3. Follow this step for heater core removal/replacement only. Disconnect the upper heater hose at the engine side and apply moderate air pressure [103.46 kPa (15 psi, 1.055 kg/cm²) maximum air pressure] into the hose for 30 seconds to blow the excess coolant out of the heater core.
4. When draining all of the coolant in the system, remove the reservoir tank and drain the coolant, then clean the reservoir tank before installation.

ENGINE COOLANT

[QR25DE]

< ON-VEHICLE MAINTENANCE >

- When draining all of the coolant in the system for engine removal or repair, open the drain plug on the cylinder block.

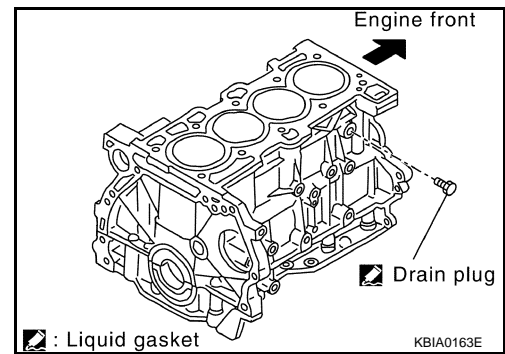

- Check the drained coolant for contaminants such as rust, corrosion or discoloration. If the coolant is contaminated, flush the engine cooling system. Refer to [CO-11, "Changing Engine Coolant"](#).

REFILLING ENGINE COOLANT

- Install the radiator drain plug. Install the reservoir tank and cylinder block drain plug, if removed for a total system drain or for engine removal or repair.
 - The radiator must be completely empty of coolant and water.**
 - Apply sealant to the threads of the cylinder block drain plugs. Use Genuine High Performance Thread Sealant or equivalent. Refer to [GI-15, "Recommended Chemical Products and Sealants"](#).**

Radiator drain plug : Refer to [CO-14, "Removal and Installation"](#) .

Cylinder block drain plug : Refer to [EM-74, "Disassembly and Assembly"](#) .

- If disconnected, reattach the upper radiator hose at the engine side.
- Set the vehicle heater controls to the full HOT and heater ON position. Push the ignition switch twice to the ON position with the Hybrid system and engine OFF as necessary to activate the heater mode.
- Install the Tool by installing the radiator cap adapter (E) onto the radiator tee opening (F). Then attach the gauge body assembly (B) with the refill hose (D) and the venturi assembly (A) to the radiator cap adapter.

Tool number : KV991J0070 (J-45695)

- A: Venturi assembly
- B: Gauge body assembly
- C: Ball valve
- D: Refill hose
- E: Radiator cap adapter
- F: Radiator tee

- Insert the refill hose (D) into the coolant mixture container that is placed at floor level. Make sure the ball valve (C) is in the closed position.
 - Use Genuine NISSAN Long Life Anti-freeze coolant or equivalent, mixed 50/50 with distilled water or demineralized water.**
 - Refer to [MA-10, "Engine Oil Recommendation"](#).

Engine coolant capacity (with reservoir tank) : Refer to [MA-10, "Fluids and Lubricants"](#).

- Install an air hose to the venturi assembly (A), the air pressure must be within specification.

Compressed air supply pressure : 5.7 - 8.5 kPa (5.6 - 8.4 kg/cm² , 80 - 120 psi)

CAUTION:

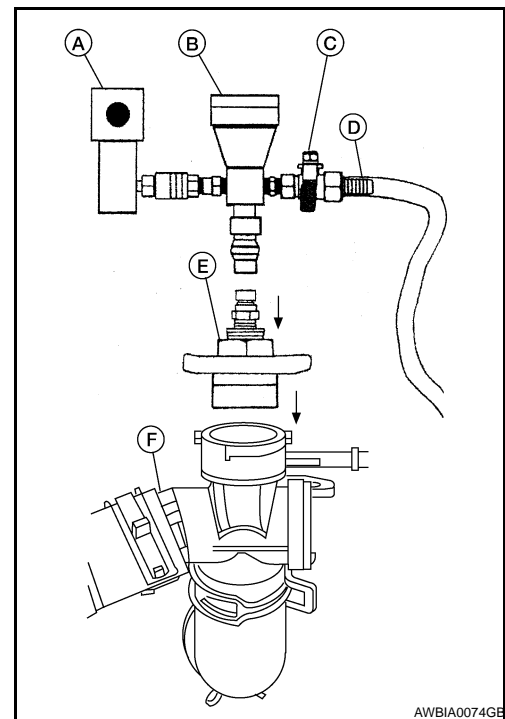

ENGINE COOLANT

< ON-VEHICLE MAINTENANCE >

[QR25DE]

The compressed air supply must be equipped with an air dryer.

- The vacuum gauge will begin to rise and there will be an audible hissing noise. During this process open the ball valve (C) on the refill hose (D) slightly. Coolant will be visible rising in the refill hose (D). Once the refill hose (D) is full of coolant, close the ball valve (C). This will purge any air trapped in the refill hose.
- Continue to draw the vacuum until the gauge reaches 28 inches of vacuum. The gauge may not reach 28 inches in high altitude locations, use the vacuum specifications below based on the altitude above sea level.

Altitude above sea level	Vacuum gauge reading
0 - 100 m (328 ft)	: 28 inches of vacuum
300 m (984 ft)	: 27 inches of vacuum
500 m (1,641 ft)	: 26 inches of vacuum
1,000 m (3,281 ft)	: 24 - 25 inches of vacuum

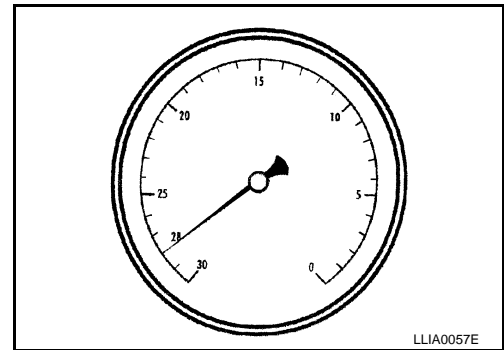

- When the vacuum gauge has reached the specified amount, disconnect the air hose and wait 20 seconds to see if the system loses any vacuum. If the vacuum level drops, perform any necessary repairs to the system and repeat steps 6 - 8 to bring the vacuum to the specified amount. Recheck for any leaks.
- Place the coolant container [with the refill hose (D) inserted] at the same level as the top of the radiator. Then open the ball valve (C) on the refill hose (D) so the coolant will be drawn up to fill the cooling system. The cooling system is full when the vacuum gauge reads zero.
CAUTION:
Do not allow the coolant container to get too low when filling, to avoid air from being drawn into the cooling system.
- Remove the Tool from the radiator neck opening.
- Fill the cooling system reservoir tank to the specified level and install the radiator cap. Turn the Hybrid system ON to the engine to warm up the cooling system and top up the system as necessary.

FLUSHING COOLING SYSTEM

- Fill the radiator from the filler cap above the radiator upper hose and reservoir tank, with water and reinstall the filler cap above the radiator upper hose.
- Turn the Hybrid system ON to the engine until it reaches normal operating temperature.
- Press the engine accelerator two or three times under no-load.
- Turn the Hybrid system off and wait until it cools down.
- Drain the water.
- Repeat steps 1 through 5 until clear water begins to drain from the radiator.

ON-VEHICLE REPAIR

RADIATOR

Removal and Installation

INFOID:000000003069065

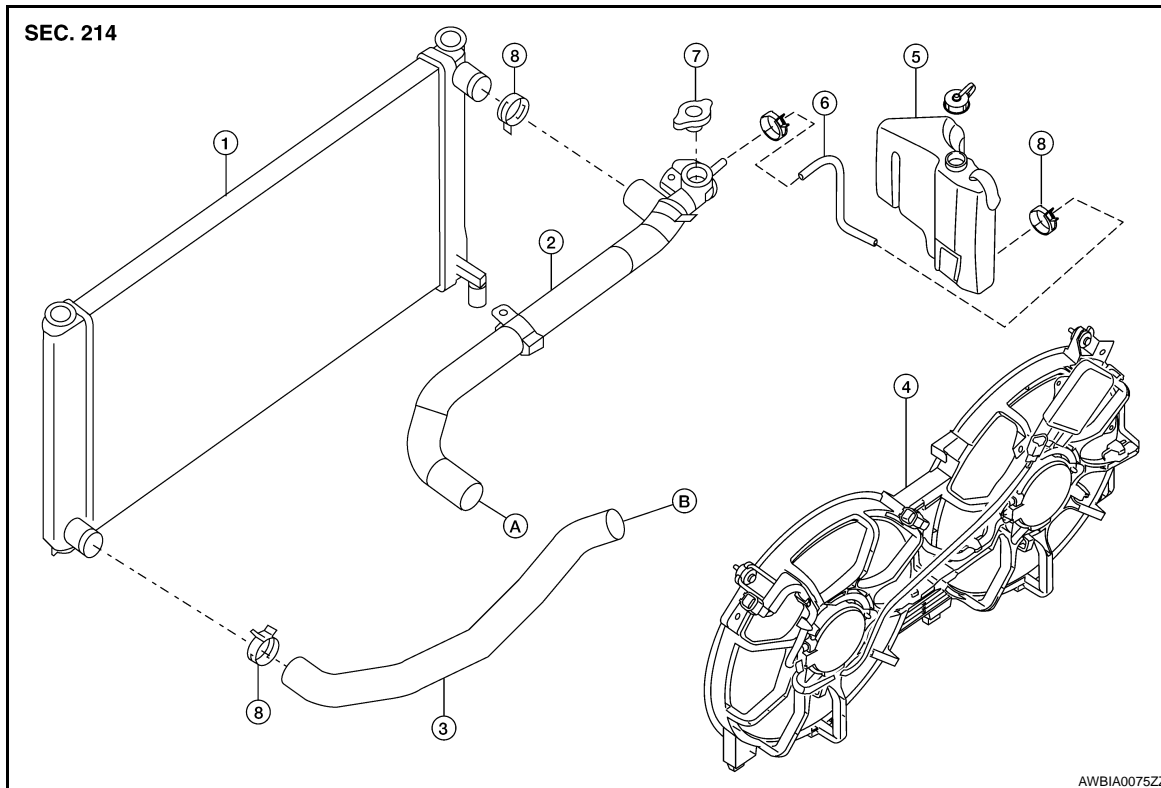

- | | | |
|------------------------------------|--------------------------|--------------------------|
| 1. Radiator and condenser assembly | 2. Radiator hose (upper) | 3. Radiator hose (lower) |
| 4. Radiator fan assembly | 5. Reservoir tank | 6. Reservoir hose |
| 7. Radiator filler cap | 8. Clamps | A. To water outlet |
| B. To water inlet | | |

WARNING:

Never remove the radiator cap when the engine and inverter are hot. Serious burns could occur from high pressure coolant escaping from the radiator and condenser assembly. Wrap a thick cloth around the cap. Slowly turn it a quarter turn to allow built-up pressure to escape. Carefully remove the cap by turning it all the way.

REMOVAL

1. Remove engine under cover.
2. Drain engine coolant from radiator and condenser assembly. Refer to [CO-11, "Changing Engine Coolant"](#).
3. Remove air cleaner duct (front)
4. Remove radiator upper hose and lower hose.
5. Remove coolant reservoir hose.
6. Drain inverter coolant from sub-radiator. Refer to [HBC-628, "Replacement"](#).
7. Remove front bumper reinforcement, Refer to [EXT-12, "Removal and Installation"](#).
8. Remove sub radiator. Refer to [HBC-638, "Removal and Installation"](#).
9. Discharge A/C system. Refer to [HA-30, "HFC-134a \(R-134a\) Service Procedure"](#).
10. Remove high side junction pipe assembly. Refer to [HA-38, "Removal and Installation for Junction Pipe"](#).
11. Remove the refrigerant pressure sensor for installation on new assembly. Refer to [HA-40, "Removal and Installation for Refrigerant Pressure Sensor"](#).

RADIATOR

[QR25DE]

< ON-VEHICLE REPAIR >

12. Remove both radiator clips.
13. Remove radiator and condensor assembly.

CAUTION:

- Do not damage or scratch the radiator and condenser assembly and sub radiator core when removing.
- When removing refrigerant components from a vehicle, immediately cap (seal) the component to minimize the entry of moisture from the atmosphere.
- When installing refrigerant components to vehicle, never remove the caps (unseal) until just before connecting the components. Connect all refrigerant loop components as quickly as possible to minimize the entry of moisture into system

INSTALLATION

Installation is in the reverse order of removal.

INSPECTION

Radiator

1. Check radiator for mud or clogging. If necessary, clean radiator as follows:
 - Be careful not to bend or damage the radiator fins.
 - When radiator is cleaned without removal, remove all surrounding parts such as cooling fan, radiator shroud and horns. Then tape the harness and electrical connectors to prevent water from entering.
- a. Apply water by hose to the back side of the radiator core, point the hose vertically downward.
- b. Apply water again to all radiator core surfaces once per minute.
- c. Stop washing when no more dirt flows off the radiator.
- d. Blow air into the back side of radiator core, point the air hose vertically downward.
 - Use compressed air lower than 490 kPa (5 kg/cm², 71 psi) and keep distance more than 30 cm (11.8 in).
- e. Blow air again into all the radiator core surfaces once per minute until no water sprays out.

A
CO
C
D
E
F
G
H
I
J
K
L
M
N
O
P

COOLING FAN

Removal and Installation

INFOID:000000003069066

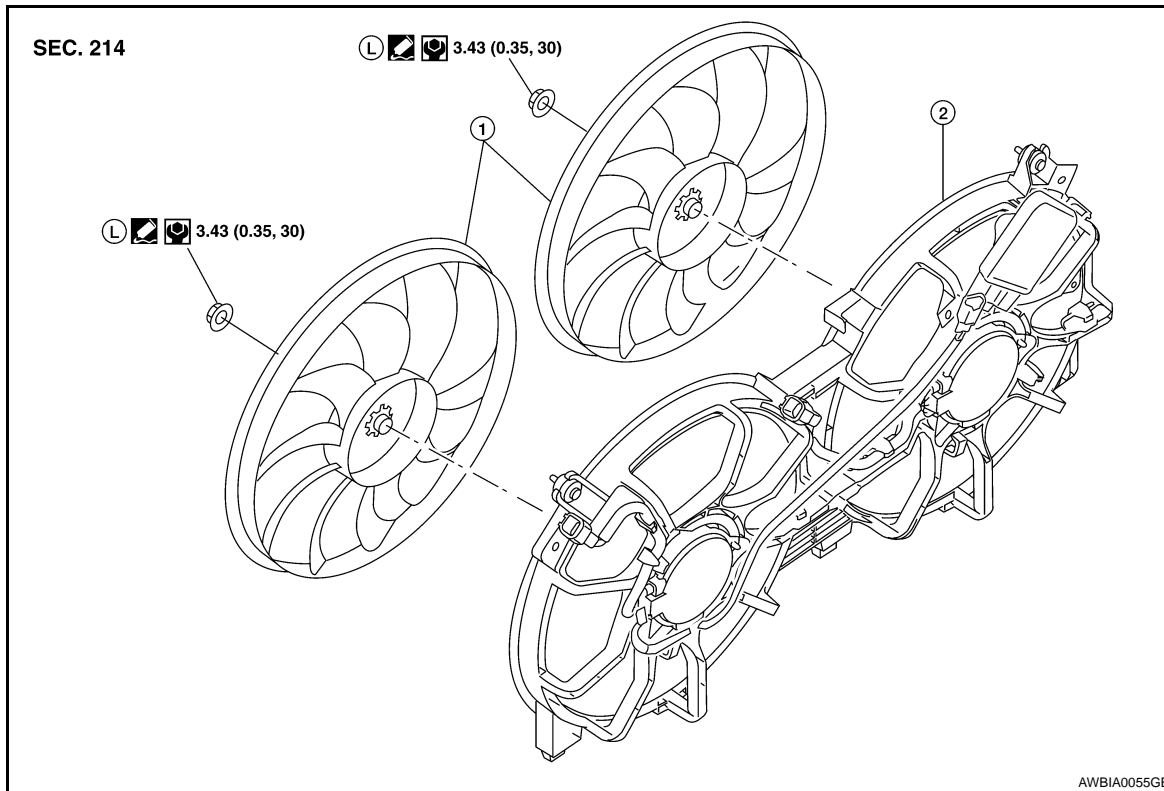

1. Fan blade 2. Radiator cooling fan shroud and motor assembly

REMOVAL

1. Disconnect the 12-volt battery negative terminal.
2. Drain engine coolant from radiator. Refer to [CO-11, "Changing Engine Coolant"](#).
CAUTION:
Perform when engine and inverter are cold.
3. Remove inverter upper bracket.
4. Remove engine undercover.
5. Drain engine coolant. Refer to [CO-11, "Changing Engine Coolant"](#).
6. Drain inverter coolant from sub-radiator. Refer to [HBC-628, "Replacement"](#).
7. Disconnect radiator upper hose.
8. Remove air cleaner duct (front). Refer to [EM-23, "Removal and Installation"](#).
9. Remove sub radiator coolant reservoir tank.
10. Disconnect ECM.
11. Remove ECM and bracket assembly.
12. Disconnect cooling fan controller.
13. Remove radiator cooling fan assembly. Refer to [CO-16, "Removal and Installation"](#).

INSTALLATION

Installation is in the reverse order of removal.

- Radiator cooling fan is controlled by ECM. For details, refer to [EC-59, "System Description"](#).

Disassembly and Assembly

INFOID:000000003069067

DISASSEMBLY

COOLING FAN

[QR25DE]

< ON-VEHICLE REPAIR >

1. Remove fan blades from fan motors.
2. Remove the fan motors from the shroud.

ASSEMBLY

Assembly is in the reverse order of disassembly.

A

CO

C

D

E

F

G

H

I

J

K

L

M

N

O

P

WATER PUMP

< ON-VEHICLE REPAIR >

[QR25DE]

WATER PUMP

Removal and Installation

INFOID:000000003069068

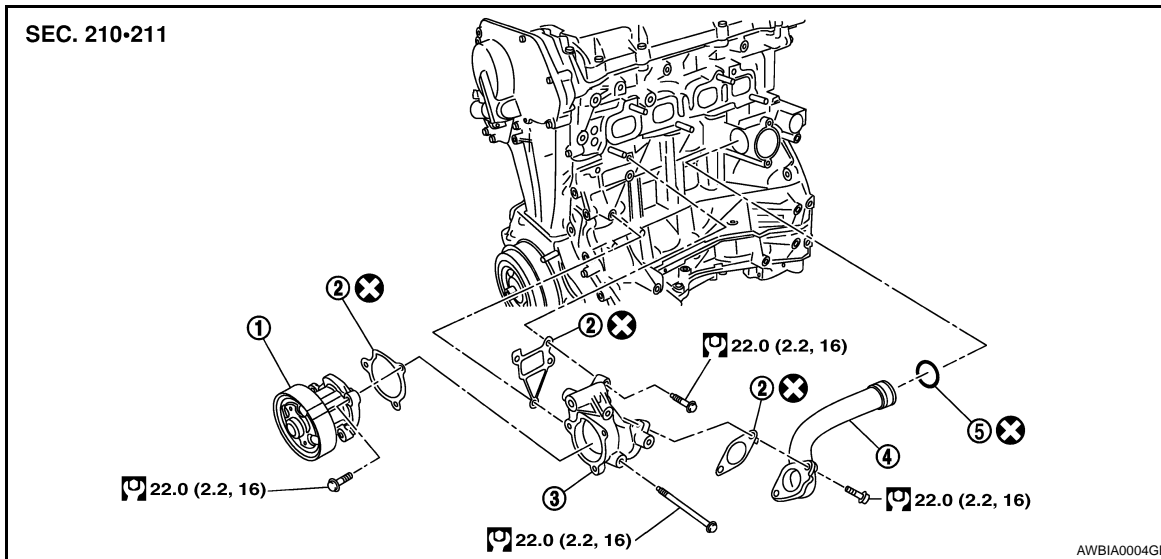

- | | | |
|---------------|------------|-----------------------|
| 1. Water pump | 2. Gaskets | 3. Water pump housing |
| 4. Water pipe | 5. O-ring | |

WARNING:

Never remove the radiator cap when the engine is hot. Serious burns could occur from high pressure coolant escaping from the radiator.

REMOVAL

1. Drain coolant. Refer to [CO-11, "Changing Engine Coolant"](#).

CAUTION:

Perform when the engine is cold.

2. Remove engine undercover.
3. Remove drive belt. Refer to [EM-15, "Removal and Installation"](#).
4. Remove engine cover using power tools.
5. Remove air cleaner duct (front).
6. Remove engine coolant reservoir.
7. Remove RH wheel and tire assembly.
8. Remove fender protector. Refer to [EXT-18, "Removal and Installation"](#).
9. Remove engine ground strap.
10. Remove idler pulley bracket.
11. Remove the water pump.

CAUTION:

- Handle the water pump vane so that it does not contact any other parts.
- Water pump cannot be disassembled and should be replaced as an assembly.

NOTE:

If necessary, the exhaust manifold catalytic convertor assembly must be removed to remove the water pipe.

INSPECTION AFTER REMOVAL

WATER PUMP

[QR25DE]

< ON-VEHICLE REPAIR >

- Visually check that there is no significant dirt or rusting on the water pump body and vane.
- Check that there is no looseness in the vane shaft, and that it turns smoothly when rotated by hand.
- If the water pump does not perform properly, replace the water pump assembly.

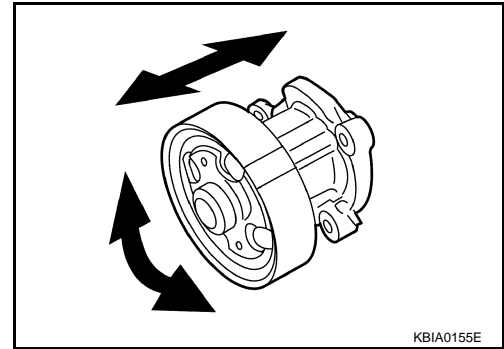

INSTALLATION

Installation is in the reverse order of removal.

- When inserting water pipe end to cylinder block, apply a neutral detergent to O-ring. Then insert it immediately.

INSPECTION AFTER INSTALLATION

- After installing the water pump, check for leaks using the radiator cap tester. Refer to [CO-10, "System Inspection"](#).

A

CO

C

D

E

F

G

H

I

J

K

L

M

N

O

P

THERMOSTAT AND THERMOSTAT HOUSING

< ON-VEHICLE REPAIR >

[QR25DE]

THERMOSTAT AND THERMOSTAT HOUSING

Removal and Installation

INFOID:000000003069069

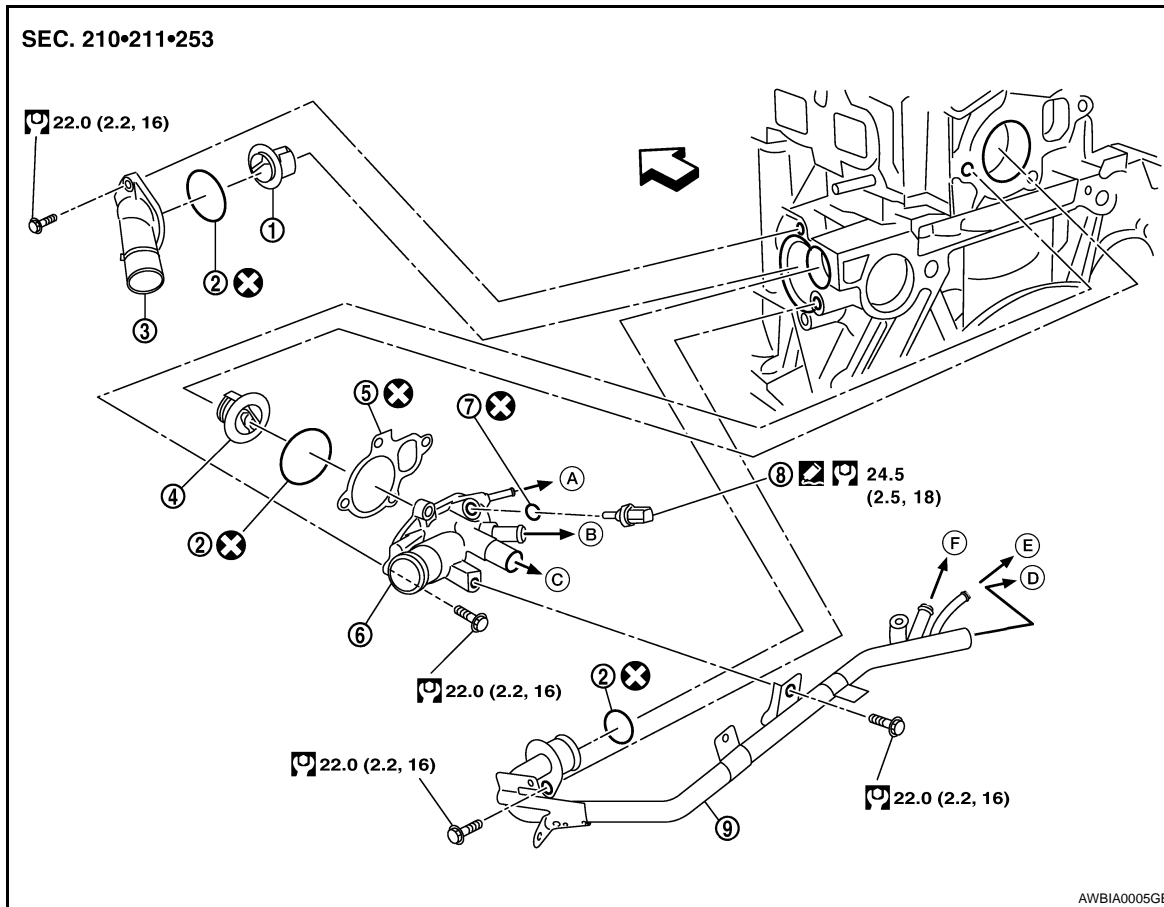

- | | | |
|-----------------------------------|--------------------------------------|--------------------------|
| 1. Thermostat | 2. O-ring | 3. Engine coolant inlet |
| 4. Water control valve | 5. Gasket | 6. Engine coolant outlet |
| 7. Copper washer | 8. Engine coolant temperature sensor | 9. Heater pipe |
| A. To electronic throttle control | B. To oil cooler | C. To heater |
| D. To heater | E. To electronic throttle control | F. To oil cooler |
| ← Engine front | | |

WARNING:

Never remove the radiator cap when the engine is hot. Serious burns could occur from high pressure coolant escaping from the radiator.

REMOVAL

CAUTION:

Perform when the engine is cold.

1. Drain engine coolant. Refer to [CO-11, "Changing Engine Coolant"](#).
2. Remove engine under cover.
3. Remove air duct (front).
4. Remove radiator lower hose from the engine coolant inlet side.
5. Remove engine coolant inlet and thermostat.

INSPECTION AFTER REMOVAL

THERMOSTAT AND THERMOSTAT HOUSING

< ON-VEHICLE REPAIR >

[QR25DE]

- Place a thread so that it is caught in the valves of the thermostat. Immerse fully in a container filled with water. Heat while stirring.
- The valve opening temperature is the temperature at which the valve opens and the falls from the thread.
- Continue heating. Check the full-open lift amount.

NOTE:

The full-open lift amount standard temperature for the thermostat is the reference value.

- After checking the full-open lift amount, lower the water temperature and check the valve closing temperature.

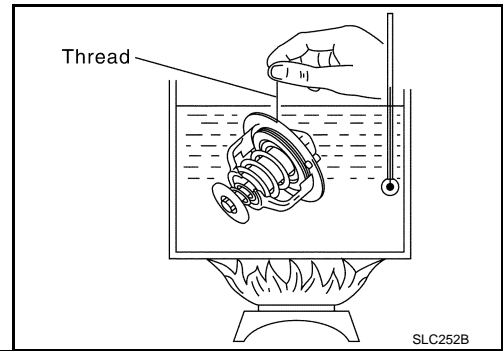

Thermostat	Standard Values
Valve opening temperature	80.5 – 83.5°C (177 – 182°F)
Valve lift	More than 8 mm / 95°C (0.315 in / 203°F)
Valve closing temperature	77°C (171°F) or higher

INSTALLATION

Installation is in the reverse order of removal.

- Install the engine coolant temperature sensor.

Use Genuine RTV Silicone Sealant or equivalent. Refer to [GI-15, "Recommended Chemical Products and Sealants"](#).

- Install the thermostat with the whole circumference of the flange part fitting securely inside the rubber ring.
- Install the thermostat with the jiggle valve facing upwards. The position deviation may be within the range of $\pm 10^\circ$.
- If necessary, to install the heater pipe, first apply a mild detergent to the O-ring and then quickly insert the pipe into the housing.
- Use a new gasket and O-ring for installation.

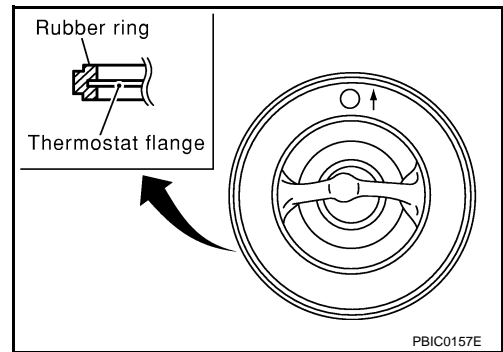

A
CO
C
D
E
F
G
H
I
J
K
L
M
N
O
P

WATER CONTROL VALVE

< ON-VEHICLE REPAIR >

[QR25DE]

WATER CONTROL VALVE

Removal and Installation

INFOID:00000003069070

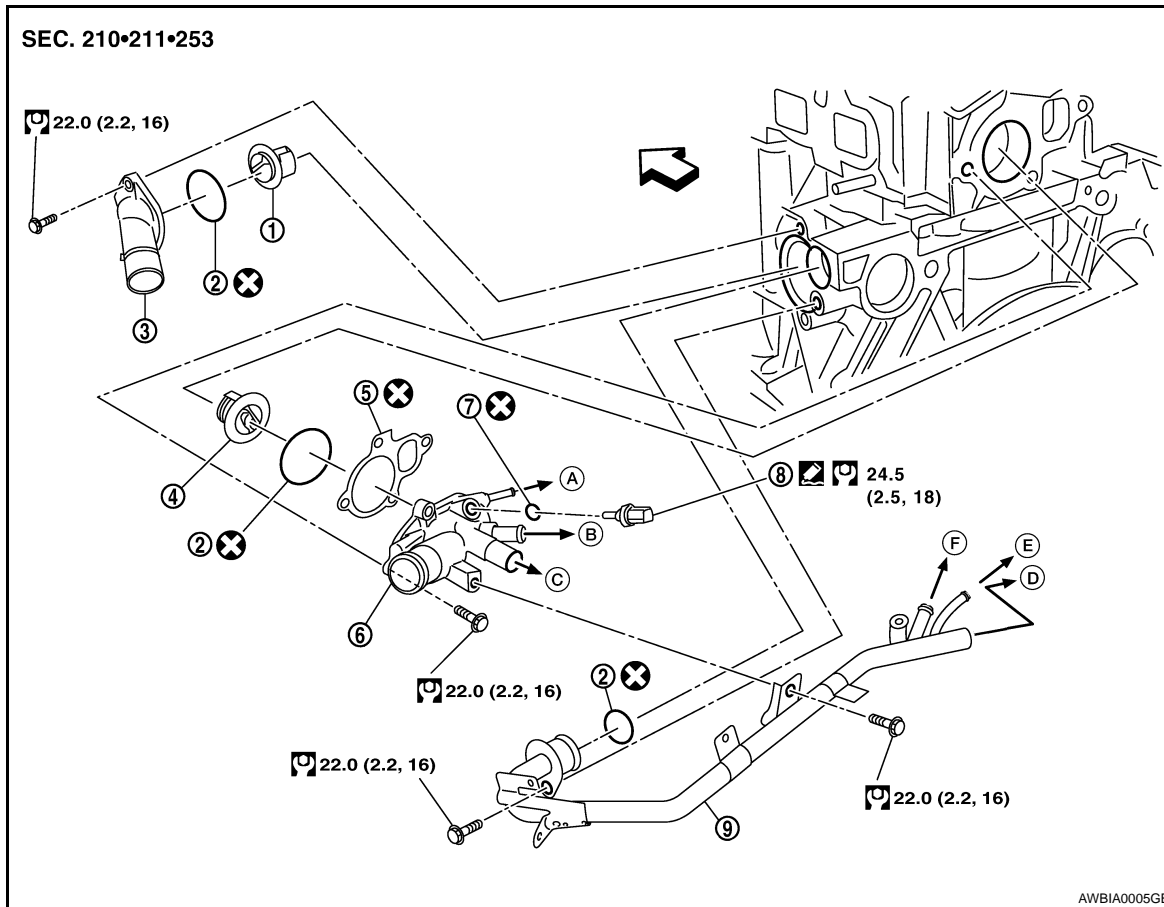

- | | | |
|-----------------------------------|--------------------------------------|--------------------------|
| 1. Thermostat | 2. O-ring | 3. Engine coolant inlet |
| 4. Water control valve | 5. Gasket | 6. Engine coolant outlet |
| 7. Copper washer | 8. Engine coolant temperature sensor | 9. Heater pipe |
| A. To electronic throttle control | B. To oil cooler | C. To heater |
| D. To heater | E. To electronic throttle control | F. To oil cooler |
| ← Engine front | | |

WARNING:

Never remove the radiator cap when the engine is hot. Serious burns could occur from high pressure coolant escaping from the radiator.

REMOVAL

CAUTION:

Perform when the engine cold.

1. Drain the engine coolant from the radiator and condenser assembly and sub-radiator. Refer to [CO-11, "Changing Engine Coolant"](#).
2. Remove air cleaner assembly. Refer to [EM-23, "Removal and Installation"](#).
3. Remove engine room cover, using power tools.
4. Disconnect the upper radiator hose, heater pipe, electric throttle control actuator inlet hose, oil cooler hose and heater hoses.
5. Remove the engine coolant temperature sensor.
6. Remove the engine coolant outlet.
7. Remove the water control valve.

WATER CONTROL VALVE

[QR25DE]

< ON-VEHICLE REPAIR >

INSPECTION AFTER REMOVAL

- Place a thread so that it is caught in the valve of the water control valve. Immerse fully in a container filled with water. Heat while stirring.
- The valve opening temperature is the temperature at which the valve opens and the falls from the thread.
- Continue heating. Check the full-open lift amount.

NOTE:

The full-open lift amount standard temperature for the water control valve is the reference value.

- After checking the full-open lift amount, lower the water temperature and check the valve closing temperature.

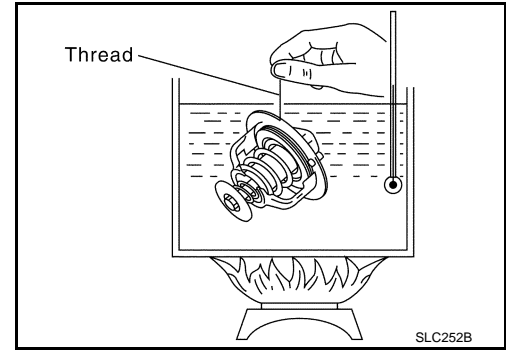

A

CO

C

D

E

F

G

H

I

J

K

L

M

N

O

P

Standard values

Water Control Valve	Standard Value
Valve opening temperature	93.5° - 96.5°C (200° - 206°F)
Full-open lift amount	More than 8 mm / 108°C (0.315 in / 226° F)
Valve closing temperature	90°C (194° F) or higher

INSTALLATION

Installation is in the reverse order of removal.

- Install the engine coolant temperature sensor.
Use Genuine RTV Silicone Sealant or equivalent. Refer to [GI-15, "Recommended Chemical Products and Sealants"](#).
- Install the water control valve with the whole circumference of the flange part fitting securely inside the rubber ring.
- Install the water control valve with the up-mark facing up and the frame center part facing upwards. The position deviation may be within the range of $\pm 10^\circ$.
- Use a new gasket and O-ring for installation.

SERVICE DATA AND SPECIFICATIONS (SDS)

< SERVICE DATA AND SPECIFICATIONS (SDS)

[QR25DE]

SERVICE DATA AND SPECIFICATIONS (SDS)

SERVICE DATA AND SPECIFICATIONS (SDS)

Capacity

INFOID:000000003069071

ℓ (US gal, Imp gal)

Coolant capacity (With reservoir tank at MAX level)	7.7 (2, 1 3/4)
-----------------------------------------------------	----------------

Thermostat

INFOID:000000003069072

Valve opening temperature	80.5 - 83.5°C (177 - 182°F)
Valve lift	More than 8 mm / 95°C (0.315 in / 203°F)
Valve closing temperature	77°C (171°F) or higher

Water Control Valve

INFOID:000000003069073

Valve opening temperature	93.5-96.5°C (200-206°F)
Valve lift	More than 8 mm / 108°C (0.315 in / 226°F)
Valve closing temperature	90°C (194°F) or higher

Radiator

INFOID:000000003069074

Unit: kPa (kg / cm², psi)

Cap relief pressure	Standard	122 - 152 (1.2 - 1.5, 18 - 22)
	Limit	107 (1.1, 16)
Leakage test pressure		157 (1.6, 23)