

A
B
C

TM

SECTION

TRANSAXLE & TRANSMISSION

TM

CONTENTS

HYBRID TRANSAXLE: RE0F01H		
FUNCTION DIAGNOSIS	Inspection	24
MECHANICAL SYSTEM	Replacement	24
Description	LINE PRESSURE TEST	25
Transaxle Unit	Inspection	25
Lubrication Mechanism	SHIFT POSITION	26
Shift Control System	Inspection and Adjustment	26
SHIFT LOCK SYSTEM	ON-VEHICLE REPAIR	27
System Diagram	CONTROL DEVICE	27
System Description	Exploded View	27
Component Parts Location	Removal and Installation	27
Component Description	Inspection and Adjustment	28
COMPONENT DIAGNOSIS	CONTROL CABLE	29
SHIFT LOCK SYSTEM	Exploded View	29
Description	Removal and Installation	29
Wiring Diagram	Inspection and Adjustment	30
Diagnosis Procedure	DIFFERENTIAL SIDE OIL SEAL	31
PRECAUTION	Exploded View	31
PRECAUTIONS	Removal and Installation	31
Precaution for Supplemental Restraint System (SRS) "AIR BAG" and "SEAT BELT PRE-TENSIONER"	PARK/NEUTRAL POSITION (PNP) SWITCH ...	32
Precautions For High-Voltage System	Exploded View	32
Precaution Necessary for Steering Wheel Rotation After Battery Disconnect	Removal and Installation	32
Service Notice or Precaution	Inspection and Adjustment	33
PREPARATION	INPUT SHAFT OIL SEAL	35
PREPARATION	Exploded View	35
Commercial Service Tools	Removal and Installation	35
ON-VEHICLE MAINTENANCE	REMOVAL AND INSTALLATION	36
FLUID	TRANSAXLE ASSEMBLY	36
	Exploded View	36
	Removal and Installation	36
	SERVICE DATA AND SPECIFICATIONS (SDS)	38

E
F
G
H
I
J
K
L
M
N
O
P

SERVICE DATA AND SPECIFICATIONS
(SDS) 38

General Specification 38

FUNCTION DIAGNOSIS

MECHANICAL SYSTEM

Description

INFOID:000000004212365

- Containing a MG2 (Motor Generator No.2) for driving the vehicle and a MG1 (Motor Generator No.1) for generating electrical power, this hybrid transaxle uses a continuously variable transmission mechanism with compound gear unit (which consists of a motor speed reduction planetary gear unit and a power split planetary gear unit) that achieve smooth and quiet operation.
- A transaxle damper that consists of a coil spring with low-twist characteristics is used in order to absorb the torque fluctuation in the drive force of the engine.
- This transaxle uses two lubrication mechanisms concurrently: a lubrication mechanism consisting of a trochoid type oil pump placed on the main shaft, and a lubrication mechanism consisting of an oil slinger on the final gear. The concurrent use of the two mechanisms reduces the drive loss of the oil pump.

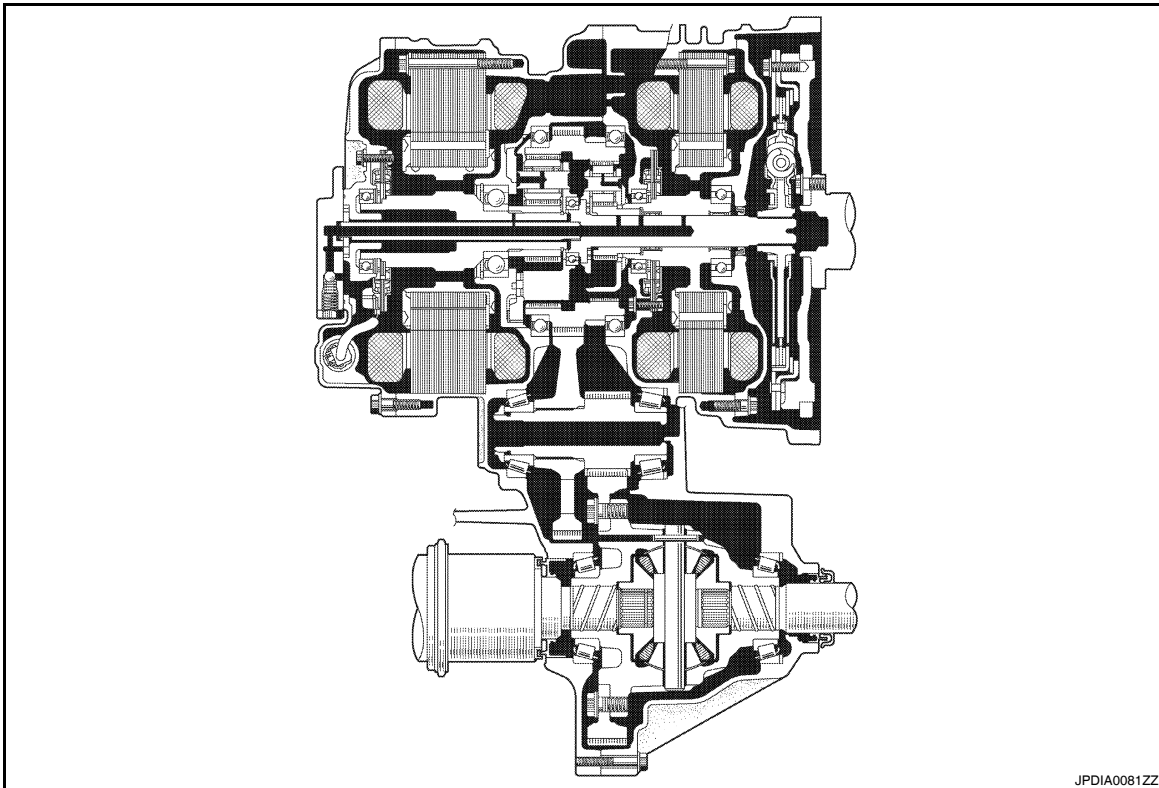

JPDIA0081ZZ

SPECIFICATIONS

A
B
C
TM
E
F
G
H
I
J
K
L
M
N
O
P

MECHANICAL SYSTEM

< FUNCTION DIAGNOSIS >

[HYBRID TRANSAXLE: RE0F01H]

Refer to [TM-38. "General Specification"](#).

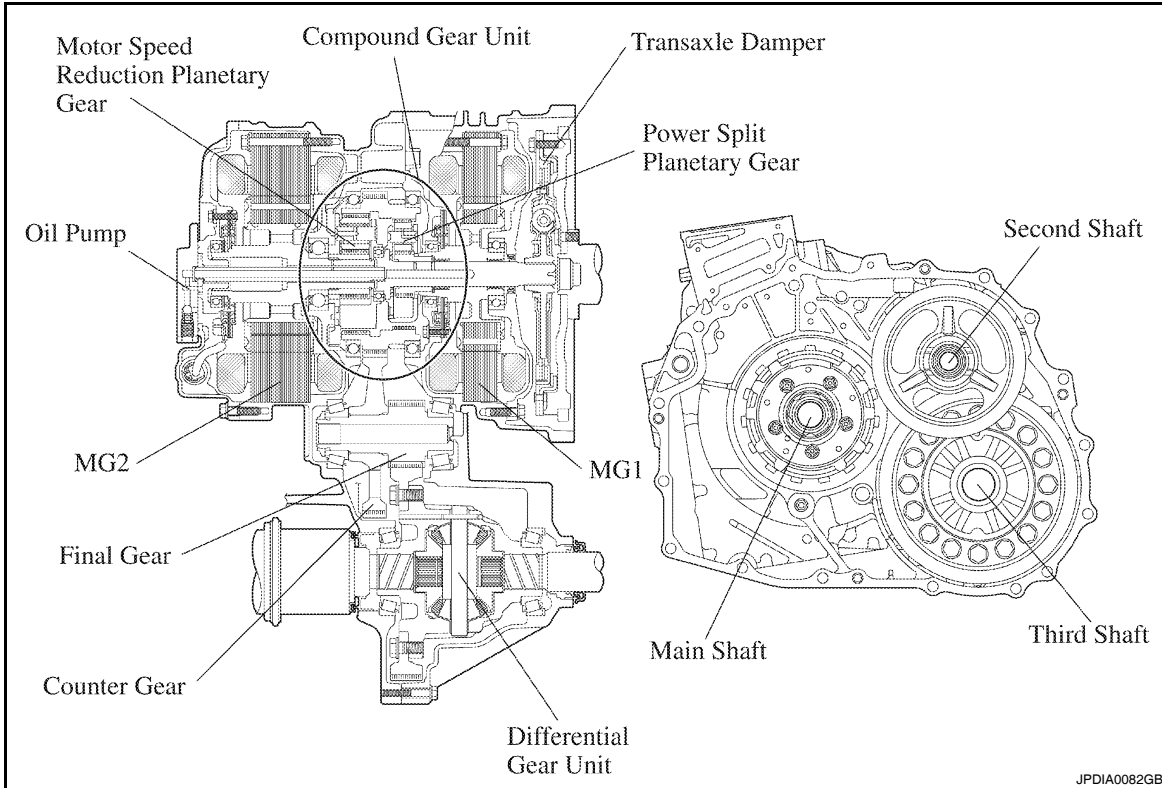

Transaxle Unit

INFOID:000000004212366

GENERAL

- This hybrid transaxle consists primarily of MG1 and MG2, a compound gear unit (which consists of a motor speed reduction planetary gear unit and a power split planetary gear unit), a counter gear unit, and a differential gear unit.
- This transaxle has a three-shaft configuration. The compound gear unit (consisting of the motor speed reduction planetary unit and a power split planetary gear unit), MG1 and MG2 are provided on the main shaft. The counter driven gear and the final drive gear are provided on the second shaft. The differential ring gear and the differential gear unit are provided on the third shaft.
- The engine, MG1 and MG2 are mechanically joined via the compound gear unit.
- The compound gear unit contains a motor speed reduction planetary gear unit and a power split planetary gear unit. The motor speed reduction planetary gear unit, whose purpose is to reduce motor speed, is used to enable the high-speed, high-output MG2 to adapt optimally to the power split planetary gear unit. The power split planetary gear unit splits the motive force of the engine two ways: one to drive the wheels, and the other to drive the MG1, so that it can function as a generator.

MECHANICAL SYSTEM

< FUNCTION DIAGNOSIS >

[HYBRID TRANSAXLE: RE0F01H]

- In the motor speed reduction planetary gear unit, the sun gear is coupled to the output shaft of MG2, and the carrier is fixed.

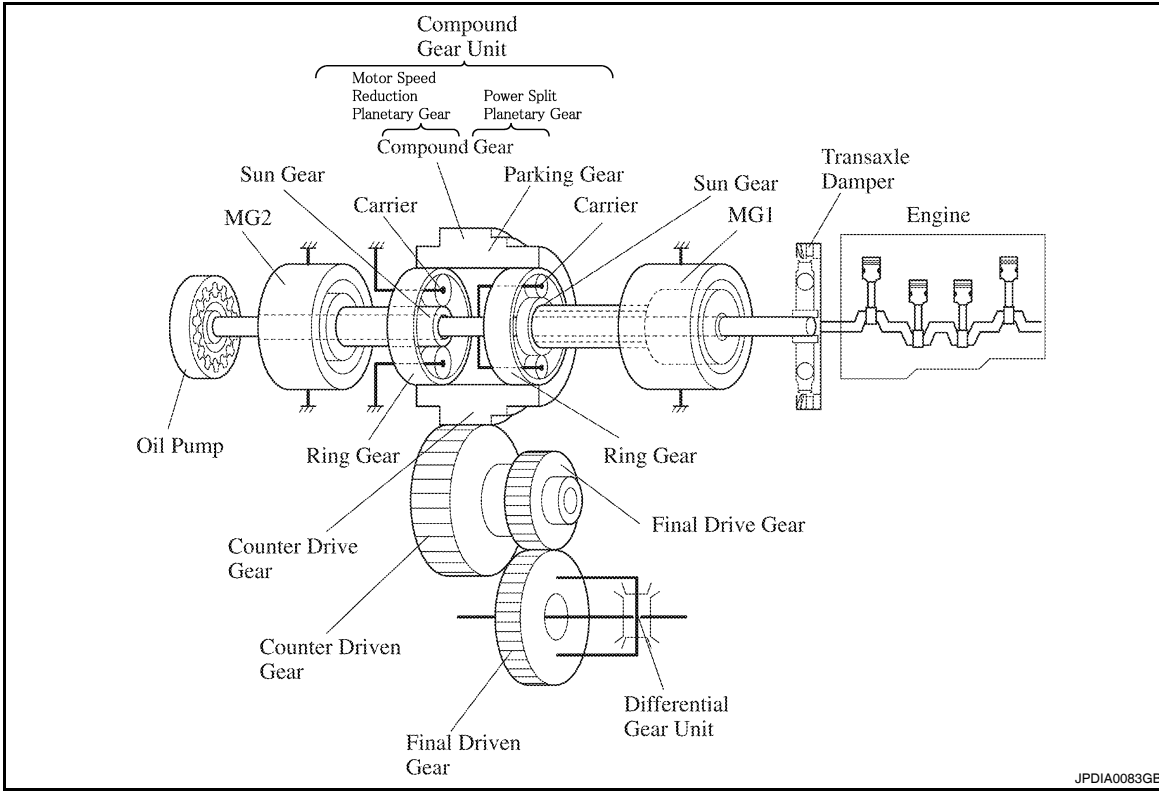

COMPOUND GEAR UNIT

General

The compound gear unit consists of a motor speed reduction planetary gear, and a power split planetary gear. Each planetary ring gear is integrated with the compound gear. Furthermore, this compound gear is integrated with a counter drive gear and parking gear.

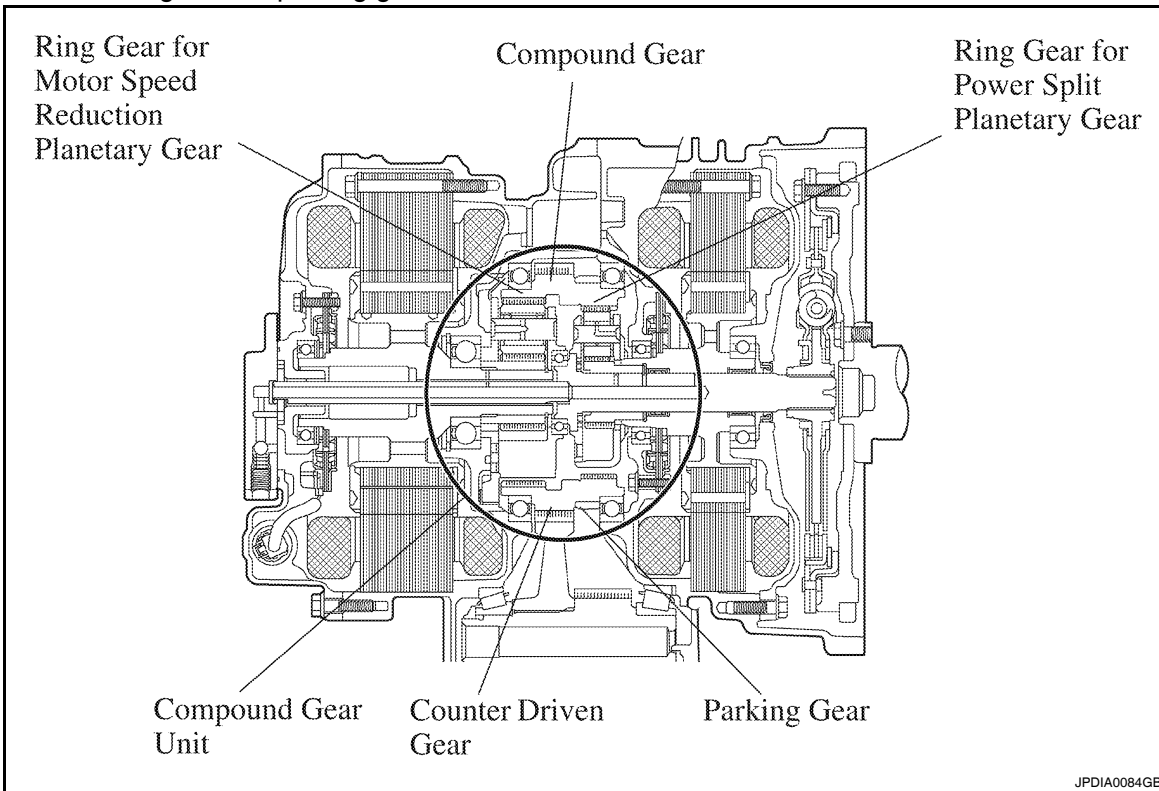

A
B
C
TM
E
F
G
H
I
J
K
L
M
N
O
P

MECHANICAL SYSTEM

< FUNCTION DIAGNOSIS >

[HYBRID TRANSAXLE: RE0F01H]

Item	Connection	
Power Split Planetary Gear	Sun Gear	MG1
	Ring Gear	Output (Wheels)
	Carrier	Engine Output Shaft
Motor Speed Reduction Planetary Gear	Sun Gear	MG2
	Ring Gear	Output (Wheels)
	Carrier	Fixed

Power Split Planetary Gear

The power split planetary gear in the compound gear unit transmits the motive force in the four ways described below.

- The engine motive force, which is input by the carrier, is output to the ring gear. Furthermore, the MG2 motive force is output to the ring gear via the motor speed reduction planetary gear. The sum of these two motive forces is transmitted in order to drive the wheels.

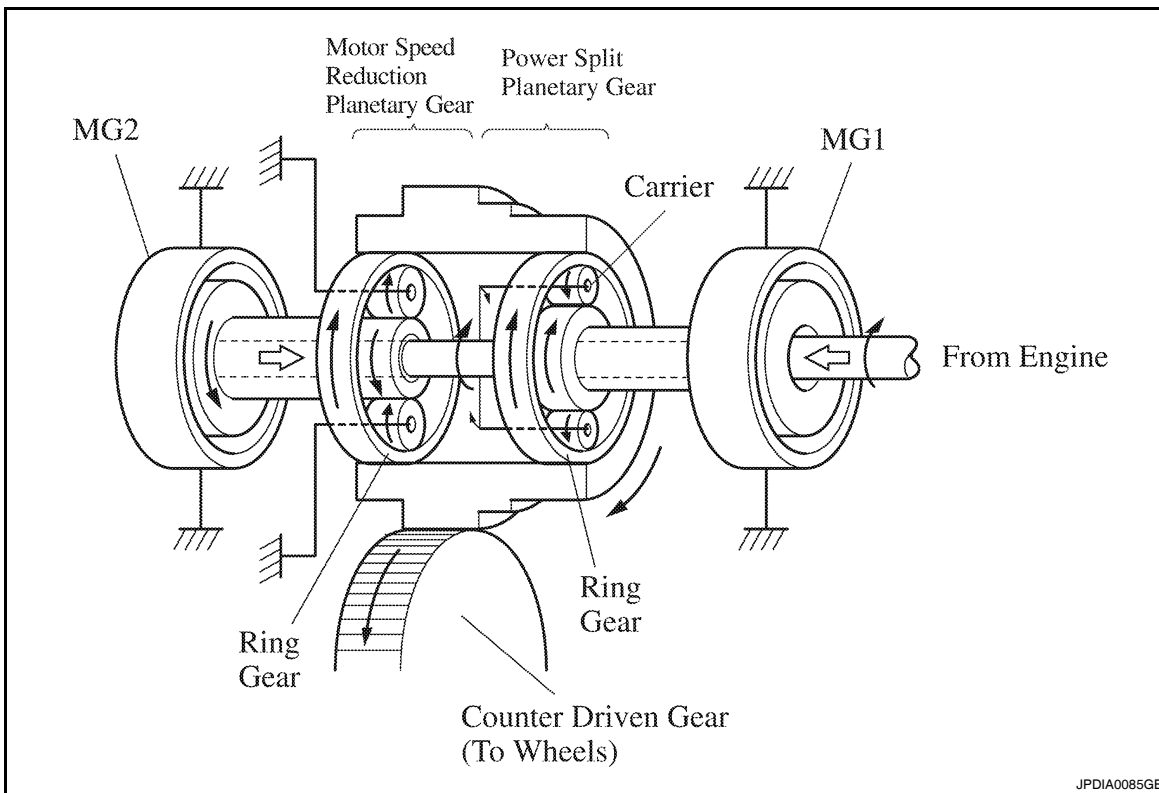

MECHANICAL SYSTEM

< FUNCTION DIAGNOSIS >

[HYBRID TRANSAXLE: RE0F01H]

- The MG2 motive force is output to the ring gear via the motor speed reduction planetary gear, and this motive force is transmitted in order to drive the wheels.

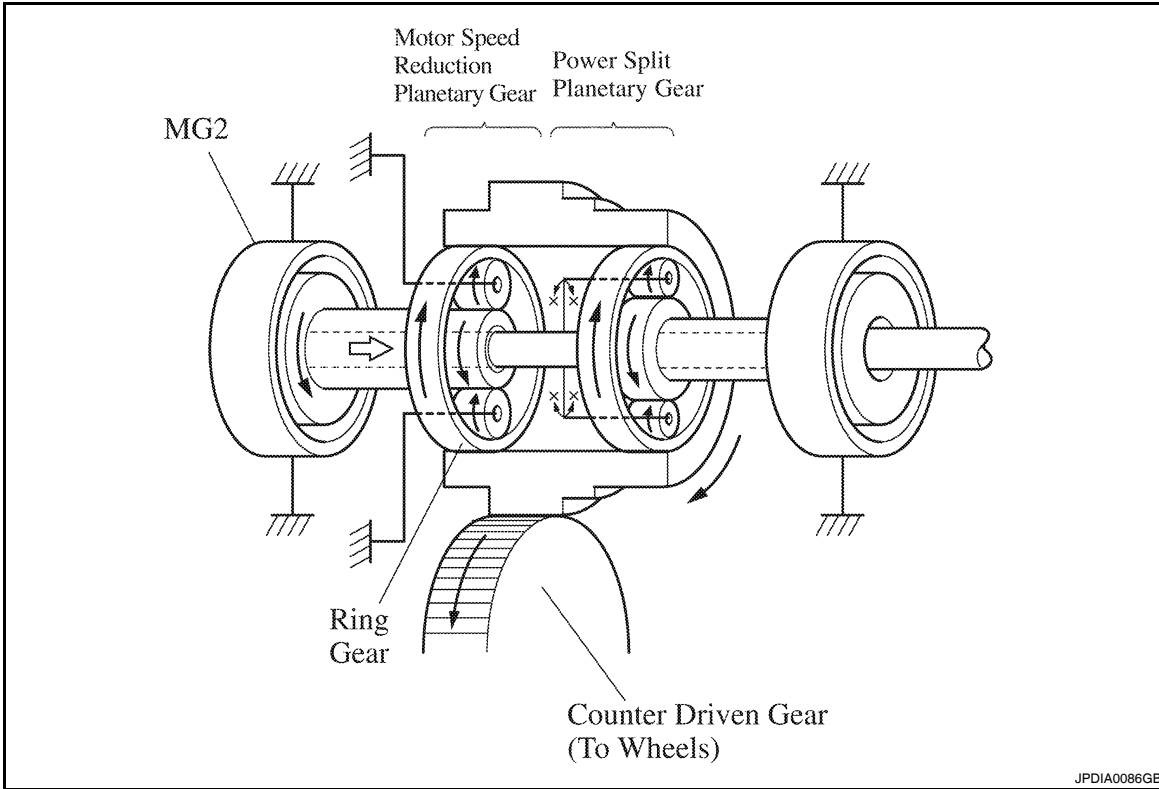

- The engine motive force, which is input by the carrier, is output to the sun gear. Thus, the motive force is transmitted in order to operate MG1 as a generator.

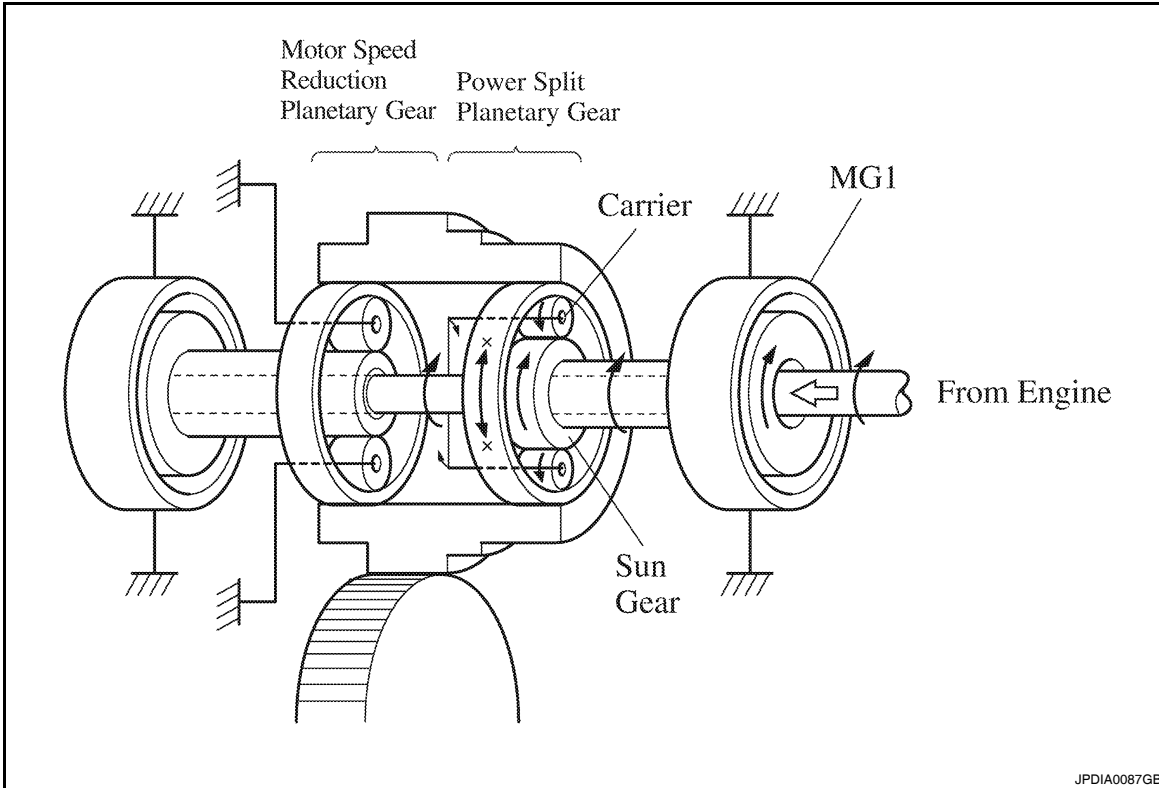

A
B
C
TM
E
F
G
H
I
J
K
L
M
N
O
P

MECHANICAL SYSTEM

< FUNCTION DIAGNOSIS >

[HYBRID TRANSAXLE: RE0F01H]

- The MG1 motive force is input by the sun gear and output to the carrier. Thus, the motive force is transmitted in order to start the engine.

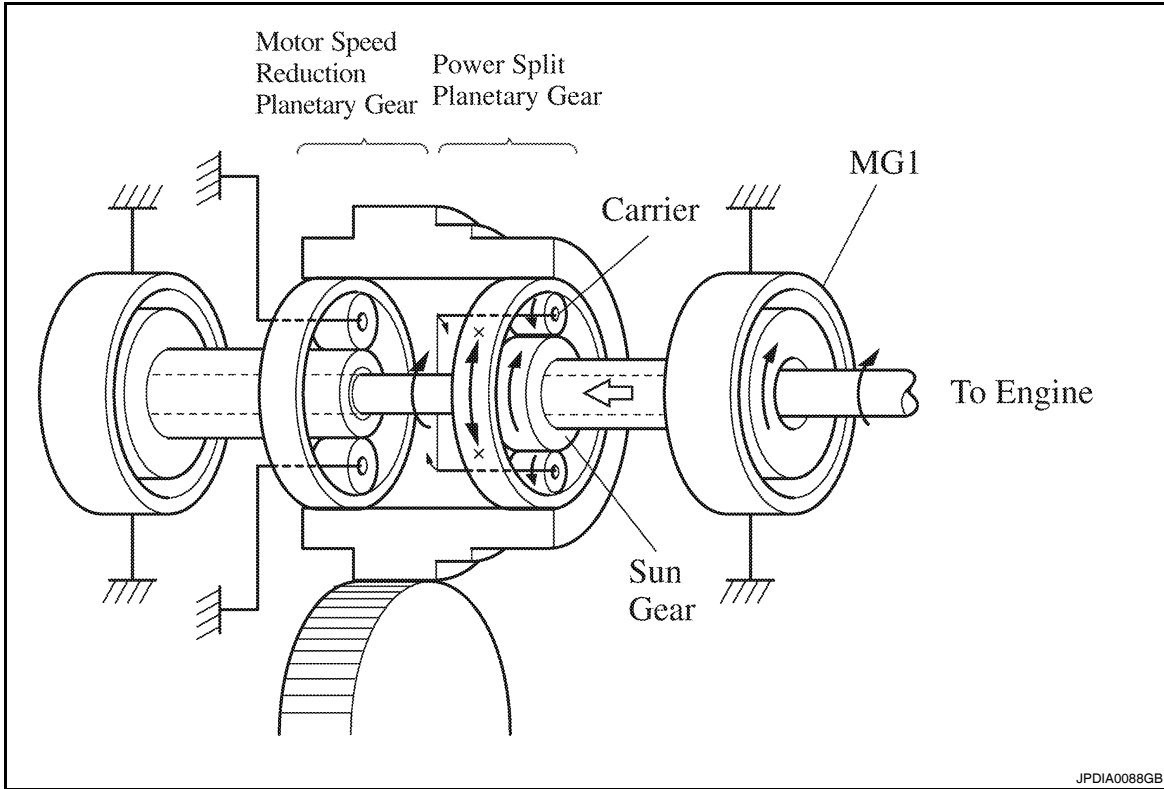

Motor Speed Reduction Planetary Gear

The carrier of the motor speed reduction planetary gear, which is located in the compound gear unit, is fixed. The MG2 motive force is input by the sun gear and is output to the ring gear, in order to drive the wheels. For this reason, the motor speed reduction planetary gear has a function to reduce the speed of MG2 and increase torque, in accordance with a set gear ratio.

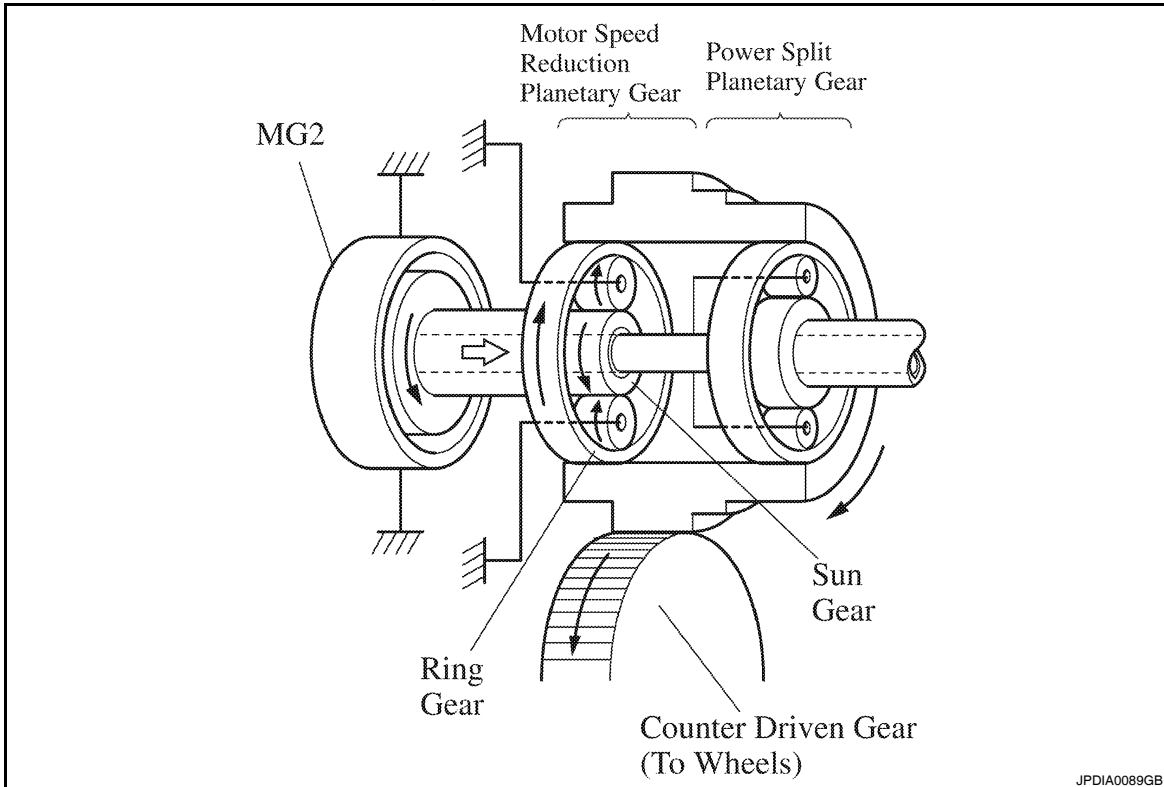

GEAR TRAIN

MECHANICAL SYSTEM

< FUNCTION DIAGNOSIS >

[HYBRID TRANSAXLE: RE0F01H]

This transaxle transmits the motive force created by the engine and MG2 to the counter drive gear and the counter driven gear of the compound gear unit, via the final gear, and to the differential gear unit, in order to drive the front wheels.

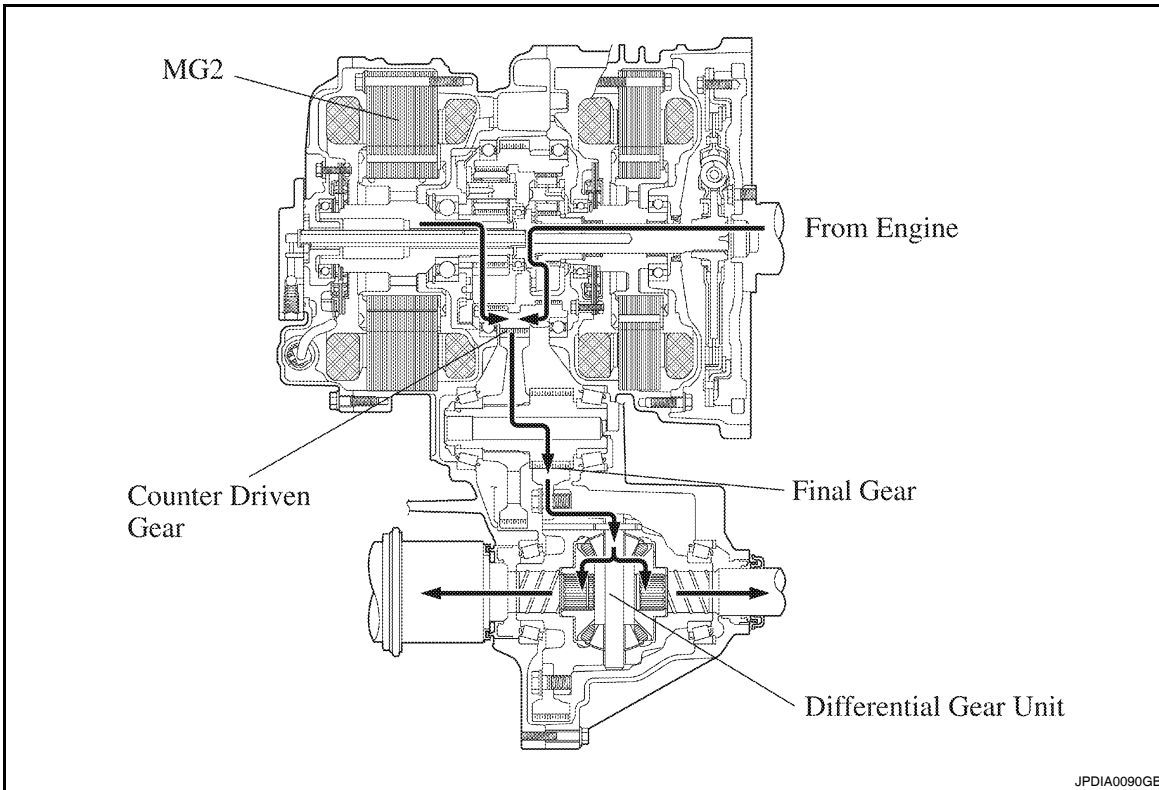

DIFFERENTIAL GEAR UNIT

For the differential gear unit, a 2-pinion type that is similar to the differential unit of the conventional transaxle is used.

TRANSAXLE DAMPER

A transaxle damper that consists of 4 coil springs with low-twist characteristics is used in order to absorb the torque fluctuation in the drive force of the engine. Furthermore, a torque fluctuation absorbing mechanism that

A
B
C
TM
E
F
G
H
I
J
K
L
M
N
O
P

MECHANICAL SYSTEM

< FUNCTION DIAGNOSIS >

[HYBRID TRANSAXLE: RE0F01H]

uses a dry-type, single-plate friction material is used. Through the use of the parts, a damper construction that excels in absorbing the vibrations of the engine motive force has been achieved.

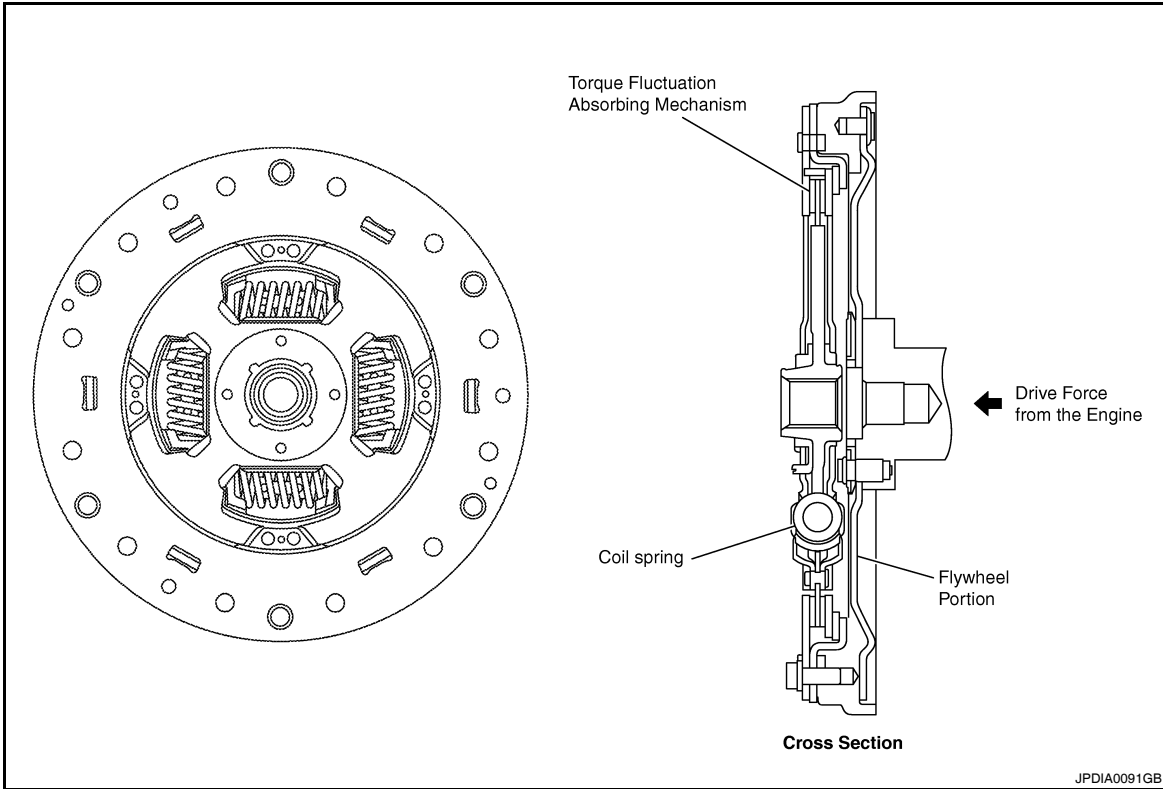

MG1 AND MG2

MG1 and MG2 are located coaxially at each end of the compound gear unit. MG1 connects to the sun gear of the power split planetary gear, and MG2 connects to the sun gear of the motor speed reduction planetary gear.

NOTE:

Do not disassemble MG1 or MG2 because they are precision components. If a malfunction is found on either of these components, replace MG1 or MG2 as a complete assembly.

Lubrication Mechanism

INFOID:000000004212367

- This transaxle is lubricated by a trochoid type oil pump placed on the main shaft.
- Furthermore, it uses a final gear with an oil sling type lubrication mechanism. This construction minimizes the drive torque of the oil pump, which reduces the drive loss.

MECHANICAL SYSTEM

[HYBRID TRANSAXLE: RE0F01H]

< FUNCTION DIAGNOSIS >

- An oil catch tank is used in this transaxle in order to supply oil in a stable manner. The oil catch tank temporarily stores the oil that is slung up, and supplies oil to each gear train from there. Furthermore, oil holes are provided in the oil catch tanks in order to efficiently supply oil to MG1 and MG2.

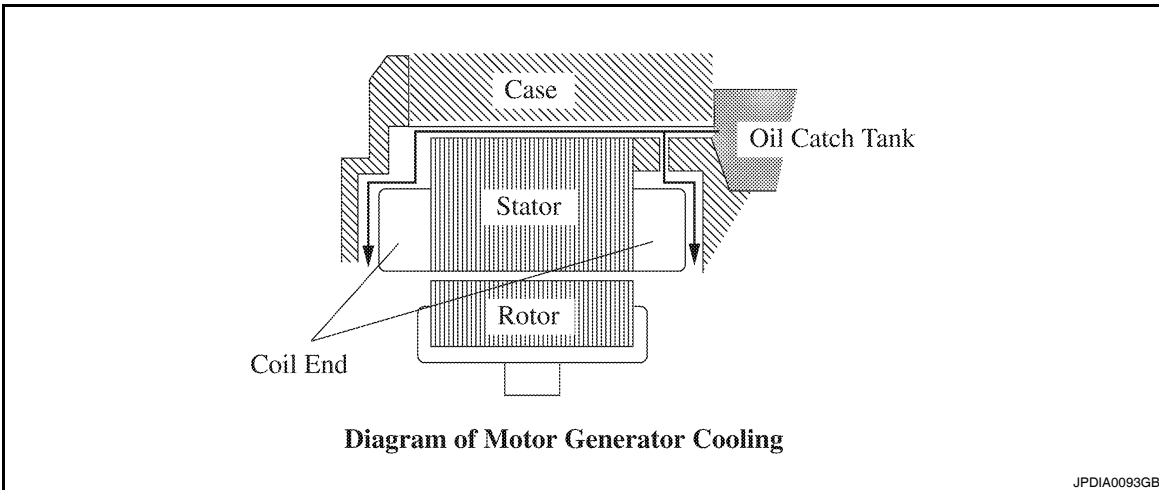
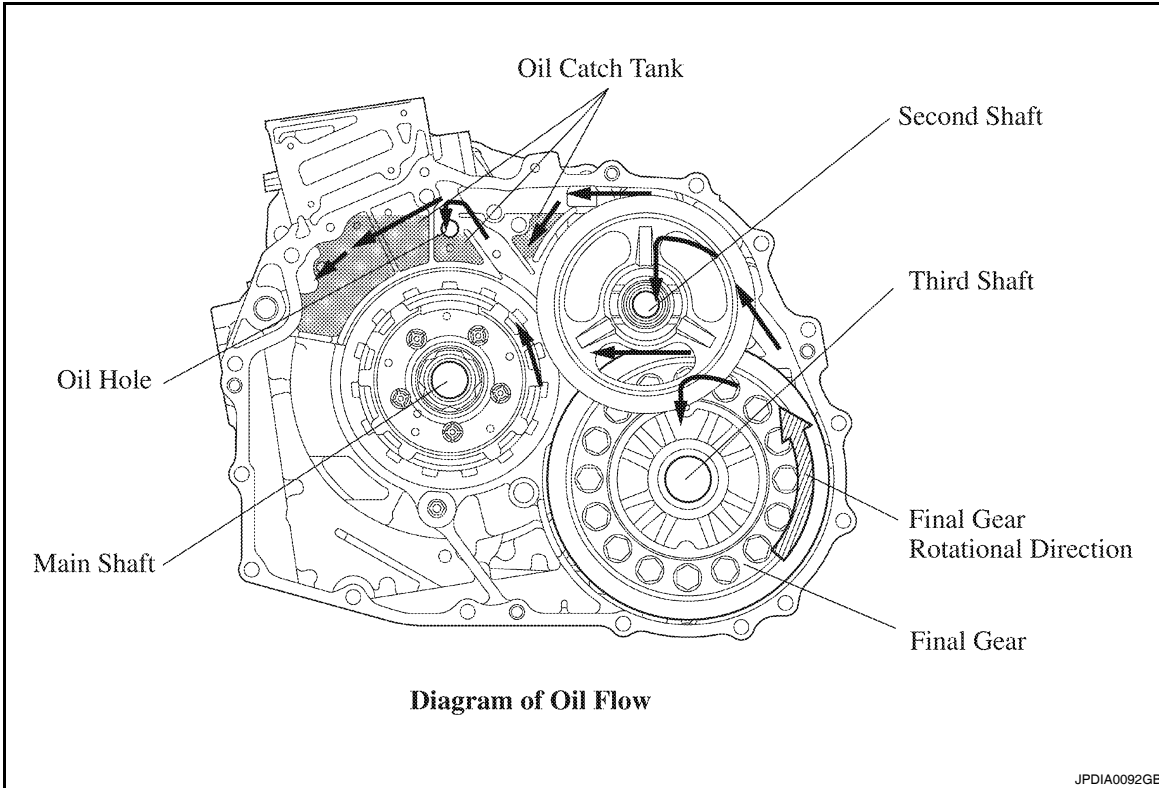

Shift Control System

INFOID:000000004212368

SHIFT CONTROL

- A shift position sensor is provided in the transaxle to detect the shift position and sends a corresponding signal to the HV ECU. Upon receiving this signal, the HV ECU optimally combines the operation of the engine, MG1 and MG2 in order to produce the respective shift positions ("P", "R", "N", "D" and "B").

MECHANICAL SYSTEM

[HYBRID TRANSAXLE: RE0F01H]

< FUNCTION DIAGNOSIS >

- However, because the movement of the wheels must be mechanically locked in the P position, a parking lock mechanism is used in the transaxle. Therefore, if the driver operates the shift lever to the P position, a cable and a linkage cause the movement of the transaxle to lock mechanically.

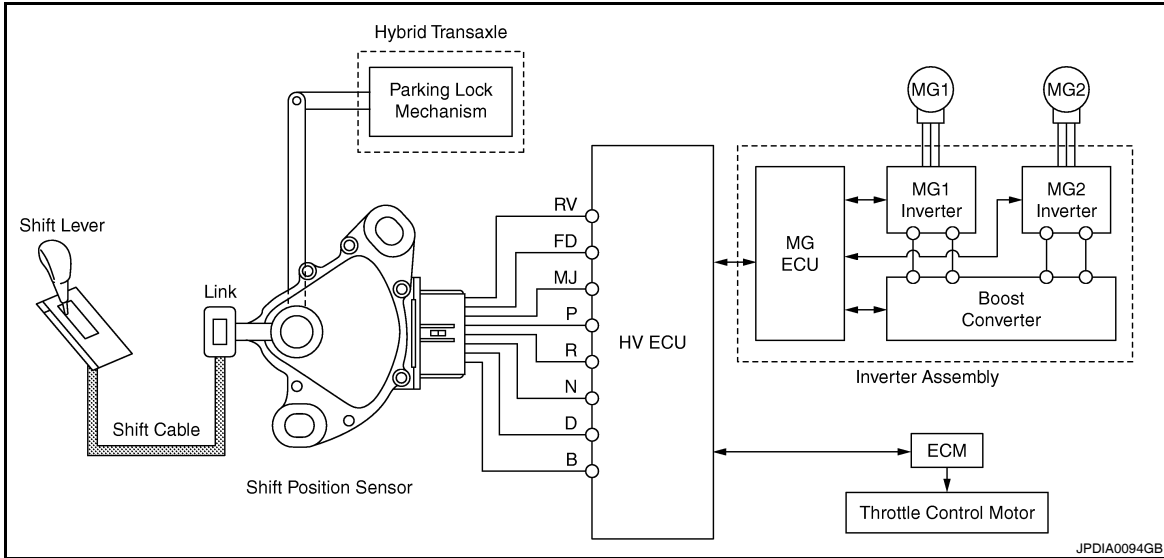

PARKING LOCK MECHANISM

- A mechanical parking lock mechanism has been provided in the compound gear. The engagement of the parking lock pawl with the parking gear that is integrated with the compound gear locks the movement of the vehicle.
- When the driver moves the shift lever to the P position, the cable at the shift lever causes the No.1 lever to rotate. The rotational movement of the No.1 lever causes the parking lock rod to slide and the parking lock pawl to push up. As a result, the parking lock pawl locks the parking gear.

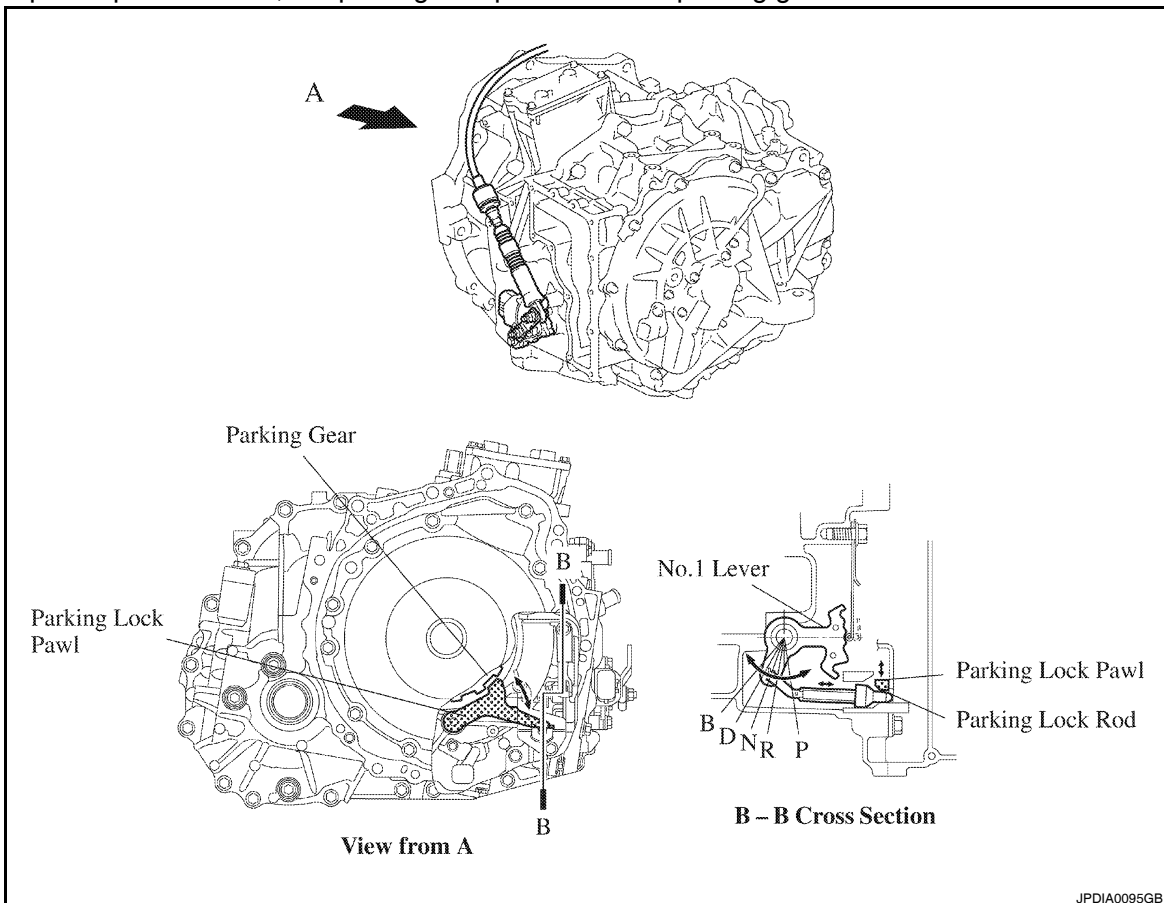

SHIFT LOCK SYSTEM

< FUNCTION DIAGNOSIS >

[HYBRID TRANSAXLE: RE0F01H]

SHIFT LOCK SYSTEM

System Diagram

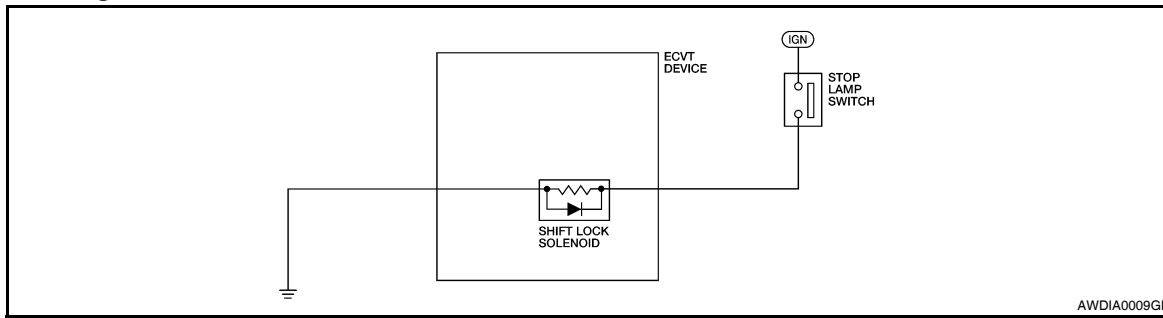

System Description

INFOID:000000004212370

The selector lever cannot be shifted from "P" position to any other position unless the ignition switch is in the ON position and the brake pedal is depressed.

Component Parts Location

INFOID:000000004212371

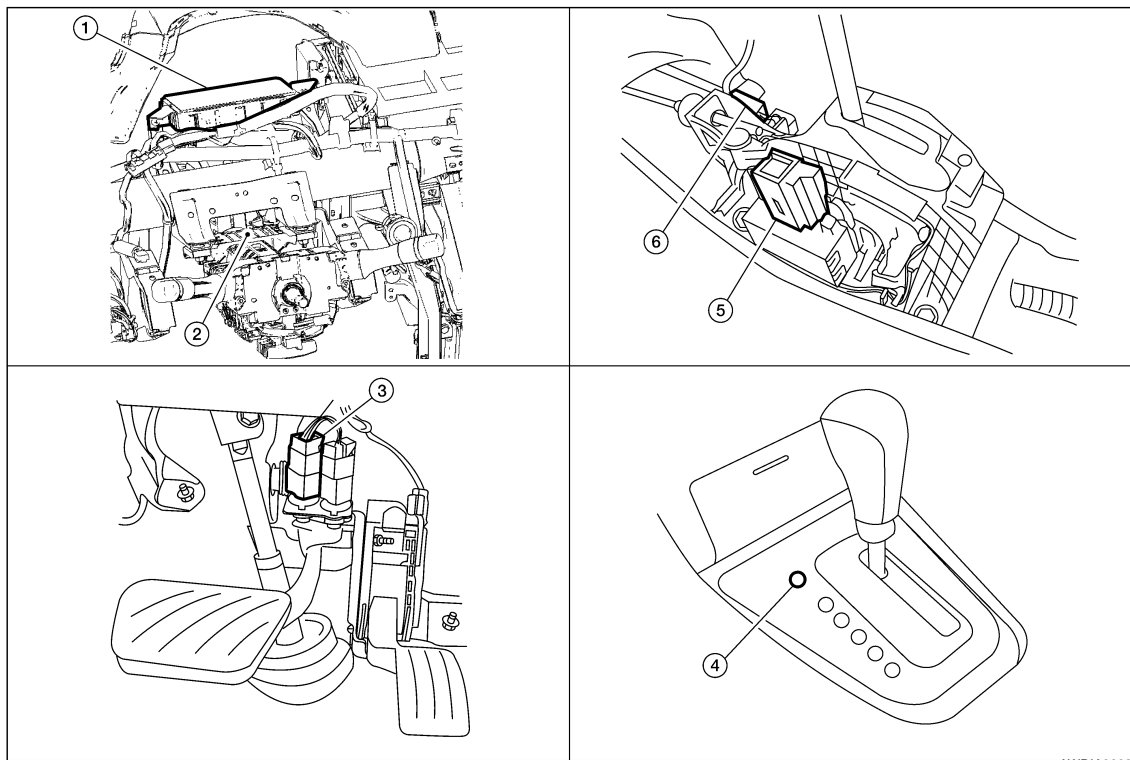

- | | | |
|---|--|------------------------------|
| 1. BCM (view with instrument panel removed) M19 | 2. Steering column | 3. Stop lamp switch E38 |
| 4. Shift lock release button | 5. Shift lock solenoid/Detent switch (key) | 6. ECVT device connector M23 |

Component Description

INFOID:000000004212372

SHIFT LOCK SYSTEM

< FUNCTION DIAGNOSIS >

[HYBRID TRANSAXLE: RE0F01H]

Component		Function
ECVT device	Shift lock solenoid	TM-13, "System Description"
	Lock plate	The lock plate restricts the position pin stroke by selector button operation according to the shift lock unit status.
	Position pin	The position pin, linking with the selector button, restricts the selector lever movement.
	Shift lock release button	Pressing the shift lock release button cancels the shift lock forcibly.
Stop lamp switch		The stop lamp switch controls the current flow to the energize the shift lock solenoid.

SHIFT LOCK SYSTEM

< COMPONENT DIAGNOSIS >

[HYBRID TRANSAXLE: RE0F01H]

COMPONENT DIAGNOSIS

SHIFT LOCK SYSTEM

Description

INFOID:000000004212373

The selector lever cannot be shifted from “P” position to any other position unless the ignition switch is in the ON position and the brake pedal is depressed.

A

B

C

TM

E

F

G

H

I

J

K

L

M

N

O

P

SHIFT LOCK SYSTEM

< COMPONENT DIAGNOSIS >

[HYBRID TRANSAXLE: RE0F01H]

Wiring Diagram

INFOID:000000004212374

ECVT SHIFT LOCK SYSTEM

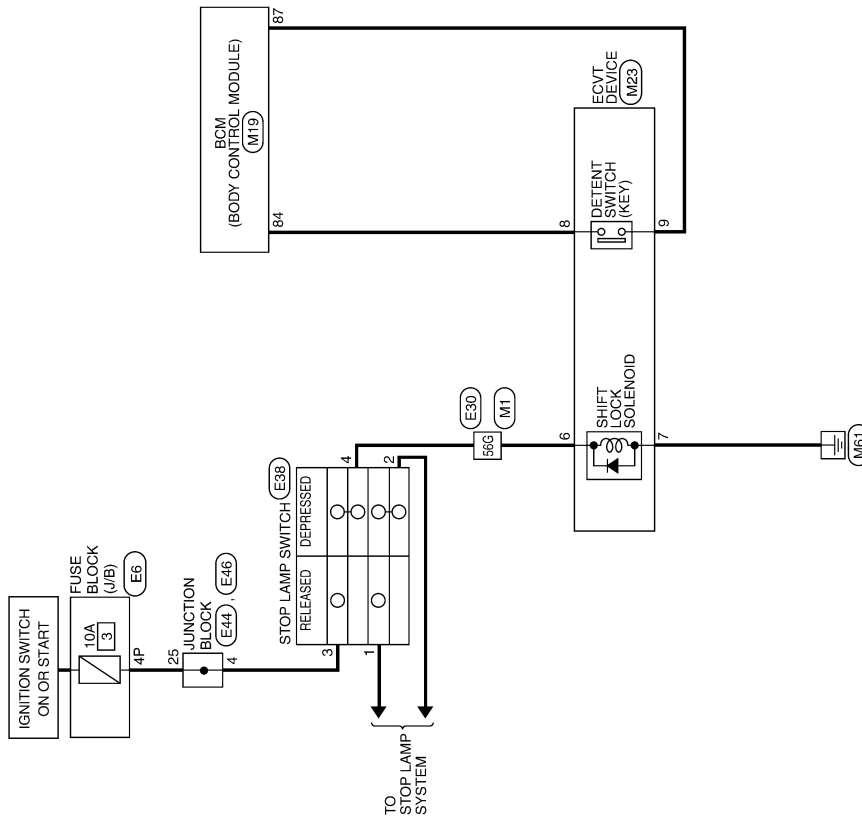

ALDWA0016GE

SHIFT LOCK SYSTEM

< COMPONENT DIAGNOSIS >

[HYBRID TRANSAXLE: RE0F01H]

ECVT SHIFT LOCK SYSTEM CONNECTORS

Connector No.	M1
Connector Name	WIRE TO WIRE
Connector Color	WHITE

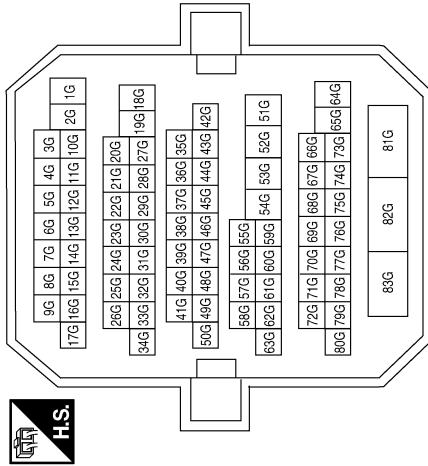

Connector No.	M19
Connector Name	BCM (BODY CONTROL MODULE)
Connector Color	BLACK

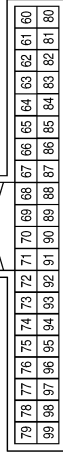

Terminal No.	Color of Wire	Signal Name
84	Y/R	AT_DEVICE_OUT
87	G/B	SHIFT_P

Connector No.	M23
Connector Name	ECVT DEVICE
Connector Color	WHITE

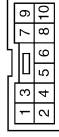

Terminal No.	Color of Wire	Signal Name
6	R/W	S/LOCK_SOL_GND
7	B	S/LOCK_SOL_INPUT
8	Y/R	DETENT_KEY_SW
9	G/B	DETENT_KEY_SW

Connector No.	E6
Connector Name	FUSE BLOCK (J/B)
Connector Color	WHITE



Terminal No.	Color of Wire	Signal Name
4P	G/R	-

A
B
C
TM
E
F
G
H
I
J
K
L
M
N
O
P

SHIFT LOCK SYSTEM

< COMPONENT DIAGNOSIS >

[HYBRID TRANSAXLE: RE0F01H]

Connector No.	E38
Connector Name	STOP LAMP SWITCH
Connector Color	WHITE



Terminal No.	Color of wire	Signal Name
1	Y/R	-
2	R/G	-
3	G/R	-
4	R/W	-

Connector No.	E30
Connector Name	WIRE TO WIRE
Connector Color	WHITE

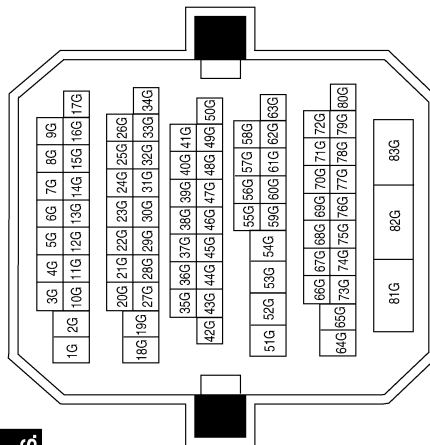

Terminal No.	Color of Wire	Signal Name
56G	R/W	

Diagnosis Procedure

1. CHECK POWER SOURCE

ABDIA0242GB

INFOID:000000004212375

SHIFT LOCK SYSTEM

[HYBRID TRANSAXLE: RE0F01H]

< COMPONENT DIAGNOSIS >

1. Disconnect ECVT device connector.
2. Turn ignition switch ON.
3. Check voltage between ECVT device connector M23 terminal 6 and ground.

ECVT device		Condition	Voltage (Approx.)
Connector	Terminal		
M23	6	Brake pedal depressed	Battery voltage
		Brake pedal released	0V

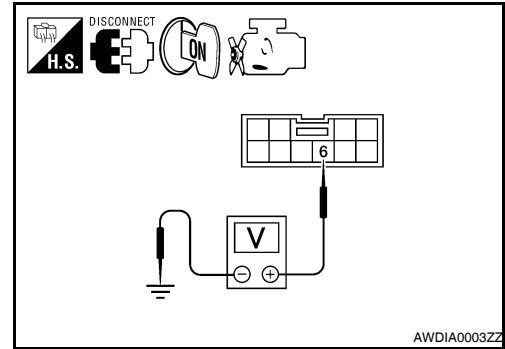

Is the inspection result normal?

- YES >> GO TO 5.
NO >> GO TO 2.

2. CHECK POWER SOURCE AT STOP LAMP SWITCH

1. Turn ignition switch OFF.
2. Disconnect stop lamp switch connector.
3. Turn ignition switch ON.
4. Check voltage between stop lamp switch connector E38 terminal 3 and ground.

Stop lamp switch		Ground	Voltage (Approx.)
Connector	Terminal		
E38	3	—	Battery voltage

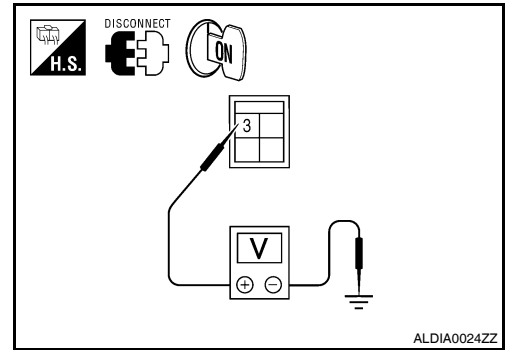

Is the inspection result normal?

- YES >> GO TO 3.
NO >> Check the following:
- Harness for short or open between fuse block (J/B) and stop lamp switch
 - 10A fuse [No. 3, located in fuse block (J/B)]

3. CHECK STOP LAMP SWITCH

1. Turn ignition switch OFF.
2. Check continuity between stop lamp switch terminals 3 and 4.

CVT device terminals	Condition	Continuity
3 and 4	Brake pedal depressed	Yes
	Brake pedal released	No

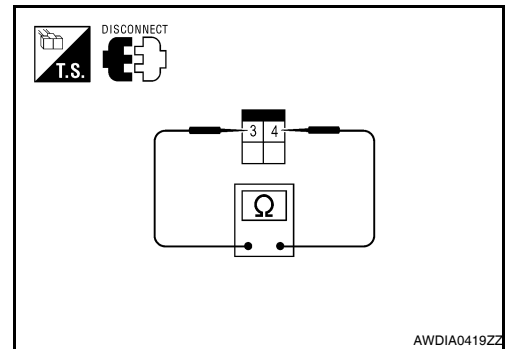

Is the inspection result normal?

- YES >> GO TO 4.
NO >> Replace stop lamp switch. Refer to [BR-19, "Exploded View"](#).

4. CHECK HARNESS BETWEEN STOP LAMP SWITCH AND ECVT DEVICE FOR OPEN

Check continuity between stop lamp switch connector E38 (A) terminal 4 and ECVT device connector M23 (B) terminal 6.

Stop lamp switch		ECVT device		Continuity
Connector	Terminal	Connector	Terminal	
E38 (A)	4	M23 (B)	6	Yes

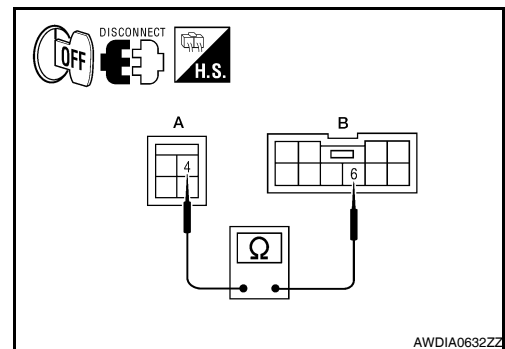

Is the inspection result normal?

- YES >> GO TO 5.
NO >> Repair harness or connectors.

5. CHECK GROUND CIRCUIT

SHIFT LOCK SYSTEM

[HYBRID TRANSAXLE: RE0F01H]

< COMPONENT DIAGNOSIS >

1. Turn ignition switch OFF.
2. Check continuity between ECVT device connector M23 terminal 7 and ground.

ECVT device		Ground	Continuity
Connector	Terminal		
M23	7	—	Yes

Is the inspection result normal?

- YES >> Replace ECVT device. Refer to [TM-27, "Removal and Installation"](#).
- NO >> Repair harness or connectors.

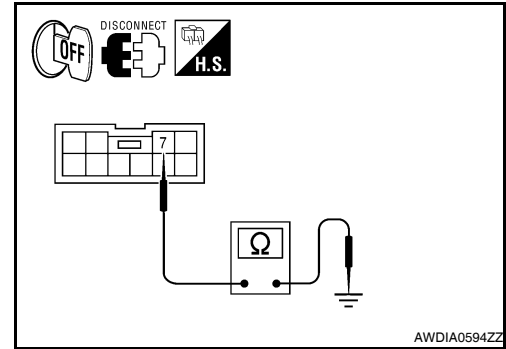

< PRECAUTION >

PRECAUTION

PRECAUTIONS

Precaution for Supplemental Restraint System (SRS) "AIR BAG" and "SEAT BELT PRE-TENSIONER"

INFOID:000000004212376

The Supplemental Restraint System such as "AIR BAG" and "SEAT BELT PRE-TENSIONER", used along with a front seat belt, helps to reduce the risk or severity of injury to the driver and front passenger for certain types of collision. This system includes seat belt switch inputs and dual stage front air bag modules. The SRS system uses the seat belt switches to determine the front air bag deployment, and may only deploy one front air bag, depending on the severity of a collision and whether the front occupants are belted or unbelted. Information necessary to service the system safely is included in the SR and SB section of this Service Manual.

WARNING:

- To avoid rendering the SRS inoperative, which could increase the risk of personal injury or death in the event of a collision which would result in air bag inflation, all maintenance must be performed by an authorized NISSAN/INFINITI dealer.
- Improper maintenance, including incorrect removal and installation of the SRS, can lead to personal injury caused by unintentional activation of the system. For removal of Spiral Cable and Air Bag Module, see the SR section.
- Do not use electrical test equipment on any circuit related to the SRS unless instructed to in this Service Manual. SRS wiring harnesses can be identified by yellow and/or orange harnesses or harness connectors.

Precautions For High-Voltage System

INFOID:000000004212377

Refer to [GI-24. "Precautions For High-Voltage System"](#).

Precaution Necessary for Steering Wheel Rotation After Battery Disconnect

INFOID:000000004212378

NOTE:

- This Procedure is applied only to models with Intelligent Key system and NVIS/IVIS (NISSAN/INFINITI VEHICLE IMMOBILIZER SYSTEM - NATS).
- Remove and install all control units after disconnecting both 12-volt battery terminals with the ignition knob in the "LOCK" position.
- Always use CONSULT-III to perform self-diagnosis as a part of each function inspection after finishing work. If DTC is detected, perform trouble diagnosis according to self-diagnostic results.

For models equipped with the Intelligent Key system and NVIS/IVIS, an electrically controlled steering lock mechanism is adopted on the key cylinder.

For this reason, if the 12-volt battery is disconnected or if the 12-volt battery is discharged, the steering wheel will lock and steering wheel rotation will become impossible.

If steering wheel rotation is required when 12-volt battery power is interrupted, follow the procedure below before starting the repair operation.

OPERATION PROCEDURE

1. Connect both 12-volt battery terminals.
 - NOTE:**
Supply power using jumper terminals if 12-volt battery is discharged.
2. Use the Intelligent Key or mechanical key to turn the ignition switch to the "ACC" position. At this time, the steering lock will be released.
3. Disconnect both 12-volt battery terminals. The steering lock will remain released and the steering wheel can be rotated.
4. Perform the necessary repair operation.
5. When the repair work is completed, return the ignition switch to the "LOCK" position before connecting the 12-volt battery terminals. (At this time, the steering lock mechanism will engage.)
6. Perform a self-diagnosis check of all control units using CONSULT-III.

Service Notice or Precaution

INFOID:000000004212379

CVT FLUID COOLER SERVICE

If CVT fluid contains friction material (clutches, brakes, etc.), or if a CVT is replaced, inspect and clean the CVT fluid cooler mounted in the radiator or replace the radiator. Flush cooler lines using cleaning solvent and compressed air after repair. For CVT fluid cooler cleaning procedure, refer to [HBC-636, "Inspection"](#). For radiator replacement, refer to [CO-14, "Removal and Installation"](#).

OBD-II SELF-DIAGNOSIS

- CVT self-diagnosis is performed by the TCM in combination with the ECM. The results can be read through the blinking pattern of the malfunction indicator lamp (MIL). Refer to the table on [HBC-81, "CONSULT-III Function"](#) for the indicator used to display each self-diagnostic result.
- The self-diagnostic results indicated by the MIL are automatically stored in both the ECM and TCM memories.

Always perform the procedure on [HBC-80, "Diagnosis Description"](#) to complete the repair and avoid unnecessary blinking of the MIL.

For details of OBD-II, refer to [HBC-80, "Diagnosis Description"](#).

- **Certain systems and components, especially those related to OBD, may use the new style slide-locking type harness connector. For description and how to disconnect, refer to [PG-59, "Description"](#).**

PREPARATION

< PREPARATION >

[HYBRID TRANSAXLE: RE0F01H]

PREPARATION

PREPARATION

Commercial Service Tools

INFOID:000000004212380

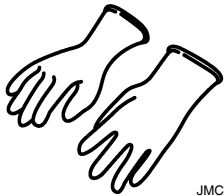
Tool name (Kent-Moore No.)	Description
Insulation groves  JM CIA0149ZZ	Guaranteed insulation performance for 1000V/300A

A
B
C
TM
E
F
G
H
I
J
K
L
M
N
O
P

ON-VEHICLE MAINTENANCE

FLUID

Inspection

INFOID:000000004212381

1. Remove the filler plug and check the fluid level as shown.

Oil level "A": MAX 5 mm (0.20 in)

2. Install the filler plug with a new gasket and tighten to the specified torque.

Filler plug : 39.2 N·m (4.0 kg·m, 29 ft·lb)

CAUTION:
Do not reuse gasket.

3. Inspect transaxle for fluid leaks.

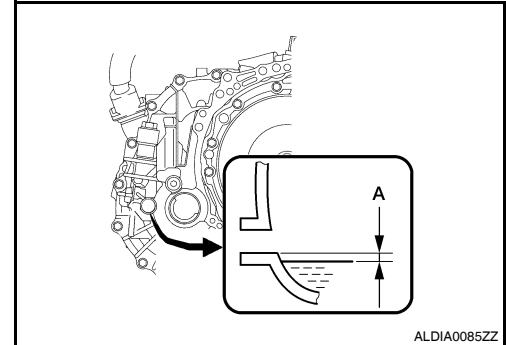

Replacement

INFOID:000000004212382

1. Remove the filler plug and gasket (1) from the transaxle.
2. Remove the drain plug and gasket (2) and drain the fluid from the transaxle.
3. Install the drain plug with a new gasket to the transaxle.

CAUTION:
Do not reuse gasket.

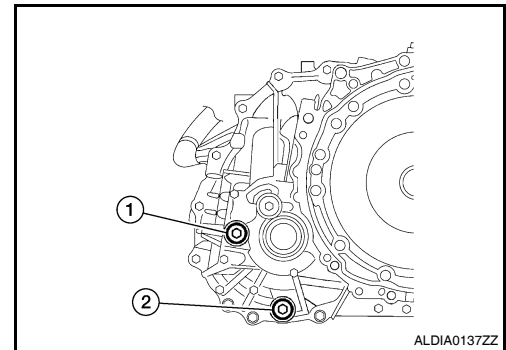

4. Fill the transaxle with specified fluid to the fluid level "A" as shown.

Fluid grade and capacity: Refer to [MA-10, "Fluids and Lubricants"](#).

Oil level "A": MAX 5 mm (0.20 in)

CAUTION:

- Use only the specified Genuine Nissan fluid, using fluid other than the Genuine Nissan specified fluid will deteriorate in driveability and durability, and may damage the transaxle, which is not covered by the warranty.
- Do not spill fluid on heat generating parts such as exhaust manifold.
- Do not overfill the transaxle.
- Recheck the fluid level after driving the vehicle to warm up the fluid.

5. Install the filler plug with a new gasket to the transaxle.

Filler plug: : 39.2 N·m (4.0 kg·m, 29 ft·lb)

CAUTION:
Do not reuse gasket.

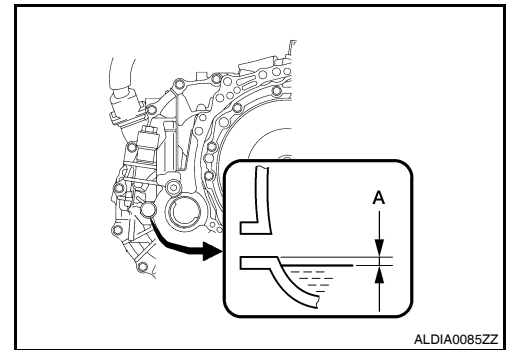

LINE PRESSURE TEST

< ON-VEHICLE MAINTENANCE >

[HYBRID TRANSAXLE: RE0F01H]

LINE PRESSURE TEST

Inspection

INFOID:000000004212383

1. Remove the fluid pump cover plug and install suitable tool (A) as shown.
2. Measure the fluid pressure.

Fluid pressure : 9.8 kPa (0.1 kg/cm², 1.4 psi) or more

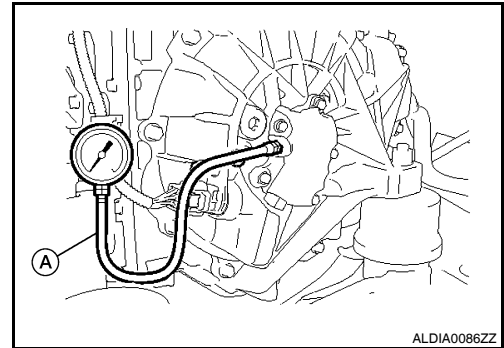

3. Remove the suitable tool and install the fluid pump cover plug (A) with a new gasket (1) and tighten to the specified torque.

Fluid pump cover plug : 8.0 N·m (0.82 kg-m, 71 in-lb)

CAUTION:
Do not reuse the gasket.

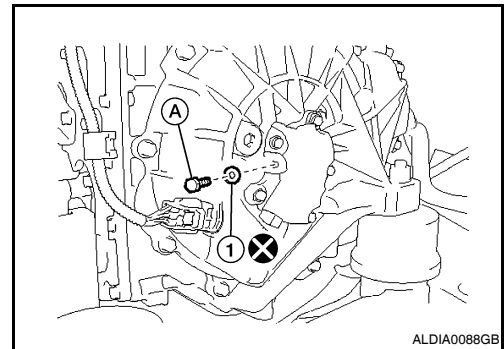

A
B
C
TM
E
F
G
H
I
J
K
L
M
N
O
P

SHIFT POSITION

Inspection and Adjustment

INFOID:000000004212384

INSPECTION

1. Place selector lever in "P" position, and turn ignition switch ON (engine stop).
2. Make sure that selector lever can be shifted to other than "P" position when brake pedal is depressed. Also make sure that selector lever can be shifted from "P" position only when brake pedal is depressed.
3. Move the selector lever and check for excessive effort, sticking, noise or rattle.
4. Confirm the selector lever stops at each position with the feel of engagement when it is moved through all the positions. Check that the actual position of the selector lever matches the position shown by the shift position indicator and the manual lever on the transaxle.
5. The method of operating the selector lever to individual positions correctly should be as shown.
 - (A): Press selector button to operate selector lever, while depressing the brake pedal.
 - (B): Press selector button to operate selector lever.
 - (C): Selector lever can be operated without pressing selector button.
6. Press the selector button in the "P", "R", and "N" positions without applying forward/backward force to selector lever, check button operation for sticking.
7. Confirm the back-up lamps illuminate only when selector lever is placed in the "R" position. Confirm the back-up lamps do not illuminate when the selector lever is pushed toward the "R" position when in the "P" or "N" position.
8. Confirm the hybrid system can only be started with the selector lever in the "P" position.
9. Make sure transaxle is locked completely in "P" position.

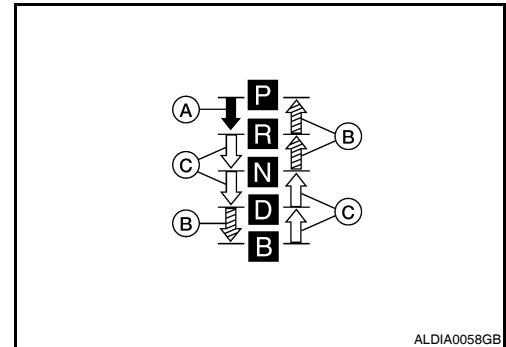

ALDIA0058GB

ADJUSTMENT

For adjustment, refer to [TM-28. "Inspection and Adjustment"](#) for control device, [TM-30. "Inspection and Adjustment"](#) for control cable and [TM-33. "Inspection and Adjustment"](#) for PNP switch.

ON-VEHICLE REPAIR

CONTROL DEVICE

Exploded View

INFOID:000000004212385

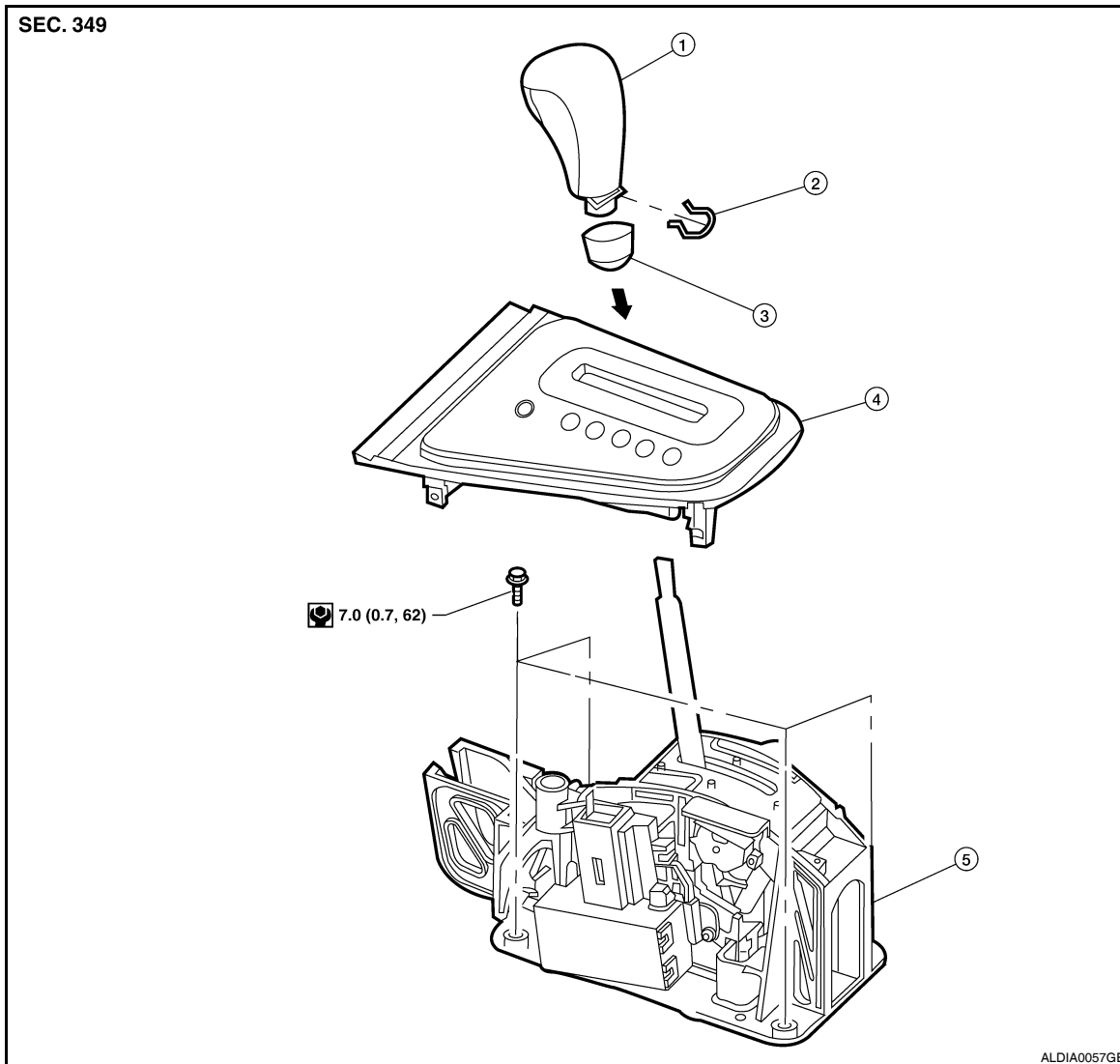

- | | | |
|-----------------------|----------------------------|---------------|
| 1. Control lever knob | 2. Lock pin | 3. Knob cover |
| 4. CVT finisher | 5. Control device assembly | |

Removal and Installation

INFOID:000000004212386

REMOVAL

1. Disconnect the 12-volt battery negative terminal. Refer to [PG-69, "Removal and Installation"](#).
2. Remove the CVT finisher.
 - Remove the control lever knob and knob cover.
 - Disconnect the CVT finisher lamp.
3. Remove the storage bin or CD changer finisher (if equipped). Refer to [JP-12, "Removal and Installation"](#).
4. Disconnect the control cable from the control device assembly.
5. Disconnect the CVT control device harness connector.
6. Remove the control device assembly bolts and remove the control device assembly.

< ON-VEHICLE REPAIR >

INSTALLATION

Installation is in the reverse order of removal.

- When installing the control cable to the control device assembly, make sure that the control cable is fully pressed in with the ribbed surface facing upward.
- After installation is completed, adjust and check transaxle position. Refer to [TM-28, "Inspection and Adjustment"](#).

Inspection and Adjustment

INFOID:000000004212387

INSPECTION

1. Place selector lever in "P" position, and turn ignition switch ON (engine stop).
2. Make sure that selector lever can be shifted to other than "P" position when brake pedal is depressed. Also make sure that selector lever can be shifted from "P" position only when brake pedal is depressed.
3. Move the selector lever and check for excessive effort, sticking, noise or rattle.
4. Confirm the selector lever stops at each position with the feel of engagement when it is moved through all the positions. Check that the actual position of the selector lever matches the position shown by the shift position indicator and the manual lever on the transaxle.
5. The method of operating the selector lever to individual positions correctly should be as shown.
 - (A): Press selector button to operate selector lever, while depressing the brake pedal.
 - (B): Press selector button to operate selector lever.
 - (C): Selector lever can be operated without pressing selector button.
6. Press the selector button in the "P", "R", and "N" positions without applying forward/backward force to selector lever, check button operation for sticking.
7. Confirm the back-up lamps illuminate only when selector lever is placed in the "R" position. Confirm the back-up lamps do not illuminate when the selector lever is pushed toward the "R" position when in the "P" or "N" position.
8. Confirm the hybrid system can only be started with the selector lever in the "P" position.
9. Make sure transaxle is locked completely in "P" position.

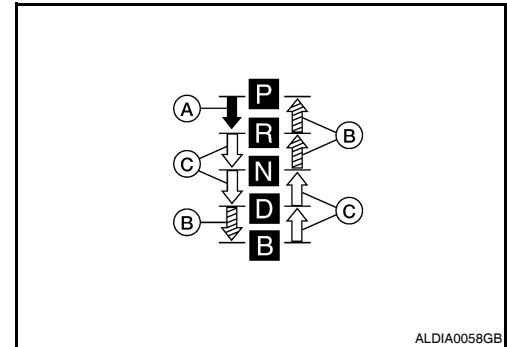

ADJUSTMENT

CAUTION:

Apply parking brake before adjustment.

1. Loosen the control cable nut.
2. Place the manual lever and the selector lever in "P" position.
3. Tighten control cable nut to specified torque.

Control cable nut: Refer to [TM-29, "Exploded View"](#).

CAUTION:

Secure the manual lever when tightening control cable nut. Make sure the manual lever stays in the "P" position.

4. Check the operation of the transaxle. Refer to [TM-26, "Inspection and Adjustment"](#).

CONTROL CABLE

< ON-VEHICLE REPAIR >

[HYBRID TRANSAXLE: RE0F01H]

CONTROL CABLE

Exploded View

INFOID:000000004212388

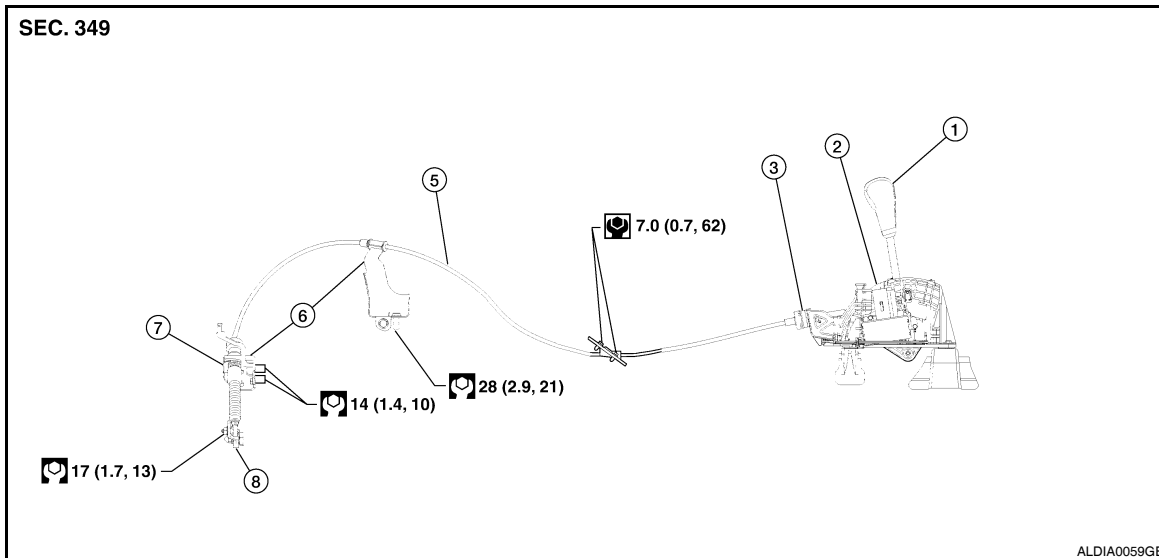

- | | | |
|---------------------|----------------------------|-------------------------|
| 1. Control lever | 2. Control device assembly | 3. Control cable socket |
| 4. Retainer grommet | 5. Control cable | 6. Bracket |
| 7. Lock plate | 8. Manual lever | |

Removal and Installation

INFOID:000000004212389

REMOVAL

1. Disconnect the 12-volt battery negative terminal. Refer to [PG-69, "Removal and Installation"](#).
2. Shift the control lever to "P" (Park) position.
3. Remove the air cleaner assembly. Refer to [EM-24, "Removal and Installation"](#).
4. Remove the control cable nut and control cable from the manual lever on the PNP switch.
5. Remove the lock plate and the control cable from the brackets.
6. Remove the instrument side mask. Refer to [IP-12, "Removal and Installation"](#).
7. Remove the instrument lower cover (LH). Refer to [IP-12, "Removal and Installation"](#).
8. Remove the console side finisher (LH). Refer to [IP-17, "Exploded View"](#).
9. Remove the console side finisher (RH). Refer to [IP-17, "Exploded View"](#).
10. Remove the CVT finisher.
 - Remove the control lever knob and knob cover.
 - Disconnect the A/T finisher lamp.
11. Remove the storage bin or CD changer finisher (if equipped). Refer to [IP-17, "Exploded View"](#).
12. Disconnect the control cable from the control device assembly.
13. Disconnect the A/C drain hose from the heater and cooling unit assembly and position aside.
14. Remove the HV ECU and bracket covering the retainer grommet. Refer to [HBC-644, "Removal and Installation"](#).
15. Remove the (parking brake control) front cable bolt and place the front cable aside. Refer to [PB-5, "Removal and Installation"](#).
16. Remove the HV ECU mounting bracket. Refer to [HBC-644, "Removal and Installation"](#).
17. Remove the control cable grommet bolts in the dash (lower) and remove the control cable.

INSTALLATION

Installation is in the reverse order of removal.

CONTROL CABLE

[HYBRID TRANSAXLE: RE0F01H]

< ON-VEHICLE REPAIR >

- When installing the control cable to the control device assembly, make sure that the control cable socket is fully pressed into the control device assembly, and the control cable end is fully pressed in with the ribbed surface facing upward.
- After installation is complete, adjust and check the transaxle position. Refer to [TM-26, "Inspection and Adjustment"](#).

Inspection and Adjustment

INFOID:000000004212390

INSPECTION

1. Place selector lever in "P" position, and turn ignition switch ON (engine stop).
2. Make sure that selector lever can be shifted to other than "P" position when brake pedal is depressed. Also make sure that selector lever can be shifted from "P" position only when brake pedal is depressed.
3. Move the selector lever and check for excessive effort, sticking, noise or rattle.
4. Confirm the selector lever stops at each position with the feel of engagement when it is moved through all the positions. Check that the actual position of the selector lever matches the position shown by the shift position indicator and the manual lever on the transaxle.
5. The method of operating the selector lever to individual positions correctly should be as shown.
 - (A): Press selector button to operate selector lever, while depressing the brake pedal.
 - (B): Press selector button to operate selector lever.
 - (C): Selector lever can be operated without pressing selector button.
6. Press the selector button in the "P", "R", and "N" positions without applying forward/backward force to selector lever, check button operation for sticking.
7. Confirm the back-up lamps illuminate only when selector lever is placed in the "R" position. Confirm the back-up lamps do not illuminate when the selector lever is pushed toward the "R" position when in the "P" or "N" position.
8. Confirm the hybrid system can only be started with the selector lever in the "P" position.
9. Make sure transaxle is locked completely in "P" position.

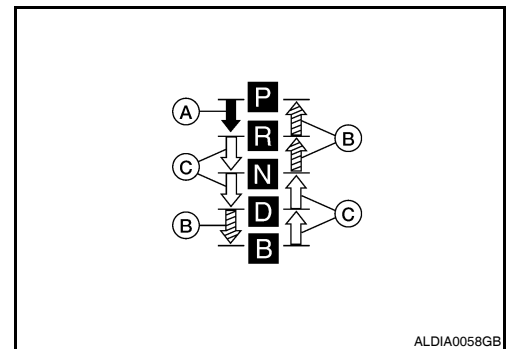

ADJUSTMENT

CAUTION:

Apply parking brake before adjustment.

1. Loosen the control cable nut.
2. Place the manual lever and the selector lever in "P" position.
3. Tighten control cable nut to specified torque.

Control cable nut: Refer to [TM-29, "Exploded View"](#).

CAUTION:

Secure the manual lever when tightening control cable nut. Make sure the manual lever stays in the "P" position.

4. Check the operation of the transaxle. Refer to [TM-28, "Inspection and Adjustment"](#).

DIFFERENTIAL SIDE OIL SEAL

< ON-VEHICLE REPAIR >

[HYBRID TRANSAXLE: RE0F01H]

DIFFERENTIAL SIDE OIL SEAL

Exploded View

INFOID:000000004212391

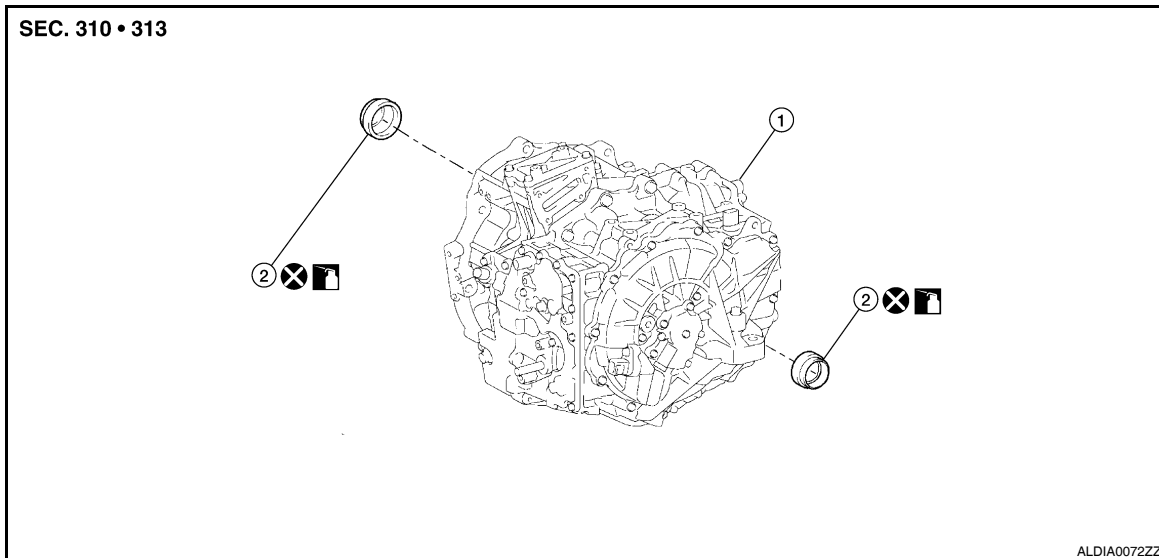

1. Transaxle assembly
2. Differential side oil seal

Removal and Installation

INFOID:000000004212392

REMOVAL

1. Remove the drive shaft. Refer to [FAX-11, "Removal and Installation \(Left Side\)"](#) and [FAX-12, "Removal and Installation \(Right Side\)"](#).
2. Remove the differential side oil seal from the transaxle assembly using suitable tool.
CAUTION:
Do not scratch transaxle assembly.

INSTALLATION

1. Drive the new differential side oil seal to the transaxle assembly until it is flush using suitable tool.

Oil seal depth : 0 ± 0.5 mm (0 ± 0.02 in)

CAUTION:

- Do not reuse differential side oil seals.
 - Apply specified transaxle fluid to the differential side oil seals.
2. Install the drive shaft. Refer to [FAX-11, "Removal and Installation \(Left Side\)"](#) and [FAX-12, "Removal and Installation \(Right Side\)"](#).
 3. Check the transaxle fluid level. Refer to [TM-24, "Inspection"](#).

PARK/NEUTRAL POSITION (PNP) SWITCH

< ON-VEHICLE REPAIR >

[HYBRID TRANSAXLE: RE0F01H]

PARK/NEUTRAL POSITION (PNP) SWITCH

Exploded View

INFOID:000000004212393

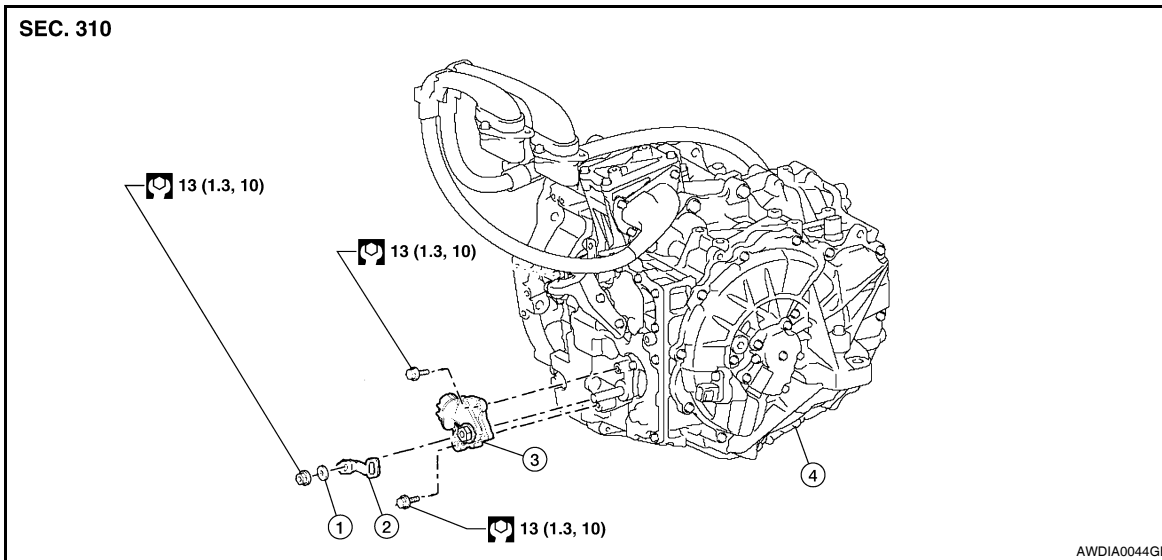

1. Lock washer
2. Manual lever
3. Park neutral position (PNP) switch
4. Transaxle assembly

Removal and Installation

INFOID:000000004212394

CAUTION:

When replacing the PNP switch, replace the manual lever (1) with new manual lever (1) or transfer the manual lever (1) from the old PNP switch to the new PNP switch. The manual lever (1) must have a rectangular hole as shown for proper operation of the transaxle.

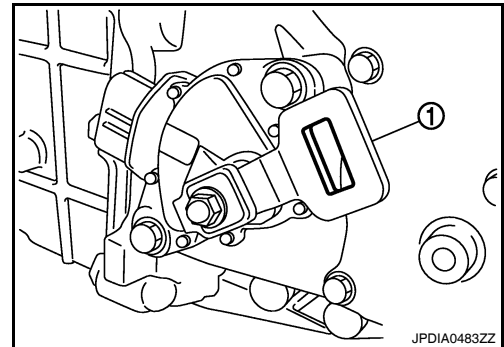

REMOVAL

1. Shift the control lever to the N (Neutral) position.
2. Remove the nut to disconnect the control cable from the manual lever on the PNP switch.
3. Remove the nut and remove the manual lever from the PNP switch.
4. Disconnect the PNP switch connector.
5. Remove the PNP switch bolts (A) and remove the PNP switch.

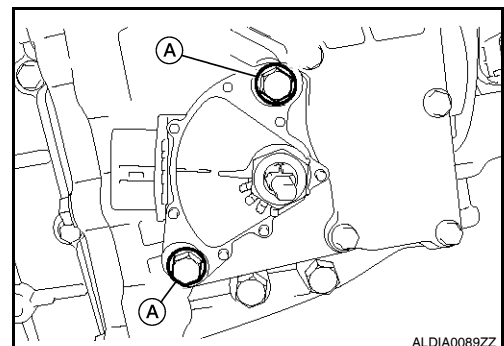

PARK/NEUTRAL POSITION (PNP) SWITCH

[HYBRID TRANSAXLE: RE0F01H]

< ON-VEHICLE REPAIR >

INSTALLATION

Installation is in the reverse order of removal.

- Align the PNP switch position indicator (A) with the neutral position line (B) when installing.

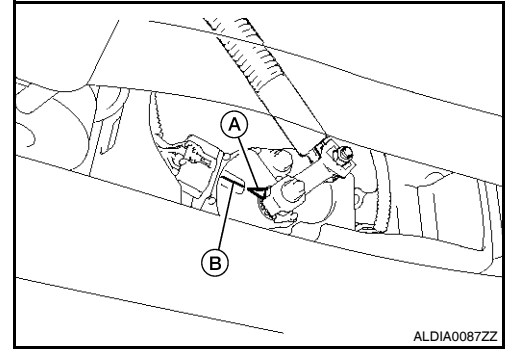

- After installation of the PNP switch, check the continuity of the PNP switch.
- After installation is complete, adjust and check the control lever position. Refer to [TM-30, "Inspection and Adjustment"](#).

Inspection and Adjustment

INFOID:000000004212395

INSPECTION

1. Shift the control lever to the "N" (Neutral) position.
2. Check position of PNP switch. The PNP switch position indicator (A) should point to the neutral position line (B) on the PNP switch as shown.

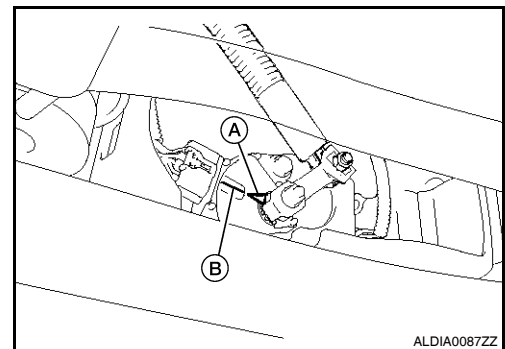

ADJUSTMENT

1. Put the control lever in the "N" position.
2. Loosen the PNP switch bolts (A).

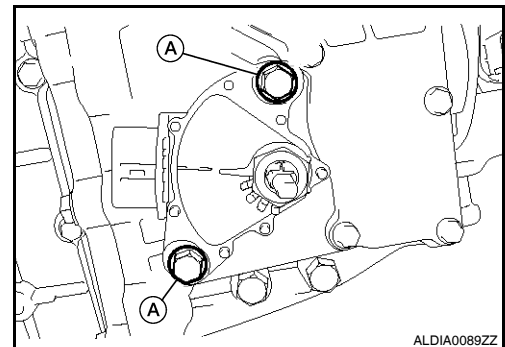

PARK/NEUTRAL POSITION (PNP) SWITCH

< ON-VEHICLE REPAIR >

[HYBRID TRANSAXLE: RE0F01H]

3. Align the PNP switch position indicator (A) with the neutral position line (B).

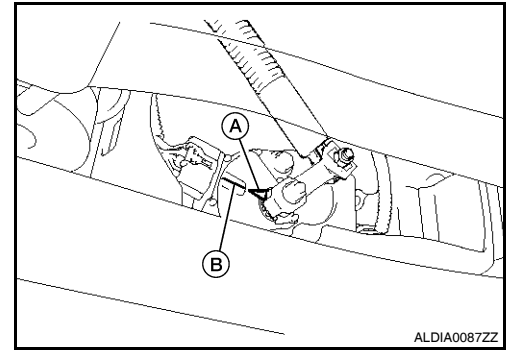

4. Tighten the PNP switch bolts (A).

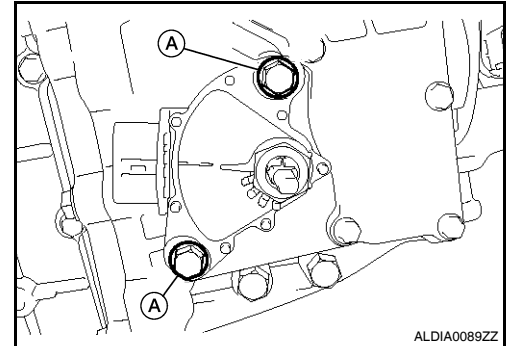

INPUT SHAFT OIL SEAL

< ON-VEHICLE REPAIR >

[HYBRID TRANSAXLE: RE0F01H]

INPUT SHAFT OIL SEAL

Exploded View

INFOID:000000004212396

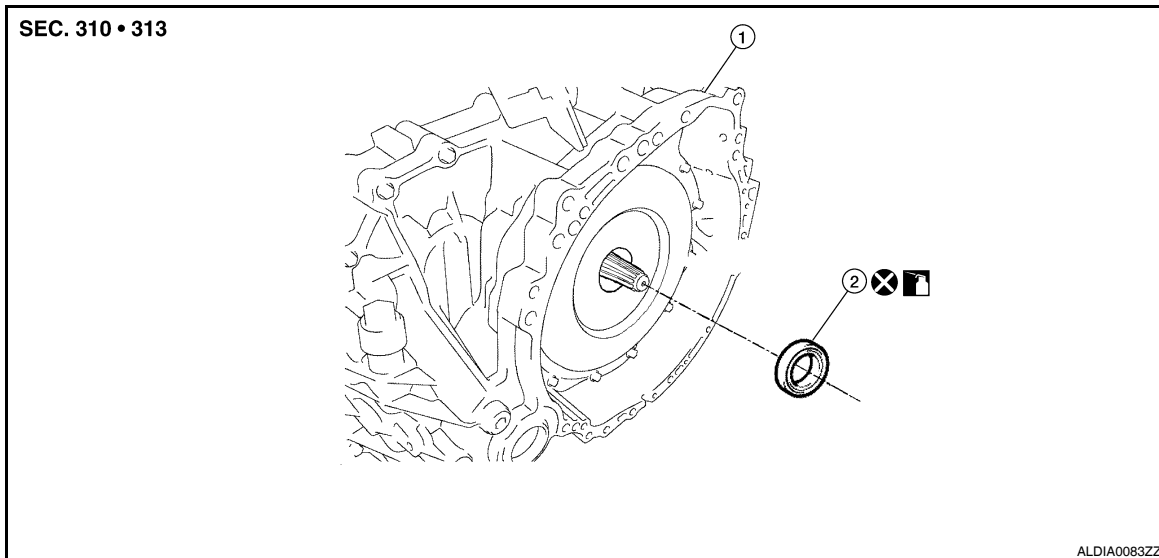

1. Transaxle assembly
2. Input shaft oil seal

Removal and Installation

INFOID:000000004212397

REMOVAL

1. Remove the transaxle assembly. Refer to [TM-36. "Removal and Installation"](#).
2. Remove the input shaft oil seal (1) from the transaxle assembly (2) using suitable tool.

CAUTION:

Do not scratch transaxle assembly.

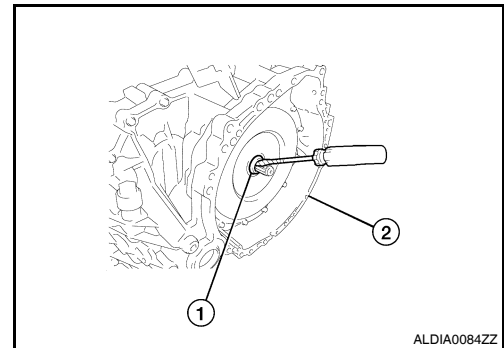

INSTALLATION

1. Install the new input shaft oil seal to the transaxle assembly.
CAUTION:
Do not reuse input shaft oil seal.
2. Install the transaxle assembly. Refer to [TM-36. "Removal and Installation"](#).

TRANSAXLE ASSEMBLY

< REMOVAL AND INSTALLATION >

[HYBRID TRANSAXLE: RE0F01H]

REMOVAL AND INSTALLATION

TRANSAXLE ASSEMBLY

Exploded View

INFOID:000000004212398

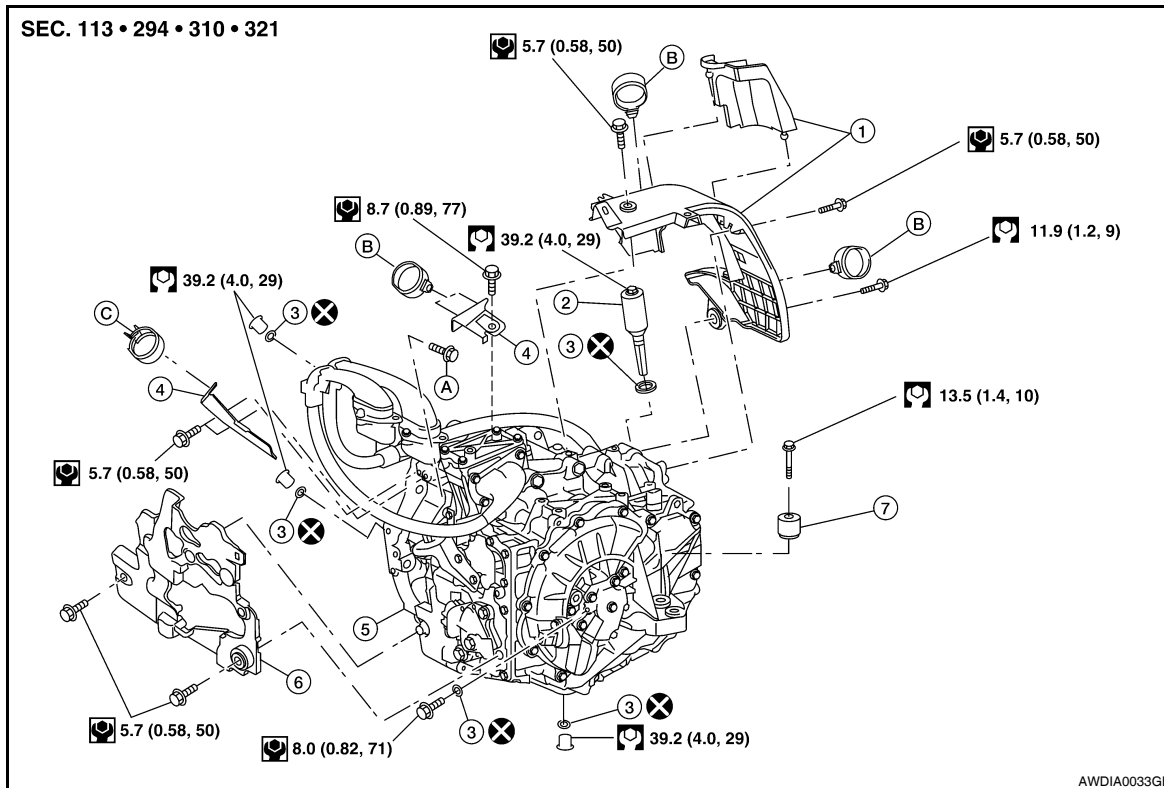

- | | | |
|-------------------|---------------------------|----------------|
| 1. Rear cover | 2. Mass damper | 3. Gasket |
| 4. Bracket | 5. Transaxle assembly | 6. Front cover |
| 7. Dynamic damper | A. Refer to Installation. | B. Clip |
| C. Clip | | |

Removal and Installation

INFOID:000000004212399

REMOVAL

1. Remove the engine and transaxle as an assembly. Refer to [EM-71. "Removal and Installation"](#).
2. Disconnect the electrical connectors from the transaxle.
3. Remove the harness from the transaxle assembly.
4. Remove the transaxle to engine and engine to transaxle bolts.
5. Separate the transaxle assembly from the engine.
6. If necessary, remove the following from the transaxle assembly:
 - Sensors, refer to [TM-32. "Removal and Installation"](#).
 - Switches
 - Mass damper with gasket
 - Dynamic damper
 - Brackets
 - Covers

INSTALLATION

Installation is in the reverse order of removal after the following.

TRANSAXLE ASSEMBLY

< REMOVAL AND INSTALLATION >

[HYBRID TRANSAXLE: RE0F01H]

1. Be sure the grommet (1) is installed flush with the flange plane as shown prior to mating the engine and transaxle.

CAUTION:

Do not use lubricating oil for lubricant.

NOTE:

Be careful that the edge does not protrude from the socket.

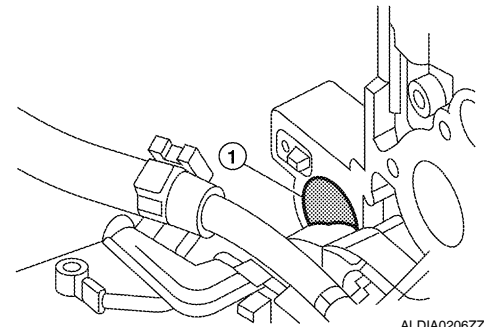

ALDIA0206ZZ

CAUTION:

- When replacing the PNP switch, replace the manual lever (1) with new manual lever (1) for transfer the manual lever (1) from the old PNP switch to the new PNP switch. The manual lever (1) must have a rectangular hole as shown for proper operation of the transaxle.
- When replacing an engine or transaxle you must make sure any dowels are installed correctly during re-assembly.
- Improper alignment caused by missing dowels may cause vibration, oil leaks or breakage of drivetrain components.
- Do not reuse O-rings or gaskets.

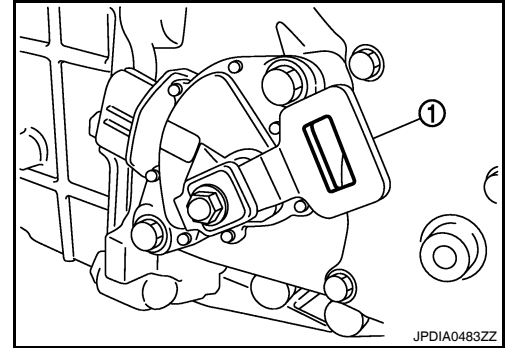

JPDIA0483ZZ

- When installing the transaxle to the engine, attach the bolts in accordance with the following standard.

- A: Transaxle to engine
- B: Engine to transaxle

Bolt No.	1	2	3	4	5	6	7
Number of bolts	1	3	2	2	2	1	1
Tightening torque N·m (kg-m, ft-lb)	48 (4.9, 35)	74.5 (7.6, 55)	74.5 (7.6, 55)	42.7 (4.4, 31)	42.7 (4.4, 31)	74.5 (7.6, 55)	48 (4.9, 35)

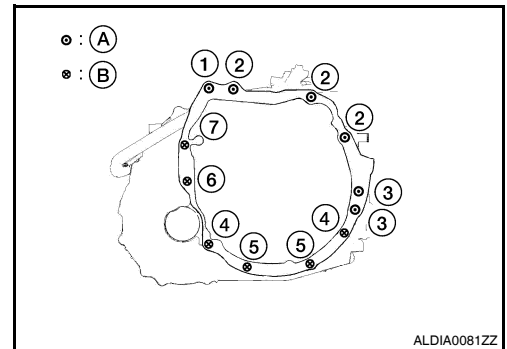

ALDIA0081ZZ

- After completing installation, check for fluid leakage, fluid level, and the positions of the transaxle. Refer to [TM-24. "Inspection"](#) and [TM-26. "Inspection and Adjustment"](#).

SERVICE DATA AND SPECIFICATIONS (SDS)

< SERVICE DATA AND SPECIFICATIONS (SDS)

[HYBRID TRANSAXLE: RE0F01H]

SERVICE DATA AND SPECIFICATIONS (SDS)

SERVICE DATA AND SPECIFICATIONS (SDS)

General Specification

INFOID:000000004212400

Applied model		QR25DE
		2WD
Transaxle model		RE0F01H
Transaxle model code number		JA80A
Power split planetary gear unit	The No. of Ring Gear Teeth	78
	The No. of Pinion Gear Teeth	23
	The No. of Sun Gear Teeth	30
Motor speed reduction planetary gear unit	The No. of Ring Gear Teeth	57
	The No. of Pinion Gear Teeth	18
	The No. of Sun Gear Teeth	23
Counter gear	The No. of Drive Gear Teeth	54
	The No. of Driven Gear Teeth	55
Final gear	The No. of Drive Gear Teeth	23
	The No. of Driven Gear Teeth	80
Total deceleration ratio		3.542
Recommended ATF type		Genuine NISSAN Matic W ATF *1
ATF capacity	liters (US qt, Imp qt)	4.1 (4 3/8, 3 5/8)
Weight (reference) *2	kg (lb)	113.3 (249.8)

CAUTION:

- Use only Genuine NISSAN Matic W ATF. Do not mix with other fluids.
- Using ATF other than Genuine NISSAN Matic W ATF will cause deterioration of driveability and transaxle durability, and may damage the transaxle, which is not covered by the NISSAN new vehicle limited warranty.

*1: Refer to [MA-10, "Fluids and Lubricants"](#).

*2: Transaxle weight specification is with the ATF at full capacity.