

SECTION **SE**  
SEAT

A  
B  
C  
D  
E  
F  
G  
H  
I  
SE  
K  
L  
M  
N  
O  
P

CONTENTS

<b>COUPE</b>		Removal and Installation .....25	
<b>COMPONENT DIAGNOSIS</b> .....	3	<b>DISASSEMBLY AND ASSEMBLY</b> .....	26
<b>POWER SEAT FOR DRIVER SIDE</b> .....	3	<b>FRONT SEAT</b> .....	26
Wiring Diagram .....	3	<b>DRIVER SIDE</b> .....	26
<b>HEATED SEAT</b> .....	7	DRIVER SIDE : Exploded View .....	26
Wiring Diagram .....	7	DRIVER SIDE : Disassembly and Assembly .....	27
<b>SYMPTOM DIAGNOSIS</b> .....	12	<b>PASSENGER SIDE</b> .....	27
<b>SQUEAK AND RATTLE TROUBLE DIAG- NOSES</b> .....	12	PASSENGER SIDE : Exploded View .....	28
Work Flow .....	12	PASSENGER SIDE : Disassembly .....	29
Generic Squeak and Rattle Troubleshooting .....	14		
Diagnostic Worksheet .....	16	<b>SEDAN</b>	
<b>PRECAUTION</b> .....	18	<b>COMPONENT DIAGNOSIS</b> .....	30
<b>PRECAUTIONS</b> .....	18	<b>POWER SEAT FOR DRIVER SIDE</b> .....	30
Precaution for Supplemental Restraint System (SRS) "AIR BAG" and "SEAT BELT PRE-TEN- SIONER" .....	18	Wiring Diagram .....	30
Precautions Necessary for Steering Wheel Rota- tion after Battery Disconnect .....	18	<b>HEATED SEAT</b> .....	35
Service Notice .....	18	Wiring Diagram .....	35
Precaution for Work .....	19	<b>SYMPTOM DIAGNOSIS</b> .....	40
<b>PREPARATION</b> .....	20	<b>SQUEAK AND RATTLE TROUBLE DIAG- NOSES</b> .....	40
<b>PREPARATION</b> .....	20	Work Flow .....	40
Special Service Tool .....	20	Generic Squeak and Rattle Troubleshooting .....	42
Commercial Service Tool .....	20	Diagnostic Worksheet .....	44
<b>ON-VEHICLE REPAIR</b> .....	21	<b>PRECAUTION</b> .....	46
<b>FRONT SEAT</b> .....	21	<b>PRECAUTIONS</b> .....	46
Exploded View .....	21	Precaution for Supplemental Restraint System (SRS) "AIR BAG" and "SEAT BELT PRE-TEN- SIONER" .....	46
Removal and Installation .....	23	Precautions Necessary for Steering Wheel Rota- tion after Battery Disconnect .....	46
<b>REAR SEAT</b> .....	24	Service Notice .....	46
Exploded View .....	24	Precaution for Work .....	47
		<b>PREPARATION</b> .....	48

<b>PREPARATION</b> .....	<b>48</b>	<b>FRONT SEAT</b> .....	<b>54</b>
Special Service Tool .....	48	<b>DRIVER SIDE</b> .....	<b>54</b>
Commercial Service Tool .....	48	DRIVER SIDE : Exploded View .....	54
<b>ON-VEHICLE REPAIR</b> .....	<b>49</b>	DRIVER SIDE : Disassembly and Assembly .....	55
<b>FRONT SEAT</b> .....	<b>49</b>	<b>PASSENGER SIDE</b> .....	<b>56</b>
Exploded View .....	49	PASSENGER SIDE : Exploded View .....	56
Removal and Installation .....	51	PASSENGER SIDE : Disassembly .....	57
<b>REAR SEAT</b> .....	<b>52</b>	<b>REAR SEAT</b> .....	<b>60</b>
Exploded View .....	52	<b>ARMREST</b> .....	<b>60</b>
Removal and Installation .....	53	ARMREST : Exploded View .....	60
<b>DISASSEMBLY AND ASSEMBLY</b> .....	<b>54</b>	ARMREST : Disassembly and Assembly .....	60

# POWER SEAT FOR DRIVER SIDE

< COMPONENT DIAGNOSIS >

[COUPE]

## COMPONENT DIAGNOSIS

### POWER SEAT FOR DRIVER SIDE

#### Wiring Diagram

INFOID:000000004206780

POWER SEAT FOR DRIVER SIDE

◊LM◊ WITH POWER LUMBAR SUPPORT

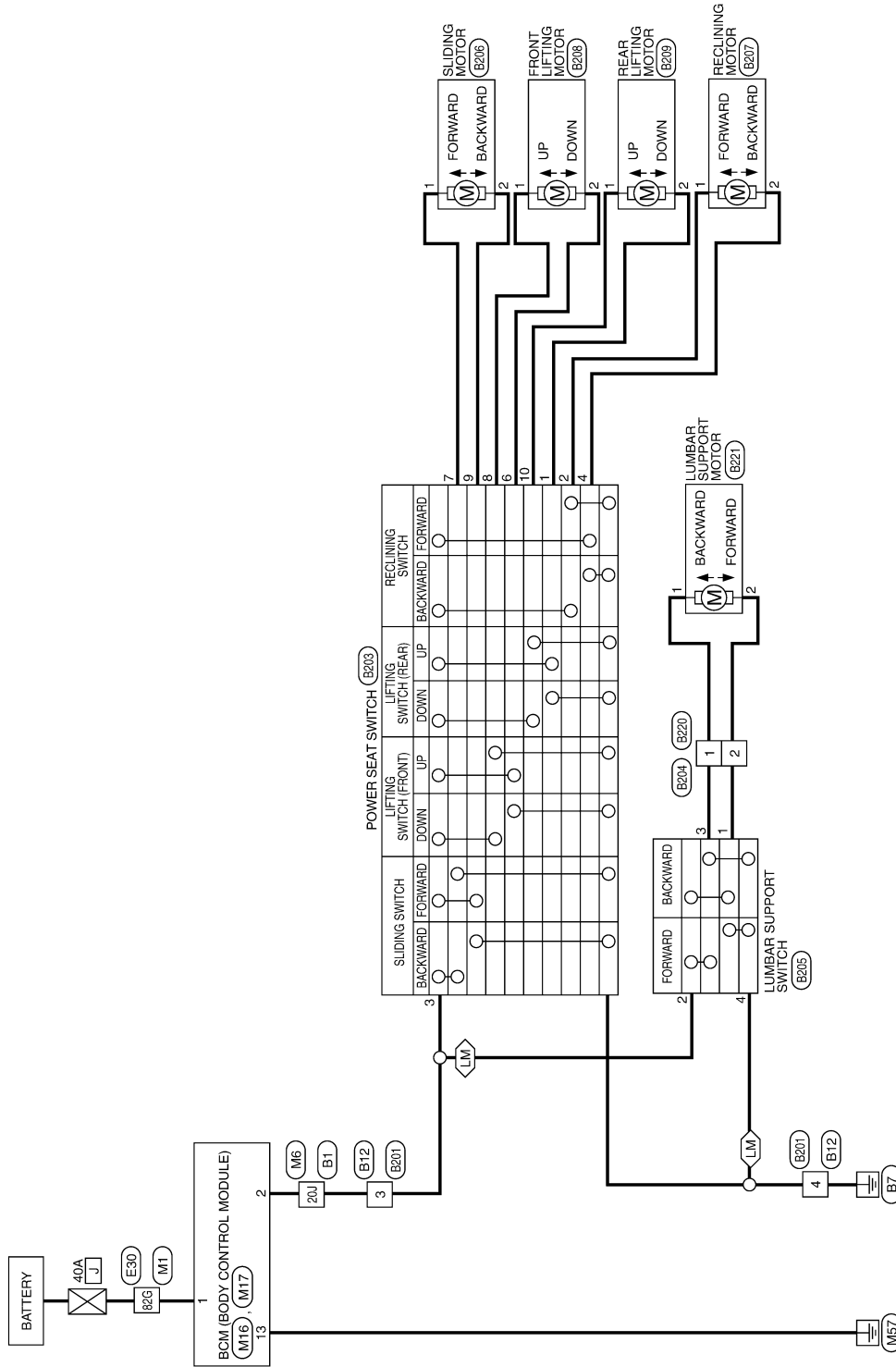

A  
B  
C  
D  
E  
F  
G  
H  
I  
SE  
K  
L  
M  
N  
O  
P

# POWER SEAT FOR DRIVER SIDE

< COMPONENT DIAGNOSIS >

[COUPE]

## POWER SEAT FOR DRIVER SIDE CONNECTORS

Connector No.	M1
Connector Name	WIRE TO WIRE
Connector Color	WHITE

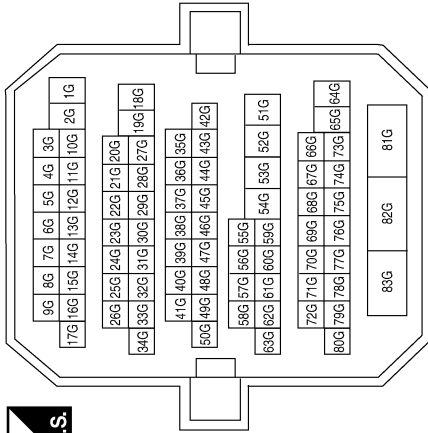

Terminal No.	Color of wire	Signal Name
82G	W/B	-

Connector No.	M6
Connector Name	WIRE TO WIRE
Connector Color	WHITE

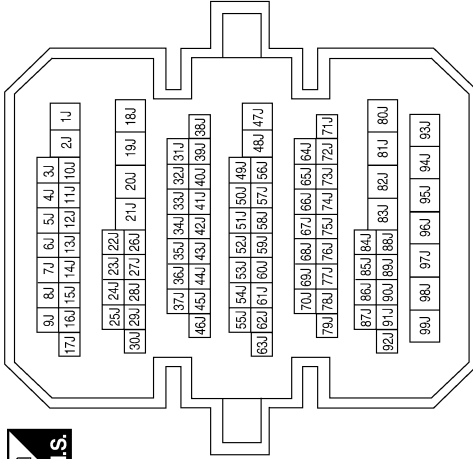

Terminal No.	Color of wire	Signal Name
20J	R/Y	-

Connector No.	M16
Connector Name	BCM (BODY CONTROL MODULE)
Connector Color	BLACK



Terminal No.	Color of wire	Signal Name
1	W/B	BAT_POWER_F/L
2	R/Y	P/W_POWER_SUPPLY_PERM

Connector No.	M17
Connector Name	BCM (BODY CONTROL MODULE)
Connector Color	WHITE

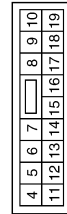

Terminal No.	Color of wire	Signal Name
13	B	GND1

ABJIA0189GB

# POWER SEAT FOR DRIVER SIDE

< COMPONENT DIAGNOSIS >

[COUPE]

Connector No.	B12
Connector Name	WIRE TO WIRE
Connector Color	WHITE

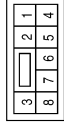

Terminal No.	Color of Wire	Signal Name
3	R/Y	-
4	B/Y	-

Connector No.	B1
Connector Name	WIRE TO WIRE
Connector Color	WHITE

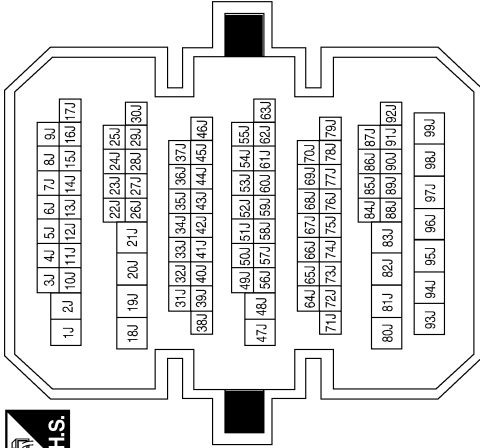

Terminal No.	Color of Wire	Signal Name
20U	R/Y	-

Connector No.	E30
Connector Name	WIRE TO WIRE
Connector Color	WHITE

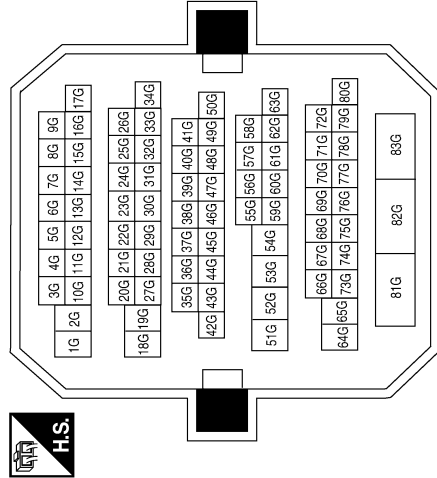

Terminal No.	Color of wire	Signal Name
82G	LG	-

Terminal No.	Color of Wire	Signal Name
1	Y	REAR LIFTING MOTOR
2	G	RECLINING MOTOR
3	R/Y	BAT
4	LG	RECLINING MOTOR
5	B	GND
6	V	FRONT LIFTING MOTOR
7	W	SLIDING MOTOR
8	O	FRONT LIFTING MOTOR
9	BR	SLIDING MOTOR
10	L	REAR LIFTING MOTOR

Connector No.	B203
Connector Name	POWER SEAT SWITCH
Connector Color	WHITE

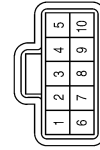

Connector No.	B201
Connector Name	WIRE TO WIRE
Connector Color	WHITE



Terminal No.	Color of Wire	Signal Name
3	R/Y	-
4	B	-

ABJIA0190GB

A B C D E F G H I SE K L M N O P

# POWER SEAT FOR DRIVER SIDE

< COMPONENT DIAGNOSIS >

[COUPE]

Connector No.	B208
Connector Name	FRONT LIFTING MOTOR
Connector Color	WHITE



Terminal No.	Color of Wire	Signal Name
1	O	DOWN +
2	V	UP +

Connector No.	B207
Connector Name	RECLINING MOTOR
Connector Color	WHITE



Terminal No.	Color of Wire	Signal Name
1	G	BACKWARD +
2	LG	FORWARD +
3	-	-
4	-	-

Connector No.	B206
Connector Name	SLIDING MOTOR
Connector Color	WHITE



Terminal No.	Color of Wire	Signal Name
1	W	BACKWARD +
2	BR	FORWARD +

Connector No.	B209
Connector Name	REAR LIFTING MOTOR
Connector Color	WHITE



Terminal No.	Color of Wire	Signal Name
1	L	DOWN +
2	Y	UP +

ABJIA0193GB

# HEATED SEAT

< COMPONENT DIAGNOSIS >

[COUPE]

## HEATED SEAT

### Wiring Diagram

INFOID:000000004206781

HEATED SEAT

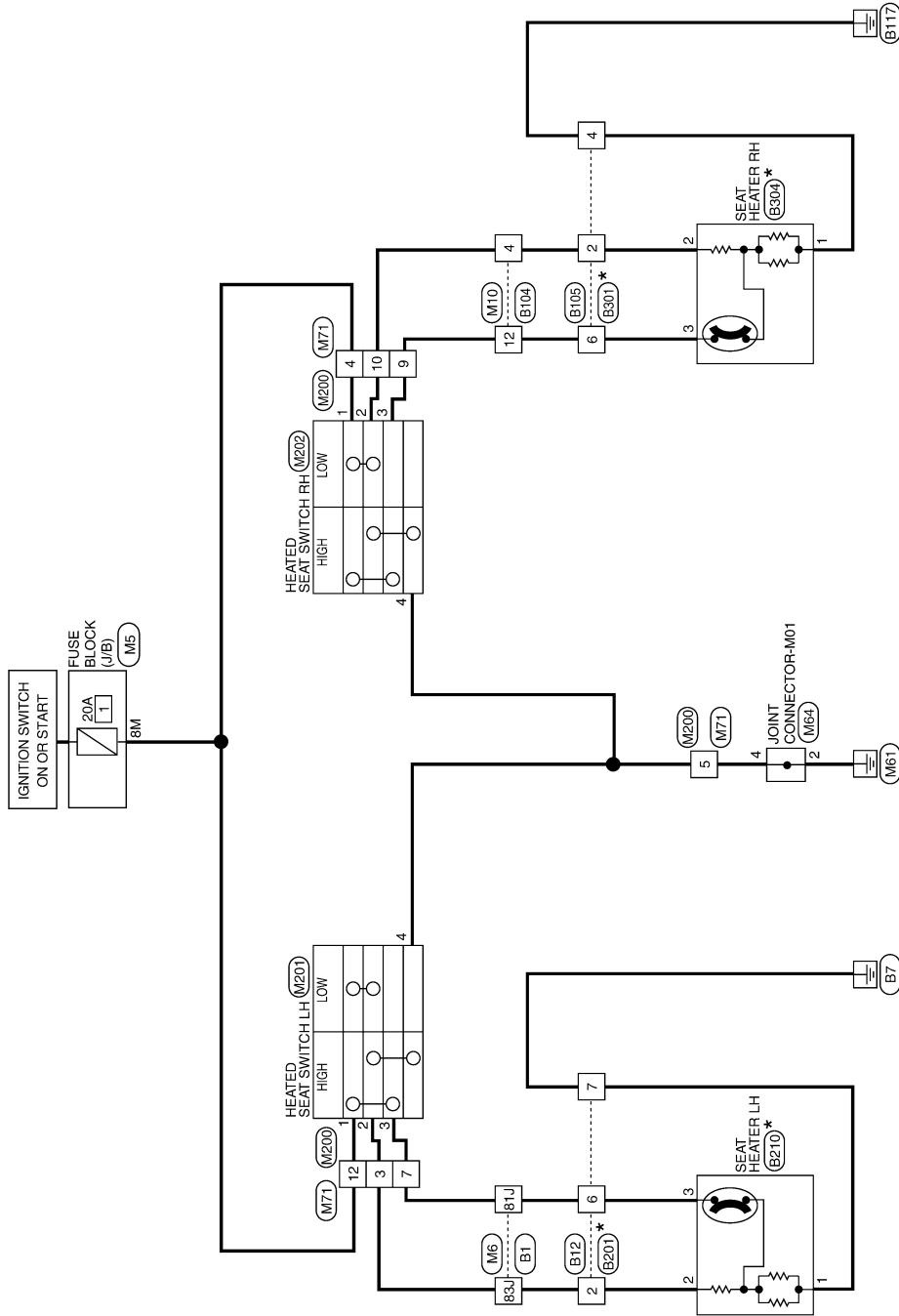

\* : THIS CONNECTOR IS NOT SHOWN IN "HARNES LAYOUT" OF PG SECTION.

AAJWA0016GE

A  
B  
C  
D  
E  
F  
G  
H  
I  
SE  
K  
L  
M  
N  
O  
P

# HEATED SEAT

< COMPONENT DIAGNOSIS >

[COUPE]

## HEATED SEAT CONNECTORS

Connector No.	M5
Connector Name	FUSE BLOCK (J/B)
Connector Color	WHITE

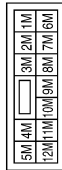

Terminal No.	Color of wire	Signal Name
8M	G/R	-

Connector No.	M6
Connector Name	WIRE TO WIRE
Connector Color	WHITE

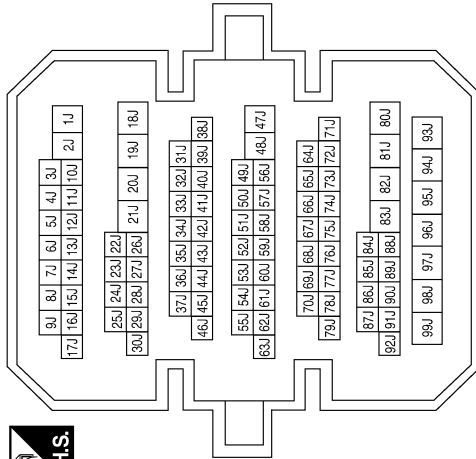

Terminal No.	Color of wire	Signal Name
81J	GR/R	-
83J	GR	-

Connector No.	M10
Connector Name	WIRE TO WIRE
Connector Color	BROWN

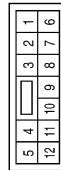

Terminal No.	Color of wire	Signal Name
4	GR/L	-
12	GR/R	-

Connector No.	M64
Connector Name	JOINT CONNECTOR-M01
Connector Color	GRAY

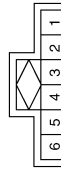

Terminal No.	Color of wire	Signal Name
2	B	-
4	B	-

Connector No.	M71
Connector Name	WIRE TO WIRE
Connector Color	WHITE

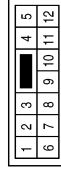

Terminal No.	Color of wire	Signal Name
3	GR	-
4	G/R	-
5	B	-
7	GR/R	-
9	GR/R	-
10	GR/L	-
12	G/R	-

ABJIA0191GB



# HEATED SEAT

< COMPONENT DIAGNOSIS >

[COUPE]

Connector No.	M200
Connector Name	WIRE TO WIRE
Connector Color	WHITE

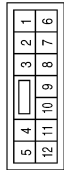

Terminal No.	Color of wire	Signal Name
3	GR	-
4	G/R	-
5	B	-
7	GR/R	-
9	GR/B	-
10	GR/L	-
12	G/R	-

Connector No.	M201
Connector Name	FRONT HEATED SEAT SWITCH LH
Connector Color	WHITE



Terminal No.	Color of wire	Signal Name
1	G/R	IGN
2	GR	HIGH - LOW +
3	GR/R	HIGH +
4	B	GND

Connector No.	M202
Connector Name	FRONT HEATED SEAT SWITCH RH
Connector Color	BROWN



Terminal No.	Color of wire	Signal Name
1	G/R	IGN
2	GR/L	HIGH - LOW +
3	GR/B	HIGH +
4	B	GND

Connector No.	B1
Connector Name	WIRE TO WIRE
Connector Color	WHITE

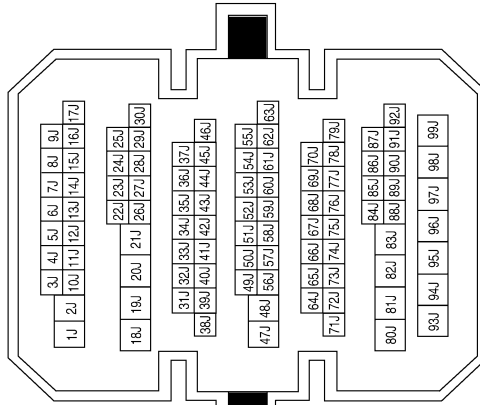

Terminal No.	Color of wire	Signal Name
81J	GR/W	-
83J	GR	-

A  
B  
C  
D  
E  
F  
G  
H  
I  
SE  
K  
L  
M  
N  
O  
P

# HEATED SEAT

< COMPONENT DIAGNOSIS >

[COUPE]

Connector No.	B105
Connector Name	WIRE TO WIRE
Connector Color	BROWN

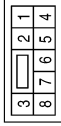

Terminal No.	Color of Wire	Signal Name
2	GR/G	-
4	B	-
6	GR/R	-

Connector No.	B104
Connector Name	WIRE TO WIRE
Connector Color	BROWN

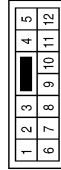

Terminal No.	Color of Wire	Signal Name
4	GR/G	-
12	GR/R	-

Connector No.	B12
Connector Name	WIRE TO WIRE
Connector Color	WHITE



Terminal No.	Color of wire	Signal Name
2	GR	-
6	GR/W	-
7	B/Y	-

Connector No.	B301
Connector Name	WIRE TO WIRE
Connector Color	WHITE



Terminal No.	Color of Wire	Signal Name
2	GR/G	-
6	GR/R	-
7	B	-

Connector No.	B210
Connector Name	FRONT SEAT HEATER LH
Connector Color	WHITE



Terminal No.	Color of Wire	Signal Name
1	B	GND
2	GR	HIGH - LOW +
3	GR/R	HIGH +

Connector No.	B201
Connector Name	WIRE TO WIRE
Connector Color	WHITE

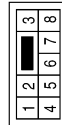

Terminal No.	Color of Wire	Signal Name
2	GR	-
6	GR/R	-
7	B	-

ABJIA0194GB

# HEATED SEAT

< COMPONENT DIAGNOSIS >

[COUPE]

A  
B  
C  
D  
E  
F  
G  
H  
I  
K  
L  
M  
N  
O  
P

**SE**

Connector No.	B304
Connector Name	FRONT SEAT HEATER RH
Connector Color	WHITE



Terminal No.	Color of Wire	Signal Name
1	B	GND
2	GR	HIGH - LOW +
3	GR/R	HIGH +

ABJIA0195GB

## SYMPTOM DIAGNOSIS

### SQUEAK AND RATTLE TROUBLE DIAGNOSES

#### Work Flow

INFOID:000000004206782

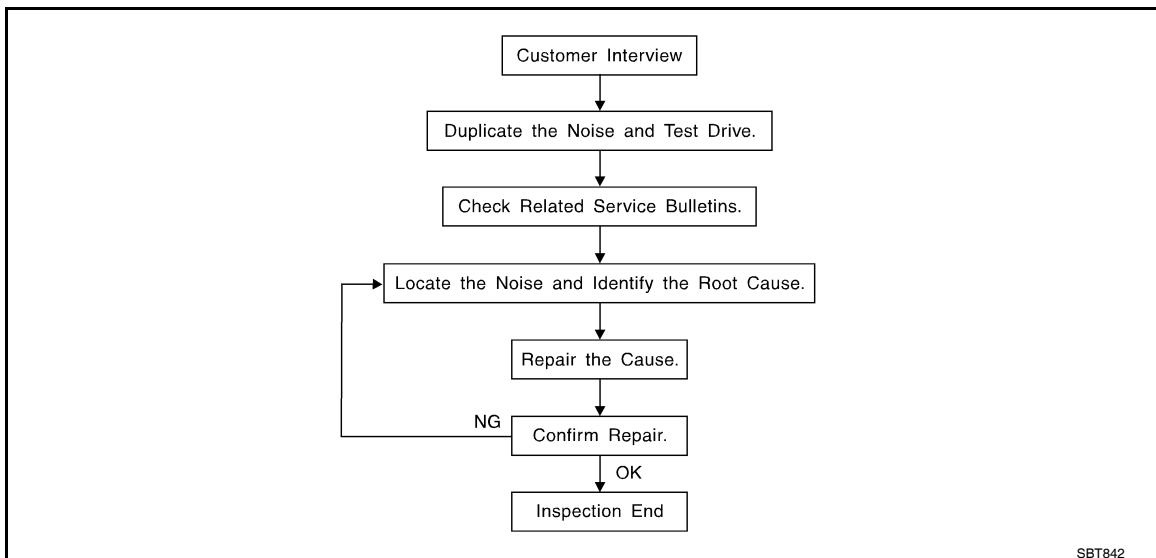

SBT842

#### CUSTOMER INTERVIEW

Interview the customer if possible, to determine the conditions that exist when the noise occurs. Use the Diagnostic Worksheet during the interview to document the facts and conditions when the noise occurs and any customer's comments; refer to [SE-16, "Diagnostic Worksheet"](#). This information is necessary to duplicate the conditions that exist when the noise occurs.

- The customer may not be able to provide a detailed description or the location of the noise. Attempt to obtain all the facts and conditions that exist when the noise occurs (or does not occur).
- If there is more than one noise in the vehicle, be sure to diagnose and repair the noise that the customer is concerned about. This can be accomplished by test driving the vehicle with the customer.
- After identifying the type of noise, isolate the noise in terms of its characteristics. The noise characteristics are provided so the customer, service adviser and technician are all speaking the same language when defining the noise.
- Squeak —(Like tennis shoes on a clean floor)  
Squeak characteristics include the light contact/fast movement/brought on by road conditions/hard surfaces = higher pitch noise/softer surfaces = lowerpitch noises/edge to surface = chirping
- Creak—(Like walking on an old wooden floor)  
Creak characteristics include firm contact/slow movement/twisting with a rotational movement/pitch dependent on materials/often brought on by activity.
- Rattle—(Like shaking a baby rattle)  
Rattle characteristics include the fast repeated contact/vibration or similar movement/loose parts/missing clip or fastener/incorrect clearance.
- Knock —(Like a knock on a door)  
Knock characteristics include hollow sounding/sometimes repeating/often brought on by driver action.
- Tick—(Like a clock second hand)  
Tick characteristics include gentle contacting of light materials/loose components/can be caused by driver action or road conditions.
- Thump—(Heavy, muffled knock noise)  
Thump characteristics include softer knock/dead sound often brought on by activity.
- Buzz—(Like a bumble bee)  
Buzz characteristics include high frequency rattle/firm contact.
- Often the degree of acceptable noise level will vary depending upon the person. A noise that you may judge as acceptable may be very irritating to the customer.
- Weather conditions, especially humidity and temperature, may have a great effect on noise level.

#### DUPLICATE THE NOISE AND TEST DRIVE

# SQUEAK AND RATTLE TROUBLE DIAGNOSES

[COUPE]

## < SYMPTOM DIAGNOSIS >

If possible, drive the vehicle with the customer until the noise is duplicated. Note any additional information on the Diagnostic Worksheet regarding the conditions or location of the noise. This information can be used to duplicate the same conditions when you confirm the repair.

If the noise can be duplicated easily during the test drive, to help identify the source of the noise, try to duplicate the noise with the vehicle stopped by doing one or all of the following:

- 1) Close a door.
  - 2) Tap or push/pull around the area where the noise appears to be coming from.
  - 3) Rev the engine.
  - 4) Use a floor jack to recreate vehicle "twist".
  - 5) At idle, apply engine load (electrical load, half-clutch on M/T models, drive position on A/T models).
  - 6) Raise the vehicle on a hoist and hit a tire with a rubber hammer.
- Drive the vehicle and attempt to duplicate the conditions the customer states exist when the noise occurs.
  - If it is difficult to duplicate the noise, drive the vehicle slowly on an undulating or rough road to stress the vehicle body.

## CHECK RELATED SERVICE BULLETINS

After verifying the customer concern or symptom, check ASIST for Technical Service Bulletins (TSBs) related to that concern or symptom.

If a TSB relates to the symptom, follow the procedure to repair the noise.

## LOCATE THE NOISE AND IDENTIFY THE ROOT CAUSE

1. Narrow down the noise to a general area. To help pinpoint the source of the noise, use a listening tool (Chassis Ear: J-39570, Engine Ear and mechanics stethoscope).
2. Narrow down the noise to a more specific area and identify the cause of the noise by:
  - removing the components in the area that you suspect the noise is coming from.  
Do not use too much force when removing clips and fasteners, otherwise clips and fastener can be broken or lost during the repair, resulting in the creation of new noise.
  - tapping or pushing/pulling the component that you suspect is causing the noise.  
Do not tap or push/pull the component with excessive force, otherwise the noise will be eliminated only temporarily.
  - feeling for a vibration with your hand by touching the component(s) that you suspect is (are) causing the noise.
  - placing a piece of paper between components that you suspect are causing the noise.
  - looking for loose components and contact marks.  
Refer to [SE-14, "Generic Squeak and Rattle Troubleshooting"](#).

## REPAIR THE CAUSE

- If the cause is a loose component, tighten the component securely.
- If the cause is insufficient clearance between components:
  - separate components by repositioning or loosening and retightening the component, if possible.
  - insulate components with a suitable insulator such as urethane pads, foam blocks, felt cloth tape or urethane tape. A Nissan Squeak and Rattle Kit (J-43980) is available through your authorized Nissan Parts Department.

### CAUTION:

**Do not use excessive force as many components are constructed of plastic and may be damaged.**

### NOTE:

Always check with the Parts Department for the latest parts information.

The following materials are contained in the Nissan Squeak and Rattle Kit (J-43980). Each item can be ordered separately as needed.

URETHANE PADS [1.5 mm (0.059 in) thick]

Insulates connectors, harness, etc.

76268-9E005: 100 × 135 mm (3.94 × 5.31 in)/76884-71L01: 60 × 85 mm (2.36 × 3.35 in)/76884-71L02: 15 × 25 mm (0.59 × 0.98 in)

INSULATOR (Foam blocks)

Insulates components from contact. Can be used to fill space behind a panel.

73982-9E000: 45 mm (1.77 in) thick, 50 × 50 mm (1.97 × 1.97 in)/73982-

50Y00: 10 mm (0.39 in) thick, 50 × 50 mm (1.97 × 1.97 in)

INSULATOR (Light foam block)

80845-71L00: 30 mm (1.18 in) thick, 30 × 50 mm (1.18 × 1.97in)

FELT CLOTHTAPE

Used to insulate where movement does not occur. Ideal for instrument panel applications.

# SQUEAK AND RATTLE TROUBLE DIAGNOSES

[COUPE]

## < SYMPTOM DIAGNOSIS >

68370-4B000: 15 × 25 mm (0.59 × 0.98 in) pad/68239-13E00: 5 mm (0.20 in) wide tape roll

The following materials, not found in the kit, can also be used to repair squeaks and rattles.

### UHMW (TEFLON) TAPE

Insulates where slight movement is present. Ideal for instrument panel applications.

### SILICONE GREASE

Used in place of UHMW tape that will be visible or not fit. Will only last a few months.

### SILICONE SPRAY

Use when grease cannot be applied.

### DUCT TAPE

Use to eliminate movement.

## CONFIRM THE REPAIR

Confirm that the cause of a noise is repaired by test driving the vehicle. Operate the vehicle under the same conditions as when the noise originally occurred. Refer to the notes on the Diagnostic Worksheet.

## Generic Squeak and Rattle Troubleshooting

INFOID:000000004206783

Refer to Table of Contents for specific component removal and installation information.

## INSTRUMENT PANEL

Most incidents are caused by contact and movement between:

1. Acrylic lens and combination meter housing
2. Instrument panel to front pillar finishers
3. Instrument panel to windshield
4. Instrument panel mounting pins
5. Wiring harnesses behind the combination meter
6. A/C defroster duct and duct joint

These incidents can usually be located by tapping or moving the components to duplicate the noise or by pressing on the components while driving to stop the noise. Most of these incidents can be repaired by applying felt cloth tape or silicon spray (in hard to reach areas). Urethane pads can be used to insulate wiring harness.

### **CAUTION:**

**Do not use silicone spray to isolate a squeak or rattle. If you saturate the area with silicone, you will not be able to recheck the repair.**

## CENTER CONSOLE

Components to pay attention to include:

1. Shifter assembly cover to finisher
2. A/C control unit and cluster lid C
3. Wiring harnesses behind audio and A/C control unit

The instrument panel repair and isolation procedures also apply to the center console.

## DOORS

Pay attention to the:

1. Finisher and inner panel making a slapping noise
2. Inside handle escutcheon to door finisher
3. Wiring harnesses tapping
4. Door striker out of alignment causing a popping noise on starts and stops

Tapping or moving the components or pressing on them while driving to duplicate the conditions can isolate many of these incidents. You can usually insulate the areas with felt cloth tape or insulator foam blocks from the Nissan Squeak and Rattle Kit (J-43980) to repair the noise.

## TRUNK

Trunk noises are often caused by a loose jack or loose items put into the trunk by the owner.

In addition look for:

1. Trunk lid bumpers out of adjustment
2. Trunk lid striker out of adjustment
3. The trunk lid torsion bars knocking together

# SQUEAK AND RATTLE TROUBLE DIAGNOSES

[COUPE]

## < SYMPTOM DIAGNOSIS >

4. A loose license plate or bracket

Most of these incidents can be repaired by adjusting, securing or insulating the item(s) or component(s) causing the noise.

## SUNROOF/HEADLINING

Noises in the sunroof/headlining area can often be traced to one of the following:

1. Sunroof lid, rail, linkage or seals making a rattle or light knocking noise
2. Sunvisor shaft shaking in the holder
3. Front or rear windshield touching headlining and squeaking

Again, pressing on the components to stop the noise while duplicating the conditions can isolate most of these incidents. Repairs usually consist of insulating with felt cloth tape.

## OVERHEAD CONSOLE (FRONT AND REAR)

Overhead console noises are often caused by the console panel clips not being engaged correctly. Most of these incidents are repaired by pushing up on the console at the clip locations until the clips engage.

In addition, look for:

1. Loose harness or harness connectors.
2. Front console map/reading lamp lens loose.
3. Loose screws at console attachment points.

## SEATS

When isolating seat noise it's important to note the position the seat is in and the load placed on the seat when the noise is present. These conditions should be duplicated when verifying and isolating the cause of the noise.

Cause of seat noise include:

1. Headrest rods and holder
2. A squeak between the seat pad cushion and frame
3. The rear seatback lock and bracket

These noises can be isolated by moving or pressing on the suspected components while duplicating the conditions under which the noise occurs. Most of these incidents can be repaired by repositioning the component or applying urethane tape to the contact area.

## UNDERHOOD

Some interior noise may be caused by components under the hood or on the engine wall. The noise is then transmitted into the passenger compartment.

Causes of transmitted underhood noise include:

1. Any component mounted to the engine wall
2. Components that pass through the engine wall
3. Engine wall mounts and connectors
4. Loose radiator mounting pins
5. Hood bumpers out of adjustment
6. Hood striker out of adjustment

These noises can be difficult to isolate since they cannot be reached from the interior of the vehicle. The best method is to secure, move or insulate one component at a time and test drive the vehicle. Also, engine RPM or load can be changed to isolate the noise. Repairs can usually be made by moving, adjusting, securing, or insulating the component causing the noise.

A  
B  
C  
D  
E  
F  
G  
H  
I  
K  
L  
M  
N  
O  
P

SE

# SQUEAK AND RATTLE TROUBLE DIAGNOSES

[COUPE]

< SYMPTOM DIAGNOSIS >

## Diagnostic Worksheet

INFOID:000000004206784

Dear Customer:

We are concerned about your satisfaction with your vehicle. Repairing a squeak or rattle sometimes can be very difficult. To help us fix your vehicle right the first time, please take a moment to note the area of the vehicle where the squeak or rattle occurs and under what conditions. You may be asked to take a test drive with a service advisor or technician to ensure we confirm the noise you are hearing.

### SQUEAK & RATTLE DIAGNOSTIC WORKSHEET

#### I. WHERE DOES THE NOISE COME FROM? (circle the area of the vehicle)

The illustrations are for reference only, and may not reflect the actual configuration of your vehicle.

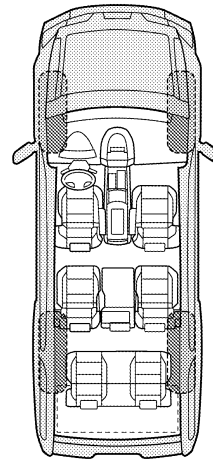
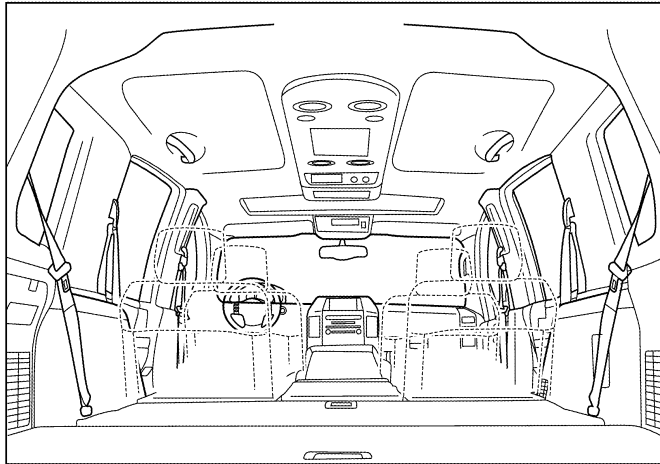
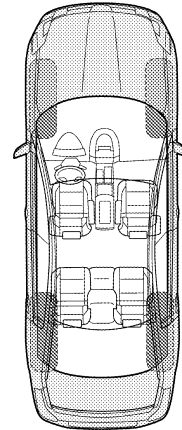
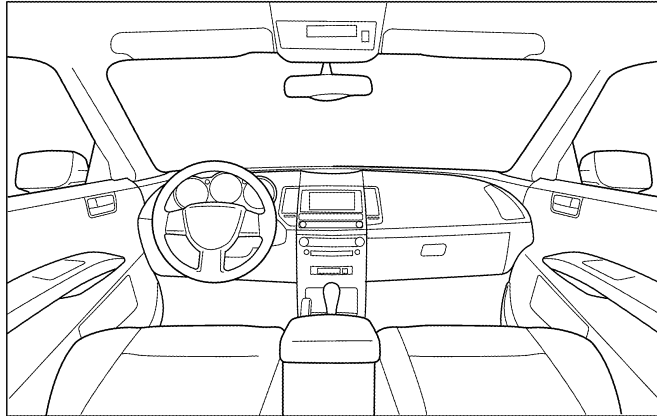

Continue to page 2 of the worksheet and briefly describe the location of the noise or rattle. In addition, please indicate the conditions which are present when the noise occurs.



# SQUEAK AND RATTLE TROUBLE DIAGNOSES

< SYMPTOM DIAGNOSIS >

[COUPE]

## SQUEAK & RATTLE DIAGNOSTIC WORKSHEET - page 2

Briefly describe the location where the noise occurs:

---

---

### II. WHEN DOES IT OCCUR? (please check the boxes that apply)

- |   |  |
|---|--|
| <input type="checkbox"/> Anytime                      | <input type="checkbox"/> After sitting out in the rain |
| <input type="checkbox"/> 1st time in the morning      | <input type="checkbox"/> When it is raining or wet     |
| <input type="checkbox"/> Only when it is cold outside | <input type="checkbox"/> Dry or dusty conditions       |
| <input type="checkbox"/> Only when it is hot outside  | <input type="checkbox"/> Other:                        |

### III. WHEN DRIVING:

- Through driveways
- Over rough roads
- Over speed bumps
- Only about \_\_\_\_ mph
- On acceleration
- Coming to a stop
- On turns: left, right or either (circle)
- With passengers or cargo
- Other: \_\_\_\_\_
- After driving \_\_\_\_ miles or \_\_\_\_ minutes

### IV. WHAT TYPE OF NOISE

- Squeak (like tennis shoes on a clean floor)
- Creak (like walking on an old wooden floor)
- Rattle (like shaking a baby rattle)
- Knock (like a knock at the door)
- Tick (like a clock second hand)
- Thump (heavy muffled knock noise)
- Buzz (like a bumble bee)

### TO BE COMPLETED BY DEALERSHIP PERSONNEL

Test Drive Notes:

---

---

---

	YES	NO	Initials of person performing
Vehicle test driven with customer	<input type="checkbox"/>	<input type="checkbox"/>	_____
- Noise verified on test drive	<input type="checkbox"/>	<input type="checkbox"/>	_____
- Noise source located and repaired	<input type="checkbox"/>	<input type="checkbox"/>	_____
- Follow up test drive performed to confirm repair	<input type="checkbox"/>	<input type="checkbox"/>	_____

VIN: \_\_\_\_\_ Customer Name \_\_\_\_\_

W.O.# \_\_\_\_\_ Date: \_\_\_\_\_

This form must be attached to Work Order

LAI0071E

A  
B  
C  
D  
E  
F  
G  
H  
I  
SE  
K  
L  
M  
N  
O  
P

&lt; PRECAUTION &gt;

## PRECAUTION

### PRECAUTIONS

#### Precaution for Supplemental Restraint System (SRS) "AIR BAG" and "SEAT BELT PRE-TENSIONER"

INFOID:000000004206785

The Supplemental Restraint System such as "AIR BAG" and "SEAT BELT PRE-TENSIONER", used along with a front seat belt, helps to reduce the risk or severity of injury to the driver and front passenger for certain types of collision. This system includes seat belt switch inputs and dual stage front air bag modules. The SRS system uses the seat belt switches to determine the front air bag deployment, and may only deploy one front air bag, depending on the severity of a collision and whether the front occupants are belted or unbelted. Information necessary to service the system safely is included in the SR and SB section of this Service Manual.

**WARNING:**

- To avoid rendering the SRS inoperative, which could increase the risk of personal injury or death in the event of a collision which would result in air bag inflation, all maintenance must be performed by an authorized NISSAN/INFINITI dealer.
- Improper maintenance, including incorrect removal and installation of the SRS, can lead to personal injury caused by unintentional activation of the system. For removal of Spiral Cable and Air Bag Module, see the SR section.
- Do not use electrical test equipment on any circuit related to the SRS unless instructed to in this Service Manual. SRS wiring harnesses can be identified by yellow and/or orange harnesses or harness connectors.

#### Precautions Necessary for Steering Wheel Rotation after Battery Disconnect

INFOID:000000004466793

**NOTE:**

- Before removing and installing any control units, first turn the push-button ignition switch to the LOCK position, then disconnect both battery cables.
- After finishing work, confirm that all control unit connectors are connected properly, then re-connect both battery cables.
- Always use CONSULT-III to perform self-diagnosis as a part of each function inspection after finishing work. If a DTC is detected, perform trouble diagnosis according to self-diagnosis results.

This vehicle is equipped with a push-button ignition switch and a steering lock unit.

If the battery is disconnected or discharged, the steering wheel will lock and cannot be turned.

If turning the steering wheel is required with the battery disconnected or discharged, follow the procedure below before starting the repair operation.

#### OPERATION PROCEDURE

1. Connect both battery cables.

**NOTE:**

Supply power using jumper cables if battery is discharged.

2. Carry the Intelligent Key or insert it to the key slot and turn the push-button ignition switch to ACC position. (At this time, the steering lock will be released.)
3. Disconnect both battery cables. The steering lock will remain released with both battery cables disconnected and the steering wheel can be turned.
4. Perform the necessary repair operation.
5. When the repair work is completed, re-connect both battery cables. With the brake pedal released, turn the push-button ignition switch from ACC position to ON position, then to LOCK position. (The steering wheel will lock when the push-button ignition switch is turned to LOCK position.)
6. Perform self-diagnosis check of all control units using CONSULT-III.

#### Service Notice

INFOID:000000004206786

- When removing or installing various parts, place a cloth or padding onto the vehicle body to prevent scratches.
- Handle trim, molding, instruments, grille, etc. carefully during removing or installing. Be careful not to oil or damage them.

# PRECAUTIONS

[COUPE]

## < PRECAUTION >

- Apply sealing compound where necessary when installing parts.
- When applying sealing compound, be careful that the sealing compound does not protrude from parts.
- When replacing any metal parts (for example body outer panel, members, etc.), be sure to take rust prevention measures.

A

## Precaution for Work

INFOID:000000004206787

B

- When removing or disassembling each component, be careful not to damage or deform it. If a component may be subject to interference, be sure to protect it with a shop cloth.
- When removing (disengaging) components with a screwdriver or similar tool, be sure to wrap the component with a shop cloth or vinyl tape to protect it.
- Protect the removed parts with a shop cloth and keep them.
- Replace a deformed or damaged clip.
- If a part is specified as a non-reusable part, always replace it with new one.
- Be sure to tighten bolts and nuts securely to the specified torque.
- After re-installation is completed, be sure to check that each part works normally.
- Follow the steps below to clean components.
- Water soluble foul: Dip a soft cloth into lukewarm water, and wring the water out of the cloth to wipe the fouled area.  
Then rub with a soft and dry cloth.
- Oily foul: Dip a soft cloth into lukewarm water with mild detergent (concentration: within 2 to 3%), and wipe the fouled area.  
Then dip a cloth into fresh water, and wring the water out of the cloth to wipe the detergent off. Then rub with a soft and dry cloth.
- Do not use organic solvent such as thinner, benzene, alcohol, and gasoline.
- For genuine leather seats, use a genuine leather seat cleaner.

C

D

E

F

G

H

I

SE

K

L

M

N

O

P

# PREPARATION

< PREPARATION >

[COUPE]

## PREPARATION

### PREPARATION

#### Special Service Tool

INFOID:000000004206788

The actual shapes of Kent-Moore tools may differ from those of special service tools illustrated here.

Tool number (Kent-Moore No.) Tool name	Description
— (J-39570) Chassis ear	Locating the noise
— (J-43980) NISSAN Squeak and Rattle Kit	Repairing the cause of noise

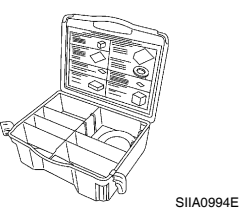
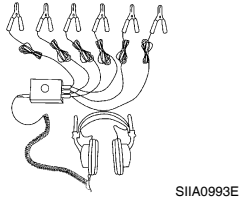

#### Commercial Service Tool

INFOID:000000004206789

(Kent-Moore No.) Tool name	Description
(J-39565) Engine ear	Locating the noise

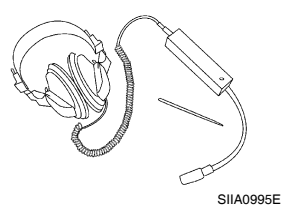

# FRONT SEAT

< ON-VEHICLE REPAIR >

[COUPE]

## ON-VEHICLE REPAIR

### FRONT SEAT

Exploded View

DRIVER'S SEAT

INFOID:000000004523218

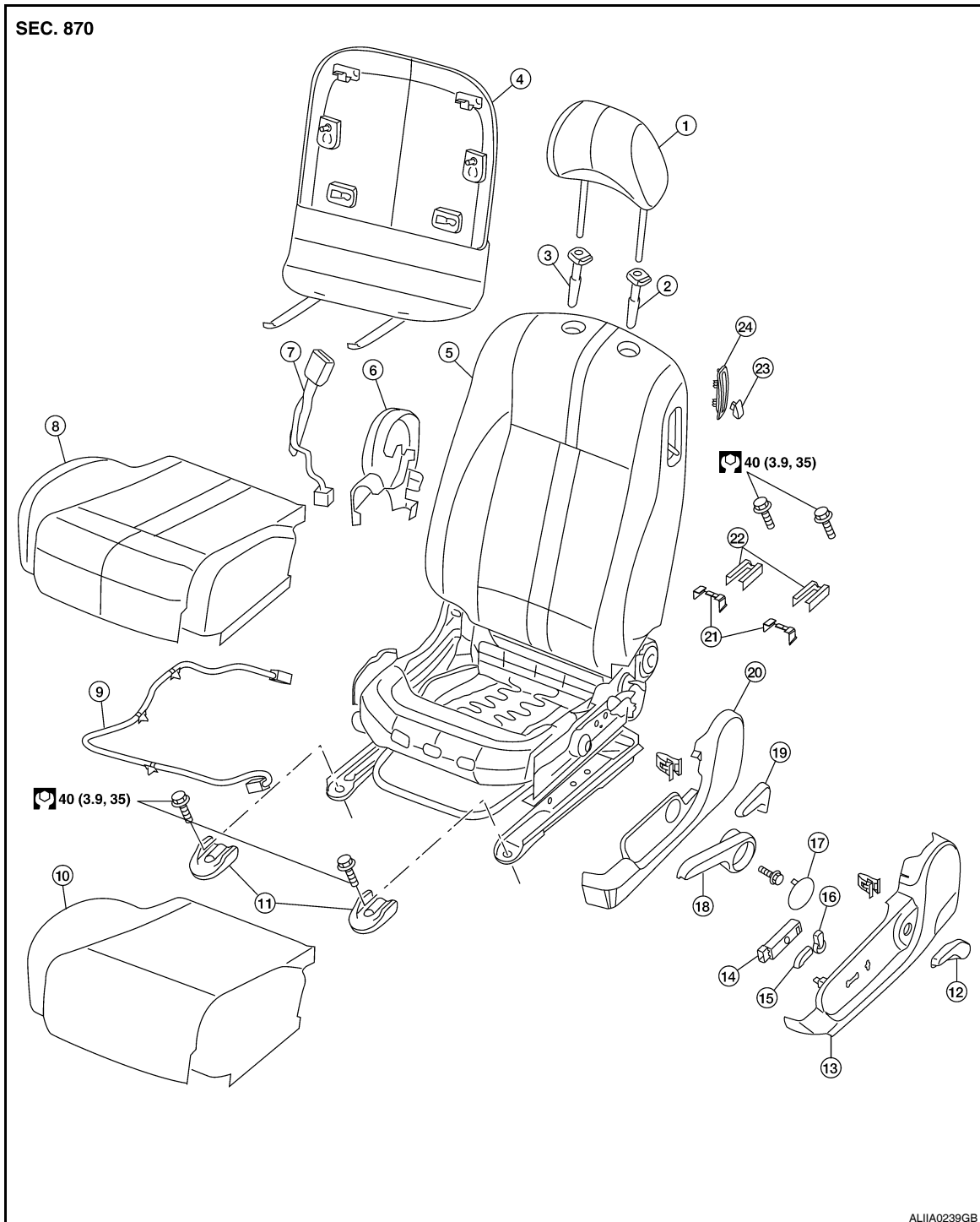

- |                      |                            |                             |
|----------------------|----------------------------|-----------------------------|
| 1. Headrest          | 2. Headrest holder (free)  | 3. Headrest holder (locked) |
| 4. Seatback board    | 5. Seatback/frame assembly | 6. Inner finisher           |
| 7. Seat belt buckle  | 8. Seat cushion trim       | 9. Seat harness             |
| 10. Seat cushion pad | 11. Front leg covers       | 12. Lumbar lever            |

A  
B  
C  
D  
E  
F  
G  
H  
I  
SE  
K  
L  
M  
N  
O  
P

# FRONT SEAT

< ON-VEHICLE REPAIR >

[COUPE]

- |                                      |                                |                               |
|--------------------------------------|--------------------------------|-------------------------------|
| 13. Power seat outer finisher        | 14. Seat switch assembly       | 15. Seat slide switch         |
| 16. Seat reclining switch            | 17. Recline lever finisher     | 18. Manual seat recline lever |
| 19. Manual seat outer lower finisher | 20. Manual seat outer finisher | 21. Manual slide cover        |
| 22. Power rear leg covers            | 23. Entry knob                 | 24. Bezel                     |

## PASSENGER'S SEAT

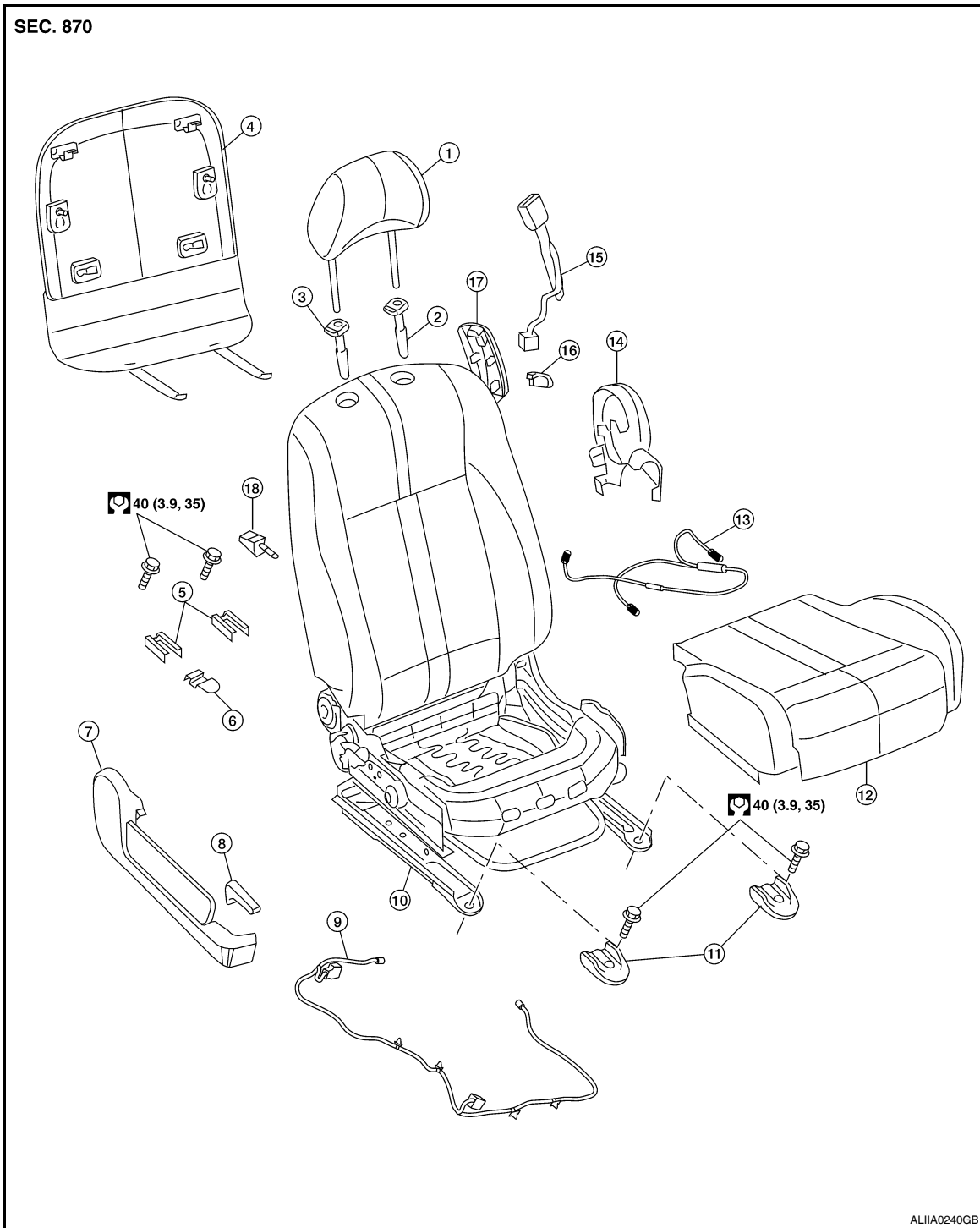

ALIIA0240GB

- |                             |                             |                           |
|-----------------------------|-----------------------------|---------------------------|
| 1. Headrest                 | 2. Headrest holder (locked) | 3. Headrest holder (free) |
| 4. Seatback board           | 5. Rear leg covers          | 6. Clip harness           |
| 7. Outer finisher           | 8. Seatback lever           | 9. Power seat harness     |
| 10. Seatback/frame assembly | 11. Front leg covers        | 12. Seat cushion assembly |

# FRONT SEAT

[COUPE]

< ON-VEHICLE REPAIR >

13. SRS seat harness

14. Inner finisher

15. Seat belt buckle

16. Release handle

17. Release handle cover

18. Kick lever

## Removal and Installation

INFOID:000000004206791

### REMOVAL

#### CAUTION:

- Before removing the front seat, turn the ignition switch off, disconnect both battery terminals and wait at least 3 minutes.
- When checking the power seat circuit for continuity using a circuit tester, do not confuse its connector with the side air bag module connector. Such an error may cause the air bag to deploy.
- Do not drop, tilt, or bump the side air bag module while installing the seat. Always handle it with care.
- After front side air bag module inflates, front seatback assembly must be replaced.
- Always replace passenger seat cushion as an assembly with Occupant Classification System.
- When removing or installing the seat trim, handle it carefully to keep dirt out and avoid damage.
- When removing and installing, use shop cloths to protect the parts from damage where they may interfere with other parts.

1. Slide the seat until the four seat bolts are visible and a tool can be inserted.
2. Disconnect the negative and positive battery terminals and wait at least 3 minutes.
3. Disconnect the harness connector for the side air bag module.
4. Disconnect the power seat harness connector and vehicle harness clip from the vehicle.
5. Remove the seat leg covers.
6. Remove the four seat bolts.

### INSTALLATION

Installation is in the reverse order of removal.

- When installing the LH front seats tighten the bolts as shown.

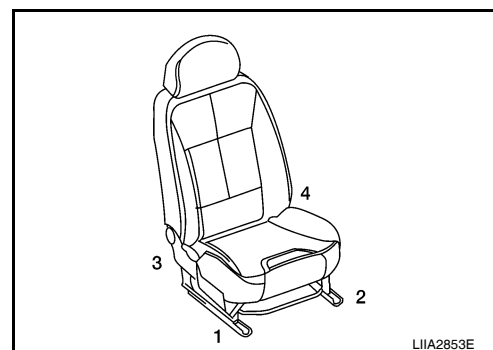

- When installing the RH front seats tighten the bolts as shown.

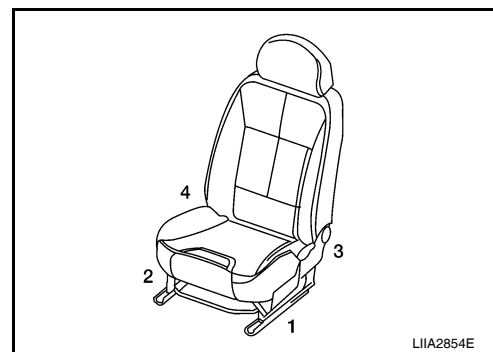

A  
B  
C  
D  
E  
F  
G  
H  
I  
SE  
K  
L  
M  
N  
O  
P

# REAR SEAT

< ON-VEHICLE REPAIR >

[COUPE]

## REAR SEAT

Exploded View

INFOID:000000004206792

SPLIT REAR SEAT

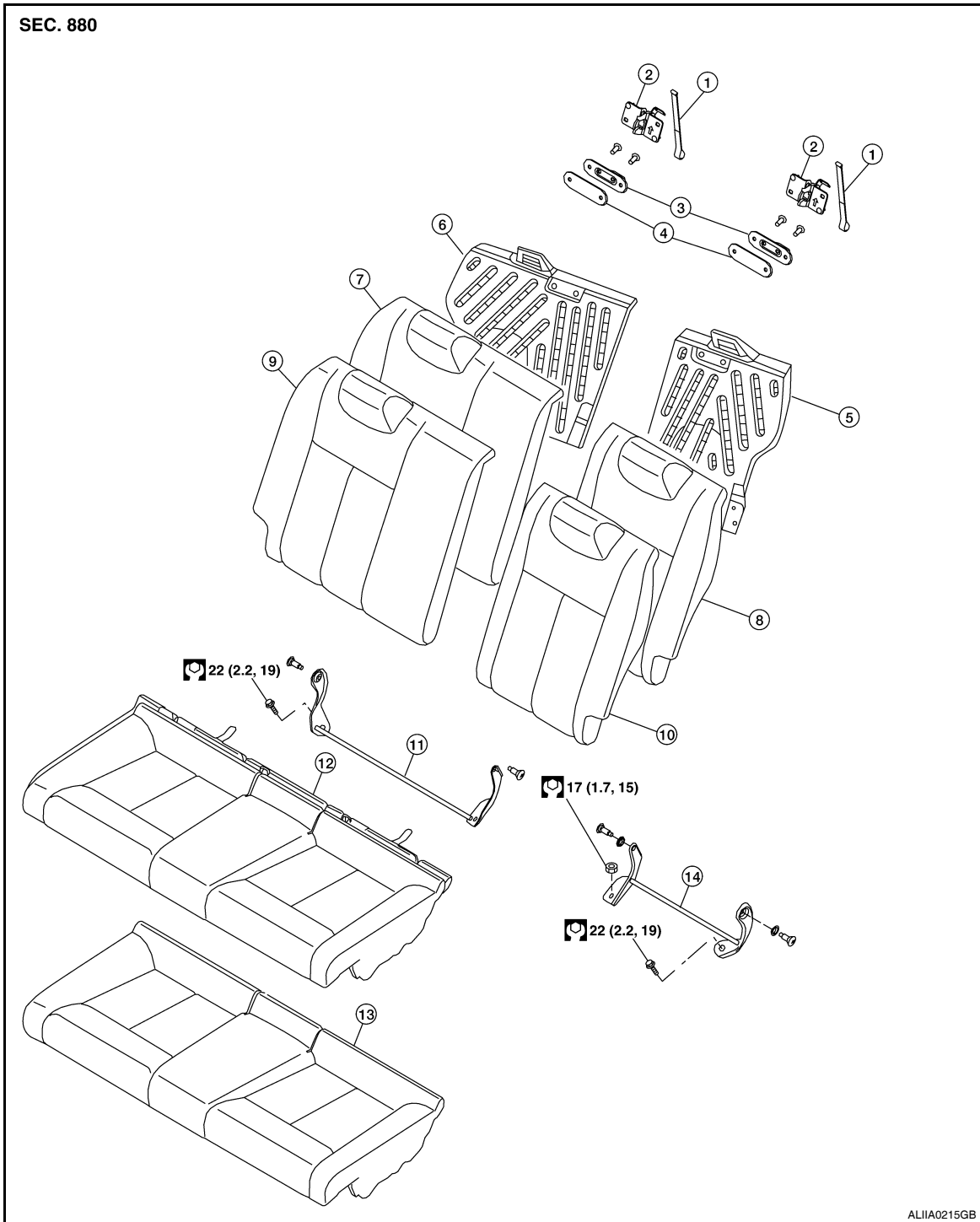

- |                                |                                |                          |
|--------------------------------|--------------------------------|--------------------------|
| 1. Release strap               | 2. Rear seat lock assembly     | 3. Rear striker assembly |
| 4. Rear seatback reinforcement | 5. LH seatback frame           | 6. RH seatback frame     |
| 7. RH seatback pad             | 8. LH seatback pad             | 9. RH seatback trim      |
| 10. LH seatback trim           | 11. RH seatback hinge assembly | 12. Seat cushion trim    |
| 13. Seat cushion pad           | 14. LH seatback hinge assembly |                          |



Removal and Installation

INFOID:000000004206793

REMOVAL

1. Remove the rear seat cushion trim and pad.
  - Pull the seat cushion upward to release the wire from the plastic hook, then pull the seat cushion forward to remove.
2. Remove the seat belt webbing from the guides.
3. Remove the seatback hinge anchor bolts and nut.
4. Remove the seatback assemblies.

INSTALLATION

Installation is in the reverse order of removal.

A  
B  
C  
D  
E  
F  
G  
H  
I  
K  
L  
M  
N  
O  
P

SE

# FRONT SEAT

< DISASSEMBLY AND ASSEMBLY >

[COUPE]

## DISASSEMBLY AND ASSEMBLY

FRONT SEAT

DRIVER SIDE

DRIVER SIDE : Exploded View

INFOID:000000004206794

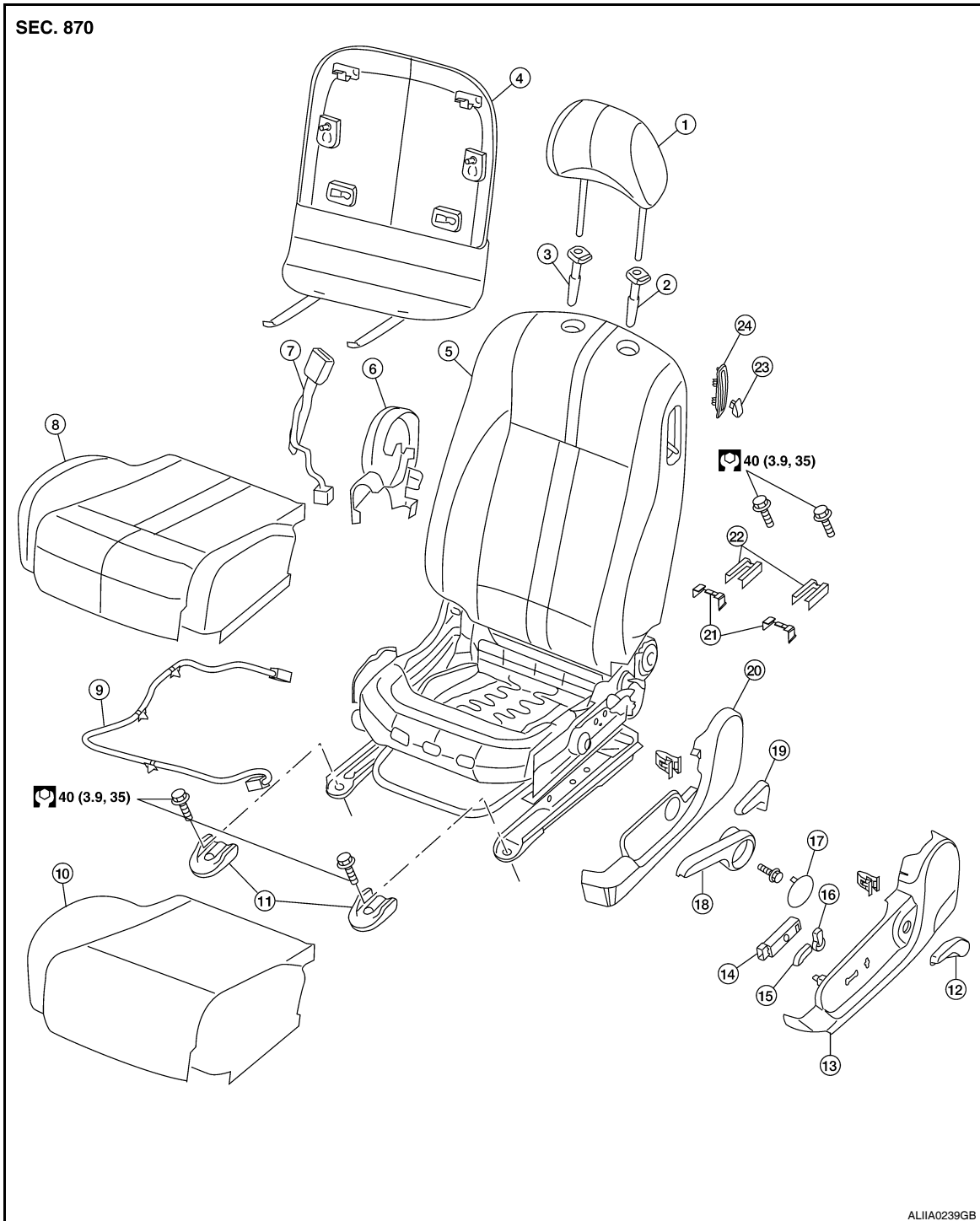

- |                      |                             |                           |
|----------------------|-----------------------------|---------------------------|
| 1. Headrest          | 2. Headrest holder (locked) | 3. Headrest holder (free) |
| 4. Seatback board    | 5. Seatback/frame assembly  | 6. Inner finisher         |
| 7. Seat belt buckle  | 8. Seat cushion trim        | 9. Seat harness           |
| 10. Seat cushion pad | 11. Front leg covers        | 12. Lumbar lever          |

# FRONT SEAT

[COUPE]

## < DISASSEMBLY AND ASSEMBLY >

- |                                |                                 |                              |
|--------------------------------|---------------------------------|------------------------------|
| 13. Power seat outer finisher  | 14. Seat switch assembly        | 15. Seat slide switch        |
| 16. Power seat recline lever   | 17. Manual seat lifter finisher | 18. Manual seat lifter lever |
| 19. Manual seat recline lever  | 20. Manual seat outer finisher  | 21. Manual slide cover       |
| 22. Power seat rear leg covers | 23. Entry knob                  | 24. Bezel                    |

A  
B

## DRIVER SIDE : Disassembly and Assembly

INFOID:000000004206795

### SEAT CUSHION TRIM AND PAD

#### Disassembly

#### CAUTION:

- During installation, the wire harness clips must be reinstalled in the holes they were originally in. Do not add additional clips.

#### NOTE:

If the vehicle has been involved in a collision, the seat must be inspected for damage. Refer to [SR-21. "For Side and Rollover Collision"](#).

1. Remove the front seat assembly. Refer to [SE-23. "Removal and Installation"](#)
2. Remove the front seat finishers and seat outer finisher.
3. Pull up (A) on the seat cushion trim flap (1).
4. Remove two rear clips retaining the seat cushion trim flap, remove seat cushion assembly.

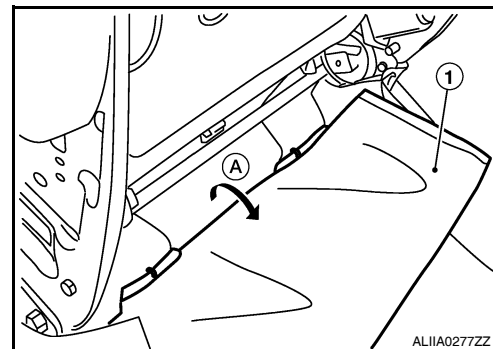

C  
D  
E  
F  
G  
H  
I

5. Remove the retainer on the seat cushion frame, then remove the harness connector for the seat heater.
6. After removing the seat cushion trim and pad, remove the hog rings to separate the trim from the pad and seat cushion heater unit.

SE

#### Assembly

Assembly is in the reverse order of disassembly.

## PASSENGER SIDE

K  
L  
M  
N  
O  
P

# FRONT SEAT

< DISASSEMBLY AND ASSEMBLY >

[COUPE]

## PASSENGER SIDE : Exploded View

INFOID:000000004206796

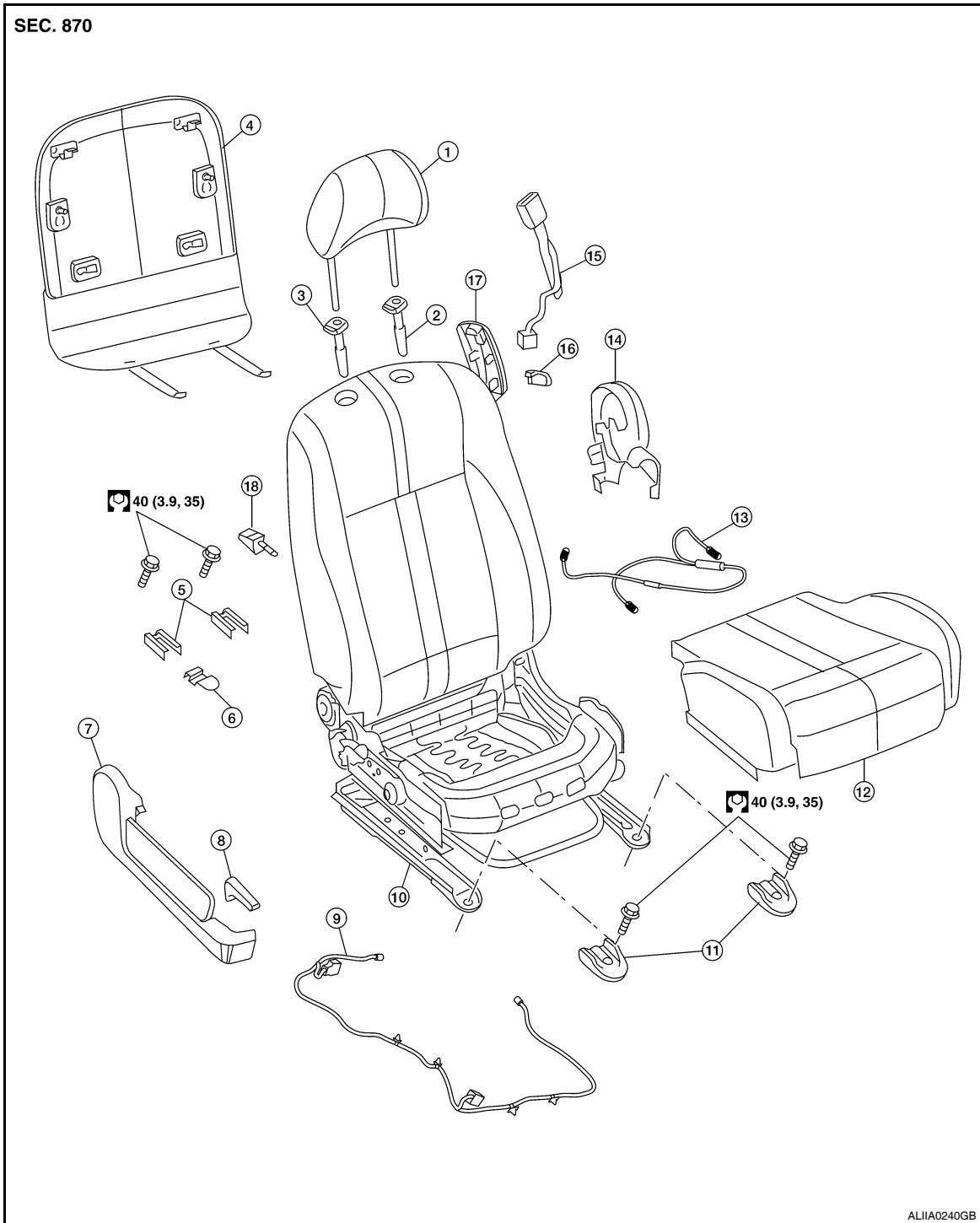

- |                             |                           |                             |
|-----------------------------|---------------------------|-----------------------------|
| 1. Headrest                 | 2. Headrest holder (free) | 3. Headrest holder (locked) |
| 4. Seatback board           | 5. Rear leg covers        | 6. Clip harness             |
| 7. Outer finisher           | 8. Seatback lever         | 9. Power seat harness       |
| 10. Seatback/frame assembly | 11. Front leg covers      | 12. Seat cushion assembly   |
| 13. SRS seat harness        | 14. Inner finisher        | 15. Seat belt buckle        |
| 16. Release handle          | 17. Release handle cover  | 18. Kick lever              |

# FRONT SEAT

< DISASSEMBLY AND ASSEMBLY >

[COUPE]

## PASSENGER SIDE : Disassembly

INFOID:00000004206797

### Disassembly and Assembly

#### Disassembly

#### **CAUTION:**

- During installation, the wire harness clips must be reinstalled in the holes they were originally in. Do not add additional clips.

#### **NOTE:**

If the vehicle has been involved in a collision, the seat must be inspected for damage. Refer to [SR-21, "For Side and Rollover Collision"](#).

1. Remove the front seat assembly. Refer to [SE-23, "Removal and Installation"](#)
2. Remove the front seat finishers and seat outer finisher.
3. Pull up (A) on the seat cushion trim flap (1).
4. Remove two rear clips retaining the seat cushion trim flap, remove seat cushion assembly.

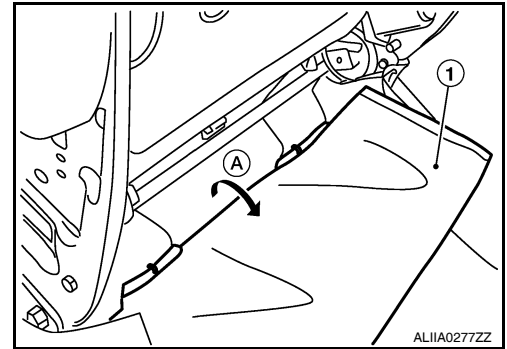

5. Remove the retainer on the seat cushion frame, then remove the harness connector for the seat heater.
6. After removing the seat cushion trim and pad, remove the hog rings to separate the trim from the pad and seat cushion heater unit.

#### Assembly

Assembly is in the reverse order of disassembly.

A  
B  
C  
D  
E  
F  
G  
H  
I  
K  
L  
M  
N  
O  
P

SE

# COMPONENT DIAGNOSIS

## POWER SEAT FOR DRIVER SIDE

### Wiring Diagram

INFOID:000000004206798

POWER SEAT FOR DRIVER SIDE

◀LM▶ : WITH POWER LUMBAR SUPPORT

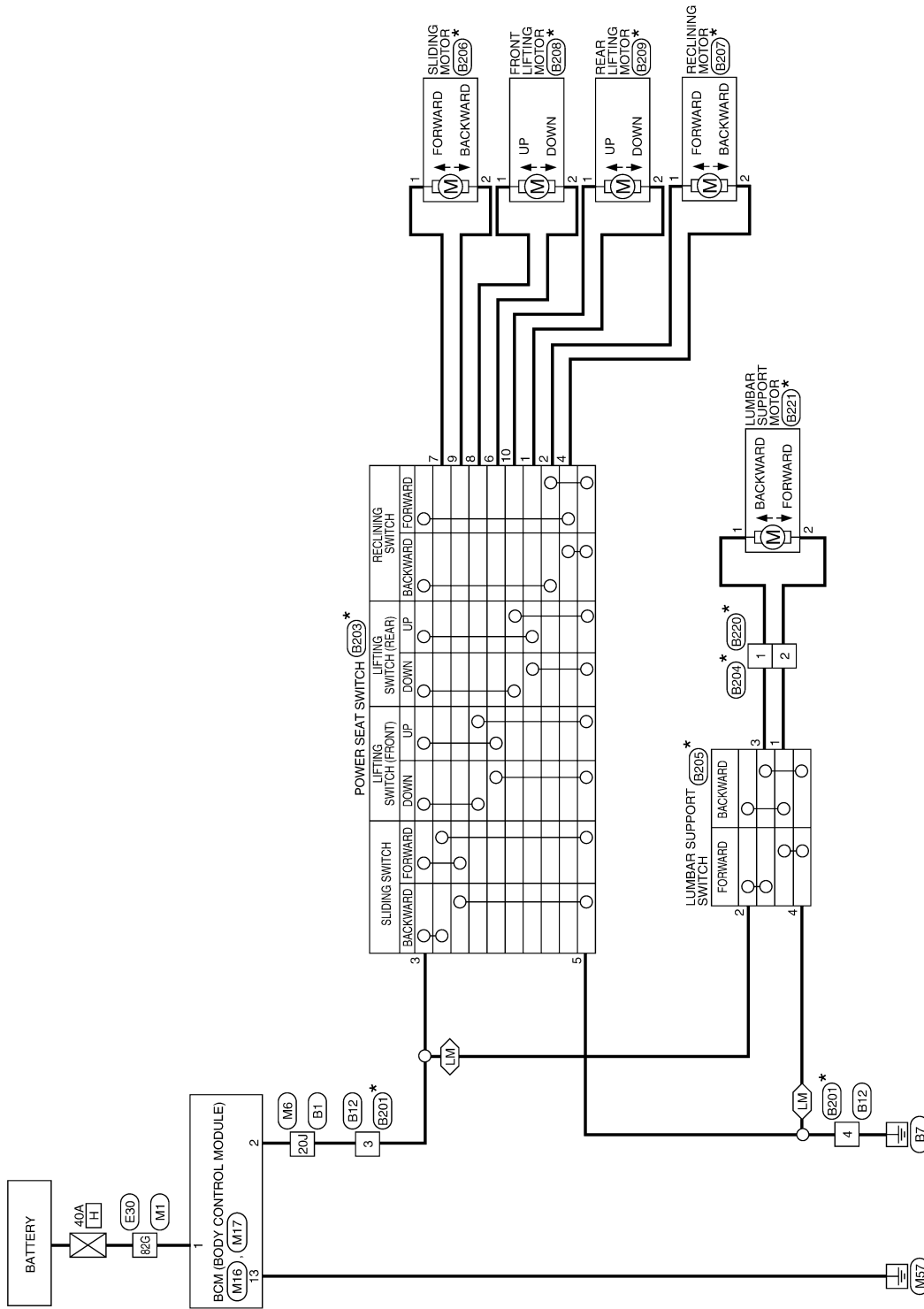

\* : THIS CONNECTOR IS NOT SHOWN IN "HARNES LAYOUT" OF PG SECTION.

ABJWA0060GE

# POWER SEAT FOR DRIVER SIDE

< COMPONENT DIAGNOSIS >

[SEDAN]

## POWER SEAT FOR DRIVER SIDE CONNECTORS

Terminal No.	Color of Wire	Signal Name
20J	R/Y	-

Connector No.	M6
Connector Name	WIRE TO WIRE
Connector Color	WHITE

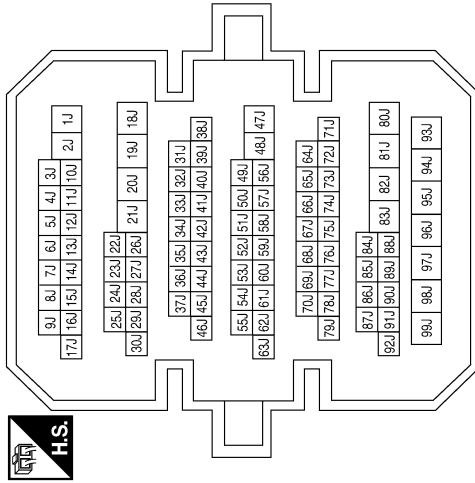

Connector No.	M1
Connector Name	WIRE TO WIRE
Connector Color	WHITE

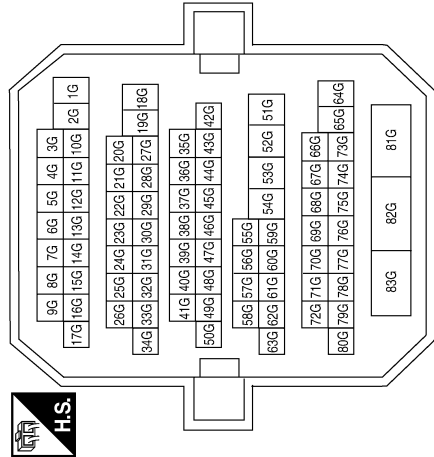

Terminal No.	Color of Wire	Signal Name
82G	W/B	-

Connector No.	M17
Connector Name	BCM (BODY CONTROL MODULE)
Connector Color	WHITE



Terminal No.	Color of Wire	Signal Name
13	B	GND1

Connector No.	M16
Connector Name	BCM (BODY CONTROL MODULE)
Connector Color	BLACK



Terminal No.	Color of Wire	Signal Name
1	W/B	BAT_POWER_F/L
2	R/Y	P/W_POWER_SUPPLY_PERM

ABJIA0185GB

A  
B  
C  
D  
E  
F  
G  
H  
I  
SE  
K  
L  
M  
N  
O  
P

# POWER SEAT FOR DRIVER SIDE

< COMPONENT DIAGNOSIS >

[SEDAN]

Connector No.	B12
Connector Name	WIRE TO WIRE
Connector Color	WHITE

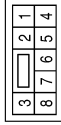

Terminal No.	Color of Wire	Signal Name
3	R/Y	-
4	B/Y	-

Connector No.	B1
Connector Name	WIRE TO WIRE
Connector Color	WHITE

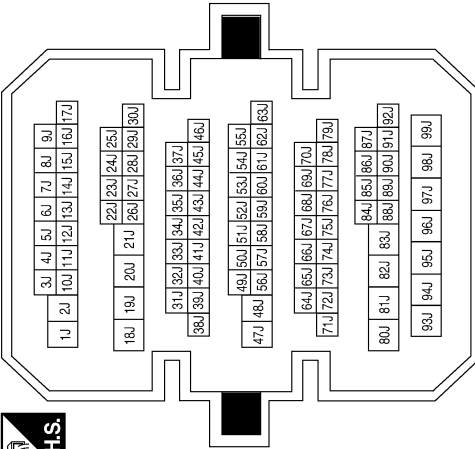

Terminal No.	Color of Wire	Signal Name
20J	R/Y	-

Connector No.	E30
Connector Name	WIRE TO WIRE
Connector Color	WHITE

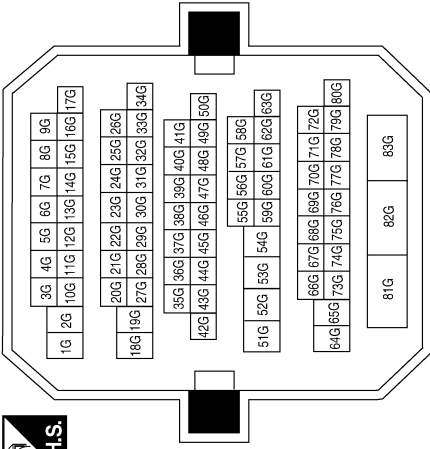

Terminal No.	Color of Wire	Signal Name
82G	W/B	-

Terminal No.	Color of Wire	Signal Name
2	G	RECLINING MOTOR
3	R/Y	BAT
4	LG	RECLINING MOTOR
5	B	GND
6	V	FRONT LIFTING MOTOR
7	W	SLIDING MOTOR
8	O	FRONT LIFTING MOTOR
9	BR	SLIDING MOTOR
10	L	REAR LIFTING MOTOR

Connector No.	B203
Connector Name	POWER SEAT SWITCH
Connector Color	WHITE

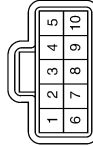

Terminal No.	Color of Wire	Signal Name
1	Y	REAR LIFTING MOTOR

Connector No.	B201
Connector Name	WIRE TO WIRE
Connector Color	WHITE

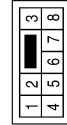

Terminal No.	Color of Wire	Signal Name
3	R/Y	-
4	B	-

ABJIA0186GB



# POWER SEAT FOR DRIVER SIDE

< COMPONENT DIAGNOSIS >

[SEDAN]

Connector No.	B206
Connector Name	SLIDING MOTOR
Connector Color	WHITE



Terminal No.	Color of Wire	Signal Name
1	W	BACKWARD +
2	BR	FORWARD +

Connector No.	B205
Connector Name	LUMBAR SUPPORT SWITCH
Connector Color	WHITE



Terminal No.	Color of Wire	Signal Name
1	R	BACKWARD +
2	R/Y	BAT
3	B/W	FORWARD +
4	B	GND

Connector No.	B204
Connector Name	WIRE TO WIRE
Connector Color	WHITE



Terminal No.	Color of Wire	Signal Name
1	B/W	-
2	R	-

Connector No.	B209
Connector Name	REAR LIFTING MOTOR
Connector Color	WHITE



Terminal No.	Color of Wire	Signal Name
1	L	DOWN +
2	Y	UP +

Connector No.	B208
Connector Name	FRONT LIFTING MOTOR
Connector Color	WHITE



Terminal No.	Color of Wire	Signal Name
1	O	DOWN +
2	V	UP +

Connector No.	B207
Connector Name	RECLINING MOTOR
Connector Color	WHITE



Terminal No.	Color of Wire	Signal Name
1	G	BACKWARD +
2	LG	FORWARD +
3	-	-
4	-	-

ABJIA0196GB

A  
B  
C  
D  
E  
F  
G  
H  
I  
SE  
K  
L  
M  
N  
O  
P

# POWER SEAT FOR DRIVER SIDE

< COMPONENT DIAGNOSIS >

[SEDAN]

Connector No.	B221
Connector Name	LUMBAR SUPPORT MOTOR
Connector Color	BLACK

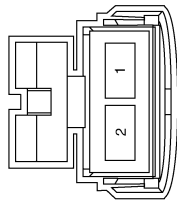

Terminal No.	Color of wire	Signal Name
1	B/W	FORWARD +
2	R	BACKWARD +

Connector No.	B220
Connector Name	WIRE TO WIRE
Connector Color	WHITE

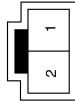

Terminal No.	Color of wire	Signal Name
1	B/W	-
2	R	-

ABJIA0197GB

# HEATED SEAT

< COMPONENT DIAGNOSIS >

[SEDAN]

## HEATED SEAT

### Wiring Diagram

INFOID:000000004206799

HEATED SEAT

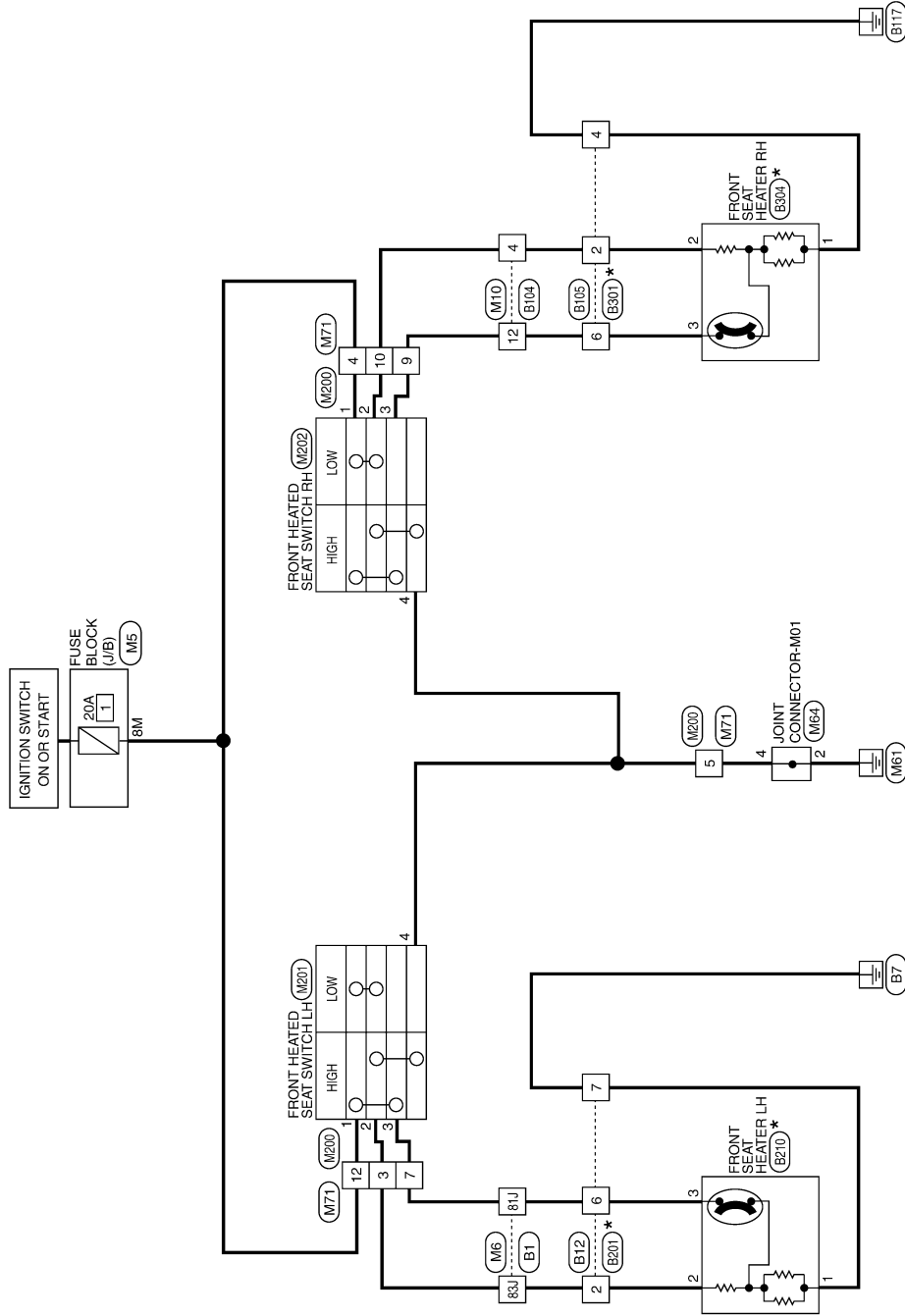

\*: THIS CONNECTOR IS NOT SHOWN IN "HARNES LAYOUT" OF PG SECTION.

AAJWA0017GE

A  
B  
C  
D  
E  
F  
G  
H  
I  
SE  
K  
L  
M  
N  
O  
P

## HEATED SEAT CONNECTORS

Connector No.	M5
Connector Name	FUSE BLOCK (J/B)
Connector Color	WHITE

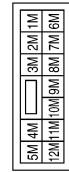

Terminal No.	Color of Wire	Signal Name
8M	G/R	-

Connector No.	M6
Connector Name	WIRE TO WIRE
Connector Color	WHITE

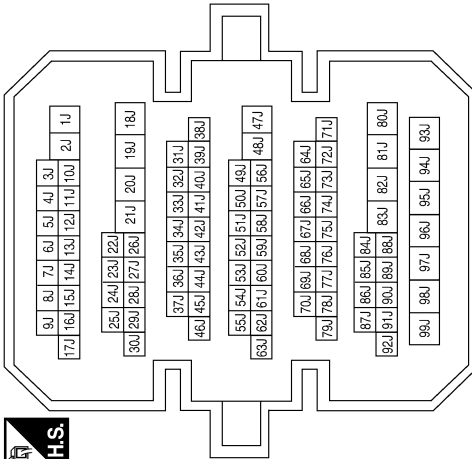

Terminal No.	Color of Wire	Signal Name
81J	GR/R	-
83J	GR	-

Connector No.	M10
Connector Name	WIRE TO WIRE
Connector Color	BROWN

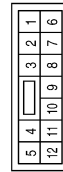

Terminal No.	Color of Wire	Signal Name
4	GR/L	-
12	GR/R	-

Connector No.	M64
Connector Name	JOINT CONNECTOR-M01
Connector Color	GRAY

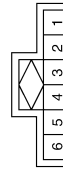

Terminal No.	Color of Wire	Signal Name
2	B	-
4	B	-

# HEATED SEAT

< COMPONENT DIAGNOSIS >

[SEDAN]

Connector No.	M201
Connector Name	FRONT HEATED SEAT SWITCH LH
Connector Color	WHITE



Terminal No.	Color of Wire	Signal Name
1	G/R	IGN
2	GR	HIGH - LOW +
3	GR/R	HIGH +
4	B	GND

Connector No.	M200
Connector Name	WIRE TO WIRE
Connector Color	WHITE

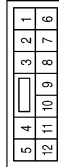

Terminal No.	Color of Wire	Signal Name
3	GR	-
4	G/R	-
5	B	-
7	GR/R	-
9	GR/B	-
10	GR/L	-
12	G/R	-

Connector No.	M71
Connector Name	WIRE TO WIRE
Connector Color	WHITE

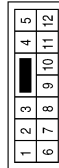

Terminal No.	Color of Wire	Signal Name
3	GR	-
4	G/R	-
5	B	-
7	GR/R	-
9	GR/R	-
10	GR/L	-
12	G/R	-

Connector No.	M202
Connector Name	FRONT HEATED SEAT SWITCH RH
Connector Color	BROWN

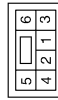

Terminal No.	Color of Wire	Signal Name
1	G/R	IGN
2	GR/L	HIGH - LOW +
3	GR/B	HIGH +
4	B	GND

ABJIA0188GB

A  
B  
C  
D  
E  
F  
G  
H  
I  
SE  
K  
L  
M  
N  
O  
P

# HEATED SEAT

< COMPONENT DIAGNOSIS >

[SEDAN]

Connector No.	B12
Connector Name	WIRE TO WIRE
Connector Color	WHITE

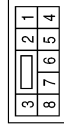

Terminal No.	Color of Wire	Signal Name
2	GR	-
6	GR/W	-
7	B/Y	-

Terminal No.	Color of Wire	Signal Name
81J	GR/W	-
83J	GR	-

Connector No.	B1
Connector Name	WIRE TO WIRE
Connector Color	WHITE

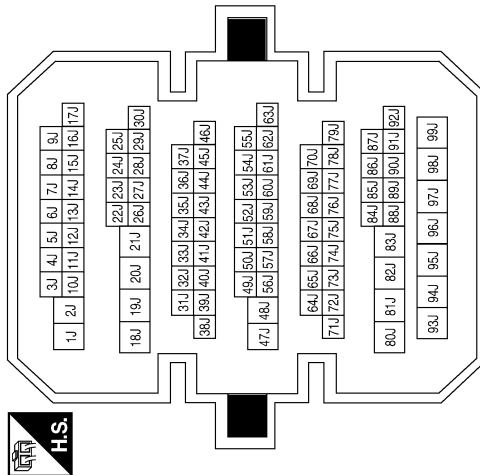

Connector No.	B210
Connector Name	FRONT SEAT HEATER LH
Connector Color	WHITE



Terminal No.	Color of Wire	Signal Name
1	B	GND
2	GR	HIGH - LOW +
3	GR/R	HIGH +

Connector No.	B105
Connector Name	WIRE TO WIRE
Connector Color	BROWN



Terminal No.	Color of Wire	Signal Name
2	GR/G	-
4	B	-
6	GR/R	-

Connector No.	B104
Connector Name	WIRE TO WIRE
Connector Color	BROWN



Terminal No.	Color of Wire	Signal Name
4	GR/G	-
12	GR/R	-

ABJIA0198GB

# HEATED SEAT

< COMPONENT DIAGNOSIS >

[SEDAN]

Connector No.	B304
Connector Name	FRONT SEAT HEATER RH
Connector Color	WHITE



Terminal No.	Color of Wire	Signal Name
1	B	GND
2	GR	HIGH - LOW +
3	GR/R	HIGH +

Connector No.	B301
Connector Name	WIRE TO WIRE
Connector Color	WHITE

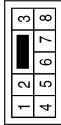

Terminal No.	Color of Wire	Signal Name
2	GR	-
6	GR/R	-
7	B	-

Connector No.	B201
Connector Name	WIRE TO WIRE
Connector Color	WHITE

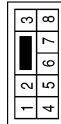

Terminal No.	Color of Wire	Signal Name
2	GR	-
6	GR/R	-
7	B	-

A  
B  
C  
D  
E  
F  
G  
H  
I  
SE  
K  
L  
M  
N  
O  
P

ABJIA0199GB

## SYMPTOM DIAGNOSIS

### SQUEAK AND RATTLE TROUBLE DIAGNOSES

#### Work Flow

INFOID:000000004206800

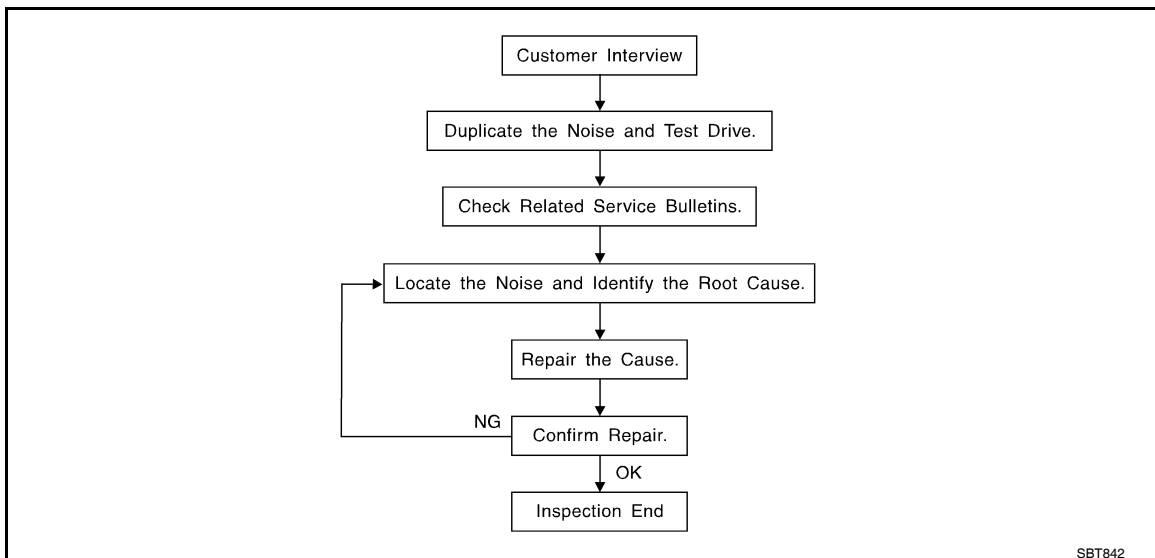

SBT842

#### CUSTOMER INTERVIEW

Interview the customer if possible, to determine the conditions that exist when the noise occurs. Use the Diagnostic Worksheet during the interview to document the facts and conditions when the noise occurs and any customer's comments; refer to [SE-44, "Diagnostic Worksheet"](#). This information is necessary to duplicate the conditions that exist when the noise occurs.

- The customer may not be able to provide a detailed description or the location of the noise. Attempt to obtain all the facts and conditions that exist when the noise occurs (or does not occur).
- If there is more than one noise in the vehicle, be sure to diagnose and repair the noise that the customer is concerned about. This can be accomplished by test driving the vehicle with the customer.
- After identifying the type of noise, isolate the noise in terms of its characteristics. The noise characteristics are provided so the customer, service adviser and technician are all speaking the same language when defining the noise.
- Squeak —(Like tennis shoes on a clean floor)  
Squeak characteristics include the light contact/fast movement/brought on by road conditions/hard surfaces = higher pitch noise/softer surfaces = lowerpitch noises/edge to surface = chirping
- Creak—(Like walking on an old wooden floor)  
Creak characteristics include firm contact/slow movement/twisting with a rotational movement/pitch dependent on materials/often brought on by activity.
- Rattle—(Like shaking a baby rattle)  
Rattle characteristics include the fast repeated contact/vibration or similar movement/loose parts/missing clip or fastener/incorrect clearance.
- Knock —(Like a knock on a door)  
Knock characteristics include hollow sounding/sometimes repeating/often brought on by driver action.
- Tick—(Like a clock second hand)  
Tick characteristics include gentle contacting of light materials/loose components/can be caused by driver action or road conditions.
- Thump—(Heavy, muffled knock noise)  
Thump characteristics include softer knock/dead sound often brought on by activity.
- Buzz—(Like a bumble bee)  
Buzz characteristics include high frequency rattle/firm contact.
- Often the degree of acceptable noise level will vary depending upon the person. A noise that you may judge as acceptable may be very irritating to the customer.
- Weather conditions, especially humidity and temperature, may have a great effect on noise level.

#### DUPLICATE THE NOISE AND TEST DRIVE



# SQUEAK AND RATTLE TROUBLE DIAGNOSES

[SEDAN]

## < SYMPTOM DIAGNOSIS >

If possible, drive the vehicle with the customer until the noise is duplicated. Note any additional information on the Diagnostic Worksheet regarding the conditions or location of the noise. This information can be used to duplicate the same conditions when you confirm the repair.

If the noise can be duplicated easily during the test drive, to help identify the source of the noise, try to duplicate the noise with the vehicle stopped by doing one or all of the following:

- 1) Close a door.
  - 2) Tap or push/pull around the area where the noise appears to be coming from.
  - 3) Rev the engine.
  - 4) Use a floor jack to recreate vehicle "twist".
  - 5) At idle, apply engine load (electrical load, half-clutch on M/T models, drive position on A/T models).
  - 6) Raise the vehicle on a hoist and hit a tire with a rubber hammer.
- Drive the vehicle and attempt to duplicate the conditions the customer states exist when the noise occurs.
  - If it is difficult to duplicate the noise, drive the vehicle slowly on an undulating or rough road to stress the vehicle body.

## CHECK RELATED SERVICE BULLETINS

After verifying the customer concern or symptom, check ASIST for Technical Service Bulletins (TSBs) related to that concern or symptom.

If a TSB relates to the symptom, follow the procedure to repair the noise.

## LOCATE THE NOISE AND IDENTIFY THE ROOT CAUSE

1. Narrow down the noise to a general area. To help pinpoint the source of the noise, use a listening tool (Chassis Ear: J-39570, Engine Ear and mechanics stethoscope).
2. Narrow down the noise to a more specific area and identify the cause of the noise by:
  - removing the components in the area that you suspect the noise is coming from.  
Do not use too much force when removing clips and fasteners, otherwise clips and fastener can be broken or lost during the repair, resulting in the creation of new noise.
  - tapping or pushing/pulling the component that you suspect is causing the noise.  
Do not tap or push/pull the component with excessive force, otherwise the noise will be eliminated only temporarily.
  - feeling for a vibration with your hand by touching the component(s) that you suspect is (are) causing the noise.
  - placing a piece of paper between components that you suspect are causing the noise.
  - looking for loose components and contact marks.  
Refer to [SE-42, "Generic Squeak and Rattle Troubleshooting"](#).

## REPAIR THE CAUSE

- If the cause is a loose component, tighten the component securely.
- If the cause is insufficient clearance between components:
  - separate components by repositioning or loosening and retightening the component, if possible.
  - insulate components with a suitable insulator such as urethane pads, foam blocks, felt cloth tape or urethane tape. A Nissan Squeak and Rattle Kit (J-43980) is available through your authorized Nissan Parts Department.

### CAUTION:

**Do not use excessive force as many components are constructed of plastic and may be damaged.**

### NOTE:

Always check with the Parts Department for the latest parts information.

The following materials are contained in the Nissan Squeak and Rattle Kit (J-43980). Each item can be ordered separately as needed.

URETHANE PADS [1.5 mm (0.059 in) thick]

Insulates connectors, harness, etc.

76268-9E005: 100 × 135 mm (3.94 × 5.31 in)/76884-71L01: 60 × 85 mm (2.36 × 3.35 in)/76884-71L02: 15 × 25 mm (0.59 × 0.98 in)

INSULATOR (Foam blocks)

Insulates components from contact. Can be used to fill space behind a panel.

73982-9E000: 45 mm (1.77 in) thick, 50 × 50 mm (1.97 × 1.97 in)/73982-

50Y00: 10 mm (0.39 in) thick, 50 × 50 mm (1.97 × 1.97 in)

INSULATOR (Light foam block)

80845-71L00: 30 mm (1.18 in) thick, 30 × 50 mm (1.18 × 1.97in)

FELT CLOTHTAPE

Used to insulate where movement does not occur. Ideal for instrument panel applications.

# SQUEAK AND RATTLE TROUBLE DIAGNOSES

[SEDAN]

## < SYMPTOM DIAGNOSIS >

68370-4B000: 15 × 25 mm (0.59 × 0.98 in) pad/68239-13E00: 5 mm (0.20 in) wide tape roll

The following materials, not found in the kit, can also be used to repair squeaks and rattles.

### UHMW (TEFLON) TAPE

Insulates where slight movement is present. Ideal for instrument panel applications.

### SILICONE GREASE

Used in place of UHMW tape that will be visible or not fit. Will only last a few months.

### SILICONE SPRAY

Use when grease cannot be applied.

### DUCT TAPE

Use to eliminate movement.

## CONFIRM THE REPAIR

Confirm that the cause of a noise is repaired by test driving the vehicle. Operate the vehicle under the same conditions as when the noise originally occurred. Refer to the notes on the Diagnostic Worksheet.

## Generic Squeak and Rattle Troubleshooting

INFOID:000000004206801

Refer to Table of Contents for specific component removal and installation information.

## INSTRUMENT PANEL

Most incidents are caused by contact and movement between:

1. Acrylic lens and combination meter housing
2. Instrument panel to front pillar finishers
3. Instrument panel to windshield
4. Instrument panel mounting pins
5. Wiring harnesses behind the combination meter
6. A/C defroster duct and duct joint

These incidents can usually be located by tapping or moving the components to duplicate the noise or by pressing on the components while driving to stop the noise. Most of these incidents can be repaired by applying felt cloth tape or silicon spray (in hard to reach areas). Urethane pads can be used to insulate wiring harness.

### **CAUTION:**

**Do not use silicone spray to isolate a squeak or rattle. If you saturate the area with silicone, you will not be able to recheck the repair.**

## CENTER CONSOLE

Components to pay attention to include:

1. Shifter assembly cover to finisher
2. A/C control unit and cluster lid C
3. Wiring harnesses behind audio and A/C control unit

The instrument panel repair and isolation procedures also apply to the center console.

## DOORS

Pay attention to the:

1. Finisher and inner panel making a slapping noise
2. Inside handle escutcheon to door finisher
3. Wiring harnesses tapping
4. Door striker out of alignment causing a popping noise on starts and stops

Tapping or moving the components or pressing on them while driving to duplicate the conditions can isolate many of these incidents. You can usually insulate the areas with felt cloth tape or insulator foam blocks from the Nissan Squeak and Rattle Kit (J-43980) to repair the noise.

## TRUNK

Trunk noises are often caused by a loose jack or loose items put into the trunk by the owner.

In addition look for:

1. Trunk lid bumpers out of adjustment
2. Trunk lid striker out of adjustment
3. The trunk lid torsion bars knocking together

# SQUEAK AND RATTLE TROUBLE DIAGNOSES

[SEDAN]

## < SYMPTOM DIAGNOSIS >

4. A loose license plate or bracket

Most of these incidents can be repaired by adjusting, securing or insulating the item(s) or component(s) causing the noise.

## SUNROOF/HEADLINING

Noises in the sunroof/headlining area can often be traced to one of the following:

1. Sunroof lid, rail, linkage or seals making a rattle or light knocking noise
2. Sunvisor shaft shaking in the holder
3. Front or rear windshield touching headlining and squeaking

Again, pressing on the components to stop the noise while duplicating the conditions can isolate most of these incidents. Repairs usually consist of insulating with felt cloth tape.

## OVERHEAD CONSOLE (FRONT AND REAR)

Overhead console noises are often caused by the console panel clips not being engaged correctly. Most of these incidents are repaired by pushing up on the console at the clip locations until the clips engage.

In addition, look for:

1. Loose harness or harness connectors.
2. Front console map/reading lamp lens loose.
3. Loose screws at console attachment points.

## SEATS

When isolating seat noise it's important to note the position the seat is in and the load placed on the seat when the noise is present. These conditions should be duplicated when verifying and isolating the cause of the noise.

Cause of seat noise include:

1. Headrest rods and holder
2. A squeak between the seat pad cushion and frame
3. The rear seatback lock and bracket

These noises can be isolated by moving or pressing on the suspected components while duplicating the conditions under which the noise occurs. Most of these incidents can be repaired by repositioning the component or applying urethane tape to the contact area.

## UNDERHOOD

Some interior noise may be caused by components under the hood or on the engine wall. The noise is then transmitted into the passenger compartment.

Causes of transmitted underhood noise include:

1. Any component mounted to the engine wall
2. Components that pass through the engine wall
3. Engine wall mounts and connectors
4. Loose radiator mounting pins
5. Hood bumpers out of adjustment
6. Hood striker out of adjustment

These noises can be difficult to isolate since they cannot be reached from the interior of the vehicle. The best method is to secure, move or insulate one component at a time and test drive the vehicle. Also, engine RPM or load can be changed to isolate the noise. Repairs can usually be made by moving, adjusting, securing, or insulating the component causing the noise.

A  
B  
C  
D  
E  
F  
G  
H  
I  
K  
L  
M  
N  
O  
P

SE

# SQUEAK AND RATTLE TROUBLE DIAGNOSES

< SYMPTOM DIAGNOSIS >

[SEDAN]

## Diagnostic Worksheet

INFOID:000000004206802

Dear Customer:

We are concerned about your satisfaction with your vehicle. Repairing a squeak or rattle sometimes can be very difficult. To help us fix your vehicle right the first time, please take a moment to note the area of the vehicle where the squeak or rattle occurs and under what conditions. You may be asked to take a test drive with a service advisor or technician to ensure we confirm the noise you are hearing.

### SQUEAK & RATTLE DIAGNOSTIC WORKSHEET

#### I. WHERE DOES THE NOISE COME FROM? (circle the area of the vehicle)

The illustrations are for reference only, and may not reflect the actual configuration of your vehicle.

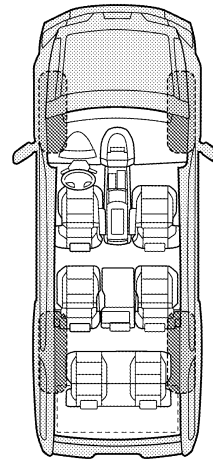
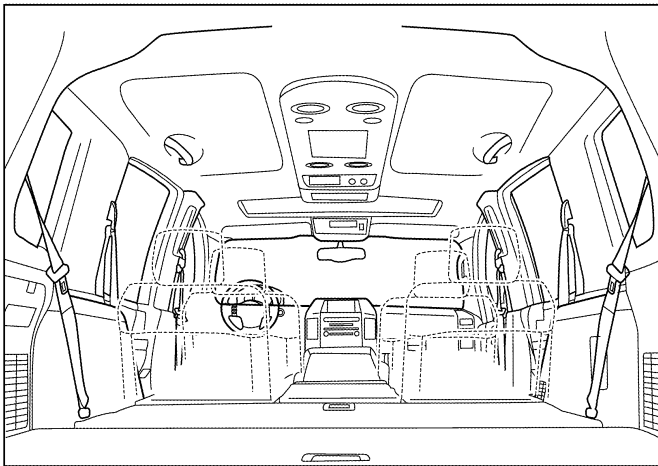
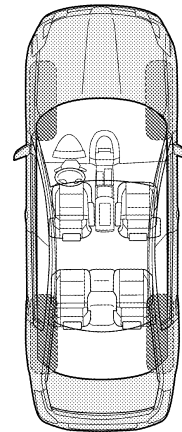
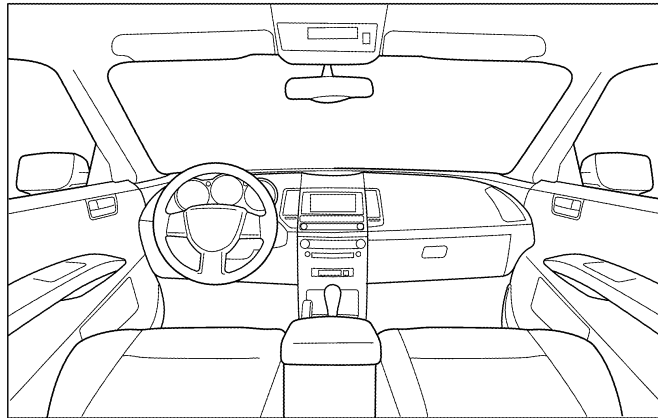

Continue to page 2 of the worksheet and briefly describe the location of the noise or rattle. In addition, please indicate the conditions which are present when the noise occurs.

# SQUEAK AND RATTLE TROUBLE DIAGNOSES

< SYMPTOM DIAGNOSIS >

[SEDAN]

## SQUEAK & RATTLE DIAGNOSTIC WORKSHEET - page 2

Briefly describe the location where the noise occurs:

---

---

### II. WHEN DOES IT OCCUR? (please check the boxes that apply)

- |   |  |
|---|--|
| <input type="checkbox"/> Anytime                      | <input type="checkbox"/> After sitting out in the rain |
| <input type="checkbox"/> 1st time in the morning      | <input type="checkbox"/> When it is raining or wet     |
| <input type="checkbox"/> Only when it is cold outside | <input type="checkbox"/> Dry or dusty conditions       |
| <input type="checkbox"/> Only when it is hot outside  | <input type="checkbox"/> Other:                        |

### III. WHEN DRIVING:

- Through driveways
- Over rough roads
- Over speed bumps
- Only about \_\_\_\_ mph
- On acceleration
- Coming to a stop
- On turns: left, right or either (circle)
- With passengers or cargo
- Other: \_\_\_\_\_
- After driving \_\_\_\_ miles or \_\_\_\_ minutes

### IV. WHAT TYPE OF NOISE

- Squeak (like tennis shoes on a clean floor)
- Creak (like walking on an old wooden floor)
- Rattle (like shaking a baby rattle)
- Knock (like a knock at the door)
- Tick (like a clock second hand)
- Thump (heavy muffled knock noise)
- Buzz (like a bumble bee)

### TO BE COMPLETED BY DEALERSHIP PERSONNEL

Test Drive Notes:

---

---

---

	YES	NO	Initials of person performing
Vehicle test driven with customer	<input type="checkbox"/>	<input type="checkbox"/>	_____
- Noise verified on test drive	<input type="checkbox"/>	<input type="checkbox"/>	_____
- Noise source located and repaired	<input type="checkbox"/>	<input type="checkbox"/>	_____
- Follow up test drive performed to confirm repair	<input type="checkbox"/>	<input type="checkbox"/>	_____

VIN: \_\_\_\_\_ Customer Name \_\_\_\_\_

W.O.# \_\_\_\_\_ Date: \_\_\_\_\_

This form must be attached to Work Order

LAI0071E

A  
B  
C  
D  
E  
F  
G  
H  
I  
SE  
K  
L  
M  
N  
O  
P

< PRECAUTION >

## PRECAUTION

### PRECAUTIONS

#### Precaution for Supplemental Restraint System (SRS) "AIR BAG" and "SEAT BELT PRE-TENSIONER"

INFOID:000000004206803

The Supplemental Restraint System such as "AIR BAG" and "SEAT BELT PRE-TENSIONER", used along with a front seat belt, helps to reduce the risk or severity of injury to the driver and front passenger for certain types of collision. This system includes seat belt switch inputs and dual stage front air bag modules. The SRS system uses the seat belt switches to determine the front air bag deployment, and may only deploy one front air bag, depending on the severity of a collision and whether the front occupants are belted or unbelted. Information necessary to service the system safely is included in the SR and SB section of this Service Manual.

**WARNING:**

- To avoid rendering the SRS inoperative, which could increase the risk of personal injury or death in the event of a collision which would result in air bag inflation, all maintenance must be performed by an authorized NISSAN/INFINITI dealer.
- Improper maintenance, including incorrect removal and installation of the SRS, can lead to personal injury caused by unintentional activation of the system. For removal of Spiral Cable and Air Bag Module, see the SR section.
- Do not use electrical test equipment on any circuit related to the SRS unless instructed to in this Service Manual. SRS wiring harnesses can be identified by yellow and/or orange harnesses or harness connectors.

#### Precautions Necessary for Steering Wheel Rotation after Battery Disconnect

INFOID:000000004466794

**NOTE:**

- Before removing and installing any control units, first turn the push-button ignition switch to the LOCK position, then disconnect both battery cables.
- After finishing work, confirm that all control unit connectors are connected properly, then re-connect both battery cables.
- Always use CONSULT-III to perform self-diagnosis as a part of each function inspection after finishing work. If a DTC is detected, perform trouble diagnosis according to self-diagnosis results.

This vehicle is equipped with a push-button ignition switch and a steering lock unit.

If the battery is disconnected or discharged, the steering wheel will lock and cannot be turned.

If turning the steering wheel is required with the battery disconnected or discharged, follow the procedure below before starting the repair operation.

#### OPERATION PROCEDURE

1. Connect both battery cables.
  - NOTE:**  
Supply power using jumper cables if battery is discharged.
2. Carry the Intelligent Key or insert it to the key slot and turn the push-button ignition switch to ACC position. (At this time, the steering lock will be released.)
3. Disconnect both battery cables. The steering lock will remain released with both battery cables disconnected and the steering wheel can be turned.
4. Perform the necessary repair operation.
5. When the repair work is completed, re-connect both battery cables. With the brake pedal released, turn the push-button ignition switch from ACC position to ON position, then to LOCK position. (The steering wheel will lock when the push-button ignition switch is turned to LOCK position.)
6. Perform self-diagnosis check of all control units using CONSULT-III.

#### Service Notice

INFOID:000000004206804

- When removing or installing various parts, place a cloth or padding onto the vehicle body to prevent scratches.
- Handle trim, molding, instruments, grille, etc. carefully during removing or installing. Be careful not to oil or damage them.

# PRECAUTIONS

[SEDAN]

## < PRECAUTION >

- Apply sealing compound where necessary when installing parts.
- When applying sealing compound, be careful that the sealing compound does not protrude from parts.
- When replacing any metal parts (for example body outer panel, members, etc.), be sure to take rust prevention measures.

A

## Precaution for Work

INFOID:000000004206805

B

- When removing or disassembling each component, be careful not to damage or deform it. If a component may be subject to interference, be sure to protect it with a shop cloth.
- When removing (disengaging) components with a screwdriver or similar tool, be sure to wrap the component with a shop cloth or vinyl tape to protect it.
- Protect the removed parts with a shop cloth and keep them.
- Replace a deformed or damaged clip.
- If a part is specified as a non-reusable part, always replace it with new one.
- Be sure to tighten bolts and nuts securely to the specified torque.
- After re-installation is completed, be sure to check that each part works normally.
- Follow the steps below to clean components.
- Water soluble foul: Dip a soft cloth into lukewarm water, and wring the water out of the cloth to wipe the fouled area.  
Then rub with a soft and dry cloth.
- Oily foul: Dip a soft cloth into lukewarm water with mild detergent (concentration: within 2 to 3%), and wipe the fouled area.  
Then dip a cloth into fresh water, and wring the water out of the cloth to wipe the detergent off. Then rub with a soft and dry cloth.
- Do not use organic solvent such as thinner, benzene, alcohol, and gasoline.
- For genuine leather seats, use a genuine leather seat cleaner.

C

D

E

F

G

H

I

SE

K

L

M

N

O

P

# PREPARATION

< PREPARATION >

[SEDAN]

## PREPARATION

### PREPARATION

#### Special Service Tool

INFOID:000000004206806

The actual shapes of Kent-Moore tools may differ from those of special service tools illustrated here.

Tool number (Kent-Moore No.) Tool name	Description
— (J-39570) Chassis ear	Locating the noise
— (J-43980) NISSAN Squeak and Rattle Kit	Repairing the cause of noise

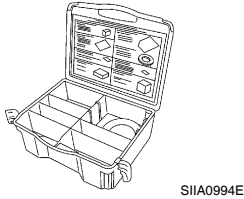
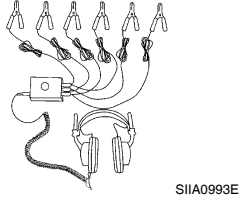

#### Commercial Service Tool

INFOID:000000004206807

(Kent-Moore No.) Tool name	Description
(J-39565) Engine ear	Locating the noise

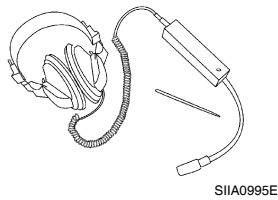



# FRONT SEAT

< ON-VEHICLE REPAIR >

[SEDAN]

## ON-VEHICLE REPAIR

### FRONT SEAT

#### Exploded View

#### DRIVER'S SEAT

INFOID:000000004206808

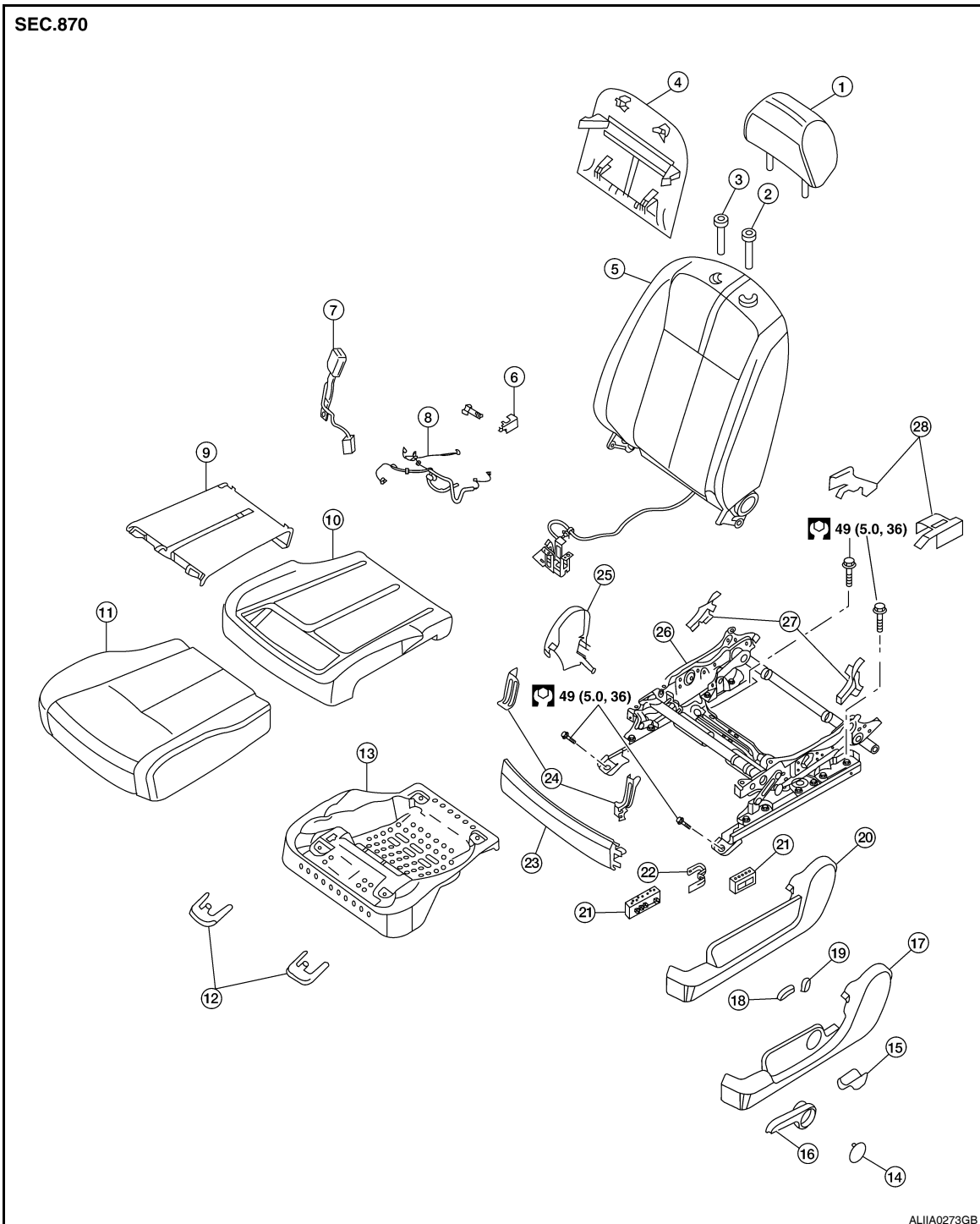

- |                     |                             |                             |
|---------------------|-----------------------------|-----------------------------|
| 1. Headrest         | 2. Headrest holder (locked) | 3. Headrest holder (free)   |
| 4. Seatback board   | 5. Seatback assembly        | 6. Slide cover              |
| 7. Seat belt buckle | 8. Seat harness             | 9. Seat cushion heater unit |
| 10. Seat cushion    | 11. Seat trim               | 12. Front leg covers        |

A  
B  
C  
D  
E  
F  
G  
H  
I  
SE  
K  
L  
M  
N  
O  
P

# FRONT SEAT

[SEDAN]

< ON-VEHICLE REPAIR >

- |                              |                                       |                                 |
|------------------------------|---------------------------------------|---------------------------------|
| 13. Seat cushion frame       | 14. Manual seat lifter lever finisher | 15. Manual seat recliner handle |
| 16. Manual seat lifter lever | 17. Manual seat outer finisher        | 18. Seat slide switch           |
| 19. Seat reclining switch    | 20. Power seat outer finisher         | 21. Seat switch assembly        |
| 22. LH seat bracket          | 23. Front seat finisher               | 24. Cushion bracket             |
| 25. Inner seat cover         | 26. Seat frame assembly               | 27. Cushion finishers           |
| 28. Rear leg covers          |                                       |                                 |

## PASSENGER'S SEAT

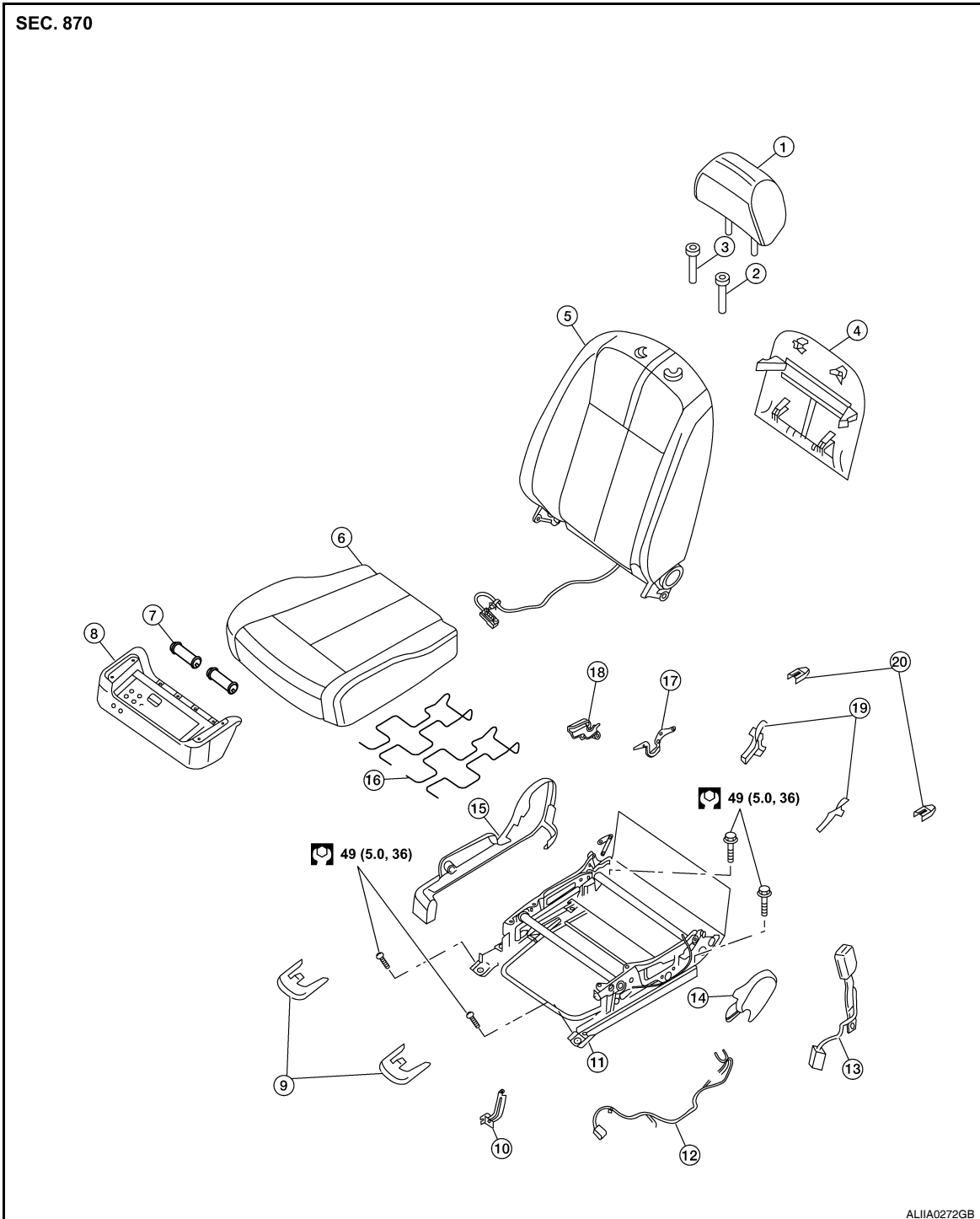

# FRONT SEAT

< ON-VEHICLE REPAIR >

[SEDAN]

- |                            |                                |                           |
|----------------------------|--------------------------------|---------------------------|
| 1. Headrest                | 2. Headrest holder (locked)    | 3. Headrest holder (free) |
| 4. Seatback board          | 5. Seatback assembly           | 6. Seat cushion assembly  |
| 7. Bushing                 | 8. Seat cushion frame assembly | 9. Front leg covers       |
| 10. Cushion bracket        | 11. Seat frame assembly        | 12. Seat harness          |
| 13. Seat belt buckle       | 14. Inner finisher             | 15. Outer finisher        |
| 16. Seat cushion supporter | 17. Recliner mechanism         | 18. Finisher              |
| 19. Cushion finishers      | 20. Rear leg covers            |                           |

A  
B  
C

## Removal and Installation

INFOID:000000004206809

### REMOVAL

#### CAUTION:

- Before removing the front seat, turn the ignition switch off, disconnect both battery terminals and wait at least 3 minutes.
- When checking the power seat circuit for continuity using a circuit tester, do not confuse its connector with the side air bag module connector. Such an error may cause the air bag to deploy.
- Do not drop, tilt, or bump the side air bag module while installing the seat. Always handle it with care.
- After front side air bag module inflates, front seatback assembly must be replaced.
- Always replace passenger seat cushion as an assembly with Occupant Classification System.
- When removing or installing the seat trim, handle it carefully to keep dirt out and avoid damage.
- When removing and installing, use shop cloths to protect the parts from damage where they may interfere with other parts.

D  
E  
F  
G  
H  
I

1. Slide the seat until the four seat bolts are visible and a tool can be inserted.
2. Disconnect the negative and positive battery terminals and wait at least 3 minutes.
3. Disconnect the harness connector for the side air bag module.
4. Disconnect the power seat harness connector and vehicle harness clip from the vehicle.
5. Remove the seat leg covers.
6. Remove the four seat bolts.

SE

### INSTALLATION

Installation is in the reverse order of removal.

- When installing the LH front seats tighten the bolts as shown.

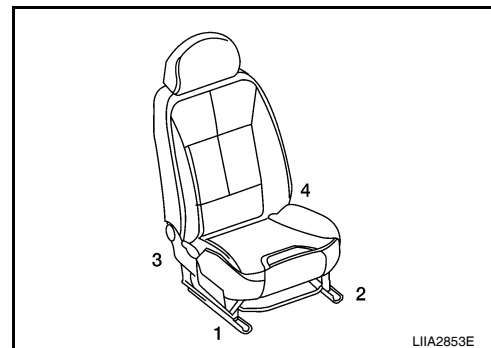

K  
L  
M  
N

- When installing the RH front seats tighten the bolts as shown.

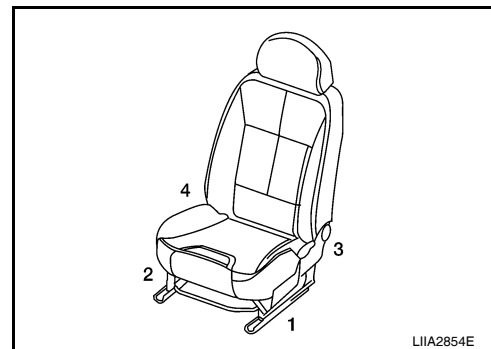

O  
P

# REAR SEAT

[SEDAN]

< ON-VEHICLE REPAIR >

## REAR SEAT

Exploded View

INFOID:000000004206810

BENCH SEAT

SEC.880

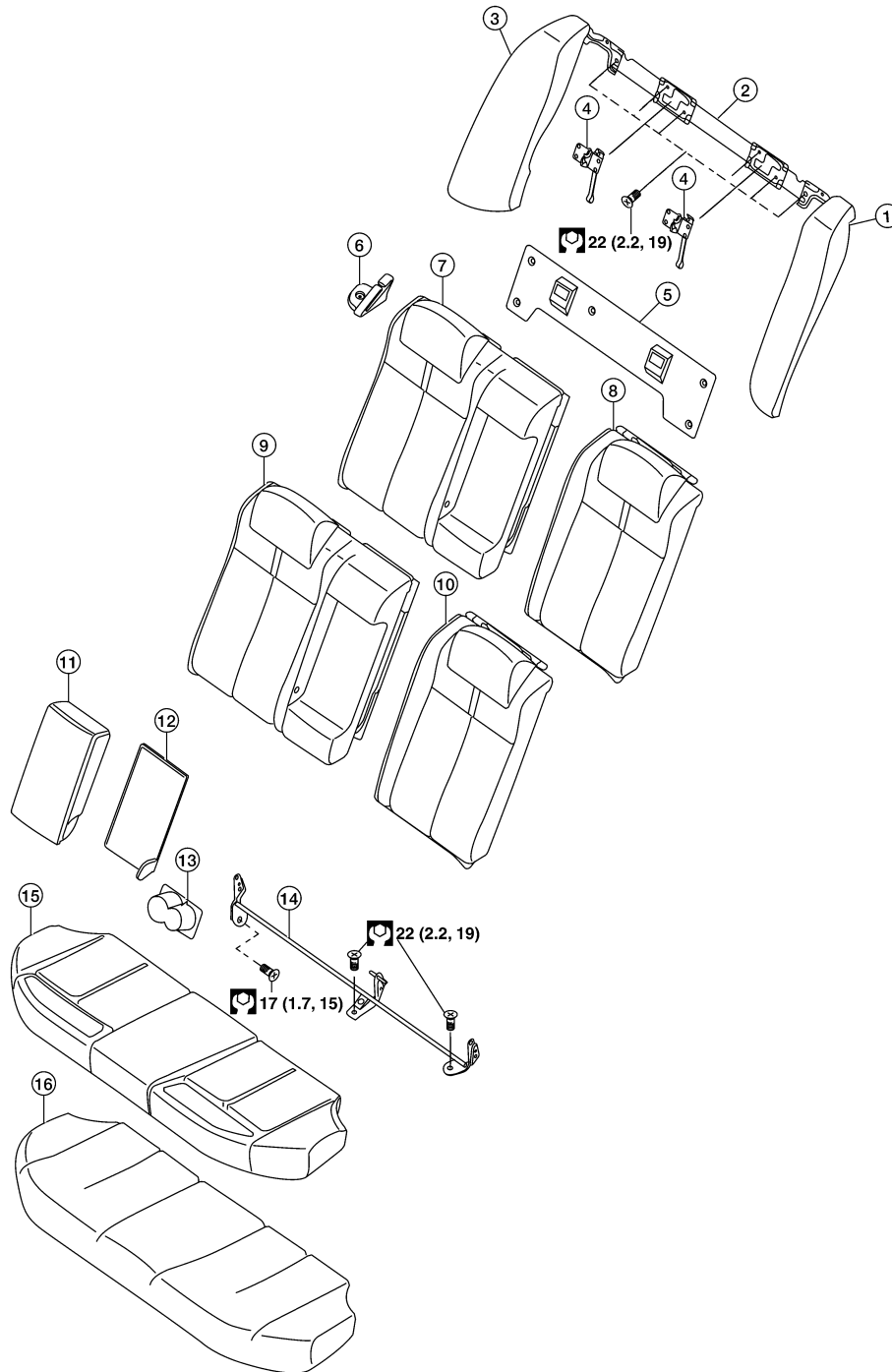

ALIA0028GB

- |                                       |                              |                                       |
|---------------------------------------|------------------------------|---------------------------------------|
| 1. Rear seat side bolster assembly LH | 2. Rear seatback latch mount | 3. Rear seat side bolster assembly RH |
| 4. Rear seatback latch                | 5. Rear seatback trim panel  | 6. Seat belt guide                    |
| 7. Rear seatback pad RH               | 8. Rear seatback pad LH      | 9. Rear seatback pad trim RH          |
| 10. Rear seatback pad trim LH         | 11. Armrest                  | 12. Armrest trim panel                |

# REAR SEAT

< ON-VEHICLE REPAIR >

[SEDAN]

13. Cup holder

14. Rear seatback hinge assembly

15. Rear seat cushion trim

16. Rear seat cushion

## Removal and Installation

INFOID:000000004206811

### REMOVAL

1. Remove the rear seat cushion trim and pad.
  - Pull the lock at the front bottom of the seat cushion forward (one for each side), and pull the seat cushion upward to release the wire from the plastic hook, then pull the seat cushion forward to remove.
2. Remove the seat belt webbing from the guides.
3. Fold seatbacks forward.
4. Remove upper seatback trim panel.
5. Remove rear side bolster bolts.
6. Lock seatbacks in upright position.
7. Remove the seatback hinge anchor bolts and nut.
8. Remove the seatback assembly.

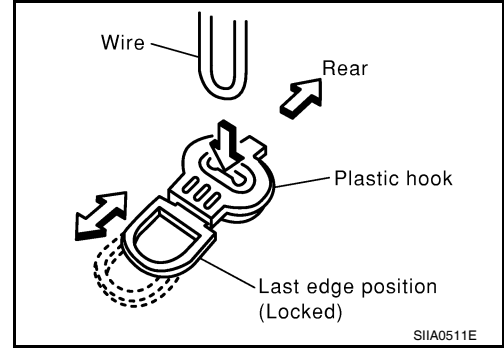

### INSTALLATION

Installation is in the reverse order of removal.

A  
B  
C  
D  
E  
F  
G  
H  
I  
K  
L  
M  
N  
O  
P

SE

# FRONT SEAT

< DISASSEMBLY AND ASSEMBLY >

[SEDAN]

## DISASSEMBLY AND ASSEMBLY

FRONT SEAT

DRIVER SIDE

DRIVER SIDE : Exploded View

INFOID:000000004523219

DRIVER'S SEAT

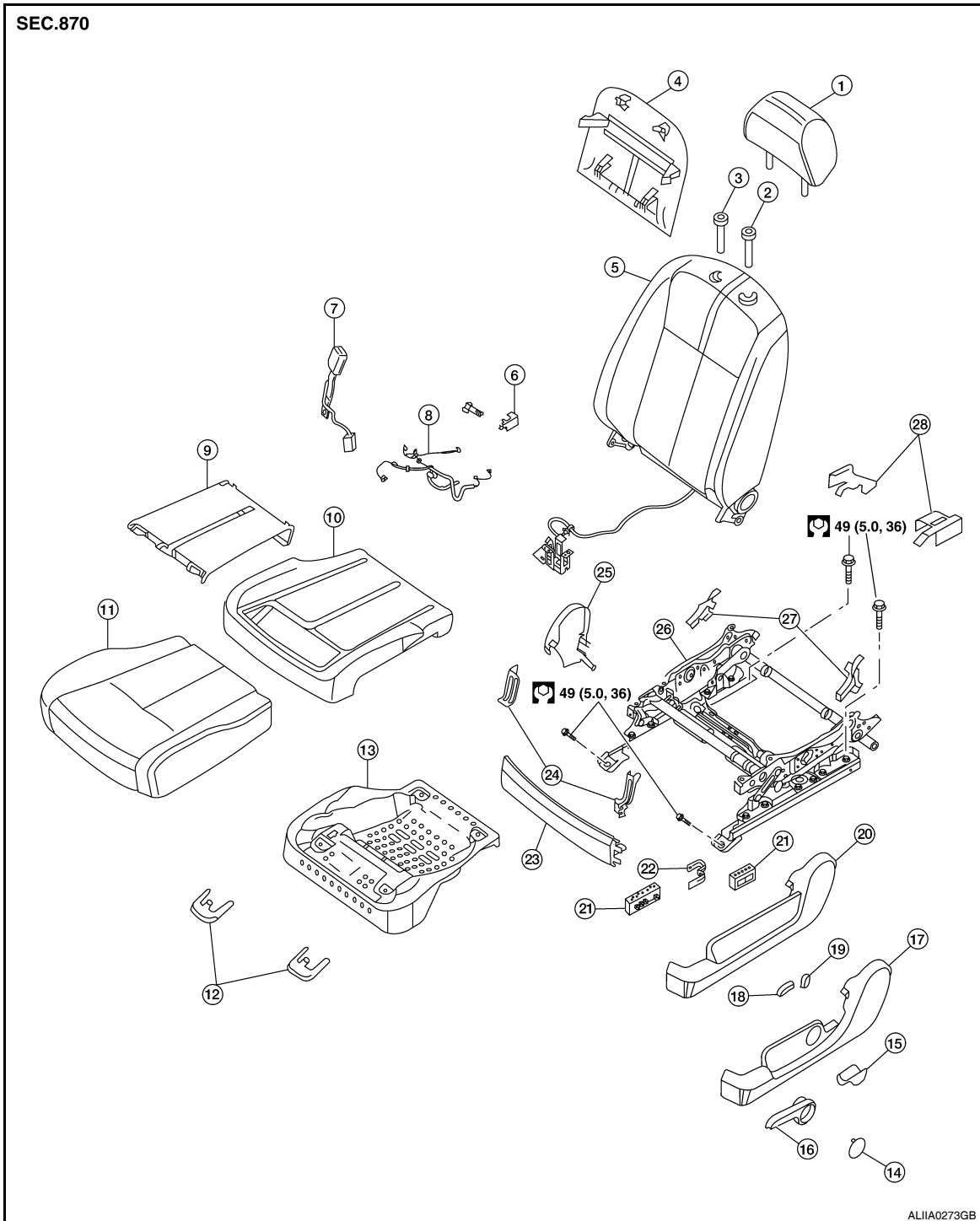

- 1. Headrest
- 4. Seatback board

- 2. Headrest holder (locked)
- 5. Seatback assembly

- 3. Headrest holder (free)
- 6. Slide cover

# FRONT SEAT

< DISASSEMBLY AND ASSEMBLY >

[SEDAN]

- |                              |                                       |                                 |
|------------------------------|---------------------------------------|---------------------------------|
| 7. Seat belt buckle          | 8. Seat harness                       | 9. Seat cushion heater unit     |
| 10. Seat cushion             | 11. Seat trim                         | 12. Front leg covers            |
| 13. Seat cushion frame       | 14. Manual seat lifter lever finisher | 15. Manual seat recliner handle |
| 16. Manual seat lifter lever | 17. Manual seat outer finisher        | 18. Seat slide switch           |
| 19. Seat reclining switch    | 20. Power seat outer finisher         | 21. Seat switch assembly        |
| 22. LH seat bracket          | 23. Front seat finisher               | 24. Cushion bracket             |
| 25. Inner seat cover         | 26. Seat frame assembly               | 27. Cushion finishers           |
| 28. Rear leg covers          |                                       |                                 |

## DRIVER SIDE : Disassembly and Assembly

INFOID:000000004206813

### SEAT CUSHION TRIM AND PAD

Disassembly

#### CAUTION:

- During installation, the wire harness clips must be reinstalled in the holes they were originally in. Do not add additional clips.

#### NOTE:

If the vehicle has been involved in a collision, the seat must be inspected for damage. Refer to [SR-21, "For Side and Rollover Collision"](#).

1. Remove the front seat assembly. Refer to [SE-51, "Removal and Installation"](#)
2. Remove the front seat finishers and seat outer finisher.
3. Pull up (A) on the seat cushion trim flap (1).
4. Remove two rear clips retaining the seat cushion trim flap, remove seat cushion assembly.

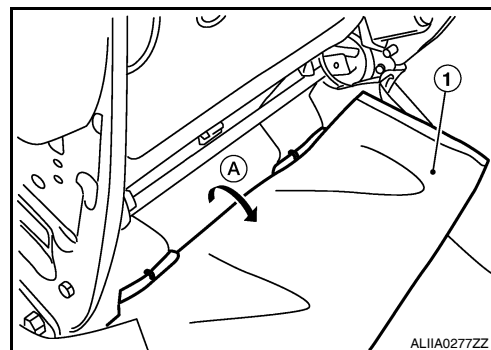

5. Remove the retainer on the seat cushion frame, then remove the harness connector for the seat heater.
6. After removing the seat cushion trim and pad, remove the hog rings to separate the trim from the pad and seat cushion heater unit.

Assembly

Assembly is in the reverse order of disassembly.

### SEATBACK BOARD

Disassembly

#### CAUTION:

- During installation, the wire harness clips must be reinstalled in the holes they were originally in. Do not add additional clips.

#### NOTE:

If the vehicle has been involved in a collision, the seat must be inspected for damage. Refer to [SR-21, "For Side and Rollover Collision"](#).

1. Slide the seat to forward position.

# FRONT SEAT

[SEDAN]

## < DISASSEMBLY AND ASSEMBLY >

2. The seatback board is attached to the seat frame with the following:
- 2 top clips (A) (must be replaced)
  - 2 side hooks (B)
  - 2 bottom hooks (C)

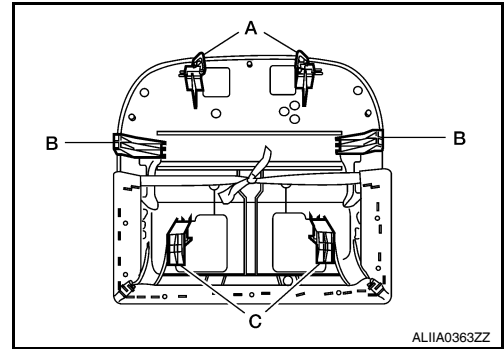

3. Hold the seatback board as shown and push in the side hooks to release them from the seat back frame.
4. Carefully pull up on the seatback board to release the bottom hooks.

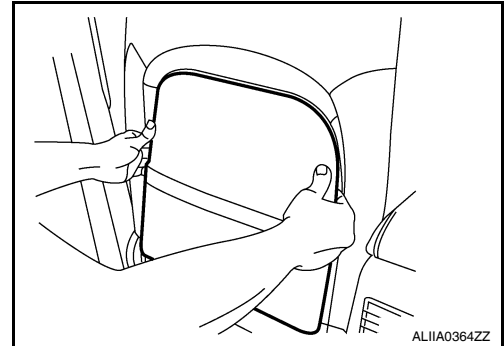

5. Reach in from the bottom of the seatback board to release the top clips. Squeeze the clips at the location shown (A) using suitable tool.

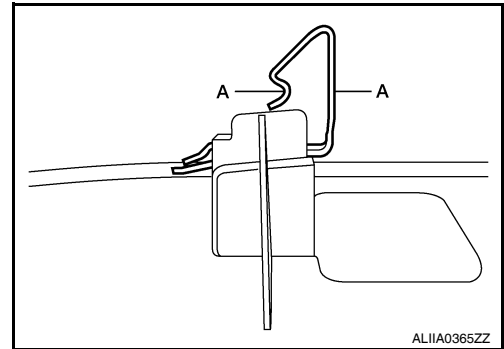

### Assembly

Assembly is in the reverse order of disassembly.

### PASSENGER SIDE

### PASSENGER SIDE : Exploded View

INFOID:000000004523220

### PASSENGER'S SEAT



# FRONT SEAT

< DISASSEMBLY AND ASSEMBLY >

[SEDAN]

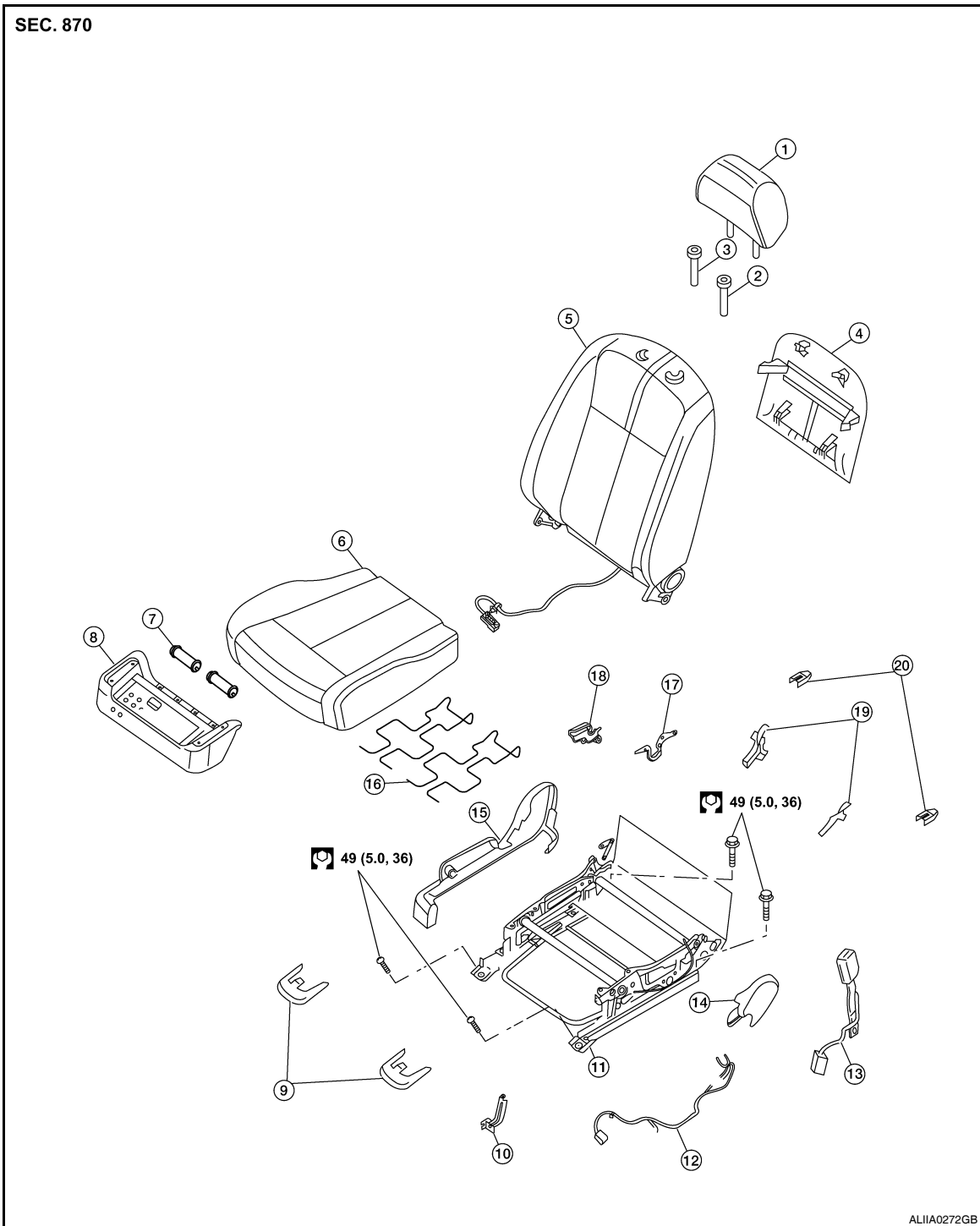

- |                            |                                |                           |
|----------------------------|--------------------------------|---------------------------|
| 1. Headrest                | 2. Headrest holder (locked)    | 3. Headrest holder (free) |
| 4. Seatback board          | 5. Seatback assembly           | 6. Seat cushion assembly  |
| 7. Bushing                 | 8. Seat cushion frame assembly | 9. Front leg covers       |
| 10. Cushion bracket        | 11. Seat frame assembly        | 12. Seat harness          |
| 13. Seat belt buckle       | 14. Inner finisher             | 15. Outer finisher        |
| 16. Seat cushion supporter | 17. Recliner mechanism         | 18. Finisher              |
| 19. Cushion finishers      | 20. Rear leg covers            |                           |

PASSENGER SIDE : Disassembly

INFOID:000000004206815

SEAT CUSHION TRIM AND PAD

# FRONT SEAT

[SEDAN]

## < DISASSEMBLY AND ASSEMBLY >

### Disassembly

#### CAUTION:

- During installation, the wire harness clips must be reinstalled in the holes they were originally in. Do not add additional clips.

#### NOTE:

If the vehicle has been involved in a collision, the seat must be inspected for damage. Refer to [SR-21, "For Side and Rollover Collision"](#).

1. Remove the front seat assembly. Refer to [SE-51, "Removal and Installation"](#)
2. Remove the front seat finishers and seat outer finisher.
3. Pull up (A) on the seat cushion trim flap (1).
4. Remove two rear clips retaining the seat cushion trim flap, remove seat cushion assembly.

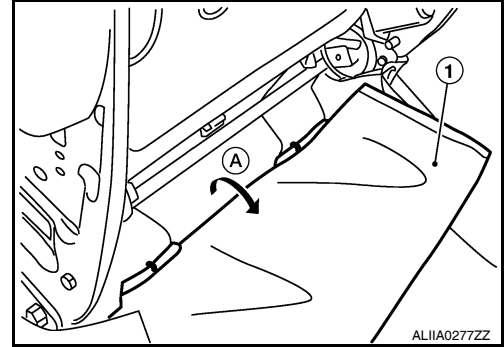

5. Remove the retainer on the seat cushion frame, then remove the harness connector for the seat heater.
6. After removing the seat cushion trim and pad, remove the hog rings to separate the trim from the pad and seat cushion heater unit.

### Assembly

Assembly is in the reverse order of disassembly.

## SEATBACK BOARD

### Disassembly

#### CAUTION:

- During installation, the wire harness clips must be reinstalled in the holes they were originally in. Do not add additional clips.

#### NOTE:

If the vehicle has been involved in a collision, the seat must be inspected for damage. Refer to [SR-21, "For Side and Rollover Collision"](#).

1. Slide the seat to forward position.
2. The seatback board is attached to the seat frame with the following:
  - 2 top clips (A) (must be replaced)
  - 2 side hooks (B)
  - 2 bottom hooks (C)

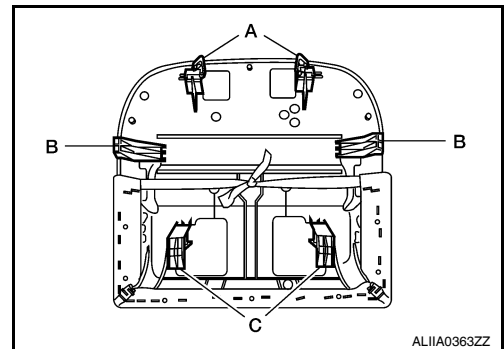

# FRONT SEAT

[SEDAN]

## < DISASSEMBLY AND ASSEMBLY >

3. Hold the seatback board as shown and push in the side hooks to release them from the seat back frame.
4. Carefully pull up on the seatback board to release the bottom hooks.

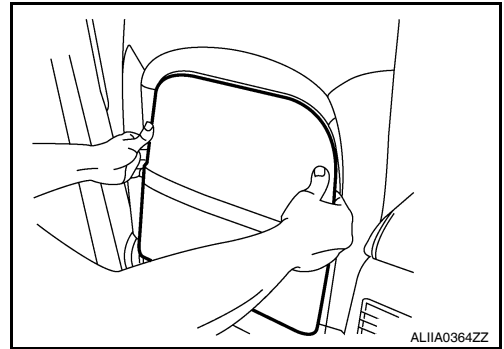

5. Reach in from the bottom of the seatback board to release the top clips. Squeeze the clips at the location shown (A) using suitable tool.

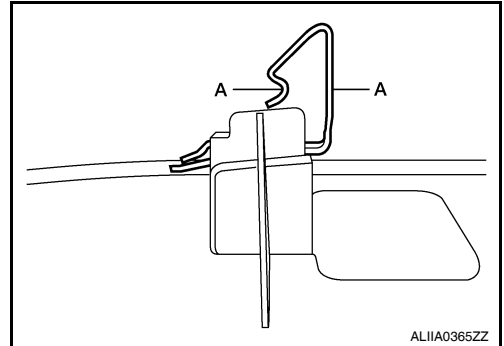

Assembly

Assembly is in the reverse order of disassembly.

A  
B  
C  
D  
E  
F  
G  
H  
I  
K  
L  
M  
N  
O  
P

SE

## REAR SEAT

< DISASSEMBLY AND ASSEMBLY >

[SEDAN]

### REAR SEAT

### ARMREST

### ARMREST : Exploded View

INFOID:000000004206816

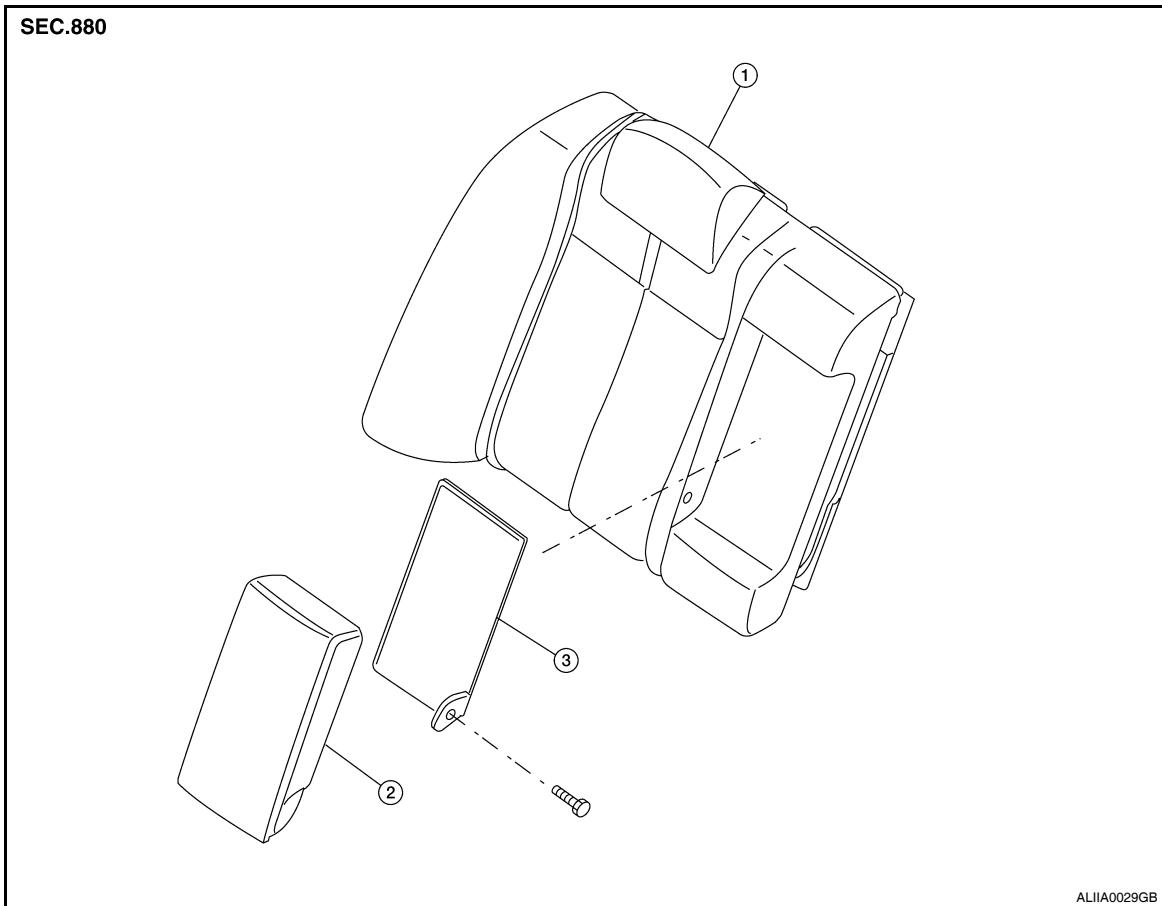

1. Right seatback trim and pad

2. Armrest

3. Armrest trim panel

### ARMREST : Disassembly and Assembly

INFOID:000000004206817

#### Disassembly

1. Fold left seatback forward.
2. Remove the armrest trim panel.
3. Remove armrest bolt and remove the armrest.

#### Assembly

Assembly is in the reverse order of disassembly.