

# ACCELERATOR CONTROL, FUEL & EXHAUST SYSTEMS

## SECTION FE

### CONTENTS

	<b>QG</b>				
<b>PREPARATION</b> .....					
Special Service Tools .....					2
Commercial Service Tools .....					2
<b>ACCELERATOR CONTROL SYSTEM</b> .....					3
Removal and Installation .....					3
Adjusting Accelerator Wire .....					3
<b>FUEL SYSTEM</b> .....					5
Checking Fuel Lines .....					5
Removal and Installation .....					5
Fuel Tank .....					6
REMOVAL .....					6
INSTALLATION .....					8
Fuel Pump, Fuel Level Sensor Unit and Fuel					
Filter .....					9
REMOVAL .....					9
INSTALLATION .....					10
<b>EXHAUST SYSTEM</b> .....					11
Checking Exhaust System .....					11
Removal and Installation .....					11
	<b>YD</b>				
<b>PREPARATION</b> .....					14
Special Service Tool .....					14
				Commercial Service Tool .....	14
				<b>ACCELERATOR CONTROL SYSTEM</b> .....	15
				Removal and Installation .....	15
				Inspection .....	15
				<b>FUEL SYSTEM</b> .....	16
				Checking Fuel Lines .....	16
				Water Draining from Fuel Filter .....	16
				DRAINING WATER .....	16
				FUEL FILTER CHECK .....	16
				Changing Fuel Filter .....	16
				REMOVAL .....	16
				INSTALLATION .....	16
				Bleeding Fuel Filter .....	17
				Checking Priming Pump .....	17
				Removal and Installation .....	17
				Fuel Tank .....	18
				REMOVAL .....	20
				INSTALLATION .....	23
				Fuel Level Sensor Unit .....	24
				REMOVAL .....	25
				INSTALLATION .....	26
				<b>EXHAUST SYSTEM</b> .....	27
				Checking Exhaust System .....	27
				Removal and Installation .....	27



# PREPARATION

QG

Special Service Tools

## Special Service Tools

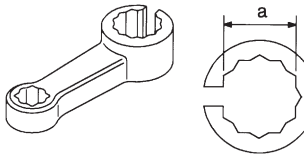
NJFE0029

Tool number Tool name	Description	
KV10114400 Heated oxygen sensor wrench		Loosening or tightening front and rear heated oxygen sensors <b>a: 22 mm (0.87 in)</b>
KV999G0010 Fuel tank lock ring socket		Removing and installing fuel tank lock ring

## Commercial Service Tools

NJFE0030

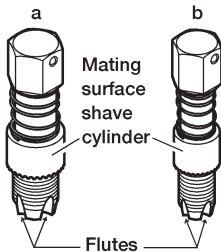
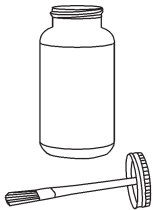
Tool number Tool name	Description	
Oxygen sensor thread cleaner		Reconditioning the exhaust system threads before installing a new oxygen sensor (Use with anti-seize lubricant shown below.) <b>a: 18 mm dia. with pitch 1.5 mm for zirconia oxygen sensor</b> <b>b: 12 mm dia. with pitch 1.25 mm for titania oxygen sensor</b>
Anti-seize lubricant (Permatex 133AR or equivalent meeting MIL specification MIL-A-907)		Lubricating oxygen sensor thread cleaning tool when reconditioning exhaust system threads

## Removal and Installation

NJFE0002

**CAUTION:**

- When removing accelerator wire, make a mark to indicate lock nut's initial position.
- Check that throttle valve opens fully when accelerator pedal is fully depressed. Also check that it returns to idle position when pedal is released.
- Check accelerator control parts for improper contact with any adjacent parts.
- When connecting accelerator wire, be careful not to twist or scratch wire.

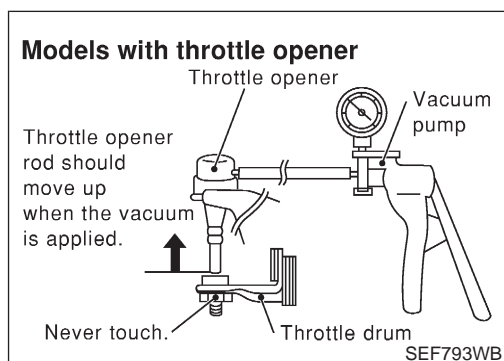
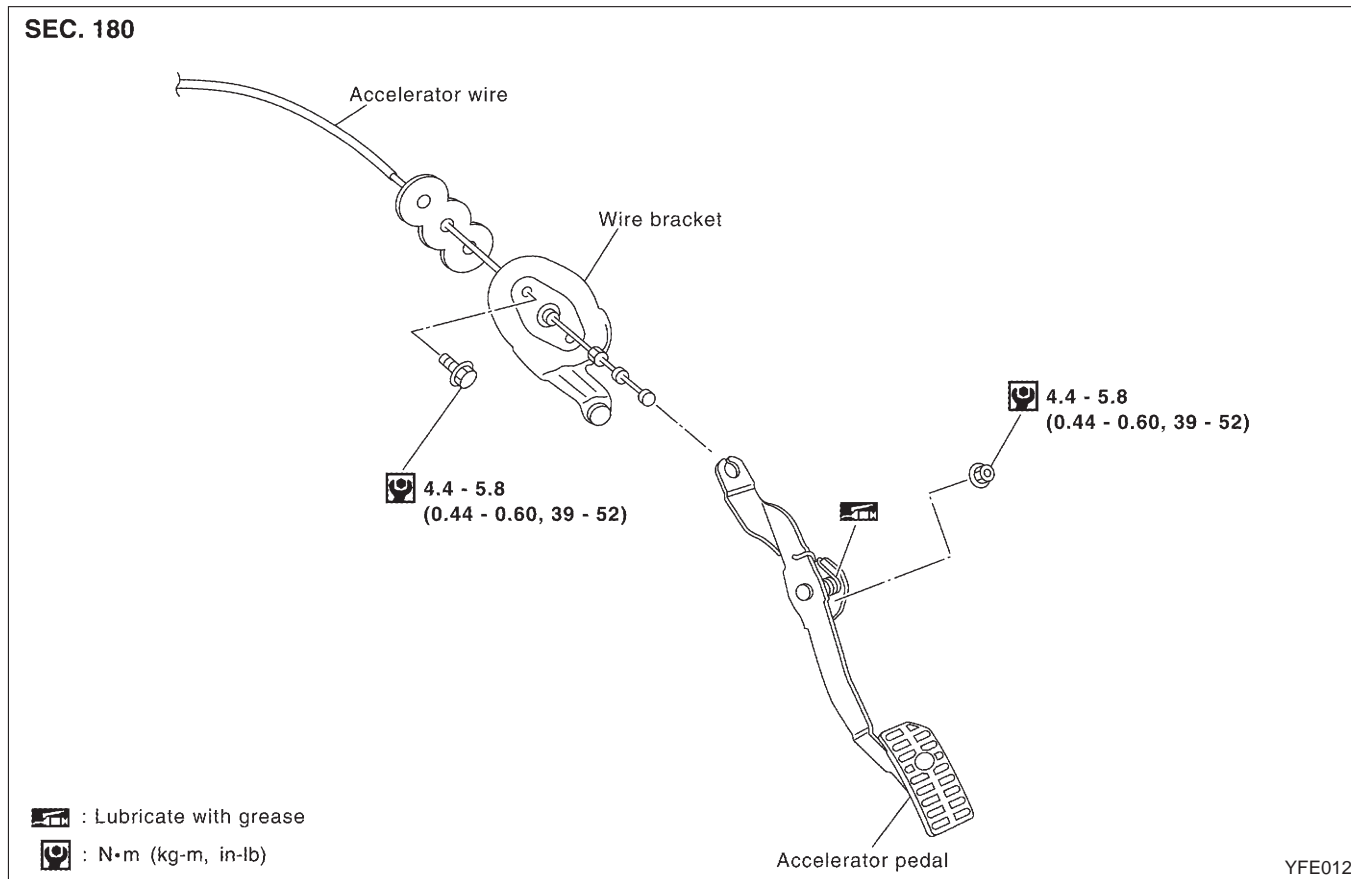

### Adjusting Accelerator Wire

NJFE0003

1. Remove the vacuum hose connected to the throttle opener.
2. Connect suitable vacuum hose to vacuum pump as shown left.
3. Apply vacuum [more than  $-40.0$  kPa ( $-400$  mbar,  $-300$  mmHg,  $-11.81$  inHg)] until the throttle drum becomes free from the rod of the throttle opener.

**Make sure that there is clearance between the throttle drum and rod.**

If NG, refer to EC-164, "Basic Inspection".

If OK, go to following step.

## ACCELERATOR CONTROL SYSTEM

QG

### Adjusting Accelerator Wire (Cont'd)

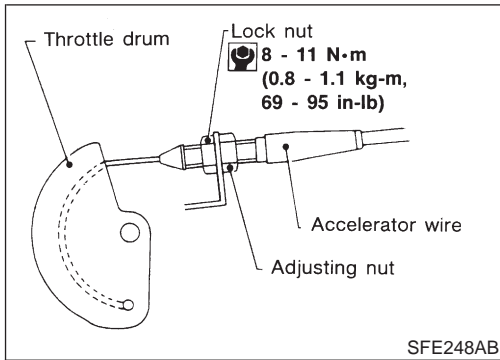

4. Loosen lock nut.
5. Tighten accelerator adjusting nut until throttle drum starts to move.
6. From that position, turn back adjusting nut 1.5 to 2 turns, and secure lock nut.
7. Release vacuum from the throttle opener.
8. Remove vacuum pump and vacuum hose from the throttle opener.
9. Reinstall the original vacuum hose to the throttle opener securely.

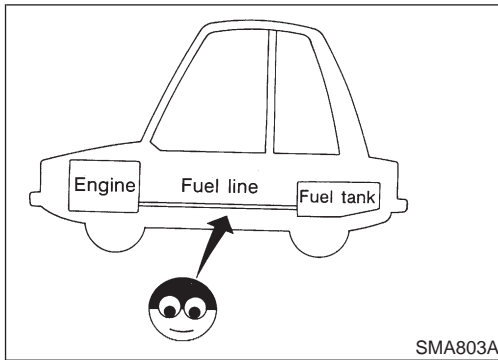

## Checking Fuel Lines

Inspect fuel lines and tank for improper attachment, leaks, cracks, damage, loose connections, chafing or deterioration. If necessary, repair or replace faulty parts.

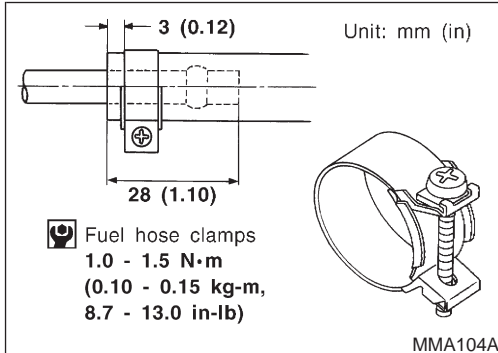
NJFE0009

### CAUTION:

Tighten high-pressure rubber hose clamp so that clamp end is 3 mm (0.12 in) from hose end.

Tightening torque specifications are the same for all rubber hose clamps.

Ensure that screw does not contact adjacent parts.

## Removal and Installation

NJFE0004

### WARNING:

When replacing fuel line parts, be sure to observe the following.

- Put a “CAUTION: FLAMMABLE” sign in workshop.
- Be sure to furnish workshop with a CO<sub>2</sub> fire extinguisher.
- Do not smoke while servicing fuel system. Keep open flames and sparks away from work area.

### CAUTION:

- Before removing fuel line parts, carry out the following procedures:
  - a) Put drained fuel in an explosion-proof container and put the lid on securely.
  - b) Release fuel pressure from fuel line. Refer to EC-38, “Fuel Pressure Release”.
  - c) Disconnect battery ground cable.
- Always replace O-ring and clamps with new ones.
- Do not kink or twist tubes when they are being installed.
- Do not tighten hose clamps excessively to avoid damaging hoses.
- After installing tubes, run engine and check for fuel leaks at connections.

## Fuel Tank

NJFE0006

### SEC. 172

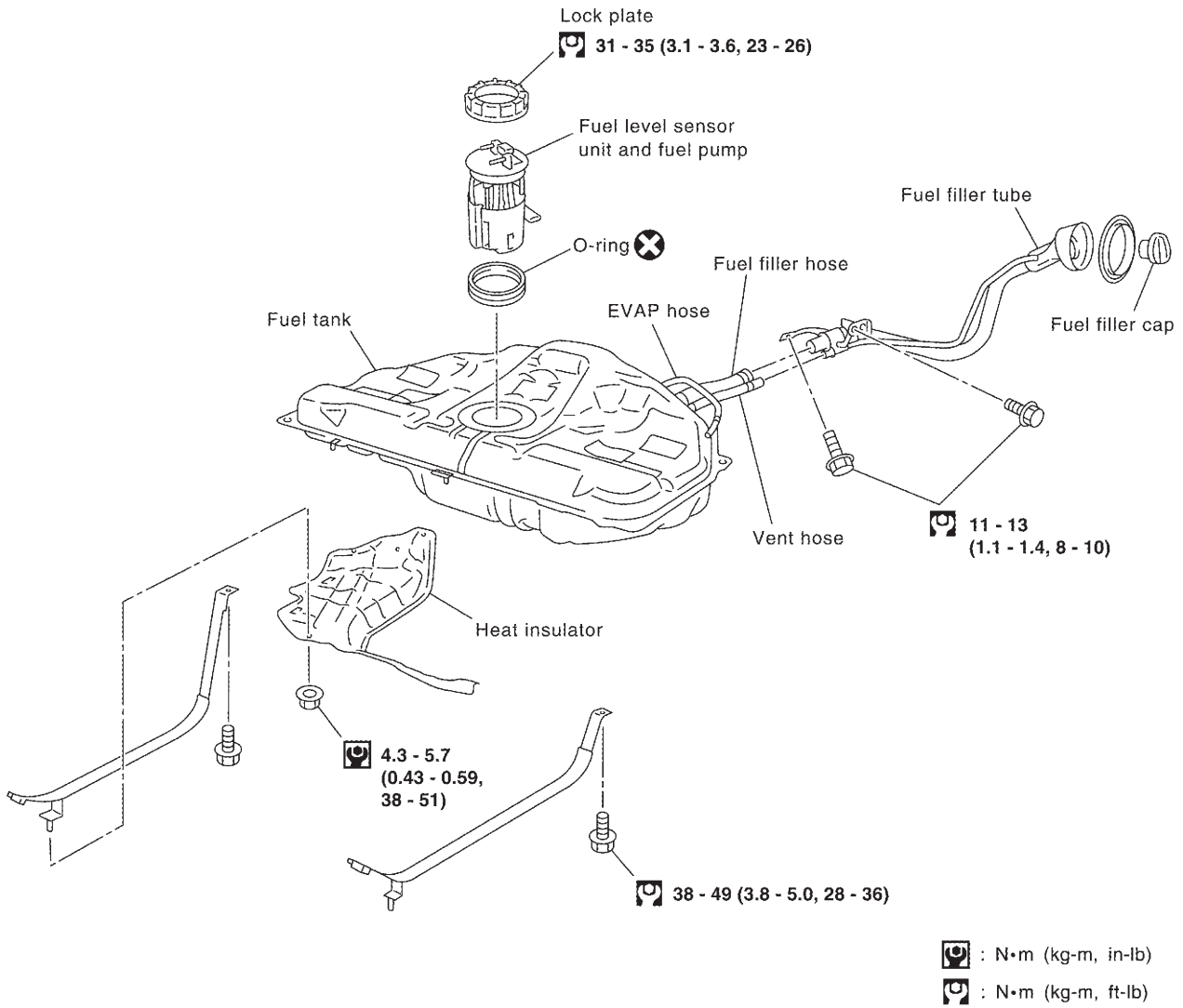

YFE013

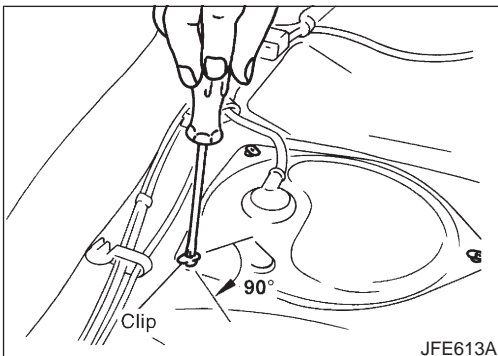

### REMOVAL

NJFE0006S01

1. Release fuel pressure from fuel line. Refer to EC-38, "Fuel Pressure Release".
2. Disconnect battery ground cable.
3. Open fuel filler lid and filler cap.
4. Drain fuel from fuel tank.
5. Remove rear seat cushion. Refer to BT-59, "Removal and Installation".
6. Remove inspection hole cover under the rear seat.

## FUEL SYSTEM

**QG**

Fuel Tank (Cont'd)

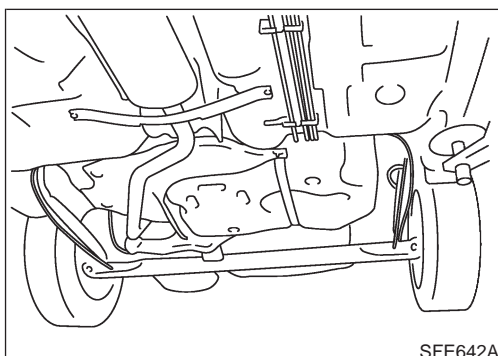
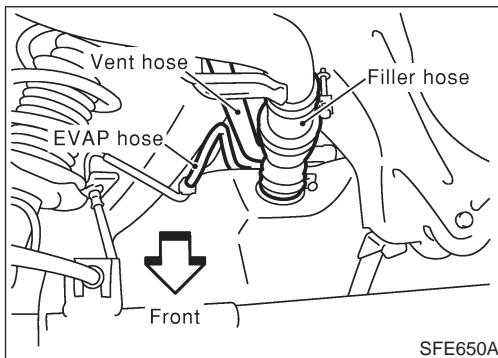
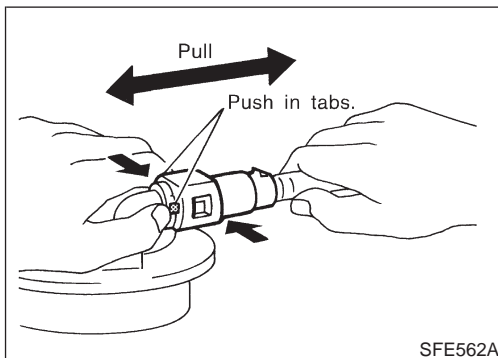
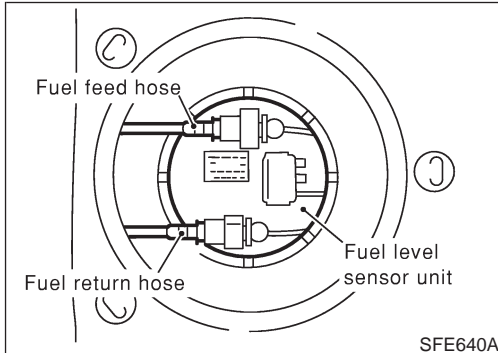
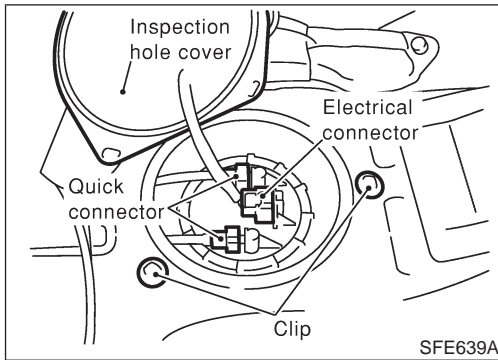

7. Disconnect electrical connector.
8. Disconnect the quick connector as follows.
  - a. Put mating marks on tubes and connectors for correct installation.

- b. Hold the connector while pushing in tabs, and pull out the tube.

**CAUTION:**

- The tube can be removed when the tabs are completely depressed. Do not twist it more than necessary.
- Do not use any tools to remove the quick connector.
- Keep the resin tube away from heat. Be especially careful when welding near the tube.
- Prevent acid liquid such as battery electrolyte etc. from getting on the resin tube.
- Do not bend or twist the tube during installation and removal.

9. From rear left area of fuel tank, remove filler hose, vent hose, and EVAP hose.

**CAUTION:**

To prevent fuel from flowing out, install a blind cap immediately after the fuel hose is disconnected.

10. Remove exhaust center tube.

## Fuel Tank (Cont'd)

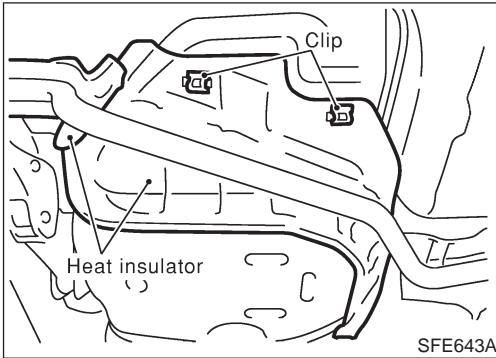

11. Remove heat insulators from fuel tank side.

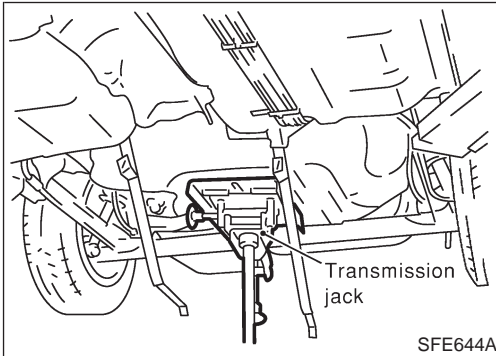

12. Set a suitable transmission jack under fuel tank.

13. Remove fuel tank mounting band bolts while supporting fuel tank.

14. Remove fuel tank.

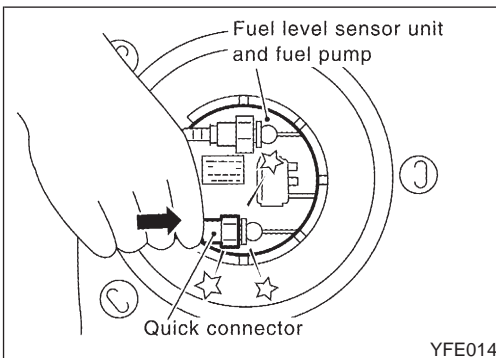

## INSTALLATION

To install, reverse the removal procedure. Connect the quick connector as follows:

NJFE006S02

- Align mating marks on tubes and connectors for correct installation.
- Insert tube into the center of the connector until you hear a click.

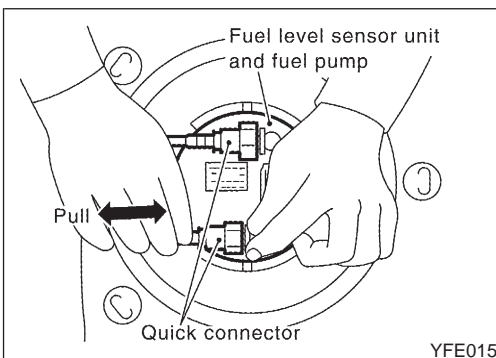

After connecting quick connector, make sure the connection is firmly made using the following method.

- Pull on the fuel tube and connector to make sure they are firmly connected.
- Start the engine, increase engine speed and verify that there are no leaks.



## Fuel Pump, Fuel Level Sensor Unit and Fuel Filter

NJFE0007

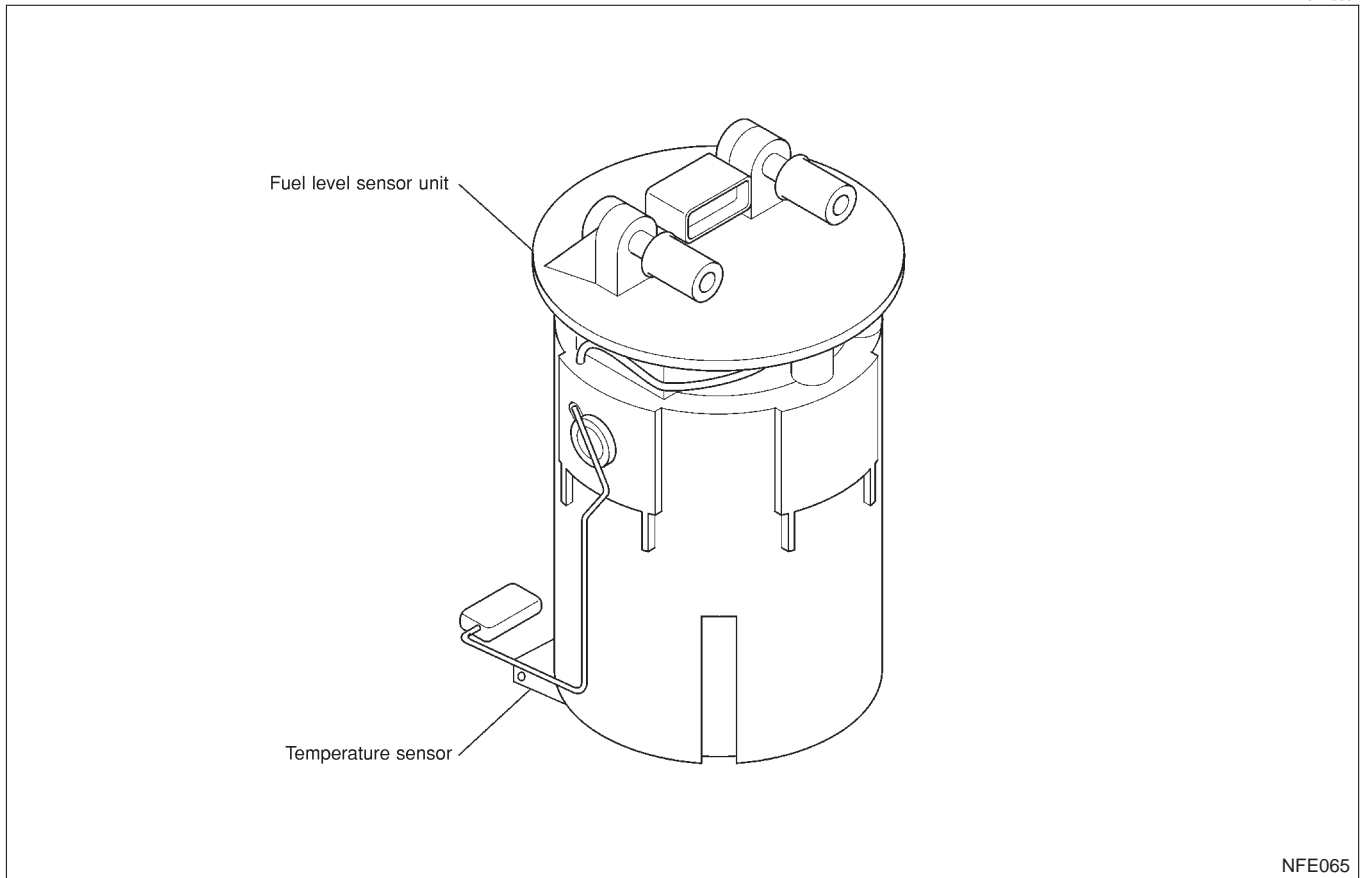

NFE065

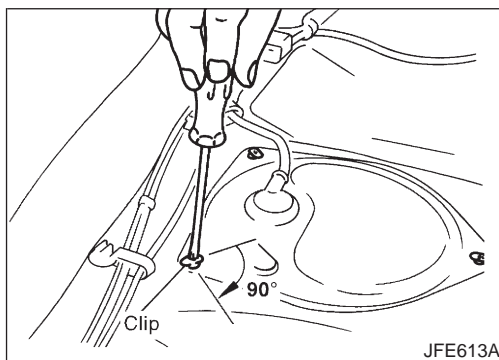

### REMOVAL

NJFE0007S01

1. Release fuel pressure from fuel line.  
Refer to EC-38, "Fuel Pressure Release".
2. Disconnect battery ground cable.
3. Open fuel filler lid and filler cap.
4. Remove rear seat cushion. Refer to BT-59, "Removal and Installation".
5. Remove inspection hole cover under the rear seat.

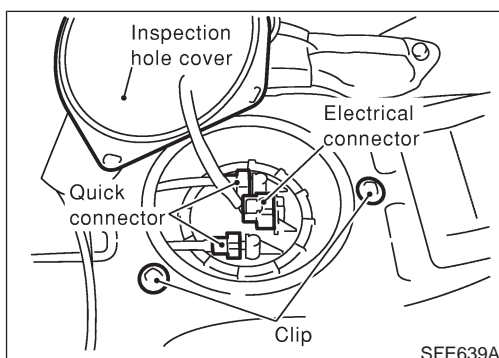

6. Disconnect electrical connector.
7. Disconnect the quick connectors.
  - For disconnect of quick connectors, refer to step 8. of "Fuel Tank Removal".

## FUEL SYSTEM

QG

Fuel Pump, Fuel Level Sensor Unit and Fuel Filter (Cont'd)

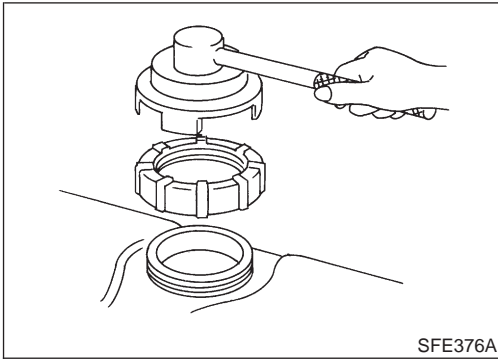

8. Remove lock ring using a lock ring socket (SST).

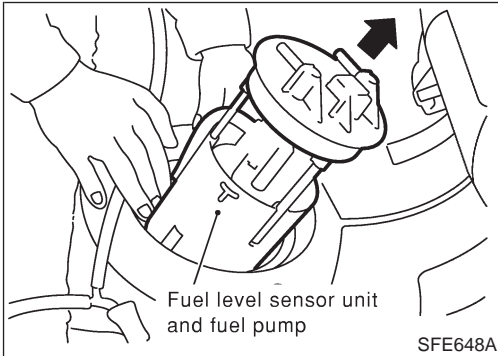

9. Pull out the fuel level sensor unit and fuel pump.

- Do not damage the arm of the fuel level sensor unit and fuel tank temperature sensor.

### INSTALLATION

Installation is in reverse order of removal.

NJFE0007S02

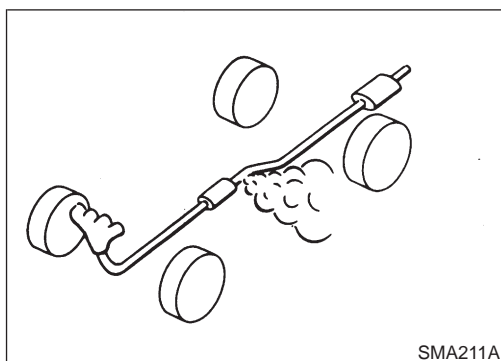

## Checking Exhaust System

NJFE0010

Check exhaust pipes, muffler and mounting for improper attachment, leaks, cracks, damage, chafing or deterioration.

## Removal and Installation

NJFE0005

### CAUTION:

- Always replace exhaust gaskets with new ones when reassembling.
- With engine running, check all tube connections for exhaust gas leaks, and entire system for unusual noises.
- Check to ensure that mounting brackets and mounting insulators are installed properly and free from undue stress. Improper installation could result in excessive noise or vibration.
- Discard any heated oxygen sensor which has been dropped from a height of more than 0.5 m (19.7 in) onto a hard surface such as a concrete floor; use a new one.
- Before installing a new oxygen sensor, clean exhaust system threads using oxygen sensor thread cleaner tool and apply anti-seize lubricant.
- Do not overtorque the oxygen sensor. Doing so may cause damage to the oxygen sensor, resulting in the MIL coming on.
- Be sure to use genuine exhaust system parts which are designed especially for heat resistance, corrosion resistance, and shape.
- Perform the operation with the exhaust system fully cooled down because the system will be heated just after the engine stops.
- Be careful not to cut your hand on the insulator edge.

# EXHAUST SYSTEM

QG

Removal and Installation (Cont'd)

## SEC. 200•208 With three way catalyst

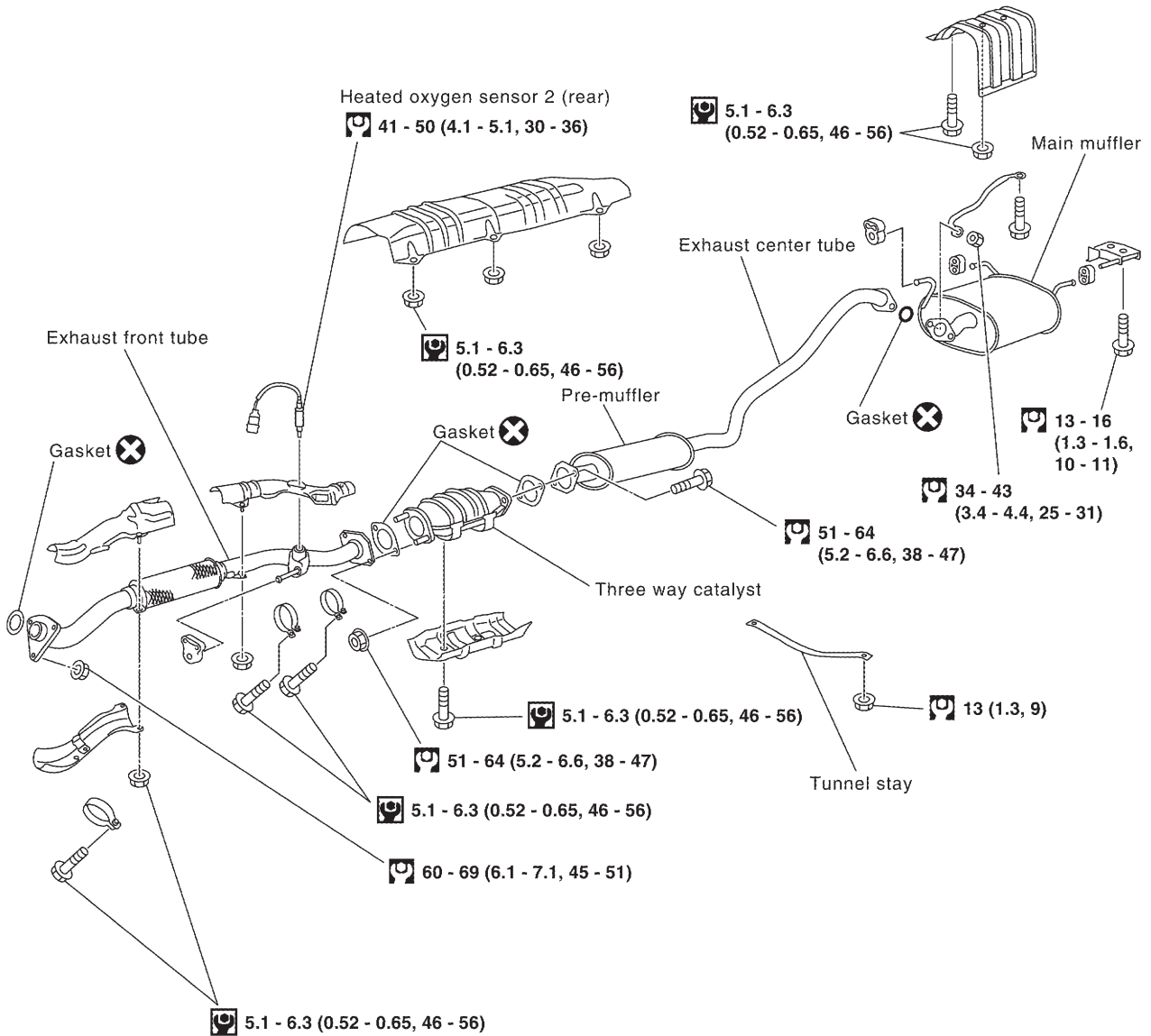

: N•m (kg-m, in-lb)

: N•m (kg-m, ft-lb)

YFE016



# PREPARATION

YD

Special Service Tool

## Special Service Tool

NJFE0031

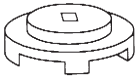
Tool number Tool name	Description
KV999G0010 Fuel tank lock ring socket	 Removing and installing fuel tank lock ring
	NT057

## Commercial Service Tool

NJFE0027

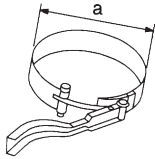
Tool name	Description
Fuel filter wrench	 Removing fuel filter <b>a: Max. 100 mm (3.94 in) dia.</b>
	NT553

## Removal and Installation

NJFE0013
**CAUTION:**

- Do not disassemble the accelerator pedal assembly. Do not remove the sensors and the switches from the assembly.
- Avoid impact from dropping etc. during handling.
- Be careful to keep the assembly away from water.
- Do not adjust the adjusting screw (painted white) of the accelerator work unit.
- When the connector of the accelerator sensor is disconnected, reconnect the connector, and touch "CLEAR" in "OFF ACCEL PO SIG" of the active test using the CONSULT-II. Or, warm up the engine, then leave it idling for approximately 10 minutes.

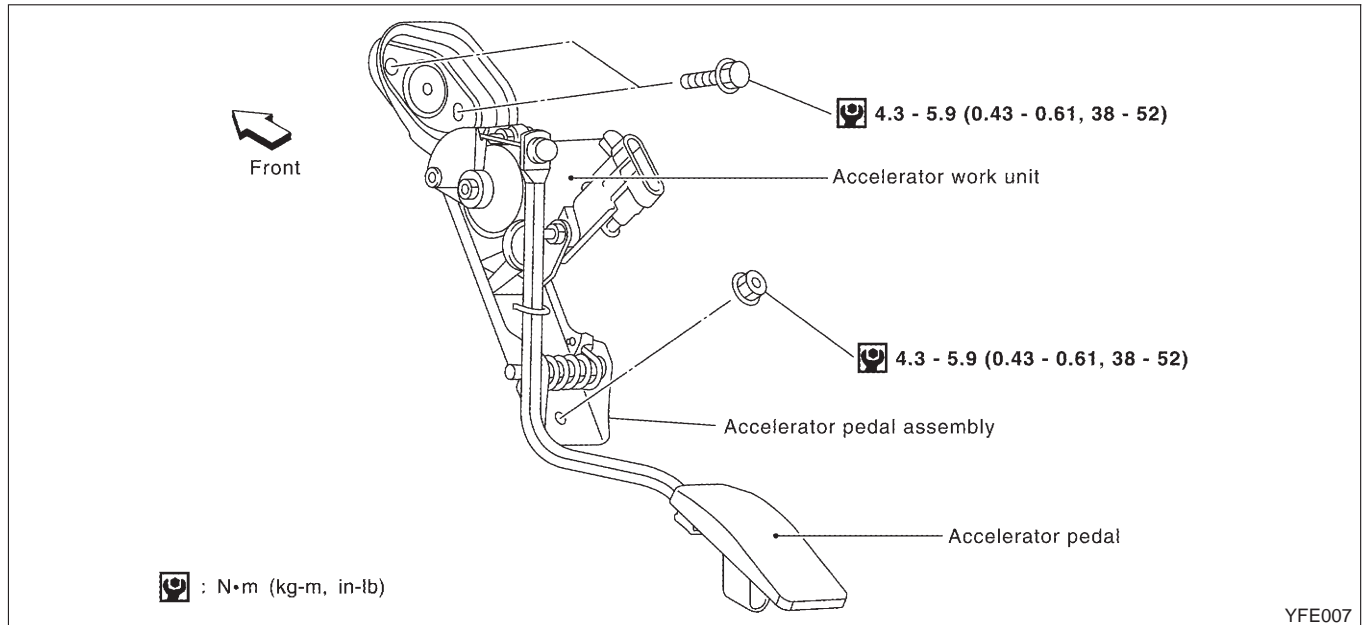

### Inspection

NJFE0020

- Check that the accelerator pedal moves smoothly within the whole operation range.
- Check that the accelerator pedal securely returns to the original position.
- Check that the drum of the accelerator work unit can be fully opened.
- Refer to EC-536, "Basic Inspection" for the inspection of the accelerator work unit and the accelerator pedal switch.

## Checking Fuel Lines

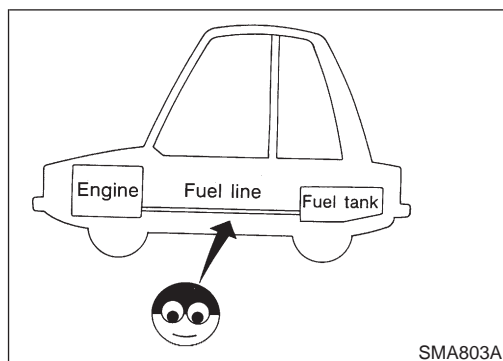

## Checking Fuel Lines

NJFE0019

Inspect fuel lines and tank for improper attachment, leaks, cracks, damage, chafing and deterioration. If necessary, repair or replace.

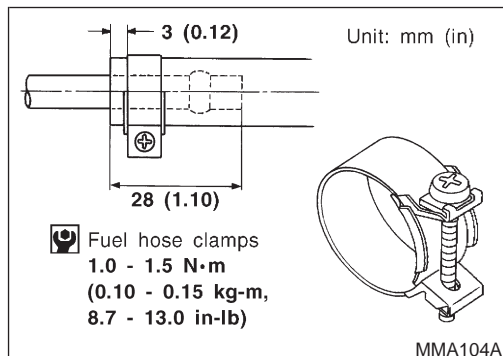

### CAUTION:

Tighten high-pressure rubber hose clamp so that clamp end is 3 mm (0.12 in) from hose end.

Tightening torque specifications are the same for all rubber hose clamps.

Ensure that screw does not contact adjacent parts.

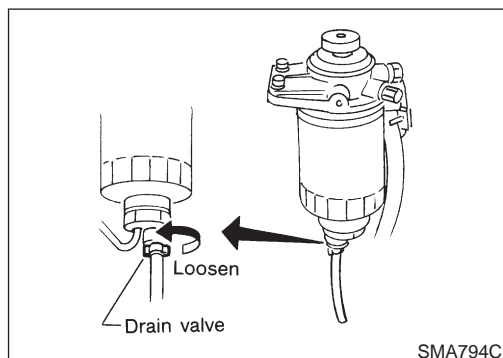

## Water Draining from Fuel Filter

NJFE0028

### DRAINING WATER

Open drain valve at the bottom of fuel filter.

NJFE0028S01

### FUEL FILTER CHECK

NJFE0028S02

Check fuel filter for fuel leakage, damage and other abnormal things.

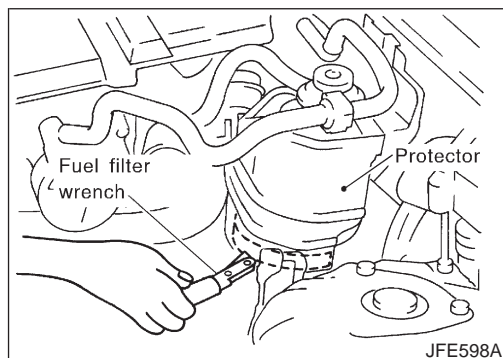

## Changing Fuel Filter

NJFE0021

### REMOVAL

NJFE0021S01

1. Take out air duct and upper air cleaner case.
2. Remove fuel filter using a fuel filter wrench (commercial service tool).

### CAUTION:

Do not spill the fuel during removal. If the fuel is spilt, immediately wipe it off. Be especially careful to prevent the fuel from adhering to the insulators of the engine mounts.

3. Remove fuel-level warning sensor from fuel filter.

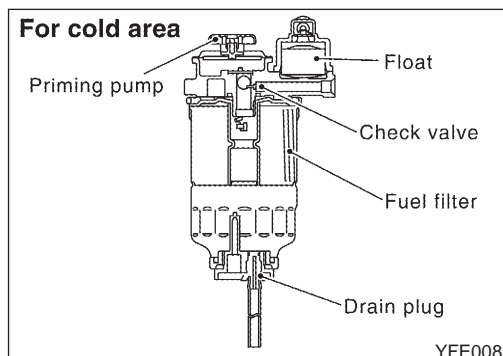

### INSTALLATION

NJFE0021S02

- Install in the reverse order of removal.
- Tighten the fuel filter so that the sealing face contacts the packing, then retighten it manually by approximately 2/3 turn.
- After installation, operate the priming pump vertically to perform air bleeding. Refer to FE-17, "Bleeding Fuel Filter".



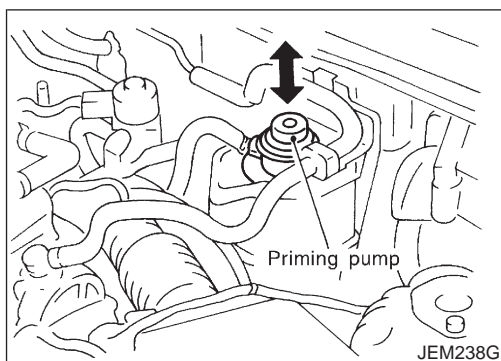

## Bleeding Fuel Filter

NJFE0023

1. After the repair, bleed air from the piping by pumping the priming pump up and down until it becomes heavy.
2. To start the engine, rotate the starter for a maximum of 30 seconds.  
To start the engine more quickly, crank the engine while pumping the priming pump (requires two workers).
3. If the engine does not start after rotating the starter for a maximum of 30 seconds, stop it once, and pump the priming pump again until it becomes heavy.
4. Rotate the starter again until the engine starts running.
5. After the engine starts, let it idle for at least 1 minute to stabilize the behavior.

### NOTE:

- When air is bled completely, pumping the priming pump suddenly becomes heavy. Stop the operation at that time.
- If it is difficult to bleed air by pumping the priming pump (the priming pump does not become heavy during pumping), disconnect the fuel supply hose between the fuel filter and the injection pump. Then, pump the priming pump up and down, and make sure that fuel comes out. (Use a pan and be careful not to spill fuel. Keep fuel clear of the engine.) After that, connect the hose, then bleed air again.

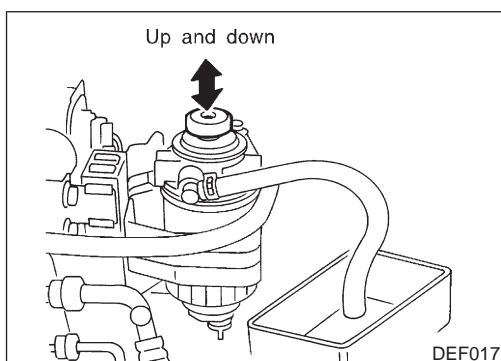

## Checking Priming Pump

NJFE0024

Before checking priming pump, make sure that fuel filter is filled with fuel.

1. Disconnect fuel return hose.  
**Place a suitable container beneath hose end.**
2. Pump priming pump and check that the fuel overflows from the hose end. If not, replace priming pump.

## Removal and Installation

NJFE0015

### WARNING:

When replacing fuel line parts, be sure to observe the following.

- Put a "CAUTION: FLAMMABLE" sign in workshop.
- Be sure to furnish workshop with a CO<sub>2</sub> fire extinguisher.
- Do not smoke while servicing fuel system. Keep open flames and sparks away from work area.

### CAUTION:

- Before removing fuel line parts, carry out the following procedures:
  - a) Put drained fuel in an explosion-proof container and put the lid on securely.
  - b) Disconnect battery ground cable.

Removal and Installation (Cont'd)

- Always replace O-ring and clamps with new ones.
- Do not kink or twist tubes when they are being installed.
- Do not tighten hose clamps excessively to avoid damaging hoses.
- After installing tubes, run engine and check for fuel leaks at connections.

## Fuel Tank

NJFE0016

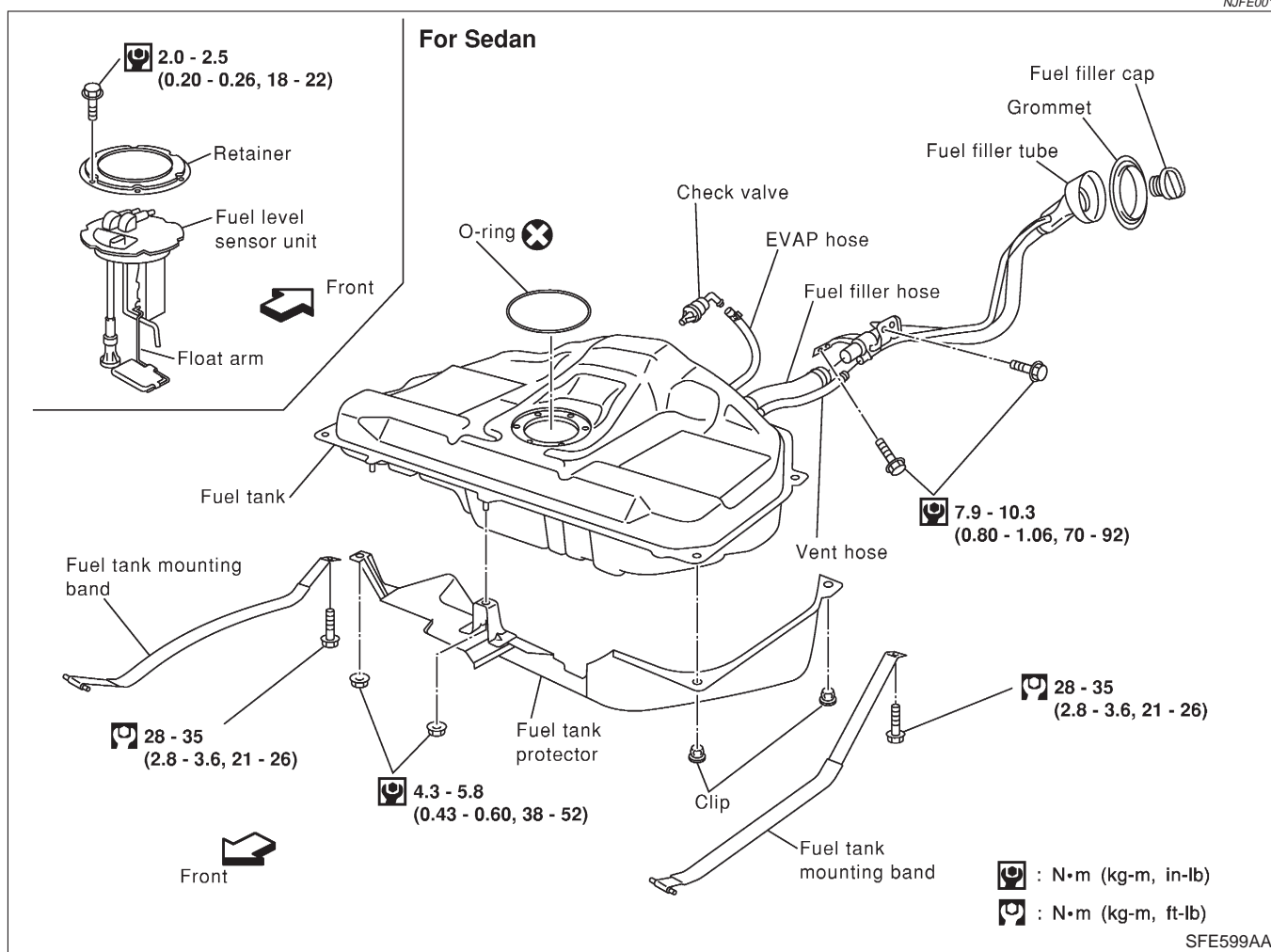

# FUEL SYSTEM

**YD**

Fuel Tank (Cont'd)

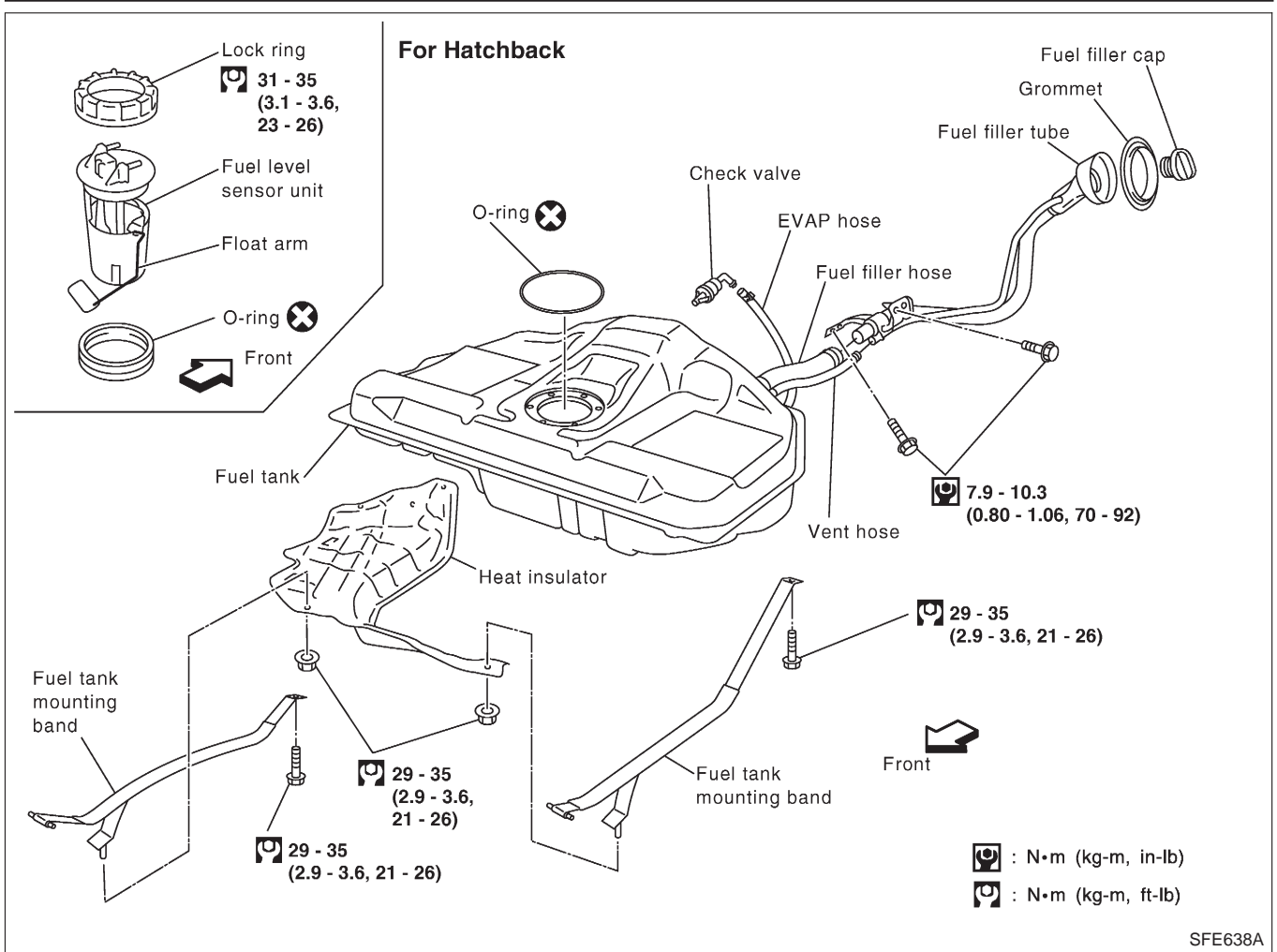

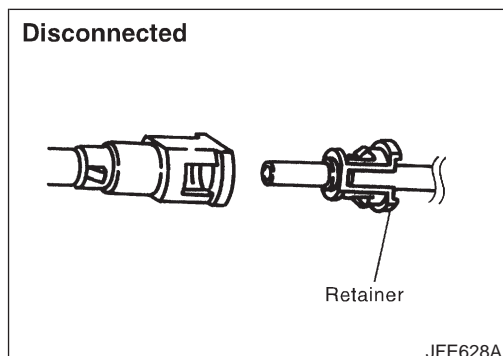
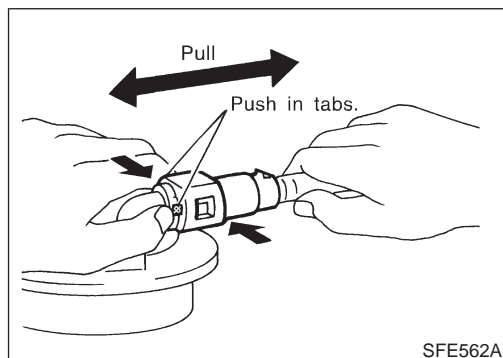
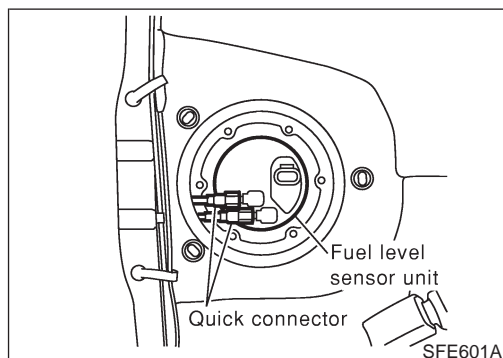
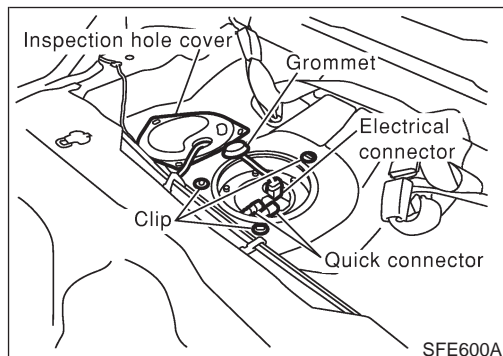
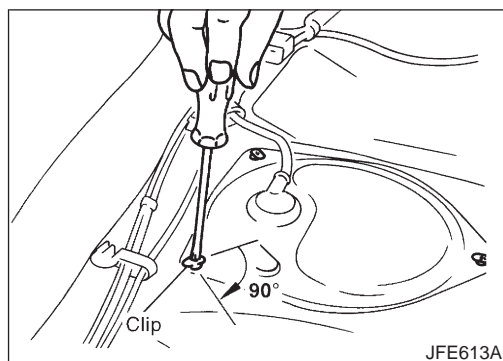

## REMOVAL

### For Sedan

NJFE0016S01

NJFE0016S0101

1. Disconnect battery ground cable.
2. Open fuel filler lid and filler cap.
3. Drain fuel from fuel tank.
4. Remove rear seat cushion. Refer to BT-59, "Removal and Installation".
5. Remove inspection hole cover under the rear seat.
6. Disconnect electrical connector.
7. Disconnect the quick connector as follows.
  - a. Put mating marks on tubes and connectors for correct installation.

- b. Hold the connector while pushing in tabs, and pull out the tube.

### CAUTION:

- The tube can be removed when the tabs are completely depressed. Do not twist it more than necessary.
- Do not use any tools to remove the quick connector.
- Keep the resin tube away from heat. Be especially careful when welding near the tube.
- Prevent acid liquid such as battery electrolyte etc. from getting on the resin tube.
- Do not bend or twist the tube during installation and removal.
- Only when the tube is replaced, remove the remaining retainer.
- When the tube is replaced, also replace the retainer with a new one.

### Retainer color:

Orange (Feed hose side)

White (Return hose side)

## FUEL SYSTEM

YD

Fuel Tank (Cont'd)

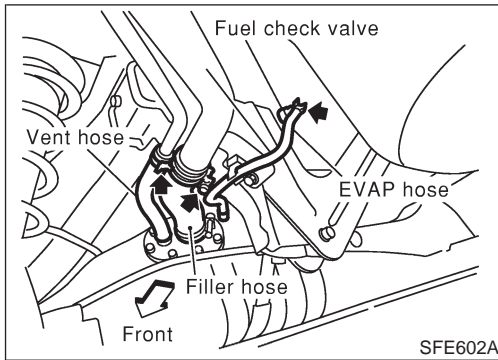

8. Remove exhaust center tube.
9. From rear left area of fuel tank, remove filler hose, vent hose, and EVAP hose.

**CAUTION:**  
To prevent fuel from flowing out, install a blind cap immediately after the fuel hose is disconnected.

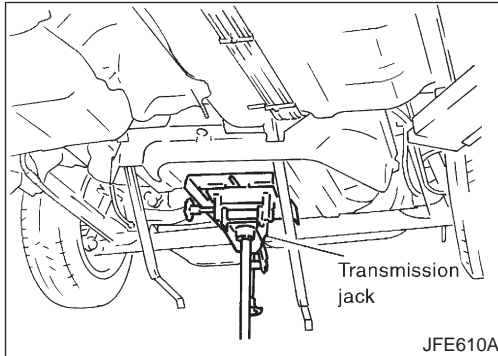

10. Set a suitable transmission jack under fuel tank.
11. Remove fuel tank mounting band bolts while supporting fuel tank.

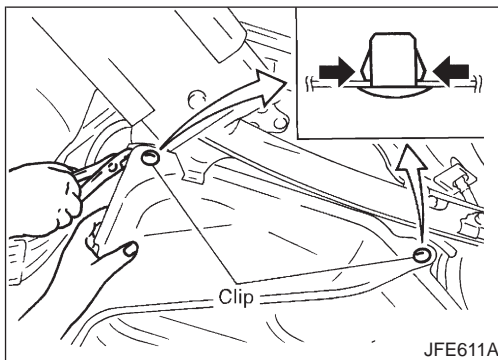

12. Lower the fuel tank by 70 to 80 mm (2.76 to 3.15 in), remove the nuts and clips holding the protector, and then remove the protector.
  - To remove the clips, use pliers to squeeze the extensions as shown by the arrows in the figure at left, and then remove the clip from above.
13. Remove fuel tank.

## Fuel Tank (Cont'd)

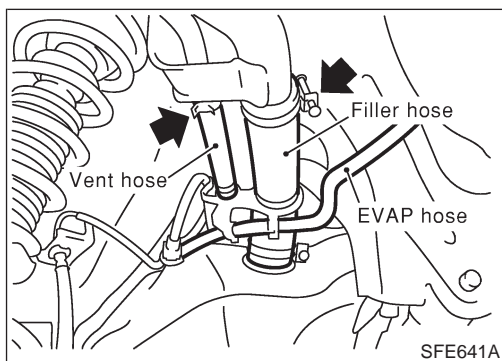
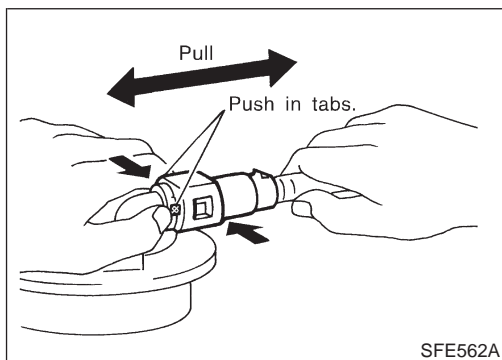
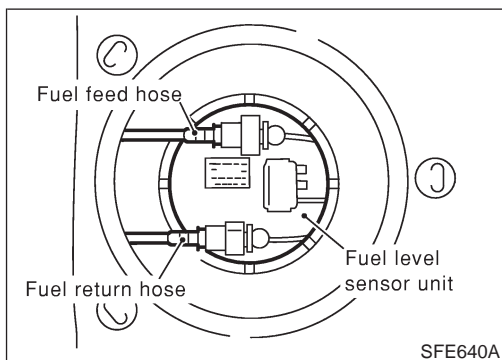
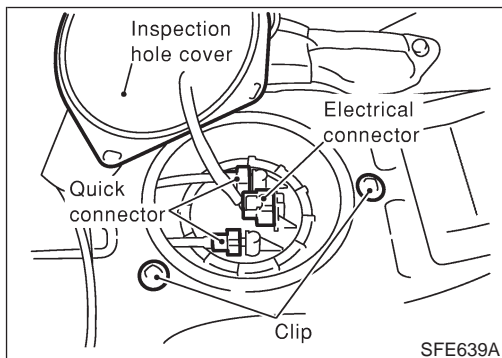
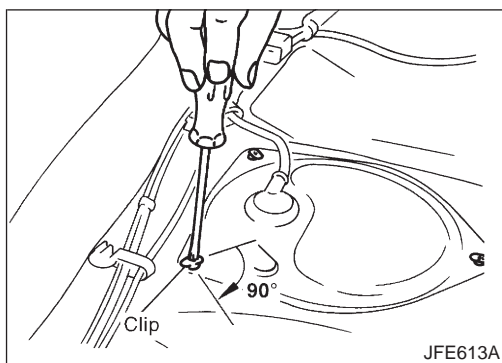

### For Hatchback

NJFE0016S0102

1. Disconnect battery ground cable.
2. Open fuel filler lid and filler cap.
3. Drain fuel from fuel tank.
4. Remove rear seat cushion. Refer to BT-59, "Removal and Installation".
5. Remove inspection hole cover under the rear seat.
6. Disconnect electrical connector.
7. Disconnect the quick connector as follows.
  - a. Put mating marks on tubes and connectors for correct installation.

- b. Hold the connector while pushing in tabs, and pull out the tube.

### CAUTION:

- The tube can be removed when the tabs are completely depressed. Do not twist it more than necessary.
- Do not use any tools to remove the quick connector.
- Keep the resin tube away from heat. Be especially careful when welding near the tube.
- Prevent acid liquid such as battery electrolyte etc. from getting on the resin tube.
- Do not bend or twist the tube during installation and removal.

8. From rear left area of fuel tank, remove filler hose, vent hose, and EVAP hose.

### CAUTION:

To prevent fuel from flowing out, install a blind cap immediately after the fuel hose is disconnected.

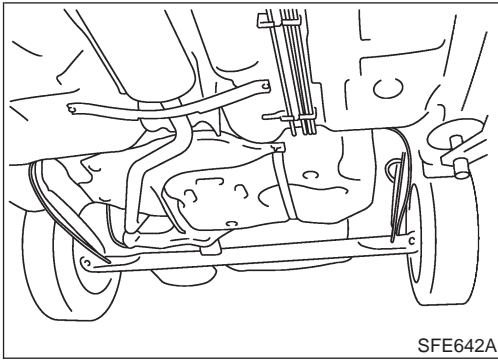

9. Remove exhaust center tube.

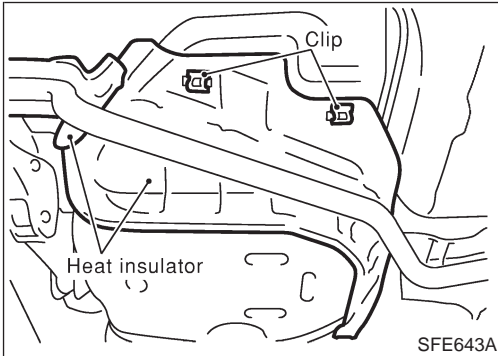

10. Remove heat insulators from fuel tank side.

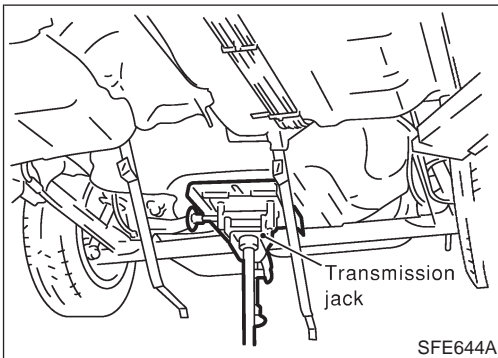

11. Set a suitable transmission jack under fuel tank.

12. Remove fuel tank mounting band bolts while supporting fuel tank.

13. Remove fuel tank.

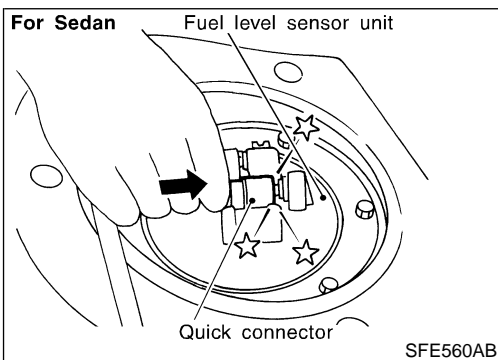

## INSTALLATION

To install, reverse the removal procedure. Connect the quick connector as follows:

NJFE0016S02

- Align mating marks on tubes and connectors for correct installation.
- Insert tube into the center of the connector until you hear a click.

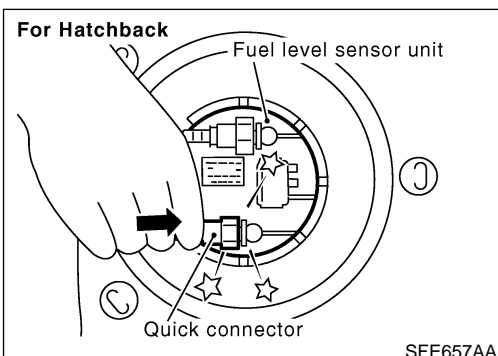

Fuel Tank (Cont'd)

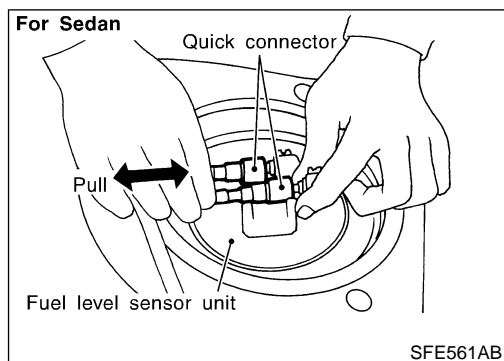

After connecting quick connector, make sure the connection is firmly made using the following method.

- Pull on the fuel tube and connector to make sure they are firmly connected.
- Start the engine, increase engine speed and verify that there are no leaks.

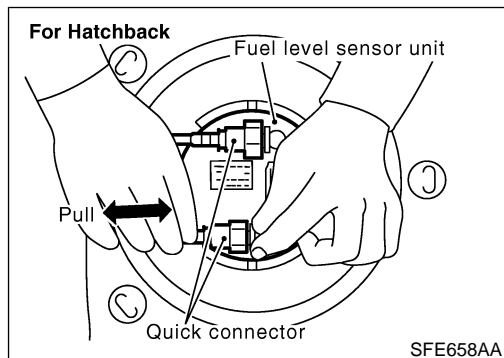

**Fuel Level Sensor Unit**

NJFE0032

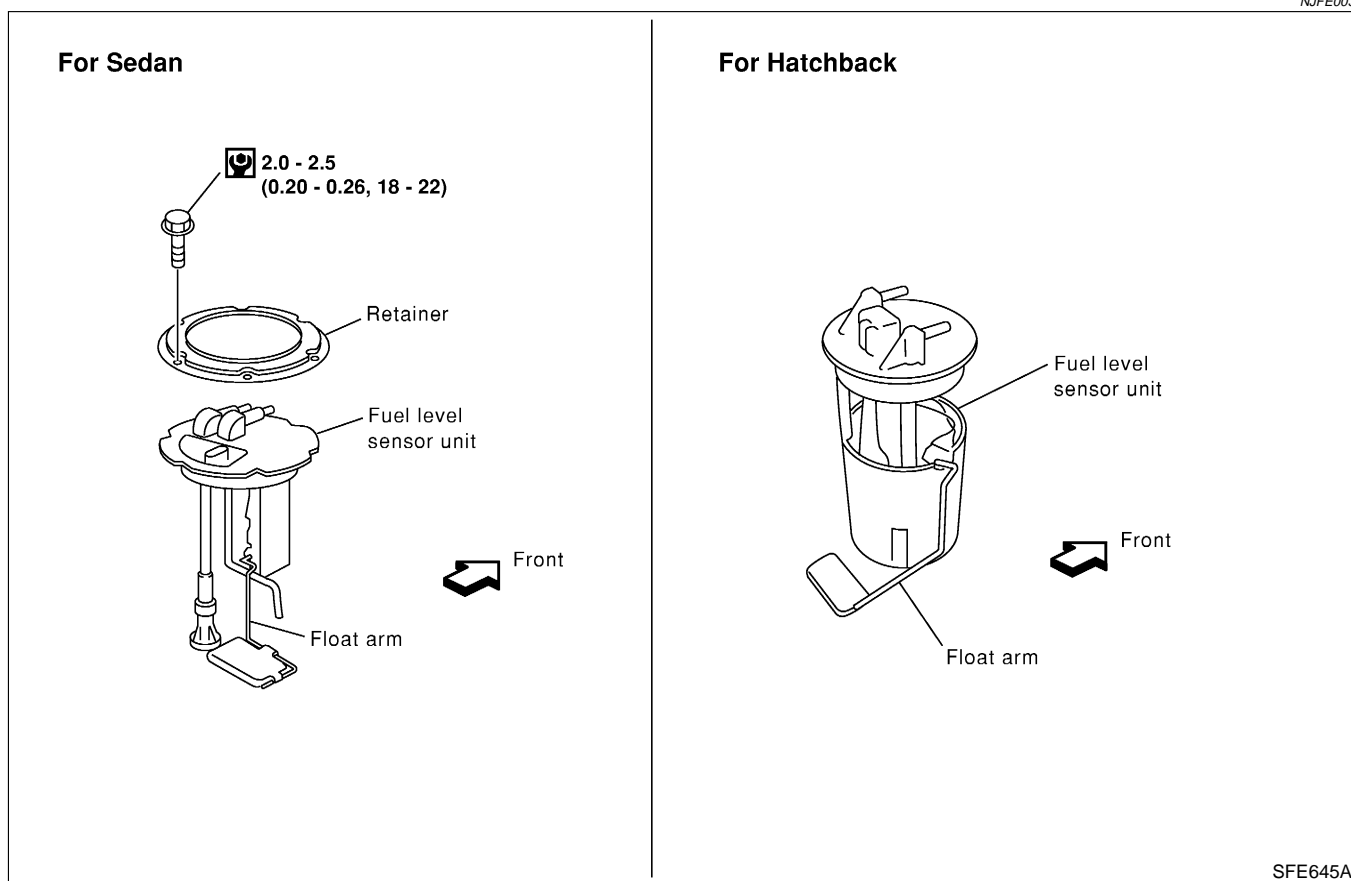



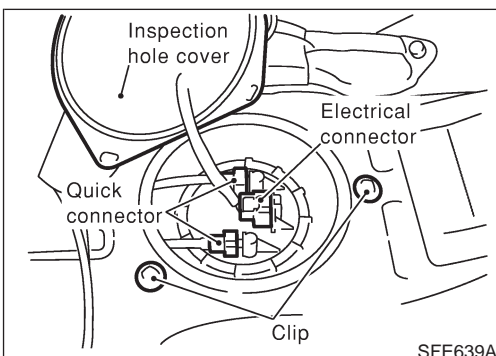
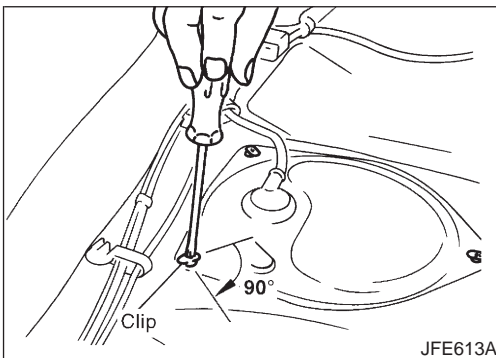
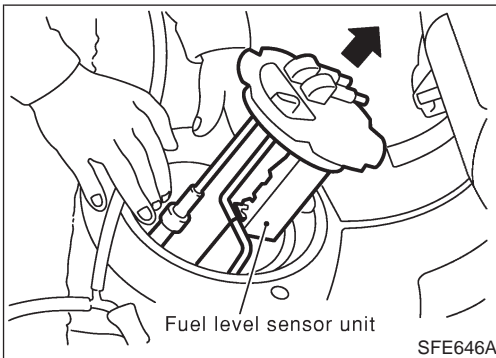
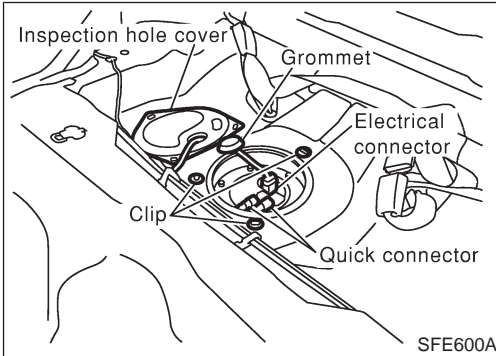
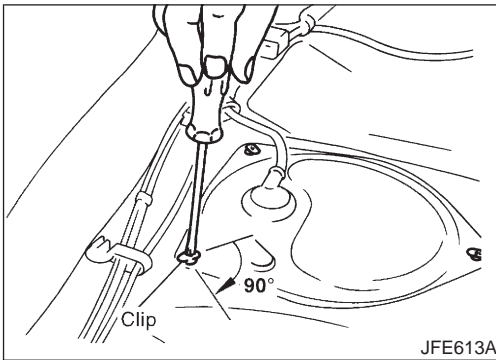

## REMOVAL

### For Sedan

NJFE0032S01

NJFE0032S0101

1. Disconnect battery ground cable.
2. Open fuel filler lid and filler cap.
3. Remove rear seat cushion. Refer to BT-59, "Removal and Installation".
4. Remove inspection hole cover under the rear seat.
5. Disconnect electrical connector.
6. Disconnect the quick connectors.
  - For disconnect of quick connectors, refer to step 7. of "Fuel Tank Removal".
7. Remove the six screws.

### CAUTION:

**Use genuine bolts only when fixing retainer.**

8. Remove retainer.
9. Pull out the fuel level sensor unit.
  - **Do not damage the arm of the fuel level sensor unit.**

### For Hatchback

NJFE0032S0102

1. Disconnect battery ground cable.
2. Open fuel filler lid and filler cap.
3. Remove rear seat cushion. Refer to BT-59, "Removal and Installation".
4. Remove inspection hole cover under the rear seat.
5. Disconnect electrical connector.
6. Disconnect the quick connectors.
  - For disconnect of quick connectors, refer to step 7. of "Fuel Tank Removal".

## Fuel Level Sensor Unit (Cont'd)

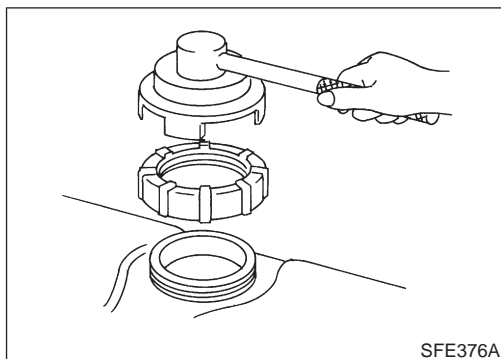

7. Remove lock ring using a lock ring socket (SST).

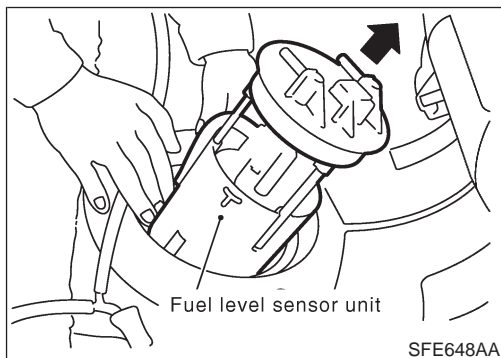

8. Pull out the fuel level sensor unit and fuel pump.

- **Do not damage the arm of the fuel level sensor unit.**

### INSTALLATION

Installation is in reverse order of removal.

NJFE0032S02

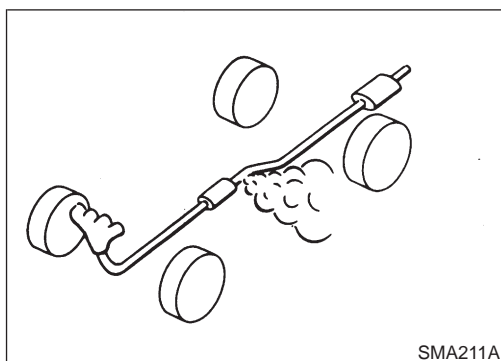

## Checking Exhaust System

NJFE0022

Check exhaust pipes, muffler and mounting for improper attachment, leaks, cracks, damage, chafing or deterioration.

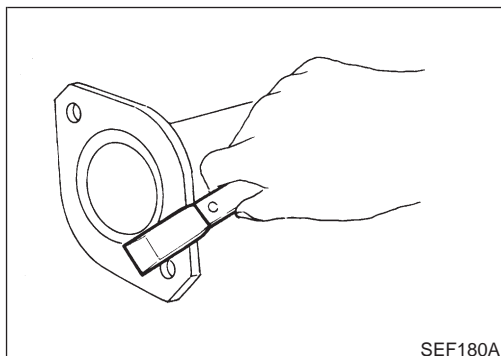

## Removal and Installation

NJFE0018

### CAUTION:

- Always replace exhaust gaskets with new ones when reassembling. If gasket remains on flange surface, scrape off completely as shown at left.
- With engine running, check all tube connections for exhaust gas leaks, and entire system for unusual noises.
- Check to ensure that mounting brackets and mounting insulators are installed properly and free from undue stress. Improper installation could result in excessive noise or vibration.
- Be sure to use genuine exhaust system parts which are designed especially for heat resistance, corrosion resistance, and shape.
- Perform the operation with the exhaust system fully cooled down because the system will be heated just after the engine stops.
- Be careful not to cut your hand on the insulator edge.

# EXHAUST SYSTEM

YD

Removal and Installation (Cont'd)

