

# FRONT & REAR SUSPENSION

## SECTION **SU**

### CONTENTS

<b>FRONT SUSPENSION</b> .....	2	INSPECTION.....	18	GI
Precautions .....	2	Upper Ball Joint and Lower Ball Joint.....	19	MA
PRECAUTIONS .....	2	REMOVAL AND INSTALLATION.....	19	EM
Preparation .....	2	INSPECTION.....	19	LC
SPECIAL SERVICE TOOLS .....	2	Service Data and Specifications (SDS).....	19	EC
COMMERCIAL SERVICE TOOLS.....	2	GENERAL SPECIFICATIONS (FRONT).....	19	FE
Noise, Vibration and Harshness (NVH)		WHEEL RUNOUT AVERAGE .....	19	CL
Troubleshooting .....	3	UPPER BALL JOINT .....	19	MT
NVH TROUBLESHOOTING CHART .....	3	LOWER BALL JOINT .....	19	AT
Components.....	5	WHEEL ALIGNMENT (UNLADEN*1).....	20	TF
2WD MODELS.....	5	<b>REAR SUSPENSION</b> .....	22	PD
4WD MODELS.....	6	Precautions .....	22	AX
On-vehicle Service.....	7	PRECAUTIONS .....	22	SU
FRONT SUSPENSION PARTS .....	7	Preparation .....	22	BR
FRONT WHEEL ALIGNMENT .....	7	COMMERCIAL SERVICE TOOLS.....	22	ST
Components.....	13	Noise, Vibration and Harshness (NVH)		RS
Shock Absorber .....	14	Troubleshooting .....	23	BT
REMOVAL AND INSTALLATION.....	14	Components.....	23	HA
INSPECTION.....	14	On-vehicle Service.....	23	SC
Torsion Bar Spring.....	14	REAR SUSPENSION PARTS .....	23	EL
REMOVAL.....	14	Removal and Installation .....	24	IDX
INSPECTION.....	15	Shock Absorber .....	24	
INSTALLATION AND ADJUSTMENT .....	15	REMOVAL AND INSTALLATION.....	24	
Stabilizer Bar .....	16	INSPECTION.....	25	
REMOVAL.....	16	Leaf Spring .....	25	
INSPECTION.....	16	REMOVAL AND INSTALLATION.....	25	
INSTALLATION.....	16	INSPECTION.....	25	
Upper Link .....	17	INSTALLATION.....	26	
REMOVAL.....	17	Stabilizer Bar .....	26	
INSTALLATION.....	17	REMOVAL.....	26	
DISASSEMBLY.....	17	INSPECTION.....	26	
INSPECTION.....	17	INSTALLATION.....	26	
ASSEMBLY .....	18	Service Data and Specifications (SDS).....	26	
Lower Link .....	18	GENERAL SPECIFICATIONS (REAR).....	26	
REMOVAL AND INSTALLATION.....	18			

# FRONT SUSPENSION

## Precautions

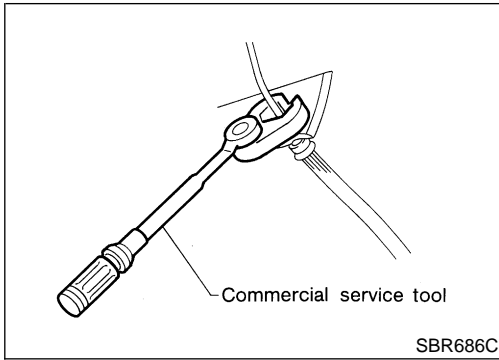

## Precautions PRECAUTIONS

- When installing rubber parts, final tightening must be carried out under unladen condition\* with tires on ground.  
\*: Fuel, radiator coolant and engine oil full. Spare tire, jack, hand tools and mats in designated positions.
- Use flare nut wrench when removing and installing brake tubes.
- After installing removed suspension parts, check wheel alignment and adjust if necessary.
- Always torque brake lines when installing.

NGSU0001

## Preparation

## SPECIAL SERVICE TOOLS

The actual shapes of Kent-Moore tools may differ from those of special service tools illustrated here.

NGSU0002

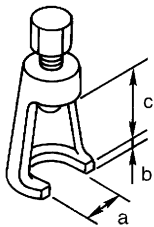
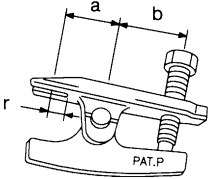
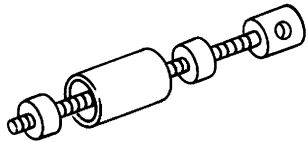
Tool number (Kent-Moore No.) Tool name	Description
ST29020001 (J24319-01) Gear arm puller	 <p>Removing ball joint for knuckle spindle a: 34 mm (1.34 in) b: 6.5 mm (0.256 in) c: 61.5 mm (2.421 in)</p>
HT72520000 (J25730-B) Ball joint remover	 <p>Removing tie-rod outer end a: 33 mm (1.30 in) b: 50 mm (1.97 in) r: R11.5 mm (0.453 in)</p>
KV40106800 ( — ) Lower link bushing puller	 <p>Removing and installing lower link bushing</p>

## COMMERCIAL SERVICE TOOLS

NGSU0003

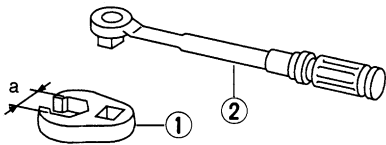
Tool name	Description
1 Flare nut crowfoot 2 Torque wrench	 <p>Removing and installing each brake piping a: 10 mm (0.39 in)</p>



# FRONT SUSPENSION

*Noise, Vibration and Harshness (NVH) Troubleshooting (Cont'd)*

---

x: Applicable

# FRONT SUSPENSION

Components

## 2WD MODELS

NGSU0005  
NGSU0005S01

### Components

#### SEC. 391•400•401

When installing rubber parts, final tightening must be carried out under unladen condition\* with tires on ground.

- \* Fuel, radiator coolant and engine oil full.
- Spare tire, jack, hand tools and mats in designated positions.

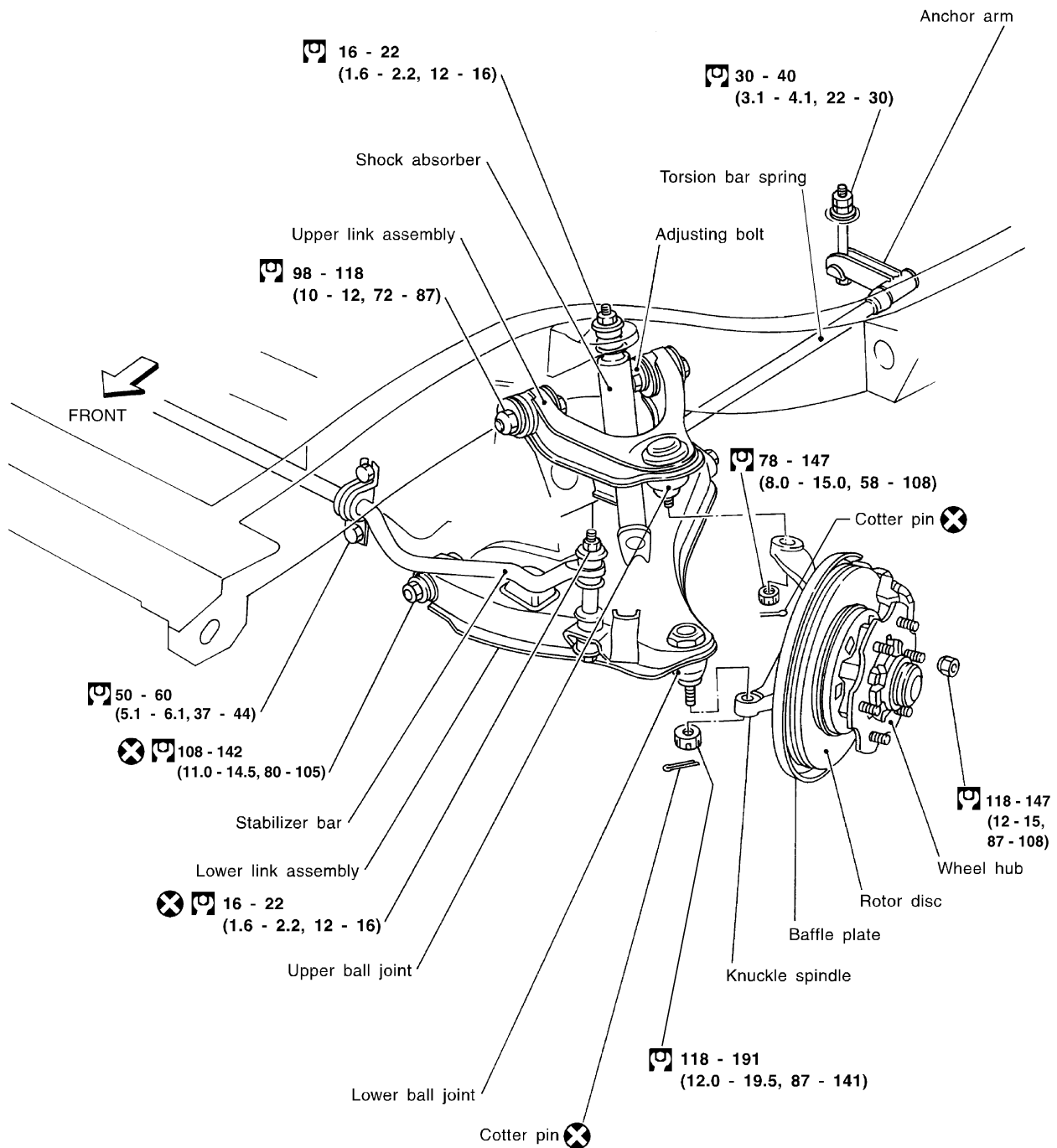

: N•m (kg-m, ft-lb)

GI  
MA  
EM  
LC  
EC  
FE  
CL  
MT  
AT  
TF  
PD  
AX  
SU  
BR  
ST  
RS  
BT  
HA  
SC  
EL  
IDX

# FRONT SUSPENSION

Components (Cont'd)

## 4WD MODELS

NGSU0005S02

### SEC. 391•400•401

When installing rubber parts, final tightening must be carried out under unladen condition\* with tires on ground.

- \* Fuel, radiator coolant and engine oil full.
- Spare tire, jack, hand tools and mats in designated positions.

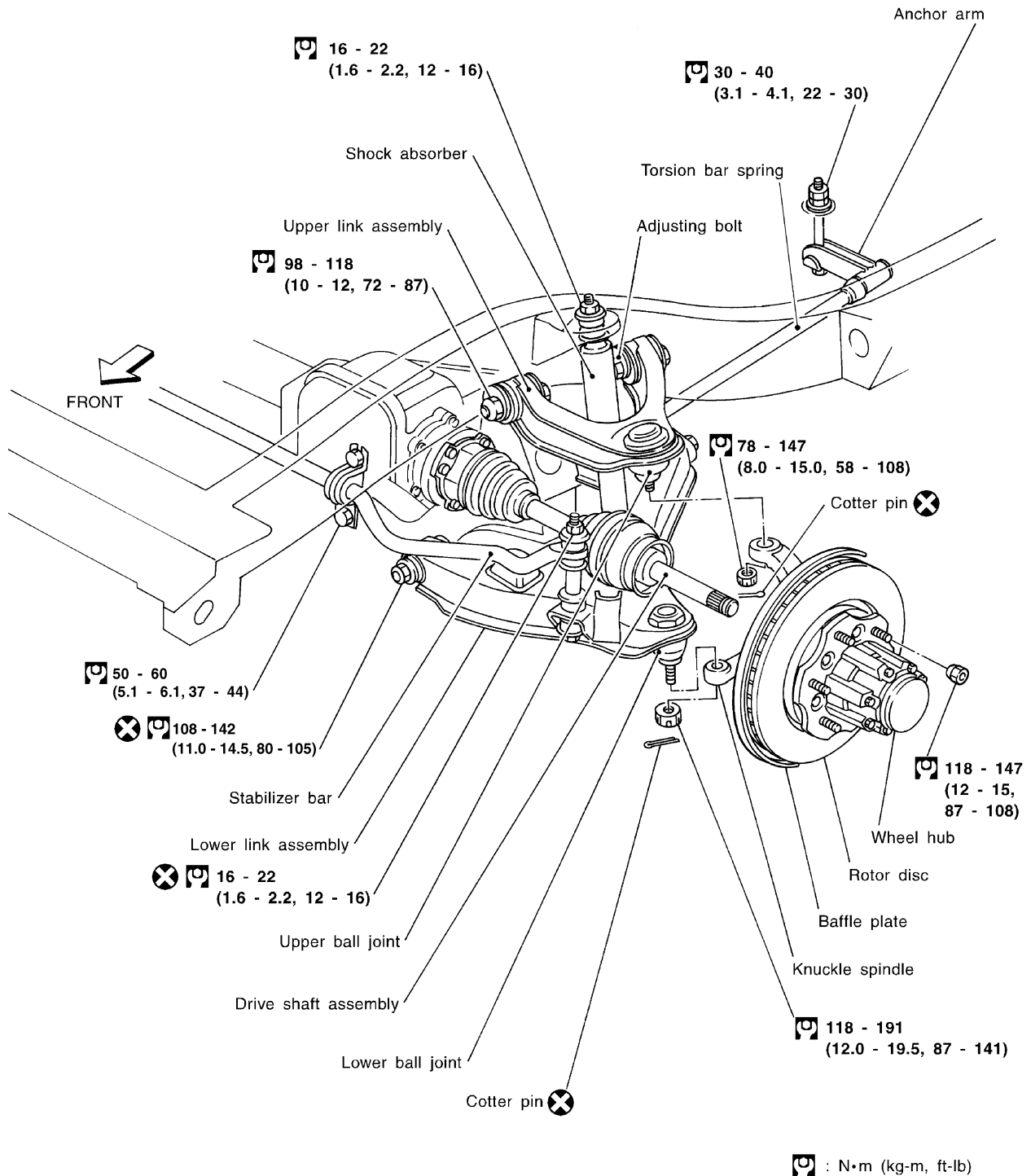

ASU058

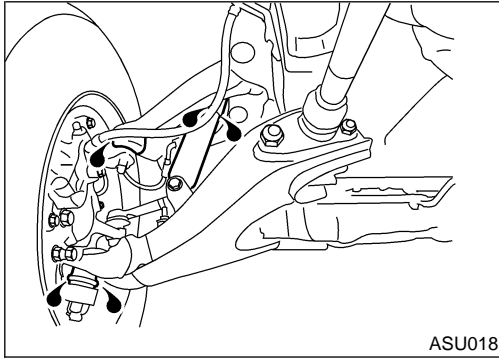
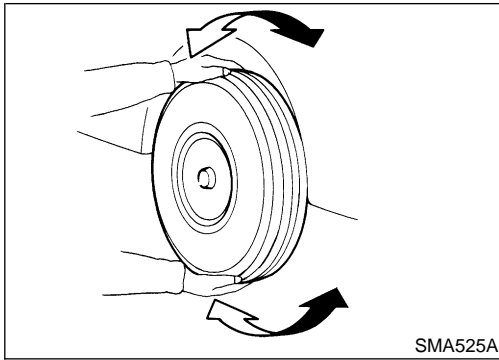

## On-vehicle Service

### FRONT SUSPENSION PARTS

NGSU0006

Check front suspension parts for excessive play, cracks, wear and other damage.

- Shake each front wheel to check for excessive play. If looseness is noted, adjust wheel bearing end play, then check ball joint end play.
- Make sure that the cotter pin is inserted.
- Retighten all nuts and bolts to the specified torque.
  - 🔧 : Refer to “FRONT SUSPENSION”, SU-13.
- Check shock absorber for oil leakage and other damage.
- Check suspension ball joint for grease leakage and ball joint dust cover for cracks and other damage.

GI  
MA  
EM  
LC  
EC  
FE  
CL  
MT

### FRONT WHEEL ALIGNMENT

NGSU0007

Before checking front wheel alignment, make a preliminary inspection (Unladen\*).

\*: Fuel, radiator coolant and engine oil full. Spare tire, jack, hand tools and mats in designated positions.

AT  
TF  
PD  
AX

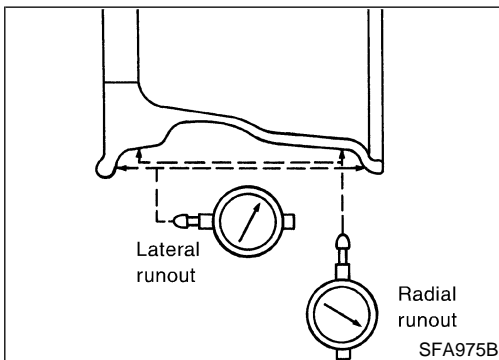

### Preliminary Inspection

#### Aluminum Wheel

NGSU0007S01

NGSU0007S0101

1. Check tires for wear and proper inflation.
2. Check wheels for deformation, cracks and other damage. If deformed, remove wheel and check wheel runout.
  - 1) Remove tire from aluminum wheel and mount wheel on a tire balance machine.
  - 2) Set dial indicator as shown in the illustration.
    - Wheel runout (Dial indicator value):  
Refer to SDS, SU-19.
3. Check front wheel bearings for looseness.
4. Check front suspension for looseness.
5. Check steering linkage for looseness.
6. Check that front shock absorbers work properly by using the standard bounce test.

SU  
BR  
ST  
RS  
BT  
HA  
SC  
EL  
IDX

# FRONT SUSPENSION

On-vehicle Service (Cont'd)

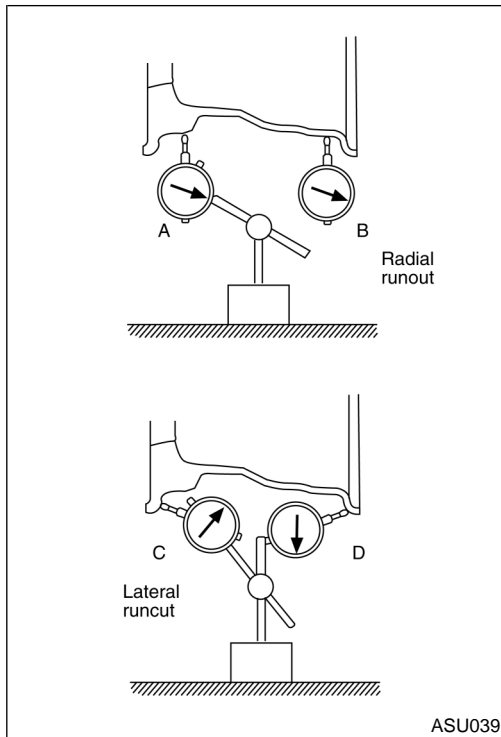

## Steel Wheel

NGSU0007S0102

1. Check tires for wear and proper inflation.
2. Check wheels for deformation, cracks and other damage. If deformed, remove wheel and check wheel runout.
  - 1) Remove tire from steel wheel and mount wheel on a tire balance machine.
  - 2) Set two dial indicator as shown in the illustrations.
  - 3) Set each dial indicator to 0.
  - 4) Rotate wheel, and check dial indicators at several points around the circumference of the wheel.
  - 5) Calculate runout at each point as shown below.  
 Radial runout =  $(A+B)/2$   
 Lateral runout =  $(C+D)/2$
  - 6) Select maximum positive runout value and the maximum negative value.  
 Add the two values to determine total runout.  
 In case a positive or negative value is not available, use the maximum value (negative or positive) for total runout.  
 If the total runout value exceeds the limit, replace steel wheel.

**Radial runout limit: 0.5 mm (0.020 in)**  
**Lateral runout limit: 0.8 mm (0.031 in)**
3. Check front wheel bearings for looseness.
4. Check front suspension for looseness.
5. Check steering linkage for looseness.
6. Check that front shock absorbers work properly by using the standard bounce test.

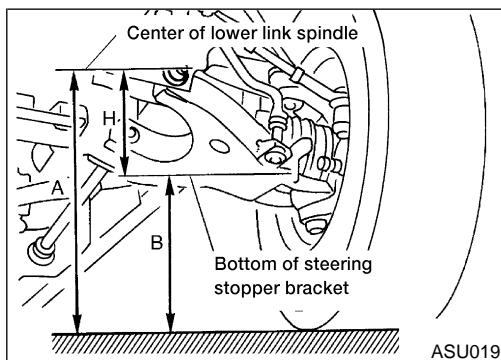

1. Check vehicle posture (Unladen):  $H = A - B$  mm (in)  
**Refer to SDS, SU-20.**
  - a. Exercise the front suspension by bouncing the front of the vehicle 4 or 5 times to ensure that the vehicle is in a neutral height attitude.
  - b. Measure wheel alignment.  
**Refer to SDS, SU-20.**
  - c. If wheel alignment is not as specified, adjust vehicle posture.  
**Refer to SDS, SU-20.**
  - d. Adjust wheel alignment.  
**Refer to SDS, SU-20.**



# FRONT SUSPENSION

On-vehicle Service (Cont'd)

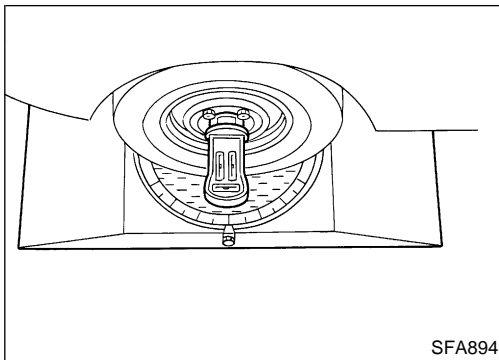

SFA894

## Camber, Caster and Kingpin Inclination

NGSU0007S02

Before checking camber, caster or kingpin inclination, move vehicle up and down on turning radius gauge to minimize friction. Ensure that the vehicle is in correct posture.

- Measure camber, caster and kingpin inclination of both right and left wheels with a suitable alignment gauge and adjust in accordance with the following procedures.

**Camber, Caster and Kingpin inclination:**  
Refer to SDS, SU-20.

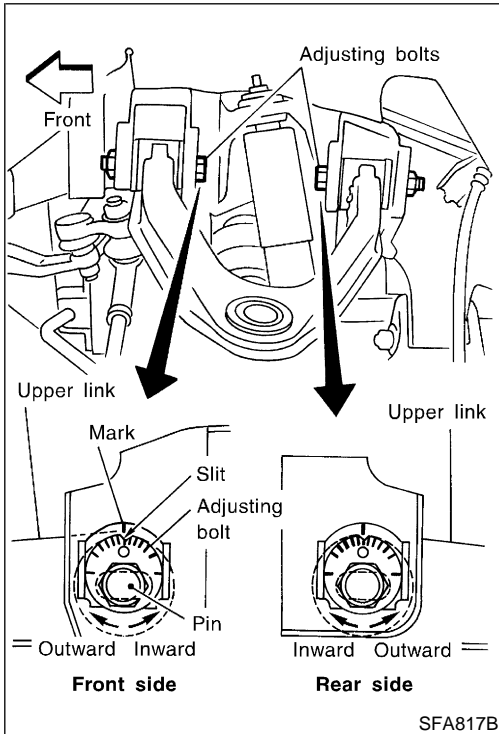

SFA817B

- In the following two cases, temporarily tighten the adjusting bolts while aligning the matching marks with the slits as shown in the figure at the left and measure the camber, caster and kingpin inclination:
  - a) When replacing the upper link or other suspension parts with new ones
  - b) When matching marks were not painted on adjusting bolts before suspension disassembly procedures
- If matching marks were already painted during suspension disassembly, align the matching marks with the slits, then temporarily tighten the adjusting bolts. Measure the camber, caster and kingpin inclination.

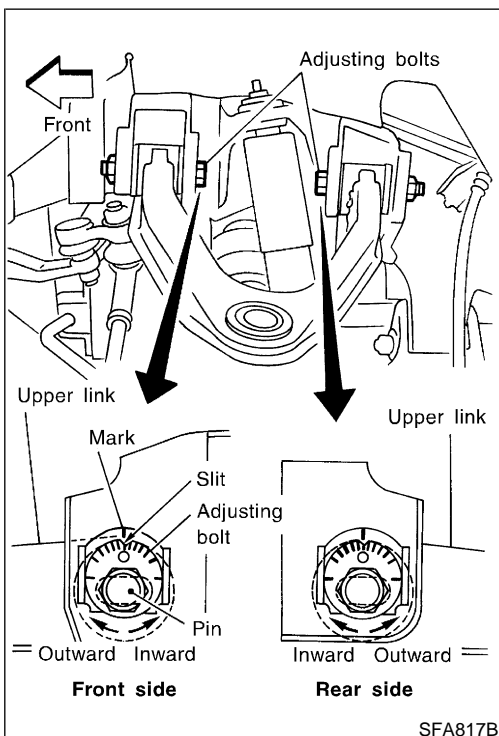

SFA817B

## Adjustment

NGSU0007S03

1. Both camber and caster angles are adjusted by adjusting bolts.
    - If the kingpin inclination is outside specifications, check the front suspension parts for wear or damage. Replace faulty parts with new ones.
  2. From the measured value, read the coordinate (or: graduation) at the intersecting point in the graph.
    - a. If the coordinate (or: graduation) at the intersecting point is positive, move the pin outward by turning the corresponding adjusting bolt by the indicated graduation.
    - b. If the coordinate (or: graduation) at the intersecting point is negative, move the pin inward by turning the corresponding adjusting bolt by the indicated graduation.

After properly moving the pin(s), tighten the front and rear adjusting bolts to specifications.
  3. Re-measure to ensure that the camber and caster are within specified tolerances.
- [Example]
- a. Measured values corresponding with the two values indicated below: (See chart for 4WD model.)

**Camber angle:  $-0^{\circ}06'$  ( $-0.10^{\circ}$ )**  
**Caster angle:  $2^{\circ}10'$  ( $2.17^{\circ}$ )**

GI  
MA  
EM  
LC  
EC  
FE  
CL  
MT  
AT  
TF  
PD  
AX  
SU  
BR  
ST  
RS  
BT  
HA  
SC  
EL  
IDX

# FRONT SUSPENSION

On-vehicle Service (Cont'd)

- Apply the above two values to the graph and determine point "A".
- The coordinate (or: graduation) indicates that both the front and rear adjusting bolts must be turned outward by 3 graduations. Turn the adjusting bolts by the amount corresponding with the 3 graduations.

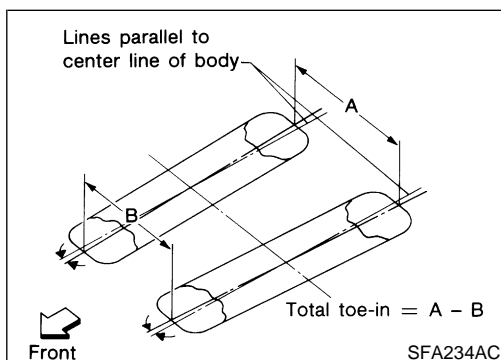
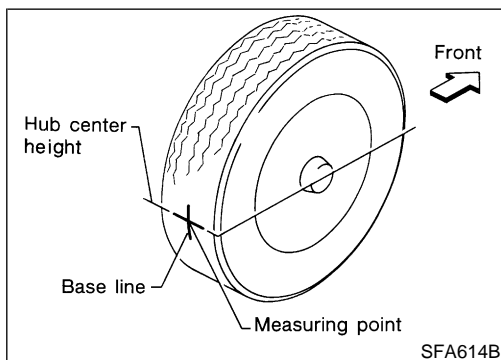
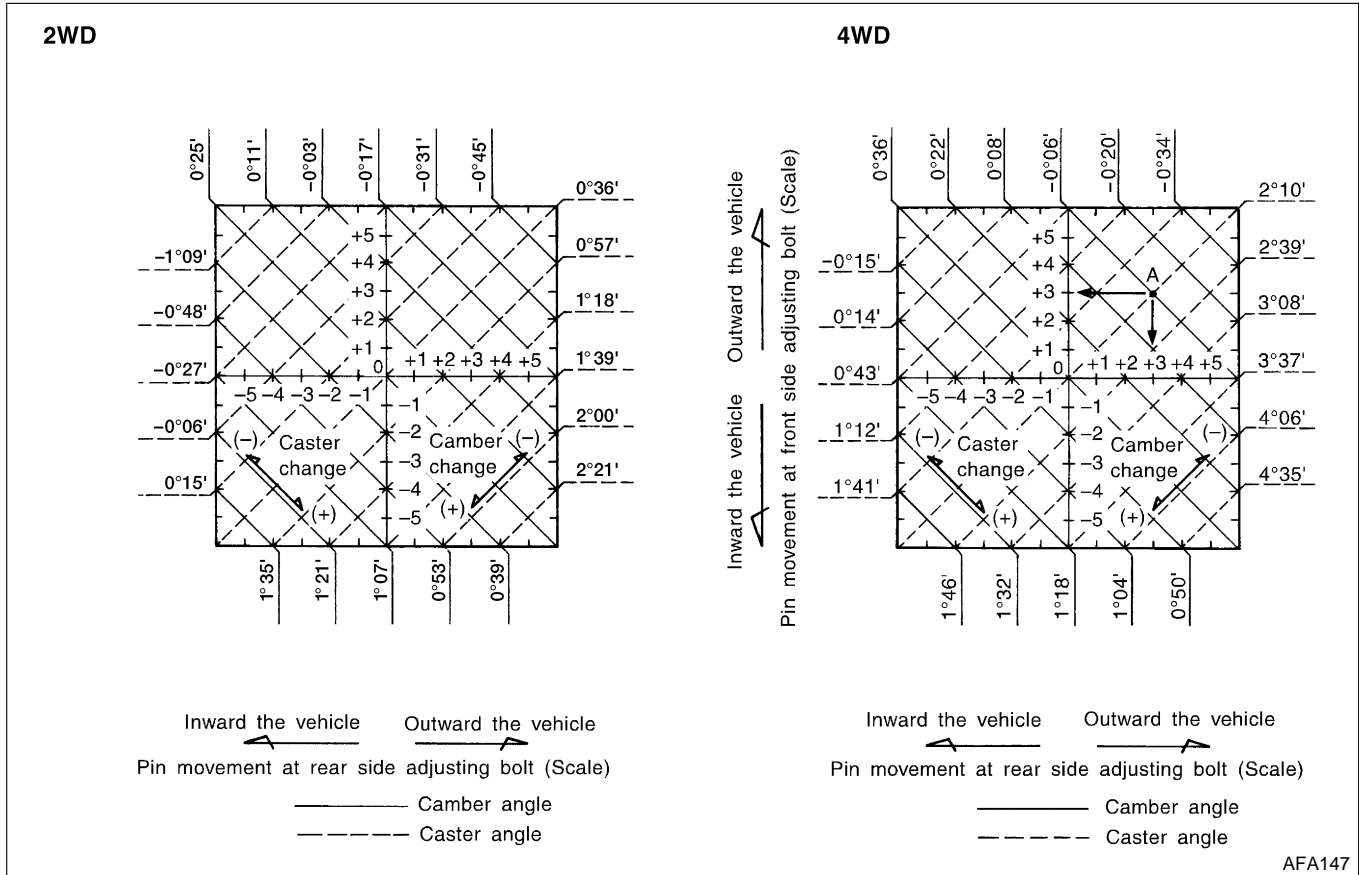

## Toe-in

Measure toe-in using the following procedure.

NGSU0007S04

### WARNING:

- Always perform the following procedure on a flat surface.
  - Make sure that no one is in front of the vehicle before pushing it.
- Bounce front of vehicle up and down to stabilize the posture.
  - Push the vehicle straight ahead about 5 m (16 ft).
  - Put a mark on base line of the tread (rear side) of both tires at the same height of hub center. This mark is a measuring point.
  - Measure distance "A" (rear side).
  - Push the vehicle slowly ahead to rotate the wheels 180 degrees (1/2 turn).
- If the wheels have rotated more than 180 degrees (1/2 turn), try the above procedure again from the beginning. Never push vehicle backward.
- Measure distance "B" (front side).

Total toe-in:

Refer to SDS, SU-20.

# FRONT SUSPENSION

On-vehicle Service (Cont'd)

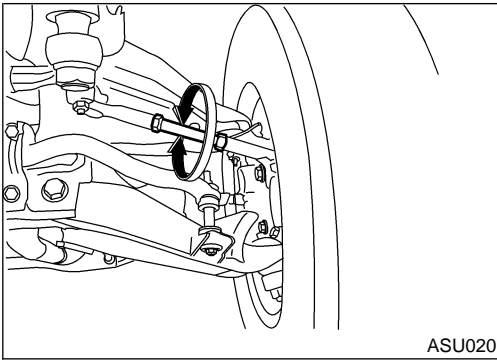

7. Adjust toe-in by varying the length of both steering tie-rods.
  - a. Loosen lock nuts.
  - b. Adjust toe-in by turning both the left and right tie-rod tubes equal amounts.

GI

MA

EM

LC

**Make sure that the tie-rod bars are screwed into the tie-rod tube more than 35 mm (1.38 in).**

**Make sure that the tie-rods are the same length.**

**Standard length (A = B):**

**2WD KA24DE models**

**343.9 mm (13.54 in)**

**2WD and 4WD VG33E models**

**297.6 mm (11.72 in)**

EC

FE

CL

- c. Tighten clamp bolts or lock nuts, then torque them.

MT

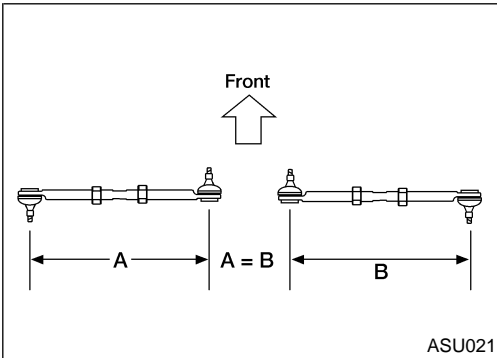

## Front Wheel Turning Angle

1. Set wheels in straight-ahead position. Then move vehicle forward until front wheels rest properly on turning radius gauge. NGSU0007S05
  2. Rotate steering wheel all the way right and left; measure turning angle.
- On power steering models, turn steering wheel to full lock and apply force (at circumference of steering wheel) of 98 to 147 N (10 to 15 kg, 22 to 33 lb) with engine at idle.
  - **Do not hold the steering wheel at full lock for more than 15 seconds.**

AT

TF

PD

AX

**Wheel turning angle (Full turn):**

**Refer to SDS, SU-20.**

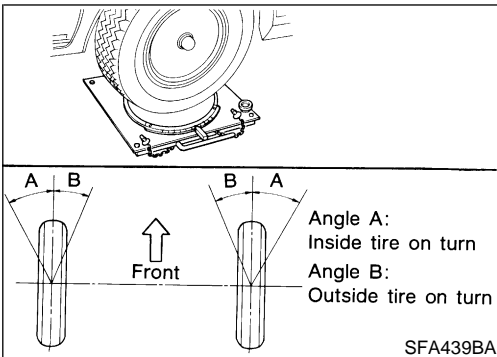

SU

BR

ST

RS

BT

HA

SC

EL

IDX

## FRONT SUSPENSION

On-vehicle Service (Cont'd)

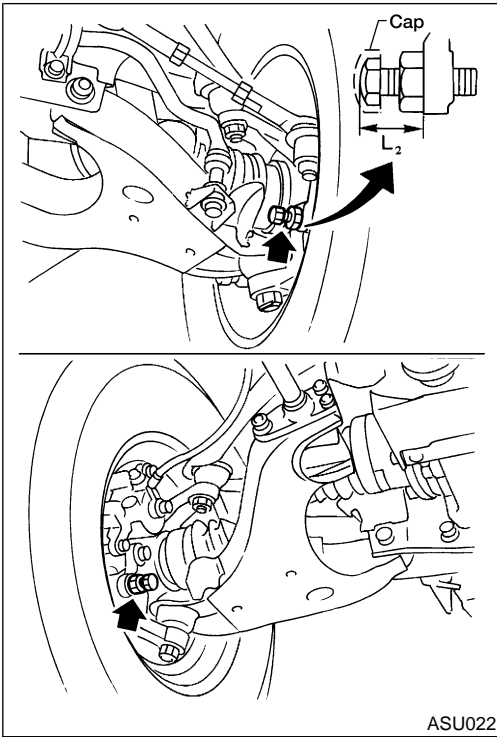

3. Adjust stopper bolt if necessary.

**Standard length "L<sub>1</sub>" (2WD KA24DE models):**

**20 mm (0.79 in)**

**(Length before cap is mounted)**

**Standard length "L<sub>2</sub>" (2WD & 4WD VG33E models):**

**Except P265/70R15 tire:**

**26.5 mm (1.043 in)**

**(Length before cap is mounted)**

**P265/70R15 tire:**

**30.0 mm (1.2 in)**

**(Length before cap is mounted)**

# FRONT SUSPENSION

Components

NGSU0008

## Components

GI  
MA  
EM  
LC  
EC  
FE  
CL  
MT  
AT  
TF  
PD  
AX  
**SU**  
BR  
ST  
RS  
BT  
HA  
SC  
EL  
IDX

SEC. 401

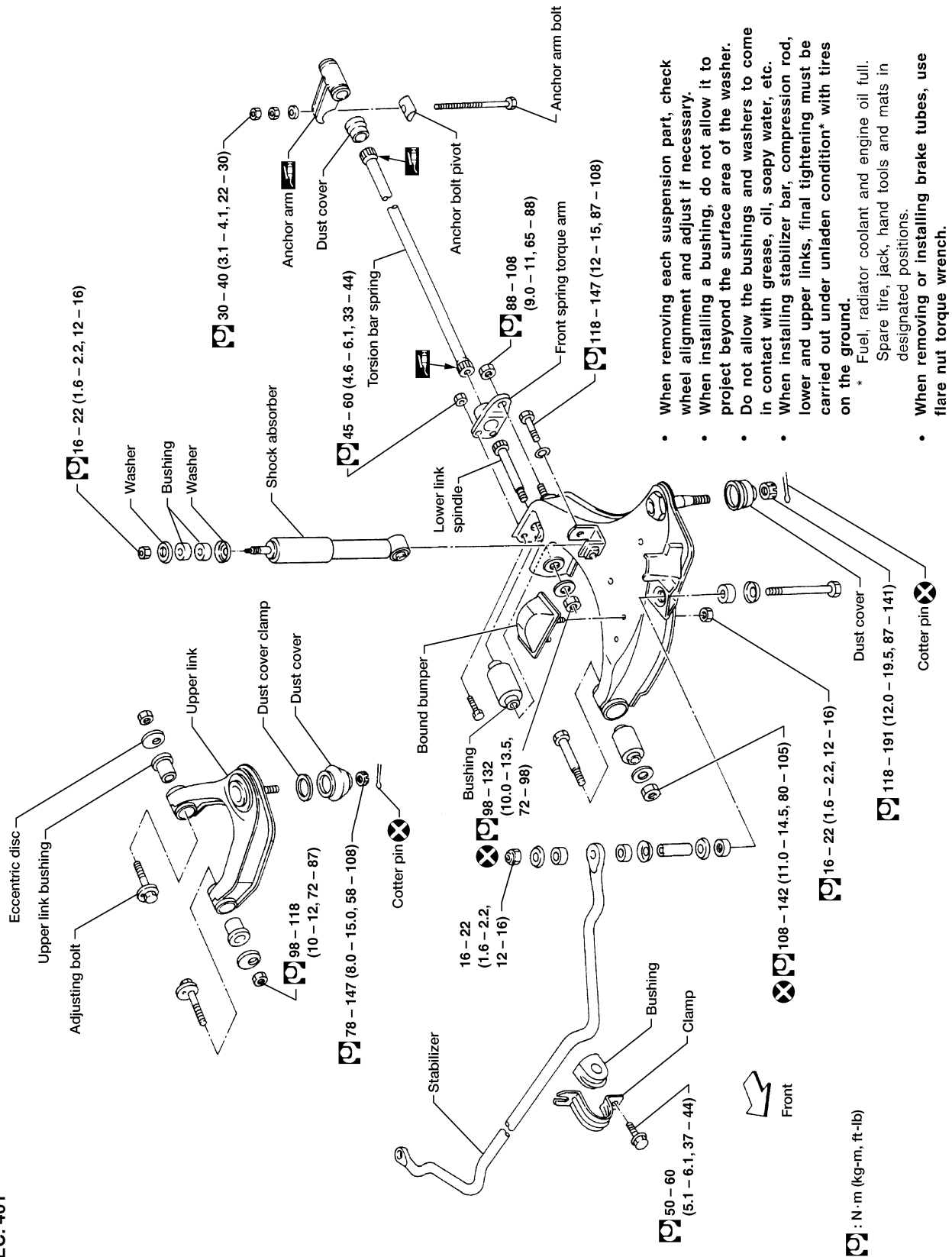

- When removing each suspension part, check wheel alignment and adjust if necessary.
- When installing a bushing, do not allow it to project beyond the surface area of the washer.
- Do not allow the bushings and washers to come in contact with grease, oil, soapy water, etc.
- When installing stabilizer bar, compression rod, lower and upper links, final tightening must be carried out under unladen condition\* with tires on the ground.
- \* Fuel, radiator coolant and engine oil full. Spare tire, jack, hand tools and mats in designated positions.
- When removing or installing brake tubes, use flare nut torque wrench.

# FRONT SUSPENSION

## Shock Absorber

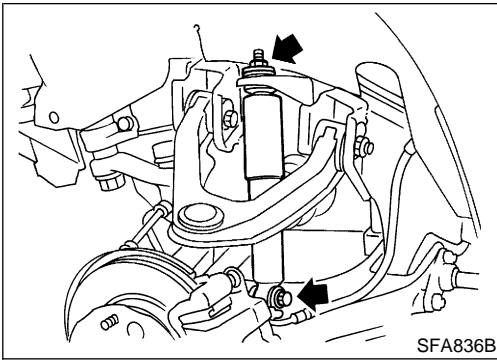

### Shock Absorber REMOVAL AND INSTALLATION

NGSU0009

1. Support lower link with jack.
2. Remove bolt and nut that hold shock absorber.

### INSPECTION

NGSU0010

Except for nonmetallic parts, clean all parts with suitable solvent and dry with compressed air.

Use compressed air to blow dirt and dust off of nonmetallic parts.

- Check for oil leakage and cracks. Replace if necessary.
- Check piston rod for cracks, deformation and other damage. Replace if necessary.
- Check rubber parts for wear, cracks, damage and deformation. Replace if necessary.

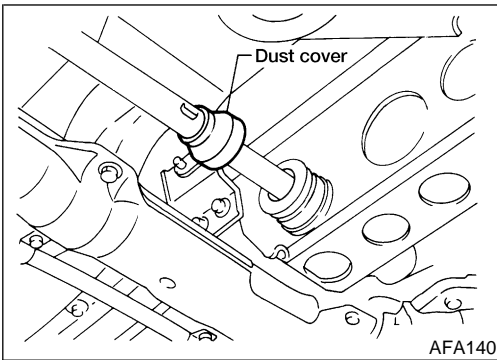

### Torsion Bar Spring

#### REMOVAL

NGSU0011

1. Move dust cover.
2. Paint matching marks on the torsion bar spring and the corresponding arm.

**Always use paint to place the matching mark; do not scribe the affected parts.**

3. Measure anchor bolt protrusion "L" and remove the lock nut and adjusting nut.

**Before removing the nuts, ensure that twisting force is eliminated from the torsion bar springs.**

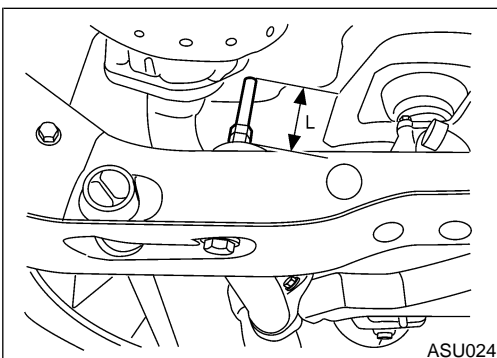
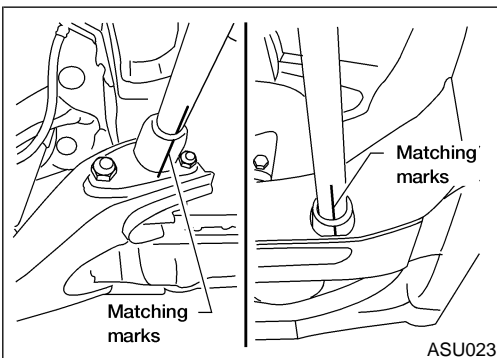

# FRONT SUSPENSION

Torsion Bar Spring (Cont'd)

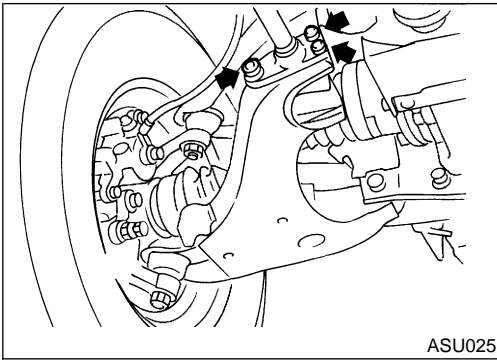

4. Remove torsion bar spring.
  - Remove torque arm fixing nuts, then withdraw torsion bar spring forward with torque arm.

GI

MA

EM

LC

## INSPECTION

- Check torsion bar spring for wear, twist, bend and other damage.
- Check serrations of each part for cracks, wear, twist and other damage.
- Check dust cover for cracks.

NGSU0012

EC

FE

CL

MT

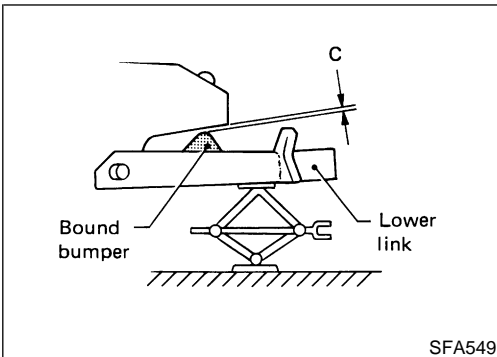

## INSTALLATION AND ADJUSTMENT

Adjustment of anchor arm adjusting nut is in tightening direction only.

NGSU0013

AT

Do not adjust by loosening anchor arm adjusting nut.

1. Coat multi-purpose grease on the serration of torsion bar spring.
2. Place lower link in the position where bound bumper clearance "C" is 0.

TF

PD

**Clearance "C": 0 mm (0 in)**

AX

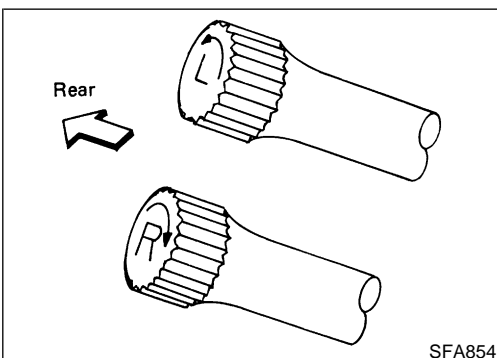

3. Install torsion bar spring with torque arm.

Be sure to install right and left torsion bar springs correctly.

SU

BR

ST

RS

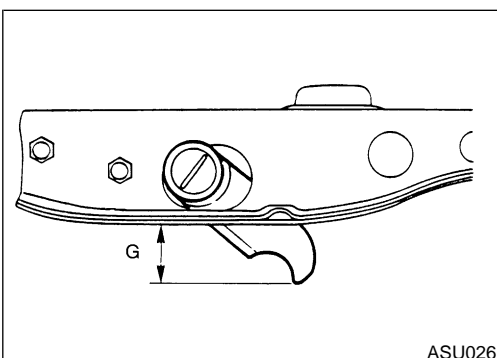

4. While aligning the anchor arm with the matching mark, install the anchor arm to the torsion bar spring. If a new torsion bar spring or anchor arm is installed, adjust anchor arm length to the dimension indicated in the figure at the left.

BT

HA

**Standard length "G":**

**2WD KA24DE models**

**6 - 18 mm (0.24 - 0.71 in)**

**2WD and 4WD VG33E models**

**25 - 39 mm (0.98 - 1.54 in)**

SC

EL

IDX

# FRONT SUSPENSION

## Torsion Bar Spring (Cont'd)

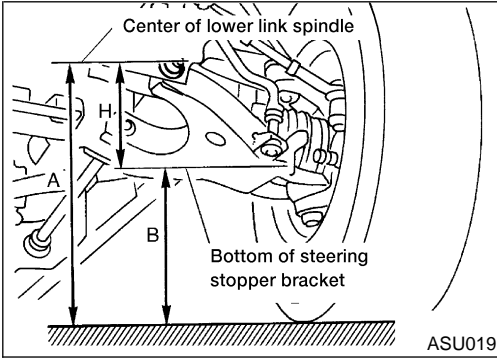
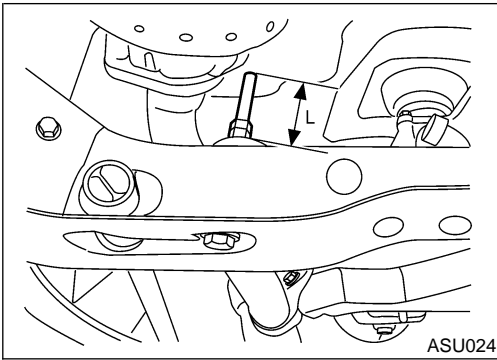

5. Tighten the adjusting nut so the torsion bar length corresponds with dimension "L" previously measured during torsion bar removal. Tighten the lock nut to specifications. If a new torsion bar spring or anchor arm is installed, tighten the adjusting nut to the dimension indicated in the figure at the left, then tighten the lock nut to specifications.

### Standard length "L":

**2WD KA24DE models**

**54 mm (2.13 in)**

**2WD & 4WD VG33E models**

**70 mm (2.76 in)**

6. Bounce vehicle with tires on ground (Unladen) to eliminate friction of suspension.
7. Measure vehicle posture "H".
  - a. Exercise the front suspension by bouncing the front of the vehicle 4 or 5 times to ensure that the vehicle is in a neutral height attitude.
  - b. Measure vehicle posture ... Dimension "H".

**$H = A - B$  mm (in) "Unladen"**

**Refer to "Wheel Alignment (Unladen)", "SDS", SU-20.**
8. If height of the vehicle is not within allowable limit, adjust vehicle posture.

**Refer to "Wheel Alignment (Unladen)", "SDS", SU-20.**
9. Check wheel alignment if necessary.

**Refer to "Wheel Alignment (Unladen)", "SDS", SU-20.**

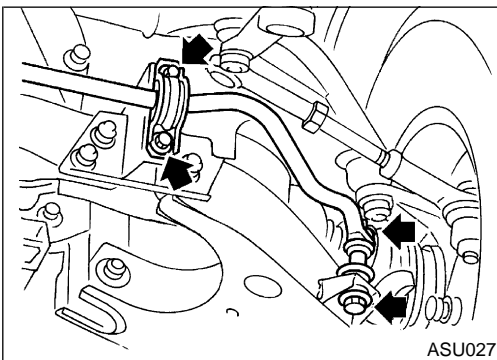

## Stabilizer Bar REMOVAL

- Remove stabilizer bar connecting bolts and clamp bolts. NGSU0014

## INSPECTION

- Check stabilizer bar for twist and deformation. Replace if necessary. NGSU0015
- Check rubber bushing for cracks, wear and deterioration. Replace if necessary.

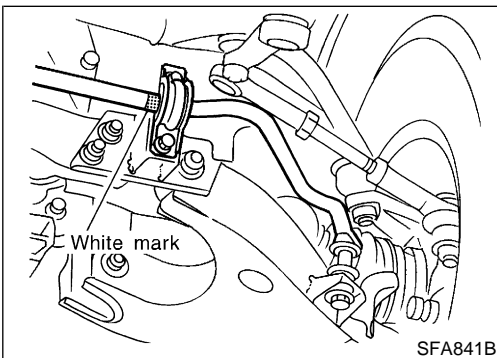

## INSTALLATION

- Install bushing outside of white mark painted on stabilizer. NGSU0016



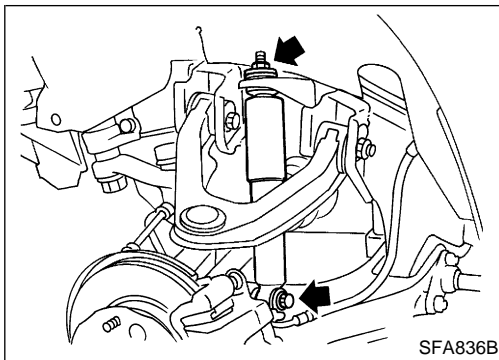

## Upper Link

### REMOVAL

1. Remove shock absorber. Refer to "Shock Absorber", SU-14. NGSU0017
2. Separate upper ball joint stud from knuckle spindle. GI  
**Support lower link with jack.** MA  
 Refer to "Knuckle Spindle", "FRONT AXLE" in AX section. EM

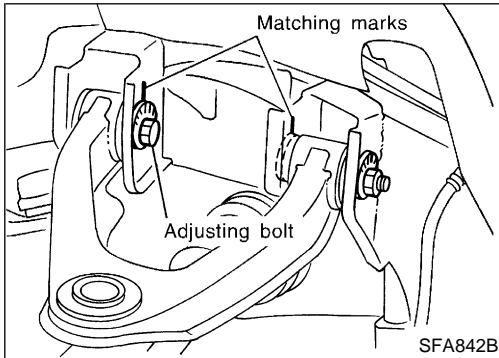

3. Put matching marks on adjusting bolts and remove adjusting bolts. LC  
EC  
FE  
CL  
MT

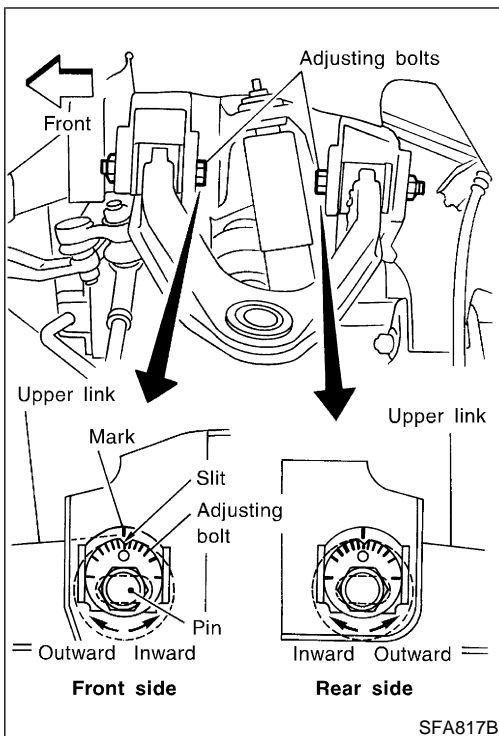

### INSTALLATION

1. While aligning the adjusting bolts with the matching marks, install the upper link. AT  
 If a new upper link or any other suspension part is installed, align the matching mark with the slit as indicated in the figure at the left, then install the upper link. TF  
 Refer to "FRONT WHEEL ALIGNMENT", "On-vehicle Service", SU-7. PD
2. Install shock absorber.
3. Tighten adjusting bolts under unladen condition with tires on ground. AX
4. After installing, check wheel alignment. Adjust if necessary. Refer to SU-7. SU

### DISASSEMBLY

- Press out upper link bushings. NGSU0019

### INSPECTION

- Check adjusting bolts and rubber bushings for damage. Replace if necessary. HA
- Check upper link for deformation and cracks. Replace if necessary. SC

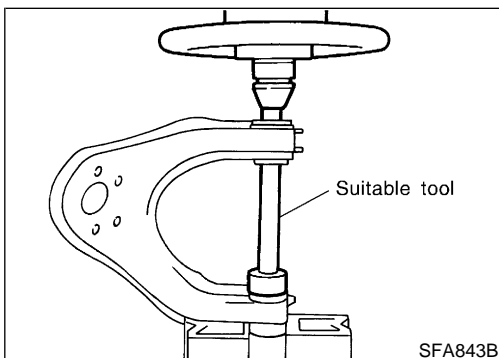

# FRONT SUSPENSION

## Upper Link (Cont'd)

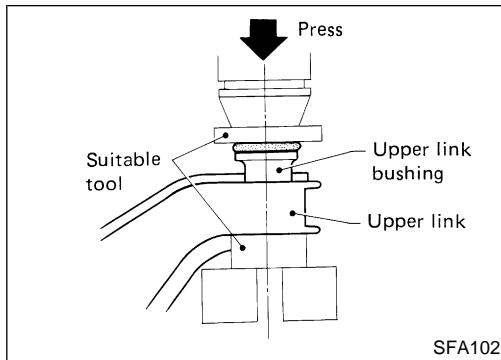

## ASSEMBLY

1. Apply soapsuds to rubber bushing.
2. Press upper link bushing.

NGSU0021

**Press bushing so that the flange of bushing securely contacts the end surface of the upper link collar.**

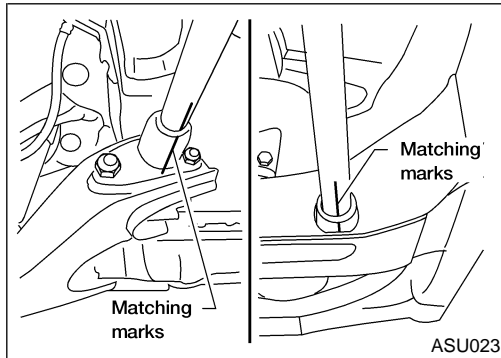

## Lower Link

### REMOVAL AND INSTALLATION

NGSU0024

1. Remove torsion bar spring. Refer to "REMOVAL", "Torsion Bar Spring", SU-14.

**Make matching marks and measure dimension "L" when loosening adjusting nut until there is no tension on torsion bar spring.**

2. Remove shock absorber lower fixing bolt.
3. Remove stabilizer bar connecting bolt.
4. Separate drive shaft from front final drive (4WD models). Refer to **AX-15**, "Drive Shaft", "FRONT AXLE".
5. Separate lower link ball joint from knuckle spindle. Refer to **AX-13**, "Knuckle Spindle", "FRONT AXLE".

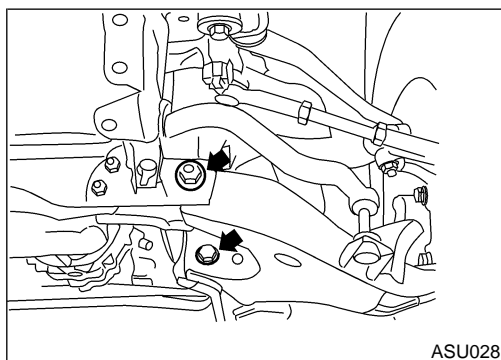
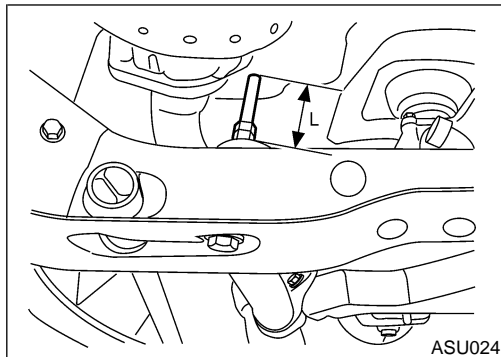

6. Remove front lower link fixing bolts.

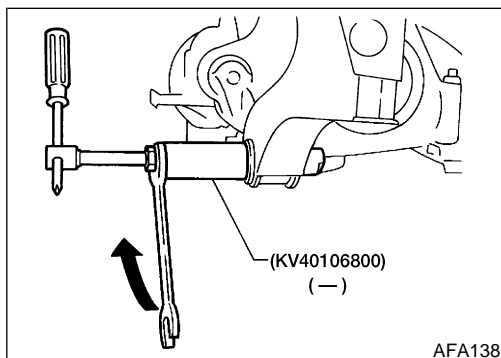

7. Remove bushing of lower link spindle from frame with Tool.
8. After installing lower link, adjust wheel alignment and vehicle height. Refer to "FRONT WHEEL ALIGNMENT", "On-vehicle Service", SU-7.

## INSPECTION

### Lower Link and Lower Link Spindle

NGSU0025

NGSU0025S01

- Check for deformation and cracks. Replace if necessary.

### Lower Link Bushing

NGSU0025S02

- Check for distortion and damage. Replace if necessary.

# FRONT SUSPENSION

Upper Ball Joint and Lower Ball Joint

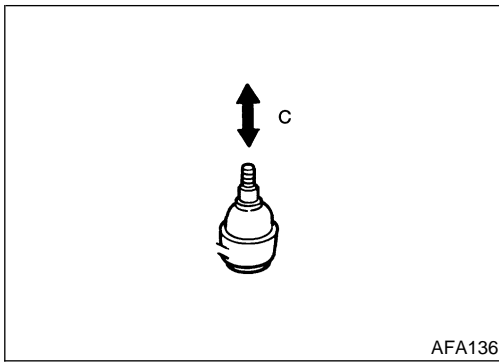

## Upper Ball Joint and Lower Ball Joint REMOVAL AND INSTALLATION

NGSU0026

- Separate knuckle spindle from upper and lower links. Refer to **AX-13**, "Knuckle Spindle", "FRONT AXLE".

## INSPECTION

NGSU0027

- Check joints for play. If ball is worn and play in axial direction is excessive or joint is hard to swing, replace as a upper link or lower link.

### Axial end play "C":

#### Upper link

0 mm (0 in)

#### Lower link

2WD KA24DE models 1.3 mm (0.051 in) or less

2WD & 4WD VG33E models 0.2 mm (0.008 in) or less

- Check dust cover for damage. Replace dust cover and dust cover clamp if necessary.

## Service Data and Specifications (SDS)

### GENERAL SPECIFICATIONS (FRONT)

NGSU0028

Suspension type	Independent double wishbone torsion bar spring
Shock absorber type	Double-acting hydraulic
Stabilizer	Standard equipment

### WHEEL RUNOUT AVERAGE

NGSU0029

Wheel type	Aluminum	Steel			
		15 inches	14 inches		
			Painted	Plated	
Radial runout limit mm (in)	0.3 (0.012)	0.5 (0.031)	0.5 (0.020)	0.5 (0.024)	
Lateral runout limit mm (in)	0.3 (0.012)	0.8 (0.031)	0.8 (0.031)	0.8 (0.031)	

### UPPER BALL JOINT

NGSU0030

Vertical end play "C" mm (in)	0 (0)
-------------------------------	-------

### LOWER BALL JOINT

NGSU0031

Applied model	2WD	4WD
Vertical end play "C" mm (in)	1.3 (0.051) or less	0.2 (0.008) or less

# FRONT SUSPENSION

Service Data and Specifications (SDS) (Cont'd)

## WHEEL ALIGNMENT (UNLADEN\*1)

-NGSU0032

### 2WD Models

NGSU0032S01

Camber Degree minute (Decimal degree)		Minimum	0°03' (0.05°)		
		Nominal	0°33' (0.55°)		
		Maximum	1°03' (1.05°)		
		Left and right difference	45' (0.75°) or less		
Caster Degree minute (Decimal degree)		Minimum	2°04' (2.07°)		
		Nominal	2°34' (2.57°)		
		Maximum	3°04' (3.07°)		
		Left and right difference	45' (0.75°) or less		
Kingpin inclination Degree minute (Decimal degree)		Minimum	10°23' (10.38°)		
		Nominal	10°53' (10.88°)		
		Maximum	11°23' (11.38°)		
Total toe-in	Distance (A – B) mm (in)	Radial tire	Minimum	3 (0.12)	
			Nominal	4 (0.16)	
			Maximum	5 (0.20)	
	Angle (left plus right) Degree minute (Decimal degree)	Radial tire	Minimum	15' (0.25°)	
			Nominal	20' (0.33°)	
			Maximum	25' (0.42°)	
Wheel turning angle	Full turn*2	Inside Degree minute (Decimal degree)		Except P265/70R15	P265/70R15
			Minimum	32°48' (32.80°)	30°48' (30.80°)
			Nominal	34°48' (34.80°)	32°48' (32.80°)
		Maximum	34°48' (34.80°)	32°48' (32.80°)	
		Outside Degree minute (Decimal degree)	Minimum	31°00' (31.00°)	28°42' (28.70°)
			Nominal	33°00' (33.00°)	30°42' (30.70°)
	Maximum		33°00' (33.00°)	30°42' (30.70°)	
	Vehicle posture	Lower arm pivot height (H) mm (in)	37.7 - 41.7 (1.484 - 1.642)		

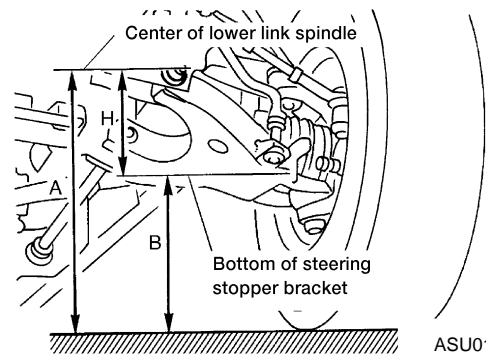

\*1: Fuel, radiator coolant and engine oil full. Spare tire, jack, hand tools and mats in designated positions.

\*2: On power steering models, wheel turning force (at circumference of steering wheel) of 98 to 147 N (10 to 15 kg, 22 to 33 lb) with engine idle.

# FRONT SUSPENSION

Service Data and Specifications (SDS) (Cont'd)

## 4WD Models

=NGSU0032S02

Camber Degree minute (Decimal degree)		Minimum	0°06' (0.10°)		GI	
		Nominal	0°36' (0.60°)			
		Maximum	1°06' (1.10°)		MA	
		Left and right difference	45' (0.75°) or less			
Caster Degree minute (Decimal degree)		Minimum	1°40' (1.67°)		EM	
		Nominal	2°10' (2.17°)			
		Maximum	2°40' (2.67°)		LC	
		Left and right difference	45' (0.75°) or less			
Kingpin inclination Degree minute (Decimal degree)		Minimum	10°18' (10.30°)		EC	
		Nominal	10°48' (10.80°)			
		Maximum	11°18' (11.30°)		FE	
Total toe-in	Distance (A – B) mm (in)	Radial tire	Minimum	3 (0.12)		
			Nominal	4 (0.16)		CL
			Maximum	5 (0.20)		
	Angle (left plus right) Degree minute (Decimal degree)	Radial tire	Minimum	15' (0.25°)		MT
			Nominal	20' (0.33°)		
			Maximum	25' (0.42°)		AT
Wheel turning angle	Full turn*2	Inside Degree minute (Decimal degree)	Except P265/70R15			
			Minimum	33°06' (33.10°)	31°00' (31.00°)	TF
			Nominal	35°06' (35.10°)	33°00' (33.00°)	
		Maximum	35°06' (35.10°)	33°00' (33.00°)	PD	
		Outside Degree minute (Decimal degree)	P265/70R15			
			Minimum	31°12' (31.20°)	29°00' (29.00°)	
Nominal	33°12' (33.20°)		31°00' (31.00°)	AX		
Maximum	33°12' (33.20°)	31°00' (31.00°)				
Vehicle posture	Lower arm pivot height (H) mm (in)		45.5 - 49.5 (1.791 - 1.949)		SU	

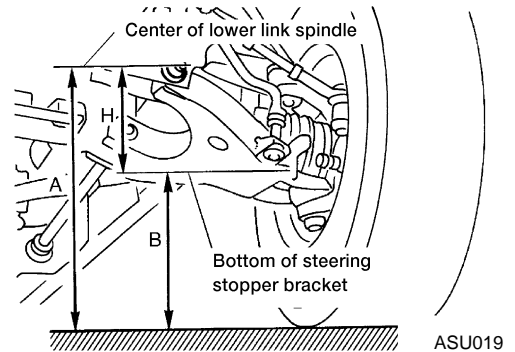

\*1: Fuel, radiator coolant and engine oil full. Spare tire, jack, hand tools and mats in designated positions.

\*2: On power steering models, wheel turning force (at circumference of steering wheel) of 98 to 147 N (10 to 15 kg, 22 to 33 lb) with engine idle.

GI  
MA  
EM  
LC  
EC  
FE  
CL  
MT  
AT  
TF  
PD  
AX  
SU  
BR  
ST  
RS  
BT  
HA  
SC  
EL  
IDX

# REAR SUSPENSION

## Precautions

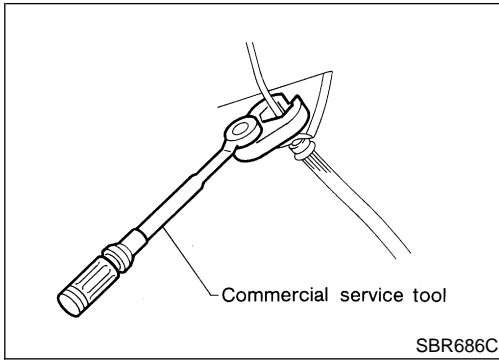

## Precautions PRECAUTIONS

- When installing rubber parts, final tightening must be carried out under unladen condition\* with tires on ground. NGSU0033  
\*: Fuel, radiator coolant and engine oil full. Spare tire, jack, hand tools and mats in designated positions.
- Use flare nut wrench when removing and installing brake tubes.
- After installing removed suspension parts, check wheel alignment and adjust if necessary.
- Always torque brake lines when installing.

## Preparation

## COMMERCIAL SERVICE TOOLS

NGSU0035

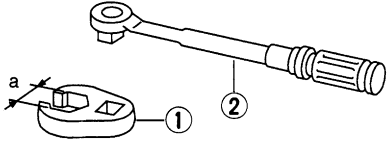
Tool name	Description
1 Flare nut crowfoot 2 Torque wrench	 <p>Removing and installing each brake piping                      a: 10 mm (0.39 in)</p> <p>NT360</p>

# REAR SUSPENSION

Noise, Vibration and Harshness (NVH) Troubleshooting

## Noise, Vibration and Harshness (NVH) Troubleshooting

=NGSU0036

Refer to "Noise, Vibration and Harshness (NVH) Troubleshooting", "FRONT SUSPENSION", SU-3.

### Components

NGSU0037

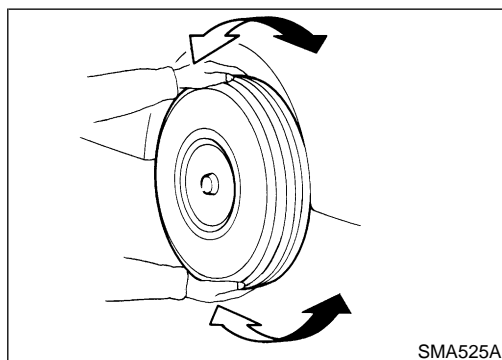
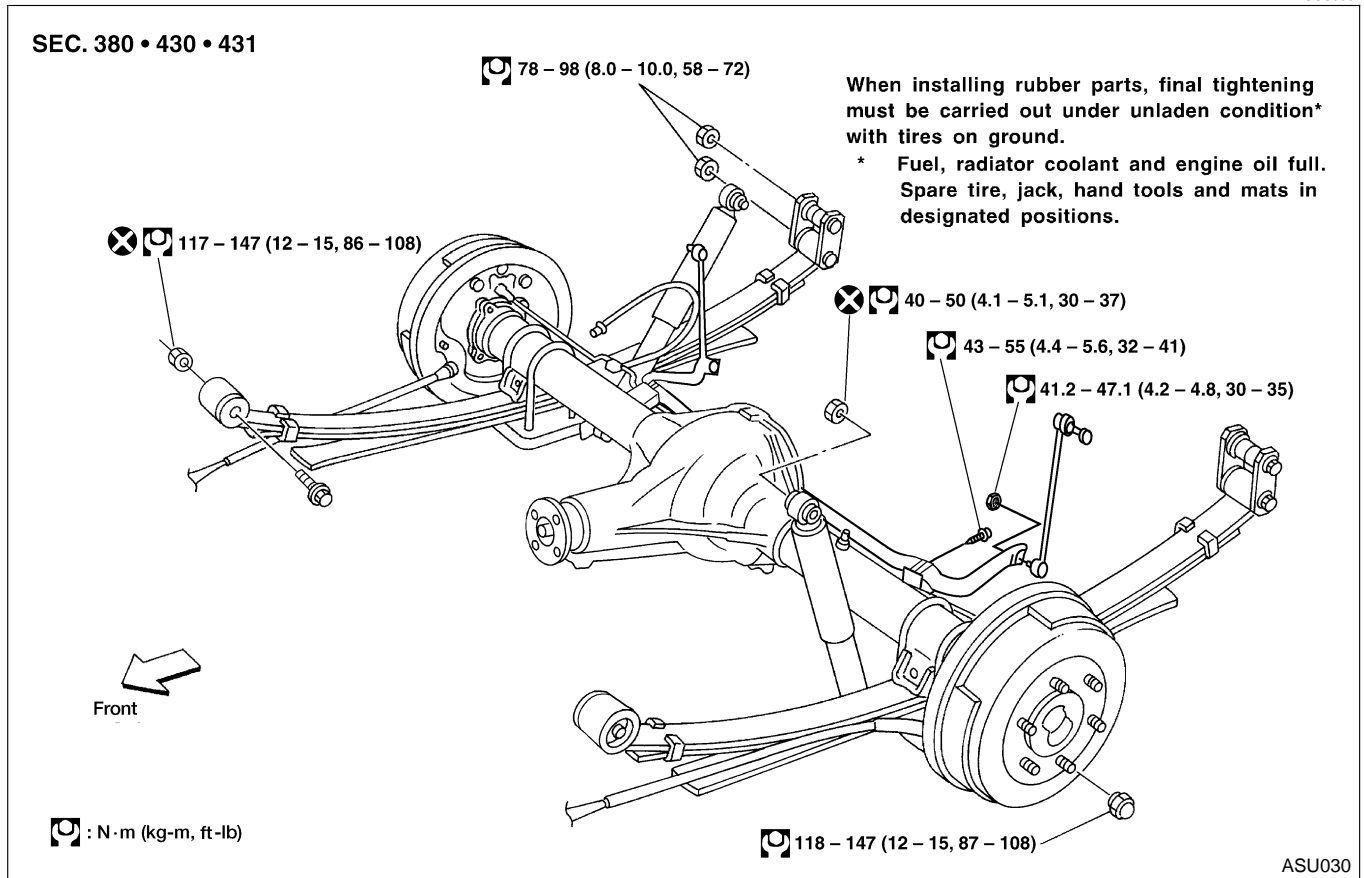

### On-vehicle Service

#### REAR SUSPENSION PARTS

NGSU0038

Check rear suspension parts for excessive play, wear and damage.

- Shake each rear wheel to check for excessive play.

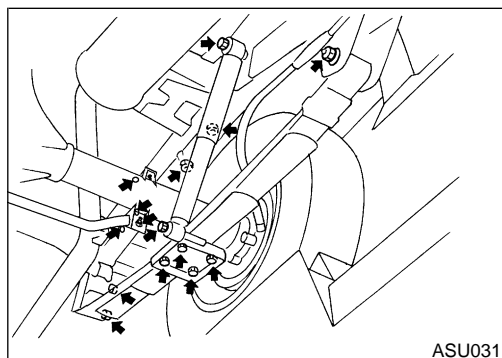

- Retighten all nuts and bolts to the specified torque.

: Refer to REAR SUSPENSION, SU-24.

GI

MA

EM

LC

EC

FE

CL

MT

AT

TF

PD

AX

SU

BR

ST

RS

BT

HA

SC

EL

IDX

# REAR SUSPENSION

On-vehicle Service (Cont'd)

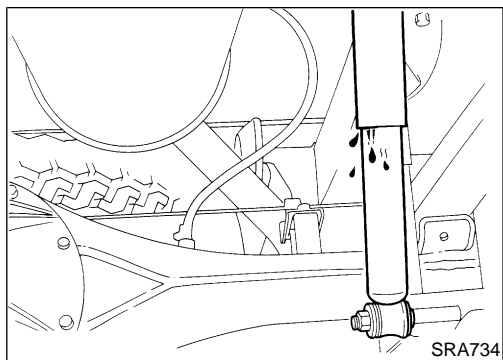

- Check shock absorber for oil leakage and other damage.
- Check shock absorber bushing for excessive wear and other damage.

## Removal and Installation

NGSU0039

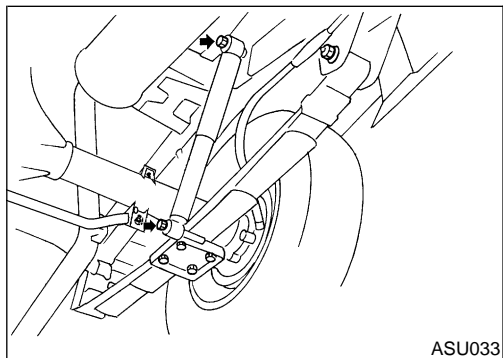
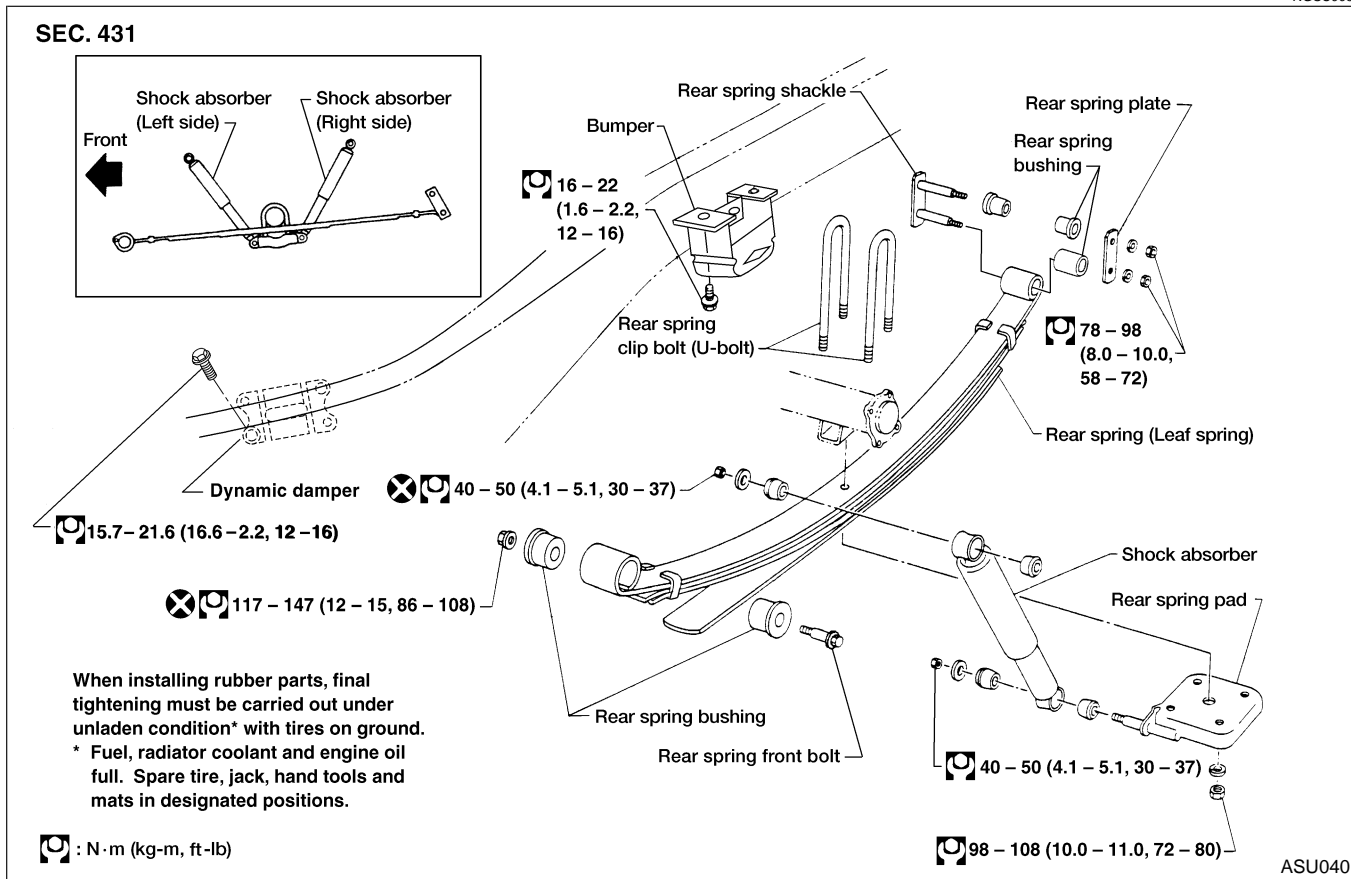

## Shock Absorber REMOVAL AND INSTALLATION

NGSU0040

- Remove shock absorber by disconnecting upper and lower end.



## INSPECTION

NGSU0041

- If oil leakage, cracks and deformation occurs, replace shock absorber assembly.
- If rubber bushings are cracked and deformed, replace rubber bushings.

GI

MA

EM

LC

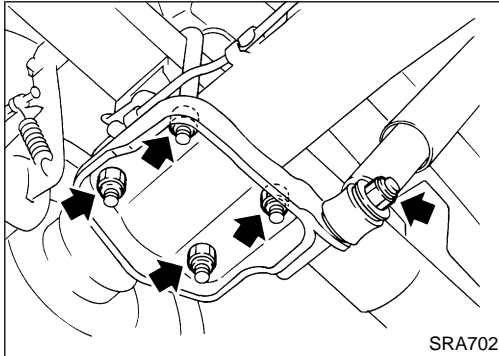

## Leaf Spring

### REMOVAL AND INSTALLATION

NGSU0042

1. Disconnect shock absorber lower end, and remove U-bolts.

EC

FE

CL

MT

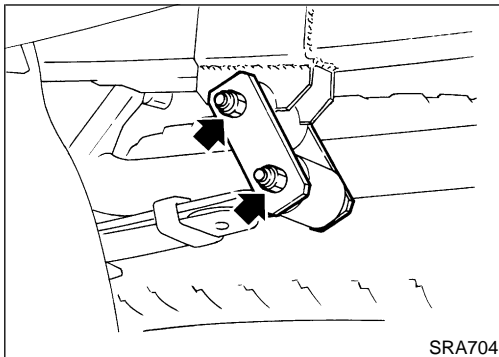

2. Disconnect spring shackle.

AT

TF

PD

AX

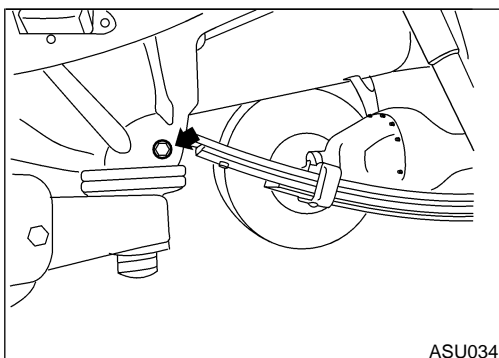

3. Disconnect front pin.

SU

BR

ST

RS

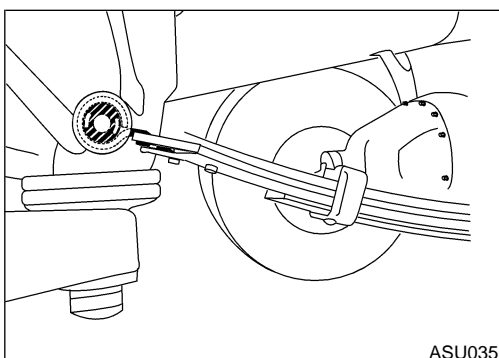

## INSPECTION

NGSU0043

- Check leaf spring for cracks. Replace if necessary.
- Check front bracket and pin, shackle, U-bolts and spring pad for wear, cracks, straightness and damaged threads. Replace if necessary.
- Check all bushings for deformation and cracks. Replace if necessary.  
(4WD models: Rear spring front bushing)  
Make sure that front bushing is properly installed.

BT

HA

SC

EL

IDX

# REAR SUSPENSION

## Leaf Spring (Cont'd)

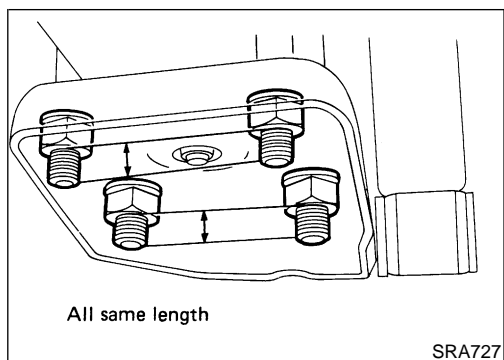

### INSTALLATION

NGSU0044

1. Apply soapsuds to rubber bushing.
2. Install spring shackle and front pin, and finger tighten the nuts.
3. Install spring pad and nuts under leaf spring or axle case.
4. Tighten U-bolt mounting nuts diagonally.

**Tighten U-bolts so that the lengths of all U-bolts under spring pad are the same.**

5. Install shock absorber, and finger tighten the nuts.

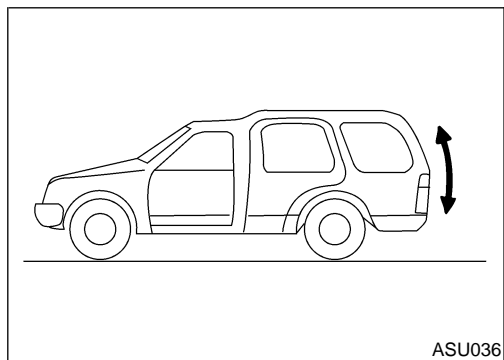

6. Remove stands and bounce the vehicle to stabilize suspension. (Unladen)

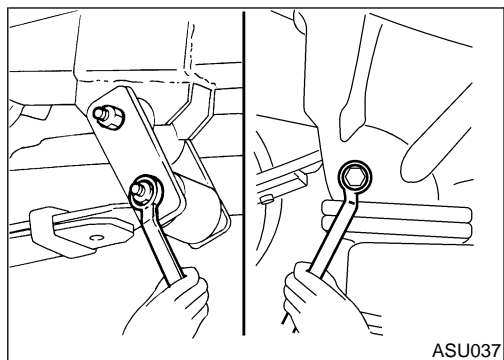

7. Tighten spring shackle nuts, front pin nuts and shock absorber nuts.

**When installing rubber parts, final tightening must be carried out under unladen condition\* with tires on the ground.**

**\* Fuel, radiator coolant and engine oil full. Spare tire, jack, hand tools and mats in designated positions.**

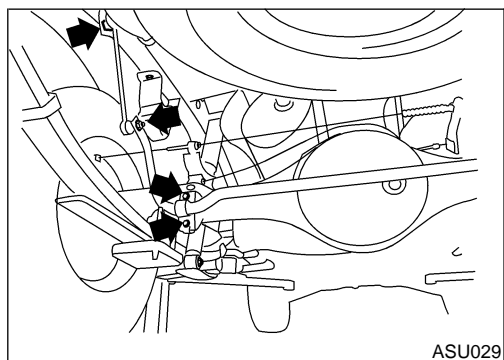

### Stabilizer Bar

#### REMOVAL

NGSU0046

- Remove stabilizer bar connecting bolts and clamp bolts.

#### INSPECTION

NGSU0047

- Check stabilizer bar for twist and deformation.
- Check rubber bushing for cracks, wear and deterioration. Replace if necessary.

#### INSTALLATION

NGSU0048

- Install bushing outside of white mark painted on stabilizer.

### Service Data and Specifications (SDS)

#### GENERAL SPECIFICATIONS (REAR)

NGSU0045

Suspension type	Rigid axle with semi-elliptic leaf spring
Shock absorber type	Double-acting hydraulic