

MANUAL TRANSAXLE

SECTION	MT
----------------	-----------

GI
MA
EM
LC
EC
FE
CL
MT
AT
FA
RA
BR
ST
BF
HA
EL
IDX

CONTENTS

PREPARATION	2	DISASSEMBLY	13
Special Service Tools.....	2	REPAIR FOR COMPONENT PARTS	16
Commercial Service Tools.....	4	Input Shaft and Gears.....	16
ON-VEHICLE SERVICE	5	Mainshaft and Gears.....	18
Replacing Oil Seal.....	5	Final Drive.....	24
Check of Position Switch.....	6	Shift Control Components.....	28
REMOVAL AND INSTALLATION	7	Case Components.....	29
Removal.....	7	ADJUSTMENT	32
Installation.....	8	Differential Side Bearing Preload.....	32
TRANSAXLE GEAR CONTROL	9	ASSEMBLY	33
MAJOR OVERHAUL	10	SERVICE DATA AND SPECIFICATIONS (SDS)	37
Case Components.....	10	General Specifications.....	37
Gear Components.....	11	Inspection and Adjustment.....	37
Shift Control Components.....	12		

PREPARATION

Special Service Tools

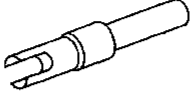
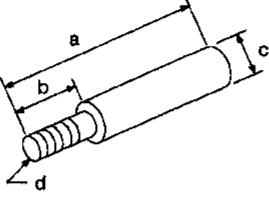
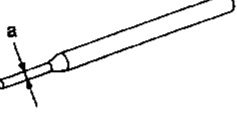
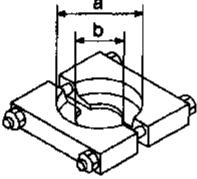
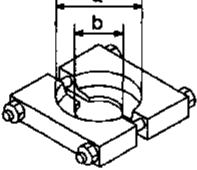
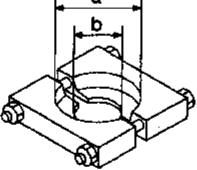
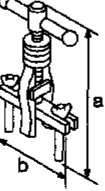
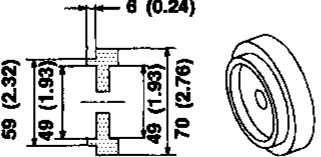
Tool number (Kent-Moore No.) Tool name	Description
KV38107700 (—) Preload adapter	 <p>Measuring turning torque of final drive assembly Selecting differential side bearing adjusting shim (Use with KV38106000.)</p> <p>NT087</p>
KV38106000 (—) Height gauge adapter (differential side bearing)	 <p>Selecting differential side bearing adjusting shim (Use with KV38105900 or KV38107700.) a: 140 mm (5.51 in) b: 40 mm (1.57 in) c: 16 mm (0.63 in) dia. d: M8 x 1.25P</p> <p>NT418</p>
KV32101000 (J25689-A) Pin punch	 <p>Removing and installing retaining pin a: 4 mm (0.16 in) dia.</p> <p>NT410</p>
ST22730000 (J25681) Puller	 <p>Removing 5th main gear a: 82 mm (3.23 in) dia. b: 30 mm (1.18 in) dia.</p> <p>NT411</p>
ST30031000 (J22912-01) Puller	 <p>Removing differential side bearing inner race (F32A) Removing 3rd and 4th synchronizer Measuring wear of 2nd & 3rd baulk ring a: 90 mm (3.54 in) dia. b: 50 mm (1.97 in) dia.</p> <p>NT411</p>
ST30021000 (J22912-01) Puller	 <p>Removing 5th synchronizer a: 110 mm (4.33 in) dia. b: 68 mm (2.68 in) dia.</p> <p>NT411</p>
ST33290001 (J34286) Puller	 <p>Removing differential oil seal Removing differential side bearing outer race a: 250 mm (9.84 in) b: 160 mm (6.30 in)</p> <p>NT414</p>
KV31103000 (—) Drift	 <p>Installing differential oil seal (Use with ST35325000.) (Except for F32V left side)</p> <p>Unit: mm (in)</p> <p>NT106</p>

PREPARATION

Special Service Tools (Cont'd)

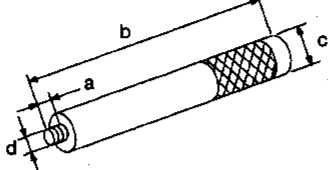
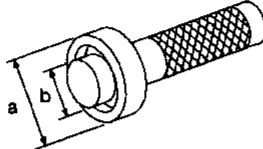
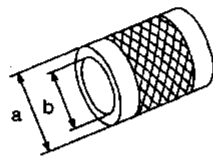
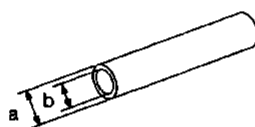
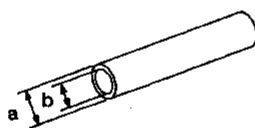
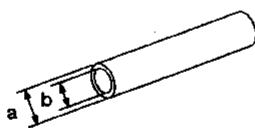
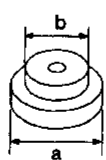
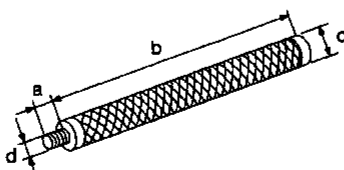
Tool number (Kent-Moore No.) Tool name	Description		
ST35325000 (—) Drift handle	 <p>NT416</p>	Installing differential oil seal (Use with KV31103000.) a: 15 mm (0.59 in) b: 215 mm (8.46 in) c: 25 mm (0.98 in) dia. d: M12 x 1.5P	GI MA
KV38102100 (J25803-01) Drift	 <p>NT084</p>	Installing input shaft rear bearing a: 44 mm (1.73 in) dia. b: 24.5 mm (0.965 in) dia.	EM LC EC
ST33200000 (J26082) Drift	 <p>NT091</p>	Installing mainshaft front bearing a: 60 mm (2.36 in) dia. b: 44.5 mm (1.752 in) dia.	FE CL
ST22350000 (J25678-01) Drift	 <p>NT065</p>	Installing input shaft front bearing a: 34 mm (1.34 in) dia. b: 28 mm (1.10 in) dia.	<div style="background-color: black; color: white; padding: 2px; display: inline-block;">MT</div> AT
ST22452000 (—) Drift	 <p>NT065</p>	Installing 1st & 2nd synchronizer Installing 3rd & 4th synchronizer Installing 5th main gear a: 45 mm (1.77 in) dia. b: 36 mm (1.42 in) dia.	FA RA
ST37750000 (J25863-01) Drift	 <p>NT065</p>	Installing input shaft oil seal Installing 5th synchronizer a: 40 mm (1.57 in) dia. b: 31 mm (1.22 in) dia.	BR ST
ST30621000 (J25742-5) Drift	 <p>NT073</p>	Installing differential side bearing outer race (F32A and right side of F32V) (Use with ST30611000.) a: 79 mm (3.11 in) dia. b: 59 mm (2.32 in) dia.	BF HA
ST30611000 (J25742-1) Drift handle	 <p>NT419</p>	(Use with ST30621000.) a: 15 mm (0.59 in) b: 335 mm (13.19 in) c: 25 mm (0.98 in) dia. d: M12 x 1.5P	EL IDX

PREPARATION

Commercial Service Tools

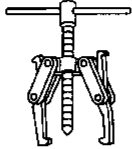
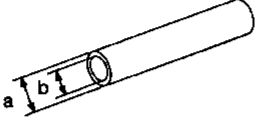
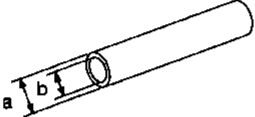
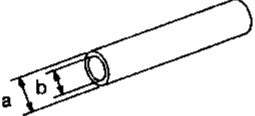
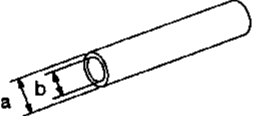
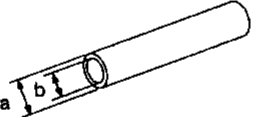
Tool name	Description	
Puller	 <p style="text-align: center;">NT077</p>	<p>Removing input shaft front bearing Removing mainshaft rear bearing</p>
Drift	 <p style="text-align: center;">NT065</p>	<p>Installing differential side bearing inner race (F32V right side and F32A)</p> <p>a: 56 mm (2.20 in) dia. b: 50.5 mm (1.988 in) dia.</p>
Drift	 <p style="text-align: center;">NT065</p>	<p>Installing striking rod oil seal</p> <p>a: 38 mm (1.50 in) dia. b: 32 mm (1.26 in) dia.</p>
Drift	 <p style="text-align: center;">NT065</p>	<p>Installing differential oil seal (F32V left side)</p> <p>a: 88 mm (3.46 in) dia. b: 72 mm (2.83 in) dia.</p>
Drift	 <p style="text-align: center;">NT065</p>	<p>Installing differential side bearing outer race (F32V left side)</p> <p>a: 104 mm (4.09 in) dia. b: 98 mm (3.86 in) dia.</p>
Drift	 <p style="text-align: center;">NT065</p>	<p>Installing differential side bearing inner race (F32V left side)</p> <p>a: 91 mm (3.58 in) dia. b: 81 mm (3.19 in) dia.</p>

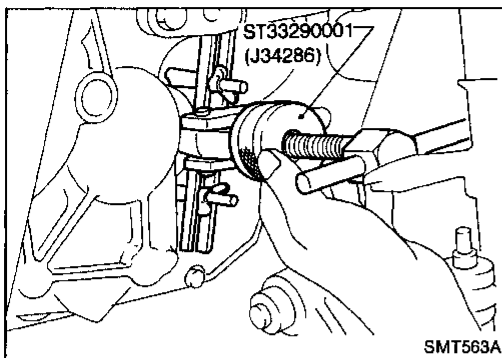

Replacing Oil Seal

DIFFERENTIAL OIL SEAL

1. Drain gear oil from transaxle.
2. Remove drive shafts — Refer to section FA.
3. Remove differential oil seal.

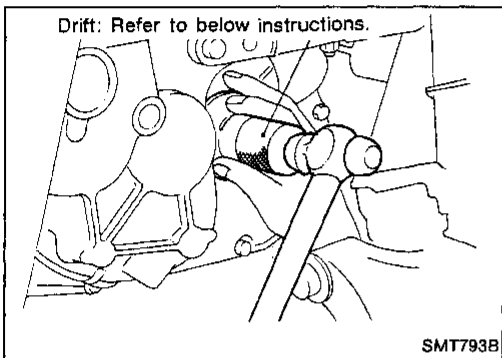

4. Install differential oil seal.
 - Apply multi-purpose grease to seal lip of oil seal before installing.
5. Install drive shafts — Refer to section FA.

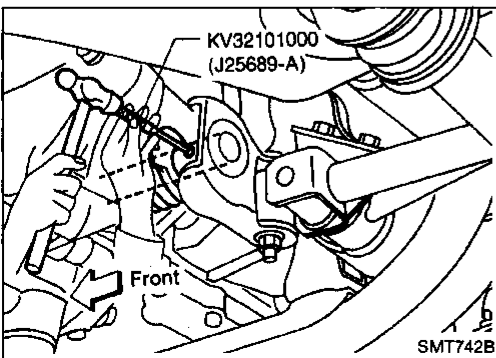
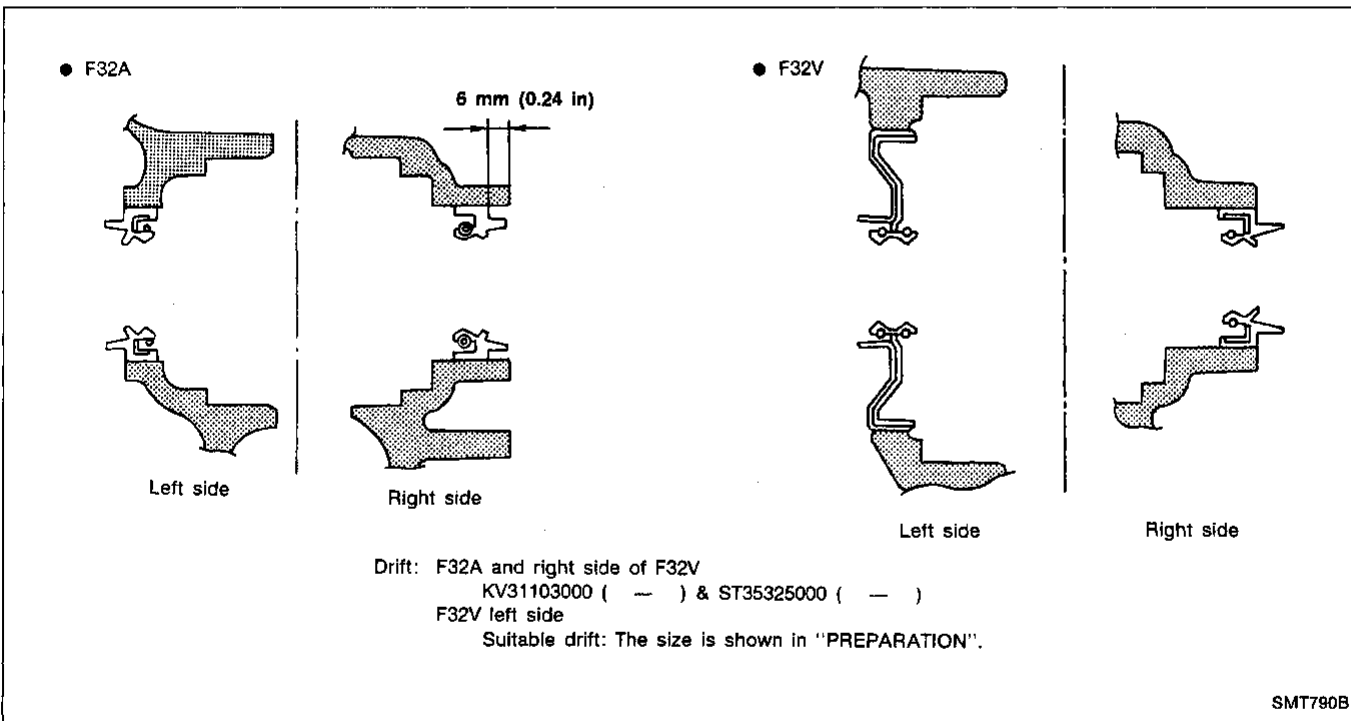

STRIKING ROD OIL SEAL

1. Remove transaxle control rod from yoke.
2. Remove retaining pin of yoke.
- Be careful not to damage boot.

GI

MA

EM

LC

EC

FE

CL

MT

AT

FA

RA

BR

ST

BF

HA

EL

IDX

ON-VEHICLE SERVICE

Replacing Oil Seal (Cont'd)

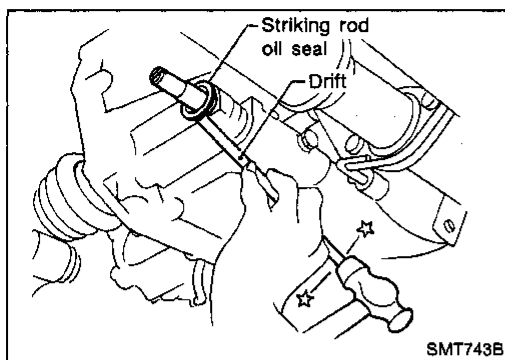

3. Remove striking rod oil seal.

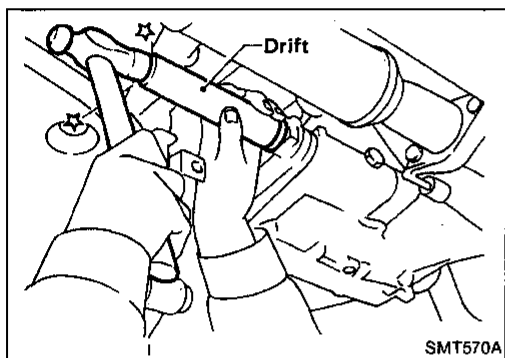

4. Install striking rod oil seal.

- Apply multi-purpose grease to seal lip of oil seal before installing.

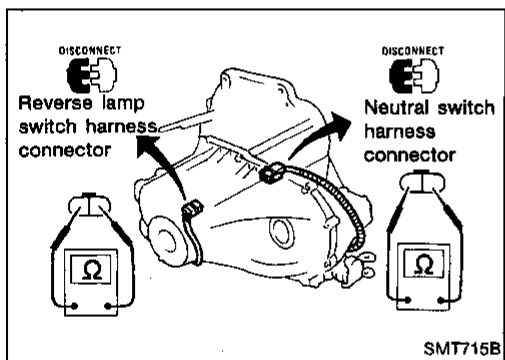

Check of Position Switch

BACK-UP LAMP SWITCH

- Check continuity.

Gear position	Continuity
Reverse	Yes
Except reverse	No

NEUTRAL SWITCH

- Check continuity.

Gear position	Continuity
Neutral	Yes
Except neutral	No

REMOVAL AND INSTALLATION

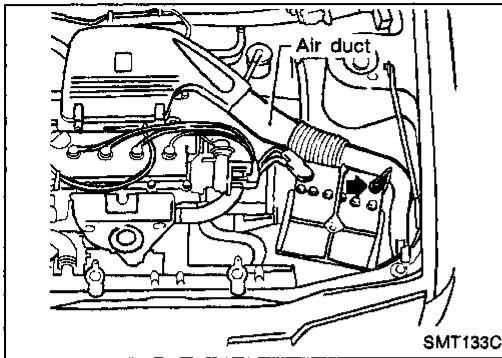

Removal

CAUTION:

When removing the transaxle assembly from engine, first remove the crankshaft position sensor (OBD) from the assembly.

Be careful not to damage sensor edge and ring gear teeth.

1. Remove battery negative terminal.
2. Remove air duct.
3. Remove crankshaft position sensor (OBD) from transaxle.
4. Disconnect clutch control cable from transaxle.
5. Disconnect speedometer cable from transaxle.
6. Disconnect back-up lamp switch, neutral switch and ground harness connectors.

GI

MA

EM

LC

EC

FE

CL

MT

AT

FA

RA

BR

ST

BF

HA

EL

IDX

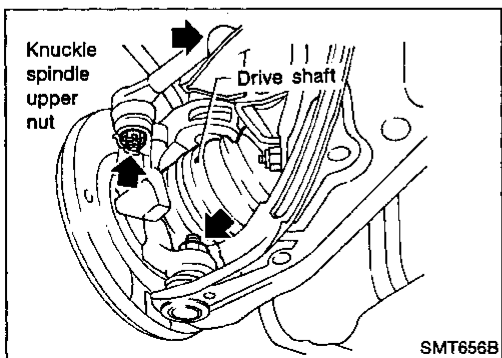
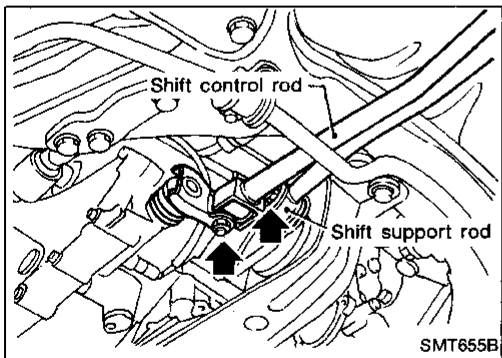
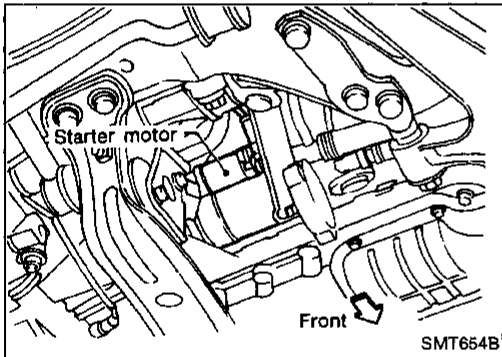
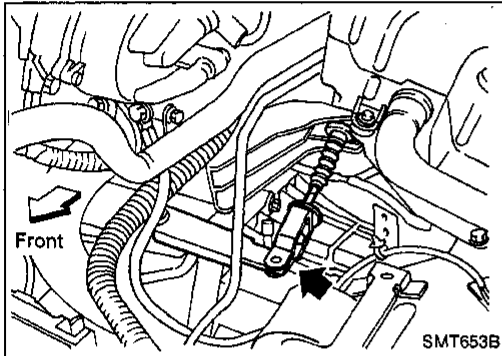

7. Remove starter motor from transaxle.

8. Remove shift control rod and support rod from transaxle.
9. Drain gear oil from transaxle.
10. Remove exhaust front tube.

11. Draw out drive shafts from transaxle — Refer to section FA.

REMOVAL AND INSTALLATION

Removal (Cont'd)

12. Support engine by placing a jack under oil pan.

CAUTION:

Do not place jack under oil pan drain plug.

13. Remove rear and LH mounts.

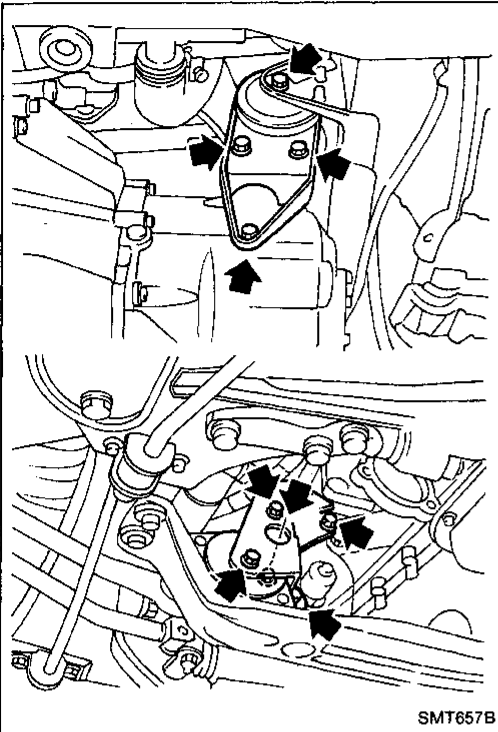

14. Raise jack for access to lower housing bolts. Remove bolts. Lower jack.

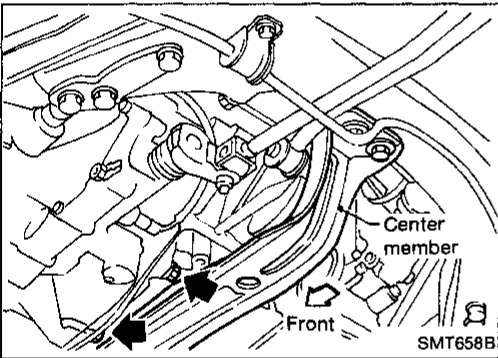

15. Remove bolts securing transaxle.

16. Lower transaxle while supporting it with a jack.

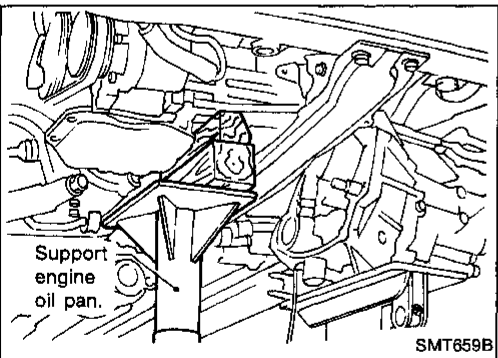

Installation

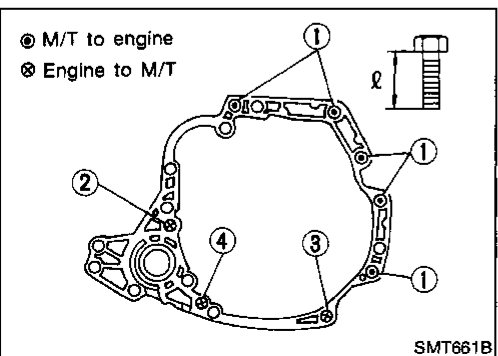

Bolt No.	Tightening torque N·m (kg-m, ft-lb)	"ℓ" mm (in)
①	70 - 79 (7.1 - 8.1, 51 - 59)	55 (2.17)
②	70 - 79 (7.1 - 8.1, 51 - 59)	65 (2.56)
③	30 - 40 (3.1 - 4.1, 22 - 30)	35 (1.38)
④	30 - 40 (3.1 - 4.1, 22 - 30)	45 (1.77)

● Reinstall any part removed.

TRANSAXLE GEAR CONTROL

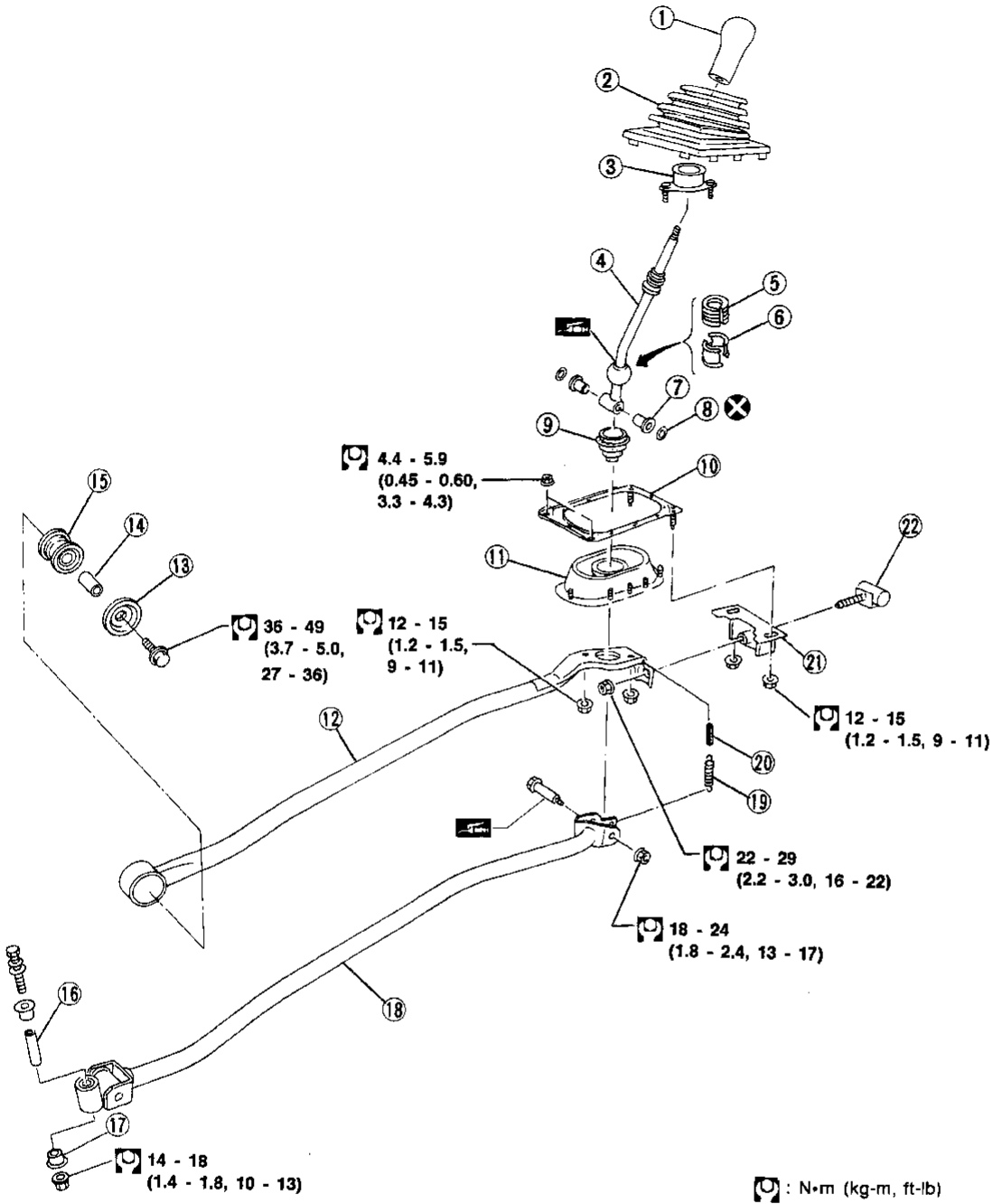

- ① Control lever knob
- ② Boot
- ③ Control lever socket
- ④ Control lever
- ⑤ Insulator
- ⑥ Seat
- ⑦ Bushing
- ⑧ O-ring

- ⑨ Dust boot
- ⑩ Plate bolt
- ⑪ Transaxle hole cover
- ⑫ Support rod
- ⑬ Plate
- ⑭ Collar
- ⑮ Bushing

- ⑯ Collar
- ⑰ Bushing
- ⑱ Control rod
- ⑲ Return spring
- ⑳ Return spring rubber
- ㉑ Holder bracket
- ㉒ Mass damper

SMT791B

GI

MA

EM

LC

EC

FE

CL

MT

AT

FA

RA

BR

ST

BF

HA

EL

IDX

MAJOR OVERHAUL

Case Components

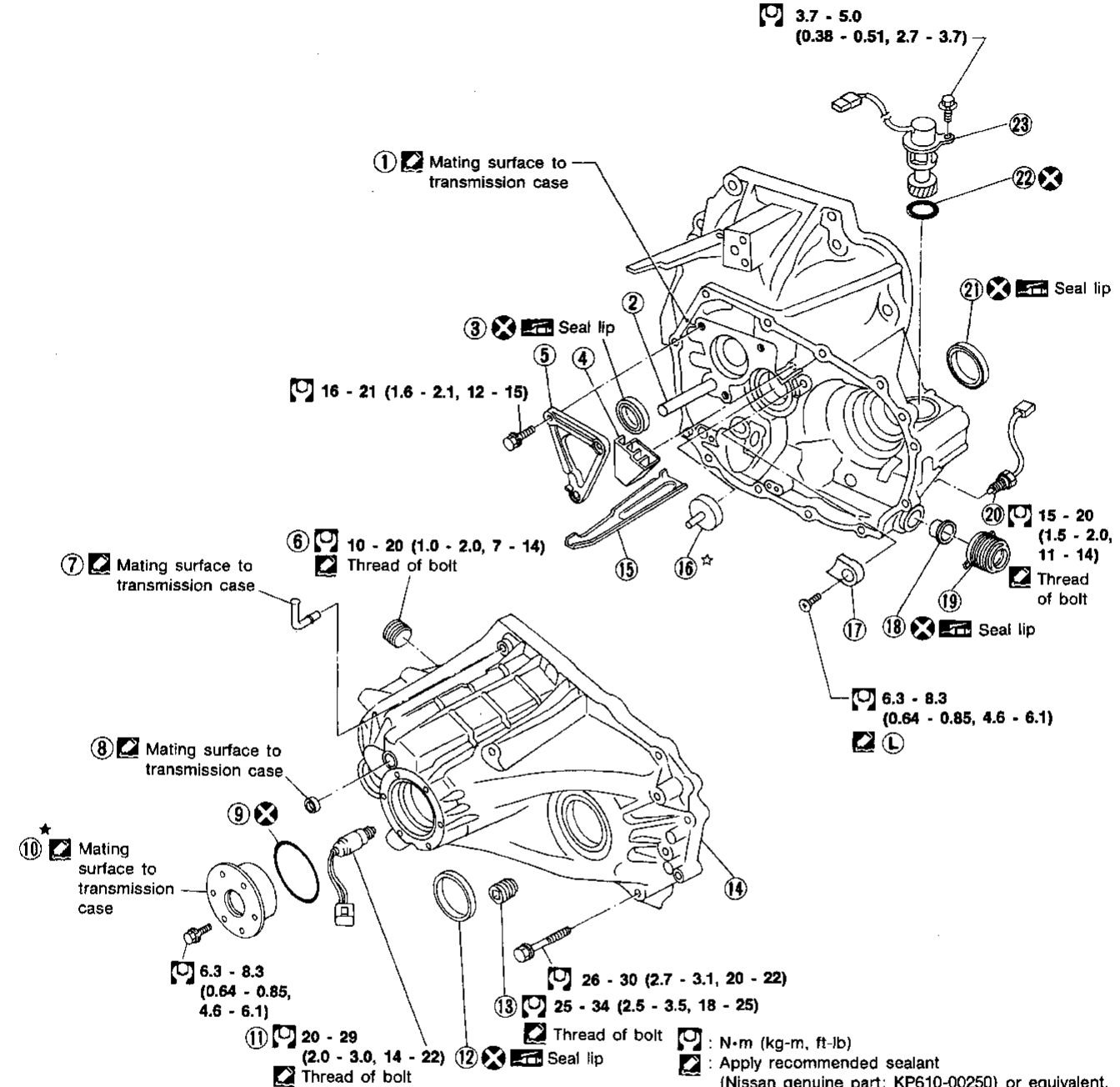

SMT648C

- | | | |
|------------------------|-------------------------|-------------------------------|
| ① Clutch housing | ⑨ O-ring | ⑰ Bearing retainer |
| ② Reverse idler shaft | ⑩ Case cover | ⑱ Striking rod oil seal |
| ③ Input shaft oil seal | ⑪ Reverse lamp switch | ⑲ Boot |
| ④ Oil pocket | ⑫ Differential oil seal | ⑳ Neutral switch |
| ⑤ Bearing retainer | ⑬ Drain plug | ㉑ Differential oil seal |
| ⑥ Filler plug | ⑭ Transmission case | ㉒ O-ring |
| ⑦ Air breather | ⑮ Oil gutter | ㉓ Speedometer pinion assembly |
| ⑧ Welch plug | ⑯ Oil channel | |

Gear Components

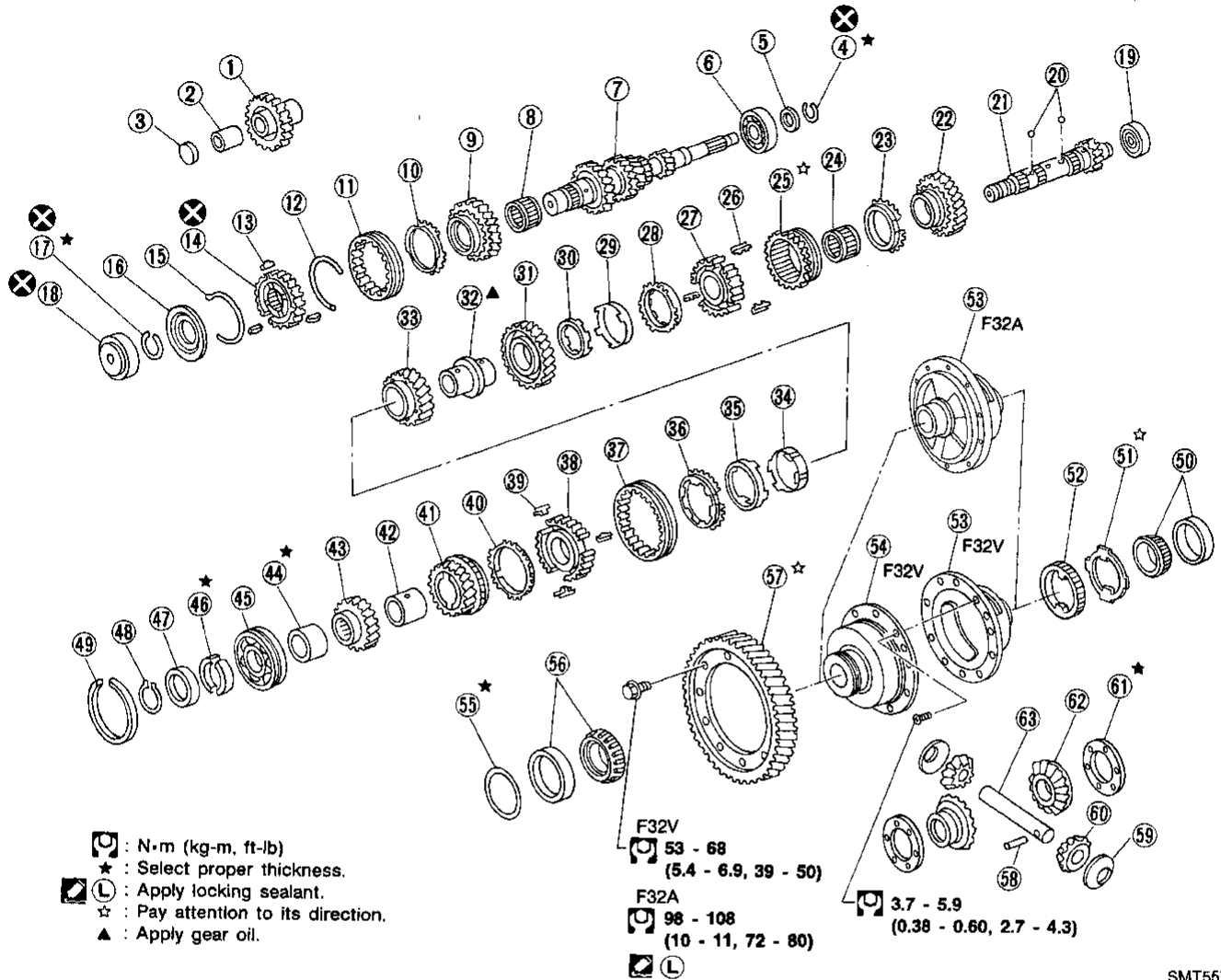

- ① Reverse idler gear
- ② Reverse idler bushing
- ③ Reverse idler spacer
- ④ Snap ring
- ⑤ Spacer
- ⑥ Input shaft front bearing
- ⑦ Input shaft
- ⑧ 5th gear needle bearing
- ⑨ 5th input gear
- ⑩ Baulk ring
- ⑪ Coupling sleeve
- ⑫ Spread spring
- ⑬ Shifting insert
- ⑭ 5th synchronizer hub
- ⑮ Spread spring
- ⑯ 5th stopper
- ⑰ Snap ring
- ⑱ Input shaft rear bearing
- ⑲ Mainshaft front bearing
- ⑳ Steel ball
- ㉑ Mainshaft
- ㉒ 1st main gear

- ㉓ Baulk ring
- ㉔ 1st gear needle bearing
- ㉕ Reverse main gear (Coupling sleeve)
- ㉖ Shifting insert
- ㉗ 1st & 2nd synchronizer hub
- ㉘ 2nd outer baulk ring
- ㉙ 2nd synchronizer cone
- ㉚ 2nd inner baulk ring
- ㉛ 2nd main gear
- ㉜ 2nd & 3rd bushing
- ㉝ 3rd main gear
- ㉞ 3rd inner baulk ring
- ㉟ 3rd synchronizer cone
- ⓫ 3rd outer baulk ring
- ⓬ Coupling sleeve
- ⓭ 3rd & 4th synchronizer hub
- ⓮ Shifting insert
- ⓯ Baulk ring
- ⓰ 4th main gear
- ⓱ 4th bushing
- ⓲ 5th main gear

- ⓴ Spacer
- ⓵ Mainshaft rear bearing
- ⓶ C-ring
- ⓷ C-ring holder
- ⓸ Snap ring
- ⓹ Snap ring
- ⓺ Differential side bearing
- ⓻ Speedometer stopper
- ⓼ Speedometer drive gear
- ⓽ Differential case
- ⓾ Viscous coupling
- ⓿ Differential side bearing adjusting shim
- ⓿ Differential side bearing
- ⓿ Final gear
- ⓿ Lock pin
- ⓿ Pinion mate gear washer
- ⓿ Pinion mate gear
- ⓿ Side gear washer
- ⓿ Side gear
- ⓿ Pinion mate shaft

SMT567C

GI
MA
EM
LC
EC
FE
CL
MT
AT
FA
RA
BR

ST
BF
HA
EL
IDX

MAJOR OVERHAUL

Shift Control Components

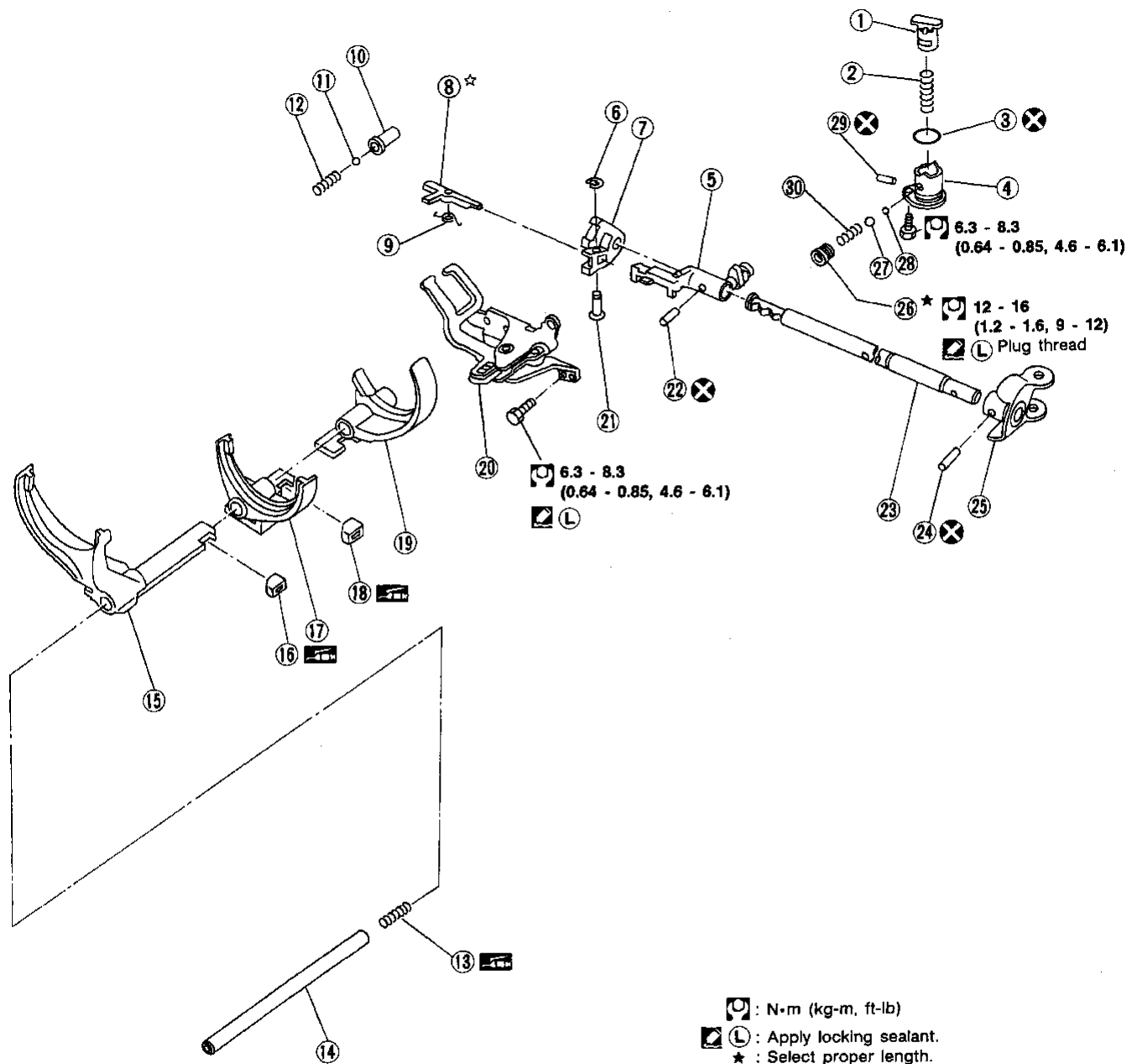

SMT642C

- | | | |
|----------------------------|-----------------------------|------------------------|
| ① Check plunger | ⑪ Shift check ball | ⑳ Interlock pin |
| ② Select return spring | ⑫ Shift check spring | ㉑ Retaining pin |
| ③ O-ring | ⑬ Fork shaft support spring | ㉒ Striking rod |
| ④ Check sleeve | ⑭ Fork shaft | ㉓ Retaining pin |
| ⑤ Striking lever | ⑮ 5th shift fork | ㉔ Yoke |
| ⑥ Snap ring | ⑯ Shifter cap | ㉕ Reverse check plug |
| ⑦ Striking interlock | ⑰ 3rd & 4th shift fork | ㉖ Check ball (Large) |
| ⑧ Reverse brake cam | ⑱ Shifter cap | ㉗ Check ball (Small) |
| ⑨ Reverse brake cam spring | ㉀ 1st & 2nd shift fork | ㉘ Stopper pin |
| ⑩ Check ball plug | ㉁ Control bracket | ㉙ Reverse check spring |

DISASSEMBLY

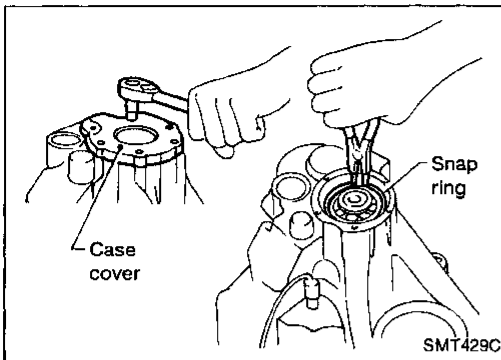

1. Remove case cover.
2. Remove mainshaft bearing snap ring.

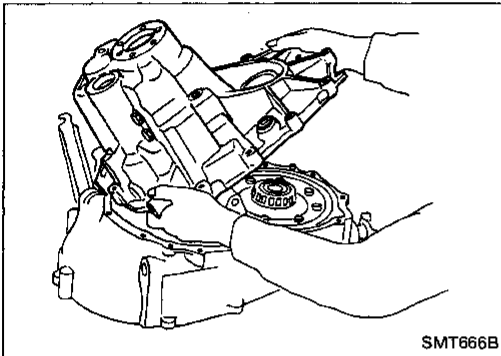

3. Remove transmission case while slightly tilting it to prevent 5th shift fork from interfering with case.

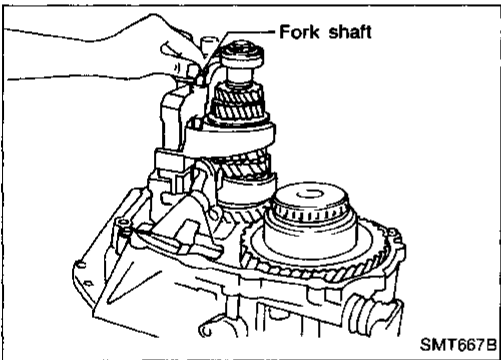

4. Draw out reverse idler spacer and fork shaft.

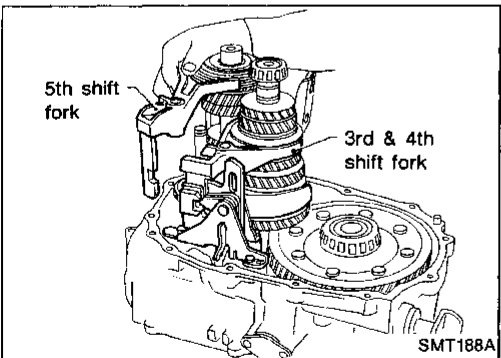

5. Remove 5th and 3rd & 4th shift forks.
 - Be careful not to lose shifter cap.

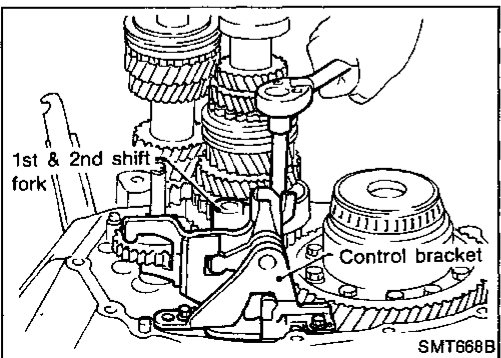

6. Remove control bracket with 1st & 2nd shift fork.

GI

MA

EM

LC

EC

FE

CL

MT

AT

FA

RA

BR

ST

BF

HA

EL

IDX

DISASSEMBLY

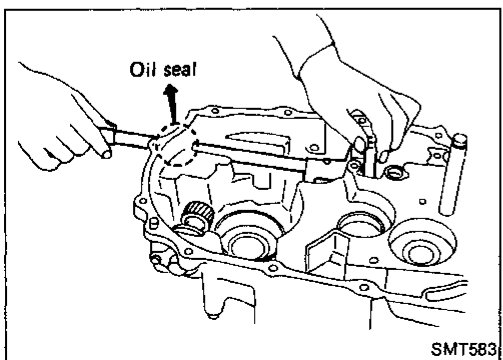
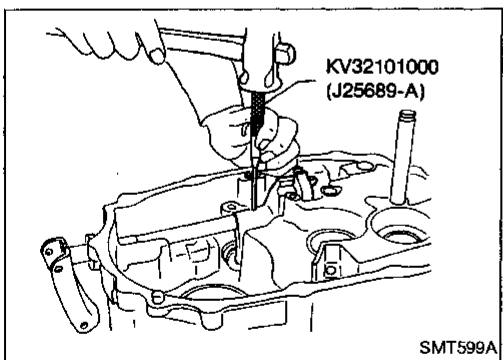
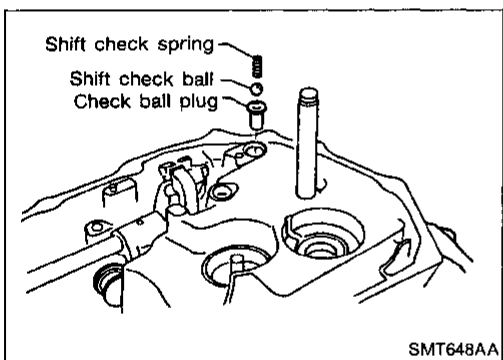
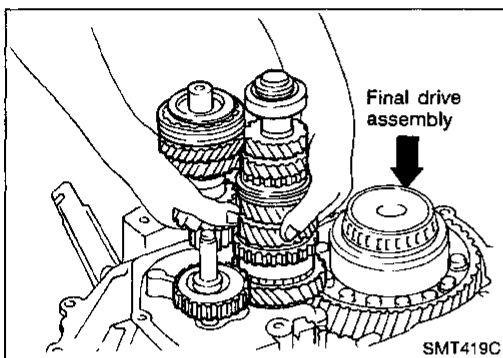
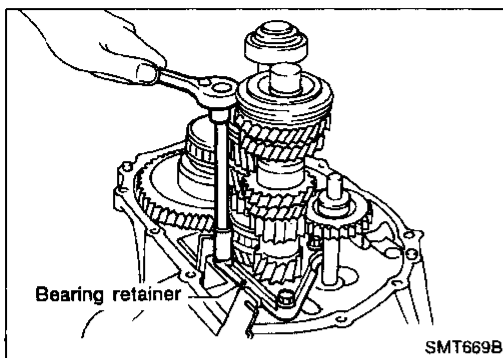

7. Remove gear components from clutch housing.
 - a. Remove input shaft front bearing retainer securing bolts.
 - b. Remove input shaft with bearing retainer, mainshaft assembly and reverse idler gear.
 - Always withdraw mainshaft straight out. Failure to do so can damage resin oil channel on clutch housing side.
 - Do not draw out reverse idler shaft from clutch housing because these fittings will be loose. When removing input shaft, be careful not to scratch oil seal lip with shaft spline.
 - c. Remove final drive assembly.
8. Remove oil pocket, shift check ball, shift check spring and check ball plug.
9. Drive retaining pin out of striking lever, then remove striking rod, striking lever and striking interlock.
 - Select a position where retaining pin does not interfere with clutch housing when removing retaining pin.
 - Be careful not to damage oil seal lip, when removing striking rod. If necessary, tape edges of striking rod.

DISASSEMBLY

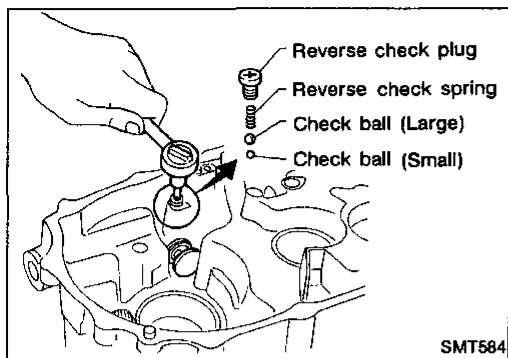

10. Remove reverse check plug, then detach reverse check spring and check balls.
 - If the smaller ball does not come out, remove it together with check sleeve assembly.

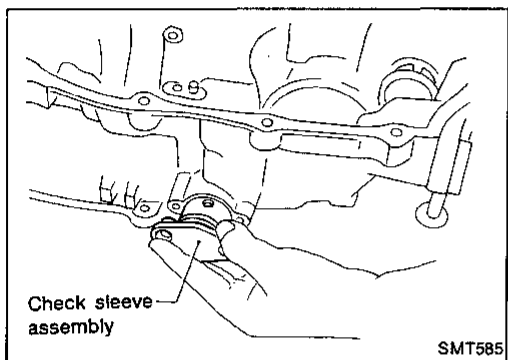

11. Remove check sleeve assembly.

GI

MA

EM

LC

EC

FE

CL

MT

AT

FA

RA

BR

ST

BF

HA

EL

IDX

Input Shaft and Gears

DISASSEMBLY

1. Before disassembly, check 5th input gear end play.
Gear end play: 0.18 - 0.31 mm (0.0071 - 0.0122 in)
 - If not within specification, disassemble and check contact surface of gear, shaft and hub. Then check clearance of snap ring groove — Refer to "Assembly — Input Shaft and Gears", MT-17.

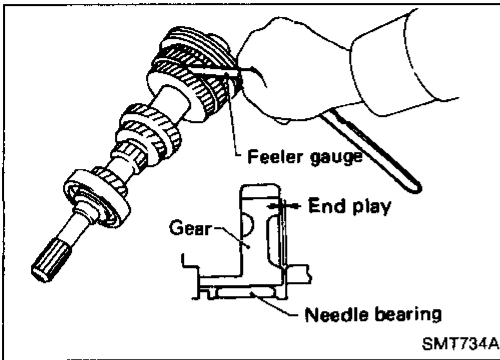

2. Remove snap ring and 5th stopper.

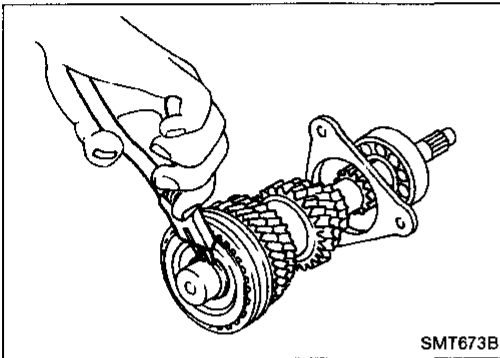

3. Remove 5th synchronizer, 5th input gear and 5th gear needle bearing.

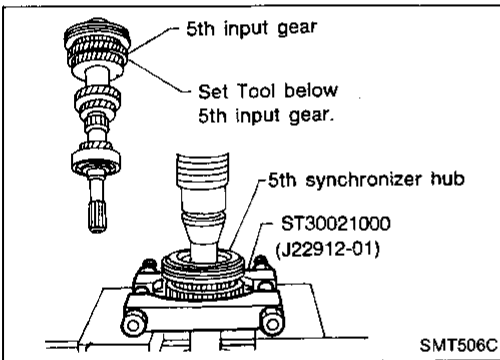

4. Remove snap ring of input shaft front bearing and input gear spacer.
5. Pull out input shaft front bearing.
6. Remove bearing retainer.

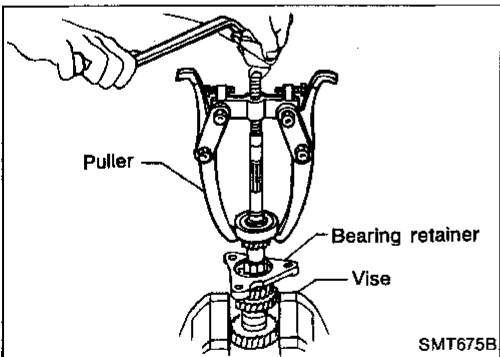

INSPECTION

Gear and shaft

- Check shaft for cracks, wear or bending.
- Check gears for excessive wear, chips or cracks.

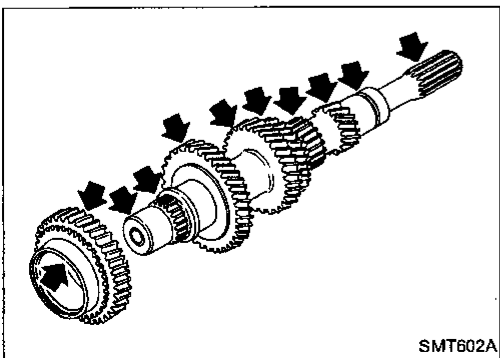

REPAIR FOR COMPONENT PARTS

Input Shaft and Gears (Cont'd)

Synchronizer

- Check spline portion of coupling sleeves, hubs and gears for wear or cracks.
- Check baulk rings for cracks or deformation.
- Check shifting inserts for wear or deformation.

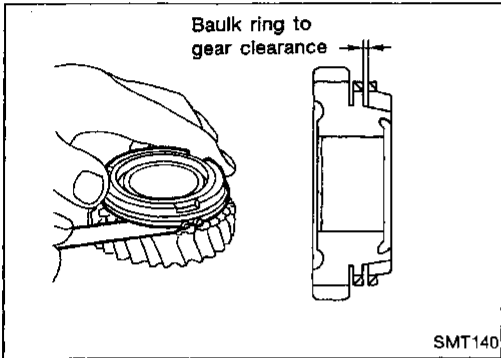
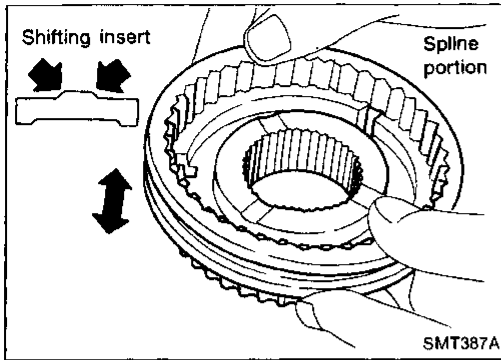

- Measure clearance between baulk ring and gear.

Clearance between baulk ring and gear:

Standard

1.0 - 1.35 mm (0.0394 - 0.0531 in)

Wear limit

0.7 mm (0.028 in)

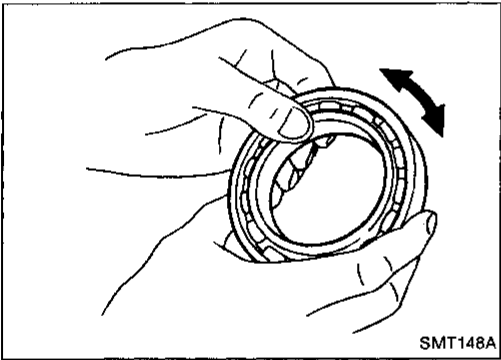

Bearing

- Make sure bearings roll freely and are free from noise, cracks, pitting or wear.

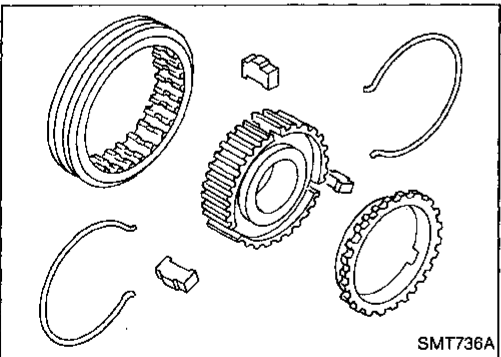

ASSEMBLY

1. Assemble 5th synchronizer.

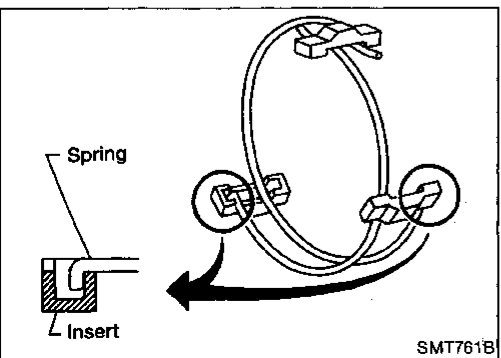

- Be careful not to hook front and rear ends of spread spring to the same insert.

GI

MA

EM

LC

EC

FE

CL

MT

AT

FA

RA

BR

ST

BF

HA

EL

IDX

REPAIR FOR COMPONENT PARTS

Input Shaft and Gears (Cont'd)

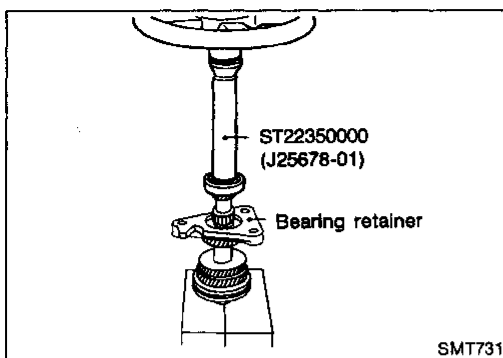

2. Install bearing retainer.
3. Press on input shaft front bearing.
4. Install input gear spacer.

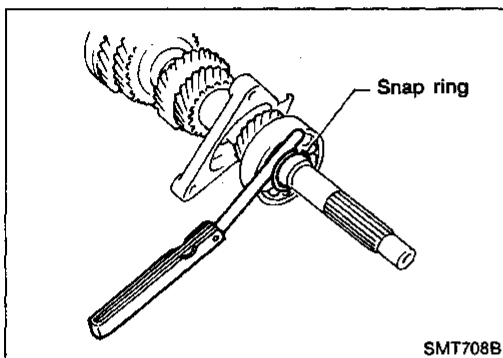

5. Select proper snap ring of input shaft front bearing to minimize clearance of groove in input shaft. Then install it.

Allowable clearance of groove:

0 - 0.1 mm (0 - 0.004 in)

Snap rings of input shaft front bearing:

Refer to SDS, MT-38.

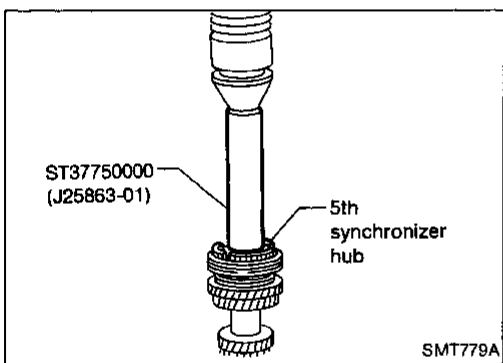

6. Install 5th gear needle bearing, 5th input gear, 5th synchronizer and 5th stopper.
7. Measure gear end play as a final check — Refer to "Disassembly — Input Shaft and Gears", MT-16.

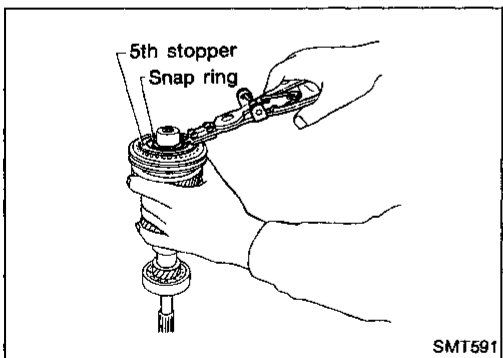

8. Select proper snap ring of 5th synchronizer hub to minimize clearance of groove in input shaft. Then install it.

Allowable clearance of groove:

0 - 0.1 mm (0 - 0.004 in)

Snap ring of 5th synchronizer:

Refer to SDS, MT-38.

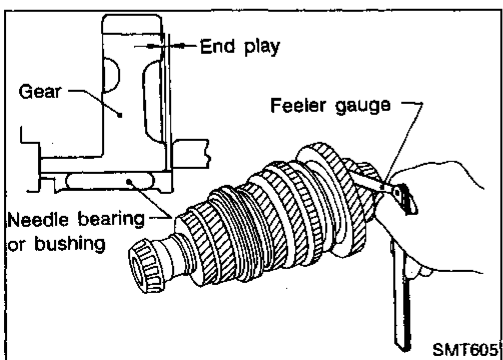

Mainshaft and Gears

DISASSEMBLY

1. Before disassembly, measure gear end play.

Gear end play:

1st main gear

0.18 - 0.31 mm (0.0071 - 0.0122 in)

2nd-4th main gear

0.20 - 0.30 mm (0.0079 - 0.0118 in)

- If end play is not within the specified limit, disassemble and check the parts.

REPAIR FOR COMPONENT PARTS

Mainshaft and Gears (Cont'd)

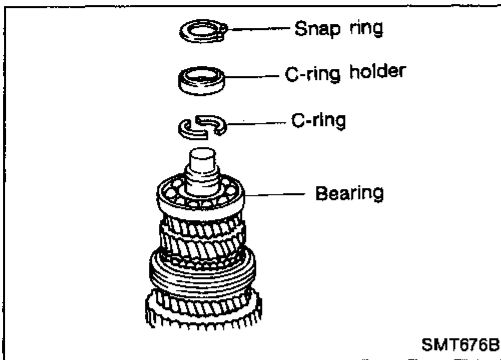

2. Remove mainshaft rear bearing snap ring, C-ring holder and C-rings.

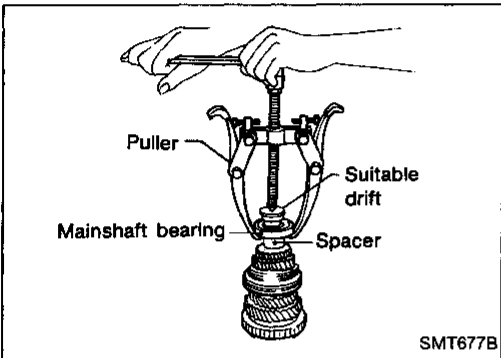

3. Remove mainshaft bearing and spacer.

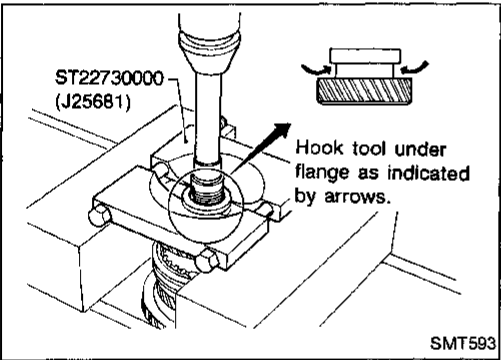

4. Remove 5th main gear.

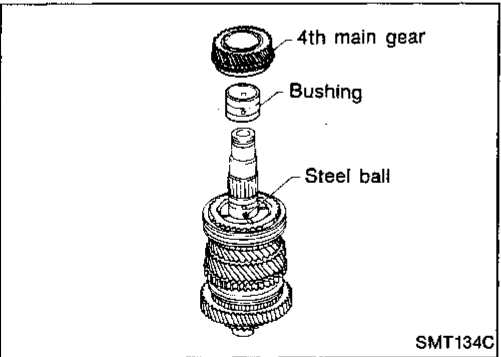

5. Remove 4th main gear, 4th bushing and steel ball.
● Take care not to lose steel ball.

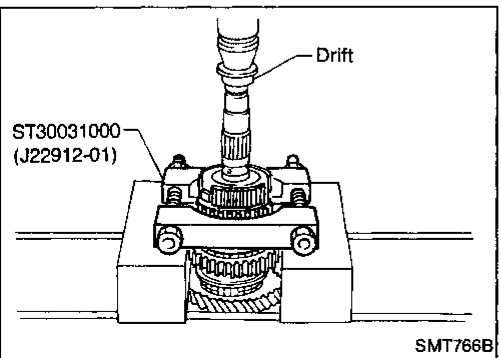

6. Remove 3rd & 4th synchronizer and 3rd main gear.

GI

MA

EM

LC

EC

FE

CL

MT

AT

FA

RA

BR

ST

BF

HA

EL

IDX

REPAIR FOR COMPONENT PARTS

Mainshaft and Gears (Cont'd)

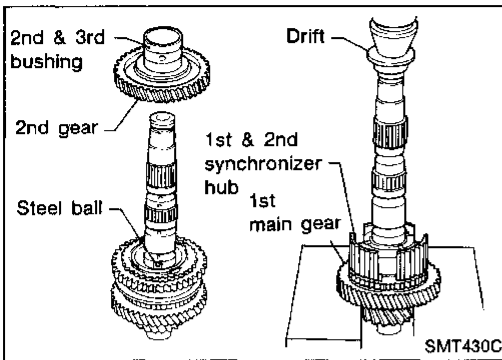

7. Remove 2nd & 3rd bushing and 2nd main gear.
 - Take care not to lose the steel ball.
8. Remove 1st & 2nd synchronizer hub and 1st main gear.

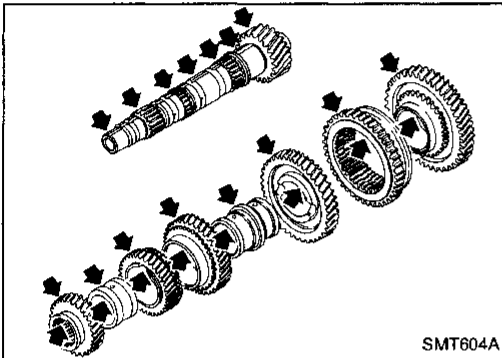

INSPECTION

Gear and shaft

- Check shaft for cracks, wear or bending.
- Check gears for excessive wear, chips or cracks.

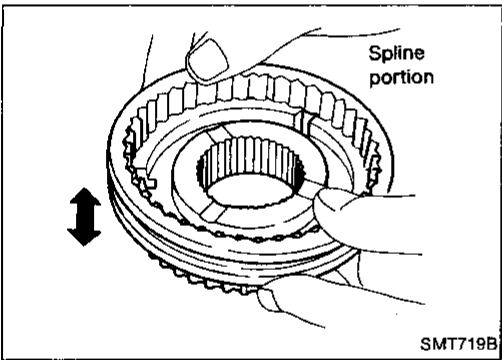

Synchronizer

- Check spline portion of coupling sleeves, hubs and gears for wear or cracks.
- Check baulk rings for cracks or deformation.
- Check shifting inserts for deformation.

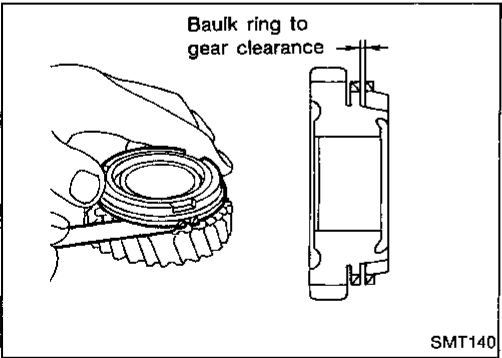

- Measure clearance between baulk ring and gear. **Clearance between baulk rings and gears, for 1st and 4th gear only:**

Standard

1.0 - 1.35 mm (0.0394 - 0.0531 in)

Wear limit

0.7 mm (0.028 in)

- 2nd and 3rd gears have inner and outer baulk rings and so have different measurements.

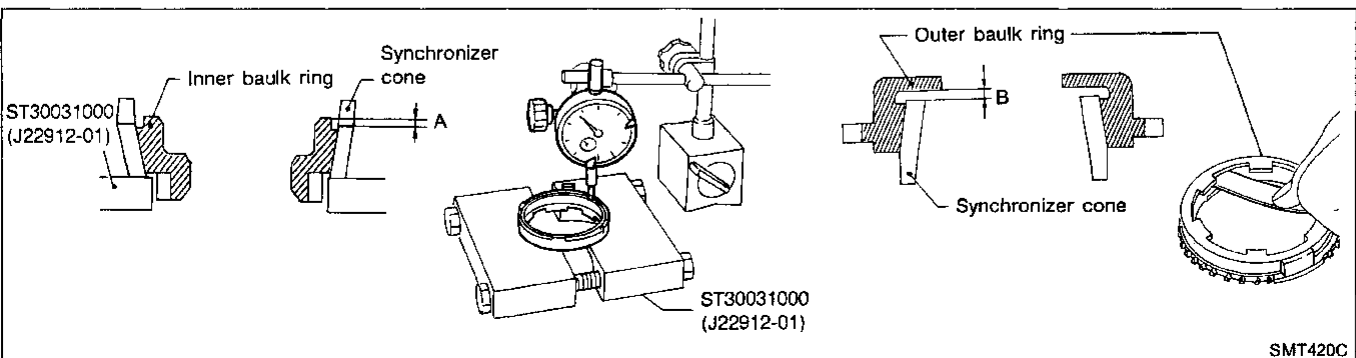

REPAIR FOR COMPONENT PARTS

Mainshaft and Gears (Cont'd)

- Measure wear of 2nd and 3rd baulk ring.
- a. Place baulk rings in position on synchronizer cone.
- b. Holding baulk ring tight and evenly against synchronizer cone, measure dimensions "A" and "B".

Standard:

A 0.7 - 0.9 mm (0.028 - 0.035 in)

B 0.6 - 1.1 mm (0.024 - 0.043 in)

Wear limit:

0.2 mm (0.008 in)

- c. If dimension "A" or "B" is smaller than the wear limit, replace baulk ring.

GI

MA

EM

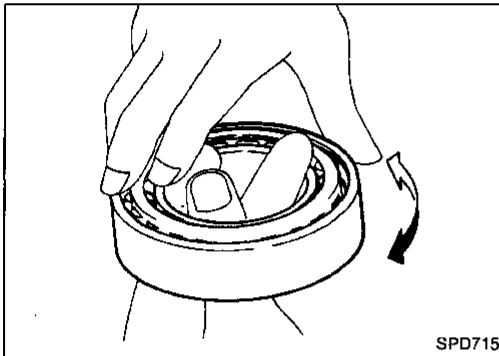

Bearing

- Make sure bearings roll freely and are free from noise, cracks, pitting or wear.
- **The mainshaft front bearing cannot be re-used. It must be replaced once removed.**

LC

EC

FE

CL

ASSEMBLY

1. Install 1st gear needle bearing, 1st main gear and baulk ring.
2. Press on 1st & 2nd synchronizer hub.

MT

AT

FA

RA

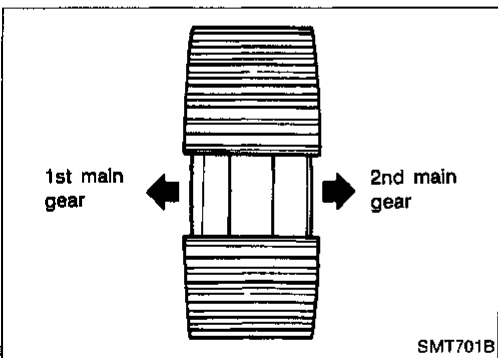
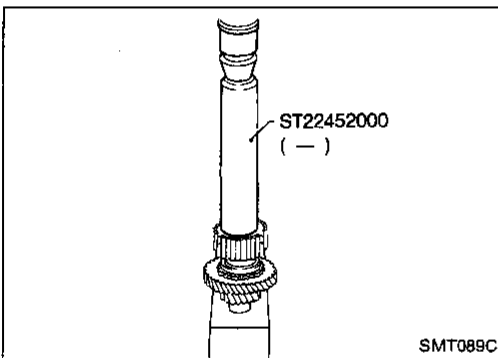

- **Ensure correct fitting of 1st & 2nd synchronizer hub.**

BR

ST

BF

HA

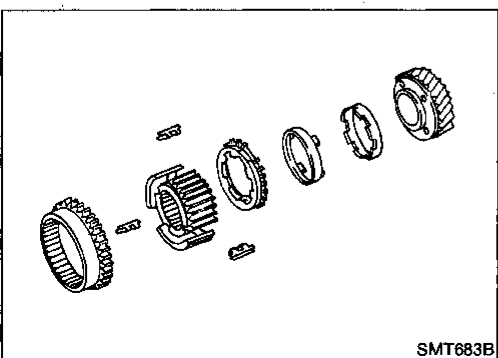

3. Install 2nd synchronizer cone, outer & inner baulk ring and 1st & 2nd coupling sleeve.

EL

IDX

REPAIR FOR COMPONENT PARTS

Mainshaft and Gears (Cont'd)

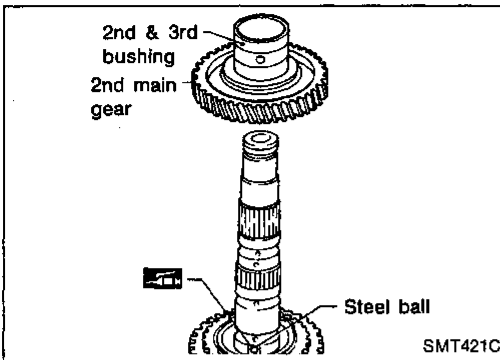

4. Install steel ball, 2nd main gear, 2nd & 3rd bushing.
 - Apply gear oil to 2nd & 3rd bushing before installing it.
 - Apply multi-purpose grease to steel ball before installing it.
 - 2nd & 3rd bushing has a groove in which steel ball fits.

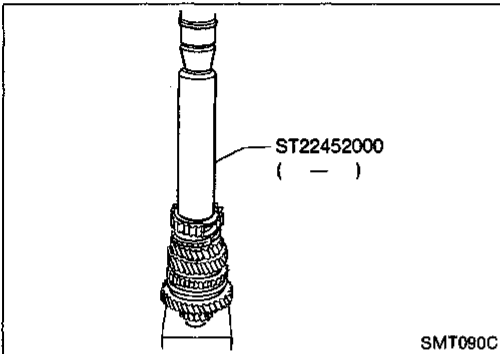

5. Install 3rd main gear, synchronizer cone, outer & inner baulk ring.
6. Press on 3rd & 4th synchronizer hub.

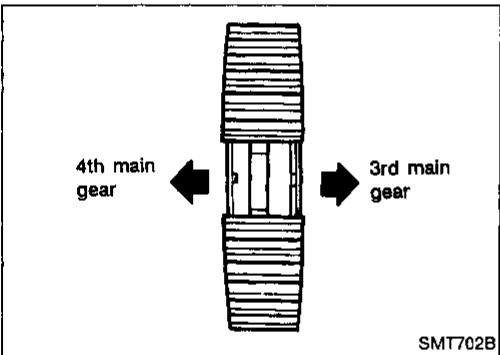

- Ensure correct fitting of 3rd & 4th synchronizer hub.
7. Install 3rd & 4th coupling sleeve and 4th baulk ring.

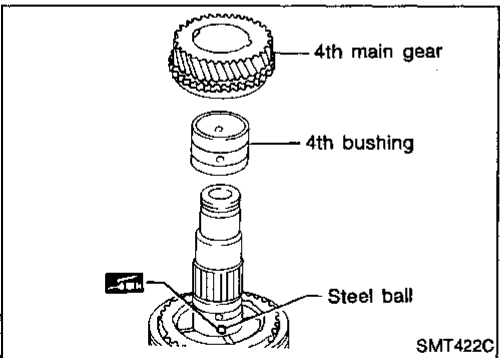

8. Install steel ball, 4th bushing and 4th main gear.
 - Apply multi-purpose grease to steel ball before installing it.
 - 4th bushing has a groove in which steel ball fits.

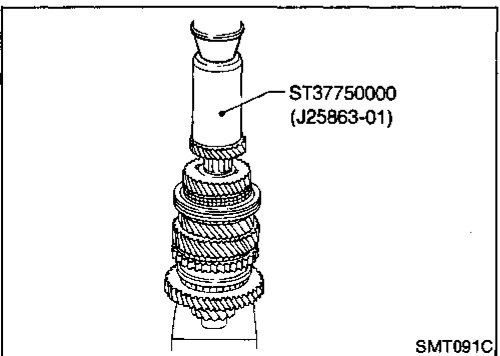

9. Press on 5th main gear.

REPAIR FOR COMPONENT PARTS

Mainshaft and Gears (Cont'd)

10. Select proper mainshaft bearing spacer to give correct bearing distance.

Bearing distance "C":

230.15 - 230.25 mm (9.0610 - 9.0649 in)

Spacers available:

Thickness mm (in)	Part number
18.91 (0.7445)	32347-50J00
18.98 (0.7472)	32347-50J01
19.05 (0.7500)	32347-50J02
19.12 (0.7528)	32347-50J03
19.19 (0.7555)	32347-50J04
19.26 (0.7583)	32347-50J05
19.33 (0.7610)	32347-50J06
19.40 (0.7638)	32347-50J07
19.47 (0.7665)	32347-50J08

GI

MA

EM

LC

EC

FE

CL

MT

AT

FA

RA

BR

ST

BF

HA

EL

IDX

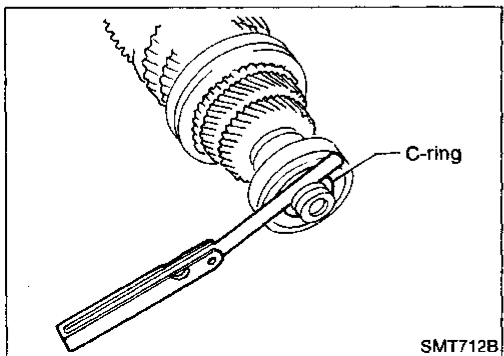
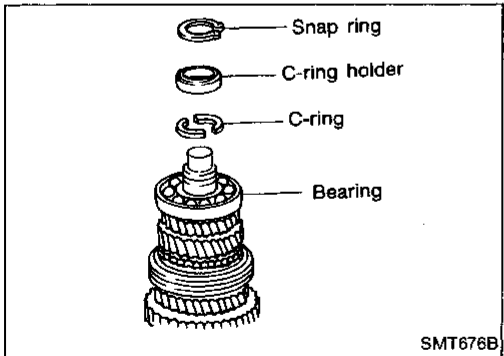
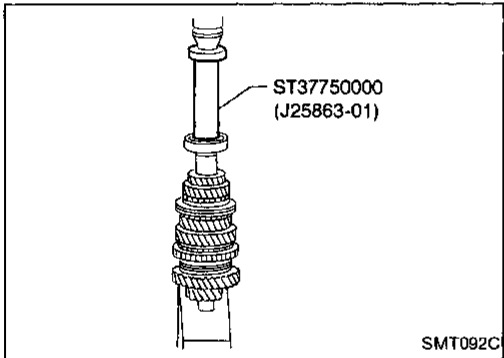
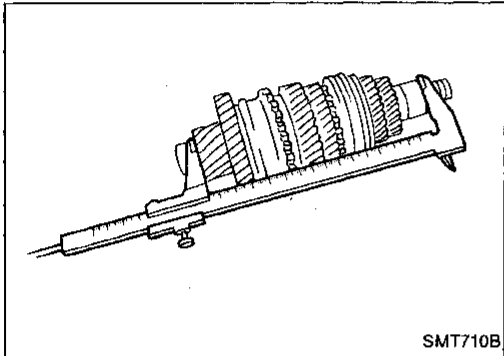
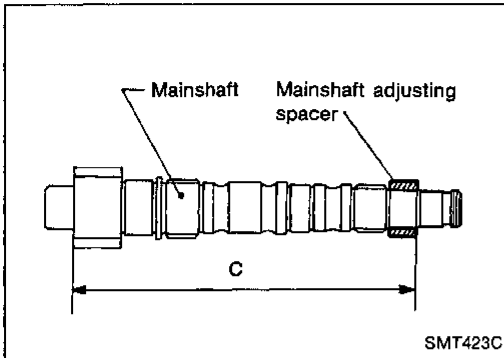

11. Press on mainshaft rear bearing.

12. Select proper C-ring to minimize clearance of groove in mainshaft and install it.

Allowable clearance of groove:

0 - 0.1 mm (0 - 0.004 in)

Mainshaft C-rings:

Refer to SDS, MT-38.

13. Install C-ring holder and snap ring.

14. Measure gear end play as the final check — Refer to "Disassembly", MT-18.

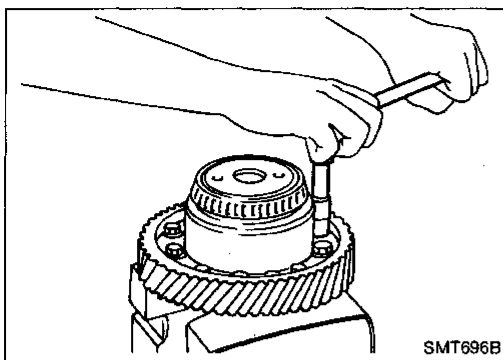

Final Drive

DISASSEMBLY

1. Remove final gear.
2. Remove speedometer drive gear by cutting it.

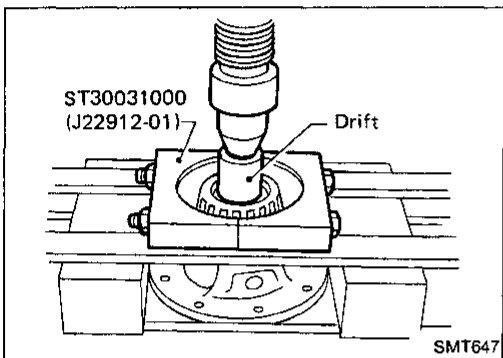

3. Pull out differential side bearings.

- Be careful not to mix up the right and left bearings — RS5F32A

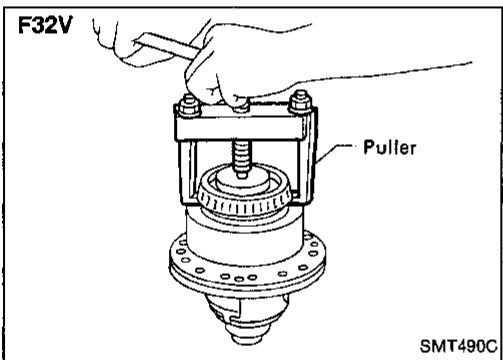

4. Remove viscous coupling.

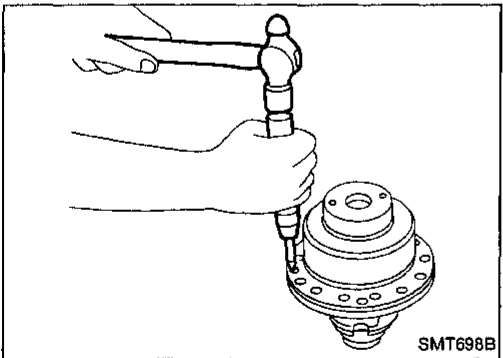

5. Drive out lock pin and draw out pinion mate shaft.
6. Remove pinion mate gears and side gears.

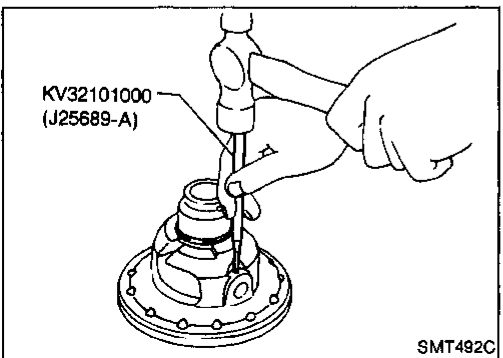

REPAIR FOR COMPONENT PARTS

Final Drive (Cont'd)

INSPECTION

Gear, washer, shaft and case

- Check mating surfaces of differential case, side gears and pinion mate gears.
- Check washers for wear.

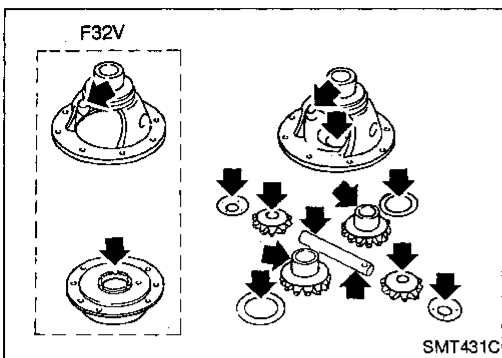

SMT431C

Viscous coupling — RS5F32V

- Check case for cracks.
- Check silicone oil for leakage.

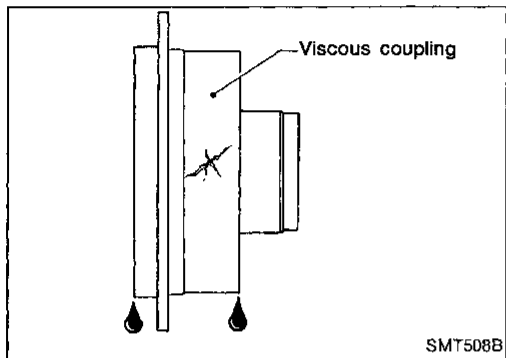

SMT508B

Bearing

- Make sure bearings roll freely and are free from noise, cracks, pitting or wear.
- **When replacing tapered roller bearing, replace outer and inner race as a set.**

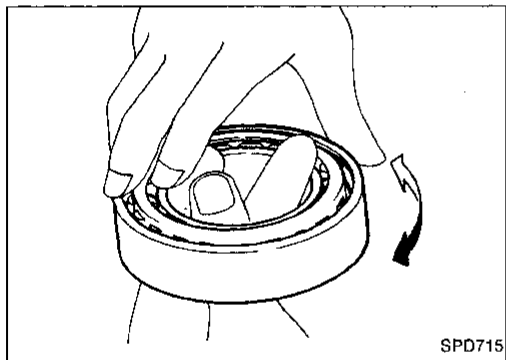

SPD715

ASSEMBLY — RS5F32A —

1. Attach side gear washers to side gears and install them in differential case. Then install pinion mate washers and pinion mate gears in place.

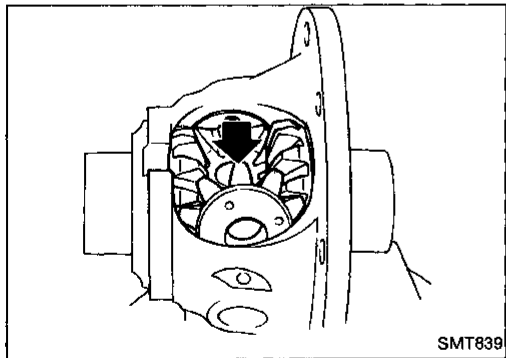

SMT839

2. Insert pinion mate shaft.
 - **When inserting, be careful not to damage pinion mate gear washers.**

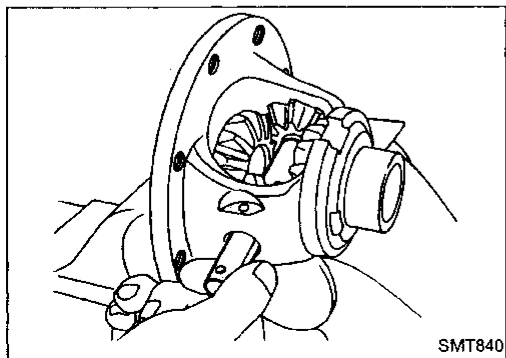

SMT840

GI

MA

EM

LC

EC

FE

CL

MT

AT

FA

RA

BR

ST

BF

HA

EL

IDX

REPAIR FOR COMPONENT PARTS

Final Drive (Cont'd)

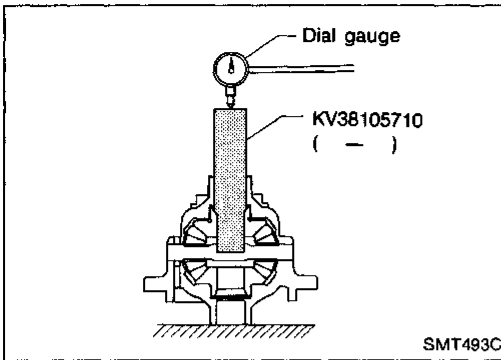

3. Measure clearance between side gear and differential case with washers using the following procedure:
 - a. Set Tool and dial indicator on side gear.
 - b. Move side gear up and down to measure dial indicator deflection. Always measure on both side gears.

Clearance between side gear and differential case with washers:
0.1 - 0.2 mm (0.004 - 0.008 in)

- c. If not within specification, adjust clearance by changing thickness of side gear washers.

Side gear washers: Refer to SDS, MT-39.

— RS5F32V —

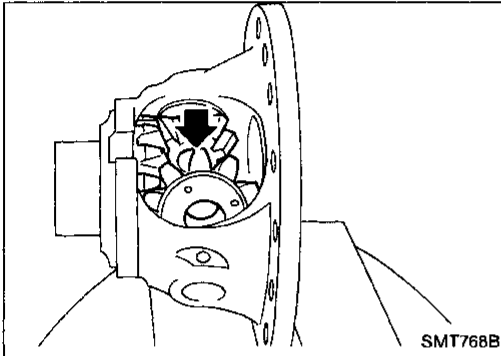

1. Attach side gear washer to side gear and install them in differential case.
Then install pinion mate washers and pinion mate gears in place.

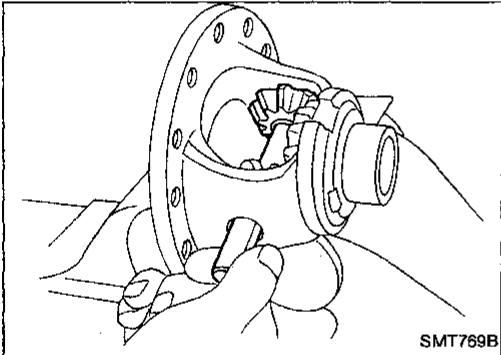

2. Insert pinion mate shaft.
 - **When inserting, be careful not to damage pinion mate gear washers.**

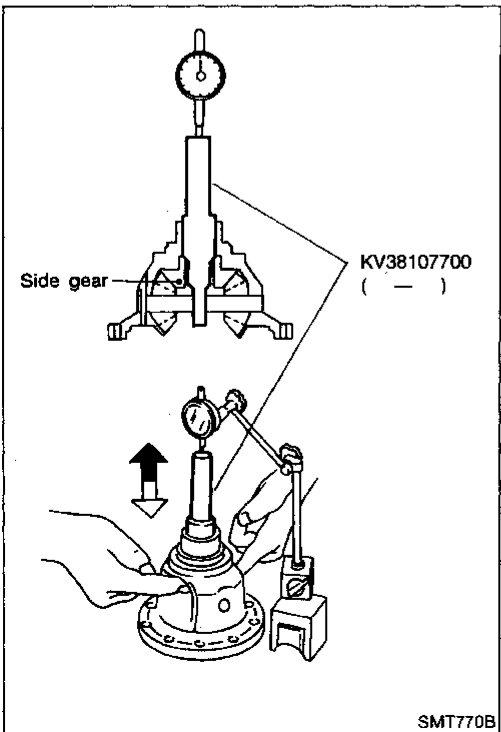

3. Measure clearance between side gear and differential case with washers following the procedure below:
 - a. Set Tool and dial indicator on side gear.
 - b. Move side gear up and down to measure dial indicator deflection.

Clearance between side gear and differential case with washers:
0 - 0.1 mm (0 - 0.004 in)

- c. If not within specification, adjust clearance by changing thickness of side gear washers.

Side gear washers for differential case side:

Thickness mm (in)	Part number
0.75 - 0.80 (0.0295 - 0.0315)	38424-D2111
0.80 - 0.85 (0.0315 - 0.0335)	38424-D2112
0.85 - 0.90 (0.0335 - 0.0354)	38424-D2113
0.90 - 0.95 (0.0354 - 0.0374)	38424-D2114
0.95 - 1.00 (0.0374 - 0.0394)	38424-D2115

REPAIR FOR COMPONENT PARTS

Final Drive (Cont'd)

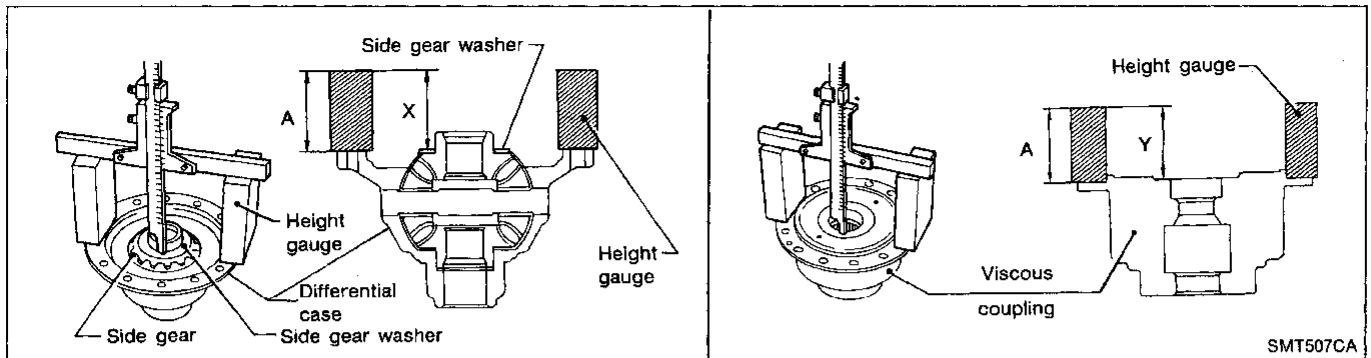

4. Measure clearance between side gear and viscous coupling with washers following the procedure below.
 - a. Set remaining side gear with washer on pinion mate gears.
 - b. Measure distance "X".
 - **Side gear might be uneven, so measure it in at least 4 places along the circumference. Then take an average reading.**
 - c. Measure dimension "Y".
Clearance between side gear and viscous coupling with washers can be obtained by " $X + Y - 2A$ ".
 - d. If not within specification, adjust clearance by changing thickness of side gear washer.

Side gear washers for viscous coupling side:

Refer to SDS, MT-39.

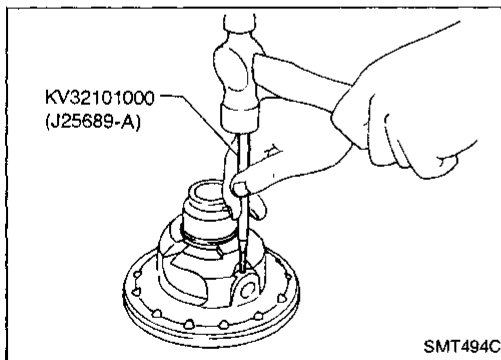

— RS5F32A & RS5F32V —

5. Install lock pin.
 - **Make sure that lock pin is flush with case.**

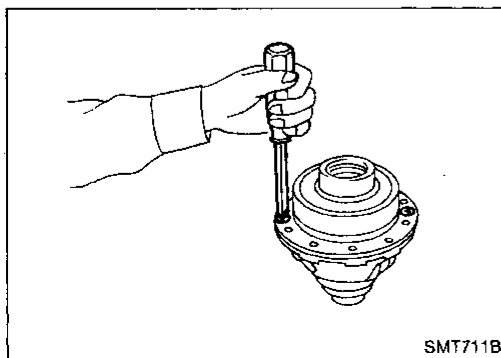

6. Install viscous coupling — RS5F32V.

REPAIR FOR COMPONENT PARTS

Final Drive (Cont'd)

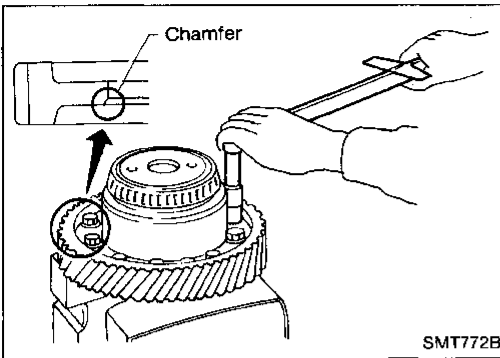

7. Install final gear.

- Apply locking sealant to final gear fixing bolts before installing them.

8. Install speedometer drive gear.

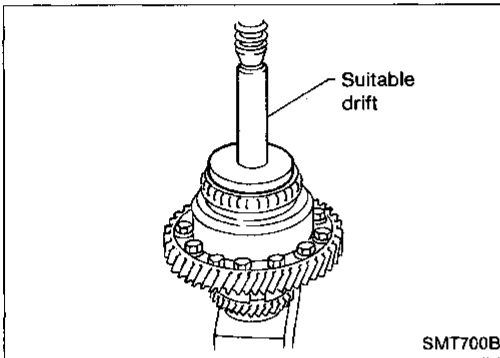

9. Press on differential side bearings.

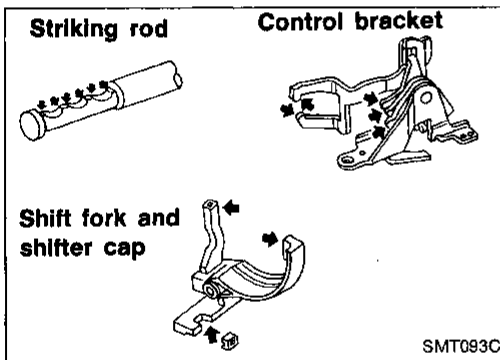

Shift Control Components

INSPECTION

- Check contact surface and sliding surface for wear, scratches, projections or other damage.

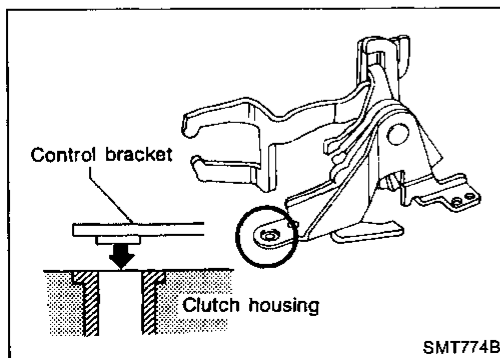
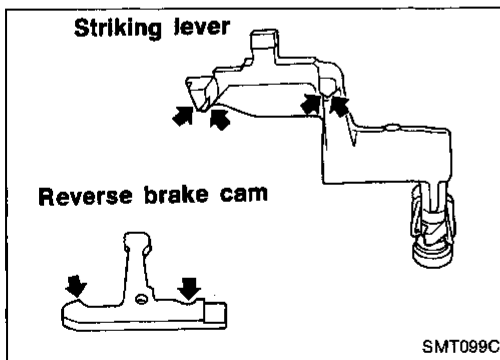

ADJUSTMENT OF INPUT SHAFT BRAKING MECHANISM

1. Install striking lever & rod, striking interlock assembly and control bracket on clutch housing exactly.

- When installing control bracket on clutch housing, assure protrusion beneath bracket is correctly seated.

REPAIR FOR COMPONENT PARTS

Shift Control Components (Cont'd)

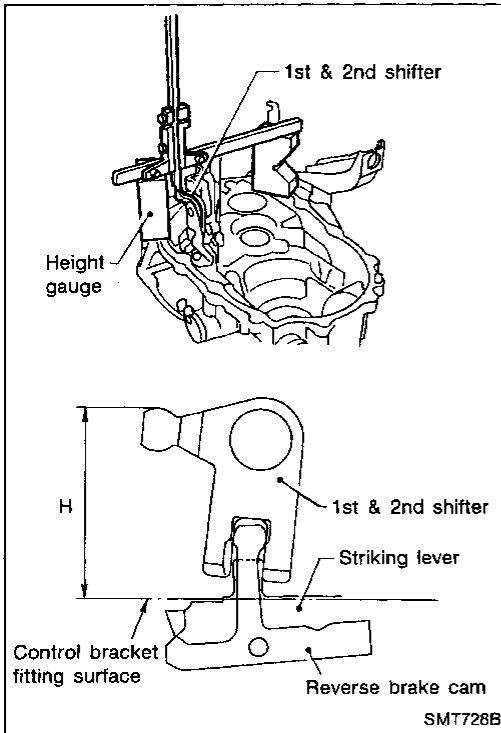

2. Measure maximum height "H" while shifting from neutral to reverse position.

Maximum height "H":

67.16 - 67.64 mm (2.6441 - 2.6630 in)

GI

MA

EM

LC

EC

FE

CL

MT

AT

FA

RA

BR

ST

BF

HA

EL

IDX

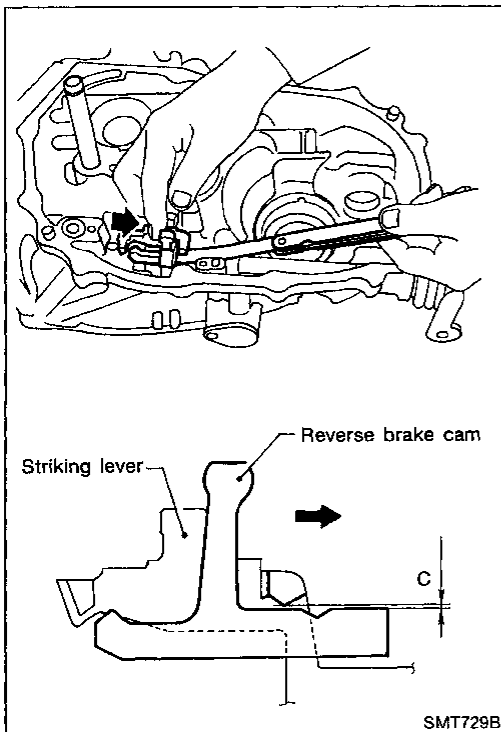

3. Measure clearance "C" between reverse brake cam and striking lever while shifting to reverse position.

Clearance "C":

0.05 - 0.20 mm (0.0020 - 0.0079 in)

If "H" or "C" is not within specification, replace the following parts as a set.

- Striking lever assembly
- Striking interlock assembly (This includes reverse brake cam.)
- Control bracket assembly

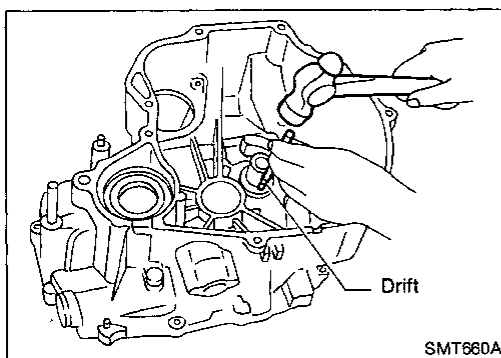

Case Components

Input shaft oil seal

1. Drive out input shaft oil seal.

REPAIR FOR COMPONENT PARTS

Case Components (Cont'd)

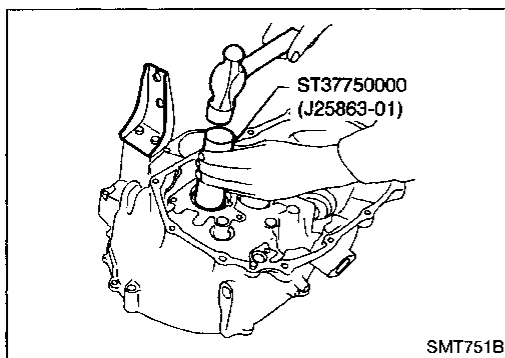

2. Install input shaft oil seal.

- Apply multi-purpose grease to seal lip of oil seal before installing.

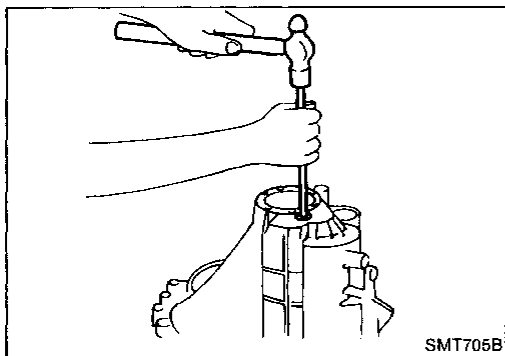

Input shaft rear bearing

1. Remove welch plug from transmission case.

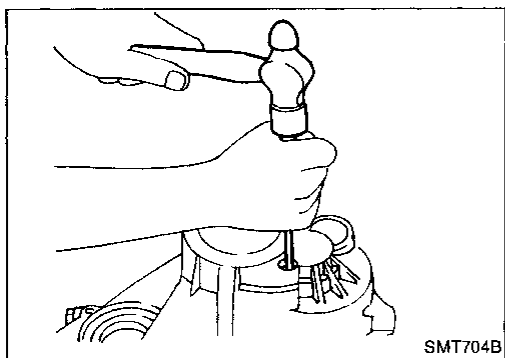

2. Remove input shaft rear bearing by tapping it from welch plug hole.

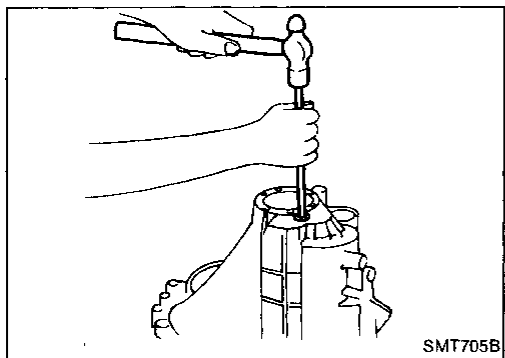

3. Install welch plug.

- Apply recommended sealant to mating surface of transmission case.

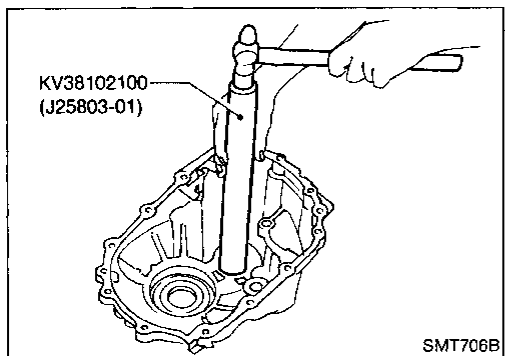

4. Install input shaft rear bearing.

REPAIR FOR COMPONENT PARTS

Case Components (Cont'd)

Mainshaft front bearing and oil channel

1. Remove mainshaft front bearing retainer.

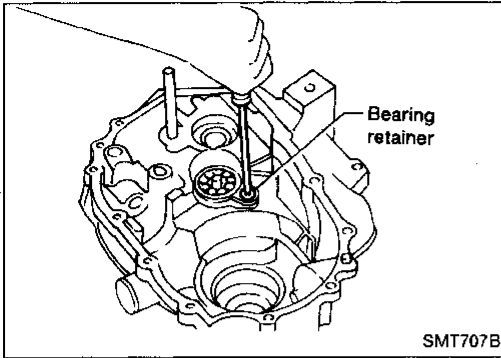

GI

MA

EM

LC

EC

FE

CL

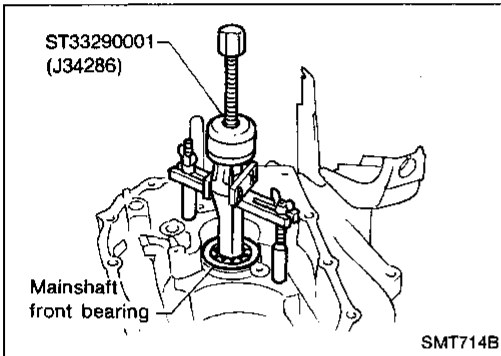

2. Remove mainshaft front bearing.
3. Remove oil channel.

MT

AT

FA

RA

BR

ST

BF

HA

EL

IDX

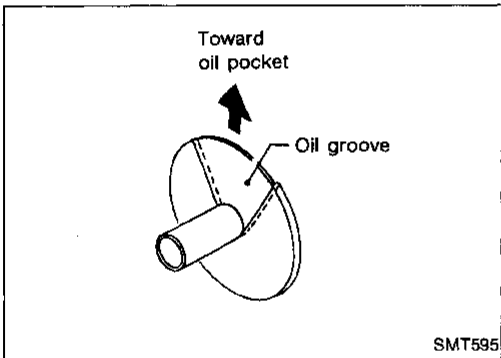

4. Install oil channel on clutch housing.

- When installing, always place it so that oil groove faces toward oil pocket.

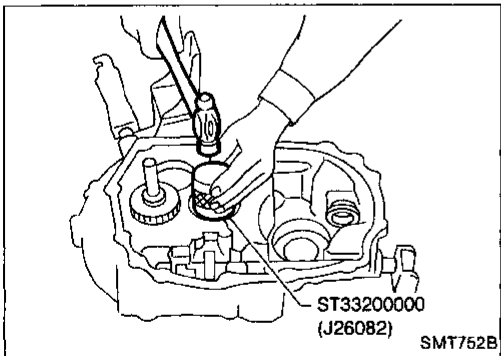

5. Install mainshaft front bearing.
6. Install mainshaft front bearing retainer.

Apply locking sealant to thread of screw before installation.

ADJUSTMENT

Differential Side Bearing Preload

If any of the following parts are replaced, adjust differential side bearing preload.

- Differential case
- Differential side bearing
- Clutch housing
- Transmission case

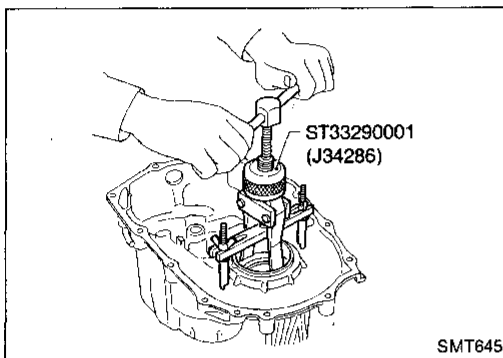

1. Remove differential side bearing outer race (transmission case side) and shim.
2. Reinstall differential side bearing outer race without shim.
3. Install final drive assembly on clutch housing.
4. Install transmission case on clutch housing.
- **Tighten transmission case fixing bolts to the specified torque.**

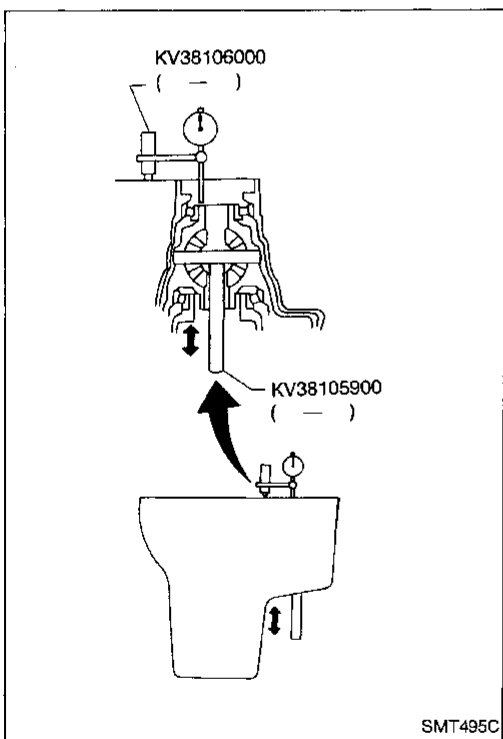

5. Set dial indicator on front end of differential case.
6. Insert Tool all the way into differential side gear.
7. Move Tool up and down and measure dial indicator deflection.
8. Select shim considering bearing preload.

$$\text{Suitable shim thickness} = \text{Dial indicator deflection} + \text{Specified bearing preload}$$

Differential side bearing adjusting shims:

Refer to SDS, MT-39.

Bearing preload:

0.25 - 0.30 mm (0.0098 - 0.0118 in)

9. Install selected shim and differential side bearing outer race.
10. Check differential side bearing turning torque.
 - a. Install final drive assembly on clutch housing.
 - b. Install transmission case on clutch housing.
- **Tighten transmission case fixing bolts to the specified torque.**

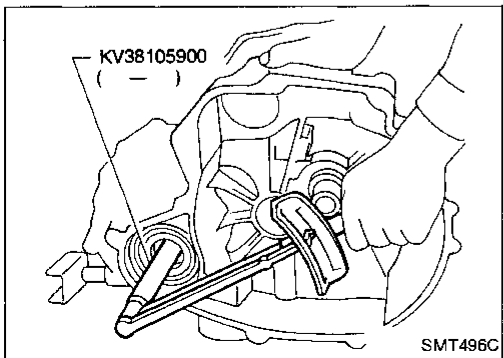

- c. Measure turning torque of final drive assembly.

Turning torque of final drive assembly (New bearing):
2.9 - 6.9 N·m (30 - 70 kg·cm, 26 - 61 in·lb)

 - **When old bearing is used again, turning torque will be slightly less than the above.**
 - **Make sure torque is close to the specified range.**
 - **Changes in turning torque of final drive assembly per revolution should be within 1.0 N·m (10 kg·cm, 8.7 in·lb) without binding.**

ASSEMBLY

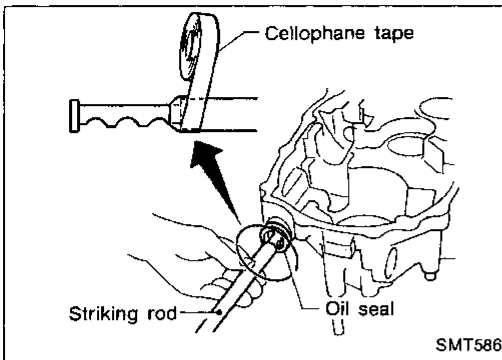

1. Install striking rod, lever and interlock.
 - **When inserting striking rod into clutch housing, tape edges of striking rod. This will prevent damaging oil seal lip.**

GI

MA

EM

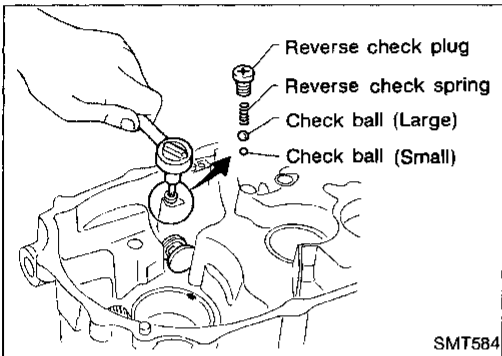

2. Install reverse check sleeve assembly.
3. Install check balls, reverse check spring and check plug.

LC

EC

FE

CL

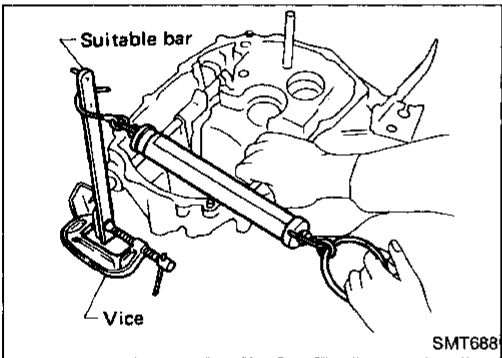

4. Check reverse check force.

Reverse check force:

4.9 - 7.4 N·m (50 - 75 kg-cm, 43 - 65 in-lb)

- If not within specification, select another check plug having a different length and reinstall it.

Available reverse check plugs:

Thickness mm (in)	Part number
7.1 (0.280)	32188-M8002
7.7 (0.303)	32188-M8003
8.3 (0.327)	32188-M8001*
8.9 (0.350)	32188-M8004

*Standard size check plug.

MT

AT

FA

RA

BR

ST

BF

HA

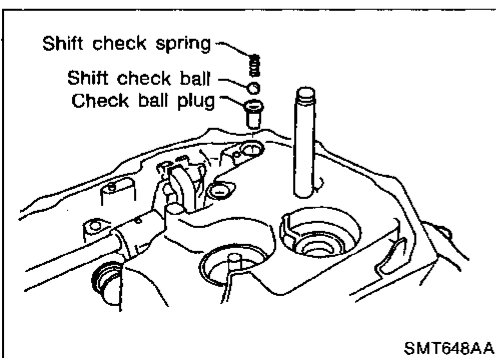

5. Install selected reverse check plug.
Apply locking sealant to thread of plug before installing it.
6. Install check ball plug, shift check ball and shift check spring.
7. Install oil pocket.

EL

IDX

ASSEMBLY

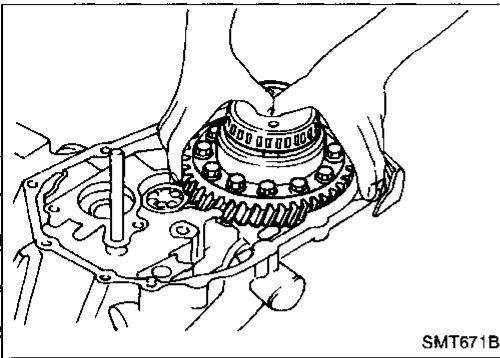

8. Install gear components onto clutch housing.
 - a. Install final drive assembly.

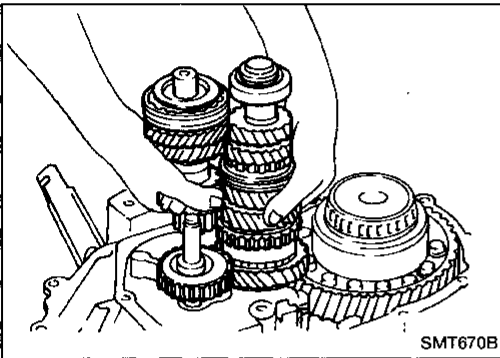

- b. Install input shaft assembly with bearing retainer, main shaft assembly and reverse idler gear.
 - Be careful not to damage oil seal lip with input shaft splines while installing the shaft.
 - Be careful not to damage oil channel when inserting main shaft into clutch housing.

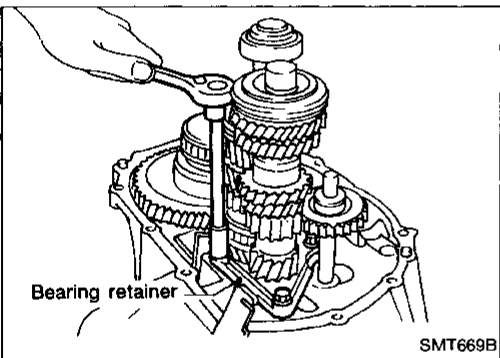

- c. Install input shaft front bearing retainer.

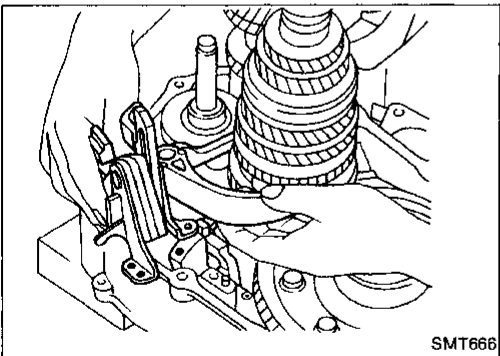

9. Apply grease to shifter caps, then install it to control bracket. Install control bracket with 1st & 2nd shift fork.

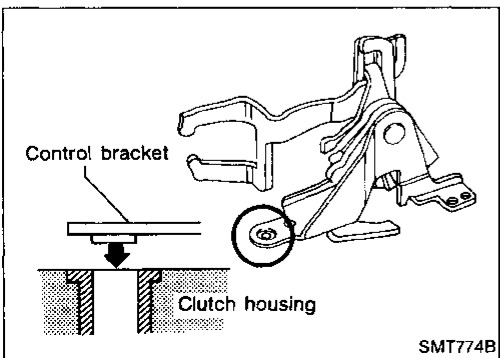

- When installing control bracket on clutch housing, ensure protrusion beneath bracket is correctly seated.
10. Install 3rd & 4th and 5th shift forks.

ASSEMBLY

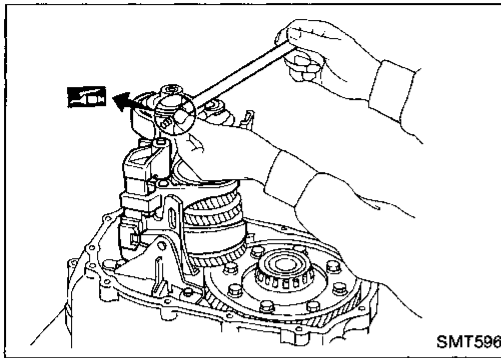

11. Insert fork shaft.
 - Apply multi-purpose grease to support spring before installing.
12. Install reverse idler spacer.

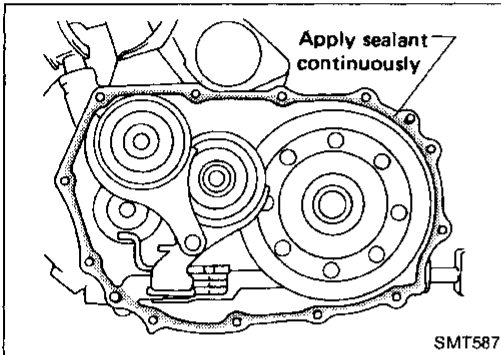

13. Apply recommended sealant to mating surface of clutch housing.

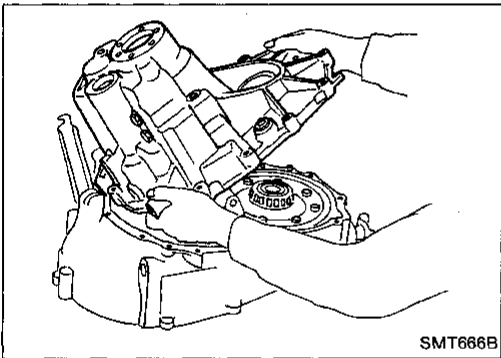

14. Install transmission case on clutch housing.

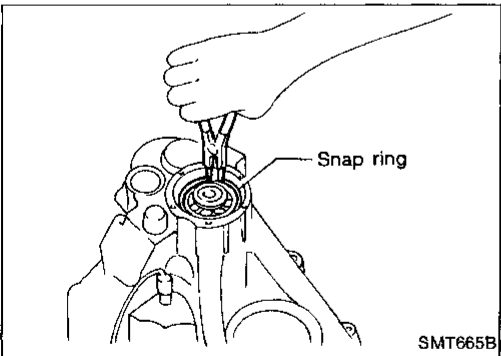

15. Install mainshaft front bearing snap ring.

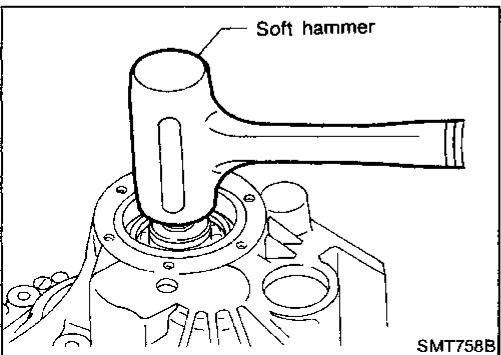

16. Tap mainshaft with a rubber hammer to ensure mainshaft rear bearing is properly seated.

GI

MA

EM

LC

EC

FE

CL

MT

AT

FA

RA

BR

ST

BF

HA

EL

IDX

ASSEMBLY

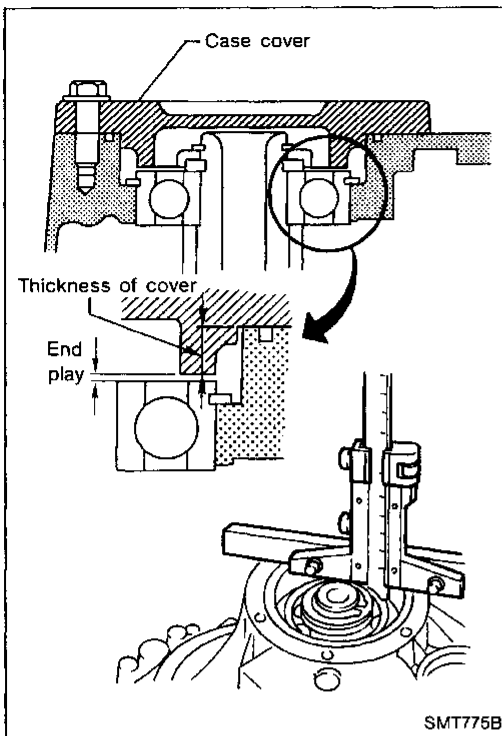

17. Check mainshaft bearing end play.

Mainshaft bearing end play:

0 - 0.1 mm (0 - 0.004 in)

- If not within specification, select another case cover having a different thickness.

Available case covers:

Refer to SDS, MT-38.

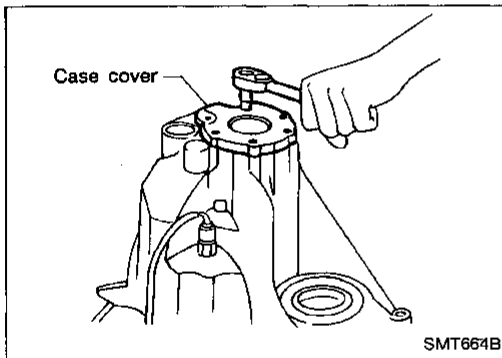

18. Install O-ring and case cover on transmission case.

Apply recommended sealant to mating surface of transmission case.

SERVICE DATA AND SPECIFICATIONS (SDS)

General Specifications

TRANSAXLE

Engine	SR20DE		
Transaxle model	RS5F32A & RS5F32V		
Number of speeds	5		
Synchromesh type	Warner		
Shift pattern			
Gear ratio		Number of teeth	
		Input gear	Main gear
1st	3.063	16	49
2nd	1.826	23	42
3rd	1.207	29	35
4th	0.926	41	38
5th	0.733	45	33
Reverse	3.153	13	41
Reverse idler gear		31	
Oil level	mm (in)	40 - 47 (1.57 - 1.85)	38 - 44 (1.50 - 1.73)
Reference			
Oil capacity		3.5 - 3.7ℓ (7-3/8 - 7-7/8 US pt, 6-1/8 - 6-1/2 Imp pt)	

FINAL GEAR

Engine	SR20DE	
Final gear ratio	4.176	
Number of teeth	Final gear/Pinion	71/17
	Side gear/Pinion mate gear	14/10

GI
MA
EM
LC
EC
FE
CL

MT

AT

FA

RA

Inspection and Adjustment

GEAR END PLAY

Gear	End play mm (in)
1st main gear	0.18 - 0.31 (0.0071 - 0.0122)
2nd main gear	0.20 - 0.30 (0.0079 - 0.0118)
3rd main gear	0.20 - 0.30 (0.0079 - 0.0118)
4th main gear	0.20 - 0.30 (0.0079 - 0.0118)
5th input gear	0.18 - 0.31 (0.0071 - 0.0122)

2nd and 3rd baulk ring

Unit: mm (in)

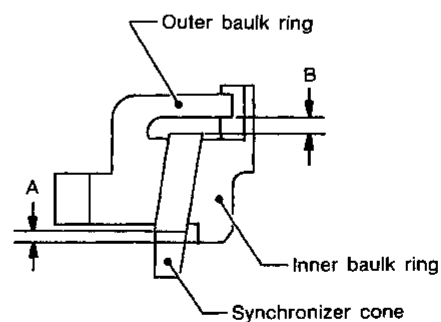

SMT649C

CLEARANCE BETWEEN BAULK RING AND GEAR

1st, 4th, 5th baulk ring

Unit: mm (in)

Standard		Wear limit
1st	0.95 - 1.45 (0.0374 - 0.0571)	
4th	0.9 - 1.45 (0.0354 - 0.0571)	0.7 (0.028)
5th	0.9 - 1.5 (0.035 - 0.059)	

Dimension	Standard	Wear limit
A	0.7 - 0.9 (0.028 - 0.035)	
B	0.6 - 1.1 (0.024 - 0.043)	0.2 (0.008)

BR

ST

BF

HA

EL

IDX

SERVICE DATA AND SPECIFICATIONS (SDS)

Inspection and Adjustment (Cont'd)

AVAILABLE CHECK PLUGS AND CASE COVERS

Reverse check plug

Reverse check turning torque (At striking rod)	4.9 - 7.4 N·m (50 - 75 kg-cm, 43 - 65 in-lb)
Length mm (in)	Part number
8.3 (0.327)	32188-M8001*
7.1 (0.280)	32188-M8002
7.7 (0.303)	32188-M8003
8.9 (0.350)	32188-M8004

* Standard check plug

Case cover

Main shaft bearing end play	0 - 0.1 mm (0 - 0.004 in)
Thickness mm (in)	Part number
10.78 (0.4244)	32131-50J00
10.83 (0.4264)	32131-50J01
10.88 (0.4283)	32131-50J02
10.93 (0.4303)	32131-50J03
10.98 (0.4323)	32131-50J04
11.03 (0.4343)	32131-50J05

AVAILABLE SNAP RINGS

Input shaft front bearing

Allowable clearance	0 - 0.1 mm (0 - 0.004 in)
Thickness mm (in)	Part number
1.27 (0.0500)	32204-M8004
1.33 (0.0524)	32204-M8005
1.39 (0.0547)	32204-M8006
1.45 (0.0571)	32204-M8007

Input shaft 5th synchronizer hub

Allowable clearance	0 - 0.1 mm (0 - 0.004 in)
Thickness mm (in)	Part number
2.00 (0.0787)	32311-M8812
2.05 (0.0807)	32311-M8813
2.10 (0.0827)	32311-M8814
2.15 (0.0846)	32311-M8815
2.20 (0.0866)	32311-M8816
2.25 (0.0886)	32311-M8817
2.30 (0.0906)	32311-M8818

AVAILABLE C-RINGS

Mainshaft C-ring

Allowable clearance	0 - 0.1 mm (0 - 0.004 in)	
Thickness mm (in)	Part number	
4.45 (0.1752)	32348-50J00	
4.52 (0.1780)	32348-50J01	
4.59 (0.1807)	32348-50J02	
4.66 (0.1835)	32348-50J03	
4.73 (0.1862)	32348-50J04	
4.80 (0.1890)	32348-50J05	
4.87 (0.1917)	32348-50J06	
4.94 (0.1945)	32348-50J07	

AVAILABLE SPACERS

Mainshaft bearing adjusting spacer

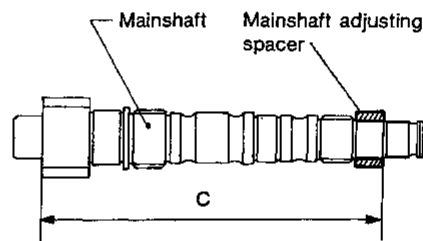

SMT423C

Bearing distance: C	230.15 - 230.25 mm (9.0610 - 9.0649 in)	
Thickness mm (in)	Part number	
18.91 (0.7445)	32347-50J00	
18.98 (0.7472)	32347-50J01	
19.05 (0.7500)	32347-50J02	
19.12 (0.7528)	32347-50J03	
19.19 (0.7555)	32347-50J04	
19.26 (0.7583)	32347-50J05	
19.33 (0.7610)	32347-50J06	
19.40 (0.7638)	32347-50J07	
19.47 (0.7665)	32347-50J08	

SERVICE DATA AND SPECIFICATIONS (SDS)

Inspection and Adjustment (Cont'd)

AVAILABLE WASHERS

Differential side gear washer

Allowable clearance between side gear and differential case or viscous coupling with washer		0.1 - 0.2 mm (0.004 - 0.008 in)		
	Thickness mm (in)	Part number		
F32A	0.75 - 0.80 (0.0295 - 0.0315)	38424-D2111		
	0.80 - 0.85 (0.0315 - 0.0335)	38424-D2112		
	0.85 - 0.90 (0.0335 - 0.0354)	38424-D2113		
	0.90 - 0.95 (0.0354 - 0.0374)	38424-D2114		
	0.95 - 1.00 (0.0374 - 0.0394)	38424-D2115		
F32V	Viscous coupling side	0.70 - 0.75 (0.0276 - 0.0295)	38424-D2110	
		0.75 - 0.80 (0.0295 - 0.0315)	38424-D2111	
		0.80 - 0.85 (0.0315 - 0.0335)	38424-D2112	
		0.85 - 0.90 (0.0335 - 0.0354)	38424-D2113	
		0.90 - 0.95 (0.0354 - 0.0374)	38424-D2114	
		0.95 - 1.00 (0.0374 - 0.0394)	38424-D2115	
		1.00 - 1.05 (0.0394 - 0.0413)	38424-D2116	
		1.05 - 1.10 (0.0413 - 0.0433)	38424-D2117	
		1.10 - 1.15 (0.0433 - 0.0453)	38424-D2118	
		1.15 - 1.20 (0.0453 - 0.0472)	38424-D2119	
		1.20 - 1.25 (0.0472 - 0.0492)	38424-D2120	
		1.25 - 1.30 (0.0492 - 0.0512)	38424-D2121	
		1.30 - 1.35 (0.0512 - 0.0531)	38424-D2122	
		Differential case side	0.75 - 0.80 (0.0295 - 0.0315)	38424-D2111
			0.80 - 0.85 (0.0315 - 0.0335)	38424-D2112
0.85 - 0.90 (0.0335 - 0.0354)	38424-D2113			
0.90 - 0.95 (0.0354 - 0.0374)	38424-D2114			
0.95 - 1.00 (0.0374 - 0.0394)	38424-D2115			

AVAILABLE SHIMS

DIFFERENTIAL SIDE BEARING PRELOAD AND ADJUSTING SHIM

Bearing preload

Differential side bearing	0.25 - 0.30 mm (0.0098 - 0.0118 in)
---------------------------	--

Turning torque (New bearing)

Final drive	2.9 - 6.9 N·m (30 - 70 kg·cm, 26 - 61 in·lb)
-------------	---

Differential side bearing adjusting shims

RS5F32A

Thickness mm (in)	Part number	Thickness mm (in)	Part number
0.44 (0.0173)	38454-M8000	0.72 (0.0283)	38454-M8007
0.48 (0.0189)	38454-M8001	0.76 (0.0299)	38454-M8008
0.56 (0.0220)	38454-M8003	0.80 (0.0315)	38454-M8009
0.60 (0.0236)	38454-M8004	0.84 (0.0331)	38454-M8010
0.64 (0.0252)	38454-M8005	0.88 (0.0346)	38454-M8011
0.68 (0.0268)	38454-M8006		

RS5F32V

Thickness mm (in)	Part number	Thickness mm (in)	Part number
0.28 (0.0110)	31439-31X00	0.68 (0.0268)	31439-31X10
0.32 (0.0126)	31439-31X01	0.72 (0.0283)	31439-31X11
0.36 (0.0142)	31439-31X02	0.76 (0.0299)	31439-31X12
0.40 (0.0157)	31439-31X03	0.80 (0.0315)	31439-31X13
0.44 (0.0173)	31439-31X04	0.84 (0.0331)	31439-31X14
0.48 (0.0189)	31439-31X05	0.88 (0.0346)	31439-31X15
0.52 (0.0205)	31439-31X06	0.92 (0.0362)	31439-31X16
0.56 (0.0220)	31439-31X07	0.96 (0.0378)	31439-31X17
0.60 (0.0236)	31439-31X08	1.44 (0.0567)	31439-31X18
0.64 (0.0252)	31439-31X09		

SERVICE DATA AND SPECIFICATIONS (SDS)

Inspection and Adjustment (Cont'd)

Reverse brake cam

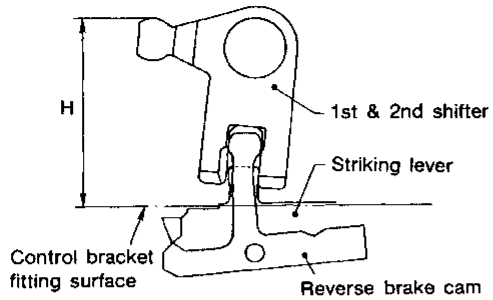

SMT735B

Maximum height "H" between the control bracket fitting surface and 1-2 shifter	mm (in)
	67.16 - 67.64 (2.6441 - 2.6630)

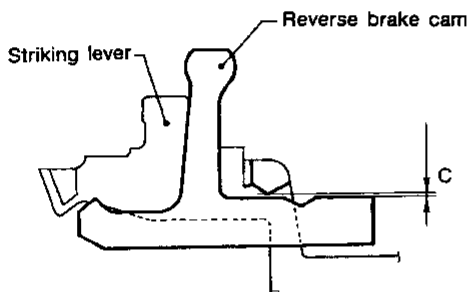

SMT736B

Clearance "C" between reverse brake cam and striking lever	mm (in)
	0.05 - 0.20 (0.0020 - 0.0079)