

SECTION BT

CONTENTS

PRECAUTIONS	2	Roof Trim.....	15
Service Notice.....	2	Trunk Room Trim.....	16
Supplemental Restraint System (SRS) "AIR BAG" and "SEAT BELT PRE-TENSIONER".....	2	EXTERIOR	17
GENERAL SERVICING	3	SEAT	23
Clip and Fastener.....	3	Front Seat.....	23
BODY END	5	Rear Seat.....	25
Body Front End.....	5	SUN ROOF	26
Body Rear End and Opener.....	6	WINDSHIELD AND WINDOWS	28
DOOR	8	Windshield and Rear Window.....	28
Front Door.....	8	MIRROR	29
Rear Door.....	9	Door Mirror.....	29
INSTRUMENT PANEL	10	REAR AIR SPOILER	30
INTERIOR TRIM	12	BODY ALIGNMENT	31
Side and Floor Trim.....	12	Engine Compartment.....	31
Door Trim.....	14	Underbody.....	33

- ★ For seat belt, refer to MA and RS section.
- ★ For wiring diagrams of body electrical systems, refer to EL section.

GI
MA
EM
LC
EC
FE
CL
MT
AT
FA
RA
BR
ST
RS
BT
HA
EL
IDX

PRECAUTIONS

Service Notice

- When removing or installing various parts, place a cloth or padding onto the vehicle body to prevent scratches.
- Handle trim, molding, instruments, grille, etc. carefully during removing or installation. Be careful not to soil or damage them.
- Apply sealing compound where necessary when installing parts.
- When applying sealing compound, be careful that the sealing compound does not protrude from parts.
- When replacing any metal parts (for example body outer panel, members, etc.), be sure to take rust prevention measures.

Supplemental Restraint System (SRS) “AIR BAG” and “SEAT BELT PRE-TENSIONER”

The Supplemental Restraint System “Air Bag” and “Seat Belt Pre-tensioner” help to reduce the risk or severity of injury to the driver and front passenger in a frontal collision. The Supplemental Restraint System consists of air bags (located in the center of the steering wheel and on the instrument panel on the passenger side), seat belt pre-tensioners, sensors, a diagnosis unit, warning lamp, wiring harness and spiral cable. Information necessary to service the system safely is included in the **RS section** of this Service Manual.







WARNING:

- **To avoid rendering the SRS inoperative, which could lead to personal injury or death in the event of a severe frontal collision, all maintenance must be performed by an authorized INFINITI dealer.**
- **Improper maintenance, including incorrect removal and installation of the SRS, can lead to personal injury caused by unintentional activation of the system.**
- **Do not use electrical test equipment on any circuit related to the SRS unless instructed to in this Service Manual. SRS wiring harnesses are covered with yellow insulation either just before the harness connectors or for the complete harness, for easy identification.**

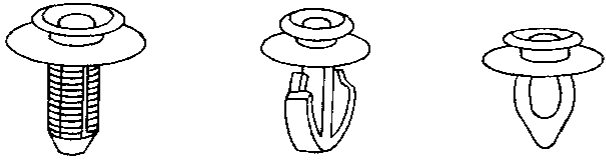
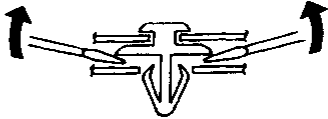
GENERAL SERVICING

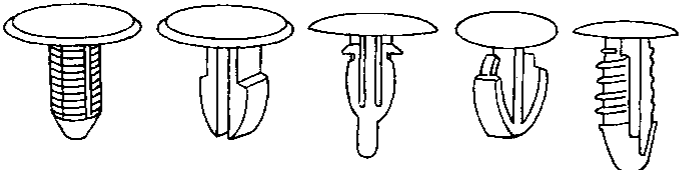
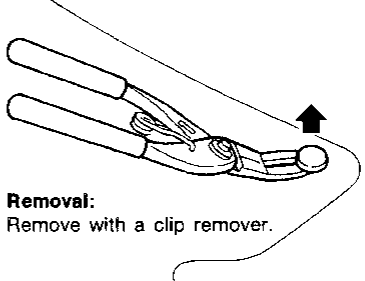
Clip and Fastener

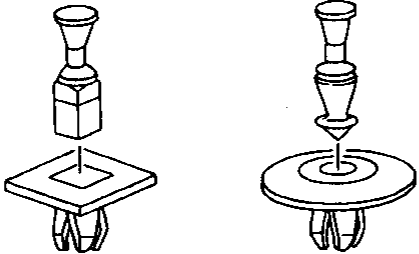
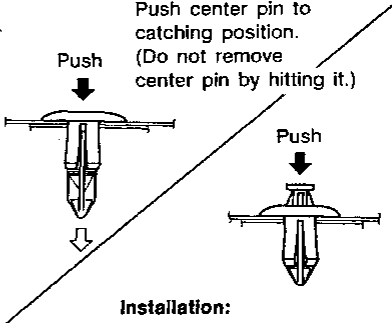

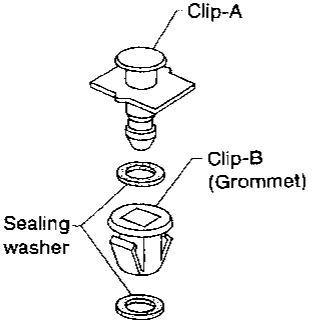
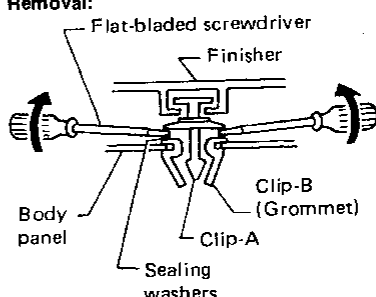



- Clips and fasteners in BT section correspond to the following numbers and symbols.
- Replace any clips and/or fasteners which are damaged during removal or installation.

No. Symbol	Shapes	Removal & Installation
	 <p style="text-align: right;">SBF302H</p>	<p>Removal: Remove by bending up with flat-bladed screwdrivers.</p>  <p style="text-align: right;">SBF367B</p>
	 <p style="text-align: right;">SBF303H</p>	 <p>Removal: Remove with a clip remover.</p> <p style="text-align: right;">SBF423H</p>
	 <p style="text-align: right;">SBF258G</p>	<p>Push center pin to catching position. (Do not remove center pin by hitting it.)</p>  <p>Installation:</p> <p style="text-align: right;">SBF708E</p>
	 <p style="text-align: right;">SBF151D</p>	<p>Removal: Flat-bladed screwdriver</p>  <p>Body panel Sealing washers Clip-A Clip-B (Grommet) Finisher</p> <p style="text-align: right;">SBF259G</p>

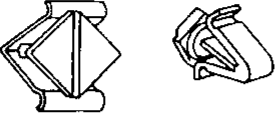
GI
 MA
 EM
 LC
 EC
 FE
 CL
 MT
 AT
 FA
 RA
 BR
 ST
 RS
BT
 HA
 EL
 IX

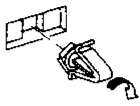
GENERAL SERVICING

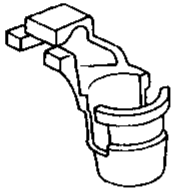
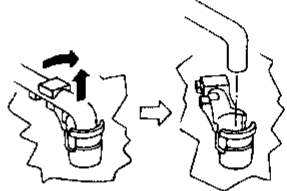
Clip and Fastener (Cont'd)

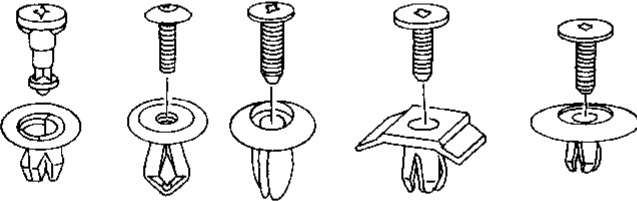
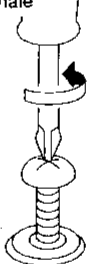
No. Symbol	Shapes	Removal & Installation
		<div style="display: flex; justify-content: space-between;"> <div style="width: 45%;"> <p>Removal:</p>  <p>Rotate 45° to remove.</p> <hr/> <p>Removal:</p>  </div> <div style="width: 45%;"> <p>Installation:</p>  </div> </div>
SBF145B	SBF085B	
		<p>Removal: Holder portion of clip must be spread out to remove rod.</p> 
SBF768B	SBF770B	
		<p>Removal:</p> <ol style="list-style-type: none"> 1. Screw out with a Phillips screwdriver. 2. Remove female portion with flat-bladed screwdriver. 
SBF078B	SBF992G	

Body Front End

- Hood adjustment: Adjust at hinge portion.
- Hood lock adjustment: After adjusting, check hood lock control operation. Apply a coat of grease to hood locks engaging mechanism.
- Hood opener: Do not attempt to bend cable forcibly. Doing so increases effort required to unlock hood.

REMOVAL — Front bumper assembly

- ① Remove clearance lamps.
- ② Remove headlamps.
- ③ Remove left and right nuts securing bumper fascia to fender.
- ④ Remove left and right screws securing bumper fascia to fender protector.
- ⑤ Remove left and right clips (C203) securing bumper fascia to radiator core lower support.
- ⑥ Remove left and right pins.
- ⑦ Remove left and right bolts securing bumper stay to side member.

SEC. 260-261-262-263-620-623-625-650

Hood lock adjustment

- Adjust hood so that hood primary lock meshes at a position 1 to 1.5 mm (0.039 to 0.059 in) lower than fender.
- After hood lock adjustment, adjust bumper rubber.
- When securing hood lock, ensure it does not tilt. Striker must be positioned at the center of hood primary lock.
- After adjustment, ensure that hood primary and secondary lock operate properly.

Hood lock secondary latch hooking length

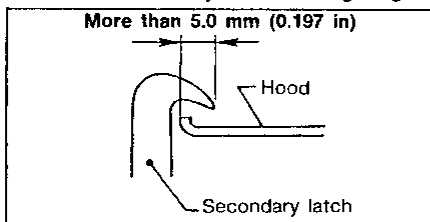

Bumper rubber adjustment

- Adjust so that hood is aligned with fender. At that time deflection is approx. 2 mm (0.08 in). [Bumper rubber free height is approx. 13 mm (0.51 in).]

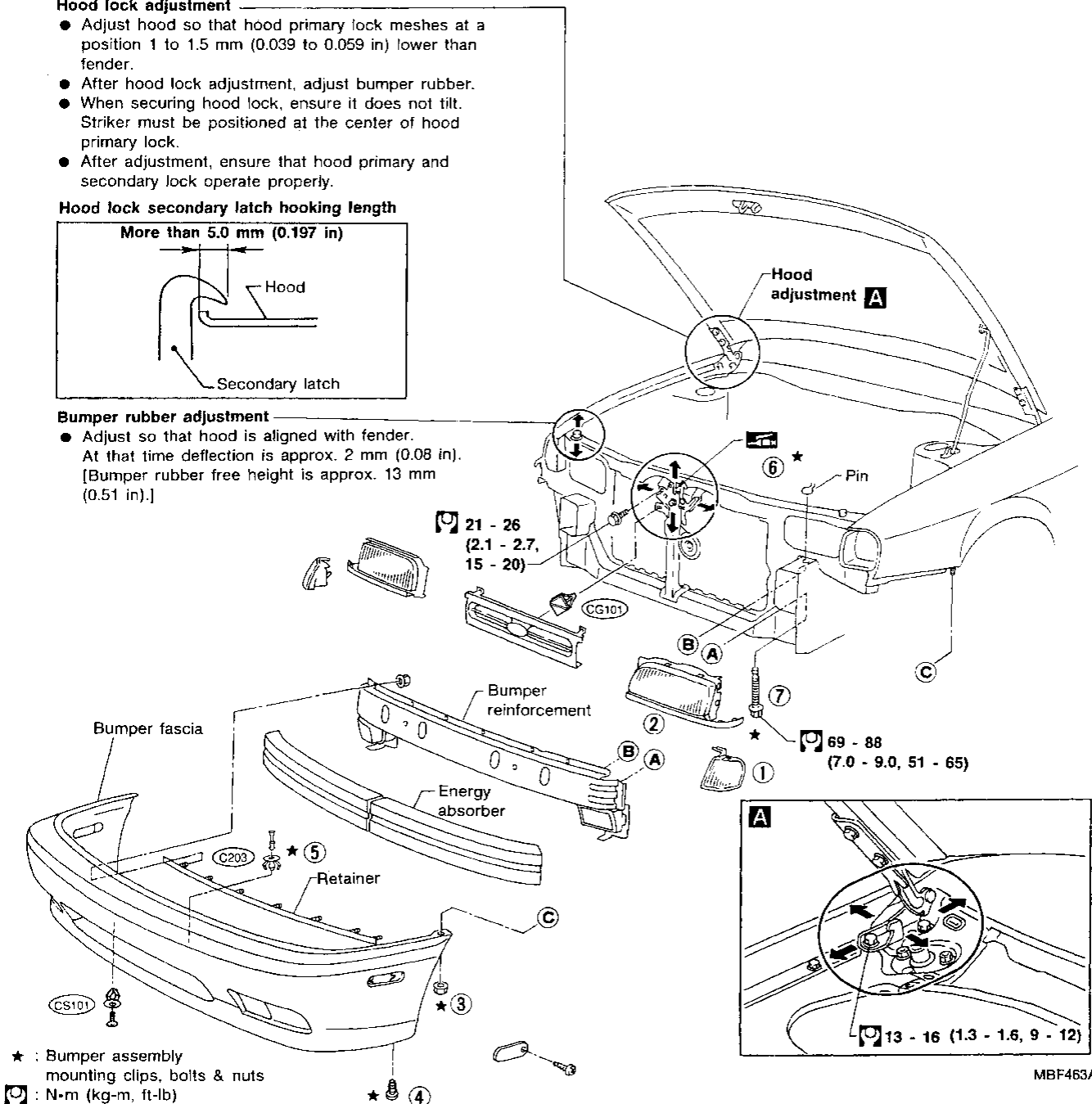

★ : Bumper assembly mounting clips, bolts & nuts
 □ : N·m (kg·m, ft·lb)

MBF463AA

GI
MA
EM
LC
EC
FE
CL
MT
AT
FA
RA
BR
ST
RS
BT
HA
EL
IDX

Body Rear End and Opener

- Trunk door adjustment: Adjust at hinge portion for proper fit.
- Trunk door lock system adjustment: Adjust striker so that it is in the center of the lock. After adjustment, check lock operation.
- Opener cable: Do not attempt to bend cable using excessive force.
- After installation, make sure that trunk lid/back door and fuel filler lid open smoothly.
- ★ For Wiring Diagram, refer to "Trunk Lid and Fuel Filler Lid Opener" in EL section.

WARNING:

- Be careful not to scratch trunk lid stay when installing back door. A scratched stay may cause gas leakage.
- The contents of the trunk lid stay are under pressure. Do not take apart, puncture, apply heat or allow fire near it.

Removal — Rear bumper assembly

- ① Remove left and right screws securing bumper fascia to wheelarch.
- ② Remove left and right bolts securing bumper fascia to bracket.
- ③ Remove the four left and right bolts securing bumper stay to rear side member.

SEC. 843•844•850

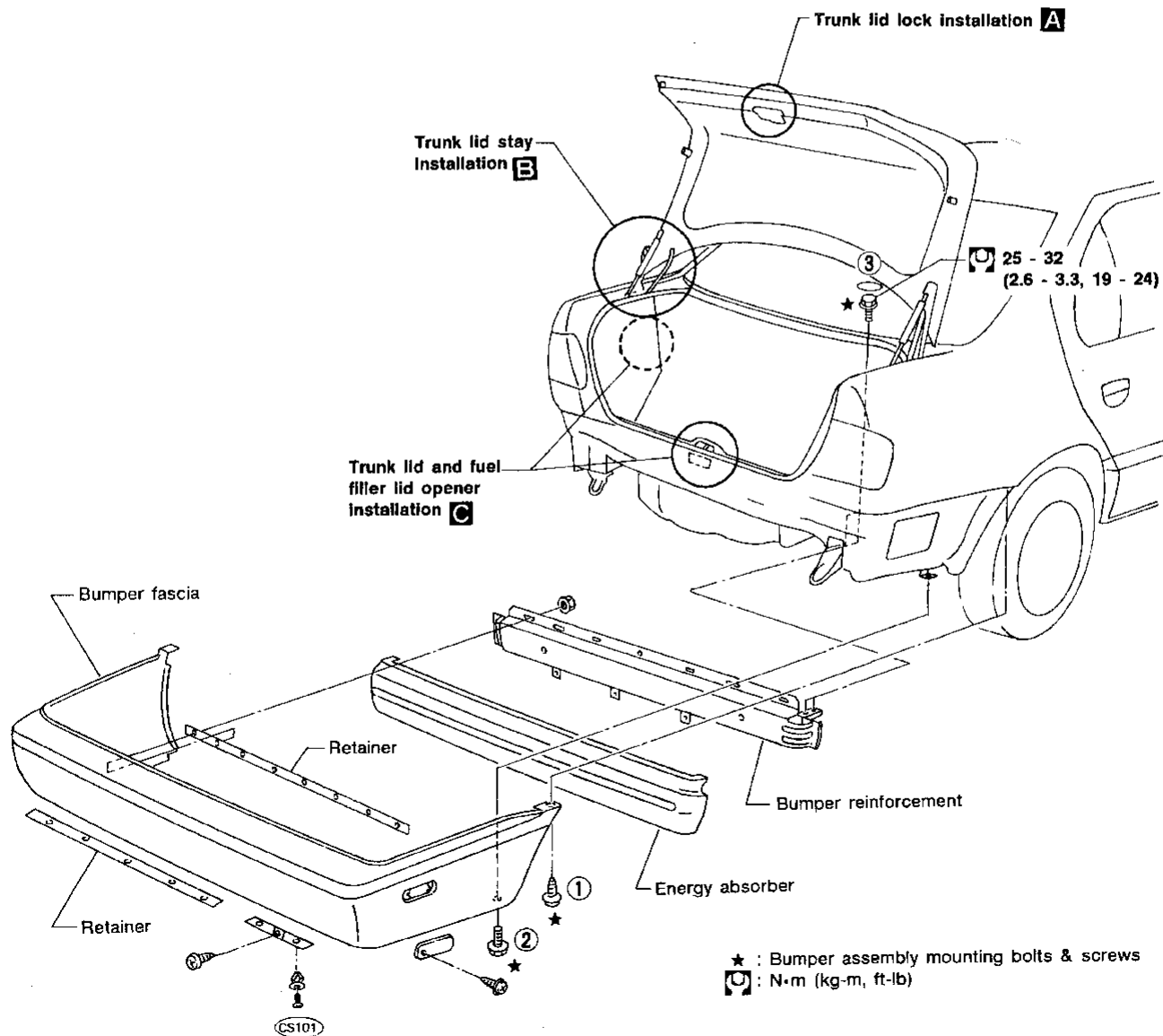



SBT102

BODY END

Body Rear End and Opener (Cont'd)

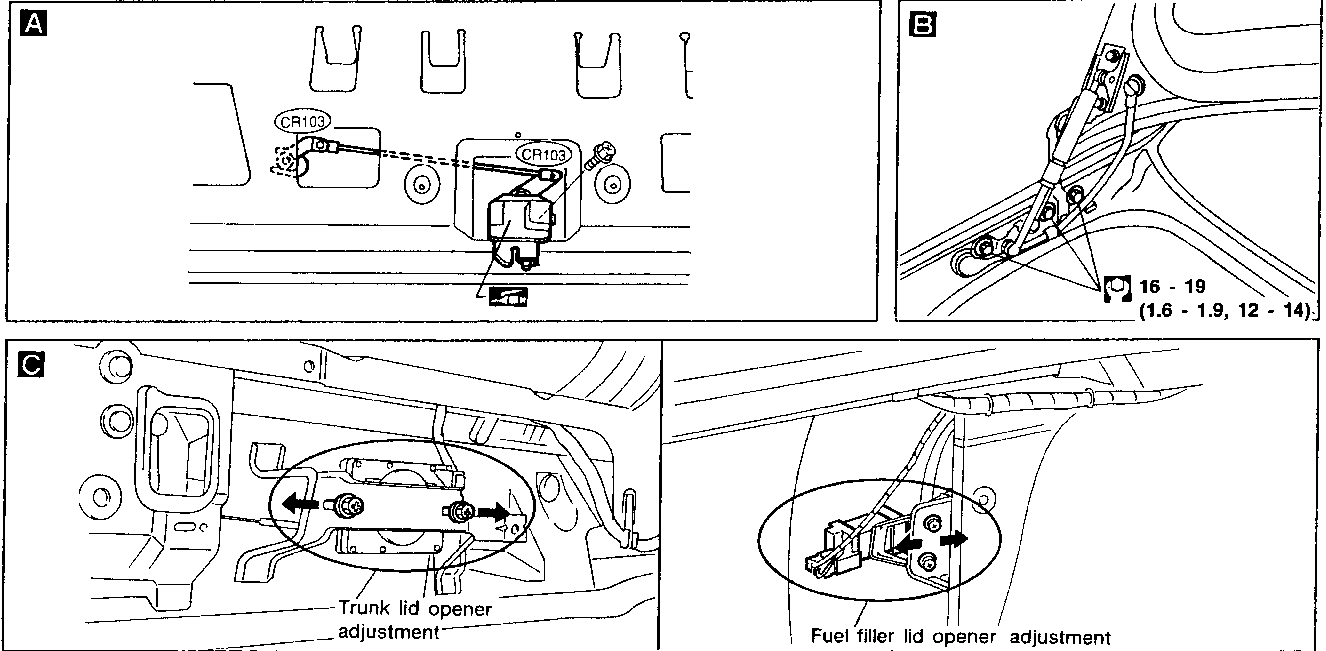
Installation (Refer to figures below.)



 : N·m (kg-m, ft-lb)

GI
MA
EM
LC
EC
FE
CL
WT
AT
FA
RA
BR
ST
RS
BT
HA
EL
IDX

DOOR

Front Door

- For removal of door trim, refer to "INTERIOR TRIM" (BT-14).
- After adjusting door or door lock, check door lock operation.

SEC. 800-803-805

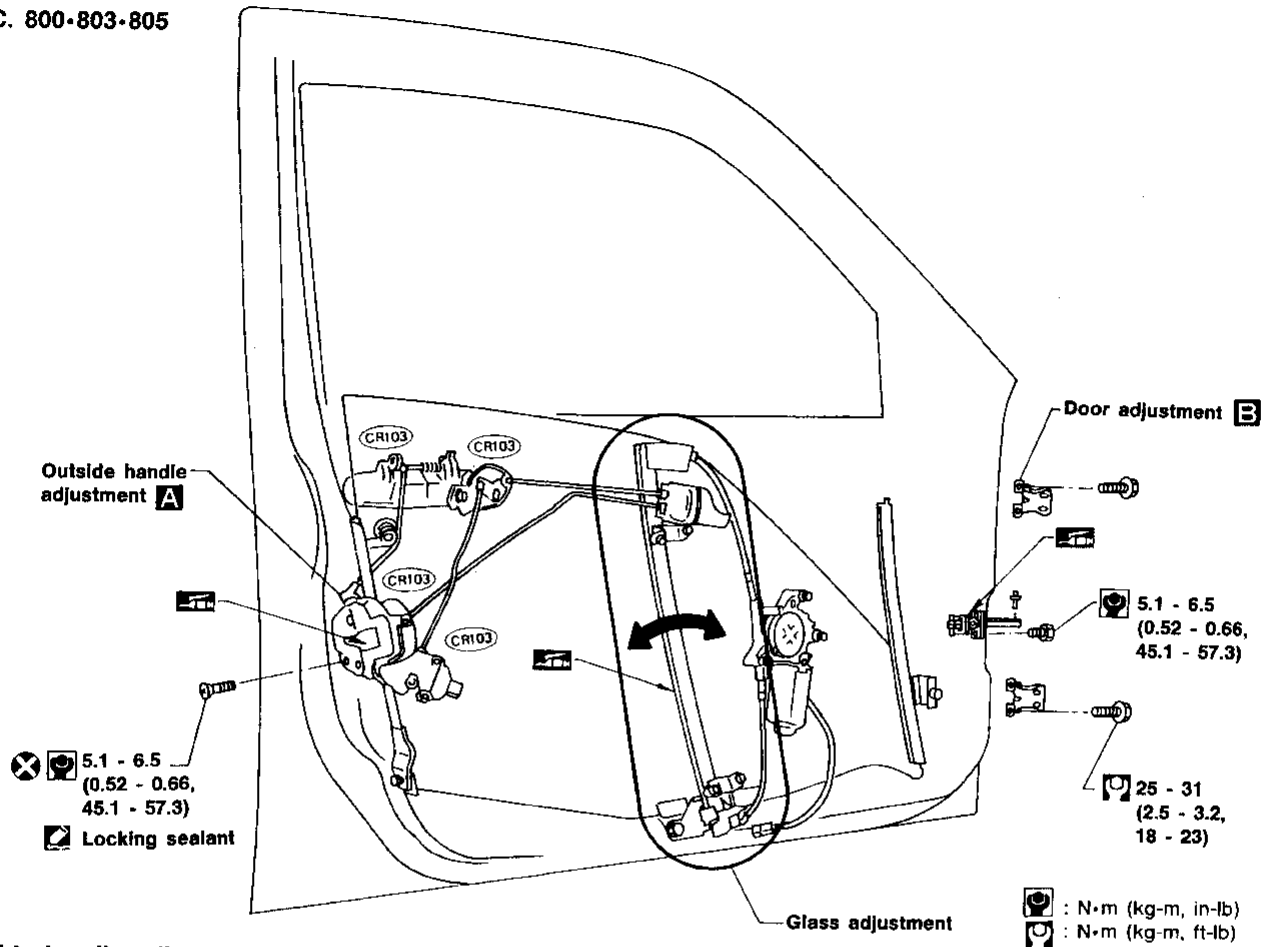

Outside handle adjustment

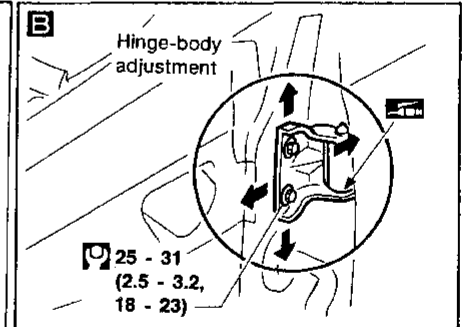
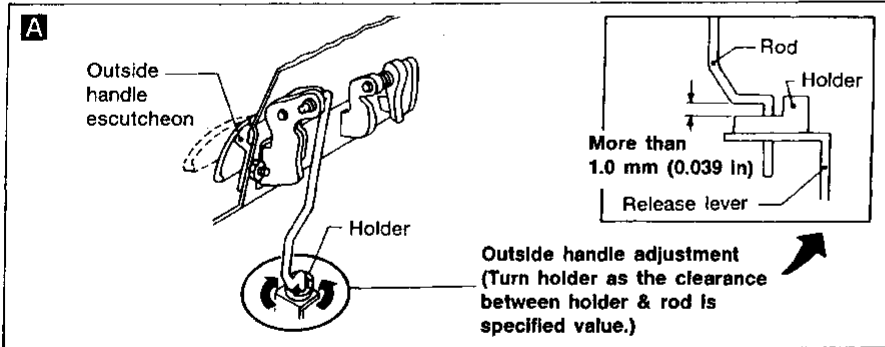

Striker adjustment

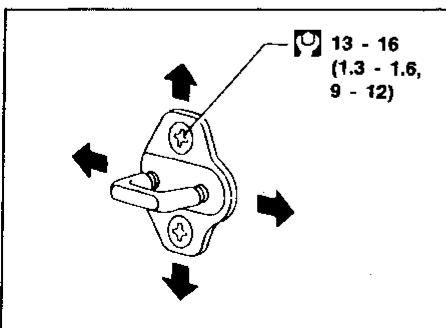

MBF064BB

DOOR

Rear Door

SEC. 820-823-825

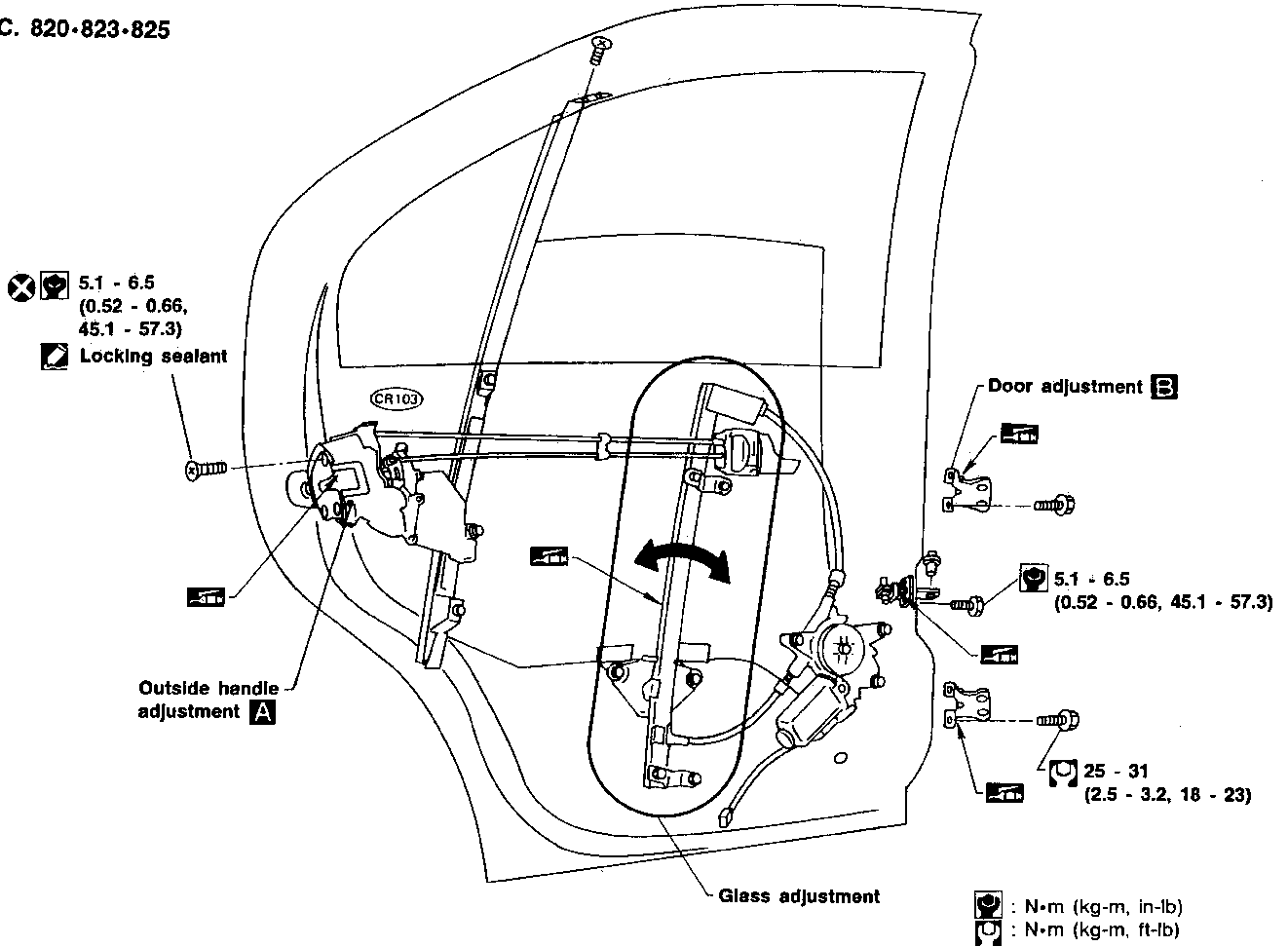

Outside handle adjustment

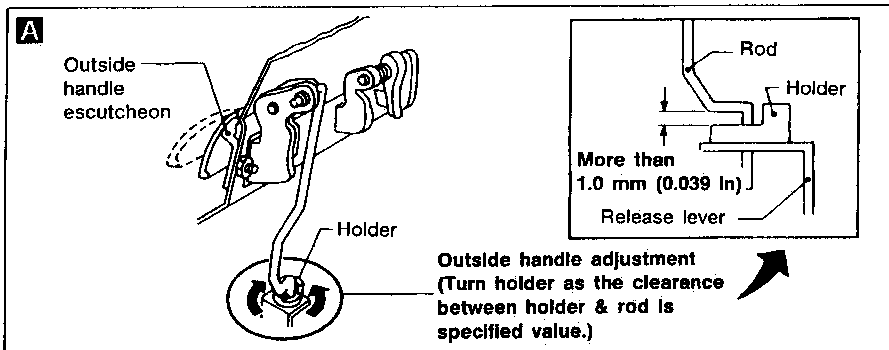

Striker adjustment

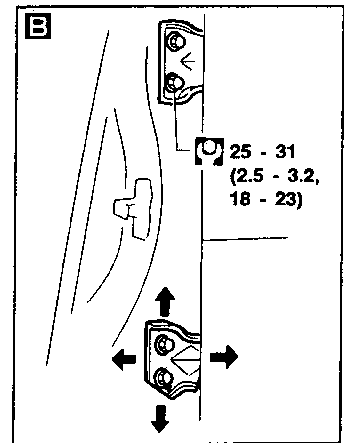
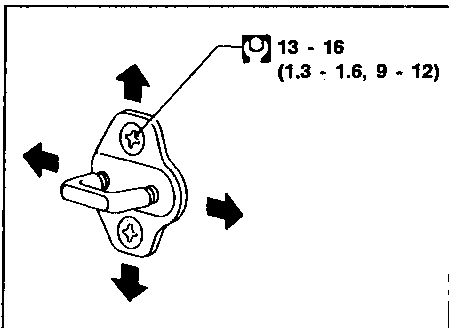

GI
MA
EM
LC
EC
FE
CL
MT
AT
FA
RA
BR
ST
RS
BT
HA
EL
IDX

INSTRUMENT PANEL

CAUTION:

- Disconnect ground terminal from battery in advance.
- Disconnect air bag system line in advance.
- Never tamper with or force air bag lid open, as this may adversely affect air bag performance.
- After an air bag inflates, the instrument panel assembly should be replaced.
- Be careful not to scratch pad and other parts.

REMOVAL — Instrument panel assembly

Pay attention so as not to scratch the parts (plastic). During installation, fit the ducting parts precisely.

- ① Remove steering wheel. Disengage air bag system in advance.
- ② Remove lower and upper column cover.
- ③ Remove lower instrument panel on driver side.
- ④ Remove cluster lid A.
- ⑤ Remove meters.
- ⑥ Remove ashtray inner case.
- ⑦ Remove cluster lid C.
- ⑧ Remove audio system parts.
- ⑨ Remove front passenger air bag module harness connector.
- ⑩ Remove glove box.
- ⑪ Remove front passenger air bag module.
- ⑫ Remove center lower instrument panel.
- ⑬ Remove heater control unit.
- ⑭ Remove ventilator on the driver's side.
- ⑮ Remove mask instrument RH/LH.
- ⑯ Remove instrument panel.

INSTALLATION

Reverse the procedures described above.

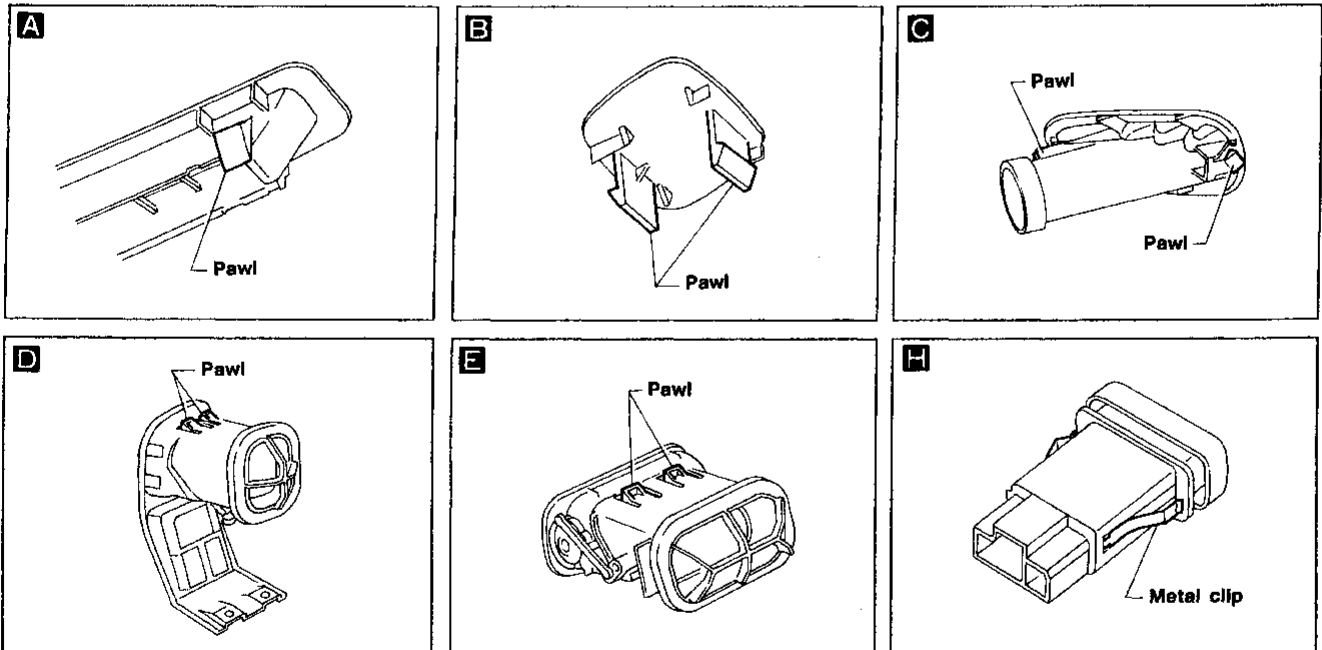

SBT104

INSTRUMENT PANEL

SEC. 248•272•280•680•685•969

★ : Instrument panel assembly mounting nuts

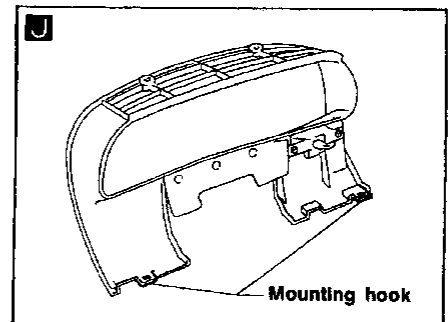
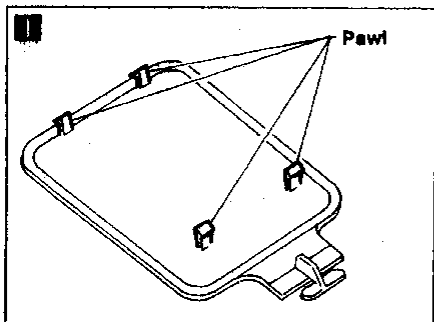
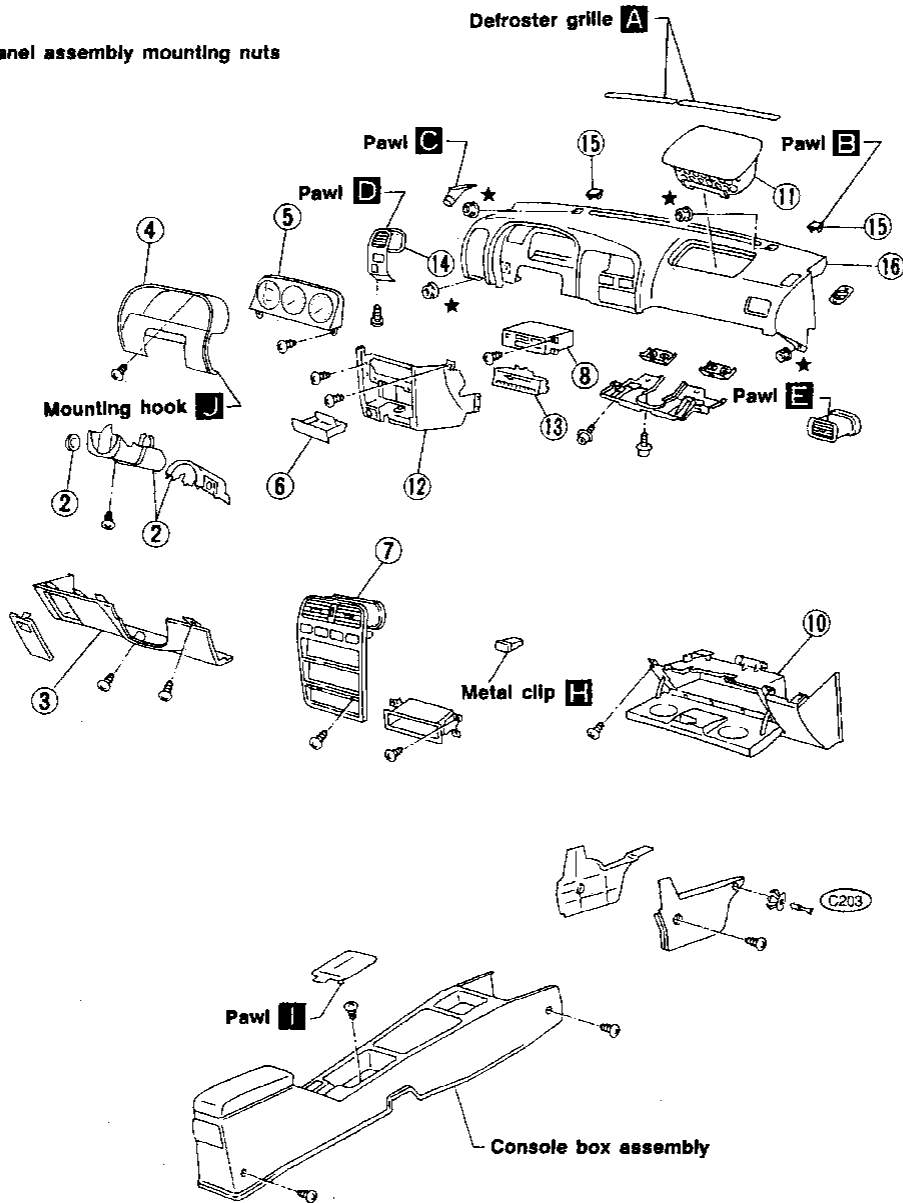

GI
MA
EM
LC
EC
FE
CL
MT
AT
FA
RA
BR
ST
RS
BT
HA
EL
IDX

INTERIOR TRIM

Side and Floor Trim

CAUTION:

- Be sure to remove front, center and rear pillar garnishes by pulling them straight out. Use a long flat-bladed screwdriver when removing metal clips from rear pillar garnish **A**.
- Wrap the tip of flat-bladed screwdriver with a cloth when removing metal clips from garnishes.

SEC. 678•749•769•799•809•828

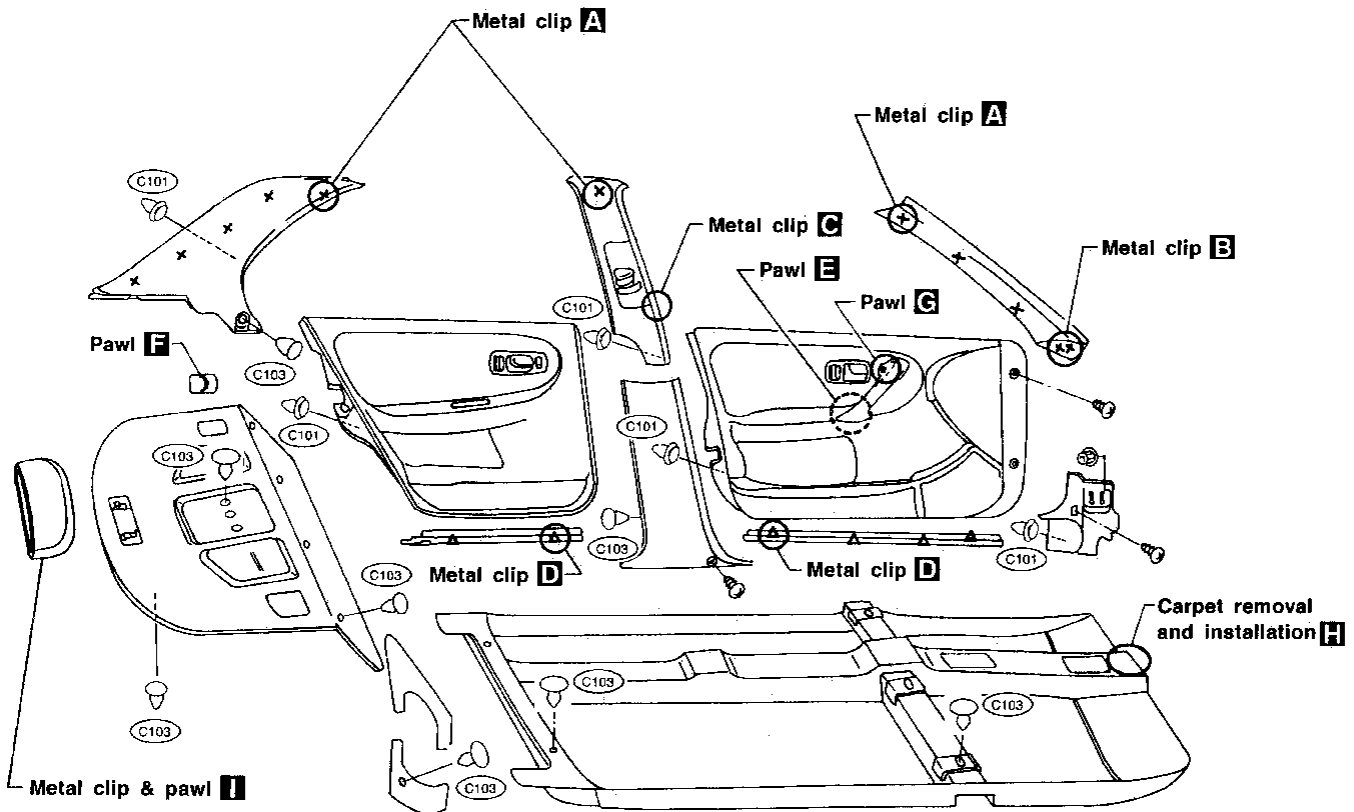

SBT106

INTERIOR TRIM

Side and Floor Trim (Cont'd)

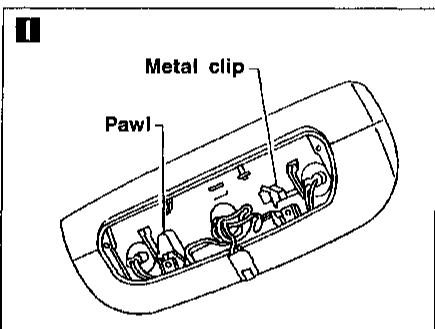
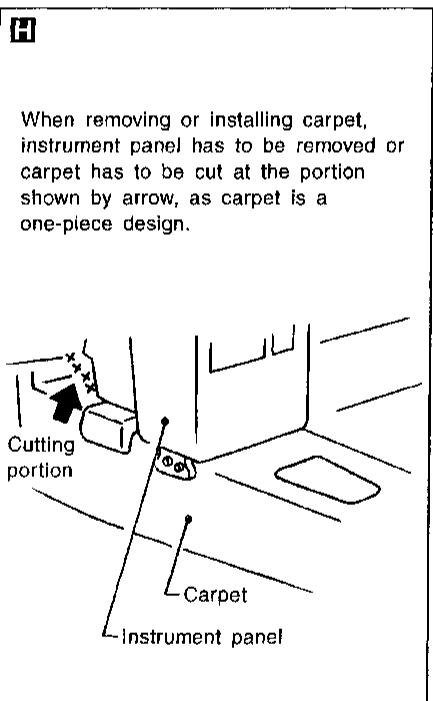
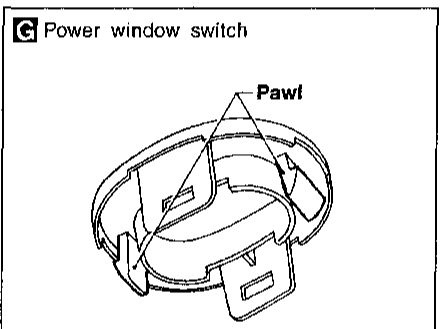
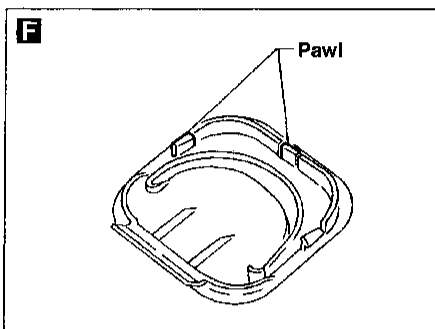
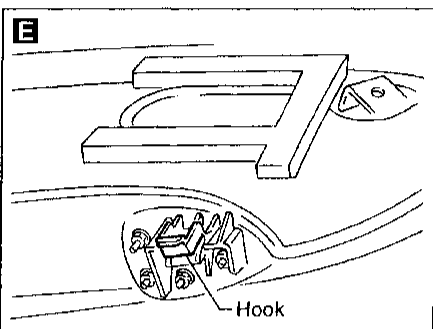
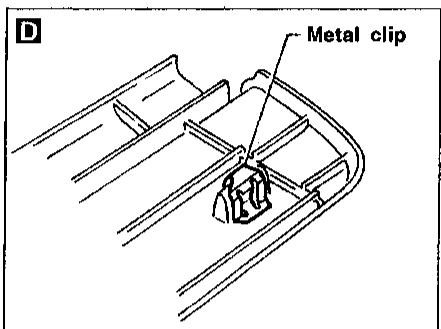
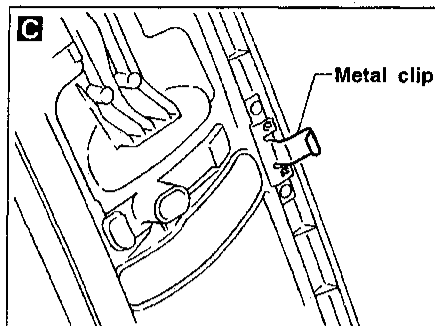
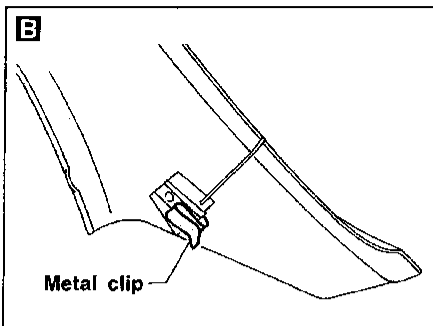
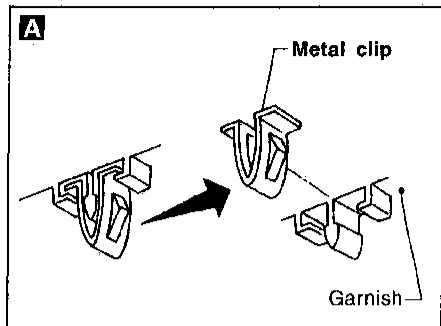

GI
MA
EM
LC
EC
FE
CL
WT
AT
FA
RA
BR
ST
RS
BT
HA
EL
IDX

INTERIOR TRIM

Door Trim

SEC. 809-828

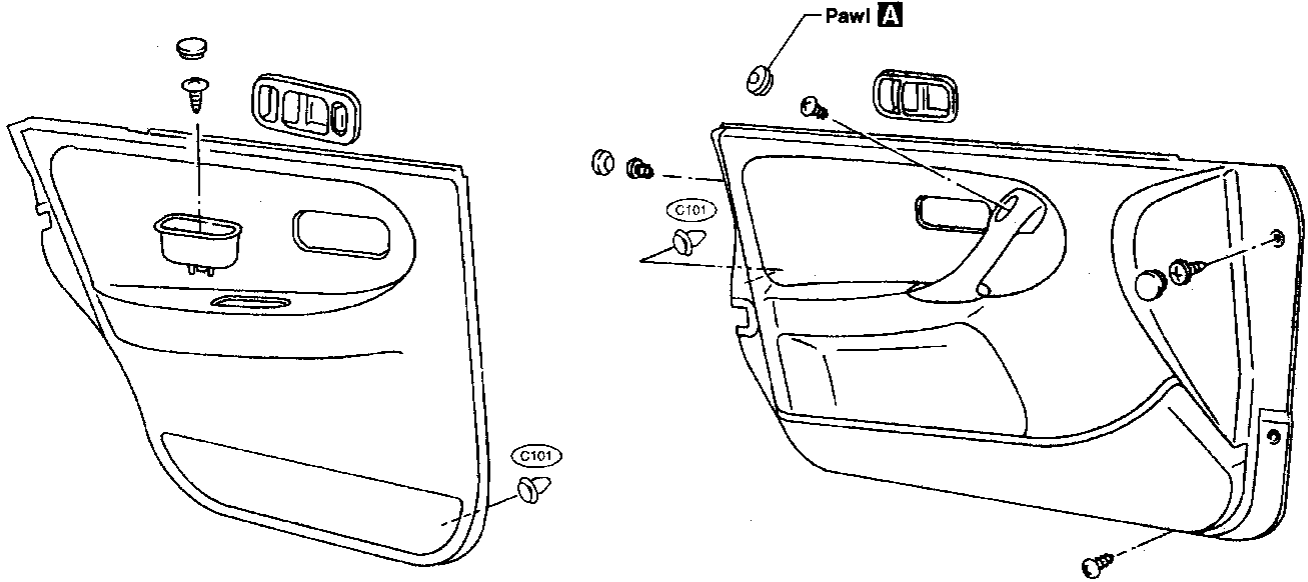

A Power window switch

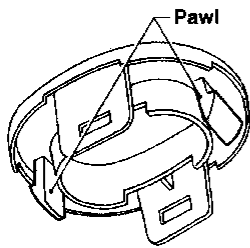

INTERIOR TRIM

Roof Trim

REMOVAL — headlining cloth

- Fully recline both front seats for easy access. Remove headlining through front passenger door.
- 1. Remove sunvisor, assist straps, room lamps and inside mirror.
- 2. Remove body side welts.
- 3. Remove front pillar garnishes, center pillar garnishes, rear quarter garnishes and roof finishers.
- 4. Remove clips and headlining cloth.

SEC. 264-738-963-964

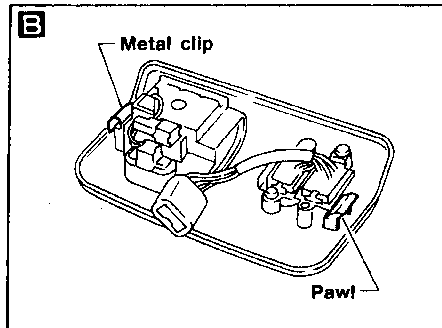
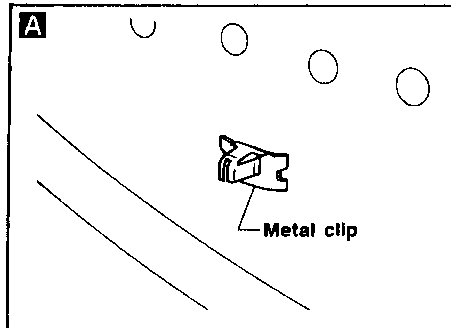
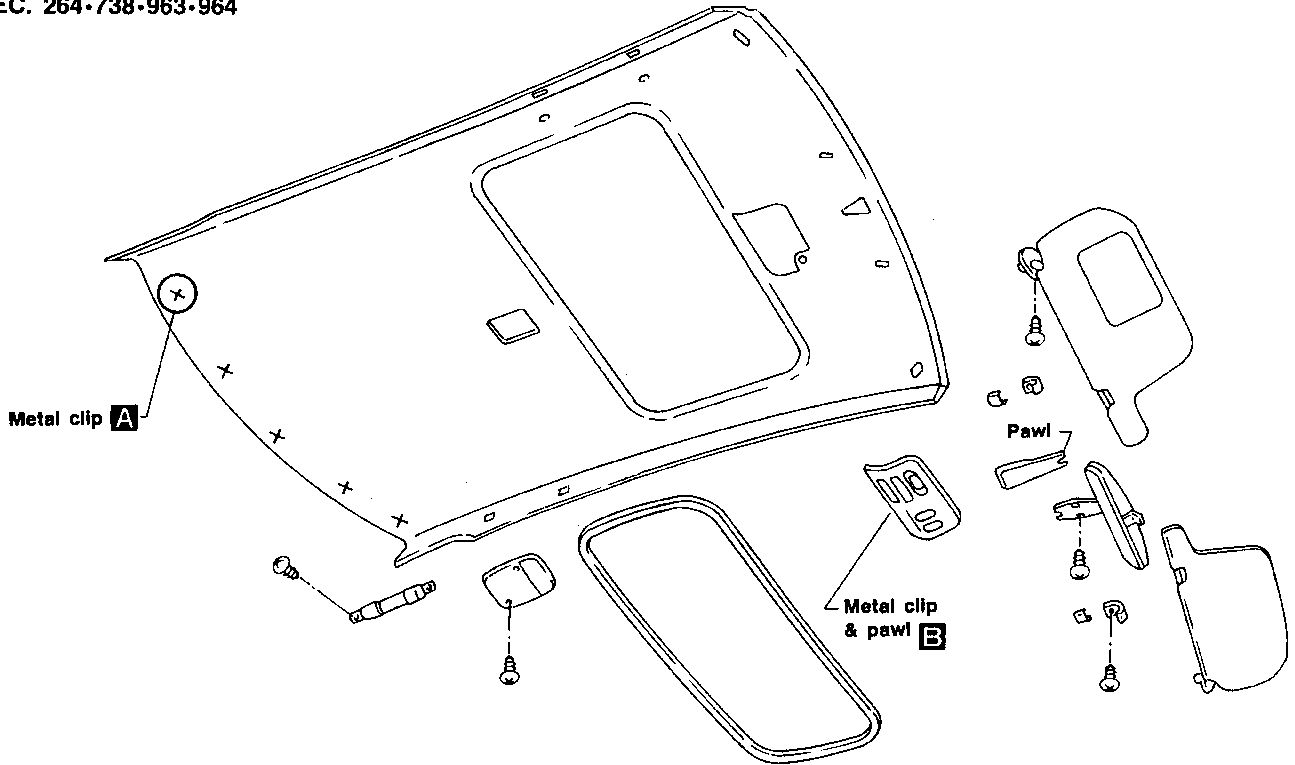

GI

MA

EM

LC

EC

FE

CL

MT

AT

FA

RA

BR

ST

RS

BT

HA

EL

IDX

INTERIOR TRIM

Trunk Room Trim

SEC. 849

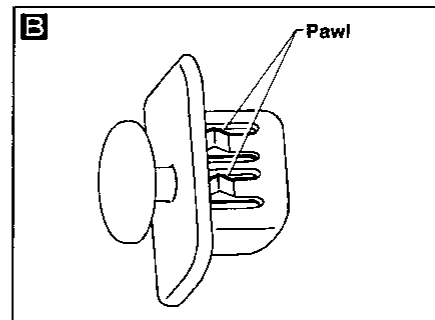
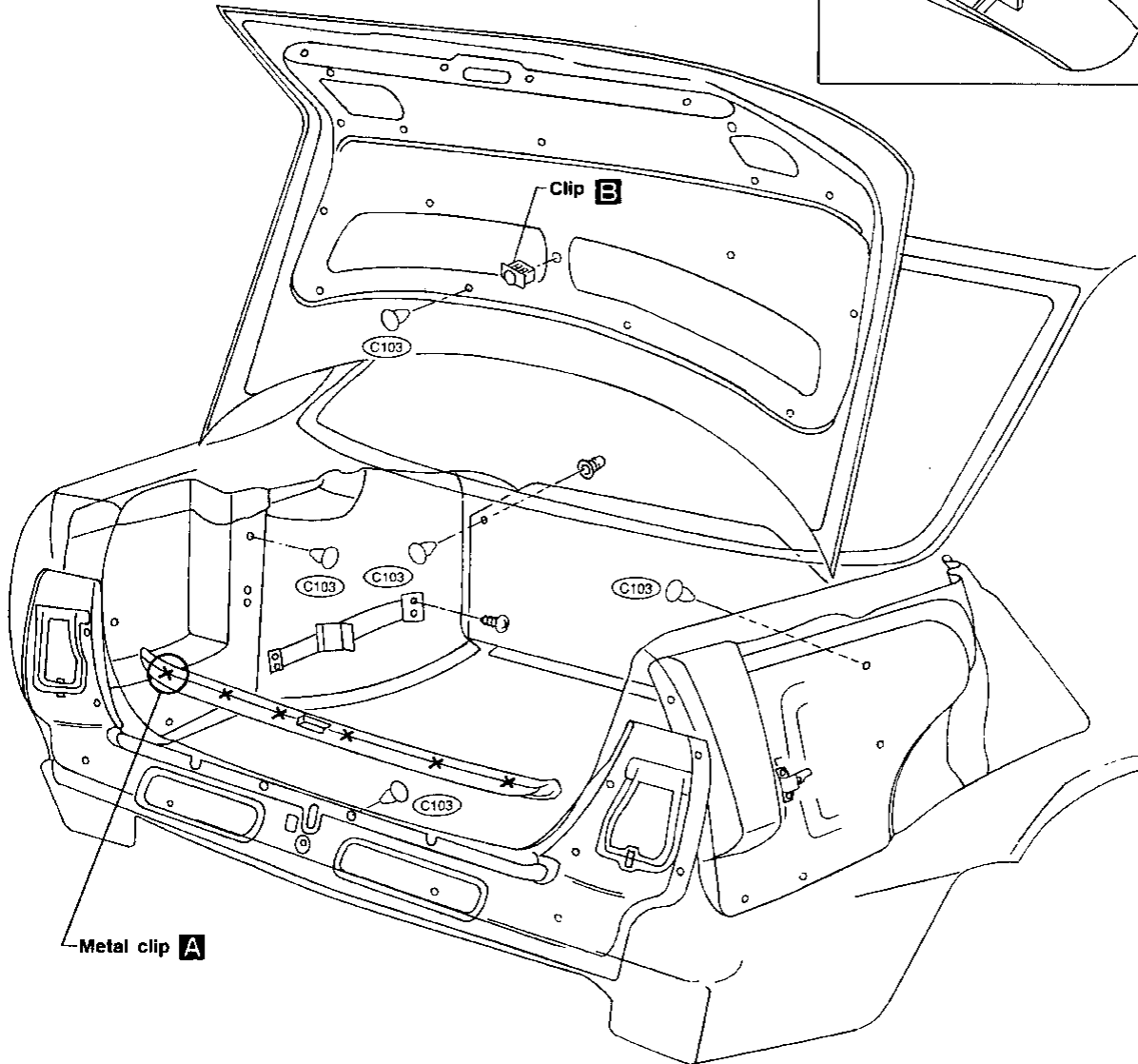
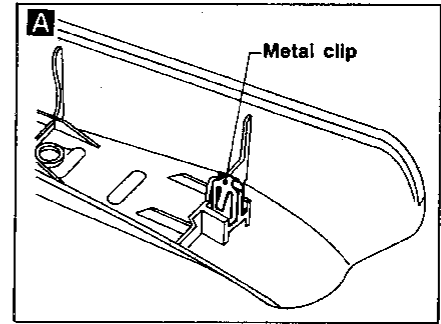

MBF904AA

EXTERIOR

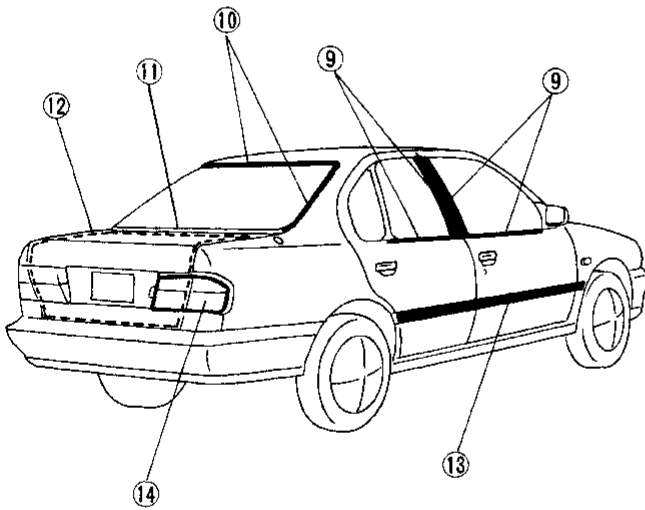
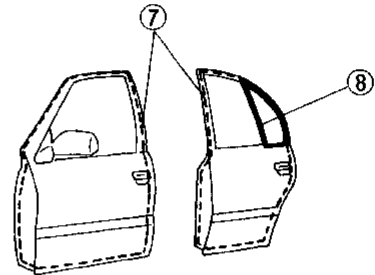
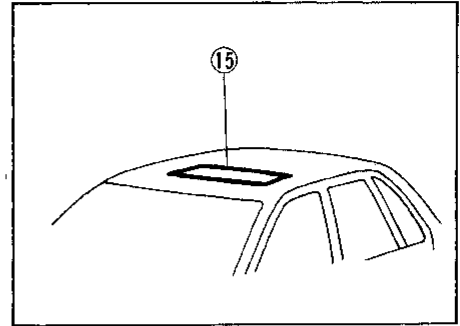
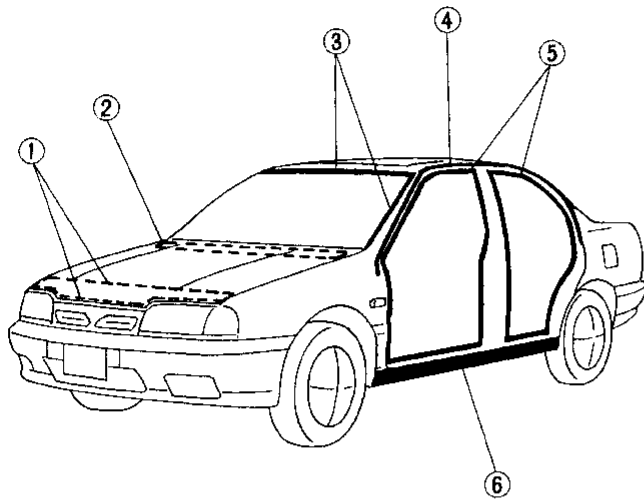

GI

MA

EM

LC

EC

FE

CL

MT

AT

FA

RA

BR

ST

RS

BT

HA

EL

IDX

① Hood front seal

SEC. 650

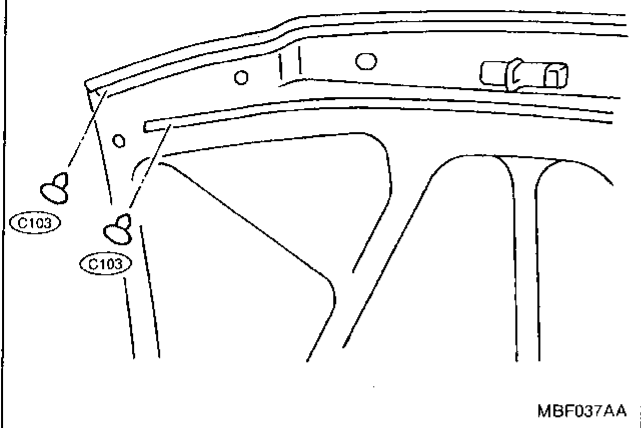

MBF037AA

② Cowl top seal and cowl top grille

SEC. 660

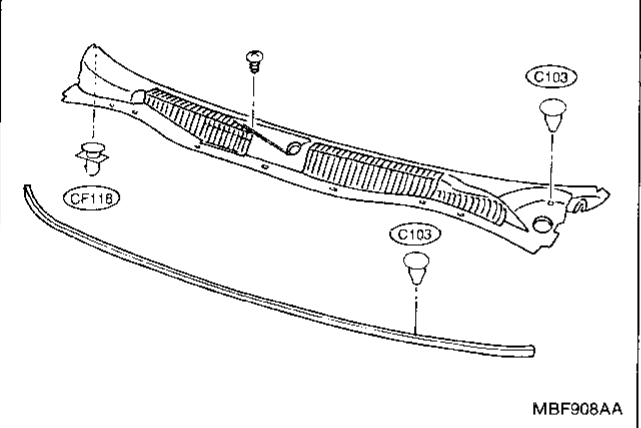

MBF908AA

③ Windshield upper molding and side molding

● Upper molding

Method 1

Cut off top portion of molding and clean glass and panel surfaces.

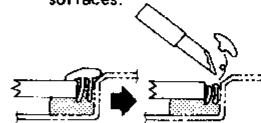

Apply sealant to top portion of molding.



Cut off lower portion of new molding.



Finish well to give it a good appearance.

Method 2

1. Cut off sealant at glass end.
2. Clean the side on which panel was mounted.
3. Set molding fastener and apply sealant to body panel, and apply primer to molding and body.

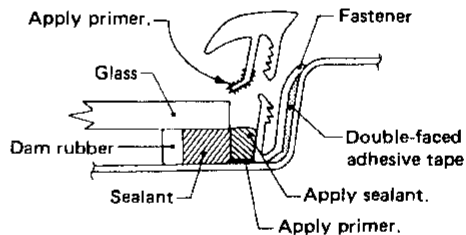

4. Install molding by aligning the molding mark located on center with vehicle center. Be sure to install tightly so that there is no gap around the corner.

SBF161E

● Side molding
Mounted with screws

④ Drip molding and opera window lower molding

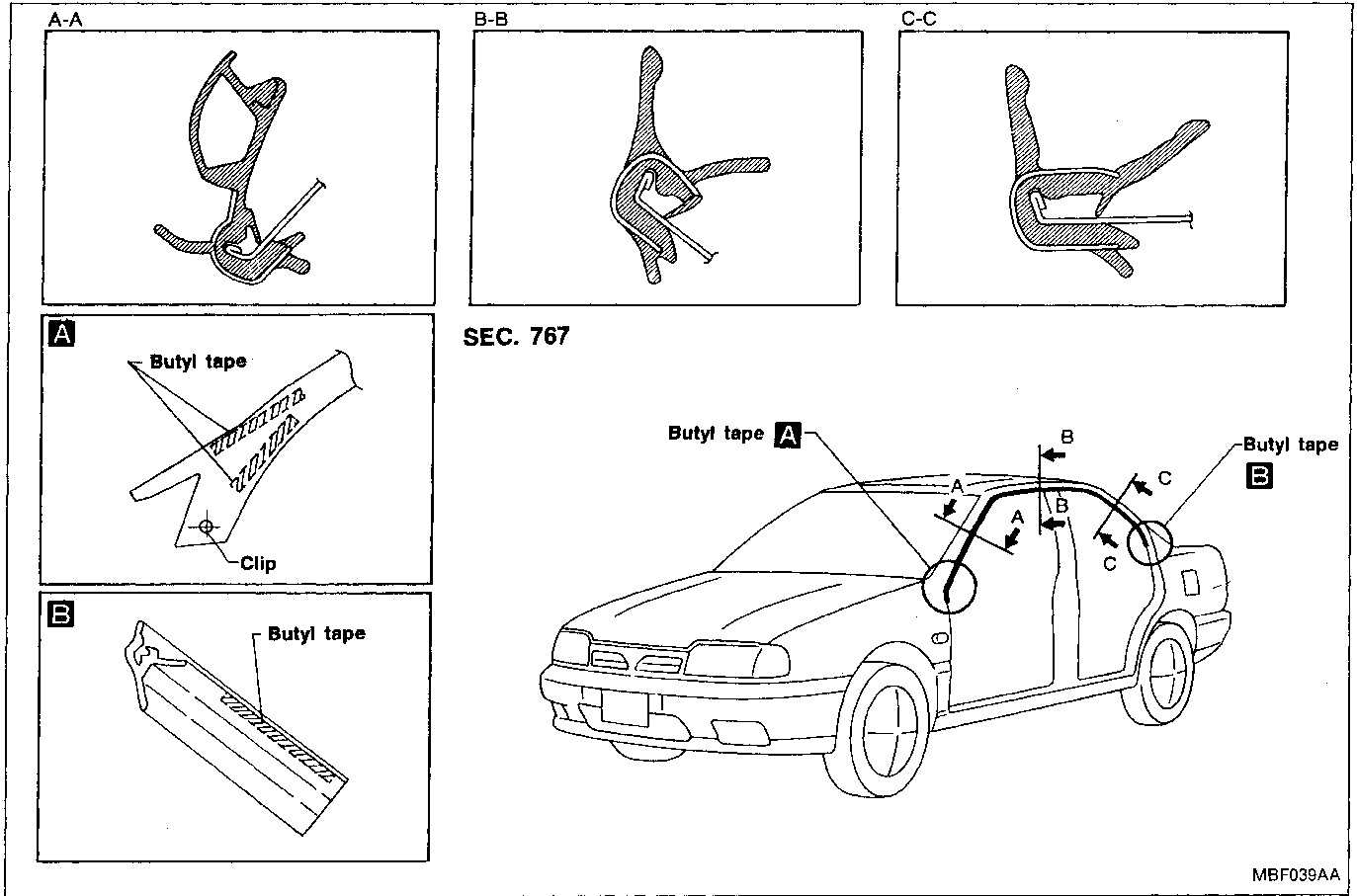

⑤ Body side welt

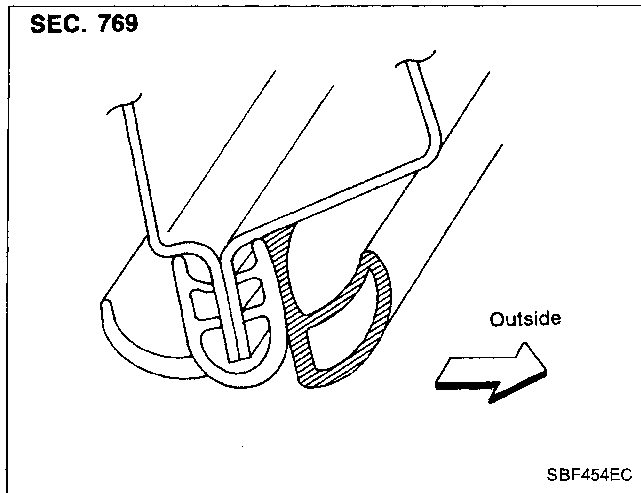

⑥ Center mudguard

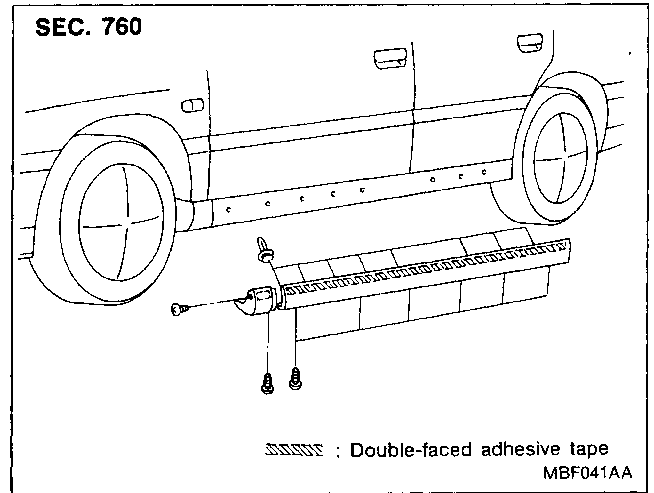

GI
MA
EM
LC
EC
FE
CL
MT
AT
FA
RA
BR
ST
RS
BT
HA
EL
IDX

EXTERIOR

⑦ Door weatherstrip

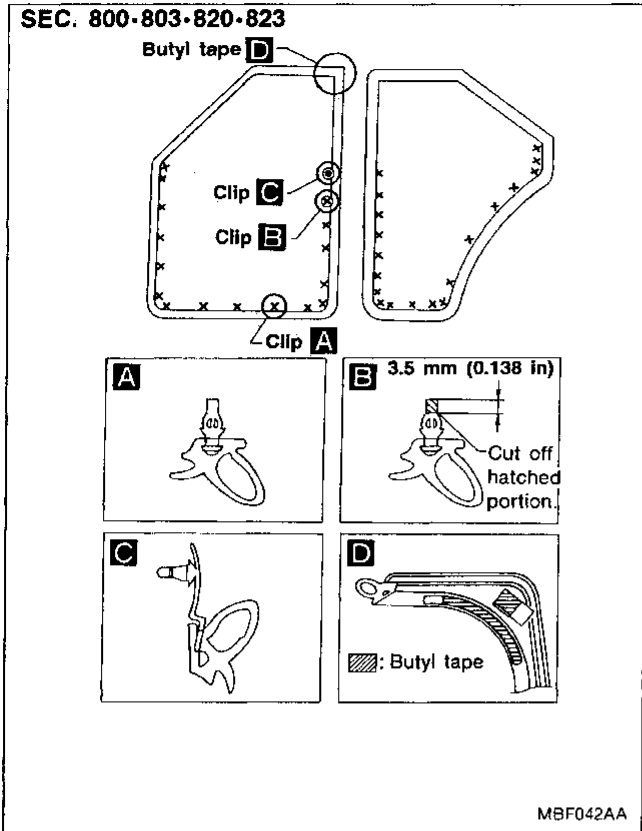

⑧ Rear door partition weatherstrip

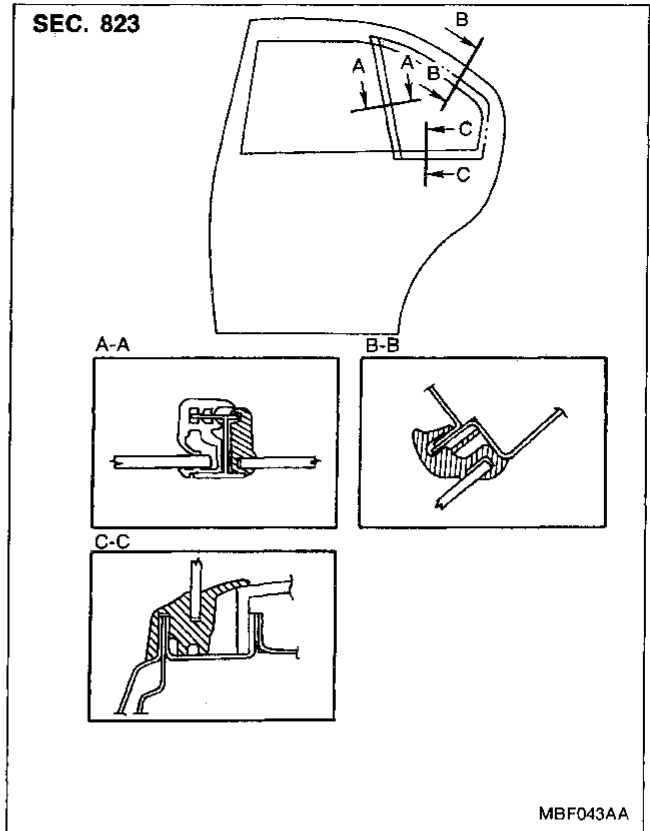

⑨ Door outside molding and door sash molding

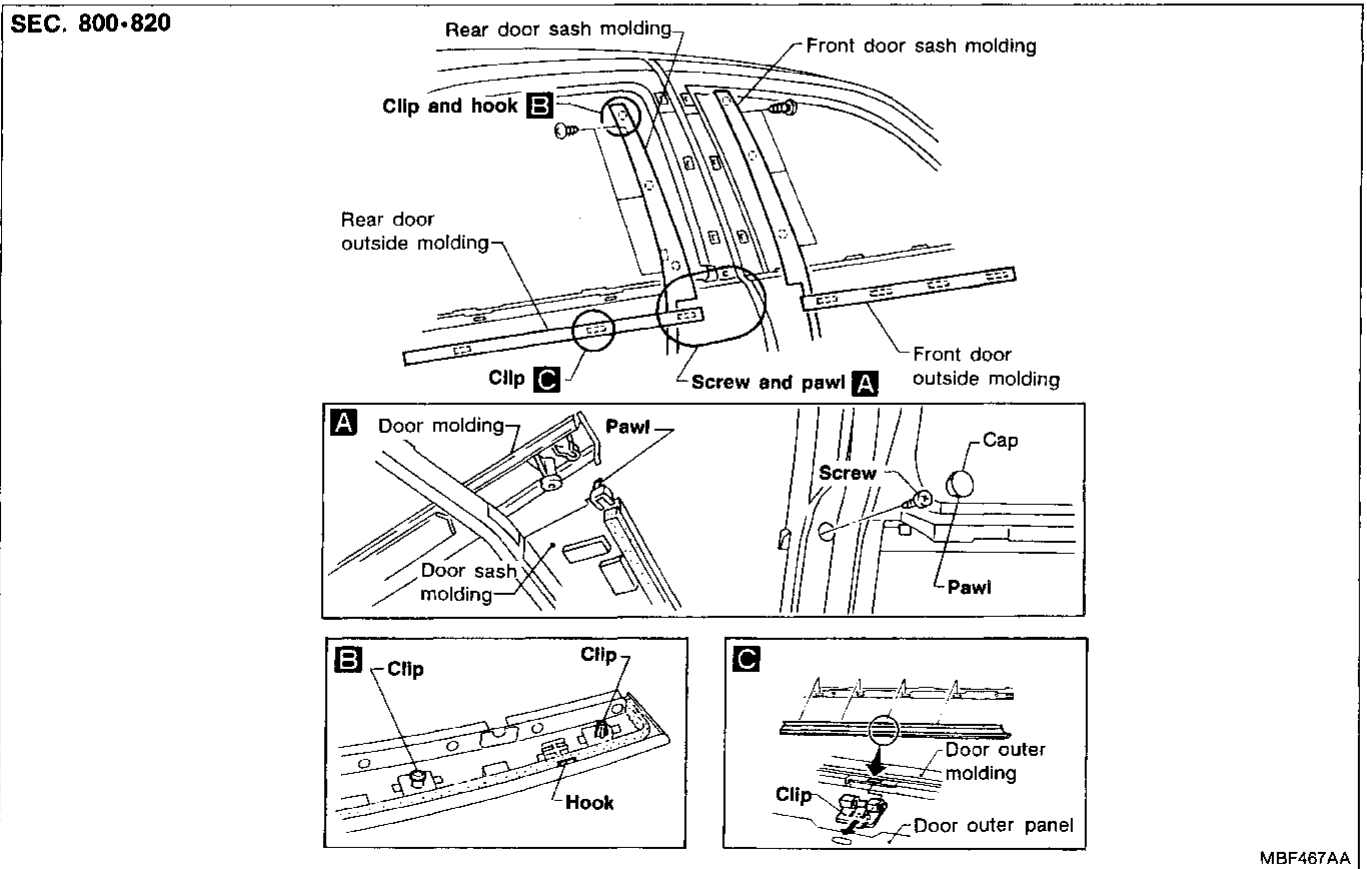

⑩ Rear window upper molding and side molding

Basically the same as windshield upper molding and side molding.

Refer to ③ Windshield upper molding and side molding.

⑪ Rear window lower rubber seal

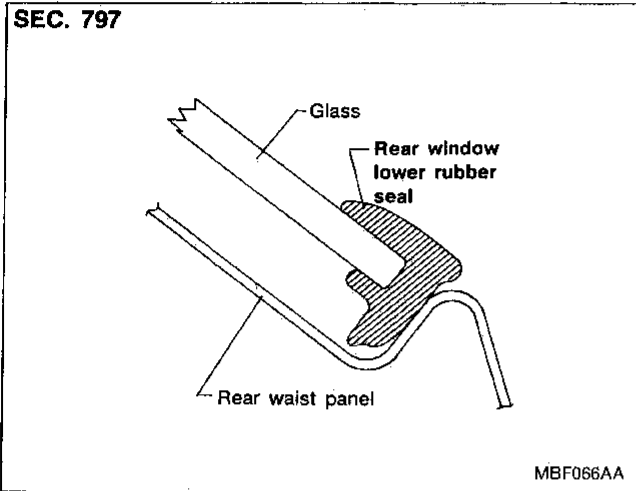

⑫ Trunk lid weatherstrip

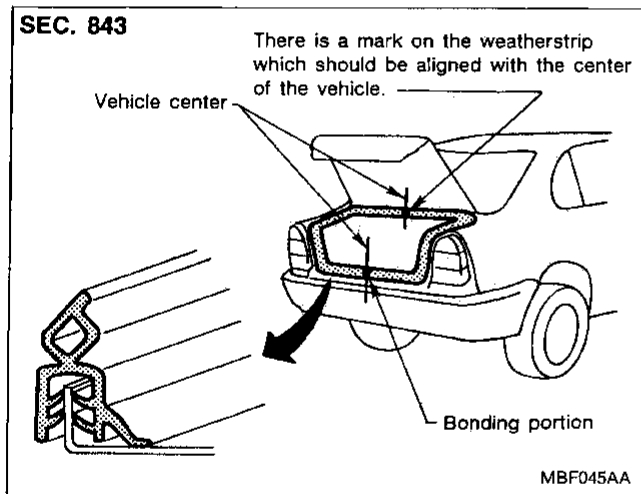

⑬ Side guard molding

SEC. 766



 : Double-faced adhesive tape

● Removal:

1. Heat molding portion to 30 to 40°C (86 to 104°F) with a heat gun.

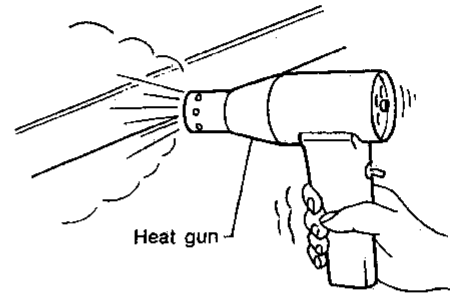

2. Raise end of molding and, while cutting off bonding agent, detach molding.

● Installation:

1. Remove all traces of bonding agent from body panel. Then clean contact face of body.
2. Heat body panel and molding to 30 to 40°C (86 to 104°F) with a heat gun. Then install molding.

MBF047AA

- With a vehicle coated with Hard Clear Coat, use double-faced 3M adhesive tape Product No. 4210 or equivalent, after priming with 3M primer Product No. N-200 or C-100 or equivalent.

GI

MA

EM

LC

EC

FE

CL

MT

AT

FA

RA

BR

ST

RS

BT

HA

EL

IDX

⑭ Rear combination lamp

SEC. 265 Removal

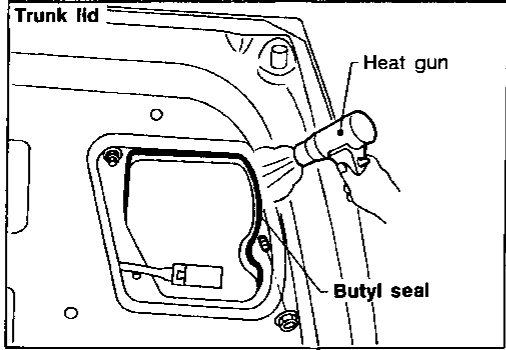
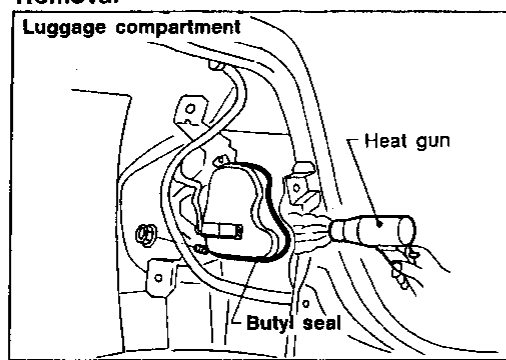

- Warm up lamp assembly area to temperature of a little below 60°C (140°F).

Installation

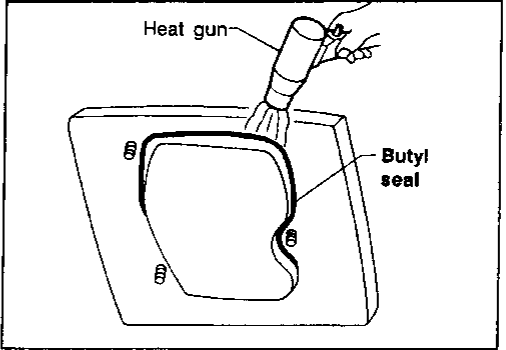
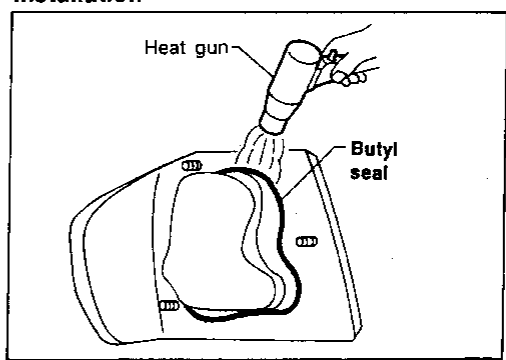

- Apply butyl seal evenly as it tends to become thin in the corners.
- Warm up lamp assembly area to temperature of a little below 60°C (140°F).

MBF050AA

⑮ Sun roof lid weatherstrip

SEC. 736

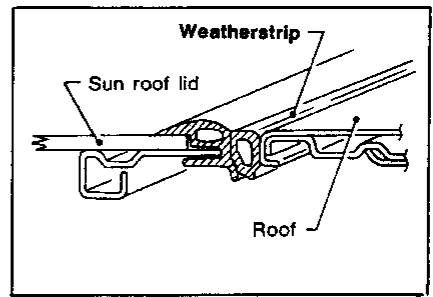
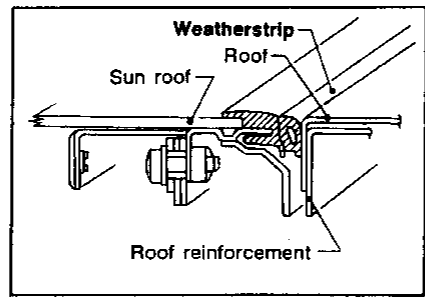
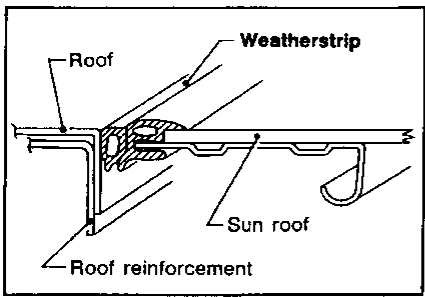
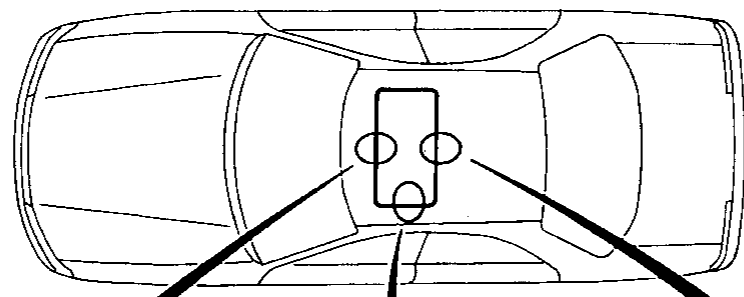

MBF418BA

SEAT

Front Seat (Cont'd)

MANUAL SEAT

SEC. 870

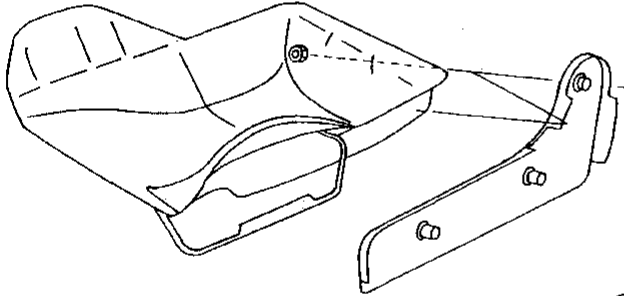
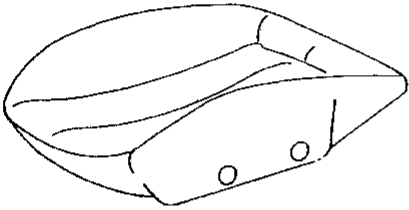
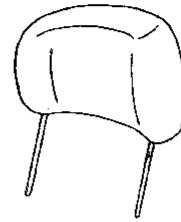
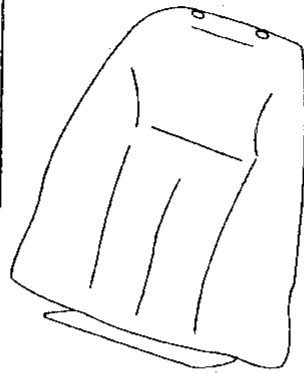
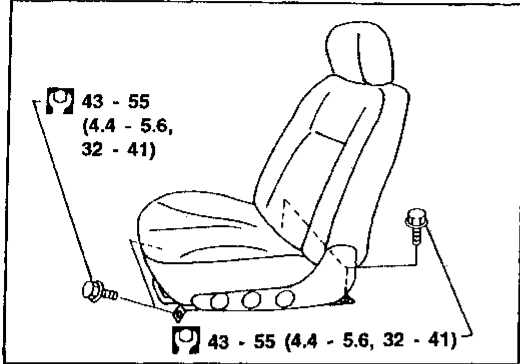

21 - 26
(2.1 - 2.7, 15 - 20)

21 - 26
(2.1 - 2.7,
15 - 20)

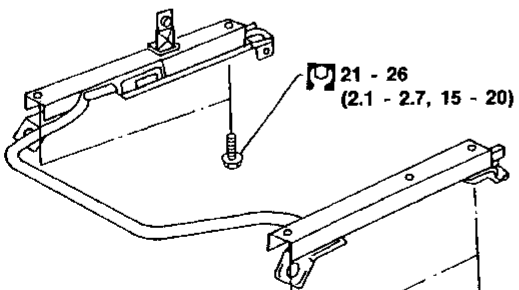

21 - 26
(2.1 - 2.7, 15 - 20)

21 - 26
(2.1 - 2.7, 15 - 20)

21 - 26
(2.1 - 2.7, 15 - 20)

- Anchor bolt tightening sequence:**
- (1) Tighten front inner anchor bolt.
 - (2) Temporarily tighten front outer anchor bolt.
 - (3) Tighten rear inner anchor bolt.
 - (4) Tighten rear outer anchor bolt.
 - (5) Tighten front outer anchor bolt.

: N·m (kg·m, ft·lb)

MBF195AA

SEAT

Rear Seat

SEC. 880

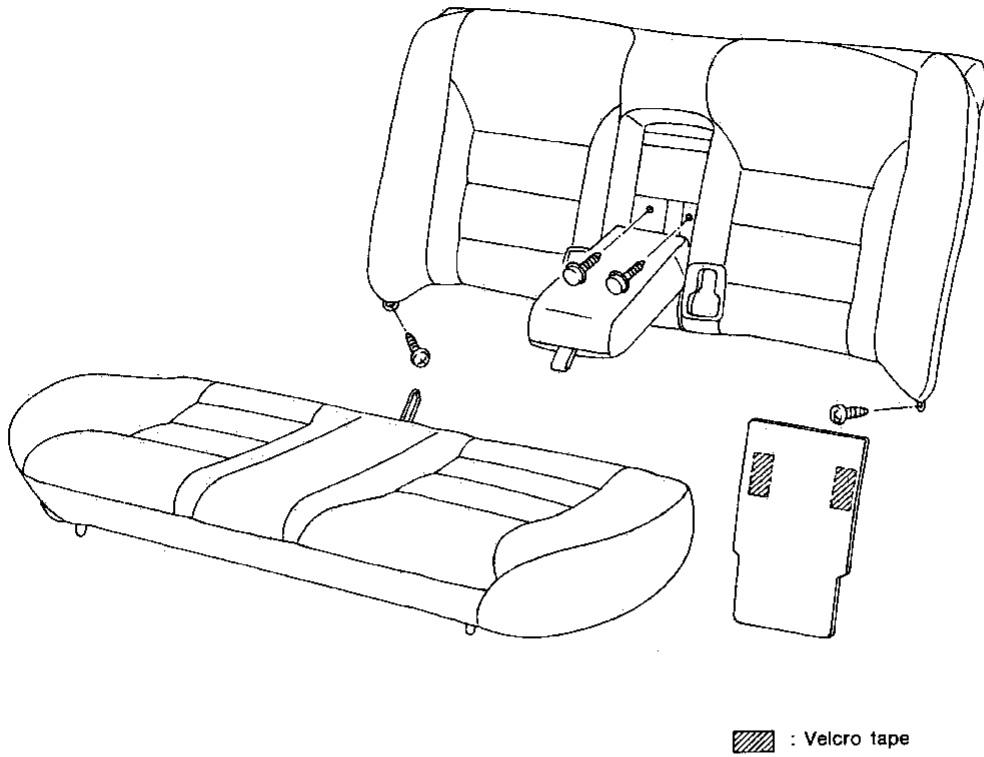

MBF196AA

GI
MA
EM
LC
EC
FE
CL
MT
AT
FA
RA
BR
ST
RS
BT
HA
EL
IDX

SUN ROOF

- After any adjustment, check sun roof operation and lid alignment.
- Handle finisher plate and glass lid with care so not to damage it.
- It is desirable for easy installation to mark each point before removal.
- ★ For Wiring Diagram, refer to “ELECTRIC SUN ROOF” in EL section.

REMOVAL — Sun roof assembly

- ① Fully close or tilt up sun roof lid assembly. Fully open sun roof shade assembly. Remove clips and side trim.
- ② Close sun roof lid, and remove the six nuts from the back of the sun roof lid.
- ③ Lift out sun roof away from roof.
- ④ Pull sun roof shade forward.
- ⑤ Remove the four shade locks located beside sun roof shade.
- ⑥ Remove sun roof shade.
- ⑦ Remove sun roof motor assembly.
- ⑧ Disconnect interior lamp harness.
- ⑨ Disconnect front and rear drain hoses.
- ⑩ Remove nuts and bolts securing sun roof rails.
- ⑪ Remove sun roof rail assembly.

SUN ROOF

SEC. 736

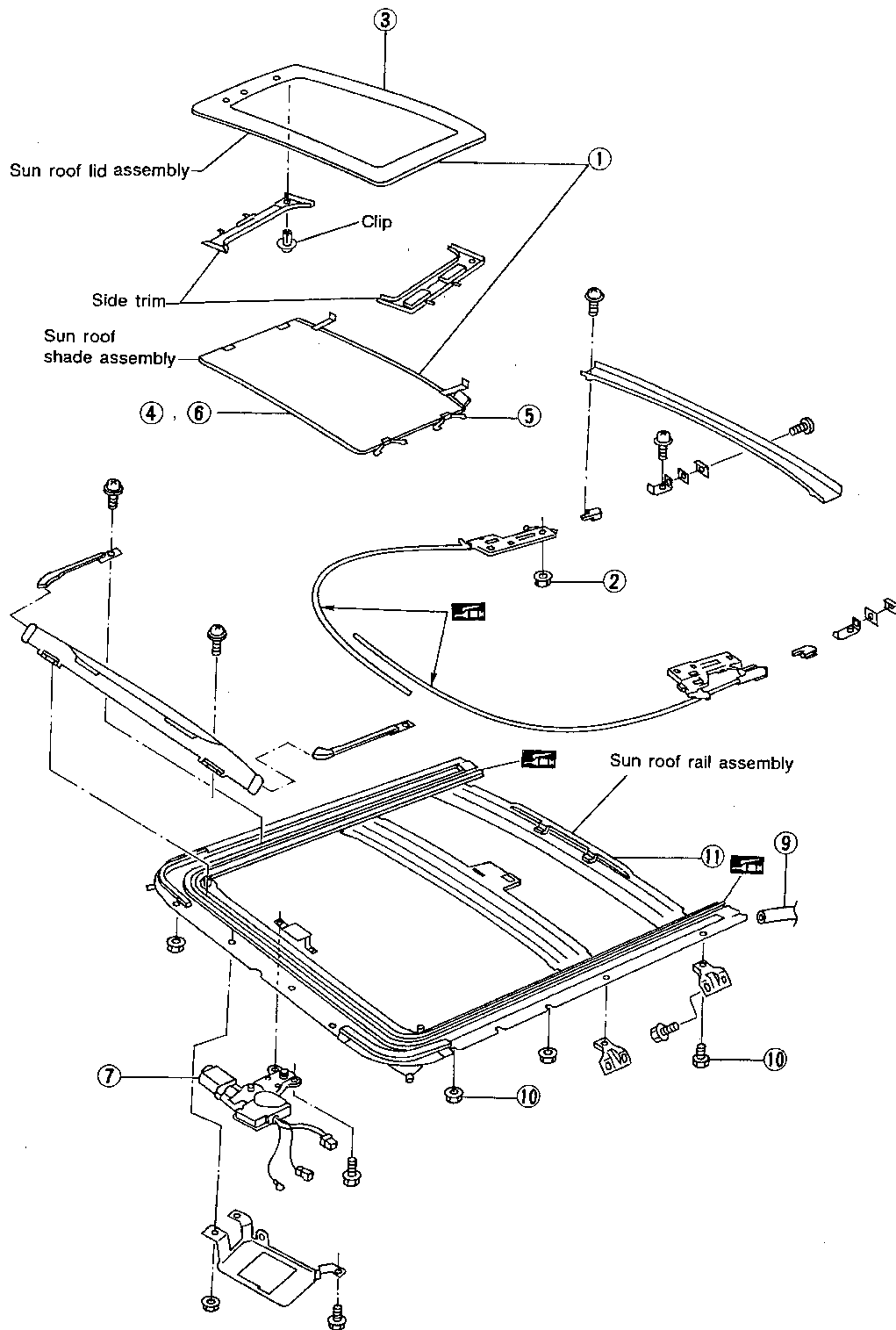

GI
MA
EM
LC
EC
FE
CL
MT
AT
FA
RA
BR
ST
RS
BT
HA
EL
IDX

WINDSHIELD AND WINDOWS

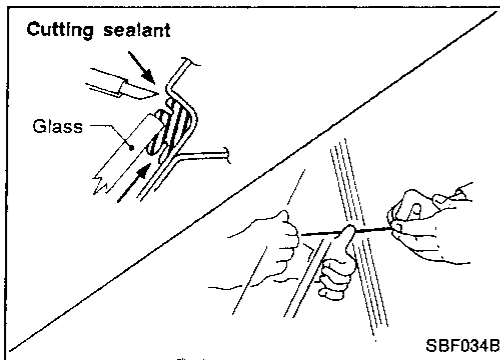

REMOVAL

After removing moldings, remove glass.

CAUTION:

Be careful not to scratch glass when removing.

INSTALLATION

- Use genuine Nissan Sealant kit or equivalent. Follow instructions furnished with it.
- After installing the glass, the vehicle should remain stationary until the sealant hardens.

WARNING:

Keep heat and open flames away as primers are flammable.

CAUTION:

Advise users not to drive the vehicle on rough roads until sealant has properly vulcanized.

- Do not use sealant which is past its usable term.
- Do not leave cartridge unattended with its cap open.
- Keep primers and sealant in a cool, dry place. Ideally, they should be stored in a refrigerator.
- Molding must be installed securely so that it is in position and leaves no gap.

Windshield and Rear Window

Body side

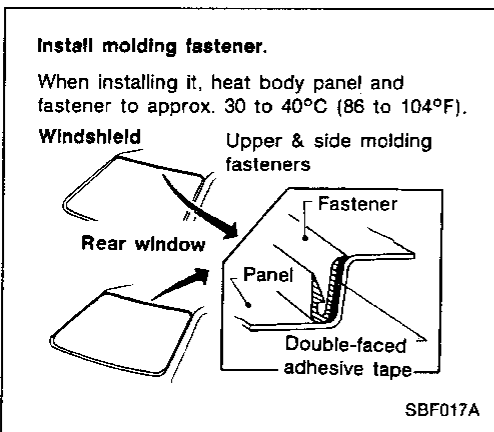
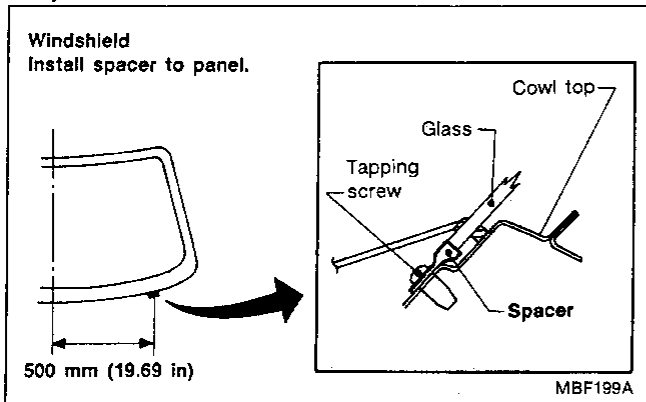

Glass side

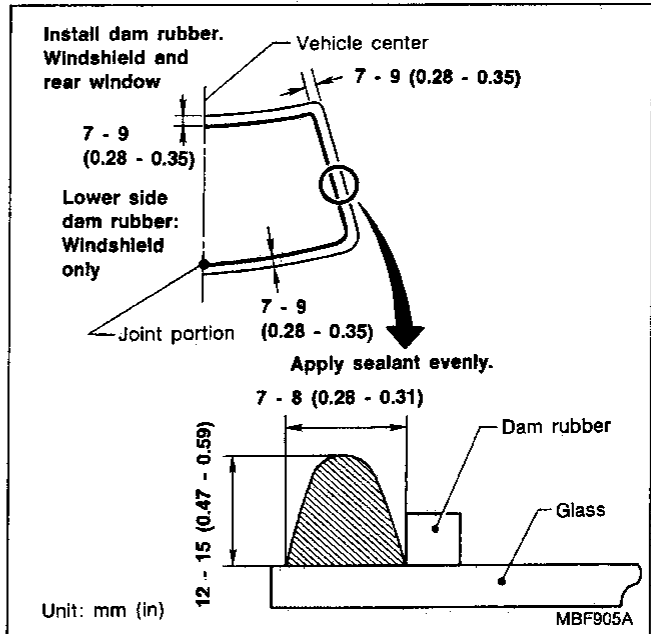

REPAIRING WATER LEAKS FOR WINDSHIELD

Leaks can be repaired without removing and reinstalling glass.

If water is leaking between caulking material and body or glass, determine the extent of leakage. This can be determined by applying water while pushing glass outward.

To stop the leak, apply primer (if necessary) and then sealant to the leak point.

MIRROR

Door Mirror

CAUTION:

Be careful not to scratch door rearview mirror body.

★ For Wiring Diagram, refer to "POWER DOOR MIRROR" in EL section.

REMOVAL — Door mirror

1. Remove door trim. Refer to "INTERIOR TRIM" (BT-14) for details.
2. Remove inner cover front corner of door.
3. Disconnect door mirror harness connector.
4. Remove harness clips.
5. Remove three bolts securing door mirror.

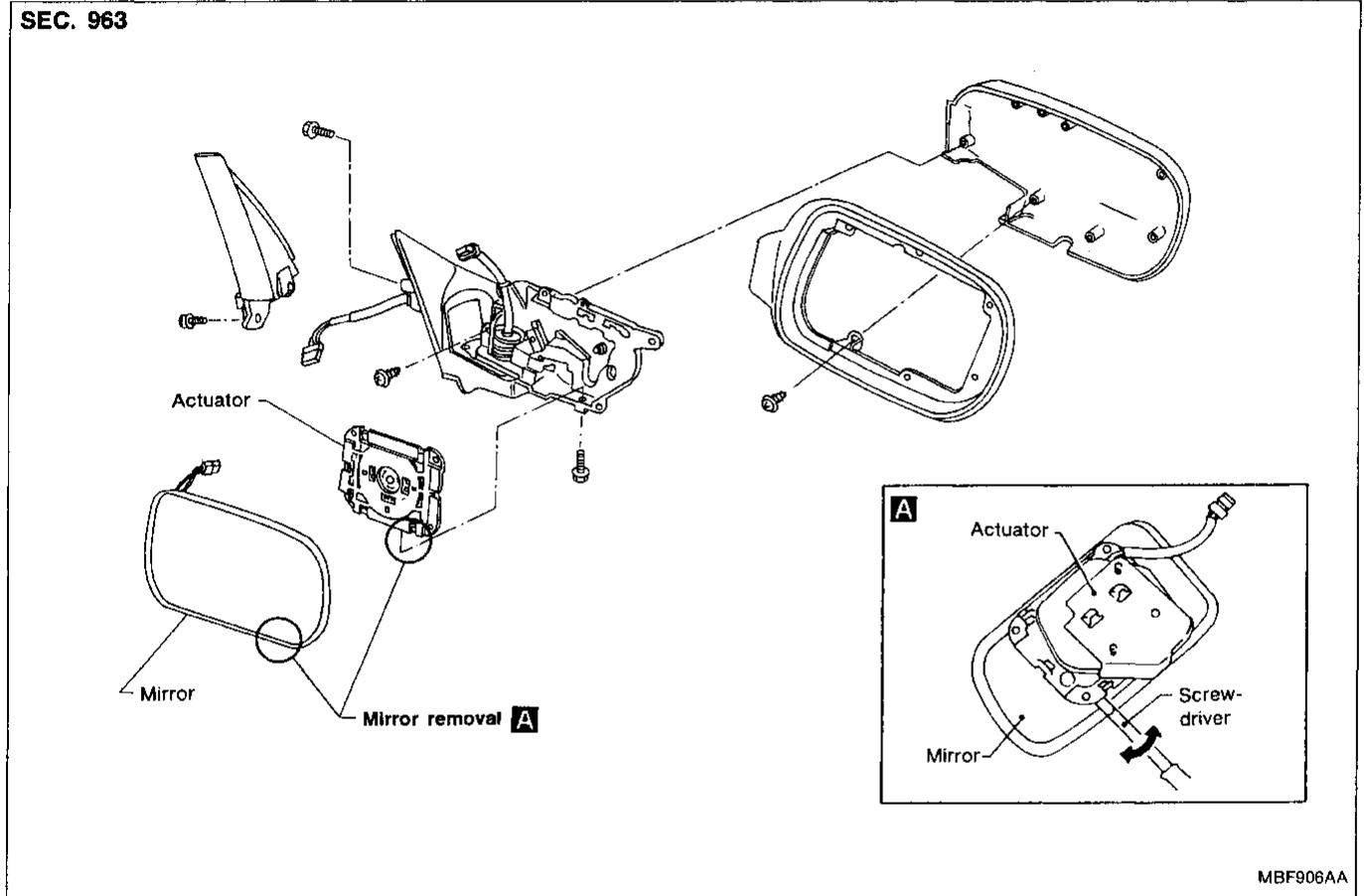

GI

MA

EM

LC

EC

FE

CL

MT

AT

FA

RA

BR

ST

RS

BT

HA

EL

IDX

REAR AIR SPOILER

- When installing, make sure that there are not gaps or waves at ends of air spoiler.
- Before installing spoiler, clean and remove oil from surface where spoiler will be mounted.

REAR AIR SPOILER

SEC. 960

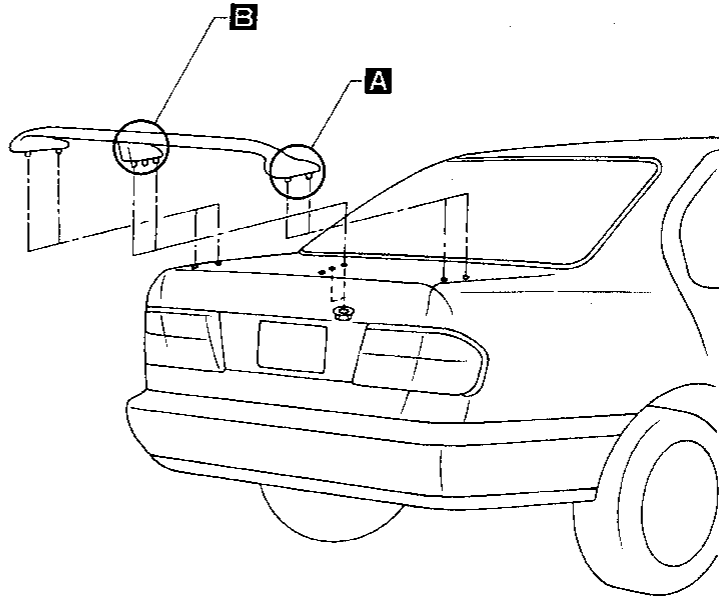
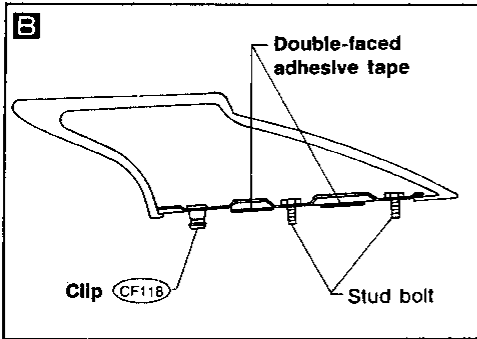
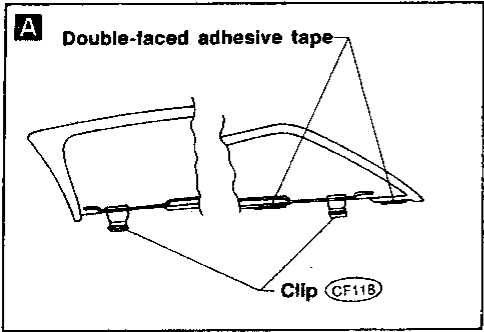

SBF614FA

BODY ALIGNMENT

- All dimensions indicated in figures are actual ones.
- When using a tracking gauge, adjust both pointers to equal length. Then check the pointers and gauge itself to make sure there is no free play.
- When a measuring tape is used, check to be sure there is no elongation, twisting or bending.
- Measurements should be taken at the center of the mounting holes.
- An asterisk (*) following the value at the measuring point indicates that the measuring point on the other side is symmetrically the same value.
- The coordinates of the measurement points are the distances measured from the standard line of "X", "Y" and "Z".

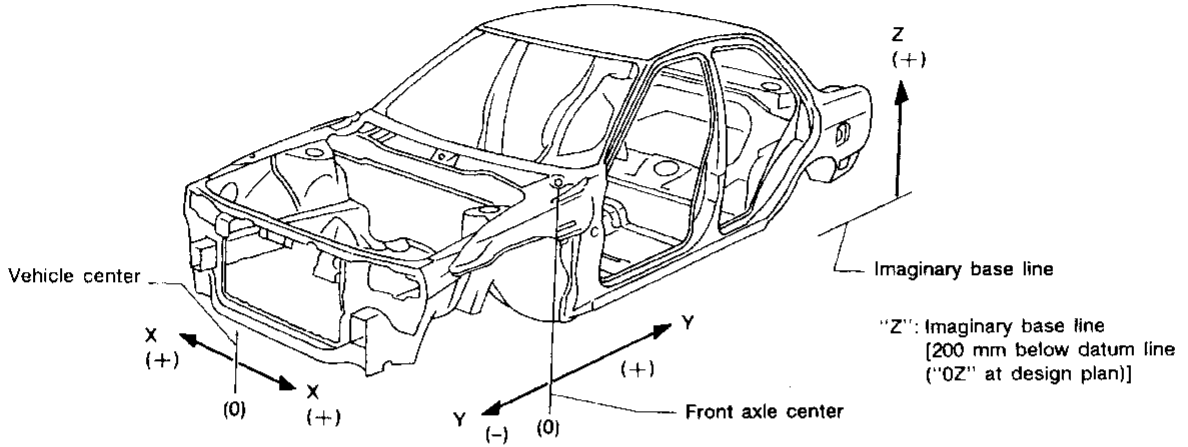

SBF874GB

Engine Compartment

MEASUREMENT

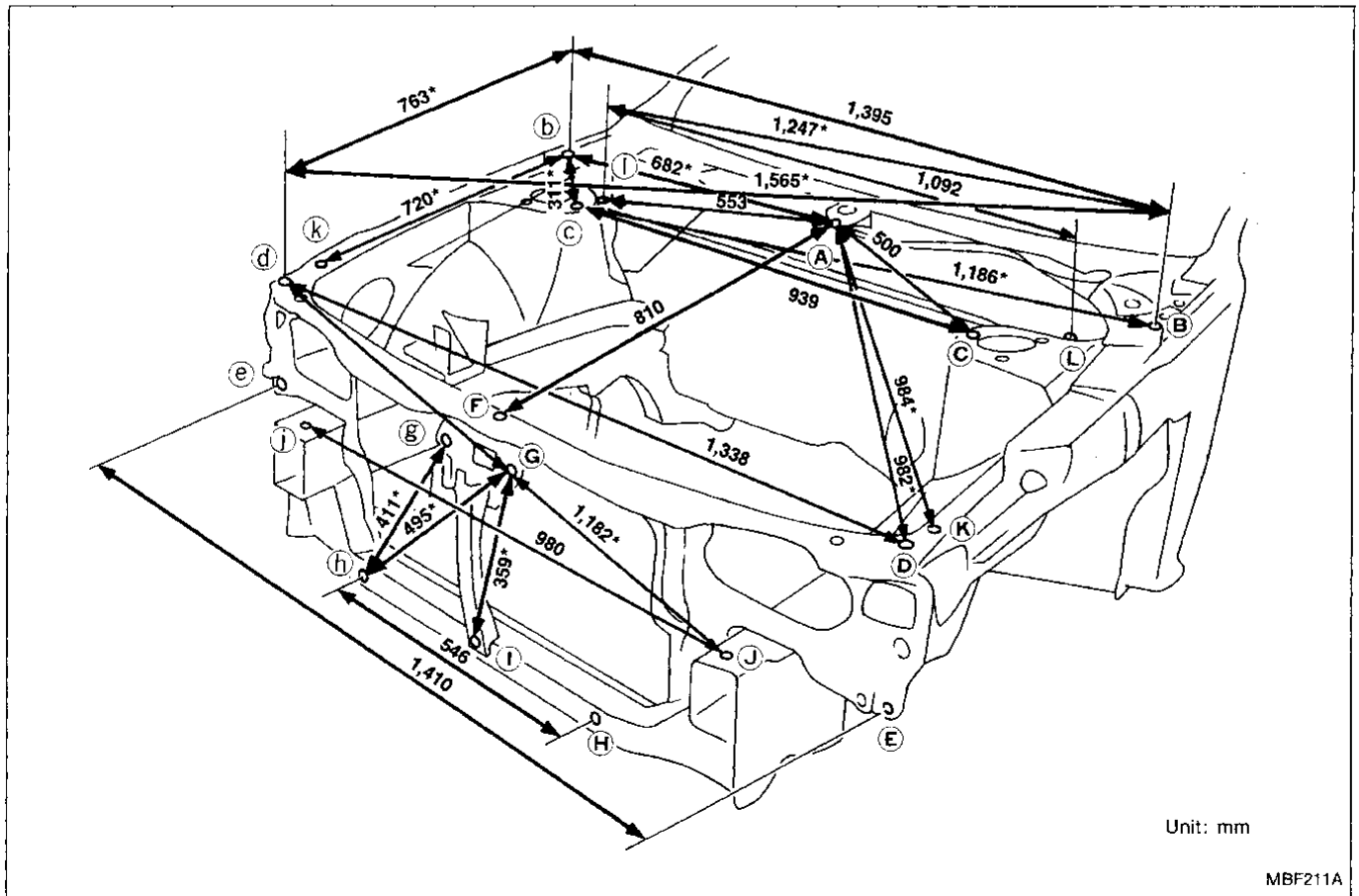

BODY ALIGNMENT

Engine Compartment (Cont'd)

MEASUREMENT POINTS

Unit: mm

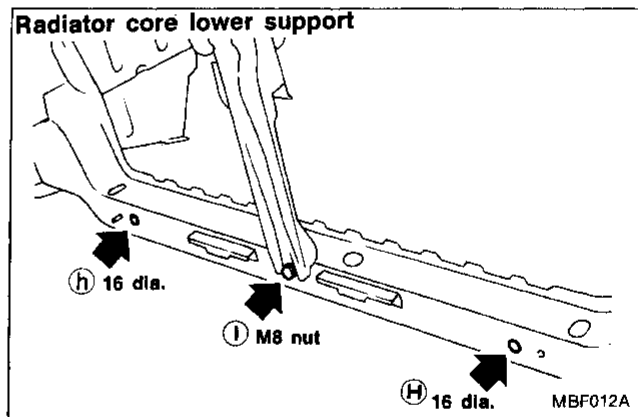
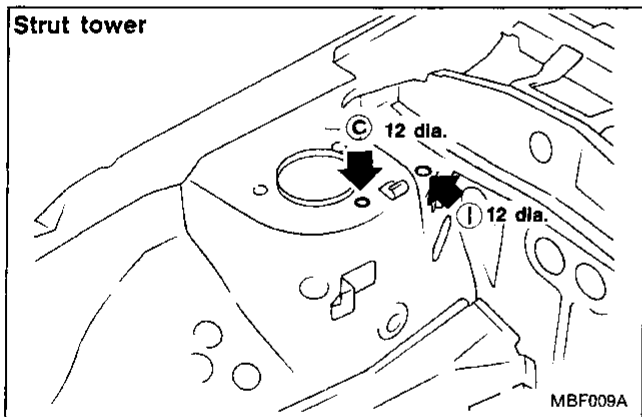
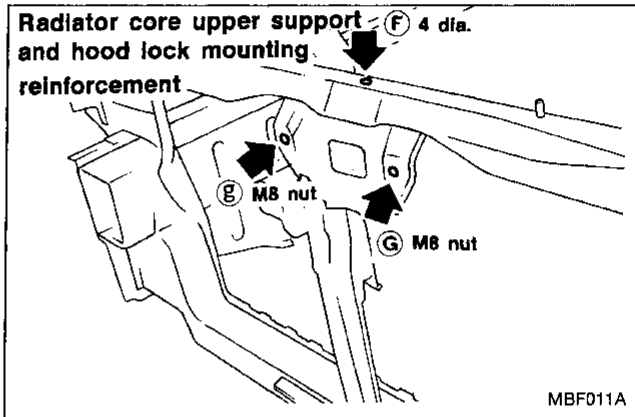
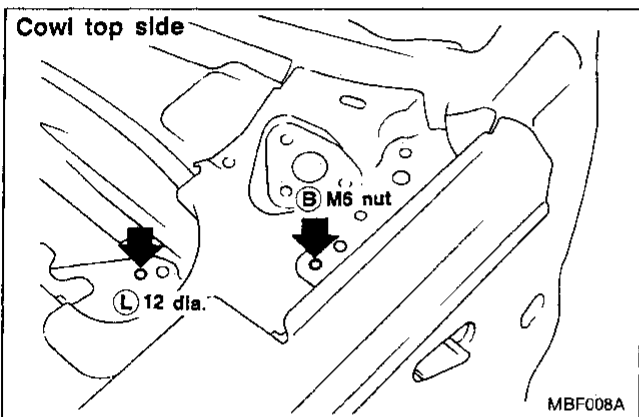
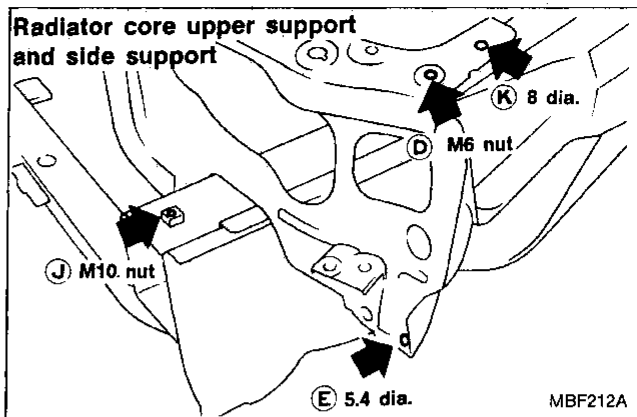
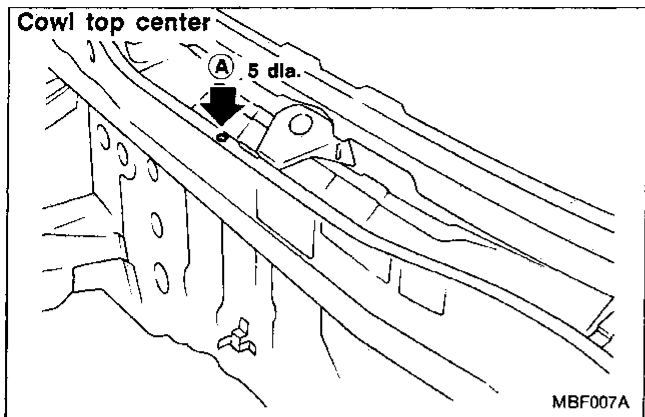

BODY ALIGNMENT

Underbody

MEASUREMENT

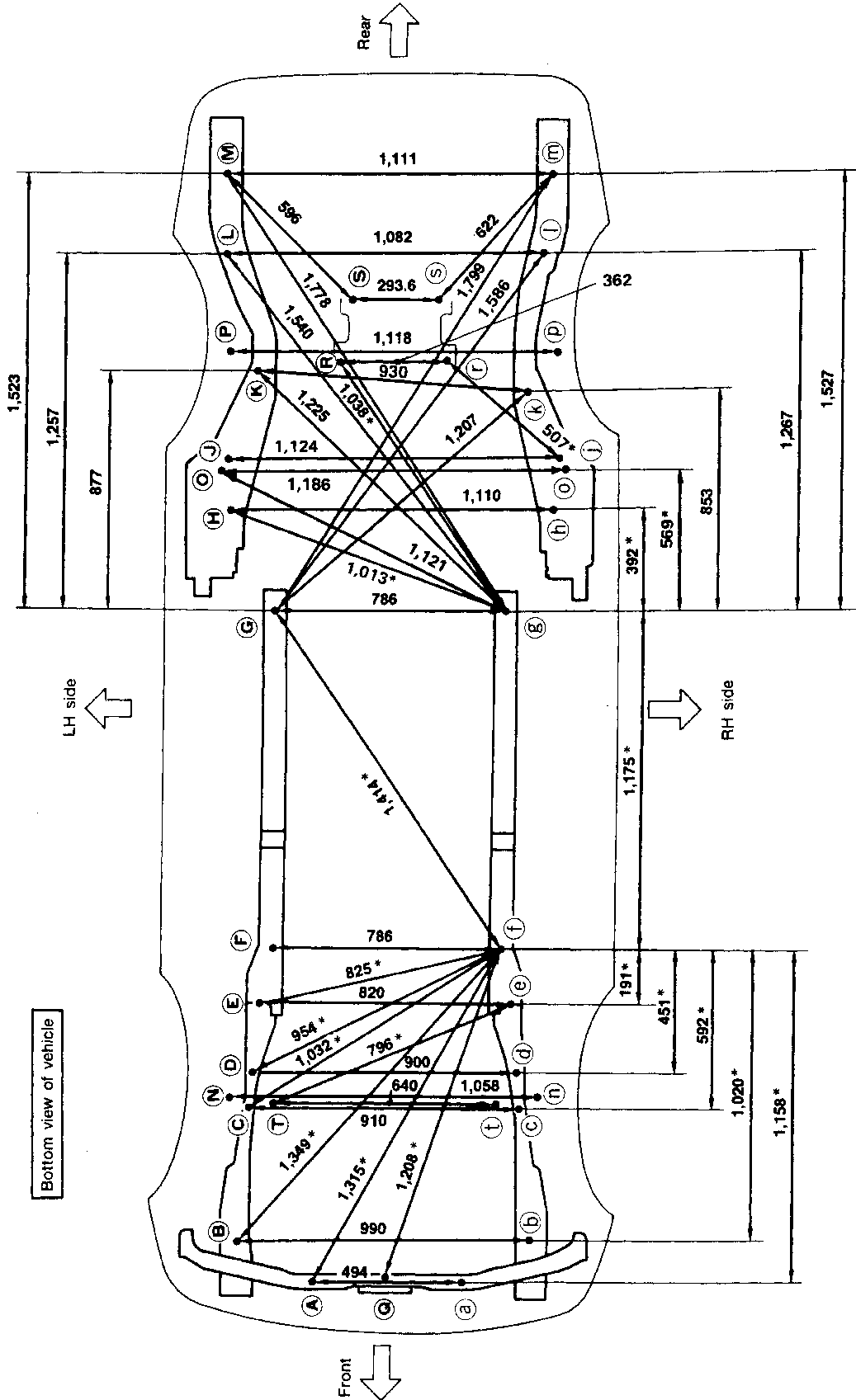

Unit: mm

All dimensions indicated in this figure are actual ones. (There are no projected dimensions.)

Bottom view of vehicle

GI
MA
EM
LC
EC
FE
CL
MT
AT
FA
RA
BR
ST
RS
BT
HA
EL
IDX

BODY ALIGNMENT

Underbody (Cont'd)

MEASUREMENT POINTS

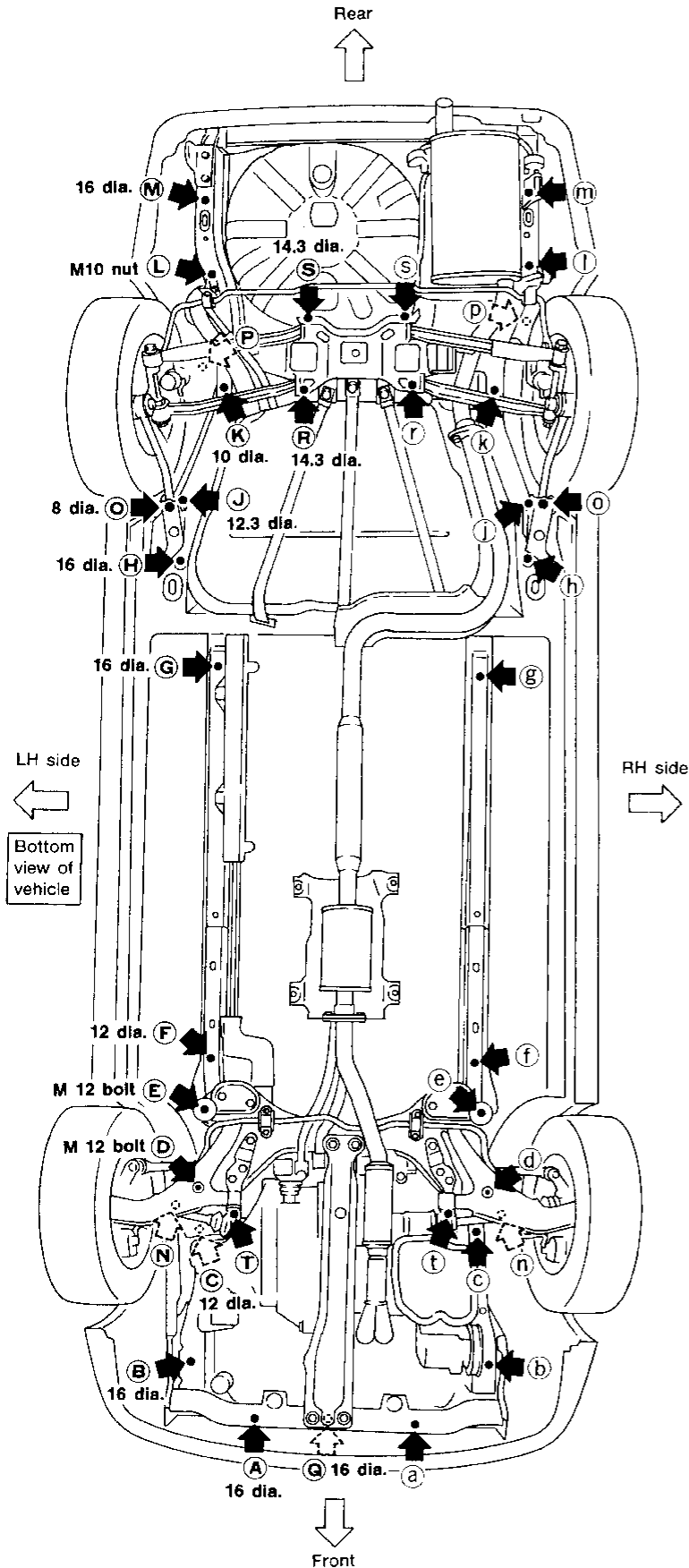

Coordinates:

(A, a)
X: 247
Y: -645
Z: 225
(B, b)
X: 495
Y: -490
Z: 355
(C, c)
X: 455
Y: -35
Z: 376
(D, d)
X: 450
Y: 70
Z: 254
(E, e)
X: 410
Y: 310
Z: 131.8
(F, f)
X: 393
Y: 500
Z: 130
(G, g)
X: 393
Y: 1,675
Z: 157
(H, h)
X: 555
Y: 2,025
Z: 228.6

(J, j)
Radius rod
bracket mounting
hole
X: 561.8
Y: 2,203
Z: 236
(K)
X: 465
Y: 2,530
Z: 338.1
(L)
X: 465
Y: 2,505
Z: 338.1
(M)
X: 536
Y: 3,180
Z: 340
(N, n)
X: 529
Y: -5
Z: 770
(O, o)
X: 593.2
Y: 2,567.7
Z: 779.8
(P, p)
X: 559.2
Y: 2,567.7
Z: 779.8
(Q, q)
X: 593
Y: 310
Z: 131.8
(R, r)
X: 410
Y: 310
Z: 131.8
(S, s)
X: 455
Y: -35
Z: 376
(T, t)
Transverse link
bush pin
X: 320
Y: -7
Z: 158

(U, u)
X: 593.1
Y: 2,206
Z: 191.8
(V, v)
X: 0
Y: -638
Z: 226
(W, w)
X: 181
Y: 2,535.9
Z: 235.6
(X, x)
X: 146.8
Y: 2,751.2
Z: 199.3
(Y, y)
X: 320
Y: -7
Z: 158

Front and rear strut tower centers

Coordinates:

(N, n)
X: 529
Y: -5
Z: 770
(P, p)
X: 559.2
Y: 2,567.7
Z: 779.8

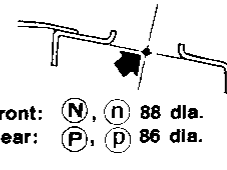

Suspension link mounting hole

Front suspension member

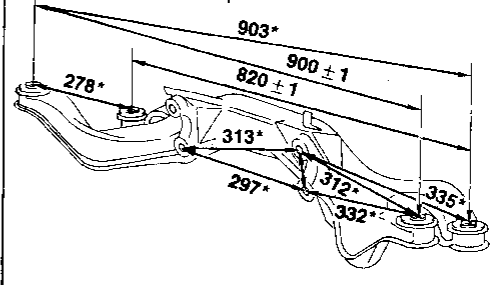

Unit: mm

MBF907AA