

CLUTCH

SECTION **CL**

GI
MA
EM
LG
EC
FE
CL
MT
AT
AX
SU
BR
ST
RS
BT
HA
SC
EL
IDX

CONTENTS

PRECAUTIONS	2	Removal	13
Precautions	2	Disassembly	13
PREPARATION	3	Inspection	14
Special Service Tools	3	Assembly	14
Commercial Service Tool	3	Installation	14
NOISE, VIBRATION AND HARSHNESS (NVH)		PIPING	15
TROUBLESHOOTING	4	Removal	15
NVH Troubleshooting Chart	4	Installation	15
CLUTCH SYSTEM	5	CLUTCH RELEASE MECHANISM	16
Components	5	Components	16
Inspection and Adjustment	6	Removal	16
ADJUSTING CLUTCH PEDAL	6	Inspection	16
BLEEDING PROCEDURE	7	Installation	16
CLUTCH MASTER CYLINDER	8	CLUTCH DISC, CLUTCH COVER AND	
Components	8	FLYWHEEL	19
Removal	8	Components	19
Installation	9	Inspection and Adjustment	19
Disassembly	9	CLUTCH DISC	19
Inspection	9	CLUTCH COVER AND FLYWHEEL	19
Assembly	9	FLYWHEEL INSPECTION	20
CLUTCH DAMPER	11	Installation	20
Components	11	SERVICE DATA AND SPECIFICATIONS (SDS)	21
Removal	11	Clutch Control System	21
Disassembly	11	Clutch Master Cylinder	21
Inspection	12	Clutch Operating Cylinder	21
Assembly	12	Clutch Damper	21
Installation	12	Clutch Disc	21
OPERATING CYLINDER	13	Clutch Cover	21
Components	13	Clutch Pedal	21

PRECAUTIONS

Precautions

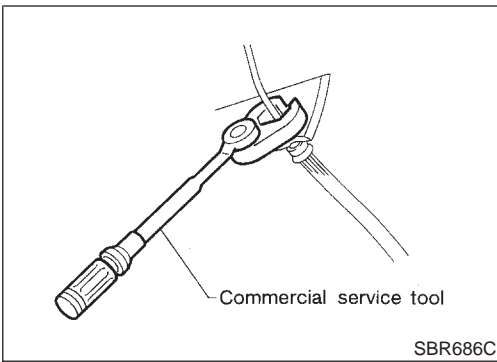

Precautions

NCCL0001

- Recommended fluid is brake fluid “DOT 3”.
- Do not reuse drained brake fluid.
- Be careful not to splash brake fluid on painted areas.
- When removing and installing clutch piping, use Tool.
- Use new brake fluid to clean or wash all parts of master cylinder, operating cylinder and clutch damper.
- Never use mineral oils such as gasoline or kerosene. It will ruin the rubber parts of the hydraulic system.

WARNING:

After cleaning clutch disc, wipe it with a dust collector. Do not use compressed air.



PREPARATION

Special Service Tools

Special Service Tools

NCCL0002

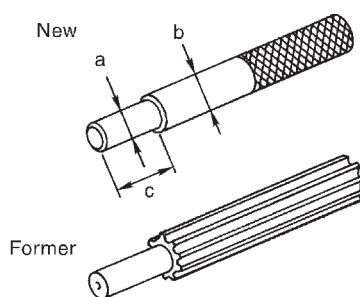
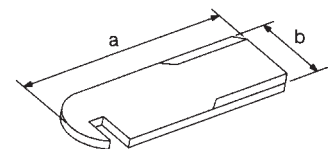
The actual shapes of Kent-Moore tools may differ from those of special service tools illustrated here.

Tool number (Kent-Moore No.) Tool name	Description	
KV30101600 (New) KV30101000 (Former) (J33213) Clutch aligning bar	 <p>New</p> <p>Former</p> <p>NT641</p>	Installing clutch cover and clutch disc a: 15.9 mm (0.626 in) dia. b: 17.9 mm (0.705 in) dia. c: 40 mm (1.57 in)
ST20050240 (—) Diaphragm spring adjusting wrench	 <p>NT404</p>	Adjusting unevenness of diaphragm spring of clutch cover a: 150 mm (5.91 in) b: 25 mm (0.98 in)
KV32101000 (J25689-A) Pin punch	 <p>NT410</p>	Removing and installing spring pin a: 4 mm (0.16 in) dia.

Commercial Service Tool

NCCL0003

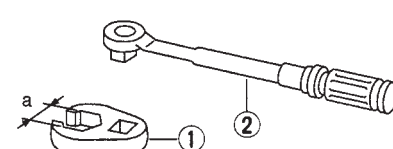
Tool name	Description	
1 Flare nut crowfoot 2 Torque wrench	 <p>NT360</p>	Removing and installing clutch piping a: 10 mm (0.39 in)

NOISE, VIBRATION AND HARSHNESS (NVH) TROUBLESHOOTING

NVH Troubleshooting Chart

NVH Troubleshooting Chart

NCCL0004/S71

Use the chart below to help you find the cause of the symptom. The numbers indicate the order of inspection. Check each part in order. If necessary, repair or replace these parts.

Reference page	SUSPECTED PARTS (Possible cause)			
CL-6	CLUTCH PEDAL (Free play out of adjustment)			
CL-7	CLUTCH LINE (Air in line)	1		
CL-8	MASTER CYLINDER PISTON CUP (Damaged)	2		
CL-13	OPERATING CYLINDER PISTON CUP (Damaged)	2		
Refer to EM-52.	ENGINE MOUNTING (Loose)	1		
CL-16	RELEASE BEARING (Worn, dirty or damaged)		1	
CL-19	CLUTCH DISC (Out of true)			5
CL-19	CLUTCH DISC (Runout is excessive)		2	5
CL-19	CLUTCH DISC (Lining broken)			5
CL-19	CLUTCH DISC (Dirty or burned)			5
CL-19	CLUTCH DISC (Oily)		2	5
CL-19	CLUTCH DISC (Worn out)		2	
CL-19	CLUTCH DISC (Hardened)		2	
CL-19	CLUTCH DISC (Lack of spline grease)			5
CL-19	DIAPHRAGM SPRING (Damaged)			6
CL-19	DIAPHRAGM SPRING (Out of tip alignment)		2	6
CL-19	CLUTCH COVER (Distortion)			4
CL-19	FLYWHEEL (Distortion)			5
Symptom				
	Clutch grabs/chatters			
	Clutch pedal spongy		1	
	Clutch noisy			
	Clutch slips		1	
	Clutch does not disengage		1	

CLUTCH SYSTEM

Components

Components

NCCL0005

SEC. 300•305•306•465

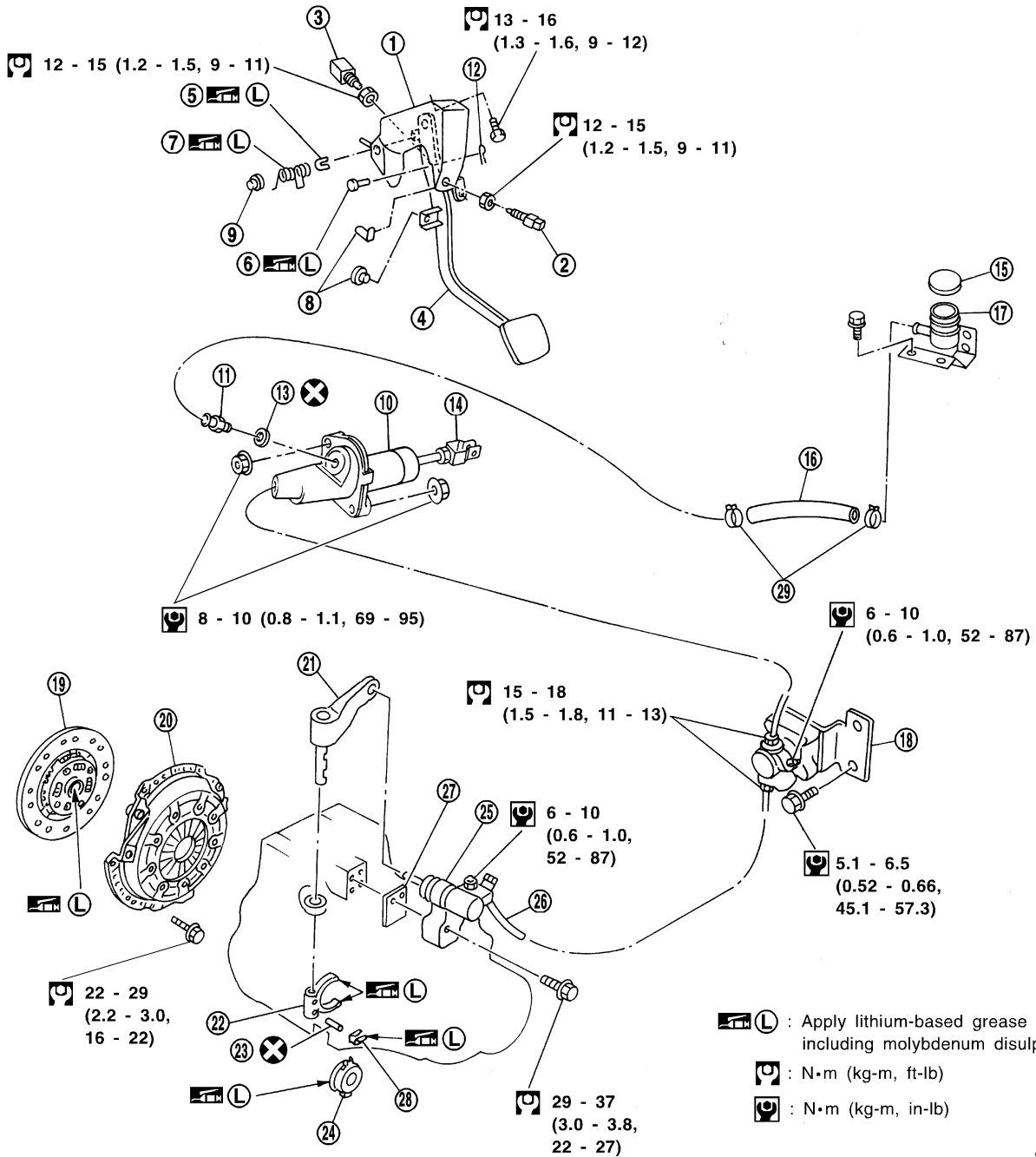

SCL818

- | | | |
|----------------------------|--------------------|----------------------------|
| 1. Clutch pedal bracket | 11. Nipple | 21. Withdrawal lever |
| 2. ASCD clutch switch | 12. Snap pin | 22. Clutch lever |
| 3. Clutch interlock switch | 13. Seal | 23. Spring pin |
| 4. Clutch pedal | 14. Clevis | 24. Release bearing |
| 5. Bush | 15. Reservoir cap | 25. Operating cylinder |
| 6. Clevis pin | 16. Hose | 26. Clutch hose |
| 7. Assist spring | 17. Reservoir tank | 27. Spacer |
| 8. Stopper rubber | 18. Clutch damper | 28. Release bearing spring |
| 9. Bush | 19. Clutch disc | 29. Hose clamp |
| 10. Clutch master cylinder | 20. Clutch cover | |

GI

MA

EM

LC

EC

FE

CL

MT

AT

AX

SU

BR

ST

RS

BT

HA

SC

EL

IDX

CLUTCH SYSTEM

Inspection and Adjustment

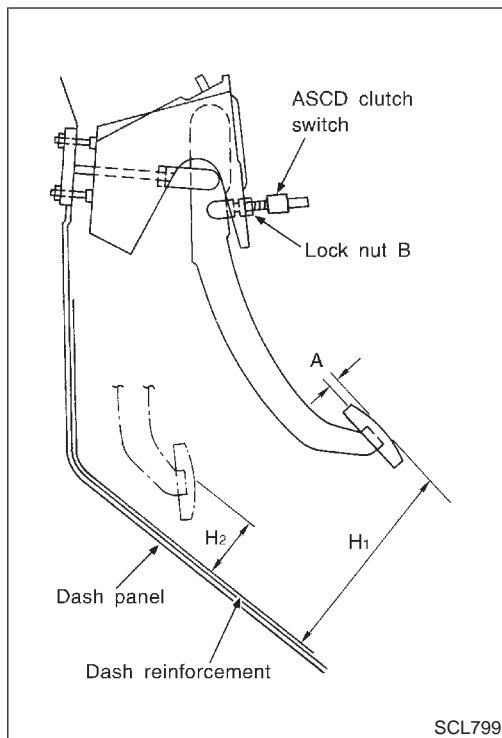

SCL799

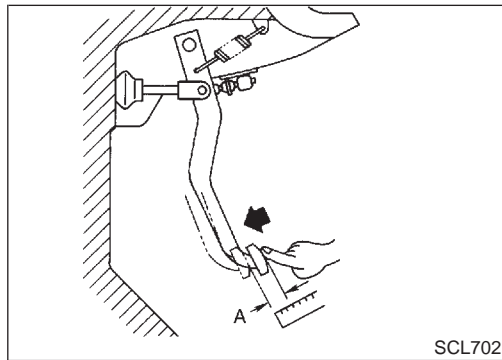

SCL702

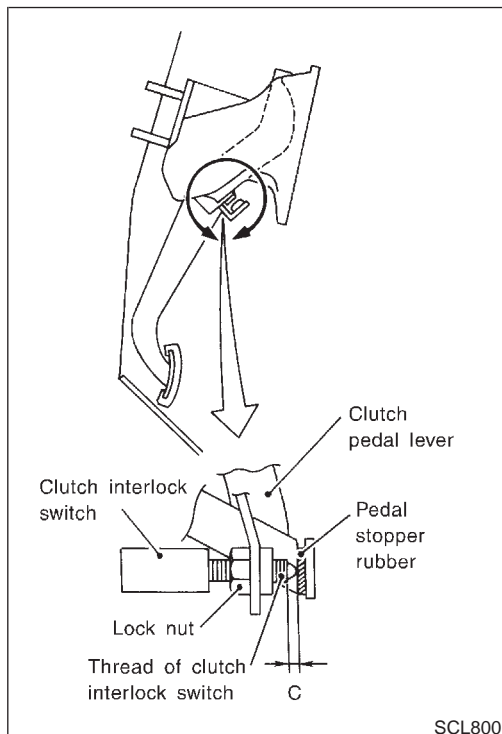

SCL800

Inspection and Adjustment

ADJUSTING CLUTCH PEDAL

NCCL0006

NCCL0006S01

NCCL0006S0101

Pedal Height

1. Verify that clutch pedal height "H₁" is within specification.
 - Measure distance between the upper surface of dash reinforcement and pedal.

Pedal height "H₁":
158 - 168 mm (6.22 - 6.61 in)

2. Adjust pedal free play with master cylinder push rod. Then tighten lock nut.

Pedal free play "A":
9 - 16 mm (0.35 - 0.63 in)

- Push or step on clutch pedal until resistance is felt, and check the distance the pedal moves.

3. Adjust clearance "C" shown in the figure while fully depressing clutch pedal fully.

Clearance C:
0.1 - 1.0 mm (0.004 - 0.039 in)

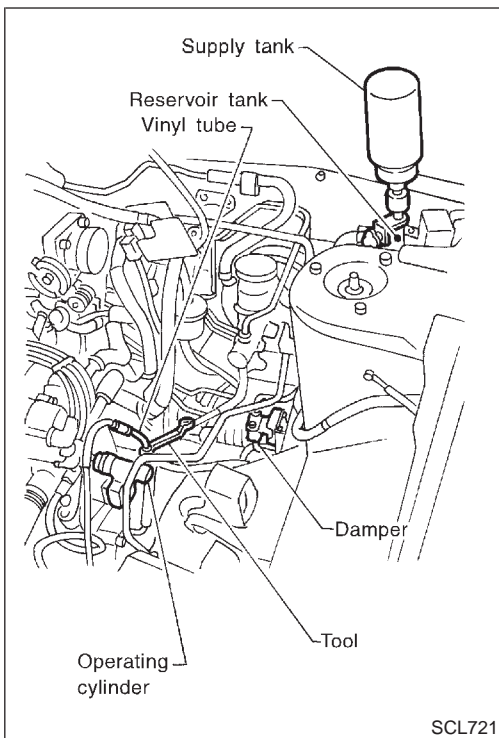

BLEEDING PROCEDURE

NCCL0006S02

1. Bleed air from clutch damper according to the following procedure.
 - **Carefully monitor fluid level at master cylinder during bleeding operation.**
 - a. Top up reservoir with recommended brake fluid.
 - b. Connect a transparent vinyl tube to air bleeder valve.
 - c. Slowly depress the clutch pedal to its full stroke and release it completely. Repeat this operation several times at 2 to 3 seconds intervals.
 - d. Open the air bleeder with the clutch pedal fully depressed.
 - e. Close the air bleeder.
 - f. Release the clutch pedal and wait at least 5 seconds.
 - g. Repeat steps c through f mentioned above, then air bubbles will no longer appear at the damper in the brake fluid.
2. Bleed air from clutch operating cylinder according to the above procedure.
3. Repeat the above bleeding procedure 1 and 2 several times.

Air bleeder valve tightening torque:

 : 6 - 10 N·m (0.6 - 1.0 kg·m, 52 - 87 in·lb)

GI
MA
EM
LC
EC
FE
CL
MT
AT
AX
SU
BR
ST
RS
BT
HA
SC
EL
IDX

CLUTCH MASTER CYLINDER

Components

Components

NCCL0007

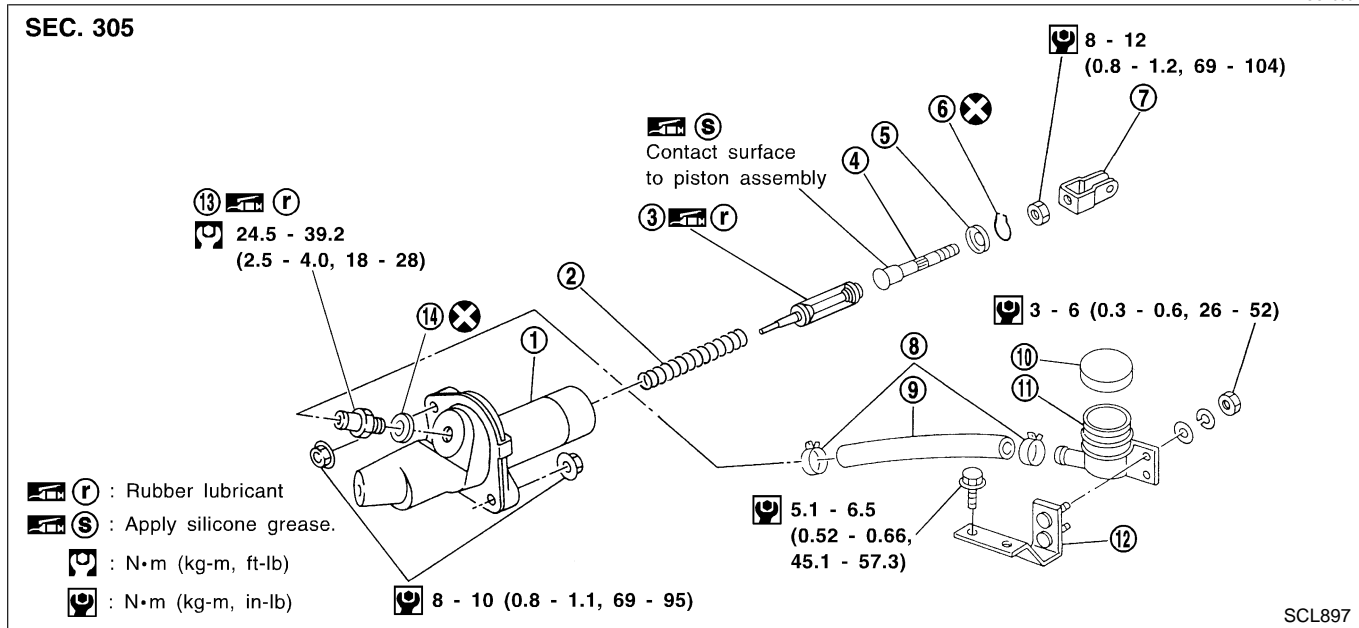

- | | | |
|---------------------------|-------------------|--------------------|
| 1. Clutch master cylinder | 6. Stopper ring | 11. Reservoir tank |
| 2. Return spring | 7. Clevis | 12. Bracket |
| 3. Piston assembly | 8. Hose clamp | 13. Nipple |
| 4. Push rod | 9. Hose | 14. Seal |
| 5. Stopper | 10. Reservoir cap | |

Removal

NCCL0008

1. Drain brake fluid.

CAUTION:

Be careful not to splash brake fluid on painted areas; it may cause paint damage. If brake fluid is splashed on painted areas, wash it away with water immediately.

2. Remove clutch tube using a flare nut wrench.
3. Remove snap pin between clutch pedal and push rod, and remove clevis pin.
4. Unscrew master cylinder assembly mounting nuts and reservoir tank bracket mounting bolts to remove master cylinder assembly from vehicle.

Installation

1. Connect clutch tube to master cylinder assembly, and hand-tighten flare nut. NCCL0009
2. Install master cylinder assembly to vehicle, and tighten mounting nuts to the specified torque. GI
MA
🔧 : 8 - 10 N·m (0.8 - 1.1 kg-m, 69 - 95 in-lb)
3. Tighten reservoir tank bracket mounting bolts. EM
🔧 : 5.1 - 6.5 N·m (0.52 - 0.66 kg-m, 45.1 - 57.3 in-lb)
4. Tighten clutch tube flare nut using a flare nut torque wrench. LC
🔧 : 15 - 18 N·m (1.5 - 1.8 kg-m, 11 - 13 ft-lb)
5. After installing clevis pin, install snap pin to connect clutch pedal to push rod. EC
6. After finishing the operation, bleed air from clutch piping. (Refer to "Bleeding Procedure", CL-7.) FE

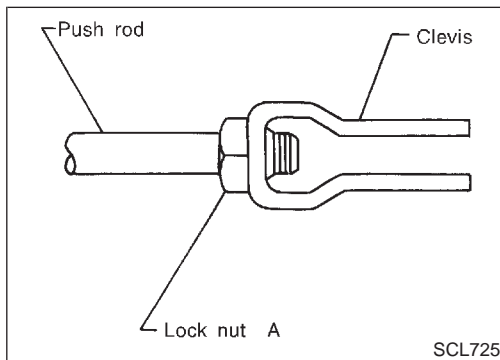

Disassembly

1. Loosen push rod lock nut A to remove clevis and lock nut A. NCCL0010 AT
2. Remove dust cover.
3. Remove stopper ring and stopper, and remove push rod from cylinder body. During removal, keep push rod depressed, to prevent piston inside master cylinder from popping out. AX
4. Remove piston assembly from cylinder body. SU

Inspection

- Inspect for the following, and replace parts if necessary. NCCL0011 ST
- Damage, wear, rust, and pinholes on the cylinder inner wall
 - Damage and deformation of the reservoir tank RS
 - Weak spring
 - Crack and deformation of the dust cover BT

Assembly

1. Apply rubber lubricant to the sliding part of piston assembly, and insert piston assembly. NCCL0012 SC
2. After installing stopper to push rod, install stopper ring while keeping piston assembly depressed by hand, so that piston assembly will not pop out. EL

CAUTION:
Stopper ring cannot be reused. Always use a new stopper ring for assembly. IDX

3. Install dust cover.

CLUTCH MASTER CYLINDER

Assembly (Cont'd)

4. Install clevis to push rod, and tighten lock nut A to the specified torque.
 : **8 - 12 N·m (0.8 - 1.2 kg-m, 69 - 104 in-lb)**
5. Install seal and nipple to cylinder body, and install spring pin using a pin punch.

Components

NCCL0013

SEC. 306

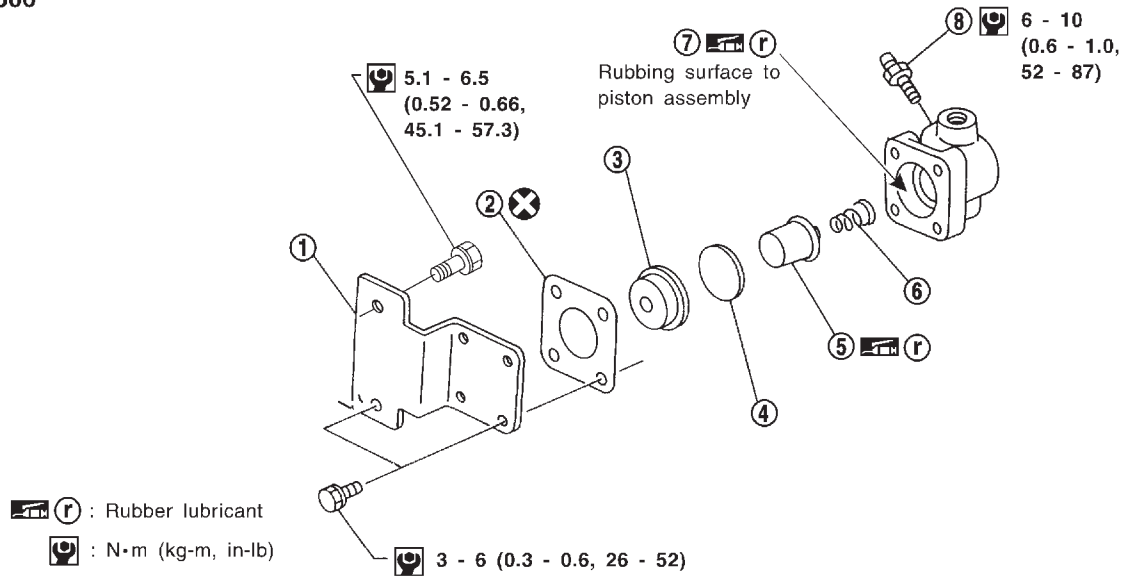

SCL805

- | | | |
|-------------------|--------------------|----------------|
| 1. Damper bracket | 4. Plate | 7. Cylinder |
| 2. Gasket | 5. Piston assembly | 8. Air bleeder |
| 3. Damper rubber | 6. Spring | |

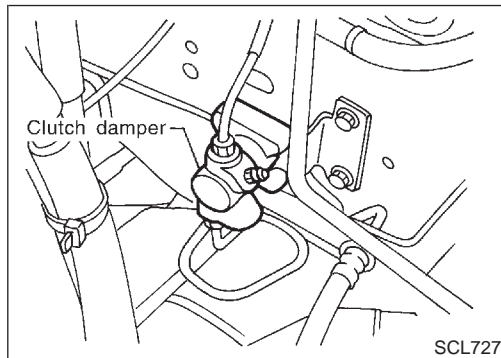

Removal

NCCL0014

1. Remove fuel filter bracket.
2. Drain brake fluid.

CAUTION:

Be careful not to splash brake fluid on painted areas; it may cause paint damage. If brake fluid is splashed on painted areas, wash it away with water immediately.

3. Remove clutch tube using a flare nut wrench.
4. Remove mounting bolts, and remove damper assembly from vehicle.

Disassembly

NCCL0015

1. Remove damper assembly mounting bolts.
2. Remove gasket, damper rubber, plate, piston assembly, and piston spring from cylinder body.

GI
MA
EM
LC
EC
FE
CL
MT
AT
AX
SU
BR
ST
RS
BT
HA
SC
EL
IDX

CLUTCH DAMPER

Inspection

Inspection

Inspect cylinder inner wall for damage, wear, rust, and pinholes, and piston cup and damper rubber for deformation. Replace if necessary. NCCL0016

Assembly

1. Clean gasket contact surface on cylinder body and damper bracket with scrapers. NCCL0017

CAUTION:

Be careful not to scratch the contact surface.

2. Apply rubber lubricant to sliding part of piston assembly and the entire inner surface of cylinder. Install piston spring, piston cup, piston assembly, damper plate, and damper rubber to cylinder body.

CAUTION:

Piston assembly cannot be reused.

3. Install gasket and damper bracket, and tighten mounting bolts to the specified torque.

 : 3 - 6 N·m (0.3 - 0.6 kg-m, 26 - 52 in-lb)

Installation

1. Install clutch tube, and hand-tighten flare nut until it stops. NCCL0018
2. Install damper assembly to vehicle.
3. Tighten flare nut to the specified torque using a flare nut torque wrench.

 : 15 - 18 N·m (1.5 - 1.8 kg-m, 11 - 13 ft-lb)

4. After finishing the operation, bleed air from clutch piping. (Refer to "Bleeding Procedure", CL-7.)

Components

NCCL0019

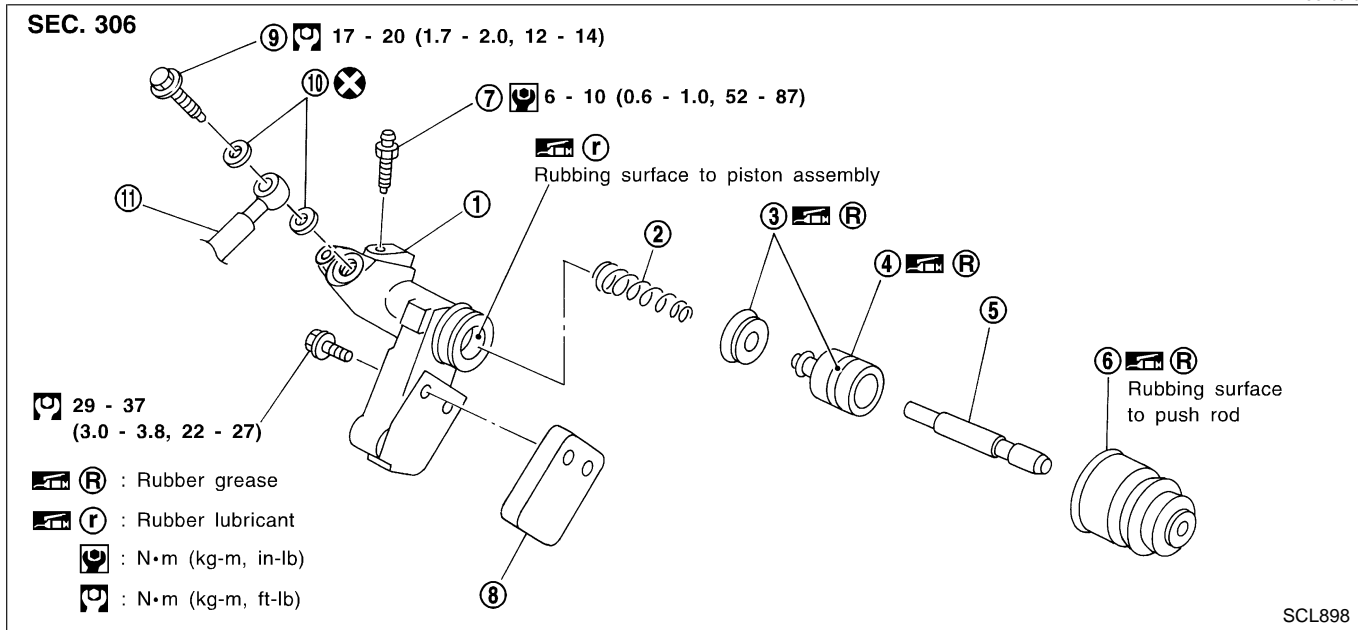

1. Cylinder body
2. Piston spring
3. Piston cup
4. Piston

5. Push rod
6. Dust cover
7. Air bleeder
8. Spacer

9. Union bolt
10. Copper washer
11. Clutch hose

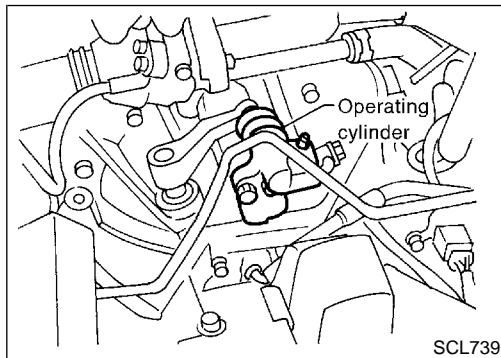

Removal

NCCL0020

1. Drain brake fluid.

CAUTION:

Be careful not to splash brake fluid on painted areas; it may cause paint damage. If brake fluid is splashed on painted areas, wash it away with water immediately.

2. Remove union bolt and clutch hose from operating cylinder.
3. Remove operating cylinder mounting bolts, and remove cylinder from vehicle.

Disassembly

NCCL0021

Remove dust cover, and remove piston assembly from cylinder body.

OPERATING CYLINDER

Inspection

Inspection

NCCL0022

Inspect for following, and replace parts if necessary.

- Damage, foreign material, wear, rust, and pinholes on the cylinder inner surface, piston, and sliding part of piston cup
- Weak spring
- Crack and deformation of dust cover

Assembly

NCCL0023

1. Apply recommended rubber grease to piston cup and piston, and insert piston assembly.
2. Install dust cover.

Installation

NCCL0024

Install the components in the reverse order of removal. Adhere to the operations described below.

CAUTION:

Install the hose without twisting it.

- **The copper washer of the union bolt should not be reused. Always use a new copper washer for installation.**
- **After finishing the operation, bleed air from the clutch piping. Refer to “Bleeding Procedure”, CL-7.**

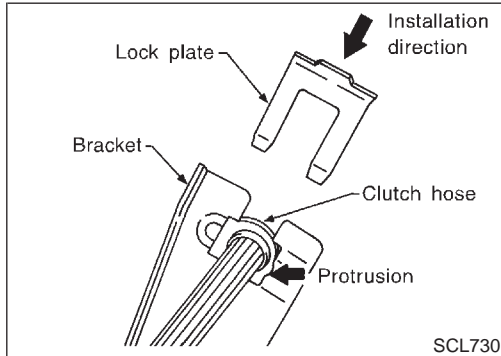
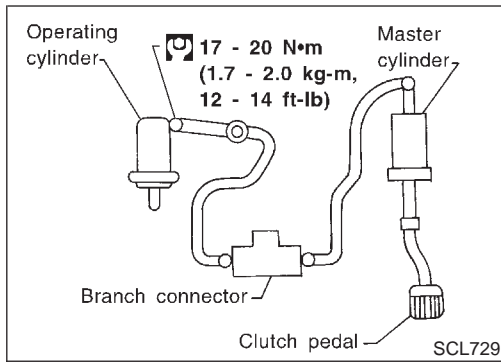

Removal

NCCL0025

1. Remove fuel filter mounting bracket.
2. Remove air cleaner and air duct.
3. Drain brake fluid.

CAUTION:

Be careful not to splash brake fluid on painted areas; it may cause paint damage. If brake fluid is splashed on painted areas, wash it away with water immediately.

4. Remove flare nut using a flare nut wrench.
5. Remove clutch hose and clutch tube.

GI

MA

EM

LC

Installation

NCCL0026

1. When installing clutch hose to bracket, face lock plate in the correct direction as shown to secure clutch hose.

CAUTION:

Install clutch hose without twisting or bending it.

2. Tighten flare nut to the specified torque, using a flare nut wrench.

 : 15 - 18 N·m (1.5 - 1.8 kg-m, 11 - 13 ft-lb)

CAUTION:

Be careful not to damage flare nut and clutch tube.

3. Install clutch hose to operating cylinder, and tighten mounting bolts to the specified torque.

 : 17 - 20 N·m (1.7 - 2.0 kg-m, 12 - 14 ft-lb)

4. After finishing the operation, bleed air from the clutch piping. Refer to "Bleeding Procedure", CL-7.

EC

FE

CL

MT

AT

AX

SU

BR

ST

RS

BT

HA

SC

EL

IDX

CLUTCH RELEASE MECHANISM

Components

Components

NCCL0027

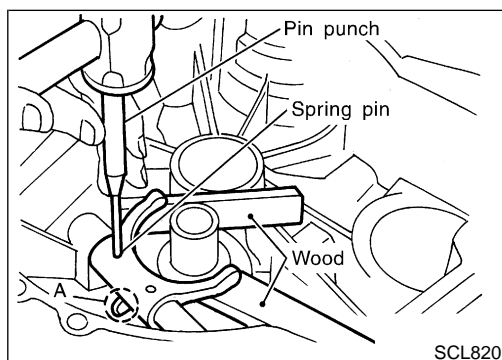
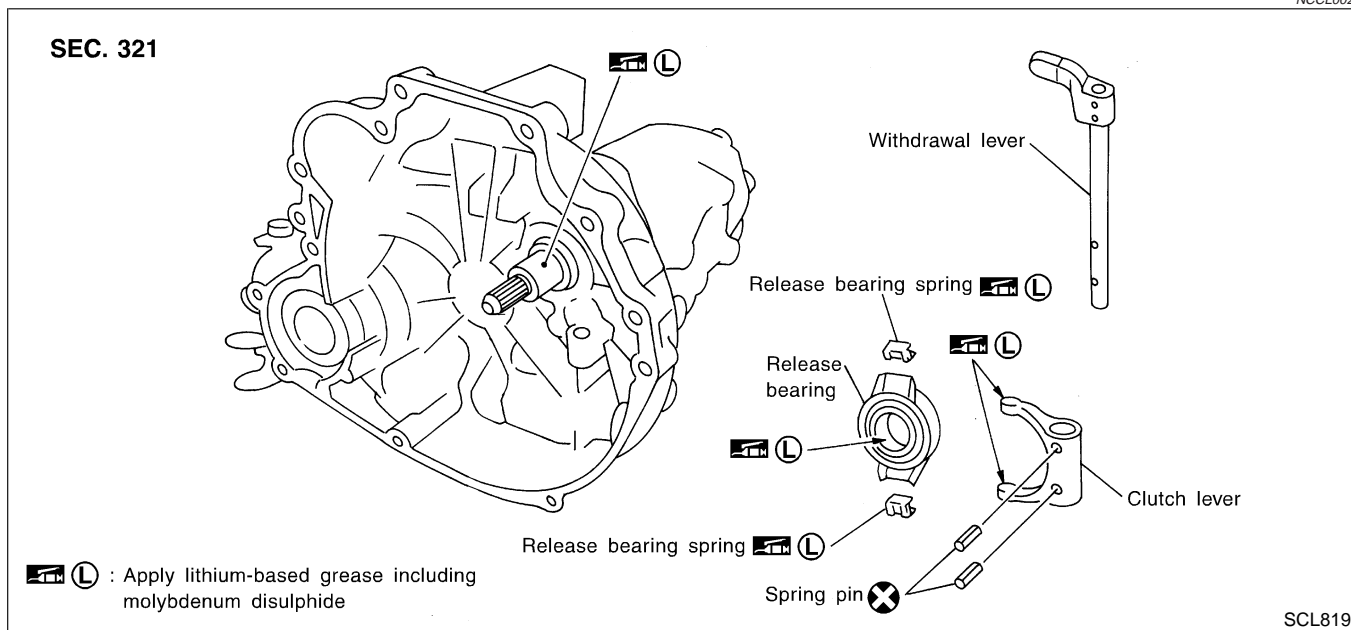

Removal

NCCL0028

1. Remove manual transaxle from vehicle. Refer to MT-12, "Removal".
2. Move withdrawal lever enough to remove release bearing, and remove release bearing from clutch lever.
3. Support clutch lever claws with an appropriate wood block, align retaining pin with A in the figure, and drive out spring pin using a pin punch.
4. Pull out withdrawal lever and remove clutch lever.

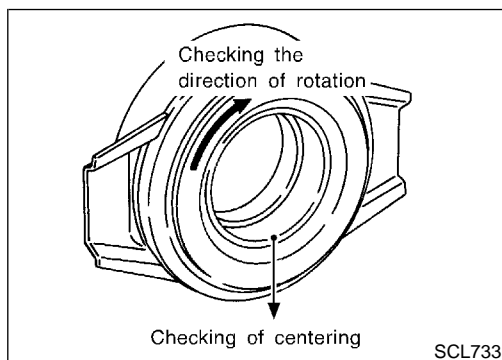

Inspection

NCCL0029

- Replace the release bearing if it is seized, damaged, faulty in rotation direction, or has poor aligning function.
- Replace the withdrawal lever if its contact surface is worn abnormally.
- Replace the clutch lever if its contact surface is worn abnormally.
- Replace the dust seal if it is deformed or cracked.

Installation

NCCL0030

CAUTION:

- Be sure to apply grease to the clutch components. Otherwise, abnormal noise, poor clutch disengagement, or clutch damage may occur. Wipe the excess grease off completely, because it may cause the clutch components to slip and shudder.
- Keep the clutch disc facing, pressure plate, and flywheel free of oil and grease.

CLUTCH RELEASE MECHANISM

Installation (Cont'd)

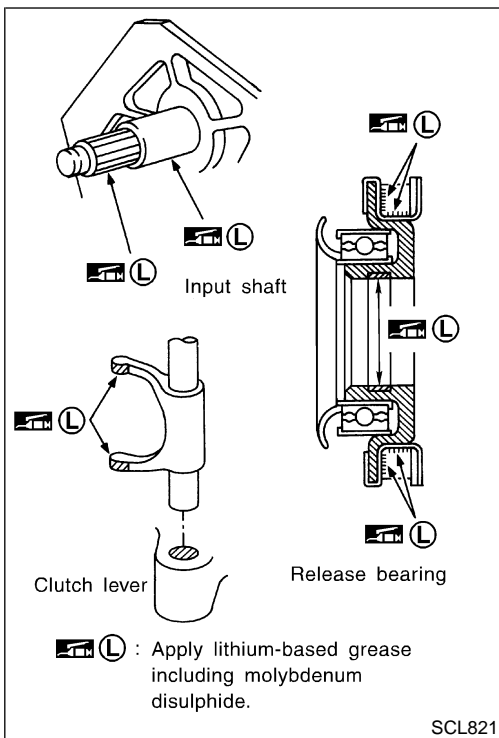

- Clean old grease and abrasive materials off the grease application area.
- Apply approximately 1 mm (0.04 in)-thick clutch sleeve grease evenly on the sliding part of the clutch lever and the release bearing spring.
- Apply just enough clutch sleeve grease to fill up the release bearing inner groove.
- Apply the clutch grease to the clutch disc and the input shaft spline. Install the clutch disc to the input shaft, remove the excess grease around the shaft, and remove the clutch disc.
- Lightly and evenly apply the clutch sleeve grease on the sliding part of the release bearing, install the release bearing, remove the excess grease around the bearing, and remove the release bearing.

GI
MA
EM
LC
EC
FE

CL

MT

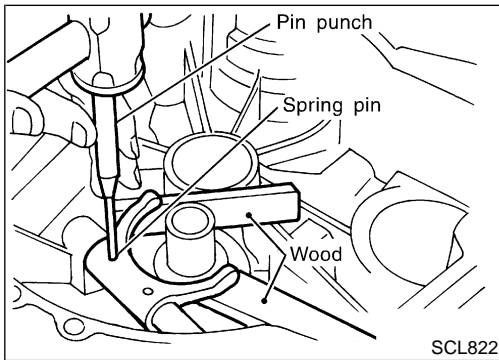

1. Assemble clutch lever to clutch housing, and insert withdrawal lever.
2. Support clutch lever claws with an appropriate wood block, and install a new spring pin using a pin punch.

CAUTION:
Spring pin cannot be reused.

AT
AX
SU
BR

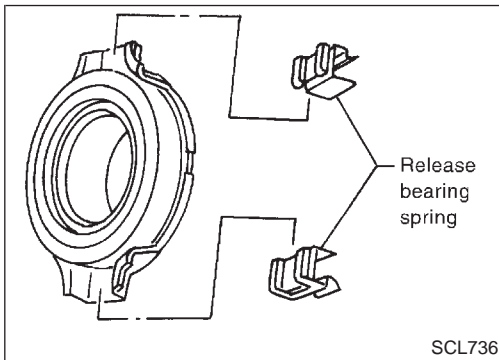

3. Install release bearing spring to release bearing as shown in the figure.

ST
RS
BT
HA

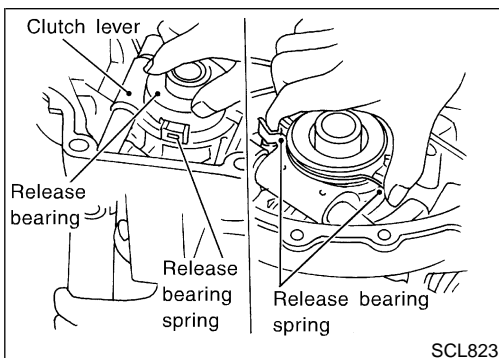

4. Operate withdrawal lever manually, press clutch spring from both sides, and install release bearing to clutch lever securely.
5. Make sure a click is heard when release bearing spring is pressed from both sides.

SC
EL
IDX

CLUTCH RELEASE MECHANISM

Installation (Cont'd)

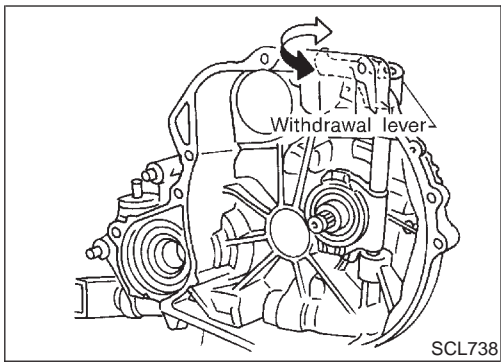

6. Make sure each sliding part operates smoothly when withdrawal lever is moved.

CAUTION:
Remove any excess grease with a shop towel.

Components

NCCL0031

SEC. 300

Flywheel

Clutch disc

Clutch cover

● Do not clean in solvent.
● When installing, be careful that grease from main drive shaft does not adhere to clutch disc.

First step:
10 - 20 (1.0 - 2.0, 7 - 14)
Final step:
22 - 29 (2.2 - 3.0, 16 - 22)

Ⓛ : Apply lithium-based grease including molybdenum disulphide.

Ⓛ : N·m (kg-m, ft-lb)

SCL270-C

GI

MA

EM

LC

EC

FE

CL

MT

0.3 mm (0.012 in)

SCL229

Inspection and Adjustment

CLUTCH DISC

Check clutch disc for wear of facing.

**Wear limit of facing surface to rivet head:
0.3 mm (0.012 in)**

NCCL0032

NCCL0032S01

AT

AX

SU

BR

Facing runout

Spline backlash

SCL221

- Check clutch disc for backlash of spline and runout of facing.

**Maximum backlash of spline (at outer edge of disc):
0.9 mm (0.035 in)**

Runout limit:

1.0 mm (0.039 in)

Distance of runout check point (from hub center):

102.5 mm (4.04 in)

- Check clutch disc for burns, discoloration or oil or grease leakage. Replace if necessary.

ST

RS

BT

HA

ST20050240

SCL466-A

CLUTCH COVER AND FLYWHEEL

NCCL0032S02

- Check clutch cover installed on vehicle for unevenness of diaphragm spring toe height.

Uneven limit:

0.7 mm (0.028 in)

- If out of limit, adjust the height with Tool.

SC

EL

IDX

CLUTCH DISC, CLUTCH COVER AND FLYWHEEL

Inspection and Adjustment (Cont'd)

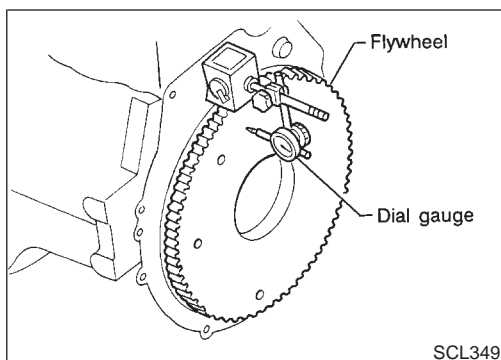

FLYWHEEL INSPECTION

- Check contact surface of flywheel for slight burns or discoloration. Repair flywheel with emery paper. NCCL0032S03
- Check flywheel runout.

Maximum allowable runout:

Refer to EM-64, "Flywheel/Drive Plate Runout".

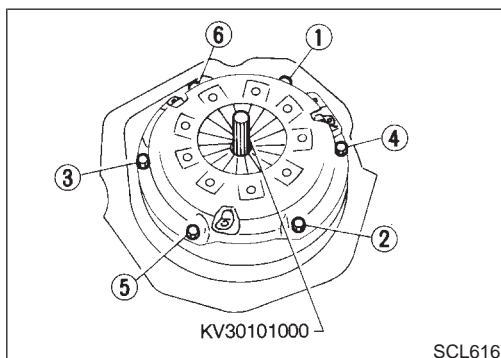

Installation

- Insert Tool into clutch disc hub when installing clutch cover and disc. NCCL0033
- **Be careful not to allow grease to contaminate clutch facing.**
- Tighten bolts in numerical order by 2 steps.

First step:

 : 10 - 20 N·m (1.0 - 2.0 kg-m, 7 - 14 ft-lb)

Final step:

 : 22 - 29 N·m (2.2 - 3.0 kg-m, 16 - 22 ft-lb)

SERVICE DATA AND SPECIFICATIONS (SDS)

Clutch Control System

Clutch Control System		<small>NCCL0034</small>
Type of clutch control	Hydraulic	GI
Clutch Master Cylinder		<small>NCCL0035</small>
		Unit: mm (in)
Inner diameter	15.87 (5/8)	MA
Clutch Operating Cylinder		<small>NCCL0036</small>
		Unit: mm (in)
Inner diameter	19.05 (3/4)	EM
Clutch Damper		<small>NCCL0037</small>
		Unit: mm (in)
Inner diameter	19.05 (3/4)	EC
Clutch Disc		<small>NCCL0038</small>
		Unit: mm (in)
Model	215	CL
Facing size (Outer dia. × inner dia. × thickness)	215 × 140 × 3.5 (8.46 × 5.51 × 0.138)	MT
Thickness of disc assembly With load	7.6 - 8.0 (0.299 - 0.315) with 3,923 N (400 kg, 882 lb)	AT
Wear limit of facing surface to rivet head	0.3 (0.012)	AX
Runout limit of facing	1.0 (0.039)	SU
Distance of runout check point (from the hub center)	102.5 (4.04)	BR
Maximum backlash of spline (at outer edge disc)	0.9 (0.035)	ST
Clutch Cover		<small>NCCL0039</small>
		Unit: mm (in)
Model	215	RS
Full-load	4,904 N (500 kg, 1,103 lb)	BT
Uneven limit of diaphragm spring toe height	0.7 (0.028)	HA
Clutch Pedal		<small>NCCL0040</small>
		Unit: mm (in)
Pedal height "H ₁ "*	158 - 168 (6.22 - 6.61)	SC
Pedal free play "A" (at pedal pad)	9 - 16 (0.35 - 0.63)	EL
Clearance "C" between pedal stopper rubber and clutch interlock switch threaded end while clutch pedal is fully depressed.	0.1 - 1.0 (0.004 - 0.039)	IDX

*: Measured from surface of dash reinforcement panel

NOTES