

MANUAL TRANSAXLE

SECTION **MT**

GI

MA

EM

LG

EC

FE

CL

MT

AT

AX

SU

BR

ST

RS

BT

HA

SC

EL

IDX

CONTENTS

PREPARATION	2	Final Drive.....	39
Special Service Tools	2	PRE-INSPECTION	39
Commercial Service Tools	4	DISASSEMBLY.....	40
NOISE, VIBRATION AND HARSHNESS (NVH)		INSPECTION.....	41
TROUBLESHOOTING	6	ASSEMBLY	42
NVH Troubleshooting Chart.....	6	Shift Control Components	45
DESCRIPTION	7	INSPECTION.....	45
Cross-sectional View	7	ASSEMBLY	46
DOUBLE-CONE SYNCHRONIZER.....	8	Clutch Housing	46
ON-VEHICLE SERVICE	9	Transaxle Case.....	50
Replacing Oil Seal.....	9	SERVICE DATA AND SPECIFICATIONS (SDS)	56
DIFFERENTIAL OIL SEAL	9	General Specifications.....	56
STRIKING ROD OIL SEAL	9	TRANSAXLE	56
Position Switch Check.....	10	FINAL GEAR	56
BACK-UP LAMP SWITCH	10	Gear End Play	57
PNP SWITCH	10	Clearance Between Baulk Ring and Gear	57
Viscous Coupling Check.....	11	3RD, 4TH, 5TH, REVERSE BAULK RING.....	57
REMOVAL AND INSTALLATION	12	1ST AND 2ND BAULK RING	57
Removal.....	12	Available Snap Rings	57
Installation.....	14	SNAP RING.....	57
OVERHAUL	15	Available C-rings.....	58
Transaxle Gear Control	15	4TH INPUT GEAR C-RING	58
Case Components.....	16	5TH INPUT GEAR REAR C-RING	58
Gear Components	17	MAINSHAFT C-RING	58
Shift Control Components	18	Available Adjusting Shims	59
Final Drive Components.....	19	INPUT SHAFT REAR BEARING ADJUSTING	
DISASSEMBLY	20	SHIM	59
Transaxle Case.....	20	MAINSHAFT ADJUSTING SHIM.....	60
Clutch Housing	22	MAINSHAFT REAR BEARING ADJUSTING SHIM	60
REPAIR FOR COMPONENT PARTS	26	Available Thrust Washer.....	61
Input Shaft and Gears	26	MAINSHAFT THRUST WASHER.....	61
DISASSEMBLY.....	26	Available Washers	61
INSPECTION.....	27	DIFFERENTIAL SIDE GEAR THRUST WASHER.....	61
ASSEMBLY	28	Available Shims - Differential Side Bearing	
Mainshaft and Gears	31	Preload and Adjusting Shim	62
DISASSEMBLY.....	31	BEARING PRELOAD	62
INSPECTION.....	32	DIFFERENTIAL SIDE BEARING ADJUSTING	
ASSEMBLY	34	SHIMS	62

PREPARATION

Special Service Tools

Special Service Tools

NCMT0001

The actual shapes of Kent-Moore tools may differ from those of special service tools illustrated here.

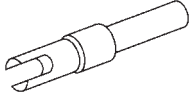
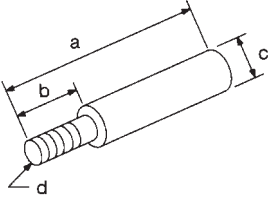
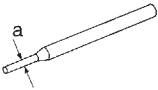
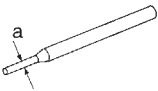
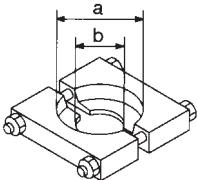
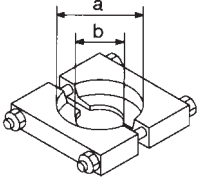
Tool number (Kent-Moore No.) Tool name	Description	
KV38107700 (J39027) Preload adapter	 NT087	Measuring turning torque of final drive assembly Measuring total turning torque Measuring clearance between side gear and differential case with washer Selecting differential side bearing adjusting shim [Use with KV38106000 (J34291-A).]
KV38106000 (J34291-A) Height gauge adapter (differential side bearing)	 NT418	Selecting differential side bearing adjusting shim [Use with KV38107700 (J39027).] a: 140 mm (5.51 in) b: 40 mm (1.57 in) c: 16 mm (0.63 in) dia. d: M8 × 1.25P
KV32101000 (J25689-A) Pin punch	 NT410	Removing and installing retaining pin Removing and installing lock pin Removing selector shaft Removing welch plug a: 4 mm (0.16 in) dia.
KV31100300 (J25689-A) Pin punch	 NT410	Removing and installing retaining pin a: 4.5 mm (0.177 in) dia.
ST30031000 (J22912-01) Puller	 NT411	Removing 3rd, 5th input gear Removing 3rd & 4th and 5th & Rev synchronizer hub Removing mainshaft rear bearing Removing 2nd gear, 5th gear bush Removing 1st & 2nd synchronizer hub, 1st and 4th main gear Removing and installing differential side bearing a: 90 mm (3.54 in) dia. b: 50 mm (1.97 in) dia.
ST30021000 (J22912-01) Puller	 NT411	Removing input shaft front and rear bearing Installing input shaft front and rear bearing Installing 5th input gear, 3rd main gear and 4th main gear Installing 1st & 2nd, 3rd & 4th and 5th & Rev synchronizer hub Installing 2nd gear bush, 5th gear bush, Rev gear bush Installing mainshaft rear bearing a: 110 mm (4.33 in) dia. b: 68 mm (2.68 in) dia.

PREPARATION

Special Service Tools (Cont'd)

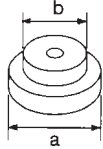
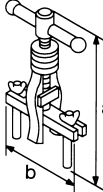
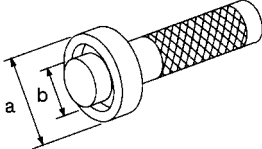
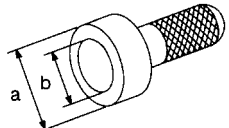
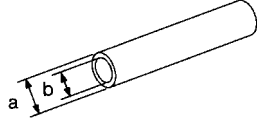
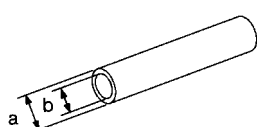
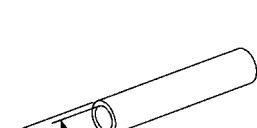
Tool number (Kent-Moore No.) Tool name	Description		
ST33061000 (J8107-2) Drift		Removing differential side bearing a: 39 mm (1.54 in) dia. b: 29.5 mm (1.16 in) dia.	GI MA EM
ST33290001 (J34286) Puller		● Removing idler gear bearing outer race a: 250 mm (9.84 in) b: 160 mm (6.30 in)	LC EC FE
ST33230000 (J25805-01) Drift		Removing differential oil seal Installing differential side bearing a: 51 mm (2.01 in) dia. b: 28.5 mm (1.122 in) dia.	CL MT
ST30720000 (J25405) Drift		Installing differential side bearing outer race (F70A and clutch housing side of F70V) a: 77 mm (3.03 in) dia. b: 55.5 mm (2.185 in) dia.	AT AX SU
ST22350000 (J25678-01) Drift		Installing input shaft front and rear bearing a: 34 mm (1.34 in) dia. b: 28 mm (1.10 in) dia.	BR ST
ST22452000 (J34335) Drift		Installing 3rd and 4th main gear Installing 5th gear bush Installing 5th & Rev synchronizer hub Installing Rev gear bush Installing mainshaft rear bearing a: 45 mm (1.77 in) dia. b: 36 mm (1.42 in) dia.	RS BT
ST37750000 (J34335) Drift		Installing input shaft oil seal Installing 5th synchronizer Installing mainshaft rear bearing Installing 5th main gear Installing 3rd & 4th synchronizer hub Installing striking rod oil seal Installing clutch housing dust seal a: 40 mm (1.57 in) dia. b: 31 mm (1.22 in) dia.	HA SC EL

IDX

PREPARATION

Special Service Tools (Cont'd)

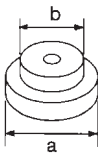
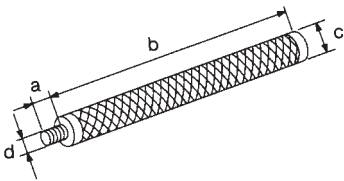
Tool number (Kent-Moore No.) Tool name	Description	
ST30621000 (J35869) Drift		Installing differential side bearing outer race [Use with ST30611000 (J25742-1).] (F70A and clutch housing side of F70V) a: 79 mm (3.11 in) dia. b: 59 mm (2.32 in) dia.
	NT073	
ST30611000 (J25742-1) Drift handle		Installing differential side bearing outer race [Use with ST30621000 (J35869).] a: 15 mm (0.59 in) b: 335 mm (13.19 in) c: 25 mm (0.98 in) dia. d: M12 × 1.5P
	NT419	

Commercial Service Tools

NCMT0002

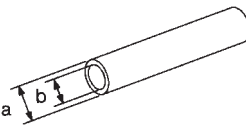
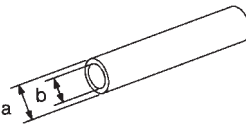
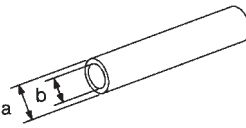
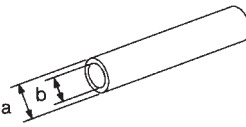
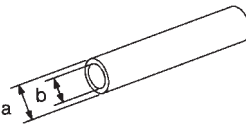
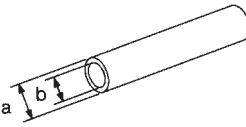
Tool name	Description	
Drift		Installing differential side bearing inner race (F70A and except viscos coupling side of F70V) a: 56 mm (2.20 in) dia. b: 50.5 mm (1.988 in) dia.
	NT065	
Drift		Installing differential oil seal (F70V transaxle case side) a: 94 mm (3.70 in) dia. b: 72 mm (2.83 in) dia.
	NT065	
Drift		Installing differential side bearing outer race (F70V viscous coupling side) a: 104 mm (4.09 in) dia. b: 98 mm (3.86 in) dia.
	NT065	
Drift		Installing differential side bearing inner race (F70V viscous coupling side) a: 91 mm (3.58 in) dia. b: 81 mm (3.19 in) dia.
	NT065	
Drift		Removing input shaft rear bearing Removing mainshaft rear bearing a: 22 mm (0.87 in) dia. b: 16 mm (0.63 in) dia.
	NT065	
Drift		Installing differential oil seal (Transaxle case side of F70A and clutch housing side of F70V) a: 58 mm (2.28 in) dia. b: 50 mm (1.97 in) dia.
	NT065	

PREPARATION

Commercial Service Tools (Cont'd)

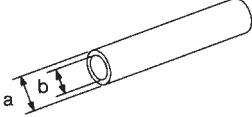
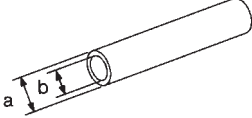
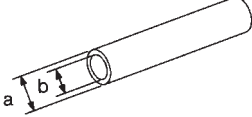
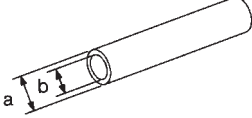
Tool name	Description	GI
Drift NT065	 <p>Installing differential oil seal (Clutch housing side of F70A) a: 54 mm (2.13 in) dia. b: 50 mm (1.97 in) dia.</p>	MA
Drift NT065	 <p>Installing 2nd gear bush a: 38 mm (1.50 in) dia. b: 33 mm (1.30 in) dia.</p>	EM
Drift NT065	 <p>Installing 3rd & 4th and 1st & 2nd synchronizer hub Installing mainshaft front bearing a: 50 mm (1.97 in) dia. b: 41 mm (1.61 in) dia.</p>	EC
Drift NT065	 <p>Installing input shaft oil seal Installing 5th input gear a: 39 mm (1.54 in) dia. b: 30 mm (1.18 in) dia.</p>	CL

MT

AT

AX

SU

BR

ST

RS

BT

HA

SC

EL

IDX

NOISE, VIBRATION AND HARSHNESS (NVH) TROUBLESHOOTING

NVH Troubleshooting Chart

NVH Troubleshooting Chart

NCMT0003/01

Use the chart below to help you find the cause of the symptom. The numbers indicate the order of the inspection. If necessary, repair or replace these parts.

Symptom	SUSPECTED PARTS (Possible cause)		Reference page
	Noise		
Hard to shift or will not shift Jumps out of gear	1	(Oil level is low.)	Refer to MA-22, "Checking M/T Oil".
	2	(Wrong oil)	
	1	(Oil level is high.)	
	2	GASKET (Damaged)	MT-16
	2	OIL SEAL (Worn or damaged)	MT-16
	2	O-RING (Worn or damaged)	MT-16
	2	CONTROL ROD (Worn)	MT-15
	2	CHECK PLUG RETURN SPRING AND CHECK BALL (Worn or damaged)	MT-18
	3	SHIFT FORK (Worn)	MT-18
	3	GEAR (Worn or damaged)	MT-17
	3	BEARING (Worn or damaged)	MT-17
	3	BAULK RING (Worn or damaged)	MT-17
	3	INSERT SPRING, SHIFTING INSERT (Damaged)	MT-17

Cross-sectional View

NCMT0004S01

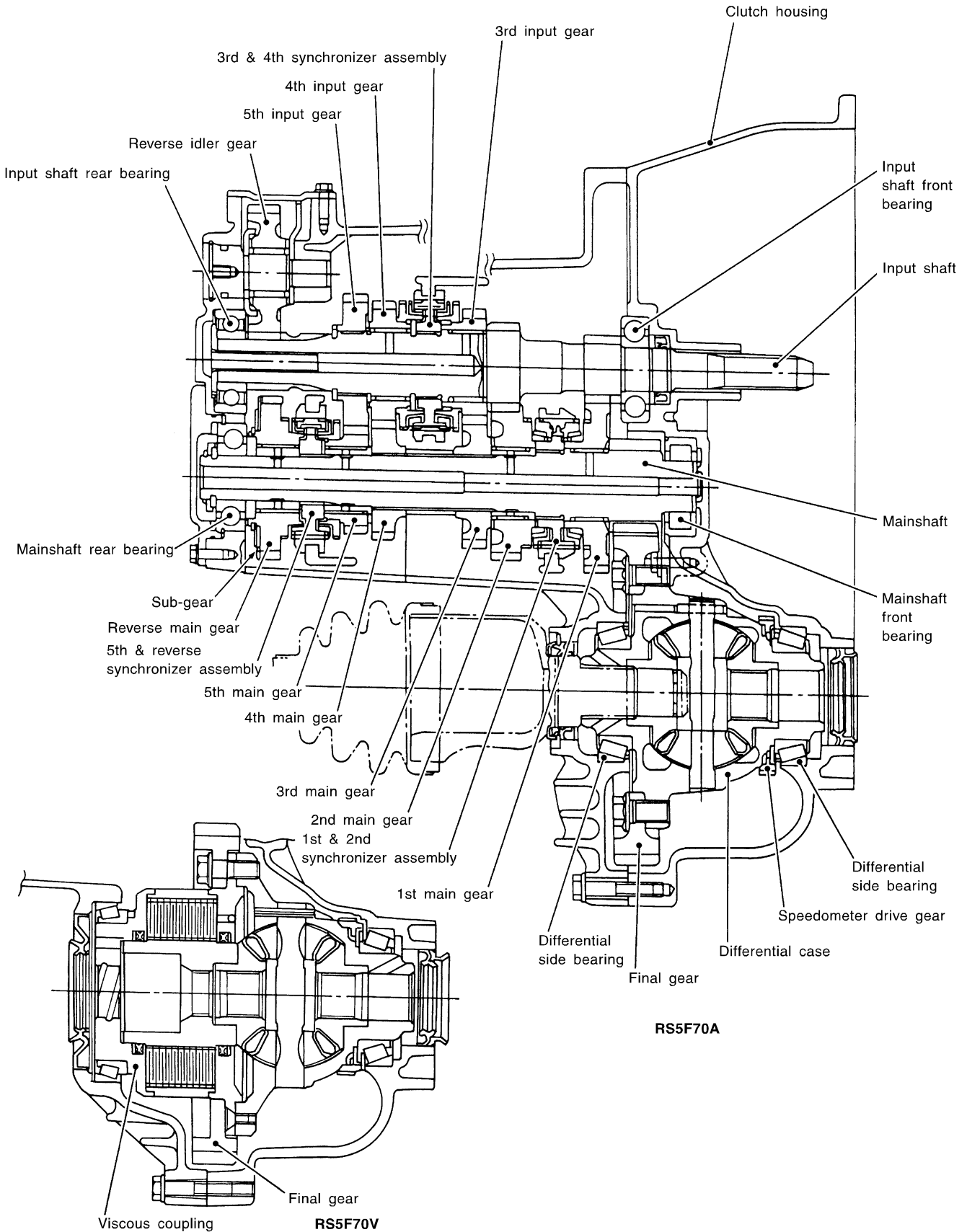

- GI
- MA
- EM
- LC
- EC
- FE
- CL
- MT**
- AT
- AX
- SU
- BR
- ST
- RS
- BT
- HA
- SC
- EL
- IDX

DESCRIPTION

Cross-sectional View (Cont'd)

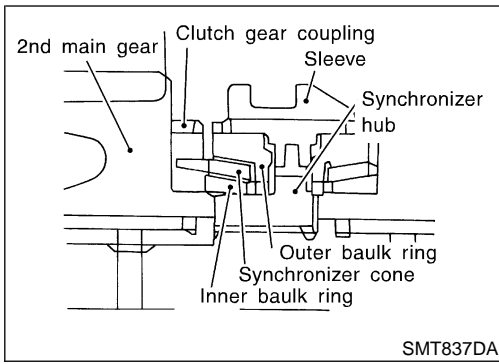

DOUBLE-CONE SYNCHRONIZER

Double-cone synchronizer is adopted for 1st and 2nd gears to reduce operating force of the shift lever. NCMT0004S0103

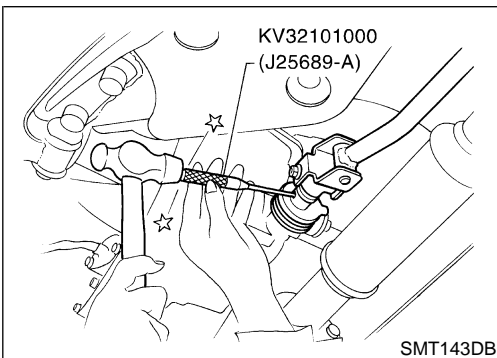
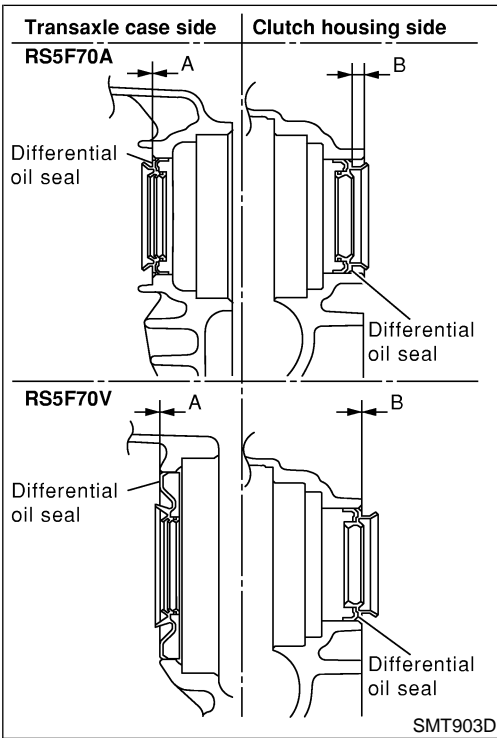
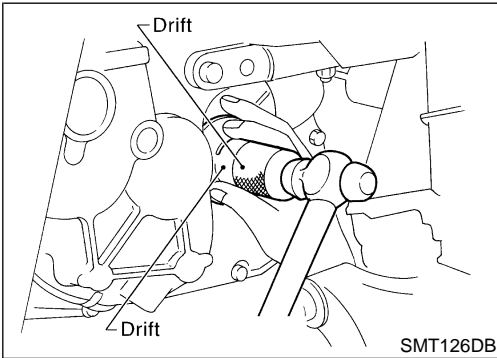
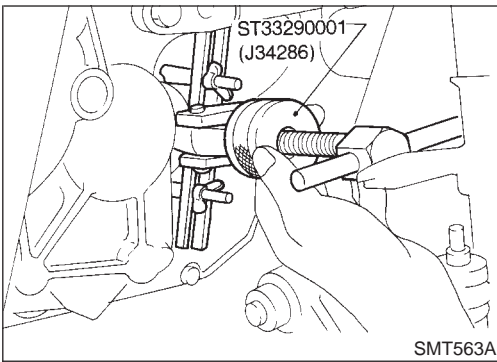

Replacing Oil Seal DIFFERENTIAL OIL SEAL

NCMT0005

NCMT0005S01

1. Drain gear oil from transaxle.
2. Remove drive shafts. Refer to AX-11, "Removal".
3. Remove differential oil seal.
4. Install differential oil seal.
 - **Apply multi-purpose grease to seal lip of oil seal before installing.**
5. Install drive shafts. Refer to AX-12, "Installation".

- **Install differential oil seal so that dimension "A" and "B" are within specifications.**

Unit: mm (in)

Item	Model	A	B
Dimension	RS5F70A	0.5 (0.020) or less	5.5 - 6.5 (0.217 - 0.256)
	RS5F70V		0.5 (0.020) or less

STRIKING ROD OIL SEAL

NCMT0005S02

1. Remove transaxle control rod from yoke.
2. Remove retaining pin of yoke.
 - **Be careful not to damage boot.**

ON-VEHICLE SERVICE

Replacing Oil Seal (Cont'd)

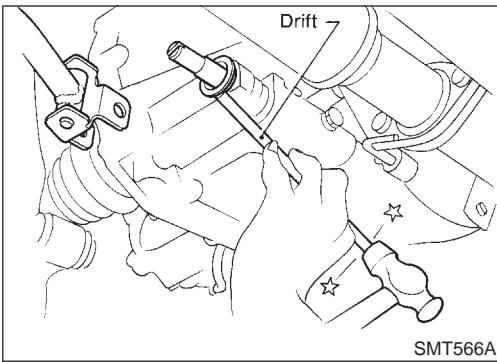

3. Remove striking rod oil seal.

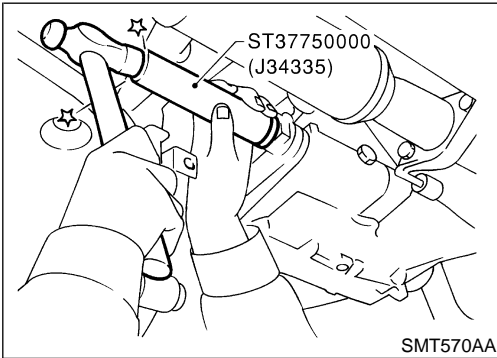

4. Install striking rod oil seal.

- Apply multi-purpose grease to seal lip of oil seal before installing.

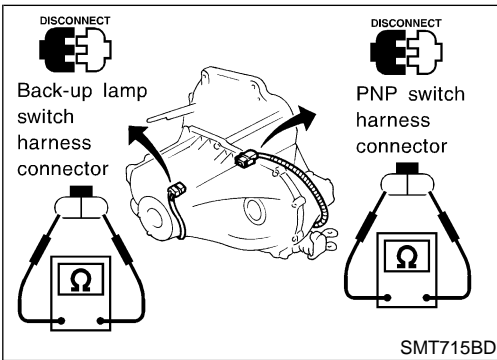

Position Switch Check BACK-UP LAMP SWITCH

NCMT0006

NCMT0006S01

- Check continuity.

Gear position	Continuity
Reverse	Yes
Except reverse	No

PNP SWITCH

NCMT0006S02

- Check continuity.

Gear position	Continuity
Neutral	Yes
Except neutral	No

NCMT0039

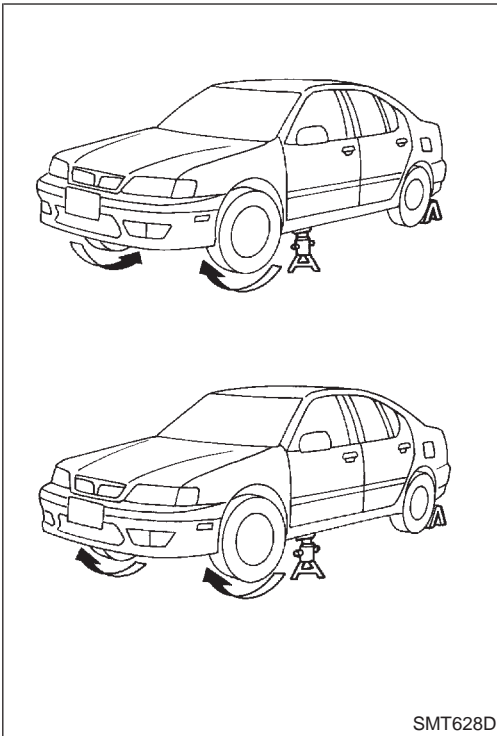

SMT628D

Viscous Coupling Check

1. Apply parking brake firmly and place shift lever in the neutral position.
2. Jack up front wheels.
3. Rotate one front wheel and check turning direction of the other front wheel.

Turning direction of the two wheels is opposite:

The viscous coupling is not functioning normally.

Turning direction of the two wheels is the same:

If differential side gear and pinion mate gear thrust washers are OK, viscous coupling is functioning normally.

GI

MA

EM

LC

EC

FE

CL

MT

AT

AX

SU

BR

ST

RS

BT

HA

SC

EL

IDX

REMOVAL AND INSTALLATION

Removal

Removal

NCMT0007S01

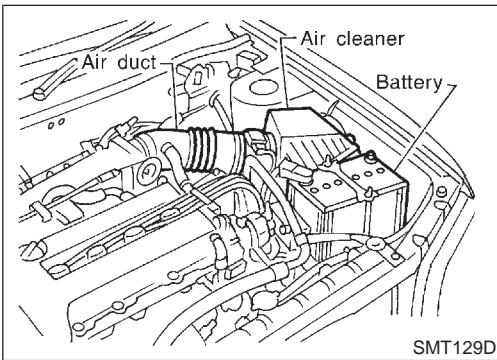
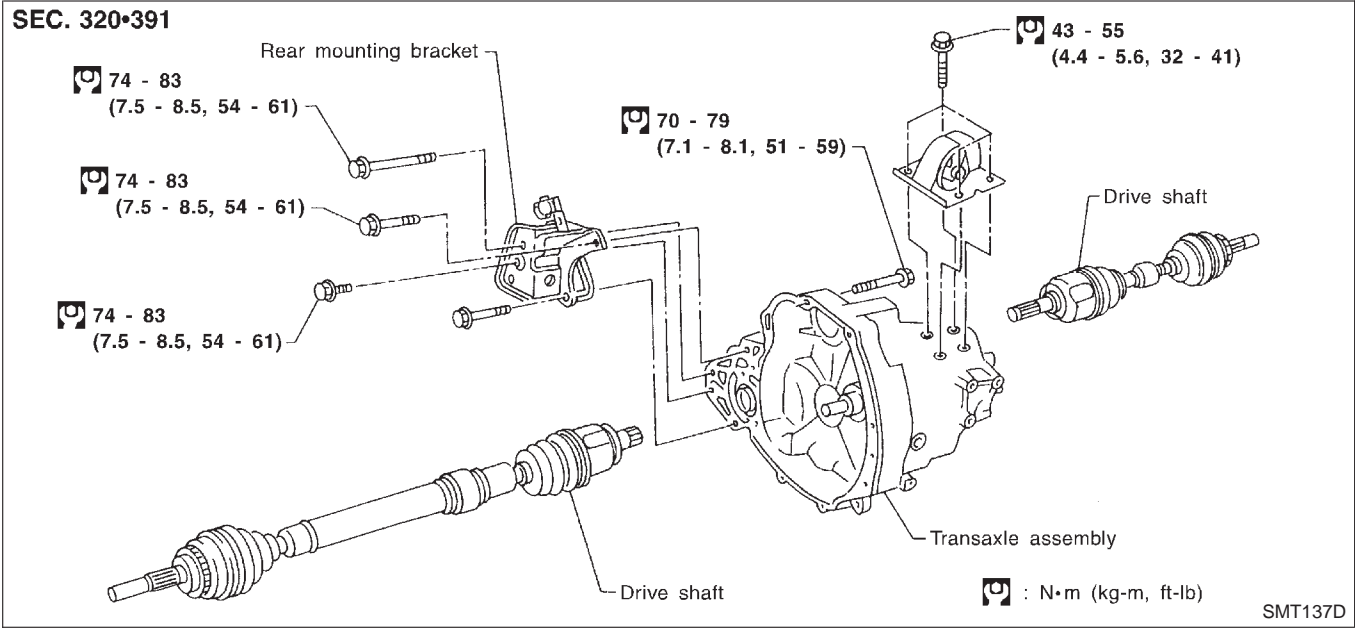

1. Remove battery negative terminal.
2. Remove air cleaner and air duct.
3. Remove clutch operating cylinder from transaxle. Refer to CL-13, "Removal".
4. Disconnect back-up lamp switch, speedometer sensor, PNP switch and ground harness connectors.

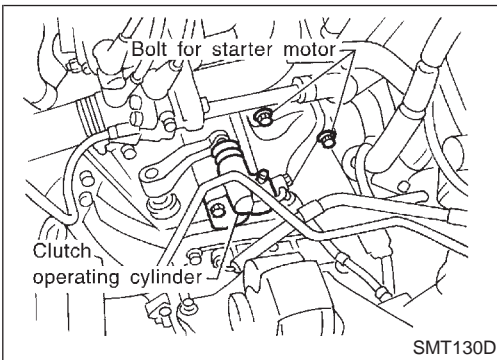

5. Remove starter motor from transaxle.

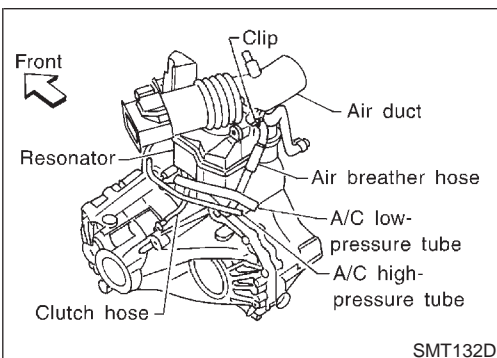

6. Remove air bleeder hose.

REMOVAL AND INSTALLATION

Removal (Cont'd)

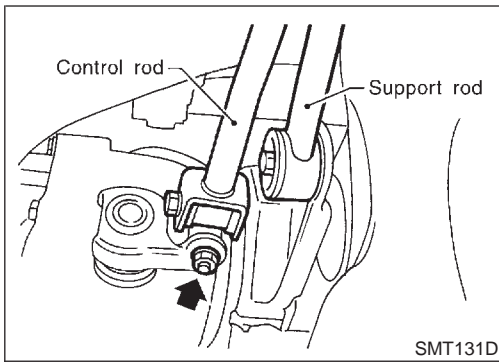

7. Remove shift control rod and support rod from transaxle.
8. Drain gear oil from transaxle.
9. Remove exhaust front tube.

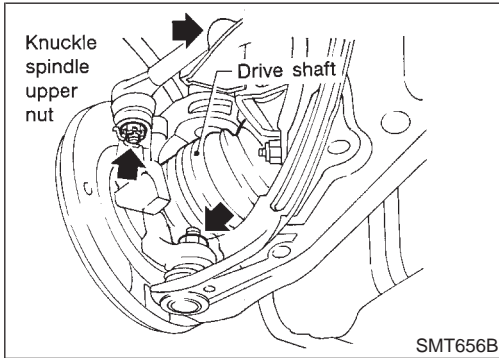

10. Draw out drive shafts from transaxle. Refer to AX-11, "Removal".

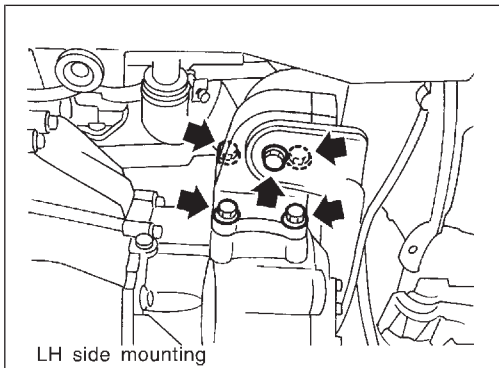

11. Support engine by placing a jack under oil pan.

CAUTION:

Do not place jack under oil pan drain plug.

12. Remove LH side and rear side mounting bolts.

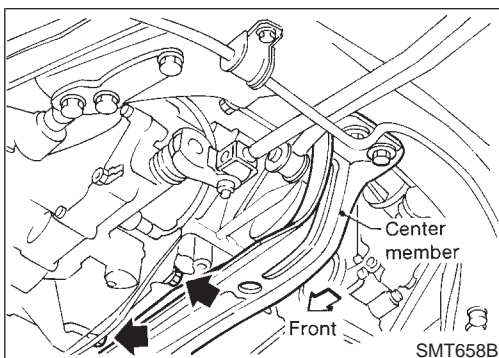
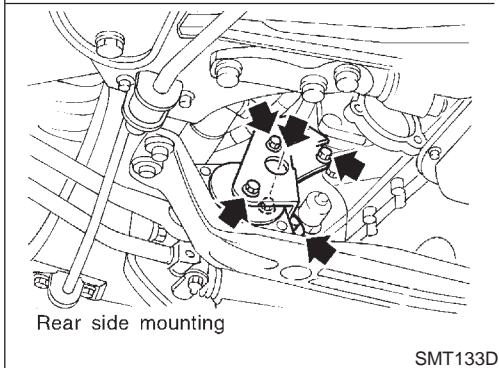

13. Raise jack for access to lower housing bolts. Remove bolts. Lower jack.

GI

MA

EM

LC

EC

FE

CL

MT

AT

AX

SU

BR

ST

RS

BT

HA

SC

EL

IDX

REMOVAL AND INSTALLATION

Removal (Cont'd)

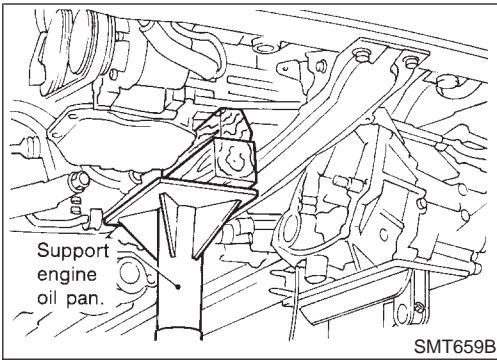

14. Remove bolts securing transaxle.
15. Lower transaxle while supporting it with a jack.

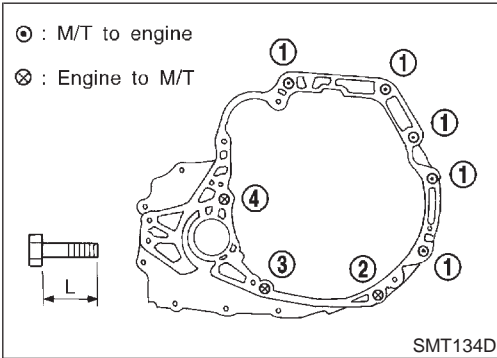

Installation

- Tighten bolts securing transaxle and install any part removed.
- Tighten starter motor bolts.

NCMT0007S02

⊙ : 41 - 52 N·m (4.2 - 5.3 kg·m, 30 - 38 ft·lb)

Bolt No.	1	2	3	4
Q'ty	5	1		
L in mm (in)	55 (2.17)	35 (1.38)	45 (1.77)	65 (2.56)
Tightening torque N·m (kg·m, ft·lb)	70 - 79 (7.1 - 8.1, 51 - 59)	30 - 40 (3.1 - 4.1, 22 - 30)		70 - 79 (7.1 - 8.1, 51 - 59)

Transaxle Gear Control

NCMT0008S01

SEC. 341

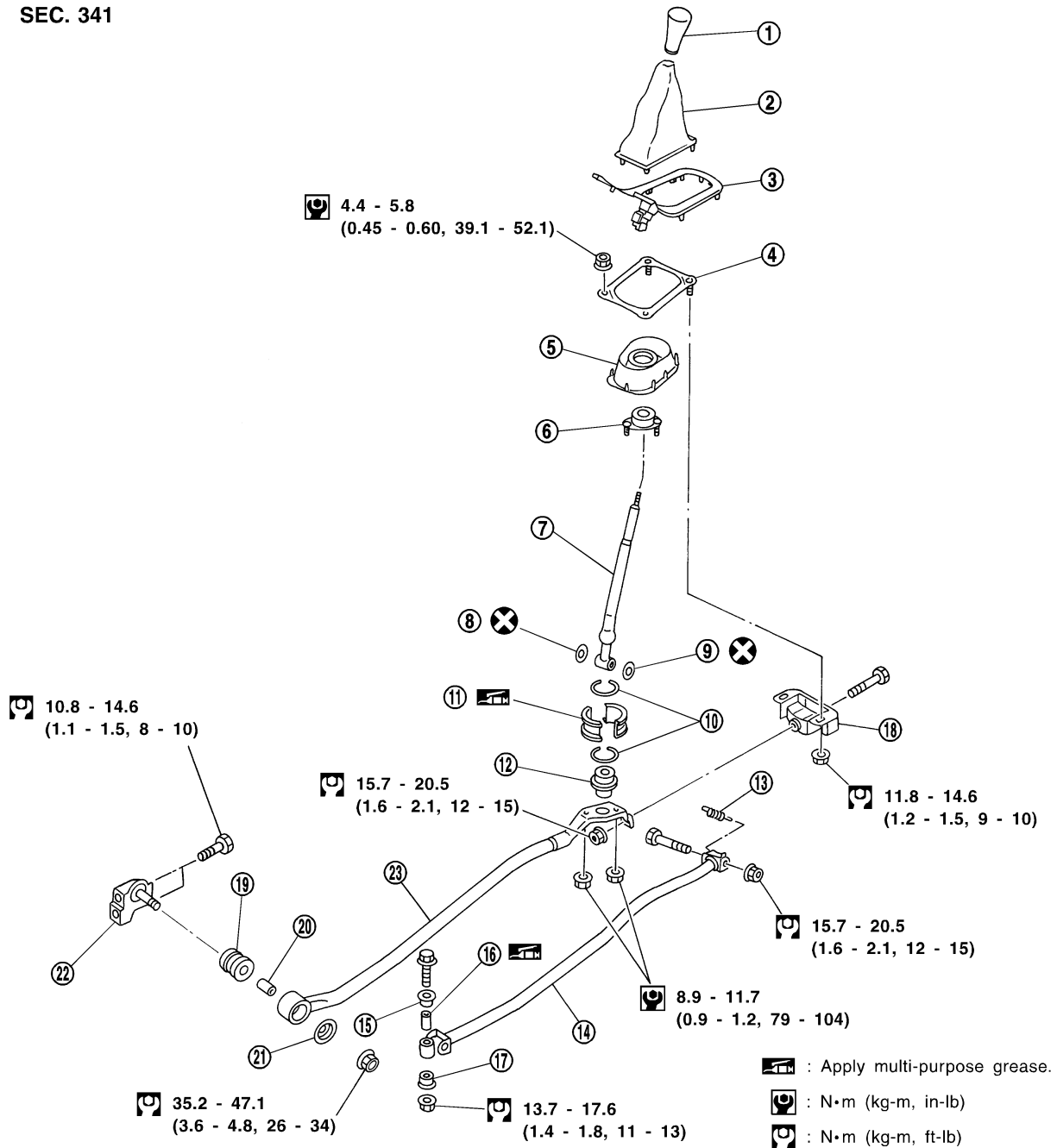

- | | | |
|--------------------------|-------------------|-------------------------|
| 1. Control lever knob | 9. O-ring | 17. Bush |
| 2. Boot | 10. Ring spring | 18. Bracket |
| 3. Finisher | 11. Bearing seat | 19. Bush |
| 4. Control lever bracket | 12. Seat | 20. Collar |
| 5. Dust cover | 13. Return spring | 21. Washer |
| 6. Socket | 14. Control rod | 22. Support rod bracket |
| 7. Control lever | 15. Bush | 23. Support rod |
| 8. O-ring | 16. Collar | |

GI

MA

EM

LC

EC

FE

CL

MT

AT

AX

SU

BR

ST

RS

BT

HA

SC

EL

IDX

SMT904D

OVERHAUL

Case Components

=NCMT0008S02

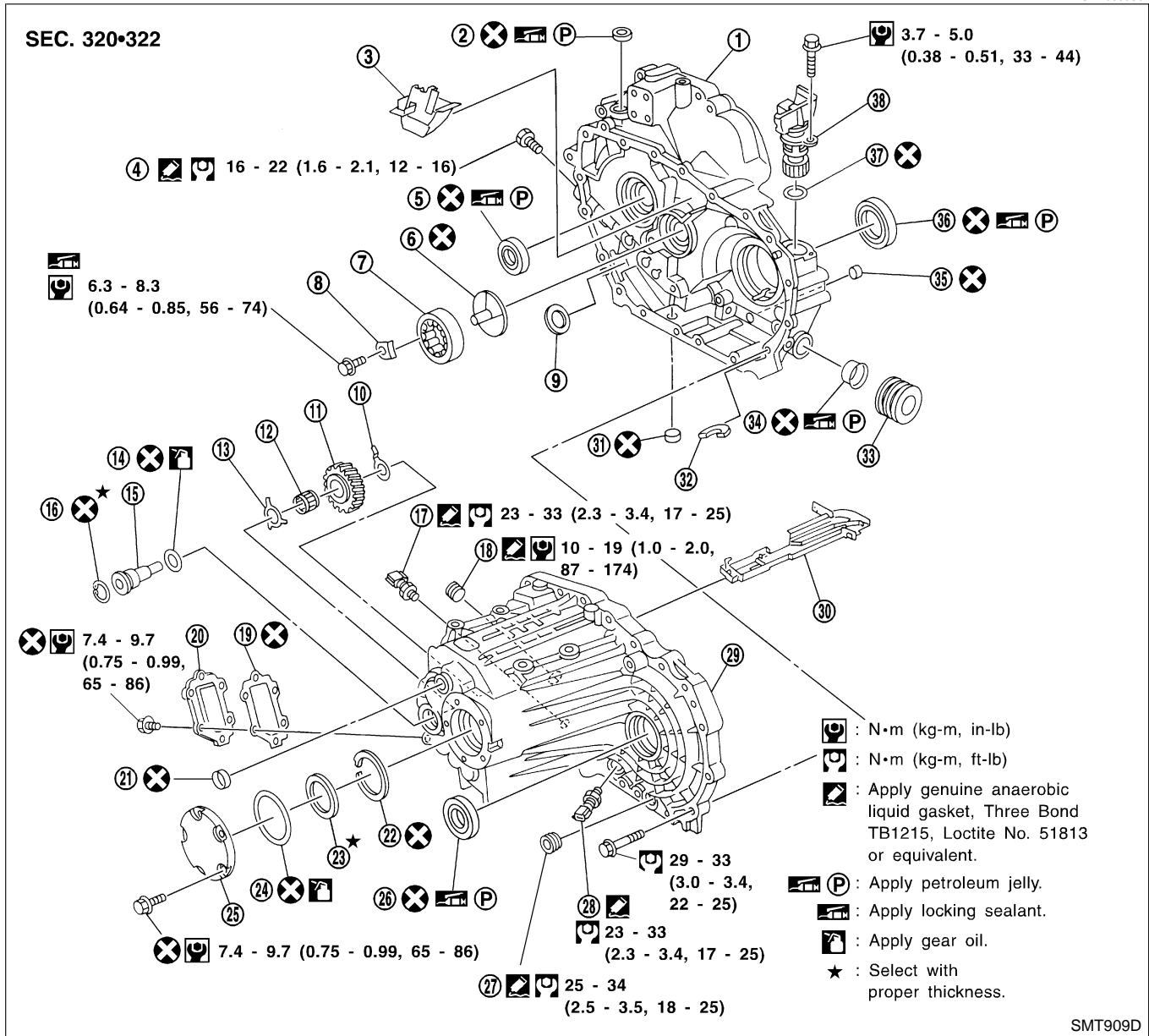



- | | | |
|--------------------------------------------|-------------------------------------------|---------------------------|
| 1. Clutch housing | 14. O-ring | 26. Differential oil seal |
| 2. Dust seal | 15. Reverse idler gear shaft | 27. Drain plug |
| 3. Oil pocket | 16. Snap ring | 28. PNP switch |
| 4. Check plug | 17. Reverse switch | 29. Transmission case |
| 5. Input shaft oil seal | 18. Filler plug | 30. Oil gutter |
| 6. Oil channel | 19. Side cover gasket | 31. Welch plug |
| 7. Mainshaft front bearing | 20. Side cover | 32. Magnet |
| 8. Bearing retainer | 21. Welch plug | 33. Boot |
| 9. Magnet | 22. Mainshaft bearing snap ring | 34. Striking rod oil seal |
| 10. Reverse idler gear front thrust washer | 23. Mainshaft rear bearing adjusting shim | 35. Welch plug |
| 11. Reverse idler gear | 24. O-ring | 36. Differential oil seal |
| 12. Reverse idler gear bearing | 25. Rear cover | 37. O-ring |
| 13. Reverse idler gear rear thrust washer | | 38. Speedometer pinion |

Gear Components

=NCMT0008S03

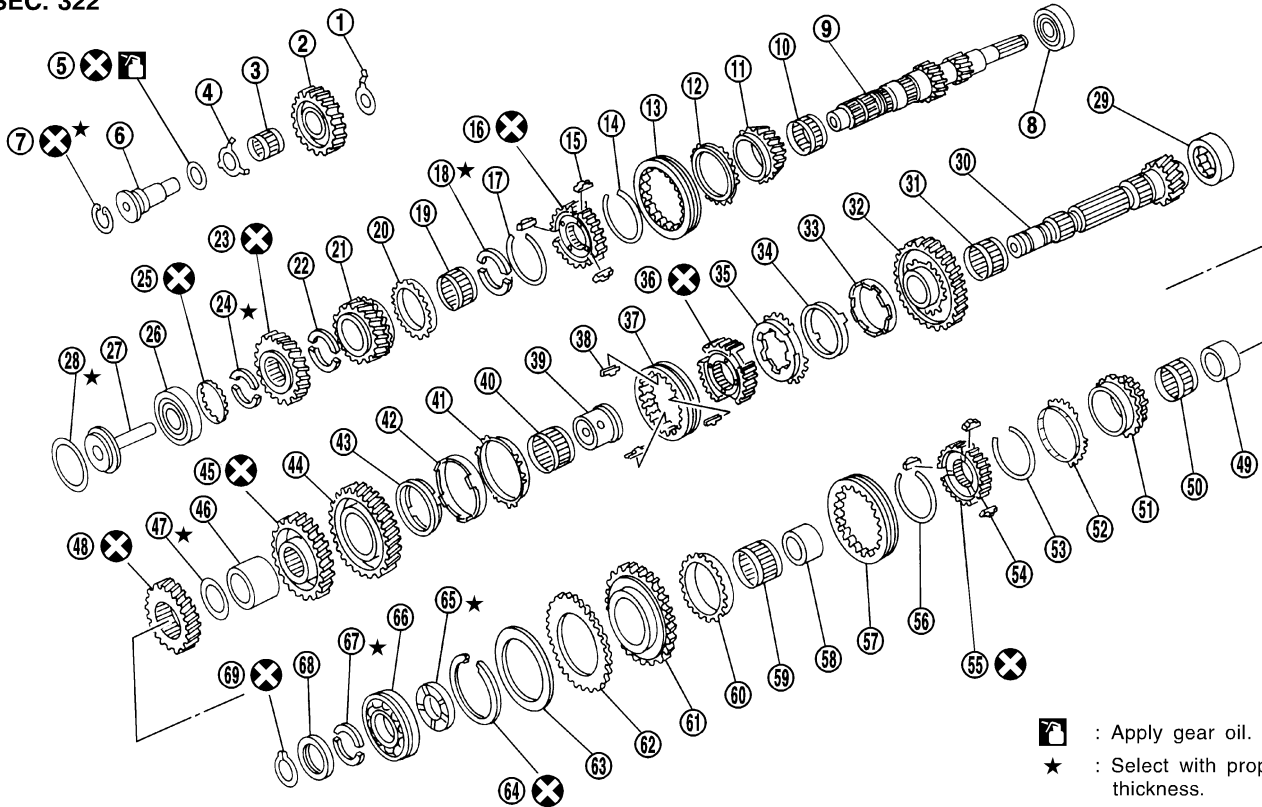
SEC. 322



 : Apply gear oil.
 ★ : Select with proper thickness.

SMT641DA

1. Reverse idler gear front thrust washer
2. Reverse idler gear
3. Reverse idler gear bearing
4. Reverse idle gear rear thrust washer
5. O-ring
6. Reverse idler gear shaft
7. Snap ring
8. Input shaft front bearing
9. Input shaft
10. 3rd gear needle bearing
11. 3rd input gear
12. 3rd gear baulk ring
13. Coupling sleeve
14. Spread spring
15. Shifting insert
16. 3rd & 4th synchronizer hub
17. Spread spring
18. 4th gear C-ring
19. 4th gear needle bearing
20. 4th gear baulk ring
21. 4th input gear
22. 5th gear front C-ring
23. 5th input gear

24. 5th gear rear C-ring
25. C-ring holder
26. Input shaft rear bearing
27. Oil channel
28. Input shaft rear bearing adjusting shim
29. Mainshaft front bearing
30. Mainshaft
31. 1st gear needle bearing
32. 1st main gear
33. 1st inner baulk ring
34. 1st synchronizer cone
35. 1st outer baulk ring
36. 1st & 2nd synchronizer hub
37. Coupling sleeve
38. Insert spring
39. 2nd gear bush
40. 2nd gear needle bearing
41. 2nd gear outer baulk ring
42. 2nd gear synchronizer cone
43. 2nd inner baulk ring
44. 2nd main gear
45. 3rd main gear
46. Spacer

47. Mainshaft adjusting shim
48. 4th main gear
49. 5th gear bush
50. 5th gear needle bearing
51. 5th main gear
52. 5th gear baulk ring
53. Spread spring
54. Shifting insert
55. 5th & reverse synchronizer hub
56. Spread spring
57. Coupling sleeve
58. Reverse gear bush
59. Reverse gear needle bearing
60. Reverse gear baulk ring
61. Reverse main gear
62. Sub-gear
63. Sub-gear washer
64. Snap ring
65. Mainshaft thrust washer
66. Mainshaft rear bearing
67. Mainshaft C-ring
68. C-ring holder
69. Snap ring

GI
 MA
 EM
 LC
 EC
 FE
 CL
MT
 AT
 AX
 SU
 BR
 ST
 RS
 BT
 HA
 SC
 EL
 IDX

OVERHAUL

Shift Control Components

=NCMT0008S04

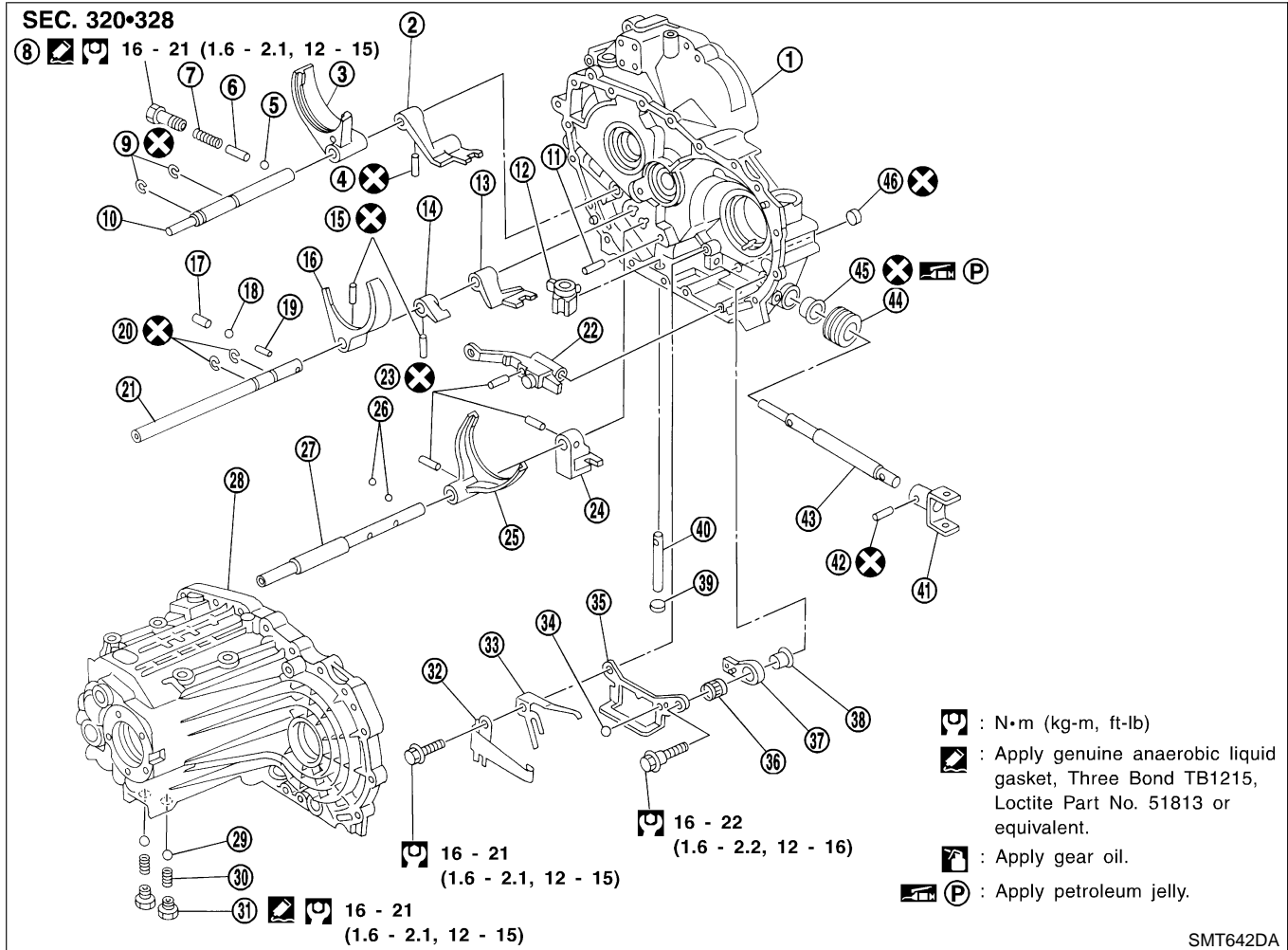



- | | | |
|------------------------------|----------------------------|------------------------------|
| 1. Clutch housing | 17. Interlock plunger | 32. Select check leaf spring |
| 2. 3rd & 4th bracket | 18. Check ball | 33. Return spring |
| 3. 3rd & 4th shift fork | 19. Interlock pin | 34. Steel ball |
| 4. Retaining pin | 20. Stopper ring | 35. Reverse gate |
| 5. Check ball | 21. 5th & reverse fork rod | 36. Return bearing |
| 6. Check pin | 22. Striking lever | 37. Selector arm |
| 7. Check spring | 23. Retaining pin | 38. Bush |
| 8. Check plug | 24. 1st & 2nd bracket | 39. Welch plug |
| 9. Stopper ring | 25. 1st & 2nd shift fork | 40. Selector shaft |
| 10. 3rd & 4th fork rod | 26. Check ball | 41. Striking yoke |
| 11. Selector shaft pin | 27. 1st & 2nd fork rod | 42. Retaining pin |
| 12. Selector | 28. Transaxle case | 43. Striking rod |
| 13. 5th & reverse bracket | 29. Check ball | 44. Dust boot |
| 14. Reverse switch bracket | 30. Check spring | 45. Striking rod oil seal |
| 15. Retaining pin | 31. Check plug | 46. Welch plug |
| 16. 5th & reverse shift fork | | |

Final Drive Components

=NCMT0008S05

SEC. 322

  RS5F70A
98 - 108
(10.0 - 11.0, 72 - 80)
RS5F70V
53 - 67
(5.4 - 6.9, 39 - 49)

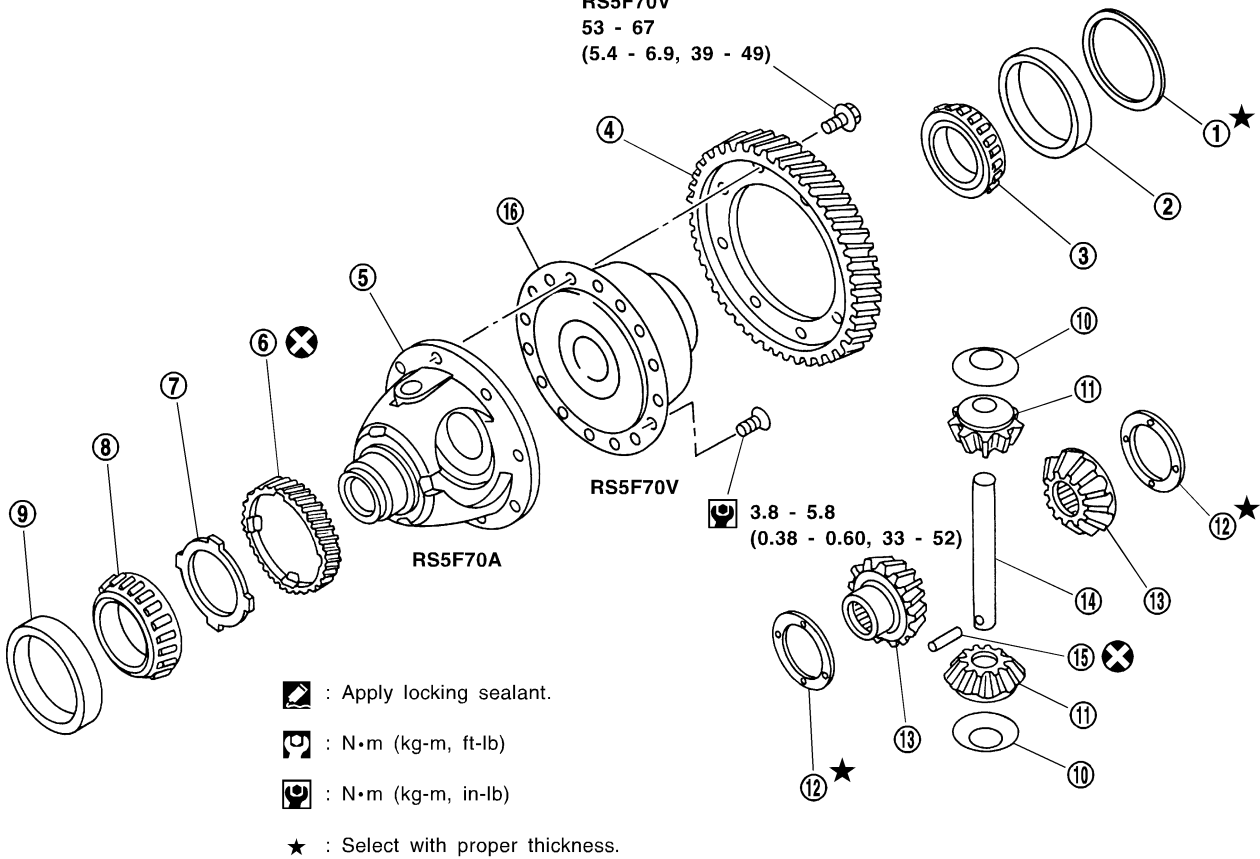

SMT905D

- | | | |
|---------------------------------------------|-----------------------------------------|-----------------------------|
| 1. Differential side bearing adjusting shim | 6. Speedometer drive gear | 12. Side gear thrust washer |
| 2. Differential side bearing outer race | 7. Speedometer stopper | 13. Side gear |
| 3. Differential side bearing | 8. Differential side bearing | 14. Pinion mate shaft |
| 4. Final gear | 9. Differential side bearing outer race | 15. Lock pin |
| 5. Differential case | 10. Pinion mate thrust washer | 16. Viscous coupling |
| | 11. Pinion mate gear | |

GI

MA

EM

LC

EC

FE

CL

MT

AT

AX

SU

BR

ST

RS

BT

HA

SC

EL

IDX

DISASSEMBLY

Transaxle Case

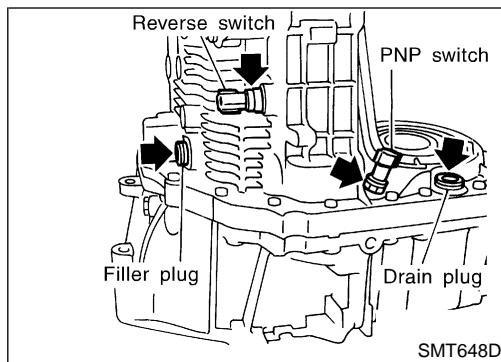

Transaxle Case

NCMT0009S01

1. Remove reverse switch, PNP switch, drain plug, and filler plug from transaxle case.

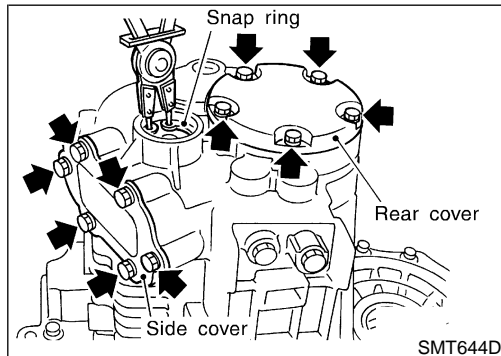

2. Remove snap rings from reverse idler shaft.
3. Remove side cover and rear cover from case.
4. Remove O-ring and mainshaft bearing adjusting shim.

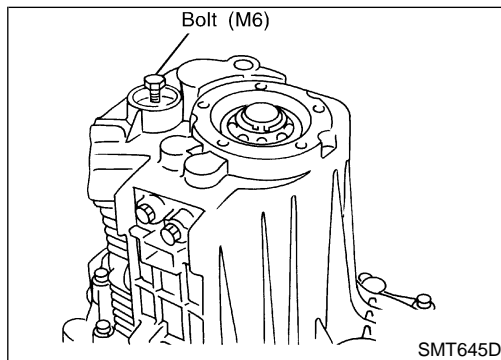

5. Remove reverse idler gear shaft.
 - a. Attach bolt (M6) to thread of reverse idler gear shaft end.
 - b. Pull out the attached bolt, and remove reverse idler gear shaft from case.
6. Remove reverse idler gear, thrust washer (front, rear), and bearing from case.

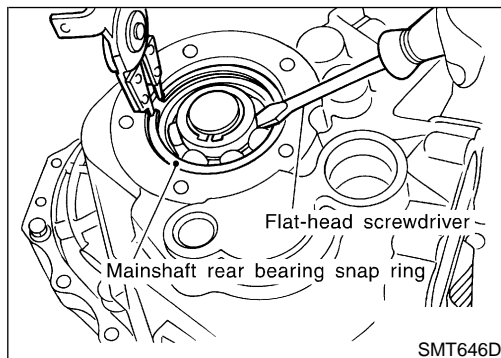

7. Remove snap ring of mainshaft bearing from case.

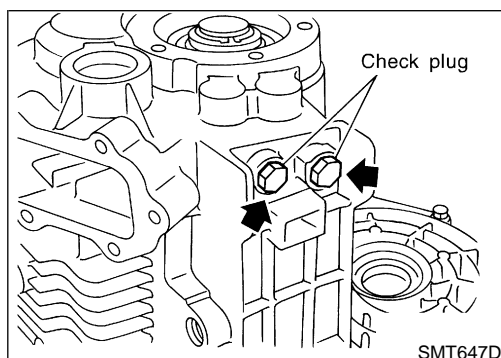

8. Remove check plugs, springs, and check balls from case.

DISASSEMBLY

Transaxle Case (Cont'd)

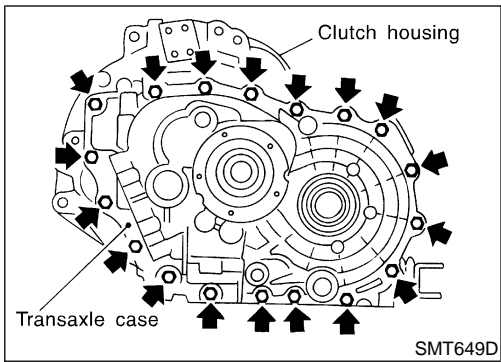

9. Remove mounting bolts.
10. Remove input shaft rear bearing adjusting shim from transaxle case.

GI

MA

EM

LC

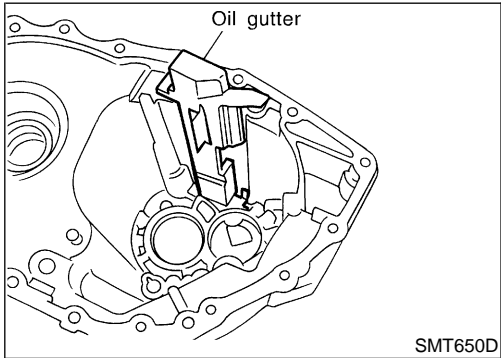

11. Remove oil gutter from case.

EC

FE

CL

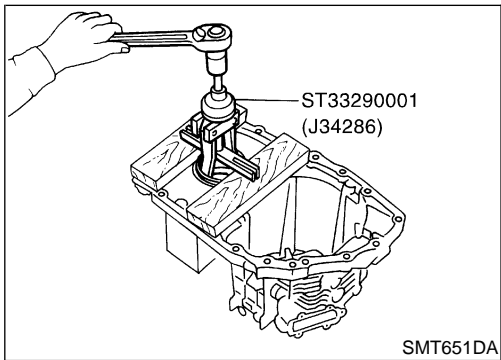

12. Remove differential side bearing outer race and adjusting shim from case.

MT

AT

AX

SU

BR

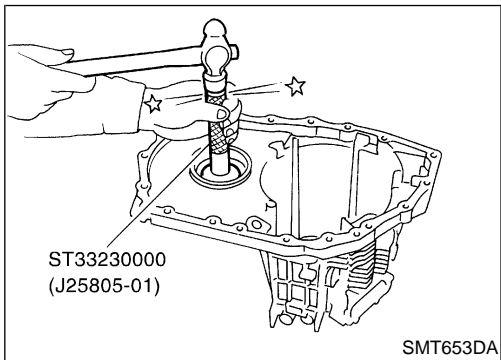

13. Remove differential oil seal from case.

ST

RS

BT

HA

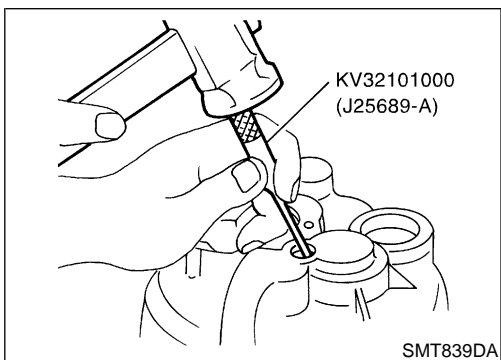

14. Remove welch plugs from case.

SC

EL

IDX

DISASSEMBLY

Clutch Housing

NCMT0009S02

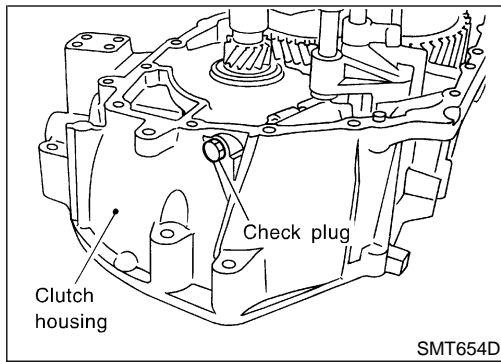

Clutch Housing

1. Remove transaxle case from clutch housing.
2. Remove magnet from housing.
3. Remove check plugs, check springs, check pins, and check balls from housing.

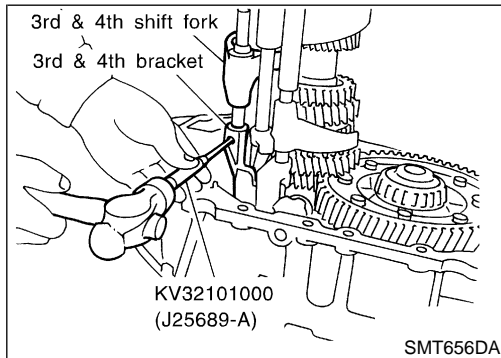

4. Remove 3rd & 4th bracket retaining pin.

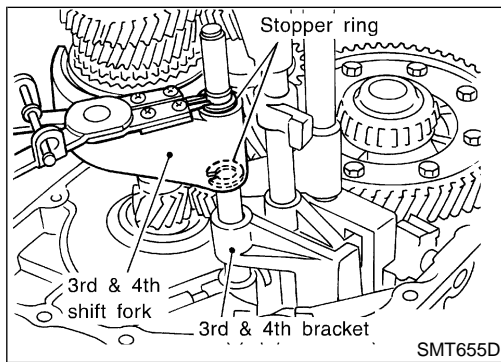

5. Remove 3rd & 4th shift fork stopper ring.
6. Remove 3rd & 4th fork rod.
7. Remove 3rd & 4th shift fork and bracket.

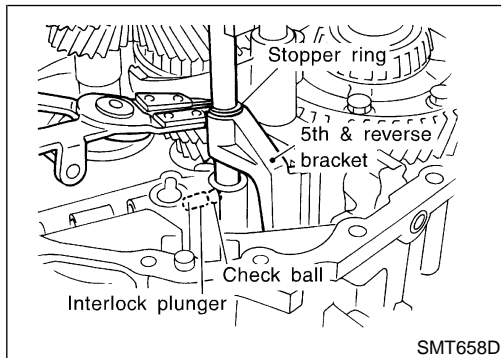

8. Remove interlock plunger and check ball.
9. Remove 5th & reverse bracket stopper ring.

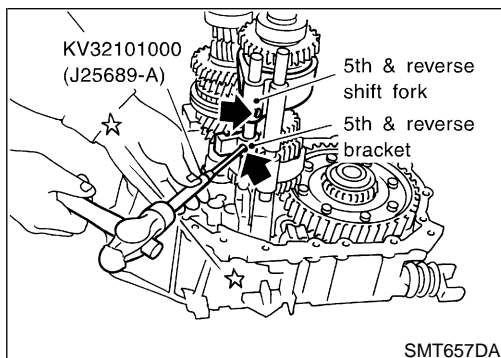

10. Remove retaining pin from 5th & reverse shift fork and reverse switch bracket.
11. Remove 5th & reverse fork rod.
12. Remove interlock pin from 5th & reverse fork rod.
13. Remove reverse switch bracket and 5th & reverse bracket.

DISASSEMBLY

Clutch Housing (Cont'd)

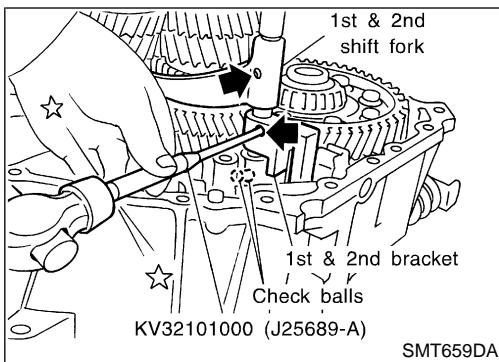

14. Remove check ball from housing.
15. Remove retaining pin for 1st & 2nd shift fork and bracket.
16. Remove 1st & 2nd fork rod.
17. Remove 5th & reverse and 1st & 2nd shift forks, and 1st & 2nd bracket.

GI

MA

EM

LC

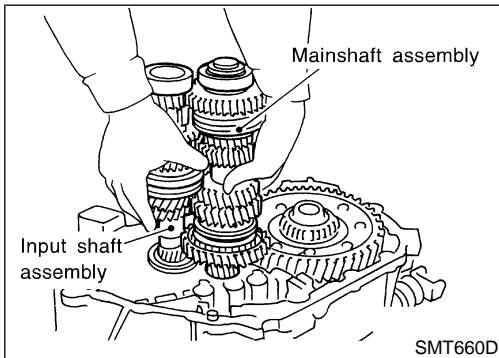

18. Remove both input shaft and mainshaft assemblies from housing.

EC

FE

CL

MT

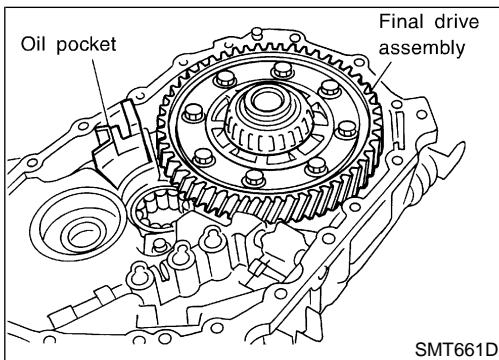

19. Remove final drive assembly from housing.
20. Remove oil pocket from housing.

AT

AX

SU

BR

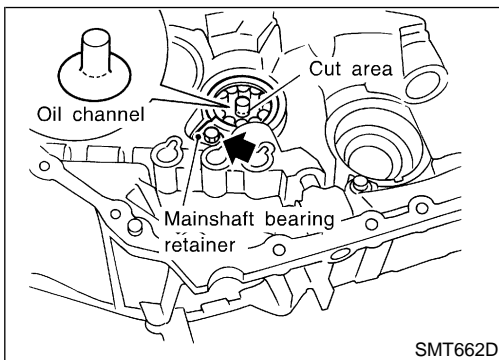

21. Remove mainshaft bearing retainer from housing.
22. Cut off oil channel using a cutter as shown in the figure.

ST

RS

BT

HA

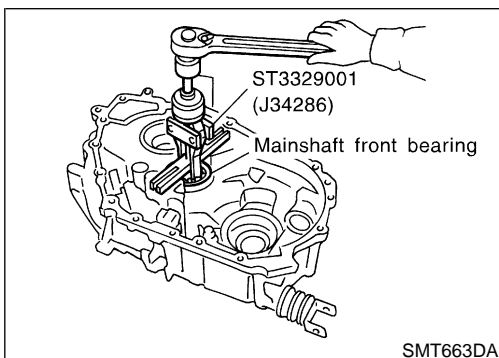

23. Remove mainshaft front bearing from housing.

SC

EL

IDX

DISASSEMBLY

Clutch Housing (Cont'd)

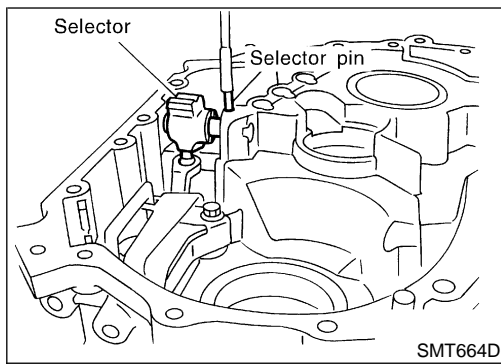

24. Using a magnet or other suitable tool, remove retaining pin from selector shaft.

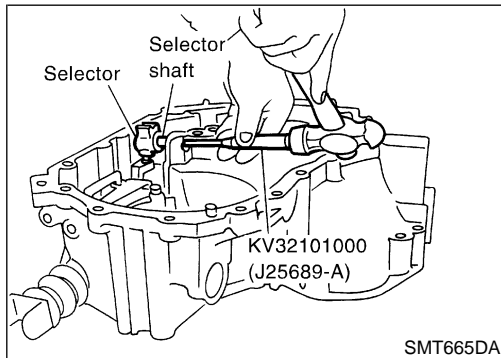

25. Remove selector shaft and plug, then remove selector.

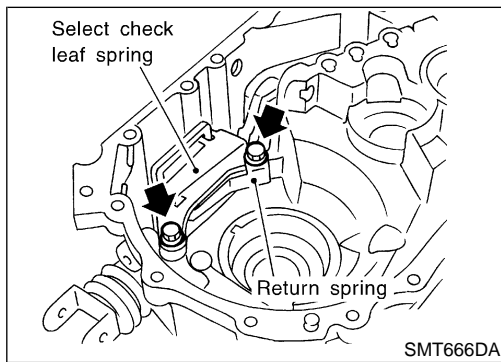

26. Remove reamer bolt, then remove select check leaf spring, return spring, steel ball, reverse gate, selector arm, bearing, and bushing.

CAUTION:
Be careful not to lose the steel ball.

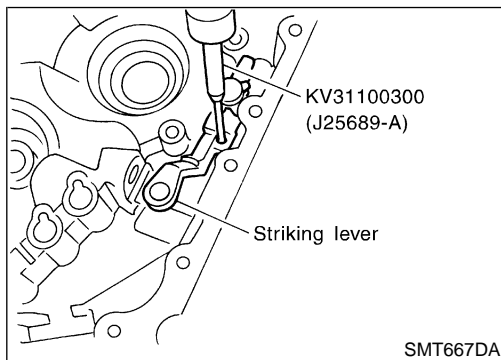

27. Remove retaining pin and plug from striking lever.

28. Remove striking rod, then striking lever from housing.

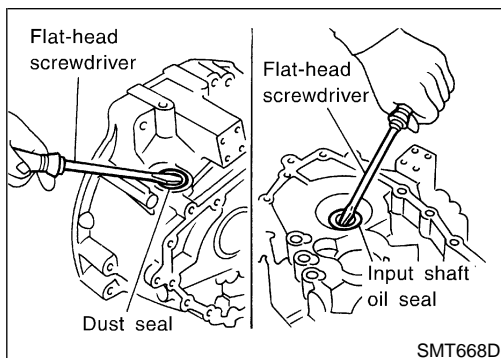

29. Using a flat-head screwdriver or other suitable tool, remove dust seal, input shaft oil seal, and striking rod oil seal from housing.

CAUTION:
When removing dust and oil seals, be careful not to damage mounting surfaces of dust seal and oil seal.

DISASSEMBLY

Clutch Housing (Cont'd)

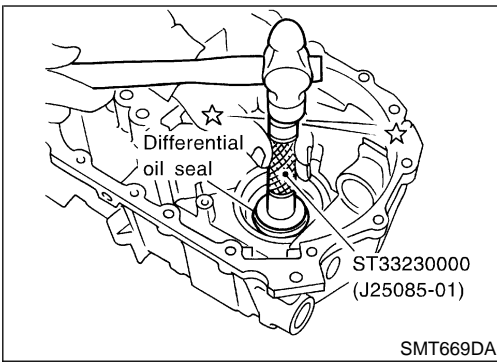

30. Remove differential oil seal from housing.

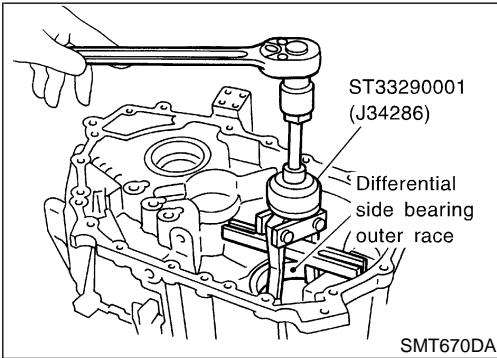

31. Remove differential side outer race from housing.

GI

MA

EM

LC

EC

FE

CL

MT

AT

AX

SU

BR

ST

RS

BT

HA

SC

EL

IDX

REPAIR FOR COMPONENT PARTS

Input Shaft and Gears

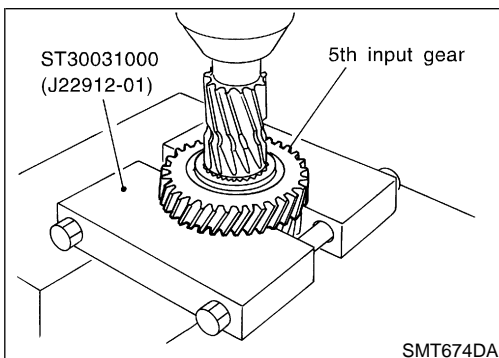
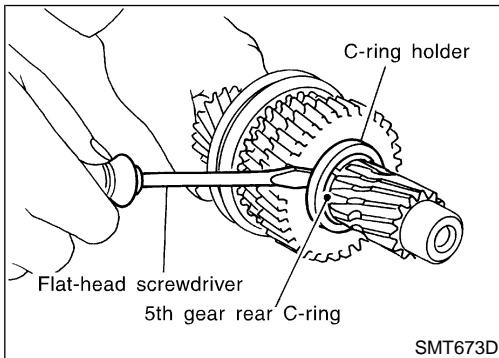
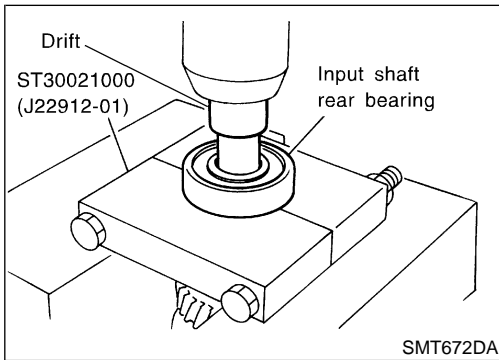
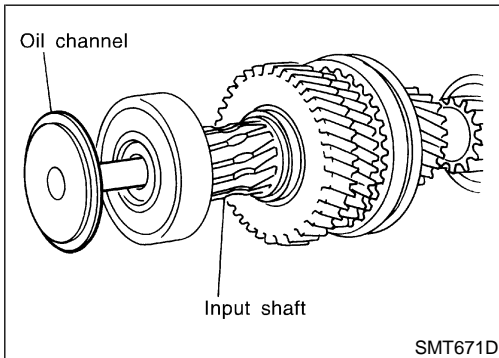
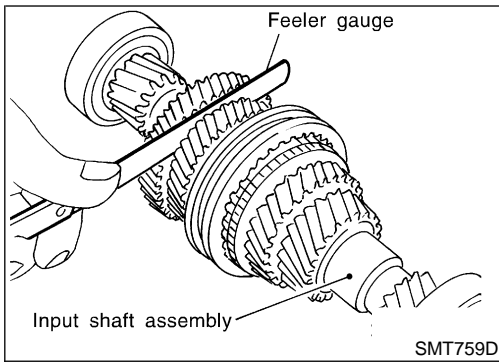

Input Shaft and Gears

DISASSEMBLY

NCMT0010

1. Before disassembly, measure the end plays of 3rd and 4th input gears.

Gear end play:

Refer to SDS, MT-57.

- If end play is not within specification, disassemble and check the parts.

2. Remove oil channel from input shaft rear bearing.

3. Press out input shaft rear bearing.

4. Remove C-ring holder.

5. Remove 5th gear rear C-ring.

6. Remove 5th input gear from input shaft.

7. Remove 5th gear front C-ring.

REPAIR FOR COMPONENT PARTS

Input Shaft and Gears (Cont'd)

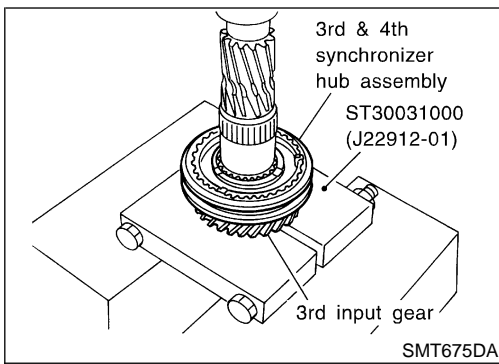

8. Remove 4th input gear, baulk ring, 4th gear needle bearing, and 4th gear C-ring from input shaft.
9. Press out both 3rd & 4th synchronizer hub assembly and 3rd input gear from input shaft.
10. Remove 3rd gear needle bearing.

GI

MA

EM

LC

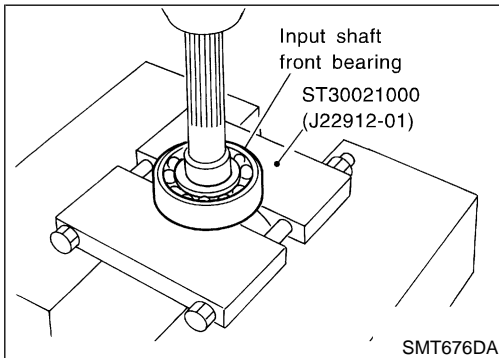

11. Press out input shaft front bearing from input shaft.

EC

FE

CL

MT

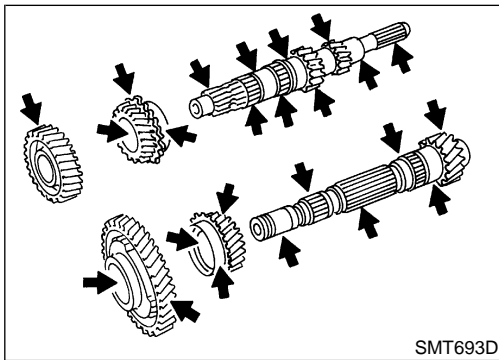

INSPECTION

Gear and Shaft

- Check shaft for cracks, wear or bending.
- Check gears for excessive wear, chips or cracks.

NCMT0011

AT

NCMT0011S01

AX

SU

BR

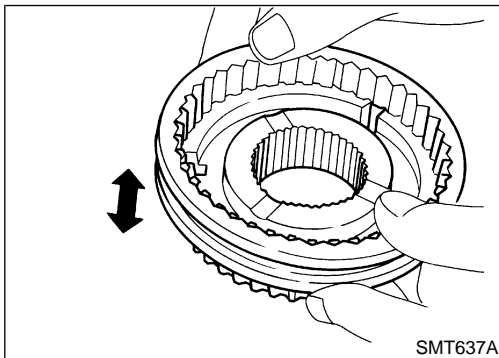

Synchronizers

- Check spline area of coupling sleeves, hubs and gears for wear or cracks.
- Check baulk rings for cracks or deformation.
- Check insert springs for wear or deformation.

NCMT0011S02

ST

RS

BT

HA

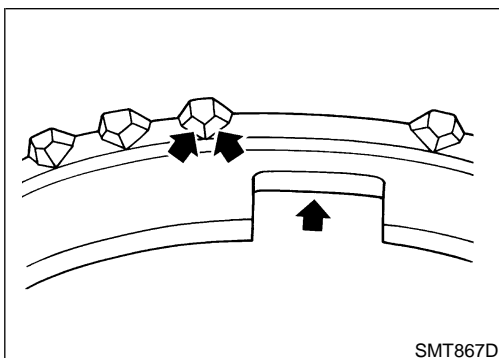

- If any crack, damage, or excessive wear is found on cam face of baulk ring or working face of insert, replace it.

SC

EL

IDX

REPAIR FOR COMPONENT PARTS

Input Shaft and Gears (Cont'd)

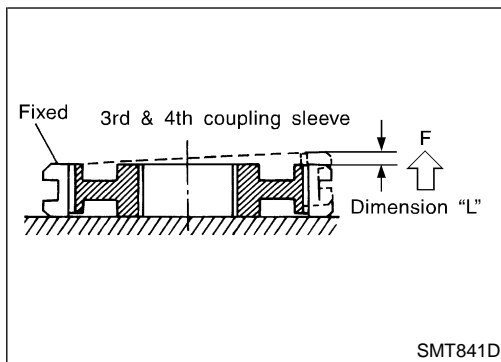

- Measure the movement (play, dimension "L") of 3rd & 4th coupling sleeve with their end fixed and the other end lifted as shown in the figure. If the movement exceeds specification, replace the sleeve.

Coupling sleeve	Length "L"
3rd & 4th	0 - 0.95 mm (0 - 0.0374 in)

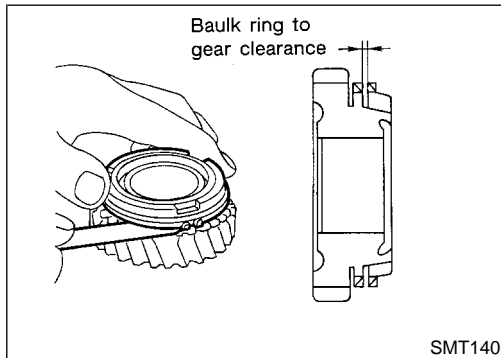

- Measure clearance between baulk ring and gear.
Clearance between baulk ring and gear:
Refer to SDS, MT-57.

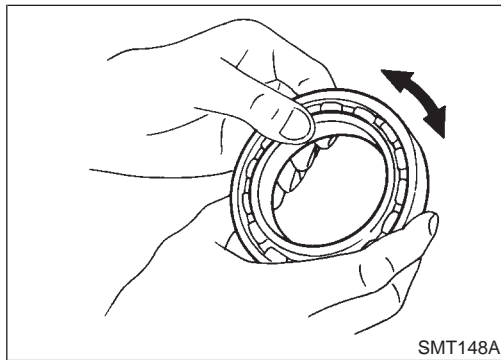

Bearing

NCMT0011S03

- Make sure bearings roll freely and are free from noise, cracks, pitting or wear.

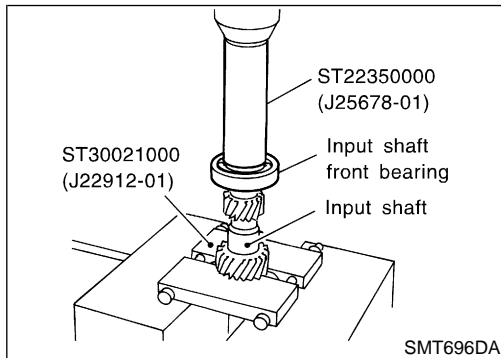

ASSEMBLY

NCMT0012

1. Press on input shaft front bearing.
2. Install 3rd gear needle, 3rd input gear and 3rd gear baulk ring bearing to input shaft.

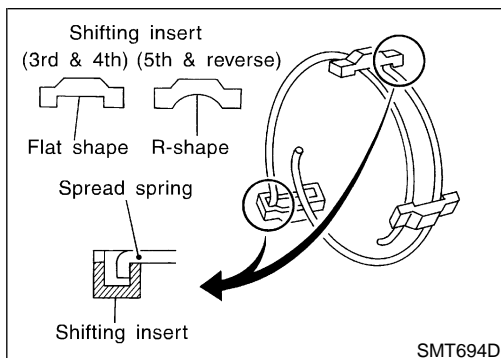

3. Install spread spring, shifting insert, and 3rd & 4th synchronizer hub onto 3rd & 4th coupling sleeve.

- Pay attention to the shape of spread spring and shifting insert for correct assembly.

Do not install spread spring hook onto the same shifting insert.

CAUTION:

Do not reuse 3rd & 4th synchronizer hub.

REPAIR FOR COMPONENT PARTS

Input Shaft and Gears (Cont'd)

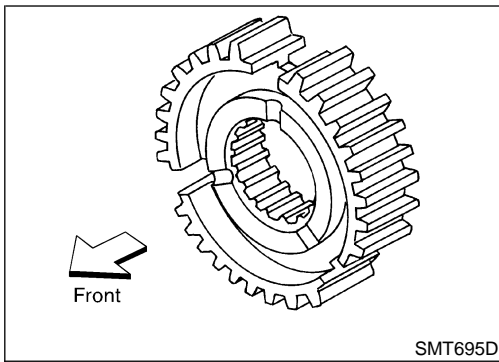

- Install synchronizer hub with its three grooves facing the front side (3rd input gear side).

GI

MA

EM

LC

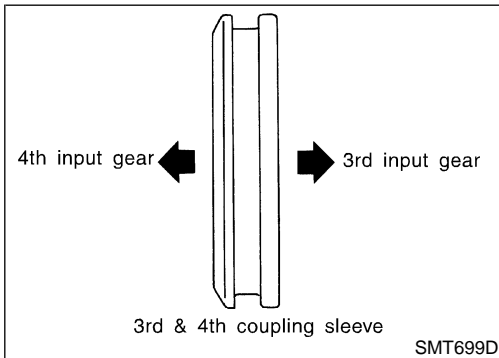

- Install 3rd & 4th coupling sleeve with its chamfered surface facing the 4th input gear side.

EC

FE

CL

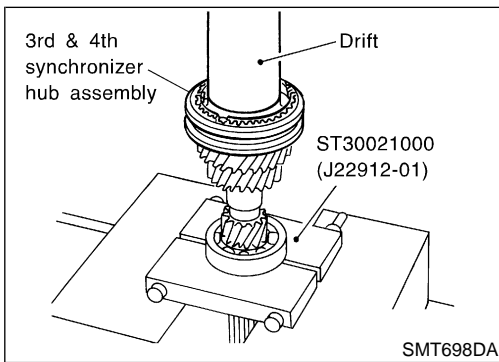

4. Position bearing replacer to the front side of input shaft front bearing.

AT

- Align grooves of shifting insert and 3rd gear baulk ring. Then, press it onto 3rd & 4th synchronizer hub assembly using a drift.

AX

5. Install 4th gear C-ring onto input shaft.

SU

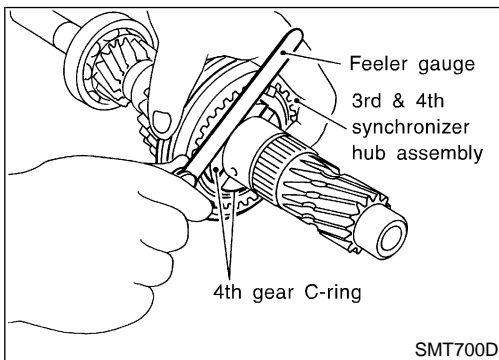

6. Measure the end play of 3rd & 4th synchronizer hub, and check if it is within allowable specification below.

ST

End play:

0 - 0.06 mm (0 - 0.0024 in)

RS

7. If not within specification, adjust the end play by changing thickness of 4th input gear C-ring.

4th input gear C-ring:

Refer to SDS, MT-58.

BT

HA

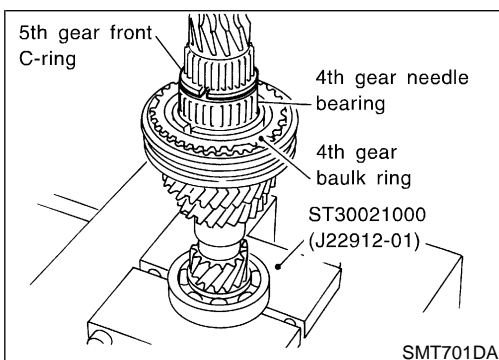

8. Install 4th gear needle bearing, 4th gear baulk ring, and 5th gear front C-ring.

SC

9. Install 4th input gear.

EL

IDX

REPAIR FOR COMPONENT PARTS

Input Shaft and Gears (Cont'd)

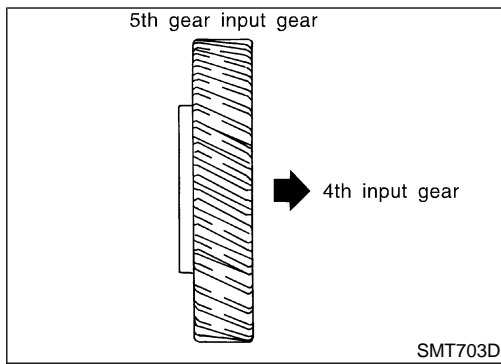

10. Position 5th input gear as shown in the figure, and install it on input shaft.

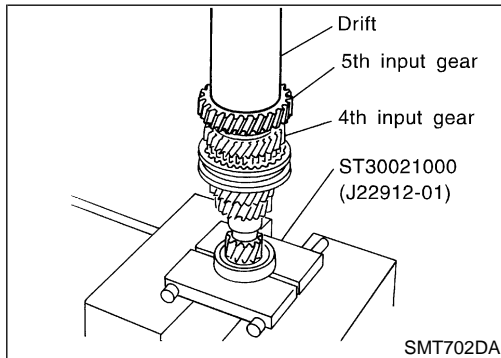

11. Install 5th input gear.

CAUTION:
Do not reuse 5th input gear.

12. Install 5th gear rear C-ring onto input shaft.

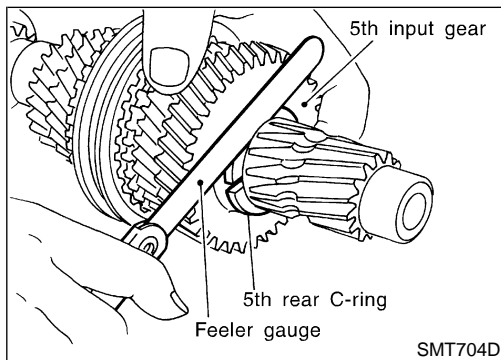

13. Measure the end play of 5th input gear, and check if it is within the allowable specification below.

End play:

0 - 0.06 mm (0 - 0.0024 in)

14. If not within specification, adjust the end play by changing thickness of the 5th input gear rear C-ring.

5th input gear rear C-ring:

Refer to SDS, MT-58.

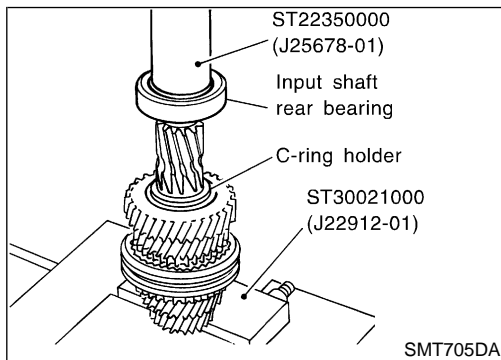

15. Install C-ring holder onto 5th gear rear C-ring.

CAUTION:
Do not reuse C-ring holder.

16. Install input shaft rear bearing.

CAUTION:
Install input shaft rear bearing with its brown surface facing the input gear side.

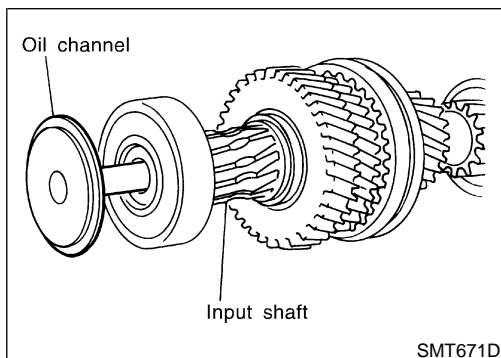

17. Install oil channel onto input shaft.

18. Measure gear end play as a final check. Refer to, MT-26.

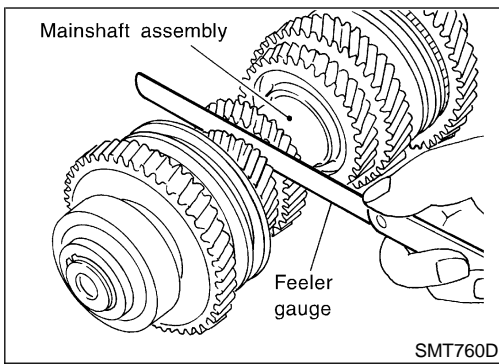

Mainshaft and Gears

DISASSEMBLY

NCMT0013

1. Before disassembly, measure gear end play.

Gear end play:

Refer to SDS, MT-57.

- If end play is not within the specified limit, disassemble and check the parts.

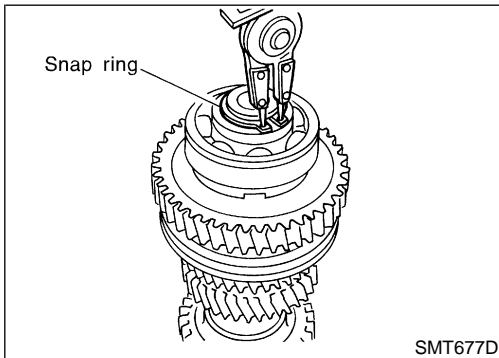

2. Remove snap ring.

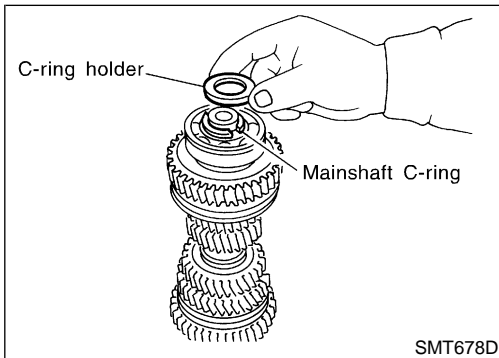

3. Remove C-ring holder and mainshaft C-ring.

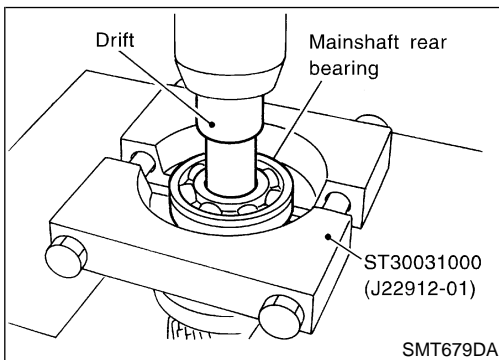

4. Press out mainshaft rear bearing from mainshaft.

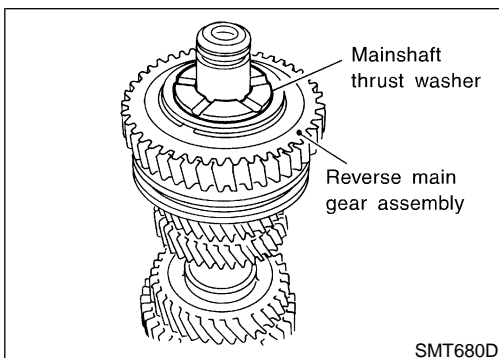

5. Remove mainshaft thrust washer.
6. Remove snap ring from mainshaft. Then, remove reverse main gear assembly, reverse gear needle bearing, and reverse gear baulk ring.

GI
MA
EM
LC
EC
FE
CL
MT
AT
AX
SU
BR
ST
RS
BT
HA
SC
EL
IDX

REPAIR FOR COMPONENT PARTS

Mainshaft and Gears (Cont'd)

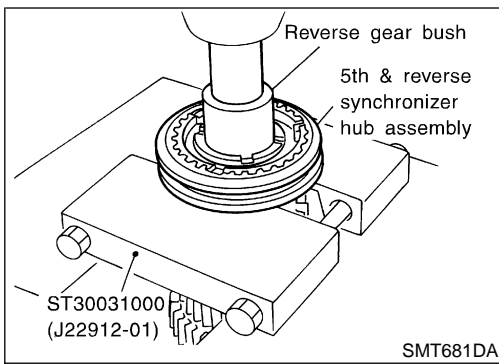

7. Place bearing replacer between 5th & reverse synchronizer hub and 5th main gear, and press out both reverse gear bushing and 5th & reverse synchronizer assembly.
8. Remove 5th main gear, 5th gear baulk ring, and 5th gear needle bearing.

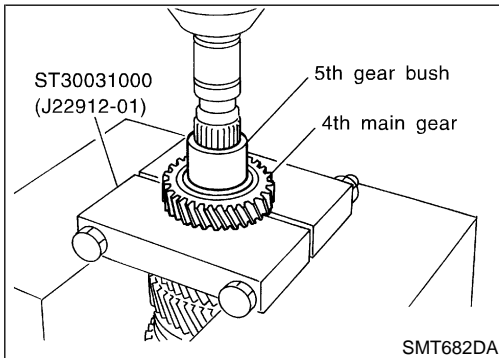

9. Place bearing replacer between 3rd and 4th main gears, and press out both 5th gear bushing and 4th main gear.

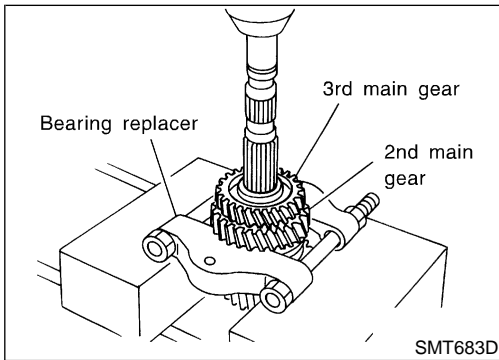

10. Remove mainshaft adjusting shim and spacer.
11. Place bearing replacer between 2nd main gear and 1st & 2nd synchronizer hub, and press out both 3rd and 2nd main gears.

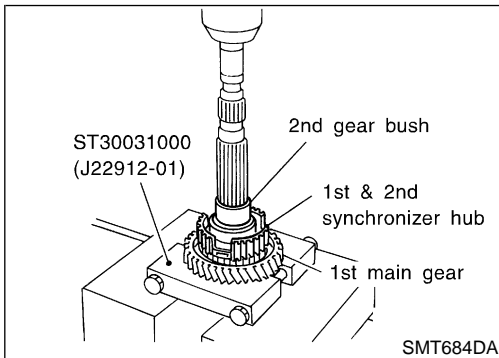

12. Remove 2nd double cone assembly, 2nd gear bushing, and coupling sleeve assembly.
13. Place bearing replacer on 1st gear front side, and press out all of 2nd gear bushing, 1st & 2nd synchronizer hub, 1st main gear, and 1st double cone.
14. Remove 1st gear needle bearing.

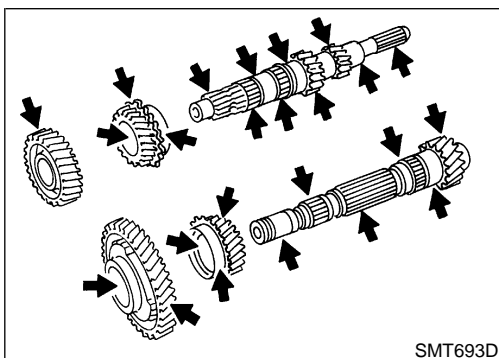

INSPECTION

Gear and Shaft

- Check shaft for cracks, wear or bending.
- Check gears for excessive wear, chips or cracks.

NCMT0014

NCMT0014S01

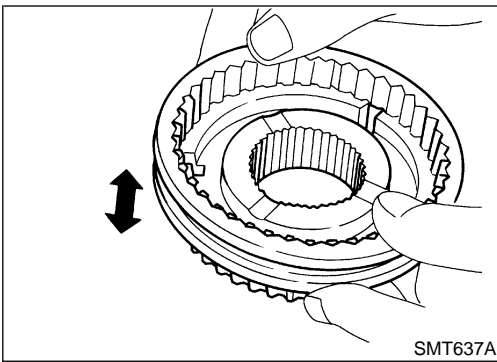

Synchronizers

NCMT0014S02

- Check spline area of coupling sleeves, hubs and gears for wear or cracks.
- Check baulk rings for cracks or deformation.
- Check insert springs for wear or deformation.

GI

MA

EM

LC

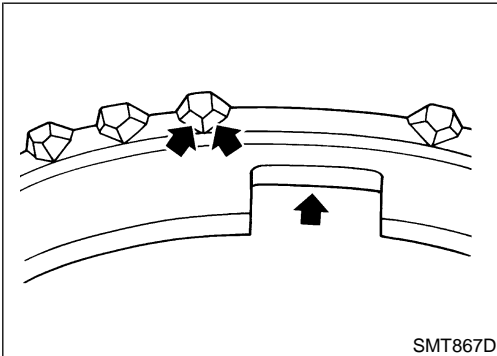

- If any crack, damage, or excessive wear is found on cam face of baulk ring or working face of insert, replace it.

EC

FE

CL

MT

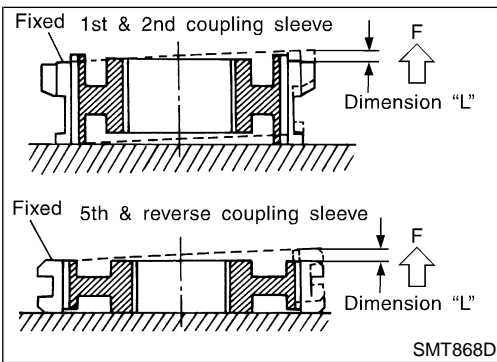

- Measure the movement (play, dimension "L") of 1st & 2nd coupling sleeve and 5th & reverse coupling sleeve with their end fixed and the other end lifted as shown in the figure. If the movement exceeds specification, replace the sleeve.

AT

AX

Coupling sleeve	Length "L"
1st & 2nd	0 - 0.68 mm (0 - 0.0268 in)
5th & Reverse	0 - 0.89 mm (0 - 0.0350 in)

SU

BR

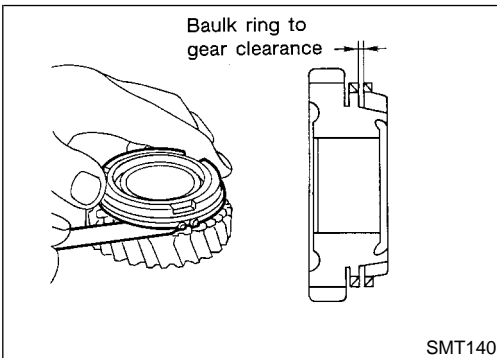

- Measure clearance between baulk ring and gear.

Clearance between baulk ring and gear:
Refer to SDS, MT-57.

ST

RS

BT

HA

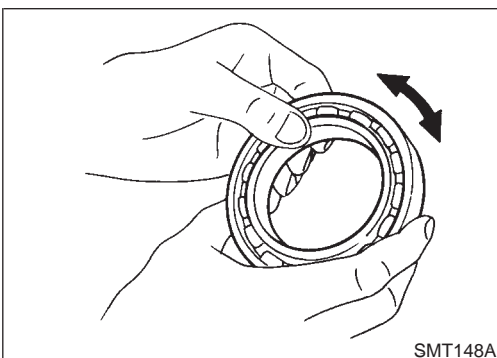

Bearing

NCMT0014S03

- Make sure bearings roll freely and are free from noise, cracks, pitting or wear.

SC

EL

IDX

REPAIR FOR COMPONENT PARTS

Mainshaft and Gears (Cont'd)

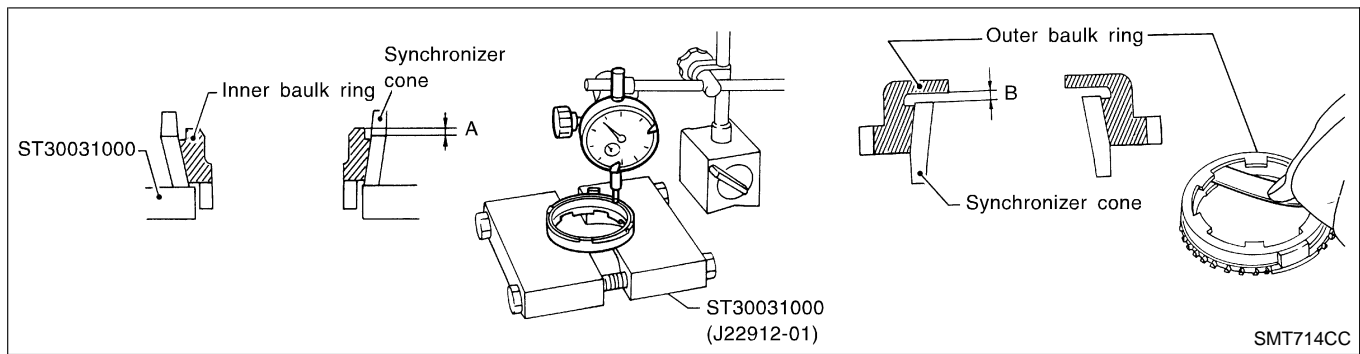

- Measure wear of 1st and 2nd baulk ring.
- a) Place baulk rings in position on synchronizer cone.
- b) While holding baulk ring against synchronizer cone as far as it will go, measure dimensions "A" and "B".

Standard:

A 0.6 - 0.8 mm (0.024 - 0.031 in)

B 0.6 - 1.1 mm (0.024 - 0.043 in)

Wear limit:

0.2 mm (0.008 in)

- If dimension "A" or "B" is smaller than the wear limit, replace outer baulk ring, inner baulk ring and synchronizer cone as a set.

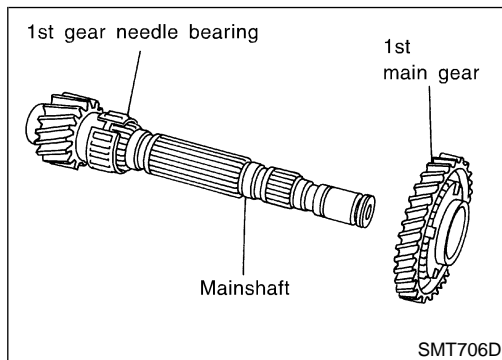

ASSEMBLY

NCMT0015

1. Install 1st gear needle bearing and 1st main gear onto mainshaft.
2. Install 1st double cone assembly onto mainshaft.

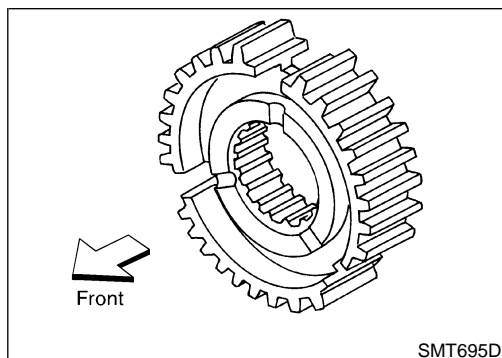

3. Install 1st & 2nd synchronizer hub with its three grooves facing the front side (1st main gear side) onto mainshaft.

CAUTION:

Do not reuse 1st & 2nd synchronizer hub.

REPAIR FOR COMPONENT PARTS

Mainshaft and Gears (Cont'd)

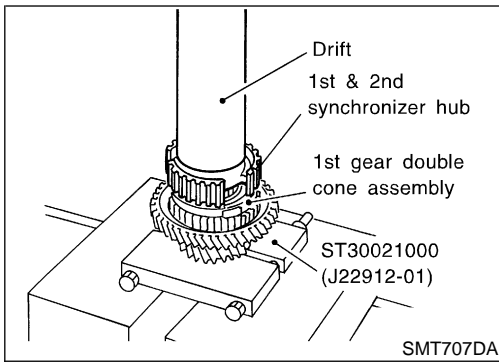

4. Install 1st & 2nd synchronizer hub.

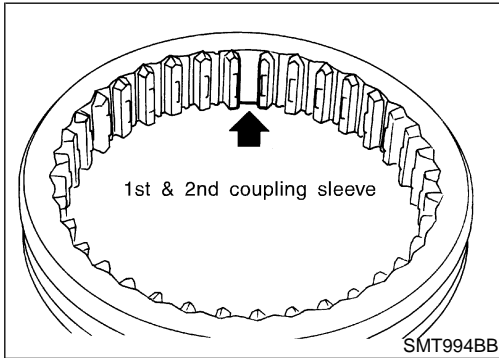

5. Install insert spring onto 1st & 2nd coupling sleeve.

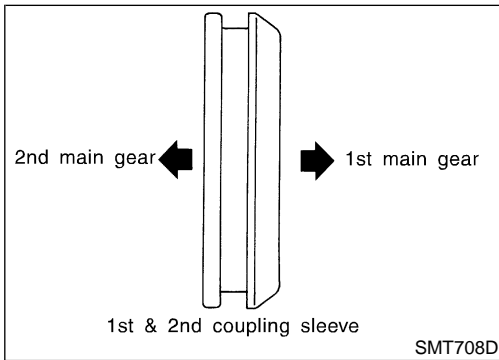

6. Install 1st & 2nd coupling sleeve with its chamfered surface facing the 1st main gear side onto 1st & 2nd synchronizer hub.

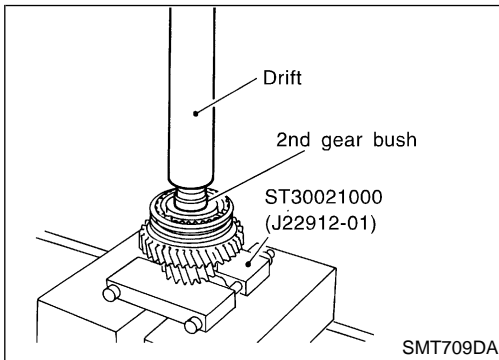

7. Install 2nd gear bushing with its flange surface facing 1st & 2nd synchronizer hub side.

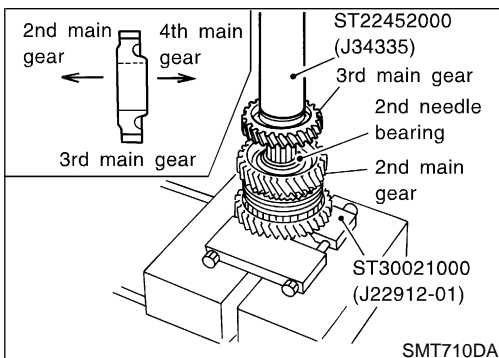

8. Install 2nd needle bearing, 2nd double cone assembly, and 2nd main gear onto mainshaft.

9. Position 3rd main gear as shown in the figure, and install it.

CAUTION:
Do not reuse 3rd main gear.

GI

MA

EM

LC

EC

FE

CL

MT

AT

AX

SU

BR

ST

RS

BT

HA

SC

EL

IDX

REPAIR FOR COMPONENT PARTS

Mainshaft and Gears (Cont'd)

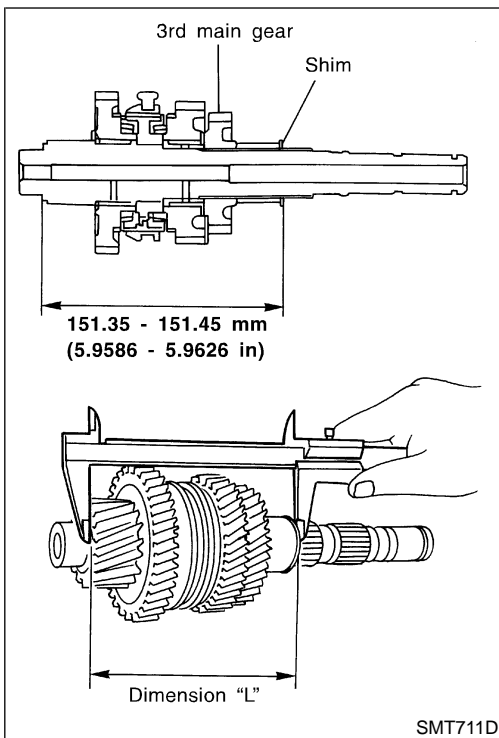

10. Install spacer and mainshaft adjusting shim onto mainshaft.
11. Select a mainshaft adjusting shim suitable to satisfy the following specification of dimension "L" and install it onto mainshaft.

Specification of dimension "L":

151.35 - 151.45 mm (5.9586 - 5.9626 in)

Mainshaft adjusting shims:

Refer to SDS, MT-60.

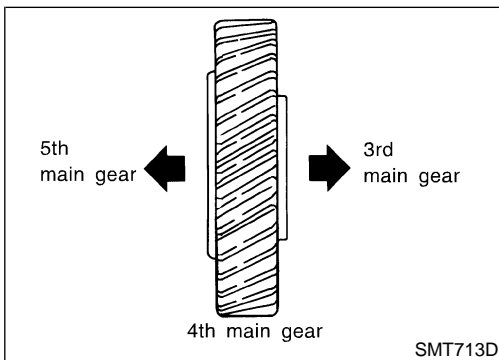

12. Position 4th main gear as shown in the figure, and install it onto mainshaft.

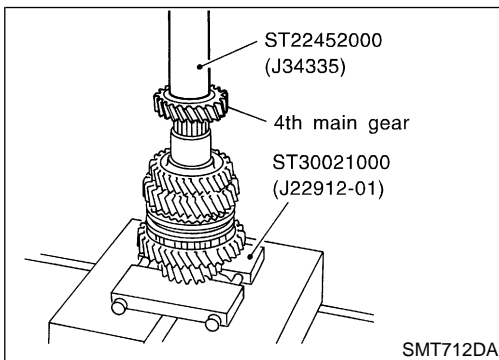

13. Install 4th main gear onto mainshaft.

CAUTION:
Do not reuse 4th main gear.

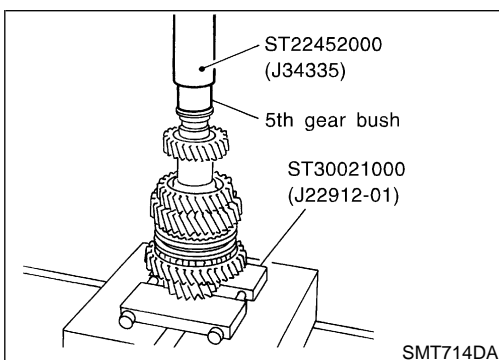

14. Install 5th gear bush with its flange surface facing the 4th main gear side.

REPAIR FOR COMPONENT PARTS

Mainshaft and Gears (Cont'd)

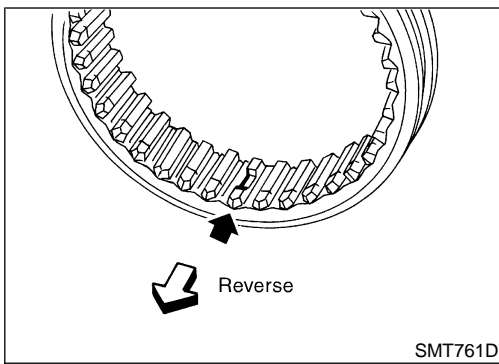

15. Install 5th needle bearing, 5th main gear, and 5th gear baulk ring onto mainshaft.

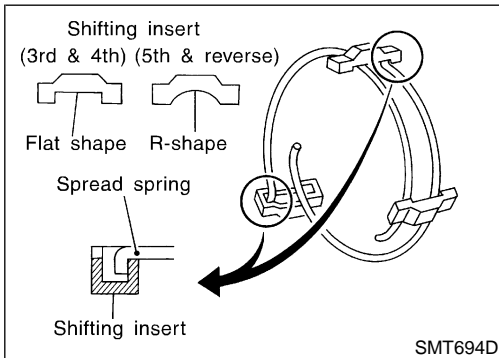

16. Being careful of the following points, install spread spring, shifting insert, and 5th & reverse synchronizer hub onto 5th & reverse coupling sleeve.

- Pay attention to the shape of spread spring and shifting insert for correct assembly. Do not install spread spring hook onto the same shifting insert.

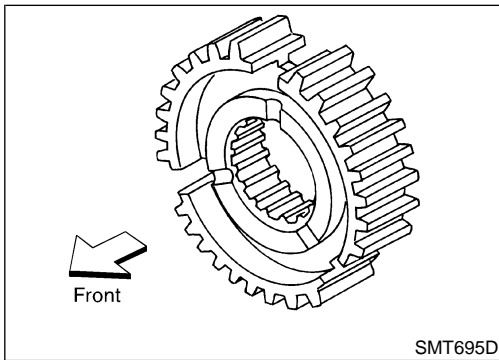

- Install synchronizer hub with its three grooves facing the front side (5th main gear side).

CAUTION:
Do not reuse 5th & reverse synchronizer hub.

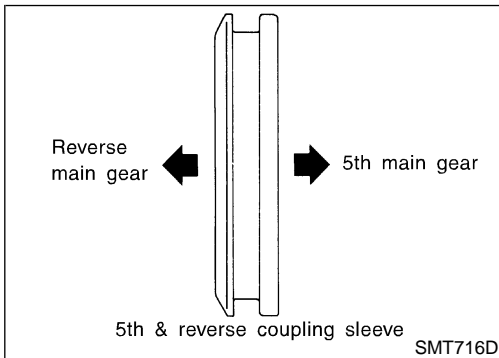

- Install 5th & reverse coupling sleeve with its chamfered surface facing the reverse main gear side.

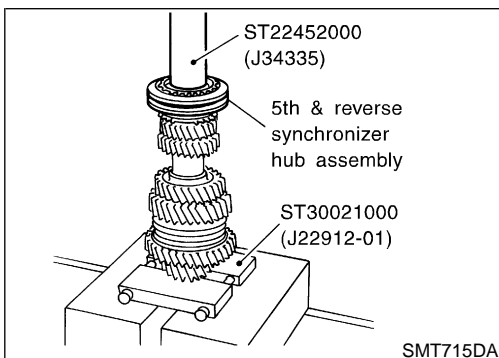

17. Install 5th & reverse synchronizer hub assembly.

GI

MA

EM

LC

EC

FE

CL

MT

AT

AX

SU

BR

ST

RS

BT

HA

SC

EL

IDX

REPAIR FOR COMPONENT PARTS

Mainshaft and Gears (Cont'd)

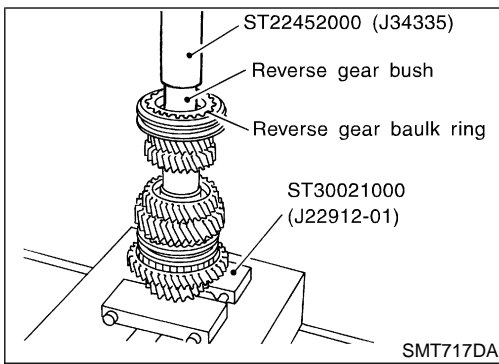

18. Install reverse gear baulk ring.
19. Install reverse gear busing.
20. Install reverse gear needle bearing.

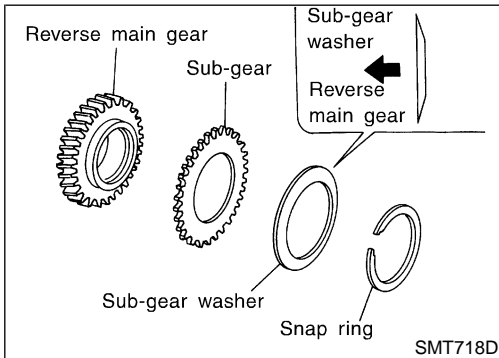

21. Install sub-gear, sub-gear washer, and snap ring onto reverse main gear.

CAUTION:

- Pay attention to direction of sub-gear washer.
- Do not reuse snap ring.

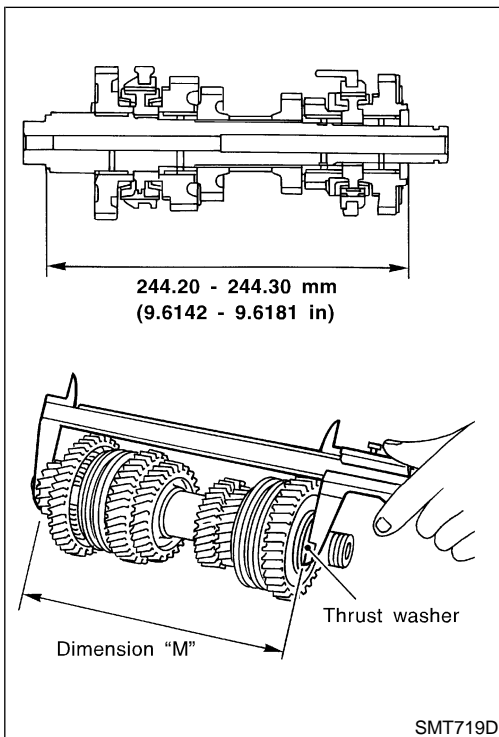

22. Install reverse main gear assembly onto mainshaft.
23. Select a thrust washer suitable to satisfy the following specification of dimension "M" (as shown in the figure), and install it onto mainshaft.

Specification of dimension "M":

244.20 - 244.30 mm (9.6142 - 9.6181 in)

Available thrust washers:

Refer to SDS, MT-61.

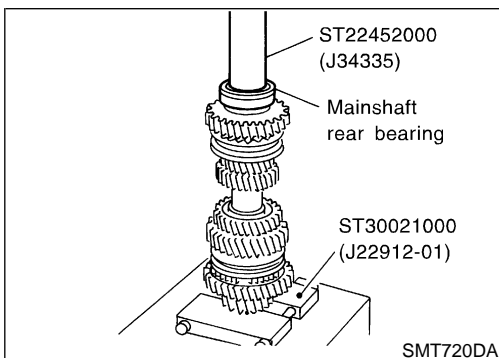

24. Install mainshaft rear bearing.

REPAIR FOR COMPONENT PARTS

Mainshaft and Gears (Cont'd)

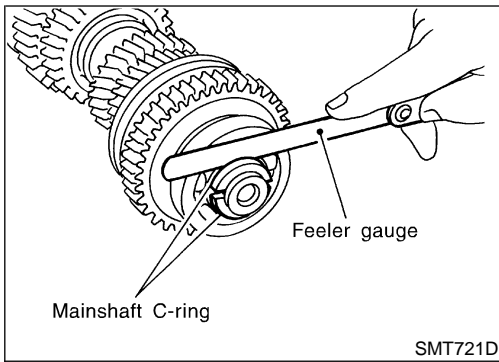

25. Install mainshaft C-ring.
26. Using feeler gauge, measure the end play of mainshaft rear bearing, and check if it satisfies the following specification.

End play:

0 - 0.06 mm (0 - 0.0024 in)

Mainshaft C-rings:

Refer to SDS, MT-58.

GI

MA

EM

LC

EC

FE

CL

MT

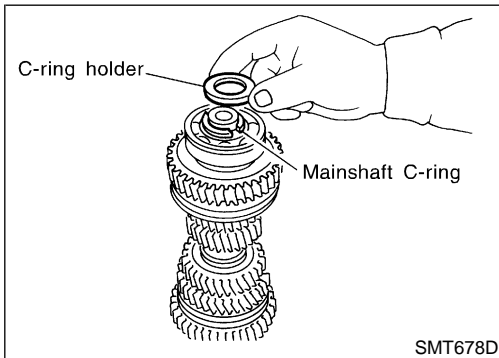

27. Install C-ring holder.

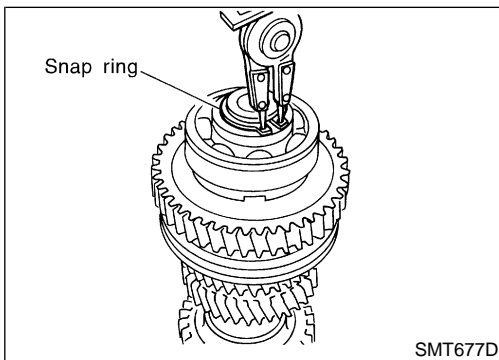

28. Install snap ring.
29. Measure gear end play as a final check. Refer to, MT-31.

AT

AX

SU

BR

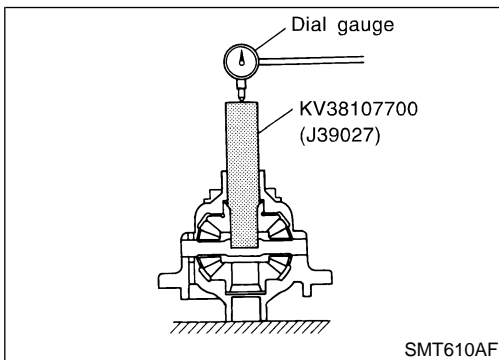

Final Drive

PRE-INSPECTION

— RS5F70A & RS5F70V (Differential case side) —

NCMT0036

NCMT0036S01

- Check the clearance between side gear and differential case as follows.

RS

1. Clean final drive assembly sufficiently to prevent side gear thrust washer, differential case, side gear, and other parts from sticking by gear oil.

BT

HA

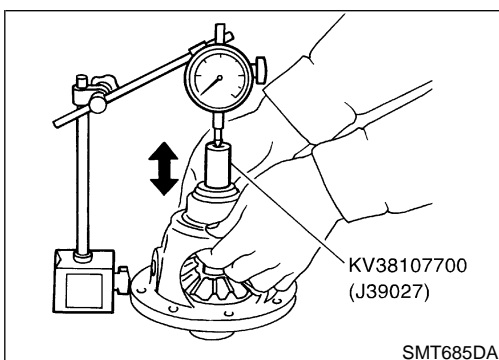

2. Upright the differential case so that the side gear to be measured faces upward.

SC

3. Place final drive adapter and dial gauge onto side gear. Move side gear up and down, and measure the clearance.

EL

Clearance between side gear and differential case:

0.1 - 0.2 mm (0.004 - 0.008 in)

IDX

4. If not within specification, adjust the clearance by changing thrust washer thickness.

5. Turn differential case upside down, and measure the clearance between side gear and differential case on the other side in the same way.

REPAIR FOR COMPONENT PARTS

Final Drive (Cont'd)

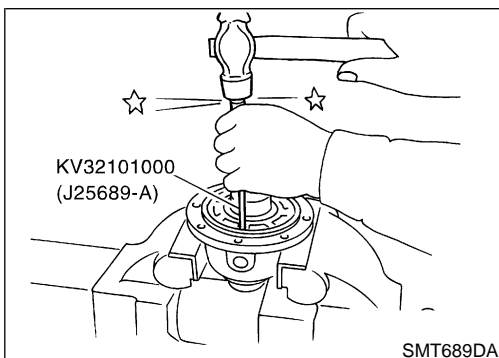
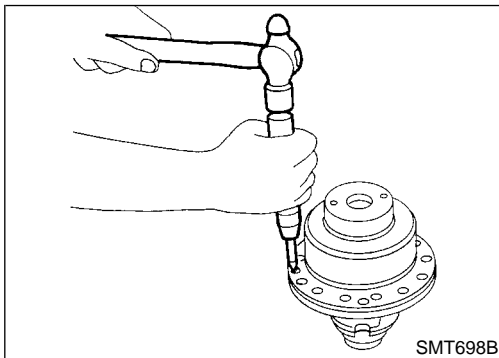
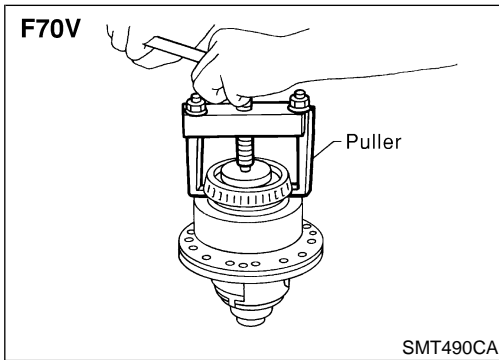
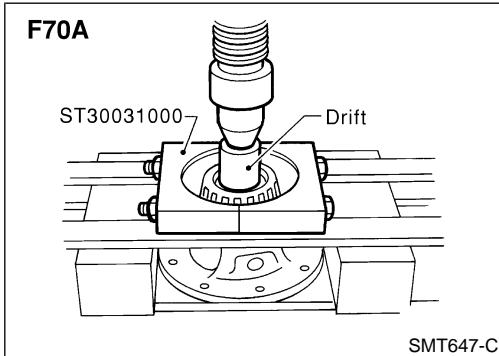
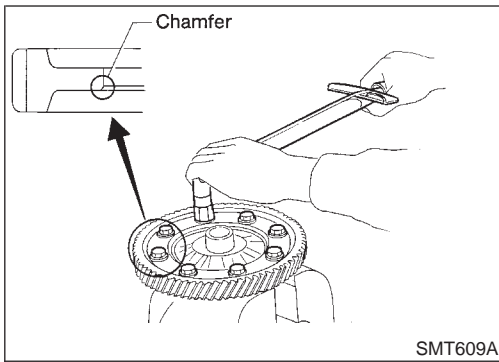

DISASSEMBLY

NCMT0016

1. Remove mounting bolts. Then, separate the final gear from differential case.
2. Make a notch and remove speedometer drive gear using a scraper or other suitable tool.
 - **Bearing replacer cannot be positioned unless speedometer drive gear is removed.**
3. Remove differential side bearing of final gear side.
4. Turn differential case upside down, and remove differential side bearing of speedometer drive gear side.
 - **Be careful not to mix up the differential side bearings — RS5F70A.**
5. Remove speedometer stopper.
6. Remove viscous coupling — RS5F70V.
7. Remove lock pins from pinion mate shaft.

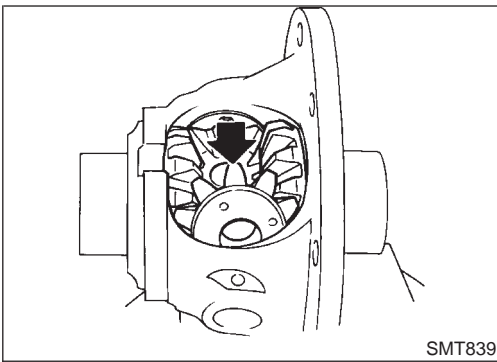

8. Remove pinion mate shaft.
9. Rotate pinion mate gear, and remove pinion mate gear, pinion mate thrust washer, side gear, and side gear thrust washer from differential case.

GI
MA
EM
LC

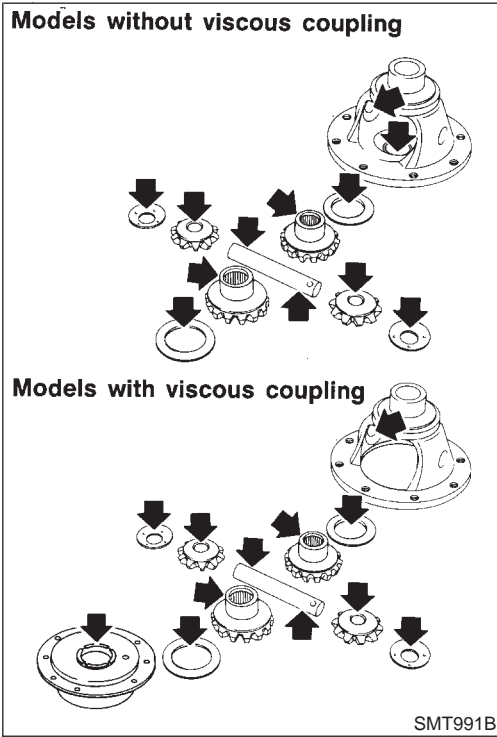

INSPECTION

Gear, Washer, Shaft and Case

- Check mating surfaces of differential case, side gears and pinion mate gears — RS5F70A and 70V.
- Check viscous coupling — RS5F70V.
- Check washers for wear.

NCMT0017
NCMT0017S01

EC
FE
CL

MT

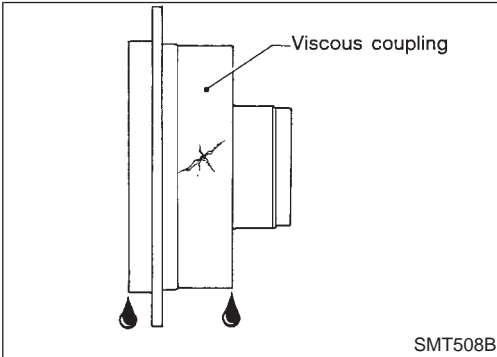

Viscous Coupling — RS5F70V

- Check case for cracks.
- Check silicone oil for leakage.

NCMT0017S05

AT
AX
SU
BR

ST
RS
BT
HA

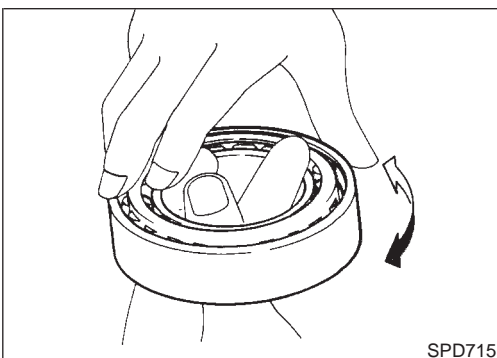

Bearing

- Make sure bearings roll freely and are free from noise, cracks, pitting or wear.
- **When replacing tapered roller bearing, replace outer and inner race as a set.**

NCMT0017S02

SC
EL
IDX

REPAIR FOR COMPONENT PARTS

Final Drive (Cont'd)

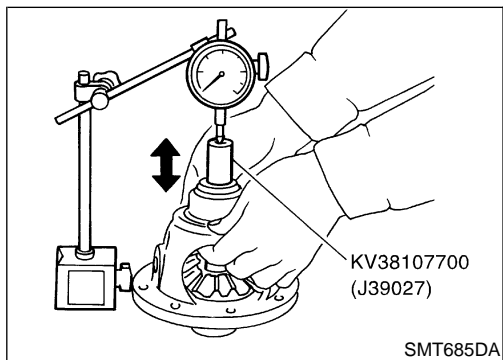
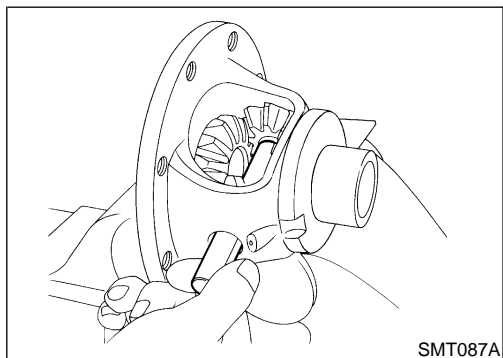
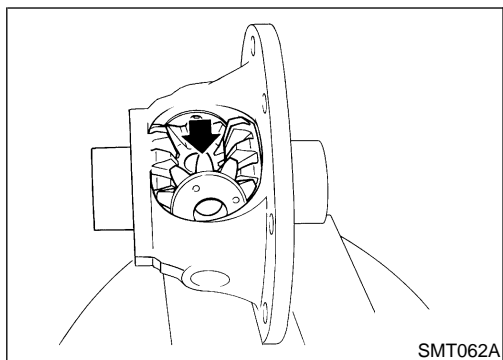

ASSEMBLY

— RS5F70A & RS5F70V —

NCMT0018

NCMT0018S03

1. Apply gear oil to sliding area of differential case, each gear, and thrust washer.
2. Install side gear thrust washer and side gear into differential case.
3. Position pinion mate gear and pinion mate thrust washer diagonally, and install them into differential case while rotating.
4. Insert pinion mate shaft into differential case.

— RS5F70A & RS5F70V (Differential case side) —

NCMT0018S04

1. Upright the differential case so that its side gear to be measured faces upward.
2. Place preload adapter and dial gauge onto side gear. Move side gear up and down, and measure the clearance.
3. Turn differential case upside down, and measure the clearance between side gear and differential case on the other side in the same way.

Clearance of side gear and differential case:

0.1 - 0.2 mm (0.004 - 0.008 in)

Differential side gear thrust washers:

Refer to SDS, MT-61.

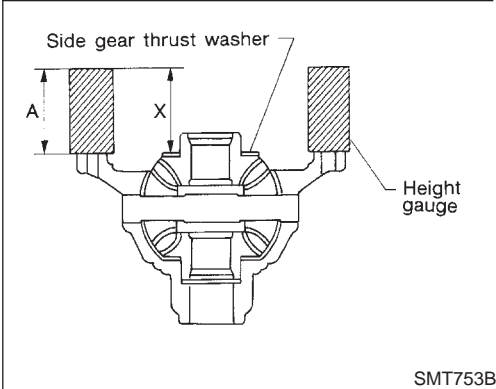
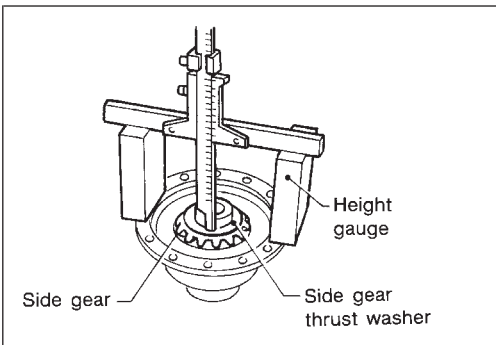

SMT753B

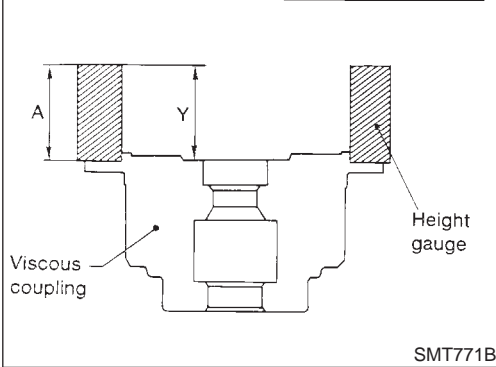
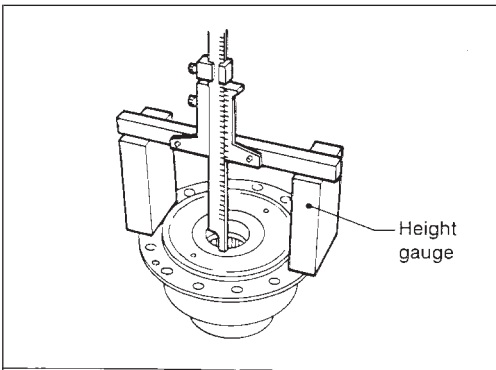

SMT771B

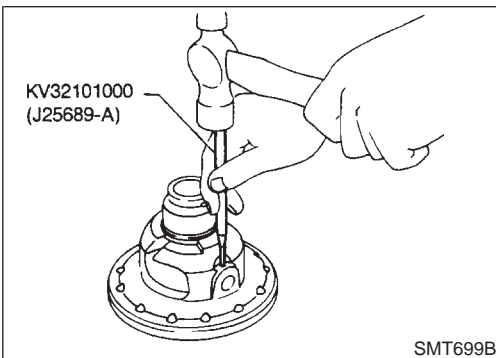

SMT699B

— RS5F70V (Viscous coupling side) —

NCMT0018S05

1. Measure clearance between side gear and viscous coupling with washers following the procedure belows.
 - a. Set remaining side gear with washer on pinion mate gears.
 - b. Measure distance "X".
 - Measure in at least 4 places around the edge of the side gear and take an average. At least 4 measurements are needed because the side gear may be uneven.
 - c. Measure dimension "Y".

Clearance between side gear and viscous coupling with washers can be obtained by " $X + Y - 2A$ ".

**Clearance between side gear and viscous coupling:
0.1 - 0.2 mm (0.004 - 0.008 in)**

- d. If not within specification, adjust clearance by changing thickness of side gear thrust washer.

**Differential side gear thrust washers:
Refer to SDS, MT-61.**

— RS5F70A & RS5F70V —

NCMT0018S06

1. Install retaining pin.
 - Make sure that retaining pin is flush with case.

GI
MA
EM
LC
EC
FE
CL
MT
AT
AX
SU
BR
ST
RS
BT
HA
SC
EL
IDX

REPAIR FOR COMPONENT PARTS

Final Drive (Cont'd)

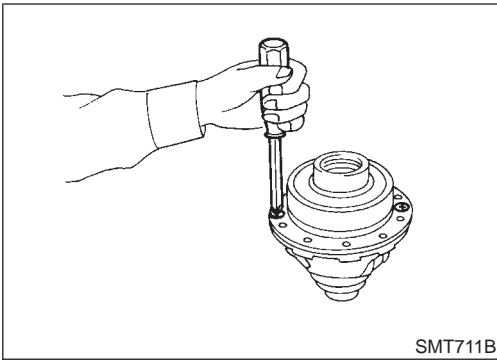

2. Install viscous coupling — RS5F70V.

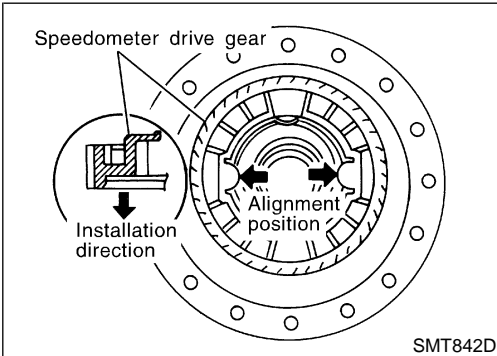

3. Align and install speedometer drive gear into differential case.
4. Install speedometer stopper.

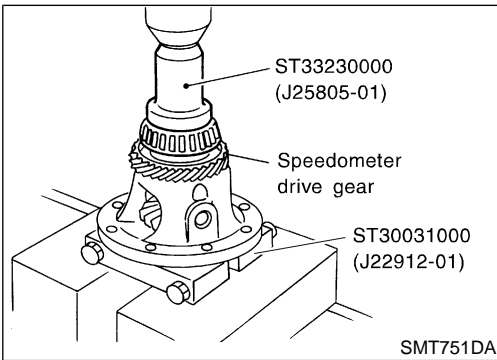

5. Install differential side bearing.
6. Turn differential case upside down, and install another differential side bearing on the other side in the same way.

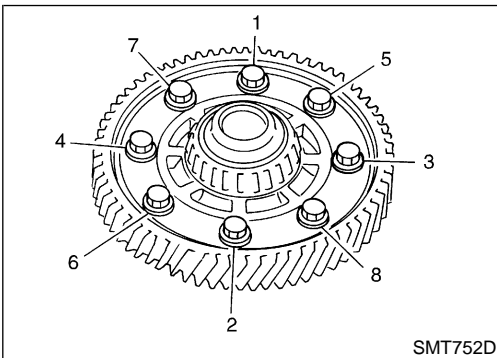

7. Install differential gear into differential case. Apply sealant onto mounting bolts, and tighten them in order as shown in the figure with specified torque.

Tightening torque:
Refer to MT-19.

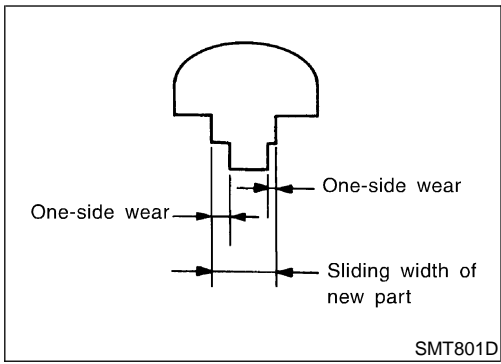

Shift Control Components

INSPECTION

- Check if the width of shift fork hook (sliding area with coupling sleeve) is within allowable specification below. =NCMT0019

Item	One-side wear specification	Sliding width of new part
1st & 2nd	0.2 mm (0.008 in)	7.80 - 7.93 mm (0.3071 - 0.3122 in)
3rd & 4th	0.2 mm (0.008 in)	7.80 - 7.93 mm (0.3071 - 0.3122 in)
5th & reverse	0.2 mm (0.008 in)	7.80 - 7.93 mm (0.3071 - 0.3122 in)

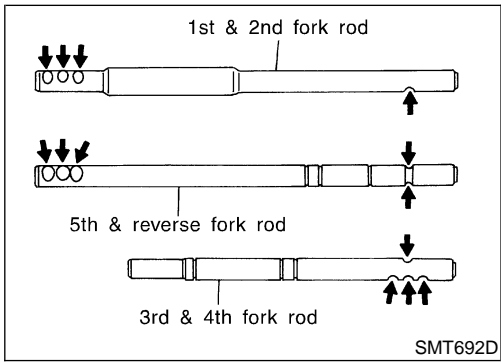

- Check if shift check groove of fork rod or 5th & reverse check groove is worn, or has any other abnormalities.

GI
MA
EM
LC
EC
FE
CL
MT
AT
AX
SU
BR
ST
RS
BT
HA
SC
EL
IDX

ASSEMBLY

Clutch Housing

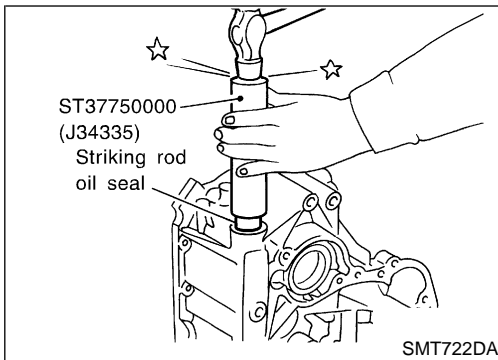

Clutch Housing

NCMT0023S01

1. Hammer the striking rod oil seal into clutch housing as far as it will go.

CAUTION:
Do not reuse striking rod oil seal.

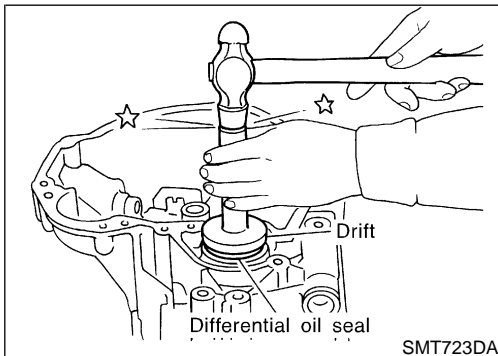

2. Hammer the differential oil seal into clutch housing until it becomes flush with clutch housing end face.

CAUTION:
Do not reuse differential oil seal.

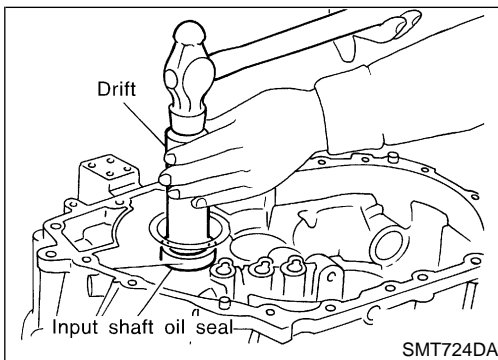

3. Hammer input shaft oil seal into clutch housing as far as it will go.

CAUTION:
Do not reuse input shaft oil seal.

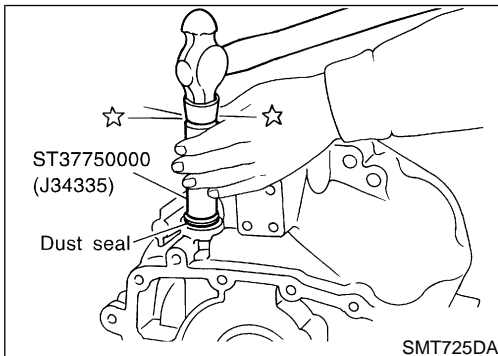

4. Hammer the dust seal into clutch housing as far as it will go.

CAUTION:
Do not reuse dust seal.

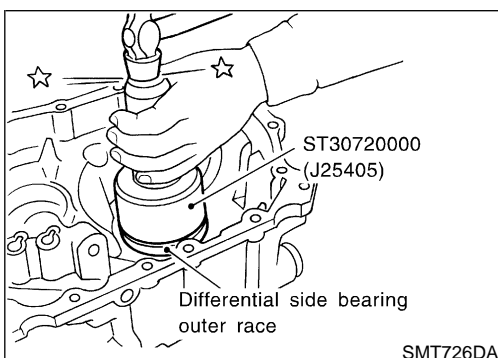

5. Install outer race of differential side bearing.

ASSEMBLY

Clutch Housing (Cont'd)

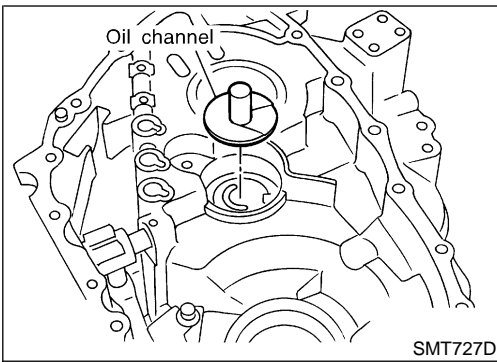

6. Install new oil channel (mainshaft).

CAUTION:
Pay attention to installation direction of oil channel.

GI

MA

EM

LC

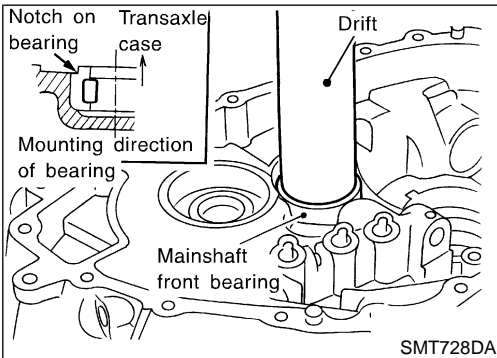

7. Align the notches on mainshaft front bearing and transaxle case. Then, install mainshaft front bearing.

EC

FE

CL

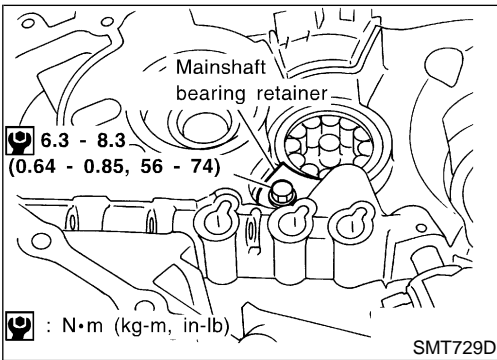

8. Install mainshaft bearing retainer, and tighten bolts with specified torque.

MT

AT

AX

SU

BR

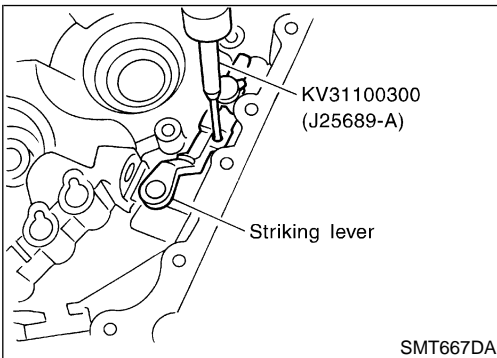

9. Attach boot, striking rod, and striking lever to clutch housing. And install retaining pin for selector lever.

CAUTION:

- Before installing striking rod, wrap the end with a vinyl tape or the like to prevent oil seal from being damaged.
- Do not reuse retaining pin.

ST

RS

BT

HA

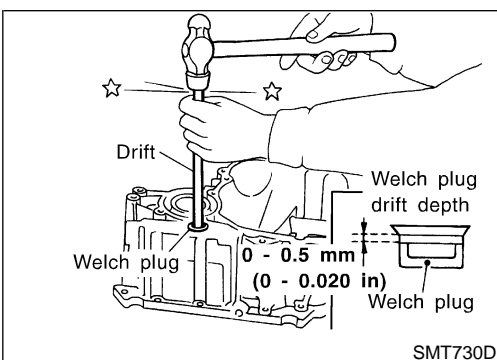

10. Hammer the welch plug (striking lever side) with a general-purpose drift [OD: 12 mm (0.47 in)].

CAUTION:
Do not reuse welch plug.

SC

EL

IDX

ASSEMBLY

Clutch Housing (Cont'd)

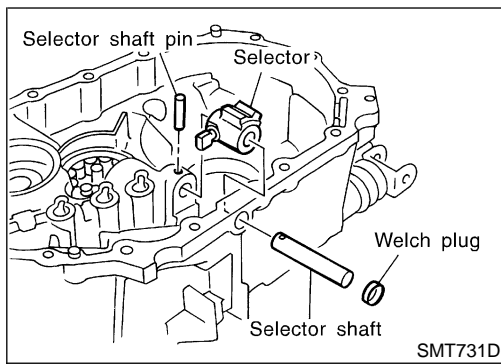

11. Install selector, selector shaft, and selector shaft pin into clutch housing.

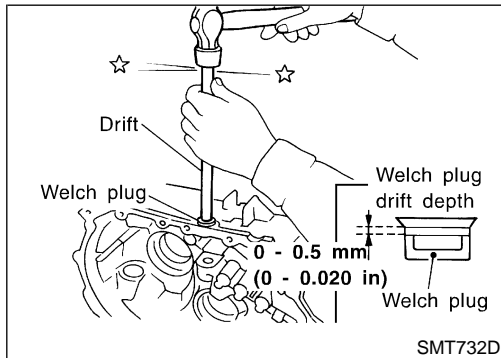

12. Hammer the welch plug (selector shaft side) with a general-purpose drift [OD: 12 mm (0.47 in)].

CAUTION:
Do not reuse welch plug.

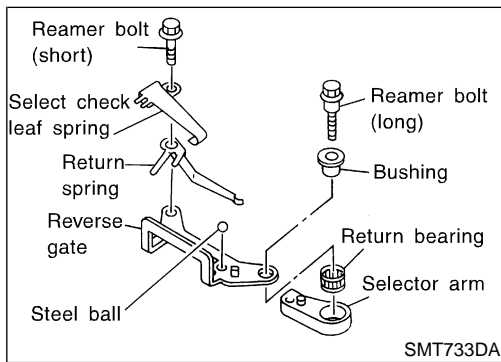

13. Install select check leaf spring, return spring, steel ball, reverse gate, selector arm, bushing, and return bearing. Then, tighten two reamer bolts with specified torque.

CAUTION:
Use correct reamer bolts for each installation point, because each bolt has a different length.

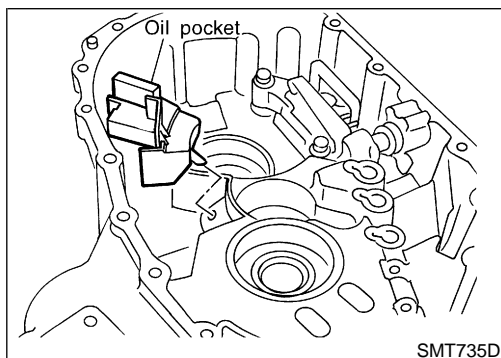
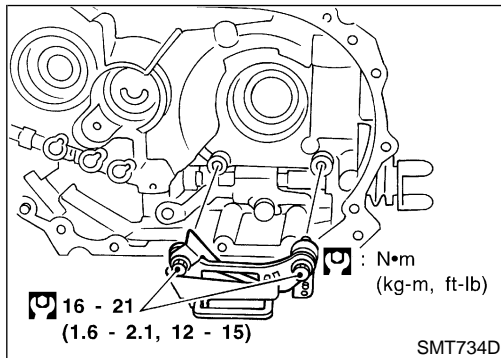

14. Install oil pocket.

ASSEMBLY

Clutch Housing (Cont'd)

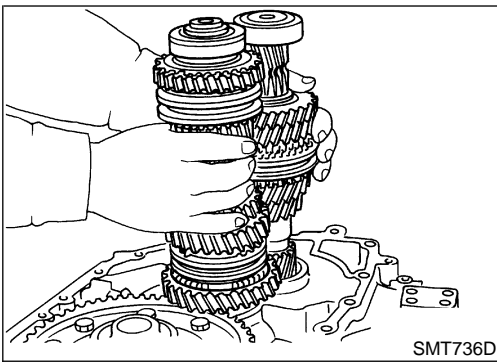

15. Install differential assembly, input shaft assembly, and main shaft assembly into clutch housing.

CAUTION:
Be careful not to damage input shaft oil seal during installation of input shaft assembly.

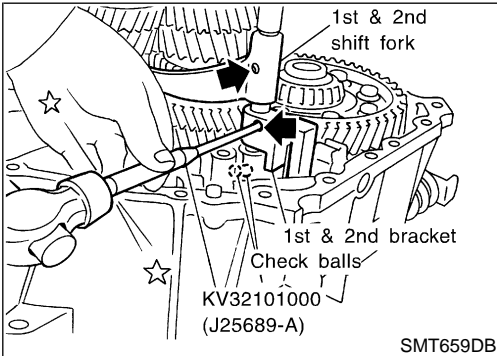

16. Install 5th & reverse shift fork.
17. Install 1st & 2nd shift fork, bracket, and fork rod.
18. Install retaining pin for 1st & 2nd bracket.

CAUTION:
Do not reuse retaining pin.

19. Install two check balls.

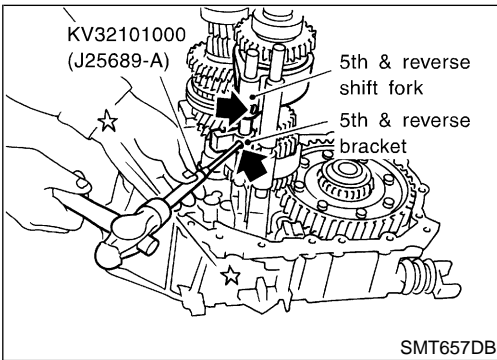

20. Install interlock pin into 5th & reverse fork rod.
21. Install reverse switch bracket, 5th & reverse bracket, and fork rod.
22. Install retaining pin for 5th & reverse shift fork and reverse switch bracket.

CAUTION:
Do not reuse retaining pin.

23. Install 5th & reverse bracket stopper ring.

CAUTION:
Do not reuse stopper pin.

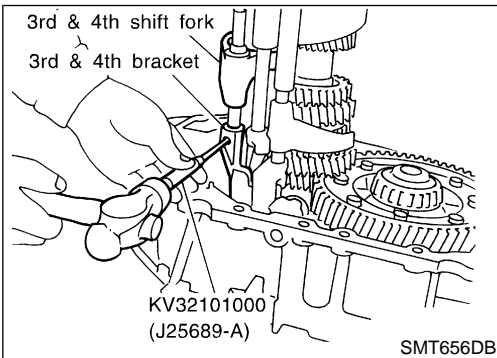

24. Install check ball and interlock plunger.
25. Install 3rd & 4th shift fork, bracket, and fork rod.
26. Install 3rd & 4th bracket retaining pin.

CAUTION:
Do not reuse retaining pin.

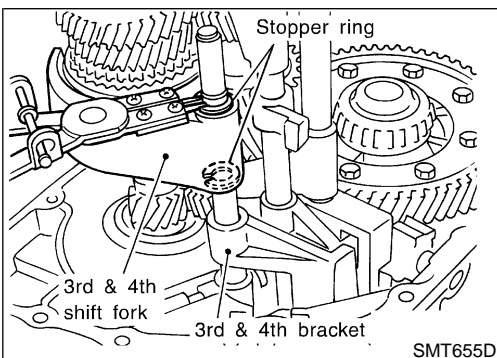

27. Install 3rd & 4th shift fork stopper ring.

CAUTION:
Do not reuse stopper ring.

28. Install check ball, check pin, and check spring, and apply Three Bond TB1215, Loctite Part No. 51813 or equivalent onto check plug. Then, tighten it with specified torque.

Tightening torque:
Refer to MT-18.

GI
MA
EM
LC
EC
FE
CL
MT
AT
AX
SU
BR
ST
RS
BT
HA
SC
EL
IDX

ASSEMBLY

Transaxle Case

NCMT0023S02

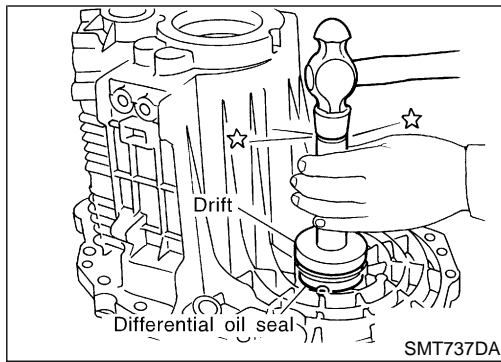

Transaxle Case

1. Insert differential oil seal into differential case until it becomes flush with case end face.

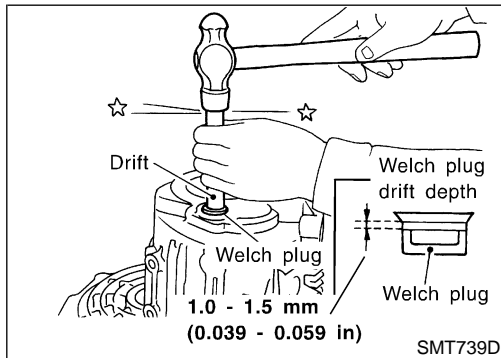

2. Install Welch plug into transaxle case.

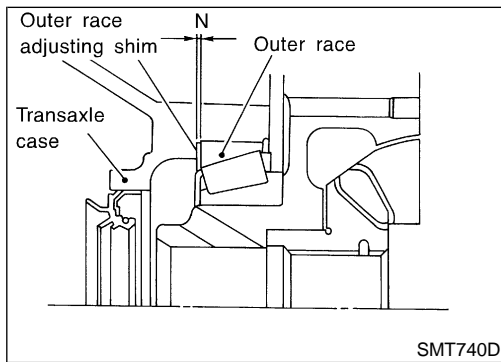

3. Calculate dimension "N" (thickness of adjusting shim) using the following procedure to satisfy specification of end play for differential side bearing.

End play: 0.15 - 0.21 mm (0.0059 - 0.0083 in)

Dimension "N" = (N1 - N2) + End play

N: Thickness of adjusting shim

N1: Distance between clutch housing case end face and mounting face of adjusting shim

N2: Distance between differential side bearing and transaxle case

Differential side bearing adjusting shims:

Refer to SDS, MT-62.

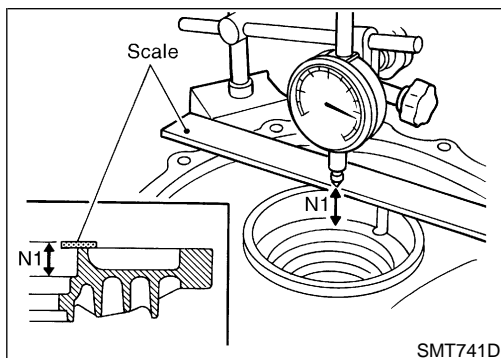

- a. Using dial gauge and scale, measure dimension "N1" between clutch housing case end face and mounting face of adjusting shim.

ASSEMBLY

Transaxle Case (Cont'd)

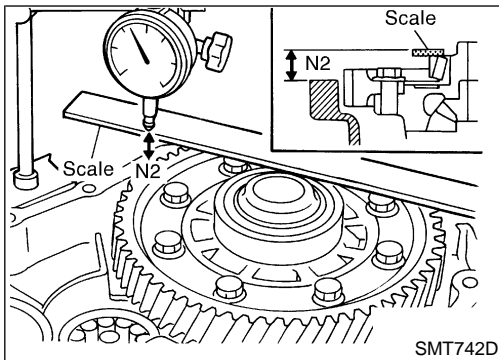

- b. Install outer race onto differential side bearing on final gear side. Holding lightly the outer race horizontally by hand, rotate final gear five times or more (for smooth movement of bearing roller).
- c. Using dial gauge and scale as shown in the figure, measure dimension "N2" between differential side bearing outer race and transaxle case end face.

GI

MA

EM

LC

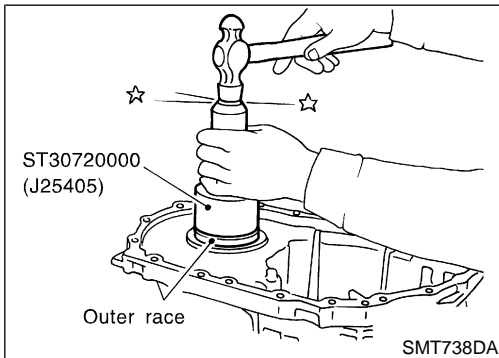

4. Install selected shim and bearing outer race.

EC

FE

CL

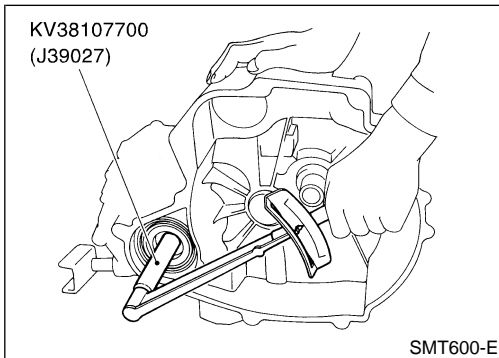

5. Measure turning torque of final drive assembly.

Turning torque of final drive assembly

(New bearing):

2.9 - 6.9 N-m (30 - 70 kg-cm, 26 - 61 in-lb)

- When old bearing is used again, turning torque will be slightly less than the above.
- Make sure torque is close to the specified range.
- Changes in turning torque of final drive assembly per revolution should be within 1.0 N-m (10 kg-cm, 8.7 in-lb) without binding.

AT

AX

SU

BR

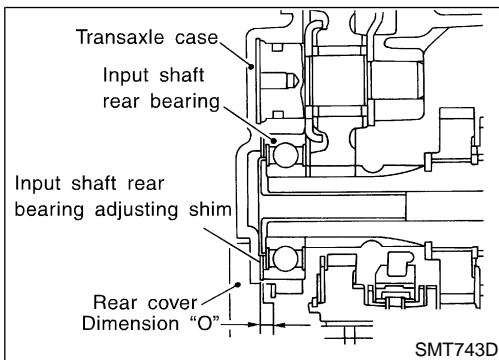

6. Calculate dimension "O" (thickness of adjusting shim) using the following procedure to satisfy specification of end play for input shaft rear bearing.

End play: 0 - 0.06 mm (0 - 0.0024 in)

Dimension "O" = (O1 - O2) + End play

O: Thickness of adjusting shim

O1: Distance between transaxle case end face and mounting face of adjusting shim

O2: Distance between clutch housing case end face and end face of input shaft rear bearing

Input shaft rear bearing adjusting shims:

Refer to SDS, MT-59.

ST

RS

BT

HA

SC

EL

IDX

ASSEMBLY

Transaxle Case (Cont'd)

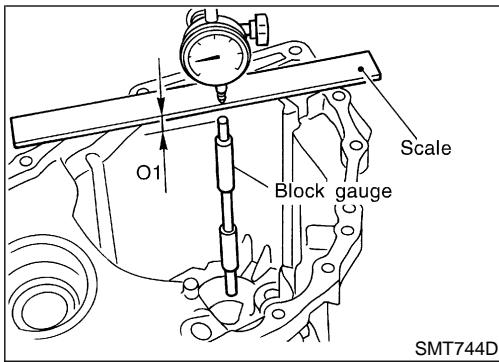

- a. Using block gauge, scale, and dial gauge, measure dimension "O1" between transaxle case end face and mounting face of adjusting shim.

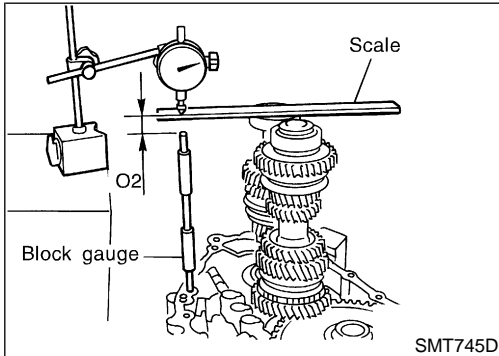

- b. Using gauge block, scale, and dial gauge as shown in the figure, measure dimension "O2" between clutch housing case end face and end face of input shaft rear bearing.
7. Install selected input shaft rear bearing adjusting shim onto input shaft.

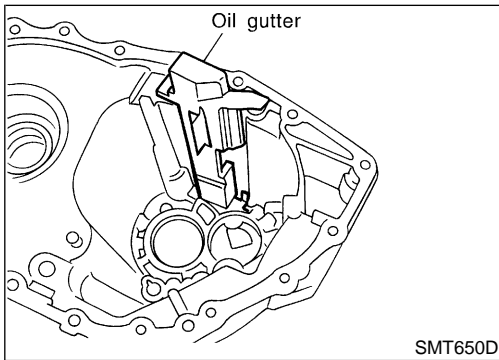

8. Install oil gutter into transaxle case.

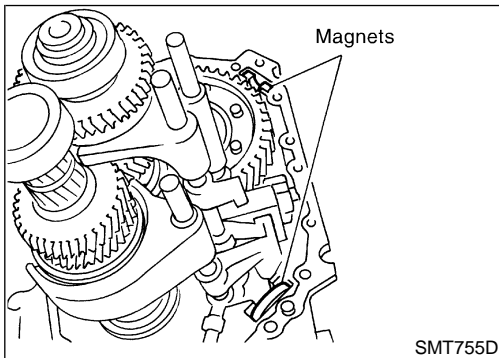

9. Install two magnets.

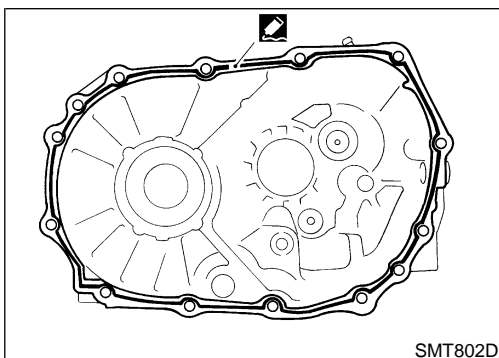

10. Clean mating surfaces of clutch housing and transaxle case. Check for cracks and damage. Then, apply Three Bond TB1215, Loctite Part No. 51813 or equivalent.

ASSEMBLY

Transaxle Case (Cont'd)

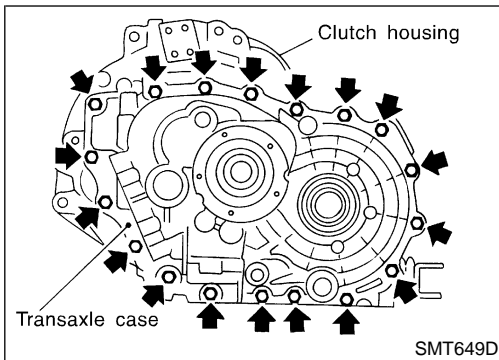

11. Install transaxle case onto clutch housing, and tighten mounting bolts with specified torque.

Tightening torque:
Refer to MT-16.

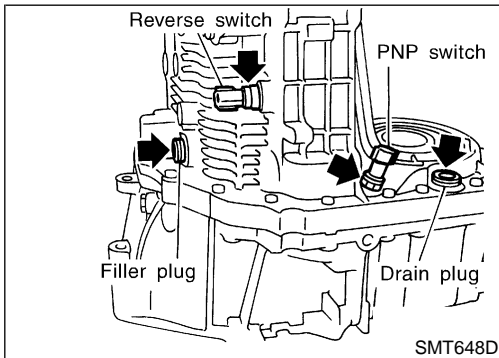

12. Apply Three Bond TB1215, Loctite Part No. 51813 or equivalent to threads of reverse switch, PNP switch, and drain plug, and install them. (Fill the case with oil before installation of filler plug.)

13. Install speedometer pinion assembly.

CAUTION:
Do not reuse O-ring.

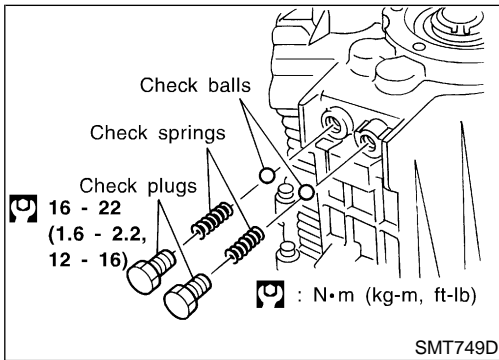

14. Install check springs and check balls. Apply sealant to the thread on the check plug, and install it.

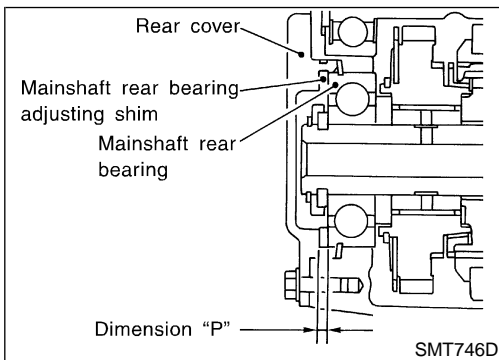

15. Calculate thickness of adjusting shim using the following procedure to satisfy specification of end play for mainshaft rear bearing.

End play: 0 - 0.06 mm (0 - 0.0024 in)

Dimension "P" = (P1 - P2) + End play

P: Thickness of adjusting shim

P1: Distance between transaxle case end face and mainshaft rear bearing

P2: Distance between adjusting shim end face of rear cover and transaxle mounting face

Mainshaft rear bearing adjusting shims:

Refer to SDS, MT-60.

GI
MA
EM
LC
EC
FE
CL
MT
AT
AX
SU
BR
ST
RS
BT
HA
SC
EL
IDX

ASSEMBLY

Transaxle Case (Cont'd)

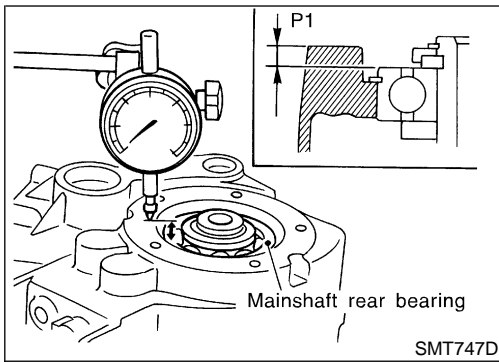

- a. Using dial gauge as shown in the figure, measure dimension "P1" between transaxle case end face and mainshaft rear bearing.

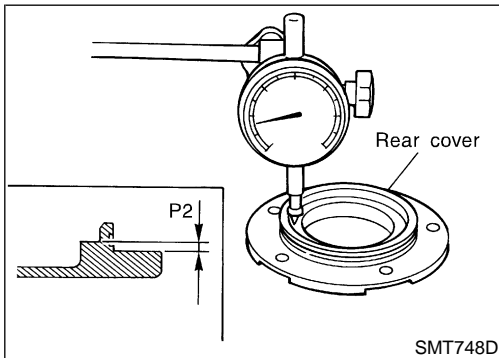

- b. Using dial gauge as shown in the figure, measure dimension "P2" between adjusting shim mounting face of rear cover and transaxle mounting face.

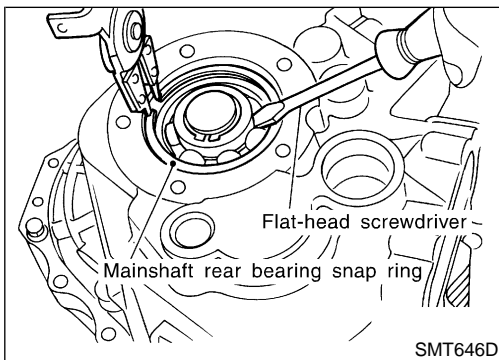

16. Using snap ring pliers as shown in the figure, install snap ring.

CAUTION:
Do not reuse snap ring.

17. Install selected mainshaft adjusting shim.

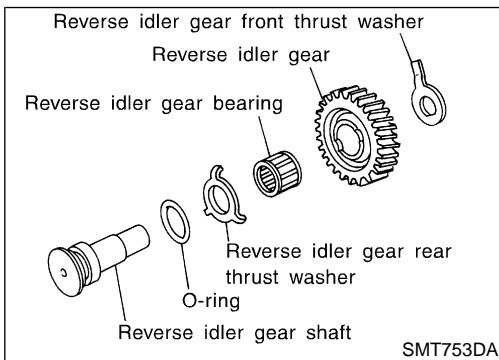

18. Install reverse idler gear, O-ring, thrust washers (front, rear), and bearing onto reverse idler shaft.

19. Install snap ring into transaxle case using snap ring pliers.

CAUTION:

- Do not reuse snap ring.
- Do not reuse O-ring.
- Before installation, apply gear oil to O-ring.

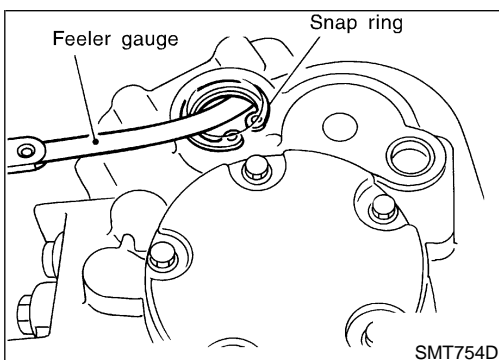

20. Using feeler gauge, measure the end play of snap ring, and select a snap ring suitable to satisfy the following specification.

End play:
0.05 - 0.25 mm (0.0020 - 0.0098 in)

Available snap ring:
Refer to SDS, MT-57.

ASSEMBLY

Transaxle Case (Cont'd)

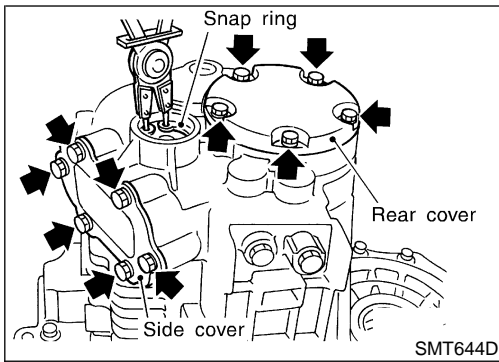

21. Install selected snap ring.

CAUTION:
Do not reuse snap ring.

22. Apply gear oil to rear cover O-ring, and install rear cover, side cover gasket, and side cover. Then tighten mounting bolts with specified torque.

Tightening torque:
Refer to MT-16.

CAUTION:
Do not reuse mounting bolts for rear cover and side cover.

GI

MA

EM

LC

EC

FE

CL

MT

AT

AX

SU

BR

ST

RS

BT

HA

SC

EL

IDX

SERVICE DATA AND SPECIFICATIONS (SDS)

General Specifications

General Specifications

NCMT0024

NCMT0024S01

TRANSAXLE

Engine		SR20DE	
Transaxle model		RS5F70A	RS5F70V
Number of speeds		5	
Synchromesh type		Warner	
Shift pattern			
Gear ratio	1st	3.333	
	2nd	1.955	
	3rd	1.286	
	4th	0.926	
	5th	0.756	
	Reverse	3.214	
Number of teeth	Input gear	1st	15
		2nd	22
		3rd	28
		4th	41
		5th	45
		Rev.	14
	Main gear	1st	50
		2nd	43
		3rd	36
		4th	38
		5th	34
		Rev.	45
	Reverse idler gear		37
Oil level (Reference) mm (in)*1		56.5 - 61.0 (2.224 - 2.402)	56.5 - 62.0 (2.224 - 2.441)
Oil capacity ℓ (US pt, Imp pt)*1		3.0 (6-3/8, 5-1/4)	
Remarks		1st & 2nd double baulk ring type synchronizer	
		Reverse sub-gear	

*1: Refer to MA-11, "Fluid and Lubricants".

FINAL GEAR

NCMT0024S02

Engine		SR20DE	
Transaxle model		RS5F70A	RS5F70V
Final gear ratio		4.176	
Number of teeth	Final gear/Pinion	71/17	
	Side gear/Pinion mate gear	14/10	

SERVICE DATA AND SPECIFICATIONS (SDS)

Gear End Play

Gear End Play

NCMT0025
Unit: mm (in)

Gear	End play
1st main gear	0.18 - 0.31 (0.0071 - 0.0122)
2nd main gear	
5th main gear	
Reverse main gear	
3rd input gear	
4th input gear	0.17 - 0.44 (0.0067 - 0.0173)

Clearance Between Baulk Ring and Gear

NCMT0026

3RD, 4TH, 5TH, REVERSE BAULK RING

NCMT0026S01
Unit: mm (in)

	Standard	Wear limit
3rd	0.90 - 1.45 (0.0354 - 0.0571)	0.7 (0.028)
4th		
5th		
Reverse	0.9 - 1.35 (0.0354 - 0.0531)	

1ST AND 2ND BAULK RING

NCMT0026S02
Unit: mm (in)

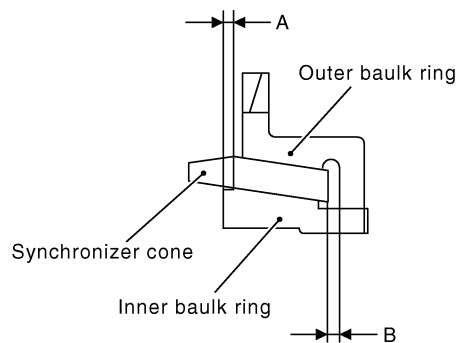

SMT906D

Dimension	Standard	Wear limit
A	0.6 - 0.8 (0.024 - 0.031)	0.2 (0.008)
B	0.6 - 1.1 (0.024 - 0.043)	

Available Snap Rings

NCMT0028

SNAP RING

NCMT0028S04

End play	0.05 - 0.25 mm (0.0020 - 0.0098 in)
Thickness	Part number*
1.45 mm (0.0571 in)	32204-6J000
1.55 mm (0.0610 in)	32204-6J001
1.65 mm (0.0650 in)	32204-6J002
1.75 mm (0.0689 in)	32204-6J003
1.85 mm (0.0728 in)	32204-6J004

*: Always check with the parts department for the latest information.

SERVICE DATA AND SPECIFICATIONS (SDS)

Available C-rings

Available C-rings

NCMT0029

4TH INPUT GEAR C-RING

NCMT0029S02

End play	0 - 0.06 mm (0 - 0.0024 in)
Thickness	Part number*
3.00 mm (0.1181 in)	32205-6J000
3.03 mm (0.1193 in)	32205-6J001
3.06 mm (0.1205 in)	32205-6J002
3.09 mm (0.1217 in)	32205-6J003
3.12 mm (0.1228 in)	32205-6J004

*: Always check with the parts department for the latest information.

5TH INPUT GEAR REAR C-RING

NCMT0029S03

End play	0 - 0.06 mm (0 - 0.0024 in)
Thickness	Part number*
2.59 mm (0.1020 in)	32205-6J005
2.62 mm (0.1031 in)	32205-6J006
2.65 mm (0.1043 in)	32205-6J007
2.68 mm (0.1055 in)	32205-6J008
2.71 mm (0.1067 in)	32205-6J009
2.74 mm (0.1079 in)	32205-6J010

*: Always check with the parts department for the latest information.

MAINSHAFT C-RING

NCMT0029S01

End play	0 - 0.06 mm (0 - 0.0024 in)
Thickness	Part number*
3.48 mm (0.1370 in)	32348-6J000
3.51 mm (0.1382 in)	32348-6J001
3.54 mm (0.1394 in)	32348-6J002
3.57 mm (0.1406 in)	32348-6J003
3.60 mm (0.1417 in)	32348-6J004
3.63 mm (0.1429 in)	32348-6J005
3.66 mm (0.1441 in)	32348-6J006
3.69 mm (0.1453 in)	32348-6J007
3.72 mm (0.1465 in)	32348-6J008
3.75 mm (0.1476 in)	32348-6J009
3.78 mm (0.1488 in)	32348-6J010
3.81 mm (0.1500 in)	32348-6J011
3.84 mm (0.1512 in)	32348-6J012
3.87 mm (0.1524 in)	32348-6J013
3.90 mm (0.1535 in)	32348-6J014
3.93 mm (0.1547 in)	32348-6J015
3.96 mm (0.1559 in)	32348-6J016

*: Always check with the parts department for the latest information.

SERVICE DATA AND SPECIFICATIONS (SDS)

Available Adjusting Shims

Available Adjusting Shims

NCMT0037

INPUT SHAFT REAR BEARING ADJUSTING SHIM

NCMT0037S01

End play	0 - 0.06 mm (0 - 0.0024 in)	
	Thickness	Part number*
	0.74 mm (0.0291 in)	32225-6J003
	0.78 mm (0.0307 in)	32225-6J004
	0.82 mm (0.0323 in)	32225-6J005
	0.86 mm (0.0339 in)	32225-6J006
	0.90 mm (0.0354 in)	32225-6J007
	0.94 mm (0.0370 in)	32225-6J008
	0.98 mm (0.0386 in)	32225-6J009
	1.02 mm (0.0402 in)	32225-6J010
	1.06 mm (0.0417 in)	32225-6J011
	1.10 mm (0.0433 in)	32225-6J012
	1.14 mm (0.0449 in)	32225-6J013
	1.18 mm (0.0465 in)	32225-6J014
	1.22 mm (0.0480 in)	32225-6J015
	1.26 mm (0.0496 in)	32225-6J016
	1.30 mm (0.0512 in)	32225-6J017
	1.34 mm (0.0528 in)	32225-6J018
	1.38 mm (0.0543 in)	32225-6J019
	1.42 mm (0.0559 in)	32225-6J020
	1.46 mm (0.0575 in)	32225-6J021
	1.50 mm (0.0591 in)	32225-6J022
	1.54 mm (0.0606 in)	32225-6J023
	1.58 mm (0.0622 in)	32225-6J024
	1.62 mm (0.0638 in)	32225-6J060
	1.66 mm (0.0654 in)	32225-6J061

*: Always check with the parts department for the latest information.

GI

MA

EM

LC

EC

FE

CL

MT

AT

AX

SU

BR

ST

RS

BT

HA

SC

EL

IDX

SERVICE DATA AND SPECIFICATIONS (SDS)

Available Adjusting Shims (Cont'd)

MAINSHAFT ADJUSTING SHIM

NCMT0037S02

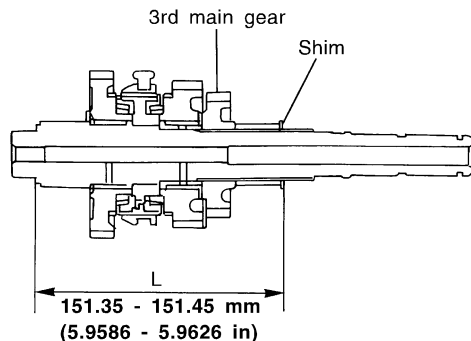

SMT907D

Standard length "L"	151.35 - 151.45 mm (5.9586 - 5.9626 in)
Thickness	Part number*
0.48 mm (0.0189 in)	32238-6J000
0.56 mm (0.0220 in)	32238-6J001
0.64 mm (0.0252 in)	32238-6J002
0.72 mm (0.0283 in)	32238-6J003
0.80 mm (0.0315 in)	32238-6J004
0.88 mm (0.0346 in)	32238-6J005

*: Always check with the parts department for the latest information.

MAINSHAFT REAR BEARING ADJUSTING SHIM

NCMT0037S03

End play	0 - 0.06 mm (0 - 0.0024 in)
Thickness	Part number*
2.99 mm (0.1177 in)	32238-6J010
3.03 mm (0.1193 in)	32238-6J011
3.07 mm (0.1209 in)	32238-6J012
3.11 mm (0.1224 in)	32238-6J013
3.15 mm (0.1240 in)	32238-6J014
3.19 mm (0.1256 in)	32238-6J015
3.23 mm (0.1272 in)	32238-6J016
3.27 mm (0.1287 in)	32238-6J017
3.31 mm (0.1303 in)	32238-6J018
3.35 mm (0.1319 in)	32238-6J019
3.39 mm (0.1335 in)	32238-6J020
3.43 mm (0.1350 in)	32238-6J021
3.47 mm (0.1366 in)	32238-6J022
3.51 mm (0.1382 in)	32238-6J023

*: Always check with the parts department for the latest information.

SERVICE DATA AND SPECIFICATIONS (SDS)

Available Thrust Washer

Available Thrust Washer

MAINSHAFT THRUST WASHER

NCMT0038

NCMT0038S01

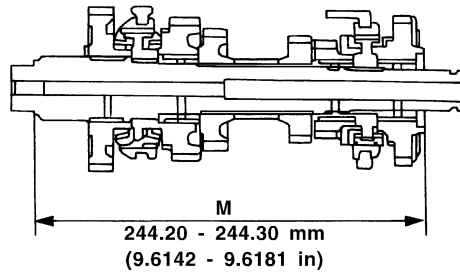

SMT843D

Standard length "M"	244.20 - 244.30 mm (9.6142 - 9.6181 in)
Thickness	Part number*
6.04 mm (0.2378 in)	32246-6J000
6.12 mm (0.2409 in)	32246-6J001
6.20 mm (0.2441 in)	32246-6J002
6.28 mm (0.2472 in)	32246-6J003
6.36 mm (0.2504 in)	32246-6J004

*: Always check with the parts department for the latest information.

Available Washers

DIFFERENTIAL SIDE GEAR THRUST WASHER

NCMT0031

— RS5F70A —

NCMT0031S01

NCMT0031S0103

Clearance between side gear and differential case	0.1 - 0.2 mm (0.004 - 0.008 in)
Thickness mm (in)	Part number*
0.75 - 0.80 (0.0295 - 0.0315)	38424-D2111
0.80 - 0.85 (0.0315 - 0.0335)	38424-D2112
0.85 - 0.90 (0.0335 - 0.0354)	38424-D2113
0.90 - 0.95 (0.0354 - 0.0374)	38424-D2114
0.95 - 1.00 (0.0374 - 0.0394)	38424-D2115

*: Always check with the parts department for the latest information.

— RS5F70V —

NCMT0031S0104

Clearance between side gear and differential case of viscous coupling	0.1 - 0.2 mm (0.004 - 0.008 in)	
Differential case side	Thickness mm (in)	Part number*
	0.75 - 0.80 (0.0295 - 0.0315)	38424-D2111
	0.80 - 0.85 (0.0315 - 0.0335)	38424-D2112
	0.85 - 0.90 (0.0335 - 0.0354)	38424-D2113
	0.90 - 0.95 (0.0354 - 0.0374)	38424-D2114
	0.95 - 1.00 (0.0374 - 0.0394)	38424-D2115

SERVICE DATA AND SPECIFICATIONS (SDS)

Available Washers (Cont'd)

Viscous coupling side	0.70 - 0.75 (0.0276 - 0.0295)	38424-D2110
	0.75 - 0.80 (0.0295 - 0.0315)	38424-D2111
	0.80 - 0.85 (0.0315 - 0.0335)	38424-D2112
	0.85 - 0.90 (0.0335 - 0.0354)	38424-D2113
	0.90 - 0.95 (0.0354 - 0.0374)	38424-D2114
	0.95 - 1.00 (0.0374 - 0.0394)	38424-D2115
	1.00 - 1.05 (0.0394 - 0.0413)	38424-D2116
	1.05 - 1.10 (0.0413 - 0.0433)	38424-D2117
	1.10 - 1.15 (0.0433 - 0.0453)	38424-D2118
	1.15 - 1.20 (0.0453 - 0.0472)	38424-D2119
	1.20 - 1.25 (0.0472 - 0.0492)	38424-D2120
	1.25 - 1.30 (0.0492 - 0.0512)	38424-D2121
	1.30 - 1.35 (0.0512 - 0.0531)	38424-D2122

*: Always check with the parts department for the latest information.

Available Shims — Differential Side Bearing Preload and Adjusting Shim

NCMT0032

BEARING PRELOAD

NCMT0032S01
Unit: mm (in)

Differential side bearing preload: T*	0.15 - 0.21 (0.0059 - 0.0083)
---------------------------------------	-------------------------------

* Install shims which are "deflection of differential case" + "T" in thickness.

DIFFERENTIAL SIDE BEARING ADJUSTING SHIMS

NCMT0032S03

— RS5F70A —

NCMT0032S0303

Thickness mm (in)	Part number*
0.44 (0.0173)	38454-M8000
0.48 (0.0189)	38454-M8001
0.52 (0.0205)	38454-M8002
0.56 (0.0220)	38454-M8003
0.60 (0.0236)	38454-M8004
0.64 (0.0252)	38454-M8005
0.68 (0.0268)	38454-M8006
0.72 (0.0283)	38454-M8007
0.76 (0.0299)	38454-M8008
0.80 (0.0315)	38454-M8009
0.84 (0.0331)	38454-M8010
0.88 (0.0346)	38454-M8011

*: Always check with the parts department for the latest information.

— RS5F70V —

NCMT0032S0304

Thickness mm (in)	Part number
0.28 (0.0110)	31439-31X00
0.32 (0.0126)	31439-31X01

SERVICE DATA AND SPECIFICATIONS (SDS)

Available Shims — Differential Side Bearing Preload and Adjusting Shim (Cont'd)

0.36 (0.0142)	31439-31X02	
0.40 (0.0157)	31439-31X03	GI
0.44 (0.0173)	31439-31X04	
0.48 (0.0189)	31439-31X05	MA
0.52 (0.0205)	31439-31X06	
0.56 (0.0220)	31439-31X07	EM
0.60 (0.0236)	31439-31X08	
0.64 (0.0252)	31439-31X09	LC
0.68 (0.0268)	31439-31X10	
0.72 (0.0283)	31439-31X11	EC
0.76 (0.0299)	31439-31X12	
0.80 (0.0315)	31439-31X13	FE
0.84 (0.0331)	31439-31X14	
0.88 (0.0346)	31439-31X15	CL
0.92 (0.0362)	31439-31X16	
0.96 (0.0378)	31439-31X17	MT
1.44 (0.0567)	31439-31X18	

*: Always check with the parts department for the latest information.

AT

AX

SU

BR

ST

RS

BT

HA

SC

EL

IDX

NOTES