

SECTION **IP**  
INSTRUMENT PANEL

A  
B  
C  
D  
E  
F  
G  
H  
IP  
J  
K  
L  
M

CONTENTS

<b>PRECAUTIONS</b> .....	<b>2</b>	DISPLAY .....	<b>6</b>
Precautions for Supplemental Restraint System (SRS) "AIR BAG" and "SEAT BELT PRE-TENSIONER" .....	2	AUDIO UNIT .....	6
Precautions .....	2	GLOVE BOX .....	6
<b>INSTRUMENT PANEL ASSEMBLY</b> .....	<b>3</b>	INSTRUMENT LOWER PANEL .....	7
Component Parts Drawing .....	3	INSTRUMENT LOWER ASSISTANCE PANEL.....	7
Removal and Installation .....	4	PASSENGER AIR BAG MODULE .....	7
TABLE OF WORK ITEM .....	4	STEERING LOCK ESCUTCHEON .....	7
METER FINISHER .....	4	STEERING COLUMN COVER .....	7
CLUSTER LID A .....	5	INSTRUMENT INNER COVER PROTECTOR .....	7
COMBINATION METER .....	5	INSTRUMENT LOWER DRIVER PANEL .....	8
A/T OR M/T FINISHER .....	5	GPS ANTENNA .....	8
CONSOLE .....	5	FRONT PILLAR GARNISH .....	8
INSTRUMENT LOWER COVER .....	5	INSTRUMENT PANEL .....	8
FRONT FLOOR CONSOLE .....	5	Disassembly and Assembly .....	8
INSTRUMENT FINISHER E .....	6	INSTRUMENT FINISHER D, ASHTRAY AND	
CLUSTER LID C .....	6	AUDIO .....	8
		GLOVE BOX .....	9

# PRECAUTIONS

## PRECAUTIONS

PFP:00001

### Precautions for Supplemental Restraint System (SRS) “AIR BAG” and “SEAT BELT PRE-TENSIONER”

EIS002FQ

The Supplemental Restraint System such as "AIR BAG" and "SEAT BELT PRE-TENSIONER", used along with a front seat belt, helps to reduce the risk or severity of injury to the driver and front passenger for certain types of collision. Information necessary to service the system safely is included in the SRS and SB section of this Service Manual.

#### **WARNING:**

- To avoid rendering the SRS inoperative, which could increase the risk of personal injury or death in the event of a collision which would result in air bag inflation, all maintenance must be performed by an authorized NISSAN/INFINITI dealer.
- Improper maintenance, including incorrect removal and installation of the SRS, can lead to personal injury caused by unintentional activation of the system. For removal of Spiral Cable and Air Bag Module, see the SRS section.
- Do not use electrical test equipment on any circuit related to the SRS unless instructed to in this Service Manual. SRS wiring harnesses can be identified by yellow and/or orange harness connectors.

## Precautions

EIS002FR

- Disconnect both battery cables in advance.
- Disconnect air bag system line in advance.
- Never tamper with or force air bag lid open, as this may adversely affect air bag performance.
- Be careful not to scratch pad and other parts.
- When removing or disassembling any part, be careful not to damage or deform it. Protect parts, which may get in the way with cloth.
- When removing parts with a screwdriver or other tool, protect parts by wrapping them with vinyl or tape.
- Keep removed parts protected with cloth.
- If a clip is deformed or damaged, replace it.
- If an un reusable part is removed, replace it with a new one.
- Tighten bolts and nuts firmly to the specified torque.
- After re-assembly has been completed, make sure each part functions correctly.
- Remove stains in the following way.

Water-soluble stains:

Dip a soft cloth in warm water, and then squeeze it tightly. After wiping the stain, wipe with a soft dry cloth.

Oil stain:

Dissolve a synthetic detergent in warm water (density of 2 to 3% or less), dip the cloth, then clean off the stain with the cloth. Next, dip the cloth in fresh water and squeeze it tightly. Then clean off the detergent completely. Then wipe the area with a soft dry cloth.

- Do not use any organic solvent, such as thinner or benzene.

# INSTRUMENT PANEL ASSEMBLY

## INSTRUMENT PANEL ASSEMBLY

PFP:68200

### Component Parts Drawing

EIS002FS

A  
B  
C  
D  
E  
F  
G  
H  
IP  
J  
K  
L  
M

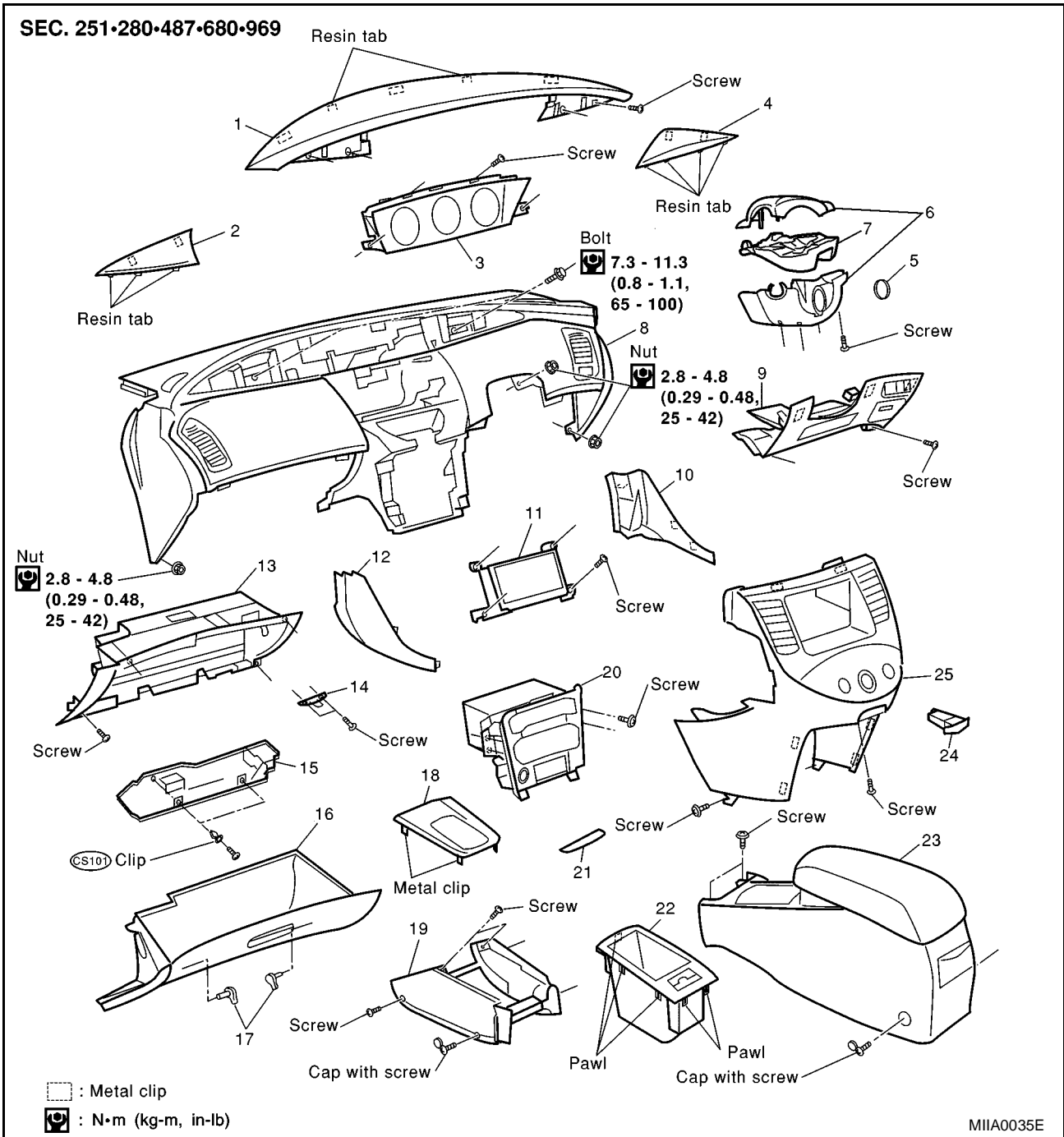

- |                                       |  |                                  |
|---------------------------------------|--|----------------------------------|
| 1. Instrument cluster lid A           | 2. Combination meter finisher (LH)     | 3. Combination meter             |
| 4. Combination meter finisher (RH)    | 5. Steering lock escutcheon            | 6. Steering column cover         |
| 7. Instrument inner cover protector   | 8. Instrument panel & pad              | 9. Instrument lower driver panel |
| 10. Instrument lower cover (RH)       | 11. Display                            | 12. Instrument lower cover (LH)  |
| 13. Instrument lower assistance panel | 14. Glove box striker                  | 15. Instrument lower panel       |
| 16. Glove box                         | 17. Glove box pin                      | 18. A/T or M/T finisher          |
| 19. Front floor console               | 20. Audio unit (Instrument finisher D) | 21. Instrument finisher E        |
| 22. Console finisher                  | 23. Center console                     | 24. Hazard switch                |
| 25. Cluster lid C                     |  |                                  |

# INSTRUMENT PANEL ASSEMBLY

EIS002FT

## Removal and Installation TABLE OF WORK ITEM

Components	Instrument panel	Combination meter	Navigation display and Audio	Console
Combination meter finisher	[1]	[1]		
Instrument cluster lid A	[2]	[2]		
Combination meter	[3]	[3]		
A/T or M/T finisher	[4]		[1]	[1]
Console	[5]		[2]	[2]
Instrument lower cover	[6]		[3]	
Front floor console	[7]		[4]	
Instrument finisher E	[8]		[5]	
Cluster lid C	[9]		[6]	
Display	[10]		[7]	
Audio	[11]		[8]	
Glove box	[12]			
Instrument lower panel	[13]			
Glove box striker	[14]			
Instrument lower assistance panel	[15]			
Front passenger air bag module	[16]			
Steering lock escutcheon	[17]			
Steering column cover	[18]			
Instrument inner cover protector	[20]			
Instrument lower driver panel	[20]			
GPS antenna	[21]			
Front pillar garnish	[22]			
Instrument panel	[23]			

[ ]: The number shows the removal order.

### METER FINISHER

- Insert a clip remover or similar tool into side of combination meter finisher. Pull to remove it.

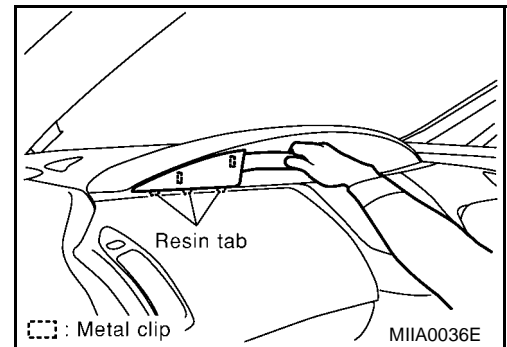

# INSTRUMENT PANEL ASSEMBLY

## CLUSTER LID A

- Remove screws, and pull instrument cluster lid A forward to unfasten clips.

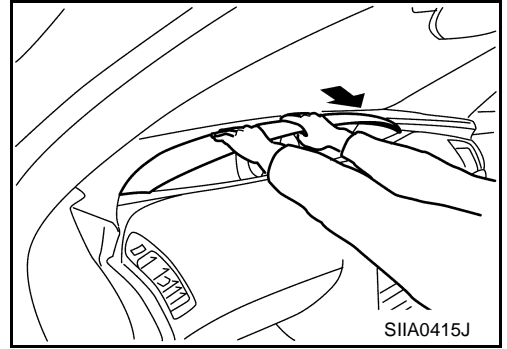

## COMBINATION METER

- Remove screws, and remove connectors. Then remove combination meter.

## A/T OR M/T FINISHER

- Insert a screwdriver, wrapped with a shop cloth, into cutout on rearward of finisher, and lift up to unfasten metal clips.

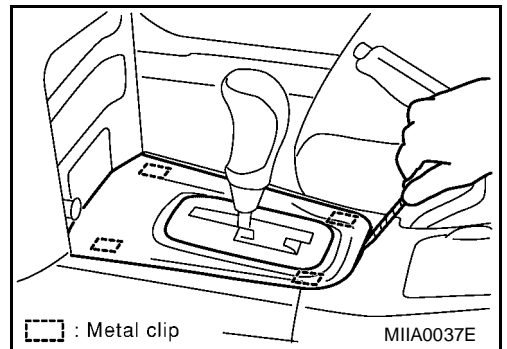

## CONSOLE

- Remove mounting screws and cap with screws and lift up to remove it.

## INSTRUMENT LOWER COVER

- Undo resin pawl on vehicle rear side by pulling to left side. Then slide cover toward rear to remove. (Left side)
- Pull to vehicle right side and undo resin pawl to remove. (Right side)

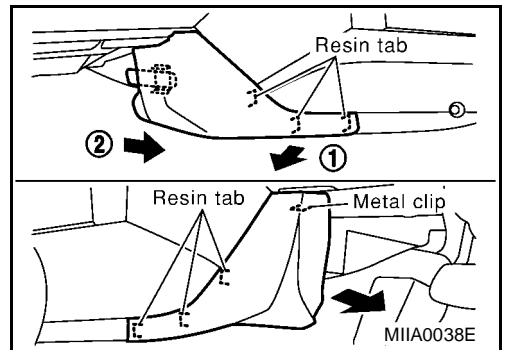

## FRONT FLOOR CONSOLE

- Remove screws and cap with screws, and remove front floor console.

A  
B  
C  
D  
E  
F  
G  
H  
IP  
J  
K  
L  
M

# INSTRUMENT PANEL ASSEMBLY

## INSTRUMENT FINISHER E

- Insert a screwdriver, wrapped with shop cloth, into the cutout on instrument finisher E, and pull instrument finisher E downward to remove.

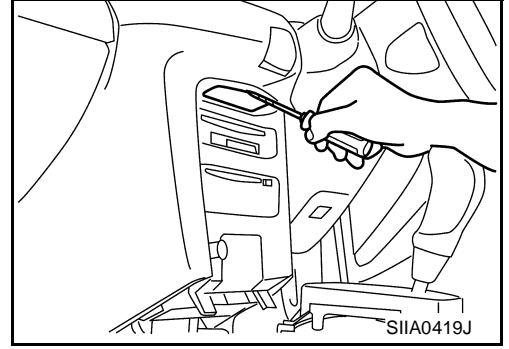

## CLUSTER LID C

1. Remove instrument finisher E, and remove screw.
2. Remove mounting screws of lower side.
3. Pull both sides of cluster lid C, unfasten lower side metal clips and resin tabs.
4. Unfasten upper side metal clips, and remove cluster lid C.
5. Remove hazard switch connector and other connectors.

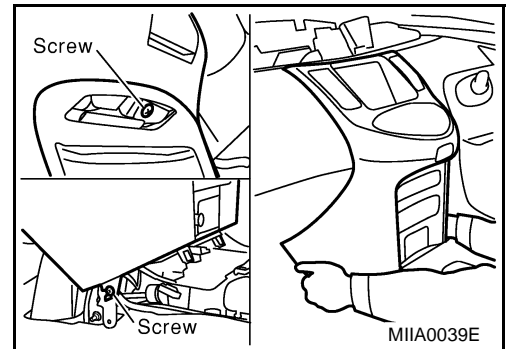

## DISPLAY

- Remove screws and disconnect connector, and remove display unit.

## AUDIO UNIT

- Remove screws and disconnect connectors, and remove audio unit.

### NOTE:

When removal and installation, protect the audio unit from cracks or damage with a shop cloth or equivalent.

## GLOVE BOX

1. Open glove box, and remove dumper clip.
2. Remove glove box pin from inside, and remove glove box.

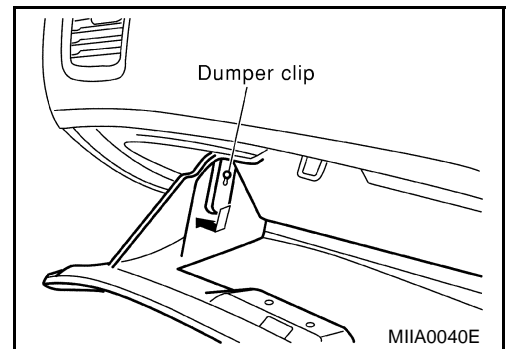

# INSTRUMENT PANEL ASSEMBLY

## INSTRUMENT LOWER PANEL

- Remove clips. Then pull to remove instrument lower panel from blower unit lower side pawl.

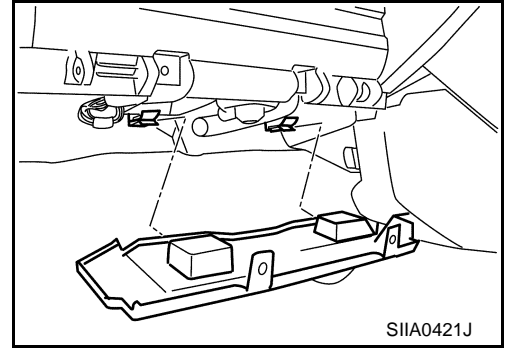

## INSTRUMENT LOWER ASSISTANCE PANEL

1. Remove installation screws on glove box striker.
2. Open lid, and remove passenger air bag module connector from lid.
3. Remove screws, and pull straight forward to remove instrument lower assistance panel.
4. Reconnect glove box lamp connector.

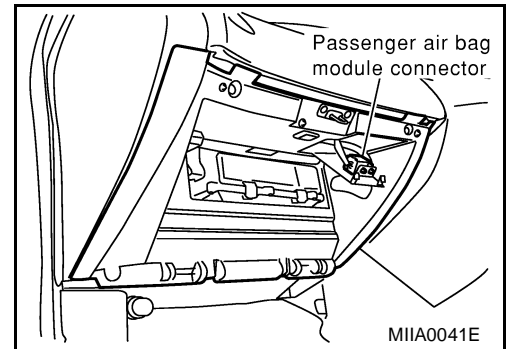

## PASSENGER AIR BAG MODULE

- Reconnect passenger air bag module connector. Then remove mounting bolts, and remove passenger air bag module. Refer to [SRS-36, "FRONT PASSENGER AIR BAG MODULE"](#).

## STEERING LOCK ESCUTCHEON

- Pull to remove steering lock escutcheon.

## STEERING COLUMN COVER

- Remove steering lock escutcheon first. Remove screws.

## INSTRUMENT INNER COVER PROTECTOR

- Remove screws, and push instrument inner cover protector straight forward to unfasten the pawl.

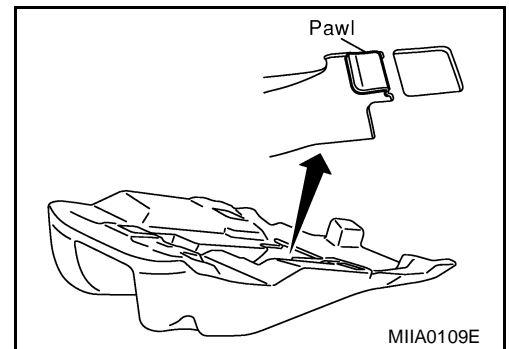

A  
B  
C  
D  
E  
F  
G  
H

IP

J  
K  
L  
M

# INSTRUMENT PANEL ASSEMBLY

## INSTRUMENT LOWER DRIVER PANEL

1. Remove screws, and pull driver-side instrument lower panel straight forward to unfasten the clip.
2. Reconnect connectors and aspirator duct.

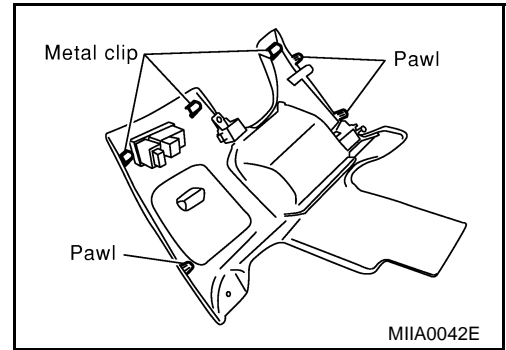

## GPS ANTENNA

- Undo screws. Disconnect and remove connector.

## FRONT PILLAR GARNISH

- Pull front pillar garnish straight forward to inner side of vehicle. Unfasten and remove metal clip. Refer to [EI-25, "BODY SIDE TRIM"](#) .

## INSTRUMENT PANEL

1. Remove key interlock cable. Refer to [AT-402, "KEY INTERLOCK CABLE"](#) .
2. Remove nuts, and lower steering column.

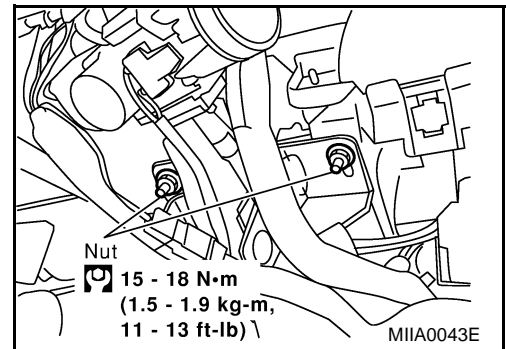

3. Remove bolts, nuts and screw from the instrument panel, and remove the instrument panel.

### NOTE:

When installing, check that the locating pin on back off the instrument panel is completely seated in locating hole on body.

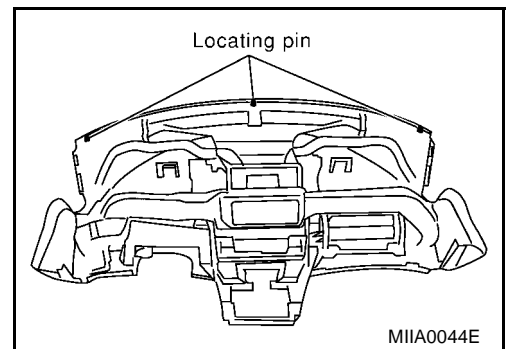

## Disassembly and Assembly

### INSTRUMENT FINISHER D, ASHTRAY AND AUDIO

1. Remove mounting screws, and remove instrument finisher D.
2. Remove mounting screws, and remove ashtray.

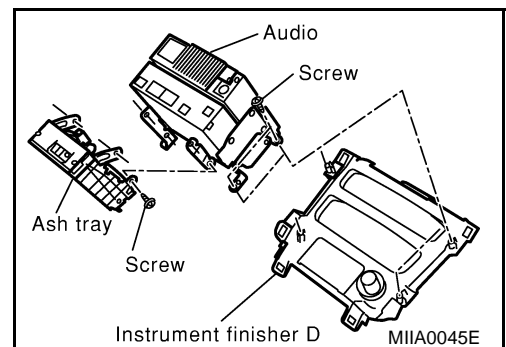

E/IS002FU



# INSTRUMENT PANEL ASSEMBLY

## GLOVE BOX

- Remove screws, and remove glove box lock.

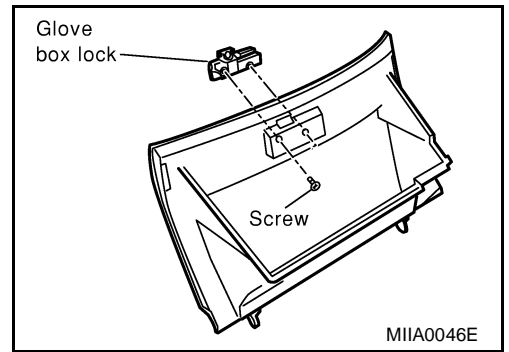

A  
B  
C  
D  
E  
F  
G  
H  
IP  
J  
K  
L  
M

# INSTRUMENT PANEL ASSEMBLY

---