

SECTION **RF**
ROOF

A
B
C
D
E
F
G
H
J
K
L
M

CONTENTS

SUNROOF	2	Fitting Adjustment	4
Precautions	2	LONGITUDINAL/LATERAL CLEARANCE	
System Description	2	ADJUSTMENT	4
RESUMING OPERATION	2	SURFACE MISMATCH ADJUSTMENT	5
Component Parts Location	2	Removal and Installation	6
Wiring Diagram — SROOF —	3	SUNROOF UNIT	7
Terminal and Reference Value for Sunroof Switch....	4	GLASS LID	8
Sunroof Lid Weatherstrip Inspection	4	SUNSHADE	9
Link and Wire Assembly Inspection	4	SUNROOF MOTOR	10

RF

SUNROOF

SUNROOF

PFP:91210

Precautions

EIS002FG

- If sunroof motor operation sound is noted but sunroof does not operate, replace motor assembly with glass lid fully closed.
- If sunroof (glass lid and motor) does not operate when using sunroof switch then remove the front cover of the luggage compartment, and rotate motor gear box drive shaft with the emergency handle (in the tool box).

System Description

EIS002FH

- Operating sunroof switch allows glass lid open/close, and tilt UP and DOWN.
- When sunroof switch is pressed firmly toward the OPEN side, glass lid automatically opens and automatic operation is stopped at a point 135 mm (5.31 in) to the fully closed position.

NOTE:

After the emergency handle is used to rotate the motor drive shaft, sunroof switch operation may not correspond to actual glass lid movement. When this happens, conduct resuming operation to restore normal operation.

RESUMING OPERATION

- If actual glass lid operation does not correspond to expected operation, operate sunroof switch to slide glass lid toward area A in the figure. This should result in resumption of normal operation.

CAUTION:

Before normal operation is resumed, expected sunroof switch operation and actual glass lid movement may not correspond. Make sure that neither head nor hands protrude from sunroof and conduct resuming operation.

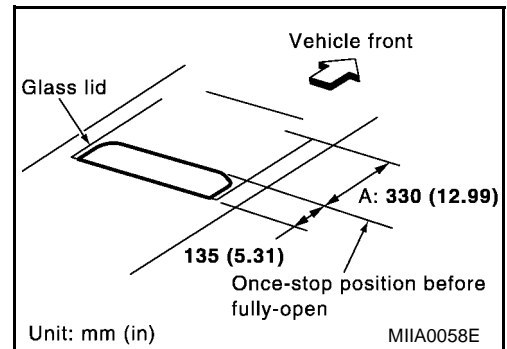

Component Parts Location

EIS002FI

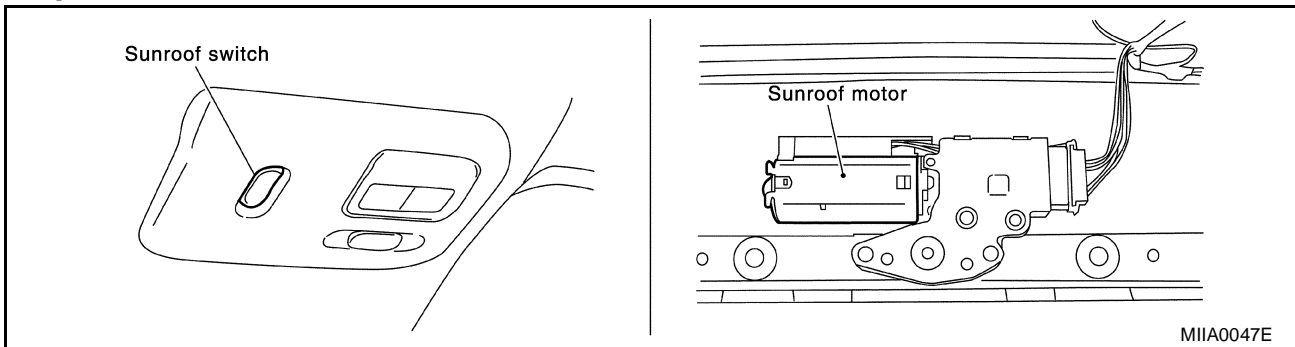

SUNROOF

Wiring Diagram — SROOF —

EIS002FJ

RF-SROOF-01

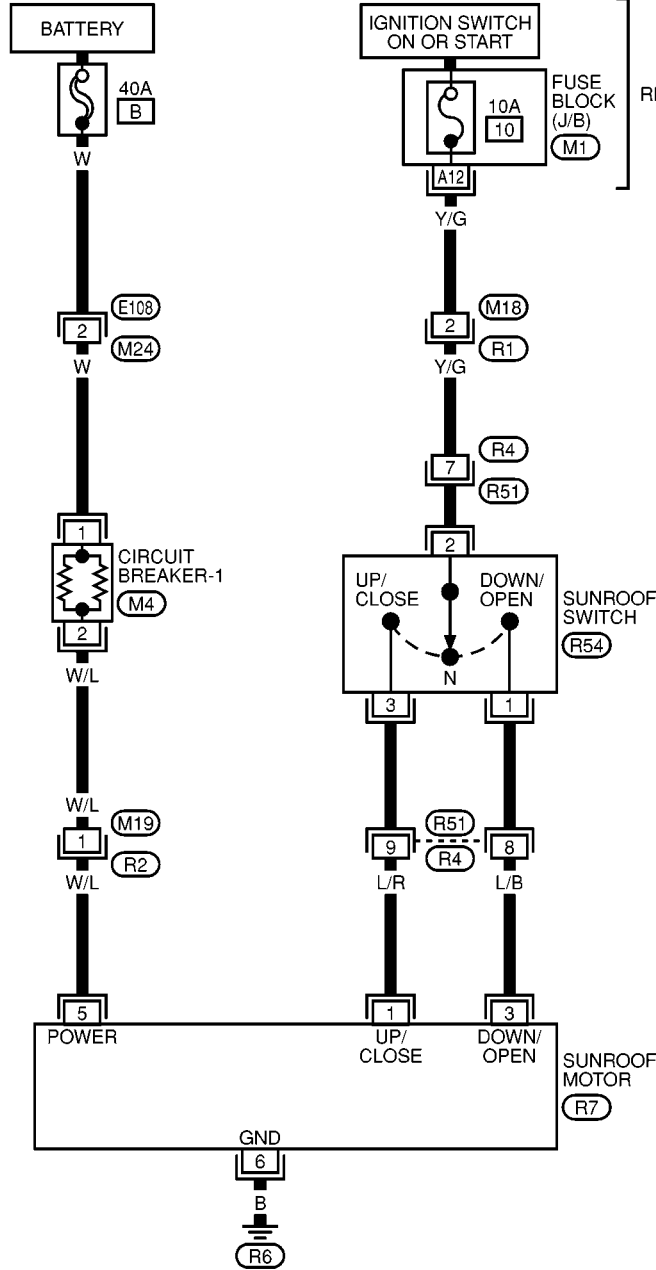

A
B
C
D
E
F
G
H
RF
J
K
L
M

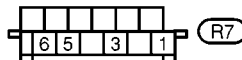
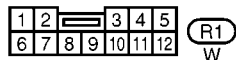
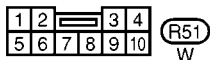
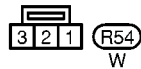
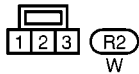
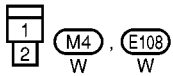

REFER TO THE FOLLOWING.
(M1) - FUSE BLOCK- JUNCTION BOX (J/B)

SUNROOF

Terminal and Reference Value for Sunroof Switch

EIS002FK

TERMI-NAL	WIRE COLOR	ITEM	CONDITION	VOLTAGE
1	L/B	Sunroof tilt DOWN or OPEN signal	Sunroof switch tilt DOWN or OPEN operation	Approx. 0 → Approx. 12
2	Y/G	IGN power supply	—	Battery voltage
3	L/R	Sunroof tilt UP or CLOSE signal	Sunroof switch tilt UP or CLOSE operation	Approx. 0 → Approx. 12

Sunroof Lid Weatherstrip Inspection

EIS002FM

If there is water leakage around glass lid, close glass lid and flush with water to determine whether it is from damaged parts or a gap.

1. Remove glass lid assembly.
2. Visually check weatherstrip for damage, deterioration, or deformation. If excess wear or damage is detected, replace glass lid assembly.

Link and Wire Assembly Inspection

EIS002FN

1. If the link coating peels off to show the base material and an abnormal noise is heard, replace it.
2. Visually confirm the wire and rail groove are properly greased. If necessary, apply body grease.

Fitting Adjustment

EIS002FO

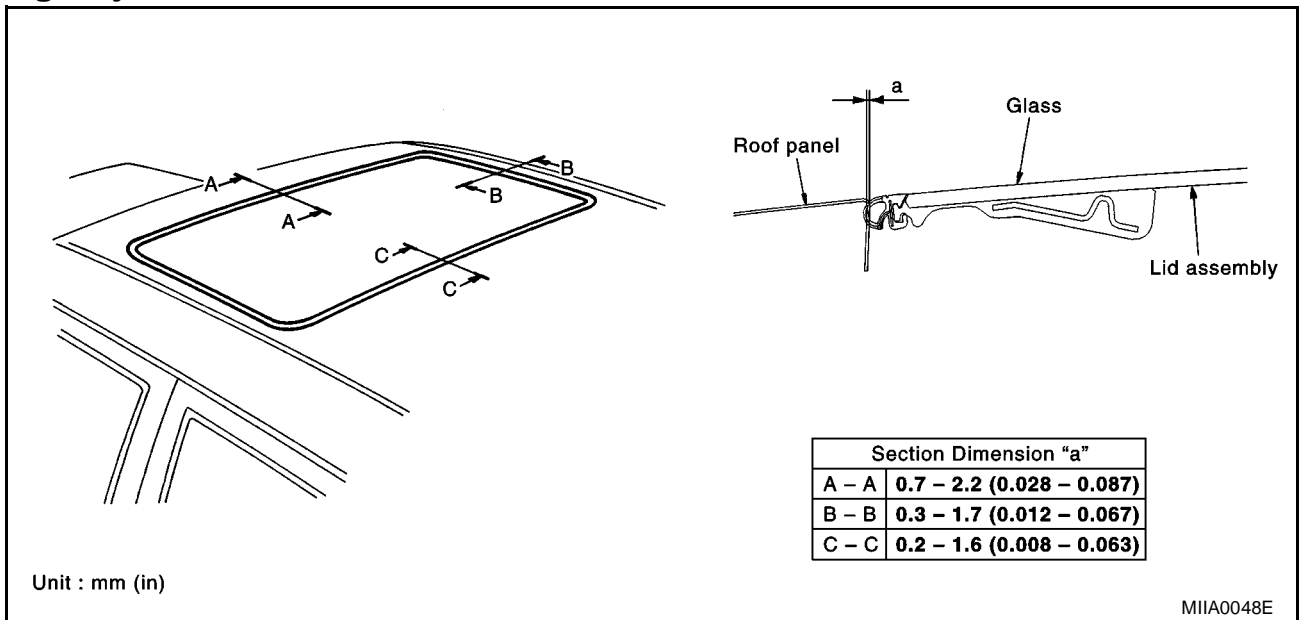

LONGITUDINAL/LATERAL CLEARANCE ADJUSTMENT

1. Tilt up glass lid to remove side trim upper and lower.
2. After loosening glass lid mounting bolts (Torx bolt: T25, 3 each on left/right), tilt down glass lid.
3. Adjust glass lid according to sections A-A, B-B, C-C as shown in the figure.
4. After adjusting glass lid, tighten nuts to the specified torque.
5. Tilt glass lid 4 to 5 times to check that it smoothly goes up and down.

SUNROOF

SURFACE MISMATCH ADJUSTMENT

1. Adjust surface height of glass lid and roof panel to 0 ± 1.5 mm (0 ± 0.059 in) by altering the number of shims between glass lid and link assembly. (Standard: 2, max: 4)
2. After fitting adjustment, use a hose to flush the entire surface of the roof with water to check for leaks.

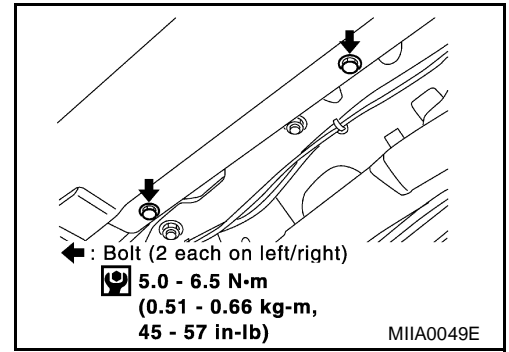

A

B

C

D

E

F

G

H

RF

J

K

L

M

SUNROOF

Removal and Installation

EIS002FP

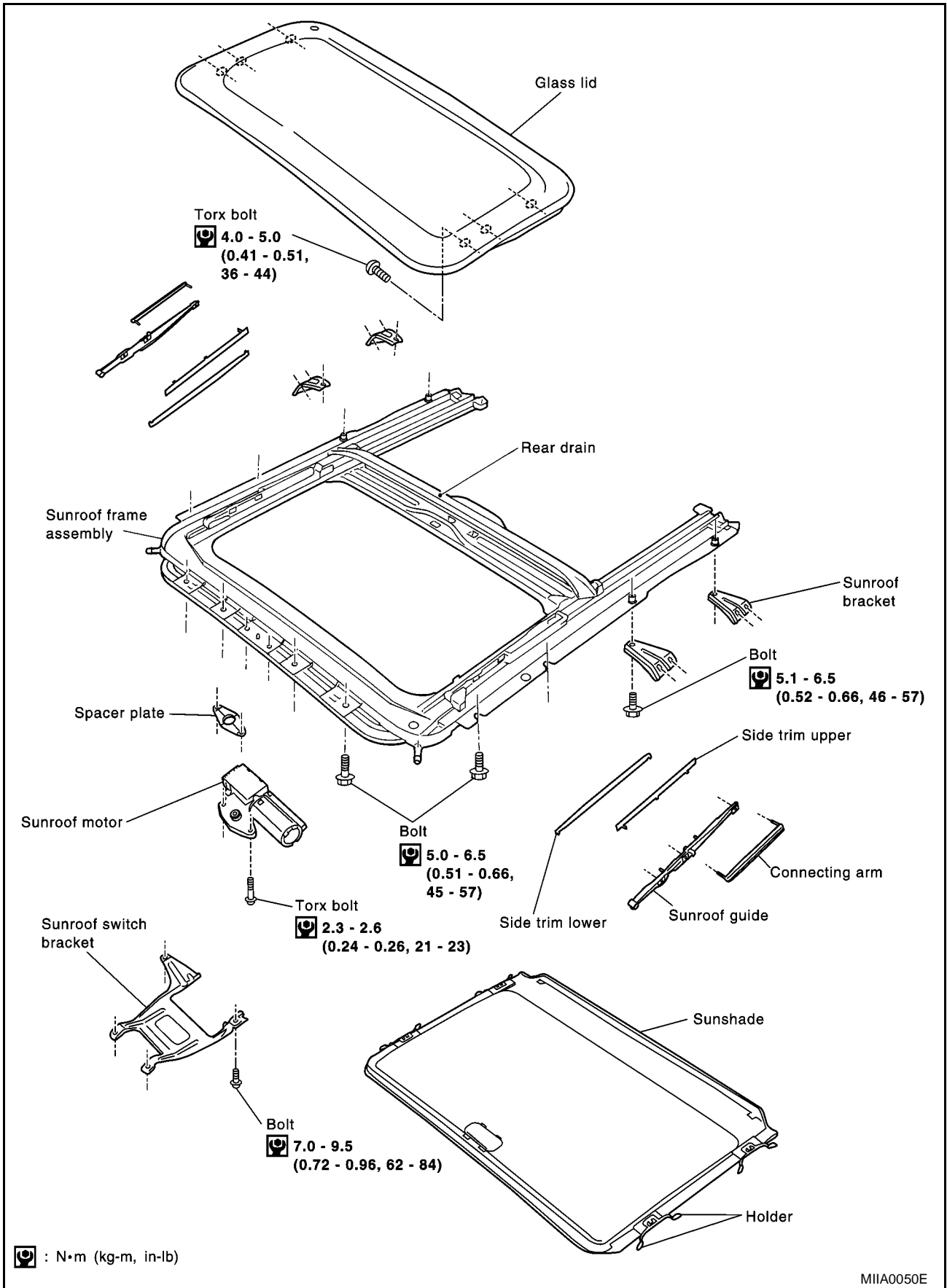

MIIA0050E

SUNROOF

SUNROOF UNIT

Removal

CAUTION:

- Removal and installation of sunroof unit must be performed by 2 persons.
- When taking sunroof unit out, use shop cloths to protect seats and trim from damage.
- After installing sunroof unit and glass lid, be sure to carry out the leak test to confirm there is no more leakage.

1. Remove headlining. Refer to [EI-32, "HEADLINING"](#).
2. Disconnect drain hoses (4).
3. Disconnect interior lamp harness.
4. Remove sunroof switch bracket mounting bolt.
5. Remove sunroof motor assembly.

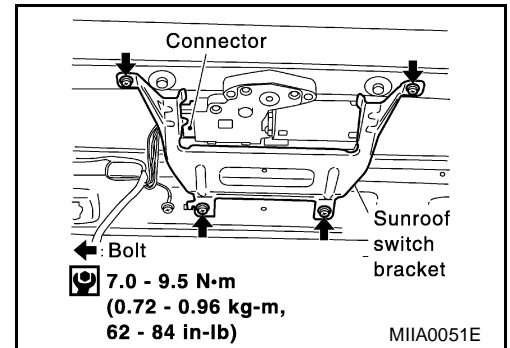

6. Remove both unit-side and body-side front sunroof bracket mounting bolts.
7. Remove both unit-side and body-side rear sunroof bracket mounting bolts.

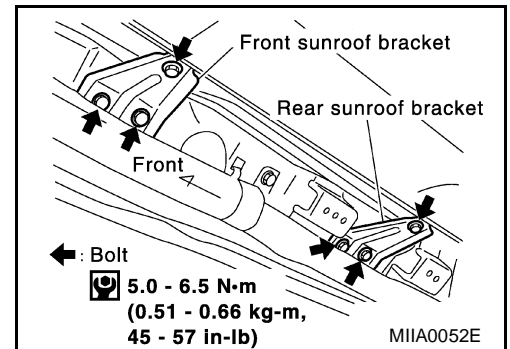

8. Remove mounting bolts on the front end.

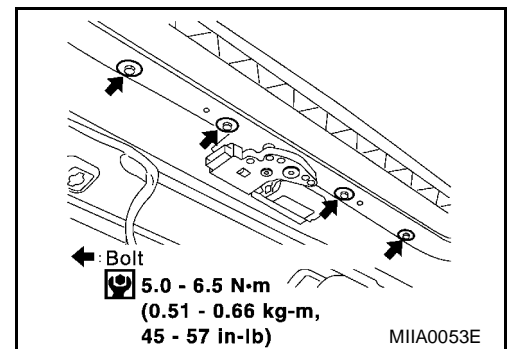

A
B
C
D
E
F
G
H
RF
J
K
L
M

SUNROOF

9. Remove mounting bolts on the side rails, and remove sunroof unit from the roof panel.
10. Remove the sunroof unit out of the passenger compartment while being careful not to damage the seats and trim.

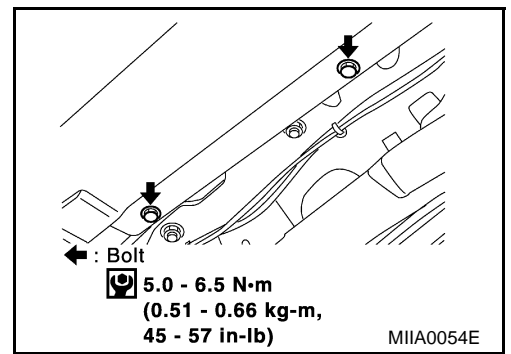

Installation

1. After bringing sunroof unit into the passenger compartment, tighten mounting nuts on the side rails (2 each on left/right). Start from the one at the front reference point.
2. Tighten mounting nuts (4) on the front end.

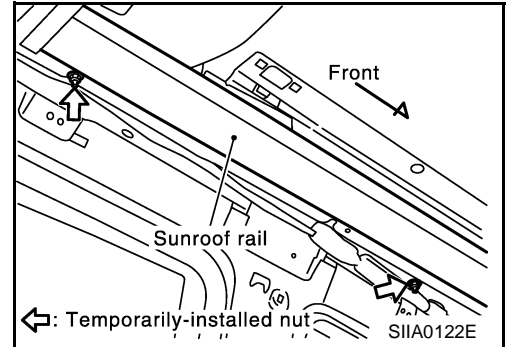

3. Align the front sunroof bracket to lower face of the rail and roof side mounting face, and tighten bolts. Then tighten bolts on the roof side.
4. Align the center and rear sunroof brackets to lower face of the rail and roof side mounting face, and tighten bolts. Then tighten bolts on the roof side.

NOTE:

Install the sunroof bracket evenly so that the roof surface has no distortion.

5. Tighten bolts on motor bracket.
6. Connect the interior lamp harness.

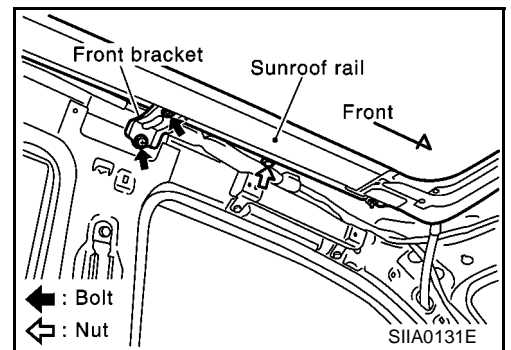

GLASS LID

Removal

1. Tilt up glass lid.
2. Remove side trim upper and lower.
3. Remove installation bolts (Torx bolt: T25, 3 each on left/right) from glass lid.
4. Remove glass lid.

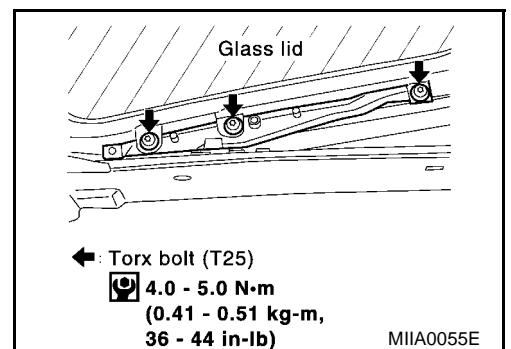

Installation

1. Tighten nuts on glass lid diagonally.
2. After installation, adjust the fit. Refer to [RF-4, "Fitting Adjustment"](#).

SUNROOF

SUNSHADE

Removal and installation

1. Remove glass lid.
2. Operate sunroof switch to OPEN side to move rear drain assembly to rear of vehicle.

NOTE:

Be sure to move to a position where sunshade and rear drain assembly do not overlap one another.

3. Use a flat-bladed screwdriver to remove left or right sunshade holders (2 locations each) from sunroof rail assembly.
4. After removing sunshade holders (one side), slightly lift up sunshade from rail to remove other holders from rail. Then remove sunshade.

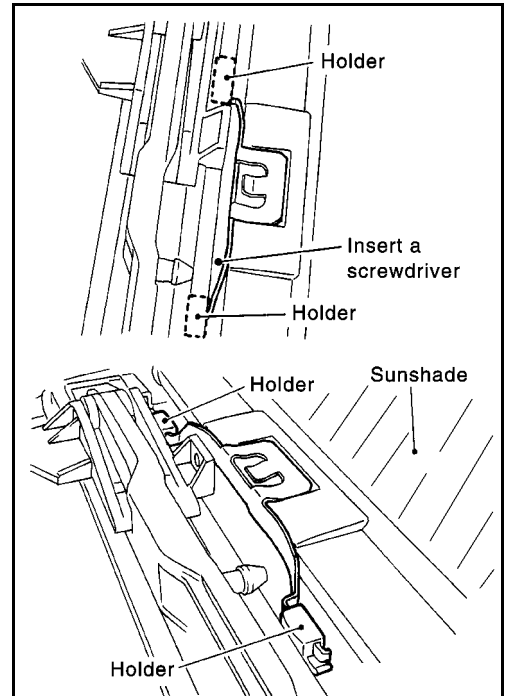

Installation

Install in the reverse order of removal.

NOTE:

- Before installing glass lid, operate sunroof switch to Tilt UP side.
 - After installation, check that sunshade opens/closes smoothly.
1. As shown in the figure, slide shade slider to remove it from the aluminum rail.
 2. Swivel shade toward the left, and remove RH shade from the aluminum rail.
 3. Slide shade forward, and remove rear shade sliders as well.
 4. Install in the reverse order of removal.

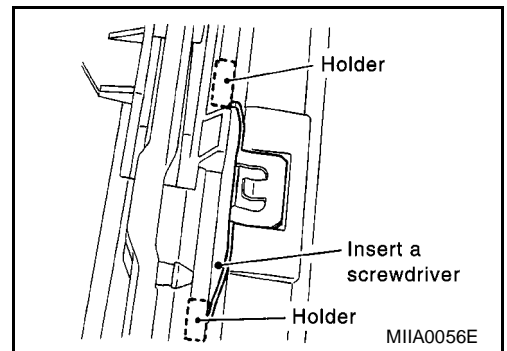

MIIA0056E

SUNROOF

SUNROOF MOTOR

Removal

1. Remove motor mounting bolts (Torx bolt: T25).
2. Remove the harness connector, and remove the sunroof motor.

NOTE:

- Remove the sunroof motor when the sunroof is in the fully-closed position.
- Never rotate the removed motor as a single unit.

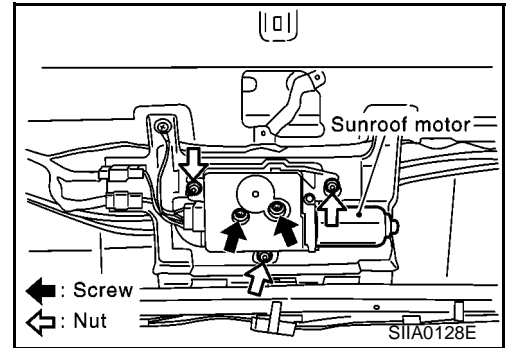

Installation

1. Move motor laterally little by little until the gear is completely engaged onto the wire on sunroof unit and the mounting surface becomes parallel. Then secure motor with screws and nuts.
2. Connect harness connector to motor, and perform initial operation for initialization.
 - To initialize, hold Tilt UP switch for approximately 10 seconds with sunroof tilted up. If this is not properly done, Tilt DOWN operation will not be performed normally.
3. After installation, check that sunroof operates normally.

NOTE:

Before installing motor, be sure to place the link and wire assembly in the symmetrical and fully closed position.