

SECTION **SE**
SEAT

A
B
C
D
E
F
G
H
SE
J
K
L
M

CONTENTS

PRECAUTIONS	2	POWER SEAT	12
Precautions for Supplemental Restraint System (SRS) "AIR BAG" and "SEAT BELT PRE-TENSIONER"	2	INSTALLATION	12
Precautions	2	Disassembly and Assembly of Seatback	13
POWER SEAT	3	SEATBACK TRIM (WITH SIDE AIR BAG)	13
Wiring Diagram – SEAT –	3	SEATBACK TRIM (WITHOUT SIDE AIR BAG)... ..	14
HEATED SEAT	5	SEATBACK TRIM AND PAD	14
Description	5	Disassembly and Assembly of Seat Cushion Trim..	15
Wiring Diagram — H/SEAT (LHD MODELS)	6	REAR SEAT	16
Wiring Diagram — H/SEAT (RHD MODELS)	8	Component Parts Drawing	16
FRONT SEAT	10	SEDAN AND WAGON MODELS	16
Component Parts Drawing	10	Removal and Installation	17
STANDARD SEAT	10	SEAT CUSHION	17
POWER SEAT	11	IN THE SEATBACK (WAGON MODELS)	17
Removal and Installation	12	REAR CENTER BRACKET	18
STANDARD SEAT	12	REAR SEATBACK STRIKER	19
		ARMREST	19
		INSTALLATION	19

PRECAUTIONS

PRECAUTIONS

PFP:00001

Precautions for Supplemental Restraint System (SRS) “AIR BAG” and “SEAT BELT PRE-TENSIONER”

EIS002FV

The Supplemental Restraint System such as "AIR BAG" and "SEAT BELT PRE-TENSIONER", used along with a front seat belt, helps to reduce the risk or severity of injury to the driver and front passenger for certain types of collision. Information necessary to service the system safely is included in the SRS and SB section of this Service Manual.

WARNING:

- To avoid rendering the SRS inoperative, which could increase the risk of personal injury or death in the event of a collision which would result in air bag inflation, all maintenance must be performed by an authorized NISSAN/INFINITI dealer.
- Improper maintenance, including incorrect removal and installation of the SRS, can lead to personal injury caused by unintentional activation of the system. For removal of Spiral Cable and Air Bag Module, see the SRS section.
- Do not use electrical test equipment on any circuit related to the SRS unless instructed to in this Service Manual. SRS wiring harnesses can be identified by yellow and/or orange harness connectors.

Precautions

EIS002FW

- When removing or disassembling any part, be careful not to damage or deform it. Protect parts, which may get in the way with cloth.
- When removing parts with a screwdriver or other tool, protect parts by wrapping them with vinyl or tape.
- Keep removed parts protected with cloth.
- If a clip is deformed or damaged, replace it.
- If an un reusable part is removed, replace it with a new one.
- Tighten bolts and nuts firmly to the specified torque.
- After re-assembly has been completed, make sure each part functions correctly.
- Remove stains in the following way.

Water-soluble stains:

Dip a soft cloth in warm water, and then squeeze it tightly. After wiping the stain, wipe with a soft dry cloth.

Oil stain:

Dissolve a synthetic detergent in warm water (density of 2 to 3% or less), dip the cloth, then clean off the stain with the cloth. Next, dip the cloth in fresh water and squeeze it tightly. Then clean off the detergent completely. Then wipe the area with a soft dry cloth.

- Do not use any organic solvent, such as thinner or benzene.

POWER SEAT

POWER SEAT

PFP:87016

Wiring Diagram – SEAT –

EIS002FX

SE-SEAT-01

⬡ W: WAGON

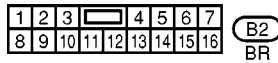
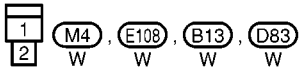
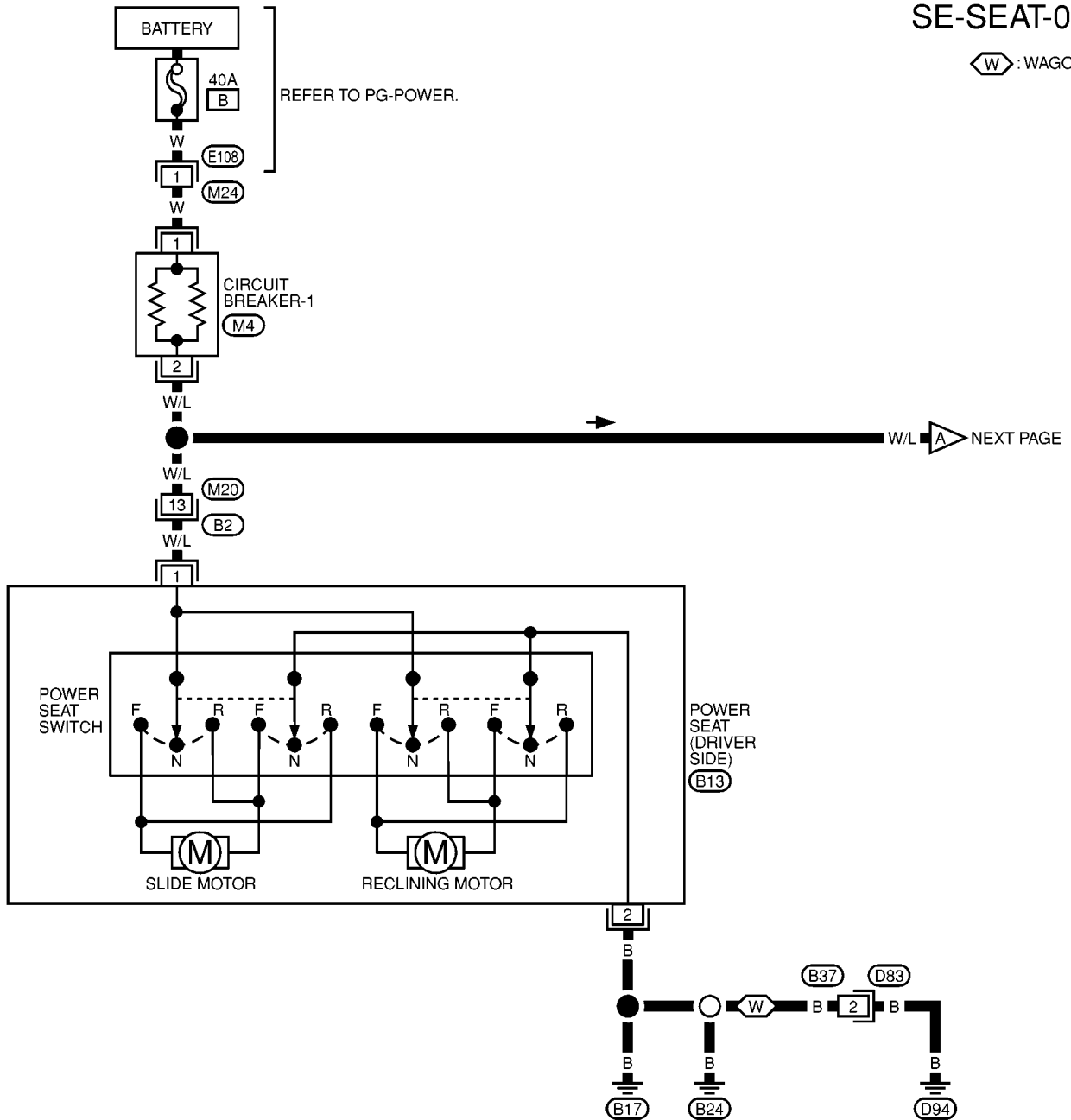

A
B
C
D
E
F
G
H
SE
J
K
L
M

POWER SEAT

SE-SEAT-02

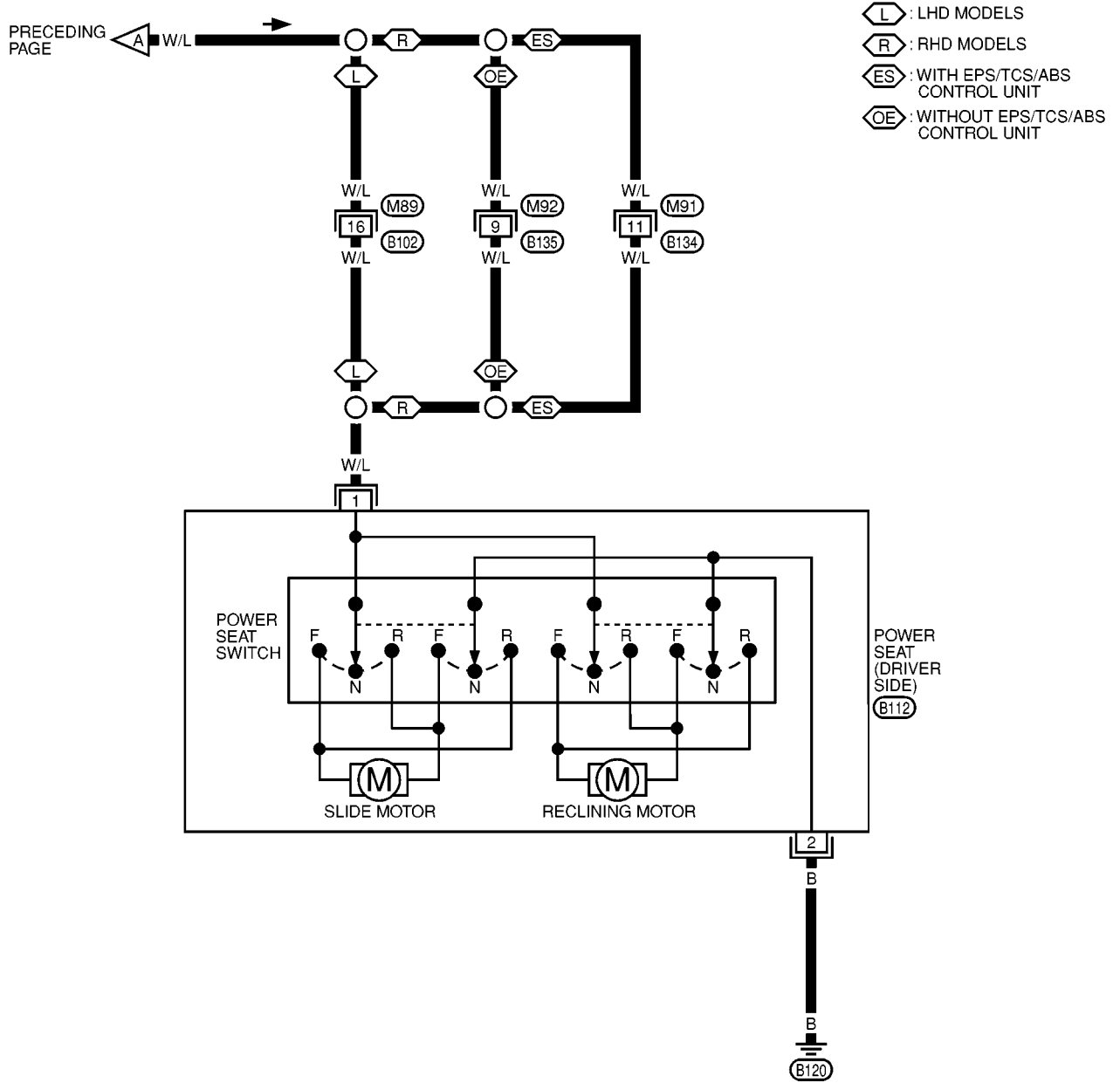

1	2	3	4	5	6	7		
8	9	10	11	12	13	14	15	16

M89
W

1	2	3	4	5		
6	7	8	9	10	11	12

M91
W

1	2	3	4		
5	6	7	8	9	10

M92
W

1
2

B112
W

MKWA0170E

HEATED SEAT

HEATED SEAT

PFP:87335

Description

EIS002FY

- When handling seat, be extremely careful not to scratch heating unit.
- To replace heating unit, seat trim and pad should be separated.
- Do not use any organic solvent, such as thinner, benzene, alcohol, etc. to clean trims.

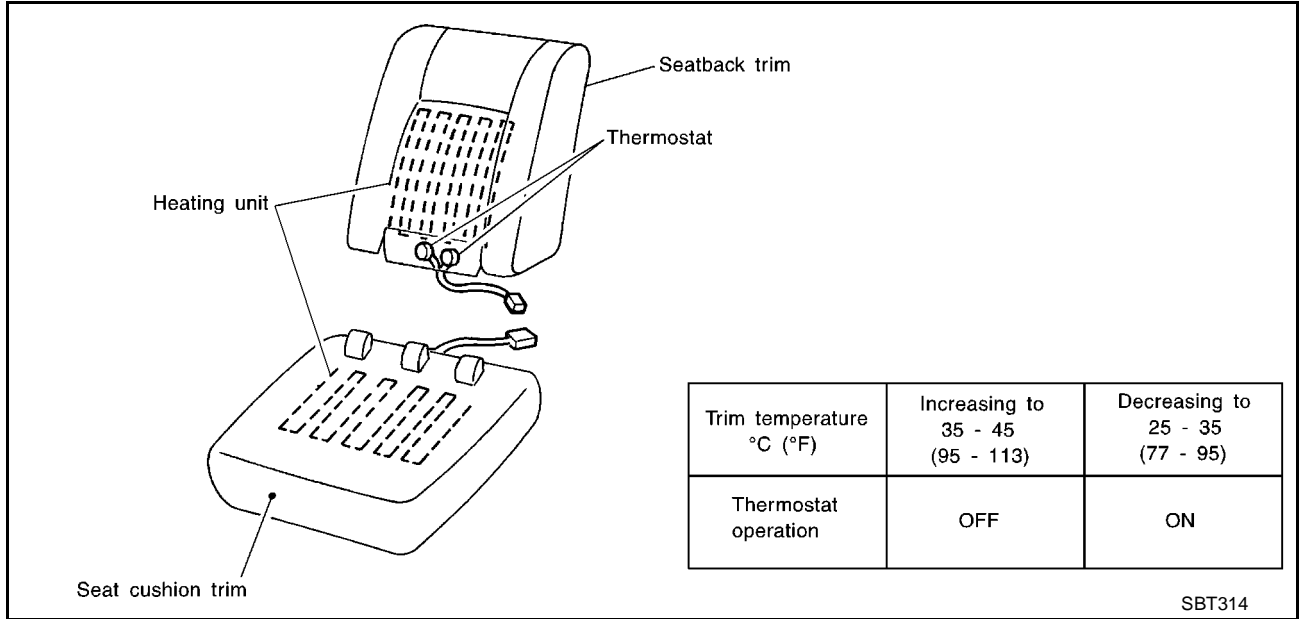

A
B
C
D
E
F
G
H
SE
J
K
L
M

HEATED SEAT

Wiring Diagram — H/SEAT (LHD MODELS)

EIS002FZ

SE-H/SEAT-01

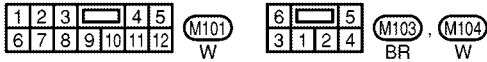
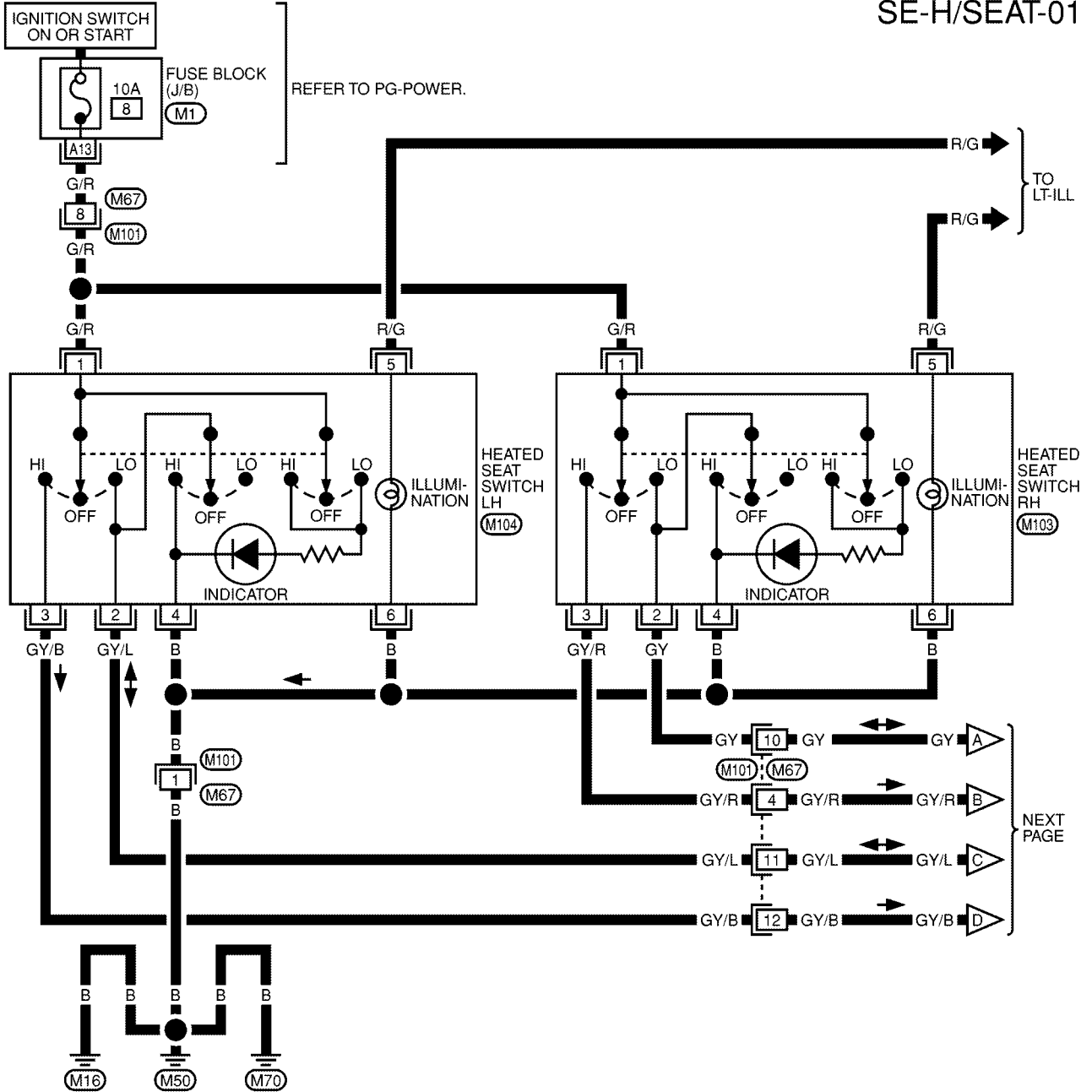

REFER TO THE FOLLOWING.

(M1) - FUSE BLOCK-
JUNCTION BOX (J/B)

MKWA0165E

HEATED SEAT

SE-H/SEAT-02

WAGON

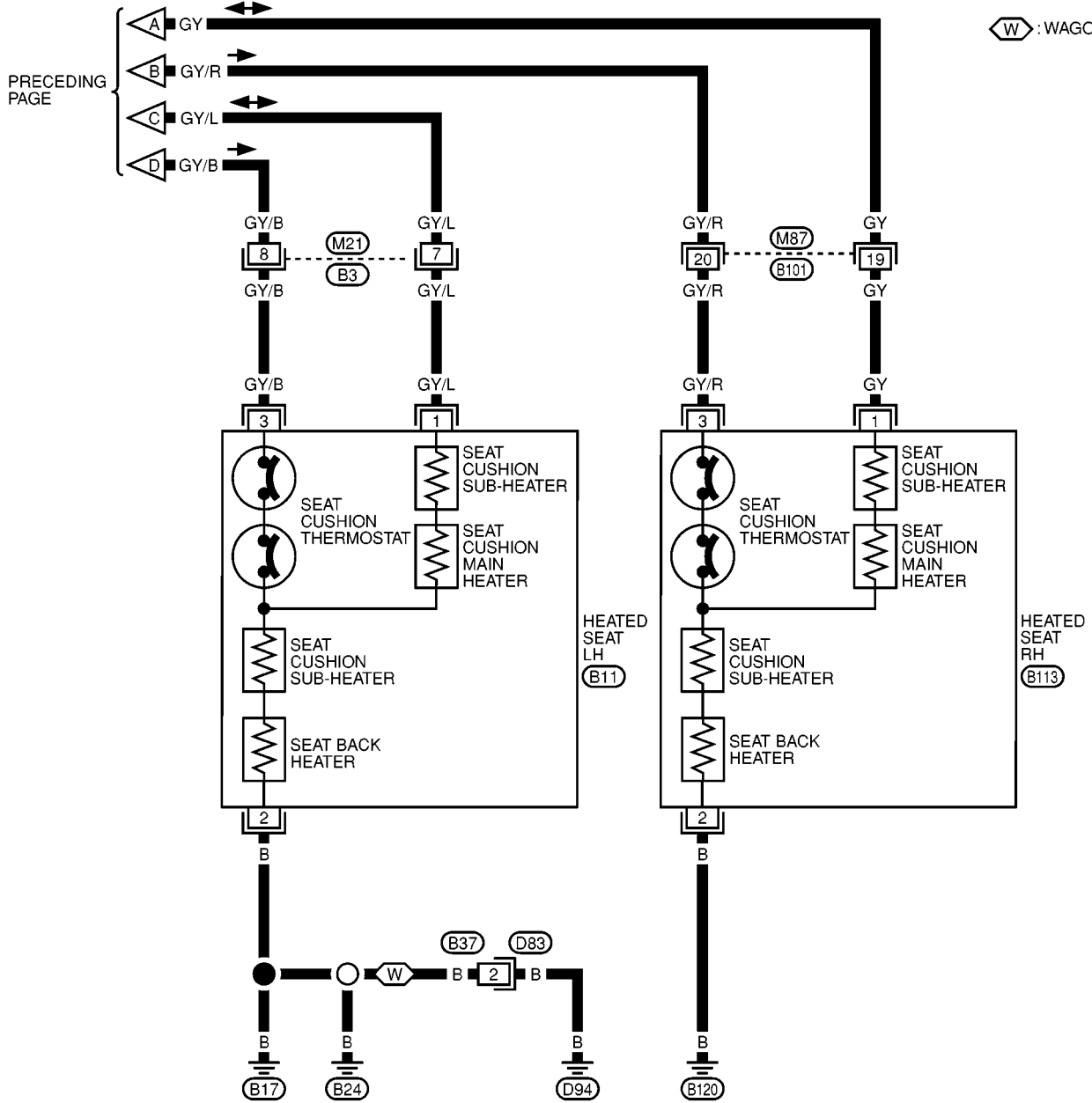

1	2	3	4	5	6	7	8	9	10	11		
12	13	14	15	16	17	18	19	20	21	22	23	24

M87
W

1	2	3	4	5	6	7	8	9		
10	11	12	13	14	15	16	17	18	19	20

B3
W

1
2
3

B11
W

B113
W

1
2

D83
W

MKWA0166E

HEATED SEAT

Wiring Diagram — H/SEAT (RHD MODELS)

EIS002G0

SE-H/SEAT-03

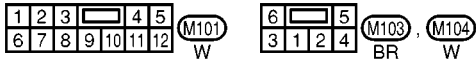
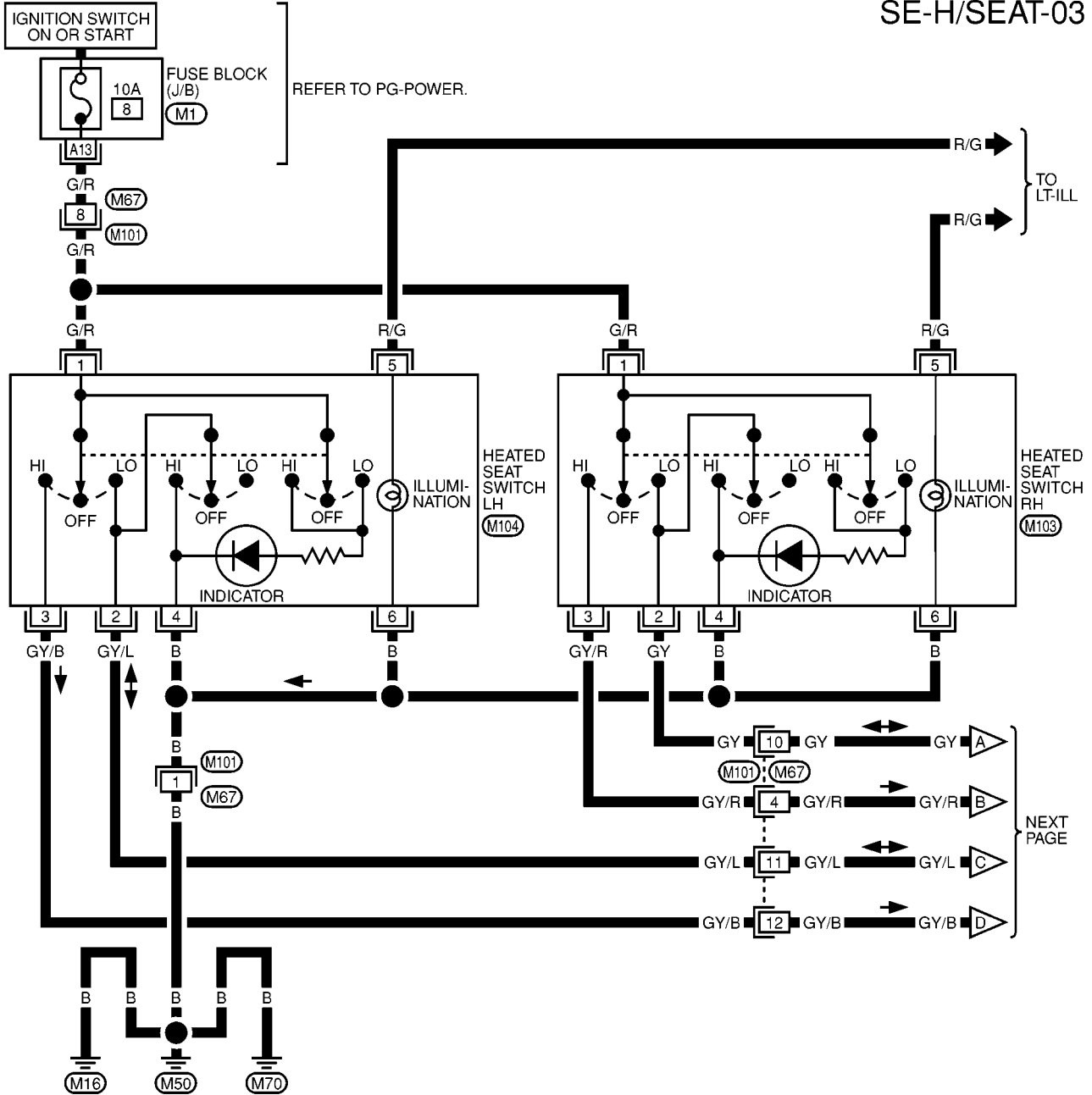

REFER TO THE FOLLOWING.

M1 - FUSE BLOCK-
JUNCTION BOX (J/B)

MKWA0167E

HEATED SEAT

SE-H/SEAT-04

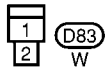
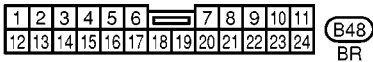
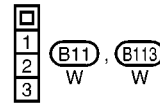
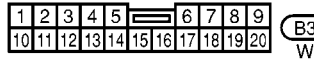
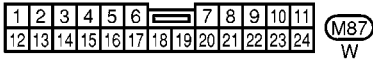
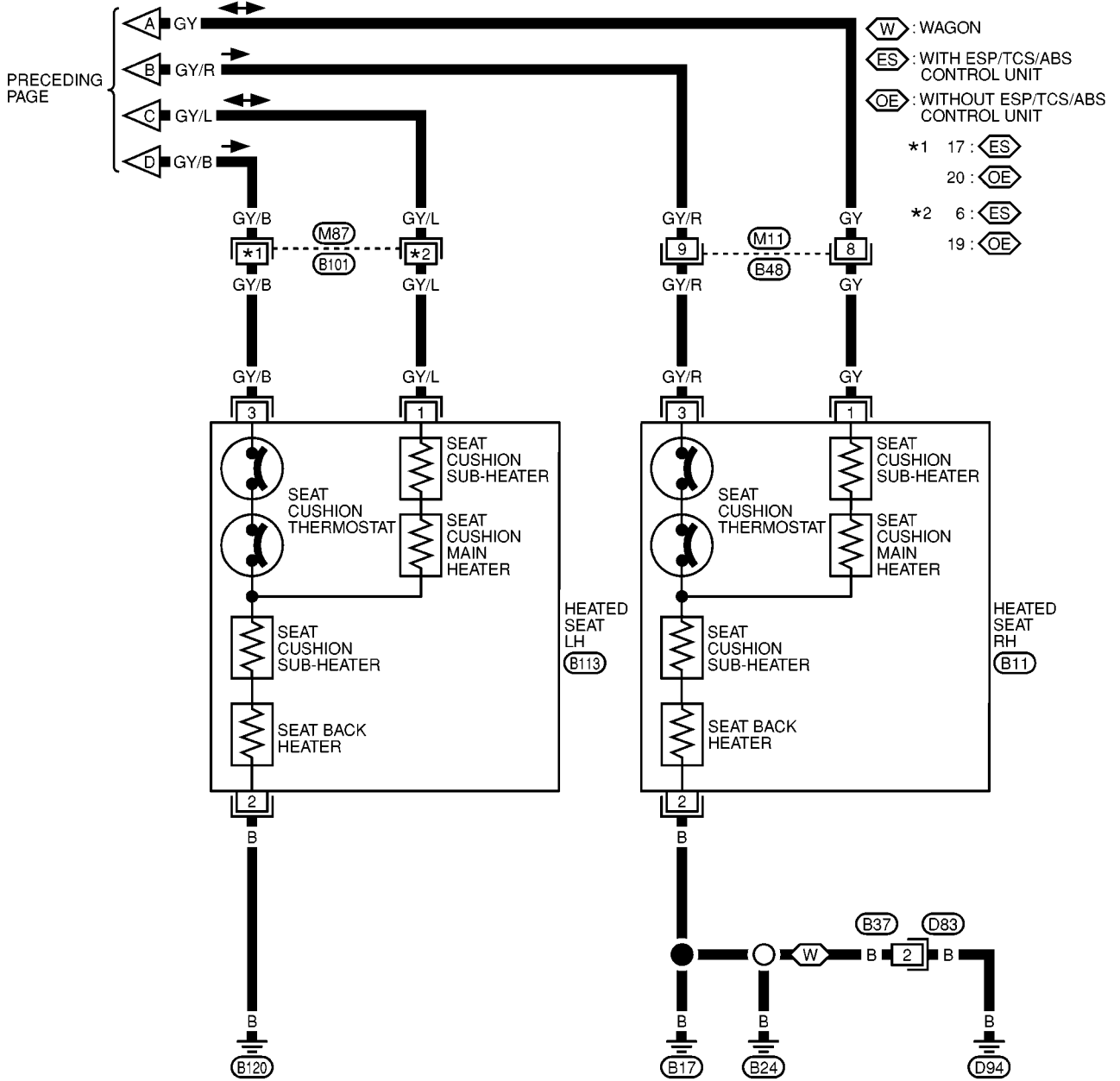

MKWA0168E

FRONT SEAT

FRONT SEAT

PFP:87000

Component Parts Drawing STANDARD SEAT

EIS002IK

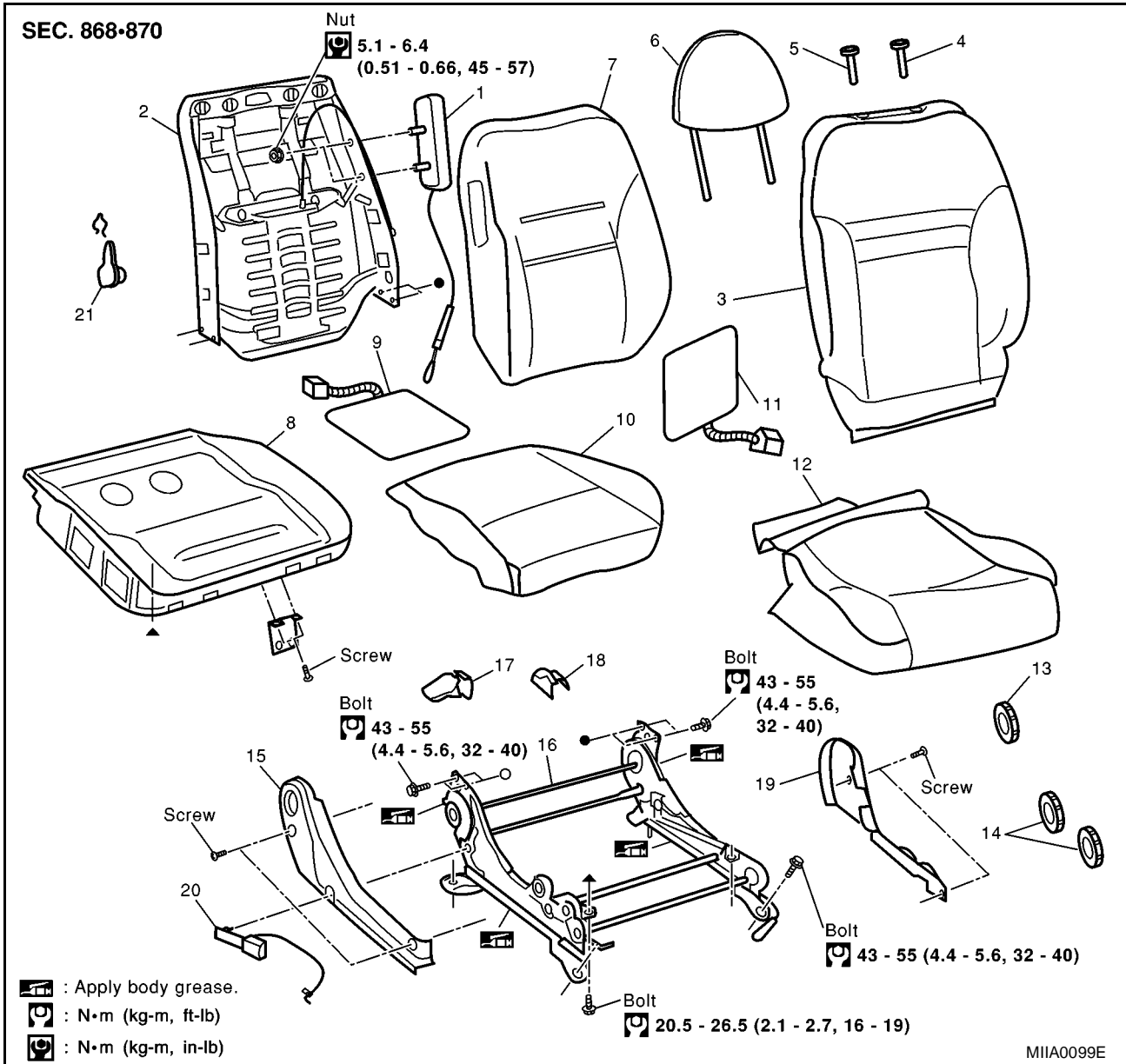

- | | | |
|--------------------------------------|-----------------------------|--------------------------------------|
| 1. Side air bag module | 2. Seatback frame | 3. Seatback trim |
| 4. Headrest holder (free) | 5. Headrest holder (locked) | 6. Headrest |
| 7. Seatback pad | 8. Seat cushion frame | 9. Seat cushion heater unit |
| 10. Seat cushion pad | 11. Seatback heater unit | 12. Seat cushion trim |
| 13. Reclining dial | 14. Lifter dial | 15. Outer seat cushion finisher (RH) |
| 16. Front seat adjuster | 17. Rear outer slide cover | 18. Rear inner slide cover (RH) |
| 19. Inner seat cushion finisher (RH) | 20. Seat belt buckle | 21. Lumbar support lever knob |

FRONT SEAT

POWER SEAT

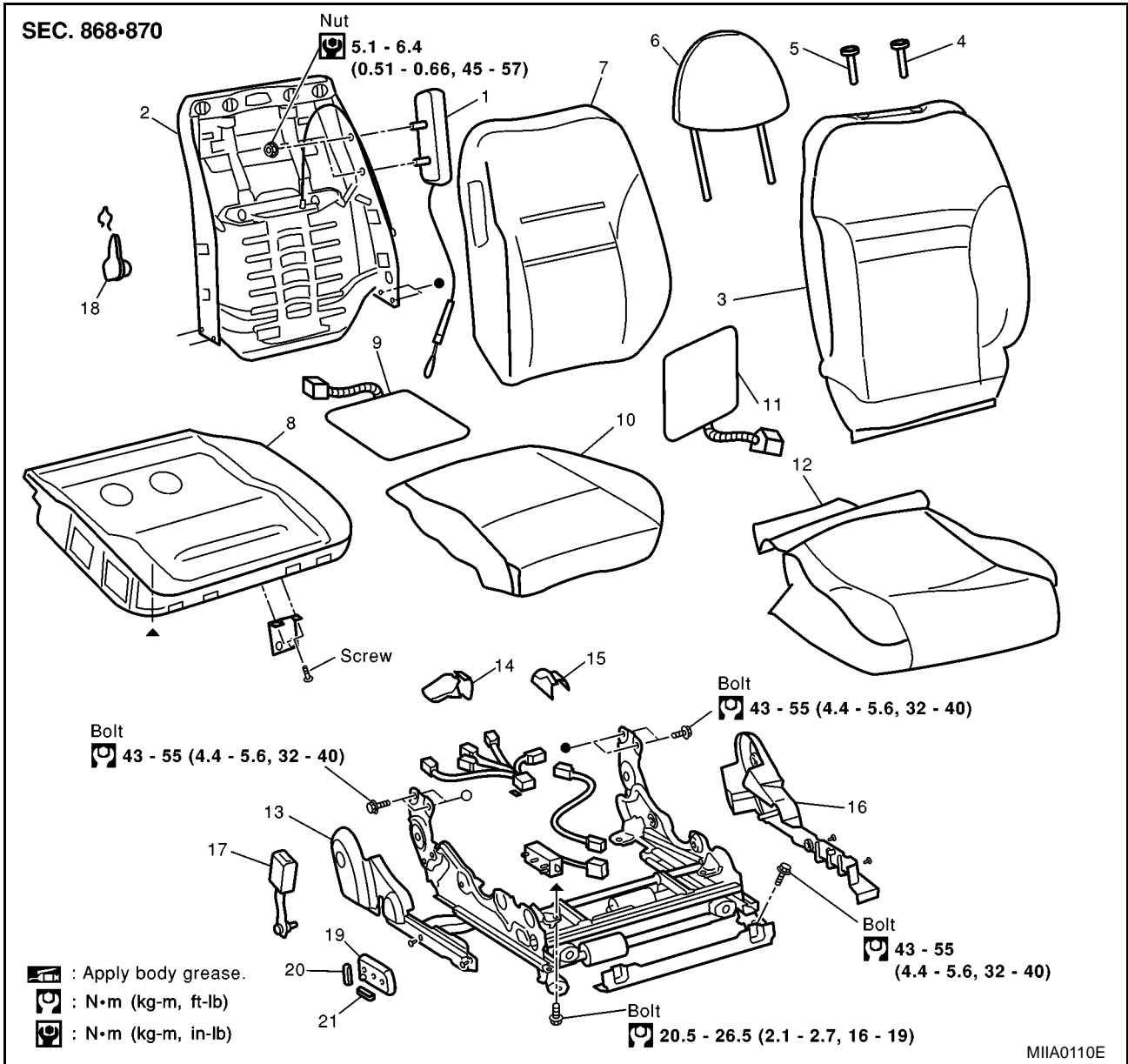

- | | | |
|-------------------------------------|--------------------------------------|---------------------------------|
| 1. Side air bag module | 2. Seatback frame | 3. Seatback pad |
| 4. Headrest | 5. Seatback grip belt | 6. Seatback board |
| 7. Seat cushion pad | 8. Headrest holder (free) | 9. Headrest holder (locked) |
| 10. Seatback trim | 11. Seat cushion trim | 12. Seat lumbar unit |
| 13. Seat cushion rear finisher | 14. Reclining device (RH) | 15. Reclining device rod |
| 16. Reclining device (LH) | 17. Seat cushion frame | 18. Driver power seat switch |
| 19. Seat cushion outer finisher | 20. Lumbar support switch knob | 21. Reclining switch knob |
| 22. Slide-lifter switch knob | 23. Seat cushion rod (RH) | 24. Lifter motor unit assembly |
| 25. Seat lifter link bracket (rear) | 26. Seat lifter link bracket (front) | 27. Seat cushion rod (LH) |
| 28. Inner sliding assembly | 29. Driver seat control unit bracket | 30. Driver seat control unit |
| 31. Flexible wire | 32. Outer sliding assembly | 33. Seat cushion front finisher |
| 34. Driver power seat harness | 35. Front leg cover (LH/RH) | 36. Rear leg cover (LH/RH) |

FRONT SEAT

EIS002IL

Removal and Installation STANDARD SEAT

1. Remove slide cover.

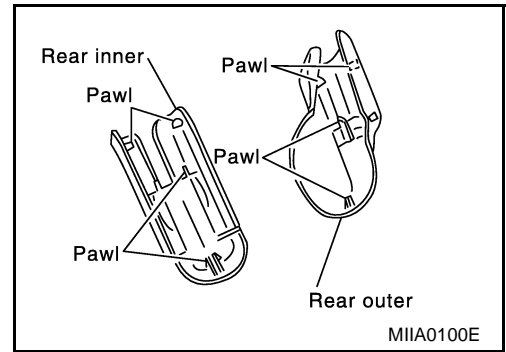

2. Remove vehicle mounting bolts.
3. Disconnect the connector and remove seat.

NOTE:

When removing and installing, using shop clothes, protect the parts from damage where it may interfere with others.

POWER SEAT

When removing or installing the seat trim, carefully handle it to keep dirt out and avoid damage.

CAUTION:

- Before removing the front seat, turn the ignition switch off, disconnect both battery cables and wait at least 3 minutes.
- When checking the power seat circuit for continuity using a circuit tester, do not confuse its connector with the side air bag module connector. Such an error may cause the air bag to deploy.
- Do not drop, tilt, or bump the side air bag module installing in the seat. Always handle it with care.

1. Remove slide cover.

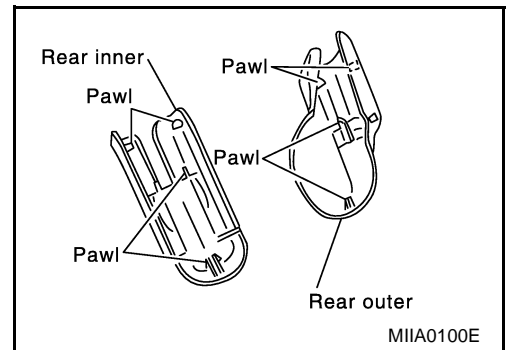

NOTE:

Slide the seat forward, then disengage the tabs on the front RH/LH of slide cover and tabs engaged into the rail. Then pull the cover toward the rear of the vehicle.

2. Slide the seat until the body mounting bolts (4) are visible and a tool can be inserted.

NOTE:

When disassembling the driver seat after removal, set the front/rear cushion lifter to the top position.

3. Disconnect the battery negative cable.
4. Remove the harness connector for the side air bag module.
5. Remove the body mounting bolts.
6. Remove the power seat harness connector and vehicle harness fixing clip out of the vehicle.

NOTE:

When removing and installing, using shop clothes, protect the parts from damage where it may interfere with others.

INSTALLATION

- Install in the reverse order of removal.

FRONT SEAT

Disassembly and Assembly of Seatback SEATBACK TRIM (WITH SIDE AIR BAG)

E/IS002IM

1. Unfasten fastener on the back of seatback.
2. Remove lower retainer.

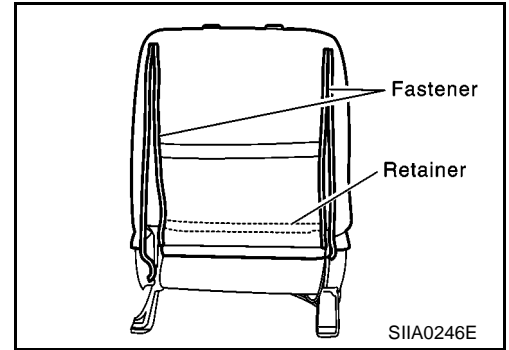

3. Remove nuts, and remove inner cross-fixed stay.

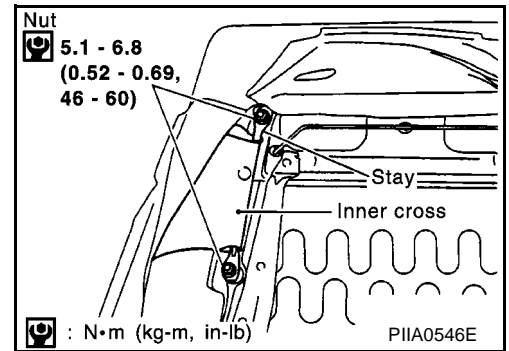

4. Hang a wire on the snap ring, and pull upward to remove. Remove lumbar support lever knob.

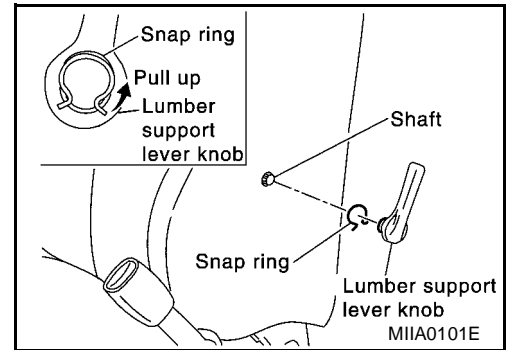

5. From the back of the seatback, press the headrest holder tab of the stay pipe hole to disengage. Then pull the headrest holder up to remove.

NOTE:

Before installing the headrest holder, check its orientation (front/rear and right/left).

6. After removing seatback trim & pad, remove hog rings to separate pad and trim.

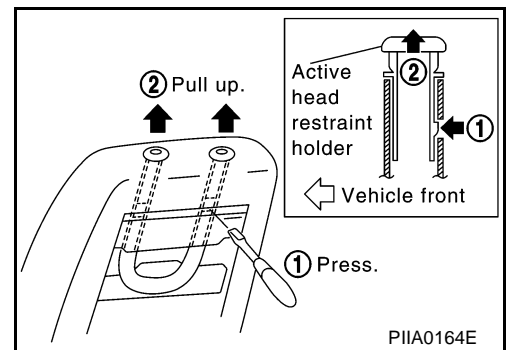

Removal of Seatback Assembly

- To remove seatback assembly, follow steps 1 to 2. After that, remove side air bag connector and bolts (4).

NOTE:

When assembling the seatback frame, make sure that the reclining device are locked on both sides, and be sure to temporarily tighten the bolts, then tighten them finally.

FRONT SEAT

SEATBACK TRIM (WITHOUT SIDE AIR BAG)

1. Disengage retainers in the lower part at the back of seatback.

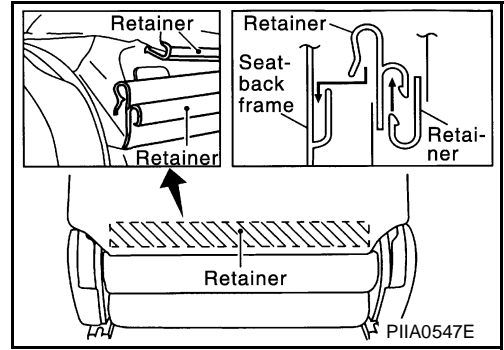

2. Pull off seatback trim.

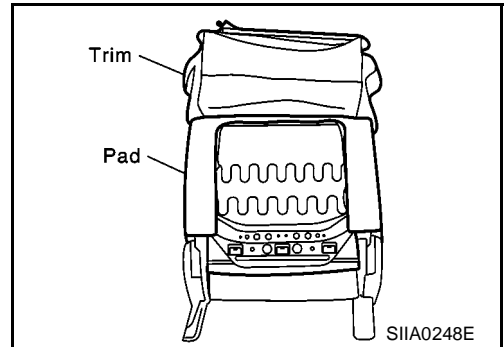

3. Hang a wire on the snap ring, and pull upward to remove. Remove lumbar support lever knob.

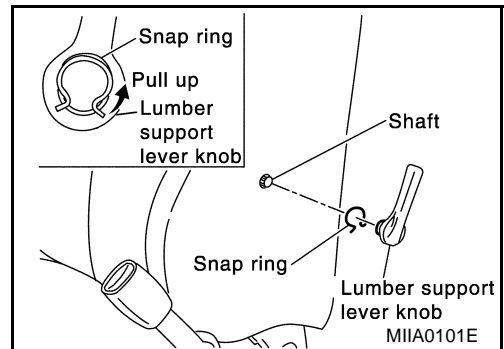

4. Pick up and push up the headrest holder tab to remove.

NOTE:

Before installing the headrest holder, check its front, rear, right and left orientation for correct installation.

5. Remove seatback trim.

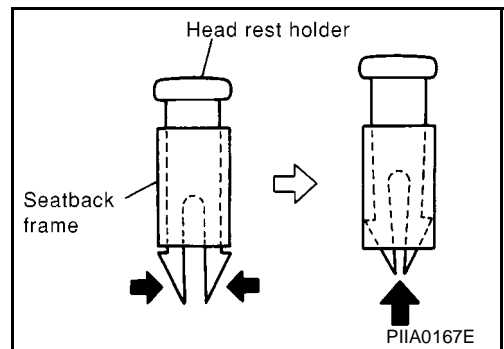

Removal of Seatback Assembly

- To remove seatback assembly, follow steps 1 to 2. After that, remove bolts.

NOTE:

When assembling the seatback frame, make sure that the reclining device are locked on both sides, and be sure to temporarily tighten the bolts, then tighten them finally.

SEATBACK TRIM AND PAD

NOTE:

- Be sure to set the front/rear cushion lifter to the top position.

FRONT SEAT

- Power seat and standard seat have similar disassembly and assembly procedures.

Disassembly and Assembly of Seat Cushion Trim

EIS002IN

1. Hang a wire on the snap ring, and pull upward to remove. Remove lifter dial and reclining dial.

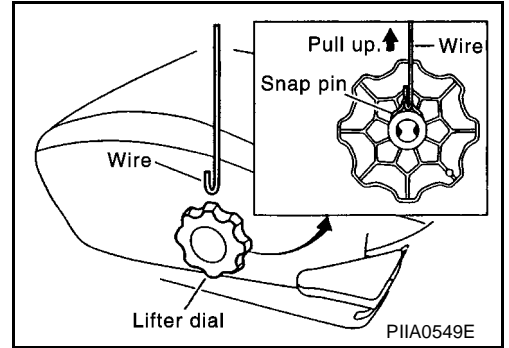

2. Remove seat harness and bolts from back of seat cushion.

NOTE:

When installing bolts, make sure both sides of the slide are locked. Be sure to temporarily tighten the bolts before final tightening.

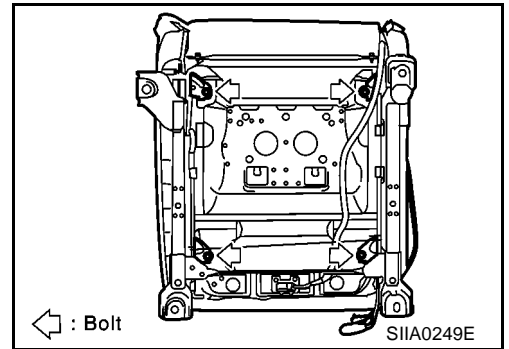

3. Remove retainer from back side of the cushion.

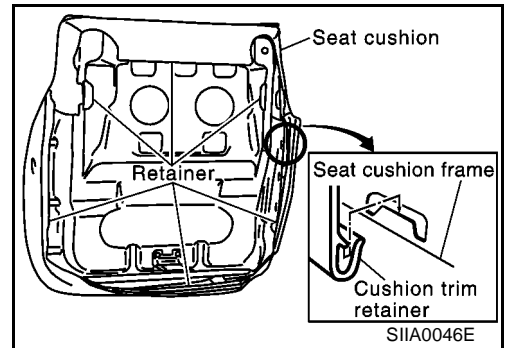

4. Pull off trim and remove hog rings.

A
B
C
D
E
F
G
H
SE
J
K
L
M

REAR SEAT

PFP:88300

EIS002P4

REAR SEAT

Component Parts Drawing SEDAN AND WAGON MODELS

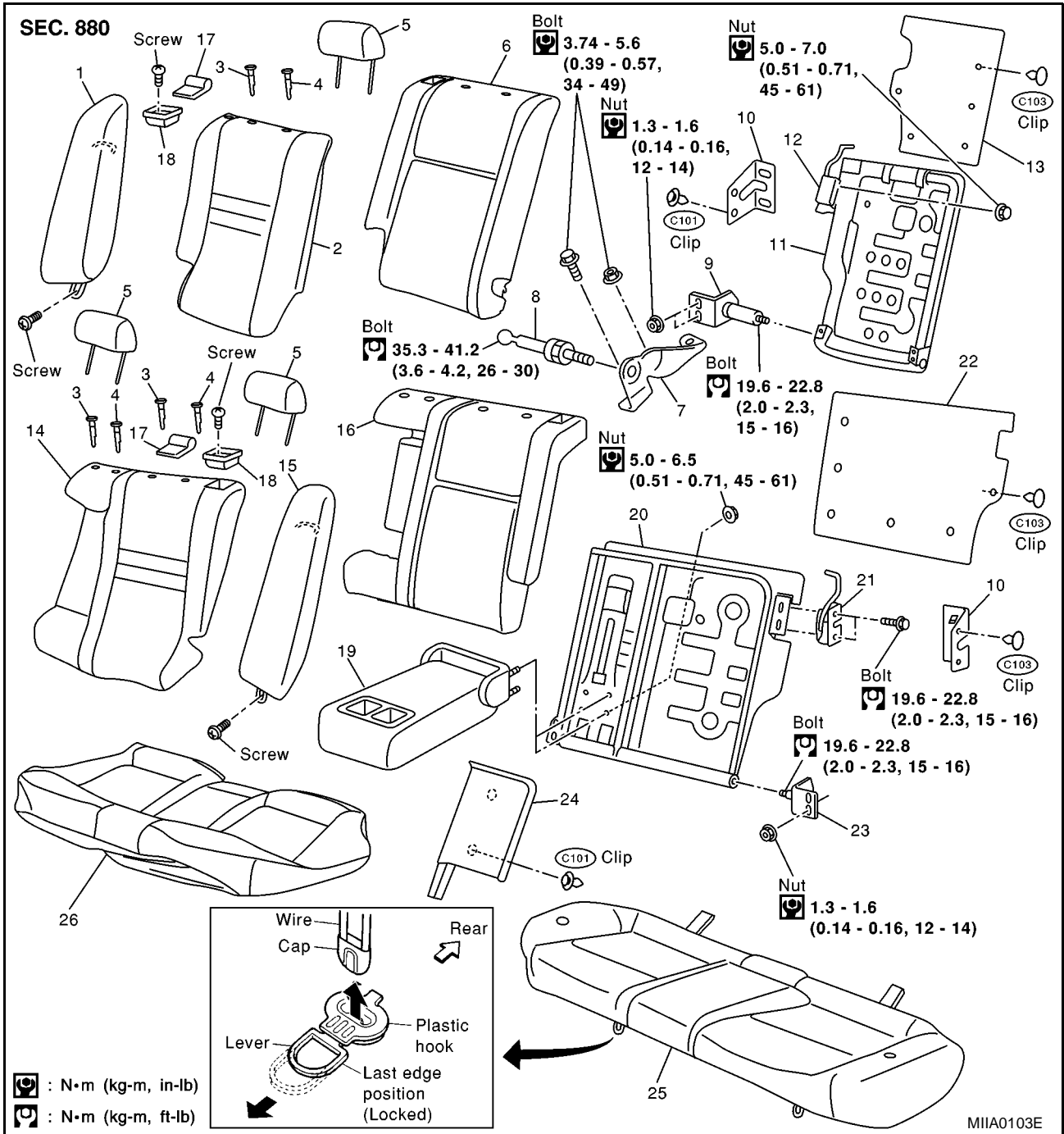

- | | | |
|--|-------------------------------|---|
| 1. Rear seatback side trim and pad (RHD) | 2. Rear seatback trim | 3. Headrest holder (free) |
| 4. Headrest holder (locked) | 5. Headrest | 6. Rear seatback pad (RHD) |
| 7. Rear seatback center hinge bracket | 8. Center hinge stud bolt | 9. Rear seatback side hinge (RHD) |
| 10. Rear seat lock protector | 11. Rear seatback frame (RHD) | 12. Rear seatback lock (RHD) |
| 13. Rear seatback carpet (RHD) | 14. Rear seatback trim (LHD) | 15. Rear seatback side trim and pad (LHD) |
| 16. Rear seatback pad | 17. Rear seatback lock knob | 18. Rear seatback lock knob finisher |
| 19. Armrest | 20. Rear seatback frame (LHD) | 21. Rear seatback lock (LHD) |

REAR SEAT

- | | | |
|-------------------------------------|------------------------------------|----------------------|
| 22. Rear seatback carpet (LHD) | 23. Rear seatback side hinge (LHD) | 24. Armrest finisher |
| 25. Rear seat cushion frame and pad | 26. Rear seat cushion trim | |

Removal and Installation

EIS002P5

Sedan and wagon models both have similar rear seat removal and installation procedures.

SEAT CUSHION

- Pull the lock at the front bottom of the seat cushion forward (1 for each side), and pull the seat cushion upward to release the wire from the plastic hook, then pull the seat cushion forward to remove.

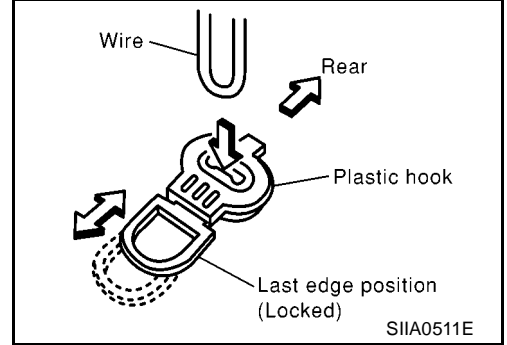

- Remove hinge bolt, and pull out the pin from the hole on the seatback.

IN THE SEATBACK (WAGON MODELS)

1. Remove luggage floor center front finisher. Refer to [EI-27, "Removal and Installation \(Wagon Models\)"](#).
2. Remove seat cushion.
3. Remove bolt and pull the rear seatback trim and pad upward to release the wire from the hook.
4. Remove nuts and seatback.

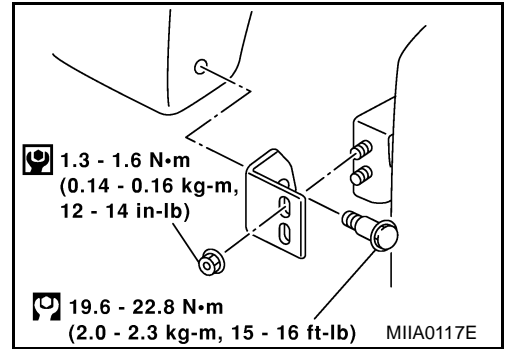

REAR SEAT

5. Remove rear seatback lock knob.
6. Remove screws and rear seatback lock knob finisher.

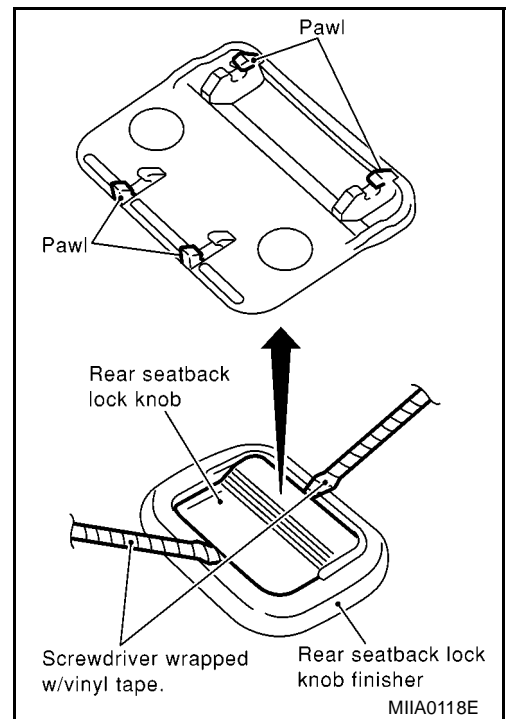

7. Remove clips C103 and rear seat lock protector.

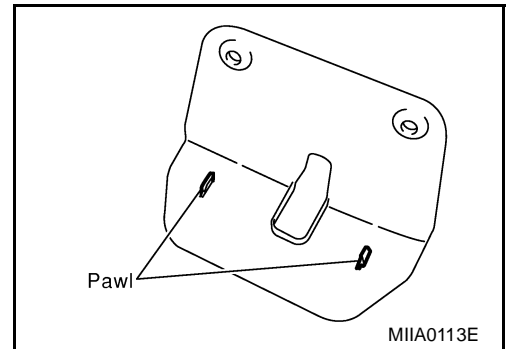

REAR CENTER BRACKET

1. Remove rear seatback.
2. Remove nuts and bolts.

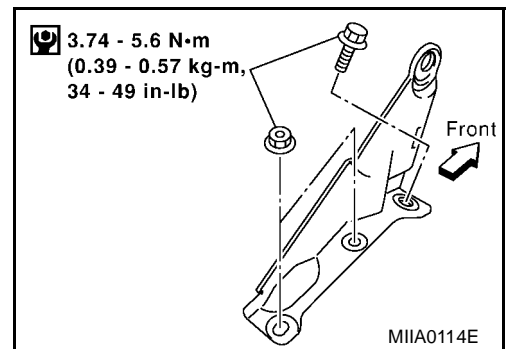

REAR SEAT

REAR SEATBACK STRIKER

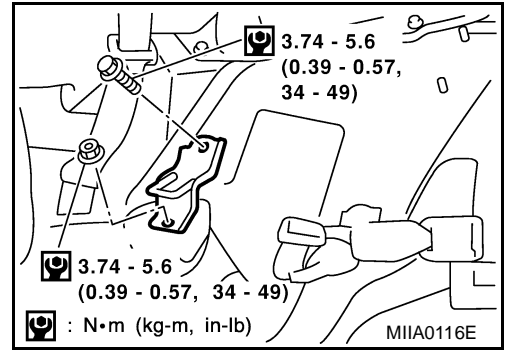

ARMREST

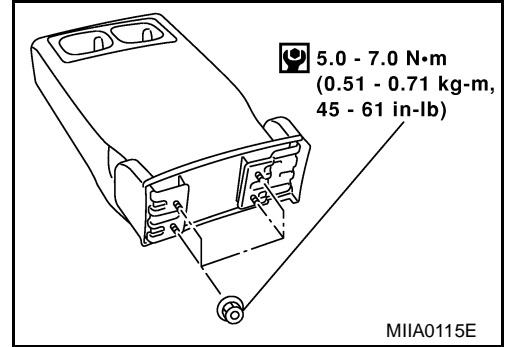

INSTALLATION

- Install in the reverse order of removal.

A
B
C
D
E
F
G
H
SE
J
K
L
M

REAR SEAT
