

NISSAN

SKYLINE

**OWNER'S MANUAL MODEL R31 SERIES
SECOND EDITION**

SKYLINE

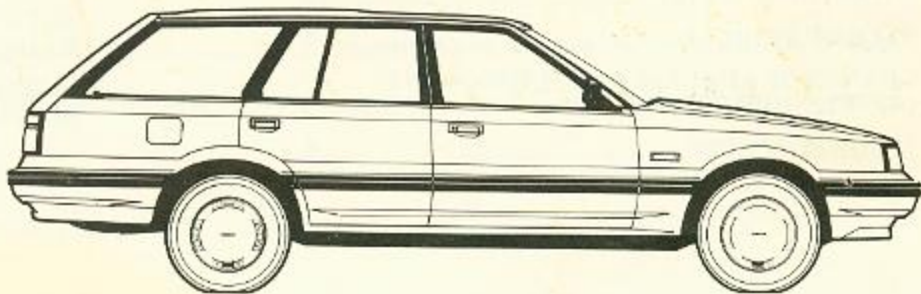
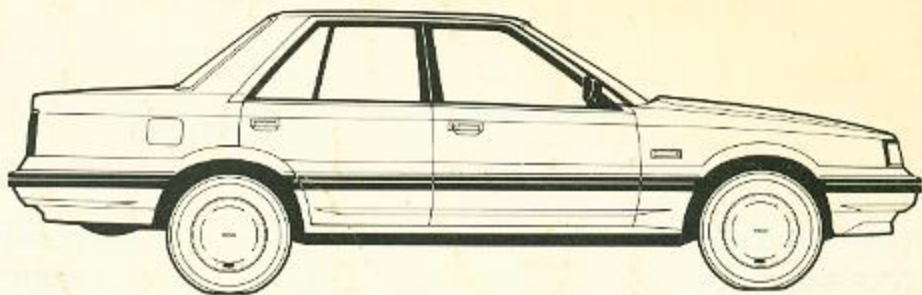

THIS MANUAL IS DIVIDED INTO TWO SECTIONS

FIRST SECTION — WARRANTY AND SERVICE

Page 2 to 36

SECOND SECTION — OWNER'S INSTRUCTIONS

Page 37 to 117

WARRANTY AND SERVICE

CONTENTS

NEW VEHICLE WARRANTY	4	CONSUMER ASSISTANCE.....	9
TYRE WARRANTY.....	5	PERIODIC MAINTENANCE SERVICE SCHEDULE CHART	10
WHAT YOU MUST DO	5	AUTHORISED NISSAN DEALER MAINTENANCE SERVICE COUPON at 1 000 km..	15
SALE OF VEHICLE.....	6	LUBRICATION AND INSPECTION SERVICE COUPONS.....	17
CHANGE OF ADDRESS AND SUBSEQUENT OWNERSHIP REGISTRATION	6		
IMPORTANT NOTE.....	6		

DESIGN CHANGE

NISSAN reserves the right at any time and from time to time to make changes in design or specifications on any *NISSAN* vehicles or any part, without incurring any obligation to make or install similar changes on vehicles and or parts previously purchased.

FROM THE SERVICE MANAGER

Congratulations on the purchase of your new NISSAN.

We are sure you will find your choice both satisfying and economical and we look forward to a long and happy association with you.

For your convenience we advise that our Service Division is located at _____

and our Telephone number there is _____

We are open from _____ until _____ on _____

Your service adviser is _____ Please contact this adviser whenever you telephone or call in.

In order that you may become fully conversant with every aspect of the operation and maintenance of your new NISSAN we strongly recommend a careful study of this manual.

If there is any subject in this publication on which you would like further information please do not hesitate to ask us.

We welcome you to our Dealership and look forward to seeing you when your new NISSAN is due for its 1 000 km maintenance service.

DEALER SERVICE MANAGER

NISSAN WARRANTY AND SERVICE

This manual identifies you as the owner of the NISSAN described herein.

As the manual will be required by your NISSAN DEALER whenever Warranty Service is required, it should be kept in an accessible place such as the glove box of the car.

If Warranty Service under the NISSAN NEW VEHICLE WARRANTY becomes necessary, such service should be performed by the selling dealer, if possible, because of his close interest in your continued satisfaction with your new NISSAN.

A separate booklet listing all NISSAN DISTRIBUTORS and DEALERS is placed in the glove box.

Certain maintenance service recommendations have been prepared and set forth in this manual to assist you in the proper care and maintenance of your NISSAN. We recommend that these be followed at all times.

WHAT IS WARRANTED

Nissan Motor Company (Australia) Pty. Ltd., hereinafter referred to as NISSAN warrants to the owner of each new Nissan vehicle that for 24 months or 40,000 km, whichever comes first, it will repair or replace any part on the vehicle which proves defective in material or workmanship free of charge except for those items listed under the section entitled "What is not covered" and subject to compliance with the section entitled "What you must do".

The warranty period begins on the date the vehicle is delivered to the first retail buyer or put into use, whichever is earlier.

Warranty repair or replacement will be performed by an authorised Nissan Dealer at its place of business within a reasonable time after delivery of the vehicle to the dealer during normal business hours.

WHAT IS NOT COVERED

Tyres are covered by a separate warranty. See under "Tyre Warranty" for details.

Genuine Nissan parts, accessories or equipment installed outside of Nissan's works may be covered by a separate Warranty.

Any non-genuine parts, accessories or equipment installed outside of Nissan's works.

Any parts and labour costs incurred in connection with required or recommended maintenance services as outlined in this Owner's Manual.

Normal maintenance services such as wheel balancing, alignment and rotation, engine tune-up, headlight aiming, replacement of light bulbs, spark plugs, PCV valve, hoses, drive belts, clutch disc, brake pads, filters, wiper blades, lubricants and coolant.

Damages or failures resulting from:

Misuse such as driving over kerbs, overloading, racing, etc.

Use of improper or dirty fuel, fluids or lubricants.

Lack of performance or proper maintenance services as outlined in this Owner's Manual

Alterations or improper repairs.

Accident, theft or fire.

Stone chipping, fuel or liquid adhesion, chemical fallout, tree sap, salt, hail, wind-storm, lightning or other unusual environmental conditions.

Normal deterioration of trim, paint or other appearance items.

Any vehicle on which the odometer reading has been changed so that mileage cannot be readily determined.

WHAT YOU MUST DO

Properly use, maintain and care for your vehicle as outlined in this Owner's Manual.

Take the vehicle to an authorised Nissan dealer's place of business during regular business hours at your expense in order to obtain warranty service.

Check for trim, paint or other appearance defects at the time the new vehicle is delivered and report the same to your selling dealer without delay.

Take the vehicle to an authorised Nissan dealer for a routine paint and body inspection at the 12 month inspection intervals specified in the accompanying paint and anti corrosion warranty booklet whilst the vehicle is under the terms of this warranty.

N.B. Inspection scheduled from date of vehicle registration.

Retain maintenance service and inspection records in the event a question should arise concerning the vehicle's maintenance.

WHAT NISSAN WILL DO

Warranty repairs or replacements with new or remanufactured parts will be made at no charge for part and/or labour

by an authorised Nissan dealer. A reasonable time to complete the repairs must be allowed after the vehicle is delivered to the dealer.

The 1,000 km inspection specified in the "Periodic Maintenance and Lubrication Service" will be carried out free of charge except for cost of oils and filter.

Nissan recognises that in addition to these warranties, further warranties, conditions and remedies may be implied by the Trade Practices Act 1984 (as amended) and the legislation of the various States and Territories of the Commonwealth and states that nothing in this warranty excludes, restricts or modifies or should be read as excluding, restricting or modifying those additional rights or any liability Nissan may have under that legislation to compensate or indemnify another person provided that where the provisions of the above legislation permit the liability of Nissan is limited to any one or more at Nissan's option of the following:

1. replacement of the goods supplied or supply of equivalent goods;
2. repair of the goods;
3. payment of the cost of replacing the goods or acquiring equivalent goods; or
4. payment of the cost of having the goods repaired.

TYRE WARRANTY

Tyres originally installed on new Nissan vehicles are warranted by the tyre manufacturer.

In order to obtain tyre warranty service, you must present the unserviceable tyres to the local tyre agent, unless otherwise directed by Nissan.

Any Nissan Dealer will assist you in requesting an adjustment through the local agent, if necessary.

CHANGE OF ADDRESS/OWNERSHIP

SALE OF VEHICLE

When you sell your *NISSAN* it is important that you transfer the Owner's Manual to the subsequent owner as it will be needed by him to show eligibility for any unexpired warranty protection, and to instruct him as to proper operation and maintenance of the vehicle.

CHANGE OF ADDRESS AND SUBSEQUENT OWNERSHIP REGISTRATION

Change of Address

Please advise us of your change of address by completing one of the attached forms, detaching and forwarding to the address given below.

NISSAN MOTOR CO. (AUST.) PTY. LTD.
P.O. BOX 644
DANDENONG, VIC., 3175.

To the Subsequent Owner

If you are the owner of a *Nissan* vehicle purchased secondhand prior to the expiration of the original new vehicle warranty you are entitled to the unexpired portion of the warranty.

Please complete one of the attached forms and forward to the address given above.

IMPORTANT

These notifications are important even after the expiration of the original vehicle warranty in order that *Nissan* will be in a position to contact you should the need arise.

NOTICE OF NAME/ADDRESS OWNERSHIP CHANGE

NAME/ADDRESS CHANGE SUBSEQUENT OWNER
PLEASE TICK APPROPRIATE SQUARE

Owner's Name R. D. BROWNE

Address 27 CENTRE ROAD
ANYTOWN Post Code 2345

Vehicle Type WPR 31.F. GXE Body No. V 10876

Engine No. RB30 000317

Date of Registration 5/9/86

Registration No. RDB 128

Date of Purchase 5/9/86

Odometer Reading at Present 11,000 km

Please print and give complete information

THANK YOU FOR YOUR CO-OPERATION

NISSAN USE ONLY

Distributor Code Dealer Code

NOTICE OF NAME/ADDRESS OWNERSHIP CHANGE

NAME/ADDRESS CHANGE SUBSEQUENT OWNER
PLEASE TICK APPROPRIATE SQUARE

Owner's
Name

Address

Post
Code

Vehicle
Type

Body
No.

Engine
No.

Date of
Registration

Registration
No.

Date of
Purchase

Odometer Reading
at Present km

Please print and give complete information
THANK YOU FOR YOUR CO-OPERATION

NISSAN USE ONLY Distributor Code Dealer Code

NOTICE OF NAME/ADDRESS OWNERSHIP CHANGE

NAME/ADDRESS CHANGE SUBSEQUENT OWNER
PLEASE TICK APPROPRIATE SQUARE

Owner's
Name

Address

Post
Code

Vehicle
Type

Body
No.

Engine
No.

Date of
Registration

Registration
No.

Date of
Purchase

Odometer Reading
at Present km

Please print and give complete information
THANK YOU FOR YOUR CO-OPERATION

NISSAN USE ONLY Distributor Code Dealer Code

NOTICE OF SPECIAL MEETING OF THE BOARD OF DIRECTORS

TO THE STOCKHOLDERS OF THE COMPANY

The Board of Directors of the Company has called this Special Meeting of the Board of Directors to be held at the Company's principal office, on the 15th day of May, 1920, at 10 o'clock in the forenoon, for the purpose of considering and acting upon the following resolutions:

Resolved, That the Board of Directors be authorized to take such action as may be deemed proper in connection with the above.

CUSTOMER ASSISTANCE GUIDE

Your continuing satisfaction as a NISSAN owner is a primary concern of NISSAN Motor Company.

Your NISSAN Dealer is equipped to provide the necessary service and maintenance for your new Skyline and is readily available to discuss any inquiry you may have

We realise however, that, despite the best intentions, misunderstandings can occur, and suggest, should a problem arise, that you take the following steps:

STEP 1

Contact your NISSAN Dealer Principal and/or Service Manager to discuss your inquiry.

If you feel the Dealer is unable to resolve the matter satisfactorily and something more should be done, then . . .

STEP 2

Contact the Owner Relations Manager at the Nissan Distributor or Regional Office in your State, (see below).

Please have the following information available.

1. Model code of vehicle.
2. Chassis number of vehicle.
3. Purchase date of vehicle.
4. Odometer reading.
5. Your Nissan Dealer's name.
6. Nature of problem.

STATE CONTACT ADDRESSES

Victoria and Tasmania

Nissan Motor Company (Aust.) Pty. Ltd.
169 Burwood Road,
Hawthorn, 3122
Telephone: 819 2777

New South Wales

Nissan Motor Company (Aust.) Pty. Ltd.
2A Birmingham Avenue,
Villawood, 2163
Telephone: 726 6999

South Australia

Nissan Motor Company (Aust.) Pty. Ltd.
1 Opala Street,
Regency Park, 5010
Telephone: 347 0111

Western Australia

Duncan Motor Company Pty. Ltd.
17-19 Hazelhurst Street,
Kewdale, 6150
Telephone: 458 5333

Queensland

Nissan Motor Company (Aust.) Pty. Ltd.
41 Lysaght Street,
Acacia Ridge, 4110
Telephone: 345 0600

RECOMMENDED PERIODIC MAINTENANCE AND LUBRICATION SCHEDULE

Item	MAINTENANCE OPERATION Periodic maintenance should be performed at number of kilometres or months whichever comes first.	MAINTENANCE SCHEDULE												
		Number of kilometres in thousands		1	10	20	30	40	50	60	70	80	90	100
		Number of months			6	12	18	24	30	36	42	48	54	60
	<i>UNDERHOOD MAINTENANCE</i>													
1	Inspect condition, attachment and routing of all hoses, pipes and ducting. Look for leaks, deterioration and wear.		x	x	x	x	x	x	x	x	x	x	x	
2	Inspect engine compartment components for damage and deterioration. Look for leakage from fluid reservoirs and engine.		x	x	x	x	x	x	x	x	x	x	x	
3	Check fluid levels, (i.e. brake and clutch master cylinders, coolant reservoir, battery, washer, bottle, automatic transmission, power steering reservoir). Check engine oil at 1000 km.	x	x	x	x	x	x	x	x	x	x	x	x	
4	If fitted with air conditioning, check refrigerant charge quantity.		x	x	x	x	x	x	x	x	x	x	x	
5	Check condition and tension of external drive belts.	x		x		x		x		x		x		
6	Inspect ignition wiring, distributor cap and rotor.			x		x		x		x		x		
7	Check PCV System.			x		x		x		x		x		
8	Change engine oil.		x	x	x	x	x	x	x	x	x	x	x	
9	Replace engine oil filter.		x	x	x	x	x	x	x	x	x	x	x	
10	Change engine coolant (L.L.C.)					x					x			
11	Change brake fluid.				x				x			x		
12	Replace fuel filter.					x					x			
13	Replace air filter. ②					x					x			
14	Replace spark plugs.					x					x			
15	Check idle R.P.M.	x	x	x		x			x		x		x	
16	Check ignition timing.			x		x			x		x		x	
17	Check exhaust gas sensor.					x			x			x		

TERMINOLOGY

INSPECT: Visually observe and, where necessary, apply force to components to ascertain security.

CHECK: Make a physical measurement for comparison with a service specification (e.g. brake pad thickness, fluid level).

RECOMMENDED PERIODIC MAINTENANCE AND LUBRICATION SCHEDULE

MAINTENANCE OPERATION Periodic maintenance should be performed at number of kilometres or months whichever comes first.		MAINTENANCE SCHEDULE												
		Number of kilometres in thousands		1	10	20	30	40	50	60	70	80	90	100
		Number of months			6	12	18	24	30	36	42	48	54	60
<i>Item</i>	<i>UNDER VEHICLE MAINTENANCE (continued)</i>													
19	Check exhaust for damage, leaks and security. ①		x	x	x	x	x	x	x	x	x	x	x	
20	Check oil levels in manual transmission and differential.	x	x	x	x	x	x	x	x	x	x	x	x	
21	Check all brake pads for serviceability. Inspect brake system for leaks, deterioration and loose, damaged or missing components.		x	x	x	x	x	x	x	x	x	x	x	
22	Inspect fuel system components for leaks, damage, deterioration and security. ①		x	x	x	x	x	x	x	x	x	x	x	
23	Inspect for leaks from engine, transmission, rear axle, steering system and clutch hydraulic system.		x	x	x	x	x	x	x	x	x	x	x	
24	Check condition of tyres including spare.	x	x	x	x	x	x	x	x	x	x	x	x	
25	Repack front wheel bearings. ①							x					x	

OUTSIDE AND INSIDE MAINTENANCE

26	Check seat belt webbing condition, buckle and retractor mechanism operation and anchorages.		x	x	x	x	x	x	x	x	x	x	x
27	Check operation of instruments and controls (Inspect wiper blade operation).		x	x	x	x	x	x	x	x	x	x	x
28	Check operation of all lights.	x	x	x	x	x	x	x	x	x	x	x	x
29	Check operation of inhibitor switch.		x	x	x	x	x	x	x	x	x	x	x
30	Check stroke and operation of clutch, foot brake and park brake.		x	x	x	x	x	x	x	x	x	x	x
31	Lubricate locks, hinges and hood latch.		x		x			x				x	
32	Body maintenance inspection.			x		x							

The numbers in circles alongside maintenance items indicates that, the item may require additional or more frequent service if driven continuously under the correspondingly numbered condition below:

① When driving along rough and/or muddy roads. ② When driving in dusty conditions.

In addition to the foregoing, vehicles used under conditions exposing them to excessive mud and/or corrosive materials — boat launching, driving along beaches, driving on tracks through fertilized paddocks, etc. — must be thoroughly flushed with fresh water to remove any deposited mud or corrosive material.

MAINTENANCE SCHEDULE

The preceding table lists the service maintenance required to ensure good engine performance, mechanical condition and safe operation of your new NISSAN.

This maintenance should be attended to at the specified intervals by your NISSAN dealer. The schedule has been established specifically for Australian operating conditions and represents the minimum maintenance schedule recommended by Nissan.

As indicated in the table, vehicles operating in adverse conditions may require additional or more frequent servicing of some items.

If your vehicle exhibits malfunctions or if the idle adjustment is not correct it is recommended that you have the systems checked by your Nissan dealer.

The following provides explanations of some maintenance items from the table. If you require further information not contained herein, a factory Service Manual is available from your Nissan dealer.

ITEMS

4. *Check air conditioning refrigerant level*
Low level is indicated by bubbles appearing at the receiver/drier sight

glass when the air conditioner is operating. If the level is low, the system should be completely evacuated and then refilled with the correct weight of refrigerant. The system should not be "topped up".

5. *Check condition and tension of external drive belts*
Refer to p. 98 for belt checking procedure. Replace drive belts found to be damaged.
6. *Inspect ignition wiring, distributor cap and rotor*
Check cap and rotor for cracks, carbon formation or erosion. Check ignition wiring for cracks in exterior insulation and for proper fit on the distributor cap and spark plugs.

CAUTION: Beware of high voltages.
Switch engine off before checking.

10. *Change engine coolant*
The cooling system should be drained flushed and refilled using a mixture of water and NISSAN Long Life Coolant (ref. p. 68).
15. *Check Idle R.P.M.*
Idle R.P.M. should be checked using an auxiliary tachometer to ensure accuracy.
16. *Check ignition timing*
Ignition timing must be checked with the proper equipment.

WARNING

1. **Semi-conductor devices cannot withstand high induction voltages (transients) therefore, always ensure that the ignition system is switched off and battery disconnected when working on electronic ignition systems.**
2. **Ensure test equipment does not emit dangerous transient voltages.**
3. **Do not open circuit, the high tension leads or circuit when testing for spark; use a test plug.**
4. **Only power timing lights with inductive pick ups should be used.**

I authorise performance of the work specified on this coupon.

I understand that I will be charged for this work which will take approx. 1.9 hours.

There will also be a charge for adjustments made as a result of checks, additional services, which are performed as required, and lubricants.

Additional Services performed.

.....
.....
.....
.....
.....
.....
.....
.....
.....

Nissan Motor Company (Australia)
Service Schedule established for
Australian operating conditions.

100 000 km

PERIODIC MAINTENANCE AND LUBRICATION SCHEDULE 100 000 KM OR 60 MONTHS

1. Inspect condition, attachment and routing of all hoses, pipes and ducting. Look for leaks, deterioration and wear.
2. Inspect engine compartment components for damage and deterioration. Look for leakage from fluid reservoirs and engine.
3. Check fluid levels, (i.e. brake and clutch master cylinders, coolant reservoir, battery, washer bottle, automatic transmission, power steering reservoir).
4. If fitted with air conditioning, check refrigerant charge quantity.
5. Check condition and tension of external drive belts.
6. Inspect ignition wiring, distributor cap and rotor.
7. Check PCV System.
8. Change engine oil.
9. Replace engine oil filter.
10. Replace spark plugs.
11. Check idle R.P.M.
12. Check ignition timing.
13. Inspect suspension, steering system and drive train for damaged, loose, worn or missing parts. ①
14. Check exhaust for damage, leaks and security. ①
15. Check oil levels in manual transmission and differential.
16. Check all brake pads for serviceability. Inspect brake system for leaks, deterioration and loose, damaged or missing components.
17. Inspect fuel system components for leaks, damage, deterioration and security. ①
18. Inspect for leaks from engine, transmission, rear axle, steering system and clutch hydraulic system.
19. Check condition of tyres including spare.
20. Repack front wheel bearings. ①
21. Check seat belt webbing condition, buckle and retractor mechanism operation and anchorages.
22. Check operation of instruments and controls (Inspect wiper blade condition).
23. Check operation of all lights.
24. Check operation of inhibitor switch.
25. Check stroke and operation of clutch, foot brake and park brake.

Owner's Instructions

CONTENTS

INTRODUCTION.....	38
BEFORE DRIVING YOUR NISSAN	40
INSTRUMENTS AND CONTROLS ..	50
STARTING AND OPERATING	60
COMFORT AND CONVENIENCE FEATURES.....	70
IN CASE OF EMERGENCY.....	89
MAINTENANCE.....	91
SPECIFICATIONS.....	115
INDEX	118

INTRODUCTION

This manual has been prepared to help you to understand the operation and maintenance of your NISSAN. Please read carefully and follow its recommendations. If any questions should arise concerning equipment fitted or its operation, contact your authorised NISSAN Dealer. The Dealer has the trained personnel, the specialised equipment and the interest to assist you in all your service requirements.

All information, specifications and illustrations in this manual are on a basis of the latest data obtainable at the time of the publication. Some data may vary from that shown depending on model and brand of components fitted. NISSAN reserves the right to make changes or improvements at any time without incurring any obligation to make or install similar changes on vehicles or parts previously purchased.

Because of the variety of options, components and features offered by NISSAN and your NISSAN Dealer, the equipment described in this manual may or may not be identified as standard or optional and may or may not be applicable to your particular vehicle. Therefore if you have any queries regarding equipment, please contact your authorised NISSAN Dealer.

MODEL R31 SERIES

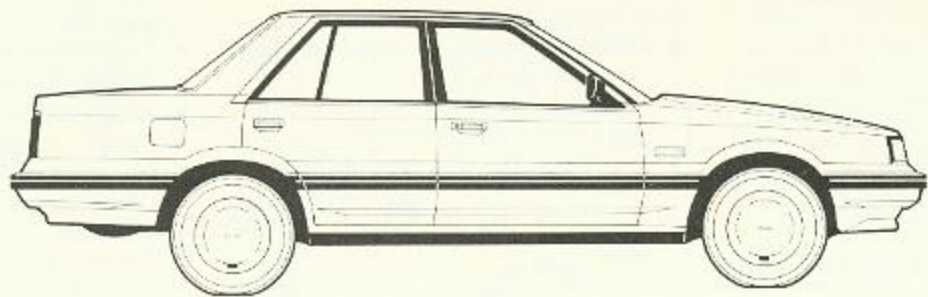

BEFORE DRIVING YOUR NISSAN

RUNNING IN

- (a) Do not use full throttle acceleration in low gears for the first 500 km.
- (b) Drive in a reasonable manner and within the legal speed limits and avoid long periods at constant speed for the first 500 km.
- (c) Do not use the vehicle for towing heavy loads above 500 kg for the first 1500 km.

WARNING: This vehicle must be run on unleaded petrol only.

SAFETY CHECKS

BEFORE ENTERING YOUR CAR

- Check that windows, mirrors and light lenses are clean.
- Visually inspect the condition of the tyres. Check tyre pressures.
- Check that the area around the car is clear.
- Make sure that the bonnet is closed securely.

AFTER ENTERING THE CAR

- Position and adjust seats.
- Adjust tilt-away steering wheel.
- Adjust inside and outside mirrors.
- Fasten seat belt and ensure any passengers do likewise.
- Check the operation of lights, switches and horn.
- Check the operation of warning lights when key is turned to 'on' position.

Fluid levels such as engine oil, engine coolant, brake and clutch fluid, windshield washer fluid and battery electrolyte should be checked frequently, or at least whenever the car is refuelled.

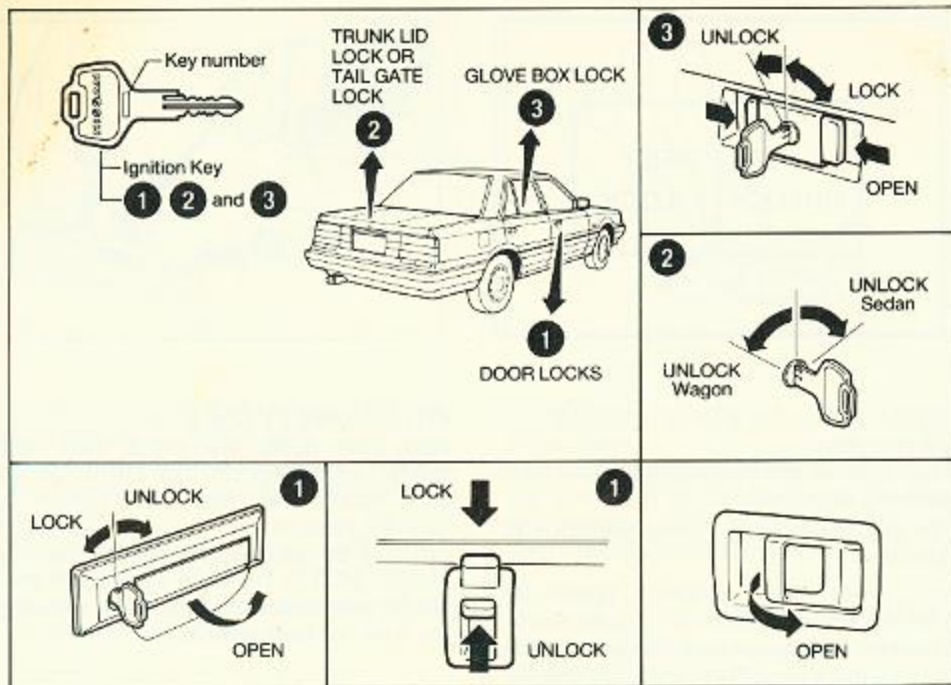

KEYS AND LOCKS

KEY

Keep a record of the key numbers so that your NISSAN Dealer will be able to supply a replacement key.

Remove the key from the switch and carry it with you when leaving your car unattended.

DOOR LOCK (MANUAL METHOD)

All doors can be locked from the inside by pushing the lock knob down after closing the door. To unlock, lift up.

Locking from Outside:

Front door LH: Push lock knob down and close door firmly.

Front door RH: This door can only be locked by the door key. That is close door, insert key and lock door. (Keys cannot be left in a locked car.)

All other doors: Push lock knob down and close door firmly.

POWER DOOR LOCKS (T.I. Only)

Locking from Outside: All doors will be locked automatically as the driver's door is locked using the key.

BOOT LID LOCK

To open, insert key in lock and turn it clockwise. The boot lid springs will open the lid.

To close, ensure that there is nothing sticking up or in a position under the hinges that will prevent the lid from closing. Push down firmly — the lock catch will automatically engage.

TAILGATE LOCK FROM "OUTSIDE",

All Wagons

To unlock, insert key in lock and turn anti-clockwise.

To lock, insert the key in lock and turn clockwise.

BEFORE DRIVING YOUR NISSAN

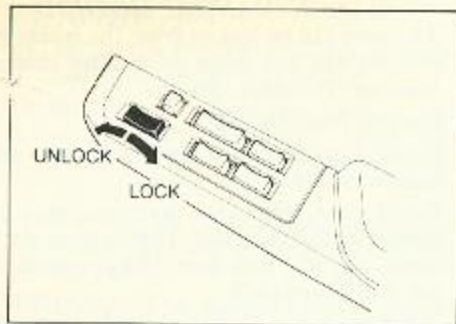

LOCKING/UNLOCKING FROM INSIDE VEHICLE (T.I. Only)

All doors except the driver's door can be locked/unlocked by pushing the lock/unlock button situated on the driver's armrest console. The driver's door must be manually locked/unlocked by the door lock knob.

NOTE: The driver's door has a manual override system incorporated that will unlock and open this door by activating the driver's door inside handle. Driver does not need to lift knob to open door.

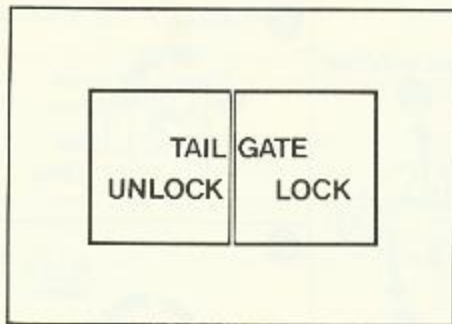

TAILGATE LOCK FROM "INSIDE" (Where fitted)

Two buttons are located just to the right of the ignition lock.

To lock the tailgate, press the "LOCK" button.

To unlock the tailgate, press the "UNLOCK" button.

To open the tailgate push the barrel of the lock cylinder.

To close the tailgate just close it firmly. (The tailgate must still be "LOCKED" by button or key for security).

BEWARE: Drivers please ensure that the **TAILGATE** is **LOCKED** BEFORE LEAVING VEHICLE.

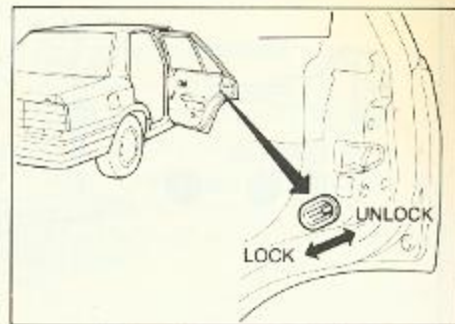

CHILD SAFETY LOCK

Both rear doors are fitted with child safety locks. Once the lock button on the child safety lock has been pushed to 'LOCK' position and the door closed, it can only be opened by using the outside handle. **NOTE:** the child safety lock cannot be unlocked from inside the car once the door has been closed.

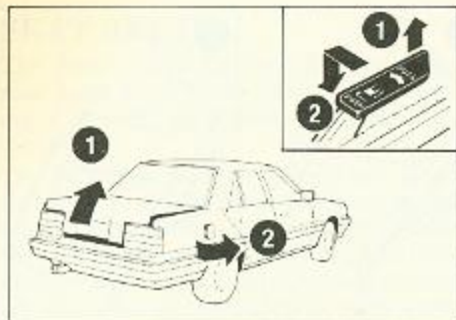

FUEL FILLER LID LOCK (GX and GXE Sedan, TI, Silhouette)

To open, push down the release lever on the floor between the driver's seat and the door.

To close the lid, just push it closed.

(All Wagons)

To open, pull up the release lever on the floor beside the driver's seat.

REMOTE BOOT LID OPENER (GX, GXE, TI, Silhouette)

When the boot lid opener lever, situated on the floor between the drivers seat and the door is pulled up the boot lid will open.

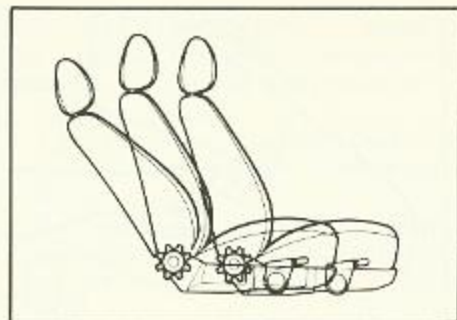

SEATS

Front Seats

Fore and aft adjustment. While sitting on the seat, pull up the handle of the slide lock situated under the front of the seat then slide the seat to the desired position.

Reclining.

While sitting in seat, turn the notched wheel on the outside rear of the seat until the desired angle is obtained.

CAUTION: Do not adjust the driver's seat while driving. The seat may abruptly jerk, which could cause driver to lose control.

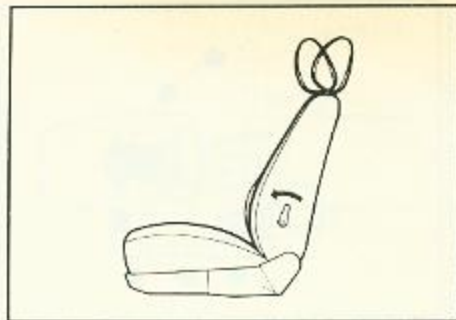

Lumbar Support

Driver's seat and passenger seat (if fitted). The lever can be moved through three positions to vary the amount of lumbar support.

Adjustable Head Restraint (Not in GX)

This normally sits back but can be pulled forward to two more positions for comfort as desired.

BEFORE DRIVING YOUR NISSAN

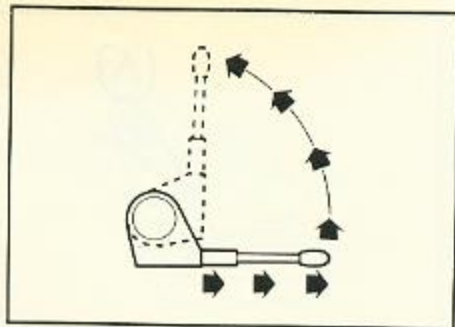

Height Adjustor (where fitted)

For driver's seat only on the right hand side between the seat and the door. Pull the lever out then pull it backwards until desired height is obtained.

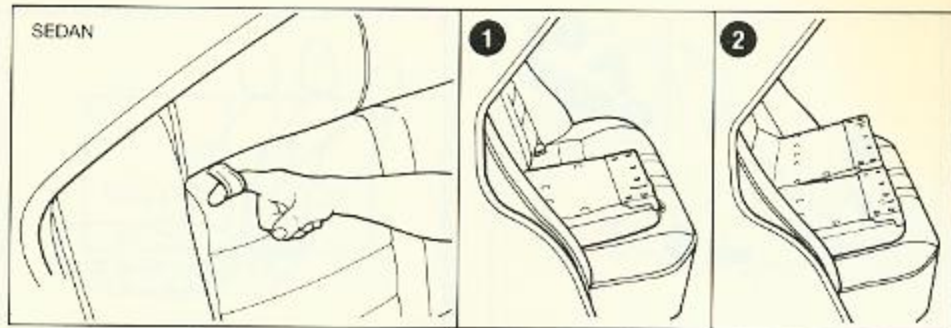

Folding Seats (Sedan)

A cloth tab is located near the right hand rear passengers right shoulder. Pull out the tab then lower part or the whole of the back seat as desired.

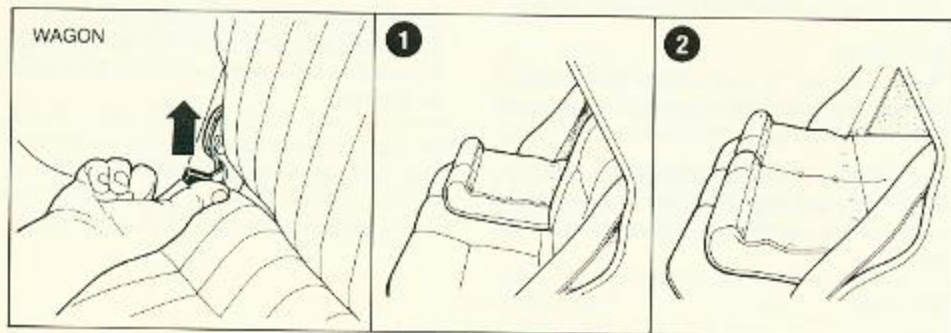

Folding Seats (Station wagon)

Ensure centre lap belt is lying flat on seat. Lift the lever located in the lower outer position. This will allow the seat back to fold down and extend the length of the rear floor.

SEAT BELTS

The front seat belts and the two outer rear seats are a three-point type consisting of an inner lap and an outer lap shoulder belt.

The outer lap shoulder belt is step laced through the locking tongue to prevent the tongue from sliding down the belt. Move the locking tongue along the belt to a convenient position but be sure that it does not allow the lap portion to be slack while being worn.

If the vehicle is parked on an incline, the belt may lock. Move the vehicle to level ground to regain free movement of the belt.

The outer lap-shoulder belt is provided with an Emergency Locking Retractor (ELR). The ELR is a belt retraction device which locks the belt only when the car speeds up, slows down or corners at a certain rate. In normal situations the ELR allows you to pull the belt out freely. However, when pulled out abruptly, the belt will lock. In such a case, allow it to rewind into the retractor about 25mm and then pull it out slowly.

CHECK ELR OPERATION

The ELR has two entirely independent systems to lock the belt when required:

1. Vehicle sensitive:

A pendulum moves and locks the belt if the speed or direction changes suddenly.

To check under safe conditions apply moderate braking and, while still braking, try to withdraw webbing from the ELR.

2. Webbing sensitive:

An inertia flywheel lags and locks the belt if the webbing is withdrawn abruptly.

To check: try to withdraw webbing from the ELR quickly.

For your assurance, all ELR's are thoroughly tested to ensure reliability and durability.

WARNING: No modifications or additions should be made by the user which will either prevent the seat belt adjusting devices from operating to remove slack, or prevent the seat belt assembly from being adjusted to remove slack.

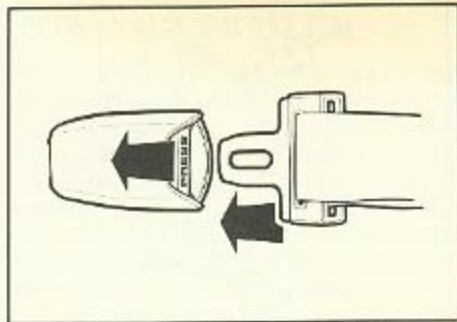

TO FASTEN SEAT BELTS:
Push locking tongue firmly into buckle.

TO RELEASE SEAT BELTS:
Push the buckle release button at top of stalk down.

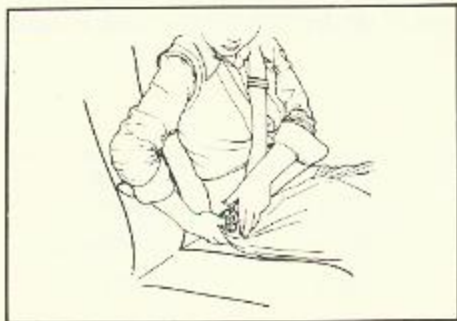

BEFORE DRIVING YOUR NISSAN



The rear centre seat belt is a two-point type without any Emergency Locking Retractor. It is fastened and unfastened in the same manner as the retractable belts.

To adjust the belt, after belt is locked, hold the adjusting device at a right angle to the belt and pull the lap belt or the free end of the lap belt till the slack is taken up.

WARNING: Seat belts are designed to bear upon the bony structure of the body, and should be worn low across the pelvis, chest and shoulders, as applicable. Wearing the lap section of the belt across the abdominal area must be avoided.

No modifications or additions should be made by the user which will either prevent the seat belt adjusting devices from operating to remove slack, or prevent the seat belt assembly from being adjusted to remove slack.

Seat belts should be adjusted as firmly as possible, consistent with comfort, to provide the protection for which they have been designed. A slack belt will greatly reduce the protection afforded to the wearer.

Care should be taken to avoid contamination of the webbing with polishes, oils, and chemicals and particularly, battery acid. Cleaning may safely be carried out using mild soap and water. Allow the belts to dry completely before using them. Do not allow wet belts to roll up in the retractor. The belt should be replaced if webbing becomes frayed, contaminated, or damaged.

It is essential to replace the entire assembly after it has been worn in severe impact even if damage to the assembly is not obvious. Belts should not be worn with straps twisted. Each seat belt assembly must only be used by one occupant: it is dangerous to put a belt around a child being carried on the occupant's lap.

If the vehicle is to be treated with an after-market rust preventative all ELRs should be removed from the vehicle during treatment. Failure to do so may render the ELRs inoperative.

BEFORE DRIVING YOUR NISSAN

CHILD RESTRAINT

Your car is designed to accommodate child restraints on the rear seat. When using a child restraint, carefully read and follow the installation instructions supplied with it.

WARNING: Child restraint anchorages are designed to withstand only those loads imposed by correctly fitted child restraints. Under no circumstances are they to be used for adult seat belts or harnesses.

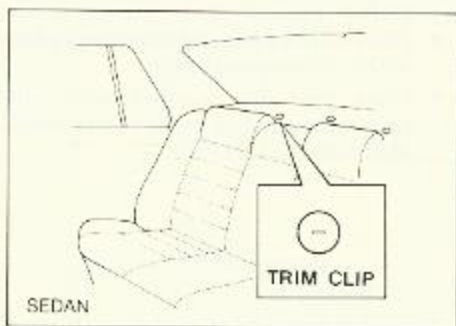

Anchorage locations.

Sedan

Under trim clips on rear parcel shelf finisher. To gain access to the anchorages, remove the trim clips.

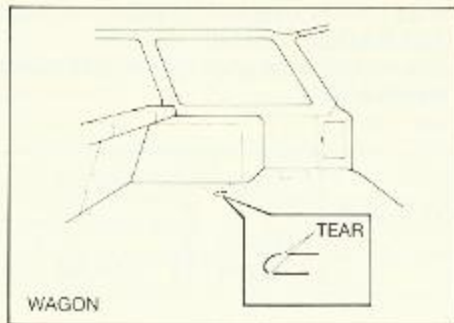

Station Wagon

Under flaps in the carpet on the luggage compartment floor. To gain access to the anchorages, lift the flaps and tear the underfelt.

NOTE: Use a bolt of $\frac{5}{16}$ in. in diameter 18 UNC and 30 mm (1.18 in.) in length. If in doubt consult your NISSAN dealer.

TOWING A TRAILER

WARNING: Your vehicle warranty may be voided if the following loads are exceeded, or a non-genuine towbar is fitted.

Towing a trailer will not only place extra stress on your car but will also affect its steering ability, durability and economy. If the need to tow a trailer arises consult your NISSAN dealer for an explanation of proper use of towing equipment.

MAXIMUM LOAD LIMITS

Maximum gross vehicle mass of a trailer (including tyres and other loaded equipment).

1. Never exceed the value specified in the following chart:

Trailer with brakes	Trailer without brakes
1200 Kg	500 Kg

BEFORE DRIVING YOUR NISSAN

2. Even if the specified value is not exceeded, it must not be greater than the smaller value of the following three.

- (i) Towing capacity displayed on a towbar.
- (ii) Trailer's gross vehicle mass marked on a coupling body.
- (iii) Gross vehicle mass marked on a trailer data plate.

MAXIMUM PERMISSIBLE TONGUE LOAD

Never load the towbar to more than the value specified in the following chart:

Trailer with brakes	Trailer without brakes
100 Kg	50 Kg

MAXIMUM PERMISSIBLE REAR AXLE LOAD

Never exceed the gross axle weight rating rear (GAWR).

G.A.W.R.	Sedan	992 Kg
	Station Wagon	992 Kg

TYRE PRESSURE

Ensure that tyres are inflated to the maximum recommended pressure (refer Tyre Placard, page 95).

SAFETY CHAIN

The safety chain is designed to prevent accidents should the connection between car and trailer fail while towing. Be sure the chain is slack enough to permit turning corners and, if possible, tight enough to prevent the towing coupling from dropping on the ground.

TRAILER BRAKES AND LIGHTING

Ensure that trailer conforms to state regulations regarding brakes and lighting. Ensure that lighting harness is long enough to allow for turns.

Operating Precautions

- Avoid towing loads in excess of 500 Kg during the running-in period.
- Avoid abrupt starts, accelerations and stops.
- Always drive at a moderate speed and within state speed limits.
- Have your car serviced more often than that specified in the recommended Maintenance Schedule.

NOTE: Because of the increase in weight and extra power required, trailer towing will increase fuel consumption.

WARNING: Never 'tap' into the vehicle's hydraulic braking system to facilitate trailer braking.

REARVIEW MIRRORS

Adjust the outside and inside mirrors before driving. For safe driving, rear vision must be unimpaired. Observe State regulations regarding rear view mirrors for vehicles towing a trailer.

INSIDE MIRROR

The inside mirror can be moved on its pivot to obtain optimum rear vision. If the vehicle is equipped with a day/night mirror it should be kept in the 'day' position except when following headlights become bothersome. For 'day' position, the adjusting lever should be moved towards the windscreen.



OUTSIDE DOOR MIRRORS

If your vehicle is equipped with manually operated mirrors, they must be moved on their pivots using the handle to obtain optimum rear vision. If your vehicle has electrically controlled mirrors, then the mirror select and adjustment switches are situated under the right hand air vent on the far right hand side of the dashboard and are operated only when the ignition switch is in "ACC" or "ON" position.

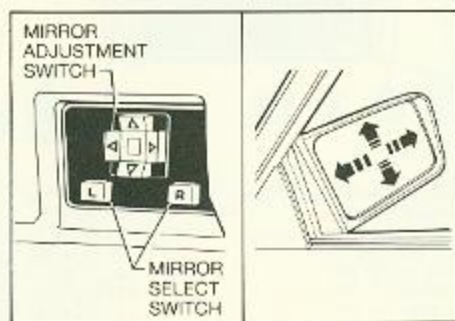

TO ADJUST MIRROR (WITH SELECT SWITCH)

Select mirror to be adjusted by pushing appropriate select switch down (L or R). Push relevant quarter of mirror adjustment switch to achieve desired position.

TILTING STEERING WHEEL

To set the steering wheel to the desired angle, pull the lock lever down, move the wheel up or down and lock in position by pushing the lock lever up as far as it will go.

CAUTION: Do not adjust the steering wheel angle while driving.

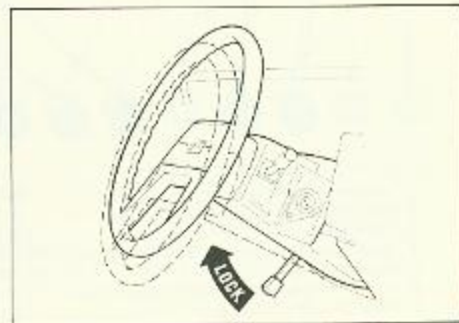

INSTRUMENTS AND CONTROLS

GX, GXE

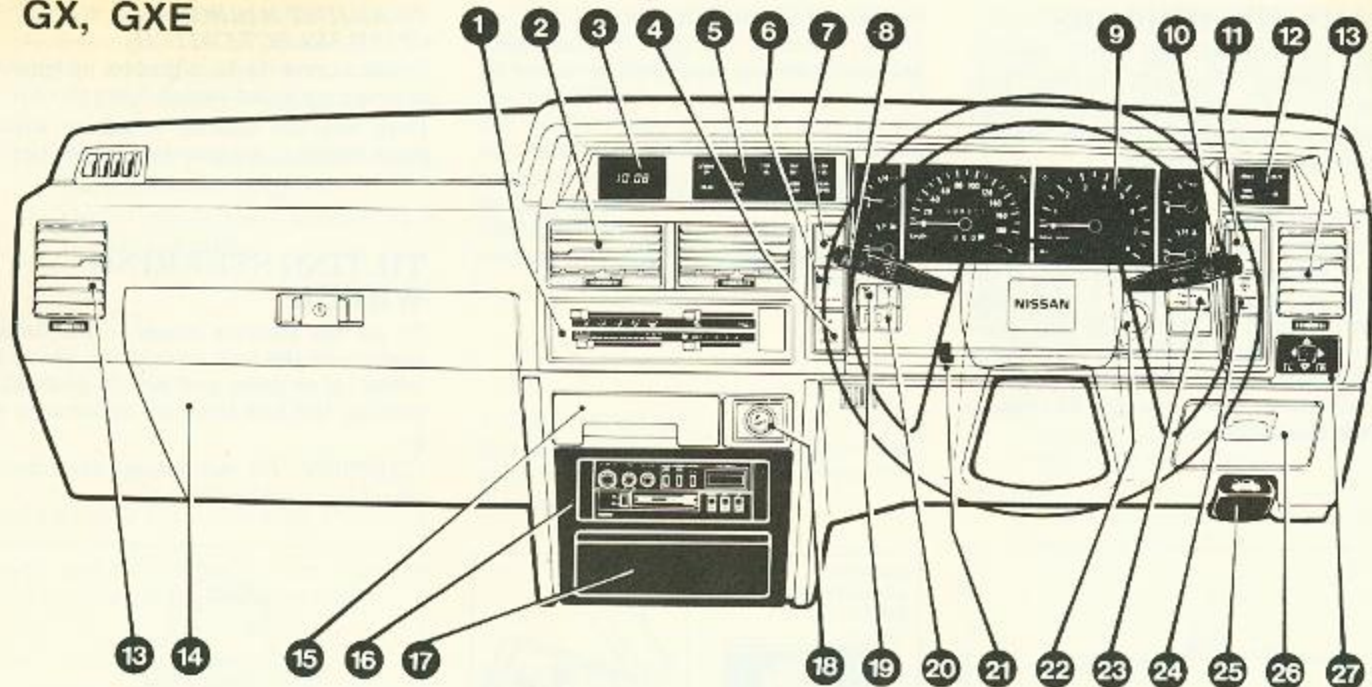

1. Heater and Air Controls (A/C Option)
2. Centre Vents
3. Digital Clock
4. Rear Window Washer Switch (Wagon)
5. Warning Lights (8)
6. Rear Window Wiper Switch (Wagon)
7. Rear Window Defogger Switch

8. Windshield Wiper and Washer Switch
9. Instrument Cluster
10. Light and Turn Signal Switch
11. Hazard Warning Switch
12. Warning Lights (4)
13. Side Vent
14. Glove Box

15. Ash Tray
16. Radio
17. Storage Compartment
18. Cigarette Lighter
19. Power Antenna Switch
20. Digital Clock Switch
21. Steering Wheel Tilt Lever

22. Ignition Switch
23. Tailgate Lock/Unlock Switch (GXE Wagon)
24. Illumination Control Switch
25. Hood Release
26. Fuse Box
27. Power Mirror Switch

TI, SILHOUETTE

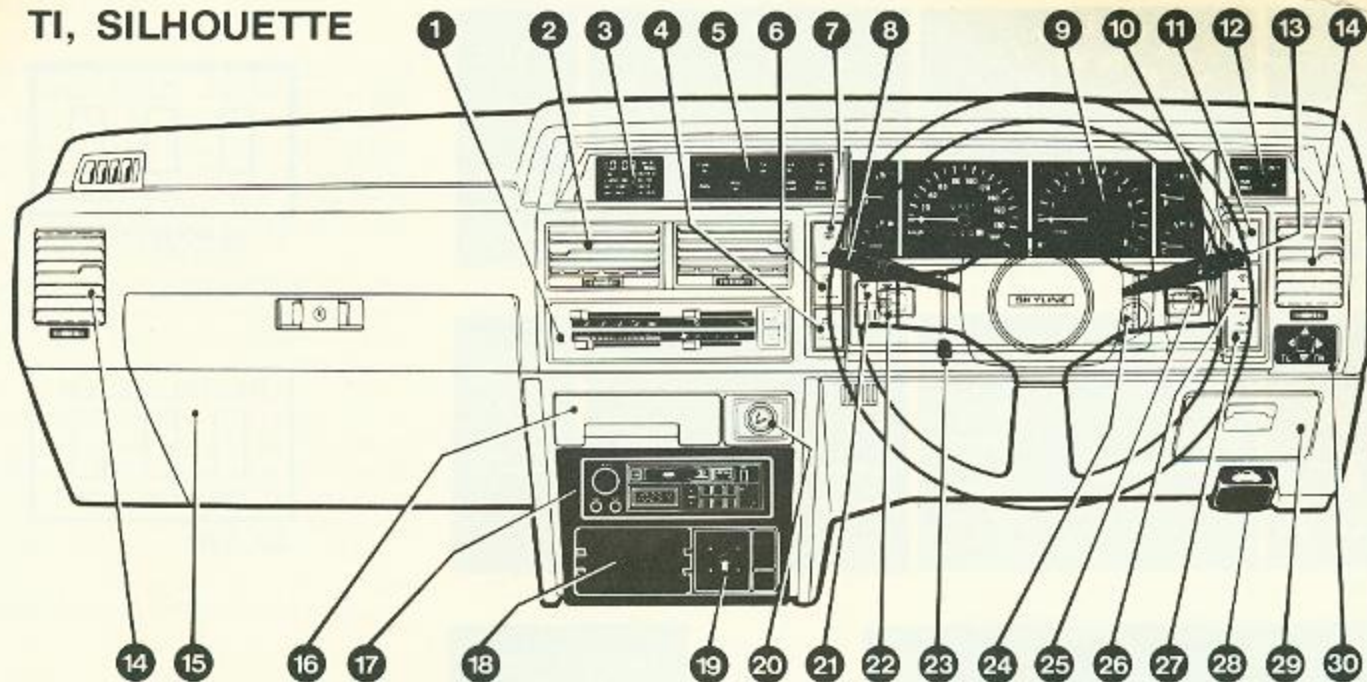

- | | | | |
|---|----------------------------------|-------------------------------|---|
| 1. Heater and Air Controls (A/C Option) | 9. Instrument Cluster | 17. Radio | 25. Tailgate Lock/Unlock Switch (GXE Wagon) |
| 2. Centre Vents | 10. Light and Turn Signal Switch | 18. Cassette Storage | 26. Illumination Control Switch |
| 3. Drive Computer | 11. Hazard Warning Switch | 19. Fader Control | 27. Cruise Control Switch |
| 4. Rear Window Washer Switch (Wagon) | 12. Warning Lights (4) | 20. Cigarette Lighter | 28. Hood Release |
| 5. Warning Lights (8) | 13. Set/Coast Button | 21. Power Antenna Switch | 29. Fuse Box |
| 6. Rear Window Wiper Switch (Wagon) | 14. Side Vent | 22. Drive Computer Switch | 30. Power Mirror Switch |
| 7. Rear Window Defogger Switch | 15. Glove Box | 23. Steering Wheel Tilt Lever | |
| 8. Windshield Wiper and Washer Switch | 16. Ash Tray | 24. Ignition Switch | |

INSTRUMENTS AND CONTROLS

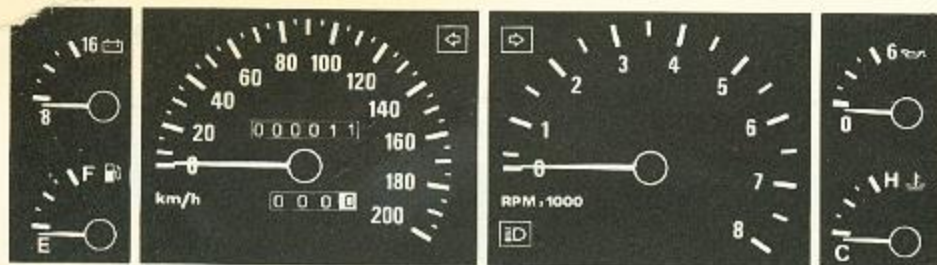

GXE, TI, SILHOUETTE

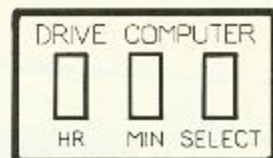

TI, SILHOUETTE

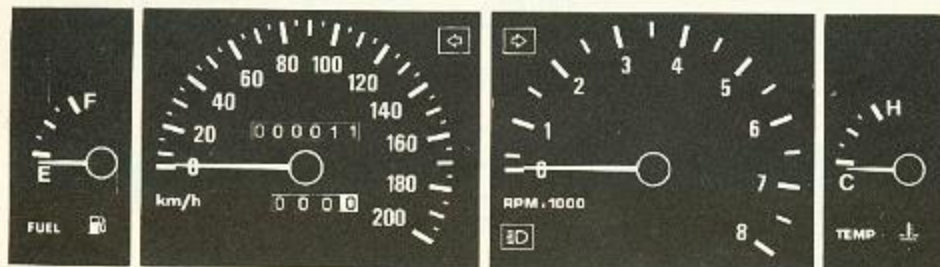

GX,

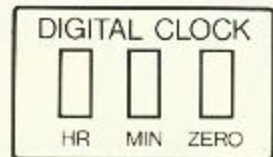

GX, GXE,



DIGITAL CLOCK (GX and GXE Only)

This clock is a quartz digital type with time display function only. When the ignition is turned to 'on' the time will be indicated on the clock dial in hours and minutes. When the parking and/or headlights are turned on the brightness of the digital display will be dimmed to reduce distraction whilst driving at night.

The time may be adjusted, but only in a forward direction by pressing the hours and minutes buttons as required. When the reset button is depressed, the clock is reset to the nearest hour taking minutes and seconds (not displayed) to zero time. This function allows the clock to be set accurately. When the ignition is turned off the illumination will go off, but as long as the battery is connected, and supplying current, the clock will continue working. If the battery is disconnected for any reason, the clock will have to be reset.

DRIVE COMPUTER/CLOCK (TI and Silhouette Only)

The drive computer has 10 functions, 8 of which are standard functions obtained by depressing the Select button. The remaining 2 are special functions obtainable by pushing the correct sequence of buttons.

Standard Functions:

TIME: Time
ELAPSED TIME: Elapsed Time
DIST TO EMPTY: Distance to Empty
DIST TRVLD: Distance Travelled
AVG SPED: Average Speed
INST FUEL: Instantaneous Fuel consumption
AVG FUEL: Average Fuel
FUEL USED: Fuel Used

Special Functions:

1. Fuel Remaining — Press Hours and Minutes buttons simultaneously.
2. Segment test — Press Select and Hours buttons simultaneously.

FUNCTION DESCRIPTIONS

Elapsed Time:

Indicates accumulated engine running time in Hours and minutes since the last reset.

The colon will flash while the engine is running.

Distance to Empty:

Is an estimate of how far the vehicle can be driven on the remaining fuel, displayed in kilometres.

(Calculated by dividing the Remaining Fuel by the Average Fuel Consumption Figure.)

After reset the Distance to Empty figure will be calculated using an average fuel consumption figure of 10 L/100 km so an indication of approximate distance to empty may be obtained, however because of variations in fuel tank readings are due to attitude of the vehicle, an accurate reading may not be obtained until an average tank volume has been established during the first 3 minutes driving.

Distance Travelled:

Distance travelled in kilometres since last reset, displayed in 0.1 km resolution up to 1000 kms and 1 km resolution there after.

Average Speed:

Average speed in km/hr since last reset. Calculated by dividing Distance Travelled by engine running time (Elapsed time) since last reset.

Resolution: 0.1 km/hr.

INSTRUMENTS AND CONTROLS

Instantaneous Fuel Consumption:

Calculated every 40 m, and displayed in Litres/100 km.

Resolution: 0.1 L/100 km.

When vehicle is stationary the last displayed value is held.

Average Fuel Consumption:

Gives Average Fuel Consumption in L/100 km since last reset. Calculated by dividing Fuel Used by Distance Travelled.

Resolution: 0.1 L/100 km.

Fuel Used:

Total fuel used since last reset measured in litres.

Resolution: 0.1 Litres.

Fuel Remaining (Special function):

Fuel remaining in Litres.

Resolution: 0.1 Litres.

Note 1 — Due to variations in attitude of the vehicle an accurate reading may not be obtained until an average has been established over the first 3 minutes of driving.

Note 2 — If fuel is added to the tank it will not be registered until the engine has been started.

Segment Test (Special function):

All Display segments will be active until another function is selected.

Selecting Function:

Press Select button to move cursor to desired function. If button is held down it will automatically step through the functions.

Buttons must be held down for 0.5 seconds before they are acknowledged.

The display will always return to Time when the engine is switched off, after which other functions may be selected as above.

Resetting Drive Information:

Press Select and Minutes buttons simultaneously while displaying any function other than time.

Time: Not affected.

Elapsed Time: Reset to 0:00.

Distance to Empty: Recalculated using Average Fuel Consumption. = 10 Litres/100 km and current Fuel Remaining.

Dist. Travelled: Reset to 0.0 km.

Average Speed: Reset to 0.0 km/hr.

Instantaneous Fuel Consumption: Reset to 0.0 Litres/100 km.

Average Fuel Consumption: Reset to 10 L/100 km.

Fuel Used: Reset to 0.0 L.

(Fuel Remaining): Not affected.

SETTING CLOCK:

Setting Hours: Depress Hours button to advance hours. Will automatically step if held down.

Setting Minutes: Depress Minutes button to advance minutes. Will automatically step if held down.

Zeroing Minutes and Seconds:

Depress Select and Minutes buttons simultaneously while display is showing time. The Colon will stop flashing and minutes and seconds will be held at zero until the buttons are released.

BATTERY DISCONNECTION:

If the battery is disconnected Time and Drive information will be lost. On re-connection of the battery Time will be set to 1:00 and the Drive information will be reset as for manual reset.

ANALOG TYPE TEMPERATURE GAUGE

When the ignition is turned to 'ON' the temperature gauge will indicate the temperature of the engine coolant. Under most driving conditions the gauge needle will remain around midway between 'C' and 'H'.

Stop/start driving, driving at sustained high speeds in hot weather, hill climbing or towing a trailer may cause the needle to move towards 'H'. This is not dangerous. However, if the needle should move all the way to 'H' position, pull out of the traffic as soon as it is safe to do so, stop the car, place the transmission in neutral (park on automatic) and run the engine at 1,000 rpm to 1,500 rpm. If the needle does not return to the normal position within a few minutes, stop the engine and inspect the cooling system.

CAUTION: Check coolant level at reservoir with engine cold.

Exercise extreme care when removing radiator cap if checking level when engine is hot.

FUEL GAUGE

When the ignition is switched on the fuel gauge will indicate the approximate amount of fuel in the tank. The position of the needle may vary slightly when going up or down hill, accelerating or braking.

SPEEDOMETER

The speedometer is graduated from 0 to 200 in kilometres per hour. Incorporated in the face of the speedometer is an odometer which registers the kilometres travelled and a trip meter which can be set to record the distance travelled each trip. The trip meter can be returned to zero by pushing the reset button on the lower left of the dial. The last digit on the tripmeter is coloured and represents tenths of a kilometre.

TACHOMETER

The tachometer is electrically operated and indicates the engine speed in revolutions/minute (R.P.M.). The dial gauge is graduated from 0-8 in thousands of revolutions. The dial is divided into three coloured zones, from 0-5750 in white, the 6000-6250 is yellow, from 6500-8000 is red. For normal driving it is recommended that engine revolutions should stay in the white zone with only short dashes in the yellow zone. Do not drive with the tachometer needle in the red zone as serious engine damage can occur.

VOLTMETER (where fitted)

The voltmeter monitors the condition of the charging system and the state of the battery.

Turn on ignition and before starting the engine, check the position of the needle on the dial. Normally it will be centred around the 12v mark on the dial. If it is below the 12v mark, it indicates a low voltage condition and the battery should be checked.

During starter operation the needle may drop to midway between the 8v and 12v marks. **THIS IS NORMAL.** When starter operation ceases and the engine is running the needle will move up towards the 16v mark. As the battery is charged the needle will drop back to the central area.

The needle will also drop down the scale as the battery discharges. If the needle does not register in the area between 12v and 16v during normal daytime driving, the battery and/or charging system should be checked so that the problem can be located and rectified.

INSTRUMENTS AND CONTROLS

OIL PRESSURE GAUGE

(where fitted)

The oil pressure gauge indicates the operating oil pressure within the engine lubrication system. When the engine is not running the gauge needle will be on zero. With the ignition switched on and the engine running, the gauge will indicate the pressure in the system.

During ordinary driving the needle will operate in the area around 3 or slightly above.

If the engine is above idle speed and the needle fails to move off zero, or fluctuates at constant engine speed, stop the engine and locate the cause of the trouble.

In cold weather the engine oil pressure may increase slightly when the engine is first started, and remain so until the engine reaches normal running temperature.

WARNING LIGHTS

HIGH BEAM

The headlights have two beams to cater for varying night driving conditions. The high beam gives better long range visibility. With the headlights on, the BLUE warning light will come on whenever high beam is selected.

BRAKE (FOOTBRAKE SYSTEM)

The footbrake system is a dual circuit design. One circuit for the front brakes and the other for the rear brakes. If one circuit should fail, the other will continue to operate. With the ignition switched on, the RED warning light will come on, if it does not come on, check the electrical system for a burned out bulb, or an open circuit.

Start the engine and depress accelerator once or twice to ensure that the alternator is charging and that the brake warning light goes out. Depress the brake pedal. If the brake warning light comes on, the footbrake system is partially inoperative because of a loss of hydraulic pressure in front or rear braking system. If this occurs, have the brakes repaired immediately. Do not drive the car unless it is safe to do so and then only at a reduced speed to the nearest garage/service station.

PARKING BRAKE

When ignition is switched on and the parking brake applied the RED warning light should come on. If it does not light up, check the electrical system for a burned out bulb or an open circuit.

CHARGE (ALTERNATOR)

The RED charge warning light will come on when the ignition is switched on. After the engine has been started and the alternator is charging the battery, the light will go out and remain out as long as the system is operating normally. If the light remains on at normal driving speeds, the alternator and electrical system should be checked.

The light may glow or flicker at low idling speeds, but if it goes out when the engine speed is increased, the system is functioning normally.

NOTE: It may be noticed that when the engine is started up without touching the accelerator pedal, the brake and charge warning lights remain on. This is normal. If there is no malfunction in the brake or charging system, the lights will go out and stay out when the engine is speeded up slightly.

OIL PRESSURE

The RED oil pressure warning light will come on when the ignition is switched on. If it does not come on check the electrical system for an open circuit or a burned out bulb. After the engine has been started the light will go out. If the engine oil pressure drops below a safe working pressure the light will come on. If the light glows steadily while driving, stop the engine and check the lubrication system to locate the cause of the trouble. The light may flicker at idle or for a few seconds after a sudden braking stop. This is normal.

DOOR AJAR

When the ignition is switched on, the RED door ajar light will come on if any door is left open.

NOTE: The light may also stay on if a door is not fully closed.

If the light does not come on, check the electrical system for an open circuit or burned out globe.

POWERSHIFT "ON" WARNING LIGHT (Automatic Only)

This will illuminate yellow when the powershift select button is pressed in to the "ON" position.

STOP AND TAILLIGHT FAILURE WARNING LIGHT

This will come on when the ignition is switched on. If it does not come on, check the electrical system for an open circuit or a burnt out globe. When the engine starts, the light will go out.

If the light remains on or comes on when driving, it indicates that either a stop light or taillight globe has failed and should be replaced.

SEAT BELT

When the ignition is turned on the RED seat belt light will flash for several seconds to act as a reminder to the occupants to fasten their seat belts.

If the light does not come on, check the electrical system for an open circuit or burned out globe.

LOW FUEL

When the volume of fuel in the fuel tank drops to about 10 litres, the low fuel warning light will illuminate red.

TURN SIGNAL

Two indicator lights are installed in the dash, one either side of the centre of the instrument panel. When the turn signal is operated the indicator light corresponding to the side selected will flash to indicate the signals are working.

TURN SIGNAL SWITCH

To signal a turn, flick the lever up for a left turn and down for a right turn. This will cause the indicator light on the side selected to flash. As the turn is completed and the steering wheel returns to the straight ahead position the signal will be cancelled. If however you are executing a gradual turn, the signals may not cancel owing to the steering wheel not being turned far enough to operate the cancelling mechanism.

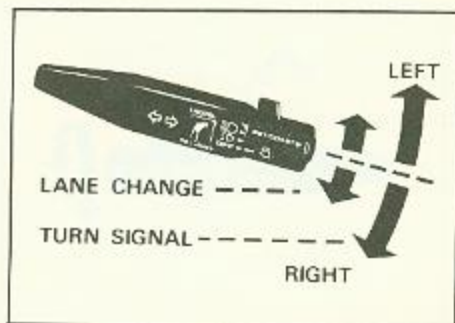

INSTRUMENTS AND CONTROLS

LANE CHANGING

To signal a lane change, move the lever only part way in the direction of turn till the indicator light flashes and hold it there till the lane change is completed. The signal will automatically cancel when the grip on the lever is released.

LIGHT SWITCH

The light switch is located on the end of the turn signal lever. The lights are operated by turning the knob in a forward direction. The first position turned to will operate the following lights: tail, number plate, parking, automatic transmission control lever indicator (where fitted) heater or air conditioner control panel, instrument panel lights and glove box light. The second position will operate the headlights and all the first position lights.

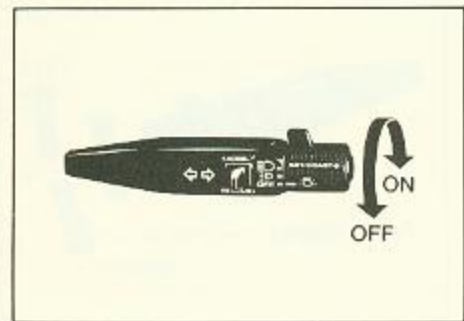

HIGH BEAM

When the turn signal switch is pushed down, away from the steering wheel, the high beam will come on. To revert to low beam, flick the switch back up.

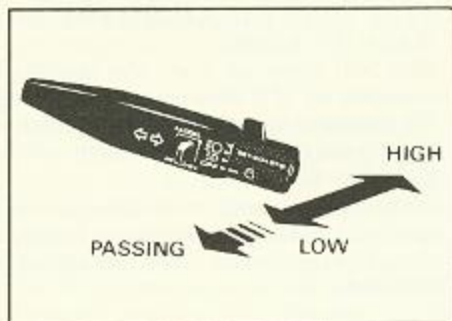

PASSING LIGHT

The passing light (headlight — high beam) will come on when the turn signal lever is pulled fully up towards the steering wheel.

NOTE: All light switch functions can be selected and will operate regardless of the position of the turn signal switch.

IGNITION SWITCH ILLUMINATION LIGHT

This switch is a special convenience when starting the car in darkness. On models with time delay interior light, the switch is illuminated while the interior light is on. On other models the illumination light is either permanently active or head lamp switch activated.

INSTRUMENT PANEL LIGHTS ILLUMINATION CONTROL

The switch is located on the right hand side of the instrument panel. To increase the illumination, press the "BRIGHT" button and hold until desired level is obtained. To decrease illumination, press the "DARK" button and follow same procedure.

HAZARD WARNING SWITCH

When the hazard warning switch is pushed on, all direction indicator lights will flash simultaneously, warning traffic of the presence of a hazard.

NOTE: It is an offence in some states to use the hazard function of indicator lights in any but emergency situations.

INSTRUMENTS AND CONTROLS

WIPER AND WASHER SWITCH

The windscreen wiper is a two speed type with an intermittent function. The first position is for intermittent, the second for low speed, and the third, for high speed.

NOTE: When intermittent is selected there may be a slight pause before the wiper gives one sweep.

The wiper switch also controls the windscreen washer.

To operate the washer, lift the switch up towards the steering wheel. Don't operate the washer continuously for more than thirty seconds, or if the reservoir is empty, and don't operate the wiper when the windscreen is dry. Don't use radiator anti-freeze in the washer, it may cause paint damage.

VARIABLE INTERMITTENT WIPE FUNCTION (where fitted)

The wiper on some models is fitted with a variable intermittent function. To vary the sweep rate, first select intermittent, then turn the knob at the end of the switch forward. The further the knob is turned, the shorter the interval between wipes.

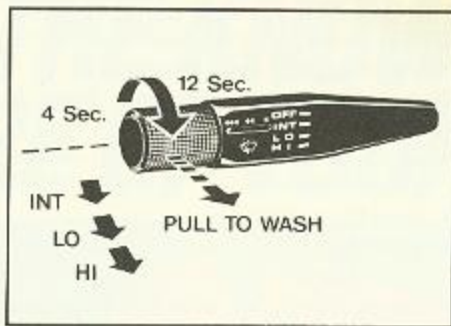

STATION WAGON. REAR WINDOW WIPER AND WASHER SWITCHES

The rear window wiper is a single speed unit operated by a push on, push off switch mounted on the left hand side of the instrument panel. To operate the washer, press the switch immediately below the wiper switch. The switch must be held in to operate the washer. Do not operate the washer continuously for more than thirty seconds or if the reservoir is empty and do not operate the wiper when the screen is dry.

NOTE: Do not use radiator antifreeze in the washer as it may cause paint damage.

NOTE: The station wagon rear screen washer uses the same reservoir as the front screen washer.

HORN

For models with only two spokes on the steering wheel, the horn may be sounded by pressing the centre pad. For models with three spokes, the horn may be sounded as above or by pressing either of the trumpets shown on the spokes.

PARKING BRAKE LEVER

To apply the parking brake, pull the lever upwards while depressing the foot brake pedal.

To release the parking brake, depress the foot brake pedal and pull the lever up sufficient to release the ratchet release button. Ensure that parking brake is fully released before driving off.

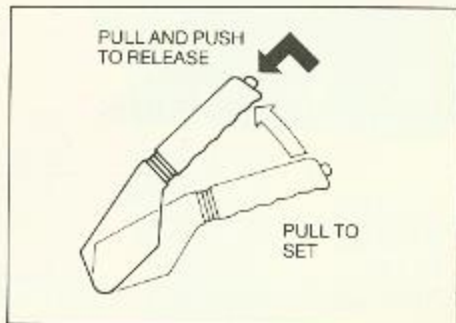

STARTING AND OPERATING

RUNNING IN SCHEDULE

All new cars require careful driving during the running-in period. Pistons, piston rings and bearings must have time to seat properly and produce smooth long-wearing surfaces. Too much strain on a new engine impedes this gradual 'bedding-in' process and is likely to shorten engine life and increase oil and fuel consumption.

During the first 1,600 km do not drive at full throttle, except for brief periods, and do not exceed the upper speed limit. Do not allow the engine to labour before changing to a lower gear when climbing a hill. Variable speeds are best during the running-in period. Always drive so that the engine runs fast enough to prevent strain. After completing the first 1,000 km the car should be taken to your authorised NISSAN Dealer for the scheduled 1,000 km service.

RUNNING IN SPEEDS

		1st	2nd	3rd	4th	5th
MANUAL TRANS- MISSION	5 speed	0-30	20-55	35-85	over 50	over 60

Fuel economy will vary during the running-in period and is dependent on driving habits and proper maintenance.

Therefore to conserve fuel and assist in proper run-in.

- Don't drive at high speeds till the engine has warmed up.
- Avoid fast starts.
- Don't allow the engine to labour in any gear.
- Avoid driving at wide throttle openings during the running-in period.
- Don't race the engine.
- Avoid extended idling periods.
- Except in an emergency, avoid heavy braking or rough usage of the brakes. This will allow the brake pads to bed in properly.

NOTE: Read section "RUNNING IN" on page 40.

IGNITION SWITCH

The ignition switch has four positions and controls the ignition, accessories and starter circuits as well as the steering lock.

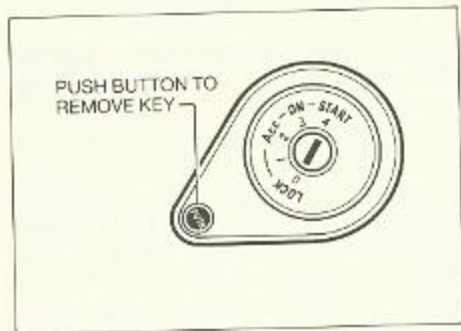

"LOCK" (NORMAL PARKING POSITION)

The ignition key can be inserted, and removed in the locked position only.

To remove the key from the steering column lock, the release button must be pressed in and the key simultaneously withdrawn.

When the key is withdrawn and the steering wheel turned, a click will be heard as the locking plunger drops into position. This makes the vehicle impossible to steer and is a deterrent to unauthorised usage.

unit km/h

**LET THE MAN
WITH THE KNOW-HOW
TAKE CARE OF YOUR NISSAN.**

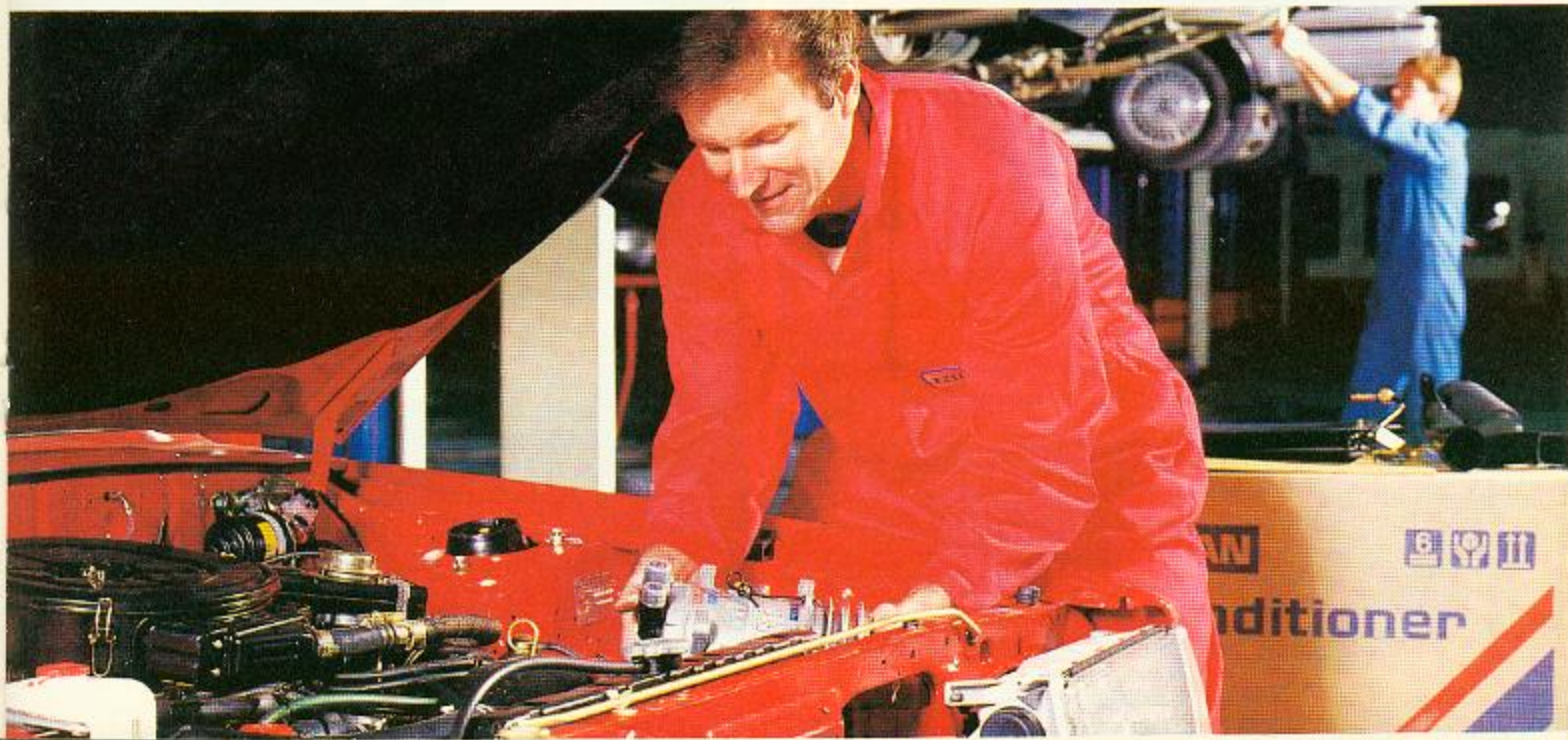

NISSAN GENUINE PARTS, ACCESSORIES & QUALITY SERVICE

Make the genuine Nissan choice in parts, accessories and service.

Genuine Nissan Parts, Accessories and Service are the best thing going for every Nissan on the road. Your Nissan Dealer has the latest technical equipment to service your Nissan and keep it at peak performance.

And Nissan keeps every genuine Nissan service specialist up to date with the latest in Nissan Know-How. They know your Nissan inside and out, from bumper to bumper, tread to top.

When your Nissan needs service, make sure it's in the right hands. Trust the man with genuine Nissan Know-How.

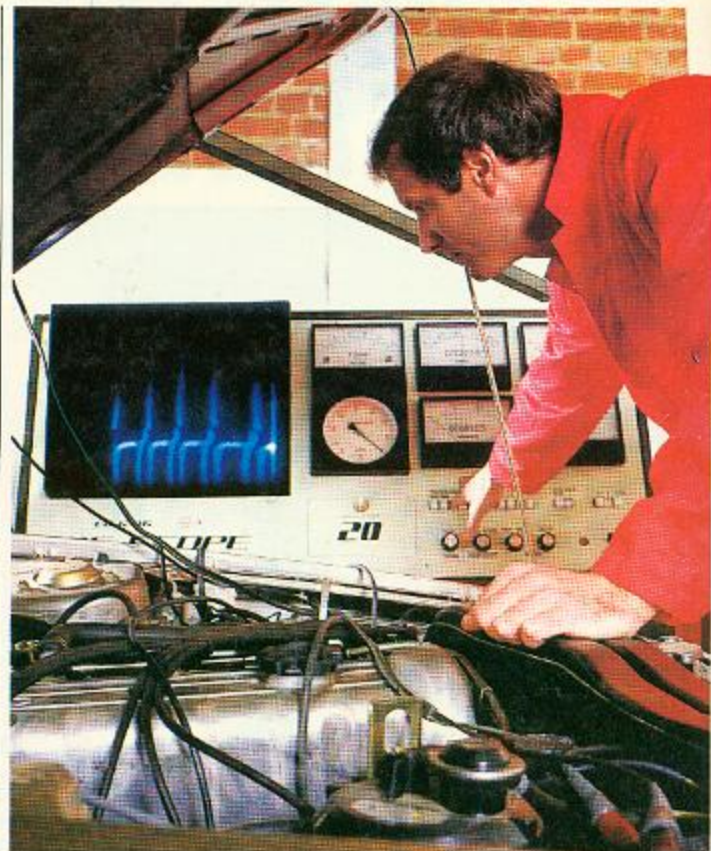

VICE

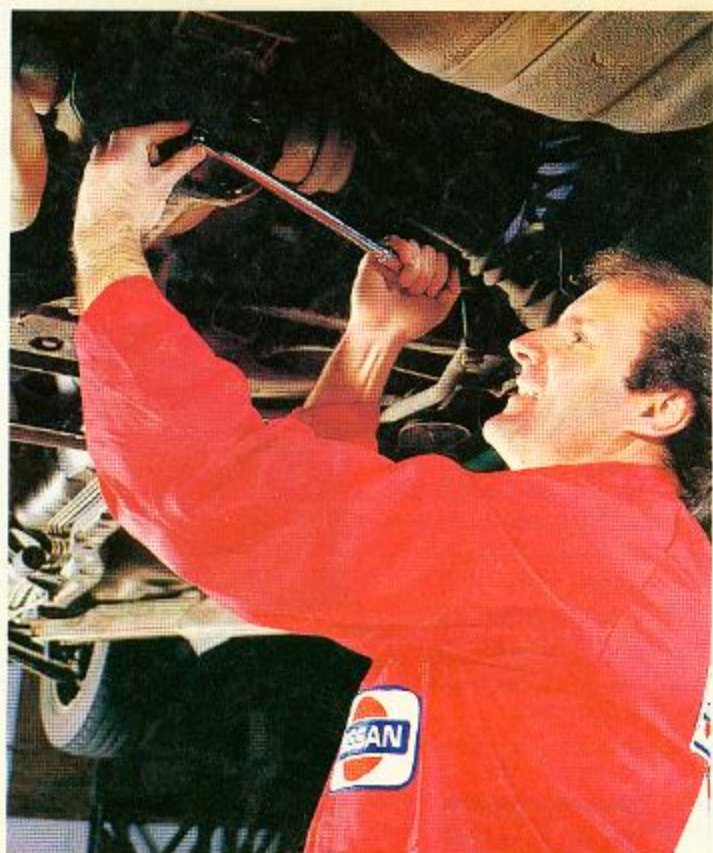

NISSAN GENUINE PARTS, ACCESSORIES & QUALITY SERVICE

Get the accessories designed just for your Nissan.

It's those little personal touches that bring out the best in your Nissan. Your Nissan Dealer has a full range of accessories that are functional, add aesthetic touches, comfort and convenience. Nissan accessories are built to the same exacting standards as your Nissan, and have full warranty cover.



Nissan Motor Oil

Nissan Motor Oil Special Blend 20W-40 is available only from your Nissan Dealer. It is formulated to suit Nissan vehicles. You can specify Nissan Motor Oil when your vehicle is serviced, and obtain it from your Nissan Dealer for topping up between oil changes.

Genuine Nissan Accessory Warranty

Nissan Motor Company (Australia) Pty. Ltd. ("Nissan") warrants all Genuine Accessories supplied by Nissan for a period of 12 months or 20,000 kilometres from date of purchase, whichever occurs first, or, if fitted in a Nissan Dealership Workshop, the balance of the vehicle warranty, whichever is longer. Therefore, accessories fitted at time of new vehicle purchase will be covered by 2 Year/40,000 kilometre new vehicle warranty. Fitment of Genuine Nissan Accessories will not jeopardise vehicle warranty.

 **NISSAN**
KNOW-HOW
BUILDING THE RIGHT CARS FOR AUSTRALIA

To unlock the steering, insert the key and while rotating the key, move the steering wheel slightly from side to side to ease the pressure on the steering lock.

'ACC' (Accessories)

When this position is selected all accessories controlled by the switch can be used.

'ON'

This is the normal operating position and not only turns on the ignition but it also operates accessories.

'START'

When the key is turned to this position it will operate the starter motor and crank the engine. The key will automatically return to 'on' when it is released.

STARTING THE ENGINE

Do not run the engine in enclosed areas. The engine produces carbon monoxide, and running the engine in a confined area could result in toxicosis.

If you should suspect that exhaust fumes are getting into the passenger compartment, have the vehicle examined and the leakage corrected immediately.

BEFORE STARTING THE ENGINE

- Make sure the parking brake is applied.
- Place the gearshift lever in "Neutral" (in "N" or "P" position for the automatic transmission). For manual transmissions, depress the clutch pedal to reduce drag from the transmission gears.

TIPS ON STARTING

- Start the engine without depressing the accelerator pedal.
- If the engine is hard to start in cold or hot weather, use the accelerator pedal to help start the engine.
- After starting the engine, release the ignition key.
- Do not run the starter motor continuously for more than 10 seconds. Wait at least 10 seconds before running it again.

WARNING: Never inhale exhaust gases. They contain carbon monoxide, a colourless and odourless gas which if inhaled in sufficient quantity, can cause death. If it is suspected that exhaust fumes are getting into the passenger compartment, have the car checked and the leakage corrected immediately.

Some cautions to observe with regard to carbon monoxide gas:

1. Do not sit in a parked car for an appreciable length of time with the engine running.
2. Do not run the engine in an enclosed space such as a garage with the door closed for any length of time.
3. If, when in an open space, it is necessary to sit in the car with the engine running, turn the vent to outside air and switch on the fan. This will force fresh air into the car.
4. Do not drive with the boot lid (or rear door on station wagon) open for any length of time because exhaust fumes from the tailpipe could be drawn into the car.
5. Always keep the front ventilator grille free from snow, leaves or any other kind of obstruction so that the car's ventilation system can function properly at all times.

STARTING AND OPERATING

CATALYTIC CONVERTER

A catalytic converter for emission control is installed in the exhaust system. Inside this converter, exhaust gases are burned at high temperature to help reduce pollutants.

Certain engine malfunctions, particularly involving the electrical, fuel injection or ignition systems, will result in large amounts of unburned fuel, causing the converter to reach elevated temperatures. Discontinue operation of the vehicle if the engine misfires, or if noticeable loss of performance or other unusual operating conditions are detected. In this case, have the vehicle inspected by an authorized NISSAN dealer.

CAUTION:

Use UNLEADED PETROL ONLY of the type recommended in "Oil and fuel recommendation". Leaded petrol will seriously damage catalytic converter. Keep an eye on your fuel gauge; running out of petrol could possibly cause damage to the catalytic converter. Refrain from racing the engine. Do not stop or park the vehicle over inflammable materials, such as dry grass, waste paper, or rags that may come into contact with the exhaust system. When parking, ensure that people or inflammable materials are kept away from the exhaust pipe.

PARKING

BEFORE LEAVING THE CAR

1. Apply the parking brake firmly.
2. Place the gearshift lever in reverse (on automatic transmission 'P' position).
NOTE: When parking on an uphill grade in manual transmission models, place the gearshift lever in the '1st' position.
3. Turn the key to 'lock and remove the key.
4. Lock all doors after ensuring that keys have not been left in car.

DRIVING, MANUAL TRANSMISSION

The manual transmission is a five-speed (5th gear overdrive).

The shift patterns are shown below.

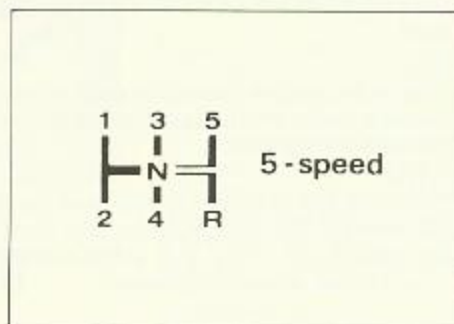

RECOMMENDED SHIFT-UP SPEEDS FOR BEST FUEL ECONOMY

(After Running In)

Unit km/h

Gear Change	Speed
1-2	15
2-3	30
3-4	45
4-5	55

NOTES:

1. When shifting one gear to another, be sure to depress the pedal all the way to the floor to avoid clashing and possibly chipping the transmission gears.
2. Shift into reverse only when the car has completely stopped.
3. Do not drive with your foot resting on the clutch pedal as damage to the clutch may result.
4. Never slip the clutch by releasing the pedal just enough to hold the car on a hill.
5. When climbing steep grades, change down to a lower gear before the engine starts to labour. To maintain safe speeds on a steep downgrade and to reduce brake wear and overheating, shift into a lower gear before starting the descent.
6. When quick acceleration is required, shift to a lower gear and accelerate until the car reaches maximum recommended speed in each gear. Do not exceed the speed limit of any gear.
7. In normal acceleration it is more economical to change to a higher gear as soon as possible without lugging or pinning.

DRIVING WITH AUTOMATIC TRANSMISSION

HOW TO OPERATE SELECTOR LEVER

Push the button located on the end of the selector lever when engaging "R" and "P" and when shifting from "2" to "1", as indicated by the arrow "♦".

The lever can be shifted freely into any of the positions indicated by the arrow "◊".

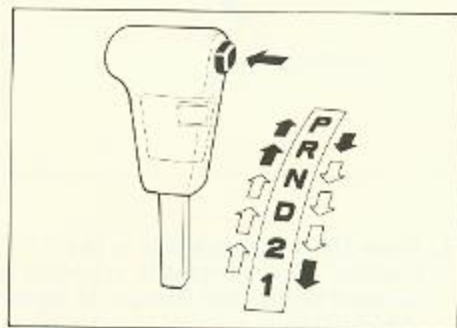

When shifting the lever from a Forward gear to Reverse, or from Reverse to a Forward gear or "Park", be sure to first bring the vehicle to a complete stop.

- Start the engine in the "P" or "N" position. It will not start in any other selector position. If it does, have your vehicle checked by your NISSAN dealer or other competent service facility.

Shift in "N" position and apply the parking brake when at a standstill for longer than a short waiting period.

Keep the engine at idling speed while shifting from "N" to any driving position.

When stopped on an upgrade, use your brakes to hold the vehicle in place to prevent overheating the transmission.

CAUTION: (When starting vehicle)

- **DEPRESS THE FOOT BRAKE PEDAL.** Shifting the selector lever to "D", "R", "2" or "1" without depressing the brake pedal causes the vehicle to move slowly (creep) when the engine is running. Be sure the brake pedal is depressed fully and the vehicle is stopped before shifting the selector lever.
- **MAKE SURE OF THE SELECTOR LEVER POSITION** Make sure the selector lever is in the desired position. "D", "1", "2" are used to move forward and "R" to back-up. Then release the parking brake lever.

STARTING AND OPERATING

- **SLOWLY DEPRESS THE ACCELERATOR PEDAL.**

Release the parking brake lever and foot brake pedal. Depress the accelerator pedal to start the vehicle and merge with traffic. (Avoid abrupt starting and spinning the tyres.) Avoid revving up the engine while the vehicle is stopped. (This could cause unexpected vehicle movement if the selector lever were in "D", "R", "2" or "1" or damage the engine if in "N" or "P".

- **WARM THE ENGINE UP.**

Due to the higher idle speeds when the engine is cold, extra caution must be exercised when shifting the selector lever into the driving position immediately after starting the engine.

When starting from cold, the transmission will not shift into 4th gear (overdrive) for the first few kilometres.

- **PARKING THE VEHICLE.**

Depress the foot brake pedal and, once the vehicle stops, move the shift selector into park position, pull the parking brake lever and release the foot brake pedal.

POWERSHIFT SWITCH (automatic transmission)

This is located on the gear shift lever and allows the driver to choose a shift schedule from the following two alternatives.

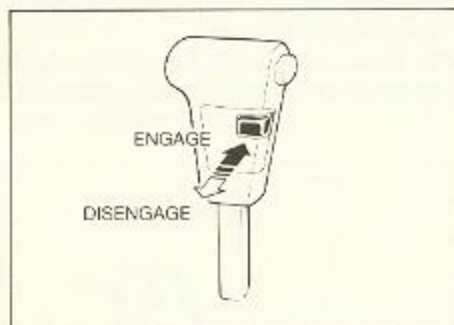

1. Press the switch inwards to the "ON" position. The powershift schedule is selected giving gear changes at higher vehicle speeds for any throttle opening. The indicator light will come on when this selection is made. If the

The power pattern driving mode is most effective for:

- Quick acceleration for passing or for entrance onto freeways, and turnpikes.
 - Uphill driving for better control of engine acceleration.
 - Downhill driving such as long slopes, and mountain roads, to obtain better engine braking (deceleration).
2. Release the switch and it will come out to the "OFF" position. This selects the economy shift schedule to give earlier gear changes and more economical driving.

NOTE: When the Powershift switch is "ON" the transmission will not shift into 4th gear (overdrive).

SELECTION OF 1st AND 2nd GEARS

"1" LOW GEAR

The "1" low gear is helpful for driving up very steep hills and for braking the vehicle on downhill grades. When downshifting into the "1" position, move the selector lever from "D" to "2" and then to "1".

Even if the selector lever is downshifted into "1", the vehicle remains in second gear until the vehicle speed drops below 50 km/h. Do not shift into the "1" position at speeds over 95 km/h. Do not exceed 60 km/h in the "1" position.

"2" SECOND GEAR:

Use the "2" position when starting on slippery roads or ascending hills or for effective engine braking on downhill grades.

Do not downshift into the "2" position at speeds over 95 km/h or drive at more than 95 km/h in "2" position.

ACCELERATOR DOWNSHIFT — IN "D" POSITION

You can get extra power and acceleration for rapid passing or hill climbing by completely depressing the accelerator pedal to downshift the gears. The accelerator downshift makes the transmission downshift into second gear when driving below 95 km/h.

STARTING AND OPERATING

CRUISE CONTROL (For TI Model Only)

The cruise control system automatically maintains a desired vehicle speed within a range of approximately 48 to 126 km/h without the necessity of operating the accelerator pedal.

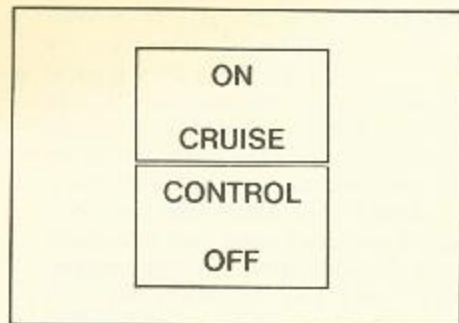

1. To operate the cruise control, push the "ON" switch. The "CRUISE ON" light will illuminate. To set the vehicle at the speed you desire, proceed with either of the following two methods. The vehicle will then automatically maintain the desired cruising speed. (The "CRUISE" light will illuminate.)

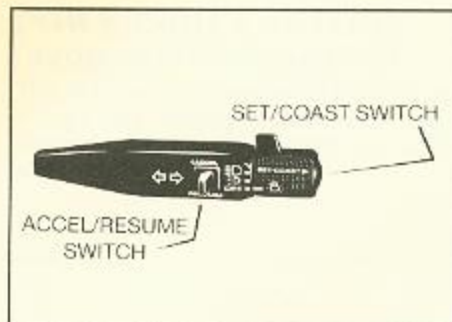

- (a) Depress the accelerator pedal and, when the vehicle attains the desired speed, momentarily press the "SET/COAST" switch.
 - (b) When the vehicle speed is within the range of approximately 48 to 126 km/h, keep pressing the "ACCEL" set switch, allowing the vehicle to accelerate without depressing the accelerator pedal. When the vehicle attains the desired speed, release the "ACCEL" set switch.
2. To increase the vehicle speed, briefly depress the accelerator pedal. When the pedal is released, the vehicle will return to the cruising speed selected prior to acceleration.

3. To reset at a faster cruising speed, proceed with either of the following two methods. The vehicle will then automatically maintain the newly selected speed.

- (a) Depress the accelerator pedal and, as the vehicle attains the desired speed, momentarily press the "SET/COAST" switch.

- (b) Keep pressing the "ACCEL." set switch, allowing the vehicle to accelerate without depressing the accelerator pedal. When the vehicle attains the desired speed, release the set switch.

4. To reset at a slower cruising speed, proceed with either of the following two methods. The vehicle will then automatically maintain the newly selected speed.

- (a) Depress the brake pedal and, as the vehicle attains the desired speed, momentarily press the "SET/COAST" switch.

- (b) Keep pressing the "SET/COAST" switch, allowing the vehicle to decelerate without depressing the brake pedal. When the vehicle attains the desired speed, release the switch.

5. To disengage the cruise control, lightly depress the brake pedal (the "CRUISE" light will go out, or push the "CONTROL OFF" switch then both the "CRUISE ON" and "CRUISE" lights will go out.

The cruise control will automatically be released if the vehicle slows down to a speed which is 10 to 18 km/h or more below the pre-set cruise speed.

- On the manual transmission model, the cruise control will automatically be released when the clutch pedal is depressed. Never shift the transmission without depressing the clutch.
 - On the automatic transmission model, the cruise control will automatically be released by shifting the control lever into the "N" range.
 - If the brake pedal is depressed while depressing the "ACCEL" set switch, the vehicle speed cannot be set until the main switch is turned "OFF" and then "ON".
6. To resume the speed selected prior to disengagement of the cruise control by depressing the brake or clutch pedal or by shifting into "N" range on an automatic transmission model, press

and release the "RESUME" set switch. The vehicle will then automatically return to the speed and maintain it if the vehicle speed is within the range of approximately 48 to 126 km/h.

- When the "RESUME" set switch is kept depressed, the vehicle will decelerate. When the "RESUME" set switch is released, the "resuming" function will start to operate.

CAUTION:

- **Avoid using the cruise control system in areas where road conditions and/or weather elements are not suitable, as in congested areas, very curvy or hilly roads with a short field of vision, slippery roads (rain, snow, ice, etc.), very windy areas, etc.**

During cruise-speed driving, keep your foot off the accelerator pedal to permit movement of the accelerator pedal.

- **On the manual transmission model, if the transmission is put into neutral position without the clutch being depressed, and the cruise control is left on, engine damage will result.**
- **For safety, make sure that the cruise control switch is set to "OFF" position when it is not being used.**

TIPS ON DRIVING

ECONOMICAL DRIVING

Attention to the following points will assist you to attain the operational economy built into your car.

1. Do not pump the accelerator — gently depress it until the desired speed has been reached, and then try to maintain that speed.
2. Always drive the car in the gear most suited to the driving conditions.
3. Maintain moderate speeds on the highway. Speeds above 80 km/h will considerably increase fuel consumption.
4. Maintain a safe distance behind other vehicles and avoid sudden stops. This will reduce wear on brake pads and use less fuel as extra fuel is required to accelerate back to driving speed.
5. Excessive engine idling increases fuel consumption. If you are held up in traffic and are faced with a wait of more than a few minutes, switch off to conserve fuel and start up again later.
6. Keep the tyres at the recommended inflation pressures for longer tyre life.

STARTING AND OPERATING

7. Keep the engine properly tuned up and follow the recommended periodic maintenance schedule. This will maintain serviceability and lower operating costs.
8. Check your tyres regularly for abnormal wear. Out of alignment wheels cause the tyres to drag resulting in premature tyre wear and additional fuel consumption.
9. If fitted with air conditioning, use only when necessary.

WET BRAKES

After washing the car or when driving under extremely wet conditions, the brake pads may get wet. Lightly apply brake several times as the car is moving slowly to dry the linings.

Do not drive the car at normal speeds until the brakes are functioning correctly.

IN COLD WEATHER

Starting off on slippery roads

When rain or snow makes the roads slippery, use caution in acceleration and clutch engagement. If the clutch is engaged too abruptly and with too high an engine speed, the wheels will spin and the car may not move forward.

Driving on slippery roads

When driving on wet or slippery roads, never brake hard. Instead, smoothly shift to a lower gear and use the braking effect of the engine.

When driving on icy roads, always proceed slowly and cautiously, turn the steering wheel gently and use the brakes only lightly. Moreover, always change gears smoothly, and never drive with the clutch pedal depressed.

If the car should go into a skid, do not apply the brakes. Release the accelerator and turn into the direction of the skid. As the car recovers from the skid, straighten out the wheels and accelerate lightly.

SPECIAL WINTER EQUIPMENT

It is recommended that the following items be carried in the car during winter in areas subject to snowfalls and freezing temperatures.

1. A scraper and stiff bristled brush to remove ice and snow from the windows.
2. A sturdy, flat board to be placed under the jack to give it support.
3. A shovel to dig the vehicle out of snowdrifts or bogs.
4. Snow chains.

Anti-freeze

Minimum outside temperature	NISSAN L.L.C.	Soft water
-15°C	30%	70%
-35°C	50%	50%

Vehicles are initially filled with a 30% solution of NISSAN L.L.C.

If temperatures below -15°C are expected, increase the concentration of L.L.C. in accordance with the above table.

BATTERY

If the correct specific gravity of the battery electrolyte is not maintained during extreme cold weather conditions, the electrolyte may freeze and damage the battery. Therefore, to maintain the battery at maximum efficiency it must be checked regularly.

DRAINING THE COOLANT WATER

If the car is to be left outside in freezing temperatures without anti-freeze, drain the coolant water from the system by removing the lower radiator hose from the radiator. Always refit the hose and replace the coolant before starting the engine. Be sure to check for leakage after running the engine.

NOTE: When refilling the cooling system after it has been drained it is recommended that NISSAN LONG LIFE COOLANT (L.L.C.) be used.

L.L.C. is a corrosion inhibitor with anti-freeze and anti-boil properties. When using L.L.C., use concentration detailed on page 69.

REPLACING LUBRICANT

When the temperature drops below -12°C it is recommended that the lubricating oil be replaced with one of lower viscosity. Refer to 'Recommended S.A.E. Viscosity Number' section.

IN HOT WEATHER

Replacing the lubricant.

When the temperature stays over 32°C the lubricating oil should be replaced with one of a higher viscosity. Refer to 'Recommended S.A.E. Viscosity Number' section.

COMFORT AND CONVENIENCE FEATURES

VENTILATION SYSTEM

Flow away outlets that act like one way valves are provided in the right rear quarter panels and the rear doors. When all the windows are closed air enters from the front vents and flows out through the rear vents. Thus providing a constant and draught-free circulation.

HEATER

The heater is controlled by four levers located in centre portion of the instrument panel.

1. The air control lever is used to direct the air flow through the desired outlets.
2. The temperature control lever is used to control the temperature of the air discharged.
3. The fan switch lever is used to control the fan speed.
4. The air intake lever is used to select outside (fresh) or inside (recirc.) air.

Two side and two centre ventilators on the dash enable you to ventilate the car without opening the windows. To draw fresh air into the car, move the air INTAKE lever to  position. If desired, the air supply may be boosted by switching the fan to any of its four speeds.

5. Air conditioner switch and light if fitted.

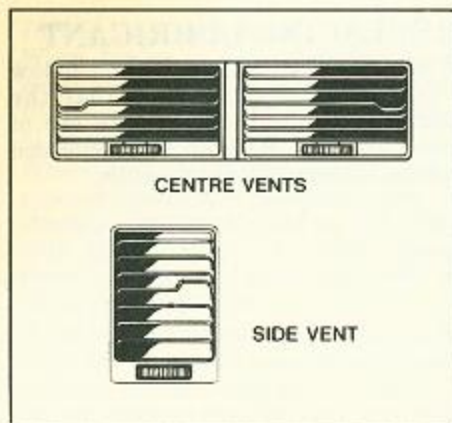

TEMPERATURE CONTROL LEVER

For normal conditions unless heating is required, leave the lever on "COLD" at the left hand side. If heating is required, slide the lever towards "HOT" on the right hand side. The closer to "HOT", the hotter the air will be from the fan.

FAN SWITCH LEVER



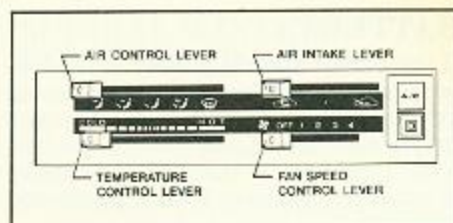

The fan has five positions as follows:

"OFF" The fan is switched off.



- 1 Low fan speed.
- 2 Low medium fan speed.
- 3 Medium high speed.
- 4 High speed.



AIR CONTROL LEVER

-  Air at face level for ventilation and cooling.
-  Bilevel air for ventilation while warming at floor level.
-  Air at floor level only for heating.
-  Air to defog windshield while heating at floor level.
-  Air for fast defogging of windshield.

AIR INTAKE LEVER

-  Recirculates only the air in the car when fast heating or cooling is needed.
-  Half way to obtain some fresh ventilation plus recirculation.
-  To obtain fresh air only for ventilation.

COMFORT AND CONVENIENCE FEATURES

HEATER OPERATION

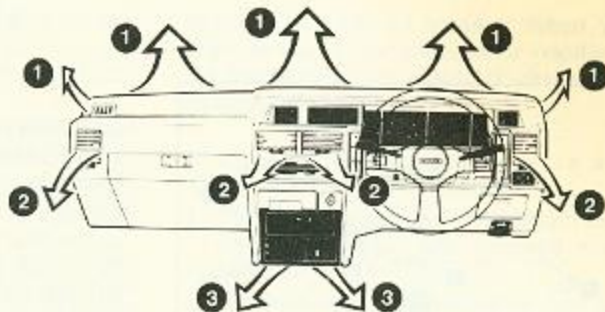

Condition Required	Air Control	Temperature Control	Fan Control	Air Intake	Air Outlets
Normal	—	COLD	OFF	—	
Ventilation		COLD	1-4	Fresh	②
Heating and Ventilation		HOT	1-4	Fresh	② ③
Heating		HOT	1-4	Recirculating or Half way	③
Heating and Defogging		HOT	1-4	Fresh	① ③
Defogging only		HOT	1-4	Fresh	①

OPERATING TIPS

- Clear any snow and ice blocking the air inlet located in front of the windshield.
- For adequate rear seat heating, keep the areas beneath the front seats clear, and operate the fan as required.
- Move the 'INTAKE' lever to the 'REC' position when driving on dusty roads.

COMFORT AND CONVENIENCE FEATURES

AIR. CONDITIONER SWITCH and INDICATOR LIGHT

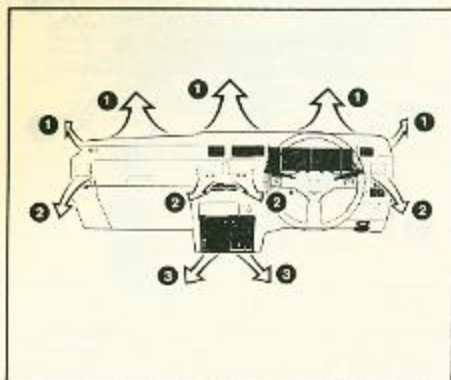
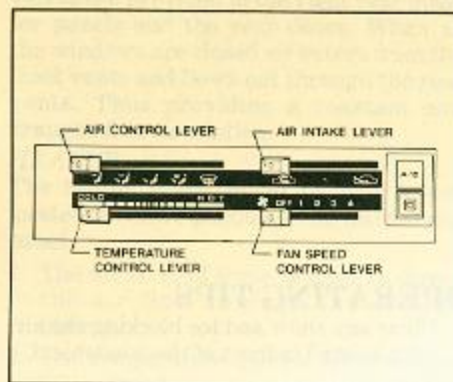

Condition Required	Air Control	Temperature Control	Fan Control	Air Intake	Air Outlets
Cooling		COLD	1-4	Fresh or Recirculation as desired	②
General De-Humidifying		HOT	1-4	Fresh	① ③
High Speed Defog or Defrost		HOT	1-4	Fresh	①

AIR CONDITIONER OPERATION

AIR CONDITIONER INDICATOR LIGHT

The light comes on when the A/C button is pressed in and the fan is working. This shows that the air conditioner is working. To switch off, repress the button which will pop out.

Heating and demisting the car

The heater operation is the same as a non-air conditioned car when the air conditioner 'AC' switch is off.

During winter as well as summer, the air conditioner can be used to demist or dehumidify the car interior.

This will remove the excess moisture from the air and demist the car windows in a few minutes.

OPERATING TIPS

Cooling the Car

- If the car interior is extremely hot first drive the car for two or three minutes with the windows open. Close the windows as soon as the hot air has been forced out of the car.

COMFORT AND CONVENIENCE FEATURES

- Keep windows closed while the air conditioner is in operation.
- Use 'recirculated air' position for general use.
- If the air in the car becomes stale, due for example to cigarette smoke, set the 'intake' lever to the 'fresh' position to supply fresh air to clear away the stale air.

When the air temperature gets too cold, turn fan speed down or slide the temperature control lever partly to the right which will make the air slightly warmer.

NOTE: In conditions of high temperature or high humidity, use recirculation position for maximum cooling

Care

IN WINTER — it is advisable to operate the air conditioner compressor for about ten minutes at least once a month.

CONDENSER — when washing the car, ensure that the condenser and radiator air passages are cleaned, particularly of dead insects. Fitment of a screen wire guard will reduce air conditioner efficiency due to restriction of air flow.

MAINTENANCE

NOTE: Water draining out under the car is normal and is the condensed moisture which the air conditioner has removed from the car.

Before the start of summer when you begin to use the air conditioner regularly, the following points should be checked by an authorised dealer.

1. Check the engine radiator and thoroughly flush it if necessary.
2. Check all water hoses for leaks, cracks, distortion, etc. and replace when necessary.
3. Pressure test the cooling system and radiator cap.
4. Re-tension the compressor and drive belts.
5. Clean the condenser and radiator air passages of insects and leaves.
6. Re-tighten the compressor and bolts securing mounting brackets and check the idler pulley if fitted.
7. Leak test the air conditioning system and top up with refrigerant if necessary.
8. Top up the compressor oil levels where necessary.

Refrigerant level:

The air conditioning system is charged with freon 12 gas. The correct amount in the system may be checked in the sight glass on top of the receiver drier tank mounted behind the front bumper bar.

When the air conditioner is first switched on bubbles will be visible in the sight glass for a short period.

With the engine running at approximately 1200 rpm, the bubbles should disappear after a few seconds. If bubbles are still visible after this time, the air conditioning system should be recharged with refrigerant gas.

Compressor belt adjustment:

The belt that drives the air conditioning compressor should be checked for wear and tension. It must be borne in mind that over-tensioning of the belt is just as injurious as under-tensioning for proper functioning of the system. You may check the belt tension, by pressing inwards at the longest span. This deflection should be approximately 7-8 mm under a 10 kg load. Excessive compressor vibration may indicate insufficient belt tension.

Condenser cleanliness:

The condenser is located between the grille and radiator. Due to its sturdy construction the condenser requires very little in the way of maintenance. However dirt and insect accumulation in the fins and tubes of the condenser will cause a sharp decrease in its efficiency and therefore affect the operation of the system.

COMFORT AND CONVENIENCE FEATURES

RADIO AND CASSETTE

The radio and cassette will operate when the ignition key is turned to the "ACC" or "ON" position.

Fully extend the antenna to optimise reception.

Radio reception is affected by station signal strength, distance from radio transmitter, buildings, bridges, mountains and other external influences. Intermittent changes in reception quality normally are caused by these external influences.

RADIO OPERATION — Philips DC 568 and DC 668

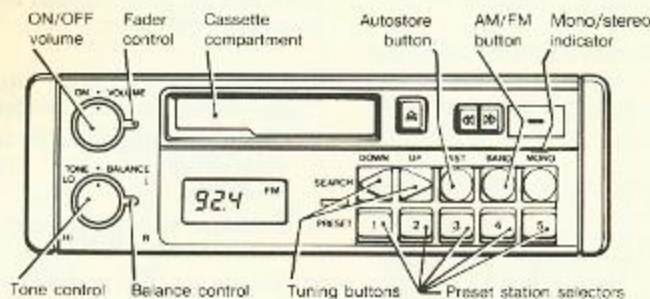

To switch on, turn the "ON/VOLUME" knob clockwise. The display will show the wave band (FM or AM) and the frequency. It may also show a preset number (e.g. P1) or the mode indicator (AS).

The display will remain for 10 seconds and then revert to the time display mode. The radio display will be recalled whenever a change to the radio settings is made. The display can also be changed from time to radio and back by pressing the "CLK" button.

TONE CONTROL

Turning the knob clockwise increases the treble response, anticlockwise increases bass response.

BALANCE CONTROL

The relative volumes of the left and right channels can be varied using the balance control. Clockwise rotation increases right speaker volume, anticlockwise increases left speaker volume.

FADER CONTROL

On models with four speakers, the relative volumes of the front and rear speakers can be varied using the fader control.

Clockwise rotation increases rear volume, anticlockwise increases front volume.

WAVE BAND SELECTION

The wave band can be switched from AM to FM by pressing the AM/FM button.

MANUAL AND SEARCH TUNING

Tuning is performed using the "UP" and "DOWN" tuning buttons. Three different tuning functions can be achieved depending on the interval between pressing and releasing one of the buttons.

1. One Step Manual Tuning

If either button is pressed and released within 0.2 seconds the frequency will change by a single step (9 kHz for AM, 100 kHz for FM). A beep will sound as the button is released to indicate the tuning step has taken place.

2. Search Tuning

If either button is pressed longer than 0.2 seconds, a beep will be heard. If the button is then released (before 2 seconds has elapsed) the radio will search for the next transmitting station.

Search tuning occurs at two sensitivity levels. Searching is started at the low sensitivity level where only strong transmitters are detected.

Furthermore, automatic search tuning always starts from the frequency to which the radio was set. Once activated, the radio scans the band looking for strong transmitters. If a transmitter is found, the search process is stopped.

If no strong transmitters are found when the highest or lowest frequency is reached, the radio switches over to the high sensitivity level so that weaker stations can be detected, and searching is continued.

Search tuning is stopped if:

- a. a transmitter is found,
- b. another button is pressed,
- c. the radio is switched off.

3. Continuous Manual Tuning

If either button is pressed for longer than 2 seconds a second beep will sound and the radio will begin changing frequency at high speed until the button is released. If either end of the frequency range is reached, the frequency changes automatically to the opposite end of the range.

PRESET STATION SELECTION

One AM and one FM station can be preset on each of the five preset channels.

When a preset station is selected by pressing and immediately releasing its corresponding button, the channel number is shown at the right hand end of the display. To alter the station on any preset channel, tune the radio to the desired frequency, then depress and hold the preset button you wish to alter until a double beep sounds and the display shows "— S —" indicating that storing of

the new station has occurred. The button can then be released.

Preset stations will be erased if the battery is disconnected.

AUTOSTORE FUNCTION

Autostore is an extended and automatic search tuning system on four sensitivity levels. The radio offers the possibility to automatically store five additional FM stations and five additional AM stations.

All other stations programmed on the normal presets (for each band) will not be erased.

This is a highly convenient feature when travelling outside your normal area. You may automatically select the strongest stations in the area without knowledge of their frequencies.

AUTOSTORE PROGRAMMING

Once the desired waveband has been selected, autostore programming can be commenced by pressing the "AST" button for more than 2.5 seconds. A beep will sound and the "AS" indicator on the display will begin to flash. This indicates that the wave band is being scanned and the five strongest stations are being automatically stored on the five preset buttons. When five stations have been located and stored a bitonal beep will sound and the radio will be tuned to preset channel P1.

This procedure can be repeated for five more stations on the other waveband.

If five stations cannot be found, the remaining channels will be programmed to the highest frequency in the band (108 MHz for FM, 1602 kHz for AM).

Use of the Autostore function will NOT erase stations stored on the normal preset channels.

REPLACING AUTOSTORED STATIONS

If a station stored on an Autostore preset button is not required it can be replaced by the next strongest station in the band in the following manner:-

Press the preset button you wish to change until the "AS" indicator on the display begins to flash.

The scan procedure is operated until the next strongest station is located and stored to the preset button. If no other station can be found, the previous preset station remains unchanged.

SELECTING AN AUTOSTORED STATION

Select the required wave band, press the "AST" button and release it within 2.5 seconds. The radio will now be in Autostore tuning mode and pressing any preset button will tune the radio to the station Autostored to that channel.

If the selected wave band has not been programmed by Autostore, and the "AST" button is pressed for less than 2.5 seconds, "— E —" will be displayed and the radio will continue to receive the previously selected station in normal mode.

SWITCHING FROM AUTOSTORE TO NORMAL MODE

To switch from Autostore mode to normal mode, press the AM/FM button. The "AS" indicator will disappear and the radio will switch to the station last selected in normal mode on the same wave band. Alternatively if either the "UP" or "DOWN" tuning button is pressed, the radio will switch to normal mode but the station will remain the same.

TRANSFERRING AUTOSTORED PRESETS TO NORMAL PRESETS

It is possible to transfer either one or all Autostored stations to normal preset channels.

Transferring one station

Select the Autostored station to be transferred.

Briefly press the "UP" or "DOWN" tuning button. The radio switches to normal tuning mode while retaining the station.

Press the required preset button until the beep sounds and "— S —" is displayed.

Transferring all five stations

Select the required wave band.

Switch the radio off.

Keep the "AST" button depressed while switching the radio back on.

The Autostored stations will now also be stored on the normal preset channels of the same wave band.

STEREO INDICATOR

The Stereo Indicator light will illuminate whenever a station is being received in stereo.

CASSETTE OPERATION

(Philips DC 568)

Holding the cassette with the open side to the right and the full reel toward the rear of the car, insert it into the cassette compartment until the tape button springs out. The cassette will play through to the end, at which point the unit will automatically switch back to radio reception.

While the cassette is playing the tape signal lamp will be on.

Play-back may be halted at any time by depressing the eject button halfway. The cassette will remain in the unit and radio reception will be resumed. This is standby mode. Play-back can be restarted by again pressing the eject button halfway.

The cassette can be removed by pushing the eject button **fully** in.

Fast Winding

Fast forward and fast rewind are operated by pushing the respective buttons. Fast winding can be stopped by pressing the opposite button. Alternatively the eject button can be pressed, which will stop the tape in standby mode and resume radio reception.

If the tape is in standby mode, the eject button must be depressed halfway before fast winding can be operated again.

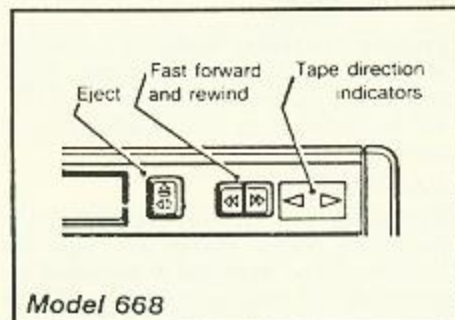
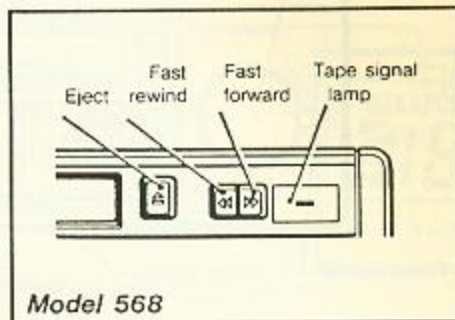

CASSETTE OPERATION

(Philips DC 668)

Holding the cassette with the open side to the right and the full reel toward the rear of the car, insert it into the cassette compartment until the tape button springs out. The cassette will play through to the end, at which point the unit will automatically change tape direction and play the other side of the cassette.

The direction of playback is shown by the tape direction indicators.

Playback can be halted by pushing the eject button fully in. The cassette will be ejected and radio reception will be resumed.

Playback Direction

While a cassette is playing the direction of playback can be changed by pressing the eject button halfway in.

Fast Forward/Rewind

For fast forward operation, press the button with arrows that show the same direction as the illuminated tape direction indicator. For rewind press the opposite button.

Normal play may be resumed by a slight touch of the other button.

RADIO OPERATION — AWA 7000E

To turn on, rotate the volume knob clockwise. The radio frequency being received will be shown in the centre of the digital display. The wave band can be changed between AM and FM by pressing the band selection switch. When the FM band is being received, one of the two FM band indicators (FM1 or FM2) will be displayed. The two FM modes are provided to allow extra FM stations to be preset.

TONE CONTROL

Separate Bass and Treble controls are provided. Turning the knobs clockwise increases response, anticlockwise decreases response.

BALANCE CONTROL

The relative volumes of the left and right channels can be varied using the balance control. Clockwise rotation increases right channel volume, anticlockwise increases left channel volume.

FADER CONTROL

The relative volumes of the front and rear speakers can be varied using the fader control. Clockwise rotation increases rear volume, anticlockwise increases front volume.

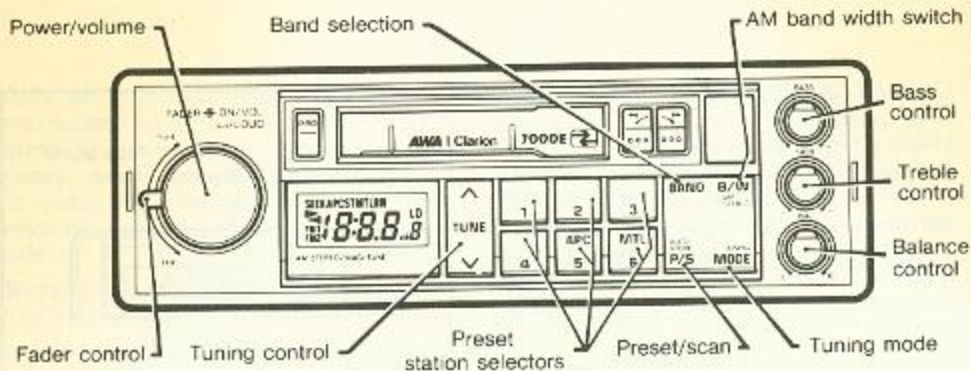

TUNING MODE

Pressing the tuning mode button selects between manual and seek tuning. When seek tuning is selected, the word "SEEK" will be displayed in the top left corner of the display.

MANUAL TUNING

Depressing the "UP" or "DOWN" end of the tuning control button will cause the frequency to be increased or decreased respectively. In manual tuning mode the frequency will change by one frequency step each time the button is pressed (9 kHz for AM, 50 kHz for FM).

SEEK TUNING

In the Seek tuning mode, the frequency will continue to change until the next transmitting station is located. If the highest (or lowest) frequency in the range is reached, seeking resumes at the opposite end of the range.

PRESET STATION SELECTION

One AM and two FM stations can be preset on each of the six preset channels. When a station is selected by pressing (and then releasing) one of the preset buttons, the channel number will be shown in the bottom right hand corner of the display.

To alter a preset station, tune the radio to the desired frequency and then depress the preset button you wish to alter for longer than 2 seconds. The radio will mute, then, after 3 seconds the sound will return and the display will begin flashing to indicate that storing of the new station has occurred. The button can then be released.

Preset stations will be erased if the battery is disconnected.

PRESET SCAN

The Preset Scan mode is activated by pressing the P/S button for less than 2 seconds. This will cause the tuner to scan the preset stations on the selected wave band, pausing at each for approximately 5 seconds.

To stop the scan operation press either the P/S button or the preset button of your choice.

When the Preset Scan is activated on the FM band, the tuner will scan presets on FM1 and then on FM2.

If a preset station cannot be received in the area you are in, the Preset Scan will bypass that channel.



AUTOSTORE FUNCTION

This function will automatically program the preset memory for each band.

This is a highly convenient feature when you are travelling outside your normal area. You may automatically select the strongest stations in a strange area without knowledge of their frequencies.

AUTOSTORE PROGRAMMING

To activate the Autostore function, press the P/S button for more than two seconds. The tuner will start to scan from the lowest frequency in the range and will store the six strongest stations received. If six stations are not available, the P/S button must be pressed again to stop the scanning process.

FM STEREO INDICATOR

If an FM station is being received in stereo, the stereo indicator (ST) will come on (centre top of display).

AM BANDWIDTH SWITCH

To optimize high frequency response on AM stereo reception, a choice of wide and narrow AM bandwidth is provided. Wide bandwidth provides better high frequency performance but allows a higher level of static. Therefore wide bandwidth should not be used for weak stations or when reception is poor.

When wide bandwidth is selected, the "BW" indicator will show on the display.

CASSETTE OPERATION AWA 7000E

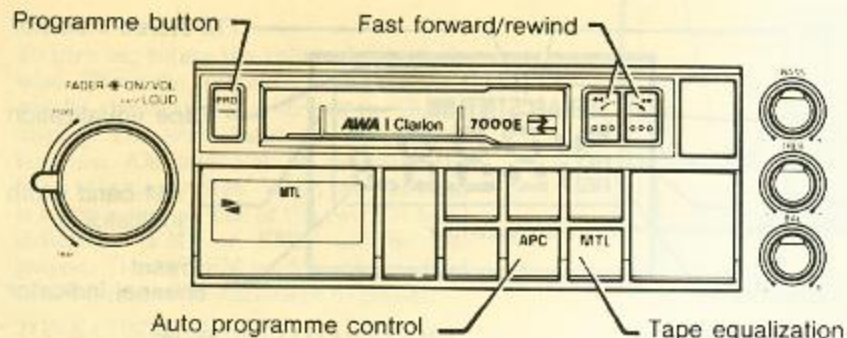

Holding the cassette with the open side to the right and the full reel toward the rear of the car, insert it into the cassette compartment.

The direction of playback is shown by the tape direction indicators.

Playback can be halted by pushing the fast forward and rewind buttons simultaneously.

The cassette will be ejected and radio reception will be resumed.

PLAYBACK DIRECTION

While a cassette is playing, the direction of playback can be changed by pressing the program button.

FAST FORWARD/REWIND

For fast forward operation, press the button with arrows that show the same direction as the illuminated tape direction indicator. For rewind press the opposite button.

Normal play may be resumed by pressing the other button or by pressing the program button which will cause play to be resumed in the opposite direction.

AUTOMATIC PROGRAM CONTROL (APC)

1. Press the A.P.C. button and the A.P.C. indicator will illuminate to indicate the function is actuated.
2. Press the fast forward (or rewind) button to send the tape in the forward (or reverse) direction at high speed.

The mechanism automatically stops at the end (or beginning) of that music segment and plays the next (or repeats the previous) segment.

NOTE:

A.P.C. may not operate if the time delay between musical segments is less than 4 seconds.

TAPE EQUALISATION

Press the tape equalisation button when playing chrome, ferrochrome and metal tapes (70 uS). On this setting the MTL indicator light at the top of the display will illuminate. When playing standard tapes press the equalisation button again to revert to the normal setting (120 uS).

COMFORT AND CONVENIENCE FEATURES

AM/FM DIGITAL STEREO RADIO AND CASSETTE

AWA

ON/OFF SWITCH AND VOLUME CONTROL

To turn on rotate the volume control knob clockwise. The radio frequency being received will be shown in the centre of the digital display. The radio band can be changed between AM and FM by pressing the band selection button. One of the three band indicators (AM, FM1, FM2) will illuminate. The two FM modes are capable of receiving the same range of frequencies. This duplication occurs to increase the number of preset FM stations available.

TONE CONTROL

Separate bass and treble controls are available. Turning clockwise increases, anticlockwise decreases the bass or treble to suit.

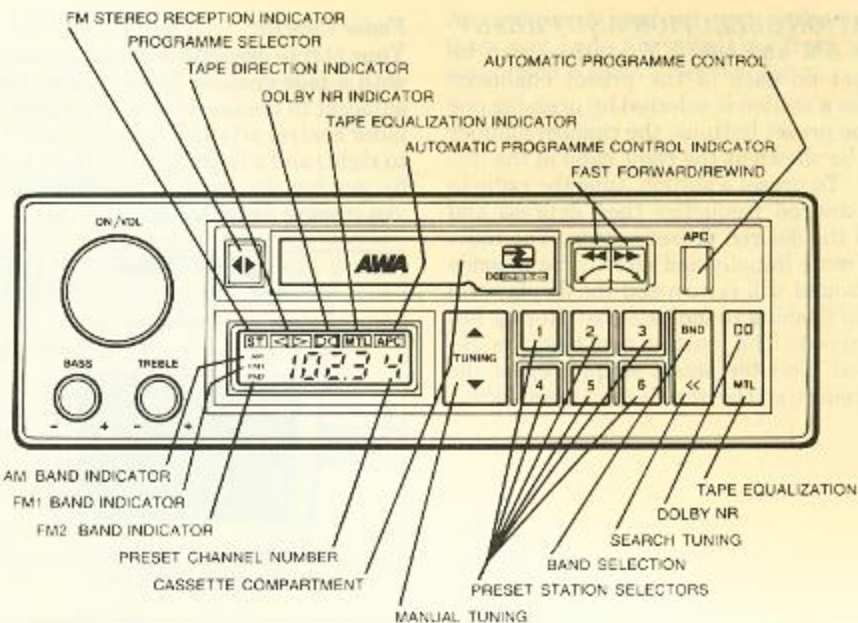

MANUAL TUNING CONTROL

Depressing the UP or DOWN end of the manual tuning switch allows the frequency to increase or decrease as required until the frequency of the desired station is displayed. AM frequency changes in steps of 9 kHz, FM in steps of 0.1 MHz.

SEARCH TUNING

Depressing the search tuning button causes the frequency to increase until the next transmitting station is located. If the highest frequency of the range is reached, searching begins again at the lowest frequency.

COMFORT AND CONVENIENCE FEATURES

STATION SELECTION AND PRESET

One AM and two FM stations can be preset on each of the preset channels. When a station is selected by pressing one of the preset buttons, the channel number will be shown at the right hand of the display. To preset a station, tune the radio to the desired frequency then depress and hold the desired preset button. The radio will mute initially and after three seconds the sound will return and the display will begin flashing to indicate that storing has occurred. The button can then be released. To alter preset simply repeat the procedure on the new desired frequency.

Fader Control

Your stereo cassette receiver is equipped with a four speaker fader control located adjacent to the cassette storage area. This fader control acts as a balance control (left to right) and a fader control (front to rear) by moving the lever in the direction that you require increased sound level.



CASSETTE OPERATION

Start

Switch the unit on by rotating the volume knob clockwise and insert a cassette. The tape will commence playing and one of the program indicators will be illuminated to show tape direction.

Stop and Eject

Press both the fast forward and rewind buttons together. The cassette will be ejected and operation is transferred to the radio.

Program Selection

Press the program selector button to reverse the direction of tape travel. The unit will play the reverse side of the tape as indicated by illumination of the other program indicator.

Fast Forward/Rewind

For fast forward operation, press the button with arrows that show the same direction as the illuminated program indicator. For rewind press the opposite button.

Either button will lock in automatically while the tape is moving at high speed and normal play may be resumed by a slight touch on the other button.

Auto Reverse

When one side of the cassette has been played completely, the mechanism will automatically reverse tape direction and commence playing the other side of the cassette.

COMFORT AND CONVENIENCE FEATURES

Tape Equalization

Set this switch to its normal position (out) when playing standard tapes (120 μ S). In this position, the MTL indicator light at the top of the display will illuminate. Press the switch in for playing chrome, ferrochrome and metal tapes (70 μ S).

DOLBY NR SWITCH

Depress the Dolby NR switch to provide Dolby Noise Reduction System and the Dolby NR indicator will light up. The Dolby NR indicator will only light while the tape is playing.

Automatic Program Control (APC)

1. Press the A.P.C. button and the A.P.C. indicator will illuminate to indicate the function is actuated.
2. Press the fast forward (or rewind) button to send the tape in the forward (or reverse) direction at high speed.

The mechanism automatically stops at the end (or beginning) of that music segment and plays the next (or repeats the previous) segment.

NOTE: A.P.C. may not operate if the time delay between musical segments is less than 4 seconds.

HEADPHONES

Some models are equipped with headphones which plug into a control point on the rear of the centre console.

TO OPERATE

Select the radio programme or cassette of your choice. Plug headphones into socket marked "OUTPUT". This will automatically transfer the sound from the rear speakers to the headphones, leaving the front speakers to operate normally.

Adjust volume of headphones on the control panel. If volume is too low increase by manipulating radio/cassette controls. Front speaker volume can be reduced by using the fader control.

WARNING: Headphones should not be used by the driver of the vehicle at any time.

Care of Headphones

When not in use, store headphones in plastic bag and place in pocket in rear of front seat. Occasionally remove foam ear pads and wash with a mild solution of soap and warm water. Dry carefully by squeezing up in a soft dry cloth.

An additional head set and replacement foam ear pads are available from your authorised NISSAN Service Agent.

COMFORT AND CONVENIENCE FEATURES

GENERAL HINTS FOR BEST RESULTS FROM YOUR RADIO & CASSETTE PLAYER

Radio

A Note on FM reception in your car

FM radio waves have a very short wavelength compared to AM, and tall buildings, hills or other obstructions may cause "shadows" with momentary loss of signal. FM waves are also reflected by some objects such as buildings, bridges etc. If the direct signal from an FM station and a reflected signal arrive at your car's antenna simultaneously a noise known as multipath interference can occur.

INTERFERENCE AND CARE OF AERIAL

Outside Interference

Despite careful design and manufacture, it is impossible to prevent all sources of radio noise. Such static that does come from power lines, trams, neon signs etc, is transmitted on the same radio frequencies as the broadcast stations. Careful tuning to stations and setting the tone control to the bass end should reduce this problem.

Ignition Interference

With the radio correctly installed using the proper suppression items, normal interference from the car's electrical system

should be minimal. To keep engine induced noise to this level, the ignition system should be kept in good order. Therefore, driving with burnt spark plugs or a worn out battery can increase radio noise as well as reduce car performance.

Care of Aerial

Aerials will give a long and trouble free life if they are given simple and routine attention. This is particularly so with a motorised aerial, where bent or grimy rods may affect its smooth and efficient operation. At least once a month the aerial should be lubricated with a dry stick lubricant.

- To maintain good quality sound, NISSAN recommends that you use cassette tapes of 60 minutes or 90 minutes maximum in length.
- Cassette tapes should be removed from the player when not in use. Store cassettes in their protective cases and away from direct sunlight, heat, moisture and magnetic sources.
- Direct sunlight can cause the cassette to become deformed. The use of deformed cassettes may cause the cassette to jam in the player.

- Do not use cassettes that have labels which are peeling and loose. If used, the label could jam in the player.
- If a cassette has loose tape, insert a pencil through one of the cassette hubs and rewind the tape firmly around the hubs. Loose tape may cause tape jamming and wavering sound quality.
- If the tape becomes jammed in the player, do not use sharp objects in an attempt to remove the tape. Consult your NISSAN dealer.
- Over a period of time, the playback head, capstan and pinch roller may gather a tape coating residue as the tape passes over the head. This residue accumulation can cause weak or wavering sound, and should be removed periodically (about every six months) with a head cleaning tape. If the residue is not removed periodically, the player may need to be overhauled for cleaning.

COMFORT AND CONVENIENCE FEATURES

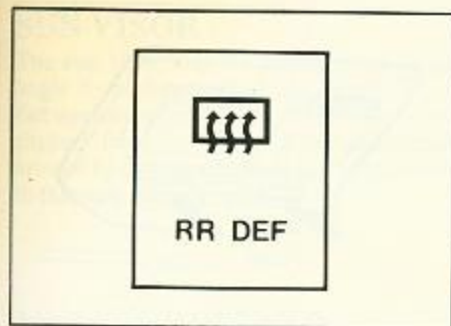

REAR WINDOW ELECTRIC DEFROSTER SWITCH

An electric defroster is built into the rear window. To heat the rear window glass press the switch in. (A warning light will glow to indicate the system is on).

When the window is clear, repress the switch. The switch operates only when the ignition switch is ON.

NOTE: When you clean the car, do not clean the inner side of the window with abrasive type cleaners, and do not use any type of scraper to remove foreign deposits from the inner glass surface.

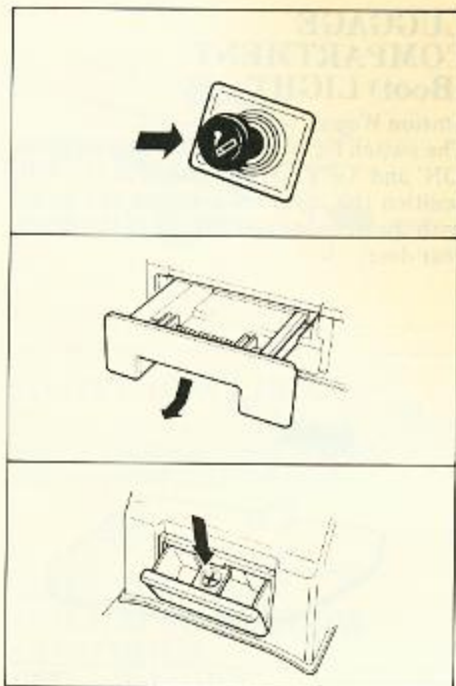

CIGARETTE LIGHTER

The cigarette lighter is located on the instrument panel face. To operate, switch ignition key to "accessories" and push the lighter in. When it becomes heated, it automatically partially ejects ready to use. When operated in the dark with driving/parking lights on, the socket is illuminated when the lighter is withdrawn.

ASH TRAYS

The ashtrays are located in the centre of the instrument panel and at the back of the centre console. To remove the instrument panel ash tray, pull it out, tilt downwards and withdraw it from its housing. To replace just push it back into place. To remove the rear ashtray, pull it open and press the centre spring clip down, the ashtray will then release. To replace just push it back.

COMFORT AND CONVENIENCE FEATURES

INTERIOR LIGHT

The interior light switch has three positions. 'OFF', 'ON' and 'DOOR'. When the switch is moved to the 'ON' position the light will come on. When moved to the 'DOOR' position the light will come on and go off with the opening and closing of the doors. In the 'OFF' position the light stays off all the time.

NOTE: On some models a time delay is installed in the interior (roof) light circuit. This relay allows the roof light to stay on for between 6 and 16 seconds after the last open door has been closed. The roof light must be in 'Door' position.

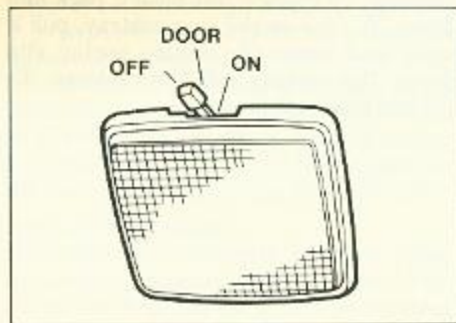

LUGGAGE COMPARTMENT (Boot) LIGHT

Station Wagon

The switch for this light has two positions. 'ON' and 'OFF'. When placed in the 'ON' position the light will come on and go off with the opening and closing of the lift-up rear door.

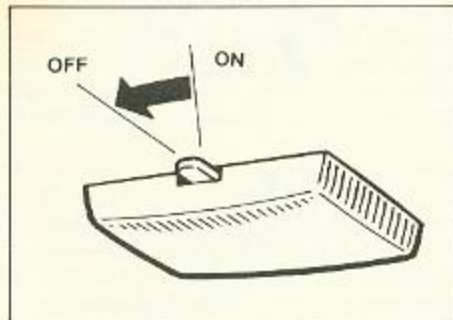

Sedan

This light has a boot lid hinge (R/H) operated switch. The light comes on when the lid is raised and goes out when it is closed.

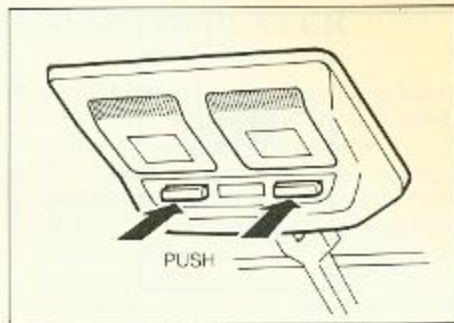

MAP LIGHTS (where fitted)

Two maplights are located just above the windscreen. To operate, press the silver button then repress to switch off.

COMFORT AND CONVENIENCE FEATURES

SUN VISOR

The sun visor may be pulled down to any angle from flat against the headlining to flat against windscreen. It can also be unclipped from its inner pivot and turned around to give shade from sunlight coming in through the side window.

ASSIST GRIPS AND COAT HOOKS

All models have an assist grip provided above each passenger door with the two rear ones having a moulded coat hook on the top side of the grip.

WINDOW CONTROLS

FOR MANUALLY OPERATED WINDOWS

Rotate the window control handle to raise or lower the window to the desired position.

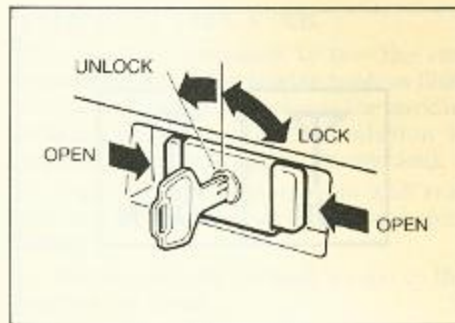

GLOVE BOX LOCK

To open, insert the key and turn anticlockwise. If not locked, press both sides of the catch together and lower the lid.

ELECTRICALLY OPERATED WINDOW CONTROLS (TI model only)

These are located on the drivers armrest.

Ignition must be "ON".

The P/W lock switch must be up to operate passenger windows. If the P/W lock switch is pressed down, passenger window controls are ineffective.

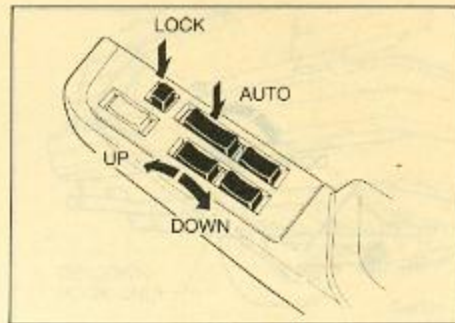

DRIVER'S WINDOW

This can be raised or lowered by the switch marked "AUTO". The window will move in the desired direction as long as the UP or DOWN side of the switch is lightly pressed. If the switch is heavily pressed, it will move further in the UP or DOWN direction and the window will continue to move even if the finger is taken off the switch.

COMFORT AND CONVENIENCE FEATURES

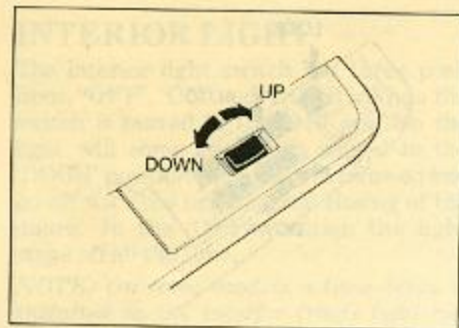

PASSENGER WINDOWS

These can be raised or lowered by switches in the drivers control set or by switches located on each passenger arm rest.

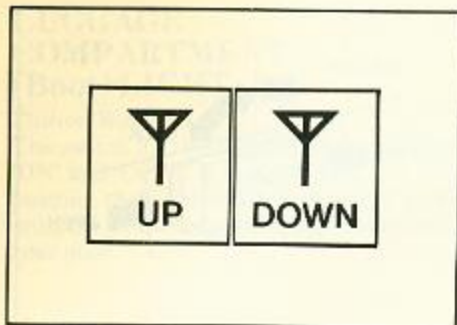

POWER ANTENNA

(where fitted)

The rear fender mounted antenna should be raised for optimum radio reception. Turn ignition switch to "ACC" or "ON". To raise or lower, press the appropriate switch UP or DOWN.

IN CASE OF EMERGENCY

HAZARD WARNING FLASHER

Use the hazard warning flasher to warn other road users that your car is disabled or parked under emergency conditions. Pull off the roadway if possible.

FREEING IMMOBILIZED CAR

In the case where the drive wheels have lost traction in sand, mud, snow, ice, etc., it may become necessary to 'rock' the car backwards and forwards to free it. To do this, straighten the front wheels, if possible, to reduce drag and engage first and reverse gear in quick succession, while simultaneously depressing the accelerator gently each time the clutch is engaged. (On automatic transmission models, move the shift lever from 'D' to 'R' position).

If the car is not freed by this procedure, anti skid materials should be placed under the spinning wheels or the car should be towed out.

Under conditions where one driving wheel is spinning and the other one is stationary **AVOID OVER-REVVING THE ENGINE**. Over-revving the engine under this condition could cause tyre and/or differential damage because the spinning wheel rotates at twice the normal driving speed.

TOWING THE CAR

If it becomes necessary to tow the car, connect a rope to the towing hook as illustrated. Before towing, release the parking brake and place the transmission in neutral ('N' for automatic transmission).

Be sure that the transmission and rear axle are in proper working order before towing.

To tow another car connect a rope to the rear towing hooks.

If a car with an automatic transmission is to be towed with its rear wheels on the ground, do not exceed 30 km/h or a greater distance than 10 km. If it has to be towed further or if the transmission is inoperative, tow with the rear wheels off the ground or remove the propeller shaft.

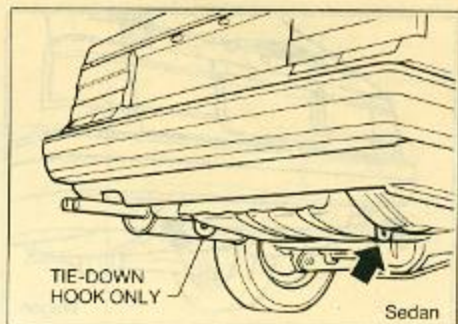
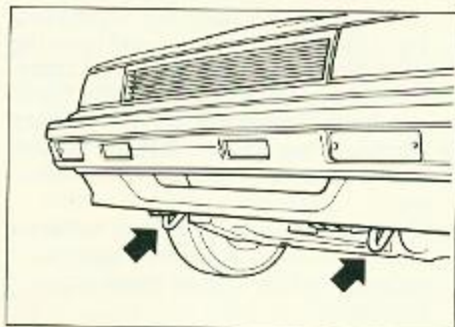

Notes:

- Tow rope should not be connected to any point other than those described in this section.
- Do not take up slack in the rope too quickly.
- Always pull the rope in a straight direction with respect to the hook. Do not apply a sideways force to the hook.
- Always observe Local or State regulations with regard to towing. Some States specify minimum length of tow rope, warning signs, licensing of towed vehicle driver, etc.

IN CASE OF EMERGENCY

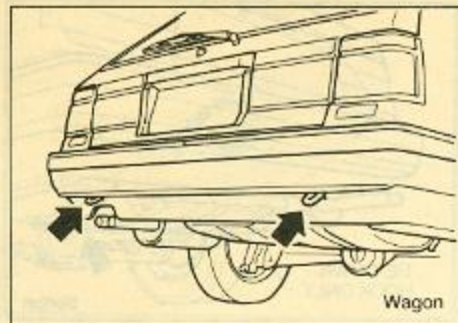

CAUTION: When the car is towed with the rear wheels raised, the steering wheel should be secured to maintain a straight ahead position. Do not lock steering by removing key from lock. Leave key in lock.

PUSH STARTING

No models should be pushed or pulled to start, since the catalytic converter may be damaged. Vehicles equipped with automatic transmissions cannot be started by pushing. Attempting to do so may damage the transmission or other components.

JUMP STARTING WITH BOOSTER BATTERY

Because the gases given off by the battery are explosive, sparks and naked flame should be kept away from it. Battery fluid is corrosive sulphuric acid solution which can cause severe burns to the skin, clothing or painted surfaces. If battery fluid should be splashed on the skin, etc., immediately flush the contaminated area with water.

The use of jumper leads and a booster battery to start an engine can be dangerous if not carried out correctly.

Always follow the instructions given below:

1. Ensure that the battery of the vehicle to be used for jump starting is 12 volt and negatively ground.
2. Position the two cars so that their batteries are as close together as possible. Pull the parking brake on and have the gear lever in neutral on manual transmissions or 'park' on automatic transmissions. Switch off all unnecessary electrical equipment (lights, heater, etc.) and ensure vehicles are not touching.
3. Remove vent caps from both batteries and place damp cloth over open filler holes to reduce risk of spark induced explosion.

NOTE: Maintenance free batteries do not have removable vent caps.

4. Run one jumper cable from the positive (+) terminal of the booster battery to the positive terminal of the discharged (flat) battery. Run the other cable from the negative (-) terminal of the booster battery to a suitable earth on the engine of the vehicle with the flat battery (such as engine sling).

CAUTION: To avoid personal injury and damage to the electrical system always connect jumper leads positive to positive; negative to negative, (red to red; black to black) (+ to +; - to engine earth).

5. Ensure the booster battery is in a fully charged condition. The engine in the vehicle being used for boost starting should NOT be running when attempting to start the engine with the flat battery.
6. Once the engine has been started, leave the jumper cables connected and allow the engine to run for a few minutes before carefully disconnecting the jumper cables in the reverse order of connection. Remove damp cloths and replace filler caps.

OPENING THE HOOD

To unlock, pull the hood lock handle located below the dash.

To open the hood, release the safety catch located on the grille under the centre edge of the hood and raise the hood.

To hold the hood open, unclip the stay and insert the end in the hole provided in the underside of the hood.

To close the hood, raise the hood slightly, remove the stay, clip it into its holder and lower the hood till it clicks over the safety catch. Push down firmly on reinforced edge of hood to engage main hood lock.

CAUTION: Pull up on edge of hood to ensure that it is locked down.

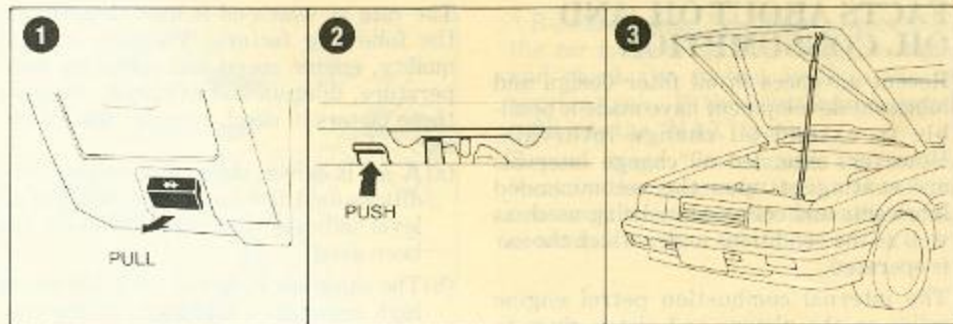

ENGINE OIL LEVEL

The engine oil should be maintained at the correct level. The best time to check it is before running the engine. This will allow oil that has been circulated through the engine to drain back into the crankcase.

To make an accurate oil level check:

- Park the car on a level surface.
- Remove the dipstick and wipe it clean.
- Reinsert the dipstick all the way into the tube for an accurate reading.
- Remove the dipstick and check the oil level. It should be between the 'H' (High) and 'L' (Low) marks.
- After taking the reading, replace the dipstick in its tube.

If the dipstick shows the oil level below the 'L' mark, add sufficient oil into the oil

filler located on the rocker cover to raise the level to the 'H' mark. Do not overfill.

Some oil addition may be required between oil changes or during the running-in period, depending on the severity of operating conditions.

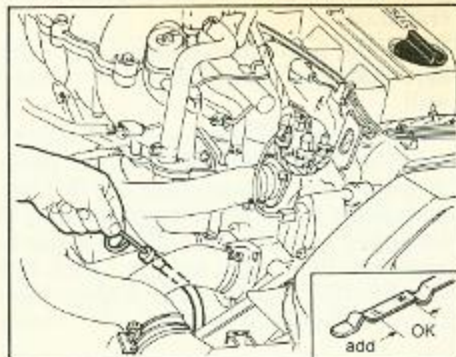

ROUTINE SERVICE

The following items should be checked daily:

- Engine oil level
- Engine coolant level
- Brake and clutch fluid level
- Windshield washer fluid level
- Battery fluid level
- Tyre inflation pressure

MAINTENANCE

FACTS ABOUT OIL AND OIL CONSUMPTION

Recent advances in oil filter design and lubricant development have made it possible to extend oil change intervals. However, extended oil change intervals are contingent upon the recommended lubricants and components being used, as well as the conditions under which the car is operated.

The internal combustion petrol engine relies on the pistons and piston rings to provide a moveable gas tight seal in the cylinder in order to transmit the power from the burned fuel to the crankshaft. To do this effectively, the pistons and rings have to be lubricated. This lubrication is provided by the oil circulating in the engine and thrown off as a spray in the crankcase.

When the piston moves down the cylinder, a thin film of oil is left on the cylinder wall.

When ignition occurs, some of this residual oil film is burned off as the piston descends on its power stroke. As this happens every power stroke (approximately 20 times per second at idle speed) it can be seen that some oil is used up. ALL ENGINES USE SOME OIL, if they didn't they would quickly wear out.

The rate at which oil is used depends on the following factors. Viscosity and oil quality, engine speed and operating temperature, dilution and oxidation. Bearing these factors in mind, consider the following:

- A car is driven under city driving conditions for 1,500 km. Daily checks of oil level indicate that little or no oil has been used.
- The same car is driven for 1,500 km at high speed on a highway. At the conclusion of the journey the oil level is checked and the engine found to have used a fair amount of oil.

The reason for the difference is that during city stop start motoring, a considerable amount of dilution takes place, so despite the fact that a normal amount of oil was used, the level did not alter.

In the second case, (b), because the engine was running at constant high speed and temperature the dilutants were 'boiled' off. Coupled with the normal oil usage, the impression would be gained that a comparatively large amount of oil had been used.

Owners should expect to use more oil with high speed operation.

New engines will generally use more oil than one that has been properly run in,

because it takes some running for the piston rings and cylinder wall to 'bed' in.

ENGINE COOLANT FORMULA

Use this formula as a minimum concentration of additive (L.L.C.). NISSAN L.L.C. (Long life coolant) — 30% by volume. Soft water — 70% by volume.

CHANGING ENGINE COOLANT

CHANGE ENGINE COOLANT EVERY 2 YEARS OR 40,000 Kms

DRAINING RADIATOR

Remove the radiator cap then open the drain cock underneath the radiator by turning anticlockwise until the coolant drains out.

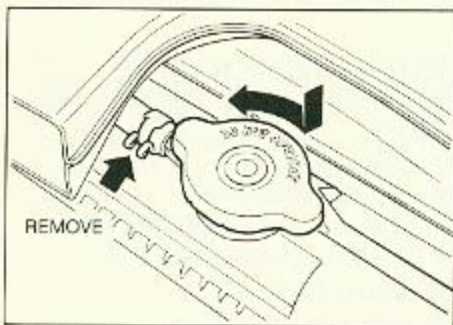

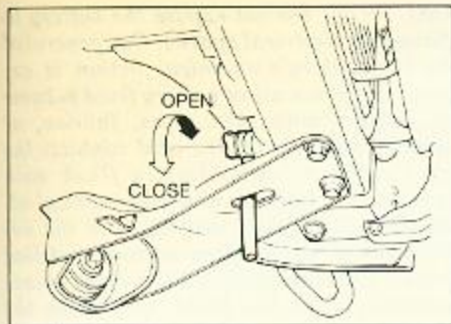

DRAINING RESERVOIR TANK

Disconnect hose from radiator cap to the reservoir tank by loosening the hose clip on the hose adjacent to the radiator cap. Lower the hose down until the coolant drains out of the reservoir tank. Securely reconnect the hose.

REFILLING

Securely tighten the drain cock under the radiator.

Set the temperature control lever on the instrument panel to "HOT".

Remove the air bleed screw to allow excess air to bleed out of the system.

Fill the radiator with coolant made to the above formula.

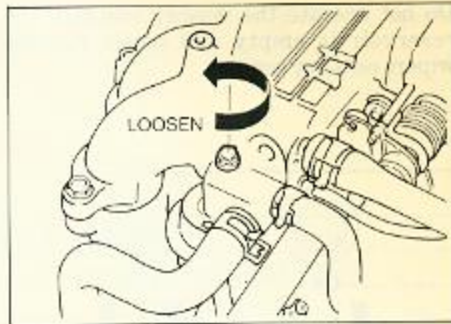

Fill the reservoir tank with coolant through the plastic screw top until the coolant is at the "MAX" mark and replace the plastic cap.

Replace the air bleed screw tightly.

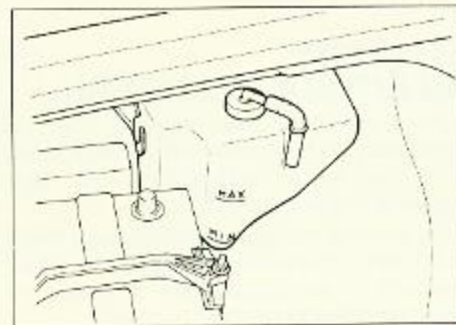

* Run the engine for a few minutes while the car is standing still. Stop the engine and check the coolant level in the reservoir tank. If the level has dropped, refill it to the "MAX" mark.

Repeat Stage * to recheck the coolant level in the reservoir tank and refill if necessary then screw on the radiator cap securely.

BRAKE AND CLUTCH FLUID LEVEL

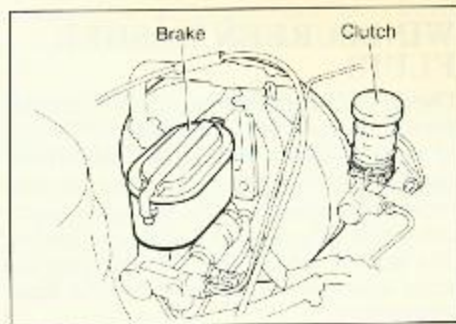

MAINTENANCE

Fluid level should be maintained at the level marked on each reservoir. If the fluid level falls considerably below this level, the brake system should be thoroughly checked by your authorised NISSAN Dealer.

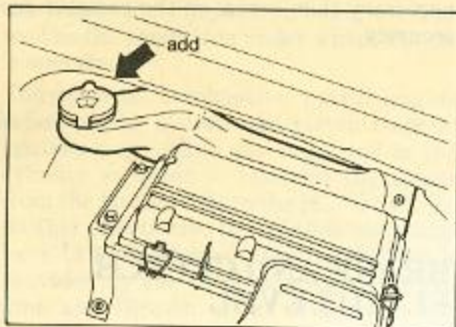

WINDSCREEN WASHER FLUID

Check the fluid level regularly in the reservoir and add fluid if necessary. The use of a good quality windscreen washer detergent additive is recommended for good wiper performance. The use of ordinary household detergent is not recommended. The station wagon rear window uses the same reservoir as is used for the front windscreen.

Do not operate the washer switch if the reservoir is empty and never operate wipers on a dry screen.

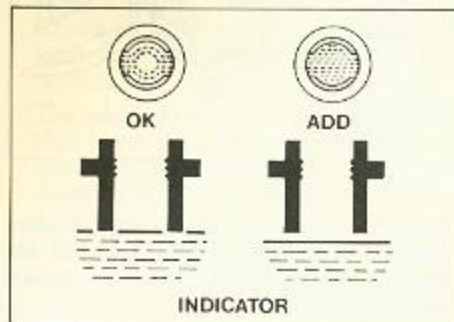

BATTERY ELECTROLYTE LEVEL

Check the fluid level in each filler. If necessary add only distilled water to bring the level to the indicator in each filler opening. Do not overfill.

The battery surface should be kept clean and dry. Periodically apply a small amount of petroleum jelly or grease to each terminal to prevent corrosion.

CAUTION: Do not expose the battery to flames or electrical sparks. Gas generated by the battery's chemical action is explosive. Do not allow battery fluid to come in contact with skin, eyes, fabrics, or painted surfaces. If the acid contacts the eyes or skin, immediately flush with water for 15 minutes and seek medical attention. If freezing weather, run the engine for a while after adding distilled water, to make sure that the water mixes properly with the fluid, otherwise the water may freeze and damage the battery. When using jumper leads follow procedure set out in section — 'Jump starting with booster battery'.

TYRE INFLATION PRESSURES

Check tyre inflation pressures frequently and maintain them at the pressures shown on the tyre placard affixed to the glove box lid of your car. Note that the specified pressures are COLD tyre pressures. Air pressure in tyres increases as the tyre heats up, such as would happen after a sustained highway journey. Incorrect tyre pressure can adversely affect tyre life, riding comfort and load carrying capacity.

OIL AND FUEL RECOMMENDATION

Your NISSAN is designed to operate using *unleaded* petrol with a minimum octane rating of 92 R.O.N.

WARNING: Use of *leaded fuel* in your NISSAN will damage the catalytic converter. It is an offence to put *leaded petrol* in the fuel tank of a NISSAN passenger vehicle produced after January 1st, 1986.

ENGINE OIL RECOMMENDATION

Use only the engine oil listed in the chart of recommended lubricants. Change engine oil at the intervals recommended in the 'Periodic Maintenance and Lubrication Schedule'. It should be noted that oil change intervals longer than those listed in the schedule will seriously affect engine life.

More frequent oil changes are recommended if the engine is operated under the following conditions:

- Short distance driving at cold outside temperatures.
- Driving in dusty conditions.
- Driving for long distances.
- Towing trailers.

TYRE REFERENCE TABLE

Rim Profile	Tyre Size	Recommended Cold Tyre	
		Inflation Pressures	
		(Fully Laden or High Speed)	
		FRONT	REAR
5½ JJ × 14	195/70 HR14	200 kpa (230 kpa)	200 kpa (230 kpa)
6 JJ × 15	205/60 HR 15	200 kpa (230 kpa)	200 kpa (230 kpa)
The tyres fitted to this vehicle shall have a max. load rating not less than 530 kg or a load index of 86 and a speed category not less than 'H'.			
MODEL R31	NISSAN MOTOR Co. (AUST.) Pty. Ltd.	99090 J7000	

MAINTENANCE

RECOMMENDED ENGINE OIL VISCOSITY

The proper oil viscosity for your engine should be determined by the average outside temperature to assure good starting of a hot or cold engine.

Select the proper oil viscosity from the following chart.

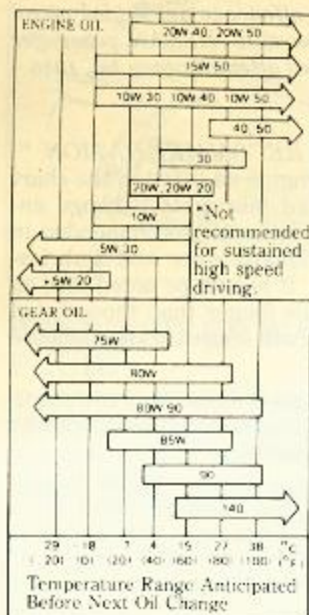

RECOMMENDED LUBRICANTS

Item	Specification	Remarks
Engine Oil	SAE Classification SF (MIL-L-2104B)	Refer to Recommended SAE Viscosity Chart
Gear Oil	Transmission	API GL4 (MIL-L-2105)
	Manual Steering	CASTROL EPLI Grease
	Power Steering	DEXRON II®
	Differential	API GL5 (MIL-L-2105 C) (SAE 80W-90)
Automatic T/M	DEXRON II®	
Multi Purpose Grease	NLGI Grease No. 2	Lithium Base Soap

Brake and Clutch Fluid

Use only NISSAN FLUID 46050-J8000 Available as P/No. 46050-J8025A (500ml)

Anti-freeze

NISSAN L.L.C.

Long Life Coolant

BRAKES

Brake Pads

Use only NISSAN GENUINE BRAKE PADS

Hand Brake

WARNING : ENSURE HAND BRAKE IS FULLY RELEASED BEFORE DRIVING OFF.

REGULAR CHECKS

The following items should be checked on a regular and frequent basis. If any deficiency is found regarding the need for repair or replacement, it should be brought to the attention of your authorised Dealer.

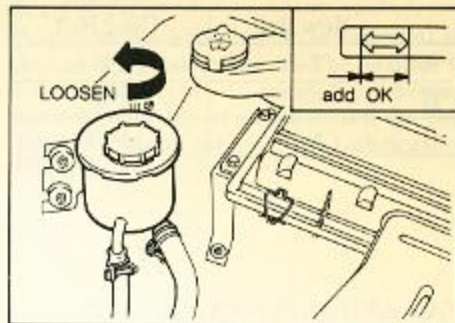

HOOD LOCK

Check the hood to see if it is closed and locked properly. Lubricate the hood lock periodically.

Wipe off surface dirt from all functioning parts and smear a little grease on them. Ensure that the lock and release mechanisms work smoothly by operating several times.

POWER STEERING FLUID LEVEL

Check the fluid level in reservoir by observing the dipstick when the fluid is cold. Add fluid as necessary to bring the level into proper range on dipstick.

AUTOMATIC TRANSMISSION FLUID

Check the fluid level at the intervals recommended in the 'Periodic Maintenance and Lubrication Schedule'.

To make an accurate fluid level check proceed as follows:—

1. Drive the car for approximately 8 km to bring the transmission up to its normal operating temperature (50°C to 80°C approximately).
2. Park the car on a level surface and apply the parking brake.
3. Place select lever in 'P' (Park) position and leave engine running.
4. Remove transmission dipstick and wipe it clean.

5. Reinsert dipstick all the way into the filling pipe.
6. Remove the dipstick immediately and note the reading.

If the fluid level is at or below the (L) mark, add enough fluid to raise the level to the (F) mark. (The difference between L and F is approximately ½ litre). **Do not overfill.** See recommended lubricants for fluid.

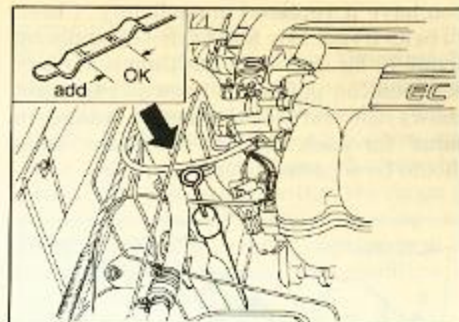

MAINTENANCE

DRIVE BELTS ENGINE COOLING SYSTEM AIR CLEANER ELEMENT OIL FILTER

DRIVE BELTS

Your vehicle may be equipped with air conditioning or power steering (depending on the model). Inspect all drive belts for wear, fraying or cracking at recommended intervals. If any belt is in poor condition have it replaced immediately. Check all belts frequently for tension by applying about 10 kg load with the thumb midway between the pulleys as shown. The chart shows the correct deflection range in 'mms' for each belt. If necessary, belts should be adjusted to correct range.

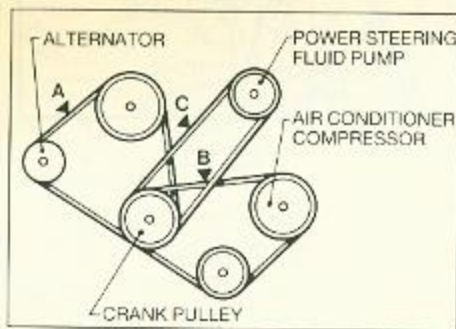

	New Belt	Used Belt
A	3-4	4-6
B	6-8	7-9
C	8-10	9-11

FAN AND ALTERNATOR BELT

1. Loosen the upper and lower alternator securing bolts until the alternator can be moved slightly.
2. Move the alternator with a prying bar until the belt tension is within the specified range. Then tighten the bolts securely.

AIR CONDITIONER AND POWER STEERING BELTS

1. Loosen the idler pulley lock nut ① or power steering pump mounting and lock bolts ① of the belt being adjusted.
2. Adjust the adjusting bolt or nut ② until the belt tension is within the specified range.
3. Tighten the idler pulley lock nut ① or power steering pump mounting and lock bolts ① securely.

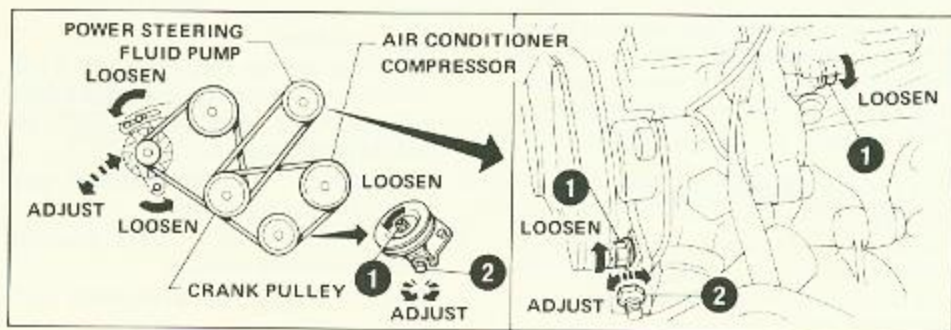

ENGINE COOLING SYSTEM

The cooling system has been filled at the factory with a solution of NISSAN long life coolant and water.

It is necessary to replace the coolant periodically as recommended in the 'Periodic Maintenance and Lubrication Schedule' section.

AIR CLEANER ELEMENT

The coated paper element cannot be cleaned. Change the element periodically as recommended in the 'Periodic Maintenance and Lubricant Schedule'. Operation under dusty conditions may require more frequent element changes.

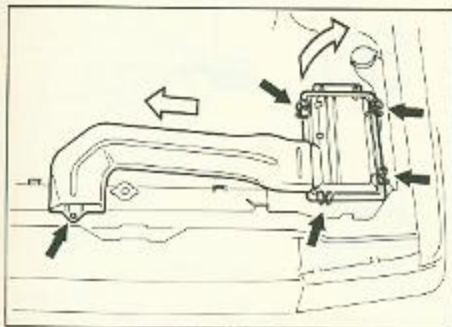

OIL FILTER

Proper oil filtration is just as essential as the use of a good engine oil. The oil filter is a cartridge type. It must be renewed periodically as recommended in the 'Periodic Maintenance and Lubrication Schedule'.

SPARK PLUGS

The plugs should be checked periodically as recommended in the 'Periodic Maintenance and Lubricant Schedule'. Remove spark plugs and inspect for deposits and the degree of erosion on the electrodes.

After cleaning, carefully adjust the spark gap. The gap should be 1.1 mm (0.043 in.).

CAUTION: This engine is equipped with a high energy ignition system. Do not handle any ignition components while the engine is running or ignition is switched on. Do not open circuit spark plug leads to test spark. Use test plug with approximate air gap setting of 5 to 6 mm, or a power timing light with inductive pick-up.

WINDSHIELD WIPER BLADES AND WASHERS

Check the wiper blades for operation and cleanliness. If the wiper blades do not wipe the windshield clean after the blades and windshield have been wiped with a cloth, renew the blades.

To adjust the washer spray, bend the nozzles so that the water stream is aimed towards the centre of each wiper sweep.

STEERING WHEEL

With the steering wheel in the straight ahead position, measure the amount of steering wheel play. With the front wheels in the straight ahead position and while watching them, turn the steering wheel from side to side within the range of movement allowed without moving the front wheels. The amount of movement of the steering wheel under this condition, is the steering wheel play.

If the play exceeds 6 mm have the steering rectified by your authorised NISSAN Dealer.

MAINTENANCE

BRAKE PEDAL

When the brake pedal is fully depressed, the distance between the upper surface of the pedal pad and the floor board should be 75 mm or more.

If this minimum distance is reduced, have the brakes inspected by your authorised NISSAN Dealer.

If the distance should abruptly be shortened, there is something wrong with the brake system. Stop driving the car immediately and have the fault rectified.

CLUTCH PEDAL (when fitted)

The clutch pedal should not encounter resistance during the first 2 mm to 5 mm of its stroke. Resistance should then be felt by the foot riding on the clutch pedal. If the pedal stroke is out of adjustment, have the clutch adjusted by your authorised NISSAN Dealer.

PARKING BRAKE

From the completely released position, apply the parking brake slowly and firmly, counting the clicks as the pawl moves over the ratchet. If the number of clicks is 7 to 9, the parking brake is in good condition. If the number of clicks is

other than this, have the parking brake adjusted by your authorised NISSAN Dealer.

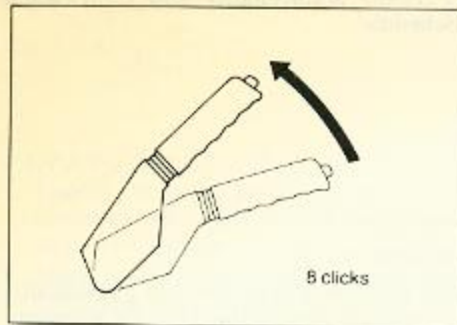

FUSES

The fuse box is located under the right side of the instrument panel. The fuses are the blade type with their value marked on the plastic portion. If a fuse has to be replaced, use one of the correct value as indicated on the fuse box cover and only after ascertaining the cause of the fuse blowing.

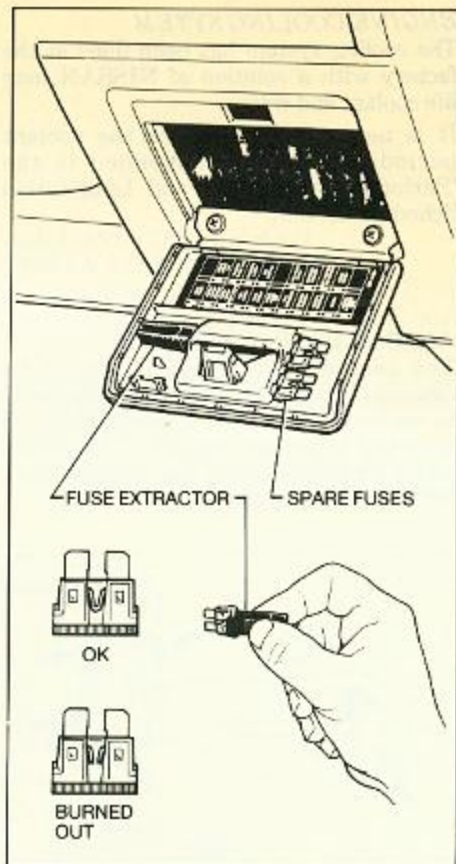

BULB SPECIFICATIONS

LIGHT	WATTAGE
Headlight Q/H	60/55
Headlamp Inner	55
Composite Beam	55
Parking Light	5
Turn Signal Light	21
Stop/Tail Light	21/5
Back-Up Light	21
Number Plate Light	5
Interior Light	10
Maplight	10
Boot Light	3.4
Luggage Compartment Light (Station Wagon)	10
Glove Box Light	3.4
Step Light Where fitted	3
Footwell Light	3.4
Cigarette Lighter Light	2.2
Ash Tray Light	1.2
Instrument Illumination and Indicator Lights	3.4 & 1.2

BULB REPLACEMENT

The replacement of each bulb is carried out as follows.

Before replacing a bulb, first make sure that the bulb to be replaced is in fact faulty, and it is not some other part of the circuit that is at fault.

If you are in any doubt, consult your authorised NISSAN Dealer.

Before commencing bulb replacement, disconnect the battery earth cable (-, black).

HEADLIGHT

MAIN GLOBE

Unplug harness connection from rear of globe. Remove rubber cap and unclip wire globe retainer. Pull out globe retainer assembly, fit new globe assembly and refit in reverse order of removal.

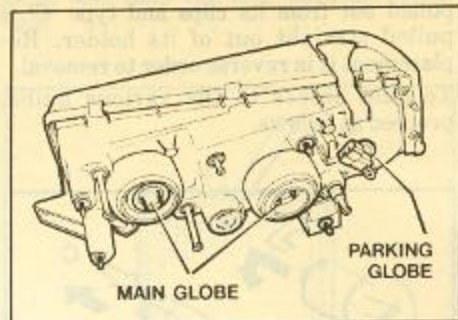

PARKING GLOBE

Twist the globe retainer anticlockwise to free the globe. Pull the globe out, fit a new globe then refit in reverse order of assembly.

NOTE: Do not touch the glass surface of the halogen bulb with bare hands or dirty gloves.

When installing the rubber cap, make sure that it is secure.

When aiming adjustment is required, see your authorised NISSAN Dealer.

MAINTENANCE

OTHER LIGHTS

All other lights have incandescent bulbs of type A, B or C. To remove them from their holders, type 'A' is gently pressed in and turned anti-clockwise, type 'B' is pulled out from its clips and type 'C' is pulled straight out of its holder. Replacement is in reverse order to removal. To gain access to the various bulbs, proceed as follows.

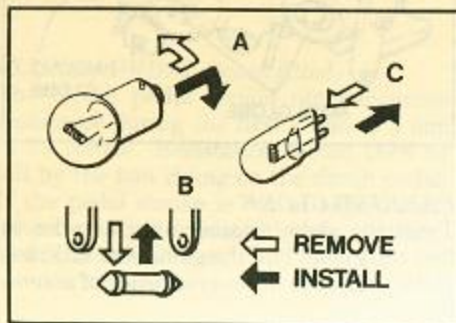

SIDE REPEATER LIGHTS

These work in conjunction with the front turn signal lights. Undo the Phillips head screws, remove the light and proceed as stated for wagon combination light. Refix using Phillips screws.

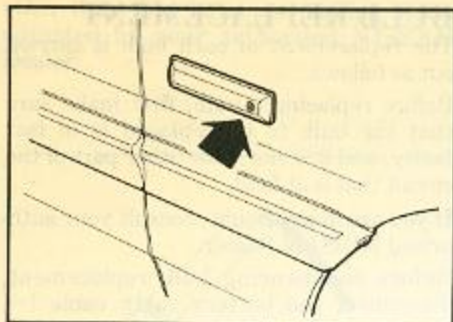

REAR COMBINATION LIGHT (Sedan)

The rear indicator, stop/tail and back-up lights are mounted in this unit. Open the boot, remove the carpet trim, grip the bulb holder, and twist in an anti-clockwise direction as viewed to remove the holder. Change the bulb and replace holder in reverse order to removal.

FRONT TURN SIGNAL LIGHT

Remove the two screws indicated by arrows. Remove light, withdraw bulb, fit replacement bulb and refit light. Tighten screws ensuring lens is secure.

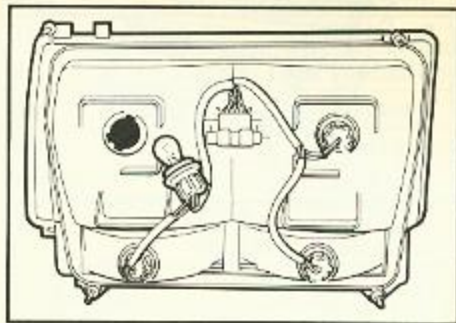
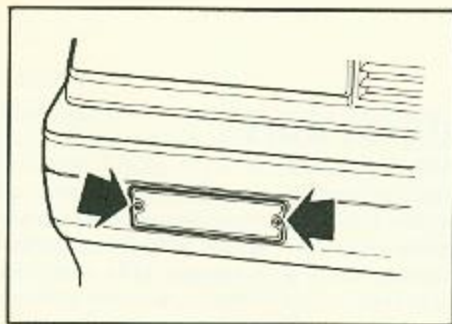

REAR COMBINATION LIGHT

(Station Wagon)

Remove the plastic cover inside the vehicle behind the lamp. Change the globe by turning the globe socket anticlockwise. Replace the globe then replace the socket by screwing clockwise.

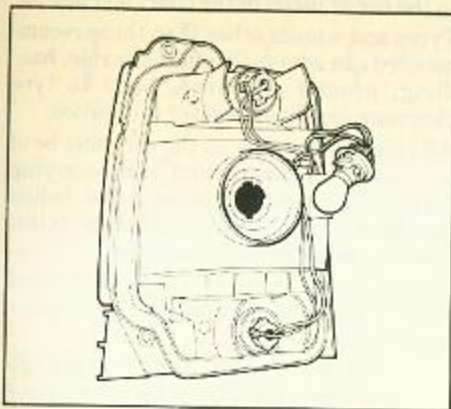

REAR LICENCE PLATE LIGHT

(Station Wagon)

This should be fitted by your NISSAN distributor.

MAP LIGHT

Globe replacement should be done by your NISSAN distributor.

REAR LICENCE PLATE LIGHT

(Sedan)

Open the boot then pull out the black harness connector. Unscrew the enclosed lamp assembly anticlockwise. Pull out the white section which contains the globe then pull the globe out. Reassemble in the reverse order and refit the complete assembly by screwing in clockwise.

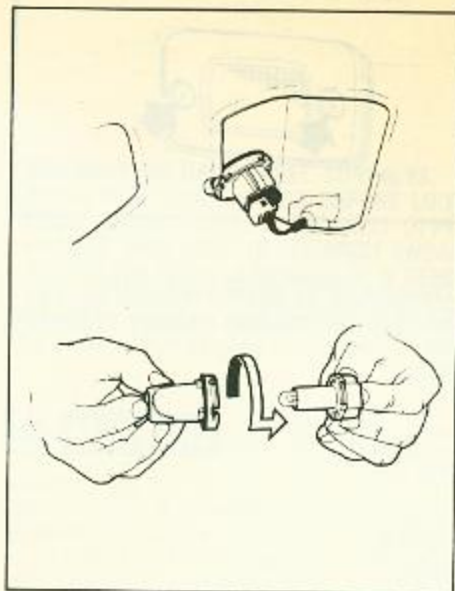

INTERIOR LIGHT

Remove the lens by inserting a flat screwdriver blade between the lens and the switch backing plate. Twist the screwdriver to remove the lens. Change the globe and snap the lens back on to the light.

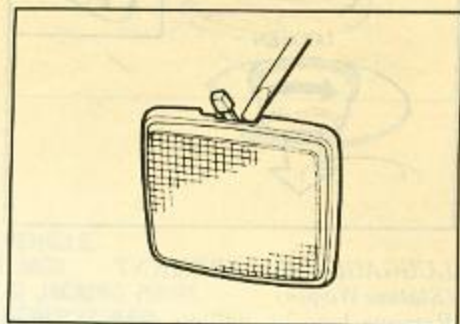

INSTRUMENT PANEL LIGHTS AND ASH TRAY LIGHT

Access to these lights in most cases can only be gained by removing the instrument cluster. Consult your authorised NISSAN Dealer.

GLOVE BOX LIGHT

This should be refitted by your NISSAN distributor.

MAINTENANCE

BOOT LIGHT (Sedan)

Twist light cover off by turning anti-clockwise viewed from underneath. Change bulb and replace cover in reverse order to removal.

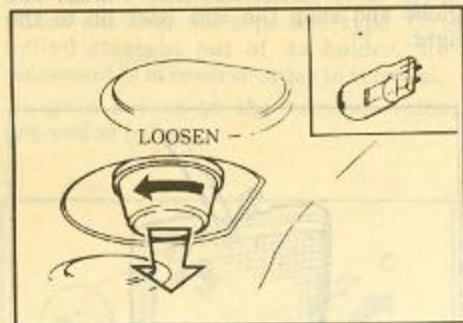

LUGGAGE COMPARTMENT

(Station Wagon)

Remove lens by pulling down. Change bulb and snap lens back into position.

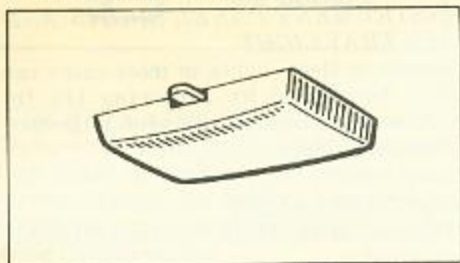

STEP LIGHT

Remove the two screws indicated by ♦. Lift off the lens, change the bulb and refit lens and screws ensuring that lens is properly seated.

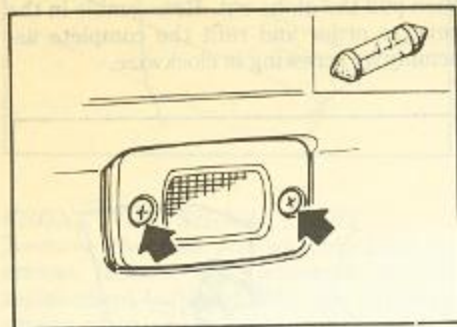

CIGARETTE LIGHTER LIGHT

Reach up behind dash and unclip light holder. Change bulb and clip holder back into place.

WHEEL AND TYRE

TYRE CARE

Tyres have tread wear indicators in the tread. When the indicators appear, the tyre should be replaced. When replacing tyres or wheels, use the tyre size and type recommended on the tyre placard affixed to the car or listed in the chart on Page 95.

Tyres and wheels other than those recommended can adversely affect the ride, handling, ground clearance, body to tyre clearance and speedometer calibration.

All tyres and wheels on the car must be of the same size, type and load carrying capacity. For safety reasons radial, belted and bias, or conventional belted tyres, must not be mixed.

If snow tyres are to be fitted, they must be of a size and type equal to the other tyres on the car.

TYRE ROTATION

The following tyre rotation system is recommended.

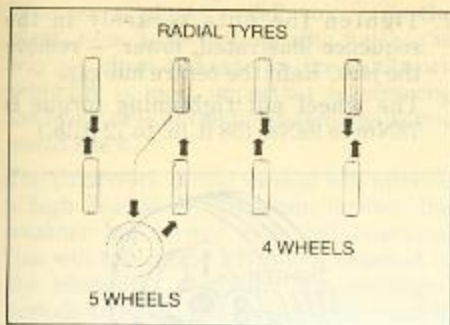

SPARE WHEEL, TYRE AND JACK STORAGE

SEDAN

The spare wheel is stored in the boot and fastened by a strap. The jack and handle are stored under the carpet in the well in the left hand side of the boot. To lift out the jack, turn the bracket that fits over the end of the handle anticlockwise. This allows the jack to loosen under the two chocks.

WAGON

The spare wheel is located under the floor mat and is fastened by a clamp plate and screw. Undo the screw to remove the wheel. The jack and handle are located inside a flap in the left hand side of the luggage compartment panel. Lift the flap clip and the flap will lower. To remove the jack, use method stated for sedan.

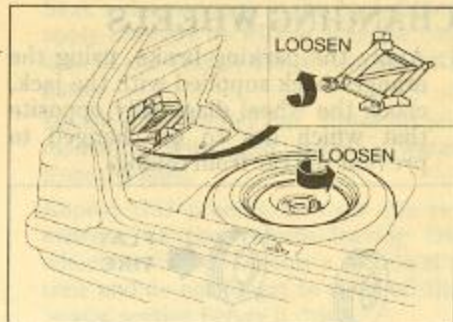

- USE ONLY ON HARD LEVEL SURFACES.
- APPLY PARK BRAKE FULLY BEFORE LIFTING VEHICLE.
- FULLY CHOCK WHEEL DIAGONALLY OPPOSITE JACK.
- ENSURE JACK HEAD IS SECURELY ENGAGED AT JACKING POINT.
- NO PERSON SHOULD REMAIN IN A VEHICLE BEING JACKED.
- ENSURE SCREW THREAD IS ADEQUATELY LUBRICATED BEFORE USE.
- CONSULT VEHICLE OWNERS MANUAL BEFORE USING JACK.



NISSAN

PART No. 99550-J7000 FOR
SKYLINE & PINTARA SEDAN
AND WAGON

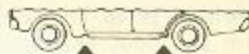

WARNING: DO NOT GET
BODILY UNDER A VEHICLE
SUPPORTED ONLY BY A JACK.
USE VEHICLE SUPPORT STANDS
SAFE WORKING LOAD 900kg



MAINTENANCE

CHANGING WHEELS

1. Apply the parking brake, using the orange chock supplied with the jack, chock the wheel diagonally opposite that which has to be changed to prevent the car from rolling.

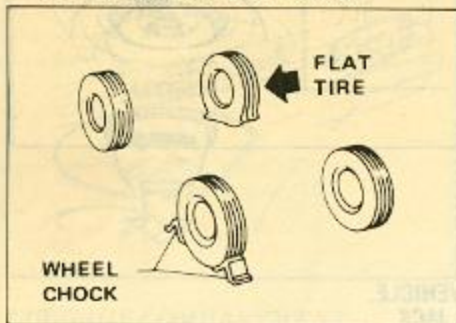

2. Place the jack under the jack up point nearest to the wheel being removed, but do not jack wheel clear of ground yet.
3. Using the wheel wrench, remove the hub centre cap.

If the spare wheel is to be used, remove it from the boot and place ready for fitting. Slacken off the wheel nuts one or two turns each by turning them in an anti-clockwise direction.

NOTE: Do not remove the wheelnuts till the wheel is clear off the ground.

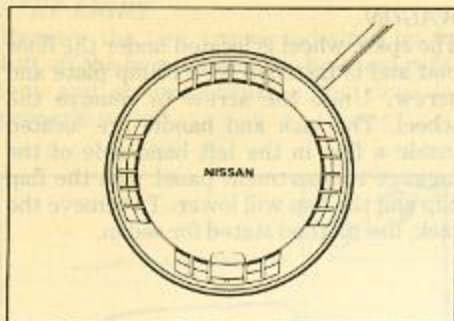

4. Raise the jack till the wheel is clear of the ground. Unscrew the wheel nuts the rest of the way and remove the wheel.

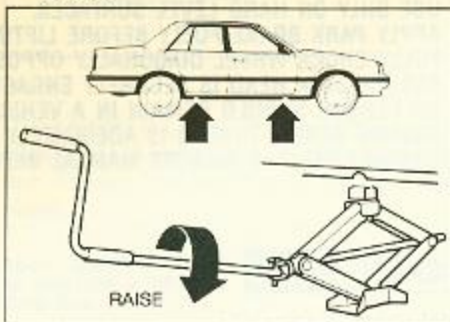

5. Place the replacement wheel on the hub and start the nuts. (Bevelled end inwards). Tighten the nuts alternately and evenly by turning them clockwise.

6. When the bevel of the nut is full against the wheel bevel and the nut can be tightened no further without the wheel turning, lower the jack till the wheel touches the ground.

7. Tighten the nuts securely in the sequence illustrated, lower — remove the jack. Refit the centre hub cap.

The wheel nut tightening torque is 78Nm to 98Nm (58 ft.lb. to 72 ft.lb.)

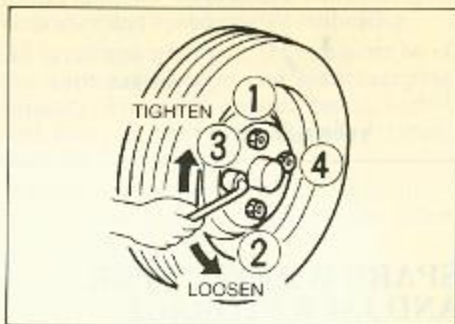

CAUTION: Never get under a car while it is supported only by a jack. Always use safety stands to support the weight when you have to get beneath the car.

8. Remove the wheel chock, replace the jack, tools and replace wheel in the boot or carrier.

Your new vehicle's paintwork finish is the result of the latest technology in protective and decorative surface coatings combined with the best equipment and techniques employed to apply them.

Whether a glossy 'solid' colour or the 'clear' over 'basecoat' metallic finish, the way you clean and care for the paintwork generally is most important in ensuring the brightness of the finish remains as you would like it.

The paintwork of the vehicle will provide a high degree of protection against the weather, but normal wear and deterioration will take place when it is exposed to the elements, especially for prolonged periods of time. You should endeavour to protect or garage your vehicle whenever possible.

SUBSTANCES POTENTIALLY HARMFUL TO AUTOMOBILE PAINTWORK

- (a) Road 'bloom' — a whitening or dulling effect of prolonged build up of exhaust pipe emissions, oils, dirt and other airborne pollutants combined with the normal weathering of paint.
- (b) Tree saps, bird droppings, salt water spray and other 'natural' environmental hazards seen as deposits that when removed too late can leave an etching or 'scar' as outlined by the shape of the dropping on the paintwork.
- (c) Tar spray, and industrial type fallout which can be of many potentially harmful types, may 'pit' the paint by chemically burning or bonding. In some cases it may cause spotting by discolouring or etching into the paint film.

NORMAL CLEANING

WARNING: WASHING — Ensure that the vehicle is cool and **do not** wash paintwork while the car is exposed to strong, hot direct sunlight.

With cold running water and starting from the roof, hose the vehicle all over from top to bottom. Do not use sponge or cloth at this stage. This will remove grit and other loosely adhering substances which could otherwise scratch the paint in the operations to follow.

To a normal household bucket filled with lukewarm water, add **no more** than two capfuls (approx. 15 ml) of an automotive type liquid detergent.

Soak a clean sponge in the bucket then apply liberally by wiping over the roof area of the vehicle and all the exterior glass.

Do not allow to dry out. Rinse off immediately with cold running water from the hose.

Repeat this process all over the remainder of the vehicle leaving the wheels until last. Do only a section at a time and do not forget to rinse off the 'soapy' section before it dries.

After a final cold water rinse all over, the vehicle should be dried with a good quality chamois leather, paying particular attention to all glass and chromed trim.

POLISHING/STAIN REMOVAL

Your original glossy baked enamel paintwork would not normally require a polish to improve its shine but depending on the degree of exposure the use of a good quality polish may assist in the protection against those elements potentially harmful to automotive paintwork described earlier.

As an example, the use of DUCO* CLEANER and POLISH or equivalent every six months or so will minimise the affect of road bloom described earlier and may aid in the removal of some other 'natural' contaminants.

It is most important that any 'Fall Out', including tree saps and bird droppings, be removed from the paintwork at the earliest opportunity. Prolonged contact may lead to permanent marring. For all types of stain removal FIRST use a warm water/detergent mixture as for washing, and rinse off with clean, running water. Repeat if necessary and dry. Many 'natural' types of fall out are water soluble and will be removed with this simple method.

Tar and other bituminous type stains may be removed with cleaners designed specifically for this purpose, or use kerosine or white spirit. Use carefully and strictly as directed. If any softening of the paintwork occurs stop immediately.

The consistent use of rubbing type compounds should be avoided as their purpose is to remove marring and embedded soil from paintwork and to this end will

also remove a fair degree of the paint surface. It is recommended that rubbing compounds such as DULUX* Burnishing Cream be used only when the paint surface has lost its smoothness from an accumulation of grit and other soil which cannot be removed by the polish alone.

In this case use DULUX Burnishing Cream followed by the DUCO CLEANER and POLISH or equivalent. Use both as directed on the label.

INTERIOR TRIM

Wipe interior trim clean with a clean damp or wet cloth or use a recommended cleaner or mild soap solution then dry with a soft cloth.

CAUTION: Make sure the cleaner selected is not harmful to the material.

CLOTH UPHOLSTERY AND CARPET

Clean with a vacuum cleaner or clothes brush.

Stains should be removed with a mild soap solution or a spot remover. (Test on an inconspicuous part of the trim to check for colour change).

Wipe with a damp clean cloth from outside of stain toward centre.

WHEELS AND UNDERBODY

When a vehicle has been used under conditions exposing it to excessive mud and/or corrosive materials such as boat launching, driving along beaches or on tracks through fertilized paddocks, etc. — it must be thoroughly flushed with fresh water to remove any deposited mud or corrosive material.

* Registered Trademark of Dulux Australia Ltd.

VACUUM CLEANING

Frequent light vacuum cleaning, particularly in areas of heavy use, will help to preserve the appearance of the material by reducing the possibility of dirt being ground in.

STAIN REMOVAL

With most stains, speed is essential. The majority of stains will vanish if treated immediately.

It is a good idea to keep the necessary materials for stain removal in one place. A suitable cleaning kit would include such items as: An approved non-alkaline wool detergent, white vinegar, household dry cleaning fluids, including methylated spirits, a small piece of sponge, clean absorbent cloths and paper towelling or white tissues.

Procedure for removing stains

1. Firstly, remove the source of the stain using one of the following methods.
2. (a) Blot up liquids by applying pressure with paper towels, tissues or dry absorbent cloths.
- (b) Scoop up solids with a knife or spoon.

(c) Brush burn or scorch marks from the surface.

Take a small piece of sponge or clean cloth and apply the first treatment from the STAIN REMOVAL CHART using a small amount of the cleaning agent at a time. With a blotting or dabbing motion, work inwards from the edge of the stain to prevent it from spreading.

Do not overwet: excessive soaking may cause rings to form on the surface, spreading the stain even further.

Do not rub; rubbing will tend to spread the stain over a larger area.

3. If the cleaning agent has removed the stain, carry out steps 5 to 7.
4. If the stain is still apparent after the first treatment, remove excess moisture from the treated area by applying pressure with paper towels, tissues, or absorbent cloths. From the additional treatments on the treatment chart select and apply the next treatment following steps 2 and 3.

Continue with recommended treatments, blotting up moisture between each new cleaning agent until stain is removed.

5. Once the cleaning agent has removed the stain, blot up excess moisture from treated area by applying pressure with paper towels, tissues or dry absorbent cloths.
6. Rinse by applying clear tepid water using a small piece of sponge or clean cloth, again working inwards from the edge of the affected area. DO NOT RUB.
7. Remove excess moisture as outlined in step 5.

UPHOLSTERY CLEANING AGENT CHART

TREATMENT CLEANING AGENT AND INSTRUCTIONS

1. Solution of one teaspoon of approved wool detergent (e.g. "Softly") and one litre of warm water.
 2. Dry cleaning fluid or lighter fuel. CAUTION: Use only in a well ventilated area and keep naked flame and lighted cigarettes away. **Do not use near vinyl parts.**
 3. Methylated spirits. CAUTION: As for 2 above.
 4. Hydrogen peroxide (20VOL). Dilute 10 to 1 with cold water. CAUTION: Do not use on dark or patterned fabric.
 5. Dye stripper. Dilute 50 to 1 with cold water. CAUTION: As for 4 above.
 6. Chewing gum remover (Freezing agent).
 7. Nail polish remover. CAUTION: Do not use near vinyl parts.
 8. Clean, warm, (NOT HOT) water.
 9. Cold water.
 10. Weak solution of white vinegar or lemon juice with cold water.
 11. Absorbent powder (e.g. salt or talc) sprinkle on spillage, leave overnight and vacuum off.
-

UPHOLSTERY STAIN REMOVAL CHART

CAUTION: Before attempting to treat stain, pre-test treatments on an inconspicuous part of the seat to check for colour change.

TYPE OF STAIN	Order of Treatment			TYPE OF STAIN	Order of Treatment		
	1st	2nd	3rd		1st	2nd	3rd
Beer	1	—	—	Ink — Ballpoint	4	1	—
Beetroot	1	—	—	Ink — Fountain Pen	8	1	—
Bleach	1	—	—	Lipstick	2	1	—
Blood	9	5	—	Metal Polish	2	1	—
Burn or Scorch Mark	4	—	—	Mildew	1	4	—
Butter	2	1	—	Milk	8	2	1
Chewing Gum	6	—	—	Mustard	1	—	—
Chocolate	1	—	—	Nail Polish	7	2	—
Cocoa	2	2	—	Oil	2	1	—
Coffee (Black or White)	2	9	1	Paint — Emulsion	2	9	1
Cooking Oils	2	9	1	Paint — Oil Base	2	1	—
Crayon	2	1	—	Rust	2	1	10
Cream	2	1	—	Salad Dressing	2	1	—
Excrement	1	—	—	Shoe Polish	2	1	—
Fruit Juice	8	—	—	Soft Drinks	8	1	4
Grass	3	1	—	Tar	2	1	—
Gravy	8	—	—	Tea (Black or White)	2	9	1
Grease	2	—	—	Urine	1	—	—
Ice Cream	1	1	—	Vomit	1	—	—
				Wine — Red	11	8	5
				Wine — White	1	—	—

MAINTENANCE

EMISSION CONTROL SYSTEMS

The control of automotive air pollution largely depends upon the development of effective emission control systems. To meet this demand, NISSAN has been making consistent and continuous efforts towards the further development of such devices.

Your NISSAN is equipped with emission control devices which are designed and built to provide emission performance levels required by Australian Design Rules. In some States owners may be subject to penalties for any modifications made to the emission control systems after delivery.

MAINTENANCE RECOMMENDATION

Please make your contribution to clean air in our environment by operating the car within the prescribed passenger and load limits and by maintaining the emission control system in accordance with our recommendations.

To maintain the original quality built into the emission control system we recommend that the system be maintained by your NISSAN Dealer who uses only Genuine NISSAN Replacement Parts. The

use of other parts which may be inferior to Genuine NISSAN Parts could lead to a reduction in the effect of the system.

EMISSION CONTROL SYSTEM

All new NISSANs are equipped with an emission control system which satisfies all applicable regulations.

With this emission control system built into NISSAN, the discharge of pollutants has been reduced substantially.

These pollutants are primarily hydrocarbons, nitrogen oxides and carbon monoxide.

Hydrocarbons and nitrogen oxides when exposed to sunlight under certain conditions produce photochemical smog.

Carbon monoxide is toxic when highly concentrated in the air.

The emission control system consists of (1) crankcase emission control system, (2) exhaust emission control system, and (3) evaporative emission control system.

CRANKCASE EMISSION CONTROL SYSTEM

This system serves to prevent the emission of blow-by gases into the atmosphere.

The function of this system depends upon the Positive Crankcase Ventilation

(P.C.V.) control valve which returns blow-by gases to the combustion chamber.

EXHAUST EMISSION CONTROL SYSTEM

Electronic Fuel Injection System

The electronic fuel injection monitors the operating conditions of the engine through various types of sensors. The electrical signals transmitted from the sensors enter the control unit where the correct injection open-valve time period is computed on the basis of preset conditions for optimum fuel injection.

This system permits operation of the car with lean air-fuel mixture, and improves exhaust performance and fuel economy.

Evaporative Emission Control System

The evaporative emission control system is used to reduce hydrocarbons emitted to the atmosphere from the fuel system. This reduction of hydrocarbons is accomplished by activated charcoals in the carbon canister.

This system is made up of the following:

1. Fuel check valve
2. Vapour vent line
3. Carbon Canister
4. Vacuum signal line
5. Canister purge line

MAINTENANCE

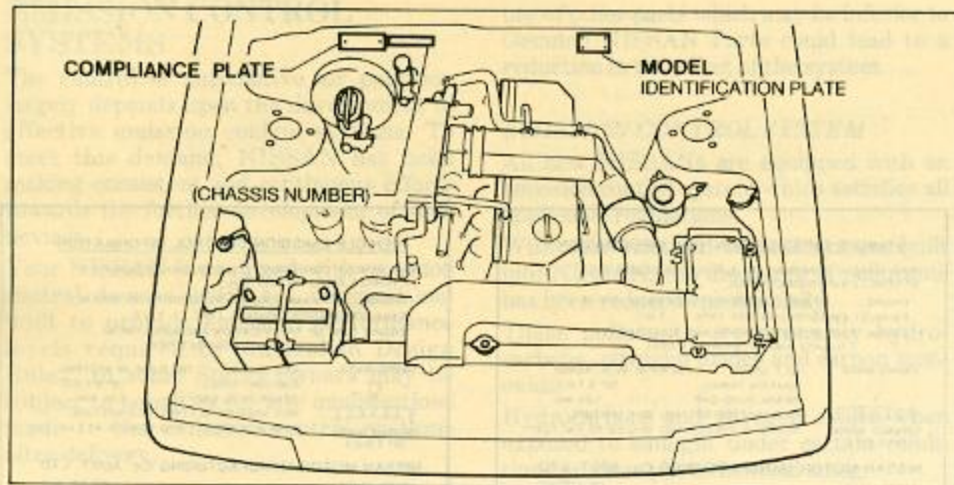

MODEL IDENTIFICATION PLATE

This is located on the left of the dash panel inside the engine compartment. The plate shows the vehicle model code, body number, serial number, engine number and built date.

COMPLIANCE PLATE

This is located on the right of the dash panel inside the engine compartment. The plate shows the manufacturers name, vehicle model, chassis number, seating capacity and Australian Design Rules with which the vehicle complies.

CHASSIS NUMBER LOCATION

The chassis number is stamped on the cowl top panel beside the compliance plate and on the model identification plate.

BUILT DATE

This is the calendar month and the year in which the body shell and power train subassemblies are conjoined and the vehicle is driven or moved from the production line.

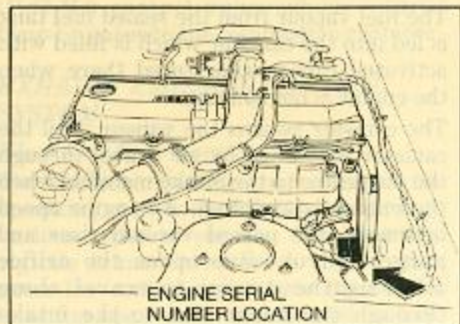

ENGINE SERIAL NUMBER LOCATION

The engine serial number is stamped on the cylinder block in the manner as shown.

SPECIFICATIONS

ENGINE DATA

Engine model		RB30 E	
Piston displacement	cc	2,962	
Bore × Stroke	mm	86 × 85	
Compression ratio		9.0:1	
Firing order		1-5-3-6-2-4	
Idling speed (after warm up)		A/C OFF	A/C ON
Manual transmission	rpm	700±50	700±50
Automatic transmission (in 'N' position)	rpm	700±50	700±50
Spark plug gap	mm	1.0 — 1.1	
Ignition timing (BTDC)			
Manual transmission	degree	15±2	
Automatic transmission (in 'N' position)	degree	15±2	
Throttle valve switch idle contact setting	rpm	250±150	
Dashpot, touch speed	AUTO rpm	900±50	
	MANUAL rpm	900±50	
Cylinder head bolt tightening torque	Nm	78 to 88	
Manifold nut tightening torque			
Intake	Nm	18 to 22	
Exhaust	Nm	27 to 35	

SPECIFICATIONS

DIMENSIONS

NOMINAL DIMENSIONS	MODEL	
	SEDAN	WAGON
Overall Length mms	4653	4650
Overall Width mms	1690	1690
Overall Height mms	1395	1395
Wheelbase mms	2610	2610
Front Track mms	1438	1438
Rear Track mms	1410	1410
SEATING CAPACITY	5	5

KERB WEIGHTS (Kgs)

MODEL	WEIGHTS	
	Manual	Auto
GX Sedan	1320	1340
GX Wagon	1360	1380
GXE Sedan	1330	1350
GXE Wagon	1370	1390
TI Sedan	N/A	1420
Silhouette	1395	1415

CAPACITIES

	Litres
Fuel tank	
Sedan	65
Station Wagon.....	65
Cooling system.....	9.6
Engine oil	
Without oil filter change	4.3*
With oil filter change	4.7*
Transmission	
5 speed FS5W71C	2.0
Automatic 4 speed E4N71B	7.2
Power steering	1.0
Rear axle (Differential carrier).....	1.7
Windscreen washer reservoir	2.5
(wagon front and rear screens share same reservoir)	

* When changing oil, run engine for a few minutes after refilling. Switch off, allow oil to settle and recheck level on dipstick to ensure that level is correct.

COMPLIANCE PLATE

This is located on the right of the driver's seat behind the engine compartment. The plate shows the manufacturer's name, vehicle model, chassis number, seating capacity and Australian Design Rules with which the vehicle complies.

MANUFACTURE

This is the calendar month and the year in which the body shell and power train sub-assemblies are constructed and the vehicle is delivered or moved from the production line.

SPECIFICATIONS

WHEEL AND TYRE

Sedan and Wagon GX, GXE	5.5 JJ × 14	195/70 HR 14
Sedan TI, Silhouette	6.0 JJ × 15	P205/60 HR 15

TYRE PRESSURES (COLD)

ALL MODELS

	Light Load	Full Load
Front	200 kPa	230 kPa
Rear	200 kPa	230 kPa

REAR AXLE RATIOS

	Automatic	Manual
	3.889	3.70

GEAR RATIOS

Gear Ratios	Manual	Automatic
	5 speed	4 Speed
1st	3.321	2.458
2nd	1.902	1.458
3rd	1.308	1.000
4th	1.000	0.686
5th	0.838	—
Reverse	3.382	2.182

TRANSMISSIONS

Manual	5 speed	FS5W71C
Automatic	4 speed	E4N71B

INDEX

Front	Light Load	Full Load
230 kPa	230 kPa	230 kPa
230 kPa	230 kPa	230 kPa

Manual	Automatic
2.70	2.70

A	
Air cleaner filter	99
Air conditioner	72
Ash trays	85
Automatic transmission fluid level	97

B	
Battery fluid level and condition	94
Boot light	86
Brake fluid level	93
Brake pedal travel	100
Bulbs	101

C	
Capacities	116
Changing wheels	106
Cigarette lighter	85
Clock	53
Cruise control	66

D	
Dimensions	116
Dimmer switch	58
Drive belts	98
Drive computer	53
Driving manual transmission	62
Driving automatic transmission	63

E	
Emission control systems	112
Engine specification	115
Engine coolant	69
Engine oil level	91

F	
Fuel filler lid opener	43
Fuel recommendation	95
Fuses	100

G	
Gauges instrument panel	54-56
Glove box lock	87

H	
Hazard warning flasher switch	58
Headlight switch lever	58
Heater	71
Hood release	91
Horn	59

I	
Ignition switch	60
Instrument panel	50-52
Instrument panel illumination	58
Interior lights	86

J/K/L

Jacking the car	105
Jump starting with booster battery	90
Keys	41
Locks	41-42

M/O

Maintenance recommendation	10-13
Map light	86
Oil consumption	92
Oil recommendation	96
Overdrive switch	65

P

Paintwork, care of	107
Parking brake	59, 100
Powershift Switch	64
Power steering fluid level	96
Power windows	87
Push starting	90

R

Radios and cassettes	74
Rear window defroster switch	85
Rear view mirrors	49
Running in speeds	60

S

Seat belts	45, 46
Seats	43
Service station information	120
Spark plugs	99

T

Tilting steering wheel	49
Tips on driving	67
Towing	47, 89
Turn signal switch lever	57
Tyre pressures	94, 117
Tyre rotation	105

V/W

Vehicle identification	114
Ventilation	70-72
Warning lights	56
Washer switch	59
Weights	116
Windshield washer fluid level	94
Winter driving	68
Wipers	59
Wiper switch	59

SERVICE STATION INFORMATION

FUEL FILLER CAP

It is located at right rear side of the vehicle. See page 43.

FUEL RECOMMENDATION

Use only Unleaded Petrol

ENGINE COOLANT ①

Check engine coolant level. For top up or refill, refer to relevant section in maintenance section of manual.

WINDSHIELD AND REAR WINDOW WASHER (Wagon) ②

Check reservoir fluid level. Always use Nissan Windshield Washer Liquid or equivalent.

BATTERY FLUID ③

Check battery fluid level. If fluid is low, add distilled water.

ENGINE OIL DIPSTICK AND FILLER CAP ④

The engine oil dipstick is located on the right side of the cylinder block. The best time to check it is before operating the engine or as the last step in a fuel stop. Maintain the oil level between 'H' and 'L' marks on the dipstick.

ENGINE OIL RECOMMENDATION

Use only recommended engine oil. See page 96 for oil viscosity chart.

BRAKE ⑤ AND CLUTCH FLUID ⑥

Check brake and clutch reservoir fluid level. Use only recommended fluid. See page 96 for brake and clutch fluid.

AUTO. TRANSMISSION FLUID ⑦

The automatic transmission fluid dipstick is located in a pipe in front of the firewall behind the engine. Maintain the fluid level between the L and F marks. Automatic transmission fluid as specified on page 96 must be used.

POWER STEERING FLUID ⑧

Keep the power steering fluid in the reservoir up to the correct level shown on the dipstick. Use only recommended fluid as specified on page 96.

TYRE PRESSURE

Keep tyres inflated to pressure shown on page 117.

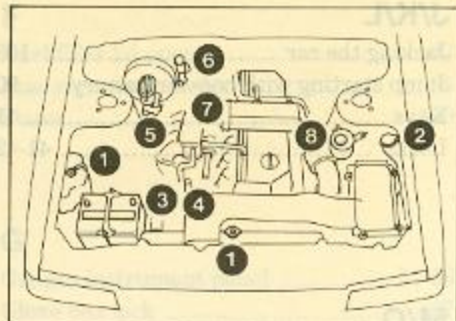

- ① Engine Coolant
- ② Windshield Washer
- ③ Battery Electrolyte
- ④ Engine Oil
- ⑤ Brake Fluid
- ⑥ Clutch Fluid
- ⑦ Automatic Transmission Fluid
- ⑧ Power Steering Fluid

MODEL R31 SERIES

OWNER'S MANUAL

VICTORIA AND TASMANIA

Regional Office

NISSAN MOTOR COMPANY (AUSTRALIA) PTY. LTD
169 Burwood Road,
Hawthorn, 3122
Telephone: 819 2777

NEW SOUTH WALES

Regional Office

NISSAN MOTOR COMPANY (AUSTRALIA) PTY. LTD
66 Berry Street,
North Sydney, 2060
Telephone: 925 0122

Parts and Service

NISSAN MOTOR COMPANY (AUSTRALIA) PTY. LTD
2A Birmingham Avenue,
Villawood, 2163
Telephone: 726 6999

SOUTH AUSTRALIA

Regional Office

NISSAN MOTOR COMPANY (AUSTRALIA) PTY. LTD
1 Opala Street,
Regency Park, 5010
Telephone: 347 0111

WESTERN AUSTRALIA

State Distributor

DUNCAN MOTOR COMPANY PTY. LTD. (Inc. in W.A.)
Wholesale Division
17-19 Hazelhurst Street,
Kewdale, 6105
Telephone: 458 5333

QUEENSLAND

Regional Office

NISSAN MOTOR COMPANY
(AUSTRALIA) PTY. LTD.
41 Lysaght Street,
Acacia Ridge, 4110
Telephone: 345 0600

Printed NOVEMBER 1987 (REPRINT)
Publication No.:99902-J7101