

## SECTION **BR**

### CONTENTS

<b>PRECAUTIONS AND PREPARATION</b> .....	2	Inspection — Lining.....	24
Precautions.....	2	Installation.....	24
Special Service Tool.....	2	<b>PARKING BRAKE CONTROL</b> .....	26
Commercial Service Tools.....	3	Removal and Installation.....	26
<b>CHECK AND ADJUSTMENT</b> .....	4	Inspection.....	26
Checking Brake Fluid Level.....	4	Adjustment.....	27
Checking Brake Line.....	4	<b>ANTI-LOCK BRAKE SYSTEM</b> .....	28
Changing Brake Fluid.....	4	Purpose.....	28
Bleeding Brake System.....	5	Operation.....	28
<b>BRAKE HYDRAULIC LINE/CONTROL VALVE</b> .....	6	ABS Hydraulic Circuit.....	28
Brake Hydraulic Line.....	6	System Components.....	29
Load Sensing Valve.....	7	System Description.....	29
<b>BRAKE PEDAL AND BRACKET</b> .....	10	Removal and Installation.....	32
Removal and Installation.....	10	<b>TROUBLE DIAGNOSES</b> .....	36
Inspection.....	10	How to Perform Trouble Diagnoses for Quick	
Adjustment.....	10	and Accurate Repair.....	36
<b>MASTER CYLINDER</b> .....	12	Preliminary Check.....	37
Removal.....	12	Component Parts and Harness Connector	
Disassembly.....	13	Location.....	38
Inspection.....	13	Circuit Diagram for Quick Pinpoint Check.....	39
Assembly.....	13	Wiring Diagram — ABS —.....	40
Installation.....	14	Self-diagnosis.....	44
<b>BRAKE BOOSTER</b> .....	15	<b>CONSULT</b> .....	47
Brake Booster.....	15	CONSULT Inspection Procedure.....	48
<b>VACUUM PIPING</b> .....	17	Ground Circuit Check.....	53
Vacuum Hose.....	17	<b>TROUBLE DIAGNOSES FOR SELF-DIAGNOSTIC</b>	
<b>FRONT DISC BRAKE</b> .....	18	<b>ITEMS</b> .....	54
Pad Replacement.....	18	Diagnostic Procedure 1 (Wheel sensor or rotor).....	54
Removal.....	20	Diagnostic Procedure 2 (ABS actuator solenoid	
Disassembly.....	20	valve).....	56
Inspection — Caliper.....	20	Diagnostic Procedure 3 (Solenoid valve relay).....	58
Inspection — Rotor.....	21	Diagnostic Procedure 4 (Motor relay or motor).....	61
Assembly.....	21	Diagnostic Procedure 5 (Low voltage).....	64
Installation.....	21	Diagnostic Procedure 6 (G sensor).....	65
<b>REAR DRUM BRAKE</b> .....	22	Diagnostic Procedure 7 (Control unit).....	66
Removal.....	22	<b>TROUBLE DIAGNOSES FOR SYMPTOMS</b> .....	67
Inspection — Wheel Cylinder.....	23	Diagnostic Procedure 8	
Wheel Cylinder Overhaul.....	24	(ABS works frequently.).....	67
Inspection — Drum.....	24		

# CONTENTS (Cont'd)

Diagnostic Procedure 9 (Unexpected pedal action).....68	Diagnostic Procedure 13 (Warning lamp does not come on when ignition switch is turned on.).....70	GI
Diagnostic Procedure 10 (Long stopping distance) .....68	Diagnostic Procedure 14 (Warning lamp stays on when ignition switch is turned on.) .....72	MA
Diagnostic Procedure 11 (ABS does not work.) .....69	Diagnostic Procedure 15 (Vehicle vibrates excessively when ABS is operating.) .....75	EM
Diagnostic Procedure 12 (Pedal vibration and noise).....69	<b>SERVICE DATA AND SPECIFICATIONS (SDS)</b> .....76	
	General Specifications.....76	
	Inspection and Adjustment .....76	IC

**When you read wiring diagrams:**

- Read GI section, "HOW TO READ WIRING DIAGRAMS".
- See EL section, "POWER SUPPLY ROUTING" for power distribution circuit.

When you perform trouble diagnoses, read GI section, "HOW TO FOLLOW FLOW CHART IN TROUBLE DIAGNOSES" and "HOW TO PERFORM EFFICIENT DIAGNOSIS FOR AN ELECTRICAL INCIDENT".

EC

FE

AT

TF

PD

FA

RA

**BR**

ST

RS

BT

HA

EL

IDX

# PRECAUTIONS AND PREPARATION

## Precautions

### SUPPLEMENTAL RESTRAINT SYSTEM (SRS) "AIR BAG"

The Supplemental Restraint System "Air Bag", used along with a seat belt, helps to reduce the risk or severity of injury to the driver and front passenger in a frontal collision. The Supplemental Restraint System consists of air bag modules (located in the center of the steering wheel and on the instrument panel on the passenger side), a diagnosis sensor unit, warning lamp, wiring harness and spiral cable. Information necessary to service the system safely is included in the **RS** section of this Service Manual.

#### WARNING:

- To avoid rendering the SRS inoperative, which could increase the risk of personal injury or death in the event of a collision which would result in air bag inflation, all maintenance must be performed by an authorized INFINITI dealer.
- Improper maintenance, including incorrect removal and installation of the SRS, can lead to personal injury caused by unintentional activation of the system.
- Do not use electrical test equipment on any circuit related to the SRS unless instructed to in this Service Manual. SRS wiring harnesses are covered with yellow insulation either just before the harness connectors or for the complete harness, for easy identification.

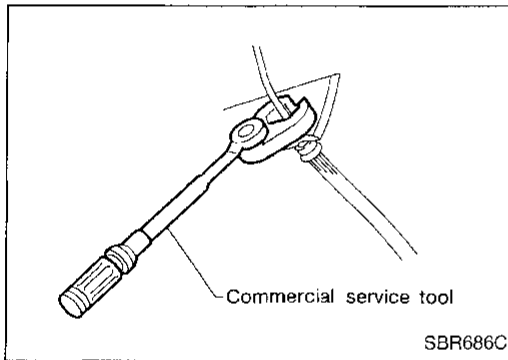

### BRAKE SYSTEM

- Use brake fluid "DOT 3".
- Never reuse drained brake fluid.
- Be careful not to splash brake fluid on painted areas; it may cause paint damage. If brake fluid is splashed on painted areas, wash it away with water immediately.
- To clean master cylinder parts, disc brake caliper parts or wheel cylinder parts, use clean brake fluid.
- Never use mineral oils such as gasoline or kerosene. They will ruin rubber parts of hydraulic system.
- Use flare nut wrench when removing and installing brake tubes.
- Always torque brake lines when installing.

#### WARNING:

- Clean brakes with a vacuum dust collector to minimize risk of health hazard from powder caused by friction.

### Special Service Tool

The actual shapes of Kent-Moore tools may differ from those of special service tools illustrated here.

Tool number (Kent-Moore No.) Tool name	Description
HT72480000 (J25852-B) Rear axle shaft bearing puller	<div data-bbox="506 1629 854 1751" data-label="Image"> <p>A technical drawing of a rear axle shaft bearing puller tool. It consists of a central shaft with a threaded end on the right and a specialized pulling mechanism on the left, including a nut and a bearing cap.</p> </div> <div data-bbox="987 1623 1336 1650" data-label="Text"> <p>Removing rear wheel sensor rotor</p> </div> <div data-bbox="418 1797 477 1822" data-label="Text"> <p>NT161</p> </div>

# PRECAUTIONS AND PREPARATION

## Commercial Service Tools

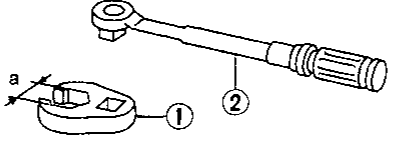
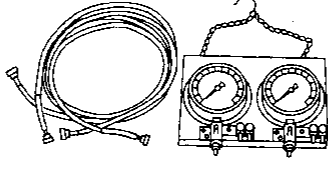
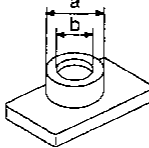
Tool name	Description
① Flare nut crowfoot ② Torque wrench	<div style="display: flex; justify-content: space-between;"> <div style="width: 60%;">  </div> <div style="width: 35%; text-align: right;">                     Removing and installing each brake piping                       a: 10 mm (0.39 in)                 </div> </div> <p style="text-align: left; margin-top: 5px;">NT360</p>
Brake fluid pressure gauge	<div style="display: flex; justify-content: space-between;"> <div style="width: 60%;">  </div> <div style="width: 35%; text-align: right;">                     Measuring brake fluid pressure                 </div> </div> <p style="text-align: left; margin-top: 5px;">NT151</p>
Rear wheel sensor rotor drift	<div style="display: flex; justify-content: space-between;"> <div style="width: 60%;">  </div> <div style="width: 35%; text-align: right;">                     Installing rear wheel sensor rotor                 </div> </div> <p style="text-align: left; margin-top: 5px;">NT509</p> <div style="text-align: right; margin-top: 10px;">                     a: 75 mm (2.95 in) dia.                      b: 63 mm (2.48 in) dia.                 </div>

GI

MA

EM

LC

EC

FE

AT

TF

PD

FA

RA

BR

ST

RS

BT

HA

EL

IDX

## CHECK AND ADJUSTMENT

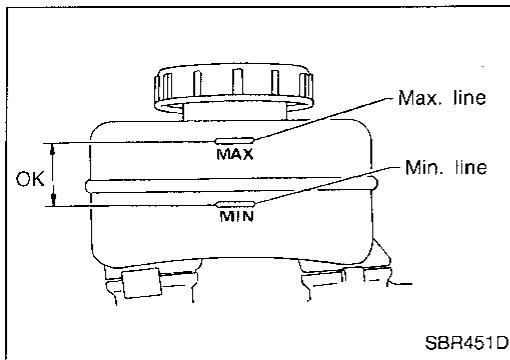

### Checking Brake Fluid Level

- Check fluid level in reservoir tank. It should be between Max and Min lines on reservoir tank.
- If fluid level is extremely low, check brake system for leaks.
- If the brake warning lamp comes on, check brake fluid level switch and parking brake switch.

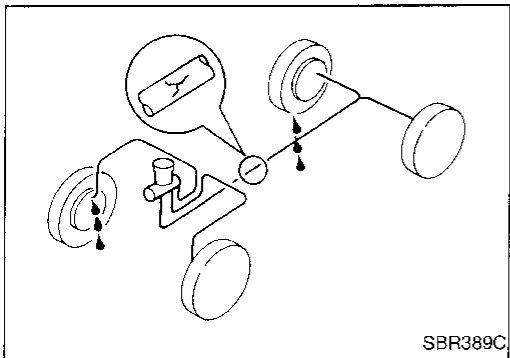

### Checking Brake Line

#### CAUTION:

If leakage occurs around joints, retighten or, if necessary, replace damaged parts.

1. Check brake lines (tubes and hoses) for cracks, deterioration or other damage. Replace any damaged parts.
2. Check for oil leakage by fully depressing brake pedal while engine is running.

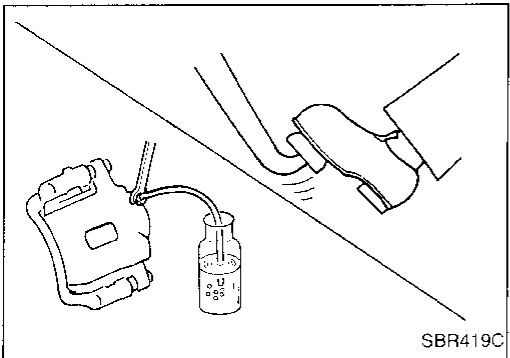

### Changing Brake Fluid

#### CAUTION:

- Refill with new brake fluid "DOT 3".
  - Always keep fluid level higher than minimum line on reservoir tank.
  - Never reuse drained brake fluid.
  - Be careful not to splash brake fluid on painted areas; it may cause paint damage. If brake fluid is splashed on painted areas, wash it away with water immediately.
1. Clean inside of reservoir tank, and refill with new brake fluid.
  2. Connect a vinyl tube to each air bleeder valve.
  3. Drain brake fluid from each air bleeder valve by depressing brake pedal.
  4. Refill until brake fluid comes out of each air bleeder valve. Use same procedure as in bleeding hydraulic system to refill brake fluid. Refer to "Bleeding Brake System", BR-5.

## CHECK AND ADJUSTMENT

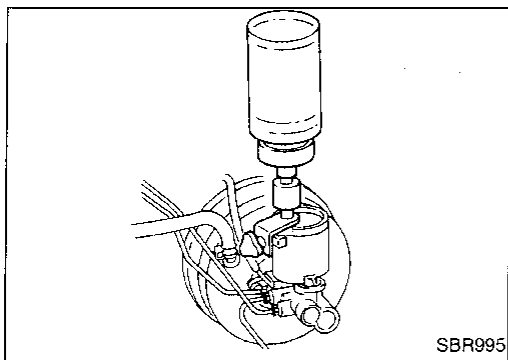

### Bleeding Brake System

#### CAUTION:

- Carefully monitor brake fluid level at master cylinder during bleeding operation.
- If master cylinder is suspected to have air inside, bleed air from master cylinder first. Refer to "Installation", "MASTER CYLINDER", BR-14.
- Fill reservoir with new brake fluid "DOT 3". Make sure it is full at all times while bleeding air out of system.
- Place a container under master cylinder to avoid spillage of brake fluid.
- For models with ABS, turn ignition switch OFF and disconnect ABS actuator connectors or battery ground cable.
- Bleed air in the following order.
  1. LSV air bleeder
  2. Left rear brake
  3. Right rear brake
  4. Left front brake
  5. Right front brake

GI

MA

EM

LC

EC

FE

AT

TF

PD

FA

RA

BR

ST

RS

BT

HA

EL

DX

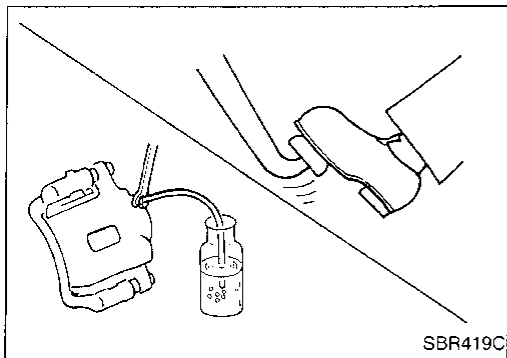

1. Connect a transparent vinyl tube to air bleeder valve.
2. Fully depress brake pedal several times.
3. With brake pedal depressed, open air bleeder valve to release air.
4. Close air bleeder valve.
5. Release brake pedal slowly.
6. Repeat steps 2. through 5. until clear brake fluid comes out of air bleeder valve.
7. Tighten air bleeder valve.

 : 7 - 9 N·m (0.7 - 0.9 kg-m, 61 - 78 in-lb)

## Brake Hydraulic Line

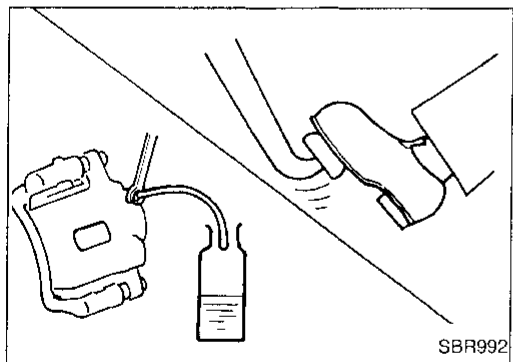
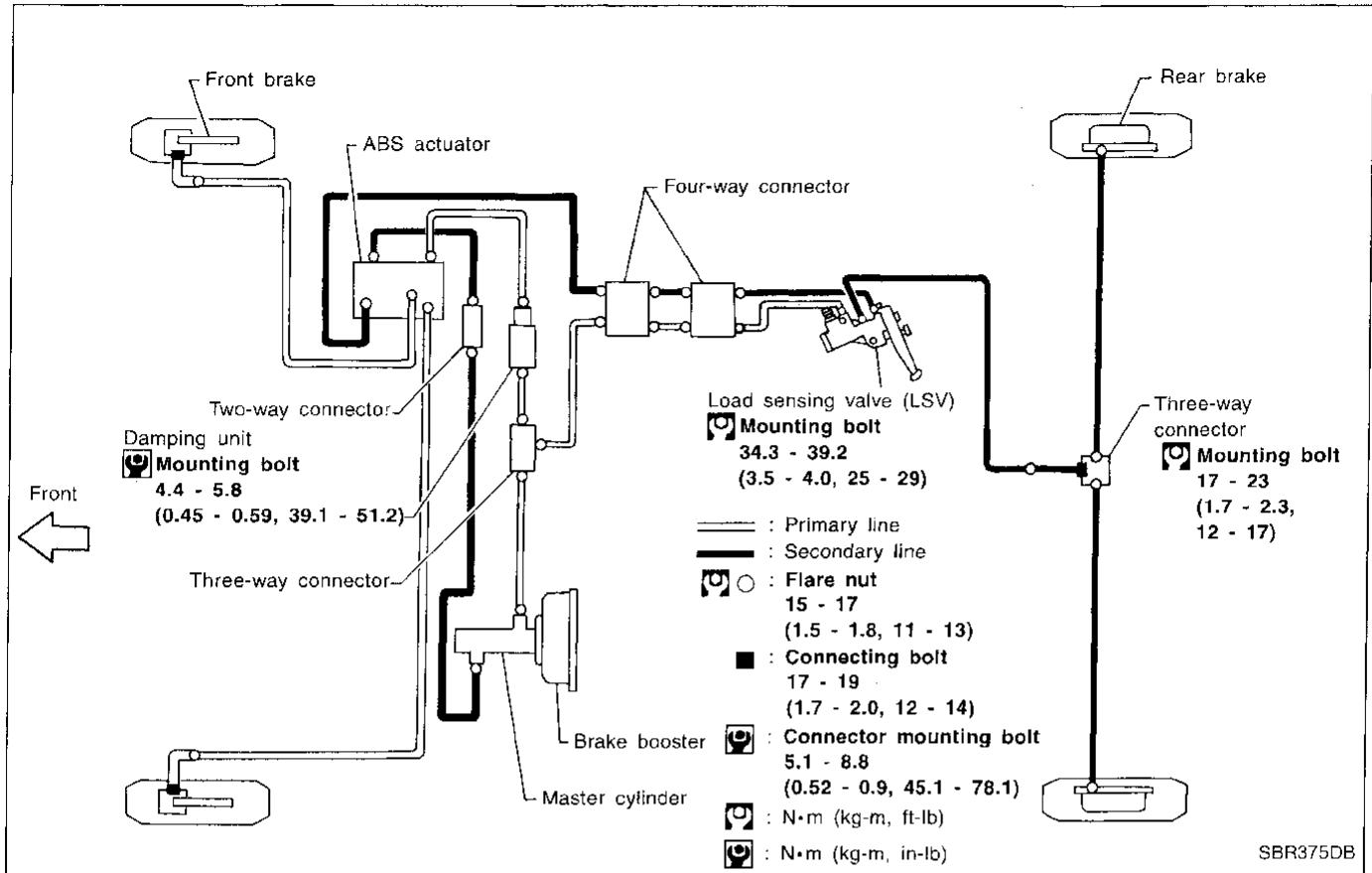

### REMOVAL

#### CAUTION:

- Be careful not to splash brake fluid on painted areas; it may cause paint damage. If brake fluid is splashed on painted areas, wash it away with water immediately.
  - All hoses must be free from excessive bending, twisting and pulling.
1. Connect vinyl tube to air bleeder valve.
  2. Drain brake fluid from each air bleeder valve by depressing brake pedal.
  3. Remove flare nut connecting brake tube and hose, then withdraw lock spring.
  4. Cover openings to prevent entrance of dirt whenever disconnecting brake line.

### INSPECTION

Check brake lines (tubes and hoses) for cracks, deterioration or other damage. Replace any damaged parts.

# BRAKE HYDRAULIC LINE/CONTROL VALVE

## Brake Hydraulic Line (Cont'd)

### INSTALLATION

#### CAUTION:

- Refill with new brake fluid "DOT 3".
  - Never reuse drained brake fluid.
1. Tighten all flare nuts and connecting bolts.
    - Flare nut:**
      - ⊗: 15 - 17 N·m (1.5 - 1.8 kg-m, 11 - 13 ft-lb)
    - Connecting bolt:**
      - ⊗: 17 - 19 N·m (1.7 - 2.0 kg-m, 12 - 14 ft-lb)
  2. Refill until new brake fluid comes out of each air bleeder valve.
  3. Bleed air. Refer to "Bleeding Brake System", BR-5.

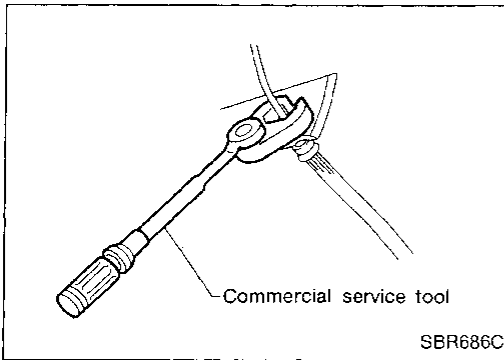

## Load Sensing Valve

### INSPECTION

#### CAUTION:

- Carefully monitor brake fluid level at master cylinder.
- Use new brake fluid "DOT 3".
- Be careful not to splash brake fluid on painted areas; it may cause paint damage. If brake fluid is splashed on paint areas, wash it away with water immediately.
- Depress pedal slowly when raising front brake pressure.
- Check rear brake pressure 2 seconds after front brake pressure reaches specified value.
- For models with ABS disconnect harness connectors from ABS actuator relay before checking.

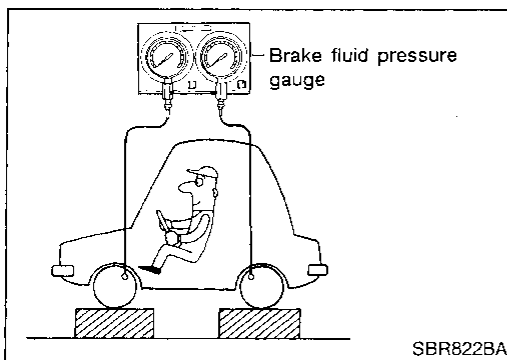
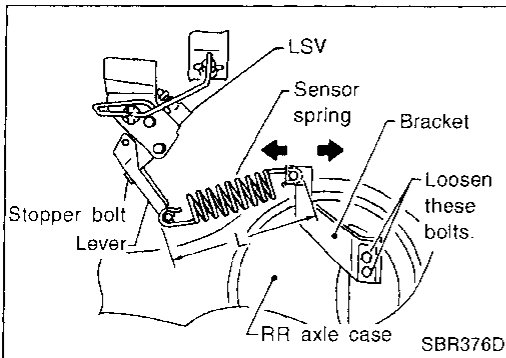

1. Ensure vehicle is unladen condition\*.
  - \* Fuel, radiator coolant and engine oil full. Spare tire, jack, hand tools and mats in designated positions.
2. Have a driver sit in the driver's seat and one person sit on the rear end. Then have the person on the rear end slowly get off the vehicle. This is necessary to stabilize suspension deflection.
3. Gradually depress brake pedal and attach a lever to the stopper bolt, then adjust length "L" as follows:
  - Length "L": Approx. 194 mm (7.64 in)**
4. Remove front LH tire.
5. Connect tool to air bleeders on front LH brake caliper and rear LH or RH brake wheel cylinder.



# BRAKE HYDRAULIC LINE/CONTROL VALVE

## Load Sensing Valve (Cont'd)

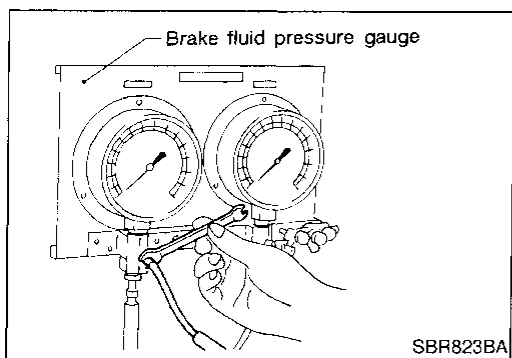

6. Install front LH tire.

**Before installing front LH tire, confirm the tool is not touching the front LH wheel.**

7. Bleed air from Tool.

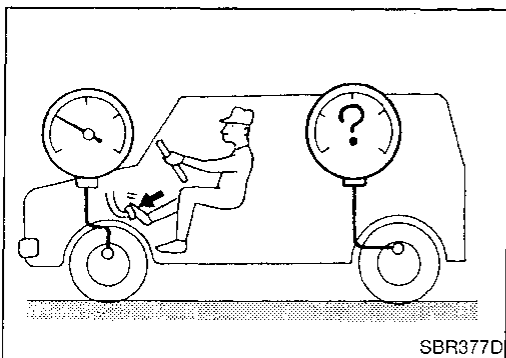

8. Raise front brake pressure to 4,904 kPa (50 kg/cm<sup>2</sup>, 711 psi) and 9,807 kPa (100 kg/cm<sup>2</sup>, 1,422 psi) and check rear brake pressure.

**Rear brake pressure:  
Refer to table below.**

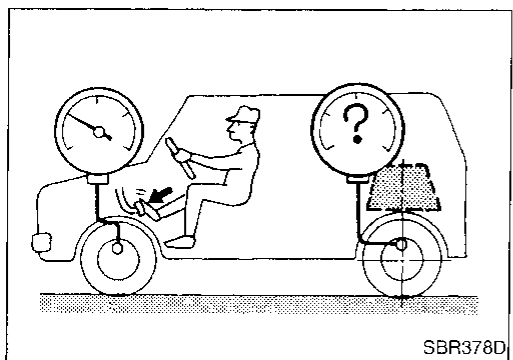

9. Set down weight slowly over axle center so that sensor spring length becomes the same as when in loaded condition (Refer to table below). Check rear brake pressure in the same way described in step 6.

Unit: kPa (kg/cm<sup>2</sup>, psi)

		Sensor spring length "L" mm (in)	Front brake pressure 4,904 (50, 711)	Front brake pressure 9,807 (100, 1,422)
Rear brake pressure	Without weight	194 (7.64)	1,667 - 2,648 (17.0 - 27.0, 242 - 384)	3,874 - 4,854 (39.5 - 49.5, 562 - 704)
	With weight	235 (9.25)	2,207 - 3,580 (22.5 - 36.5, 320 - 519)	4,413 - 5,786 (45.0 - 59.0, 640 - 839)

\*: Depressed brake pedal.

10. Bleed air after disconnecting the tool. Refer to "Bleeding Brake System", BR-5.

11. Install front LH tire.

## REMOVAL AND INSTALLATION

### CAUTION:

- Refill with new brake fluid "DOT 3".
- Be careful not to splash brake fluid on painted areas; it may cause paint damage. If brake fluid is splashed on painted areas, wash it away with water immediately.
- Do not reuse Load Sensing Valve once it is disassembled.
- Replace damaged Load Sensing Valve as an assembly.
- When disassembling, apply multi-purpose grease to all rubbing areas.

# BRAKE HYDRAULIC LINE/CONTROL VALVE

## Load Sensing Valve (Cont'd)

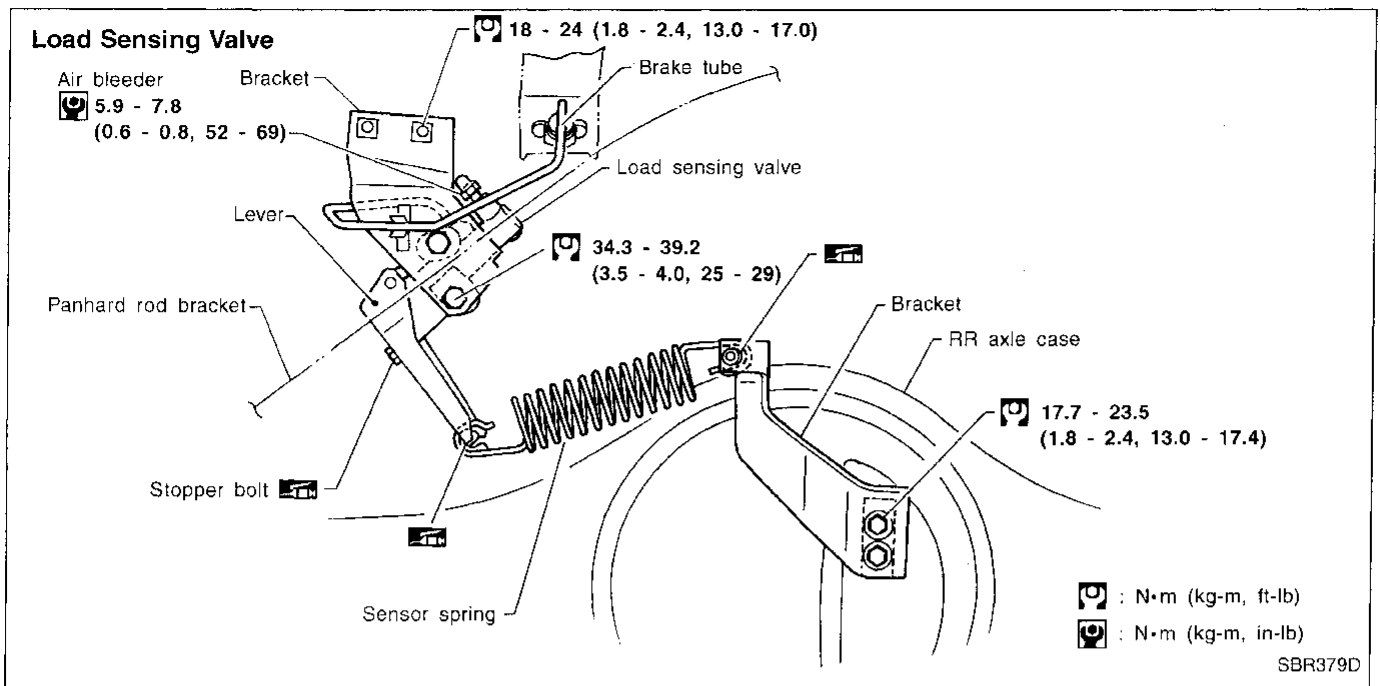

1. Tighten all flare nuts and mounting bolts.

### Flare nut:

□: 15 - 17 N·m (1.5 - 1.8 kg-m, 11 - 13 ft-lb)

2. Refill until new brake fluid comes out of each air bleeder valve.
3. Bleed air. Refer to "Bleeding Brake System", BR-5.

GI  
MA  
EM  
LC  
EC  
FE  
AT  
TF  
PD  
FA  
RA  
BR  
ST  
RS  
BT  
HA  
EL  
IDX

# BRAKE PEDAL AND BRACKET

## Removal and Installation

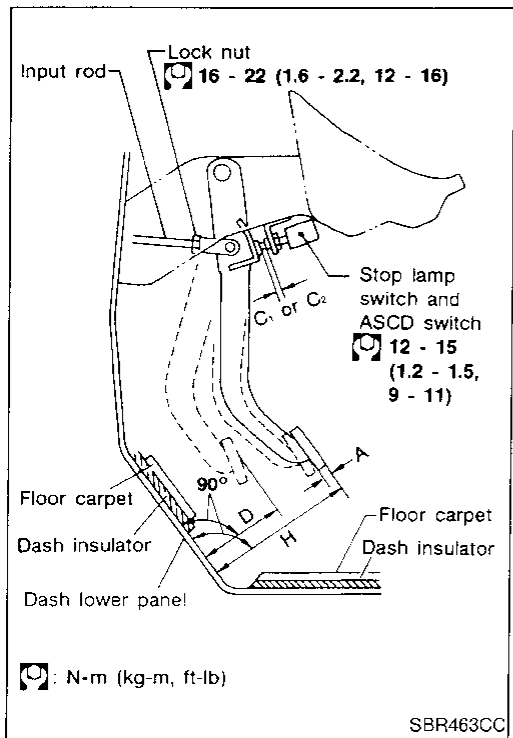
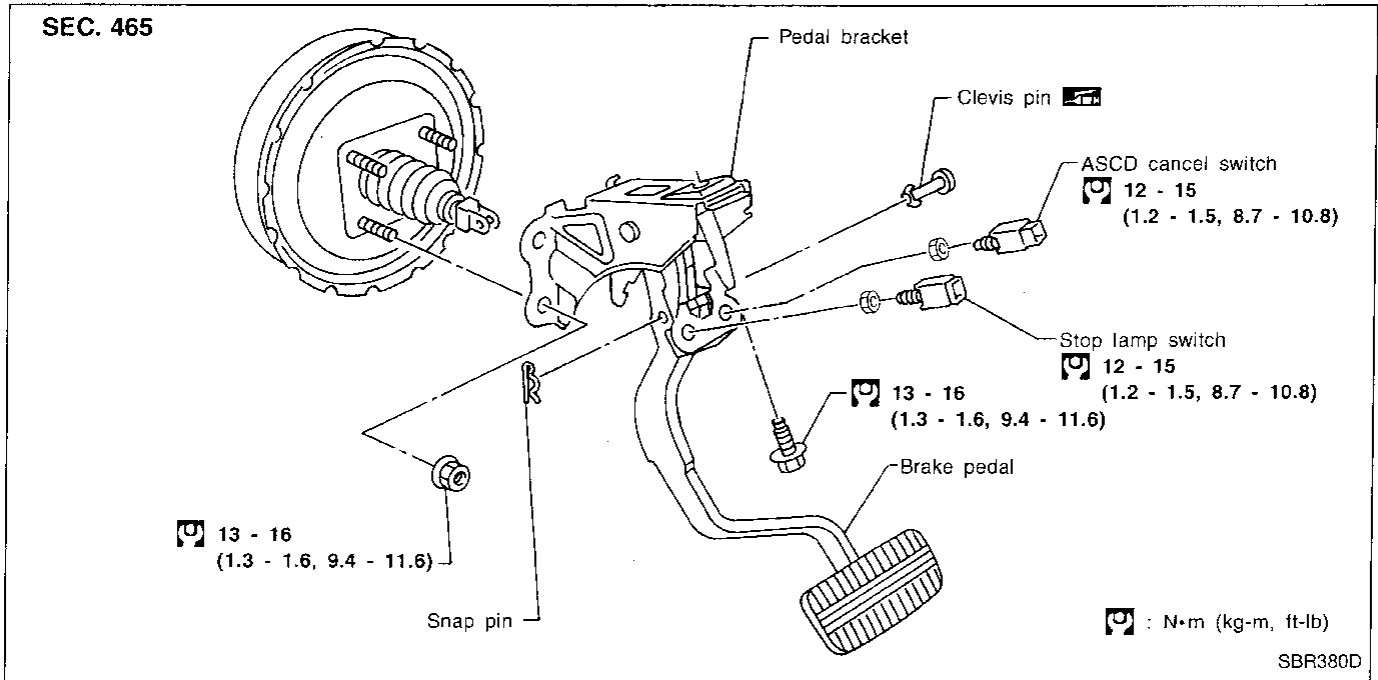

## Inspection

Check brake pedal for following items.

- Brake pedal bend
- Clevis pin deformation
- Crack of any welded portion
- Crack or deformation of clevis pin stopper

## Adjustment

Check brake pedal free height from dash lower panel.

- H:** Free height  
Refer to SDS (BR-76).
- D:** Depressed height  
Refer to SDS (BR-76).  
Under force of 490 N (50 kg, 110 lb) with engine running
- C<sub>1</sub>, C<sub>2</sub>:** Clearance between pedal stopper and threaded end of stop lamp switch and ASDC switch  
0.3 - 1.0 mm (0.012 - 0.039 in)
- A:** Pedal free play  
1 - 3 mm (0.04 - 0.12 in)

If necessary, adjust brake pedal free height.

## BRAKE PEDAL AND BRACKET

### Adjustment (Cont'd)

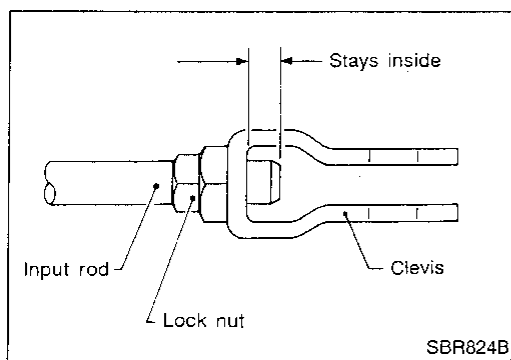

1. Loosen lock nut and adjust pedal free height by turning brake booster input rod. Then tighten lock nut.

**Make sure that tip of input rod stays inside.**

2. Adjust clearance "C<sub>1</sub>" and "C<sub>2</sub>" with stop lamp switch and ASCD switch respectively. Then tighten lock nuts.

3. Check pedal free play.

**Make sure that stop lamp is off when pedal is released.**

4. Check brake pedal's depressed height while engine is running. If depressed height is below specified value, check brake system for leaks, accumulation of air or any damage to components (master cylinder, wheel cylinder, etc.). Then make necessary repairs.

GI

MA

EM

LC

EC

FE

AT

TF

PD

FA

RA

**BR**

ST

RS

BT

HA

EL

IDX

# MASTER CYLINDER

## Removal

### CAUTION:

- Be careful not to splash brake fluid on painted areas; it may cause paint damage. If brake fluid is splashed on painted areas, wash it away with water immediately.
  - In the case of brake fluid leakage from the master cylinder, disassemble the cylinder. Then check piston cups for deformation or scratches and replace necessary parts.
1. Connect a vinyl tube to air bleeder valve.
  2. Drain brake fluid from each air bleeder valve, depressing brake pedal to empty fluid from master cylinder.
  3. Remove brake pipe flare nuts.
  4. Remove master cylinder mounting nuts.

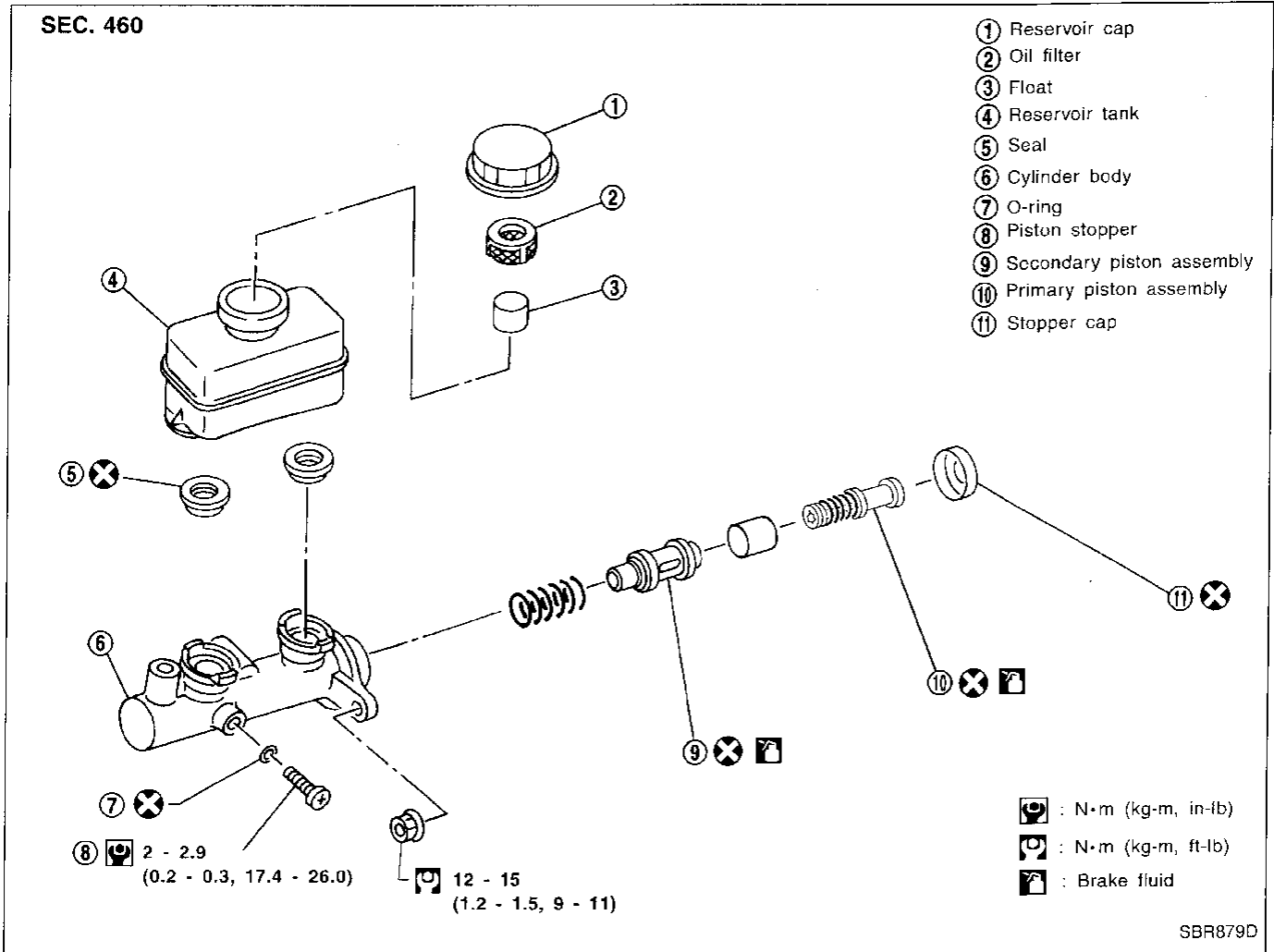

# MASTER CYLINDER

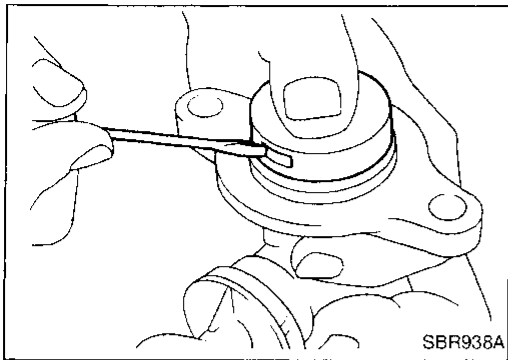

## Disassembly

1. Bend claws of stopper cap outward.

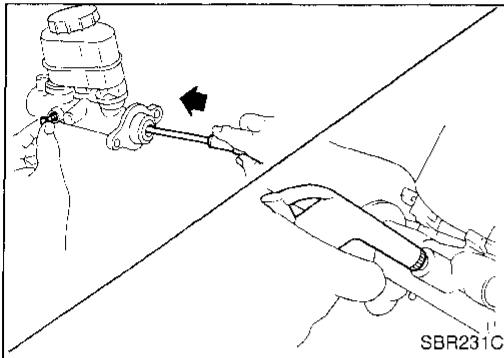

2. Remove piston stopper while piston is pushed into cylinder.
3. Remove piston assemblies.

**If it is difficult to remove secondary piston assembly, gradually apply compressed air through fluid outlet.**

4. Draw out reservoir tank.

## Inspection

Check master cylinder inner wall for pin holes or scratches. Replace if damaged.

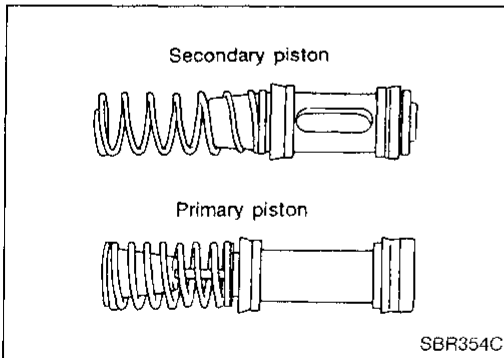

## Assembly

1. Insert secondary piston assembly. Then insert primary piston assembly.
  - Pay attention to direction of piston cups in figure at left. Also, insert pistons squarely to avoid scratches on cylinder bore.
  - Pay attention to alignment of secondary piston slit with valve stopper mounting hole of cylinder body.

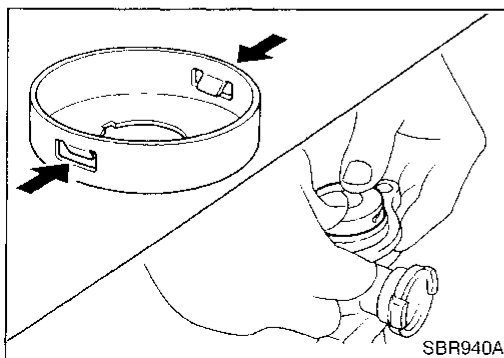

2. Install stopper cap.  
**Before installing stopper cap, ensure that claws are bent inward.**
3. Push reservoir tank seals into cylinder body.
4. Push reservoir tank into cylinder body.

GI

MA

EM

LC

EC

FE

AT

TF

PD

FA

RA

BR

ST

RS

BT

HA

EL

IDX

## MASTER CYLINDER

### Assembly (Cont'd)

5. Install valve stopper while piston is pushed into cylinder.

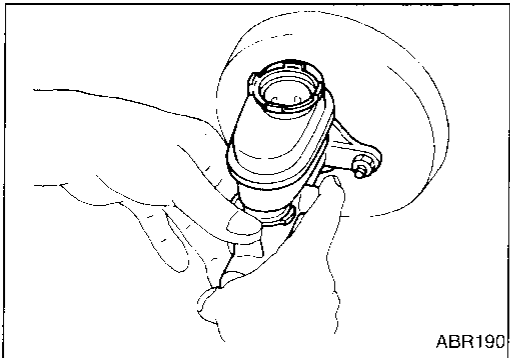
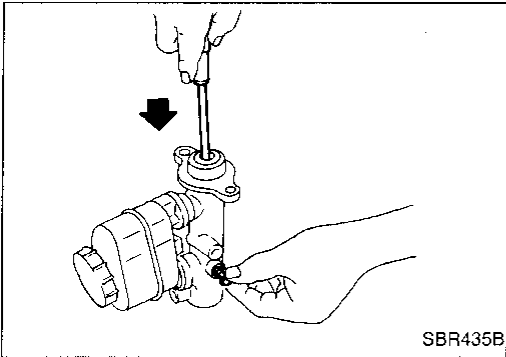

### Installation

#### CAUTION:

- Refill with new brake fluid "DOT 3".
  - Never reuse drained brake fluid.
1. Place master cylinder onto brake booster and secure mounting nuts lightly.
  2. Torque mounting nuts.  
⚙️: 12 - 15 N·m (1.2 - 1.5 kg-m, 9 - 11 ft-lb)
  3. Fill up reservoir tank with new brake fluid.
  4. Plug all ports on master cylinder with fingers to prevent air suction while releasing brake pedal.
  5. Have driver depress brake pedal slowly several times until no air comes out of master cylinder.
  6. Fit brake lines to master cylinder.
  7. Tighten flare nuts.  
⚙️: 15 - 17 N·m (1.5 - 1.8 kg-m, 11 - 13 ft-lb)
  8. Bleed air. Refer to "Bleeding Brake System", BR-5.

# BRAKE BOOSTER

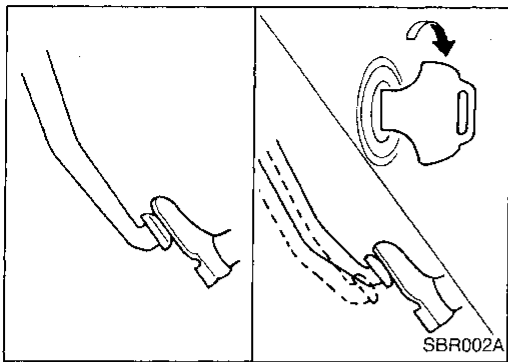

## Brake Booster

### ON-VEHICLE SERVICE

#### Operating check

- Depress brake pedal several times with engine off. After exhausting vacuum, make sure there is no change in pedal stroke.
- Depress brake pedal, then start engine. If pedal goes down slightly, operation is normal.

#### Airtight check

- Start engine, and stop it after one or two minutes. Depress brake pedal several times slowly. Booster is airtight if pedal stroke is less each time.
- Depress brake pedal while engine is running, and stop engine with pedal depressed. The pedal stroke should not change after holding pedal down for **30 seconds**.

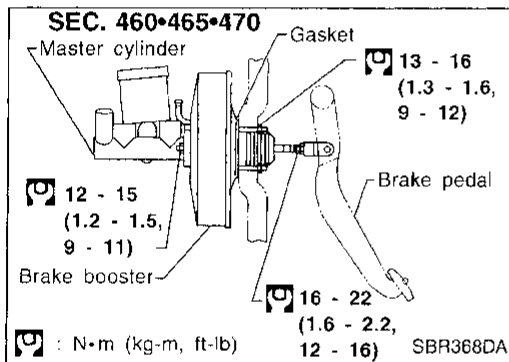
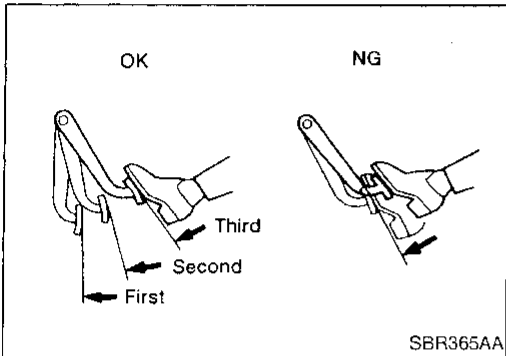

## REMOVAL

### CAUTION:

- Be careful not to splash brake fluid on painted areas; it may cause paint damage. If brake fluid is splashed on painted areas, wash it away with water immediately.
- Be careful not to deform or bend brake pipes, during removal of booster.

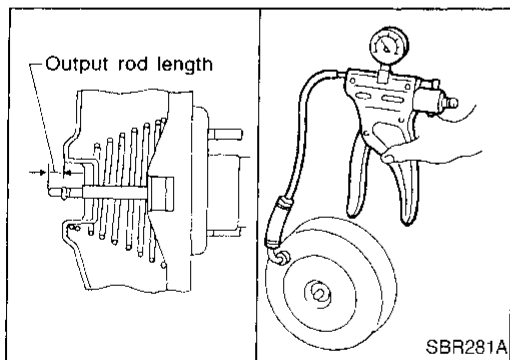

## INSPECTION

### Output rod length check

1. Apply vacuum of  $-66.7 \text{ kPa}$  ( $-500 \text{ mmHg}$ ,  $-19.69 \text{ inHg}$ ) to brake booster with a hand vacuum pump.
2. Check output rod length.

#### Specified length:

10.275 - 10.525 mm (0.4045 - 0.4144 in)

## INSTALLATION

### CAUTION:

- Be careful not to deform or bend brake pipes during installation of booster.
- Replace clevis pin if damaged.
- Refill with new brake fluid "DOT 3".
- Never reuse drained brake fluid.
- Take care not to damage brake booster mounting bolt thread when installing. Due to the narrow angle of installation, the threads can be damaged by the dash panel.

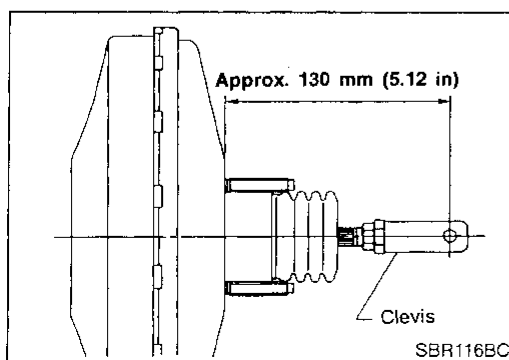



## BRAKE BOOSTER

---

### Brake Booster (Cont'd)

1. Before fitting booster, temporarily adjust clevis to dimension shown.
2. Fit booster, then secure mounting nuts (brake pedal bracket to brake booster) lightly.
3. Connect brake pedal and booster input rod with clevis pin.
4. Secure mounting nuts.  
**Specification: 13 - 16 N·m (1.3 - 1.6 kg-m, 9 - 12 ft-lb)**
5. Install master cylinder. Refer to "Installation" in "MASTER CYLINDER", BR-14.
6. Adjust brake pedal height and free play.  
Refer to "Adjustment" in "BRAKE PEDAL AND BRACKET", BR-10.
7. Secure lock nut for clevis.  
**Ⓞ: 16 - 22 N·m (1.6 - 2.2 kg-m, 12 - 16 ft-lb)**
8. Bleed air. Refer to "Bleeding Brake System", BR-5.

## Vacuum Hose

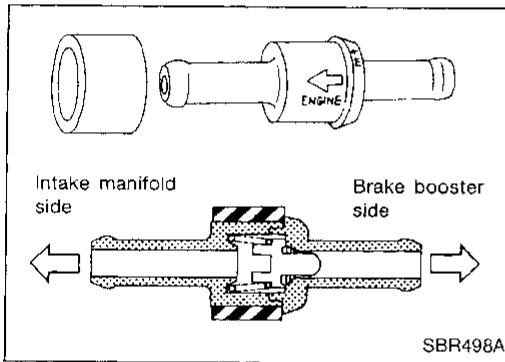
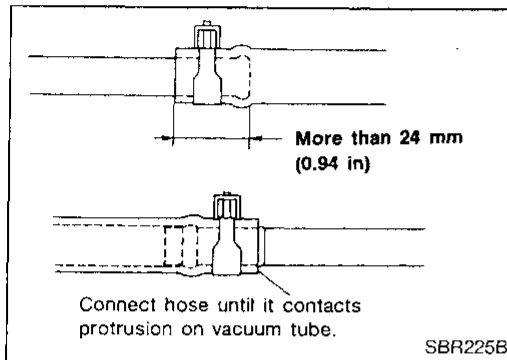
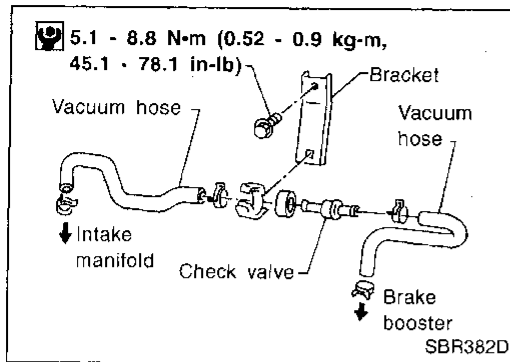

### REMOVAL AND INSTALLATION

#### CAUTION:

When installing vacuum hoses, pay attention to the following points.

- Do not apply any oil or lubricants to vacuum hose and check valve.
- Insert vacuum tube into vacuum hose as shown.
- Install check valve, paying attention to its direction.

### INSPECTION

#### Hoses and connectors

Check vacuum lines, connections and check valve for airtightness, improper attachment chafing and deterioration.

#### Check valve

Check vacuum with a vacuum pump.

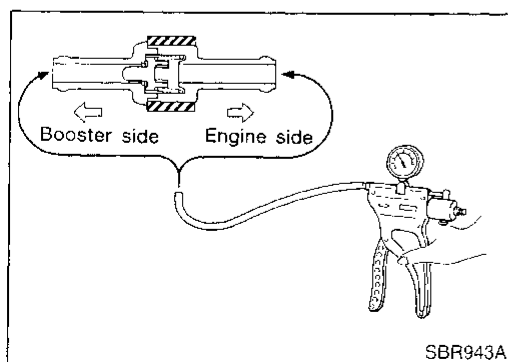

Connect to booster side	Vacuum should exist.
Connect to engine side	Vacuum should not exist.

## Pad Replacement

### WARNING:

Clean brakes with a vacuum dust collector to minimize the hazard of airborne particles or other materials.

### CAUTION:

- When cylinder body is open, do not depress brake pedal, or piston will pop out.
- Be careful not to damage piston boot or get oil on rotor. Always replace shims when replacing pads.
- If shims are rusted or show peeling of the rubber coat, replace them with new shims.
- It is not necessary to remove connecting bolt except for disassembly or replacement of caliper assembly. In this case, suspend cylinder body with wire so as not to stretch brake hose.
- Carefully monitor brake fluid level because brake fluid will return to reservoir when pushing back piston.

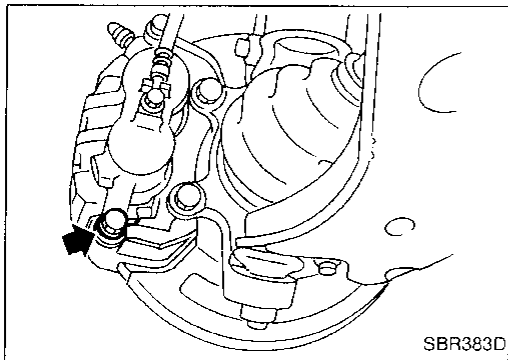

1. Remove master cylinder reservoir cap.
2. Remove lower pin bolt.

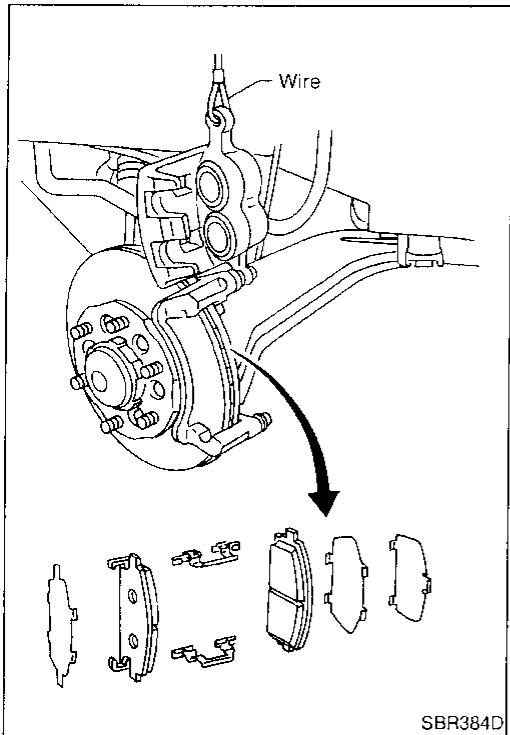

3. Open cylinder body upward. Then remove pad retainers, and inner and outer shims.

### Standard pad thickness:

11.0 mm (0.433 in)

### Pad wear limit:

2.0 mm (0.079 in)

Carefully monitor brake fluid level because brake fluid will return to reservoir when pushing back piston.

# FRONT DISC BRAKE

## SEC. 440

: N·m (kg-m, ft-lb)

: N·m (kg-m, in-lb)

(P) : PBC (Poly Butyl Cuprysil) grease or silicon-based grease point

(R) : Rubber grease point

(B) : Brake fluid point

(R) To sliding portion

③ 72 - 97  
(7.3 - 9.9, 53 - 72)

⑪ 17 - 20  
(1.7 - 2.0, 12 - 14)

⑬ 32 - 42  
(3.3 - 4.3, 24 - 31)  
 ⑭ 7 - 9  
(0.7 - 0.9, 61 - 78)

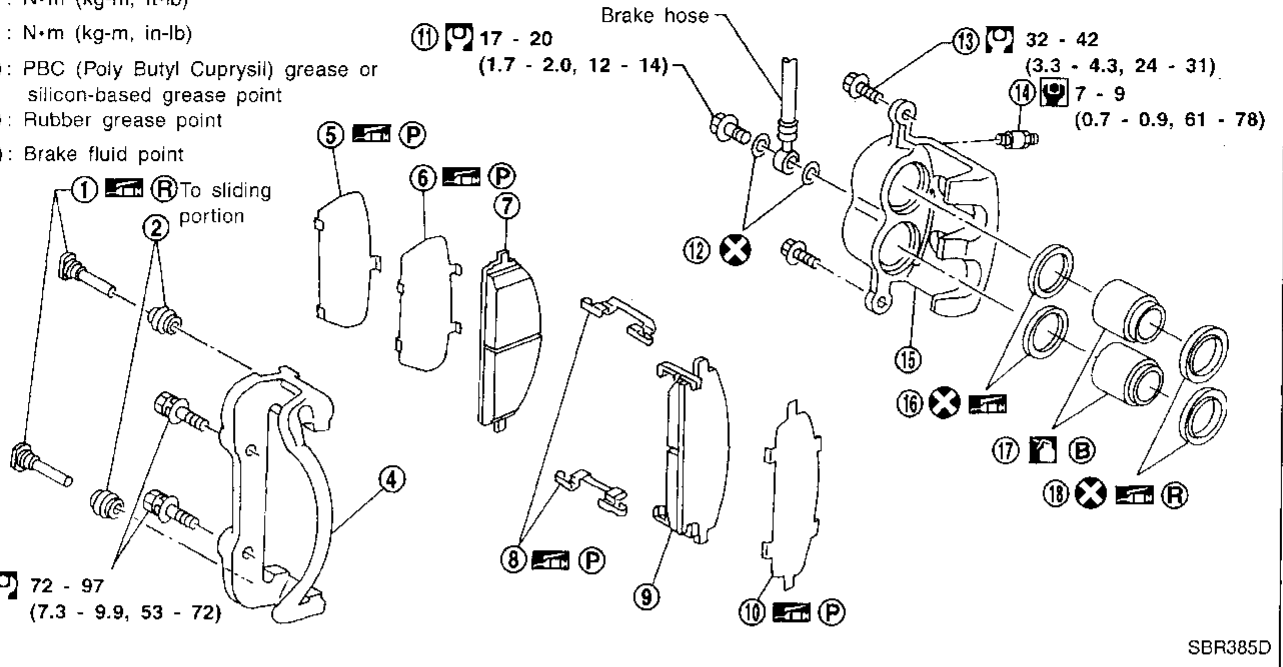

SBR385D

- ① Main pin
- ② Pin boot
- ③ Torque member fixing bolt
- ④ Torque member
- ⑤ Shim cover
- ⑥ Inner shim

- ⑦ Inner pad
- ⑧ Pad retainer
- ⑨ Outer pad
- ⑩ Outer shim
- ⑪ Connecting bolt
- ⑫ Copper washer

- ⑬ Main pin bolt
- ⑭ Bleed valve
- ⑮ Cylinder body
- ⑯ Piston seal
- ⑰ Piston
- ⑱ Piston boot

GI

MA

EM

LC

EC

FE

AT

TF

PD

FA

RA

**BR**

ST

RS

BT

HA

EL

IDX

# FRONT DISC BRAKE

## Removal

### WARNING:

Clean brake pads with a vacuum dust collector to minimize the hazard of airborne particles or other materials.

### CAUTION:

Suspend caliper assembly with wire so as not to stretch brake hose.

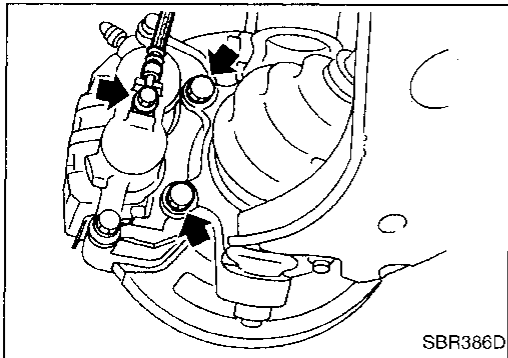

Remove torque member fixing bolts and connecting bolt.

**It is not necessary to remove connecting bolt except for disassembly or replacement of caliper assembly. In this case, suspend caliper assembly with wire so as not to stretch brake hose.**

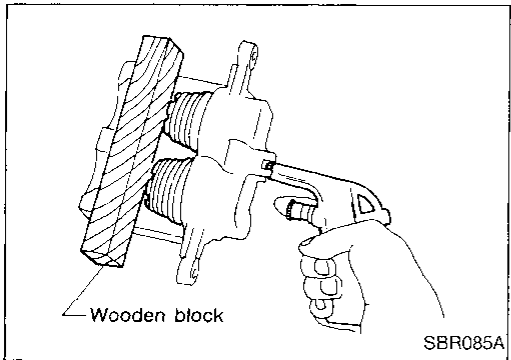

## Disassembly

### WARNING:

Do not place your fingers in front of piston.

### CAUTION:

Do not scratch or score cylinder wall.

1. Push out piston with dust seal with compressed air.
2. Remove piston seal with a suitable tool.

## Inspection — Caliper

### CYLINDER BODY

- Check inside surface of cylinder for score, rust, wear, damage or presence of foreign objects. If any of the above conditions are observed, replace cylinder body.
- Minor damage from rust or foreign objects may be eliminated by polishing surface with a fine emery paper. Replace cylinder body if necessary.

### CAUTION:

Use brake fluid to clean. Never use mineral oil.

### PISTON

Check piston for score, rust, wear, damage or presence of foreign objects. Replace if any of the above conditions are observed.

### CAUTION:

Piston sliding surface is plated. Do not polish with emery paper even if rust or foreign objects are stuck to sliding surface.

### SLIDE PIN, PIN BOLT AND PIN BOOT

Check for wear, cracks, rust or other damage. Replace if any of the above conditions are observed.

# FRONT DISC BRAKE

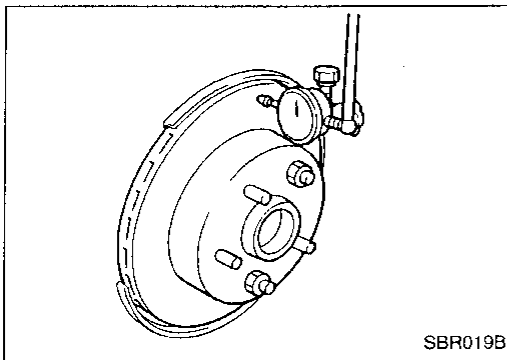

## Inspection — Rotor

### RUNOUT

1. Secure rotor to wheel hub with at least two nuts (M12 x 1.25).
2. Check runout using a dial indicator.

**Make sure that wheel bearing axial end play is within the specifications before measuring. Refer to "Front Wheel Bearing" in FA section.**

**Maximum runout:  
0.1 mm (0.004 in)**

3. If the runout is out of specification, find minimum runout position as follows:
  - a. Remove nuts and rotor from wheel hub.
  - b. Shift the rotor one hole and secure rotor to wheel hub with nuts.
  - c. Measure runout.
  - d. Repeat steps a. to c. so that minimum runout position can be found.
4. If the runout is still out of specification, turn rotor with on-car brake lathe ("MAD, DL-8700", "AMMCO 700 and 705" or equivalent).

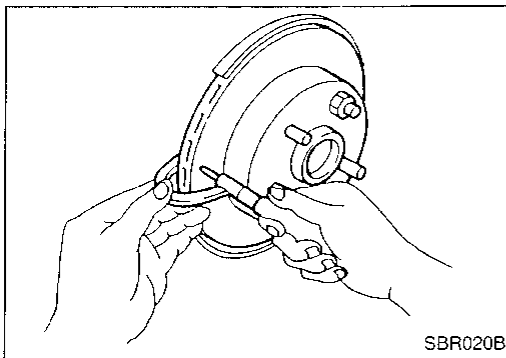

### THICKNESS

**Thickness variation (At least 8 positions):  
Maximum 0.015 mm (0.0006 in)**

If thickness variation exceeds the specification, turn rotor with on-car brake lathe.

**Rotor repair limit:  
26.0 mm (1.024 in)**

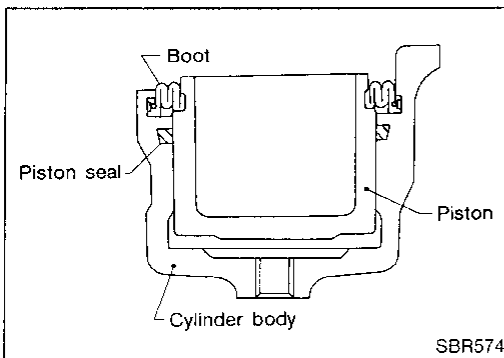

### Assembly

1. Insert piston seal into groove on cylinder body.
2. With piston boot fitted to piston, insert piston boot into groove on cylinder body and install piston.
3. Properly secure piston boot

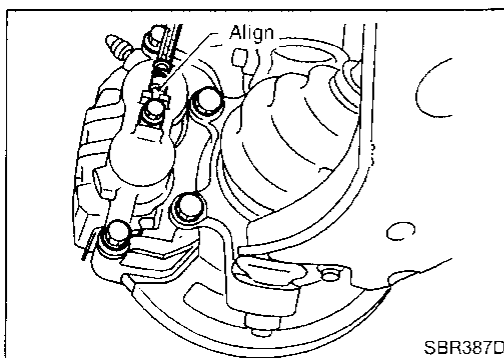

### Installation

#### CAUTION:

- Refill with new brake fluid "DOT 3".
  - Never reuse drained brake fluid.
1. Install caliper assembly.
  2. Install brake hose to caliper securely.
  3. Install all parts and secure all bolts.
  4. Bleed air. Refer to "Bleeding Brake System", BR-5.

GI  
MA  
EM  
LC  
EC  
FE  
AT  
TF  
PD  
FA  
RA  
BR  
ST  
RS  
BT  
HA  
EL  
IDX

# REAR DRUM BRAKE

SEC. 441

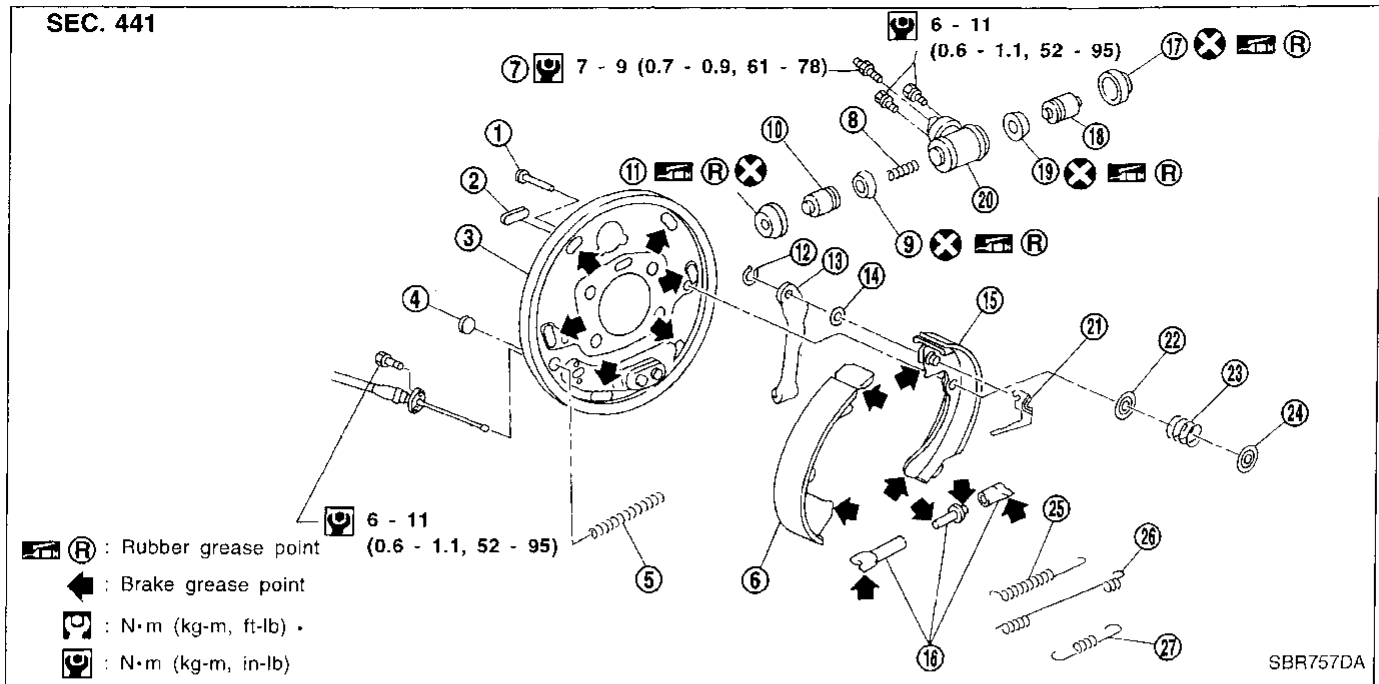

SBR757DA

- |                       |                 |                        |                         |
|-----------------------|-----------------|------------------------|-------------------------|
| ① Shoe hold pin       | ⑧ Spring        | ⑬ Shoe (trailing side) | ⑳ Spring seat           |
| ② Plug                | ⑨ Piston cup    | ⑭ Adjuster             | ㉑ Shoe hold spring      |
| ③ Back plate          | ⑩ Piston        | ⑮ Boot                 | ㉒ Retainer              |
| ④ Check plug          | ⑪ Boot          | ⑯ Piston               | ㉓ Adjuster spring       |
| ⑤ Spring              | ⑫ Retainer ring | ⑰ Piston cup           | ㉔ Return spring (upper) |
| ⑥ Shoe (leading side) | ⑬ Toggle lever  | ⑱ Wheel cylinder       | ㉕ Return spring (lower) |
| ⑦ Air bleeder         | ⑭ Wave washer   | ㉖ Adjuster lever       |                         |

## Removal

### WARNING:

Clean brake lining with a vacuum dust collector to minimize the hazard of airborne asbestos or other materials.

### CAUTION:

Make sure parking brake lever is released completely.

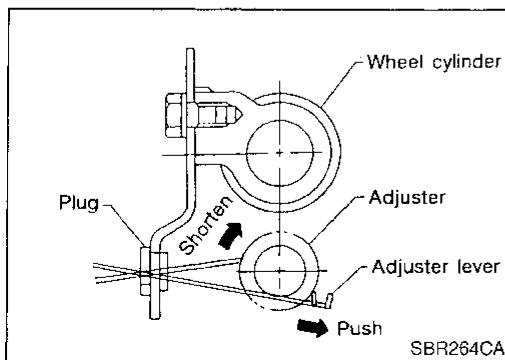

SBR264CA

1. Release parking brake lever fully, then remove drum.
- If drum is hard to remove, the following procedures should be carried out.
- a. Remove plug. Then shorten adjuster to make clearance between brake shoe and drum as shown.

# REAR DRUM BRAKE

## Removal (Cont'd)

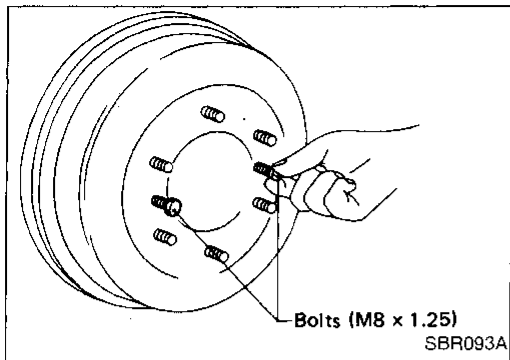

b. Tighten the two bolts gradually.

CI

MA

EM

LC

EC

FE

AT

TF

PD

FA

RA

BR

ST

RS

BT

HA

EL

IDX

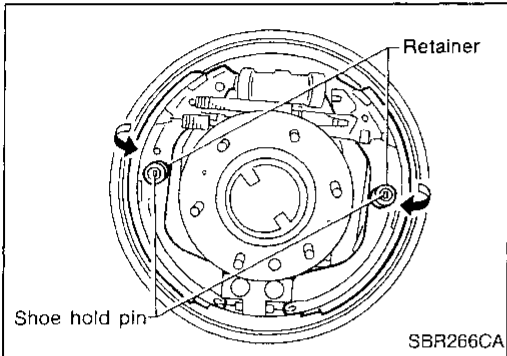

2. After removing shoe hold pin by rotating push retainer, remove leading shoe then remove trailing shoe. Remove spring by rotating shoes in direction arrow.

**Be careful not to damage wheel cylinder piston boots.**

3. Remove adjuster.

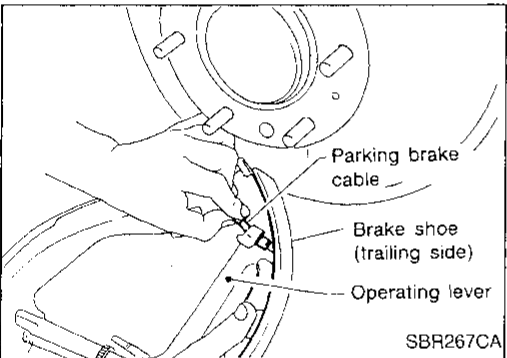

4. Disconnect parking brake cable from toggle lever.

**Be careful not to damage parking brake cable when separating it.**

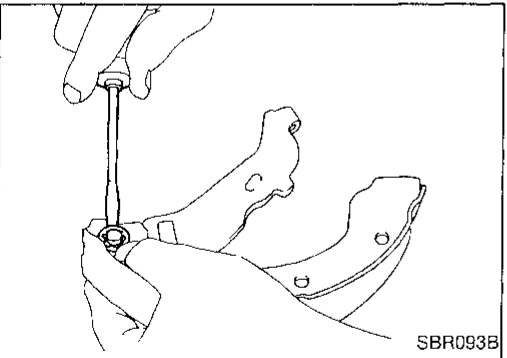

5. Remove retainer ring with a suitable tool. Then separate toggle lever and brake shoe.

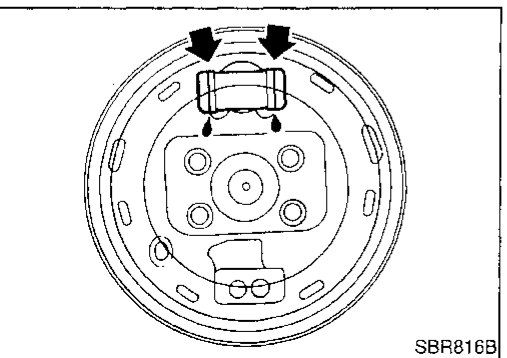

## Inspection — Wheel Cylinder

- Check wheel cylinder for leakage.
- Check for wear, damage and loose conditions. Replace if any such condition exists.



# REAR DRUM BRAKE

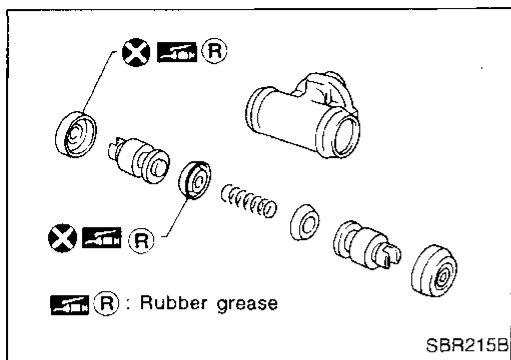

## Wheel Cylinder Overhaul

- Check all internal parts for wear, rust and damage. Replace if necessary.
- Pay attention so as not to scratch cylinder when installing pistons.

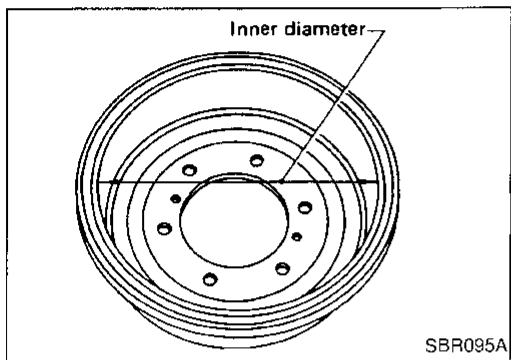

## Inspection — Drum

Maximum inner diameter:

296.5 mm (11.67 in)

Out-of-roundness:

0.03 mm (0.0012 in) or less

- Contact surface should be fine finished with No. 120 to 150 emery paper.
- Using a drum lathe, lathe brake drum if it shows scoring, partial wear or stepped wear.
- After brake drum has been completely reconditioned or replaced, check drum and shoes for proper contact pattern.

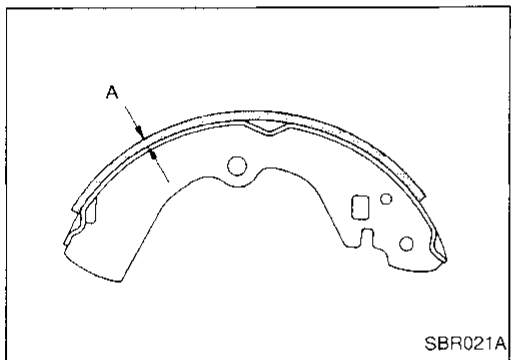

## Inspection — Lining

Check lining thickness.

Standard lining thickness:

6.1 mm (0.240 in)

Lining wear limit (A):

1.5 mm (0.059 in)

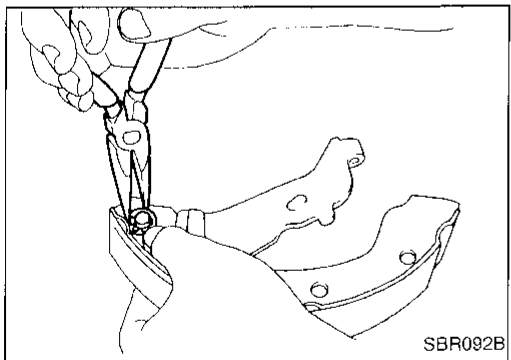

## Installation

Always perform shoe clearance adjustment. Refer to BR-27.

1. Fit toggle lever to brake shoe (trailing side) with retainer ring.
2. Apply brake grease to the contact areas (indicated by arrows and hatching) shown at left.

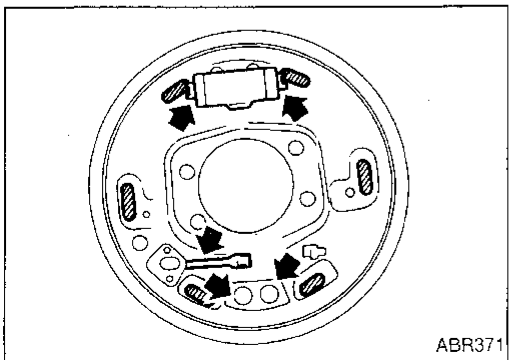

# REAR DRUM BRAKE

## Installation (Cont'd)

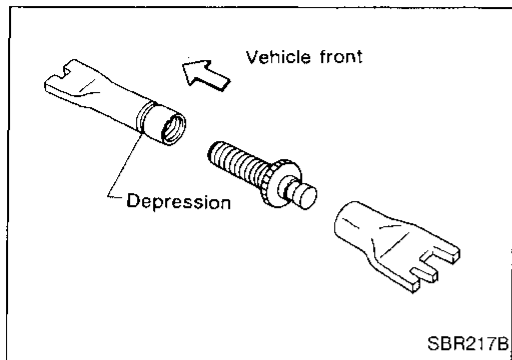

3. Shorten adjuster by rotating it.

- Pay attention to direction of adjuster.

Wheel	Screw	Depression
Left	Left-hand thread	Yes
Right	Right-hand thread	No

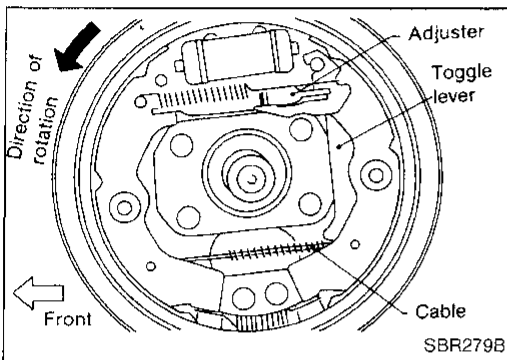

4. Connect parking brake cable to toggle lever.

5. Install all parts.

**Be careful not to damage wheel cylinder piston boots.**

6. Check all parts are installed properly.

**Pay attention to direction of adjuster assembly.**

7. Install brake drum.

8. When installing new wheel cylinder or overhauling wheel cylinder, bleed air. Refer to "Bleeding Brake System", BR-5.

9. Adjust parking brake. Refer to BR-27.

GI

MA

EM

LC

EC

FE

AT

TF

PD

FA

RA

**BR**

ST

RS

BT

HA

EL

IDX



# PARKING BRAKE CONTROL

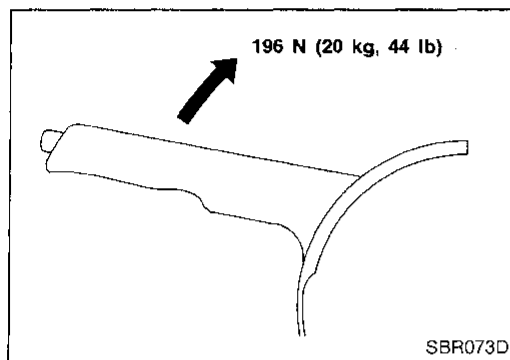
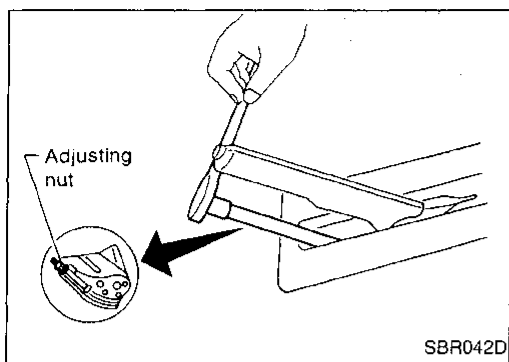

## Adjustment

1. Adjust clearance between shoe and drum as follows:
  - a. Release parking brake lever and loosen adjusting nut.
  - b. Depress brake pedal fully at least 10 times with engine running.
2. Pull control lever 4 - 5 notches. Then adjust control lever by turning adjusting nut.

3. Pull control lever with specified amount of force. Check lever stroke and ensure smooth operation.

**Number of notches: 6 - 8**

4. Bend warning lamp switchplate to ensure:
  - Warning lamp comes on when lever is lifted "A" notches.
  - Warning lamp goes out when lever is fully released.

**Number of "A" notches : 1 or less**

GI

MA

EM

LC

EC

FE

AT

TF

PD

FA

RA

**BR**

ST

RS

BT

HA

EL

IDX

# ANTI-LOCK BRAKE SYSTEM

## Purpose

The Anti-Lock Brake System (ABS) consists of electronic and hydraulic components. It allows for control of braking force so locking of the wheels can be avoided.

The ABS:

- 1) Improves proper tracking performance through steering wheel operation.
- 2) Eases obstacle avoidance through steering wheel operation.
- 3) Improves vehicle stability.

## Operation

- When the vehicle speed is less than 10 km/h (6 MPH) this system does not work.
- The Anti-Lock Brake System (ABS) has a self-test function. The system turns on the ABS warning lamp for 1 second each time the ignition switch is turned "ON". After the engine is started, the ABS warning lamp turns off. The system performs a test the first time the vehicle reaches 6 km/h (4 MPH). A mechanical noise may be heard as the ABS performs this self-test. This is a normal part of the self-test feature. If a malfunction is found during this check, the ABS warning lamp will stay on.
- While driving, a mechanical noise may be heard during ABS operation. This is a normal condition.

## ABS Hydraulic Circuit

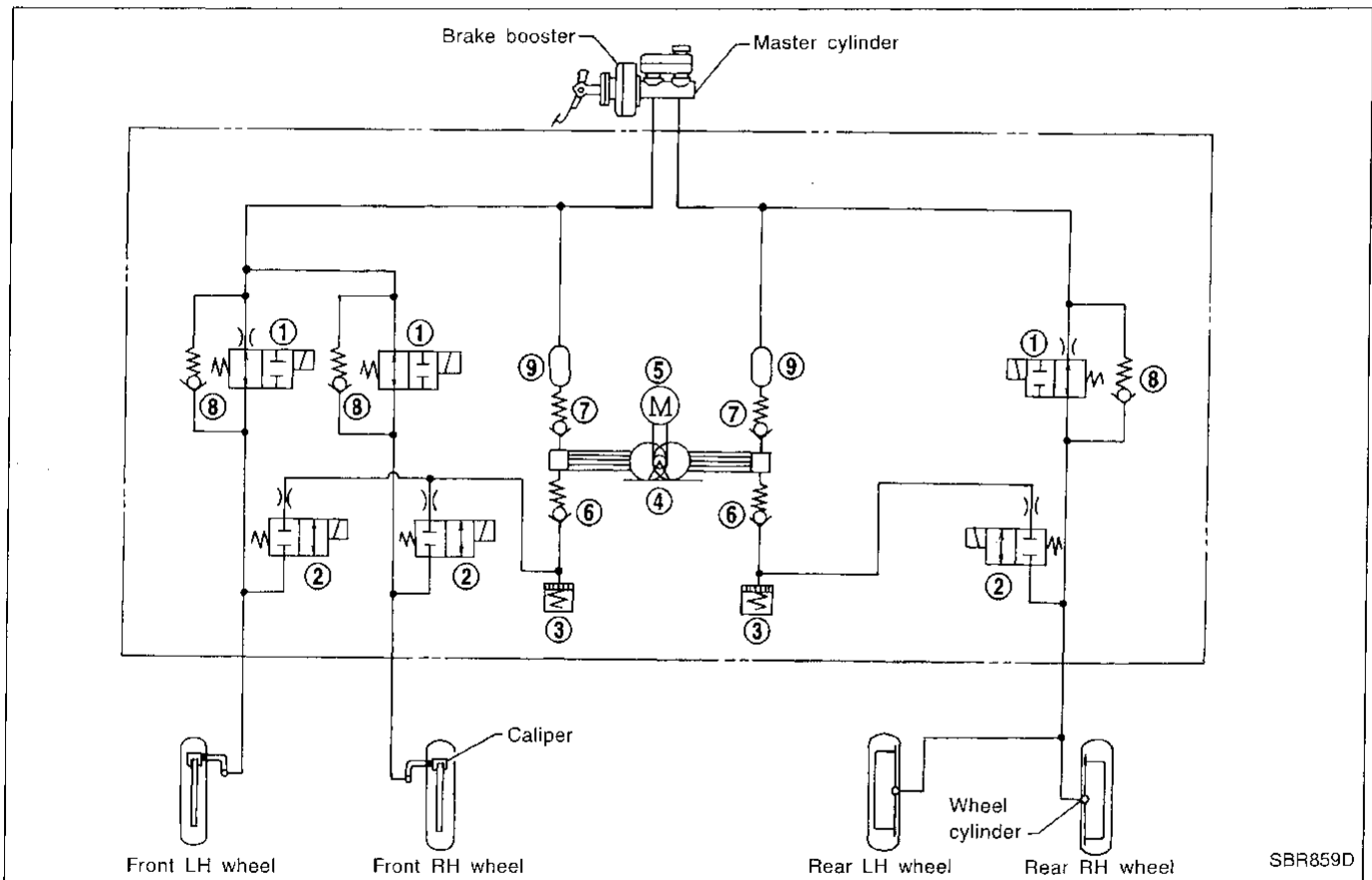

- |                         |               |                      |
|-------------------------|---------------|----------------------|
| ① Inlet solenoid valve  | ④ Pump        | ⑦ Outlet valve       |
| ② Outlet solenoid valve | ⑤ Motor       | ⑧ Bypass check valve |
| ③ Reservoir             | ⑥ Inlet valve | ⑨ Damper             |

## System Components

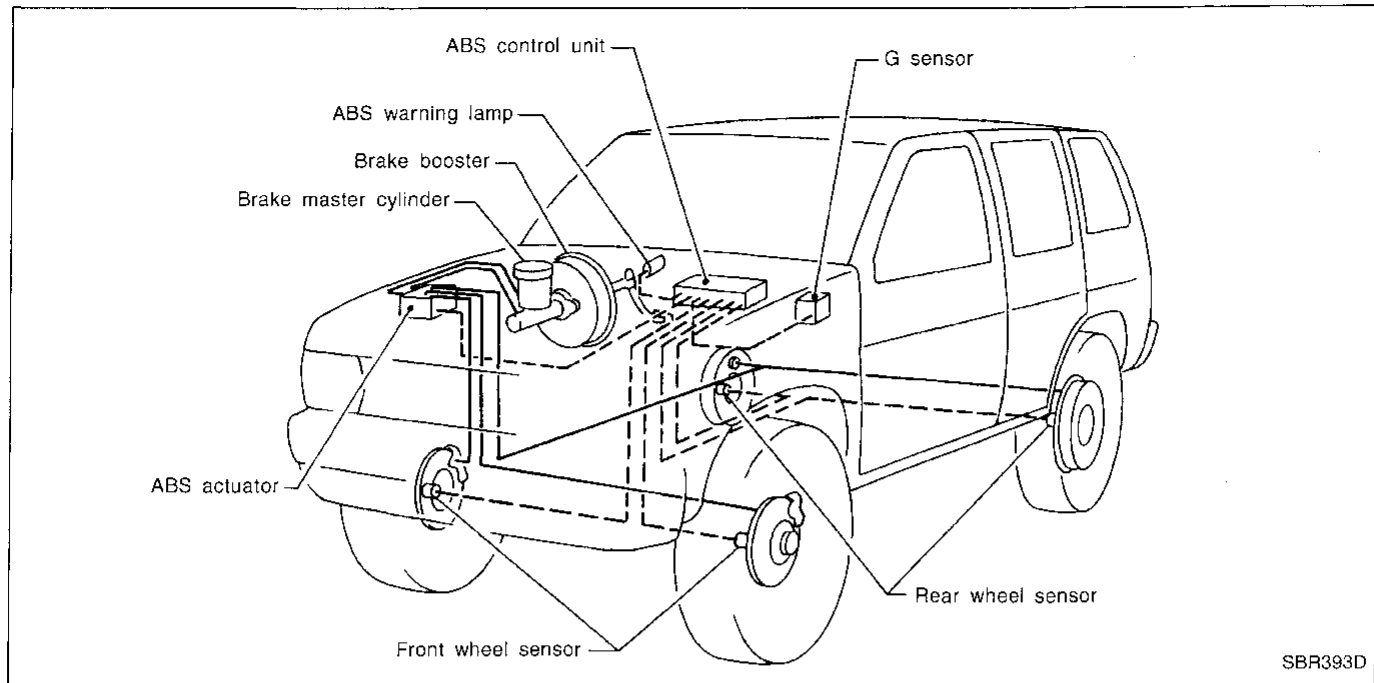

GI  
MA  
EM  
LC  
EC  
FE  
AT  
TF  
PD  
FA  
RA

**BR**

ST  
RS  
BT  
HA  
EL  
DX

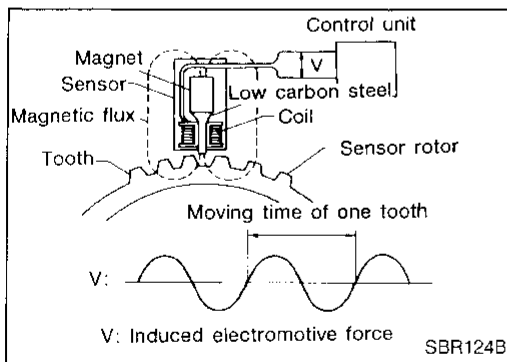

## System Description

### SENSOR

The sensor unit consists of a gear-shaped sensor rotor and a sensor element. The element contains a bar magnet around which a coil is wound. The sensor is installed on the back of the brake rotor and the back of the rear brake drum. As the wheel rotates, the sensor generates a sine-wave pattern. The frequency and voltage increase(s) as the rotating speed increases.

### CONTROL UNIT

The control unit computes the wheel rotating speed by the signal current sent from the sensor. Then it supplies a DC current to the actuator solenoid valve. It also controls ON-OFF operation of the valve relay and motor relay. If any electrical malfunction should be detected in the system, the control unit causes the warning lamp to light up. In this condition, the ABS will be deactivated by the control unit, and the vehicle's brake system reverts to normal operation.

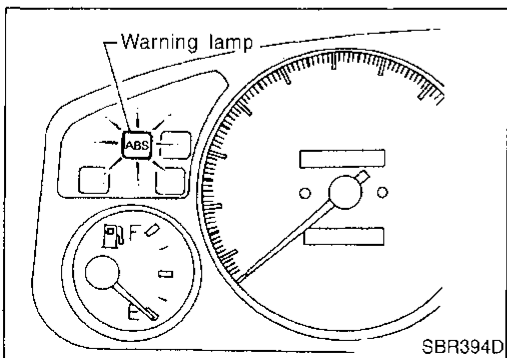

# ANTI-LOCK BRAKE SYSTEM

## System Description (Cont'd)

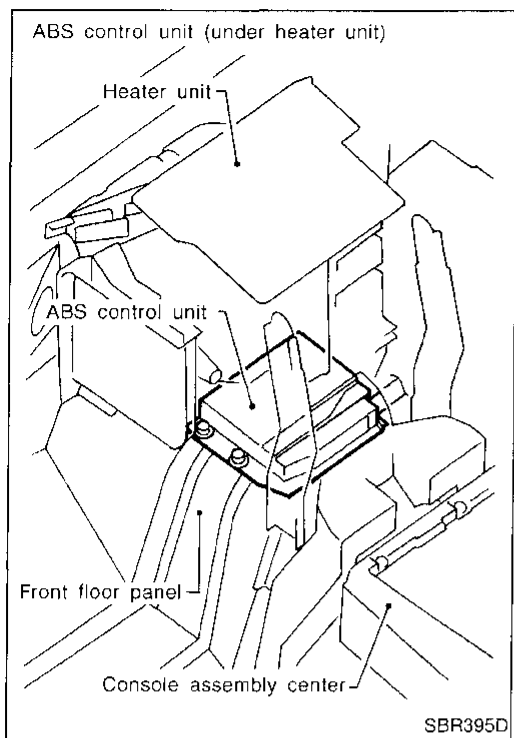

### G SENSOR

The G sensor senses deceleration during braking to determine whether the vehicle is being driven on a high  $\mu$  road (asphalt road, etc.) or a low  $\mu$  road (snow-covered road, etc.). It then sends a signal to the ABS control unit.

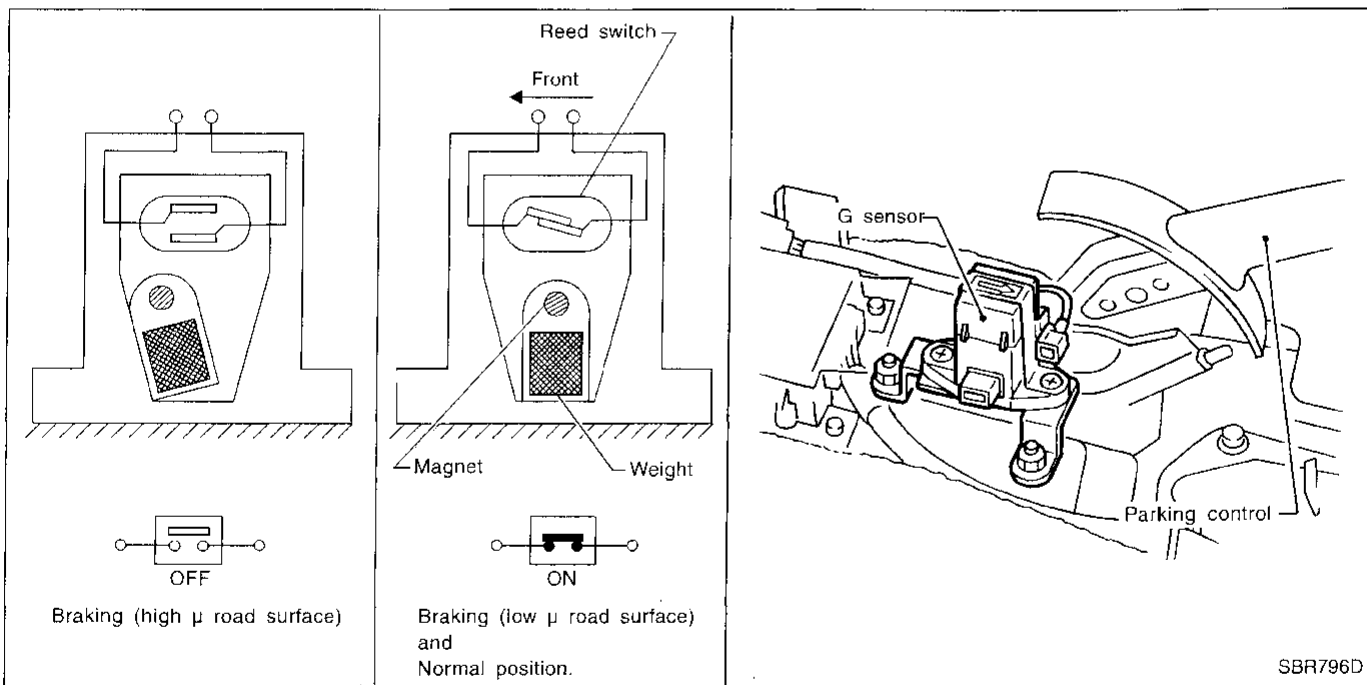

The reed switch turns on when it is affected by a magnetic field. During sudden deceleration (braking on a high  $\mu$  road), the weight moves and the magnet in the weight moves away from the reed switch. The magnetic field then diminishes and the reed switch turns off.

# ANTI-LOCK BRAKE SYSTEM

## System Description (Cont'd)

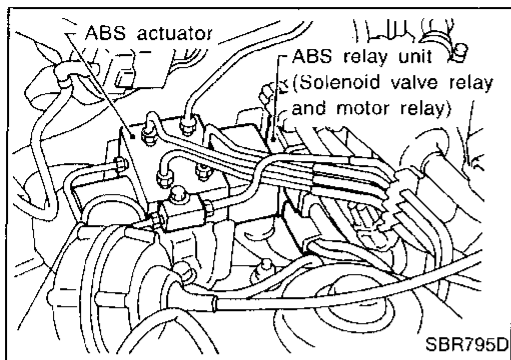

### ACTUATOR

The actuator contains:

- An electric motor and pump
- Two relays
- Six solenoid valves, each inlet and outlet for
  - LH front
  - RH front
  - Rear

These components control the hydraulic circuit. The ABS control unit directs the actuator to increase, hold or decrease hydraulic pressure to all or individual wheels.

### ABS actuator operation

		Inlet solenoid valve	Outlet solenoid valve	
Normal brake operation		OFF (Open)	OFF (Closed)	Master cylinder brake fluid pressure is directly transmitted to caliper via the inlet solenoid valve.
ABS operation	Pressure hold	ON (Closed)	OFF (Closed)	Hydraulic circuit is shut off to hold the caliper brake fluid pressure.
	Pressure decrease	ON (Closed)	ON (Open)	Caliper brake fluid is sent to reservoir via the outlet solenoid valve. Then it is pushed up to the master cylinder by pump.
	Pressure increase	OFF (Open)	OFF (Closed)	Master cylinder brake fluid pressure is transmitted to caliper.

GI  
MA  
EM  
LC  
EC  
FE  
AT  
TF  
PD  
FA  
RA  
BR  
ST  
RS  
BT  
HA  
EL  
IDX



# ANTI-LOCK BRAKE SYSTEM

## Removal and Installation

### CAUTION:

Be careful not to damage sensor edge and sensor rotor teeth. When removing the front or rear wheel hub assembly, disconnect the ABS wheel sensor from the assembly and move it away.

### FRONT WHEEL SENSOR

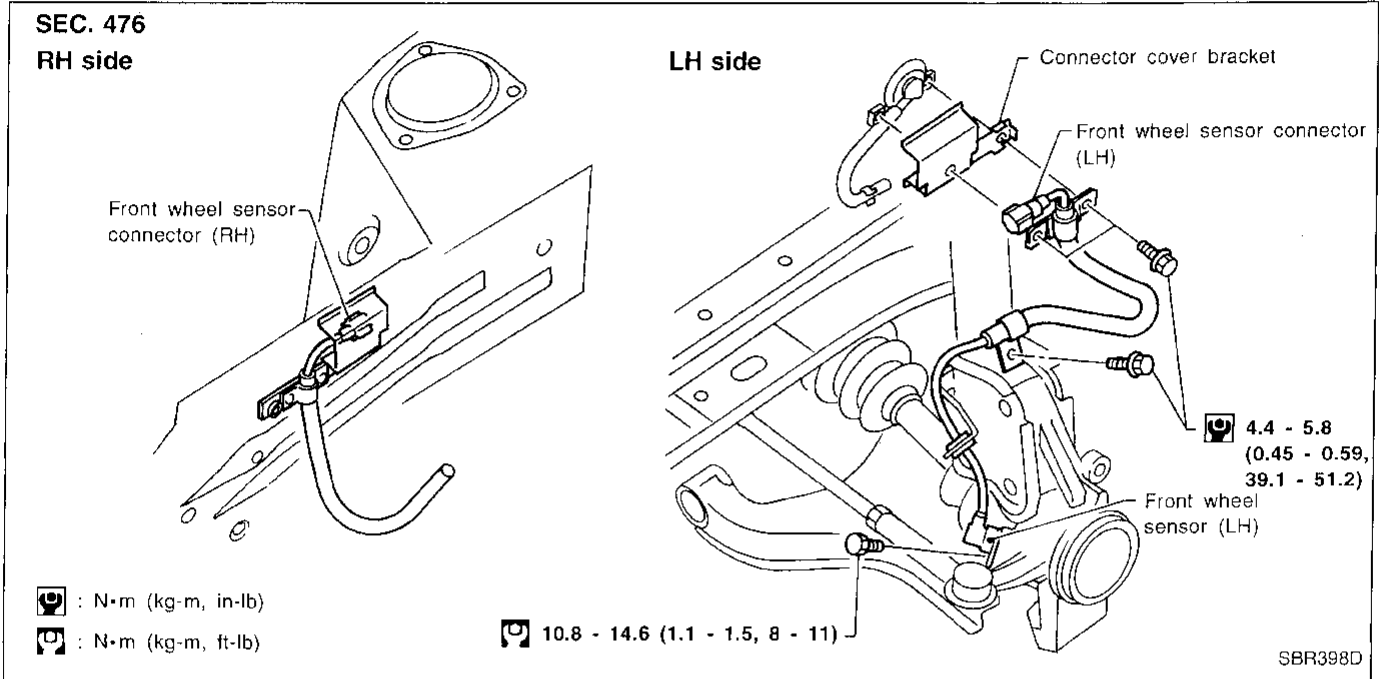

### REAR WHEEL SENSOR

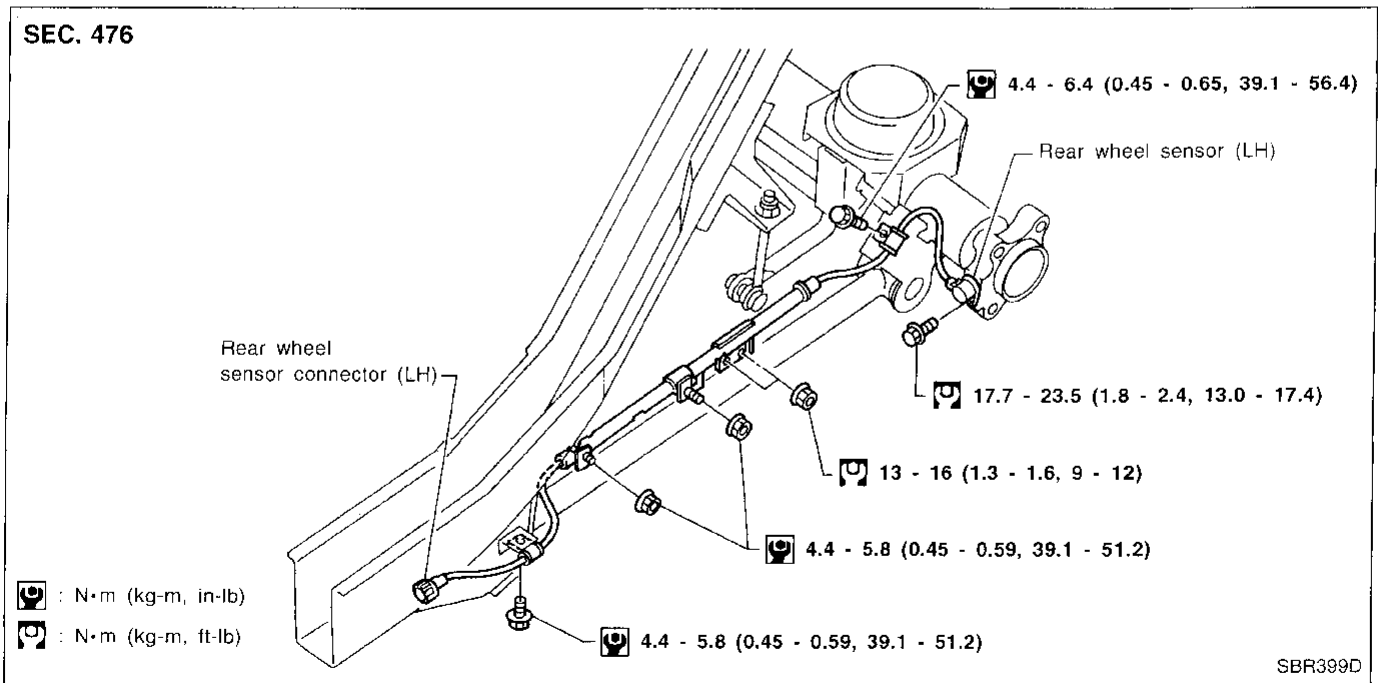

# ANTI-LOCK BRAKE SYSTEM

## Removal and Installation (Cont'd)

### FRONT SENSOR ROTOR

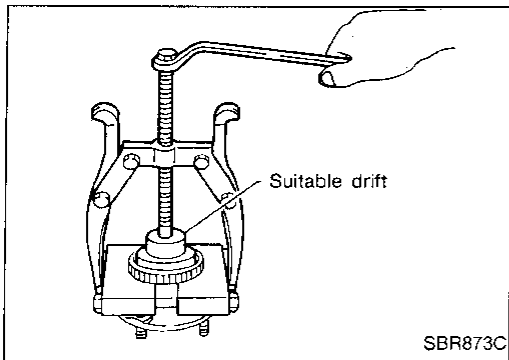

#### Removal

1. Remove the front wheel hub. Refer to FA section ("FRONT AXLE").
2. Remove the sensor rotor using suitable puller, drift and bearing replacer.

GI

MA

EM

LC

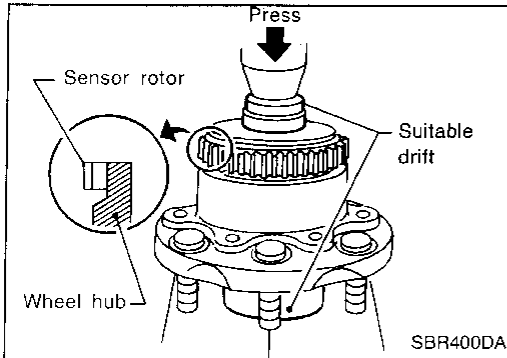

#### Installation

Install the sensor rotor using suitable drift and press.

- Always replace sensor rotor with new one.
- Pay attention to the direction of front sensor rotor as shown in figure.

EC

FE

AT

TF

### REAR SENSOR ROTOR

#### Removal

- Remove the sensor rotor using Tool.

PD

FA

RA

BR

ST

RS

BT

HA

EL

DX

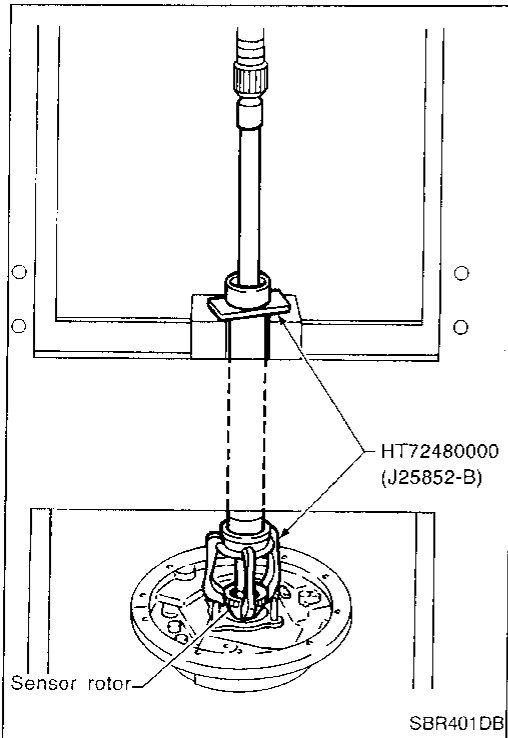

#### Installation

Install the sensor rotor using suitable drift and press.

- Always replace sensor rotor with new one.
- Pay attention to the direction of front sensor rotor as shown in figure.

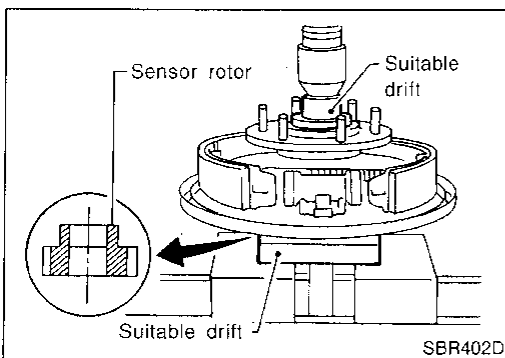

# ANTI-LOCK BRAKE SYSTEM

## Removal and Installation (Cont'd)

### CONTROL UNIT

Location: Under heater unit.

Make sure that the sensor shield ground cable is secured with mounting bolt.

### Removal

1. Remove the floor carpet from the top of the control unit.
2. Remove the 3 bolts (A) securing module and module bracket to the side of floor tunnel.
3. Remove module from the left side of floor tunnel.
4. Disconnect module connector.

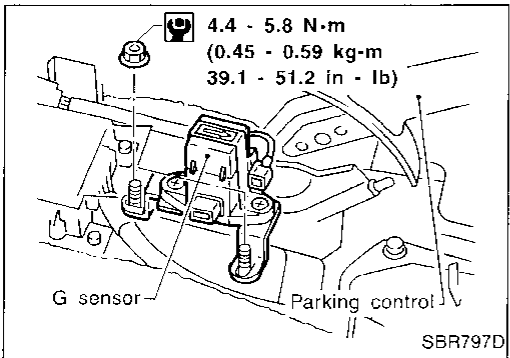
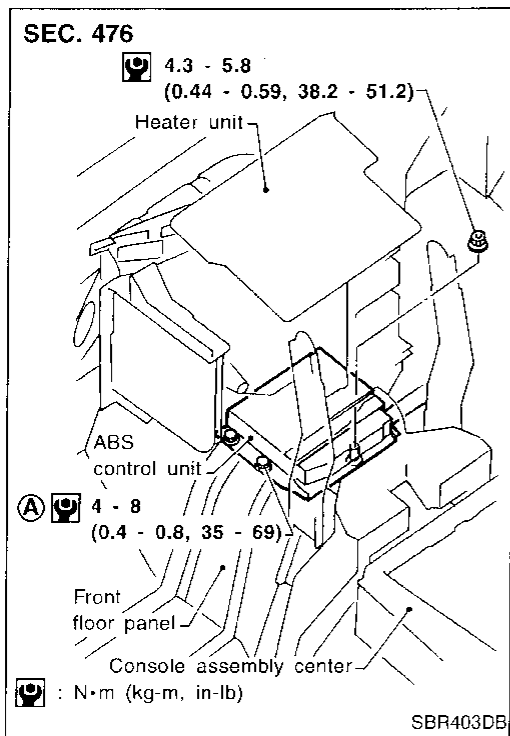

### G SENSOR

Always replace G sensor if bumped or dropped. Otherwise, performance characteristics of G sensor will be changed, which in turn changes ABS control performance characteristics.

# ANTI-LOCK BRAKE SYSTEM

## Removal and Installation (Cont'd)

### ACTUATOR

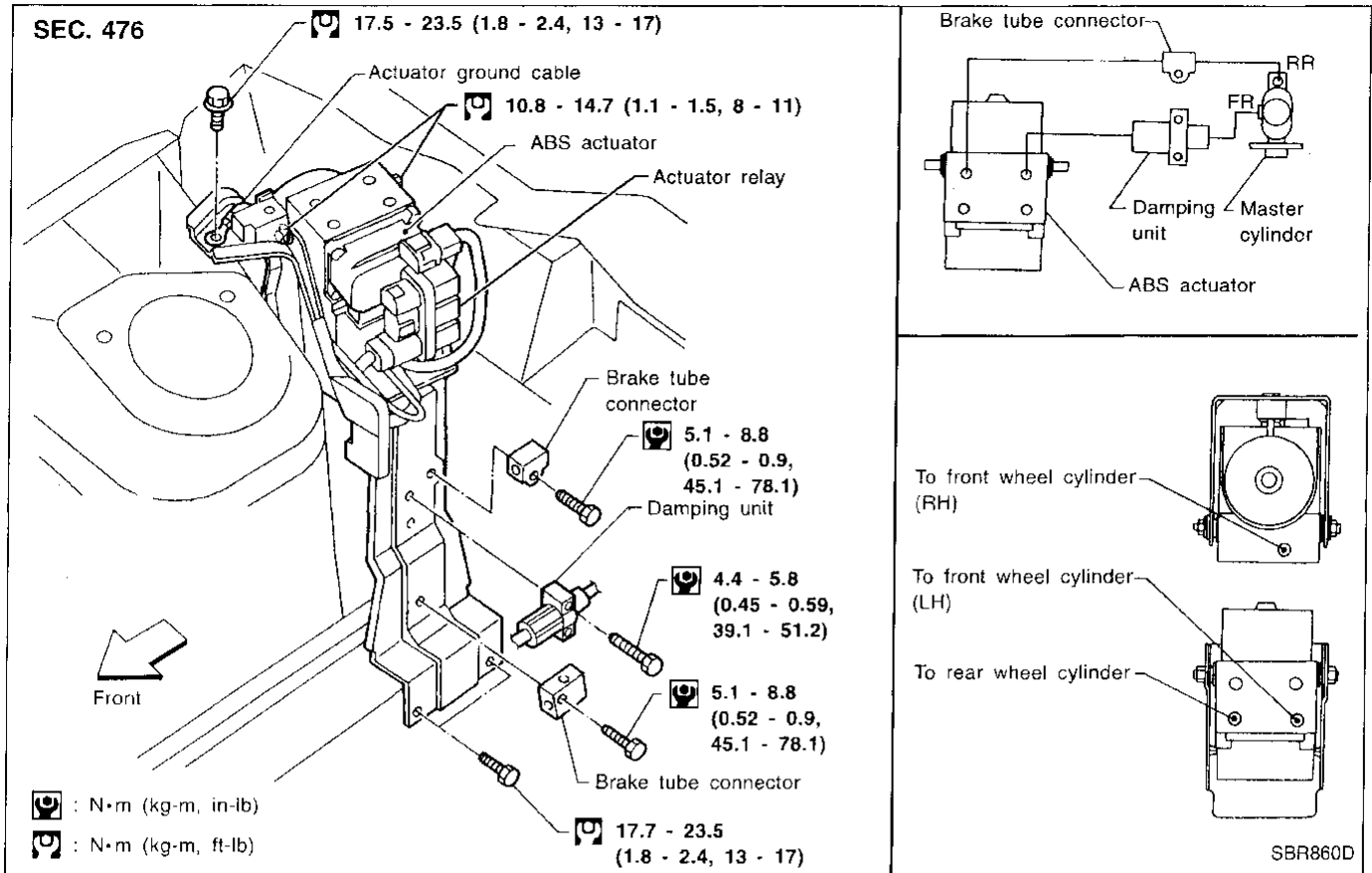

### Removal

1. Disconnect battery cable.
2. Drain brake fluid. Refer to "Changing Brake Fluid", BR-4.
3. Remove mounting bracket fixing bolts and nuts.
4. Disconnect connector, brake pipes and remove fixing nuts and actuator ground cable.

### Installation

#### CAUTION:

After installation, refill brake fluid. Then bleed air. Refer to "Bleeding Brake System", BR-5.

1. Tighten actuator ground cable.

Place ground cable at a notch of mounting bracket.

2. Connect brake pipes temporarily.
3. Tighten fixing bolts and nuts.
4. Tighten brake pipes.
5. Connect connector and battery cable.

### ACTUATOR RELAYS

1. Disconnect battery cable.
2. Remove actuator relay unit.

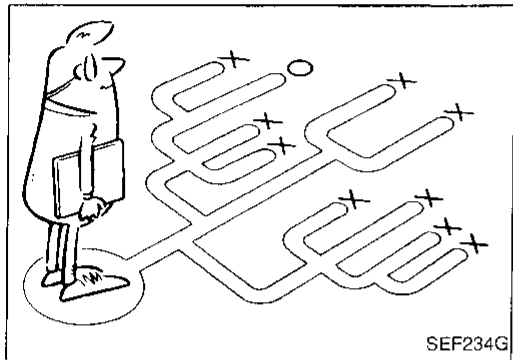
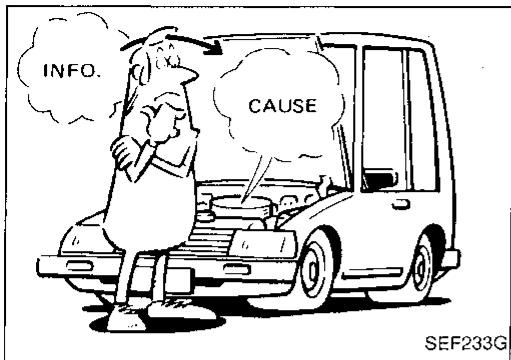

## How to Perform Trouble Diagnoses for Quick and Accurate Repair

### INTRODUCTION

The ABS system has an electronic control unit to control major functions. The control unit accepts input signals from sensors and instantly drives the actuators. It is essential that both kinds of signals are proper and stable. It is also important to check for conventional problems: such as air leaks in booster lines, lack of brake fluid, or other problems with the brake system.

It is much more difficult to diagnose a problem that occurs intermittently rather than continuously. Most intermittent problems are caused by poor electric connections or faulty wiring. In this case, careful checking of suspicious circuits may help prevent the replacement of good parts.

A visual check only may not find the cause of the problems, so a road test should be performed.

Before undertaking actual checks, take a few minutes to talk with a customer who approaches with a ABS complaint. The customer is a very good source of information on such problems; especially intermittent ones. Through the talks with the customer, find out what symptoms are present and under what conditions they occur. Start your diagnosis by looking for "conventional" problems first. This is one of the best ways to troubleshoot brake problems on an ABS controlled vehicle.

GI  
 MA  
 EM  
 LC  
 EC  
 FE  
 AT  
 TF  
 PD  
 FA  
 RA  
**BR**  
 ST  
 RS  
 BT  
 HA  
 EL  
 IIX

## Preliminary Check

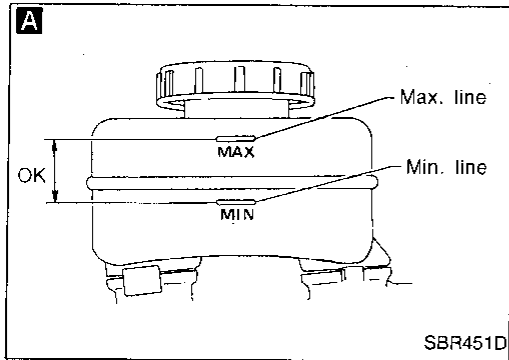

**A**

**Check brake fluid level in reservoir tank.**

Low fluid level may indicate brake pad wear or leakage from brake line.

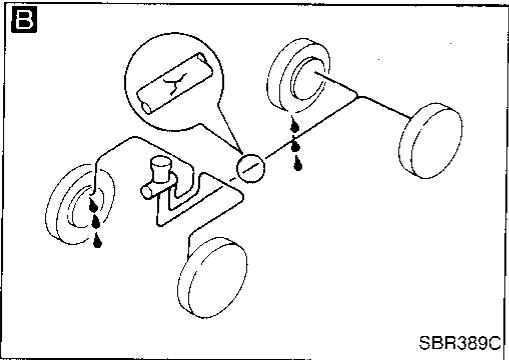

**B**

Check brake line for leakage. NG → Repair.

OK → [down arrow]

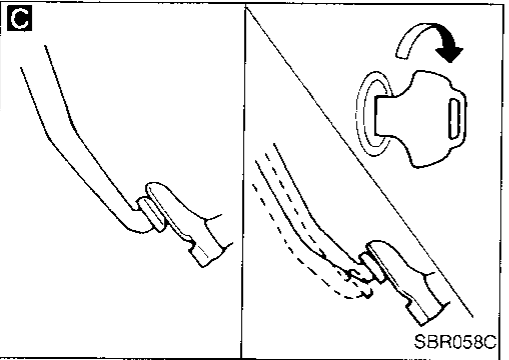

**C**

Check brake booster for operation and air tightness. Refer to BR-15. NG → Replace.

OK → [down arrow]

**D**

Check brake pads and rotor. Refer to BR-18, 21. NG → Replace.

OK → [down arrow]

**A**

Check brake fluid level in reservoir tank again. NG → Fill up brake fluid.

OK → [down arrow]

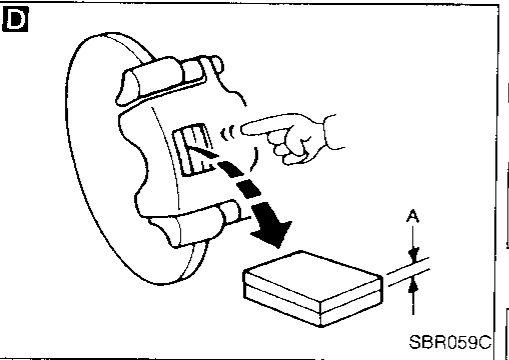

**E**

Check warning lamp activation. When ignition switch is turned on, warning lamp turns on. NG → Check fuse, warning lamp bulb and warning lamp circuit.

OK → [down arrow]

Check warning lamp for deactivation after engine is started. NG → Go to Self-diagnosis, BR-44, 48.

OK → [down arrow]

Drive vehicle at speeds over 30 km/h (20 MPH) for at least one minute.

[down arrow]

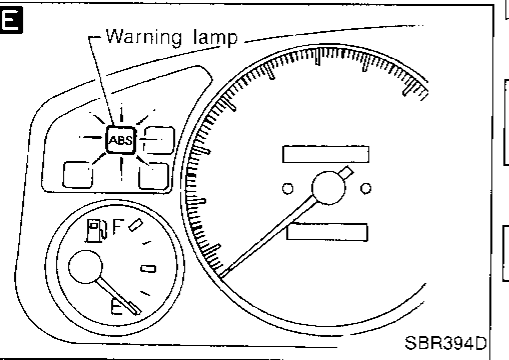

Ensure warning lamp remains off while driving. NG → Go to Self-diagnosis, BR-44, 48.

OK → [down arrow]

END

## Component Parts and Harness Connector Location

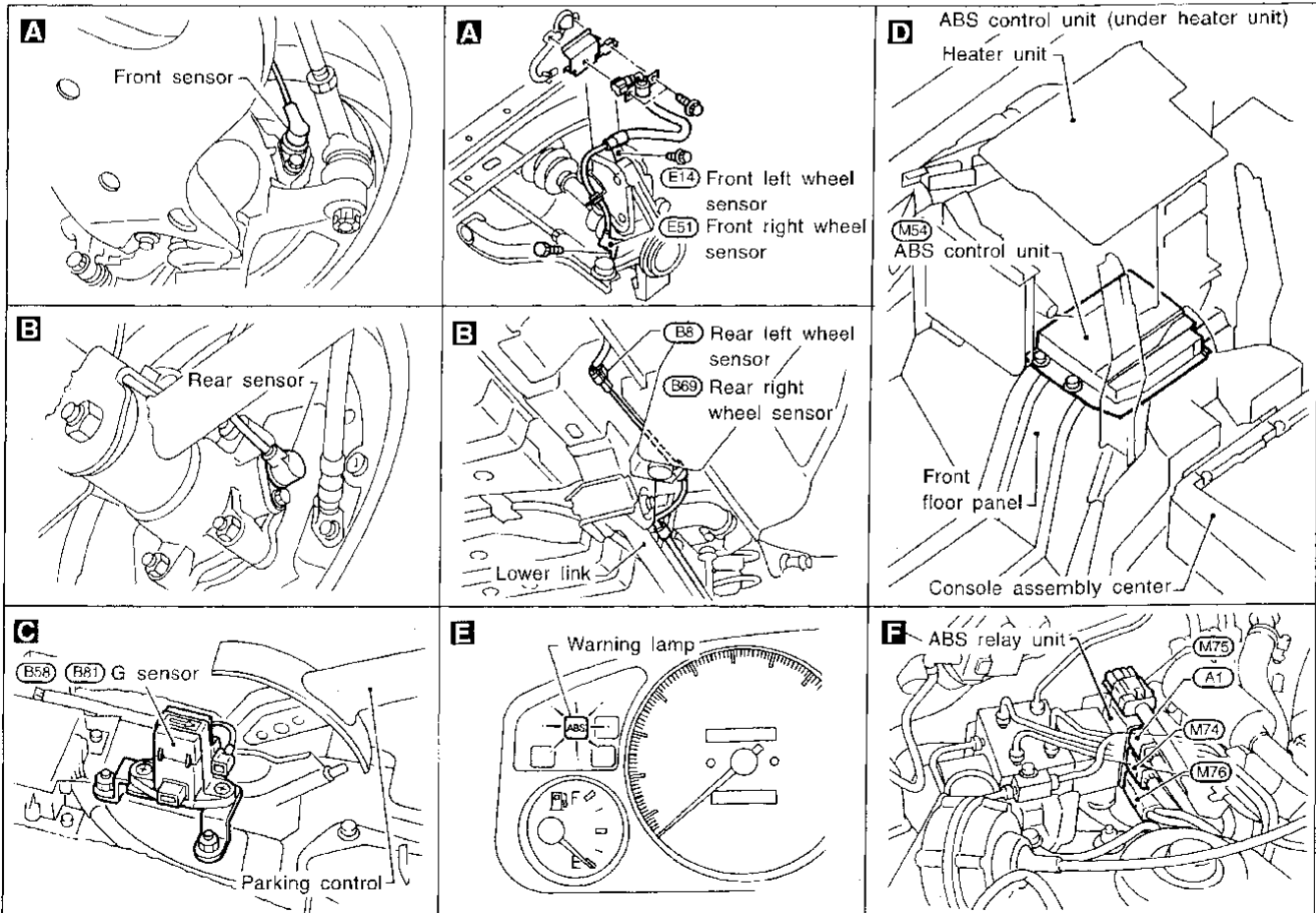
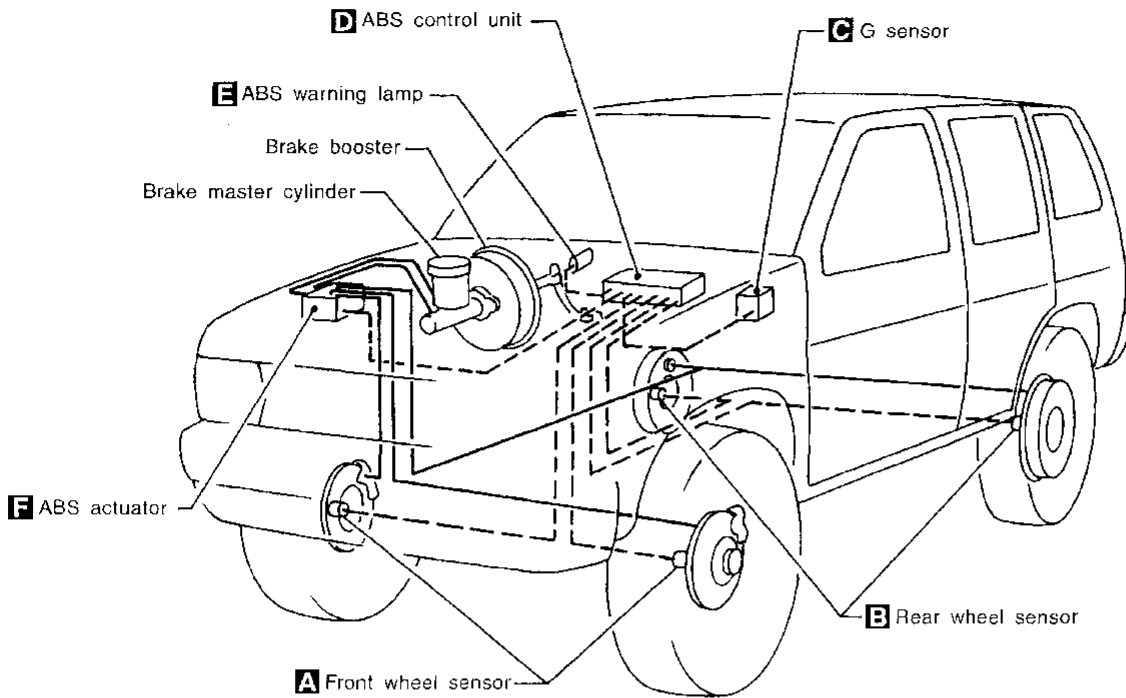

Circuit Diagram for Quick Pinpoint Check

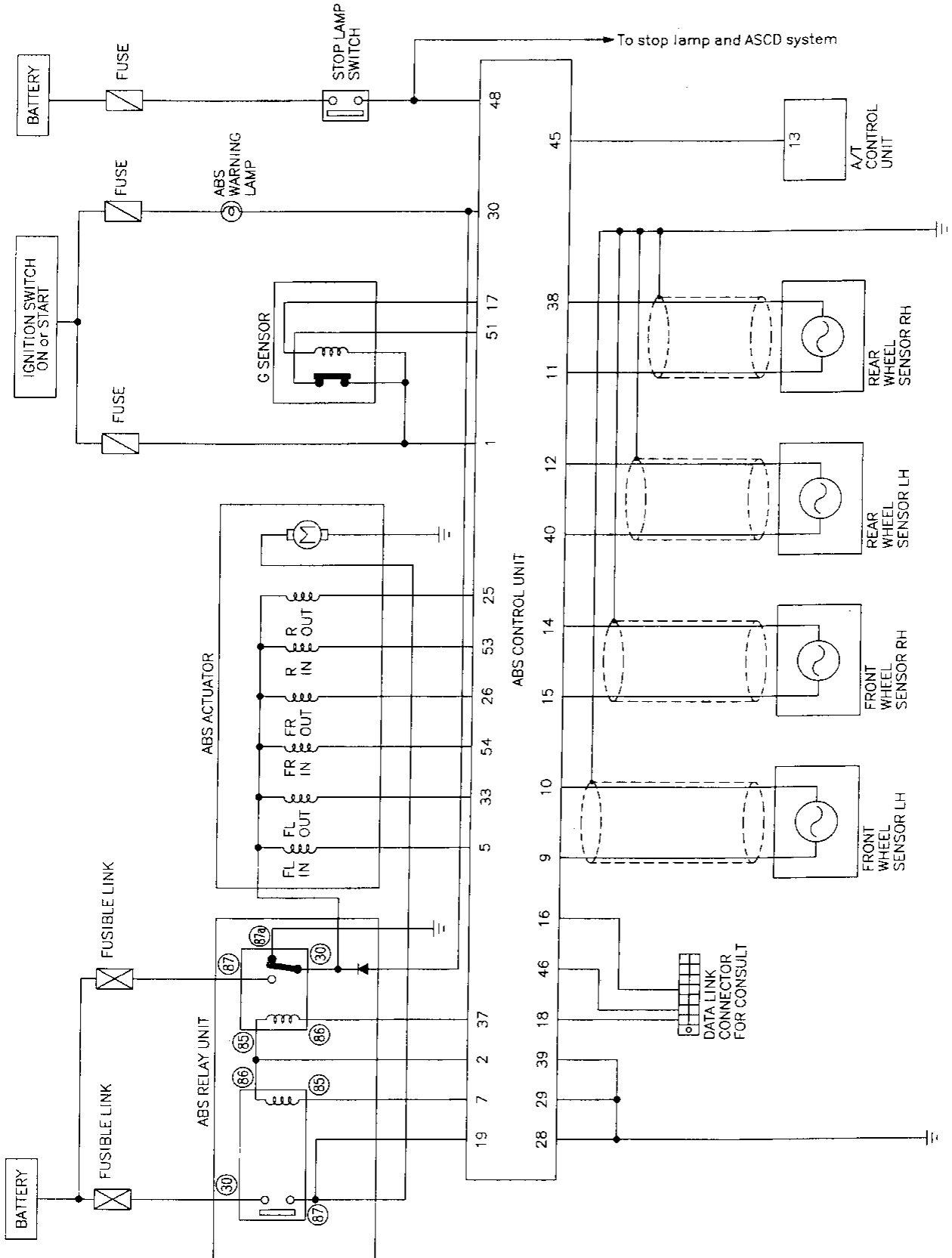

- GI
- MA
- EM
- LC
- EC
- FE
- AT
- TF
- PD
- FA
- RA
- BR**
- ST
- RS
- BT
- HA
- EL
- IDX



Wiring Diagram — ABS —

BR-ABS-01

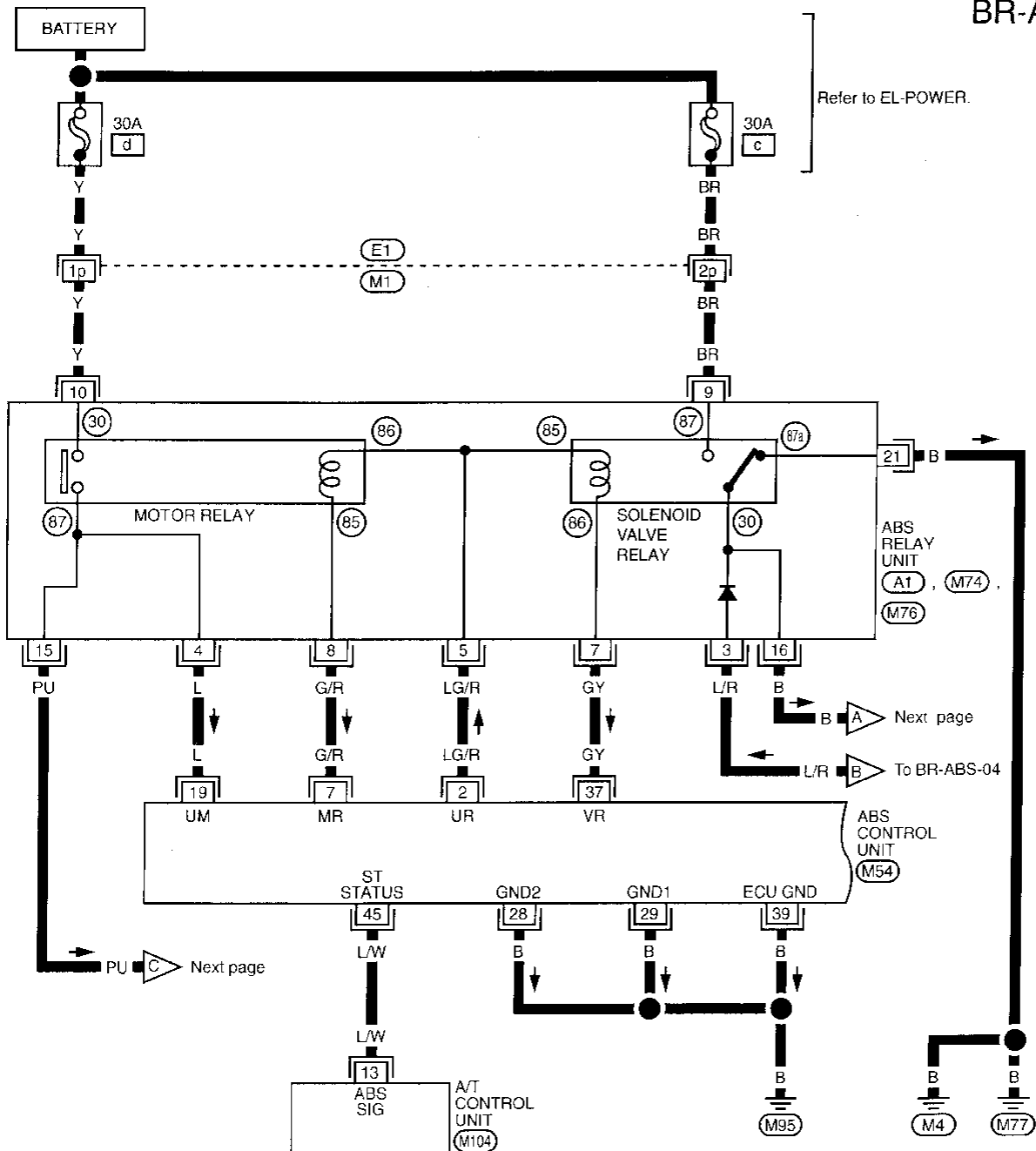

Refer to EL-POWER.

Refer to last page (Foldout page).

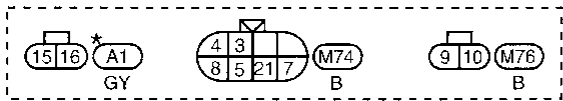

\*: This connector is not shown in "HARNESS LAYOUT", EL section.

E1, M1  
M104

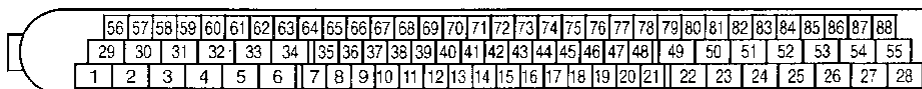

M54  
B  
T.S.

# TROUBLE DIAGNOSES

## Wiring Diagram — ABS — (Cont'd)

BR-ABS-02

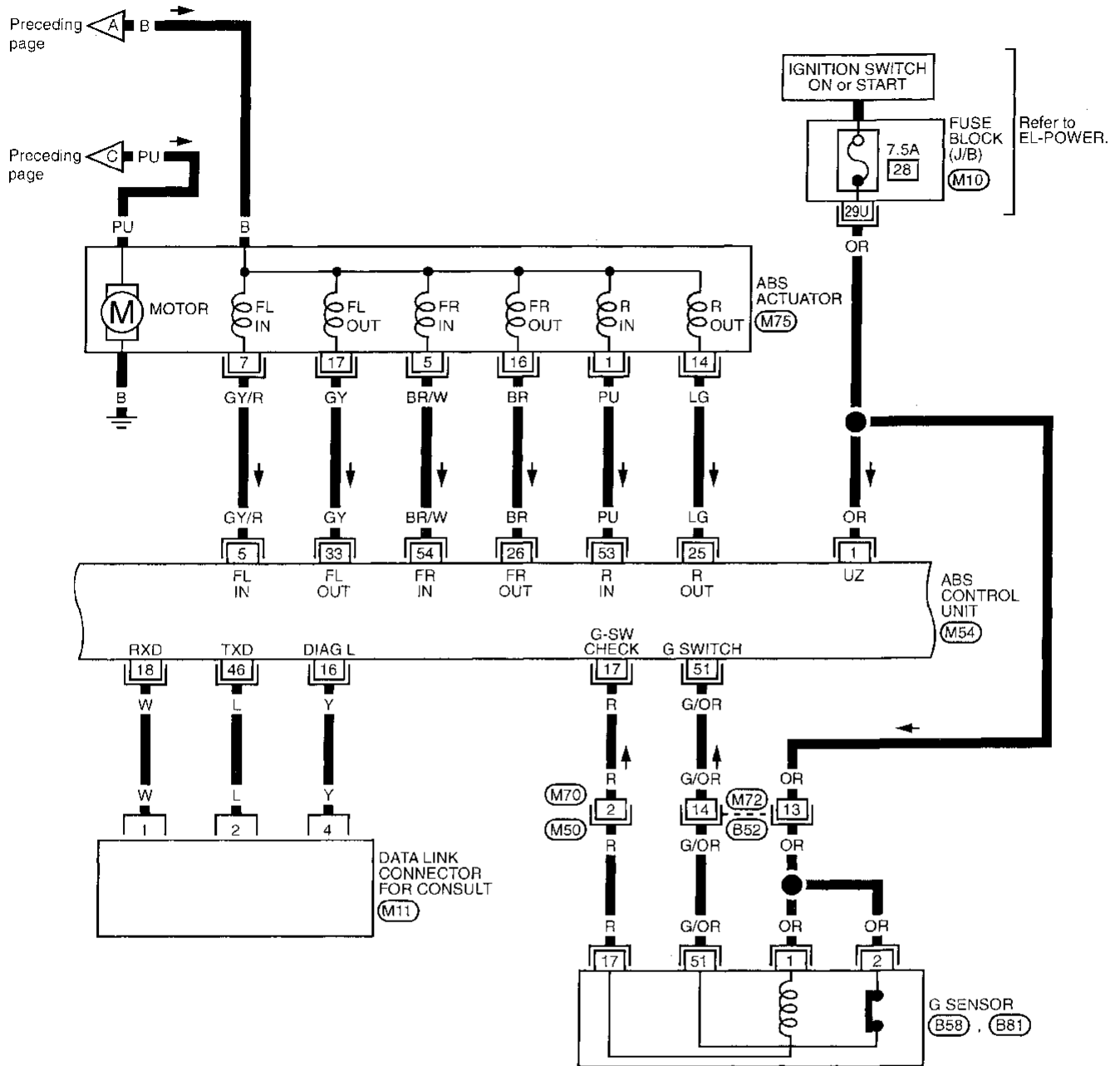

GI  
MA  
EM  
LC  
EC  
FE  
AT  
TF  
PD  
FA  
RA  
**BR**  
ST  
RS  
BT  
HA  
EL  
IDX

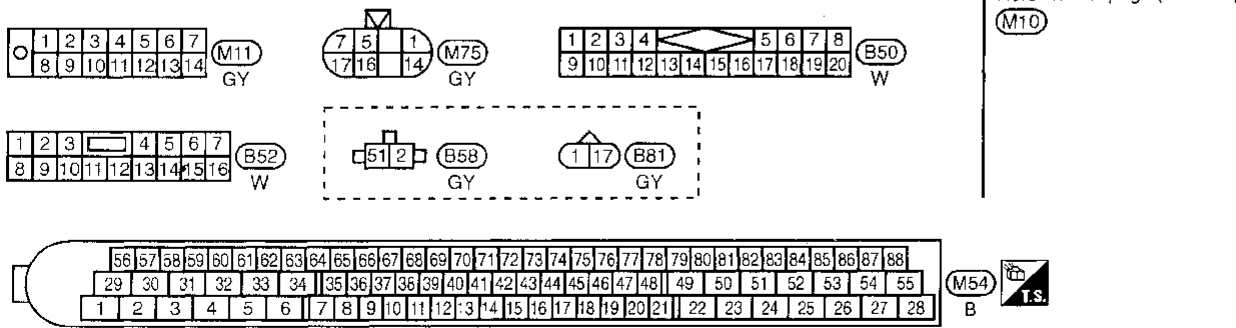

Refer to last page (Foldout page).  
M10

# TROUBLE DIAGNOSES

## Wiring Diagram — ABS — (Cont'd)

BR-ABS-03

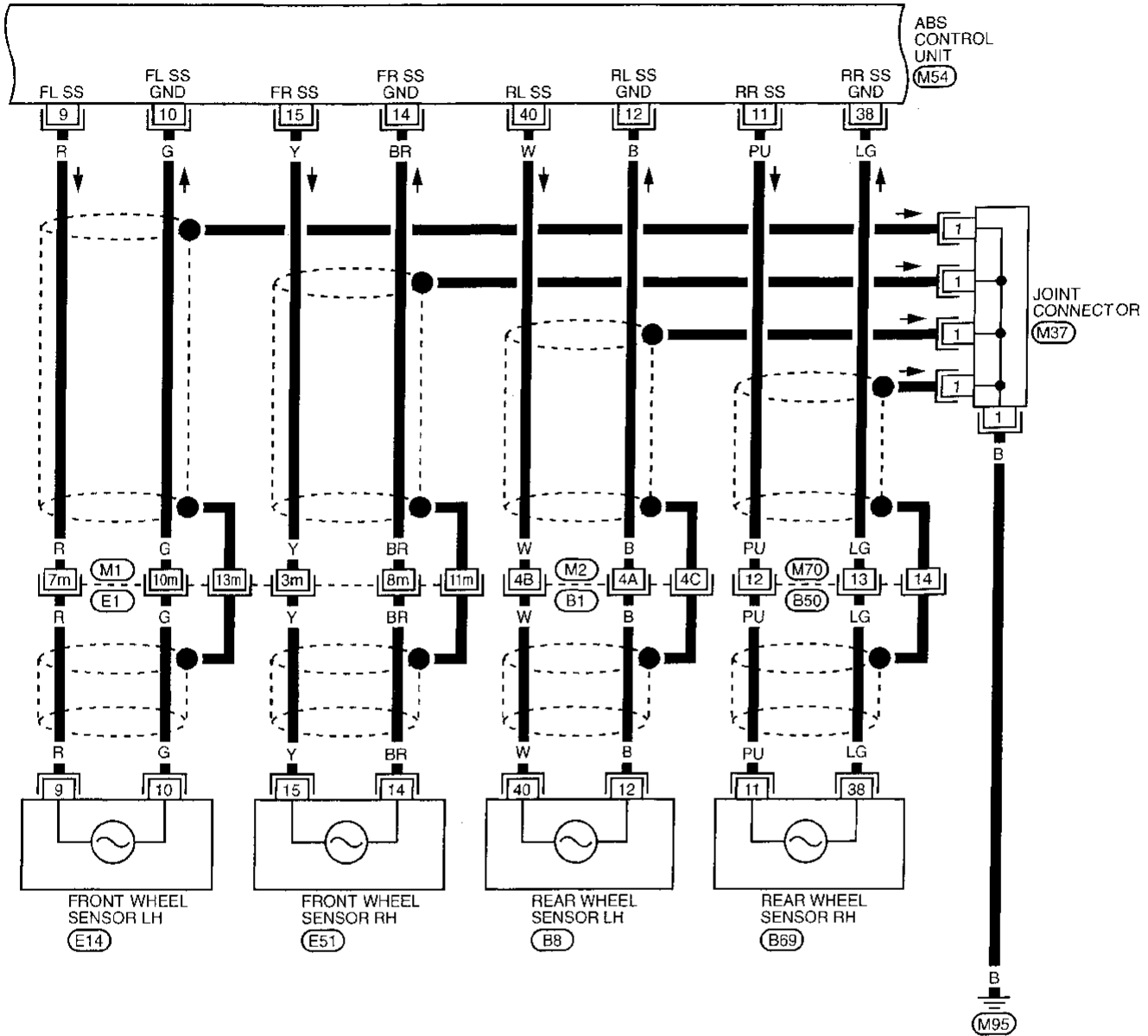

Refer to last page (Foldout page).

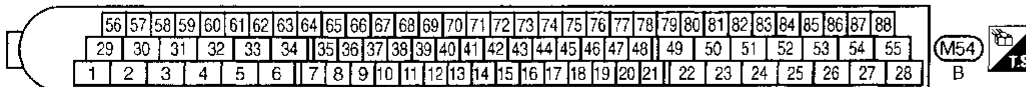
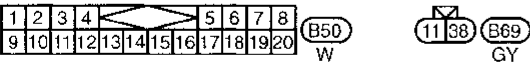

- (E1) (M1)
- (M2) (B1)

# TROUBLE DIAGNOSES

## Wiring Diagram — ABS — (Cont'd)

BR-ABS-04

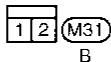
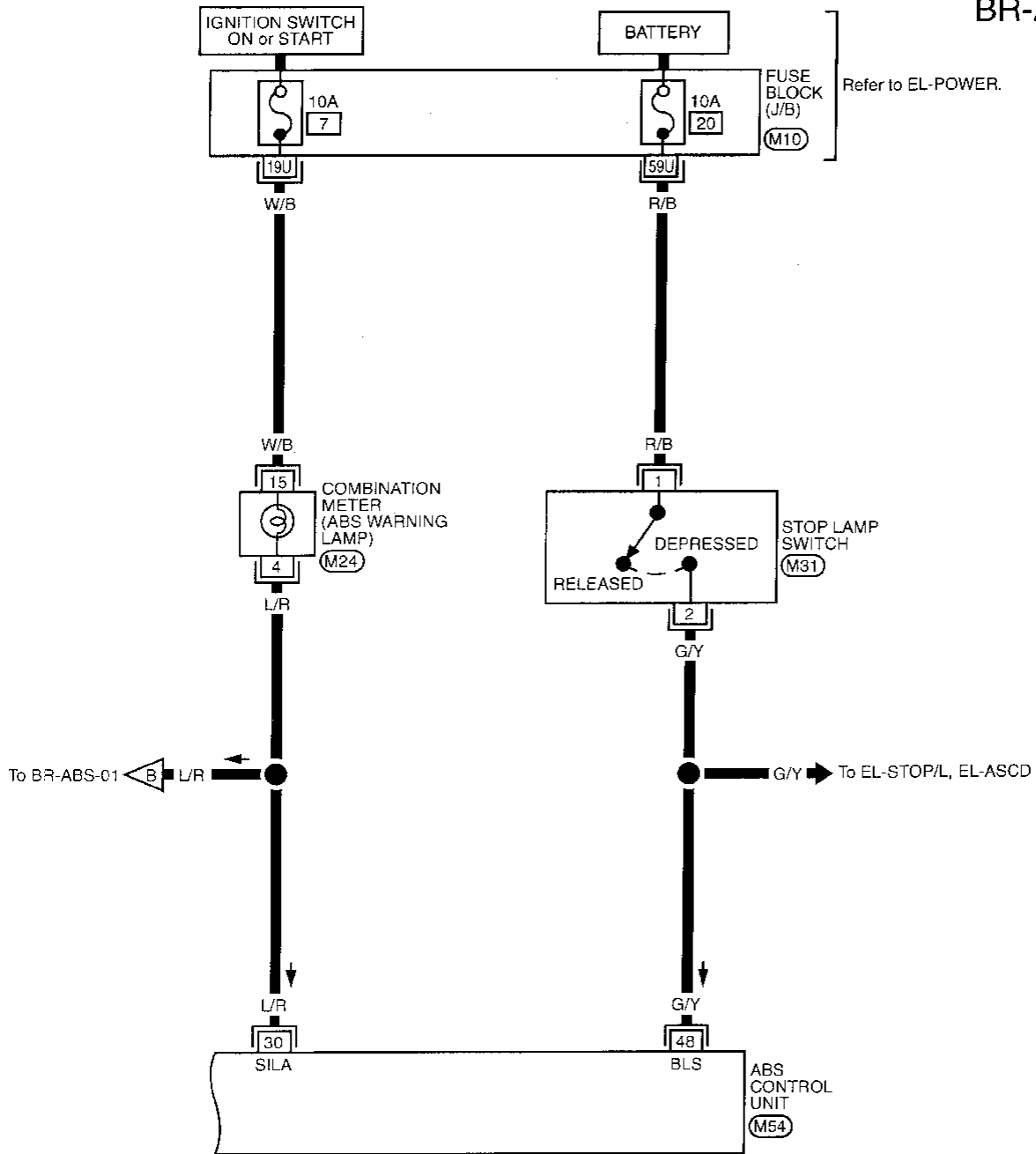

Refer to last page (Foldout page).

(M10)

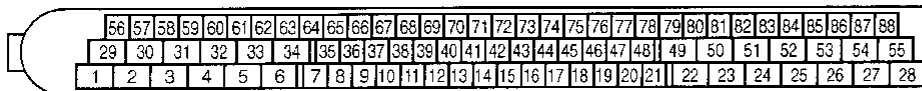

(M54) B

CI  
MA  
EM  
LC  
EC  
FE  
AT  
TF  
PD  
FA  
RA  
**BR**  
ST  
RS  
BT  
HA  
EL  
IDX

## Self-diagnosis

### FUNCTION

- When a problem occurs in the ABS, the warning lamp on the instrument panel comes on. To start the self-diagnostic results mode, ground the self-diagnostic (check) terminal located on "Data Link Connector for CONSULT". The location of the malfunction is indicated by the warning lamp flashing.

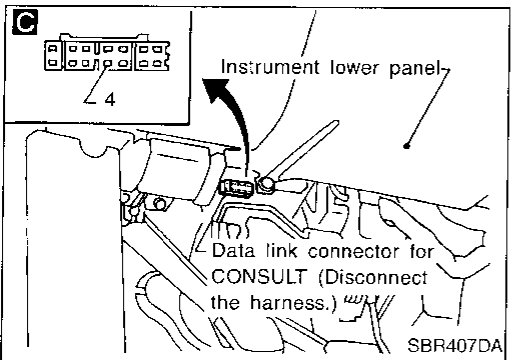
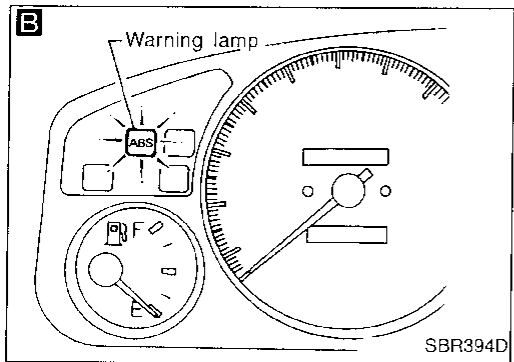
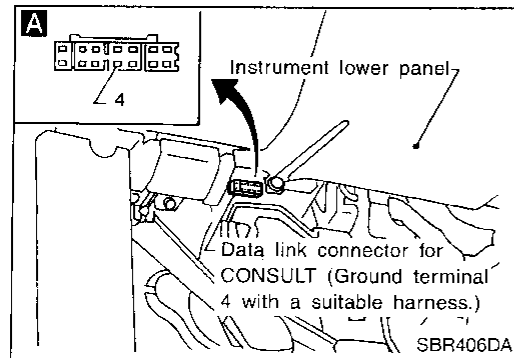

### SELF-DIAGNOSIS PROCEDURE

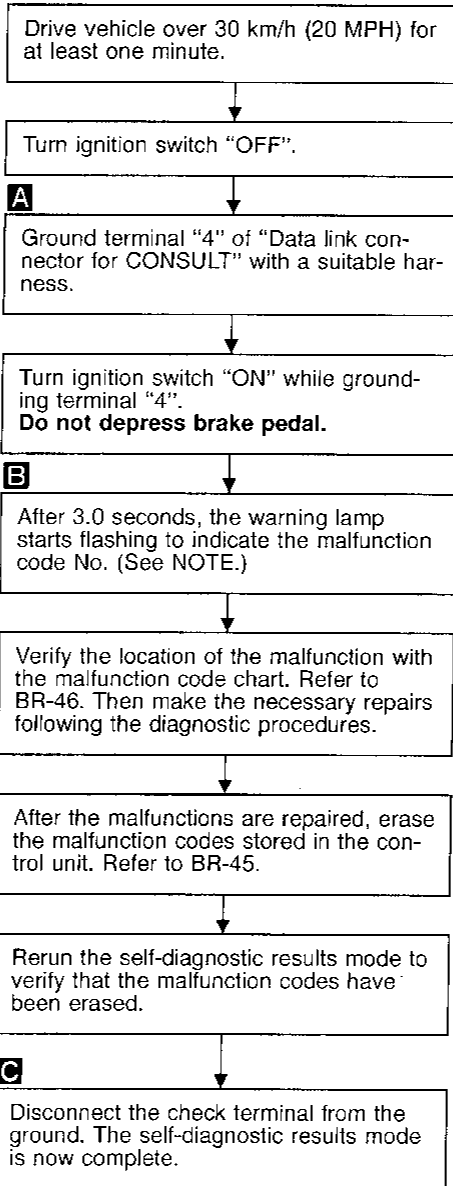

**NOTE:** The indication terminates after five minutes. However, when the ignition switch is turned from "OFF" to "ON", the indication starts flashing again.

# TROUBLE DIAGNOSES

## Self-diagnosis (Cont'd)

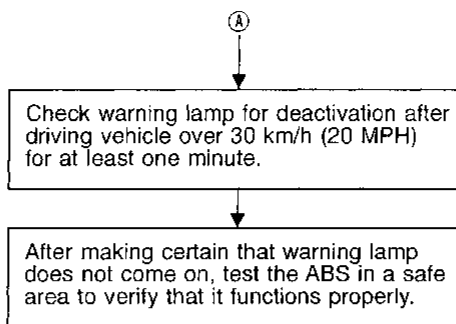

CI

MA

EM

LC

EC

FE

AT

TF

PD

FA

RA

BR

ST

RS

BT

HA

EL

IDX

### HOW TO READ SELF-DIAGNOSTIC RESULTS (Malfunction codes)

- Determine the code No. by counting the number of times the warning lamp flashes on and off.
- When several malfunctions occur at one time, up to three code numbers can be stored; the latest malfunction will be indicated first.
- The indication begins with the start code 12. After that a maximum of three code numbers appear in the order of the latest one first. The indication then returns to the start code 12 to repeat (the indication will stay on for five minutes at the most).
- The malfunction code chart is given on the next page.

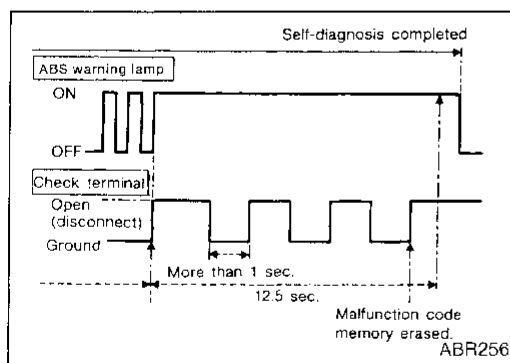
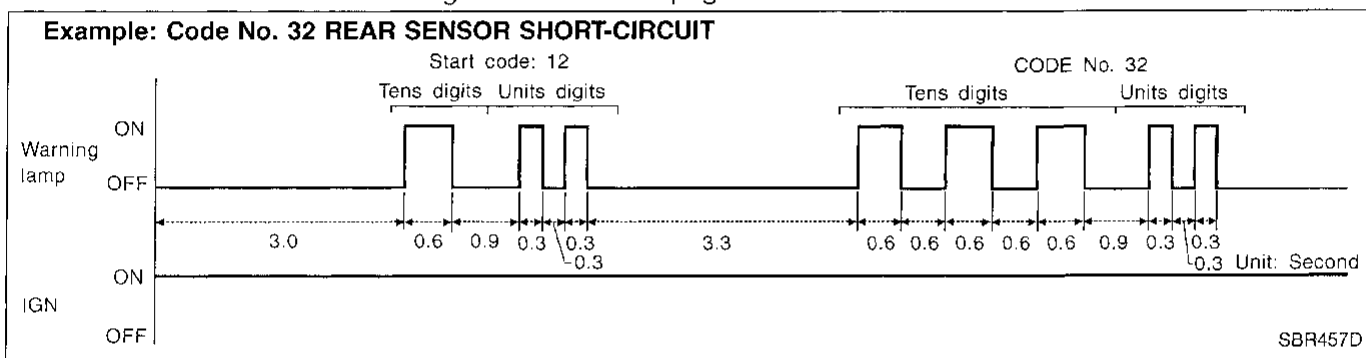

### HOW TO ERASE SELF-DIAGNOSTIC RESULTS (Malfunction codes)

1. Disconnect the check terminal from ground (ABS warning lamp will stay lit).
2. Within 12.5 seconds, ground the check terminal 3 times. Each terminal ground must last more than 1 second. The ABS warning lamp goes out after the erase operation has been completed.
3. Perform self-diagnosis again. Refer to BR-44. Only the start-code should appear, no malfunction codes.

## TROUBLE DIAGNOSES

### Self-diagnosis (Cont'd)

#### MALFUNCTION CODE/SYMPTOM CHART

Code No. (No. of warning lamp flashes)	Malfunctioning part	Diagnostic procedure
45	Actuator front left outlet solenoid valve	2
46	Actuator front left inlet solenoid valve	2
41	Actuator front right outlet solenoid valve	2
42	Actuator front right inlet solenoid valve	2
55	Actuator rear outlet solenoid valve	2
56	Actuator rear inlet solenoid valve	2
25	★1 Front left sensor (open-circuit)	1
26	★1 Front left sensor (short-circuit)	1
21	★1 Front right sensor (open-circuit)	1
22	★1 Front right sensor (short-circuit)	1
31	★1 Rear right sensor (open-circuit)	1
32	★1 Rear right sensor (short-circuit)	1
35	★1 Rear left sensor (open-circuit)	1
36	★1 Rear left sensor (short-circuit)	1
18	★1 Sensor rotor	1
17	G sensor and circuit	6
61	★3 Actuator motor or motor relay	4
63	Solenoid valve relay	3
57	★2 Power supply (Low voltage)	5
71	Control unit	7
Warning lamp stays on when ignition switch is turned on	Control unit power supply circuit Warning lamp bulb circuit Control unit or control unit connector Solenoid valve relay stuck Power supply for solenoid valve relay coil	14
Warning lamp does not come on when ignition switch is turned on	Fuse, warning lamp bulb or warning lamp circuit Control unit	13
Pedal vibration and noise	—	12
Long stopping distance	—	10
Unexpected pedal action	—	9
ABS does not work	—	11
ABS works frequently	—	8
Vehicle vibrates excessively when ABS is operating.	ABS control unit to A/T control unit circuit	15

- ★1: If one or more wheels spin on a rough or slippery road for 40 seconds or more, the ABS warning lamp will illuminate. This does not indicate a malfunction. Only in the case of the short-circuit (Code Nos. 26, 22, 32 and 36), after repair the ABS warning lamp also illuminates when the ignition switch is turned "ON". In this case, drive the vehicle at speeds greater than 30 km/h (19 MPH) for approximately 1 minute as specified in "SELF-DIAGNOSIS PROCEDURE", BR-44. Check to ensure that the ABS warning lamp goes out while the vehicle is being driven.
- ★2: The trouble code "57", which refers to a low power supply voltage, does not indicate that the ABS control unit is malfunctioning. Do not replace the ABS control unit with a new one.
- ★3: The trouble code "61" can sometimes appear when the ABS motor is not properly grounded. If it appears, be sure to check the condition of the ABS motor ground circuit connection.

# TROUBLE DIAGNOSES

## CONSULT

### CONSULT APPLICATION TO ABS

ITEM	SELF-DIAGNOSTIC RESULTS	DATA MONITOR	ACTIVE TEST
Front right wheel sensor	X	X	—
Front left wheel sensor	X	X	—
Rear right wheel sensor	X	X	—
Rear left wheel sensor	X	X	—
G switch (G sensor)	X	X	X
Stop lamp switch	—	X	—
Front right inlet solenoid valve	X	X	X
Front right outlet solenoid valve	X	X	X
Front left inlet solenoid valve	X	X	X
Front left outlet solenoid valve	X	X	X
Rear inlet solenoid valve	X	X	X
Rear outlet solenoid valve	X	X	X
Actuator solenoid valve relay	X	X	—
Actuator motor relay (ABS MOTOR is shown on the Data Monitor screen.)	X	X	X
ABS warning lamp	—	X	—
Battery voltage	X	X	—
ABS operating signal	—	X	X

X: Applicable

—: Not applicable

### ECU (ABS control unit) part number mode

Ignore the ECU part number displayed in the ECU PART NUMBER MODE. Refer to parts catalog to order the ECU.

GI  
MA  
EM  
LC  
EC  
FE  
AT  
TF  
PD  
RA  
BR  
ST  
RS  
BT  
HA  
EL  
IDX



## CONSULT Inspection Procedure SELF-DIAGNOSIS PROCEDURE

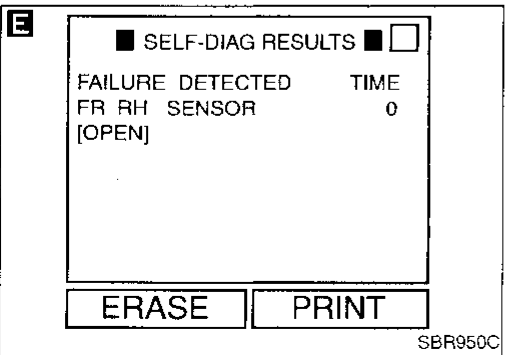
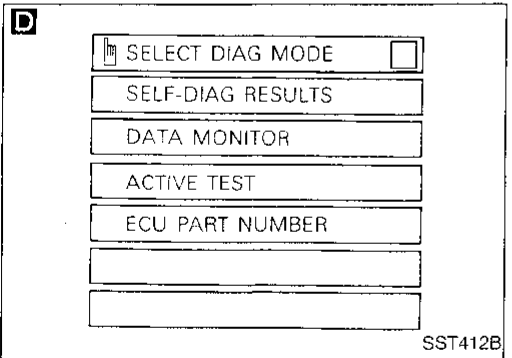
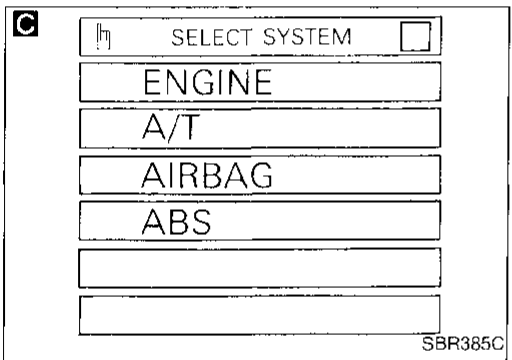
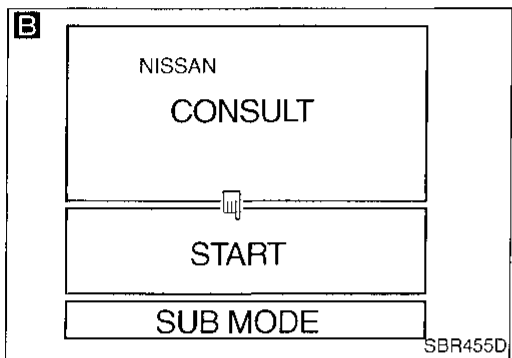
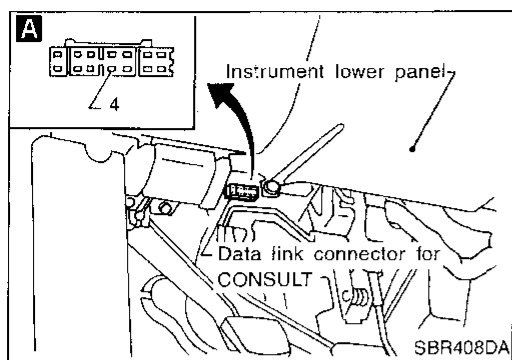

**A**

- 1) Turn ignition switch OFF.
- 2) Connect CONSULT to Data Link Connector for CONSULT.

1) Start engine.  
2) Drive vehicle over 30 km/h (20 MPH) for at least one minute.

**B** 1) Stop vehicle with engine running and touch "START" on CONSULT screen.

**C** 2) Touch "ABS".

**D** 3) Touch "SELF-DIAG RESULTS".

- The screen shows the detected malfunction and how many times the ignition switch has been turned since the malfunction.

Make the necessary repairs following the diagnostic procedures.

**E** After the malfunctions are repaired, erase the self-diagnostic results stored in the control unit by touching "ERASE".

Check warning lamp for deactivation after driving vehicle over 30 km/h (20 MPH) for at least one minute.

Test the ABS in a safe area to verify that it functions properly.

**Note:** "SELF-DIAG RESULTS" screen shows the detected malfunction and how many times the ignition switch has been turned since the malfunction.

# TROUBLE DIAGNOSES

## CONSULT Inspection Procedure (Cont'd)

### SELF-DIAGNOSTIC RESULTS MODE

Diagnostic item	Diagnostic item is detected when ...	Diagnostic procedure
FR RH SENSOR★ [OPEN]	● Circuit for front right wheel sensor is open. (An abnormally high input voltage is entered.)	1
FR LH SENSOR★ [OPEN]	● Circuit for front left wheel sensor is open. (An abnormally high input voltage is entered.)	1
RR RH SENSOR★ [OPEN]	● Circuit for rear right sensor is open. (An abnormally high input voltage is entered.)	1
RR LH SENSOR★ [OPEN]	● Circuit for rear left sensor is open. (An abnormally high input voltage is entered.)	1
FR RH SENSOR★ [SHORT]	● Circuit for front right wheel sensor is shorted. (An abnormally low input voltage is entered.)	1
FR LH SENSOR★ [SHORT]	● Circuit for front left wheel sensor is shorted. (An abnormally low input voltage is entered.)	1
RR RH SENSOR★ [SHORT]	● Circuit for rear right sensor is shorted. (An abnormally low input voltage is entered.)	1
RR LH SENSOR★ [SHORT]	● Circuit for rear left sensor is shorted. (An abnormally low input voltage is entered.)	1
ABS SENSOR★ [ABNORMAL SIGNAL]	● Teeth damage on sensor rotor or improper installation of wheel sensor. (Abnormal wheel sensor signal is entered.)	1
FR RH IN ABS SOL [OPEN, SHORT]	● Circuit for front right inlet solenoid valve is open. (An abnormally low output voltage is entered.)	2
FR LH IN ABS SOL [OPEN, SHORT]	● Circuit for front left inlet solenoid valve is open. (An abnormally low output voltage is entered.)	2
FR RH OUT ABS SOL [OPEN, SHORT]	● Circuit for front right outlet solenoid valve is open. (An abnormally low output voltage is entered.)	2
FR LH OUT ABS SOL [OPEN, SHORT]	● Circuit for front left outlet solenoid valve is open. (An abnormally low output voltage is entered.)	2
RR IN ABS SOL [OPEN, SHORT]	● Circuit for rear right outlet solenoid valve is shorted. (An abnormally high output voltage is entered.)	2
RR OUT ABS SOL [OPEN, SHORT]	● Circuit for rear left outlet solenoid valve is shorted. (An abnormally high output voltage is entered.)	2
ABS ACTUATOR RELAY [ABNORMAL]	● Actuator solenoid valve relay is ON, even if control unit sends off signal. ● Actuator solenoid valve relay is OFF, even if control unit sends on signal.	3
ABS MOTOR RELAY [ABNORMAL]	● Circuit for ABS motor relay is open or shorted. ● Circuit for actuator motor is open or shorted. ● Actuator motor relay is stuck.	4
BATTERY VOLT [VB-LOW]	● Power source voltage supplied to ABS control unit is abnormally low.	5
CONTROL UNIT	● Function of calculation in ABS control unit has failed.	7
G-SENSOR [ABNORMAL]	● G sensor circuit is open or shorted.	6

★: If one or more wheels spin on a rough or slippery road for 40 seconds or more, the ABS warning lamp will illuminate. This does not indicate a malfunction. Only in the case of the short-circuit (Code Nos. 26, 22, 32 and 36), after repair the ABS warning lamp also illuminates when the ignition switch is turned "ON". In this case, drive the vehicle at speeds greater than 30 km/h (19 MPH) for approximately 1 minute as specified in "SELF-DIAGNOSIS PROCEDURE", BR-44. Check to ensure that the ABS warning lamp goes out while the vehicle is being driven.

# TROUBLE DIAGNOSES

## CONSULT Inspection Procedure (Cont'd) DATA MONITOR PROCEDURE

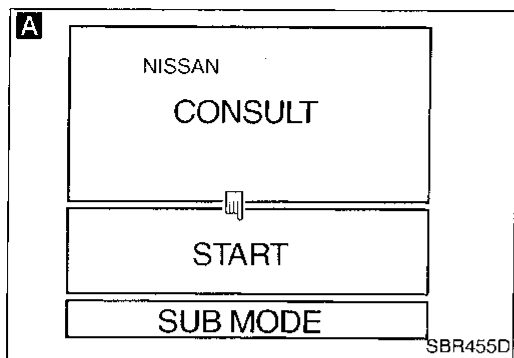

- 1) Turn ignition switch OFF.
- 2) Connect CONSULT to Data Link Connector for CONSULT.
- 3) Turn ignition switch ON.

- A 1) Touch "START" on CONSULT screen.
- B 2) Touch "ABS".
- C 3) Touch "DATA MONITOR".

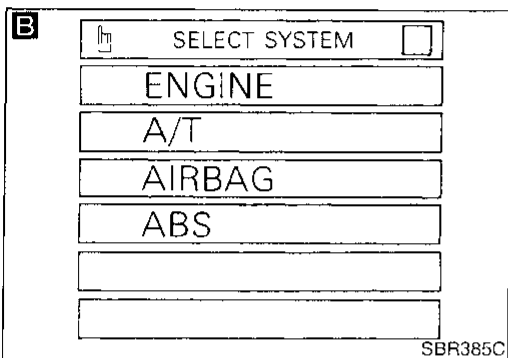

- D 1) Touch "SETTING" on "SELECT MONITOR ITEM" screen.
- E 2) Touch "LONG TIME" on "SET RECORDING COND" screen.
- D 3) Touch "START" on "SELECT MONITOR ITEM".

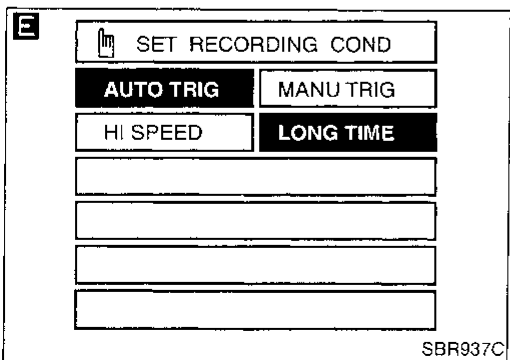
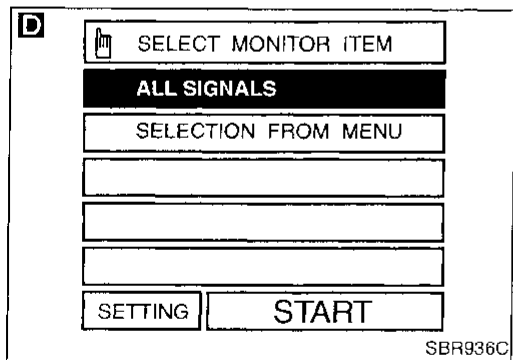
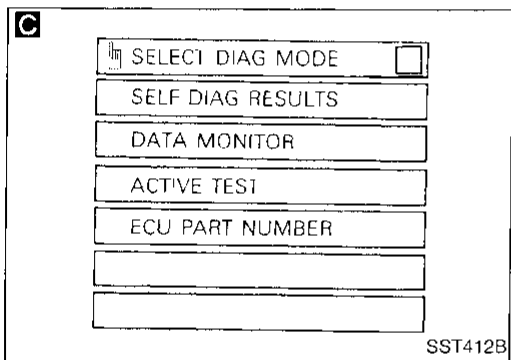

# TROUBLE DIAGNOSES

## CONSULT Inspection Procedure (Cont'd)

### ACTIVE TEST PROCEDURE

- When conducting Active test, vehicle must be stationary.
- When ABS warning lamp stays on, never conduct Active test.

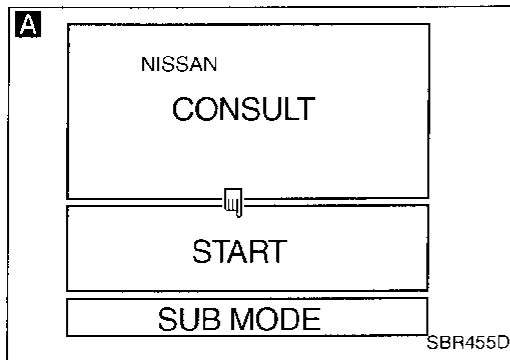

- 1) Turn ignition switch OFF.
- 2) Connect CONSULT to Data Link Connector for CONSULT.
- 3) Start engine.

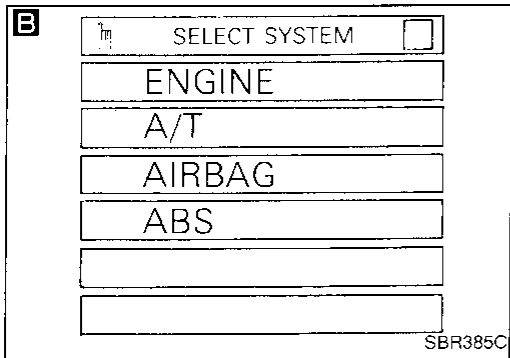

- 1) Touch "START" on CONSULT screen.
- 2) Touch "ABS".
- 3) Touch "ACTIVE TEST".

- 1) Select active test item by touching screen.
- 2) Touch "START".

Carry out the active test by touching screen key.

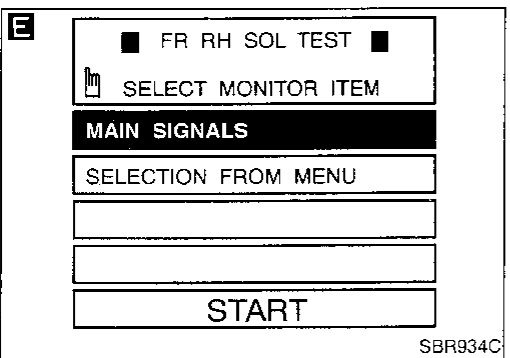
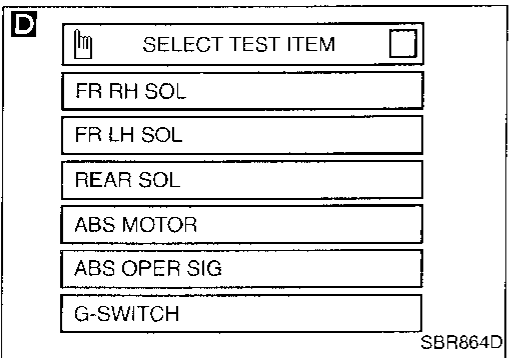
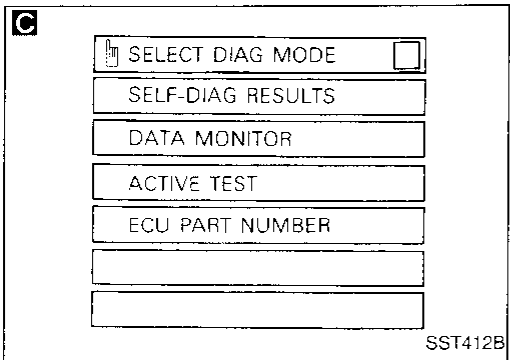

GI  
MA  
EM  
LC  
EC  
FE  
AT  
TF  
PD  
FA  
RA  
BR  
ST  
RS  
BT  
HA  
EL  
IDX

## TROUBLE DIAGNOSES

### CONSULT Inspection Procedure (Cont'd)

#### DATA MONITOR MODE

MONITOR ITEM	CONDITION	SPECIFICATION
FR RH SENSOR FR LH SENSOR RR RH SENSOR RR LH SENSOR	Drive vehicle. (Each wheel is rotating.)	Wheel speed signal (Almost the same speed as speedometer.)
STOP LAMP SW	Brake is depressed.	Depress the pedal: ON Release the pedal: OFF
G-SWITCH	Vehicle is driven. Vehicle is stopped. Brake is applied.	During sudden braking while driving on high $\mu$ roads (asphalt roads, etc.): OFF While vehicle is stopped or during constant-speed driving: ON
FR RH IN SOL FR RH OUT SOL FR LH IN SOL FR LH OUT SOL RR IN SOL RR OUT SOL	1. Drive vehicle at speeds over 30 km/h (20 MPH) for at least one minute. 2. Engine is running.	Operating conditions for each solenoid valve are indicated. ABS is not operating: OFF
MOTOR RELAY		ABS is not operating: OFF ABS is operating: ON
ACTUATOR RELAY	Ignition switch is ON or engine is running.	Ignition switch ON (Engine stops): OFF Engine running: ON
WARNING LAMP		ABS warning lamp is turned on: ON ABS warning lamp is turned off: OFF
BATTERY VOLT		Power supply voltage for control unit
ABS OPER SIG		ABS is not operating : OFF ABS is operating : ON

#### ACTIVE TEST MODE

TEST ITEM	CONDITION	JUDGEMENT												
FR RH SOLENOID FR LH SOLENOID REAR SOLENOID	Engine is running.	Brake fluid pressure control operation  <table style="margin-left: auto; margin-right: auto;"> <tr> <td></td> <td style="text-align: center;">IN SOL</td> <td style="text-align: center;">OUT SOL</td> </tr> <tr> <td>UP (Increase):</td> <td style="text-align: center;">OFF</td> <td style="text-align: center;">OFF</td> </tr> <tr> <td>KEEP (Hold):</td> <td style="text-align: center;">ON</td> <td style="text-align: center;">OFF</td> </tr> <tr> <td>DOWN (Decrease):</td> <td style="text-align: center;">ON</td> <td style="text-align: center;">ON</td> </tr> </table>		IN SOL	OUT SOL	UP (Increase):	OFF	OFF	KEEP (Hold):	ON	OFF	DOWN (Decrease):	ON	ON
		IN SOL	OUT SOL											
UP (Increase):	OFF	OFF												
KEEP (Hold):	ON	OFF												
DOWN (Decrease):	ON	ON												
ABS MOTOR		ABS actuator motor ON: Motor runs (ABS motor relay ON) OFF: Motor stops (ABS motor relay OFF)												
ABS OPER SIG	Ignition switch is ON or engine is running.	ON : Set ABS OPER SIG "ON" (ABS is operating.) OFF: Set ABS OPER SIG "OFF" (ABS is not operating.)												
G SWITCH	Ignition switch is ON.	G SWITCH (G SENSOR), ON : Set G SWITCH MONITOR "ON" (G switch circuit is closed.) OFF: Set G SWITCH MONITOR "OFF" (G switch circuit is open.)												

**Note: Active test will automatically stop ten seconds after the test starts. (LIMIT SIGNAL monitor shows ON.)**

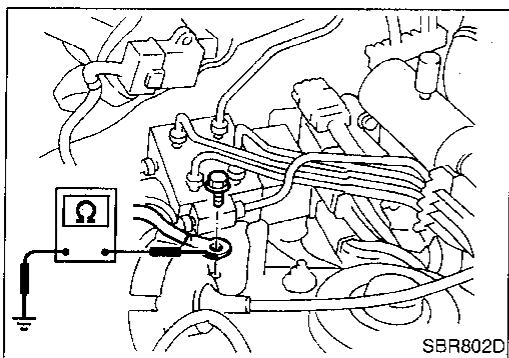

## Ground Circuit Check

### ACTUATOR MOTOR GROUND

- Remove actuator motor earth terminal.
- Check resistance between actuator motor earth terminal and body ground.

**Resistance: approximately 0Ω**

GI

MA

EM

LC

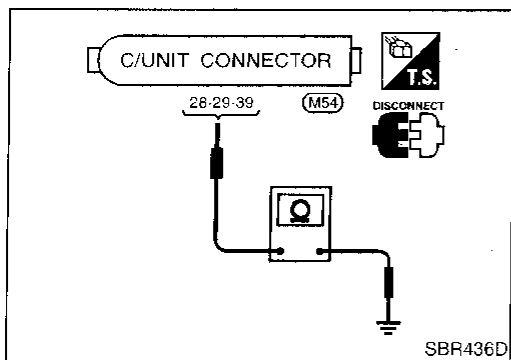

### CONTROL UNIT GROUND

- Check resistance between control unit connector terminals and ground.

**Resistance: approximately 0Ω**

EC

FE

AT

TF

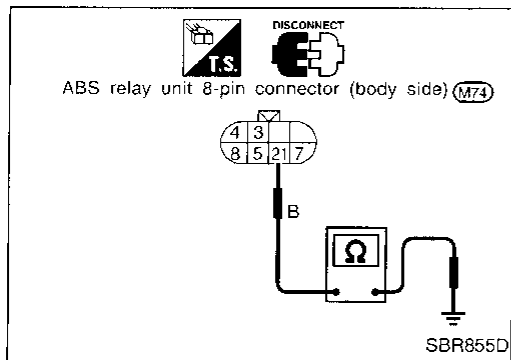

### ACTUATOR GROUND

- Check resistance between ABS relay unit harness 8-pin connector (body side) terminal ② and ground.

**Resistance: approximately 0Ω**

PD

FA

RA

BR

ST

RS

BT

HA

EL

IDX

## Diagnostic Procedure 1 (Wheel sensor or rotor)

**Malfunction code No. 21, 22, 25, 26, 31, 32, 35, 36 or 18**

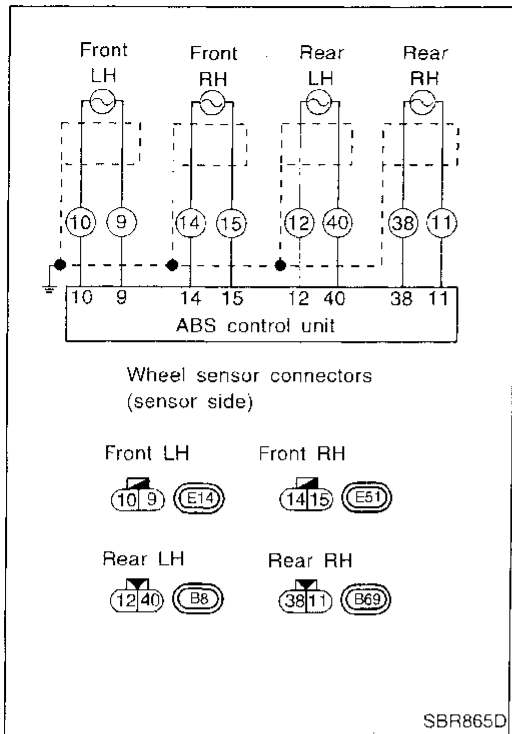

1. Disconnect connectors from control unit and wheel sensor of malfunction code No. Check terminals for damage or loose connections. Then reconnect connectors.

2. Carry out self-diagnosis again.  
**Does warning lamp activate again?**

No → Inspection end

Yes

**A**

**WHEEL SENSOR ELECTRICAL CHECK**

1. Disconnect control unit connector.

2. Check resistance between control unit connector (M54) terminals.

Code No. 21 or 22 (Front RH wheel)  
Terminals 14 and 15

Code No. 25 or 26 (Front LH wheel)  
Terminals 10 and 9

Code No. 31 or 32 (Rear RH wheel)  
Terminals 11 and 38

Code No. 35 or 36 (Rear LH wheel)  
terminals 12 and 40

**Resistance: Front 0.9 - 1.1 kΩ**  
**Rear 1.44 - 1.76 kΩ**

OK → (See next page.)

NG

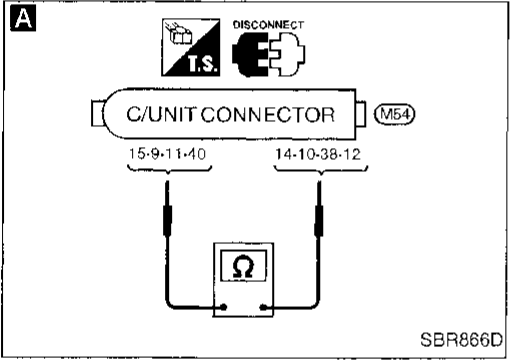

**B**

**CHECK WHEEL SENSOR.**

Check each sensor for resistance.  
**Resistance: Front 0.9 - 1.1 kΩ**  
**Refer 1.44 - 1.76 kΩ**

OK →

NG

Check the following.

- Harness connectors (M54, E51, E14, B69, B8)
- Harness for open or short between wheel sensor connectors and control unit

If NG, repair harness or connectors.

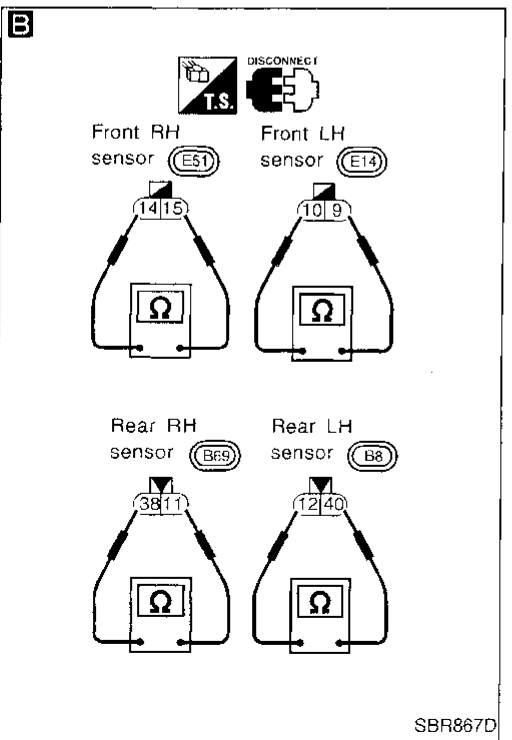

Replace wheel sensor.

# TROUBLE DIAGNOSES FOR SELF-DIAGNOSTIC ITEMS

## Diagnostic Procedure 1 (Wheel sensor or rotor) (Cont'd)

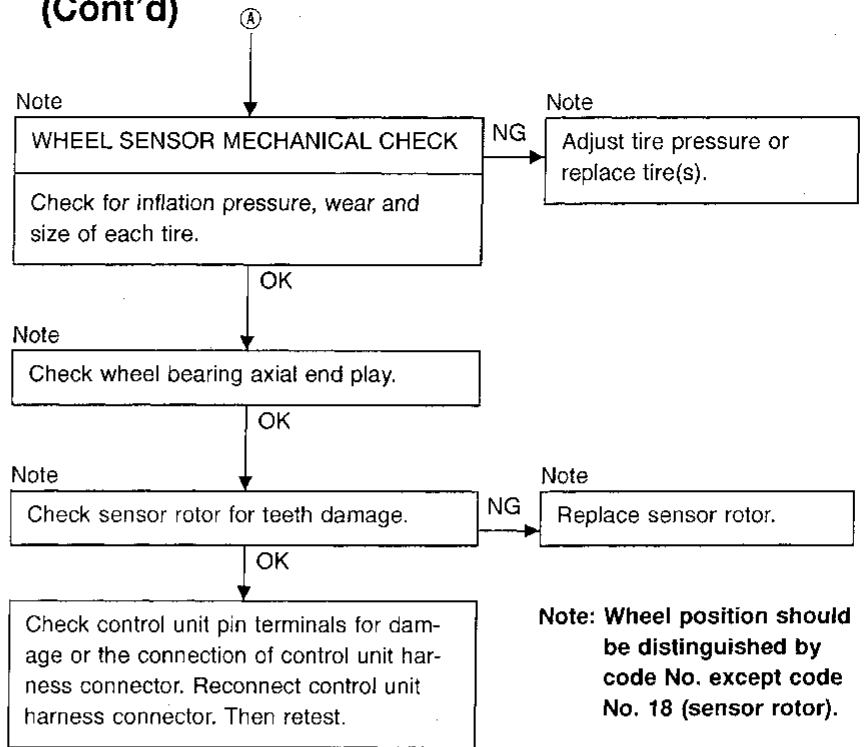

GI  
MA  
EM  
LC  
EC  
FE  
AT  
TF  
PD  
FA  
RA  
BR  
ST  
RS  
BT  
HA  
EL  
DX



## Diagnostic Procedure 2 (ABS actuator solenoid valve)

Malfunction code No. 41, 45, 55, 42, 46, 56

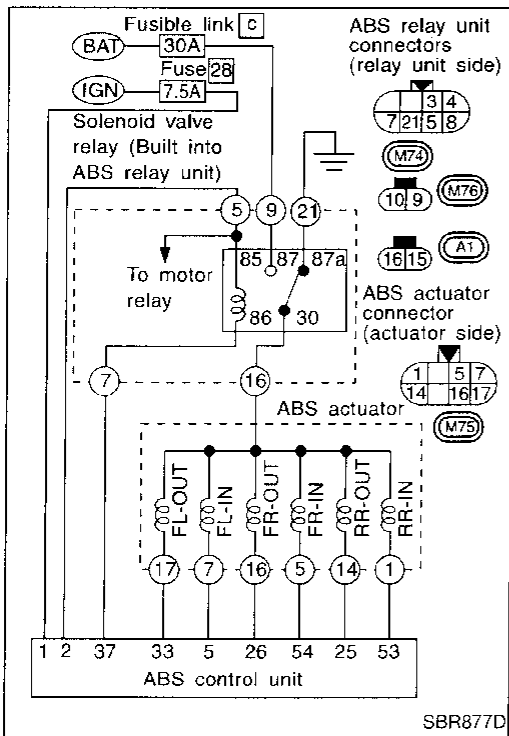

1. Disconnect connectors from control unit, ABS actuator and ABS relay unit. Check terminals for damage or loose connections. Then reconnect connectors.
2. Carry out self-diagnosis again.  
**Does warning lamp activate again?**

No → Inspection end

Yes

**A**

### ABS ACTUATOR SOLENOID VALVE CHECK

1. Disconnect connectors from control unit and ABS relay unit.
2. Check resistance between control unit connector terminals and ABS relay unit 2-pin connector (A1) (ABS actuator side) terminal.

OK → (Go to next page.)

Code No.	Control unit	ABS actuator	Resistance
41	(26)	(16)	3.1 - 6.2Ω
45	(33)	(16)	
55	(5)	(16)	
42	(5)	(16)	6.2 - 12.3Ω
46	(7)	(16)	
56	(1)	(16)	

NG

**B**

1. Disconnect ABS actuator 8-pin connector.
2. Check resistance between ABS actuator 8-pin connector (M75) (ABS actuator side) terminals and ABS relay unit 2-pin connector (A1) (ABS actuator side) terminal.

- OK →
- Check the following.
- Harness connectors (M54, M75, A1)
  - Harness for open or short between ABS relay unit connector and control unit
  - Harness for open or short between ABS actuator 8-pin connector and ABS relay unit 2-pin connector
- If NG, repair harness or connectors.

Code No.	ABS actuator 8-pin	ABS relay unit 2-pin	Resistance
41	(16)	(16)	3.1 - 6.2Ω
45	(17)	(16)	
55	(14)	(16)	
42	(5)	(16)	6.2 - 12.3Ω
46	(7)	(16)	
56	(1)	(16)	

NG

**A**

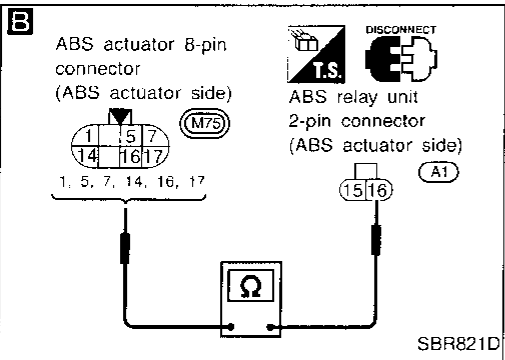
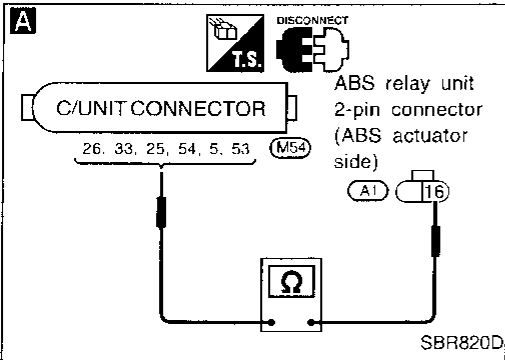

# TROUBLE DIAGNOSES FOR SELF-DIAGNOSTIC ITEMS

## Diagnostic Procedure 2 (ABS actuator solenoid valve) (Cont'd)

(A)

Check resistance between solenoid valve terminals  
①, ⑤, ⑦, ⑭, ⑯, ⑰.

ABS actuator			Resistance
	⑭	⑯	
OUT solenoid valve	⑭	⑰	6.2 - 12.4Ω
	⑯	⑰	
	⑰	⑰	
OUT and IN solenoid valve	⑭, ⑯, ⑰	①, ⑤, ⑦	9.3 - 18.5Ω
IN solenoid valve	①	⑤	12.4 - 24.6Ω
	①	⑦	
	⑤	⑦	

OK

Check the following.

- Harness connectors (M54), (M75), (A1)
- Harness for open or short between actuator connector and control unit
- Harness for open or short between ABS actuator 8-pin connector and ABS relay unit 2-pin connector

If NG, repair harness or connectors.

NG

Replace actuator.

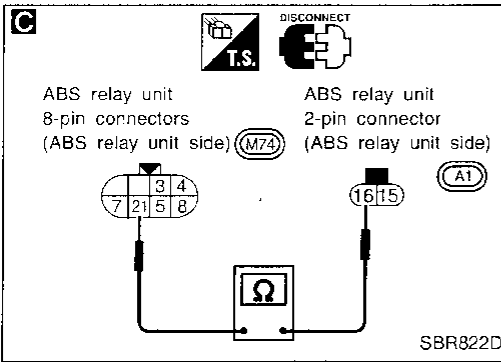

(B)

1. Disconnect ABS relay unit connectors.  
2. Check continuity between ABS relay unit 2-pin connector (A1) (ABS relay unit side) terminal ⑯ and ABS relay unit 8-pin connector (M74) (ABS relay unit side) terminal ⑰.  
**Continuity should exist.**

OK

Go to Diagnostic Procedure 3, BR-58.

NG

Replace ABS relay unit.

GI  
MA  
EM  
LC  
EC  
FE  
AT  
TF  
PD  
FA  
RA  
BR  
ST  
RS  
BT  
HA  
EL  
IDX

## Diagnostic Procedure 3 (Solenoid valve relay)

Malfunction code No. 63

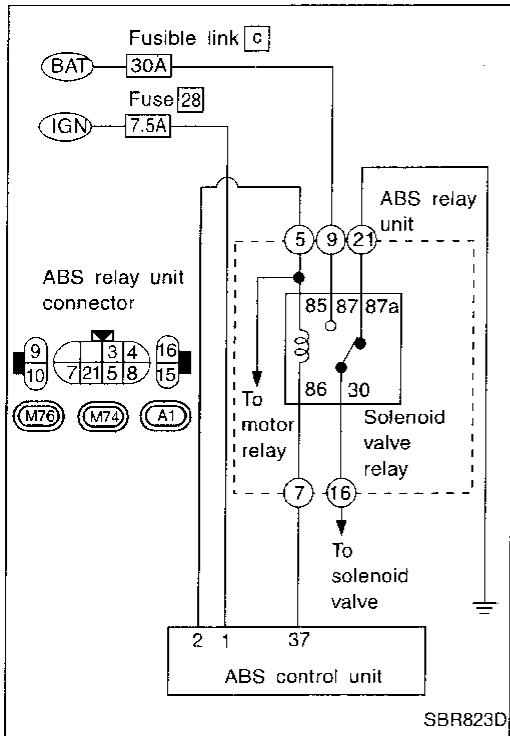

**SOLENOID VALVE POWER SUPPLY CHECK**

NG → (A) (Skip page.)

Check 30A fusible link [C]. For fusible link layout, refer to POWER SUPPLY ROUTING in EL section.

OK

Check 7.5A fuse [28]. For fuse layout, refer to POWER SUPPLY ROUTING in EL section.

NG → (B) (Skip page.)

OK

1. Disconnect connectors from control unit and ABS actuator. Check terminals for damage or loose connection. Then reconnect connectors.

2. Carry out self-diagnosis again.

**Does warning lamp activate again?**

No → Inspection end

Yes

**GROUND CIRCUIT CHECK**

NG → Repair harness and connectors.

Refer to CONTROL UNIT GROUND and ACTUATOR GROUND in Ground Circuit Check, BR-53.

OK

**SOLENOID VALVE POWER SUPPLY CHECK**

NG → Check the following.

- Harness connector (M76)
- Harness for open or short between ABS relay unit and fuse

If NG, repair harness or connectors.

1. Disconnect connectors from ABS relay unit.

2. Check voltage between ABS relay unit 2-pin connector (M76) (body side) terminal (9) and ground.

**Battery voltage should exist.**

OK

(C)

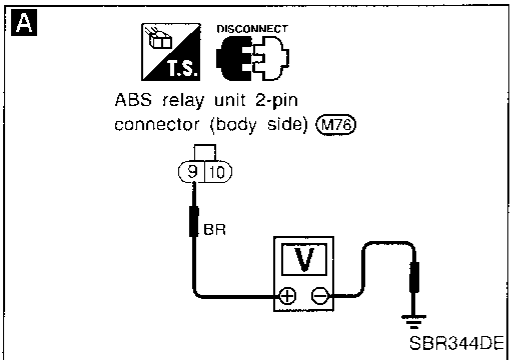

# TROUBLE DIAGNOSES FOR SELF-DIAGNOSTIC ITEMS

## Diagnostic Procedure 3 (Solenoid valve relay) (Cont'd)

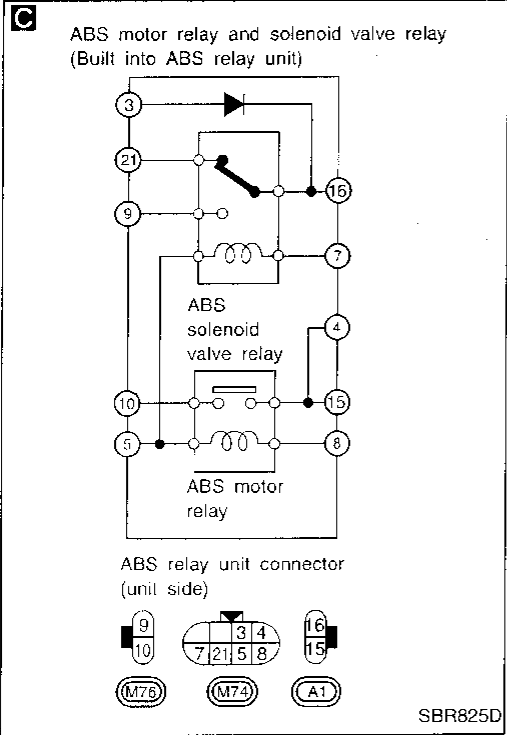
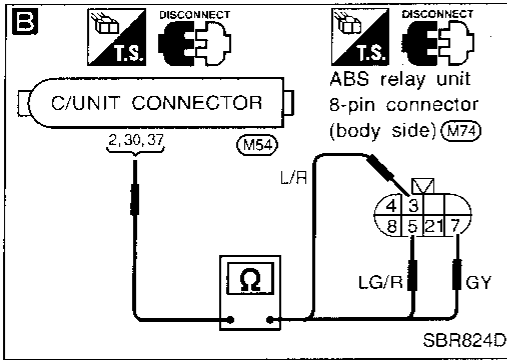

**B**

**CIRCUIT CHECK**

1. Disconnect ABS relay unit 8-pin connector (M74) and control unit connector (M54).
2. Check continuity between control unit connector terminals and ABS relay unit 8-pin connector (M74) (body side) terminals.

Control unit	ABS relay unit
①⑦	⑦
②	⑤
③⑩	③

**Continuity should exist.**

NG → Check the following.  
 • Harness connectors (M54), (M74)  
 • Harness for open or short between ABS relay unit 8-pin connector terminal (body side) and control unit  
 If NG, repair harness or connectors.

OK

**C**

**SOLENOID VALVE RELAY CHECK**

Relay type	Solenoid valve relay
Condition	Continuity existence between terminals ⑤ and ⑦
Battery voltage not applied between each terminal	⑤ and ⑦
Battery voltage applied between each terminal	⑤ and ⑦
Check resistance between each terminal	⑤ and ⑦
	70.8 - 157.8Ω

NG → Replace ABS relay unit.

OK

Go to Diagnostic Procedure 2, BR-56.

CI  
MA  
EM  
LC  
EC  
FE  
AT  
TF  
PD  
FA  
RA  
BR  
ST  
RS  
BT  
HA  
EL  
IDX

# TROUBLE DIAGNOSES FOR SELF-DIAGNOSTIC ITEMS

## Diagnostic Procedure 3 (Solenoid valve relay) (Cont'd)

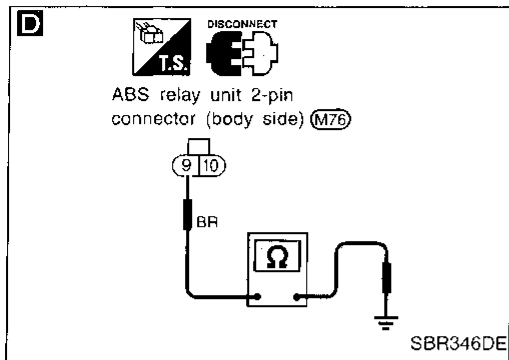

**A**

Replace fusible link.  
Does the fusible link blow out when ignition switch is turned "ON"?

No → Inspection end

Yes →

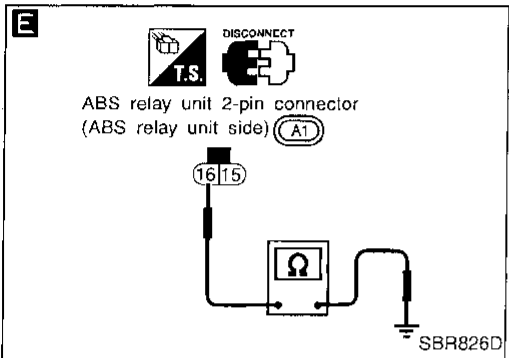

**D**

**RELAY UNIT POWER SUPPLY CIRCUIT**

1. Disconnect ABS relay unit 2-pin connector (M76).  
2. Check continuity between ABS relay unit 2-pin connector (M76) (body side) terminal ⑨ and ground.  
**Continuity should not exist.**

NG → Check the following.  
• Harness connector (M76)  
• Harness for open or short between ABS relay unit and fusible link  
If NG, repair harness or connectors.

OK →

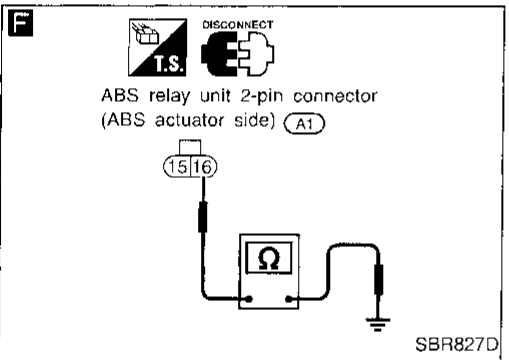

**E**

1. Disconnect ABS relay unit 2-pin connector (A1).  
2. Check continuity between ABS relay unit 2-pin connector (A1) (ABS relay unit side) terminal ⑯ and ground.  
**Continuity should not exist.**

NG → Replace ABS relay unit.

OK →

**F**

Check continuity between ABS relay unit 2-pin connector (A1) (ABS actuator side) terminal ⑯ and ground.  
**Continuity should not exist.**

NG → Replace ABS actuator.

OK → Go to Diagnostic Procedure 2, BR-56.

**B**

Replace fuse.  
Does the fuse blow out when ignition switch is turned "ON"?

Yes → Check the following.  
• Harness connector (M54)  
• Harness for open or short between ABS control unit connector and fuse  
If NG, repair harness or connectors.

No → Inspection end

## Diagnostic Procedure 4 (Motor relay or motor)

### Malfunction code No. 61

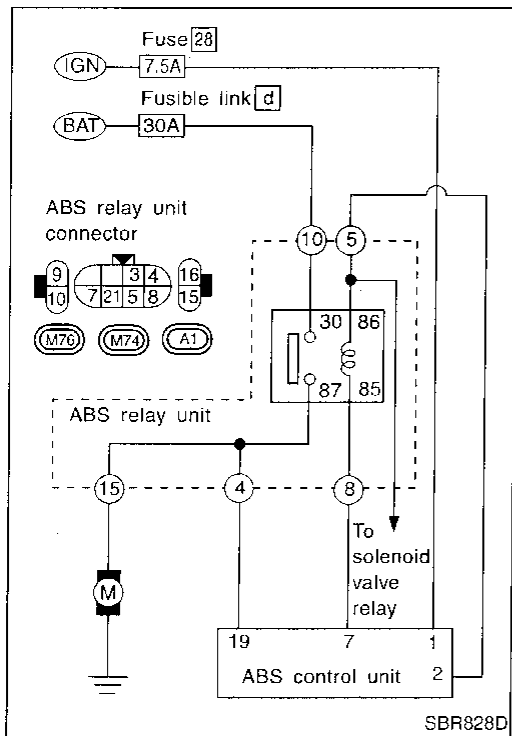

**MOTOR POWER SUPPLY CIRCUIT**

Check 30A fusible link **d** for ABS relay unit. For fusible link layout, refer to POWER SUPPLY ROUTING in EL section.

NG → **B** (Skip page.)

↓ OK

Check 7.5A fuse **28**. For fuse layout, refer to POWER SUPPLY ROUTING in EL section.

NG → **C** (See next page.)

↓ OK

1. Disconnect connectors from control unit and ABS relay unit. Check terminals for damage or loose connection. Then reconnect connectors.

2. Carry out self-diagnosis again.

**Does warning lamp activate again?**

No → Inspection end

↓ Yes

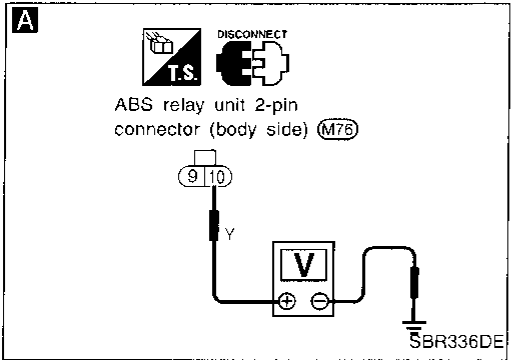

**A**

1. Disconnect ABS relay unit 2-pin connector **(M76)**.

2. Check voltage between connector (body side) terminal **10** and ground.

**Battery voltage should exist.**

NG → Check the following.

- Harness connector **(M76)**
- Harness for open or short between ABS relay unit and fusible link

If NG, repair harness or connectors.

↓ OK

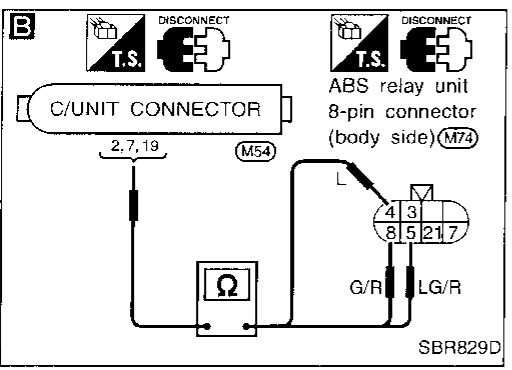

**B**

**CIRCUIT CHECK**

1. Disconnect ABS relay unit 8-pin connector **(M74)** and control unit connector **(M54)**.

2. Check continuity between control unit connector terminals and ABS relay unit 8-pin connector **(M74)** (body side) terminals.

Control unit	ABS relay unit
⑦	⑧
⑯	④
②	⑤

**Continuity should exist.**

NG → Check the following.

- Harness connectors **(M54), (M74)**
- Harness for open or short between ABS relay unit terminal (body side) and control unit

If NG, repair harness or connectors.

↓ OK

Ⓐ

(Go to next page.)

GI  
 MA  
 EM  
 LC  
 EC  
 FE  
 AT  
 TF  
 PD  
 FA  
 RA  
 BR  
 ST  
 RS  
 BT  
 HA  
 EL  
 DX

# TROUBLE DIAGNOSES FOR SELF-DIAGNOSTIC ITEMS

## Diagnostic Procedure 4 (Motor relay or motor) (Cont'd)

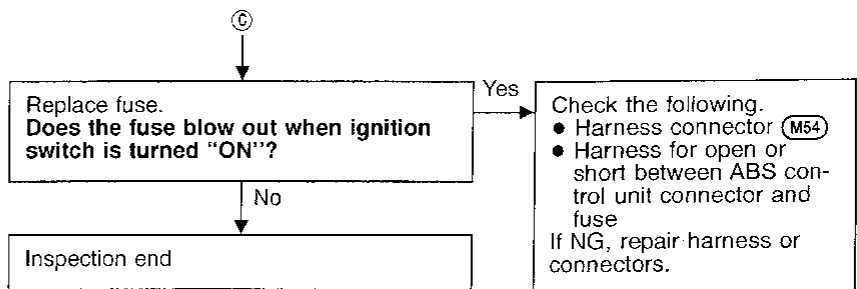
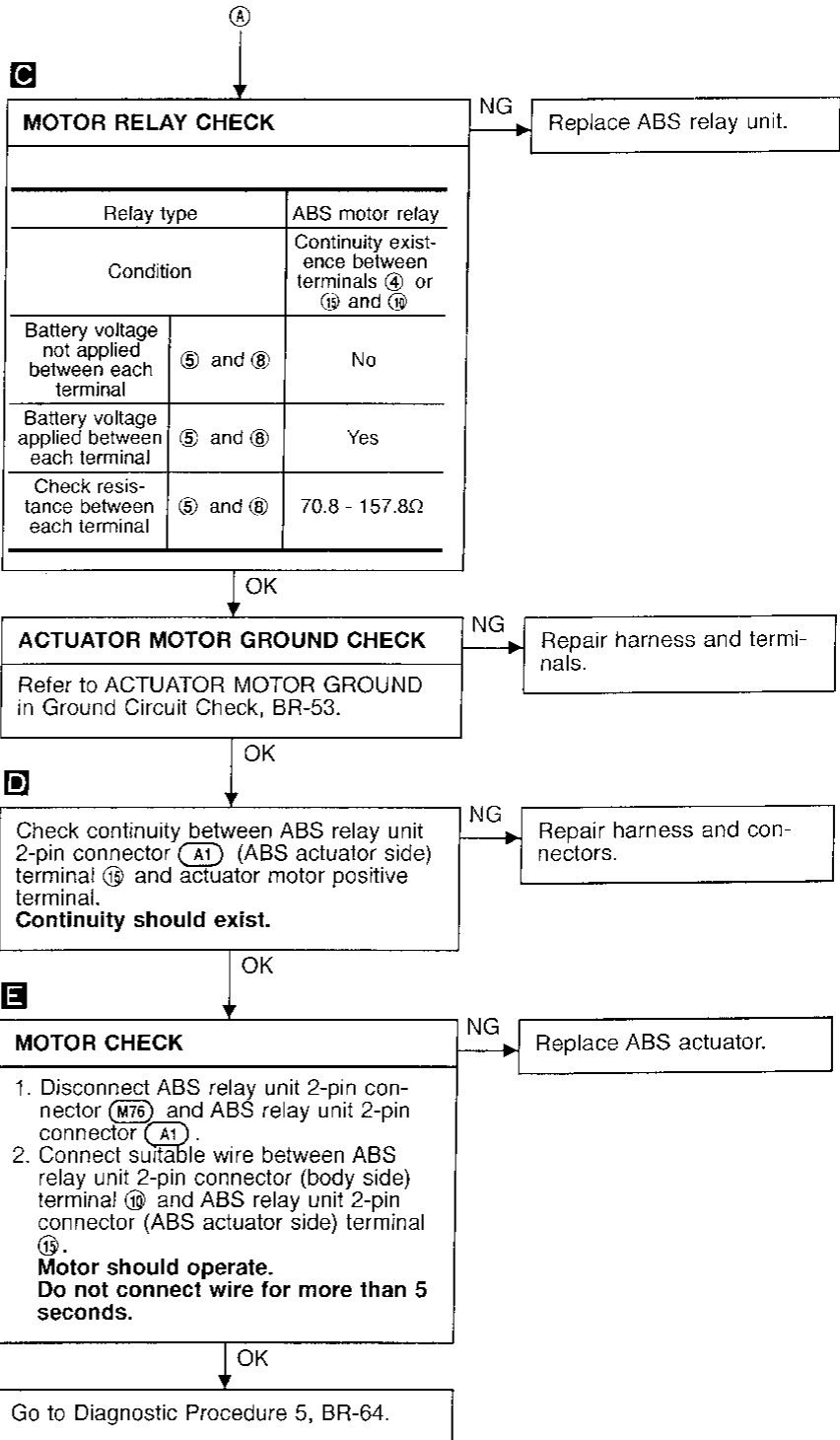
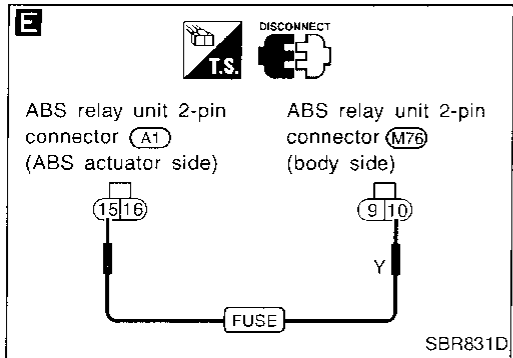
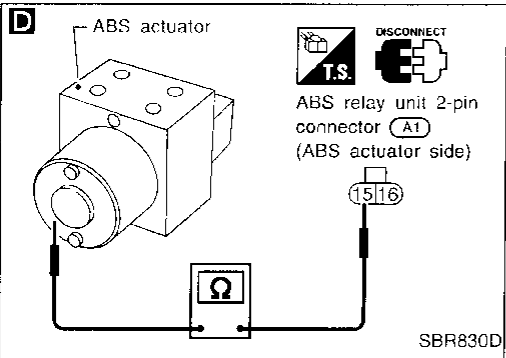
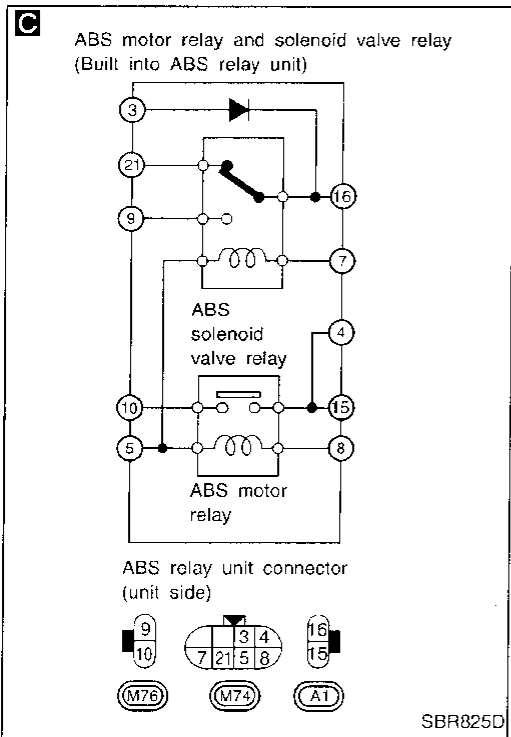

# TROUBLE DIAGNOSES FOR SELF-DIAGNOSTIC ITEMS

## Diagnostic Procedure 4 (Motor relay or motor) (Cont'd)

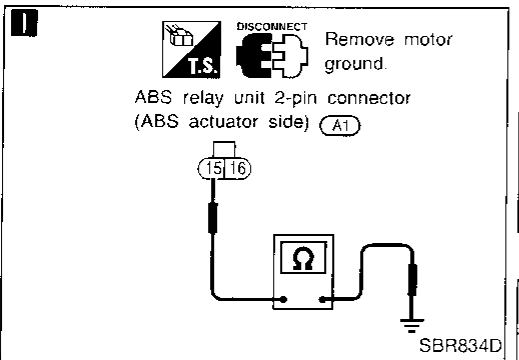
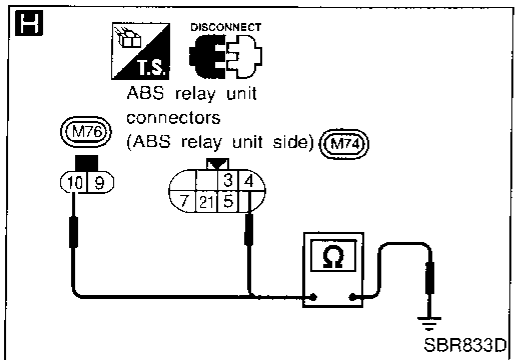
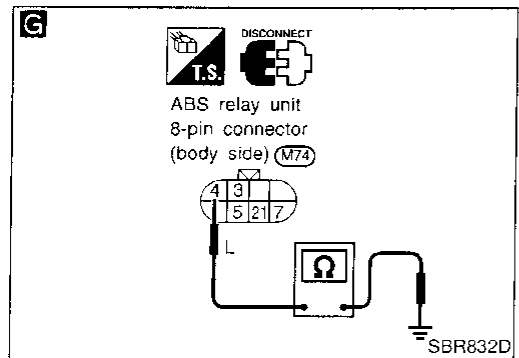
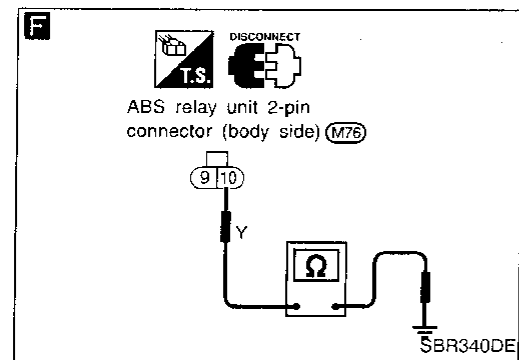

⑧

Replace fusible link.  
Does the fusible link blow out when ignition switch is turned "ON"?

No → Inspection end

Yes →

**F**

**MOTOR POWER SUPPLY CIRCUIT**

1. Disconnect battery cable and ABS relay unit 2-pin connector (M76).  
2. Check continuity between ABS relay unit 2-pin connector (M76) (body side) terminal ⑩ and ground.  
**Continuity should not exist.**

NG → Check the following.  
• Harness connector (M76)  
• Harness for open or short between ABS relay unit and fuse  
If NG, repair harness or connectors.

OK →

**G**

1. Disconnect ABS relay unit 8-pin connector and control unit connector.  
2. Check continuity between ABS relay unit 8-pin connector (M74) (body side) terminal ④ and ground.  
**Continuity should not exist.**

NG → Check the following.  
• Harness connectors (M54), (M74)  
• Harness for open or short between ABS relay unit terminal (body side) and control unit  
If NG, repair harness or connectors.

OK →

**H**

Check continuity between ABS relay unit 8-pin connector (M74) (ABS relay unit side) terminal ④ and ground, 2-pin connector (M76) (ABS relay unit side) terminal ⑩ and ground.  
**Continuity should not exist.**

NG → Replace ABS relay unit.

OK →

**I**

1. Remove motor ground.  
2. Check continuity between ABS relay unit 2-pin connector (A1) (ABS actuator side) terminal ⑮ and ground.  
**Continuity should not exist.**

NG → Replace ABS actuator.

OK →

**MOTOR CHECK**

Go to **E** in Diagnostic Procedure 4 (preceding page).

OK →

Check control unit pin terminals for damage or the connection of control unit harness connector.  
Reconnect control unit harness connector.  
Then retest.

GI  
MA  
EM  
LC  
EC  
FE  
AT  
TF  
PD  
FA  
RA  
BR  
ST  
RS  
BT  
HA  
EL  
DX



# TROUBLE DIAGNOSES FOR SELF-DIAGNOSTIC ITEMS

## Diagnostic Procedure 5 (Low voltage)

### Malfunction code No. 57

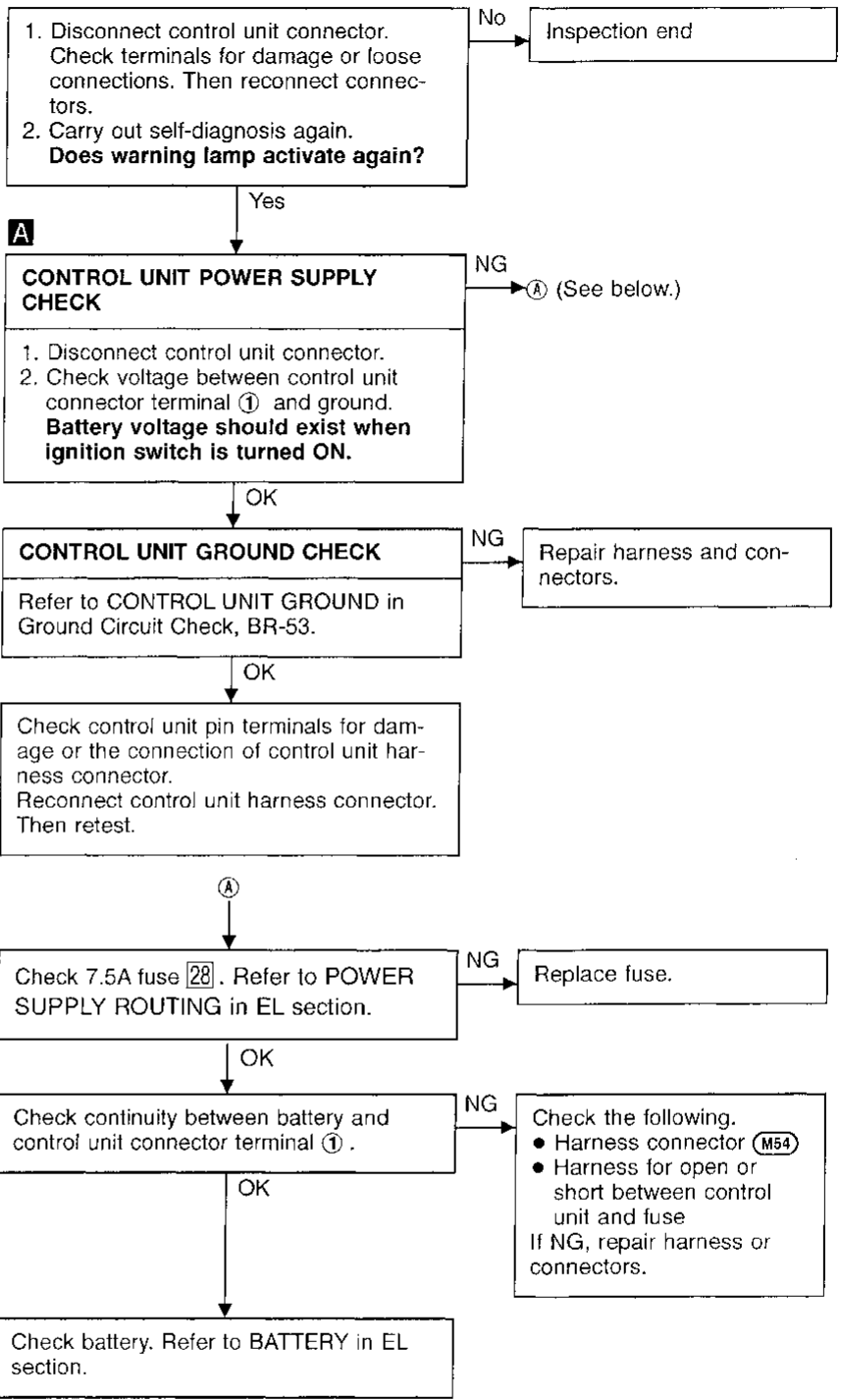
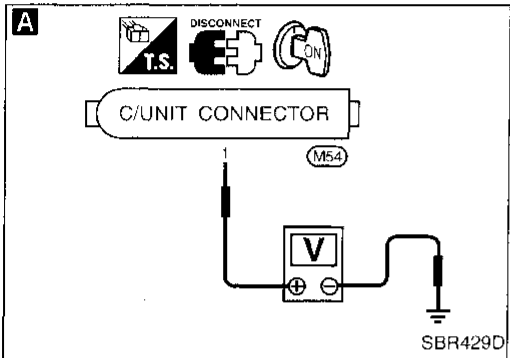
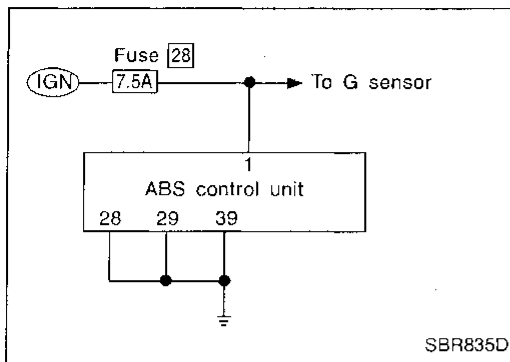

# TROUBLE DIAGNOSES FOR SELF-DIAGNOSTIC ITEMS

## Diagnostic Procedure 6 (G sensor) (Cont'd) ELECTRICAL COMPONENTS INSPECTION

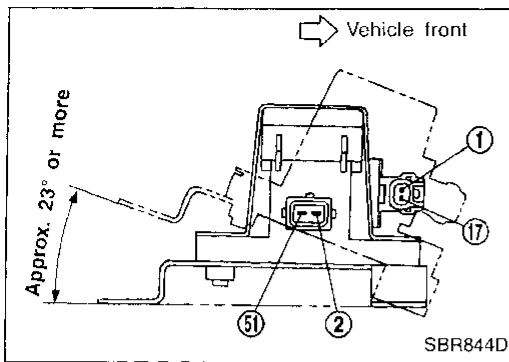

### G sensor

#### CAUTION:

The G sensor is easily damaged if it sustains an impact. Be careful not to drop or bump it.

1. Measure resistance between terminals ② and ⑤① of G sensor unit connector.

G sensor condition	Resistance between terminals ② and ⑤①	G sensor switch condition
Installed in vehicle	1.4 - 1.6 kΩ	"ON"
Tilted as shown in figure	4.7 - 5.5 kΩ	"OFF"

2. Measure resistance between terminals ① and ①⑦ of the G sensor unit connector.

Resistance:	70 - 124 Ω
-------------	------------

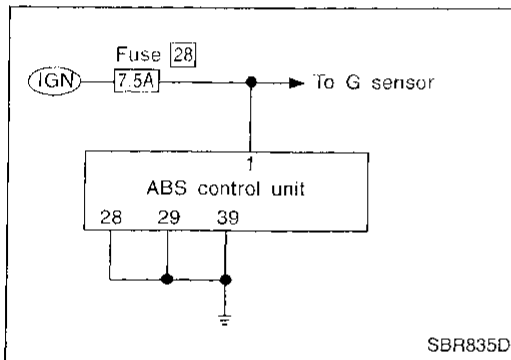

## Diagnostic Procedure 7 (Control unit)

### Malfunction code No. 71

1. Disconnect control unit connector. Check terminals for damage or loose connections. Then reconnect connectors.
2. Carry out self-diagnosis again.  
**Does warning lamp activate again?**

No → Inspection end

Yes

#### CONTROL UNIT POWER SUPPLY CHECK

Check voltage. Refer to **A** in Diagnostic Procedure 5, BR-64.

Does warning lamp indicate code No. 71 again?

Yes → Replace control unit.

No

Inspect the system according to the code No.

## Diagnostic Procedure 6 (G sensor)

Malfunction code No. 17

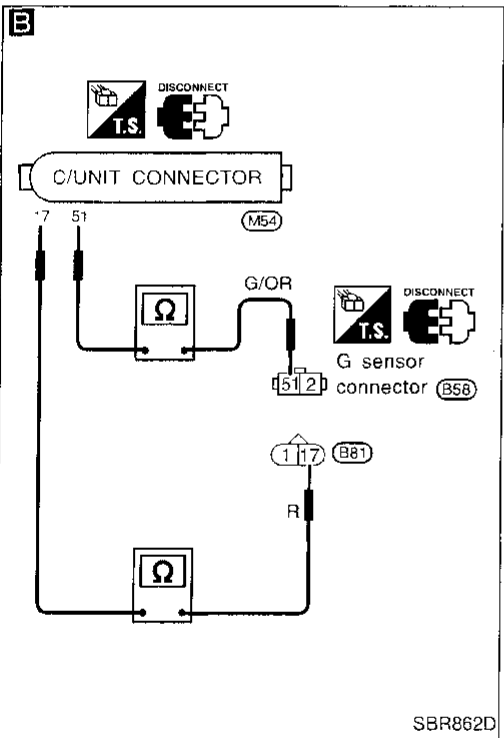
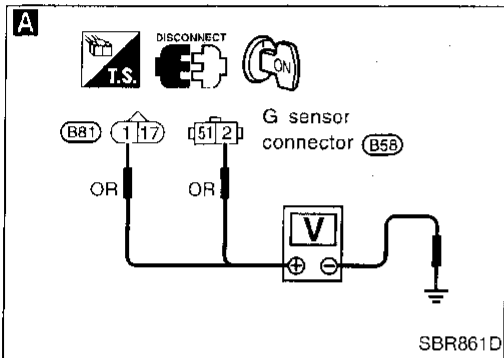
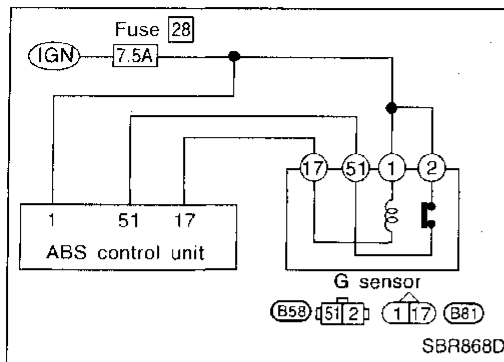

**G SENSOR POWER SUPPLY CIRCUIT**

NG → Replace fuse.

Check 7.5A fuse 28 for control unit. For fuse layout, refer to POWER SUPPLY ROUTING in EL section.

OK

1. Disconnect connectors from control unit and G sensor. Check terminals for damage or loose connection. Then reconnect connectors.

2. Carry out self-diagnosis again.

**Does warning lamp activate again?**

No → Inspection end

Yes

**G SENSOR CHECK**

NG → Replace G sensor.

Refer to G SENSOR in Electrical Components Inspection, BR-66.

OK

**A**

Check voltage between G sensor connector terminals ①, ② and ground.

**Battery voltage should exist.**

NG → Check the following.

- Harness connectors (B58, B81)
- Harness for open or short between G sensor and fuse

If NG, repair harness or connectors.

OK

**B**

1. Disconnect harness connector from control unit.

2. Check continuity between control unit connector terminals ⑦, ⑤ and G sensor connector terminals ①, ②.

**Continuity should exist.**

NG → Check the following.

- Harness connectors (M54, B58, B81)
- Harness for open or short between G sensor connector and control unit

If NG, repair harness or connectors.

OK

Check control unit pin terminals for damage or the connection of control unit harness connector. Reconnect control unit harness connector. Then retest.

GI  
MA  
EM  
LC  
EC  
FE  
AT  
TF  
PD  
FA  
RA  
**BR**  
ST  
RS  
BT  
HA  
EL  
IDX

**Diagnostic Procedure 8  
(ABS works frequently.)**

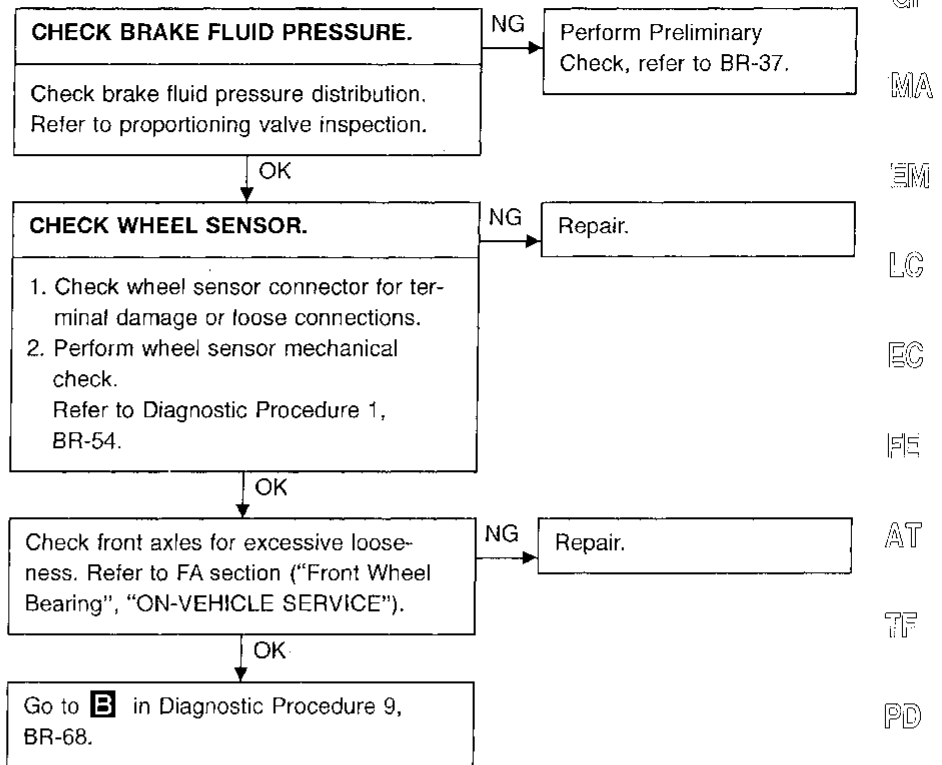

GI  
MA  
EM  
LG  
EC  
FE  
AT  
TF  
PD  
FA  
RA  
**BR**  
ST  
RS  
BT  
HA  
EL  
IDX

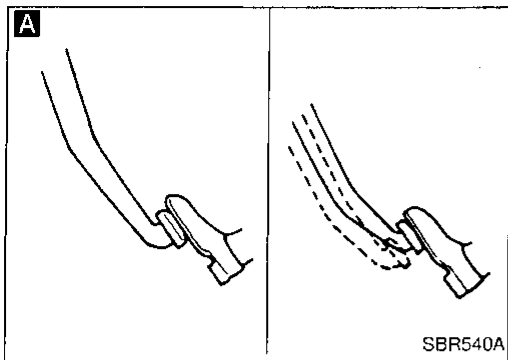

## Diagnostic Procedure 9 (Unexpected pedal action)

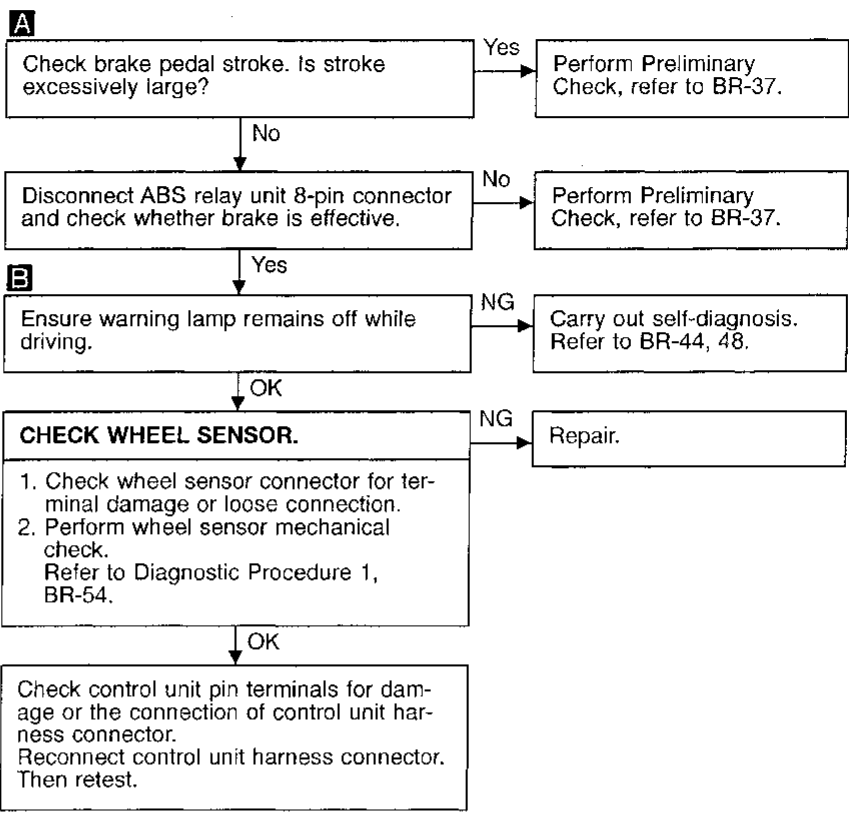
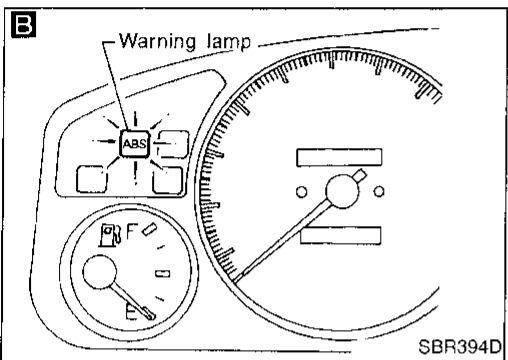

## Diagnostic Procedure 10 (Long stopping distance)

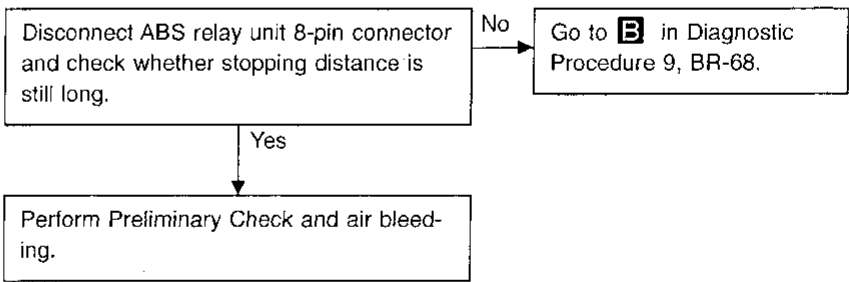

**Note:** Stopping distance may be larger than vehicles without ABS when road condition is slippery.

## Diagnostic Procedure 11 (ABS does not work.)

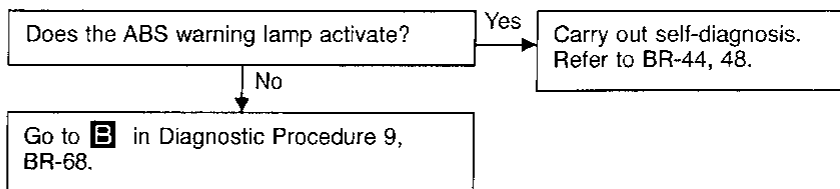

**Note: ABS does not work when vehicle speed is under 10 km/h (6 MPH).**

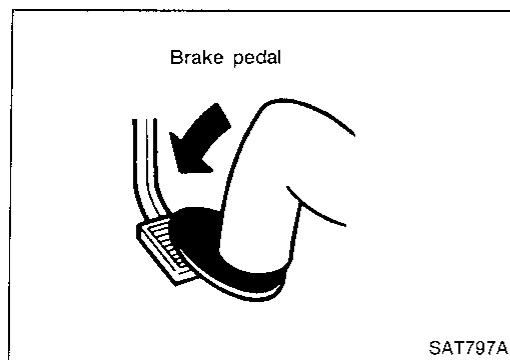

## Diagnostic Procedure 12 (Pedal vibration and noise)

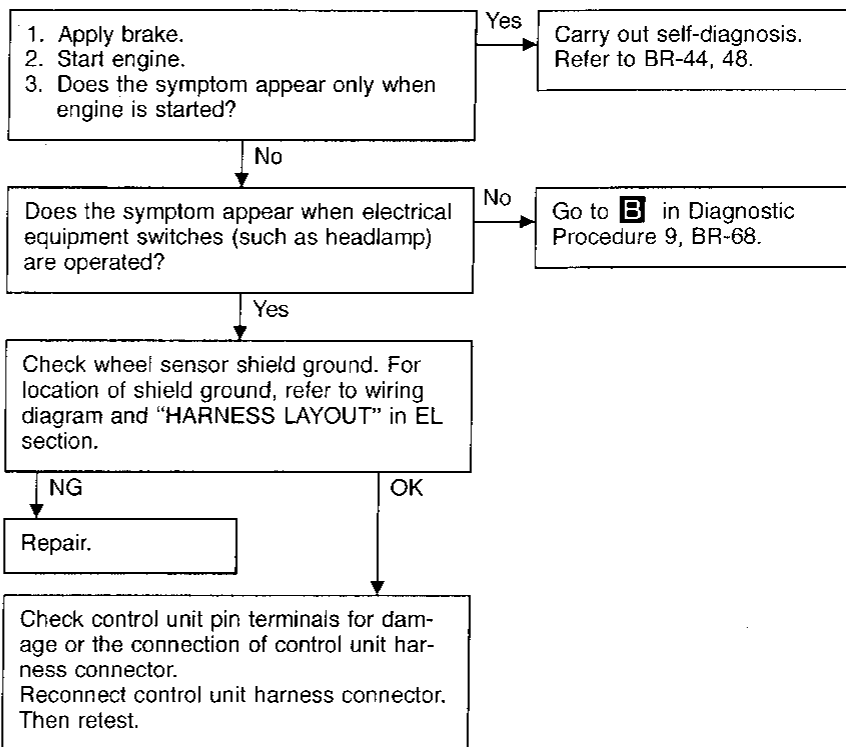

**Note: ABS may operate and cause vibration under any of the following conditions.**

- Applying brake gradually when shifting or operating clutch.
- Low friction (slippery) road.
- High speed cornering.
- Driving over bumps and pot holes.
- Engine speed is over 5,000 rpm with vehicle stopped.

GI  
MA  
EM  
LC  
EC  
FE  
AT  
TF  
PD  
FA  
RA  
**BR**  
ST  
RS  
BT  
HA  
EL  
IDX

## Diagnostic Procedure 13 (Warning lamp does not come on when ignition switch is turned on.)

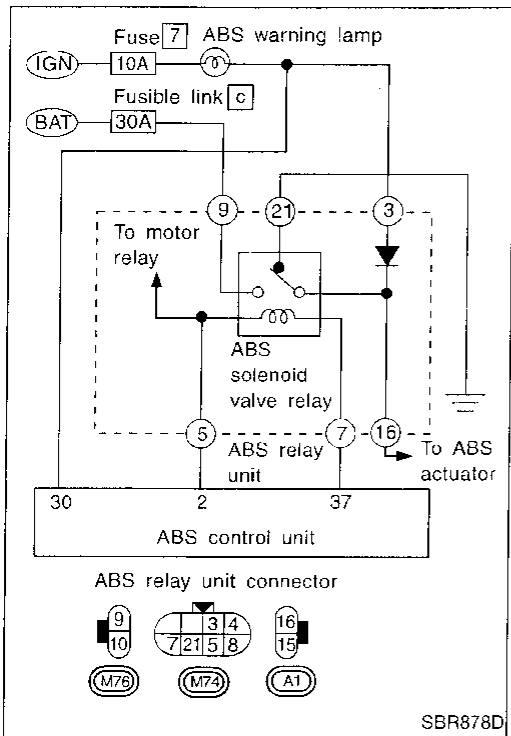

### WARNING LAMP CIRCUIT CHECK

Check 10A fuse 7 for warning lamp. For fuse layout, refer to POWER SUPPLY ROUTING in EL section.

NG → Replace fuse.

OK ↓

- A**
1. Install 10A fuse.
  2. Disconnect connectors from control unit and actuator.
  3. Check voltage between control unit connector terminal 30 and ground after turning ignition switch "ON".  
**Battery voltage should exist after turning ignition switch "ON".**

NG → Check warning lamp bulb.

Replace bulb.

NG ↑

OK ↓

Repair harness and connectors between fuse and control unit connector terminal 30 (including combination meter).

OK ↓

- B**
1. Turn ignition switch "OFF".  
Disconnect ABS relay unit 8-pin connector.
  2. Check continuity between control unit connector terminal 30 and ABS relay unit 8-pin connector (body side) terminal 3.  
**Continuity should exist.**

NG → Repair harness and connectors between warning lamp (combination meter) and ABS relay unit 8-pin connector (body side) terminal 3.

OK ↓

- C**
1. Disconnect ABS relay unit 8-pin connector.
  2. Check continuity between ABS relay unit harness 8-pin connector (body side) terminal 21 and body ground.  
**Continuity should exist.**

NG → Repair harness and connectors.

OK ↓

(Go to next page.)

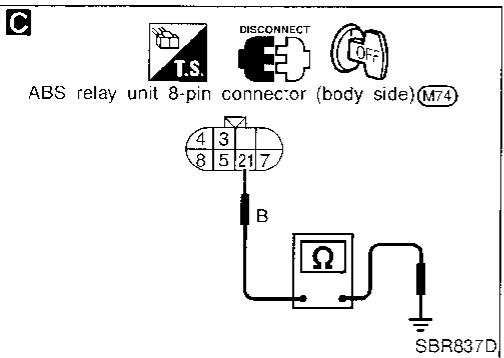
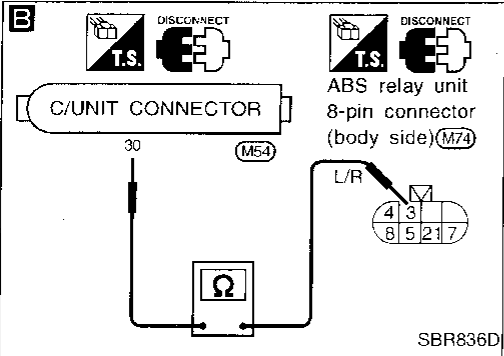
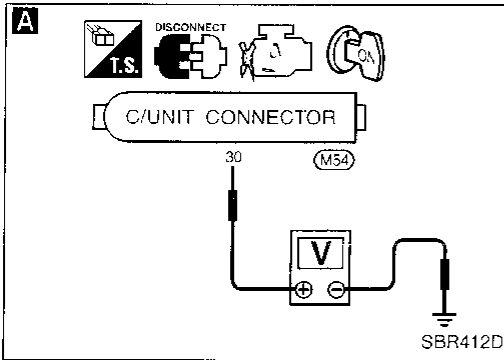

# TROUBLE DIAGNOSES FOR SYMPTOMS

## Diagnostic Procedure 13 (Warning lamp does not come on when ignition switch is turned on.) (Cont'd)

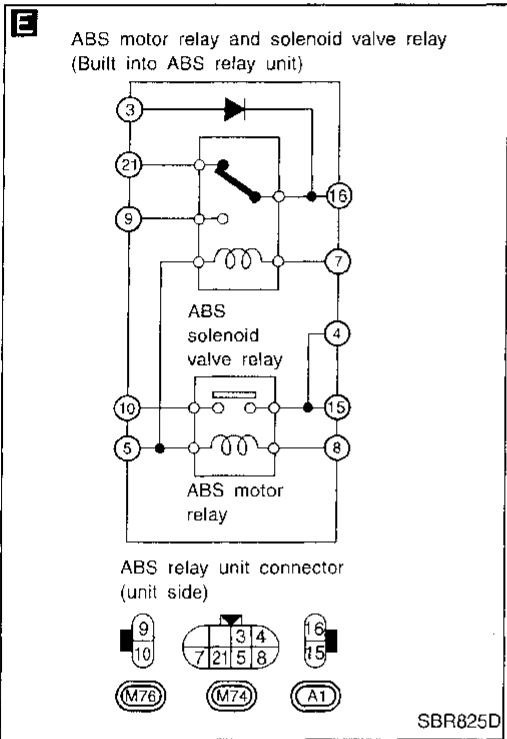
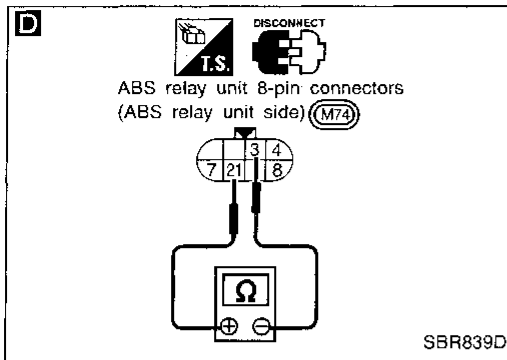

**D**

1. Disconnect ABS relay unit 8-pin connector.
2. Check continuity between ABS relay unit 8-pin connector (ABS relay unit side) terminals ③ ⊖ and ② ⊕. **Continuity should exist.**

**Note: Pay attention to tester polarity\*.**

NG → Replace ABS relay unit.

OK →

**CONTROL UNIT POWER SUPPLY CIRCUIT.**

NG → Repair harness and connectors.

OK → Go to **A** in Diagnostic Procedure 14, BR-72.

**E**

**CHECK SOLENOID VALVE RELAY.**

NG → Replace ABS relay unit.

OK →

Relay type	Solenoid valve relay	
Condition	Continuity existence between terminals ③ or ⑤ and ②	
Battery voltage not applied between each terminal	⑤ and ⑦	Yes
Battery voltage applied between each terminal	⑤ and ⑦	No
Check resistance between each terminal	⑤ and ⑦	Approx. 100Ω

OK → Go to Diagnostic Procedure 5, BR-64.

\*: Specifications may vary depending on the type of tester. Before performing this inspection, refer to the instruction manual of the tester.

GI  
MA  
EM  
LC  
EC  
FE  
AT  
TF  
PD  
FA  
RA  
BR  
ST  
RS  
BT  
HA  
EL  
IDX



## Diagnostic Procedure 14 (Warning lamp stays on when ignition switch is turned on.)

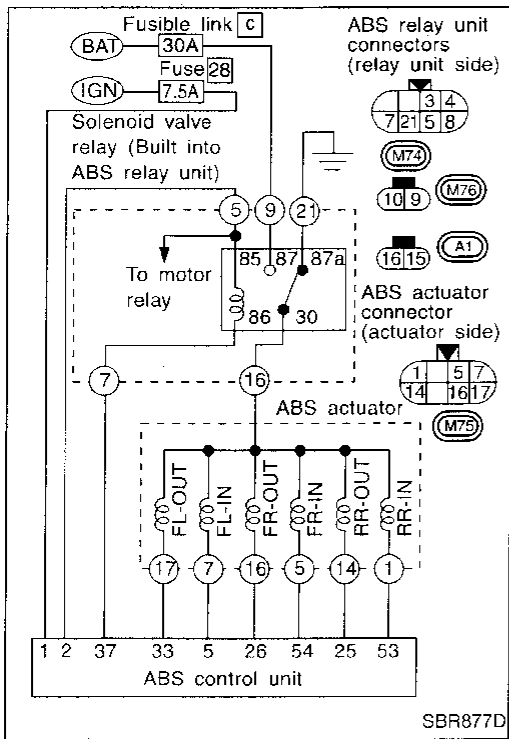

**CONTROL UNIT POWER SUPPLY CIRCUIT**

NG → ⓑ (Skip page.)

Check 7.5A fuse 28 for control unit.  
 For fuse layout, refer to POWER SUPPLY ROUTING in EL section.

**A**

1. Disconnect connector from control unit.  
 2. Check voltage between control unit connector terminal ① and ground after turning ignition switch "ON".  
**Battery voltage should exist.**

NG → Check the following.  
 • Harness connector (M54)  
 • Harness for open or short between control unit and fuse  
 If NG, repair harness or connectors.

**B**

**SOLENOID VALVE RELAY COIL POWER SUPPLY CIRCUIT**

1. Turn ignition switch "OFF". Disconnect ABS relay unit 8-pin connector.  
 2. Check continuity between control unit connector terminals and ABS relay unit 8-pin connector (body side) terminals.  
**Continuity should exist.**

Control unit	ABS relay unit
②	⑤
③	⑦

NG → Check the following.  
 • Harness connectors (M54), (M74)  
 • Harness for open or short between solenoid valve relay unit terminal (body side) and control unit  
 If NG, repair harness or connectors.

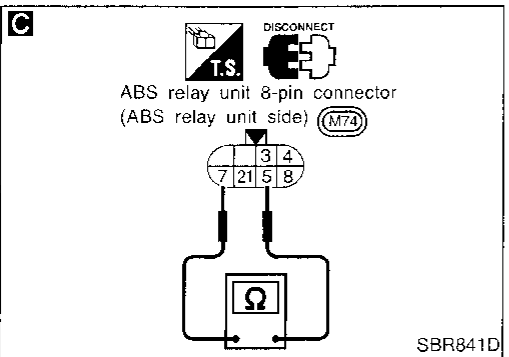
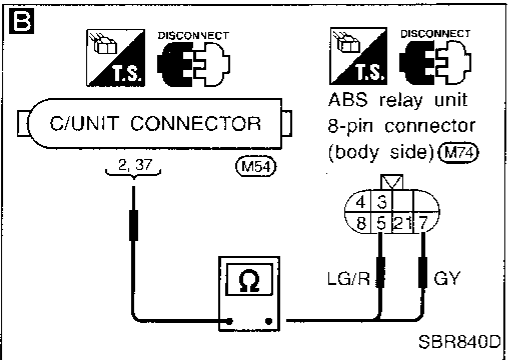
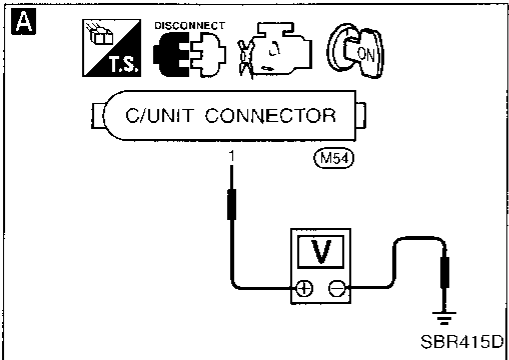

**C**

**CIRCUIT CHECK**

1. Disconnect ABS relay unit 8-pin connector.  
 2. Check continuity between ABS relay unit 8-pin connector (ABS relay unit side) terminals ⑤ and ⑦.  
**Continuity should exist.**

NG → Replace ABS relay unit.

**SOLENOID VALVE RELAY CHECK**

Go to **E** in Diagnostic Procedure 13, BR-71.

NG → Replace ABS relay unit.

OK → ⓐ (Go to next page.)

# TROUBLE DIAGNOSES FOR SYMPTOMS

## Diagnostic Procedure 14 (Warning lamp stays on when ignition switch is turned on.) (Cont'd)

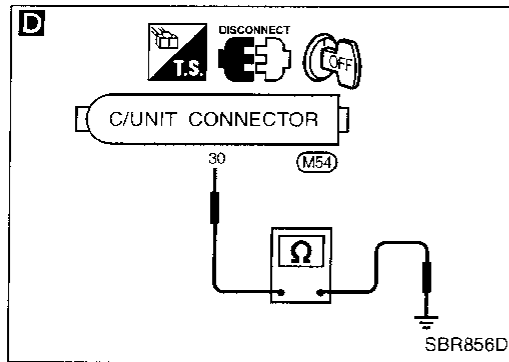

**D**

**GROUND-SHORT CHECK FOR WARNING LAMP CIRCUIT.**

1. Turn ignition switch "OFF".
2. Disconnect connectors from control unit and ABS relay unit 8-pin connector.
3. Check continuity between control unit connector terminal ③ and body ground. **Continuity should not exist.**

NG → Check the following.

- Harness connector (M54)
- Harness for open or short between control unit and fuse

If NG, repair harness or connectors.

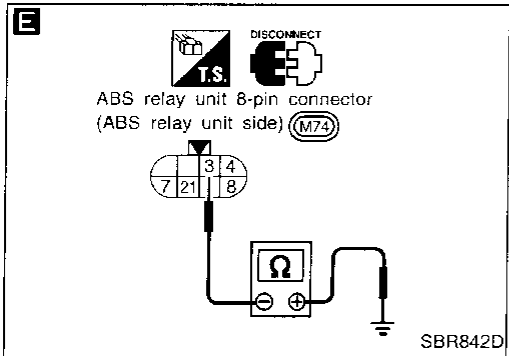

**E**

1. Disconnect actuator ground terminal and ABS relay unit 8-pin connector.
2. Check continuity between ABS relay unit 8-pin connector (ABS relay unit side) terminal ③ and body ground. **Continuity should not exist.**

Note: Pay attention to tester polarity\*.

NG → Replace ABS relay unit.

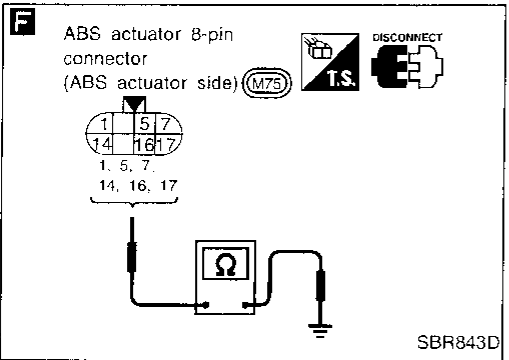

**F**

**SOLENOID VALVE CIRCUIT**

1. Disconnect ABS actuator 8-pin connector.
2. Check continuity between each ABS actuator 8-pin connector (ABS actuator side) terminals and body ground. **Continuity should not exist.**

NG → Replace ABS actuator.

OK

Check control unit pin terminals for damage or the connection of control unit harness connector.  
Reconnect control unit harness connector.  
Then retest.

\*: Specifications may vary depending on the type of tester.  
Before performing this inspection, refer to the instruction manual of the tester.

GI  
MA  
EM  
LC  
EC  
FE  
AT  
TF  
PD  
FA  
RA  
BR  
ST  
RS  
BT  
HA  
EL  
DX

# TROUBLE DIAGNOSES FOR SYMPTOMS

## Diagnostic Procedure 14 (Warning lamp stays on when ignition switch is turned on.) (Cont'd)

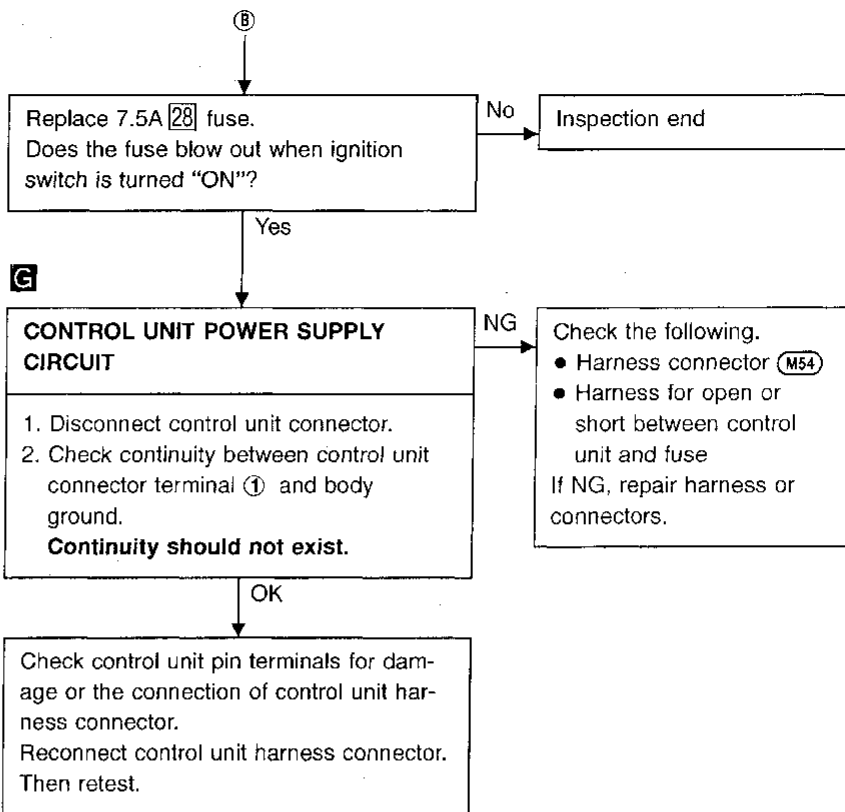
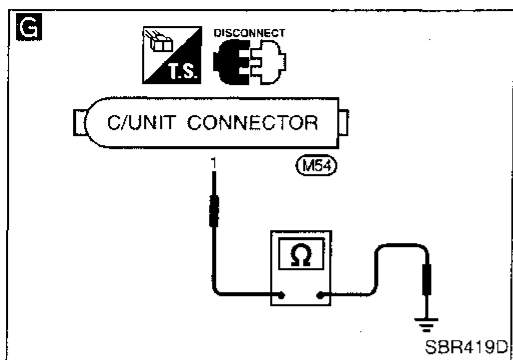

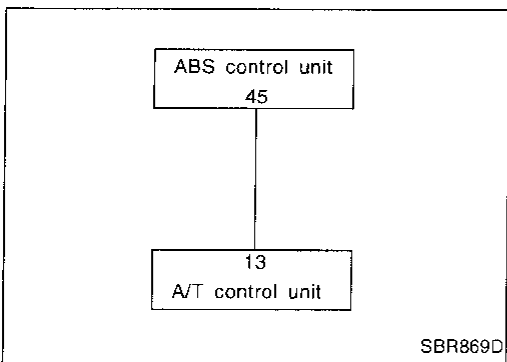

## Diagnostic Procedure 15 (Vehicle vibrates excessively when ABS is operating.)

- While ABS is operating, brake pedal vibrates slightly. This is not a problem.
- If vehicle vibration is greater in the AUTO mode than in the 2WD mode, there is the possibility of failure in the communication line between the ABS control unit and A/T control unit. Check and locate the cause of the problem.

GI  
MA  
EW  
LC  
EC  
FE  
AT  
TF  
PD  
FA  
RA  
BR  
ST  
RS  
BT  
HA  
EL  
IDX

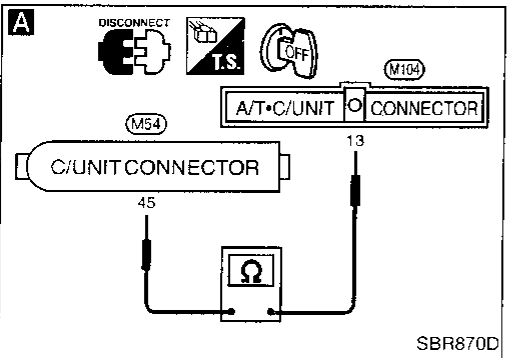

Perform self-diagnosis for the ABS control unit and A/T control unit.  
**Are there any malfunctions?**

Yes → Inspect or repair the system according to the self-diagnostic item.  
OK →

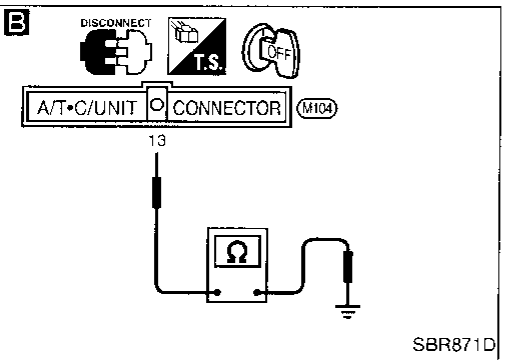

No →

OK →

**A**

1. Disconnect connectors from ABS control unit and A/T control unit. Check terminals for damage or loose connection.
2. Check continuity between ABS control unit connector terminal ⑤ and A/T control unit connector terminal ⑬.  
**Continuity should exist.**

NG → Check the following.  
• Harness connectors (M54, M104)  
• Harness for open or short between ABS control unit and A/T control unit  
If NG, repair harness or connectors.  
OK →

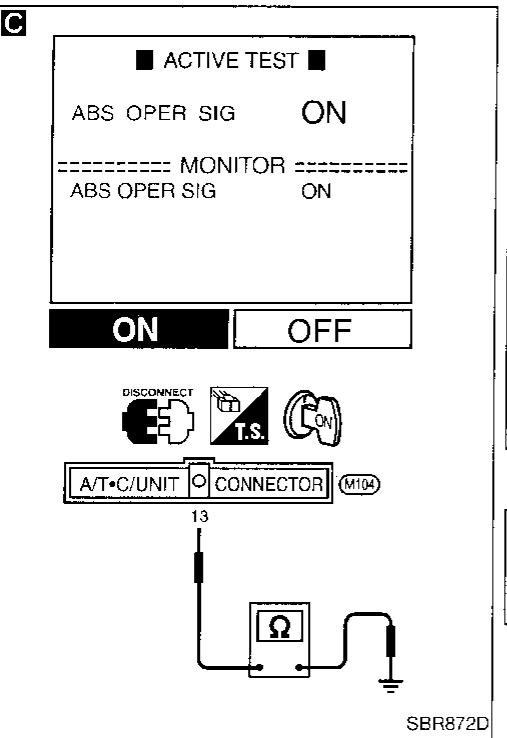

**B**

1. Reconnect only ABS control unit connector.
2. Check continuity between A/T control unit connector terminal ⑬ and ground.  
**Continuity should not exist.**

NG → Replace ABS control unit.  
OK →

**C**

1. Connect CONSULT to Data Link Connector for CONSULT.
2. Turn ignition switch "ON". Set CONSULT in the active test mode to output an ABS operating signal! (Refer to "ACTIVE TEST PROCEDURE", "CONSULT Inspection Procedure", BR-51.)
3. An ABS operating signal lasts for 10 seconds. During the time the signal is being output, check resistance between A/T control unit connector terminal ⑬ and ground.  
**Resistance: 0.5Ω, max.**

NG → Replace ABS control unit.  
OK →

CHECK A/T CONTROL UNIT.  
Refer to TF section ("TROUBLE DIAGNOSIS FOR ABS OPERATION SIGNAL").

# SERVICE DATA AND SPECIFICATIONS (SDS)

## General Specifications

Front brake	
Brake model	AD31VA
Cylinder bore diameter × number of pistons mm (in)	44.45 (1.7500) × 2
Pad length × width × thickness mm (in)	132.0 × 52.5 × 11 (5.20 × 2.067 × 0.43)
Rotor outer diameter × thickness mm (in)	283 × 28 (11.14 × 1.10)
Rear brake	
Brake model	LT30C
Cylinder bore diameter mm (in)	20.64 (13/16)
Lining length × width × thickness mm (in)	296 × 50 × 6.1 (11.65 × 1.97 × 0.240)
Drum inner diameter mm (in)	295.0 (11.61)
Master cylinder	
Bore diameter mm (in)	25.40 (1)
Control valve	
Valve model	Linkage type load sensing valve
Split point [kPa (kg/cm <sup>2</sup> , psi)] × reducing ratio	(Variable) × 0.18
Brake booster	
Booster model	M215T
Diaphragm diameter mm (in)	Pri.: 230 (9.06) Sec.: 205 (8.07)
Recommended brake fluid	DOT 3

## Inspection and Adjustment

### DISC BRAKE

Unit: mm (in)

Brake model	AD31VA
Pad wear limit	
Minimum thickness	2.0 (0.079)
Rotor repair limit	
Minimum thickness	26.0 (1.024)

### DRUM BRAKE

Unit: mm (in)

Brake model	LT30C
Lining wear limit	
Minimum thickness	1.5 (0.059)
Drum repair limit	
Maximum inner diameter	296.5 (11.67)
Out-of-round limit	0.03 (0.0012)

### BRAKE PEDAL

Unit: mm (in)

Free height "H"	175 - 185 (6.89 - 7.28)
Depressed height "D" [under force of 490 N (50 kg, 110 lb) with engine running]	70 (2.76)
Clearance "C" between pedal stopper and threaded end of stop lamp switch or ASCD switch	0.3 - 1.0 (0.012 - 0.039)
Pedal free play	
At clevis	1.0 - 3.0 (0.039 - 0.118)
At pedal pad	4 - 12 (0.16 - 0.47)

\*: Measured from surface of dash lower panel to pedal pad

### PARKING BRAKE CONTROL

Control type	Center lever
Lever stroke [under force of 196 N (20 kg, 44 lb)]	6 - 8
Lever stroke when warning switch comes on	1