

CONTENTS

DIAGNOSTIC TROUBLE CODE INDEX2	ON BOARD DIAGNOSTIC SYSTEM	
Alphabetical & P No. Index for DTC2	DESCRIPTION36	
PRECAUTIONS AND PREPARATION4	Introduction36	
Special Service Tools4	Two Trip Detection Logic36	
Commercial Service Tool.....4	Emission-related Diagnostic Information37	
Supplemental Restraint System (SRS) "AIR BAG".....4	Malfunction Indicator Lamp (MIL).....48	
Precautions for On Board Diagnostic (OBD)	OBD System Operation Chart.....51	
System of Engine and A/T.....5	CONSULT56	
Engine Fuel & Emission Control System6	Generic Scan Tool (GST)68	
Precautions7	TROUBLE DIAGNOSIS — Introduction70	
ENGINE AND EMISSION CONTROL OVERALL	Introduction70	
SYSTEM9	Diagnostic Worksheet.....70	
ECCS Component Parts Location.....9	TROUBLE DIAGNOSIS — Work Flow72	
Circuit Diagram11	Work Flow72	
System Diagram12	Description for Work Flow73	
Vacuum Hose Drawing13	TROUBLE DIAGNOSIS — Basic Inspection74	
System Chart.....14	Basic Inspection.....74	
ENGINE AND EMISSION BASIC CONTROL	TROUBLE DIAGNOSIS — General Description76	
SYSTEM DESCRIPTION15	Diagnostic Trouble Code (DTC) Inspection	
Multiport Fuel Injection (MFI) System15	Priority Chart.....76	
Distributor Ignition (DI) System17	Fail-Safe Chart.....77	
Air Conditioning Cut Control.....18	Symptom Matrix Chart.....78	
Fuel Cut Control (at no load & high engine speed)19	CONSULT Reference Value in Data Monitor	
EVAPORATIVE EMISSION SYSTEM20	Mode81	
Description20	Major Sensor Reference Graph in Data Monitor	
Inspection.....20	Mode83	
Evaporative Emission Line Drawing.....22	ECM Terminals and Reference Value85	
POSITIVE CRANKCASE VENTILATION24	TROUBLE DIAGNOSIS FOR POWER SUPPLY94	
Description24	Main Power Supply and Ground Circuit.....94	
Inspection.....24	TROUBLE DIAGNOSIS FOR DTC P0100100	
BASIC SERVICE PROCEDURE25	Mass Air Flow Sensor (MAFS)100	
Fuel Pressure Release25	TROUBLE DIAGNOSIS FOR DTC P0105106	
Fuel Pressure Check25	Absolute Pressure Sensor.....106	
Injector Removal and Installation26	TROUBLE DIAGNOSIS FOR DTC P0110113	
Fast Idle Cam (FIC) Inspection and Adjustment.....27	Intake Air Temperature Sensor113	
Idle Speed/Ignition Timing/Idle Mixture Ratio	TROUBLE DIAGNOSIS FOR DTC P0115118	
Adjustment29	Engine Coolant Temperature Sensor (ECTS)118	
	TROUBLE DIAGNOSIS FOR DTC P0120123	
	Throttle Position Sensor123	

CONTENTS (Cont'd)

TROUBLE DIAGNOSIS FOR DTC P0125	129	EGRC-BPT Valve Function	219
Engine Coolant Temperature (ECT) Sensor	129	TROUBLE DIAGNOSIS FOR DTC P0420, P0430	221
TROUBLE DIAGNOSIS FOR DTC P0130, P0150	134	Three Way Catalyst Function	221
Closed Loop Control.....	134	TROUBLE DIAGNOSIS FOR DTC P0440	224
TROUBLE DIAGNOSIS FOR DTC P0130	135	Evaporative Emission (EVAP) Control System	
Front Heated Oxygen Sensor (Front HO2S)		(Small Leak).....	224
(Right bank)	135	TROUBLE DIAGNOSIS FOR DTC P0443	233
TROUBLE DIAGNOSIS FOR DTC P0135	140	Evaporative Emission (EVAP) Canister Purge	
Front Heated Oxygen Sensor Heater (Right		Control Valve/Solenoid Valve	233
bank)	140	TROUBLE DIAGNOSIS FOR DTC P0446	242
TROUBLE DIAGNOSIS FOR DTC P0136	144	Evaporative Emission (EVAP) Canister Vent	
Rear Heated Oxygen Sensor (Rear HO2S)		Control Valve	242
(Right bank)	144	TROUBLE DIAGNOSIS FOR DTC P0450	247
TROUBLE DIAGNOSIS FOR DTC P0141	148	Evaporative Emission (EVAP) Control System	
Rear Heated Oxygen Sensor Heater (Right		Pressure Sensor	247
bank)	148	TROUBLE DIAGNOSIS FOR DTC P0500	252
TROUBLE DIAGNOSIS FOR DTC P0150	153	Vehicle Speed Sensor (VSS)	252
Front Heated Oxygen Sensor (Front HO2S) (Left		TROUBLE DIAGNOSIS FOR DTC P0505	256
bank)	153	Idle Air Control Valve (IACV) — Auxiliary Air	
TROUBLE DIAGNOSIS FOR DTC P0155	158	Control (AAC) Valve	256
Front Heated Oxygen Sensor Heater (Left bank) ...	158	TROUBLE DIAGNOSIS FOR DTC P0510	261
TROUBLE DIAGNOSIS FOR DTC P0156	162	Closed Throttle Position Switch.....	261
Rear Heated Oxygen Sensor (Rear HO2S) (Left		TROUBLE DIAGNOSIS FOR DTC P0600	266
bank)	162	A/T Control.....	266
TROUBLE DIAGNOSIS FOR DTC P0161	166	TROUBLE DIAGNOSIS FOR DTC P0605	269
Rear Heated Oxygen Sensor Heater (Left bank)....	166	Engine Control Module (ECM)-ECCS Control	
TROUBLE DIAGNOSIS FOR DTC P0171	170	Module	269
Fuel Injection System Function (Right bank)		TROUBLE DIAGNOSIS FOR DTC P0705	271
(Lean side)	170	Park/Neutral Position Switch	271
TROUBLE DIAGNOSIS FOR DTC P0172	175	TROUBLE DIAGNOSIS FOR DTC P1105	277
Fuel Injection System Function (Right bank)		Manifold Absolute Pressure (MAP)/Barometric	
(Rich side).....	175	Pressure (BARO) Switch Solenoid Valve.....	277
TROUBLE DIAGNOSIS FOR DTC P0174	180	TROUBLE DIAGNOSIS FOR DTC P1320	283
Fuel Injection System Function (Left bank) (Lean		Ignition Signal	283
side)	180	TROUBLE DIAGNOSIS FOR DTC P1336	289
TROUBLE DIAGNOSIS FOR DTC P0175	185	Crankshaft Position Sensor (CKPS) (OBD)	
Fuel Injection System Function (Left bank) (Rich		(COG)	289
side)	185	TROUBLE DIAGNOSIS FOR DTC P1400	294
TROUBLE DIAGNOSIS FOR DTC P0180	190	EGRC-Solenoid Valve	294
Tank Fuel Temperature Sensor	190	TROUBLE DIAGNOSIS FOR DTC P1401	299
TROUBLE DIAGNOSIS FOR DTC P0300 - P0306	193	EGR Temperature Sensor	299
No. 6 - 1 Cylinder Misfire, Multiple Cylinder		TROUBLE DIAGNOSIS FOR DTC P1441	304
Misfire	193	Vacuum Cut Valve Bypass Valve	304
TROUBLE DIAGNOSIS FOR DTC P0325	197	TROUBLE DIAGNOSIS FOR DTC P1445	309
Knock Sensor (KS).....	197	Evaporative Emission (EVAP) Canister Purge	
TROUBLE DIAGNOSIS FOR DTC P0335	200	Volume Control Valve	309
Crankshaft Position Sensor (CKPS) (OBD)	200	TROUBLE DIAGNOSIS FOR DTC P1447	317
TROUBLE DIAGNOSIS FOR DTC P0340	205	Evaporative Emission (EVAP) Control System	
Camshaft Position Sensor (CMPS)	205	Purge Flow Monitoring.....	317
TROUBLE DIAGNOSIS FOR DTC P0400	211	TROUBLE DIAGNOSIS FOR DTC P1605	326
EGR Function	211	A/T Diagnosis Communication Line	326
TROUBLE DIAGNOSIS FOR DTC P0402	219		

CONTENTS (Cont'd)

TRUBLE DIAGNOSIS FOR NON-DETECTABLE

ITEMS	329
Injector	329
Start Signal	333
Fuel Pump	336
Power Steering Oil Pressure Switch	341

IACV-FICD Solenoid Valve	345
MIL & Data Link Connectors	349
SERVICE DATA AND SPECIFICATIONS (SDS)	350
General Specifications.....	350
Inspection and Adjustment	350

GI

MA

EM

LC

EC

FE

AT

TF

PD

FA

RA

BR

ST

RS

BT

HA

EL

IDX

When you read wiring diagrams:

- Read GI section, "HOW TO READ WIRING DIAGRAMS".
- Read EL section, "POWER SUPPLY ROUTING" for power distribution circuit.

When you perform trouble diagnoses, read GI section, "HOW TO FOLLOW FLOW CHART IN TROUBLE DIAGNOSES" and "HOW TO PERFORM EFFICIENT DIAGNOSIS FOR AN ELECTRICAL INCIDENT".

DIAGNOSTIC TROUBLE CODE INDEX

Alphabetical & P No. Index for DTC

ALPHABETICAL INDEX FOR DTC

Items (CONSULT screen terms)	DTC*7		Reference page	Items (CONSULT screen terms)	DTC*7		Reference page
	ECM*1	CONSULT GST*2			ECM*1	CONSULT GST*2	
Unable to access ECCS	—	—	EC-77	FUEL SYS RICH/BK1	0114	P0172	EC-175
ABSOL PRESS SENSOR	0803	P0105	EC-106	FUEL SYS RICH/BK2	0209	P0175	EC-185
A/T 1ST SIGNAL	1103	P0731	AT-72	IACV-AAC VALVE	0205	P0505	EC-256
A/T 2ND SIGNAL	1104	P0732	AT-75	IGN SIGNAL-PRIMARY	0201	P1320	EC-283
A/T 3RD SIGNAL	1105	P0733	AT-77	INHIBITOR SWITCH	1101	P0705	AT-59
A/T 4TH SIG OR TCC	1106	P0734	AT-79	INT AIR TEMP SEN	0401	P0110	EC-113
A/T COMM LINE	—	P0600	EC-266	KNOCK SENSOR	0304	P0325	EC-197
A/T DIAG COMM LINE	0804	P1605	EC-326	LINE PRESSURE S/V	1205	P0745	AT-92
A/T TCC SIGNAL	1107	P0744	AT-87	MAP/BARO SW SOL/V	1302	P1105	EC-277
CAMSHAFT POSI SEN	0101	P0340	EC-205	MASS AIR FLOW SEN*3	0102	P0100	EC-100
CLOSED LOOP-B1	0307	P0130	EC-134	MULTI CYL MISFIRE	0701	P0300	EC-193
CLOSED LOOP-B2	0308	P0150*3	EC-134	NO SELF DIAGNOSTIC FAILURE INDICATED	0505	P0000	—
CLOSED THRL POS SW	0203	P0510	EC-261	NO SELF DIAGNOSTIC FAILURE INDICATED	Flash- ing*6	No DTC	EC-48
COOLANT TEMP SEN*3	0103	P0115	EC-118	OVER HEAT	0208	P1900*5	LC-17
*COOLANT TEMP SEN	0908	P0125	EC-129	OVERRUN CLUTCH S/V	1203	P1760	AT-103
CRANK P/S (OBD) COG	0905	P1336	EC-289	PARK/NEUT POSI SW	1003	P0705	EC-271
CRANK POS SEN (OBD)	0802	P0335	EC-200	PURG CONT/V & S/V	0807	P0443	EC-233
CYL 1 MISFIRE	0608	P0301	EC-193	PURG VOLUME CONT/V	1008	P1445	EC-309
CYL 2 MISFIRE	0607	P0302	EC-193	REAR O2 SENSOR-B1	0707	P0136	EC-144
CYL 3 MISFIRE	0606	P0303	EC-193	REAR O2 SENSOR-B2	0708	P0156	EC-162
CYL 4 MISFIRE	0605	P0304	EC-193	RR O2 SEN HTR-B1	0902	P0141	EC-148
CYL 5 MISFIRE	0604	P0305	EC-193	RR O2 SEN HTR-B2	1002	P0161	EC-166
CYL 6 MISFIRE	0603	P0306	EC-193	SHIFT SOLENOID/V A*3	1108	P0750	AT-95
ECM	0301	P0605	EC-269	SHIFT SOLENOID/V B*3	1201	P0755	AT-98
EGR SYSTEM	0302	P0400	EC-211	TANK FUEL TEMP SEN	0402	P0180	EC-190
EGR TEMP SENSOR	0305	P1401	EC-299	THROTTLE POSI SEN*3	0403	P0120	EC-123
EGRC SOLENOID/V	1005	P1400	EC-294	THRTL POSI SEN A/T*3	1206	P1705	AT-101
EGRC-BPT VALVE	0306	P0402	EC-219	TOR CONV CLUTCH SV	1204	P0740	AT-84
ENGINE SPEED SIG*4	1207	P0725	AT-70	TW CATALYST SYSTEM-B1	0702	P0420	EC-221
EVAP PURG FLOW/MON	0111	P1447	EC-317	TW CATALYST SYSTEM-B2	0703	P0430	EC-221
EVAP SYS PRES SEN	0704	P0450	EC-247	VC/V BYPASS/V	0801	P1441	EC-304
EVAP (SMALL LEAK)	0705	P0440	EC-224	VEHICLE SPEED SEN	0104	P0500	EC-252
FLUID TEMP SENSOR	1208	P0710	AT-65	VENT CONTROL VALVE	0903	P0446	EC-242
FR O2 SEN HTR-B1	0901	P0135	EC-140	VHCL SPEED SEN A/T*4	1102	P0720	AT-68
FR O2 SEN HTR-B2	1001	P0155	EC-158				
FRONT O2 SENSOR-B1	0503	P0130	EC-135				
FRONT O2 SENSOR-B2	0303	P0150	EC-153				
FUEL SYS LEAN/BK1	0115	P0171	EC-170				
FUEL SYS LEAN/BK2	0210	P0174	EC-180				

- *1: In Diagnostic Test Mode II (Self-diagnostic results). These numbers are controlled by NISSAN.
- *2: These numbers are prescribed by SAE J2012.
- *3: When the fail-safe operation occurs, the MIL illuminates.
- *4: The MIL illuminates after A/T control unit enters the fail-safe mode in two consecutive trips, if both the "Revolution sensor" and the "Engine speed signal" meet the fail-safe condition at the same time.
- *5: Since this diagnosis does not meet P1900 of SAE J2012, it is indicated only by CONSULT.
- *6: While engine is running.
- *7: 1st trip DTC No. is the same as DTC No.
- NOTE: Regarding JR50 models, "B1" indicates right bank and "B2" indicates left bank.

DIAGNOSTIC TROUBLE CODE INDEX

Alphabetical & P No. Index for DTC (Cont'd)

P NO. INDEX FOR DTC

DTC*7		Items (CONSULT screen terms)	Reference page	DTC*7		Items (CONSULT screen terms)	Reference page
CONSULT GST*2	ECM*1			CONSULT GST*2	ECM*1		
—	—	Unable to access ECSS	EC-77	P0420	0702	TW CATALYST SYSTEM-B1	EC-221
P0000	0505	NO SELF DIAGNOSTIC FAILURE INDICATED	—	P0430	0703	TW CATALYST SYSTEM-B2	EC-221
No DTC	Flash- ing*6	NO SELF DIAGNOSTIC FAILURE INDICATED	EC-48	P0440	0705	EVAP (SMALL LEAK)	EC-224
P0100	0102	MASS AIR FLOW SEN*3	EC-100	P0443	0807	PURG CONT/V & S/V	EC-233
P0105	0803	ABSOL PRESS SENSOR	EC-106	P0446	0903	VENT CONTROL VALVE	EC-242
P0110	0401	INT AIR TEMP SEN	EC-113	P0450	0704	EVAP SYS PRES SEN	EC-247
P0115	0103	COOLANT TEMP SEN	EC-118	P0500	0104	VEHICLE SPEED SEN	EC-252
P0120	0403	THROTTLE POSI SEN*3	EC-123	P0505	0205	IACV-AAC VALVE	EC-256
P0125	0908	*COOLANT TEMP SEN	EC-129	P0510	0203	CLOSED THRL POS SW	EC-261
P0130	0307	CLOSED LOOP-B1	EC-134	P0600	—	A/T COMM LINE	EC-266
P0130	0503	FRONT O2 SENSOR-B1	EC-135	P0605	0301	ECM	EC-269
P0135	0901	FR O2 SEN HTR-B1	EC-140	P0705	1003	PARK/NEUT POSI SW	EC-271
P0136	0707	REAR O2 SENSOR-B1	EC-144	P0705	1101	INHIBITOR SWITCH	AT-59
P0141	0902	RR O2 SEN HTR-B1	EC-148	P0710	1208	FLUID TEMP SENSOR	AT-65
P0150	0308	CLOSED LOOP-B2	EC-134	P0720	1102	VHCL SPEED SEN A/T*4	AT-68
P0150	0303	FRONT O2 SENSOR-B2	EC-153	P0725	1207	ENGINE SPEED SIG*4	AT-70
P0155	1001	FR O2 SEN HTR-B2	EC-158	P0731	1103	A/T 1ST SIGNAL	AT-72
P0156	0708	REAR O2 SENSOR-B2	EC-162	P0732	1104	A/T 2ND SIGNAL	AT-75
P0161	1002	RR O2 SEN HTR-B2	EC-166	P0733	1105	A/T 3RD SIGNAL	AT-77
P0171	0115	FUEL SYS LEAN/BK1	EC-170	P0734	1106	A/T 4TH SIG OR TCC	AT-79
P0172	0114	FUEL SYS RICH/BK1	EC-175	P0740	1204	TOR CONV CLUTCH SV	AT-84
P0174	0210	FUEL SYS LEAN/BK2	EC-180	P0744	1107	A/T TCC SIGNAL	AT-87
P0175	0209	FUEL SYS RICH/BK2	EC-185	P0745	1205	LINE PRESSURE S/V	AT-92
P0180	0402	TANK FUEL TEMP SEN	EC-190	P0750	1108	SHIFT SOLENOID/V A*3	AT-95
P0300	0701	MULTI CYL MISFIRE	EC-193	P0755	1201	SHIFT SOLENOID/V B*3	AT-98
P0301	0608	CYL 1 MISFIRE	EC-193	P1105	1302	MAP/BARO SW SOL/V	EC-277
P0302	0607	CYL 2 MISFIRE	EC-193	P1320	0201	IGN SIGNAL-PRIMARY	EC-283
P0303	0606	CYL 3 MISFIRE	EC-193	P1336	0905	CRANK P/S (OBD) COG	EC-289
P0304	0605	CYL 4 MISFIRE	EC-193	P1400	1005	EGRC SOLENOID/V	EC-294
P0305	0604	CYL 5 MISFIRE	EC-193	P1401	0305	EGR TEMP SENSOR	EC-299
P0306	0603	CYL 6 MISFIRE	EC-193	P1441	0801	VC/V BYPASS/V	EC-304
P0325	0304	KNOCK SENSOR	EC-197	P1445	1008	PURG VOLUME CONT/V	EC-309
P0335	0802	CRANK POS SEN (OBD)	EC-200	P1447	0111	EVAP PURG FLOW/MON	EC-317
P0340	0101	CAMSHAFT POSI SEN	EC-205	P1605	0804	A/T DIAG COMM LINE	EC-326
P0400	0302	EGR SYSTEM	EC-211	P1705	1206	THRTL POSI SEN A/T*3	AT-101
P0402	0306	EGRC-BPT VALVE	EC-219	P1760	1203	OVERRUN CLUTCH S/V	AT-103
				P1900*5	0208	OVER HEAT	LC-17

*1: In Diagnostic Test Mode II (Self-diagnostic results). These numbers are controlled by NISSAN.

*2: These numbers are prescribed by SAE J2012.

*3: When the fail-safe operation occurs, the MIL illuminates.

*4: The MIL illuminates after A/T control unit enters the fail-safe mode in two consecutive trips, if both the "Revolution sensor" and the "Engine speed signal" meet the fail-safe condition at the same time.

*5: Since this diagnosis does not meet P1900 of SAE J2012, it is indicated only by CONSULT.

*6: While engine is running.

*7: 1st trip DTC No. is the same as DTC No.

NOTE: Regarding JR50 models, "B1" indicates right bank and "B2" indicates left bank.

PRECAUTIONS AND PREPARATION

Special Service Tools

The actual shapes of Kent-Moore tools may differ from those of special service tools illustrated here.

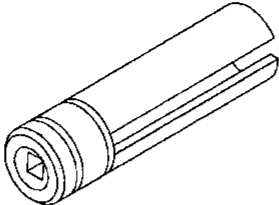
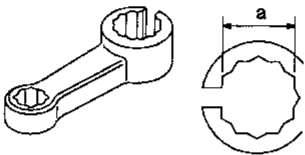
Tool number (Kent-Moore No.) Tool name	Description
KV10117100 (J36471-A) Heated oxygen sensor wrench	<div style="text-align: right;">Loosening or tightening front heated oxygen sensor with 22 mm (0.87 in) hexagon nut</div> <div style="text-align: center;">  </div> <div style="text-align: left;">NT379</div>
KV10114400 (J-38365) Heated oxygen sensor wrench	<div style="text-align: right;">Loosening or tightening rear heated oxygen sensor</div> <div style="text-align: center;">  </div> <div style="text-align: left;">NT636</div> <div style="text-align: right;">a: 22 mm (0.87 in)</div>

Commercial Service Tool

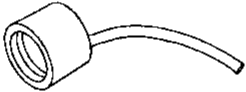
Tool name	Description
Fuel filler cap adapter	<div style="text-align: right;">Checking fuel tank vacuum relief valve opening pressure</div> <div style="text-align: center;">  </div> <div style="text-align: left;">NT653</div>

Supplemental Restraint System (SRS) "AIR BAG"

The Supplemental Restraint System "Air Bag", used along with a seat belt, helps to reduce the risk or severity of injury to the driver and front passenger in a frontal collision. The Supplemental Restraint System consists of air bag modules (located in the center of the steering wheel and on the instrument panel on the passenger side), a diagnosis sensor unit, warning lamp, wiring harness and spiral cable. Information necessary to service the system safely is included in the **RS** section of this Service Manual.

WARNING:

- To avoid rendering the SRS inoperative, which could increase the risk of personal injury or death in the event of a collision which would result in air bag inflation, all maintenance must be performed by an authorized INFINITI dealer.
- Improper maintenance, including incorrect removal and installation of the SRS, can lead to personal injury caused by unintentional activation of the system.
- Do not use electrical test equipment on any circuit related to the SRS unless instructed to in this Service Manual. SRS wiring harnesses are covered with yellow insulation either just before the harness connectors or for the complete harness, for easy identification.

Precautions for On Board Diagnostic (OBD) System of Engine and A/T

The ECM (ECCS control module) has an on board diagnostic system. It will light up the malfunction indicator lamp (MIL) to warn the driver of a malfunction causing emission deterioration.

CAUTION:

- Be sure to turn the ignition switch "OFF" and disconnect the negative battery terminal before any repair or inspection work. The open/short circuit of related switches, sensors, solenoid valves, etc. will cause the MIL to light up.
- Be sure to connect and lock the connectors securely after work. A loose (unlocked) connector will cause the MIL to light up due to the open circuit. (Be sure the connector is free from water, grease, dirt, bent terminals, etc.)
- Be sure to route and secure the harnesses properly after work. The interference of the harness with a bracket, etc. may cause the MIL to light up due to the short circuit.
- Be sure to connect rubber tubes properly after work. A misconnected or disconnected rubber tube may cause the MIL to light up due to the malfunction of the EGR system or fuel injection system, etc.
- Be sure to erase the unnecessary malfunction information (repairs completed) from the ECM or A/T control unit before returning the vehicle to the customer.

GI

MA

EM

LC

EC

FE

AT

TF

PD

FA

RA

BR

ST

RS

BT

HA

EL

IDX

Engine Fuel & Emission Control System

ECM (ECCS Control Module)

- Do not disassemble ECM.
- If a battery terminal is disconnected, the memory will return to the ECM value.

The ECM will now start to self-control at its initial value. Engine operation can vary slightly when the terminal is disconnected. However, this is not an indication of a problem. Do not replace parts because of a slight variation.

WIRELESS EQUIPMENT

- When installing CB ham radio or a mobile phone, be sure to observe the following as it may adversely affect electronic control systems depending on its installation location.
 - 1) Keep the antenna as far away as possible from the electronic control units.
 - 2) Keep the antenna feeder line more than 20 cm (7.9 in) away from the harness of electronic controls. Do not let them run parallel for a long distance.
 - 3) Adjust the antenna and feeder line so that the standing-wave ratio can be kept smaller.
 - 4) Be sure to ground the radio to vehicle body.

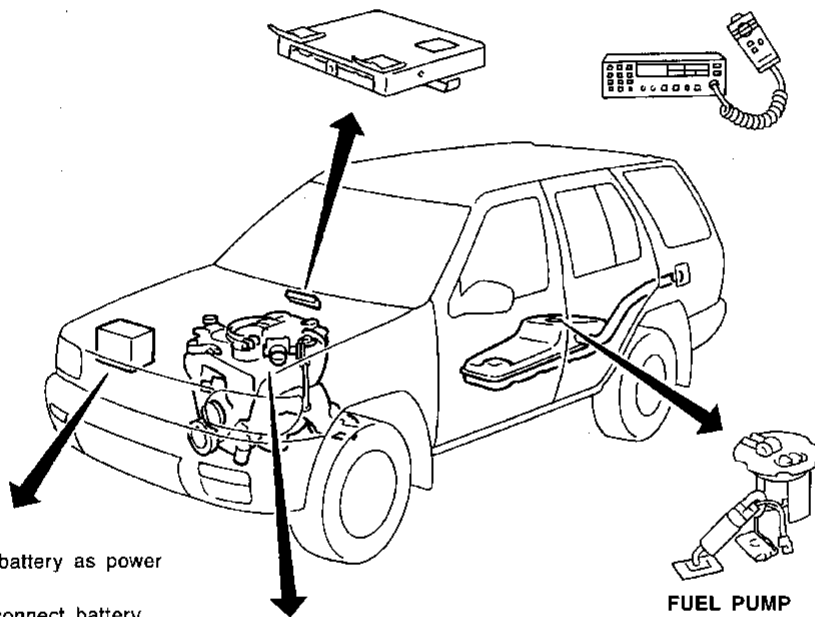

BATTERY

- Always use a 12 volt battery as power source.
- Do not attempt to disconnect battery cables while engine is running.

WHEN STARTING

- Do not depress accelerator pedal when starting.
- Immediately after starting, do not rev up engine unnecessarily.
- Do not rev up engine just prior to shutdown.

ECM PARTS HANDLING

- Handle mass air flow sensor carefully to avoid damage.
- Do not disassemble mass air flow sensor.
- Do not clean mass air flow sensor with any type of detergent.
- Do not disassemble IACV-AAC valve.
- Even a slight leak in the air intake system can cause serious problems.
- Do not shock or jar the camshaft position sensor or crankshaft position sensor (OBD).

FUEL PUMP

- Do not operate fuel pump when there is no fuel in lines.
- Tighten fuel hose clamps to the specified torque. (Refer to MA section.)

ECM HARNESS HANDLING

- Securely connect ECM harness connectors.
A poor connection can cause an extremely high (surge) voltage to develop in coil and condenser, thus resulting in damage to ICs.
- Keep ECM harness at least 10 cm (3.9 in.) away from adjacent harnesses to prevent an ECM system malfunction due to receiving external noise, degraded operation of ICs, etc.
- Keep ECM parts and harnesses dry.
- Before removing parts, turn off ignition switch and then disconnect battery ground cable.

PRECAUTIONS AND PREPARATION

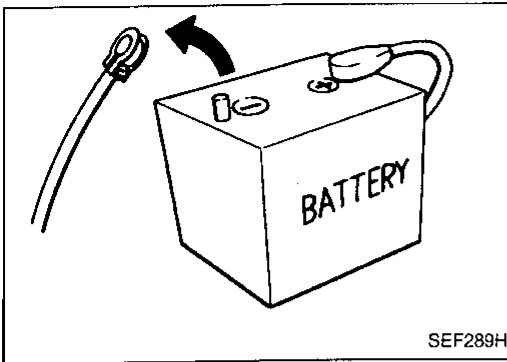

Precautions

- Before connecting or disconnecting the ECM harness connector, turn ignition switch OFF and disconnect negative battery terminal. Failure to do so may damage the ECM because battery voltage is applied to ECM even if ignition switch is turned off.

GI
MA
EM
LC

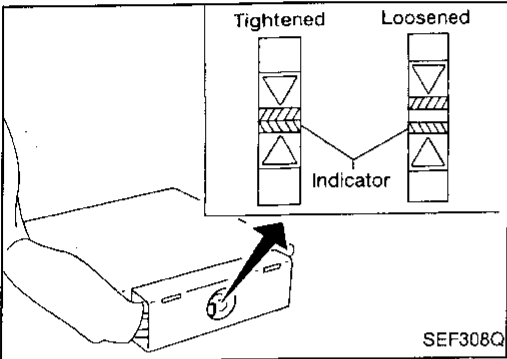

- When connecting ECM harness connector, tighten securing bolt until the gap between orange indicators disappears.

: 3.0 - 5.0 N·m (0.3 - 0.5 kg·m, 26 - 43 in·lb)

EC
FE
AT
TF

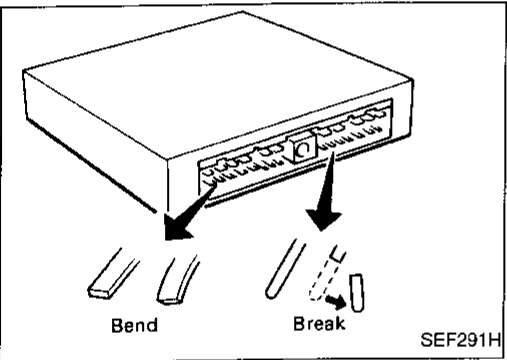

- When connecting or disconnecting pin connectors into or from ECM, take care not to damage pin terminals (bend or break).

Make sure that there are not any bends or breaks on ECM pin terminal, when connecting pin connectors.

PD
FA
RA
BR

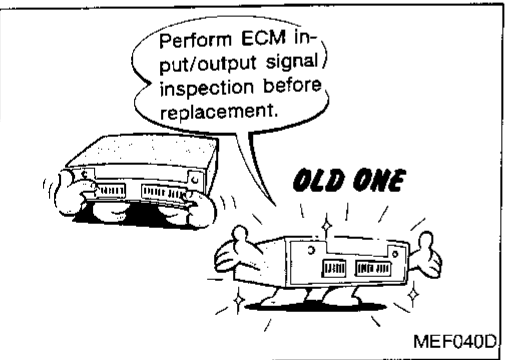

- Before replacing ECM, perform Terminals and Reference Value inspection and make sure ECM functions properly. Refer to EC-85.

ST
RS
BT
HA

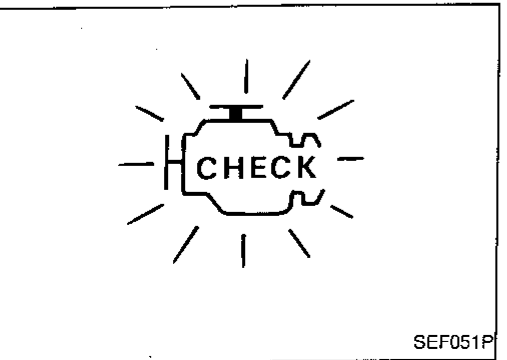

- After performing each TROUBLE DIAGNOSIS, perform "OVERALL FUNCTION CHECK" or "DTC (Diagnostic Trouble Code) CONFIRMATION PROCEDURE".

The DTC should not be displayed in the "DTC CONFIRMATION PROCEDURE" if the repair is completed. The "OVERALL FUNCTION CHECK" should be a good result if the repair is completed.

EL
IDX

PRECAUTIONS AND PREPARATION

Precautions (Cont'd)

- When measuring ECM signals with a circuit tester, never allow the two tester probes to contact. Accidental contact of probes will cause a short circuit and damage the ECM power transistor.

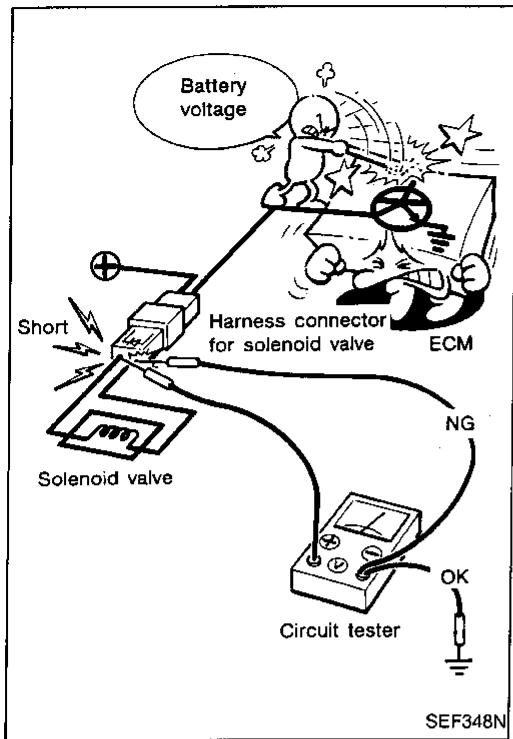

ENGINE AND EMISSION CONTROL OVERALL SYSTEM

ECCS Component Parts Location

GI

MA

EM

LC

EC

FE

AT

TF

PD

FA

RA

BR

ST

RS

BT

HA

EL

IDX

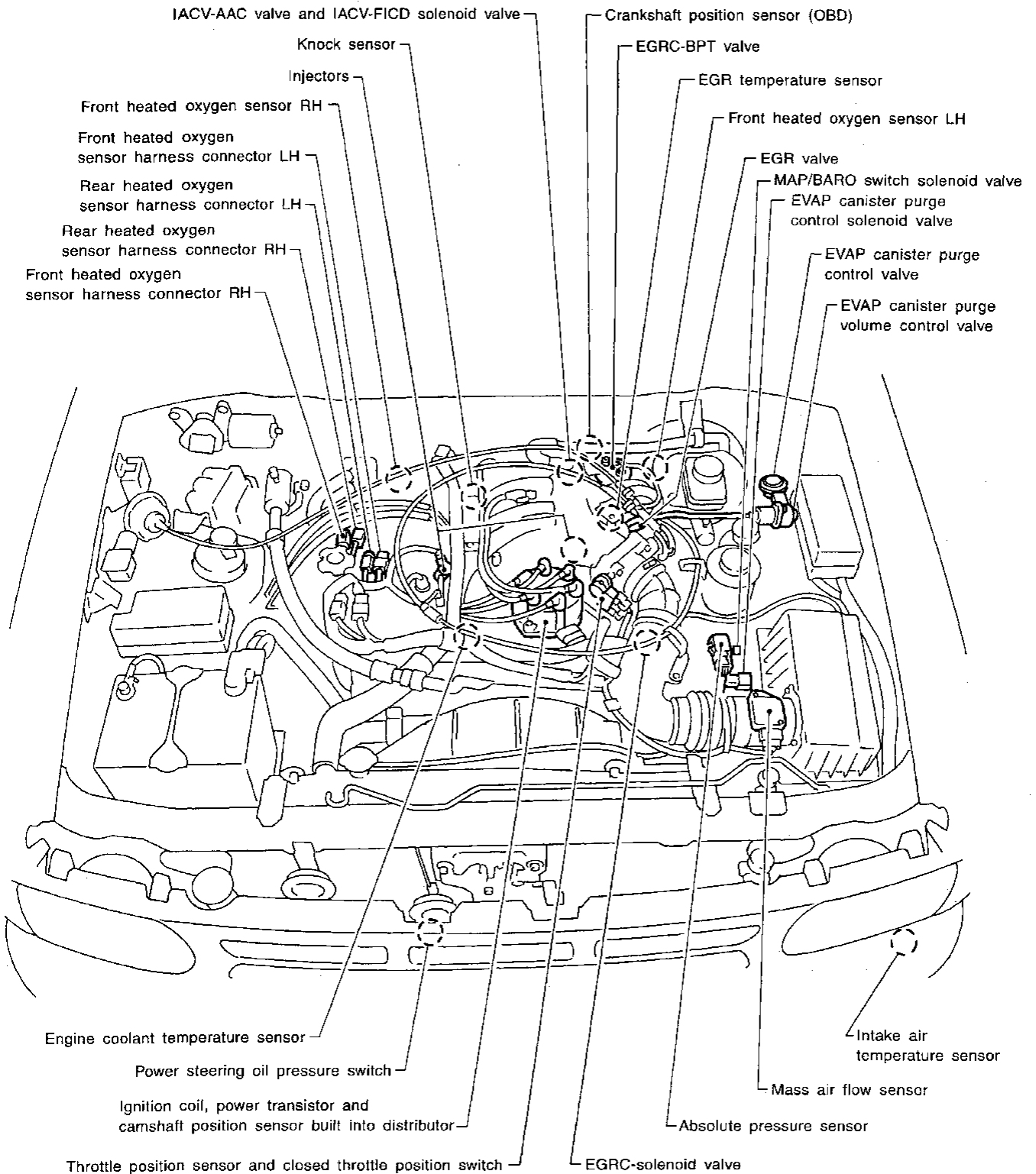

ENGINE AND EMISSION CONTROL OVERALL SYSTEM

ECCS Component Parts Location (Cont'd)

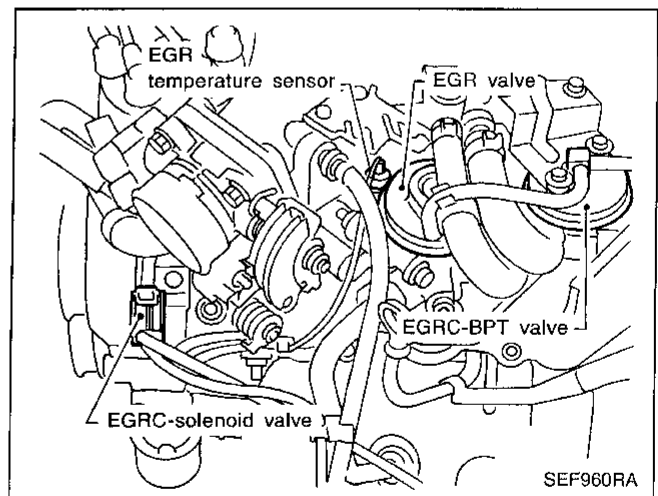
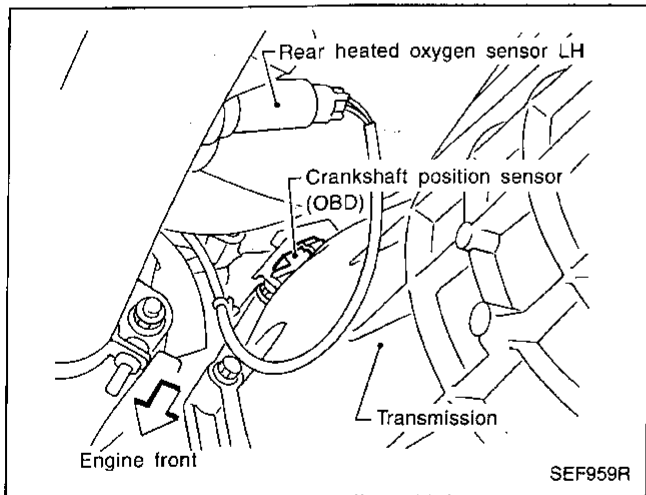
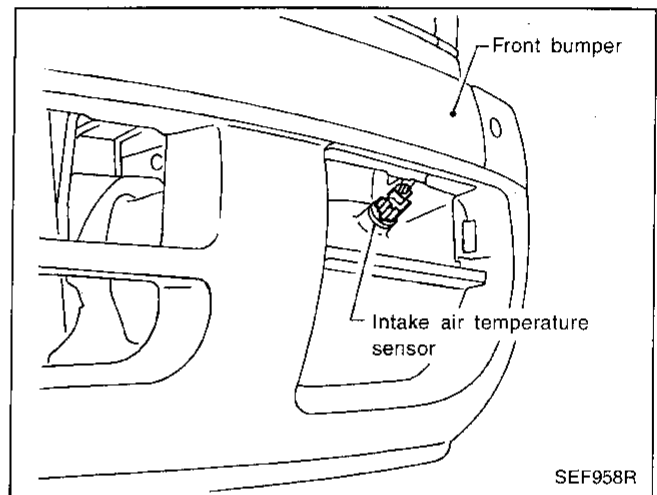
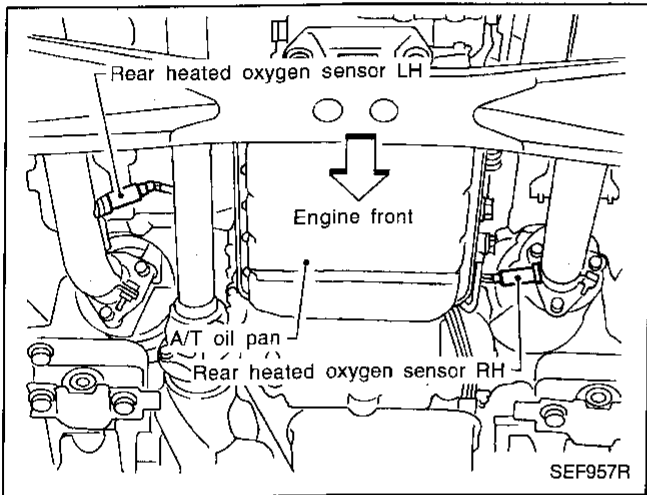
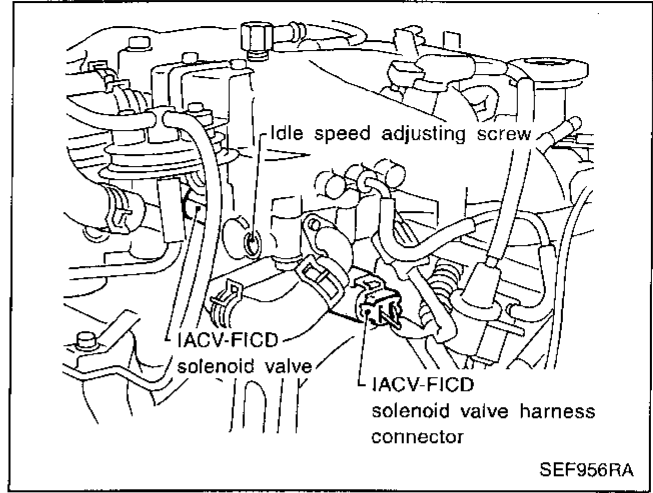
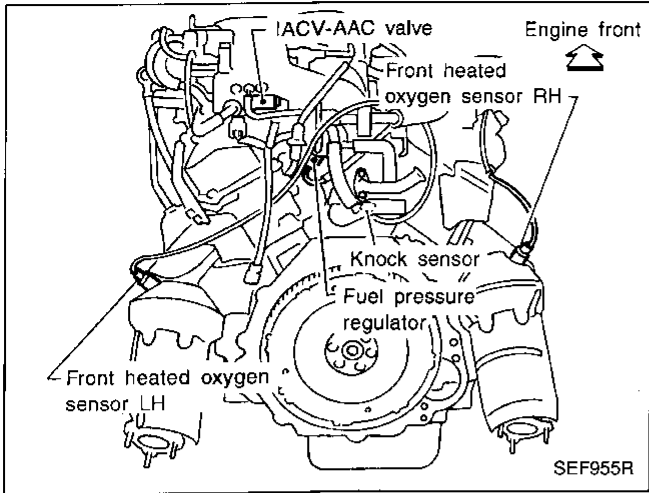

ENGINE AND EMISSION CONTROL OVERALL SYSTEM

Circuit Diagram

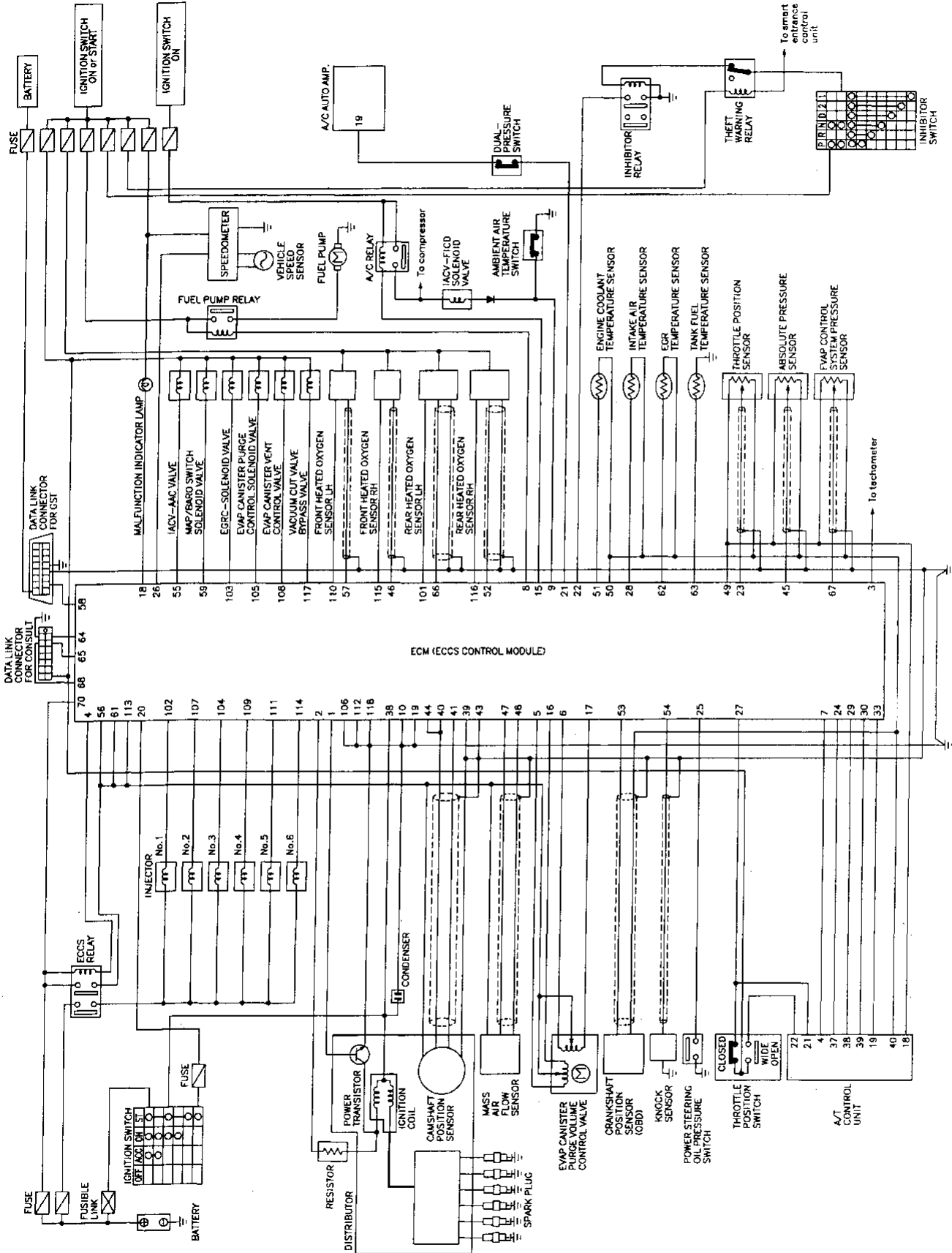

GI
MA
EM
LC
EC
FE
AT
TF
PD
FA
RA
BR
ST
RS
BT
HA
EL
IDX

System Diagram

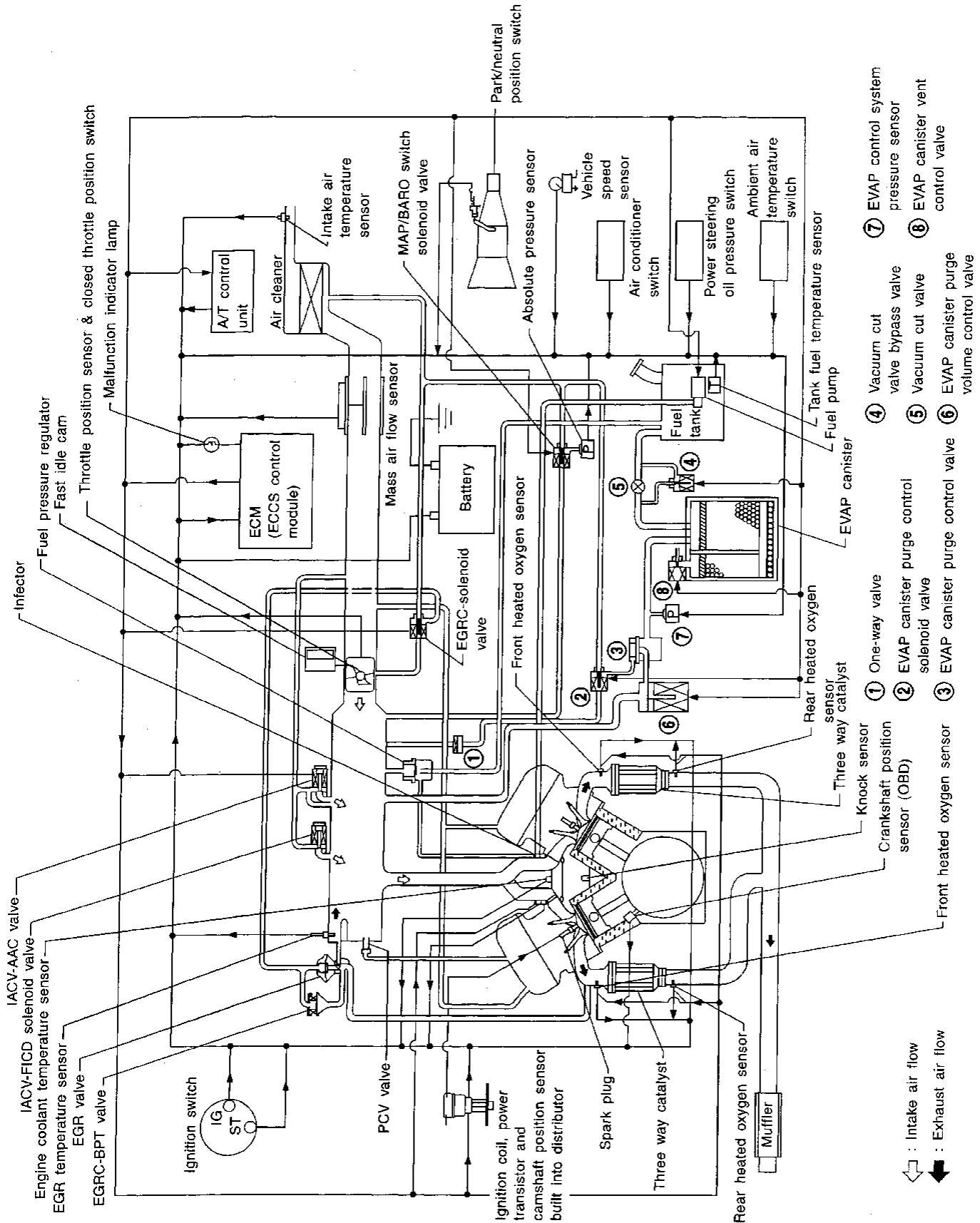

Vacuum Hose Drawing

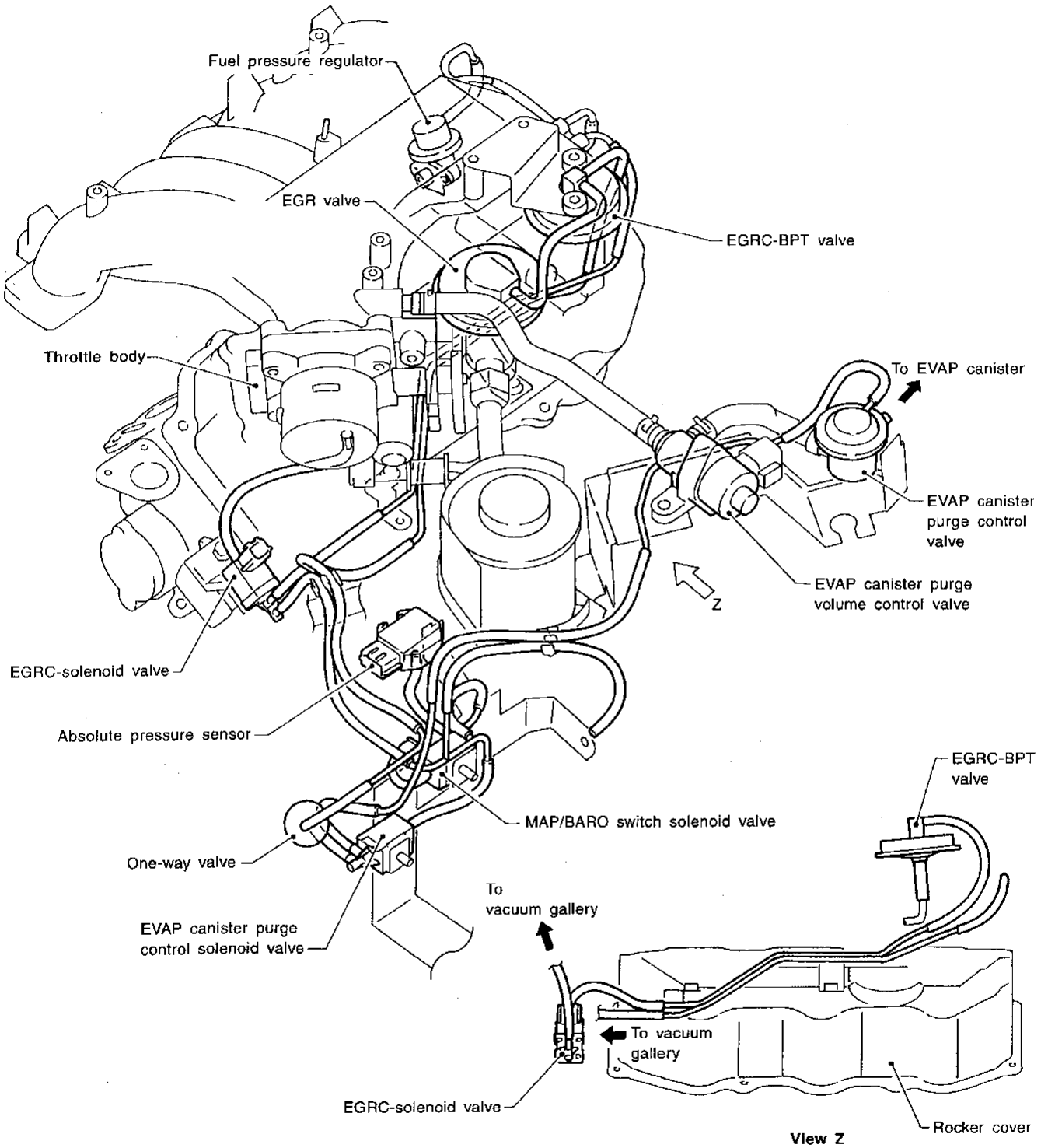

GI
MA
EM
LC
EC
FE
AT
TF
PD
FA
RA
BR
ST
RS
BT
HA
EL
IDX

ENGINE AND EMISSION CONTROL OVERALL SYSTEM

System Chart

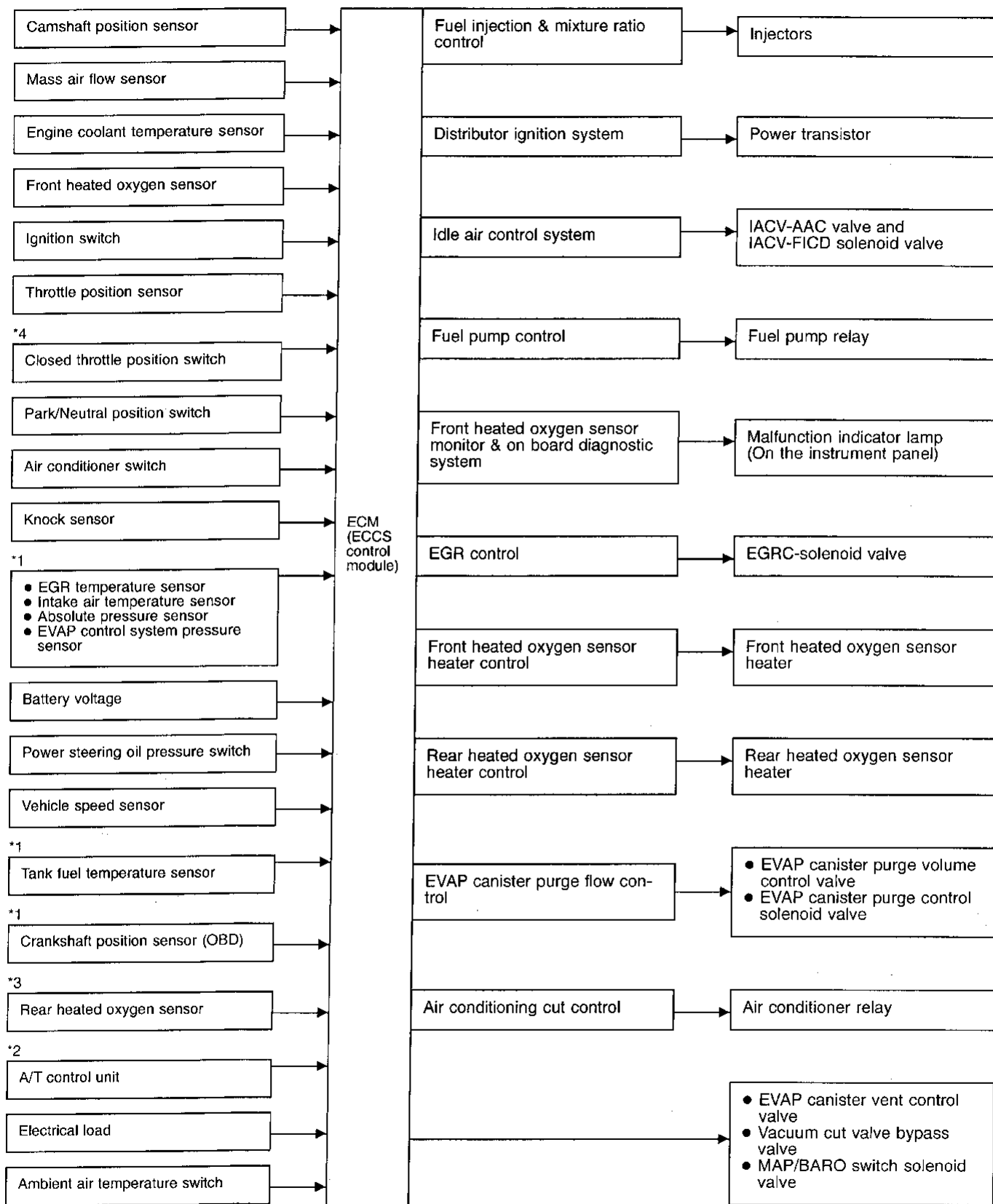

*1: These sensors are not used to control the engine system. They are used only for the on board diagnosis.

*2: The DTC related to A/T will be sent to ECM.

*3: This sensor is not used to control the engine system under normal conditions.

*4: This switch will operate in place of the throttle position sensor to control EVAP parts if the sensor malfunctions.

Multiport Fuel Injection (MFI) System

INPUT/OUTPUT SIGNAL LINE

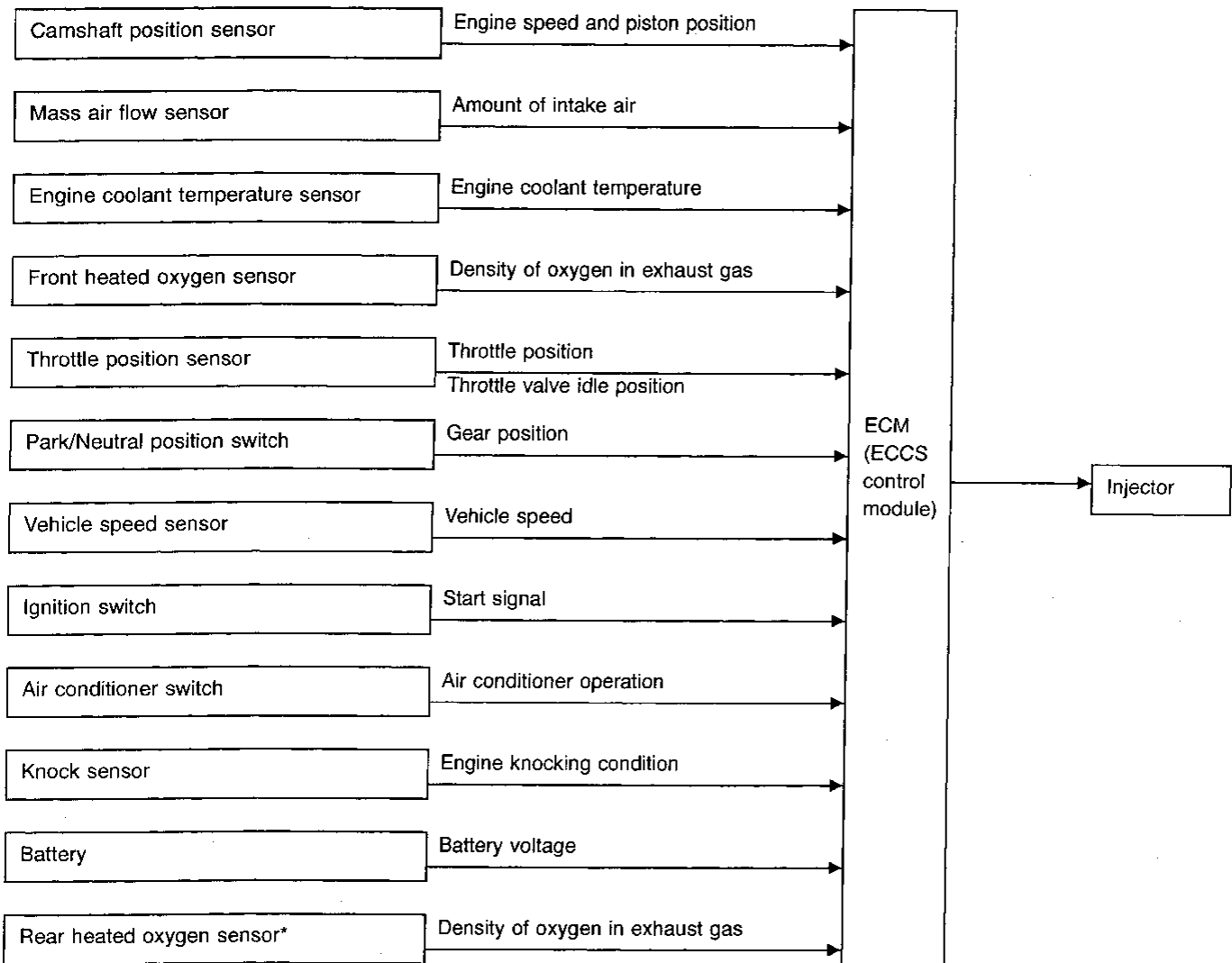

* Under normal conditions, this sensor is not for engine control operation.

BASIC MULTIPOINT FUEL INJECTION SYSTEM

The amount of fuel injected from the fuel injector is determined by the ECM. The ECM controls the length of time the valve remains open (injection pulse duration). The amount of fuel injected is a program value in the ECM memory. The program value is preset by engine operating conditions. These conditions are determined by input signals (for engine speed and intake air) from both the camshaft position sensor and the mass air flow sensor.

VARIOUS FUEL INJECTION INCREASE/DECREASE COMPENSATION

In addition, the amount of fuel injected is compensated to improve engine performance under various operating conditions as listed below.

(Fuel increase)

- During warm-up
- When starting the engine
- During acceleration
- Hot-engine operation
- When selector lever is changed from "N" to "D"
- High-load, high-speed operation

(Fuel decrease)

- During deceleration
- During high engine speed operation

ENGINE AND EMISSION BASIC CONTROL SYSTEM DESCRIPTION

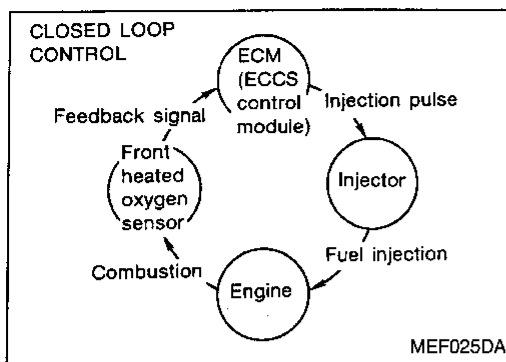

Multiport Fuel Injection (MFI) System (Cont'd) MIXTURE RATIO FEEDBACK CONTROL (CLOSED LOOP CONTROL)

The mixture ratio feedback system provides the best air-fuel mixture ratio for driveability and emission control. The three way catalyst can then better reduce CO, HC and NOx emissions. This system uses a front heated oxygen sensor in the exhaust manifold to monitor if the engine operation is rich or lean. The ECM adjusts the injection pulse width according to the sensor voltage signal. For more information about the front heated oxygen sensor, refer to EC-135, 153. This maintains the mixture ratio within the range of stoichiometric (ideal air-fuel mixture).

This stage is referred to as the closed loop control condition.

Rear heated oxygen sensor is located downstream of the three way catalyst. Even if the switching characteristics of the front heated oxygen sensor shift, the air-fuel ratio is controlled to stoichiometric by the signal from the rear heated oxygen sensor.

OPEN LOOP CONTROL

The open loop system condition refers to when the ECM detects any of the following conditions. Feedback control stops in order to maintain stabilized fuel combustion.

- Deceleration and acceleration
- High-load, high-speed operation
- Engine idling
- Malfunction of front heated oxygen sensor or its circuit
- Insufficient activation of front heated oxygen sensor at low engine coolant temperature
- High engine coolant temperature
- During warm-up
- When starting the engine

MIXTURE RATIO SELF-LEARNING CONTROL

The mixture ratio feedback control system monitors the mixture ratio signal transmitted from the front heated oxygen sensor. This feedback signal is then sent to the ECM. The ECM controls the basic mixture ratio as close to the theoretical mixture ratio as possible. However, the basic mixture ratio is not necessarily controlled as originally designed. Both manufacturing differences (i.e., mass air flow sensor hot wire) and characteristic changes during operation (i.e., injector clogging) directly affect mixture ratio. Accordingly, the difference between the basic and theoretical mixture ratios is monitored in this system. This is then computed in terms of "injection pulse duration" to automatically compensate for the difference between the two ratios.

"Fuel trim" refers to the feedback compensation value compared against the basic injection duration. Fuel trim includes short term fuel trim and long term fuel trim.

"Short term fuel trim" is the short-term fuel compensation used to maintain the mixture ratio at its theoretical value. The signal from the front heated oxygen sensor indicates whether the mixture ratio is RICH or LEAN compared to the theoretical value. The signal then triggers a reduction in fuel volume if the mixture ratio is rich, and an increase in fuel volume if it is lean.

"Long term fuel trim" is overall fuel compensation carried out long-term to compensate for continual deviation of the short term fuel trim from the central value. Such deviation will occur due to individual engine differences, wear over time and changes in the usage environment.

ENGINE AND EMISSION BASIC CONTROL SYSTEM DESCRIPTION

Multiport Fuel Injection (MFI) System (Cont'd)

FUEL INJECTION TIMING

Two types of systems are used.

Sequential multiport fuel injection system

Fuel is injected into each cylinder during each engine cycle according to the firing order. This system is used when the engine is running.

Simultaneous multiport fuel injection system

Fuel is injected simultaneously into all six cylinders twice each engine cycle. In other words, pulse signals of the same width are simultaneously transmitted from the ECM.

The six injectors will then receive the signals two times for each engine cycle.

This system is used when the engine is being started and/or if the fail-safe system (CPU) is operating.

FUEL SHUT-OFF

Fuel to each cylinder is cut off during deceleration or operation of the engine at excessively high speeds.

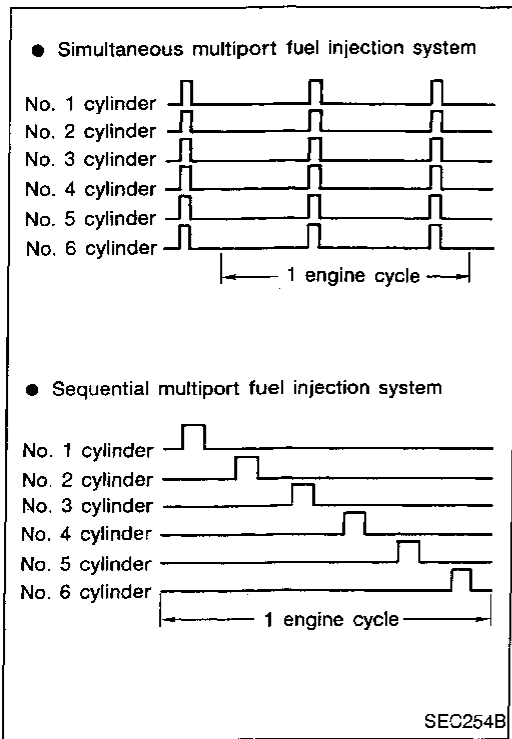

Distributor Ignition (DI) System

INPUT/OUTPUT SIGNAL LINE

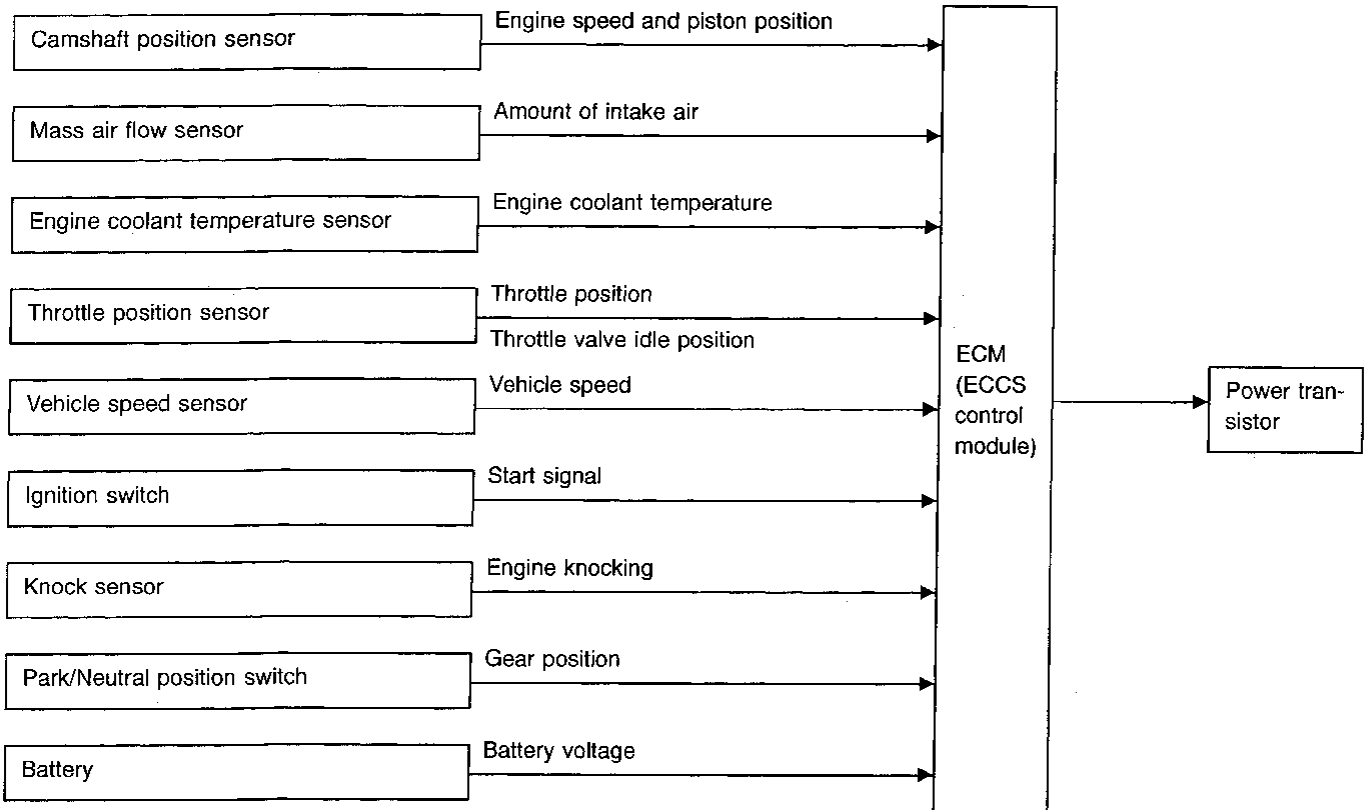

ENGINE AND EMISSION BASIC CONTROL SYSTEM DESCRIPTION

Distributor Ignition (DI) System (Cont'd)

SYSTEM DESCRIPTION

The ignition timing is controlled by the ECM to maintain the best air-fuel ratio for every running condition of the engine.

The ignition timing data is stored in the ECM. This data forms the map shown.

The ECM receives information such as the injection pulse width and camshaft position sensor signal. Computing this information, ignition signals are transmitted to the power transistor.

e.g., N: 1,800 rpm, Tp: 1.50 msec

A °BTDC

During the following conditions, the ignition timing is revised by the ECM according to the other data stored in the ECM.

- At starting
- During warm-up
- At idle
- At low battery voltage
- During acceleration

The knock sensor retard system is designed only for emergencies. The basic ignition timing is programmed within the anti-knocking zone, if recommended fuel is used under dry conditions. The retard system does not operate under normal driving conditions.

If engine knocking occurs, the knock sensor monitors the condition. The signal is transmitted to the ECM (ECCS control module). The ECM retards the ignition timing to eliminate the knocking condition.

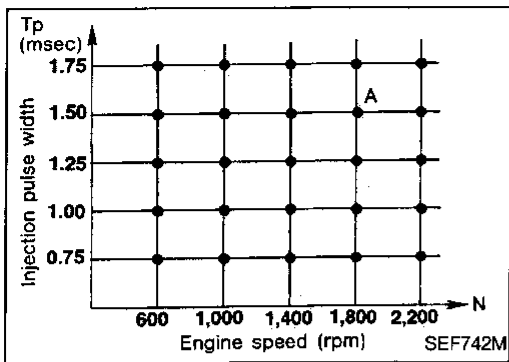

Air Conditioning Cut Control

INPUT/OUTPUT SIGNAL LINE

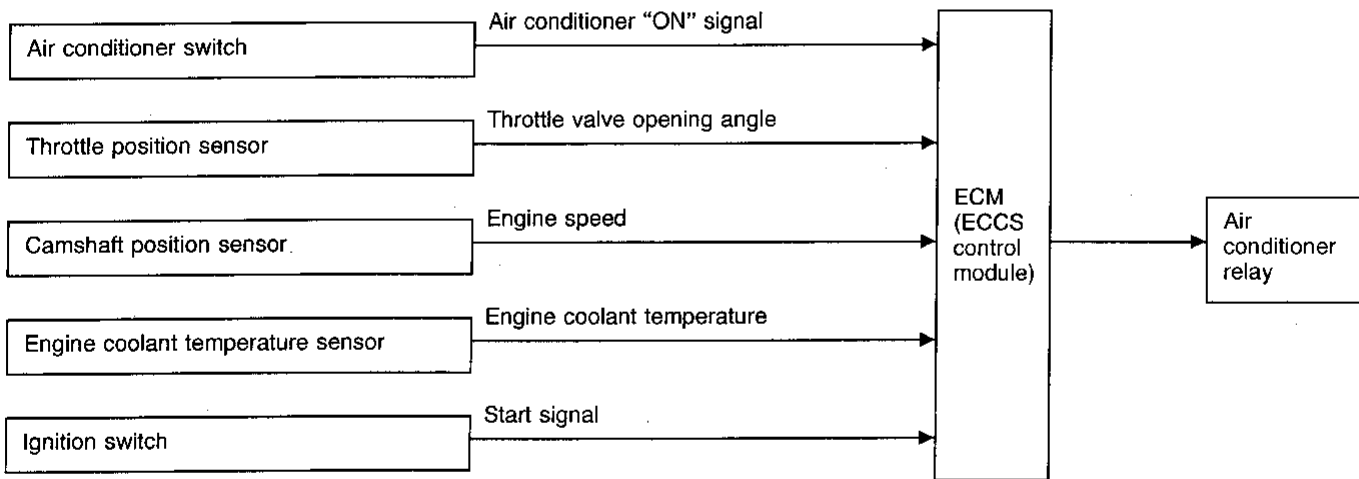

SYSTEM DESCRIPTION

This system improves engine operation when the air conditioner is used.

Under the following conditions, the air conditioner is turned off.

- When the accelerator pedal is fully depressed.
- When cranking the engine.
- At high engine speeds.
- When the engine coolant temperature becomes excessively high.

Fuel Cut Control (at no load & high engine speed)

INPUT/OUTPUT SIGNAL LINE

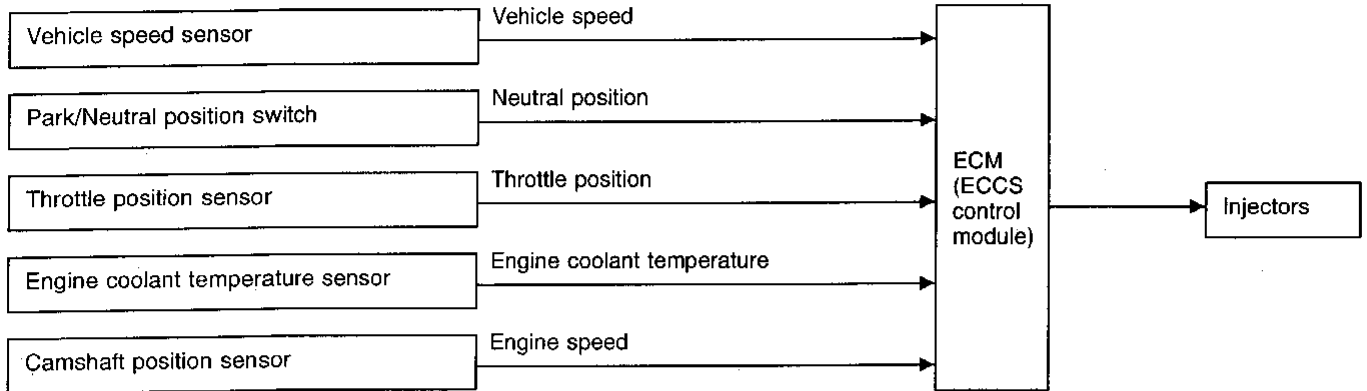

If the engine speed is above 2,500 rpm with no load (for example, in neutral and engine speed over 2,500 rpm) fuel will be cut off after some time. The exact time when the fuel is cut off varies based on engine speed.

Fuel cut will operate until the engine speed reaches 2,000 rpm, then fuel cut is cancelled.

NOTE:

This function is different from deceleration control listed under "Multiport Fuel Injection (MFI) System", EC-15.

GI
MA
EM
LC
EC
FE
AT
TF
PD
FA
RA
BR
ST
RS
BT
HA
EL
IDX

EVAPORATIVE EMISSION SYSTEM

Description

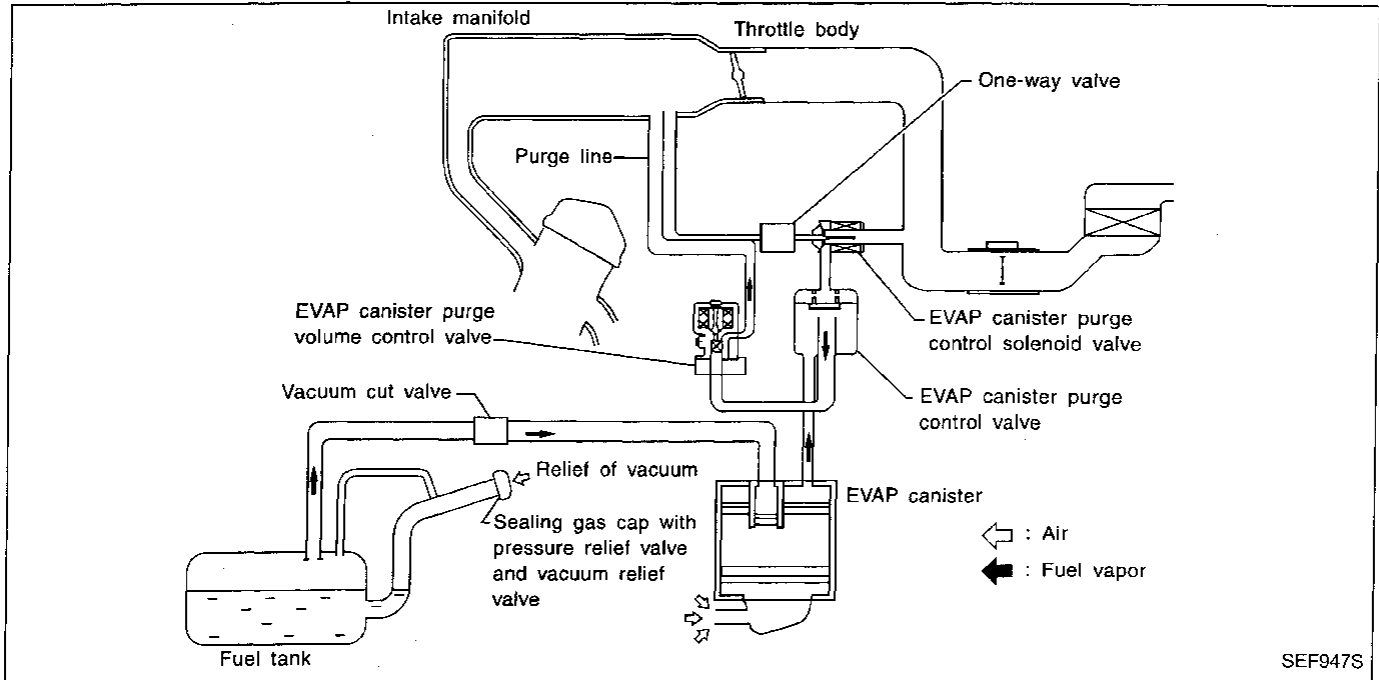

The evaporative emission system is used to reduce hydrocarbons emitted into the atmosphere from the fuel system. This reduction of hydrocarbons is accomplished by activated charcoals in the EVAP canister.

The fuel vapor from sealed fuel tank is led into the EVAP canister when the engine is off. The fuel vapor is then stored in the EVAP canister. The EVAP canister retains the fuel vapor until the EVAP canister is purged by air.

When the engine is running, the air is drawn through the bottom of the EVAP canister. The fuel vapor will then be led to the intake manifold.

When the engine runs at idle, the EVAP canister purge control valve is closed. Only a small amount of vapor flows into the intake manifold through the constant purge orifice.

As the engine speed increases and the throttle vacuum rises, the EVAP canister purge control valve opens. The vapor is sucked through both main purge and constant purge orifices.

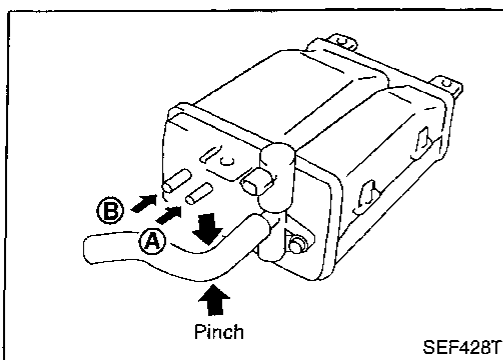

Inspection

EVAP CANISTER

Check EVAP canister as follows:

1. Pinch the fresh air hose.
2. Blow air port (A) and check that it flows freely out of port (B).

EVAPORATIVE EMISSION SYSTEM

Inspection (Cont'd)

TIGHTENING TORQUE

Tighten EVAP canister as shown in the figure.

Make sure new O-ring is installed properly between EVAP canister and EVAP vent control valve.

GI

MA

EM

LC

EC

FE

AT

TF

PD

FA

RA

BR

ST

RS

BT

HA

EL

IDX

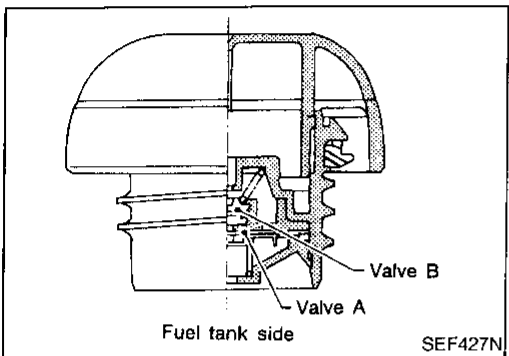
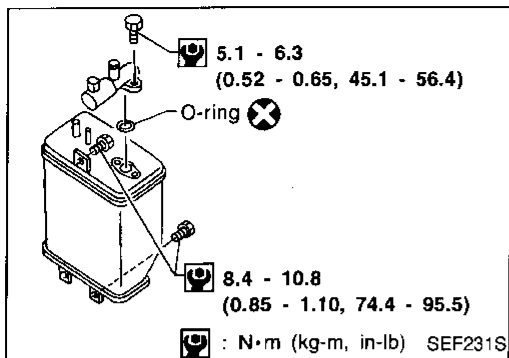

FUEL TANK VACUUM RELIEF VALVE (Built into fuel filler cap)

1. Wipe clean valve housing.
2. Check valve opening pressure and vacuum.

Pressure:

15.3 - 20.0 kPa (0.156 - 0.204 kg/cm², 2.22 - 2.90 psi)

Vacuum:

-6.0 to -3.3 kPa (-0.061 to -0.034 kg/cm², -0.87 to -0.48 psi)

3. If out of specification, replace fuel filler cap as an assembly.

CAUTION:

Use only a genuine fuel filler cap as a replacement. If an incorrect fuel filler cap is used, the MIL may come on.

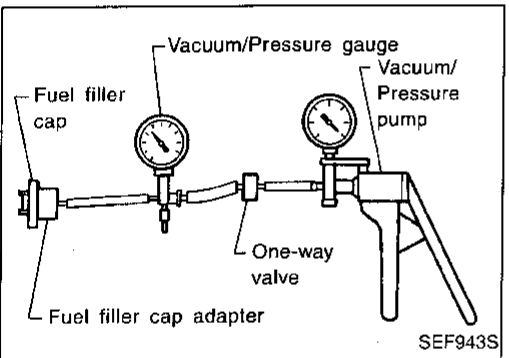

EVAP CANISTER PURGE CONTROL VALVE

Refer to EC-233.

VACUUM CUT VALVE

Refer to EC-304.

EVAPORATIVE EMISSION (EVAP) CANISTER PURGE VOLUME CONTROL VALVE

Refer to EC-309.

EVAPORATIVE EMISSION (EVAP) CANISTER PURGE CONTROL SOLENOID VALVE

Refer to EC-233.

TANK FUEL TEMPERATURE SENSOR

Refer to EC-190.

EVAPORATIVE EMISSION SYSTEM

Evaporative Emission Line Drawing

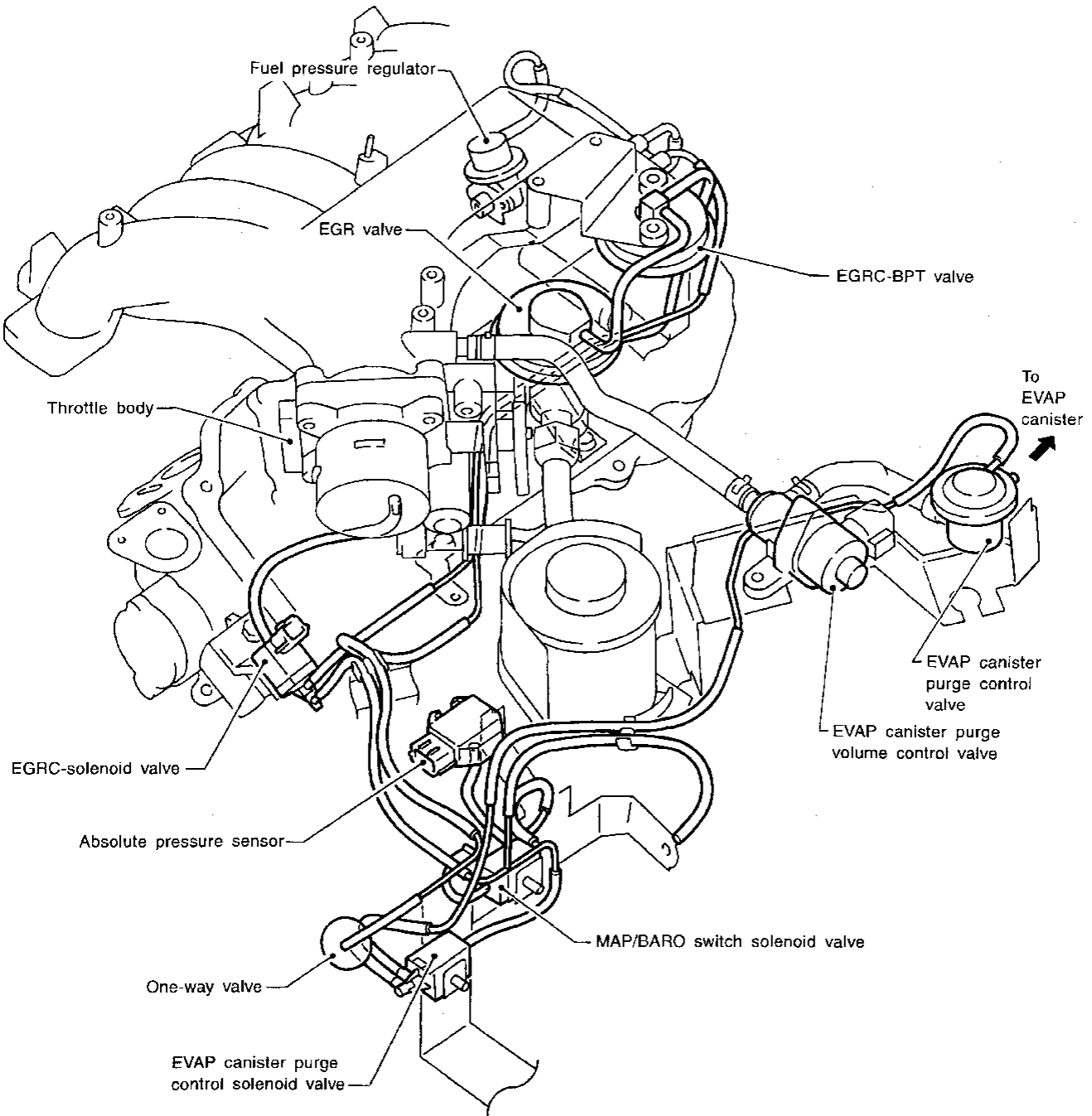

EVAPORATIVE EMISSION SYSTEM

Evaporative Emission Line Drawing (Cont'd)

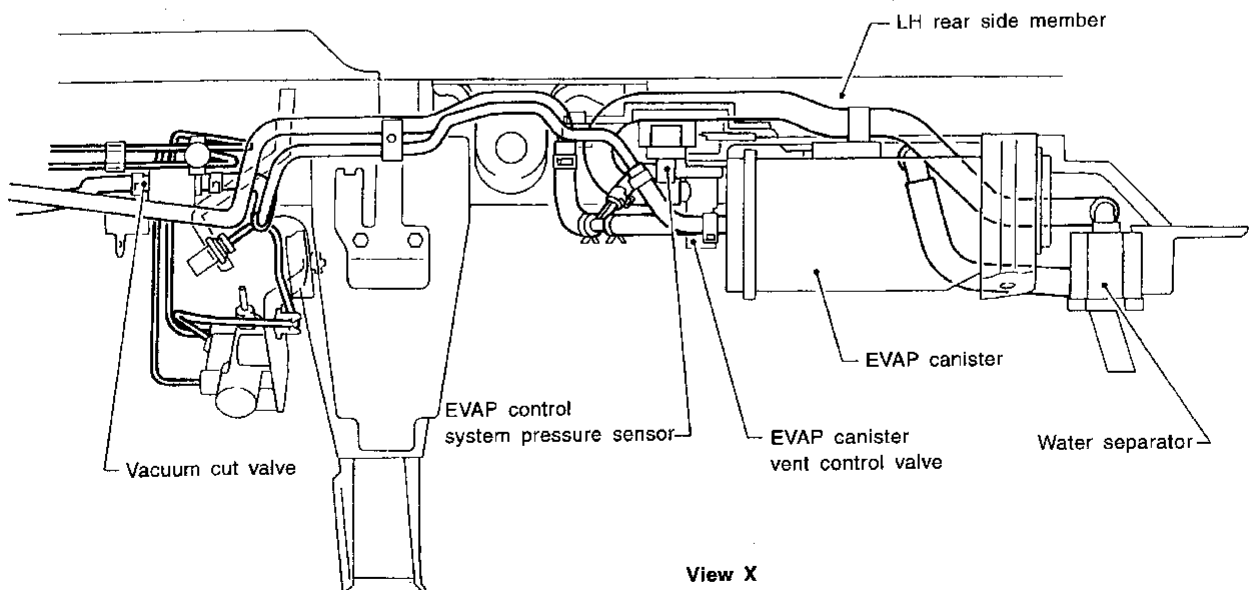
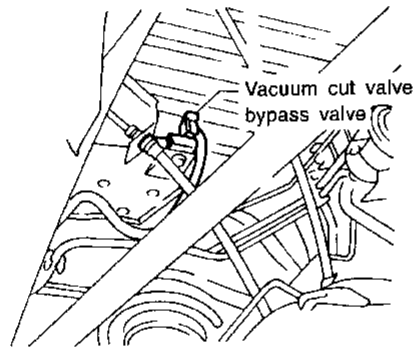
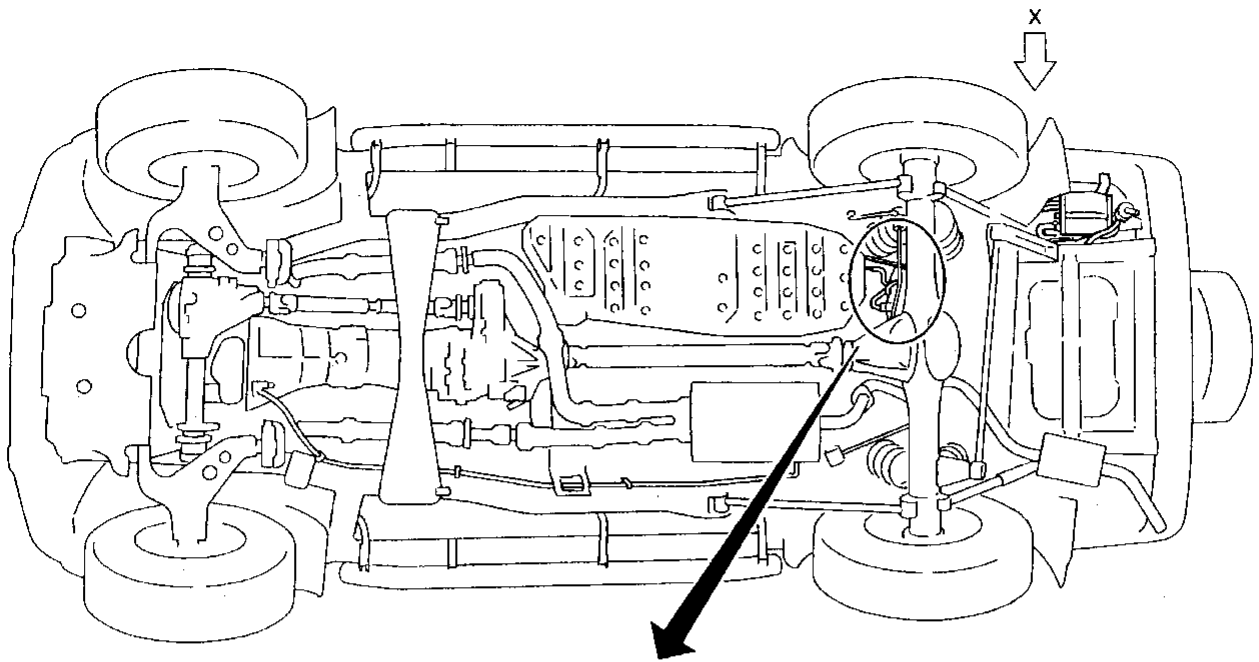

GI

MA

EM

LC

EC

FE

AT

TF

PD

FA

RA

BR

ST

RS

BT

HA

EL

IDX

POSITIVE CRANKCASE VENTILATION

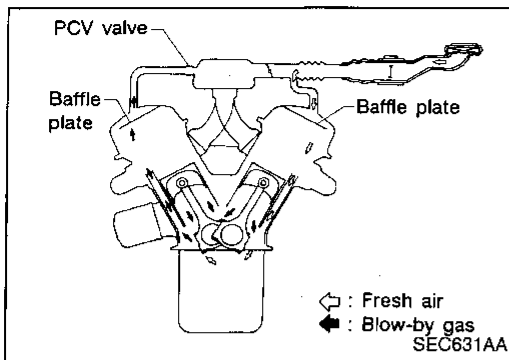

Description

This system returns blow-by gas to the intake manifold. The positive crankcase ventilation (PCV) valve is provided to conduct crankcase blow-by gas to the intake manifold. During partial throttle operation of the engine, the intake manifold sucks the blow-by gas through the PCV valve. Normally, the capacity of the valve is sufficient to handle any blow-by and a small amount of ventilating air. The ventilating air is then drawn from the air inlet tubes into the crankcase. In this process the air passes through the hose connecting air inlet tubes to rocker cover. Under full-throttle condition, the manifold vacuum is insufficient to draw the blow-by flow through the valve. The flow goes through the hose connection in the reverse direction. On vehicles with an excessively high blow-by, the valve does not meet the requirement. This is because some of the flow will go through the hose connection to the air inlet tubes under all conditions.

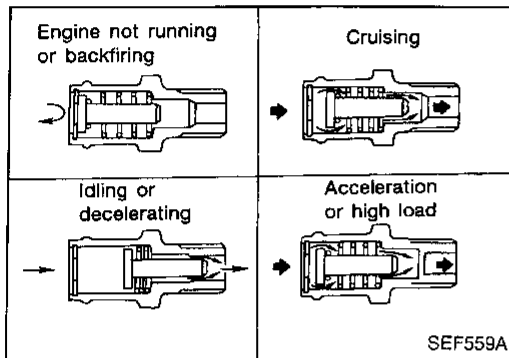

Inspection

PCV (Positive Crankcase Ventilation) VALVE

With engine running at idle, remove PCV hose from PCV valve; if the valve is working properly, a hissing noise will be heard as air passes through it and a strong vacuum should be felt immediately when a finger is placed over valve inlet.

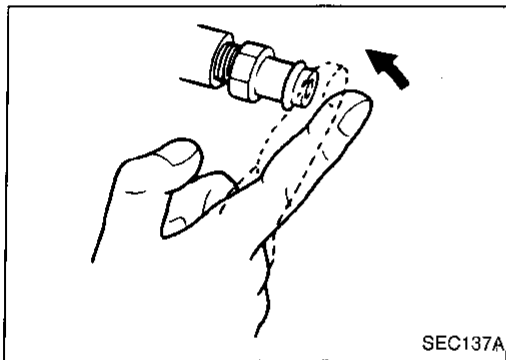

PCV HOSE

1. Check hoses and hose connections for leaks.
2. Disconnect all hoses and clean with compressed air. If any hose cannot be freed of obstructions, replace.

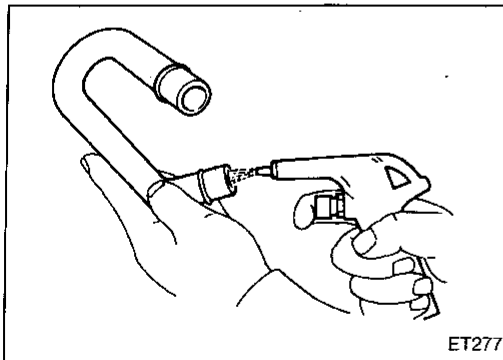

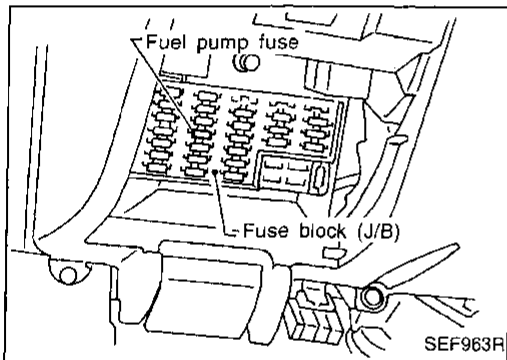
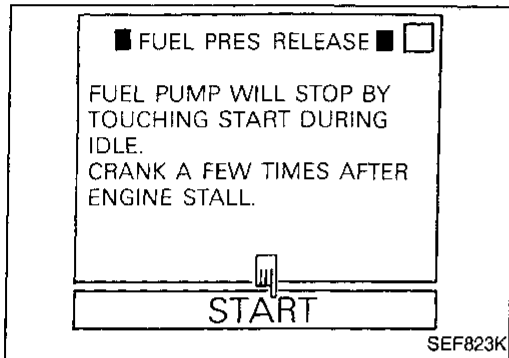
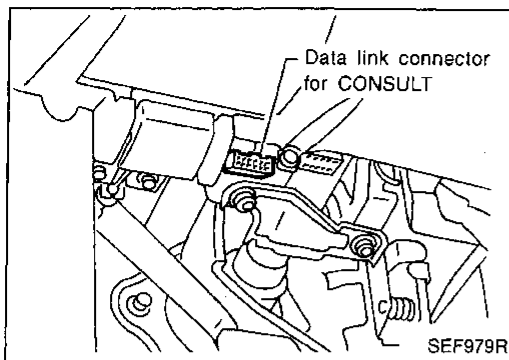

Fuel Pressure Release

Before disconnecting fuel line, release fuel pressure from fuel line to eliminate danger.

1. Turn ignition switch "ON".
2. Perform "FUEL PRESSURE RELEASE" in "WORK SUPPORT" mode with CONSULT.
3. Start engine.
4. After engine stalls, crank it two or three times to release all fuel pressure.
5. Turn ignition switch "OFF".

1. Remove fuel pump fuse located in fuse box.
2. Start engine.
3. After engine stalls, crank it two or three times to release all fuel pressure.
4. Turn ignition switch "OFF".
5. Reinstall fuel pump fuse after servicing fuel system.

Fuel Pressure Check

- When reconnecting fuel line, always use new clamps.
- Make sure that clamp screw does not contact adjacent parts.
- Use a torque driver to tighten clamps.
- Use Pressure Gauge to check fuel pressure.
- Do not perform fuel pressure check with system operating. Fuel pressure gauge may indicate false readings.

1. Release fuel pressure to zero.
2. Disconnect fuel hose between fuel filter and fuel tube (engine side).
3. Install pressure gauge between fuel filter and fuel tube.
4. Start engine and check for fuel leakage.
5. Read the indication of fuel pressure gauge.

At idling:

With vacuum hose connected

Approximately 235 kPa (2.4 kg/cm², 34 psi)

With vacuum hose disconnected

Approximately 294 kPa (3.0 kg/cm², 43 psi)

6. Stop engine and disconnect fuel pressure regulator vacuum hose from intake manifold.
7. Plug intake manifold with a rubber cap.
8. Connect variable vacuum source to fuel pressure regulator.

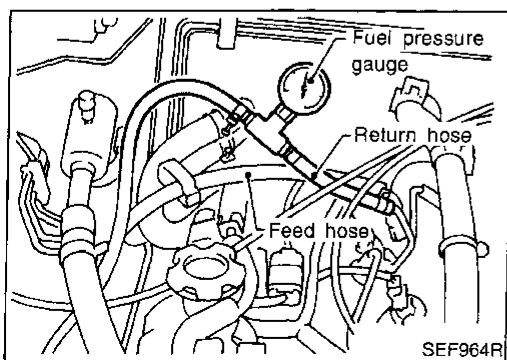

BASIC SERVICE PROCEDURE

Fuel Pressure Check (Cont'd)

9. Start engine and read indication of fuel pressure gauge as vacuum is changed.

Fuel pressure should decrease as vacuum increases. If results are unsatisfactory, replace fuel pressure regulator.

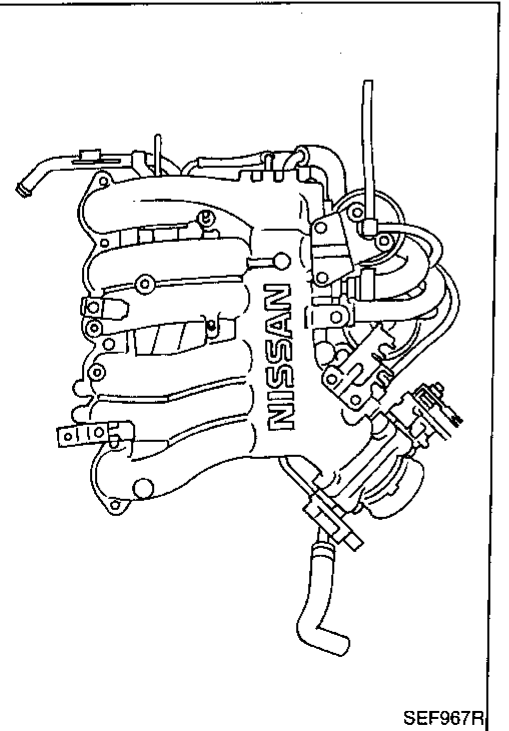
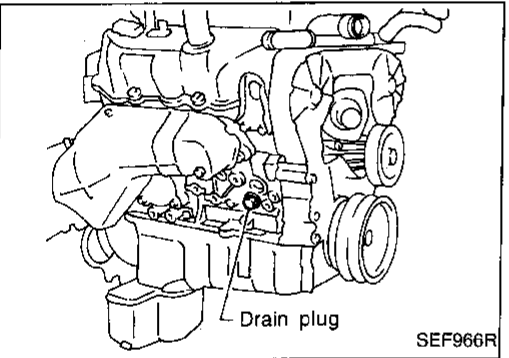
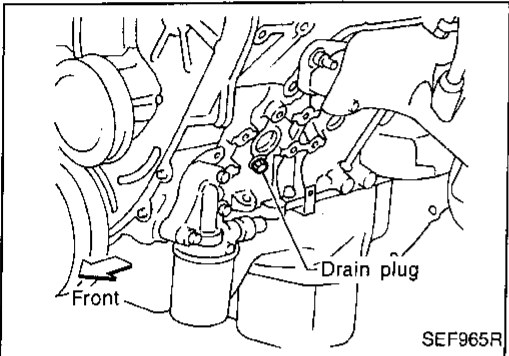
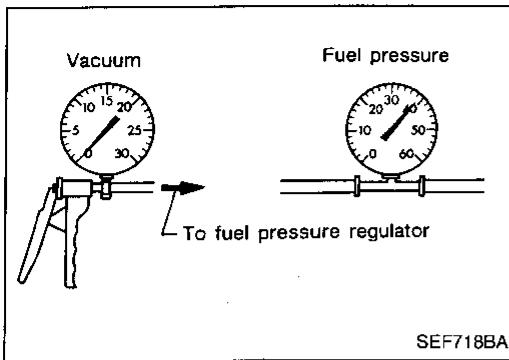

Injector Removal and Installation

1. Release fuel pressure to zero. Refer to previous page.
2. Drain coolant by removing drain plugs from both sides of cylinder block.
3. Separate ASCD and accelerator control wire from intake manifold collector.
4. Remove intake manifold collector from engine.
The following parts should be disconnected or removed.
 - a. Harness connectors for
 - IACV-AAC valve
 - IACV-FICD solenoid valve
 - Throttle position sensor and closed throttle position switch assembly
 - EGRC-solenoid valve
 - EGR temperature sensor
 - Ground harness
 - b. PCV hoses
 - c. Vacuum hoses for
 - Brake booster
 - EGRC-solenoid valve
 - Fuel pressure regulator
 - EVAP canister
 - EGRC-BPT valve
 - d. Air hoses from
 - Air duct
 - IACV-AAC valve
 - e. Water hoses for
 - Throttle body
 - Air relief plug
 - f. EVAP canister purge hose
 - g. EGR flare tube
5. Remove injector fuel tube assembly.
The following parts should be disconnected or removed.
 - Vacuum hose for fuel pressure regulator
 - Fuel feed and return hose
 - All injectors harness connectors
 - **Push injector tail piece.**
 - **Do not pull on connector.**
 - **Do not extract injector by pinching.**

BASIC SERVICE PROCEDURE

Injector Removal and Installation (Cont'd)

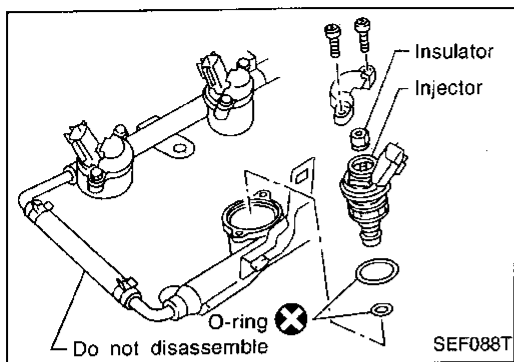

6. Push out any malfunctioning injector from injector fuel tube.
7. Replace or clean injector as necessary.
 - **Always replace O-rings with new ones.**
 - **Lubricate O-rings with engine oil.**
8. Install injector to injector fuel tube assembly.

GI

MA

EM

LC

EC

FE

AT

TF

PD

FA

RA

BR

ST

RS

BT

HA

EL

IDX

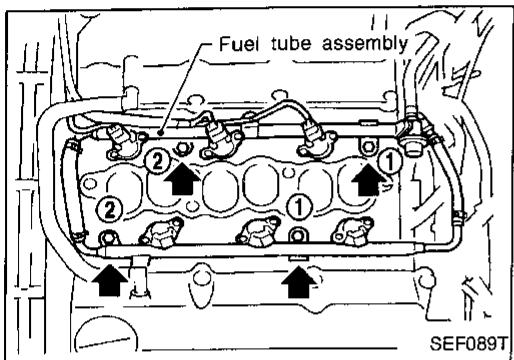

9. Install injectors with fuel tube assembly to intake manifold. **Tighten in numerical order shown in the figure.**

- a) First, tighten all bolts to 6 to 7 N·m (0.6 to 0.7 kg·m, 4.3 to 5.1 ft-lb).
 - b) Then, tighten all bolts to 10.8 to 14.7 N·m (1.1 to 1.5 kg·m, 8 to 11 ft-lb).
10. Reinstall any part removed in reverse order of removal.

CAUTION:

After properly connecting fuel hose to injector and fuel tube, check connection for fuel leakage.

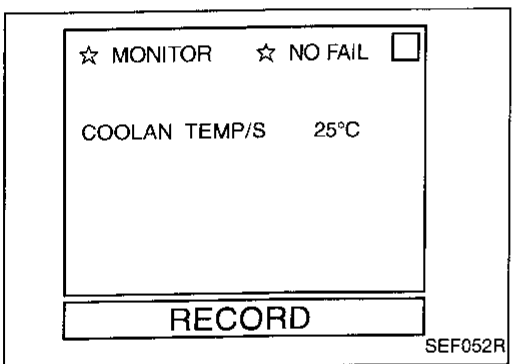

Fast Idle Cam (FIC) Inspection and Adjustment

1. Turn ignition switch "ON".
2. See "COOLAN TEMP/S" in "DATA MONITOR" mode with CONSULT.
3. When engine coolant temperature is $25 \pm 5^\circ\text{C}$ ($77 \pm 9^\circ\text{F}$), make sure that the center of mark (A) is aligned with mark (B) as shown in the figure.

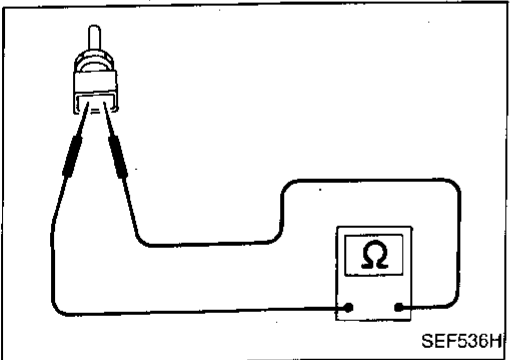

1. Turn ignition switch "OFF".
2. Disconnect engine coolant temperature sensor harness connector and check resistance as shown in the figure.
3. Start engine and warm it up. When the resistance of engine coolant temperature sensor is 1.65 to 2.4 kΩ, make sure that the center of mark (A) is aligned with mark (B) as shown in the figure.

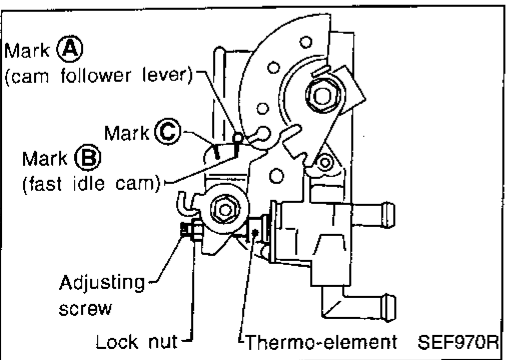

- If NG, adjust by turning adjusting screw.

Lock nut:

⊙ : 0.98 - 1.96 N·m (10 - 20 kg·cm, 8.7 - 17.4 in-lb)

BASIC SERVICE PROCEDURE

Fast Idle Cam (FIC) Inspection and Adjustment (Cont'd)

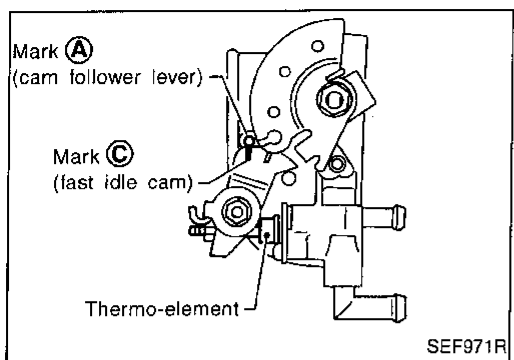

4. Start engine and warm it up.
 5. When engine coolant temperature is $80\pm 5^{\circ}\text{C}$ ($176\pm 9^{\circ}\text{F}$), check the following.
 - The center of mark **A** is aligned with mark **C**.
 - The cam follower lever's roller is not touching the fast idle cam.
 5. When the resistance of engine coolant temperature sensor is 0.26 to 0.39 k Ω , check the following.
 - The center of mark **A** is aligned with mark **C**.
 - The cam follower lever's roller is not touching the fast idle cam.
- If NG, replace thermo-element and perform the above inspection and adjustment again.

Idle Speed/Ignition Timing/Idle Mixture Ratio Adjustment

PREPARATION

1. Make sure that the following parts are in good order.
 - Battery
 - Ignition system
 - Engine oil and coolant levels
 - Fuses
 - ECM harness connector
 - Vacuum hoses
 - Air intake system (Oil filler cap, oil level gauge, etc.)
 - Fuel pressure
 - Engine compression
 - EGR valve operation
 - Throttle valve
 - EVAP canister purge control valve

2. On air conditioner equipped models, checks should be carried out while the air conditioner is "OFF".
3. On automatic transmission equipped models, when checking idle rpm, ignition timing and mixture ratio, checks should be carried out while shift lever is in "N" position.
4. When measuring "CO" percentage, insert probe more than 40 cm (15.7 in) into tail pipe.
5. Turn off headlamps, heater blower, rear defogger.
6. Keep front wheels pointed straight ahead.
7. Make the check after the cooling fan has stopped.

GI
 MA
 EM
 LC
 EC
 FE
 AT
 TF
 PD
 FA
 RA
 BR
 ST
 RS
 BT
 HA
 EL
 IDX

Overall inspection sequence

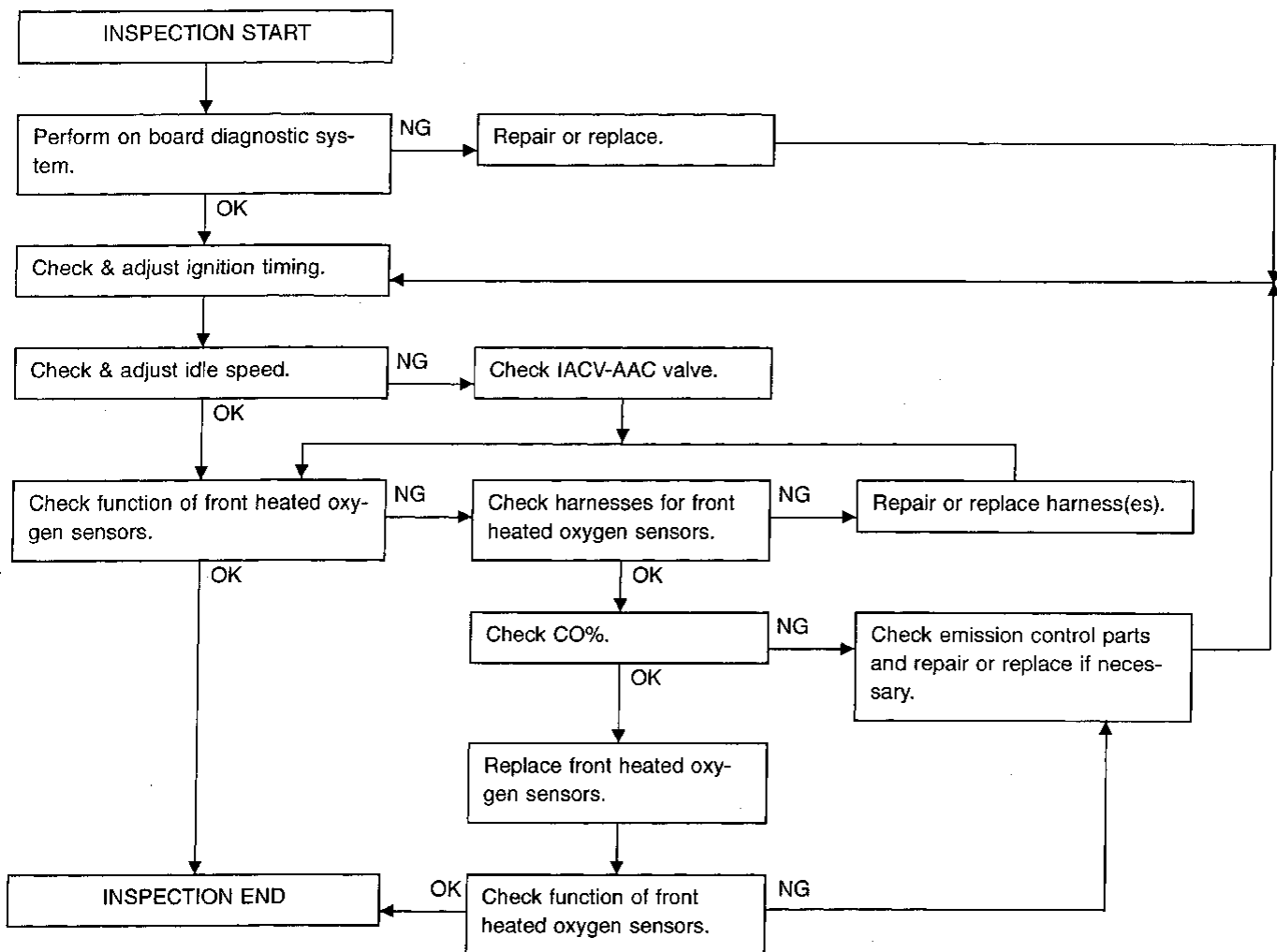

BASIC SERVICE PROCEDURE

Idle Speed/Ignition Timing/Idle Mixture Ratio Adjustment (Cont'd)

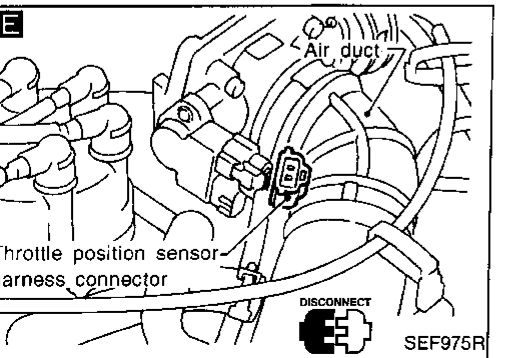
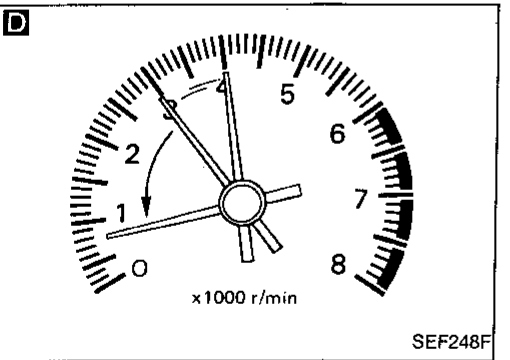
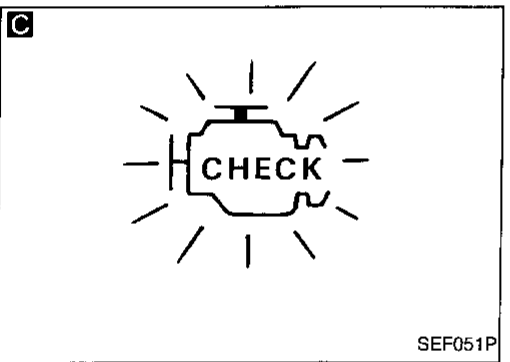
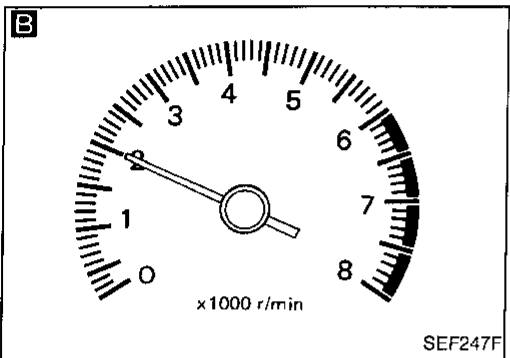
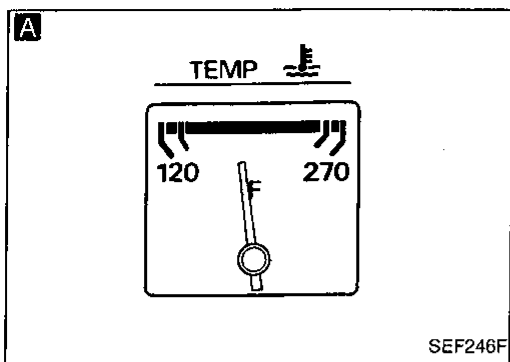

START

- Visually check the following:
- Air cleaner clogging
 - Hoses and ducts for leaks
 - EGR valve operation
 - Electrical connectors
 - Gasket
 - Throttle valve and throttle position sensor operation

A Start engine and warm it up until engine coolant temperature indicator points to the middle of gauge. Ensure engine stays below 1,000 rpm.

B Open engine hood and run engine at about 2,000 rpm for about 2 minutes under no-load.

C Perform diagnostic test mode II (Self-diagnostic results). Refer to EC-49.

OK → NG → Repair or replace components as necessary.

D Run engine at about 2,000 rpm for about 2 minutes under no-load. Rev engine (2,000 - 3,000 rpm) two or three times under no-load, then run engine at idle speed.

E Turn off engine and disconnect throttle position sensor harness connector.

Start and rev engine (2,000 - 3,000 rpm) two or three times under no-load, then run at idle speed.

F Check ignition timing with a timing light.
15°±2° BTDC (in "N" position)

OK → NG → Adjust ignition timing by turning distributor after loosening securing bolts.

G Turn off engine and connect throttle position sensor harness connector to throttle position sensor.

BASIC SERVICE PROCEDURE

Idle Speed/Ignition Timing/Idle Mixture Ratio Adjustment (Cont'd)

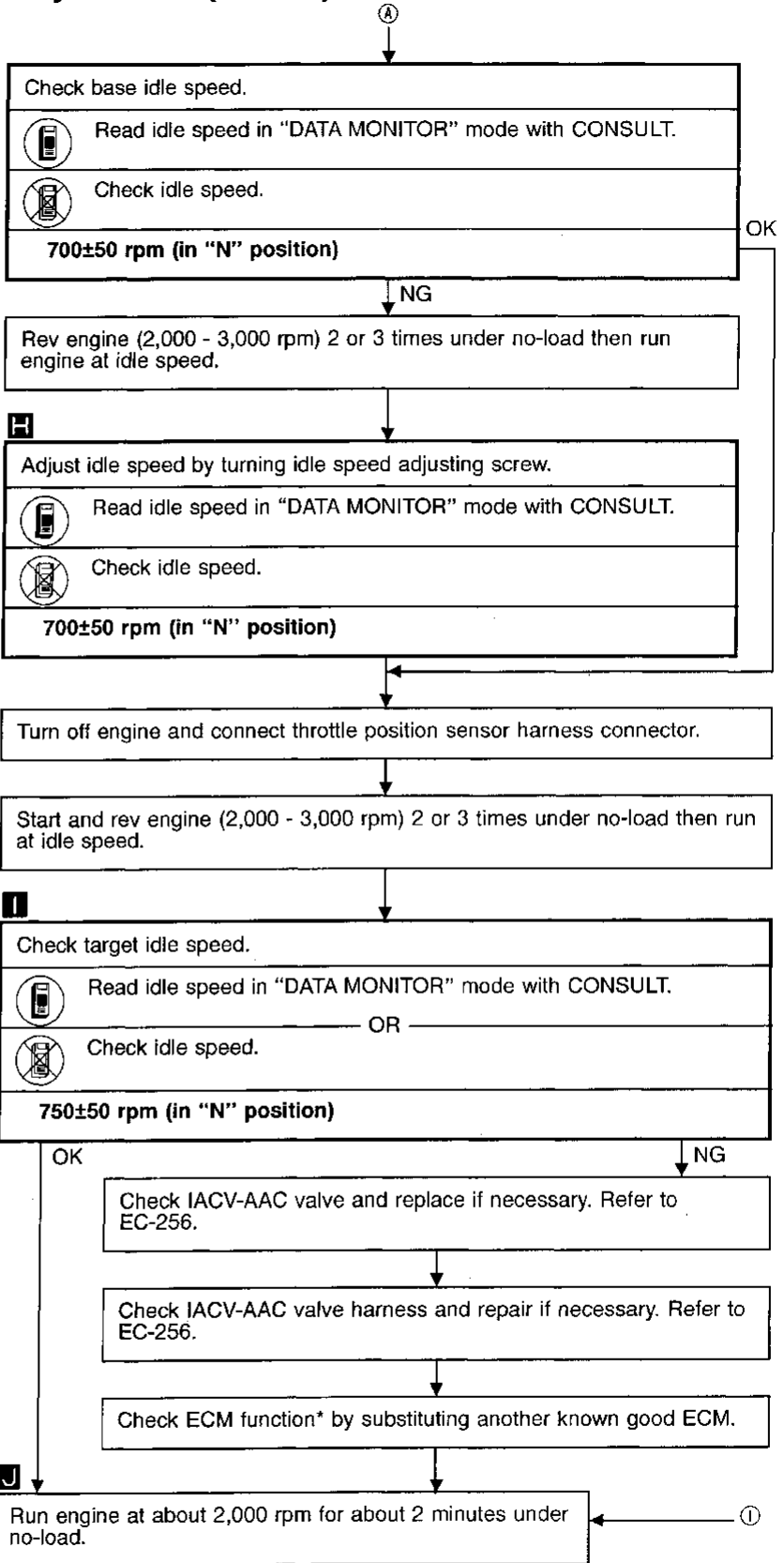
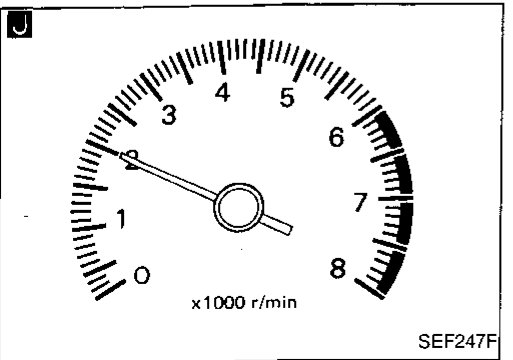
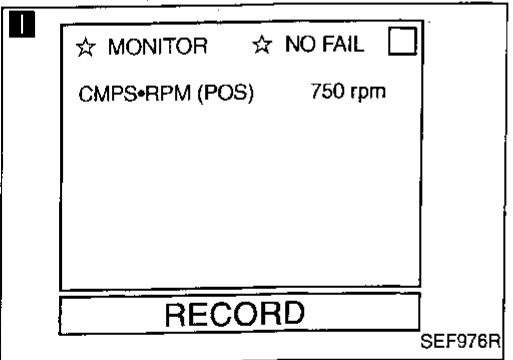
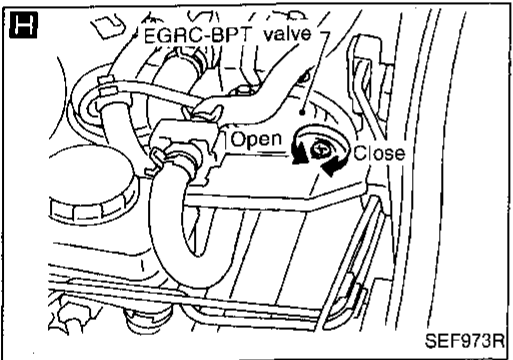
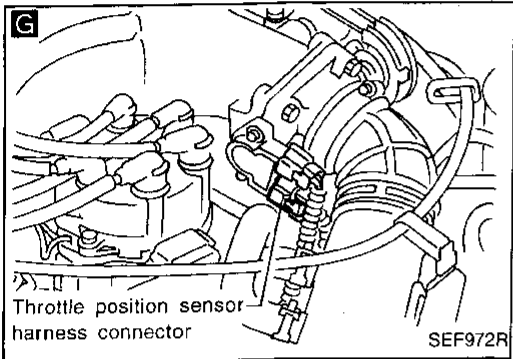
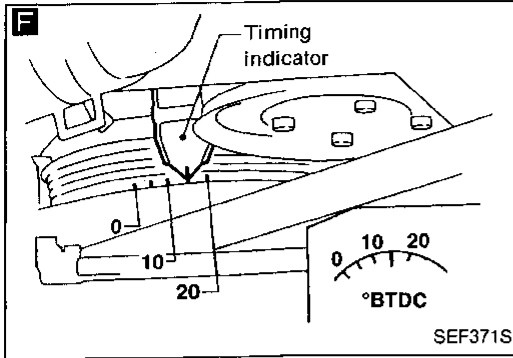

*: ECM may be the cause a problem, but this is rarely the case.

GI
MA
EM
OK
LC
EC
FE
AT
TF
PD
FA
RA
BR
ST
RS
BT
HA
EL
IDX

BASIC SERVICE PROCEDURE

Idle Speed/Ignition Timing/Idle Mixture Ratio Adjustment (Cont'd)

K

☆ MONITOR ☆ NO FAIL

CMPS•RPM (POS) 2087rpm
 FR O2 MNTR-B1 LEAN
 FR O2 MNTR-B2 RICH

RECORD

SEF929Q

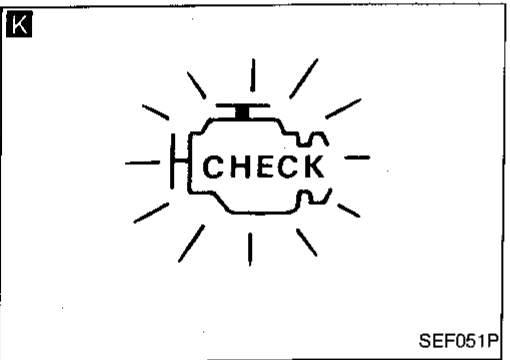
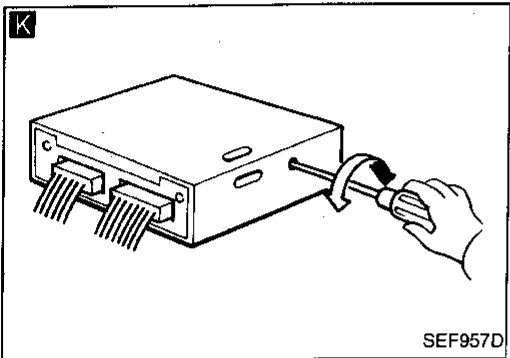

K

①

Check front heated oxygen sensor LH signal.

1. See "FR O2 MNTR-B2" in "DATA MONITOR" mode.

2. Running engine at 2,000 rpm under no-load (engine is warmed up sufficiently), check that the monitor fluctuates between "LEAN" and "RICH" more than 5 times during 10 seconds.

1 time: RICH → LEAN → RICH
2 times: RICH → LEAN → RICH → LEAN → RICH

OR

1. Set "Left bank front heated oxygen sensor monitor" in the Diagnostic Test Mode II. Refer to EC-49.

2. Make sure that malfunction indicator lamp goes on more than 5 times during 10 seconds at 2,000 rpm.

Monitor does not fluctuate. Malfunction indicator lamp does not blink.

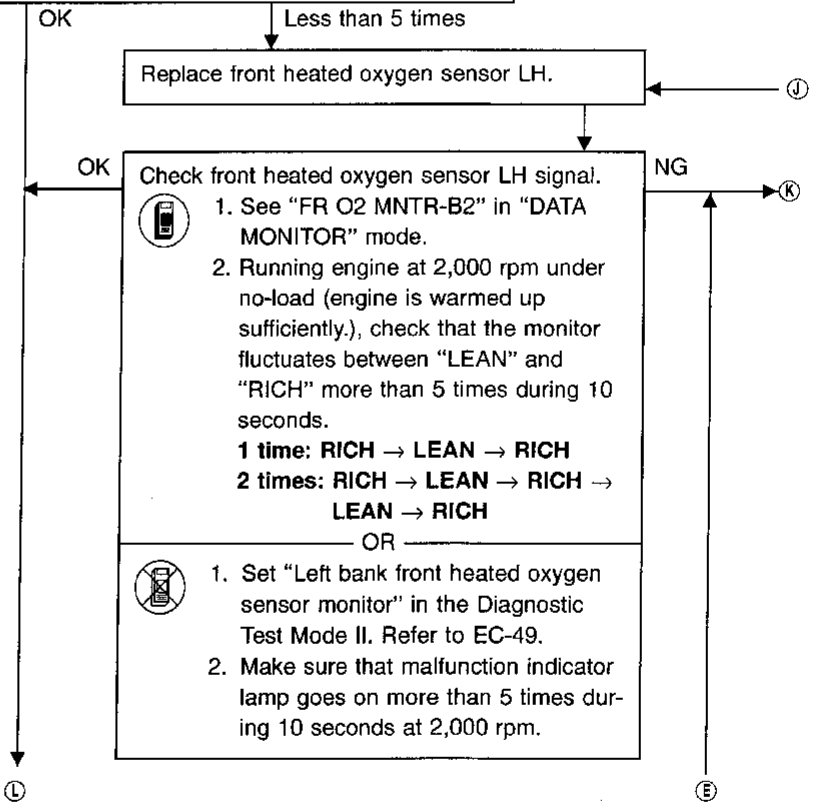

BASIC SERVICE PROCEDURE

Idle Speed/Ignition Timing/Idle Mixture Ratio Adjustment (Cont'd)

MONITOR NO FAIL

CMPS•RPM (POS)	2087rpm
FR O2 MNTR-B1	LEAN
FR O2 MNTR-B2	RICH

RECORD

SEF929Q

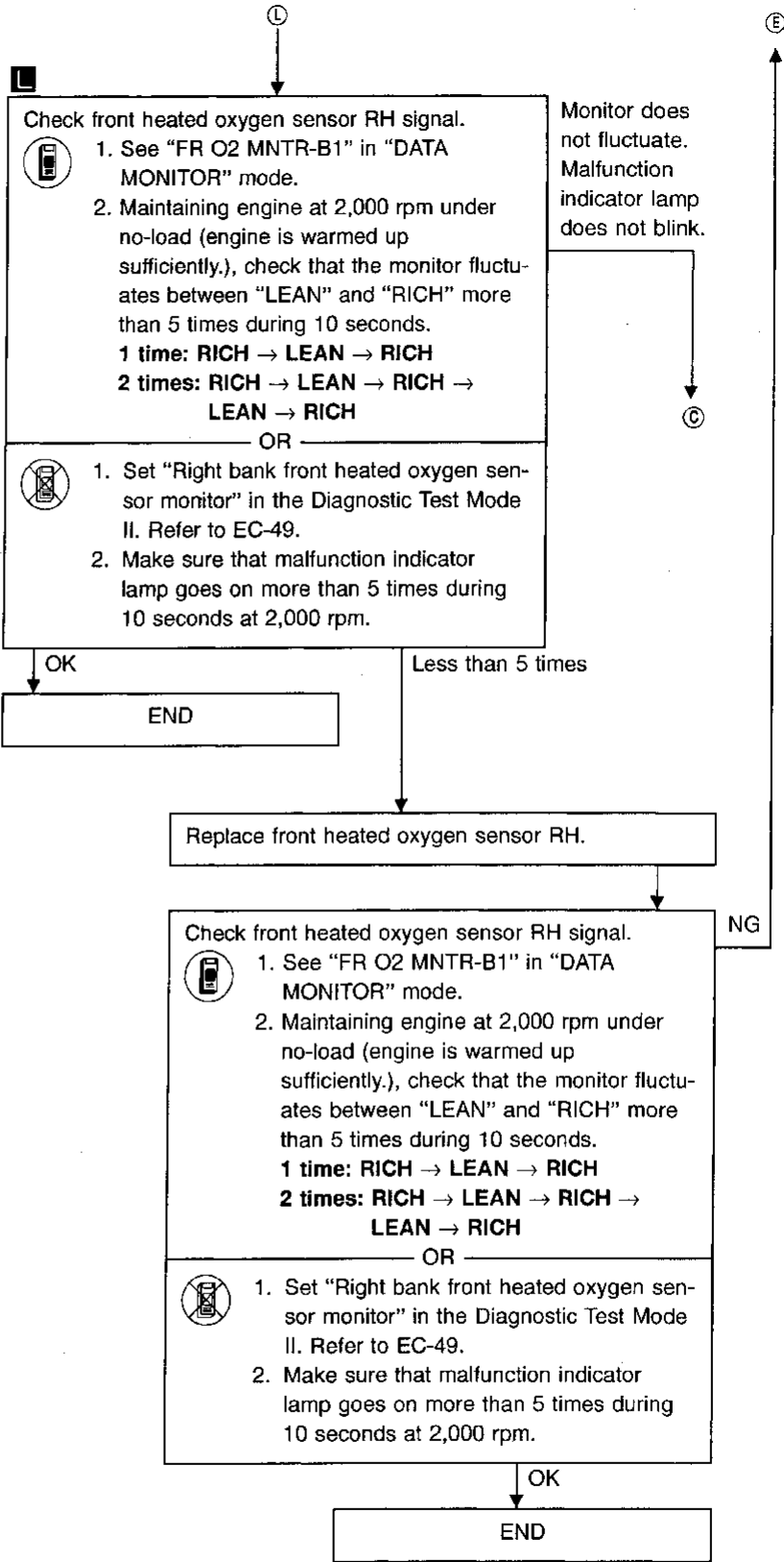
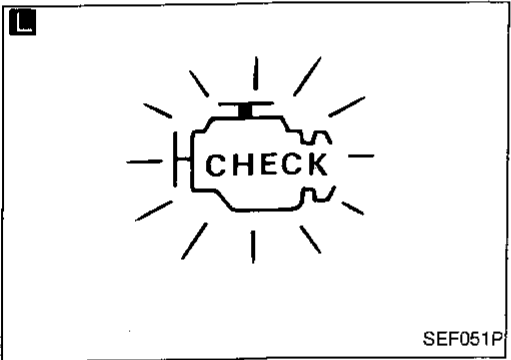
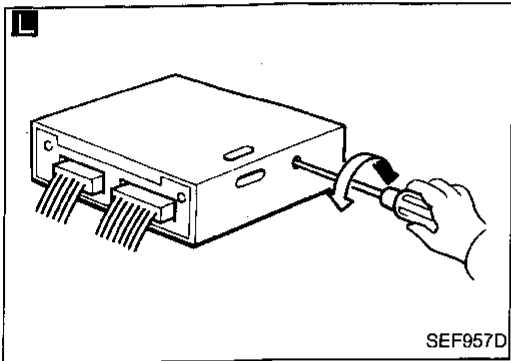

GI
MA
EM
LC
EC
FE
AT
TF
PD
FA
RA
BR
ST
RS
BT
HA
EL
IDX

BASIC SERVICE PROCEDURE

Idle Speed/Ignition Timing/Idle Mixture Ratio Adjustment (Cont'd)

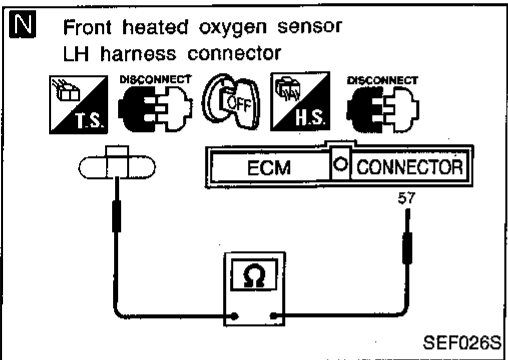
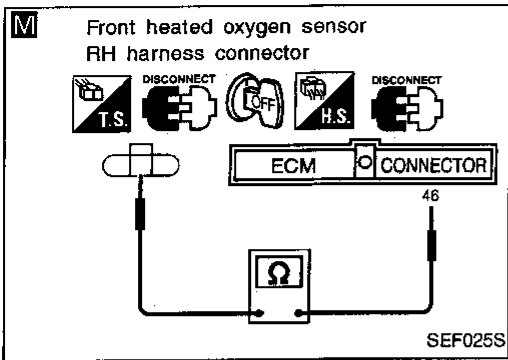

M

Check front heated oxygen sensor RH harness:

1. Turn off engine and disconnect battery ground cable.
2. Disconnect ECM SMJ harness connector from ECM.
3. Disconnect front heated oxygen sensor RH harness connector.
4. Check for continuity between terminal No. ④ of ECM SMJ harness connector and harness connector for front heated oxygen sensor RH.

Continuity exists. OK
 Continuity does not exist. NG

OK → Connect ECM SMJ harness connector to ECM.

NG → Repair or replace harness. → ①

N

Check front heated oxygen sensor LH harness:

1. Turn off engine and disconnect battery ground cable.
2. Disconnect ECM SMJ harness connector from ECM.
3. Disconnect front heated oxygen sensor LH harness connector.
4. Check for continuity between terminal No. ⑤ of ECM SMJ harness connector and harness connector for front heated oxygen sensor LH.

Continuity exists. OK
 Continuity does not exist. NG

OK → Connect ECM SMJ harness connector to ECM.

NG → Repair or replace harness. → ①

③

BASIC SERVICE PROCEDURE

Idle Speed/Ignition Timing/Idle Mixture Ratio Adjustment (Cont'd)

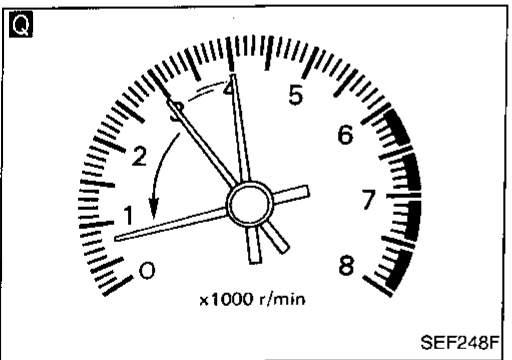
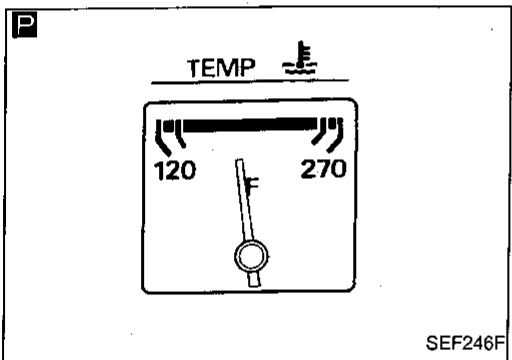
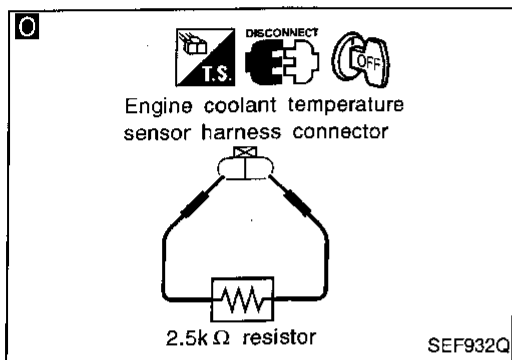
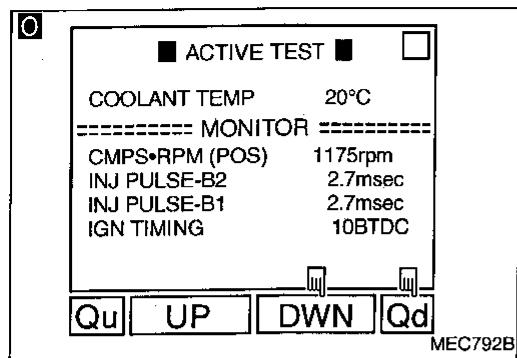

- ③
- ①
- Select "COOLANT TEMP" in "ACTIVE TEST" mode.
 - Set "COOLANT TEMP" to 20°C (68°F) by touching "DWN" and "Qd".
- OR
- Disconnect engine coolant temperature sensor harness connector.
 - Connect a resistor (2.5 kΩ) between terminals of engine coolant temperature sensor harness connector.

② Start engine and warm it up until engine coolant temperature indicator points to the middle of gauge.

③ Rev engine (2,000 - 3,000 rpm) two or three times under no-load, then run engine at idle speed.

Check "CO" %.

Idle CO: 0.2 - 8%

After checking CO%,

- Disconnect the resistor from terminals of engine coolant temperature sensor.
- Connect engine coolant temperature sensor harness connector to engine coolant temperature sensor.

NG

Connect front heated oxygen sensor harness connectors to front heated oxygen sensor.

Check fuel pressure regulator. Refer to EC-25.

Check mass air flow sensor and its circuit. Refer to EC-100.

Check injector and its circuit. Refer to EC-329. Clean or replace if necessary.

Check engine coolant temperature sensor and its circuit. Refer to EC-118.

Check ECM function* by substituting another known good ECM.

*: ECM may be the cause of a problem, but this is rarely the case.

GI
MA
EM
LC
EC
FE
AT
TF
PD
FA
RA
BR
ST
RS
BT
HA
EL
IDX

ON BOARD DIAGNOSTIC SYSTEM DESCRIPTION

Introduction

The ECM (ECCS control module) has an on board diagnostic system, which detects malfunctions related to engine sensors or actuators. The ECM also records various emission-related diagnostic information including:

- Diagnostic Trouble Code (DTC)Mode 3 of SAE J1979
- Freeze Frame dataMode 2 of SAE J1979
- System Readiness Test (SRT) codeMode 1 of SAE J1979
- 1st Trip Diagnostic Trouble Code (1st Trip DTC)Mode 7 of SAE J1979
- 1st Trip Freeze Frame data
- Test values and Test limitsMode 6 of SAE J1979

The above information can be checked using procedures listed in the table below.

	DTC	1st trip DTC	Freeze Frame data	1st trip Freeze Frame data	SRT code	Test value
Diagnostic test mode II (Self-diagnostic results)	○	○*1				
CONSULT	○	○	○	○	○	○
GST	○	○*2	○		○	○

*1: When DTC and 1st trip DTC simultaneously appear on the display, they cannot be clearly distinguished from each other.

*2: 1st trip DTCs for self-diagnoses concerning SRT items cannot be shown on the GST display.

The malfunction indicator lamp (MIL) on the instrument panel lights up when the same malfunction is detected in two consecutive trips (Two trip detection logic), or when the ECM enters fail-safe mode (Refer to EC-77.).

Two Trip Detection Logic

When a malfunction is detected for the first time, 1st trip DTC and 1st trip Freeze Frame data are stored in the ECM memory. The MIL will not light up at this stage. (1st trip)

If the same malfunction is detected again during the next drive, the DTC and Freeze Frame data are stored in the ECM memory, and the MIL lights up. The MIL lights up at the same time when the DTC is stored. (2nd trip) The "trip" in the "Two Trip Detection Logic" means a driving mode in which self-diagnosis is performed during vehicle operation. Specific on board diagnostic items will cause the ECM to light up or blink the MIL, and store DTC and Freeze Frame data, even in the 1st trip, as shown below.

Items	MIL			DTC		1st trip DTC	
	1st trip		2nd trip lighting up	1st trip displaying	2nd trip displaying	1st trip displaying	2nd trip displaying
	Blinking	Lighting up					
Misfire (Possible three way catalyst damage) — DTC: P0300 - P0306 (0701, 0603 - 0608) is being detected	X			X		X	
Misfire (Possible three way catalyst damage) — DTC: P0300 - P0306 (0701, 0603 - 0608) has been detected		X		X		X	
Closed loop control — DTC: P0130 (0307), P0150 (0308)		X		X		X	
Fail-safe items (Refer to EC-77.)		X		X*1		X*1	
Except above			X		X	X	X

*1: Except "ECM".

Emission-related Diagnostic Information

DTC AND 1ST TRIP DTC

The 1st trip DTC (whose number is the same as the DTC number) is displayed for the latest self-diagnostic result obtained. If the ECM memory was cleared previously, and the 1st trip DTC did not reoccur, the 1st trip DTC will not be displayed. If a malfunction is detected during the 1st trip, the 1st trip DTC is stored in the ECM memory. The MIL will not light up (two trip detection logic). If the same malfunction is not detected in the 2nd trip (meeting the required driving pattern), the 1st trip DTC is cleared from the ECM memory. If the same malfunction is detected in the 2nd trip, both the 1st trip DTC and DTC are stored in the ECM memory and the MIL lights up. In other words, the DTC is stored in the ECM memory and the MIL lights up when the same malfunction occurs in two consecutive trips. If a 1st trip DTC is stored and a non-diagnostic operation is performed between the 1st and 2nd trips, only the 1st trip DTC will continue to be stored. For malfunctions that blink or light up the MIL during the 1st trip, the DTC and 1st trip DTC are stored in the ECM memory. Procedures for clearing the DTC and the 1st trip DTC from the ECM memory are described in "HOW TO ERASE EMISSION-RELATED DIAGNOSTIC INFORMATION". Refer to EC-46.

For malfunctions in which 1st trip DTCs are displayed, refer to EC-44. These items are required by legal regulations to continuously monitor the system/component. In addition, the items monitored non-continuously are also displayed on CONSULT.

1st trip DTC is specified in Mode 7 of SAE J1979. 1st trip DTC detection occurs without lighting up the MIL and therefore does not warn the driver of a problem. However, 1st trip DTC detection will not prevent the vehicle from being tested, for example during Inspection/Maintenance (I/M) tests.

When a 1st trip DTC is detected, check, print out or write down and erase (1st trip) DTC and Freeze Frame data as specified in "Work Flow" procedure Step II, refer to page EC-72. Then perform "DTC confirmation procedure" or "Overall function check" to try to duplicate the problem. If the malfunction is duplicated, the item requires repair.

How to read DTC and 1st trip DTC

DTC and 1st trip DTC can be read by the following methods.

 1. The number of blinks of the malfunction indicator lamp in the Diagnostic Test Mode II (Self-Diagnostic Results) Examples: 0101, 0201, 1003, 1104, etc.
These DTCs are controlled by NISSAN.

 2. CONSULT or GST (Generic Scan Tool) Examples: P0340, P1320, P0705, P0750, etc.
These DTCs are prescribed by SAE J2012.

 (CONSULT also displays the malfunctioning component or system.)

- 1st trip DTC No. is the same as DTC No.
- Output of a DTC indicates a malfunction. However, Mode II and GST do not indicate whether the malfunction is still occurring or has occurred in the past and has returned to normal. CONSULT can identify malfunction status as shown below. Therefore, using CONSULT (if available) is recommended.

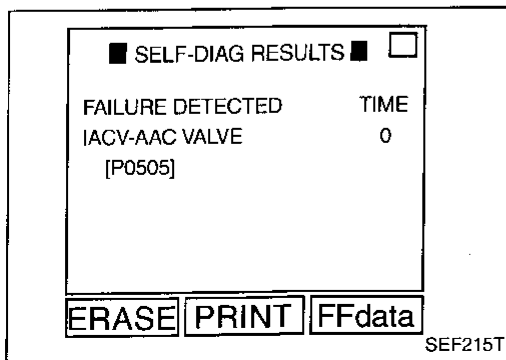

A sample of CONSULT display for DTC is shown at left. DTC or 1st trip DTC of a malfunction is displayed in SELF-DIAGNOSTIC RESULTS mode of CONSULT. Time data indicates how many times the vehicle was driven after the last detection of a DTC. If the DTC is being detected currently, the time data will be "0".

ON BOARD DIAGNOSTIC SYSTEM DESCRIPTION

Emission-related Diagnostic Information (Cont'd)

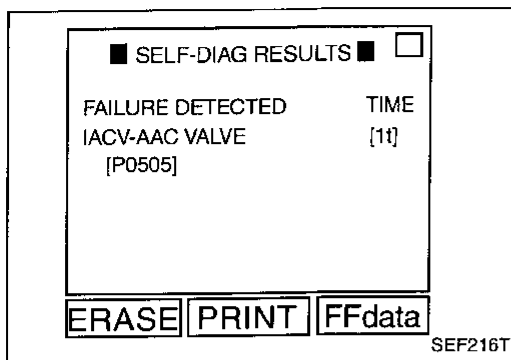

If a 1st trip DTC is stored in the ECM, the time data will be “[1t]”.

FREEZE FRAME DATA AND 1ST TRIP FREEZE FRAME DATA

The ECM records the driving conditions such as fuel system status, calculated load value, engine coolant temperature, short term fuel trim, long term fuel trim, engine speed, vehicle speed and absolute pressure sensor at the moment a malfunction is detected.

Data which are stored in the ECM memory, along with the 1st trip DTC, are called 1st trip freeze frame data. The data, stored together with the DTC data, are called freeze frame data and displayed on CONSULT or GST. The 1st trip freeze frame data can only be displayed on the CONSULT screen, not on the GST. For details, see EC-59.

Only one set of freeze frame data (either 1st trip freeze frame data or freeze frame data) can be stored in the ECM. 1st trip freeze frame data is stored in the ECM memory along with the 1st trip DTC. There is no priority for 1st trip freeze frame data and it is updated each time a different 1st trip DTC is detected. However, once freeze frame data (2nd trip detection/MIL on) is stored in the ECM memory, 1st trip freeze frame data is no longer stored. Remember, only one set of freeze frame data can be stored in the ECM. The ECM has the following priorities to update the data.

Priority	Items	
1	Freeze frame data	Misfire — DTC: P0300 - P0306 (0701, 0603 - 0608) Fuel Injection System Function — DTC: P0171 (0115), P0172 (0114), P0174 (0210), P0175 (0209)
2		Except the above items (Includes A/T related items)
3	1st trip freeze frame data	

For example, the EGR malfunction (Priority: 2) was detected and the freeze frame data was stored in the 2nd trip. After that when the misfire (Priority: 1) is detected in another trip, the freeze frame data will be updated from the EGR malfunction to the misfire. The 1st trip freeze frame data is updated each time a different malfunction is detected. There is no priority for 1st trip freeze frame data. However, once freeze frame data is stored in the ECM memory, first trip freeze data is no longer stored (because only one freeze frame data or first trip freeze frame data can be stored in the ECM). If freeze frame data is stored in the ECM memory and freeze frame data with the same priority occurs later, the first (original) freeze frame data remains unchanged in the ECM memory.

Both 1st trip freeze frame data and freeze frame data (along with the DTCs) are cleared when the ECM memory is erased. Procedures for clearing the ECM memory are described in “HOW TO ERASE EMISSION-RELATED DIAGNOSTIC INFORMATION”. Refer to EC-46.

SYSTEM READINESS TEST (SRT) CODE

System Readiness Test (SRT) code is specified in Mode 1 of SAE J1979. It indicates whether the self-diagnostic tests for non-continuously monitored items have been completed or not.

Inspection/Maintenance (I/M) tests of the on board diagnostic (OBD) II system may become the legal requirements in some states/areas. All SRT codes must be set in this case. Unless all SRT codes are set, conducting the I/M test may not be allowed.

SRT codes are set after self-diagnosis has been performed two or more times. This occurs regardless of whether the diagnosis is in “OK” or “NG”, and whether or not the diagnosis is performed in consecutive trips. The following table lists the five SRT items (14 test items) for the ECCS used in JR50 models.

ON BOARD DIAGNOSTIC SYSTEM DESCRIPTION

Emission-related Diagnostic Information (Cont'd)

SRT items	Self-diagnostic test items
Catalyst monitoring	<ul style="list-style-type: none"> ● Three way catalyst function (right bank) P0420 (0702) ● Three way catalyst function (left bank) P0430 (0703)
EVAP system monitoring	<ul style="list-style-type: none"> ● EVAP control system (Small Leak) P0440 (0705) ● EVAP control system purge flow monitoring P1447 (0111)
Oxygen sensor monitoring	<ul style="list-style-type: none"> ● Front heated oxygen sensor (right bank) P0130 (0503) ● Rear heated oxygen sensor (right bank) P0136 (0707) ● Front heated oxygen sensor (left bank) P0150 (0303) ● Rear heated oxygen sensor (left bank) P0156 (0708)
Oxygen sensor heater monitoring	<ul style="list-style-type: none"> ● Front heated oxygen sensor heater (right bank) P0135 (0901) ● Rear heated oxygen sensor heater (right bank) P0141 (0902) ● Front heated oxygen sensor heater (left bank) P0155 (1001) ● Rear heated oxygen sensor heater (left bank) P0161 (1002)
EGR system monitoring	<ul style="list-style-type: none"> ● EGR function P0400 (0302) ● EGRC-BPT valve function P0402 (0306)

Together with the DTC, the SRT code is cleared from the ECM memory using the method described later (Refer to EC-46). In addition, after ECCS components/system are repaired or if the battery terminals remain disconnected for more than 24 hours, all SRT codes may be cleared from the ECM memory.

How to display SRT code

1. Selecting "SRT" in "SRT-OBD TEST VALUE" mode with CONSULT.
 For items whose SRT codes are set, a "CMPLT" is displayed on the CONSULT screen; for items whose SRT codes are not set, "INCMP" is displayed.

2. Selecting Mode 1 with GST (Generic Scan Tool)

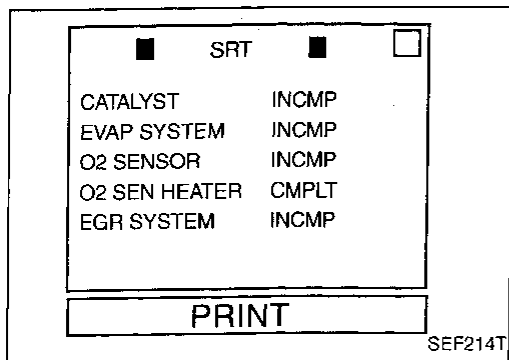

A sample of CONSULT display for SRT code is shown at left. "INCMP" means the self-diagnosis is incomplete and SRT is not set. "CMPLT" means the self-diagnosis is complete and SRT is set.

How to set SRT code

To set all SRT codes, self-diagnosis for the items indicated above must be performed two or more times. Each diagnosis may require a long period of actual driving under various conditions. The most efficient driving pattern in which SRT codes can be properly set is explained on the next page. The driving pattern should be performed two times or more to set all SRT codes.

ON BOARD DIAGNOSTIC SYSTEM DESCRIPTION

Emission-related Diagnostic Information (Cont'd)

Driving pattern

Note: Always drive vehicle in safe manner according to traffic conditions and obey all traffic laws.
Refer to next page for more information and explanation of chart.

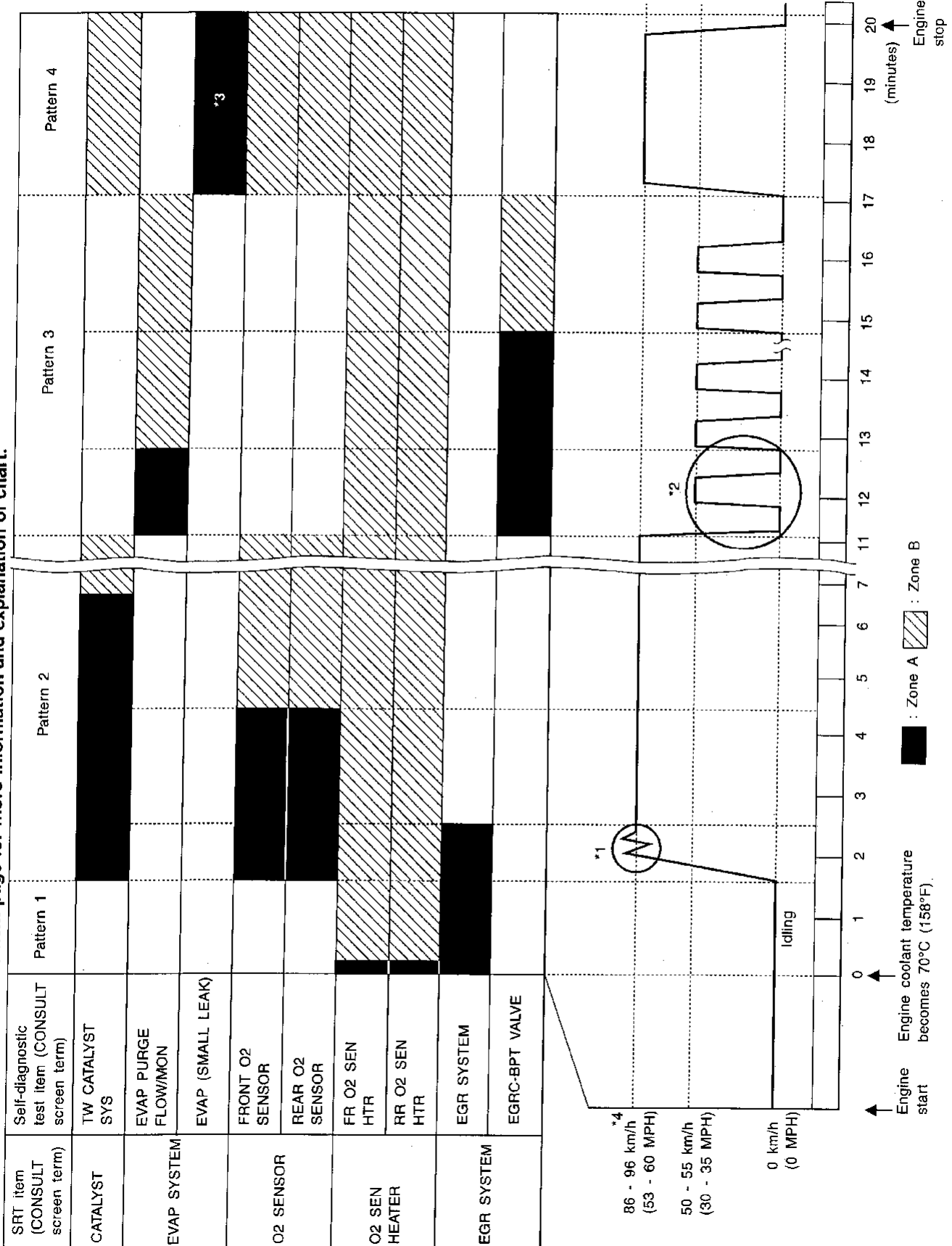

ON BOARD DIAGNOSTIC SYSTEM DESCRIPTION

Emission-related Diagnostic Information (Cont'd)

- The time required for each diagnosis varies with road surface conditions, weather, altitude, individual driving habits, etc.

Zone A refers to the range where the time required, for the diagnosis under normal conditions*, is the shortest. Zone B refers to the range where the diagnosis can still be performed if the diagnosis is not completed within zone A.

*: Normal conditions refer to the following:

- Sea level
- Flat road
- Ambient air temperature: 20 - 30°C (68 - 86°F)
- Diagnosis is performed as quickly as possible under normal conditions.

Under different conditions [For example: ambient air temperature other than 20 - 30°C (68 - 86°F)], diagnosis may also be performed.

- Pattern 1: • **The engine is started at the engine coolant temperature of -10 to 35°C (14 to 95°F) (where the voltage between the ECM terminals ⑤ and ⑥ is 3.0 - 4.3V).**
- **The engine must be operated at idle speed until the engine coolant temperature is greater than 70°C (158°F) (where the voltage between the ECM terminals ⑤ and ⑥ is lower than 1.4V).**

- Pattern 2: • When steady-state driving is performed again even after it is interrupted, each diagnosis can be conducted. In this case, the time required for diagnosis may be extended.

- Pattern 3: • The driving pattern outlined in *2 must be repeated at least 3 times.
On M/T models, shift gears following "suggested upshift speeds" schedule at right.

- Pattern 4: • Tests are performed after the engine has been operated for at least 12 minutes.
- The accelerator pedal must be held very steady during steady-state driving.
 - If the accelerator pedal is moved, the test must be conducted all over again.

- *1: Depress the accelerator pedal until vehicle speed is 90 km/h (56 MPH), then release the accelerator pedal and keep it released for more than 10 seconds. Depress the accelerator pedal until vehicle speed is 90 km/h (56 MPH) again.

- *2: Operate the vehicle in the following driving pattern.
- 1) Decelerate vehicle to 0 km/h and let engine idle.
 - 2) Repeat driving pattern shown below at least 10 times.
 - **During acceleration, hold the accelerator pedal as steady as possible. (The THROTL POS SEN value of CONSULT should be between 0.8 to 1.2V.)**
 - 3) Repeat steps 1 and 2 until the EGR system SRT is set.

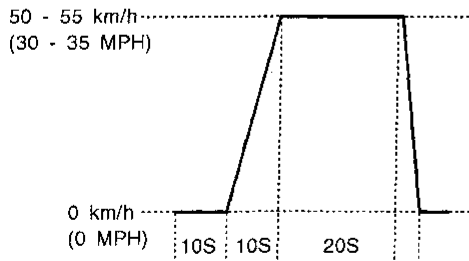

SEF414S

- *3: The driving pattern may be omitted when EVAP (SMALL LEAK) checks are performed using the FUNCTION TEST mode of CONSULT.

- *4: Checking the vehicle speed with CONSULT or GST is advised.

Suggested transmission gear position for A/T models

Set the selector lever in the "D" position with the overdrive switch turned ON.

Suggested maximum speed in each gear

Downshift to a lower gear if the engine is not running smoothly, or if you need to accelerate.

Do not exceed the maximum suggested speed (shown below) in any gear. For level road driving, use the highest gear suggested for that speed. Always observe posted speed limits and drive according to the road conditions to ensure safe operation. Do not over-rev the engine when shifting to a lower gear as it may cause engine damage or loss of vehicle control.

Gear	km/h (MPH)
	2WD (AUTO models)
1st	50 (30)
2nd	95 (60)

GI

MA

EM

LC

EC

FE

AT

TF

PD

FA

PA

BR

ST

RS

BT

HA

EL

IDX

ON BOARD DIAGNOSTIC SYSTEM DESCRIPTION

Emission-related Diagnostic Information (Cont'd)

TEST VALUE AND TEST LIMIT

The following is the information specified in Mode 6 of SAE J1979.

The test value is a parameter used to determine whether a system/circuit diagnostic test is "OK" or "NG" while being monitored by the ECM during self-diagnosis. The test limit is a reference value which is specified as the maximum or minimum value and is compared with the test value being monitored.

Items for which these data (test value and test limit) are displayed are the same as SRT code items (14 test items).

These data (test value and test limit) are specified by Test ID (TID) and Component ID (CID) and can be displayed on the CONSULT screen or GST.

X: Applicable
—: Not applicable

SRT item (CONSULT display)	Self-diagnostic test item	TID*1	CID*1	Test value	Test limit	Application
CATALYST	Three way cata- lyst function (Right bank)	01H	01H	Parameter 1	Max.	X
	Three way cata- lyst function (Left bank)	03H	02H	Parameter 1	Max.	X
EVAP SYSTEM	EVAP control system (Small leak)	05H	03H	Parameter 1	Max.	X
	EVAP control system purge flow monitoring	06H	83H	Parameter 2	Min.	X
O2 SENSOR	Front heated oxygen sensor (Right bank)	09H	04H	Parameter 1	Max.	X
		0AH	84H	Parameter 2	Min.	X
		0BH	04H	Parameter 3	Max.	X
		0CH	04H	Parameter 4	Max.	X
		0DH	04H	Parameter 5	Max.	X
	Front heated oxygen sensor (Left bank)	11H	05H	Parameter 1	Max.	X
		12H	85H	Parameter 2	Min.	X
		13H	05H	Parameter 3	Max.	X
		14H	05H	Parameter 4	Max.	X
		15H	05H	Parameter 5	Max.	X
	Rear heated oxygen sensor (Right bank)	19H	86H	Parameter 6	Min.	X
		1AH	86H	Parameter 7	Min.	X
		1BH	06H	Parameter 8	Max.	X
		1CH	06H	Parameter 9	Max.	X
	Rear heated oxygen sensor (Left bank)	21H	87H	Parameter 6	Min.	X
		22H	87H	Parameter 7	Min.	X
23H		07H	Parameter 8	Max.	X	
24H		07H	Parameter 9	Max.	X	

ON BOARD DIAGNOSTIC SYSTEM DESCRIPTION

Emission-related Diagnostic Information (Cont'd)

X: Applicable
—: Not applicable

SRT Item (CONSULT display)	Self-diagnostic test item	TID*1	CID*1	Test value	Test limit	Application
O2 SENSOR HEATER	Front heated oxygen sensor heater (Right bank)	29H	08H	Parameter 1	Max.	X
		2AH	88H	Parameter 1	Min.	X
	Front heated oxygen sensor heater (Left bank)	2BH	09H	Parameter 1	Max.	X
		2CH	89H	Parameter 1	Min.	X
	Rear heated oxygen sensor heater (Right bank)	2DH	0AH	Parameter 1	Max.	X
		2EH	8AH	Parameter 1	Min.	X
	Rear heated oxygen sensor heater (Left bank)	2FH	0BH	Parameter 1	Max.	X
		30H	8BH	Parameter 1	Min.	X
EGR SYSTEM	EGR function	31H	8CH	Parameter 1	Min.	X
		32H	8CH	Parameter 2	Min.	X
		33H	8CH	Parameter 3	Min.	X
		34H	8CH	Parameter 4	Min.	X
		35H	0CH	Parameter 5	Max.	X
	EGRC-BPT valve function	36H	0CH	Parameter 6	Max.	X
		37H	8CH	Parameter 7	Min.	X

*1: TID and CID are hexadecimals and are shown only on GST.

GI
MA
EM
LC
EC
FE
AT
TF
PD
FA
RA
BR
ST
RS
BT
HA
EL
IDX

ON BOARD DIAGNOSTIC SYSTEM DESCRIPTION

Emission-related Diagnostic Information (Cont'd)

EMISSION-RELATED DIAGNOSTIC INFORMATION ITEMS

X: Applicable
—: Not applicable

Items (CONSULT screen terms)	DTC*4		SRT code	Test value/ Test limit	1st trip DTC	Reference page
	CONSULT GST*2	ECM*1				
NO SELF DIAGNOSTIC FAILURE INDICATED	P0000	0505	—	—	—	—
MASS AIR FLOW SEN	P0100	0102	—	—	X	EC-100
ABSOL PRESS SENSOR	P0105	0803	—	—	X	EC-106
INT AIR TEMP SEN	P0110	0401	—	—	X	EC-113
COOLANT TEMP SEN	P0115	0103	—	—	X	EC-118
THROTTLE POSI SEN	P0120	0403	—	—	X	EC-123
*COOLANT TEMP SEN	P0125	0908	—	—	X	EC-129
CLOSED LOOP	P0130	0307	—	—	X	EC-134
FRONT O2 SENSOR-B1	P0130	0503	X	X	X*3	EC-135
FR O2 SEN HTR-B1	P0135	0901	X	X	X*3	EC-140
REAR O2 SENSOR-B1	P0136	0707	X	X	X*3	EC-144
RR O2 SEN HTR-B1	P0141	0902	X	X	X*3	EC-148
FRONT O2 SENSOR-B2	P0150	0303	X	X	X*3	EC-153
FR O2 SEN HTR-B2	P0155	1001	X	X	X*3	EC-158
REAR O2 SENSOR-B2	P0156	0708	X	X	X*3	EC-162
RR O2 SEN HTR-B2	P0161	1002	X	X	X*3	EC-166
FUEL SYS LEAN/BK1	P0171	0115	—	—	X	EC-170
FUEL SYS RICH/BK1	P0172	0114	—	—	X	EC-175
FUEL SYS LEAN/BK2	P0174	0210	—	—	X	EC-180
FUEL SYS RICH/BK2	P0175	0209	—	—	X	EC-185
TANK FUEL TEMP SEN	P0180	0402	—	—	X	EC-190
MULTI CYL MISFIRE	P0300	0701	—	—	X	EC-193
CYL 1 MISFIRE	P0301	0608	—	—	X	EC-193
CYL 2 MISFIRE	P0302	0607	—	—	X	EC-193
CYL 3 MISFIRE	P0303	0606	—	—	X	EC-193
CYL 4 MISFIRE	P0304	0605	—	—	X	EC-193
CYL 5 MISFIRE	P0305	0604	—	—	X	EC-193
CYL 6 MISFIRE	P0306	0603	—	—	X	EC-193
KNOCK SENSOR	P0325	0304	—	—	X	EC-197
CRANK POS SEN (OBD)	P0335	0802	—	—	—	EC-200
CAMSHAFT POSI SEN	P0340	0101	—	—	X	EC-205
EGR SYSTEM	P0400	0302	X	X	X*3	EC-211
EGRC-BPT valve	P0402	0306	X	X	X*3	EC-219
TW CATALYST SYS-B1	P0420	0702	X	X	X*3	EC-221
TW CATALYST SYS-B2	P0430	0703	X	X	X*3	EC-221
EVAP (SMALL LEAK)	P0440	0705	X	X	X*3	EC-317

*1: In Diagnostic Test Mode II (Self-diagnostic results). These numbers are controlled by NISSAN.

*2: These numbers are prescribed by SAE J2012.

*3: These are not displayed with GST.

*4: 1st trip DTC No. is the same as DTC No.

Note: Regarding JR50 models, "B1" indicates right bank and "B2" indicates left bank.

ON BOARD DIAGNOSTIC SYSTEM DESCRIPTION

Emission-related Diagnostic Information (Cont'd)

X: Applicable
—: Not applicable

Items (CONSULT screen terms)	DTC*4		SRT code	Test value/ Test limit	1st trip DTC	Reference page
	CONSULT GST*2	ECM*1				
PURG CONT/V & S/V	P0443	0807	—	—	X	EC-233
VENT CONTROL VALVE	P0446	0903	—	—	X	EC-242
EVAP SYS PRES SEN	P0450	0704	—	—	X	EC-247
VEHICLE SPEED SEN	P0500	0104	—	—	X	EC-252
IACV-AAC VALVE	P0505	0205	—	—	X	EC-256
CLOSED THRL POS SW	P0510	0203	—	—	X	EC-261
A/T COMM LINE	P0600	—	—	—	—	EC-266
ECM	P0605	0301	—	—	X	EC-269
PARK/NEUT POSI SW	P0705	1003	—	—	X	EC-271
INHIBITOR SWITCH	P0705	1101	—	—	X	AT-59
FLUID TEMP SENSOR	P0710	1208	—	—	X	AT-65
VHCL SPEED SEN A/T	P0720	1102	—	—	X	AT-68
ENGINE SPEED SIG	P0725	1207	—	—	X	AT-70
A/T 1ST SIGNAL	P0731	1103	—	—	X	AT-72
A/T 2ND SIGNAL	P0732	1104	—	—	X	AT-75
A/T 3RD SIGNAL	P0733	1105	—	—	X	AT-77
A/T 4TH SIG OR TCC	P0734	1106	—	—	X	AT-79
TOR CONV CLUTCH SV	P0740	1204	—	—	X	AT-84
A/T TCC SIGNAL	P0744	1107	—	—	X	AT-87
LINE PRESSURE S/V	P0745	1205	—	—	X	AT-92
SHIFT SOLENOID/V A	P0750	1108	—	—	X	AT-95
SHIFT SOLENOID/V B	P0755	1201	—	—	X	AT-98
MAP/BARO SW SOL/V	P1105	1302	—	—	X	EC-277
IGN SIGNAL-PRIMARY	P1320	0201	—	—	X	EC-283
CRANK P/S (OBD) COG	P1336	0905	—	—	X	EC-289
EGRC SOLENOID/V	P1400	1005	—	—	X	EC-294
EGR TEMP SENSOR	P1401	0305	—	—	X	EC-299
VC/V BYPASS/V	P1441	0801	—	—	X	EC-304
PURG VOLUME CONT/V	P1445	1008	—	—	X	EC-309
EVAP PURG FLOW/MON	P1447	0111	X	X	X*3	EC-317
A/T DIAG COMM LINE	P1605	0804	—	—	X	EC-326
THRTL POSI SEN A/T	P1705	1206	—	—	X	AT-101
OVERRUN CLUTCH S/V	P1760	1203	—	—	X	AT-103

*1: In Diagnostic Test Mode II (Self-diagnostic results). These numbers are controlled by NISSAN.

*2: These numbers are prescribed by SAE J2012.

*3: These are not displayed with GST.



*4: 1st trip DTC No. is the same as DTC No.

ON BOARD DIAGNOSTIC SYSTEM DESCRIPTION

Emission-related Diagnostic Information (Cont'd)

HOW TO ERASE EMISSION-RELATED DIAGNOSTIC INFORMATION

The emission-related diagnostic information can be erased by the following methods.

-  Selecting "ERASE" in the "SELF-DIAG RESULTS" mode with CONSULT
-  Selecting Mode 4 with GST (Generic Scan Tool)
-  Changing the diagnostic test mode from Diagnostic Test Mode II to Mode I by turning the mode selector on the ECM (Refer to EC-49.)
- **If the battery is disconnected, the emission-related diagnostic information will be lost after approx. 24 hours.**
- **Erasing the emission-related diagnostic information using CONSULT or GST is easier and quicker than switching the mode selector on the ECM.**

The following data are cleared when the ECM memory is erased.

1. Diagnostic trouble codes
2. 1st trip diagnostic trouble codes
3. Freeze frame data
4. 1st trip freeze frame data
5. System readiness test (SRT) codes
6. Test values
7. Others

Actual work procedures are explained using a DTC as an example. Be careful so that not only the DTC, but all of the data listed above, are cleared from the ECM memory during work procedures.

How to erase DTC (With CONSULT)

Note: If the diagnostic trouble code is not for A/T related items (see EC-2), skip steps 2 through 4.

1. If the ignition switch stays "ON" after repair work, be sure to turn ignition switch "OFF" once. Wait at least 5 seconds and then turn it "ON" (engine stopped) again.
 2. Turn CONSULT "ON" and touch "A/T".
 3. Touch "SELF-DIAG RESULTS".
 4. Touch "ERASE". (The DTC in the A/T control unit will be erased.) Then touch "BACK" twice.
 5. Touch "ENGINE".
 6. Touch "SELF-DIAG RESULTS".
 7. Touch "ERASE". (The DTC in the ECM will be erased.)
- If DTCs are displayed for both ECM and A/T control unit, they need to be erased individually from the ECM and A/T control unit.

ON BOARD DIAGNOSTIC SYSTEM DESCRIPTION

Emission-related Diagnostic Information (Cont'd)

How to erase DTC (With CONSULT)

1. If the ignition switch stays "ON" after repair work, be sure to turn ignition switch "OFF" once. Wait at least 5 seconds and then turn it "ON" (engine stopped) again.

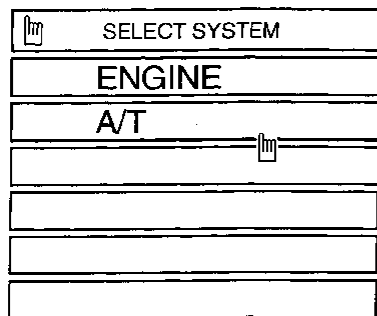

2. Turn CONSULT "ON", and touch "A/T".

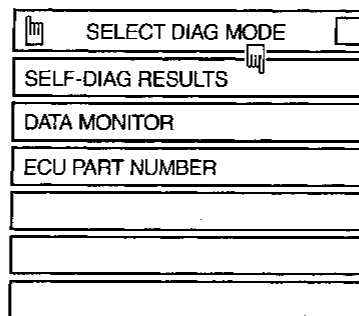

3. Touch "SELF-DIAG RESULTS".

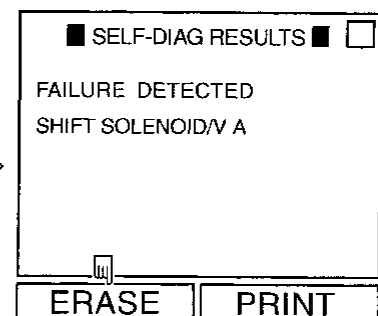

4. Touch "ERASE". (The DTC in the A/T control unit will be erased.)

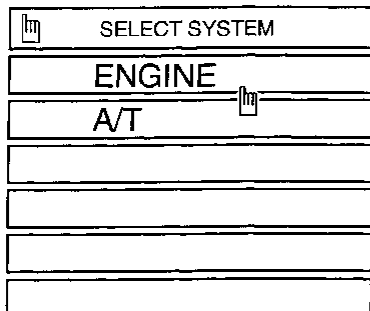
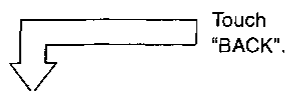

5. Touch "ENGINE".

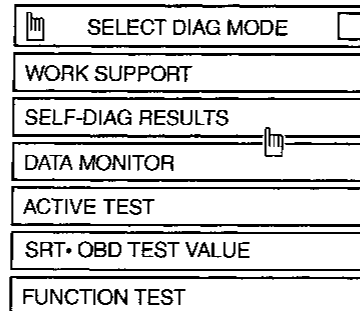

6. Touch "SELF-DIAG RESULTS".

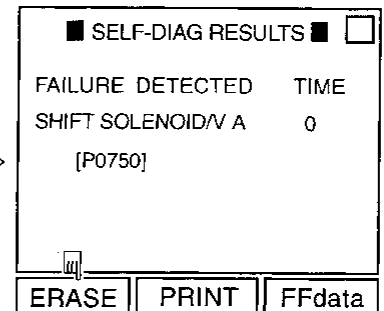

7. Touch "ERASE". (The DTC in the ECM will be erased.)

SEF372S

How to erase DTC (With GST)

Note: If the diagnostic trouble code is not for A/T related items (see EC-2), skip step 2.

1. If the ignition switch stays "ON" after repair work, be sure to turn ignition switch "OFF" once. Wait at least 5 seconds and then turn it "ON" (engine stopped) again.
2. Perform "SELF-DIAGNOSTIC PROCEDURE (Without CONSULT)" in AT section titled "TROUBLE DIAGNOSIS", "Self-diagnosis". (The engine warm-up step can be skipped when performing the diagnosis only to erase the DTC.)
3. Select Mode 4 with GST (Generic Scan Tool).

How to erase DTC (No Tools)

Note: If the diagnostic trouble code is not for A/T related items (see EC-2), skip step 2.

1. If the ignition switch stays "ON" after repair work, be sure to turn ignition switch "OFF" once. Wait at least 5 seconds and then turn it "ON" again.
2. Perform "SELF-DIAGNOSTIC PROCEDURE (Without CONSULT)" in AT section titled "TROUBLE DIAGNOSIS", "Self-diagnosis". (The engine warm-up step can be skipped when performing the diagnosis only to erase the DTC.)
3. Change the diagnostic test mode from Mode II to Mode I by turning the mode selector on the ECM. (See EC-49.)

ON BOARD DIAGNOSTIC SYSTEM DESCRIPTION

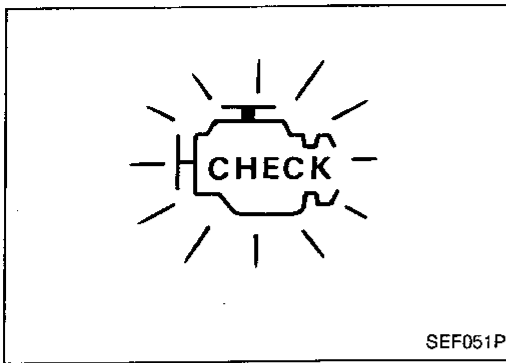

Malfunction Indicator Lamp (MIL)

1. The malfunction indicator lamp will light up when the ignition switch is turned ON without the engine running. This is a bulb check.
 - If the malfunction indicator lamp does not light up, refer to EL section ("WARNING LAMPS AND CHIME") or see EC-349.
2. When the engine is started, the malfunction indicator lamp should go off. If the lamp remains on, the on board diagnostic system has detected an engine system malfunction.

ON BOARD DIAGNOSTIC SYSTEM FUNCTION

The on board diagnostic system has the following four functions.

Diagnostic Test Mode I



1. BULB CHECK : This function checks the MIL bulb for damage (blown, open circuit, etc.).
If the MIL does not come on, check MIL circuit and ECM test mode selector. (See next page.)
2. MALFUNCTION WARNING : This is a usual driving condition. When a malfunction is detected twice in two consecutive driving cycles (two trip detection logic), the MIL will light up to inform the driver that a malfunction has been detected. The following malfunctions will light up or blink the MIL in the 1st trip.
 - "Misfire (Possible three way catalyst damage)"
 - "Closed loop control"
 - Fail-safe mode

Diagnostic Test Mode II

3. SELF-DIAGNOSTIC RESULTS : This function allows DTCs and 1st trip DTCs to be read.
4. FRONT HEATED OXYGEN SENSOR MONITOR : This function allows the fuel mixture condition (lean or rich), monitored by front heated oxygen sensor, to be read.

MIL flashing without DTC

If the ECM is in Diagnostic Test Mode II, MIL may flash when engine is running. In this case, check ECM test mode selector following "HOW TO SWITCH DIAGNOSTIC TEST MODES" on next page. How to switch the diagnostic test (function) modes, and details of the above functions are described later. (Refer to EC-49.)

Condition		Diagnostic Test Mode I	Diagnostic Test Mode II
Ignition switch in "ON" position 	Engine stopped 	BULB CHECK	SELF-DIAGNOSTIC RESULTS
	Engine running 	MALFUNCTION WARNING	FRONT HEATED OXYGEN SENSOR MONITOR

ON BOARD DIAGNOSTIC SYSTEM DESCRIPTION

Malfunction Indicator Lamp (MIL) (Cont'd)

HOW TO SWITCH DIAGNOSTIC TEST MODES

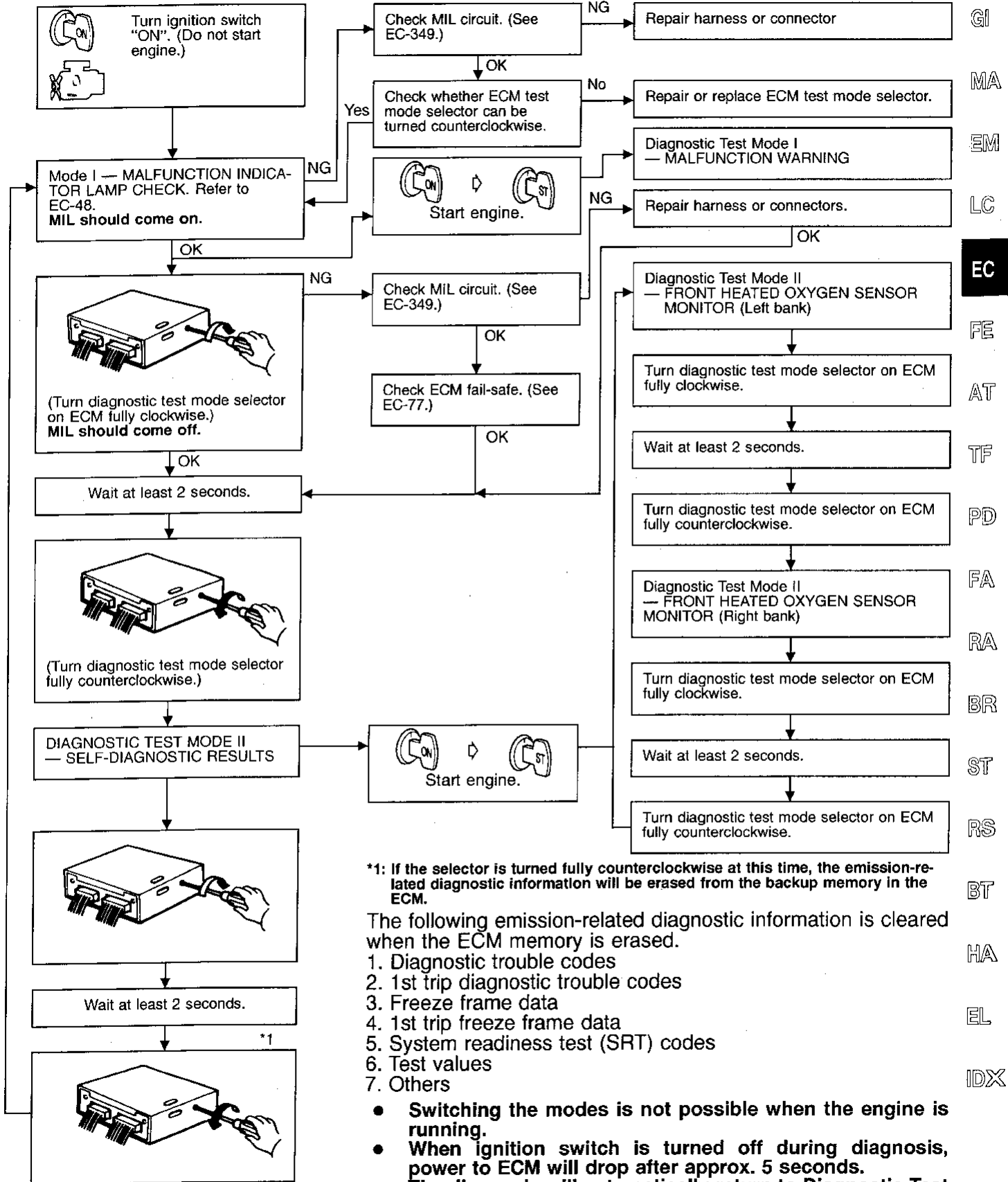

*1: If the selector is turned fully counterclockwise at this time, the emission-related diagnostic information will be erased from the backup memory in the ECM.

The following emission-related diagnostic information is cleared when the ECM memory is erased.

1. Diagnostic trouble codes
2. 1st trip diagnostic trouble codes
3. Freeze frame data
4. 1st trip freeze frame data
5. System readiness test (SRT) codes
6. Test values
7. Others

- Switching the modes is not possible when the engine is running.
- When ignition switch is turned off during diagnosis, power to ECM will drop after approx. 5 seconds. The diagnosis will automatically return to Diagnostic Test Mode I.
- Turn back diagnostic test mode selector to the fully counterclockwise position whenever vehicle is in use.

ON BOARD DIAGNOSTIC SYSTEM DESCRIPTION

Malfunction Indicator Lamp (MIL) (Cont'd)

DIAGNOSTIC TEST MODE I—BULB CHECK

In this mode, the MALFUNCTION INDICATOR LAMP on the instrument panel should stay ON. If it remains OFF, check the bulb. Refer to EL section ("WARNING LAMPS AND CHIME") or see EC-349.

DIAGNOSTIC TEST MODE I—MALFUNCTION WARNING

MALFUNCTION INDICATOR LAMP	Condition
ON	When the malfunction is detected or the ECM's CPU is malfunctioning.
OFF	No malfunction.

- These Diagnostic Trouble Code Numbers are clarified in Diagnostic Test Mode II (SELF-DIAGNOSTIC RESULTS).

DIAGNOSTIC TEST MODE II—SELF-DIAGNOSTIC RESULTS

In this mode, the DTC and 1st trip DTC are indicated by the number of blinks of the MALFUNCTION INDICATOR LAMP.

The DTC and 1st trip DTC are displayed at the same time. If the MIL does not illuminate in diagnostic test mode 1 (Malfunction warning), all displayed items are 1st trip DTC's. If only one code is displayed when the MIL illuminates in diagnostic test mode II (SELF-DIAGNOSTIC RESULTS), it is a DTC; if two or more codes are displayed, they may be either DTC's or 1st trip DTC's. DTC No. is same as that of 1st trip DTC. These unidentified codes can be identified by using the consult or GST. A DTC will be used as an example for how to read a code.

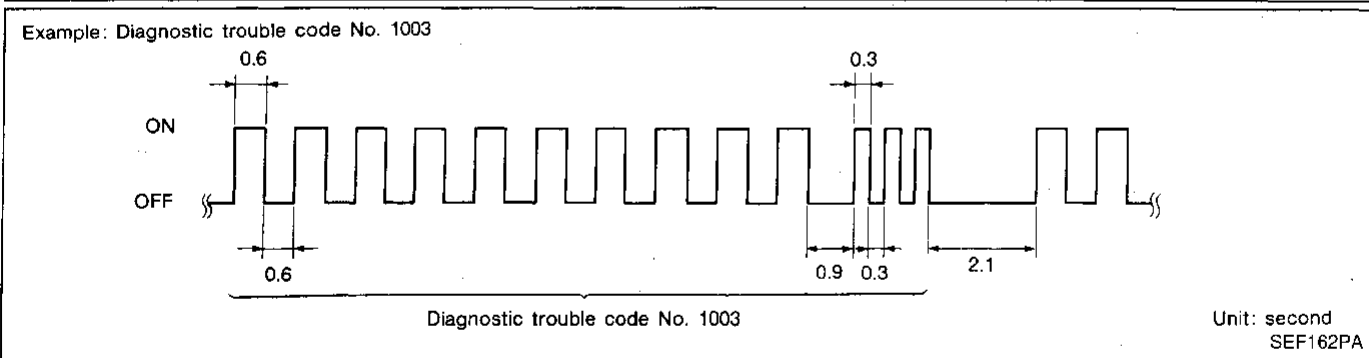
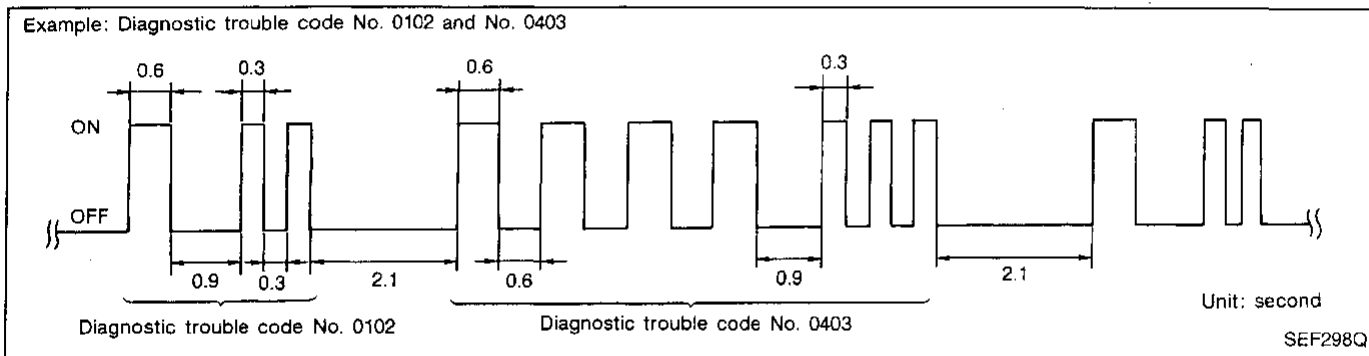

Long (0.6 second) blinking indicates the two LH digits of number and short (0.3 second) blinking indicates the two RH digits of number. For example, the malfunction indicator lamp blinks 10 times for 6 seconds (0.6 sec x 10 times) and then it blinks three times for about 1 second (0.3 sec x 3 times). This indicates the DTC "1003" and refers to the malfunction of the park/neutral position switch.

In this way, all the detected malfunctions are classified by their diagnostic trouble code numbers. The DTC "0505" refers to no malfunction. (See DIAGNOSTIC TROUBLE CODE (DTC) INDEX, EC-2.)

ON BOARD DIAGNOSTIC SYSTEM DESCRIPTION

Malfunction Indicator Lamp (MIL) (Cont'd)

How to erase diagnostic test mode II (Self-diagnostic results)

The diagnostic trouble code can be erased from the backup memory in the ECM when the diagnostic test mode is changed from Diagnostic Test Mode II to Diagnostic Test Mode I. (Refer to "HOW TO SWITCH DIAGNOSTIC TEST MODES".)

- If the battery is disconnected, the diagnostic trouble code will be lost from the backup memory after approx. 24 hours.
- Be careful not to erase the stored memory before starting trouble diagnoses.

DIAGNOSTIC TEST MODE II — FRONT HEATED OXYGEN SENSOR MONITOR

In this mode, the MALFUNCTION INDICATOR LAMP displays the condition of the fuel mixture (lean or rich) which is monitored by the front heated oxygen sensor.

MALFUNCTION INDICATOR LAMP	Fuel mixture condition in the exhaust gas	Air fuel ratio feedback control condition
ON	Lean	Closed loop system
OFF	Rich	
*Remains ON or OFF	Any condition	Open loop system

*: Maintains conditions just before switching to open loop.

To check the front heated oxygen sensor function, start engine in the Diagnostic Test Mode II and warm it up until engine coolant temperature indicator points to the middle of the gauge.
Next run engine at about 2,000 rpm for about 2 minutes under no-load conditions. Then make sure that the MALFUNCTION INDICATOR LAMP comes ON more than 5 times within 10 seconds with engine running at 2,000 rpm under no-load.

OBD System Operation Chart

RELATIONSHIP BETWEEN MIL, 1ST TRIP DTC, DTC, AND DETECTABLE ITEMS

- When a malfunction is detected for the first time, the 1st trip DTC and the 1st trip freeze frame data are stored in the ECM memory.
- When the same malfunction is detected in two consecutive trips, the DTC and the freeze frame data are stored in the ECM memory, and the MIL will come on. For details, refer to "Two Trip Detection Logic" on EC-36.
- The MIL will go off after the vehicle is driven 3 times with no malfunction. The drive is counted only when the recorded driving pattern is met (as stored in the ECM). If another malfunction occurs while counting, the counter will reset.
- The DTC and the freeze frame data will be stored until the vehicle is driven 40 times (driving pattern A) without the same malfunction recurring (except for Misfire and Fuel Injection System). For Misfire and Fuel Injection System, the DTC and freeze frame data will be stored until the vehicle is driven 80 times (driving pattern C) without the same malfunction recurring. The "TIME" in "SELF-DIAGNOSTIC RESULTS" mode of CONSULT will count the number of times the vehicle is driven.
- The 1st trip DTC is not displayed when the self-diagnosis results in "OK" for the 2nd trip.

SUMMARY CHART

Items	Fuel Injection System	Misfire	Except the lefts
MIL (goes off)	3 (pattern B)	3 (pattern B)	3 (pattern B)
DTC, Freeze Frame Data (no display)	80 (pattern C)	80 (pattern C)	40 (pattern A)
1st Trip DTC (clear)	1 (pattern C), *1	1 (pattern C), *1	1 (pattern B)
1st Trip Freeze Frame Data (clear)	*1, *2	*1, *2	1 (pattern B)

Details about patterns "A", "B", and "C" are on EC-55.

*1: Clear timing is at the moment OK is detected.

*2: Clear timing is when the same malfunction is detected in the 2nd trip.

ON BOARD DIAGNOSTIC SYSTEM DESCRIPTION

OBD System Operation Chart (Cont'd)

RELATIONSHIP BETWEEN MIL, DTC, 1ST TRIP DTC AND DRIVING PATTERNS FOR "MISFIRE" <EXHAUST QUALITY DETERIORATION>, "FUEL INJECTION SYSTEM"

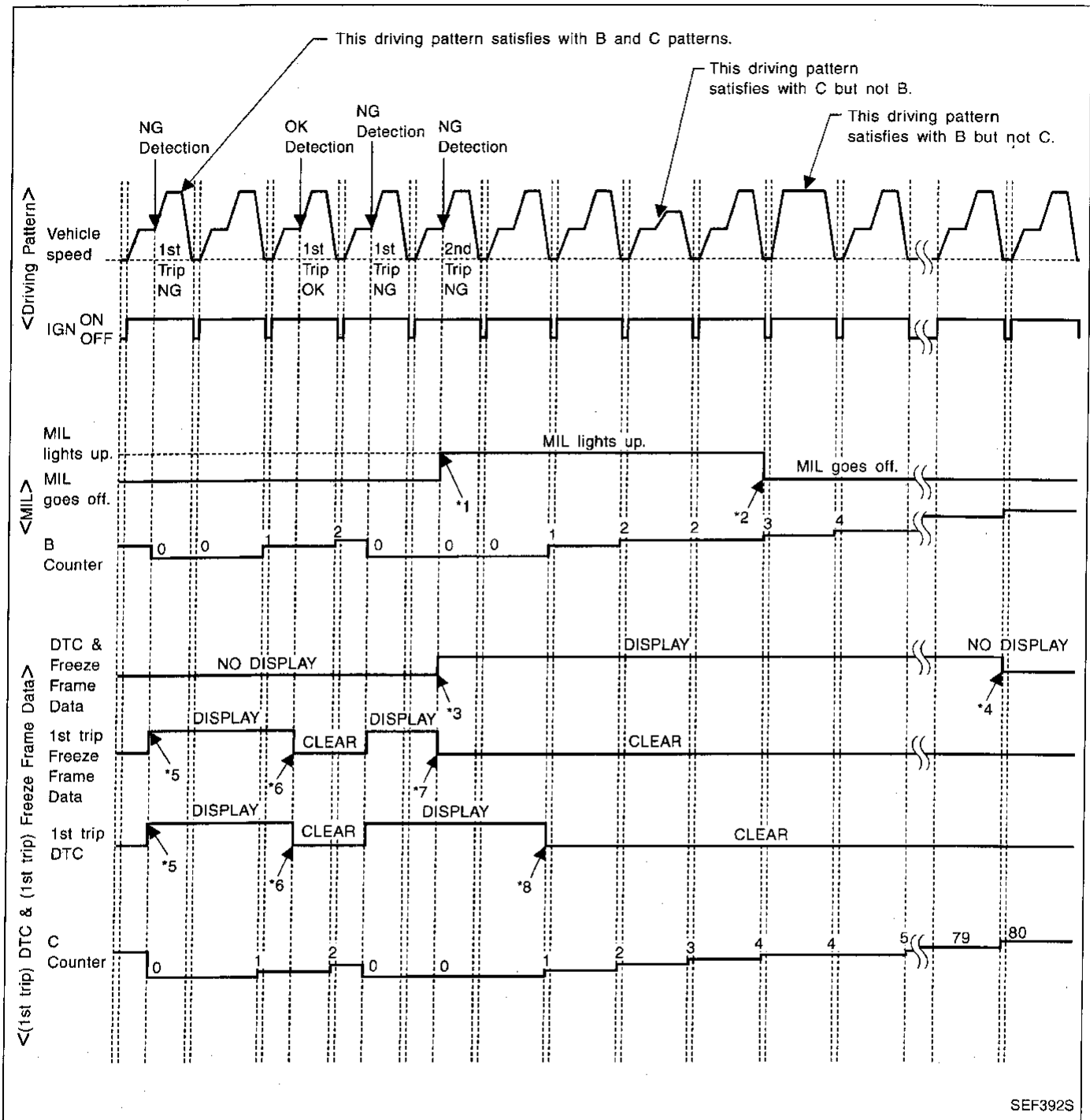

SEF392S

- *1: When the same malfunction is detected in two consecutive trips, MIL will light up.
- *2: MIL will go off after vehicle is driven 3 times (pattern B) without any malfunctions.
- *3: When the same malfunction is detected in two consecutive trips, the DTC and the freeze frame data will be stored in ECM.
- *4: The DTC and the freeze frame data will not be displayed any longer after vehicle is driven 80 times (pattern C) without the same malfunction.
(The DTC and the freeze frame data still remain in ECM.)

- *5: When a malfunction is detected for the first time, the 1st trip DTC and the 1st trip freeze frame data will be stored in ECM.
- *6: The 1st trip DTC and the 1st trip freeze frame data will be cleared at the moment OK is detected.
- *7: When the same malfunction is detected in the 2nd trip, the 1st trip freeze frame data will be cleared.
- *8: 1st trip DTC will be cleared when vehicle is driven once (pattern C) without the same malfunction after DTC is stored in ECM.

ON BOARD DIAGNOSTIC SYSTEM DESCRIPTION

OBD System Operation Chart (Cont'd)

EXPLANATION FOR DRIVING PATTERNS FOR "MISFIRE <EXHAUST QUALITY DETERIORATION>", "FUEL INJECTION SYSTEM"

<Driving pattern B>

Driving pattern B means the vehicle operation as follows:

All components and systems should be monitored at least once by the OBD system.

- The B counter will be cleared when the malfunction is detected once regardless of the driving pattern.
- The B counter will be counted up when driving pattern B is satisfied without any malfunction.
- The MIL will go off when the B counter reaches 3. (*2 in "OBD SYSTEM OPERATION CHART")

<Driving pattern C>

Driving pattern C means the vehicle operation as follows:

(1) The following conditions should be satisfied at the same time:

Engine speed: (Engine speed in the freeze frame data) ± 375 rpm

Calculated load value: (Calculated load value in the freeze frame data) $\times (1 \pm 0.1)$ [%]

Engine coolant temperature (T) condition:

- When the freeze frame data shows lower than 70°C (158°F), "T" should be lower than 70°C (158°F).
- When the freeze frame data shows higher than or equal to 70°C (158°F), "T" should be higher than or equal to 70°C (158°F).

Example:

If the stored freeze frame data is as follows:

Engine speed: 850 rpm, Calculated load value: 30%, Engine coolant temperature: 80°C (176°F)

To be satisfied with driving pattern C, the vehicle should run under the following conditions:

Engine speed: 475 - 1,225 rpm, Calculated load value: 27 - 33%, Engine coolant temperature: more than $\geq 70^\circ\text{C}$ (158°F)

- The C counter will be cleared when the malfunction is detected regardless of (1).
- The C counter will be counted up when (1) is satisfied without the same malfunction.
- The DTC will not be displayed after C counter reaches 80.
- The 1st trip DTC will be cleared when C counter is counted once without the same malfunction after DTC is stored in ECM.

GI

MA

EM

LC

EC

FE

AT

TF

PD

FA

RA

BR

ST

RS

BT

HA

EL

IDX

ON BOARD DIAGNOSTIC SYSTEM DESCRIPTION

OBd System Operation Chart (Cont'd)

RELATIONSHIP BETWEEN MIL, DTC, 1ST TRIP DTC AND DRIVING PATTERNS EXCEPT FOR "MISFIRE <EXHAUST QUALITY DETERIORATION>", "FUEL INJECTION SYSTEM"

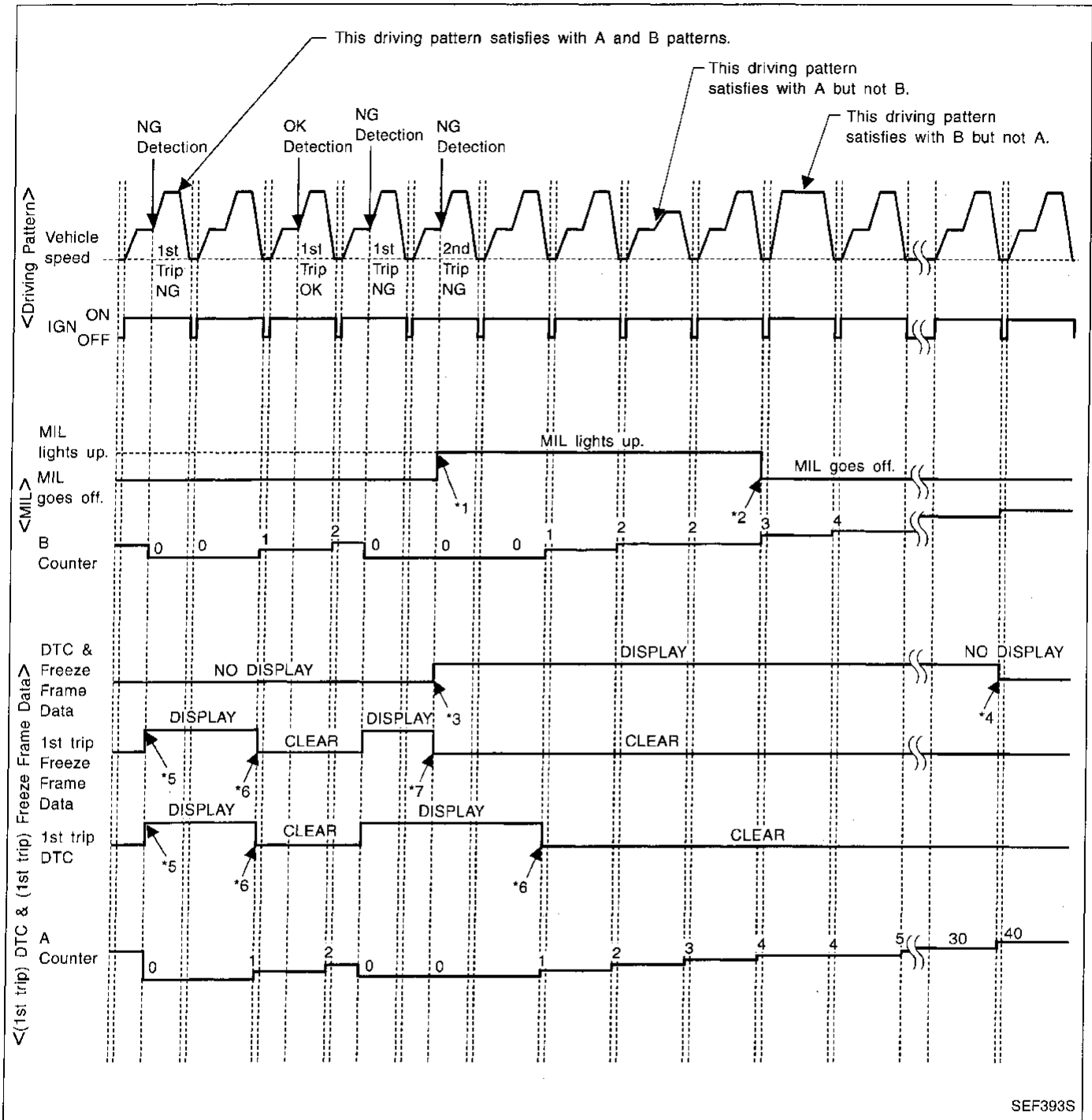

SEF393S

- *1: When the same malfunction is detected in two consecutive trips, MIL will light up.
- *2: MIL will go off after vehicle is driven 3 times (pattern B) without any malfunctions.
- *3: When the same malfunction is detected in two consecutive trips, the DTC and the freeze frame data will be stored in ECM.
- *4: The DTC and the freeze frame data will not be displayed any longer after vehicle is driven 40 times (pattern A) without the same malfunction.
(The DTC and the freeze frame data still remain in ECM.)

- *5: When a malfunction is detected for the first time, the 1st trip DTC and the 1st trip freeze frame data will be stored in ECM.
- *6: 1st trip DTC will be cleared after vehicle is driven once (pattern B) without the same malfunction.
- *7: When the same malfunction is detected in the 2nd trip, the 1st trip freeze frame data will be cleared.

ON BOARD DIAGNOSTIC SYSTEM DESCRIPTION

OBD System Operation Chart (Cont'd)

EXPLANATION FOR DRIVING PATTERNS EXCEPT FOR "MISFIRE <EXHAUST QUALITY DETERIORATION>", "FUEL INJECTION SYSTEM"

<Driving pattern A>

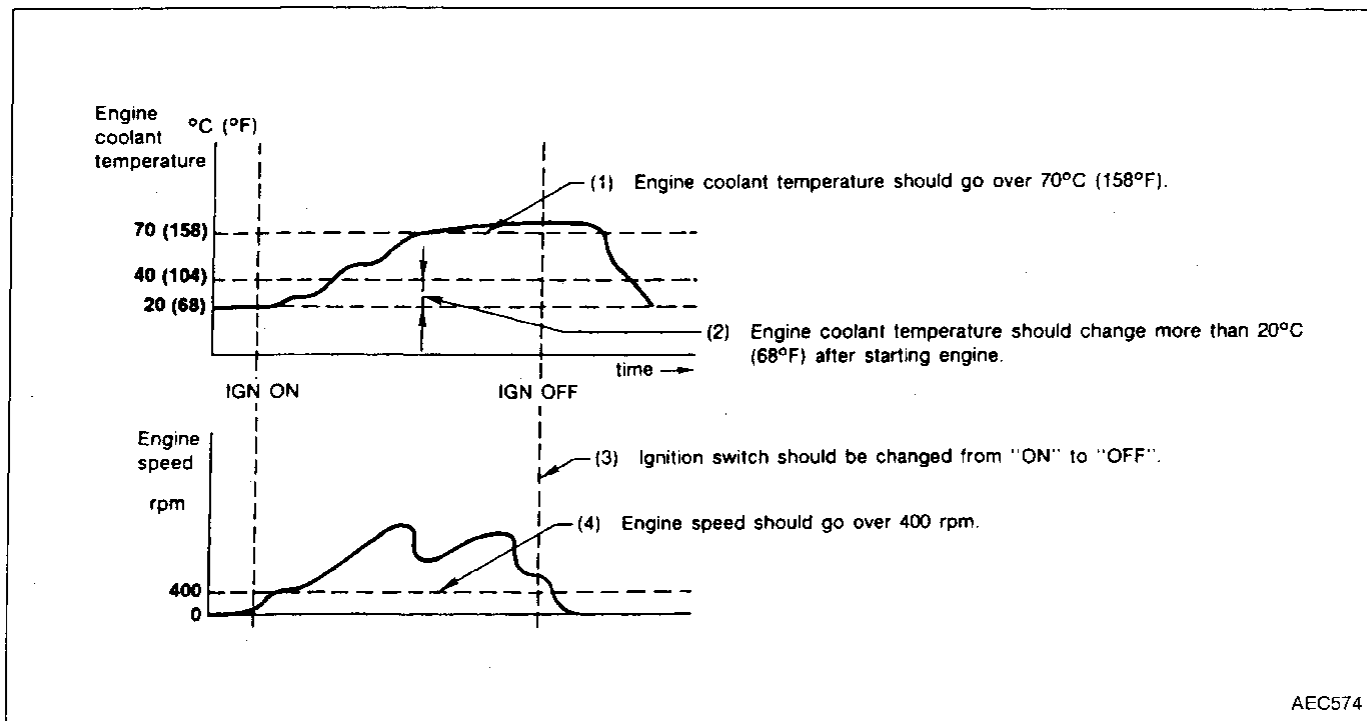

- The A counter will be cleared when the malfunction is detected regardless of (1) - (4).
- The A counter will be counted up when (1) - (4) are satisfied without the same malfunction.
- The DTC will not be displayed after the A counter reaches 40.

<Driving pattern B>

Driving pattern B means the vehicle operation as follows:

All components and systems should be monitored at least once by the OBD system.

- The B counter will be cleared when the malfunction is detected once regardless of the driving pattern.
- The B counter will be counted up when driving pattern B is satisfied without any malfunctions.
- The MIL will go off when the B counter reaches 3 (*2 in "OBD SYSTEM OPERATION CHART").

ON BOARD DIAGNOSTIC SYSTEM DESCRIPTION

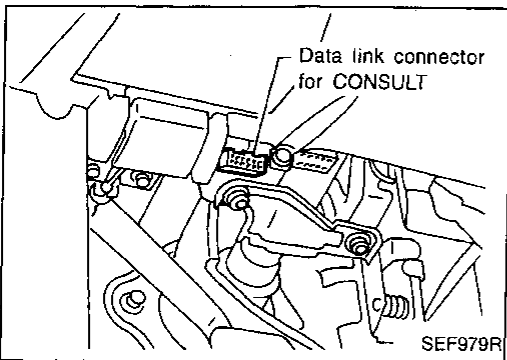

CONSULT

CONSULT INSPECTION PROCEDURE

1. Turn off ignition switch.
2. Connect "CONSULT" to data link connector for CONSULT. (Data link connector for CONSULT is located behind the fuse box cover.)
3. Turn on ignition switch.
4. Touch "START".

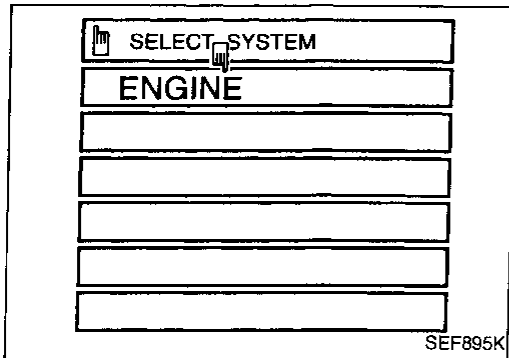
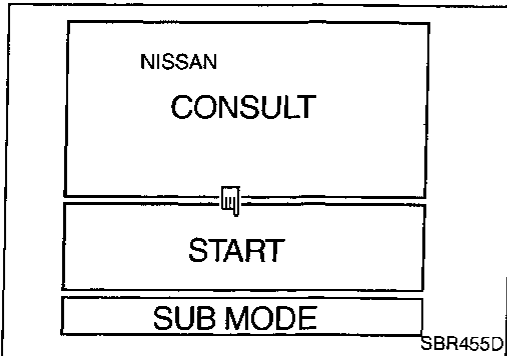

5. Touch "ENGINE".

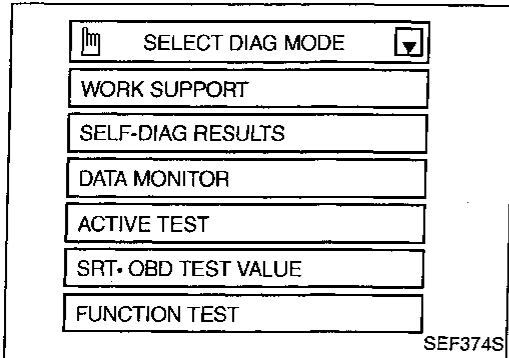

6. Perform each diagnostic test mode according to each service procedure.

For further information, see the CONSULT Operation Manual. This sample shows the display when using the UE951 program card. Screen differs in accordance with the program card used.

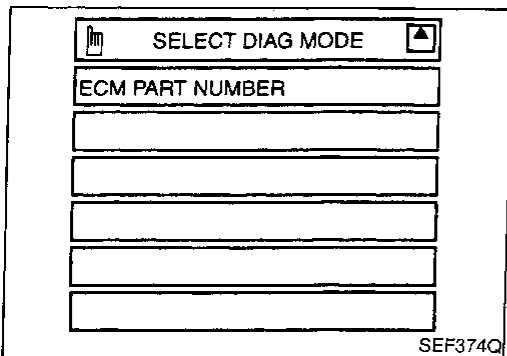

ON BOARD DIAGNOSTIC SYSTEM DESCRIPTION

CONSULT (Cont'd)

ECCS COMPONENT PARTS/CONTROL SYSTEMS APPLICATION

Item		DIAGNOSTIC TEST MODE						
		WORK SUP-PORT	SELF-DIAGNOSTIC RESULTS*1		DATA MONITOR	ACTIVE TEST	FUNCTION TEST	SRT-OBD TEST VALUE
				FREEZE FRAME DATA*2				
ECCS COMPONENT PARTS	INPUT	Camshaft position sensor		X	X	X		
		Mass air flow sensor		X		X		
		Engine coolant temperature sensor		X	X	X	X	
		Front heated oxygen sensor		X		X		X
		Rear heated oxygen sensor		X		X		X
		Vehicle speed sensor		X	X	X		X
		Throttle position sensor	X	X		X		X
		Tank fuel temperature sensor		X		X	X	
		EVAP control system pressure sensor		X		X		
		Absolute pressure sensor		X		X		
		EGR temperature sensor		X		X		
		Intake air temperature sensor		X		X		
		Crankshaft position sensor (OBD)		X				
		Knock sensor		X				
		Ignition switch (start signal)				X		X
		Closed throttle position switch		X				
		Closed throttle position switch (throttle position sensor signal)				X		X
		Air conditioner switch				X		
		Park/Neutral position switch		X		X		X
		Power steering oil pressure switch				X		X
	Air conditioner switch				X			
	Battery voltage				X			
	Ambient air temperature switch				X			
	OUTPUT	Injectors				X	X	X
		Power transistor (Ignition timing)		X (Ignition signal)		X	X	X
		IACV-AAC valve	X	X		X	X	X
		EVAP canister purge volume control valve		X		X	X	
		Air conditioner relay				X		
		Fuel pump relay	X			X	X	X
		EGRC-solenoid valve		X		X	X	X
		Front heated oxygen sensor heater		X		X		X
		Rear heated oxygen sensor heater		X		X		X
		EVAP canister purge control solenoid valve		X		X	X	
EVAP canister vent control valve			X		X			
Vacuum cut valve bypass valve			X		X			
MAP/BARO switch solenoid valve			X		X	X		
Calculated load value			X	X				

X: Applicable

*1: This item includes 1st trip DTCs.

*2: This mode includes 1st trip freeze frame data or freeze frame data. The items appear on CONSULT screen in freeze frame data mode only if a 1st trip DTC or DTC is detected. For details, refer to EC-38.

ON BOARD DIAGNOSTIC SYSTEM DESCRIPTION

CONSULT (Cont'd)

FUNCTION

Diagnostic test mode	Function
Work support	This mode enables a technician to adjust some devices faster and more accurately by following the indications on the CONSULT unit.
Self-diagnostic results	Self-diagnostic results such as 1st trip DTC, DTCs and 1st trip freeze frame data or freeze frame data can be read and erased quickly.*1
Data monitor	Input/Output data in the ECM can be read.
Active test	Diagnostic Test Mode in which CONSULT drives some actuators apart from the ECMs and also shifts some parameters in a specified range.
SRT-OBD test value	The status of system monitoring tests and the test values/test limits can be read.
Function test	Conducted by CONSULT instead of a technician to determine whether each system is "OK" or "NG".
ECM part numbers	ECM part numbers can be read.

*1 The following emission-related diagnostic information is cleared when the ECM memory is erased.

1. Diagnostic trouble codes
2. 1st trip diagnostic trouble codes
3. Freeze frame data
4. 1st trip freeze frame data
5. System readiness test (SRT) codes
6. Test values
7. Others

WORK SUPPORT MODE

WORK ITEM	CONDITION	USAGE
THRTL POS SEN ADJ	CHECK THE THROTTLE POSITION SENSOR SIGNAL. ADJUST IT TO THE SPECIFIED VALUE BY ROTATING THE SENSOR BODY UNDER THE FOLLOWING CONDITIONS. <ul style="list-style-type: none"> ● IGN SW "ON" ● ENG NOT RUNNING ● ACC PEDAL NOT PRESSED 	When adjusting throttle position sensor initial position
IACV-AAC VALVE ADJ	SET ENGINE SPEED AT THE SPECIFIED VALUE UNDER THE FOLLOWING CONDITIONS. <ul style="list-style-type: none"> ● ENGINE WARMED UP ● NO-LOAD 	When adjusting idle speed
FUEL PRESSURE RELEASE	<ul style="list-style-type: none"> ● FUEL PUMP WILL STOP BY TOUCHING "START" DURING IDLING. ● CRANK A FEW TIMES AFTER ENGINE STALLS. 	When releasing fuel pressure from fuel line

ON BOARD DIAGNOSTIC SYSTEM DESCRIPTION

CONSULT (Cont'd)

SELF-DIAGNOSTIC MODE

DTC and 1st trip DTC

Regarding items of "DTC and 1st trip DTC", refer to "DIAGNOSTIC TROUBLE CODE INDEX (See EC-2.)"

Freeze frame data and 1st trip freeze frame data

Freeze frame data item*1	Description
DIAG TROUBLE CODE [PXXXX]	<ul style="list-style-type: none"> ECCS component part/control system has a trouble code, it is displayed as "PXXXX". [Refer to "Alphabetical & P No. Index for DTC (EC-2)."]
FUEL SYS-B1*2	<ul style="list-style-type: none"> "Fuel injection system status" at the moment a malfunction is detected is displayed. One mode in the following is displayed. <ul style="list-style-type: none"> "MODE 2": Open loop due to detected system malfunction "MODE 3": Open loop due to driving conditions (power enrichment, deceleration enrichment) "MODE 4": Closed loop - using oxygen sensor(s) as feedback for fuel control "MODE 5": Open loop - has not yet satisfied condition to go to closed loop
FUEL SYS-B2*2	<ul style="list-style-type: none"> "MODE 4": Closed loop - using oxygen sensor(s) as feedback for fuel control "MODE 5": Open loop - has not yet satisfied condition to go to closed loop
CAL/LD VALUE [%]	<ul style="list-style-type: none"> The calculated load value at the moment a malfunction is detected is displayed.
COOLANT TEMP [°C] or [°F]	<ul style="list-style-type: none"> The engine coolant temperature at the moment a malfunction is detected is displayed.
S-FUEL TRIM-B1 [%]	<ul style="list-style-type: none"> "Short-term fuel trim" at the moment a malfunction is detected is displayed.
S-FUEL TRIM-B2 [%]	<ul style="list-style-type: none"> The short-term fuel trim indicates dynamic or instantaneous feedback compensation to the base fuel schedule.
L-FUEL TRIM-B1 [%]	<ul style="list-style-type: none"> "Long-term fuel trim" at the moment a malfunction is detected is displayed.
L-FUEL TRIM-B2 [%]	<ul style="list-style-type: none"> The long-term fuel trim indicates much more gradual feedback compensation to the base fuel schedule than short-term fuel trim.
ENGINE SPEED [rpm]	<ul style="list-style-type: none"> The engine speed at the moment a malfunction is detected is displayed.
VHCL SPEED [km/h] or [mph]	<ul style="list-style-type: none"> The vehicle speed at the moment a malfunction is detected is displayed.
ABSOL PRESS [kPa] or [kg/cm ²] or [psi]	<ul style="list-style-type: none"> The absolute pressure at the moment a malfunction is detected is displayed.

*1: The items are the same as those of 1st trip freeze frame data.

*2: Regarding JR50 model, "B1" indicates right bank and "B2" indicates left bank.

GI
 MA
 EM
 LC
EC
 FE
 AT
 TF
 PD
 FA
 RA
 BR
 ST
 RS
 BT
 HA
 EL
 IDX

ON BOARD DIAGNOSTIC SYSTEM DESCRIPTION

CONSULT (Cont'd)

DATA MONITOR MODE

Monitored item [Unit]	ECM input signals	Main signals	Description	Remarks
CMPS-RPM [POS] [rpm]	<input type="radio"/>	<input type="radio"/>	<ul style="list-style-type: none"> Indicates the engine speed computed from the POS signal (1° signal) of the camshaft position sensor. 	
MAS AIR/FL SE [V]	<input type="radio"/>	<input type="radio"/>	<ul style="list-style-type: none"> The signal voltage of the mass air flow sensor is displayed. 	<ul style="list-style-type: none"> When the engine is stopped, a certain value is indicated.
COOLAN TEMP/S [°C] or [°F]	<input type="radio"/>	<input type="radio"/>	<ul style="list-style-type: none"> The engine coolant temperature (determined by the signal voltage of the engine coolant temperature sensor) is displayed. 	<ul style="list-style-type: none"> When the engine coolant temperature sensor is open or short-circuited, ECM enters fail-safe mode. The engine coolant temperature determined by the ECM is displayed.
FR O2 SEN-B2 [V]	<input type="radio"/>	<input type="radio"/>	<ul style="list-style-type: none"> The signal voltage of the front heated oxygen sensor is displayed. 	
FR O2 SEN-B1 [V]	<input type="radio"/>			
RR O2 SEN-B1 [V]	<input type="radio"/>	<input type="radio"/>	<ul style="list-style-type: none"> The signal voltage of the rear heated oxygen sensor is displayed. 	
RR O2 SEN-B2 [V]	<input type="radio"/>			
FR O2 MNTR-B2 [RICH/LEAN]	<input type="radio"/>	<input type="radio"/>	<ul style="list-style-type: none"> Display of front heated oxygen sensor signal during air-fuel ratio feedback control: RICH ... means the mixture became "rich", and control is being affected toward a leaner mixture. LEAN ... means the mixture became "lean", and control is being affected toward a rich mixture. 	<ul style="list-style-type: none"> After turning ON the ignition switch, "RICH" is displayed until air-fuel mixture ratio feedback control begins. When the air-fuel ratio feedback is clamped, the value just before the clamping is displayed continuously.
FR O2 MNTR-B1 [RICH/LEAN]	<input type="radio"/>	<input type="radio"/>		
RR O2 MNTR-B1 [RICH/LEAN]	<input type="radio"/>		<ul style="list-style-type: none"> Display of rear heated oxygen sensor signal: RICH ... means the amount of oxygen after three way catalyst is relatively small. LEAN ... means the amount of oxygen after three way catalyst is relatively large. 	<ul style="list-style-type: none"> When the engine is stopped, a certain value is indicated.
RR O2 MNTR-B2 [RICH/LEAN]	<input type="radio"/>	<input type="radio"/>		
VHCL SPEED SE [km/h] or [mph]	<input type="radio"/>	<input type="radio"/>	<ul style="list-style-type: none"> The vehicle speed computed from the vehicle speed sensor signal is displayed. 	

NOTE:

Any monitored item that does not match the vehicle being diagnosed is deleted from the display automatically.
Regarding JR50 model, "B1" indicates right bank and "B2" indicates left bank.

ON BOARD DIAGNOSTIC SYSTEM DESCRIPTION

CONSULT (Cont'd)

Monitored item [Unit]	ECM input signals	Main signals	Description	Remarks
BATTERY VOLT [V]	<input type="radio"/>	<input type="radio"/>	<ul style="list-style-type: none"> The power supply voltage of ECM is displayed. 	
THRTL POS SEN [V]	<input type="radio"/>	<input type="radio"/>	<ul style="list-style-type: none"> The throttle position sensor signal voltage is displayed. 	
TANK F/TMP SE [°C] or [°F]	<input type="radio"/>		<ul style="list-style-type: none"> The fuel temperature judged from the tank fuel temperature sensor signal voltage is displayed. 	
EGR TEMP SEN [V]	<input type="radio"/>		<ul style="list-style-type: none"> The signal voltage of the EGR temperature sensor is displayed. 	
INT/A TEMP SE [°C] or [°F]	<input type="radio"/>		<ul style="list-style-type: none"> The intake air temperature determined by the signal voltage of the intake air temperature sensor is indicated. 	
START SIGNAL [ON/OFF]	<input type="radio"/>	<input type="radio"/>	<ul style="list-style-type: none"> Indicates [ON/OFF] condition from the starter signal. 	<ul style="list-style-type: none"> After starting the engine, [OFF] is displayed regardless of the starter signal.
CLSD THL/P SW [ON/OFF]	<input type="radio"/>	<input type="radio"/>	<ul style="list-style-type: none"> Indicates [ON/OFF] condition from the throttle position sensor signal. 	
AIR COND SIG [ON/OFF]	<input type="radio"/>	<input type="radio"/>	<ul style="list-style-type: none"> Indicates [ON/OFF] condition of the air conditioner switch as determined by the air conditioner signal. 	
P/N POSI SW [ON/OFF]	<input type="radio"/>	<input type="radio"/>	<ul style="list-style-type: none"> Indicates [ON/OFF] condition from the park/neutral position switch signal. 	
PW/ST SIGNAL [ON/OFF]	<input type="radio"/>	<input type="radio"/>	<ul style="list-style-type: none"> [ON/OFF] condition of the power steering oil pressure switch determined by the power steering oil pressure signal is indicated. 	
AMB TEMP SW [ON/OFF]	<input type="radio"/>	<input type="radio"/>	<ul style="list-style-type: none"> Indicates [ON/OFF] condition from the ambient air temperature switch signal. 	
IGNITION SW [ON/OFF]	<input type="radio"/>		<ul style="list-style-type: none"> Indicates [ON/OFF] condition from ignition switch. 	
INJ PULSE-B2 [msec]		<input type="radio"/>	<ul style="list-style-type: none"> Indicates the actual fuel injection pulse width compensated by ECM according to the input signals. 	<ul style="list-style-type: none"> When the engine is stopped, a certain computed value is indicated.
INJ PULSE-B1 [msec]				
B/FUEL SCHDL [msec]		<input type="radio"/>	<ul style="list-style-type: none"> "Base fuel schedule" indicates the fuel injection pulse width programmed into ECM, prior to any learned on board correction. 	
IGN TIMING [BTDC]		<input type="radio"/>	<ul style="list-style-type: none"> Indicates the ignition timing computed by ECM according to the input signals. 	<ul style="list-style-type: none"> When the engine is stopped, a certain value is indicated.
IACV-AAC/V [%]		<input type="radio"/>	<ul style="list-style-type: none"> Indicates the idle air control valve (AAC valve) control value computed by ECM according to the input signals. 	
PURG VOL C/V [step]			<ul style="list-style-type: none"> Indicates the EVAP canister purge volume control valve computed by the ECM according to the input signals. The opening becomes larger as the value increases. 	
A/F ALPHA-B2 [%]			<ul style="list-style-type: none"> The mean value of the air-fuel ratio feedback correction factor per cycle is indicated. 	<ul style="list-style-type: none"> When the engine is stopped, a certain value is indicated.
A/F ALPHA-B1 [%]				<ul style="list-style-type: none"> This data also includes the data for the air-fuel ratio learning control.
EVAP SYS PRES [V]			<ul style="list-style-type: none"> The signal voltage of EVAP control system pressure sensor is displayed. 	
AIR COND RLY [ON/OFF]		<input type="radio"/>	<ul style="list-style-type: none"> The air conditioner relay control condition (determined by ECM according to the input signal) is indicated. 	
FUEL PUMP RLY [ON/OFF]		<input type="radio"/>	<ul style="list-style-type: none"> Indicates the fuel pump relay control condition determined by ECM according to the input signals. 	

ON BOARD DIAGNOSTIC SYSTEM DESCRIPTION

CONSULT (Cont'd)

Monitored item [Unit]	ECM input signals	Main signals	Description	Remarks
EGRC SOL/V [ON/OFF]			<ul style="list-style-type: none"> The control condition of the EGRC-solenoid valve (determined by ECM according to the input signal) is indicated. ON ... EGR operation is cut-off OFF ... EGR is operational 	
VENT CONT/V [ON/OFF]			<ul style="list-style-type: none"> The control condition of the EVAP canister vent control valve (determined by ECM according to the input signal) is indicated. ON ... Closed OFF ... Open 	
FR O2 HTR-B1 [ON/OFF]			<ul style="list-style-type: none"> Indicates [ON/OFF] condition of front heated oxygen sensor heater determined by ECM according to the input signals. 	
FR O2 HTR-B2 [ON/OFF]				
RR O2 HTR-B1 [ON/OFF]			<ul style="list-style-type: none"> Indicates [ON/OFF] condition of rear heated oxygen sensor heater determined by ECM according to the input signals. 	
RR O2 HTR-B2 [ON/OFF]				
VC/V BYPASS/V [ON/OFF]			<ul style="list-style-type: none"> The control condition of the vacuum cut valve bypass valve (determined by ECM according to the input signal) is indicated. ON ... Open OFF ... Closed 	
PURG CONT S/V [ON/OFF]			<ul style="list-style-type: none"> The control condition of the EVAP canister purge control solenoid valve (computed by the engine control module according to the input signals) is indicated. ON ... Canister purge is operational OFF ... Canister purge operation is cut-off 	
CAL/LD VALUE [%]			<ul style="list-style-type: none"> "Calculated load value" indicates the value of the current airflow divided by peak airflow. 	
ABSOL TH-P/S [%]			<ul style="list-style-type: none"> "Absolute throttle position sensor" indicates the throttle opening computed by ECM according to the signal voltage of the throttle position sensor. 	
MASS AIRFLOW [g·m/s]			<ul style="list-style-type: none"> Indicates the mass airflow computed by ECM according to the signal voltage of the mass airflow sensor. 	
MAP/BARO SW/V [MAP/BARO]			<ul style="list-style-type: none"> The control condition of the MAP/BARO switch solenoid valve (determined by ECM according to the input signal) is indicated. MAP ... Intake manifold absolute pressure BARO ... Barometric pressure 	
ABSOL PRES/SE [V]			<ul style="list-style-type: none"> The signal voltage of the absolute pressure sensor is displayed. 	
VOLTAGE [V]			<ul style="list-style-type: none"> Voltage measured by the voltage probe. 	
PULSE [msec] or [Hz] or [%]			<ul style="list-style-type: none"> Pulse width, frequency or duty cycle measured by the pulse probe. 	<ul style="list-style-type: none"> Only "#" is displayed if item is unable to be measured. Figures with "#"s are temporary ones. They are the same figures as an actual piece of data which was just previously measured.

ON BOARD DIAGNOSTIC SYSTEM DESCRIPTION

CONSULT (Cont'd)

ACTIVE TEST MODE

TEST ITEM	CONDITION	JUDGEMENT	CHECK ITEM (REMEDY)
FUEL INJECTION	<ul style="list-style-type: none"> Engine: Return to the original trouble condition Change the amount of fuel injection using CONSULT. 	If trouble symptom disappears, see CHECK ITEM.	<ul style="list-style-type: none"> Harness and connector Fuel injectors Front heated oxygen sensor
IACV-AAC/V OPENING	<ul style="list-style-type: none"> Engine: After warming up, idle the engine. Change the IACV-AAC valve opening percent using CONSULT. 	Engine speed changes according to the opening percent.	<ul style="list-style-type: none"> Harness and connector IACV-AAC valve
ENG COOLANT TEMP	<ul style="list-style-type: none"> Engine: Return to the original trouble condition Change the engine coolant temperature using CONSULT. 	If trouble symptom disappears, see CHECK ITEM.	<ul style="list-style-type: none"> Harness and connector Engine coolant temperature sensor Fuel injectors
IGNITION TIMING	<ul style="list-style-type: none"> Engine: Return to the original trouble condition Timing light: Set Retard the ignition timing using CONSULT. 	If trouble symptom disappears, see CHECK ITEM.	<ul style="list-style-type: none"> Adjust initial ignition timing
POWER BALANCE	<ul style="list-style-type: none"> Engine: After warming up, idle the engine. A/C switch "OFF" Shift lever "N" Cut off each injector signal one at a time using CONSULT. 	Engine runs rough or dies.	<ul style="list-style-type: none"> Harness and connector Compression Injectors Power transistor Spark plugs Ignition coils
FUEL PUMP RELAY	<ul style="list-style-type: none"> Ignition switch: ON (Engine stopped) Turn the fuel pump relay "ON" and "OFF" using CONSULT and listen to operating sound. 	Fuel pump relay makes the operating sound.	<ul style="list-style-type: none"> Harness and connector Fuel pump relay
EGRC SOLENOID VALVE	<ul style="list-style-type: none"> Ignition switch: ON Turn solenoid valve "ON" and "OFF" with the CONSULT and listen to operating sound. 	Solenoid valve makes an operating sound.	<ul style="list-style-type: none"> Harness and connector Solenoid valve
SELF-LEARNING CONT	<ul style="list-style-type: none"> In this test, the coefficient of self-learning control mixture ratio returns to the original coefficient by touching "CLEAR" on the screen. 		
PURG VOL CONT/V	<ul style="list-style-type: none"> Engine: After warming up, run engine at 1,500 rpm. Change the EVAP canister purge volume control valve opening step using CONSULT. 	Engine speed changes according to the opening step.	<ul style="list-style-type: none"> Harness and connector EVAP canister purge volume control valve
TANK F/TEMP SEN	<ul style="list-style-type: none"> Change the tank fuel temperature using CONSULT. 		
MAP/BARO SW/V	<ul style="list-style-type: none"> Ignition switch: ON (Engine stopped) Turn the MAP/BARO switch solenoid valve between "MAP" and "BARO" using CONSULT and listen for operating sound. 	MAP/BARO switch solenoid valve makes an operating sound.	<ul style="list-style-type: none"> Harness and connector MAP/BARO switch solenoid valve
PURG CONT S/V	<ul style="list-style-type: none"> Engine: Run engine at 2,000 rpm. Turn the EVAP canister purge control solenoid valve "ON" and "OFF" using CONSULT and listen for operating sound. 	EVAP canister purge control solenoid valve makes an operating sound. Check vacuum signal for EVAP canister purge control valve. VC ON ... Vacuum exists. VC OFF ... Vacuum does not exist.	<ul style="list-style-type: none"> Harness and connector EVAP canister purge control solenoid valve Vacuum hose

GI
 MA
 EM
 LC
 EC
 FE
 AT
 TF
 PD
 FA
 RA
 BR
 ST
 RS
 BT
 HA
 EL
 IDX

ON BOARD DIAGNOSTIC SYSTEM DESCRIPTION

CONSULT (Cont'd)

FUNCTION TEST MODE

FUNCTION TEST ITEM	CONDITION	JUDGEMENT		CHECK ITEM (REMEDY)
SELF-DIAG RESULTS	<ul style="list-style-type: none"> Ignition switch: ON (Engine stopped) Displays the results of on board diagnostic system. 	—		Objective system
CLOSED THROTTLE POSI	<ul style="list-style-type: none"> Ignition switch: ON (Engine stopped) Throttle position sensor circuit is tested when throttle is opened and closed fully. ("IDLE POSITION" is the test item name for the vehicles in which idle is selected by throttle position sensor.) 	Throttle valve: opened	OFF	<ul style="list-style-type: none"> Harness and connector Throttle position sensor (Closed throttle position) Throttle position sensor (Closed throttle position) adjustment Throttle linkage Verify operation in DATA MONITOR mode.
		Throttle valve: closed	ON	
THROTTLE POSI SEN CKT	<ul style="list-style-type: none"> Ignition switch: ON (Engine stopped) Throttle position sensor circuit is tested when throttle is opened and closed fully. 	Range (Throttle valve fully opened — Throttle valve fully closed)	More than 3.0V	<ul style="list-style-type: none"> Harness and connector Throttle position sensor Throttle position sensor adjustment Throttle linkage Verify operation in DATA MONITOR mode.
PARK/NEUT POSI SW CKT	<ul style="list-style-type: none"> Ignition switch: ON (Engine stopped) Inhibitor position switch circuit is tested when shift lever is manipulated. 	Out of N/P positions	OFF	<ul style="list-style-type: none"> Harness and connector Inhibitor switch Linkage or Inhibitor switch adjustment
		In N/P positions	ON	
FUEL PUMP CIRCUIT	<ul style="list-style-type: none"> Ignition switch: ON (Engine stopped) Fuel pump circuit is tested by checking the pulsation in fuel pressure when fuel tube is pinched. 	There is pressure pulsation on the fuel feed hose.		<ul style="list-style-type: none"> Harness and connector Fuel pump Fuel pump relay Fuel filter clogging Fuel level
EGRC SOLV CIRCUIT	<ul style="list-style-type: none"> Ignition switch: ON (Engine stopped) EGRC-solenoid valve circuit is tested by checking solenoid valve operating noise. 	The solenoid valve makes an operating sound every 3 seconds.		<ul style="list-style-type: none"> Harness and connector EGRC-solenoid valve
START SIGNAL CIRCUIT	<ul style="list-style-type: none"> Ignition switch: ON → START Start signal circuit is tested when engine is started by operating the starter. Battery voltage and engine coolant temperature before cranking, and average battery voltage, mass air flow sensor output voltage and cranking speed during cranking are displayed. 	Start signal: OFF → ON		<ul style="list-style-type: none"> Harness and connector Ignition switch

ON BOARD DIAGNOSTIC SYSTEM DESCRIPTION

CONSULT (Cont'd)

FUNCTION TEST ITEM	CONDITION	JUDGEMENT		CHECK ITEM (REMEDY)
PW/ST SIGNAL CIRCUIT	<ul style="list-style-type: none"> Ignition switch: ON (Engine running) Power steering circuit is tested when steering wheel is rotated fully and then set to a straight line running position. 	Locked position	ON	<ul style="list-style-type: none"> Harness and connector Power steering oil pressure switch Power steering oil pump
		Neutral position	OFF	
VEHICLE SPEED SEN CKT	<ul style="list-style-type: none"> Vehicle speed sensor circuit is tested when vehicle is running at a speed of 10 km/h (6 MPH) or higher. 	Vehicle speed sensor input signal is greater than 4 km/h (2 MPH)		<ul style="list-style-type: none"> Harness and connector Vehicle speed sensor Speedometer
IGN TIMING ADJ	<ul style="list-style-type: none"> After warming up, idle the engine. Ignition timing is checked by reading ignition timing with a timing light and checking whether it agrees with specifications. 	The timing light indicates the same value on the screen.		<ul style="list-style-type: none"> Adjust ignition timing (by moving camshaft position sensor or distributor) Camshaft position sensor drive mechanism
MIXTURE RATIO TEST	<ul style="list-style-type: none"> Air-fuel ratio feedback circuit (injection system, ignition system, vacuum system, etc.) is tested by examining the front heated oxygen sensor output at 2,000 rpm under non-loaded state. 	Front heated oxygen sensor COUNT: More than 5 times during 10 seconds		<ul style="list-style-type: none"> INJECTION SYS (Injector, fuel pressure regulator, harness or connector) IGNITION SYS (Spark plug, power transistor, ignition coil, harness or connector) VACUUM SYS (Intake air leaks) Front heated oxygen sensor circuit Front heated oxygen sensor operation Fuel pressure high or low Mass air flow sensor
IACV-AAC/V SYSTEM	<ul style="list-style-type: none"> After warming up, idle the engine. IACV-AAC valve system is tested by detecting change in engine speed when IACV-AAC valve opening is changed to 0%, 20% and 80%. 	Difference in engine speed is greater than 150 rpm between when valve opening is at 80% and 20%.		<ul style="list-style-type: none"> Harness and connector IACV-AAC valve Air passage restriction between air inlet and IACV-AAC valve IAS (Idle adjusting screw) adjustment
POWER BALANCE	<ul style="list-style-type: none"> After warming up, idle the engine. Injector operation of each cylinder is stopped one after another, and resultant change in engine rotation is examined to evaluate combustion of each cylinder. (This is only displayed for models where a sequential multiport fuel injection system is used.) 	Difference in engine speed is greater than 25 rpm before and after cutting off the injector of each cylinder.		<ul style="list-style-type: none"> Injector circuit (Injector, harness or connector) Ignition circuit (Spark plug, ignition coil with power transistor harness or connector) Compression Valve timing

GI

MA

EM

LC

EC

FE

AT

TF

PD

FA

RA

BR

ST

RS

BT

HA

EL

IDX

ON BOARD DIAGNOSTIC SYSTEM DESCRIPTION

CONSULT (Cont'd)

FUNCTION TEST ITEM	CONDITION	JUDGEMENT	CHECK ITEM (REMEDY)
<p>★EVAP (SMALL LEAK)</p>	<ul style="list-style-type: none"> ● After warming up, idle the engine etc. ● EVAP system is tested by using the evaporative gas pressure in the fuel tank or engine intake manifold pressure. 	<ul style="list-style-type: none"> ● EVAP control system has no leak. ● EVAP control system operates properly. 	<ul style="list-style-type: none"> ● Incorrect fuel tank vacuum relief valve ● Incorrect fuel filler cap used ● Fuel filler cap remains open or fails to close. ● Foreign matter caught in fuel filler cap. ● Leak is in line between intake manifold and EVAP canister purge control valve. ● Foreign matter caught in EVAP canister vent control valve. ● EVAP canister or fuel tank leaks ● EVAP purge line tube leaks ● EVAP purge line rubber tube bent. ● Blocked or bent rubber tube to EVAP control system pressure sensor ● EVAP canister purge control valve ● EVAP canister purge volume control valve ● EVAP canister purge control solenoid valve ● Absolute pressure sensor ● Tank fuel temperature sensor ● MAP/BARO switch solenoid valve ● Blocked or bent rubber tube to MAP/BARO switch solenoid valve ● O-ring of EVAP canister vent control valve is missing or damaged.

★: Always select "SINGLE TEST" with CONSULT when performing the "FUNCTION TEST".

ON BOARD DIAGNOSTIC SYSTEM DESCRIPTION

CONSULT (Cont'd)

REAL TIME DIAGNOSIS IN DATA MONITOR MODE

CONSULT has two kinds of triggers and they can be selected by touching "SETTING" in "DATA MONITOR" mode.

1. "AUTO TRIG" (Automatic trigger):

- The malfunction will be identified on the CONSULT screen in real time. In other words, DTC/1st trip DTC and malfunction item will be displayed at the moment the malfunction is detected by ECM.

DATA MONITOR can be performed continuously until a malfunction is detected. However, DATA MONITOR cannot continue any longer after the malfunction detection.

2. "MANU TRIG" (Manual trigger):

- DTC/1st trip DTC and malfunction item will not be displayed automatically on CONSULT screen even though a malfunction is detected by ECM.

DATA MONITOR can be performed continuously even though a malfunction is detected.

Use these triggers as follows:

1. "AUTO TRIG"

- While trying to detect the DTC/1st trip DTC by performing the "DTC CONFIRMATION PROCEDURE", be sure to select to "DATA MONITOR (AUTO TRIG)" mode. You can confirm the malfunction at the moment it is detected.

- While narrowing down the possible causes, CONSULT should be set in "DATA MONITOR (AUTO TRIG)" mode, especially in case the incident is intermittent.

When you are inspecting the circuit by gently shaking (or twisting) the suspicious connectors, components and harness in the "DTC CONFIRMATION PROCEDURE", the moment a malfunction is found the DTC/1st trip DTC will be displayed. (Refer to GI section, "Incident Simulation Tests" in "HOW TO PERFORM EFFICIENT DIAGNOSIS FOR AN ELECTRICAL INCIDENT".)

2. "MANU TRIG"

- If the malfunction is displayed as soon as "DATA MONITOR" is selected, reset CONSULT to "MANU TRIG". By selecting "MANU TRIG" you can monitor and store the data. The data can be utilized for further diagnosis, such as a comparison with the value for the normal operating condition.

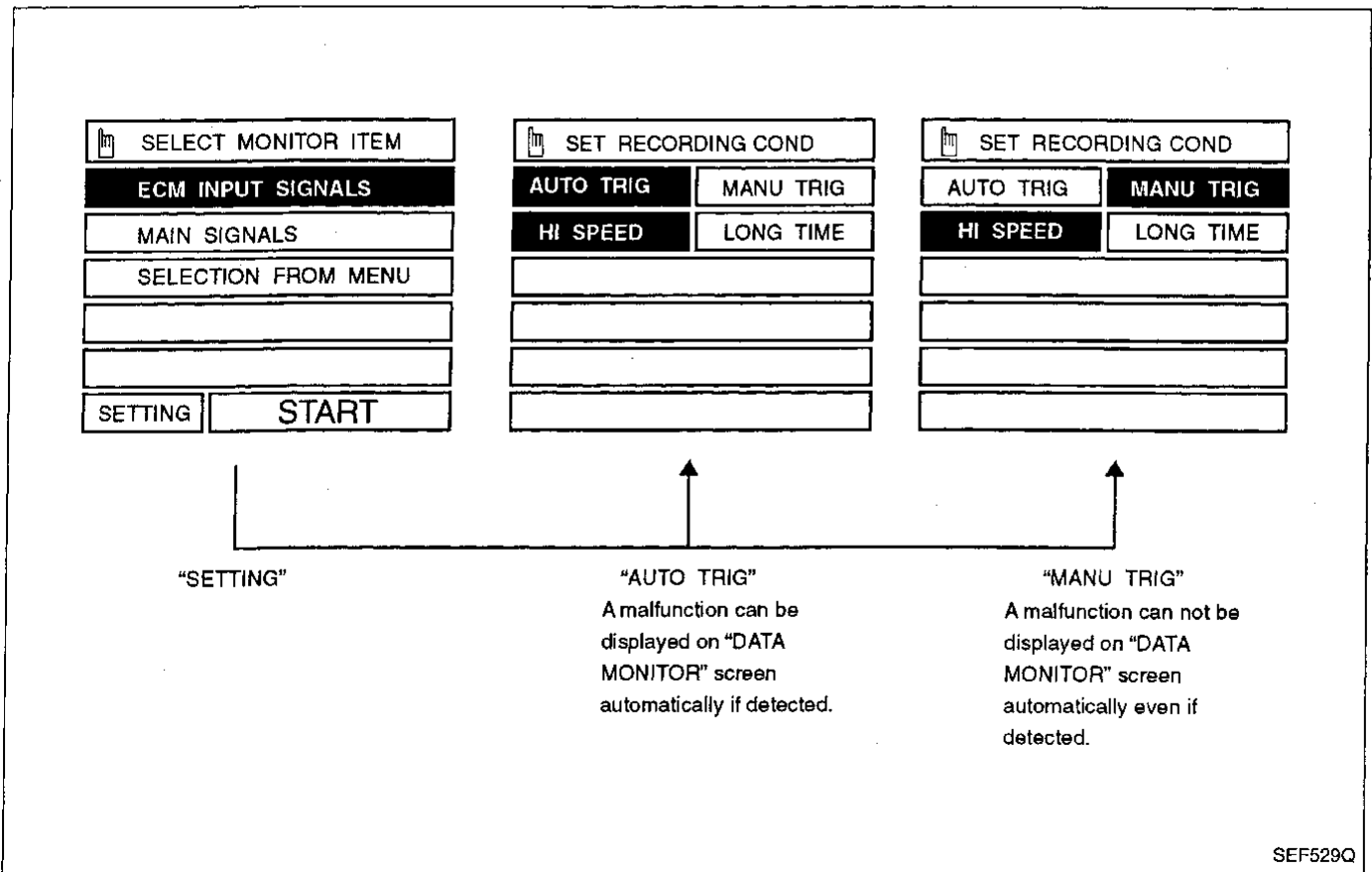

ON BOARD DIAGNOSTIC SYSTEM DESCRIPTION

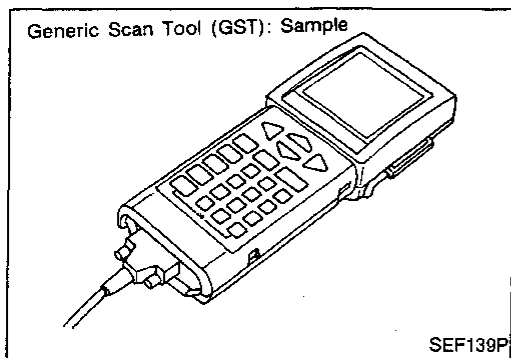

Generic Scan Tool (GST)

DESCRIPTION

Generic Scan Tool (OBDII scan tool) complying with SAE J1978 has 7 different functions explained on the next page. ISO9141 is used as the protocol. The name "GST" or "Generic Scan Tool" is used in this service manual.

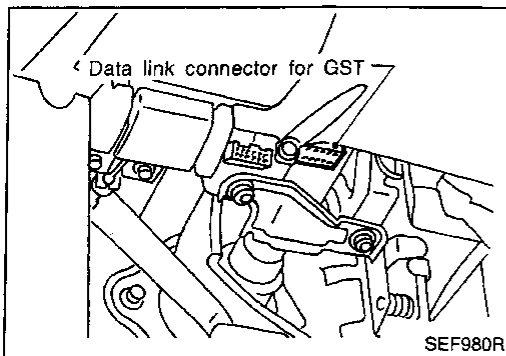

GST INSPECTION PROCEDURE

1. Turn off ignition switch.
 2. Connect "GST" to data link connector for GST. (Data link connector for GST is located under LH dash panel near the fuse box cover.)
 3. Turn on ignition switch.
 4. Enter the program according to instruction on the screen or in the operation manual.
- (*: Regarding GST screens in this section, sample screens are shown.)

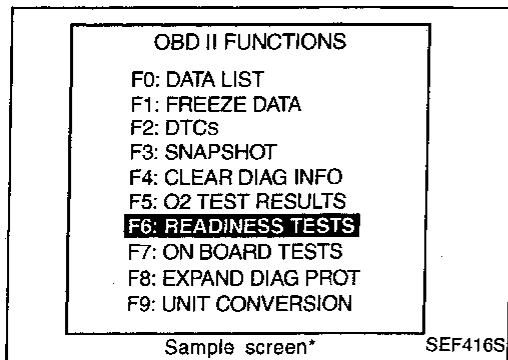
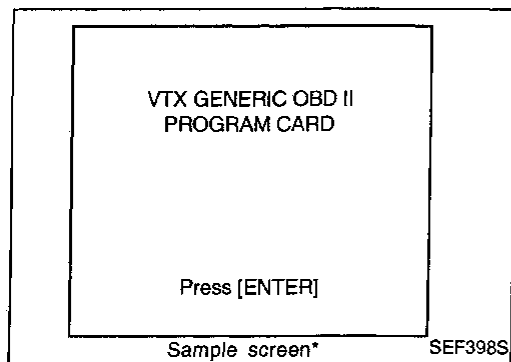

5. Perform each diagnostic mode according to each service procedure.

For further information, see the GST Operation Manual of the tool maker.

ON BOARD DIAGNOSTIC SYSTEM DESCRIPTION

Generic Scan Tool (GST) (Cont'd)

FUNCTION

Diagnostic test mode		Function
MODE 1	READINESS TESTS	This mode gains access to current emission-related data values, including analog inputs and outputs, digital inputs and outputs, and system status information.
MODE 2	(FREEZE DATA)	This mode gains access to emission-related data value which were stored by ECM during the freeze frame. [For details, refer to "Freeze Frame Data" (EC-59).]
MODE 3	DTCs	This mode gains access to emission-related power train trouble codes which were stored by ECM.
MODE 4	CLEAR DIAG INFO	This mode can clear all emission-related diagnostic information. This includes: <ul style="list-style-type: none"> • Clear number of diagnostic trouble codes (MODE 1) • Clear diagnostic trouble codes (MODE 3) • Clear trouble code for freeze frame data (MODE 1) • Clear freeze frame data (MODE 2) • Clear heated oxygen sensor test data (MODE 5) • Reset status of system monitoring test (MODE 1) • Clear on board monitoring test results (MODE 6 and 7)
MODE 5	(O2 TEST RESULTS)	This mode gains access to the on board heated oxygen sensor monitoring test results.
MODE 6	(ON BOARD TESTS)	This mode accesses the results of on board diagnostic monitoring tests of specific components/systems that are not continuously monitored.
MODE 7	(ON BOARD TESTS)	This mode enables the off board test drive to obtain test results for emission-related powertrain components/systems that are continuously monitored during normal driving conditions.

GI

MA

EM

LC

EC

FE

AT

TF

PD

FA

RA

BR

ST

RS

BT

HA

EL

IDX

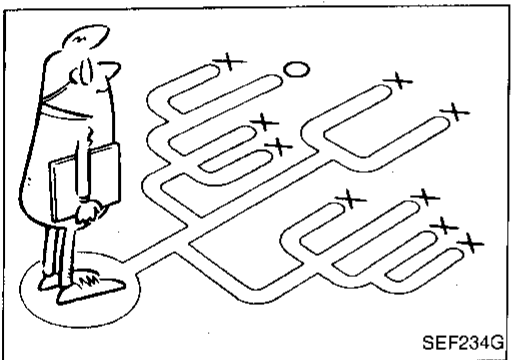
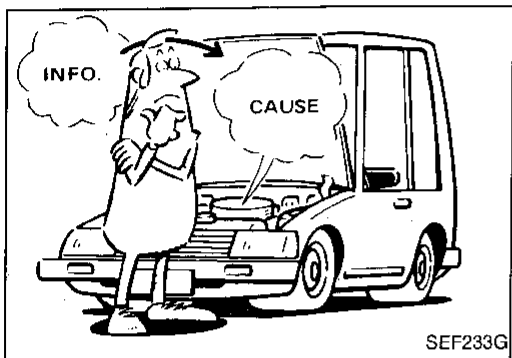
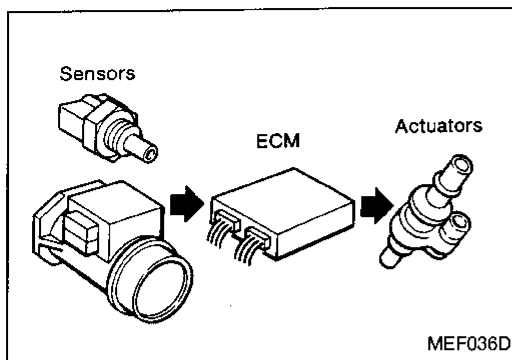

KEY POINTS	
WHAT Vehicle & engine model
WHEN Date, Frequencies
WHERE Road conditions
HOW Operating conditions, Weather conditions, Symptoms

SEF907L

Introduction

The engine has an ECM to control major systems such as fuel control, ignition control, idle air control system, etc. The ECM accepts input signals from sensors and instantly drives actuators. It is essential that both input and output signals are proper and stable. At the same time, it is important that there are no problems such as vacuum leaks, fouled spark plugs, or other problems with the engine.

It is much more difficult to diagnose a problem that occurs intermittently rather than continuously. Most intermittent problems are caused by poor electric connections or improper wiring. In this case, careful checking of suspected circuits may help prevent the replacement of good parts.

A visual check only may not find the cause of the problems. A road test with CONSULT (or GST) or a circuit tester connected should be performed. Follow the "Work Flow" on EC-72.

Before undertaking actual checks, take a few minutes to talk with a customer who approaches with a driveability complaint. The customer can supply good information about such problems, especially intermittent ones. Find out what symptoms are present and under what conditions they occur. A "Diagnostic Worksheet" like the example on next page should be used.

Start your diagnosis by looking for "conventional" problems first. This will help troubleshoot driveability problems on an electronically controlled engine vehicle.

Diagnostic Worksheet

There are many operating conditions that lead to the malfunction of engine components. A good grasp of such conditions can make trouble-shooting faster and more accurate.

In general, each customer feels differently about a problem. It is important to fully understand the symptoms or conditions for a customer complaint.

Utilize a diagnostic worksheet like the one on the next page in order to organize all the information for troubleshooting.

Some conditions may cause the malfunction indicator lamp to come on steady or blink and DTC to be detected. Examples:

- Vehicle ran out of fuel, which caused the engine to misfire.
- Fuel filler cap was left off or incorrectly screwed on, allowing fuel to evaporate into the atmosphere [for the models with EVAP (SMALL LEAK) diagnosis].

Work Flow

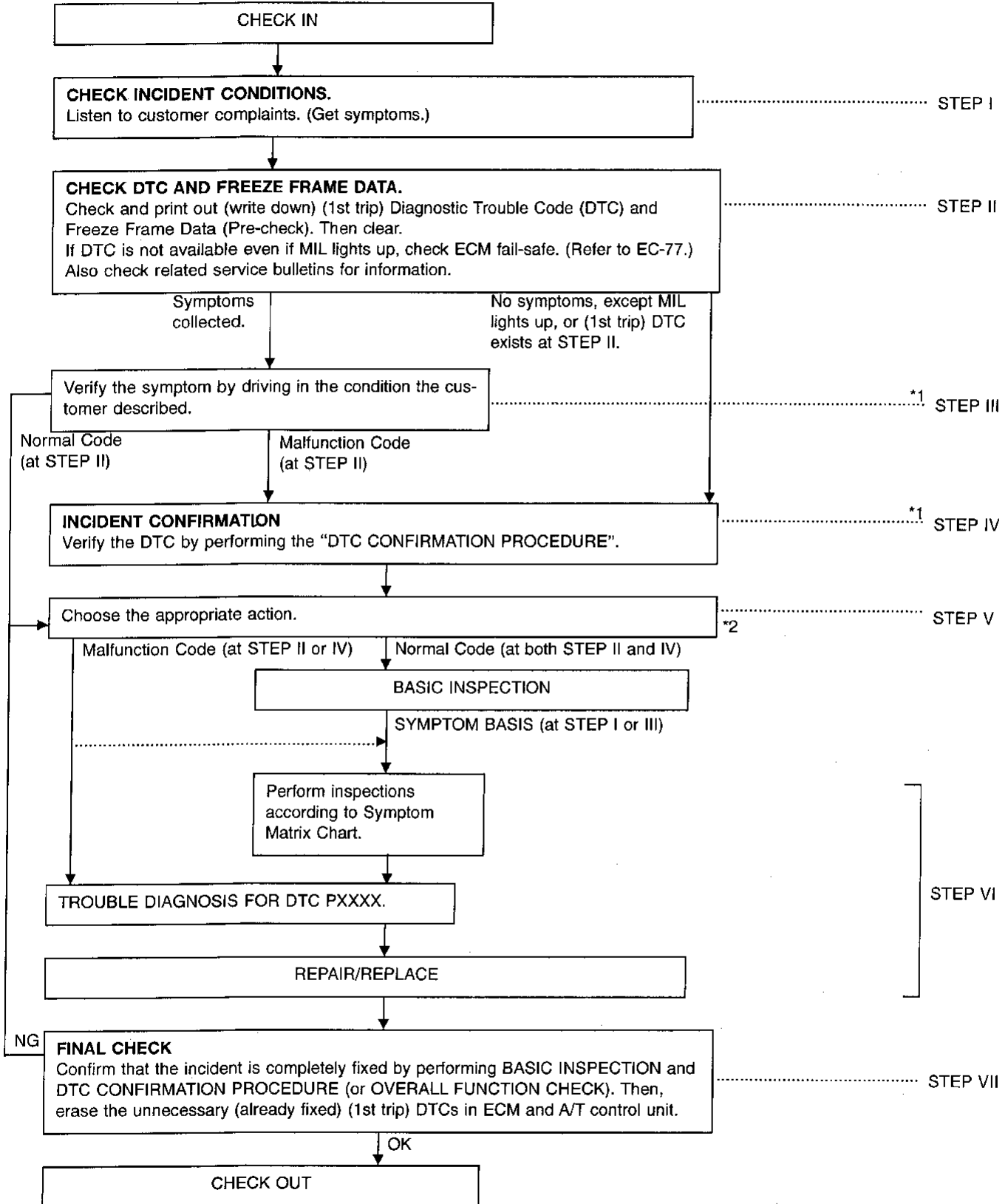

*1: If the incident cannot be duplicated, refer to GI section ("Incident Simulation Tests", "HOW TO PERFORM EFFICIENT DIAGNOSIS FOR AN ELECTRICAL INCIDENT").

*2: If the on board diagnostic system cannot be performed, check main power supply and ground circuit. Refer to "TROUBLE DIAGNOSIS FOR POWER SUPPLY", EC-94.

TROUBLE DIAGNOSIS — Work Flow

Description for Work Flow

STEP	DESCRIPTION	
STEP I	Get detailed information about the conditions and the environment when the incident/symptom occurred using the "DIAGNOSTIC WORK SHEET", EC-71.	GI
STEP II	Before confirming the concern, check and write down (print out using CONSULT or Generic Scan Tool) the (1st trip) Diagnostic Trouble Code (DTC) and the (1st trip) freeze frame data, then erase the code and the data. (Refer to EC-46.) The (1st trip) DTC and the (1st trip) freeze frame data can be used when duplicating the incident at STEP III & IV. Study the relationship between the cause, specified by (1st trip) DTC, and the symptom described by the customer. (The "Symptom Matrix Chart" will be useful. See EC-78.) Also check related service bulletins for information.	MA EM LC
STEP III	Try to confirm the symptom and under what conditions the incident occurs. The "DIAGNOSTIC WORK SHEET" and the freeze frame data are useful to verify the incident. Connect CONSULT to the vehicle in DATA MONITOR (AUTO TRIG) mode and check real time diagnosis results. If the incident cannot be verified, perform INCIDENT SIMULATION TESTS. (Refer to GI section.) If the malfunction code is detected, skip STEP IV and perform STEP V.	EC FE
STEP IV	Try to detect the (1st trip) Diagnostic Trouble Code by driving in (or performing) the "DTC CONFIRMATION PROCEDURE". Check and read the (1st trip) DTC and (1st trip) freeze frame data by using CONSULT or Generic Scan Tool. During the (1st trip) DTC verification, be sure to connect CONSULT to the vehicle in DATA MONITOR (AUTO TRIG) mode and check real time diagnosis results. If the incident cannot be verified, perform INCIDENT SIMULATION TESTS. (Refer to GI section.) In case the "DTC CONFIRMATION PROCEDURE" is not available, perform the "OVERALL FUNCTION CHECK" instead. The (1st trip) DTC cannot be displayed by this check, however, this simplified "check" is an effective alternative. The "NG" result of the "OVERALL FUNCTION CHECK" is the same as the (1st trip) DTC detection.	AT TF PD
STEP V	Take the appropriate action based on the results of STEP I through IV. If the malfunction code is indicated, proceed to TROUBLE DIAGNOSIS FOR DTC PXXXX. If the normal code is indicated, proceed to the BASIC INSPECTION. (Refer to EC-74.) Then perform inspections according to the Symptom Matrix Chart. (Refer to EC-78.)	FA RA
STEP VI	Identify where to begin diagnosis based on the relationship study between symptom and possible causes. Inspect the system for mechanical binding, loose connectors or wiring damage using (tracing) "Harness Layouts". Gently shake the related connectors, components or wiring harness with CONSULT set in "DATA MONITOR (AUTO TRIG)" mode. Check the voltage of the related ECM terminals or monitor the output data from the related sensors with CONSULT. Refer to EC-81. The "DIAGNOSTIC PROCEDURE" in EC section contains a description based on open circuit inspection. A short circuit inspection is also required for the circuit check in the DIAGNOSTIC PROCEDURE. For details, refer to GI section ("HOW TO PERFORM EFFICIENT DIAGNOSIS FOR AN ELECTRICAL INCIDENT", "Circuit Inspection"). Repair or replace the malfunction parts.	BR ST RS
STEP VII	Once you have repaired the circuit or replaced a component, you need to run the engine in the same conditions and circumstances which resulted in the customer's initial complaint. Perform the "DTC CONFIRMATION PROCEDURE" and confirm the normal code [Diagnostic trouble code No. P0000 or 0505] is detected. If the incident is still detected in the final check, perform STEP VI by using a different method from the previous one. Before returning the vehicle to the customer, be sure to erase the unnecessary (already fixed) (1st trip) DTC in ECM and A/T control unit. (Refer to EC-44.)	BT HA EL

IDX

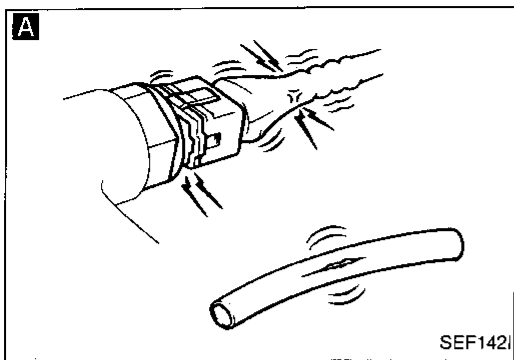

Basic Inspection

Precaution:

Perform Basic Inspection without electrical or mechanical loads applied;

- Headlamp switch is OFF,
- Air conditioner switch is OFF,
- Rear window defogger switch is OFF,
- Steering wheel is in the straight-ahead position, etc.

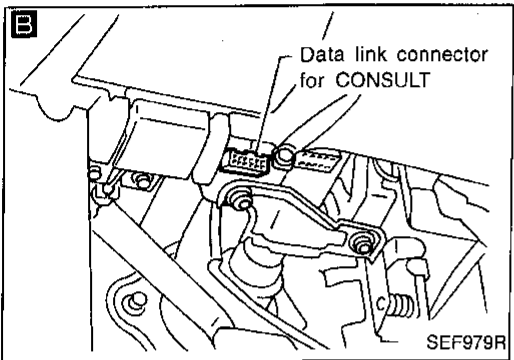

A

BEFORE STARTING

1. Check service records for any recent repairs that may indicate a related problem, or the current need for scheduled maintenance.
2. Open engine hood and check the following:
 - Harness connectors for improper connections
 - Vacuum hoses for splits, kinks, or improper connections
 - Wiring for improper connections, pinches, or cuts

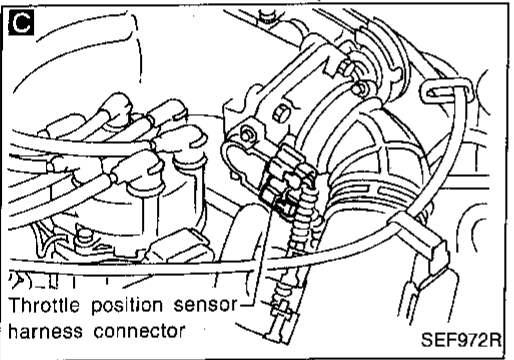

B

CONNECT CONSULT TO THE VEHICLE.
Connect "CONSULT" to the data link connector for CONSULT and select "ENGINE" from the menu. Refer to EC-56.

DOES ENGINE START?

No → Go to **D**

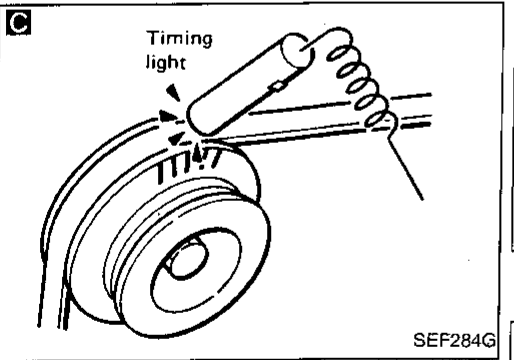

C

CHECK IGNITION TIMING.

1. Warm up engine sufficiently.
2. Stop engine and disconnect throttle position sensor harness connector.
3. Start engine.
4. Check ignition timing at idle using timing light.

Ignition timing:
15°±2° BTDC

NG → Adjust ignition timing by turning distributor.

CHECK BASE IDLE SPEED.
Does engine speed fall to the following speed?
700±50 rpm (in "N" position)

NG → Adjust engine speed by turning idle speed adjusting screw.

(Go to **A** on next page.)

TROUBLE DIAGNOSIS — Basic Inspection

Basic Inspection (Cont'd)

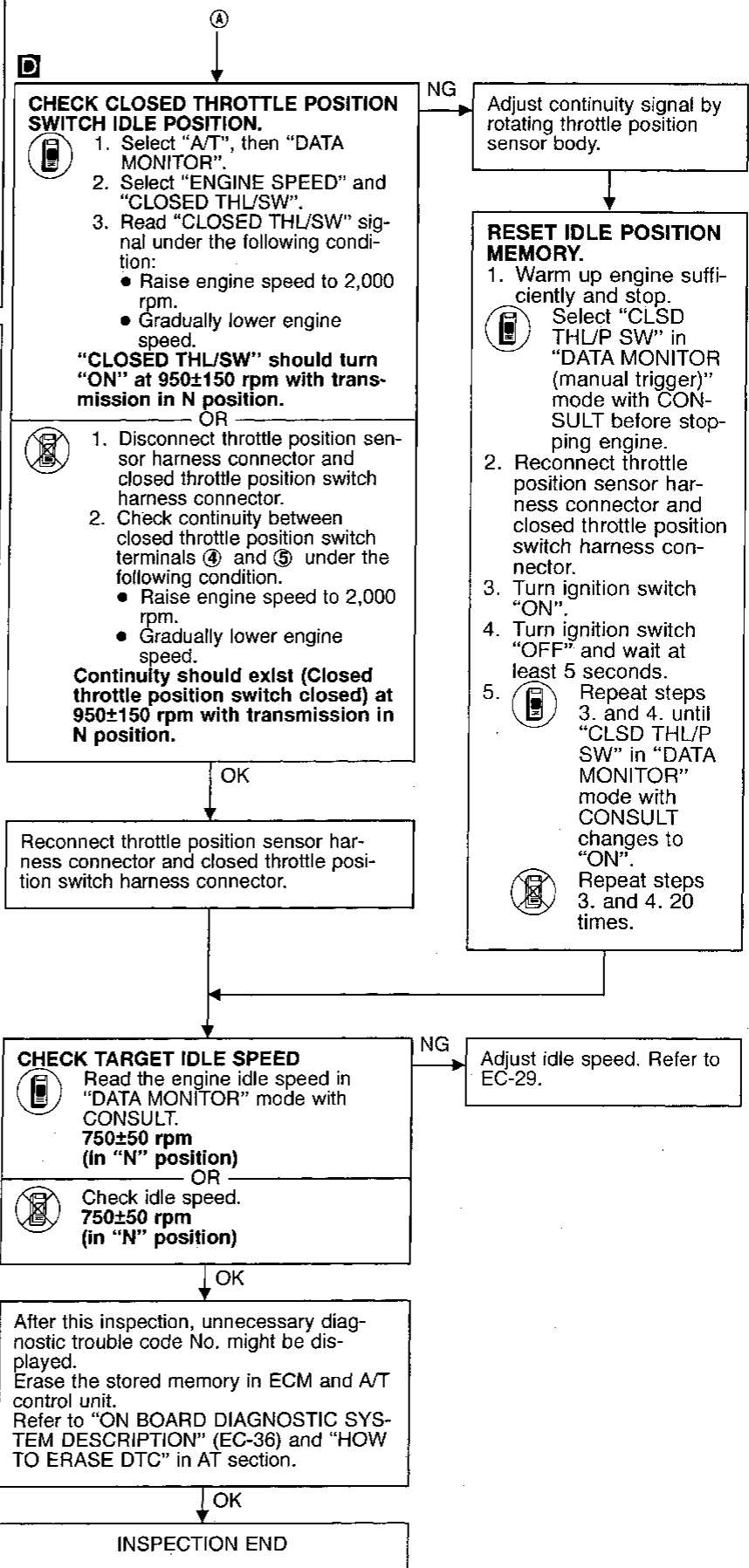
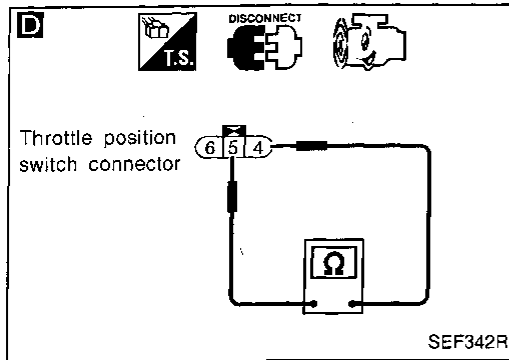
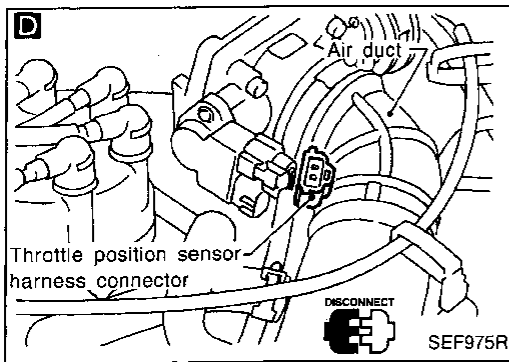

GI
MA
EM
LC
EC
FE
AT
TF
PD
FA
RA
BR
ST
RS
BT
HA
EL
IDX

TROUBLE DIAGNOSIS — General Description

Diagnostic Trouble Code (DTC) Inspection Priority Chart

If some DTCs are displayed at the same time, perform inspections one by one based on the following priority chart.

Priority	Detected items (DTC)		
1	<ul style="list-style-type: none"> ● ECM (P0605, 0301) ● Mass air flow sensor circuit (P0100, 0102) ● Throttle position sensor circuit (P0120, 0403) ● EGRC-solenoid valve circuit (P1400, 1005) ● A/T diagnosis communication line (P1605, 0804) 	<ul style="list-style-type: none"> ● Camshaft position sensor circuit (P0340, 0101) ● Vehicle speed sensor circuit (P0500, 0104) ● Intake air temperature sensor circuit (P0110, 0401) ● Knock sensor circuit (P0325, 0304) ● Tank fuel temperature sensor circuit (P0180, 0402) 	<ul style="list-style-type: none"> ● Engine coolant temperature sensor circuit (P0115, 0103) (P0125, 0908) ● Ignition signal circuit (P1320, 0201) ● Park/Neutral position switch circuit (P0705, 1003)
2	<ul style="list-style-type: none"> ● EGR temperature sensor circuit (P1401, 0305) ● A/T related sensors, solenoid valves and switches (P0705-P0710, 1101-1208) ● Absolute pressure sensor circuit (P0105, 0803) ● MAP/BARO switch solenoid valve circuit (P1105, 1302) ● Closed throttle position switch circuit (P0510, 0203) 	<ul style="list-style-type: none"> ● Front heated oxygen sensor heater circuit (P0135, 0901) (P0155, 1001) ● Crankshaft position sensor (OBD) circuit (P0335, 0802) (P1336, 0905) ● EVAP canister purge control valve/solenoid valve circuit (P0443, 0807) ● Vacuum cut valve bypass valve circuit (P1441, 0801) 	<ul style="list-style-type: none"> ● Front heated oxygen sensor circuit (P0130, 0503) (P0150, 0303) ● Rear heated oxygen sensor circuit (P0136, 0707) (P0156, 0708) ● Rear heated oxygen sensor heater circuit (P0141, 0902) (P0161, 1002) ● EVAP control system pressure sensor circuit (P0450, 0704) ● EVAP canister vent control valve circuit (P0446, 0903) ● EVAP canister purge volume control valve circuit (P1445, 1008) ● EVAP control system purge flow monitoring (P1447, 0111)
3	<ul style="list-style-type: none"> ● EGR function (P0400, 0302) ● EVAP control system (SMALL LEAK) (P0440, 0705) ● EGRC-BPT valve function (P0402, 0306) ● IACV-AAC valve circuit (P0505, 0205) 	<ul style="list-style-type: none"> ● Misfire (P0306 - P0300, 0603 - 0701) ● Closed loop control (P0130, 0307) (P0150, 0308) ● Improper shifting (P0731 - P0734, 1103 - 1106) 	<ul style="list-style-type: none"> ● Fuel injection system function (P0172, 0114), (P0171, 0115), (P0175, 0209), (P0174, 0210) ● Three way catalyst function (P0420, 0702) (P0430, 0703) ● Signal circuit from A/T control unit to ECM (P0600)

TROUBLE DIAGNOSIS — General Description

Fail-Safe Chart

The ECM enters fail-safe mode, if any of the following malfunctions is detected due to the open or short circuit. When the ECM enters the fail-safe mode, the MIL illuminates.

DTC No.		Detected items	Engine operating condition in fail-safe mode												
CONSULT GST	ECM*1														
P0100	0102	Mass air flow sensor circuit	Engine speed will not rise more than 2,400 rpm due to the fuel cut.												
P0115	0103	Engine coolant temperature sensor circuit	<p>Engine coolant temperature will be determined by ECM based on the time after turning ignition switch "ON" or "START". CONSULT displays the engine coolant temperature decided by ECM.</p> <table border="1" style="width: 100%; border-collapse: collapse;"> <thead> <tr> <th style="text-align: center;">Condition</th> <th style="text-align: center;">Engine coolant temperature decided (CONSULT display)</th> </tr> </thead> <tbody> <tr> <td>Just as ignition switch is turned ON or Start</td> <td style="text-align: center;">40°C (104°F)</td> </tr> <tr> <td>More than approx. 4 minutes after ignition ON or Start</td> <td style="text-align: center;">80°C (176°F)</td> </tr> <tr> <td>Except as shown above</td> <td style="text-align: center;">40 - 80°C (104 - 176°F) (Depends on the time)</td> </tr> </tbody> </table>	Condition	Engine coolant temperature decided (CONSULT display)	Just as ignition switch is turned ON or Start	40°C (104°F)	More than approx. 4 minutes after ignition ON or Start	80°C (176°F)	Except as shown above	40 - 80°C (104 - 176°F) (Depends on the time)				
Condition	Engine coolant temperature decided (CONSULT display)														
Just as ignition switch is turned ON or Start	40°C (104°F)														
More than approx. 4 minutes after ignition ON or Start	80°C (176°F)														
Except as shown above	40 - 80°C (104 - 176°F) (Depends on the time)														
P0120	0403	Throttle position sensor circuit	<p>Throttle position will be determined based on the injected fuel amount and the engine speed. Therefore, acceleration will be poor.</p> <table border="1" style="width: 100%; border-collapse: collapse;"> <thead> <tr> <th style="text-align: center;">Condition</th> <th style="text-align: center;">Driving condition</th> </tr> </thead> <tbody> <tr> <td>When engine is idling</td> <td style="text-align: center;">Normal</td> </tr> <tr> <td>When accelerating</td> <td style="text-align: center;">Poor acceleration</td> </tr> </tbody> </table>	Condition	Driving condition	When engine is idling	Normal	When accelerating	Poor acceleration						
Condition	Driving condition														
When engine is idling	Normal														
When accelerating	Poor acceleration														
Unable to access ECCS	Unable to access Diagnostic Test Mode II	ECM	<p>ECM fail-safe activating condition The computing function of the ECM was judged to be malfunctioning. When the fail-safe system activates (i.e., if the ECM detects a malfunction condition in the CPU of ECM), the MALFUNCTION INDICATOR LAMP on the instrument panel lights to warn the driver. However it is not possible to access ECCS and DTC cannot be confirmed.</p> <p>Engine control with fail-safe When ECM fail-safe is operating, fuel injection, ignition timing, fuel pump operation, and IACV-AAC valve operation are controlled under certain limitations.</p> <table border="1" style="width: 100%; border-collapse: collapse;"> <thead> <tr> <th colspan="2" style="text-align: center;">ECM fail-safe operation</th> </tr> </thead> <tbody> <tr> <td style="text-align: center;">Engine speed</td> <td style="text-align: center;">Engine speed will not rise more than 3,000 rpm</td> </tr> <tr> <td style="text-align: center;">Fuel injection</td> <td style="text-align: center;">Simultaneous multiport fuel injection system</td> </tr> <tr> <td style="text-align: center;">Ignition timing</td> <td style="text-align: center;">Ignition timing is fixed at the preset valve</td> </tr> <tr> <td style="text-align: center;">Fuel pump</td> <td style="text-align: center;">Fuel pump relay is "ON" when engine is running and "OFF" when engine stalls</td> </tr> <tr> <td style="text-align: center;">IACV-AAC valve</td> <td style="text-align: center;">Full open</td> </tr> </tbody> </table> <p>Replace ECM, if ECM fail-safe condition is confirmed.</p>	ECM fail-safe operation		Engine speed	Engine speed will not rise more than 3,000 rpm	Fuel injection	Simultaneous multiport fuel injection system	Ignition timing	Ignition timing is fixed at the preset valve	Fuel pump	Fuel pump relay is "ON" when engine is running and "OFF" when engine stalls	IACV-AAC valve	Full open
ECM fail-safe operation															
Engine speed	Engine speed will not rise more than 3,000 rpm														
Fuel injection	Simultaneous multiport fuel injection system														
Ignition timing	Ignition timing is fixed at the preset valve														
Fuel pump	Fuel pump relay is "ON" when engine is running and "OFF" when engine stalls														
IACV-AAC valve	Full open														

*1: In Diagnostic Test Mode II (Self-diagnostic results)

TROUBLE DIAGNOSIS — General Description

Symptom Matrix Chart

SYSTEM — Basic engine control system		SYMPTOM													Reference page
		HARD/NO START/RESTART (EXCP. HA)	ENGINE STALL	HESITATION/SURGING/FLAT SPOT	SPARK KNOCK/DETONATION	LACK OF POWER/POOR ACCELERATION	HIGH IDLE/LOW IDLE	ROUGH IDLE/HUNTING	IDLING VIBRATION	SLOW/NO RETURN TO IDLE	OVERHEATS/WATER TEMPERATURE HIGH	EXCESSIVE FUEL CONSUMPTION	EXCESSIVE OIL CONSUMPTION	BATTERY DEAD (UNDER CHARGE)	
Warranty symptom code		AA	AB	AC	AD	AE	AF	AG	AH	AJ	AK	AL	AM	HA	
Fuel	Fuel pump circuit	●	●	●	○	●	○	○	○	○	○	○	○	○	EC-336
	Fuel pressure regulator system	●	○	●	○	○	○	○	○	○	○	○	○	○	EC-25
	Injector circuit	●	●	●	○	●	○	●	○	○	○	○	○	○	EC-329
	Evaporative emission system	○	○	○	○	○	○	○	○	○	○	○	○	○	EC-20
Air	Positive crankcase ventilation system	○	●	○	○	○	○	●	○	○	○	○	○	○	EC-24
	Incorrect idle speed adjustment	●	●	○	○	○	●	●	○	○	○	○	○	○	EC-29
	IACV-AAC valve circuit	○	●	○	○	○	●	●	○	○	○	○	○	○	EC-256
	IACV-FICD solenoid valve circuit	○	○	○	○	○	○	○	○	○	○	○	○	○	EC-345
Ignition	Incorrect ignition timing adjustment	●	●	●	●	●	○	○	○	○	○	○	○	○	EC-29
	Ignition circuit	●	○	●	○	●	○	○	○	○	○	○	○	○	EC-283
EGR	EGRC-solenoid valve circuit	○	○	●	○	○	○	○	○	○	○	○	○	○	EC-294
	EGR system	○	●	●	●	○	○	○	○	○	○	○	○	○	EC-211
Main power supply and ground circuit		●	○	○	○	○	○	○	○	○	○	○	○	○	EC-94
Air conditioner circuit		○	○	○	○	○	○	○	○	○	○	○	○	○	HA section

● ; High Possibility Item
○ ; Low Possibility Item

(continued on next page)

TROUBLE DIAGNOSIS — General Description

Symptom Matrix Chart (Cont'd)

SYSTEM — ECCS system		SYMPTOM													Reference page
		HARD/NO START/RESTART (EXCP. HA)	ENGINE STALL	HESITATION/SURGING/FLAT SPOT	SPARK KNOCK/DETONATION	LACK OF POWER/POOR ACCELERATION	HIGH IDLE/LOW IDLE	ROUGH IDLE/HUNTING	IDLING VIBRATION	SLOW/NO RETURN TO IDLE	OVERHEATS/WATER TEMPERATURE HIGH	EXCESSIVE FUEL CONSUMPTION	EXCESSIVE OIL CONSUMPTION	BATTERY DEAD (UNDER CHARGE)	
Warranty symptom code		AA	AB	AC	AD	AE	AF	AG	AH	AJ	AK	AL	AM	HA	
ECCS	Camshaft position sensor circuit	●	●	●	●	●		●	○			●			EC-205
	Mass air flow sensor circuit	●	●	●	○	●		●	○			●			EC-100
	Front heated oxygen sensor circuit		●	●	○	●		●	○			●			EC-135, 153
	Engine coolant temperature sensor circuit	●	○	○	○	○	○	●	○	○		○			EC-118, 129
	Throttle position sensor circuit		●	●		●	●	●	○	○		●			EC-123
	Incorrect throttle position sensor adjustment		●	●		●	●	●	○	○		○			EC-74
	Vehicle speed sensor circuit		○	○		○						○			EC-252
	Knock sensor circuit			○	○	○						○			EC-197
	ECM	○	○	○	○	○	○	○	○	○	○	○			EC-269, 77
	Start signal circuit	○													EC-333
	Park/Neutral position switch circuit			○		○		○	○			○			EC-271
	Power steering oil pressure switch circuit		○					○	○						EC-341

● ; High Possibility Item
○ ; Low Possibility Item

(continued on next page)

GI
 MA
 EM
 LC
EC
 FE
 AT
 TF
 PD
 FA
 RA
 BR
 ST
 RS
 BT
 HA
 EL
 IDX

TROUBLE DIAGNOSIS — General Description

Symptom Matrix Chart (Cont'd)

SYSTEM — Engine mechanical & other		SYMPTOM													Reference page
		HARD/NO START/RESTART (EXCP. HA)	ENGINE STALL	HESITATION/SURGING/FLAT SPOT	SPARK KNOCK/DETONATION	LACK OF POWER/POOR ACCELERATION	HIGH IDLE/LOW IDLE	ROUGH IDLE/HUNTING	IDLING VIBRATION	SLOW/NO RETURN TO IDLE	OVERHEATS/WATER TEMPERATURE HIGH	EXCESSIVE FUEL CONSUMPTION	EXCESSIVE OIL CONSUMPTION	BATTERY DEAD (UNDER CHARGE)	
Warranty symptom code		AA	AB	AC	AD	AE	AF	AG	AH	AJ	AK	AL	AM	HA	
Fuel	Fuel tank	<input type="checkbox"/>	<input type="checkbox"/>												
	Fuel piping	<input type="checkbox"/>	<input type="checkbox"/>	<input type="checkbox"/>	<input type="checkbox"/>	<input type="checkbox"/>		<input type="checkbox"/>	<input type="checkbox"/>			<input type="checkbox"/>			
	Vapor lock		<input type="checkbox"/>												
	Valve deposit	<input type="checkbox"/>	<input type="checkbox"/>	<input type="checkbox"/>	<input type="checkbox"/>	<input type="checkbox"/>		<input type="checkbox"/>	<input type="checkbox"/>			<input type="checkbox"/>			
	Poor fuel (Heavy weight gasoline, Low octane)	<input type="checkbox"/>	<input type="checkbox"/>	<input type="checkbox"/>	<input type="checkbox"/>	<input type="checkbox"/>		<input type="checkbox"/>	<input type="checkbox"/>			<input type="checkbox"/>			
Air	Air duct		<input type="checkbox"/>	<input type="checkbox"/>		<input type="checkbox"/>		<input type="checkbox"/>	<input type="checkbox"/>			<input type="checkbox"/>			
	Air cleaner		<input type="checkbox"/>	<input type="checkbox"/>		<input type="checkbox"/>		<input type="checkbox"/>	<input type="checkbox"/>			<input type="checkbox"/>			
	Air leakage from air duct (Mass air flow sensor — throttle body)	<input type="checkbox"/>	<input type="checkbox"/>	<input type="checkbox"/>	<input type="checkbox"/>	<input type="checkbox"/>	<input type="checkbox"/>	<input type="checkbox"/>	<input type="checkbox"/>	<input type="checkbox"/>		<input type="checkbox"/>			
	Throttle body, Throttle wire	<input checked="" type="checkbox"/>	<input checked="" type="checkbox"/>	<input checked="" type="checkbox"/>		<input checked="" type="checkbox"/>	<input checked="" type="checkbox"/>	<input checked="" type="checkbox"/>	<input type="checkbox"/>	<input checked="" type="checkbox"/>		<input type="checkbox"/>			FE section
	Air leakage from intake manifold/Collector/Gasket	<input type="checkbox"/>	<input checked="" type="checkbox"/>	<input checked="" type="checkbox"/>	<input type="checkbox"/>	<input type="checkbox"/>	<input type="checkbox"/>	<input checked="" type="checkbox"/>	<input type="checkbox"/>	<input type="checkbox"/>		<input type="checkbox"/>			
Cranking	Battery	<input type="checkbox"/>	<input type="checkbox"/>	<input type="checkbox"/>		<input type="checkbox"/>		<input type="checkbox"/>	<input type="checkbox"/>			<input type="checkbox"/>		<input type="checkbox"/>	
	Alternator circuit	<input type="checkbox"/>	<input type="checkbox"/>	<input type="checkbox"/>		<input type="checkbox"/>		<input type="checkbox"/>	<input type="checkbox"/>			<input type="checkbox"/>		<input type="checkbox"/>	EL section
	Starter circuit	<input checked="" type="checkbox"/>													
	Drive plate	<input type="checkbox"/>													
	Inhibitor switch	<input type="checkbox"/>													AT section
Engine	Cylinder head	<input type="checkbox"/>	<input type="checkbox"/>	<input type="checkbox"/>	<input type="checkbox"/>	<input type="checkbox"/>		<input type="checkbox"/>	<input type="checkbox"/>			<input type="checkbox"/>			
	Cylinder head gasket	<input type="checkbox"/>	<input type="checkbox"/>	<input type="checkbox"/>	<input type="checkbox"/>	<input type="checkbox"/>		<input type="checkbox"/>	<input type="checkbox"/>		<input checked="" type="checkbox"/>	<input type="checkbox"/>	<input type="checkbox"/>		
	Cylinder block	<input type="checkbox"/>	<input type="checkbox"/>	<input type="checkbox"/>	<input type="checkbox"/>	<input type="checkbox"/>		<input type="checkbox"/>	<input type="checkbox"/>			<input type="checkbox"/>	<input type="checkbox"/>		
	Piston	<input type="checkbox"/>	<input type="checkbox"/>	<input type="checkbox"/>	<input type="checkbox"/>	<input type="checkbox"/>		<input type="checkbox"/>	<input type="checkbox"/>			<input type="checkbox"/>	<input type="checkbox"/>		
	Piston ring	<input type="checkbox"/>	<input type="checkbox"/>	<input type="checkbox"/>	<input type="checkbox"/>	<input type="checkbox"/>		<input type="checkbox"/>	<input type="checkbox"/>			<input type="checkbox"/>	<input type="checkbox"/>		
	Connecting rod	<input type="checkbox"/>	<input type="checkbox"/>	<input type="checkbox"/>	<input type="checkbox"/>	<input type="checkbox"/>		<input type="checkbox"/>	<input type="checkbox"/>			<input type="checkbox"/>	<input type="checkbox"/>		
	Bearing	<input type="checkbox"/>	<input type="checkbox"/>	<input type="checkbox"/>	<input type="checkbox"/>	<input type="checkbox"/>		<input type="checkbox"/>	<input type="checkbox"/>			<input type="checkbox"/>	<input type="checkbox"/>		
	Crankshaft	<input checked="" type="checkbox"/>	<input checked="" type="checkbox"/>	<input checked="" type="checkbox"/>	<input type="checkbox"/>	<input checked="" type="checkbox"/>		<input type="checkbox"/>	<input type="checkbox"/>			<input type="checkbox"/>	<input type="checkbox"/>		
Valve mechanism	Timing belt	<input checked="" type="checkbox"/>	<input checked="" type="checkbox"/>	<input type="checkbox"/>	<input type="checkbox"/>	<input checked="" type="checkbox"/>		<input checked="" type="checkbox"/>	<input type="checkbox"/>			<input type="checkbox"/>			
	Camshaft	<input type="checkbox"/>	<input type="checkbox"/>	<input type="checkbox"/>	<input type="checkbox"/>	<input type="checkbox"/>		<input type="checkbox"/>	<input type="checkbox"/>			<input type="checkbox"/>			
	Intake valve	<input type="checkbox"/>	<input type="checkbox"/>	<input type="checkbox"/>	<input type="checkbox"/>	<input type="checkbox"/>		<input type="checkbox"/>	<input type="checkbox"/>			<input type="checkbox"/>	<input type="checkbox"/>		
	Exhaust valve	<input type="checkbox"/>	<input type="checkbox"/>	<input type="checkbox"/>	<input type="checkbox"/>	<input type="checkbox"/>		<input type="checkbox"/>	<input type="checkbox"/>			<input type="checkbox"/>	<input type="checkbox"/>		
	Hydraulic lash adjuster		<input type="checkbox"/>	<input type="checkbox"/>	<input type="checkbox"/>	<input type="checkbox"/>		<input type="checkbox"/>	<input type="checkbox"/>			<input type="checkbox"/>	<input type="checkbox"/>		
Exhaust	Exhaust manifold/Tube/Muffler/Gasket	<input type="checkbox"/>	<input type="checkbox"/>	<input type="checkbox"/>	<input type="checkbox"/>	<input type="checkbox"/>		<input type="checkbox"/>	<input type="checkbox"/>			<input type="checkbox"/>			
	Three way catalyst	<input type="checkbox"/>	<input type="checkbox"/>	<input type="checkbox"/>	<input type="checkbox"/>	<input checked="" type="checkbox"/>		<input type="checkbox"/>	<input type="checkbox"/>			<input type="checkbox"/>			
Lubrication	Oil pan/Oil strainer/Oil pump/Oil filter/Oil gallery	<input checked="" type="checkbox"/>	<input checked="" type="checkbox"/>	<input type="checkbox"/>	<input type="checkbox"/>	<input type="checkbox"/>		<input checked="" type="checkbox"/>	<input checked="" type="checkbox"/>			<input type="checkbox"/>	<input checked="" type="checkbox"/>		
	Oil level (Low)/Filthy oil	<input type="checkbox"/>	<input type="checkbox"/>	<input type="checkbox"/>	<input type="checkbox"/>	<input type="checkbox"/>		<input type="checkbox"/>	<input type="checkbox"/>			<input type="checkbox"/>	<input type="checkbox"/>		
Cooling	Radiator/Hose/Radiator filler cap	<input type="checkbox"/>	<input type="checkbox"/>	<input type="checkbox"/>	<input type="checkbox"/>	<input type="checkbox"/>		<input type="checkbox"/>	<input type="checkbox"/>		<input checked="" type="checkbox"/>	<input type="checkbox"/>			
	Thermostat	<input type="checkbox"/>	<input type="checkbox"/>	<input type="checkbox"/>	<input type="checkbox"/>	<input type="checkbox"/>	<input type="checkbox"/>	<input type="checkbox"/>	<input type="checkbox"/>	<input type="checkbox"/>	<input type="checkbox"/>	<input type="checkbox"/>			
	Water pump	<input type="checkbox"/>	<input type="checkbox"/>	<input type="checkbox"/>	<input type="checkbox"/>	<input type="checkbox"/>		<input type="checkbox"/>	<input type="checkbox"/>		<input checked="" type="checkbox"/>	<input type="checkbox"/>			
	Water gallery	<input type="checkbox"/>	<input type="checkbox"/>	<input type="checkbox"/>	<input type="checkbox"/>	<input type="checkbox"/>		<input type="checkbox"/>	<input type="checkbox"/>		<input type="checkbox"/>	<input type="checkbox"/>			
	Cooling fan	<input type="checkbox"/>	<input type="checkbox"/>	<input type="checkbox"/>	<input type="checkbox"/>	<input type="checkbox"/>	<input type="checkbox"/>	<input type="checkbox"/>	<input type="checkbox"/>	<input type="checkbox"/>	<input type="checkbox"/>	<input type="checkbox"/>			
Coolant level (low)/Contaminated coolant	<input type="checkbox"/>	<input type="checkbox"/>	<input type="checkbox"/>	<input type="checkbox"/>	<input type="checkbox"/>		<input type="checkbox"/>	<input type="checkbox"/>			<input type="checkbox"/>	<input type="checkbox"/>			

● ; High Possibility Item
○ ; Low Possibility Item

TROUBLE DIAGNOSIS — General Description

CONSULT Reference Value in Data Monitor Mode

Remarks:

- Specification data are reference values.
- Specification data are output/input values which are detected or supplied by the ECM at the connector.
- * Specification data may not be directly related to their components signals/values/operations.
i.e. Adjust ignition timing with a timing light before monitoring IGN TIMING, because the monitor may show the specification data in spite of the ignition timing not being adjusted to the specification data. This IGN TIMING monitors the data calculated by the ECM according to the signals input from the camshaft position sensor and other ignition timing related sensors.
- If the real-time diagnosis results are NG and the on board diagnostic system results are OK when diagnosing the mass air flow sensor, first check to see if the fuel pump control circuit is normal.

MONITOR ITEM	CONDITION		SPECIFICATION
CMPS-RPM (POS)	<ul style="list-style-type: none"> ● Tachometer: Connect ● Run engine and compare tachometer indication with the CONSULT value. 		Almost the same speed as the CONSULT value.
MAS AIR/FL SE	<ul style="list-style-type: none"> ● Engine: After warming up ● Air conditioner switch: "OFF" ● Shift lever: "N" ● No-load 	Idle	1.0 - 1.7V
		2,500 rpm	1.5 - 2.1V
COOLAN TEMP/S	<ul style="list-style-type: none"> ● Engine: After warming up 		More than 70°C (158°F)
FR O2 SEN-B2 FR O2 SEN-B1	<ul style="list-style-type: none"> ● Engine: After warming up 	Maintaining engine speed at 2,000 rpm	0 - 0.3V ↔ Approx. 0.6 - 1.0V
FR O2 MNTR-B2 FR O2 MNTR-B1			LEAN ↔ RICH Changes more than 5 times during 10 seconds.
RR O2 SEN-B1 RR O2 SEN-B2			0 - 0.3V ↔ Approx. 0.6 - 1.0V
RR O2 MNTR-B1 RR O2 MNTR-B2			LEAN ↔ RICH
VHCL SPEED SE	<ul style="list-style-type: none"> ● Turn drive wheels and compare speedometer indication with the CONSULT value 		Almost the same speed as the CONSULT value
BATTERY VOLT	<ul style="list-style-type: none"> ● Ignition switch: ON (Engine stopped) 		11 - 14V
THRTL POS SEN	<ul style="list-style-type: none"> ● Ignition switch: ON (Engine stopped) 	Throttle valve: fully closed	0.3 - 0.7V
		Throttle valve: fully opened	Approx. 4.0V
EGR TEMP SEN	<ul style="list-style-type: none"> ● Engine: After warming up 		Less than 4.5V
START SIGNAL	<ul style="list-style-type: none"> ● Ignition switch: ON → START → ON 		OFF → ON → OFF
CLSD THL/P SW	<ul style="list-style-type: none"> ● Ignition switch: ON (Engine stopped) 	Throttle valve: Idle position	ON
		Throttle valve: Slightly open	OFF
AIR COND SIG	<ul style="list-style-type: none"> ● Engine: After warming up, idle the engine 	Air conditioner switch: "OFF"	OFF
		Air conditioner switch: "ON" (Compressor operates.)	ON
P/N POSI SW	<ul style="list-style-type: none"> ● Ignition switch: ON 	Shift lever: "P" or "N"	ON
		Except above	OFF
PW/ST SIGNAL	<ul style="list-style-type: none"> ● Engine: After warming up, idle the engine 	Steering wheel in neutral position (forward direction)	OFF
		The steering wheel is turned	ON
AMB TEMP SW	<ul style="list-style-type: none"> ● Ignition switch: ON ● Compare ambient temperature with the following: 	Below 23.5°C (74°F)	OFF
		Above 23.5°C (74°F)	ON

TROUBLE DIAGNOSIS — General Description

CONSULT Reference Value in Data Monitor Mode (Cont'd)

MONITOR ITEM	CONDITION	SPECIFICATION
IGNITION SW	● Ignition switch: ON → OFF → ON	ON → OFF → ON
INJ PULSE-B2	<ul style="list-style-type: none"> ● Engine: After warming up ● Air conditioner switch: "OFF" ● Shift lever: "N" ● No-load 	Idle
INJ PULSE-B1		2,000 rpm
B/FUEL SCHDL	ditto	Idle
		2,000 rpm
IGN TIMING	ditto	Idle
		2,000 rpm
IACV-AAC/V	ditto	Idle
		2,000 rpm
PURG VOL C/V	<ul style="list-style-type: none"> ● Engine: After warming up ● Air conditioner switch "OFF" 	Idle
		Vehicle running (Shift lever "1")
A/F ALPHA-B2	<ul style="list-style-type: none"> ● Engine: After warming up 	Maintaining engine speed at 2,000 rpm
A/F ALPHA-B1		
EVAP SYS PRES	● Ignition switch: ON	Approx. 3.4V
AIR COND RLY	● Air conditioner switch: OFF → ON	OFF → ON
FUEL PUMP RLY	<ul style="list-style-type: none"> ● Ignition switch is turned ON (Operates for 5 seconds) ● Engine running and cranking 	ON
	Except as shown above	OFF
EGRC SOL/V	<ul style="list-style-type: none"> ● Engine: After warming up ● Air conditioner switch: "OFF" ● Shift lever: "N" ● No-load 	Idle
		Engine speed: Revving from 1,500 to 4,000 rpm
VENT CONT/V	● Ignition switch: ON	OFF
FR O2 HTR-B1	● Engine speed: Idle	ON
FR O2 HTR-B2	● Engine speed: Above 3,200 rpm	OFF
RR O2 HTR-B1	● Engine speed: Idle	ON
RR O2 HTR-B2	● Engine speed: Above 3,200 rpm	OFF
VC/V BYPASS/V	● Ignition switch: ON	OFF
PURG CONT S/V	<ul style="list-style-type: none"> ● Engine: After warming up 	Idle
		2,000 rpm
CAL/LD VALUE	<ul style="list-style-type: none"> ● Engine: After warming up ● Air conditioner switch: "OFF" ● Shift lever: "N" ● No-load 	Idle
		2,500 rpm
ABSOL TH/P/S	<ul style="list-style-type: none"> ● Ignition switch: ON (Engine stopped) 	Throttle valve: fully closed
		Throttle valve: fully opened
MASS AIRFLOW	<ul style="list-style-type: none"> ● Engine: After warming up ● Air conditioner switch: "OFF" ● Shift lever: "N" ● No-load 	Idle
		2,500 rpm
MAP/BARO SW/V	● Ignition switch: ON	BARO
	● Engine: After warming up	Idle: For 10 seconds after engine start
ABSOL PRES/SE	<ul style="list-style-type: none"> ● Engine: After warming up 	Engine is not running
		Idle (5 seconds after starting engine)

Major Sensor Reference Graph in Data Monitor Mode

The following are the major sensor reference graphs in "DATA MONITOR" mode.
(Select "HI SPEED" in "DATA MONITOR" with CONSULT.)

THRTL POS SEN, ABSOL TH·P/S, CLSD THL/P SW

Below is the data for "THRTL POS SEN", "ABSOL TH·P/S" and "CLSD THL/P SW" when depressing the accelerator pedal with the ignition switch "ON".
The signal of "THRTL POS SEN" and "ABSOL TH·P/S" should rise gradually without any intermittent drop or rise after "CLSD THL/P SW" is changed from "ON" to "OFF".

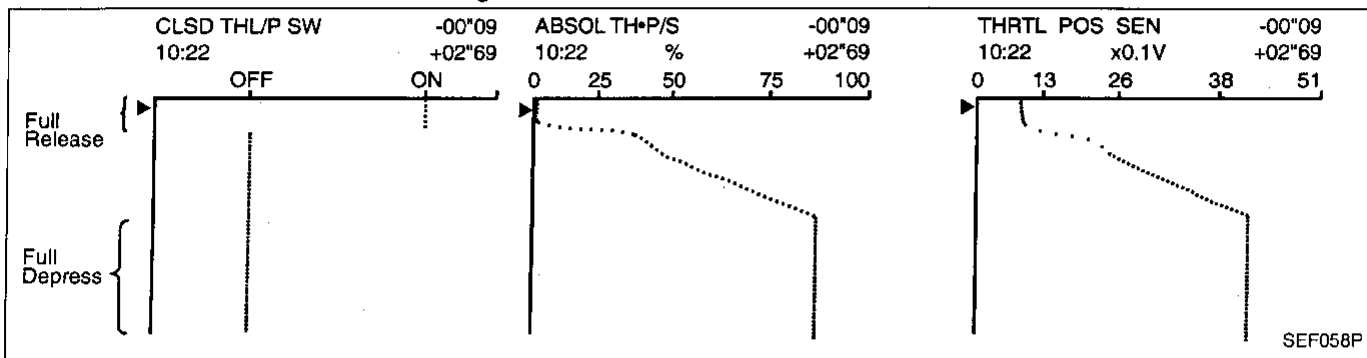

CMPS·RPM (POS), MAS AIR/FL SE, THRTL POS SEN, RR O2 SEN-B1, FR O2 SEN-B1, INJ PULSE-B1

Below is the data for "CMPS·RPM (POS)", "MAS AIR/FL SE", "THRTL POS SEN", "RR O2 SEN-B1", "FR O2 SEN-B1" and "INJ PULSE-B1" when revving engine quickly up to 4,800 rpm under no load after warming up engine sufficiently.

Each value is for reference, the exact value may vary.

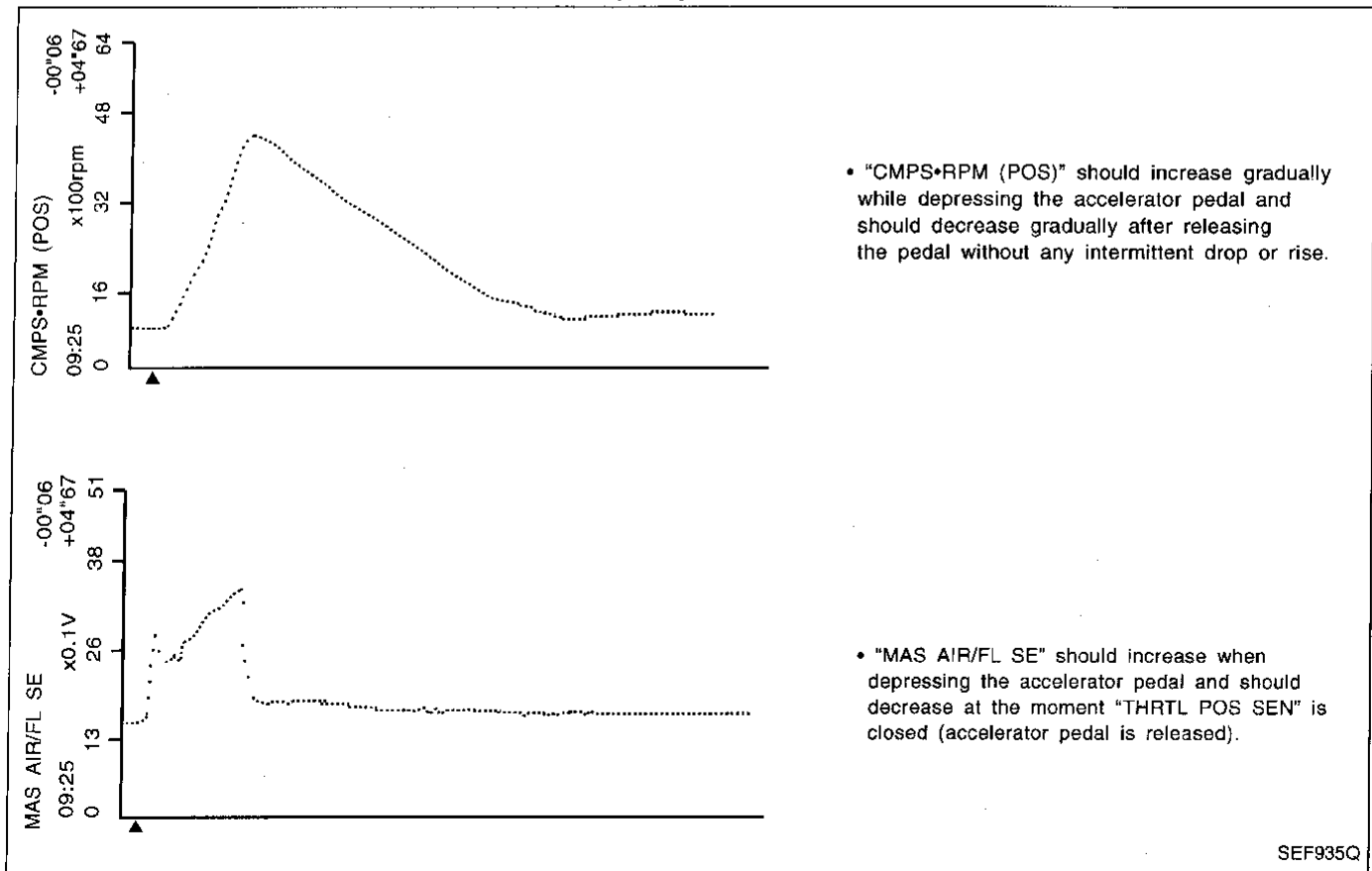

TROUBLE DIAGNOSIS — General Description

Major Sensor Reference Graph in Data Monitor Mode (Cont'd)

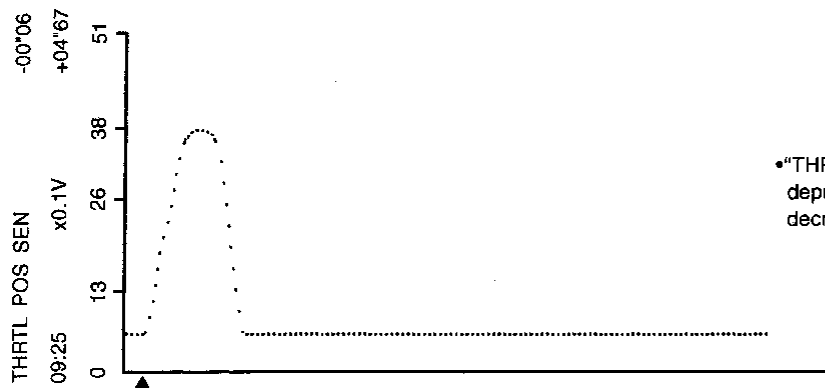

•"THRTL POS SEN" should increase while depressing the accelerator pedel and should decrease while releasing it.

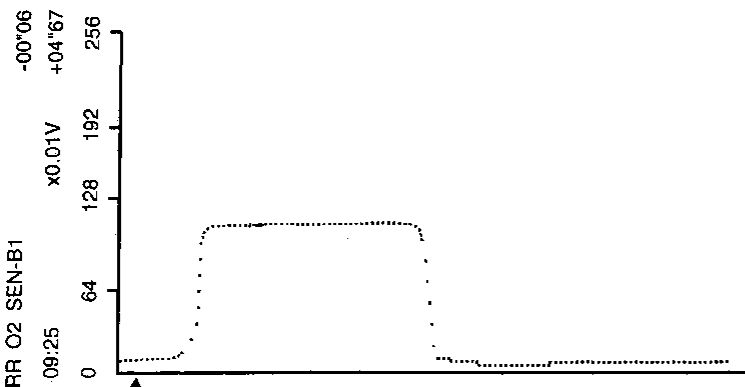

•"RR O2 SEN-B1" may increase immediately after depressing the accelerator pedel and may decrease after releasing the pedel.

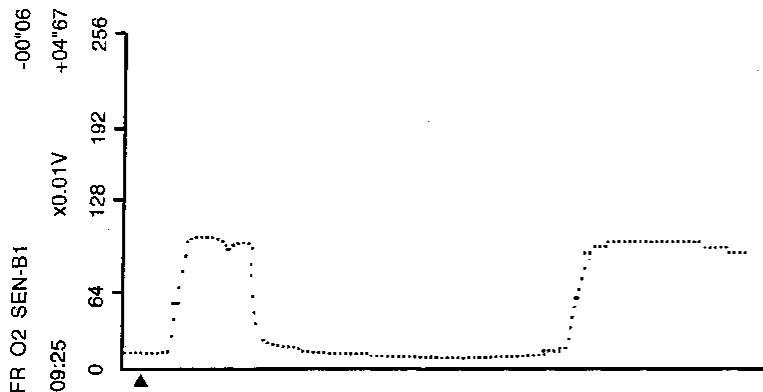

•"FR O2 SEN-B1" may increase immediately after depressing the accelerator pedel and may decrease after releasing the pedel.

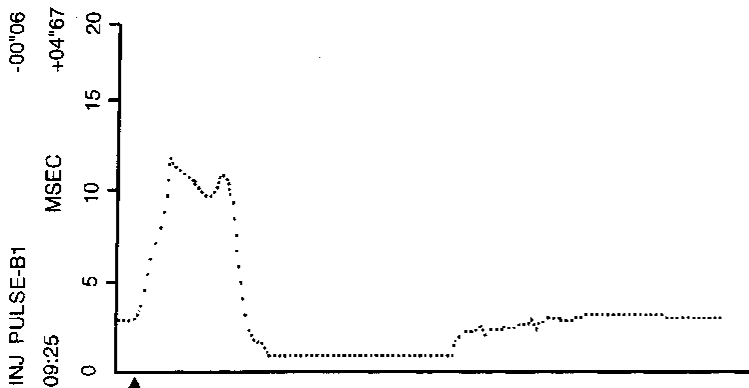

•"INJ PULSE-B1" should increase when depressing the accelerator pedel and should decrease when the pedel is released.

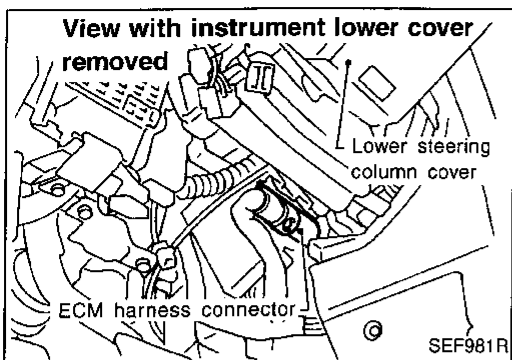

ECM Terminals and Reference Value

PREPARATION

1. ECM is located behind the instrument lower cover. For this inspection:
 - Remove instrument lower cover.

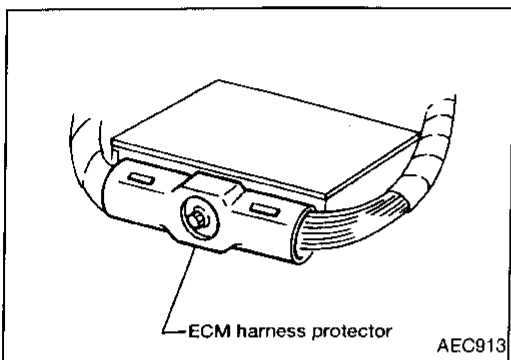

2. Remove ECM harness protector.

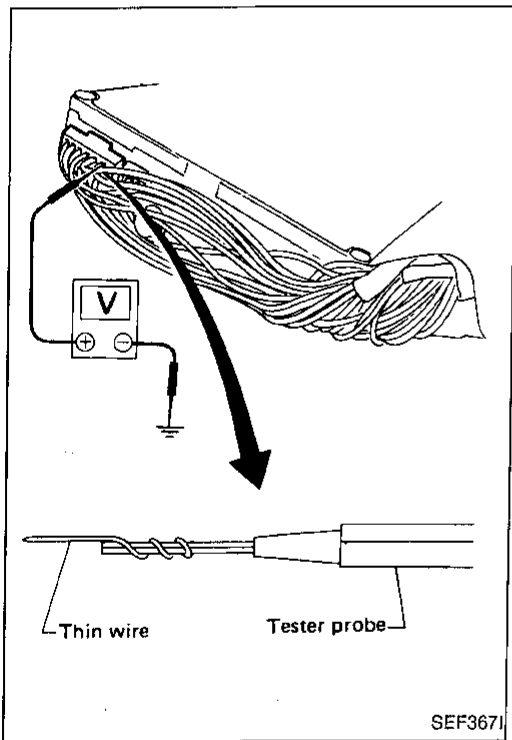

3. Perform all voltage measurements with the connector connected. Extend tester probe as shown to perform tests easily.
 - Open harness securing clip to make testing easier.
 - Use extreme care not to touch 2 pins at one time.
 - Data is for comparison and may not be exact.

ECM HARNESS CONNECTOR TERMINAL LAYOUT

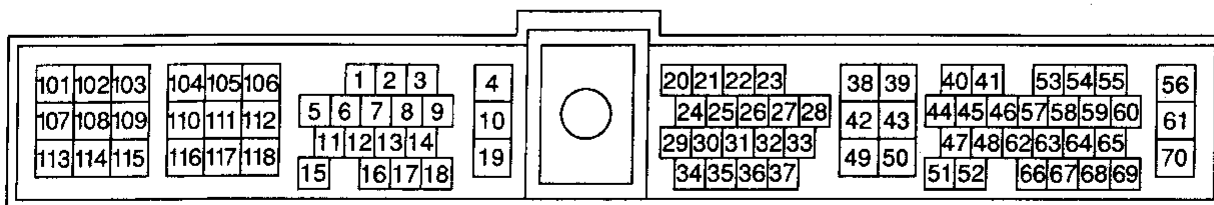

SEF064P

GI
 MA
 EM
 LC
EC
 FE
 AT
 TF
 PD
 FA
 RA
 BR
 ST
 RS
 BT
 HA
 EL
 IDX

TROUBLE DIAGNOSIS — General Description

ECM Terminals and Reference Value (Cont'd)

ECM INSPECTION TABLE

Specification data are reference values and are measured between each terminal and Ⓞ (ECCS ground).

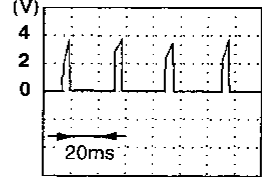
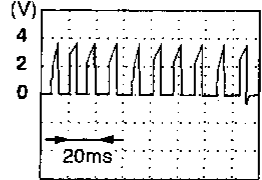
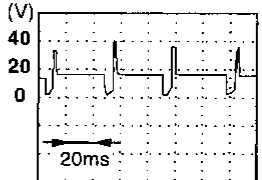
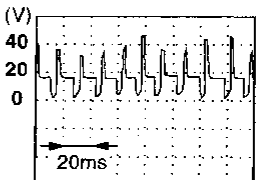
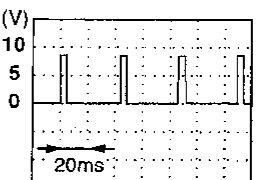
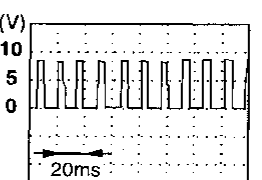
TER-MINAL NO.	WIRE COLOR	ITEM	CONDITION	DATA (DC Voltage)
1	W/B	Ignition signal	<p>Engine is running.</p> <p>└ Idle speed</p>	<p>0.9V</p>  <p>SEF186T</p>
			<p>Engine is running.</p> <p>└ Engine speed is 2,000 rpm</p>	<p>1.1 - 1.3V</p>  <p>SEF187T</p>
2	W/G	Ignition check	<p>Engine is running. (Warm-up condition)</p> <p>└ Idle speed</p>	<p>8.7V</p>  <p>SEF188T</p>
			<p>Engine is running.</p> <p>└ Engine speed is 2,000 rpm.</p>	<p>Approximately 13V</p>  <p>SEF189T</p>
3	W	Tachometer	<p>Engine is running. (Warm-up condition)</p> <p>└ Idle speed</p>	<p>3.7V</p>  <p>SEF190T</p>
			<p>Engine is running.</p> <p>└ Engine speed is 2,000 rpm</p>	<p>5V</p>  <p>SEF191T</p>

TROUBLE DIAGNOSIS — General Description

ECM Terminals and Reference Value (Cont'd)

TER-MINAL NO.	WIRE COLOR	ITEM	CONDITION	DATA (DC Voltage)	
4	L/B	ECCS relay (Self-shutoff)	Engine is running. Ignition switch "OFF" └ For a few seconds after turning ignition switch "OFF"	0 - 1V	GI MA EM
			Ignition switch "OFF" └ A few seconds passed after turning ignition switch "OFF"	BATTERY VOLTAGE (11 - 14V)	LC
5	L	EVAP canister purge volume control valve	Engine is running. └ Idle speed	0 - 0.4V or BATTERY VOLTAGE (11 - 14V)	EC
6	YL				
7	Y/G	A/T check signal	Ignition switch "ON" Engine is running.	0 - 3.0V	FE AT
8	R/L	Fuel pump relay	Ignition switch "ON" └ For 5 seconds after turning ignition switch "ON"	0 - 1V	TF
			Engine is running. Ignition switch "ON" └ More than 5 seconds after turning ignition switch "ON"	BATTERY VOLTAGE (11 - 14V)	PD FA
9	G/OR	Ambient air temperature switch	Ignition switch "ON" └ Idle speed └ Ambient air temperature is above 23.5°C (74°F) └ Air conditioner is operating	0V	RA
			Ignition switch "ON" └ Idle speed └ Ambient air temperature is below 23.5°C (74°F) └ Air conditioner is operating	BATTERY VOLTAGE (11 - 14V)	BR ST
10	B	ECCS ground	Engine is running. └ Idle speed	Engine ground	RS
15	G/R	Air conditioner relay	Engine is running. └ Both A/C switch and blower switch are "ON"	Approximately 0V	BT
			Engine is running. └ A/C switch is "OFF"	BATTERY VOLTAGE (11 - 14V)	HA
16	W/B	EVAP canister purge volume control valve	Engine is running. └ Idle speed	0 - 0.4V or BATTERY VOLTAGE (11 - 14V)	EL
17	R/G				
18	G/R	Malfunction indicator lamp	Ignition switch "ON"	Approximately 0.1V	IDX
			Engine is running. └ Idle speed	BATTERY VOLTAGE (11 - 14V)	
19	B	ECCS ground	Engine is running. └ Idle speed	Engine ground	

*: Any mode except "OFF", ambient air temperature above 10°C (50°F).

TROUBLE DIAGNOSIS — General Description

ECM Terminals and Reference Value (Cont'd)

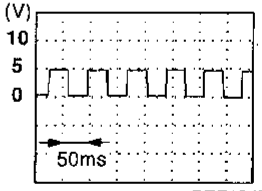
TER-MINAL NO.	WIRE COLOR	ITEM	CONDITION	DATA (DC Voltage)
20	B/Y	Start signal	Ignition switch "ON"	Approximately 0V
			Ignition switch "START"	BATTERY VOLTAGE (11 - 14V)
21	B/W	Air conditioner switch	Engine is running. └ Both air conditioner switch and blower switch are "ON" (Compressor operates)	Approximately 0V
			Engine is running. └ Air conditioner switch is "OFF"	BATTERY VOLTAGE (11 - 14V)
22	L/B	Inhibitor switch	Ignition switch "ON" └ Gear position is "N" or "P"	Approximately 0V
			Ignition switch "ON" └ Except the above gear position	Approximately 5V
23	W	Throttle position sensor	Ignition switch "ON" └ Accelerator pedal released	0.3 - 0.7V
			Ignition switch "ON" └ Accelerator pedal fully depressed	Approximately 4V
24	PU/W	A/T signal No. 1	Ignition switch "ON"	6 - 8V
			Engine is running. └ Idle speed	
25	R/B	Power steering oil pressure switch	Engine is running. └ Steering wheel is being turned	Approximately 0V
			Engine is running. └ Steering wheel is not being turned	Approximately 5V
26	W/L	Vehicle speed sensor	Engine is running. └ Lift up the vehicle. └ In 1st gear position └ Idle speed	1.9 - 2.1V  SEF194T
27	OR/W	Throttle position switch (Closed position)	Ignition switch "ON" (Warm-up condition) └ Accelerator pedal released	BATTERY VOLTAGE (11 - 14V)
			Ignition switch "ON" └ Accelerator pedal depressed	Approximately 0V
28	Y/L	Intake air temperature sensor	Engine is running.	Approximately 0 - 4.8V Output voltage varies with intake air temperature.

TROUBLE DIAGNOSIS — General Description

ECM Terminals and Reference Value (Cont'd)

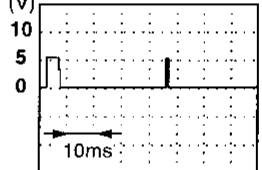
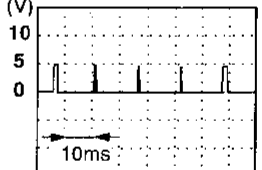
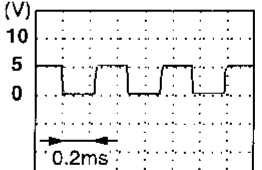
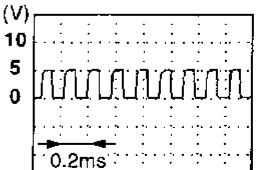
TER-MINAL NO.	WIRE COLOR	ITEM	CONDITION	DATA (DC Voltage)
29	P/B	A/T signal No. 2	<div style="border: 1px solid black; padding: 2px; display: inline-block;">Ignition switch "ON"</div> <div style="border: 1px solid black; padding: 2px; display: inline-block;">Engine is running.</div> Idle speed	6 - 8V
30	P	A/T signal No. 3	<div style="border: 1px solid black; padding: 2px; display: inline-block;">Ignition switch "ON"</div>	0V
33	P	Throttle position sensor signal	<div style="border: 1px solid black; padding: 2px; display: inline-block;">Ignition switch "ON"</div> Accelerator pedal released	Approximately 0.4V
			<div style="border: 1px solid black; padding: 2px; display: inline-block;">Ignition switch "ON"</div> Accelerator pedal fully depressed	Approximately 4V
38	B/W	Ignition switch	<div style="border: 1px solid black; padding: 2px; display: inline-block;">Ignition switch "OFF"</div>	0V
			<div style="border: 1px solid black; padding: 2px; display: inline-block;">Ignition switch "ON"</div>	BATTERY VOLTAGE (11 - 14V)
39	B	ECCS ground	<div style="border: 1px solid black; padding: 2px; display: inline-block;">Engine is running.</div> Idle speed	Engine ground
40	L	Camshaft position sensor (Reference signal)	<div style="border: 1px solid black; padding: 2px; display: inline-block;">Engine is running.</div> Idle speed	1.1V  SEF199T
			<div style="border: 1px solid black; padding: 2px; display: inline-block;">Engine is running.</div> Engine speed is 2,000 rpm.	1.1V  SEF200T
41	B/W	Camshaft position sensor (Position signal)	<div style="border: 1px solid black; padding: 2px; display: inline-block;">Engine is running.</div> (Warm-up condition) Idle speed	Approximately 2.5V  SEF195T
			<div style="border: 1px solid black; padding: 2px; display: inline-block;">Engine is running.</div> Engine speed is 2,000 rpm.	Approximately 2.5V  SEF196T

GI
 MA
 EM
 LC
EC
 FE
 AT
 TF
 PD
 FA
 RA
 BR
 ST
 RS
 BT
 HA
 EL
 IDX

TROUBLE DIAGNOSIS — General Description

ECM Terminals and Reference Value (Cont'd)

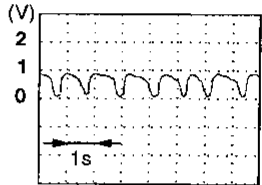
TER-MINAL NO.	WIRE COLOR	ITEM	CONDITION	DATA (DC Voltage)
43	B	ECCS ground	Engine is running. └ Idle speed	Engine ground (Probe this terminal with ⊖ tester probe when measuring.)
45	W	Absolute pressure sensor	Ignition switch "ON" └ Engine is not running.	Approximately 4.4V
			Engine is running. (Warm-up condition) └ Idle speed (5 seconds after starting engine)	Approximately 1.2V
46	W	Front heated oxygen sensor (RH)	Engine is running. └ After warming up sufficiently and engine speed is 2,000 rpm	0 - Approximately 1.0V 
47	W	Mass air flow sensor	Engine is running. (Warm-up condition) └ Idle speed	1.3 - 1.7V
			Engine is running. (Warm-up condition) └ Engine speed is 2,500 rpm	1.7 - 2.1V
48	B	Mass air flow sensor ground	Engine is running. (Warm-up condition) └ Idle speed	Approximately 0V
49	P/B	Sensors' power supply	Ignition switch "ON"	Approximately 5V
50	B	Sensors' ground	Engine is running. (Warm-up condition) └ Idle speed	Approximately 0V
51	LG/R	Engine coolant temperature sensor	Engine is running.	Approximately 0 - 4.8V Output voltage varies with engine coolant temperature.
52	L/W	Rear heated oxygen sensor (RH)	Engine is running. └ After warming up sufficiently and engine speed is 2,000 rpm	0 - Approximately 1.0V

TROUBLE DIAGNOSIS — General Description

ECM Terminals and Reference Value (Cont'd)

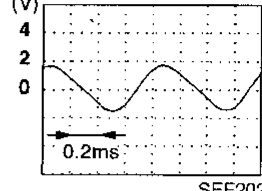
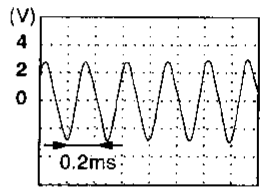
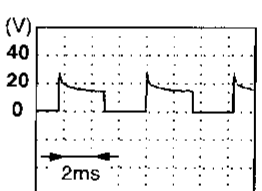
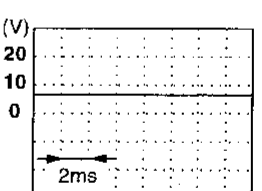
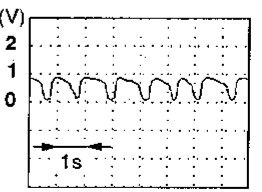
TER-MINAL NO.	WIRE COLOR	ITEM	CONDITION	DATA (DC Voltage)
53	L	Crankshaft position sensor (OBD)	<div style="border: 1px solid black; padding: 2px; display: inline-block;">Engine is running.</div> (Warm-up condition) └ Idle speed	Approximately 1.4V (AC range) 
			<div style="border: 1px solid black; padding: 2px; display: inline-block;">Engine is running.</div> └ Engine speed is 2,000 rpm	Approximately 1.4V (AC range) 
54	W	Knock sensor	<div style="border: 1px solid black; padding: 2px; display: inline-block;">Engine is running.</div> └ Idle speed	Approximately 2.5V
55	OR	IACV-AAC valve	<div style="border: 1px solid black; padding: 2px; display: inline-block;">Engine is running.</div> (Warm-up condition) └ Idle speed	8 - 11V 
			<div style="border: 1px solid black; padding: 2px; display: inline-block;">Engine is running.</div> (Warm-up condition) └ Engine speed is 2,000 rpm	5 - 8V 
56	B/W	Power supply for ECM	<div style="border: 1px solid black; padding: 2px; display: inline-block;">Ignition switch "ON"</div>	BATTERY VOLTAGE (11 - 14V)
61	B/W			
57	W	Front heated oxygen sensor (LH)	<div style="border: 1px solid black; padding: 2px; display: inline-block;">Engine is running.</div> └ After warming up sufficiently and engine speed is 2,000 rpm	0 - Approximately 1.0V 
58	LG/R	Data link connector for GST	<div style="border: 1px solid black; padding: 2px; display: inline-block;">Engine is running.</div> └ Idle speed (GST is disconnected)	6 - 10V

CI
 MA
 EM
 LC
 EC
 FE
 AT
 TF
 PD
 FA
 RA
 BR
 ST
 RS
 BT
 HA
 EL
 IDX

TROUBLE DIAGNOSIS — General Description

ECM Terminals and Reference Value (Cont'd)

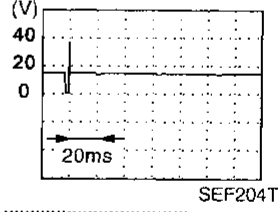
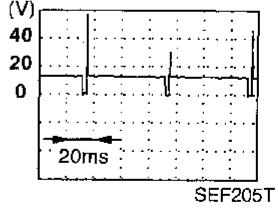
TER-MINAL NO.	WIRE COLOR	ITEM	CONDITION	DATA (DC Voltage)
59	Y/B	MAP/BARO switch solenoid valve	<div style="border: 1px solid black; padding: 2px; display: inline-block;">Ignition switch "ON"</div> Engine is not running	BATTERY VOLTAGE (11 - 14V)
			<div style="border: 1px solid black; padding: 2px; display: inline-block;">Engine is running.</div> After engine warming up Idle (for 10 seconds after engine start)	Approximately 0V
62	P/G	EGR temperature sensor	<div style="border: 1px solid black; padding: 2px; display: inline-block;">Engine is running.</div> (Warm-up condition) Idle speed	Less than 4.5V
			<div style="border: 1px solid black; padding: 2px; display: inline-block;">Engine is running.</div> (Warm-up condition) EGR system is operating	0 - 1.5V
63	Y	Tank fuel temperature sensor	<div style="border: 1px solid black; padding: 2px; display: inline-block;">Engine is running.</div>	Approximately 0 - 4.8V Output voltage varies with fuel temperature.
64	W	Data link connector for CONSULT	<div style="border: 1px solid black; padding: 2px; display: inline-block;">Engine is running.</div>	Approximately 0V
65	L		Idle speed (Connect CONSULT and select "DATA MONITOR" mode.)	Approximately 4 - 9V
68	OR			Approximately 3.5V*
66	W	Rear heated oxygen sensor (LH)	<div style="border: 1px solid black; padding: 2px; display: inline-block;">Engine is running.</div> After warming up sufficiently and engine speed is 2,000 rpm	0 - Approximately 1.0V
67	G	EVAP control system pressure sensor	<div style="border: 1px solid black; padding: 2px; display: inline-block;">Ignition switch "ON"</div>	Approximately 3.4V
70	W/R	Power supply (Back-up)	<div style="border: 1px solid black; padding: 2px; display: inline-block;">Ignition switch "OFF"</div>	BATTERY VOLTAGE (11 - 14V)
102	W	Injector No. 1		BATTERY VOLTAGE (11 - 14V)
104	Y/R	Injector No. 3	<div style="border: 1px solid black; padding: 2px; display: inline-block;">Engine is running.</div> (Warm-up condition) Idle speed	
107	Y	Injector No. 2		
109	W/L	Injector No. 4		
111	W/G	Injector No. 5	<div style="border: 1px solid black; padding: 2px; display: inline-block;">Engine is running.</div> (Warm-up condition) Engine speed is 2,000 rpm	
114	W/B	Injector No. 6		
101	PU/R	Rear heated oxygen sensor heater (LH)	<div style="border: 1px solid black; padding: 2px; display: inline-block;">Engine is running.</div> Engine speed is below 3,200 rpm	Approximately 0.4V
			<div style="border: 1px solid black; padding: 2px; display: inline-block;">Engine is running.</div> Engine speed is above 3,200 rpm	BATTERY VOLTAGE (11 - 14V)

TROUBLE DIAGNOSIS — General Description

ECM Terminals and Reference Value (Cont'd)

TER-MINAL NO.	WIRE COLOR	ITEM	CONDITION	DATA (DC Voltage)	
103	L/W	EGRC-solenoid valve	Engine is running. └ Idle speed	0 - 0.7V	GI
			Engine is running. └ Engine speed is above 2,000 rpm	BATTERY VOLTAGE (11 - 14V)	MA EM
105	Y/R	EVAP canister purge control solenoid valve	Engine is running. └ Idle speed	BATTERY VOLTAGE (11 - 14V)	LC
			Engine is running. └ Engine speed is 2,000 rpm	Approximately 0V	EC
106	B	ECCS ground	Engine is running. └ Idle speed	Engine ground	FE
108	Y/G	EVAP canister vent control valve	Ignition switch "ON"	BATTERY VOLTAGE (11 - 14V)	AT
110	PU/W	Front heated oxygen sensor heater (LH)	Engine is running. └ Engine speed is below 3,200 rpm	Approximately 0.4V	TF
			Engine is running. └ Engine speed is above 3,200 rpm	BATTERY VOLTAGE (11 - 14V)	PD
112	B	ECCS ground	Engine is running. └ Idle speed	Engine ground	FA
113	B/W	Current return	Engine is running. └ Idle speed	BATTERY VOLTAGE (11 - 14V)	RA
115	PU	Front heated oxygen sensor heater (RH)	Engine is running. └ Engine speed is below 3,200 rpm	Approximately 0.4V	BR
			Engine is running. └ Engine speed is above 3,200 rpm	BATTERY VOLTAGE (11 - 14V)	ST
116	PU/G	Rear heated oxygen sensor heater (RH)	Engine is running. └ Engine speed is below 3,200 rpm	Approximately 0.4V	RS
			Engine is running. └ Engine speed is above 3,200 rpm	BATTERY VOLTAGE (11 - 14V)	BT HA
117	G/R	Vacuum cut valve bypass valve	Ignition switch "ON"	BATTERY VOLTAGE (11 - 14V)	EL
118	B	ECCS ground	Engine is running. └ Idle speed	Engine ground	EL IDX

Main Power Supply and Ground Circuit

EC-MAIN-01

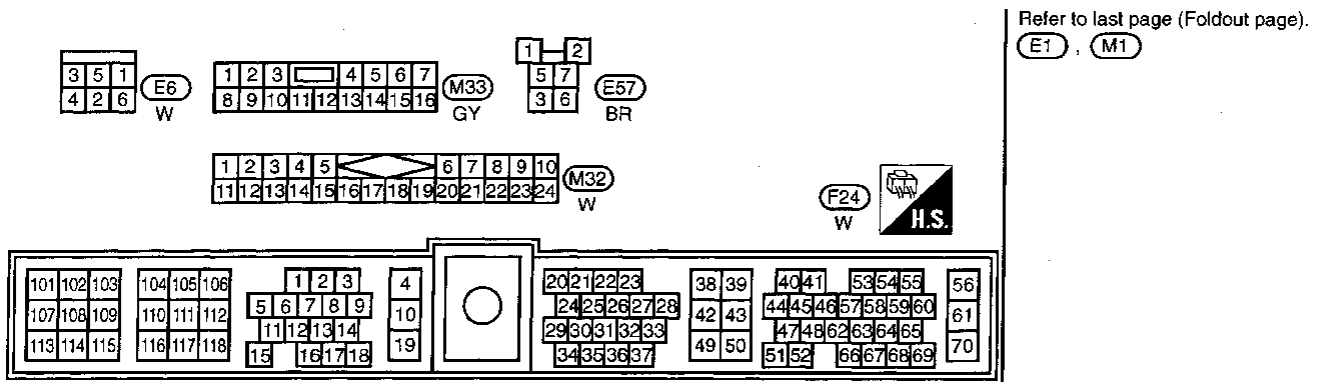
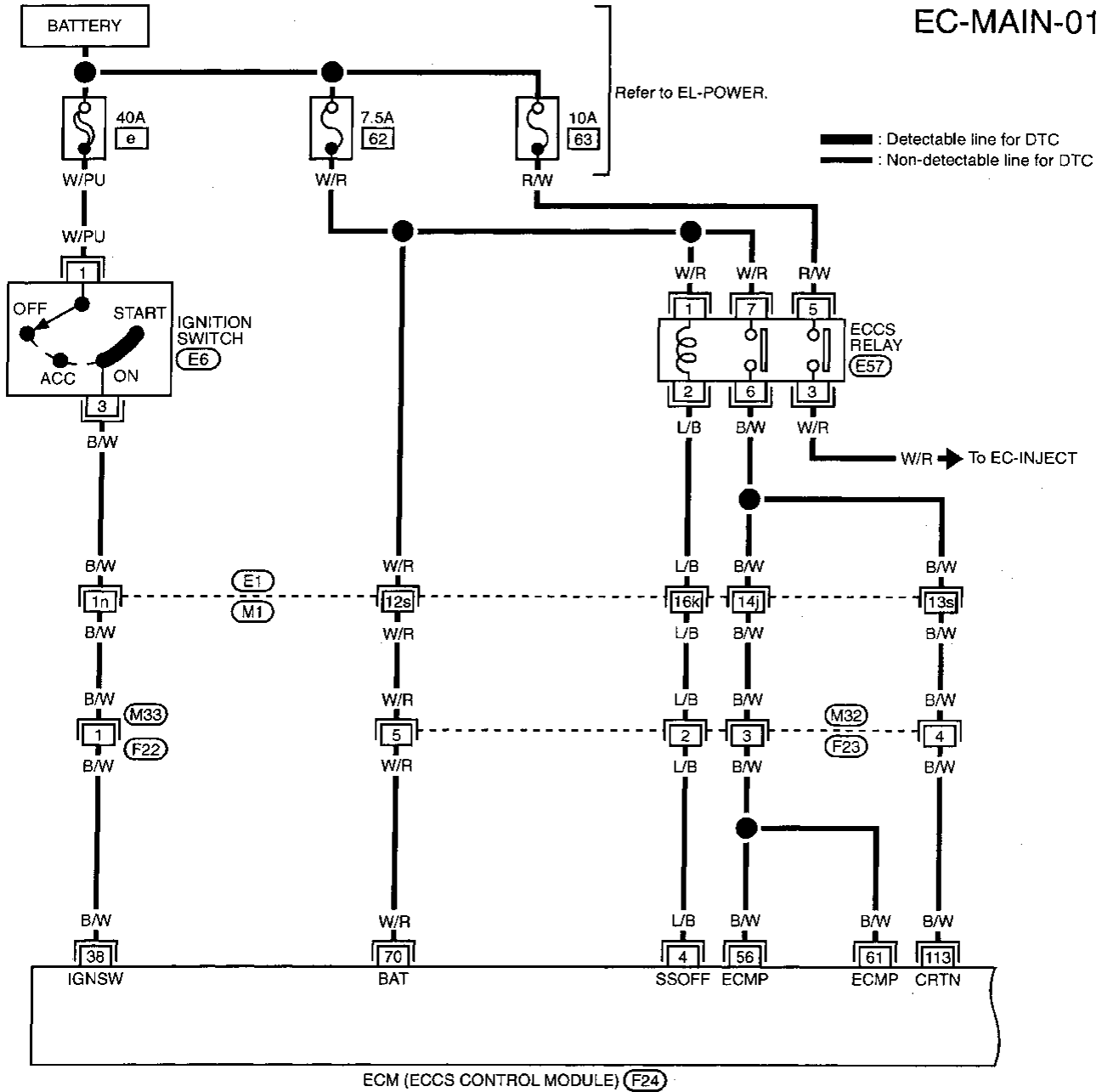

TROUBLE DIAGNOSIS FOR POWER SUPPLY

Main Power Supply and Ground Circuit (Cont'd)

EC-MAIN-02

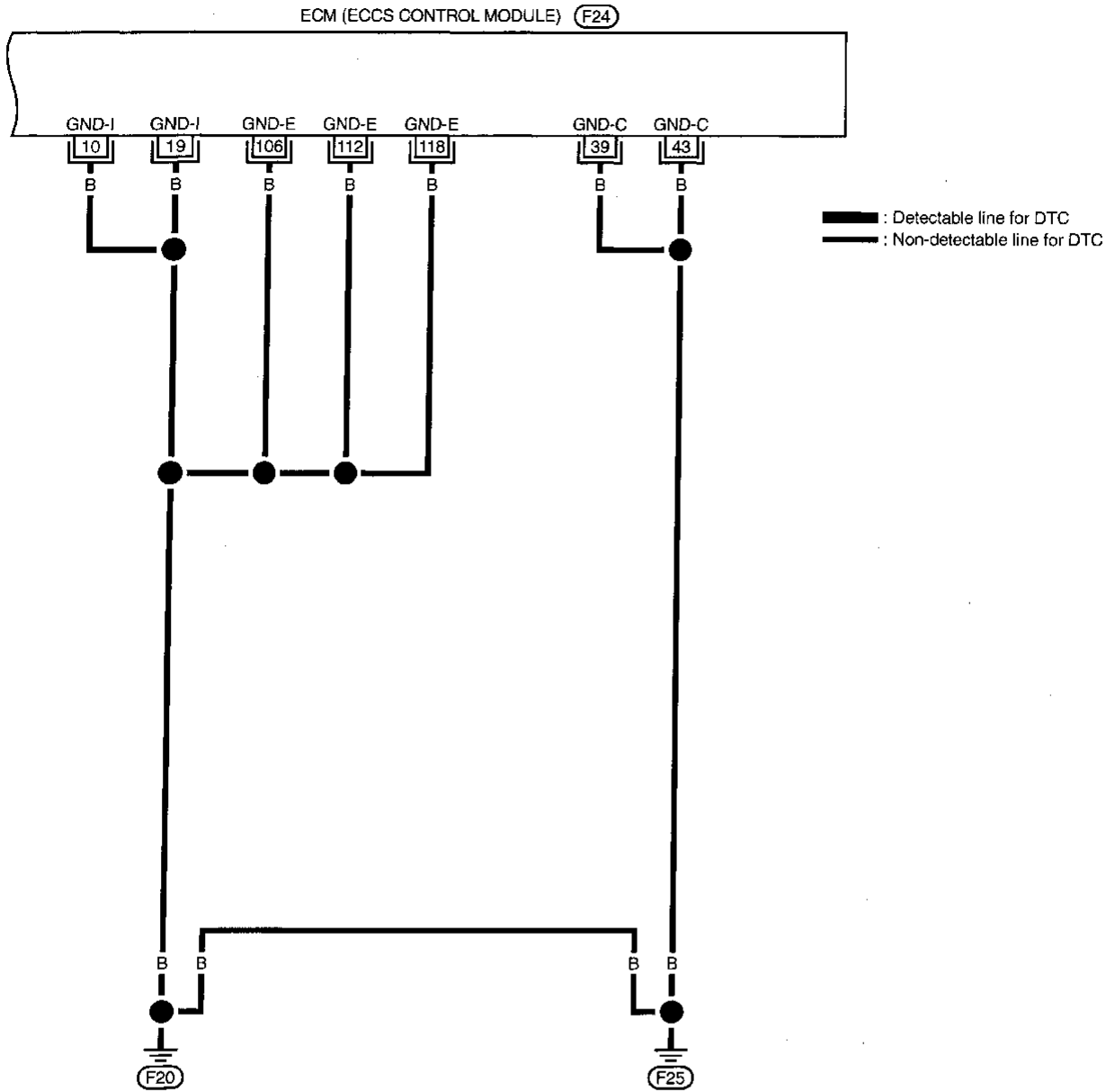

GI
 MA
 EM
 LC
EC
 FE
 AT
 TF
 PD
 FA
 RA
 BR
 ST
 RS
 BT
 HA
 EL
 DX

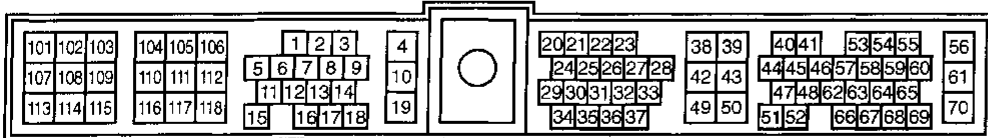

TROUBLE DIAGNOSIS FOR POWER SUPPLY

Main Power Supply and Ground Circuit (Cont'd)

ECM TERMINALS AND REFERENCE VALUE

Specification data are reference values and are measured between each terminal and ④ (ECCS ground).

TER-MINAL NO.	WIRE COLOR	ITEM	CONDITION	DATA (DC Voltage)
4	L/B	ECCS relay (Self-shutoff)	<div style="border: 1px solid black; padding: 2px;">Engine is running.</div> <div style="border: 1px solid black; padding: 2px;">Ignition switch "OFF"</div> <div style="margin-left: 20px;">└ For a few seconds after turning ignition switch "OFF"</div>	0 - 1V
			<div style="border: 1px solid black; padding: 2px;">Ignition switch "OFF"</div> <div style="margin-left: 20px;">└ A few seconds passed after turning ignition switch "OFF"</div>	BATTERY VOLTAGE (11 - 14V)
10	B	ECCS ground	<div style="border: 1px solid black; padding: 2px;">Engine is running.</div> <div style="margin-left: 20px;">└ Idle speed</div>	Engine ground
19	B	ECCS ground	<div style="border: 1px solid black; padding: 2px;">Engine is running.</div> <div style="margin-left: 20px;">└ Idle speed</div>	Engine ground
38	B/W	Ignition switch	<div style="border: 1px solid black; padding: 2px;">Ignition switch "OFF"</div>	0V
			<div style="border: 1px solid black; padding: 2px;">Ignition switch "ON"</div>	BATTERY VOLTAGE (11 - 14V)
39	B	ECCS ground	<div style="border: 1px solid black; padding: 2px;">Engine is running.</div> <div style="margin-left: 20px;">└ Idle speed</div>	Engine ground
43	B	ECCS ground	<div style="border: 1px solid black; padding: 2px;">Engine is running.</div> <div style="margin-left: 20px;">└ Idle speed</div>	Engine ground (Probe this terminal with ⊖ tester probe when measuring.)
56	B/W	Power supply for ECM	<div style="border: 1px solid black; padding: 2px;">Ignition switch "ON"</div>	BATTERY VOLTAGE (11 - 14V)
61	B/W			
70	W/R	Power supply (Back-up)	<div style="border: 1px solid black; padding: 2px;">Ignition switch "OFF"</div>	BATTERY VOLTAGE (11 - 14V)
106	B	ECCS ground	<div style="border: 1px solid black; padding: 2px;">Engine is running.</div> <div style="margin-left: 20px;">└ Idle speed</div>	Engine ground
112	B	ECCS ground	<div style="border: 1px solid black; padding: 2px;">Engine is running.</div> <div style="margin-left: 20px;">└ Idle speed</div>	Engine ground
113	B/W	Current return	<div style="border: 1px solid black; padding: 2px;">Engine is running.</div> <div style="margin-left: 20px;">└ Idle speed</div>	BATTERY VOLTAGE (11 - 14V)
118	B	ECCS ground	<div style="border: 1px solid black; padding: 2px;">Engine is running.</div> <div style="margin-left: 20px;">└ Idle speed</div>	Engine ground

TROUBLE DIAGNOSIS FOR POWER SUPPLY

Main Power Supply and Ground Circuit (Cont'd)

DIAGNOSTIC PROCEDURE

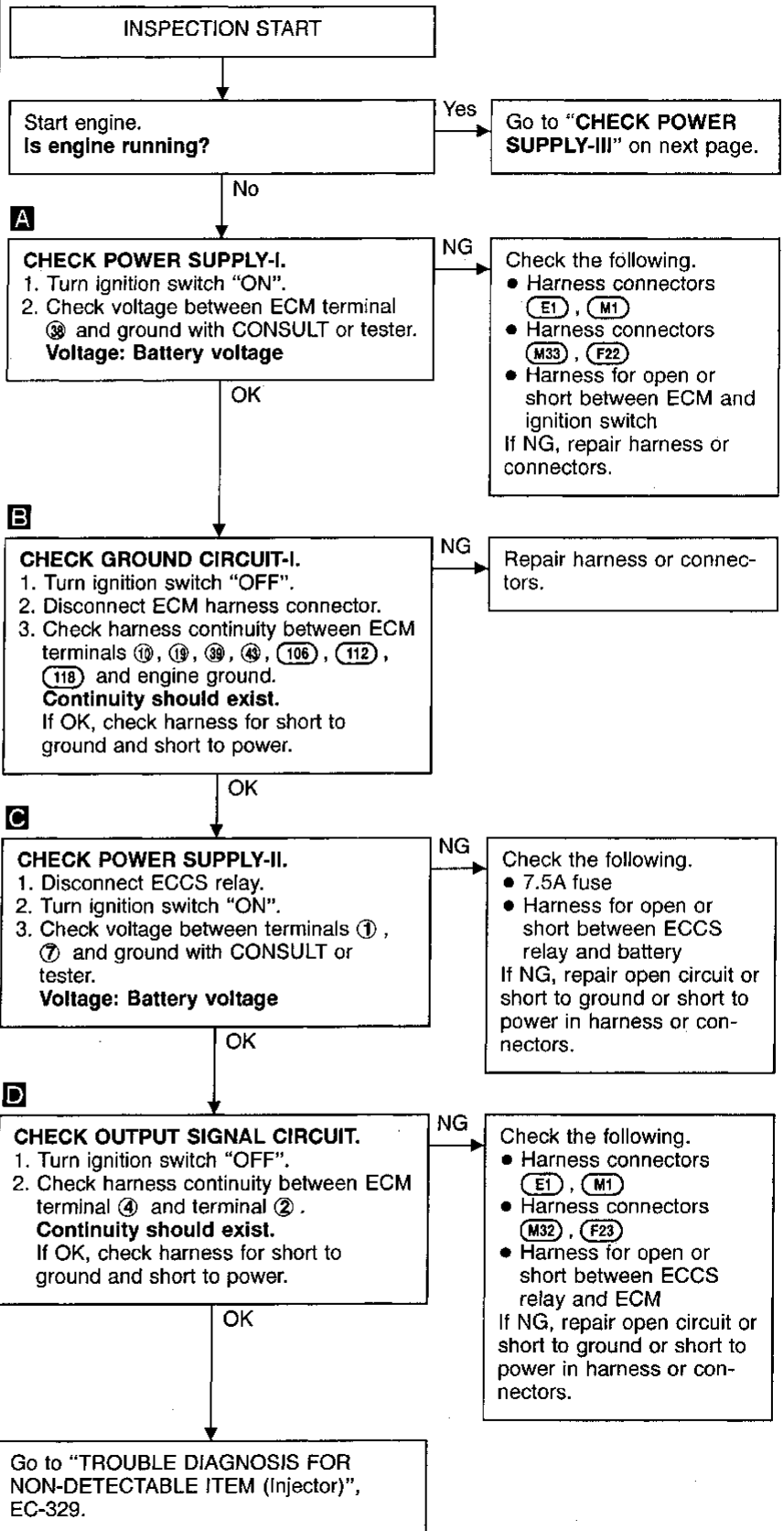
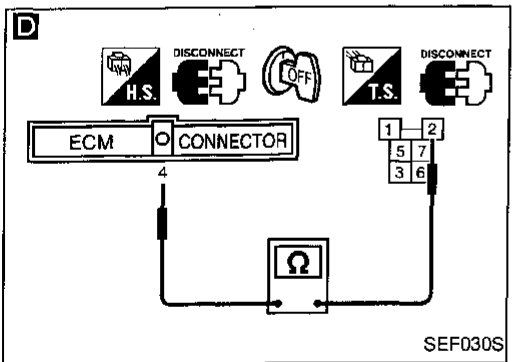
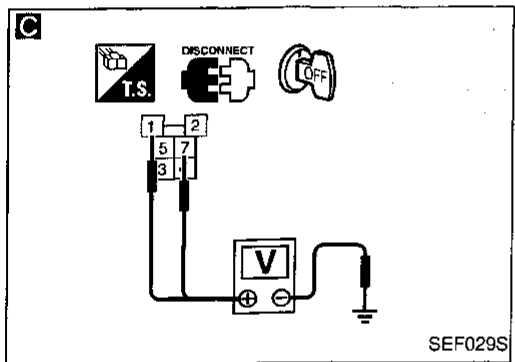
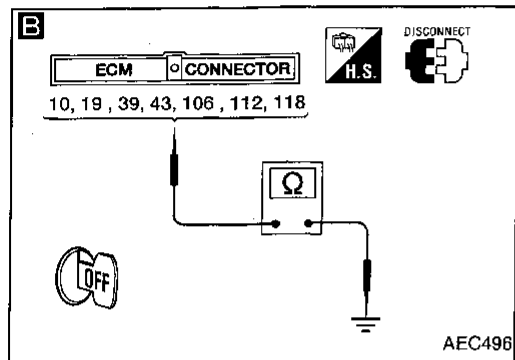
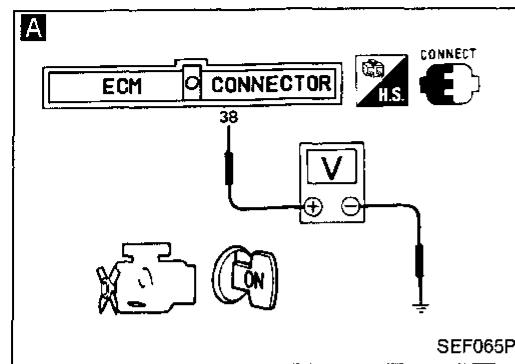

GI
MA
EM
LC
EC
FE
AT
TF
PD
FA
RA
BR
ST
RS
BT
HA
EL
IDX

TROUBLE DIAGNOSIS FOR POWER SUPPLY

Main Power Supply and Ground Circuit (Cont'd)

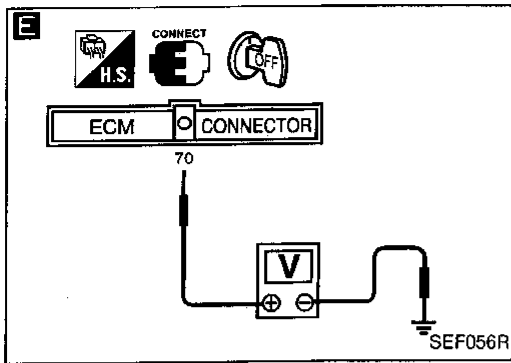

E

CHECK POWER SUPPLY-III.

1. Stop engine.
2. Check voltage between ECM terminal ⑦ and ground with CONSULT or tester.

Voltage: Battery voltage

NG

Check the following.

- Harness connectors (F23, M32)
- Harness connectors (M1, E1)
- Harness for open or short between ECM and fuse

If NG, repair harness or connectors.

OK

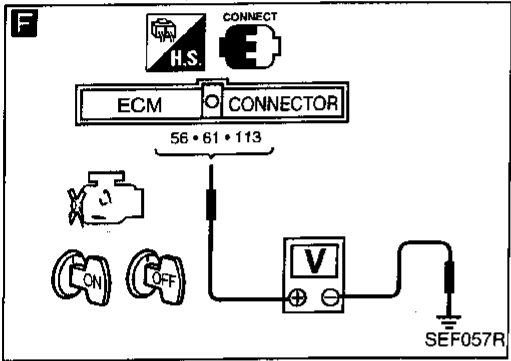

F

CHECK POWER SUPPLY-IV.

1. Turn ignition switch "ON" and then "OFF".
2. Check voltage between ECM terminals ⑤, ⑥, ⑪ and ground with CONSULT or tester.

Voltage:
After turning ignition switch "OFF", battery voltage will exist for a few seconds, then drop to approximately 0V.

OK

Go to **K** "CHECK GROUND CIRCUIT-II" on next page.

Case-1: Battery voltage does not exist.
Case-2: Battery voltage exists for more than a few seconds.

NG

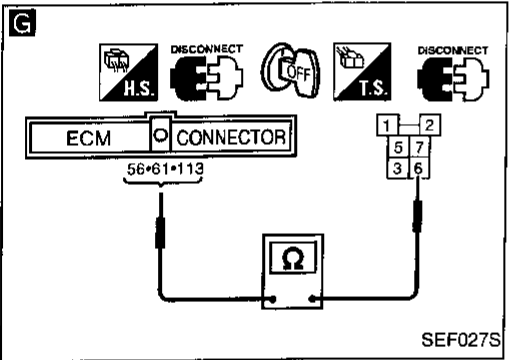

G

CHECK HARNESS CONTINUITY BETWEEN ECCS RELAY AND ECM

1. Disconnect ECM harness connector.
2. Disconnect ECCS relay.
3. Check harness continuity between ECM terminals ⑤, ⑥, ⑪ and relay terminal ⑥.

Continuity should exist.
If OK, check harness for short to ground and short to power.

NG

Check the following.

- Harness connectors (F23, M32)
- Harness connectors (E1, M1)
- Harness for open or short between ECCS relay and ECM

If NG, repair open circuit or short to ground or short to power in harness or connectors.

OK

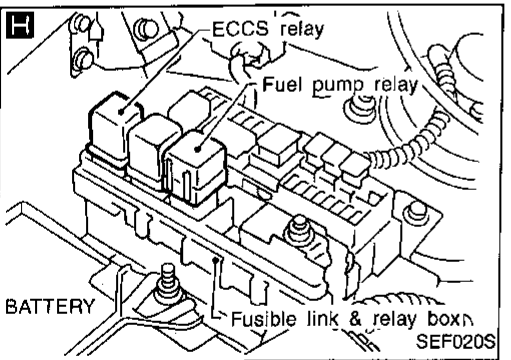

H

CHECK VOLTAGE BETWEEN ECCS RELAY AND GROUND.

Check voltage between relay terminals ①, ⑦ and ground with CONSULT or tester.

Voltage: Battery voltage

NG

Check the following.

- Harness for open or short between ECCS relay and 7.5A fuse

If NG, repair harness or connectors.

OK

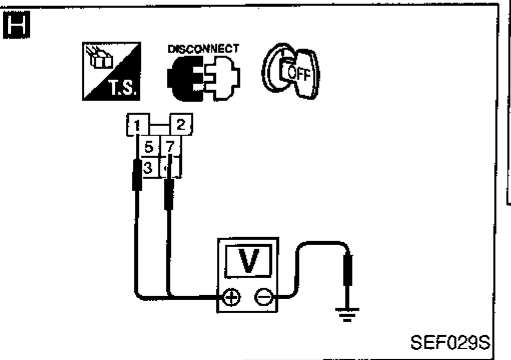

Ⓐ

TROUBLE DIAGNOSIS FOR POWER SUPPLY

Main Power Supply and Ground Circuit (Cont'd)

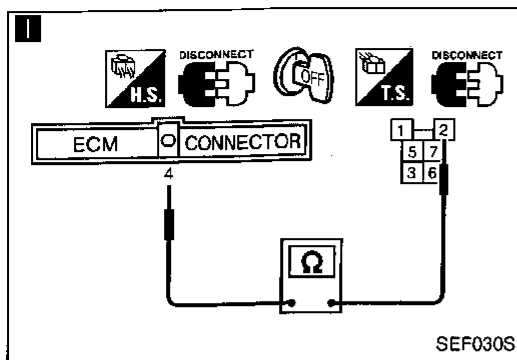

SEF030S

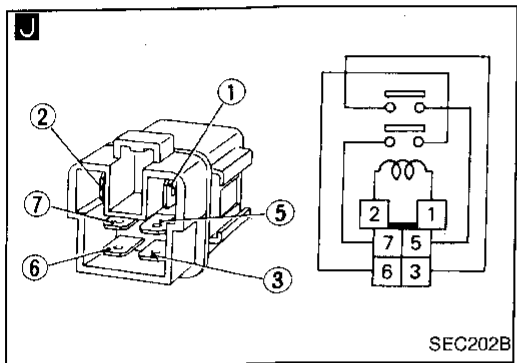

SEC202B

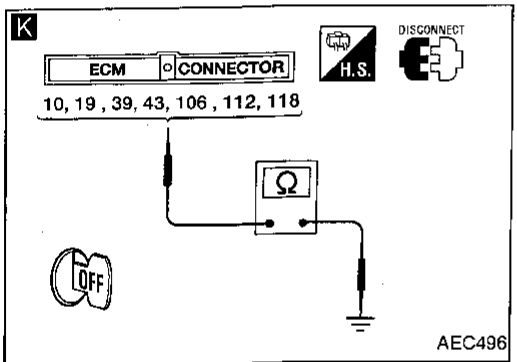

AEC496

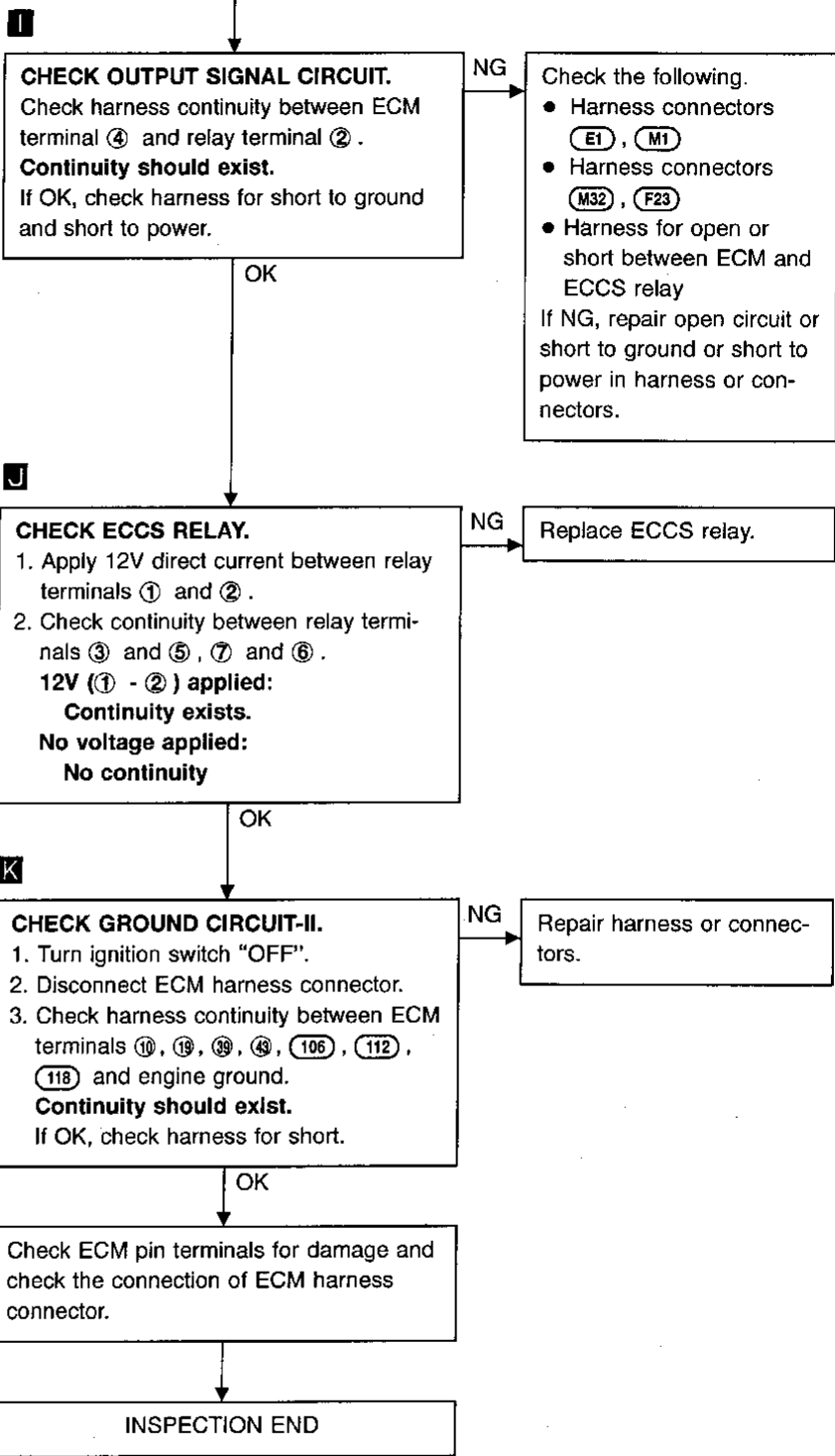

GI
MA
EM
LC
EC
FE
AT
TF
PD
FA
RA
BR
ST
RS
BT
HA
EL
IDX

TROUBLE DIAGNOSIS FOR DTC P0100

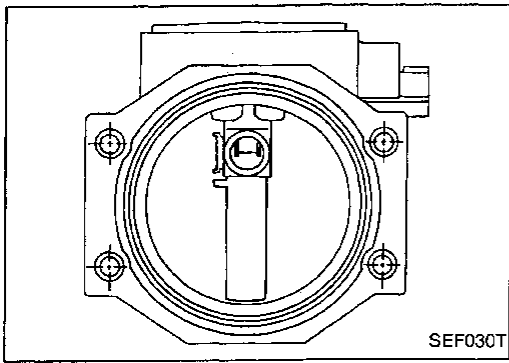

Mass Air Flow Sensor (MAFS)

COMPONENT DESCRIPTION

The mass air flow sensor is placed in the stream of intake air. It measures the intake flow rate by measuring a part of the entire intake flow. It consists of a hot wire that is supplied with electric current from the ECM. The temperature of the hot wire is controlled by the ECM a certain amount. The heat generated by the hot wire is reduced as the intake air flows around it. The more air, the greater the heat loss.

Therefore, the ECM must supply more electric current to maintain the temperature of the hot wire as air flow increases. The ECM detects the air flow by means of this current change.

CONSULT REFERENCE VALUE IN DATA MONITOR MODE

Specification data are reference values.

MONITOR ITEM	CONDITION	SPECIFICATION
MAS AIR/FL SE	<ul style="list-style-type: none"> ● Engine: After warming up ● Air conditioner switch: "OFF" ● Shift lever: "N" ● No-load Idle	1.0 - 1.7V
	2,500 rpm	1.5 - 2.1V
CAL/LD VALUE	<ul style="list-style-type: none"> ● Engine: After warming up ● Air conditioner switch: "OFF" ● Shift lever: "N" ● No-load Idle	18.5 - 26.0%
	2,500 rpm	18.0 - 21.0%
MASS AIRFLOW	<ul style="list-style-type: none"> ● Engine: After warming up ● Air conditioner switch: "OFF" ● Shift lever: "N" ● No-load Idle	3.3 - 4.8 g·m/s
	2,500 rpm	12.0 - 14.9 g·m/s

ECM TERMINALS AND REFERENCE VALUE

Specification data are reference values and are measured between each terminal and Ⓞ (ECCS ground).

TER-MINAL NO.	WIRE COLOR	ITEM	CONDITION	DATA (DC Voltage)
47	W	Mass air flow sensor	Engine is running. (Warm-up condition) └ Idle speed	1.3 - 1.7V
			Engine is running. (Warm-up condition) └ Engine speed is 2,500 rpm	1.7 - 2.1V
48	B	Mass air flow sensor ground	Engine is running. (Warm-up condition) └ Idle speed	Approximately 0V

TROUBLE DIAGNOSIS FOR DTC P0100

Mass Air Flow Sensor (MAFS) (Cont'd)

ON BOARD DIAGNOSIS LOGIC

Diagnostic Trouble Code No.	Malfunction is detected when ...	Check Items (Possible Cause)
P0100 0102	A) An excessively high or low voltage from the sensor is sent to ECM.* B), C) Voltage sent to ECM is not practical when compared with the camshaft position sensor and throttle position sensor signals.	<ul style="list-style-type: none"> • Harness or connectors (The sensor circuit is open or shorted.) • Mass air flow sensor

*: When this malfunction is detected, the ECM enters fail-safe mode and the MIL lights up.

Detected items	Engine operating condition in fail-safe mode
Mass air flow sensor circuit	Engine speed will not rise more than 2,400 rpm due to the fuel cut.

DIAGNOSTIC TROUBLE CODE CONFIRMATION PROCEDURE

Perform "Procedure for malfunction A" first. If the 1st trip DTC cannot be confirmed, perform "Procedure for malfunction B". If there is no problem on "Procedure for malfunction B", perform "Procedure for malfunction C".

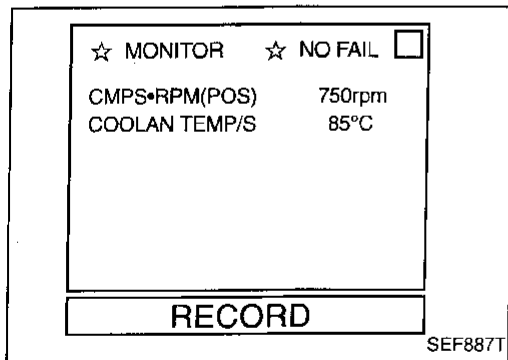
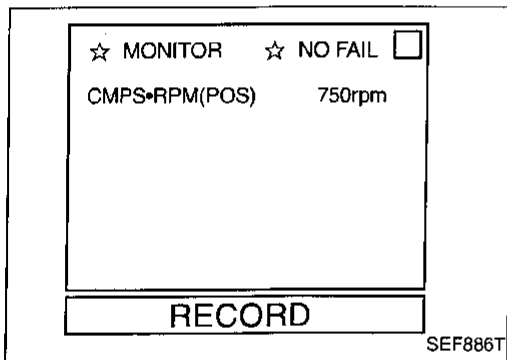

Procedure for malfunction A

- 1) Turn ignition switch "ON", and wait at least 6 seconds.
- 2) Select "DATA MONITOR" mode with CONSULT.
- 3) Start engine and wait at least 3 seconds.

OR

- 1) Turn ignition switch "ON", and wait at least 6 seconds.
- 2) Start engine and wait at least 3 seconds.
- 3) Select "MODE 7" with GST.

OR

- 1) Turn ignition switch "ON", and wait at least 6 seconds.
- 2) Start engine and wait at least 3 seconds.
- 3) Turn ignition switch "OFF", wait at least 5 seconds and then turn "ON".
- 4) Perform "Diagnostic Test Mode II (Self-diagnostic results)" with ECM.

Procedure for malfunction B

- 1) Turn ignition switch "ON".
- 2) Select "DATA MONITOR" mode with CONSULT.
- 3) Start engine and warm it up sufficiently.
- 4) Run engine for at least 10 seconds at idle speed.

OR

- 1) Start engine and warm it up sufficiently.
- 2) Run engine for at least 10 seconds at idle speed.
- 3) Select "MODE 7" with GST.

OR

- 1) Start engine and warm it up sufficiently.
- 2) Run engine for at least 10 seconds at idle speed.
- 3) Turn ignition switch "OFF", wait at least 5 seconds and then turn "ON".
- 4) Perform "Diagnostic Test Mode II (Self-diagnostic results)" with ECM.

TROUBLE DIAGNOSIS FOR DTC P0100

Mass Air Flow Sensor (MAFS) (Cont'd)

Procedure for malfunction C

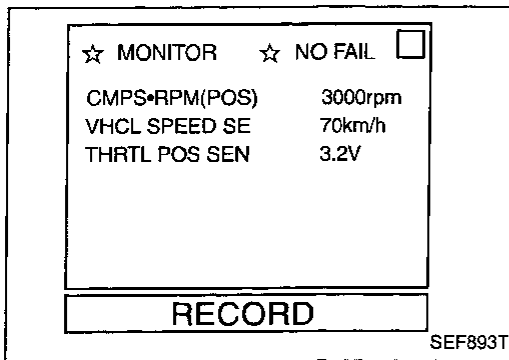

- 1) Turn ignition switch "ON".
- 2) Select "DATA MONITOR" mode with CONSULT.
- 3) Start engine.
- 4) Maintain the following conditions for at least 10 seconds.

Engine speed: More than 2,000 rpm

THRTL POS SEN: More than 3V

Gear position: "1" or "2" range

CAUTION:

Do not run vehicle at speeds greater than 80 km/h (50 MPH).

OR

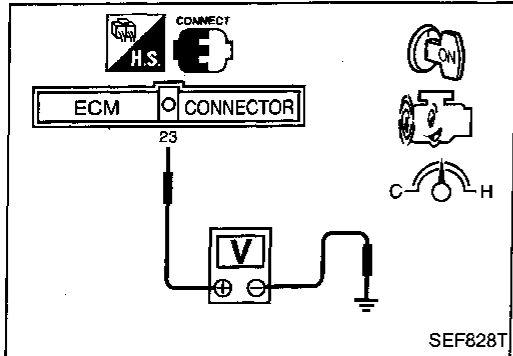

- 1) Start engine.
- 2) Maintain the following conditions for at least 10 seconds.

Engine speed: More than 2,000 rpm

**Voltage between ECM terminal 23 and ground:
More than 3V**

Gear position: "1" or "2" range

- 3) Select "MODE 7" with GST.

CAUTION:

Do not run vehicle at speeds greater than 80 km/h (50 MPH).

OR



- 1) Start engine.
- 2) Maintain the following conditions for at least 10 seconds.

Engine speed: More than 2,000 rpm

**Voltage between ECM terminal 23 and ground:
More than 3V**

Gear position: "1" or "2" range

- 3) Stop the vehicle, turn ignition switch "OFF", wait at least 5 seconds and then turn "ON".

- 4) Perform "Diagnostic Test Mode II (Self-diagnostic results)" with ECM.

CAUTION:

Do not run vehicle at speeds greater than 80 km/h (50 MPH).

TROUBLE DIAGNOSIS FOR DTC P0100

Mass Air Flow Sensor (MAFS) (Cont'd)

EC-MAFS-01

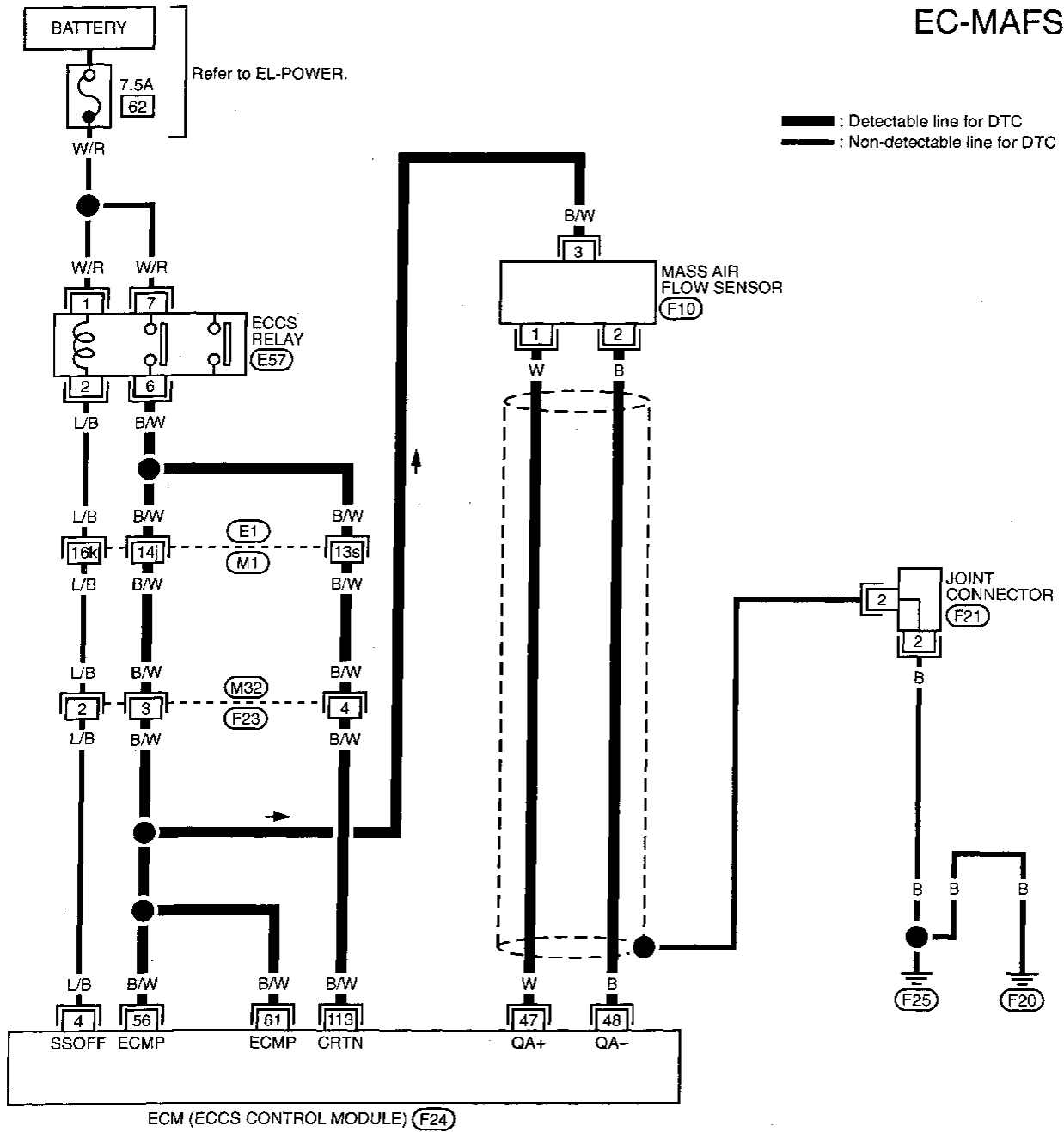

GI
 MA
 EM
 LC
EC
 FE
 AT
 TF
 PD
 FA
 RA
 BR
 ST
 RS
 BT
 HA
 EL
 IDX

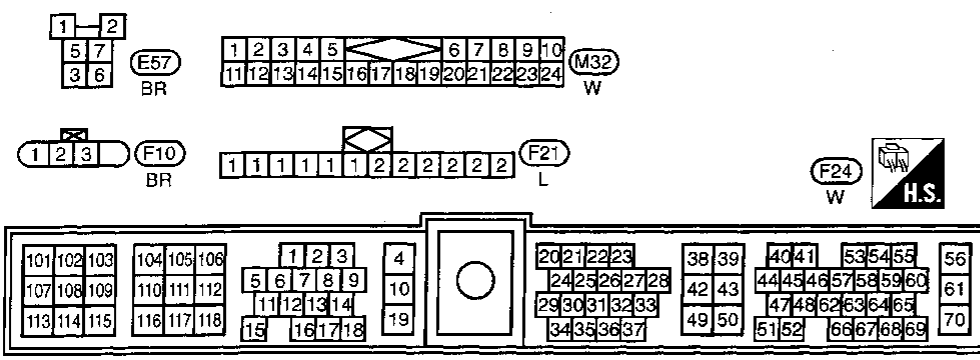

Refer to last page (Foldout page).
 (E1) (M1)

TROUBLE DIAGNOSIS FOR DTC P0100

Mass Air Flow Sensor (MAFS) (Cont'd)

DIAGNOSTIC PROCEDURE

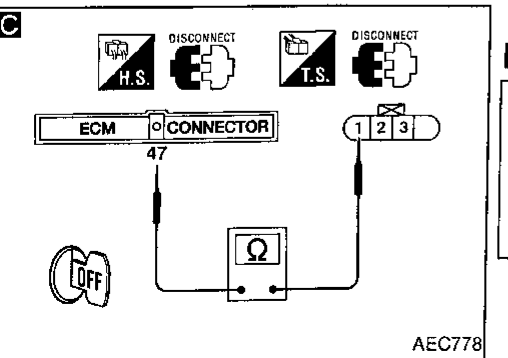
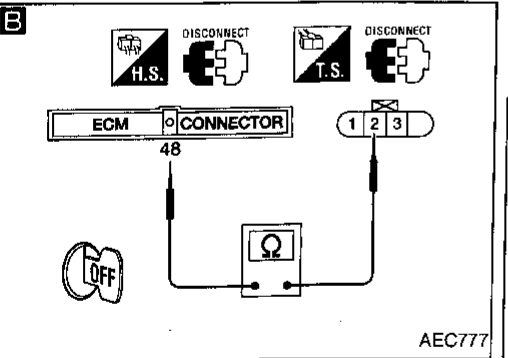
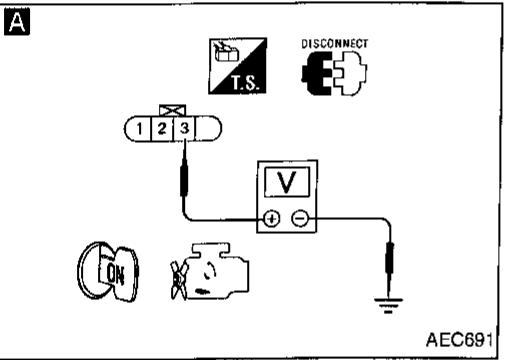
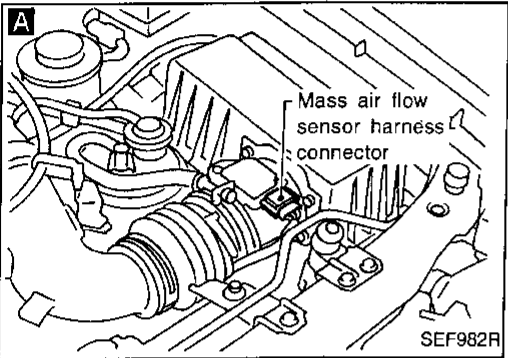
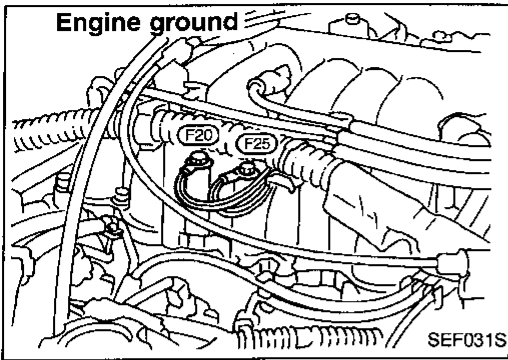

INSPECTION START

CHECK SHIELD CIRCUIT.

1. Turn ignition switch "OFF".
 2. Loosen and retighten engine ground screws.
 3. Remove joint connector.
 4. Check the following.
 - Continuity between joint connector terminal and ground
 - Joint connector (Refer to "HARNESS LAYOUT" in EL section.)
- Continuity should exist.**
If OK, check harness for short to ground and short to power. Then reconnect joint connector.

NG

Repair harness or connectors.

OK

CHECK POWER SUPPLY.

1. Disconnect mass air flow sensor harness connector.
 2. Turn ignition switch "ON".
 3. Check voltage between terminal ③ and ground with CONSULT or tester.
- Voltage: Battery voltage**

NG

Check the following.

- Harness connectors (F23, M32)
- Harness connectors (M1, E1)
- Harness for open or short between ECCS relay and mass air flow sensor
- Harness for open or short between mass air flow sensor and ECM

If NG, repair harness or connectors.

OK

CHECK GROUND CIRCUIT.

1. Turn ignition switch "OFF".
 2. Disconnect ECM harness connector.
 3. Check harness continuity between terminal ② and ECM terminal ④.
- Continuity should exist.**
If OK, check harness for short to ground and short to power.

NG

Repair harness or connectors.

OK

CHECK INPUT SIGNAL CIRCUIT.

- Check harness continuity between terminal ① and ECM terminal ⑦.
- Continuity should exist.**
If OK, check harness for short.

NG

Repair harness or connectors.

OK

Ⓐ

TROUBLE DIAGNOSIS FOR DTC P0100

Mass Air Flow Sensor (MAFS) (Cont'd)

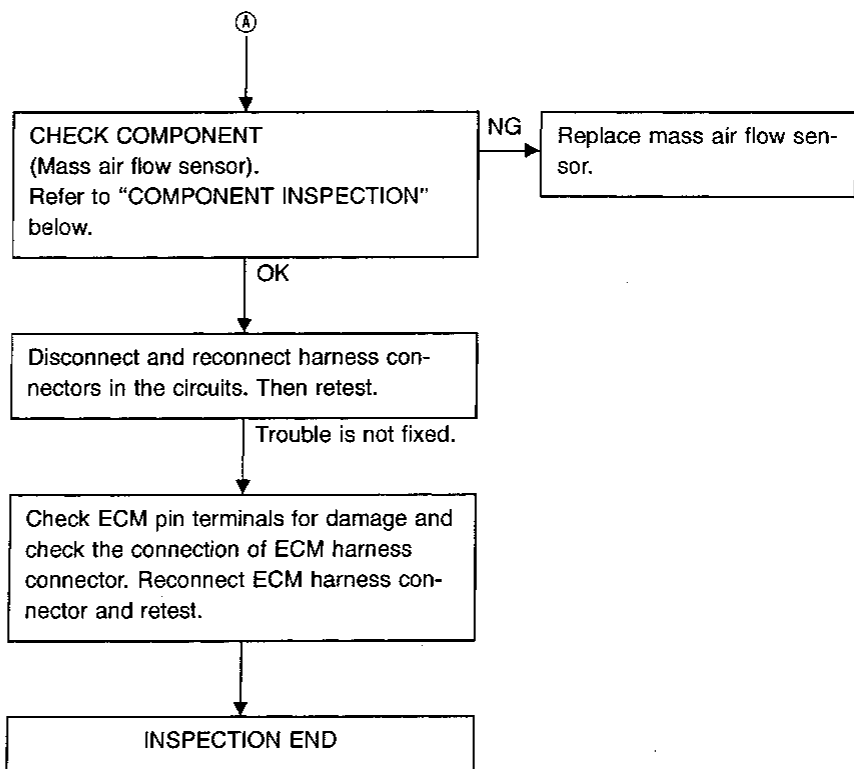

GI

MA

EM

LC

EC

FE

AT

TF

PD

FA

RA

BR

ST

RS

BT

HA

EL

IDX

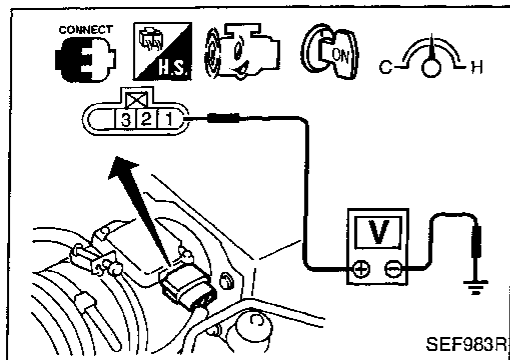

COMPONENT INSPECTION

Mass air flow sensor

1. Turn ignition switch "ON".
2. Start engine and warm it up sufficiently.
3. Check voltage between terminal ① and ground.

Conditions	Voltage V
Ignition switch "ON" (Engine stopped.)	Less than 1.0
Idle (Engine is warmed-up sufficiently.)	1.3 - 1.7
2,500 rpm (Engine is warmed-up sufficiently.)	1.7 - 2.1
Idle to about 4,000 rpm*	1.3 - 1.7 to Approx. 4.0

*: Check for linear voltage rise in response to increases to about 4,000 rpm in engine speed.

4. If NG, remove mass air flow sensor from air duct. Check hot wire for damage or dust.

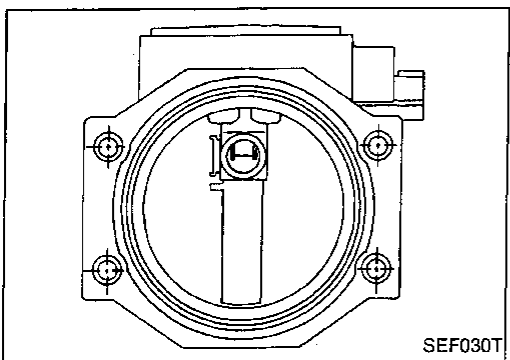

TROUBLE DIAGNOSIS FOR DTC P0105

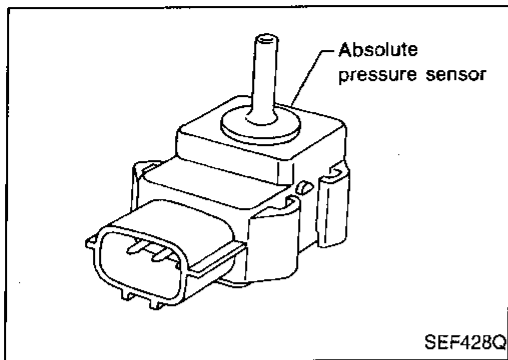

SEF428Q

Absolute Pressure Sensor

COMPONENT DESCRIPTION

The absolute pressure sensor is connected to the MAP/BARO switch solenoid valve by a hose. The sensor detects ambient barometric pressure and intake manifold pressure and sends the voltage signal to the ECM. As the pressure increases, the voltage rises. The absolute pressure sensor is not used to control the engine system. It is used only for on board diagnosis.

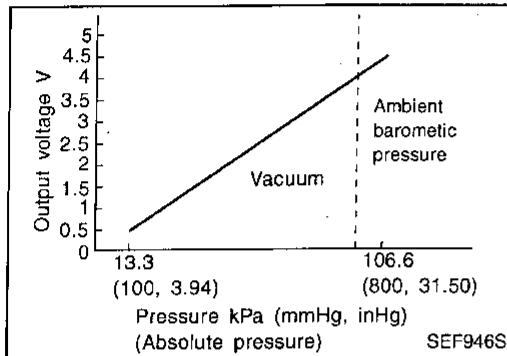

SEF946S

ON BOARD DIAGNOSIS LOGIC

Diagnostic Trouble Code No.	Malfunction is detected when	Check Items (Possible Cause)
P0105 0803	A) An excessively low or high voltage from the sensor is sent to ECM.	<ul style="list-style-type: none"> • Harness or connectors (Absolute pressure sensor circuit is open or shorted.) • Absolute pressure sensor
	B) A high voltage from the sensor is sent to ECM under light load driving conditions.	<ul style="list-style-type: none"> • Hoses (Hoses between the intake manifold and absolute pressure sensor are disconnected or clogged.) • Intake air leaks • Absolute pressure sensor
	C) A low voltage from the sensor is sent to ECM under heavy load driving conditions.	<ul style="list-style-type: none"> • Absolute pressure sensor

DIAGNOSTIC TROUBLE CODE CONFIRMATION PROCEDURE

Perform "Procedure for malfunction A" first. If the 1st trip DTC cannot be confirmed, perform "Procedure for malfunction B". If the 1st trip DTC is not confirmed on "Procedure for malfunction B", perform "Procedure for malfunction C".

Procedure for malfunction A

- 1) Turn ignition switch "ON".
 - 2) Select "DATA MONITOR" mode with CONSULT.
 - 3) Wait at least 6 seconds.
- OR
- 1) Turn ignition switch "ON" and wait at least 6 seconds.
 - 2) Select "MODE 7" with GST.
- OR
- 1) Turn ignition switch "ON" and wait at least 6 seconds.
 - 2) Turn ignition switch "OFF", wait at least 5 seconds and then turn "ON".
 - 3) Perform "Diagnostic Test Mode II (Self-diagnostic results)" with ECM.

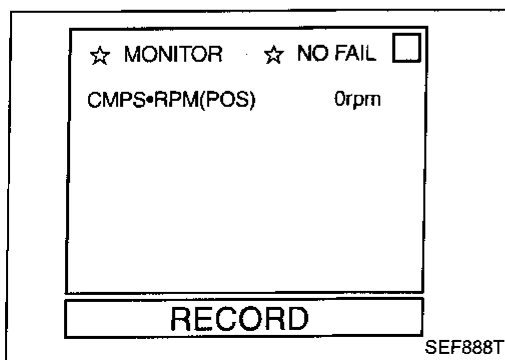

SEF888T

TROUBLE DIAGNOSIS FOR DTC P0105

Absolute Pressure Sensor (Cont'd)

Procedure for malfunction B

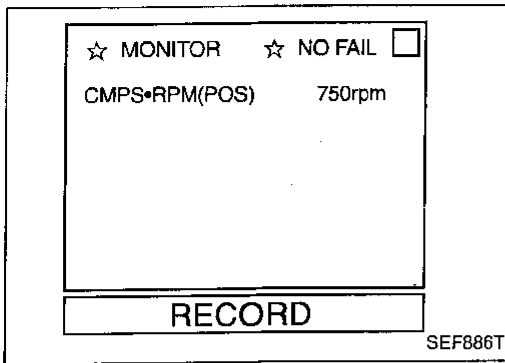

- 1) Start engine and warm it up sufficiently.
- 2) Turn ignition switch "OFF" and wait at least 5 seconds.
- 3) Turn ignition switch "ON" and select "DATA MONITOR" mode with CONSULT.
- 4) Start engine and let it idle.
- 5) Wait at least 15 seconds.

GI

MA

OR



- 1) Start engine and warm it up sufficiently.
- 2) Turn ignition switch "OFF" and wait at least 5 seconds.
- 3) Start engine.
- 4) Let engine idle and wait at least 15 seconds.
- 5) Select "MODE 7" with GST.

EM

LC

OR



- 1) Start engine and warm it up sufficiently.
- 2) Turn ignition switch "OFF" and wait at least 5 seconds.
- 3) Start engine.
- 4) Let engine idle and wait at least 15 seconds.
- 5) Turn ignition switch "OFF", wait at least 5 seconds and then turn "ON".
- 6) Perform "Diagnostic Test Mode II (Self-diagnostic results)" with ECM.

EC

FE

AT

TF

PD

FA

RA

BR

ST

RS

BT

HA

EL

IDX

TROUBLE DIAGNOSIS FOR DTC P0105

Absolute Pressure Sensor (Cont'd)

Procedure for malfunction C

☆ MONITOR	☆ NO FAIL	<input type="checkbox"/>
CMPS•RPM(POS)	4000rpm	
VHCL SPEED SE	70km/h	
B/FUEL SCHDL	4.8ms	
RECORD		

SEF894T

-  1) Start engine and warm it up sufficiently.
2) Turn ignition switch "OFF" and wait at least 5 seconds.
3) Turn ignition switch "ON".
4) Select "DATA MONITOR" mode with CONSULT.
5) Start engine again and wait at least 15 seconds.
6) Maintain the following conditions for at least 5 seconds.
Engine speed: 3,000 rpm - 4,800 rpm
Gear position: "1" or "2" range
B/FUEL SCHDL: More than 4.6 ms

CAUTION:

Do not run vehicle at speeds greater than 80 km/h (50 MPH).

OR

-  1) Start engine and warm it up sufficiently.
2) Turn ignition switch "OFF" and wait at least 5 seconds.
3) Turn ignition switch "ON".
4) Start engine again and wait at least 15 seconds.
5) Maintain the following conditions for at least 5 seconds.
Engine speed: 3,000 rpm - 4,800 rpm
Gear position: "1" or "2" range

CAUTION:

Do not run vehicle at speeds greater than 80 km/h (50 MPH).

- 6) Select "Mode 7" with GST.

OR

-  1) Start engine and warm it up sufficiently.
2) Turn ignition switch "OFF" and wait at least 5 seconds.
3) Start engine again and wait at least 15 seconds.
4) Maintain the following conditions for at least 5 seconds.
Engine speed: 3,000 rpm - 4,800 rpm
Gear position: "1" or "2" range

CAUTION:

Do not run vehicle at speeds greater than 80 km/h (50 MPH).

- 5) Stop the vehicle, turn ignition switch "OFF", wait at least 5 seconds and then turn "ON".
6) Perform "Diagnostic Test Mode II (Self-diagnostic results)" with ECM.

TROUBLE DIAGNOSIS FOR DTC P0105

Absolute Pressure Sensor (Cont'd)

EC-AP/SEN-01

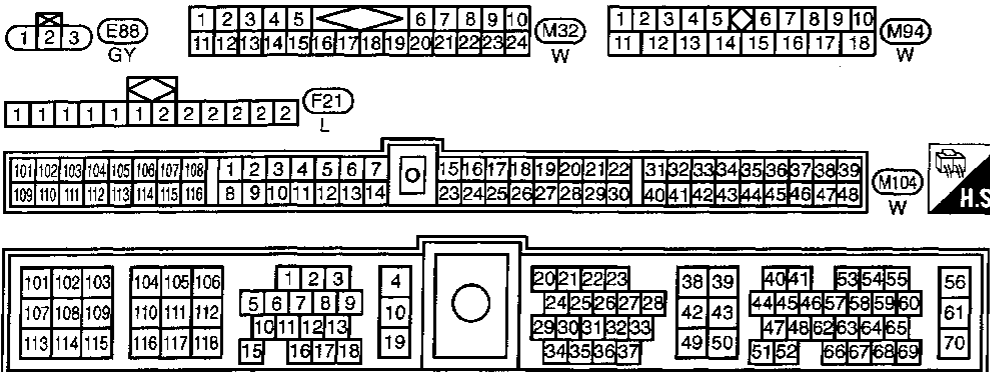
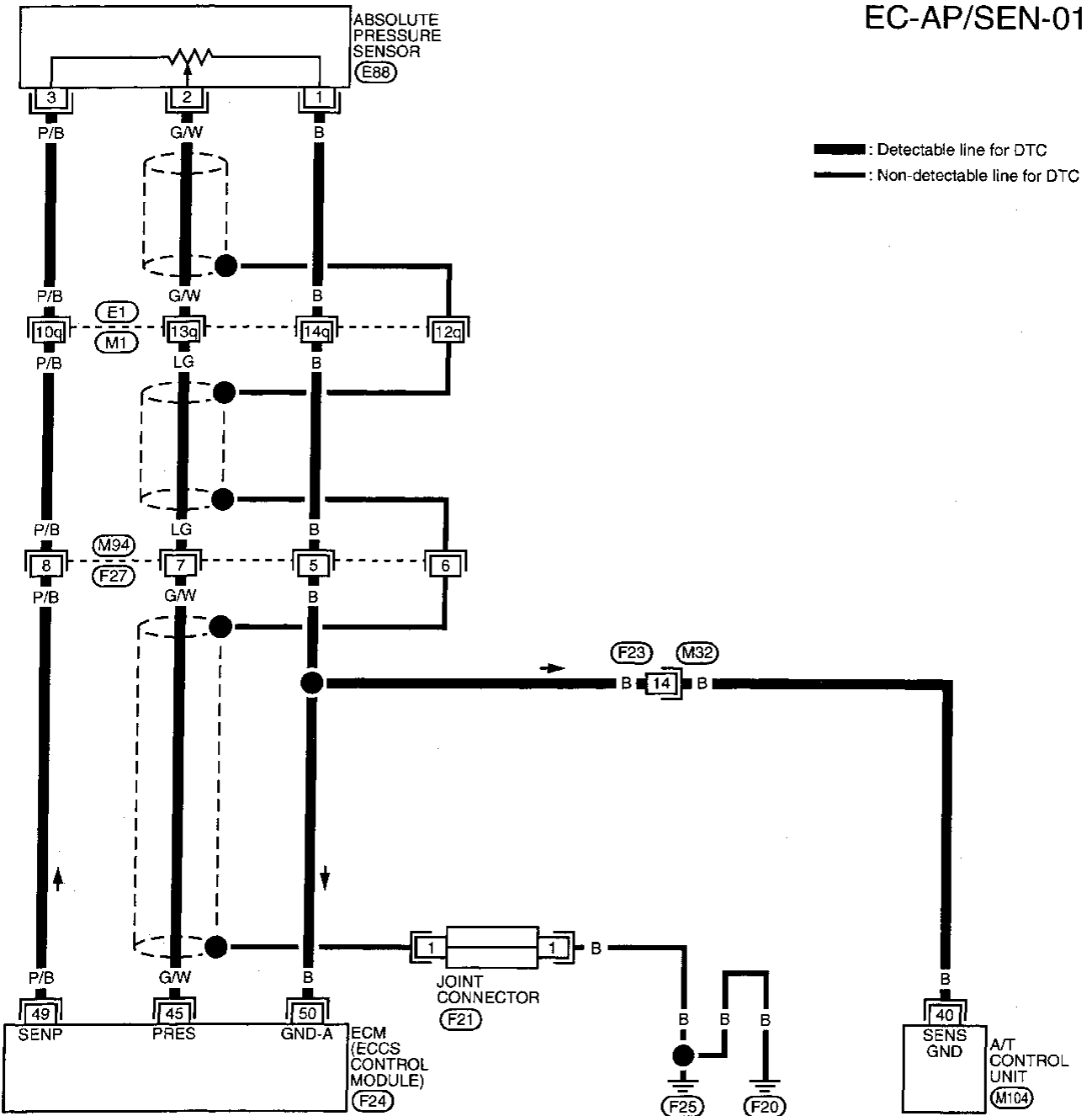

Refer to last page (Foldout page).

(E1) (M1)

TROUBLE DIAGNOSIS FOR DTC P0105

Absolute Pressure Sensor (Cont'd)

DIAGNOSTIC PROCEDURE

If the trouble is duplicated after "Procedure for malfunction A or C", perform "Procedure A" below. If the trouble is duplicated after "Procedure for malfunction B", perform "Procedure B" on next page.

Procedure A

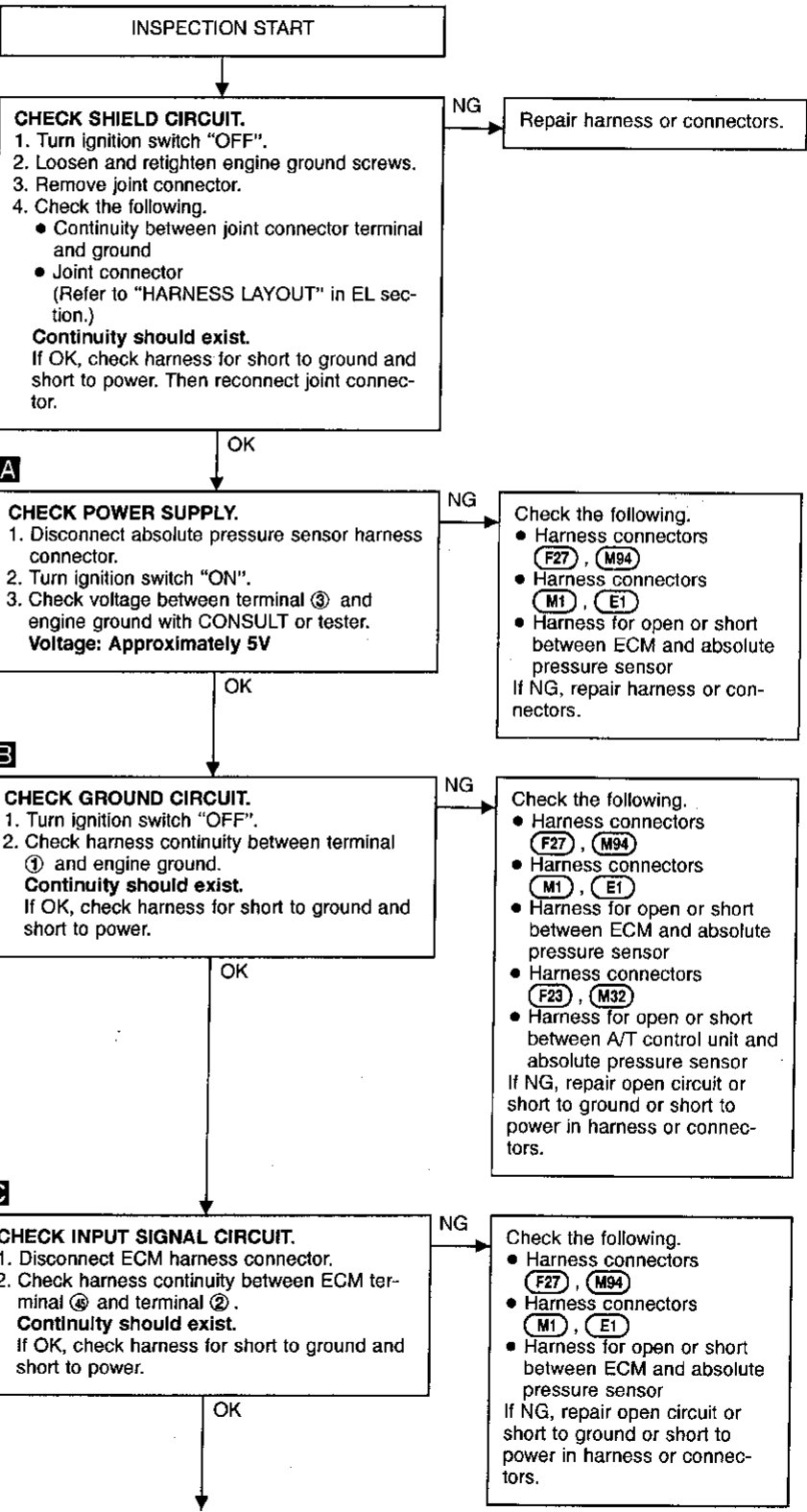
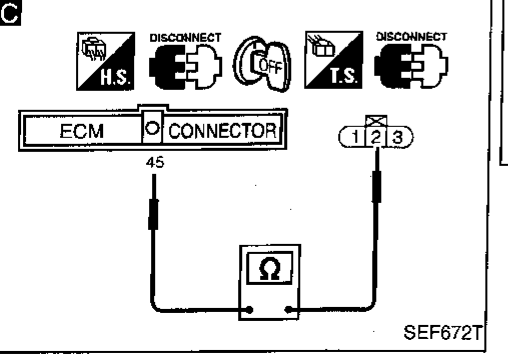
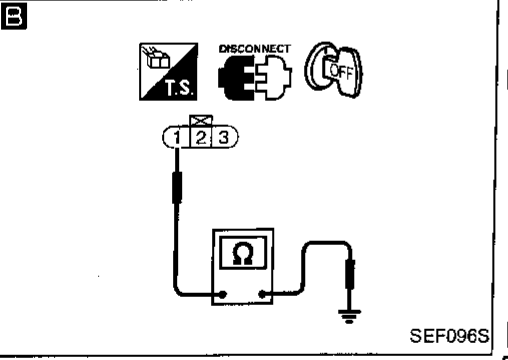
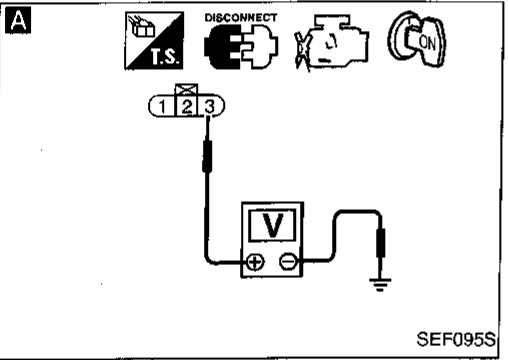
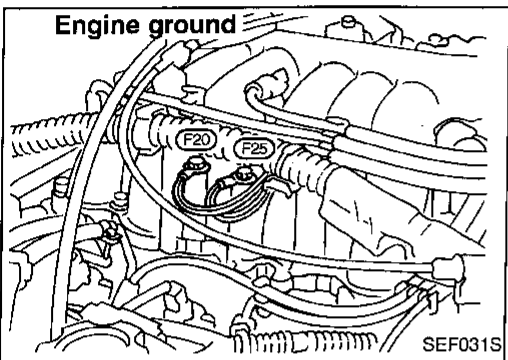
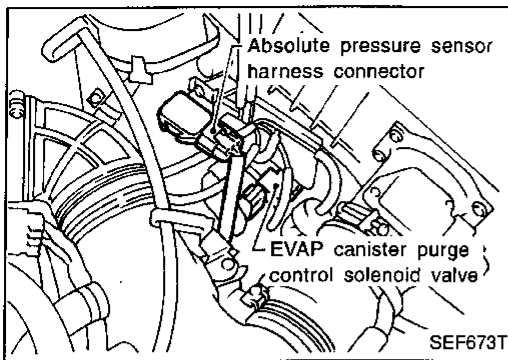

TROUBLE DIAGNOSIS FOR DTC P0105

Absolute Pressure Sensor (Cont'd)

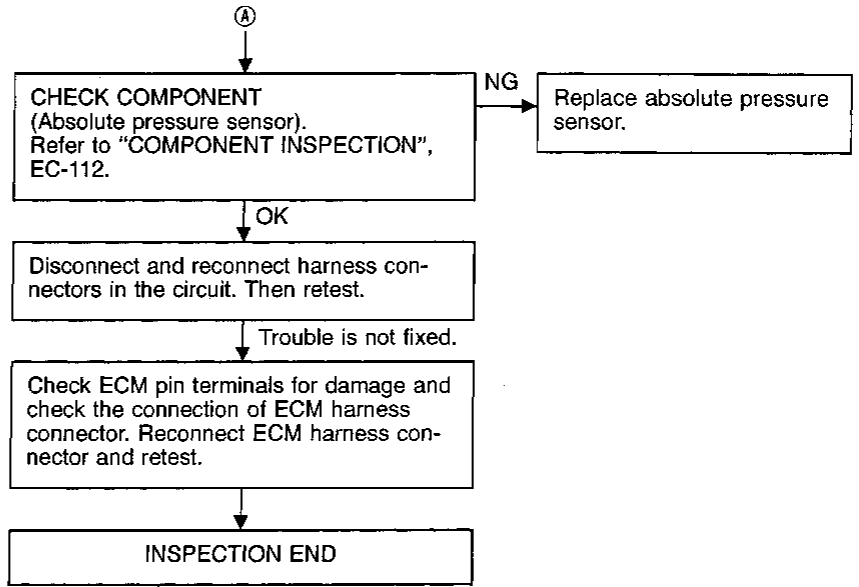

GI
MA
EM
LC
EC
FE
AT
TF
PD
FA
RA
BR
ST
RS
BT
HA
EL
IDX

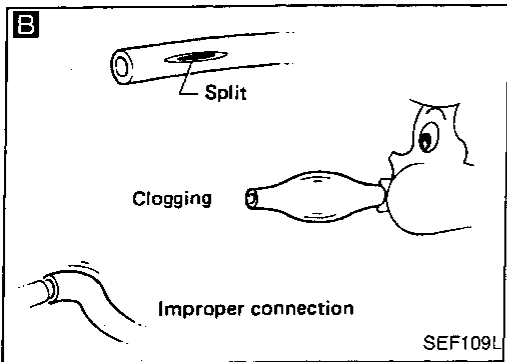
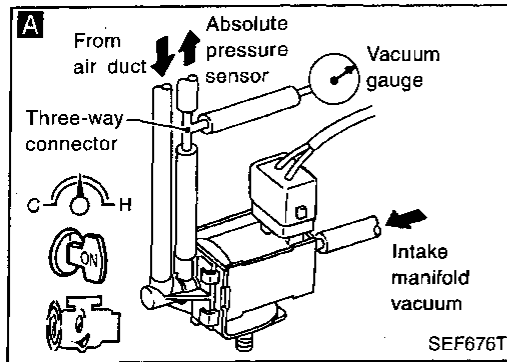

Procedure B

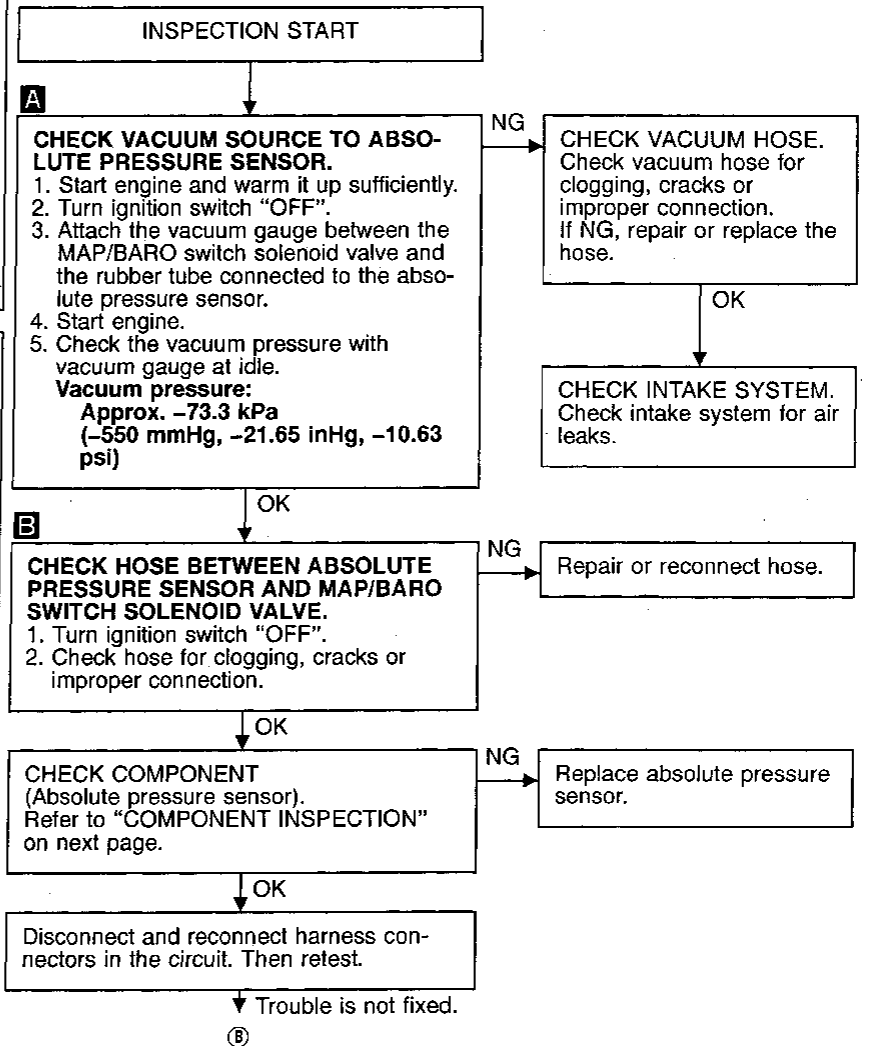

TROUBLE DIAGNOSIS FOR DTC P0105

Absolute Pressure Sensor (Cont'd)

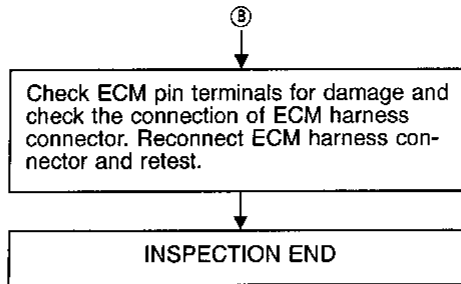

COMPONENT INSPECTION

Absolute pressure sensor

1. Start engine and warm it up sufficiently.
2. Perform "MAP/BARO SW/V" in "ACTIVE TEST" mode with CONSULT.
3. Check the following.
 - When "MAP" is selected, "ABSOL PRES/SE" indicates approximately 1.3V.
 - When "BARO" is selected, "ABSOL PRES/SE" indicates approximately 4.3V.If NG, go to step 4; if OK, inspection end.
4. Turn ignition switch "OFF".
5. Remove absolute pressure sensor with its harness connector connected.
6. Remove hose from absolute pressure sensor.
7. Turn ignition switch "ON" and check output voltage between terminal ② and engine ground.
The voltage should be 3.2 to 4.8 V.
8. Use pump to apply vacuum of -26.7 kPa (-200 mmHg, -7.87 inHg, -3.87 psi) to absolute pressure sensor as shown in figure and check the output voltage.
The voltage should be 1.0 to 1.4 V lower than the value measured in step 3.

CAUTION:

Always calibrate the vacuum pump gauge when using it.

9. If NG, replace absolute pressure sensor.

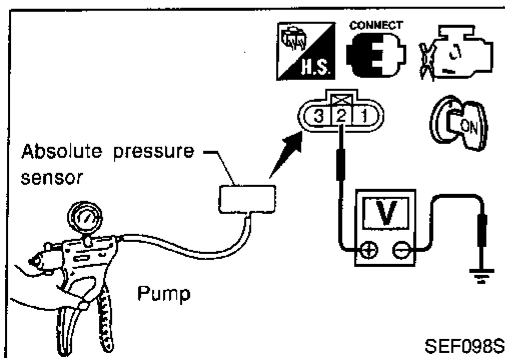
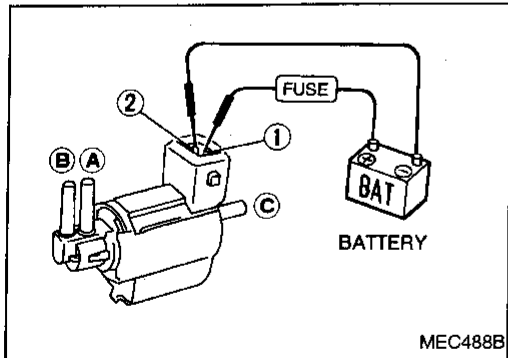
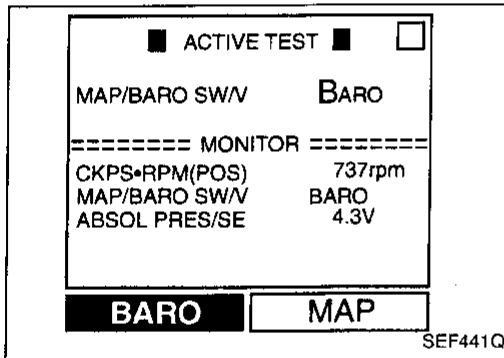
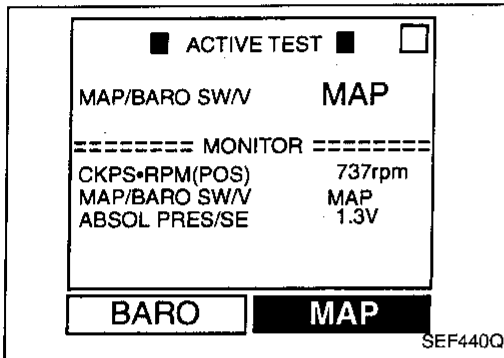

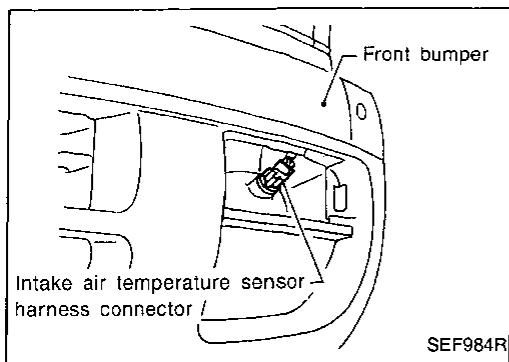

Intake Air Temperature Sensor

COMPONENT DESCRIPTION

The intake air temperature sensor is mounted to the air duct housing. The sensor detects intake air temperature and transmits a signal to the ECM.

The temperature sensing unit uses a thermistor which is sensitive to the change in temperature. Electrical resistance of the thermistor decreases in response to the temperature rise.

This sensor is not used to control the engine system. It is used only for the on board diagnosis.

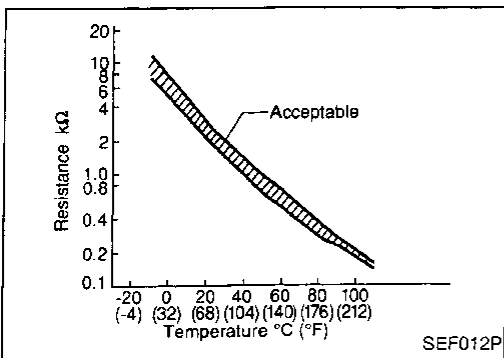

<Reference data>

Intake air temperature °C (°F)	Voltage* (V)	Resistance kΩ
20 (68)	3.5	2.1 - 2.9
80 (176)	1.23	0.27 - 0.38

*: These data are reference values and are measured between ECM terminal 28 (Intake air temperature sensor) and ECM terminal 43 (ECCS ground).

ON BOARD DIAGNOSIS LOGIC

Diagnostic Trouble Code No.	Malfunction is detected when ...	Check Items (Possible Cause)
P0110 0401	A) An excessively low or high voltage from the sensor is sent to ECM. B) Rationally incorrect voltage from the sensor is sent to ECM, compared with the voltage signal from engine coolant temperature sensor.	<ul style="list-style-type: none"> • Harness or connectors (The sensor circuit is open or shorted.) • Intake air temperature sensor

DIAGNOSTIC TROUBLE CODE CONFIRMATION PROCEDURE

Perform "Procedure for malfunction A" first. If DTC cannot be confirmed, perform "Procedure for malfunction B".

Procedure for malfunction A

- 1) Turn ignition switch "ON".
 - 2) Select "DATA MONITOR" mode with CONSULT.
 - 3) Wait at least 5 seconds.
- OR
- 1) Turn ignition switch "ON" and wait at least 5 seconds.
 - 2) Select MODE 7 with GST.
- OR
- 1) Turn ignition switch "ON" and wait at least 5 seconds.
 - 2) Turn ignition switch "OFF", wait at least 5 seconds and then turn "ON".
 - 3) Perform "Diagnostic Test Mode II (Self-diagnostic results)" with ECM.

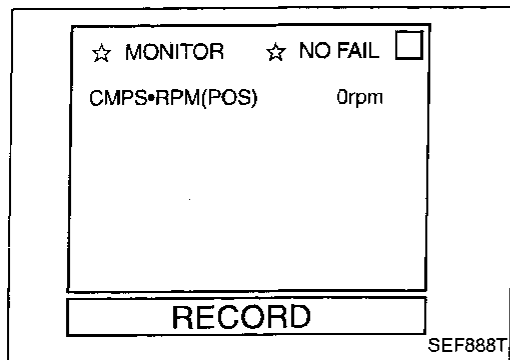

TROUBLE DIAGNOSIS FOR DTC P0110

Intake Air Temperature Sensor (Cont'd)

Procedure for malfunction B

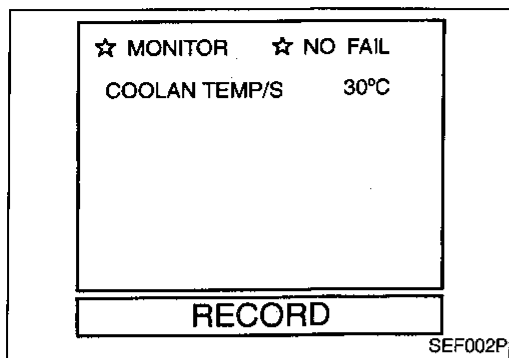

FUEL SYS #1	OPEN
FUEL SYS #2	UNUSED
CALC LOAD	0%
COOLANT TEMP	23°C
SHORT FT #1	0%
LONG FT #1	0%
ENGINE SPD	0RPM
VEHICLE SPD	0km/h
IGN ADVANCE	5.0°
INTAKE AIR	25°C
MAF	0.0gm/sec
THROTTLE POS	0%
O2S LOCATION	3
O2S B1,S1	0.380V
O2FT B1,S1	0%
O2S B1,S2	0.000V

SEF950N

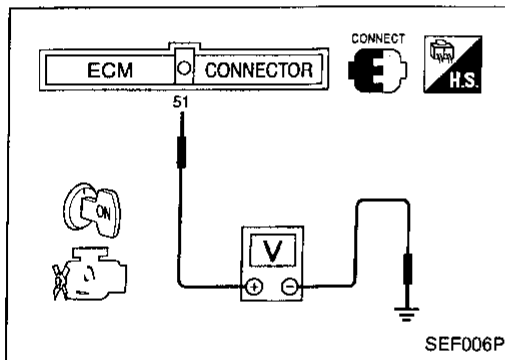

- 1) Lift up vehicle and open engine hood.
- 2) Wait until engine coolant temperature is less than 90°C (194°F).
 - (a) Turn ignition switch "ON".
 - (b) Select "DATA MONITOR" mode with CONSULT.
 - (c) Check the engine coolant temperature.
 - (d) If the engine coolant temperature is not less than 90°C (194°F), turn ignition switch "OFF" and cool down engine.
- Perform the following steps before engine coolant temperature is above 90°C (194°F).
- 3) Turn ignition switch "ON".
- 4) Select "DATA MONITOR" mode with CONSULT.
- 5) Start engine.
- 6) Shift selector lever to "D" position.
- 7) Hold vehicle speed at 70 to 80 km/h (43 to 50 MPH) for 2 minutes.

OR



- 1) Lift up vehicle and open engine hood.
- 2) Wait until engine coolant temperature is less than 90°C (194°F).
 - (a) Turn ignition switch "ON".
 - (b) Select MODE 1 with GST.
 - (c) Check the engine coolant temperature.
 - (d) If the engine coolant temperature is not less than 90°C (194°F), turn ignition switch "OFF" and cool down engine.
- Perform the following steps before engine coolant temperature is above 90°C (194°F).
- 3) Start engine.
- 4) Shift selector lever to "D" position.
- 5) Hold vehicle speed at 70 to 80 km/h (43 to 50 MPH) for 2 minutes.
- 6) Select MODE 7 with GST.

OR



- 1) Lift up vehicle and open engine hood.
- 2) Wait until engine coolant temperature is less than 90°C (194°F).
 - (a) Turn ignition switch "ON".
 - (b) Check voltage between ECM terminal ⑤1 and ground.

Voltage: More than 1.0 (V)
 - (c) If the voltage is not more than 1.0 (V), turn ignition switch "OFF" and cool down engine.
- Perform the following steps before the voltage is below 1.0V.
- 3) Start engine.
- 4) Shift selector lever to "D" position.
- 5) Hold vehicle speed at 70 to 80 km/h (43 to 50 MPH) for 2 minutes.
- 6) Turn ignition switch "OFF", wait at least 5 seconds and then turn "ON".
- 7) Perform "Diagnostic Test Mode II (Self-diagnostic results)" with ECM.

TROUBLE DIAGNOSIS FOR DTC P0110

Intake Air Temperature Sensor (Cont'd)

EC-IATS-01

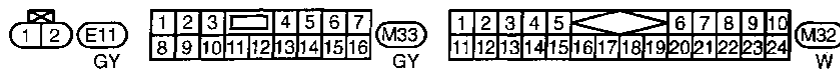
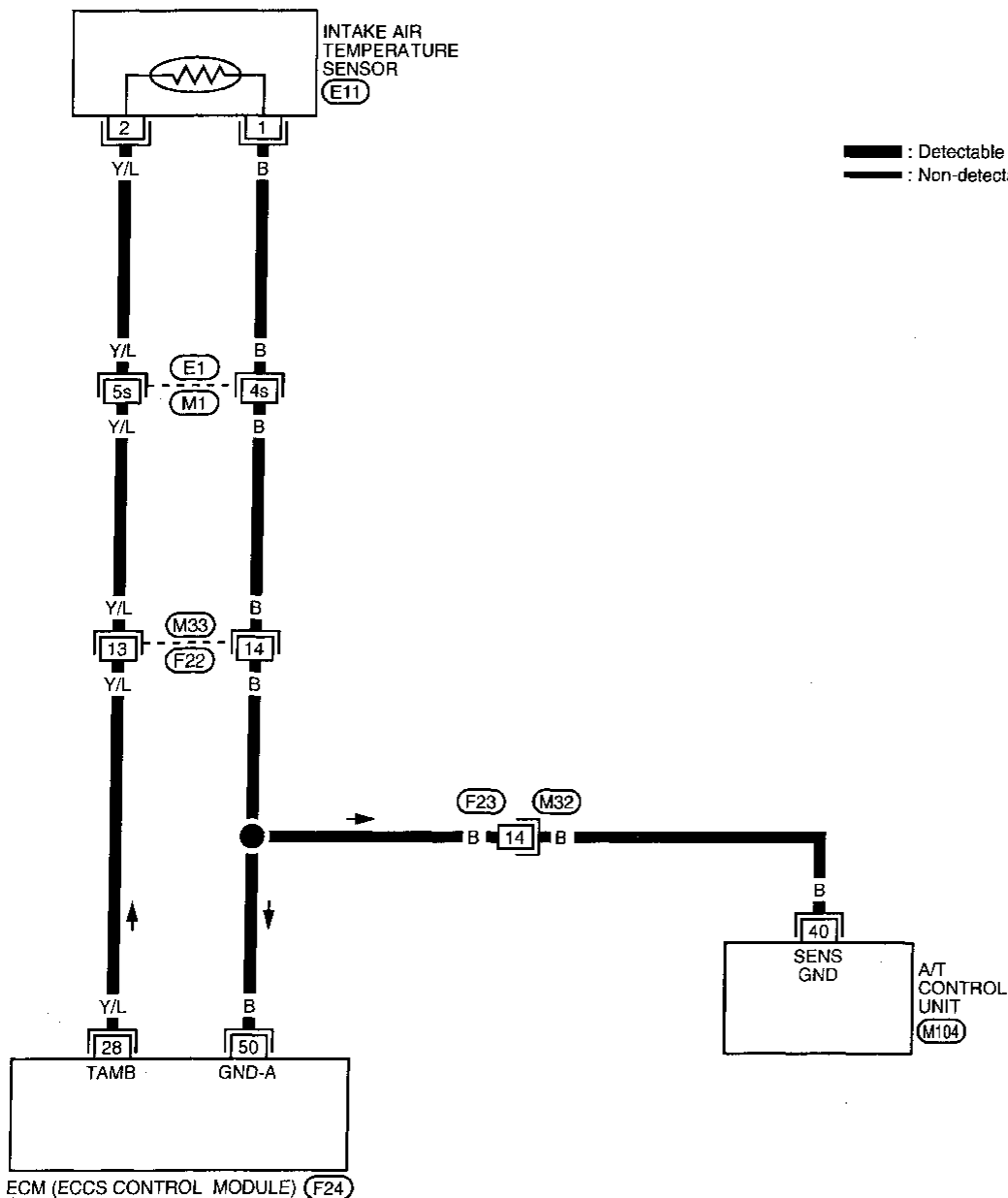

Refer to last page (Foldout page).

E1, M1

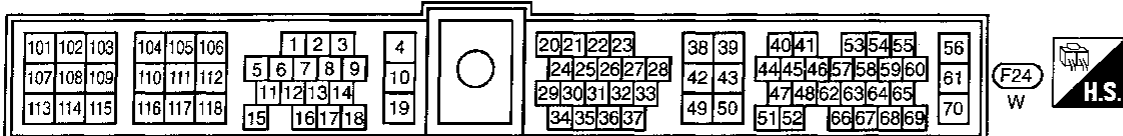
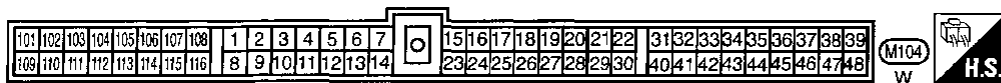

TROUBLE DIAGNOSIS FOR DTC P0110

Intake Air Temperature Sensor (Cont'd) DIAGNOSTIC PROCEDURE

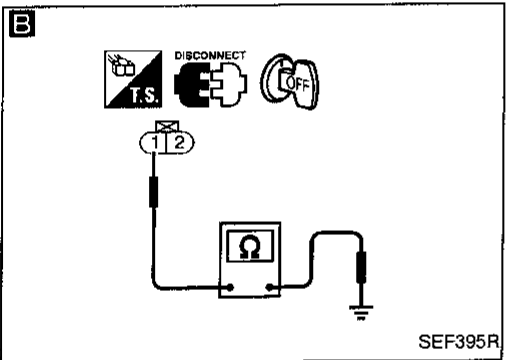
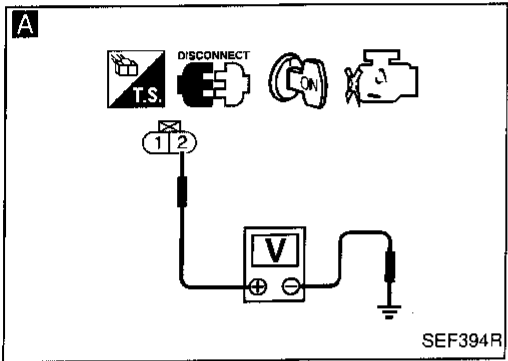
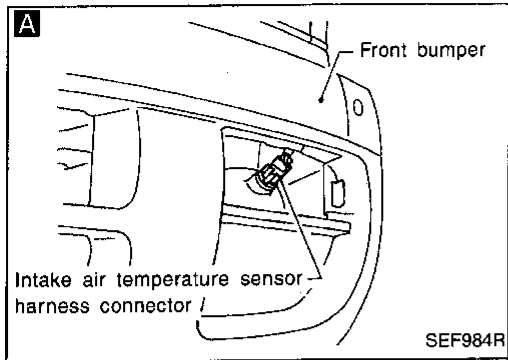

INSPECTION START

A
CHECK POWER SUPPLY.
1. Turn ignition switch "OFF".
2. Disconnect intake air temperature sensor harness connector.
3. Turn ignition switch "ON".
4. Check voltage between terminal ② and ground.
Voltage:
Approximately 5V

NG

Check the following.

- Harness connectors (F22), (M33)
- Harness connectors (M1), (E1)
- Harness for open or short between ECM and intake air temperature sensor

If NG, repair harness or connectors.

B
CHECK GROUND CIRCUIT.
1. Turn ignition switch "OFF".
2. Check harness continuity between terminal ① and engine ground.
Continuity should exist.
If OK, check harness for short to ground and short to power.

NG

Check the following.

- Harness connectors (F22), (M33)
- Harness connectors (F23), (M32)
- Harness connectors (M1), (E1)
- Harness for open or short between ECM and intake air temperature sensor
- Harness for open or short between A/T control unit and intake air temperature sensor

If NG, repair open circuit or short to ground or short to power in harness or connectors.

CHECK COMPONENT
(Intake air temperature sensor). Refer to "COMPONENT INSPECTION" on next page.

NG

Replace intake air temperature sensor.

OK

Disconnect and reconnect harness connectors in the circuit. Then retest.

Trouble is not fixed.

Check ECM pin terminals for damage and check the connection of ECM harness connector.
Reconnect ECM harness connector and retest.

INSPECTION END

TROUBLE DIAGNOSIS FOR DTC P0110

Intake Air Temperature Sensor (Cont'd) COMPONENT INSPECTION

Intake air temperature sensor

Check resistance as shown in the figure.

GI
MA
EM
LC
EC
FE
AT
TF
PD
FA
RA
BR
ST
RS
BT
HA
EL
IDX

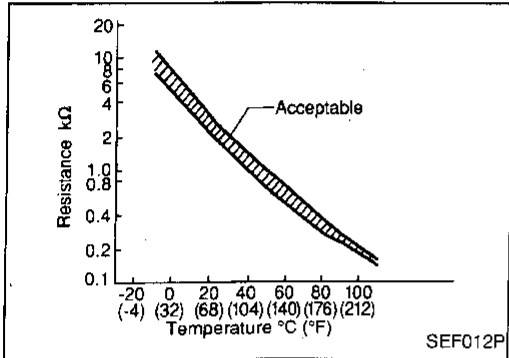
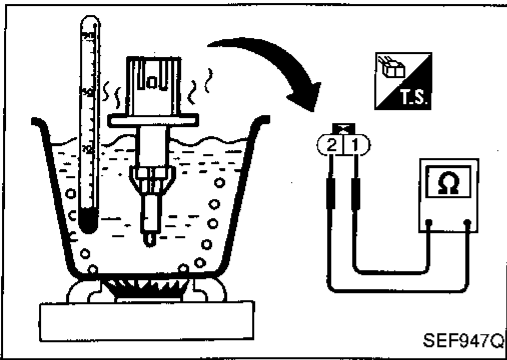

(Reference data)

Intake air temperature °C (°F)	Resistance kΩ
20 (68)	2.1 - 2.9
80 (176)	0.27 - 0.38

If NG, replace intake air temperature sensor.

TROUBLE DIAGNOSIS FOR DTC P0115

Engine Coolant Temperature Sensor (ECTS)

COMPONENT DESCRIPTION

The engine coolant temperature sensor is used to detect the engine coolant temperature. The sensor modifies a voltage signal from the ECM. The modified signal returns to the ECM as the engine coolant temperature input. The sensor uses a thermistor which is sensitive to the change in temperature. The electrical resistance of the thermistor decreases as temperature increases.

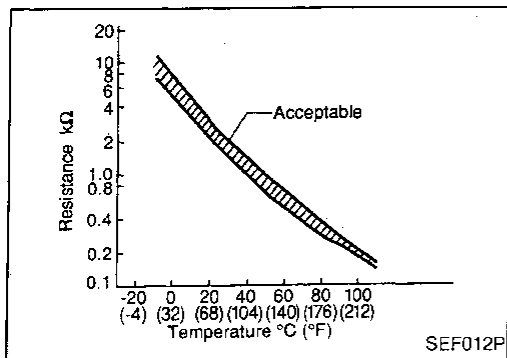
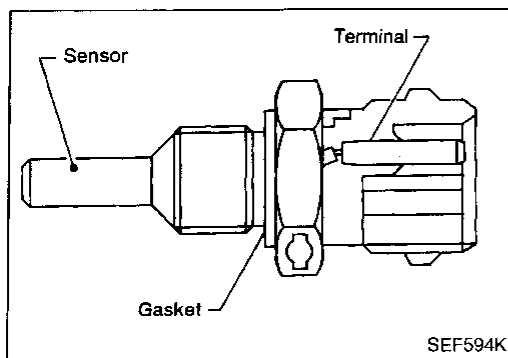

(Reference data)

Engine coolant temperature °C (°F)	Voltage* (V)	Resistance (kΩ)
-10 (14)	4.4	7.0 - 11.4
20 (68)	3.5	2.1 - 2.9
50 (122)	2.2	0.68 - 1.00
90 (194)	0.9	0.236 - 0.260

*: These data are reference values and are measured between ECM terminal ⑤ (Engine coolant temperature sensor) and ECM terminal ④ (ECSS ground).

ON BOARD DIAGNOSIS LOGIC

Diagnostic Trouble Code No.	Malfunction is detected when ...	Check Items (Possible Cause)
P0115 0103	<ul style="list-style-type: none"> An excessively high or low voltage from the sensor is sent to ECM.* 	<ul style="list-style-type: none"> Harness or connectors (The sensor circuit is open or shorted.) Engine coolant temperature sensor

*: When this malfunction is detected, the ECM enters fail-safe mode and the MIL lights up.

Detected items	Engine operating condition in fail-safe mode								
Engine coolant temperature sensor circuit	<p>Engine coolant temperature will be determined by ECM based on the time after turning ignition switch "ON" or "START". CONSULT displays the engine coolant temperature decided by ECM.</p> <table border="1"> <thead> <tr> <th>Condition</th> <th>Engine coolant temperature decided (CONSULT display)</th> </tr> </thead> <tbody> <tr> <td>Just as ignition switch is turned ON or Start</td> <td>40°C (104°F)</td> </tr> <tr> <td>More than approx. 4 minutes after ignition ON or Start</td> <td>80°C (176°F)</td> </tr> <tr> <td>Except as shown above</td> <td>40 - 80°C (104 - 176°F) (Depends on the time)</td> </tr> </tbody> </table>	Condition	Engine coolant temperature decided (CONSULT display)	Just as ignition switch is turned ON or Start	40°C (104°F)	More than approx. 4 minutes after ignition ON or Start	80°C (176°F)	Except as shown above	40 - 80°C (104 - 176°F) (Depends on the time)
Condition	Engine coolant temperature decided (CONSULT display)								
Just as ignition switch is turned ON or Start	40°C (104°F)								
More than approx. 4 minutes after ignition ON or Start	80°C (176°F)								
Except as shown above	40 - 80°C (104 - 176°F) (Depends on the time)								



TROUBLE DIAGNOSIS FOR DTC P0115

Engine Coolant Temperature Sensor (ECTS) (Cont'd)

☆ MONITOR	☆ NO FAIL	<input type="checkbox"/>
CMPS-RPM(POS)	0rpm	
RECORD		

SEF888T

DIAGNOSTIC TROUBLE CODE CONFIRMATION PROCEDURE

-  1) Turn ignition switch "ON".
2) Select "DATA MONITOR" mode with CONSULT.
3) Wait at least 5 seconds.
- OR
-  1) Turn ignition switch "ON" and wait at least 5 seconds.
2) Select "MODE 7" with GST.
- OR
-  1) Turn ignition switch "ON" and wait at least 5 seconds.
2) Turn ignition switch "OFF", wait at least 5 seconds and then turn "ON".
3) Perform "Diagnostic Test Mode II (Self-diagnostic results)" with ECM.

GI

MA

EM

LC

EC

FE

AT

TF

PD

FA

RA

BR

ST

RS

BT

HA

EL

IDX

TROUBLE DIAGNOSIS FOR DTC P0115

Engine Coolant Temperature Sensor (ECTS) (Cont'd)

EC-ECTS-01

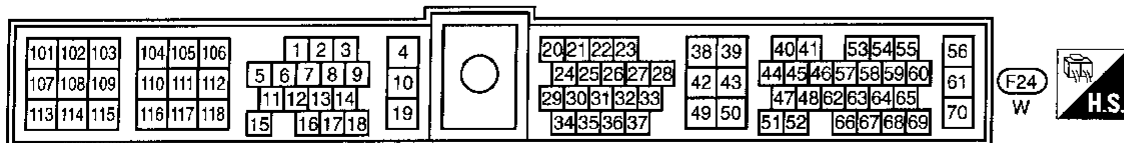
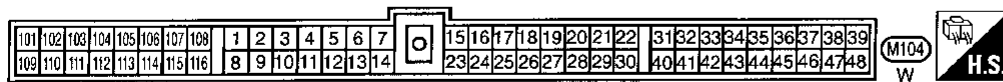
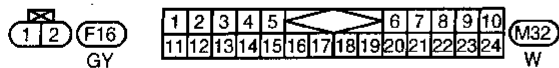
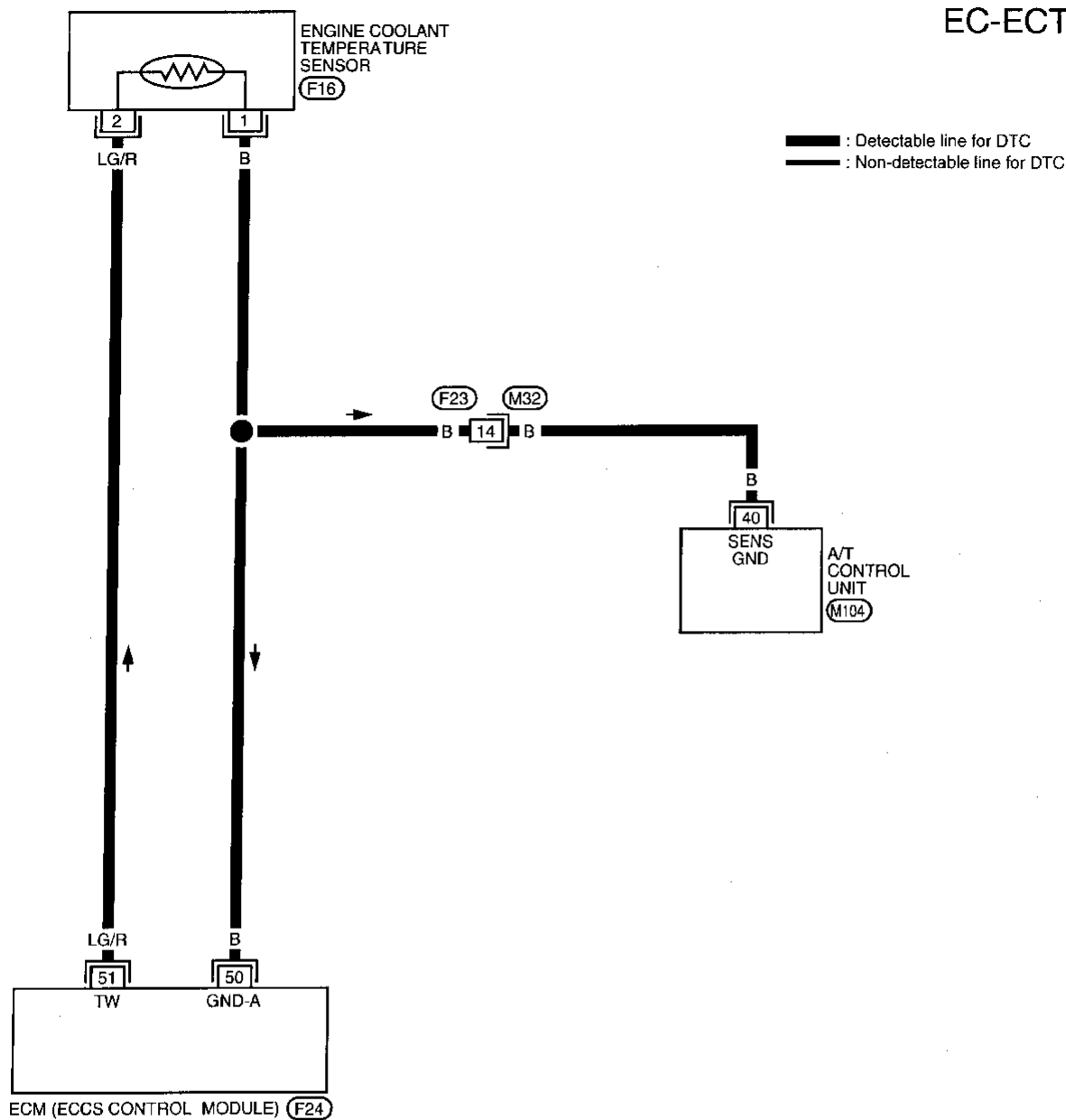

TROUBLE DIAGNOSIS FOR DTC P0115

Engine Coolant Temperature Sensor (ECTS) (Cont'd)

DIAGNOSTIC PROCEDURE

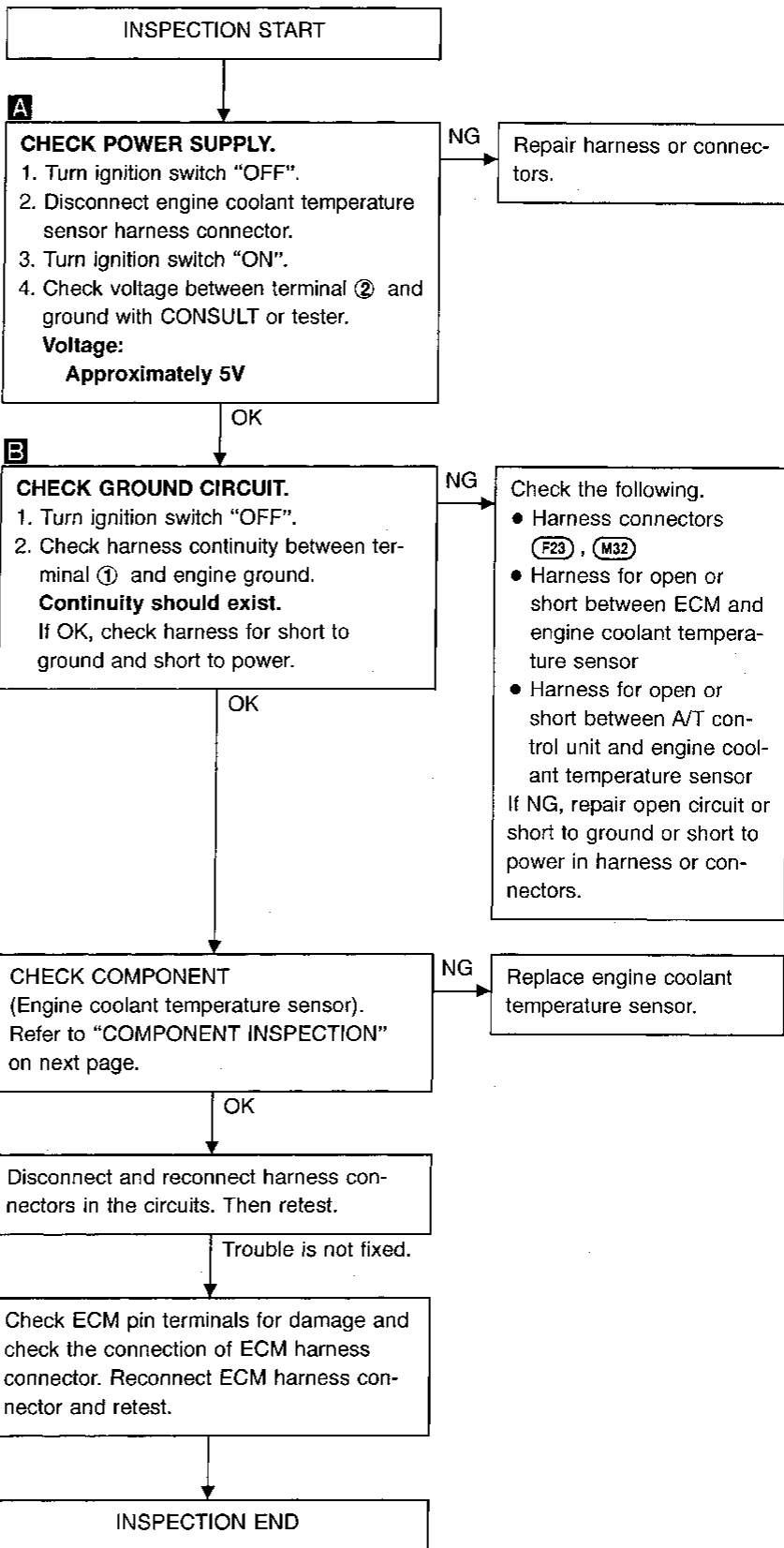
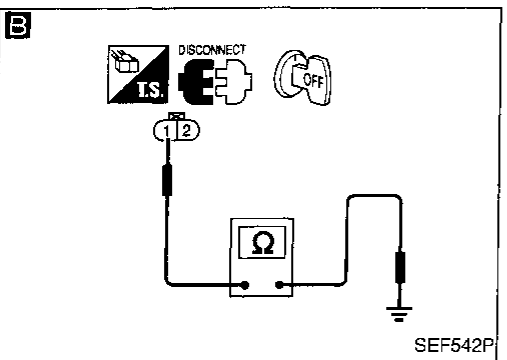
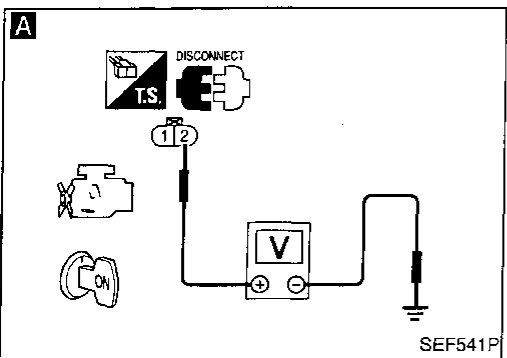
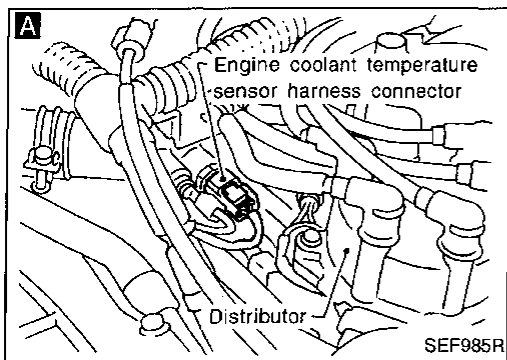

GI
MA
EM
LC
EC
FE
AT
TF
PD
FA
RA
BR
ST
RS
BT
HA
EL
IDX

TROUBLE DIAGNOSIS FOR DTC P0115

Engine Coolant Temperature Sensor (ECTS) (Cont'd)

COMPONENT INSPECTION

Engine coolant temperature sensor

Check resistance as shown in the figure.

⟨Reference data⟩

Temperature °C (°F)	Resistance kΩ
20 (68)	2.1 - 2.9
50 (122)	0.68 - 1.00
90 (194)	0.236 - 0.260

If NG, replace engine coolant temperature sensor.

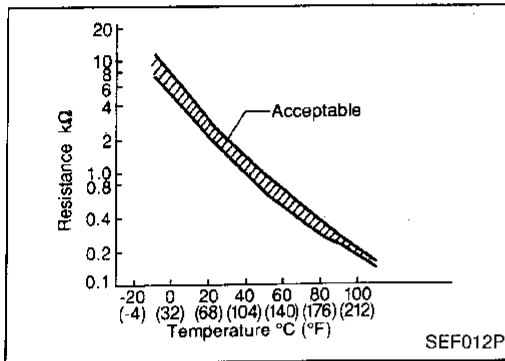
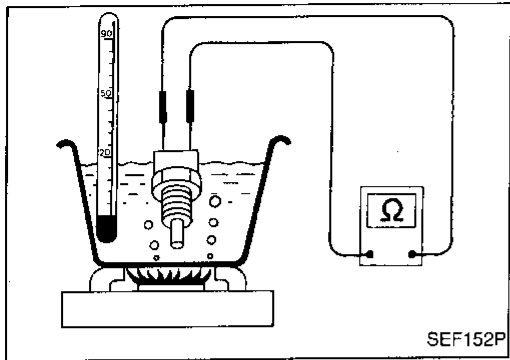

TROUBLE DIAGNOSIS FOR DTC P0120

Throttle Position Sensor

Note: If both DTC P0120 (0403) and DTC P0510 (0203) are displayed, perform TROUBLE DIAGNOSIS FOR DTC P0510 first. (See EC-261.)

COMPONENT DESCRIPTION

The throttle position sensor responds to the accelerator pedal movement. This sensor is a kind of potentiometer which transforms the throttle position into output voltage, and emits the voltage signal to the ECM. In addition, the sensor detects the opening and closing speed of the throttle valve and feeds the voltage signal to the ECM.

Idle position of the throttle valve is determined by the ECM receiving the signal from the throttle position sensor. This sensor controls engine operation such as fuel cut. On the other hand, the "Wide open and closed throttle position switch", which is built into the throttle position sensor unit, is not used for engine control.

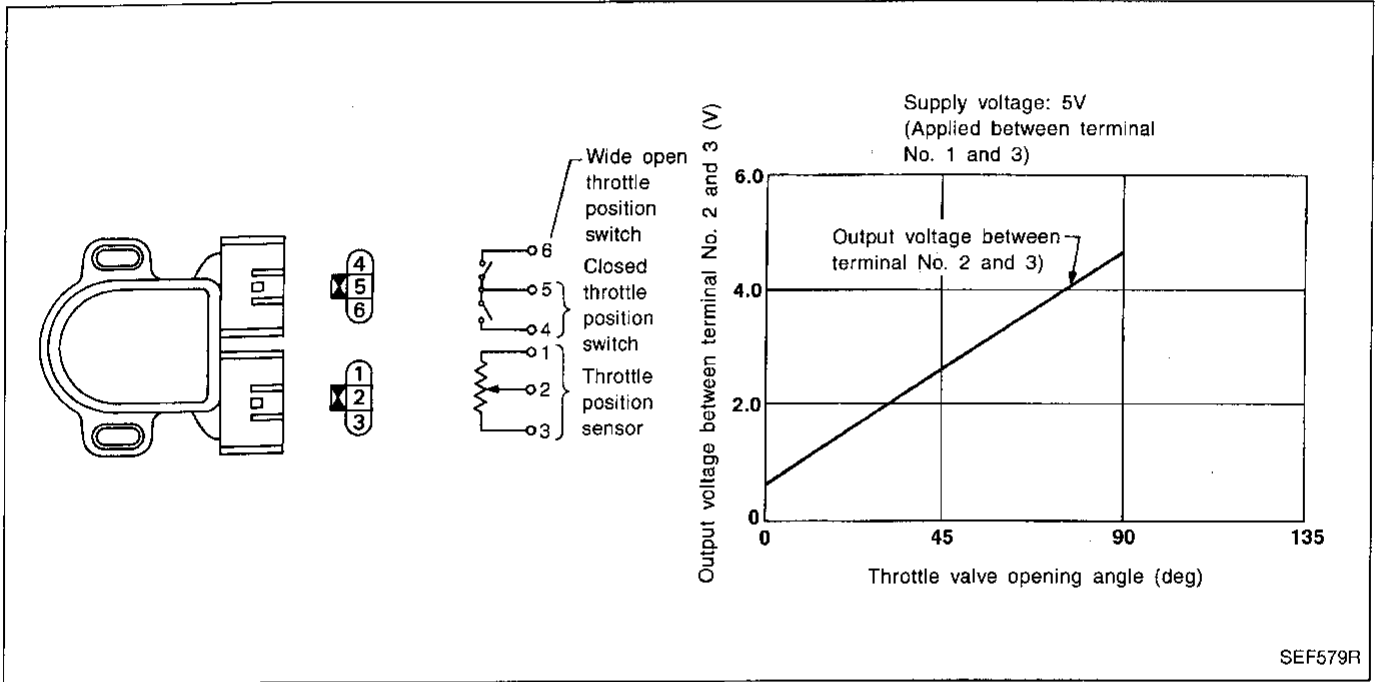

CONSULT REFERENCE VALUE IN DATA MONITOR MODE

Specification data are reference values.

MONITOR ITEM	CONDITION	SPECIFICATION
THRTL POS SEN	● Ignition switch: ON (Engine stopped)	Throttle valve: fully closed 0.3 - 0.7V
		Throttle valve: fully opened Approx. 4.0V
ABSOL TH·P/S	● Ignition switch: ON (Engine stopped)	Throttle valve: fully closed 0.0%
		Throttle valve: fully opened Approx. 80%

TROUBLE DIAGNOSIS FOR DTC P0120

Throttle Position Sensor (Cont'd)

ECM TERMINALS AND REFERENCE VALUE

Specification data are reference values and are measured between each terminal and Ⓒ (ECCS ground).

TER-MINAL NO.	WIRE COLOR	ITEM	CONDITION	DATA (DC Voltage)
23	W	Throttle position sensor	Ignition switch "ON" └ Accelerator pedal released	0.3 - 0.7V
			Ignition switch "ON" └ Accelerator pedal fully depressed	Approximately 4V
33	P	Throttle position sensor signal	Ignition switch "ON" └ Accelerator pedal released	Approximately 0.4V
			Ignition switch "ON" └ Accelerator pedal fully depressed	Approximately 4V
49	P/B	Sensors' power supply	Ignition switch "ON"	Approximately 5V
50	B	Sensors' ground	Engine is running. (Warm-up condition) └ Idle speed	Approximately 0V

ON BOARD DIAGNOSIS LOGIC

Diagnostic Trouble Code No.	Malfunction is detected when ...	Check Items (Possible Cause)
P0120 0403	<ul style="list-style-type: none"> An excessively low or high voltage from the sensor is sent to ECM.* Voltage sent to ECM is not practical when compared with mass air flow sensor and camshaft position sensor signals. 	<ul style="list-style-type: none"> Harness or connectors (The sensor circuit is open or shorted.) Throttle position sensor

*: When this malfunction is detected, the ECM enters fail-safe mode and the MIL lights up.

Detected items	Engine operating condition in fail-safe mode					
Throttle position sensor circuit	Throttle position will be determined based on the injected fuel amount and the engine speed. Therefore, acceleration will be poor.					
	<table border="1" style="width: 100%;"> <thead> <tr> <th>Condition</th> <th>Driving condition</th> </tr> </thead> <tbody> <tr> <td>When engine is idling</td> <td>Normal</td> </tr> <tr> <td>When accelerating</td> <td>Poor acceleration</td> </tr> </tbody> </table>	Condition	Driving condition	When engine is idling	Normal	When accelerating
Condition	Driving condition					
When engine is idling	Normal					
When accelerating	Poor acceleration					

TROUBLE DIAGNOSIS FOR DTC P0120

Throttle Position Sensor (Cont'd)

DIAGNOSTIC TROUBLE CODE CONFIRMATION PROCEDURE

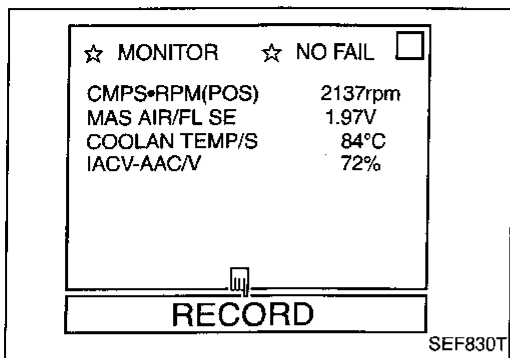

- 1) Start engine and warm it up sufficiently.
- 2) Select "DATA MONITOR" mode with CONSULT.
- 3) Maintain the following conditions for at least 10 seconds.

Gear position: "1" or "2" range
Engine speed: More than 2,000 rpm
MAS AIR/FL SE: More than 3V
COOLANT TEMP/S: More than 70°C (158°F)
IACV-AAC/V: Less than 80%

CAUTION:

Do not run vehicle at speeds greater than 80 km/h (50 MPH).

OR

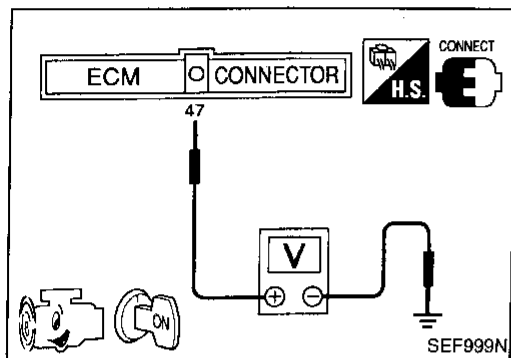

- 1) Start engine and warm it up sufficiently.
- 2) Maintain the following conditions for at least 10 seconds.

Gear position: "1" or "2" range
Engine speed: More than 2,000 rpm
Voltage between ECM terminal 47 and ground: More than 3V
Voltage between ECM terminal 55 and ground: More than 4V

CAUTION:

Do not run vehicle at speeds greater than 80 km/h (50 MPH).

OR

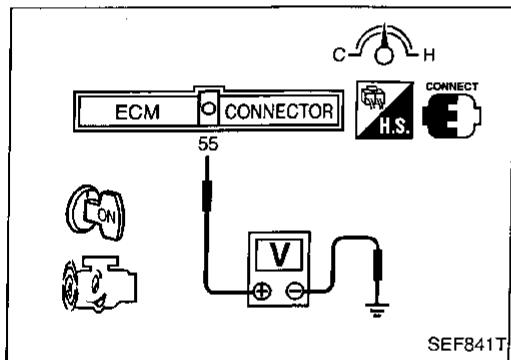

- 1) Start engine and warm it up sufficiently.
- 2) Maintain the following conditions for at least 10 seconds.

Gear position: "1" or "2" range
Engine speed: More than 2,000 rpm
Voltage between ECM terminal 47 and ground: More than 3V
Voltage between ECM terminal 55 and ground: More than 4V

CAUTION:

Do not run vehicle at speeds greater than 80 km/h (50 MPH).

- 3) Stop the vehicle, turn ignition switch "OFF", wait at least 5 seconds and then turn "ON".
- 4) Perform "DIAGNOSTIC TEST MODE (Self-diagnostic results)" with ECM.

TROUBLE DIAGNOSIS FOR DTC P0120

Throttle Position Sensor (Cont'd)

EC-TPS-01

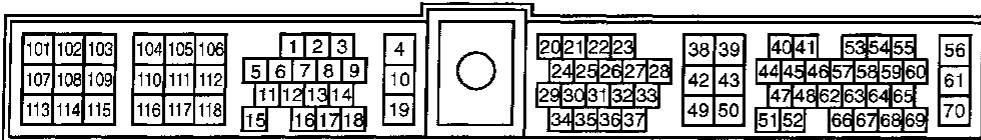
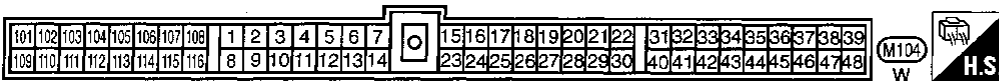
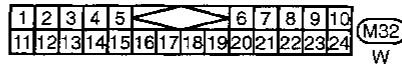
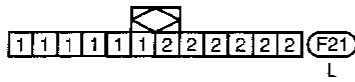
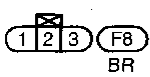
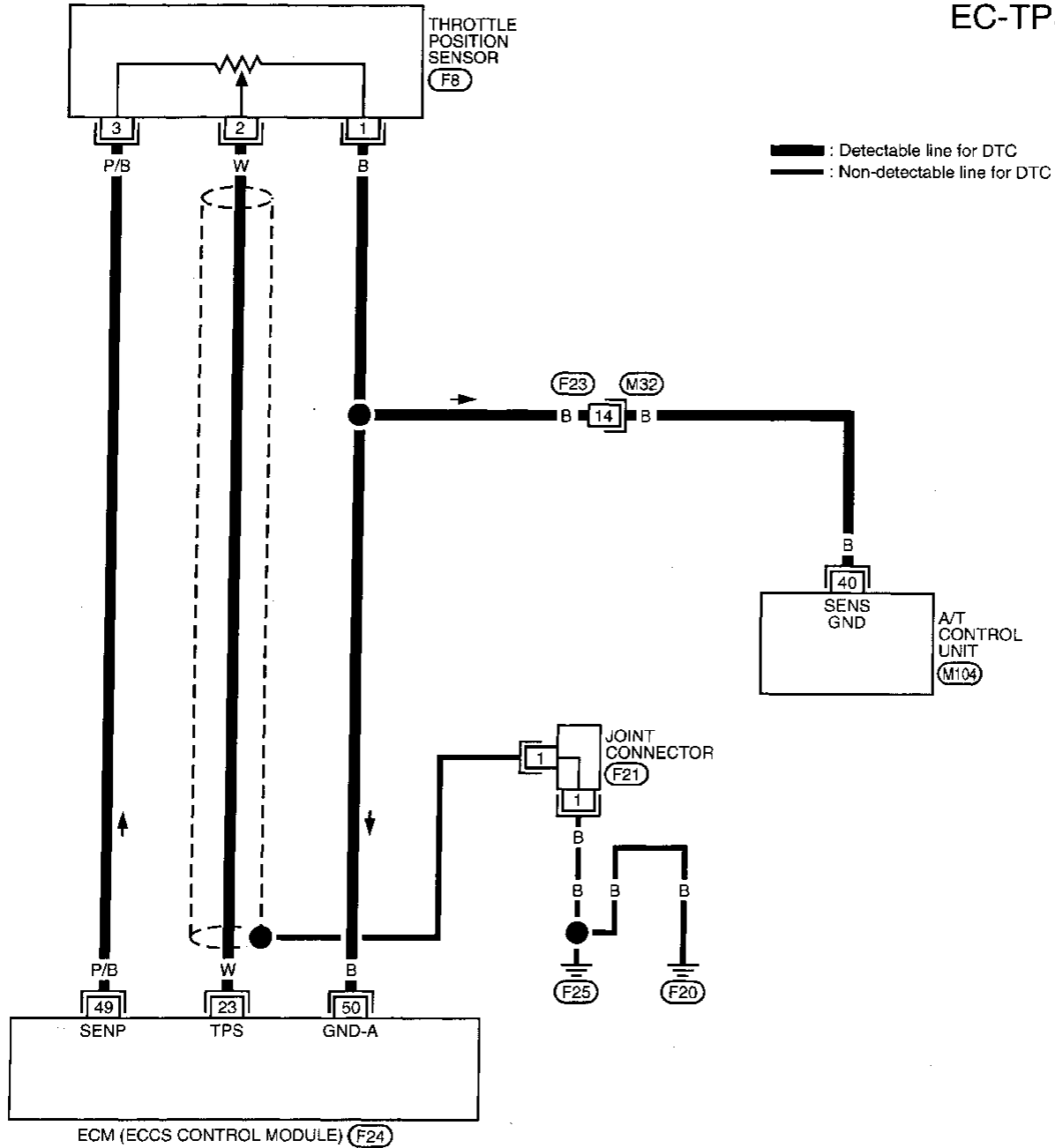

TROUBLE DIAGNOSIS FOR DTC P0120

Throttle Position Sensor (Cont'd)

DIAGNOSTIC PROCEDURE

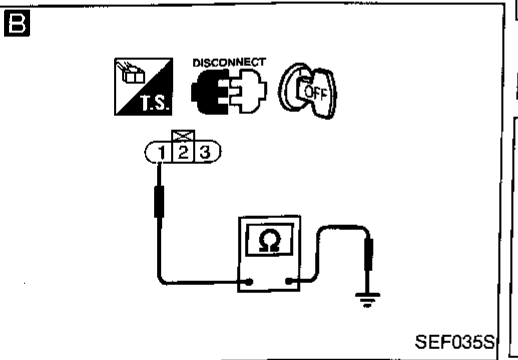
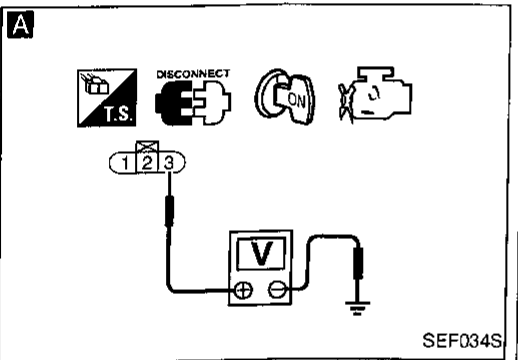
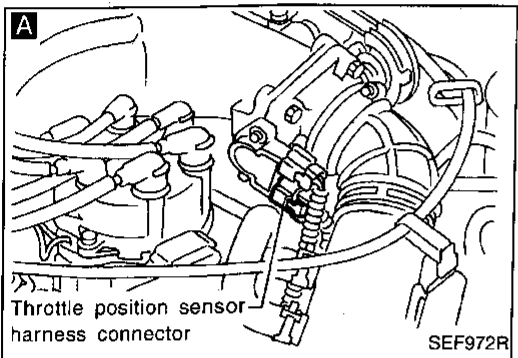
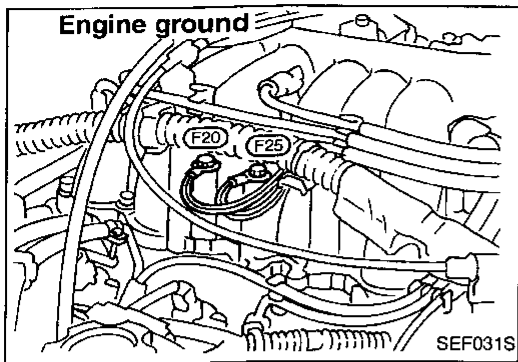

INSPECTION START

ADJUST THROTTLE POSITION SENSOR.
Perform "Basic Inspection", EC-74.

OK

CHECK SHIELD CIRCUIT.

1. Turn ignition switch "OFF".
2. Loosen and retighten engine ground screws.
3. Remove joint connector.
4. Check the following.
 - Continuity between joint connector terminal and ground
 - Joint connector (Refer to "HARNES LAYOUT" in EL section.)

Continuity should exist.
If OK, check harness for short to ground and short to power. Then reconnect joint connector.

NG Repair harness or connectors.

OK

CHECK POWER SUPPLY.

1. Disconnect throttle position sensor harness connector.
2. Turn ignition switch "ON".
3. Check voltage between terminal ③ and ground with CONSULT or tester.

Voltage: Approximately 5V

NG Repair harness or connectors.

OK

CHECK GROUND CIRCUIT.

1. Turn ignition switch "OFF".
2. Check harness continuity between terminal ① and engine ground.

Continuity should exist.
If OK, check harness for short to ground and short to power.

NG Check the following.

- Harness connectors (F23), (M32)
- Harness for open or short between ECM and throttle position sensor
- Harness for open or short between A/T control unit and throttle position sensor

If NG, repair open circuit or short to ground or short to power in harness or connectors.

OK

④

GI
MA
EM
LC
EC
FE
AT
TF
PD
FA
RA
BR
ST
RS
BT
HA
EL
IDX

TROUBLE DIAGNOSIS FOR DTC P0120

Throttle Position Sensor (Cont'd)

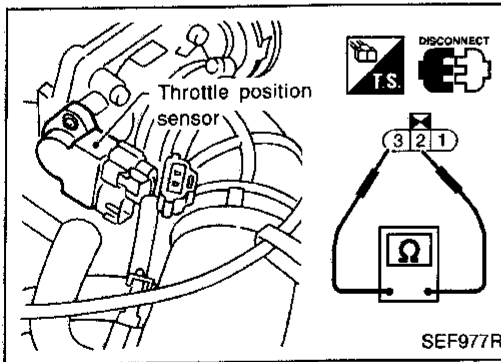
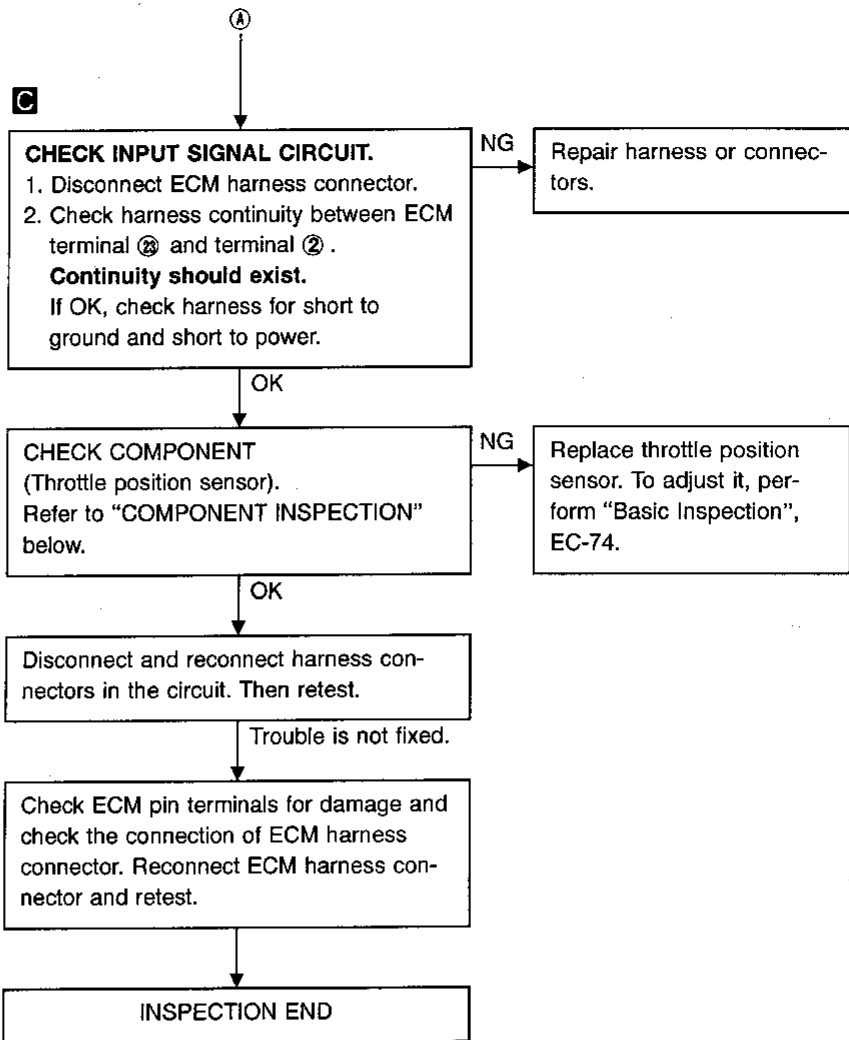
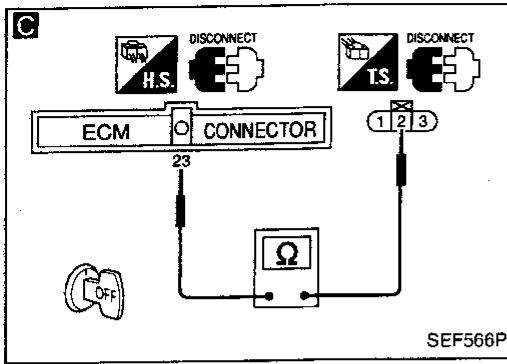

COMPONENT INSPECTION Throttle position sensor

1. Disconnect throttle position sensor harness connector.
2. Make sure that resistance between terminals ② and ③ changes when opening throttle valve manually.

Throttle valve conditions	Resistance [at 25°C (77°F)]
Completely closed	Approximately 0.5 kΩ
Partially open	0.5 - 4 kΩ
Completely open	Approximately 4 kΩ

If NG, replace throttle position sensor.
To adjust it, perform "Basic Inspection", EC-74.

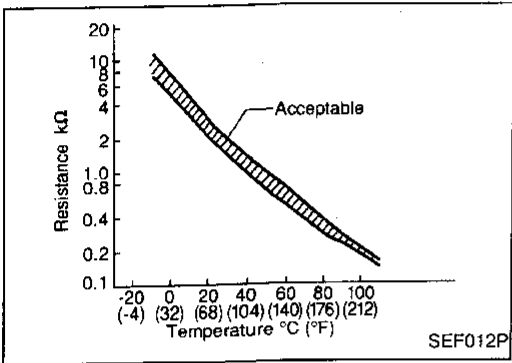
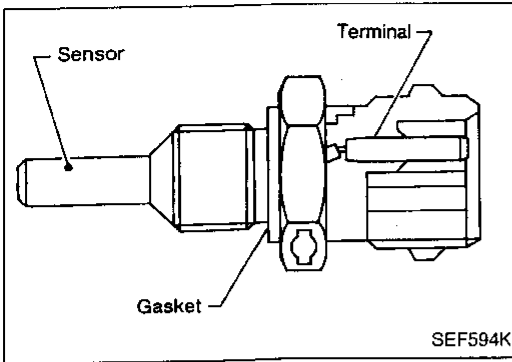

Engine Coolant Temperature (ECT) Sensor

COMPONENT DESCRIPTION

The engine coolant temperature sensor is used to detect the engine coolant temperature. The sensor modifies a voltage signal from the ECM. The modified signal returns to the ECM as the engine coolant temperature input. The sensor uses a thermistor which is sensitive to the change in temperature. The electrical resistance of the thermistor decreases as temperature increases.

<Reference data>

Engine coolant temperature °C (°F)	Voltage* (V)	Resistance (kΩ)
-10 (14)	4.4	9.2
20 (68)	3.5	2.1 - 2.9
50 (122)	2.2	0.68 - 1.00
90 (194)	0.9	0.236 - 0.260

*: These data are reference values and are measured between ECM terminal ⑤ (Engine coolant temperature sensor) and ECM terminal ④ (ECSS ground).

ON BOARD DIAGNOSIS LOGIC

Diagnostic Trouble Code No.	Malfunction is detected when ...	Check Items (Possible Cause)
P0125 0908	<ul style="list-style-type: none"> • Voltage sent to ECM from the sensor is not practical, even when some time has passed after starting the engine. • Engine coolant temperature is insufficient for closed loop fuel control. 	<ul style="list-style-type: none"> • Harness or connectors (High resistance in the circuit) • Engine coolant temperature sensor • Thermostat

GI
MA
EM
LC
EC
FE
AT
TF
PD
FA
RA
BR
ST
RS
BT
HA
EL
IDX

TROUBLE DIAGNOSIS FOR DTC P0125

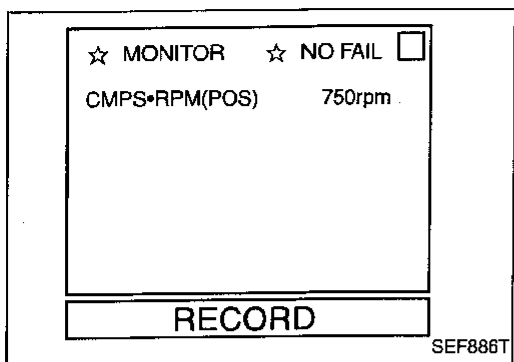

Engine Coolant Temperature (ECT) Sensor (Cont'd)

DIAGNOSTIC TROUBLE CODE CONFIRMATION PROCEDURE

Note: If both DTC P0115 (0103) and P0125 (0908) are displayed, first perform "TROUBLE DIAGNOSIS FOR DTC P0115". Refer to EC-118.



- 1) Turn ignition switch "ON".
- 2) Select "DATA MONITOR" mode with CONSULT.
- 3) Start engine and run it for 14 minutes at idle speed.

CAUTION:

Be careful not to overheat engine.

OR



- 1) Start engine and run it for 14 minutes at idle speed.
- 2) Select "MODE 7" with GST.

CAUTION:

Be careful not to overheat engine.

OR



- 1) Start engine and run it for 14 minutes at idle speed.
- 2) Turn ignition switch "OFF", wait at least 5 seconds and then turn "ON".
- 3) Perform "Diagnostic Test Mode II (Self-diagnostic results)" with ECM.

CAUTION:

Be careful not to overheat engine.

TROUBLE DIAGNOSIS FOR DTC P0125

Engine Coolant Temperature (ECT) Sensor (Cont'd)

EC-ECTS-01

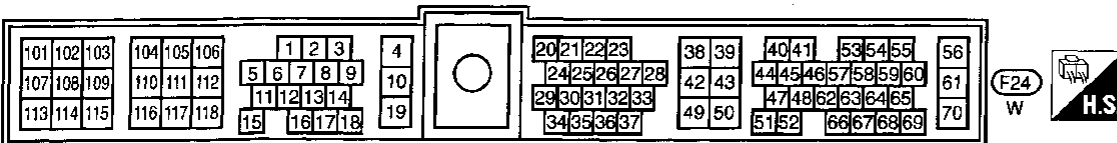
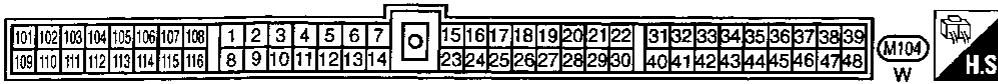
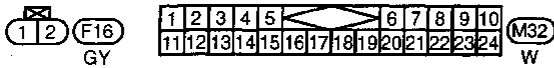
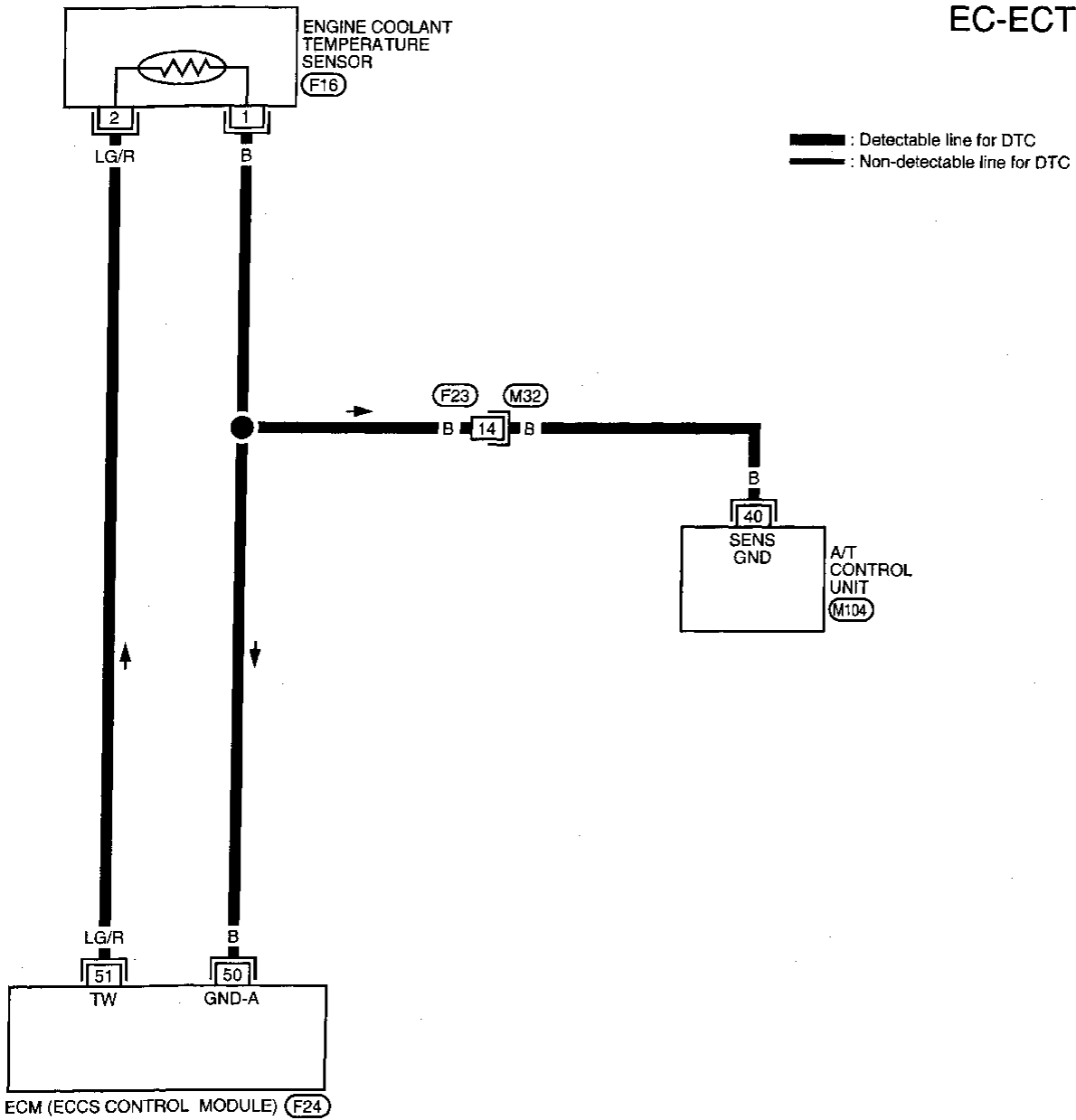

GI
MA
EM
LC
EC
FE
AT
TF
PD
FA
RA
BR
ST
RS
BT
HA
EL
IDX

TROUBLE DIAGNOSIS FOR DTC P0125

Engine Coolant Temperature (ECT) Sensor (Cont'd)

DIAGNOSTIC PROCEDURE

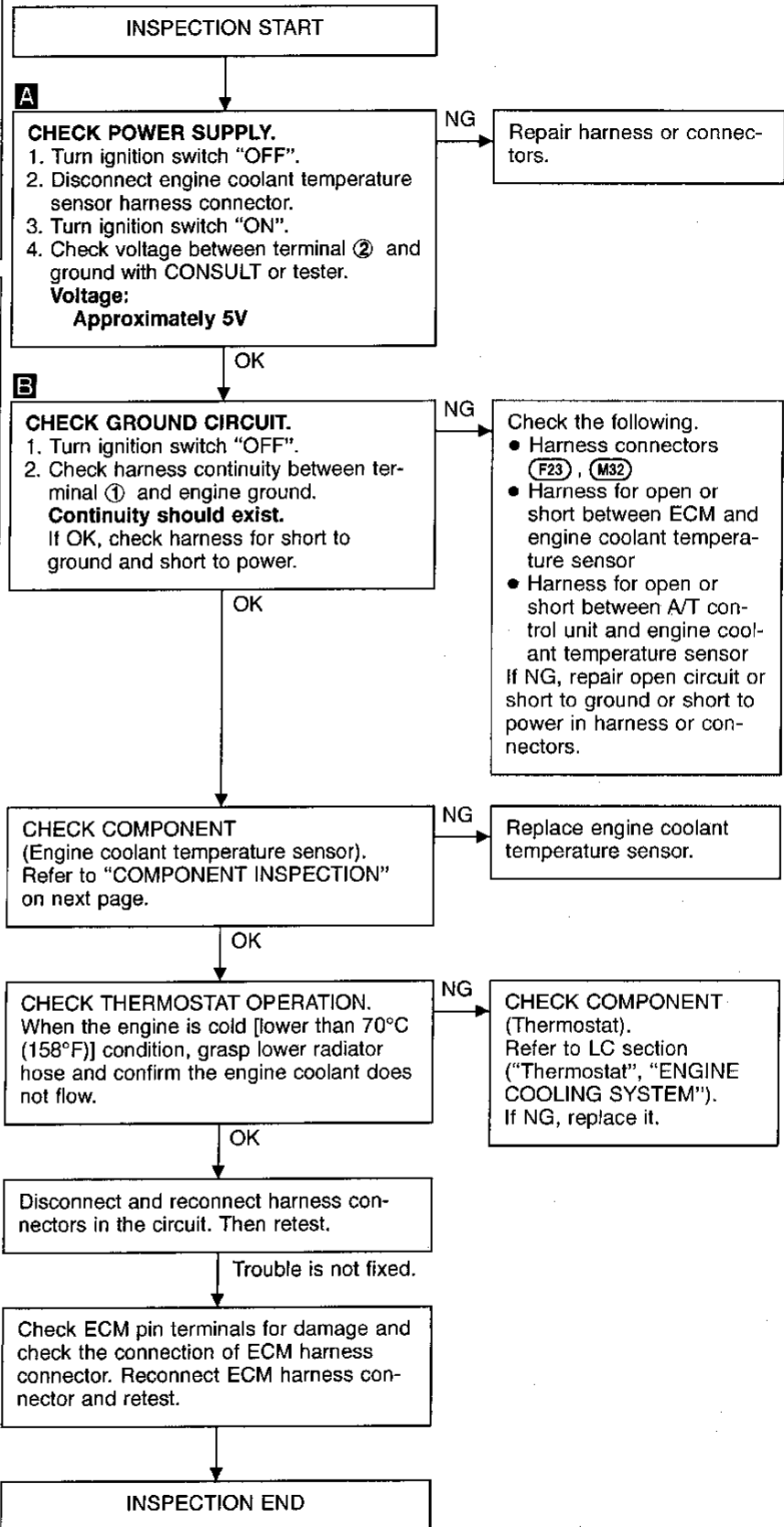
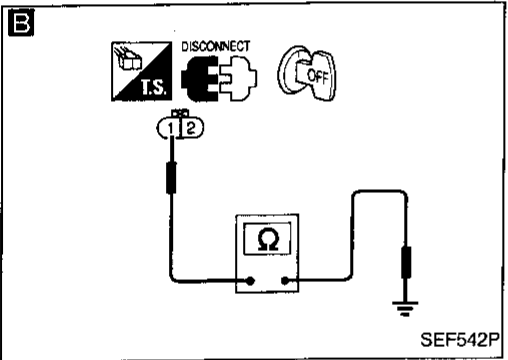
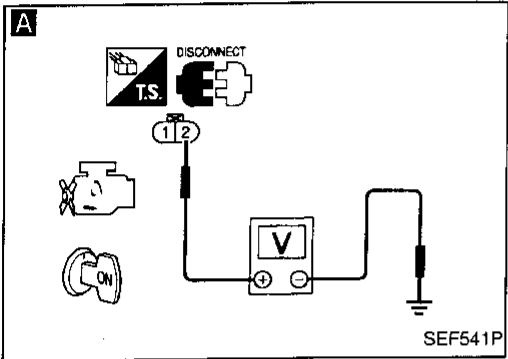
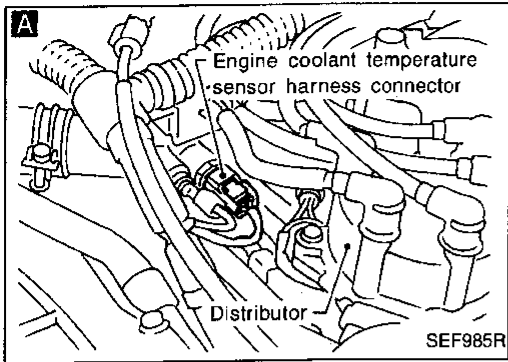

TROUBLE DIAGNOSIS FOR DTC P0125

Engine Coolant Temperature (ECT) Sensor (Cont'd)

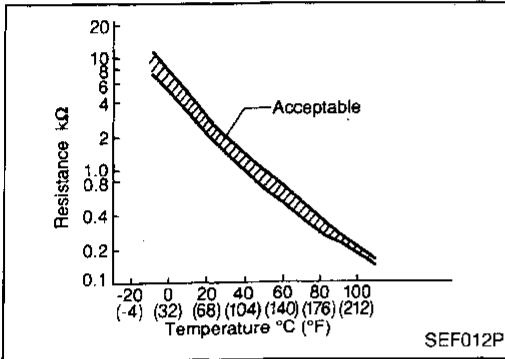
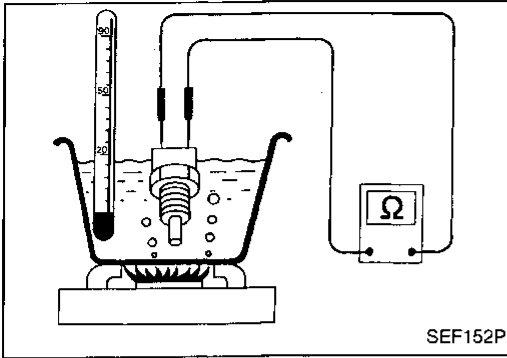

COMPONENT INSPECTION

Engine coolant temperature sensor

Check resistance as shown in the figure.

⟨Reference data⟩

Temperature °C (°F)	Resistance kΩ
20 (68)	2.1 - 2.9
50 (122)	0.68 - 1.0
90 (194)	0.236 - 0.260

If NG, replace engine coolant temperature sensor.

GI

MA

EM

LC

EC

FE

AT

TF

PD

FA

RA

BR

ST

RS

BT

HA

EL

IDX

Closed Loop Control

ON BOARD DIAGNOSIS LOGIC

★ The closed loop control has the one trip detection logic.

Diagnostic Trouble Code No.	Malfunction is detected when ...	Check Items (Possible Cause)
P0130 0307	<ul style="list-style-type: none"> • The closed loop control function for right bank does not operate even when vehicle is driving in the specified condition. 	<ul style="list-style-type: none"> • The front heated oxygen sensor (Right bank) circuit is open or shorted. • Front heated oxygen sensor (Right bank) • Front heated oxygen sensor heater (Right bank)
P0150 0308	<ul style="list-style-type: none"> • The closed loop control function for left bank does not operate even when vehicle is driving in the specified condition. 	<ul style="list-style-type: none"> • The front heated oxygen sensor (Left bank) circuit is open or shorted. • Front heated oxygen sensor (Left bank) • Front heated oxygen sensor heater (Left bank)

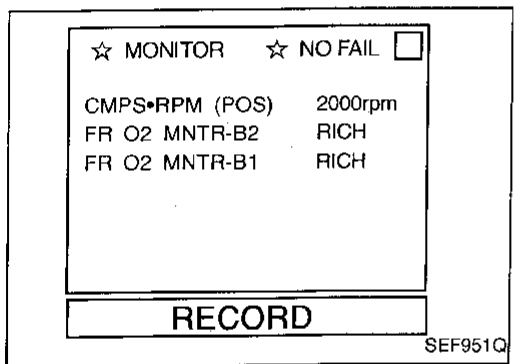

OVERALL FUNCTION CHECK

Use this procedure to check the overall function of the closed loop control. During this check, a 1st trip DTC might not be confirmed.

- 1) Start engine and warm it up sufficiently.
 - 2) Select "MANU TRIG" and "HI SPEED" in "DATA MONITOR" mode with CONSULT, and select "FRO2 MNTR-B1(B2)".
 - 3) Hold engine speed at 2,000 rpm under no load during the following steps.
 - 4) Touch "RECORD" on CONSULT screen.
 - 5) Check the following.
 - "FR O2 MNTR-B1(B2)" in "DATA MONITOR" mode changes from "RICH" to "LEAN" to "RICH" 5 times in 10 seconds.
- 5 times (cycles) are counted as shown below:

cycle | 1 | 2 | 3 | 4 | 5 |
 FR O2 MNTR-B1(B2) R-L-R-L-R-L-R-L-R-L-R

R = "FR O2 MNTR-B1(B2)", "RICH"
 L = "FR O2 MNTR-B1(B2)", "LEAN"

OR

- 1) Start engine and warm it up sufficiently.
- 2) Make sure that malfunction indicator lamp comes on more than 5 times within 10 seconds while keeping at 2,000 rpm in Diagnostic Test Mode II (Front heated oxygen sensor monitor).

DIAGNOSTIC PROCEDURE

For right bank

Refer to TROUBLE DIAGNOSIS FOR DTC P0130, EC-135.
 Refer to TROUBLE DIAGNOSIS FOR DTC P0135, EC-140.

For left bank

Refer to TROUBLE DIAGNOSIS FOR DTC P0150, EC-153.
 Refer to TROUBLE DIAGNOSIS FOR DTC P0155, EC-158.

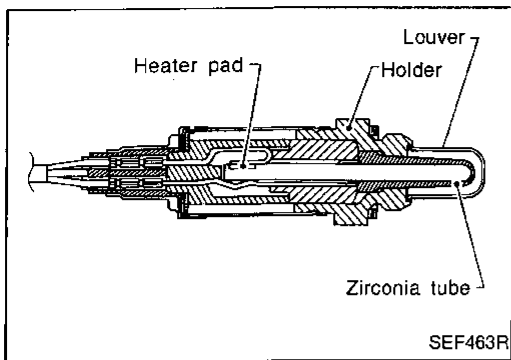

Front Heated Oxygen Sensor (Front HO2S) (Right bank)

COMPONENT DESCRIPTION

The front heated oxygen sensor (right bank) is placed into the front tube (right bank). It detects the amount of oxygen in the exhaust gas compared to the outside air. The front heated oxygen sensor (right bank) has a closed-end tube made of ceramic zirconia. The zirconia generates voltage from approximately 1V in richer conditions to 0V in leaner conditions. The front heated oxygen sensor (right bank) signal is sent to the ECM. The ECM adjusts the injection pulse duration to achieve the ideal air-fuel ratio. The ideal air-fuel ratio occurs near the radical change from 1V to 0V.

GI
MA
EM
LC

EC

FE

AT

TF

PD

FA

RA

BR

ST

RS

BT

HA

EL

IDX

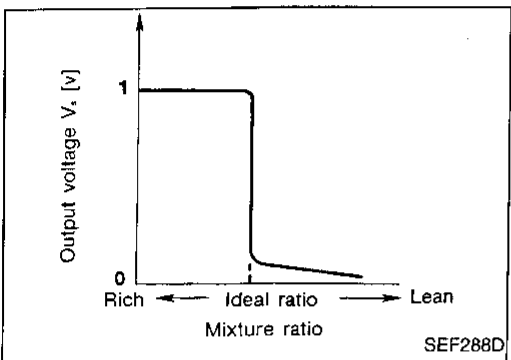

CONSULT REFERENCE VALUE IN DATA MONITOR MODE

Specification data are reference values.

MONITOR ITEM	CONDITION	SPECIFICATION
FR O2 SEN-B1 FR O2 MNTR-B1	<ul style="list-style-type: none"> Engine: After warming up Maintaining engine speed at 2,000 rpm	0 - 0.3V ↔ Approx. 0.6 - 1.0V LEAN ↔ RICH Changes more than 5 times during 10 seconds.

ECM TERMINALS AND REFERENCE VALUE

Specification data are reference values and are measured between each terminal and ④ (ECSS ground).

TER-MINAL NO.	WIRE COLOR	ITEM	CONDITION	DATA (DC Voltage)
46	W	Front heated oxygen sensor (RH)	Engine is running. After warming up sufficiently and engine speed is 2,000 rpm	0 - Approximately 1.0V

ON BOARD DIAGNOSIS LOGIC

Diagnostic Trouble Code No.	Malfunction is detected when ...	Check Items (Possible Cause)
P0130 0503	<ul style="list-style-type: none"> An excessively high voltage from the sensor is sent to ECM. The voltage from the sensor is constantly approx. 0.3V. The maximum and minimum voltages from the sensor are not reached to the specified voltages. It takes more time for the sensor to respond between rich and lean than the specified time. 	<ul style="list-style-type: none"> Harness or connectors (The sensor circuit is open or shorted.) Front heated oxygen sensor (Right bank) Fuel pressure Injectors Intake air leaks

TROUBLE DIAGNOSIS FOR DTC P0130

Front Heated Oxygen Sensor (Front HO2S) (Right bank) (Cont'd)

OVERALL FUNCTION CHECK

Use this procedure to check the overall function of the front heated oxygen sensor circuit. During this check, a 1st trip DTC might not be confirmed.



- 1) Start engine and warm it up sufficiently.
- 2) Select "MANU TRIG" and "HI SPEED" in "DATA MONITOR" mode with CONSULT, and select "FR O2 SEN-B1" and "FR O2 MNTR-B1".
- 3) Hold engine speed at 2,000 rpm under no load during the following steps.
- 4) Touch "RECORD" on CONSULT screen.
- 5) Check the following.
 - "FR O2 MNTR-B1" in "DATA MONITOR" mode changes from "RICH" to "LEAN" to "RICH" 5 times in 10 seconds.

5 times (cycles) are counted as shown below:

cycle | 1 | 2 | 3 | 4 | 5 |

FR O2 MNTR-B1 R-L-R-L-R-L-R-L-R

R = "FR O2 MNTR-B1", "RICH"
L = "FR O2 MNTR-B1", "LEAN"

- "FR O2 SEN-B1" voltage goes above 0.6V at least once.
- "FR O2 SEN-B1" voltage goes below 0.3V at least once.
- The voltage never exceeds 1.0V.

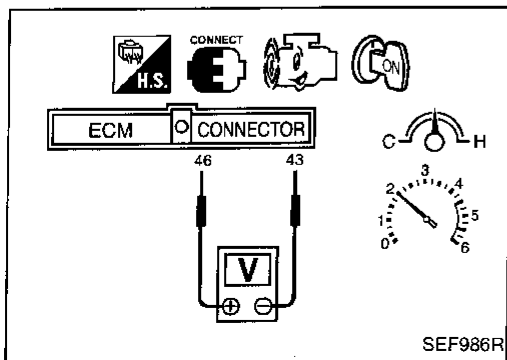
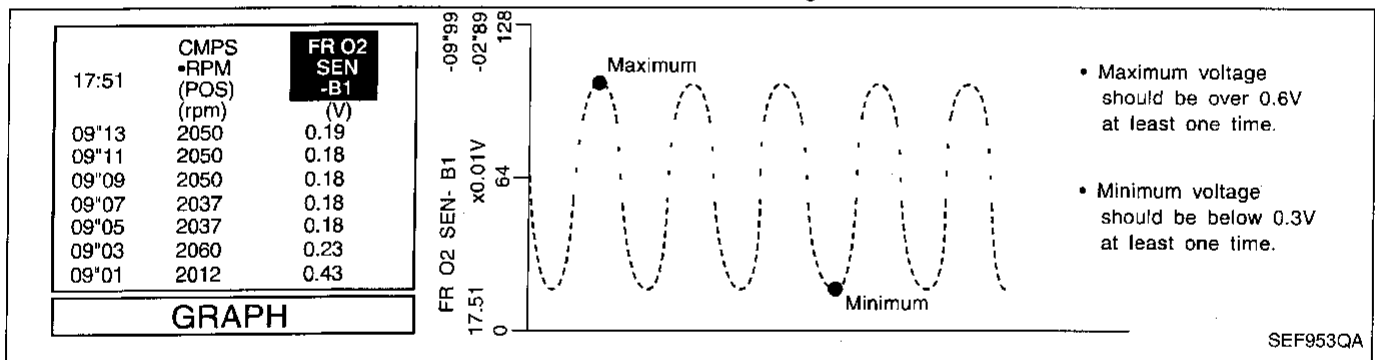
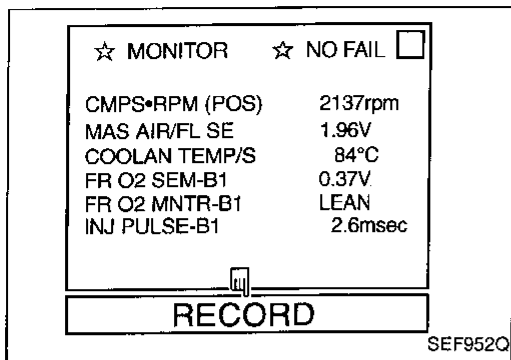

OR



- 1) Start engine and warm it up sufficiently.
- 2) Set voltmeter probes between ECM terminal ④⑥ (sensor signal) and ④③ (engine ground).
- 3) Check the following with engine speed held at 2,000 rpm constant under no load.
 - Malfunction indicator lamp goes on more than 5 times within 10 seconds in Diagnostic Test Mode II (FRONT HEATED OXYGEN SENSOR MONITOR).
 - The maximum voltage is over 0.6V at least one time.
 - The minimum voltage is below 0.3V at least one time.
 - The voltage never exceeds 1.0V.

TROUBLE DIAGNOSIS FOR DTC P0130

Front Heated Oxygen Sensor (Front HO2S) (Right bank) (Cont'd)

EC-FRO2RH-01

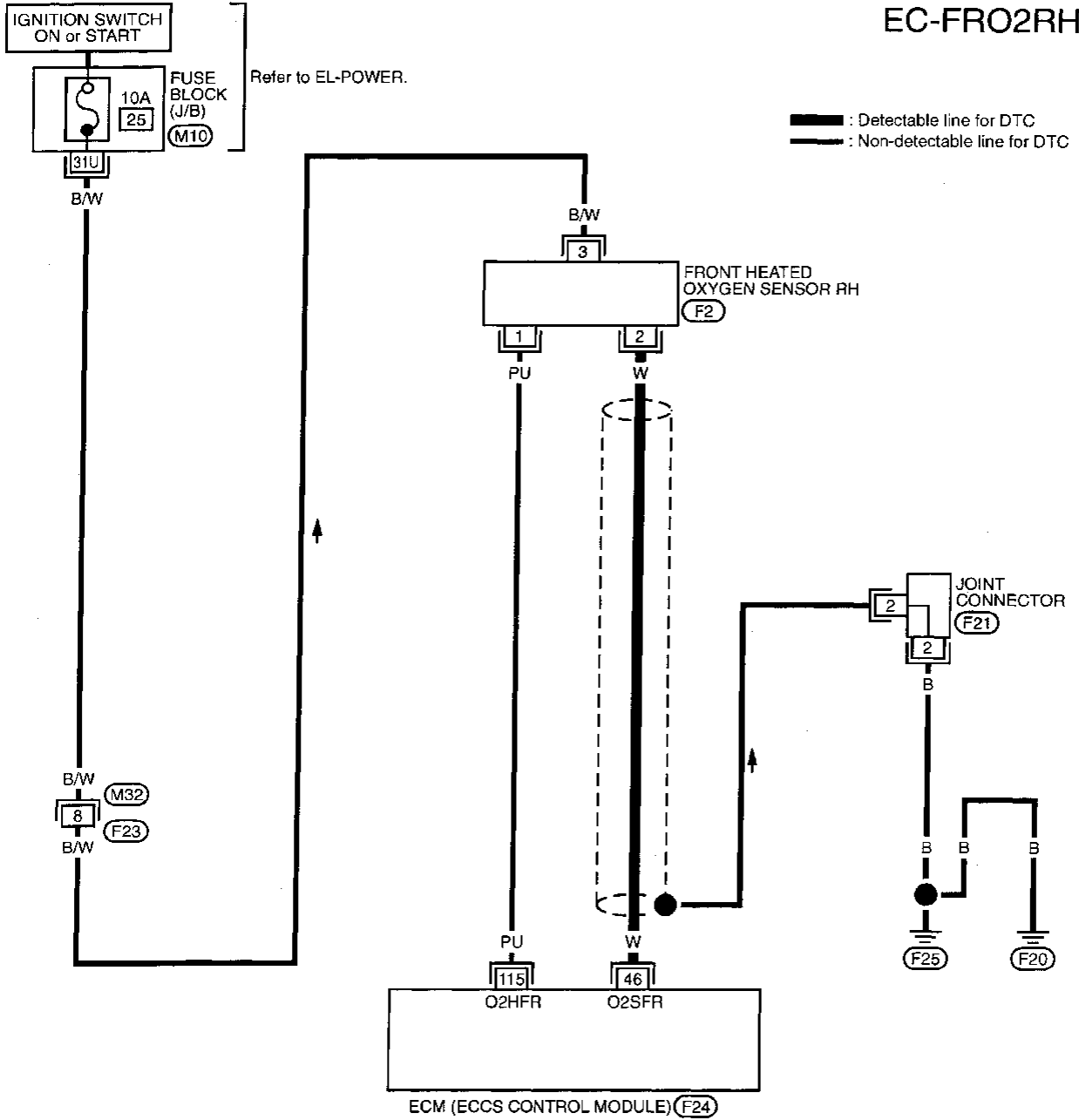

GI
MA
EM
LC
EC
FE
AT
TF
PD
FA
RA
BR
ST
RS
BT
HA
EL
IDX

Refer to last page (Foldout page).
M10

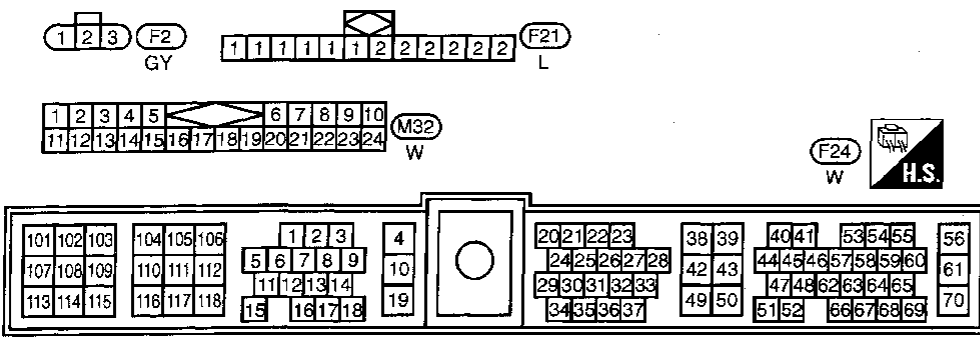

TROUBLE DIAGNOSIS FOR DTC P0130

Front Heated Oxygen Sensor (Front HO2S) (Right bank) (Cont'd)

DIAGNOSTIC PROCEDURE

INSPECTION START

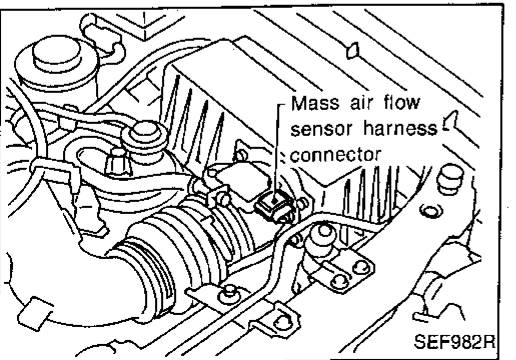
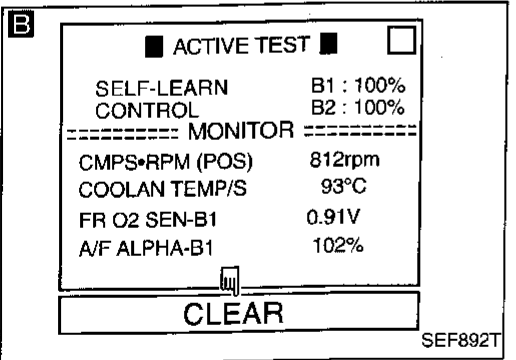
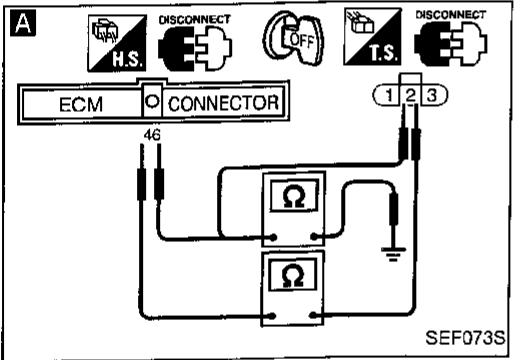
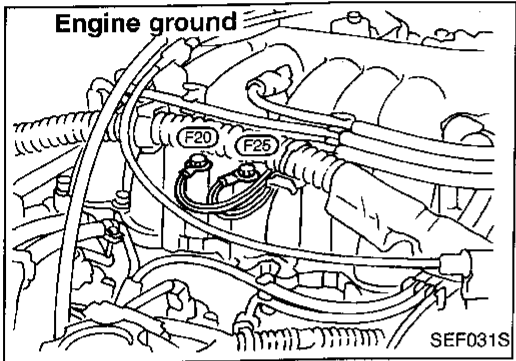
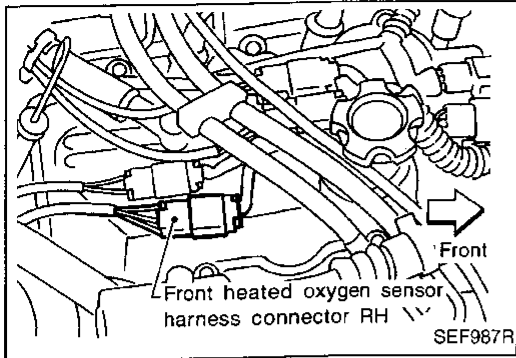

CHECK SHIELD CIRCUIT.

1. Turn ignition switch "OFF".
2. Loosen and retighten engine ground screws.
3. Remove joint connector.
4. Check the following.
 - Continuity between joint connector terminal and ground
 - Joint connector (Refer to "HARNESS LAYOUT" in EL section.)

Continuity should exist.

If OK, check harness for short to ground and short to power. Then reconnect joint connector.

NG → Repair harness or connectors.

OK

A

CHECK INPUT SIGNAL CIRCUIT.

1. Disconnect front heated oxygen sensor RH harness connector and ECM harness connector.
2. Check harness continuity between ECM terminal ④ and terminal ②. **Continuity should exist.**
3. Check harness continuity between ECM terminal ④ (or terminal ②) and ground. **Continuity should not exist.**

If OK, check harness for short to ground and short to power.

NG → Repair harness or connectors.

OK

Ⓐ

TROUBLE DIAGNOSIS FOR DTC P0130

Front Heated Oxygen Sensor (Front HO2S) (Right bank) (Cont'd)

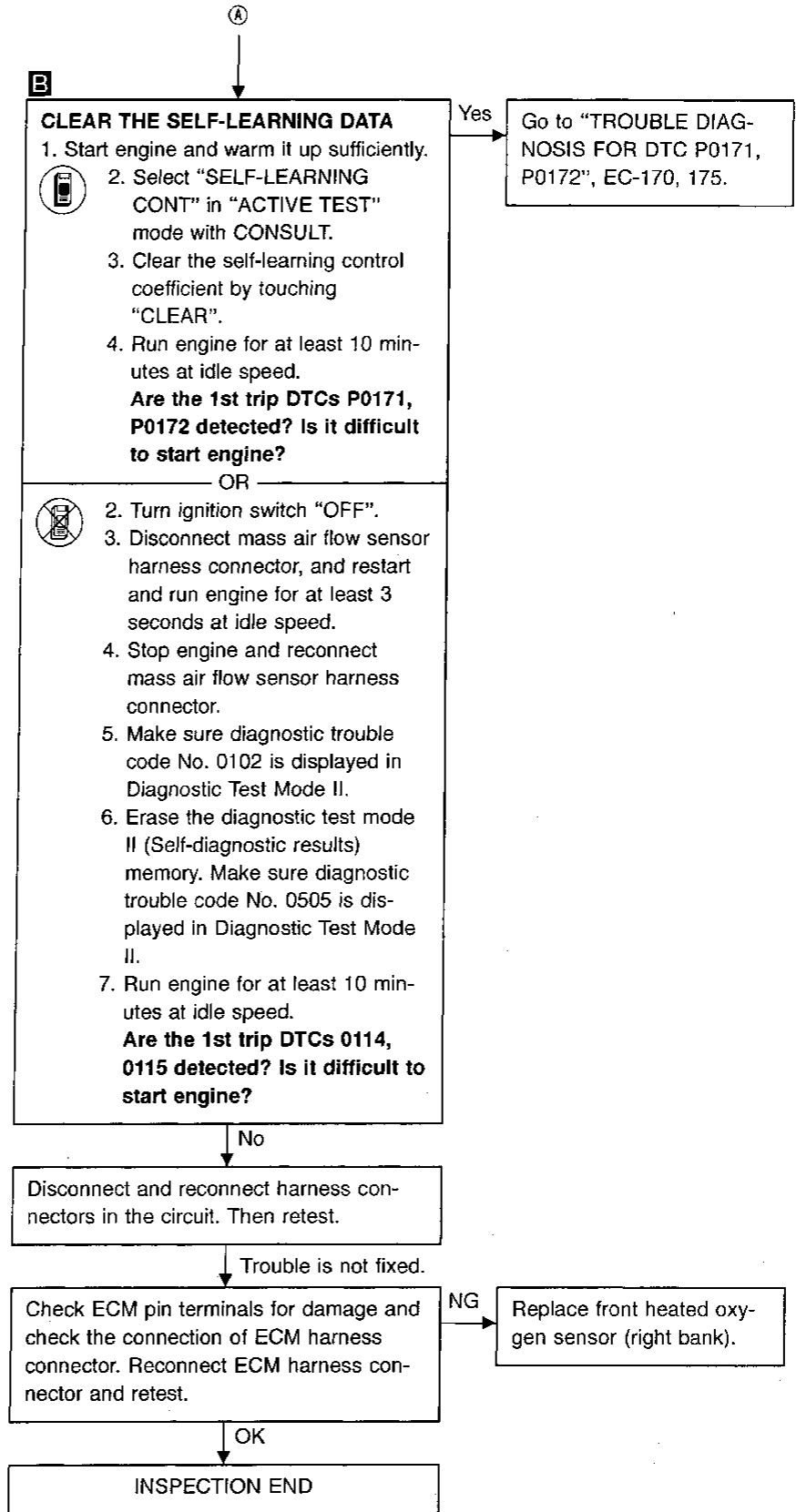

GI

MA

EM

LC

EC

FE

AT

TF

PD

FA

RA

BR

ST

RS

BT

HA

EL

IDX

TROUBLE DIAGNOSIS FOR DTC P0135

Front Heated Oxygen Sensor Heater (Right bank)

SYSTEM DESCRIPTION

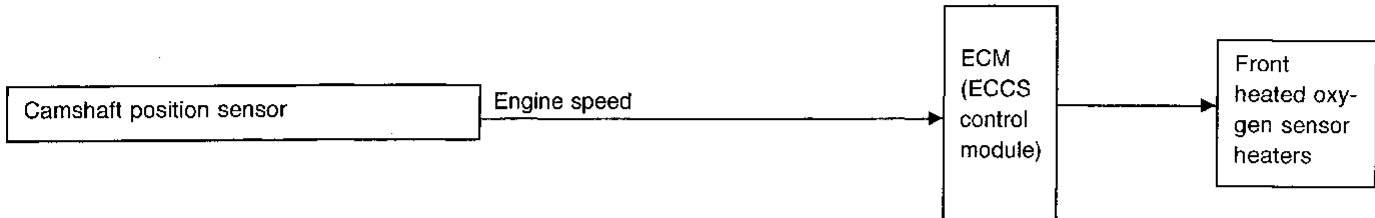

The ECM performs ON/OFF control of the front heated oxygen sensor heaters corresponding to the engine speed.

OPERATION

Engine speed rpm	Front heated oxygen sensor heaters
Above 3,200	OFF
Below 3,200	ON

CONSULT REFERENCE VALUE IN DATA MONITOR MODE

Specification data are reference values.

MONITOR ITEM	CONDITION	SPECIFICATION
FR O2 HTR-B1	• Engine speed: Idle	ON
	• Engine speed: Above 3,200 rpm	OFF

ECM TERMINALS AND REFERENCE VALUE

Specification data are reference values and are measured between each terminal and Ⓞ (ECCS ground).

TER-MINAL NO.	WIRE COLOR	ITEM	CONDITION	DATA (DC Voltage)
115	PU	Front heated oxygen sensor heater (RH)	Engine is running. └ Engine speed is below 3,200 rpm	Approximately 0.4V
			Engine is running. └ Engine speed is above 3,200 rpm	BATTERY VOLTAGE (11 - 14V)

ON BOARD DIAGNOSIS LOGIC

Diagnostic Trouble Code No.	Malfunction is detected when	Check Items (Possible Cause)
P0135 0901	<ul style="list-style-type: none"> The current amperage in the front heated oxygen sensor heater (Right bank) circuit is out of the normal range. (An improper voltage drop signal is sent to ECM through the front heated oxygen sensor heater.) 	<ul style="list-style-type: none"> Harness or connectors (The front heated oxygen sensor heater circuit is open or shorted.) Front heated oxygen sensor heater (Right bank)

TROUBLE DIAGNOSIS FOR DTC P0135

Front Heated Oxygen Sensor Heater (Right bank) (Cont'd)

DIAGNOSTIC TROUBLE CODE CONFIRMATION PROCEDURE

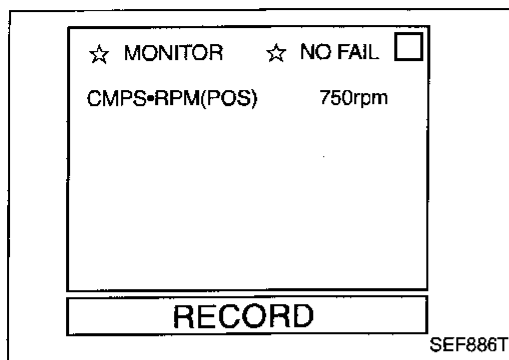

- 1) Turn ignition switch "ON" and select "DATA MONITOR" mode with CONSULT.
- 2) Start engine and run it for at least 5 seconds at idle speed.

OR



- 1) Start engine and run it for at least 5 seconds at idle speed.
- 2) Turn ignition switch "OFF" and wait at least 5 seconds.
- 3) Start engine and run it for at least 5 seconds at idle speed.
- 4) Select "MODE 3" with GST.

OR



- 1) Start engine and run it for at least 5 seconds at idle speed.
- 2) Turn ignition switch "OFF", wait at least 5 seconds and then turn "ON".
- 3) Perform "Diagnostic Test Mode II (Self-diagnostic results)" with ECM.

- When using GST, "DIAGNOSTIC TROUBLE CODE CONFIRMATION PROCEDURE" should be performed twice as much as when using CONSULT or ECM (Diagnostic Test Mode II) because GST cannot display MODE 7 (1st trip DTC) concerning this diagnosis. Therefore, using CONSULT or ECM (Diagnostic Test Mode II) is recommended.

GI

MA

EM

LC

EC

FE

AT

TF

PD

FA

RA

BR

ST

RS

BT

HA

EL

IDX

TROUBLE DIAGNOSIS FOR DTC P0135

Front Heated Oxygen Sensor Heater (Right bank) (Cont'd)

EC-FO2H-R-01

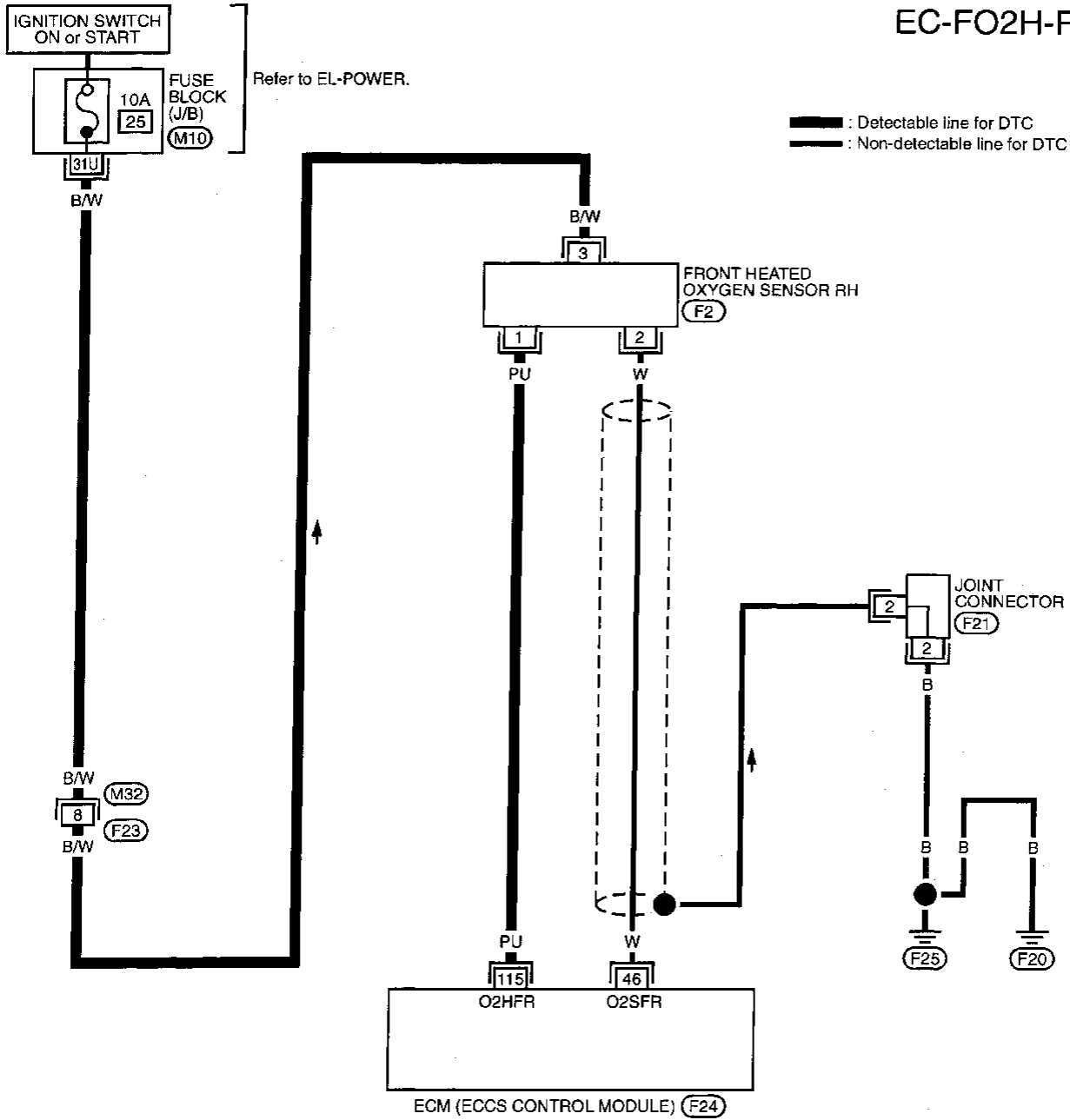

Refer to last page (Foldout page).

(M10)

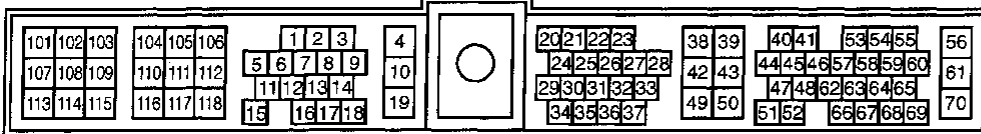
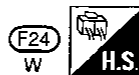
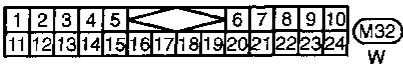

TROUBLE DIAGNOSIS FOR DTC P0135

Front Heated Oxygen Sensor Heater (Right bank) (Cont'd)

DIAGNOSTIC PROCEDURE

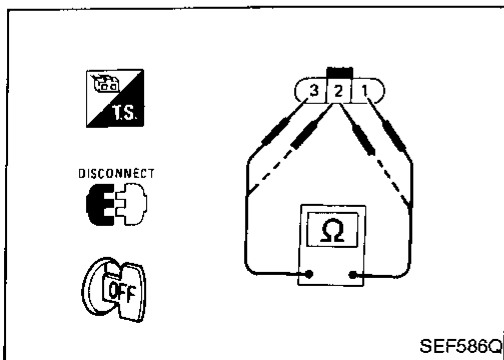
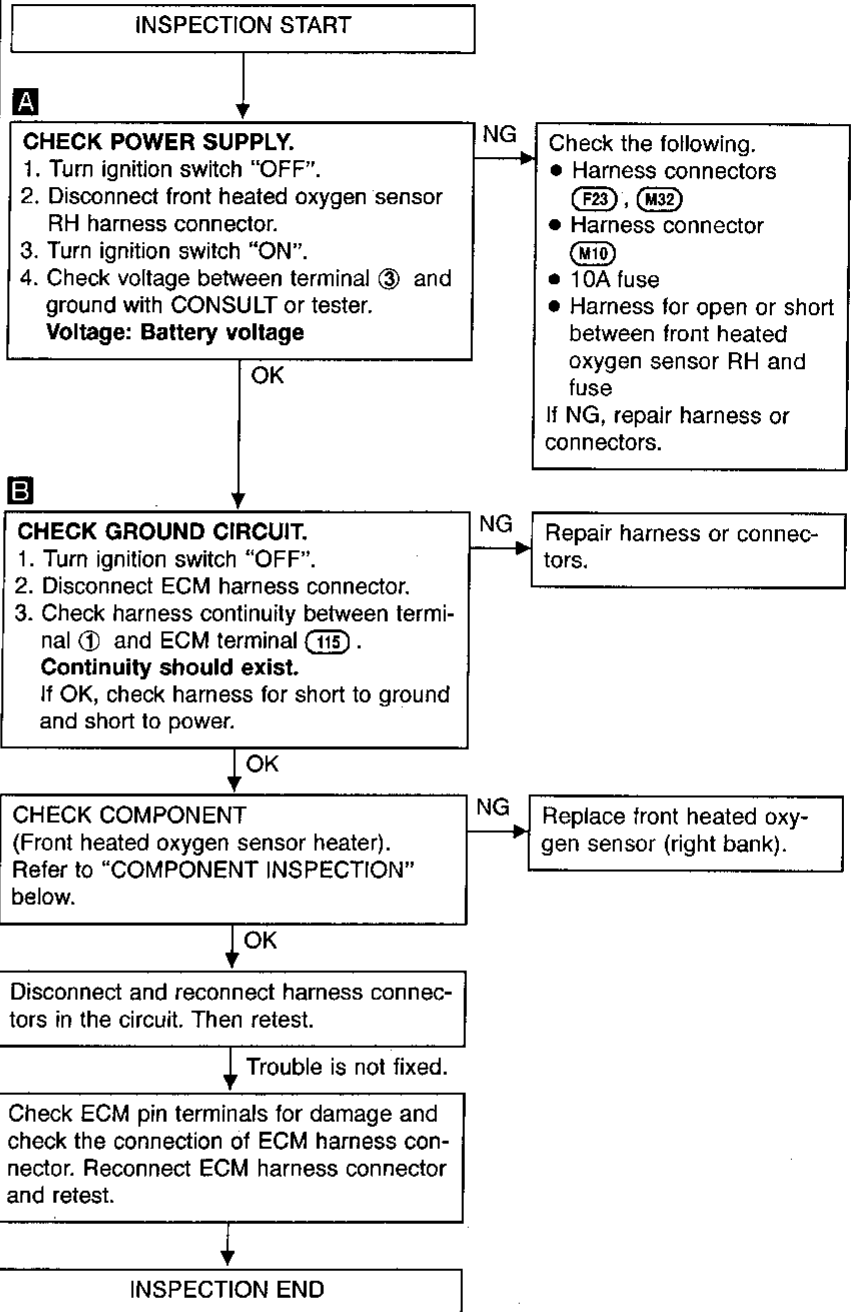
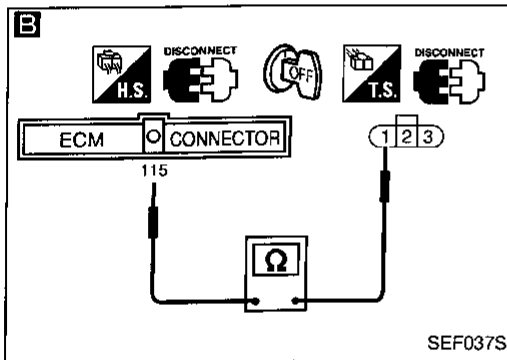
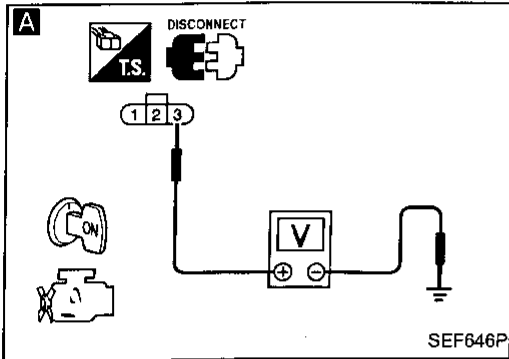
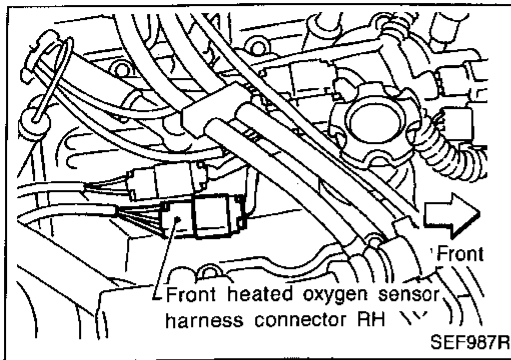

COMPONENT INSPECTION

Front heated oxygen sensor heater

Check resistance between terminals ③ and ①.

Resistance: 2.3 - 4.3Ω at 25°C (77°F)

Check continuity between terminals ② and ①, ③ and ②.

Continuity should not exist.

If NG, replace the front heated oxygen sensor.

CAUTION:

Discard any heated oxygen sensor which has been dropped from a height of more than 0.5 m (19.7 in) onto a hard surface such as a concrete floor; use a new one.

TROUBLE DIAGNOSIS FOR DTC P0136

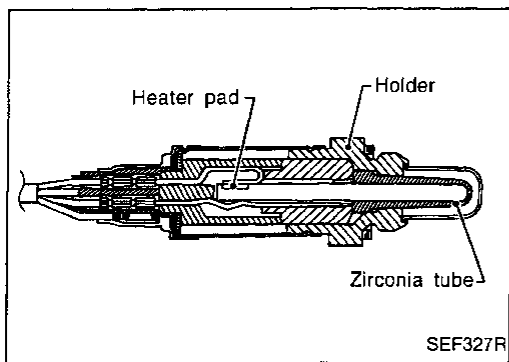

Rear Heated Oxygen Sensor (Rear HO2S) (Right bank)

COMPONENT DESCRIPTION

The rear heated oxygen sensor (Rear HO2S), after three way catalyst, monitors the oxygen level in the exhaust gas.

Even if switching characteristics of the front heated oxygen sensor are shifted, the air fuel ratio is controlled to stoichiometric, by the signal from the rear heated oxygen sensor.

This sensor is made of ceramic zirconia. The zirconia generates voltage from approximately 1V in richer conditions to 0V in leaner conditions.

Under normal conditions the rear heated oxygen sensor is not used for engine control operation.

CONSULT REFERENCE VALUE IN DATA MONITOR MODE

Specification data are reference values.

MONITOR ITEM	CONDITION	SPECIFICATION
RR O2 SEN-B1	<ul style="list-style-type: none"> Engine: After warming up 	Maintaining engine speed at 2,000 rpm
RR O2 MNTR-B1		0 - 0.3V ↔ Approx. 0.6 - 1.0V LEAN ↔ RICH

ECM TERMINALS AND REFERENCE VALUE

Specification data are reference values and are measured between each terminal and Ⓞ (ECCS ground).

TER-MINAL NO.	WIRE COLOR	ITEM	CONDITION	DATA (DC Voltage)
52	LW	Rear heated oxygen sensor (RH)	<div style="border: 1px solid black; padding: 2px;">Engine is running.</div> <ul style="list-style-type: none"> After warming up sufficiently and engine speed is 2,000 rpm 	0 - Approximately 1.0V

ON BOARD DIAGNOSIS LOGIC

The rear heated oxygen sensor has a much longer switching time between rich and lean than the front heated oxygen sensor. The oxygen storage capacity before the three way catalyst causes the longer switching time. To judge the malfunctions of rear heated oxygen sensor, ECM monitors the sensor's voltage value and the switching response during the various driving condition such as fuel-cut.

Diagnostic Trouble Code No.	Malfunction is detected when ...	Check Items (Possible Cause)
P0136 0707	<ul style="list-style-type: none"> An excessively high voltage from the sensor is sent to ECM. The maximum and minimum voltages from the sensor are not reached to the specified voltages. It takes more time for the sensor to respond between rich and lean than the specified time. 	<ul style="list-style-type: none"> Harness or connectors (The sensor circuit is open or shorted.) Rear heated oxygen sensor (Right bank) Fuel pressure Injectors Intake air leaks

TROUBLE DIAGNOSIS FOR DTC P0136

Rear Heated Oxygen Sensor (Rear HO2S) (Right bank) (Cont'd)

OVERALL FUNCTION CHECK

Use this procedure to check the overall function of the rear heated oxygen sensor circuit. During this check, a 1st trip DTC might not be confirmed.

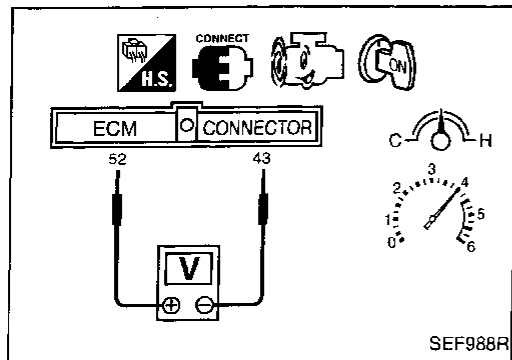
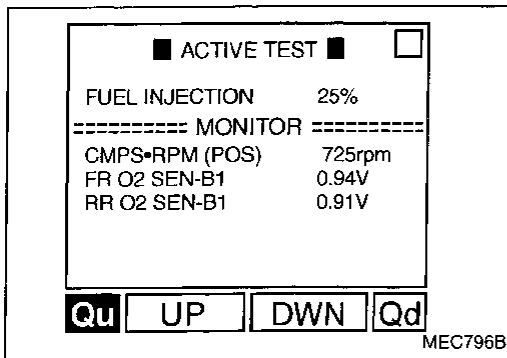

- 1) Start engine and warm it up sufficiently.
- 2) Select "FUEL INJECTION" in "ACTIVE TEST" mode, and select "RR O2 SEN-B1" as the monitor item with CONSULT.
- 3) Check "RR O2 SEN-B1" at idle speed when adjusting "FUEL INJECTION" to $\pm 25\%$.
"RR O2 SEN-B1" should be above 0.48V at least once when the "FUEL INJECTION" is +25%.
"RR O2 SEN-B1" should be below 0.43V at least once when the "FUEL INJECTION" is -25%.

OR

- 1) Start engine and warm it up sufficiently.
- 2) Set voltmeter probes between ECM terminals ② (sensor signal) and ④ (engine ground).
- 3) Check the voltage when racing up to 4,000 rpm under no load at least 10 times.
(depress and release accelerator pedal as soon as possible)

The voltage should be above 0.48V and below 0.43V at least once during this procedure.

If the voltage can be confirmed in step 3, step 4 is not necessary.

- 4) Keep vehicle at idling for 10 minutes, then check the voltage. Or check the voltage when coasting from 80 km/h (50 MPH) in 3rd gear position.

The voltage should be above 0.48V and below 0.43V at least once during this procedure.

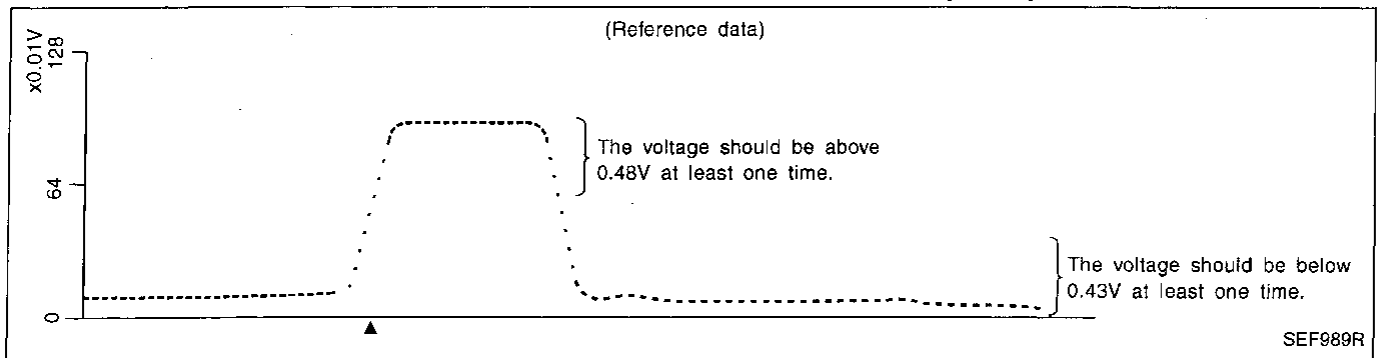

TROUBLE DIAGNOSIS FOR DTC P0136

Rear Heated Oxygen Sensor (Rear HO2S) (Right bank) (Cont'd)

EC-RRO2RH-01

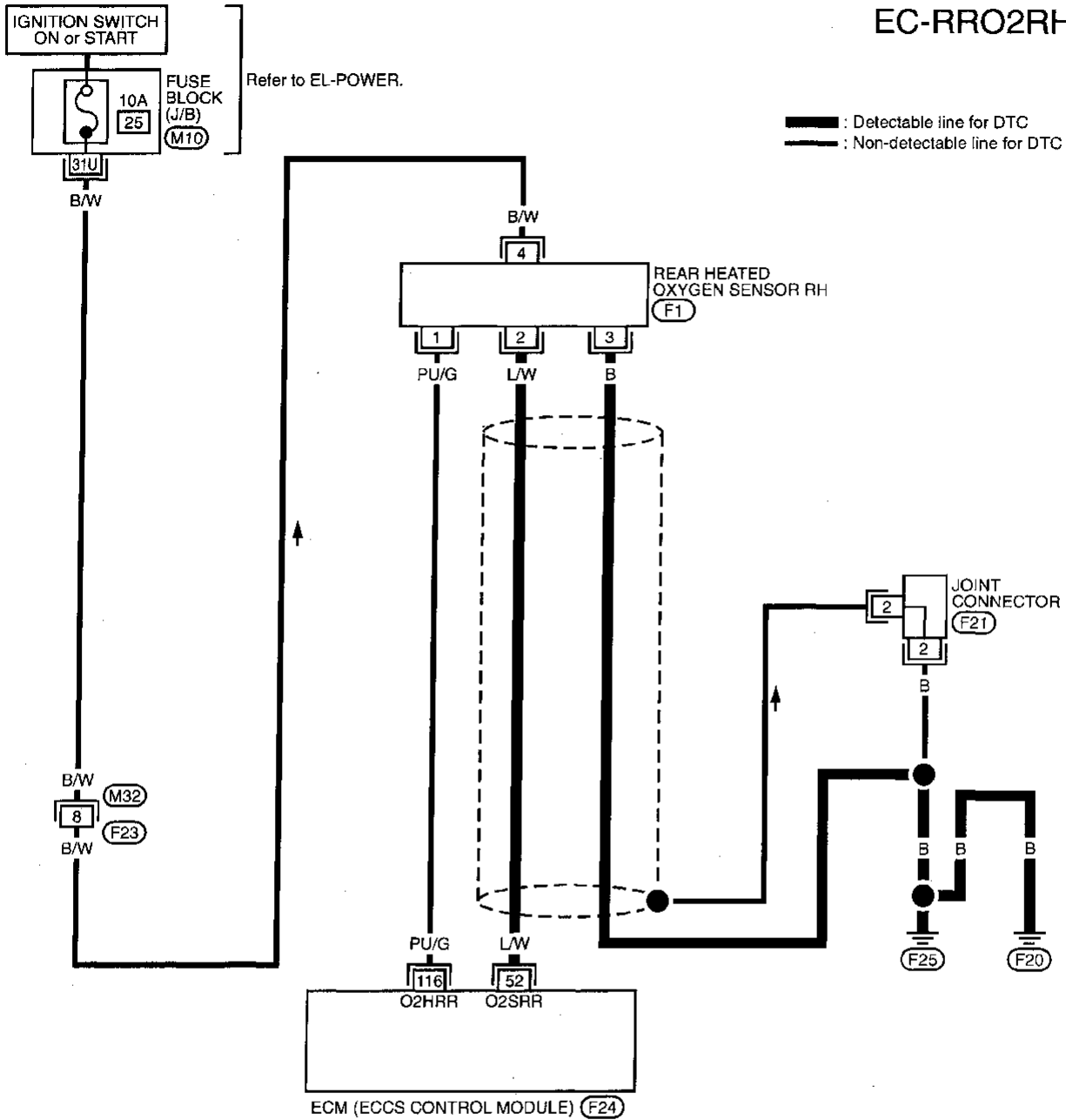

Refer to last page (Foldout page).

(M10)

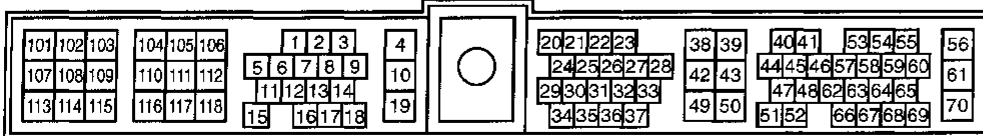
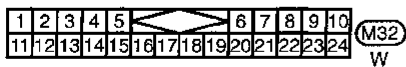
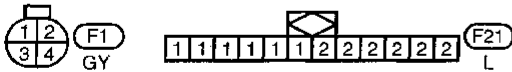

TROUBLE DIAGNOSIS FOR DTC P0136

Rear Heated Oxygen Sensor (Rear HO2S) (Right bank) (Cont'd)

DIAGNOSTIC PROCEDURE

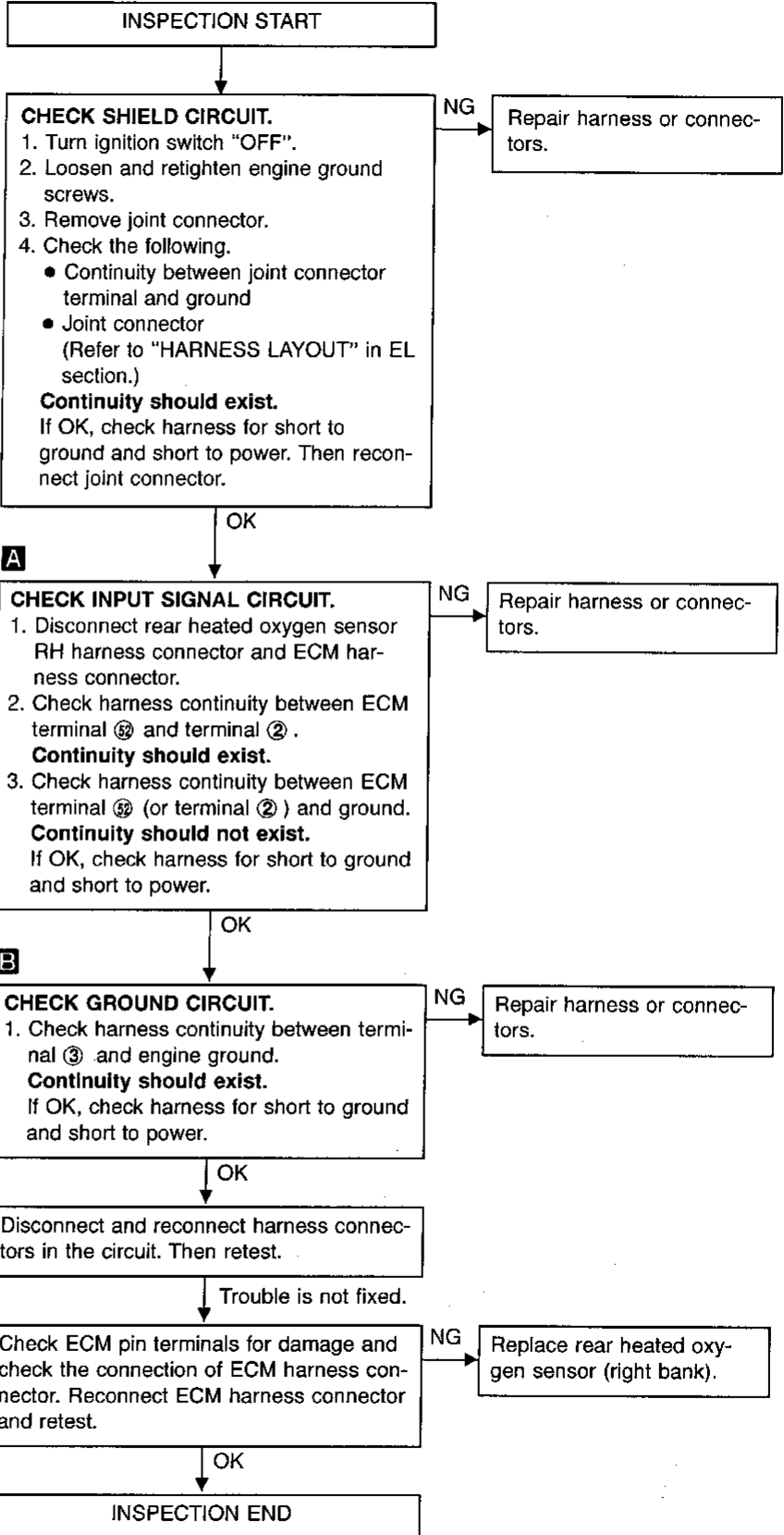
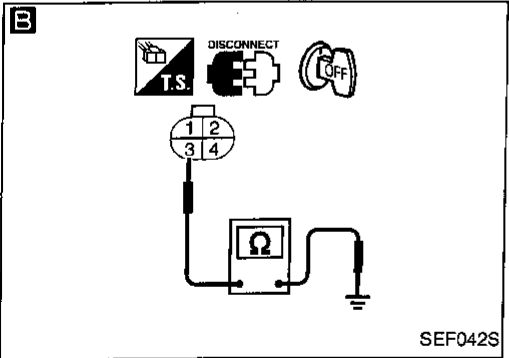
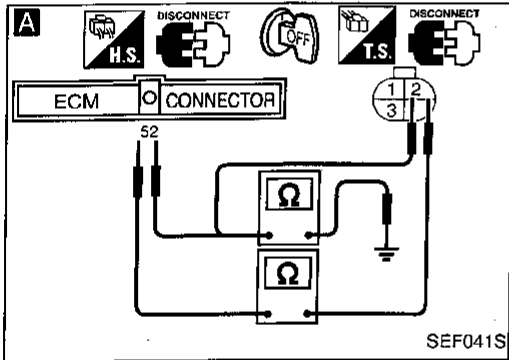
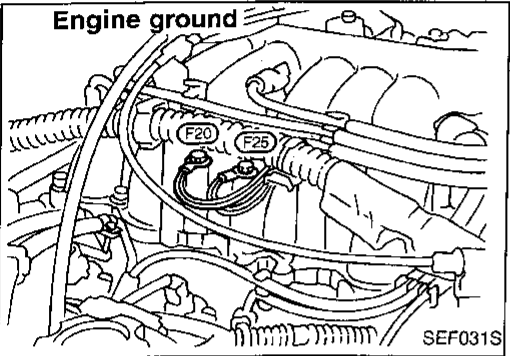
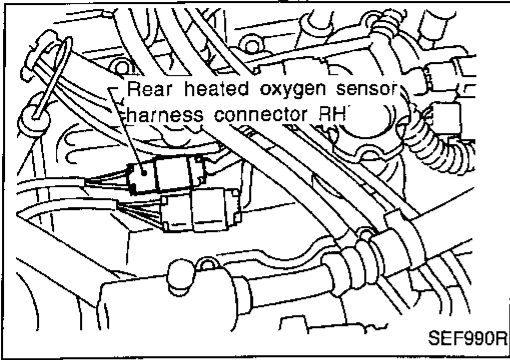

GI
MA
EM
LC
EC
FE
AT
TF
PD
FA
RA
BR
ST
RS
BT
HA
EL
IDX

TROUBLE DIAGNOSIS FOR DTC P0141

Rear Heated Oxygen Sensor Heater (Right bank)

SYSTEM DESCRIPTION

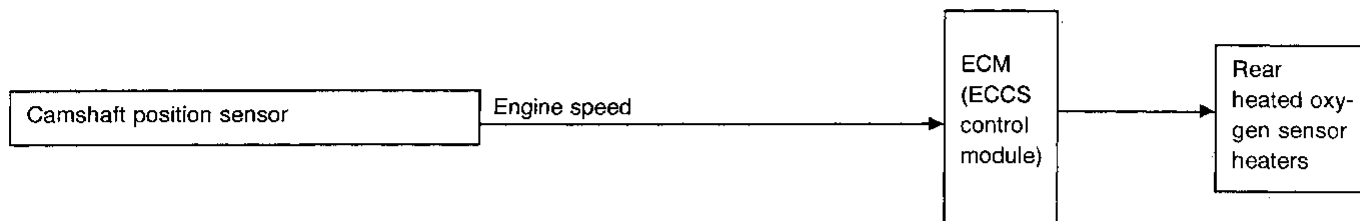

The ECM performs ON/OFF control of the rear heated oxygen sensor heaters corresponding to the engine speed.

OPERATION

Engine speed rpm	Rear heated oxygen sensor heaters
Above 3,200	OFF
Below 3,200	ON

CONSULT REFERENCE VALUE IN DATA MONITOR MODE

Specification data are reference values.

MONITOR ITEM	CONDITION	SPECIFICATION
RR O2 HTR-B1	• Engine speed: Idle	ON
	• Engine speed: Above 3,200 rpm	OFF

ECM TERMINALS AND REFERENCE VALUE

Specification data are reference values and are measured between each terminal and Ⓞ (ECCS ground).

TER-MINAL NO.	WIRE COLOR	ITEM	CONDITION	DATA (DC Voltage)
116	PU/G	Rear heated oxygen sensor heater (RH)	Engine is running. └ Engine speed is below 3,200 rpm	Approximately 0.4V
			Engine is running. └ Engine speed is above 3,200 rpm	BATTERY VOLTAGE (11 - 14V)

ON BOARD DIAGNOSIS LOGIC

Diagnostic Trouble Code No.	Malfunction is detected when	Check Items (Possible Cause)
P0141 0902	<ul style="list-style-type: none"> The current amperage in the rear heated oxygen sensor heater (Right bank) circuit is out of the normal range. (An improper voltage drop signal is sent to ECM through the rear heated oxygen sensor heater.) 	<ul style="list-style-type: none"> Harness or connectors (The rear heated oxygen sensor heater circuit is open or shorted.) Rear heated oxygen sensor heater (Right bank)

TROUBLE DIAGNOSIS FOR DTC P0141

Rear Heated Oxygen Sensor Heater (Right bank) (Cont'd)

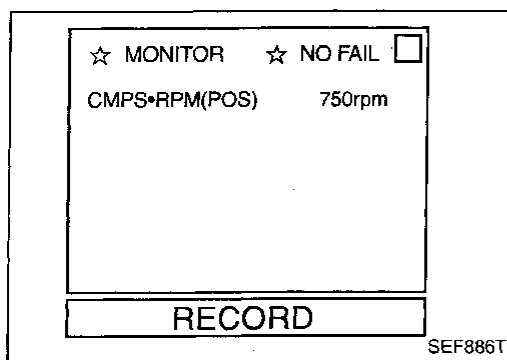

DIAGNOSTIC TROUBLE CODE CONFIRMATION PROCEDURE

-  1) Turn ignition switch "ON" and select "DATA MONITOR" mode with CONSULT.
2) Start engine and run it for at least 5 seconds at idle speed.

OR

-  1) Start engine and run it for at least 5 seconds at idle speed.
2) Turn ignition switch "OFF" and wait at least 5 seconds.
3) Start engine and run it for at least 5 seconds at idle speed.
4) Select "MODE 3" with GST.

OR

-  1) Start engine and run it for at least 5 seconds at idle speed.
2) Turn ignition switch "OFF", wait at least 5 seconds and then turn "ON".
3) Perform "Diagnostic Test Mode II (Self-diagnostic results)" with ECM.

- When using GST, "DIAGNOSTIC TROUBLE CODE CONFIRMATION PROCEDURE" should be performed twice as much as when using CONSULT or ECM (Diagnostic Test Mode II) because GST cannot display MODE 7 (1st trip DTC) concerning this diagnosis. Therefore, using CONSULT or ECM (Diagnostic Test Mode II) is recommended.

GI

MA

EM

LC

EC

FE

AT

TF

PD

FA

RA

BR

ST

RS

BT

HA

EL

IDX

TROUBLE DIAGNOSIS FOR DTC P0141

Rear Heated Oxygen Sensor Heater (Right bank) (Cont'd)

EC-RO2H-R-01

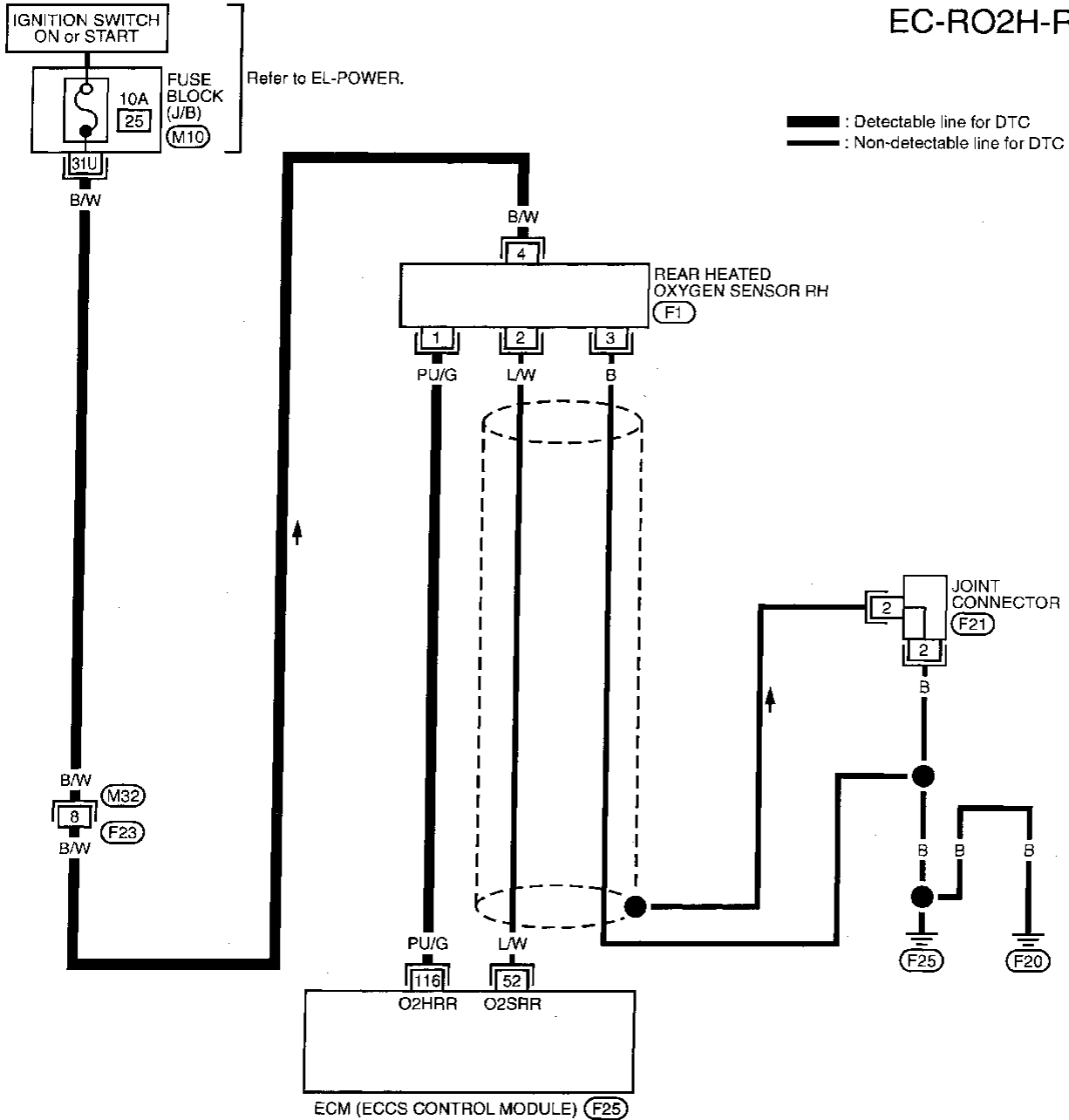

Refer to last page (Foldout page).

(M10)

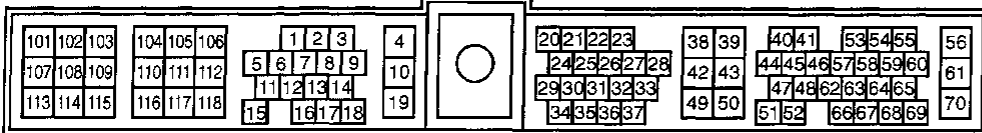
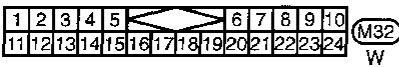
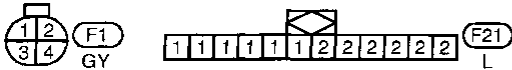

TROUBLE DIAGNOSIS FOR DTC P0141

Rear Heated Oxygen Sensor Heater (Right bank) (Cont'd)

DIAGNOSTIC PROCEDURE

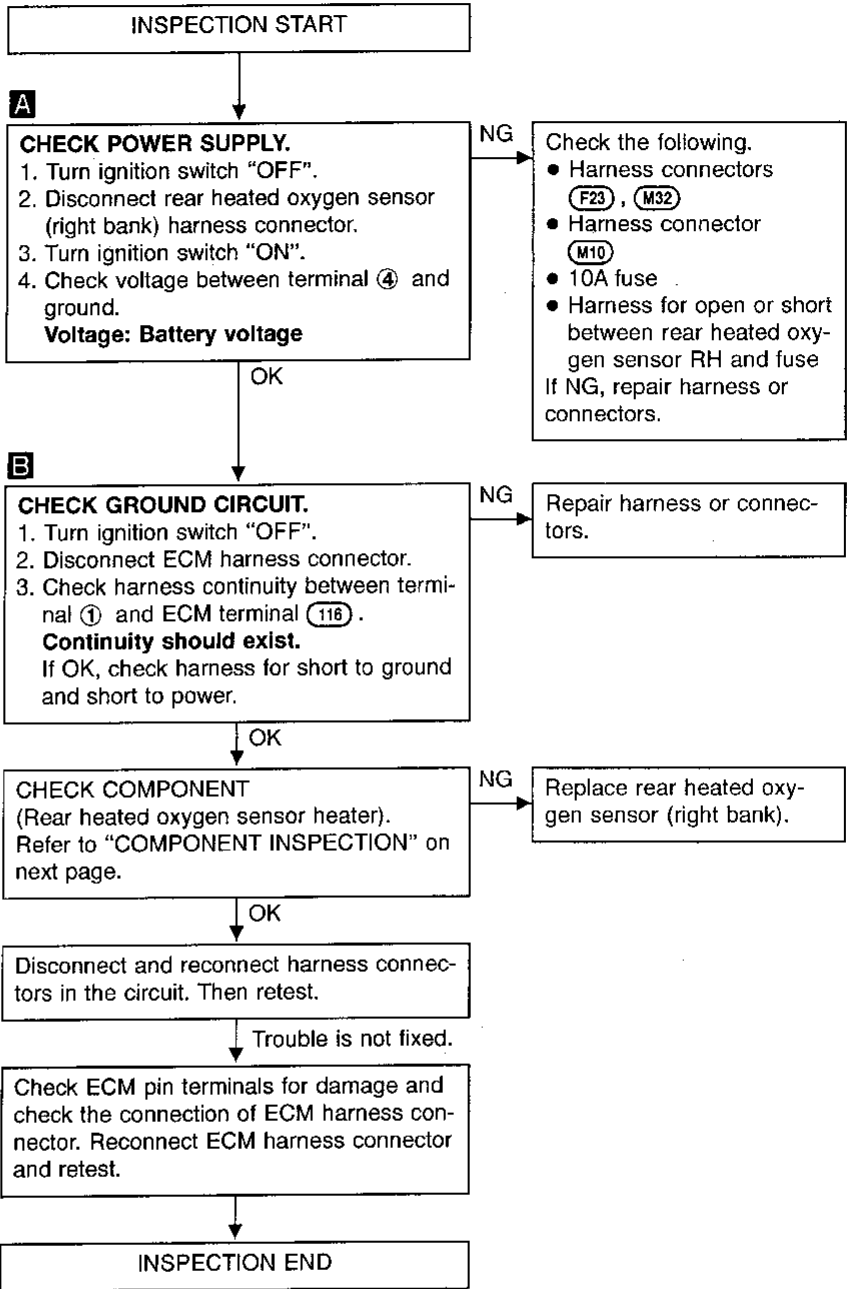
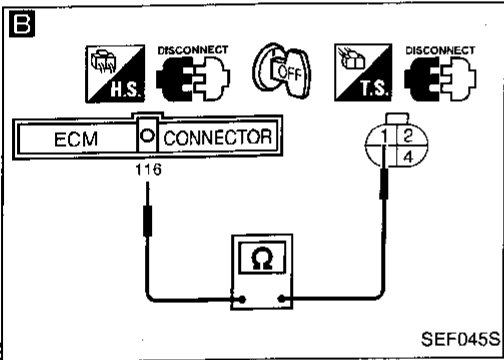
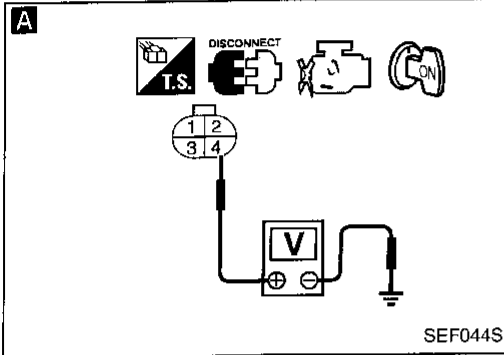
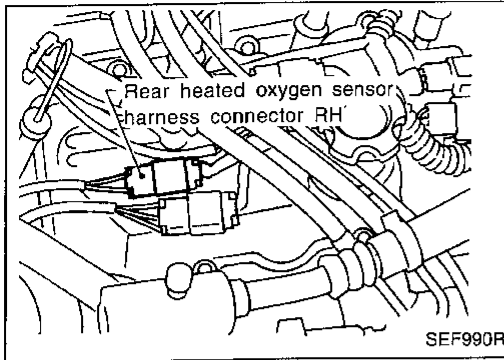

GI

MA

EM

LC

EC

FE

AT

TF

PD

FA

RA

BR

ST

RS

BT

HA

EL

IDX

TROUBLE DIAGNOSIS FOR DTC P0141

Rear Heated Oxygen Sensor Heater (Right bank) (Cont'd)

COMPONENT INSPECTION

Rear heated oxygen sensor heater

Check the following.

1. Check resistance between terminals ④ and ①.
Resistance: 2.3 - 4.3Ω at 25°C (77°F)
2. Check continuity.

Terminal No.	Continuity
② and ①, ③, ④	No
③ and ①, ②, ④	

If NG, replace the rear heated oxygen sensor.

CAUTION:

Discard any heated oxygen sensor which has been dropped from a height of more than 0.5 m (19.7 in) onto a hard surface such as a concrete floor; use a new one.

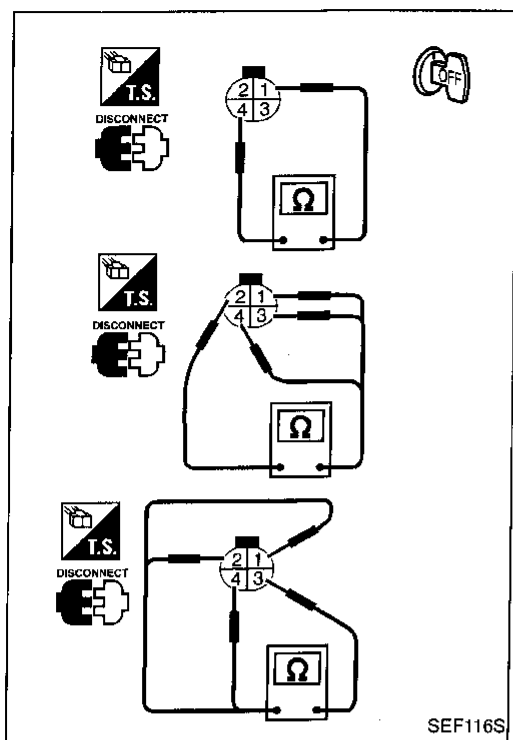

TROUBLE DIAGNOSIS FOR DTC P0150

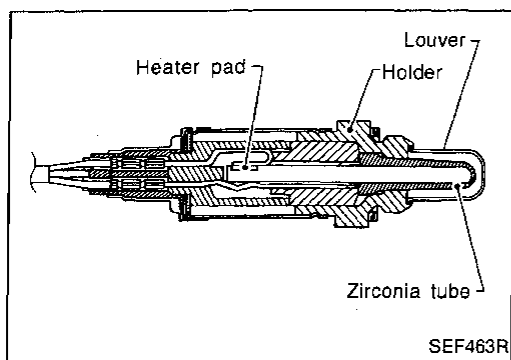

Front Heated Oxygen Sensor (Front HO2S) (Left bank)

COMPONENT DESCRIPTION

The front heated oxygen sensor (left bank) is placed into the front tube (left bank). It detects the amount of oxygen in the exhaust gas compared to the outside air. The front heated oxygen sensor (left bank) has a closed-end tube made of ceramic zirconia. The zirconia generates voltage from approximately 1V in richer conditions to 0V in leaner conditions. The front heated oxygen sensor (left bank) signal is sent to the ECM. The ECM adjusts the injection pulse duration to achieve the ideal air-fuel ratio. The ideal air-fuel ratio occurs near the radical change from 1V to 0V.

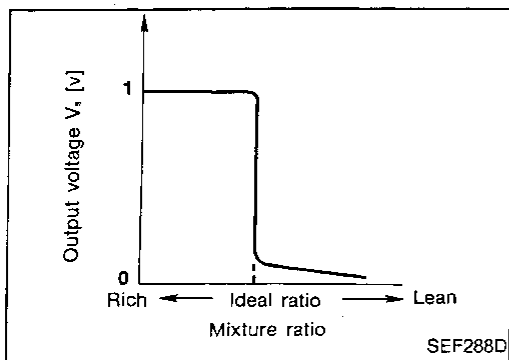

CONSULT REFERENCE VALUE IN DATA MONITOR MODE

Specification data are reference values.

MONITOR ITEM	CONDITION		SPECIFICATION
FR O2 SEN-B2 FR O2 MNTR-B2	<ul style="list-style-type: none"> Engine: After warming up 	Maintaining engine speed at 2,000 rpm	0 - 0.3V ↔ Approx. 0.6 - 1.0V LEAN ↔ RICH Changes more than 5 times during 10 seconds.

ECM TERMINALS AND REFERENCE VALUE

Specification data are reference values and are measured between each terminal and Ⓞ (ECCS ground).

TER-MINAL NO.	WIRE COLOR	ITEM	CONDITION	DATA (DC Voltage)
57	W	Front heated oxygen sensor (LH)	Engine is running. After warming up sufficiently and engine speed is 2,000 rpm	0 - Approximately 1.0V

ON BOARD DIAGNOSIS LOGIC

Diagnostic Trouble Code No.	Malfunction is detected when ...	Check Items (Possible Cause)
P0150 0303	<ul style="list-style-type: none"> An excessively high voltage from the sensor is sent to ECM. The voltage from the sensor is constantly approx. 0.3V. The maximum and minimum voltages from the sensor are not reached to the specified voltages. It takes more time for the sensor to respond between rich and lean than the specified time. 	<ul style="list-style-type: none"> Harness or connectors (The sensor circuit is open or shorted.) Front heated oxygen sensor (Left bank) Fuel pressure Injectors Intake air leaks

TROUBLE DIAGNOSIS FOR DTC P0150

Front Heated Oxygen Sensor (Front HO2S) (Left bank) (Cont'd)

OVERALL FUNCTION CHECK

Use this procedure to check the overall function of the front heated oxygen sensor circuit. During this check, a 1st trip DTC might not be confirmed.

☆ MONITOR ☆ NO FAIL

CMPS•RPM (POS)	2137rpm
MAS AIR/FL SE	1.96V
COOLAN TEMP/S	84°C
FR O2 SEN-B2	0.37V
FR O2 MNTR-B2	LEAN
INJ PULSE-B2	2.6msec

RECORD

SEF962Q

- 1) Start engine and warm it up sufficiently.
 - 2) Select "MANU TRIG" and "HI SPEED" in "DATA MONITOR" mode with CONSULT, and select "FR O2 SEN-B2" and "FR O2 MNTR-B2".
 - 3) Hold engine speed at 2,000 rpm under no load during the following steps.
 - 4) Touch "RECORD" on CONSULT screen.
 - 5) Check the following.
 - "FR O2 MNTR-B2" in "DATA MONITOR" mode changes from "RICH" to "LEAN" to "RICH" 5 times in 10 seconds.
- 5 times (cycles) are counted as shown below:

cycle | 1 | 2 | 3 | 4 | 5 |
FR O2 MNTR-B2 R-L-R-L-R-L-R-L-R-L-R

R = "FR O2 MNTR-B2", "RICH"
L = "FR O2 MNTR-B2", "LEAN"

- "FR O2 SEN-B2" voltage goes above 0.6V at least once.
- "FR O2 SEN-B2" voltage goes below 0.3V at least once.
- The voltage never exceeds 1.0V.

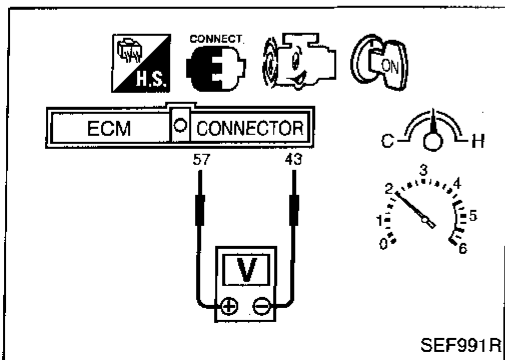
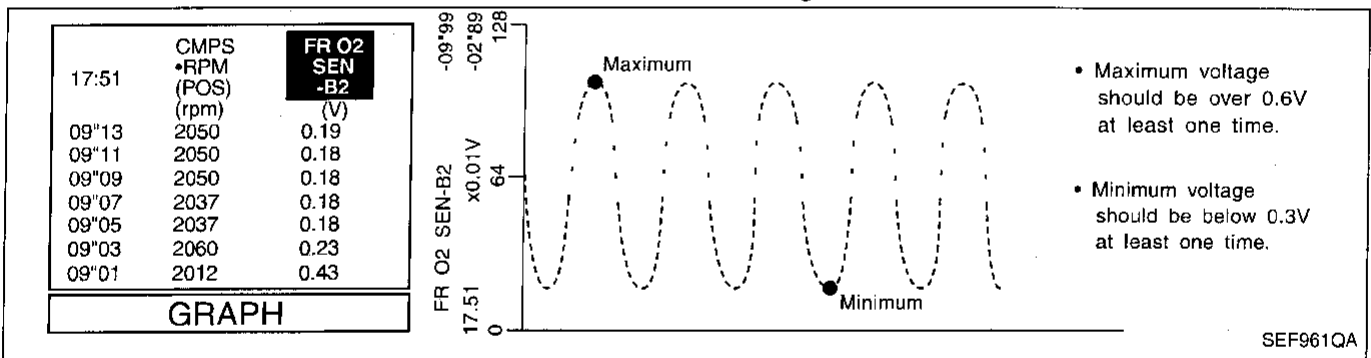

OR

- 1) Start engine and warm it up sufficiently.
- 2) Set voltmeter probes between ECM terminal ⑤ (sensor signal) and ④ (engine ground).
- 3) Check the following with engine speed held at 2,000 rpm constant under no load.
 - Malfunction indicator lamp goes on more than 5 times within 10 seconds in Diagnostic Test Mode II (FRONT HEATED OXYGEN SENSOR MONITOR).
 - The maximum voltage is over 0.6V at least one time.
 - The minimum voltage is below 0.3V at least one time.
 - The voltage never exceeds 1.0V.

TROUBLE DIAGNOSIS FOR DTC P0150

Front Heated Oxygen Sensor (Front HO2S) (Left bank) (Cont'd)

EC-FRO2LH-01

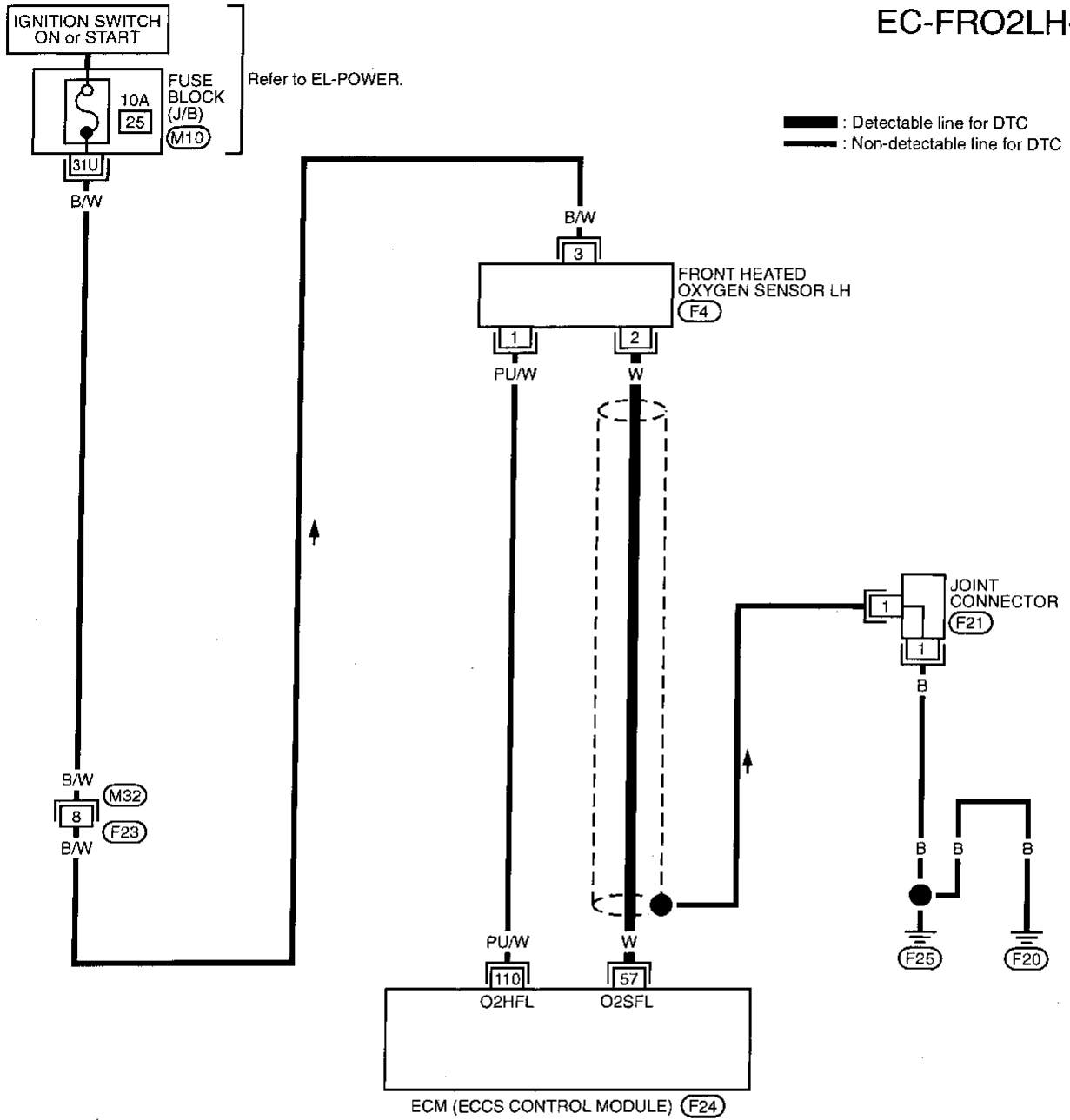

GI
 MA
 EM
 LC
EC
 FE
 AT
 TF
 PD
 FA
 RA
 BR
 ST
 RS
 BT
 HA
 EL
 IDX

Refer to last page (Foldout page).

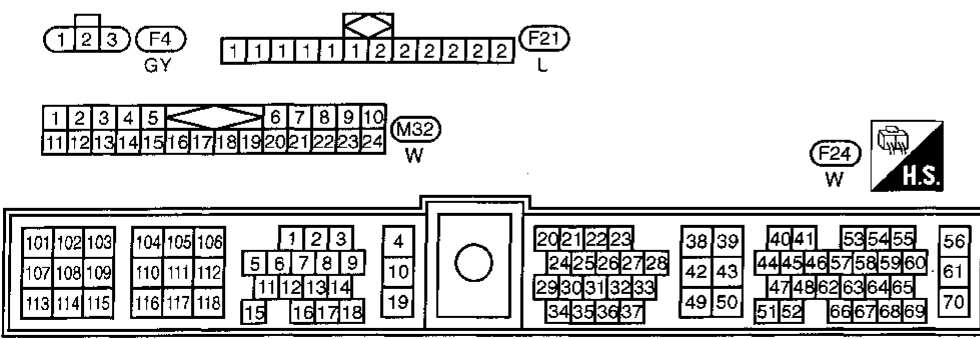

TROUBLE DIAGNOSIS FOR DTC P0150

Front Heated Oxygen Sensor (Front HO2S) (Left bank) (Cont'd)

DIAGNOSTIC PROCEDURE

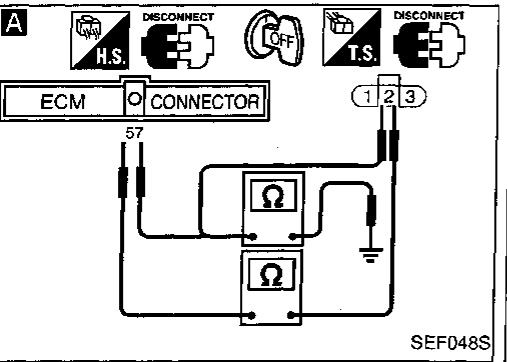
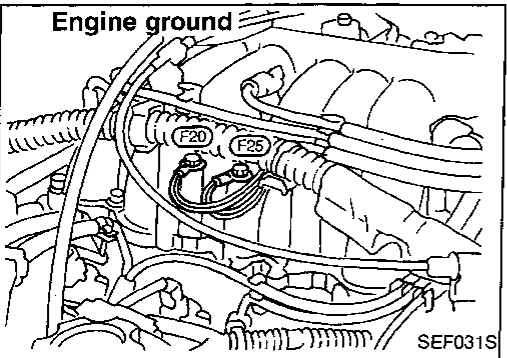
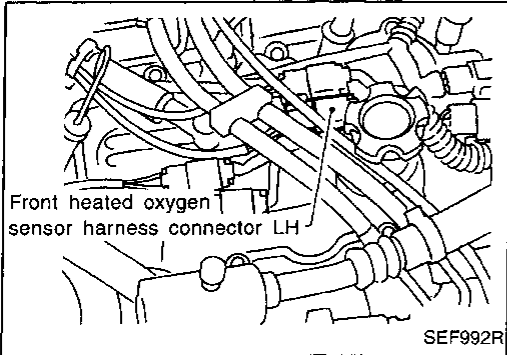

B

■ ACTIVE TEST ■	
SELF-LEARN CONTROL	100%
----- MONITOR -----	
CMPS•RPM (POS)	812rpm
COOLAN TEMP/S	93°C
FR O2 SEN-B2	0.91V
A/F ALPHA-B2	102%
CLEAR	

SEF964Q

INSPECTION START

CHECK SHIELD CIRCUIT.

1. Turn ignition switch "OFF".
2. Loosen and retighten engine ground screws.
3. Remove joint connector.
4. Check the following.
 - Continuity between joint connector terminal and ground
 - Joint connector (Refer to "HARNESS LAYOUT" in EL section.)

Continuity should exist.
If OK, check harness for short to ground and short to power. Then reconnect joint connector.

NG → Repair harness or connectors.

CHECK INPUT SIGNAL CIRCUIT.

1. Disconnect front heated oxygen sensor LH harness connector and ECM harness connector.
2. Check harness continuity between ECM terminal ⑤ and terminal ②.
Continuity should exist.
3. Check harness continuity between ECM terminal ⑤ (or terminal ②) and ground.
Continuity should not exist.

If OK, check harness for short to ground and short to power.

NG → Repair harness or connectors.

OK
Ⓐ

TROUBLE DIAGNOSIS FOR DTC P0150

Front Heated Oxygen Sensor (Front HO2S) (Left bank) (Cont'd)

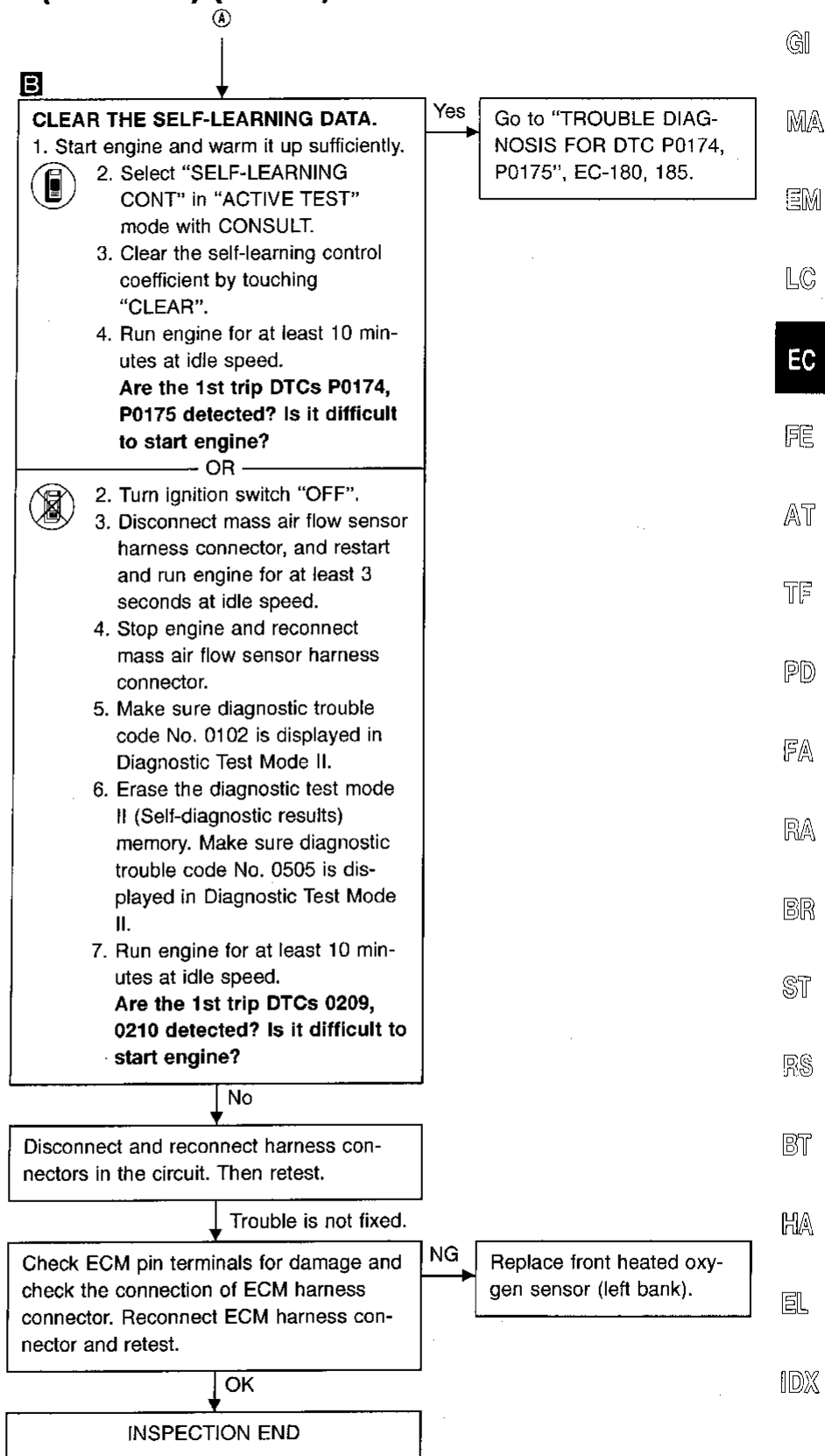

GI

MA

EM

LC

EC

FE

AT

TF

PD

FA

RA

BR

ST

RS

BT

HA

EL

IDX

TROUBLE DIAGNOSIS FOR DTC P0155

Front Heated Oxygen Sensor Heater (Left bank)

SYSTEM DESCRIPTION

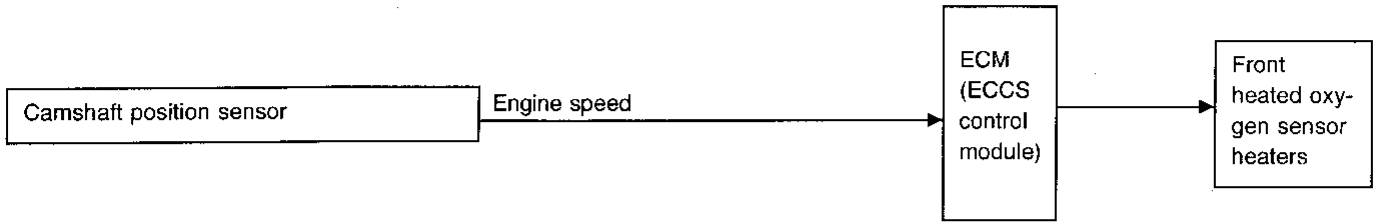

The ECM performs ON/OFF control of the front heated oxygen sensor heaters corresponding to the engine speed.

OPERATION

Engine speed rpm	Front heated oxygen sensor heaters
Above 3,200	OFF
Below 3,200	ON

CONSULT REFERENCE VALUE IN DATA MONITOR MODE

Specification data are reference values.

MONITOR ITEM	CONDITION	SPECIFICATION
FR O2 HTR-B2	• Engine speed: Idle	ON
	• Engine speed: Above 3,200 rpm	OFF

ECM TERMINALS AND REFERENCE VALUE

Specification data are reference values and are measured between each terminal and Ⓞ (ECCS ground).

TER-MINAL NO.	WIRE COLOR	ITEM	CONDITION	DATA (DC Voltage)
110	PU/W	Front heated oxygen sensor heater (LH)	<div style="border: 1px solid black; padding: 2px;">Engine is running.</div> Engine speed is below 3,200 rpm	Approximately 0.4V
			<div style="border: 1px solid black; padding: 2px;">Engine is running.</div> Engine speed is above 3,200 rpm	BATTERY VOLTAGE (11 - 14V)

ON BOARD DIAGNOSIS LOGIC

Diagnostic Trouble Code No.	Malfunction is detected when	Check Items (Possible Cause)
P0155 1001	<ul style="list-style-type: none"> The current amperage in the front heated oxygen sensor heater (Left bank) circuit is out of the normal range. (An improper voltage drop signal is sent to ECM through the front heated oxygen sensor heater.) 	<ul style="list-style-type: none"> Harness or connectors (The front heated oxygen sensor heater circuit is open or shorted.) Front heated oxygen sensor heater (Left bank)

TROUBLE DIAGNOSIS FOR DTC P0155

Front Heated Oxygen Sensor Heater (Left bank) (Cont'd)

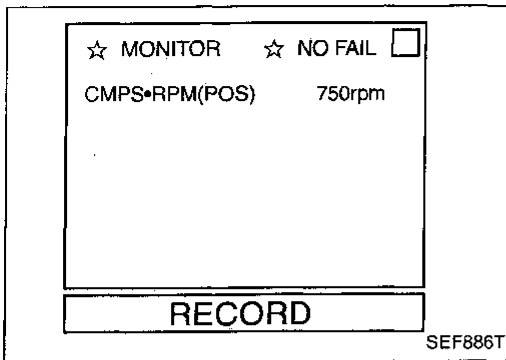

DIAGNOSTIC TROUBLE CODE CONFIRMATION PROCEDURE



- 1) Turn ignition switch "ON" and select "DATA MONITOR" mode with CONSULT.
- 2) Start engine and run it for at least 5 seconds at idle speed.

OR



- 1) Start engine and run it for at least 5 seconds at idle speed.
- 2) Turn ignition switch "OFF" and wait at least 5 seconds.
- 3) Start engine and run it for at least 5 seconds at idle speed.
- 4) Select "MODE 3" with GST.

OR



- 1) Start engine and run it for at least 5 seconds at idle speed.
- 2) Turn ignition switch "OFF", wait at least 5 seconds and then turn "ON".
- 3) Perform "Diagnostic Test Mode II (Self-diagnostic results)" with ECM.

- When using GST, "DIAGNOSTIC TROUBLE CODE CONFIRMATION PROCEDURE" should be performed twice as much as when using CONSULT or ECM (Diagnostic Test Mode II) because GST cannot display MODE 7 (1st trip DTC) concerning this diagnosis. Therefore, using CONSULT or ECM (Diagnostic Test Mode II) is recommended.

GI

MA

EM

LC

EC

FE

AT

TF

PD

FA

RA

BR

ST

RS

BT

HA

EL

IDX

TROUBLE DIAGNOSIS FOR DTC P0155

Front Heated Oxygen Sensor Heater (Left bank) (Cont'd)

EC-FO2H-L-01

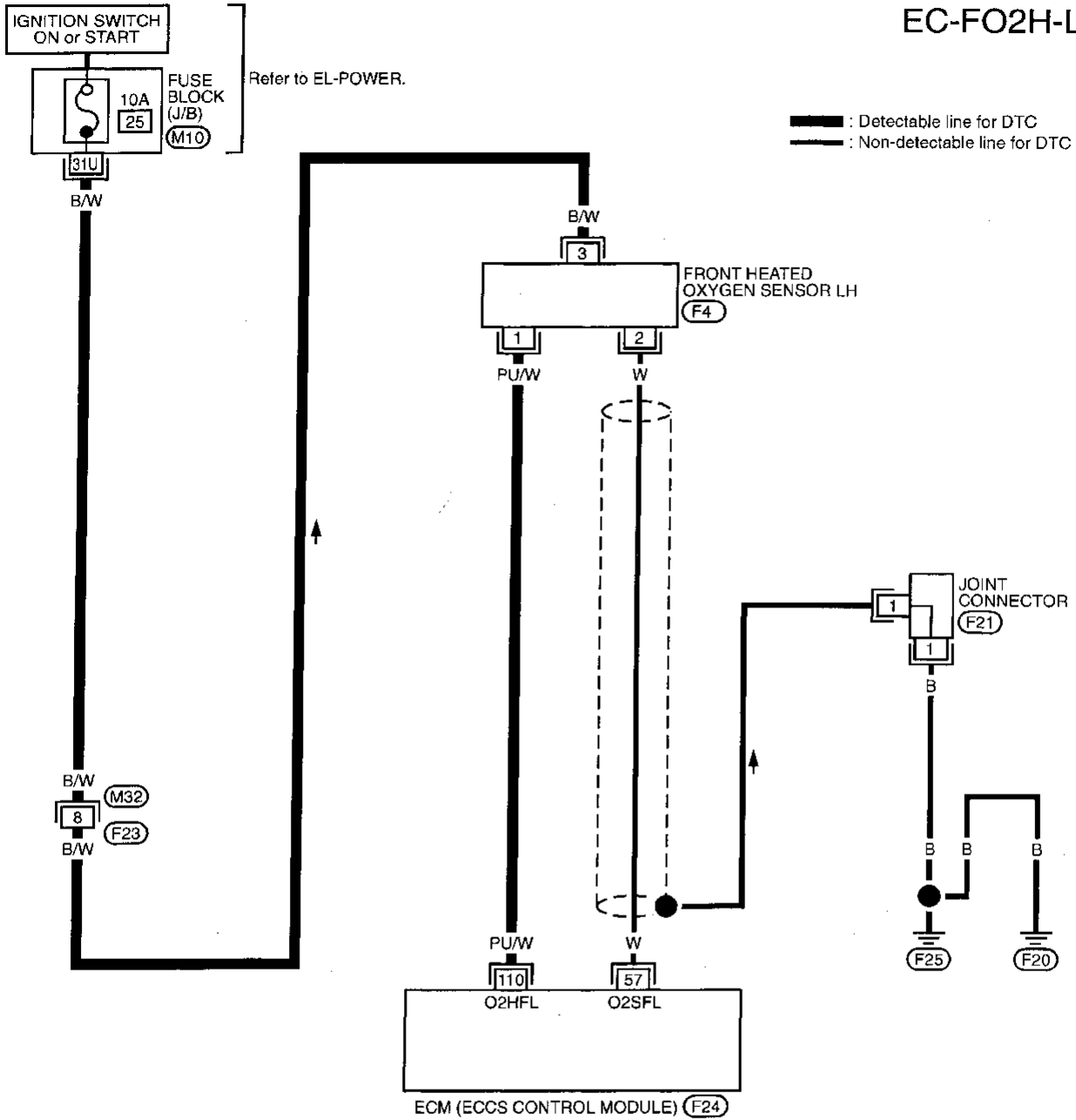

Refer to last page (Foldout page).

(M10)

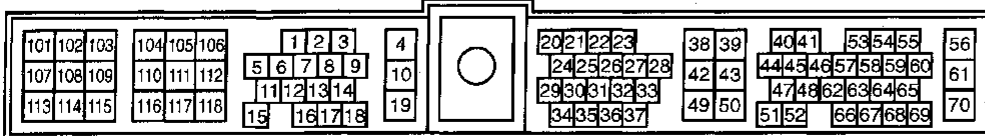
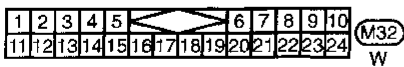

TROUBLE DIAGNOSIS FOR DTC P0155

Front Heated Oxygen Sensor Heater (Left bank) (Cont'd)

DIAGNOSTIC PROCEDURE

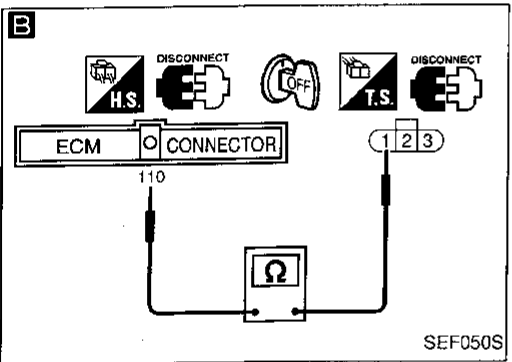
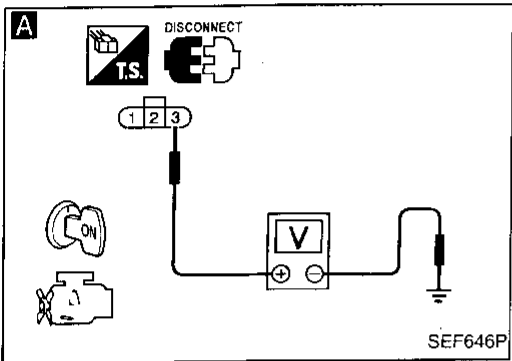
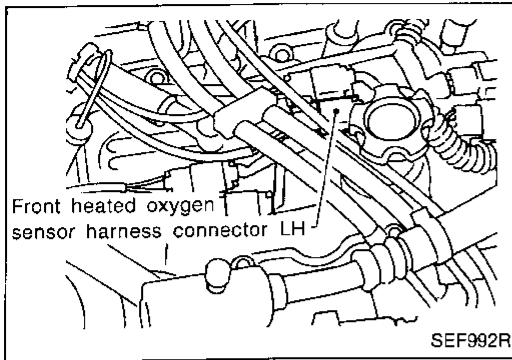

INSPECTION START

A
CHECK POWER SUPPLY.
1. Turn ignition switch "OFF".
2. Disconnect front heated oxygen sensor LH harness connector.
3. Turn ignition switch "ON".
4. Check voltage between terminal ③ and ground.
Voltage: Battery voltage

NG → Check the following.
• Harness connectors
• Harness connector (F23, M32)
• Harness connector (M10)
• 10A fuse
• Harness for open or short between front heated oxygen sensor LH and fuse
If NG, repair harness or connectors.

OK ↓
B
CHECK GROUND CIRCUIT.
1. Turn ignition switch "OFF".
2. Disconnect ECM harness connector.
3. Check harness continuity between terminal ① and ECM terminal (110).
Continuity should exist.
If OK, check harness for short to ground and short to power.

NG → Repair harness or connectors.

OK ↓
CHECK COMPONENT
(Front heated oxygen sensor heater). Refer to "COMPONENT INSPECTION" below.

NG → Replace front heated oxygen sensor (left bank).

OK ↓
Disconnect and reconnect harness connectors in the circuit. Then retest.

Trouble is not fixed.
Check ECM pin terminals for damage and check the connection of ECM harness connector. Reconnect ECM harness connector and retest.

INSPECTION END

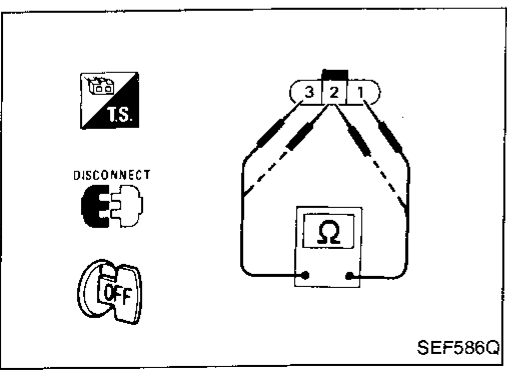

COMPONENT INSPECTION

Front heated oxygen sensor heater

Check resistance between terminals ③ and ①.

Resistance: 2.3 - 4.3Ω at 25°C (77°F)

Check continuity between terminals ② and ①, ③ and ②.

Continuity should not exist.

If NG, replace the front heated oxygen sensor.

CAUTION:

Discard any heated oxygen sensor which has been dropped from a height of more than 0.5 m (19.7 in) onto a hard surface such as a concrete floor; use a new one.

GI
MA
EM
LC
EC
FE
AT
TF
PD
FA
RA
BR
ST
RS
BT
HA
EL
IDX

TROUBLE DIAGNOSIS FOR DTC P0156

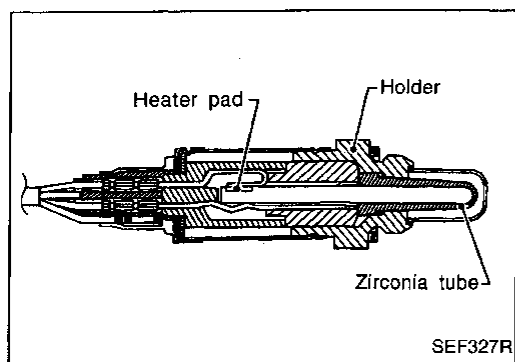

Rear Heated Oxygen Sensor (Rear HO2S) (Left bank)

COMPONENT DESCRIPTION

The rear heated oxygen sensor (Rear HO2S), after three way catalyst, monitors the oxygen level in the exhaust gas.

Even if switching characteristics of the front heated oxygen sensor are shifted, the air fuel ratio is controlled to stoichiometric, by the signal from the rear heated oxygen sensor.

This sensor is made of ceramic zirconia. The zirconia generates voltage from approximately 1V in richer conditions to 0V in leaner conditions.

Under normal conditions the rear heated oxygen sensor is not used for engine control operation.

CONSULT REFERENCE VALUE IN DATA MONITOR MODE

Specification data are reference values.

MONITOR ITEM	CONDITION		SPECIFICATION
RR O2 SEN-B2	● Engine: After warming up	Maintaining engine speed at 2,000 rpm	0 - 0.3V ↔ Approx. 0.6 - 1.0V
RR O2 MNTR-B2			LEAN ↔ RICH

ECM TERMINALS AND REFERENCE VALUE

Specification data are reference values and are measured between each terminal and Ⓞ (ECCS ground).

TER-MINAL NO.	WIRE COLOR	ITEM	CONDITION	DATA (DC Voltage)
66	W	Rear heated oxygen sensor (LH)	<div style="border: 1px solid black; padding: 2px; display: inline-block;">Engine is running.</div> After warming up sufficiently and engine speed is 2,000 rpm	0 - Approximately 1.0V

ON BOARD DIAGNOSIS LOGIC

The rear heated oxygen sensor has a much longer switching time between rich and lean than the front heated oxygen sensor. The oxygen storage capacity before the three way catalyst causes the longer switching time. To judge the malfunctions of rear heated oxygen sensor, ECM monitors the sensor's voltage value and the switching response during the various driving condition such as fuel-cut.

Diagnostic Trouble Code No.	Malfunction is detected when ...	Check Items (Possible Cause)
P0156 0708	<ul style="list-style-type: none"> ● An excessively high voltage from the sensor is sent to ECM. ● The maximum and minimum voltages from the sensor are not reached to the specified voltages. ● It takes more time for the sensor to respond between rich and lean than the specified time. 	<ul style="list-style-type: none"> ● Harness or connectors (The sensor circuit is open or shorted.) ● Rear heated oxygen sensor (Left bank) ● Fuel pressure ● Injectors ● Intake air leaks

TROUBLE DIAGNOSIS FOR DTC P0156

Rear Heated Oxygen Sensor (Rear HO2S) (Left bank) (Cont'd)

OVERALL FUNCTION CHECK

Use this procedure to check the overall function of the rear heated oxygen sensor circuit. During this check, a 1st trip DTC might not be confirmed.

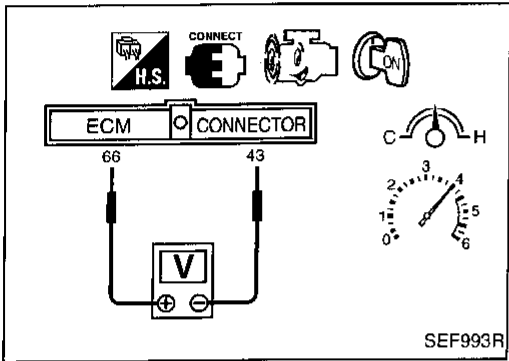
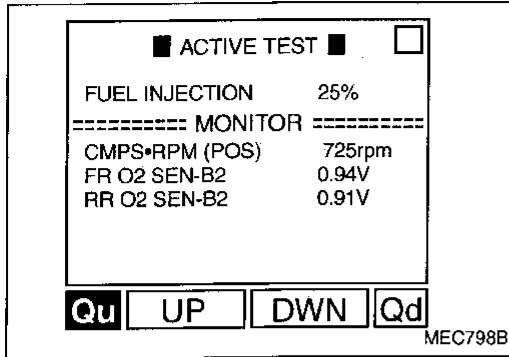

- 1) Start engine and warm it up sufficiently.
- 2) Select "FUEL INJECTION" in "ACTIVE TEST" mode, and select "RR O2 SEN-B2" as the monitor item with CONSULT.
- 3) Check "RR O2 SEN-B2" at idle speed when adjusting "FUEL INJECTION" to $\pm 25\%$.
 "RR O2 SEN-B2" should be above 0.48V at least once when the "FUEL INJECTION" is +25%.
 "RR O2 SEN-B2" should be below 0.43V at least once when the "FUEL INJECTION" is -25%.

OR

- 1) Start engine and warm it up sufficiently.
- 2) Set voltmeter probes between ECM terminals 66 (sensor signal) and 43 (engine ground).
- 3) Check the voltage when racing up to 4,000 rpm under no load at least 10 times.
 (depress and release accelerator pedal as soon as possible)

The voltage should be above 0.48V and below 0.43V at least once during this procedure.

If the voltage can be confirmed in step 3, step 4 is not necessary.

- 4) Keep vehicle at idling for 10 minutes, then check the voltage. Or check the voltage when coasting from 80 km/h (50 MPH) in 3rd gear position.

The voltage should be above 0.48V and below 0.43V at least once during this procedure.

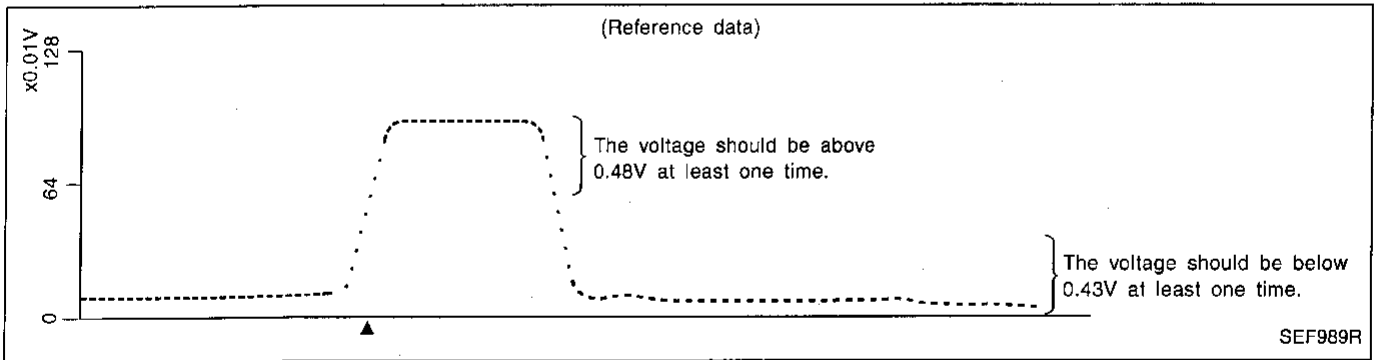

GI
MA
EM
LC
EC
FE
AT
TF
PD
FA
RA
BR
ST
RS
BT
HA
EL
IDX

TROUBLE DIAGNOSIS FOR DTC P0156

Rear Heated Oxygen Sensor (Rear HO2S) (Left bank) (Cont'd)

EC-RRO2LH-01

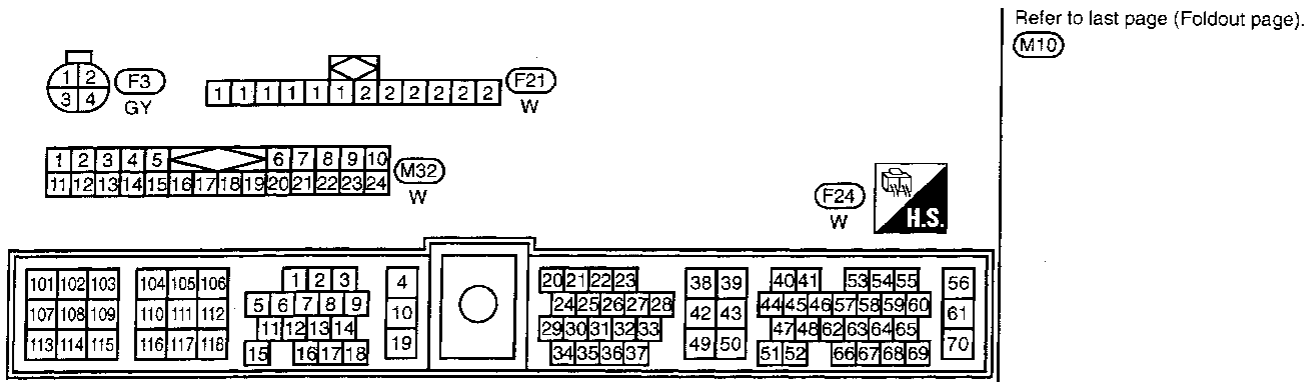
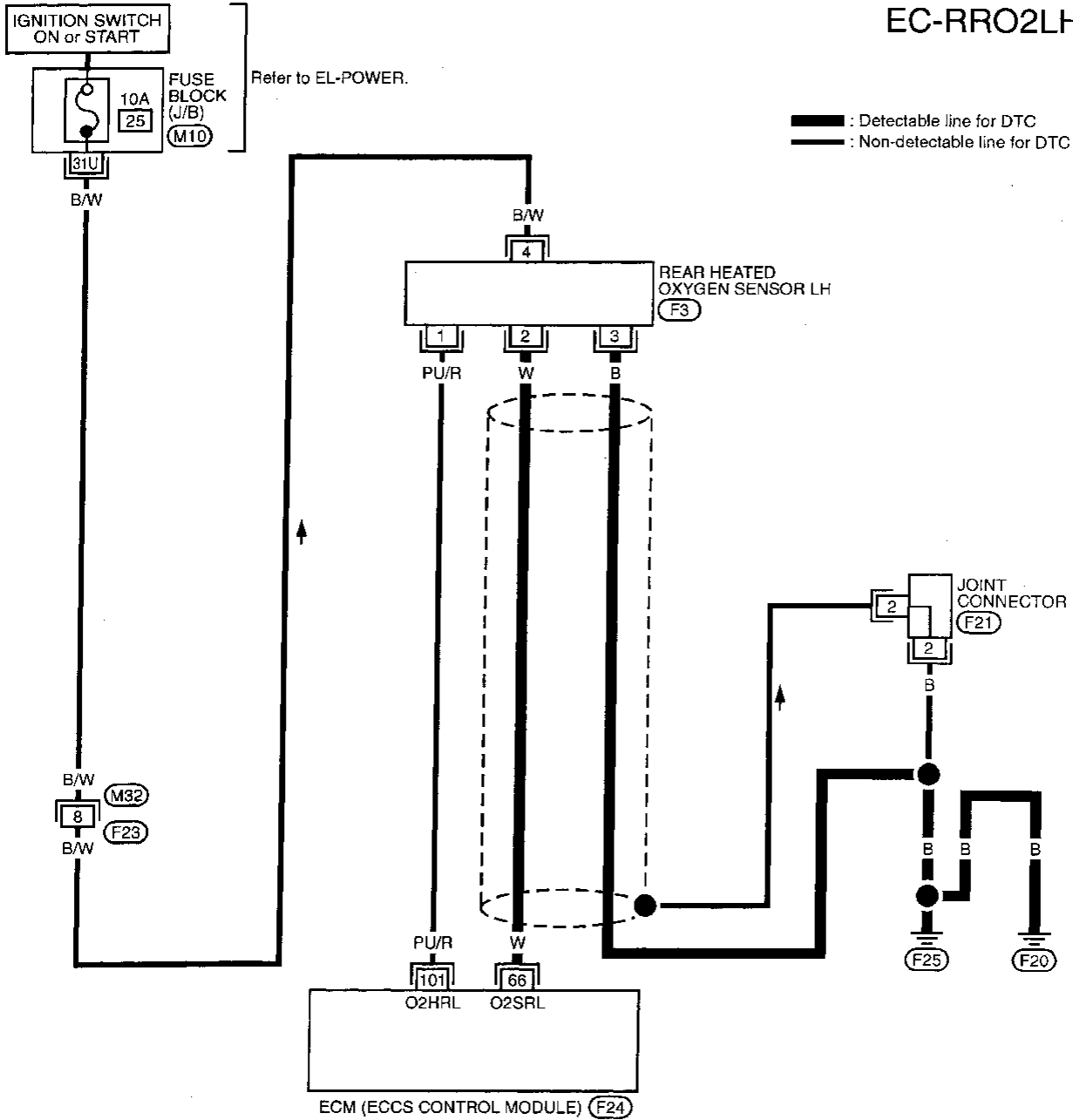

TROUBLE DIAGNOSIS FOR DTC P0156

Rear Heated Oxygen Sensor (Rear HO2S) (Left bank) (Cont'd)

DIAGNOSTIC PROCEDURE

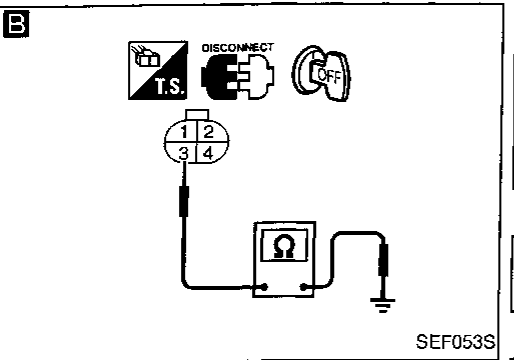
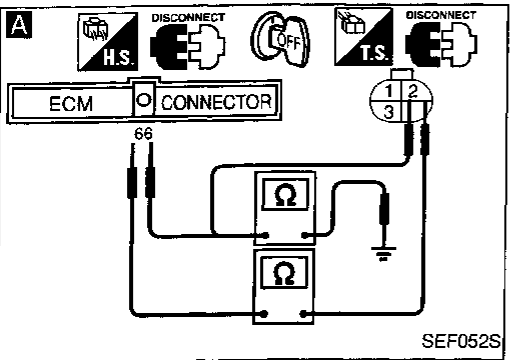
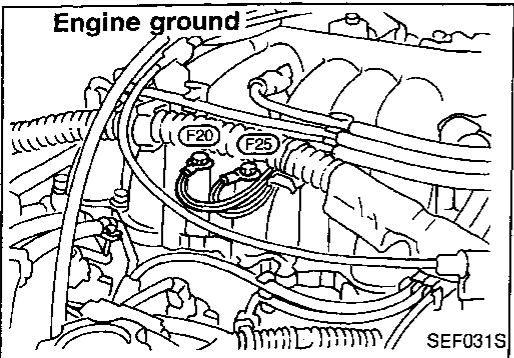
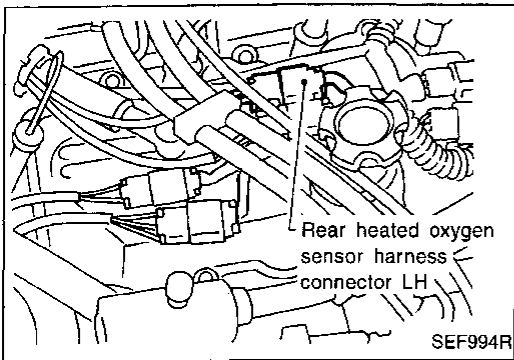

INSPECTION START

CHECK SHIELD CIRCUIT.

1. Turn ignition switch "OFF".
2. Loosen and retighten engine ground screws.
3. Remove joint connector.
4. Check the following.
 - Continuity between joint connector terminal and ground
 - Joint connector (Refer to "HARNES LAYOUT" in EL section.)

Continuity should exist.

If OK, check harness for short to ground and short to power. Then reconnect joint connector.

NG → Repair harness or connectors.

OK

A CHECK INPUT SIGNAL CIRCUIT.

1. Disconnect rear heated oxygen sensor (left bank) harness connector and ECM harness connector.
2. Check harness continuity between ECM terminal ⑥ and terminal ② .
Continuity should exist.
3. Check harness continuity between ECM terminal ⑥ (or terminal ②) and ground.
Continuity should not exist.

If OK, check harness for short to ground and short to power.

NG → Check the following.
• Harness for open or short between ECM and rear heated oxygen sensor LH
If NG, repair open circuit or short to ground or short to power in harness or connectors.

OK

B CHECK GROUND CIRCUIT.

- Check harness continuity between terminal ③ and engine ground.
Continuity should exist.
- If OK, check harness for short to ground and short to power.

NG → Repair harness or connectors.

OK

Disconnect and reconnect harness connectors in the circuit. Then retest.

Trouble is not fixed.

Check ECM pin terminals for damage and check the connection of ECM harness connector. Reconnect ECM harness connector and retest.

NG → Replace rear heated oxygen sensor.

OK

INSPECTION END

GI
MA
EM
LC
EC
FE
AT
TF
PD
FA
RA
BR
ST
RS
BT
HA
EL
IDX

TROUBLE DIAGNOSIS FOR DTC P0161

Rear Heated Oxygen Sensor Heater (Left bank)

SYSTEM DESCRIPTION

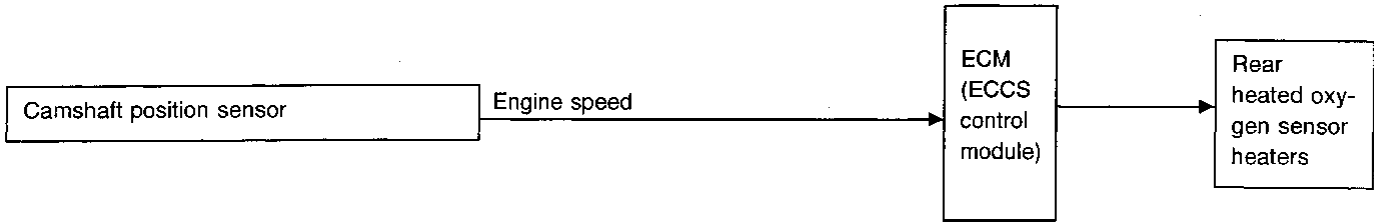

The ECM performs ON/OFF control of the rear heated oxygen sensor heaters corresponding to the engine speed.

OPERATION

Engine speed rpm	Rear heated oxygen sensor heaters
Above 3,200	OFF
Below 3,200	ON

CONSULT REFERENCE VALUE IN DATA MONITOR MODE

Specification data are reference values.

MONITOR ITEM	CONDITION	SPECIFICATION
RR O2 HTR-B2	• Engine speed: Idle	ON
	• Engine speed: Above 3,200 rpm	OFF

ECM TERMINALS AND REFERENCE VALUE

Specification data are reference values and are measured between each terminal and Ⓞ (ECCS ground).

TER-MINAL NO.	WIRE COLOR	ITEM	CONDITION	DATA (DC Voltage)
101	PU/R	Rear heated oxygen sensor heater (LH)	Engine is running. └ Engine speed is below 3,200 rpm	Approximately 0.4V
			Engine is running. └ Engine speed is above 3,200 rpm	BATTERY VOLTAGE (11 - 14V)

ON BOARD DIAGNOSIS LOGIC

Diagnostic Trouble Code No.	Malfunction is detected when	Check Items (Possible Cause)
P0161 1002	<ul style="list-style-type: none"> The current amperage in the rear heated oxygen sensor heater (Left bank) circuit is out of the normal range. (An improper voltage drop signal is sent to ECM through the rear heated oxygen sensor heater.) 	<ul style="list-style-type: none"> Harness or connectors (The rear heated oxygen sensor heater circuit is open or shorted.) Rear heated oxygen sensor heater (Left bank)

TROUBLE DIAGNOSIS FOR DTC P0161

Rear Heated Oxygen Sensor Heater (Left bank) (Cont'd)

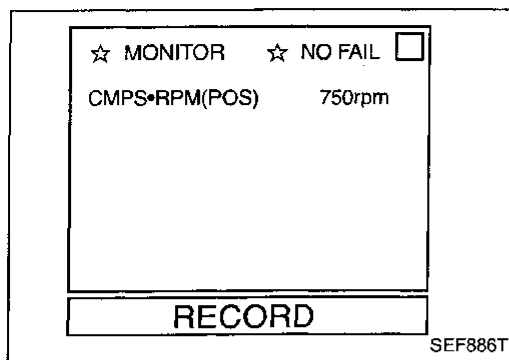

DIAGNOSTIC TROUBLE CODE CONFIRMATION PROCEDURE

-  1) Turn ignition switch "ON" and select "DATA MONITOR" mode with CONSULT.
2) Start engine and run it for at least 5 seconds at idle speed.

OR

-  1) Start engine and run it for at least 5 seconds at idle speed.
2) Turn ignition switch "OFF" and wait at least 5 seconds.
3) Start engine and run it for at least 5 seconds at idle speed.
4) Select "MODE 3" with GST.

OR

-  1) Start engine and run it for at least 5 seconds at idle speed.
2) Turn ignition switch "OFF", wait at least 5 seconds and then turn "ON".
3) Perform "Diagnostic Test Mode II (Self-diagnostic results)" with ECM.

- When using GST, "DIAGNOSTIC TROUBLE CODE CONFIRMATION PROCEDURE" should be performed twice as much as when using CONSULT or ECM (Diagnostic Test Mode II) because GST cannot display MODE 7 (1st trip DTC) concerning this diagnosis. Therefore, using CONSULT or ECM (Diagnostic Test Mode II) is recommended.

GI

MA

EM

LC

EC

FE

AT

TF

PD

FA

RA

BR

ST

RS

BT

HA

EL

IDX

TROUBLE DIAGNOSIS FOR DTC P0161

Rear Heated Oxygen Sensor Heater (Left bank) (Cont'd)

EC-RO2H-L-01

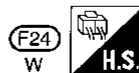
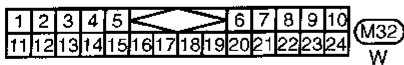
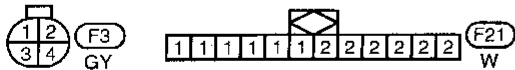
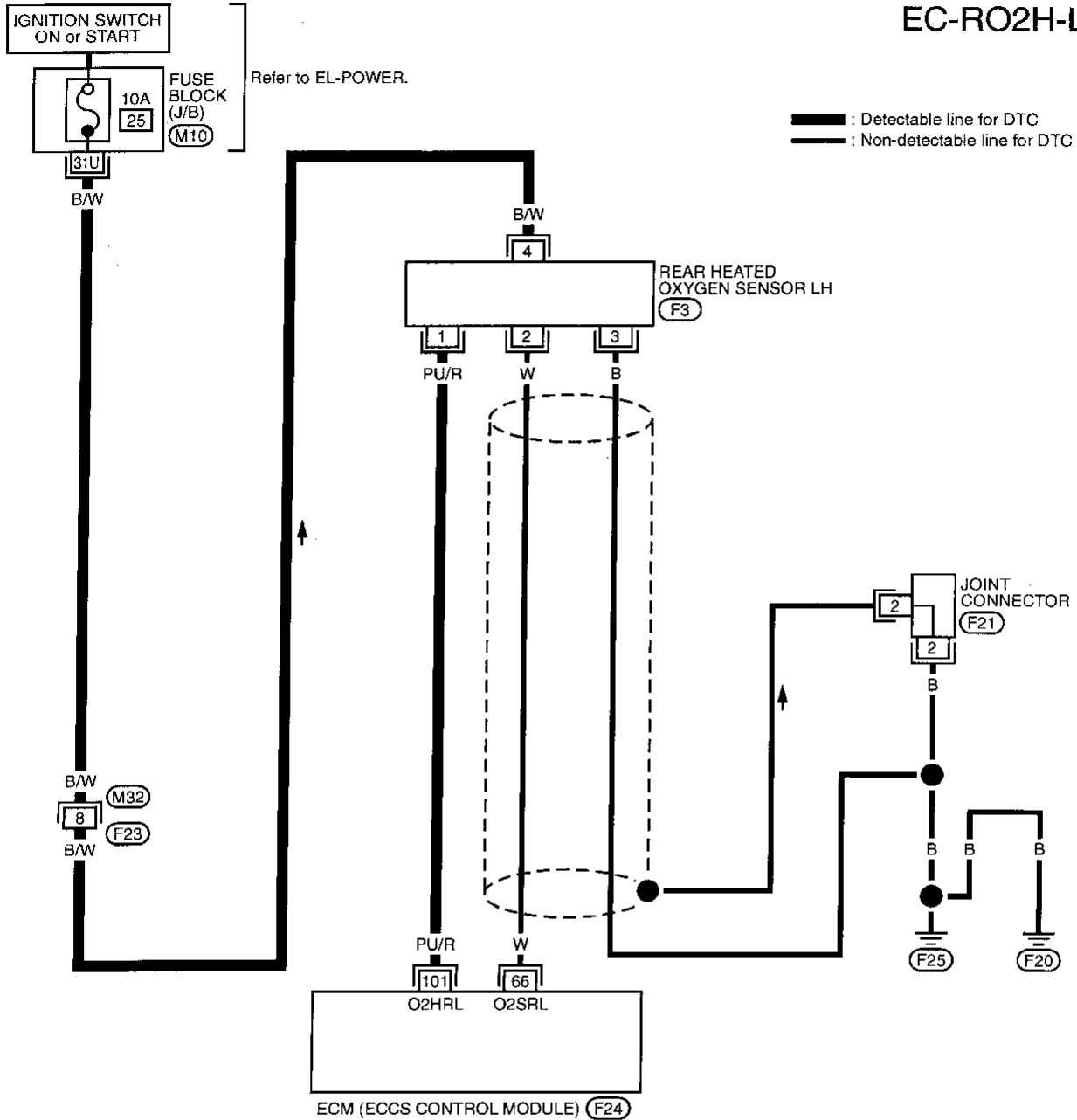

Refer to last page (Foldout page).

(M10)

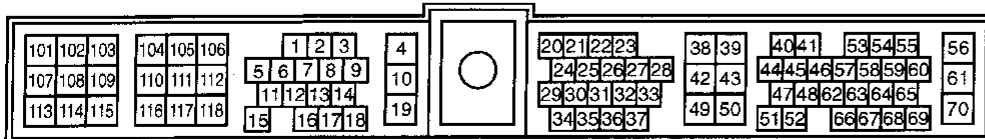

TROUBLE DIAGNOSIS FOR DTC P0161

Rear Heated Oxygen Sensor Heater (Left bank) (Cont'd)

DIAGNOSTIC PROCEDURE

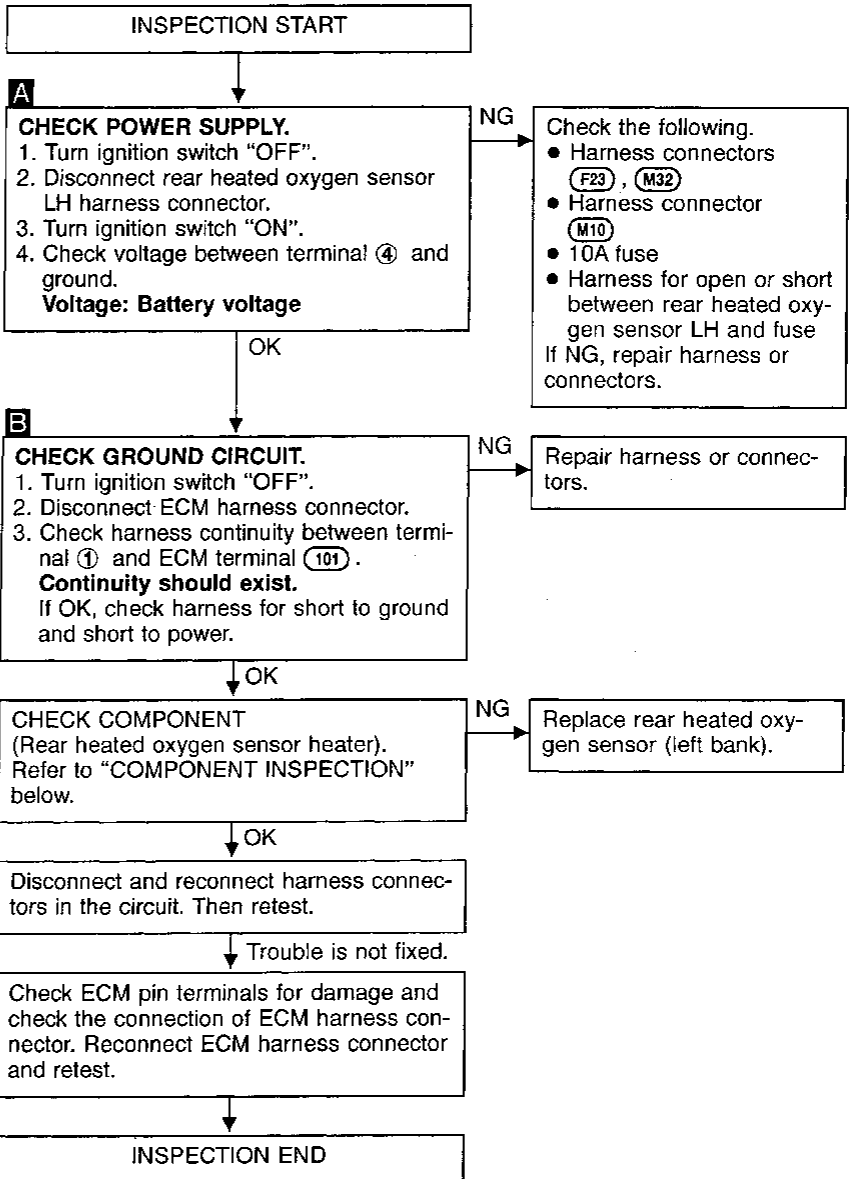
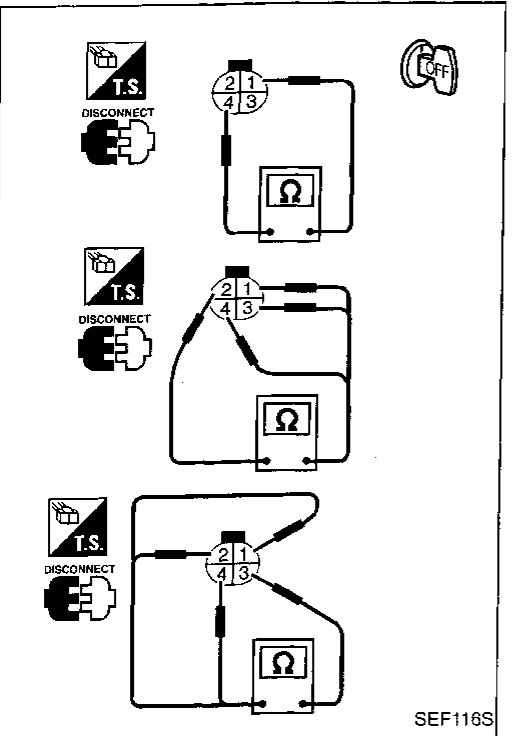
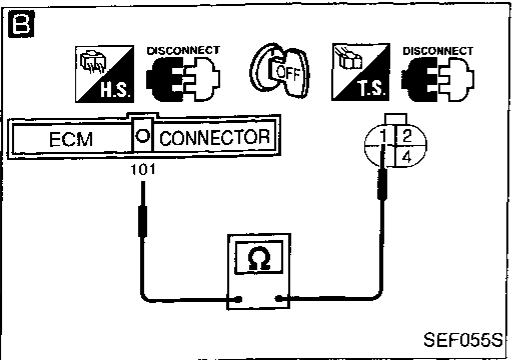
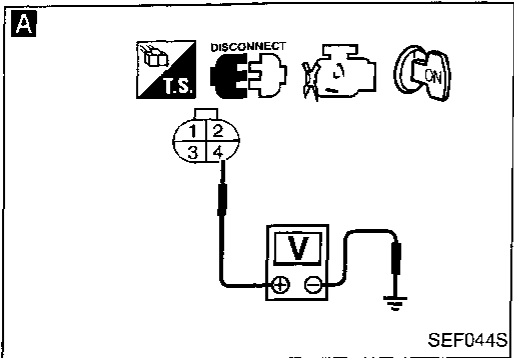
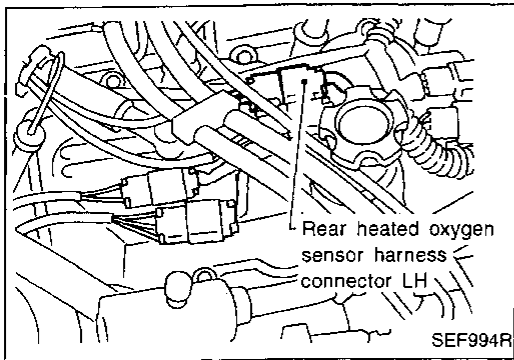

COMPONENT INSPECTION

Rear heated oxygen sensor heater

Check the following.

1. Check resistance between terminals 4 and 1.
Resistance: 2.3 - 4.3Ω at 25°C (77°F)
2. Check continuity.

Terminal No.	Continuity
2 and 1, 3, 4	No
3 and 1, 2, 4	

If NG, replace the rear heated oxygen sensor.

CAUTION:

Discard any heated oxygen sensor which has been dropped from a height of more than 0.5 m (19.7 in) onto a hard surface such as a concrete floor; use a new one.

GI
MA
EM
LC
EC
FE
AT
TF
PD
FA
RA
BR
ST
RS
BT
HA
EL
IDX

Fuel Injection System Function (Right bank) (Lean side)

ON BOARD DIAGNOSIS LOGIC

With the Air/Fuel Mixture Ratio Self-Learning Control, the actual mixture ratio can be brought closely to the theoretical mixture ratio based on the mixture ratio feedback signal from the front heated oxygen sensors. The ECM calculates the necessary compensation to correct the offset between the actual and the theoretical ratios. In case the amount of the compensation value is extremely large (The actual mixture ratio is too lean.), the ECM judges the condition as the fuel injection system malfunction and light up the MIL (2 trip detection logic).

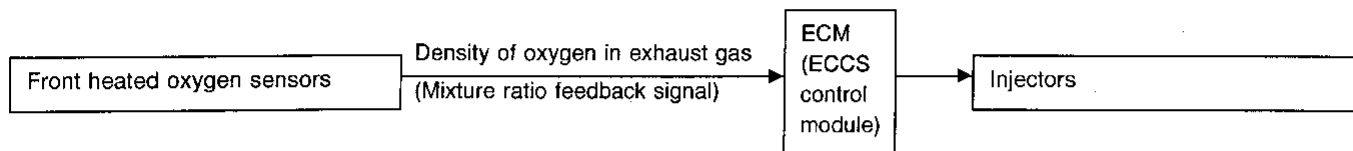

Diagnostic Trouble Code No.	Malfunction is detected when ...	Check Items (Possible Cause)
P0171 0115	<ul style="list-style-type: none"> ● Fuel injection system does not operate properly. ● The amount of mixture ratio compensation is too large. (The mixture ratio is too lean.) 	<ul style="list-style-type: none"> ● Intake air leaks ● Front heated oxygen sensor (Right bank) ● Injectors (Right bank) ● Exhaust gas leaks ● Incorrect fuel pressure ● Lack of fuel ● Mass air flow sensor

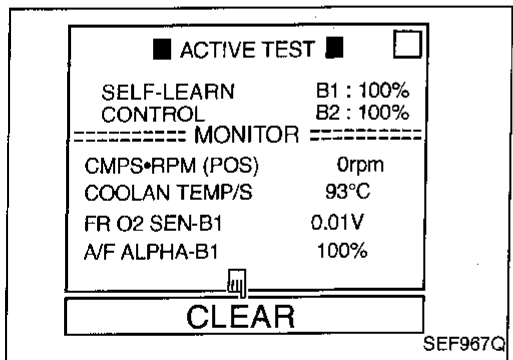

DIAGNOSTIC TROUBLE CODE CONFIRMATION PROCEDURE (Overall)

- 1) Start engine and warm it up sufficiently.
- 2) Turn ignition switch "OFF" and wait at least 5 seconds.
- 3) Turn ignition switch "ON" and select "SELF-LEARN CONTROL" in "ACTIVE TEST" mode with CONSULT.
- 4) Clear the self-learning control coefficient by touching "CLEAR".
- 5) Select "DATA MONITOR" mode with CONSULT.
- 6) Start engine again and run it for at least 10 minutes at idle speed.
The 1st trip DTC P0171 should be detected at this stage, if a malfunction exists.
- 7) If it is difficult to start engine at step 6, the fuel injection system has a malfunction, too.
- 8) Crank engine while depressing accelerator pedal. If engine starts, go to "DIAGNOSTIC PROCEDURE". If engine does not start, check exhaust and intake air leak visually.

OR

TROUBLE DIAGNOSIS FOR DTC P0171

Fuel Injection System Function (Right bank) (Lean side) (Cont'd)

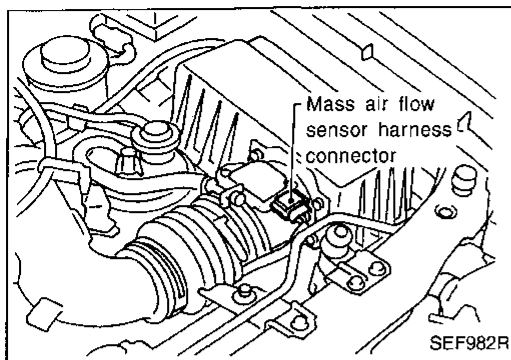

- 1) Start engine and warm it up sufficiently.
- 2) Turn ignition switch "OFF" and wait at least 5 seconds.
- 3) Disconnect mass air flow sensor harness connector. Then restart and run engine for at least 3 seconds at idle speed.
- 4) Stop engine and reconnect mass air flow sensor harness connector.
- 5) Select "MODE 7" with GST. Make sure 1st trip DTC P0100 is detected.
- 6) Select "MODE 4" with GST and erase the 1st trip DTC P0100.
- 7) Start engine again and run it for at least 10 minutes at idle speed.
- 8) Select "MODE 7" with GST. The 1st trip DTC P0171 should be detected at this stage, if a malfunction exists.
- 9) If it is difficult to start engine at step 8, the fuel injection system has a malfunction.
- 10) Crank engine while depressing accelerator pedal. If engine starts, go to "DIAGNOSTIC PROCEDURE". If engine does not start, check exhaust and intake air leak visually.

GI

MA

EM

LC

EC

FE

AT

OR

TF

- 1) Start engine and warm it up sufficiently.
- 2) Turn ignition switch "OFF" and wait at least 5 seconds.
- 3) Disconnect mass air flow sensor harness connector. Then restart and run engine for at least 3 seconds at idle speed.
- 4) Stop engine and reconnect mass air flow sensor harness connector.
- 5) Turn ignition switch "ON".
- 6) Perform Diagnostic Test Mode II (Self-diagnostic results) with ECM. Make sure 1st trip DTC 0102 is detected.
- 7) Erase the 1st trip DTC 0102 by changing from Diagnostic Test Mode II to Diagnostic Test Mode I.
- 8) Perform Diagnostic Test Mode II (Self-diagnostic results) with ECM. Make sure DTC 0505 is detected.
- 9) Start engine again and run it for at least 10 minutes at idle speed.
The 1st trip DTC 0115 should be detected at this stage, if a malfunction exists.
- 10) If it is difficult to start engine at step 9, the fuel injection system also has a malfunction.
- 11) Crank engine while depressing accelerator pedal. If engine starts, go to "DIAGNOSTIC PROCEDURE". If engine does not start, check exhaust and intake air leak visually.

PD

FA

RA

BR

ST

RS

BT

HA

EL

IDX

TROUBLE DIAGNOSIS FOR DTC P0171

Fuel Injection System Function (Right bank) (Lean side) (Cont'd)

EC-FUELRH-01

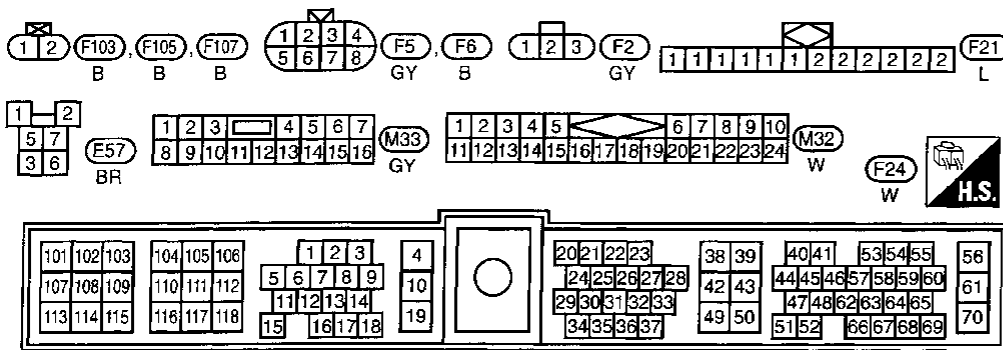
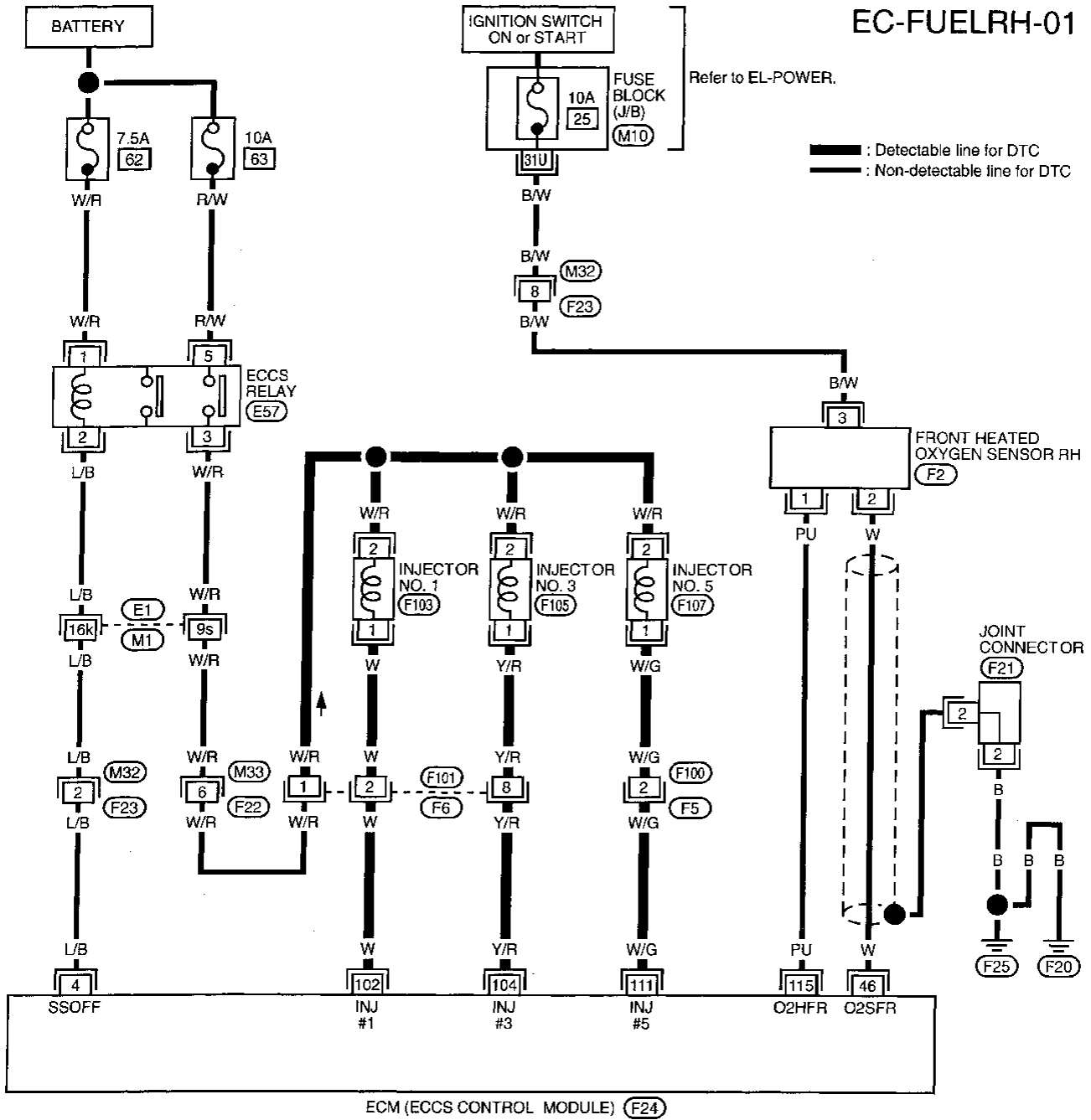

Refer to last page (Foldout page).

TROUBLE DIAGNOSIS FOR DTC P0171

Fuel Injection System Function (Right bank) (Lean side) (Cont'd)

DIAGNOSTIC PROCEDURE

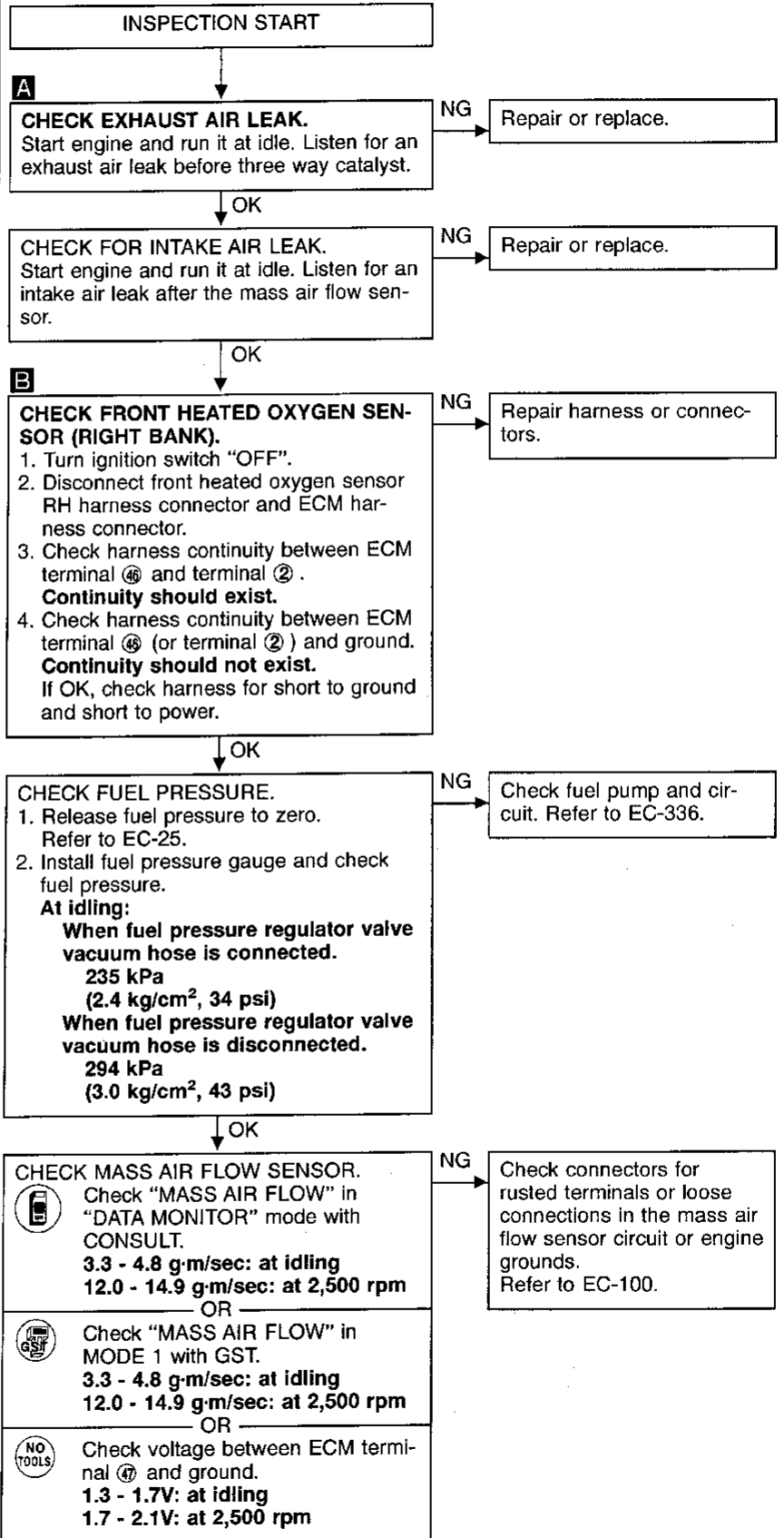
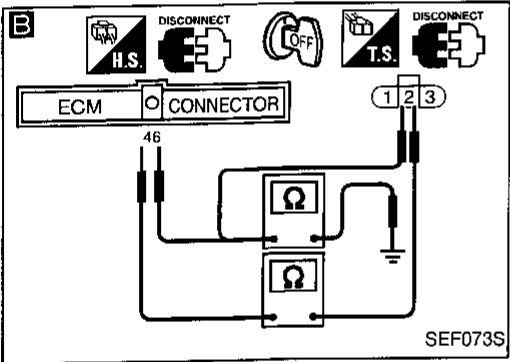
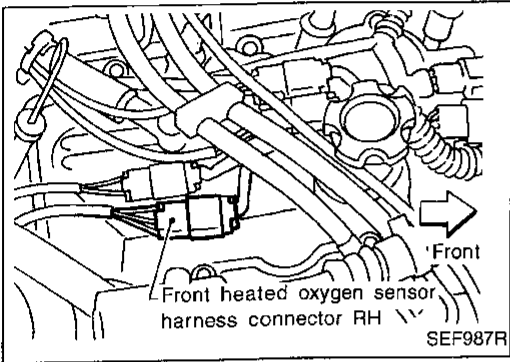
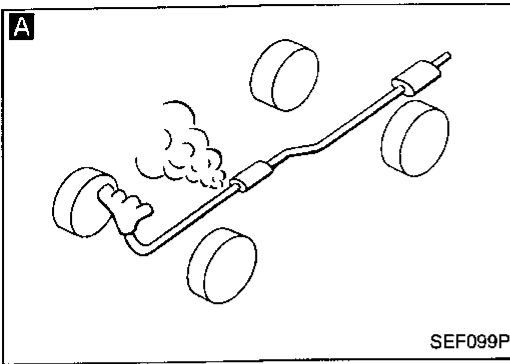

GI
MA
EM
LC
EC
FE
AT
TF
PD
FA
RA
BR
ST
RS
BT
HA
EL
IDX

TROUBLE DIAGNOSIS FOR DTC P0171

Fuel Injection System Function (Right bank) (Lean side) (Cont'd)

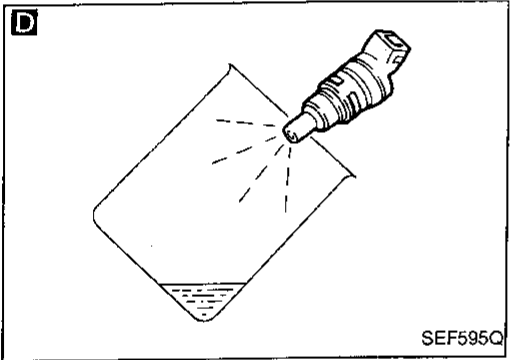
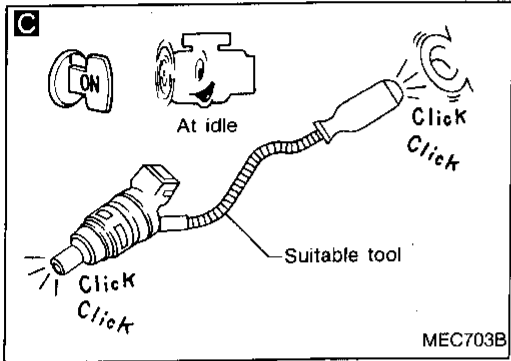
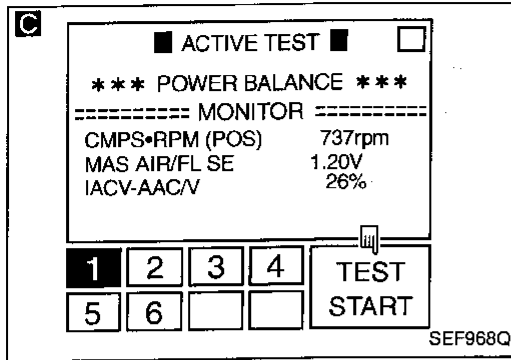

C

CHECK FUNCTION OF INJECTORS (RIGHT BANK).

1. Install all parts removed.
2. Start engine.
3. Perform "POWER BALANCE" in "ACTIVE TEST" mode with CONSULT.
4. Make sure that each circuit produces a momentary engine speed drop.

OR

3. Listen to each injector operating sound. **Clicking noise should be heard.**

NG → Perform TROUBLE DIAGNOSIS FOR NON-DETECTABLE ITEMS, "Injectors", EC-329. Repair harness or connectors.

OK → Confirm that the engine is cooled down and there are no fire hazards near the vehicle.

1. Turn ignition switch "OFF".
2. Disconnect injector harness connectors on left bank.
3. Remove injector gallery on right bank. Refer to EC-26. Keep fuel hose and all injectors connected to injector gallery. The injector harness connectors on right bank should remain connected.

D

1. Disconnect all ignition coil harness connectors.
2. Crank engine for about 3 seconds. Make sure that fuel sprays out from injectors.

NG → Replace injectors from which fuel does not spray out.

OK → Check ECM pin terminals for damage and check the connection of ECM harness connector. Reconnect ECM harness connector and retest.

INSPECTION END

Fuel Injection System Function (Right bank) (Rich side)

ON BOARD DIAGNOSIS LOGIC

With the Air/Fuel Mixture Ratio Self-Learning Control, the actual mixture ratio can be brought closely to the theoretical mixture ratio based on the mixture ratio feedback signal from the front heated oxygen sensors. The ECM calculates the necessary compensation to correct the offset between the actual and the theoretical ratios. In case the amount of the compensation value is extremely large (The actual mixture ratio is too rich.), the ECM judges the condition as the fuel injection system malfunction and light up the MIL (2 trip detection logic).

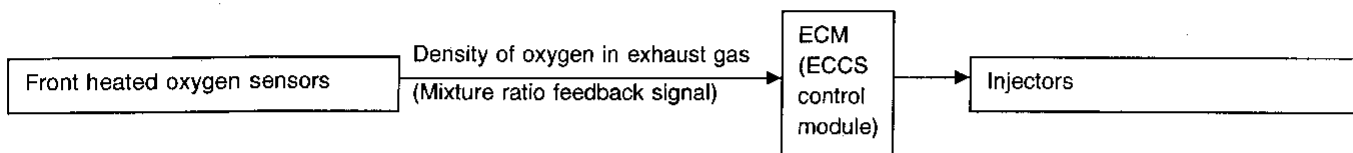

Diagnostic Trouble Code No.	Malfunction is detected when ...	Check Items (Possible Cause)
P0172 0114	<ul style="list-style-type: none"> Fuel injection system does not operate properly. The amount of mixture ratio compensation is too large. (The mixture ratio is too rich.) 	<ul style="list-style-type: none"> Front heated oxygen sensor (Right bank) Injectors (Right bank) Exhaust gas leaks Incorrect fuel pressure Mass air flow sensor

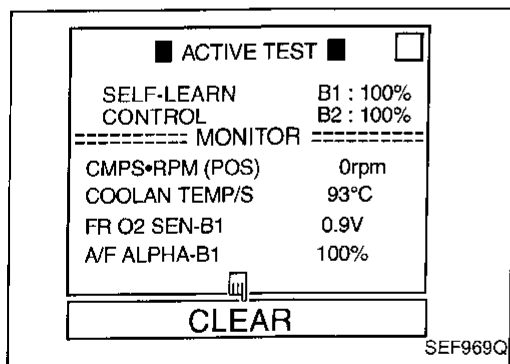

DIAGNOSTIC TROUBLE CODE CONFIRMATION PROCEDURE (Overall)

- 1) Start engine and warm it up sufficiently.
- 2) Turn ignition switch "OFF" and wait at least 5 seconds.
- 3) Turn ignition switch "ON" and select "SELF-LEARN CONTROL" in "ACTIVE TEST" mode with CONSULT.
- 4) Clear the self-learning control coefficient by touching "CLEAR".
- 5) Select "DATA MONITOR" mode with CONSULT.
- 6) Start engine again and run it for at least 10 minutes at idle speed.
The 1st trip DTC P0172 should be detected at this stage, if a malfunction exists.
- 7) If it is difficult to start engine at step 6, the fuel injection system has a malfunction, too.
- 8) Crank engine while depressing accelerator pedal.
If engine starts, go to "DIAGNOSTIC PROCEDURE", EC-173. If engine does not start, remove ignition plugs and check for fouling, etc.

OR

TROUBLE DIAGNOSIS FOR DTC P0172

Fuel Injection System Function (Right bank) (Rich side) (Cont'd)

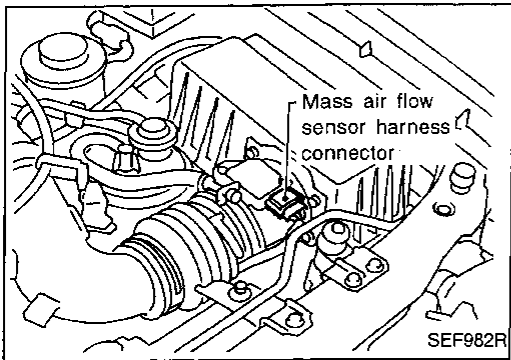

- 1) Start engine and warm it up sufficiently.
- 2) Turn ignition switch "OFF" and wait at least 5 seconds.
- 3) Disconnect mass air flow sensor harness connector. Then restart and run engine for at least 3 seconds at idle speed.
- 4) Stop engine and reconnect mass air flow sensor harness connector.
- 5) Select "MODE 7" with GST. Make sure 1st trip DTC P0100 is detected.
- 6) Select "MODE 4" with GST and erase the 1st trip DTC P0100.
- 7) Start engine again and run it for at least 10 minutes at idle speed.
- 8) Select "MODE 7" with GST. The 1st trip DTC P0171 should be detected at this stage, if a malfunction exists.
- 9) If it is difficult to start engine at step 8, the fuel injection system has a malfunction.
- 10) Crank engine while depressing accelerator pedal. If engine starts, go to "DIAGNOSTIC PROCEDURE". If engine does not start, check exhaust and intake air leak visually.

OR



- 1) Disconnect mass air flow sensor harness connector.
- 2) Start engine and run it for at least 3 seconds at idle speed.
- 3) Stop engine and reconnect mass air flow sensor harness connector.
- 4) Turn ignition switch "ON".
- 5) Perform Diagnostic Test Mode II (Self-diagnostic results) with ECM. Make sure 1st trip DTC 0102 is detected.
- 6) Erase the 1st trip DTC 0102 by changing from Diagnostic Test Mode II to Diagnostic Test Mode I.
- 7) Perform Diagnostic Test Mode II (Self-diagnostic results) with ECM. Make sure DTC 0505 is detected.
- 8) Start engine again and run it for at least 10 minutes at idle speed.
The 1st trip DTC 0114 should be detected at this stage, if a malfunction exists.
- 9) If it is difficult to start engine at step 8, the fuel injection system also has a malfunction.
- 10) Crank engine while depressing accelerator pedal.
If engine starts, go to "DIAGNOSTIC PROCEDURE", EC-173. If engine does not start, remove ignition plugs and check for fouling, etc.

TROUBLE DIAGNOSIS FOR DTC P0172

Fuel Injection System Function (Right bank) (Rich side) (Cont'd)

EC-FUEL RH-01

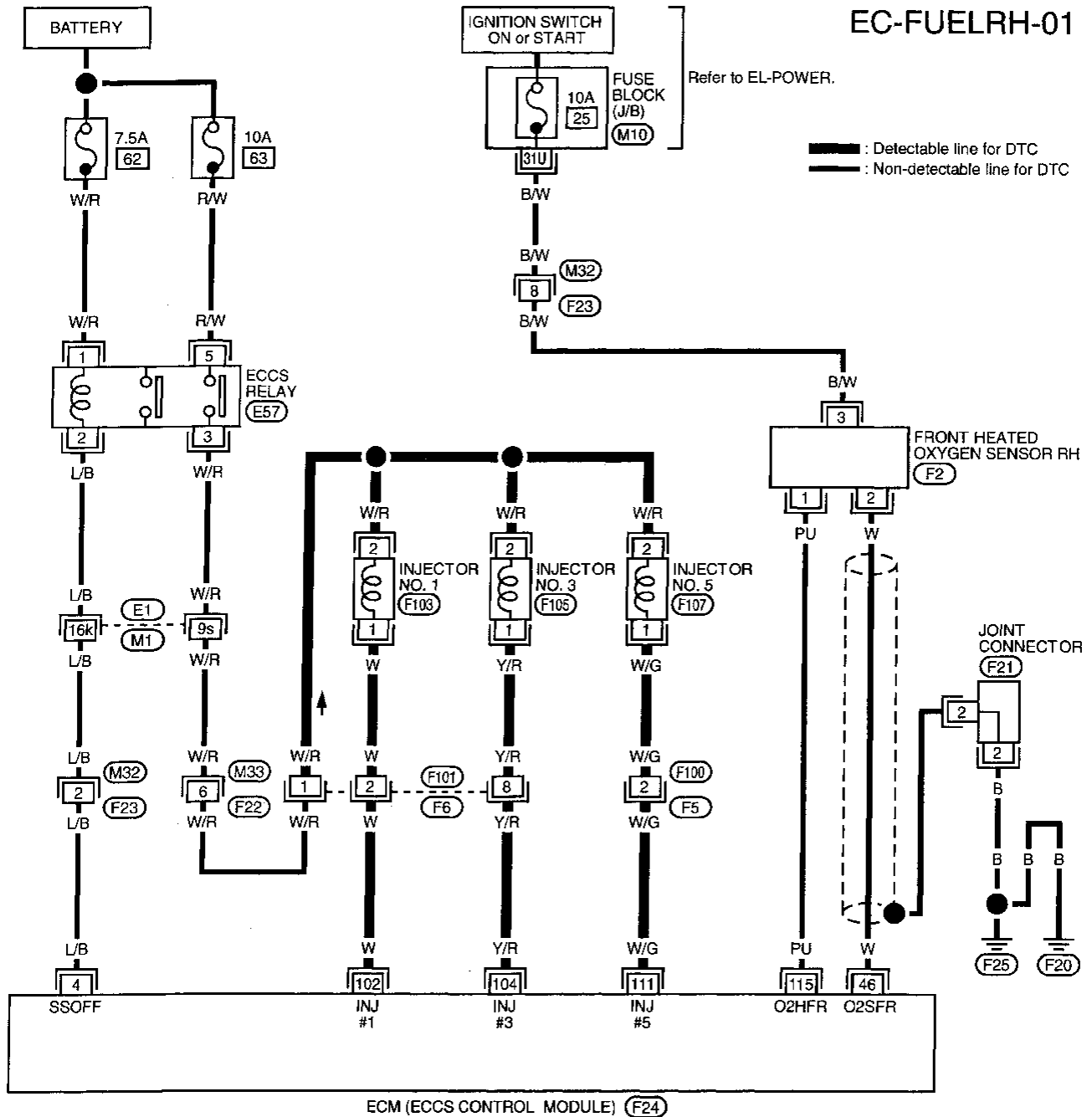

GI
 MA
 EM
 LC
EC
 FE
 AT
 TF
 PD
 FA
 RA
 BR
 ST
 RS
 BT
 HA
 EL
 IDX

Refer to last page (Foldout page).

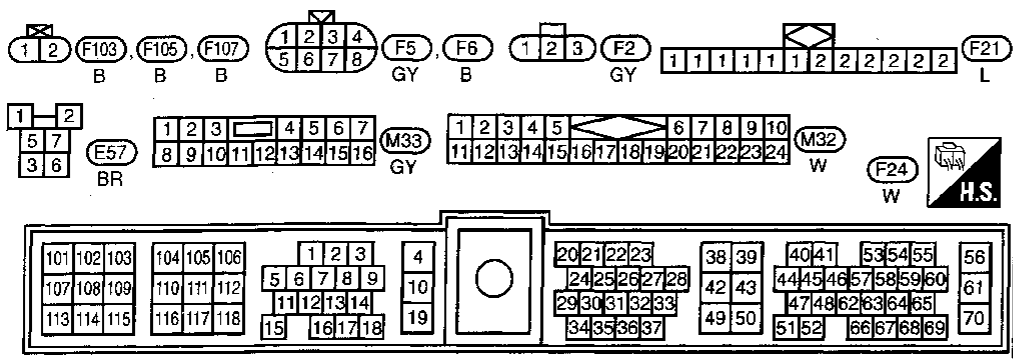

TROUBLE DIAGNOSIS FOR DTC P0172

Fuel Injection System Function (Right bank) (Rich side) (Cont'd)

DIAGNOSTIC PROCEDURE

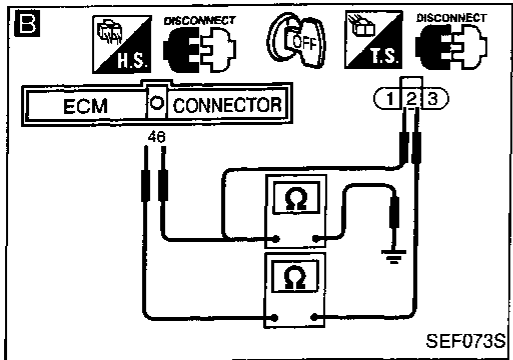
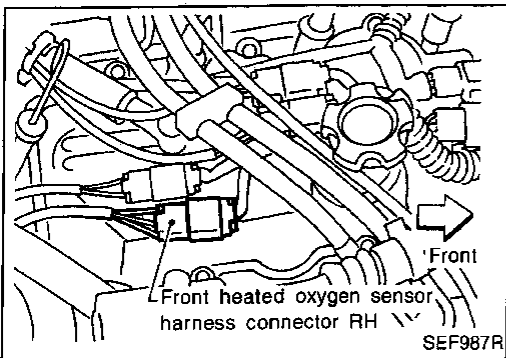
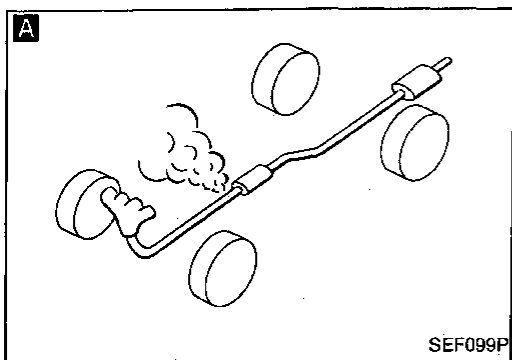

INSPECTION START

A
CHECK FOR EXHAUST AIR LEAK.
Start engine and run it at idle. Listen for an exhaust air leak before the three way catalyst.

NG → Repair or replace.

OK

B
CHECK FRONT HEATED OXYGEN SENSOR (RIGHT BANK).
1. Turn ignition switch "OFF".
2. Disconnect front heated oxygen sensor RH harness connector and ECM harness connector.
3. Check harness continuity between ECM terminal ④ and terminal ②. **Continuity should exist.**
4. Check harness continuity between ECM terminal ④ (or terminal ②) and ground. **Continuity should not exist.**
If OK, check harness for short to ground and short to power.

NG → Repair harness or connectors.

OK

CHECK FUEL PRESSURE.
1. Release fuel pressure to zero. Refer to EC-25.
2. Install fuel pressure gauge and check fuel pressure.
At idling:
When fuel pressure regulator valve vacuum hose is connected.
Approximately 235 kPa (2.4 kg/cm², 34 psi)
When fuel pressure regulator valve vacuum hose is disconnected.
Approximately 294 kPa (3.0 kg/cm², 43 psi)

NG → Check fuel pump and circuit. Refer to EC-336.

OK

CHECK MASS AIR FLOW SENSOR.
Check "MASS AIR FLOW" in "DATA MONITOR" mode with CONSULT.
3.3 - 4.8 g-m/sec: at idling
12.0 - 14.9 g-m/sec: at 2,500 rpm
OR
Check "MASS AIR FLOW" in MODE 1 with GST.
3.3 - 4.8 g-m/sec: at idling
12.0 - 14.9 g-m/sec: at 2,500 rpm
OR
NO TOOLS Check voltage between ECM terminal ④ and ground.
1.3 - 1.7V: at idling
1.7 - 2.1V: at 2,500 rpm

NG → Check connectors for rusted terminals or loose connections in the mass air flow sensor circuit or engine grounds. Refer to EC-100.

OK

Ⓐ

TROUBLE DIAGNOSIS FOR DTC P0172

Fuel Injection System Function (Right bank) (Rich side) (Cont'd)

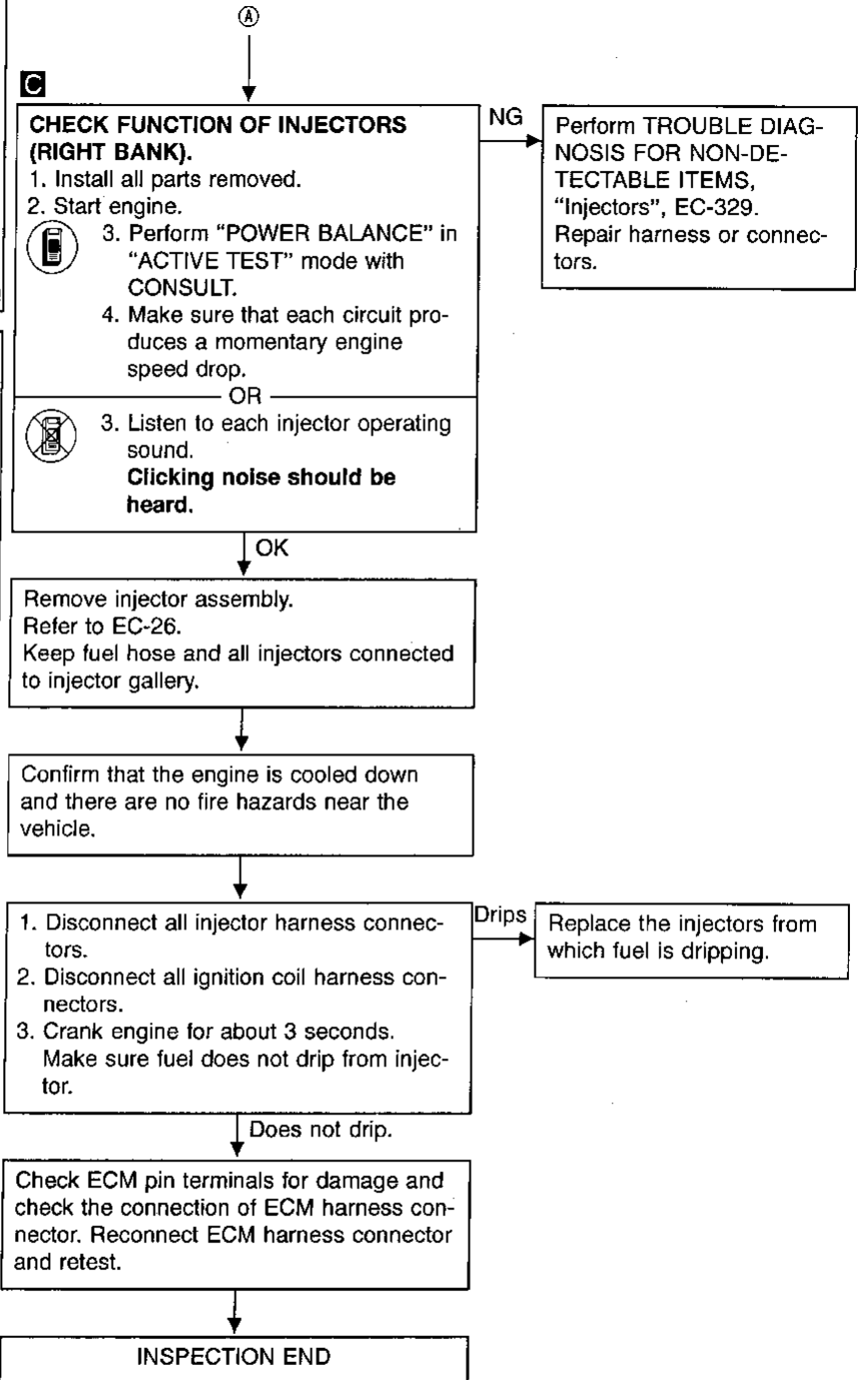
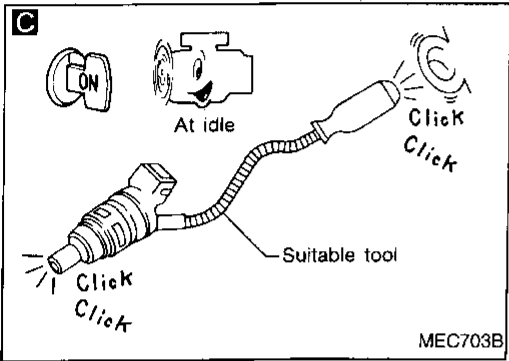
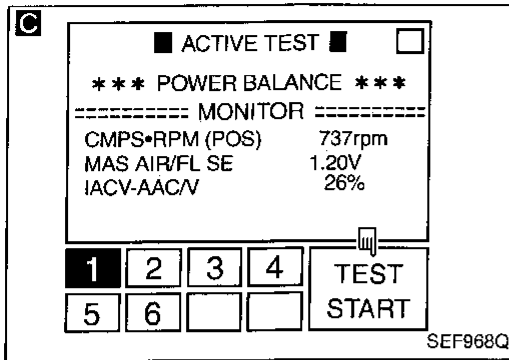

GI
MA
EM
LC
EC
FE
AT
TF
PD
FA
RA
BR
ST
RS
BT
HA
EL
IDX

Fuel Injection System Function (Left bank) (Lean side)

ON BOARD DIAGNOSIS LOGIC

With the Air/Fuel Mixture Ratio Self-Learning Control, the actual mixture ratio can be brought closely to the theoretical mixture ratio based on the mixture ratio feedback signal from the front heated oxygen sensors. The ECM calculates the necessary compensation to correct the offset between the actual and the theoretical ratios. In case the amount of the compensation value is extremely large (The actual mixture ratio is too lean.), the ECM judges the condition as the fuel injection system malfunction and light up the MIL (2 trip detection logic).

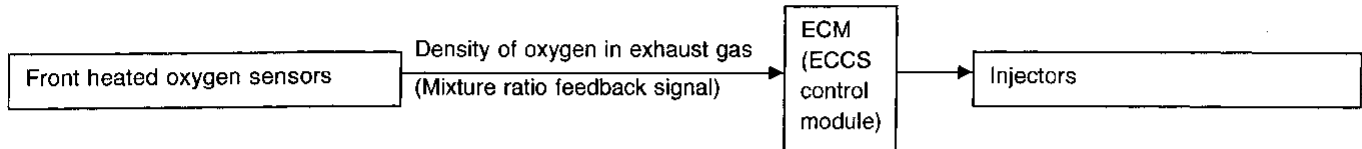

Diagnostic Trouble Code No.	Malfunction is detected when ...	Check Items (Possible Cause)
P0174 0210	<ul style="list-style-type: none"> ● Fuel injection system does not operate properly. ● The amount of mixture ratio compensation is too large. (The mixture ratio is too lean.) 	<ul style="list-style-type: none"> ● Intake air leaks ● Front heated oxygen sensor (Left bank) ● Injectors (Left bank) ● Exhaust gas leaks ● Incorrect fuel pressure ● Lack of fuel ● Mass air flow sensor

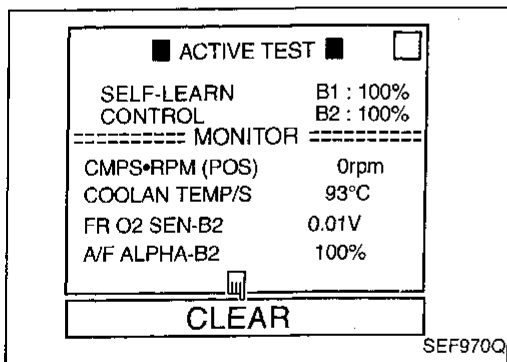

DIAGNOSTIC TROUBLE CODE CONFIRMATION PROCEDURE (Overall)

- 1) Start engine and warm it up sufficiently.
- 2) Turn ignition switch "OFF" and wait at least 5 seconds.
- 3) Turn ignition switch "ON" and select "SELF-LEARN CONTROL" in "ACTIVE TEST" mode with CONSULT.
- 4) Clear the self-learning control coefficient by touching "CLEAR".
- 5) Select "DATA MONITOR" mode with CONSULT.
- 6) Start engine again and run it for at least 10 minutes at idle speed.
The 1st trip DTC P0174 should be detected at this stage, if a malfunction exists.
- 7) If it is difficult to start engine at step 6, the fuel injection system has a malfunction, too.
- 8) Crank engine while depressing accelerator pedal. If engine starts, go to "DIAGNOSTIC PROCEDURE". If engine does not start, check exhaust and intake air leak visually.

OR

TROUBLE DIAGNOSIS FOR DTC P0174

Fuel Injection System Function (Left bank) (Lean side) (Cont'd)

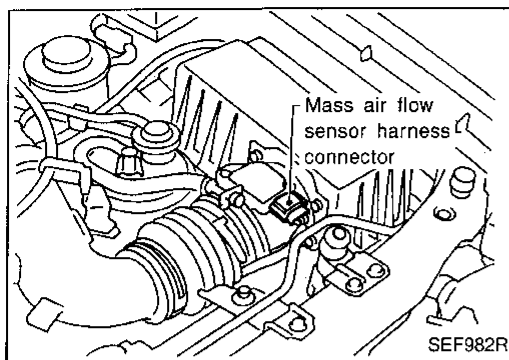

- 1) Start engine and warm it up sufficiently.
- 2) Turn ignition switch "OFF" and wait at least 5 seconds.
- 3) Disconnect mass air flow sensor harness connector. Then restart and run engine for at least 3 seconds at idle speed.
- 4) Stop engine and reconnect mass air flow sensor harness connector.
- 5) Select "MODE 7" with GST. Make sure 1st trip DTC P0100 is detected.
- 6) Select "MODE 4" with GST and erase the 1st trip DTC P0100.
- 7) Start engine again and run it for at least 10 minutes at idle speed.
- 8) Select "MODE 7" with GST. The 1st trip DTC P0171 should be detected at this stage, if a malfunction exists.
- 9) If it is difficult to start engine at step 8, the fuel injection system has a malfunction.
- 10) Crank engine while depressing accelerator pedal. If engine starts, go to "DIAGNOSTIC PROCEDURE". If engine does not start, check exhaust and intake air leak visually.

GI

MA

EM

LC

EC

FE

AT

OR

TF



- 1) Start engine and warm it up sufficiently.
- 2) Turn ignition switch "OFF" and wait at least 5 seconds.
- 3) Disconnect mass air flow sensor harness connector. Then restart and run engine for at least 3 seconds at idle speed.
- 4) Stop engine and reconnect mass air flow sensor harness connector.
- 5) Turn ignition switch "ON".
- 6) Perform Diagnostic Test Mode II (Self-diagnostic results) with ECM. Make sure 1st trip DTC 0102 is detected.
- 7) Erase the 1st trip DTC 0102 by changing from Diagnostic Test Mode II to Diagnostic Test Mode I.
- 8) Perform Diagnostic Test Mode II (Self-diagnostic results) with ECM. Make sure DTC 0505 is detected.
- 9) Start engine again and run it for at least 10 minutes at idle speed.
The 1st trip DTC 0210 should be detected at this stage, if a malfunction exists.
- 10) If it is difficult to start engine at step 9, the fuel injection system also has a malfunction.
- 11) Crank engine while depressing accelerator pedal. If engine starts, go to "DIAGNOSTIC PROCEDURE". If engine does not start, check exhaust and intake air leak visually.

PD

FA

RA

BR

ST

RS

BT

HA

EL

IDX

TROUBLE DIAGNOSIS FOR DTC P0174

Fuel Injection System Function (Left bank) (Lean side) (Cont'd)

EC-FUELLH-01

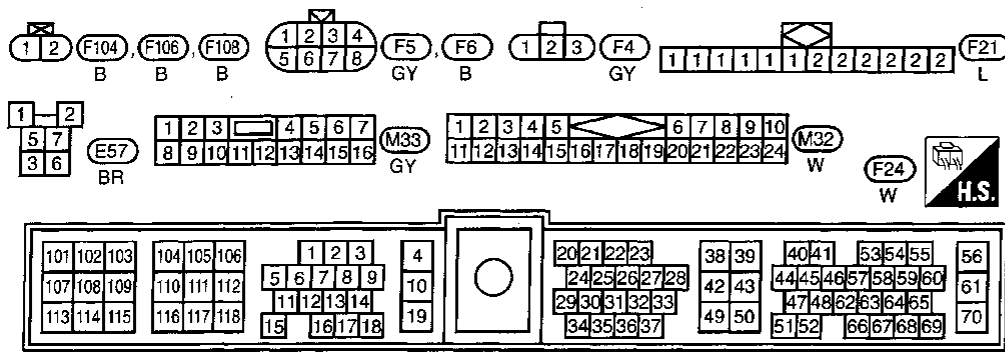
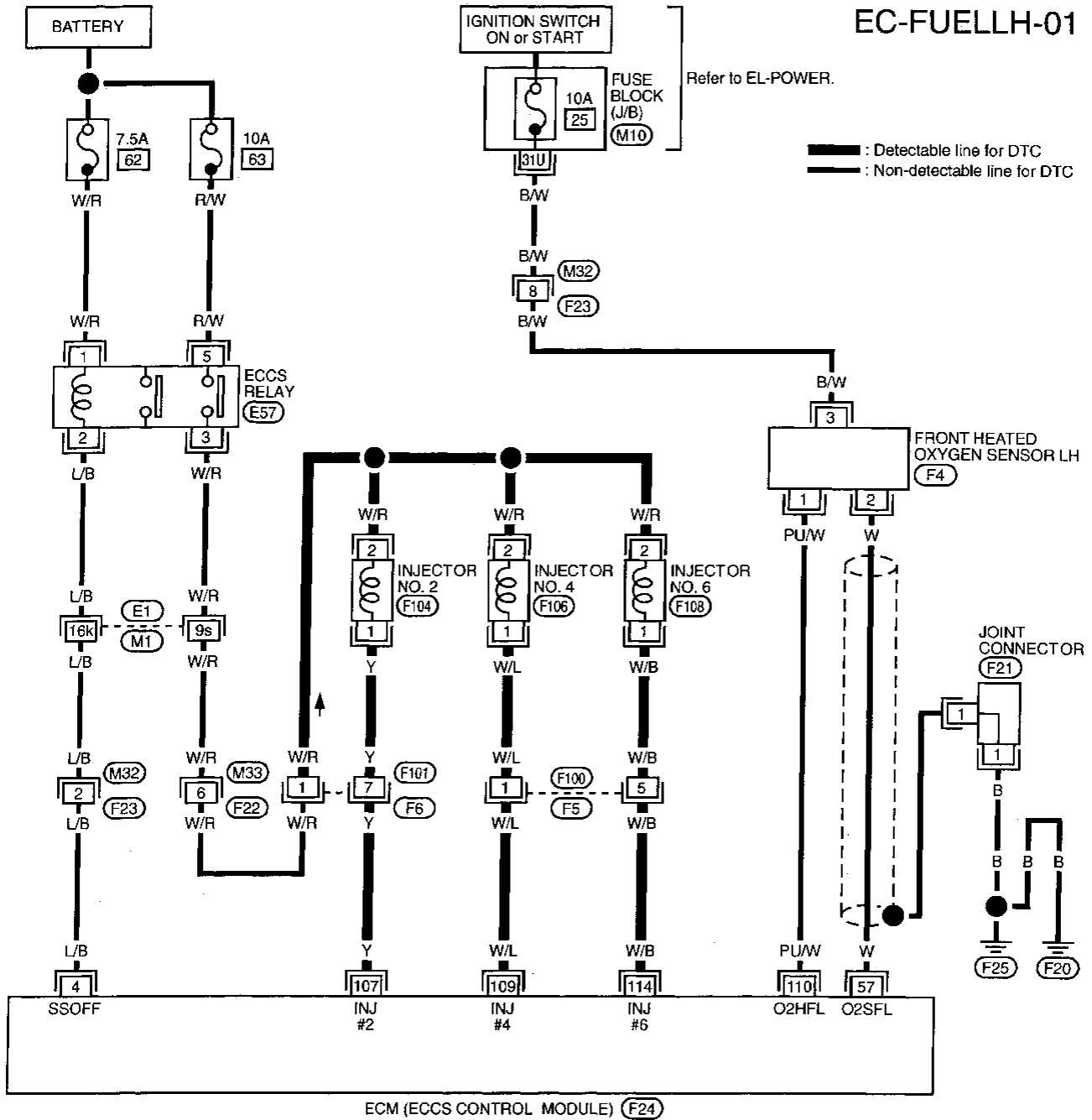

TROUBLE DIAGNOSIS FOR DTC P0174

Fuel Injection System Function (Left bank) (Lean side) (Cont'd)

DIAGNOSTIC PROCEDURE

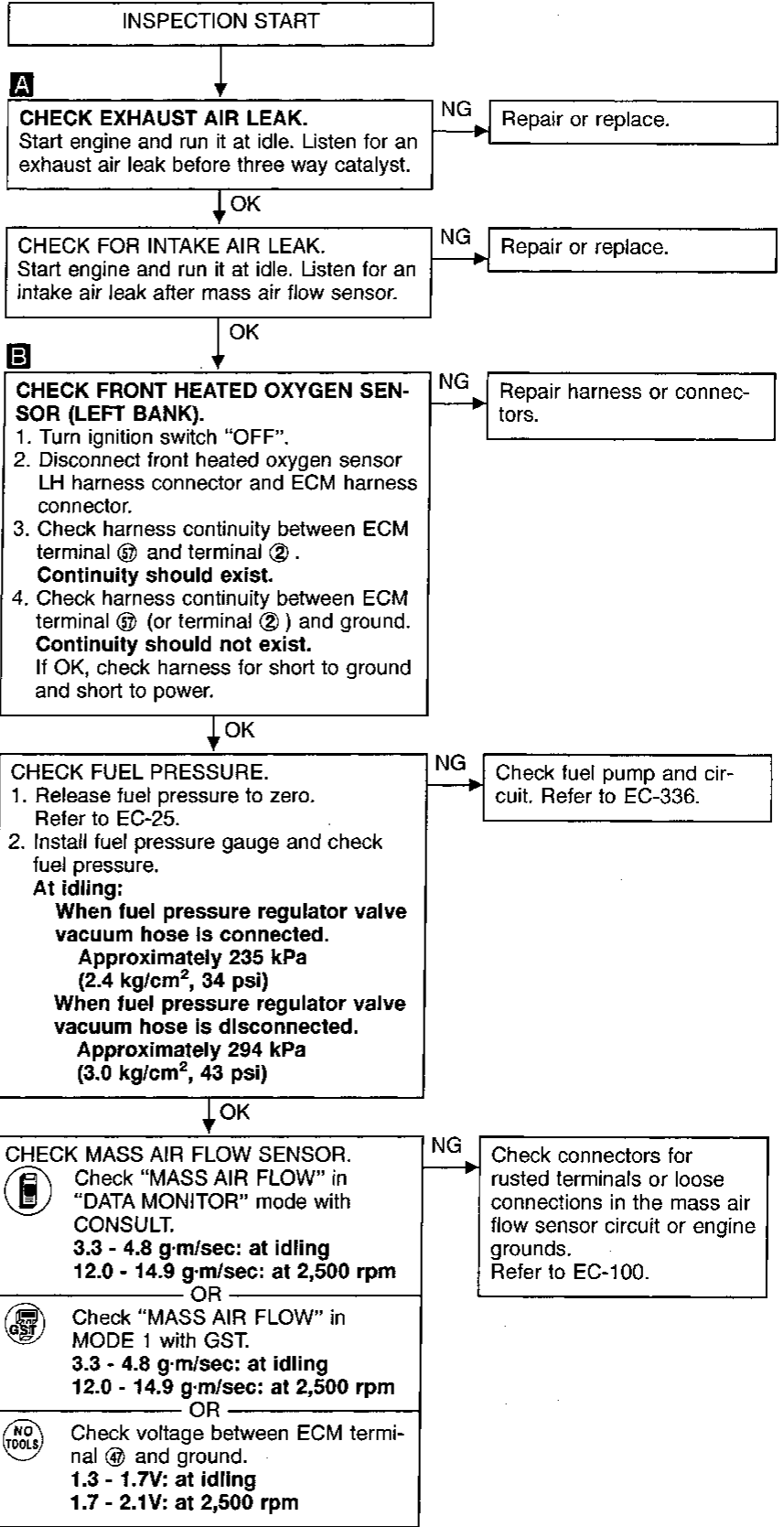
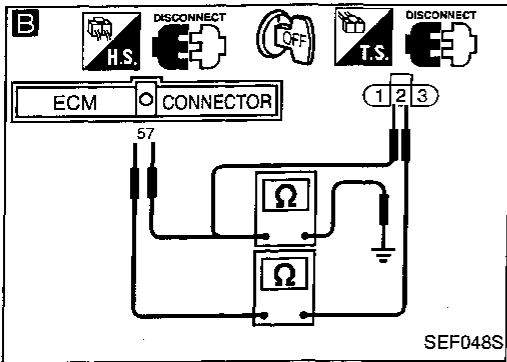
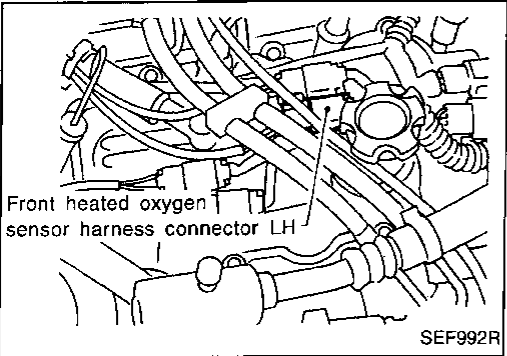
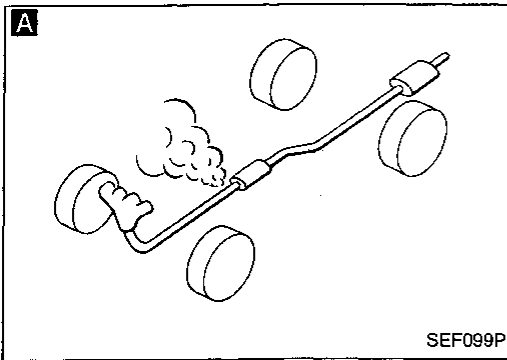

GI
MA
EM
LC
EC
FE
AT
TF
PD
FA
RA
BR
ST
RS
BT
HA
EL
IDX

TROUBLE DIAGNOSIS FOR DTC P0174

Fuel Injection System Function (Left bank) (Lean side) (Cont'd)

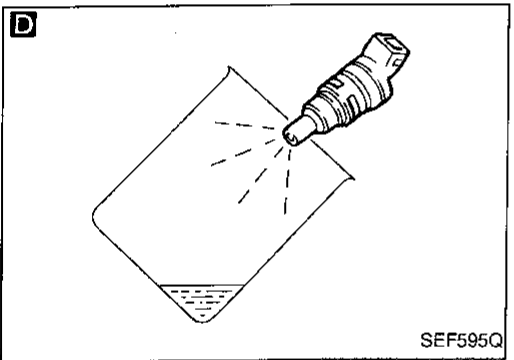
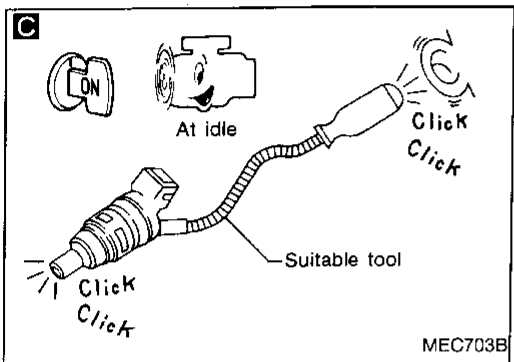
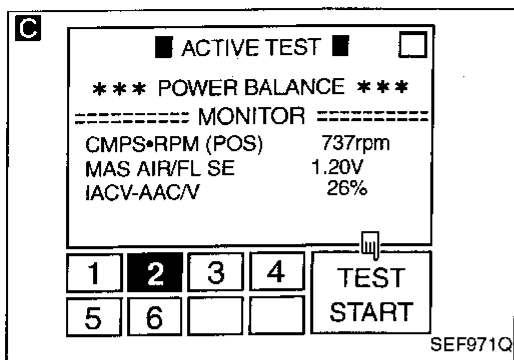

C

CHECK FUNCTION OF INJECTORS (LEFT BANK).

1. Install all parts removed.
2. Start engine.
3. Perform "POWER BALANCE" in "ACTIVE TEST" mode with CONSULT.
4. Make sure that each circuit produces a momentary engine speed drop.

OR

3. Listen to each injector operating sound. **Clicking noise should be heard.**

NG → Perform TROUBLE DIAGNOSIS FOR NON-DETECTABLE ITEMS, "Injectors", EC-329. Repair harness or connectors.

OK → Confirm that the engine is cooled down and there are no fire hazards near the vehicle.

1. Turn ignition switch "OFF".
2. Disconnect injector harness connectors on right bank.
3. Remove injector gallery on left bank. Refer to EC-26. Keep fuel hose and all injectors connected to injector gallery. The injector harness connectors on left bank should remain connected.

D

1. Disconnect all ignition coil harness connectors.
2. Crank engine for about 3 seconds. Make sure that fuel sprays out from injector.

NG → Replace injectors from which fuel does not spray out.

OK → Check ECM pin terminals for damage and check the connection of ECM harness connector. Reconnect ECM harness connector and retest.

INSPECTION END

Fuel Injection System Function (Left bank)
(Rich side)

ON BOARD DIAGNOSIS LOGIC

With the Air/Fuel Mixture Ratio Self-Learning Control, the actual mixture ratio can be brought closely to the theoretical mixture ratio based on the mixture ratio feedback signal from the front heated oxygen sensors. The ECM calculates the necessary compensation to correct the offset between the actual and the theoretical ratios. In case the amount of the compensation value is extremely large (The actual mixture ratio is too rich.), the ECM judges the condition as the fuel injection system malfunction and light up the MIL (2 trip detection logic).

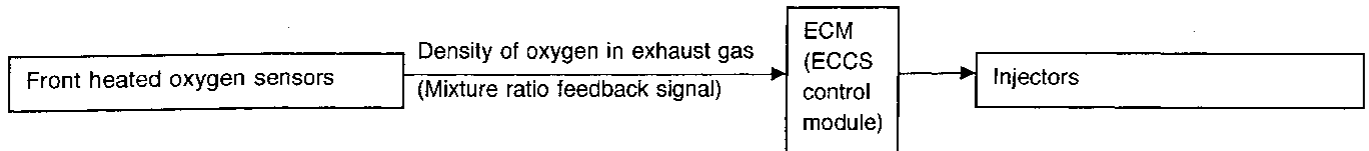

Diagnostic Trouble Code No.	Malfunction is detected when ...	Check Items (Possible Cause)
P0175 0209	<ul style="list-style-type: none"> Fuel injection system does not operate properly. The amount of mixture ratio compensation is too large. (The mixture ratio is too rich.) 	<ul style="list-style-type: none"> Front heated oxygen sensor (Left bank) Injectors (Left bank) Exhaust gas leaks Incorrect fuel pressure Mass air flow sensor

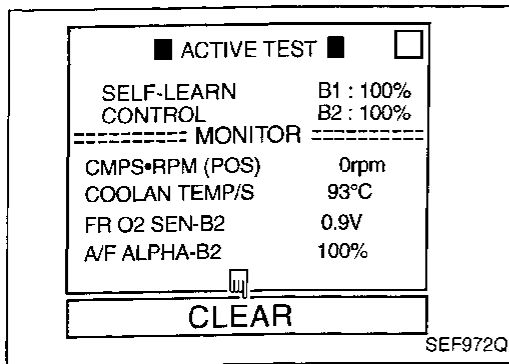

DIAGNOSTIC TROUBLE CODE CONFIRMATION PROCEDURE (Overall)

- Start engine and warm it up sufficiently.
- Turn ignition switch "OFF" and wait at least 5 seconds.
- Turn ignition switch "ON" and select "SELF-LEARN CONTROL" in "ACTIVE TEST" mode with CONSULT.
- Clear the self-learning control coefficient by touching "CLEAR".
- Select "DATA MONITOR" mode with CONSULT.
- Start engine again and run it for at least 10 minutes at idle speed.
The 1st trip DTC P0175 should be detected at this stage, if a malfunction exists.
- If it is difficult to start engine at step 6, the fuel injection system has a malfunction, too.
- Crank engine while depressing accelerator pedal.
If engine starts, go to "DIAGNOSTIC PROCEDURE", EC-183. If engine does not start, remove ignition plugs and check for fouling, etc.

OR

TROUBLE DIAGNOSIS FOR DTC P0175

Fuel Injection System Function (Left bank) (Rich side) (Cont'd)

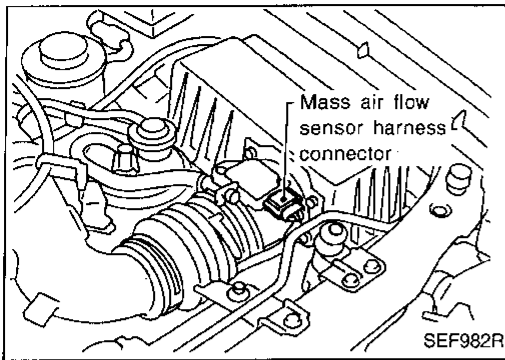

- 1) Start engine and warm it up sufficiently.
- 2) Turn ignition switch "OFF" and wait at least 5 seconds.
- 3) Disconnect mass air flow sensor harness connector. Then restart and run engine for at least 3 seconds at idle speed.
- 4) Stop engine and reconnect mass air flow sensor harness connector.
- 5) Select "MODE 7" with GST. Make sure 1st trip DTC P0100 is detected.
- 6) Select "MODE 4" with GST and erase the 1st trip DTC P0100.
- 7) Start engine again and run it for at least 10 minutes at idle speed.
- 8) Select "MODE 7" with GST. The 1st trip DTC P0171 should be detected at this stage, if a malfunction exists.
- 9) If it is difficult to start engine at step 8, the fuel injection system has a malfunction.
- 10) Crank engine while depressing accelerator pedal. If engine starts, go to "DIAGNOSTIC PROCEDURE". If engine does not start, check exhaust and intake air leak visually.

OR



- 1) Disconnect mass air flow sensor harness connector.
- 2) Start engine and run it for at least 3 seconds at idle speed.
- 3) Stop engine and reconnect mass air flow sensor harness connector.
- 4) Turn ignition switch "ON".
- 5) Perform Diagnostic Test Mode II (Self-diagnostic results) with ECM. Make sure 1st trip DTC 0102 is detected.
- 6) Erase the 1st trip DTC 0102 by changing from Diagnostic Test Mode II to Diagnostic Test Mode I.
- 7) Perform Diagnostic Test Mode II (Self-diagnostic results) with ECM. Make sure DTC 0505 is detected.
- 8) Start engine again and run it for at least 10 minutes at idle speed.
The 1st trip DTC 0209 should be detected at this stage, if a malfunction exists.
- 9) If it is difficult to start engine at step 8, the fuel injection system also has a malfunction.
- 10) Crank engine while depressing accelerator pedal. If engine starts, go to "DIAGNOSTIC PROCEDURE", EC-183. If engine does not start, remove ignition plugs and check for fouling, etc.

TROUBLE DIAGNOSIS FOR DTC P0175

Fuel Injection System Function (Left bank) (Rich side) (Cont'd)

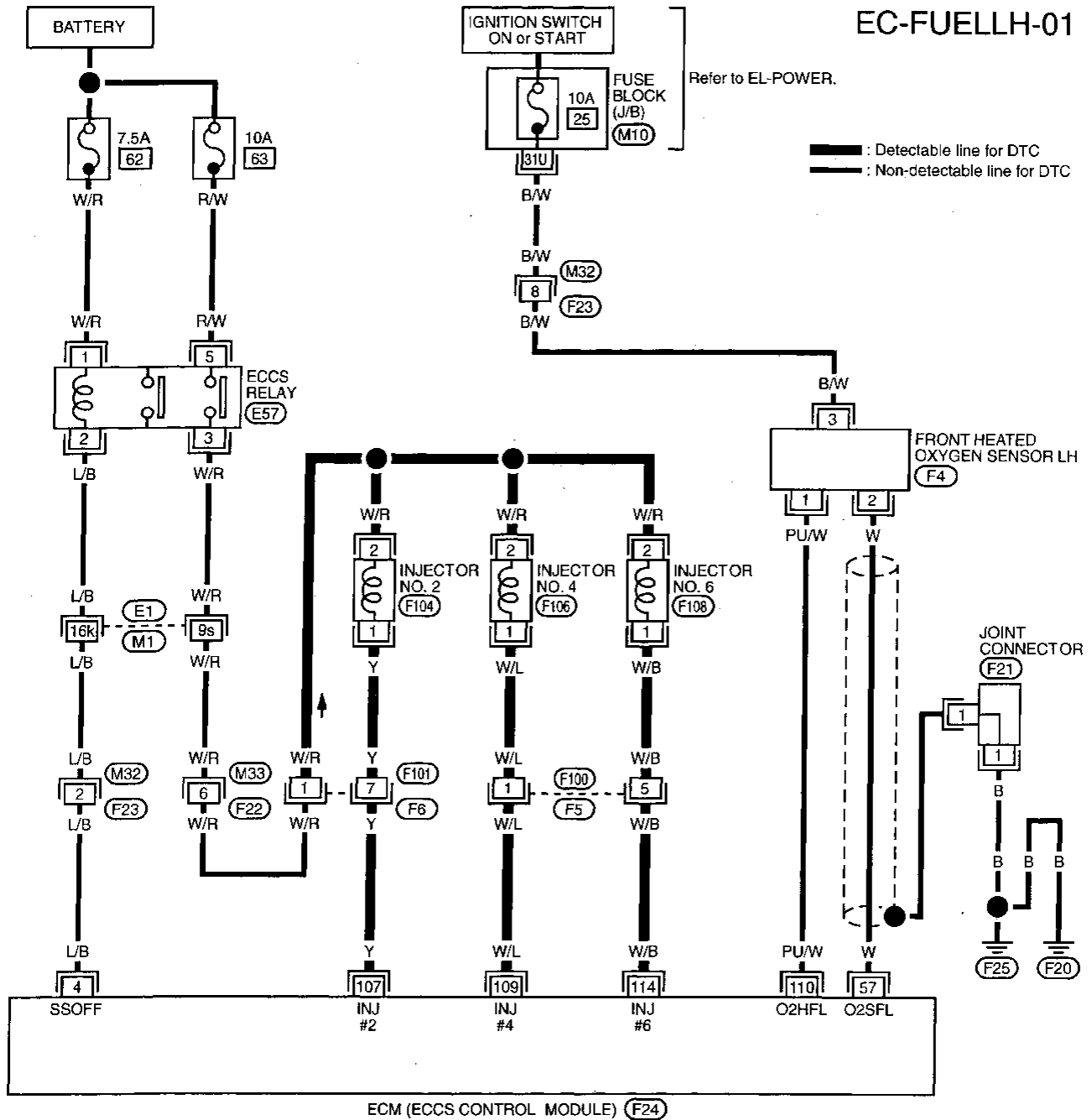

GI
 MA
 EM
 LC
EC
 FE
 AT
 TF
 PD
 FA
 RA
 BR
 ST
 RS
 BT
 HA
 EL
 IDX

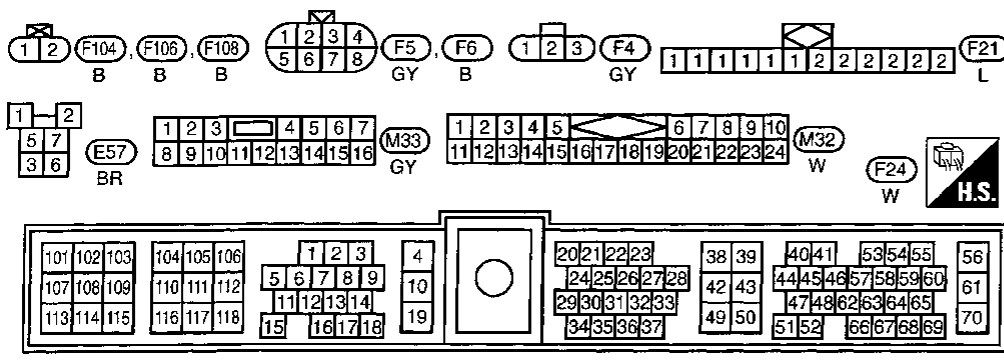

TROUBLE DIAGNOSIS FOR DTC P0175

Fuel Injection System Function (Left bank) (Rich side) (Cont'd)

DIAGNOSTIC PROCEDURE

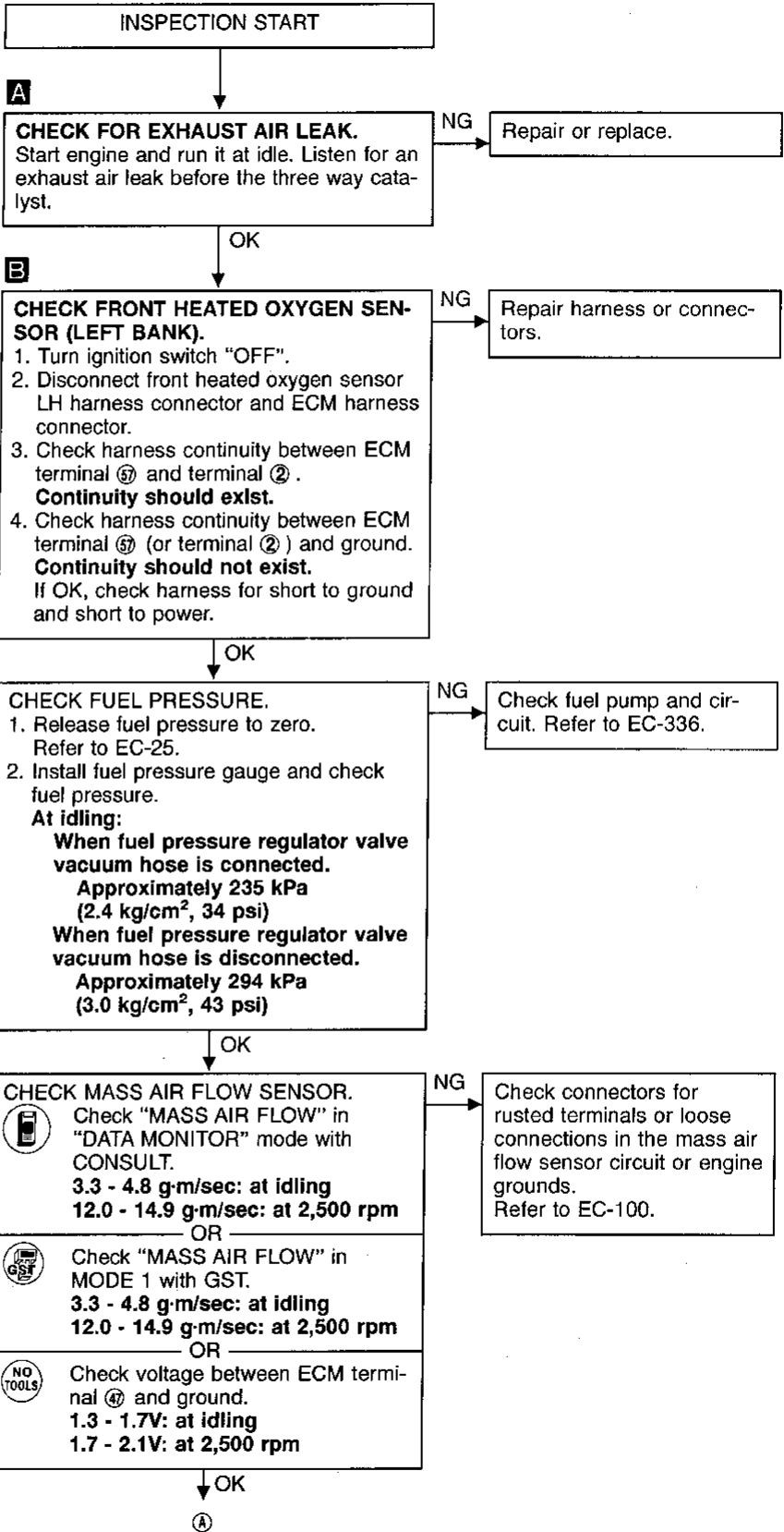
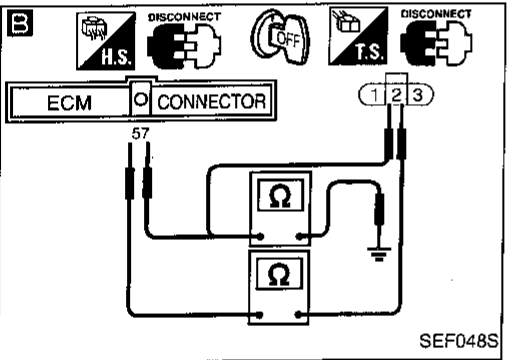
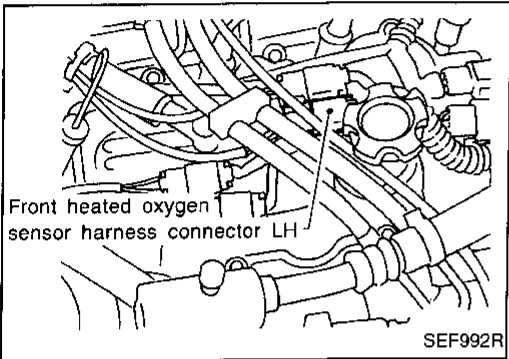
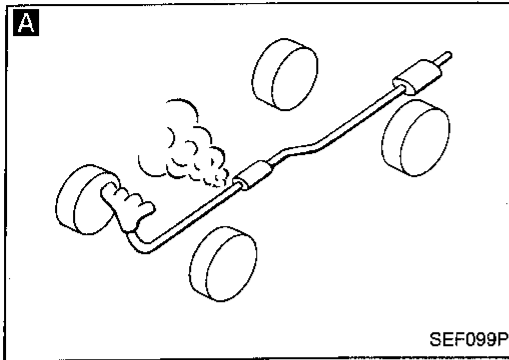

TROUBLE DIAGNOSIS FOR DTC P0175

Fuel Injection System Function (Left bank) (Rich side) (Cont'd)

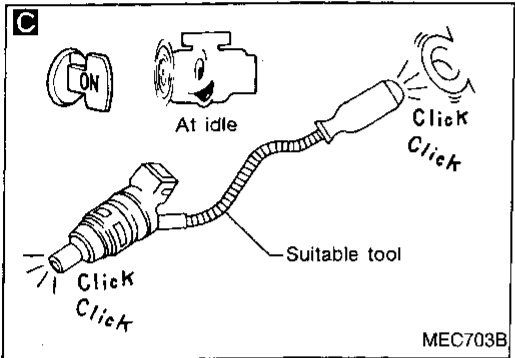
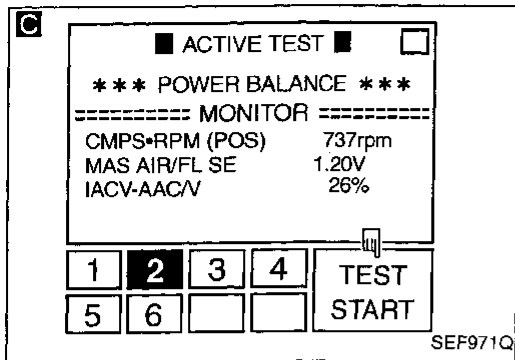

C

CHECK FUNCTION OF INJECTORS (LEFT BANK).

1. Install all parts removed.
2. Start engine.
3. Perform "POWER BALANCE" in "ACTIVE TEST" mode with CONSULT.
4. Make sure that each circuit produces a momentary engine speed drop.

OR

3. Listen to each injector operating sound. **Clicking noise should be heard.**

NG → Perform TROUBLE DIAGNOSIS FOR NON-DETECTABLE ITEMS, "Injectors", EC-329. Repair harness or connectors.

OK → Remove injector assembly. Refer to EC-26. Keep fuel hose and all injectors connected to injector gallery.

Confirm that the engine is cooled down and there are no fire hazards near the vehicle.

1. Disconnect all injector harness connectors.
2. Disconnect all ignition coil harness connectors.
3. Crank engine for about 3 seconds. Make sure fuel does not drip from injector.

Drips → Replace the injectors from which fuel is dripping.

Does not drip. → Check ECM pin terminals for damage and check the connection of ECM harness connector. Reconnect ECM harness connector and retest.

INSPECTION END

GI
MA
EM
LC
EC
FE
AT
TF
PD
FA
RA
BR
ST
RS
BT
HA
EL
IDX

TROUBLE DIAGNOSIS FOR DTC P0180

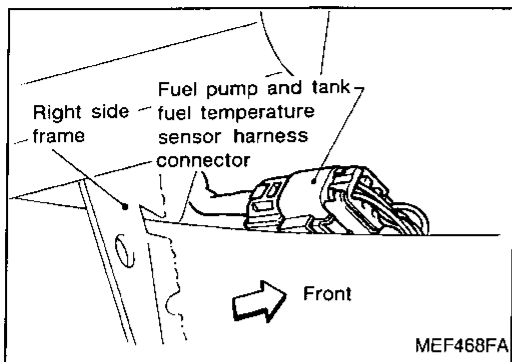

Tank Fuel Temperature Sensor

COMPONENT DESCRIPTION

The tank fuel temperature sensor is used to detect the fuel temperature inside the fuel tank. The sensor modifies a voltage signal from the ECM. The modified signal returns to the ECM as the fuel temperature input. The sensor uses a thermistor which is sensitive to the change in temperature. The electrical resistance of the thermistor decreases as temperature increases.

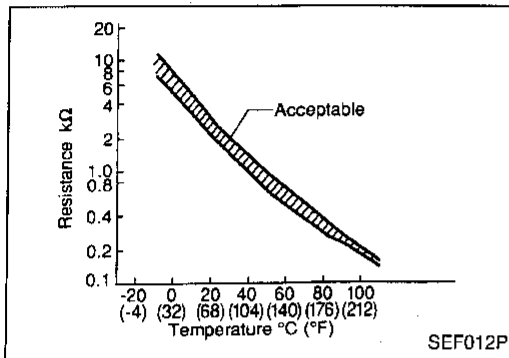

<Reference data>

Fluid temperature °C (°F)	Voltage* (V)	Resistance (kΩ)
20 (68)	3.5	2.3 - 2.7
50 (122)	2.2	0.79 - 0.90

*: These data are reference values and are measured between ECM terminal ⑬ (Tank fuel temperature sensor) and ECM terminal ⑭ (ECCS ground).

ON BOARD DIAGNOSIS LOGIC

Diagnostic Trouble Code No.	Malfunction is detected when ...	Check Items (Possible Causes)
P0180 0402	<ul style="list-style-type: none"> An excessively high or low voltage is sent to ECM. Rationally incorrect voltage is sent to ECM, compared with the voltage signals from engine coolant temperature sensor and intake air temperature sensor. 	<ul style="list-style-type: none"> Harness or connectors (The sensor circuit is open or shorted.) Tank fuel temperature sensor

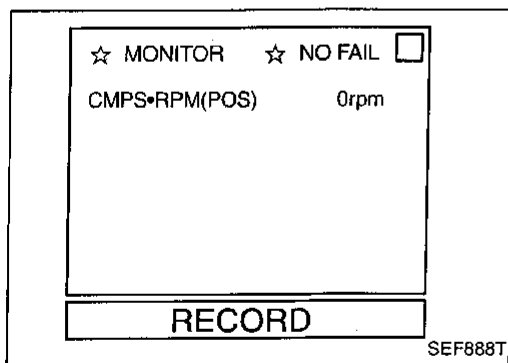

DIAGNOSTIC TROUBLE CODE CONFIRMATION PROCEDURE

- Turn ignition switch "ON".
 - Select "DATA MONITOR" mode with CONSULT.
 - Wait at least 12 seconds.
- OR
- Turn ignition switch "ON" and wait at least 12 seconds.
 - Select "MODE 7" with GST.
- OR
- Turn ignition switch "ON" and wait at least 12 seconds.
 - Turn ignition switch "OFF", wait at least 5 seconds and then turn "ON".
 - Perform "Diagnostic Test Mode II (Self-diagnostic results)" with ECM.

TROUBLE DIAGNOSIS FOR DTC P0180

Tank Fuel Temperature Sensor (Cont'd)

EC-TFTS-01

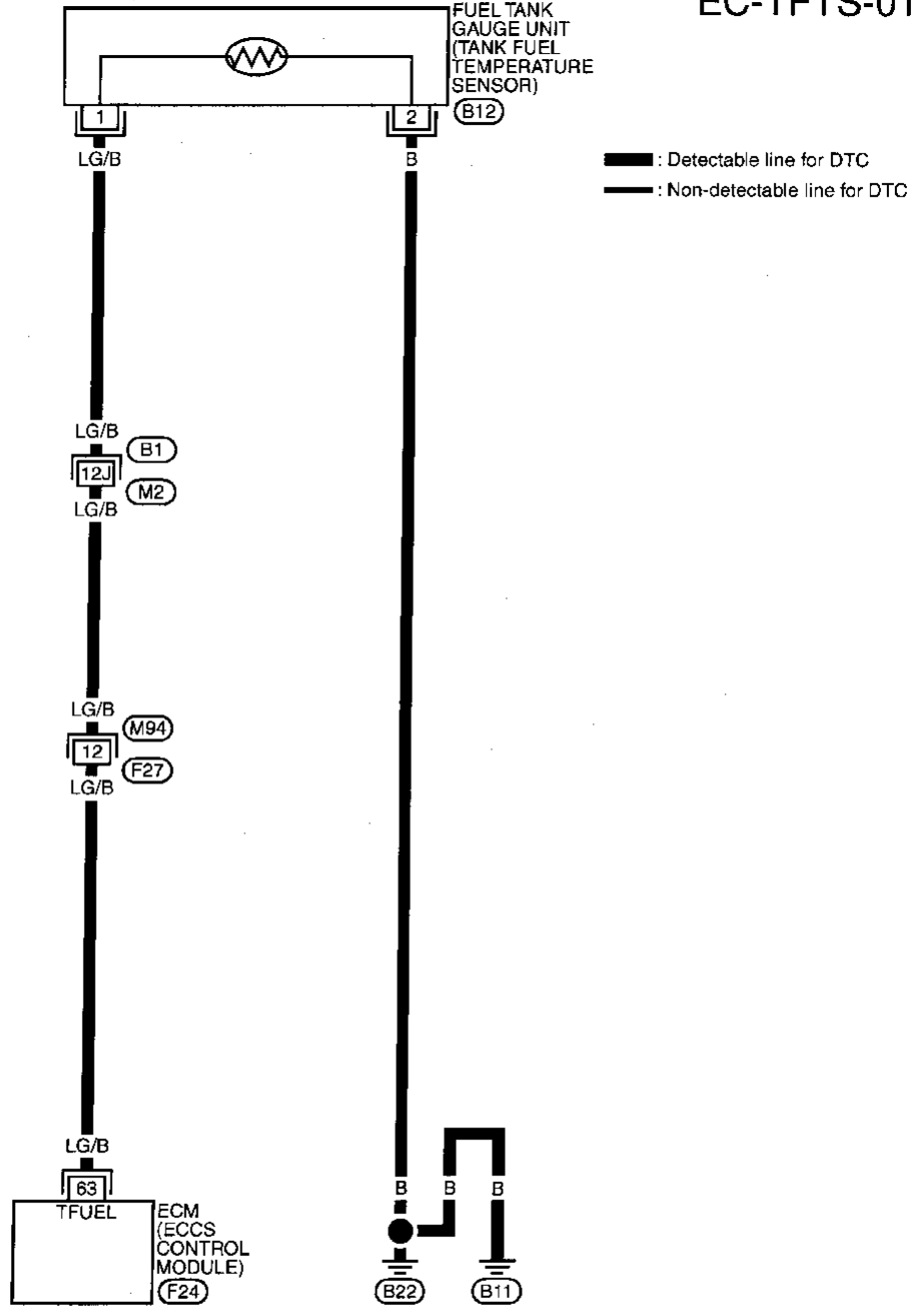

GI

MA

EM

LC

EC

FE

AT

TF

PD

FA

RA

BR

ST

RS

BT

HA

EL

IDX

Refer to last page (Foldout page).

(B1) (M2)

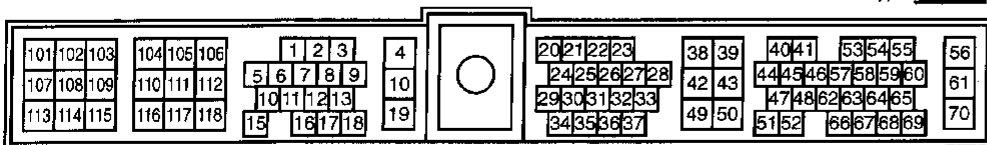
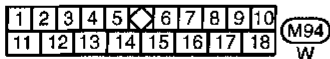
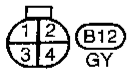

TROUBLE DIAGNOSIS FOR DTC P0180

Tank Fuel Temperature Sensor (Cont'd) DIAGNOSTIC PROCEDURE

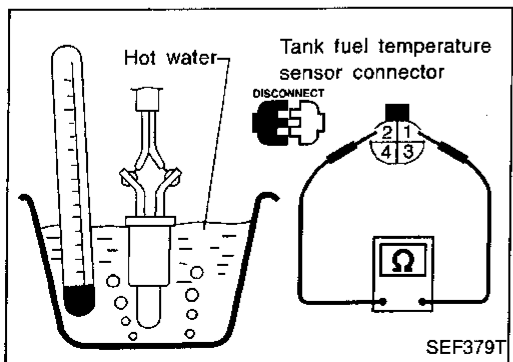
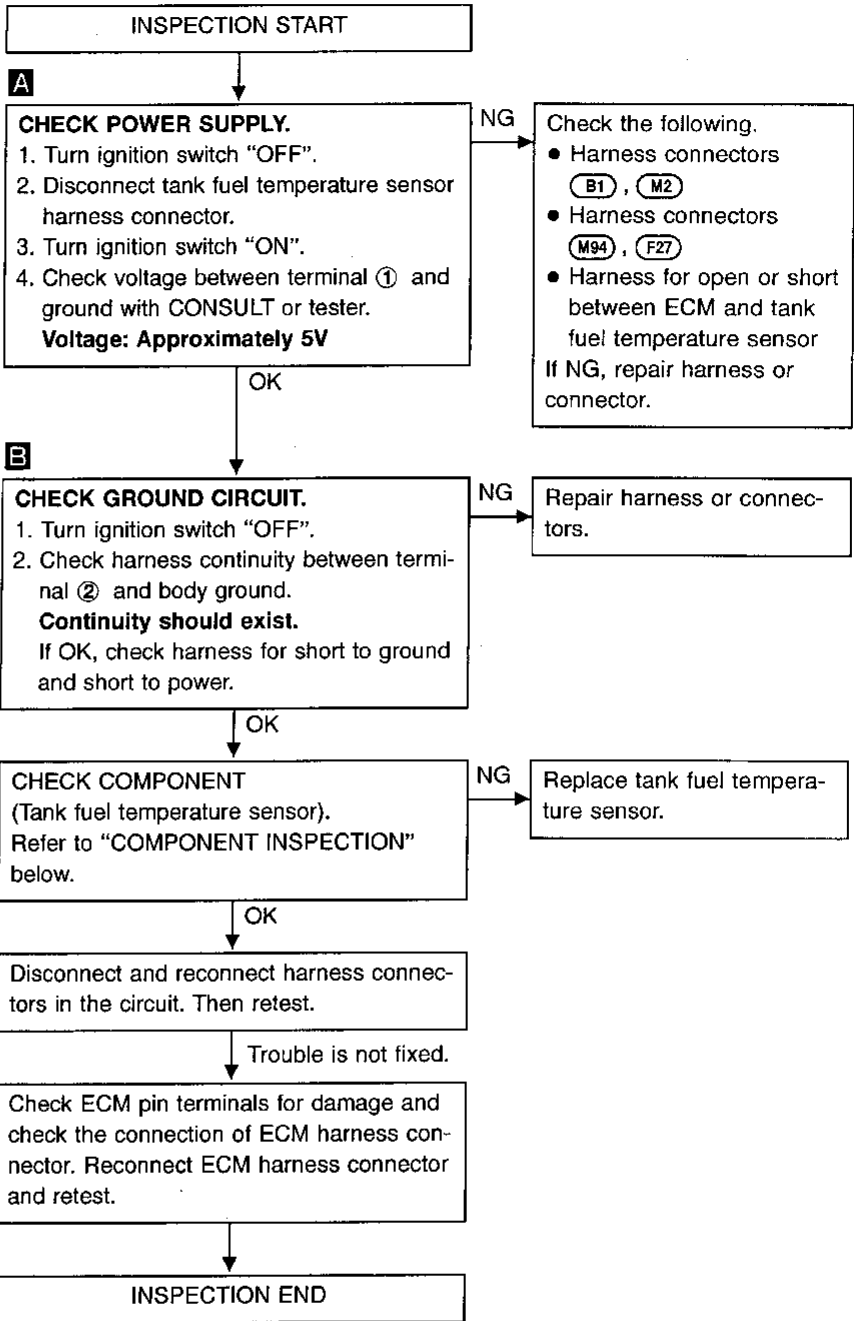
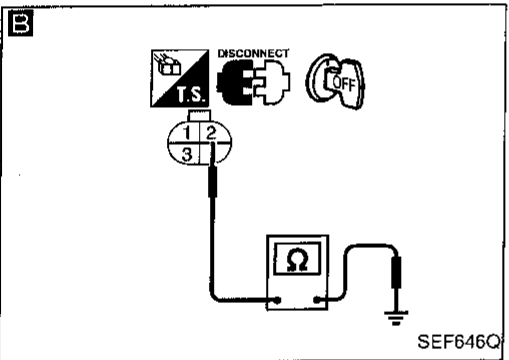
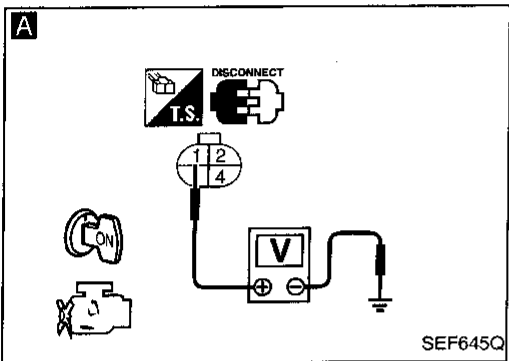
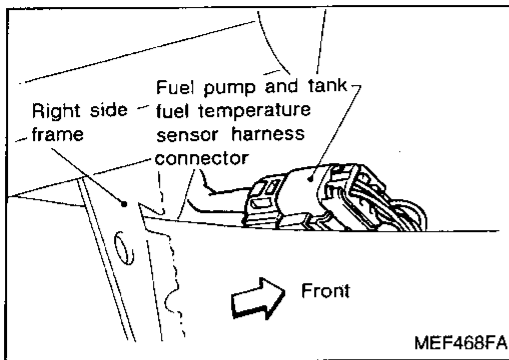

COMPONENT INSPECTION

Tank fuel temperature sensor

Check resistance by heating with hot water or heat gun as shown in the figure.

Temperature °C (°F)	Resistance kΩ
20 (68)	2.3 - 2.7
50 (122)	0.79 - 0.90

If NG, replace tank fuel temperature sensor.

No. 6 - 1 Cylinder Misfire, Multiple Cylinder Misfire

ON BOARD DIAGNOSIS LOGIC

If a misfire occurs, the engine speed will fluctuate. If the fluctuation is detected by the crankshaft position sensor (OBD), the misfire is diagnosed.

The misfire detection logic consists of the following two conditions.

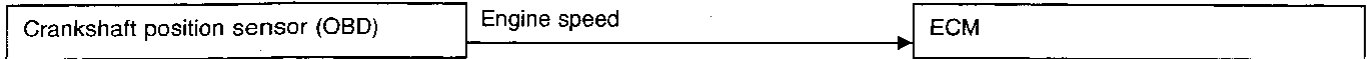

1. One Trip Detection Logic (Three Way Catalyst Damage)

When a misfire is detected which will overheat and damage the three way catalyst, the malfunction indicator lamp (MIL) will start blinking; even during the first trip. In this condition, ECM monitors the misfire every 200 revolutions.

If the misfire frequency decreases to a level that will not damage the three way catalyst, the MIL will change from blinking to lighting up.

(After the first trip detection, the MIL will light up from engine starting. If a misfire is detected that will cause three way catalyst damage, the MIL will start blinking.)

2. Two Trip Detection Logic (Exhaust quality deterioration)

When a misfire that will not damage the three way catalyst (but will affect exhaust emission) occurs, the malfunction indicator lamp will light up based on two trip detection logic. In this condition, ECM monitors the misfire for every 1,000 revolutions of the engine.

Diagnostic Trouble Code No.	Malfunction is detected when ...	Check Items (Possible Cause)
P0300 (0701)	<ul style="list-style-type: none"> Multiple cylinders misfire. 	<ul style="list-style-type: none"> Improper spark plug
P0301 (0608)	<ul style="list-style-type: none"> No. 1 cylinder misfires. 	<ul style="list-style-type: none"> Insufficient compression
P0302 (0607)	<ul style="list-style-type: none"> No. 2 cylinder misfires. 	<ul style="list-style-type: none"> Incorrect fuel pressure
P0303 (0606)	<ul style="list-style-type: none"> No. 3 cylinder misfires. 	<ul style="list-style-type: none"> EGR valve
P0304 (0605)	<ul style="list-style-type: none"> No. 4 cylinder misfires. 	<ul style="list-style-type: none"> The injector circuit is open or shorted
P0305 (0604)	<ul style="list-style-type: none"> No. 5 cylinder misfires. 	<ul style="list-style-type: none"> Injectors
P0306 (0603)	<ul style="list-style-type: none"> No. 6 cylinder misfires. 	<ul style="list-style-type: none"> Intake air leak The ignition secondary circuit is open or shorted Lack of fuel Drive plate

DIAGNOSTIC TROUBLE CODE CONFIRMATION PROCEDURE (Overall)

- 1) Turn ignition switch "ON", and select "DATA MONITOR" mode with CONSULT.
 - 2) Start engine and warm it up sufficiently.
 - 3) Turn ignition switch "OFF" and wait at least 5 seconds.
 - 4) Start engine again and drive at 1,500 - 3,000 rpm for at least 3 minutes. Hold the accelerator pedal as steady as possible.
- Note: Refer to the freeze frame data for the test driving conditions.**

OR

- 1) Start engine and warm it up sufficiently.
 - 2) Turn ignition switch "OFF" and wait at least 5 seconds.
 - 3) Start engine again and drive at 1,500 - 3,000 rpm for at least 3 minutes. Hold the accelerator pedal as steady as possible.
 - 4) Select "MODE 7" with GST.
- Note: Refer to the freeze frame data for the test driving conditions.**

OR

- 1) Start engine and warm it up sufficiently.
- 2) Turn ignition switch "OFF" and wait at least 5 seconds.
- 3) Start engine again and drive at 1,500 - 3,000 rpm for at least 3 minutes. Hold the accelerator pedal as steady as possible.
- 4) Perform "Diagnostic Test Mode II (Self-diagnostic results)" with ECM.

No. 6 - 1 Cylinder Misfire, Multiple Cylinder Misfire (Cont'd)

DIAGNOSTIC PROCEDURE

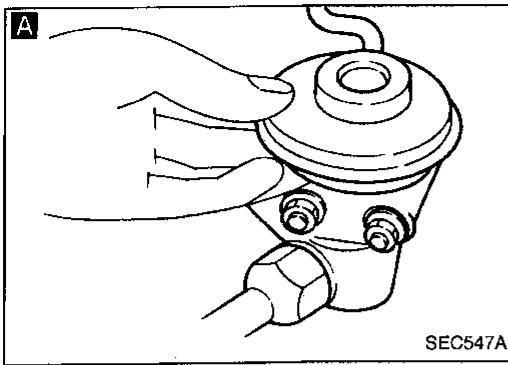

INSPECTION START

CHECK FOR INTAKE AIR LEAK.
Start engine and run it at idle speed. Listen for the sound of the intake air leak.

NG → Discover air leak location and repair.

OK

CHECK FOR EXHAUST SYSTEM CLOGGING.
Stop engine and visually check exhaust tube, three way catalyst and muffler for dents.

NG → Repair or replace it.

OK

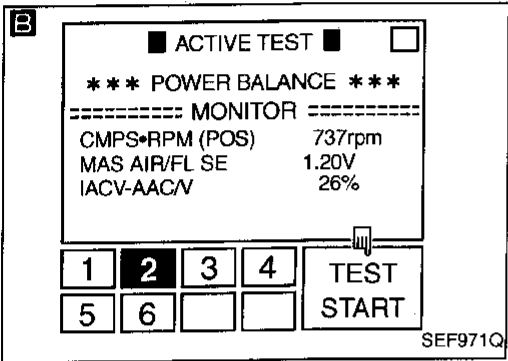

CHECK EGR FUNCTION.
Perform OVERALL FUNCTION CHECK (Procedure for malfunction B) for EGR Function. Refer to EC-211.

NG → Repair EGR system.

OK

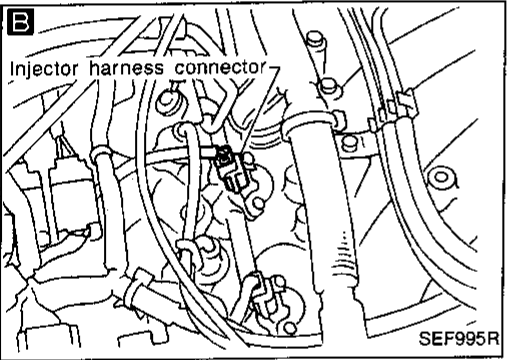

PERFORM POWER BALANCE TEST.

1. Perform "POWER BALANCE" in "ACTIVE TEST" mode.
2. Is there any cylinder which does not produce a momentary engine speed drop?

OR

When disconnecting each injector harness connector one at a time, is there any cylinder which does not produce a momentary engine speed drop?

No → Go to E on next page.

Yes

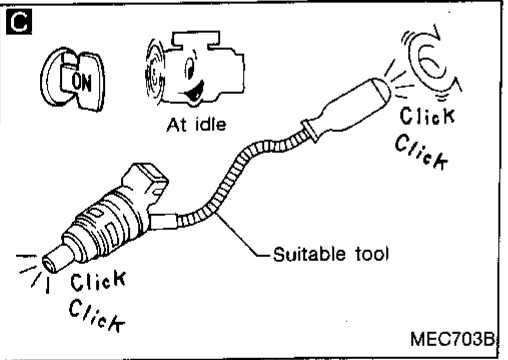

CHECK INJECTOR.
Does each injector make an operating sound at idle?

No → Check injector(s) and circuit(s). Refer to EC-329.

Yes

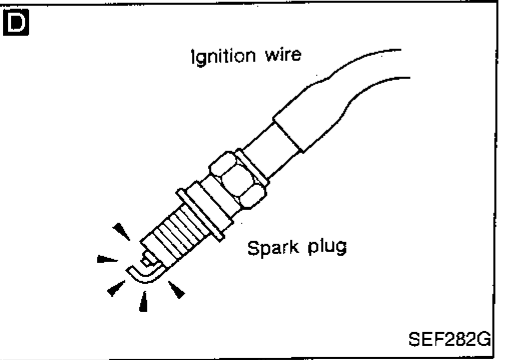

CHECK IGNITION SPARK.

1. Disconnect ignition wire from spark plug.
2. Connect a known good spark plug to the ignition wire.
3. Place end of spark plug against a suitable ground and crank engine.
4. Check for spark.

NG → **CHECK COMPONENT (Ignition wires).** Refer to "COMPONENT INSPECTION", EC-196.

OK →
NG → Replace.

OK

Check ignition coil, power transistor and their circuits. Refer to EC-283.

(Go to A on next page.)

TROUBLE DIAGNOSIS FOR DTC P0300 - P0306

No. 6 - 1 Cylinder Misfire, Multiple Cylinder Misfire (Cont'd)

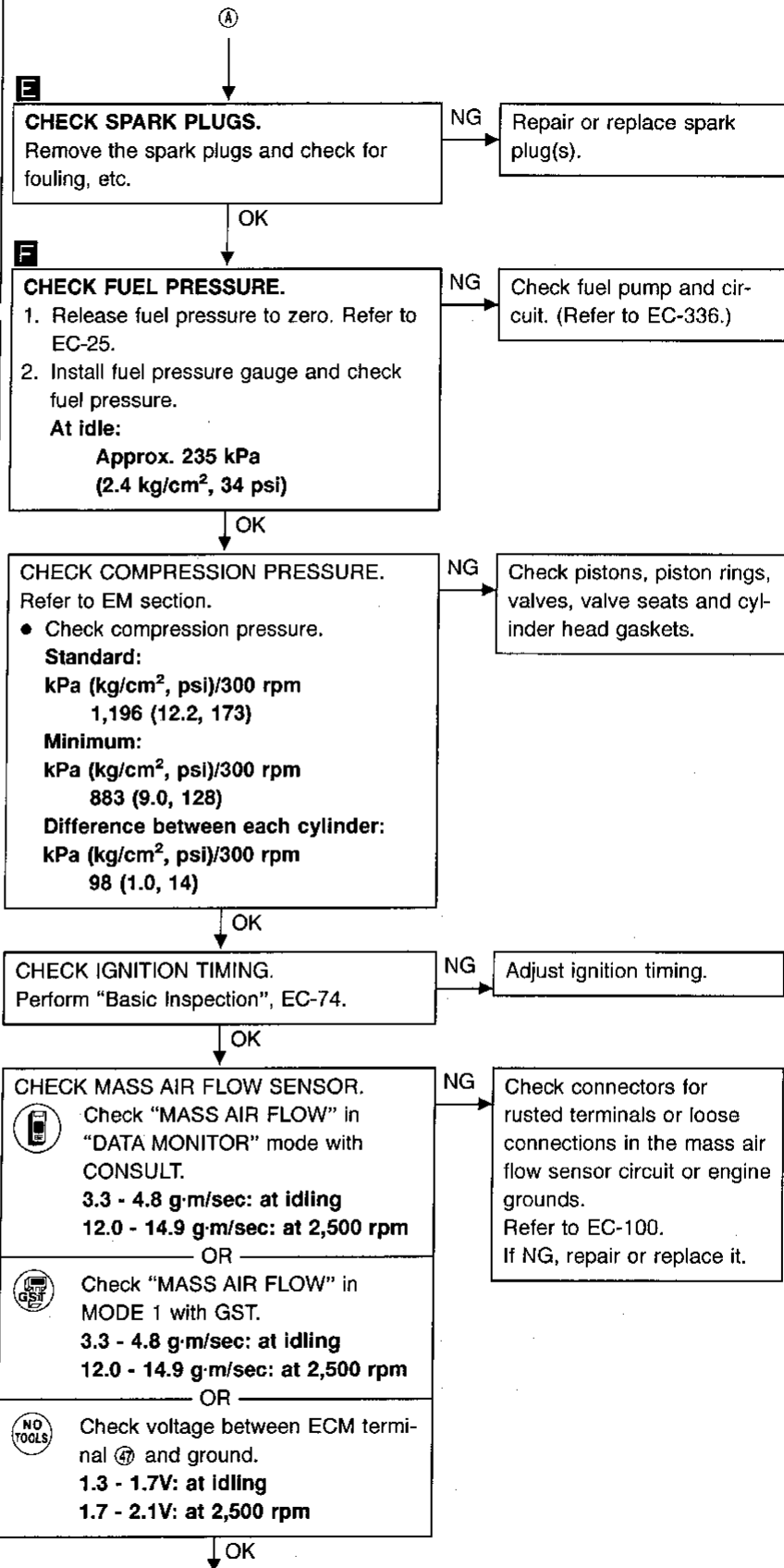
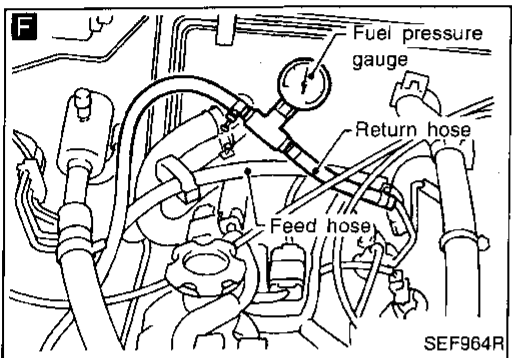
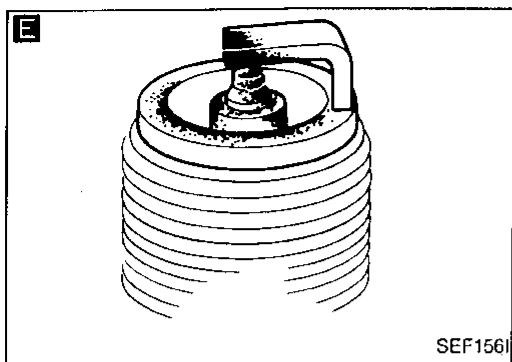

(Go to Ⓑ on next page.)

GI
 MA
 EM
 LC
 EC
 FE
 AT
 TF
 PD
 FA
 RA
 BR
 ST
 RS
 BT
 HA
 EL
 IDX

TROUBLE DIAGNOSIS FOR DTC P0300 - P0306

No. 6 - 1 Cylinder Misfire, Multiple Cylinder Misfire (Cont'd)

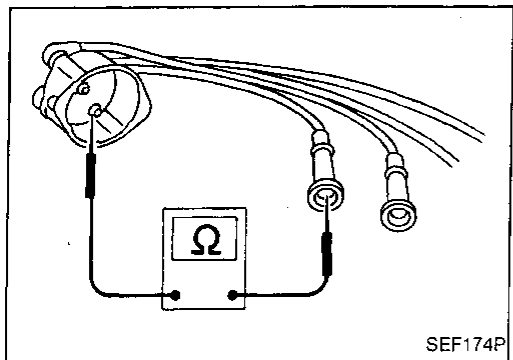
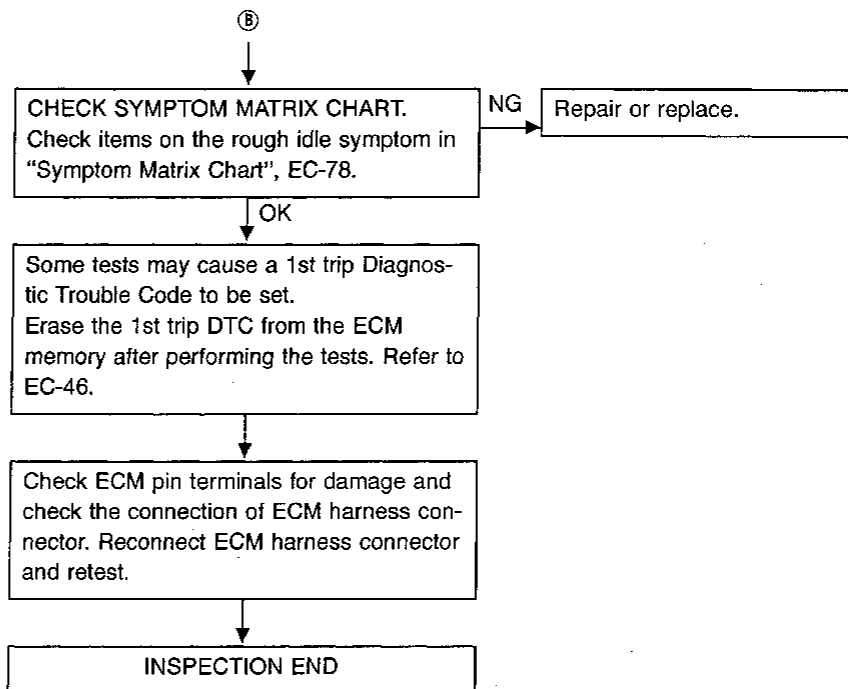

COMPONENT INSPECTION

Ignition wires

1. Inspect wires for cracks, damage, burned terminals and for improper fit.
2. Measure the resistance of wires to their distributor cap terminal. Move each wire while testing to check for intermittent breaks.

Resistance:

Cylinder No.	Resistance kΩ [at 25°C (77°F)]
1	Approximately 6.5
2	Approximately 10.0
3	Approximately 8.5
4	Approximately 12.5
5	Approximately 8.5
6	Approximately 11.0

If the resistance exceeds the above specification, inspect ignition wire to distributor cap connection. Clean connection or replace the ignition wire with a new one.

TROUBLE DIAGNOSIS FOR DTC P0325

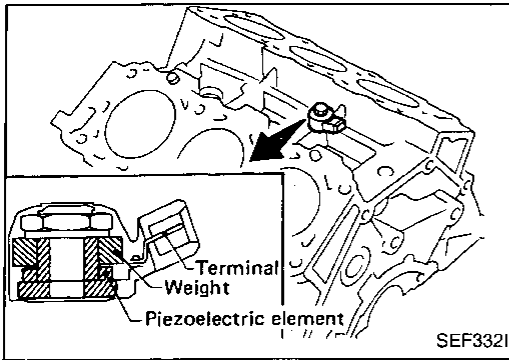

Knock Sensor (KS)

COMPONENT DESCRIPTION

The knock sensor is attached to the cylinder block. It senses engine knocking using a piezoelectric element. A knocking vibration from the cylinder block is sensed as vibrational pressure. This pressure is converted into a voltage signal and sent to the ECM.

GI
MA
EM
LC

* Freeze frame data will not be stored in the ECM for the knock sensor. The MIL will not light for knock sensor malfunction. The knock sensor has one trip detection logic.

ECM TERMINALS AND REFERENCE VALUE

Specification data are reference values and are measured between each terminal and Ⓞ (ECCS ground).

TER-MINAL NO.	WIRE COLOR	ITEM	CONDITION	DATA (DC Voltage)
54	W	Knock sensor	Engine is running. └ Idle speed	Approximately 2.5V

EC
FE

ON BOARD DIAGNOSIS LOGIC

Diagnostic Trouble Code No.	Malfunction is detected when	Check Items (Possible Cause)
P0325 0304	<ul style="list-style-type: none"> An excessively low or high voltage from the knock sensor is sent to ECM. 	<ul style="list-style-type: none"> Harness or connectors (The knock sensor circuit is open or shorted.) Knock sensor

AT
TF
PD

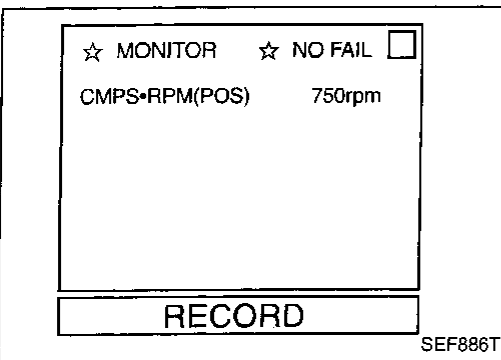

DIAGNOSTIC TROUBLE CODE CONFIRMATION PROCEDURE

Note: Before performing the following procedure, confirm that battery voltage is more than 10V.

- ① 1) Turn ignition switch "ON" and select "DATA MONITOR" mode with CONSULT.
2) Start engine and run it for at least 5 seconds at idle speed.

OR

- ② 1) Start engine and run it for at least 5 seconds at idle speed.
2) Select "MODE 3" with GST.

OR

- ③ 1) Start engine and run it for at least 5 seconds at idle speed.
2) Turn ignition switch "OFF", wait at least 5 seconds and then turn "ON".
3) Perform "Diagnostic Test Mode II" (Self-diagnostic results) with ECM.

FA
RA
BR

ST
RS
BT
HA
EL

IDX

TROUBLE DIAGNOSIS FOR DTC P0325

Knock Sensor (KS) (Cont'd)

EC-KS-01

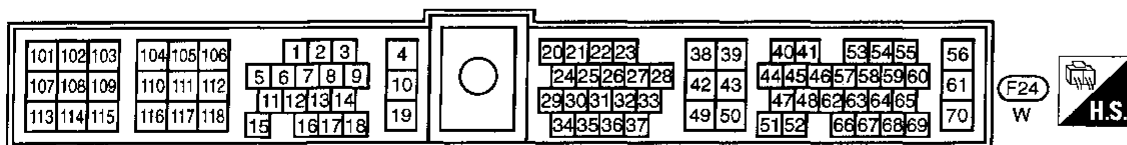
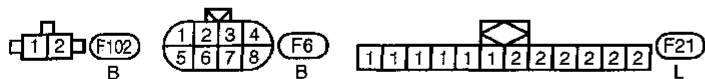
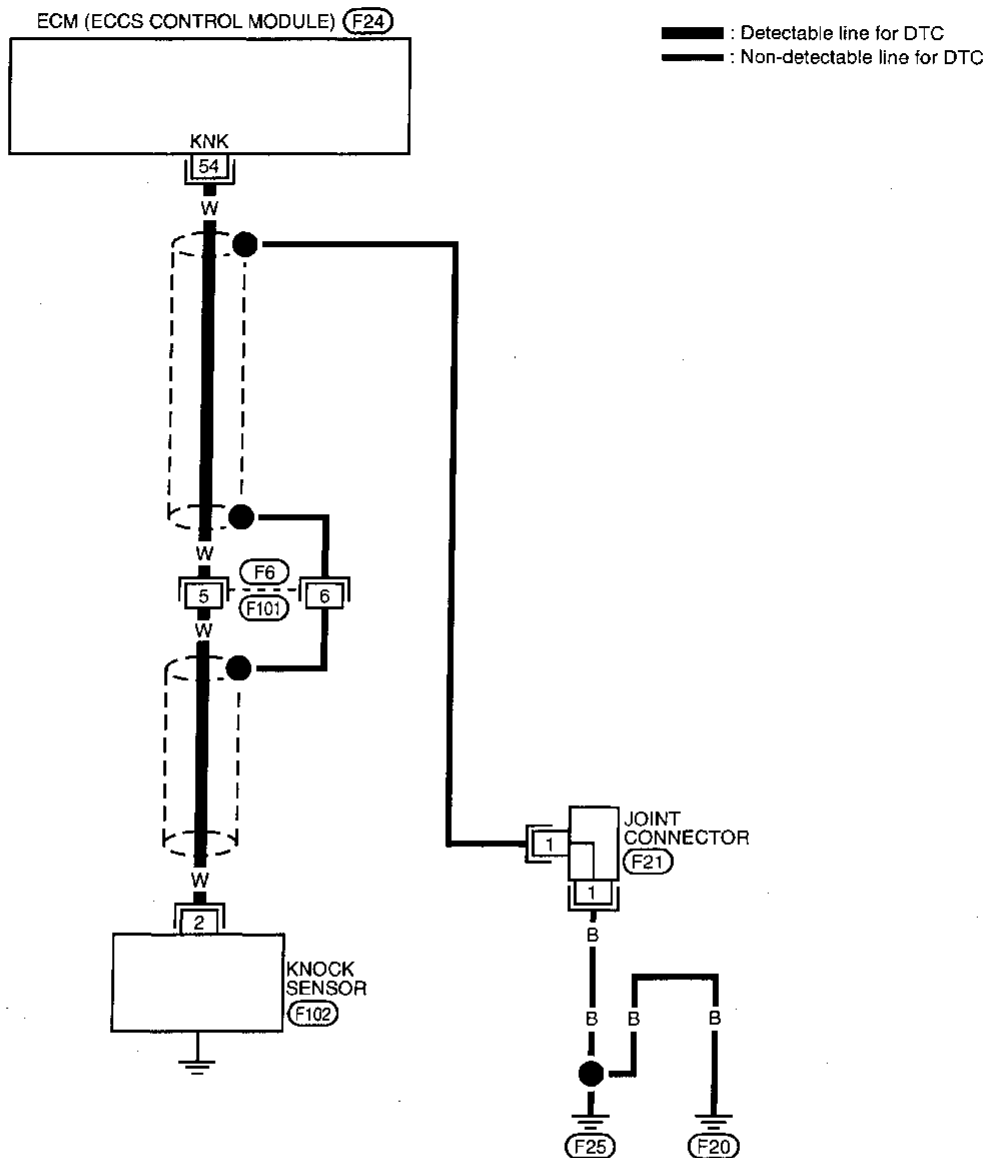

TROUBLE DIAGNOSIS FOR DTC P0325

Knock Sensor (KS) (Cont'd)

DIAGNOSTIC PROCEDURE

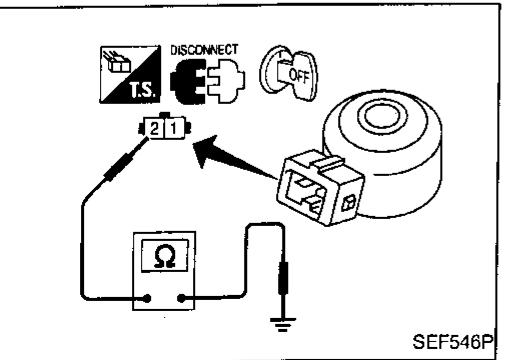
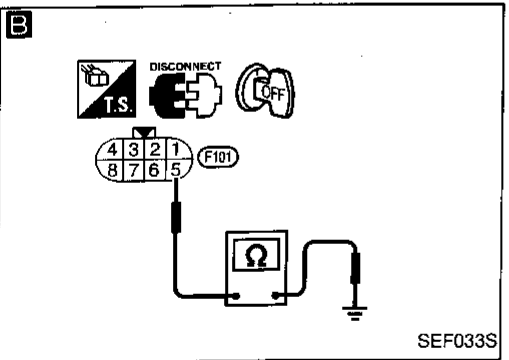
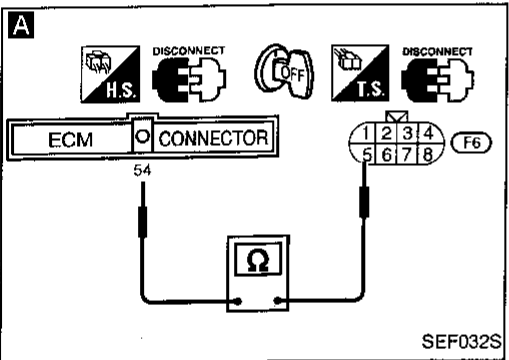
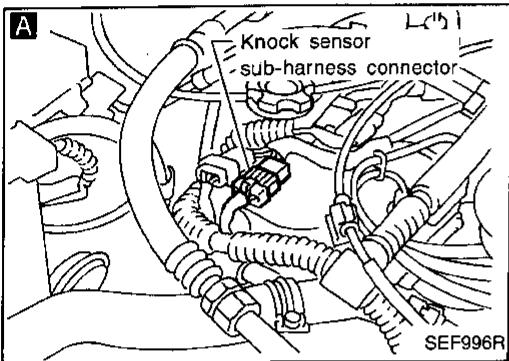
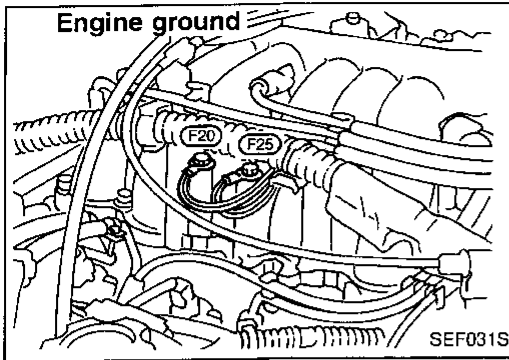

INSPECTION START

CHECK SHIELD CIRCUIT.

1. Turn ignition switch "OFF".
2. Loosen and retighten engine ground screws.
3. Remove joint connector.
4. Check the following.
 - Continuity between joint connector terminal and ground
 - Joint connector (Refer to "HARNES LAYOUT" in EL section.)

Continuity should exist.
If OK, check harness for short to ground and short to power. Then reconnect joint connector.

NG → Repair harness or connectors.

CHECK INPUT SIGNAL CIRCUIT-1.

1. Disconnect ECM harness connector and knock sensor sub-harness connector.
2. Check harness continuity between sub-harness connector terminal ⑤ and ECM terminal ④.

Continuity should exist.
If OK, check harness for short to ground and short to power.

NG → Check the following.

- Harness connectors (F6, F101)
- Harness for open or short between ECM and knock sensor

 If NG, repair open circuit or short to ground or short to power in harness or connectors.

CHECK INPUT SIGNAL CIRCUIT-2.

Check resistance between harness connector terminal ⑤ and engine ground.

Resistance:
Approximately 500 - 620 kΩ [at 25°C (77°F)]

If OK, check harness for short. It is necessary to use an ohmmeter which can measure more than 10 MΩ.

NG → Check the following.

- Harness connectors (F6, F101)
- Harness for open or short between knock sensor sub-harness connector and knock sensor
- Knock sensor (Refer to "COMPONENT INSPECTION" below.)

 If NG, repair harness or connectors. If NG, replace knock sensor.

Disconnect and reconnect harness connectors in the circuit. Then retest.

Trouble is not fixed.

Check ECM pin terminals for damage and check the connection of ECM harness connector. Reconnect ECM harness connector and retest.

INSPECTION END

COMPONENT INSPECTION

Knock sensor

- Use an ohmmeter which can measure more than 10 MΩ.
1. Disconnect knock sensor harness connector.
 2. Check resistance between terminal ② and ground.
- Resistance: 500 - 620 kΩ [at 25°C (77°F)]**

CAUTION:
Do not use any knock sensors that have been dropped or physically damaged. Use only new ones.

GI
MA
EM
LC
EC
FE
AT
TF
PD
FA
RA
BR
ST
RS
BT
HA
EL
IDX

TROUBLE DIAGNOSIS FOR DTC P0335

Crankshaft Position Sensor (CKPS) (OBD)

COMPONENT DESCRIPTION

The crankshaft position sensor (OBD) is located on the transaxle housing facing the gear teeth (cogs) of the flywheel or drive plate. It detects the fluctuation of the engine revolution.

The sensor consists of a permanent magnet, core and coil.

When the engine is running, the high and low parts of the teeth cause the gap with the sensor to change.

The changing gap causes the magnetic field near the sensor to change.

Due to the changing magnetic field, the voltage from the sensor changes.

The ECM receives the voltage signal and detects the fluctuation of the engine revolution.

This sensor is not directly used to control the engine system. It is used only for the on board diagnosis of misfire.

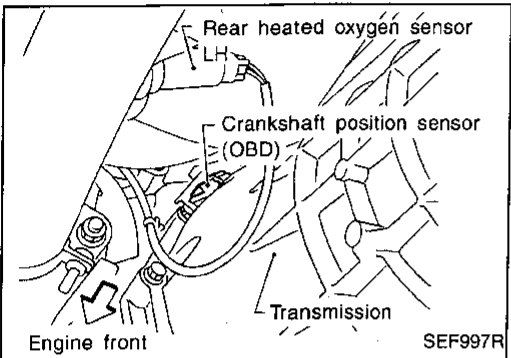
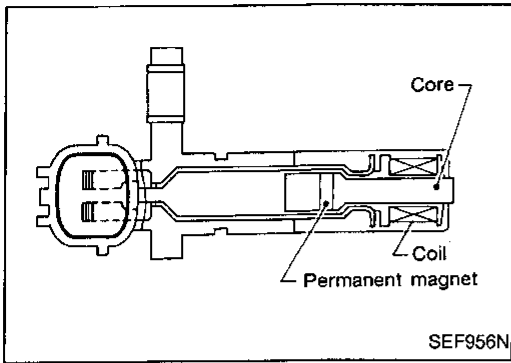

ECM TERMINALS AND REFERENCE VALUE

Specification data are reference values and are measured between each terminal and Ⓒ (ECCS ground).

TER-MINAL NO.	WIRE COLOR	ITEM	CONDITION	DATA (AC Voltage)
53	L	Crankshaft position sensor (OBD)	<div style="border: 1px solid black; padding: 2px;">Engine is running.</div> (Warm-up condition) ↳ Idle speed	Approximately 1.4V
			<div style="border: 1px solid black; padding: 2px;">Engine is running.</div> ↳ Engine speed is 2,000 rpm	Approximately 1.4V

ON BOARD DIAGNOSIS LOGIC

Diagnostic Trouble Code No.	Malfunction is detected when	Check Items (Possible Cause)
P0335 0802	<ul style="list-style-type: none"> The proper pulse signal from the crankshaft position sensor (OBD) is not sent to ECM while the engine is running at the specified engine speed. 	<ul style="list-style-type: none"> Harness or connectors (The crankshaft position sensor (OBD) circuit is open.) Crankshaft position sensor (OBD)

TROUBLE DIAGNOSIS FOR DTC P0335

Crankshaft Position Sensor (CKPS) (OBD) (Cont'd)

DIAGNOSTIC TROUBLE CODE CONFIRMATION PROCEDURE

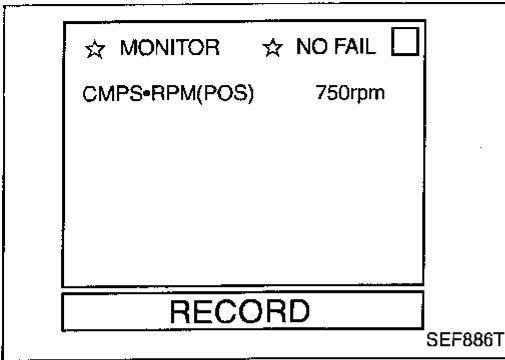

- 1) Turn ignition switch "ON" and select "DATA MONITOR" mode with CONSULT.
- 2) Start engine and run it for at least 15 seconds at idle speed.

OR



- 1) Start engine and run it for at least 15 seconds at idle speed.
- 2) Select "MODE 7" with GST.

OR



- 1) Start engine and run it for at least 15 seconds at idle speed.
- 2) Turn ignition switch "OFF", wait at least 5 seconds and then turn "ON".
- 3) Perform "Diagnostic Test Mode II" (Self-diagnostic results) with ECM.

GI

MA

EM

LC

EC

FE

AT

TF

PD

FA

RA

BR

ST

RS

BT

HA

EL

IDX

TROUBLE DIAGNOSIS FOR DTC P0335

Crankshaft Position Sensor (CKPS) (OBD) (Cont'd)

EC-CKPS-01

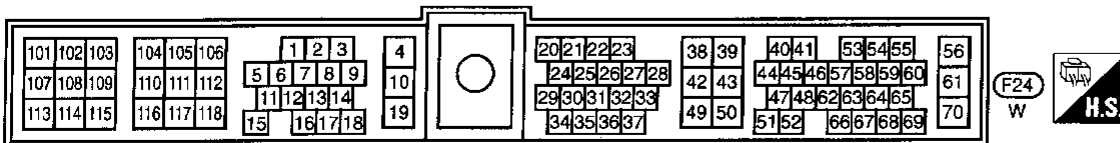
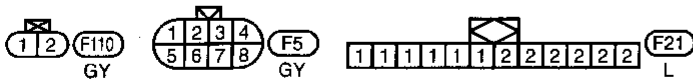
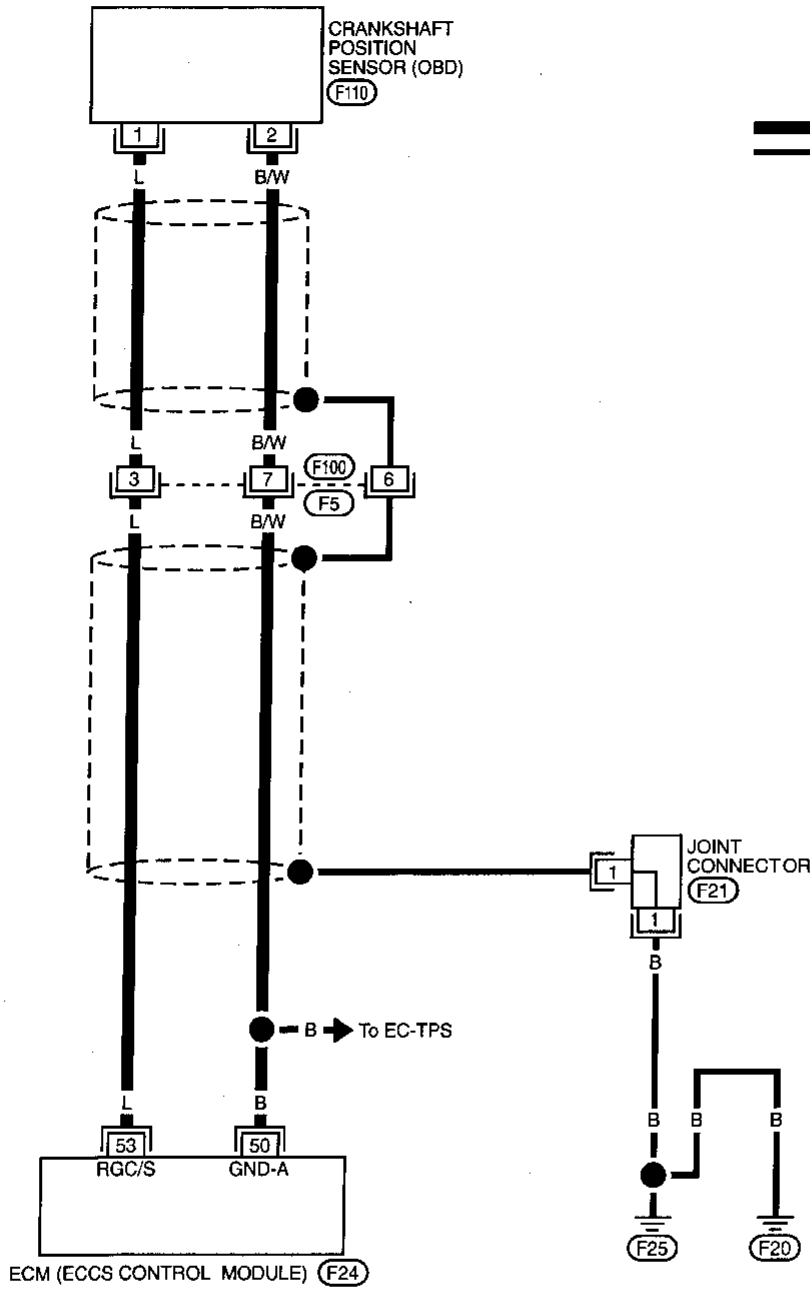

TROUBLE DIAGNOSIS FOR DTC P0335

Crankshaft Position Sensor (CKPS) (OBD) (Cont'd)

DIAGNOSTIC PROCEDURE

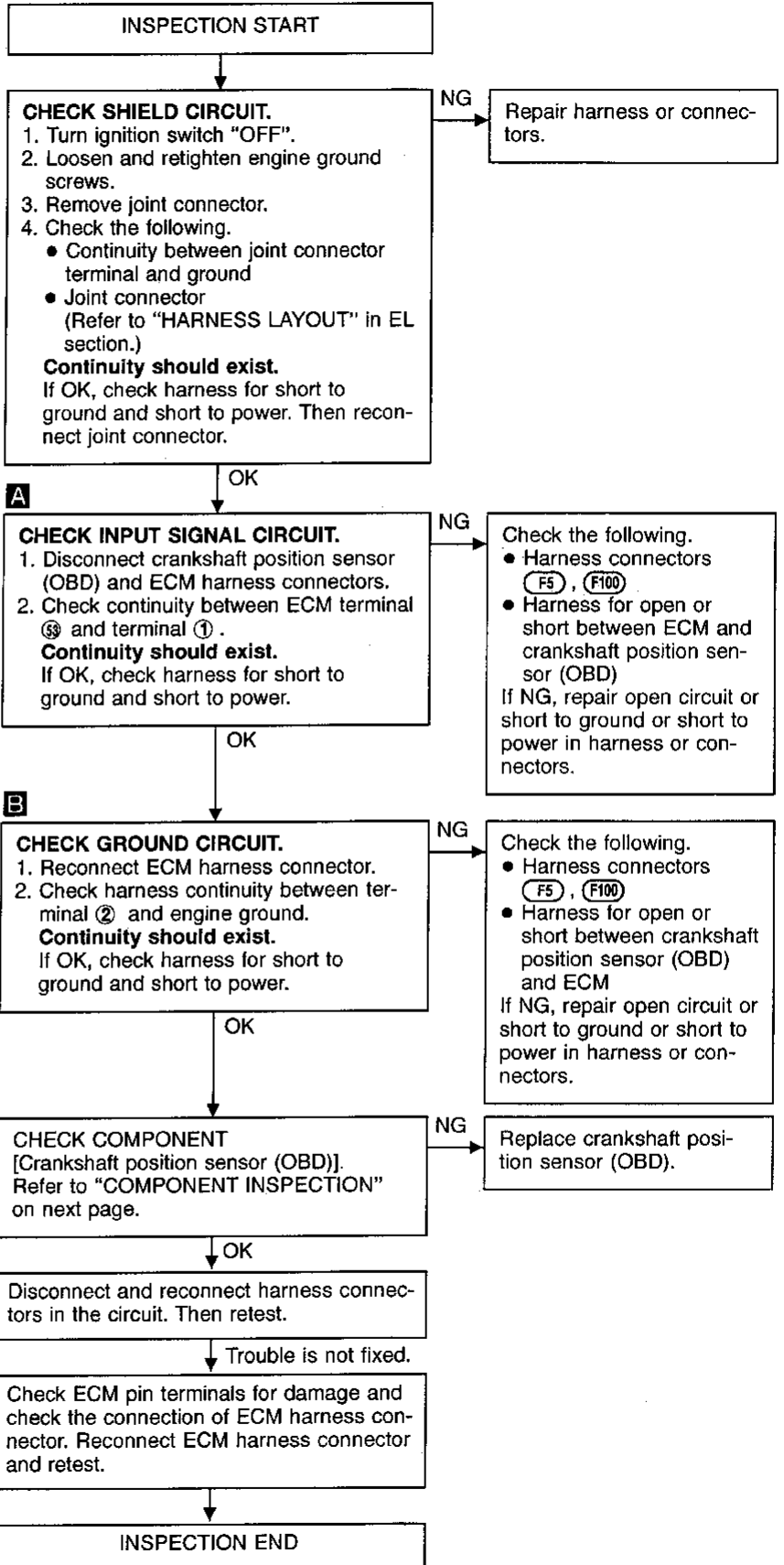
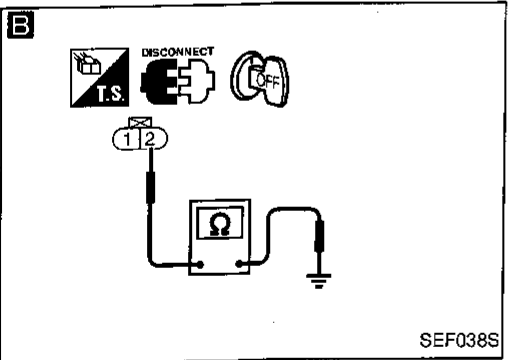
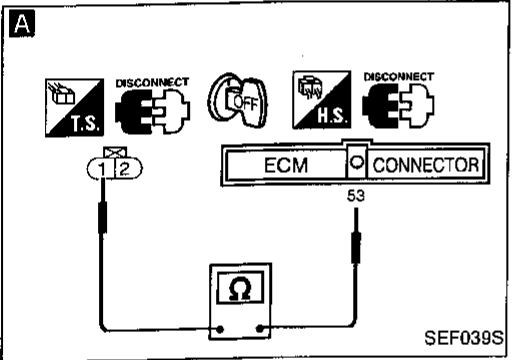
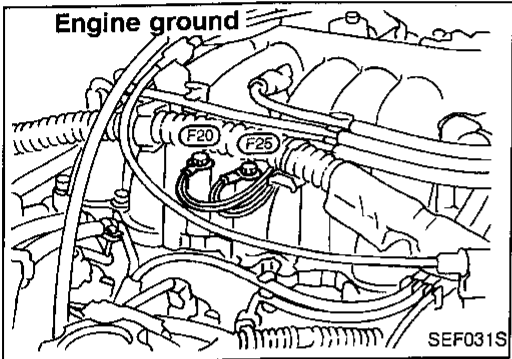
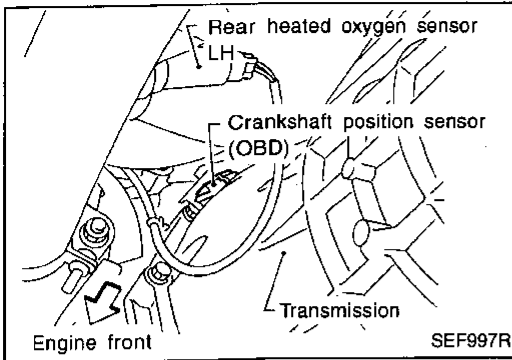

GI
MA
EM
LC
EC
FE
AT
TF
PD
FA
RA
BR
ST
RS
BT
HA
EL
IDX

TROUBLE DIAGNOSIS FOR DTC P0335

Crankshaft Position Sensor (CKPS) (OBD) (Cont'd)

COMPONENT INSPECTION

Crankshaft position sensor (OBD)

1. Disconnect crankshaft position sensor (OBD) harness connector.
2. Loosen the fixing bolt of the sensor.
3. Remove the sensor.
4. Visually check the sensor for chipping.

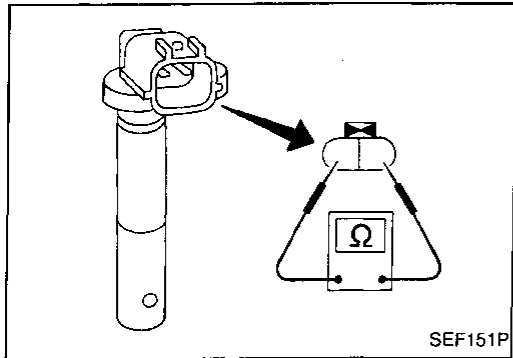
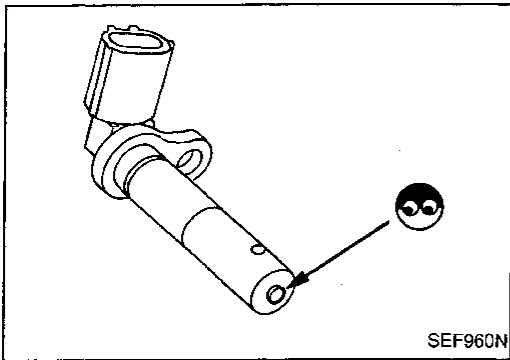

5. Check resistance as shown in the figure.
Resistance: Approximately 166.5 - 203.5 Ω
[at 20°C (68°F)]
If NG, replace crankshaft position sensor (OBD).

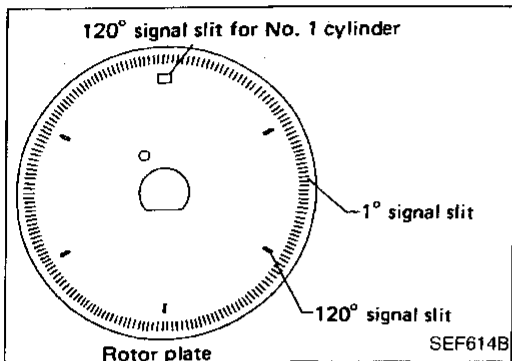
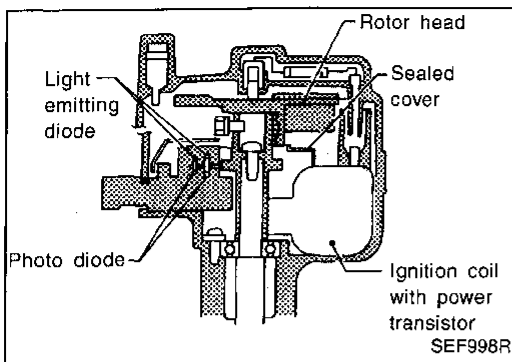

Camshaft Position Sensor (CMPS)

COMPONENT DESCRIPTION

The camshaft position sensor is a basic component of the ECCS. It monitors engine speed and piston position. These input signals to the ECM are used to control fuel injection, ignition timing and other functions.

The camshaft position sensor has a rotor plate and a wave-forming circuit. The rotor plate has 360 slits for a 1° (POS) signal and 6 slits for a 120° (REF) signal. The wave-forming circuit consists of Light Emitting Diodes (LED) and photo diodes.

The rotor plate is positioned between the LED and the photo diode. The LED transmits light to the photo diode. As the rotor plate turns, the slits cut the light to generate rough-shaped pulses. These pulses are converted into on-off signals by the wave-forming circuit and sent to the ECM.

The distributor is not repairable and must be replaced as an assembly except distributor cap.

GI
MA
EM
LC
EC

FE
AT
TF

ECM TERMINALS AND REFERENCE VALUE

Specification data are reference values and are measured between each terminal and ④ (ECCS ground).

TER-MINAL NO.	WIRE COLOR	ITEM	CONDITION	DATA (DC Voltage)
4	L/B	ECCS relay (Self-shutoff)	Engine is running. Ignition switch "OFF" └ For a few seconds after turning ignition switch "OFF"	0 - 1V
			Ignition switch "OFF" └ A few seconds passed after turning ignition switch "OFF"	BATTERY VOLTAGE (11 - 14V)
40	L	Camshaft position sensor (Reference signal)	Engine is running. └ Idle speed	1.1V SEF199T
44	L		Engine is running. └ Engine speed is 2,000 rpm.	1.1V SEF200T

PD
FA
RA
BR
ST
RS
BT
HA
EL
IDX

TROUBLE DIAGNOSIS FOR DTC P0340

Camshaft Position Sensor (CMPS) (Cont'd)

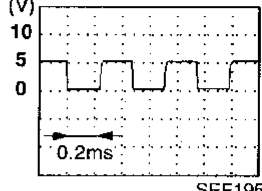
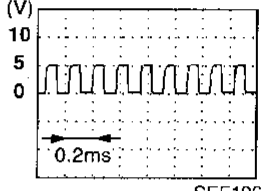
TER-MINAL NO.	WIRE COLOR	ITEM	CONDITION	DATA (DC Voltage)
41	B/W	Camshaft position sensor (Position signal)	<div style="border: 1px solid black; padding: 2px; display: inline-block;">Engine is running.</div> (Warm-up condition) └ Idle speed	Approximately 2.5V 
			<div style="border: 1px solid black; padding: 2px; display: inline-block;">Engine is running.</div> └ Engine speed is 2,000 rpm.	Approximately 2.5V 
56	B/W	Power supply for ECM	<div style="border: 1px solid black; padding: 2px; display: inline-block;">Ignition switch "ON"</div>	BATTERY VOLTAGE (11 - 14V)
61	B/W		<div style="border: 1px solid black; padding: 2px; display: inline-block;">Engine is running.</div> └ Idle speed	BATTERY VOLTAGE (11 - 14V)

ON BOARD DIAGNOSIS LOGIC

Diagnostic Trouble Code No.	Malfunction is detected when	Check Items (Possible Cause)
P0340 0101	A) Either 1° or 120° signal is not sent to ECM for the first few seconds during engine cranking. B) Either 1° or 120° signal is not sent to ECM often enough while the engine speed is higher than the specified engine speed. C) The relation between 1° and 120° signal is not in the normal range during the specified engine speed.	<ul style="list-style-type: none"> ● Harness or connectors (The camshaft position sensor circuit is open or shorted.) ● Camshaft position sensor ● Starter motor (Refer to EL section.) ● Starting system circuit (Refer to EL section.) ● Dead (Weak) battery

TROUBLE DIAGNOSIS FOR DTC P0340

Camshaft Position Sensor (CMPS) (Cont'd)

DIAGNOSTIC TROUBLE CODE CONFIRMATION PROCEDURE

Before performing the following procedure, confirm that battery voltage is more than 10.5V.

Perform "Procedure for malfunction A" first. If DTC cannot be confirmed, perform "Procedure for malfunction B and C".

Procedure for malfunction A

- 1) Turn ignition switch "ON".
- 2) Select "DATA MONITOR" mode with CONSULT.
- 3) Crank engine for at least 2 seconds.

OR

- 1) Crank engine for at least 2 seconds.
- 2) Select "MODE 7" with GST.

OR

- 1) Crank engine for at least 2 seconds.
- 2) Turn ignition switch "OFF", wait at least 5 seconds and then turn "ON".
- 3) Perform "Diagnostic Test Mode II" (Self-diagnostic results) with ECM.

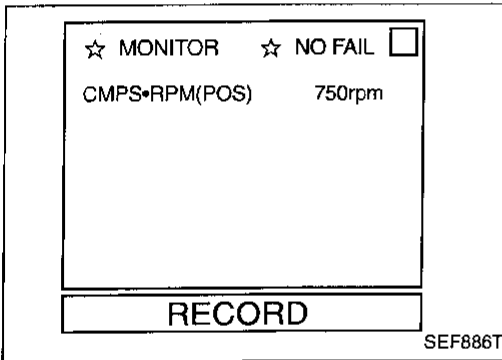

Procedure for malfunction B and C

- 1) Turn ignition switch "ON".
- 2) Select "DATA MONITOR" mode with CONSULT.
- 3) Start engine and run it for at least 2 seconds at idle speed.

OR

- 1) Start engine and run it for at least 2 seconds at idle speed.
- 2) Select "MODE 7" with GST.

OR

- 1) Start engine and run it for at least 2 seconds at idle speed.
- 2) Turn ignition switch "OFF", wait at least 5 seconds and then turn "ON".
- 3) Perform "Diagnostic Test Mode II" (Self-diagnostic results) with ECM.

TROUBLE DIAGNOSIS FOR DTC P0340

Camshaft Position Sensor (CMPS) (Cont'd)

EC-CMPS-01

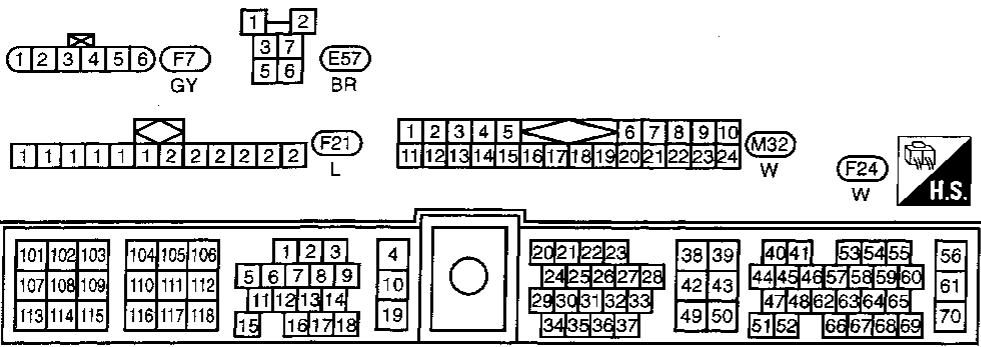
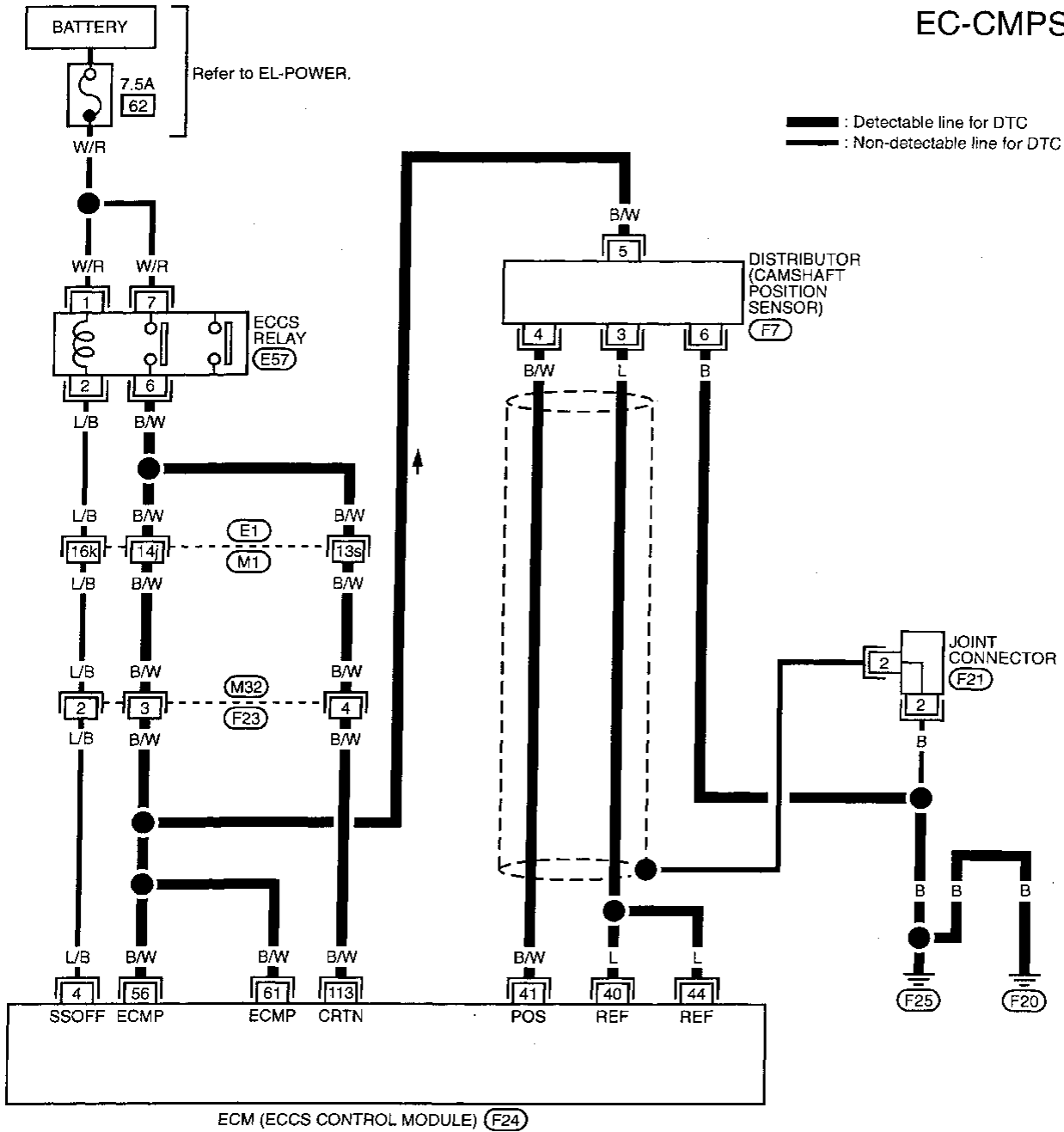

Refer to last page (Foldout page).

(E1), (M1)

TROUBLE DIAGNOSIS FOR DTC P0340

Camshaft Position Sensor (CMPS) (Cont'd) DIAGNOSTIC PROCEDURE (DETECTABLE CIRCUIT)

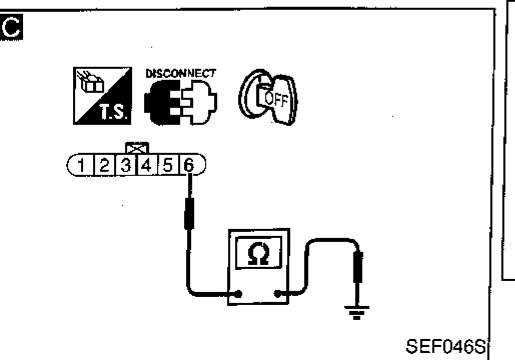
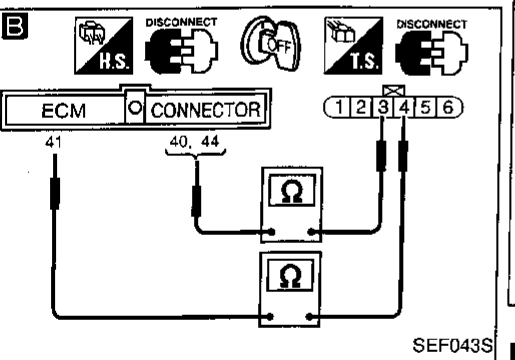
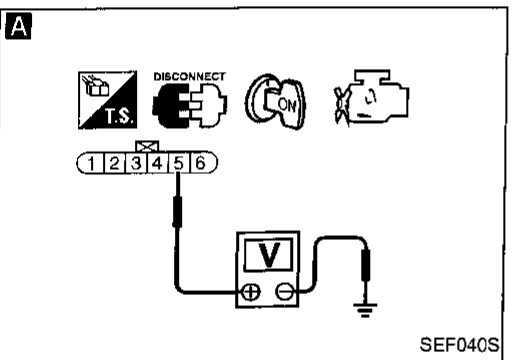
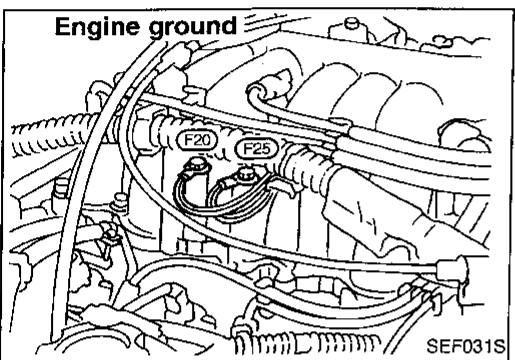
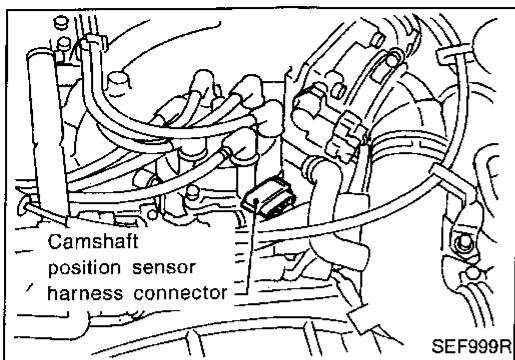

INSPECTION START

CHECK SHIELD CIRCUIT.
1. Turn ignition switch "OFF".
2. Loosen and retighten engine ground screws.
3. Remove joint connector.
4. Check the following.
• Continuity between joint connector terminal and ground
• Joint connector (Refer to "HARNES LAYOUT" in EL section.)
Continuity should exist.
If OK, check harness for short to ground and short to power. Then reconnect joint connector.

NG → Repair harness or connectors.

A
CHECK POWER SUPPLY.
1. Disconnect camshaft position sensor harness connector.
2. Turn ignition switch "ON".
3. Check voltage between terminal ⑤ and ground with CONSULT or tester.
Voltage: Battery voltage

NG → Check the following.
• Harness connectors (F23, M32)
• Harness connectors (M1, E1)
• Harness for open or short between camshaft position sensor and ECCS relay
• Harness for open or short between camshaft position sensor and ECM
If NG, repair harness or connectors.

B
CHECK INPUT SIGNAL CIRCUIT.
1. Turn ignition switch "OFF".
2. Disconnect ECM harness connector.
3. Check harness continuity between sensor terminal ④ and ECM terminals ④, sensor terminal ③ and ECM terminals ④, ④.
Continuity should exist.
If OK, check harness for short to ground and short to power.

NG → Repair harness or connectors.

C
CHECK GROUND CIRCUIT.
1. Turn ignition switch "OFF".
2. Disconnect camshaft position sensor harness connector.
3. Check harness continuity between sensor terminal ⑥ and engine ground.
Continuity should exist.
If OK, check harness for short to ground and short to power.

NG → Repair harness or connectors.

OK
A

GI
MA
EM
LC
EC
FE
AT
TF
PD
FA
RA
BR
ST
RS
BT
HA
EL
IDX

TROUBLE DIAGNOSIS FOR DTC P0340

Camshaft Position Sensor (CMPS) (Cont'd)

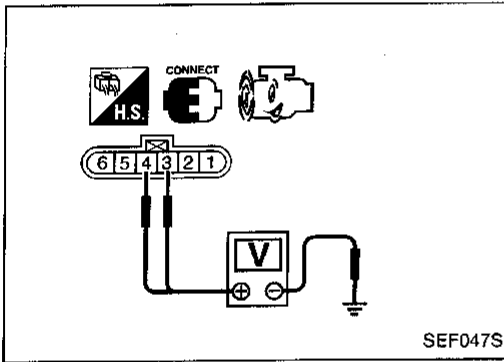
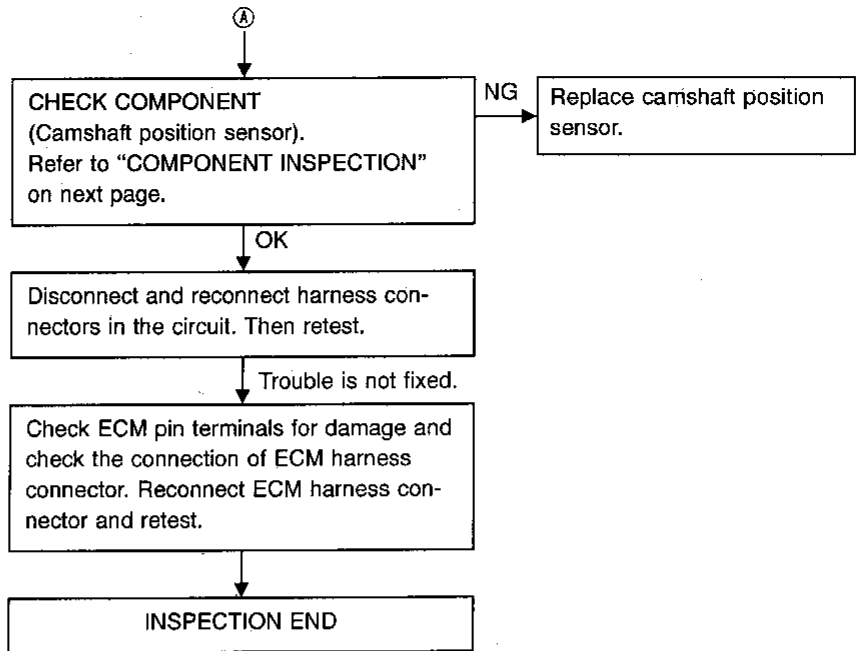

COMPONENT INSPECTION

Camshaft position sensor

1. Start engine.
2. Check voltage between camshaft position sensor terminals ③, ④ and ground with AC range.

Condition	Terminal	Voltage
Engine running at idle	③ and ground	Approximately 1.0V* (AC)
	④ and ground	Approximately 2.4V* (AC)

*: Average voltage for pulse signal (Actual pulse signal can be confirmed by oscilloscope.)

If NG, replace distributor assembly with camshaft position sensor.

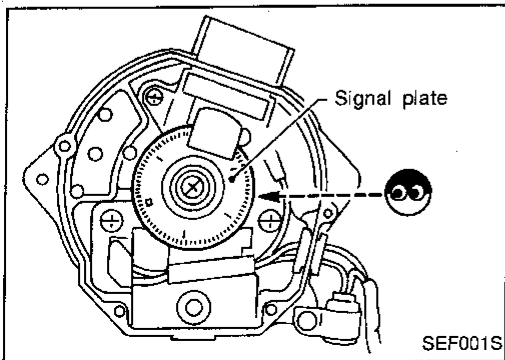

3. Remove distributor cap. Visually check signal plate for damage or dust.

After this inspection, DTC P0340 (0101) might be displayed with camshaft position sensor functioning properly. Erase the stored memory.

EGR Function

SYSTEM DESCRIPTION

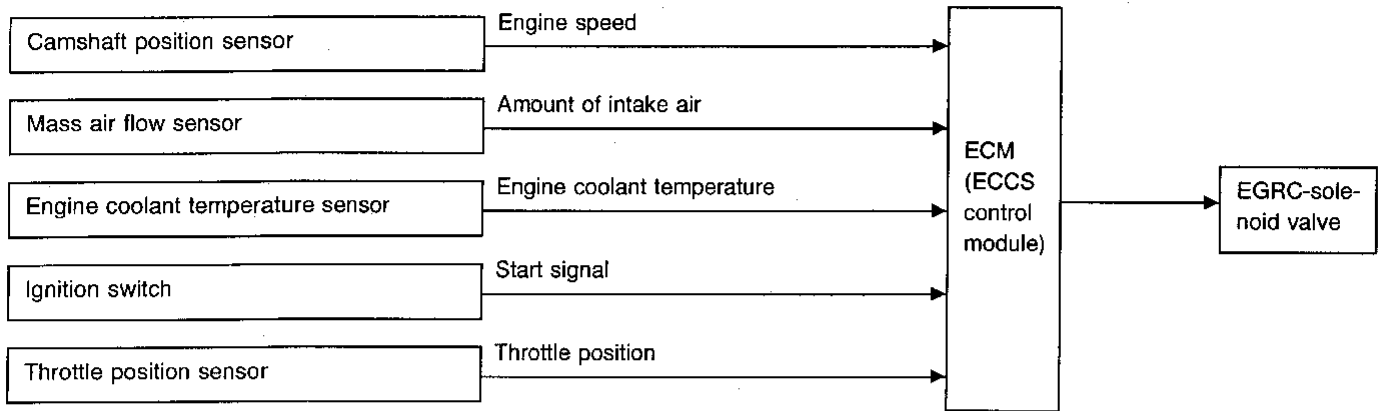

This system cuts and controls vacuum applied to the EGR valve to suit engine operating conditions. This cut-and-control operation is accomplished through the ECM and the EGRC-solenoid valve. When the ECM detects any of the following conditions, current flows through the solenoid valve. This causes the port vacuum to be discharged into the atmosphere. The EGR valve remains closed.

- Low engine coolant temperature
- Engine starting
- High-speed engine operation
- Engine idling
- Excessively high engine coolant temperature
- Mass air flow sensor malfunction

EGR and vacuum

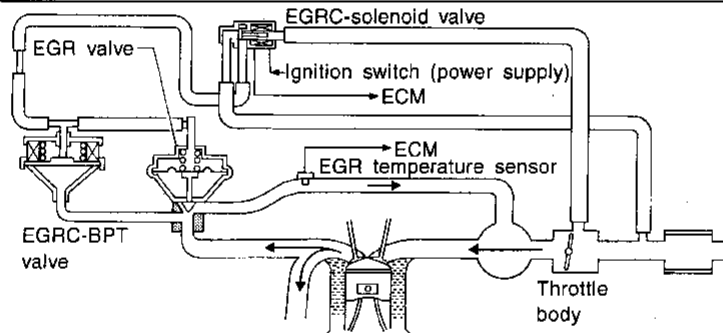

SEF641Q

COMPONENT DESCRIPTION

Exhaust gas recirculation (EGR) valve

The EGR valve controls the amount of exhaust gas routed to the intake manifold. Vacuum is applied to the EGR valve in response to throttle valve opening. The vacuum controls the movement of a taper valve connected to the vacuum diaphragm in the EGR valve.

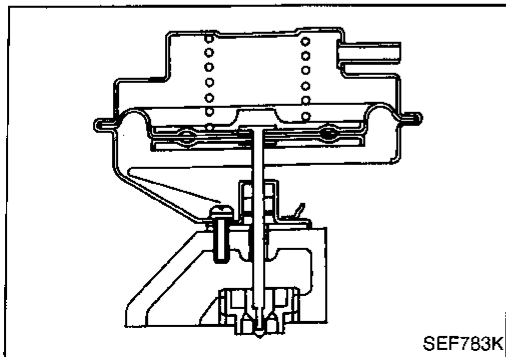

SEF783K

TROUBLE DIAGNOSIS FOR DTC P0400

EGR Function (Cont'd)

EGRC-solenoid valve

The EGRC-solenoid valve responds to signals from the ECM. When the ECM sends an ON (ground) signal, the coil in the solenoid valve is energized. A plunger will then move to cut the vacuum signal (from the throttle body to the EGR valve).

When the ECM sends an OFF signal, the vacuum signal passes through the solenoid valve. The signal then reaches the EGR valve.

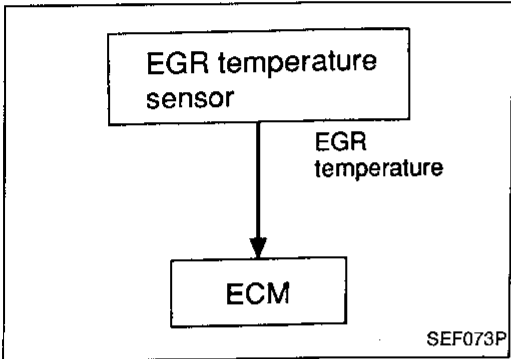
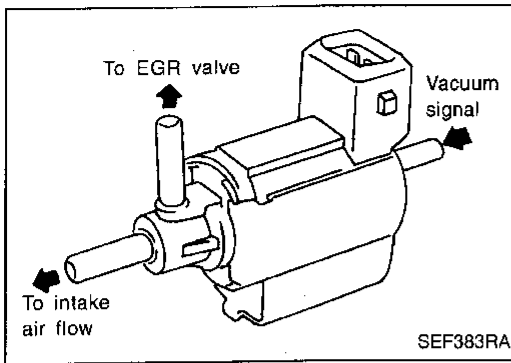

ON BOARD DIAGNOSIS LOGIC

If the absence of EGR flow is detected by EGR temperature sensor under the condition that calls for EGR, a low-flow malfunction is diagnosed.

If EGR temperature sensor detects EGR flow under the condition that does not call for EGR, a high-flow malfunction is diagnosed.

Diagnostic Trouble Code No.	Malfunction is detected when ...	Check Items (Possible Cause)
P0400 0302	A) The exhaust gas recirculation (EGR) flow is excessively low during the specified driving condition.	<ul style="list-style-type: none"> ● EGR valve stuck closed ● EGRC-BPT valve leaking ● Passage blocked ● EGRC-solenoid valve ● Tube leaking for EGR valve ● EGR temperature sensor
	B) The exhaust gas recirculation (EGR) flow is excessively high during the specified driving condition.	<ul style="list-style-type: none"> ● EGRC-solenoid valve ● EGR valve leaking or stuck open ● EGR temperature sensor

OVERALL FUNCTION CHECK

Use this procedure to check the overall EGR function. During this check, a 1st trip DTC might not be confirmed.

Before starting with the following procedure, check the engine coolant temperature of the freeze frame data with CONSULT or Generic Scan Tool.

If the engine coolant temperature is higher than or equal to 75°C (167°F), perform only "Procedure for malfunction A".

If the engine coolant temperature is lower than 75°C (167°F), perform both "Procedure for malfunction A" and "Procedure for malfunction B".

If the 1st trip freeze frame data or the freeze frame data for another malfunction is stored in the ECM, perform both "Procedure for malfunction A" and "Procedure for malfunction B". In this case, check 1st trip DTCs and/or DTCs in the ECM and inspections one by one based on "INSPECTION PRIORITY", EC-76.



TROUBLE DIAGNOSIS FOR DTC P0400

EGR Function (Cont'd)

Procedure for malfunction A

- 1) Start engine and warm it up sufficiently.
- 2) Check the EGR valve lifting when revving from 2,000 rpm up to 4,000 rpm under no load using the following methods.

EGR valve should lift up and down without sticking.

- 
 - Select "EGRC SOLENOID VALVE" in "ACTIVE TEST" mode with CONSULT and turn the solenoid valve "OFF".
- 
 - Disconnect harness connectors (M32) and (F23). (The DTC for EGRC-solenoid valve will be displayed, however, ignore it.)

If NG, go to **A** in DIAGNOSTIC PROCEDURE on EC-216.

- 3) Check voltage between EGR temperature sensor harness connector terminal ① and ground at idle speed.

Less than 4.5V should exist.

- 4) Turn ignition switch "OFF".
- 5) Check harness continuity between EGR temperature sensor harness connector terminal ② and ECM terminal ⑤0.

Continuity should exist.

- 6) Perform "COMPONENTS INSPECTION", "EGR temperature sensor". Refer to EC-218.

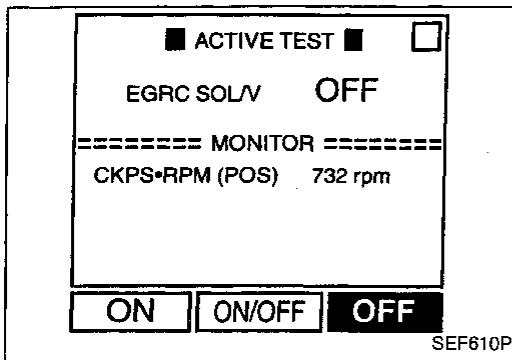

SEF610P

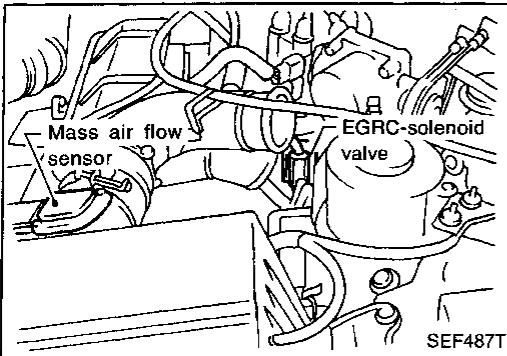

SEF487T

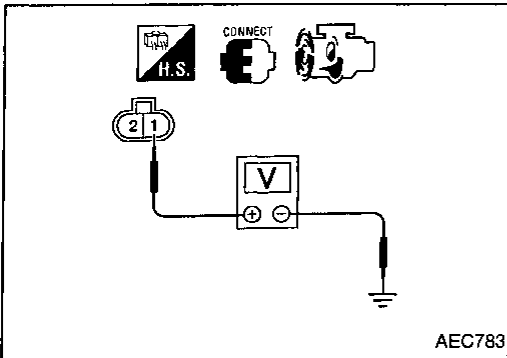

AEC783

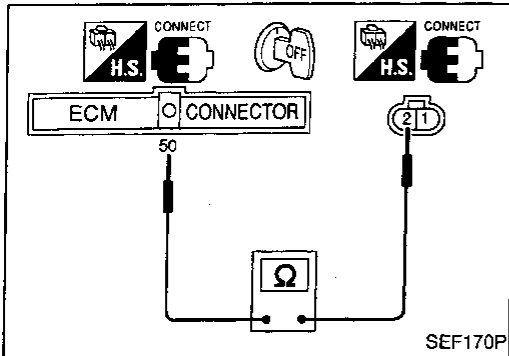

SEF170P

Overall function check

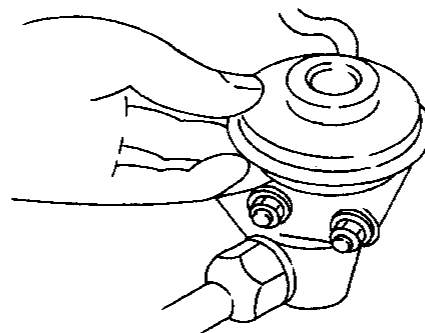
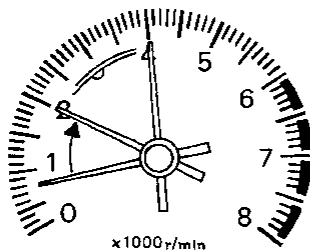

Check the EGR valve lifting when revving engine from 2,000 rpm up to 4,000 rpm.

SEF642Q

TROUBLE DIAGNOSIS FOR DTC P0400

EGR Function (Cont'd)

Procedure for malfunction B

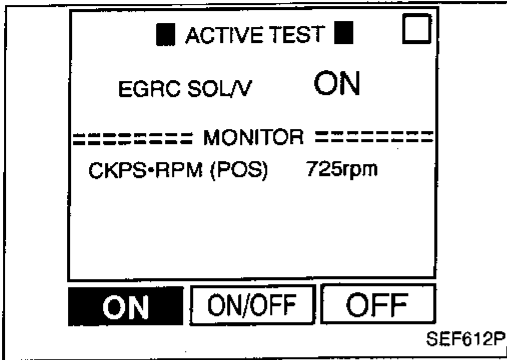

- 1) Start engine.
- 2) Select "EGRC SOLENOID VALVE" in "ACTIVE TEST" mode with CONSULT and turn the solenoid valve "ON".
- 3) Check for the EGR valve lifting when revving from 2,000 rpm up to 4,000 rpm under no load.

EGR valve should be closed and should not lift up.

OR

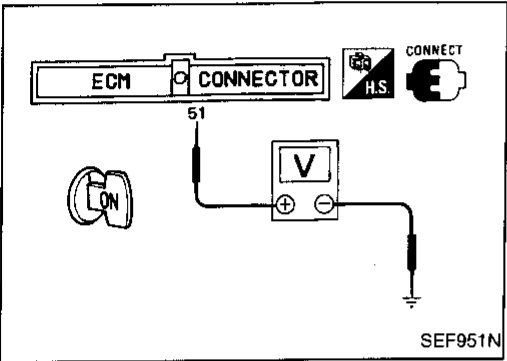

- 1) Turn ignition switch "ON".
- 2) Confirm the engine coolant temperature is lower than 70°C (158°F) in "Mode 1" with generic scan tool. Perform the following steps before its temperature becomes higher than 70°C (158°F).

- 3) Start engine.
- 4) Check for the EGR valve lifting when revving from 2,000 rpm up to 4,000 rpm under no load.

EGR valve should be closed and should not lift up.

OR

- 1) Turn ignition switch "ON".
- 2) Confirm the voltage between ECM terminal ⑤1 and ground is higher than 1.6V. Perform the following steps before the voltage becomes lower than 1.6V.

- 3) Start engine.
- 4) Check for the EGR valve lifting when revving from 2,000 rpm up to 4,000 rpm under no load.

EGR valve should be closed and should not lift up.

Overall function check

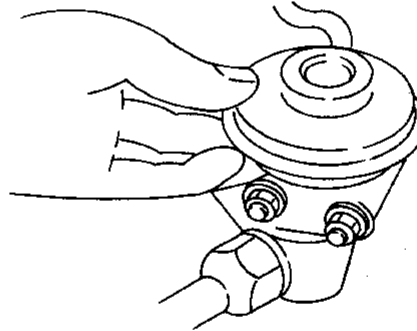
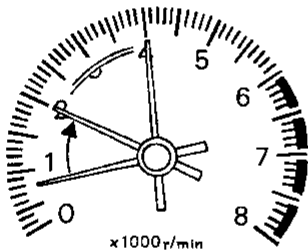

Check the EGR valve lifting when revving engine from 2,000 rpm up to 4,000 rpm.

SEF642Q

TROUBLE DIAGNOSIS FOR DTC P0400

EGR Function (Cont'd) DIAGNOSTIC PROCEDURE

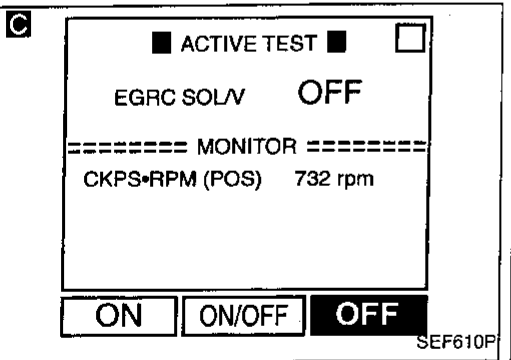
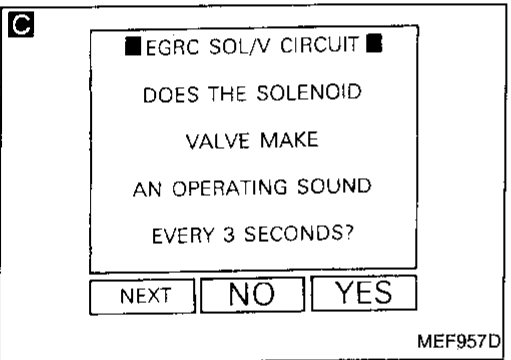
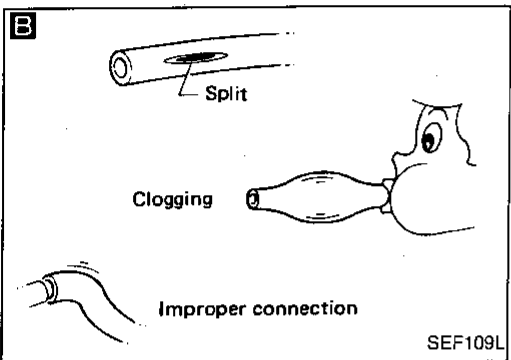
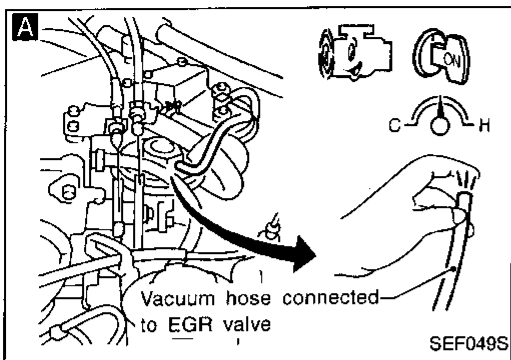

INSPECTION START

A

CHECK VACUUM SOURCE TO EGR VALVE.

1. Start engine and warm it up sufficiently.
2. Disconnect vacuum hose to EGR valve.
3. Check for vacuum existence.

Vacuum should not exist at idle.

4. Check for vacuum existence when revving from 2,000 rpm up to 4,000 rpm with the following methods.

- Select "EGRC SOLENOID VALVE" in "ACTIVE TEST" mode with CONSULT and turn the solenoid valve "OFF".

OR

- Disconnect EGRC-solenoid valve harness connector. (The DTC for EGRC-solenoid valve will be displayed, however, ignore it.)

Vacuum should exist when revving engine.

OK → CHECK COMPONENTS (EGR valve). Refer to "COMPONENTS INSPECTION", EC-217.

NG → Replace EGR valve.

B

CHECK VACUUM HOSE.

Check vacuum hose for clogging, cracks or improper connection.

NG → Repair or replace vacuum hose.

C

CHECK COMPONENT (EGRC-solenoid valve).

1. Turn ignition switch "ON".
2. Perform "EGRC SOL/V CIRCUIT" in "FUNCTION TEST" mode with CONSULT.

OR

1. Turn ignition switch "ON".
2. Turn EGRC-solenoid valve "ON" and "OFF" in "ACTIVE TEST" mode with CONSULT and check operating sound.

OR

1. Turn ignition switch "ON".
2. Check operating sound of the solenoid valve when disconnecting and reconnecting EGRC-solenoid valve harness connector. (The DTC or the 1st trip DTC for the EGRC-solenoid valve will be displayed, however, ignore it.)

NG → Repair or replace EGRC-solenoid valve or repair circuit.

OK → CHECK COMPONENT (EGRC-solenoid valve). Refer to "COMPONENT INSPECTION" on next page.

NG → Replace EGRC-solenoid valve.

OK
①

TROUBLE DIAGNOSIS FOR DTC P0400

EGR Function (Cont'd)

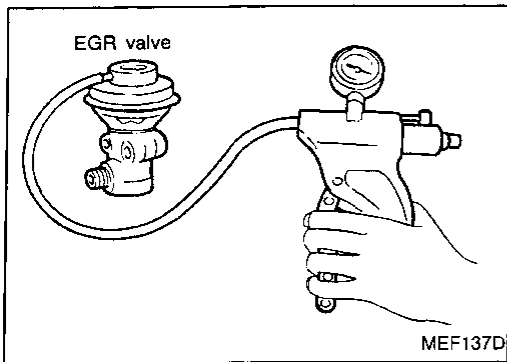
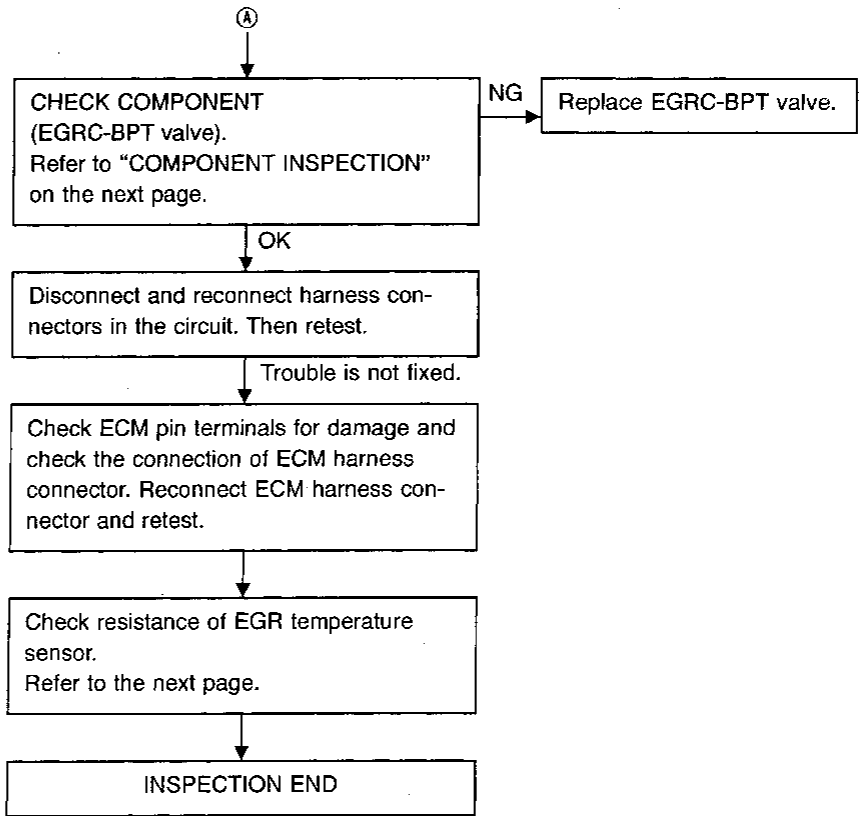

COMPONENT INSPECTION

EGR valve

Apply vacuum to EGR vacuum port with a hand vacuum pump.
EGR valve spring should lift.
If NG, replace EGR valve.

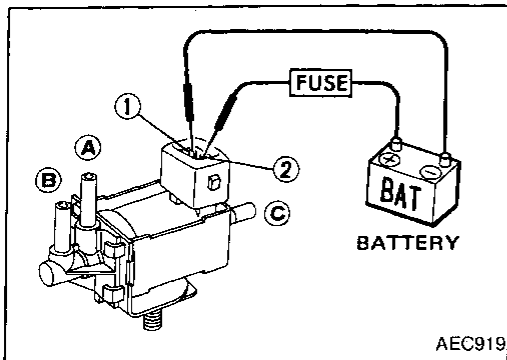

EGRC-solenoid valve

Check solenoid valve, following the table as shown below:

Conditions	Air passage continuity between (A) and (B)	Air passage continuity between (A) and (C)
12V direct current supply between terminals ① and ②	Yes	No
No supply	No	Yes

If NG, replace EGRC-solenoid valve.

GI
MA
EM
LC
EC
FE
AT
TF
PD
FA
RA
BR
ST
RS
BT
HA
EL
IDX

TROUBLE DIAGNOSIS FOR DTC P0400

EGR Function (Cont'd)

EGR temperature sensor

Check resistance change and resistance value.

<Reference data>

EGR temperature °C (°F)	Voltage (V)	Resistance (MΩ)
0 (32)	4.81	7.9 - 9.7
50 (122)	2.82	0.57 - 0.70
100 (212)	0.8	0.08 - 0.10

If NG, replace EGR temperature sensor.

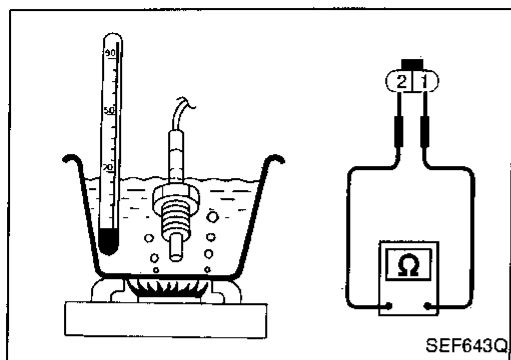

SEF643Q

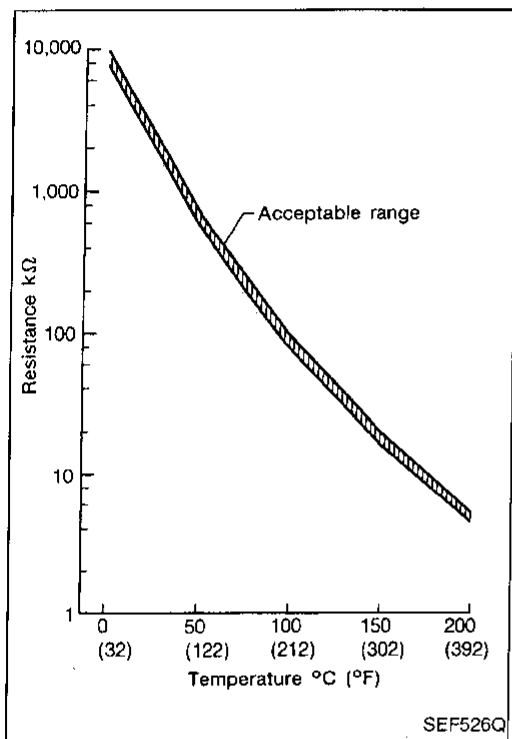

SEF526Q

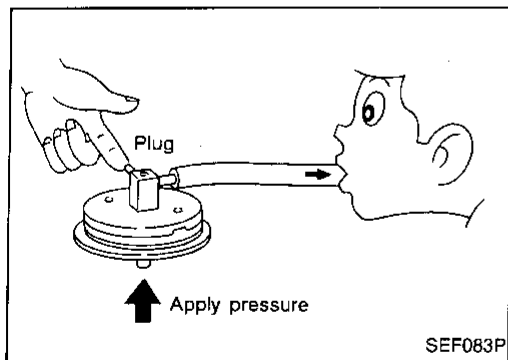

SEF083P

EGRC-BPT valve

1. Plug one of two ports of EGRC-BPT valve.
2. Vacuum from the other port and check for leakage while applying a pressure above 0.981 kPa (100 mmH₂O, 3.94 inH₂O) from under EGRC-BPT valve.
3. If a leakage is noted, replace the valve.

EGRC-BPT Valve Function

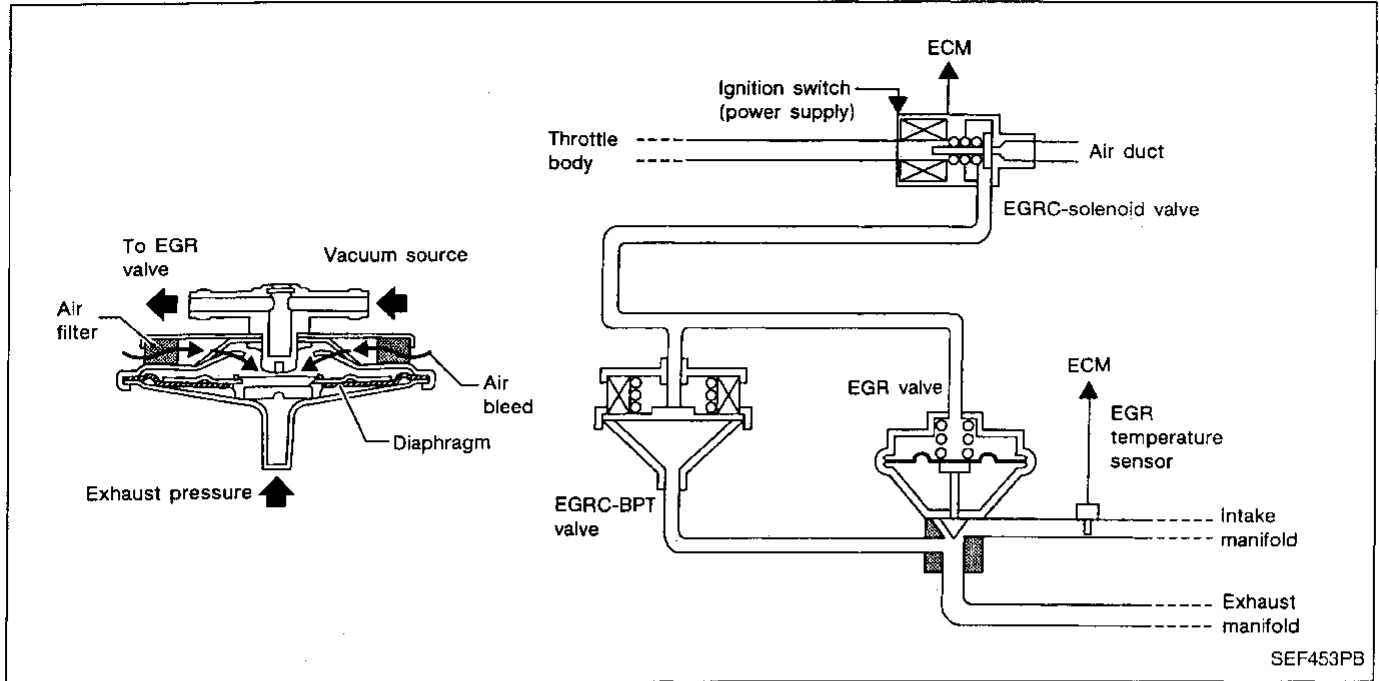

SYSTEM DESCRIPTION

The EGRC-BPT valve monitors exhaust pressure to activate the diaphragm, controlling throttle body vacuum applied to the EGR valve. In other words, recirculated exhaust gas is controlled in response to positioning of the EGR valve or to engine operation.

ON BOARD DIAGNOSIS LOGIC

If too much EGR flow exists due to an EGRC-BPT valve malfunction, off idle engine roughness will increase. If the roughness is large, then the vacuum to the EGR valve is interrupted through the EGRC-solenoid valve. If the engine roughness is reduced at that time, the EGRC-BPT valve malfunction is indicated.

Diagnostic Trouble Code No.	Malfunction is detected when ...	Check Items (Possible Cause)
P0402 0306	<ul style="list-style-type: none"> The EGRC-BPT valve does not operate properly. 	<ul style="list-style-type: none"> EGRC-BPT valve Misconnected rubber tube Blocked rubber tube Intake manifold EGR passage

OVERALL FUNCTION CHECK

Use this procedure to check the overall function of the EGRC-BPT valve. During this check, a 1st trip DTC might not be confirmed.

1. Disconnect the rubber tube to the EVAP canister purge control solenoid valve at the EGRC-solenoid valve.
2. Disconnect the rubber tube to the EGRC-solenoid valve at the EGRC-BPT valve. Connect the intake manifold and the EGRC-BPT valve with a rubber tube that has 0.5 mm (0.020 in) dia. orifice. (The intake manifold vacuum will be directly applied to the EGRC-BPT valve.)
3. Start engine.
4. Check for the EGR valve lifting with engine at idle speed under no load.
EGR valve should remain closed.
5. Check the EGR valve lifting when revving from 1,500 rpm up to 3,000 rpm under no load.
EGR valve should lift up, and go down without sticking when the engine is returned to idle.
6. Check rubber tube between EGRC-solenoid valve and throttle body for misconnection, cracks or blockages.

TROUBLE DIAGNOSIS FOR DTC P0402

EGRC-BPT Valve Function (Cont'd)

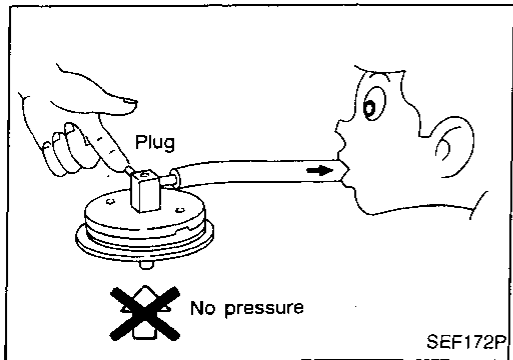
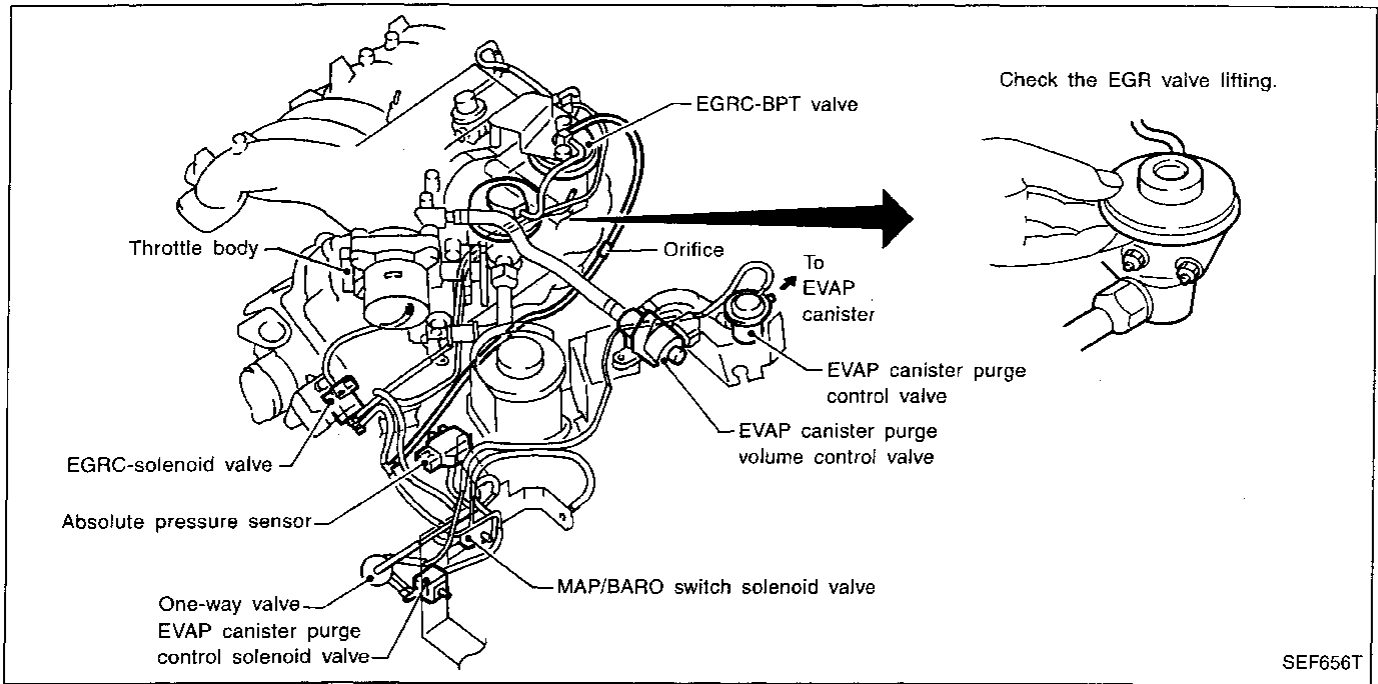

COMPONENT INSPECTION

EGRC-BPT valve

1. Plug one of two ports of EGRC-BPT valve.
2. Vacuum from the other port and check leakage without applying any pressure from under EGR-BPT valve.
Leakage should exist.

Three Way Catalyst Function

ON BOARD DIAGNOSIS LOGIC

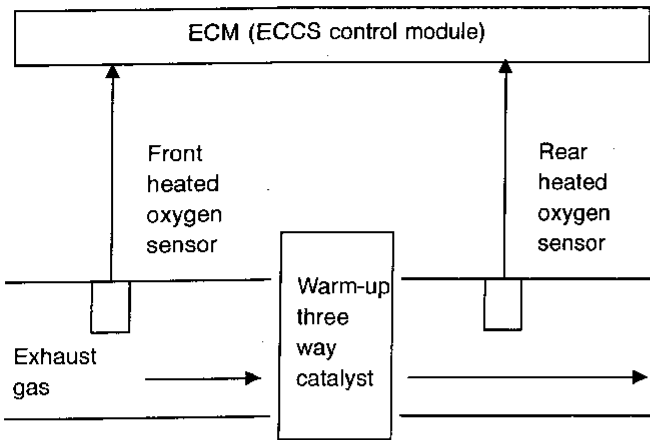

The ECM monitors the switching frequency ratio of front and rear heated oxygen sensors. A warm-up three way catalyst with high oxygen storage capacity will indicate a low switching frequency of rear heated oxygen sensor. As oxygen storage capacity decreases, the rear heated oxygen sensor switching frequency will increase. When the frequency ratio of front and rear heated oxygen sensors approaches a specified limit value, the warm-up three way catalyst malfunction is diagnosed.

Diagnostic Trouble Code No.	Malfunction is detected when ...	Check Items (Possible Cause)
For right bank P0420 0702	<ul style="list-style-type: none"> • Warm-up three way catalyst does not operate properly. • Warm-up three way catalyst does not have enough oxygen storage capacity. 	<ul style="list-style-type: none"> • Warm-up three way catalyst • Exhaust tube • Intake air leaks • Injectors • Injector leaks
For left bank P0430 0703		

OVERALL FUNCTION CHECK

Use this procedure to check the overall function of the three way catalyst. During this check, a 1st trip DTC might not be confirmed.

GJ
MA
EM
LC
EC
FE
AT
TF
PD
FA
RA
BR
ST
RS
BT
HA
EL
IDX

TROUBLE DIAGNOSIS FOR DTC P0420, P0430

Three Way Catalyst Function (Cont'd)

☆ MONITOR	☆ NO FAIL	<input type="checkbox"/>
CMPS-RPM (POS)	2037rpm	
FR O2 SEN-B2	0.68V	
FR O2 SEN-B1	0.08V	
RR O2 SEN-B1	0.05V	
RR O2 SEN-B2	0.04V	
FR O2 MNTR-B2	RICH	
FR O2 MNTR-B1	LEAN	
RR O2 MNTR-B1	LEAN	
RR O2 MNTR-B2	LEAN	
RECORD		

SEF988Q

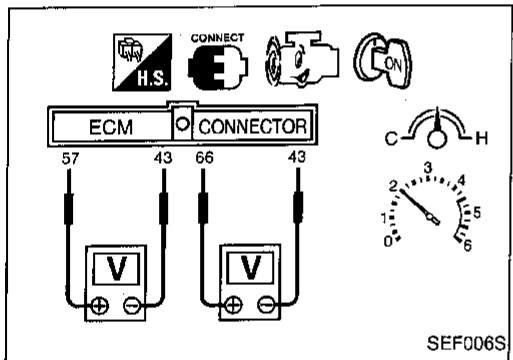
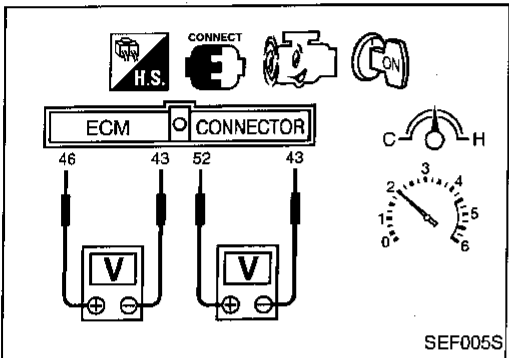

- 1) Start engine and warm it up sufficiently.
- 2) Set "MANU TRIG" and "HI SPEED", then select "FR O2 SEN-B1", "FR O2 SEN-B2", "RR O2 SEN-B1", "RR O2 SEN-B2", "FR O2 MNTR-B2", "FR O2 MNTR-B1", "RR O2 MNTR-B1", "RR O2 MNTR-B2" in "DATA MONITOR" mode with CONSULT.
- 3) Touch "RECORD" on CONSULT screen with engine speed held at 2,000 rpm constant under no load.
- 4) Make sure that the switching frequency between "RICH" and "LEAN" of "RR O2 MNTR-B1" or "RR O2 MNTR-B2" is very less than that of "FR O2 MNTR-B1" or "FR O2 MNTR-B2".

Switching frequency ratio =

Rear heated oxygen sensor switching frequency

Front heated oxygen sensor switching frequency

This ratio should be less than 0.75.

If the ratio is greater than above, the three way catalyst is not operating properly.

Note: If the "FR O2 MNTR-B1" or "FR O2 MNTR-B2" does not indicate "RICH" and "LEAN" periodically more than 5 times within 10 seconds at step 3, perform TROUBLE DIAGNOSIS FOR DTC P0130 or P0150 first. (See EC-135 or EC-153.)

OR



- 1) Start engine and warm it up sufficiently.
- 2) Set voltmeters probes between ECM terminals ④⑥ [front heated oxygen sensor (right bank) signal], ⑤⑦ [front heated oxygen sensor (left bank) signal] and ④③ (engine ground), and ECM terminals ⑤② [rear heated oxygen sensor (right bank) signal], ⑥⑥ [rear heated oxygen sensor (left bank) signal] and ④③ (engine ground).
- 3) Keep engine speed at 2,000 rpm constant under no load.
- 4) Make sure that the voltage switching frequency (high & low) between ECM terminals ⑤② and ④③, or ⑥⑥ and ④③ is very less than that of ECM terminals ④⑥ and ④③, or ⑤⑦ and ④③.

Switching frequency ratio =

Rear heated oxygen sensor voltage switching frequency

Front heated oxygen sensor voltage switching frequency

This ratio should be less than 0.75.

If the ratio is greater than above, it means three way catalyst does not operate properly.

Note: If the voltage at terminal ④⑥ or ⑤⑦ does not switch periodically more than 5 times within 10 seconds at step 3, perform TROUBLE DIAGNOSIS FOR DTC P0130 or P0150 first. (See EC-135 or EC-153.)

TROUBLE DIAGNOSIS FOR DTC P0420, P0430

Three Way Catalyst Function (Cont'd)

DIAGNOSTIC PROCEDURE

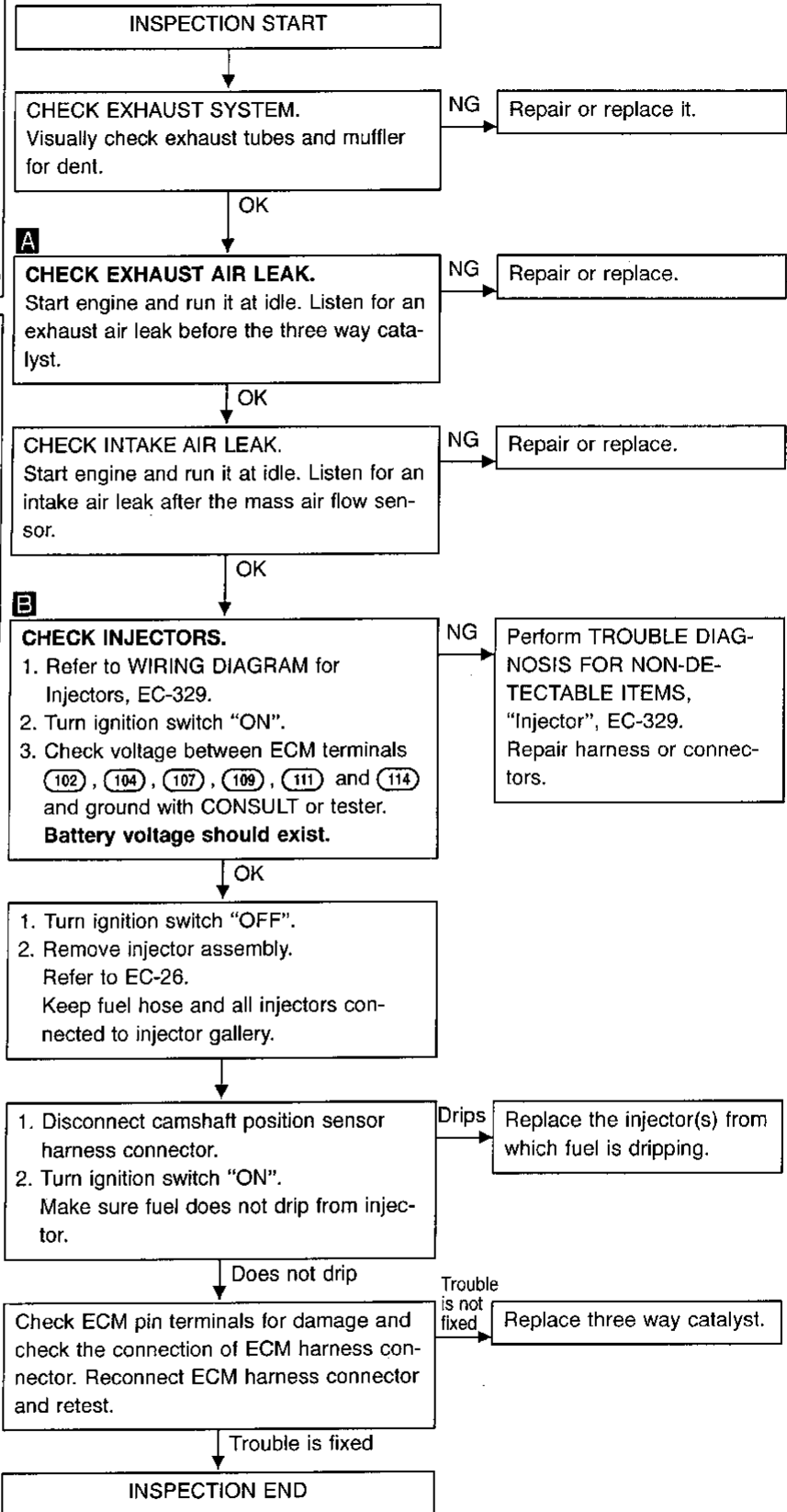
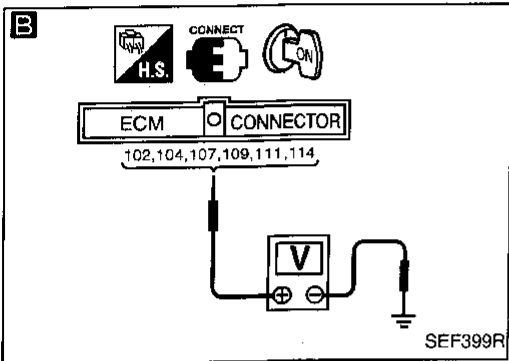
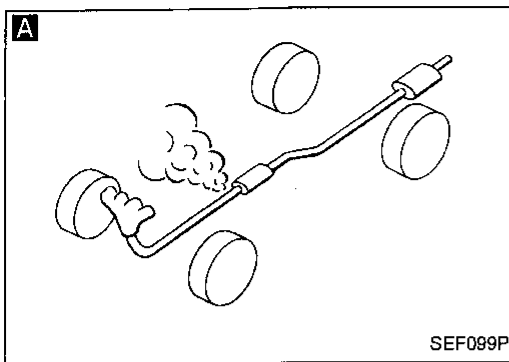

GI
MA
EM
LC
EC
FE
AT
TF
PD
FA
RA
BR
ST
RS
BT
HA
EL
IDX

TROUBLE DIAGNOSIS FOR DTC P0440

Evaporative Emission (EVAP) Control System (Small Leak)

Note: If both DTC P0440 and P0446 are displayed, perform TROUBLE DIAGNOSIS FOR DTC P0446 first.
(See EC-242.)

ON BOARD DIAGNOSIS LOGIC

This diagnosis uses two methods to detect leaks in the EVAP purge line.

The first method, the pressure test, makes use of vapor pressure in the fuel tank. The second method, the vacuum test, makes use of engine intake manifold vacuum.

Pressure test

The EVAP canister vent control valve is closed to shut the EVAP purge line. The vacuum cut valve bypass valve will then be opened to clear the line between the fuel tank and the EVAP canister purge control valve. The EVAP control system pressure sensor can now monitor the pressure inside the fuel tank.

If pressure increases, the ECM will check for leaks in the line between the vacuum cut valve and EVAP canister purge control valve. If no pressure does not increase, the ECM will perform the "Vacuum test".

Vacuum test

If pressure does not increase in the "Pressure test", the ECM will check for leaks in the line between the fuel tank and EVAP canister purge control valve, under the following "Vacuum test" conditions.

The vacuum cut valve bypass valve is opened to clear the line between the fuel tank and the EVAP canister purge control valve. The EVAP canister vent control valve will then be closed to shut the EVAP purge line off. The EVAP canister purge volume control valve and EVAP canister purge control valve are opened to depressurize the EVAP purge line using intake manifold vacuum. After this occurs, the EVAP canister purge control valve and EVAP canister purge volume control valve will be closed.

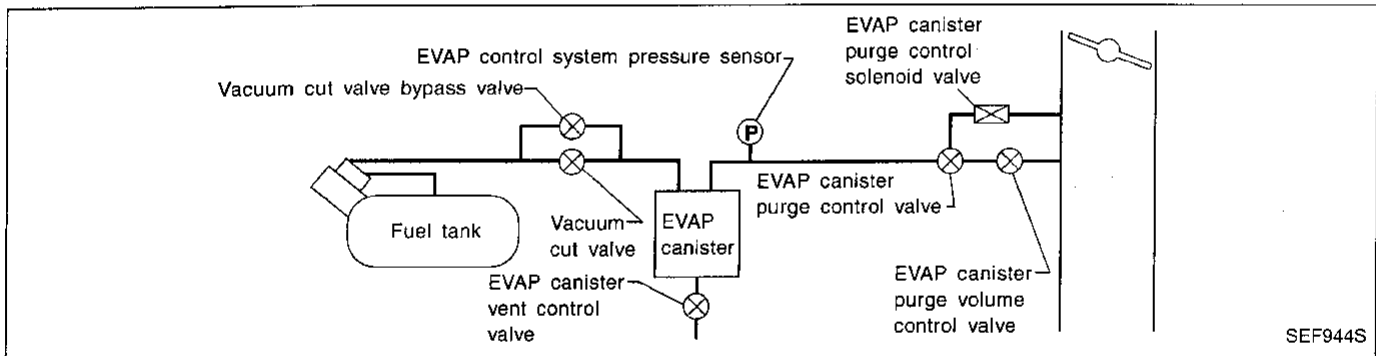

TROUBLE DIAGNOSIS FOR DTC P0440

Evaporative Emission (EVAP) Control System (Small Leak) (Cont'd)

ON BOARD DIAGNOSIS LOGIC

Diagnostic Trouble Code No.	Malfunction is detected when	Check Items (Possible Cause)
P0440 0705	<ul style="list-style-type: none"> • EVAP control system has a leak. • EVAP control system does not operate properly. 	<ul style="list-style-type: none"> • Incorrect fuel tank vacuum relief valve • Incorrect fuel filler cap used • Fuel filler cap remains open or fails to close. • Foreign matter caught in fuel filler cap. • Leak is in line between intake manifold and EVAP canister purge control valve. • Foreign matter caught in EVAP canister vent control valve. • EVAP canister or fuel tank leaks • EVAP purge line (pipe and rubber tube) leaks • EVAP purge line rubber tube bent. • Blocked or bent rubber tube to EVAP control system pressure sensor • Loose or disconnected rubber tube • EVAP canister purge control valve • EVAP canister purge volume control valve • EVAP canister purge control solenoid valve • Absolute pressure sensor • Tank fuel temperature sensor • MAP/BARO switch solenoid valve • Blocked or bent rubber tube to MAP/BARO switch solenoid valve • O-ring of EVAP canister vent control valve is missing or damaged.

CAUTION:

- Use only a genuine fuel filler cap as a replacement. If an incorrect fuel filler cap is used, the MIL may come on.
- If the fuel filler cap is not tightened properly, the MIL may come on.
- Use only a genuine rubber tube as a replacement.

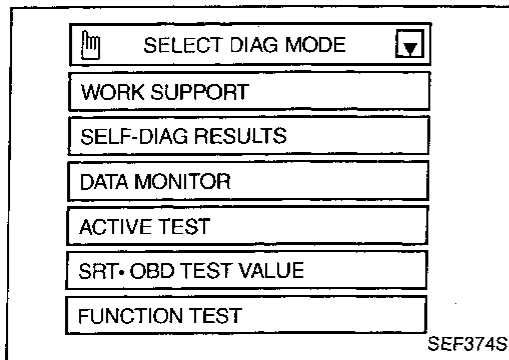

DIAGNOSTIC TROUBLE CODE CONFIRMATION PROCEDURE



CAUTION:

- Always select "SINGLE TEST" with CONSULT when performing the "FUNCTION TEST".
 - Perform "FUNCTION TEST" when the fuel level is less than 3/4 full. If not, inspect fuel filler cap and fuel tank separately. Refer to EC-228.
- 1) Select "EVAP (SMALL LEAK)" in "FUNCTION TEST" mode with CONSULT.
Follow the instructions displayed.
 - 2) Make sure that "OK" is displayed with "EVAP (SMALL LEAK)". (If "NG" is displayed, refer to "DIAGNOSTIC PROCEDURE".)
Refer to EC-228.

OR

TROUBLE DIAGNOSIS FOR DTC P0440

Evaporative Emission (EVAP) Control System (Small Leak) (Cont'd)

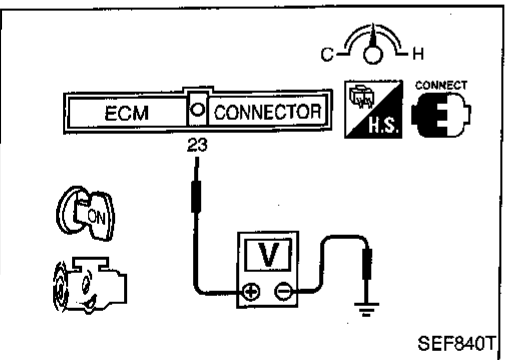
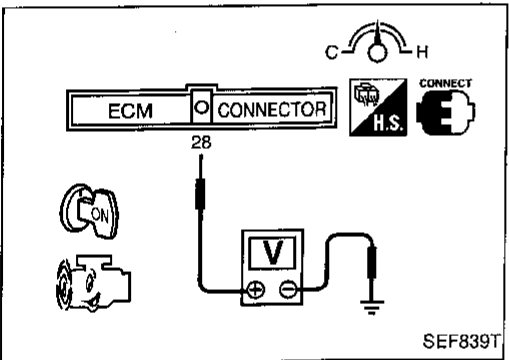
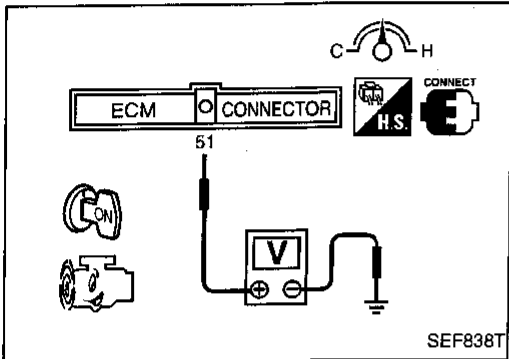
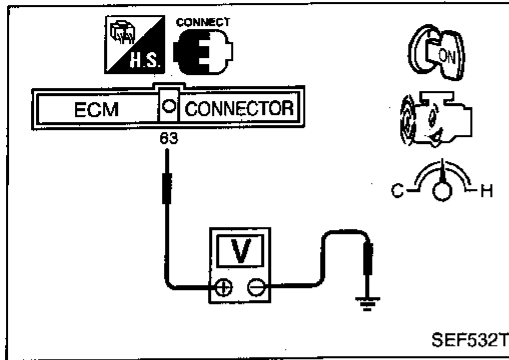

- 1) Start engine and warm it up sufficiently.
- 2) Check voltage between ECM terminal ⑥③ and ground (**Voltage 1**).
Voltage: 1.9 - 4.2V
- 3) Check voltage between ECM terminal ⑤① and ground.
Voltage: 0.8 - 1.5V
Perform the following procedure before the voltage drops below 0.8V. If the voltage drops below 0.8V, cool down the engine and perform the entire procedure once again.
- 4) Check voltage between ECM terminal ②⑧ and ground.
Voltage: 1.9 - 4.1V
- 5) Turn ignition switch "OFF" and wait at least 5 seconds.
- 6) Turn ignition switch "ON" and wait at least 15 seconds.
- 7) Restart engine and let it idle for at least 80 seconds.
- 8) Maintain the following conditions for at least 80 seconds.
Gear position: Suitable gear position
Vehicle speed: 40 - 80 km/h (25 - 50 MPH)
Engine speed: 1,500 - 3,000 rpm
Check voltage between ECM terminal ⑤① and ground: 0.8 - 1.5V
- 9) Decelerate the vehicle to 0 km/h (0 MPH) and let engine idle.
- 10) Maintain the following conditions for at least 5 seconds.
Gear position: "1" or "2" range
Engine speed: 2,500 - 3,400 rpm
- 11) Perform steps 9, 10 more than 20 times.
- 12) Decelerate the vehicle speed to 0 km/h (0 MPH) and let engine idle.
- 13) Maintain the following conditions for at least 10 seconds consecutively.
Gear position: Suitable gear position
Vehicle speed: 40 - 80 km/h (25 - 50 MPH)
Engine speed: 1,500 - 3,000 rpm
- 14) Decelerate the vehicle to idle and wait at least 10 seconds.
- 15) Check voltage between ECM terminal ⑥③ and ground (**Voltage 2**).
Voltage: 1.9 - 4.2V
- 16) Check voltage decrease between **voltage 1** and **2**.
Voltage 1 - Voltage 2 ≥ 0.1V
- 17) Check voltage between ECM terminal ②③ and ground (**Voltage 3**).
Voltage: 0.3 - 0.7V
- 18) Maintain the following conditions for 9 minutes measuring voltage between ECM terminal ②③ and ground (**Voltage 4**), after 12 minutes have passed from restarting engine in step 5.
Gear position: Suitable gear position
Vehicle speed: 20 - 80 km/h (12 - 50 MPH)
Engine speed: 1,000 - 3,500 rpm
Voltage between ECM terminal ②③ and ground: 1.9 - 4.1V
Voltage 4 - Voltage 3 ≤ 1.0V
- 19) Stop the vehicle, turn ignition switch "OFF", wait at least 5 seconds, and then turn "ON".
- 20) Perform "Diagnostic Test Mode II (Self-diagnostic results)" with ECM.

TROUBLE DIAGNOSIS FOR DTC P0440

Evaporative Emission (EVAP) Control System (Small Leak) (Cont'd)

NOTE:

- Hold the accelerator pedal as steady as possible during driving in steps 8, 10, 13 and 18.
- If the driving conditions are not satisfied in steps 8, 10, 13, and 18, restart the procedure.
- It is better that the fuel level is low.
- Open the hood during warming up engine or continuous idling of 30 seconds or more.
Close the hood before driving the vehicle.
(EX: Step 1, 5, 13 etc)

GI

MA

EM

LC

EC

FE

AT

TF

PD

FA

RA

BR

ST

RS

BT

HA

EL

IDX

TROUBLE DIAGNOSIS FOR DTC P0440

Evaporative Emission (EVAP) Control System (Small Leak) (Cont'd)

DIAGNOSTIC PROCEDURE

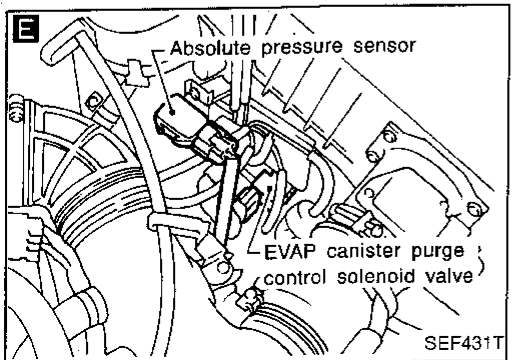
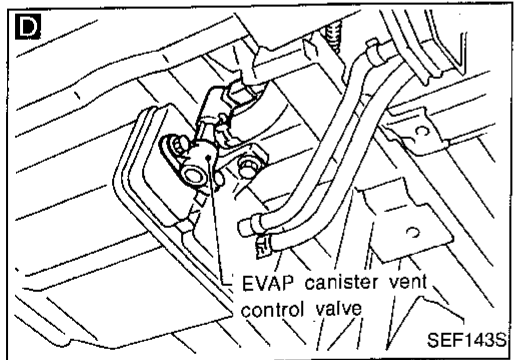
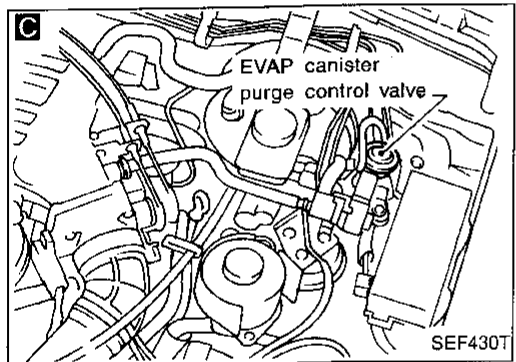
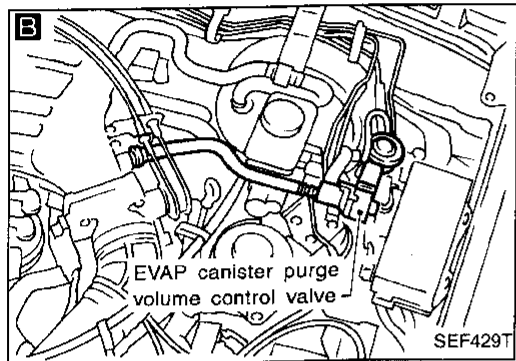
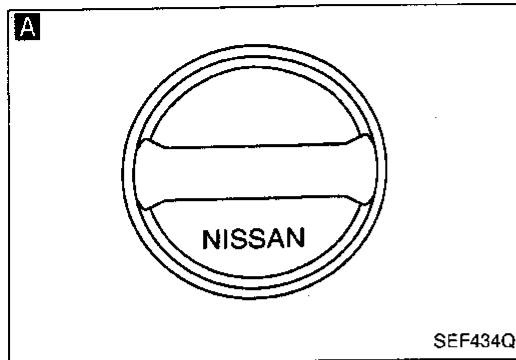

INSPECTION START

A
CHECK FUEL FILLER CAP.
1. Check that fuel filler cap does not remain open, closes properly and does not contain foreign matter.
2. Check for genuine fuel filler cap design.
3. Check fuel tank vacuum relief valve. Refer to "EVAPORATIVE EMISSION SYSTEM", EC-21.

NG →
1. Open fuel filler cap, then clean cap and fuel filler neck threads using air blower.
2. Replace with genuine fuel filler cap.

OK
B
CHECK COMPONENT (EVAP canister purge volume control valve). Refer to "COMPONENT INSPECTION", EC-230.

NG →
Replace EVAP canister purge volume control valve.

OK
C
CHECK COMPONENT (EVAP canister purge control valve). Refer to "COMPONENT INSPECTION", EC-231.

NG →
Replace EVAP canister purge control valve.

OK
D
CHECK COMPONENT (EVAP canister vent control valve). Refer to "COMPONENT INSPECTION", EC-231.

NG →
Replace EVAP canister vent control valve.

OK
E
CHECK COMPONENT (EVAP canister purge control solenoid valve).
1. Disconnect vacuum hose to EVAP canister purge control valve.
2. Start engine.
3. Perform "PURG CONT S/V" in "ACTIVE TEST" mode.
4. Select "ON" on CONSULT screen to turn on "PURG CONT S/V".
5. Check vacuum hose for vacuum when revving engine up to 2,000 rpm.
Vacuum should exist.

NG →
Check the following.
• EVAP canister purge control solenoid valve. Refer to "COMPONENTS INSPECTION", EC-231.
• Vacuum hoses for clogging or disconnection. Refer to "Vacuum Hose Drawing", EC-231.

OR
1. Start engine and warm it up sufficiently.
2. Stop engine.
3. Jack up drive wheels.
4. Disconnect vacuum hose to EVAP canister purge control valve.
5. Start engine.
6. Check vacuum hose for vacuum when revving engine up to 2,000 rpm.
Vacuum should exist.

OK
A

TROUBLE DIAGNOSIS FOR DTC P0440

Evaporative Emission (EVAP) Control System (Small Leak) (Cont'd)

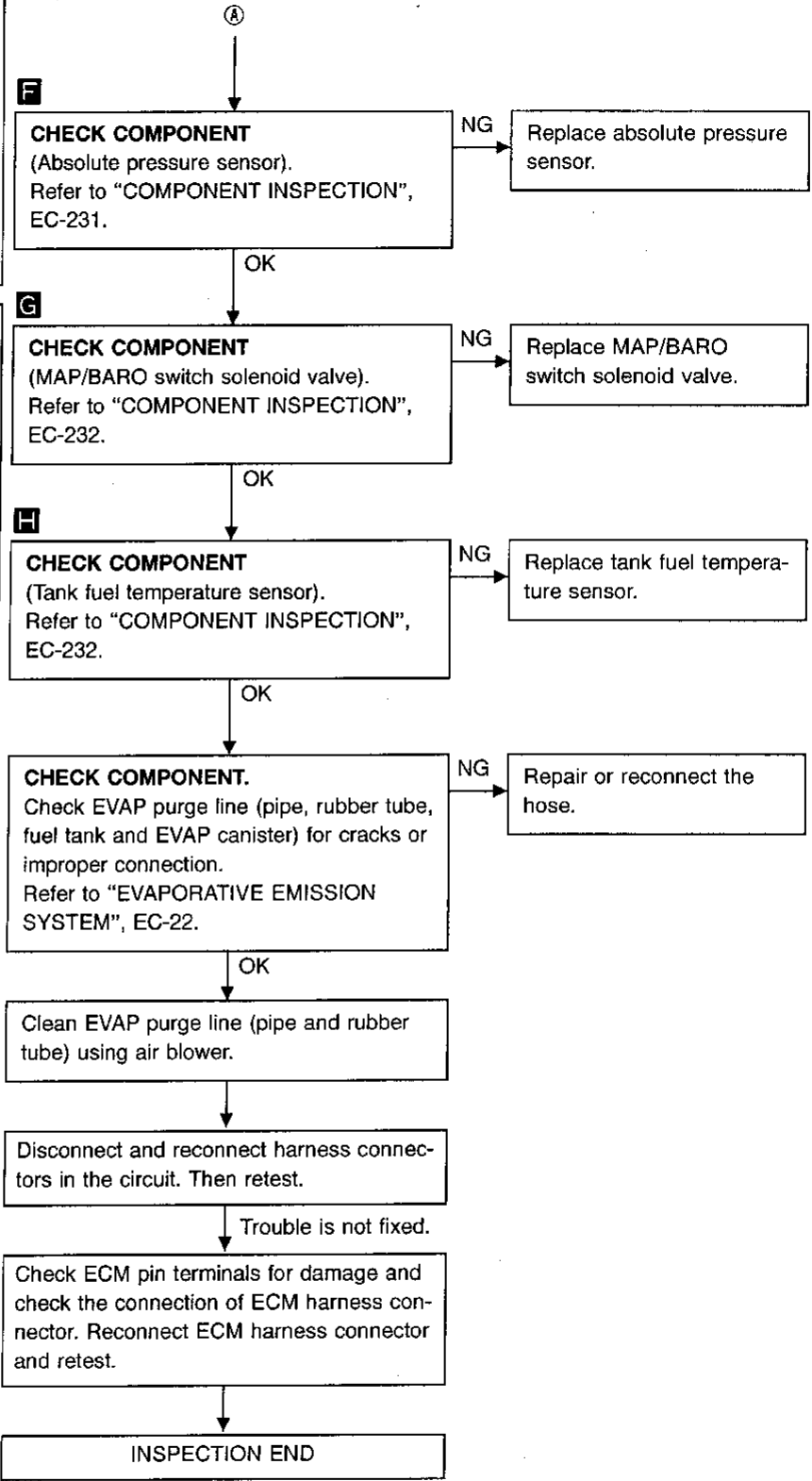
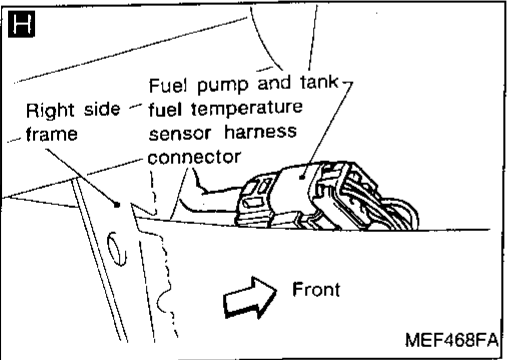
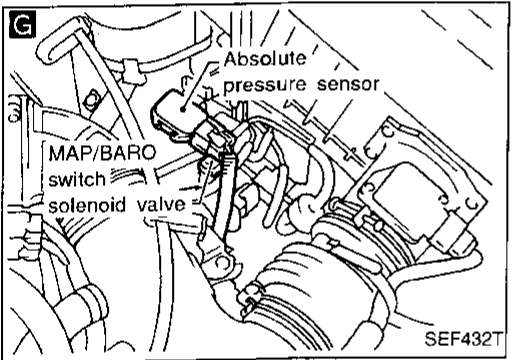
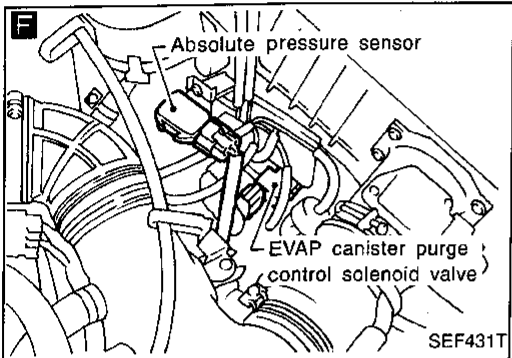
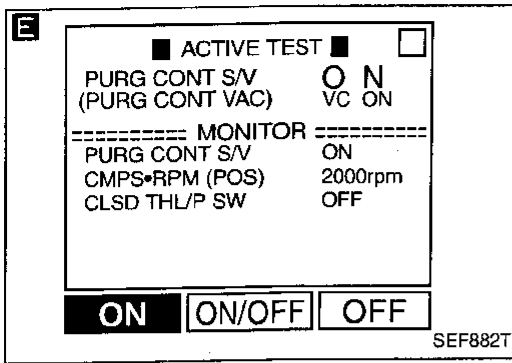

GI
MA
EM
LC
EC
FE
AT
TF
PD
FA
RA
BR
ST
RS
BT
HA
EL
IDX

TROUBLE DIAGNOSIS FOR DTC P0440

Evaporative Emission (EVAP) Control System (Small Leak) (Cont'd)

COMPONENT INSPECTION

EVAP canister purge volume control valve

1. Disconnect EVAP canister purge volume control valve harness connector.
2. Check resistance between the following terminals.
terminal ② and terminals ①, ③
terminal ⑤ and terminals ④, ⑥

Resistance:

Approximately 30Ω [At 25°C (77°F)]

3. Reconnect EVAP canister purge volume control valve harness connector.
4. Remove EVAP canister purge volume control valve from intake manifold collector and disconnect hoses from the valve.
(Plug the purge hoses. The EVAP canister purge volume control valve harness connector should remain connected.)
5. Turn ignition switch "ON".
6. Perform "PURG VOL CONT/V" in "ACTIVE TEST" mode with CONSULT. Check that EVAP canister purge volume control valve shaft moves smoothly forward and backward according to the valve opening.
If NG, replace the EVAP canister purge volume control valve.

OR



1. Disconnect EVAP canister purge volume control valve harness connector.
2. Check resistance between the following terminals.
terminal ② and terminals ①, ③
terminal ⑤ and terminals ④, ⑥

Resistance:

Approximately 30Ω [At 25°C (77°F)]

3. Reconnect EVAP canister purge volume control valve harness connector.
4. Remove EVAP canister purge volume control valve from intake manifold collector and disconnect hoses from the valve.
(Plug the purge hoses. The EVAP canister purge volume control valve harness connector should remain connected.)
5. Turn ignition switch "ON" and "OFF". Check that EVAP canister purge volume control valve shaft moves smoothly forward and backward according to the ignition switch position.
If NG, replace the EVAP canister purge volume control valve.

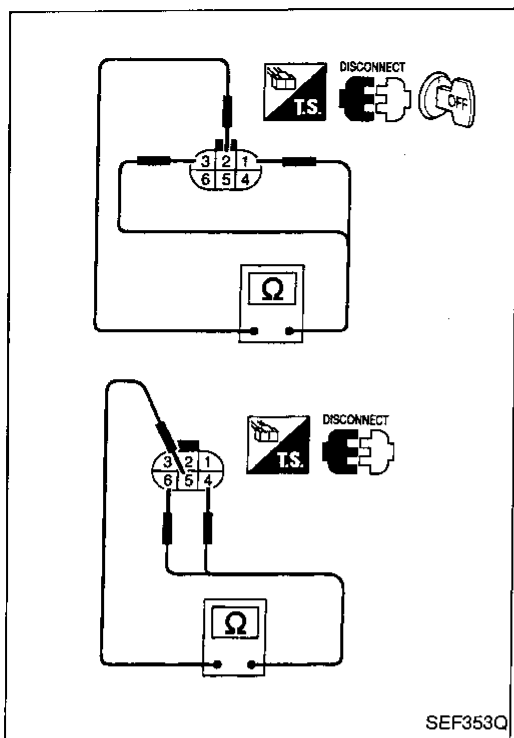

SEF353Q

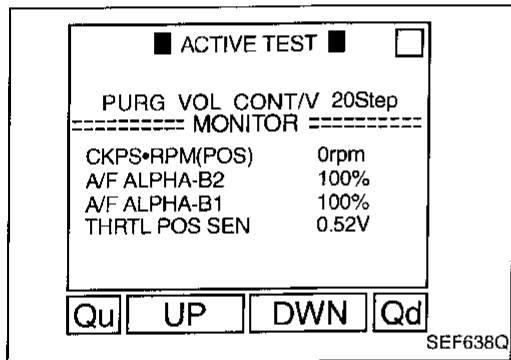

SEF638Q

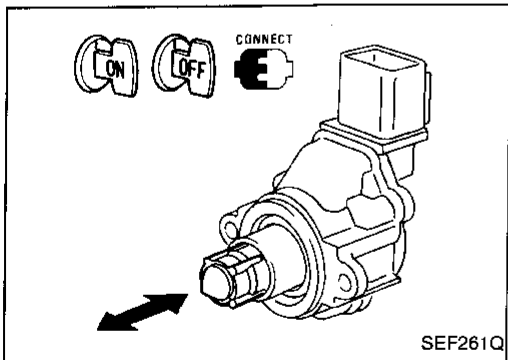

SEF261Q

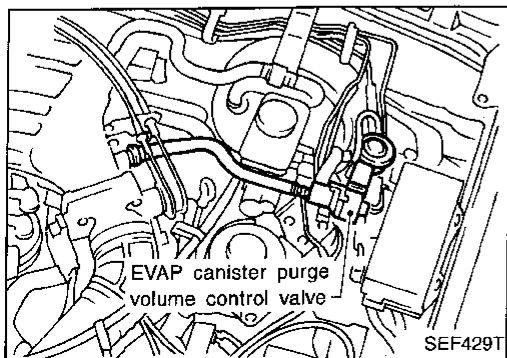

SEF429T

TROUBLE DIAGNOSIS FOR DTC P0440

Evaporative Emission (EVAP) Control System (Small Leak) (Cont'd)

EVAP canister purge control solenoid valve

Check air passage continuity.

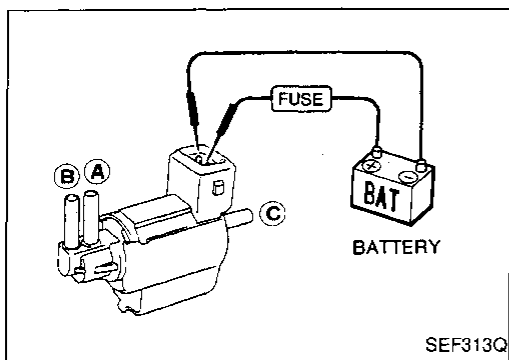

Condition	Air passage continuity between (A) and (B)	Air passage continuity between (A) and (C)
12V direct current supply between terminals	Yes	No
No supply	No	Yes

If NG, replace solenoid valve.

GI
MA
EM
LC

EC

FE

AT

TF

PD

FA

RA

BR

ST

RS

BT

HA

EL

IDX

HA

HA

HA

HA

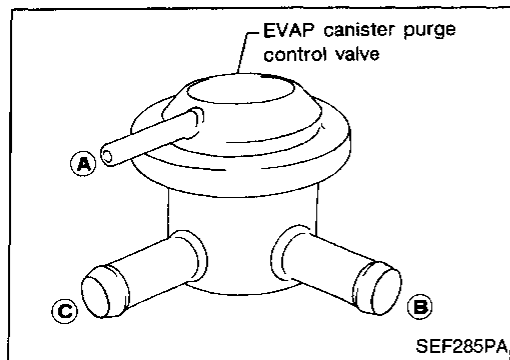

EVAP canister purge control valve

Check EVAP canister purge control valve as follows:

1. Plug the port (B).
2. Apply pressure [80.0 kPa (600 mmHg, 23.62 inHg)] to port (A). Then keep it for 15 seconds, and check there is no leakage.
3. Repeat step 2 for port (C).

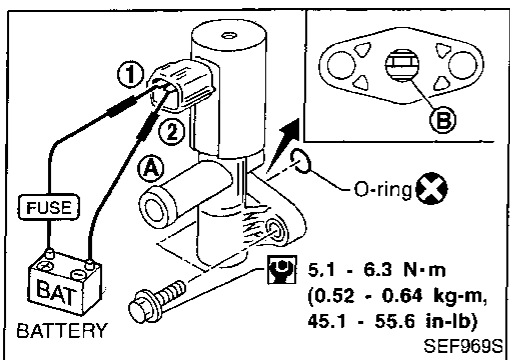

EVAP canister vent control valve

Check air passage continuity.

Condition	Air passage continuity between (A) and (B)
12V direct current supply between terminals (1) and (2)	No
No supply	Yes

If NG, clean valve using air blower or replace as necessary.

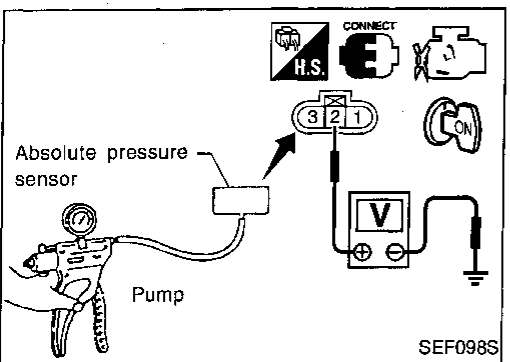

Absolute pressure sensor

1. Remove absolute pressure sensor from bracket with its harness connector connected.
2. Remove hose from absolute pressure sensor.
3. Turn ignition switch "ON" and check output voltage between terminal (2) and engine ground.
The voltage should be 3.2 to 4.8 V.
4. Use pump to apply vacuum of -26.7 kPa (-200 mmHg, -7.87 inHg, -3.87 psi) to absolute pressure sensor as shown in figure and check the output voltage.
The voltage should be 1.0 to 1.4 V lower than the value measured in step 3.

TROUBLE DIAGNOSIS FOR DTC P0440

Evaporative Emission (EVAP) Control System (Small Leak) (Cont'd)

CAUTION:

Always calibrate the vacuum pump gauge when using it.

- If NG, replace absolute pressure sensor.

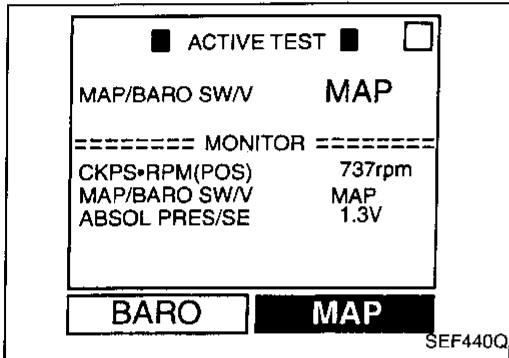

MAP/BARO switch solenoid valve

- Start engine and warm it up sufficiently.
- Perform "MAP/BARO SW/V" in "ACTIVE TEST" mode with CONSULT.
- Check the following.
 - When "MAP" is selected, "ABSOL PRES/SE" indicates approximately 1.3V.
 - When "BARO" is selected, "ABSOL PRES/SE" indicates approximately 4.3V.
- If NG, replace solenoid valve.

OR

- Remove MAP/BARO switch solenoid valve.
- Check air passage continuity.

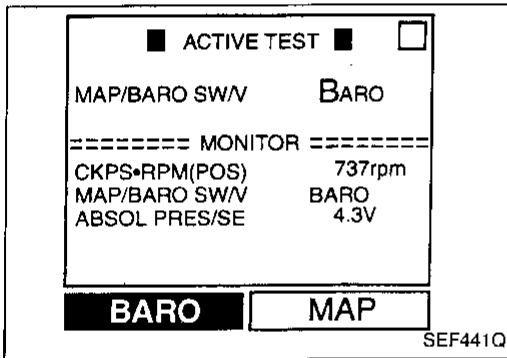

Condition	Air passage continuity between (A) and (B)	Air passage continuity between (A) and (C)
12V direct current supply between terminals ① and ②	Yes	No
No supply	No	Yes

- If NG, replace solenoid valve.

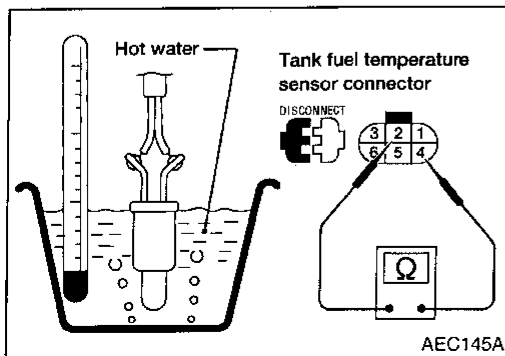
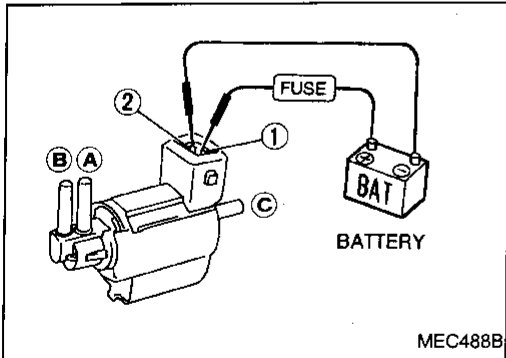

Tank fuel temperature sensor

Check resistance by heating with hot water or heat gun as shown in the figure.

Temperature °C (°F)	Resistance kΩ
20 (68)	2.3 - 2.7
50 (122)	0.79 - 0.90

If NG, replace tank fuel temperature sensor.

Evaporative Emission (EVAP) Canister Purge Control Valve/Solenoid Valve

SYSTEM DESCRIPTION

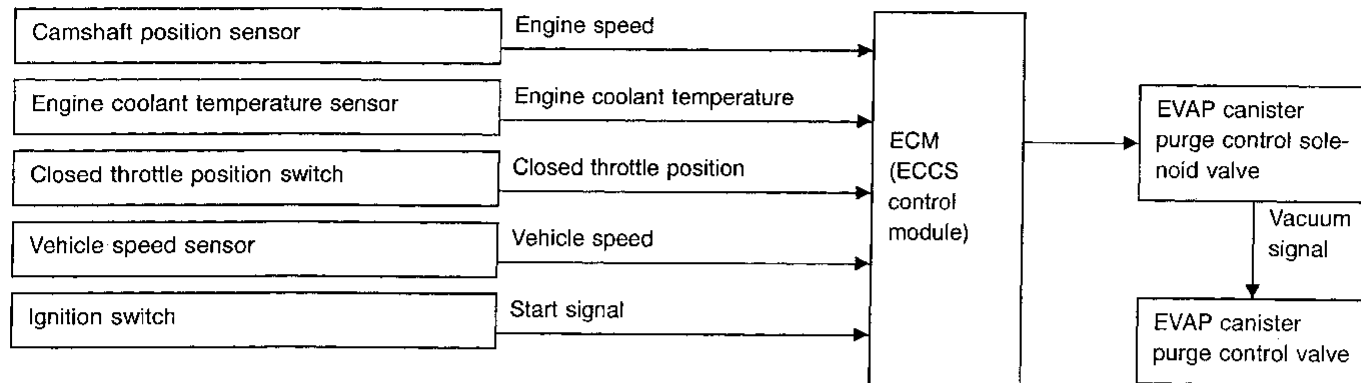

This system controls the vacuum signal applied to the EVAP canister purge control valve. When the ECM detects any of the following conditions, current does not flow through the EVAP canister purge control solenoid valve. The solenoid valve cuts the vacuum signal so that the EVAP canister purge control valve remains closed.

- Ignition switch "ON"
- Closed throttle position
- Low or high engine coolant temperature
- During deceleration
- Engine stopped
- Low vehicle speed

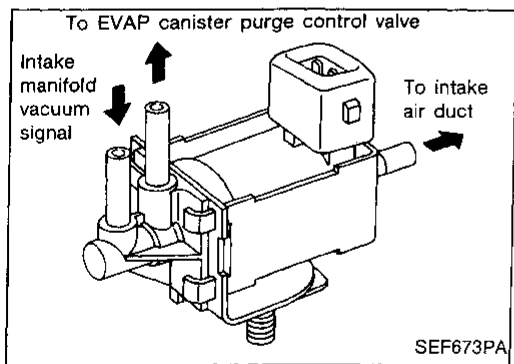

COMPONENT DESCRIPTION

EVAP canister purge control solenoid valve

The EVAP canister purge control solenoid valve responds to signals from the ECM. When the ECM sends an OFF signal, the vacuum signal (from the intake manifold to the EVAP canister purge control valve) is cut. When the ECM sends an ON (ground) signal, the vacuum signal passes through the EVAP canister purge control solenoid valve. The signal then opens the EVAP canister purge control valve.

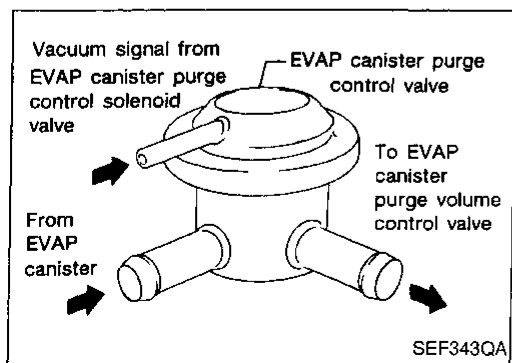

EVAP canister purge control valve

When the vacuum signal is cut by EVAP canister purge control solenoid valve, EVAP canister purge control valve closes.

GI
MA
EM
LC
EC
FE
AT
TF
PD
FA
RA
BR
ST
RS
BT
HA
EL
IDX

TROUBLE DIAGNOSIS FOR DTC P0443

Evaporative Emission (EVAP) Canister Purge Control Valve/Solenoid Valve (Cont'd)

EVAPORATIVE EMISSION SYSTEM DIAGRAM

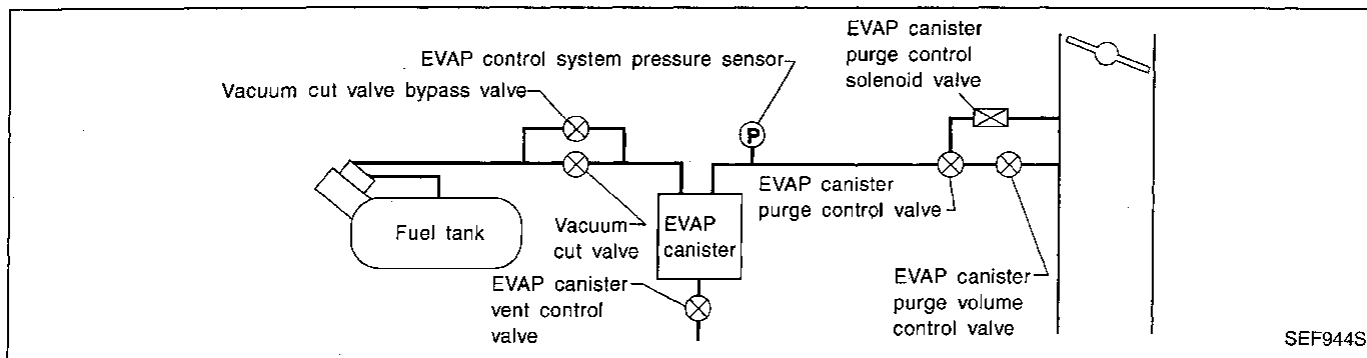

CONSULT REFERENCE VALUE IN DATA MONITOR MODE

Specification data are reference values.

MONITOR ITEM	CONDITION	SPECIFICATION
PURG CONT S/V	● Engine: After warming up	OFF
		ON

ECM TERMINALS AND REFERENCE VALUE

Specification data are reference values and are measured between each terminal and Ⓞ (ECCS ground).

TER-MINAL NO.	WIRE COLOR	ITEM	CONDITION	DATA (DC Voltage)
105	Y/R	EVAP canister purge control solenoid valve	Engine is running. └ Idle speed	BATTERY VOLTAGE (11 - 14V)
			Engine is running. └ Engine speed is 2,000 rpm.	Approximately 0V

ON BOARD DIAGNOSIS LOGIC

Diagnostic Trouble Code No.	Malfunction is detected when	Check Items (Possible Cause)
P0443 0807	A) The improper voltage signal is sent to ECM through EVAP canister purge control solenoid valve.	<ul style="list-style-type: none"> ● Harness or connectors (The EVAP canister purge control solenoid valve circuit is open or shorted.) ● EVAP canister purge control solenoid valve
	B) EVAP canister purge control valve does not operate properly (stuck open).	<ul style="list-style-type: none"> ● EVAP canister purge control valve ● EVAP canister purge control solenoid valve ● Vacuum hoses for clogging or disconnection ● EVAP control system pressure sensor

TROUBLE DIAGNOSIS FOR DTC P0443

Evaporative Emission (EVAP) Canister Purge Control Valve/Solenoid Valve (Cont'd)

DIAGNOSTIC TROUBLE CODE CONFIRMATION PROCEDURE

Perform "Procedure for malfunction A" first. If the (1st trip) DTC cannot be confirmed, perform "Procedure for malfunction B".

☆ MONITOR	☆ NO FAIL	<input type="checkbox"/>
CMPS•RPM(POS)	0rpm	
RECORD		

SEF888T

☆ MONITOR	☆ NO FAIL	<input type="checkbox"/>
CMPS•RPM(POS)	750rpm	
COOLAN TEMP/S	85°C	
RECORD		

SEF842T

☆ MONITOR	☆ NO FAIL	<input type="checkbox"/>
CMPS•RPM(POS)	2000rpm	
VHCL SPEED SE	60km/h	
COOLAN TEMP/S	85°C	
RECORD		

SEF843T

Procedure for malfunction A

-  1) Turn ignition switch "ON".
2) Select "DATA MONITOR" mode with CONSULT.
3) Wait at least 5 seconds.

- OR
-  1) Turn ignition switch "ON" and wait at least 5 seconds.
2) Select "MODE 7" with GST.

- OR
-  1) Turn ignition switch "ON" and wait at least 5 seconds.
2) Perform "Diagnostic Test Mode II (Self-diagnostic results)" with ECM.

Procedure for malfunction B

-  1) Lift up vehicle.
2) Start engine and warm it up sufficiently.
3) Select "DATA MONITOR" mode with CONSULT.
4) Check coolant temperature.
COOLAN TEMP/S: 40 - 100°C (104 - 212°F)
5) Turn ignition switch "OFF" and wait at least 5 seconds.
6) Turn ignition switch "ON" and wait at least 15 seconds.
7) Restart engine and let it idle for at least 80 seconds.
8) Maintain the following conditions for at least 30 seconds.

Gear position: Suitable gear position
VHCL SPEED SE: 40 - 80 km/h (25 - 50 MPH)
Engine speed: 1,500 - 3,000 rpm
COOLAN TEMP/S: 40 - 100°C (104 - 212°F)

NOTE:

- Hold the accelerator pedal as steady as possible during driving in steps 8.
- If the driving conditions are not satisfied in steps 8, restart the procedure.
- It is better that the fuel level is low.

GI
MA
EM
LC
EC
FE
AT
TF
PD
FA
RA
BR
ST
RS
BT
HA
EL
IDX

TROUBLE DIAGNOSIS FOR DTC P0443

Evaporative Emission (EVAP) Canister Purge Control Valve/Solenoid Valve (Cont'd)

ENGINE SPD	825RPM
COOLANT TEMP	69°C
VEHICLE SPD	0MPH
IGN ADVANCE	8.0°
CALC LOAD	28.2%
MAP	36KPaA
MAF	5.20gm/s
THROTTLE POS	0.0%
INTAKE AIR	27°C
FUEL SYS #1	OLDRIVE
FUEL SYS #2	UNUSED
SHORT FT #1	0.8%
LONG FT #1	0.0%
O2S B1 S1	0.200V
O2FT B1 S1	0.8%
O2S B1 S2	0.010V

SEF519R

OR



- 1) Lift up vehicle.
- 2) Start engine and warm it up sufficiently.
- 3) Select "MODE 1" with GST.
- 4) Check coolant temperature.
Coolant temperature: 40 - 100°C (104 - 212°F)
 Be sure that water temperature does not exceed 100°C. If it becomes higher than 100°C, cool down the engine and perform the procedure again from the beginning.
- 5) Turn ignition switch "OFF" and wait at least 5 seconds.
- 6) Turn ignition switch "ON" and wait at least 15 seconds.
- 7) Restart engine and let it idle for at least 80 seconds.
- 8) Maintain the following conditions for at least 30 seconds.
Gear position : Suitable gear position
Vehicle speed: 40 - 80 km/h (25 - 50 MPH)
Engine speed : 1,500 - 3,000 rpm
Coolant temperature: 40 - 100°C (104 - 212°F)
- 9) Select "MODE 7" with GST.

NOTE:

- Hold the accelerator pedal as steady as possible during driving in steps 8.
- If the driving conditions are not satisfied in steps 8, restart the procedure.
- It is better that the fuel level is low.

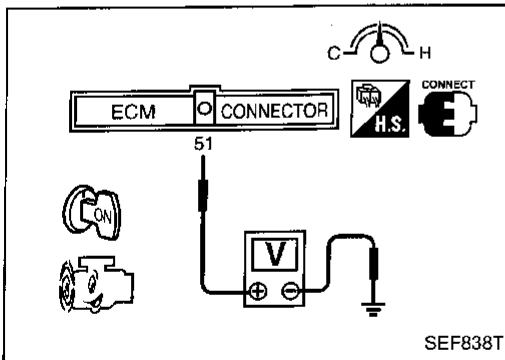

OR



- 1) Lift up vehicle.
- 2) Start engine and warm it up sufficiently.
- 3) Check voltage between ECM terminal ⑤① and ground
Voltage: 0.8 - 1.5V
 Perform the following procedure before the voltage drops below 0.8V. If the voltage drops below 0.8V, cool down the engine and perform the entire procedure all over again.
- 4) Turn ignition switch "OFF" and wait at least 5 seconds.
- 5) Turn ignition switch "ON" and wait at least 15 seconds.
- 6) Restart engine and let it idle for at least 80 seconds.
- 7) Maintain the following conditions for at least 30 seconds.
Gear position : Suitable gear position
Vehicle speed: 40 - 80 km/h (25 - 50 MPH)
Engine speed : 1,500 - 3,000 rpm
Check voltage between ECM terminal ⑤① and ground: 0.8 - 1.5 V
- 8) Stop the vehicle, turn ignition switch "OFF", wait at least 5 seconds, and then turn "ON".
- 9) Perform "Diagnostic Test Mode II (Self-diagnostic results)" with ECM.

TROUBLE DIAGNOSIS FOR DTC P0443

Evaporative Emission (EVAP) Canister Purge Control Valve/Solenoid Valve (Cont'd)

NOTE:

- Hold the accelerator pedal as steady as possible during driving in steps 7.
- If the driving conditions are not satisfied in steps 7, restart the procedure.
- It is better that the fuel level is low.

GI

MA

EM

LC

EC

FE

AT

TF

PD

FA

RA

BR

ST

RS

BT

HA

EL

IDX

TROUBLE DIAGNOSIS FOR DTC P0443

Evaporative Emission (EVAP) Canister Purge Control Valve/Solenoid Valve (Cont'd)

EC-CANI/V-01

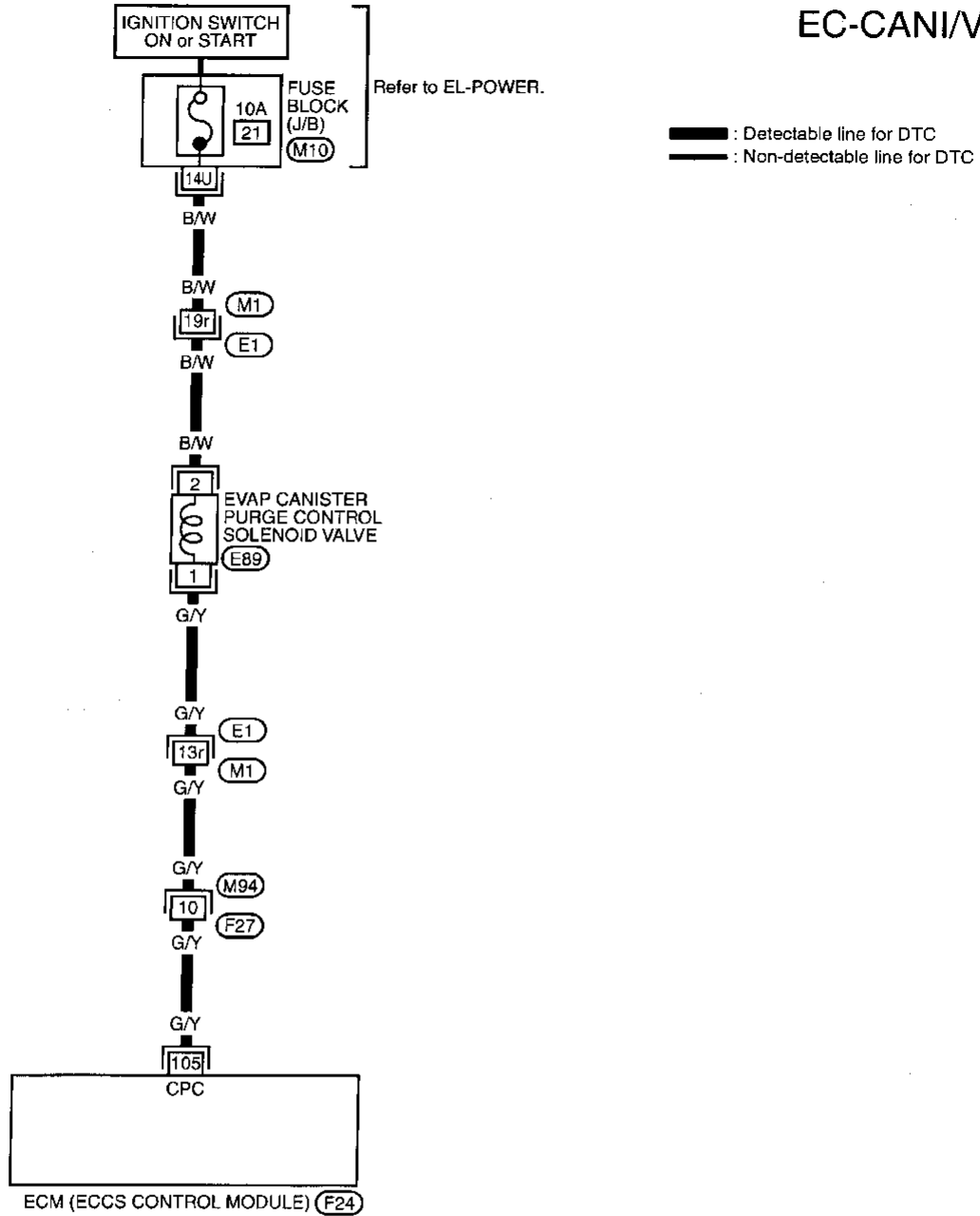

Refer to last page (Foldout page).

E1, M1
M10

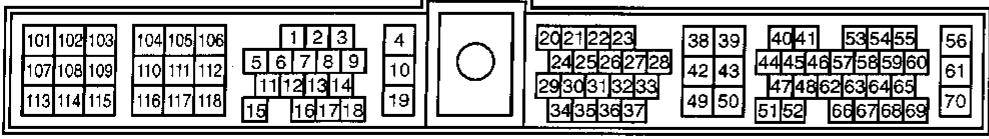
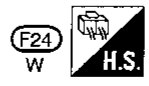
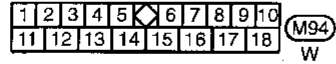
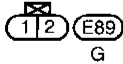

TROUBLE DIAGNOSIS FOR DTC P0443

Evaporative Emission (EVAP) Canister Purge Control Valve/Solenoid Valve (Cont'd)

DIAGNOSTIC PROCEDURE

Procedure for malfunction A

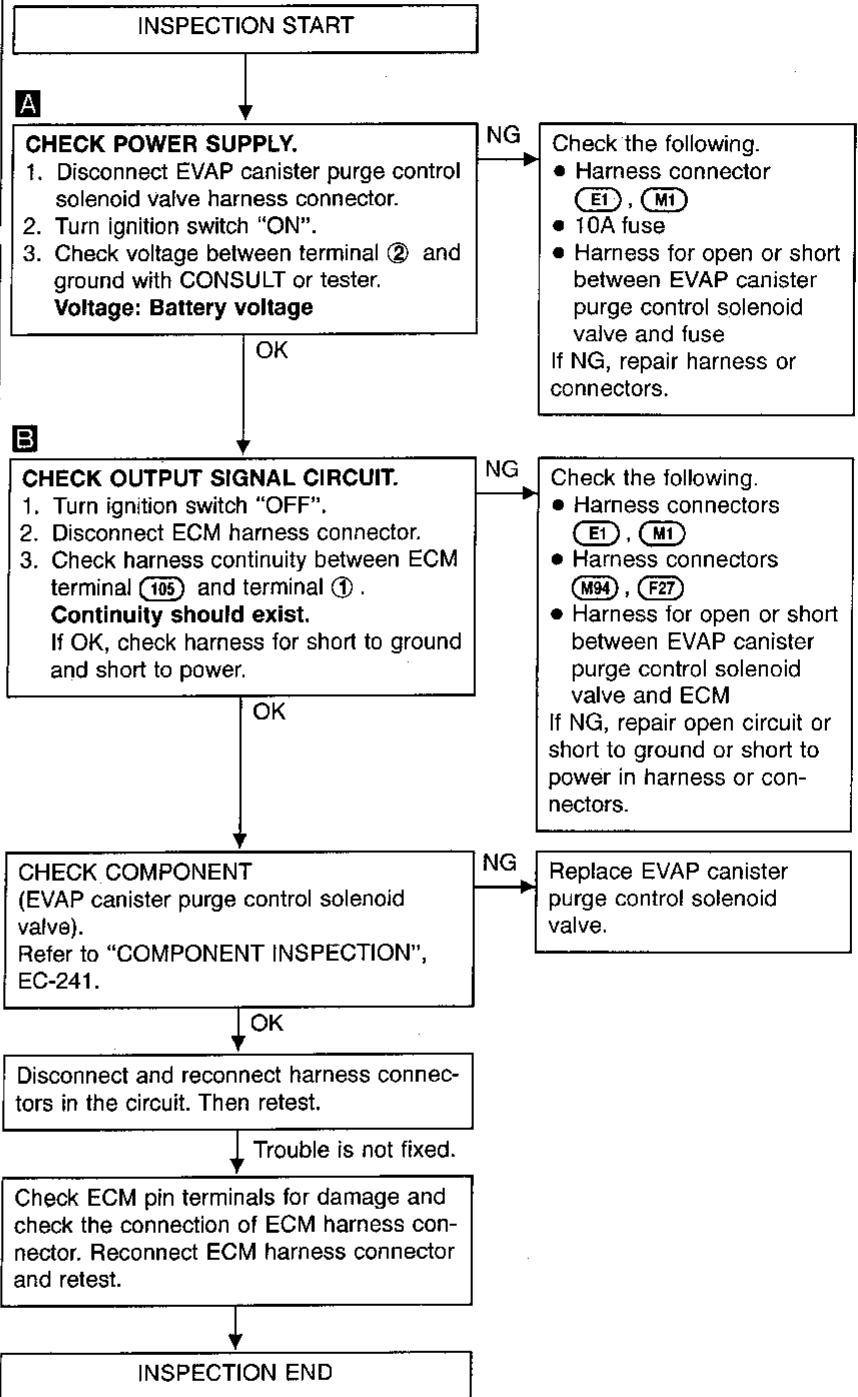
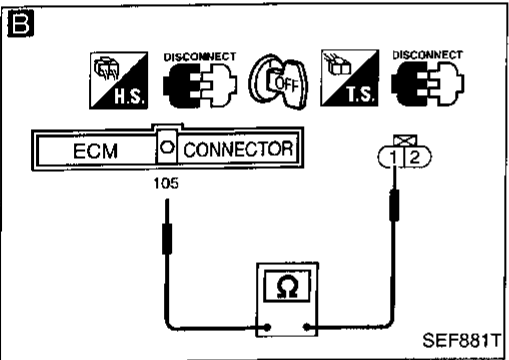
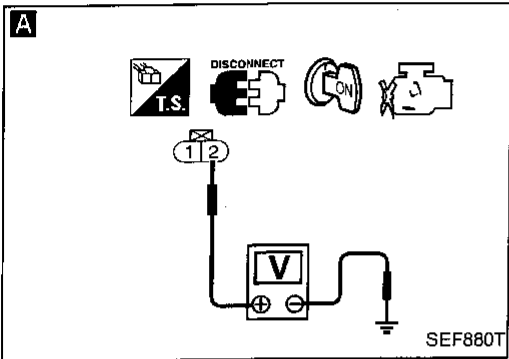
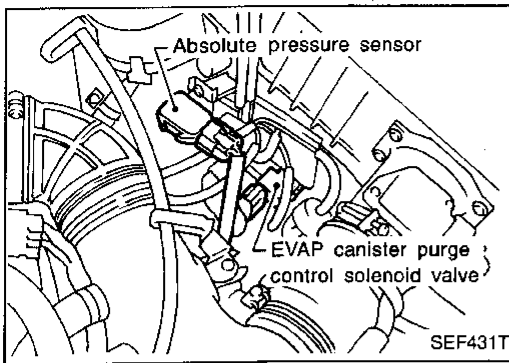

GI
MA
EM
LC
EC
FE
AT
TF
PD
FA
RA
BR
ST
RS
BT
HA
EL
IDX

TROUBLE DIAGNOSIS FOR DTC P0443

Evaporative Emission (EVAP) Canister Purge Control Valve/Solenoid Valve (Cont'd)

Procedure for malfunction B

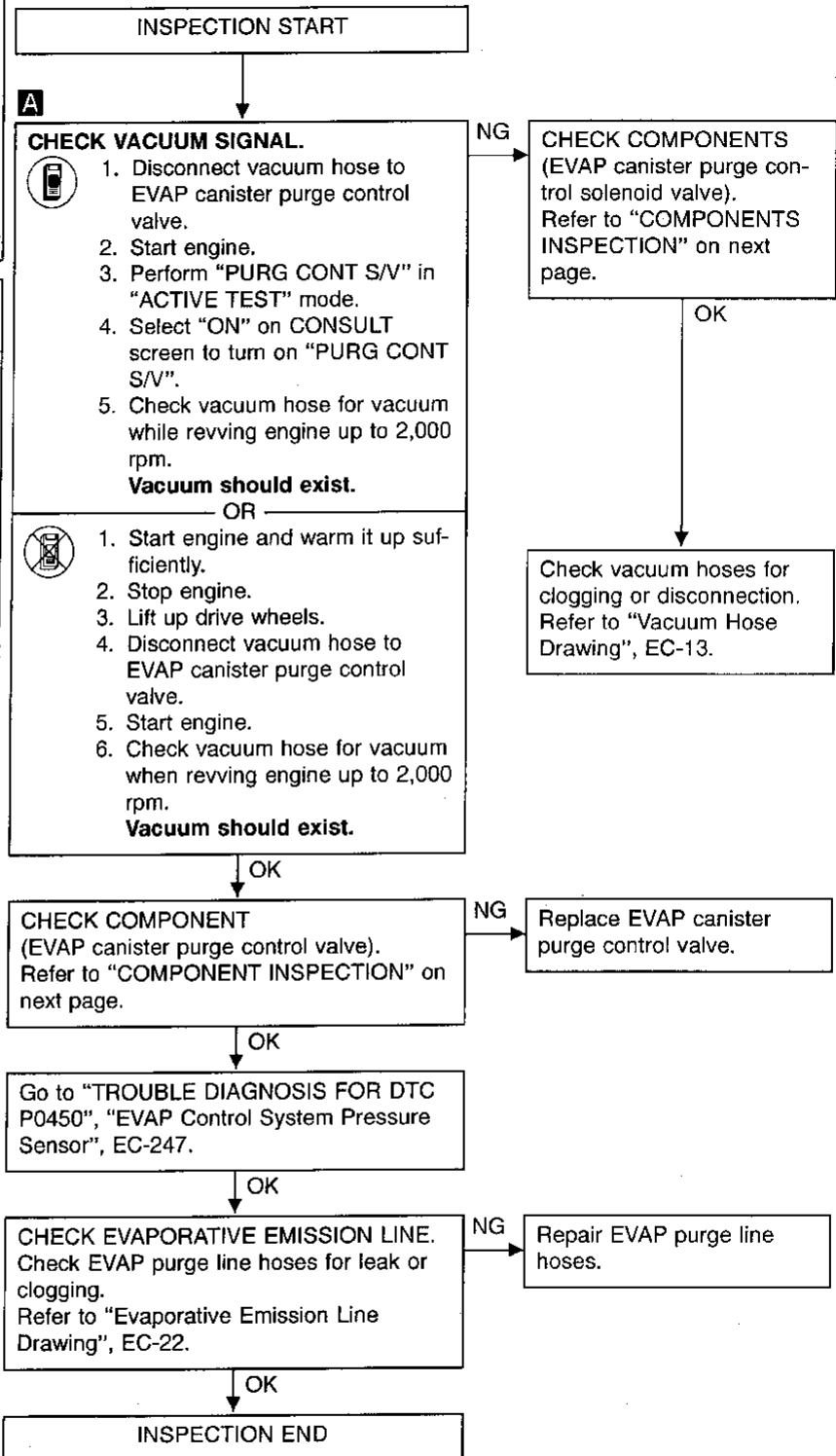
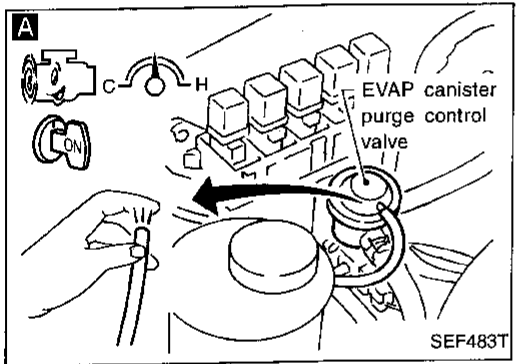
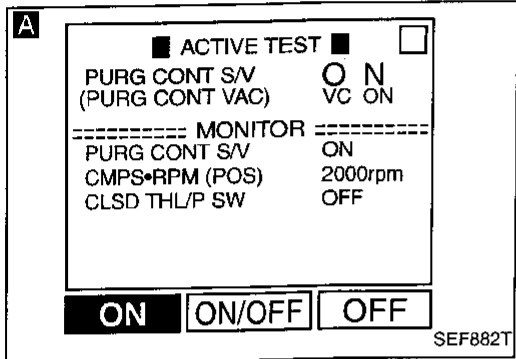
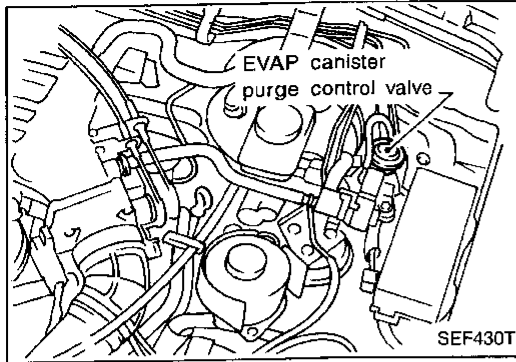

TROUBLE DIAGNOSIS FOR DTC P0443

Evaporative Emission (EVAP) Canister Purge Control Valve/Solenoid Valve (Cont'd)

COMPONENT INSPECTION

EVAP canister purge control solenoid valve

Check air passage continuity.

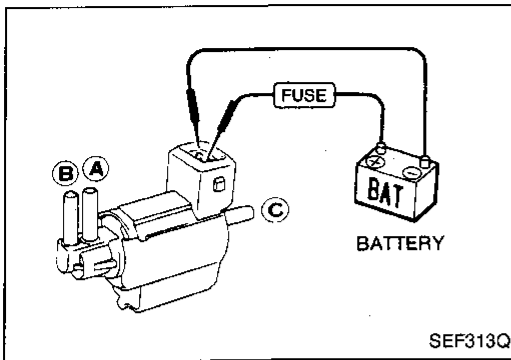

Condition	Air passage continuity between (A) and (B)	Air passage continuity between (A) and (C)
12V direct current supply between terminals	Yes	No
No supply	No	Yes

If NG, replace solenoid valve.

GI

MA

EM

LC

EC

FE

AT

TF

PD

FA

RA

BR

ST

RS

BT

HA

EL

IDX

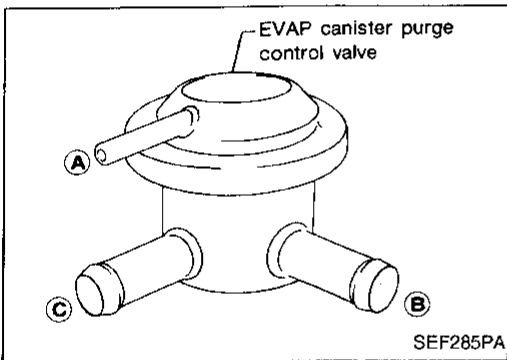

EVAP canister purge control valve

Check EVAP canister purge control valve as follows.

1. Plug the port (B).
2. Apply pressure [80.0 kPa (600 mmHg, 23.62 inHg, 11.60 psi)] to port (A). Then keep it for 15 seconds, and check there is no leakage.
3. Repeat step 2 for port (C).

TROUBLE DIAGNOSIS FOR DTC P0446

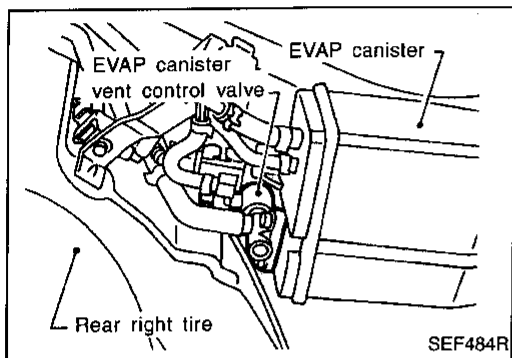
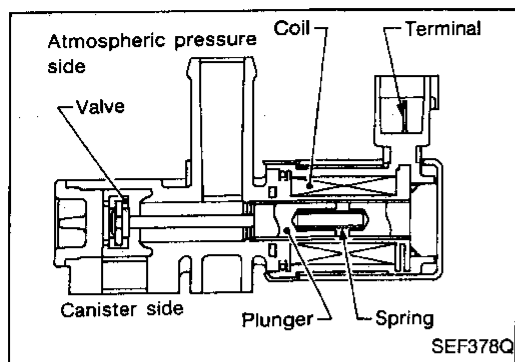

Evaporative Emission (EVAP) Canister Vent Control Valve

COMPONENT DESCRIPTION

Note:

If both DTC P0440 and P0446 are displayed, perform **TROUBLE DIAGNOSIS FOR DTC P0446** first.

The EVAP canister vent control valve is located on the EVAP canister and is used to seal the canister vent.

This solenoid (the EVAP canister vent control valve) responds to signals from the ECM.

When the ECM sends an ON signal, the coil in the solenoid valve is energized.

A plunger will then move to seal the canister vent. The ability to seal the vent is necessary for the on board diagnosis of other evaporative emission control system components.

This solenoid valve is used only for diagnosis, and usually remains opened.

When the vent is closed, under normal purge conditions, the evaporative emission control system is depressurized and allows "EVAP Control System (Small Leak)" diagnosis.

CONSULT REFERENCE VALUE IN DATA MONITOR MODE

Specification data are reference values.

MONITOR ITEM	CONDITION	SPECIFICATION
VENT CONT/V	● Ignition switch: ON	OFF

ECM TERMINALS AND REFERENCE VALUE

Specification data are reference values and are measured between each terminal and Ⓒ (ECCS ground).

TER-MINAL NO.	WIRE COLOR	ITEM	CONDITION	DATA (DC Voltage)
108	Y/G	EVAP canister vent control valve	Ignition switch "ON"	BATTERY VOLTAGE (11 - 14V)

ON BOARD DIAGNOSIS LOGIC

Diagnostic Trouble Code No.	Malfunction is detected when	Check Items (Possible Cause)
P0446 0903	A) An improper voltage signal is sent to ECM through EVAP canister vent control valve.	● Harness or connectors (EVAP canister vent control valve circuit is open or shorted.)
	B) EVAP canister vent control valve does not operate properly.	● EVAP canister vent control valve ● EVAP control system pressure sensor ● Blocked rubber tube to EVAP canister vent control valve ● WATER-SEPARATOR

TROUBLE DIAGNOSIS FOR DTC P0446

Evaporative Emission (EVAP) Canister Vent Control Valve (Cont'd)

DIAGNOSTIC TROUBLE CODE CONFIRMATION PROCEDURE

Perform "Procedure for malfunction A". If the DTC cannot be confirmed, perform "Procedure for malfunction B".

GI

MA

EM

LC

EC

FE

AT

TF

PD

FA

RA

BR

ST

RS

BT

HA

EL

IDX

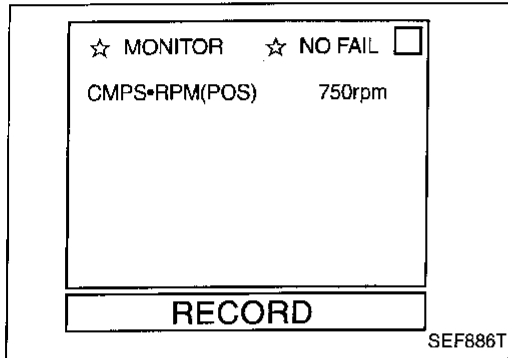

Procedure for malfunction A

- 1) Turn ignition switch "ON".
- 2) Select "DATA MONITOR" mode with CONSULT.
- 3) Start engine and wait at least 8 seconds.

OR

- 1) Start engine and wait at least 8 seconds.
- 2) Select "MODE 7" with GST.

OR

- 1) Start engine and wait at least 5 seconds.
- 2) Turn ignition switch "OFF", wait at least 8 seconds and then turn "ON".
- 3) Perform "Diagnostic Test Mode II (Self-diagnostic results)" with ECM.

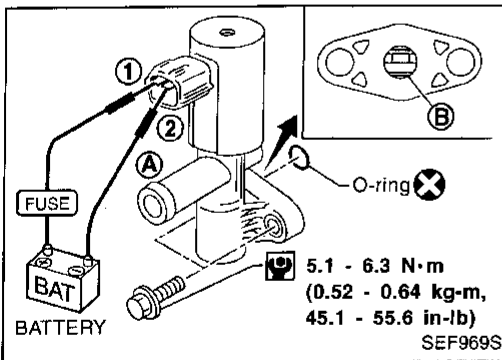

OVERALL FUNCTION CHECK

Use this procedure to check the overall function of the EVAP canister vent control valve circuit. During this check, a DTC might not be confirmed.

Procedure for malfunction B

- 1) Remove EVAP canister vent control valve from EVAP canister and disconnect hoses from the valve.
- 2) Check air passage continuity.

Condition	Air passage continuity between (A) and (B)
12V direct current supply between terminals ① and ②	No
No supply	Yes

TROUBLE DIAGNOSIS FOR DTC P0446

Evaporative Emission (EVAP) Canister Vent Control Valve (Cont'd)

EC-VENT/V-01

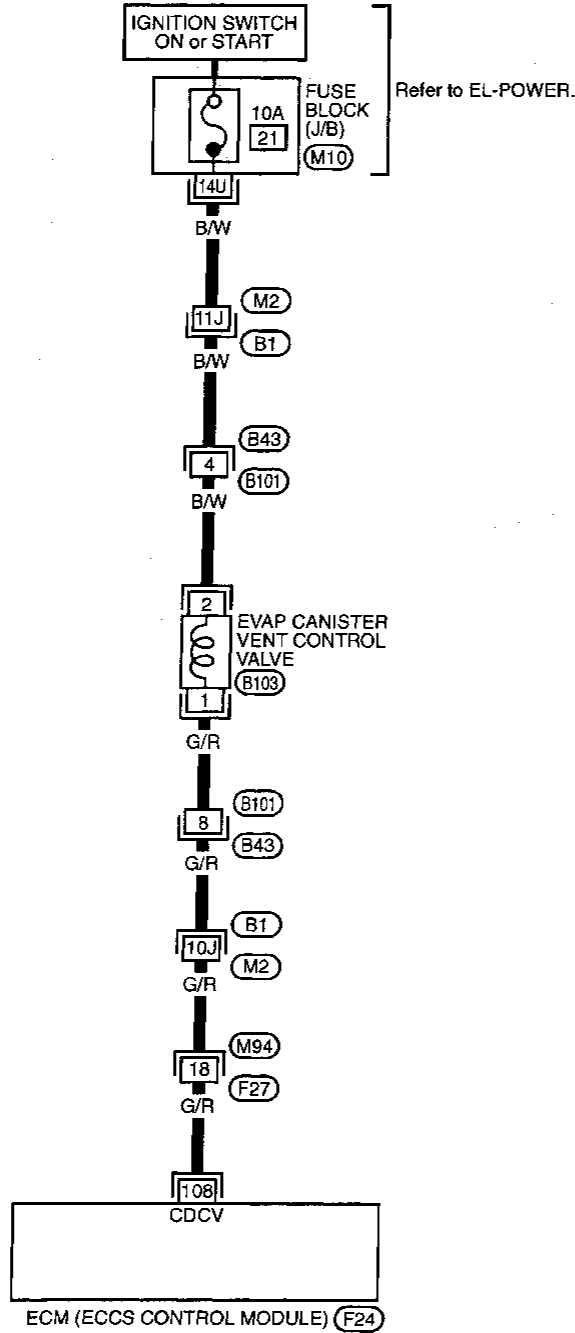

: Detectable line for DTC
 : Non-detectable line for DTC

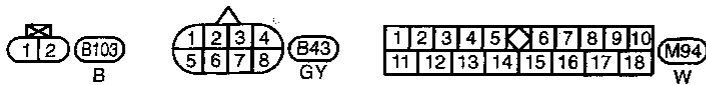

Refer to last page (Foldout page).

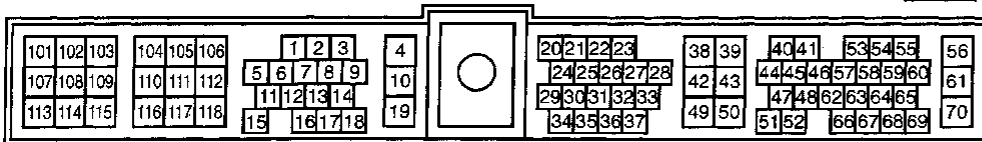
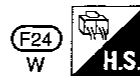
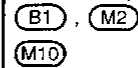

TROUBLE DIAGNOSIS FOR DTC P0446

Evaporative Emission (EVAP) Canister Vent Control Valve (Cont'd)

DIAGNOSTIC PROCEDURE

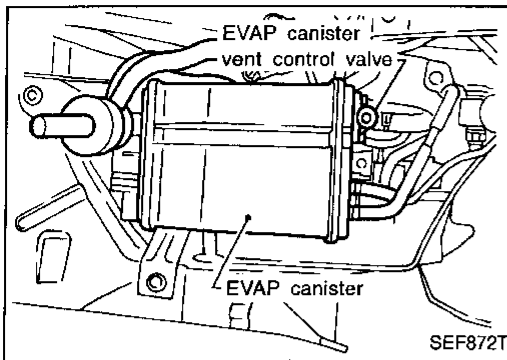

INSPECTION START

A
CHECK POWER SUPPLY.
 1. Disconnect EVAP canister vent control valve harness connector.
 2. Turn ignition switch "ON".
 3. Check voltage between terminal ② and ground with CONSULT or tester.
Voltage: Battery voltage

NG → Check the following.
 • Harness connectors (M2, B1)
 • Harness connectors (B43, B101)
 • 10A fuse
 • Harness for open or short between EVAP canister vent control valve and fuse
 If NG, repair harness or connectors.

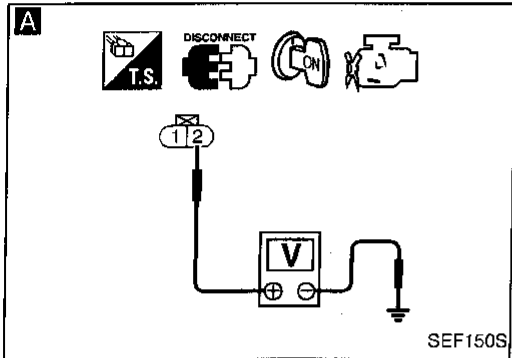

OK →
B
CHECK OUTPUT SIGNAL CIRCUIT.
 1. Turn ignition switch "OFF".
 2. Disconnect ECM harness connector.
 3. Check harness continuity between ECM terminal ⑩ and terminal ①.
Continuity should exist.
 If OK, check harness for short to ground and short to power.

NG → Check the following.
 • Harness connectors (B101, B43)
 • Harness connectors (B1, M2)
 • Harness connectors (M94, F27)
 • Harness for open or short between EVAP canister vent control valve and ECM
 If NG, repair open circuit or short to ground or short to power in harness or connectors.

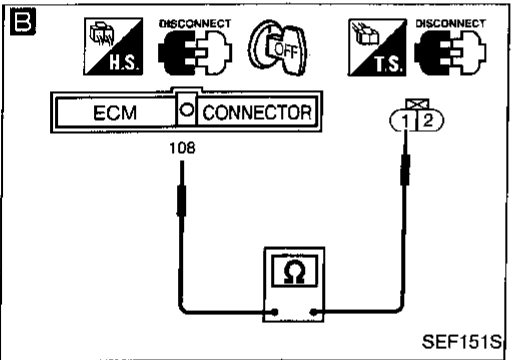

OK →
CHECK RUBBER TUBE FOR CLOGGING.
 Check obstructed rubber tube to EVAP canister vent control valve and clean the rubber tube using air blower.

OK →
CHECK COMPONENT (EVAP canister vent control valve).
 Refer to "COMPONENT INSPECTION" on next page.

NG → Replace EVAP canister vent control valve.

OK →
CHECK COMPONENT (EVAP control system pressure sensor).
 Refer to "COMPONENT INSPECTION" on next page.

NG → Replace EVAP control system pressure sensor.

OK →
 Disconnect and reconnect harness connectors in the circuit. Then retest.

Trouble is not fixed.
 Check ECM pin terminals for damage and check the connection of ECM harness connector. Reconnect ECM harness connector and retest.

INSPECTION END

GI
 MA
 EM
 LC
EC
 FE
 AT
 TF
 PD
 FA
 RA
 BR
 ST
 RS
 BT
 HA
 EL
 IDX

TROUBLE DIAGNOSIS FOR DTC P0446

Evaporative Emission (EVAP) Canister Vent Control Valve (Cont'd)

COMPONENT INSPECTION

EVAP canister vent control valve

Check air passage continuity.

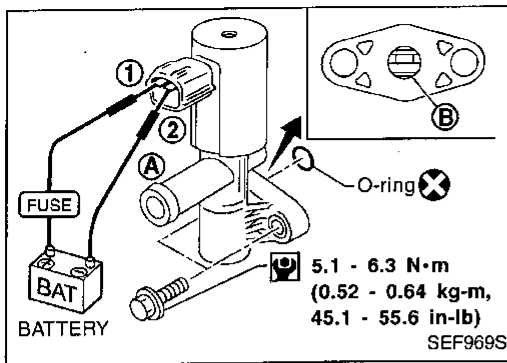

Condition	Air passage continuity between (A) and (B)
12V direct current supply between terminals ① and ②	No
No supply	Yes

If NG, clean valve using air blower or replace as necessary.

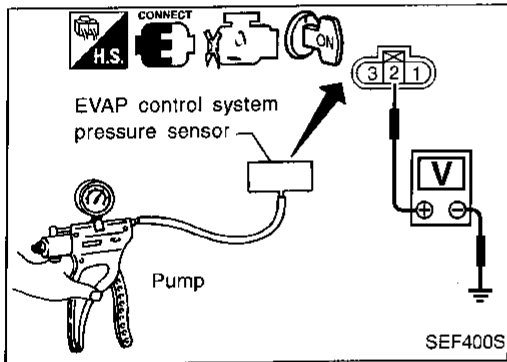

EVAP control system pressure sensor

1. Remove EVAP control system pressure sensor with its harness connector connected.
2. Remove hose from EVAP control system pressure sensor.
3. Use pump to apply vacuum and pressure to EVAP control system pressure sensor as shown in figure.
4. Check output voltage between terminal ② and engine ground.

Pressure (Relative to atmospheric pressure)	Voltage (V)
0 kPa (0 mmHg, 0 inHg, 0 psi)	3.0 - 3.6
-9.3 kPa (-70 mmHg, -2.76 inHg, -1.35 psi)	0.4 - 0.6

CAUTION:

Always calibrate the vacuum pump gauge when using it.

5. If NG, replace EVAP control system pressure sensor.

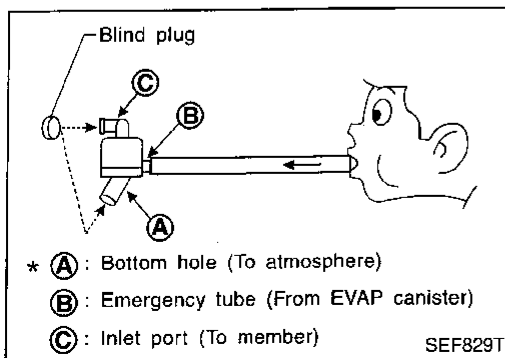

WATER-SEPARATOR

1. Check visually for cracks or flaws in the appearance.
2. Check visually for cracks or flaws in the hose.
3. Check that (A) and (C) are not clogged by blowing air from (B) with (A), and then (C) plugged.
4. In case of NG in items 1 - 3, replace the parts.

NOTE:

- Do not disassemble water separator.

TROUBLE DIAGNOSIS FOR DTC P0450

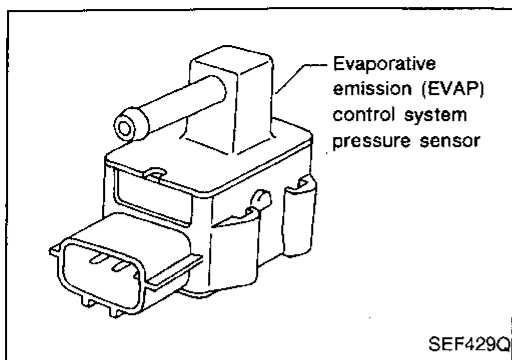

Evaporative Emission (EVAP) Control System Pressure Sensor

COMPONENT DESCRIPTION

The EVAP control system pressure sensor detects pressure in the purge line. The sensor output voltage to the ECM increases as pressure increases. The EVAP control system pressure sensor is not used to control the engine system. It is used only for on board diagnosis.

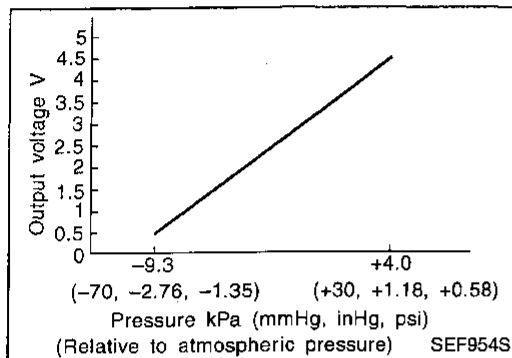

CONSULT REFERENCE VALUE IN DATA MONITOR MODE

Specification data are reference values.

MONITOR ITEM	CONDITION	SPECIFICATION
EVAP SYS PRES	● Ignition switch: ON	Approx. 3.4V

ECM TERMINALS AND REFERENCE VALUE

Specification data are reference values and are measured between each terminal and Ⓞ (ECCS ground).

TER-MINAL NO.	WIRE COLOR	ITEM	CONDITION	DATA (DC Voltage)
49	P/B	Sensors' power supply	Ignition switch "ON"	Approximately 5V
67	G	EVAP control system pressure sensor	Ignition switch "ON"	Approximately 3.4V

ON BOARD DIAGNOSIS LOGIC

Diagnostic Trouble Code No.	Malfunction is detected when	Check Items (Possible Cause)
P0450 0704	● An improper voltage signal from EVAP control system pressure sensor is sent to ECM.	<ul style="list-style-type: none"> ● Harness or connectors (The EVAP control system pressure sensor circuit is open or shorted.) ● EVAP control system pressure sensor ● EVAP canister vent control valve (The valve is stuck open.)

TROUBLE DIAGNOSIS FOR DTC P0450

Evaporative Emission (EVAP) Control System Pressure Sensor (Cont'd)

DIAGNOSTIC TROUBLE CODE CONFIRMATION PROCEDURE

☆ MONITOR	☆ NO FAIL	<input type="checkbox"/>
CMPS•RPM(POS)	750rpm	
COOLANT TEMP/S	85°C	
TANK F/TMP SE	29°C	
RECORD		

SEF890T



- 1) Start engine and warm it up sufficiently.
- 2) Check that tank fuel temperature is above 0°C (32°F).
- 3) Turn ignition switch "OFF" and wait at least 5 seconds.
- 4) Turn ignition switch "ON".
- 5) Select "DATA MONITOR" mode with CONSULT.
- 6) Wait at least 5 seconds.

OR



- 1) Start engine and warm it up sufficiently.
- 2) Check that voltage between ECM terminal ⑥7 and ground is less than 4.2V.
- 3) Turn ignition switch "OFF" and wait at least 5 seconds.
- 4) Turn ignition switch "ON" and wait at least 5 seconds.
- 5) Select "MODE 7" with GST.

OR



- 1) Start engine and warm it up sufficiently.
- 2) Check that voltage between ECM terminal ⑥7 and ground is less than 4.2V.
- 3) Turn ignition switch "OFF" and wait at least 5 seconds.
- 4) Turn ignition switch "ON" and wait at least 5 seconds.
- 5) Turn ignition switch "OFF", wait at least 5 seconds and then turn "ON".
- 6) Perform "Diagnostic Test Mode II (Self-diagnostic results)" with ECM.

TROUBLE DIAGNOSIS FOR DTC P0450

Evaporative Emission (EVAP) Control System Pressure Sensor (Cont'd)

DIAGNOSTIC PROCEDURE

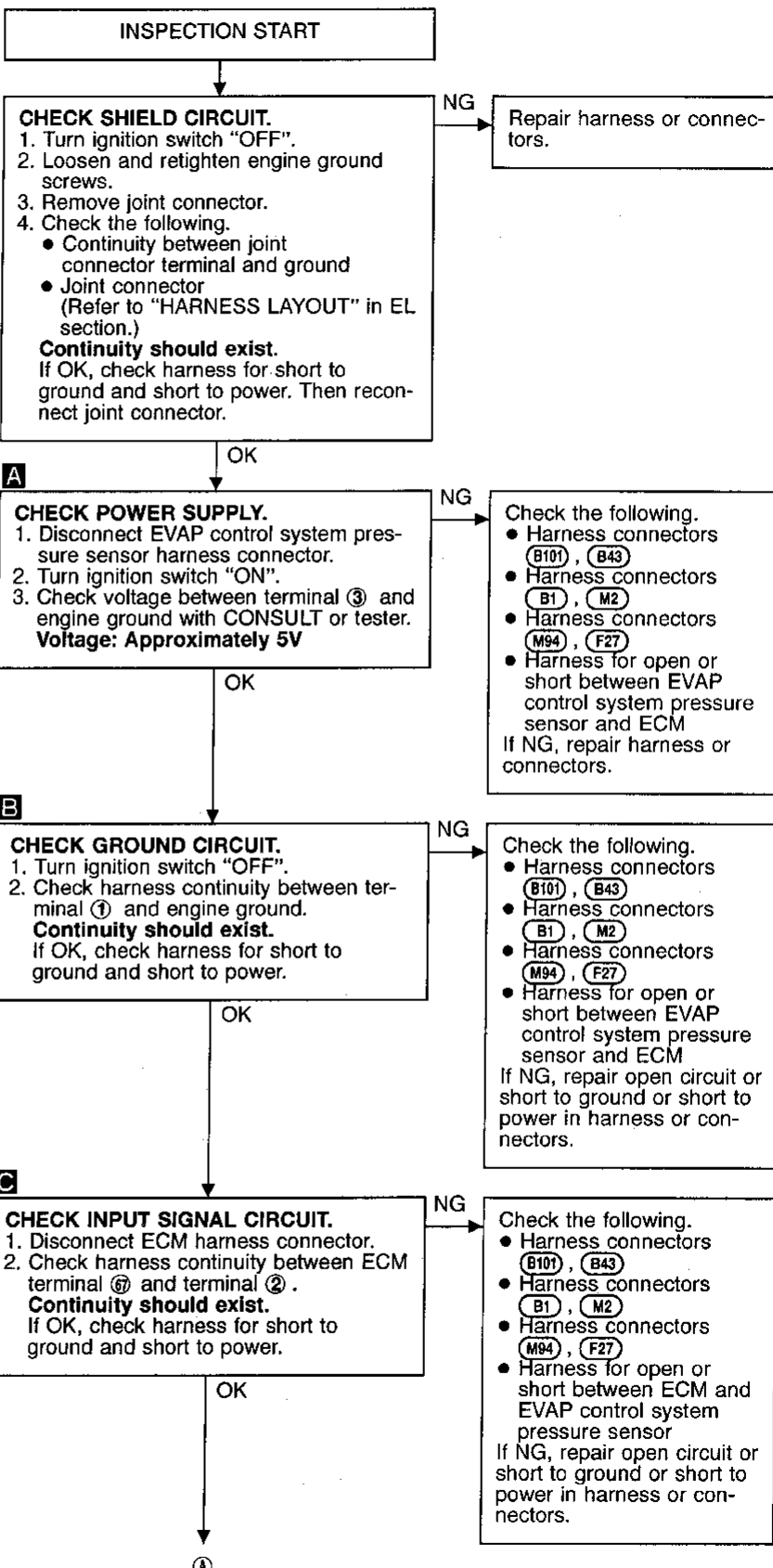
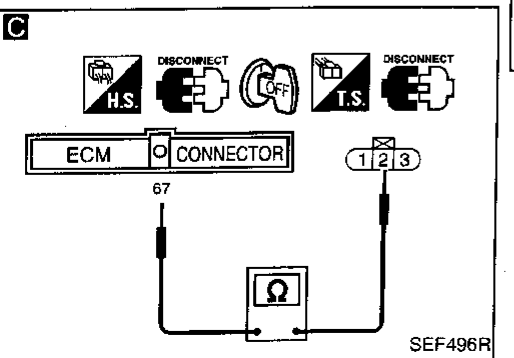
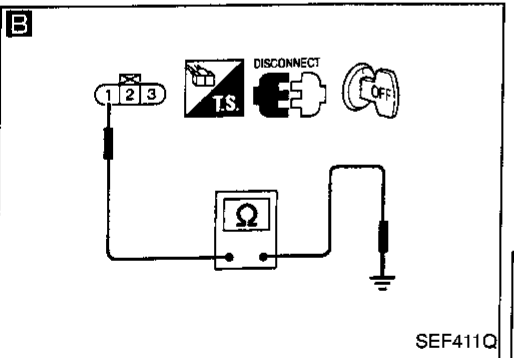
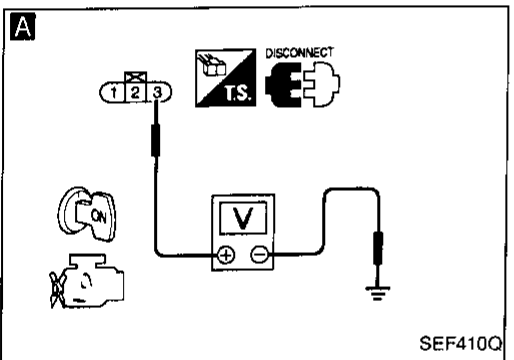
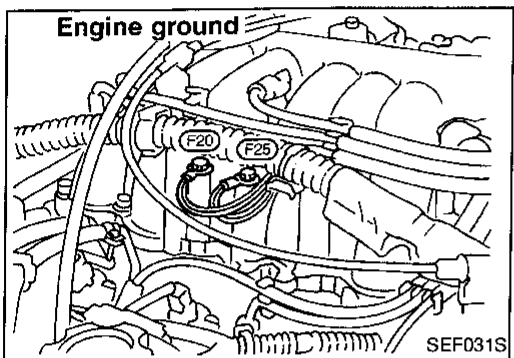
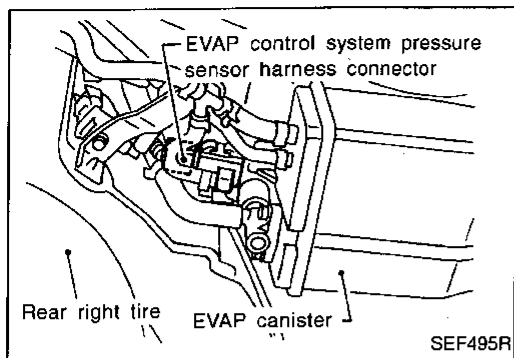

TROUBLE DIAGNOSIS FOR DTC P0450

Evaporative Emission (EVAP) Control System Pressure Sensor (Cont'd)

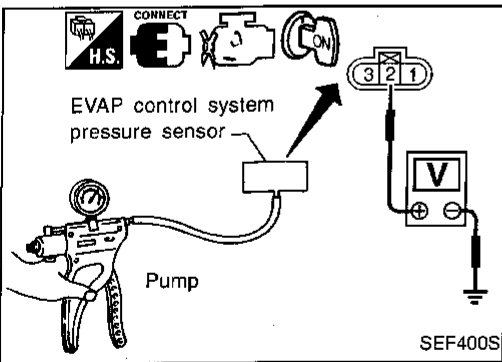
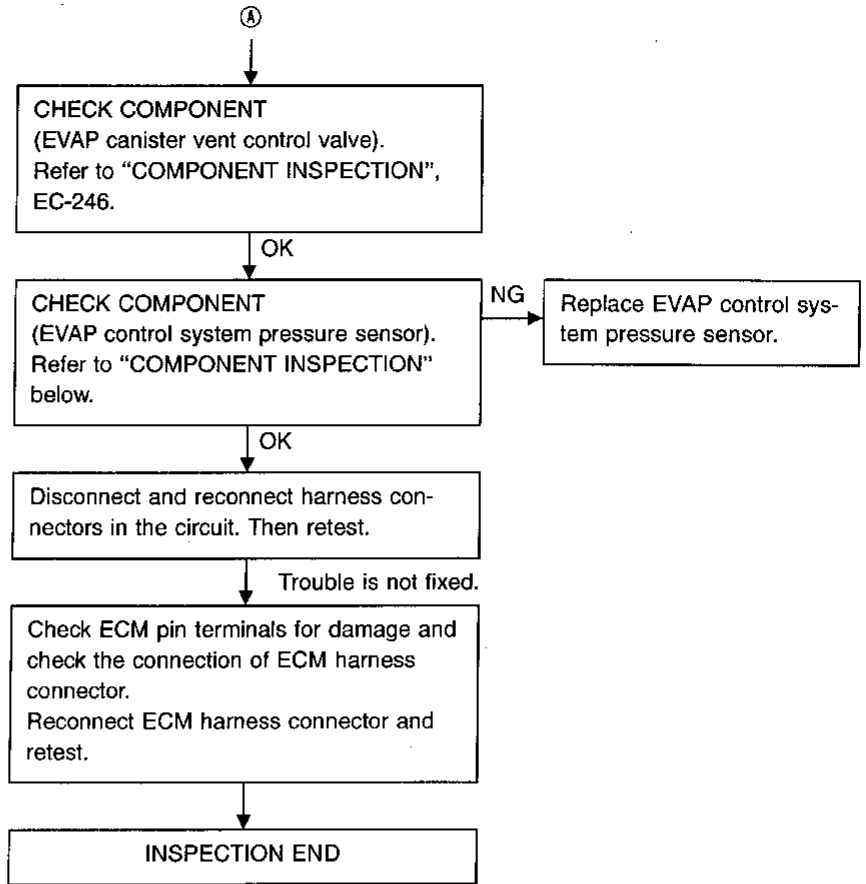

COMPONENT INSPECTION

EVAP control system pressure sensor

1. Remove EVAP control system pressure sensor with its harness connector connected.
2. Remove hose from EVAP control system pressure sensor.
3. Use pump to apply vacuum and pressure to EVAP control system pressure sensor as shown in figure.
4. Check output voltage between terminal ② and engine ground.

Pressure (Relative to atmospheric pressure)	Voltage (V)
0 kPa (0 mmHg, 0 inHg, 0 psi)	3.0 - 3.6
-9.3 kPa (-70 mmHg, -2.76 inHg, -1.35 psi)	0.4 - 0.6

CAUTION:

Always calibrate the vacuum pump gauge when using it.

5. If NG, replace EVAP control system pressure sensor.

TROUBLE DIAGNOSIS FOR DTC P0500

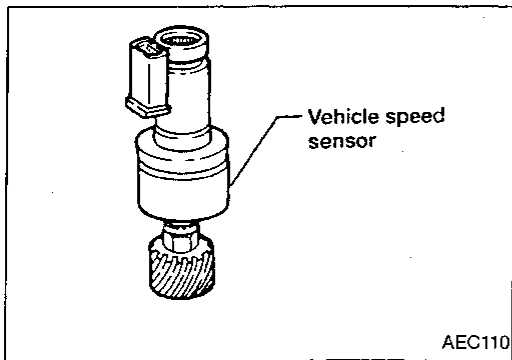

Vehicle Speed Sensor (VSS)

COMPONENT DESCRIPTION

The vehicle speed sensor is installed in the transaxle. It contains a pulse generator which provides a vehicle speed signal to the speedometer. The speedometer then sends a signal to the ECM.

ECM TERMINALS AND REFERENCE VALUE

Specification data are reference values and are measured between each terminal and Ⓒ (ECCS ground).

TER-MINAL NO.	WIRE COLOR	ITEM	CONDITION	DATA (DC Voltage)
26	W/L	Vehicle speed sensor	<div style="border: 1px solid black; padding: 2px; display: inline-block;">Engine is running.</div> <ul style="list-style-type: none"> └ Lift up the vehicle. └ In 1st gear position └ Idle speed 	1.9 - 2.1V <p style="text-align: right;">SEF194T</p>

ON BOARD DIAGNOSIS LOGIC

Diagnostic Trouble Code No.	Malfunction is detected when	Check Items (Possible Cause)
P0500 0104	<ul style="list-style-type: none"> ● The almost 0 km/h (0 MPH) signal from vehicle speed sensor is sent to ECM even when vehicle is being driven. 	<ul style="list-style-type: none"> ● Harness or connector (The vehicle speed sensor circuit is open or shorted.) ● Vehicle speed sensor

TROUBLE DIAGNOSIS FOR DTC P0500

Vehicle Speed Sensor (VSS) (Cont'd) DIAGNOSTIC TROUBLE CODE CONFIRMATION PROCEDURE

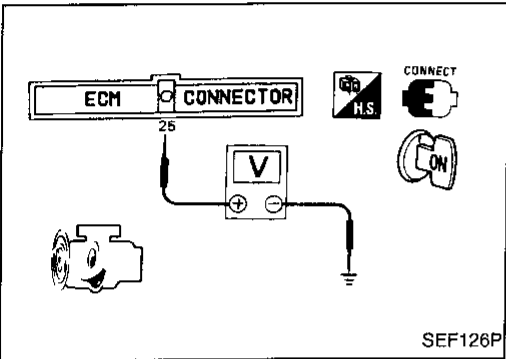
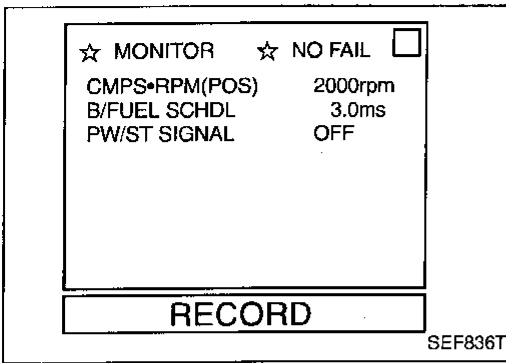

- 1) Lift up vehicle.
- 2) Start engine and warm it up sufficiently.
- 3) Select "DATA MONITOR" mode with CONSULT.
- 4) Maintain the following conditions for at least 10 seconds.

Engine speed : 1,400 - 2,800 rpm
B/FUEL SCHDL: 2.3 - 4.5 ms
Gear position : "D" or "2" range
PW/ST SIGNAL: OFF

CAUTION:

Do not run vehicle at speeds greater than 80 km/h (50 MPH).

OR



- 1) Lift up vehicle.
- 2) Start engine and warm it up sufficiently.
- 3) Maintain the following conditions for at least 10 seconds.

Engine speed : 1,400 - 2,800 rpm
Intake : -53.3 to -33.3 kPa
manifold vacuum (-400 to -250 mmHg,
-15.75 to -9.84 inHg)

Gear position : "D" or "2" range
Voltage between : Approximately 5V
ECM terminal ②
and ground

- 4) Select "MODE 7" with GST.

CAUTION:

Do not run vehicle at speeds greater than 80 km/h (50 MPH).

OR



- 1) Start engine and warm it up sufficiently.
- 2) Perform test drive for at least 10 seconds continuously under the following recommended condition.

Engine speed : 1,400 - 2,800 rpm
Intake : -53.3 to -33.3 kPa
manifold vacuum (-400 to -250 mmHg,
-15.75 to -9.84 inHg)

Gear position : "D" or "2" range
Voltage between : Approximately 5V
ECM terminal ②
and ground

- 3) Stop the vehicle, turn ignition switch "OFF", wait at least 5 seconds and then turn "ON".
- 4) Perform "Diagnostic Test Mode II" (Self-diagnostic results) with ECM.

CAUTION:

Do not run vehicle at speeds greater than 80 km/h (50 MPH).

Even though 1st trip DTC is not detected, perform the above test drive at least one more time.

GI
MA
EM
LC
EC
FE
AT
TF
PD
FA
RA
BR
ST
RS
BT
HA
EL
IDX

TROUBLE DIAGNOSIS FOR DTC P0500

Vehicle Speed Sensor (VSS) (Cont'd)

EC-VSS-01

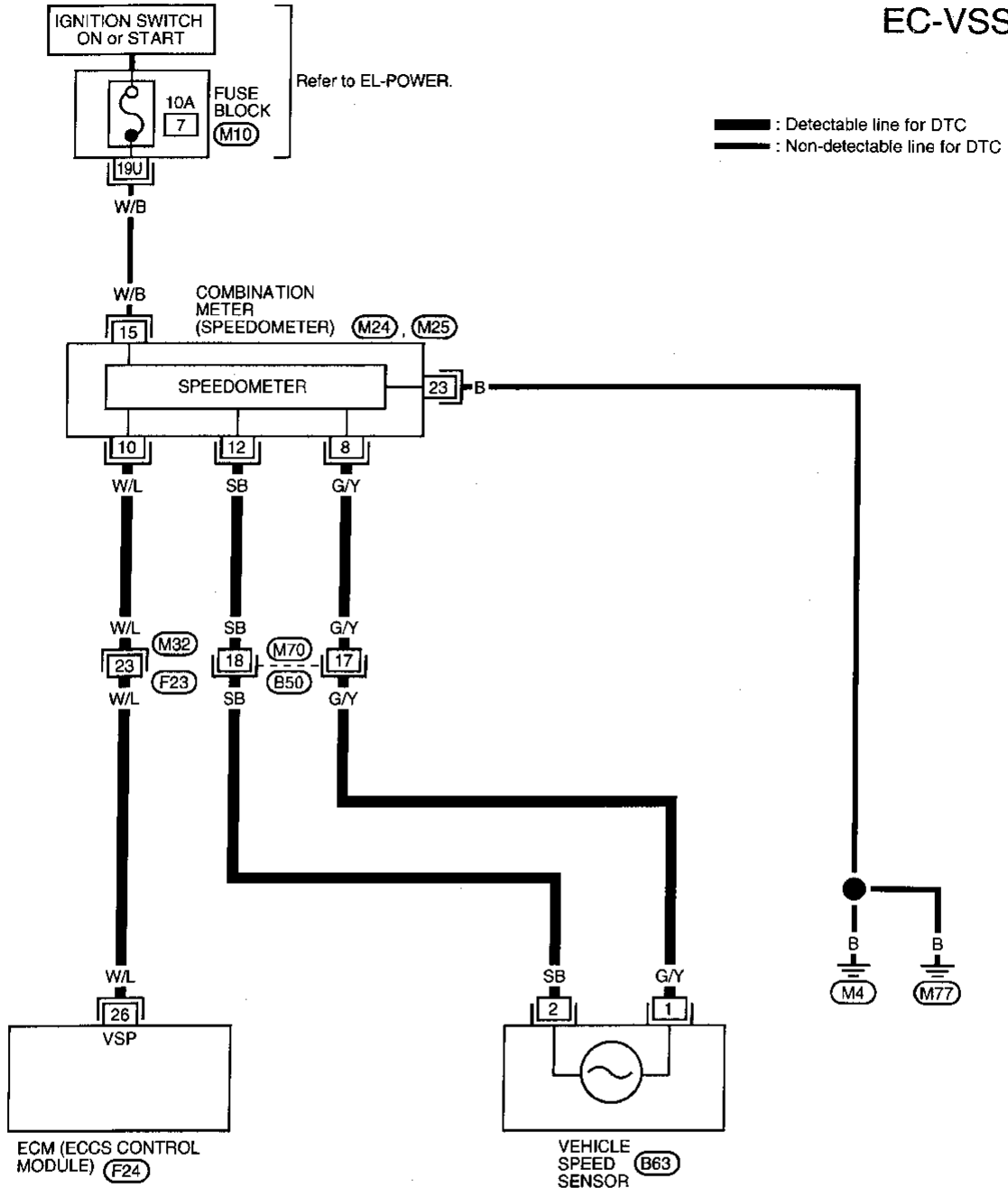

Refer to last page (Foldout page).

(M10)

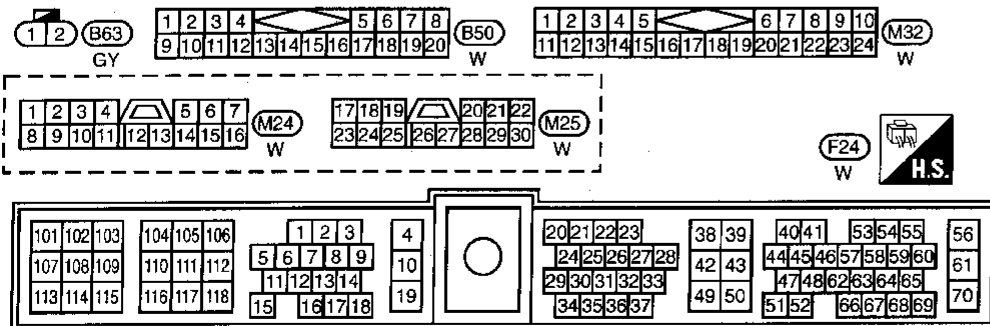

TROUBLE DIAGNOSIS FOR DTC P0500

Vehicle Speed Sensor (VSS) (Cont'd)

DIAGNOSTIC PROCEDURE

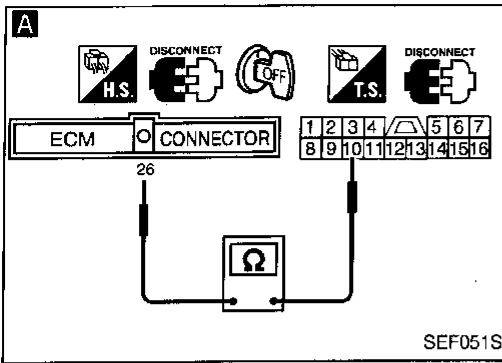

SEF051S

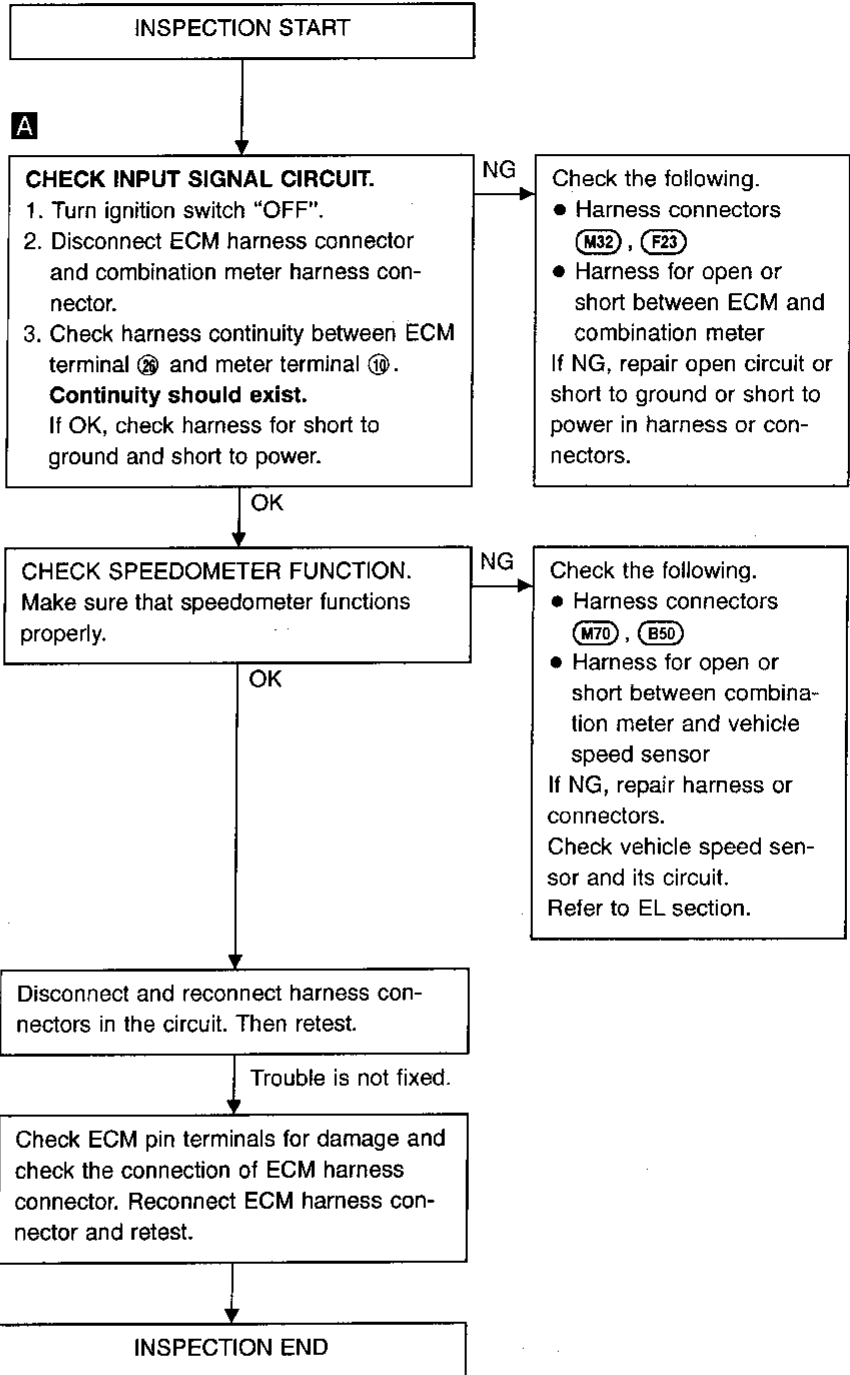

GI

MA

EM

LC

EC

FE

AT

TF

PD

FA

RA

BR

ST

RS

BT

HA

EL

IDX

Idle Air Control Valve (IACV) — Auxiliary Air Control (AAC) Valve

SYSTEM DESCRIPTION

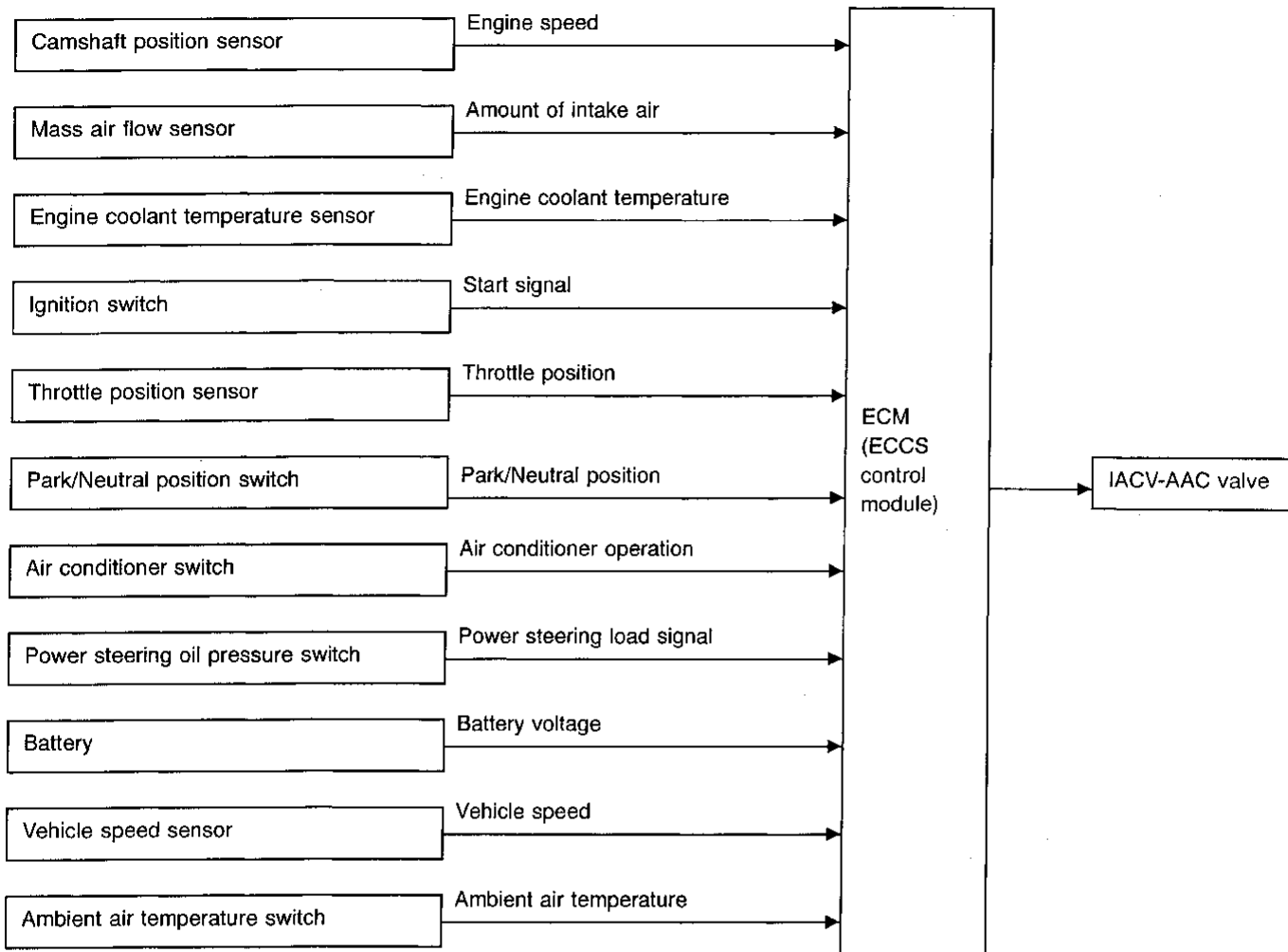

This system automatically controls engine idle speed to a specified level. Idle speed is controlled through fine adjustment of the amount of air which bypasses the throttle valve via IACV-AAC valve. The IACV-AAC valve repeats ON/OFF operation according to the signal sent from the ECM. The camshaft position sensor detects the actual engine speed and sends a signal to the ECM. The ECM then controls the ON/OFF time of the IACV-AAC valve so that engine speed coincides with the target value memorized in ECM. The target engine speed is the lowest speed at which the engine can operate steadily. The optimum value stored in the ECM is determined by taking into consideration various engine conditions, such as during warm up, deceleration, and engine load (air conditioner and power steering).

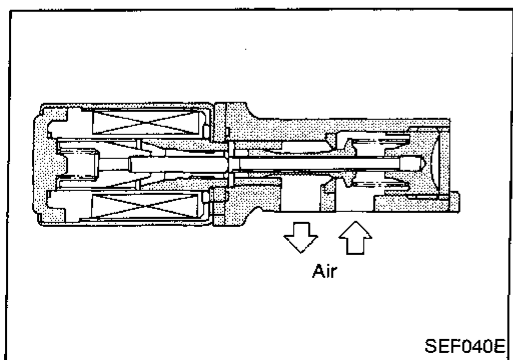

COMPONENT DESCRIPTION

IACV-AAC valve

The IACV-AAC valve is moved by ON/OFF pulses from the ECM. The longer the ON pulse, the greater the amount of air that will flow through the valve. The more air that flows through the valve, the higher the idle speed.

TROUBLE DIAGNOSIS FOR DTC P0505

Idle Air Control Valve (IACV) — Auxiliary Air Control (AAC) Valve (Cont'd)

CONSULT REFERENCE VALUE IN DATA MONITOR MODE

Specification data are reference values.

MONITOR ITEM	CONDITION	SPECIFICATION
IACV-AAC/V	<ul style="list-style-type: none"> ● Engine: After warming up ● Air conditioner switch: "OFF" ● Shift lever: "N" ● No-load 	Idle
		2,000 rpm
		10 - 20%
		—

ECM TERMINALS AND REFERENCE VALUE

Specification data are reference values and are measured between each terminal and Ⓞ (ECCS ground).

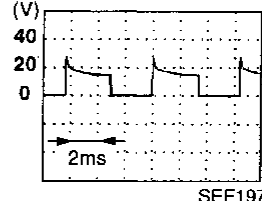
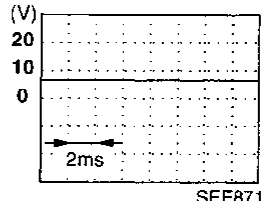
TER-MINAL NO.	WIRE COLOR	ITEM	CONDITION	DATA (DC Voltage)
55	OR	IACV-AAC valve	<div style="border: 1px solid black; padding: 2px; display: inline-block;">Engine is running.</div> (Warm-up condition) └ Idle speed	8 - 11V 
			<div style="border: 1px solid black; padding: 2px; display: inline-block;">Engine is running.</div> (Warm-up condition) └ Engine speed is 2,000 rpm	5 - 8V 

ON BOARD DIAGNOSIS LOGIC

Diagnostic Trouble Code No.	Malfunction is detected when	Check Items (Possible Cause)
P0505 0205	A) The IACV-AAC valve does not operate properly.	<ul style="list-style-type: none"> ● Harness or connectors (The IACV-AAC valve circuit is open.) ● IACV-AAC valve
	B) The IACV-AAC valve does not operate properly.	<ul style="list-style-type: none"> ● Harness or connectors (The IACV-AAC valve circuit is shorted.) ● IACV-AAC valve

TROUBLE DIAGNOSIS FOR DTC P0505

Idle Air Control Valve (IACV) — Auxiliary Air Control (AAC) Valve (Cont'd)

DIAGNOSTIC TROUBLE CODE CONFIRMATION PROCEDURE

Perform "Procedure for malfunction A" first. If DTC cannot be confirmed, perform "Procedure for malfunction B".

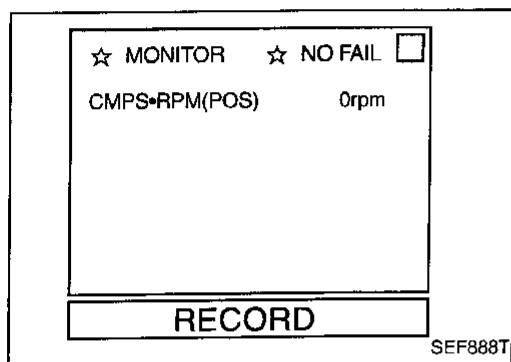

Procedure for malfunction A



- 1) Turn ignition switch "ON".
- 2) Select "DATA MONITOR" mode with CONSULT.
- 3) Wait at least 2 seconds.

OR



- 1) Turn ignition switch "ON" and wait at least 2 seconds.
- 2) Select "MODE 7" with GST.

OR



- 1) Turn ignition switch "ON" and wait at least 2 seconds.
- 2) Turn ignition switch "OFF", wait at least 5 seconds and then turn "ON".
- 3) Perform "Diagnostic Test Mode II (Self-diagnostic results)" with ECM.

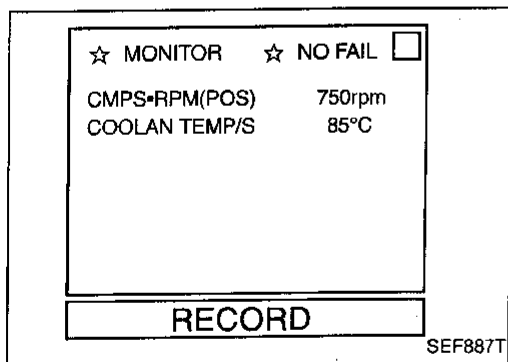

Procedure for malfunction B



- 1) Start engine and warm it up sufficiently.
- 2) Turn ignition switch "OFF" and wait at least 5 seconds.
- 3) Turn ignition switch "ON" again and select "DATA MONITOR" mode with CONSULT.
- 4) Start engine and run it for at least 1 minute at idle speed.

OR



- 1) Start engine and warm it up sufficiently.
- 2) Turn ignition switch "OFF" and wait at least 5 seconds.
- 3) Start engine again and run it for at least 1 minute at idle speed.
- 4) Select "MODE 7" with GST.

OR



- 1) Start engine and warm it up sufficiently.
- 2) Turn ignition switch "OFF" and wait at least 5 seconds.
- 3) Start engine again and run it for at least 1 minute at idle speed.
- 4) Turn ignition switch "OFF", wait at least 5 seconds and then turn "ON".
- 5) Perform "Diagnostic Test Mode II (Self-diagnostic results)" with ECM.

TROUBLE DIAGNOSIS FOR DTC P0505

Idle Air Control Valve (IACV) — Auxiliary Air Control (AAC) Valve (Cont'd)

EC-AAC/V-01

GI

MA

EM

LC

EC

FE

AT

TF

PD

FA

RA

BR

ST

RS

BT

HA

EL

IDX

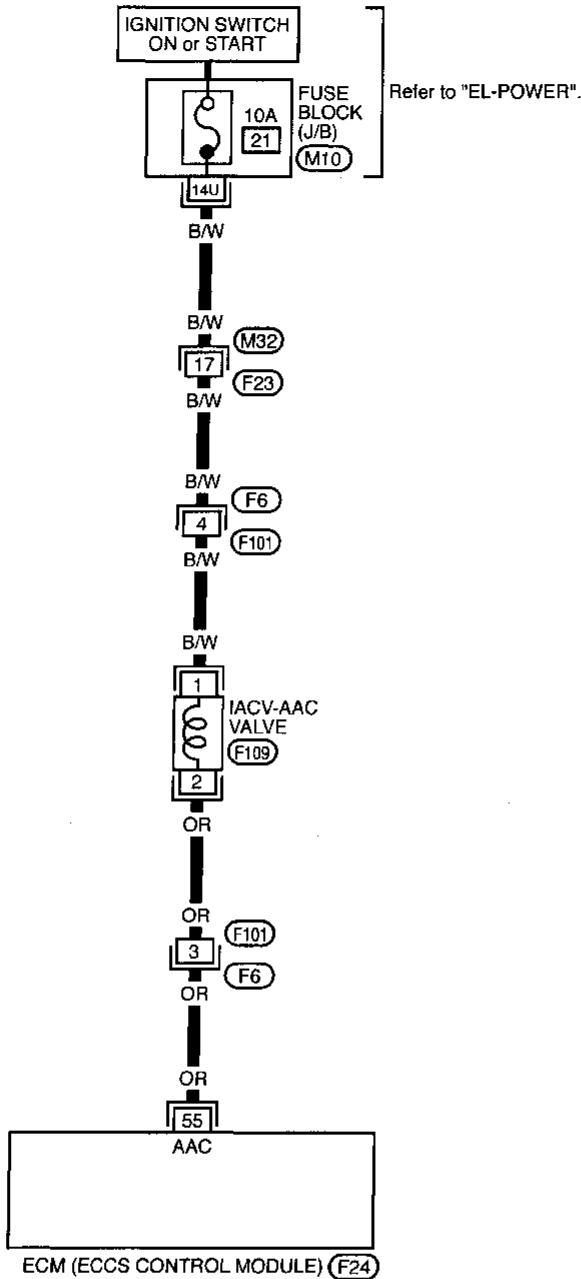

— : Detectable line for DTC
 — : Non-detectable line for DTC

Refer to last page (Foldout page).

(M10)

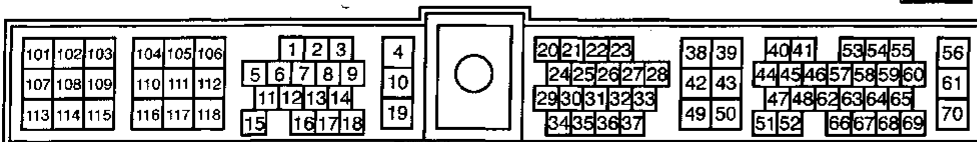
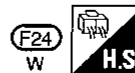
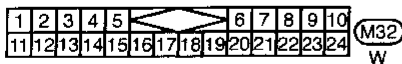
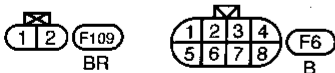

TROUBLE DIAGNOSIS FOR DTC P0505

Idle Air Control Valve (IACV) — Auxiliary Air Control (AAC) Valve (Cont'd)

DIAGNOSTIC PROCEDURE

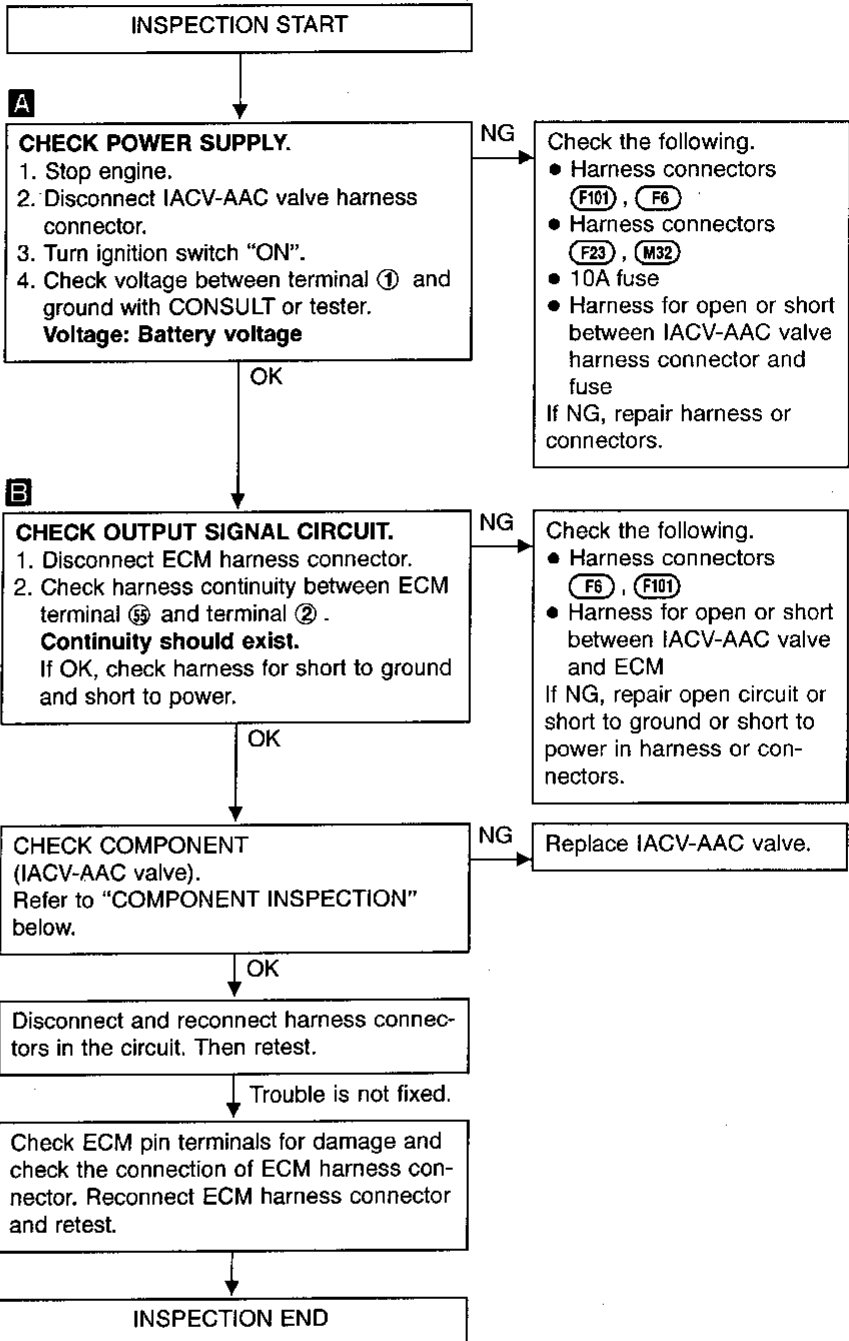
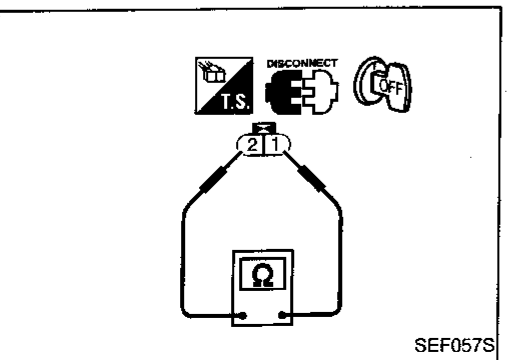
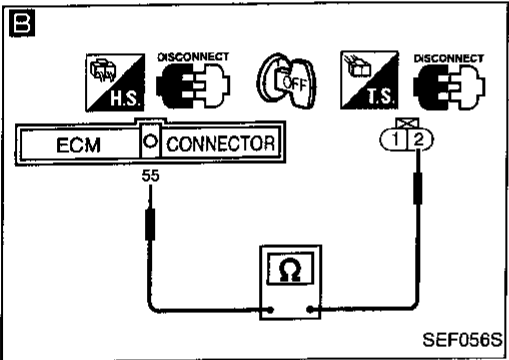
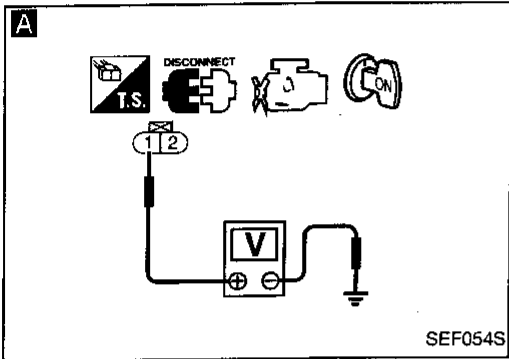
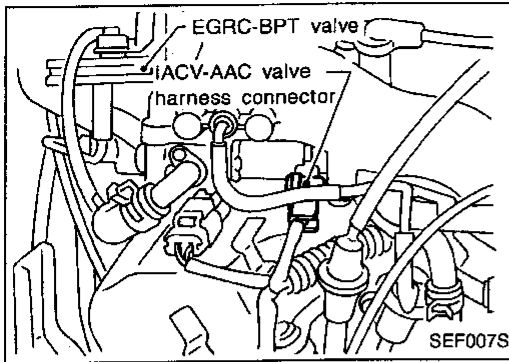

COMPONENT INSPECTION

IACV-AAC valve

Disconnect IACV-AAC valve harness connector.

- Check IACV-AAC valve resistance.

Resistance:

Approximately 10Ω [at 25°C (77°F)]

- Check plunger for seizing or sticking.
- Check for broken spring.

TROUBLE DIAGNOSIS FOR DTC P0510

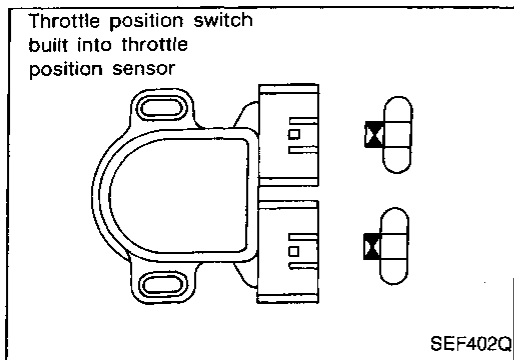

Closed Throttle Position Switch

COMPONENT DESCRIPTION

A closed throttle position switch and wide open throttle position switch are built into the throttle position sensor unit. The wide open throttle position switch is used only for A/T control.

When the throttle valve is in the closed position, the closed throttle position switch sends a voltage signal to the ECM. The ECM only uses this signal to open or close the EVAP canister purge control valve when the throttle position sensor is malfunctioning.

CONSULT REFERENCE VALUE IN DATA MONITOR MODE

Specification data are reference values.

MONITOR ITEM	CONDITION	SPECIFICATION
CLSD THL/P SW	● Ignition switch: ON (Engine stopped)	Throttle valve: Idle position ON
		Throttle valve: Slightly open OFF

ECM TERMINALS AND REFERENCE VALUE

Specification data are reference values and are measured between each terminal and Ⓒ (ECCS ground).

TER-MINAL NO.	WIRE COLOR	ITEM	CONDITION	DATA (DC Voltage)
27	OR/W	Throttle position switch (Closed position)	Ignition switch "ON" (Warm-up condition) └ Accelerator pedal released	BATTERY VOLTAGE (11 - 14V)
			Ignition switch "ON" └ Accelerator pedal depressed	Approximately 0V

ON BOARD DIAGNOSIS LOGIC

Diagnostic Trouble Code No.	Malfunction is detected when	Check Items (Possible Cause)
P0510 0203	● Battery voltage from the closed throttle position switch is sent to ECM with the throttle valve opened.	<ul style="list-style-type: none"> ● Harness or connectors (The closed throttle position switch circuit is shorted.) ● Closed throttle position switch

TROUBLE DIAGNOSIS FOR DTC P0510

Closed Throttle Position Switch (Cont'd)

DIAGNOSTIC TROUBLE CODE CONFIRMATION PROCEDURE

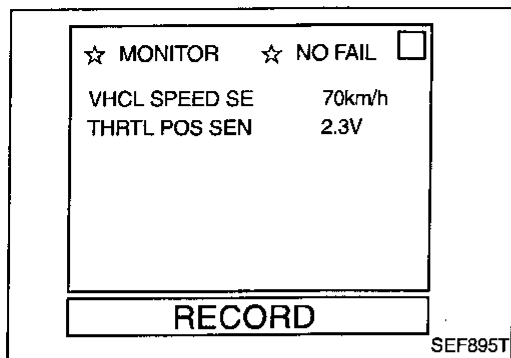

- 1) Start engine and warm it up sufficiently.
- 2) Turn ignition switch "OFF" and wait at least 5 seconds.
- 3) Turn ignition switch "ON".
- 4) Select "DATA MONITOR" mode with CONSULT.
- 5) Start engine again and wait at least 5 seconds.
- 6) Maintain the following conditions for at least 5 seconds.
Gear position : Suitable gear position
VHCL SPEED SE: More than 4 km/h (2 MPH)
THRTL POS SEN: More than 2V

CAUTION:

Do not run vehicle at speeds greater than 80 km/h (50 MPH).

OR

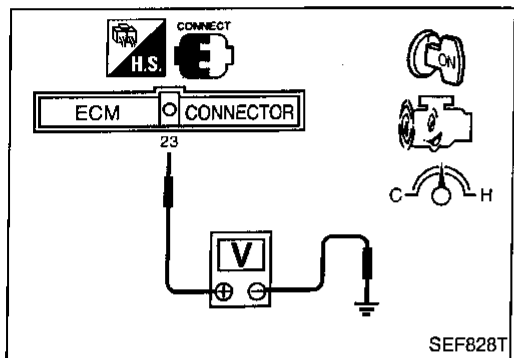

- 1) Start engine and warm it up sufficiently.
- 2) Turn ignition switch "OFF" and wait at least 5 seconds.
- 3) Turn ignition switch "ON".
- 4) Start engine again and wait at least 5 seconds.
- 5) Maintain the following conditions for at least 5 seconds.
Gear position : Suitable gear position
Vehicle speeds : More than 4 km/h (2 MPH)
Voltage between: More than 2V
ECM terminal ②③
and ground

CAUTION:

Do not run vehicle at speeds greater than 80 km/h (50 MPH).

- 6) Select "MODE 7" with GST.

OR



- 1) Start engine and warm it up sufficiently.
- 2) Turn ignition switch "OFF" and wait at least 5 seconds.
- 3) Turn ignition switch "ON".
- 4) Start engine again and wait at least 5 seconds.
- 5) Maintain the following conditions for at least 5 seconds.
Gear position : Suitable gear position
Vehicle speeds : More than 4 km/h (2 MPH)
Voltage between: More than 2V
ECM terminal ②③
and ground

CAUTION:

Do not run vehicle at speeds greater than 80 km/h (50 MPH).

- 6) Stop the vehicle, turn ignition switch "OFF", wait at least 5 seconds and then turn "ON".
- 7) Perform "Diagnostic Test Mode II (Self-diagnostic results)" with ECM.

TROUBLE DIAGNOSIS FOR DTC P0510

Closed Throttle Position Switch (Cont'd)

EC-TP/SW-01

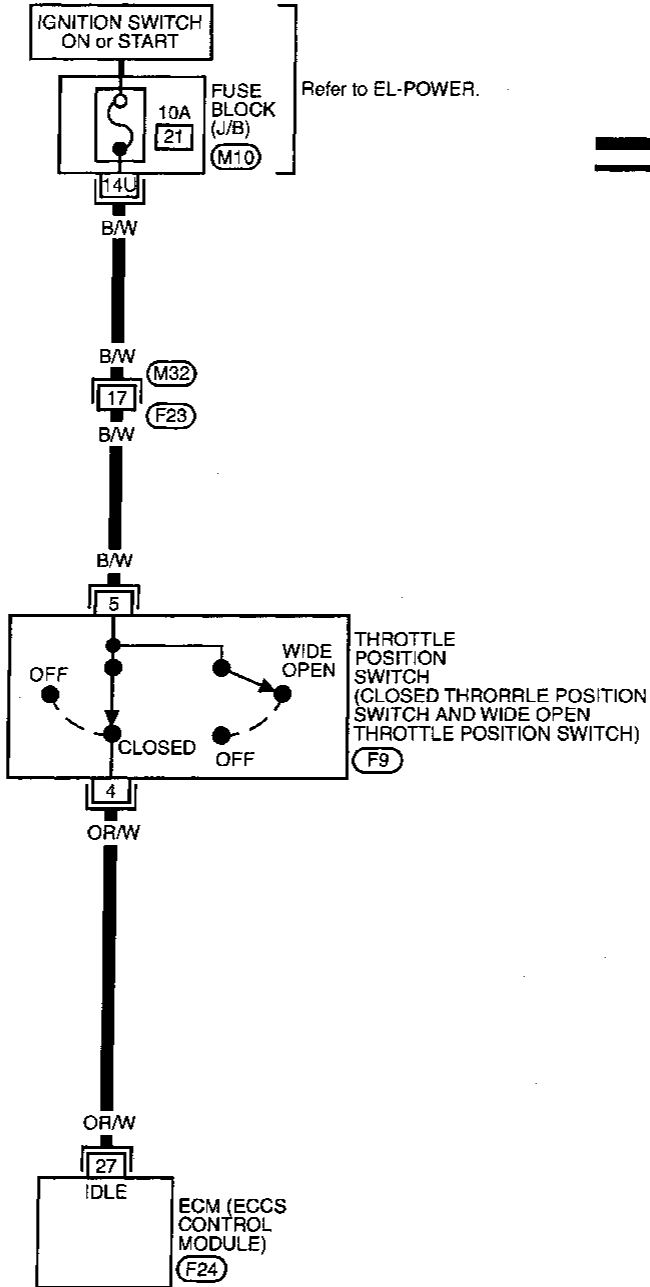

— : Detectable line for DTC
— : Non-detectable line for DTC

GI

MA

EM

LC

EC

FE

AT

TF

PD

FA

RA

BR

ST

RS

BT

HA

EL

IDX

Refer to last page (Foldout page).

(M10)

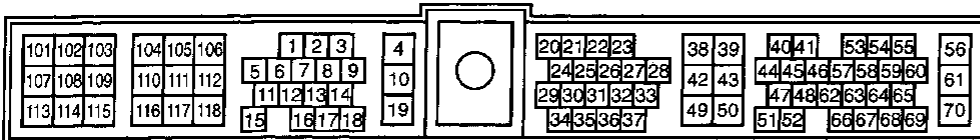
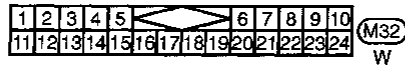
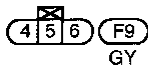

TROUBLE DIAGNOSIS FOR DTC P0510

Closed Throttle Position Switch (Cont'd)

DIAGNOSTIC PROCEDURE

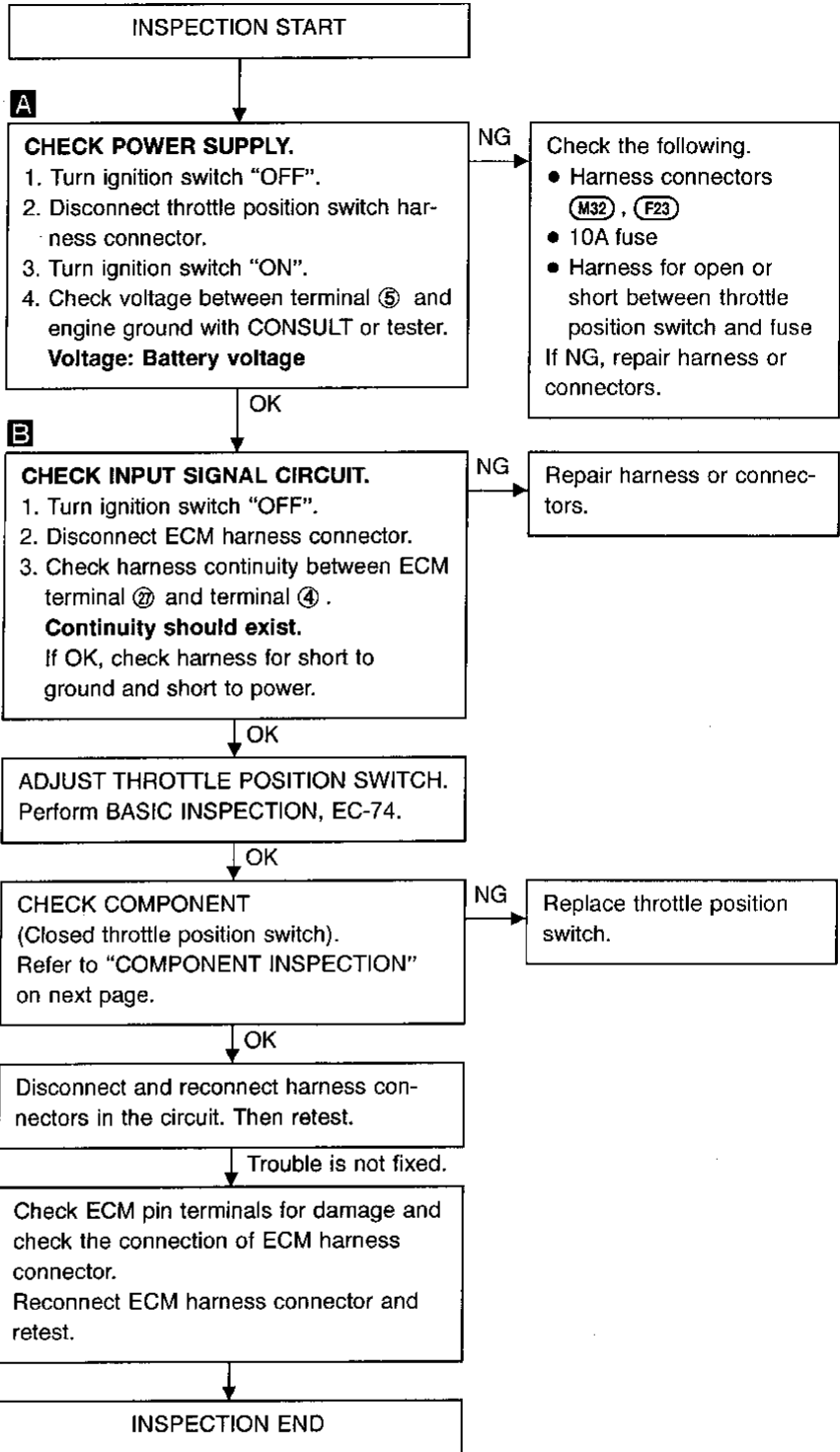
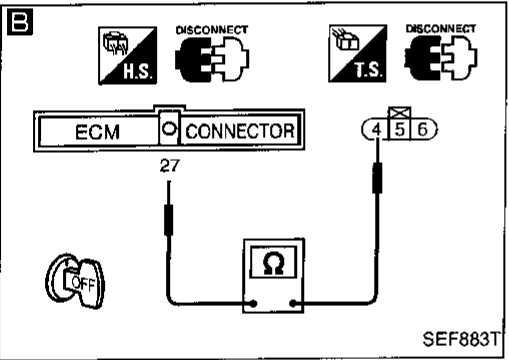
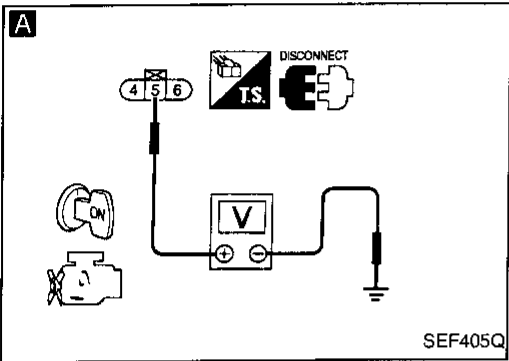
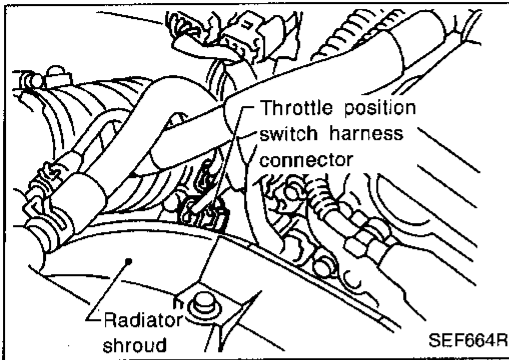

TROUBLE DIAGNOSIS FOR DTC P0510

Closed Throttle Position Switch (Cont'd) COMPONENT INSPECTION

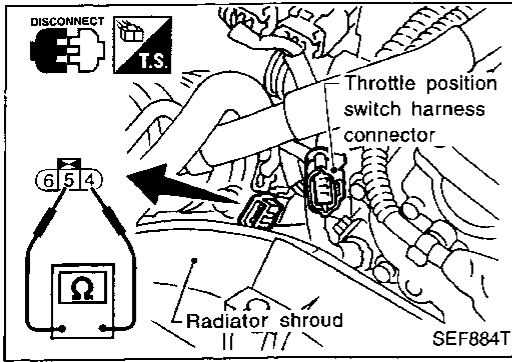

Closed throttle position switch

1. Start engine and warm it up sufficiently.
2. Turn ignition switch "OFF".
3. Disconnect throttle position switch harness connector.
4. Check continuity between terminals ⑤ and ④ while opening throttle valve manually.

Throttle valve conditions	Continuity
Completely closed	Yes
Partially open or completely open	No

If NG, replace throttle position switch.

GI
MA
EM
LC
EC
FE
AT
TF
PD
FA
RA
BR
ST
RS
BT
HA
EL
IDX

TROUBLE DIAGNOSIS FOR DTC P0600

A/T Control

COMPONENT DESCRIPTION

These circuit lines are used to control the smooth shifting up and down of A/T during the hard acceleration/ deceleration.

Voltage signals are exchanged between ECM and A/T control unit.

ECM TERMINALS AND REFERENCE VALUE

Specification data are reference values and are measured between each terminal and ④ (ECCS ground).

TER-MINAL NO.	WIRE COLOR	ITEM	CONDITION	DATA (DC Voltage)
24	PU/W	A/T signal No. 1	Ignition switch "ON" Engine is running. └ Idle speed	6 - 8V
29	P/B	A/T signal No. 2	Ignition switch "ON" Engine is running. └ Idle speed	6 - 8V
30	P	A/T signal No. 3	Ignition switch "ON"	0V

ON BOARD DIAGNOSIS LOGIC

Diagnostic Trouble Code No.	Malfunction is detected when ...	Check Item (Possible Cause)
P0600	<ul style="list-style-type: none"> ECM receives incorrect voltage from A/T control unit continuously. 	<ul style="list-style-type: none"> Harness or connectors (The circuit between ECM and A/T control unit is open or shorted.)

*: This DTC can be detected only by "DATA MONITOR (AUTO TRIG)" with CONSULT.

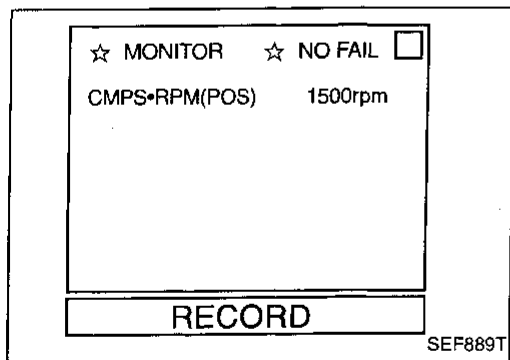

DIAGNOSTIC TROUBLE CODE CONFIRMATION PROCEDURE

- Turn ignition switch "ON".
- Select "DATA MONITOR" mode with CONSULT.
- Start engine, and race more than 1,000 rpm once, then wait at least 40 seconds.

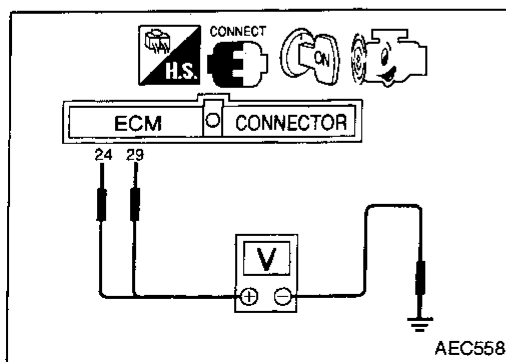

OVERALL FUNCTION CHECK

Use this procedure to check the overall function of the A/T control. During this check, a DTC might not be confirmed.

- Turn ignition switch "ON".
- Start engine.
- Check voltage between ECM terminal ②④ and ground.
ECM terminal ②⑨ and ground.
Voltage: Approximately 7V

TROUBLE DIAGNOSIS FOR DTC P0600

A/T Control (Cont'd)

EC-AT/C-01

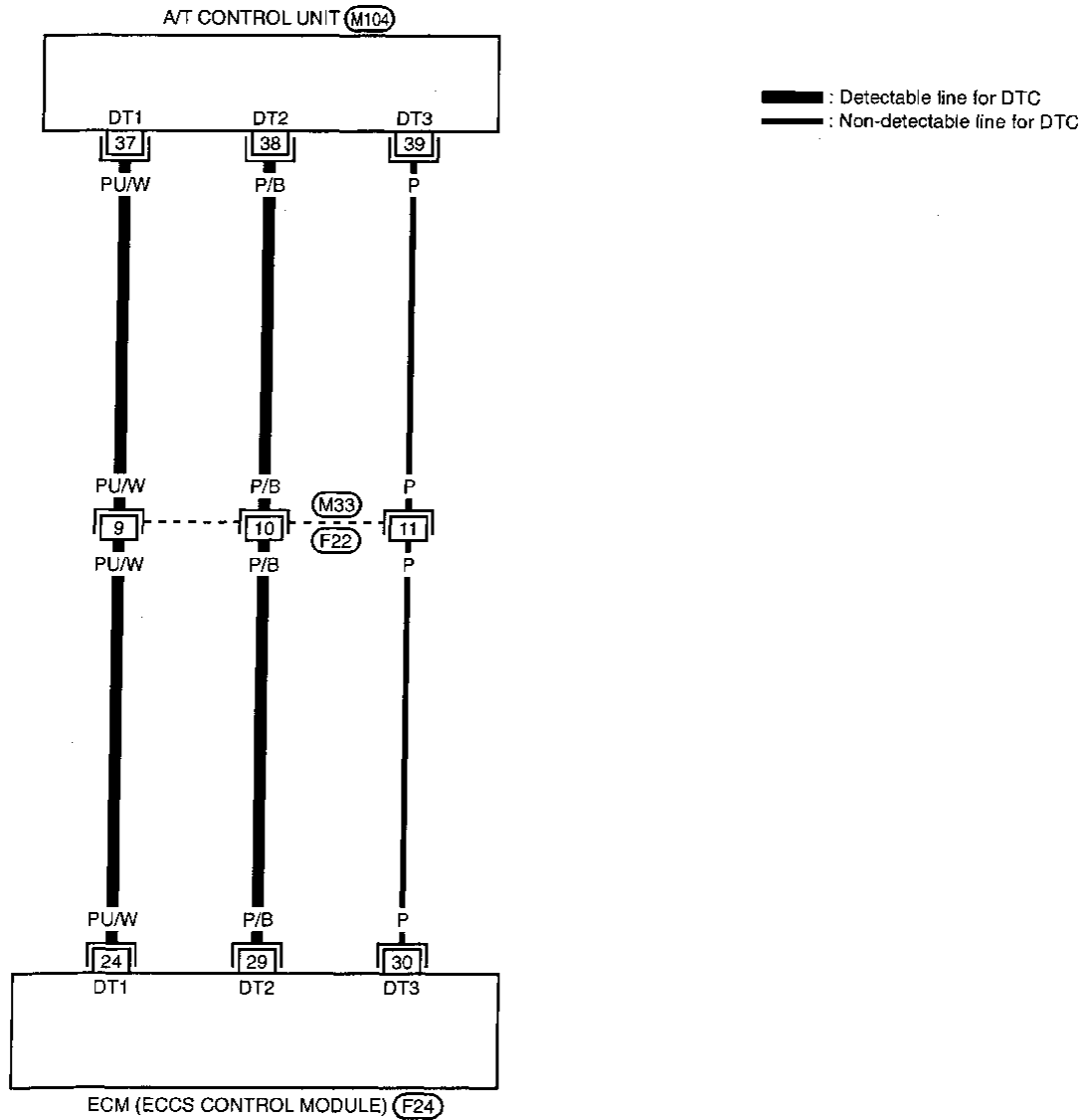

GI
MA
EM
LC
EC
FE
AT
TF
PD
FA
RA
BR
ST
RS
BT
HA
EL
IDX

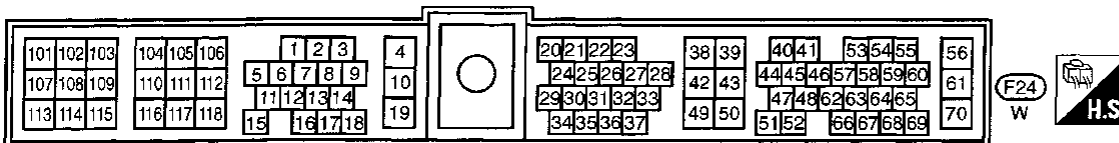
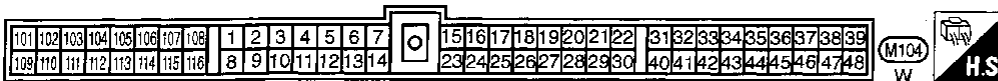
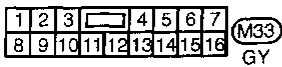

TROUBLE DIAGNOSIS FOR DTC P0600

A/T Control (Cont'd) DIAGNOSTIC PROCEDURE

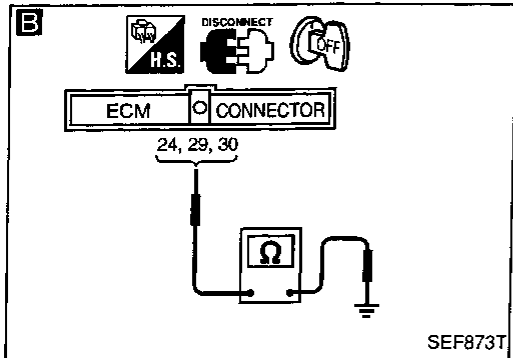
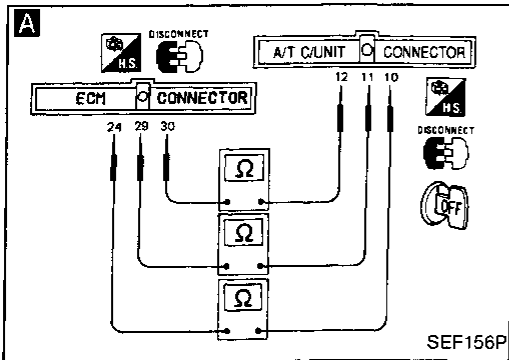
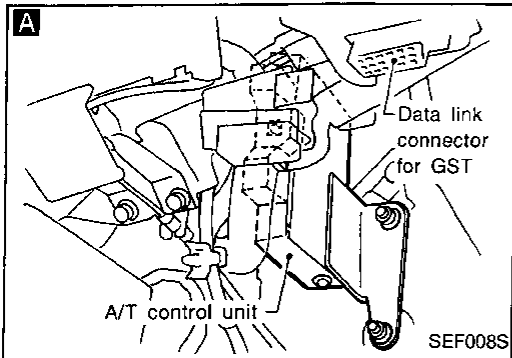
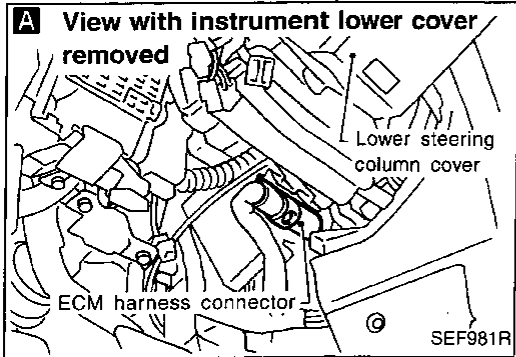

INSPECTION START

A

CHECK INPUT SIGNAL CIRCUIT.

1. Turn ignition switch "OFF".
2. Disconnect ECM harness connector and A/T control unit harness connector.
3. Check harness continuity between ECM terminal ②④ and terminal ⑩, ECM terminal ②⑨ and terminal ⑪, ECM terminal ③⑩ and terminal ⑫.

Continuity should exist.

NG

Check the following.

- Harness connectors (F22), (M33)
- Harness for open or short between ECM and A/T control unit

If NG, repair harness or connectors.

OK

B

CHECK INPUT SIGNAL CIRCUIT.

Check harness continuity between ECM terminal ②④ and ground, ECM terminal ②⑨ and ground, ECM terminal ③⑩ and ground.

Continuity should not exist.

If OK, check harness for short to ground and short to power.

NG

Check the harness for open or short between ECM and A/T control unit. If NG, repair open circuit or short to ground or short to power in harness.

OK

Disconnect and reconnect harness connectors in the circuit. Then retest.

Trouble is not fixed.

Check ECM pin terminals and A/T control unit pin terminals for damage and check the connection of ECM harness connector. Reconnect ECM harness connector and retest.

INSPECTION END

TROUBLE DIAGNOSIS FOR DTC P0605

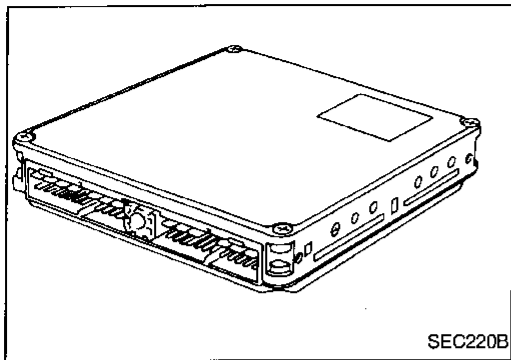

Engine Control Module (ECM)-ECCS Control Module

COMPONENT DESCRIPTION

The ECM consists of a microcomputer, diagnostic test mode selector, and connectors for signal input and output and for power supply. The unit controls the engine.

GI
MA
EM
LC
EC
FE
AT
TF
PD
RA
BR
ST
RS
BT
HA
EL
IDX

ON BOARD DIAGNOSIS LOGIC

Diagnostic Trouble Code No.	Malfunction is detected when	Check Item (Possible Cause)
P0605 0301	<ul style="list-style-type: none"> ECM calculation function is malfunctioning. 	<ul style="list-style-type: none"> ECM (ECCS control module)

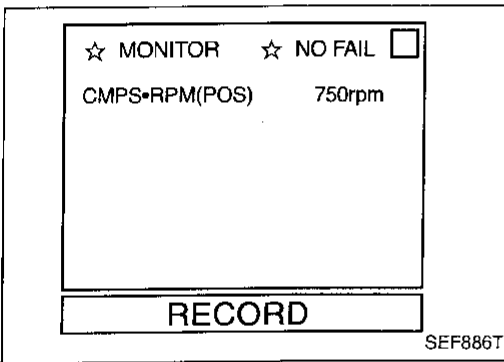

DIAGNOSTIC TROUBLE CODE CONFIRMATION PROCEDURE

- 1) Turn ignition switch "ON".
 - 2) Select "DATA MONITOR" mode with CONSULT.
 - 3) Start engine.
 - 4) Run engine for at least 2 seconds at idle speed.
- OR
- 1) Turn ignition switch "ON".
 - 2) Start engine.
 - 3) Run engine for at least 2 seconds at idle speed.
 - 4) Select "Mode 7" with GST.
- OR
- 1) Turn ignition switch "ON".
 - 2) Start engine and wait at least 2 seconds.
 - 3) Turn ignition switch "OFF", wait at least 5 seconds and then turn "ON".
 - 4) Perform "Diagnostic Test Mode II" (Self-diagnostic results) with ECM.

TROUBLE DIAGNOSIS FOR DTC P0605

Engine Control Module (ECM)-ECCS Control Module (Cont'd)

DIAGNOSTIC PROCEDURE

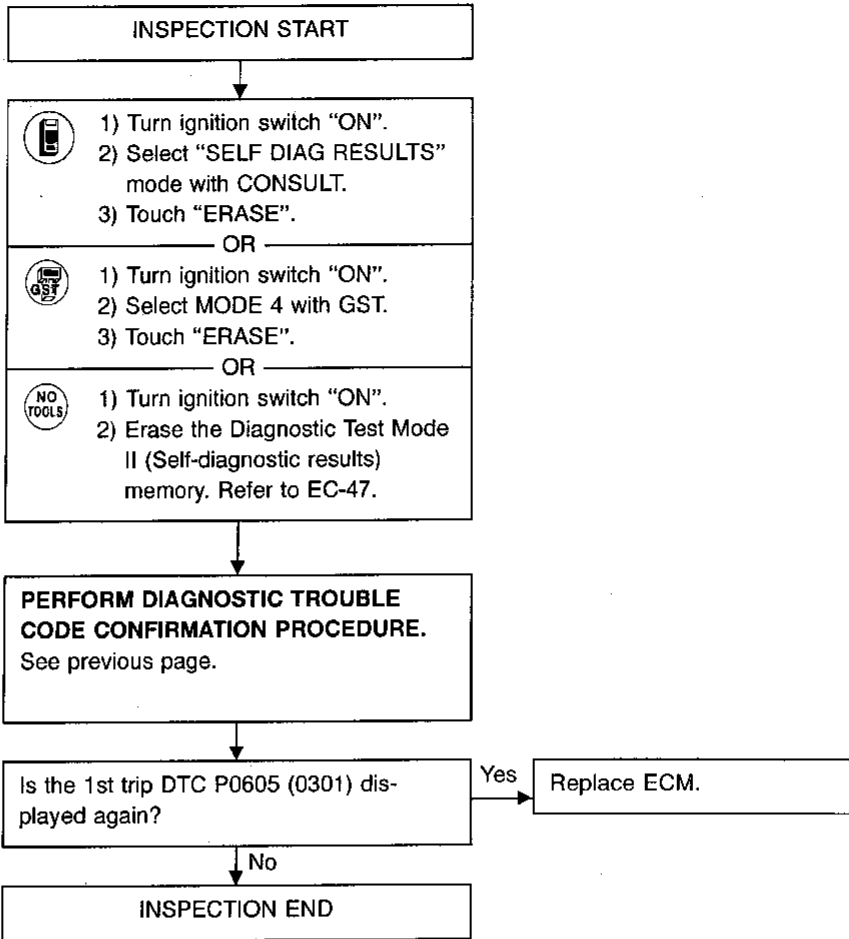

TROUBLE DIAGNOSIS FOR DTC P0705

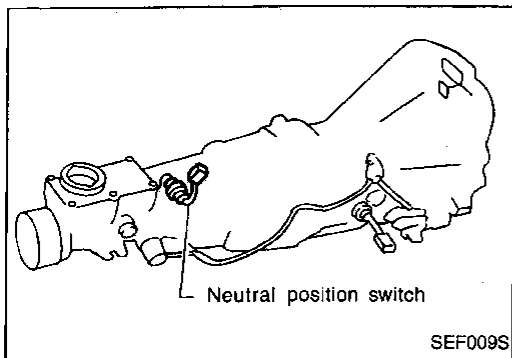

Park/Neutral Position Switch

COMPONENT DESCRIPTION

When the gear position is "P" or "N", park/neutral position switch is "ON".

ECM detects the position because the continuity of the line (the "ON" signal) exists.

ECM receives signals from park position switch.

GI
MA
EM
LC
EC
FE
AT
TF
PD
FA
RA
BR
ST
RS
BT
HA
EL
IDX

CONSULT REFERENCE VALUE IN DATA MONITOR MODE

Specification data are reference values.

MONITOR ITEM	CONDITION		SPECIFICATION
P/N POSI SW	● Ignition switch: ON	Shift lever: "P" or "N"	ON
		Except above	OFF

ECM TERMINALS AND REFERENCE VALUE

Specification data are reference values and are measured between each terminal and Ⓞ (ECCS ground).

TER-MINAL NO.	WIRE COLOR	ITEM	CONDITION	DATA (DC Voltage)
22	L/B	Inhibitor switch	Ignition switch "ON" └ Gear position is "N" or "P"	Approximately 0V
			Ignition switch "ON" └ Except the above gear position	Approximately 5V

ON BOARD DIAGNOSIS LOGIC

Diagnostic Trouble Code No.	Malfunction is detected when	Check Items (Possible Cause)
P0705 1003	<ul style="list-style-type: none"> The signal of the park/neutral position switch is not changed in the process of engine starting and driving. 	<ul style="list-style-type: none"> Harness or connectors <ol style="list-style-type: none"> (The neutral position switch or inhibitor switch circuit is open or shorted.) (The circuit between ECM and A/T control unit is open or shorted.) Inhibitor switch A/T control unit

TROUBLE DIAGNOSIS FOR DTC P0705

☆ MONITOR	☆ NO FAIL	<input type="checkbox"/>
CMPS•RPM(POS)	2400rpm	
VHCL SPEED SE	75km/h	
RECORD		

SEF896T

Park/Neutral Position Switch (Cont'd) DIAGNOSTIC TROUBLE CODE CONFIRMATION PROCEDURE



- 1) Start engine and warm it up sufficiently.
- 2) Turn ignition switch "OFF" and wait at least 5 seconds.
- 3) Turn ignition switch "ON".
- 4) Select "DATA MONITOR" mode with CONSULT.
- 5) Start engine again and maintain the following conditions for at least 1 minute.

Engine speed : 1,600 - 2,650 rpm

Gear position : "D" range

VHCL SPEED SE: 70 km/h - 80 km/h (43 - 50 MPH)

OR



- 1) Start engine and warm it up sufficiently.
- 2) Turn ignition switch "OFF" and wait at least 5 seconds.
- 3) Turn ignition switch "ON".
- 4) Start engine again and maintain the following conditions for at least 1 minute.

Engine speed: 1,600 - 2,650 rpm

Gear position: "D" range

Vehicle speed: 70 km/h - 80 km/h (43 - 50 MPH)

- 5) Select "MODE 7" with GST.

OR



- 1) Start engine and warm it up sufficiently.
- 2) Turn ignition switch "OFF" and wait at least 5 seconds.
- 3) Turn ignition switch "ON".
- 4) Start engine again and maintain the following conditions for at least 1 minute.

Engine speed: 1,600 - 2,650 rpm

Gear position: "D" range

Vehicle speed: 70 km/h - 80 km/h (43 - 50 MPH)

- 5) Stop the vehicle, turn ignition switch "OFF", wait at least 5 seconds and then turn "ON".
- 6) Perform "Diagnostic Test Mode II (Self-diagnostic results)" with ECM.

TROUBLE DIAGNOSIS FOR DTC P0705

Park/Neutral Position Switch (Cont'd)

EC-PNP/SW-01

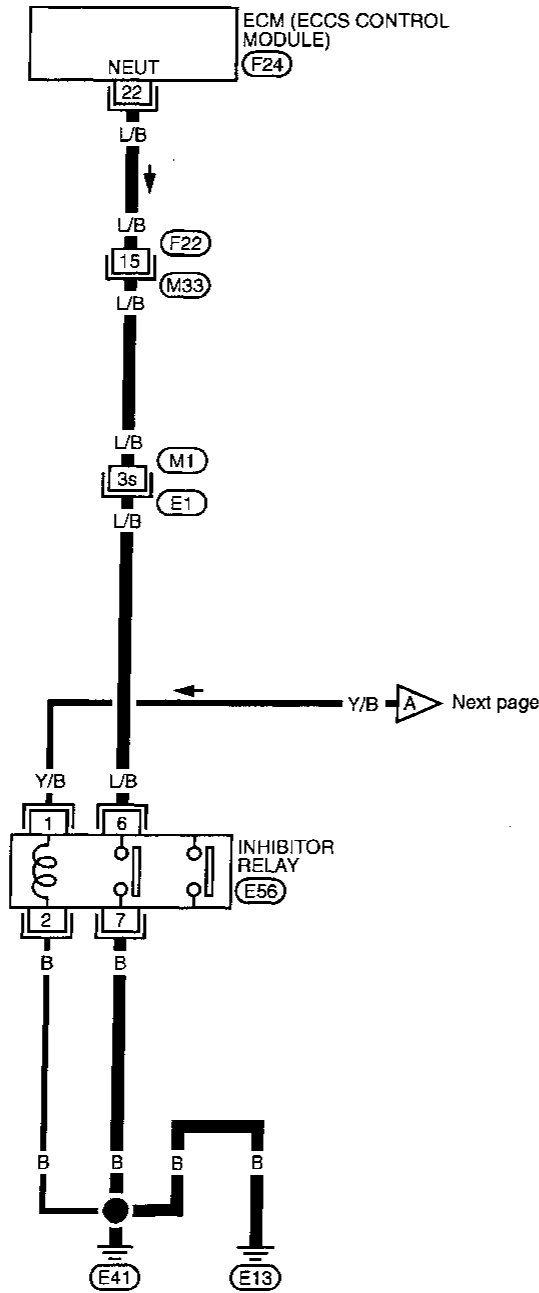

: Detectable line for DTC
 : Non-detectable line for DTC

GI
MA
EM
LC
EC
FE
AT
TF
PD
FA
RA
BR
ST
RS
BT
HA
EL
IDX

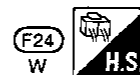
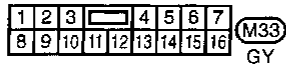
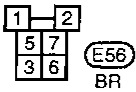

Refer to last page (Foldout page).

(E1) , (M1)

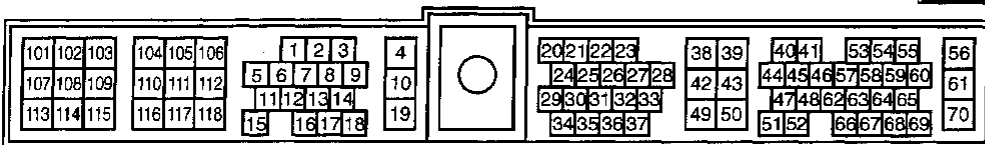

TROUBLE DIAGNOSIS FOR DTC P0705

Park/Neutral Position Switch (Cont'd)

EC-PNP/SW-02

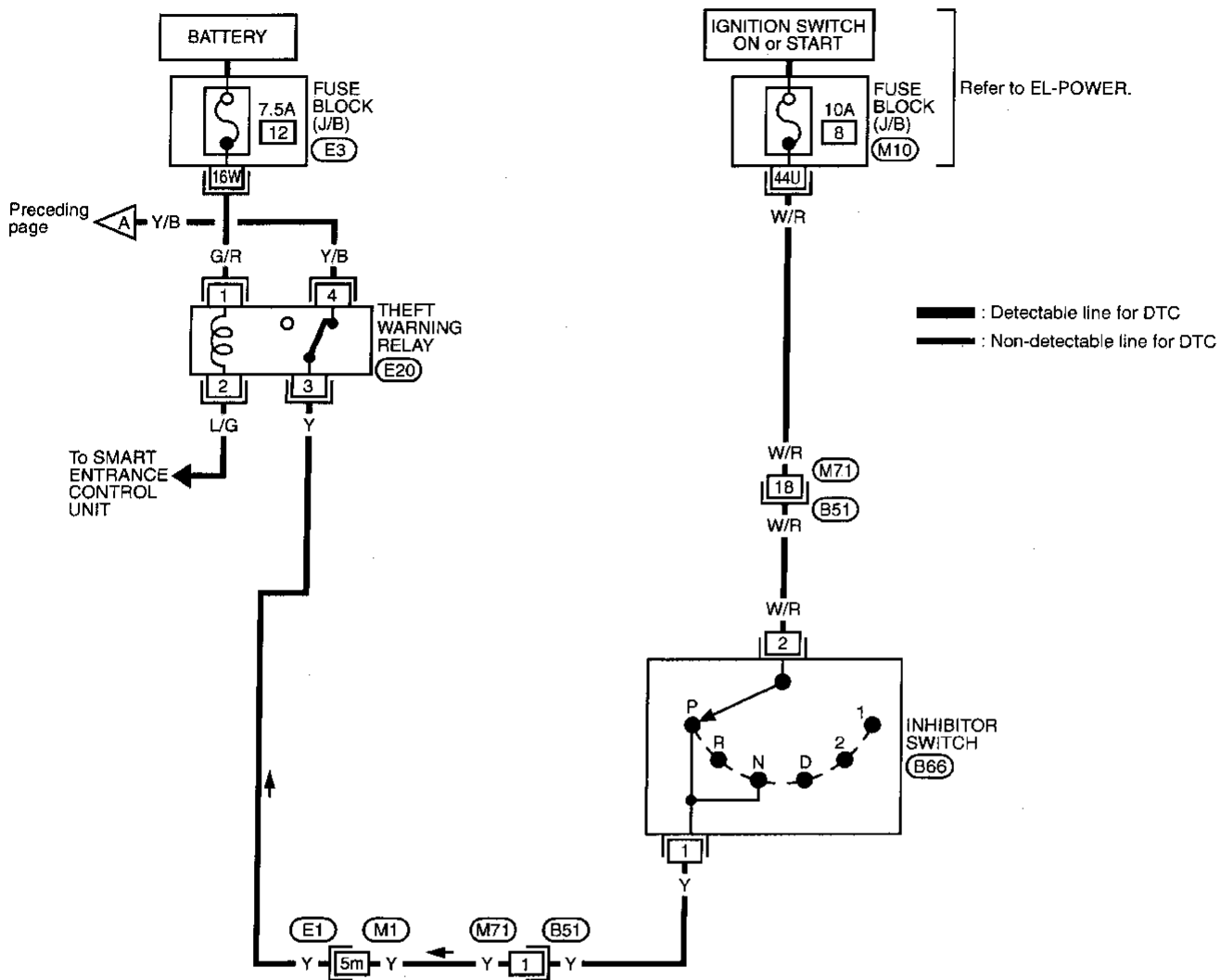

Refer to last page (Foldout page).

- (M10) , (E3)
- (M1) , (E1)

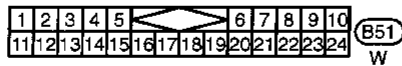
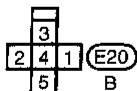

TROUBLE DIAGNOSIS FOR DTC P0705

Park/Neutral Position Switch (Cont'd)

DIAGNOSTIC PROCEDURE

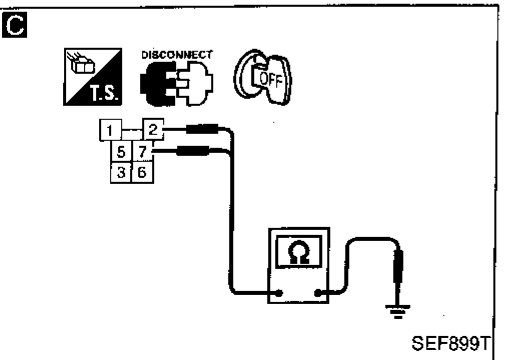
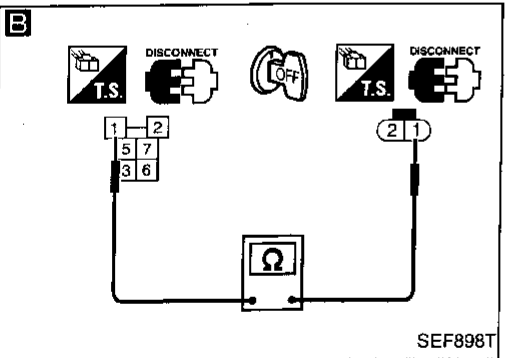
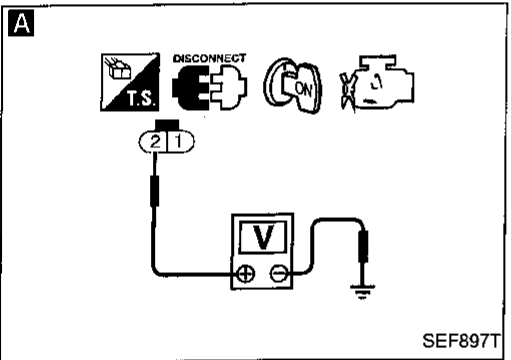
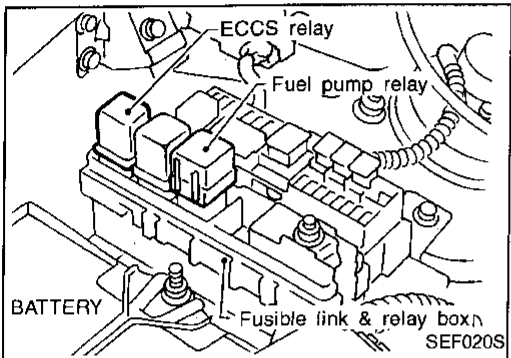
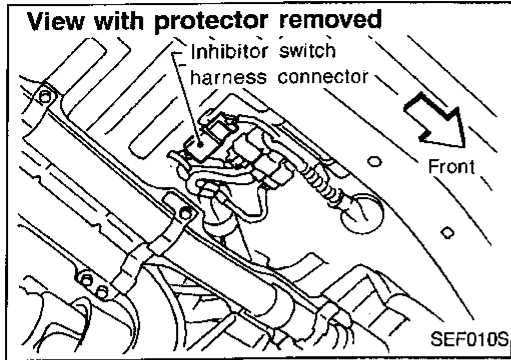

Inhibitor switch

INSPECTION START

A

CHECK POWER SUPPLY.

1. Disconnect inhibitor switch harness connector.
2. Turn ignition switch "ON".
3. Check voltage between terminal ② and ground with CONSULT or tester.

Voltage: Battery voltage

NG

Check the following.

- Harness connectors (M71), (B51)
- 10A fuse
- Harness for open or short between inhibitor switch and fuse

If NG, repair harness or connectors.

B

CHECK OUTPUT SIGNAL CIRCUIT-I.

1. Turn ignition switch "OFF".
2. Disconnect park/neutral position relay harness connector.
3. Check harness continuity between relay terminal ① and inhibitor switch terminal ①.

Continuity should exist.

If OK, check harness for short to ground and short to power.

NG

Check the following.

- Harness connectors (M71), (B51)
- Harness connectors (E1), (M1)
- Theft warning relay (With anti-theft system)
- Harness for open or short between inhibitor switch and inhibitor relay

If NG, repair open circuit or short to ground or short to power in harness or connectors.

C

CHECK GROUND CIRCUIT.

1. Check harness continuity between terminals ⑦, ② and body ground.

Continuity should exist.

If OK, check harness for short to ground and short to power.

NG

Check the following.

- Harness for open or short between inhibitor relay and body ground

If NG, repair open circuit or short to ground or short to power in harness or connectors.

OK

A

GI
MA
EM
LC
EC
FE
AT
TF
PD
FA
RA
BR
ST
RS
BT
HA
EL
IDX

TROUBLE DIAGNOSIS FOR DTC P0705

Park/Neutral Position Switch (Cont'd)

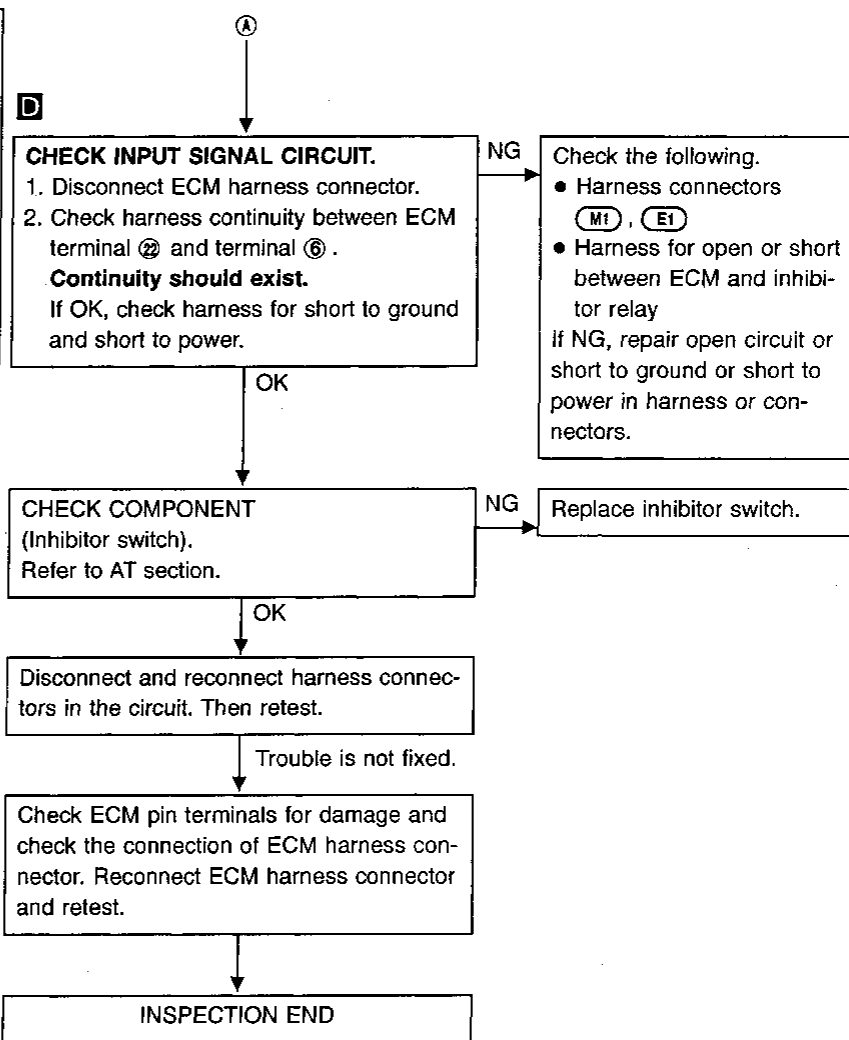
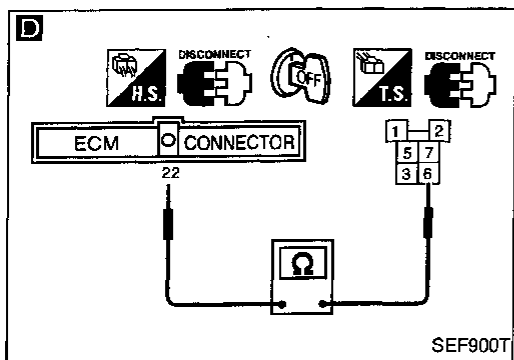

Manifold Absolute Pressure (MAP)/Barometric Pressure (BARO) Switch Solenoid Valve

GI
MA
EM
LC
EC

SYSTEM DESCRIPTION

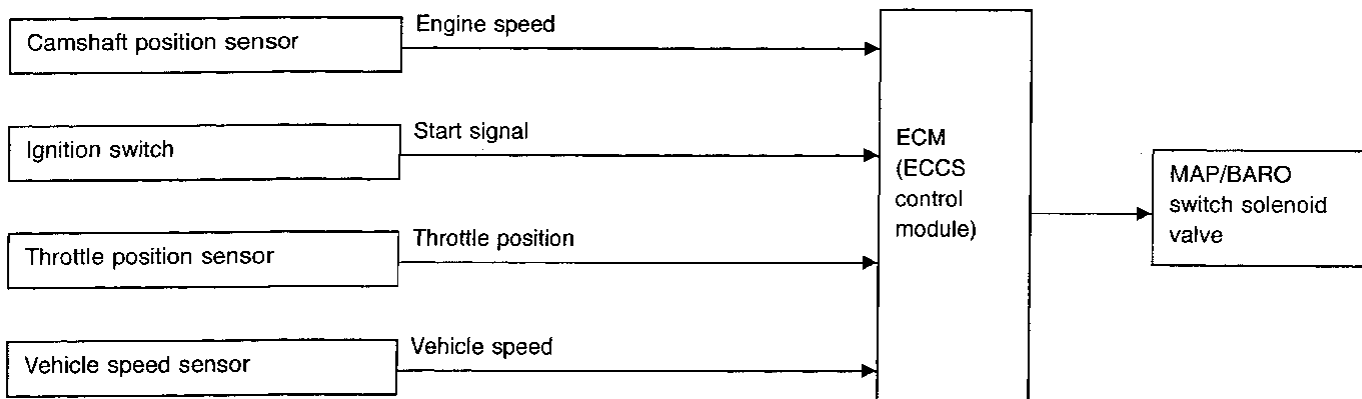

FE
AT
TF
PD
FA
RA

This system allows the absolute pressure sensor to monitor either ambient barometric pressure or intake manifold pressure. The MAP/BARO switch solenoid valve switches between two passages by ON-OFF pulse signals from the ECM. (One passage is from the intake air duct, the other is from the intake manifold.) Either ambient barometric pressure or intake manifold pressure is applied to the absolute pressure sensor.

Solenoid	Conditions
ON	<ul style="list-style-type: none"> • Immediately after turning ignition switch ON or • More than 5 minutes after the solenoid valve shuts OFF. <p style="text-align: center;">and</p> <ul style="list-style-type: none"> • Throttle valve is shut or almost fully shut for more than 1 second <p style="text-align: center;">and</p> <ul style="list-style-type: none"> • Vehicle speed is less than 100 km/h (62 MPH).

BR
ST
RS
BT
HA

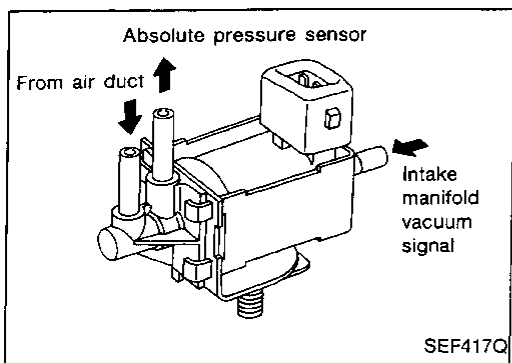

COMPONENT DESCRIPTION

The MAP/BARO switch solenoid valve switches its air flow passage according to the voltage signal sent from the ECM. When voltage is supplied from the ECM, the MAP/BARO switch solenoid turns "ON". Then, the absolute pressure sensor can monitor the ambient barometric pressure. When voltage is not supplied from the ECM, the MAP/BARO switch solenoid valve turns "OFF". Then, the sensor monitors intake manifold pressure.

EL
IDX

CONSULT REFERENCE VALUE IN DATA MONITOR MODE

Specification data are reference values.

MONITOR ITEM	CONDITION	SPECIFICATION
MAP/BARO SW/V	• Ignition switch: ON	BARO
	• Engine: After warming up	Idle (for 10 seconds after engine start)

TROUBLE DIAGNOSIS FOR DTC P1105

Manifold Absolute Pressure (MAP)/Barometric Pressure (BARO) Switch Solenoid Valve (Cont'd)

ECM TERMINALS AND REFERENCE VALUE

Specification data are reference values and are measured between each terminal and Ⓒ (ECCS ground).

TER-MINAL NO.	WIRE COLOR	ITEM	CONDITION	DATA (DC Voltage)
59	Y/B	MAP/BARO switch solenoid valve	Ignition switch "ON" └ Engine is not running.	BATTERY VOLTAGE (11 - 14V)
			Engine is running └ After engine warming up └ Idle (for 10 seconds after engine start)	Approximately 0V

ON BOARD DIAGNOSIS LOGIC

Diagnostic Trouble Code No.	Malfunction is detected when	Check Items (Possible Cause)
P1105 1302	<ul style="list-style-type: none"> MAP/BARO switch solenoid valve receives the voltage supplied though ECM does not supply the voltage to the valve. There is little difference between MAP/BARO switch solenoid valve input voltage at ambient barometric pressure and voltage at intake manifold pressure. 	<ul style="list-style-type: none"> Harness or connectors (MAP/BARO switch solenoid valve circuit is open or shorted.) Hoses (Hoses are clogged or disconnected.) Absolute pressure sensor MAP/BARO switch solenoid valve

☆ MONITOR
☆ NO FAIL

CMPS•RPM(POS)	750rpm
COOLAN TEMP/S	85°C

RECORD

SEF887T

DIAGNOSTIC TROUBLE CODE CONFIRMATION PROCEDURE

- 1) Start engine and warm it up sufficiently.
 - 2) Turn ignition switch "OFF" and wait at least 5 seconds.
 - 3) Turn ignition switch "ON" and select "DATA MONITOR" mode with CONSULT.
 - 4) Start engine and let it idle.
 - 5) Wait at least 15 seconds.
- OR
- 1) Start engine and warm it up sufficiently.
 - 2) Turn ignition switch "OFF" and wait at least 5 seconds.
 - 3) Start engine and let it idle.
 - 4) Wait at least 15 seconds.
 - 5) Select "MODE 7" with GST.
- OR
- 1) Start engine and warm it up sufficiently.
 - 2) Turn ignition switch "OFF" and wait at least 5 seconds.
 - 3) Start engine and let it idle.
 - 4) Wait at least 15 seconds.
 - 5) Turn ignition switch "OFF", wait at least 5 seconds and then turn "ON".
 - 6) Perform "Diagnostic Test Mode II (Self-diagnostic results)" with ECM.

TROUBLE DIAGNOSIS FOR DTC P1105

Manifold Absolute Pressure (MAP)/Barometric Pressure (BARO) Switch Solenoid Valve (Cont'd)

EC-SW/V-01

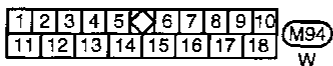
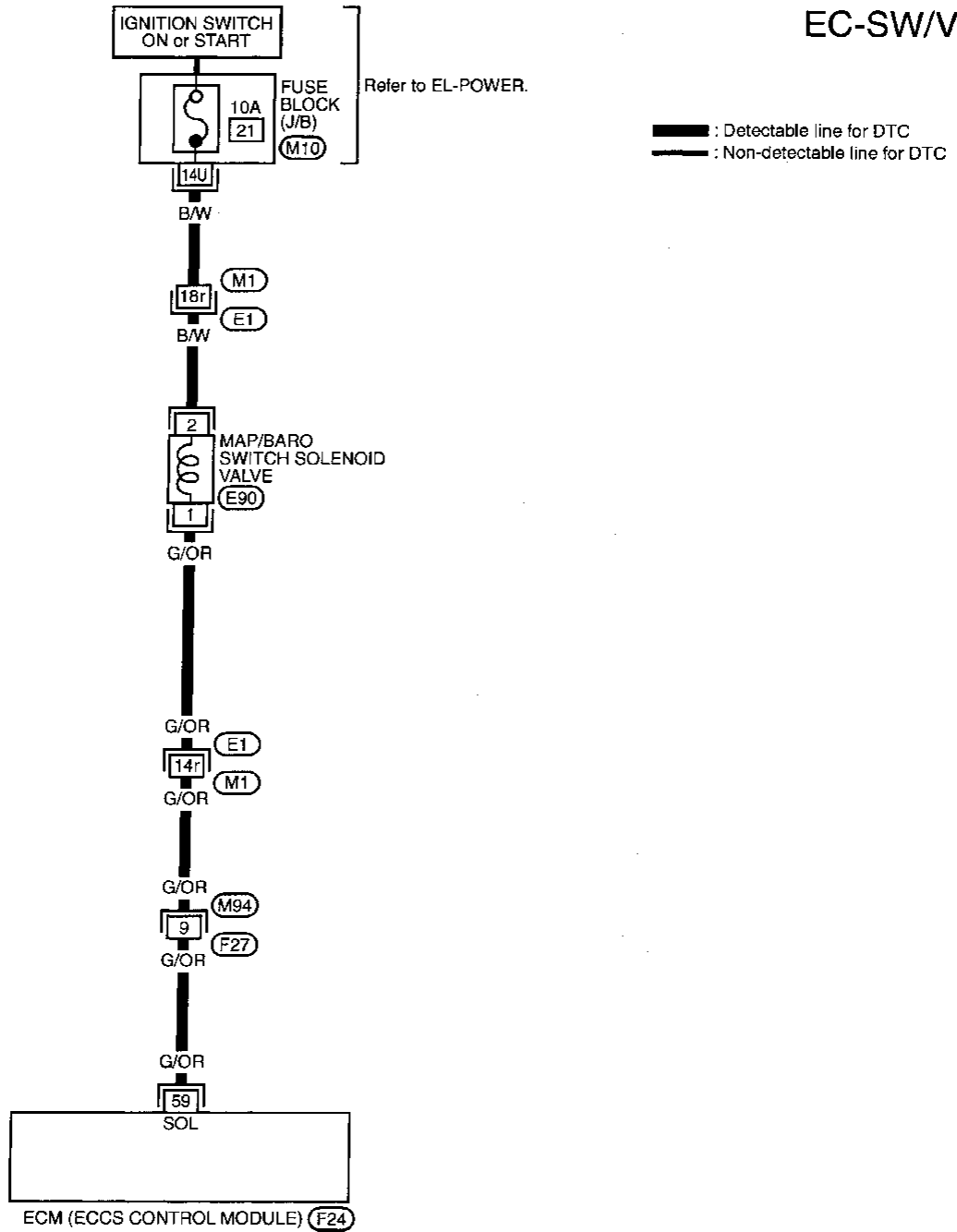

Refer to last page (Foldout page).

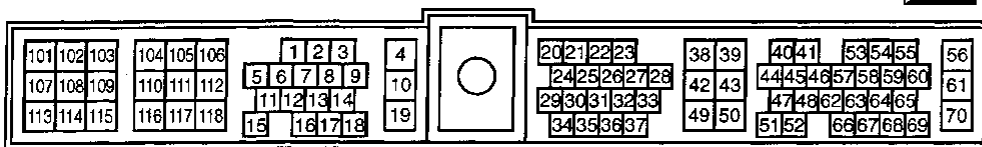
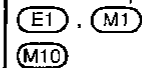

GI
MA
EM
LC
EC
FE
AT
TF
PD
FA
RA
BR
ST
RS
BT
HA
EL
IDX

TROUBLE DIAGNOSIS FOR DTC P1105

Manifold Absolute Pressure (MAP)/Barometric Pressure (BARO) Switch Solenoid Valve (Cont'd)

DIAGNOSTIC PROCEDURE

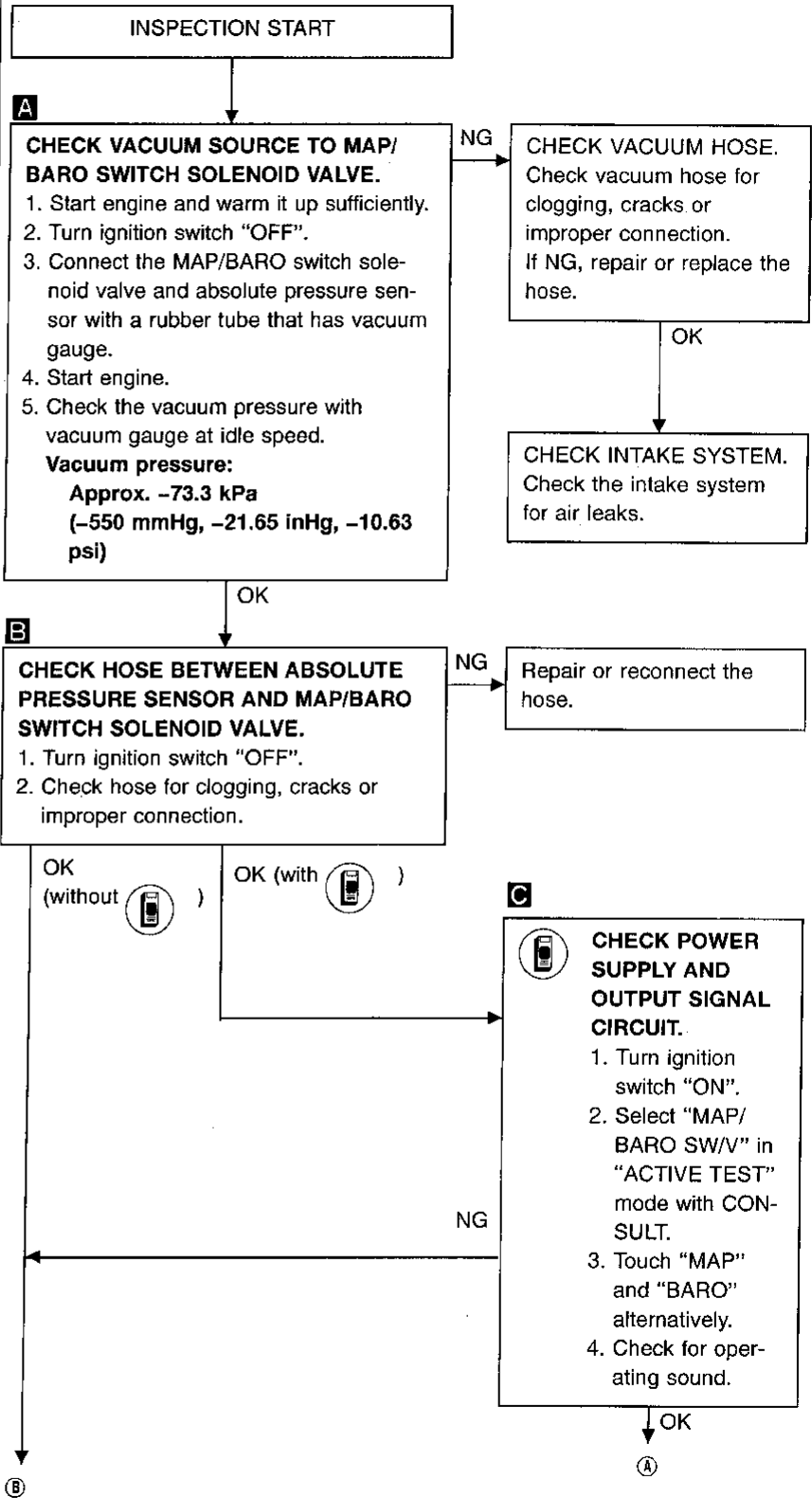
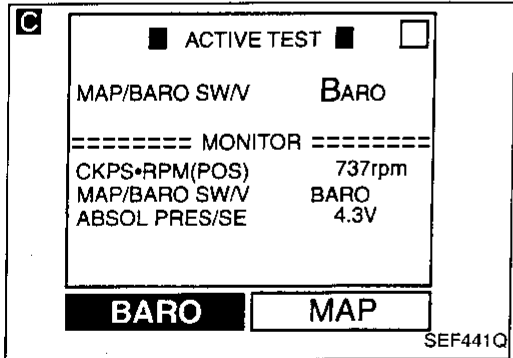
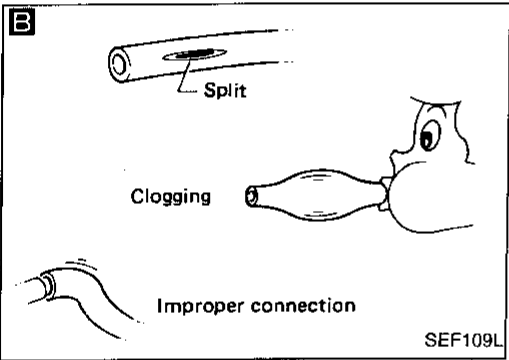
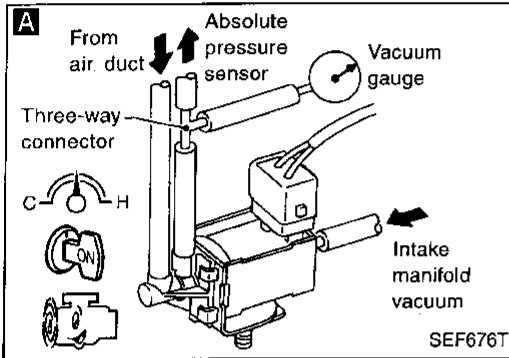
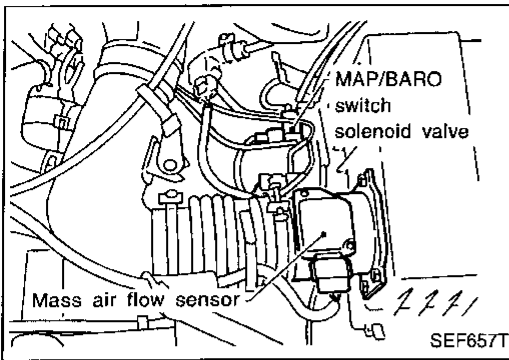

TROUBLE DIAGNOSIS FOR DTC P1105

Manifold Absolute Pressure (MAP)/Barometric Pressure (BARO) Switch Solenoid Valve (Cont'd)

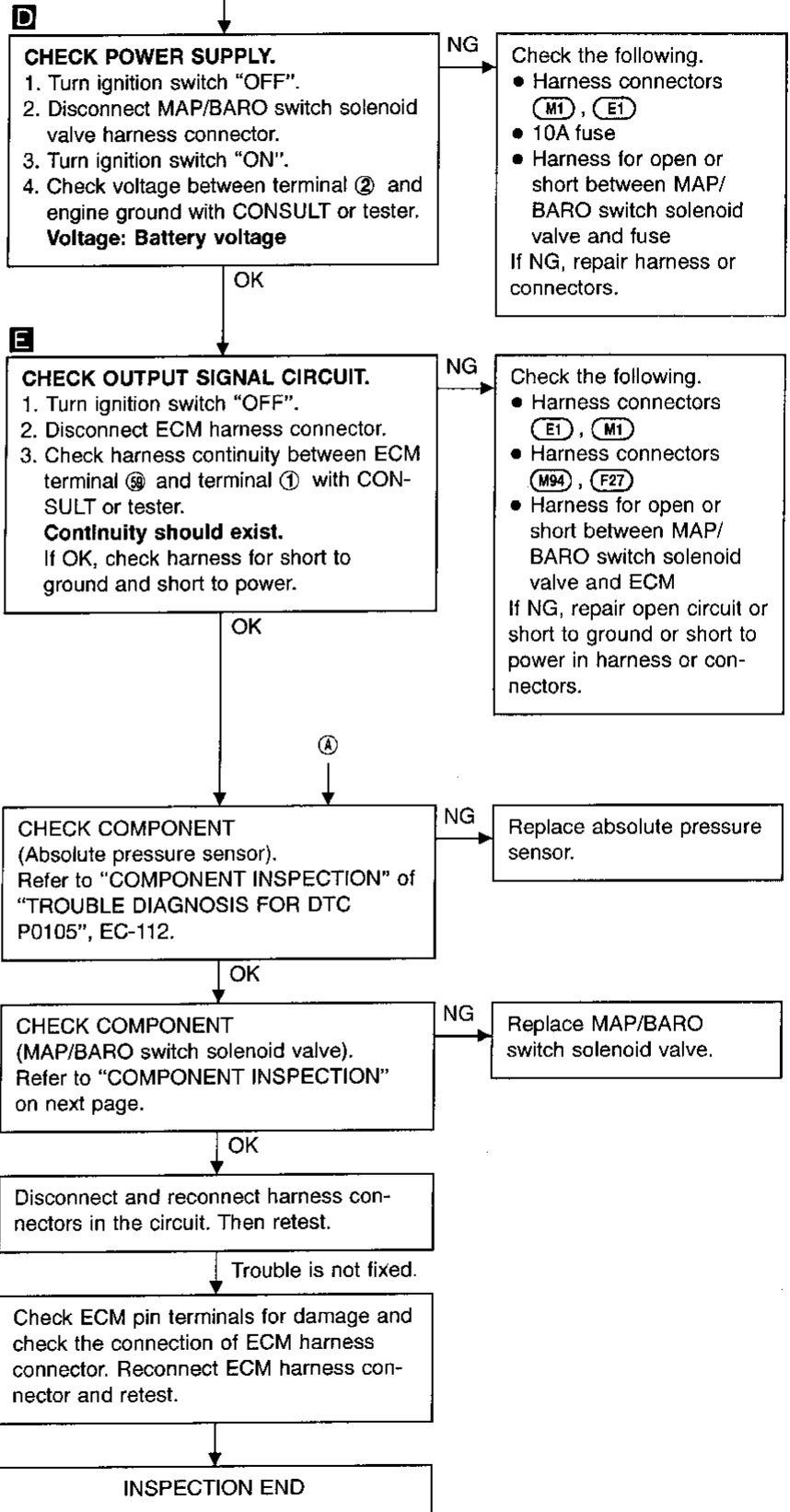
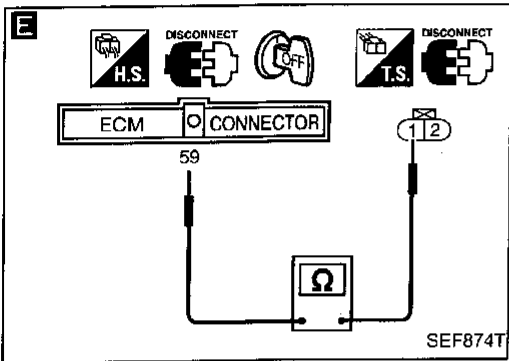
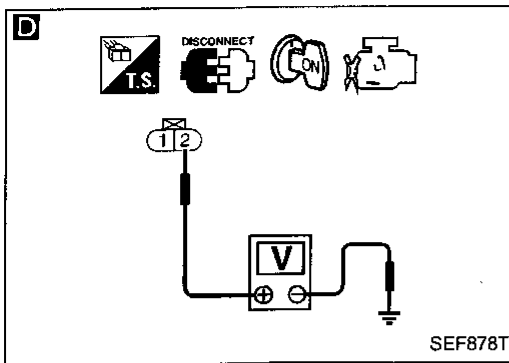

GI
MA
EM
LC
EC
FE
AT
TF
PD
FA
RA
BR
ST
RS
BT
HA
EL
IDX

TROUBLE DIAGNOSIS FOR DTC P1105

Manifold Absolute Pressure (MAP)/Barometric Pressure (BARO) Switch Solenoid Valve (Cont'd)

COMPONENT INSPECTION

MAP/BARO switch solenoid valve

1. Start engine and warm it up sufficiently.
2. Perform "MAP/BARO SW/V" in "ACTIVE TEST" mode with CONSULT.
3. Check the following.
 - When "MAP" is selected, "ABSOL PRES/SE" indicates approximately 1.3V.
 - When "BARO" is selected, "ABSOL PRES/SE" indicates approximately 4.3V.
4. If NG, replace solenoid valve.

OR

1. Remove MAP/BARO switch solenoid valve.
2. Check air passage continuity.

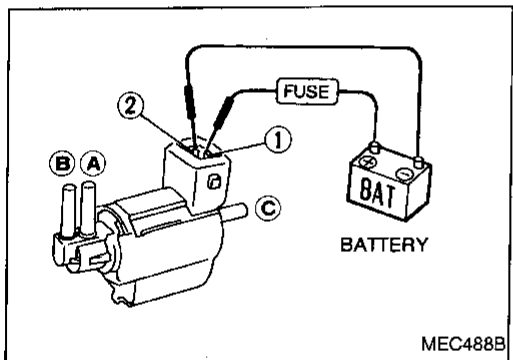
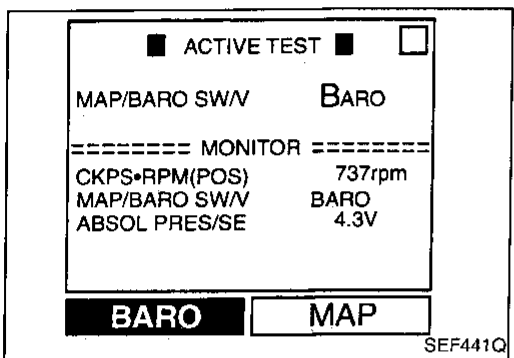
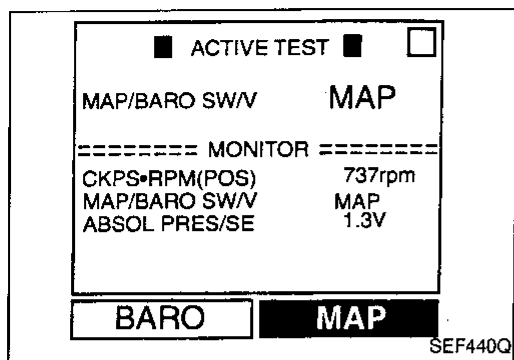

Condition	Air passage continuity between (A) and (B)	Air passage continuity between (A) and (C)
12V direct current supply between terminals ① and ②	Yes	No
No supply	No	Yes

3. If NG, replace solenoid valve.

TROUBLE DIAGNOSIS FOR DTC P1320

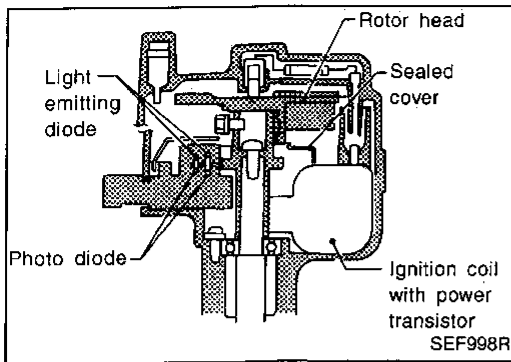

Ignition Signal

COMPONENT DESCRIPTION

Ignition coil & power transistor

The ignition signal from the ECM is sent to the power transistor. The power transistor switches on and off the ignition coil primary circuit. As the primary circuit is turned on and off, the proper high voltage is induced in the coil secondary circuit.

GI

MA

EM

LC

EC

FE

AT

TF

PD

FA

RA

BR

ST

RS

BT

HA

EL

IDX

CONSULT REFERENCE VALUE IN DATA MONITOR MODE

Specification data are reference values.

MONITOR ITEM	CONDITION	SPECIFICATION
IGNITION SW	● Ignition switch: ON → OFF → ON	ON → OFF → ON

ECM TERMINALS AND REFERENCE VALUE

Specification data are reference values and are measured between each terminal and Ⓞ (ECCS ground).

TER-MINAL NO.	WIRE COLOR	ITEM	CONDITION	DATA (DC Voltage)
1	W/B	Ignition signal	Engine is running. └ Idle speed	0.9V
			Engine is running. └ Engine speed is 2,000 rpm	1.1 - 1.3V
2	W/G	Ignition check	Engine is running. (Warm-up condition) └ Idle speed	8.7V
			Engine is running. └ Engine speed is 2,000 rpm.	Approximately 13V

TROUBLE DIAGNOSIS FOR DTC P1320

Ignition Signal (Cont'd)

ON BOARD DIAGNOSIS LOGIC

Diagnostic Trouble Code No.	Malfunction is detected when ...	Check Items (Possible Cause)
P1320 0201	<ul style="list-style-type: none"> ● The ignition signal in the primary circuit is not sent to ECM during engine cranking or running. 	<ul style="list-style-type: none"> ● Harness or connectors (The ignition primary circuit is open or shorted.) ● Power transistor unit. ● Resistor ● Camshaft position sensor ● Camshaft position sensor circuit

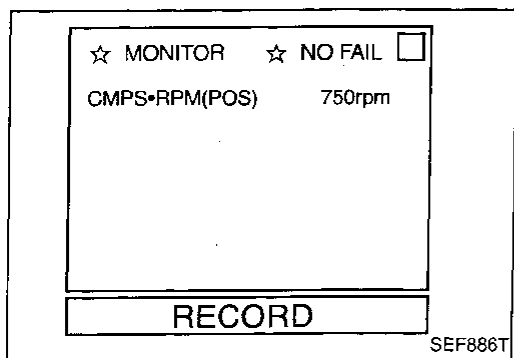

DIAGNOSTIC TROUBLE CODE CONFIRMATION PROCEDURE

Note: If both DTC P0340 (0101) and P1320 (0201) are displayed, perform TROUBLE DIAGNOSIS FOR DTC P0340 first. Refer to EC-205.



- 1) Turn ignition switch "ON".
- 2) Select "DATA MONITOR" mode with CONSULT.
- 3) Start engine. (If engine does not run, turn ignition switch to "START" for at least 5 seconds.)

OR



- 1) Turn ignition switch "ON".
- 2) Start engine. (If engine does not run, turn ignition switch to "START" for at least 5 seconds.)
- 3) Select MODE 7 with GST.

OR



- 1) Turn ignition switch "ON".
- 2) Start engine. (If engine does not run, turn ignition switch to "START" for at least 5 seconds.)
- 3) Turn ignition switch "OFF" and wait at least 5 seconds, then turn "ON".
- 4) Perform "Diagnostic Test Mode II" (Self-diagnostic results) with ECM.

TROUBLE DIAGNOSIS FOR DTC P1320

Ignition Signal (Cont'd)

EC-IGN/SG-01

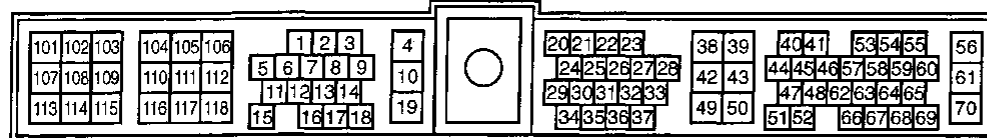
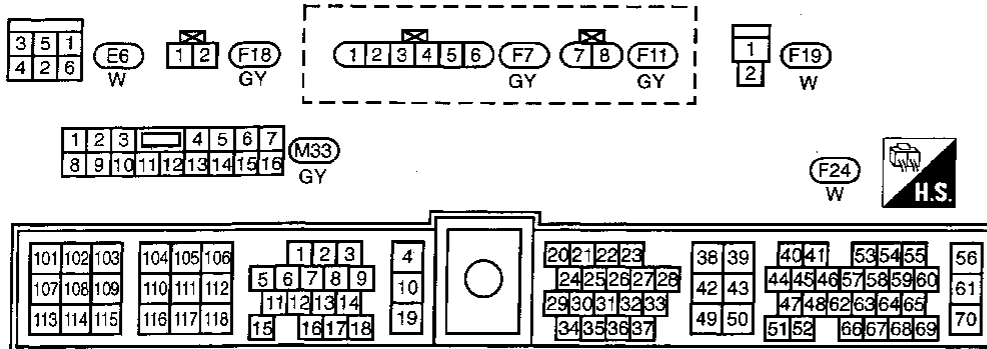
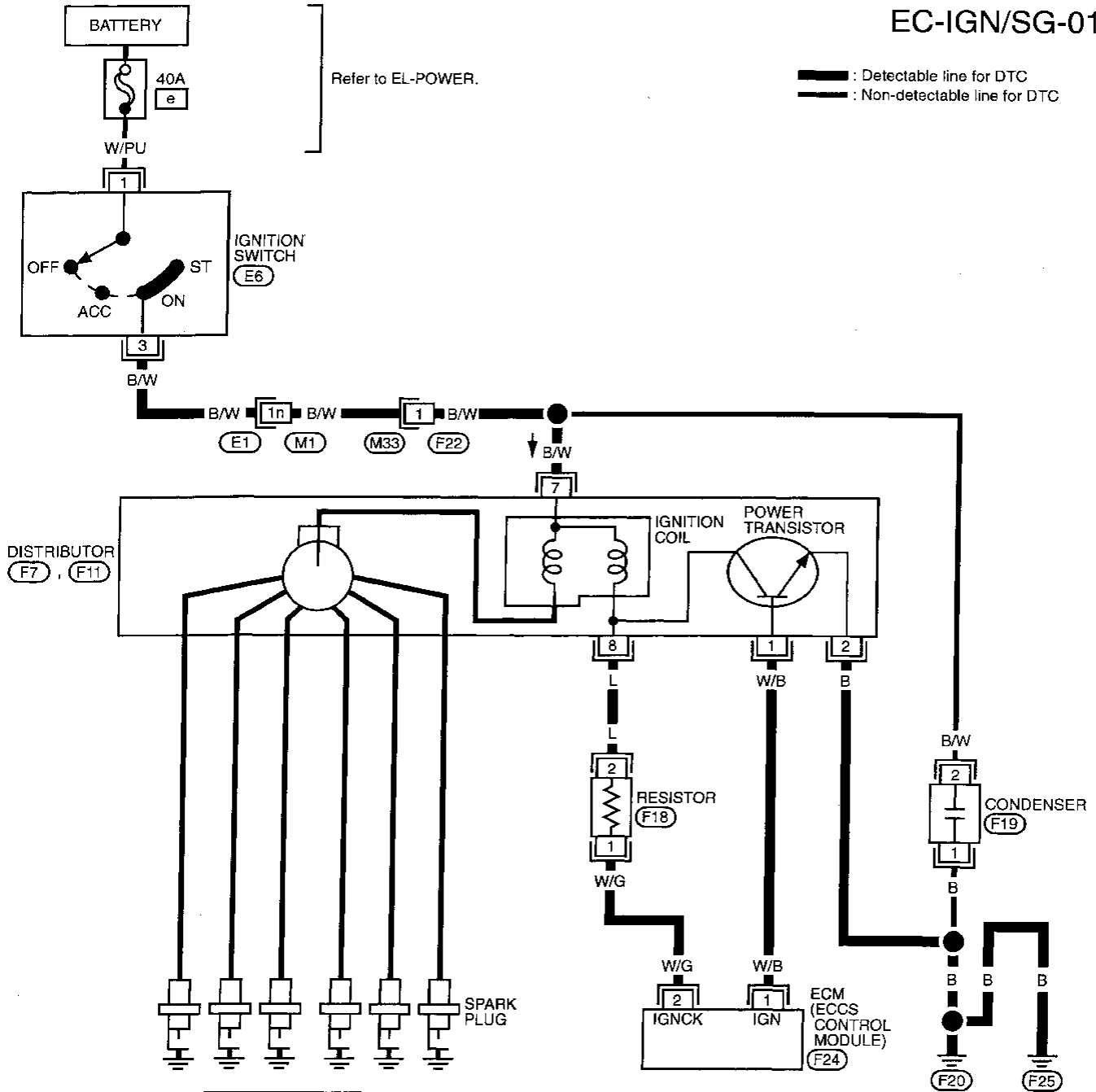

GI
 MA
 EM
 LC
EC
 FE
 AT
 TF
 PD
 FA
 RA
 BR
 ST
 RS
 BT
 HA
 EL
 IDX

TROUBLE DIAGNOSIS FOR DTC P1320

Ignition Signal (Cont'd) DIAGNOSTIC PROCEDURE

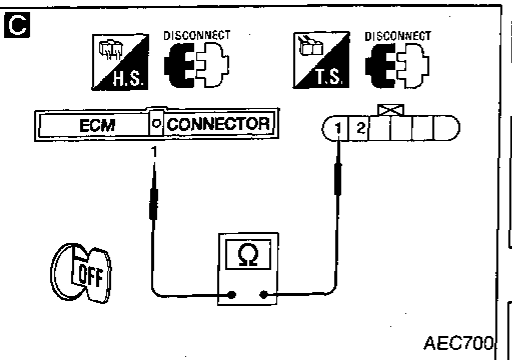
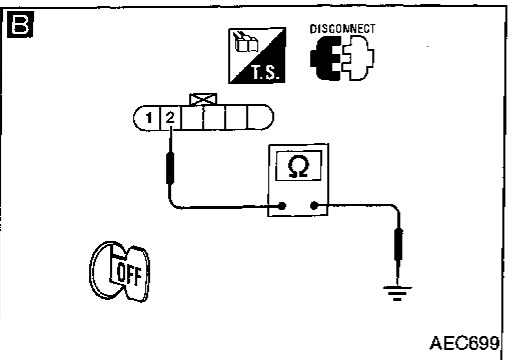
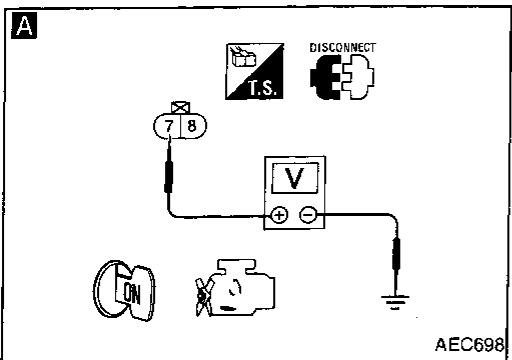
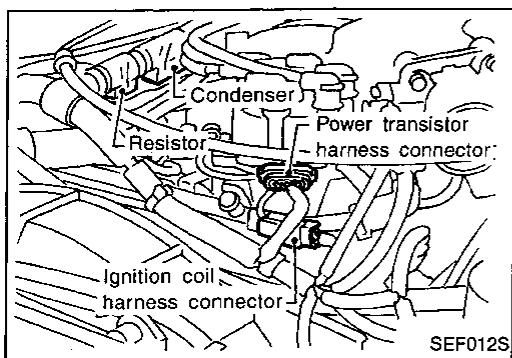

INSPECTION START

Turn ignition switch "OFF", and restart engine.
Is engine running?

Yes → A

No

A
CHECK POWER SUPPLY.
1. Turn ignition switch "OFF".
2. Disconnect ignition coil harness connector.
3. Turn ignition switch "ON".
4. Check voltage between terminal ⑦ and ground with CONSULT or tester.
Voltage: Battery voltage

NG → Check the following.
• Harness connectors F22, M33
• Harness connectors M1, E1
• Harness for open or short between ignition coil and ignition switch
If NG, repair harness or connectors.

B
CHECK GROUND CIRCUIT.
1. Turn ignition switch "OFF".
2. Disconnect power transistor harness connector.
3. Check harness continuity between terminal ② and engine ground.
Continuity should exist.
If OK, check harness for short to ground and short to power.

NG → Repair harness or connectors.

C
CHECK INPUT SIGNAL CIRCUIT.
1. Disconnect ECM harness connector.
2. Check harness continuity between ECM terminal ① and power transistor terminal ①.
Continuity should exist.
If OK, check harness for short to ground and short to power.

NG → Repair harness or connectors.

CHECK COMPONENTS
(Ignition coil, power transistor).
Refer to "COMPONENT INSPECTION", EC-288.

NG → Replace malfunctioning component(s).

Disconnect and reconnect harness connectors in the circuit. Then retest.

Trouble is not fixed.

Check ECM pin terminals for damage or the connection of ECM harness connector. Reconnect ECM harness connector and retest.

INSPECTION END

TROUBLE DIAGNOSIS FOR DTC P1320

Ignition Signal (Cont'd)

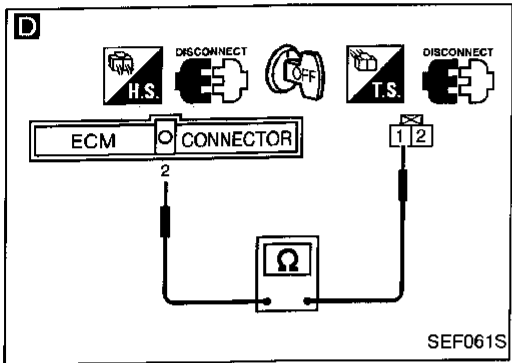
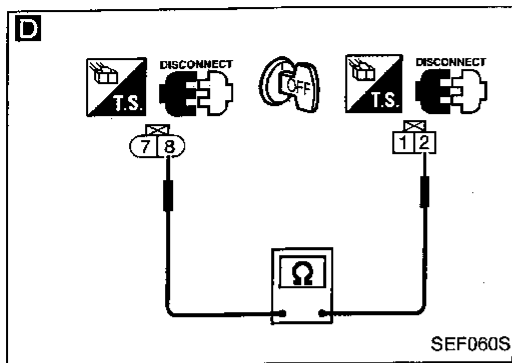

D

CHECK INPUT SIGNAL CIRCUIT.

1. Stop engine.
2. Disconnect ignition coil harness connector.
3. Strip tape covering resistor and condenser.
4. Disconnect resistor harness connector.
5. Disconnect ECM harness connector.
6. Check harness continuity between ignition coil terminal ⑧ and resistor terminal ①, resistor terminal ① and ECM terminal ②.

Continuity should exist.

If OK, check harness for short to ground and short to power.

NG → Repair harness or connectors.

OK

CHECK COMPONENTS

(Resistor).
Refer to "COMPONENT INSPECTION" on next page.

NG → Replace resistor.

OK

Disconnect and reconnect harness connectors in the circuit. Then retest.

Trouble is not fixed.

Check ECM pin terminals for damage or the connection of ECM harness connector. Reconnect ECM harness connector and retest.

INSPECTION END

GI

MA

EM

LC

EC

FE

AT

TF

PD

FA

RA

BR

ST

RS

BT

HA

EL

IDX

TROUBLE DIAGNOSIS FOR DTC P1320

Ignition Signal (Cont'd) COMPONENT INSPECTION

Ignition coil

1. Disconnect ignition coil harness connector.
2. Check resistance as shown in the figure.

Terminal	Resistance [at 25°C (77°F)]
⑦ - ⑧ (Primary coil)	0.5 - 1.0 Ω
⑦ - ⑨ (Secondary coil)	Approximately 12 kΩ

For checking secondary coil, remove distributor cap and measure resistance between coil tower metal tip ⑨ and terminal ⑦.

If NG, replace distributor assembly as a unit.

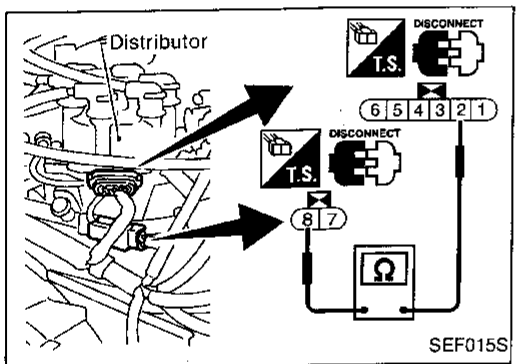
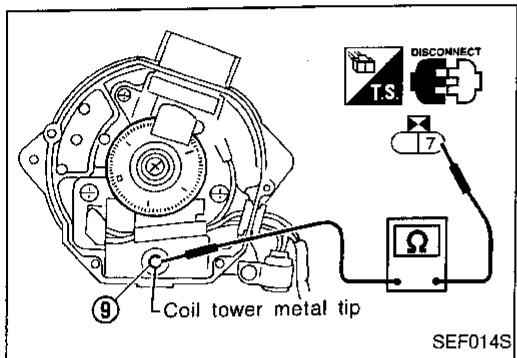
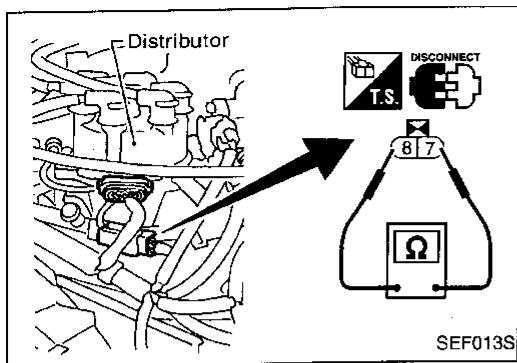

Power transistor

1. Disconnect camshaft position sensor & power transistor harness connector and ignition coil harness connector.
2. Check power transistor resistance between terminals ② and ⑧.

Terminals	Resistance	Result
② and ⑧	Except 0Ω	OK
	0Ω	NG

If NG, replace distributor assembly.

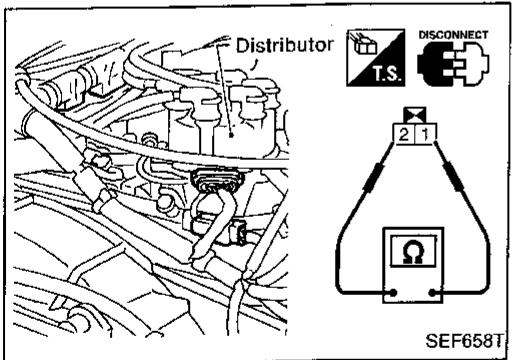

Resistor

1. Disconnect resistor harness connector.
2. Check resistance between terminals ① and ②.
Resistance: Approximately 2.2 kΩ [at 25°C (77°F)]
If NG, replace resistor.

TROUBLE DIAGNOSIS FOR DTC P1336

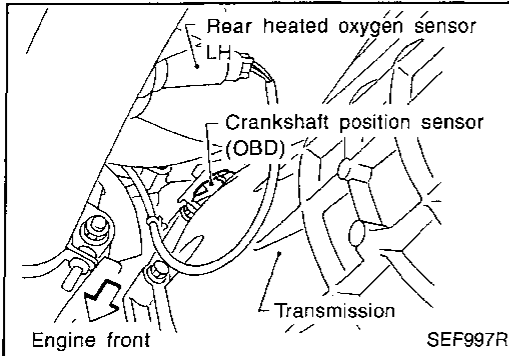
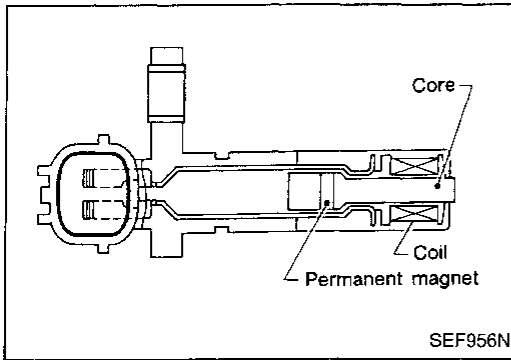

Crankshaft Position Sensor (CKPS) (OBD) (COG)

COMPONENT DESCRIPTION

The crankshaft position sensor (OBD) is located on the transmission housing facing the gear teeth (cogs) of the flywheel or drive plate. It detects the fluctuation of the engine revolution.

The sensor consists of a permanent magnet, core and coil. When the engine is running, the high and low parts of the teeth cause the gap with the sensor to change.

The changing gap causes the magnetic field near the sensor to change.

Due to the changing magnetic field, the voltage from the sensor changes.

The ECM receives the voltage signal and detects the fluctuation of the engine revolution.

This sensor is not directly used to control the engine system. It is used only for the on board diagnosis of misfire.

GI

MA

EM

LC

EC

FE

AT

TF

PD

FA

RA

BR

ST

RS

BT

HA

EL

IDX

ECM TERMINALS AND REFERENCE VALUE

Specification data are reference values and are measured between each terminal and Ⓞ (ECCS ground).

TER-MINAL NO.	WIRE COLOR	ITEM	CONDITION	DATA (DC Voltage)
53	L	Crankshaft position sensor (OBD)	Engine is running. (Warm-up condition) ↳ Idle speed	Approximately 1.4V SEF202T
			Engine is running. ↳ Engine speed is 2,000 rpm	Approximately 1.4V SEF203T

ON BOARD DIAGNOSIS LOGIC

Diagnostic Trouble Code No.	Malfunction is detected when	Check Items (Possible Cause)
P1336 0905	<ul style="list-style-type: none"> • A chipping of the flywheel or drive plate gear tooth (cog) is detected by the ECM. 	<ul style="list-style-type: none"> • Harness or connectors • Crankshaft position sensor (OBD) • Drive plate

TROUBLE DIAGNOSIS FOR DTC P1336

Crankshaft Position Sensor (CKPS) (OBD) (COG) (Cont'd)

DIAGNOSTIC TROUBLE CODE CONFIRMATION PROCEDURE

☆ MONITOR	☆ NO FAIL	<input type="checkbox"/>
CMPS•RPM(POS)	750rpm	
RECORD		

SEF886T



- 1) Turn ignition switch "ON" and select "DATA MONITOR" mode with CONSULT.
- 2) Start engine and run it for at least 2 minutes at idle speed.

OR



- 1) Start engine and run it for at least 2 minutes at idle speed.
- 2) Select "MODE 7" with GST.

OR



- 1) Start engine and run it for at least 2 minutes at idle speed.
- 2) Turn ignition switch "OFF", wait at least 5 seconds and then turn "ON".
- 3) Perform "Diagnostic Test Mode II" (Self-diagnostic results) with ECM.

TROUBLE DIAGNOSIS FOR DTC P1336

Crankshaft Position Sensor (CKPS) (OBD) (COG) (Cont'd)

EC-CKPS-01

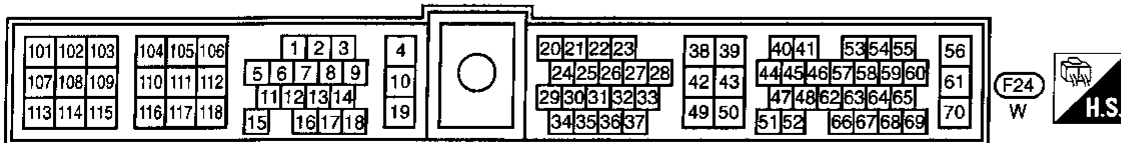
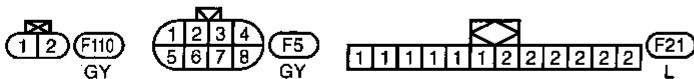
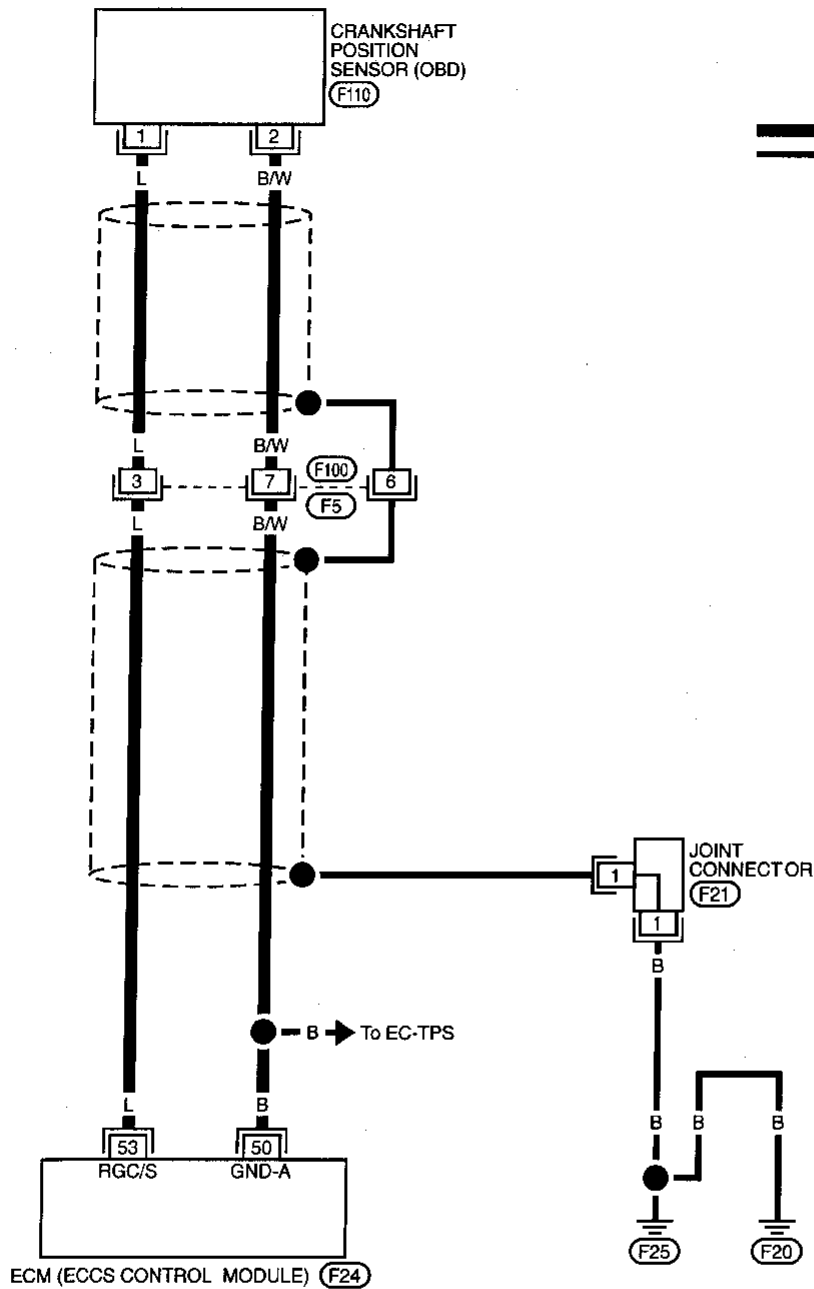

TROUBLE DIAGNOSIS FOR DTC P1336

Crankshaft Position Sensor (CKPS) (OBD) (COG) (Cont'd)

DIAGNOSTIC PROCEDURE

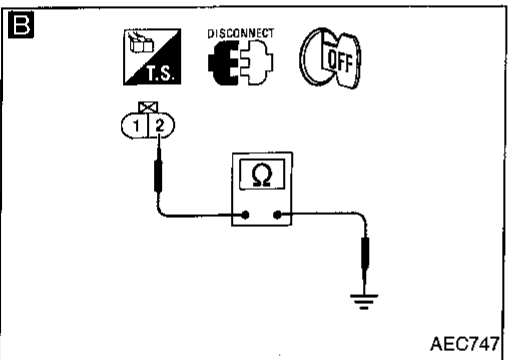
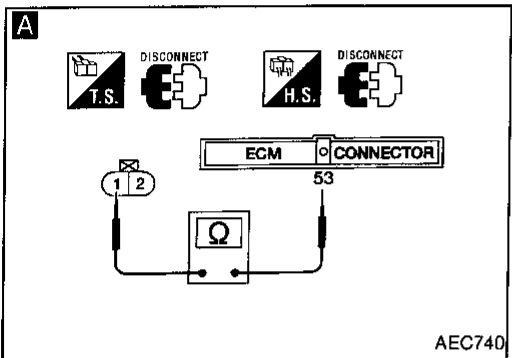
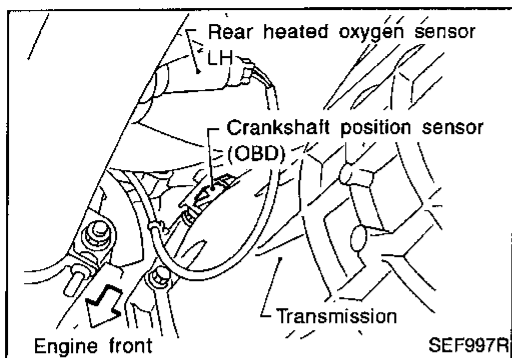

INSPECTION START

CHECK SHIELD CIRCUIT.

1. Turn ignition switch "OFF".
 2. Loosen and retighten engine ground screws.
 3. Remove joint connector.
 4. Check the following.
 - Continuity between joint connector terminal and ground
 - Joint connector (Refer to "HARNES LAYOUT" in EL section.)
- Continuity should exist.**
If OK, check harness for short to ground and short to power. Then reconnect joint connector.

NG → Repair harness or connectors.

OK

CHECK INPUT SIGNAL CIRCUIT.

1. Disconnect crankshaft position sensor (OBD) and ECM harness connectors.
 2. Check continuity between ECM terminal ③ and terminal ①.
- Continuity should exist.**
If OK, check harness for short to ground and short to power.

NG → Check the following.

- Harness connectors (F100, F5)
- Harness for open or short between ECM and crankshaft position sensor (OBD)

If NG, repair open circuit or short to ground or short to power in harness or connectors.

OK

CHECK GROUND CIRCUIT.

1. Reconnect ECM harness connectors.
 2. Check harness continuity between terminal ② and engine ground.
- Continuity should exist.**
If OK, check harness for short to ground and short to power.

NG → Check the following.

- Harness connectors (F100, F5)
- Harness for open or short between crankshaft position sensor (OBD) and ECM

If NG, repair open circuit or short to ground or short to power in harness or connectors.

OK

Loosen and retighten the fixing bolt of the crankshaft position sensor (OBD). Then retest.

Trouble is not fixed.

CHECK COMPONENT [Crankshaft position sensor (OBD)]. Refer to "COMPONENT INSPECTION" on next page.

NG → Replace crankshaft position sensor (OBD).

OK

Ⓐ

TROUBLE DIAGNOSIS FOR DTC P1336

Crankshaft Position Sensor (CKPS) (OBD) (COG) (Cont'd)

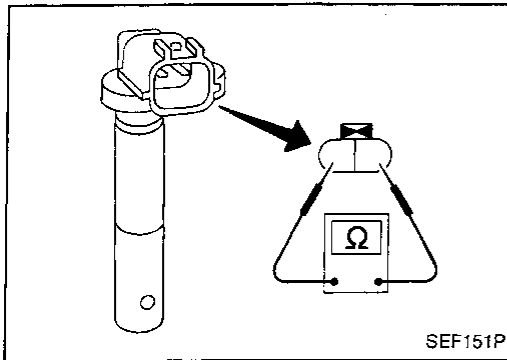
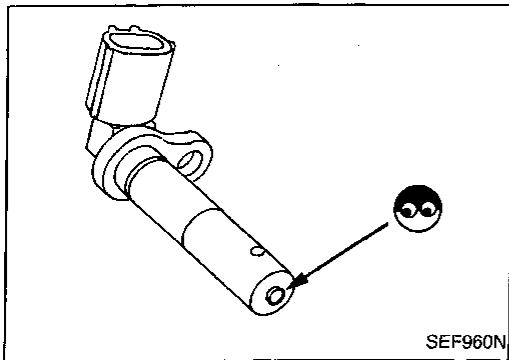
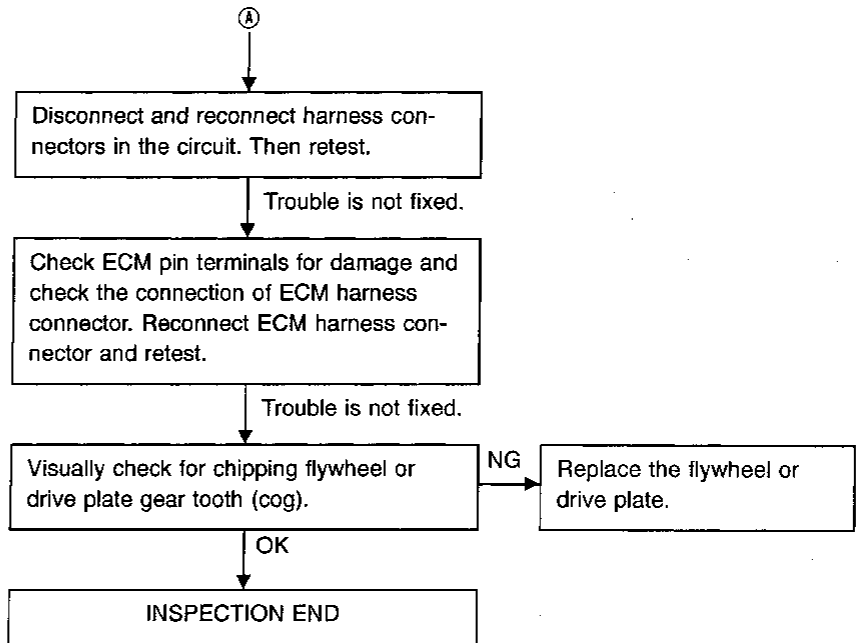

COMPONENT INSPECTION

Crankshaft position sensor (OBD)

1. Disconnect crankshaft position sensor (OBD) harness connector.
2. Loosen the fixing bolt of the sensor.
3. Remove the sensor.
4. Visually check the sensor for chipping.
5. Check resistance as shown in the figure.
Resistance: Approximately 166.5 - 203.5Ω [at 20°C (68°F)]

GI
MA
EM
LC
EC
FE
AT
TF
PD
FA
RA
BR
ST
RS
BT
HA
EL
IDX

TROUBLE DIAGNOSIS FOR DTC P1400

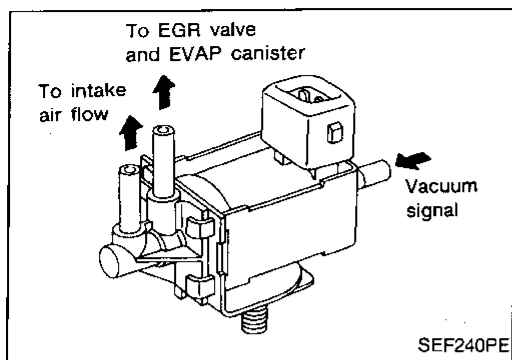

EGRC-Solenoid Valve

COMPONENT DESCRIPTION

The EGRC-solenoid valve responds to signals from the ECM. When the ECM sends an ON (ground) signal, the coil in the solenoid valve is energized. A plunger will then move to cut the vacuum signal from the throttle body to the EGR valve.

When the ECM sends an OFF signal, the vacuum signal passes through the solenoid valve. The signal then reaches the EGR valve.

CONSULT REFERENCE VALUE IN DATA MONITOR MODE

Specification data are reference values.

MONITOR ITEM	CONDITION		SPECIFICATION
EGRC SOL/V	<ul style="list-style-type: none"> Engine: After warming up Air conditioner switch: "OFF" Shift lever: "N" No-load 	Idle	ON
		Engine speed: Revving from 1,500 to 4,000 rpm	OFF

ECM TERMINALS AND REFERENCE VALUE

Specification data are reference values and are measured between each terminal and ④ (ECCS ground).

TER-MINAL NO.	WIRE COLOR	ITEM	CONDITION	DATA (DC Voltage)
103	L/W	EGRC-solenoid valve	<div style="border: 1px solid black; display: inline-block; padding: 2px;">Engine is running.</div> (Warm-up condition) └ Idle speed	0 - 0.7V
			<div style="border: 1px solid black; display: inline-block; padding: 2px;">Engine is running.</div> (Warm-up condition) └ Engine speed is above 2,000 rpm	BATTERY VOLTAGE (11 - 14V)

ON BOARD DIAGNOSIS LOGIC

Diagnostic Trouble Code No.	Malfunction is detected when	Check Items (Possible Cause)
P1400 1005	<ul style="list-style-type: none"> The improper voltage signal is sent to ECM through EGRC-solenoid valve. 	<ul style="list-style-type: none"> Harness or connectors (The EGRC-solenoid valve circuit is open or shorted.) EGRC-solenoid valve

TROUBLE DIAGNOSIS FOR DTC P1400

EGRC-Solenoid Valve (Cont'd)

DIAGNOSTIC TROUBLE CODE CONFIRMATION PROCEDURE

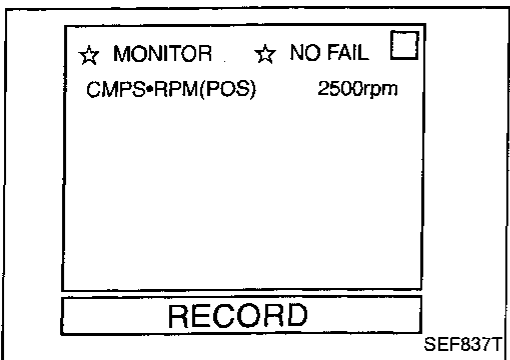
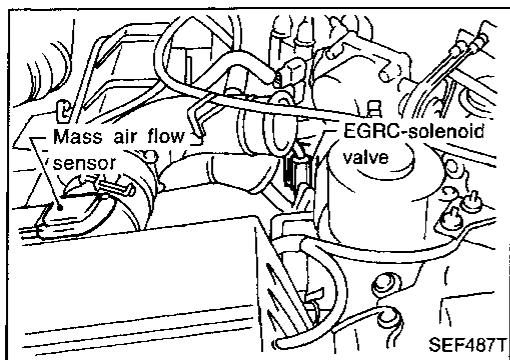

- 1) Start engine and warm it up sufficiently.
- 2) Turn ignition switch "OFF" and wait at least 5 seconds.
- 3) Turn ignition switch "ON".
- 4) Select "DATA MONITOR" with CONSULT.
- 5) Maintain the following conditions for at least 5 seconds.
Engine speed: 2,000 - 3,000 rpm

OR



- 1) Start engine and wait it up sufficiently.
- 2) Turn ignition switch "OFF" and wait at least 5 seconds.
- 3) Start engine again and maintain the following conditions for at least 5 seconds.
Engine speed: 2,000 - 3,000 rpm
- 4) Select "MODE 7" with GST.

OR



- 1) Start engine and warm it up sufficiently.
- 2) Turn ignition switch "OFF" and wait at least 5 seconds.
- 3) Start engine again and maintain the following conditions for at least 5 seconds.
Engine speed: 2,000 - 3,000 rpm
- 4) Turn ignition switch "OFF", wait at least 5 seconds and then turn "ON".
- 5) Perform "Diagnostic Test Mode II (Self-diagnostic results)" with ECM.

GI

MA

EM

LC

EC

FE

AT

TF

PD

FA

RA

BR

ST

RS

BT

HA

EL

IDX

TROUBLE DIAGNOSIS FOR DTC P1400

EGRC-Solenoid Valve (Cont'd)

EC-EGRC/V-01

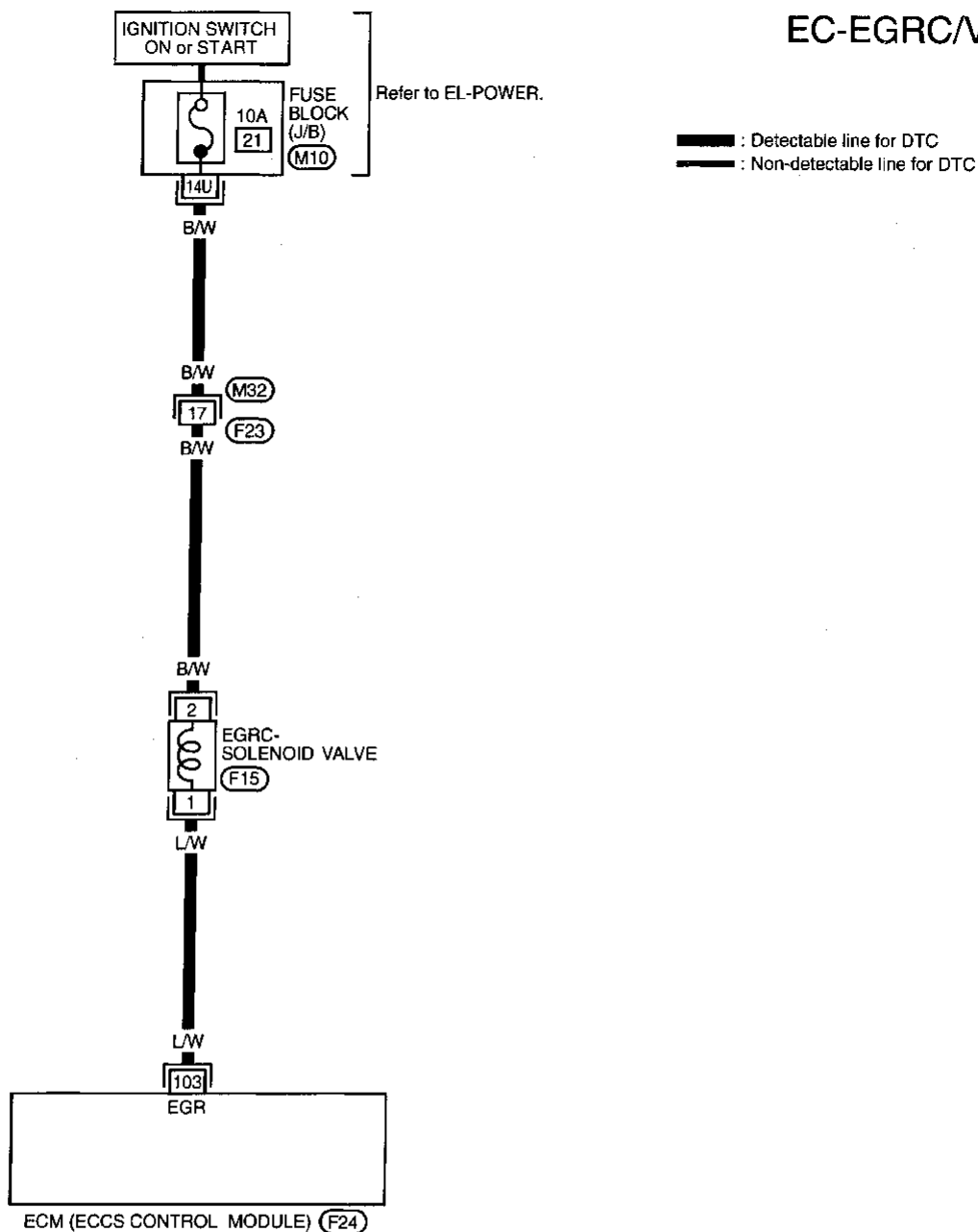

Refer to last page (Foldout page).

(M10)

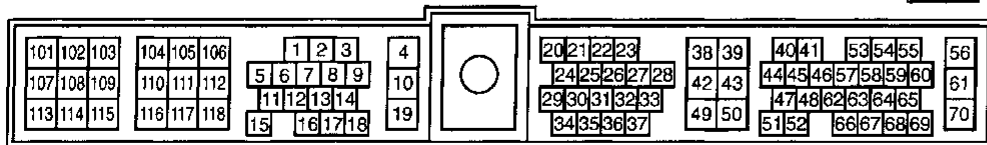
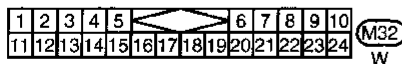

TROUBLE DIAGNOSIS FOR DTC P1400

EGRC-Solenoid Valve (Cont'd)

DIAGNOSTIC PROCEDURE

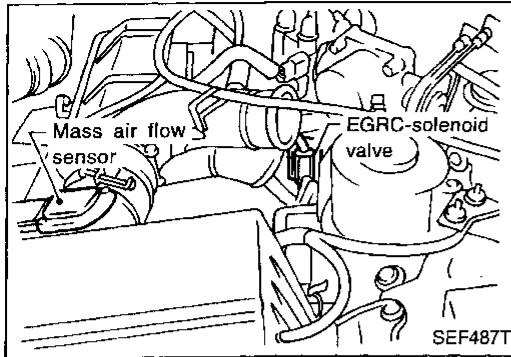

INSPECTION START

A

CHECK POWER SUPPLY.

1. Turn ignition switch "OFF".
2. Disconnect EGRC-solenoid valve harness connector.
3. Turn ignition switch "ON".
4. Check voltage between terminal ② and ground with CONSULT or tester.

Voltage: Battery voltage

NG

Check the following.

- Harness connectors (F23), (M32)
- 10A fuse
- Harness for open or short between EGRC-solenoid valve and fuse

If NG, repair harness or connectors.

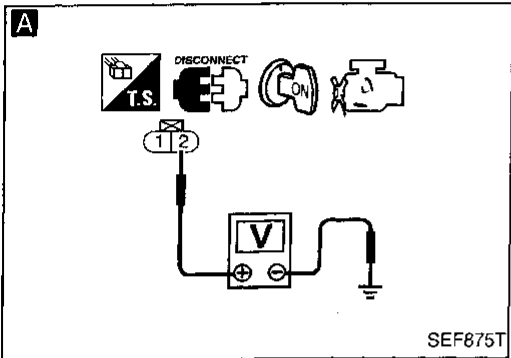

OK

B

CHECK OUTPUT SIGNAL CIRCUIT.

1. Turn ignition switch "OFF".
2. Disconnect ECM harness connector.
3. Check harness continuity between ECM terminal (103) and terminal ①.

Continuity should exist.

If OK, check harness for short to ground and short to power.

NG

Check the following.

- Harness for open or short between EGRC-solenoid valve and ECM

If NG, repair open circuit or short to ground or short to power in harness or connectors.

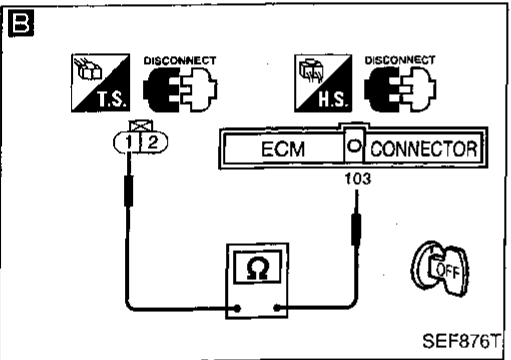

OK

CHECK COMPONENT (EGRC-solenoid valve).

Refer to "COMPONENT INSPECTION" on next page.

NG

Replace EGRC-solenoid valve.

OK

Disconnect and reconnect harness connectors in the circuit. Then retest.

Trouble is not fixed.

Check ECM pin terminals for damage and check the connection of ECM harness connector. Reconnect ECM harness connector and retest.

INSPECTION END

GI
MA
EM
LC
EC
FE
AT
TF
PD
FA
RA
BR
ST
RS
BT
HA
EL
IDX

TROUBLE DIAGNOSIS FOR DTC P1400

EGRC-Solenoid Valve (Cont'd) COMPONENT INSPECTION

EGRC-solenoid valve

Check air passage continuity.

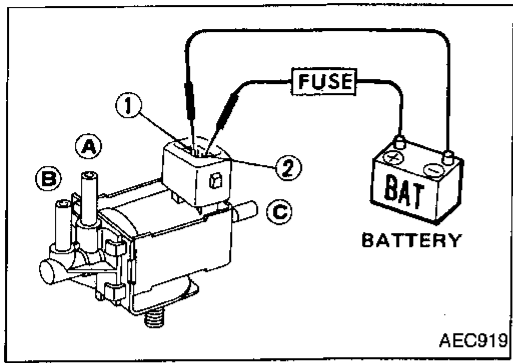

Condition	Air passage continuity between ① and ②	Air passage continuity between ① and ③
12V direct current supply between terminals ① and ②	Yes	No
No supply	No	Yes

If NG, replace solenoid valve.

TROUBLE DIAGNOSIS FOR DTC P1401

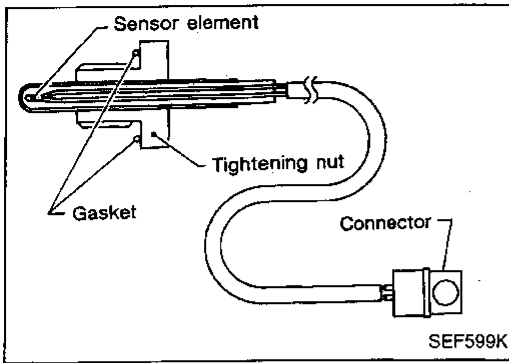

EGR Temperature Sensor

COMPONENT DESCRIPTION

The EGR temperature sensor detects temperature changes in the EGR passage way. When the EGR valve opens, hot exhaust gases flow, and the temperature in the passage way changes. The EGR temperature sensor is a thermistor that modifies a voltage signal sent from the ECM. This modified signal then returns to the ECM as an input signal. As the temperature increases, EGR temperature sensor resistance decreases. This sensor is not used to control the engine system.

It is used only for the on board diagnosis.

<Reference data>

EGR temperature °C (°F)	Voltage* (V)	Resistance (MΩ)
0 (32)	4.81	7.9 - 9.7
50 (122)	2.82	0.57 - 0.70
100 (212)	0.8	0.08 - 0.10

*: These data are reference values and are measured between ECM terminal ② (EGR temperature sensor) and ECM terminal ④ (ECCS ground).
When EGR system is operating.
Voltage: 0 - 1.5V

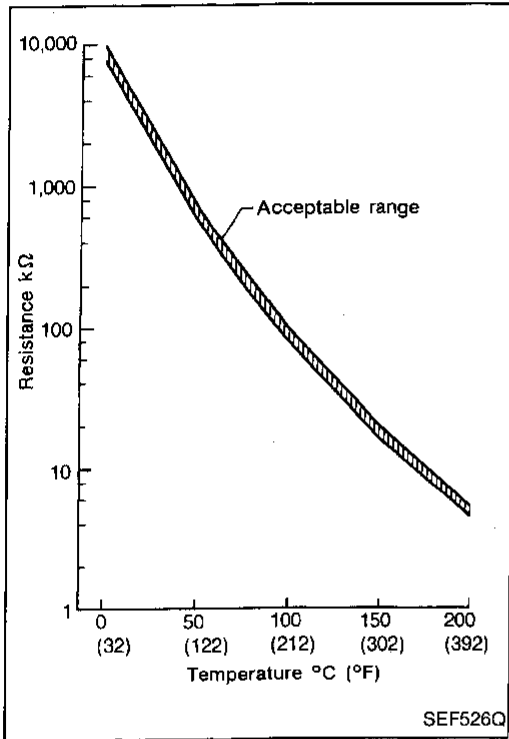

ON BOARD DIAGNOSIS LOGIC

Diagnostic Trouble Code No.	Malfunction is detected when	Check Items (Possible Cause)
P1401 0305	A) An excessively low voltage from the EGR temperature sensor is sent to ECM even when engine coolant temperature is low.	<ul style="list-style-type: none"> ● Harness or connectors (The EGR temperature sensor circuit is shorted.) ● EGR temperature sensor ● Malfunction of EGR function, EGRC-BPT valve or EGRC-solenoid valve
	B) An excessively high voltage from the EGR temperature sensor is sent to ECM even when engine coolant temperature is high.	<ul style="list-style-type: none"> ● Harness or connectors (The EGR temperature sensor circuit is open.) ● EGR temperature sensor ● Malfunction of EGR function, EGRC-BPT valve or EGRC-solenoid valve

GI
MA
EM
LC
EC
FE
AT
TF
PD
FA
RA
BR
ST
RS
BT
HA
EL
IDX

TROUBLE DIAGNOSIS FOR DTC P1401

EGR Temperature Sensor (Cont'd)

OVERALL FUNCTION CHECK

Use this procedure to check the overall function of the EGR temperature sensor. During this check, a 1st trip DTC might not be confirmed.

Procedure for malfunction A and B

- 1) Turn ignition switch "ON" and select "DATA MONITOR" mode with CONSULT.
- 2) Confirm that engine coolant temperature and intake air temperature are lower than 40°C (104°F). (If necessary, wait until the temperatures equal atmospheric temperature.)
- 3) Confirm that "EGR TEMP SEN" reading is between 3.45V and 5.0V.
- 4) Start engine and warm it up sufficiently.
- 5) Run engine at idle for at least 2 minutes.
- 6) Confirm that EGR valve is not lifting. If NG, go to TROUBLE DIAGNOSES FOR DTC P0400 and P0402, (See pages EC-211 and 219).
- 7) Read "EGR TEMP SEN" at about 1,500 rpm with EGR valve lifted up to the full position by hand.
Voltage should decrease to less than 1.0V.
- 8) If step 7 is OK, perform TROUBLE DIAGNOSES FOR DTC P0400, P0402 and P1400, EC-211, 219 and 294.

OR

- 1) Turn ignition switch "ON".
- 2) Confirm that voltage between ECM terminals ②⑧, ⑤① and ground are more than 2.72V. (If necessary, wait until engine coolant temperature and intake air temperature equal atmospheric temperature.)
- 3) Confirm that voltage between ECM terminal ⑥② and ground is between 3.45V and 5.0V.
- 4) Start engine and warm it up sufficiently.
- 5) Run engine at idle for at least 2 minutes.
- 6) Confirm that EGR valve is not lifting. If NG, go to TROUBLE DIAGNOSES FOR DTC P0400 and P0402, (See pages EC-211 and 219).
- 7) Check voltage between ECM terminal ⑥② and ground at about 1,500 rpm with EGR valve lifted up to the full position by hand.
Voltage should decrease to less than 1.0V.
- 8) If step 7 is OK, perform TROUBLE DIAGNOSES FOR DTC P0400, P0402 and P1400, (See pages EC-211, 219 and 294).

★ MONITOR	★ NO FAIL	<input type="checkbox"/>
CMPS•RPM(POS)	0rpm	
COOLANT TEMP/S	20°C	
EGR TEMP SEN	4.3V	
INT/A TEMP SE	22°C	

SEF903T

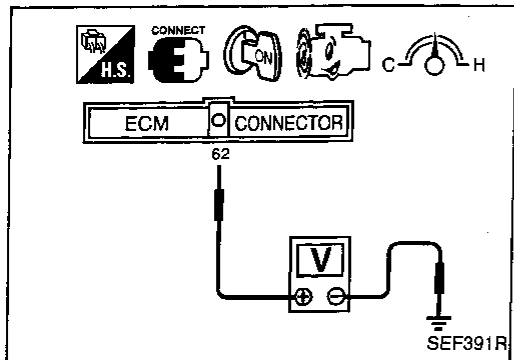
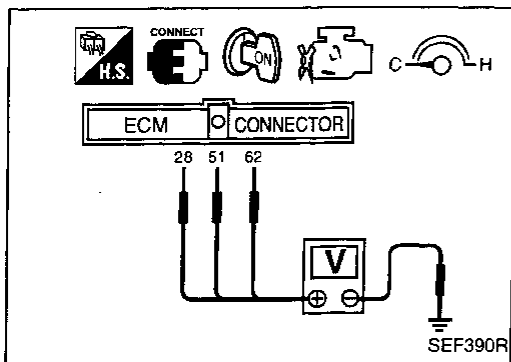
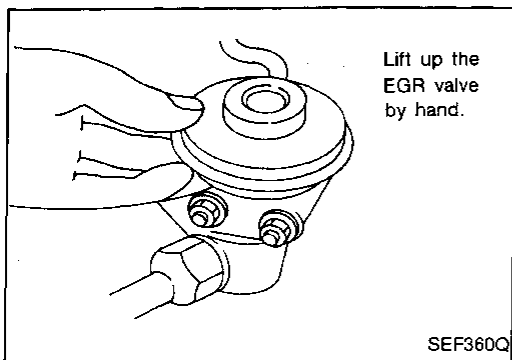

TROUBLE DIAGNOSIS FOR DTC P1401

EGR Temperature Sensor (Cont'd)

EC-EGR/TS-01

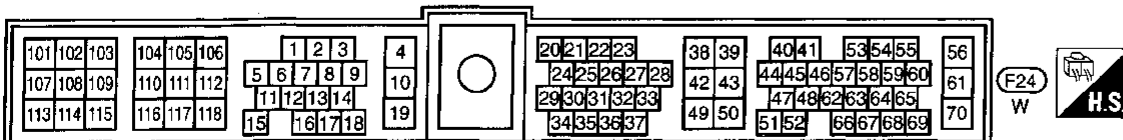
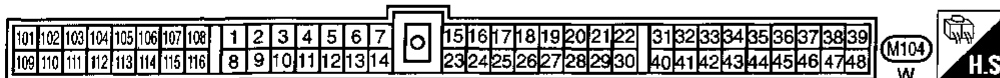
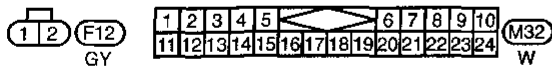
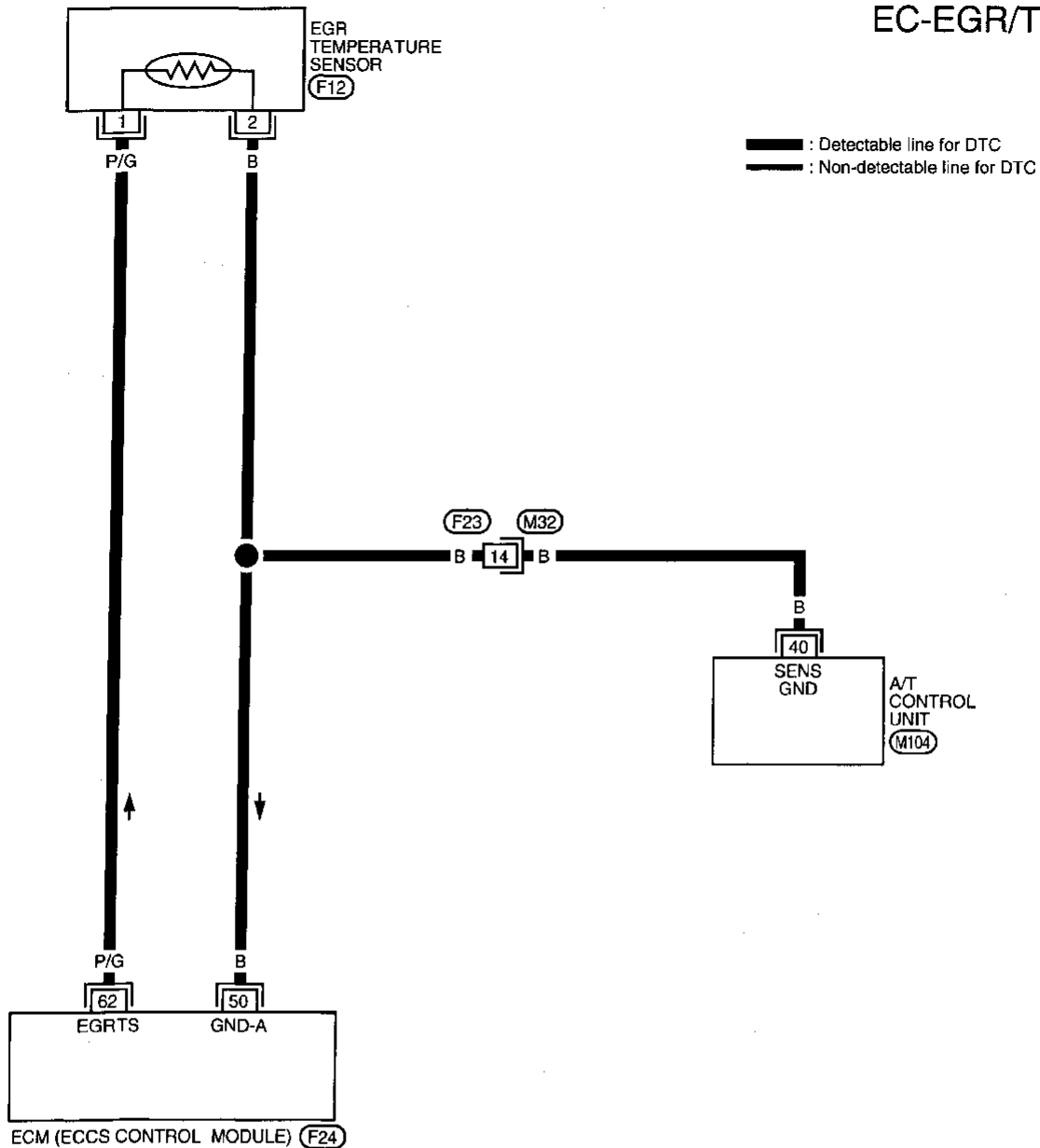

TROUBLE DIAGNOSIS FOR DTC P1401

EGR Temperature Sensor (Cont'd)

DIAGNOSTIC PROCEDURE

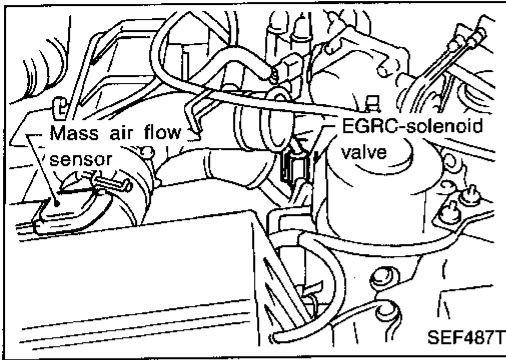

INSPECTION START

A

CHECK POWER SUPPLY.

1. Disconnect EGR temperature sensor harness connector.
2. Turn ignition switch "ON".
3. Check voltage between terminal ① and ground with CONSULT or tester.

Voltage: Approximately 5V

NG → Repair harness or connectors.

B

CHECK GROUND CIRCUIT.

1. Turn ignition switch "OFF".
2. Check harness continuity between terminal ② and engine ground.

Continuity should exist.
If OK, check harness for short to ground or short to power.

NG → Check the following.

- Harness connectors (F23), (M32)
- Harness for open or short between ECM and EGR temperature sensor
- Harness for open or short between A/T control unit and EGR temperature sensor

If NG, repair open circuit or short to ground or short to power in harness or connector.

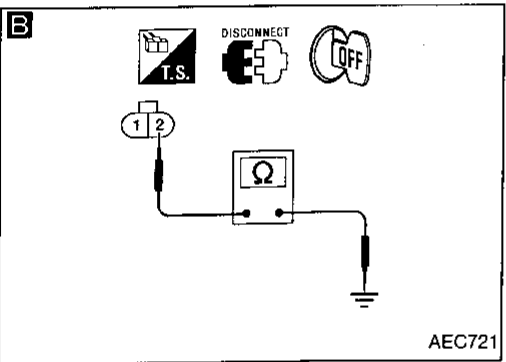
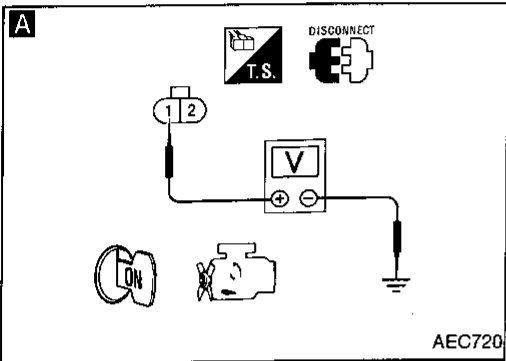

CHECK COMPONENT
(EGR temperature sensor).
Refer to "COMPONENT INSPECTION" below.

NG → Replace EGR temperature sensor.

OK → Disconnect and reconnect harness connectors in the circuit. Then retest.

Trouble is not fixed.
Check ECM pin terminals for damage and check the connection of ECM harness connector. Reconnect ECM harness connector and retest.

INSPECTION END

TROUBLE DIAGNOSIS FOR DTC P1401

EGR Temperature Sensor (Cont'd)

COMPONENT INSPECTION

EGR temperature sensor

Check resistance change and resistance value.

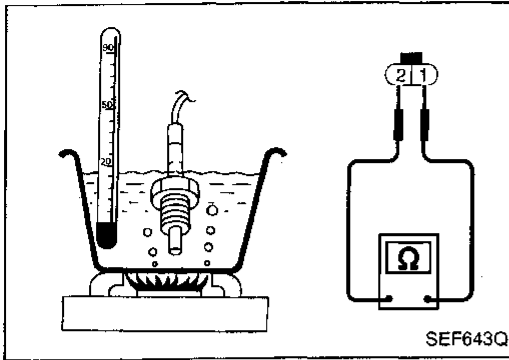

SEF643Q

<Reference data>

EGR temperature °C (°F)	Voltage (V)	Resistance (MΩ)
0 (32)	4.81	7.9 - 9.7
50 (122)	2.82	0.57 - 0.70
100 (212)	0.8	0.08 - 0.10

If NG, replace EGR temperature sensor.

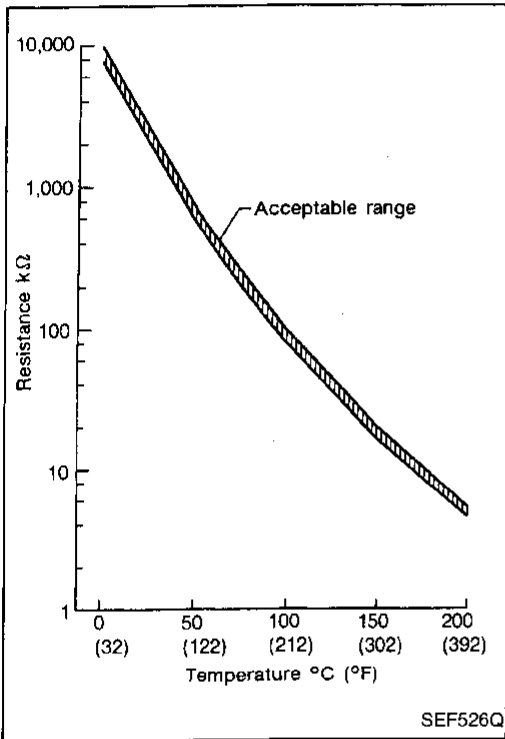

SEF526Q

GI

MA

EM

LC

EC

FE

AT

TF

PD

FA

RA

BR

ST

RS

BT

HA

EL

IDX

TROUBLE DIAGNOSIS FOR DTC P1441

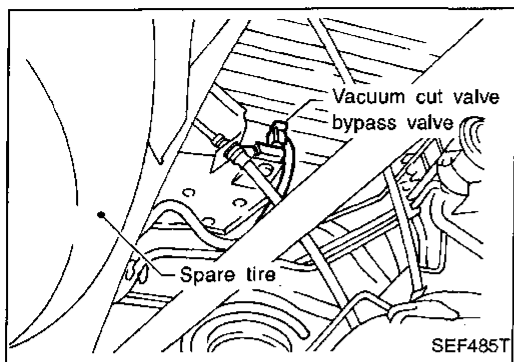

Vacuum Cut Valve Bypass Valve

COMPONENT DESCRIPTION

The vacuum cut valve and vacuum cut valve bypass valve are installed in parallel on the EVAP purge line between the fuel tank and the EVAP canister.

The vacuum cut valve prevents the intake manifold vacuum from being applied to the fuel tank.

The vacuum cut valve bypass valve is a solenoid type valve and generally remains closed. It opens only for on board diagnosis.

The vacuum cut valve bypass valve responds to signals from the ECM. When the ECM sends an ON (ground) signal, the valve is opened. The vacuum cut valve is then bypassed to apply intake manifold vacuum to the fuel tank.

EVAPORATIVE EMISSION SYSTEM DIAGRAM

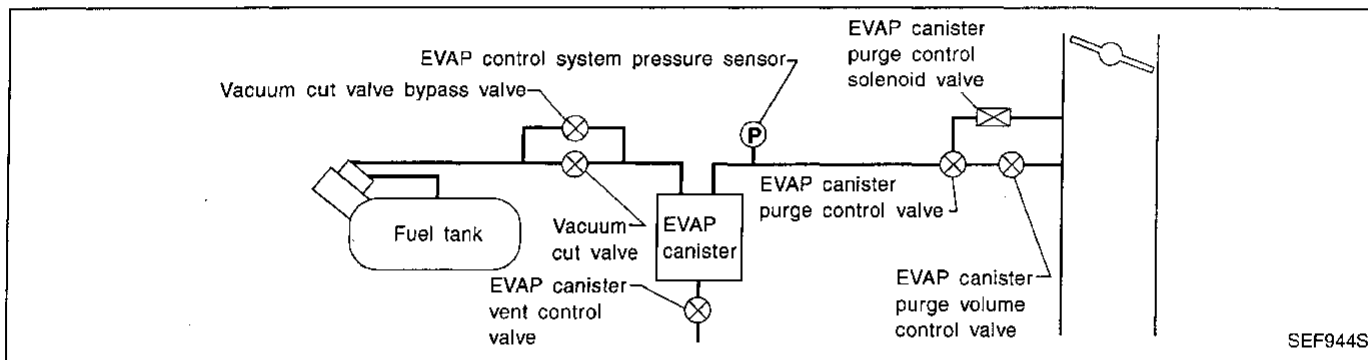

CONSULT REFERENCE VALUE IN DATA MONITOR MODE

Specification data are reference values.

MONITOR ITEM	CONDITION	SPECIFICATION
VC/V BYPASS/V	● Ignition switch: ON	OFF

ECM TERMINALS AND REFERENCE VALUE

Specification data are reference values and are measured between each terminal and Ⓞ (ECCS ground).

TER-MINAL NO.	WIRE COLOR	ITEM	CONDITION	DATA (DC Voltage)
117	G/R	Vacuum cut valve bypass valve	Ignition switch "ON"	BATTERY VOLTAGE (11 - 14V)

ON BOARD DIAGNOSIS LOGIC

Diagnostic Trouble Code No.	Malfunction is detected when	Check Items (Possible Cause)
P1441 0801	<p>A) An improper voltage signal is sent to ECM through vacuum cut valve bypass valve.</p> <p>B) Vacuum cut valve bypass valve does not operate properly.</p>	<ul style="list-style-type: none"> ● Harness or connectors (The vacuum cut valve bypass valve circuit is open or shorted.) ● Vacuum cut valve bypass valve ● Vacuum cut valve bypass valve ● Vacuum cut valve ● Bypass hoses for clogging ● EVAP control system pressure sensor

TROUBLE DIAGNOSIS FOR DTC P1441

Vacuum Cut Valve Bypass Valve (Cont'd)

DIAGNOSTIC TROUBLE CODE CONFIRMATION PROCEDURE

Perform "Procedure for malfunction A" first. If DTC cannot be confirmed, perform "OVERALL FUNCTION CHECK", "Procedure for malfunction B".

GI

MA

EM

LC

EC

FE

AT

TF

PD

FA

RA

BR

ST

RS

BT

HA

EL

IDX

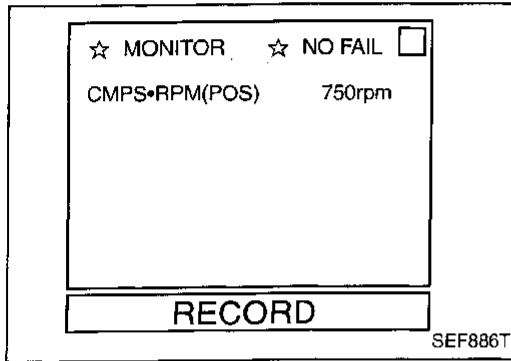

Procedure for malfunction A



- 1) Turn ignition switch "ON".
- 2) Select "DATA MONITOR" mode with CONSULT.
- 3) Start engine and wait at least 5 seconds.

OR



- 1) Start engine and wait at least 5 seconds.
- 2) Select "MODE 7" with GST.

OR



- 1) Start engine and wait at least 5 seconds.
- 2) Turn ignition switch "OFF", wait at least 5 seconds and then turn "ON".
- 3) Perform "Diagnostic Test Mode II (Self-diagnostic results)" with ECM.

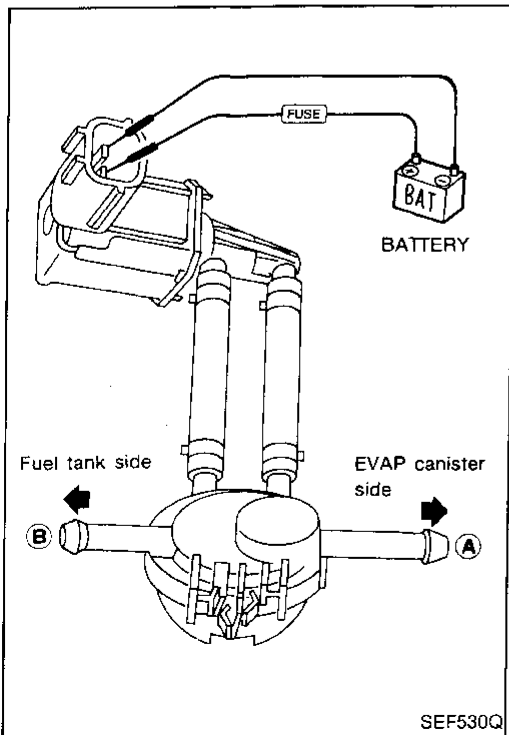

OVERALL FUNCTION CHECK

Procedure for malfunction B

- 1) Remove vacuum cut valve and vacuum cut valve bypass valve as an assembly.
- 2) Apply vacuum to port (A) and check that there is no suction from port (B).
- 3) Apply vacuum to port (B) and check that there is suction from port (A).
- 4) Blow air in port (B) and check that there is a resistance to flow out of port (A).
- 5) Supply battery voltage to the terminal.
- 6) Blow air in port (A) and check that air flows freely out of port (B).
- 7) Blow air in port (B) and check that air flows freely out of port (A).

TROUBLE DIAGNOSIS FOR DTC P1441

Vacuum Cut Valve Bypass Valve (Cont'd)

EC-BYPS/V-01

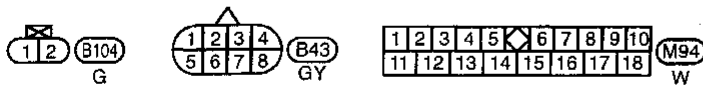
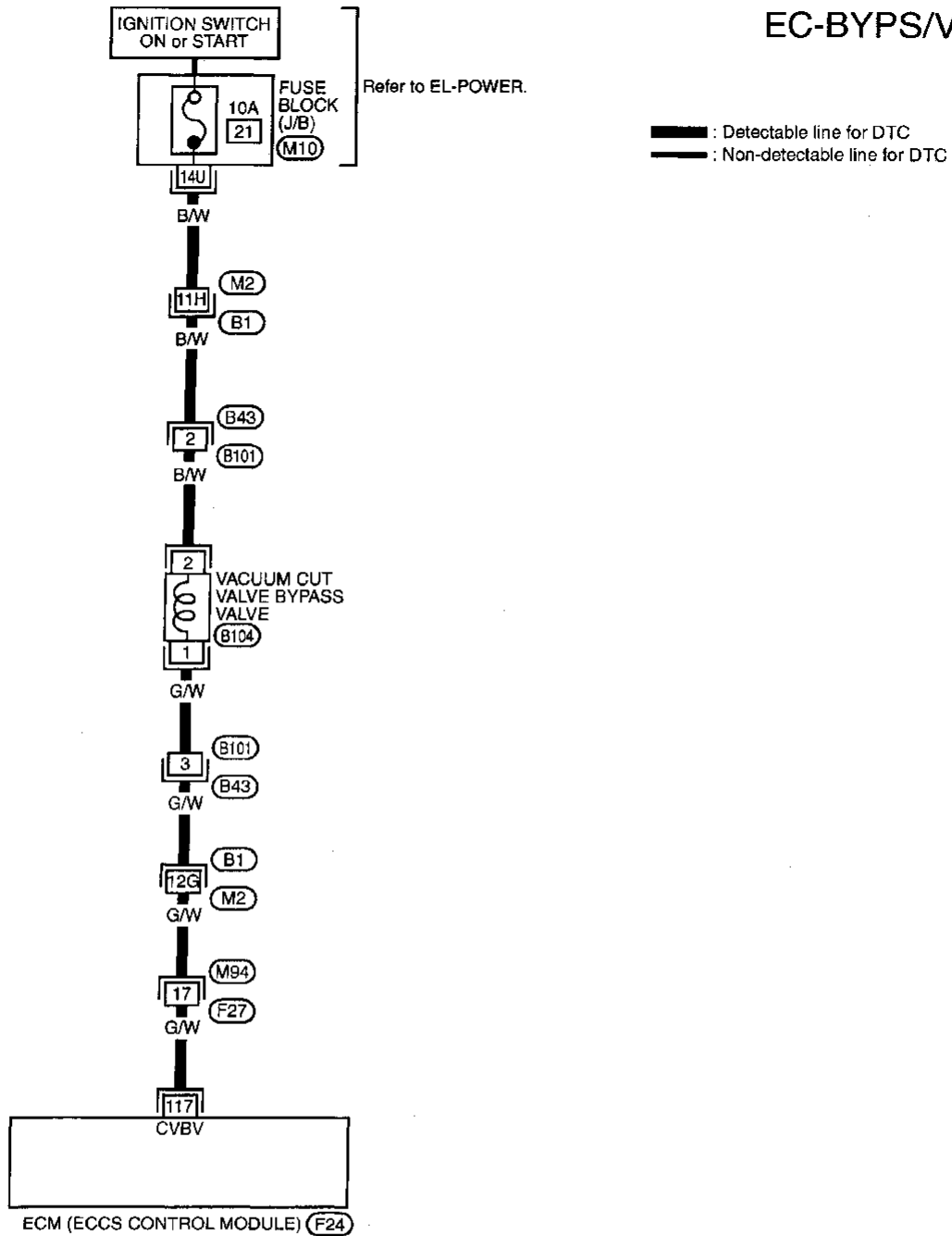

Refer to last page (Foldout page).

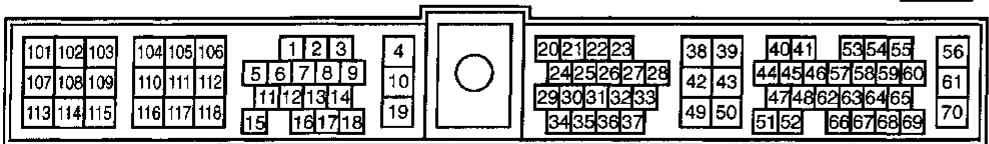
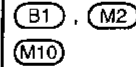

TROUBLE DIAGNOSIS FOR DTC P1441

Vacuum Cut Valve Bypass Valve (Cont'd)

DIAGNOSTIC PROCEDURE

Procedure for malfunction A

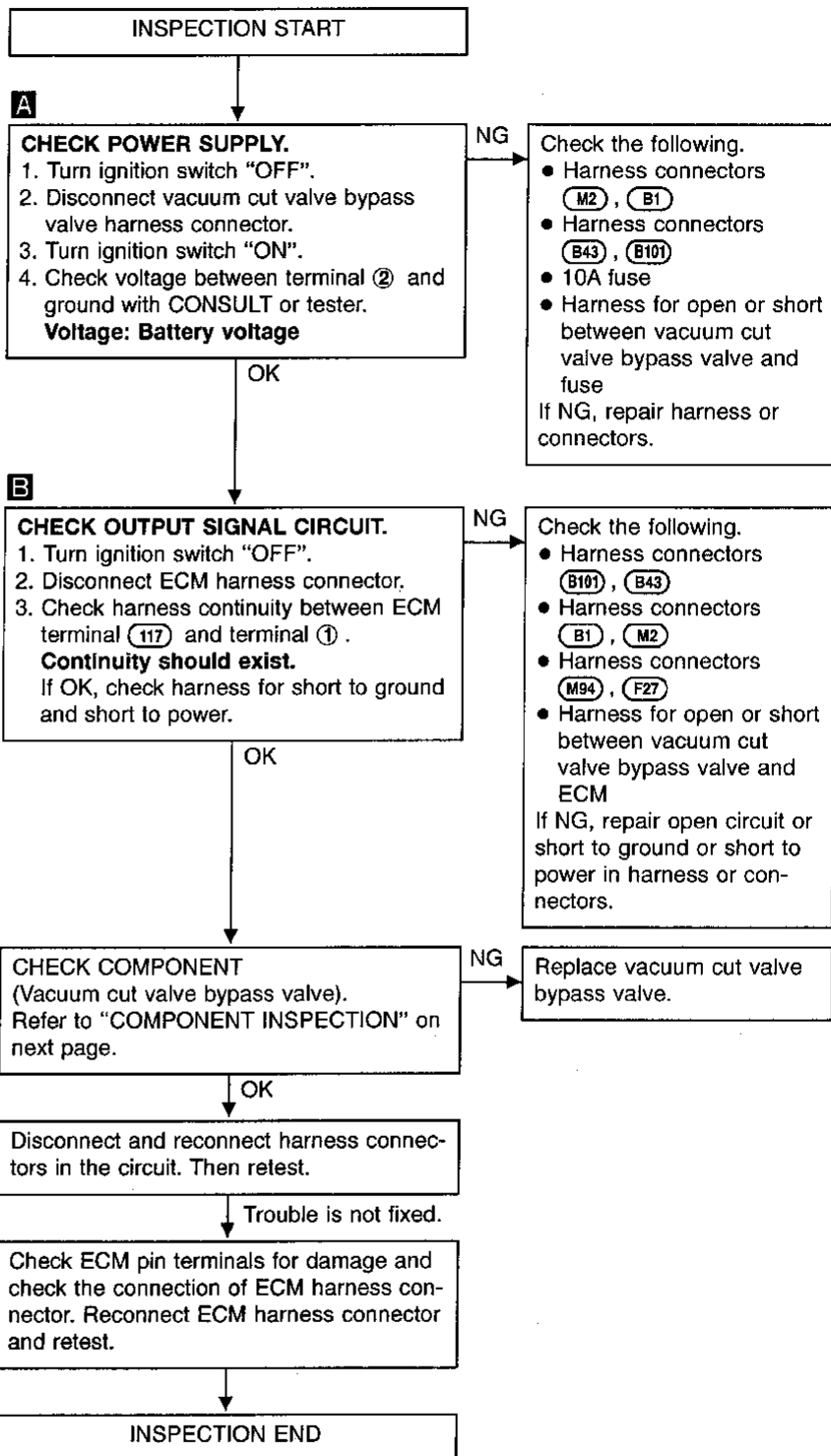
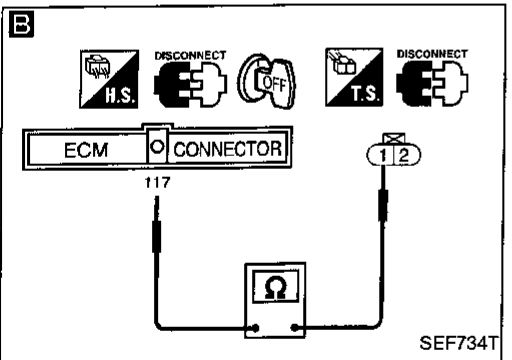
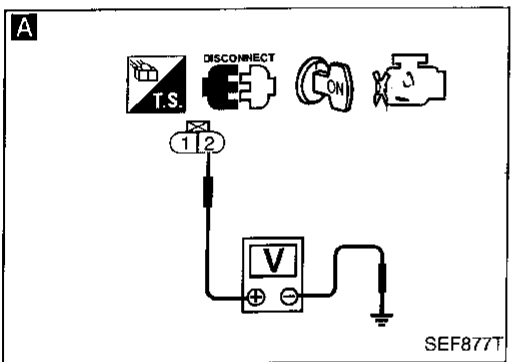
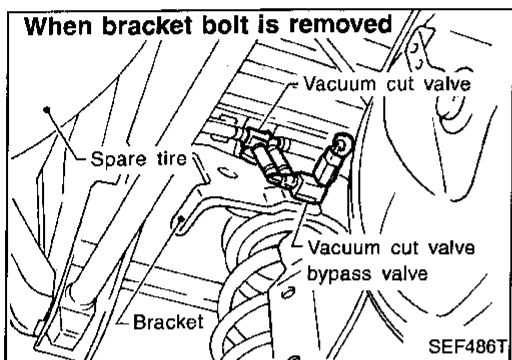
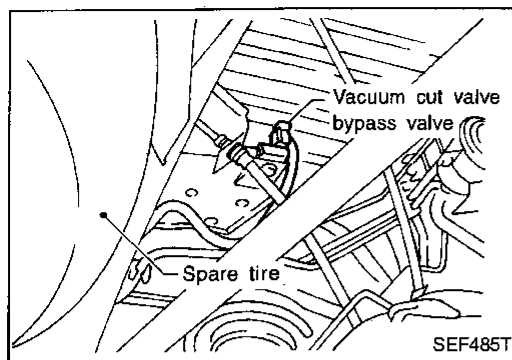

GI
MA
EM
LC
EC
FE
AT
TF
PD
FA
RA
BR
ST
RS
BT
HA
EL
IDX

TROUBLE DIAGNOSIS FOR DTC P1441

Vacuum Cut Valve Bypass Valve (Cont'd)

DIAGNOSTIC PROCEDURE

Procedure for malfunction B

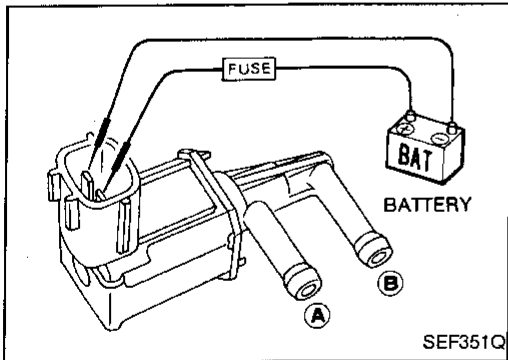
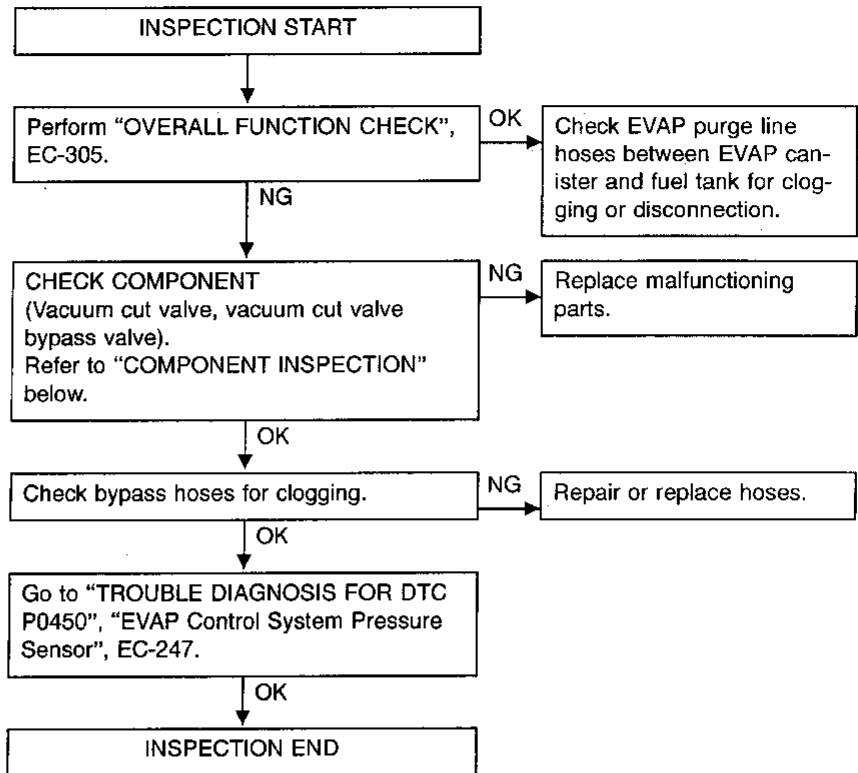

COMPONENT INSPECTION

Vacuum cut valve bypass valve

Check air passage continuity.

Condition	Air passage continuity between (A) and (B)
12V direct current supply between terminals	Yes
No supply	No

If NG, replace vacuum cut valve bypass valve.

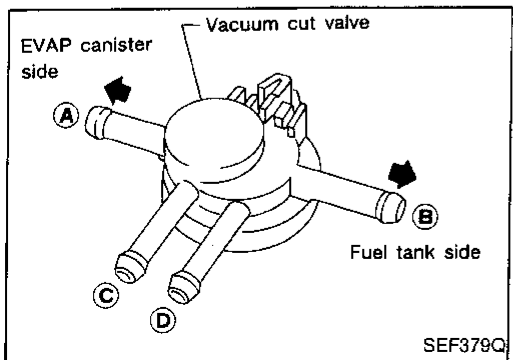

Vacuum cut valve

Check vacuum cut valve as follows:

1. Plug port (C) and (D) with fingers.
2. Apply vacuum to port (A) and check that there is no suction from port (B).
3. Apply vacuum to port (B) and check that there is suction from port (A).
4. Blow air in port (B) and check that there is a resistance to flow out of port (A).
5. Open port (C) and (D).
6. Blow air in port (A) check that air flows freely out of port (C).
7. Blow air in port (B) check that air flows freely out of port (D).

Evaporative Emission (EVAP) Canister Purge Volume Control Valve

SYSTEM DESCRIPTION

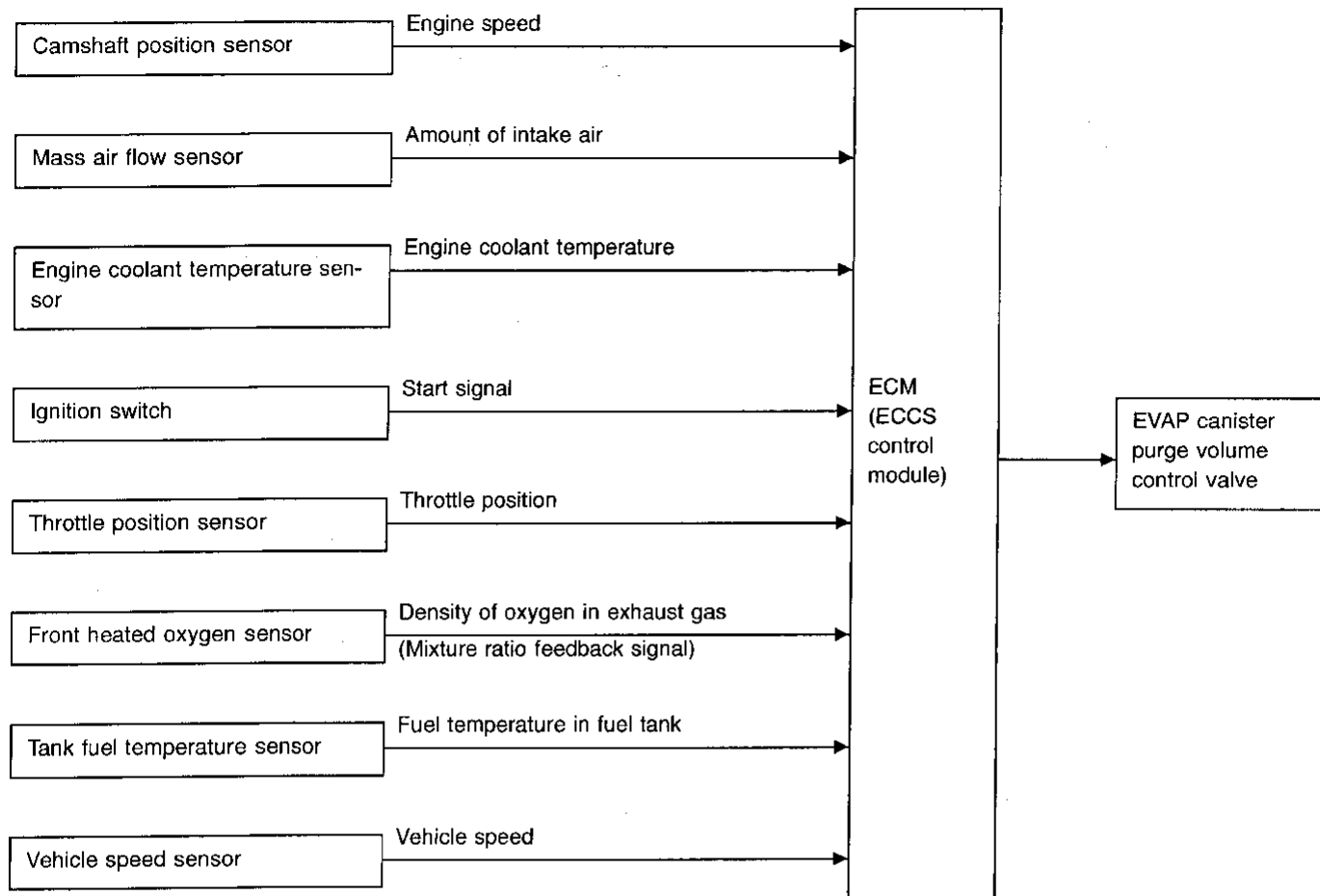

This system controls flow rate of fuel vapor from the EVAP canister. The opening of the vapor by-pass passage in the EVAP canister purge volume control valve changes to control the flow rate. A built-in step motor moves the valve in steps corresponding to the ECM output pulses. The opening of the valve varies for optimum engine control. The optimum value stored in the ECM is determined by considering various engine conditions. When the engine is operating, the flow rate of fuel vapor from the EVAP canister is regulated as the air flow changes.

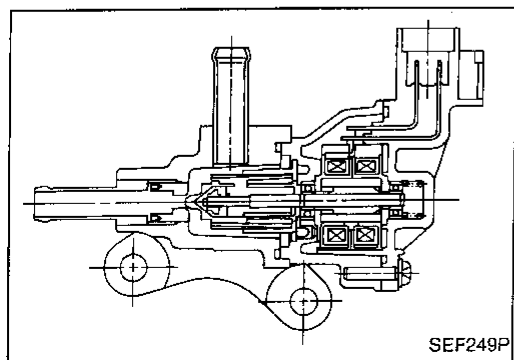

COMPONENT DESCRIPTION

The EVAP canister purge volume control valve uses a step motor to control the flow rate of fuel vapor from the EVAP canister. This motor has four winding phases. It operates according to the output pulse signal of the ECM. Two windings are turned ON and OFF in sequence. Each time an ON pulse is issued, the valve opens or closes, changing the flow rate. When no change in the flow rate is needed, the ECM does not issue the pulse signal. A certain voltage signal is issued so that the valve remains at that particular opening.

TROUBLE DIAGNOSIS FOR DTC P1445

Evaporative Emission (EVAP) Canister Purge Volume Control Valve (Cont'd)

CONSULT REFERENCE VALUE IN DATA MONITOR MODE

Specification data are reference values.

MONITOR ITEM	CONDITION	SPECIFICATION
PURG VOL C/V	<ul style="list-style-type: none"> ● Engine: After warming up ● Air conditioner switch "OFF" 	Idle
		Vehicle running (Shift lever "1")
		0 step
		—

ECM TERMINALS AND REFERENCE VALUE

Specification data are reference values and are measured between each terminal and Ⓞ (ECCS ground).

TER-MINAL NO.	WIRE COLOR	ITEM	CONDITION	DATA (DC Voltage)
4	L/B	ECCS relay (Self-shutoff)	Engine is running.	0 - 1V
			Ignition switch "OFF"	
			└ For a few seconds after turning ignition switch "OFF"	
			Ignition switch "OFF"	BATTERY VOLTAGE (11 - 14V)
			└ A few seconds passed after turning ignition switch "OFF"	
56	B/W	Power supply for ECM	Ignition switch "ON"	BATTERY VOLTAGE (11 - 14V)
61	B/W			
113	B/W	Current return	Engine is running. └ Idle speed	BATTERY VOLTAGE (11 - 14V)
5	L	EVAP canister purge volume control valve	Engine is running.	0 - 0.4V or BATTERY VOLTAGE (11 - 14V)
6	YL		└ Idle speed	
16	W/B	EVAP canister purge volume control valve	Engine is running.	0 - 0.4V or BATTERY VOLTAGE (11 - 14V)
17	R/G		└ Idle speed	

ON BOARD DIAGNOSIS LOGIC

Diagnostic Trouble Code No.	Malfunction is detected when	Check Items (Possible Cause)
P1445 1008	A) An improper voltage signal is sent to ECM through the valve.	<ul style="list-style-type: none"> ● Harness or connectors (The valve circuit is open or shorted.) ● EVAP canister purge volume control valve
	B) The canister purge flow is detected during the specified driving conditions, even when EVAP canister purge volume control valve is completely closed.	<ul style="list-style-type: none"> ● EVAP control system pressure sensor ● EVAP canister purge volume control valve (The valve is stuck open.) ● EVAP canister purge control valve ● Hoses (Hoses are connected incorrectly.)

TROUBLE DIAGNOSIS FOR DTC P1445

Evaporative Emission (EVAP) Canister Purge Volume Control Valve (Cont'd)

DIAGNOSTIC TROUBLE CODE CONFIRMATION PROCEDURE

Perform "Procedure for malfunction A" first. If the DTC cannot be confirmed, perform "Procedure for malfunction B".

Procedure for malfunction A

- 1) Lift up drive wheels.
- 2) Turn ignition switch "ON" and select "DATA MONITOR" mode with CONSULT.
- 3) Start engine and let it idle for at least 90 seconds.
- 4) Move selector/gearshift lever to "1" range.
- 5) Race engine from idle to 2,000 to 3,000 rpm more than 10 times.

OR

- 1) Lift up drive wheels.
- 2) Start engine and let it idle for at least 90 seconds.
- 3) Move selector/gearshift lever to "1" range.
- 4) Race engine from idle to 2,000 to 3,000 rpm more than 10 times.
- 5) Select "MODE 7" with GST.

OR

- 1) Lift up drive wheels.
- 2) Start engine and let it idle for at least 90 seconds.
- 3) Move selector/gearshift lever to "1" range.
- 4) Race engine from idle to 2,000 to 3,000 rpm more than 10 times.
- 5) Turn ignition switch "OFF", wait at least 5 seconds and then turn "ON".
- 6) Perform Diagnostic Test Mode II (Self-diagnostic results) with ECM.

☆ MONITOR	☆ NO FAIL	<input type="checkbox"/>
CMPS•RPM(POS)	750rpm	
COOLAN TEMP/S	85°C	
RECORD		

SEF842T

☆ MONITOR	☆ NO FAIL	<input type="checkbox"/>
CMPS•RPM(POS)	2000rpm	
VHCL SPEED SE	60km/h	
COOLAN TEMP/S	85°C	
RECORD		

SEF843T

Procedure for malfunction B

- 1) Lift up vehicle.
- 2) Start engine and warm it up sufficiently.
- 3) Select "DATA MONITOR" mode with CONSULT.
- 4) Check coolant temperature.
COOLAN TEMP/S: 40 - 100°C (104 - 212°F)
- 5) Turn ignition switch "OFF" and wait at least 5 seconds.
- 6) Turn ignition switch "ON" and wait at least 15 seconds.
- 7) Restart engine and let it idle for at least 80 seconds.
- 8) Maintain the following conditions for at least 80 seconds.

Gear position: Suitable gear position

Vehicle speed: 40 - 80 km/h (25 - 50 MPH)

Engine speed: 1,500 - 3,000 rpm

COOLAN TEMP/S: 40 - 100°C (104 - 212°F)

NOTE:

- Hold the accelerator pedal as steady as possible during driving in steps 8.
- If the driving conditions are not satisfied in steps 8, restart the procedure.
- It is better that the fuel level is low.

TROUBLE DIAGNOSIS FOR DTC P1445

Evaporative Emission (EVAP) Canister Purge Volume Control Valve (Cont'd)

ENGINE SPD	825RPM
COOLANT TEMP	69°C
VEHICLE SPD	0MPH
IGN ADVANCE	8.0°
CALC LOAD	28.2%
MAP	36KPaA
MAF	5.20gm/s
THROTTLE POS	0.0%
INTAKE AIR	27°C
FUEL SYS #1	OLDRIVE
FUEL SYS #2	UNUSED
SHORT FT #1	0.8%
LONG FT #1	0.0%
O2S B1 S1	0.200V
O2FT B1 S1	0.8%
O2S B1 S2	0.010V

SEF519R

OR



- 1) Lift up vehicle.
- 2) Start engine and warm it up sufficiently.
- 3) Select "MODE 1" with GST.
- 4) Check coolant temperature.
Coolant temperature: 40 - 100°C (104 - 212°F)
Be sure that water temperature does not exceed 100°C. If it becomes higher than 100°C, cool down the engine and perform the procedure again from the beginning.
- 5) Turn ignition switch "OFF" and wait at least 5 seconds.
- 6) Turn ignition switch "ON" and wait at least 15 seconds.
- 7) Restart engine and let it idle for at least 80 seconds.
- 8) Maintain the following conditions for at least 80 seconds.
Gear position: Suitable gear position
Vehicle speed: 40 - 80 km/h (25 - 50 MPH)
Engine speed: 1,500 - 3,000 rpm
Coolant temperature: 40 - 100°C (104 - 212°F)
- 9) Select "MODE 7" with GST.

NOTE:

- Hold the accelerator pedal as steady as possible during driving in steps 8.
- If the driving conditions are not satisfied in steps 8, restart the procedure.
- It is better that the fuel level is low.

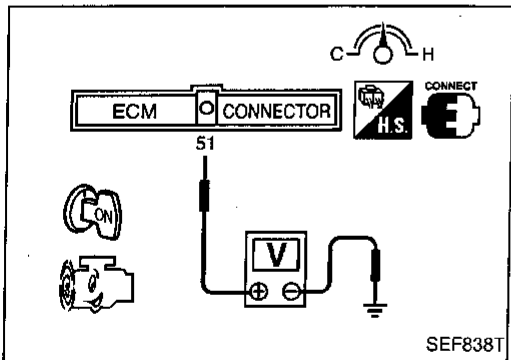

OR



- 1) Lift up vehicle.
- 2) Start engine and warm it up sufficiently.
- 3) Check voltage between ECM terminal ⑤ and ground
Voltage: 0.8 - 1.5V
Perform the following procedure before the voltage drops below 0.8V. If the voltage drops below 0.8V, cool down the engine and perform the entire procedure all over again.
- 4) Turn ignition switch "OFF" and wait at least 5 seconds.
- 5) Turn ignition switch "ON" and wait at least 15 seconds.
- 6) Restart engine and let it idle for at least 80 seconds.
- 7) Maintain the following conditions for at least 80 seconds.
Gear position: Suitable gear position
Vehicle speed: 40 - 80 km/h (25 - 50 MPH)
Engine speed: 1,500 - 3,000 rpm
Check voltage between ECM terminal ⑤ and ground: 0.8 - 1.5 V
- 8) Turn ignition switch "OFF", wait at least 5 seconds, and then turn "ON".
- 9) Perform "Diagnostic Test Mode II (Self-diagnostic results)" with ECM.

TROUBLE DIAGNOSIS FOR DTC P1445

Evaporative Emission (EVAP) Canister Purge Volume Control Valve (Cont'd)

NOTE:

- Hold the accelerator pedal as steady as possible during driving in steps 7.
- If the driving conditions are not satisfied in steps 7, restart the procedure.
- It is better that the fuel level is low.

GI

MA

EM

LC

EC

FE

AT

TF

PD

FA

RA

BR

ST

RS

BT

HA

EL

IDX

TROUBLE DIAGNOSIS FOR DTC P1445

Evaporative Emission (EVAP) Canister Purge Volume Control Valve (Cont'd)

EC-PGC/V-01

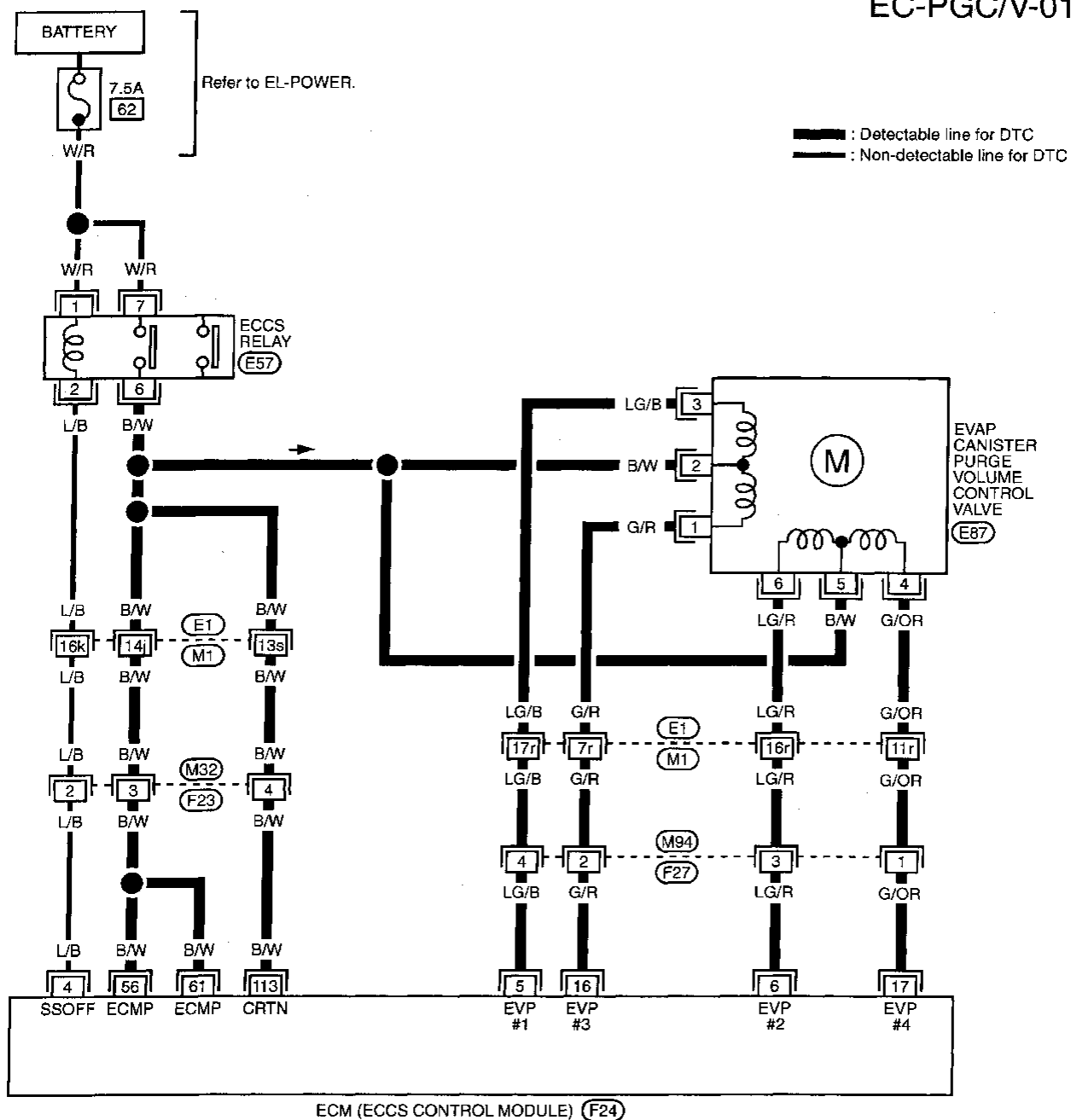

Refer to last page (Foldout page).

(E1), (M1)

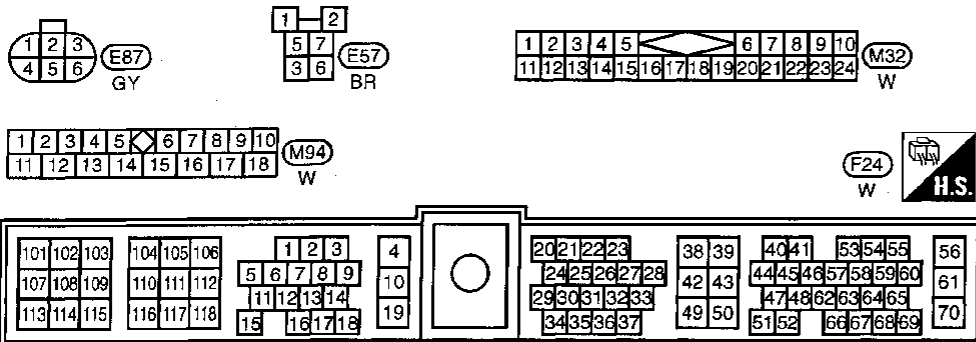

TROUBLE DIAGNOSIS FOR DTC P1445

Evaporative Emission (EVAP) Canister Purge Volume Control Valve (Cont'd)

DIAGNOSTIC PROCEDURE

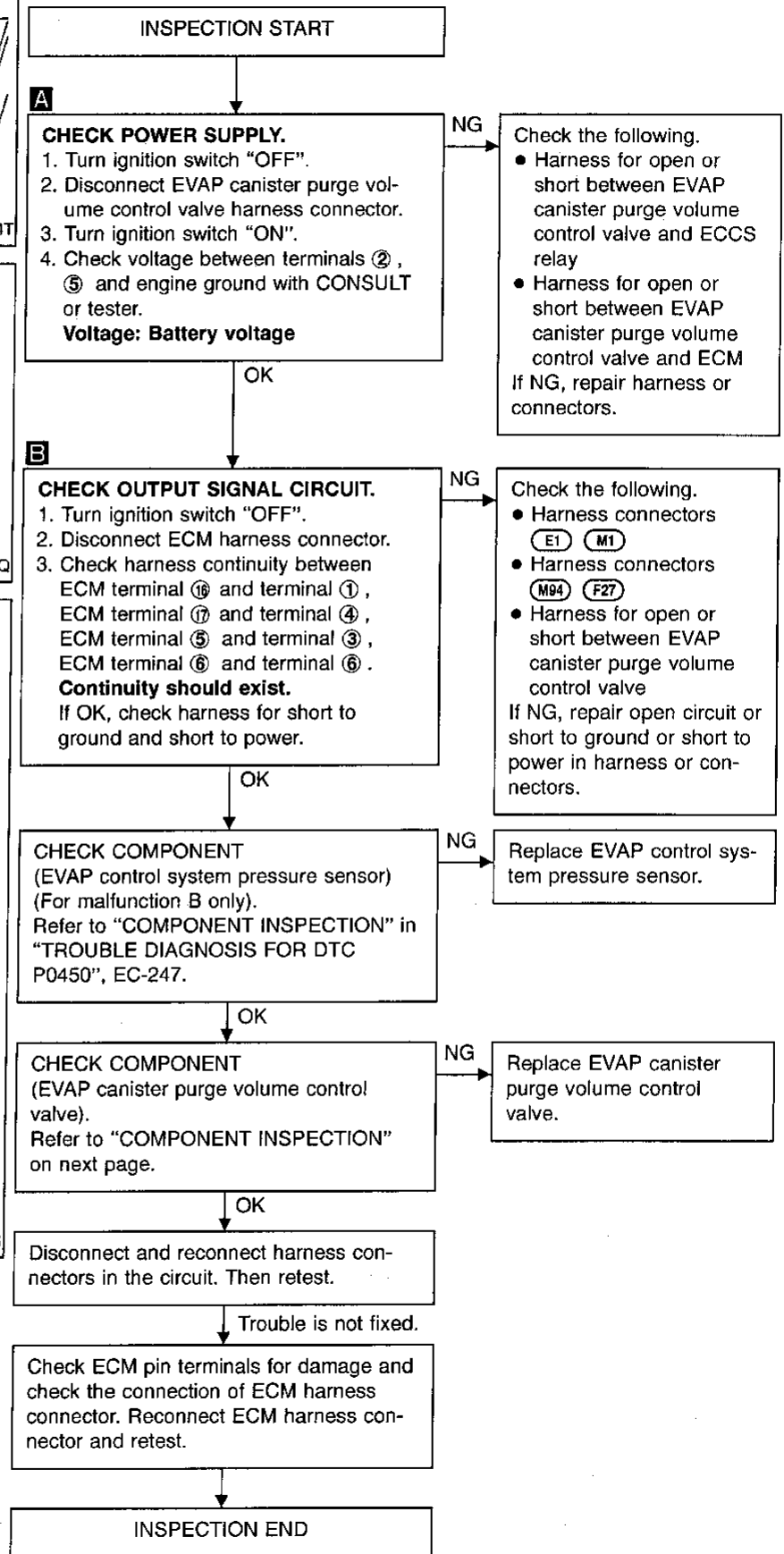
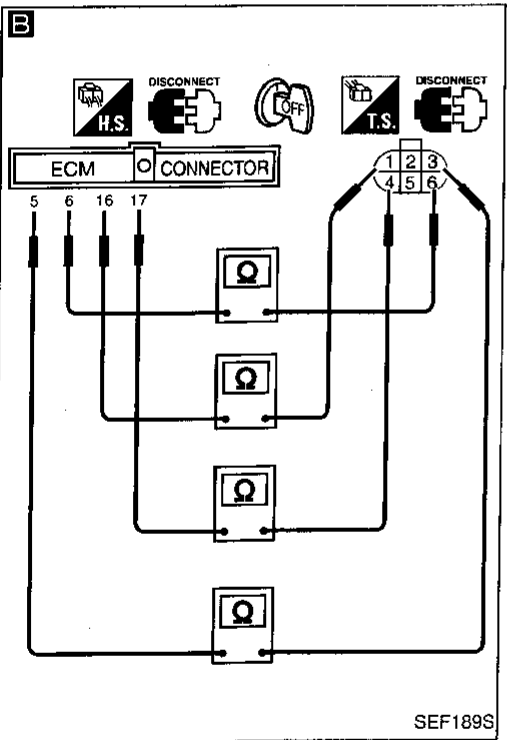
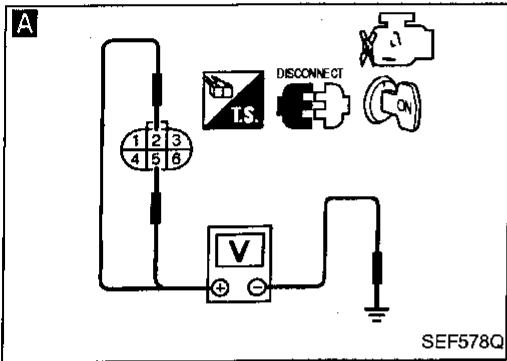
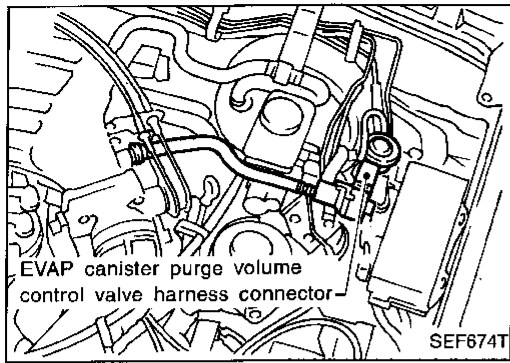

GI
MA
EM
LC
EC
FE
AT
TF
PD
FA
RA
BR
ST
RS
BT
HA
EL
IDX

TROUBLE DIAGNOSIS FOR DTC P1445

Evaporative Emission (EVAP) Canister Purge Volume Control Valve (Cont'd)

COMPONENT INSPECTION

EVAP canister purge volume control valve

1. Disconnect EVAP canister purge volume control valve harness connector.
2. Check resistance between the following terminals.
terminal ② and terminals ①, ③
terminal ⑤ and terminals ④, ⑥

Resistance:

Approximately 30Ω [At 25°C (77°F)]

3. Reconnect EVAP canister purge volume control valve harness connector.
4. Remove EVAP canister purge volume control valve from intake manifold collector and disconnect hoses from the valve.
(Plug the purge hoses. The EVAP canister purge volume control valve harness connector should remain connected.)
5. Turn ignition switch "ON".
6. Perform "PURG VOL CONT/V" in "ACTIVE TEST" mode with CONSULT. Check that EVAP canister purge volume control valve shaft moves smoothly forward and backward according to the valve opening.
If NG, replace the EVAP canister purge volume control valve.

OR

1. Disconnect EVAP canister purge volume control valve harness connector.
2. Check resistance between the following terminals.
terminal ② and terminals ①, ③
terminal ⑤ and terminals ④, ⑥

Resistance:

Approximately 30Ω [At 25°C (77°F)]

3. Reconnect EVAP canister purge volume control valve harness connector.
4. Remove EVAP canister purge volume control valve from intake manifold collector and disconnect hoses from the valve.
(Plug the purge hoses. The EVAP canister purge volume control valve harness connector should remain connected.)
5. Turn ignition switch "ON" and "OFF". Check that EVAP canister purge volume control valve shaft moves smoothly forward and backward according to the ignition switch position.
If NG, replace the EVAP canister purge volume control valve.

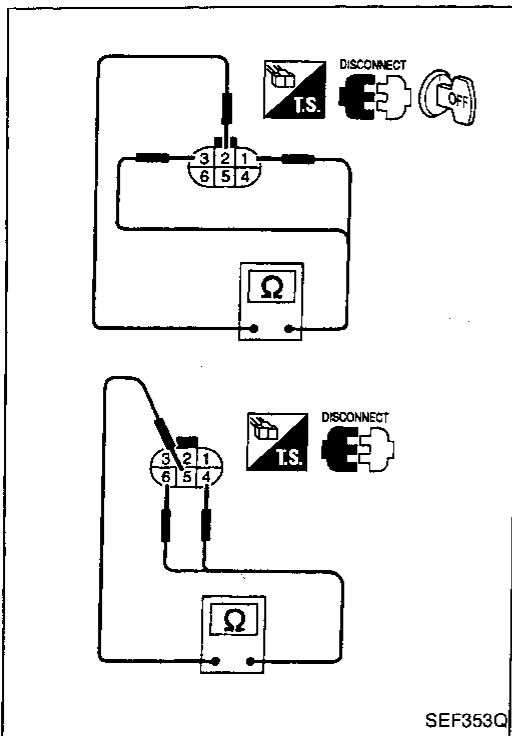

SEF353Q

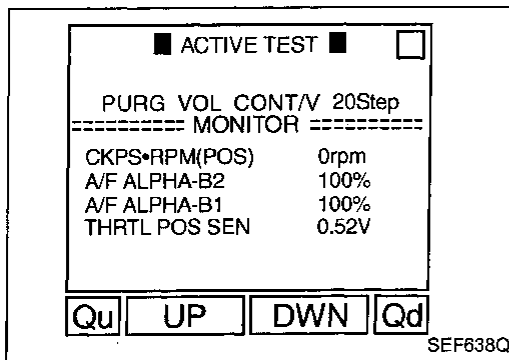

SEF638Q

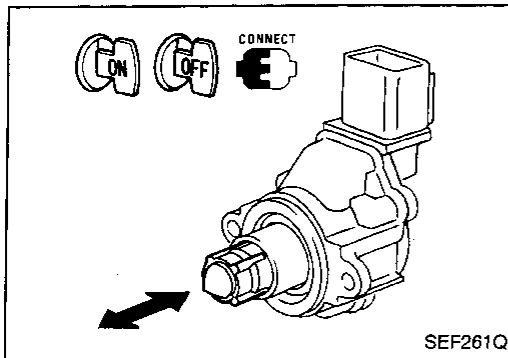

SEF261Q

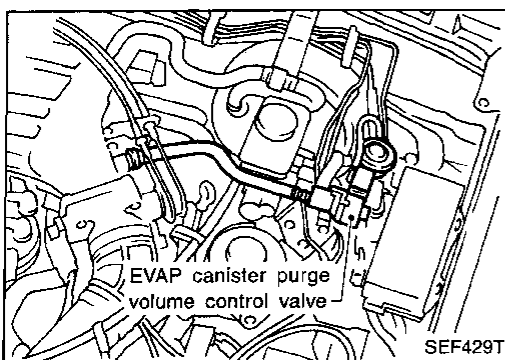

SEF429T

TROUBLE DIAGNOSIS FOR DTC P1447

Evaporative Emission (EVAP) Control System Purge Flow Monitoring

Note: If both DTC P0510 and P1447 are displayed, perform TROUBLE DIAGNOSIS FOR DTC P0510 first.
(See EC-261.)

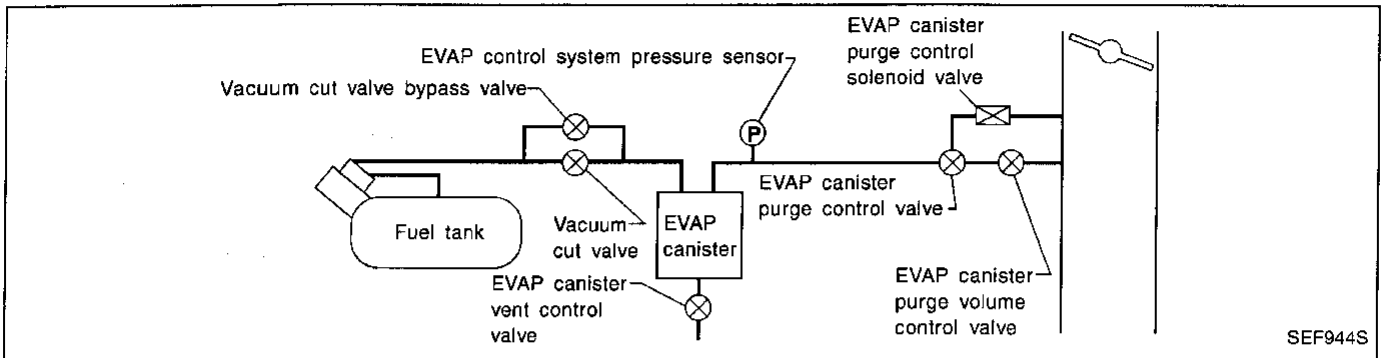

SYSTEM DESCRIPTION

In this evaporative emission (EVAP) control system, purge flow occurs during non-closed throttle conditions. Purge volume is related to air intake volume. Under normal purge conditions (non-closed throttle), the EVAP canister purge volume control valve and EVAP canister purge control valve are open. Purge flow exposes the EVAP control system pressure sensor to intake manifold vacuum.

ON BOARD DIAGNOSIS LOGIC

Under normal conditions (non-closed throttle), sensor output voltage indicates if pressure drop and purge flow are adequate. If not, a fault is determined.

Diagnostic Trouble Code No.	Malfunction is detected when	Check Items (Possible Cause)
P1447 0111	<ul style="list-style-type: none"> ● EVAP control system does not operate properly. ● EVAP control system has a leak between intake manifold and EVAP control system pressure sensor. 	<ul style="list-style-type: none"> ● EVAP canister purge volume control valve stuck closed ● EVAP canister purge control valve stuck closed ● EVAP control system pressure sensor ● Loose or disconnected rubber tube ● Blocked rubber tube ● EVAP canister purge control solenoid valve ● Blocked or bent rubber tube to MAP/BARO switch solenoid valve ● Cracked EVAP canister ● Absolute pressure sensor ● MAP/BARO switch solenoid valve ● Closed throttle position switch

TROUBLE DIAGNOSIS FOR DTC P1447

Evaporative Emission (EVAP) Control System Purge Flow Monitoring (Cont'd)

DIAGNOSTIC TROUBLE CODE CONFIRMATION PROCEDURE

☆ MONITOR ☆ NO FAIL <input type="checkbox"/> CMPS•RPM(POS) 750rpm COOLAN TEMP/S 85°C
RECORD

SEF842T

☆ MONITOR ☆ NO FAIL <input type="checkbox"/> CMPS•RPM(POS) 2000rpm VHCL SPEED SE 60km/h COOLAN TEMP/S 85°C
RECORD

SEF843T

☆ MONITOR ☆ NO FAIL <input type="checkbox"/> CMPS•RPM(POS) 3000rpm VHCL SPEED SE 60km/h
RECORD

SEF844T



- 1) Start engine and warm it up sufficiently.
- 2) Select "DATA MONITOR" mode with CONSULT.
- 3) Check coolant temperature.
COOLAN TEMP/S: 40 - 100°C (104 - 212°F)
- 4) Turn ignition switch "OFF" and wait at least 5 seconds.
- 5) Turn ignition switch "ON" and wait at least 15 seconds.
- 6) Restart engine and let it idle for at least 80 seconds.
- 7) Maintain the following conditions for at least 80 seconds.

Gear position: Suitable gear position
Vehicle speed: 40 - 80 km/h (25 - 50 MPH)
Engine speed: 1,500 - 3,000 rpm
COOLAN TEMP/S: 40 - 100°C (104 - 212°F)

- 8) Decelerate the vehicle to 0 km/h (0 MPH) and let engine idle.

- 9) Maintain the following conditions for at least 5 seconds.

Gear position: "1" or "2" range
Engine speed: 2,500 - 3,400 rpm
EVAP purge volume control valve: 16 - 50 step

CAUTION:

Do not run vehicle at speeds greater than 80 km/h (50 MPH).

- 10) Perform steps 8, 9 more than 10 times.
- 11) Decelerate the vehicle speed to 0 km/h (0 MPH) and let engine idle.
- 12) Maintain the following conditions for at least 10 seconds consecutively.
Gear position: Suitable gear position
Vehicle speed: 40 - 80 km/h (25 - 50 MPH)
Engine speed: 1,500 - 3,000 rpm

NOTE:

- Hold the accelerator pedal as steady as possible during driving in steps 7, 9 and 12.
- If the driving conditions are not satisfied in steps 7, 9 and 12, restart the procedure.
- It is better that the fuel level is low.

TROUBLE DIAGNOSIS FOR DTC P1447

Evaporative Emission (EVAP) Control System Purge Flow Monitoring (Cont'd)

ENGINE SPD	825RPM
COOLANT TEMP	69°C
VEHICLE SPD	0MPH
IGN ADVANCE	8.0°
CALC LOAD	28.2%
MAP	36KPaA
MAF	5.20gm/s
THROTTLE POS	0.0%
INTAKE AIR	27°C
FUEL SYS #1	OLDRIVE
FUEL SYS #2	UNUSED
SHORT FT #1	0.8%
LONG FT #1	0.0%
O2S B1 S1	0.200V
O2FT B1 S1	0.8%
O2S B1 S2	0.010V

SEF519R



- OR
- 1) Start engine and warm it up sufficiently.
 - 2) Select "MODE 1" with GST.
 - 3) Check coolant temperature.
Coolant temperature: 40 - 100°C (104 - 212°F)
 Be sure that water temperature does not exceed 100°C. If it becomes higher than 100°C, cool down the engine and perform the procedure again from the beginning.
 - 4) Turn ignition switch "OFF" and wait at least 5 seconds.
 - 5) Turn ignition switch "ON" and wait at least 15 seconds.
 - 6) Restart engine and let it idle for at least 80 seconds.
 - 7) Maintain the following conditions for at least 80 seconds.

Gear position : Suitable gear position
Vehicle speed : 40 - 80 km/h (25 - 50 MPH)
Engine speed : 1,500 - 3,000 rpm
Coolant temperature: 40 - 100°C (104 - 212°F)

- 8) Decelerate the vehicle to 0 km/h (0 MPH) and let engine idle.
- 9) Maintain the following conditions for at least 5 seconds.
Gear position: "1" or "2" range
Engine speed: 2,500 - 3,400 rpm

CAUTION:

Do not run vehicle at speeds greater than 80 km/h (50 MPH).

- 10) Perform steps 8, 9 more than 20 times.
- 11) Decelerate the vehicle speed to 0 km/h (0 MPH) and let engine idle.
- 12) Maintain the following conditions for at least 10 seconds consecutively.
Gear position: Suitable gear position
Vehicle speed: 40 - 80 km/h (25 - 50 MPH)
Engine speed: 1,500 - 3,000 rpm
- 13) Select "MODE 3" with GST.

NOTE:

- Hold the accelerator pedal as steady as possible during driving in steps 7, 9 and 12.
- If the driving conditions are not satisfied in steps 7, 9 and 12, restart the procedure.
- It is better that the fuel level is low.
- When using GST, "DIAGNOSTIC TROUBLE CODE CONFIRMATION PROCEDURE" should be performed twice as much as when using CONSULT or ECM (Diagnostic Test Mode II) because GST cannot display MODE 7 (1st trip DTC) concerning this diagnosis. Therefore, using CONSULT or ECM (Diagnostic Test Mode II) is recommended.

GI
 MA
 EM
 LC
 EC
 FE
 AT
 TF
 PD
 FA
 RA
 BR
 ST
 RS
 BT
 HA
 EL
 IDX

TROUBLE DIAGNOSIS FOR DTC P1447

Evaporative Emission (EVAP) Control System Purge Flow Monitoring (Cont'd)

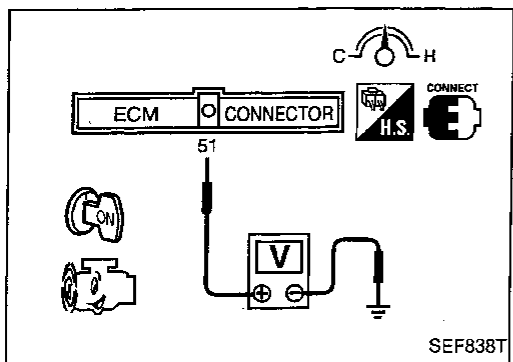

OR



- 1) Start engine and warm it up sufficiently.
- 2) Check voltage between ECM terminal ⑤① and ground
Voltage: 0.8 - 1.5V
Perform the following procedure before the voltage drops below 0.8V. If the voltage drops below 0.8V, cool down the engine and perform the entire procedure all over again.
- 3) Turn ignition switch "OFF" and wait at least 5 seconds.
- 4) Turn ignition switch "ON" and wait at least 15 seconds.
- 5) Restart engine and let it idle for at least 80 seconds.
- 6) Maintain the following conditions for at least 80 seconds.
Gear position: Suitable gear position
Vehicle speed: 40 - 80 km/h (25 - 50 MPH)
Engine speed: 1,500 - 3,000 rpm
Check voltage between ECM terminal ⑤① and ground: 0.8 - 1.5V
- 7) Decelerate the vehicle to 0 km/h (0 MPH) and let engine idle.
- 8) Maintain the following conditions for at least 5 seconds.
Gear position: "1" or "2" range
Engine speed: 2,500 - 3,400 rpm

CAUTION:

Do not run vehicle at speeds greater than 80 km/h (50 MPH).

- 9) Perform steps 7, 8 more than 20 times.
- 10) Decelerate the vehicle speed to 0 km/h (0 MPH) and let engine idle.
- 11) Maintain the following conditions for at least 10 seconds consecutively.
Gear position: Suitable gear position
Vehicle speed: 40 - 80 km/h (25 - 50 MPH)
Engine speed: 1,500 - 3,000 rpm
- 12) Stop the vehicle, turn ignition switch "OFF", wait at least 5 seconds, and then turn "ON".
- 13) Perform "Diagnostic Test Mode II (Self-diagnostic results)" with ECM.

NOTE:

- Hold the accelerator pedal as steady as possible during driving in steps 6, 8 and 11.
- If the driving conditions are not satisfied in steps 6, 8 and 11, restart the procedure.
- It is better that the fuel level is low.

TROUBLE DIAGNOSIS FOR DTC P1447

Evaporative Emission (EVAP) Control System Purge Flow Monitoring (Cont'd)

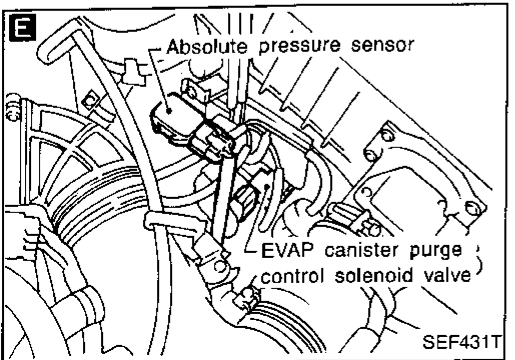
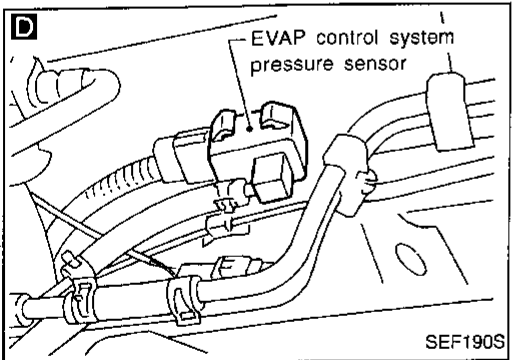
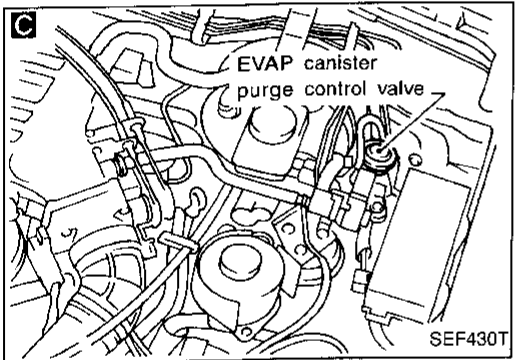
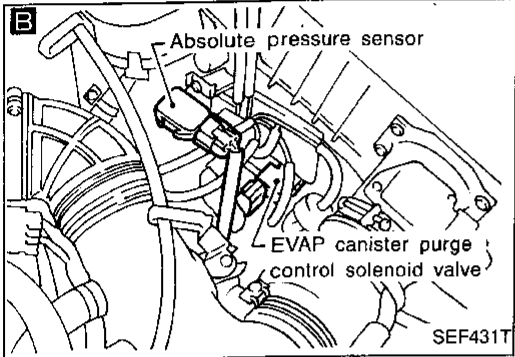
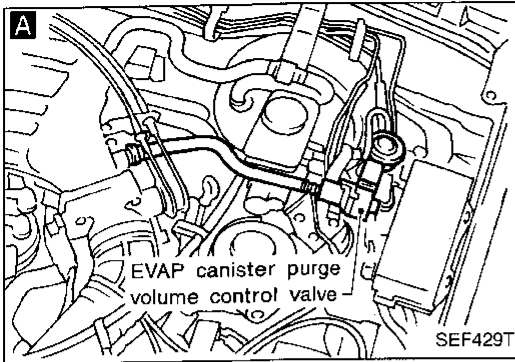

DIAGNOSTIC PROCEDURE

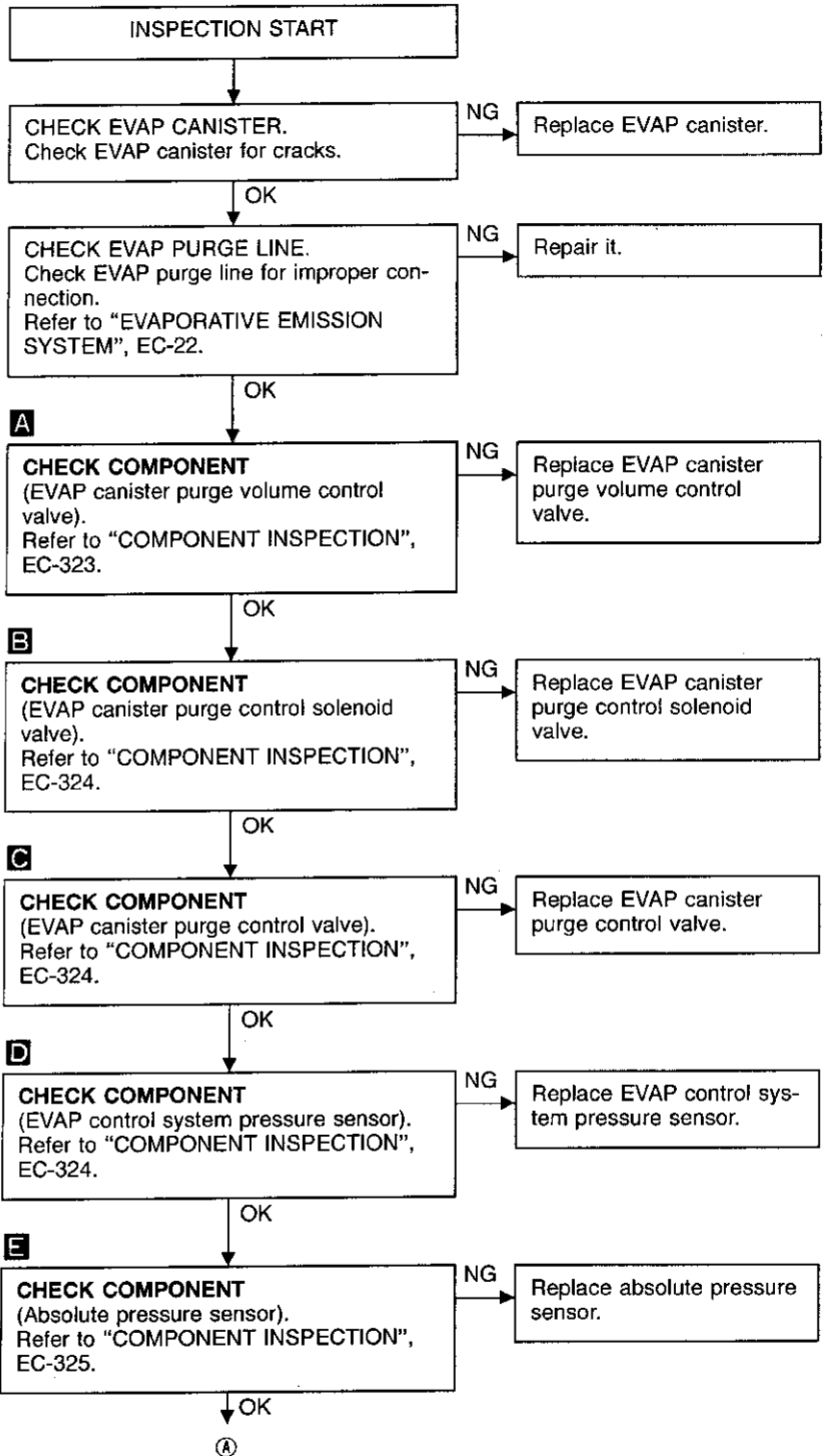

GI
MA
EM
LC
EC
FE
AT
TF
PD
FA
RA
BR
ST
RS
BT
HA
EL
IDX

TROUBLE DIAGNOSIS FOR DTC P1447

Evaporative Emission (EVAP) Control System Purge Flow Monitoring (Cont'd)

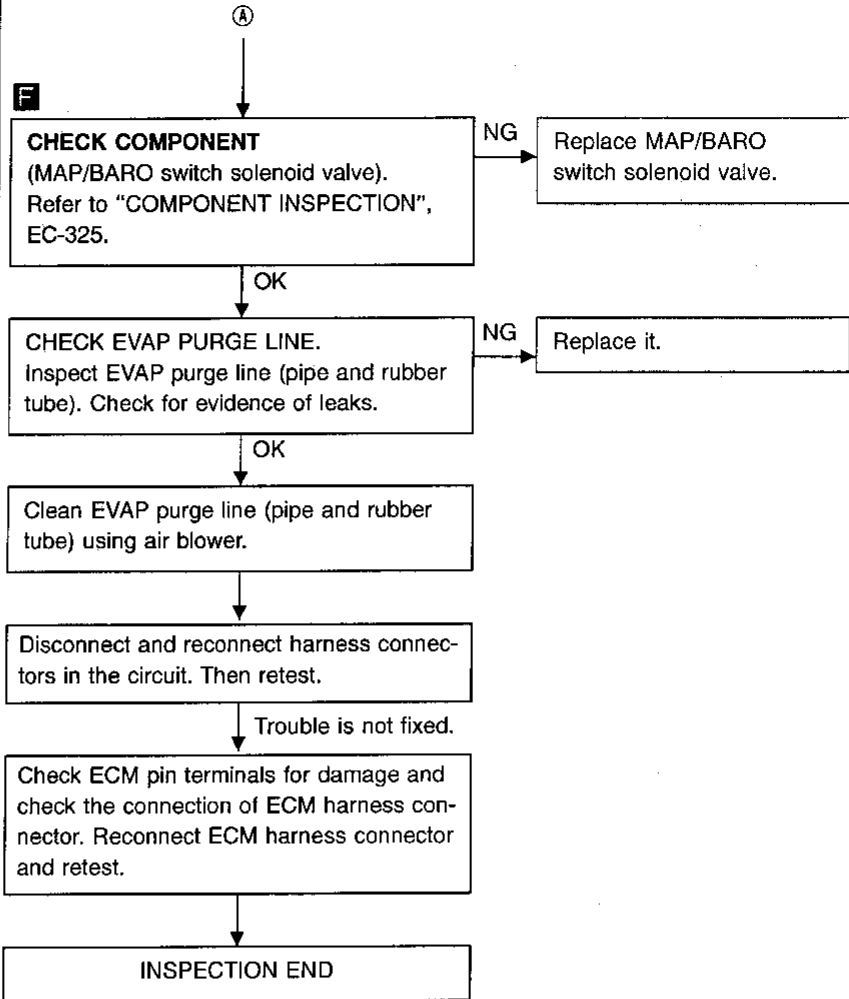
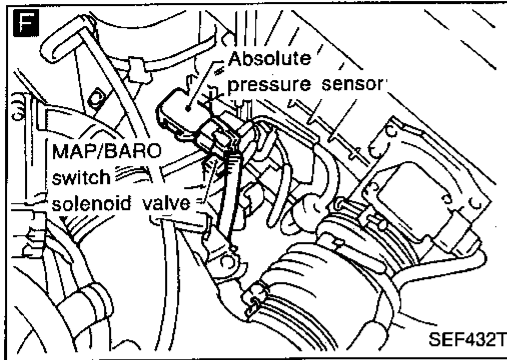

TROUBLE DIAGNOSIS FOR DTC P1447

Evaporative Emission (EVAP) Control System Purge Flow Monitoring (Cont'd)

COMPONENT INSPECTION

EVAP canister purge volume control valve



- 1) Disconnect EVAP canister purge volume control valve harness connector.
- 2) Check resistance between the following terminals.
terminal ② and terminals ①, ③
terminal ⑤ and terminals ④, ⑥

Resistance:

Approximately 30Ω [At 25°C (77°F)]

- 3) Reconnect EVAP canister purge volume control valve harness connector.
- 4) Remove EVAP canister purge volume control valve from intake manifold collector and disconnect hoses from the valve.

(Plug the purge hoses. The EVAP canister purge volume control valve harness connector should remain connected.)

- 5) Turn ignition switch "ON".
- 6) Perform "PURG VOL CONT/V" in "ACTIVE TEST" mode with CONSULT. Check that EVAP canister purge volume control valve shaft moves smoothly forward and backward according to the valve opening.

If NG, replace the EVAP canister purge volume control valve.

OR



- 1) Disconnect EVAP canister purge volume control valve harness connector.
- 2) Check resistance between the following terminals.
terminal ② and terminals ①, ③
terminal ⑤ and terminals ④, ⑥

Resistance:

Approximately 30Ω [At 25°C (77°F)]

- 3) Reconnect EVAP canister purge volume control valve harness connector.
- 4) Remove EVAP canister purge volume control valve from intake manifold collector and disconnect hoses from the valve.

(Plug the purge hoses. The EVAP canister purge volume control valve harness connector should remain connected.)

- 5) Turn ignition switch "ON" and "OFF". Check that EVAP canister purge volume control valve shaft moves smoothly forward and backward according to the ignition switch position.

If NG, replace the EVAP canister purge volume control valve.

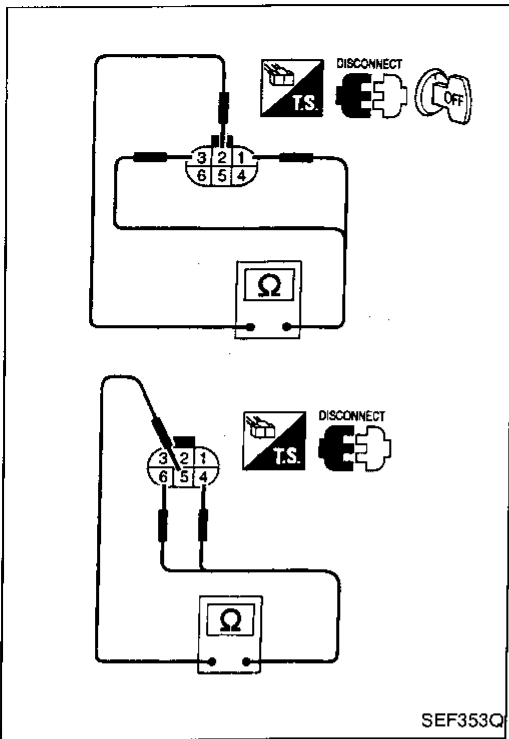

SEF353Q

ACTIVE TEST	
PURG VOL CONT/V 20Step	
----- MONITOR -----	
CKPS-RPM(POS)	0rpm
A/F ALPHA-B2	100%
A/F ALPHA-B1	100%
THRTL POS SEN	0.52V
Qu	UP
DWN	Qd

SEF638Q

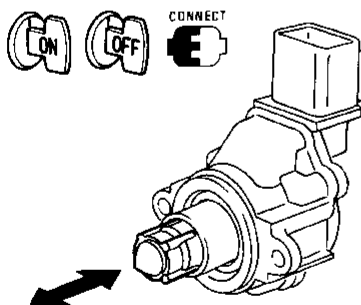

SEF261Q

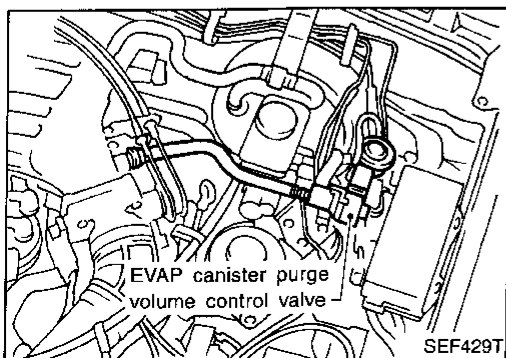

SEF429T

TROUBLE DIAGNOSIS FOR DTC P1447

Evaporative Emission (EVAP) Control System Purge Flow Monitoring (Cont'd)

EVAP canister purge control valve

Check EVAP canister purge control valve as follows:

1. Plug the port ②.
2. Apply pressure [80.0 kPa (600 mmHg, 23.62 inHg, 11.60 psi)] to port ①. Then keep it for 15 seconds, and check there is no leakage.
3. Repeat step 2 for port ③.

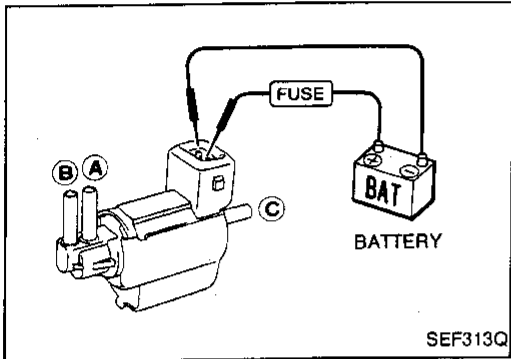
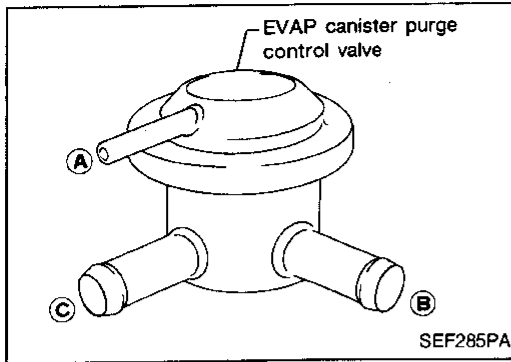

EVAP canister purge control solenoid valve

Check air passage continuity.

Condition	Air passage continuity between ① and ②	Air passage continuity between ① and ③
12V direct current supply between terminals	Yes	No
No supply	No	Yes

If NG, replace solenoid valve.

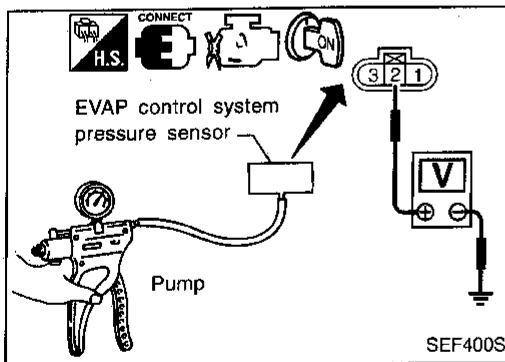

EVAP control system pressure sensor

1. Remove EVAP control system pressure sensor with its harness connector connected.
2. Remove hose from EVAP control system pressure sensor.
3. Use pump to apply vacuum and pressure to EVAP control system pressure sensor as shown in figure.
4. Check output voltage between terminal ② and engine ground.

Pressure (Relative to atmospheric pressure)	Voltage (V)
0 kPa (0 mmHg, 0 inHg, 0 psi)	3.0 - 3.6
-9.3 kPa (-70 mmHg, -2.76 inHg, -1.35 psi)	0.4 - 0.6

CAUTION:

Always calibrate the vacuum pump gauge when using it.

5. If NG, replace EVAP control system pressure sensor.

TROUBLE DIAGNOSIS FOR DTC P1447

Evaporative Emission (EVAP) Control System Purge Flow Monitoring (Cont'd)

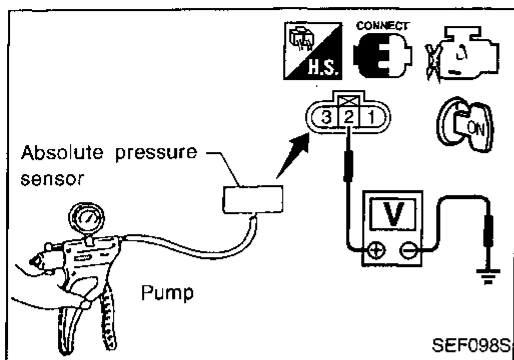

Absolute pressure sensor

1. Remove absolute pressure sensor with its harness connector connected.
2. Remove hose from absolute pressure sensor.
3. Turn ignition switch "ON" and check output voltage between terminal ② and engine ground.

The voltage should be 3.2 to 4.8 V.

4. Use pump to apply vacuum of -26.7 kPa (-200 mmHg, -7.87 inHg, -3.87 psi) to absolute pressure sensor as shown in figure and check the output voltage.

The voltage should be 1.0 to 1.4 V lower than the value measured in step 3.

CAUTION:

Always calibrate the vacuum pump gauge when using it.

5. If NG, replace absolute pressure sensor.

GI
MA
EM
LC
EC

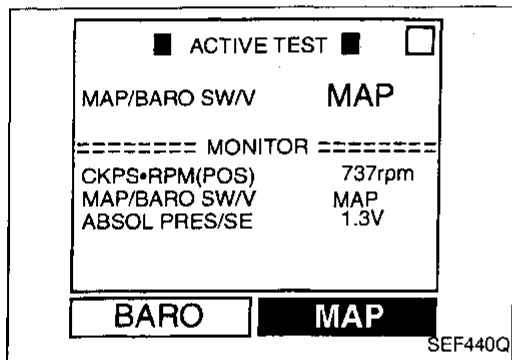

MAP/BARO switch solenoid valve

1. Start engine and warm it up sufficiently.
2. Perform "MAP/BARO SW/V" in "ACTIVE TEST" mode with CONSULT.
3. Check the following.
 - When "MAP" is selected, "ABSOL PRES/SE" indicates approximately 1.3V.
 - When "BARO" is selected, "ABSOL PRES/SE" indicates approximately 4.3V.
4. If NG, replace solenoid valve.

AT
TF
PD
FA
RA
BR

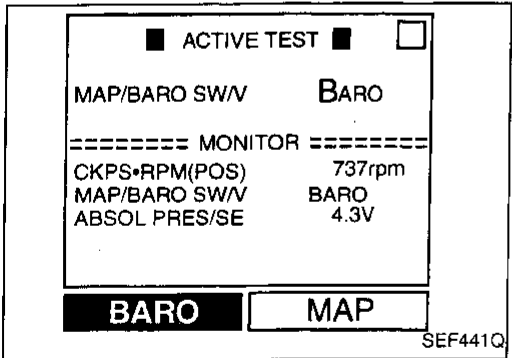

- OR
1. Remove MAP/BARO switch solenoid valve.
 2. Check air passage continuity.

Condition	Air passage continuity between ① and ②	Air passage continuity between ① and ③
12V direct current supply between terminals ① and ②	Yes	No
No supply	No	Yes

ST
RS
BT
HA

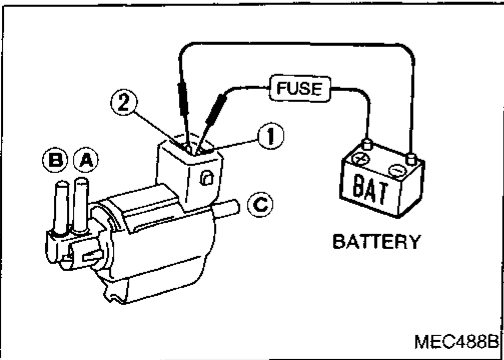

EL
IDX

TROUBLE DIAGNOSIS FOR DTC P1605

A/T Diagnosis Communication Line

COMPONENT DESCRIPTION

The malfunction information related to A/T (Automatic Transmission) is transferred through the line (circuit) from A/T control unit to ECM. Therefore, be sure to erase the malfunction information such as DTC not only in A/T control unit but also ECM after the A/T related repair.

ECM TERMINALS AND REFERENCE VALUE

Specification data are reference values and are measured between each terminal and ④ (ECCS ground).

TER-MINAL NO.	WIRE COLOR	ITEM	CONDITION	DATA (DC Voltage)
7	Y/G	A/T check signal	Ignition switch "ON" Engine is running.	0 - 3.0V

ON BOARD DIAGNOSIS LOGIC

Diagnostic Trouble Code No.	Malfunction is detected when ...	Check Items (Possible Cause)
P1605 0804	<ul style="list-style-type: none"> An incorrect signal from A/T control units is sent to ECM. 	<ul style="list-style-type: none"> Harness or connectors (The communication line circuit between ECM and A/T control unit is open or shorted.) Dead (Weak) battery A/T control unit

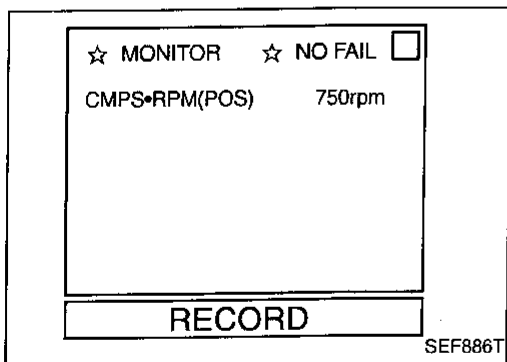

DIAGNOSTIC TROUBLE CODE CONFIRMATION PROCEDURE

Note: Before performing the following procedure, confirm that battery voltage is more than 10.5V.



- 1) Turn ignition switch "ON".
- 2) Select "DATA MONITOR" mode with CONSULT.
- 3) Start engine and wait at least 40 seconds.

OR



- 1) Turn ignition switch "ON".
- 2) Start engine and wait at least 40 seconds.
- 3) Select "MODE 7" with GST.

OR



- 1) Turn ignition switch "ON".
- 2) Start engine and wait at least 40 seconds.
- 3) Turn ignition switch "OFF", wait at least 5 seconds and then turn "ON".
- 4) Perform "Diagnostic Test Mode II" (Self-diagnostic results) with ECM.

TROUBLE DIAGNOSIS FOR DTC P1605

A/T Diagnosis Communication Line (Cont'd)

EC-ATDIAG-01

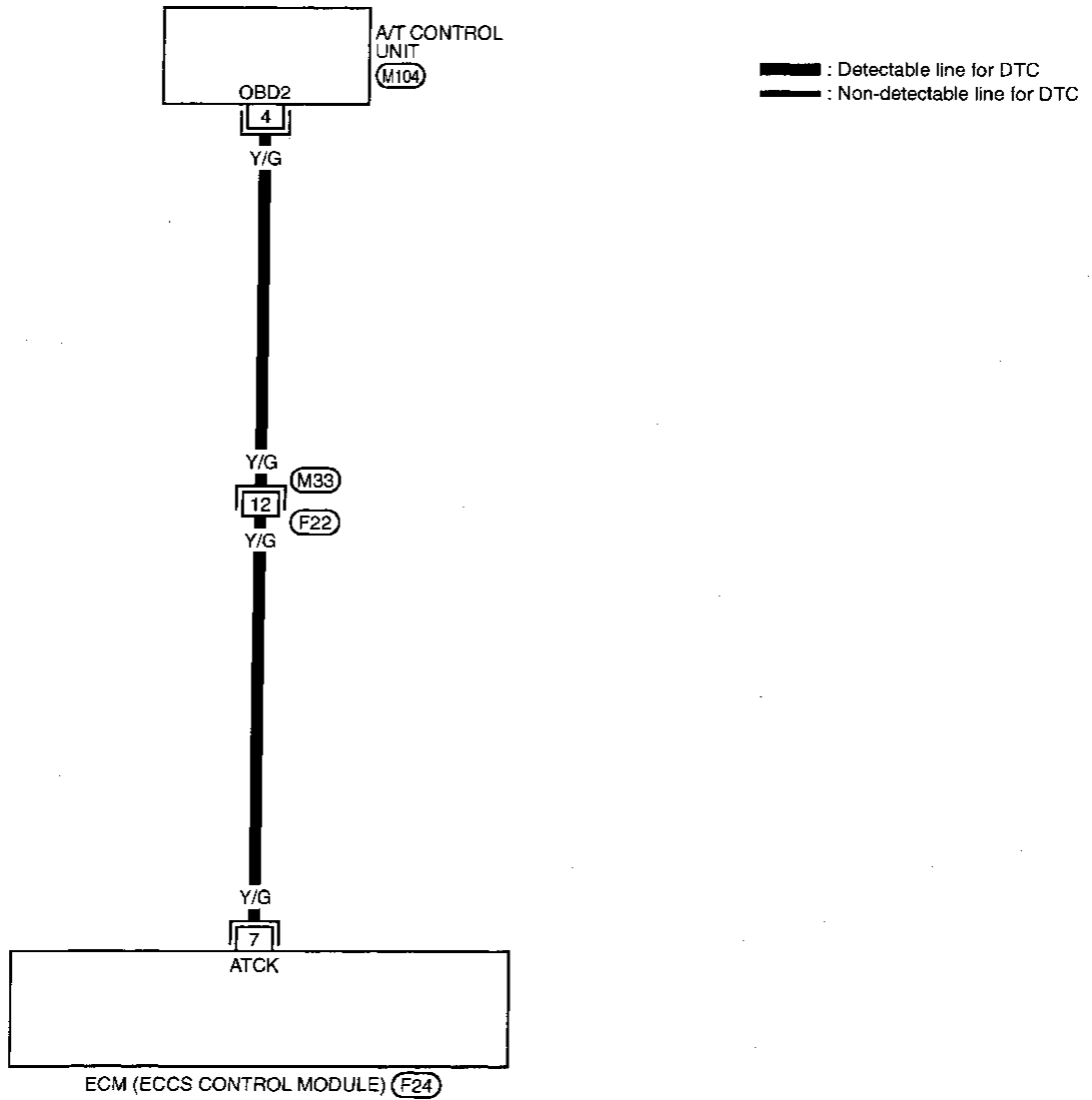

GI
MA
EM
LC
EC
FE
AT
TF
PD
FA
RA
BR
ST
RS
BT
HA
EL
IDX

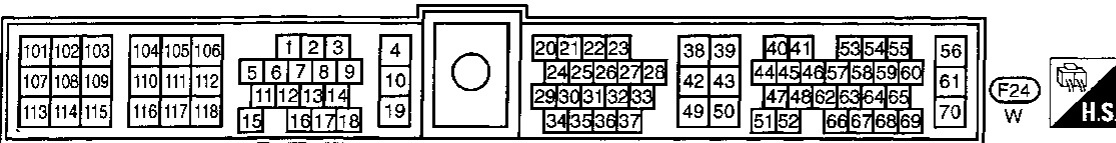
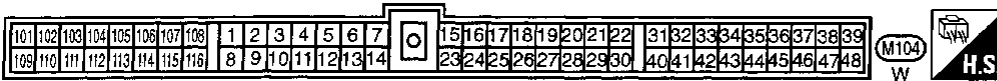
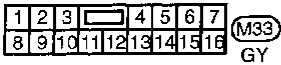

TROUBLE DIAGNOSIS FOR DTC P1605

A/T Diagnosis Communication Line (Cont'd)

DIAGNOSTIC PROCEDURE

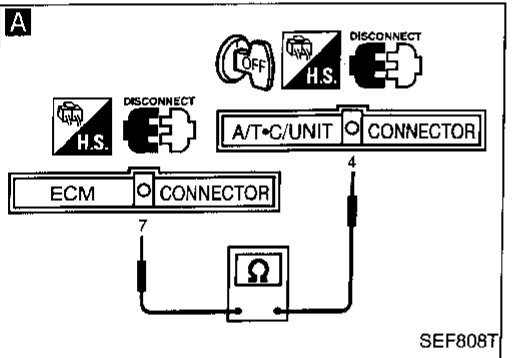
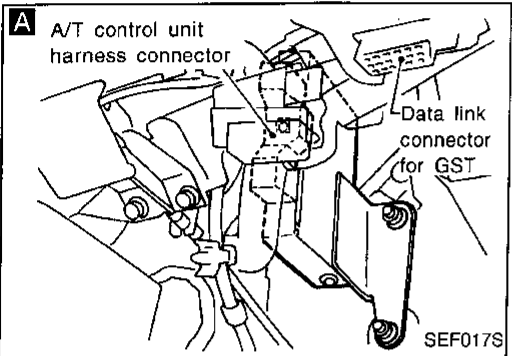
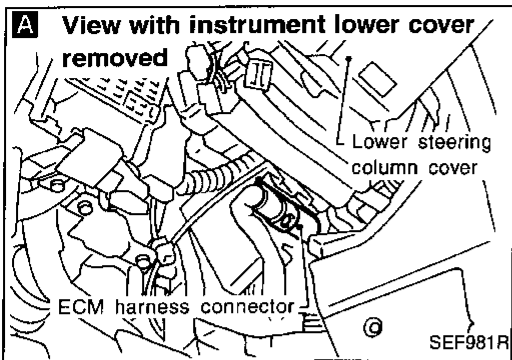

INSPECTION START

A

CHECK INPUT SIGNAL CIRCUIT.

1. Turn ignition switch "OFF".
2. Disconnect ECM harness connector and A/T control unit harness connector.
3. Check harness continuity between ECM terminal ⑦ and A/T control unit terminal ④.

Continuity should exist.

If OK, check harness for short to ground and short to power.

NG

Check the following.

- Harness connectors
 (M33), (F22)
- Harness for open or short between ECM and A/T control unit

If NG, repair open circuit or short to ground or short to power in harness or connectors.

OK

Disconnect and reconnect harness connectors in the circuit. Then retest.

Trouble is not fixed.

Check ECM pin terminals and A/T control unit pin terminals for damage and check the connection of ECM harness connector. Reconnect ECM harness connector and retest.

INSPECTION END

TROUBLE DIAGNOSIS FOR NON-DETECTABLE ITEMS

Injector

EC-INJECT-01

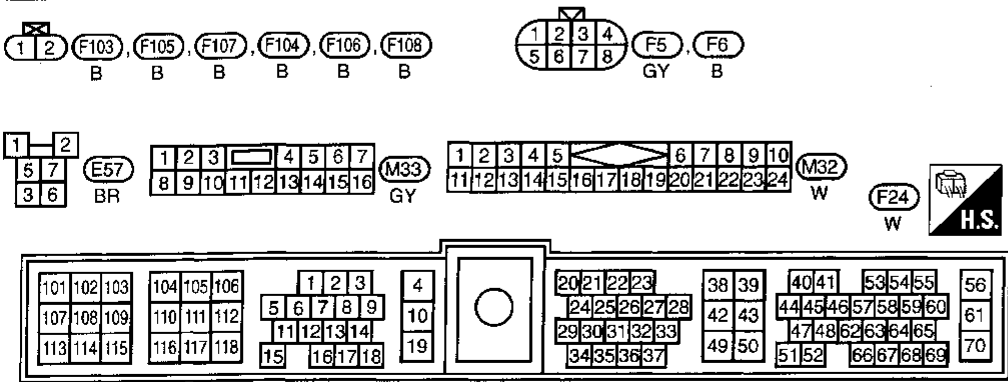
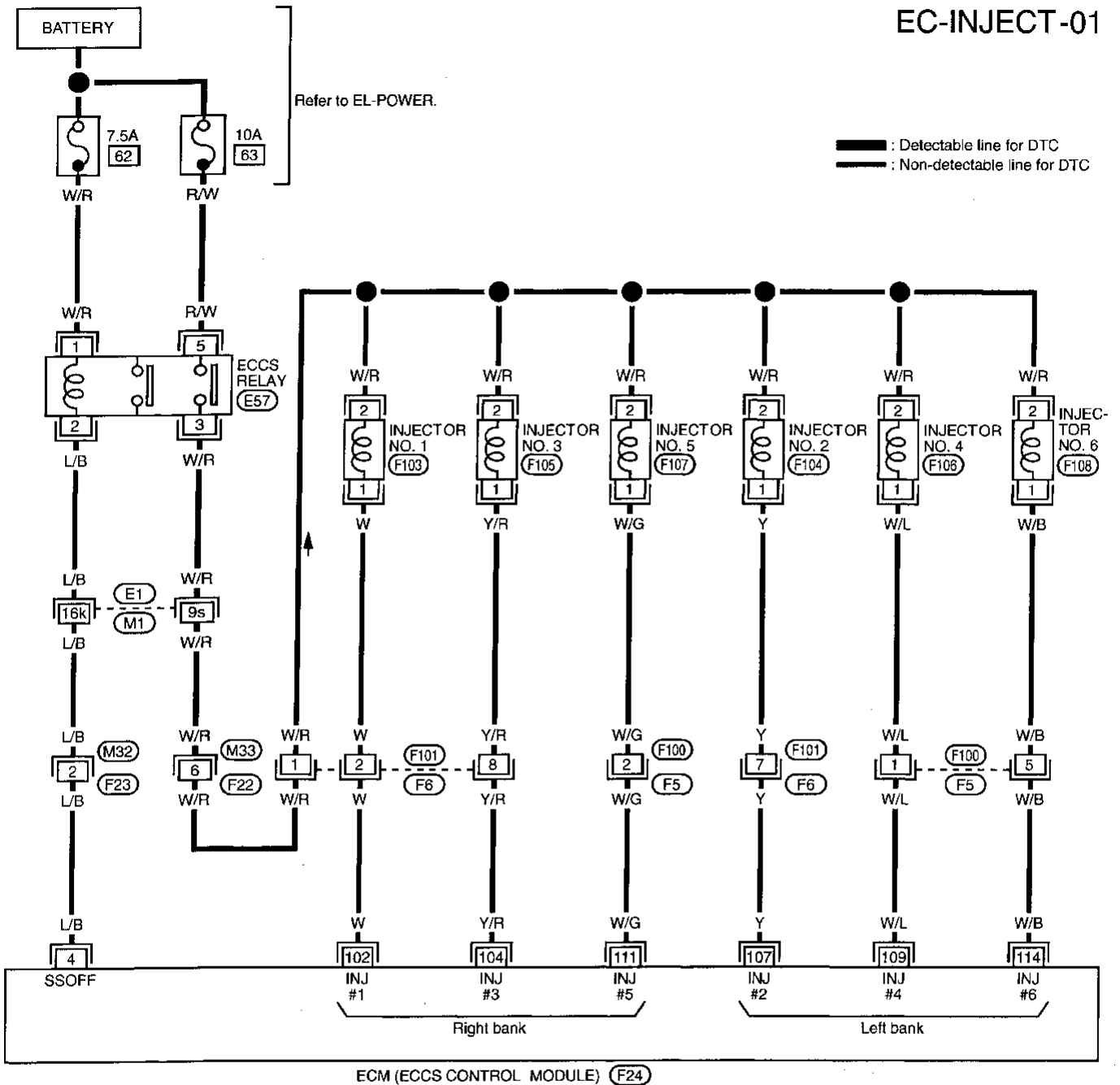

Refer to last page (Foldout page).
E1, M1

GI
MA
EM
LC
EC
FE
AT
TF
PD
FA
RA
BR
ST
RS
BT
HA
EL
IDX

TROUBLE DIAGNOSIS FOR NON-DETECTABLE ITEMS

Injector (Cont'd)

COMPONENT DESCRIPTION

The fuel injector is a small, precise solenoid valve. When the ECM supplies a ground to the injector circuit, the coil in the injector is energized. The energized coil pulls the needle valve back and allows fuel to flow through the injector into the intake manifold. The amount of fuel injected depends upon the injection pulse duration. Pulse duration is the length of time the injector remains open. The ECM controls the injection pulse duration based on engine fuel needs.

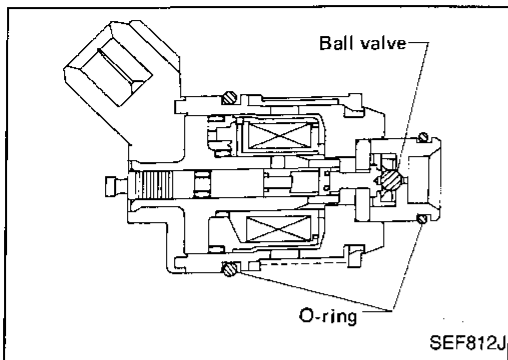

ECM TERMINALS AND REFERENCE VALUE

Specification data are reference values and are measured between each terminal and Ⓞ (ECCS ground).

TER-MINAL NO.	WIRE COLOR	ITEM	CONDITION	DATA (DC Voltage)
4	L/B	ECCS relay (Self-shutoff)	Engine is running. Ignition switch "OFF" └ For a few seconds after turning ignition switch "OFF"	0 - 1V
			Ignition switch "OFF" └ A few seconds passed after turning ignition switch "OFF"	BATTERY VOLTAGE (11 - 14V)
102	W	Injector No. 1		BATTERY VOLTAGE (11 - 14V)
104	Y/R	Injector No. 3	Engine is running. (Warm-up condition) └ Idle speed	<p style="text-align: right;">SEF204T</p>
107	Y	Injector No. 2		
109	W/L	Injector No. 4		
111	W/G	Injector No. 5	Engine is running. (Warm-up condition) └ Engine speed is 2,000 rpm	<p style="text-align: right;">SEF205T</p>
114	W/B	Injector No. 6		

TROUBLE DIAGNOSIS FOR NON-DETECTABLE ITEMS

Injector (Cont'd) DIAGNOSTIC PROCEDURE

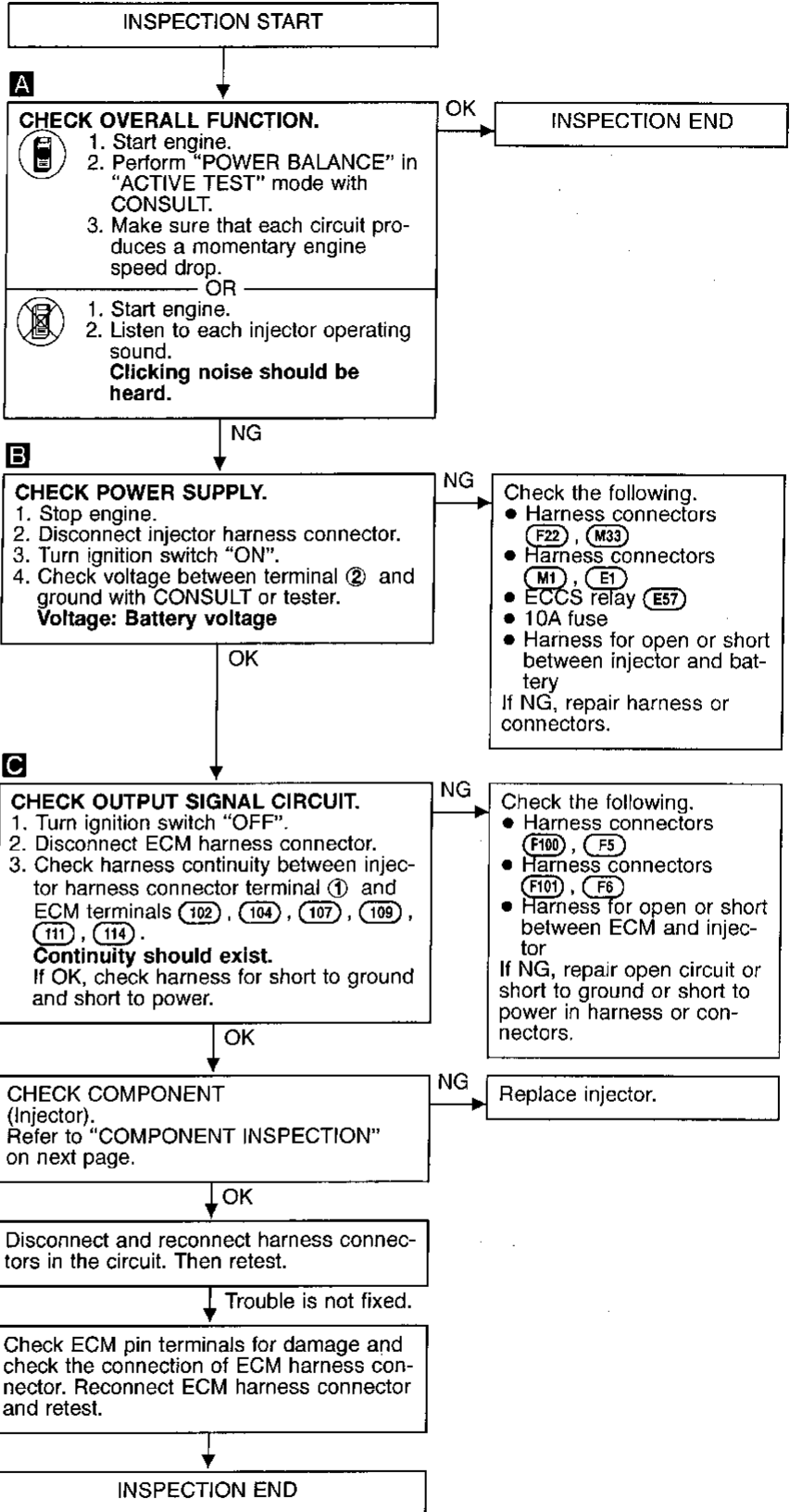
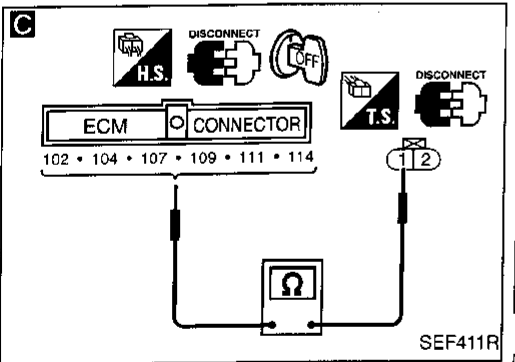
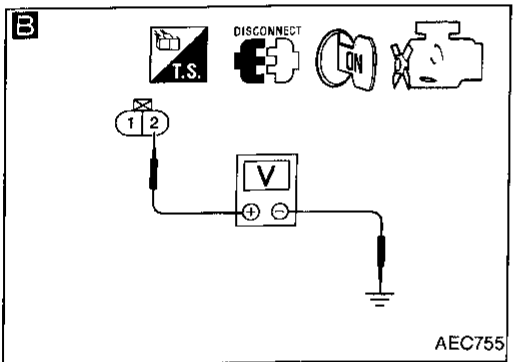
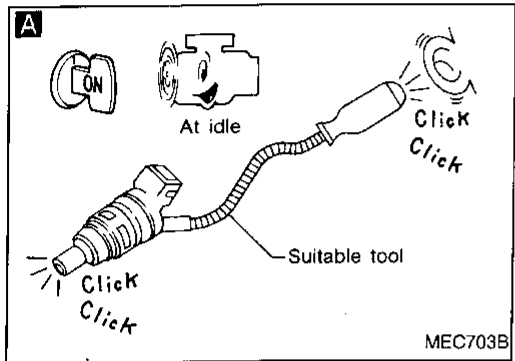
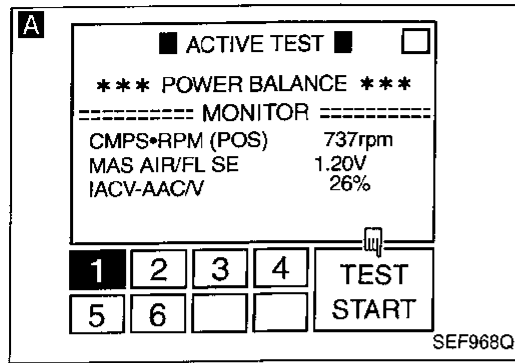

GI
MA
EM
LC
EC
FE
AT
TF
PD
FA
RA
BR
ST
RS
BT
HA
EL
IDX

TROUBLE DIAGNOSIS FOR NON-DETECTABLE ITEMS

Injector (Cont'd) COMPONENT INSPECTION

Injector

1. Disconnect injector harness connector.
2. Check resistance between terminals as shown in the figure.
Resistance: 10 - 14Ω [at 25°C (77°F)]
If NG, replace injector.

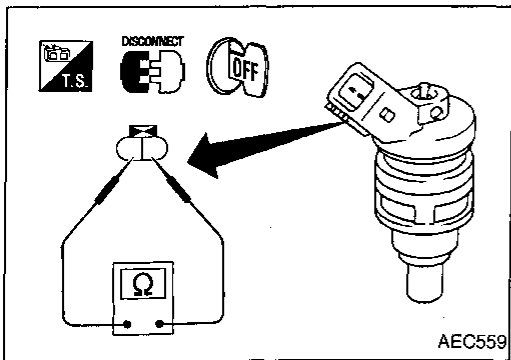

TROUBLE DIAGNOSIS FOR NON-DETECTABLE ITEMS

Start Signal

EC-S/SIG-01

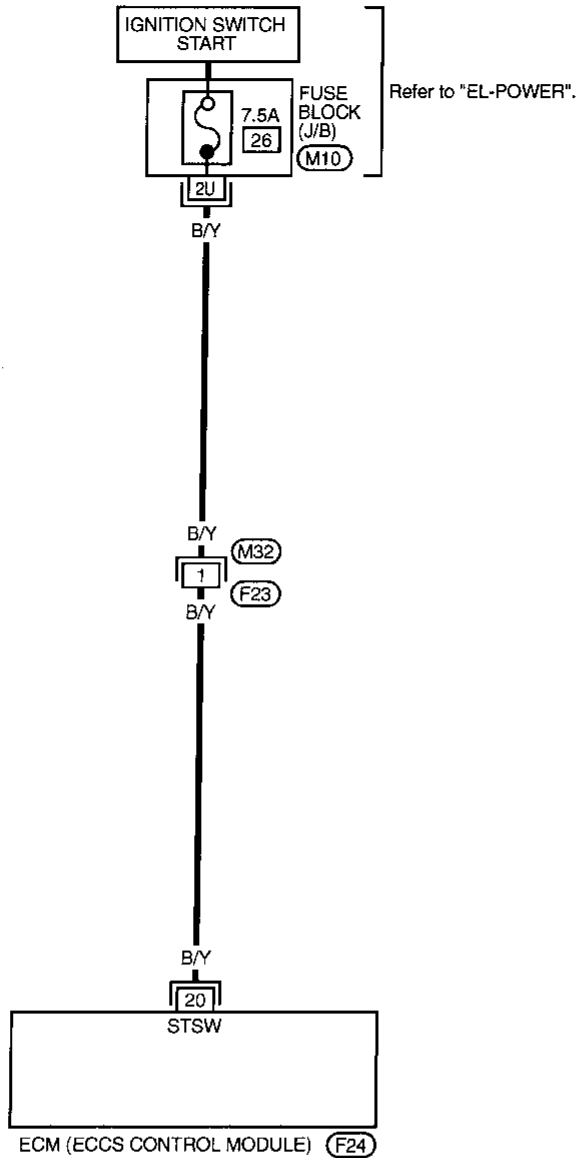

: Detectable line for DTC
 : Non-detectable line for DTC

GI
MA
EM
LC
EC
FE
AT
TF
PD
FA
RA
BR
ST
RS
BT
HA
EL
IDX

Refer to last page (Foldout page).

(M10)

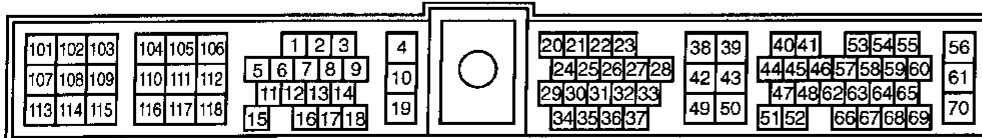
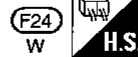
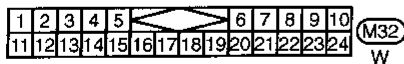

TROUBLE DIAGNOSIS FOR NON-DETECTABLE ITEMS

Start Signal (Cont'd)

CONSULT REFERENCE VALUE IN DATA MONITOR MODE

Specification data are reference values.

MONITOR ITEM	CONDITION	SPECIFICATION
START SIGNAL	• Ignition switch: ON → START → ON	OFF → ON → OFF

ECM TERMINALS AND REFERENCE VALUE

Specification data are reference values and are measured between each terminal and ④ (ECCS ground).

TER-MINAL NO.	WIRE COLOR	ITEM	CONDITION	DATA (DC Voltage)
20	B/Y	Start signal	Ignition switch "ON"	Approximately 0V
			Ignition switch "START"	BATTERY VOLTAGE (11 - 14V)

TROUBLE DIAGNOSIS FOR NON-DETECTABLE ITEMS

Start Signal (Cont'd) DIAGNOSTIC PROCEDURE

A

■ START SIGNAL CKT ■

1. CLOSE THROTTLE, SHIFT TO P OR N RANGE.
2. TOUCH START AND START ENGINE IMMEDIATELY.

NEXT START

SEF191L

A

☆ MONITOR ☆ NO FAIL

START SIGNAL OFF

CLSD TH/P SW ON

AIR COND SIG OFF

P/N POSI SW ON

RECORD

SEF111P

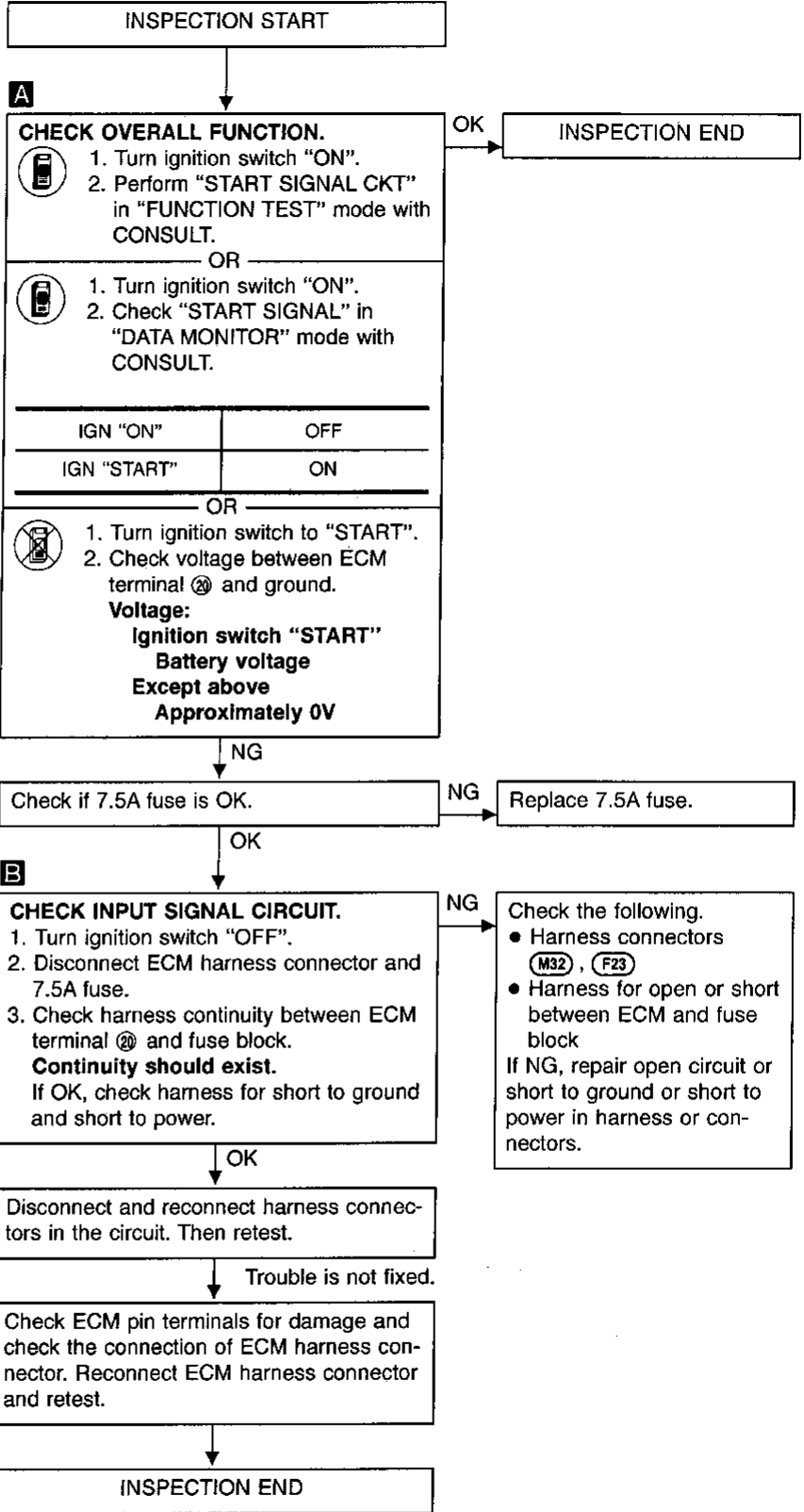
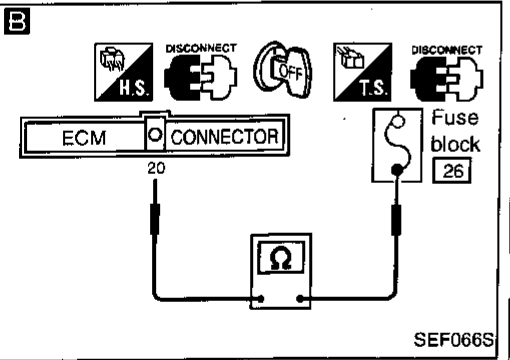
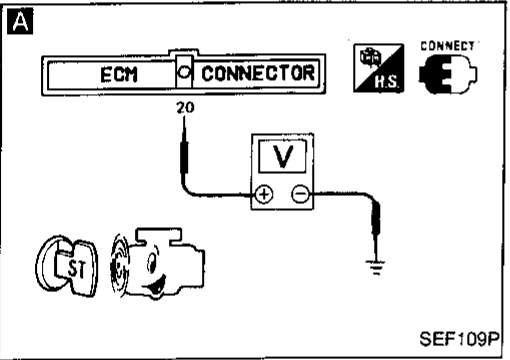

GI
MA
EM
LC
EC
FE
AT
TF
PD
FA
RA
BR
ST
RS
BT
HA
EL
IDX

TROUBLE DIAGNOSIS FOR NON-DETECTABLE ITEMS

Fuel Pump

SYSTEM DESCRIPTION

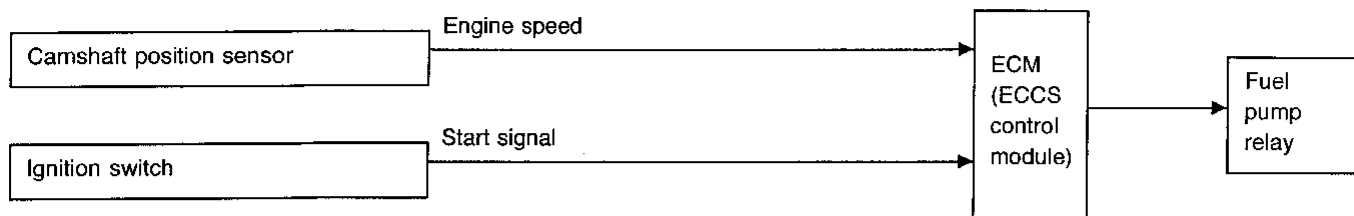

The ECM activates the fuel pump for several seconds after the ignition switch is turned on to improve engine startability. If the ECM receives a 120° signal from the camshaft position sensor, it knows that the engine is rotating, and causes the pump to perform. If the 120° signal is not received when the ignition switch is on, the engine stalls. The ECM stops pump operation and prevents battery discharging, thereby improving safety. The ECM does not directly drive the fuel pump. It controls the ON/OFF fuel pump relay, which in turn controls the fuel pump.

Condition	Fuel pump operation
Ignition switch is turned to ON.	Operates for 5 seconds
Engine running and cranking	Operates
When engine is stopped	Stops in 1.5 seconds
Except as shown above	Stops

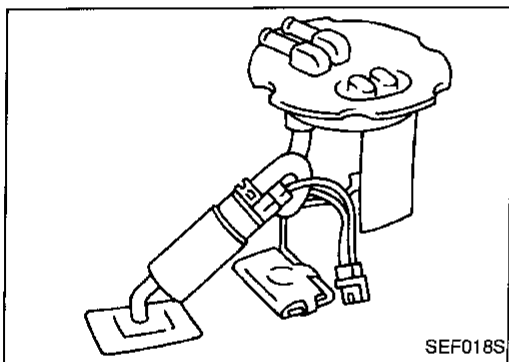

COMPONENT DESCRIPTION

The fuel pump with a fuel damper is an in-tank type (the pump and damper are located in the fuel tank).

CONSULT REFERENCE VALUE IN DATA MONITOR MODE

Specification data are reference values.

MONITOR ITEM	CONDITION	SPECIFICATION
FUEL PUMP RLY	<ul style="list-style-type: none"> Ignition switch is turned to ON (Operates for 5 seconds) Engine running and cranking 	ON
	Except as shown above	OFF

ECM TERMINALS AND REFERENCE VALUE

Specification data are reference values and are measured between each terminal and Ⓒ (ECCS ground).

TER-MINAL NO.	WIRE COLOR	ITEM	CONDITION	DATA (DC Voltage)
8	R/L	Fuel pump relay	Ignition switch "ON" └ For 5 seconds after turning ignition switch "ON"	0 - 1V
			Engine is running.	
			Ignition switch "ON" └ More than 5 seconds after turning ignition switch "ON"	BATTERY VOLTAGE (11 - 14V)

TROUBLE DIAGNOSIS FOR NON-DETECTABLE ITEMS

Fuel Pump (Cont'd)

EC-F/PUMP-01

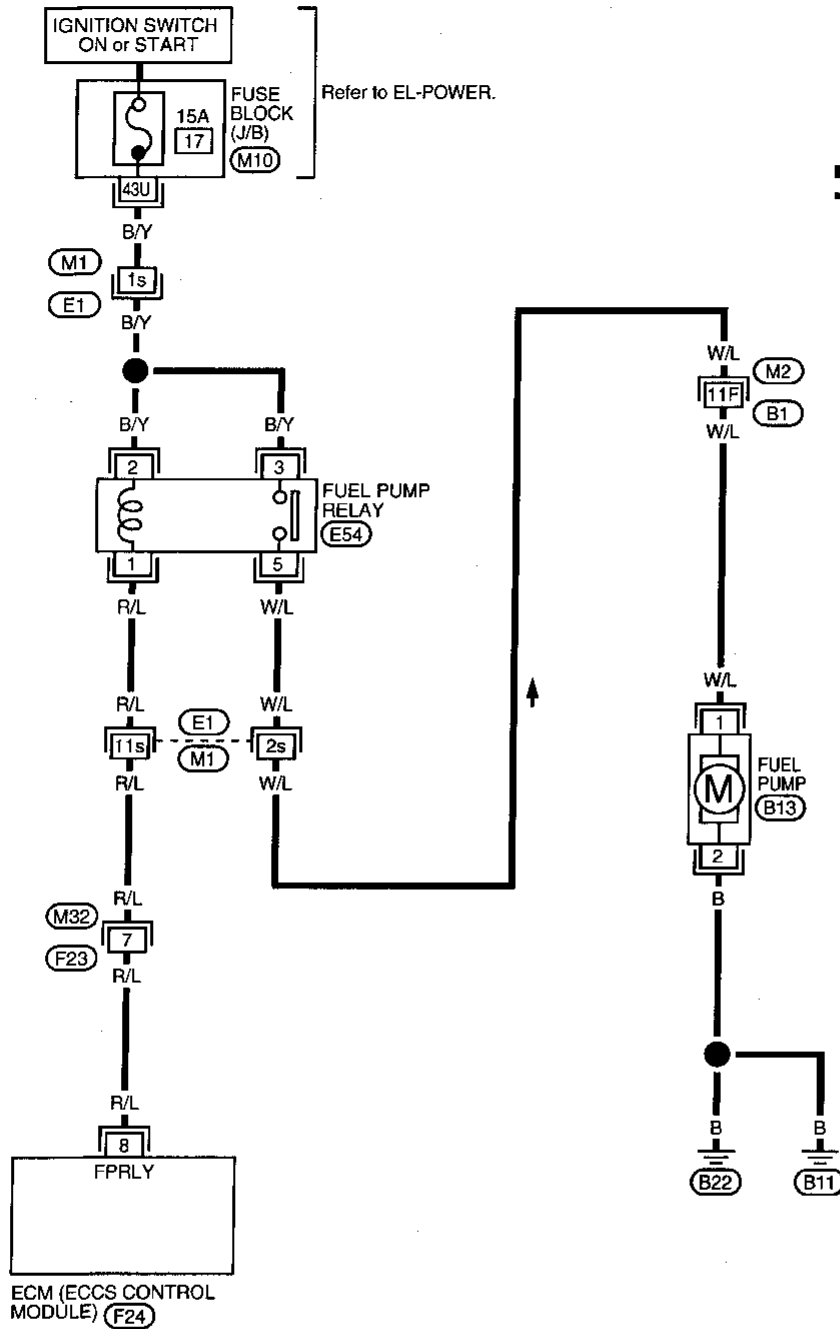

— : Detectable line for DTC
 — : Non-detectable line for DTC

GI
 MA
 EM
 LC
 EC
 FE
 AT
 TF
 PD
 FA
 RA
 BR
 ST
 RS
 BT
 HA
 EL
 IDX

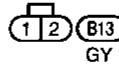
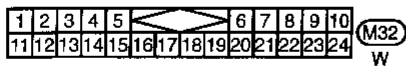
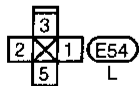

Refer to last page (Foldout page).

(E1), (M1)
 (M2), (B1)
 (M10)

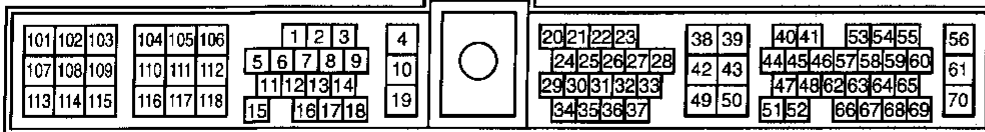

TROUBLE DIAGNOSIS FOR NON-DETECTABLE ITEMS

Fuel Pump (Cont'd) DIAGNOSTIC PROCEDURE

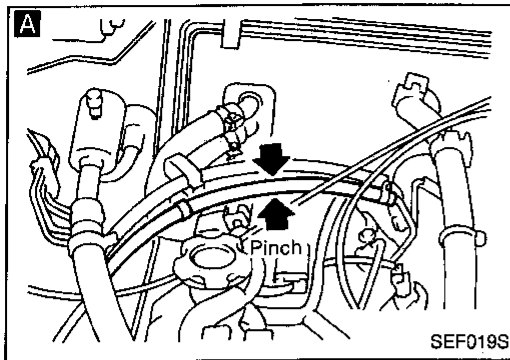

INSPECTION START

A
CHECK OVERALL FUNCTION.
1. Turn ignition switch "ON".
2. Pinch fuel feed hose with fingers.
Fuel pressure pulsation should be felt on the fuel feed hose for 5 seconds after ignition switch is turned "ON".

OK → INSPECTION END

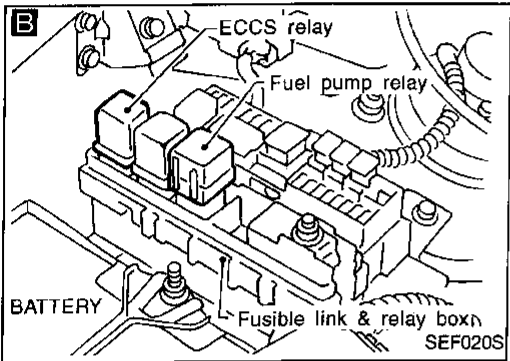

B
CHECK POWER SUPPLY.
1. Turn ignition switch "OFF".
2. Disconnect fuel pump relay.
3. Turn ignition switch "ON".
4. Check voltage between terminals ②, ③ and ground with CONSULT or tester.
Voltage: Battery voltage

NG → Check the following.

- Harness connectors (E1), (M1)
- 15A fuse
- Harness for open or short between fuse and fuel pump relay

 If NG, repair harness or connectors.

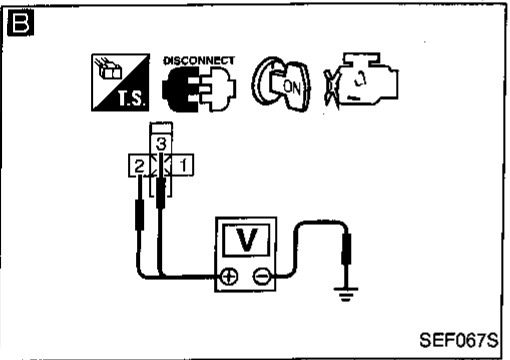

C
CHECK POWER AND GROUND CIRCUIT.
1. Turn ignition switch "OFF".
2. Disconnect fuel pump harness connector.
3. Check harness continuity between terminal ② and body ground, terminal ① and fuel pump relay connector terminal ⑤.
Continuity should exist.
If OK, check harness for short to ground and short to power.

NG → Check the following.

- Harness connectors (M2), (B1)
- Harness connectors (E1), (M1)
- Harness for open or short between fuel pump and body ground
- Harness for open or short between fuel pump and fuel pump relay

 If NG, repair open circuit or short to ground or short to power in harness or connectors.

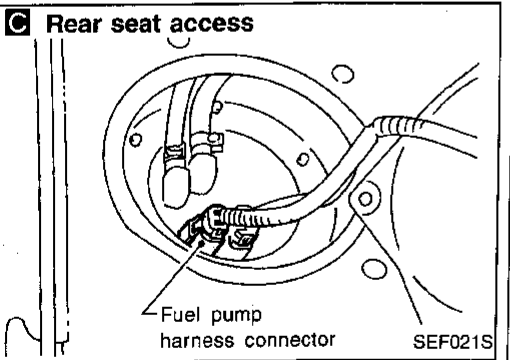

D
CHECK OUTPUT SIGNAL CIRCUIT.
1. Disconnect ECM harness connector.
2. Check harness continuity between ECM terminal ⑧ and fuel pump relay connector terminal ①.
Continuity should exist.
If OK, check harness for short to ground and short to power.

NG → Check the following.

- Harness connectors (F23), (M32)
- Harness connectors (M1), (E1)
- Harness for open or short between ECM and fuel pump relay

 If NG, repair open circuit or short to ground or short to power in harness or connectors.

OK → (A)

TROUBLE DIAGNOSIS FOR NON-DETECTABLE ITEMS

Fuel Pump (Cont'd)

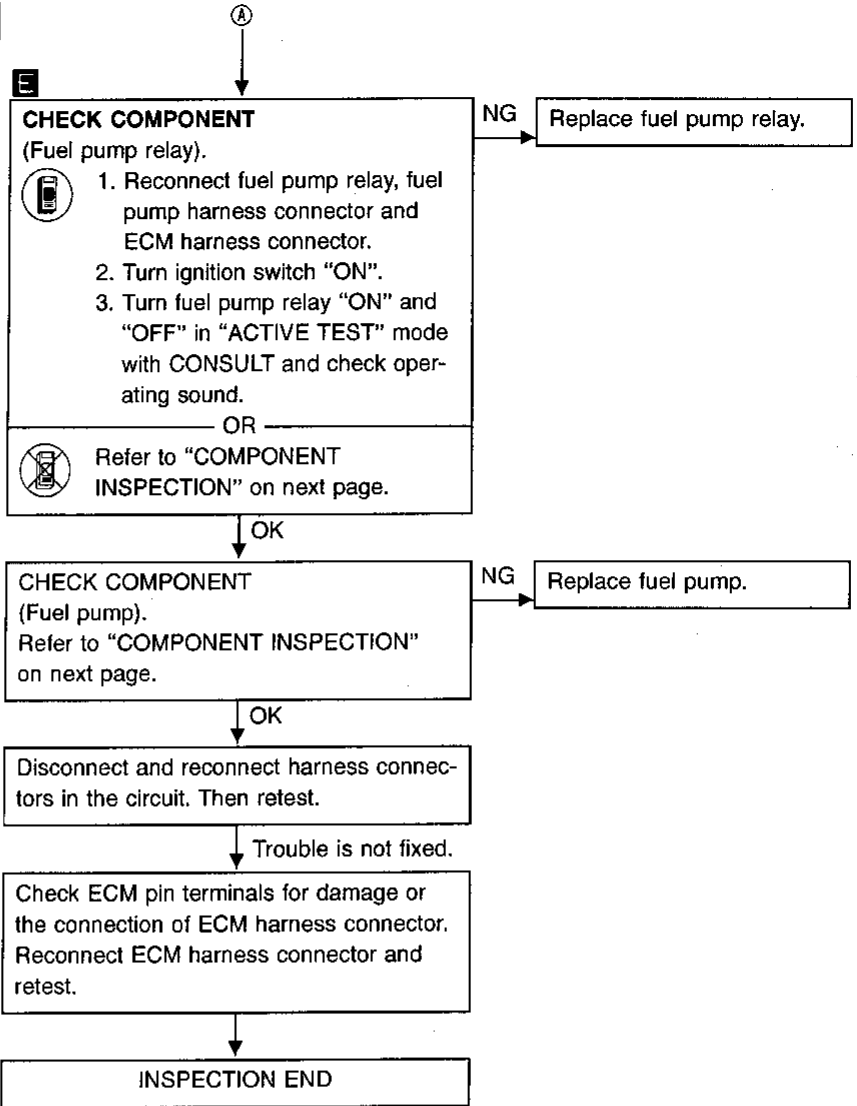
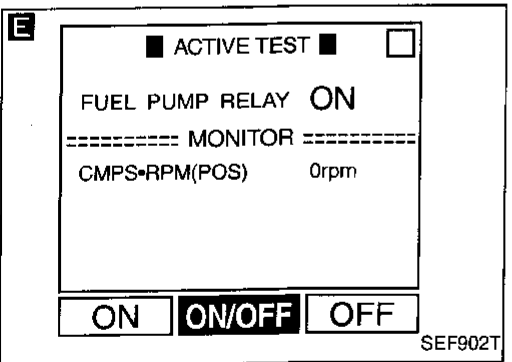
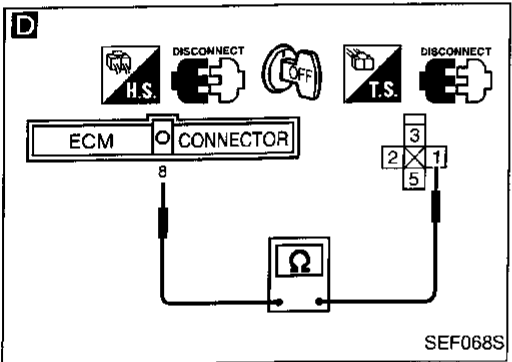
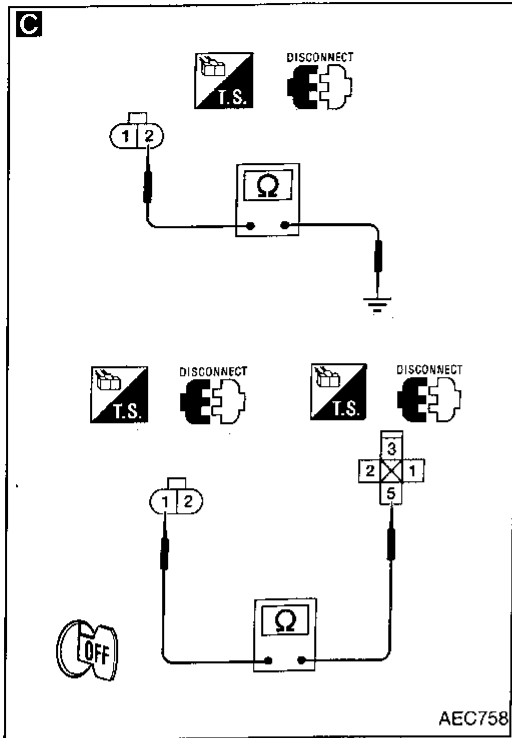

GI
MA
EM
LC
EC
FE
AT
TF
PD
FA
RA
BR
ST
RS
BT
HA
EL
IDX

TROUBLE DIAGNOSIS FOR NON-DETECTABLE ITEMS

Fuel Pump (Cont'd) COMPONENT INSPECTION

Fuel pump relay

Check continuity between terminals ③ and ⑤ .

Conditions	Continuity
12V direct current supply between terminals ① and ②	Yes
No current supply	No

If NG, replace relay.

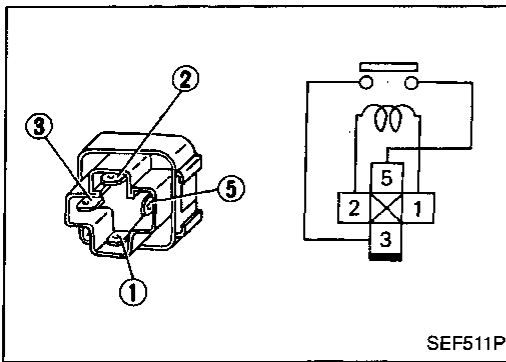

Fuel pump

1. Disconnect fuel pump harness connector.
2. Check resistance between terminals ① and ② .
Resistance: 0.2 - 5.0Ω [at 25°C (77°F)]
If NG, replace fuel pump.

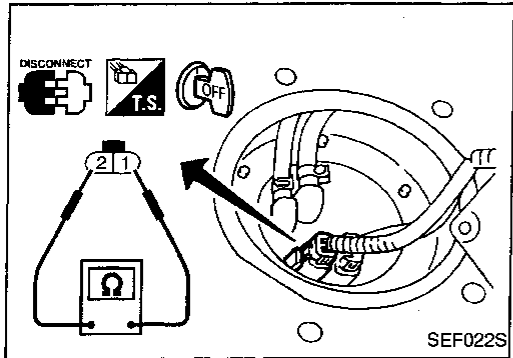

TROUBLE DIAGNOSIS FOR NON-DETECTABLE ITEMS

Power Steering Oil Pressure Switch

EC-PST/SW-01

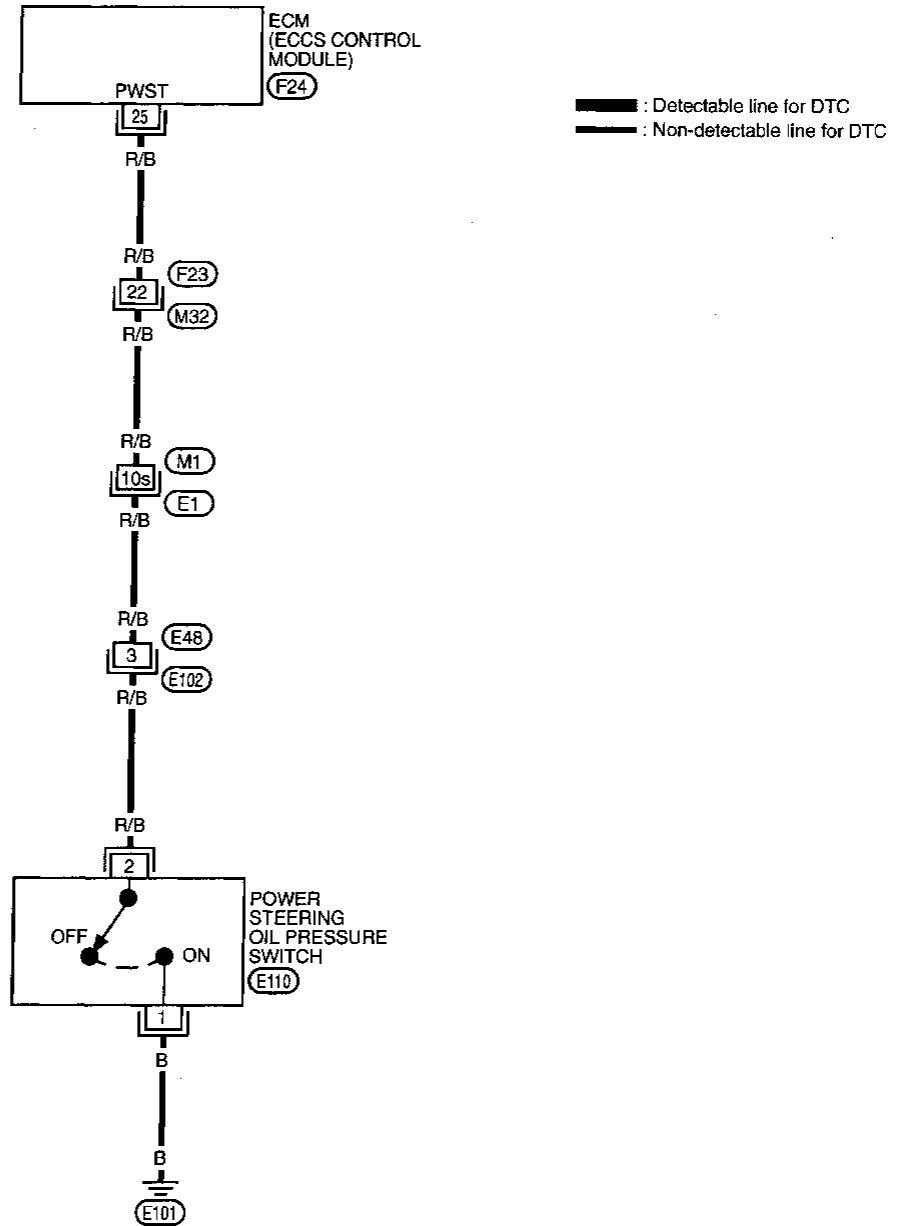

GI
 MA
 EM
 LC
EC
 FE
 AT
 TF
 PD
 FA
 RA
 BR
 ST
 RS
 BT
 HA
 EL
 IDX

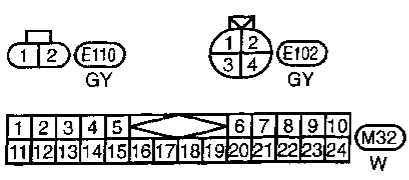

Refer to last page (Foldout page).

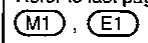

101	102	103	104	105	106	1	2	3	4	20	21	22	23	38	39	40	41	53	54	55	56						
107	108	109	110	111	112	5	6	7	8	9	10	24	25	26	27	28	42	43	44	45	46	57	58	59	60	61	
113	114	115	116	117	118	11	12	13	14	15	16	17	18	19	29	30	31	32	33	47	48	62	63	64	65	70	

TROUBLE DIAGNOSIS FOR NON-DETECTABLE ITEMS

Power Steering Oil Pressure Switch (Cont'd)

COMPONENT DESCRIPTION

The power steering oil pressure switch is attached to the power steering high-pressure tube and detects a power steering load. When a power steering load is detected, it signals the ECM. The ECM adjusts the IACV-AAC valve to increase the idle speed and adjust for the increased load.

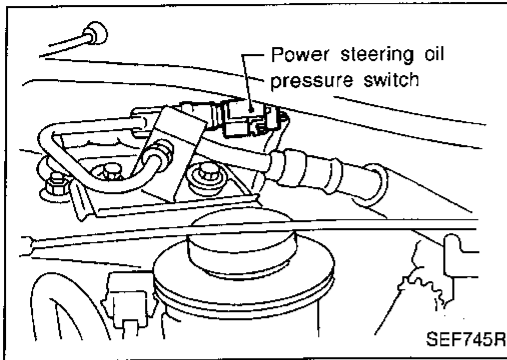

CONSULT REFERENCE VALUE IN DATA MONITOR MODE

Specification data are reference values.

MONITOR ITEM	CONDITION	SPECIFICATION
PW/ST SIGNAL	<ul style="list-style-type: none"> • Engine: After warming up, idle the engine 	Steering wheel in neutral position (forward direction) OFF
		The steering wheel is turned ON

ECM TERMINALS AND REFERENCE VALUE

Specification data are reference values and are measured between each terminal and ④③ (ECCS ground).

TER-MINAL NO.	WIRE COLOR	ITEM	CONDITION	DATA (DC Voltage)
25	R/B	Power steering oil pressure switch	<div style="border: 1px solid black; display: inline-block; padding: 2px;">Engine is running.</div> └ Steering wheel is being turned	Approximately 0V
			<div style="border: 1px solid black; display: inline-block; padding: 2px;">Engine is running.</div> └ Steering wheel is not being turned	Approximately 5V

TROUBLE DIAGNOSIS FOR NON-DETECTABLE ITEMS

Power Steering Oil Pressure Switch (Cont'd)

DIAGNOSTIC PROCEDURE

A

■ PW/ST SIGNAL CIRCUIT ■

HOLD STEERING WHEEL
IN A FULL
LOCKED POSITION
THEN
TOUCH START

NEXT **START**

MEF023E

A

☆MONITOR ☆NO FAIL

PW/ST SIGNAL OFF

RECORD

SEF591I

A

SEF126P

B

SEF069S

C

SEF070S

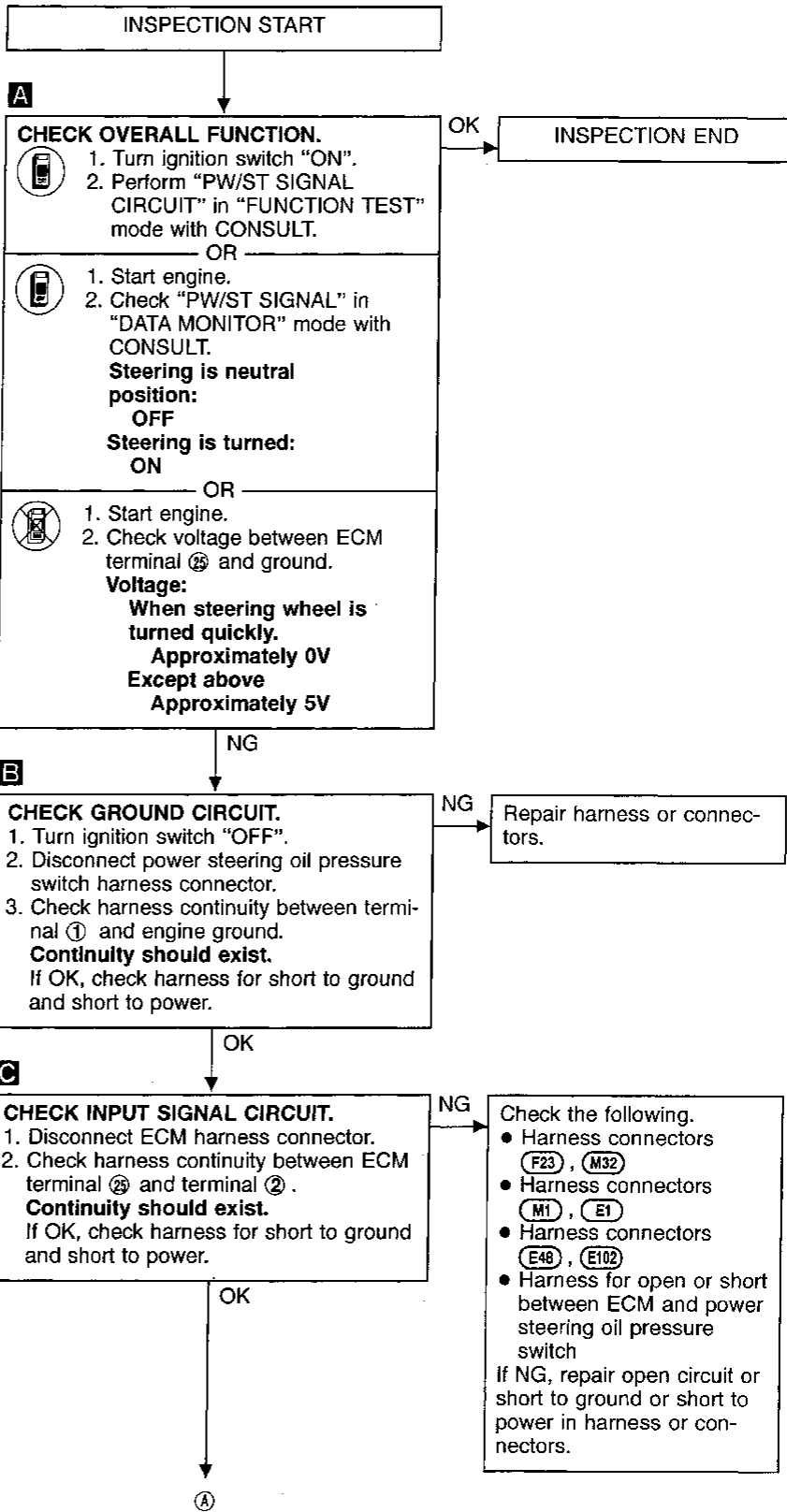

GI
MA
EM
LC
EC
FE
AT
TF
PD
FA
RA
BR
ST
RS
BT
HA
EL
IDX

TROUBLE DIAGNOSIS FOR NON-DETECTABLE ITEMS

Power Steering Oil Pressure Switch (Cont'd)

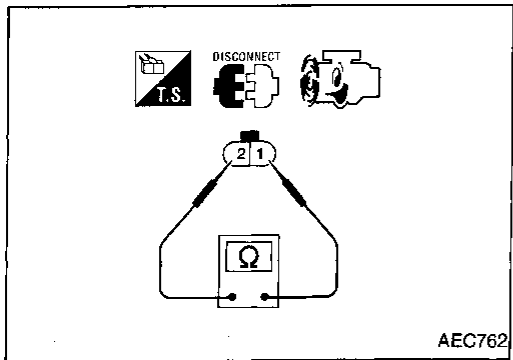
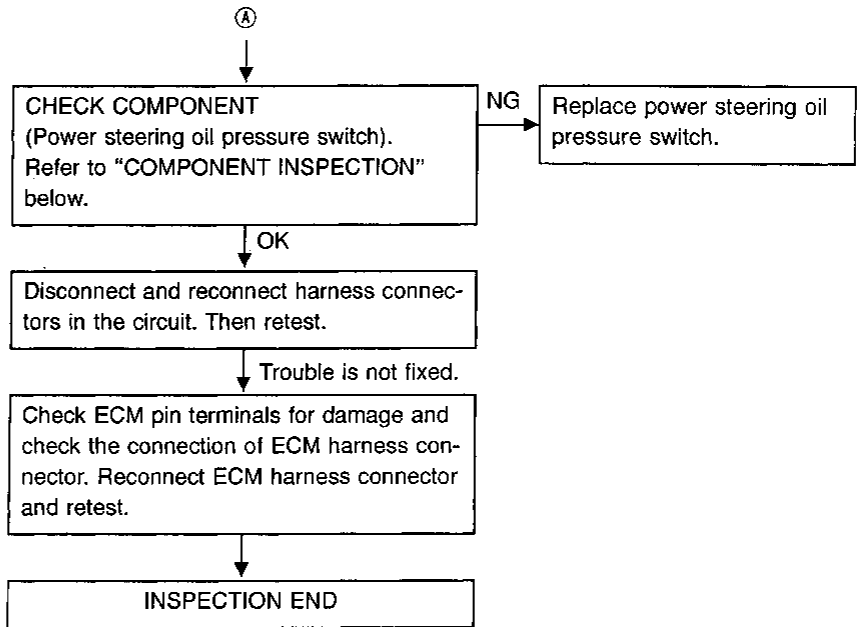

COMPONENT INSPECTION

Power steering oil pressure switch

1. Disconnect power steering oil pressure switch harness connector then start engine.
2. Check continuity between terminals ① and ②.

Conditions	Continuity
Steering wheel is being turned	Yes
Steering wheel is not being turned	No

If NG, replace power steering oil pressure switch.

IACV-FICD Solenoid Valve

EC-FICD-01

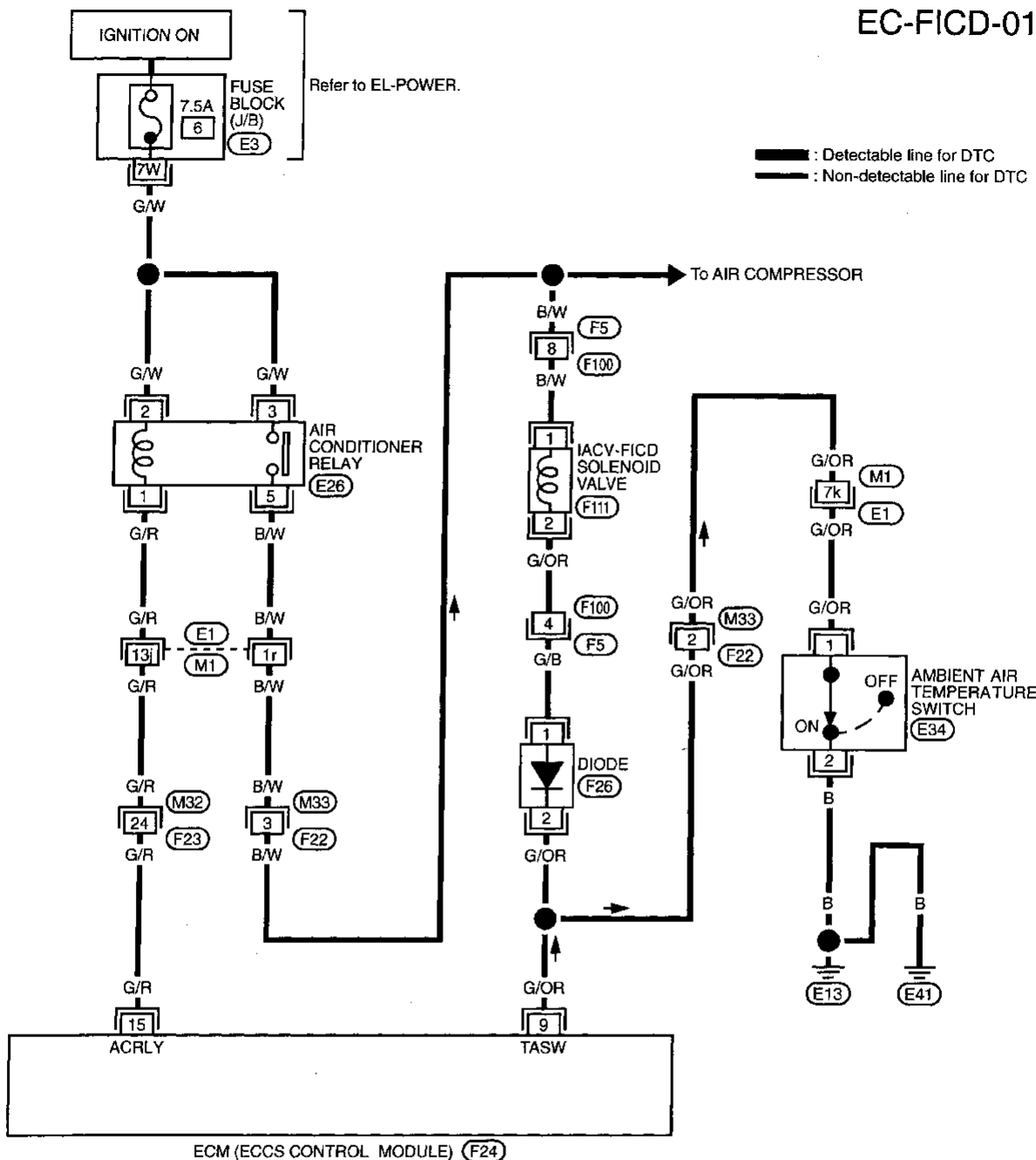

GI
 MA
 EM
 LC
EC
 FE
 AT
 TF
 PD
 FA
 RA
 BR
 ST
 RS
 BT
 HA
 EL
 IDX

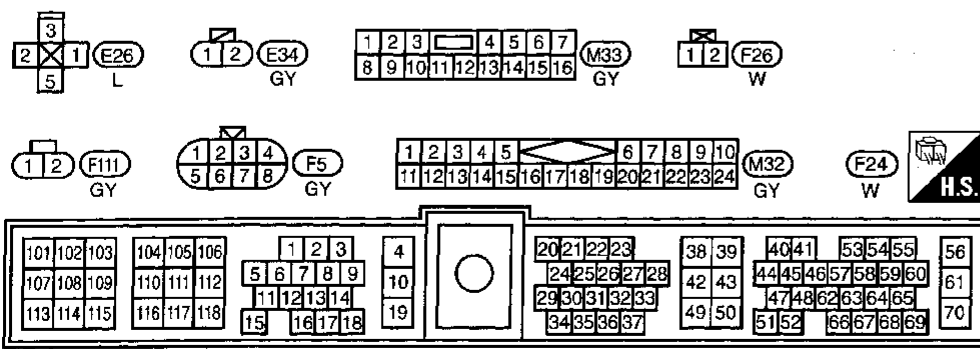

Refer to last page (Foldout page).
 (E1), (M1)
 (E3)

TROUBLE DIAGNOSIS FOR NON-DETECTABLE ITEMS

IACV-FICD Solenoid Valve (Cont'd)

COMPONENT DESCRIPTION

When the air conditioner is on, the IACV-FICD solenoid valve supplies additional air to adjust to the increased load.

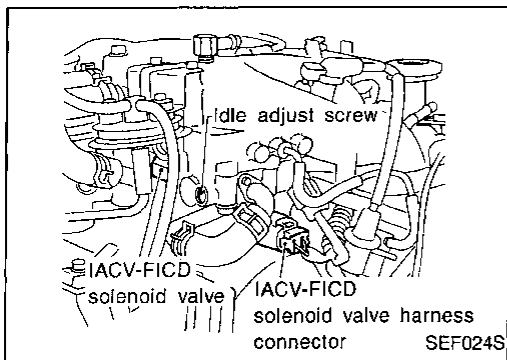

ECM TERMINALS AND REFERENCE VALUE

Specification data are reference values and are measured between each terminal and Ⓒ (ECCS ground).

TER-MINAL NO.	WIRE COLOR	ITEM	CONDITION	DATA (DC Voltage)
21	B/W	Air conditioner switch	<div style="border: 1px solid black; padding: 2px;">Engine is running.</div> <ul style="list-style-type: none"> └ Both air conditioner switch and blower switch are "ON" (Compressor operates) 	Approximately 0V
			<div style="border: 1px solid black; padding: 2px;">Engine is running.</div> <ul style="list-style-type: none"> └ Air conditioner switch is "OFF" 	BATTERY VOLTAGE (11 - 14V)
15	G/R	Air conditioner relay	<div style="border: 1px solid black; padding: 2px;">Engine is running.</div> <ul style="list-style-type: none"> └ Both A/C switch and blower switch are "ON"* 	Approximately 0V
			<div style="border: 1px solid black; padding: 2px;">Engine is running.</div> <ul style="list-style-type: none"> └ A/C switch is "OFF" 	BATTERY VOLTAGE (11 - 14V)
9	G/OR	Ambient air temperature switch	<div style="border: 1px solid black; padding: 2px;">Ignition switch "ON"</div> <ul style="list-style-type: none"> └ Idle speed └ Ambient air temperature is above 23.5°C (74°F) └ Air conditioner is operating 	0V
			<div style="border: 1px solid black; padding: 2px;">Ignition switch "ON"</div> <ul style="list-style-type: none"> └ Idle speed └ Ambient air temperature is below 23.5°C (74°F) └ Air conditioner is operating 	BATTERY VOLTAGE (11 - 14V)

TROUBLE DIAGNOSIS FOR NON-DETECTABLE ITEMS

IACV-FICD Solenoid Valve (Cont'd)

DIAGNOSTIC PROCEDURE

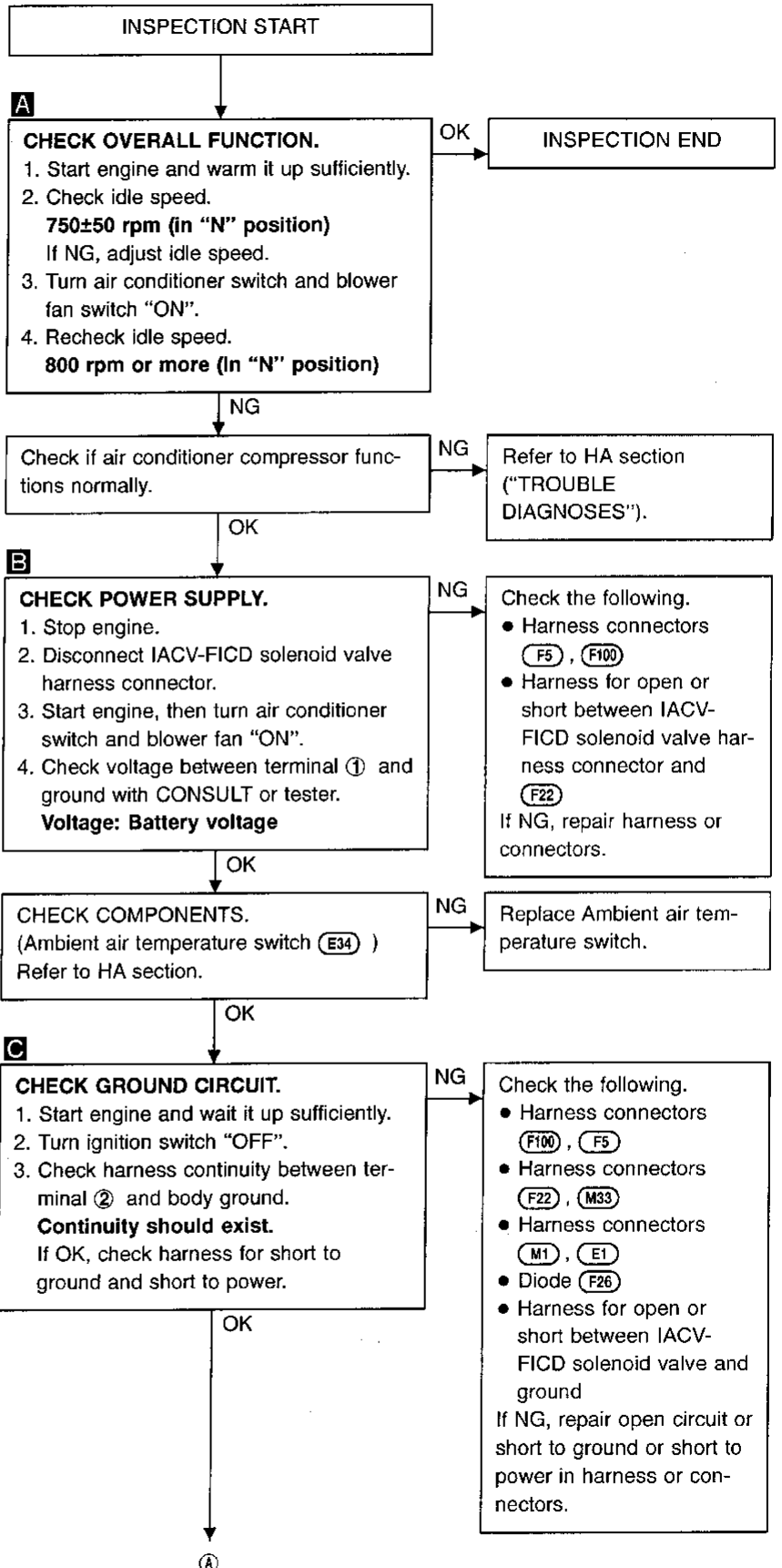
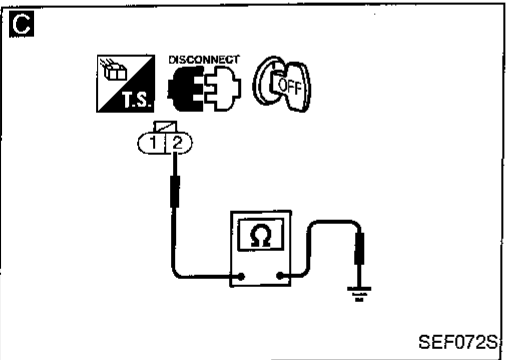
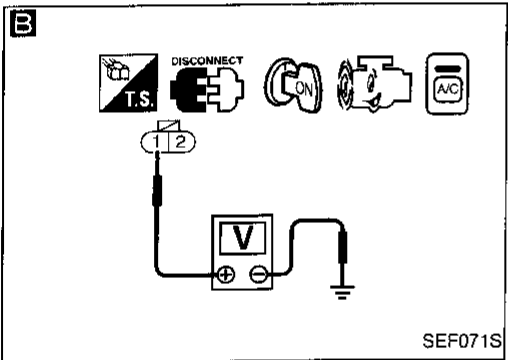
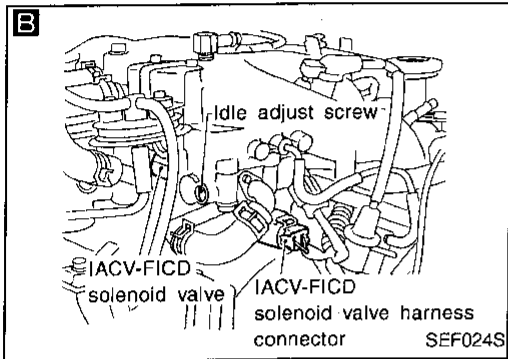
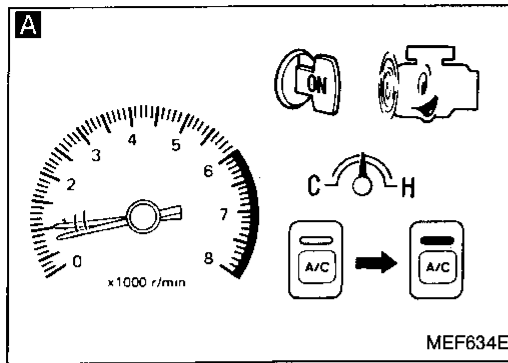

GI
MA
EM
LC
EC
FE
AT
TF
PD
FA
RA
BR
ST
RS
BT
HA
EL
IDX

TROUBLE DIAGNOSIS FOR NON-DETECTABLE ITEMS

IACV-FICD Solenoid Valve (Cont'd)

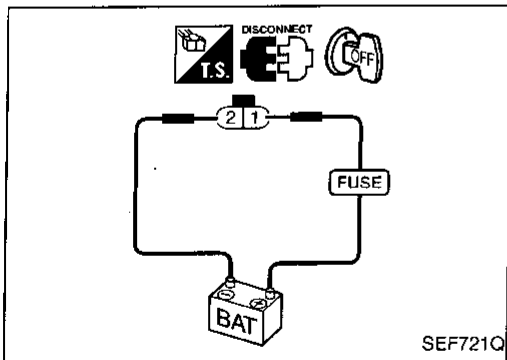
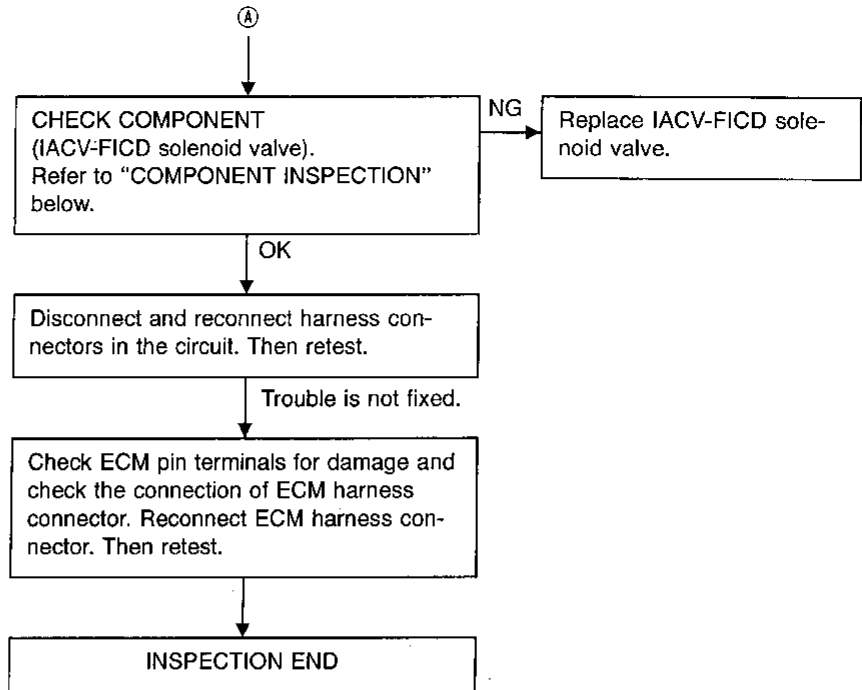

COMPONENT INSPECTION

IACV-FICD solenoid valve

Disconnect IACV-FICD solenoid valve harness connector.

- Check for clicking sound when applying 12V direct current to terminals.

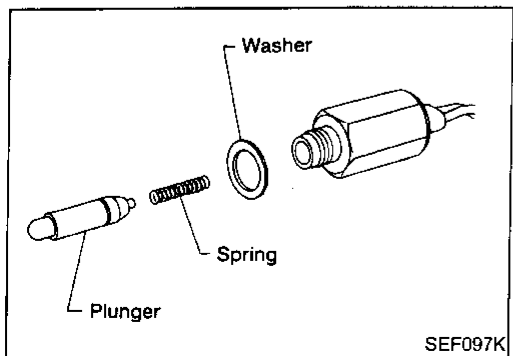

- Check plunger for seizing or sticking.
- Check for broken spring.

SERVICE DATA AND SPECIFICATIONS (SDS)

General Specifications

FUEL PRESSURE REGULATOR Fuel pressure at idling kPa (kg/cm ² , psi)	
Vacuum hose is connected	Approximately 235 (2.4, 34)
Vacuum hose is disconnected	Approximately 294 (3.0, 43)

Inspection and Adjustment

Idle speed*1	rpm	
No-load*2 (in "N" position)		750±50 (700*3)
Air conditioner: ON (in "N" position)		850 or more
Ignition timing		15°±2° BTDC*3
Closed throttle position switch touch speed ("OFF" to "ON") (in "N" position)	rpm	950±150*3

*1: Feedback controlled and needs no adjustments

*2: Under the following conditions:

- Air conditioner switch: OFF
- Electric load: OFF (Lights, heater fan & rear defogger)
- Steering wheel: Kept in straight-ahead position

*3: Disconnect throttle position sensor

IGNITION COIL

Primary voltage	V	12
Primary resistance [at 20°C (68°F)]	Ω	Approximately 1.0
Secondary resistance [at 20°C (68°F)]	kΩ	Approximately 10

MASS AIR FLOW SENSOR

Supply voltage	V	Battery voltage (11 - 14)
Output voltage at idle	V	1.3 - 1.7*
Mass air flow (Using CONSULT or GST)	g-m/sec	3.3 - 4.8 at idle* 12.0 - 14.9 at 2,500 rpm*

*: Engine is warmed up sufficiently and running under no-load.

ENGINE COOLANT TEMPERATURE SENSOR

Temperature °C (°F)	Resistance kΩ
20 (68)	2.1 - 2.9
50 (122)	0.68 - 1.00
90 (194)	0.236 - 0.260

EGR TEMPERATURE SENSOR

EGR temperature °C (°F)	Voltage (V)	Resistance (MΩ)
0 (32)	4.81	7.9 - 9.7
50 (122)	2.82	0.57 - 0.70
100 (212)	0.8	0.08 - 0.10

FRONT HEATED OXYGEN SENSOR HEATER

Resistance [at 25°C (77°F)]	Ω	2.3 - 4.3
-----------------------------	---	-----------

FUEL PUMP

Resistance [at 25°C (77°F)]	Ω	0.2 - 5.0
-----------------------------	---	-----------

IACV-AAC VALVE

Resistance [at 25°C (77°F)]	Ω	Approximately 10.0
-----------------------------	---	--------------------

INJECTOR

Resistance [at 25°C (77°F)]	Ω	10 - 14
-----------------------------	---	---------

RESISTOR

Resistance [at 25°C (77°F)]	kΩ	Approximately 2.2
-----------------------------	----	-------------------

THROTTLE POSITION SENSOR

Throttle valve conditions	Resistance kΩ [at 25°C (77°F)]
Completely closed	Approximately 0.5
Partially open	0.5 - 4.0
Completely open	Approximately 4.0

SERVICE DATA AND SPECIFICATIONS (SDS)

Inspection and Adjustment (Cont'd)

CALCULATED LOAD VALUE

	Calculated load value % (Using CONSULT or GST)
At idle	18.0 - 26.0
At 2,500 rpm	18.0 - 21.0

INTAKE AIR TEMPERATURE SENSOR

Temperature °C (°F)	Resistance kΩ
20 (68)	2.1 - 2.9
80 (176)	0.27 - 0.38

REAR HEATED OXYGEN SENSOR HEATER

Resistance [at 25°C (77°F)]	Ω	2.3 - 4.3
-----------------------------	---	-----------

CRANKSHAFT POSITION SENSOR (OBD)

Resistance [at 20°C (68°F)]	Ω	166.5 - 203.5
-----------------------------	---	---------------

GI

MA

EM

LC

EC

FE

AT

TF

PD

FA

RA

BR

ST

RS

BT

HA

EL

IDX