

PROPELLER SHAFT & DIFFERENTIAL CARRIER

SECTION PD

GT
MA
EM
LC
EC
FE
AT
TF
PD
FA
RA
BR
ST
RS
BT
HA
EL
IDX

CONTENTS

<p>PREPARATION2 Special Service Tools2</p> <p style="text-align: center;">PROPELLER SHAFT</p> <p>PROPELLER SHAFT6 On-vehicle Service.....7 Removal and Installation7 Inspection.....7 Disassembly.....8 Assembly9</p> <p style="text-align: center;">FINAL DRIVE</p> <p>ON-VEHICLE SERVICE10 Front Oil Seal Replacement (Front final drive)10 Front Oil Seal Replacement (Rear final drive)10 Rear Cover Gasket Replacement11</p> <p>REMOVAL AND INSTALLATION12 Removal.....12 Installation12</p> <p style="text-align: center;">R200A</p> <p>FRONT FINAL DRIVE13 DISASSEMBLY14 Pre-inspection.....14 Final Drive Housing14 Differential Case17 Differential Side Shaft.....17</p> <p>INSPECTION.....19 Ring Gear and Drive Pinion19 Differential Case Assembly.....19 Bearing.....19</p>	<p>ADJUSTMENT20 Side Bearing Preload.....20 Pinion Gear Height and Pinion Bearing Preload.....21 Tooth Contact.....26</p> <p>ASSEMBLY27 Differential Side Shaft.....27 Differential Case27 Final Drive Housing29</p> <p style="text-align: center;">H233B</p> <p>REAR FINAL DRIVE33 DISASSEMBLY34 Pre-inspection34 Differential Carrier.....34 Differential Case36</p> <p>INSPECTION.....38 Ring Gear and Drive Pinion38 Differential Case Assembly.....38 Bearing.....38</p> <p>LIMITED SLIP DIFFERENTIAL39 Preparation for Disassembly39 Disassembly.....40 Inspection.....40 Adjustment.....41 Assembly43</p> <p>ADJUSTMENT45 Pinion Gear Height45 Tooth Contact.....48</p> <p>ASSEMBLY49 Differential Case49 Differential Carrier.....50</p> <p>SERVICE DATA AND SPECIFICATIONS (SDS)53 Propeller Shaft53 Final Drive.....54</p>
--	--

PREPARATION

Special Service Tools

The actual shapes of Kent-Moore tools may differ from those of special service tools illustrated here.

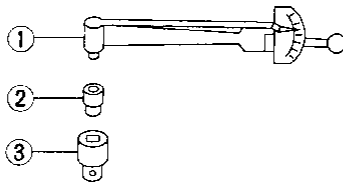
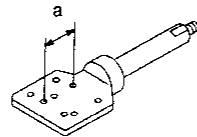
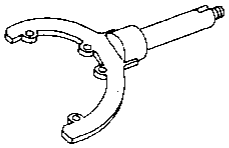
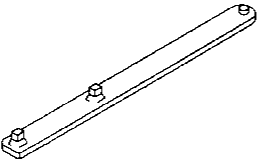
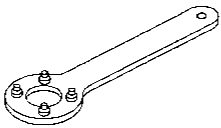
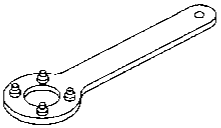
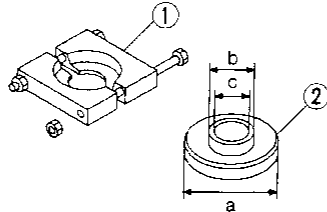
Tool number (Kent-Moore No.) Tool name	Description	Unit application		
		R200A	H233B	
ST3127S000 (See J25765-A) Preload gauge ① GG91030000 (J25765-A) Torque wrench ② HT62940000 (—) Socket adapter ③ HT62900000 (—) Socket adapter	 NT124	Measuring pinion bearing preload and total preload	X	X
KV38100800 (J34310, J25604-01) Differential attachment	 NT119	Mounting final drive (To use, make a new hole.) a: 152 mm (5.98 in)	X	—
ST06340000 (J24310, J34310) Differential attachment	 NT140	Mounting final drive	—	X
ST32580000 (J34312) Differential side bearing adjusting nut wrench	 NT141	Adjusting side bearing preload and backlash (ring gear-drive pinion)	—	X
ST38060002 (J34311) Drive pinion flange wrench	 NT113	Removing and installing propeller shaft lock nut, and drive pinion lock nut	X	—
KV38104700 (J34311) Drive pinion flange wrench	 NT113	Removing and installing propeller shaft lock nut, and drive pinion lock nut	—	X
ST3090S000 (—) Drive pinion rear inner race puller set ① ST30031000 (J22912-01) Puller ② ST30901000 (J26010-01) Base	 NT527	Removing and installing drive pinion rear inner cone a: 79 mm (3.11 in) dia. b: 45 mm (1.77 in) dia. c: 35 mm (1.38 in) dia.	X	X



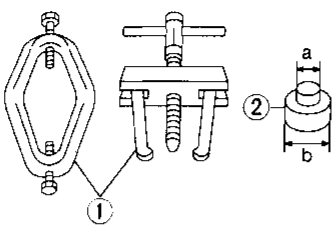
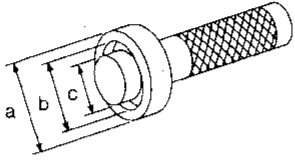
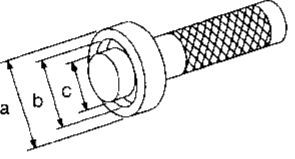
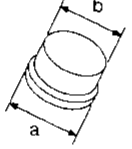
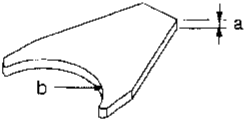
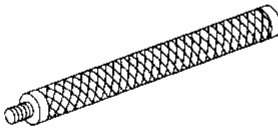
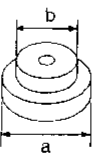
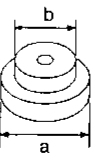

PREPARATION

Special Service Tools (Cont'd)

Tool number (Kent-Moore No.) Tool name	Description	Unit application			
		R200A	H233B		
ST3306S001 Differential side bearing puller set ① ST33051001 (J22888-20) Body ② ST33061000 (J8107-2) Adapter NT072		Removing and installing differential side bearing inner cone a: 28.5 mm (1.122 in) dia. b: 38 mm (1.50 in) dia.	X	X	GI MA EM LC
KV38100300 (J25523) Differential side bearing drift NT085		Installing side bearing inner cone a: 54 mm (2.13 in) dia. b: 46 mm (1.81 in) dia. c: 32 mm (1.26 in) dia.	X	—	EC FE
ST33190000 (J25523) Differential side bearing drift NT085		Installing side bearing inner cone a: 52 mm (2.05 in) dia. b: 45.5 mm (1.791 in) dia. c: 34 mm (1.34 in) dia.	—	X	AT TF
ST33081000 (—) Side bearing puller adapter NT431		Installing side bearing inner cone a: 43 mm (1.69 in) dia. b: 33.5 mm (1.319 in) dia.	—	X	PD FA RA
KV38100600 (J25267) Side bearing spacer drift NT528		Installing side bearing spacer a: 8 mm (0.31 in) b: R42.5 mm (1.673 in)	X	—	BR ST
ST30611000 (J25742-1) Drift NT090		Installing pinion rear bearing outer race (Use with ST30621000 or ST30613000)	X	X	RS BT
ST30621000 (J25742-5) Drift NT073		Installing pinion rear bearing outer race (Use with ST30611000) a: 79 mm (3.11 in) dia. b: 59 mm (2.32 in) dia.	X	X	FA EL
ST30613000 (J25742-3) Drift NT073		Installing pinion front bearing outer race (Use with ST30611000) a: 72 mm (2.83 in) dia. b: 48 mm (1.89 in) dia.	X	X	IDX

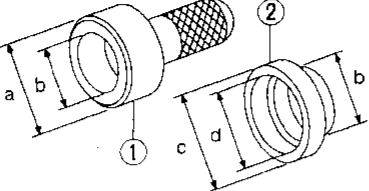
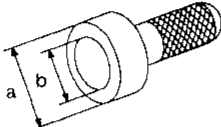
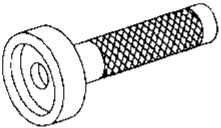
PREPARATION

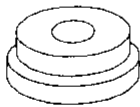
Special Service Tools (Cont'd)

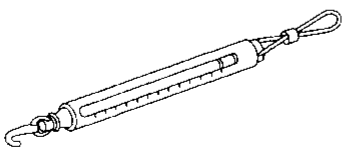
Tool number (Kent-Moore No.) Tool name	Description	Unit application		
		R200A	H233B	
KV381025S0 (—) Oil seal fitting tool ① ST30720000 (J25405) Drift bar ② KV38102510 (—) Drift	 <p>NT525</p>	Installing front oil seal	—	X
KV38100500 (J25273) Gear carrier front oil seal drift	 <p>NT115</p>	Installing front oil seal	X	—
KV38100200 (J26233) Gear carrier side oil seal drift	 <p>NT120</p>	Installing side oil seal	X	—
(J34309) Differential shim selector	 <p>NT134</p>	Adjusting bearing pre-load and gear height	X	X
(J25269-4) Side bearing discs (2 Req'd)	 <p>NT136</p>	Selecting pinion height adjusting washer	X	—
(J25269-18) Side bearing discs (2 Req'd)	 <p>NT135</p>	Selecting pinion height adjusting washer	—	X
(J8129) Spring gauge	 <p>NT127</p>	Measuring carrier turning torque	X	X

PREPARATION

Special Service Tools (Cont'd)

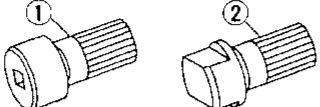
Tool number (Kent-Moore No.) Tool name	Description	Unit application		
		R200A	H233B	
KV381052S0 (—) Rear axle shaft dummy		—	X	GI
① KV38105210 (—) Torque wrench side ② KV38105220 (—) Vice side NT142				MA
				EM
				LC
				EC
				FE
				AT
				TF
				PD
				FA
				RA
				BR
				ST
				RS
				BT
				HA
				EL
				IDX

PROPELLER SHAFT

Front propeller shaft (Model 2F71H)

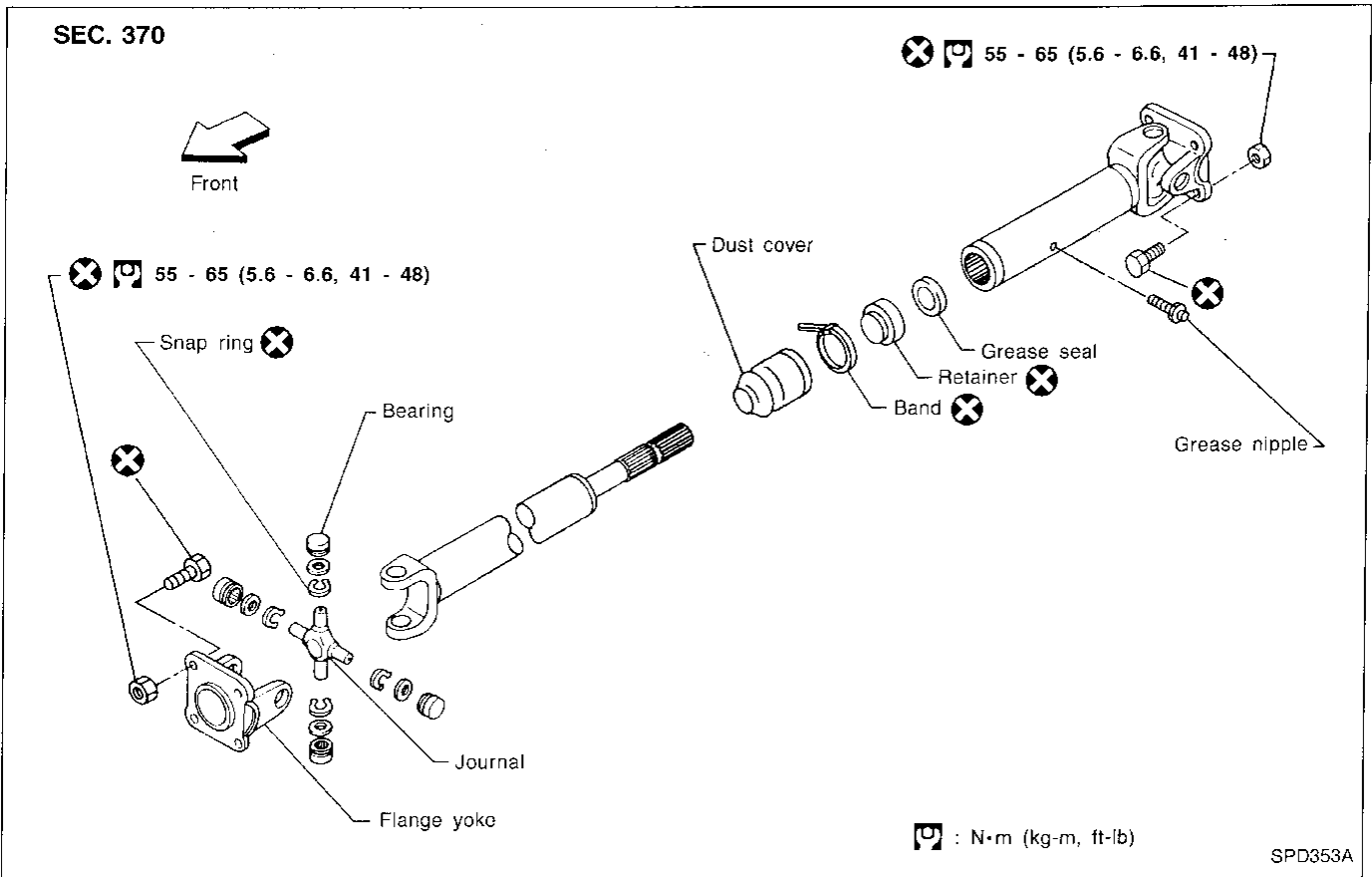

Rear propeller shaft (Model 2S80B)

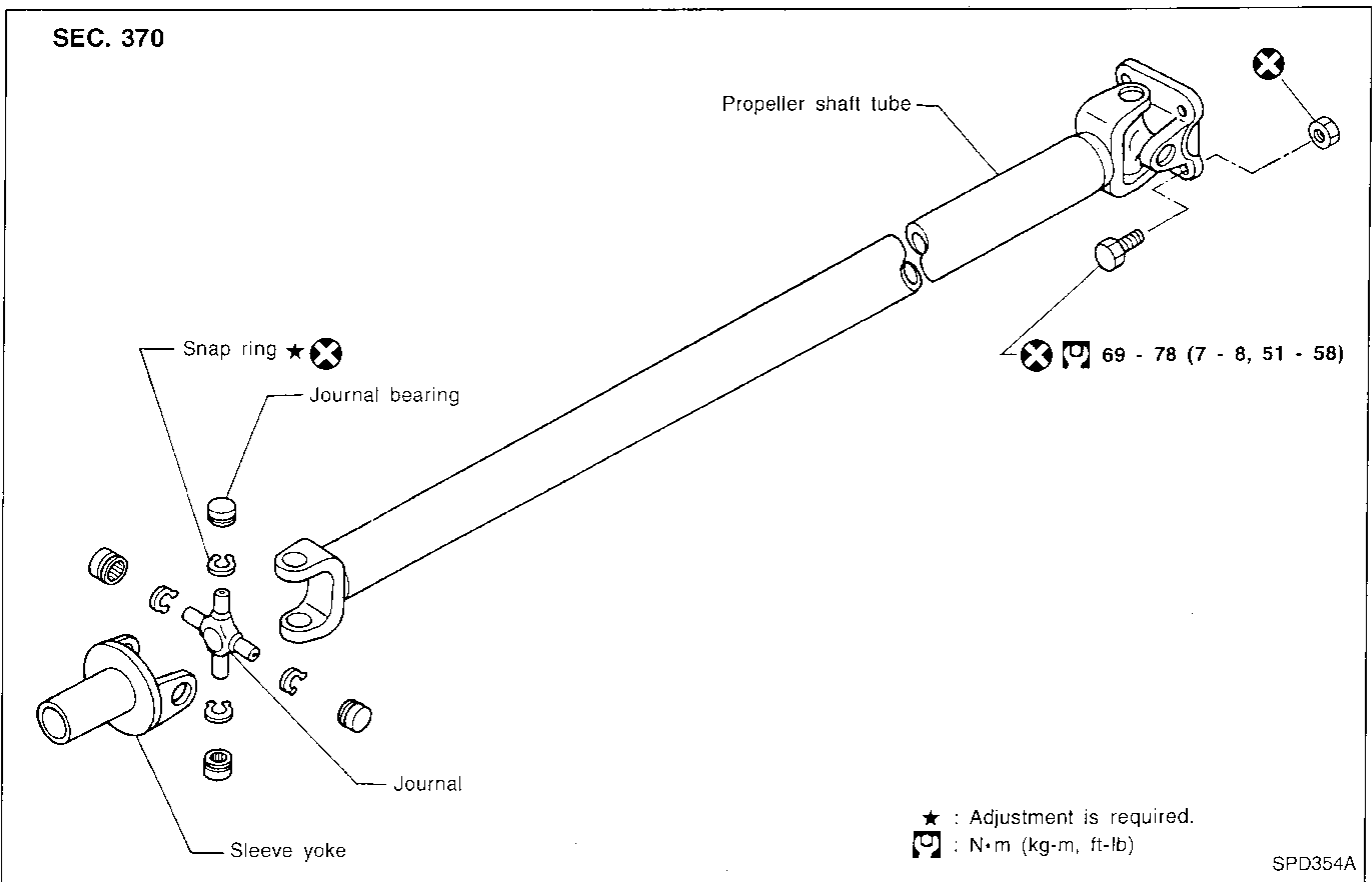

PROPELLER SHAFT

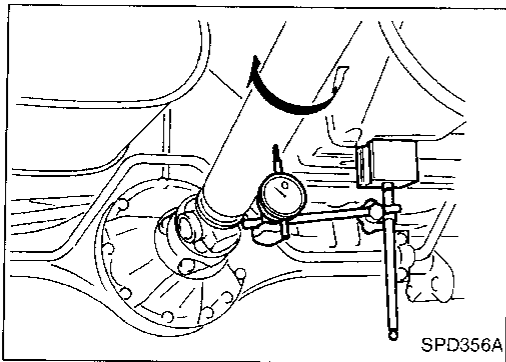

On-vehicle Service

PROPELLER SHAFT VIBRATION

If vibration is present at high speed, inspect propeller shaft runout first.

1. Raise rear wheels.
2. Measure propeller shaft runout at several points by rotating final drive companion flange with hands.

Runout limit: 0.6 mm (0.024 in)

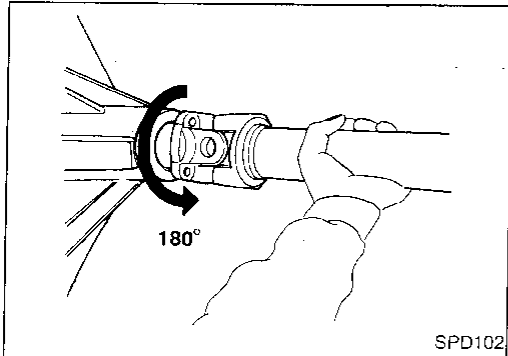

3. If runout exceeds specifications, disconnect propeller shaft at final drive companion flange; then rotate companion flange 180 degrees and reconnect propeller shaft.
4. Check runout again. If runout still exceeds specifications, replace propeller shaft assembly.
5. Perform road test.

APPEARANCE CHECKING

- Inspect propeller shaft tube surface for dents or cracks. If damaged, replace propeller shaft assembly.
- If center bearing is noisy or damaged, replace center bearing.

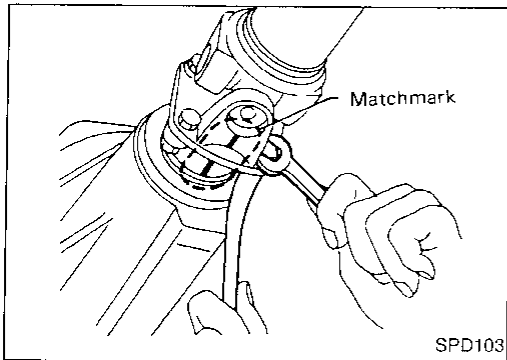

Removal and Installation

- Put match marks on flanges and separate propeller shaft from final drive.

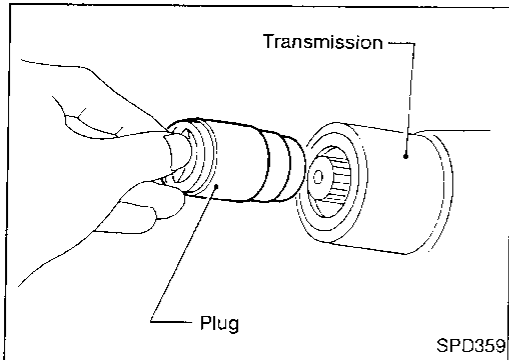

- Draw out propeller shaft from transmission and plug up rear end of transmission rear extension housing.

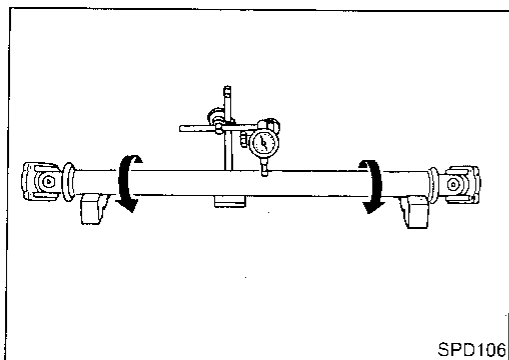

Inspection

- Inspect propeller shaft runout. If runout exceeds specifications, replace propeller shaft assembly.

Runout limit: 0.6 mm (0.024 in)

GI

MA

EM

LC

EC

FE

AT

TF

PD

FA

RA

BR

ST

RS

BT

HA

EL

DX

PROPELLER SHAFT

Inspection (Cont'd)

- Inspect journal axial play.
If the play exceeds specifications, replace propeller shaft assembly.

Journal axial play:
0.02 mm (0.0008 in) or less

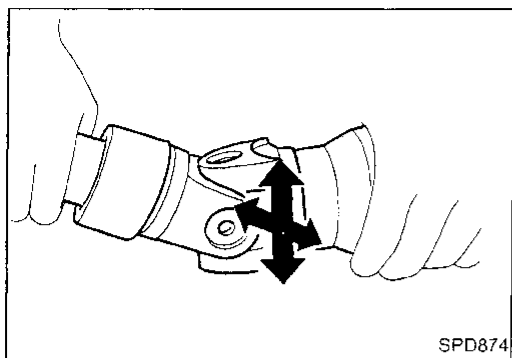

Disassembly

JOURNAL (71H and 80B)

1. Put match marks on shaft and flange or yoke.

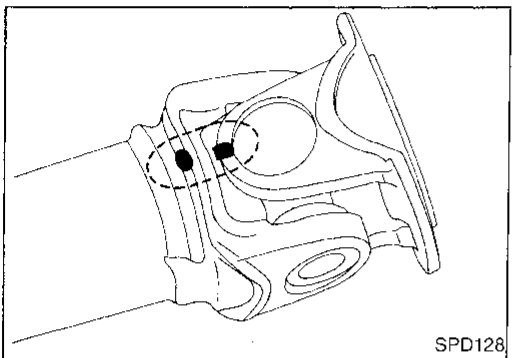

2. Remove snap ring.

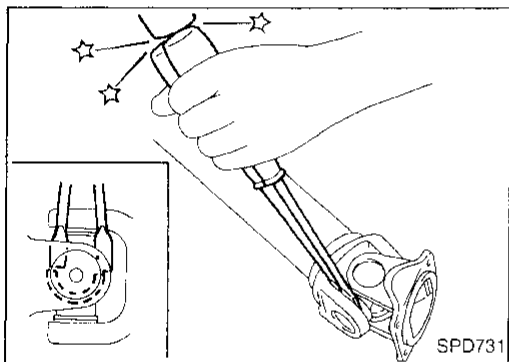

3. Remove pushed out journal bearing by lightly tapping yoke with a hammer, taking care not to damage journal and yoke hole.

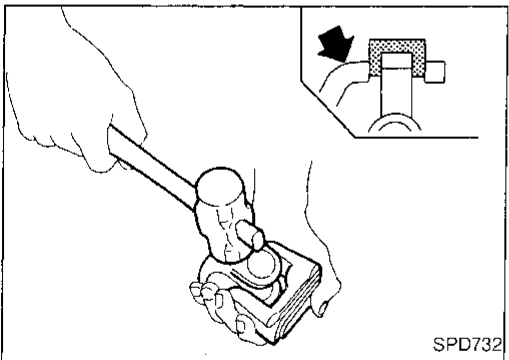

4. Remove bearing at opposite side in above operation.
Put marks on disassembled parts so that they can be reinstalled in their original positions from which they were removed.

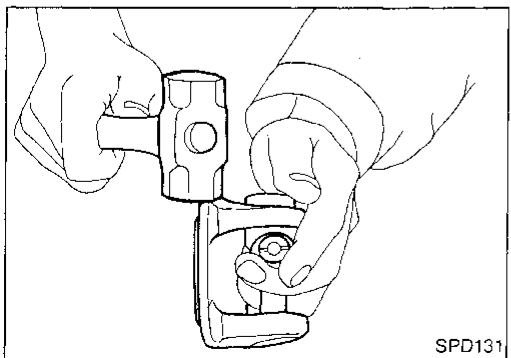

PROPELLER SHAFT

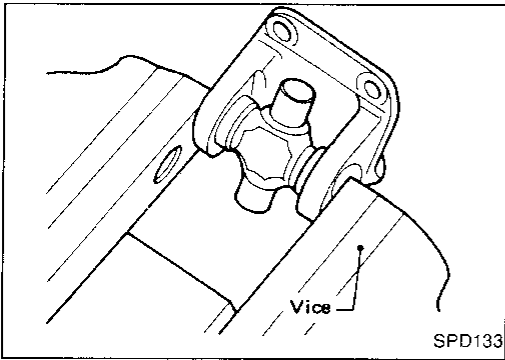

Assembly

JOURNAL (71H and 80B)

1. Assemble journal bearing. Apply recommended multi-purpose grease on bearing inner surface.

When assembling, be careful that needle bearing does not fall down.

GI

MA

EM

LC

EC

FE

AT

TF

PD

FA

RA

BR

ST

RS

BT

HA

EL

IDX

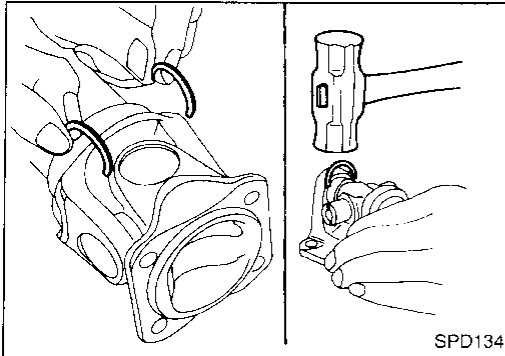

2. Select snap ring that will provide specified play in axial direction of journal, and install them.
Refer to SDS (PD-53).

Select snap rings with a difference in thickness at both sides within 0.06 mm (0.0024 in).

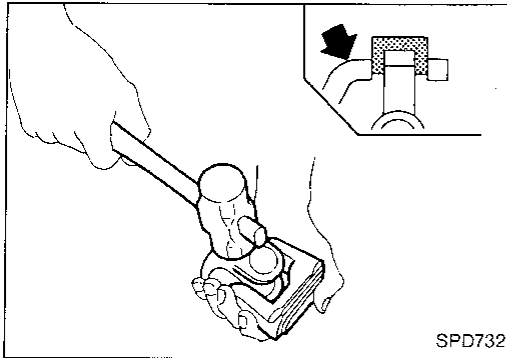

3. Adjust thrust clearance between bearing and snap ring to zero by tapping yoke.

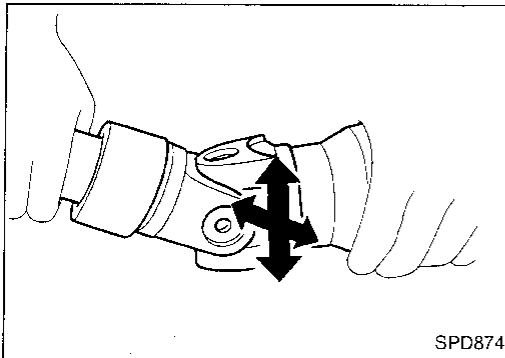

4. Check to see that journal moves smoothly and check for axial play.

Axial play: 0.02 mm (0.0008 in) or less

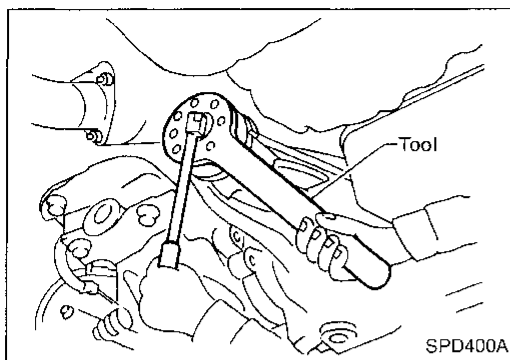

Front Oil Seal Replacement (Front final drive)

1. Remove front propeller shaft.
2. Loosen drive pinion nut.
Tool number: ST38060002 (J34311)

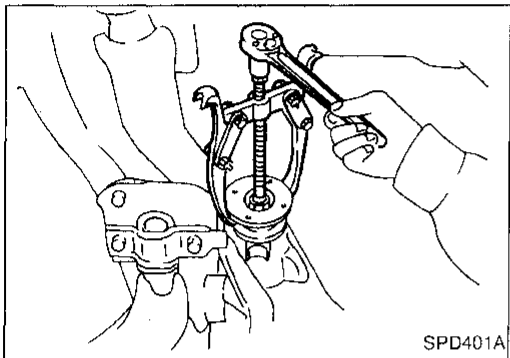

3. Remove companion flange with puller.

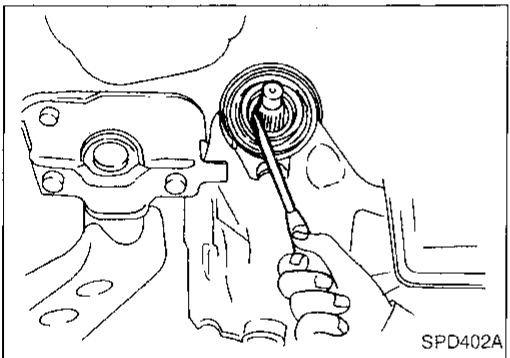

4. Remove front oil seal.

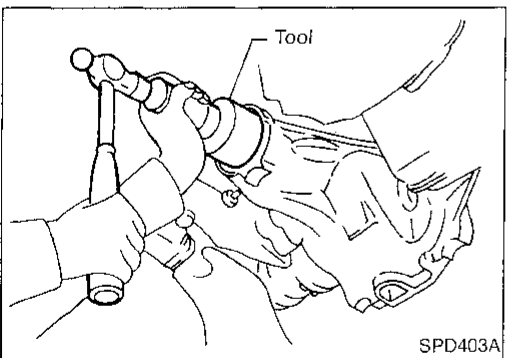

5. Apply multi-purpose grease to cavity at sealing lips of oil seal. Press front oil seal into carrier.
6. Install companion flange and drive pinion nut.
7. Install propeller shaft.
Tool number: KV38100500 (J25273)

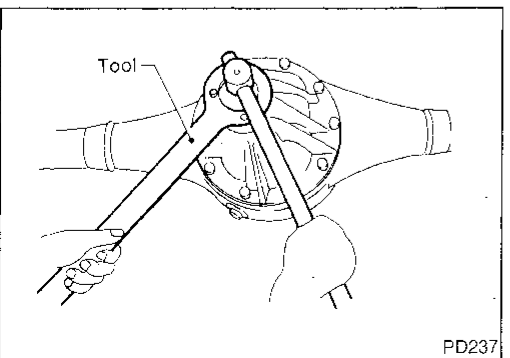

Front Oil Seal Replacement (Rear final drive)

1. Remove propeller shaft.
2. Loosen drive pinion nut.
Tool number: KV38104700 (J34311)

**Front Oil Seal Replacement (Rear final drive)
(Cont'd)**

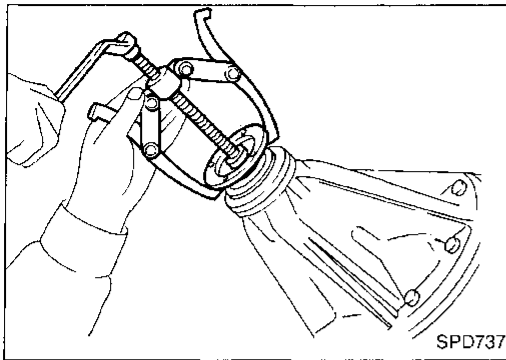

3. Remove companion flange with puller.

GI

MA

EM

LC

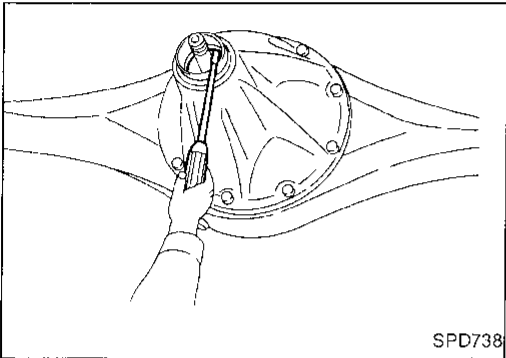

4. Remove front oil seal.

EC

FE

AT

TF

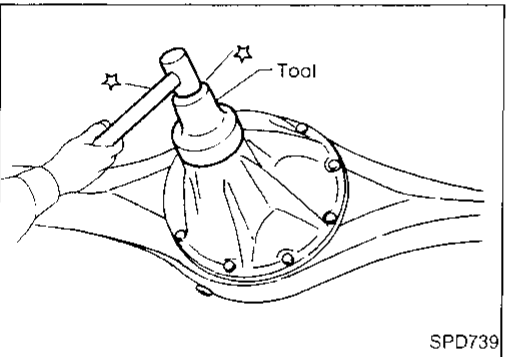

5. Apply multi-purpose grease to cavity at sealing lips of oil seal. Press front oil seal into carrier.

**Tool number:
KV38100500 (J25273)**

PD

6. Install companion flange and drive pinion nut.

FA

7. Install rear propeller shaft.

RA

BR

Rear Cover Gasket Replacement

ST

1. Drain gear oil.
2. Remove rear cover and rear cover gasket.
3. Install new rear cover gasket and rear cover.
4. Fill final drive with recommended gear oil.

RS

BT

FA

EL

IDX

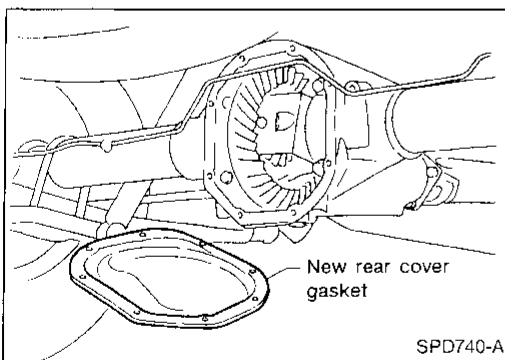

Removal

- Remove front and rear of propeller shaft.

Plug front end of transfer.

- Remove drive shaft. Refer to FA section ("Drive Shaft", "FRONT AXLE").
- Remove axle shaft. Refer to RA section ("REAR AXLE").
- Remove front and rear final drive mounting bolts.

CAUTION:

Be careful not to damage spline, sleeve yoke and front oil seal when removing propeller shaft.

Installation

- Fill final drive with recommended gear oil.

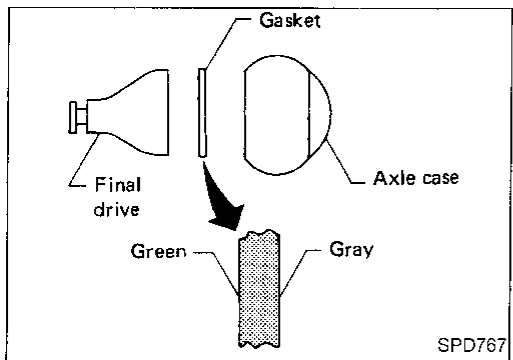
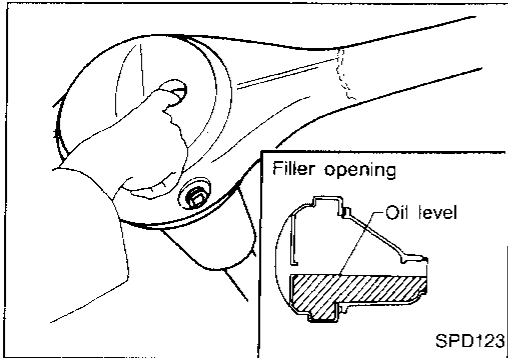

- Pay attention to the direction of gasket (H233B only).

SEC. 381

☆ : Adjustment is required.

★ : Using locking agent [Loctite (stud lock) or equivalent]

Ⓜ : N·m (kg-m, ft-lb)

☒ : Apply recommended sealant (Nissan genuine part: KP610-00250) or equivalent.

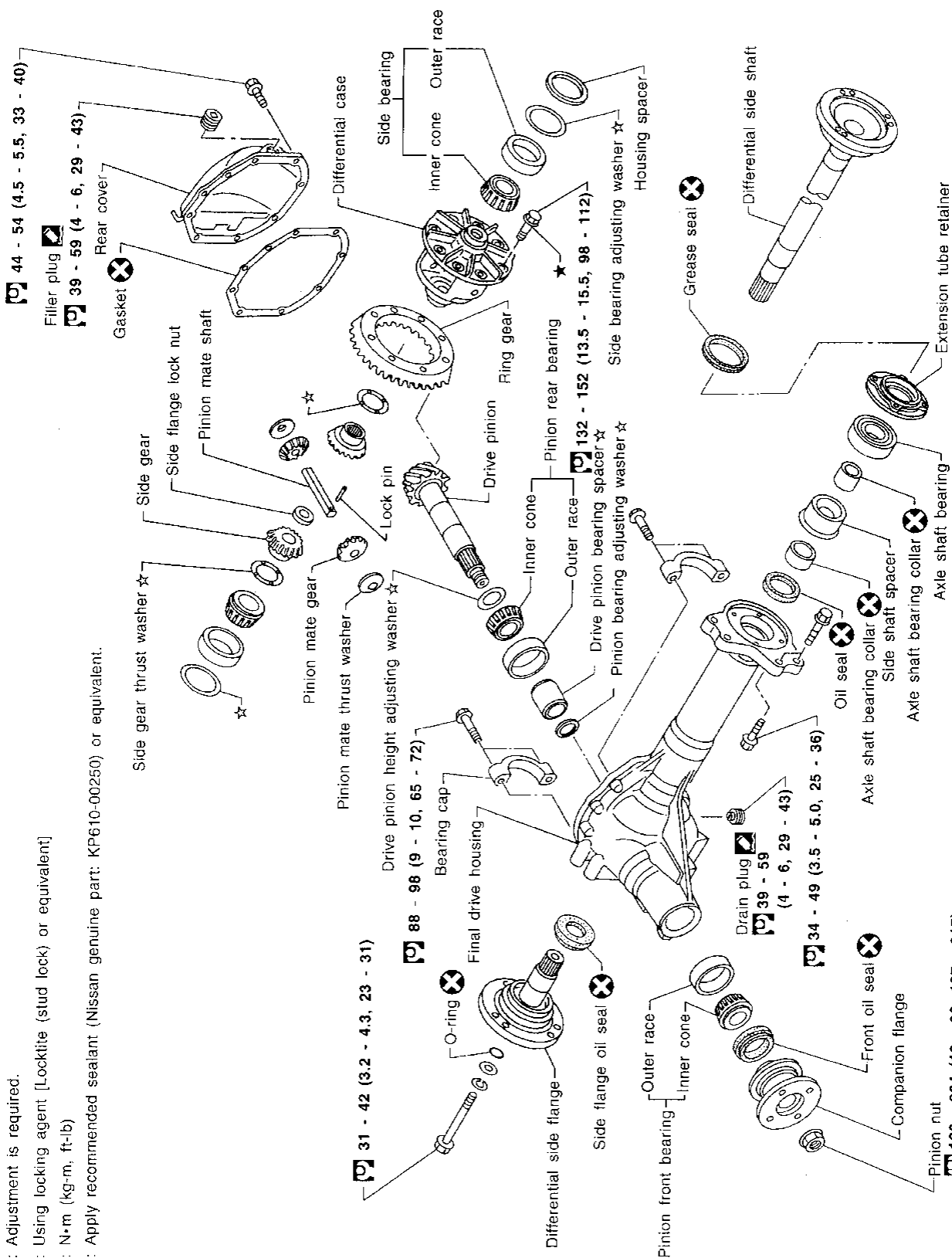

GI
MA
EM
LC
EC
FE
AT
TF
PD
FA
RA
BR
ST
RS
BT
HA
EL
IDX

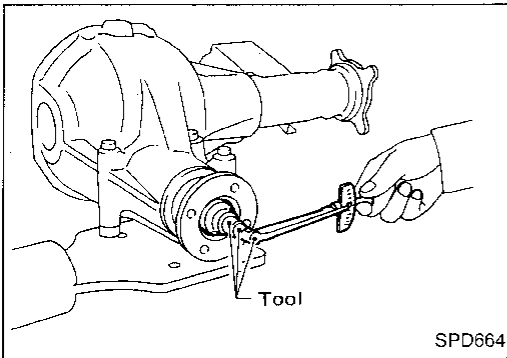

SPD664

Pre-inspection

Before disassembling final drive, perform the following inspection.

- Total preload
 - 1) Turn drive pinion in both directions several times to set bearing rollers.
 - 2) Check total preload with Tool.

Tool number: ST3127S000 (J25765-A)

Total preload:

1.4 - 1.7 N·m (14 - 17 kg·cm, 12 - 15 in·lb)

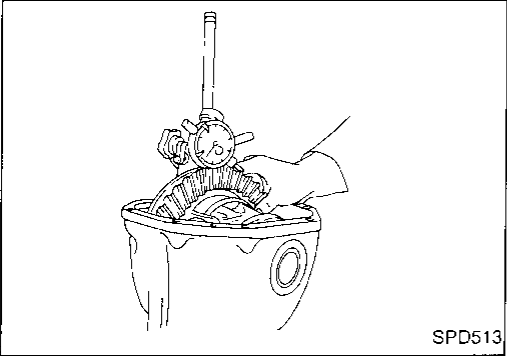

SPD513

- Ring gear to drive pinion backlash
Check backlash of ring gear with a dial indicator at several points.

Ring gear-to-drive pinion backlash:

0.10 - 0.15 mm (0.0039 - 0.0059 in)

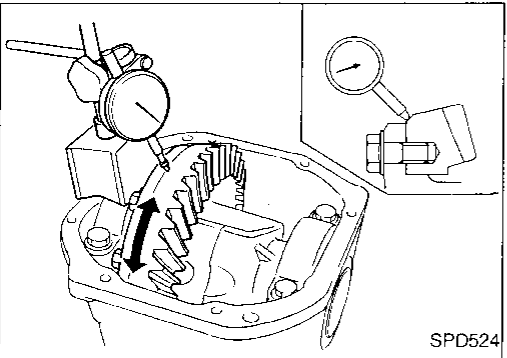

SPD524

- Ring gear runout
Check runout of ring gear with a dial indicator.

Runout limit:

0.05 mm (0.0020 in)

- Tooth contact
Check tooth contact. Refer to ADJUSTMENT (PD-26).

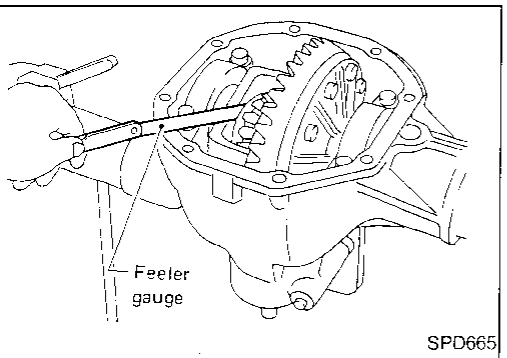

SPD665

- Side gear to pinion mate gear backlash
Using a feeler gauge, measure clearance between side gear thrust washer and differential case.

Clearance between side gear thrust washer and differential case:

Less than 0.15 mm (0.0059 in)

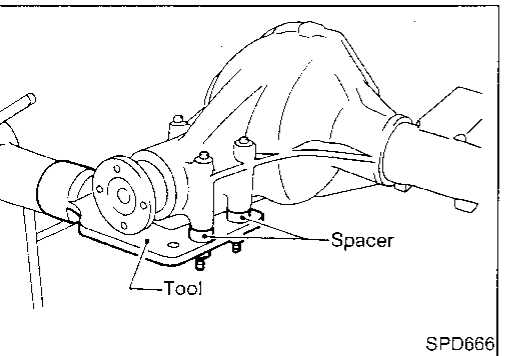

SPD666

Final Drive Housing

1. Using three spacers [20 mm (0.79 in)], mount final drive assembly on Tool.

Tool number:

KV38100800 (J34310, J25604-01)

Final Drive Housing (Cont'd)

- Remove differential side shaft assembly.

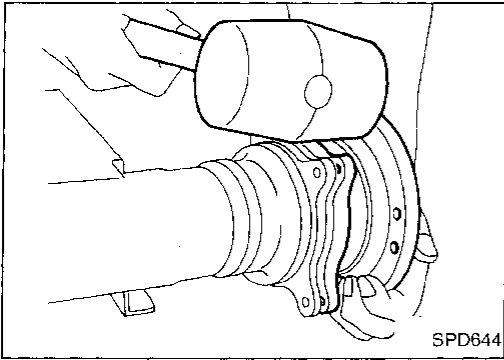

- Remove differential side flange.

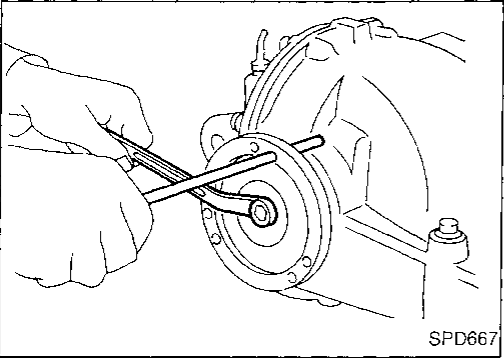

- Put match marks on one side of side bearing cap with paint or punch to ensure that it is replaced in proper position during reassembly.

Bearing caps are line-bored during manufacture and should be put back in their original places.

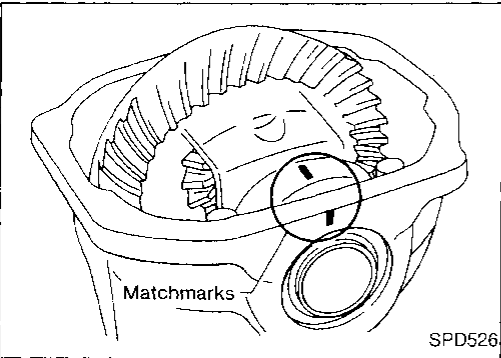

- Remove side bearing caps.

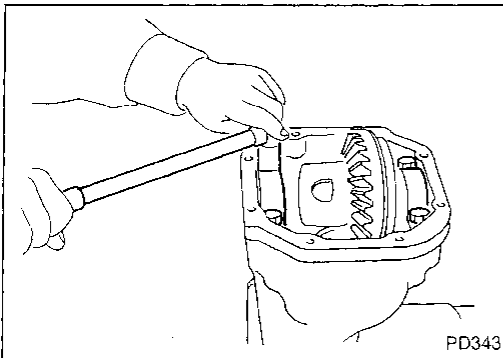

- Remove differential case assembly with a pry bar.

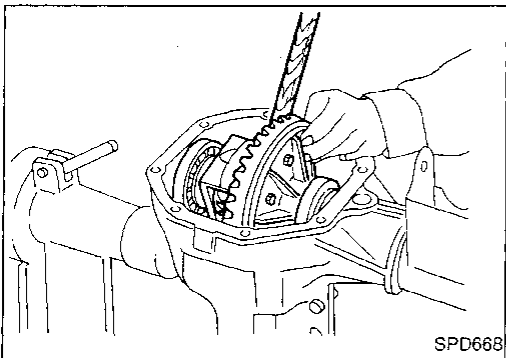

GI

MA

EM

LC

EC

FE

AT

TF

PD

FA

RA

BR

ST

RS

BT

HA

EL

IDX

Final Drive Housing (Cont'd)

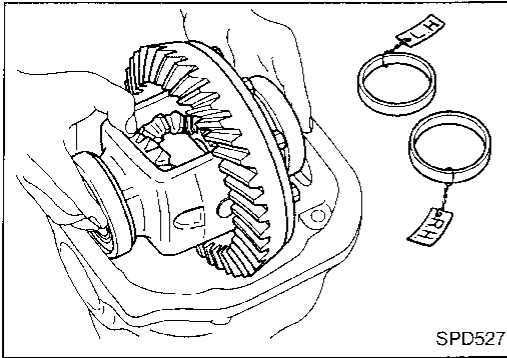

Be careful to keep the side bearing outer races together with their respective inner cones — don't mix them up.

CAUTION:

Side bearing spacer is placed on either the left or right depending upon final drive gear ratio. It should be labeled so that it may be replaced correctly.

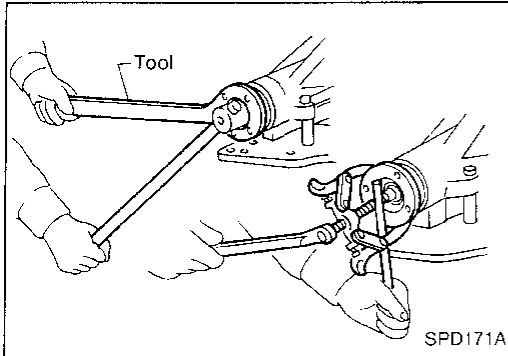

7. Loosen drive pinion nut.

Tool number: ST38060002 (J34311)

8. Remove companion flange with puller.

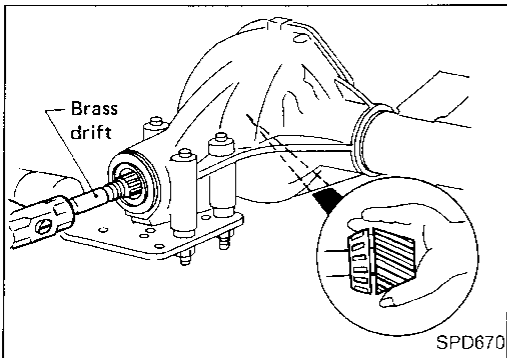

9. Take out drive pinion together with rear bearing inner cone, drive pinion bearing spacer and pinion bearing adjusting washer.

10. Remove front oil seal and pinion front bearing inner cone.

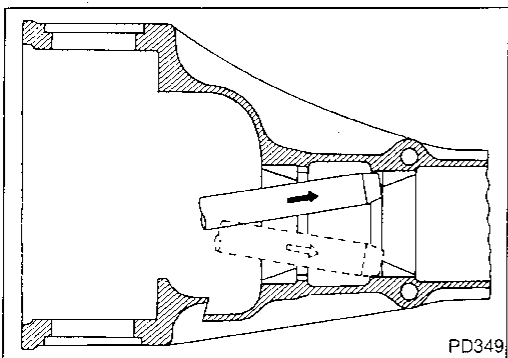

11. Remove pinion bearing outer races with a brass drift.

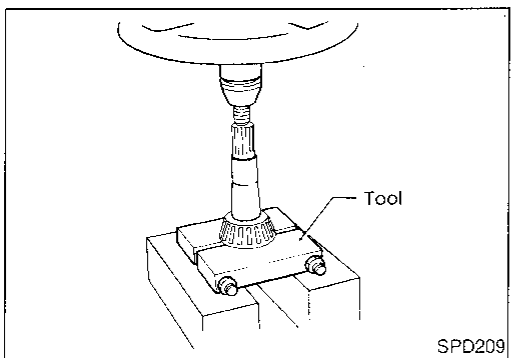

12. Remove pinion rear bearing inner cone and drive pinion height adjusting washer.

Tool number: ST30031000 (J22912-01)

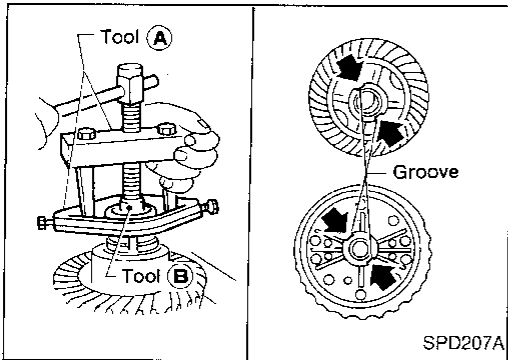

Differential Case

1. Remove side bearing inner cones.
To prevent damage to bearing, engage puller jaws in grooves.

Tool number:

- Ⓐ ST33051001 (J22888-20)
- Ⓑ ST33061000 (J8107-2)

GI
MA
EM

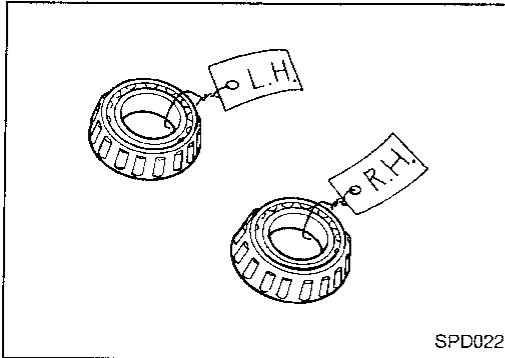

Be careful not to confuse the right and left hand parts.
Keep bearing and bearing race for each side together.

LC
EC
FE
AT

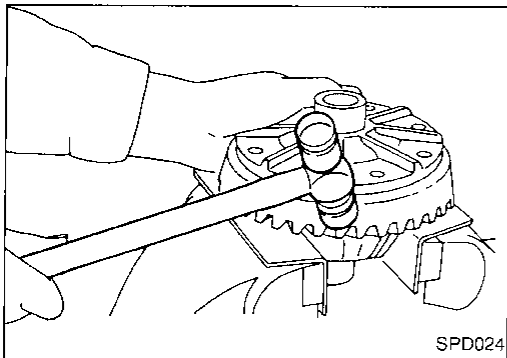

2. Loosen ring gear bolts in a criss-cross pattern.
3. Tap ring gear off the differential case with a soft hammer.
Tap evenly all around to keep ring gear from binding.

PD

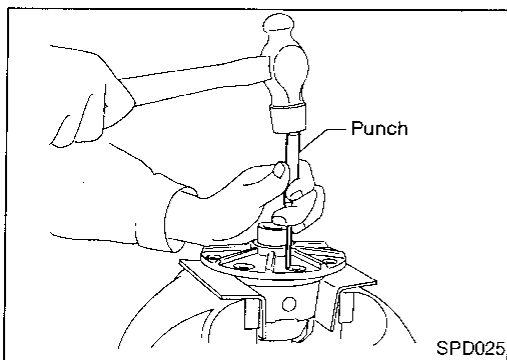

4. Punch off pinion mate shaft lock pin from ring gear side.

FA
RA
BR
ST
RS
BT

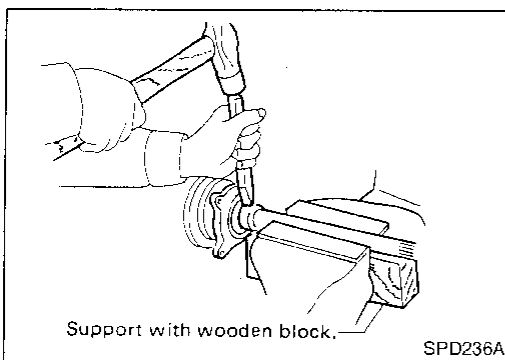

Differential Side Shaft

1. Cut collar with cold chisel. Be careful not to damage differential side shaft.

HA
EL
IDX

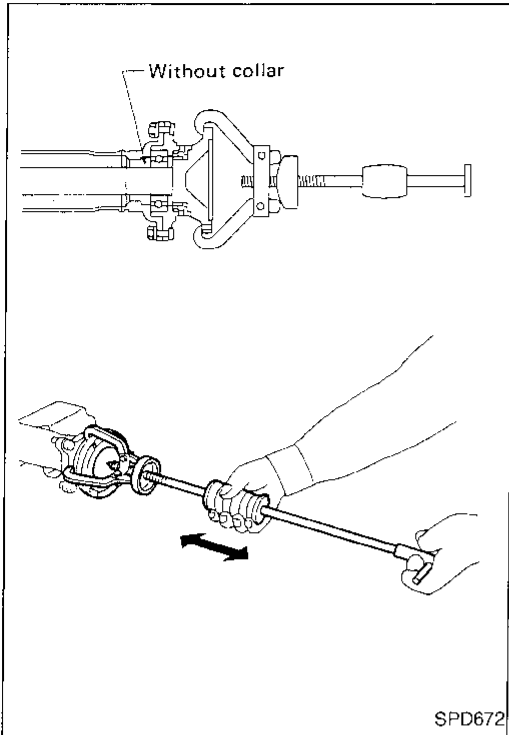
Differential Side Shaft (Cont'd)

2. Reinstall differential side shaft into extension tube and secure with bolts. Remove rear axle bearing by drawing out differential side shaft from rear axle bearing with puller.

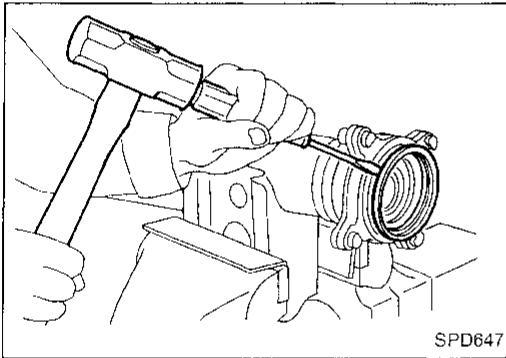

3. Remove grease seal and oil seal.

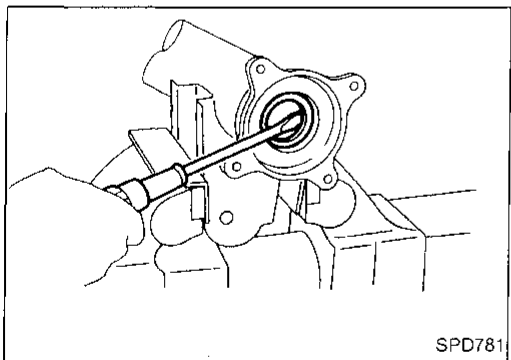

Ring Gear and Drive Pinion

Check gear teeth for scoring, cracking or chipping.
If any damaged part is evident, replace ring gear and drive pinion as a set (hypoid gear set).

GI

MA

EM

LC

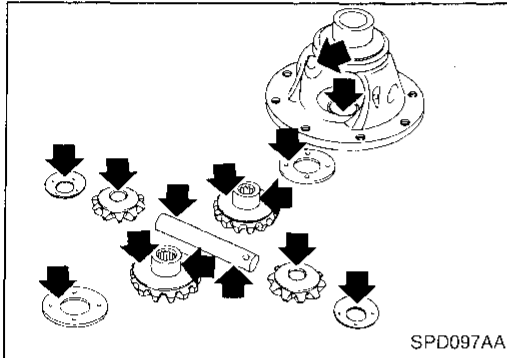

Differential Case Assembly

Check mating surfaces of differential case, side gears, pinion mate gears, pinion mate shaft and thrust washers.

EC

FE

AT

TF

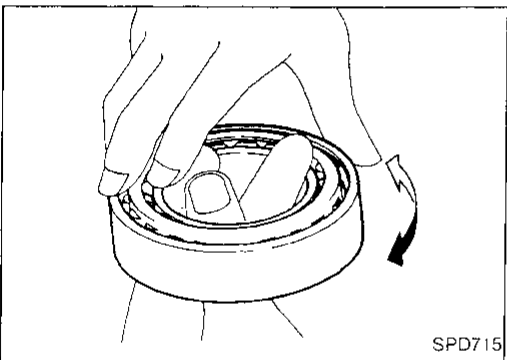

Bearing

1. Thoroughly clean bearing.
2. Check bearing for wear, scratches, pitting or flaking.
Check tapered roller bearing for smooth rotation. If damaged, replace outer race and inner cone as a set.

PD

FA

RA

BR

ST

RS

BT

HA

EL

IDX

For quiet and reliable final drive operation, the following five adjustments must be made correctly:

1. Side bearing preload
2. Pinion gear height
3. Pinion bearing preload
4. Ring gear-to-pinion backlash. Refer to ASSEMBLY (PD-31).
5. Ring and pinion gear tooth contact pattern

Side Bearing Preload

A selection of carrier side bearing adjusting washer is required for successful completion of this procedure.

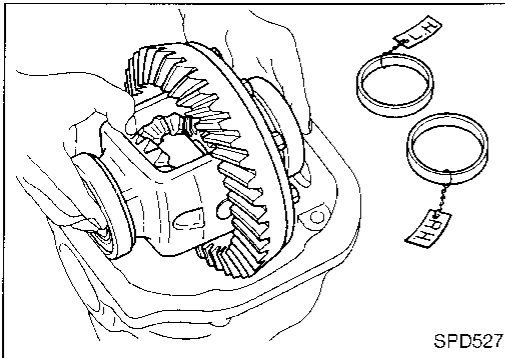

1. Make sure all parts are clean and that the bearings are well lubricated with light oil or "DEXRON™" type automatic transmission fluid.
2. Place the differential carrier, with side bearings and bearing races installed, into the final drive housing.

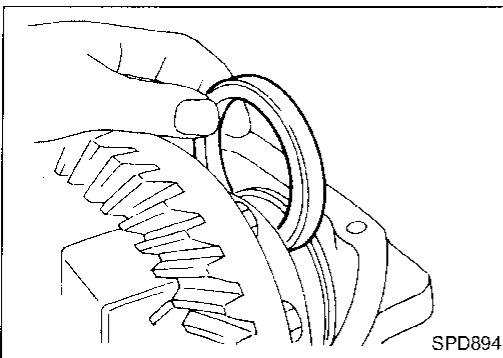

3. Put the side bearing spacer in place.

CAUTION:

Side bearing spacer is placed on either the right or left depending upon final drive gear ratio. Be sure to replace it on the correct side.

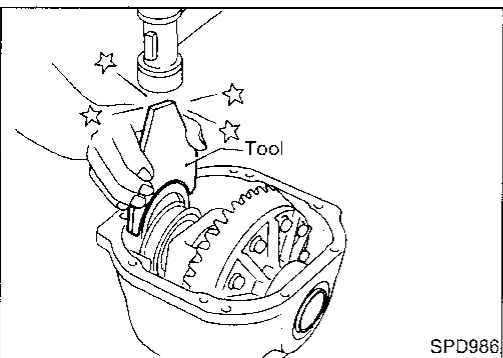

4. Using Tool, install original carrier side bearing preload shims on the carrier end, opposite the ring gear.

Tool number: KV38100600 (J25267)

Side Bearing Preload (Cont'd)

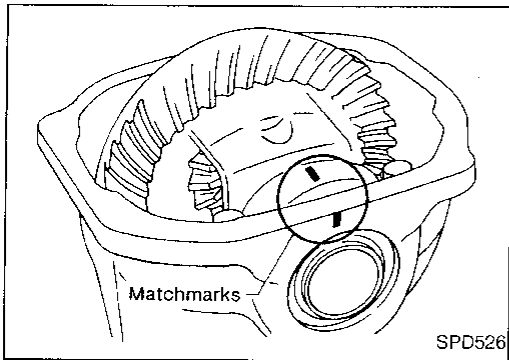

5. Install the side bearing caps in their correct locations and torque the bearing cap retaining bolts.

Specification:

88 - 98 N·m (9 - 10 kg·m, 65 - 72 ft·lb)

6. Turn the carrier several times to seat the bearings.

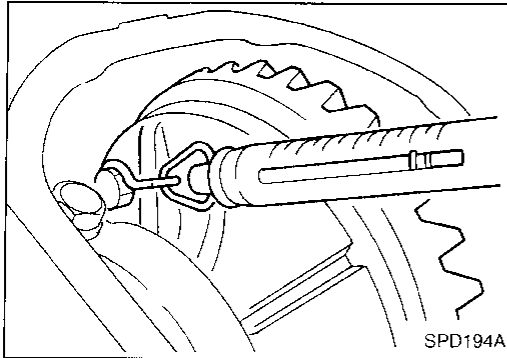

7. Measure the turning torque of the carrier at the ring gear retaining bolts with a spring gauge, J8129.

Specification:

34.3 - 39.2 N (3.5 - 4.0 kg, 7.7 - 8.8 lb)
of pulling force at the ring gear bolt.

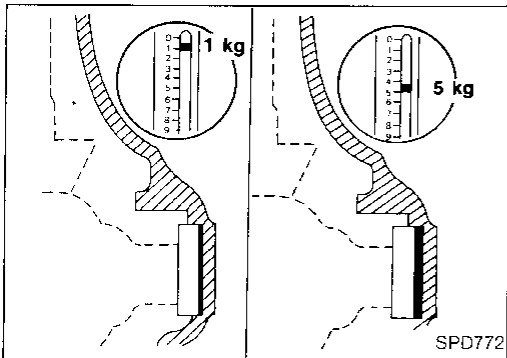

8. If the carrier turning torque is not within the specification range, increase or decrease the total thickness of the side bearing adjusting washers until the turning torque is correct. If the turning torque is less than the specified range, install washers of greater thickness; if the turning torque is greater than the specification, install thinner washers. See the SDS section for washer dimensions and part numbers.

9. Record the total amount of washer thickness required for the correct carrier side bearing preload.

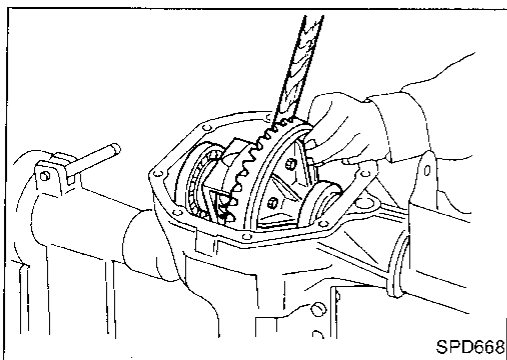

10. Remove the carrier from the final drive housing, saving the selected preload washers for later use during the assembly of the final drive unit.

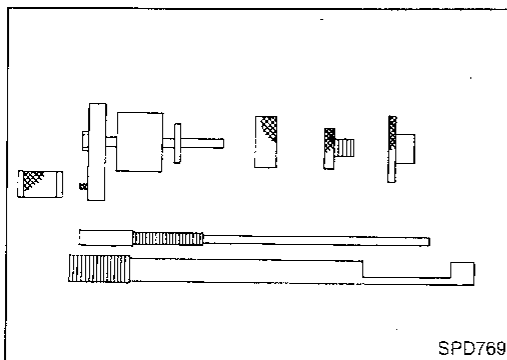

Pinion Gear Height and Pinion Bearing Preload

1. Make sure all parts are clean and that the bearings are well lubricated.
2. Assemble the pinion gear bearings into the pinion pre-load shim selector tool, J34309.

GI

MA

EM

LC

EC

FE

AT

TF

PD

FA

RA

BR

ST

RS

BT

HA

EL

DX

Pinion Gear Height and Pinion Bearing Preload (Cont'd)

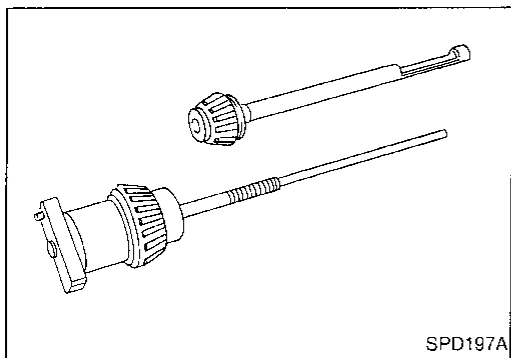

- **Front Pinion Bearing** — make sure the J34309-3 front pinion bearing seat is secured tightly against the J34309-2 gauge anvil. Then turn the front pinion bearing pilot, J34309-5, to secure the bearing in its proper position.
- **Rear Pinion Bearing** — the rear pinion bearing pilot, J34309-15, is used to center the rear pinion bearing only. The rear pinion bearing locking seat, J34309-4, is used to lock the bearing to the assembly.

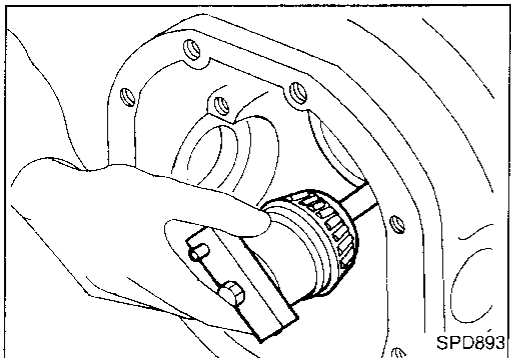

3. Place the pinion preload shim selector tool, J34309-1, gauge screw assembly with the pinion rear bearing inner cone installed into the final drive housing.

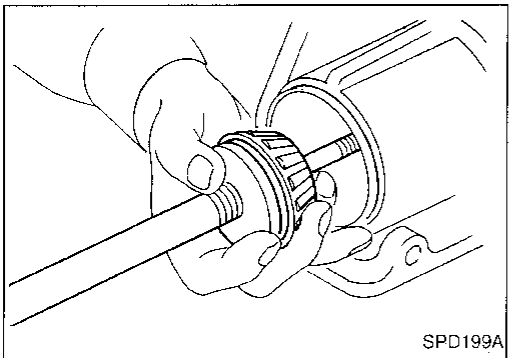

4. Assemble the front pinion bearing inner cone and the J34309-2 gauge anvil together with the J34309-1 gauge screw in the final drive housing. Make sure that the pinion height gauge plate, J34309-16, will turn a full 360 degrees, and tighten the two sections together by hand.

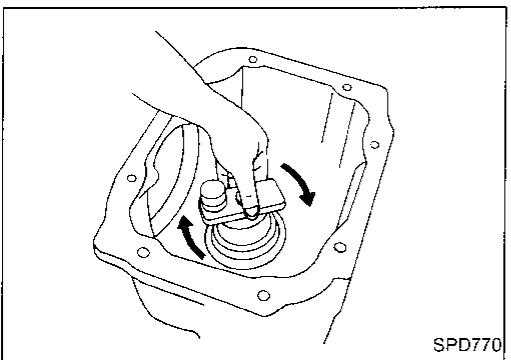

5. Turn the assembly several times to seat the bearings.

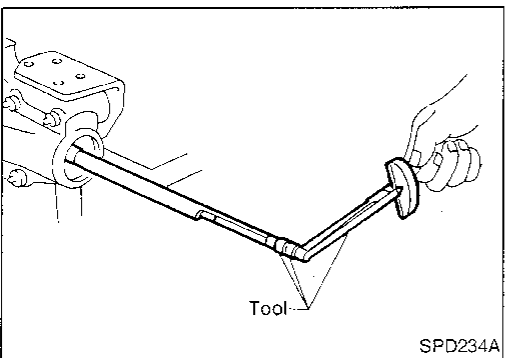

6. Measure the turning torque at the end of the J34309-2 gauge anvil using Tool.

Tool number:

ST3127S000 (J25765-A)

Turning torque specification:

1.0 - 1.3 N·m (10 - 13 kg·cm, 8.7 - 11.3 in·lb)

Pinion Gear Height and Pinion Bearing Preload (Cont'd)

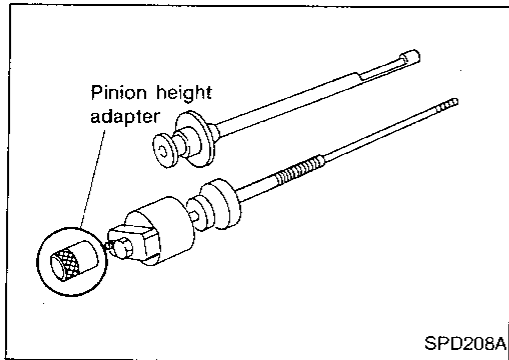

- Place the J34309-1 "R200A" pinion height adapter onto the gauge plate and tighten it by hand.

CAUTION:

Make sure all machined surfaces are clean.

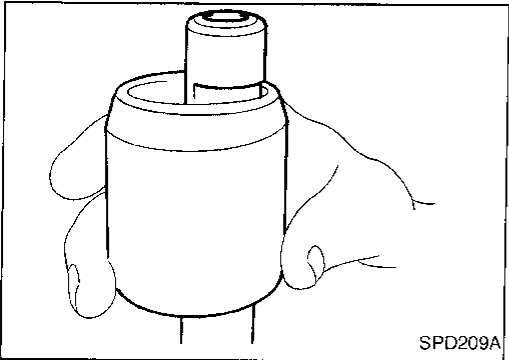

PINION BEARING PRELOAD WASHER SELECTION

- Place the solid pinion bearing spacer, small end first, over the J34309-2 gauge anvil and seat the small end squarely against the tip of the J34309-1 gauge screw in the tool recessed portion.

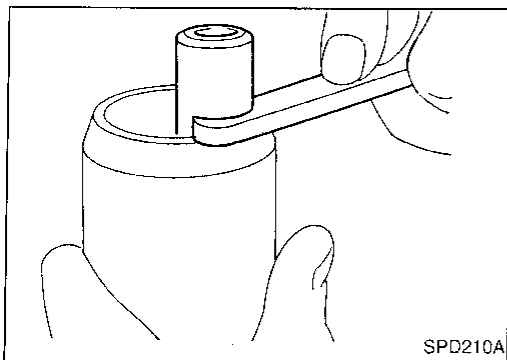
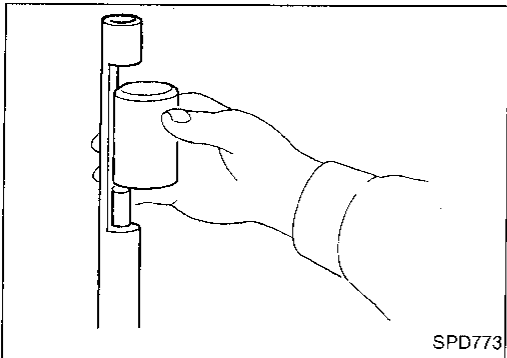

- Select the correct thickness of pinion bearing preload adjusting washer using a standard gauge of 3.5 mm (0.138 in) and your J34309-101 feeler gauge. The exact measure you get with your gauges is the thickness of the adjusting washer required. Select the correct washer.

Drive pinion bearing preload adjusting washer:

Refer to SDS (PD-54).

- Set your selected, correct pinion bearing preload adjusting washer aside for use when assembling the pinion gear and bearings into the final drive.

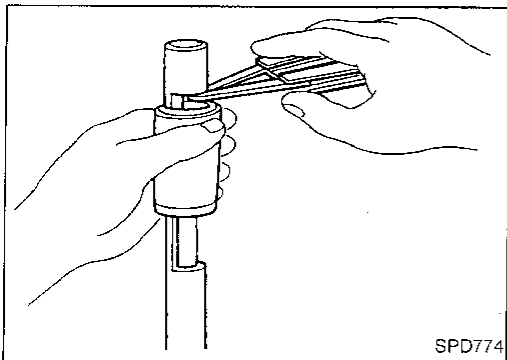

GI

MA

EM

LC

EC

FE

AT

TF

PD

FA

RA

BR

ST

RS

BT

HA

EL

IDX

Pinion Gear Height and Pinion Bearing Preload (Cont'd)

PINION HEIGHT ADJUSTING WASHER SELECTION

11. Now, position the side bearing discs, J25269-4, and arbor firmly into the side bearing bores.

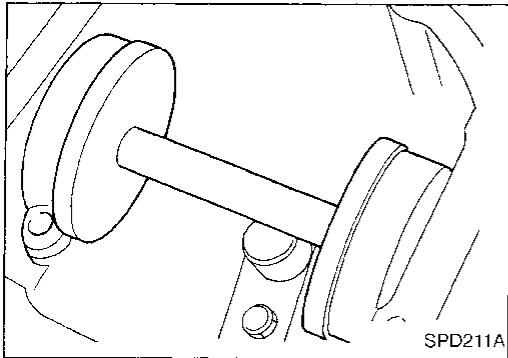

12. Install the side bearing caps and tighten the cap bolts.

Specification:

88 - 98 N·m (9 - 10 kg·m, 65 - 72 ft·lb)

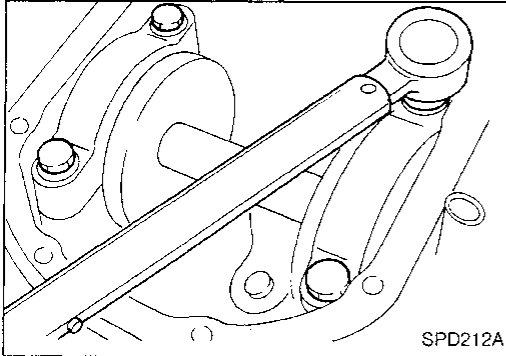

13. Select the correct standard pinion height adjusting washer thickness by using a standard gauge of 3.0 mm (0.118 in) and your J34309-101 feeler gauge. Measure the gap between the J34309-11 "R200A" pinion height adapter and the arbor.

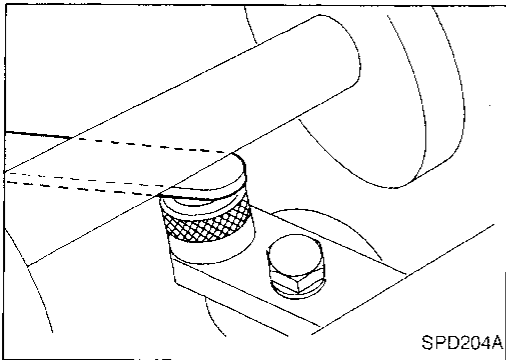

14. Write down your exact total measurement.

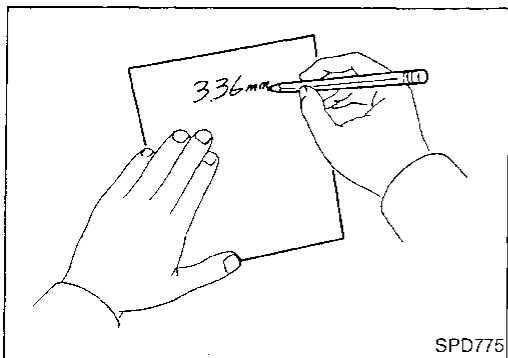

15. Correct the pinion height washer size by referring to the "pinion head number".

There are two numbers painted on the pinion gear. The first one refers to the pinion and ring gear as a matched set and should be the same as the number on the ring gear. The second number is the "pinion head height number", and it refers to the ideal pinion height from standard for quietest operation.

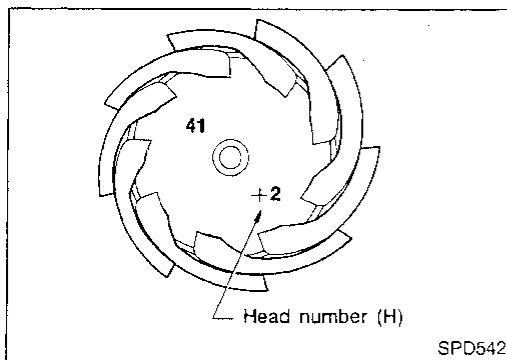

Pinion Gear Height and Pinion Bearing Preload (Cont'd)

Use the following chart to determine the correct pinion height washer.

Pinion Head Height Number	Add or Remove from the Standard Pinion Height Washer Thickness Measurement
-6	Add 0.06 mm (0.0024 in)
-5	Add 0.05 mm (0.0020 in)
-4	Add 0.04 mm (0.0016 in)
-3	Add 0.03 mm (0.0012 in)
-2	Add 0.02 mm (0.0008 in)
-1	Add 0.01 mm (0.0004 in)
0	Use the selected washer thickness
+1	Subtract 0.01 mm (0.0004 in)
+2	Subtract 0.02 mm (0.0008 in)
+3	Subtract 0.03 mm (0.0012 in)
+4	Subtract 0.04 mm (0.0016 in)
+5	Subtract 0.05 mm (0.0020 in)
+6	Subtract 0.06 mm (0.0024 in)

16. Select the correct drive pinion height washer.

**Drive pinion height adjusting washer:
Refer to SDS (PD-54).**

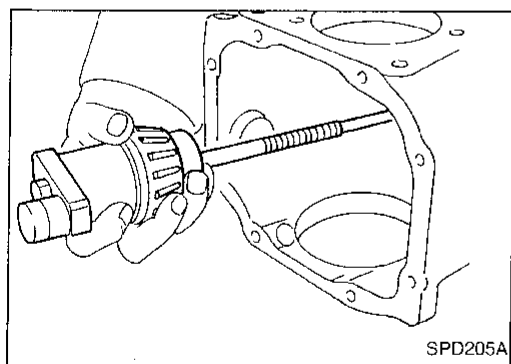

17. Remove the J34309 pinion preload shim selector tool from the final drive housing and disassemble to retrieve the pinion bearings.

Tooth Contact

Gear tooth contact pattern check is necessary to verify correct relationship between ring gear and drive pinion.

Hypoid gear sets which are not positioned properly in relation to one another may be noisy, or have short life, or both. With a pattern check, the most desirable contact for low noise level and long life can be assured.

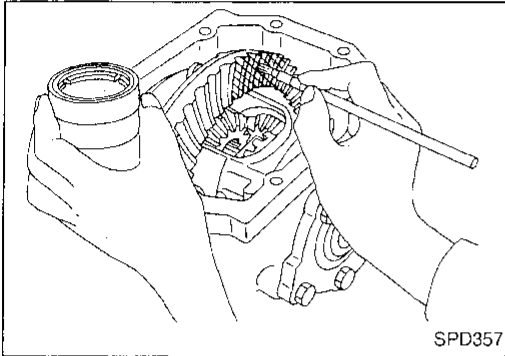

1. Thoroughly clean ring gear and drive pinion teeth.
2. Sparingly apply a mixture of powdered ferric oxide and oil or equivalent to 3 or 4 teeth of ring gear drive side.

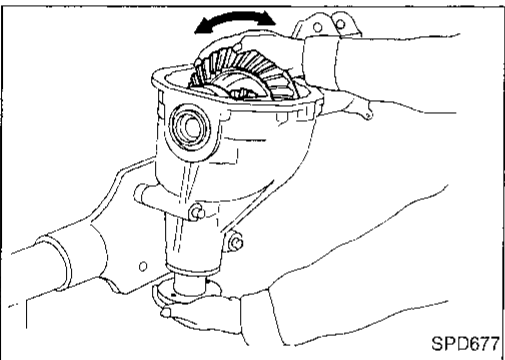

3. Hold companion flange steady by hand and rotate the ring gear in both directions.

Usually the pattern will be correct if shims are correctly calculated and the backlash is correct. However, in rare cases, trial and error processes may be employed to obtain a correct pattern. The tooth pattern is the best indication of how well a differential has been set up.

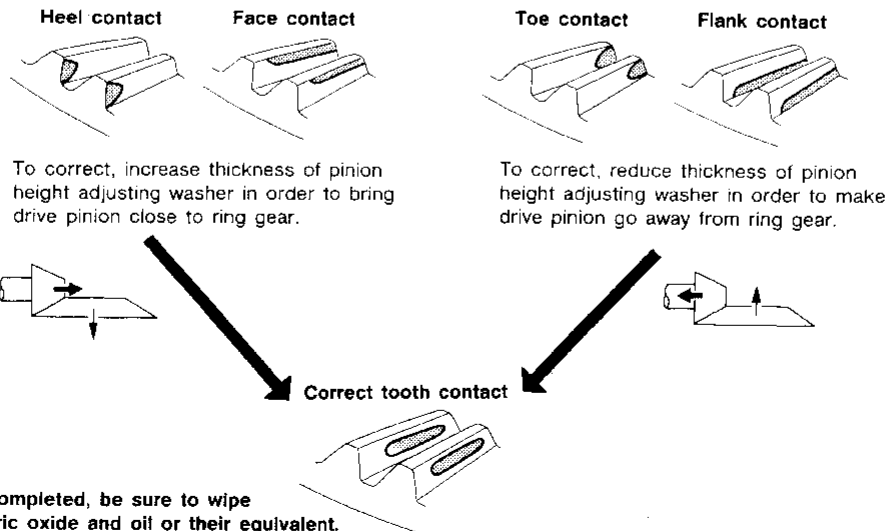

When adjustment is completed, be sure to wipe off completely the ferric oxide and oil or their equivalent.

SPD007-B

Differential Side Shaft

1. Install oil seal and grease seal.

GI
MA
EM
LG
EC
FE
AT
TF

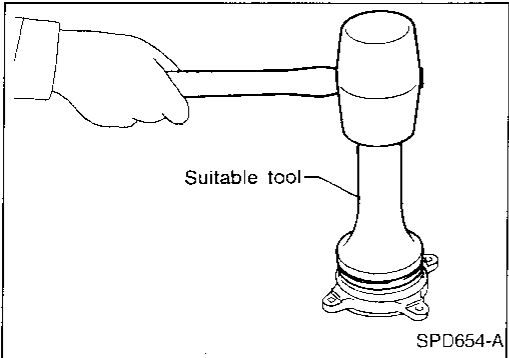
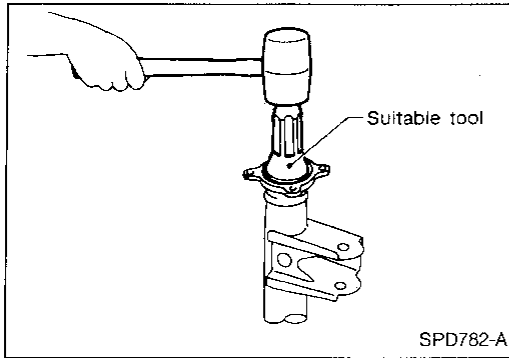

2. Install extension tube retainer, rear axle bearing and rear axle shaft bearing collar on differential side shaft.

PD

FA

RA

BR

ST

RS

BT

HA

EL

IDX

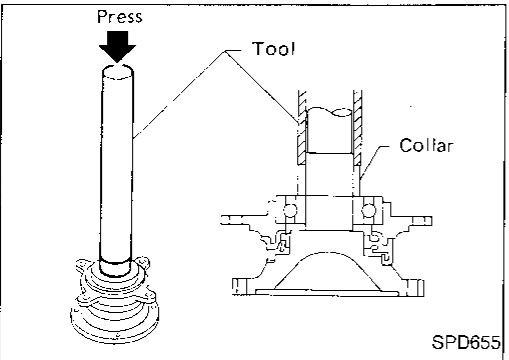

Differential Case

1. Install side gears, pinion mate gears and thrust washers into differential case.

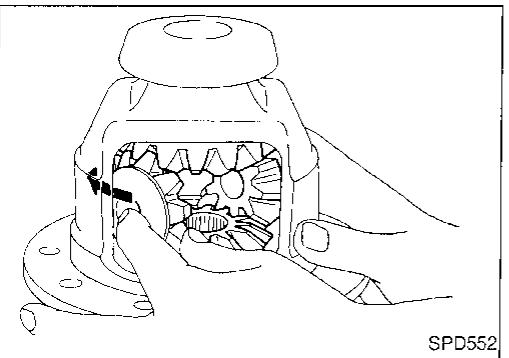

2. Fit pinion mate shaft to differential case so that it meets lock pin holes.
3. Adjust backlash between side gear and pinion mate gear by selecting side gear thrust washer. Refer to SDS (PD-54).

Backlash between side gear and pinion mate gear (Clearance between side gear thrust washer and differential case):
 Less than 0.15 mm (0.0059 in)

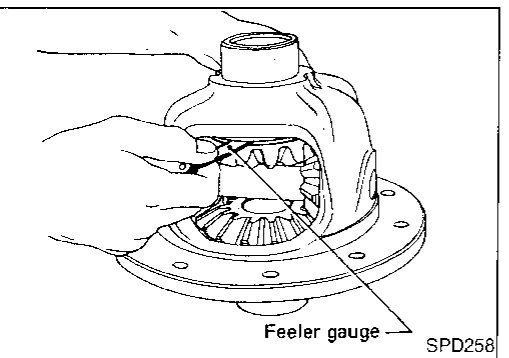

Differential Case (Cont'd)

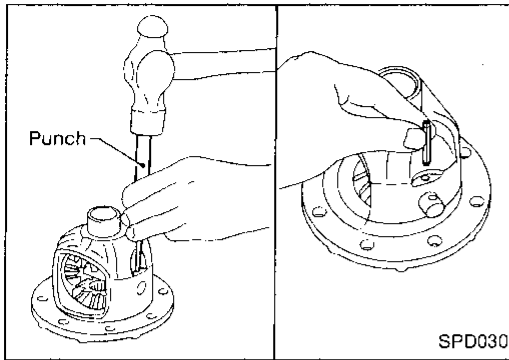

4. Install pinion mate shaft lock pin with a punch.
Make sure lock pin is flush with case.

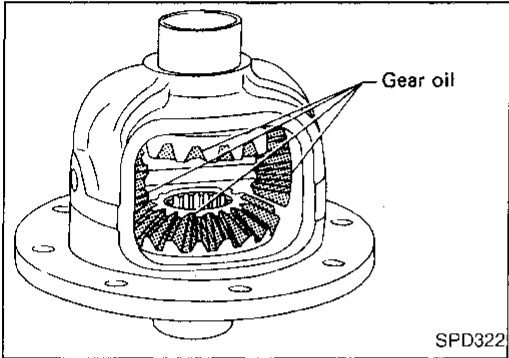

5. Apply gear oil to gear tooth surfaces and thrust surfaces and check to see they turn properly.

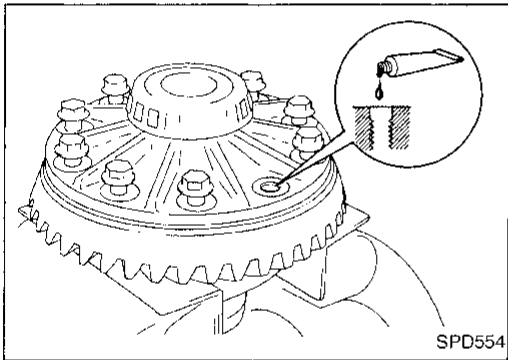

6. Install differential case assembly on ring gear.
 7. Apply locking agent [Loctite (stud lock) or equivalent] to ring gear bolts, and install them.

Tighten bolts in a criss-cross pattern, lightly tapping bolt head with a hammer.

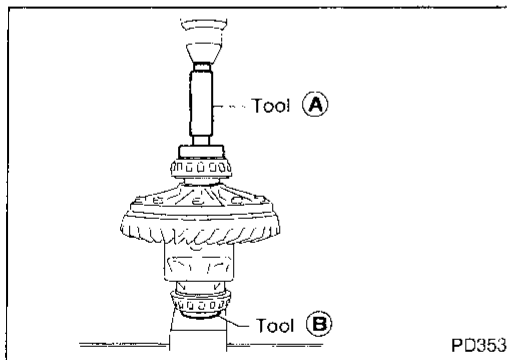

8. Press-fit side bearing inner cones on differential case with Tool.

Tool number:

- Ⓐ KV38100300 (J25523)
- Ⓑ ST33061000 (J8107-2)

Final Drive Housing

1. Press-fit front and rear bearing outer races with Tools.

Tool number:

- (A) ST30611000 (J25742-1)
- (B) ST30621000 (J25742-5)
- (C) ST30613000 (J25742-3)

GI
MA
EM
LC
EC
EE
AT
TF

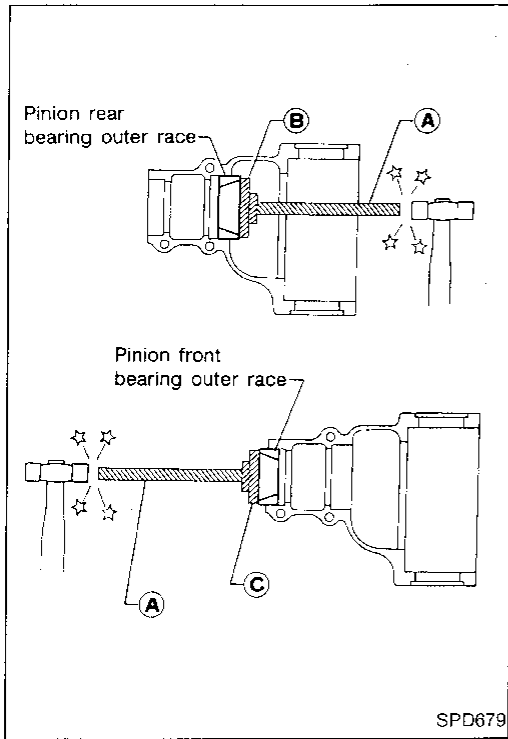

2. Select drive pinion height adjusting washer and pinion bearing adjusting washer. Refer to ADJUSTMENT (PD-21).
3. Install drive pinion height adjusting washer in drive pinion, and press-fit pinion rear bearing inner cone in it, using press and Tool.

Tool number:

ST30901000 (J26010-01)

PD
FA

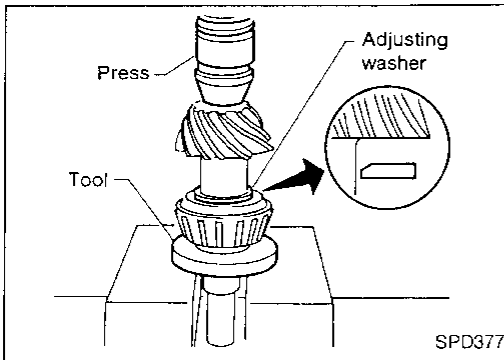

4. Place pinion front bearing inner cone in final drive housing.

ST
RS
BT
HA

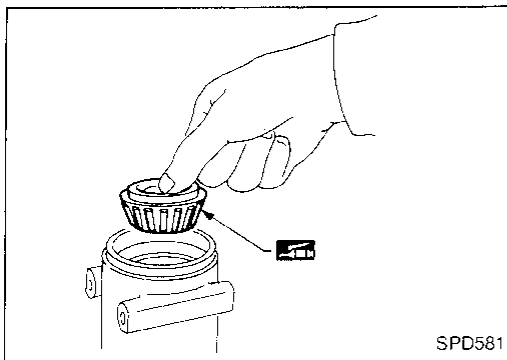

5. Apply multi-purpose grease to cavity at sealing lips of oil seal. Install front oil seal.

Tool number:

KV38100500 (J25273)

EL
IDX

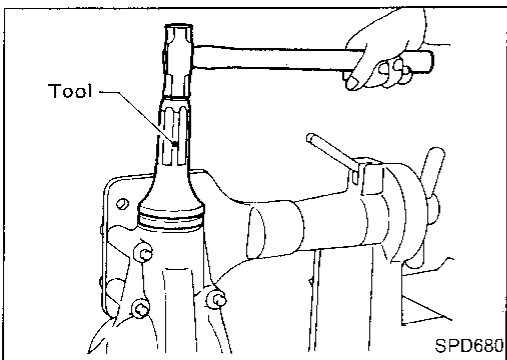

Final Drive Housing (Cont'd)

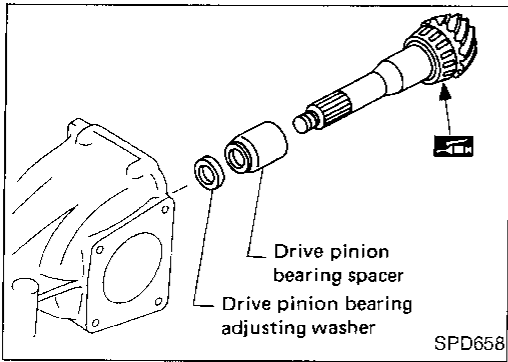

- Place drive pinion bearing spacer, drive pinion bearing adjusting washer and drive pinion in final drive housing.

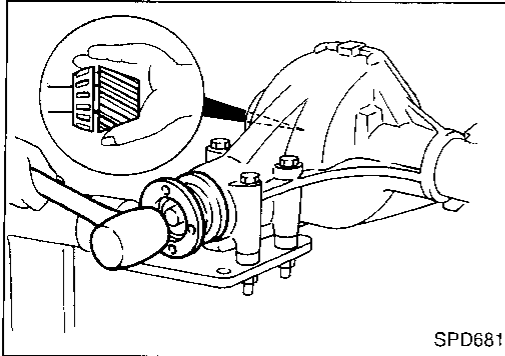

- Insert companion flange into drive pinion by tapping the companion flange with a soft hammer.

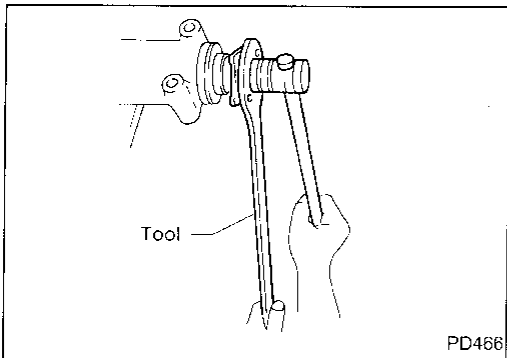

- Tighten pinion nut to the specified torque.
The threaded portion of drive pinion and pinion nut should be free from oil or grease.

Tool number: ST38060002 (J34311)

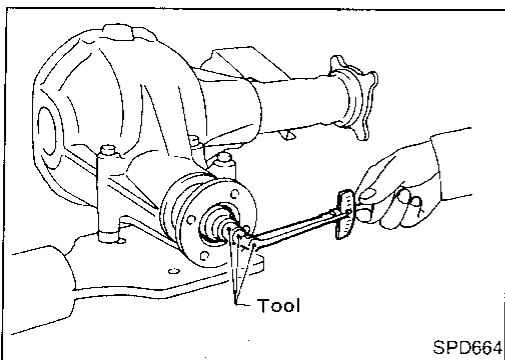

- Turn drive pinion in both directions several revolutions, and measure pinion bearing preload.

Tool number: ST3127S000 (J25765-A)

Pinion bearing preload:

1.1 - 1.4 N·m

(11 - 14 kg-cm, 9.5 - 12.2 in-lb)

When pinion bearing preload is outside the specifications, replace pinion bearing adjusting washer and spacer with a different thickness.

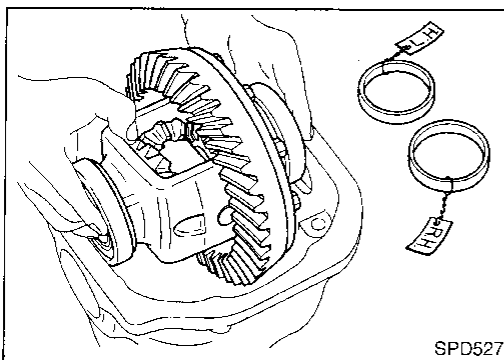

- Select side bearing adjusting washer. Refer to ADJUSTMENT (PD-20).
- Install differential case assembly with side bearing outer races into final drive housing.

Final Drive Housing (Cont'd)

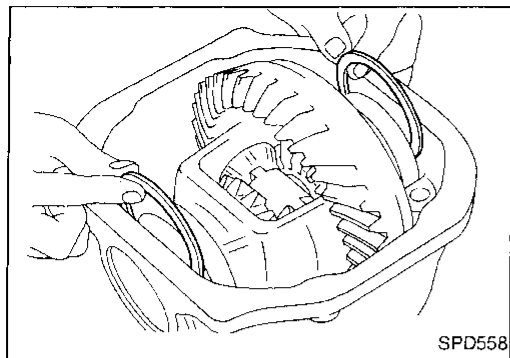

12. Insert left and right side bearing adjusting washers in place between side bearings and final drive housing.

GI
MA
EM
LC

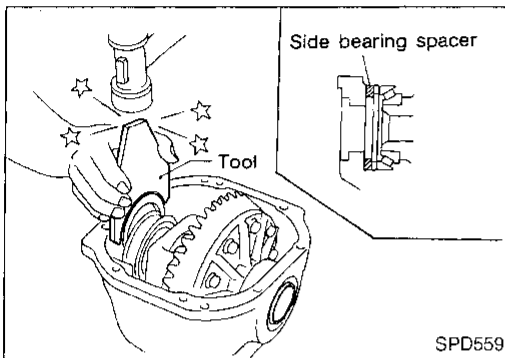

13. Drive in side bearing spacer with Tool.
Tool number: KV38100600 (J25267)

EC
FE
AT
TF

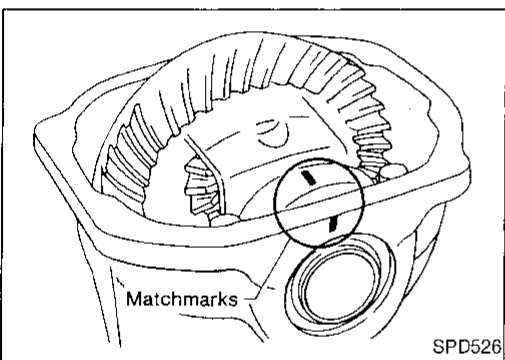

14. Align mark on bearing cap with that on final drive housing and install bearing cap on final drive housing.

PD
FA
RA
BR

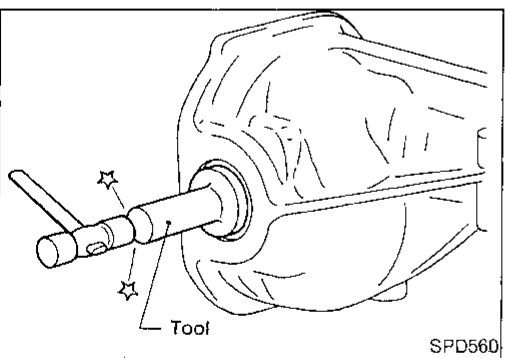

15. Apply multi-purpose grease to cavity at sealing lips of oil seal. Install side oil seal.
Tool number: KV38100200 (J26233)

ST
RS
BT
HA

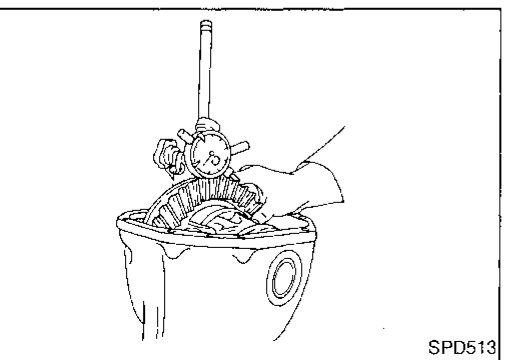

16. Measure ring gear to drive pinion backlash with a dial indicator.

EL
IDX

Ring gear-to-drive pinion backlash:
0.10 - 0.15 mm (0.0039 - 0.0059 in)

- If backlash is too small, decrease thickness of right shim and increase thickness of left shim by the same amount.
If backlash is too great, reverse the above procedure.

Never change the total amount of shims as it will change the bearing preload.

Final Drive Housing (Cont'd)

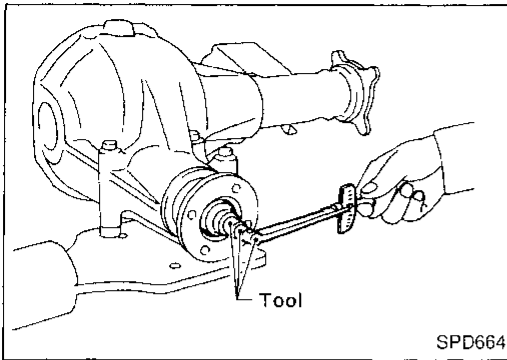

17. Check total preload with Tool.

When checking preload, turn drive pinion in both directions several times to set bearing rollers.

Tool number: ST3127S000 (J25765-A)

Total preload:

1.4 - 1.7 N·m

(14 - 17 kg·cm, 12 - 15 in·lb)

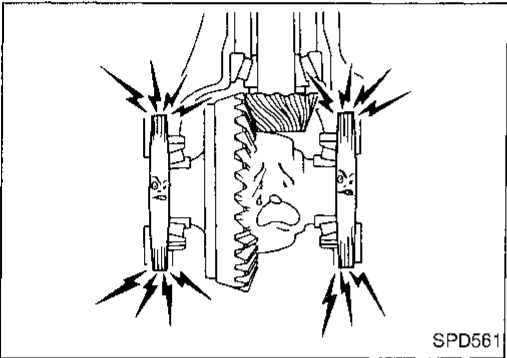

- If preload is too great, remove the same amount of shim from each side.
- If preload is too small, add the same amount of shim to each side.

Never add or remove a different number of shims for each side as it will change ring gear to drive pinion backlash.

18. Recheck ring gear to drive pinion backlash because increase or decrease in thickness of shims will cause change of ring gear-to-pinion backlash.

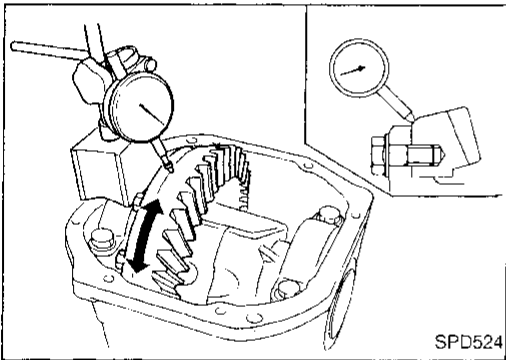

19. Check runout of ring gear with a dial indicator.

Runout limit:

0.05 mm (0.0020 in)

- If backlash varies excessively in different places, the variance may have resulted from foreign matter caught between the ring gear and the differential case.
- If the backlash varies greatly when the runout of the ring gear is within a specified range, the hypoid gear set or differential case should be replaced.

20. Check tooth contact. Refer to ADJUSTMENT (PD-26).

21. Install rear cover and gasket.

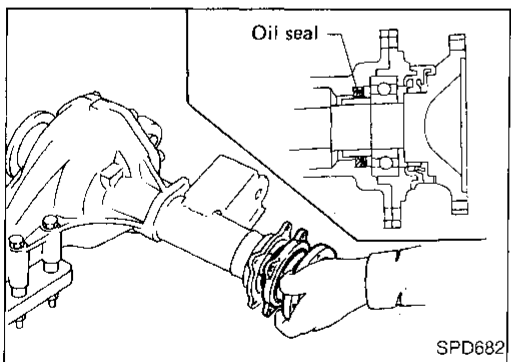

22. Install differential side shaft assembly.

REAR FINAL DRIVE

H233B

SEC. 380

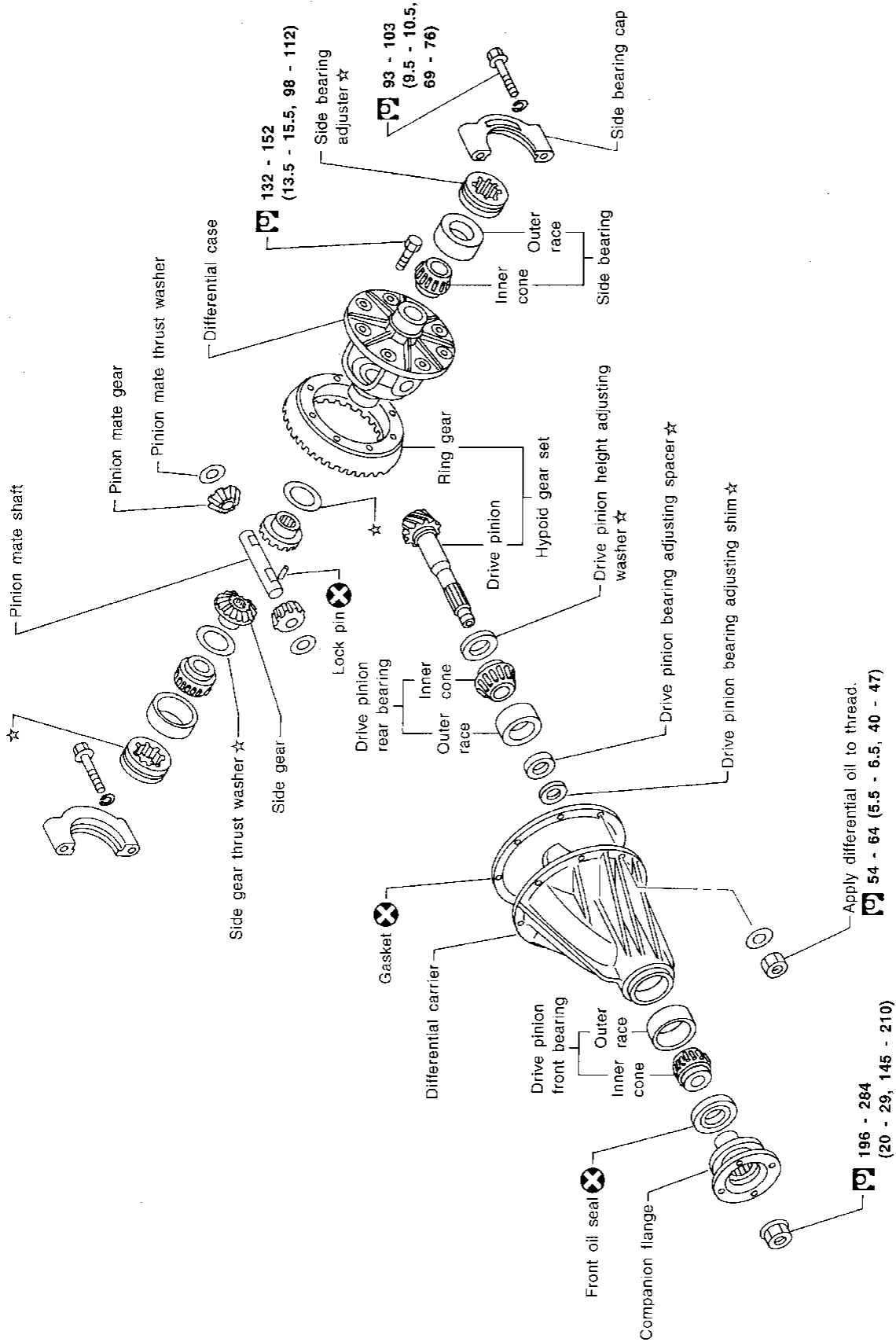

: N·m (kg-m, ft-lb)

☆ : Adjustment is required.

- GI
- MA
- EM
- LC
- EC
- FE
- AT
- TF
- PD**
- FA
- RA
- BR
- ST
- RS
- BT
- HA
- EL
- IDX

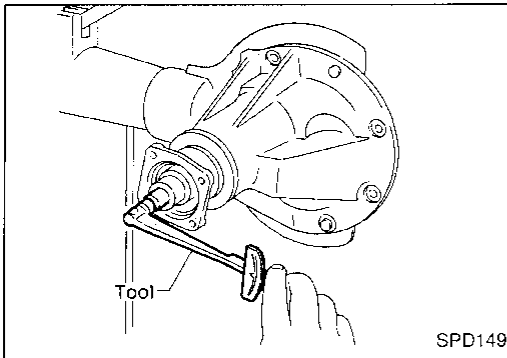

Pre-inspection

Before disassembling final drive, perform the following inspection.

- Total preload
 - 1) Turn drive pinion in both directions several times to seat bearing rollers correctly.
 - 2) Check total preload with Tool.

Tool number: ST3127S000 (J25765-A)

Total preload:

1.7 - 2.5 N·m

(17 - 25 kg·cm, 15 - 22 in·lb)

- Ring gear to drive pinion backlash
Check backlash of ring gear with a dial indicator at several points.

Ring gear-to-drive pinion backlash:

0.13 - 0.18 mm (0.0051 - 0.0071 in)

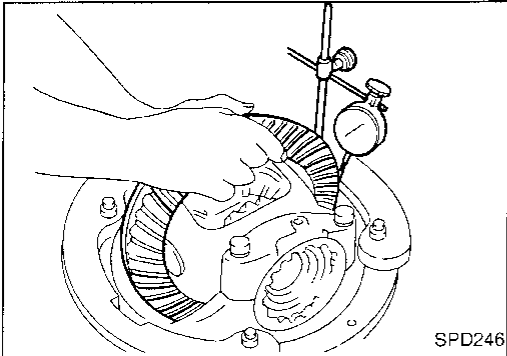

- Ring gear runout
Check runout of ring gear with a dial indicator.

Runout limit:

0.08 mm (0.0031 in)

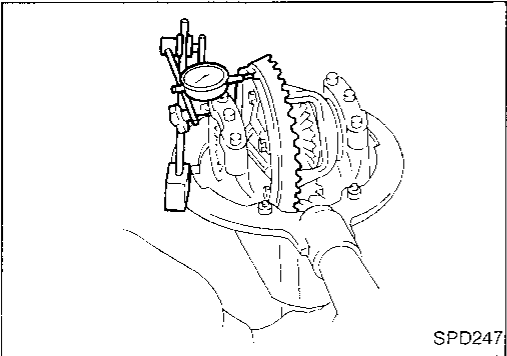

- Tooth contact
Check tooth contact. Refer to ADJUSTMENT (PD-48).
- Side gear to pinion mate gear backlash
Measure clearance between side gear thrust washer and differential case with a feeler gauge.

Clearance between side gear thrust washer and differential case:

0.10 - 0.20 mm (0.0039 - 0.0079 in)

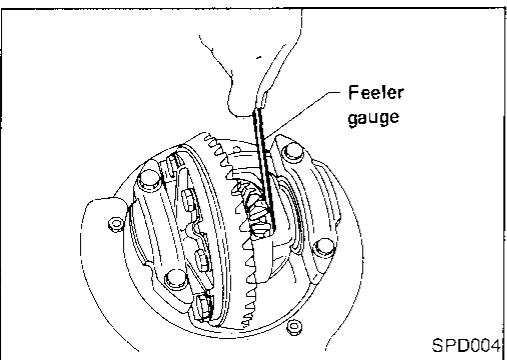

Differential Carrier

1. Mount final drive assembly on Tool.

Tool number:

ST06340000 (J24310, J34310)

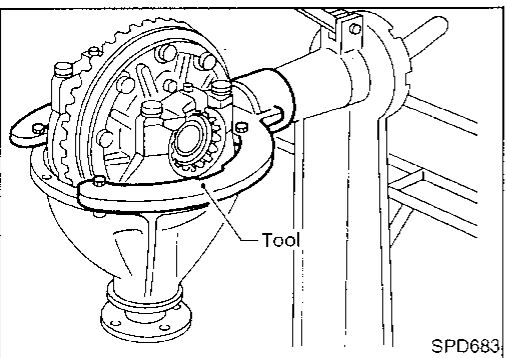

Differential Carrier (Cont'd)

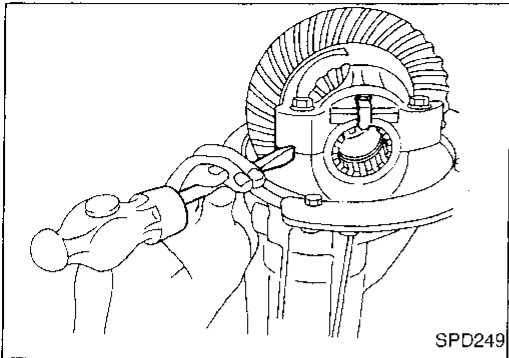

- Put match marks on one side of side bearing cap with paint or punch to ensure that it is replaced in proper position during reassembly.

Bearing caps are line-bored during manufacture and should be put back in their original places.

GI

MA

EM

LC

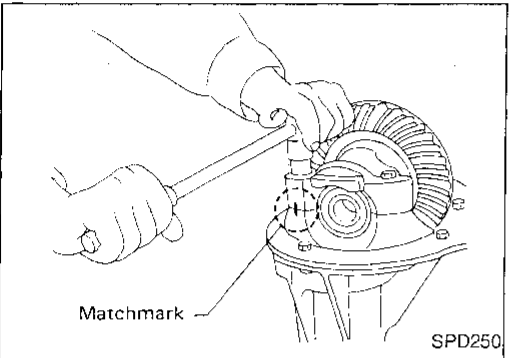

- Remove side lock fingers and side bearing caps.

EC

FE

AT

TF

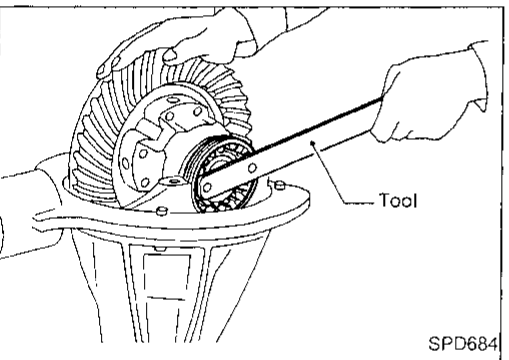

- Remove side bearing adjuster with Tool.
Tool number: ST32580000 (J34312)

PD

FA

RA

BR

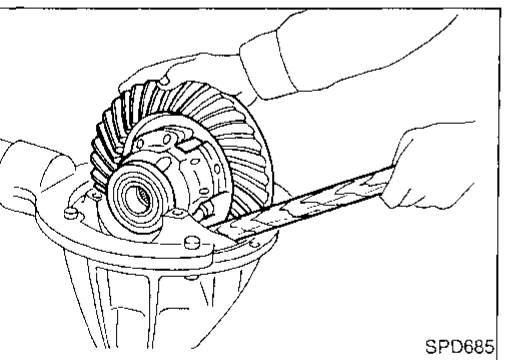

- Remove differential case assembly with a pry bar.

ST

RS

BT

HA

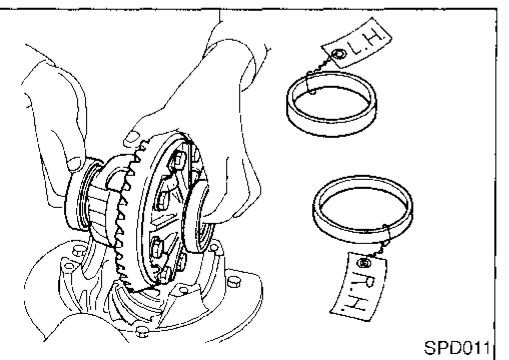

Be careful to keep the side bearing outer races together with their respective inner cones — do not mix them up.

EL

DX

Differential Carrier (Cont'd)

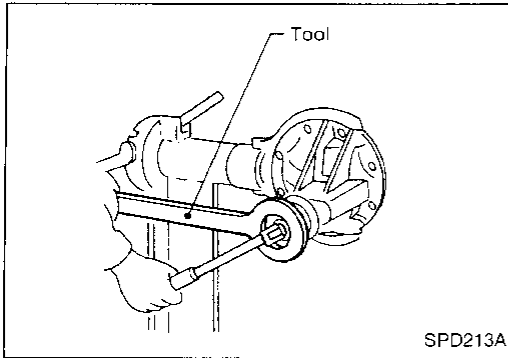

6. Remove drive pinion nut with Tool.
Tool number: KV38104700 (J34311)
7. Remove companion flange with puller.

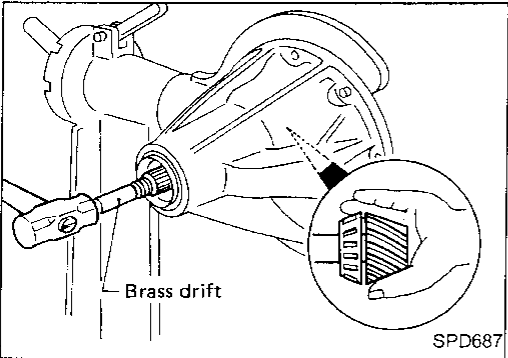

8. Take out drive pinion together with pinion rear bearing inner cone, drive pinion bearing spacer and pinion bearing adjusting shim.

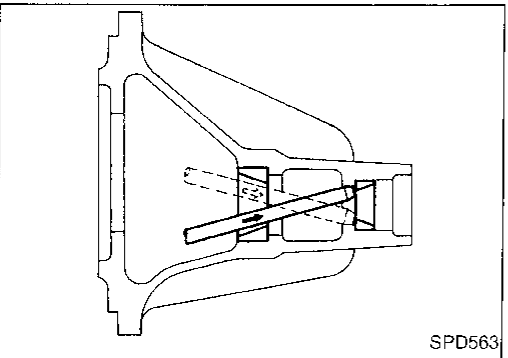

9. Remove front oil seal and pinion front bearing inner cone.
10. Remove pinion bearing outer races with a brass drift.

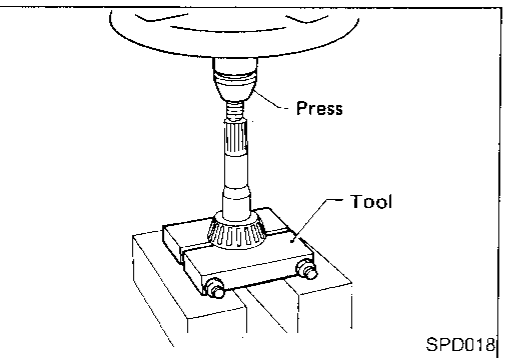

11. Remove pinion rear bearing inner cone and drive pinion adjusting washer.
Tool number: ST30031000 (J22912-01)

Differential Case

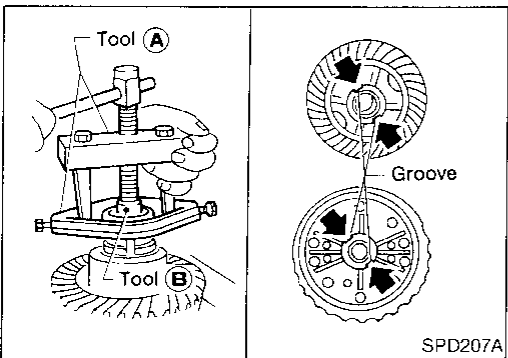

1. Remove side bearing inner cones.
To prevent damage to bearing, engage puller jaws in groove.
Tool number:
 - (A) ST33051001 (J22888-20)
 - (B) ST33061000 (J8107-2)

Differential Case (Cont'd)

Be careful not to confuse the left and right hand parts.
Keep bearing and bearing race for each side together.

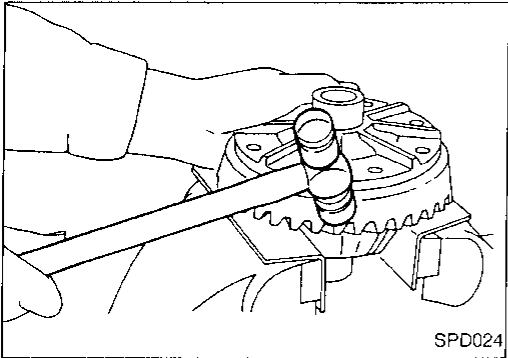
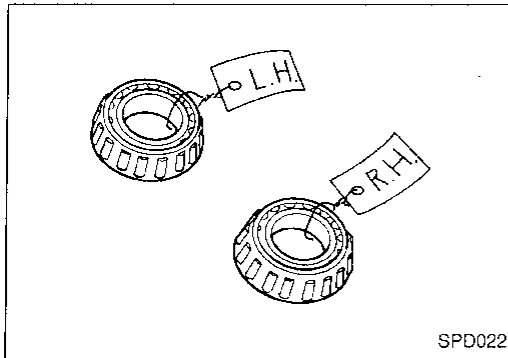

2. Loosen ring gear bolts in a criss-cross pattern.
3. Tap ring gear off differential case with a soft hammer.
Tap evenly all around to keep ring gear from binding.

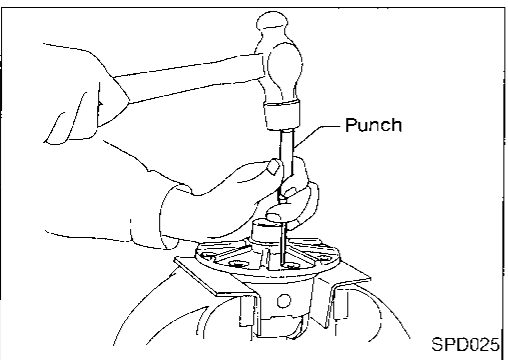

4. Drive out pinion mate shaft lock pin, with punch from ring gear side.
Lock pin is calked at pin hole mouth on differential case.

GI

MA

EM

LC

EC

FE

AT

TF

PD

FA

RA

BR

ST

RS

BT

HA

EL

DX

Ring Gear and Drive Pinion

Check gear teeth for scoring, cracking or chipping.
If any damaged part is evident, replace ring gear and drive pinion as a set (hypoid gear set).

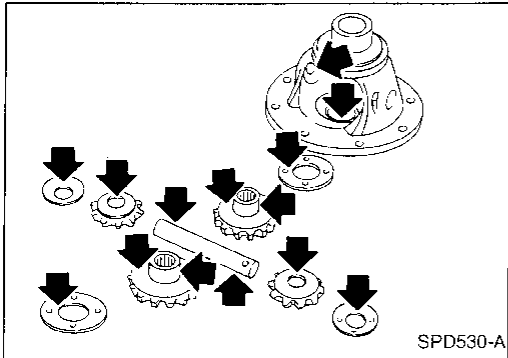

Differential Case Assembly

Check mating surfaces of differential case, side gears, pinion mate gears, pinion mate shaft, and thrust washers.

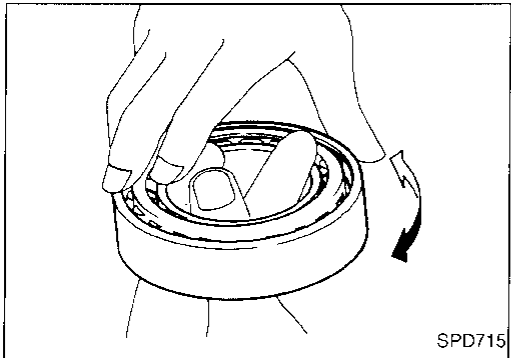

Bearing

1. Thoroughly clean bearing.
2. Check bearings for wear, scratches, pitting or flaking.
Check tapered roller bearing for smooth rotation. If damaged, replace outer race and inner cone as a set.

SEC. 380

No. of discs and plates (One side)

Model	H233B
Friction disc	2
Friction plate	9
Spring plate	2

Differential case couple bolt

64 - 74 (6.5 - 7.5, 47 - 54)

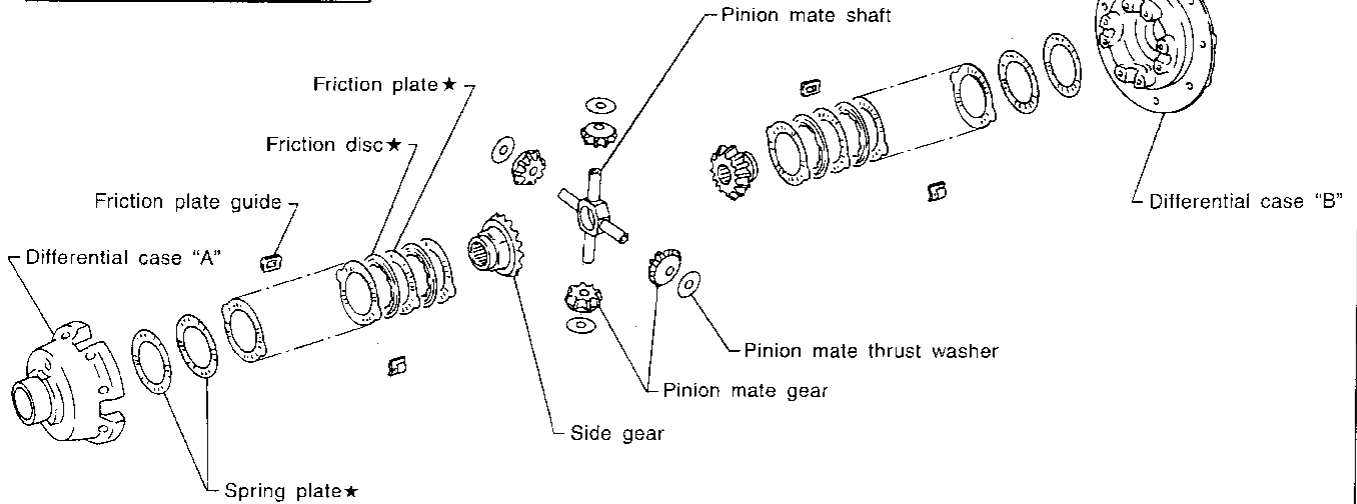

★ : For number of discs or plates, refer to table.

U : N·m (kg-m, ft-lb)

SPD404A

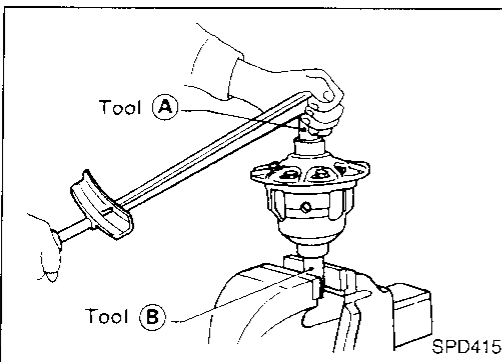

CAUTION:

Do not run engine when one wheel (rear) is off the ground.

Preparation for Disassembly

CHECKING DIFFERENTIAL TORQUE

Measure differential torque with Tool.

If it is not within the specifications, inspect components of limited slip differential.

Differential torque:

88 - 108 N·m

(9 - 11 kg-m, 65 - 80 ft-lb)

Tool number:

Ⓐ KV38105210 (—)

Ⓑ KV38105220 (—)

GI
MA
EM
LC
EC
FE
AT
TF
PD
FA
RA
BR
ST
RS
BT
EA
EL
IDX

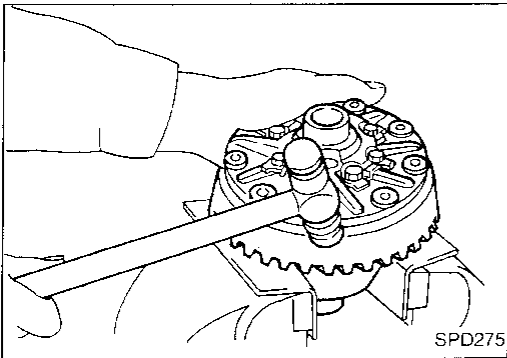

Disassembly

1. Remove side bearing inner cone with Tool.
2. Loosen ring gear bolts in a criss-cross pattern.
3. Tap ring gear off gear case with a soft hammer.
Tap evenly all around to keep ring gear from binding.

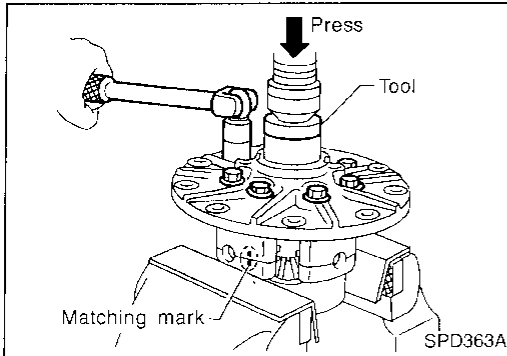

4. Remove couple bolts on differential cases A and B with a press.
Tool number: ST33081000 (—)
5. Separate differential case A and B.
Draw out component parts (discs and plates, etc.).

Put marks on gears and pressure rings so that they can be reinstalled in their original positions from which they were removed.

Inspection

CONTACT SURFACES

1. Clean the disassembled parts in suitable solvent and blow dry with compressed air.
2. If following surfaces are found with burrs or scratches, smooth with oil stone.
 - ① Differential case B
 - ② Differential case A
 - ③ Side gear
 - ④ Pinion mate gear
 - ⑤ Pinion mate shaft
 - ⑥ Friction plate guide

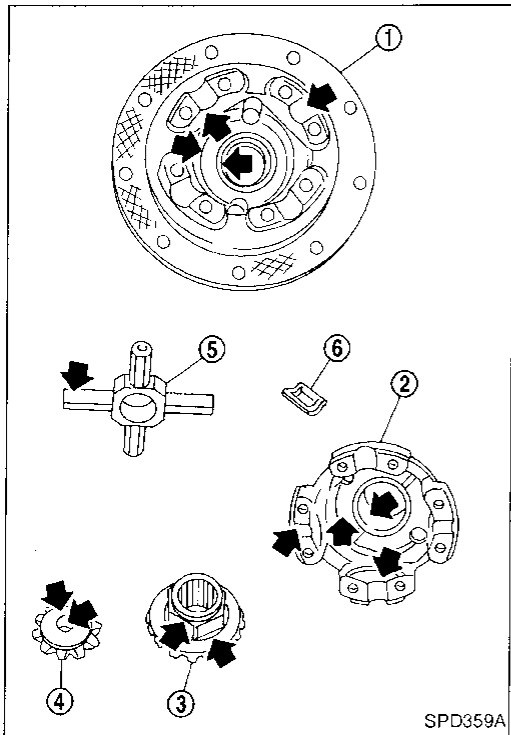

DISC AND PLATE

1. Clean the discs and plates in suitable solvent and blow dry with compressed air.
2. Inspect discs and plates for wear, nicks and burrs.

Inspection (Cont'd)

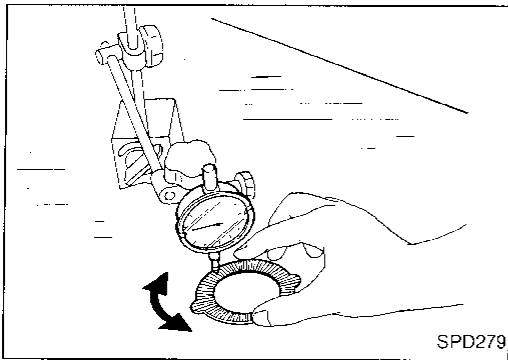

SPD279

- To test if friction disc or plate is not distorted, place it on a surface plate and rotate it by hand with indicating finger of dial gauge resting against disc or plate surface.

**Allowable warpage:
0.08 mm (0.0031 in)**

If it exceeds limits, replace with a new plate to eliminate possibility of clutch slippage or sticking.

GI

MA

EW

LC

EC

FE

AT

TF

PD

FA

RA

BR

ST

RS

BT

HA

EL

IDX

- Measure frictional surfaces and projected portions of friction disc, friction plate, spring plate, and determine each part's differences to see if the specified wear limit has been exceeded. If any part has worn beyond the wear limit, and deformed or fatigued, replace it with a new one that is the same thickness as the projected portion.

**Wear limit:
0.1 mm (0.004 in) or less
A - B = Wear limit mm (in)**

- : Measuring points
- A: Projected portion
- B: Frictional surface

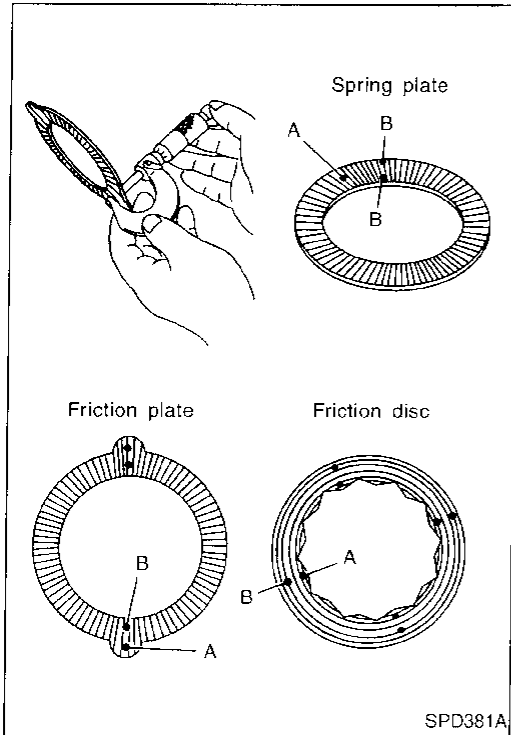

SPD381A

Adjustment

FRICION DISC AND FRICTION PLATE END PLAY

End play of friction disc and friction plate can be calculated by using following equation and should be adjusted within following range. Adjustment can be made by selecting friction disc having two different thicknesses.

**End play E:
0.05 - 0.15 mm (0.0020 - 0.0059 in)**

E = A - (B + C)

- A: Length of differential case contact surface to differential case inner bottom.
- B: Total thickness of friction discs, friction plates, spring disc and spring plate in differential case on one side.
- C: Length of differential case contact surface to back side of side gear.

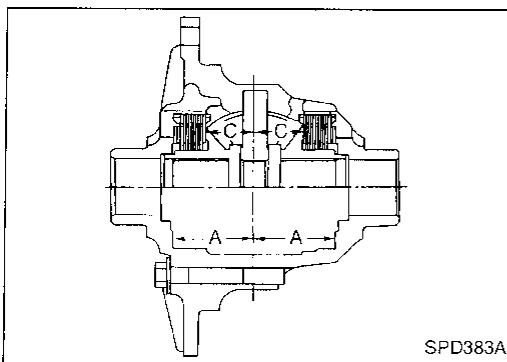

SPD383A

Adjustment (Cont'd)

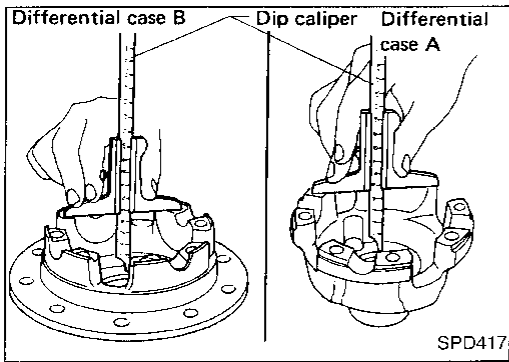

1. Measure values of "A".
Standard length A:
 49.50 - 49.55 mm (1.9488 - 1.9508 in)

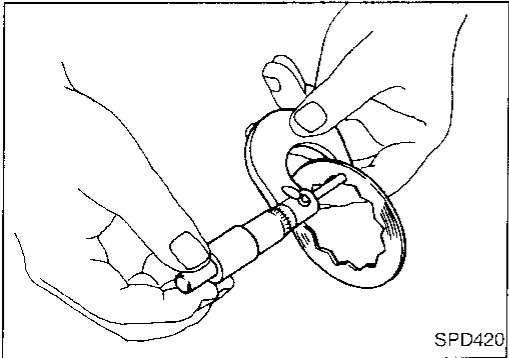

2. Measure thickness of each disc and plate.
Total thickness "B":
 19.24 - 20.26 mm (0.7575 - 0.7976 in)

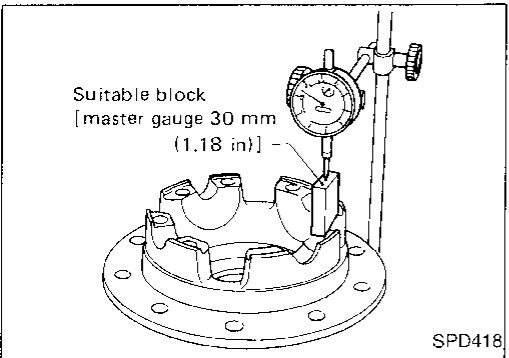

3. Measure values of "C".
 (1) Attach a dial indicator to the base plate.
 (2) Place differential case B on the base plate, and install a master gauge on case B.

Then adjust the dial indicator scale to zero with its tip on the master gauge.

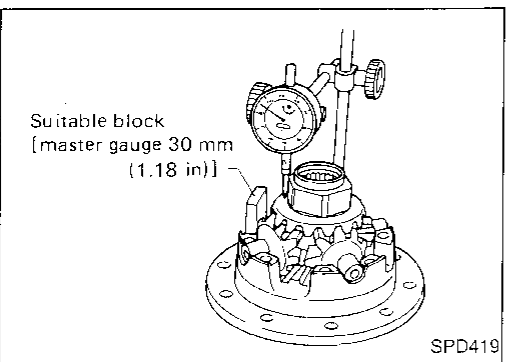

- (3) Install pinion mate gears, side gears and pinion mate shaft in differential case B.
- (4) Set dial indicator's tip on the side gear, and read the indication.

Example:

$$E = A - D = A - (B + C) = 0.05 \text{ to } 0.15 \text{ mm}$$

$$A = 49.52 \text{ mm}$$

$$B = 19.45 \text{ mm}$$

$$C = 29.7 \text{ mm}$$

$$D = B + C$$

$$E = A - D$$

$$B \dots 19.45$$

$$A \dots 49.52$$

$$+C \dots 29.7$$

$$-D \dots 49.15$$

$$49.15$$

$$0.37$$

From the above equation, end play of 0.37 mm exceeds the specified range of 0.05 to 0.15 mm.

Select suitable discs and plates to adjust correctly.

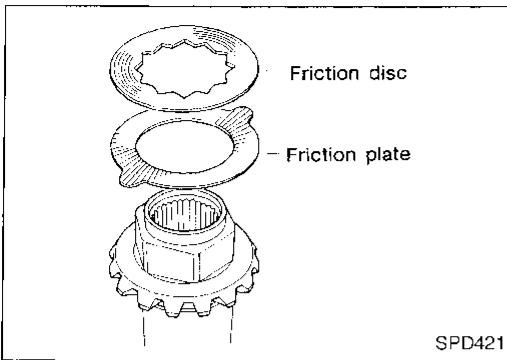

Assembly

Prior to assembling discs and plates, properly lubricate them by dipping them in limited slip differential oil.

1. Alternately position specified number of friction plates and friction discs on rear of side gear.

Always position a friction plate first on rear of side gear.

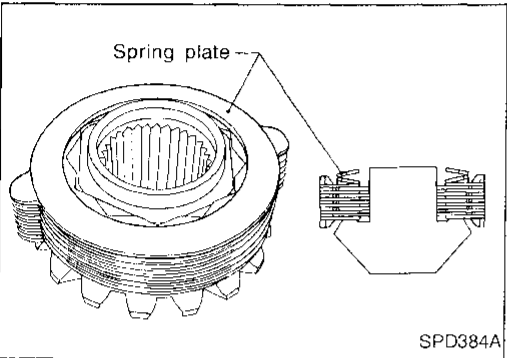

2. Install spring plate.

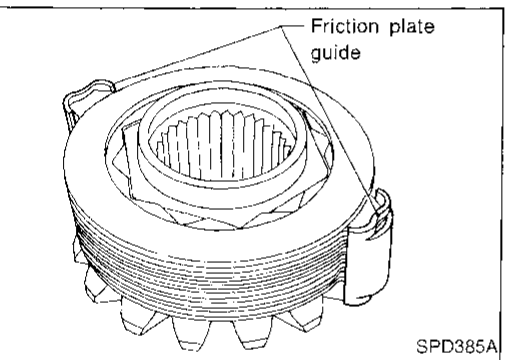

3. Install friction plate guides.

Correctly align the raised portions of friction plates, and apply grease to inner surfaces of friction plate guides to prevent them from falling.

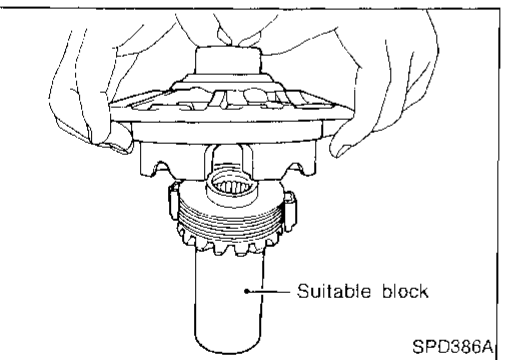

4. Install differential case B over side gear, discs, plates and friction plate guide assembly.

- Install differential case B while supporting friction plate guides with your middle finger inserted through oil hole in differential case.
- Be careful not to detach spring disc from the hexagonal part of the side gear.

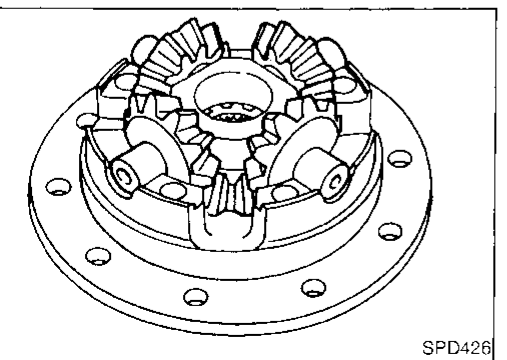

5. Install pinion mate gears and pinion mate thrust washers on pinion mate shaft, then install pinion mate shaft in differential case B.

GI

MA

EM

LC

EC

FE

AT

TF

PD

FA

RA

BR

ST

RS

BT

HA

EL

IDX

Assembly (Cont'd)

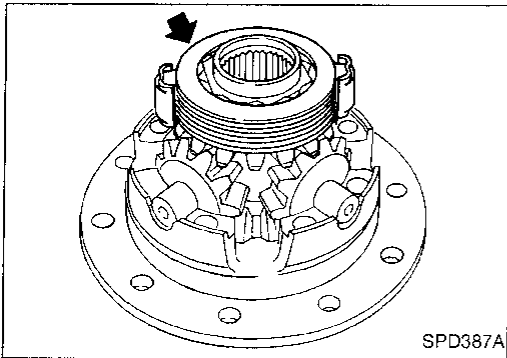

6. Install side gear to pinion mate gears.
7. Install each disc and plate.

Use same procedures as outlined in steps 1. through 4. above.

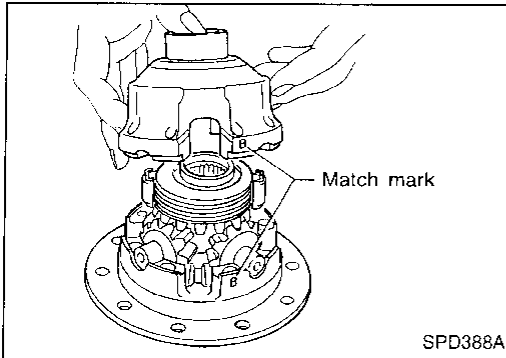

8. Install differential case A.

Position differential cases A and B by correctly aligning marks stamped on cases.

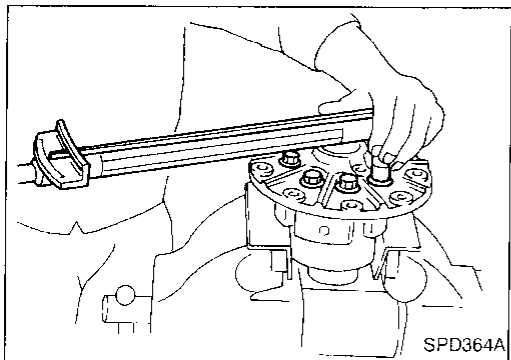

9. Tighten differential case couple bolts.

10. Place ring gear on differential case and tighten ring gear bolts.

Tighten bolts in a criss-cross pattern, lightly tapping bolt head with a hammer.

Then bend up lock straps to lock the bolts in place.

11. Install side bearing inner cone.
12. Check differential torque.

For quiet and reliable final drive operation, the following five adjustments must be made correctly:

1. Side bearing preload
2. Pinion gear height
3. Side bearing preload
4. Ring gear-to-pinion backlash. Refer to ASSEMBLY (PD-52).
5. Ring and pinion gear tooth contact pattern

GI

MA

EM

LC

EC

FE

AT

TF

PD

FA

RA

BR

ST

RS

BT

HA

EL

IDX

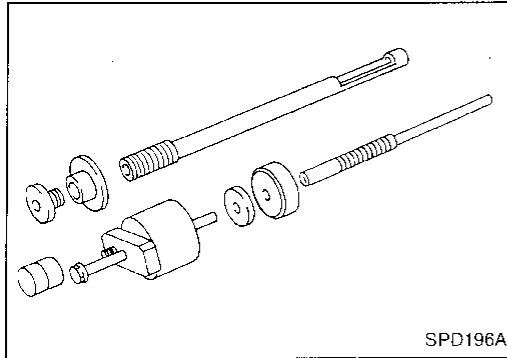

SPD196A

Pinion Gear Height

1. Make sure all parts are clean and that the bearings are well lubricated.
2. Assemble the pinion gear bearings into the pinion pre-load shim selector tool, J34309.

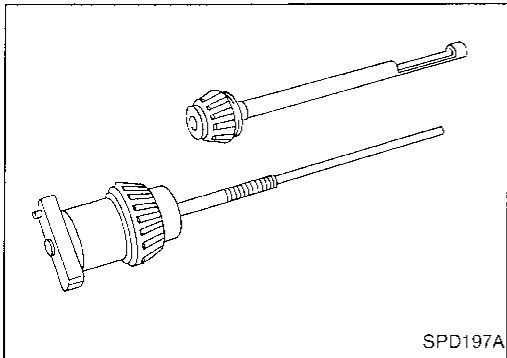

SPD197A

- **Rear Pinion Bearing** — the rear pinion bearing pilot, J34309-8, is used to center the rear pinion bearing only. The rear pinion bearing locking seat, J34309-4, is used to lock the bearing to the assembly.
- **Front Pinion Bearing** — make sure the J34309-3, front pinion bearing seat is secured tightly against the J34309-2 gauge anvil. Then turn the front pinion bearing pilot, J34309-5, to secure the bearing in its proper position.

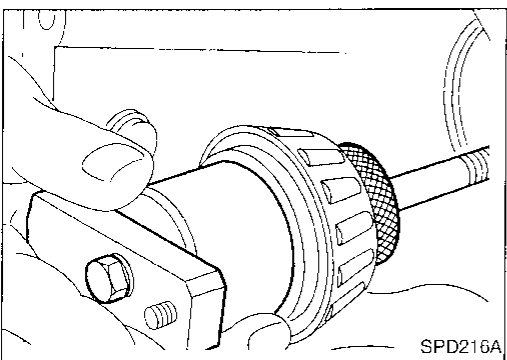

SPD216A

3. Place the pinion preload shim selector tool gauge screw assembly, J34309-1, with the pinion rear bearing inner cone installed, into the final drive housing.

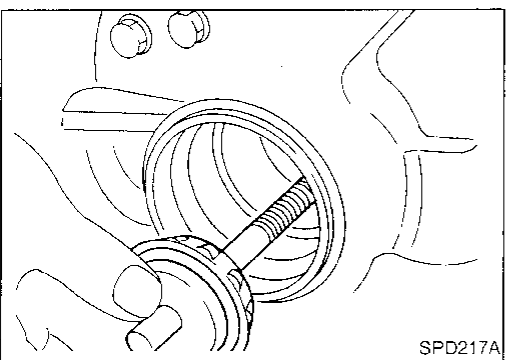

SPD217A

4. Install the J34309-2 gauge anvil with the front pinion bearing into the final drive housing and assemble it to the J34309-1 gauge screw. Make sure that the J34309-16 gauge plate will turn a full 360 degrees, and tighten the two sections by hand to set bearing pre-load.
5. Turn the assembly several times to seat the bearings.

Pinion Gear Height (Cont'd)

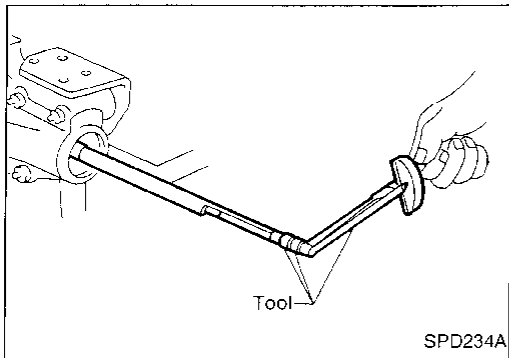

6. Measure the turning torque at the end of the J34309-2 gauge anvil using Tool.

Tool number:

ST3127S000 (J25765-A)

Turning torque specification:

0.4 - 0.9 N·m (4 - 9 kg·cm, 3.5 - 7.8 in·lb)

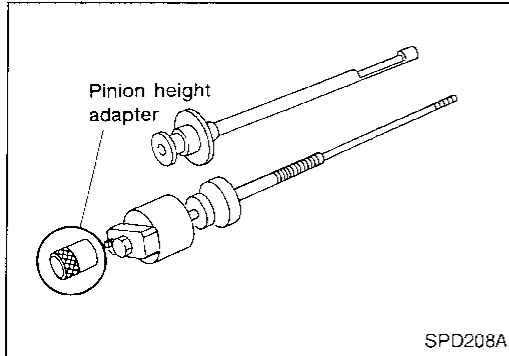

7. Place the J34309-12 "H233B" pinion height adapter onto the gauge plate and tighten it by hand.

CAUTION:

Make sure all machined surfaces are clean.

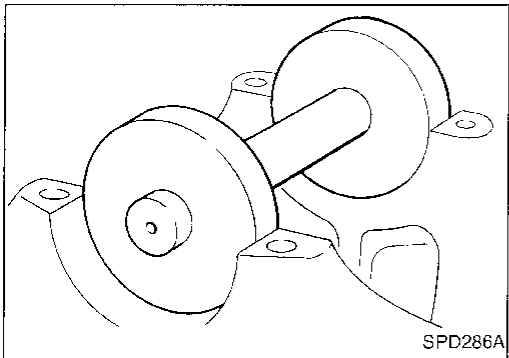

PINION HEIGHT ADJUSTING WASHER SELECTION

8. Position the J25269-18 side bearing discs and the arbor into the side bearing bores.

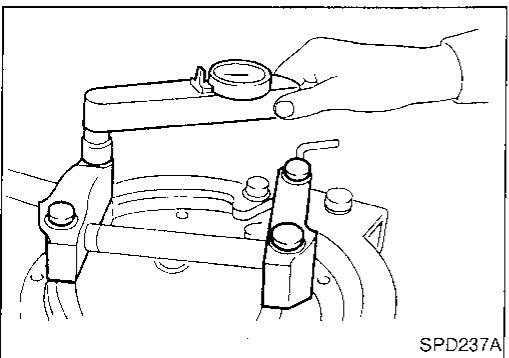

9. Install the bearing caps and torque the bolts.

Specification:

93 - 103 N·m (9.5 - 10.5 kg·m, 69 - 76 ft·lb)

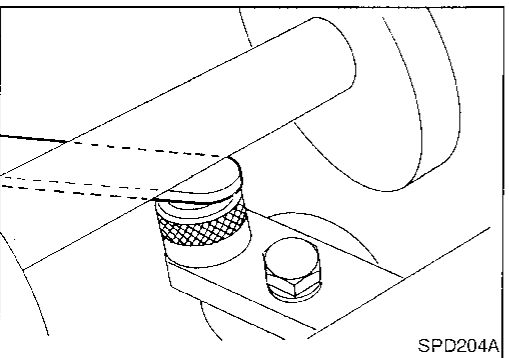

10. Select the correct standard pinion height adjusting washer thickness using a standard gauge of 2.5, 3.0, or 3.5 mm (0.098, 0.118, or 0.138 in) and your J34309-101 feeler gauge. Measure the distance between the J34309-12 "H233B" pinion height adapter and the arbor.

Pinion Gear Height (Cont'd)

11. Write down your exact total measurement.

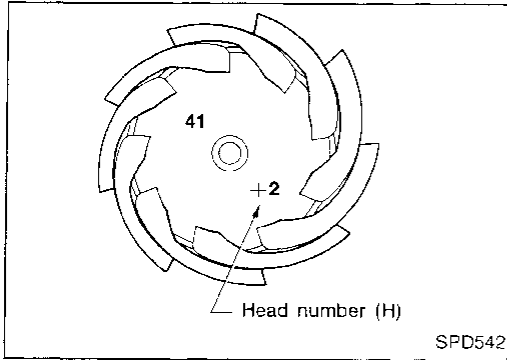
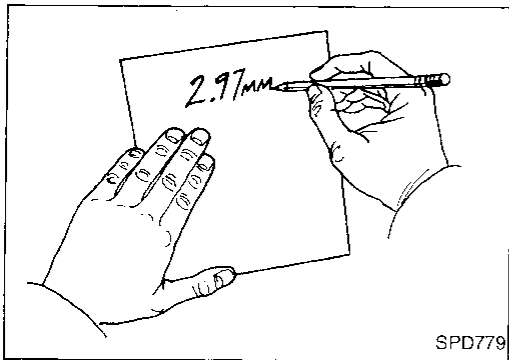

12. Correct the pinion height washer size by referring to the “pinion head height number”.

There are two numbers painted on the pinion gear. The first one refers to the pinion and ring gear as a matched set and should be the same as the number on the ring gear. The second number is the “pinion head height number”, and it refers to the ideal pinion height from standard for the quietest operation. Use the following chart to determine the correct pinion height washer.

Pinion Head Height Number	Add or Remove from the Selected Standard Pinion Height Washer Thickness Measurement
-6	Add 0.06 mm (0.0024 in)
-5	Add 0.05 mm (0.0020 in)
-4	Add 0.04 mm (0.0016 in)
-3	Add 0.03 mm (0.0012 in)
-2	Add 0.02 mm (0.0008 in)
-1	Add 0.01 mm (0.0004 in)
0	Use the selected washer thickness
+1	Subtract 0.01 mm (0.0004 in)
+2	Subtract 0.02 mm (0.0008 in)
+3	Subtract 0.03 mm (0.0012 in)
+4	Subtract 0.04 mm (0.0016 in)
+5	Subtract 0.05 mm (0.0020 in)
+6	Subtract 0.06 mm (0.0024 in)

13. Select the correct pinion height washer.

**Drive pinion height adjusting washer:
Refer to SDS (PD-55).**

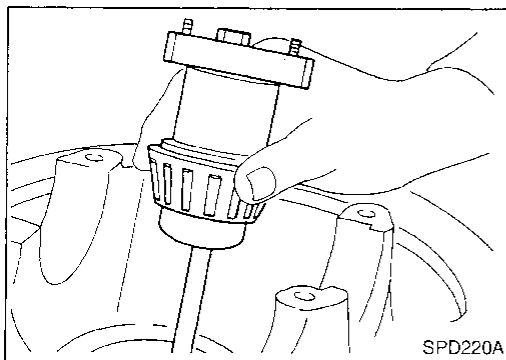

14. Remove the J34309 pinion preload shim selector tool from the final drive housing and disassemble to retrieve the pinion bearings.

GI
MA
EM
LG
EC
FE
AT
TF

PD
FA
HA
BR
ST
RS
BT

HA
EL
HX

Tooth Contact

Gear tooth contact pattern check is necessary to verify correct relationship between ring gear and drive pinion. Hypoid gear sets which are not positioned properly in relation to one another may be noisy, or have short life or both. With a pattern check, the most desirable contact for low noise level and long life can be assured.

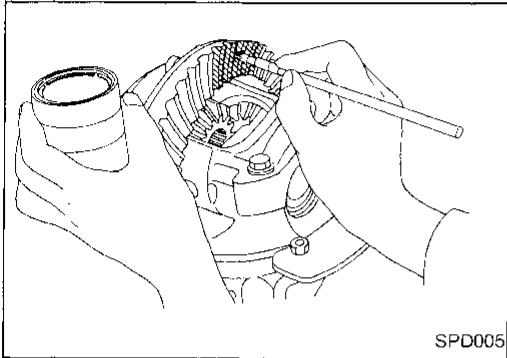

1. Thoroughly clean ring gear and drive pinion teeth.
2. Sparingly apply a mixture of powdered ferric oxide and oil or equivalent to 3 or 4 teeth of ring gear drive side.

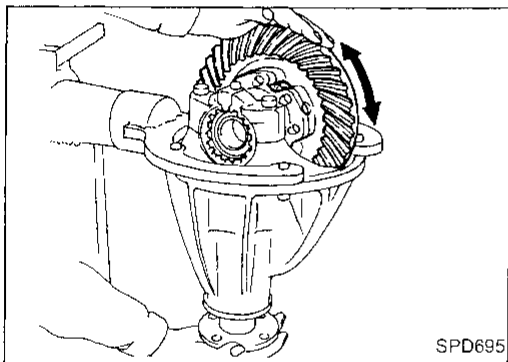

3. Hold companion flange steady by hand and rotate the ring gear in both directions.

Usually the pattern will be correct if shims are correctly calculated and the backlash is correct. However, in rare cases, trial and error processes may be employed to obtain a correct pattern. The tooth pattern is the best indication of how well a differential has been set up.

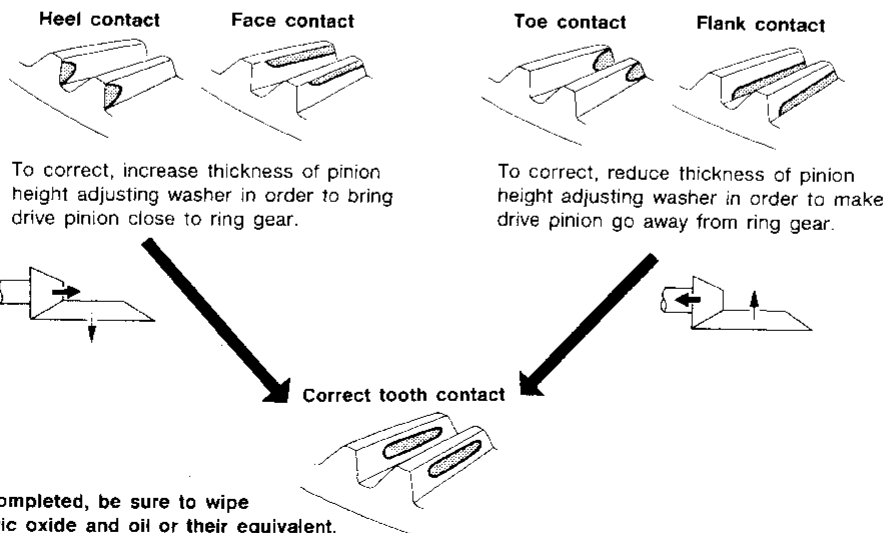

When adjustment is completed, be sure to wipe off completely the ferric oxide and oil or their equivalent.

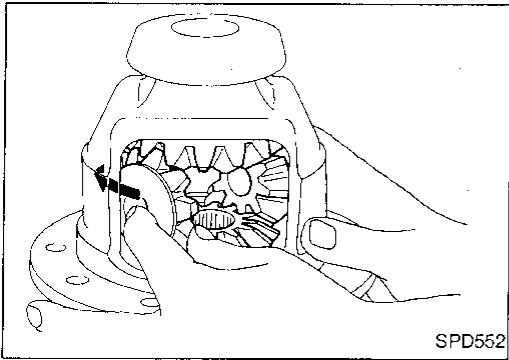

Differential Case

1. Install side gears, pinion mate gears and thrust washers into differential case.

GI

MA

EM

LC

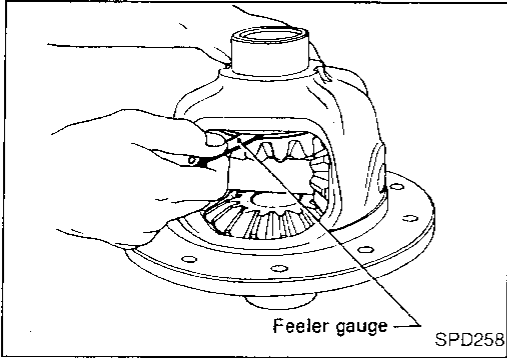

2. Fit pinion mate shaft to differential case so that it meets lock pin holes.
3. Adjust backlash between side gear and pinion mate gear by selecting side gear thrust washer. Refer to SDS (PD-55).

EC

FE

AT

Backlash between side gear and pinion mate gear (Clearance between side gear thrust washer and differential case):
 0.10 - 0.20 mm (0.0039 - 0.0079 in)

TF

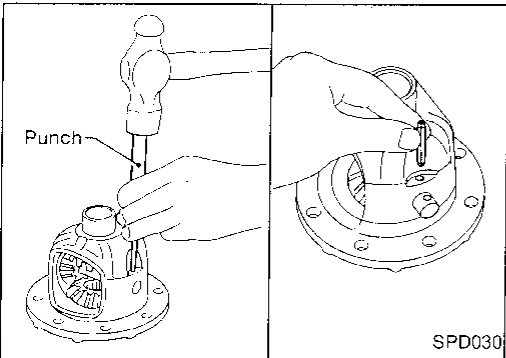

4. Install pinion mate shaft lock pin with a punch. **Make sure lock pin is flush with case.**

PD

FA

RA

BR

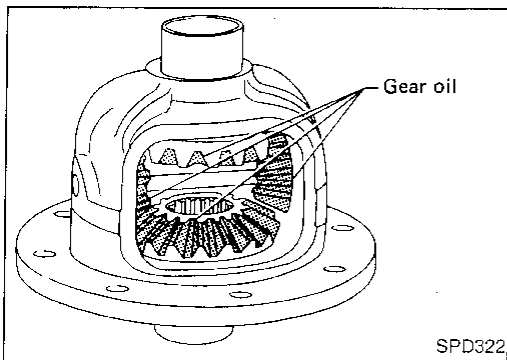

5. Apply gear oil to gear tooth surfaces and thrust surfaces and check to see they turn properly.

ST

6. Install differential case assembly on ring gear.

Tighten bolts in a criss-cross pattern, lightly tapping bolt head with a hammer.

RS

BT

HA

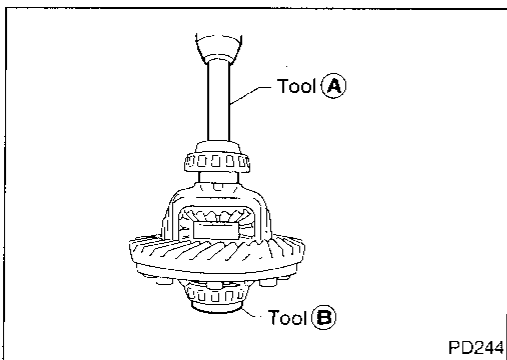

7. Press-fit side bearing inner cones on differential case with Tool.

EL

Tool number:

Ⓐ ST33190000 (J25523)

Ⓑ ST33081000 (—)

IDX

Differential Carrier

1. Press-fit front and rear bearing outer races with Tools.

Tool number:

- Ⓐ ST30611000 (J25742-1)
- Ⓑ ST30621000 (J25742-5)
- Ⓒ ST30613000 (J25742-3)

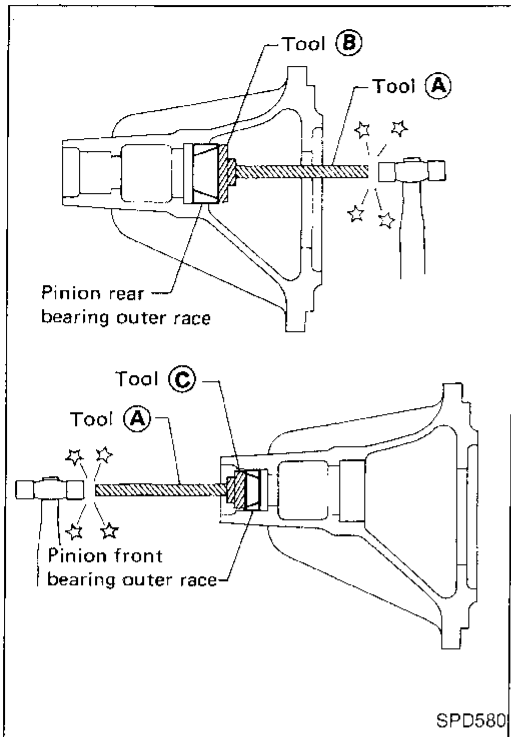

2. Select drive pinion height adjusting washer. Refer to ADJUSTMENT (PD-45).
3. Install drive pinion adjusting washer in drive pinion, and press-fit pinion rear bearing inner cone in it, with press and Tool.

Tool number:

ST30901000 (J26010-01)

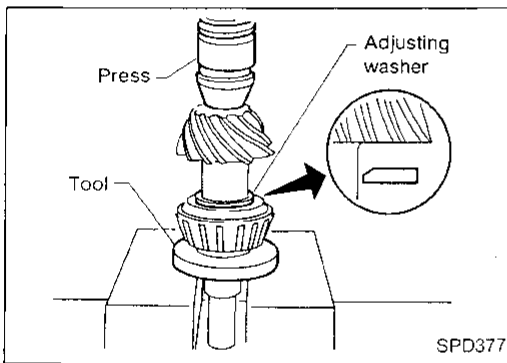

4. Place pinion front bearing inner cone in gear carrier.

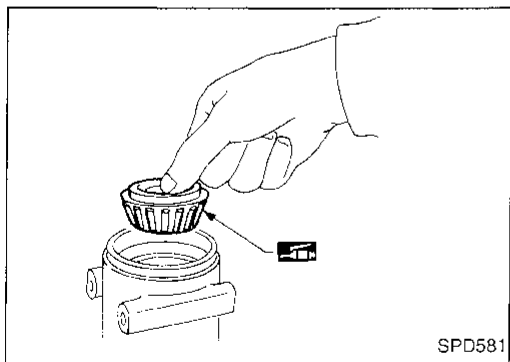

5. Apply multi-purpose grease to cavity at sealing lips of oil seal. Install front oil seal.

Tool number:

- Ⓐ ST30720000 (J25405)
- Ⓑ KV38102510 (—)

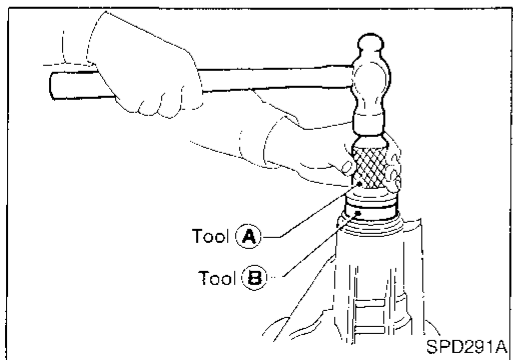

Differential Carrier (Cont'd)

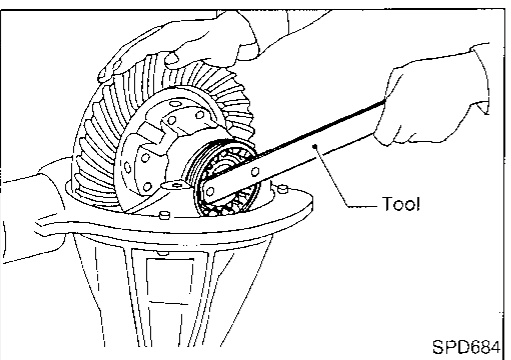
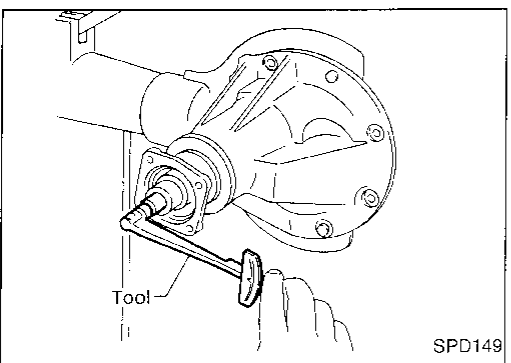
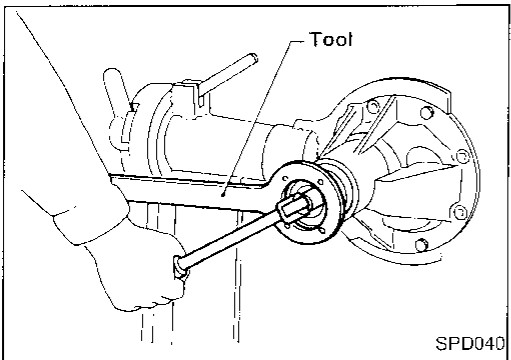
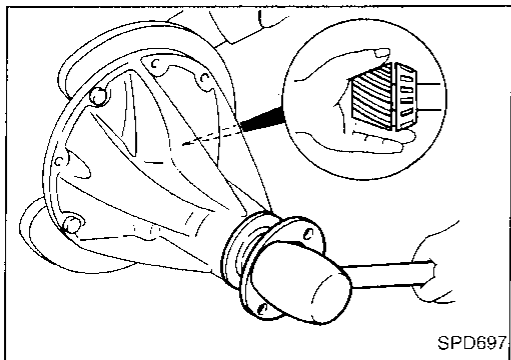
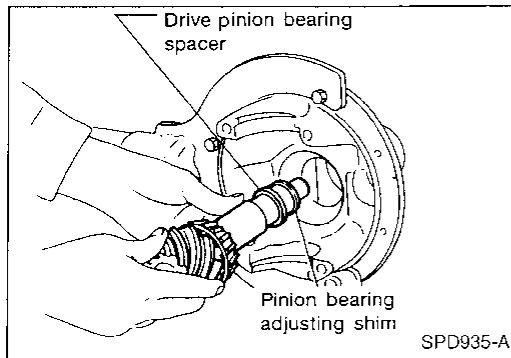

6. Install drive pinion bearing spacer, pinion bearing adjusting shim and drive pinion in gear carrier.

7. Insert companion flange into drive pinion by tapping the companion flange with a soft hammer.

8. Tighten pinion nut to the specified torque.
The threaded portion of drive pinion and pinion nut should be free from oil or grease.

Tool number: KV38104700 (J34311)

9. Turn drive pinion in both directions several times, and measure pinion bearing preload.

Tool number: ST3127S000 (J25765-A)

Pinion bearing preload (Without front oil seal):

1.4 - 1.7 N·m (14 - 17 kg-cm, 12 - 15 in-lb)

If preload is out of specification, adjust the thickness of spacer and shim combination by replacing shim and spacer with thinner one.

- Start from the combination of thickest spacer and shim.
- Combine each spacer and shim thickness one by one until the correct specification are achieved.

**Drive pinion bearing preload adjusting spacer and shim:
Refer to SDS (PD-56).**

10. Install differential case assembly with side bearing outer races into gear carrier.

11. Position side bearing adjusters on gear carrier with threads properly engaged; screw in adjusters lightly at this stage of assembly.

Tool number: ST32580000 (J34312)

GI
MA
EM
LC
EC
FE
AT
TF
PD
FA
FA
BR
ST
RS
BT
HA
EL
DX

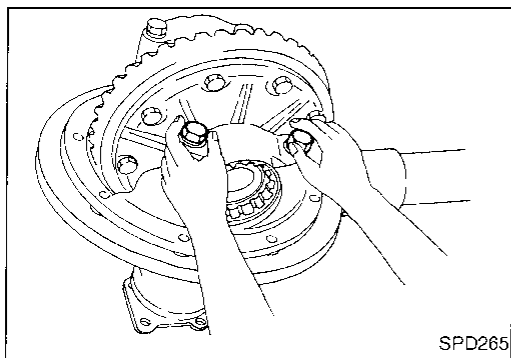
Differential Carrier (Cont'd)

12. Align mark on bearing cap with that on gear carrier and install bearing cap on gear carrier.
- Do not tighten at this point to allow further tightening of side bearing adjusters.

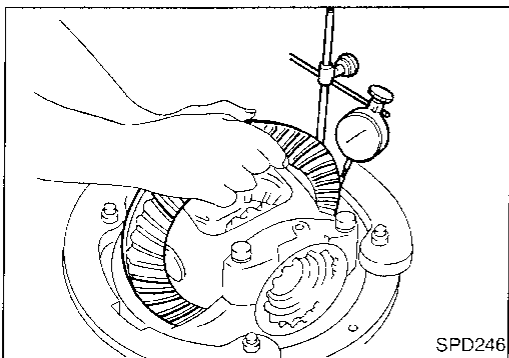

13. Tighten both right and left side bearing adjusters alternately and measure ring gear backlash and total preload at the same time. Adjust right and left side bearing adjusters by tightening them alternately so that proper ring gear backlash and total preload can be obtained.

Ring gear-to-drive pinion backlash:
0.13 - 0.18 mm (0.0051 - 0.0071 in)

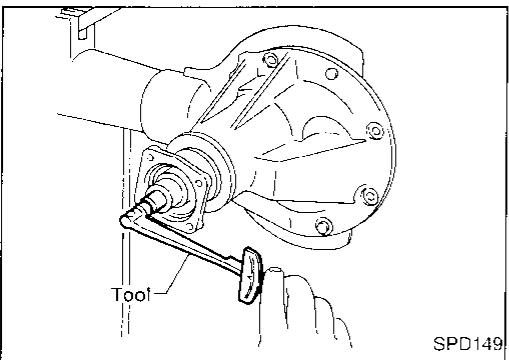

- When checking preload, turn drive pinion in both directions several times to set bearing rollers.

Tool number: ST3127S000 (J25765-A)

Total preload:

1.7 - 2.5 N·m (17 - 25 kg-cm, 15 - 22 in-lb)

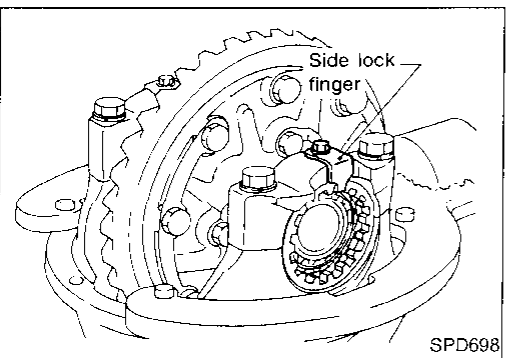

14. Tighten side bearing cap bolts.
15. Install side lock finger in place to prevent rotation during operation.

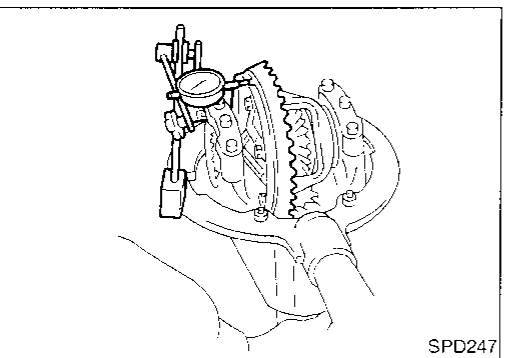

16. Check runout of ring gear with a dial indicator.
- Runout limit: 0.08 mm (0.0031 in)**
- If backlash varies excessively in different places, the variance may have resulted from foreign matter caught between the ring gear and the differential case.
 - If the backlash varies greatly when the runout of the ring gear is within a specified range, the hypoid gear set or differential case should be replaced.
17. Check tooth contact. Refer to ADJUSTMENT (PD-48).

SERVICE DATA AND SPECIFICATIONS (SDS)

Propeller Shaft

GENERAL SPECIFICATIONS

Location	Front	Rear
Propeller shaft model	2F71H	2S80B
Number of joints	2	
Coupling method with transmission	Flange type	Sleeve type
Type of journal bearings	Solid type (disassembly type)	
Distance between yokes mm (in)	71 (2.80)	80 (3.15)
Shaft length (Spider to spider) mm (in)	565 (22.24)	927 (36.50)
Shaft outer diameter mm (in)	50.8 (2.000)	75 (2.95)

SERVICE DATA

Unit: mm (in)

Propeller shaft runout limit	0.6 (0.024)
Journal axial play	0.02 (0.0008) or less

Snap ring (80B)

Unit: mm (in)

Thickness	Color	Part number
1.99 (0.0783)	White	37146-C9400
2.02 (0.0795)	Yellow	37147-C9400
2.05 (0.0807)	Red	37148-C9400
2.08 (0.0819)	Green	37149-C9400
2.11 (0.0831)	Blue	37150-C9400
2.14 (0.0843)	Light brown	37151-C9400
2.17 (0.0854)	Black	37152-C9400
2.20 (0.0866)	No paint	37153-C9400

Snap ring (71H)

Unit: mm (in)

Thickness	Color	Part number
1.99 (0.0783)	White	37146-01G00
2.02 (0.0795)	Yellow	37147-01G00
2.05 (0.0807)	Red	37148-01G00
2.08 (0.0819)	Green	37149-01G00
2.11 (0.0831)	Blue	37150-01G00
2.14 (0.0843)	Light brown	37151-01G00
2.17 (0.0854)	Pink	37152-01G00
2.20 (0.0866)	No paint	37153-01G00

SERVICE DATA AND SPECIFICATIONS (SDS)

Final Drive

GENERAL SPECIFICATIONS

Front final drive	Standard	Option
	R200A	
	2-pinion	
Gear ratio	4.636	
Number of teeth (Ring gear/drive pinion)	51/11	
Oil capacity (Approx.) ℓ (US pt, Imp pt)	2.05 (4-3/8, 3-5/8)	
Rear final drive	H233B	
	2-pinion	LSD
	4.636	
Number of teeth (Ring gear/drive pinion)	51/11	
Oil capacity (Approx.) ℓ (US pt, Imp pt)	2.8 (5-7/8, 4-7/8)	

INSPECTION AND ADJUSTMENT (R200A)

Ring gear runout

Ring gear runout limit	mm (in)	0.05 (0.0020)
------------------------	---------	---------------

Side gear adjustment

Side gear backlash (Clearance between side gear and differential case)	mm (in)	Less than 0.15 (0.0059)
---	---------	-------------------------

Available side gear thrust washers

Thickness mm (in)	Part number
0.75 (0.0295)	38424-N3110
0.78 (0.0307)	38424-N3111
0.81 (0.0319)	38424-N3112
0.84 (0.0331)	38424-N3113
0.87 (0.0343)	38424-N3114
0.90 (0.0354)	38424-N3115
0.93 (0.0366)	38424-N3116

Side bearing adjustment

Differential carrier assembly turning resistance	N (kg, lb)	34.3 - 39.2 (3.5 - 4.0, 7.7 - 8.8)
--	------------	---------------------------------------

Available side bearing adjusting washers

Thickness mm (in)	Part number
2.00 (0.0787)	38453-N3100
2.05 (0.0807)	38453-N3101
2.10 (0.0827)	38453-N3102
2.15 (0.0846)	38453-N3103
2.20 (0.0866)	38453-N3104
2.25 (0.0886)	38453-N3105
2.30 (0.0906)	38453-N3106
2.35 (0.0925)	38453-N3107
2.40 (0.0945)	38453-N3108
2.45 (0.0965)	38453-N3109
2.50 (0.0984)	38453-N3110
2.55 (0.1004)	38453-N3111
2.60 (0.1024)	38453-N3112

Total preload adjustment

Total preload	N-m (kg-cm, in-lb)	1.4 - 1.7 (14 - 17, 12 - 15)
Ring gear backlash	mm (in)	0.10 - 0.15 (0.0039 - 0.0059)

Drive pinion height adjustment

Available pinion height adjusting washers

Thickness mm (in)	Part number
3.09 (0.1217)	38154-P6017
3.12 (0.1228)	38154-P6018
3.15 (0.1240)	38154-P6019
3.18 (0.1252)	38154-P6020
3.21 (0.1264)	38154-P6021
3.24 (0.1276)	38154-P6022
3.27 (0.1287)	38154-P6023
3.30 (0.1299)	38154-P6024
3.33 (0.1311)	38154-P6025
3.36 (0.1323)	38154-P6026
3.39 (0.1335)	38154-P6027
3.42 (0.1346)	38154-P6028
3.45 (0.1358)	38154-P6029
3.48 (0.1370)	38154-P6030
3.51 (0.1382)	38154-P6031
3.54 (0.1394)	38154-P6032
3.57 (0.1406)	38154-P6033
3.60 (0.1417)	38154-P6034
3.63 (0.1429)	38154-P6035
3.66 (0.1441)	38154-P6036

Drive pinion preload adjustment

Drive pinion bearing preload adjusting method	Adjusting washer and spacer
Drive pinion preload	N-m (kg-cm, in-lb)
With front oil seal	1.1 - 1.4 (11 - 14, 9.5 - 12.2)

Available drive pinion bearing preload adjusting washers

Thickness mm (in)	Part number
3.81 (0.1500)	38125-61001
3.83 (0.1508)	38126-61001
3.85 (0.1516)	38127-61001
3.87 (0.1524)	38128-61001
3.89 (0.1531)	38129-61001
3.91 (0.1539)	38130-61001
3.93 (0.1547)	38131-61001
3.95 (0.1555)	38132-61001
3.97 (0.1563)	38133-61001
3.99 (0.1571)	38134-61001
4.01 (0.1579)	38135-61001
4.03 (0.1587)	38136-61001
4.05 (0.1594)	38137-61001
4.07 (0.1602)	38138-61001
4.09 (0.1610)	38139-61001

Available drive pinion bearing preload adjusting spacers

Length mm (in)	Part number
54.50 (2.1457)	38165-B4000
54.80 (2.1575)	38165-B4001
55.10 (2.1693)	38165-B4002
55.40 (2.1811)	38165-B4003
55.70 (2.1929)	38165-B4004
56.00 (2.2047)	38165-61001

SERVICE DATA AND SPECIFICATIONS (SDS)

Final Drive (Cont'd)

INSPECTION AND ADJUSTMENT (H233B)

Ring gear runout

Ring gear runout limit	mm (in)	0.08 (0.0031)
------------------------	---------	---------------

Side gear adjustment

Side gear backlash (Clearance between side gear and differential case)	mm (in)	0.10 - 0.20 (0.0039 - 0.0079)
---	---------	----------------------------------

Available side gear thrust washers

Thickness mm (in)	Part number
1.75 (0.0689)	38424-T5000
1.80 (0.0709)	38424-T5001
1.85 (0.0728)	38424-T5002

— Additional service for limited slip differential model —

Differential torque adjustment

Differential torque	N-m (kg-m, ft-lb)	88 - 108 (9 - 11.65 - 80)
Number of discs and plates (One side)		
Friction disc		2
Friction plate		9
Spring plate		2
Wear limit of plate and disc	mm (in)	0.1 (0.004)
Allowable warpage of friction disc and plate	mm (in)	0.08 (0.0031)

Available discs and plates

Plate name	Thickness mm (in)	Part number
Friction disc	1.48 - 1.52 (0.0583 - 0.0598)	38433-C6002 (Standard type)
	1.38 - 1.42 (0.0543 - 0.0559)	38433-C6004 (Adjusting type)
	1.58 - 1.62 (0.0622 - 0.0638)	38433-C6003 (Adjusting type)
Friction plate	1.48 - 1.52 (0.0583 - 0.0598)	38432-C6001 (Standard type)
	1.38 - 1.42 (0.0543 - 0.0559)	38432-C6002 (Adjusting type)
Spring plate	1.48 - 1.52 (0.0583 - 0.0598)	38435-S9200

Drive pinion height adjustment

Available pinion height adjusting washers

Thickness mm (in)	Part number
2.58 (0.1016)	38151-01J00
2.61 (0.1028)	38151-01J01
2.64 (0.1039)	38151-01J02
2.67 (0.1051)	38151-01J03
2.70 (0.1063)	38151-01J04
2.73 (0.1075)	38151-01J05
2.76 (0.1087)	38151-01J06
2.79 (0.1098)	38151-01J07
2.82 (0.1110)	38151-01J08
2.85 (0.1122)	38151-01J09
2.88 (0.1134)	38151-01J10
2.91 (0.1146)	38151-01J11
2.94 (0.1157)	38151-01J12
2.97 (0.1169)	38151-01J13
3.00 (0.1181)	38151-01J14
3.03 (0.1193)	38151-01J15
3.06 (0.1205)	38151-01J16
3.09 (0.1217)	38151-01J17
3.12 (0.1228)	38151-01J18
3.15 (0.1240)	38151-01J19
3.18 (0.1252)	38151-01J60
3.21 (0.1264)	38151-01J61
3.24 (0.1276)	38151-01J62
3.27 (0.1287)	38151-01J63
3.30 (0.1299)	38151-01J64
3.33 (0.1311)	38151-01J65
3.36 (0.1323)	38151-01J66
3.39 (0.1335)	38151-01J67
3.42 (0.1346)	38151-01J68
3.45 (0.1358)	38151-01J69
3.48 (0.1370)	38151-01J70
3.51 (0.1382)	38151-01J71
3.54 (0.1394)	38151-01J72
3.57 (0.1406)	38151-01J73
3.60 (0.1417)	38151-01J74
3.63 (0.1429)	38151-01J75
3.66 (0.1441)	38151-01J76

G'

MA

EM

LC

EC

FE

AT

TF

PD

FA

RA

BR

ST

RS

BT

HA

EL

DX

SERVICE DATA AND SPECIFICATIONS (SDS)

Final Drive (Cont'd)

Drive pinion preload adjustment

Drive pinion bearing preload adjusting method	Adjusting shim and spacer
Drive pinion preload N-m (kg-cm, in-lb)	
Without front oil seal	1.4 - 1.7 (14 - 17, 12 - 15)

Available front drive pinion bearing adjusting shims

Thickness mm (in)	Part number
2.31 (0.0909)	38125-82100
2.33 (0.0917)	38126-82100
2.35 (0.0925)	38127-82100
2.37 (0.0933)	38128-82100
2.39 (0.0941)	38129-82100
2.41 (0.0949)	38130-82100
2.43 (0.0957)	38131-82100
2.45 (0.0965)	38132-82100
2.47 (0.0972)	38133-82100
2.49 (0.0980)	38134-82100
2.51 (0.0988)	38135-82100
2.53 (0.0996)	38136-82100
2.55 (0.1004)	38137-82100
2.57 (0.1012)	38138-82100
2.59 (0.1020)	38139-82100

Available drive pinion bearing adjusting spacers

Thickness mm (in)	Part number
4.50 (0.1772)	38165-76000
4.75 (0.1870)	38166-76000
5.00 (0.1969)	38167-76000
5.25 (0.2067)	38166-01J00
5.50 (0.2165)	38166-01J10

Total preload adjustment

Total preload N-m (kg-cm, in-lb)	1.7 - 2.5 (17 - 25, 15 - 22)
Ring gear backlash mm (in)	0.13 - 0.18 (0.0051 - 0.0071)
Side bearing adjusting method	Side adjuster