

SECTION **BR**

CONTENTS

PRECAUTION	2	Inspection.....	17
Supplemental Restraint System (SRS) "AIR BAG"	2	OUTPUT ROD LENGTH CHECK	17
Precautions for Brake System.....	2	Installation.....	18
Wiring Diagrams and Trouble Diagnosis.....	2	VACUUM PIPING	19
PREPARATION	3	Vacuum Hose	19
Special Service Tools	3	Removal and Installation	19
Commercial Service Tools	3	Inspection.....	19
NOISE, VIBRATION AND HARSHNESS (NVH)		HOSES AND CONNECTORS	19
TROUBLESHOOTING	4	CHECK VALVE.....	19
NVH Troubleshooting Chart.....	4	FRONT DISC BRAKE	20
ON-VEHICLE SERVICE	5	Components.....	20
Checking Brake Fluid Level.....	5	Pad Replacement	20
Checking Brake Line	5	Removal.....	21
Changing Brake Fluid.....	5	Disassembly.....	22
Bleeding Brake System	6	Inspection.....	22
BRAKE HYDRAULIC LINE	7	CALIPER.....	22
Hydraulic Circuit.....	7	ROTOR.....	22
Removal.....	7	Assembly	23
Inspection.....	8	Installation.....	23
Installation.....	8	Brake Burnishing Procedure.....	23
LOAD SENSING VALVE	9	REAR DRUM BRAKE	24
Inspection.....	9	Components.....	24
Removal and Installation	10	Removal.....	24
BRAKE PEDAL AND BRACKET	12	Inspection.....	25
Removal and Installation	12	WHEEL CYLINDER.....	25
Inspection.....	12	Wheel Cylinder Overhaul.....	26
Adjustment.....	12	Inspection.....	26
MASTER CYLINDER	14	DRUM.....	26
Removal.....	14	LINING.....	26
Disassembly.....	14	Installation.....	26
Inspection.....	15	PARKING BRAKE CONTROL	28
Assembly	15	Components.....	28
Installation.....	16	Removal and Installation	28
BRAKE BOOSTER	17	Inspection.....	28
On-vehicle Service.....	17	Adjustment	29
OPERATING CHECK	17		
AIRTIGHT CHECK	17		
Removal.....	17		

	ABS	
DESCRIPTION		30
Purpose.....		30

CONTENTS (Cont'd)

Operation	30	SOLENOID VALVE RELAY	57	CI
ABS Hydraulic Circuit	30	Diagnostic Procedure	57	
System Components	31	MOTOR RELAY OR MOTOR	60	MA
System Description.....	31	Diagnostic Procedure	60	
SENSOR.....	31	LOW VOLTAGE	64	EM
CONTROL UNIT	31	Diagnostic Procedure	64	
G SENSOR	32	G SENSOR	65	LC
ACTUATOR.....	33	Diagnostic Procedure	65	
Component Parts and Harness Connector		Electrical Components Inspection	67	EC
Location	34	G SENSOR	67	
Circuit Diagram for Quick Pinpoint Check.....	35	CONTROL UNIT	68	EC
Wiring Diagram — ABS —	36	Diagnostic Procedure	68	
ON BOARD DIAGNOSTIC SYSTEM		TROUBLE DIAGNOSES FOR SYMPTOMS	69	
DESCRIPTION	40	1. ABS Works Frequently	69	FE
Self-diagnosis	40	2. Unexpected Pedal Action	69	
FUNCTION.....	40	3. Long Stopping Distance	70	AT
SELF-DIAGNOSIS PROCEDURE.....	40	4. ABS Does Not Work.....	71	
HOW TO READ SELF-DIAGNOSTIC RESULTS		5. Pedal Vibration and Noise.....	71	TF
(MALFUNCTION CODES)	41	6. Warning Lamp Does Not Come On When		
HOW TO ERASE SELF-DIAGNOSTIC RESULTS		Ignition Switch Is Turned On	72	PD
(MALFUNCTION CODES)	41	7. Warning Lamp Stays On When Ignition Switch		
CONSULT	42	Is Turned On.....	75	AX
CONSULT APPLICATION TO ABS	42	8. Vehicle Vibrates Excessively When ABS Is		
ECU (ABS CONTROL UNIT) PART NUMBER		Operating	78	SU
MODE.....	42	REMOVAL AND INSTALLATION	80	
CONSULT Inspection Procedure.....	43	Front Wheel Sensor.....	80	BR
SELF-DIAGNOSIS PROCEDURE.....	43	Rear Wheel Sensor	80	
SELF-DIAGNOSTIC RESULTS MODE.....	44	Front Sensor Rotor.....	81	ST
DATA MONITOR PROCEDURE	45	REMOVAL.....	81	
ACTIVE TEST PROCEDURE	46	INSTALLATION.....	81	RS
DATA MONITOR MODE.....	47	Rear Sensor Rotor.....	81	
ACTIVE TEST MODE	47	REMOVAL.....	81	BT
TROUBLE DIAGNOSIS — INTRODUCTION	48	INSTALLATION.....	81	
How to Perform Trouble Diagnoses for Quick		Control Unit.....	82	HA
and Accurate Repair	48	REMOVAL.....	82	
INTRODUCTION.....	48	G Sensor.....	82	SC
TROUBLE DIAGNOSIS — BASIC INSPECTION	49	Actuator.....	83	
Preliminary Check.....	49	REMOVAL.....	83	IEL
Ground Circuit Check	51	INSTALLATION.....	83	
ACTUATOR MOTOR GROUND	51	Actuator Relays	84	
CONTROL UNIT GROUND.....	51	SERVICE DATA AND SPECIFICATIONS (SDS)	85	HA
ACTUATOR GROUND	51	General Specifications.....	85	
TROUBLE DIAGNOSIS — GENERAL		Disc Brake	85	SC
DESCRIPTION	52	Drum Brake.....	85	
Malfunction Code/Symptom Chart.....	52	Brake Pedal	85	IEL
WHEEL SENSOR OR ROTOR	53	Parking Brake Control	86	
Diagnostic Procedure	53			
ABS ACTUATOR SOLENOID VALVE	55			
Diagnostic Procedure	55			

IDX

PRECAUTION

Supplemental Restraint System (SRS) "AIR BAG"

Supplemental Restraint System (SRS) "AIR BAG"

NBBH0001

The Supplemental Restraint System "AIR BAG", used along with a seat belt, helps to reduce the risk or severity of injury to the driver and front passenger in a frontal collision. The Supplemental Restraint System consists of air bag modules (located in the center of the steering wheel and on the instrument panel on the passenger side), a diagnosis sensor unit, warning lamp, wiring harness and spiral cable. Information necessary to service the system safely is included in the **RS section** of this Service Manual.

WARNING:

- To avoid rendering the SRS inoperative, which could increase the risk of personal injury or death in the event of a collision which would result in air bag inflation, all maintenance must be performed by an authorized INFINITI dealer.
- Improper maintenance, including incorrect removal and installation of the SRS, can lead to personal injury caused by unintentional activation of the system.
- Do not use electrical test equipment on any circuit related to the SRS unless instructed to in this Service Manual. SRS wiring harnesses are covered with yellow insulation either just before the harness connectors or for the complete harness, for easy identification.

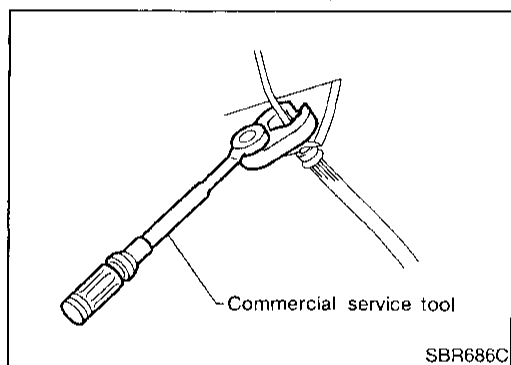

Precautions for Brake System

NBBR0002

- Use brake fluid "DOT 3".
- Never reuse drained brake fluid.
- Be careful not to splash brake fluid on painted areas; it may cause paint damage. If brake fluid is splashed on painted areas, wash it away with water immediately.
- To clean master cylinder parts, disc brake caliper parts or wheel cylinder parts, use clean brake fluid.
- Never use mineral oils such as gasoline or kerosene. They will ruin rubber parts of hydraulic system.
- Use flare nut wrench when removing and installing brake tubes.
- Always torque brake lines when installing.

WARNING:

- Clean brakes with a vacuum dust collector to minimize risk of health hazard from powder caused by friction.

Wiring Diagrams and Trouble Diagnosis

NBBR0003

When you read wiring diagrams, refer to the followings:

- "HOW TO READ WIRING DIAGRAMS" in GI section
- "POWER SUPPLY ROUTING" for power distribution circuit in EL section

When you perform trouble diagnosis, refer to the followings:

- "HOW TO FOLLOW TEST GROUP IN TROUBLE DIAGNOSIS" in GI section
- "HOW TO PERFORM EFFICIENT DIAGNOSIS FOR AN ELECTRICAL INCIDENT" in GI section

PREPARATION

Special Service Tools

Special Service Tools

NBBR0004

The actual shapes of Kent-Moore tools may differ from those of special service tools illustrated here.

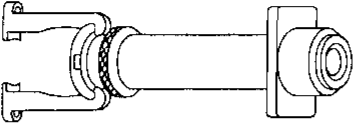
Tool number (Kent-Moore No.) Tool name	Description	
HT72480000 (J25852-B) Rear axle shaft bearing puller		Removing rear wheel sensor rotor
NT161		

CI

MA

EM

LC

Commercial Service Tools

NBBR0005

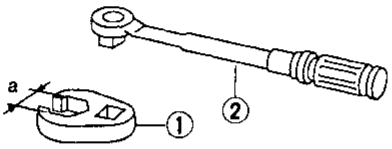
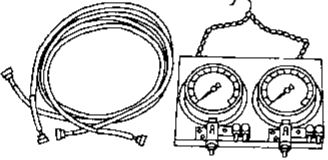
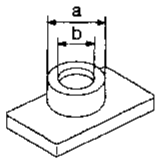
Tool name	Description	
1 Flare nut crowfoot 2 Torque wrench		Removing and installing each brake piping a: 10 mm (0.39 in)
NT360		
Brake fluid pressure gauge		Measuring brake fluid pressure
NT151		
Rear wheel sensor rotor drift		Installing rear wheel sensor rotor a: 75 mm (2.95 in) dia. b: 63 mm (2.48 in) dia.
NT509		

EC

FE

AT

TF

PD

AX

SU

BR

ST

RS

BT

HA

SC

EL

IDX

NOISE, VIBRATION AND HARSHNESS (NVH) TROUBLESHOOTING

NVH Troubleshooting Chart

NVH Troubleshooting Chart

NBBR0085S01

Use the chart below to help you find the cause of the symptom. If necessary, repair or replace these parts.

Symptom		BRAKE	Noise	Shake	Shimmy, Judder	Possible cause and SUSPECTED PARTS	Reference page
			x			Linings or pads - damaged	BR-20, 26
			x			Linings or pads - uneven wear	BR-20, 26
			x			Return spring damaged	BR-24
			x			Shims damaged	BR-20
				x		Rotor or drum imbalance	—
				x		Rotor or drum damage	—
				x		Rotor or drum runout	BR-22, 26
				x		Rotor or drum deformation	—
				x		Rotor or drum deflection	—
				x		Rotor or drum rust	—
				x		Rotor thickness variation	BR-23
				x		Drum out of round	BR-26
			x			PROPELLER SHAFT	NVH in PD section
			x			DIFFERENTIAL	NVH in PD section
			x			DRIVE SHAFT	NVH in AX section
			x			AXLE	NVH in AX section
			x			SUSPENSION	NVH in SU section
			x			TIRES	NVH in SU section
			x			ROAD WHEEL	NVH in SU section
			x			STEERING	NVH in ST section

x: Applicable

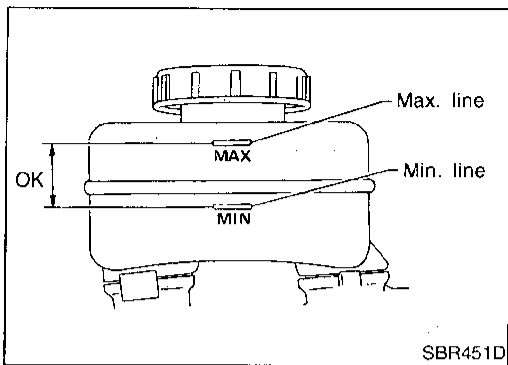

SBR451D

Checking Brake Fluid Level

NBBR0006

- Check fluid level in reservoir tank. It should be between Max and Min lines on reservoir tank.
- If fluid level is extremely low, check brake system.
- If the brake warning lamp comes on, check brake fluid level switch and parking brake switch.

GI

MA

EM

LC

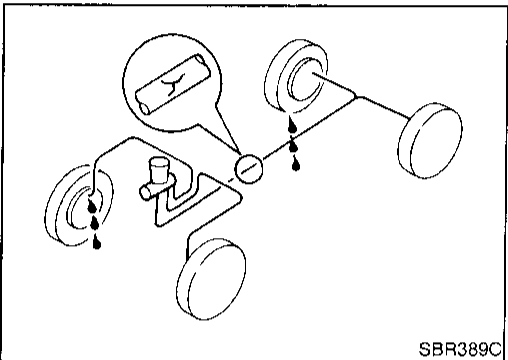

SBR389C

Checking Brake Line

NBBR0007

CAUTION:

If leakage occurs around joints, retighten or, if necessary, replace damaged parts.

1. Check brake lines (tubes and hoses) for cracks, deterioration or other damage. Replace any damaged parts.
2. Check for oil leakage by fully depressing brake pedal while engine is running.

EC

FE

AT

TF

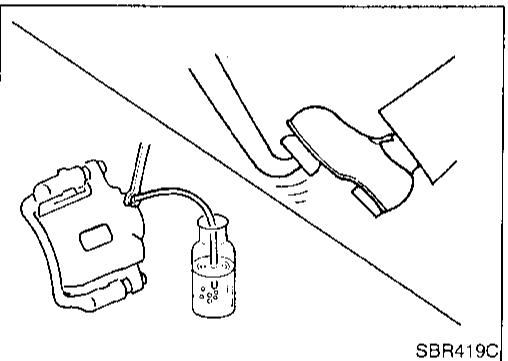

SBR419C

Changing Brake Fluid

NBBR0008

CAUTION:

- Refill with new brake fluid "DOT 3".
- Always keep fluid level higher than minimum line on reservoir tank.
- Never reuse drained brake fluid.
- Be careful not to splash brake fluid on painted areas; it may cause paint damage. If brake fluid is splashed on painted areas, wash it away with water immediately.

PD

AX

SU

BR

1. Clean inside of reservoir tank, and refill with new brake fluid.
2. Connect a vinyl tube to each air bleeder valve.
3. Drain brake fluid from each air bleeder valve by depressing brake pedal.
4. Refill until brake fluid comes out of each air bleeder valve. Use same procedure as in bleeding hydraulic system to refill brake fluid. Refer to "Bleeding Brake System", BR-6.

ST

RS

BT

HA

SC

EL

JDX

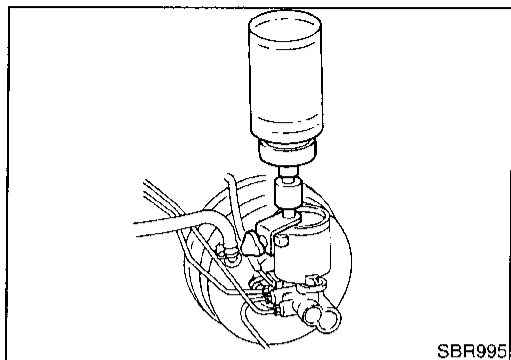

Bleeding Brake System

=NBBR0009

CAUTION:

- Carefully monitor brake fluid level at master cylinder during bleeding operation.
- If master cylinder is suspected to have air inside, bleed air from master cylinder first. Refer to "Installation", "MASTER CYLINDER", BR-16.
- Fill reservoir with new brake fluid "DOT 3". Make sure it is full at all times while bleeding air out of system.
- Place a container under master cylinder to avoid spillage of brake fluid.
- For models with ABS, turn ignition switch OFF and disconnect ABS actuator connectors or battery ground cable.
- Bleed air in the following order.
 1. LSV air bleeder
 2. Left rear brake
 3. Right rear brake
 4. Left front brake
 5. Right front brake

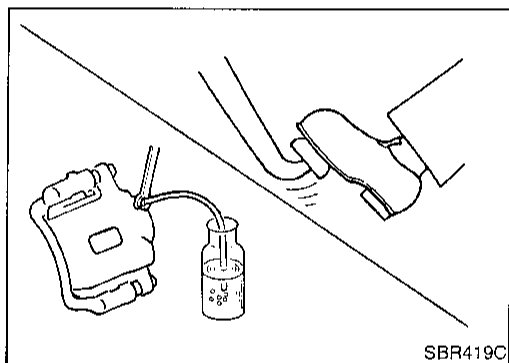

1. Connect a transparent vinyl tube to air bleeder valve.
2. Fully depress brake pedal several times.
3. With brake pedal depressed, open air bleeder valve to release air.
4. Close air bleeder valve.
5. Release brake pedal slowly.
6. Repeat steps 2. through 5. until clear brake fluid comes out of air bleeder valve.
7. Tighten air bleeder valve.

 : 7 - 9 N·m (0.7 - 0.9 kg-m, 61 - 78 in-lb)

Hydraulic Circuit

NBBR0010

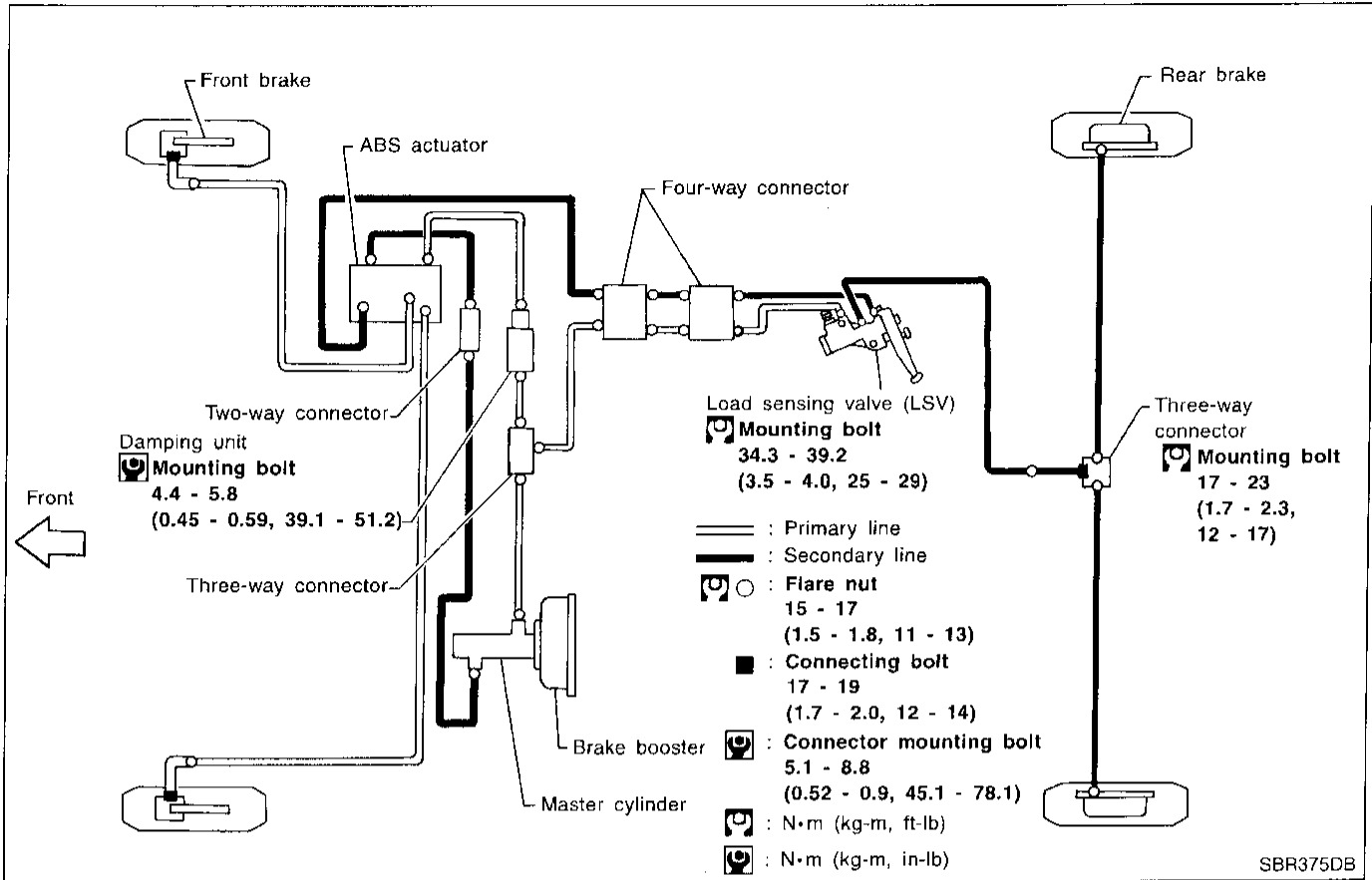

GI
MA
EM
LC
EC
FE
AT
TF
PD
AX

SU

BR

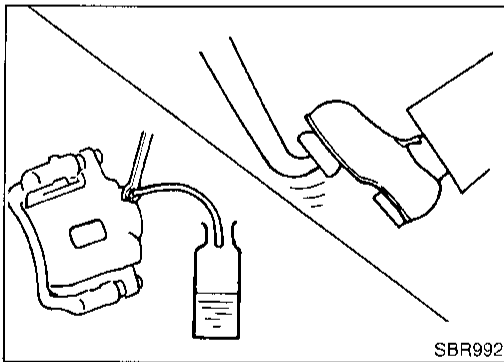

Removal

NBBR0011

CAUTION:

- Be careful not to splash brake fluid on painted areas; it may cause paint damage. If brake fluid is splashed on painted areas, wash it away with water immediately.
 - All hoses must be free from excessive bending, twisting and pulling.
1. Connect vinyl tube to air bleeder valve.
 2. Drain brake fluid from each air bleeder valve by depressing brake pedal.
 3. Remove flare nut connecting brake tube and hose, then withdraw lock spring.
 4. Cover openings to prevent entrance of dirt whenever disconnecting brake line.

ST

RS

BT

HA

SC

EL

DX

BRAKE HYDRAULIC LINE

Inspection

Inspection

Check brake lines (tubes and hoses) for cracks, deterioration or other damage. Replace any damaged parts.

NBBR0012

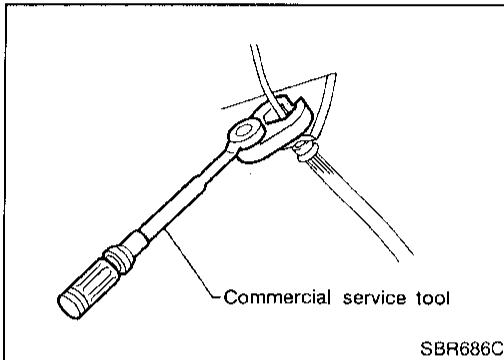

Installation

CAUTION:

NBBR0013

- Refill with new brake fluid "DOT 3".
 - Never reuse drained brake fluid.
1. Tighten all flare nuts and connecting bolts.

Flare nut:

 : 15 - 17 N·m (1.5 - 1.8 kg-m, 11 - 13 ft-lb)

Connecting bolt:

 : 17 - 19 N·m (1.7 - 2.0 kg-m, 12 - 14 ft-lb)

2. Refill until new brake fluid comes out of each air bleeder valve.
3. Bleed air. Refer to "Bleeding Brake System", BR-6.

NBBR0014

Inspection

CAUTION:

- Carefully monitor brake fluid level at master cylinder.
- Use new brake fluid "DOT 3".
- Be careful not to splash brake fluid on painted areas; it may cause paint damage. If brake fluid is splashed on paint areas, wash it away with water immediately.
- Depress pedal slowly when raising front brake pressure.
- Check rear brake pressure 2 seconds after front brake pressure reaches specified value.
- For models with ABS disconnect harness connectors from ABS actuator relay before checking.

GI

MA

EM

LC

EC

FE

AT

TF

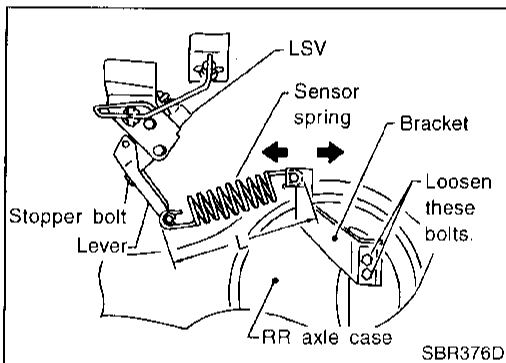

1. Ensure vehicle is unladen condition*.
*Fuel, radiator coolant and engine oil full. Spare tire, jack, hand tools and mats in designated positions.
2. Have a driver sit in the driver's seat and one person sit on the rear end. Then have the person on the rear end slowly get off the vehicle. This is necessary to stabilize suspension deflection.
3. Gradually depress brake pedal and attach a lever to the stopper bolt, then adjust length "L" as follows:
Length "L": Approx. 194 mm (7.64 in)

PD

AX

SU

BR

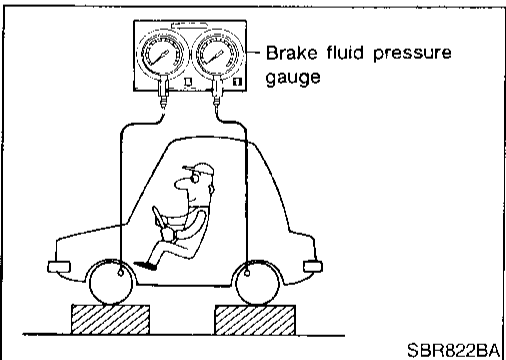

4. Remove front LH tire.
5. Connect tool to air bleeders on front LH brake caliper and rear LH or RH brake wheel cylinder.

ST

RS

BT

HA

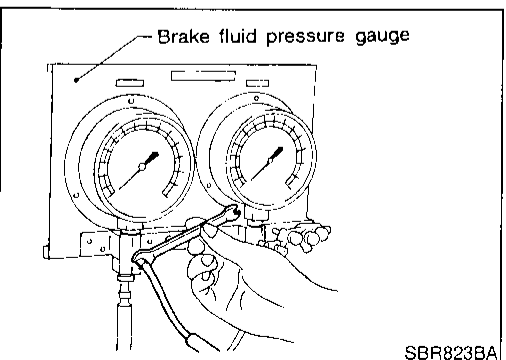

6. Install front LH tire.
Before installing front LH tire, confirm the tool is not touching the front LH wheel.
7. Bleed air from Tool.

SC

EL

IDX

LOAD SENSING VALVE

Inspection (Cont'd)

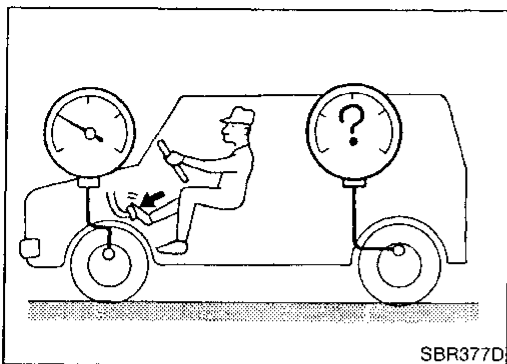

- Raise front brake pressure to 4,904 kPa (50 kg/cm², 711 psi) and 9,807 kPa (100 kg/cm², 1,422 psi) and check rear brake pressure.

**Rear brake pressure:
Refer to table below.**

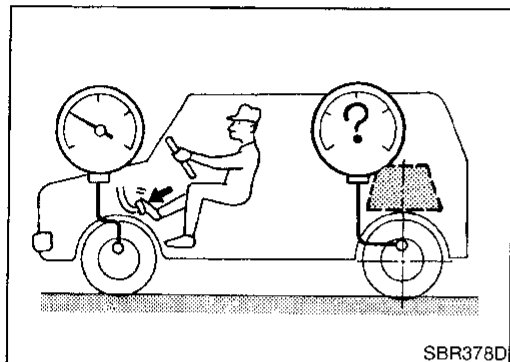

- Set down weight slowly over axle center so that sensor spring length becomes the same as when in loaded condition (Refer to table below). Check rear brake pressure in the same way described in step 6.

Unit: kPa (kg/cm², psi)

		Sensor spring length "L" mm (in)	Front brake pressure 4,904 (50, 711)	Front brake pressure 9,807 (100, 1,422)
Rear brake pressure	Without weight	194 (7.64)	1,667 - 2,648 (17.0 - 27.0, 242 - 384)	3,874 - 4,854 (39.5 - 49.5, 562 - 704)
	With weight	235 (9.25)	2,207 - 3,580 (22.5 - 36.5, 320 - 519)	4,413 - 5,786 (45.0 - 59.0, 640 - 839)

*: Depressed brake pedal.

- Bleed air after disconnecting the tool. Refer to "Bleeding Brake System", BR-6.
- Install front LH tire.

Removal and Installation

CAUTION:

NBBH0015

- Refill with new brake fluid "DOT 3".
- Be careful not to splash brake fluid on painted areas; it may cause paint damage. If brake fluid is splashed on painted areas, wash it away with water immediately.
- Do not reuse Load Sensing Valve once it is disassembled.
- Replace damaged Load Sensing Valve as an assembly.
- When disassembling, apply multi-purpose grease to all rubbing areas.

LOAD SENSING VALVE

Removal and Installation (Cont'd)

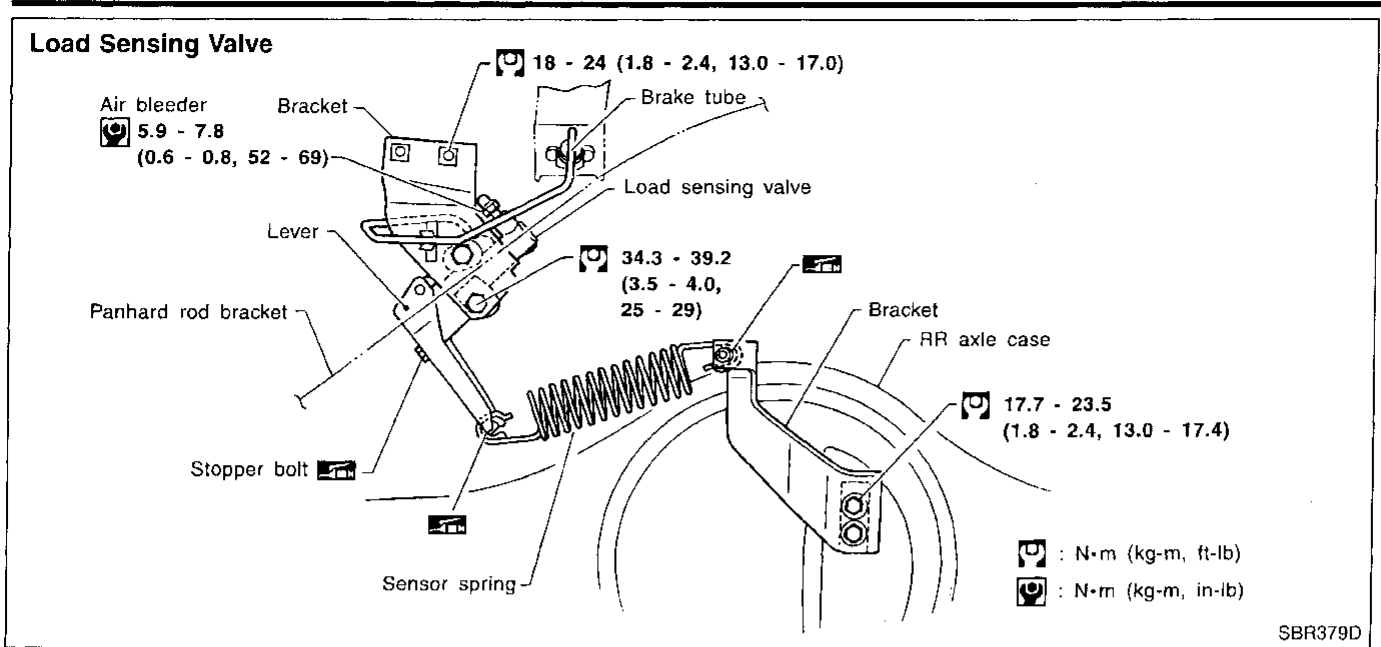

1. Tighten all flare nuts and mounting bolts.

Flare nut:

□ : 15 - 17 N·m (1.5 - 1.8 kg-m, 11 - 13 ft-lb)

2. Refill until new brake fluid comes out of each air bleeder valve.
3. Bleed air. Refer to "Bleeding Brake System", BR-6.

GI

MA

EM

LC

EC

FE

AT

TF

PD

AX

SU

BR

ST

RS

BT

HA

SC

EL

IDX

BRAKE PEDAL AND BRACKET

Removal and Installation

Removal and Installation

NBBR0016

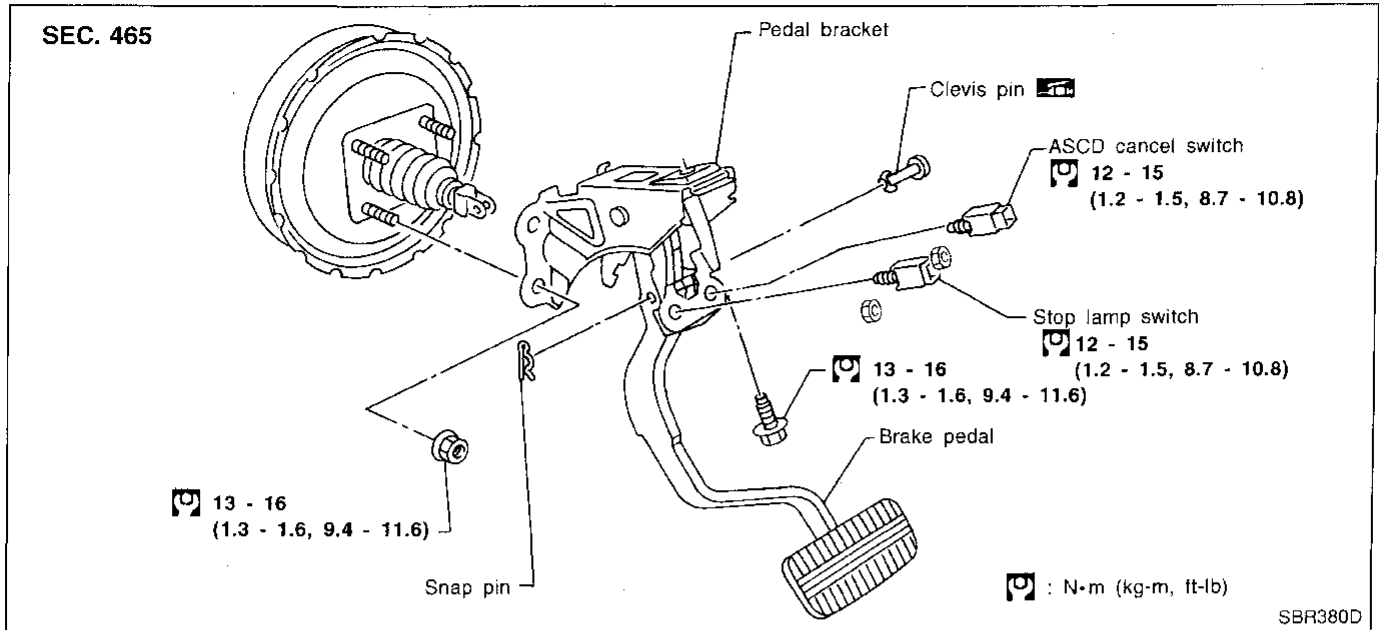

Inspection

NBBR0017

Check brake pedal for following items.

- Brake pedal bend
- Clevis pin deformation
- Crack of any welded portion
- Crack or deformation of clevis pin stopper

Adjustment

NBBR0018

Check brake pedal free height from dash lower panel.

H: Free height

Refer to SDS (BR-85).

D: Depressed height

Refer to SDS (BR-85).

Under force of 490 N (50 kg, 110 lb) with engine running

C₁, C₂: Clearance between pedal stopper and threaded end of stop lamp switch and ASCD switch
0.3 - 1.0 mm (0.012 - 0.039 in)

A: Pedal free play

1 - 3 mm (0.04 - 0.12 in)

If necessary, adjust brake pedal free height.

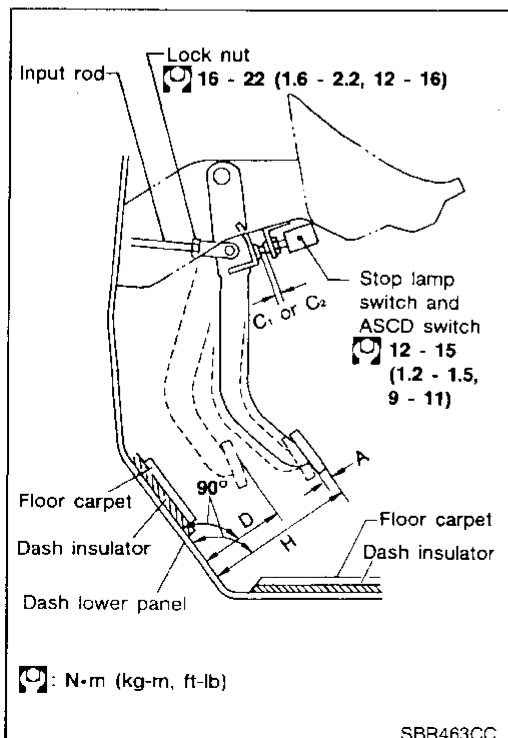

BRAKE PEDAL AND BRACKET

Adjustment (Cont'd)

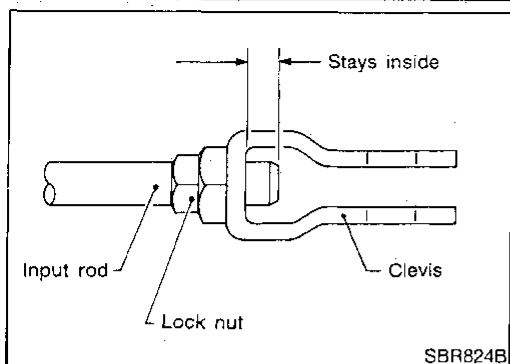

1. Loosen lock nut and adjust pedal free height by turning brake booster input rod. Then tighten lock nut.

Make sure that tip of input rod stays inside.

2. Adjust clearance "C₁" and "C₂" with stop lamp switch and ASCD switch respectively. Then tighten lock nuts.
3. Check pedal free play.

Make sure that stop lamp is off when pedal is released.

4. Check brake pedal's depressed height while engine is running. If depressed height is below specified value, check brake system for leaks, accumulation of air or any damage to components (master cylinder, wheel cylinder, etc.). Then make necessary repairs.

GI

MA

EM

LC

EC

FE

AT

TF

PD

AX

SU

BR

ST

RS

BT

HA

SC

EL

IDX

MASTER CYLINDER

Removal

Removal

NBBR0019

CAUTION:

- Be careful not to splash brake fluid on painted areas; it may cause paint damage. If brake fluid is splashed on painted areas, wash it away with water immediately.
 - In the case of brake fluid leakage from the master cylinder, disassemble the cylinder. Then check piston cups for deformation or scratches and replace necessary parts.
1. Connect a vinyl tube to air bleeder valve.
 2. Drain brake fluid from each air bleeder valve, depressing brake pedal to empty fluid from master cylinder.
 3. Remove brake pipe flare nuts.
 4. Remove master cylinder mounting nuts.

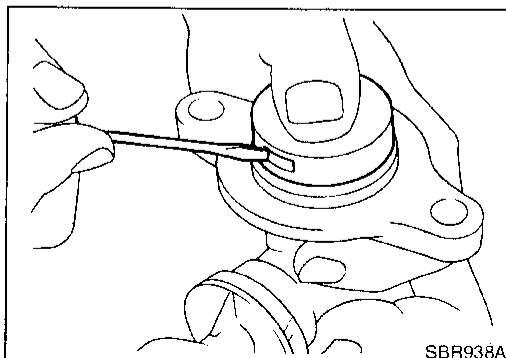
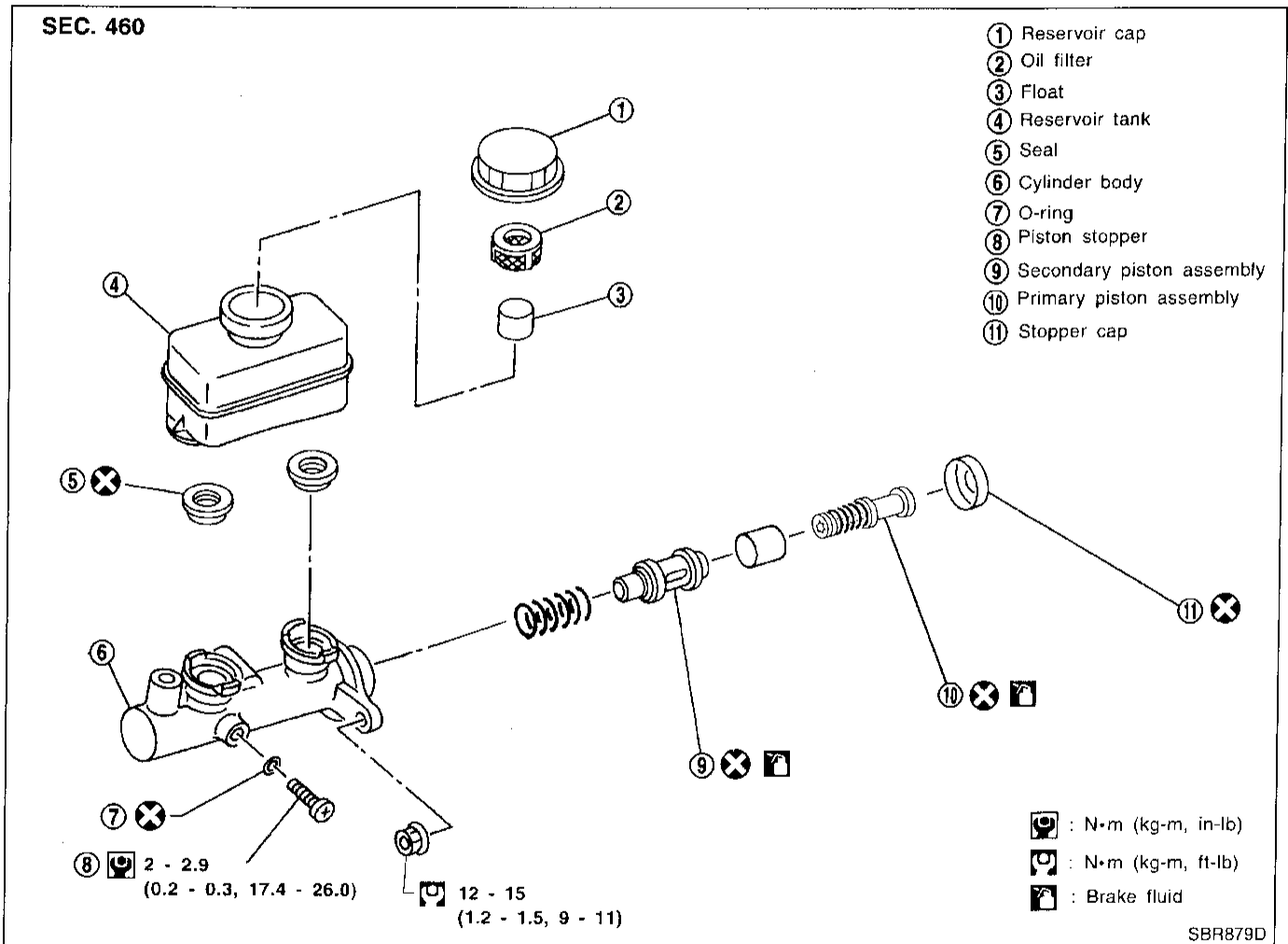

Disassembly

1. Bend claws of stopper cap outward.

NBBR0020

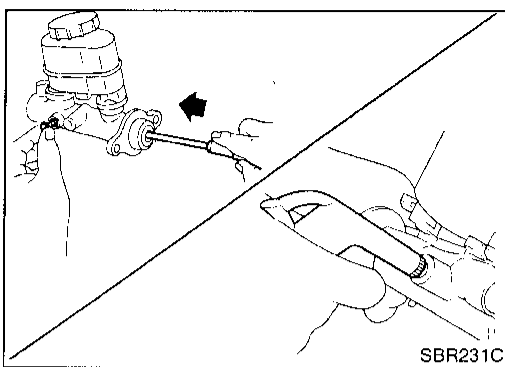

2. Remove piston stopper while piston is pushed into cylinder.

3. Remove piston assemblies.

If it is difficult to remove secondary piston assembly, gradually apply compressed air through fluid outlet.

4. Draw out reservoir tank.

GI

MA

EM

LC

Inspection

Check master cylinder inner wall for pin holes or scratches. Replace if damaged.

NBBR0021

EC

FE

AT

TF

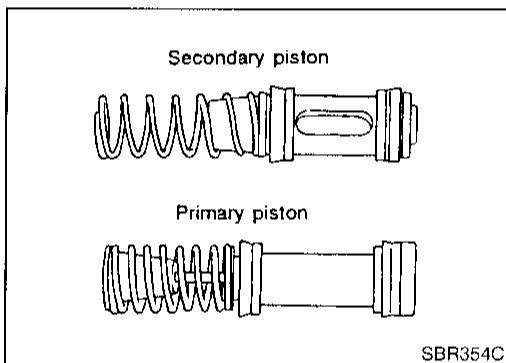

Assembly

1. Insert secondary piston assembly. Then insert primary piston assembly.

- Pay attention to direction of piston cups in figure at left. Also, insert pistons squarely to avoid scratches on cylinder bore.

- Pay attention to alignment of secondary piston slit with valve stopper mounting hole of cylinder body.

NBBR0022

PD

AX

SU

BR

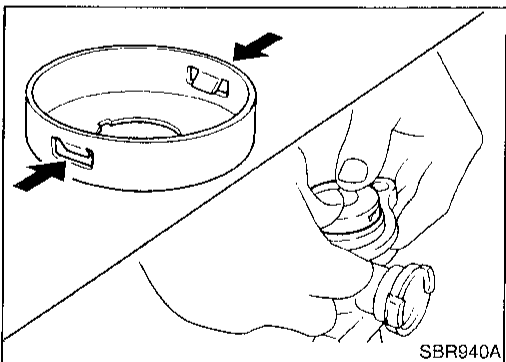

2. Install stopper cap.

Before installing stopper cap, ensure that claws are bent inward.

3. Push reservoir tank seals into cylinder body.

4. Push reservoir tank into cylinder body.

ST

RS

BT

HA

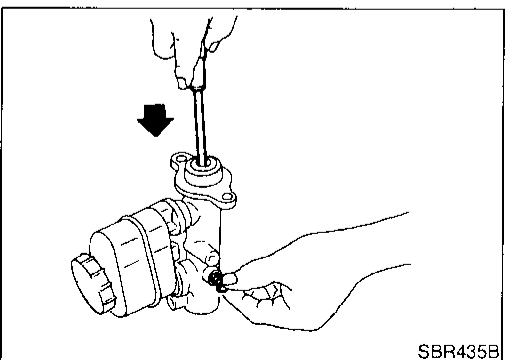

5. Install valve stopper while piston is pushed into cylinder.

SC

EL

IDX

MASTER CYLINDER

Installation

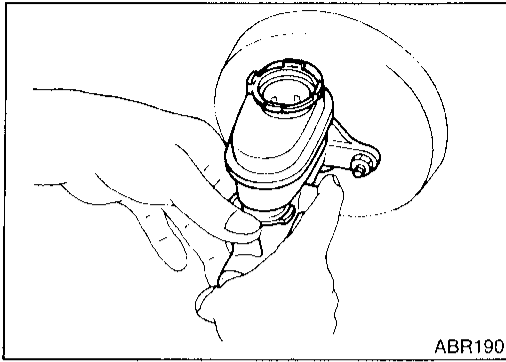

NBBR0023

Installation

CAUTION:

- Refill with new brake fluid "DOT 3".
 - Never reuse drained brake fluid.
1. Place master cylinder onto brake booster and secure mounting nuts lightly.
 2. Torque mounting nuts.
⌚ : 12 - 15 N·m (1.2 - 1.5 kg-m, 9 - 11 ft-lb)
 3. Fill up reservoir tank with new brake fluid.
 4. Plug all ports on master cylinder with fingers to prevent air suction while releasing brake pedal.
 5. Have driver depress brake pedal slowly several times until no air comes out of master cylinder.
 6. Fit brake lines to master cylinder.
 7. Tighten flare nuts.
⌚ : 15 - 17 N·m (1.5 - 1.8 kg-m, 11 - 13 ft-lb)
 8. Bleed air. Refer to "Bleeding Brake System", BR-6.

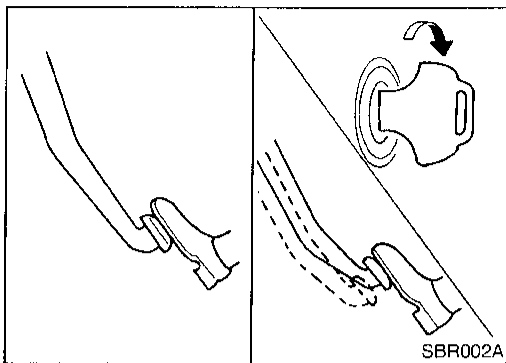

On-vehicle Service

OPERATING CHECK

NBBR0024

NBBR0024S01

1. Depress brake pedal several times with engine off. After exhausting vacuum, make sure there is no change in pedal stroke.
2. Depress brake pedal, then start engine. If pedal goes down slightly, operation is normal.

AIRTIGHT CHECK

NBBR0024S02

1. Start engine, and stop it after one or two minutes. Depress brake pedal several times slowly. Booster is airtight if pedal stroke is less each time.
2. Depress brake pedal while engine is running, and stop engine with pedal depressed. The pedal stroke should not change after holding pedal down for **30 seconds**.

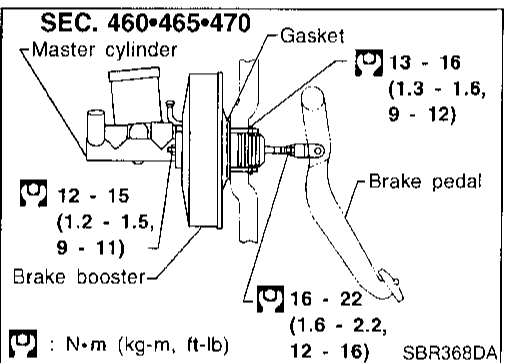
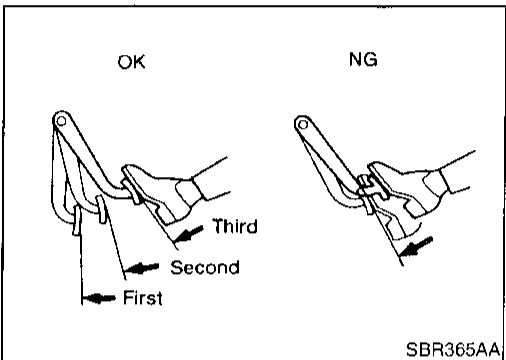

Removal

NBBR0025

CAUTION:

- Be careful not to splash brake fluid on painted areas; it may cause paint damage. If brake fluid is splashed on painted areas, wash it away with water immediately.
- Be careful not to deform or bend brake pipes, during removal of booster.

Inspection

NBBR0026

OUTPUT ROD LENGTH CHECK

NBBR0026S01

1. Apply vacuum of -66.7 kPa (-500 mmHg , -19.69 inHg) to brake booster with a hand vacuum pump.
2. Check output rod length.

Specified length:

10.275 - 10.525 mm (0.4045 - 0.4144 in)

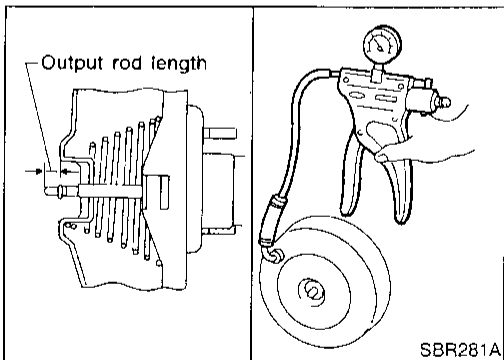

BRAKE BOOSTER

Installation

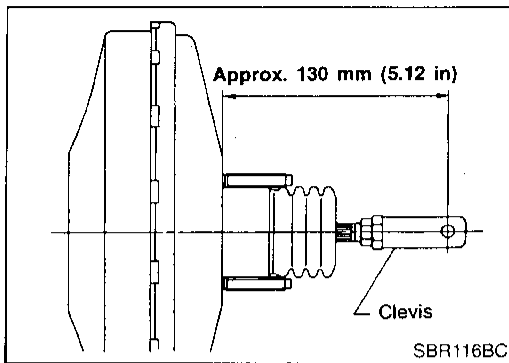

=NBBR0027

Installation

CAUTION:

- Be careful not to deform or bend brake pipes during installation of booster.
- Replace clevis pin if damaged.
- Refill with new brake fluid "DOT 3".
- Never reuse drained brake fluid.
- Take care not to damage brake booster mounting bolt thread when installing. Due to the narrow angle of installation, the threads can be damaged by the dash panel.

1. Before fitting booster, temporarily adjust clevis to dimension shown.
2. Fit booster, then secure mounting nuts (brake pedal bracket to brake booster) lightly.
3. Connect brake pedal and booster input rod with clevis pin.
4. Secure mounting nuts.

Specification: 13 - 16 N·m (1.3 - 1.6 kg·m, 9 - 12 ft·lb)

5. Install master cylinder. Refer to "Installation" in "MASTER CYLINDER", BR-16.
6. Adjust brake pedal height and free play. Refer to "Adjustment" in "BRAKE PEDAL AND BRACKET", BR-12.
7. Secure lock nut for clevis.

□ : 16 - 22 N·m (1.6 - 2.2 kg·m, 12 - 16 ft·lb)

8. Bleed air. Refer to "Bleeding Brake System", BR-6.

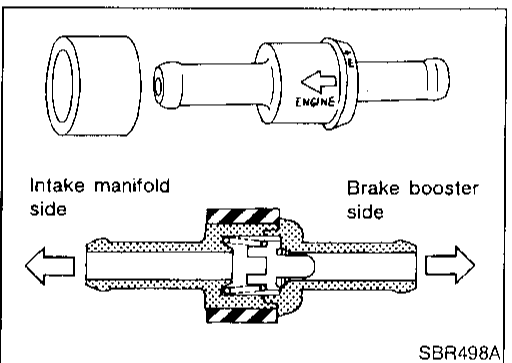
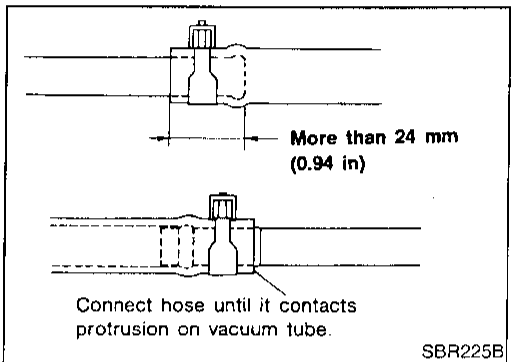
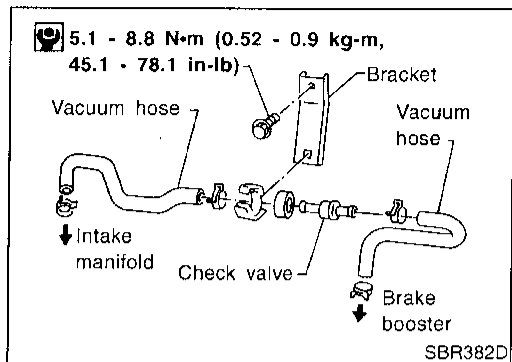

Vacuum Hose

NBBR0028

Removal and Installation

NBBH0029

CAUTION:

When installing vacuum hoses, pay attention to the following points.

- Do not apply any oil or lubricants to vacuum hose and check valve.
- Insert vacuum tube into vacuum hose as shown.
- Install check valve, paying attention to its direction.

Inspection

NBBR0030

HOSES AND CONNECTORS

NBBR0030S01

Check vacuum lines, connections and check valve for airtightness, improper attachment chafing and deterioration.

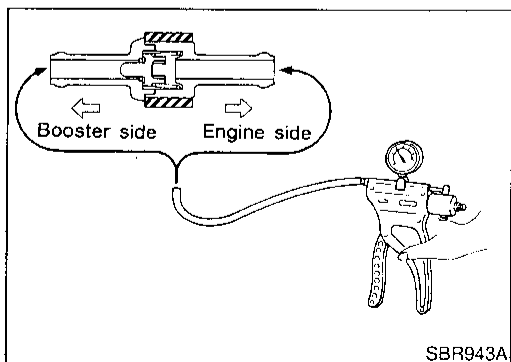

CHECK VALVE

NBBR0030S02

Check vacuum with a vacuum pump.

Connect to booster side	Vacuum should exist.
Connect to engine side	Vacuum should not exist.

GI

MA

EM

LC

EC

FE

AT

TF

PD

AX

SU

BR

ST

RS

BT

HA

SC

EL

IDX

1213

FRONT DISC BRAKE

Components

Components

NBBR0031

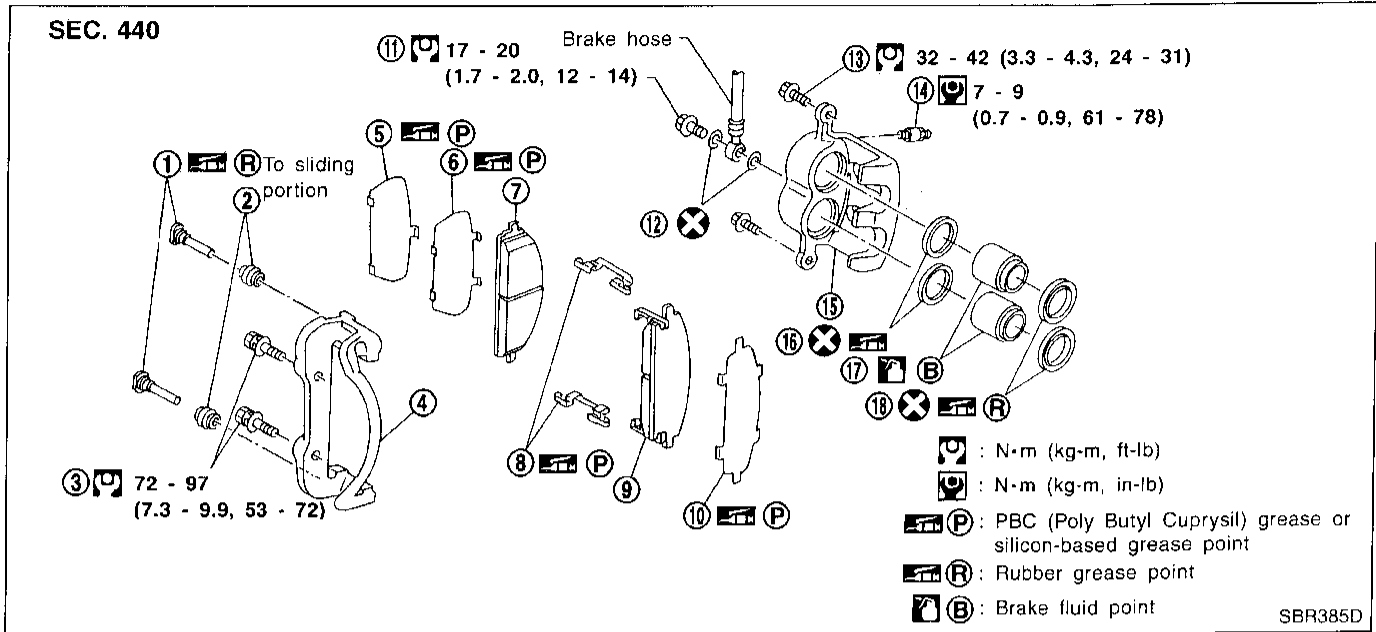

- | | | |
|------------------------------|---------------------|-------------------|
| 1. Main pin | 7. Inner pad | 13. Main pin bolt |
| 2. Pin boot | 8. Pad retainer | 14. Bleed valve |
| 3. Torque member fixing bolt | 9. Outer pad | 15. Cylinder body |
| 4. Torque member | 10. Outer shim | 16. Piston seal |
| 5. Shim cover | 11. Connecting bolt | 17. Piston |
| 6. Inner shim | 12. Copper washer | 18. Piston boot |

Pad Replacement

NBBR0032

WARNING:

Clean brakes with a vacuum dust collector to minimize the hazard of airborne particles or other materials.

CAUTION:

- When cylinder body is open, do not depress brake pedal, or piston will pop out.
- Be careful not to damage piston boot or get oil on rotor. Always replace shims when replacing pads.
- If shims are rusted or show peeling of the rubber coat, replace them with new shims.
- It is not necessary to remove connecting bolt except for disassembly or replacement of caliper assembly. In this case, suspend cylinder body with wire so as not to stretch brake hose.
- Carefully monitor brake fluid level because brake fluid will return to reservoir when pushing back piston.

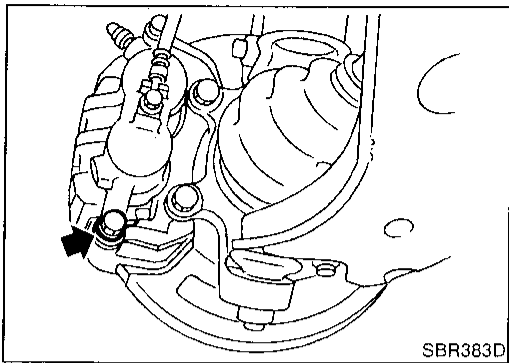

1. Remove master cylinder reservoir cap.
2. Remove lower pin bolt.

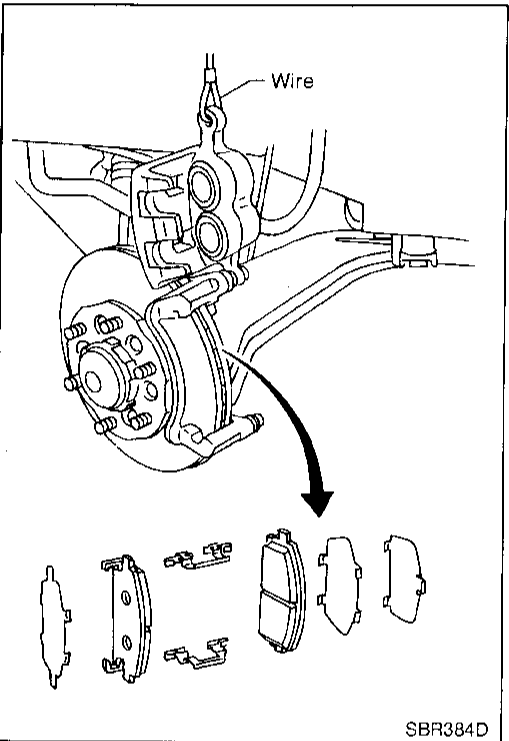

3. Open cylinder body upward. Then remove pad retainers, and inner and outer shims.

Standard pad thickness:

11.0 mm (0.433 in)

Pad wear limit:

2.0 mm (0.079 in)

Carefully monitor brake fluid level because brake fluid will return to reservoir when pushing back piston.

Removal

WARNING:

Clean brake pads with a vacuum dust collector to minimize the hazard of airborne particles or other materials.

CAUTION:

Suspend caliper assembly with wire so as not to stretch brake hose.

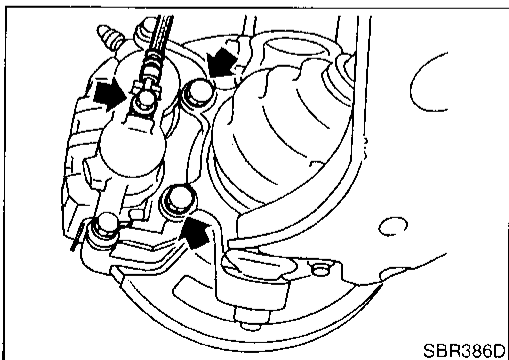

Remove torque member fixing bolts and connecting bolt. It is not necessary to remove connecting bolt except for disassembly or replacement of caliper assembly. In this case, suspend caliper assembly with wire so as not to stretch brake hose.

GI

MA

EM

LC

EC

FE

AT

TF

PD

AX

SJ

BR

NBBR0033 ST

RS

BT

HA

SC

EL

IDX

FRONT DISC BRAKE

Disassembly

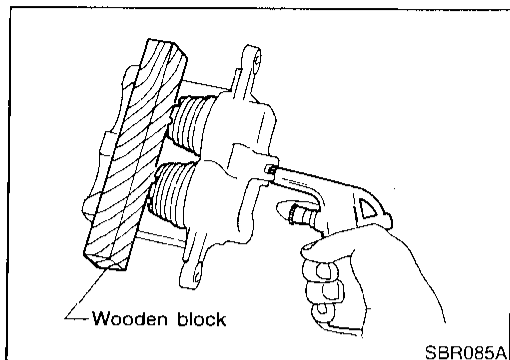

Disassembly

NBBR0034

WARNING:

Do not place your fingers in front of piston.

CAUTION:

Do not scratch or score cylinder wall.

1. Push out piston with dust seal with compressed air.
2. Remove piston seal with a suitable tool.

Inspection

NBBR0035

CALIPER

NBBR0035S01

Cylinder Body

NBBR0035S0101

- Check inside surface of cylinder for score, rust, wear, damage or presence of foreign objects. If any of the above conditions are observed, replace cylinder body.
- Minor damage from rust or foreign objects may be eliminated by polishing surface with a fine emery paper. Replace cylinder body if necessary.

CAUTION:

Use brake fluid to clean. Never use mineral oil.

Piston

NBBR0035S0102

Check piston for score, rust, wear, damage or presence of foreign objects. Replace if any of the above conditions are observed.

CAUTION:

Piston sliding surface is plated. Do not polish with emery paper even if rust or foreign objects are stuck to sliding surface.

Slide Pin, Pin Bolt and Pin Boot

NBBR0035S0103

Check for wear, cracks, rust or other damage. Replace if any of the above conditions are observed.

ROTOR

NBBR0035S02

Runout

NBBR0035S0201

1. Secure rotor to wheel hub with at least two nuts (M12 × 1.25).
2. Check runout using a dial indicator.

Make sure that wheel bearing axial end play is within the specifications before measuring. Refer to "Front Wheel Bearing" in AX section.

Maximum runout:

0.1 mm (0.004 in)

3. If the runout is out of specification, find minimum runout position as follows:
 - a. Remove nuts and rotor from wheel hub.
 - b. Shift the rotor one hole and secure rotor to wheel hub with nuts.
 - c. Measure runout.
 - d. Repeat steps a. to c. so that minimum runout position can be found.
4. If the runout is still out of specification, turn rotor with on-car brake lathe ("MAD, DL-8700", "AMMCO 700 and 705" or equivalent).

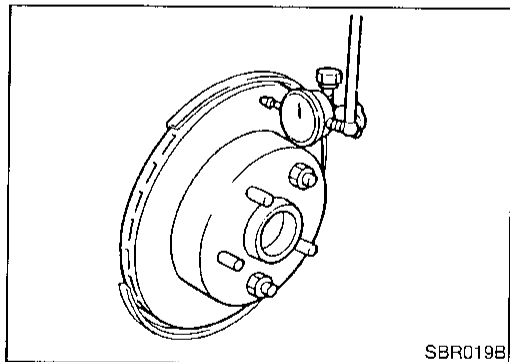

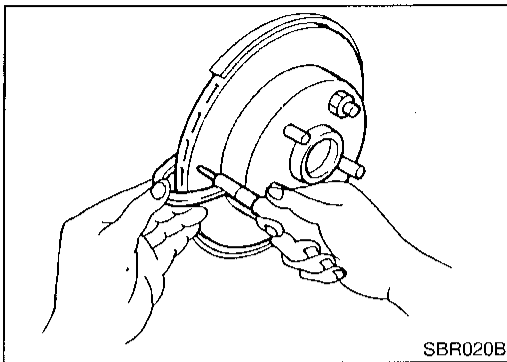

Thickness

NBBR003&S0202

Thickness variation (At least 8 positions):

Maximum 0.015 mm (0.0006 in)

If thickness variation exceeds the specification, turn rotor with on-car brake lathe.

Rotor repair limit:

26.0 mm (1.024 in)

GI

MA

EM

LC

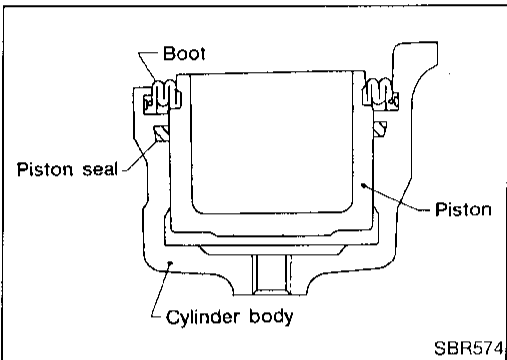

Assembly

NBBR0036

1. Insert piston seal into groove on cylinder body.
2. With piston boot fitted to piston, insert piston boot into groove on cylinder body and install piston.
3. Properly secure piston boot

EC

FE

AT

TF

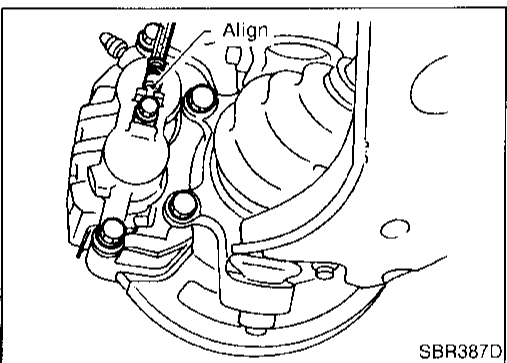

Installation

NBBR0037

CAUTION:

- Refill with new brake fluid "DOT 3".
- Never reuse drained brake fluid.

1. Install caliper assembly.
2. Install brake hose to caliper securely.
3. Install all parts and secure all bolts.
4. Bleed air. Refer to "Bleeding Brake System", BR-6.

PD

AX

SU

BR

Brake Burnishing Procedure

NBBR0086

When experiencing soft brake pedal feel at very low mileage, or after replacing the rotor, burnish the brake pad contact surfaces according to the following procedures.

CAUTION:

Only perform this procedure under safe road and traffic conditions. Use extreme caution.

1. Drive the vehicle on a straight smooth road at 50 km/h (31 MPH).
2. Use medium brake pedal/foot effort to bring the vehicle to a complete stop from 50 km/h (31 MPH). Adjust brake pedal/foot pressure such that vehicle stopping time equals 3 to 5 seconds.
3. To cool the brake system, drive the vehicle at 50 km/h (31 MPH) for 1 minute without stopping.
4. Repeat steps 1 to 3 10 times or more to complete the burnishing procedure.

ST

RS

BT

HA

SC

EL

IDX

REAR DRUM BRAKE

Components

NBBR0038

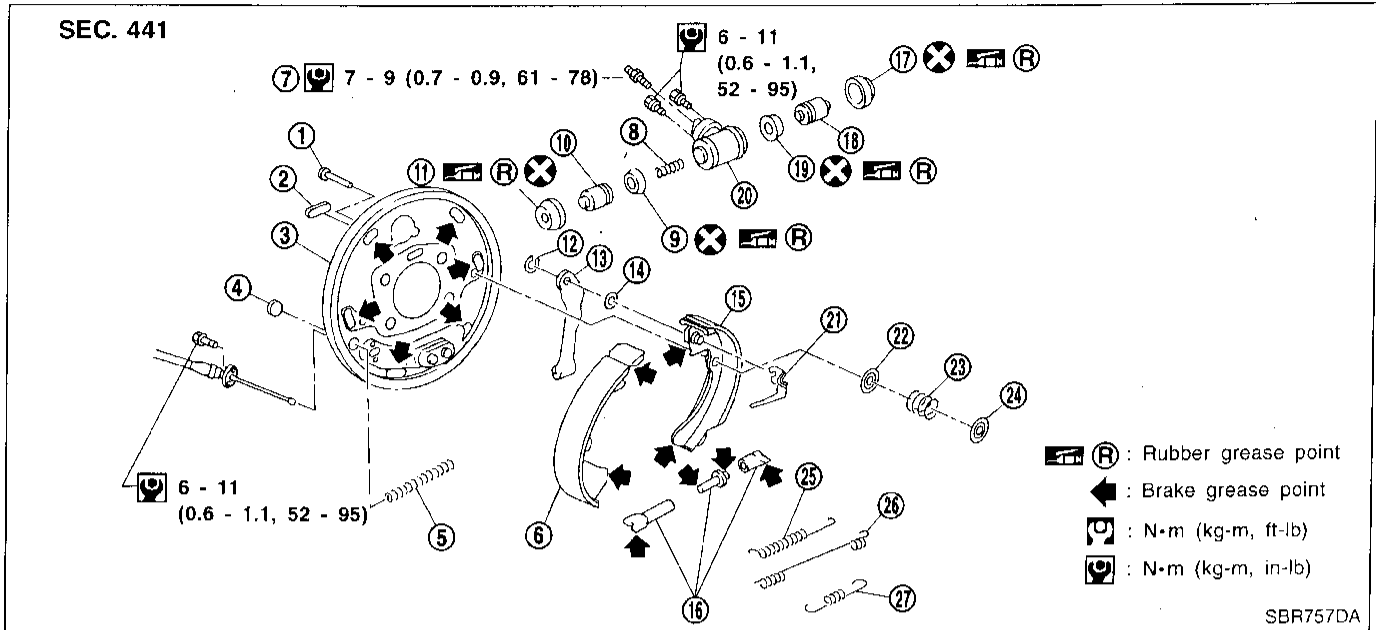

SBR757DA

- | | | |
|------------------------|--------------------------|---------------------------|
| 1. Shoe hold pin | 10. Piston | 19. Piston cup |
| 2. Plug | 11. Boot | 20. Wheel cylinder |
| 3. Back plate | 12. Retainer ring | 21. Adjuster lever |
| 4. Check plug | 13. Toggle lever | 22. Spring seat |
| 5. Spring | 14. Wave washer | 23. Shoe hold spring |
| 6. Shoe (leading side) | 15. Shoe (trailing side) | 24. Retainer |
| 7. Air bleeder | 16. Adjuster | 25. Adjuster spring |
| 8. Spring | 17. Boot | 26. Return spring (upper) |
| 9. Piston cup | 18. Piston | 27. Return spring (lower) |

Removal

NBBR0039

WARNING:

Clean brake lining with a vacuum dust collector to minimize the hazard of airborne asbestos or other materials.

CAUTION:

Make sure parking brake lever is released completely.

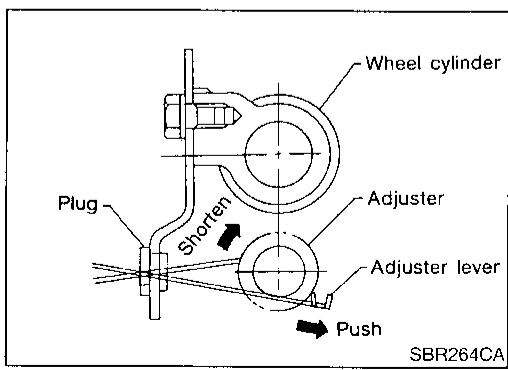

1. Release parking brake lever fully, then remove drum. **If drum is hard to remove, the following procedures should be carried out.**
 - a. Remove plug. Then shorten adjuster to make clearance between brake shoe and drum as shown.

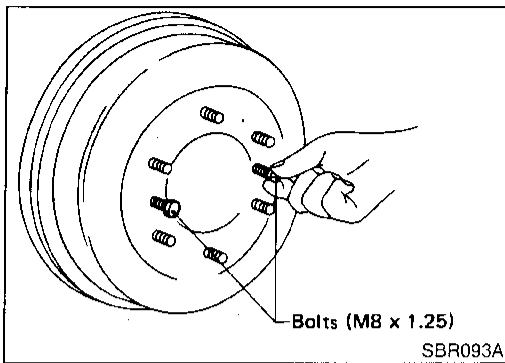

b. Tighten the two bolts gradually.

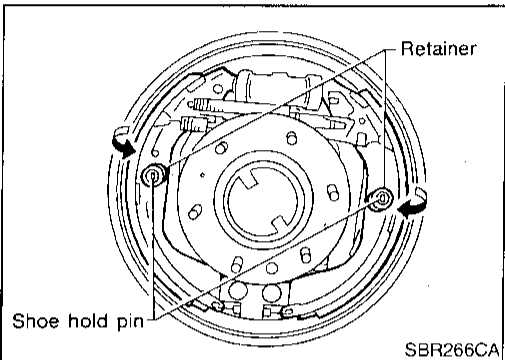

2. After removing shoe hold pin by rotating push retainer, remove leading shoe then remove trailing shoe. Remove spring by rotating shoes in direction arrow.

Be careful not to damage wheel cylinder piston boots.

3. Remove adjuster.

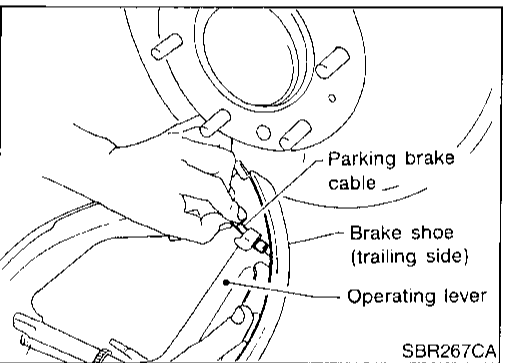

4. Disconnect parking brake cable from toggle lever.

Be careful not to damage parking brake cable when separating it.

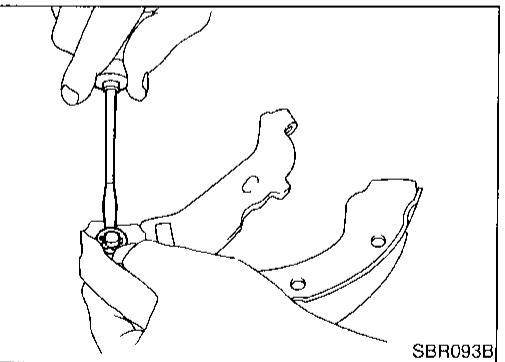

5. Remove retainer ring with a suitable tool. Then separate toggle lever and brake shoe.

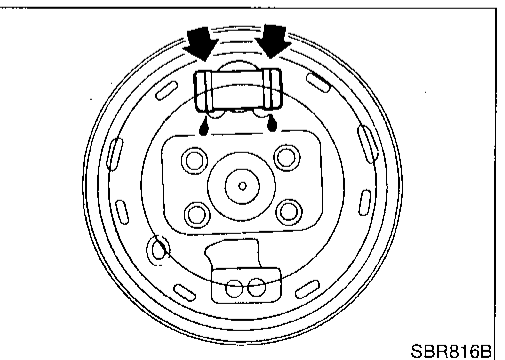

Inspection

WHEEL CYLINDER

- Check wheel cylinder for leakage.
- Check for wear, damage and loose conditions. Replace if any such condition exists.

NBBR0040

NBBR0040S01

GI

MA

EM

LG

EC

FE

AT

TF

PD

AX

SU

BR

ST

RS

BT

HA

SC

EL

IDX

REAR DRUM BRAKE

Wheel Cylinder Overhaul

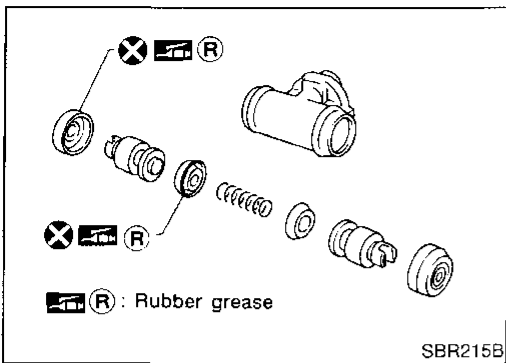

Wheel Cylinder Overhaul

- Check all internal parts for wear, rust and damage. Replace if necessary. NBBR0041
- Pay attention so as not to scratch cylinder when installing pistons.

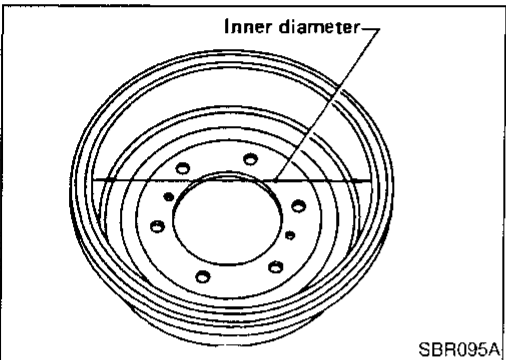

Inspection

DRUM

Maximum inner diameter: 296.5 mm (11.67 in)

Out-of-roundness: 0.03 mm (0.0012 in) or less

- Contact surface should be fine finished with No. 120 to 150 emery paper.
- Using a drum lathe, lathe brake drum if it shows scoring, partial wear or stepped wear.
- After brake drum has been completely reconditioned or replaced, check drum and shoes for proper contact pattern.

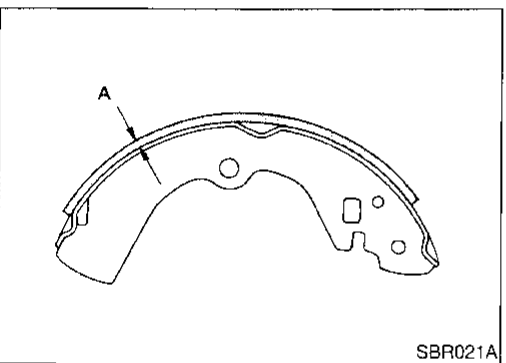

LINING

Check lining thickness.

Standard lining thickness:

6.1 mm (0.240 in)

Lining wear limit (A):

1.5 mm (0.059 in)

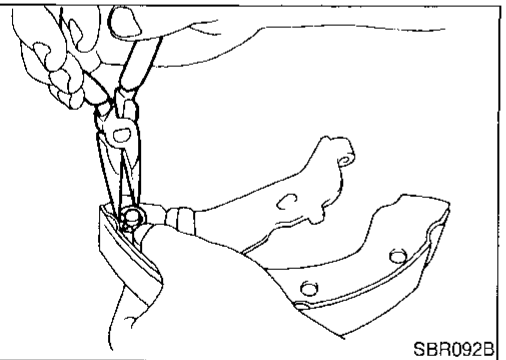

Installation

Always perform shoe clearance adjustment. Refer to BR-29. NBBR0043

1. Fit toggle lever to brake shoe (trailing side) with retainer ring.
2. Apply brake grease to the contact areas (indicated by arrows and hatching) shown at left.

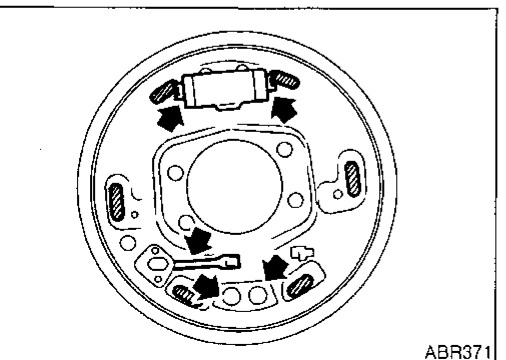

REAR DRUM BRAKE

Installation (Cont'd)

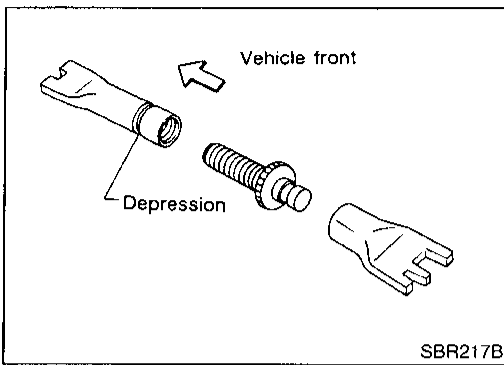

SBR217B

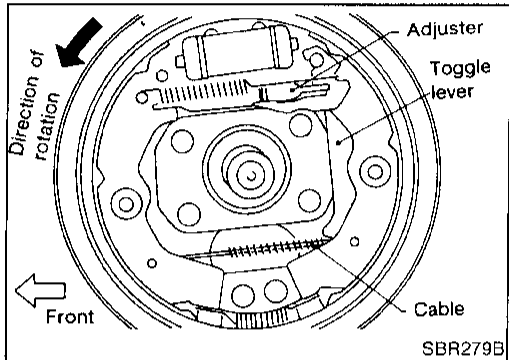

SBR279B

3. Shorten adjuster by rotating it.

● Pay attention to direction of adjuster.

Wheel	Screw	Depression
Left	Left-hand thread	Yes
Right	Right-hand thread	No

4. Connect parking brake cable to toggle lever.

5. Install all parts.

Be careful not to damage wheel cylinder piston boots.

6. Check all parts are installed properly.

Pay attention to direction of adjuster assembly.

7. Install brake drum.

8. When installing new wheel cylinder or overhauling wheel cylinder, bleed air. Refer to "Bleeding Brake System", BR-6.

9. Adjust parking brake. Refer to "Adjustment", "PARKING BRAKE CONTROL", BR-29.

GI

MA

EM

LC

EC

FE

AT

TF

PD

AX

SU

BR

ST

RS

BT

HA

SC

EL

IDX

PARKING BRAKE CONTROL

Components

Components

NBBR0044

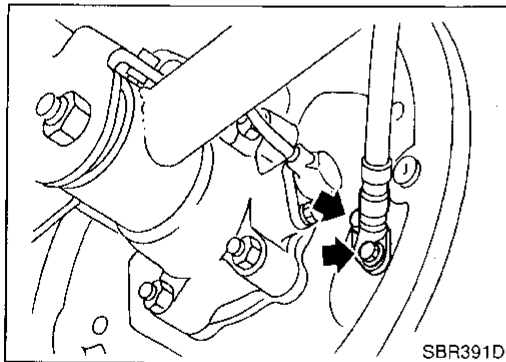
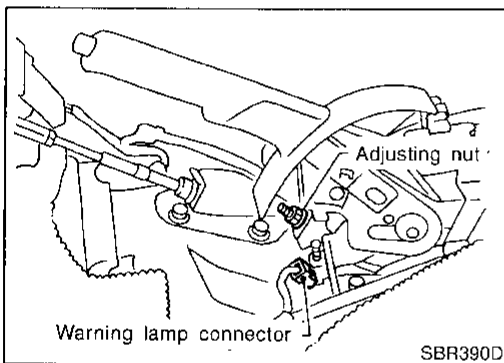
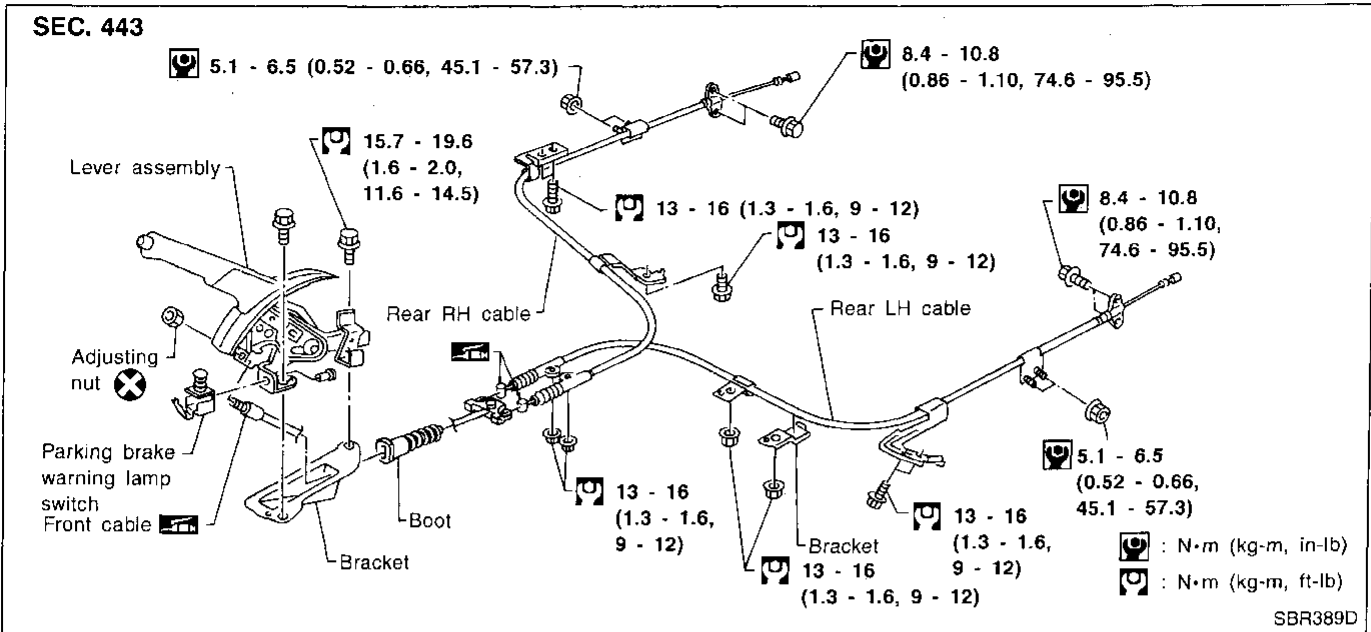

Removal and Installation

NBBR0045

1. To remove parking brake cable, first remove center console.
2. Disconnect warning lamp connector.
3. Remove bolts, slacken off and remove adjusting nut.
4. Disconnect cable. Refer to "Removal", "REAR DRUM BRAKE", BR-24.

Inspection

NBBR0046

1. Check control lever for wear or other damage. Replace if necessary.
2. Check wires for discontinuity or deterioration. Replace if necessary.
3. Check warning lamp and switch. Replace if necessary.
4. Check parts at each connecting portion and, if deformed or damaged, replace.

PARKING BRAKE CONTROL

Adjustment

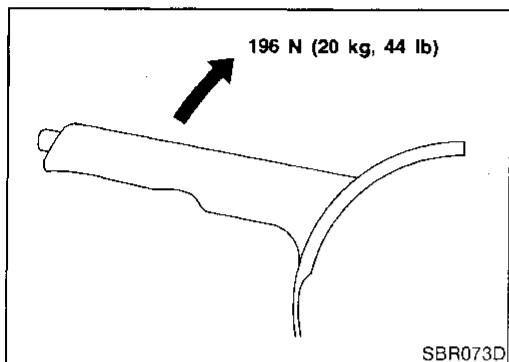
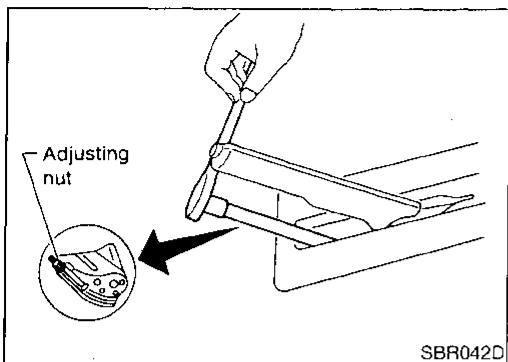

Adjustment

NBBR0047

1. Adjust clearance between shoe and drum as follows:
 - a. Release parking brake lever and loosen adjusting nut.
 - b. Depress brake pedal fully at least 10 times with engine running.
2. Pull control lever 4 - 5 notches. Then adjust control lever by turning adjusting nut.

GI

MA

EM

LC

3. Pull control lever with specified amount of force. Check lever stroke and ensure smooth operation.

Number of notches: 6 - 8

EC

FE

AT

TF

4. Bend warning lamp switchplate to ensure:
 - Warning lamp comes on when lever is lifted "A" notches.
 - Warning lamp goes out when lever is fully released.

Number of "A" notches: 1 or less

PD

AX

SU

BR

ST

RS

BT

HA

SC

EL

IDX

Purpose

Purpose

The Anti-Lock Brake System (ABS) consists of electronic and hydraulic components. It allows for control of braking force so locking of the wheels can be avoided.

- 1) Improves proper tracking performance through steering wheel operation.
- 2) Eases obstacle avoidance through steering wheel operation.
- 3) Improves vehicle stability.

Operation

- When the vehicle speed is less than 10 km/h (6 MPH) this system does not work.
- The Anti-Lock Brake System (ABS) has a self-test function. The system turns on the ABS warning lamp for 1 second each time the ignition switch is turned "ON". After the engine is started, the ABS warning lamp turns off. The system performs a test the first time the vehicle reaches 6 km/h (4 MPH). A mechanical noise may be heard as the ABS performs this self-test. This is a normal part of the self-test feature. If a malfunction is found during this check, the ABS warning lamp will stay on.
- While driving, a mechanical noise may be heard during ABS operation. This is a normal condition.

ABS Hydraulic Circuit

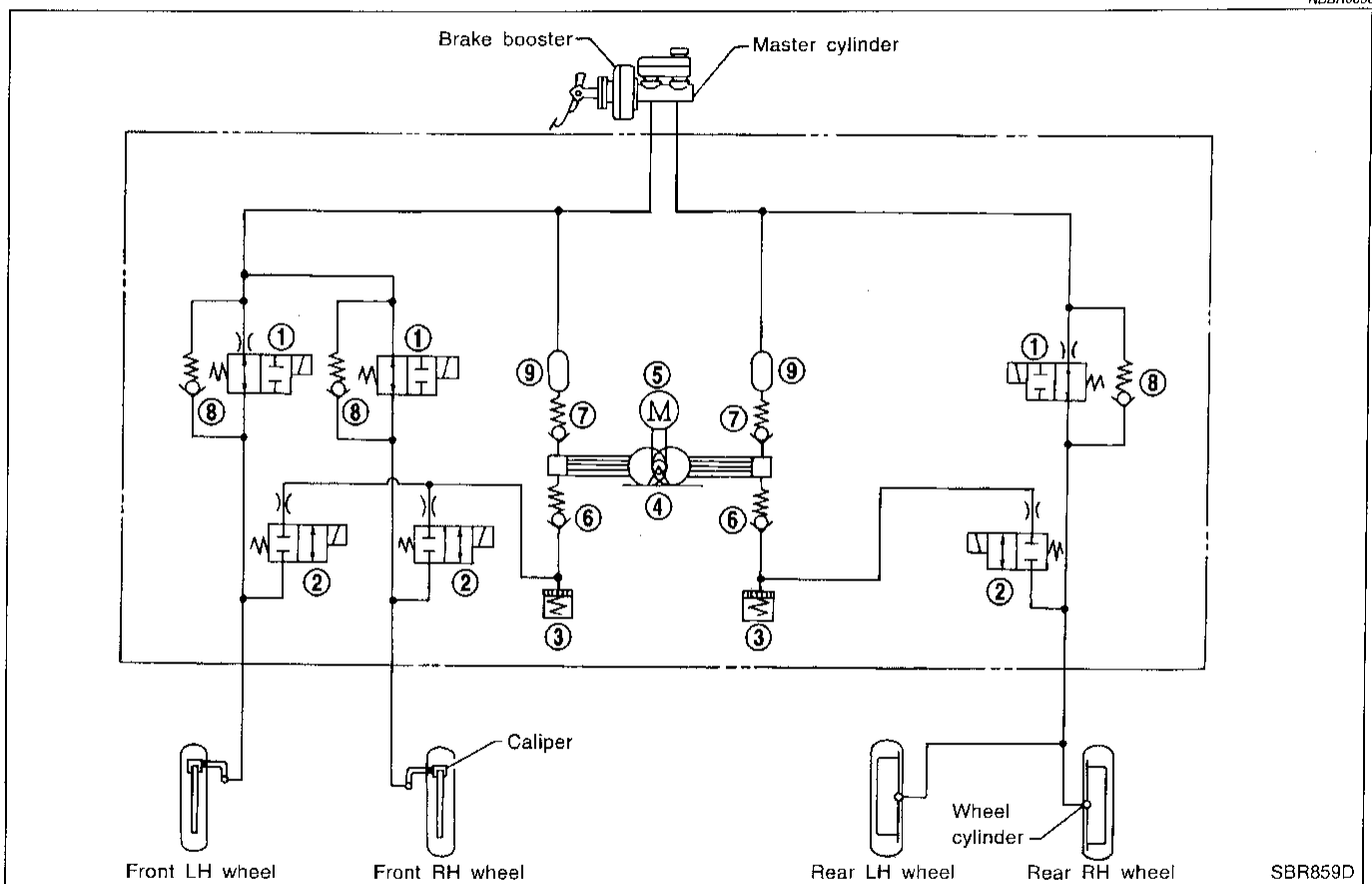

- | | | |
|--------------------------|----------------|-----------------------|
| 1. Inlet solenoid valve | 4. Pump | 7. Outlet valve |
| 2. Outlet solenoid valve | 5. Motor | 8. Bypass check valve |
| 3. Reservoir | 6. Inlet valve | 9. Damper |

System Components

NBBR0051

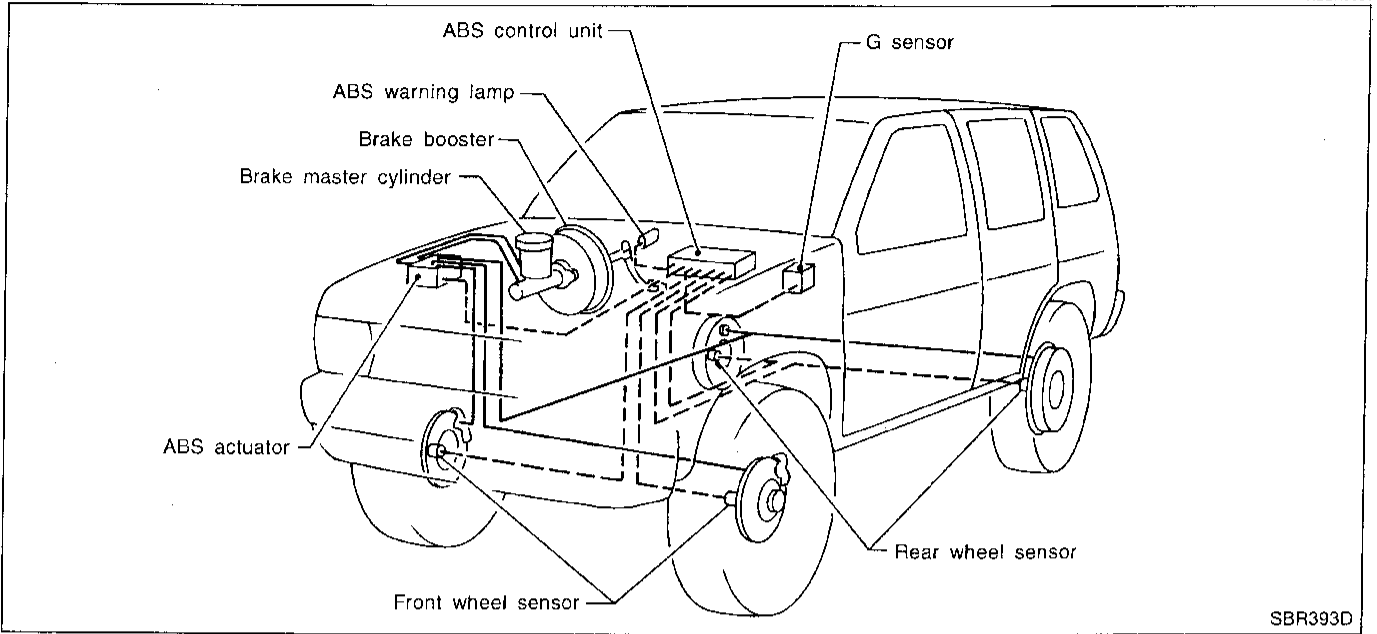

SBR393D

GI
MA
EM
LC
EC
FE
AT
TF

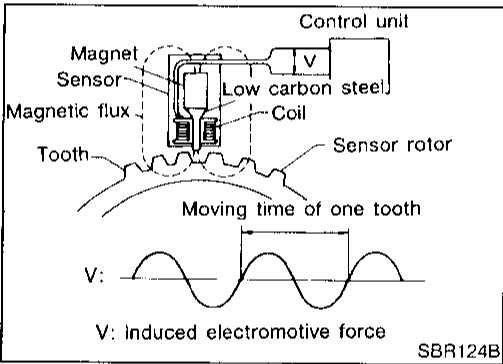

SBR124B

System Description
SENSOR

NBBR0052

NBBR0052S01

The sensor unit consists of a gear-shaped sensor rotor and a sensor element. The element contains a bar magnet around which a coil is wound. The sensor is installed on the back of the brake rotor and the back of the rear brake drum. As the wheel rotates, the sensor generates a sine-wave pattern. The frequency and voltage increase(s) as the rotating speed increases.

PD
AX
SU

BR

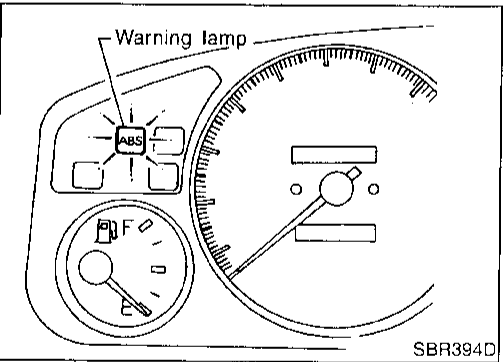

SBR394D

CONTROL UNIT

NBBR0052S02

The control unit computes the wheel rotating speed by the signal current sent from the sensor. Then it supplies a DC current to the actuator solenoid valve. It also controls ON-OFF operation of the valve relay and motor relay. If any electrical malfunction should be detected in the system, the control unit causes the warning lamp to light up. In this condition, the ABS will be deactivated by the control unit, and the vehicle's brake system reverts to normal operation.

ST
RS
BT
HA
SC
EL
IDX

System Description (Cont'd)

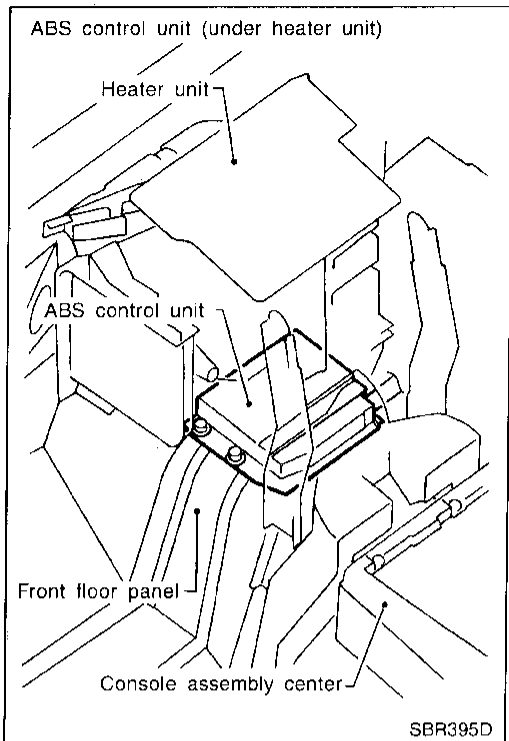

G SENSOR

NBBR0052503

The G sensor senses deceleration during braking to determine whether the vehicle is being driven on a high μ road (asphalt road, etc.) or a low μ road (snow-covered road, etc.). It then sends a signal to the ABS control unit.

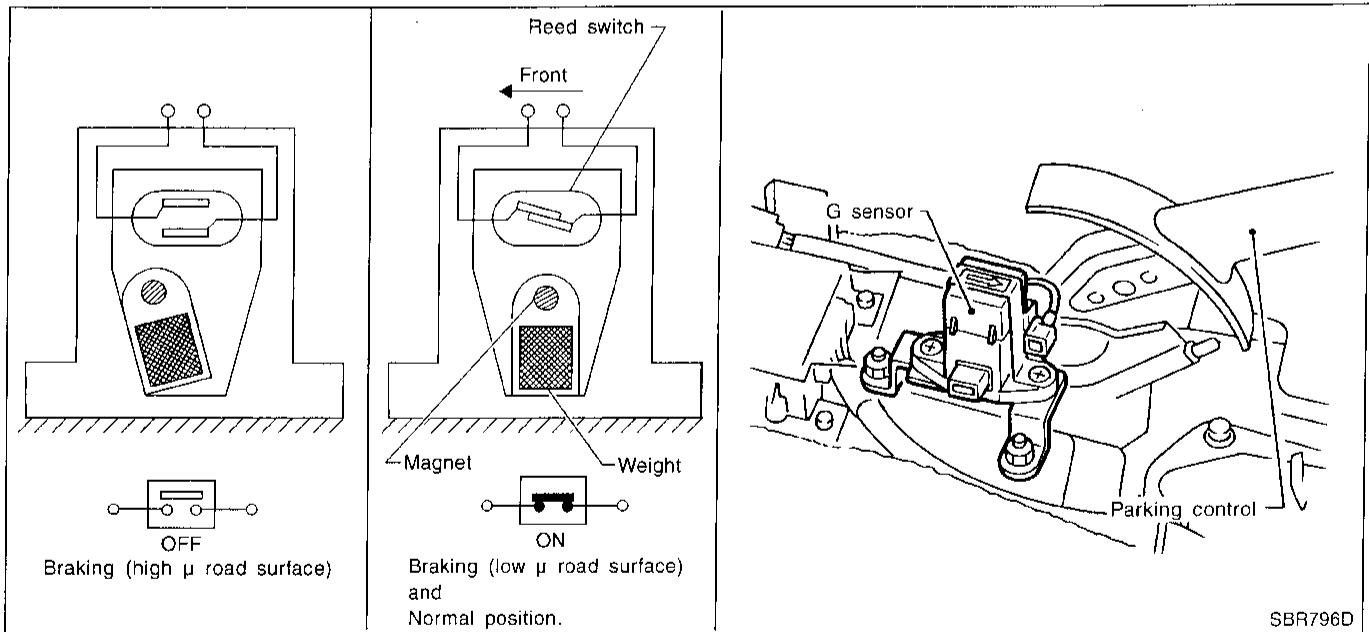

The reed switch turns on when it is affected by a magnetic field. During sudden deceleration (braking on a high μ road), the weight moves and the magnet in the weight moves away from the reed switch. The magnetic field then diminishes and the reed switch turns off.

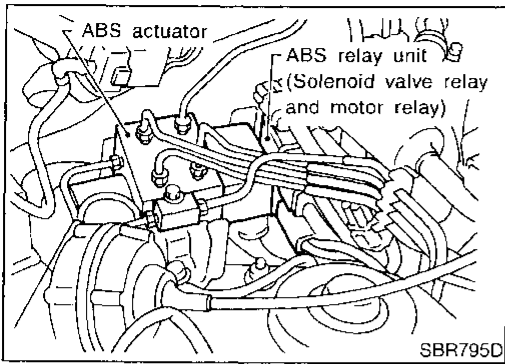

ACTUATOR

NBBR0052S04

The actuator contains:

- An electric motor and pump
- Two relays
- Six solenoid valves, each inlet and outlet for
 - LH front
 - RH front
 - Rear

These components control the hydraulic circuit. The ABS control unit directs the actuator to increase, hold or decrease hydraulic pressure to all or individual wheels.

ABS Actuator Operation

NBBR0052S0401

		Inlet solenoid valve	Outlet solenoid valve	
Normal brake operation		OFF (Open)	OFF (Closed)	Master cylinder brake fluid pressure is directly transmitted to caliper via the inlet solenoid valve.
ABS operation	Pressure hold	ON (Closed)	OFF (Closed)	Hydraulic circuit is shut off to hold the caliper brake fluid pressure.
	Pressure decrease	ON (Closed)	ON (Open)	Caliper brake fluid is sent to reservoir via the outlet solenoid valve. Then it is pushed up to the master cylinder by pump.
	Pressure increase	OFF (Open)	OFF (Closed)	Master cylinder brake fluid pressure is transmitted to caliper.

GI

MA

EM

LC

EC

FE

AT

TF

PD

AX

SU

BR

ST

RS

BT

HA

SC

EL

IDX

Component Parts and Harness Connector Location

NBBR0053

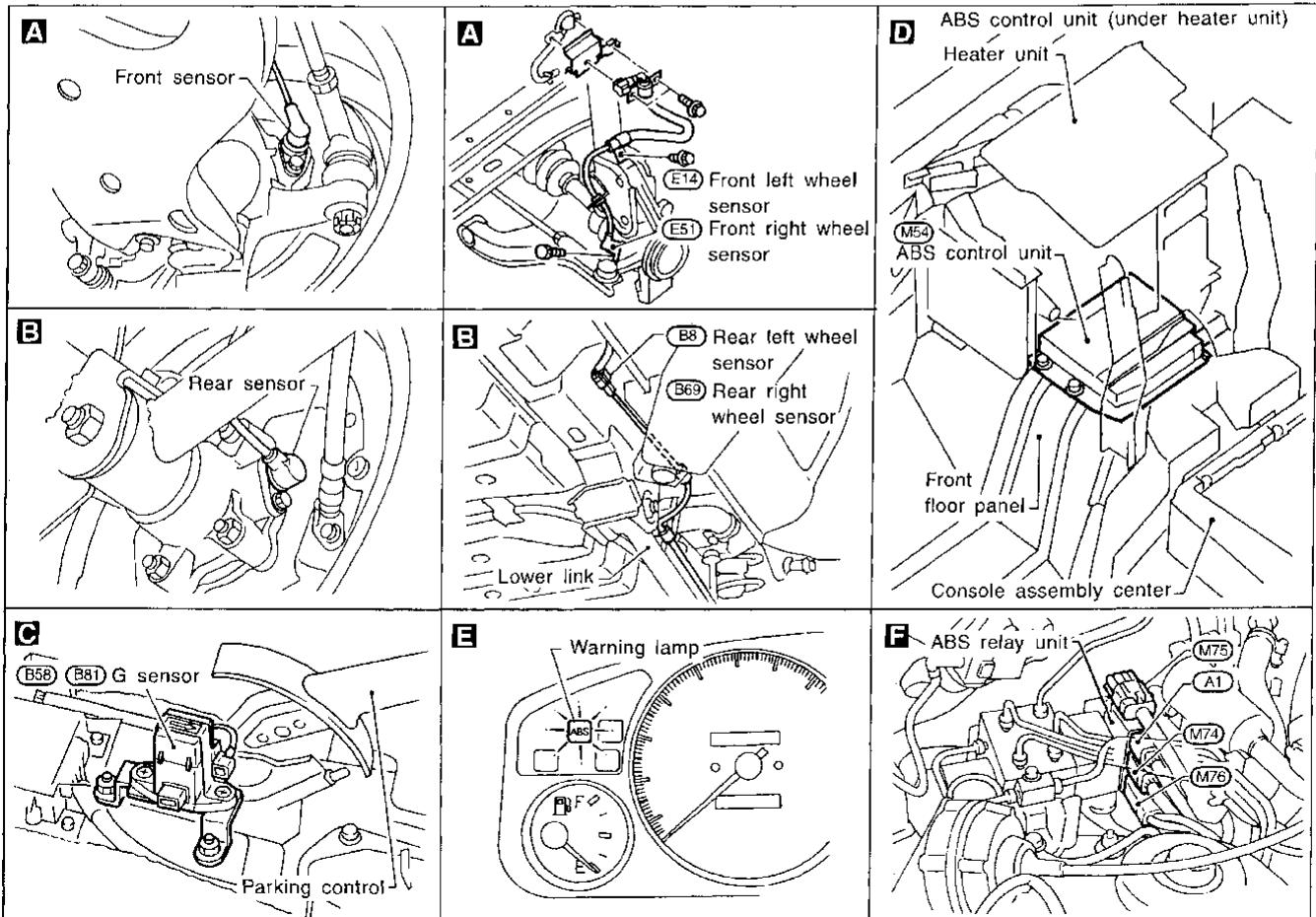
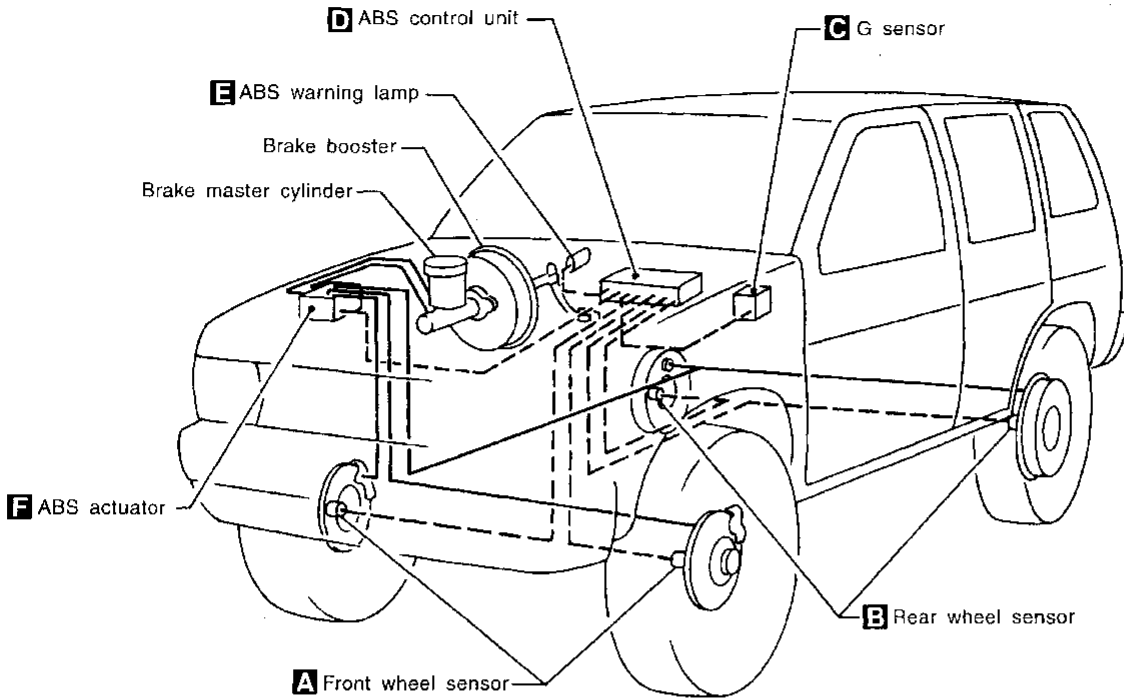

SBR800D

Circuit Diagram for Quick Pinpoint Check

NBBR0054

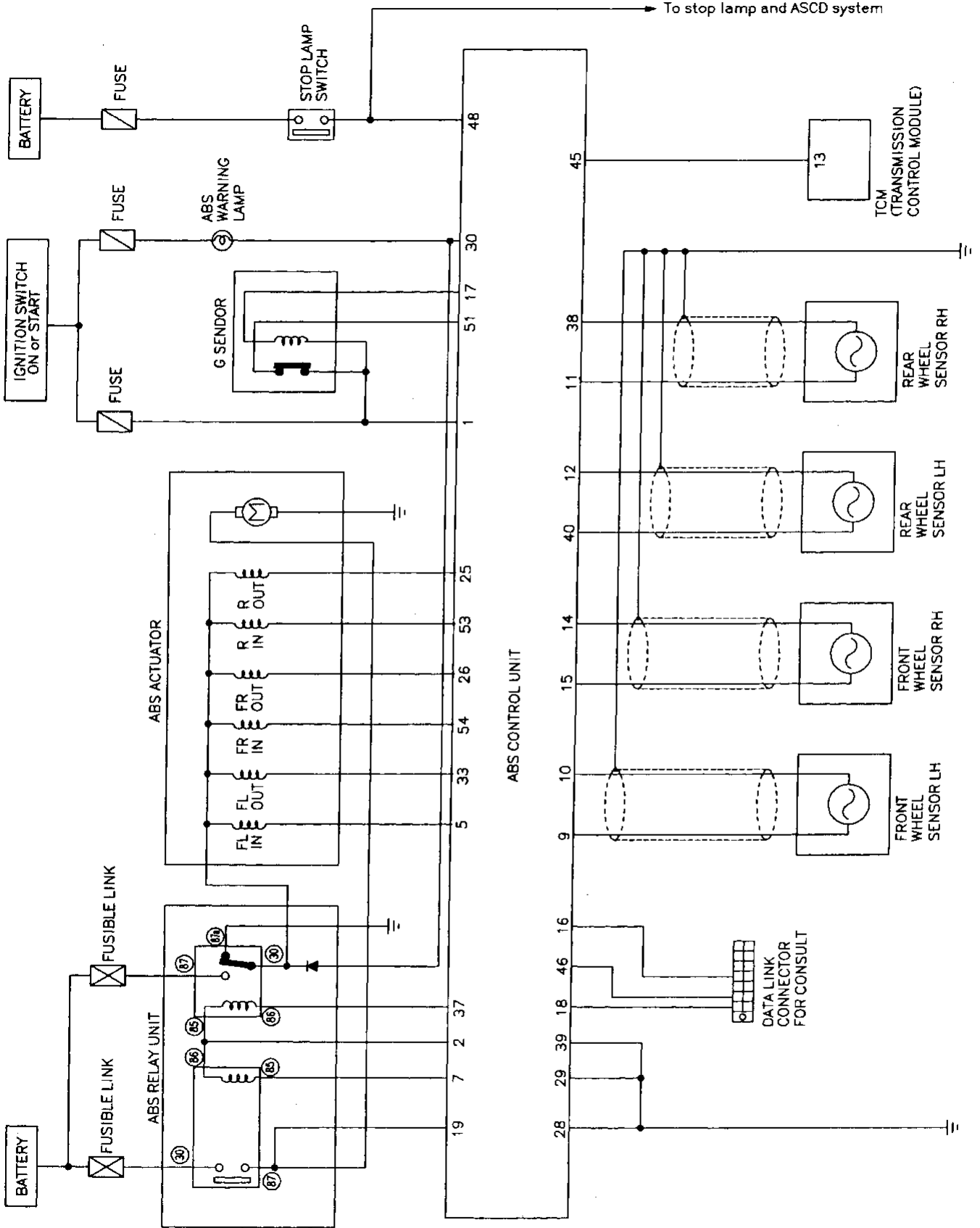

- GI
- MA
- EM
- LC
- EC
- FE
- AT
- TF
- PD
- AX
- SU
- BR**
- ST
- RS
- BT
- HA
- SC
- EL
- DX

MBR289A

Wiring Diagram — ABS —

NBBH0055

BR-ABS-01

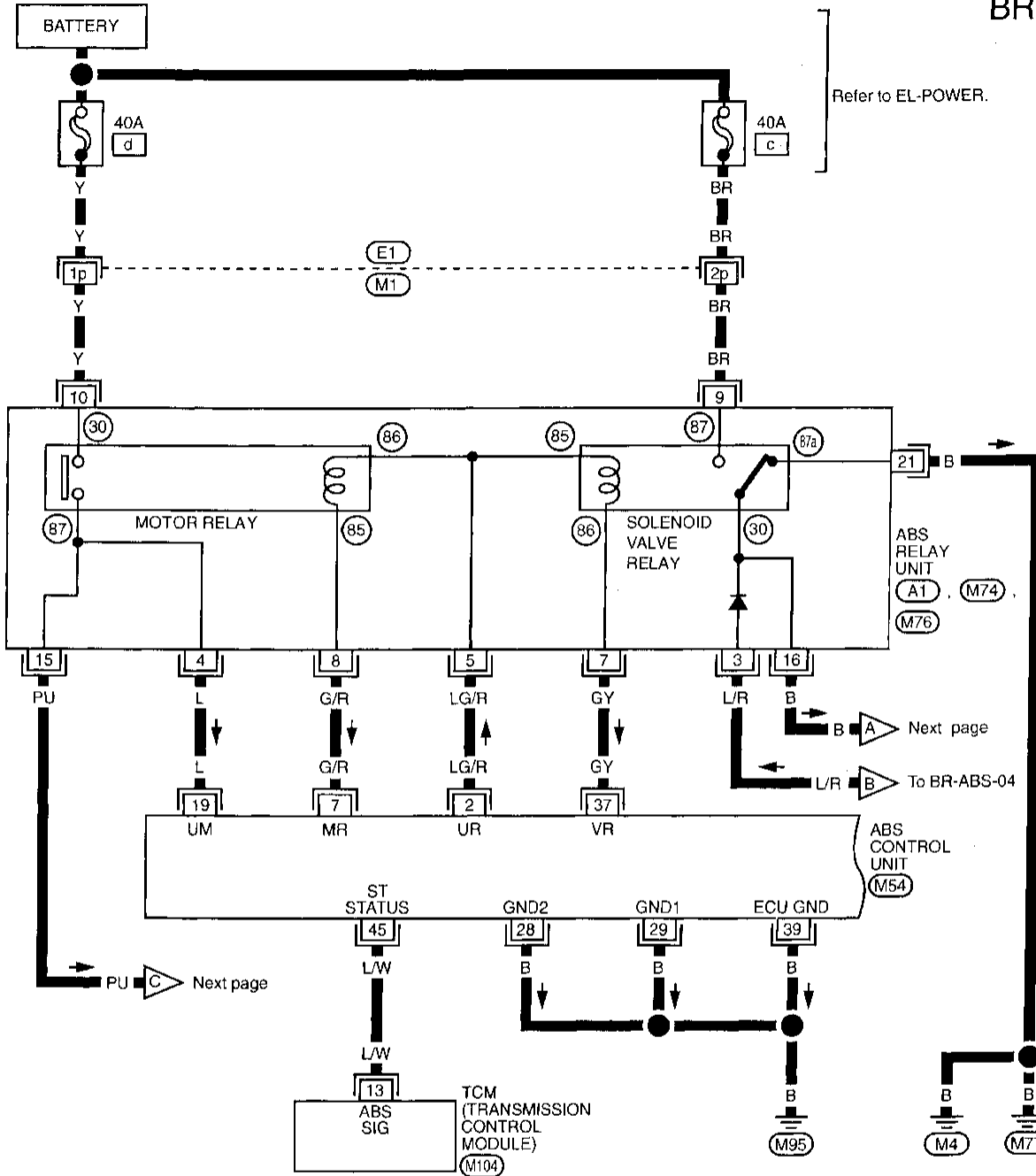

Refer to EL-POWER.

Next page

To BR-ABS-04

Next page

Refer to last page (Foldout page).

- (M1), (E1)
- (M104)

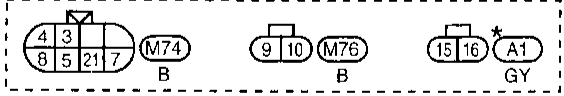

* : This connector is not shown in "HARNES LAYOUT", EL section.

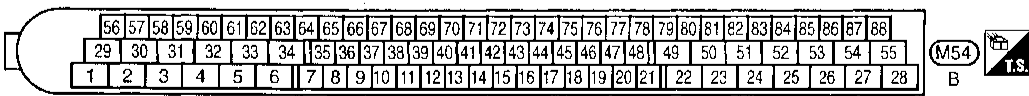

BR-ABS-02

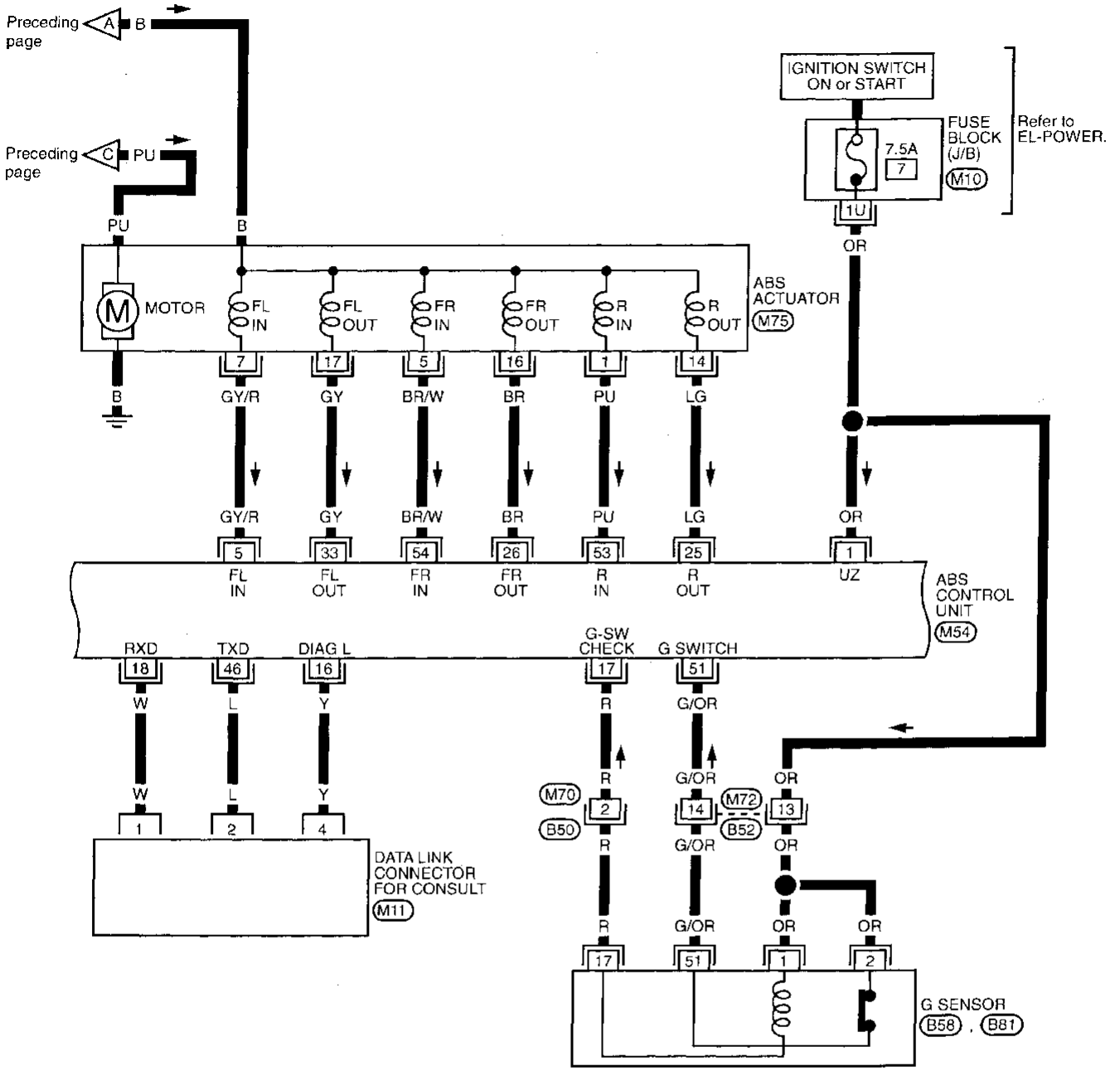

GI
MA
EM
LC
EC
FE
AT
TF
PD
AX
SU
BR
ST
RS
BT
HA
SC
EL
DX

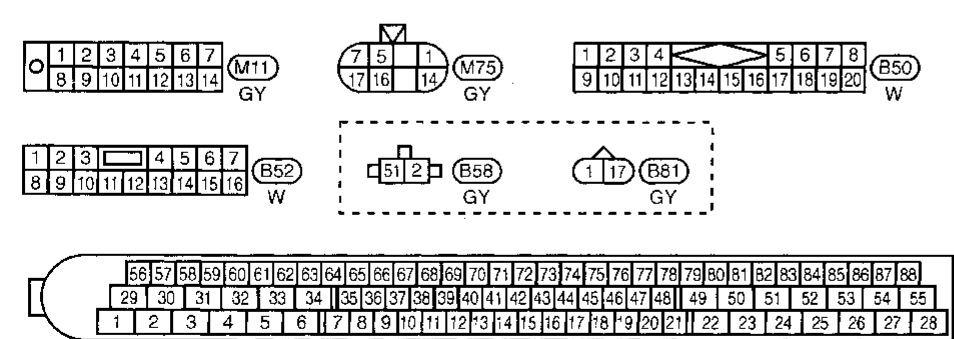

Refer to last page (Foldout page).

(M10)

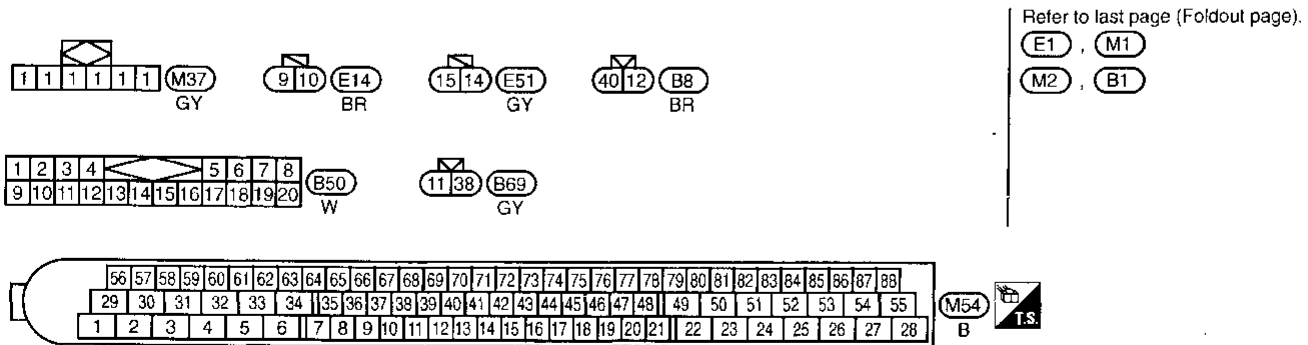
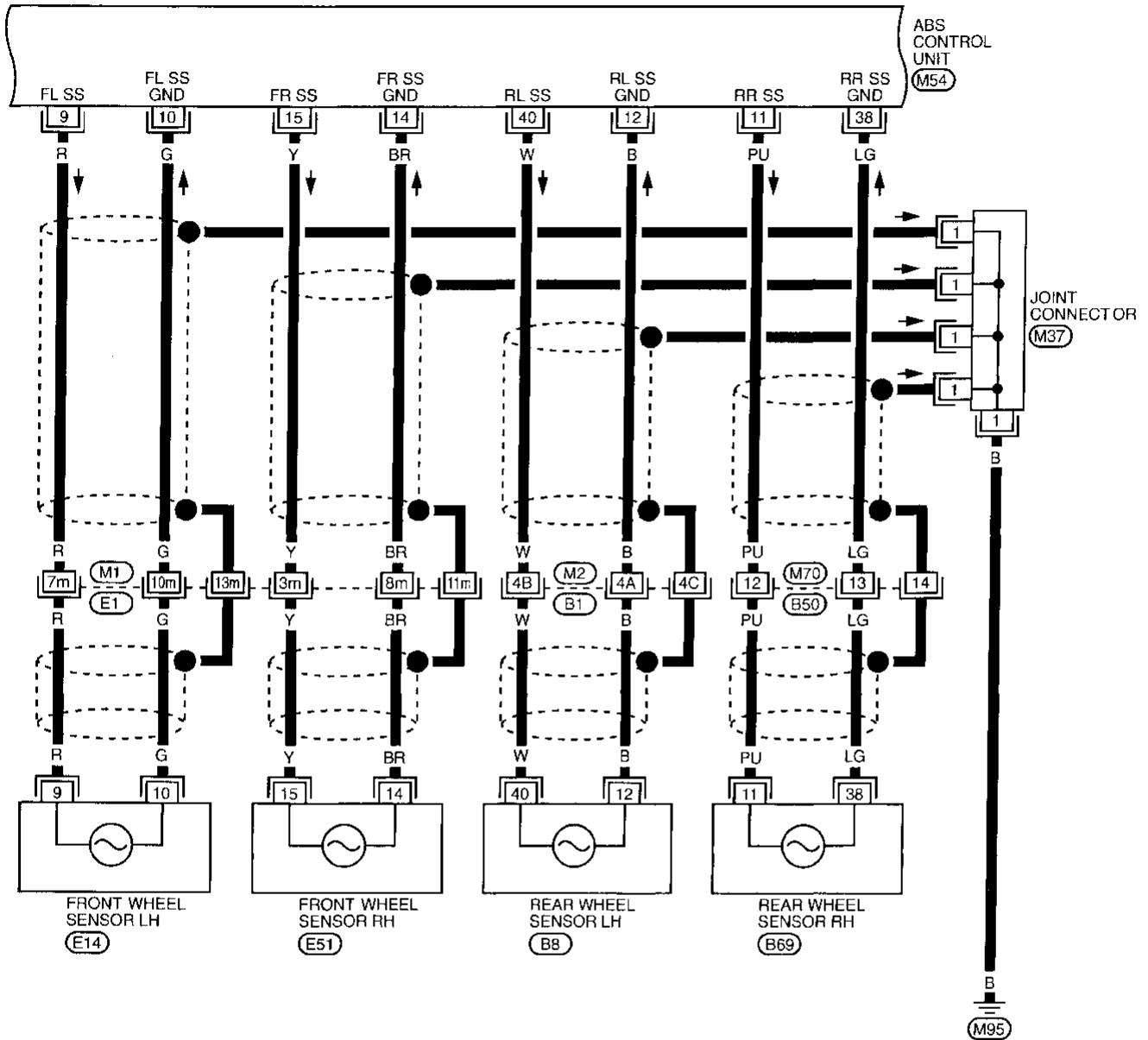

BR-ABS-04

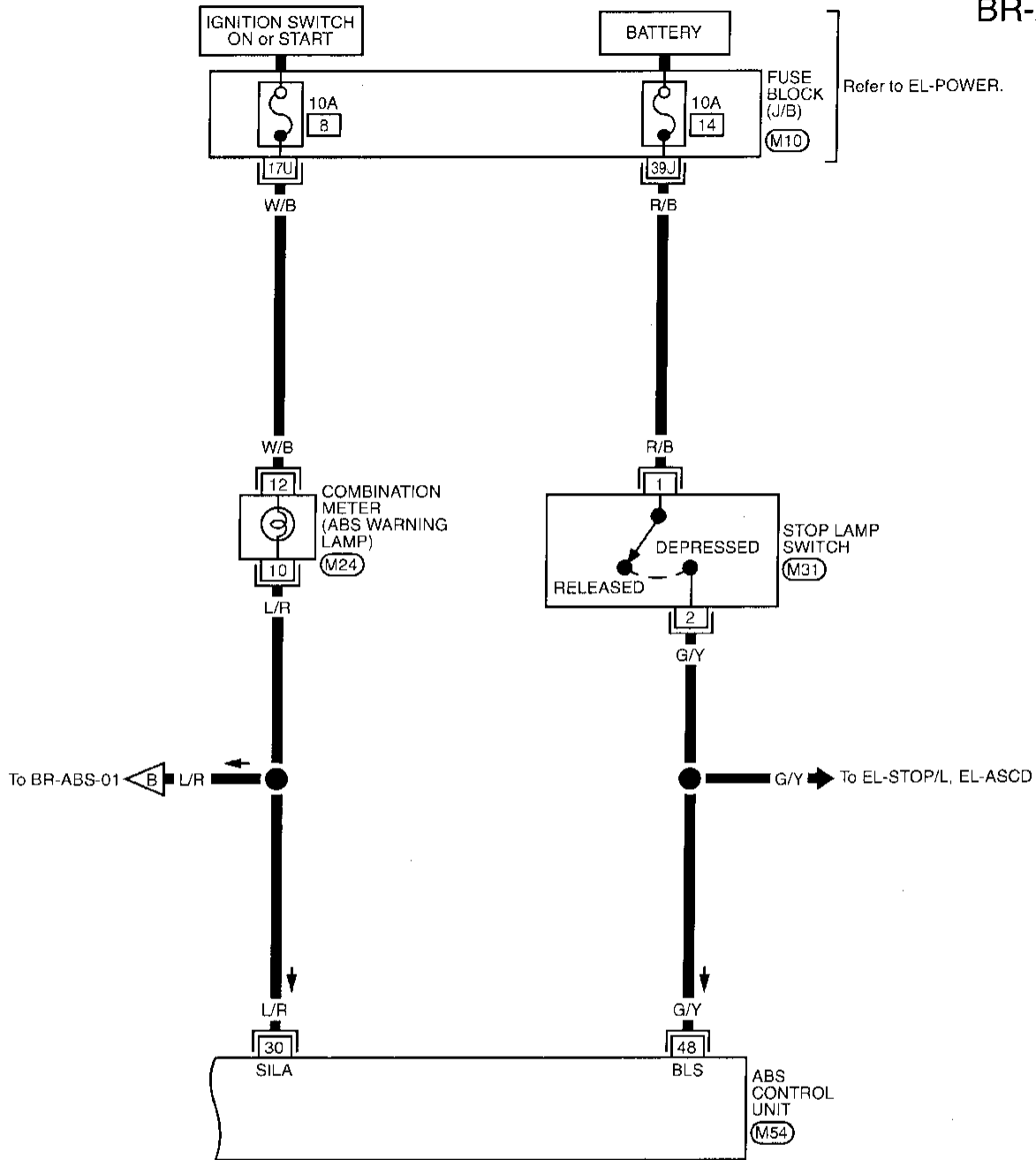

GI
MA
EM
LC
EC
FE
AT
TF
PD
AX
SU
BR
ST
RS
BT
HA
SC
EL
IDX

Refer to last page (Foldout page).

(M10)

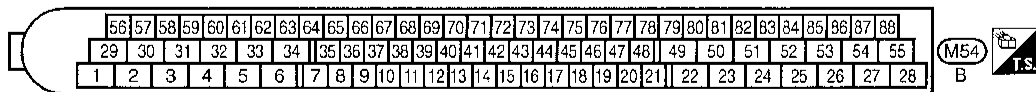
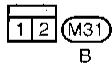
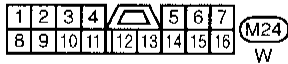

Self-diagnosis

NBBR0056

FUNCTION

NBBR0056S01

- When a problem occurs in the ABS, the warning lamp on the instrument panel comes on. To start the self-diagnostic results mode, ground the self-diagnostic (check) terminal located on "Data Link Connector for CONSULT". The location of the malfunction is indicated by the warning lamp flashing.

SELF-DIAGNOSIS PROCEDURE

NBBR0056S02

- Drive vehicle over 30 km/h (19 MPH) for at least one minute.
- Turn ignition switch "OFF".
- Ground terminal "4" of "Data link connector for CONSULT" with a suitable harness.
- Turn ignition switch "ON" while grounding terminal "4".
Do not depress brake pedal.
- After 3.0 seconds, the warning lamp starts flashing to indicate the malfunction code No. (See NOTE.)
- Verify the location of the malfunction with the malfunction code chart. Refer to BR-52. Then make the necessary repairs following the diagnostic procedures.
- After the malfunctions are repaired, erase the malfunction codes stored in the control unit. Refer to BR-41.
- Rerun the self-diagnostic results mode to verify that the malfunction codes have been erased.
- Disconnect the check terminal from the ground. The self-diagnostic results mode is now complete.
- Check warning lamp for deactivation after driving vehicle over 30 km/h (19 MPH) for at least one minute.
- After making certain that warning lamp does not come on, test the ABS in a safe area to verify that it functions properly.

NOTE:

The indication terminates after five minutes. However, when the ignition switch is turned from "OFF" to "ON", the indication starts flashing again.

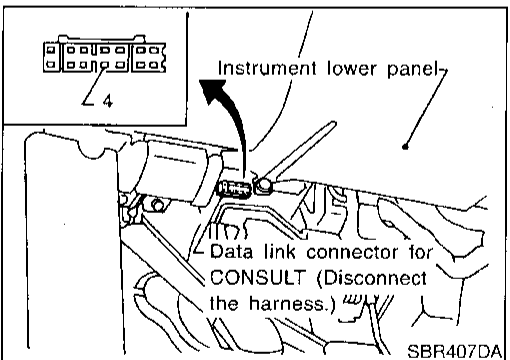
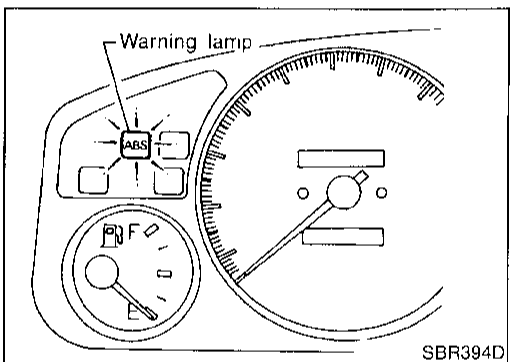
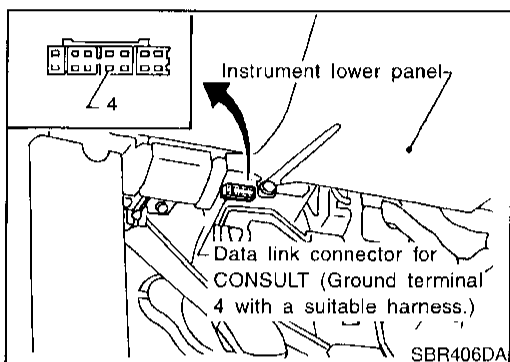

HOW TO READ SELF-DIAGNOSTIC RESULTS (MALFUNCTION CODES)

1. Determine the code No. by counting the number of times the warning lamp flashes on and off.
2. When several malfunctions occur at one time, up to three code numbers can be stored; the latest malfunction will be indicated first.
3. The indication begins with the start code 12. After that a maximum of three code numbers appear in the order of the latest one first. The indication then returns to the start code 12 to repeat (the indication will stay on for five minutes at the most).
4. The malfunction code chart is given on the next page.

-NBBR0056S03

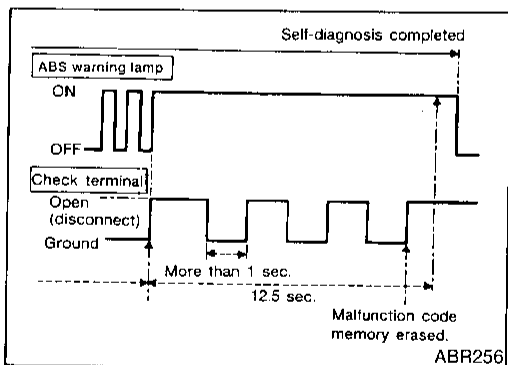
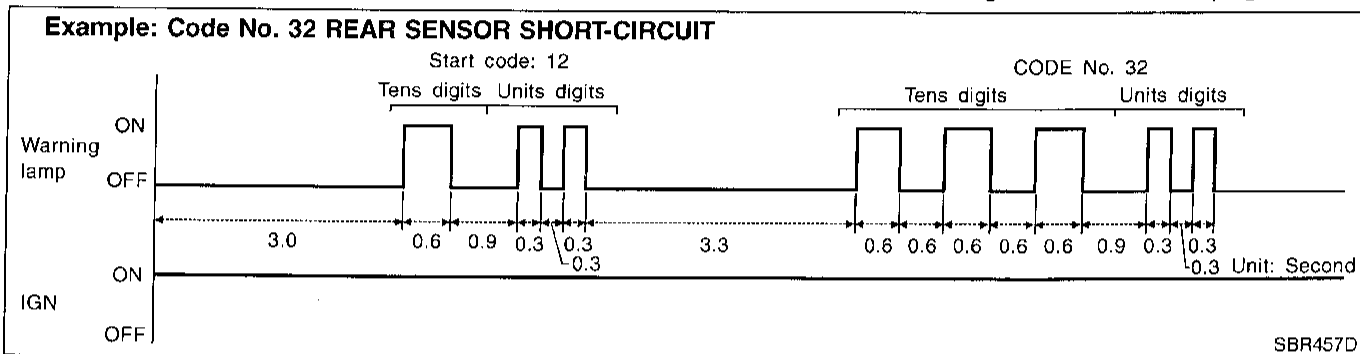

HOW TO ERASE SELF-DIAGNOSTIC RESULTS (MALFUNCTION CODES)

NBBR0056S04

1. Disconnect the check terminal from ground (ABS warning lamp will stay lit).
2. Within 12.5 seconds, ground the check terminal 3 times. Each terminal ground must last more than 1 second. The ABS warning lamp goes out after the erase operation has been completed.
3. Perform self-diagnosis again. Refer to BR-40. Only the start-code should appear, no malfunction codes.

GI

MA

EM

LC

EC

FE

AT

TF

PD

AX

SU

BR

ST

RS

BT

HA

SC

EL

IDX

CONSULT

CONSULT

=NBBR0057

CONSULT APPLICATION TO ABS

NBBR0057S01

ITEM	SELF-DIAGNOSTIC RESULTS	DATA MONITOR	ACTIVE TEST
Front right wheel sensor	x	x	—
Front left wheel sensor	x	x	—
Rear right wheel sensor	x	x	—
Rear left wheel sensor	x	x	—
G switch (G sensor)	x	x	x
ABS sensor	x	—	—
Stop lamp switch	—	x	—
Front right inlet solenoid valve	x	x	x
Front right outlet solenoid valve	x	x	x
Front left inlet solenoid valve	x	x	x
Front left outlet solenoid valve	x	x	x
Rear inlet solenoid valve	x	x	x
Rear outlet solenoid valve	x	x	x
Actuator solenoid valve relay	x	x	—
Actuator motor relay (ABS MOTOR is shown on the Data Monitor screen.)	x	x	x
ABS warning lamp	—	x	—
Battery voltage	x	x	—
Control unit	x	—	—
ABS operating signal	—	x	x

x: Applicable
 —: Not applicable

ECU (ABS CONTROL UNIT) PART NUMBER MODE

NBBR0057S02

Ignore the ECU part number displayed in the ECU PART NUMBER MODE. Refer to parts catalog to order the ECU.

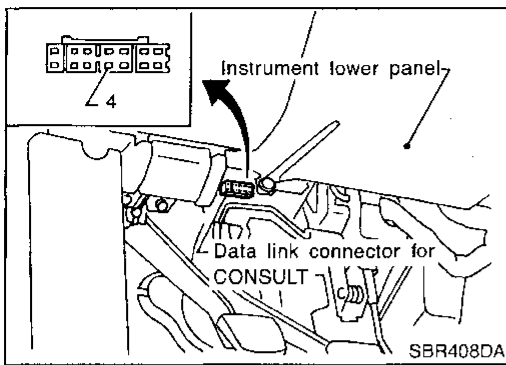

CONSULT Inspection Procedure

-NBBR0058

SELF-DIAGNOSIS PROCEDURE

NBBR0058S01

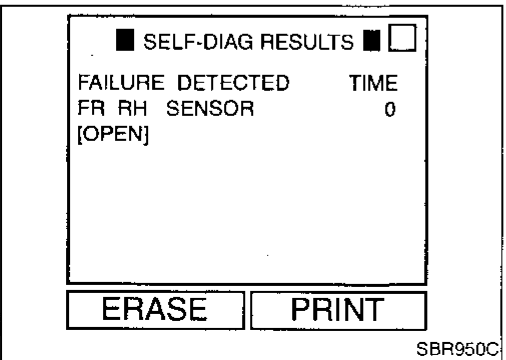
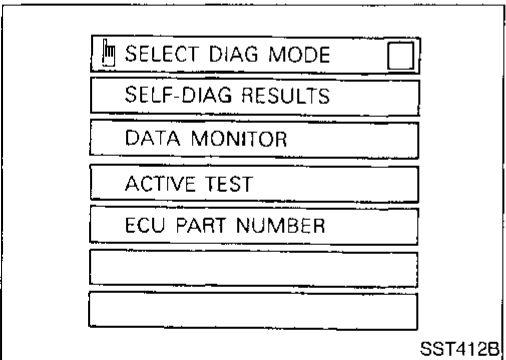
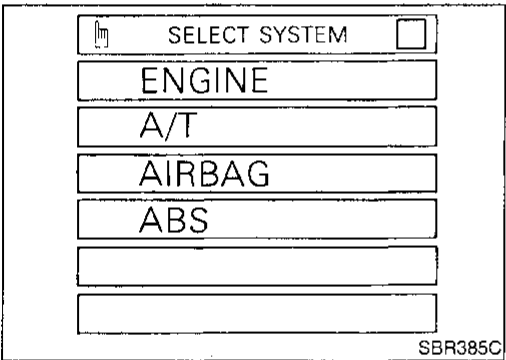
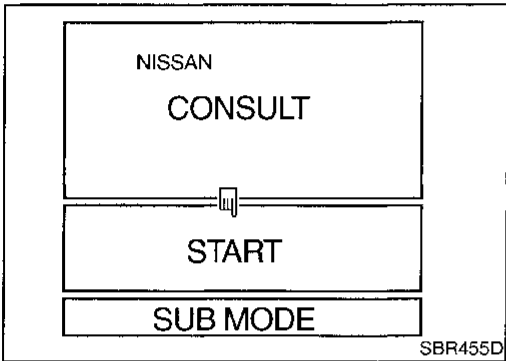

1. Turn ignition switch OFF.
2. Connect CONSULT to Data Link Connector for CONSULT.
3. Start engine.
4. Drive vehicle over 30 km/h (19 MPH) for at least one minute.

5. Stop vehicle with engine running and touch "START" on CONSULT screen.

6. Touch "ABS".

7. Touch "SELF-DIAG RESULTS".

- The screen shows the detected malfunction and how many times the ignition switch has been turned since the malfunction.

8. Make the necessary repairs following the diagnostic procedures.

9. After the malfunctions are repaired, erase the self-diagnostic results stored in the control unit by touching "ERASE".

10. Check warning lamp for deactivation after driving vehicle over 30 km/h (19 MPH) for at least one minute.

11. Test the ABS in a safe area to verify that it functions properly.

NOTE:

"SELF-DIAG RESULTS" screen shows the detected malfunction and how many times the ignition switch has been turned since the malfunction.

GI
MA
EM
LC
EC
FE
AT
TF
PD
AX
SU
BR
ST
RS
BT
CA
SC
EL
IDX

SELF-DIAGNOSTIC RESULTS MODE

NBBF0058S02

Diagnostic item	Diagnostic item is detected when ...	Reference Page
FR RH SENSOR★ [OPEN]	<ul style="list-style-type: none"> ● Circuit for front right wheel sensor is open. (An abnormally high input voltage is entered.) 	BR-53
FR LH SENSOR★ [OPEN]	<ul style="list-style-type: none"> ● Circuit for front left wheel sensor is open. (An abnormally high input voltage is entered.) 	BR-53
RR RH SENSOR★ [OPEN]	<ul style="list-style-type: none"> ● Circuit for rear right sensor is open. (An abnormally high input voltage is entered.) 	BR-53
RR LH SENSOR★ [OPEN]	<ul style="list-style-type: none"> ● Circuit for rear left sensor is open. (An abnormally high input voltage is entered.) 	BR-53
FR RH SENSOR★ [SHORT]	<ul style="list-style-type: none"> ● Circuit for front right wheel sensor is shorted. (An abnormally low input voltage is entered.) 	BR-53
FR LH SENSOR★ [SHORT]	<ul style="list-style-type: none"> ● Circuit for front left wheel sensor is shorted. (An abnormally low input voltage is entered.) 	BR-53
RR RH SENSOR★ [SHORT]	<ul style="list-style-type: none"> ● Circuit for rear right sensor is shorted. (An abnormally low input voltage is entered.) 	BR-53
RR LH SENSOR★ [SHORT]	<ul style="list-style-type: none"> ● Circuit for rear left sensor is shorted. (An abnormally low input voltage is entered.) 	BR-53
ABS SENSOR★ [ABNORMAL SIGNAL]	<ul style="list-style-type: none"> ● Teeth damage on sensor rotor or improper installation of wheel sensor. (Abnormal wheel sensor signal is entered.) 	BR-53
FR RH IN ABS SOL [OPEN, SHORT]	<ul style="list-style-type: none"> ● Circuit for front right inlet solenoid valve is open. (An abnormally low output voltage is entered.) 	BR-55
FR LH IN ABS SOL [OPEN, SHORT]	<ul style="list-style-type: none"> ● Circuit for front left inlet solenoid valve is open. (An abnormally low output voltage is entered.) 	BR-55
FR RH OUT ABS SOL [OPEN, SHORT]	<ul style="list-style-type: none"> ● Circuit for front right outlet solenoid valve is open. (An abnormally low output voltage is entered.) 	BR-55
FR LH OUT ABS SOL [OPEN, SHORT]	<ul style="list-style-type: none"> ● Circuit for front left outlet solenoid valve is open. (An abnormally low output voltage is entered.) 	BR-55
RR IN ABS SOL [OPEN, SHORT]	<ul style="list-style-type: none"> ● Circuit for rear right outlet solenoid valve is shorted. (An abnormally high output voltage is entered.) 	BR-55
RR OUT ABS SOL [OPEN, SHORT]	<ul style="list-style-type: none"> ● Circuit for rear left outlet solenoid valve is shorted. (An abnormally high output voltage is entered.) 	BR-55
ABS ACTUATOR RELAY [ABNORMAL]	<ul style="list-style-type: none"> ● Actuator solenoid valve relay is ON, even if control unit sends off signal. ● Actuator solenoid valve relay is OFF, even if control unit sends on signal. 	BR-57
ABS MOTOR RELAY [ABNORMAL]	<ul style="list-style-type: none"> ● Circuit for ABS motor relay is open or shorted. ● Circuit for actuator motor is open or shorted. ● Actuator motor relay is stuck. 	BR-60
BATTERY VOLT [VB-LOW]	<ul style="list-style-type: none"> ● Power source voltage supplied to ABS control unit is abnormally low. 	BR-64
CONTROL UNIT	<ul style="list-style-type: none"> ● Function of calculation in ABS control unit has failed. 	BR-68
G-SENSOR [ABNORMAL]	<ul style="list-style-type: none"> ● G sensor circuit is open or shorted. 	BR-65

★: If one or more wheels spin on a rough or slippery road for 40 seconds or more, the ABS warning lamp will illuminate. This does not indicate a malfunction. Only in the case of the short-circuit (Code Nos. 26, 22, 32 and 36), after repair the ABS warning lamp also illuminates when the ignition switch is turned "ON". In this case, drive the vehicle at speeds greater than 30 km/h (19 MPH) for approximately 1 minute as specified in "SELF-DIAGNOSIS PROCEDURE", BR-40. Check to ensure that the ABS warning lamp goes out while the vehicle is being driven.

NBBR0058503

DATA MONITOR PROCEDURE

1. Turn ignition switch OFF.
2. Connect CONSULT to Data Link Connector for CONSULT.
3. Turn ignition switch ON.
4. Touch "START" on CONSULT screen.

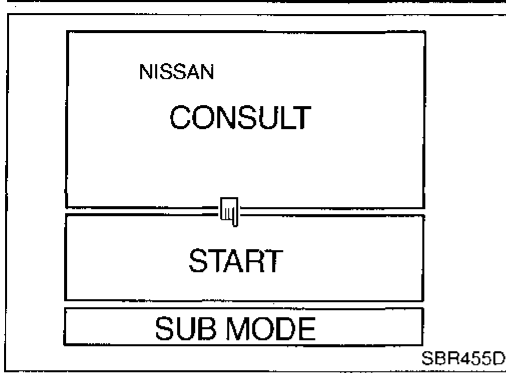

SBR455D

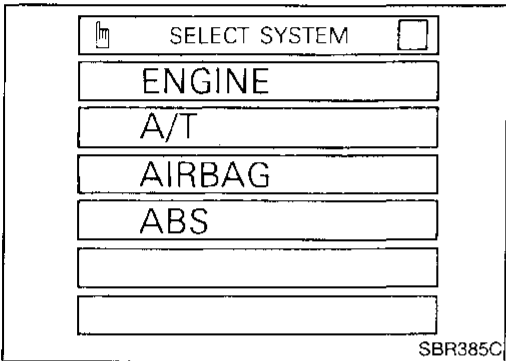

SBR385C

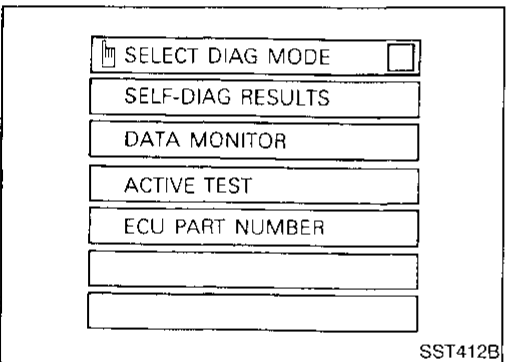

SST412B

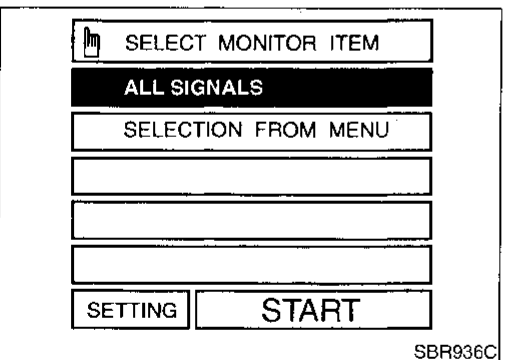

SBR936C

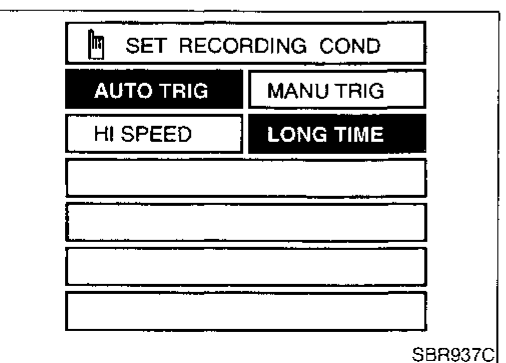

SBR937C

5. Touch "ABS".

6. Touch "DATA MONITOR".

7. Touch "SETTING" on "SELECT MONITOR ITEM" screen.

8. Touch "LONG TIME" on "SET RECORDING COND" screen.
9. Touch "START" on "SELECT MONITOR ITEM".

GI

MA

EM

LC

EC

FE

AT

TF

PD

AX

SU

BR

ST

RS

BT

HA

SC

EL

IDX

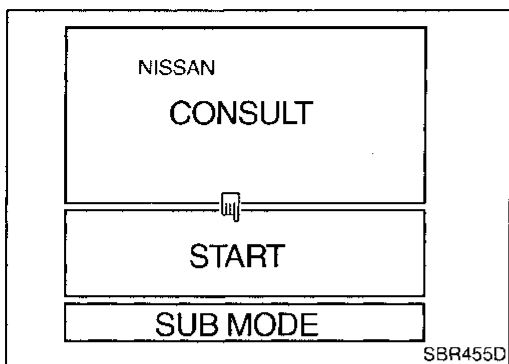

SBR455D

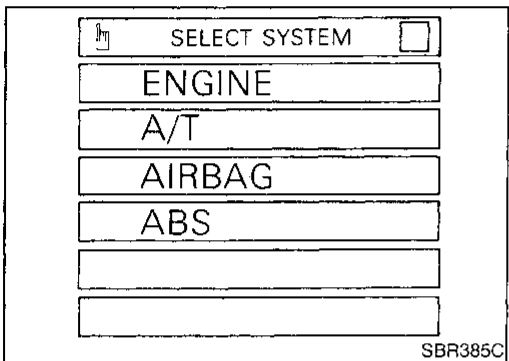

SBR385C

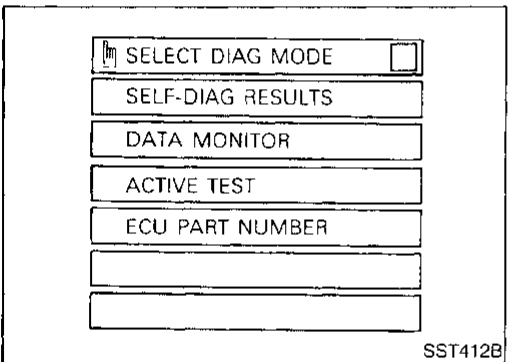

SST412B

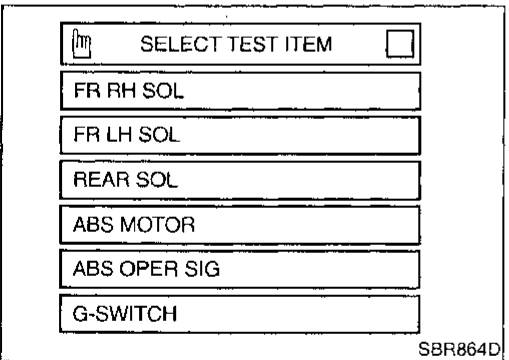

SBR864D

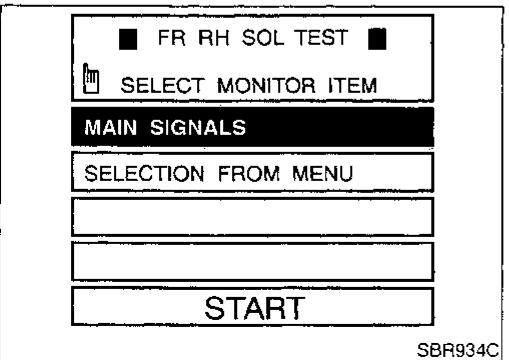

SBR934C

ACTIVE TEST PROCEDURE

NBBR0058604

- When conducting Active test, vehicle must be stationary.
 - When ABS warning lamp stays on, never conduct Active test.
1. Turn ignition switch OFF.
 2. Connect CONSULT to Data Link Connector for CONSULT.
 3. Start engine.
 4. Touch "START" on CONSULT screen.
 5. Touch "ABS".
 6. Touch "ACTIVE TEST".
 7. Select active test item by touching screen.
 8. Touch "START".
 9. Carry out the active test by touching screen key.

ON BOARD DIAGNOSTIC SYSTEM DESCRIPTION

ABS

CONSULT Inspection Procedure (Cont'd)

DATA MONITOR MODE

NBBR0058S05

MONITOR ITEM	CONDITION	SPECIFICATION	
FR RH SENSOR FR LH SENSOR RR RH SENSOR RR LH SENSOR	Drive vehicle. (Each wheel is rotating.)	Wheel speed signal (Almost the same speed as speedometer.)	GI MA
STOP LAMP SW	Brake is depressed.	Depress the pedal: ON Release the pedal: OFF	EM
G-SWITCH	Vehicle is driven. Vehicle is stopped. Brake is applied.	During sudden braking while driving on high μ roads (asphalt roads, etc.): OFF While vehicle is stopped or during constant-speed driving: ON	LC
FR RH IN SOL FR RH OUT SOL FR LH IN SOL FR LH OUT SOL RR IN SOL RR OUT SOL	1. Drive vehicle at speeds over 30 km/h (19 MPH) for at least one minute. 2. Engine is running.	Operating conditions for each solenoid valve are indicated. ABS is not operating: OFF	EC FE
MOTOR RELAY		ABS is not operating: OFF ABS is operating: ON	AT
ACTUATOR RELAY	Ignition switch is ON or engine is running.	Ignition switch ON (Engine stops): OFF Engine running: ON	TF
WARNING LAMP		ABS warning lamp is turned on: ON ABS warning lamp is turned off: OFF	PD
BATTERY VOLT		Power supply voltage for control unit	
ABS OPER SIG		ABS is not operating: OFF ABS is operating: ON	AX

ACTIVE TEST MODE

NBBR0058S06

TEST ITEM	CONDITION	JUDGEMENT		
FR RH SOLENOID FR LH SOLENOID REAR SOLENOID	Engine is running.	Brake fluid pressure control operation	BR	
			IN SOL OUT SOL	
		UP (Increase):	OFF OFF	ST
		KEEP (Hold):	ON OFF	RS
ABS MOTOR		DOWN (Decrease):	ON ON	
		ABS actuator motor ON: Motor runs (ABS motor relay ON) OFF: Motor stops (ABS motor relay OFF)	BT	
ABS OPER SIG	Ignition switch is ON or engine is running.	ON: Set ABS OPER SIG "ON" (ABS is operating.) OFF: Set ABS OPER SIG "OFF" (ABS is not operating.)	HA	
G SWITCH	Ignition switch is ON.	G SWITCH (G SENSOR), ON: Set G SWITCH MONITOR "ON" (G switch circuit is closed.) OFF: Set G SWITCH MONITOR "OFF" (G switch circuit is open.)	SC	

NOTE:

Active test will automatically stop ten seconds after the test starts. (TEST IS STOPPED monitor shows ON.)

How to Perform Trouble Diagnoses for Quick and Accurate Repair

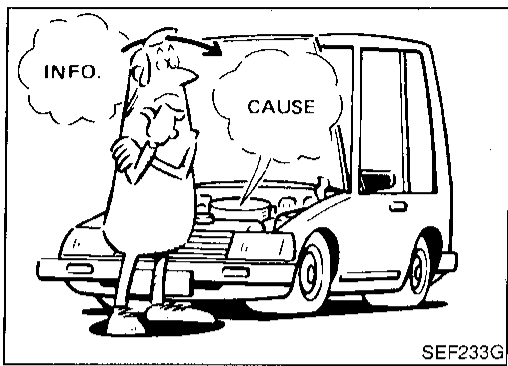

SEF233G

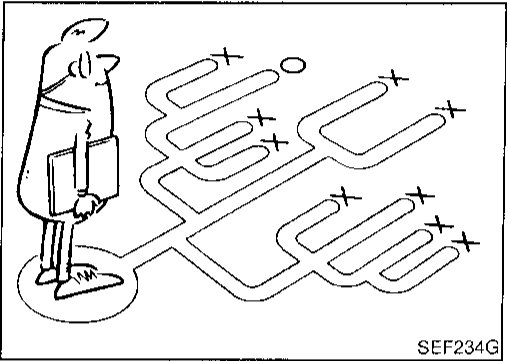

SEF234G

How to Perform Trouble Diagnoses for Quick and Accurate Repair

NBBR0059

INTRODUCTION

NBBR0059S01

The ABS system has an electronic control unit to control major functions. The control unit accepts input signals from sensors and instantly drives the actuators. It is essential that both kinds of signals are proper and stable. It is also important to check for conventional problems: such as air leaks in booster lines, lack of brake fluid, or other problems with the brake system.

It is much more difficult to diagnose a problem that occurs intermittently rather than continuously. Most intermittent problems are caused by poor electric connections or faulty wiring. In this case, careful checking of suspicious circuits may help prevent the replacement of good parts.

A visual check only may not find the cause of the problems, so a road test should be performed.

Before undertaking actual checks, take a few minutes to talk with a customer who approaches with a ABS complaint. The customer is a very good source of information on such problems; especially intermittent ones. Through the talks with the customer, find out what symptoms are present and under what conditions they occur. Start your diagnosis by looking for "conventional" problems first. This is one of the best ways to troubleshoot brake problems on an ABS controlled vehicle. Also check related Service bulletins for information.

Preliminary Check

NBBR0060

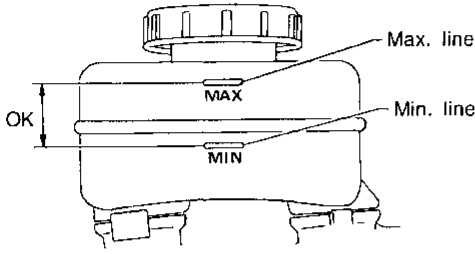
1	CHECK BRAKE FLUID LEVEL
<p>Check brake fluid level in reservoir tank. Low fluid level may indicate brake pad wear or leakage from brake line.</p>	
	
SBR451D	
<p>Is brake fluid filled between MAX and MIN lines on reservoir tank and/or has brake fluid been contaminated?</p>	
Yes	▶ GO TO 2.
No	▶ Repair. GO TO 2.

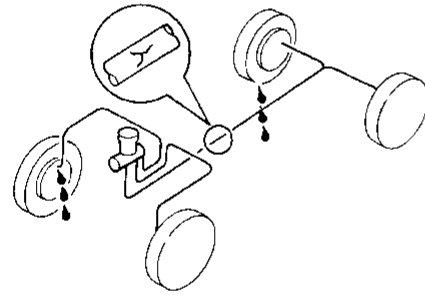
2	CHECK BRAKE LINE
<p>Check brake line for leakage.</p>	
	
SBR389C	
<p>Is leakage present at or around brake lines, tubes or hoses or are any of these parts cracked or damaged?</p>	
Yes	▶ GO TO 3.
No	▶ Repair. GO TO 3.

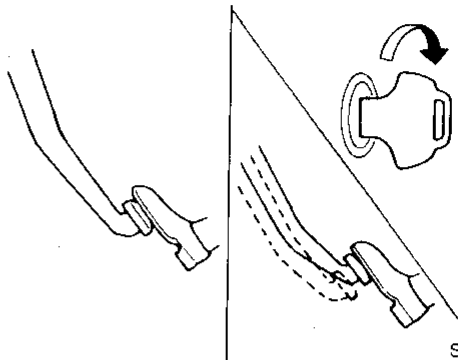
3	CHECK BRAKE BOOSTER OPERATION
<p>Check brake booster for operation and air tightness. Refer to (BR-17).</p>	
	
SBR058C	
<p>Is brake booster airtight and functioning properly?</p>	
Yes	▶ GO TO 4.
No	▶ Replace. GO TO 4.

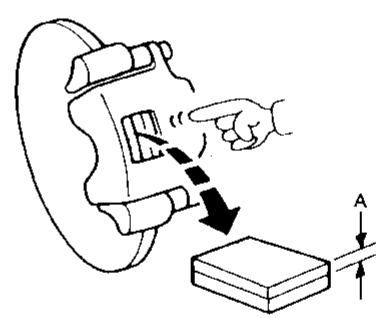
4	CHECK BRAKE PAD AND ROTOR
<p>Check brake pad and rotor. Refer to (BR-20, BR-22).</p>	
	
SBR059C	
<p>Are brake pads and rotors functioning properly?</p>	
Yes	▶ GO TO 5.
No	▶ Replace.

GI
 MA
 EM
 LC
 EC
 FE
 AT
 TF
 PD
 AX
 SU
BR
 ST
 RS
 BT
 HA
 SC
 EL
 IDX

Preliminary Check (Cont'd)

5	RECHECK BRAKE FLUID LEVEL
Check brake fluid level in reservoir tank again.	
SBR451D	
<p style="text-align: center;">Is brake fluid filled between MAX and MIN lines on reservoir tank and/or has brake fluid been contaminated?</p>	
Yes	▶ GO TO 6.
No	▶ Fill up brake fluid.

6	CHECK WARNING LAMP ACTIVATION
Check warning lamp activation.	
SBR394D	
<p style="text-align: center;">Does warning lamp turn on when ignition switch is turned "ON"?</p>	
Yes	▶ GO TO 7.
No	▶ Check fuse, warning lamp bulb and warning lamp circuit.

7	CHECK WARNING LAMP DEACTIVATION
Check warning lamp for deactivation after engine is started.	
Does warning lamp turn off when engine is started?	
Yes	▶ GO TO 8.
No	▶ Go to Self-diagnosis (BR-40, 43).

8	DRIVE VEHICLE
Drive vehicle at speeds over 30 km/h (19 MPH) for at least one minute.	
Does warning lamp remain off after vehicle has been driven at 30 km/h (19 MPH) for at least one minute?	
Yes	▶ END
No	▶ Go to Self-diagnosis (BR-40, 43).

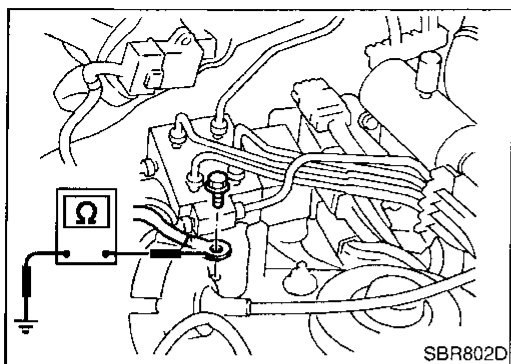

Ground Circuit Check
ACTUATOR MOTOR GROUND

=NBBR0061

NBBR0061SU1

1. Remove actuator motor earth terminal.
2. Check resistance between actuator motor earth terminal and body ground.

Resistance: approximately 0Ω

GI

MA

EM

LC

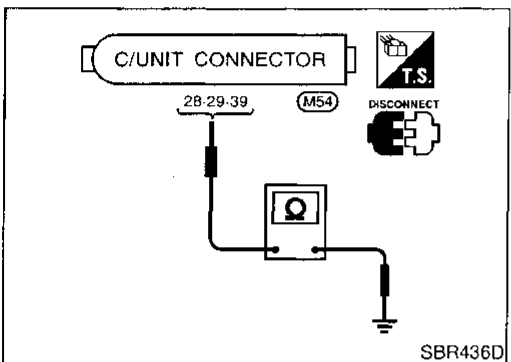

CONTROL UNIT GROUND

NBBR0061S02

- Check resistance between control unit connector terminals and ground.

Resistance: approximately 0Ω

EC

FE

AT

TF

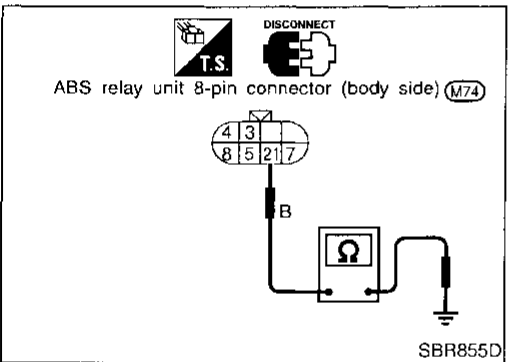

ACTUATOR GROUND

NBBR0061S03

- Check resistance between ABS relay unit harness 8-pin connector (body side) terminal 21 and ground.

Resistance: approximately 0Ω

PD

AX

SU

BR

ST

RS

BT

HA

SC

EL

IDX

Malfunction Code/Symptom Chart

NBR0062

Code No. (No. of warning lamp flashes)	Malfunctioning part	Reference Page
45	Actuator front left outlet solenoid valve	BR-55
46	Actuator front left inlet solenoid valve	BR-55
41	Actuator front right outlet solenoid valve	BR-55
42	Actuator front right inlet solenoid valve	BR-55
55	Actuator rear outlet solenoid valve	BR-55
56	Actuator rear inlet solenoid valve	BR-55
25 ★1	Front left sensor (open-circuit)	BR-53
26 ★1	Front left sensor (short-circuit)	BR-53
21 ★1	Front right sensor (open-circuit)	BR-53
22 ★1	Front right sensor (short-circuit)	BR-53
31 ★1	Rear right sensor (open-circuit)	BR-53
32 ★1	Rear right sensor (short-circuit)	BR-53
35 ★1	Rear left sensor (open-circuit)	BR-53
36 ★1	Rear left sensor (short-circuit)	BR-53
18 ★1	Sensor rotor	BR-53
17	G sensor and circuit	BR-65
61 ★3	Actuator motor or motor relay	BR-60
63	Solenoid valve relay	BR-57
57 ★2	Power supply (Low voltage)	BR-64
71	Control unit	BR-68
Warning lamp stays on when ignition switch is turned on.	Control unit power supply circuit Warning lamp bulb circuit Control unit or control unit connector Solenoid valve relay stuck Power supply for solenoid valve relay coil	BR-75
Warning lamp does not come on when ignition switch is turned on.	Fuse, warning lamp bulb or warning lamp circuit Control unit	BR-72
Pedal vibration and noise	—	BR-71
Long stopping distance	—	BR-70
Unexpected pedal action	—	BR-69
ABS does not work	—	BR-71
ABS works frequently	—	BR-69
Vehicle vibrates excessively when ABS is operating.	ABS control unit to TCM circuit	BR-78

★1: If one or more wheels spin on a rough or slippery road for 40 seconds or more, the ABS warning lamp will illuminate. This does not indicate a malfunction. Only in the case of the short-circuit (Code Nos. 26, 22, 32 and 36), after repair the ABS warning lamp also illuminates when the ignition switch is turned "ON". In this case, drive the vehicle at speeds greater than 30 km/h (19 MPH) for approximately 1 minute as specified in "SELF-DIAGNOSIS PROCEDURE", BR-40. Check to ensure that the ABS warning lamp goes out while the vehicle is being driven.

★2: The trouble code "57", which refers to a low power supply voltage, does not indicate that the ABS control unit is malfunctioning. Do not replace the ABS control unit with a new one.

★3: The trouble code "61" can sometimes appear when the ABS motor is not properly grounded. If it appears, be sure to check the condition of the ABS motor ground circuit connection.

Diagnostic Procedure

Malfunction code No. 21, 22, 25, 26, 31, 32, 35, 36 or 18

NBBR0063

NOTE:

Wheel position should be distinguished by code No. except code No. 18 (sensor rotor).

GI
MA
EM
LC
EC
FE
AT
TF
PD
AX
SU
BR
ST
RS
BT
HA
SC
EL
IDX

1	INSPECTION START
Wheel sensor inspection	
<p>Wheel sensor connectors (sensor side)</p> <p>Front LH Front RH</p> <p>10 9 (E14) 14 15 (E51)</p> <p>Rear LH Rear RH</p> <p>12 40 (B8) 38 11 (B69)</p>	
<small>SBR865D</small>	
▶	GO TO 2.

2	CHECK CONNECTOR
<p>1. Disconnect connectors from control unit and wheel sensor of malfunction code No. Check terminals for damage or loose connection. Then reconnect connectors.</p> <p>2. Carry out self-diagnosis again.</p>	
Does warning lamp activate again?	
Yes	▶ GO TO 3.
No	▶ INSPECTION END

3	CHECK WHEEL SENSOR ELECTRICAL
<p>1. Disconnect control unit connector.</p> <p>2. Check resistance between control unit connector M54 terminals.</p> <p>Code No. 21 or 22 (Front RH wheel) Terminals 14 and 15</p> <p>Code No. 25 or 26 (Front LH wheel) Terminals 10 and 9</p> <p>Code No. 31 or 32 (Rear RH wheel) Terminals 11 and 38</p> <p>Code No. 35 or 36 (Rear LH wheel) Terminals 12 and 40</p> <p>Resistance: Front 0.9 - 1.1 kΩ Rear 1.44 - 1.76 kΩ</p>	
<small>SBR866D</small>	
Is front resistance 0.9 - 1.1 kΩ and rear resistance 1.44 - 1.76 kΩ?	
Yes	▶ GO TO 5.
No	▶ GO TO 4.

Diagnostic Procedure (Cont'd)

4	CHECK WHEEL SENSOR
<p>Check each sensor for resistance. Resistance: Front 0.9 - 1.1 kΩ Rear 1.44 - 1.76 kΩ</p>	
SBR867D	
<p>Is front resistance 0.9 - 1.1 kΩ and rear resistance 1.44 - 1.76 kΩ?</p>	
Yes	<p>▶ Check the following.</p> <ul style="list-style-type: none"> ● Harness connectors M54, E51, E14, B69, B8 ● Harness for open or short between wheel sensor connectors and control unit <p>If NG, repair harness or connectors.</p>
No	▶ Replace wheel sensor.

6	CHECK WHEEL BEARING
<p>Check wheel bearing axial end play. (See NOTE)</p> <p style="text-align: center;">Is wheel bearing axial end play within specifications? Refer to AX section ("On-vehicle Service", "FRONT AXLE" and "REAR AXLE").</p>	
Yes	▶ GO TO 7.
No	▶ Check wheel bearing. Refer to AX section ("On-vehicle Service", "FRONT AXLE" and "REAR AXLE").

7	CHECK SENSOR ROTOR
<p>Check sensor rotor for teeth damage. (See NOTE)</p> <p style="text-align: center;">Is sensor rotor free from damage?</p>	
Yes	▶ Check control unit pin terminals for damage or the connection of control unit harness connector. Reconnect control unit harness connector. Then retest.
No	▶ Replace sensor rotor. (See NOTE)

5	CHECK WHEEL SENSOR MECHANICAL
<p>Check for inflation pressure, wear and size of each tire. (See NOTE)</p> <p style="text-align: center;">Are tire pressure and size correct and is tire wear within specifications?</p>	
Yes	▶ GO TO 6.
No	▶ Adjust tire pressure or replace tire(s). (See NOTE)

Diagnostic Procedure

Malfunction code No. 41, 45, 55, 42, 46, 56

NBBR0064

1	INSPECTION START
<p>ABS actuator solenoid valve inspection</p> <p style="text-align: right;">SBR094E</p>	
▶ GO TO 2.	

2	CHECK CONNECTOR
<p>1. Disconnect connectors from control unit, ABS actuator and ABS relay unit. Check terminals for damage or loose connections. Then reconnect connectors.</p> <p>2. Carry out self-diagnosis again.</p> <p style="text-align: center;">Does warning lamp activate again?</p>	
Yes	▶ GO TO 3.
No	▶ INSPECTION END

3	CHECK ABS ACTUATOR SOLENOID VALVE CIRCUIT
<p>1. Disconnect connectors from control unit and ABS relay unit.</p> <p>2. Check resistance between control unit connector terminals and ABS relay unit 2-pin connector A1 (ABS actuator side) terminal.</p> <p style="text-align: center;">Resistance: 3.1 - 6.2Ω</p> <p style="text-align: center;">Code No. 41: Control unit 26, ABS relay unit 16</p> <p style="text-align: center;">Code No. 45: Control unit 33, ABS relay unit 16</p> <p style="text-align: center;">Code No. 55: Control unit 25, ABS relay unit 16</p> <p style="text-align: center;">Resistance: 6.2 - 12.3Ω</p> <p style="text-align: center;">Code No. 42: Control unit 54, ABS relay unit 16</p> <p style="text-align: center;">Code No. 46: Control unit 5, ABS relay unit 16</p> <p style="text-align: center;">Code No. 56: Control unit 53, ABS relay unit 16</p> <p style="text-align: right;">SBR820D</p> <p style="text-align: center;">Is resistance within specifications?</p>	
Yes	▶ GO TO 6.
No	▶ GO TO 4.

GI

MA

EM

LC

EC

FE

AT

TF

PD

AX

SU

BR

ST

RS

BT

FA

SC

EL

IDX

4 CHECK ABS ACTUATOR SOLENOID VALVE CIRCUIT

1. Disconnect ABS actuator 8-pin connector.
 2. Check resistance between ABS actuator 8-pin connector M75 (ABS actuator side) terminals and ABS relay unit 2-pin connector A1 (ABS actuator side) terminal.

Resistance: 3.1 - 6.2Ω
Code No. 41: ABS actuator 16, ABS relay unit 16
Code No. 45: ABS actuator 17, ABS relay unit 16
Code No. 55: ABS actuator 14, ABS relay unit 16

Resistance: 6.2 - 12.3Ω
Code No. 42: ABS actuator 5, ABS relay unit 16
Code No. 46: ABS actuator 7, ABS relay unit 16
Code No. 56: ABS actuator 1, ABS relay unit 16

ABS actuator 8-pin connector (ABS actuator side)

1, 5, 7, 14, 16, 17

DISCONNECT

ABS relay unit 2-pin connector (ABS actuator side)

15, 16

SBR821D

Is resistance within specifications?

Yes	▶	<p>Check the following.</p> <ul style="list-style-type: none"> Harness connectors M54, M75, A1 Harness for open or short between ABS relay unit connector and control unit Harness for open or short between ABS actuator 8-pin connector and ABS relay unit 2-pin connector <p>If NG, repair harness or connectors.</p>
No	▶	GO TO 5.

5 CHECK ABS ACTUATOR SOLENOID VALVE

Check resistance between solenoid valve terminals 1, 5, 7, 14, 16, 17.

	ABS actuator		Resistance
	14	16	
OUT solenoid valve	14	17	6.2 - 12.4Ω
	16	17	
OUT and IN solenoid valve	14, 16, 17	1, 5, 7	9.3 - 18.5Ω
IN solenoid valve	1	5	12.4 - 24.6Ω
	1	7	
	5	7	

MTBL0001

Is resistance within specifications?

Yes	▶	<p>Check the following.</p> <ul style="list-style-type: none"> Harness connectors M54, M75, A1 Harness for open or short between actuator connector and control unit Harness for open or short between ABS actuator 8-pin connector and ABS relay unit 2-pin connector <p>If NG, repair harness or connectors.</p>
No	▶	Replace actuator.

6 CHECK ABS ACTUATOR SOLENOID VALVE RELAY

1. Disconnect ABS relay unit connectors.
 2. Check continuity between ABS relay unit 2-pin connector A1 (ABS relay unit side) terminal 16 and ABS relay unit 8-pin connector M74 (ABS relay unit side) terminal 21. **Continuity should exist.**

ABS relay unit 8-pin connectors (ABS relay unit side)

3, 4, 7, 21, 5, 8

DISCONNECT

ABS relay unit 2-pin connector (ABS relay unit side)

16, 15

SBR822D

Does continuity exist?

Yes	▶	Go to "SOLENOID VALVE RELAY" (BR-57).
No	▶	Replace ABS relay unit.

Diagnostic Procedure

Malfunction code No. 63

GI

MA

EM

LC

EC

FE

AT

TF

PD

AX

SU

BR

ST

RS

BT

HA

SC

EL

IDX

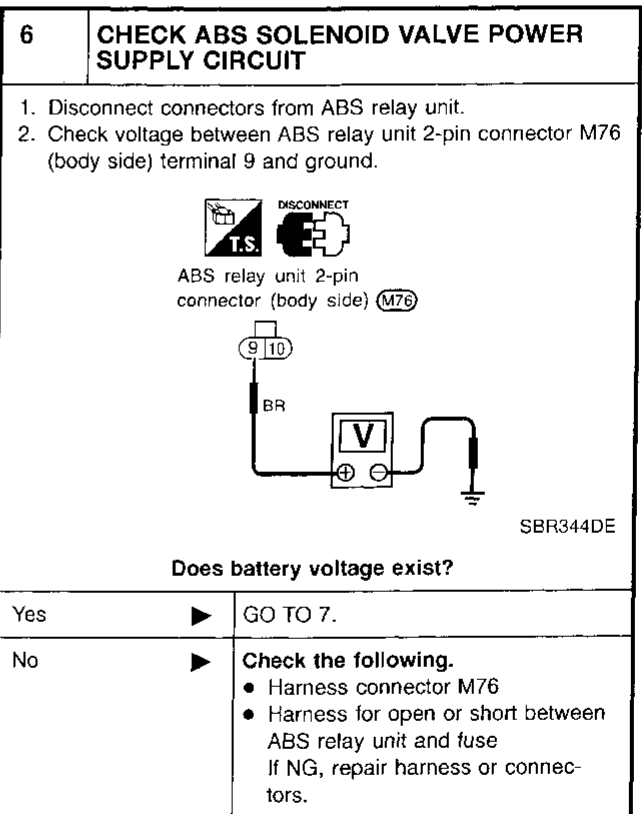
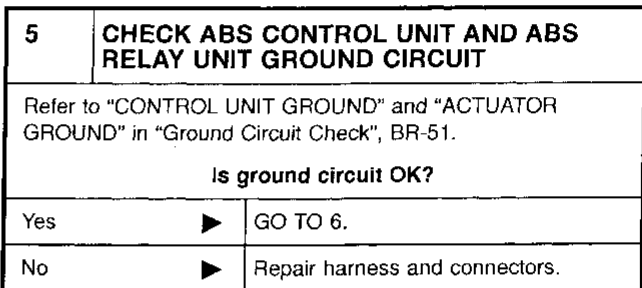
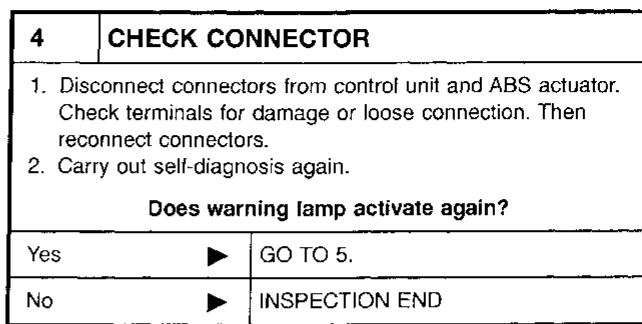
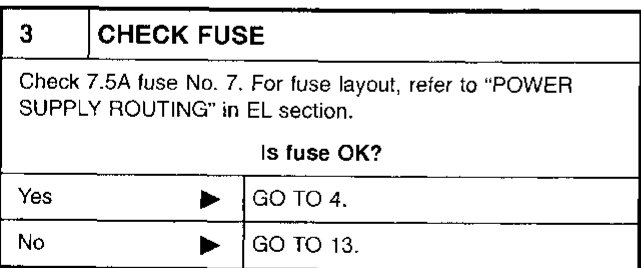
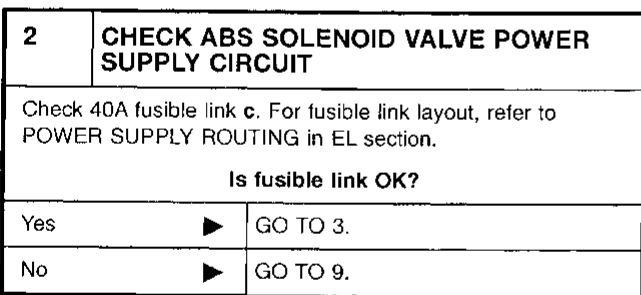
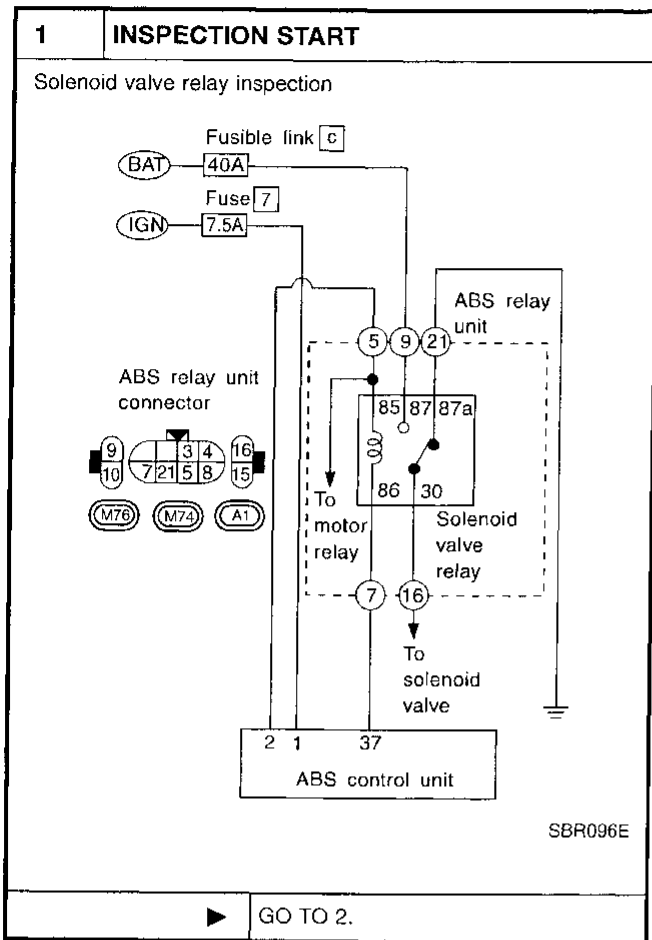

7	CHECK CIRCUIT
1. Disconnect ABS relay unit 8-pin connector M74 and control unit connector M54. 2. Check continuity between control unit connector terminals and ABS relay unit 8-pin connector M74 (body side) terminals. Check continuity: between Control unit 37 and ABS relay unit 7 between Control unit 2 and ABS relay unit 5 between Control unit 30 and ABS relay unit 3 Continuity should exist.	
Does continuity exist?	
Yes	▶ GO TO 8.
No	▶ Check the following. <ul style="list-style-type: none"> • Harness connectors M54, M74 • Harness for open or short between ABS relay unit 8-pin connector terminal (body side) and control unit. If NG, repair harness or connectors.

8	CHECK ABS SOLENOID VALVE RELAY
1. Disconnect ABS relay unit connectors. 2. Check continuity between ABS relay unit 2-pin connector A1 (ABS relay unit side) terminal 16 and ABS relay unit 8-pin connector M74 (ABS relay unit side) terminal 21. Relay type: Solenoid valve relay Condition: Continuity existence between terminals 16 and 21 Battery voltage not applied between terminals 5 and 7:	
Yes Battery voltage applied between terminals 5 and 7: No Check resistance between terminals 5 and 8: 70.8 - 157.8Ω	
ABS relay unit connector (unit side)	
SBR825D	
Are voltage and resistance within specifications?	
Yes	▶ Go to "ABS ACTUATOR SOLENOID VALVE", BR-55.
No	▶ Replace ABS relay unit.

9	REPLACE FUSIBLE LINK
Replace fusible link. Does the fusible link blow out when ignition switch is turned "ON"?	
Yes	▶ GO TO 10.
No	▶ INSPECTION END

10	CHECK ABS RELAY UNIT POWER SUPPLY CIRCUIT
<p>1. Disconnect ABS relay unit 2-pin connector M76. 2. Check continuity between ABS relay unit 2-pin connector M76 (body side) terminal 9 and ground. Continuity should not exist.</p>	
<p>DISCONNECT T.S. </p> <p>ABS relay unit 2-pin connector (body side) (M76)</p> <p>9 10 BR</p> <p style="text-align: right;">SBR346DE</p>	
Does continuity exist?	
Yes	▶ GO TO 11.
No	▶ Check the following.
	<ul style="list-style-type: none"> • Harness connector M76 • Harness for open or short between ABS relay unit and fusible link If NG, repair harness or connectors.

11	CHECK ABS SOLENOID VALVE RELAY
<p>1. Disconnect ABS relay unit 2-pin connector A1. 2. Check continuity between ABS relay unit 2-pin connector A1 (ABS relay unit side) terminal 16 and ground. Continuity should not exist.</p>	
<p>DISCONNECT T.S. </p> <p>ABS relay unit 2-pin connector (ABS relay unit side) (A1)</p> <p>16 15</p> <p style="text-align: right;">SBR826D</p>	
Does continuity exist?	
Yes	▶ GO TO 12.
No	▶ Replace ABS relay unit.

12	CHECK ABS SOLENOID VALVE
<p>Check continuity between ABS relay unit 2-pin connector A1 (ABS actuator side) terminal 16 and ground. Continuity should not exist.</p>	
<p>DISCONNECT T.S. </p> <p>ABS relay unit 2-pin connector (ABS actuator side) (A1)</p> <p>15 16</p> <p style="text-align: right;">SBR827D</p>	
Does continuity exist?	
Yes	▶ Go to "ABS ACTUATOR SOLENOID VALVE", BR-55.
No	▶ Replace ABS actuator.

13	REPLACE FUSE
<p>Replace fuse.</p> <p style="text-align: center;">Does the fuse blow out when ignition switch is turned "ON"?</p>	
Yes	▶ Check the following.
	<ul style="list-style-type: none"> • Harness connector M54 • Harness for open or short between ABS control unit connector and fuse If NG, repair harness or connectors.
No	▶ INSPECTION END

CI
 MA
 EM
 LC
 EC
 FE
 AT
 TF
 PD
 AX
 SU
 BR
 ST
 RS
 BT
 HA
 SC
 EL
 IDX

Diagnostic Procedure Malfunction code No. 61

NBBR0066

1	INSPECTION START
ABS motor relay inspection	
▶ GO TO 2.	

2	CHECK FUSIBLE LINK
Check 40A fusible link d for ABS relay unit. For fusible link layout, refer to POWER SUPPLY ROUTING in EL section.	
Is fusible link OK?	
Yes	▶ GO TO 3.
No	▶ GO TO 12.

3	CHECK FUSE
Check 7.5A fuse No. 7. For fuse layout, refer to "POWER SUPPLY ROUTING" in EL section.	
Is fuse OK?	
Yes	▶ GO TO 4.
No	▶ GO TO 11.

4	CHECK CONNECTOR
<ol style="list-style-type: none"> 1. Disconnect connectors from control unit and ABS relay unit. Check terminals for damage or loose connection. Then reconnect connectors. 2. Carry out self-diagnosis again. 	
Does warning lamp activate again?	
Yes	▶ GO TO 5.
No	▶ INSPECTION END

5	CHECK ABS RELAY UNIT POWER SUPPLY CIRCUIT
<ol style="list-style-type: none"> 1. Disconnect ABS relay unit 2-pin connector M76. 2. Check voltage between connector (body side) terminal 10 and ground. 	
Does battery voltage exist?	
Yes	▶ GO TO 6.
No	▶ Check the following. <ul style="list-style-type: none"> • Harness connector M76 • Harness for open or short between ABS relay unit and fusible link If NG, repair harness or connectors.

6	CHECK CIRCUIT
<p>1. Disconnect ABS relay unit 8-pin connector M74 and control unit connector M54.</p> <p>2. Check continuity between control unit connector terminals and ABS relay unit 8-pin connector M74 (body side) terminals.</p> <p style="text-align: center;">Check continuity</p> <p style="text-align: center;">between Control unit 7 and ABS relay unit 8 between Control unit 19 and ABS relay unit 4 between Control unit 2 and ABS relay unit 5</p> <p style="text-align: right;">SBR829D</p>	
Does continuity exist?	
Yes	▶ GO TO 7.
No	<p>▶ Check the following.</p> <ul style="list-style-type: none"> • Harness connectors M54, M74 • Harness for open or short between ABS relay unit terminal (body side) and control unit <p>If NG, repair harness or connectors.</p>

7	CHECK ABS MOTOR RELAY
<p>1. Disconnect ABS relay unit connectors.</p> <p>2. Check continuity between ABS relay unit 8-pin connector M74 (ABS relay unit side) terminal 5 and terminal 8.</p> <p style="text-align: center;">Relay type: ABS motor relay</p> <p style="text-align: center;">Condition: Continuity existence between terminals 4 or 15 and 10</p> <p>Battery voltage not applied between terminals 5 and 8:</p> <p style="text-align: center;">No</p> <p>Battery voltage applied between terminals 5 and 8:</p> <p style="text-align: center;">Yes</p> <p>Check resistance between terminals 5 and 8: 70.8 - 157.8Ω</p> <p style="text-align: center;">ABS motor relay and solenoid valve relay (Built into ABS relay unit)</p> <p style="text-align: center;">ABS relay unit connector (unit side)</p> <p style="text-align: right;">SBR825D</p>	
Are voltage and resistance within specifications?	
Yes	▶ GO TO 8.
No	▶ Replace ABS relay unit.

8	CHECK ABS ACTUATOR MOTOR GROUND CIRCUIT
<p>Refer to "ACTUATOR MOTOR GROUND" in "Ground Circuit Check", BR-51.</p> <p style="text-align: center;">Is ground circuit OK?</p>	
Yes	▶ GO TO 9.
No	▶ Repair harness and terminals.

GI
MA
EM
LC
EC
FE
AT
TF
PD
AX
SU
BR
ST
RS
BT
HA
SC
EL
IDX

9	CHECK ABS ACTUATOR CIRCUIT
<p>Check continuity between ABS relay unit 2-pin connector A1 (ABS actuator side) terminal 15 and actuator motor ground terminal.</p>	
<p style="text-align: right;">SBR102E</p>	
Does continuity exist?	
Yes	▶ GO TO 10.
No	▶ Repair harness and connectors.

10	CHECK MOTOR
<ol style="list-style-type: none"> 1. Disconnect ABS relay unit 2-pin connector M76 and ABS relay unit 2-pin connector A1. 2. Connect suitable wire between ABS relay unit 2-pin connector (body side) terminal 10 and ABS relay unit 2-pin connector (ABS actuator side) terminal 15. Do not connect wire for more than 5 seconds. 	
<p style="text-align: right;">SBR831D</p>	
Does motor operate?	
Yes	▶ Go to "LOW VOLTAGE", BR-64.
No	▶ Replace ABS actuator.

11	REPLACE FUSE
<p>Replace fuse.</p> <p style="text-align: center;">Does the fuse blow out when ignition switch is turned "ON"?</p>	
Yes	▶ Check the following. <ul style="list-style-type: none"> ● Harness connector M54 ● Harness for open or short between ABS control unit connector and fuse <p>If NG, repair harness or connectors.</p>
No	▶ INSPECTION END

12	REPLACE FUSIBLE LINK
<p>Replace fusible link.</p> <p style="text-align: center;">Does the fusible link blow out when ignition switch is turned "ON"?</p>	
Yes	▶ GO TO 13.
No	▶ INSPECTION END

13	CHECK ABS MOTOR POWER SUPPLY CIRCUIT
<ol style="list-style-type: none"> 1. Disconnect battery cable and ABS relay unit 2-pin connector M76. 2. Check continuity between ABS relay unit 2-pin connector M76 (body side) terminal 10 and ground. 	
<p style="text-align: right;">SBR340DE</p>	
Does continuity exist?	
Yes	▶ Check the following. <ul style="list-style-type: none"> ● Harness connector M76 ● Harness for open or short between ABS relay unit and fuse <p>If NG, repair harness or connectors.</p>
No	▶ GO TO 14.

14	CHECK ABS CONTROL UNIT CIRCUIT
<p>1. Disconnect ABS relay unit 8-pin connector and control unit connector.</p> <p>2. Check continuity between ABS relay unit 8-pin connector M74 (body side) terminal 4 and ground.</p>	
<p>DISCONNECT T.S. </p> <p>ABS relay unit 8-pin connector (body side) (M74)</p> <p>SBR832D</p>	
Does continuity exist?	
Yes	<p>▶ Check the following.</p> <ul style="list-style-type: none"> • Harness connectors M54, M74 • Harness for open or short between ABS relay unit terminal (body side) and control unit <p>If NG, repair harness or connectors.</p>
No	▶ GO TO 15.

15	CHECK ABS MOTOR RELAY
<p>Check continuity between ABS relay unit 8-pin connector M74 (ABS relay unit side) terminal 4 and ground, 2-pin connector M76 (ABS relay unit side) terminal 10 and ground.</p>	
<p>DISCONNECT T.S. </p> <p>ABS relay unit connectors (ABS relay unit side) (M74)</p> <p>SBR833D</p>	
Does continuity exist?	
Yes	▶ Replace ABS relay unit.
No	▶ GO TO 16.

16	CHECK ABS MOTOR POWER SUPPLY CIRCUIT
<p>1. Remove motor ground.</p> <p>2. Check continuity between ABS relay unit 2-pin connector A1 (ABS actuator side) terminal 15 and ground.</p>	
<p>DISCONNECT T.S. </p> <p>Remove motor ground.</p> <p>ABS relay unit 2-pin connector (ABS actuator side) (A1)</p> <p>SBR834D</p>	
Does continuity exist?	
Yes	▶ Replace ABS actuator.
No	▶ GO TO 17.

17	CHECK MOTOR
<p>Refer to "10. CHECK MOTOR", BR-62.</p>	
Does motor operate?	
Yes	▶ Check control unit pin terminals for damage or the connection of control unit harness connector. Reconnect control unit harness connector. Then retest.
No	▶ Replace ABS actuator.

GI
MA
EM
LC
EC
FE
AT
TF
PD
AX
SU
BR
ST
RS
BT
HA
SC
EL
IDX

Diagnostic Procedure

Malfunction code No. 57

NBBR0067

1	INSPECTION START
ABS control unit power supply and ground circuit inspection	
SBR098E	
▶ GO TO 2.	

2	CHECK CONNECTOR
<ol style="list-style-type: none"> 1. Disconnect control unit connector. Check terminals for damage or loose connections. Then reconnect connectors. 2. Carry out self-diagnosis again. 	
Does warning lamp activate again?	
Yes	▶ GO TO 3.
No	▶ INSPECTION END

3	CHECK ABS CONTROL UNIT POWER SUPPLY CIRCUIT
<ol style="list-style-type: none"> 1. Disconnect control unit connector. 2. Check voltage between control unit connector terminal 1 and ground. 	
SBR429D	
Does battery voltage exist when ignition switch is turned ON?	
Yes	▶ GO TO 4.
No	▶ GO TO 5.

4	CHECK ABS CONTROL UNIT GROUND CIRCUIT
Refer to "CONTROL UNIT GROUND" in "Ground Circuit Check", BR-51.	
Is ground circuit OK?	
Yes	▶ Check control unit pin terminals for damage or the connection of control unit harness connector. Reconnect control unit harness connector. Then retest.
No	▶ Repair harness and connectors.

5	CHECK FUSE
Check 7.5A fuse No. 7. Refer to "POWER SUPPLY ROUTING" in EL section.	
Is fuse OK?	
Yes	▶ GO TO 6.
No	▶ Replace fuse.

6	CHECK ABS CONTROL UNIT POWER SUPPLY CIRCUIT
Check continuity between battery and control unit connector terminal 1.	
Does continuity exist?	
Yes	▶ Check battery. Refer to "BATTERY" in EL section.
No	▶ Check the following. <ul style="list-style-type: none"> • Harness connector M54 • Harness for open or short between control unit and fuse If NG, repair harness or connectors.

Diagnostic Procedure

Malfunction code No. 17

NBBR0069

GI

MA

EM

LC

EC

FE

AT

TF

PD

AX

SU

BR

ST

RS

BT

HA

SC

EL

IDX

1	INSPECTION START
G sensor inspection	
SBR099E	
▶ GO TO 2.	

2	CHECK FUSE
Check 7.5A fuse No. 7 for control unit. For fuse layout, refer to "POWER SUPPLY ROUTING" in EL section.	
Is fuse OK?	
Yes	▶ GO TO 3.
No	▶ Replace fuse.

3	CHECK CONNECTOR
<ol style="list-style-type: none"> 1. Disconnect connectors from control unit and G sensor. Check terminals for damage or loose connection. Then reconnect connectors. 2. Carry out self-diagnosis again. 	
Does warning lamp activate again?	
Yes	▶ GO TO 4.
No	▶ INSPECTION END

4	CHECK G SENSOR
Refer to "G SENSOR" in "Electrical Components Inspection", BR-67.	
Is resistance within specifications?	
Yes	▶ GO TO 5.
No	▶ Replace G sensor.

5	CHECK G SENSOR POWER SUPPLY CIRCUIT
Check voltage between G sensor connector terminals 1, 2 and ground.	
SBR861D	
Does battery voltage exist?	
Yes	▶ GO TO 6.
No	▶ Check the following. <ul style="list-style-type: none"> • Harness connectors B58, B81 • Harness for open or short between G sensor and fuse If NG, repair harness or connectors.

6 CHECK CIRCUIT

1. Disconnect harness connector from control unit.
2. Check continuity between control unit connector terminals 17, 51 and G sensor connector terminals 17, 51.

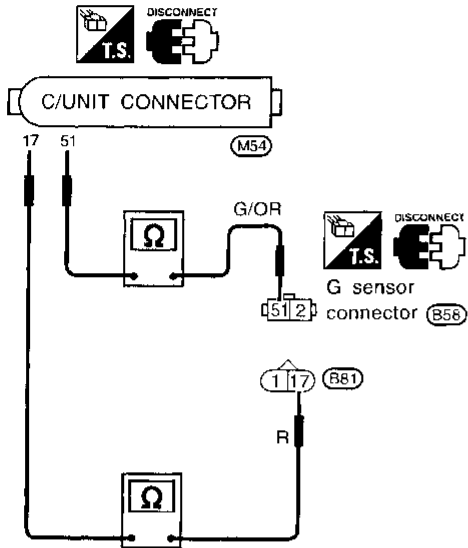

SBR862D

Does continuity exist?

Yes	▶	Check control unit pin terminals for damage or the connection of control unit harness connector. Reconnect control unit harness connector. Then retest.
No	▶	<p>Check the following.</p> <ul style="list-style-type: none"> • Harness connectors M54, B58, B81 • Harness for open or short between G sensor connector and control unit <p>If NG, repair harness or connectors.</p>

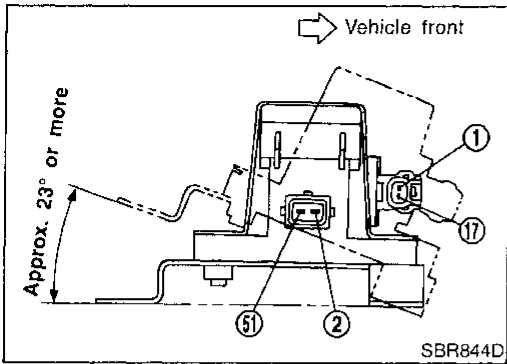

Electrical Components Inspection

-NBBR0069

G SENSOR

NBBR0069S01

CAUTION:

The G sensor is easily damaged if it sustains an impact. Be careful not to drop or bump it.

1. Measure resistance between terminals 2 and 51 of G sensor unit connector.

G sensor condition	Resistance between terminals 2 and 51	G sensor switch condition
Installed in vehicle	1.4 - 1.6 kΩ	"ON"
Tilted as shown in figure	4.7 - 5.5 kΩ	"OFF"

2. Measure resistance between terminals 1 and 17 of the G sensor unit connector.

Resistance: 70 - 124Ω

CI
MA
EM
LC
EC
FE
AT
TF
PD
AX
SU
BR
ST
RS
BT
HA
SC
EL
IDX

Diagnostic Procedure

Malfunction code No. 71

NBBR0070

1	INSPECTION START
ABS control unit power supply and ground circuit inspection	
SBR098E	
▶ GO TO 2.	

2	CHECK CONNECTOR
1. Disconnect control unit connector. Check terminals for damage or loose connections. Then reconnect connectors. 2. Carry out self-diagnosis again.	
Does warning lamp activate again?	
Yes	▶ GO TO 3.
No	▶ INSPECTION END

3	CHECK ABS CONTROL UNIT POWER SUPPLY CIRCUIT
Check voltage. Refer to "3. CHECK ABS CONTROL UNIT POWER SUPPLY CIRCUIT" in "Diagnostic Procedure", "LOW BOLTAGE", BR-64.	
Does battery voltage exist when ignition switch is turned ON?	
Yes	▶ GO TO 4.
No	▶ Repair.

4	CHECK WARNING LAMP INDICATION
Does warning lamp indicate code No. 71 again?	
Yes	▶ Replace control unit.
No	▶ Inspect the system according to the code No.

1. ABS Works Frequently

NBBR0071

1	CHECK BRAKE FLUID PRESSURE	
Check brake fluid pressure distribution. Refer to proportioning valve inspection.		
Is brake fluid pressure distribution normal?		
Yes	▶	GO TO 2.
No	▶	Perform Preliminary Check. Refer to BR-49.

2	CHECK WHEEL SENSOR	
1. Check wheel sensor connector for terminal damage or loose connections. 2. Perform wheel sensor mechanical check. Refer to WHEEL SENSOR OR ROTOR, BR-53.		
Are wheel sensors functioning properly?		
Yes	▶	GO TO 3.
No	▶	Repair.

3	CHECK FRONT AXLE	
Check front axles for excessive looseness. Refer to AX section ("Front Wheel Bearing", "ON-VEHICLE SERVICE").		
Is front axle installed properly?		
Yes	▶	Go to "CHECK WARNING LAMP INDICATION" in "2. Unexpected Pedal Action", BR-70.
No	▶	Repair.

GI
MA
EM
LC
EC
FE
AT
TF
PD
AX
SU

BR

2. Unexpected Pedal Action

NBBR0072

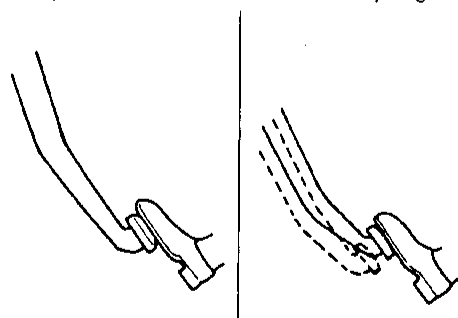
1	CHECK BRAKE PEDAL STROKE	
Check brake pedal stroke. Is stroke excessively large?		
		
SBR540A		
Yes	▶	Perform Preliminary Check. Refer to BR-49.
No	▶	GO TO 2.

2	CHECK CONNECTOR AND PERFORMANCE	
Disconnect ABS relay unit 8-pin connector and check whether brake is effective.		
Does connector function properly when brake pedal is depressed?		
Yes	▶	GO TO 3.
No	▶	Perform Preliminary Check. Refer to BR-49.

ST
RS
BT
HA
SC
EL
IDX

2. Unexpected Pedal Action (Cont'd)

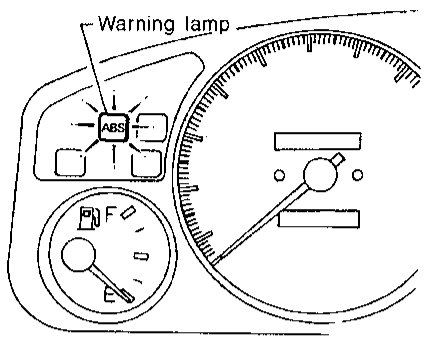
3	CHECK WARNING LAMP INDICATION
Ensure warning lamp remains off while driving.	
	
SBR394D	
Is warning lamp turned off?	
Yes	▶ GO TO 4.
No	▶ Carry out self-diagnosis. Refer to BR-40, BR-43.

4	CHECK WHEEL SENSOR
<ol style="list-style-type: none"> 1. Check wheel sensor connector for terminal damage or loose connection. 2. Perform wheel sensor mechanical check. Refer to "Diagnostic Procedure", "WHEEL SENSOR ROTOR", BR-53. 	
Is wheel sensor mechanism OK?	
Yes	▶ Check control unit pin terminals for damage or the connection of control unit harness connector. Reconnect control unit harness connector. Then retest.
No	▶ Repair.

3. Long Stopping Distance

NBBR0073

1	CHECK CONNECTOR AND PERFORMANCE
Disconnect ABS relay unit 8-pin connector and check whether stopping distance is still long.	
Does connector function properly when brake pedal is depressed?	
Yes	▶ Perform Preliminary Check and air bleeding.
No	▶ Go to "CHECK WARNING LAMP INDICATION" in "Diagnostic Procedure", "2. Unexpected Pedal Action", BR-70.

NOTE:

Stopping distance may be larger than vehicles without ABS when road condition is slippery.

4. ABS Does Not Work

=NBBR0074

1	CHECK WARNING LAMP INDICATION	
Does the ABS warning lamp activate?		
Yes	▶	Carry out self-diagnosis. Refer to BR-40, 43.
No	▶	Go to "CHECK WARNING LAMP INDICATION" in "Diagnostic Procedure", "Unexpected Pedal Action", BR-70.

NOTE:
ABS does not work when vehicle speed is under 10 km/h (6 MPH).

GI
MA
EM
LC
EC
FE
AT
TF

5. Pedal Vibration and Noise

NBBR0075

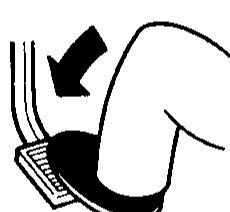
1	INSPECTION START	
Pedal vibration and noise inspection		
<p>Brake pedal</p>  <p style="text-align: right; font-size: small;">SAT797A</p>		
▶		GO TO 2.

2	CHECK SYMPTOM	
1. Apply brake. 2. Start engine.		
Does the symptom appear only when engine is started?		
Yes	▶	Carry out self-diagnosis. Refer to BR-40, 43.
No	▶	GO TO 3.

3	RECHECK SYMPTOM	
Does the symptom appear when electrical equipment switches (such as headlamp) are operated?		
Yes	▶	GO TO 3.
No	▶	Go to "CHECK WARNING LAMP INDICATION" in Diagnostic Procedure, "Unexpected Pedal Action", BR-70.

4	CHECK WHEEL SENSOR	
Check wheel sensor shield ground. For location of shield ground, refer to wiring diagram and "HARNESS LAYOUT" in EL section.		
Is wheel sensor shield grounded properly?		
Yes	▶	Check control unit pin terminals for damage or the connection of control unit harness connector. Reconnect control unit harness connector. Then retest.
No	▶	Repair.

PD
AX
SU
BR
ST
RS
BT
HA
SC
EL
IDX

NOTE:
ABS may operate and cause vibration under any of the following conditions.

- Applying brake gradually when shifting or operating clutch.

5. Pedal Vibration and Noise (Cont'd)

- Low friction (slippery) road.
- High speed cornering.
- Driving over bumps and pot holes.
- Engine speed is over 5,000 rpm with vehicle stopped.

6. Warning Lamp Does Not Come On When Ignition Switch Is Turned On

NBR0076

1	INSPECTION START
Warning lamp circuit inspection	
SBR100E	
▶ GO TO 2.	

2	CHECK FUSE
Check 10A fuse No. 8 for warning lamp. For fuse layout, refer to "POWER SUPPLY ROUTING" in EL section.	
Is fuse OK?	
Yes	▶ GO TO 3.
No	▶ Replace fuse.

3	CHECK ABS CONTROL UNIT POWER SUPPLY CIRCUIT
<ol style="list-style-type: none"> 1. Install 10A fuse. 2. Disconnect connectors from control unit and actuator. 3. Check voltage between control unit connector terminal 30 and ground after turning ignition switch "ON". 	
SBR412D	
Does battery voltage exist after turning ignition switch "ON"?	
Yes	▶ GO TO 5.
No	▶ GO TO 4.

4	CHECK WARNING LAMP
Check warning lamp bulb.	
Is warning lamp bulb OK?	
Yes	▶ Repair harness and connectors between fuse and control unit connector terminal 30 (including combination meter).
No	▶ Replace bulb.

TROUBLE DIAGNOSES FOR SYMPTOMS

ABS

6. Warning Lamp Does Not Come On When Ignition Switch Is Turned On (Cont'd)

5	CHECK CIRCUIT
<p>1. Turn ignition switch "OFF". Disconnect ABS relay unit 8-pin connector.</p> <p>2. Check continuity between control unit connector terminal 30 and ABS relay unit 8-pin connector (body side) terminal 3.</p>	
SBR836D	
Does continuity exist?	
Yes	▶ GO TO 6.
No	▶ Repair harness and connectors between warning lamp (combination meter) and ABS relay unit 8-pin connector (body side) terminal 3.

6	CHECK ABS RELAY UNIT GROUND CIRCUIT
<p>1. Disconnect ABS relay unit 8-pin connector.</p> <p>2. Check continuity between ABS relay unit harness 8-pin connector (body side) terminal 21 and body ground.</p>	
SBR837D	
Does continuity exist?	
Yes	▶ GO TO 7.
No	▶ Repair harness and connectors.

7	CHECK ABS SOLENOID VALVE RELAY
<p>1. Disconnect ABS relay unit 8-pin connector.</p> <p>2. Check continuity between ABS relay unit 8-pin connector (ABS relay unit side) terminals 3 (-) and 21 (+).</p>	
<p>NOTE: Pay attention to tester polarity. Specifications may vary depending on the type of tester. Before performing this inspection, refer to the instruction manual of the tester.</p>	
SBR839D	
Does continuity exist?	
Yes	▶ GO TO 8.
No	▶ Replace ABS relay unit.

8	CHECK ABS CONTROL UNIT POWER SUPPLY CIRCUIT
<p>Go to "3. CHECK ABS CONTROL UNIT POWER SUPPLY CIRCUIT" in "Diagnostic Procedure", "Warning Lamp Stays On When Ignition Switch Is Turned On", BR-75.</p>	
Does battery voltage exist?	
Yes	▶ GO TO 9.
No	▶ Repair harness and connectors.

CI
MA
EM
LC
EC
FE
AT
TF
PD
AX
SU
BR
SI
RS
BT
HA
SC
EL
IDX

6. Warning Lamp Does Not Come On When Ignition Switch Is Turned On (Cont'd)

9

CHECK ABS SOLENOID VALVE RELAY

1. Disconnect ABS relay unit connectors.
2. Check continuity existence between ABS relay unit 8-pin connector M74 (ABS relay unit side) terminal 3 or 2-pin connector A1 (ABS relay unit side) terminal 16 and 8-pin connector M74 (ABS relay unit side) terminal 21.

Relay type:

Solenoid valve relay

Condition:

Continuity existence between terminals 3 or 16 and 21

Battery voltage not applied between terminals 5 and 7:

Yes

Battery voltage applied between terminals 5 and 7:

No

Check resistance between terminals 5 and 7:

Approx. 100Ω

ABS motor relay and solenoid valve relay
(Built into ABS relay unit)

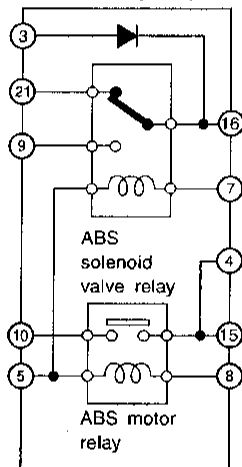

ABS relay unit connector
(unit side)

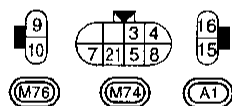

SBR825D

Are voltage and resistance within specifications?

Yes	▶	Go to "Diagnostic Procedure", "LOW VOLTAGE", BR-64.
No	▶	Replace ABS relay unit.

7. Warning Lamp Stays On When Ignition Switch Is Turned On

-NBBR0077

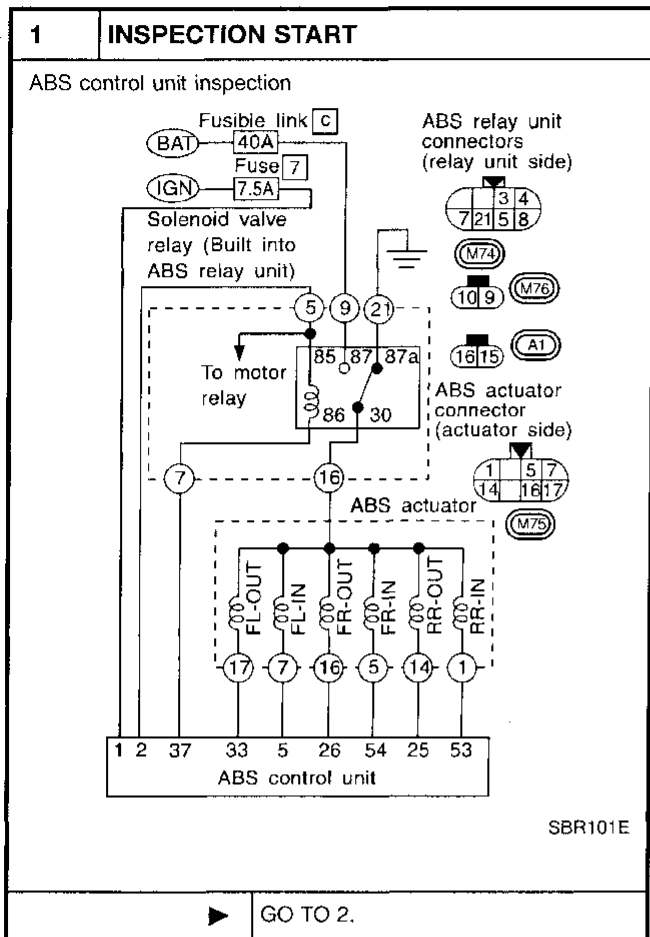

2 CHECK FUSE

Check 7.5A fuse No. 7 for control unit. For fuse layout, refer to "POWER SUPPLY ROUTING" in EL section.

Is fuse OK?	
Yes	▶ GO TO 3.
No	▶ GO TO 10.

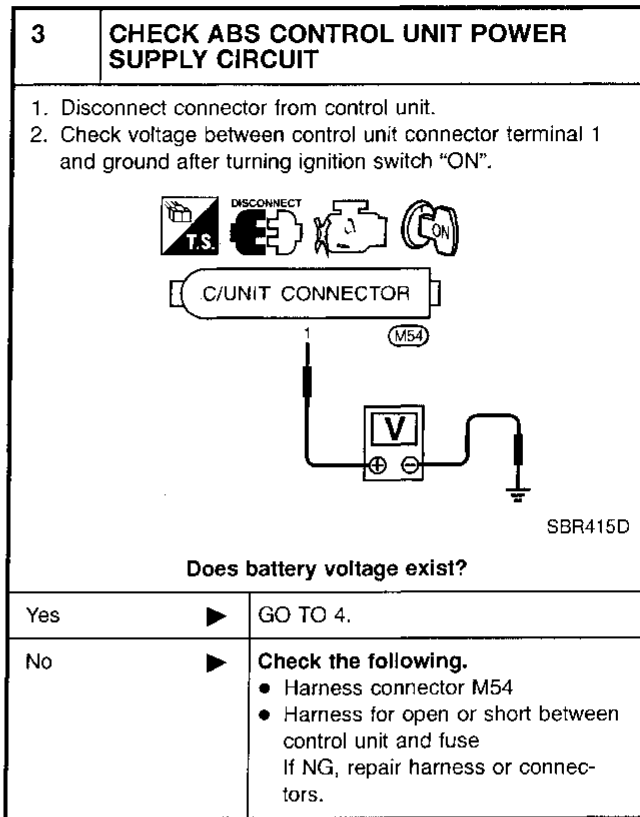

GI
MA
EM
LC
EC
FE
AT
TF
PD
AX
SU
BR
ST
RS
BT
HA
SC
EL
IDX

7. Warning Lamp Stays On When Ignition Switch Is Turned On (Cont'd)

4	CHECK ABS SOLENOID VALVE RELAY COIL POWER SUPPLY CIRCUIT
<ol style="list-style-type: none"> 1. Turn ignition switch "OFF". Disconnect ABS relay unit 8-pin connector. 2. Check continuity between control unit connector terminals and ABS relay unit 8-pin connector (body side) terminals. Check continuity: between Control unit 2 and ABS relay unit 5 between Control unit 37 and ABS relay unit 7 	
Does continuity exist?	
Yes	▶ GO TO 5.
No	▶ Check the following. <ul style="list-style-type: none"> • Harness connectors M54, M74 • Harness for open or short between solenoid valve relay unit terminal (body side) and control unit If NG, repair harness or connectors.

5	CHECK ABS SOLENOID VALVE RELAY COIL
<ol style="list-style-type: none"> 1. Disconnect ABS relay unit 8-pin connector. 2. Check continuity between ABS relay unit 8-pin connector (ABS relay unit side) terminals 5 and 7. 	
Does continuity exist?	
Yes	▶ GO TO 6.
No	▶ Replace ABS relay unit.

6	CHECK ABS SOLENOID VALVE RELAY
Go to "6. Warning Lamp Does Not Come On When Ignition Switch Is Turned On", BR-72.	
Does continuity exist?	
Yes	▶ GO TO 7.
No	▶ Replace ABS relay unit.

7	CHECK WARNING LAMP GROUND CIRCUIT
<ol style="list-style-type: none"> 1. Turn ignition switch "OFF". 2. Disconnect connectors from control unit and ABS relay unit 8-pin connector. 3. Check continuity between control unit connector terminal 30 and body ground. 	
Does continuity exist?	
Yes	▶ Check the following. <ul style="list-style-type: none"> • Harness connector M54 • Harness for open or short between control unit and fuse If NG, repair harness or connectors.
No	▶ GO TO 8.

8	CHECK ABS SOLENOID VALVE RELAY						
<ol style="list-style-type: none"> 1. Disconnect actuator ground terminal and ABS relay unit 8-pin connector. 2. Check continuity between ABS relay unit 8-pin connector (ABS relay unit side) terminal 3 and body ground. <p>NOTE: Pay attention to tester polarity. Specifications may vary depending on the type of tester. Before performing this inspection, refer to the instruction manual of the tester.</p> <div style="text-align: center;"> <p>Does continuity exist?</p> <table border="1" style="width: 100%; border-collapse: collapse;"> <tr> <td style="width: 15%;">Yes</td> <td style="width: 10%; text-align: center;">▶</td> <td>Replace ABS relay unit.</td> </tr> <tr> <td>No</td> <td style="text-align: center;">▶</td> <td>GO TO 9.</td> </tr> </table> </div>		Yes	▶	Replace ABS relay unit.	No	▶	GO TO 9.
Yes	▶	Replace ABS relay unit.					
No	▶	GO TO 9.					

9	CHECK ABS SOLENOID VALVE CIRCUIT						
<ol style="list-style-type: none"> 1. Disconnect ABS actuator 8-pin connector. 2. Check continuity between each ABS actuator 8-pin connector (ABS actuator side) terminal and body ground. <div style="text-align: center;"> <p>Does continuity exist?</p> <table border="1" style="width: 100%; border-collapse: collapse;"> <tr> <td style="width: 15%;">Yes</td> <td style="width: 10%; text-align: center;">▶</td> <td>Replace ABS actuator.</td> </tr> <tr> <td>No</td> <td style="text-align: center;">▶</td> <td>Check control unit pin terminals for damage or the connection of control unit harness connector. Reconnect control unit harness connector. Then retest.</td> </tr> </table> </div>		Yes	▶	Replace ABS actuator.	No	▶	Check control unit pin terminals for damage or the connection of control unit harness connector. Reconnect control unit harness connector. Then retest.
Yes	▶	Replace ABS actuator.					
No	▶	Check control unit pin terminals for damage or the connection of control unit harness connector. Reconnect control unit harness connector. Then retest.					

10	REPLACE FUSE						
<p>Replace 7.5A fuse No. 7. Does the fuse blow out when ignition switch is turned "ON"?</p> <table border="1" style="width: 100%; border-collapse: collapse;"> <tr> <td style="width: 15%;">Yes</td> <td style="width: 10%; text-align: center;">▶</td> <td>GO TO 11.</td> </tr> <tr> <td>No</td> <td style="text-align: center;">▶</td> <td>INSPECTION END</td> </tr> </table>		Yes	▶	GO TO 11.	No	▶	INSPECTION END
Yes	▶	GO TO 11.					
No	▶	INSPECTION END					

11	CHECK ABS CONTROL UNIT POWER SUPPLY CIRCUIT						
<ol style="list-style-type: none"> 1. Disconnect control unit connector. 2. Check continuity between control unit connector terminal 1 and body ground. <div style="text-align: center;"> <p>Does continuity exist?</p> <table border="1" style="width: 100%; border-collapse: collapse;"> <tr> <td style="width: 15%;">Yes</td> <td style="width: 10%; text-align: center;">▶</td> <td> <p>Check the following.</p> <ul style="list-style-type: none"> ● Harness connector M54 ● Harness for open or short between control unit and fuse <p>If NG, repair harness or connectors.</p> </td> </tr> <tr> <td>No</td> <td style="text-align: center;">▶</td> <td>Check control unit pin terminals for damage or the connection of control unit harness connector. Reconnect control unit harness connector. Then retest.</td> </tr> </table> </div>		Yes	▶	<p>Check the following.</p> <ul style="list-style-type: none"> ● Harness connector M54 ● Harness for open or short between control unit and fuse <p>If NG, repair harness or connectors.</p>	No	▶	Check control unit pin terminals for damage or the connection of control unit harness connector. Reconnect control unit harness connector. Then retest.
Yes	▶	<p>Check the following.</p> <ul style="list-style-type: none"> ● Harness connector M54 ● Harness for open or short between control unit and fuse <p>If NG, repair harness or connectors.</p>					
No	▶	Check control unit pin terminals for damage or the connection of control unit harness connector. Reconnect control unit harness connector. Then retest.					

CI
 MA
 EM
 LC
 EC
 FE
 AT
 TF
 PD
 AX
 SU
 BR
 ST
 RS
 BT
 HA
 SC
 EL
 IDX

8. Vehicle Vibrates Excessively When ABS Is Operating

8. Vehicle Vibrates Excessively When ABS Is Operating

NBBR0078

- While ABS is operating, brake pedal vibrates slightly. This is not a problem.
- If vehicle vibration is greater in the AUTO mode than in the 2WD mode, there is the possibility of failure in the communication line between the ABS control unit and TCM. Check and locate the cause of the problem.

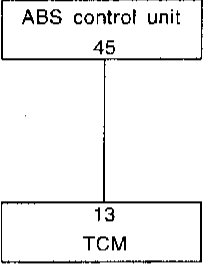
1	INSPECTION START
Inspection for excessive vibration of vehicle	
	
SBR869DA	
▶ GO TO 2.	

2	CARRY OUT SELF-DIAGNOSIS
Perform self-diagnosis for the ABS control unit and TCM.	
Are there any malfunctions?	
Yes	▶ GO TO 3.
No	▶ GO TO 4.

3	INSPECTION OR REPAIR
Inspect or repair the system according to the self-diagnostic item.	
OK	▶ GO TO 4.

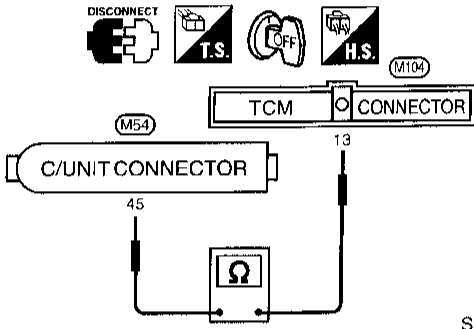
4	CHECK CIRCUIT
<ol style="list-style-type: none"> 1. Disconnect connectors from ABS control unit and TCM. Check terminals for damage or loose connection. 2. Check continuity between ABS control unit connector terminal 45 and TCM connector terminal 13. 	
	
SBR159E	
Does continuity exist?	

Yes	▶ GO TO 5.
No	▶ Check the following. <ul style="list-style-type: none"> • Harness connectors M54, M104 • Harness for open or short between ABS control unit and TCM If NG, repair harness or connectors.

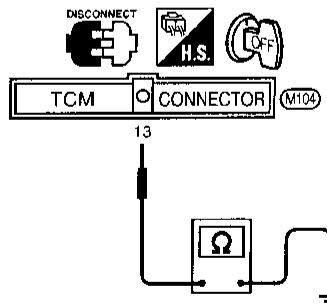
5	CHECK ABS OPERATING SIGNAL CIRCUIT
<ol style="list-style-type: none"> 1. Reconnect only ABS control unit connector. 2. Check continuity between TCM connector terminal 13 and ground. Continuity should not exist.	
	
SBR114E	
Does continuity exist?	

Yes	▶ Replace ABS control unit.
No	▶ GO TO 6.

TROUBLE DIAGNOSES FOR SYMPTOMS

ABS

8. Vehicle Vibrates Excessively When ABS Is Operating (Cont'd)

6 CHECK ABS OPERATING SIGNAL

1. Connect CONSULT to Data Link Connector for CONSULT.
2. Turn ignition switch "ON". Set CONSULT in the active test mode to output an ABS operating signal.
(Refer to "ACTIVE TEST PROCEDURE", "CONSULT Inspection Procedure", BR-46.)
3. An ABS operating signal lasts for 10 seconds. During the time the signal is being output, check resistance between TCM connector terminal 13 and ground.
Resistance: 0.5Ω, max.

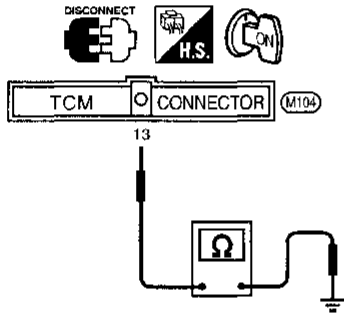
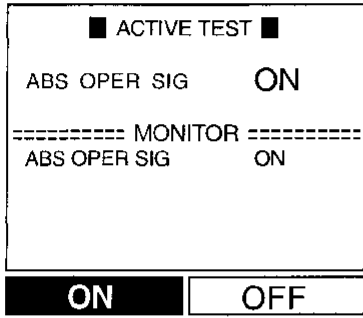

SBR115E

Is resistance within specifications?

Yes	▶	CHECK TCM. Refer to TF section ("TROUBLE DIAGNOSIS FOR ABS OPERATION SIGNAL").
No	▶	Replace ABS control unit.

GI
MA
EM
LC
EC
FE
AT
TF
PD
AX
SU
BR
ST
RS
BT
HA
SC
EL
IDX

REMOVAL AND INSTALLATION

=NBBR0079

ABS

Front Wheel Sensor

CAUTION:

Be careful not to damage sensor edge and sensor rotor teeth. When removing the front or rear wheel hub assembly, disconnect the ABS wheel sensor from the assembly and move it away.

Front Wheel Sensor

NBBR0079S01

SEC. 476

RH side

Front wheel sensor connector (RH)

 : N·m (kg-m, in-lb)

 : N·m (kg-m, ft-lb)

LH side

Connector cover bracket

Front wheel sensor connector (LH)

 4.4 - 5.8
(0.45 - 0.59,
39.1 - 51.2)

Front wheel sensor (LH)

 10.8 - 14.6 (1.1 - 1.5, 8 - 11)

SBR398D

Rear Wheel Sensor

NBBR0079S02

SEC. 476

Rear wheel sensor connector (LH)

 4.4 - 6.4 (0.45 - 0.65, 39.1 - 56.4)

Rear wheel sensor (LH)

 17.7 - 23.5 (1.8 - 2.4, 13.0 - 17.4)

 13 - 16 (1.3 - 1.6, 9 - 12)

 4.4 - 5.8 (0.45 - 0.59, 39.1 - 51.2)

 4.4 - 5.8 (0.45 - 0.59, 39.1 - 51.2)

 : N·m (kg-m, in-lb)

 : N·m (kg-m, ft-lb)

SBR399D

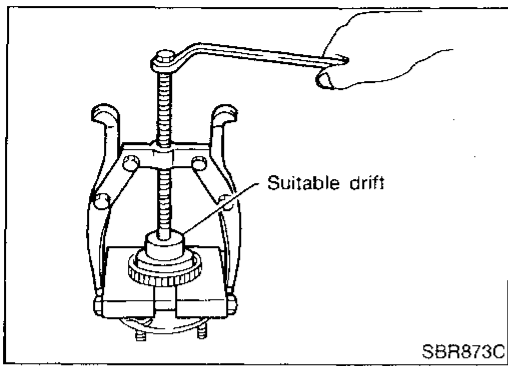

Front Sensor Rotor

NBBR0079S03

REMOVAL

1. Remove the front wheel hub. Refer to AX section ("FRONT AXLE").
2. Remove the sensor rotor using suitable puller, drift and bearing replacer.

NBBR0079S0301

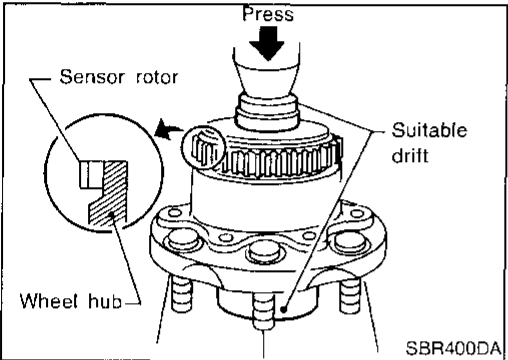

INSTALLATION

Install the sensor rotor using suitable drift and press.

NBBR0079S0302

- Always replace sensor rotor with new one.
- Pay attention to the direction of front sensor rotor as shown in figure.

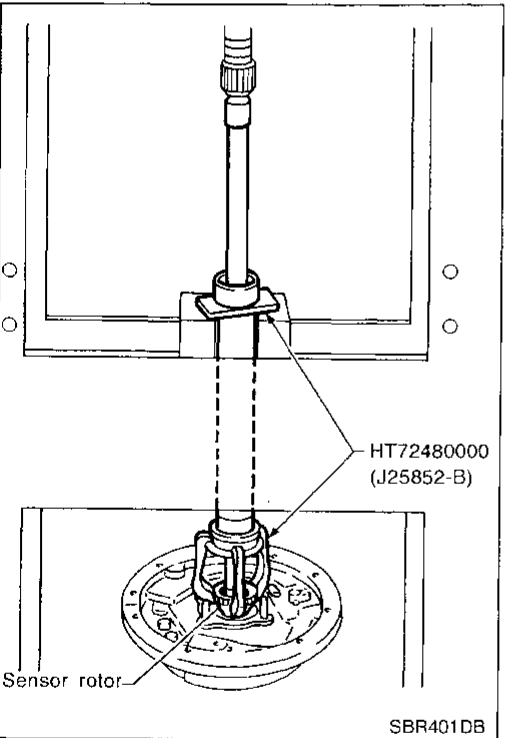

Rear Sensor Rotor

NBBR0079S04

REMOVAL

- Remove the sensor rotor using Tool.

NBBR0076S0401

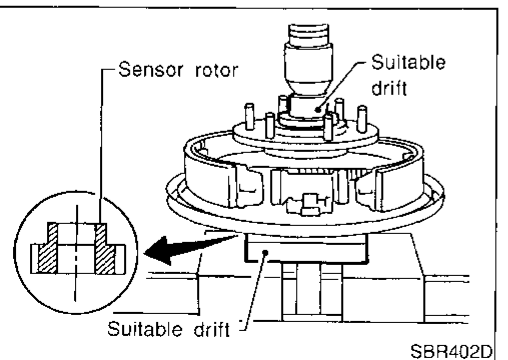

INSTALLATION

Install the sensor rotor using suitable drift and press.

NBBR0076S0402

- Always replace sensor rotor with new one.
- Pay attention to the direction of front sensor rotor as shown in figure.

GI
MA
EM
LC
EC
FE
AT
TF
PD
AX
SU
BR
ST
RS
BT
HA
SC
EL
IDX

Control Unit

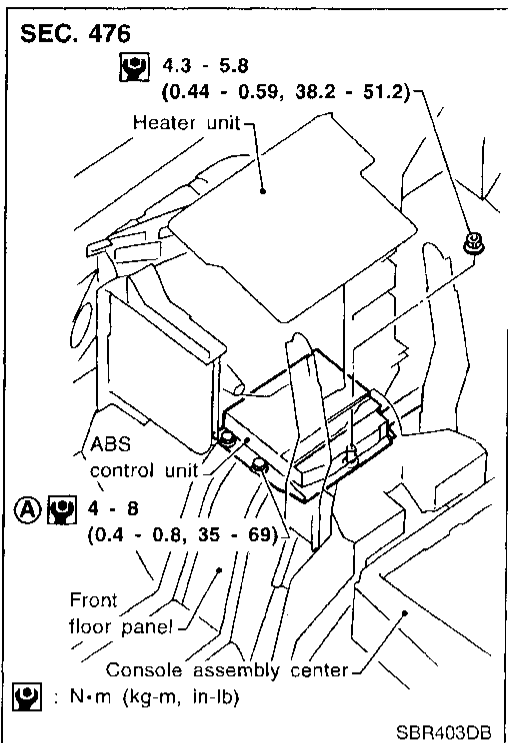

Control Unit

NBBR0079S05

Location: Under heater unit.

Make sure that the sensor shield ground cable is secured with mounting bolt.

REMOVAL

NBBR0079S0501

1. Remove the floor carpet from the top of the control unit.
2. Remove the 3 bolts A securing module and module bracket to the side of floor tunnel.
3. Remove module from the left side of floor tunnel.
4. Disconnect module connector.

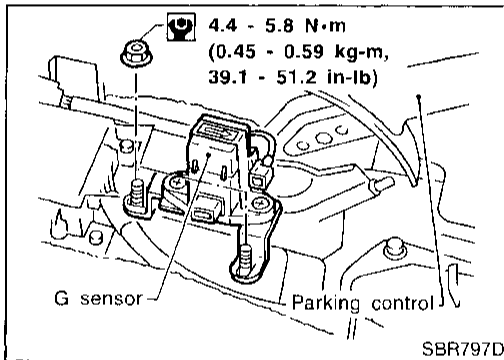

G Sensor

NBBR0079S06

Always replace G sensor if bumped or dropped. Otherwise, performance characteristics of G sensor will be changed, which in turn changes ABS control performance characteristics.

Actuator

NBBR0079S07

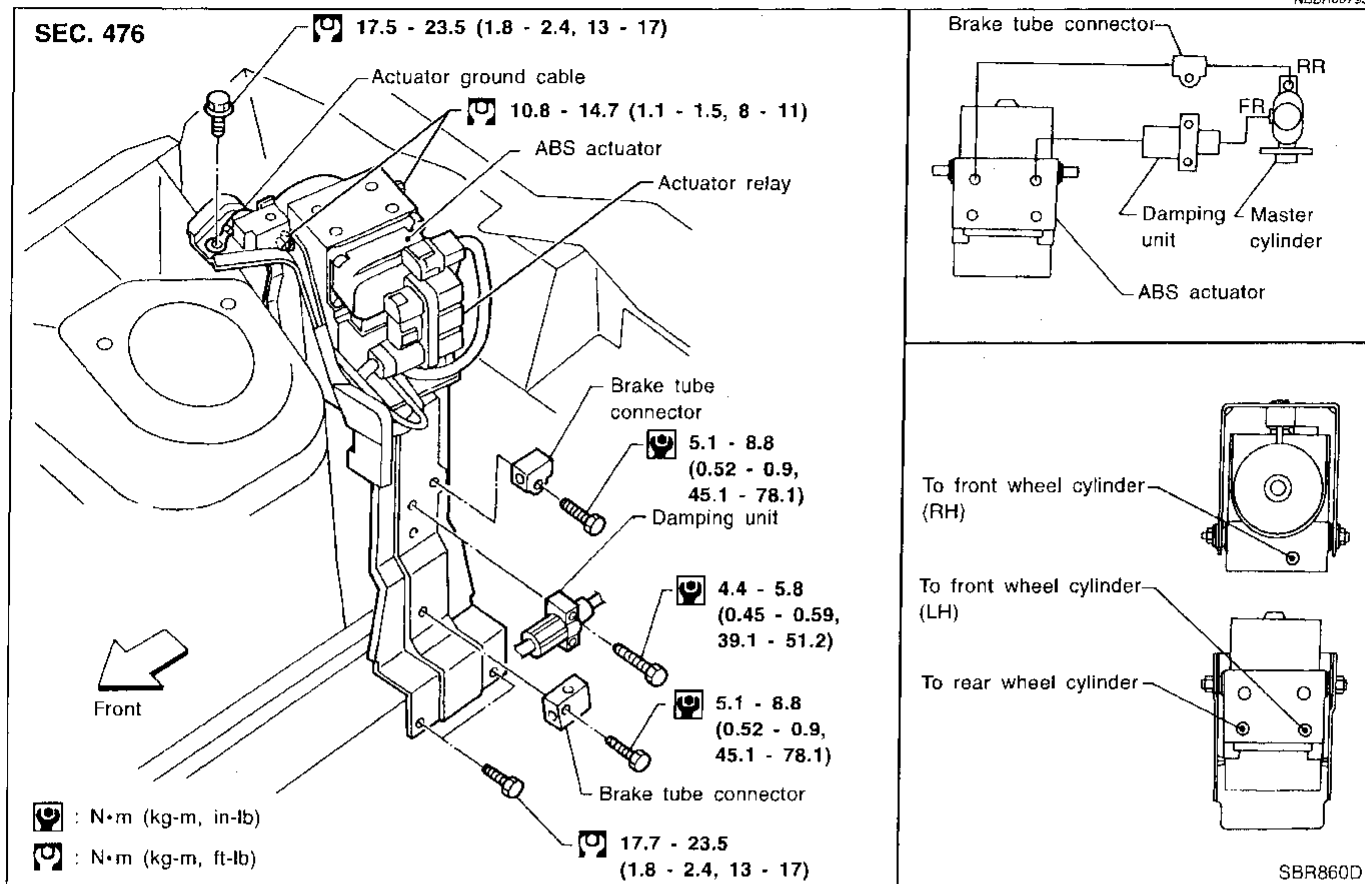

REMOVAL

NBBR0079S0701

1. Disconnect battery cable.
2. Drain brake fluid. Refer to "Changing Brake Fluid", BR-5.
3. Remove mounting bracket fixing bolts and nuts.
4. Disconnect connector, brake pipes and remove fixing nuts and actuator ground cable.

INSTALLATION

NBBR0079S0702

CAUTION:

After installation, refill brake fluid. Then bleed air. Refer to "Bleeding Brake System", BR-6.

1. Tighten actuator ground cable.

Place ground cable at a notch of mounting bracket.

2. Connect brake pipes temporarily.
3. Tighten fixing bolts and nuts.
4. Tighten brake pipes.
5. Connect connector and battery cable.

Actuator Relays

NBBR0079S08

1. Disconnect battery cable.
2. Remove actuator relay unit.

SERVICE DATA AND SPECIFICATIONS (SDS)

General Specifications

General Specifications

NBBR0080
Unit: mm (in)

Front brake	Brake model	AD31VA	GI
	Cylinder bore diameter × number of pistons	44.45 (1.7500) × 2	MA
	Pad Length × width × thickness	132.0 × 52.5 × 11 (5.20 × 2.067 × 0.43)	EM
	Rotor outer diameter × thickness	283 × 28 (11.14 × 1.10)	
Rear brake	Brake model	LT30C	LC
	Cylinder bore diameter	20.64 (13/16)	EC
	Lining length × width × thickness	296 × 50 × 6.1 (11.65 × 1.97 × 0.240)	FE
	Drum inner diameter	295.0 (11.61)	AT
Master cylinder	Bore diameter	25.40 (1)	TF
Control valve	Valve model	Linkage type load sensing valve	
	Split point kPa (kg/cm ² , psi) × reducing ratio	(Variable) × 0.18	PD
Brake booster	Booster model	M215T	
	Diaphragm diameter	Pri: 230 (9.06) Sec: 205 (8.07)	
Recommended brake fluid		DOT 3	

Disc Brake

NBBR0081
Unit: mm (in)

Brake model	AD31VA	AX
Pad wear limit	Minimum thickness	2.0 (0.079)
Rotor repair limit	Minimum thickness	26.0 (1.024)

Drum Brake

NBBR0082
Unit: mm (in)

Brake model	LT30C	ST
Lining wear limit	Minimum thickness	1.5 (0.059)
Drum repair limit	Maximum inner diameter	296.5 (11.67)
	Out-of-round limit	0.03 (0.0012)

Brake Pedal

NBBR0083
Unit: mm (in)

Free height "H"	175 - 185 (6.89 - 7.28)	HA
Depressed height "D" [under force of 490 N (50 kg, 110 lb) with engine running]	70 (2.76)	SC
Clearance "C" between pedal stopper and threaded end of stop lamp switch or ASCD switch	0.3 - 1.0 (0.012 - 0.039)	EL
Pedal free play	At clevis	1.0 - 3.0 (0.039 - 0.118)
	At pedal pad	4 - 12 (0.16 - 0.47)

*: Measured from surface of dash lower panel to pedal pad

SERVICE DATA AND SPECIFICATIONS (SDS)

Parking Brake Control

Parking Brake Control

NBBR00694

Control Type	Center lever
Lever stroke [under force of 196 N (20 kg, 44 lb)]	6 - 8
Lever stroke when warning switch comes on	1