

AUTOMATIC TRANSMISSION

SECTION **AT**

GI

MA

EM

LC

EF &
EC

CONTENTS

FE

CL

MT

AT

TF

PD

FA

RA

BR

ST

BF

HA

EL

IDX

PREPARATION AND PRECAUTIONS	3
Special Service Tools	3
Service Notice	4

RE4R01A	
DESCRIPTION	5
Cross-Sectional View	5
Hydraulic Control Circuits	6

RL4R01A	
DESCRIPTION	7
Cross-Sectional View	7
Hydraulic Control Circuits	8

RE4R01A & RL4R01A	
DESCRIPTION	9
Shift Mechanism	9

RE4R01A	
DESCRIPTION	11
Control System	11

RE4R01A & RL4R01A	
TROUBLE DIAGNOSES	13
Contents	13
TROUBLE DIAGNOSES — A/T Shift Lock System	95
Contents	95
ON-VEHICLE SERVICE	106
Control Valve Assembly and Accumulators	
Inspection	106
Revolution Sensor Replacement — RE4R01A	107
Rear Oil Seal Replacement	108
Parking Components Inspection	108
Governor Valve — RL4R01A	109

Throttle Wire Adjustment — RL4R01A	109
Inhibitor Switch Adjustment	110
Manual Control Linkage Adjustment	110
Kickdown Switch Adjustment	111

REMOVAL AND INSTALLATION	112
Removal	112
Installation	113

MAJOR OVERHAUL	115
RE4R01A	115
RL4R01A	117
Oil Channel — RE4R01A	119
Oil Channel — RL4R01A	120
Locations of Needle Bearings, Thrust Washers	
and Snap Rings	121

DISASSEMBLY	122
Disassembly	122

REPAIR FOR COMPONENT PARTS	136
Oil Pump — RE4R01A and RL4R01A	136
Control Valve Assembly — RE4R01A	140
Control Valve Assembly — RL4R01A	146
Control Valve Upper Body — RE4R01A	151
Control Valve Upper Body — RL4R01A	157
Control Valve Lower Body — RE4R01A	161
Control Valve Lower Body — RL4R01A	163
Governor Valve Assembly — RL4R01A	165
Oil Distributor	166
Reverse Clutch — RE4R01A and RL4R01A	167
High Clutch — RE4R01A and RL4R01A	171
Forward and Overrun Clutches — RE4R01A	
and RL4R01A	173
Low & Reverse Brake — RE4R01A and	
RL4R01A	177
Forward Clutch Drum Assembly — RE4R01A	
and RL4R01A	181
Rear Internal Gear and Forward Clutch Hub	
— RE4R01A and RL4R01A	183

CONTENTS (Cont'd.)

Band Servo Piston Assembly — RE4R01A and RL4R01A	186	Adjustment	201
Parking Pawl Components — RE4R01A and RL4R01A	190	Assembly (2)	204
ASSEMBLY	192	SERVICE DATA AND SPECIFICATIONS (SDS)	211
Assembly (1)	192	General Specifications.....	211
		Specifications and Adjustment.....	211

When you read wiring diagrams:

- Read GI section, "HOW TO READ WIRING DIAGRAMS".
- See EL section, "POWER SUPPLY ROUTING" for power distribution circuit.

When you perform trouble diagnoses, read GI section, "HOW TO FOLLOW FLOW CHART IN TROUBLE DIAGNOSES".

PREPARATION AND PRECAUTIONS

Special Service Tools

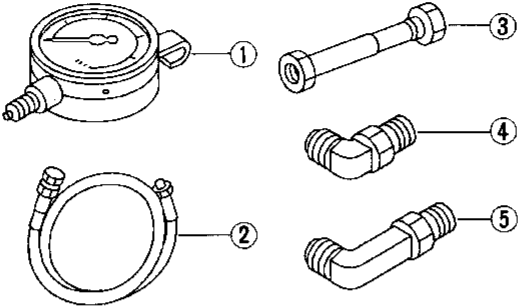
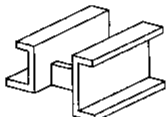
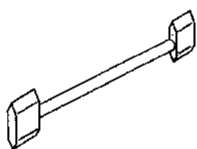
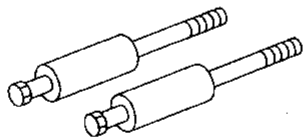
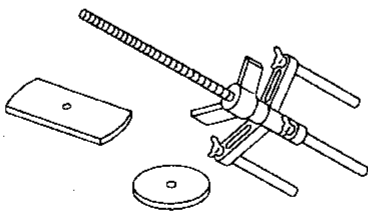
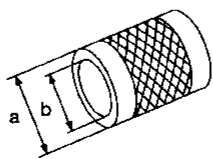
Tool number (Kent-Moore No.) Tool name	Description	
ST2505S001 (J25695-A) Oil pressure gauge set ① ST25051001 (—) Oil pressure gauge ② ST25052000 (—) Hose ③ ST25053000 (—) Joint pipe ④ ST25054000 (—) Adapter ⑤ ST25055000 (—) Adapter	 <p style="text-align: right;">Measuring line pressure</p> <p style="text-align: left;">NT097</p>	GI MA EM LC EF & EC FE CL
ST07870000 (J37068) Transmission case stand	 <p style="text-align: left;">NT094</p>	Disassembling and assembling A/T MT AT
KV31102100 (J37065) Torque converter one-way clutch check tool	 <p style="text-align: left;">NT098</p>	Checking one-way clutch in torque con- verter TF PD
ST25850000 (J25721-A) Sliding hammer	 <p style="text-align: left;">NT095</p>	Removing oil pump assembly FA RA
KV31102400 (J34285 and J34285-87) Clutch spring compressor	 <p style="text-align: left;">NT096</p>	Removing and installing clutch return springs BR ST
ST33200000 (J26082) Drift	 <p style="text-align: left;">NT091</p>	Installing oil pump housing oil seal Installing rear oil seal a: 60 mm (2.36 in) dia. b: 44.5 mm (1.752 in) dia. BF HA EL IDX

PREPARATION AND PRECAUTIONS

Special Service Tools (Cont'd)

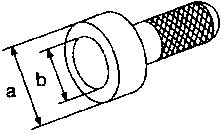
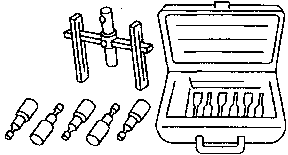
Tool number (Kent-Moore No.) Tool name	Description
ST30720000 (J34331) Drift	<div style="text-align: center;">  </div> <p style="text-align: right;">Installing rear oil seal</p> <p style="text-align: right;">a: 77 mm (3.03 in) dia. b: 55.5 mm (2.185 in) dia.</p> <p style="text-align: left;">NT115</p>
(J34291) Shim setting gauge set	<div style="text-align: center;">  </div> <p style="text-align: right;">Selecting oil pump cover bearing race and oil pump thrust washer</p> <p style="text-align: left;">NT101</p>

Service Notice

- Before proceeding with disassembly, thoroughly clean the outside of the transmission. It is important to prevent the internal parts from becoming contaminated by dirt or other foreign matter.
- Disassembly should be done in a clean work area.
- Use line-free cloth or towels for wiping parts clean. Common shop rags can leave fibers that could interfere with the operation of the transmission.
- When disassembling parts, place them in order in a parts rack so that they can be put back into the unit in their proper positions.
- All parts should be carefully cleaned with a general purpose, non-flammable solvent before inspection or reassembly.
- Gaskets, seals and O-rings should be replaced any time the transmission is disassembled.
- It is very important to perform functional tests whenever they are indicated.
- The valve body contains precision parts and requires extreme care when parts are removed and serviced. Place removed parts in order on a parts rack so they can be put back in the valve body in the same positions and sequences. Care will also prevent springs and small parts from becoming scattered or lost.
- Properly installed valves, sleeves, plugs, etc. will slide along their bores in the valve body under their own weight.
- Before assembly, apply a coat of recommended ATF to all parts. Petroleum jelly may be applied to O-rings and seals and used to hold small bearings and washers in place during reassembly. Do not use grease.
- Extreme care should be taken to avoid damage to O-rings, seals and gaskets when assembling.
- During overhaul, if excessive foreign material is found in the oil pan or clogging the strainer, flush or replace ATF cooler as required. Refer to TROUBLE DIAGNOSES Remarks. AT-19
- After overhaul, refill the transmission with new ATF.
- Even when the drain plug is removed, the old A/T fluid will remain in the torque converter and the A/T fluid cooling system. Always follow the procedures under "Changing A/T Fluid" in the MA section when changing A/T fluid.

Cross-Sectional View

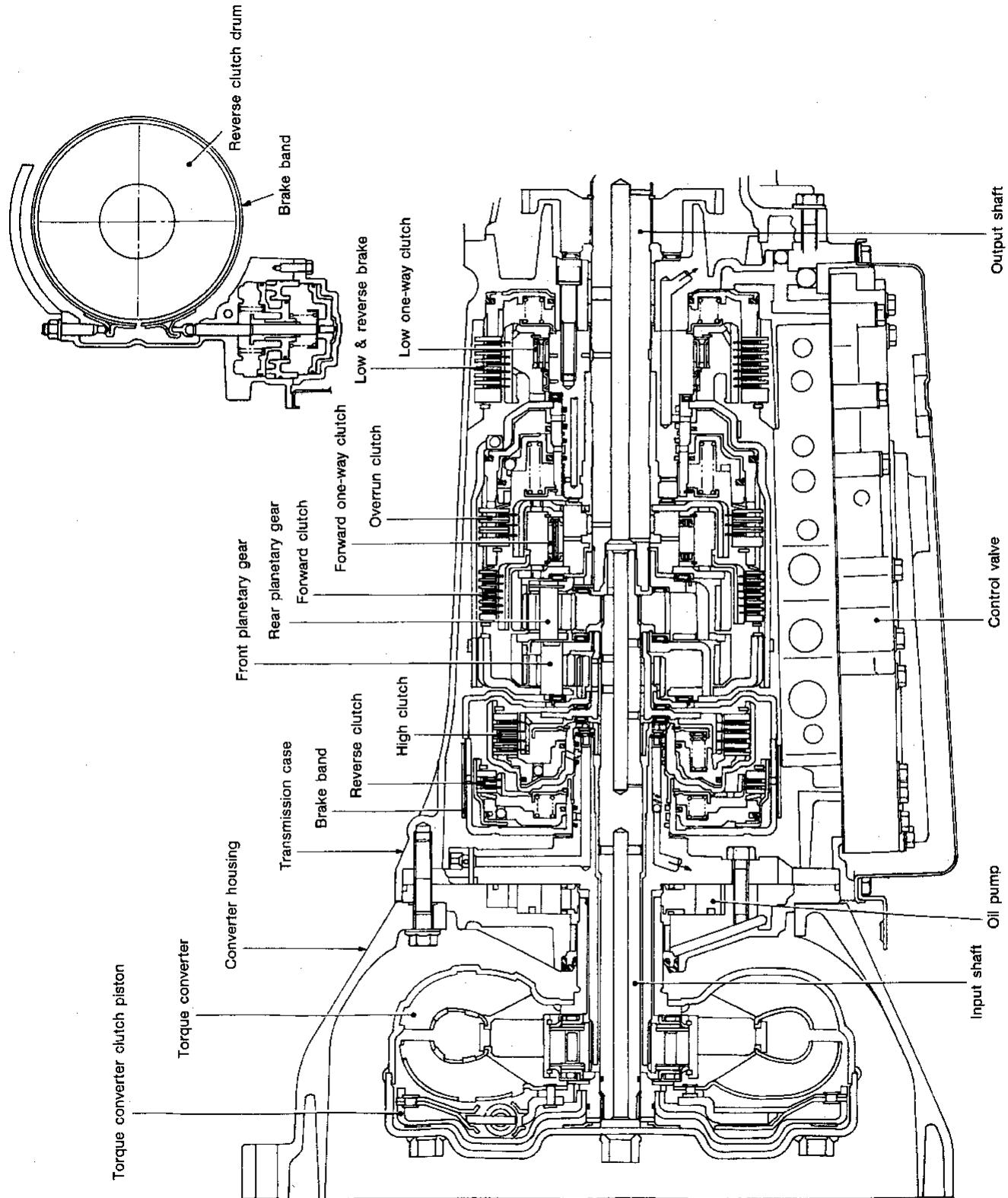

GI

MA

EM

LC

EF & EC

FE

CL

MT

AT

TF

PD

FA

RA

BR

ST

BF

HA

EL

Hydraulic Control Circuits

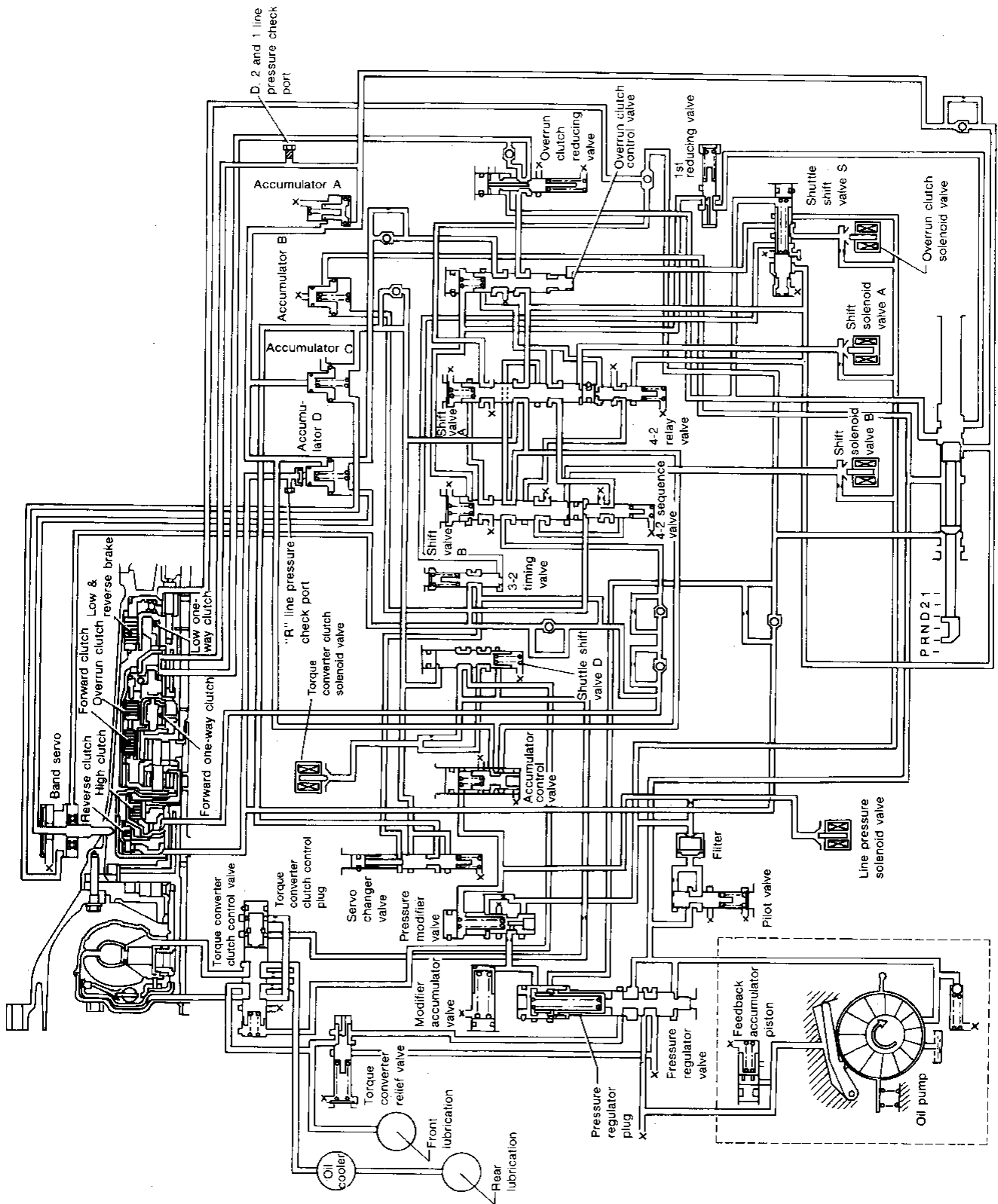

Cross-Sectional View

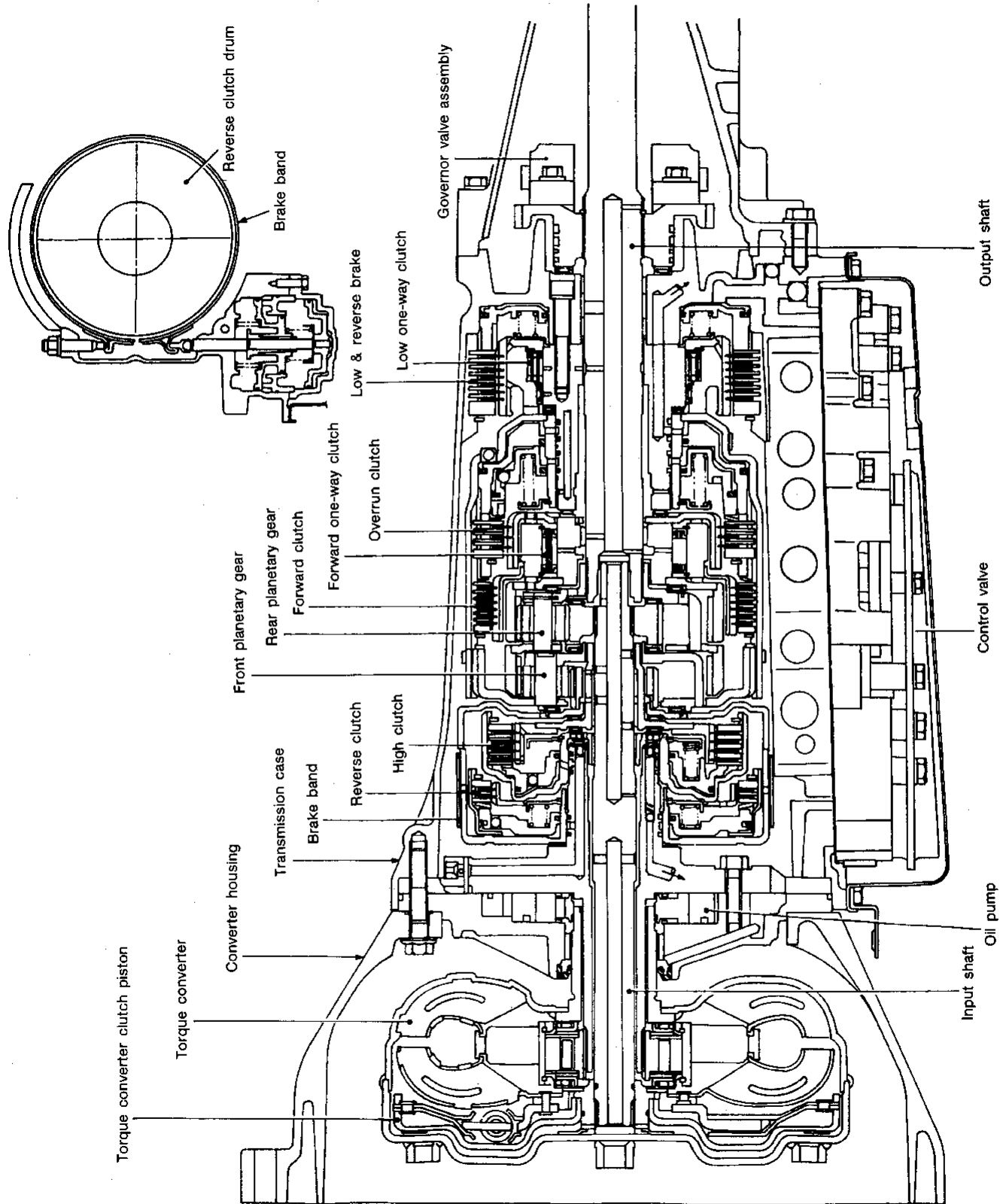

GI
 MA
 EM
 LC
 EF &
 EC
 FE
 CL
 MT
AT
 TF
 PD
 FA
 RA
 BR
 ST
 BF
 HA
 EL

Hydraulic Control Circuits

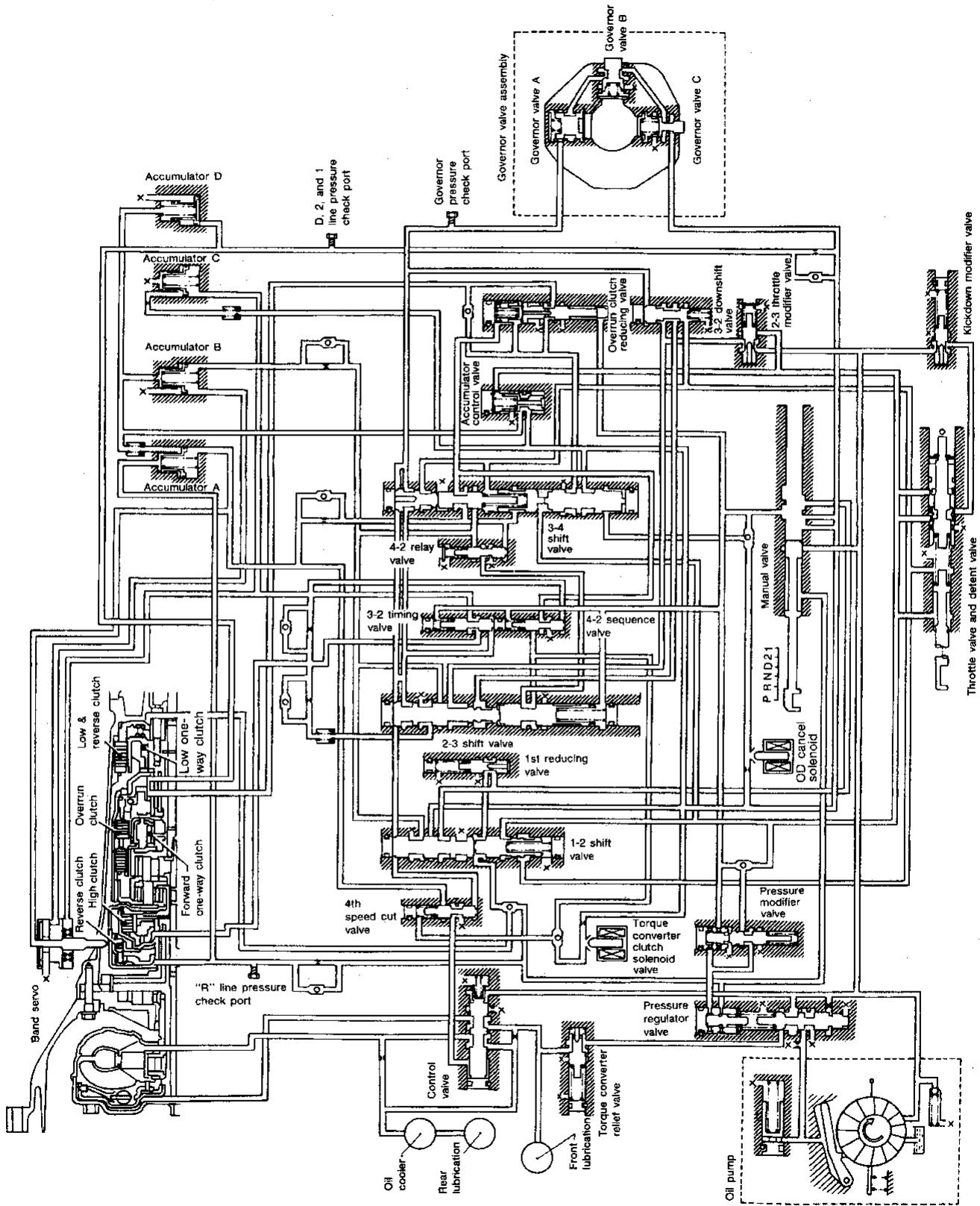

Shift Mechanism

The RL4R01A and RE4R01A automatic transmissions use compact, dual planetary gear systems to improve power-transmission efficiency, simplify construction and reduce weight.

They also employ an optimum shift control and superwide gear ratios to improve starting performance and acceleration during medium and high-speed operation.

Two one-way clutches are also employed: one is used for the forward clutch and the other for the low clutch. These one-way clutches, combined with four accumulators, reduce shifting shock to a minimum.

CONSTRUCTION

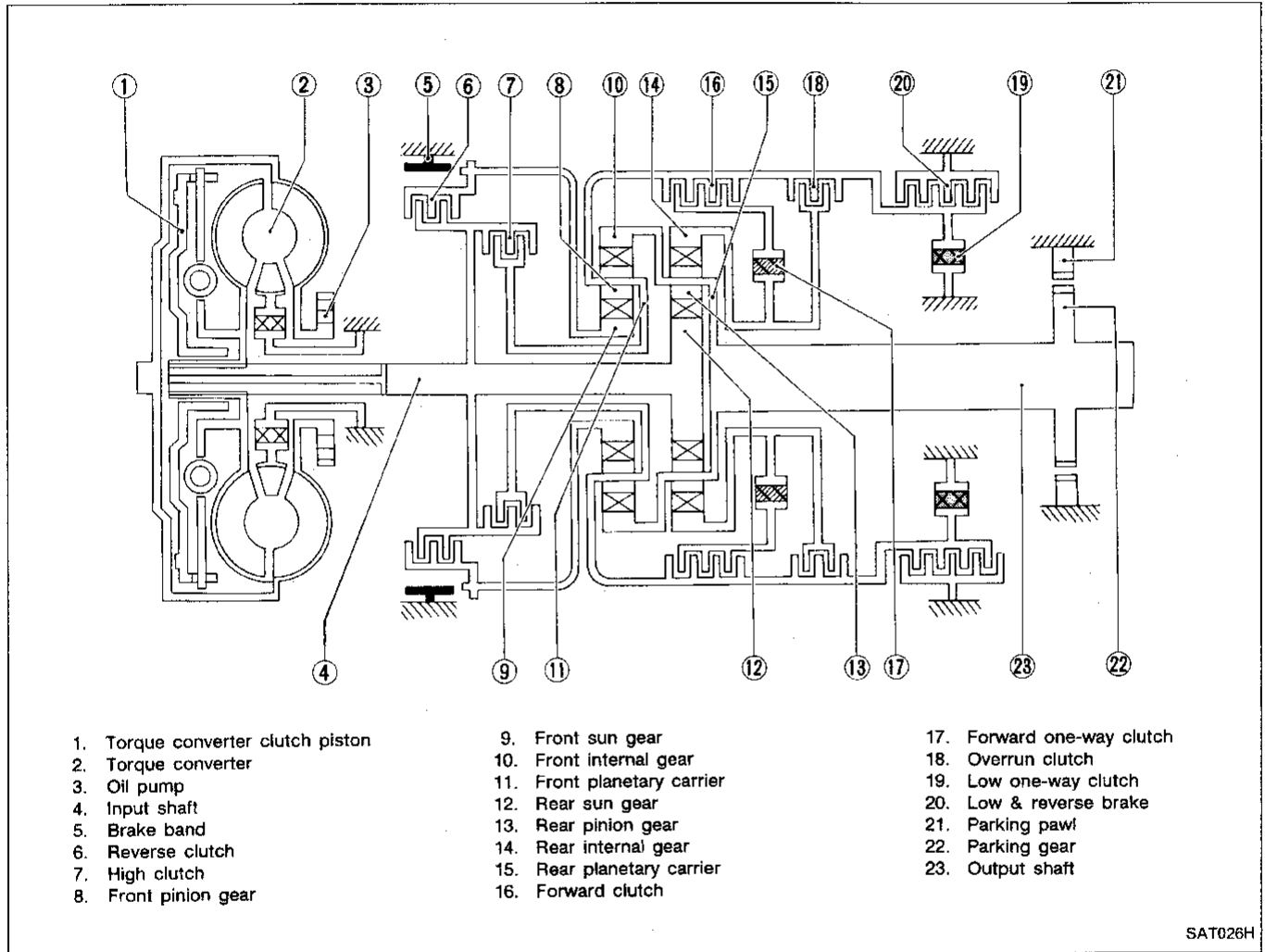

GI

MA

EM

LC

EF &
EC

FE

CL

MT

AT

TF

PD

FA

RA

BR

ST

BF

HA

EL

DX

Shift Mechanism (Cont'd)

FUNCTION OF CLUTCH AND BRAKE

Control members	Abbr.	Function
Reverse clutch	R/C	To transmit input power to front sun gear
High clutch	H/C	To transmit input power to front planetary carrier
Forward clutch	F/C	To connect front planetary carrier with forward one-way clutch
Overrun clutch	O/C	To connect front planetary carrier with rear internal gear
Brake band	B/B	To lock front sun gear
Forward one-way clutch	F/O.C	When forward clutch is engaged, to stop rear internal gear from rotating in opposite direction.
Low one-way clutch	L/O.C	At D ₁ position, to prevent rear internal gear from rotating in opposite direction.
Low & reverse brake	L & R/B	To lock rear internal gear (2, 1 ₂ and 1 ₁), to lock front planetary carrier (R position)

OPERATION OF CLUTCH AND BRAKE

Shift position	Reverse clutch	High clutch	Forward clutch	Overrun clutch	Band servo			Forward one-way clutch	Low one-way clutch	Low & reverse brake	Lock-up	Remarks
					2nd apply	3rd release	4th apply					
P												PARK POSITION
R	○									○		REVERSE POSITION
N												NEUTRAL POSITION
D *4	1st		○	⊙				●	●			Automatic shift 1 ↔ 2 ↔ 3 ↔ 4
	2nd		○	⊙	○			●				
	3rd		○	○	⊙	*2 ⊗	⊗	●				
	4th		○	⊗		*3 ⊗	⊗	○			○	
2	1st		○	⊙				●	●			Automatic shift 1 ↔ 2
	2nd		○	○	○			●				
1	1st		○	○				●		○		Locks (held stationary) in 1st speed 1 ← 2
	2nd		○	○	○			●				

*1 : Operates when overdrive switch is set in "OFF" position.

*2 : Oil pressure is applied to both 2nd "apply" side and 3rd "release" side of band servo piston. However, because oil pressure area on the "release" side is greater than that on the "apply" side, brake band does not contract.

*3 : Oil pressure is applied to 4th "apply" side in condition *2 above, and brake band contracts.

*4 : A/T will not shift to 4th when overdrive switch is set to "OFF" position.

○ : Operates

⊙ : Operates when throttle opening is less than 1/16. Engine brake activates.

● : Operates during "progressive" acceleration.

⊗ : Operates but does not affect power transmission.

⊙ : Operates when throttle opening is less than 1/16 but does not affect engine brake.

Control System

OUTLINE

The RE4R01A automatic transmission senses vehicle operating conditions through various sensors. It always controls the optimum shift position and reduces shifting and lock-up shocks.

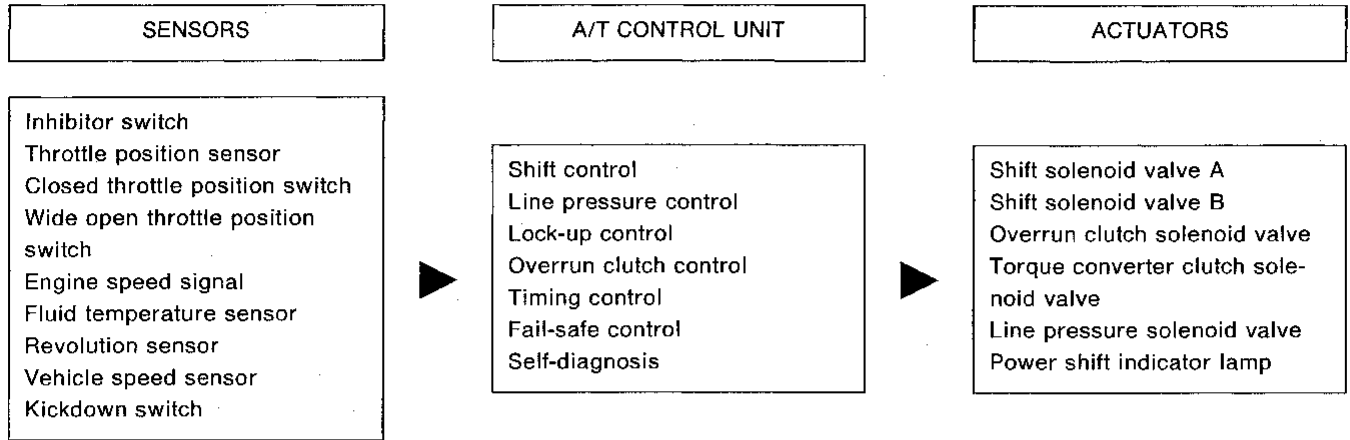

CONTROL SYSTEM

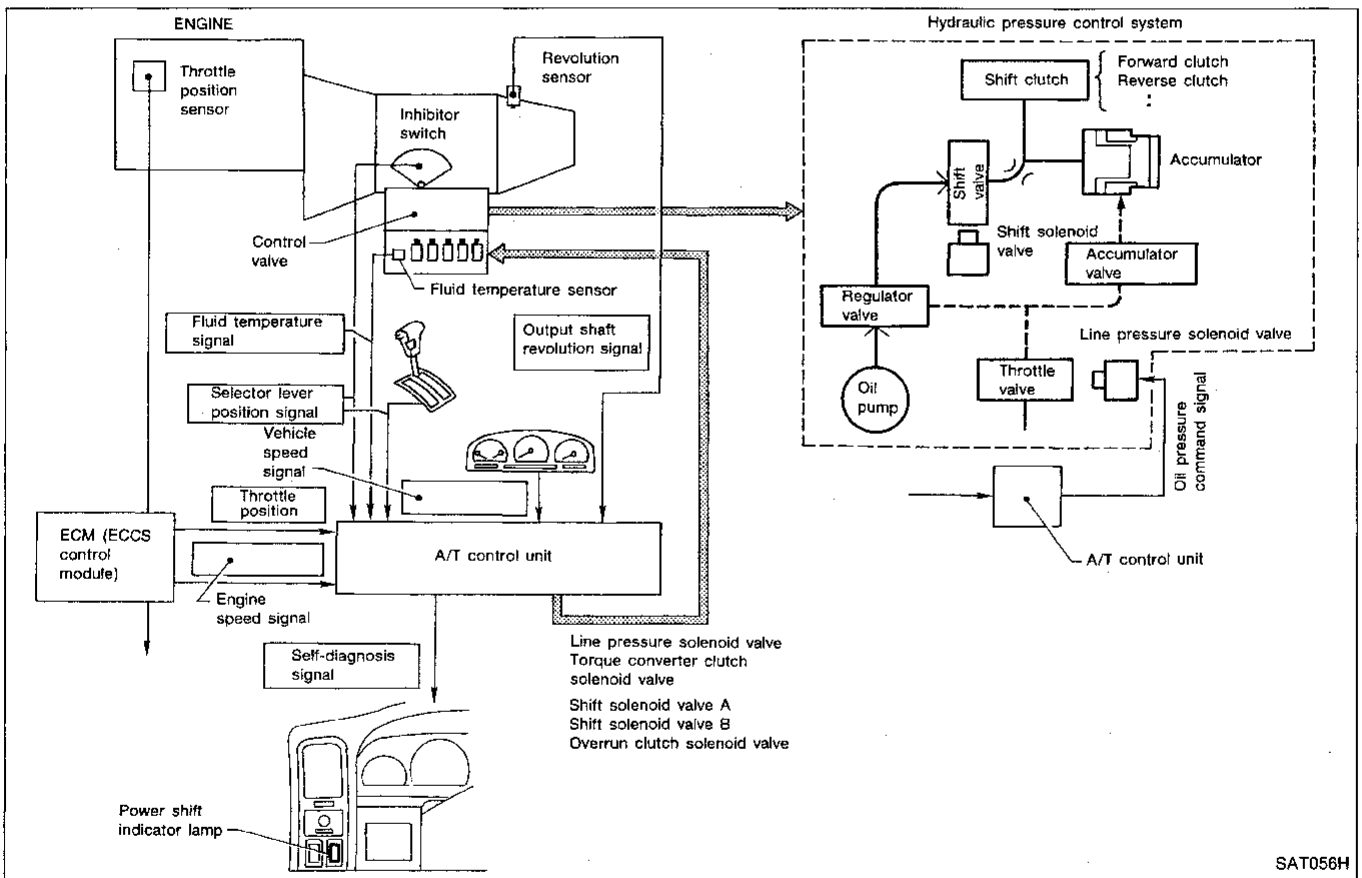

Control System (Cont'd)

A/T CONTROL UNIT FUNCTION

The A/T control unit receives signals sent from various switches and sensors, determines required line pressure, shifting point, lock-up operation, engine brake operation, and sends required signals to the respective solenoids.

INPUT/OUTPUT SIGNAL OF A/T CONTROL UNIT

	Sensors and solenoid valves	Function
Input	Inhibitor switch	Detects select lever position and sends a signal to A/T control unit.
	Throttle position sensor	Detects throttle valve position and sends a signal to A/T control unit.
	Closed throttle position switch	Detects throttle valve's fully-closed position and sends a signal to A/T control unit.
	Wide open throttle position switch	Detects a throttle valve position of greater than 1/2 of full throttle should throttle sensor malfunction and sends a signal to A/T control unit.
	Engine speed signal	From ECM (ECCS control module).
	Fluid temperature sensor	Detects transmission fluid temperature and sends a signal to A/T control unit.
	Revolution sensor	Detects output shaft rpm and sends a signal to A/T control unit.
	Vehicle speed sensor	Used as an auxiliary vehicle speed sensor. Sends a signal when revolution sensor (installed on transmission) malfunction.
	Kickdown switch	Detects full throttle position (accelerator pedal fully depressed). Sends a signal to A/T control unit when throttle position sensor malfunctions.
Output	Shift solenoid valve A/B	Selects shifting point suited to driving conditions in relation to a signal sent from A/T control unit.
	Line pressure solenoid valve	Regulates (or decreases) line pressure suited to driving conditions in relation to a signal sent from A/T control unit.
	Torque converter clutch solenoid valve	Regulates (or decreases) lock-up pressure suited to driving conditions in relation to a signal sent from A/T control unit.
	Overrun clutch solenoid valve	Controls an "engine brake" effect suited to driving conditions in relation to a signal sent from A/T control unit.
	Diagnostic information display	Shows A/T control unit faults, when A/T control components malfunction.

Contents

— RE4R01A —

How to Perform Trouble Diagnoses for Quick and Accurate Repair	AT-15	
Remarks	AT-19	
Preliminary Check	AT-20	GI
A/T Electrical Parts Location	AT-34	
Wiring Diagram	AT-36	
Circuit Diagram for Quick Pinpoint Check	AT-38	MA
Self-diagnosis	AT-39	
SELF-DIAGNOSTIC PROCEDURE	AT-39	
JUDGEMENT OF SELF-DIAGNOSIS CODE	AT-40	EM
REVOLUTION SENSOR CIRCUIT CHECK	AT-42	
VEHICLE SPEED SENSOR CIRCUIT CHECK	AT-42	LC
THROTTLE POSITION SENSOR CIRCUIT CHECK	AT-43	
SHIFT SOLENOID VALVE A CIRCUIT CHECK	AT-44	
SHIFT SOLENOID VALVE B CIRCUIT CHECK	AT-45	EF & EC
OVERRUN CLUTCH SOLENOID VALVE CIRCUIT CHECK	AT-46	
TORQUE CONVERTER CLUTCH SOLENOID VALVE CIRCUIT CHECK	AT-47	
FLUID TEMPERATURE SENSOR CIRCUIT AND		
A/T CONTROL UNIT POWER SOURCE CIRCUIT CHECKS	AT-48	FE
ENGINE SPEED SIGNAL CIRCUIT CHECK	AT-49	
LINE PRESSURE SOLENOID VALVE CIRCUIT CHECK	AT-50	CL
INHIBITOR, OVERDRIVE, KICKDOWN AND CLOSED THROTTLE POSITION		
SWITCH CIRCUIT CHECKS	AT-51	
Diagnostic Procedure 1		MT
(SYMPTOM: Power shift indicator lamp does not come on for about 2 seconds when turning ignition switch to "ON".)	AT-53	AT
Diagnostic Procedure 2		
(SYMPTOM: OD OFF indicator lamp does not come on when setting overdrive switch to "OFF" position.)	AT-54	TF
Diagnostic Procedure 3		
(SYMPTOM: Engine cannot be started with selector lever in "P" or "N" position or engine can be started with selector lever in "D", "2", "1" or "R" position.)	AT-54	PD
Diagnostic Procedure 4		
(SYMPTOM: Vehicle moves when it is pushed forward or backward with selector lever in "P" position.)	AT-54	FA
Diagnostic Procedure 5		
(SYMPTOM: Vehicle moves forward or backward when setting "N" position.)	AT-55	RA
Diagnostic Procedure 6		
(SYMPTOM: There is large shock when changing from "N" to "R" position.)	AT-56	BR
Diagnostic Procedure 7		
(SYMPTOM: Vehicle does not creep backward when selecting "R" position.)	AT-57	
Diagnostic Procedure 8		ST
(SYMPTOM: Vehicle does not creep forward when selecting "D", "2" and "1" position.)	AT-58	
Diagnostic Procedure 9		
(SYMPTOM: Vehicle cannot be started from D ₁ on Cruise test — Part 1.)	AT-59	BF
Diagnostic Procedure 10		
(SYMPTOM: A/T does not shift from D ₁ to D ₂ at the specified speed. A/T does not shift from D ₄ to D ₂ when depressing accelerator pedal fully at the specified speed.)	AT-60	HA
Diagnostic Procedure 11		
(SYMPTOM: A/T does not shift from D ₂ to D ₃ at the specified speed.)	AT-61	EL

Contents (Cont'd)

Diagnostic Procedure 12
 (SYMPTOM: A/T does not shift from D₃ to D₄ at the specified speed.) AT-62

Diagnostic Procedure 13
 (SYMPTOM: A/T does not perform lock-up at the specified speed.) AT-63

Diagnostic Procedure 14
 (SYMPTOM: A/T does not hold lock-up condition for more than 30 seconds.) AT-64

Diagnostic Procedure 15
 (SYMPTOM: Lock-up is not released when accelerator pedal is released.) AT-64

Diagnostic Procedure 16
 (SYMPTOM: Engine speed does not return to idle smoothly when A/T is shifted from D₄ to D₃ with accelerator pedal released.
 Vehicle does not decelerate by engine brake when changing overdrive switch to "OFF" position with accelerator pedal released.
 Vehicle does not decelerate by engine brake when changing selector lever from "D" to "2" position with accelerator pedal released.) AT-65

Diagnostic Procedure 17
 (SYMPTOM: Vehicle does not start from D₁ on Cruise test — Part 2)..... AT-66

Diagnostic Procedure 18
 (SYMPTOM: A/T does not shift from D₄ to D₂ when changing overdrive switch to "OFF" position.) AT-66

Diagnostic Procedure 19
 (SYMPTOM: A/T does not shift from D₃ to 2₂ when changing selector lever from "D" to "2" position.) AT-66

Diagnostic Procedure 20
 (SYMPTOM: A/T does not shift from 2₂ to 1₁ when changing selector lever from "2" to "1" position.) AT-67

Diagnostic Procedure 21
 (SYMPTOM: Vehicle does not decelerate by engine brake when shifting from 2₂ (1₂) to 1₁.) AT-67

Electrical Components Inspection AT-68

Final Check AT-73

Symptom Chart AT-77

— RL4R01A —

Preliminary Check (Prior to Road Testing) AT-79

Road Testing AT-80

Stall Testing AT-87

Pressure Testing AT-89

Circuit Diagram AT-91

Wiring Diagram AT-92

Electrical Components Inspection AT-93

How to Perform Trouble Diagnoses for Quick and Accurate Repair

A good understanding of the malfunctioning conditions can make troubleshooting faster and more accurate.

In general, the feeling about a problem depends on each customer. It is important to fully understand the symptoms or under what conditions a customer complains.

Make good use of the two sheets provided, "Information from customer" and "Diagnostic worksheet", in order to perform the best troubleshooting possible.

WORK FLOW

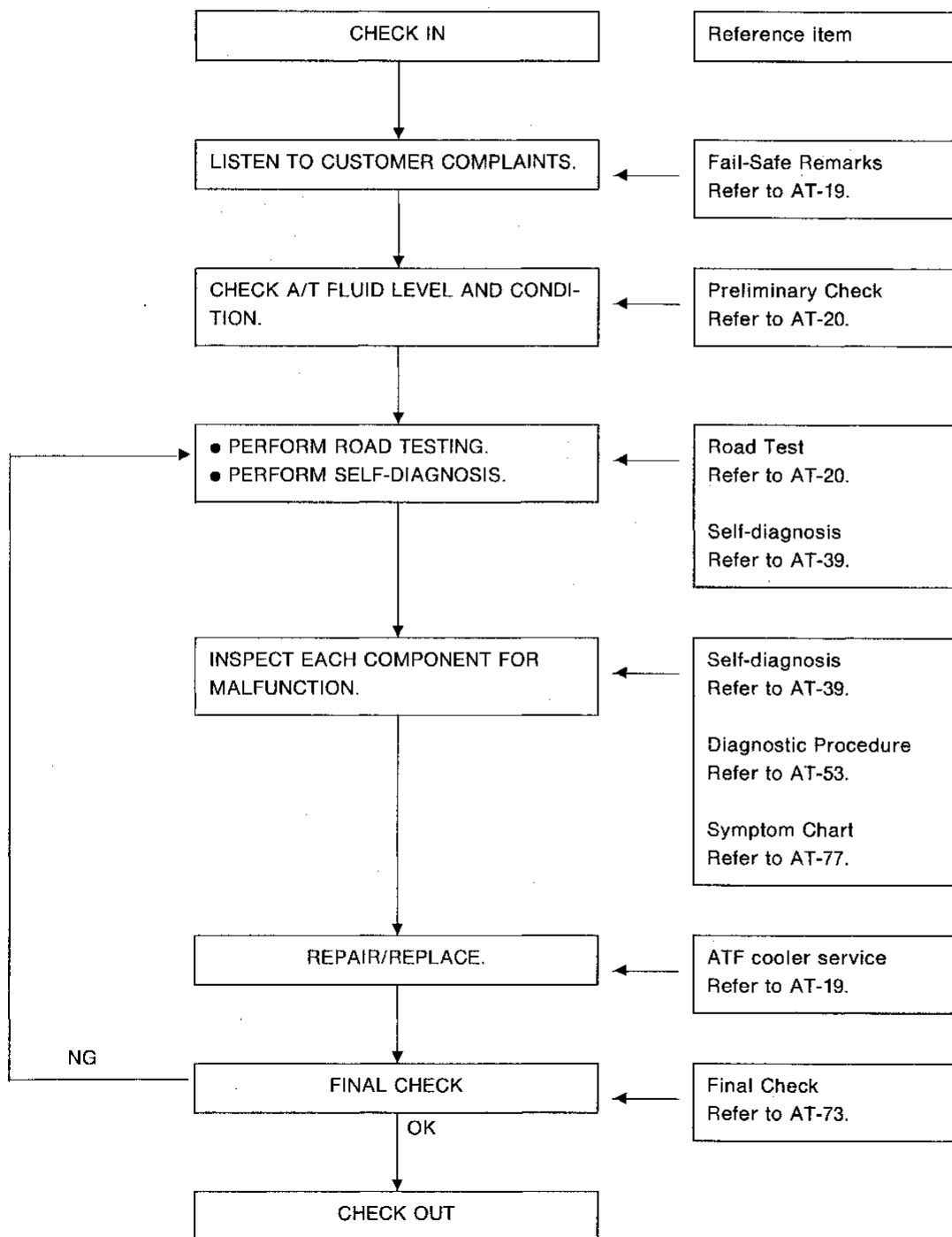

GI
MA
EM
LC
EF & EC
FE
CL
MT
AT
TF
PD
FA
RA
BR
ST
BF
HA
EL
IDX

How to Perform Trouble Diagnoses for Quick and Accurate Repair (Cont'd)

INFORMATION FROM CUSTOMER

KEY POINTS

WHAT Vehicle & A/T model

WHEN Date, Frequencies

WHERE Road conditions

HOW Operating conditions, Symptoms

Customer name MR/MS	Model & Year	VIN
Trans. model RE4R01A	Engine VG30E	Mileage
Incident Date	Manuf. Date	In Service Date
Frequency	<input type="checkbox"/> Continuous <input type="checkbox"/> Intermittent (times a day)	
Symptoms	<input type="checkbox"/> Vehicle does not move. (<input type="checkbox"/> Any position <input type="checkbox"/> Particular position)	
	<input type="checkbox"/> No up-shift (<input type="checkbox"/> 1st → 2nd <input type="checkbox"/> 2nd → 3rd <input type="checkbox"/> 3rd → O/D)	
	<input type="checkbox"/> No down-shift (<input type="checkbox"/> O/D → 3rd <input type="checkbox"/> 3rd → 2nd <input type="checkbox"/> 2nd → 1st)	
	<input type="checkbox"/> Lockup malfunction	
	<input type="checkbox"/> Shift point too high or too low.	
	<input type="checkbox"/> Shift shock or slip (<input type="checkbox"/> N → D <input type="checkbox"/> Lockup <input type="checkbox"/> Any drive position)	
	<input type="checkbox"/> Noise or vibration	
	<input type="checkbox"/> No kickdown	
	<input type="checkbox"/> No pattern select	
	<input type="checkbox"/> Others ()	
Power shift indicator lamp	The indicator lamp blinks for about 8 seconds.	
	<input type="checkbox"/> Come on	<input type="checkbox"/> Come off

How to Perform Trouble Diagnoses for Quick and Accurate Repair (Cont'd)

DIAGNOSTIC WORKSHEET

1.	<input type="checkbox"/> Read the Fail-safe Remarks and listen to customer complaints.	AT-19
2.	<input type="checkbox"/> CHECK A/T FLUID <input type="checkbox"/> Leakage (Follow specified procedure) <input type="checkbox"/> Fluid condition <input type="checkbox"/> Fluid level	AT-20
3.	<input type="checkbox"/> Perform all ROAD TESTING and mark required procedures.	AT-20
	3-1 Check before engine is started. <input type="checkbox"/> Diagnostic Procedure 1 (Power shift indicator lamp comes on for 2 seconds.) <input type="checkbox"/> SELF-DIAGNOSTIC PROCEDURE — Mark detected items. <div style="display: flex; justify-content: space-between;"> <div style="width: 48%;"> <input type="checkbox"/> 1. Revolution sensor <input type="checkbox"/> 2. Vehicle speed sensor <input type="checkbox"/> 3. Throttle position sensor <input type="checkbox"/> 4. Shift-solenoid valve A <input type="checkbox"/> 5. Shift-solenoid valve B <input type="checkbox"/> 6. Overrun clutch solenoid valve <input type="checkbox"/> 7. Torque converter clutch solenoid valve </div> <div style="width: 48%;"> <input type="checkbox"/> 8. Fluid temperature sensor and A/T control unit power source <input type="checkbox"/> 9. Engine speed signal <input type="checkbox"/> 10. Line pressure solenoid valve <input type="checkbox"/> 11. Battery <input type="checkbox"/> 12. Others </div> </div> <input type="checkbox"/> Diagnostic Procedure 2 (OD OFF indicator lamp comes on.)	AT-21
	3-2. Check at idle <input type="checkbox"/> Diagnostic Procedure 3 (Engine starts only in P and N position) <input type="checkbox"/> Diagnostic Procedure 4 (In P position, vehicle does not move when pushed) <input type="checkbox"/> Diagnostic Procedure 5 (In N position, vehicle moves) <input type="checkbox"/> Diagnostic Procedure 6 (Select shock. N → R position) <input type="checkbox"/> Diagnostic Procedure 7 (Vehicle creeps backward in R position) <input type="checkbox"/> Diagnostic Procedure 8 (Vehicle creeps forward in D, 2 or 1 position)	AT-22
	3-3. Cruise test Part-1 <input type="checkbox"/> Diagnostic Procedure 9 (Vehicle starts from D ₁) <input type="checkbox"/> Diagnostic Procedure 10 <input type="checkbox"/> Diagnostic Procedure 11 } (A/T shift schedule: D ₁ → D ₂ /D ₂ → D ₃ /D ₃ → D ₄) <input type="checkbox"/> Diagnostic Procedure 12 <input type="checkbox"/> Diagnostic Procedure 13 (Shift schedule: Lock-up) <input type="checkbox"/> Diagnostic Procedure 14 (Lock-up condition more than 30 seconds) <input type="checkbox"/> Diagnostic Procedure 15 (Lock-up released) <input type="checkbox"/> Diagnostic Procedure 16 (Engine speed return to idle. Light braking D ₄ → D ₃)	AT-23

GI
MA
EM
LC
EF & EC
FE
CL
MT
AT
TF
PD
FA
RA
BR
ST
BF
HA
EL
IDX

How to Perform Trouble Diagnoses for Quick and Accurate Repair (Cont'd)

	<p>Part-2</p> <ul style="list-style-type: none"> <input type="checkbox"/> Diagnostic Procedure 17 (Vehicle starts from D₁) <input type="checkbox"/> Diagnostic Procedure 10 (Kickdown: D₄ → D₂) <input type="checkbox"/> Diagnostic Procedure 11 (Shift schedule: D₂ → D₃) <input type="checkbox"/> Diagnostic Procedure 12 (Shift schedule: D₃ → D₄ and engine brake) 	<p>AT-25</p>		
	<p>Part-3</p> <ul style="list-style-type: none"> <input type="checkbox"/> Diagnostic Procedure 18 (D₄ → D₃ when OD switch ON → OFF) <input type="checkbox"/> Diagnostic Procedure 16 (Engine brake in D₃) <input type="checkbox"/> Diagnostic Procedure 19 (D₃ → 2₂ when selector lever D → 2 position) <input type="checkbox"/> Diagnostic Procedure 16 (Engine brake in 2₂) <input type="checkbox"/> Diagnostic Procedure 20 (2₂ → 1₁, when selector lever 2 → 1 position) <input type="checkbox"/> Diagnostic Procedure 21 (Engine brake in 1₁) <input type="checkbox"/> SELF-DIAGNOSTIC PROCEDURE — Mark detected items. <table style="width: 100%; border: none;"> <tr> <td style="width: 50%; vertical-align: top;"> <ul style="list-style-type: none"> <input type="checkbox"/> 1. Revolution sensor <input type="checkbox"/> 2. Vehicle speed sensor <input type="checkbox"/> 3. Throttle position sensor <input type="checkbox"/> 4. Shift solenoid valve A <input type="checkbox"/> 5. Shift solenoid valve B <input type="checkbox"/> 6. Overrun clutch solenoid valve <input type="checkbox"/> 7. Torque converter clutch solenoid valve </td> <td style="width: 50%; vertical-align: top;"> <ul style="list-style-type: none"> <input type="checkbox"/> 8. Fluid temperature sensor and A/T control unit power source <input type="checkbox"/> 9. Engine speed signal <input type="checkbox"/> 10. Line pressure solenoid valve <input type="checkbox"/> 11. Battery <input type="checkbox"/> 12. Others </td> </tr> </table> 	<ul style="list-style-type: none"> <input type="checkbox"/> 1. Revolution sensor <input type="checkbox"/> 2. Vehicle speed sensor <input type="checkbox"/> 3. Throttle position sensor <input type="checkbox"/> 4. Shift solenoid valve A <input type="checkbox"/> 5. Shift solenoid valve B <input type="checkbox"/> 6. Overrun clutch solenoid valve <input type="checkbox"/> 7. Torque converter clutch solenoid valve 	<ul style="list-style-type: none"> <input type="checkbox"/> 8. Fluid temperature sensor and A/T control unit power source <input type="checkbox"/> 9. Engine speed signal <input type="checkbox"/> 10. Line pressure solenoid valve <input type="checkbox"/> 11. Battery <input type="checkbox"/> 12. Others 	<p>AT-26</p>
<ul style="list-style-type: none"> <input type="checkbox"/> 1. Revolution sensor <input type="checkbox"/> 2. Vehicle speed sensor <input type="checkbox"/> 3. Throttle position sensor <input type="checkbox"/> 4. Shift solenoid valve A <input type="checkbox"/> 5. Shift solenoid valve B <input type="checkbox"/> 6. Overrun clutch solenoid valve <input type="checkbox"/> 7. Torque converter clutch solenoid valve 	<ul style="list-style-type: none"> <input type="checkbox"/> 8. Fluid temperature sensor and A/T control unit power source <input type="checkbox"/> 9. Engine speed signal <input type="checkbox"/> 10. Line pressure solenoid valve <input type="checkbox"/> 11. Battery <input type="checkbox"/> 12. Others 			
<p>4.</p>	<p><input type="checkbox"/> Perform the Diagnostic Procedures marked in ROAD TESTING. Refer to the Symptom Chart when you perform the procedures. (The chart also shows some other possible symptoms and the components inspection orders.)</p>	<p>AT-77</p>		
<p>5.</p>	<p>Perform FINAL CHECK. If NG, go back to "CHECK A/T FLUID".</p> <ul style="list-style-type: none"> <input type="checkbox"/> Stall test — Mark possible damaged components/others. <table style="width: 100%; border: none;"> <tr> <td style="width: 50%; vertical-align: top;"> <ul style="list-style-type: none"> <input type="checkbox"/> Torque converter one-way clutch <input type="checkbox"/> Reverse clutch <input type="checkbox"/> Forward clutch <input type="checkbox"/> Overrun clutch <input type="checkbox"/> Forward one-way clutch <input type="checkbox"/> Low & reverse brake </td> <td style="width: 50%; vertical-align: top;"> <ul style="list-style-type: none"> <input type="checkbox"/> Low one-way clutch <input type="checkbox"/> Engine <input type="checkbox"/> Line pressure is low <input type="checkbox"/> Clutches and brakes except high clutch and brake band are OK. </td> </tr> </table> <input type="checkbox"/> Pressure test — Suspected parts: 	<ul style="list-style-type: none"> <input type="checkbox"/> Torque converter one-way clutch <input type="checkbox"/> Reverse clutch <input type="checkbox"/> Forward clutch <input type="checkbox"/> Overrun clutch <input type="checkbox"/> Forward one-way clutch <input type="checkbox"/> Low & reverse brake 	<ul style="list-style-type: none"> <input type="checkbox"/> Low one-way clutch <input type="checkbox"/> Engine <input type="checkbox"/> Line pressure is low <input type="checkbox"/> Clutches and brakes except high clutch and brake band are OK. 	<p>AT-73</p>
<ul style="list-style-type: none"> <input type="checkbox"/> Torque converter one-way clutch <input type="checkbox"/> Reverse clutch <input type="checkbox"/> Forward clutch <input type="checkbox"/> Overrun clutch <input type="checkbox"/> Forward one-way clutch <input type="checkbox"/> Low & reverse brake 	<ul style="list-style-type: none"> <input type="checkbox"/> Low one-way clutch <input type="checkbox"/> Engine <input type="checkbox"/> Line pressure is low <input type="checkbox"/> Clutches and brakes except high clutch and brake band are OK. 			

Remarks

FAIL-SAFE

The A/T control unit has an electronic Fail-Safe (limp home mode) to allow the vehicle to be driven even in the event of damage of a major electrical input or output device circuit.

In this condition, the vehicle runs in third gear in positions 1, 2 or D and will not upshift. Customer may say "Sluggish, poor acceleration".

When Fail-safe operation occurs the next time the key is turned to the ON position, the power shift indicator lamp will blink for about 8 seconds. (For diagnosis, refer to AT-21.)

If the vehicle is driven under extreme conditions such as excessive wheel spinning and emergency braking suddenly after, Fail-Safe may be activated even if all electrical circuits are undamaged.

In this case, normal shift pattern can be returned by turning key OFF for 3 seconds and then back ON. The blinking of the OD OFF indicator lamp for about 8 seconds will appear only once and be cleared.

The customer may resume normal driving conditions by chance.

Always follow the "WORK FLOW" (Refer to AT-15.)

The SELF-DIAGNOSIS results will be as follows:

The first SELF-DIAGNOSIS will indicate the damage of the vehicle speed sensor or the revolution sensor.

During the next SELF-DIAGNOSIS performed after checking the sensor, no damages will be indicated.

ATF COOLER SERVICE

If the oil pan contains foreign matter in large quantities or if the strainer is excessively clogged during A/T overhaul, service the ATF cooler as follows:

- 1) RE4R01A with VG30E engine — Fin type
Replace the radiator lower tank (which includes ATF cooler) with a new one, then flush the cooler line using cleaning solvent and compressed air.
- 2) RL4R01A with KA24 engine — Tube type
Flush the ATF cooler and cooler line using cleaning solvent and compressed air.

GI
MA
EM
LC
EF & EC
FE
CL
MT
AT
TF
PD
FA
RA
BR
ST
BF
HA
EL
IDX

Preliminary Check

A/T FLUID CHECK

Fluid leakage check

1. Clean area suspected of leaking, — for example, mating surface of converter housing and transmission case.
2. Start engine, apply foot brake, place selector lever in "D" position and wait a few minutes.
3. Stop engine.
4. Check for fresh leakage.

Fluid condition check

Fluid color	Suspected problem
Dark or black with burned odor	Wear of frictional material
Milky pink	Water contamination — Road water entering through filler tube or breather
Varnished fluid, light to dark brown and tacky	Oxidation — Over or under filling, Overheating

Fluid level check — Refer to section MA.

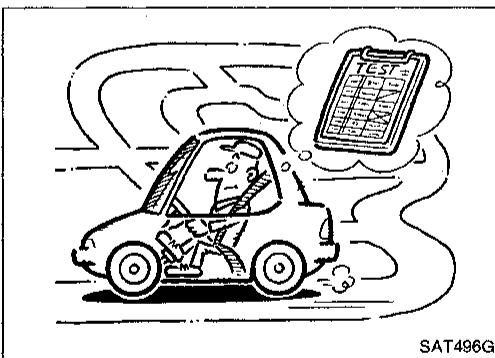
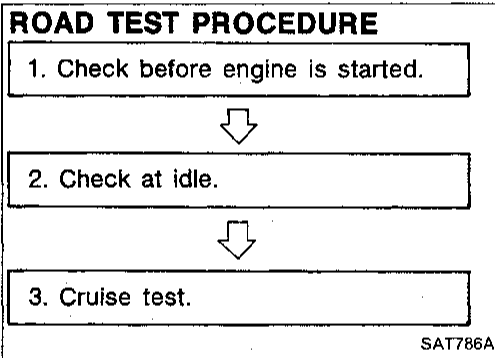

ROAD TESTING

Description

- The purpose of this road test is to determine overall performance of automatic transmission and analyze causes of problems.
- The road test consists of the following three parts:
 1. Check before engine is started
 2. Check at idle
 3. Cruise test
- Before road test, familiarize yourself with all test procedures and items to check.
- Conduct tests on all items. Troubleshoot items which check out No Good after road test. Refer to "Self-diagnosis" and "Diagnostic Procedure" (AT-39).

Preliminary Check (Cont'd)

1. Check before engine is started

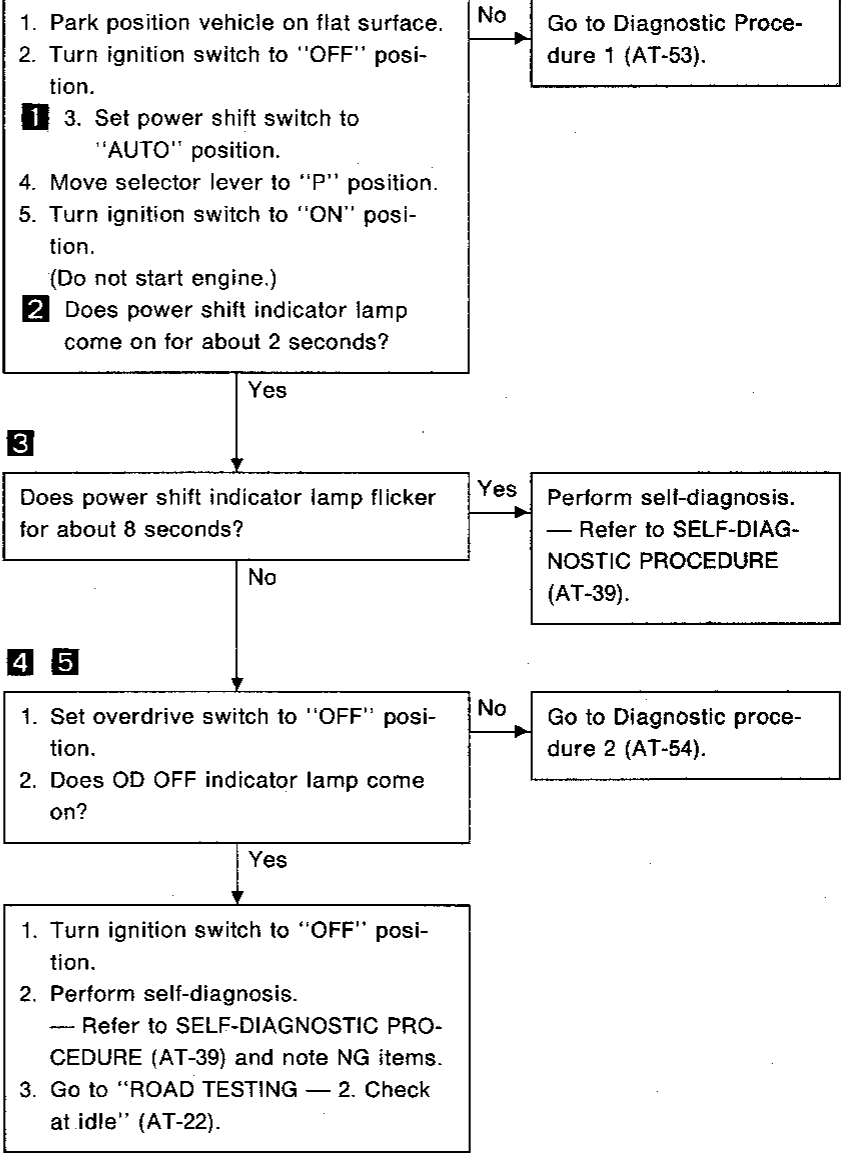
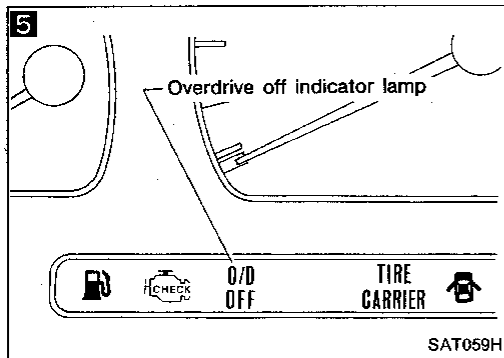
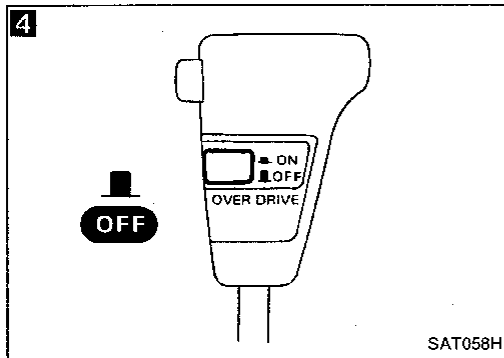
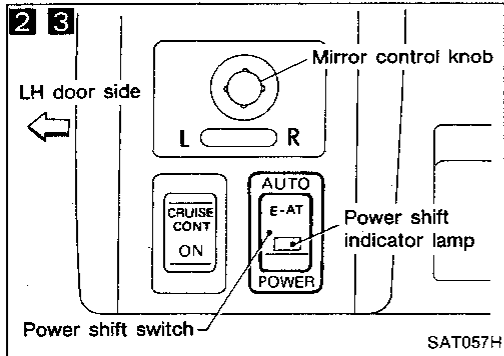
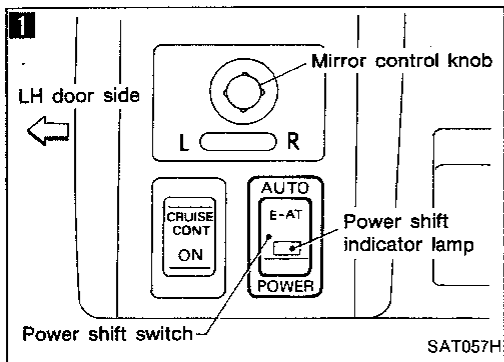

GI
MA
EM
LC
EF & EC
FE
CL
MT
AT
TF
PD
FA
RA
BR
ST
BF
HA
EL
IDX

Preliminary Check (Cont'd)

2. Check at idle

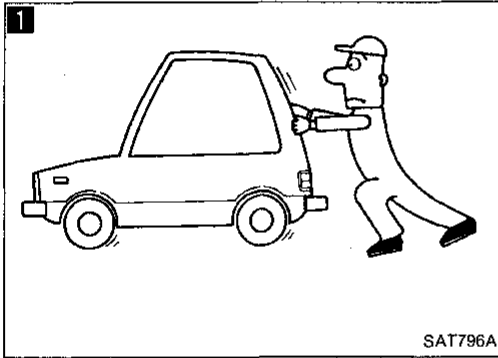
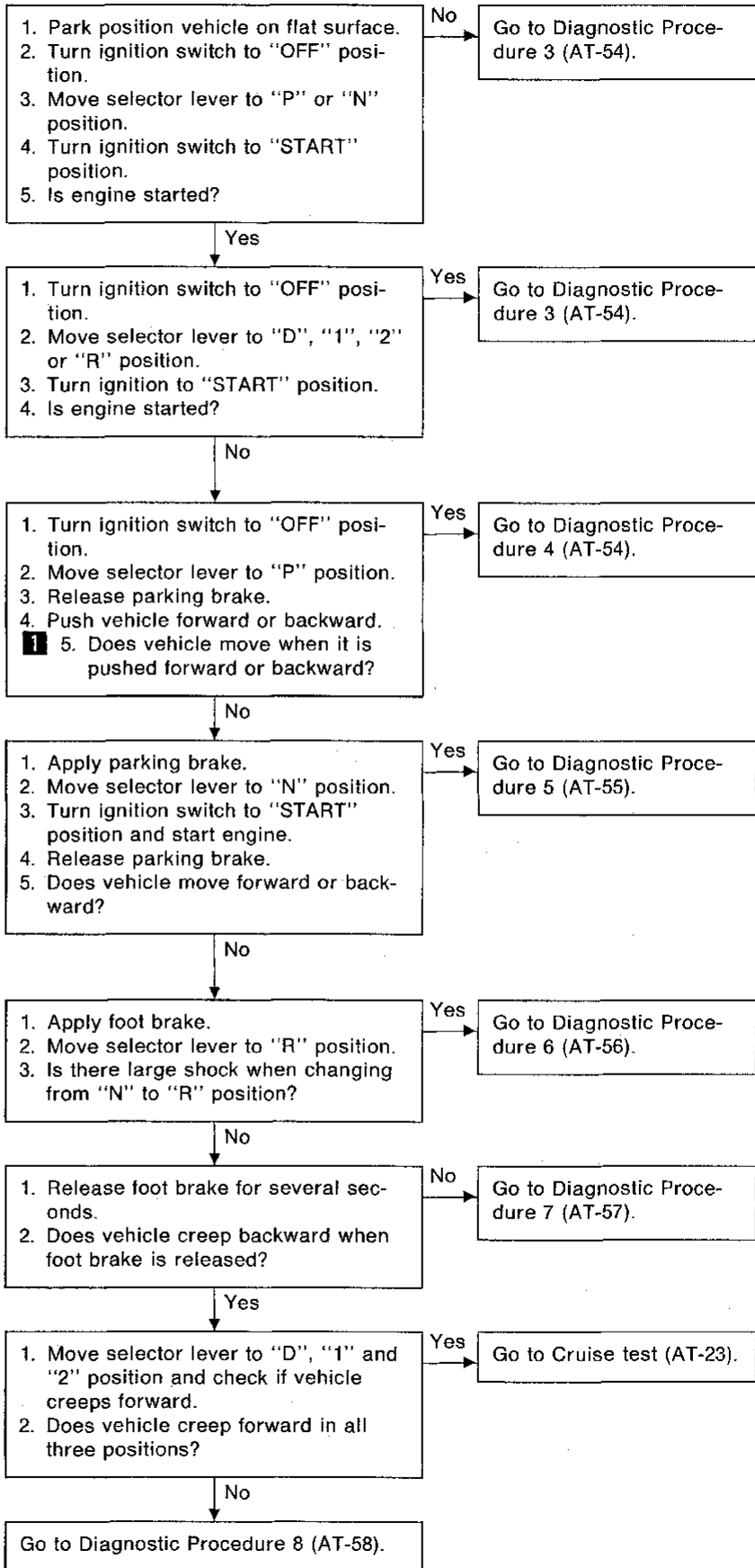

Preliminary Check (Cont'd)

3. Cruise test

- Check all items listed in Parts 1 through 3.
- Throttle position can be controlled by voltage across terminals ① and ⑮ of A/T control unit.

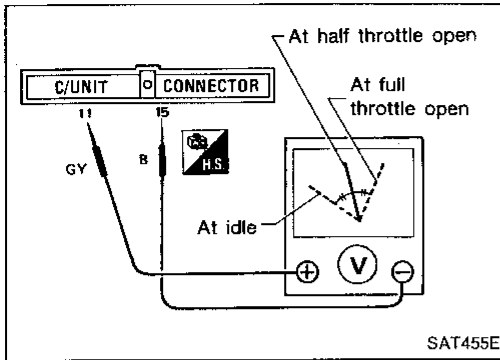

Cruise test — Part 1

Warm up engine until engine oil and ATF reach operating temperature after vehicle has been driven approx. 10 minutes.

ATF operating temperature:
50 - 80°C (122 - 176°F)

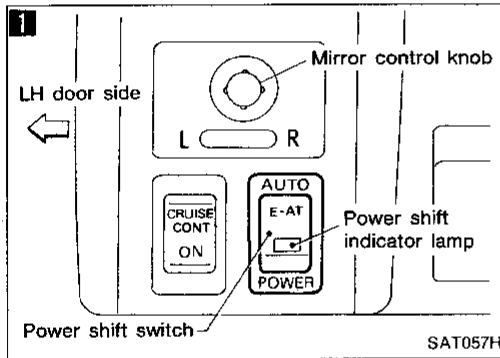

1. Park position vehicle on flat surface.
1. Set power shift switch in "AUTO" position.
3. Set overdrive switch in "ON" position.
4. Move selector lever to "P" position.
5. Turn ignition switch to "ON" position and start engine.
6. Move selector lever to "D" position.
2. 7. Accelerate vehicle by constantly depressing accelerator pedal half-way.
8. Does vehicle start from D₁?

No
Go to Diagnostic Procedure 9 (AT-59).

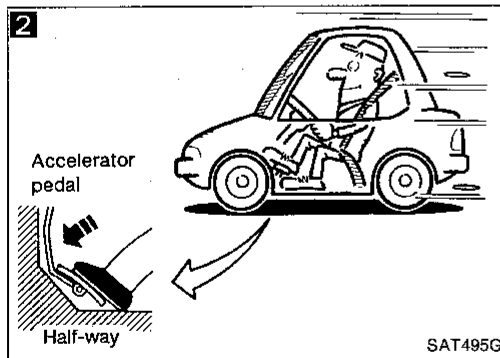

3. Does A/T shift from D₁ to D₂ at the specified speed?
Specified speed when shifting from D₁ to D₂:
Refer to Shift schedule (AT-28).

No
Go to Diagnostic Procedure 10 (AT-60).

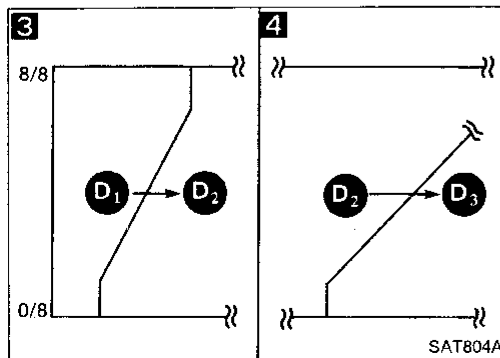

4. Does A/T shift from D₂ to D₃ at the specified speed?
Specified speed when shifting from D₂ to D₃:
Refer to Shift schedule (AT-28).

No
Go to Diagnostic Procedure 11 (AT-61).

Yes
A

GI
MA
EM
LC
EF & EC
FE
CL
MT
AT
TF
PD
FA
RA
BR
ST
BF
HA
EL
IDX

Preliminary Check (Cont'd)

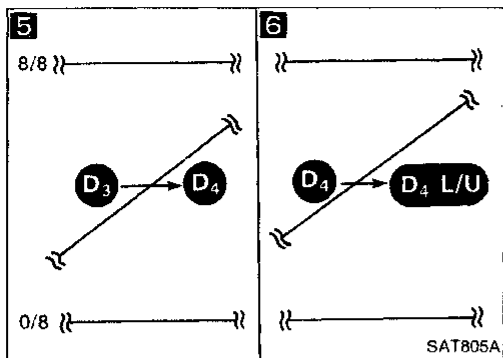

5

Does A/T shift from D₃ to D₄ at the specified speed?
Specified speed when shifting from D₃ to D₄:
Refer to Shift schedule (AT-28).

No → Go to Diagnostic Procedure 12 (AT-62).

Yes →

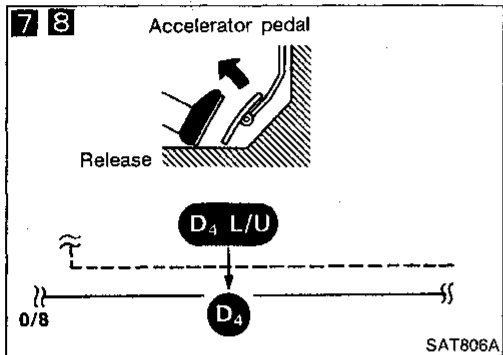

6

Does A/T perform lock-up at the specified speed?
Specified speed when lock-up occurs:
Refer to Shift schedule (AT-28).

No → Go to Diagnostic Procedure 13 (AT-63).

Yes →

Does A/T hold lock-up condition for more than 30 seconds?

No → Go to Diagnostic Procedure 14 (AT-64).

Yes →

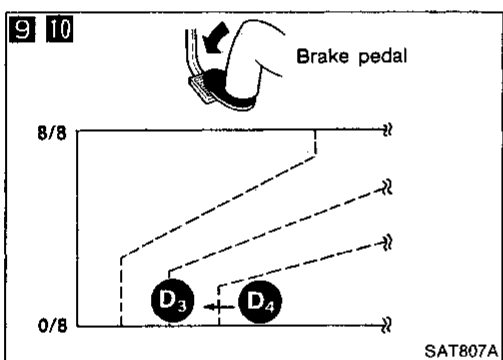

7 8

1. Release accelerator pedal.
 2. Is lock-up released when accelerator pedal is released?

No → Go to Diagnostic Procedure 15 (AT-64).

Yes →

9 10

1. Decelerate vehicle by applying foot brake lightly.
 2. Does engine speed return to idle smoothly when A/T is shifted from D₄ to D₃?

No → Go to Diagnostic Procedure 16 (AT-65).

Yes →

1. Stop vehicle.
 2. Go to "Cruise test — Part 2" (AT-25).

Preliminary Check (Cont'd)

Cruise test — Part 2

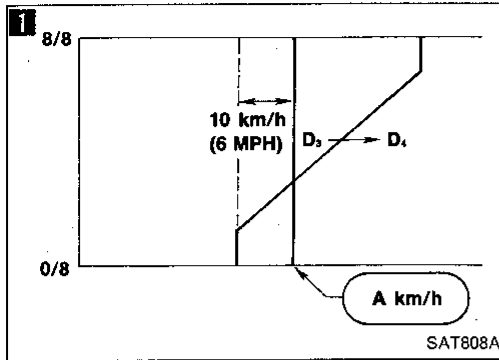

1. Confirm power shift switch is in "AUTO" position and overdrive switch is in "ON" position.
2. Confirm selector lever is in "D" position.
3. Accelerate vehicle by half throttle again.

Does vehicle start from D₁? No → Go to Diagnostic Procedure 17 (AT-66).

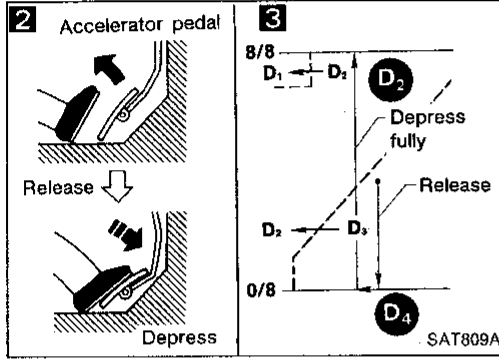

1. Accelerate vehicle to A km/h as shown in illustration.
2. Release accelerator pedal and then quickly depress it fully.
3. Does A/T shift from D₄ to D₂ as soon as accelerator pedal is depressed fully?

Does A/T shift from D₂ to D₃ at the specified speed?
Specified speed when shifting from D₂ to D₃:
Refer to Shift schedule (AT-28).

No → Go to Diagnostic Procedure 11 (AT-61).

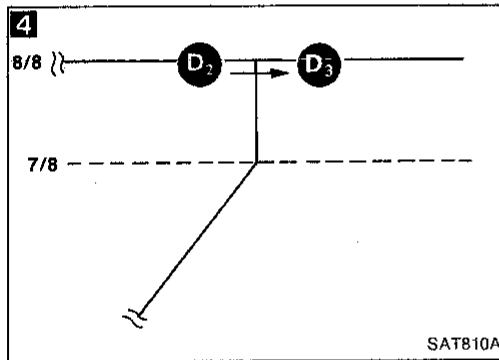

Does A/T shift from D₃ to D₄ and does vehicle decelerate by engine brake?
No → Go to Diagnostic Procedure 12 (AT-62).

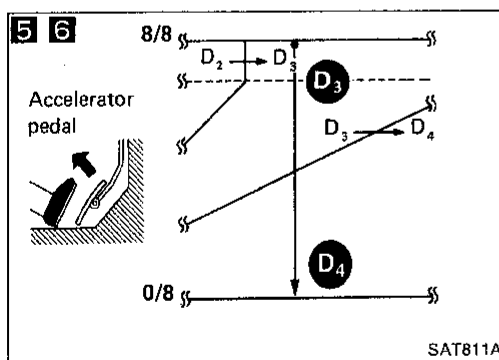

1. Stop vehicle.
2. Go to "Cruise test — Part 3" (AT-26).

GI
MA
EM
LC
EF & EC
FE
CL
MT
AT
TF
PD
FA
RA
BR
ST
BF
HA
EL
IDX

Preliminary Check (Cont'd)

Cruise test — Part 3

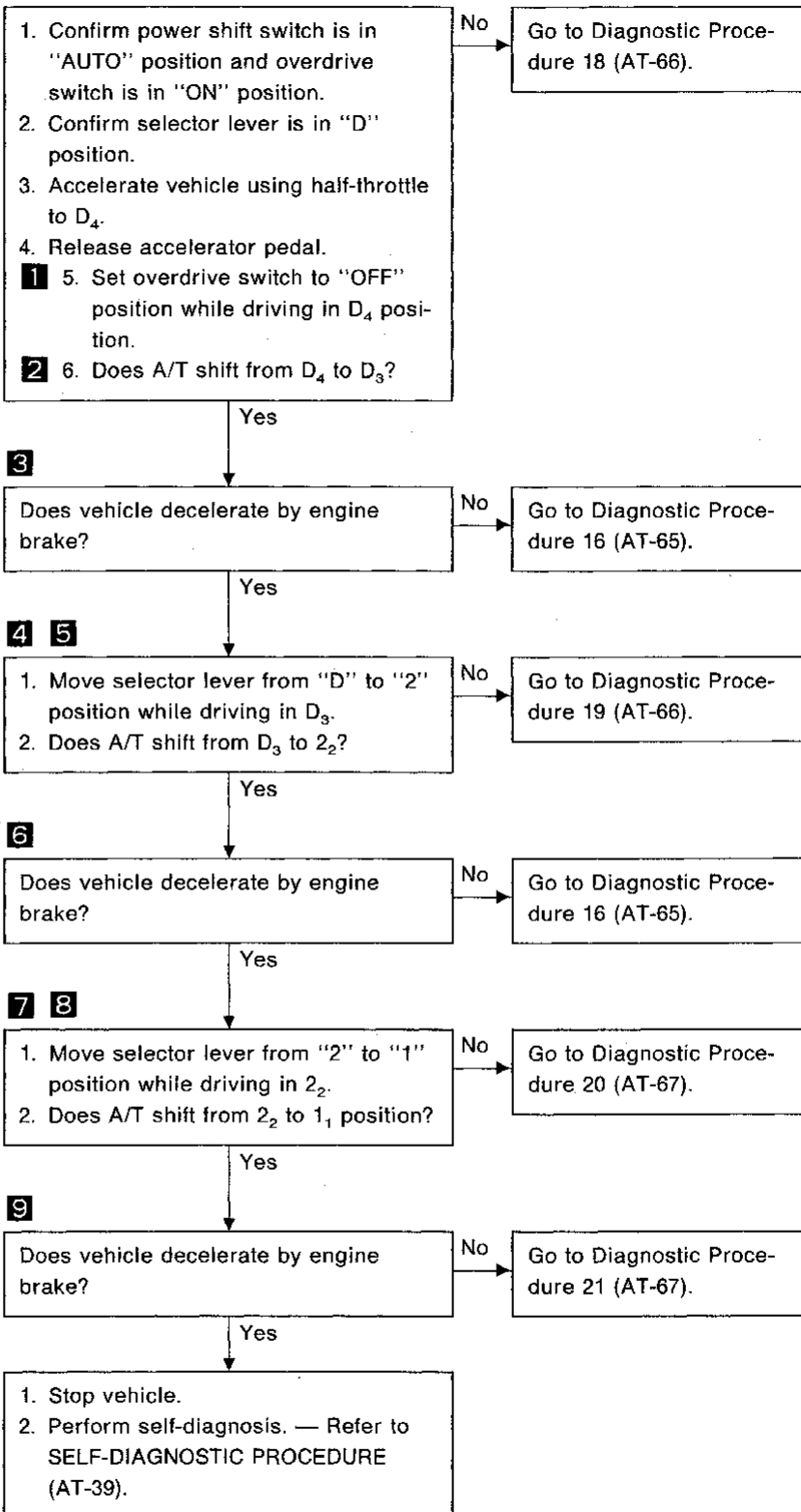
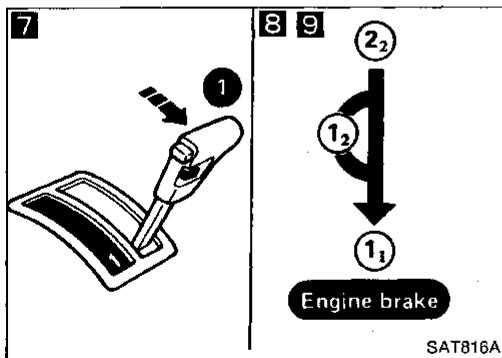
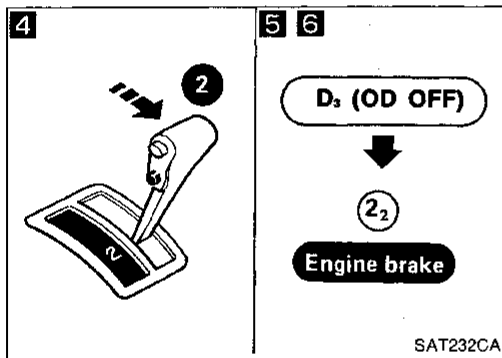
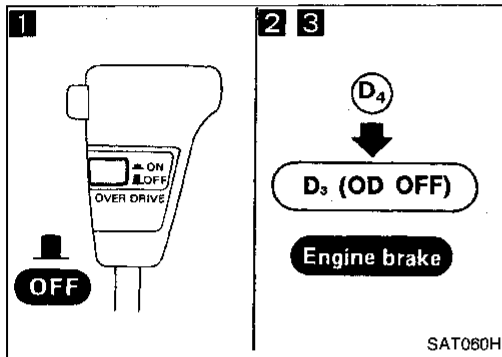

Preliminary Check (Cont'd)

Vehicle speed when shifting gears

VG30E engine 4WD (Final gear ratio: 4.375)

Throttle position	Vehicle speed km/h (MPH)						
	D ₁ → D ₂	D ₂ → D ₃	D ₃ → D ₄	D ₄ → D ₃	D ₃ → D ₂	D ₂ → D ₁	1 ₂ → 1 ₁
Full throttle	50 - 54 (31 - 34)	97 - 105 (60 - 65)	162 - 172 (101 - 107)	157 - 167 (98 - 104)	92 - 100 (57 - 62)	38 - 42 (24 - 26)	38 - 42 (24 - 26)
Half throttle	32 - 36 (20 - 22)	64 - 70 (40 - 43)	111 - 119 (69 - 74)	65 - 75 (40 - 45)	29 - 35 (18 - 22)	10 - 14 (6 - 9)	38 - 42 (24 - 26)

VG30E engine 4WD (Final gear ratio: 4.625)

Throttle position	Vehicle speed km/h (MPH)						
	D ₁ → D ₂	D ₂ → D ₃	D ₃ → D ₄	D ₄ → D ₃	D ₃ → D ₂	D ₂ → D ₁	1 ₂ → 1 ₁
Full throttle	46 - 50 (29 - 31)	90 - 98 (56 - 61)	150 - 160 (93 - 99)	145 - 155 (90 - 96)	86 - 94 (53 - 58)	38 - 42 (24 - 26)	38 - 42 (24 - 26)
Half throttle	30 - 34 (19 - 22)	60 - 66 (37 - 41)	103 - 111 (64 - 69)	60 - 68 (37 - 42)	28 - 34 (17 - 21)	10 - 14 (6 - 9)	38 - 42 (24 - 26)

VG30E engine 2WD

Throttle position	Vehicle speed km/h (MPH)						
	D ₁ → D ₂	D ₂ → D ₃	D ₃ → D ₄	D ₄ → D ₃	D ₃ → D ₂	D ₂ → D ₁	1 ₂ → 1 ₁
Full throttle	52 - 56 (32 - 35)	99 - 107 (62 - 66)	159 - 169 (99 - 105)	154 - 164 (96 - 102)	91 - 99 (57 - 62)	44 - 48 (27 - 30)	38 - 42 (24 - 26)
Half throttle	32 - 36 (20 - 22)	66 - 72 (41 - 45)	105 - 113 (65 - 70)	69 - 77 (43 - 48)	29 - 35 (18 - 22)	10 - 14 (6 - 9)	38 - 42 (24 - 26)

Vehicle speed when performing and releasing lock-up

VG30E engine 4WD (Final gear ratio: 4.375)

Throttle position	OD switch [Shift position]	Vehicle speed km/h (MPH)	
		Lock-up "ON"	Lock-up "OFF"
Full throttle	ON [D ₄]	163 - 171 (101 - 106)	158 - 168 (98 - 104)
	OFF [D ₃]	97 - 105 (60 - 65)	92 - 108 (57 - 67)
Half throttle	ON [D ₄]	110 - 118 (68 - 73)	82 - 90 (51 - 56)
	OFF [D ₃]	76 - 84 (47 - 52)	71 - 79 (44 - 49)

VG30E engine 4WD (Final gear ratio: 4.625)

Throttle position	OD switch [Shift position]	Vehicle speed km/h (MPH)	
		Lock-up "ON"	Lock-up "OFF"
Full throttle	ON [D ₄]	151 - 159 (94 - 99)	146 - 154 (91 - 96)
	OFF [D ₃]	90 - 98 (56 - 61)	86 - 94 (53 - 58)
Half throttle	ON [D ₄]	103 - 111 (64 - 69)	83 - 91 (52 - 57)
	OFF [D ₃]	76 - 84 (47 - 52)	71 - 79 (44 - 49)

VG30E engine 2WD

Throttle position	OD switch [Shift position]	Vehicle speed km/h (MPH)	
		Lock-up "ON"	Lock-up "OFF"
Full throttle	ON [D ₄]	160 - 168 (99 - 104)	155 - 163 (96 - 101)
	OFF [D ₃]	99 - 107 (62 - 66)	91 - 99 (57 - 62)
Half throttle	ON [D ₄]	101 - 109 (63 - 68)	82 - 90 (51 - 56)
	OFF [D ₃]	76 - 84 (47 - 52)	71 - 79 (44 - 49)

Preliminary Check (Cont'd)

Shift schedule (Standard pattern: OD ON) / VG30E engine 4WD (Final drive gear ratio: 4.375)

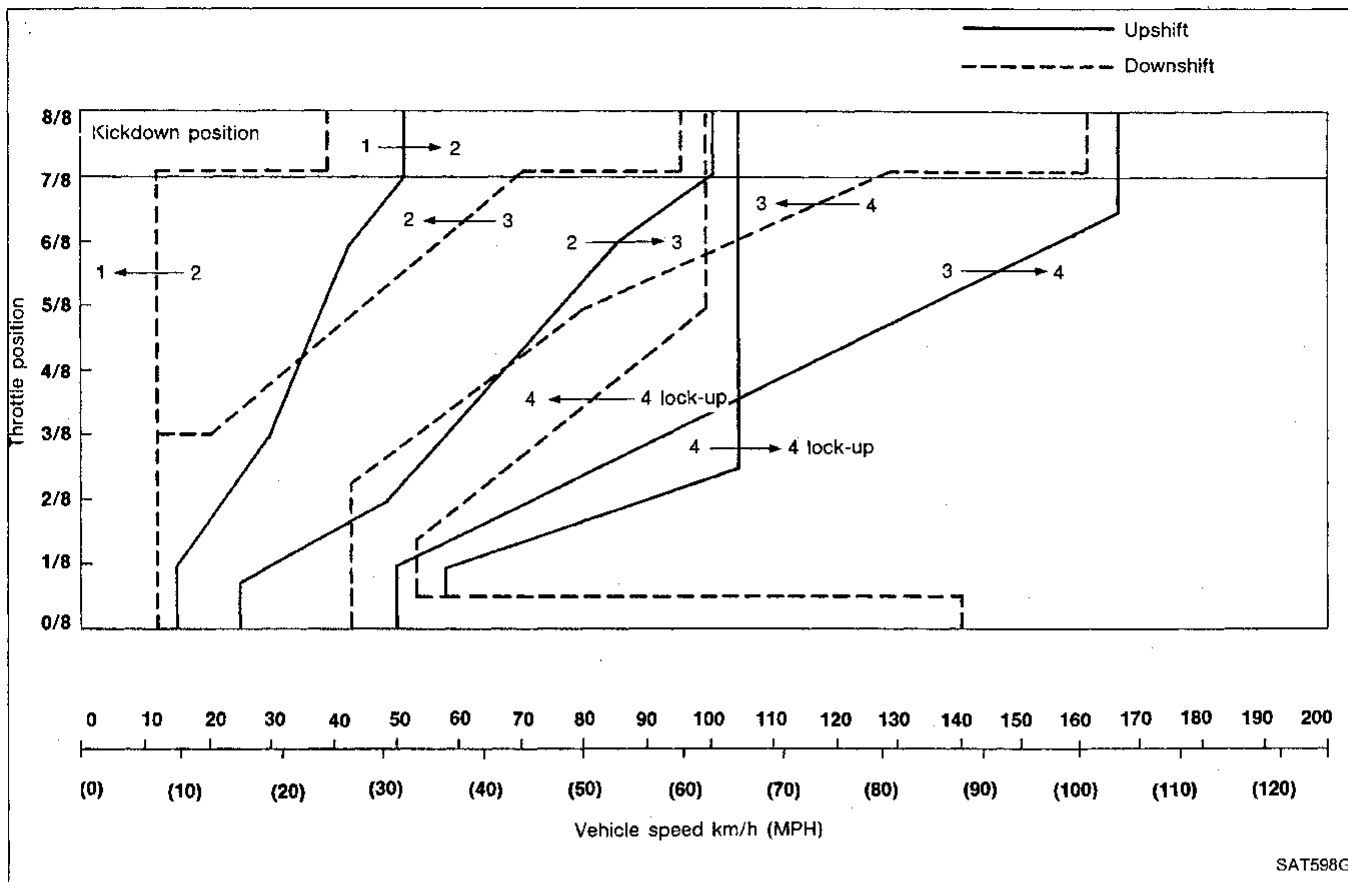

SAT598G

Shift schedule (Power pattern: OD ON) / VG30E engine 4WD (Final drive gear ratio: 4.375)

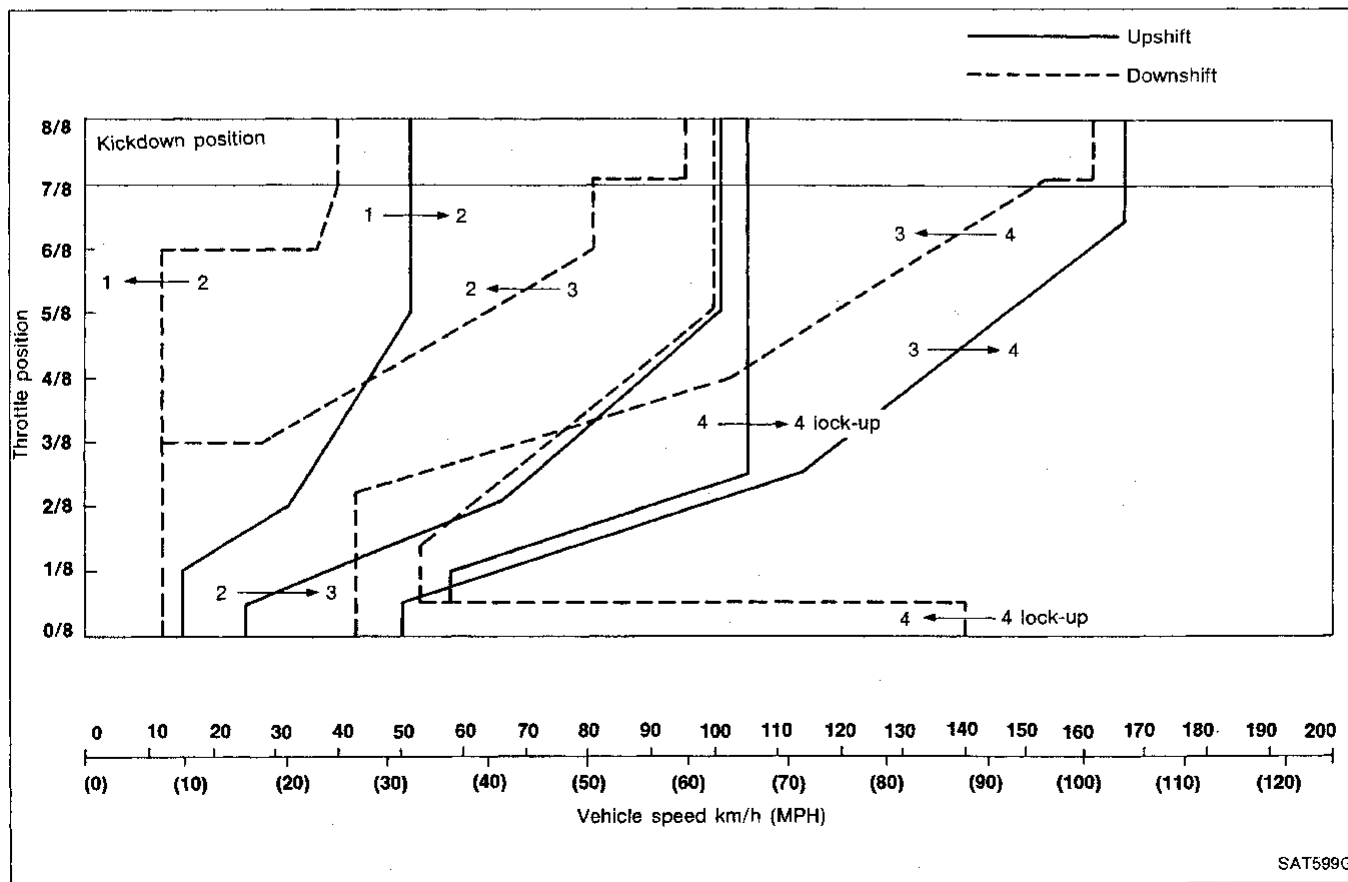

SAT599G

Preliminary Check (Cont'd)

Shift schedule (Standard pattern: OD OFF)

VG30E engine 4WD (Final drive gear ratio: 4.375)

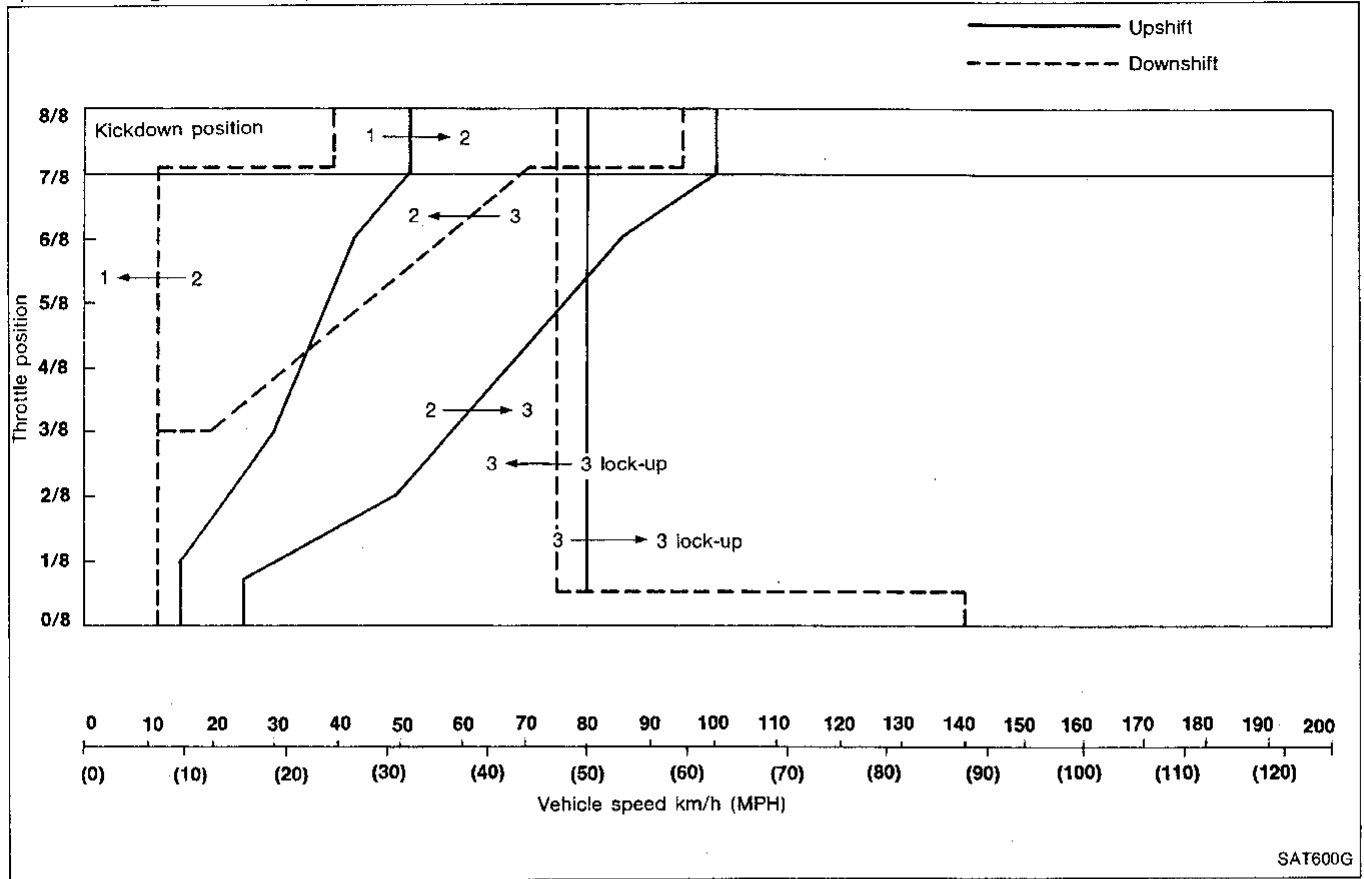

SAT600G

Shift schedule (Power pattern: OD OFF) / VG30E engine 4WD (Final drive gear ratio: 4.375)

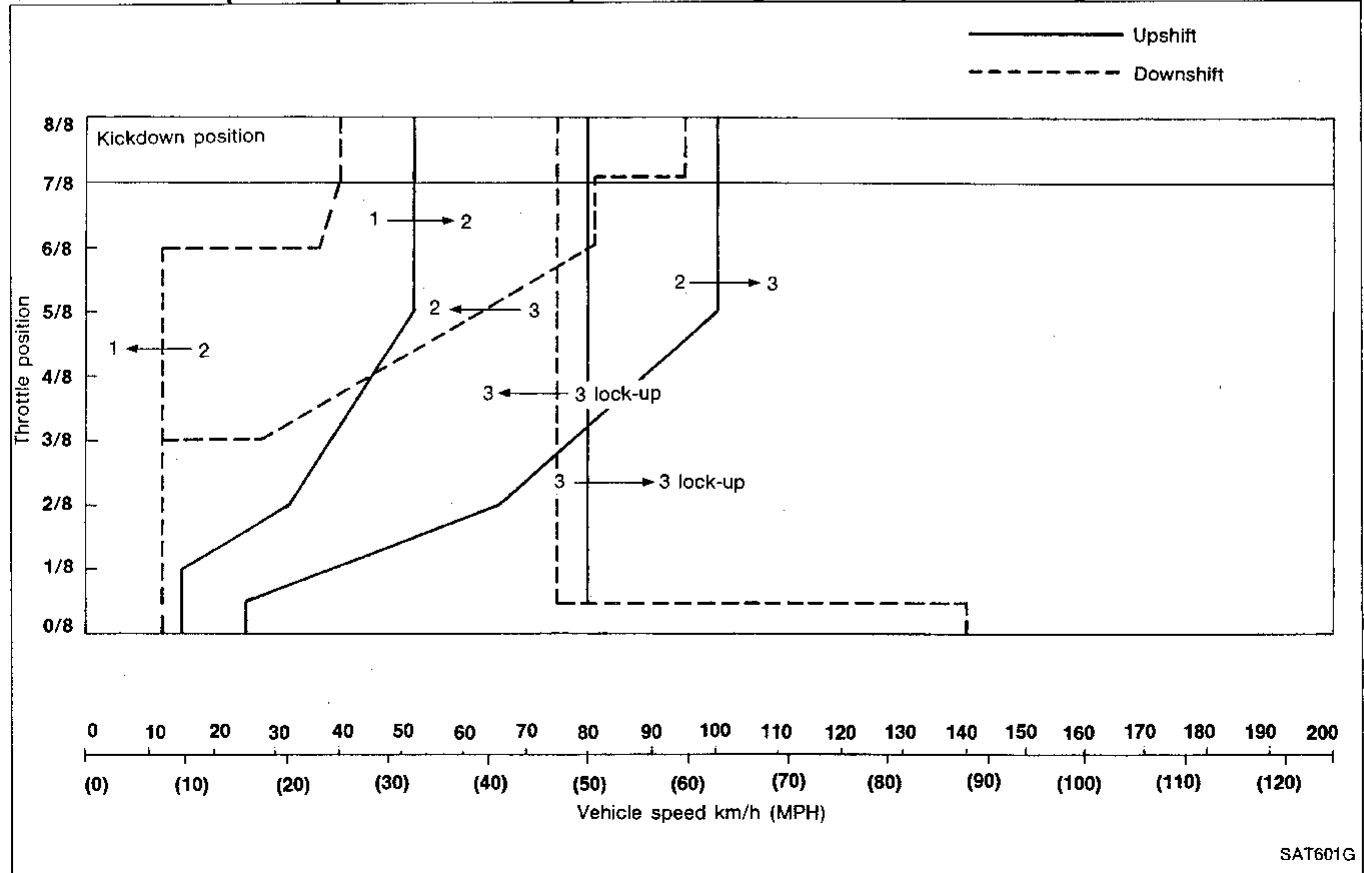

SAT601G

GI
MA
EM
LC
EF & EC
FE
CL
MT
AT
TF
PD
FA
RA
BR
ST
BF
HA
EL
IDX

Preliminary Check (Cont'd)

Shift schedule (Standard pattern: OD ON) / VG30E engine 4WD (Final drive gear ratio: 4.625)

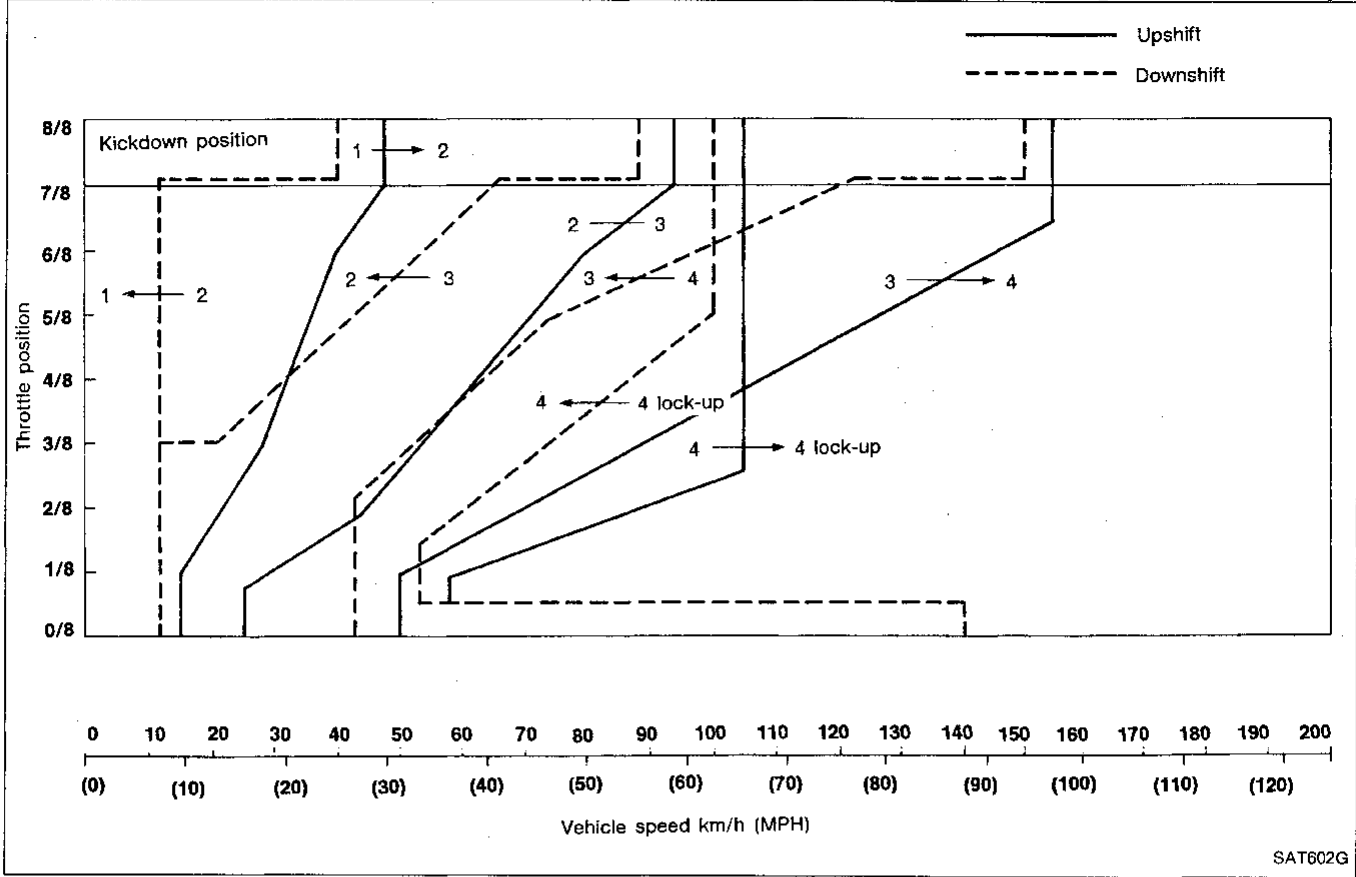

SAT602G

Shift schedule (Power pattern: OD ON) / VG30E engine 4WD (Final drive gear ratio: 4.625)

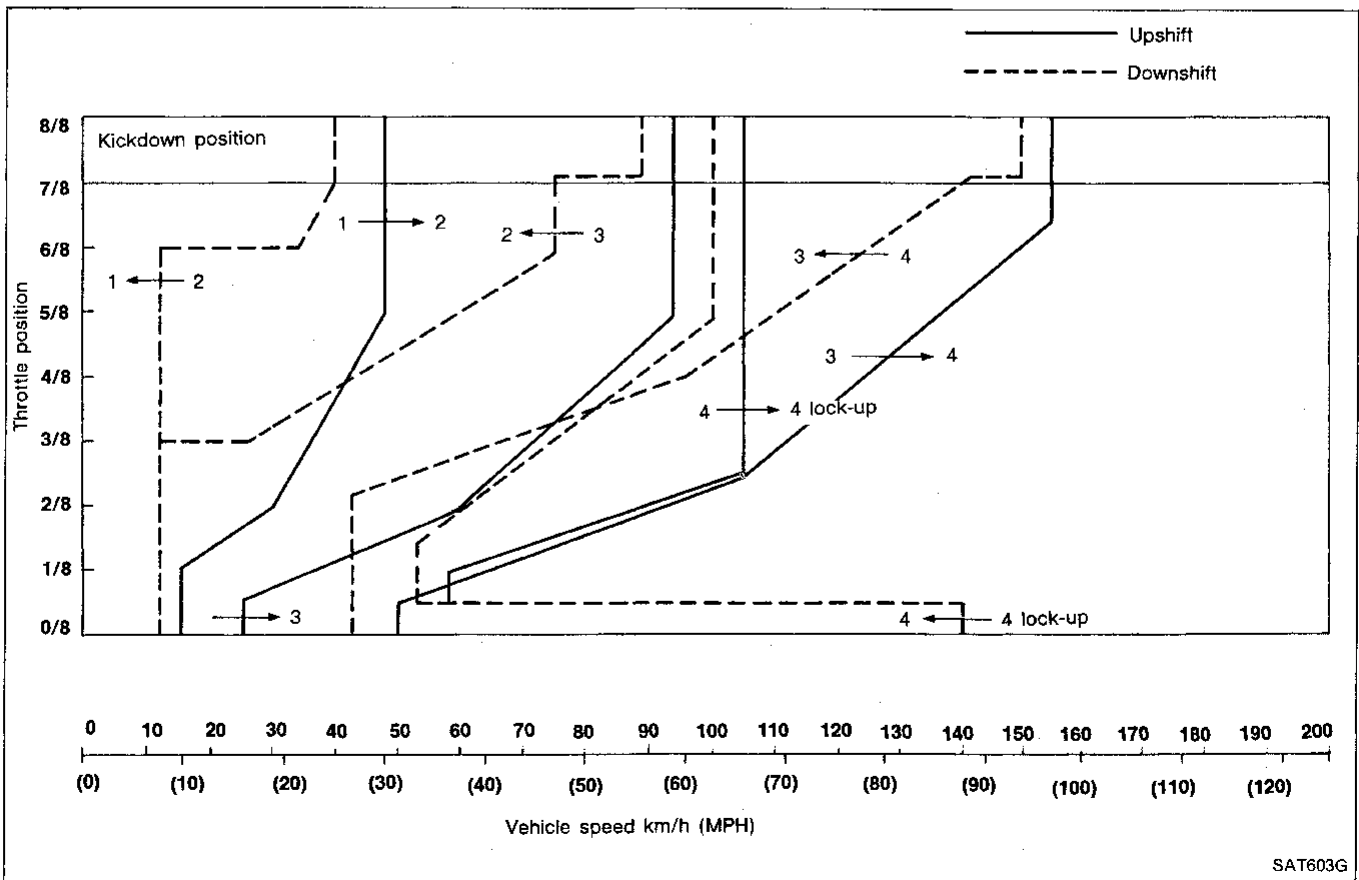

SAT603G

Preliminary Check (Cont'd)

Shift schedule (Standard pattern: OD OFF)

VG30E engine 4WD (Final drive gear ratio: 4.625)

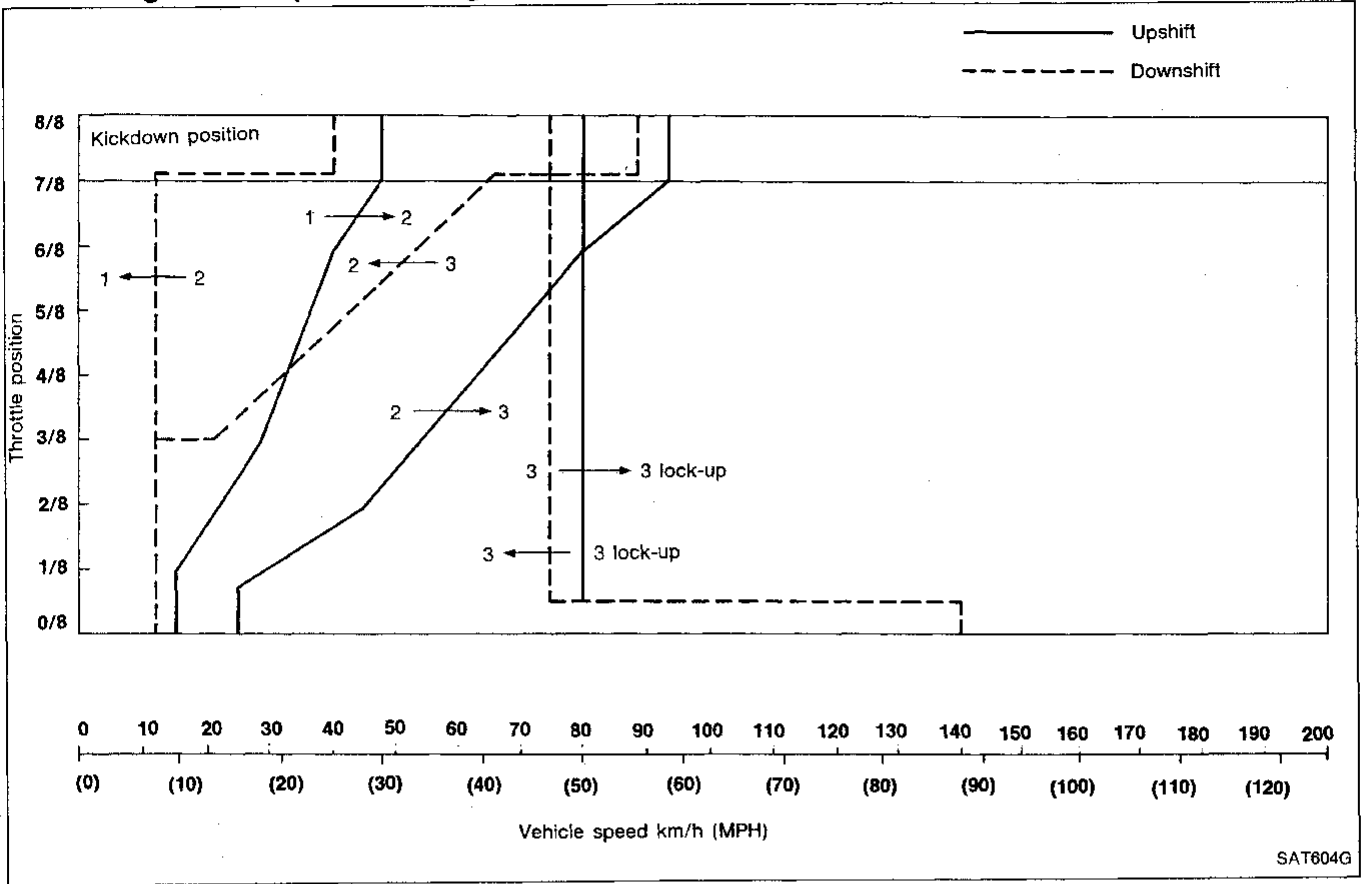

GI
MA
EM
LC
EF & EC
FE
CL
WT
AT

Shift schedule (Power pattern: OD OFF) / VG30E engine 4WD (Final drive gear ratio: 4.625)

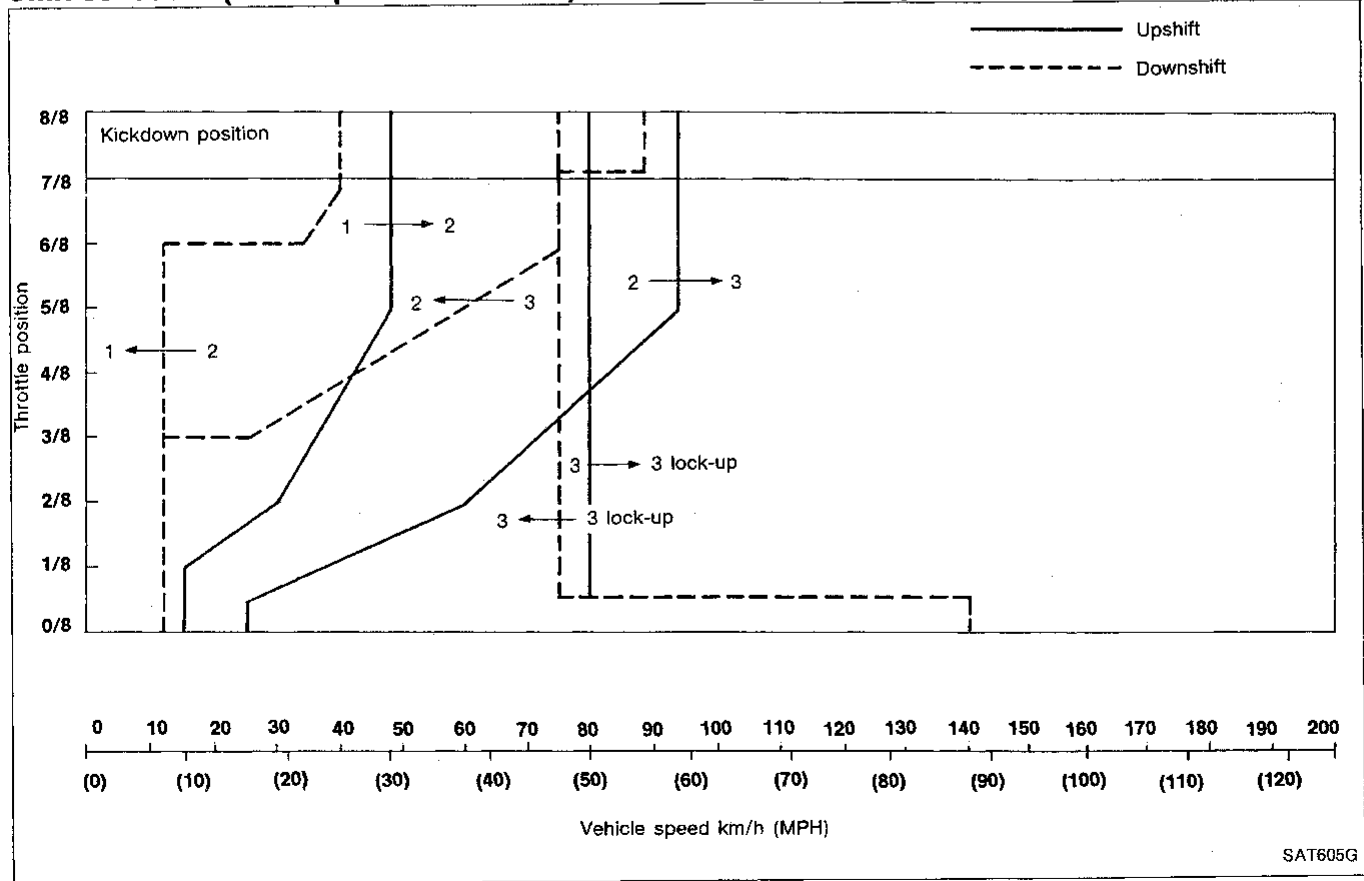

TF
PD
FA
RA
BR
ST
BF
HA
EL
IDX

Preliminary Check (Cont'd)

Shift schedule (Standard pattern: OD ON) / VG30E engine 2WD

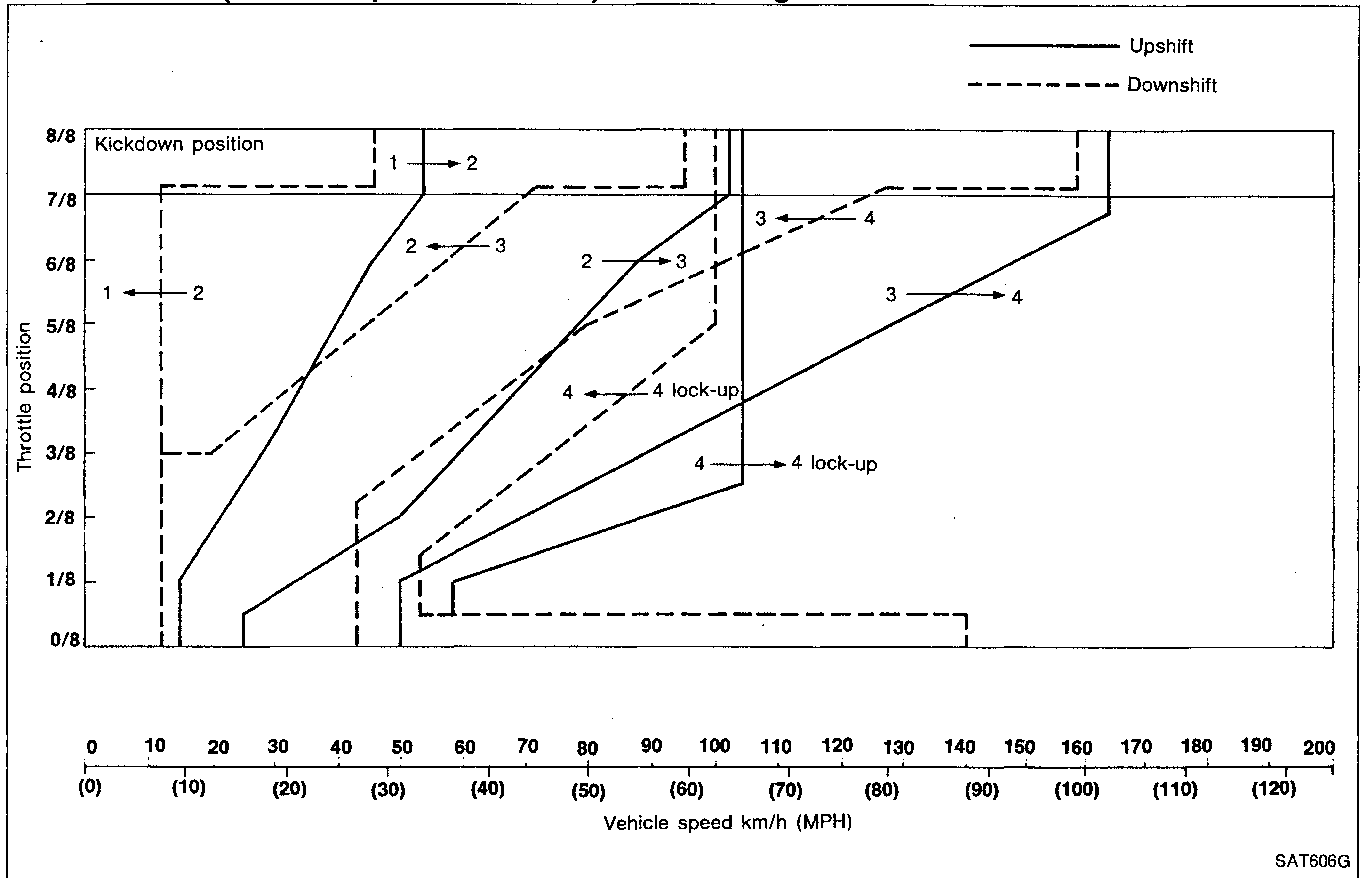

SAT606G

Shift schedule (Power pattern: OD ON) / VG30E engine 2WD

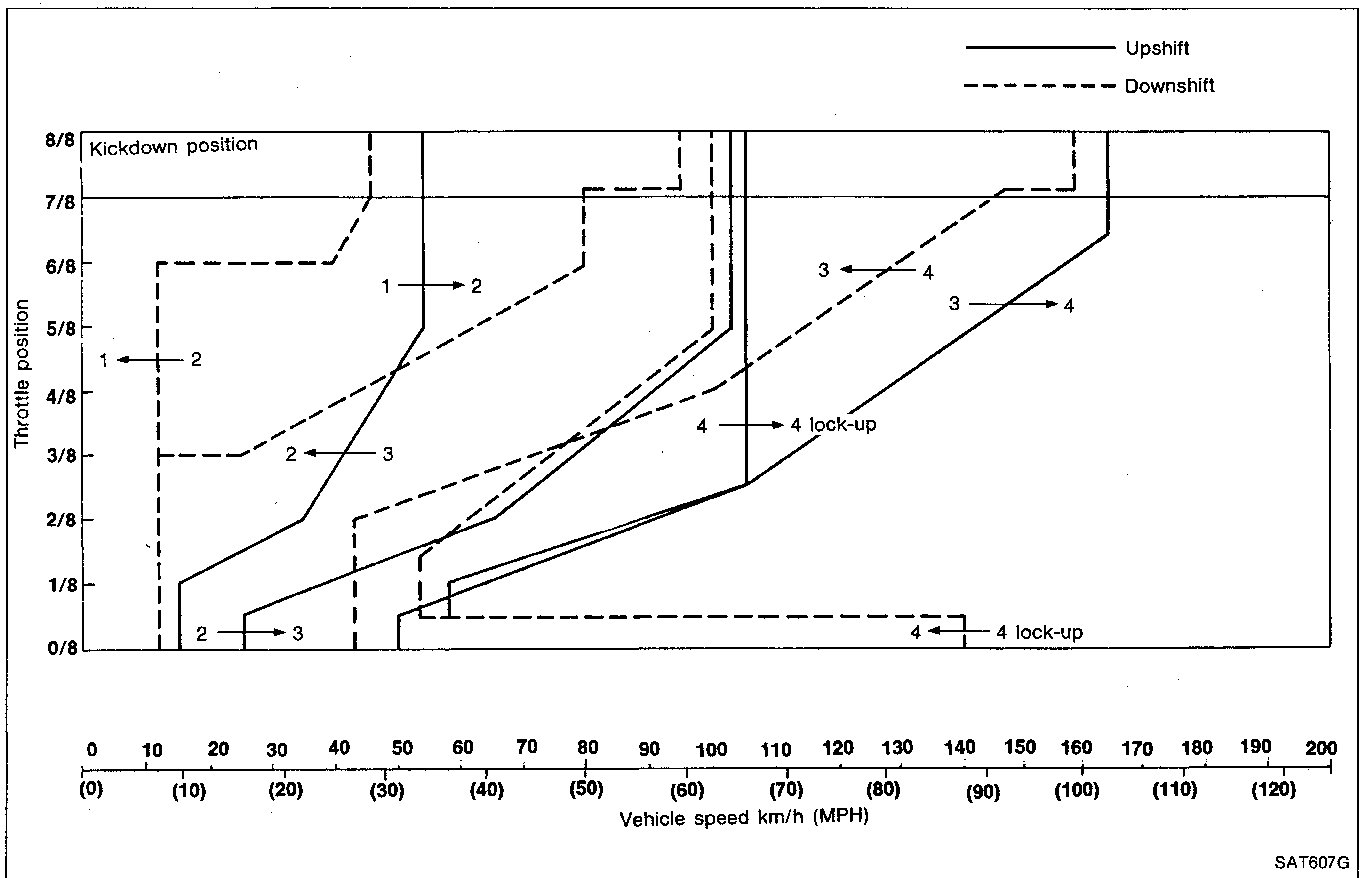

SAT607G

Preliminary Check (Cont'd)

Shift schedule (Standard pattern: OD OFF) / VG30E engine 2WD

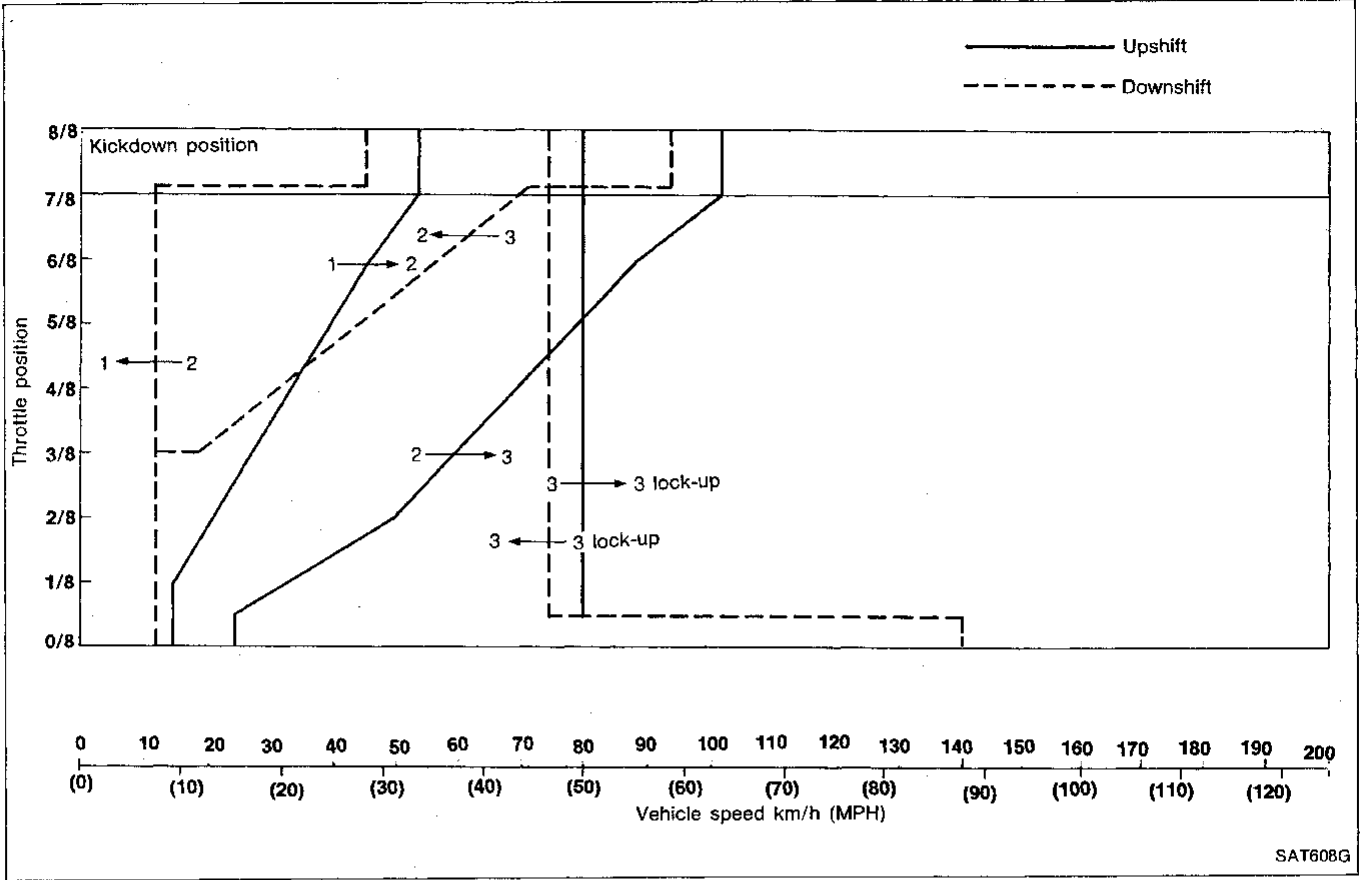

GI
MA
EM
LC
EF & EC
FE
CL
MT
AT

Shift schedule (Power pattern: OD OFF) / VG30E engine 2WD

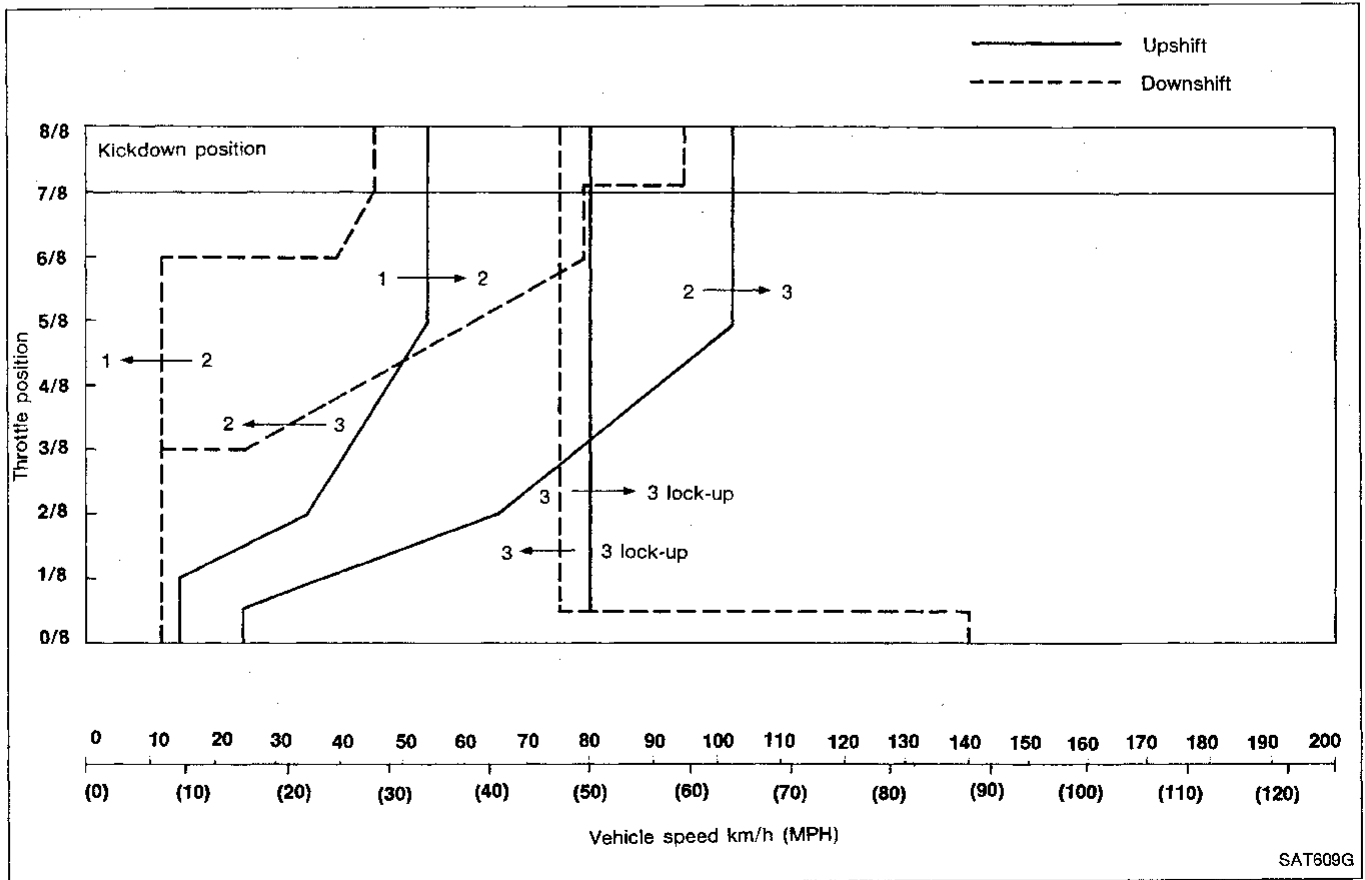

TF
PD
FA
RA
BR
ST
BF
HA
EL
IDX

A/T Electrical Parts Location

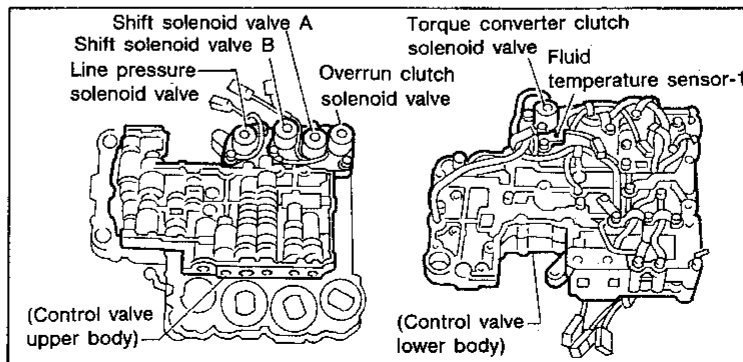
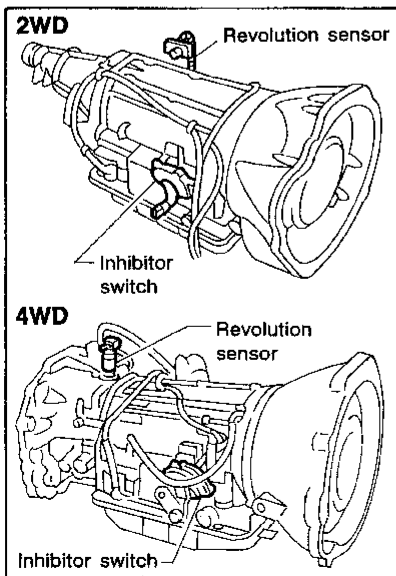
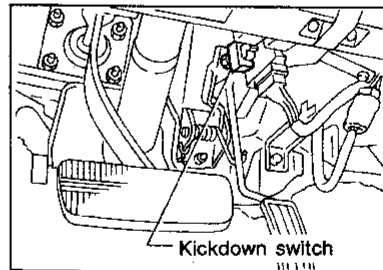
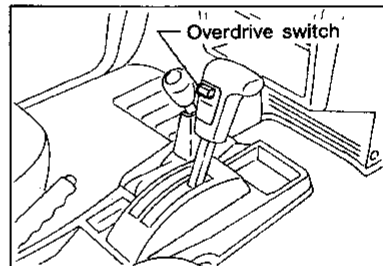
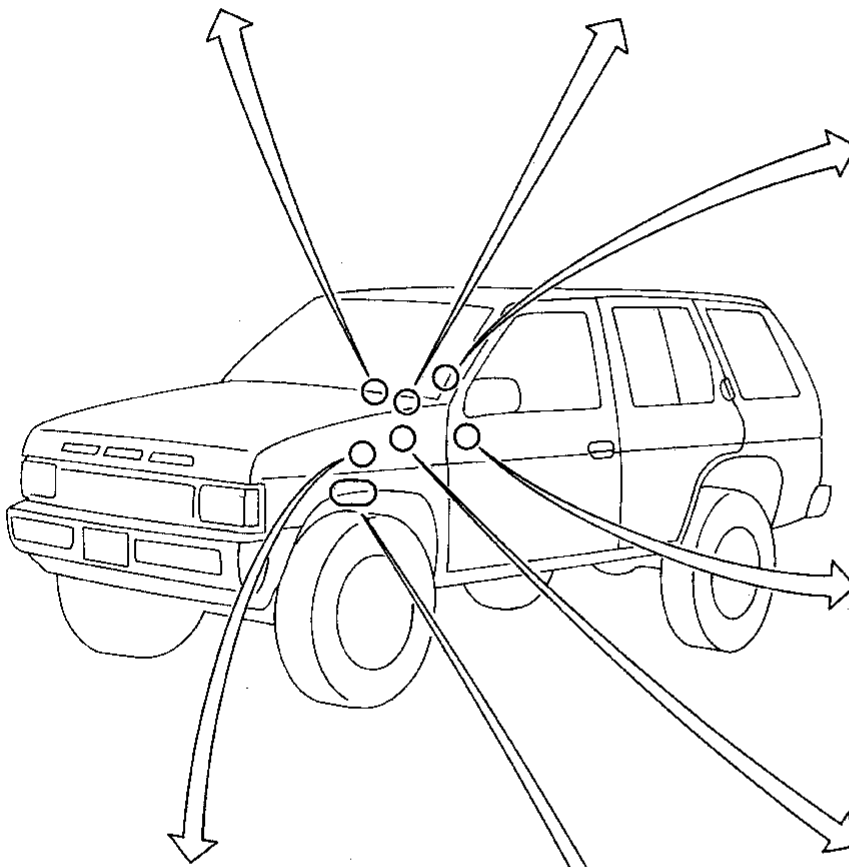
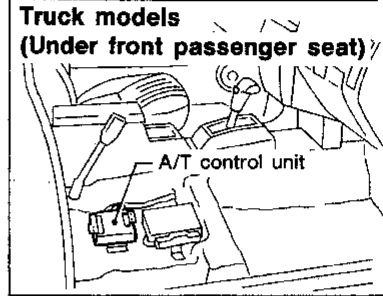
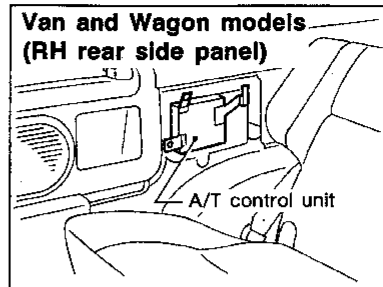
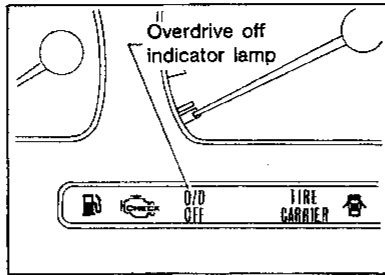
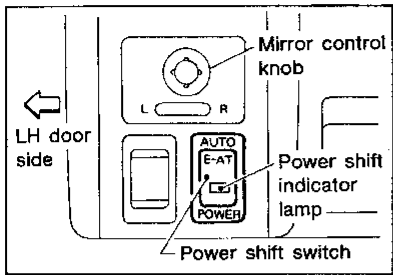

A/T Electrical Parts Location (Cont'd)

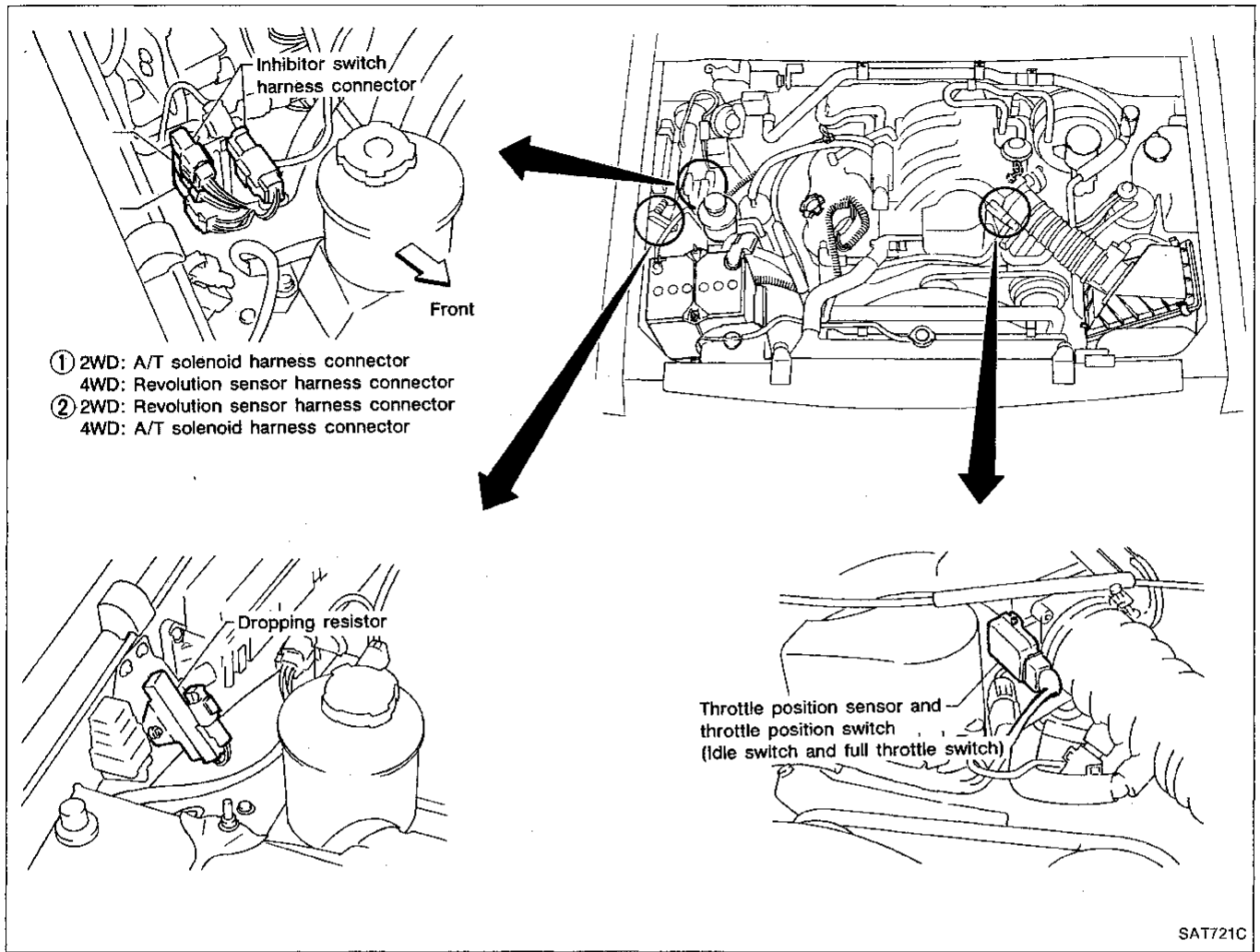

GI
 MA
 EM
 LC
 EF & EC
 FE
 CL
 MT
 AT
 FA
 RA
 BR
 ST
 BF
 HA
 EL
 IDX

Wiring Diagram

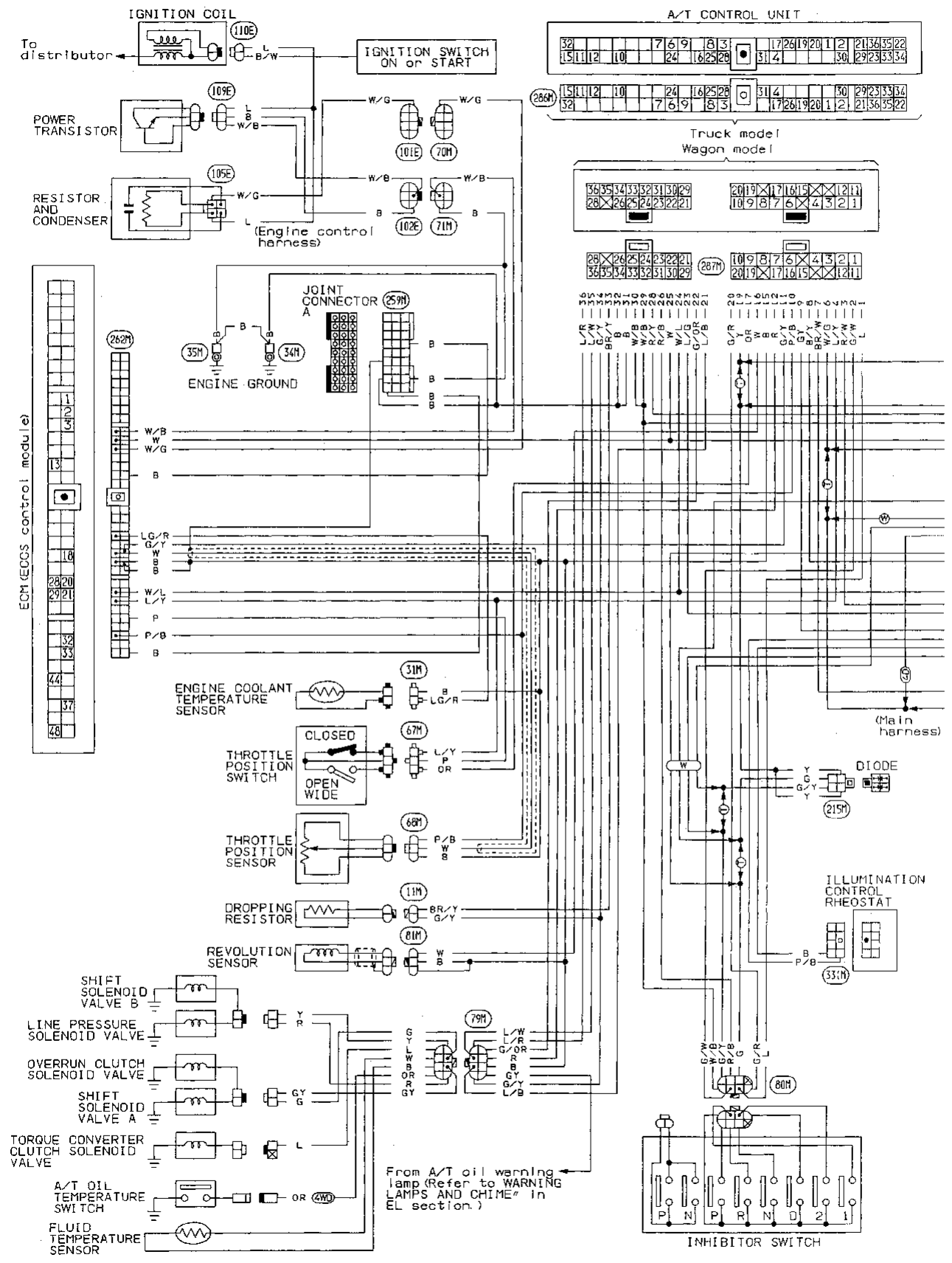

Wiring Diagram (Cont'd)

- (4WD): 4-wheel drive model (M): M/T model
- (W): Wagon model (4D): 4-door Wagon model
- (T): Truck model
- (A): A/T model

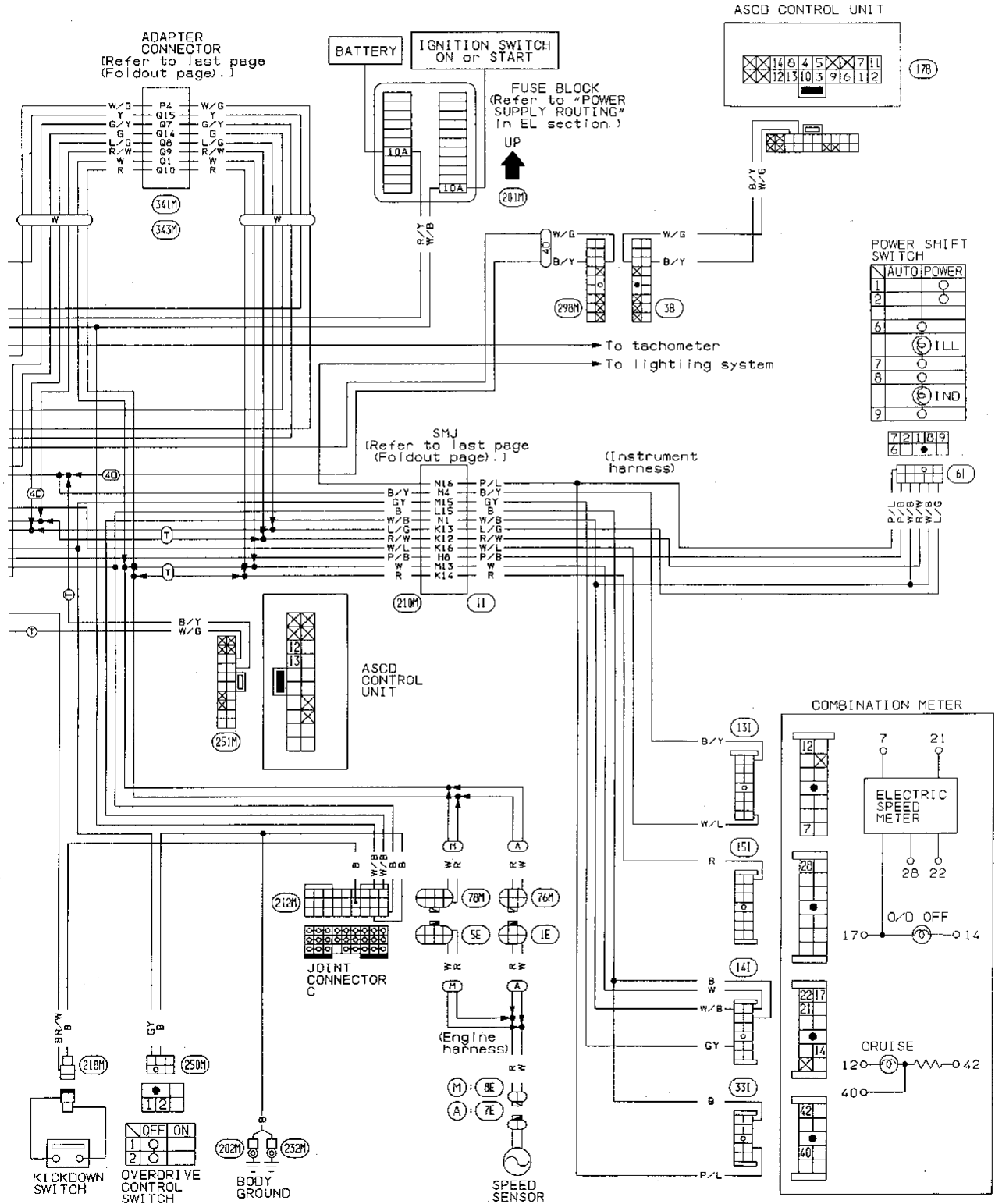

GI
MA
EM
LC
EF & EC
FE
CL
MT
AT
TF
PD
FA
RA
BR
ST
BF
HA
EL

Circuit Diagram for Quick Pinpoint Check

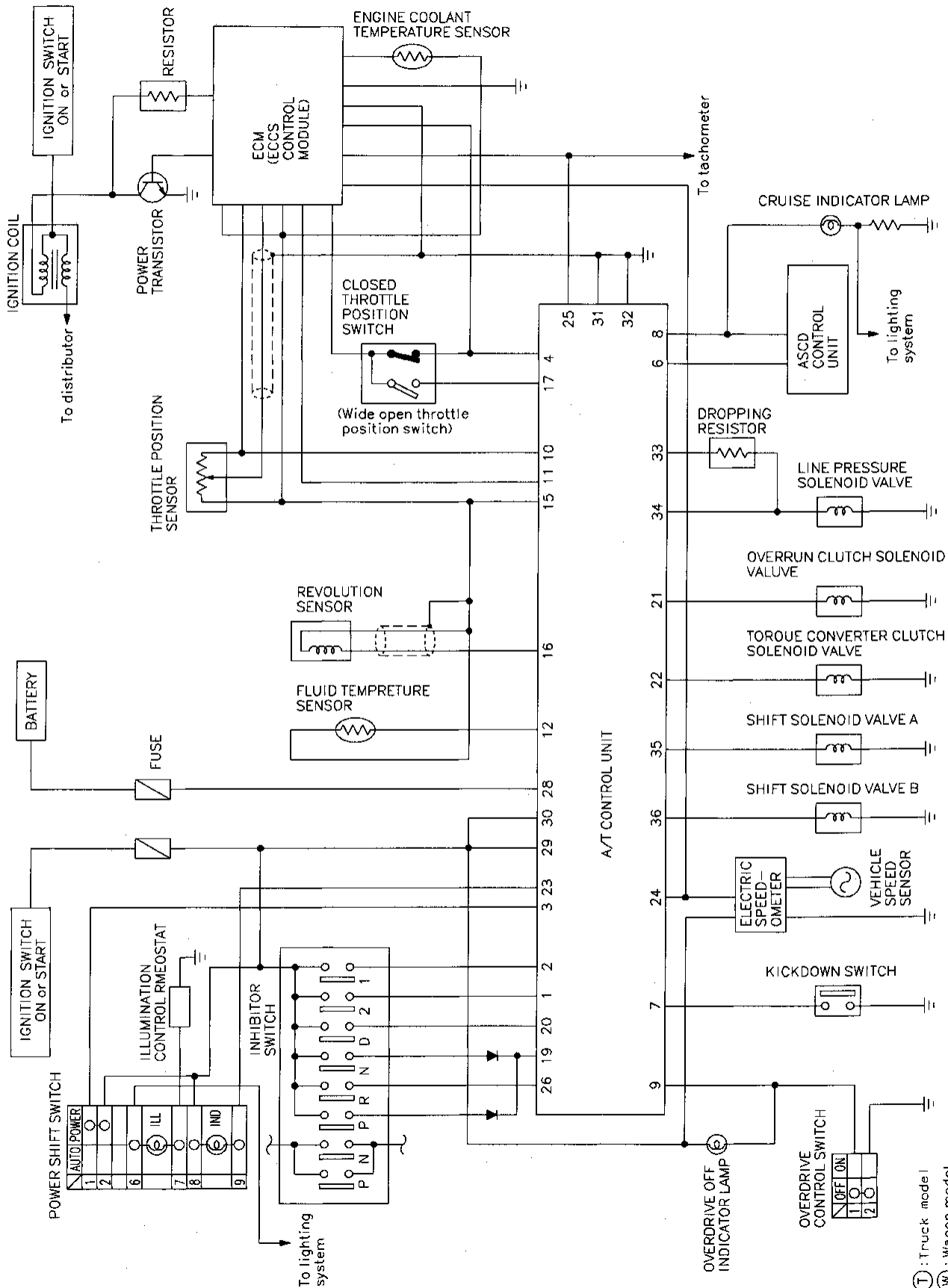

Self-diagnosis

SELF-DIAGNOSTIC PROCEDURE

DIAGNOSIS START

1. Start engine and warm it up to normal engine operating temperature.
2. Turn ignition switch to "OFF" position.
3. Set power shift switch to "AUTO" position.
- 1** 4. Set overdrive switch to "ON" position.
- 2** 5. Move selector lever to "P" position.
6. Turn ignition switch to "ON" position. (Do not start engine.)
- 3** 7. Does power shift indicator lamp come on for about 2 seconds?

No
Go to Diagnostic Procedure 1 (AT-53).

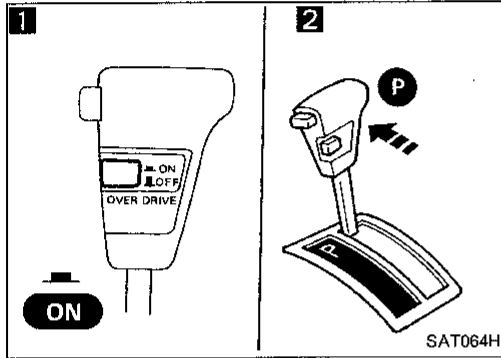

Yes

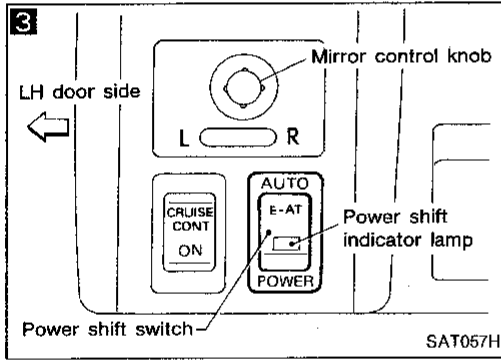

1. Turn ignition switch to "ACC" position.
2. Move selector lever to "D" position.
3. Set overdrive switch to "OFF" position.
4. Turn ignition switch to "ON" position. (Do not start engine.)
- Wait for more than 2 seconds after ignition switch "ON".
5. Move selector lever to "2" position.
6. Set overdrive switch to "ON" position.
- 4** 7. Move selector lever to "1" position.
- 5** 8. Set overdrive switch to "OFF" position.
- 6** 9. Depress accelerator pedal fully and release it.
10. Check power shift indicator lamp. Refer to JUDGEMENT OF SELF-DIAGNOSIS CODE on next page.

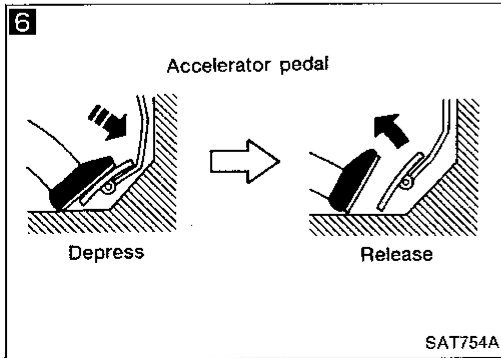
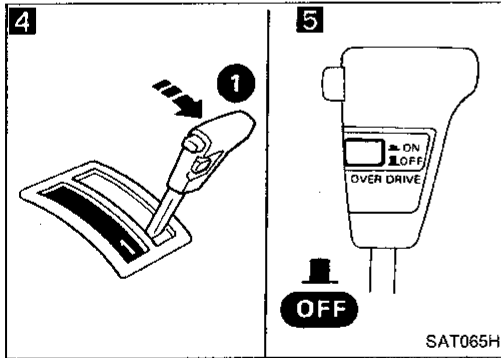

DIAGNOSIS END

GI
MA
EM
LC
EF & EC
FE
CL
MT
AT
TF
PD
FA
RA
BR
ST
BF
HA
EL
IDX

Self-diagnosis (Cont'd)

JUDGEMENT OF SELF-DIAGNOSIS CODE

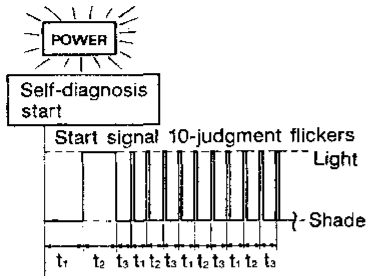
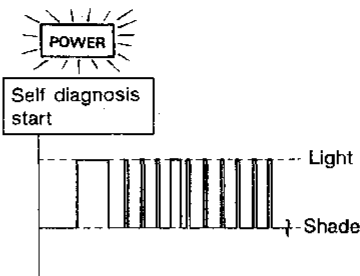
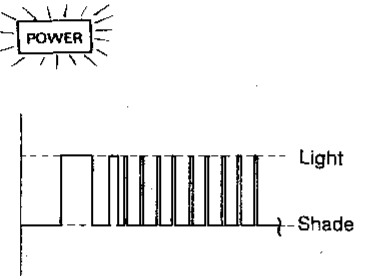
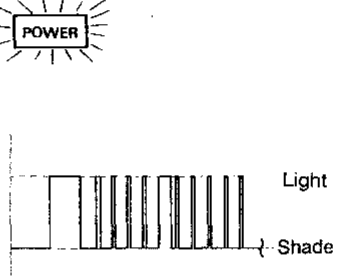
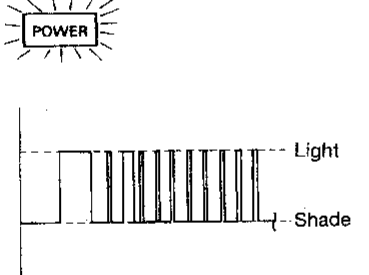
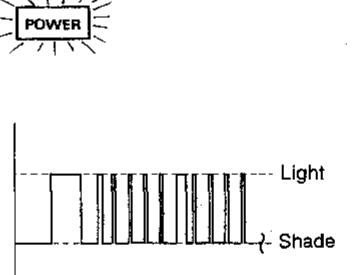
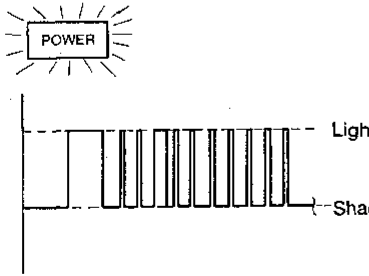
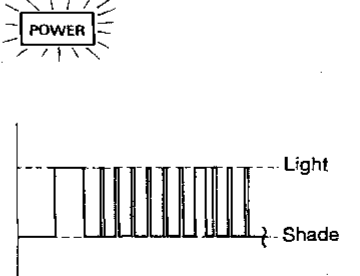
Power shift indicator lamp:	Power shift indicator lamp:
<p>All judgement flickers are same.</p>  <p>SAT162G</p> <p>All circuits that can be confirmed by self-diagnosis are OK.</p>	<p>4th judgement flicker is longer than others.</p>  <p>SAT166G</p> <p>Shift solenoid valve A circuit is short-circuited or disconnected. Go to SHIFT SOLENOID VALVE A CIRCUIT CHECK.</p>
<p>1st judgement flicker is longer than others.</p>  <p>SAT163G</p> <p>Revolution sensor circuit is short-circuited or disconnected. Go to REVOLUTION SENSOR CIRCUIT CHECK.</p>	<p>5th judgement flicker is longer than others.</p>  <p>SAT167G</p> <p>Shift solenoid valve B circuit is short-circuited or disconnected. Go to SHIFT SOLENOID VALVE B CIRCUIT CHECK.</p>
<p>2nd judgement flicker is longer than others.</p>  <p>SAT164G</p> <p>Vehicle speed sensor circuit is short-circuited or disconnected. Go to VEHICLE SPEED SENSOR CIRCUIT CHECK.</p>	<p>6th judgement flicker is longer than others.</p>  <p>SAT168G</p> <p>Overrun clutch solenoid valve circuit is short-circuited or disconnected. Go to OVERRUN CLUTCH SOLENOID VALVE CIRCUIT CHECK.</p>
<p>3rd judgement flicker is longer than others.</p>  <p>SAT165G</p> <p>Throttle position sensor circuit is short-circuited or disconnected. Go to THROTTLE POSITION SENSOR CIRCUIT CHECK.</p>	<p>7th judgement flicker is longer than others.</p>  <p>SAT169G</p> <p>Torque converter clutch solenoid valve circuit is short-circuited or disconnected. Go to TORQUE CONVERTER CLUTCH SOLENOID VALVE CIRCUIT CHECK.</p>

t₁ = 2.5 seconds t₂ = 2.0 seconds t₃ = 1.0 second

Self-diagnosis (Cont'd)

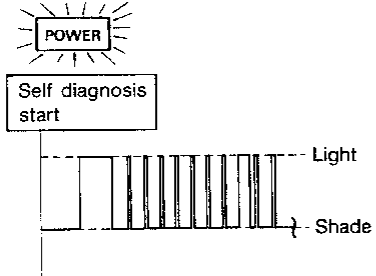
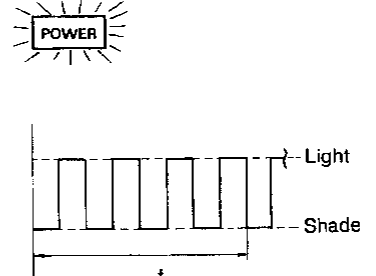
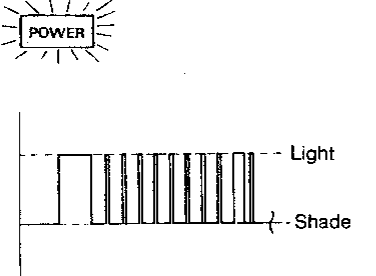
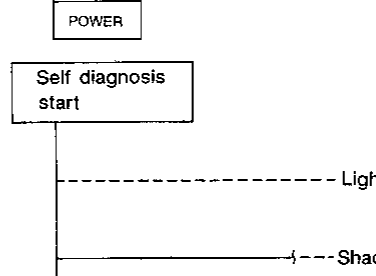
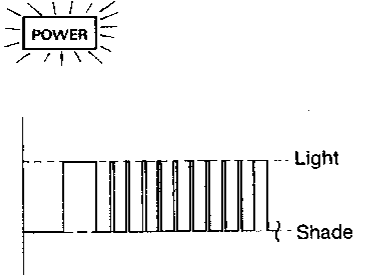
Power shift indicator lamp:	Power shift indicator lamp:
<p>8th judgement flicker is longer than others.</p>  <p>SAT170G</p> <p>Fluid temperature sensor is disconnected or A/T control unit power source circuit is damaged. Go to FLUID TEMPERATURE SENSOR CIRCUIT AND A/T CONTROL UNIT POWER SOURCE CIRCUIT CHECK.</p>	<p>Flickers as shown below.</p>  <p>SAT173G</p> <p>Battery power is low. Battery has been disconnected for a long time. Battery is connected conversely. (When reconnecting A/T control unit connectors. — This is not a problem.)</p>
<p>9th judgement flicker is longer than others.</p>  <p>SAT171G</p> <p>Engine speed signal circuit is short-circuited or disconnected. Go to ENGINE SPEED SIGNAL CIRCUIT CHECK.</p>	<p>Comes on continuously.</p>  <p>SAT286G</p> <p>Inhibitor switch, overdrive switch, kickdown switch or idle switch circuit is disconnected or A/T control unit is damaged. Go to INHIBITOR, OVERDRIVE, KICKDOWN AND IDLE SWITCH CIRCUIT CHECKS.</p>
<p>10th judgement flicker is longer than others.</p>  <p>SAT172G</p> <p>Line pressure solenoid valve circuit is short-circuited or disconnected. Go to LINE PRESSURE SOLENOID CIRCUIT CHECK.</p>	

t₄ = 1.0 second

GI
MA
EM
LC
EF & EC
FE
CL
WT
AT
TF
PD
FA
RA
BR
ST
BF
HA
EL
IDX

Self-diagnosis (Cont'd)

REVOLUTION SENSOR CIRCUIT CHECK

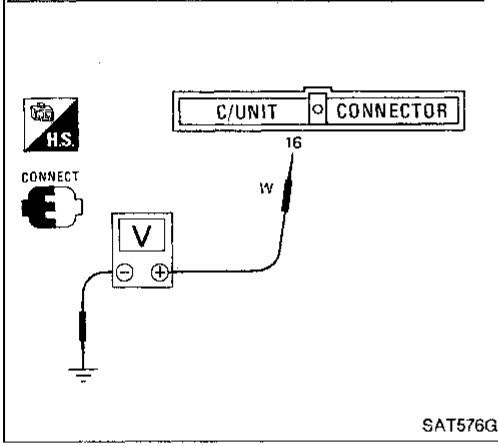
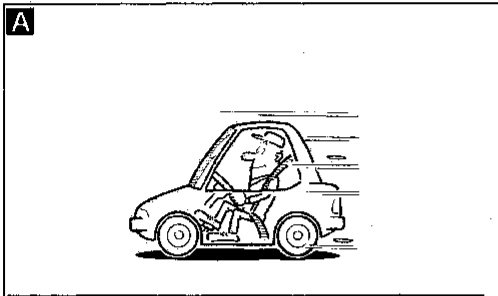
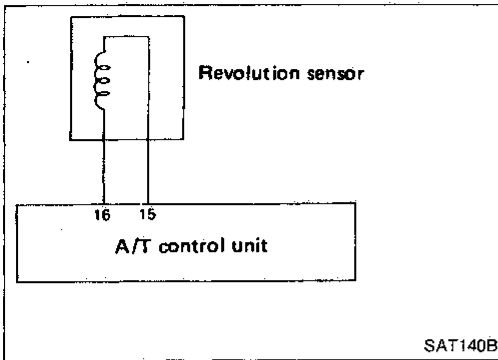

CHECK REVOLUTION SENSOR. — Refer to "Electrical Components Inspection" (AT-68).

NG → Repair or replace revolution sensor.

OK ↓

A

CHECK INPUT SIGNAL.

1. Turn ignition switch to "START" position and start engine.
2. Check voltage between A/T control unit terminal ⑯ and ground while driving. (Measure with AC range.)

Voltage:
 At 0 km/h (0 MPH): 0V
 At 30 km/h (19 MPH): 1V or more
 (Voltage rises gradually in response to vehicle speed)

NG → Check the following items.

- Harness continuity between A/T control unit and revolution sensor (Main harness)
- Harness continuity between revolution sensor and ECM (Main harness)
- Ground circuit for ECM — Refer to section EF & EC.

OK ↓

Perform self-diagnosis again after driving for a while.

NG →

1. Perform A/T control unit input/output signal inspection.
2. If NG, recheck A/T control unit pin terminals for damage or connection of A/T control unit harness connector.

OK ↓

INSPECTION END

VEHICLE SPEED SENSOR CIRCUIT CHECK

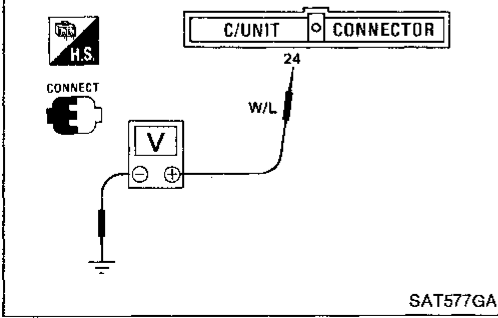
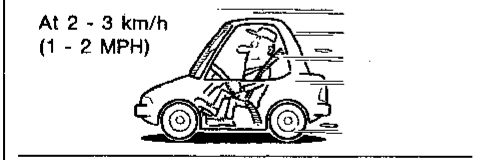
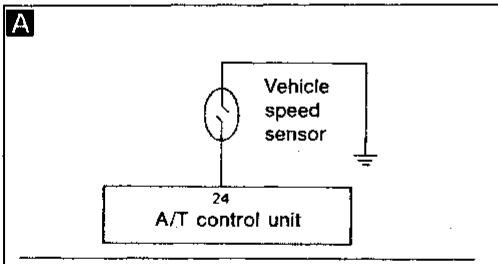

A

CHECK INPUT SIGNAL.

1. Turn ignition switch to "START" position and start engine.
2. Check voltage between A/T control unit terminal ⑳ and ground while driving at 2 to 3 km/h (1 to 2 MPH) for 1 m (3 ft) or more.

Voltage:
 Varies from 0V to 5V

NG → Check the following items.

- Vehicle speed sensor and ground circuit for vehicle speed sensor — Refer to section EL.
- Harness continuity between A/T control unit and vehicle speed sensor (Main harness)

OK ↓

Perform self-diagnosis again after driving for a while.

NG →

1. Perform A/T control unit input/output signal inspection.
2. If NG, recheck A/T control unit pin terminals for damage or connection of A/T control unit harness connector.

OK ↓

INSPECTION END

Self-diagnosis (Cont'd)

THROTTLE POSITION SENSOR CIRCUIT CHECK

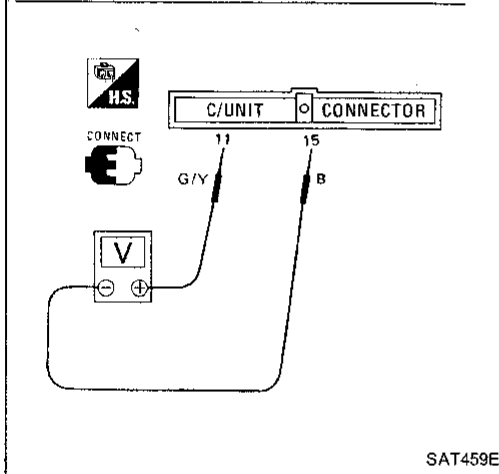
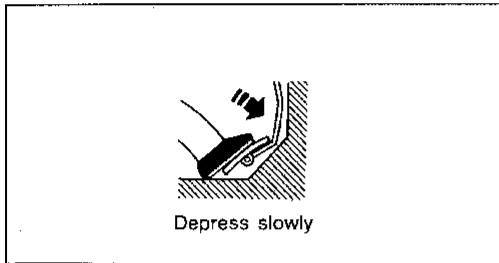
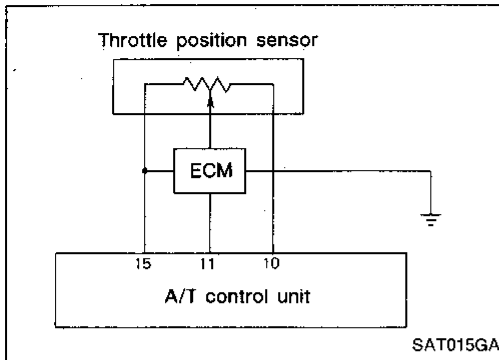

CHECK INPUT SIGNAL.

1. Turn ignition switch to "ON" position. (Do not start engine.)
2. Check voltage between A/T control unit terminal ⑪ and ⑮ while accelerator pedal is depressed slowly.

Voltage:

Fully-closed throttle:

0.2 - 0.6V

Fully-open throttle:

2.9 - 3.9V

(Voltage rises gradually in response to throttle valve opening.)

NG

Check harness continuity between ECM and A/T control unit regarding throttle position sensor circuit. (Main harness)

OK

Perform self-diagnosis again after driving for a while.

NG

1. Perform A/T control unit input/output signal inspection.
2. If NG, recheck A/T control unit pin terminals for damage or connection of A/T control unit harness connector.

OK

INSPECTION END

GI

MA

EM

LC

EF & EC

FE

CL

MT

AT

TF

PD

FA

RA

BR

ST

BF

HA

EL

IDX

Self-diagnosis (Cont'd)

SHIFT SOLENOID VALVE A CIRCUIT CHECK

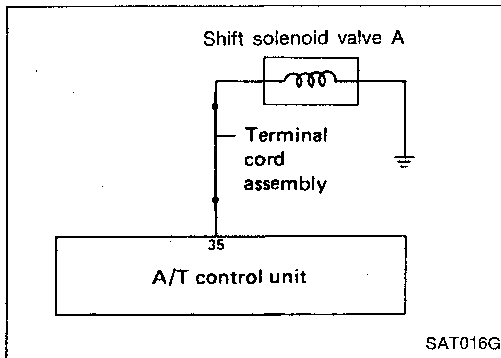

A

CHECK GROUND CIRCUIT.

1. Turn ignition switch to "OFF" position.
2. Disconnect terminal cord assembly connector in engine compartment.
3. Check resistance between terminal 35 and ground.

Resistance: 20 - 30Ω

NG

1. Remove control valve assembly. — Refer to "ON-VEHICLE SERVICE" (AT-106).
2. Check the following items.
 - Shift solenoid valve A — Refer to "Electrical Components Inspection" (AT-68).
 - Harness continuity of terminal cord assembly

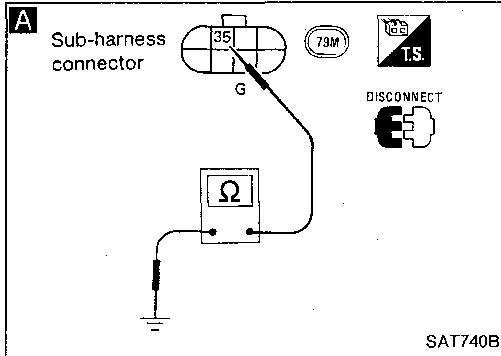

OK

B

CHECK POWER SOURCE CIRCUIT.

1. Turn ignition switch to "OFF" position.
2. Disconnect A/T control unit 16-pin connector.
3. Check resistance between terminal 35 and A/T control unit terminal 35.

Resistance: Approximately 0Ω

4. Reinstall any part removed.

NG

Repair or replace harness between A/T control unit and terminal cord assembly. (Main harness)

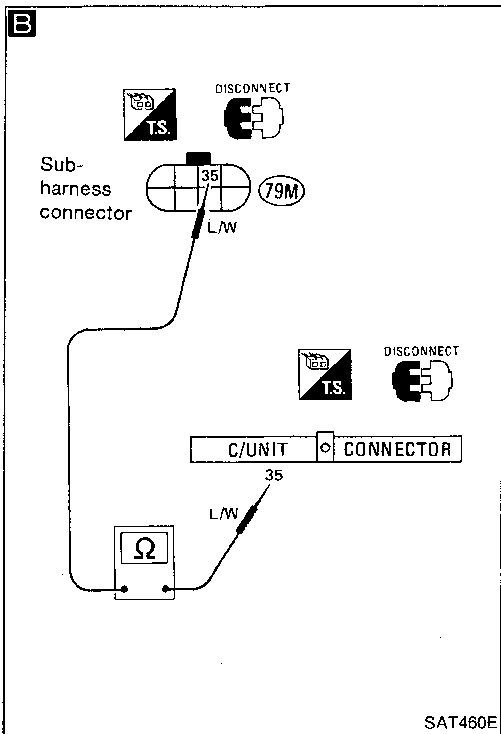

OK

Perform self-diagnosis after driving for a while.

NG

INSPECTION END

1. Perform A/T control unit input/output signal inspection.

2. If NG, recheck A/T control unit pin terminals for damage or connection of A/T control unit harness connector.

Self-diagnosis (Cont'd)

SHIFT SOLENOID VALVE B CIRCUIT CHECK

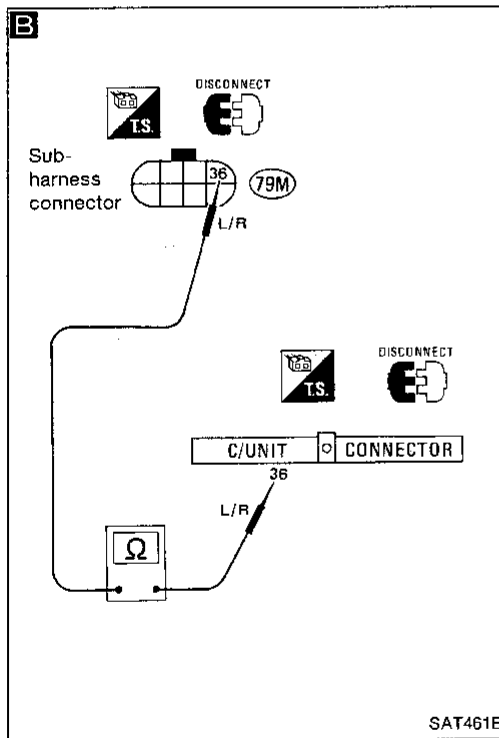
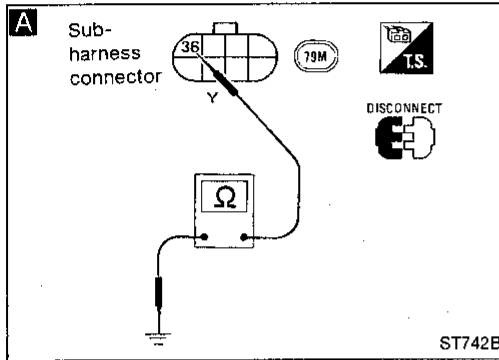
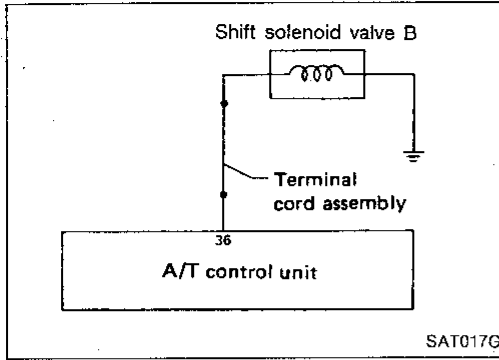

A

CHECK GROUND CIRCUIT.

1. Turn ignition switch to "OFF" position.
2. Disconnect terminal cord assembly connector in engine compartment.
3. Check resistance between terminal 36 and ground.

Resistance: 20 - 30Ω

NG → 1. Remove control valve assembly. — Refer to "ON-VEHICLE SERVICE" (AT-106).

2. Check the following items.

- Shift solenoid valve B — Refer to "Electrical Components Inspection" (AT-68).
- Harness continuity of terminal cord assembly

OK ↓

B

CHECK POWER SOURCE CIRCUIT.

1. Turn ignition switch to "OFF" position.
2. Disconnect A/T control unit 16-pin connector.
3. Check resistance between terminal 36 and A/T control unit terminal 36.

Resistance: Approximately 0Ω

NG → Repair or replace harness between A/T control unit and terminal cord assembly. (Main harness)

OK ↓

Perform self-diagnosis after driving for a while.

NG → 1. Perform A/T control unit input/output signal inspection.

2. If NG, recheck A/T control unit pin terminals for damage or connection of A/T control unit harness connector.

OK ↓

INSPECTION END

GI
MA
EM
LC
EF & EC
FE
CL
MT
AT
TF
PD
FA
RA
BR
ST
BF
HA
EL
IDX

Self-diagnosis (Cont'd)

OVERRUN CLUTCH SOLENOID VALVE CIRCUIT CHECK

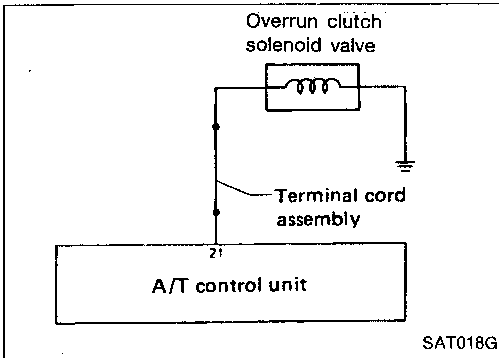

A

CHECK GROUND CIRCUIT.

1. Turn ignition switch to "OFF" position.
2. Disconnect terminal cord assembly connector in engine compartment.
3. Check resistance between terminal ②1 and ground.

Resistance: 20 - 30Ω

NG →

1. Remove control valve assembly. — Refer to "ON-VEHICLE SERVICE" (AT-106).
2. Check the following items.
 - Overrun clutch solenoid valve. — Refer to "Electrical Components Inspection" (AT-68).
 - Harness continuity of terminal cord assembly

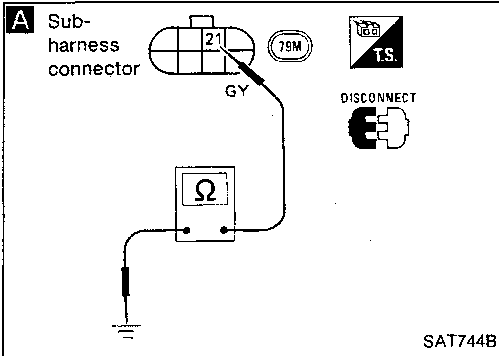

OK ↓

B

CHECK POWER SOURCE CIRCUIT.

1. Turn ignition switch to "OFF" position.
2. Disconnect A/T control unit 16-pin connector.
3. Check resistance between terminal ②1 and A/T control unit terminal ②1.

Resistance: Approximately 0Ω

4. Reinstall any part removed.

NG →

Repair or replace harness between A/T control unit and terminal cord assembly. (Main harness)

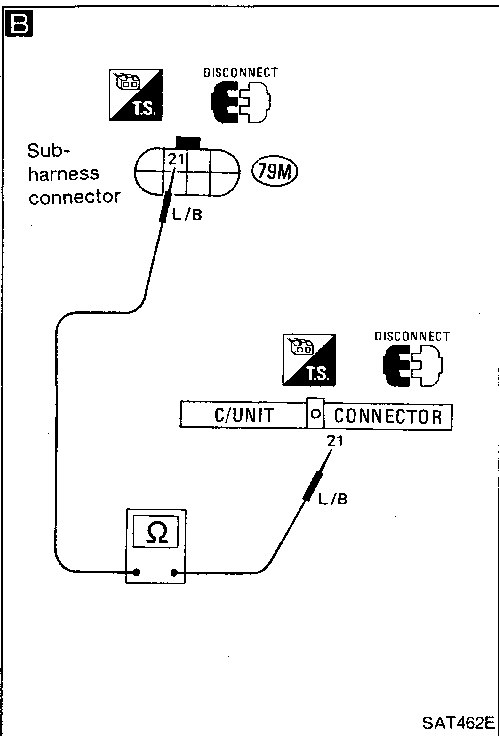

OK ↓

Perform self-diagnosis after driving for a while.

OK ↓

INSPECTION END

NG →

1. Perform A/T control unit input/output signal inspection.
2. If NG, recheck A/T control unit pin terminals for damage or connection of A/T control unit harness connector.

Self-diagnosis (Cont'd)

TORQUE CONVERTER CLUTCH SOLENOID VALVE CIRCUIT CHECK

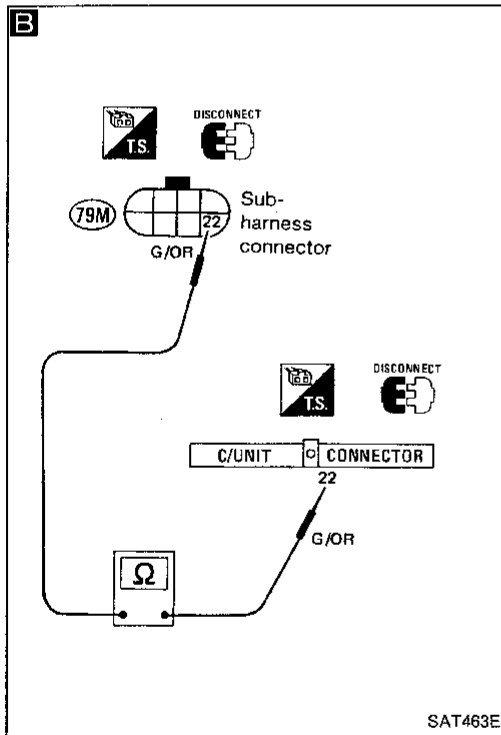
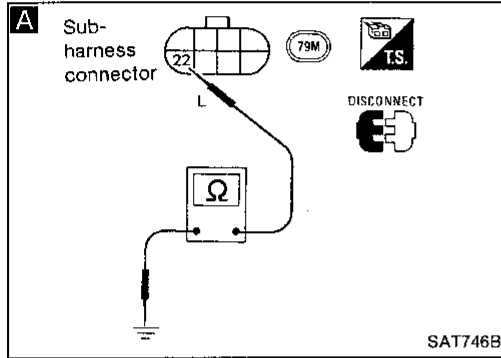
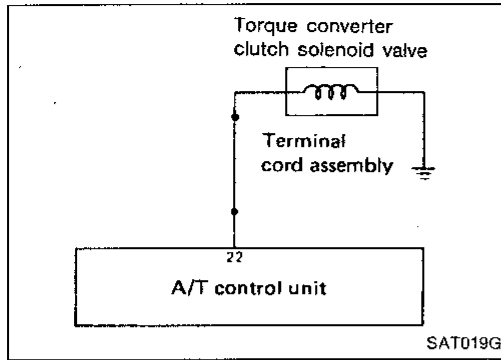

A

CHECK GROUND CIRCUIT.

1. Turn ignition switch to "OFF" position.
2. Disconnect terminal cord assembly connector in engine compartment.
3. Check resistance between terminal 22 and ground.

Resistance: 2.5 - 5Ω

NG

1. Remove oil pan. — Refer to "ON-VEHICLE SERVICE" (AT-106).
2. Check the following items.
 - Torque converter clutch solenoid valve — Refer to "Electrical Components Inspection" (AT-68).
 - Harness continuity of terminal cord assembly

OK

B

CHECK POWER SOURCE CIRCUIT.

1. Turn ignition switch to "OFF" position.
2. Disconnect A/T control unit 16-pin connector.
3. Check resistance between terminal 22 and A/T control unit terminal 22.

Resistance: Approximately 0Ω

4. Reinstall any part removed.

NG

Repair or replace harness between A/T control unit and terminal cord assembly. (Main harness)

OK

Perform self-diagnosis after driving for a while.

OK

INSPECTION END

NG

1. Perform A/T control unit input/output signal inspection.
2. If NG, recheck A/T control unit pin terminals for damage or connection of A/T control unit harness connector.

GE
MA
EM
LC
EF & EC
FE
CL
MT
AT
TF
PD
FA
RA
BR
ST
BF
HA
EL
IDX

Self-diagnosis (Cont'd)

FLUID TEMPERATURE SENSOR CIRCUIT AND A/T CONTROL UNIT POWER SOURCE CIRCUIT CHECKS

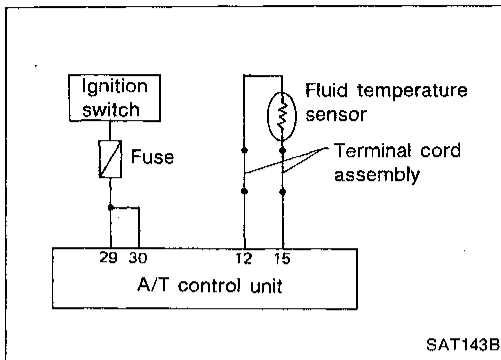

A
CHECK A/T CONTROL UNIT POWER SOURCE.
 1. Turn ignition switch to "ON" position. (Do not start engine.)
 2. Check voltage between A/T control unit terminals 29, 30 and ground.
Battery voltage should exist.

NG → Check the following items.
 ● Harness continuity between ignition switch and A/T control unit (Main harness)
 ● Ignition switch and fuse — Refer to section EL.

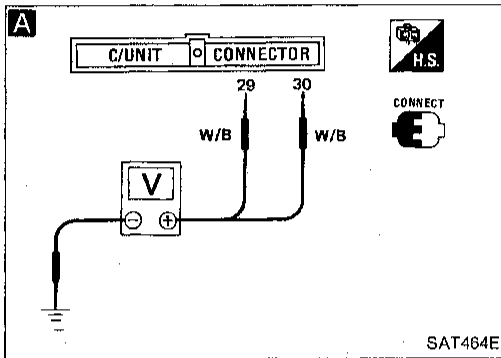

B
CHECK FLUID TEMPERATURE SENSOR WITH TERMINAL CORD ASSEMBLY.
 1. Turn ignition switch to "OFF" position.
 2. Disconnect terminal cord assembly connector in engine compartment.
 3. Check resistance between terminals 12 and 15 when A/T is cold.
Resistance:
 Cold [20°C (68°F)]
 Approximately 2.5 kΩ
 4. Reinstall any part removed.

NG → 1. Remove oil pan.
 2. Check the following items.
 ● Fluid temperature sensor — Refer to "Electrical Components Inspection" (AT-68).
 ● Harness continuity of terminal cord assembly

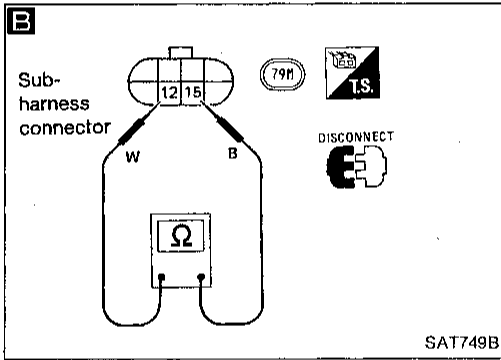

C
CHECK INPUT SIGNAL OF FLUID TEMPERATURE SENSOR.
 1. Turn ignition switch to "ON" position and start engine.
 2. Check voltage between A/T control unit terminal 12 and ground while warming up A/T.
Voltage:
 Cold [20°C (68°F)] →
 Hot [80°C (176°F)]:
 1.56V → 0.45V

NG → Check the following items.
 ● Harness continuity between A/T control unit and terminal cord assembly (Main harness)

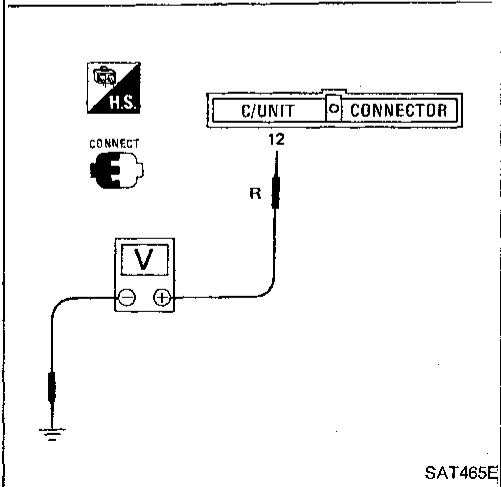
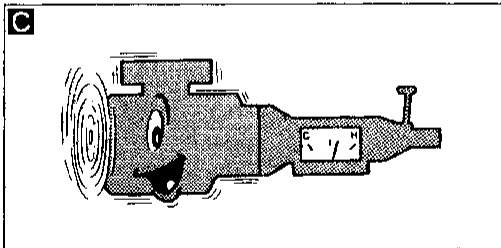

Perform self-diagnosis after driving for a while.

NG → 1. Perform A/T control unit input/output signal inspection.
 2. If NG, recheck A/T control unit pin terminals for damage or connection of A/T control unit harness connector.

OK →
INSPECTION END

Self-diagnosis (Cont'd)

ENGINE SPEED SIGNAL CIRCUIT CHECK

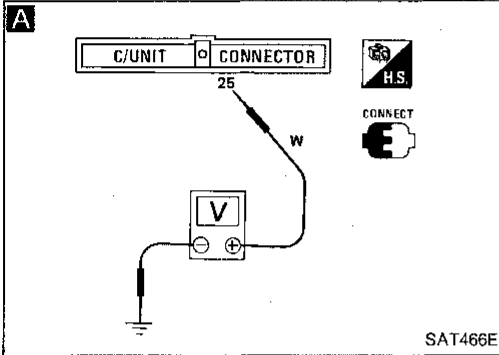
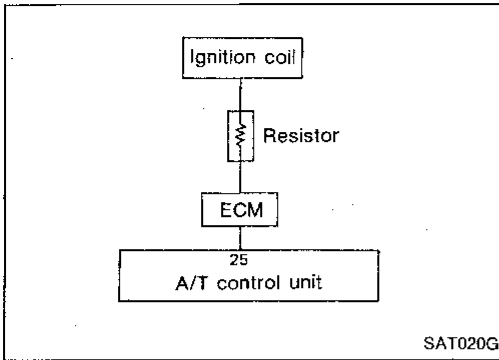

```

    graph TD
      Start[Perform self-diagnosis for engine control. Check ignition signal circuit condition.] -- NG --> NG1[Check ignition signal circuit for engine control. — Refer to section EF & EC.]
      Start -- OK --> A[A]
      A[CHECK INPUT SIGNAL.  
1. Turn ignition switch to "ON" position. (Do not start engine.)  
2. Check voltage between A/T control unit terminal 25 and ground.  
Voltage: 9.5 - 12V] -- NG --> NG2[Check the following items.  
• Harness continuity between A/T control unit and ignition coil.  
• Resistor  
• Ignition coil — Refer to section EF & EC.]
      A -- OK --> B[Perform self-diagnosis again after driving for a while.]
      B -- NG --> NG3[1. Perform A/T control unit input/output signal inspection.  
2. If NG, recheck A/T control unit pin terminals for damage or connection of A/T control unit harness connector.]
      B -- OK --> End[INSPECTION END]
  
```

GI

MA

EM

LC

EF & EC

FE

CL

MT

AT

TF

PD

FA

RA

BR

ST

BF

HA

EL

IDX

Self-diagnosis (Cont'd)

LINE PRESSURE SOLENOID VALVE CIRCUIT CHECK

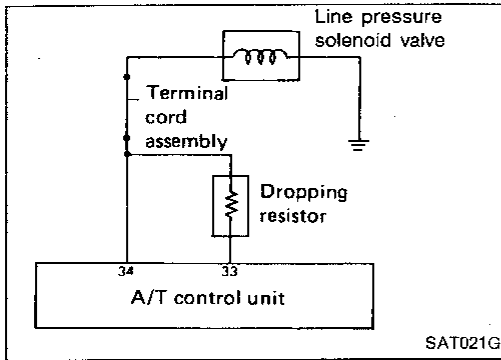

A
CHECK GROUND CIRCUIT.
 1. Turn ignition switch to "OFF" position.
 2. Disconnect terminal cord assembly connector in engine compartment.
 3. Check resistance between terminal 34 and ground.
Resistance: 2.5 - 5Ω

NG →
 1. Remove control valve assembly. — Refer to "ON-VEHICLE SERVICE" (AT-106).
 2. Check the following items.
 ● Line pressure solenoid valve — Refer to "Electrical Components Inspection" (AT-68).
 ● Harness continuity of terminal cord assembly

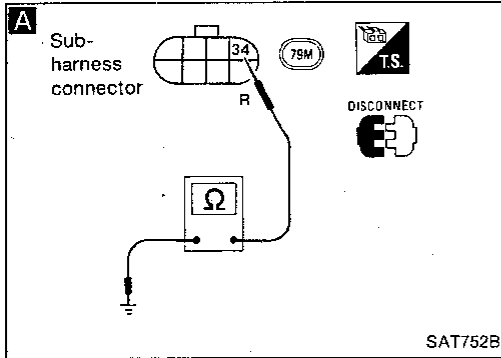

B
CHECK POWER SOURCE CIRCUIT.
 1. Turn ignition switch to "OFF" position.
 2. Disconnect A/T control unit 16-pin connector.
 3. Check resistance between terminal 34 and A/T control unit terminal 33.
Resistance: 11.2 - 12.8Ω

NG →
 Check the following items.
 ● Dropping resistor — Refer to "Electrical Components Inspection" (AT-68).
 ● Harness continuity between A/T control unit 33 and terminal cord assembly (Main harness)

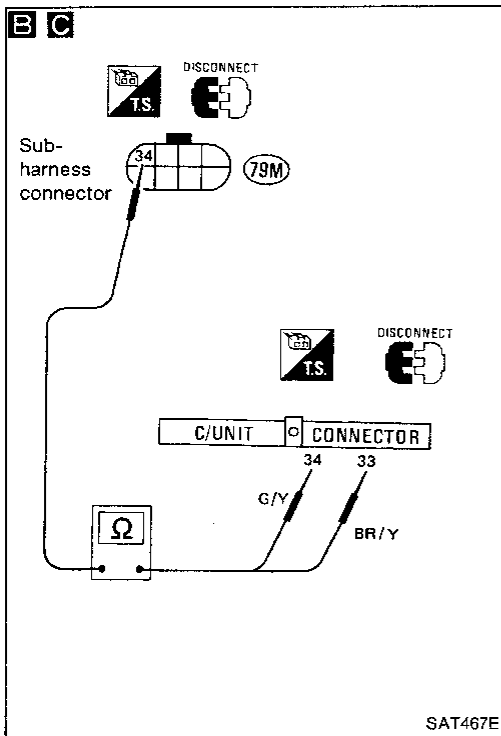

C
CHECK POWER SOURCE CIRCUIT.
 1. Turn ignition switch to "OFF" position.
 2. Check resistance between terminal 34 and A/T control unit terminal 34.
Resistance: Approximately 0Ω
 3. Reinstall any part removed.

NG →
 Repair or replace harness between A/T control unit 34 and terminal cord assembly.

Perform self-diagnosis after driving for a while.

NG →
 1. Perform A/T control unit input/output signal inspection.
 2. If NG, recheck A/T control unit pin terminals for damage or connection of A/T control unit harness connector.

INSPECTION END

Self-diagnosis (Cont'd)

INHIBITOR, OVERDRIVE, KICKDOWN AND CLOSED THROTTLE POSITION SWITCH CIRCUIT CHECKS

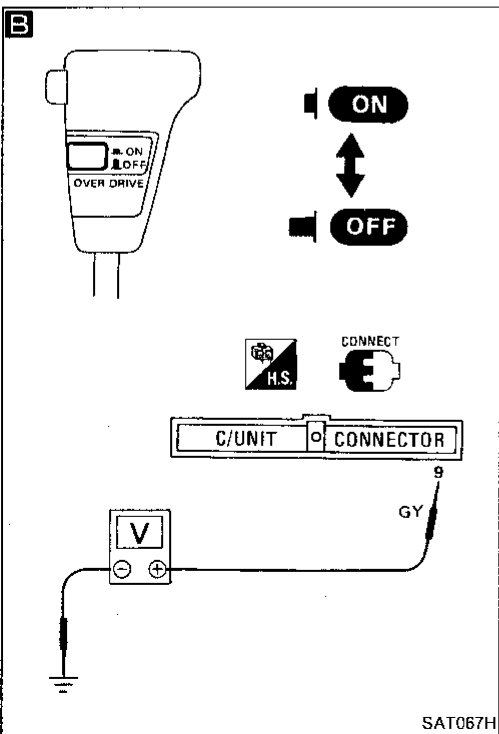
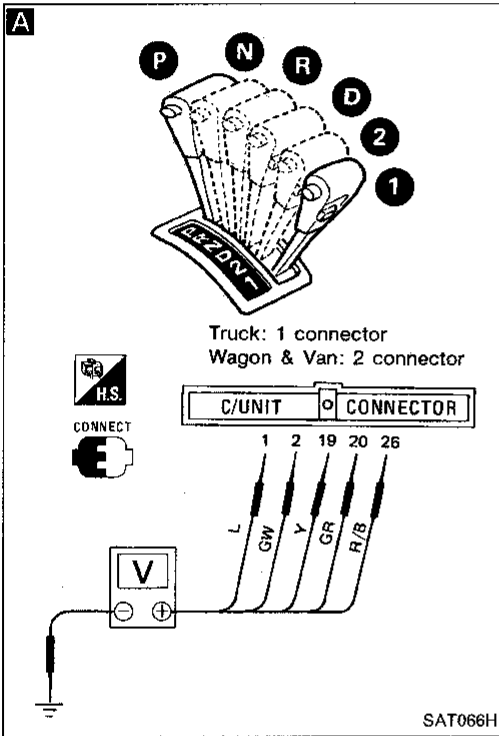
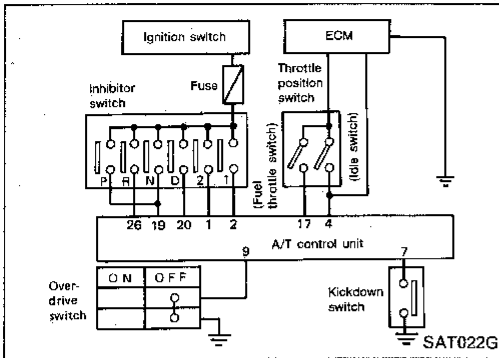

A

CHECK INHIBITOR SWITCH CIRCUIT.

1. Turn ignition switch to "ON" position. (Do not start engine.)
2. Check voltage between A/T control unit terminals ①, ②, ⑱, ⑳, ⑳ and ground while moving selector lever through each position.

Voltage:
B: Battery voltage
0: 0V

Lever position	Terminal No.				
	⑱	⑳	⑳	①	②
P, N	B	0	0	0	0
R	0	B	0	0	0
D	0	0	B	0	0
2	0	0	0	B	0
1	0	0	0	0	B

NG → Check the following items.

- Inhibitor switch — Refer to "Electrical Components Inspection" (AT-68).
- Harness continuity between ignition switch and inhibitor switch (Main harness)
- Harness continuity between inhibitor switch and A/T control unit (Main harness)

OK ↓

B

CHECK OVERDRIVE SWITCH CIRCUIT.

1. Turn ignition switch to "ON" position. (Do not start engine.)
2. Check voltage between A/T control unit terminals ⑨ and ground when overdrive switch is in "ON" position and in "OFF" position.

Switch position	Voltage
ON	Battery voltage
OFF	1V or less

NG → Check the following items.

- Overdrive switch — Refer to "Electrical Components Inspection" (AT-68).
- Harness continuity between A/T control unit and overdrive switch (Main harness)
- Harness continuity of ground circuit for overdrive switch (Main harness)

OK ↓

Ⓐ

GI
MA
EM
LC
EF & EC
FE
CL
MT
AT
TF
PD
FA
RA
BR
ST
BF
HA
EL
IDX

Self-diagnosis (Cont'd)

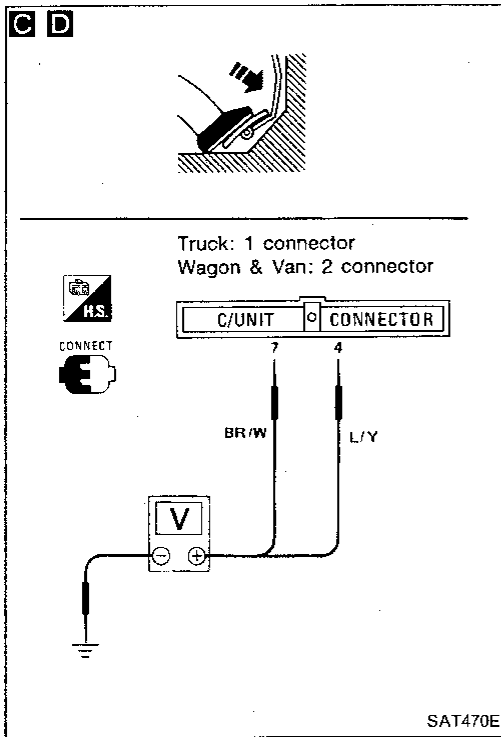

A

C

CHECK KICKDOWN SWITCH CIRCUIT.

1. Turn ignition switch to "ON" position. (Do not start engine.)
2. Check voltage between A/T control unit terminal ⑦ and ground while depressing accelerator pedal slowly. (after warming up engine)

Voltage:

- When releasing accelerator pedal: 3 - 8V
- When depressing accelerator pedal fully: 1V or less

NG

Check the following items.

- Kickdown switch
- Harness continuity between A/T control unit and kickdown switch (Main harness)
- Harness continuity of ground circuit for kick-down switch

OK

D

CHECK CLOSED THROTTLE POSITION SWITCH CIRCUIT.

- Check voltage between A/T control unit terminal ④ and ground in the same way as kickdown switch circuit.

Voltage:

- When releasing accelerator pedal: 8 - 15V
- When depressing accelerator pedal fully: 1V or less

NG

Perform self-diagnosis for engine control. Check closed throttle position switch circuit.

OK

Check harness continuity between A/T control unit and closed throttle position switch. (Main harness)

NG

Check closed throttle position switch circuit for engine control. — Refer to section EF & EC.

OK

Perform self-diagnosis again after driving for a while.

NG

1. Perform A/T control unit input/output signal inspection.
2. If NG, recheck A/T control unit pin terminals for damage or connection of A/T control unit harness connector.

OK

INSPECTION END

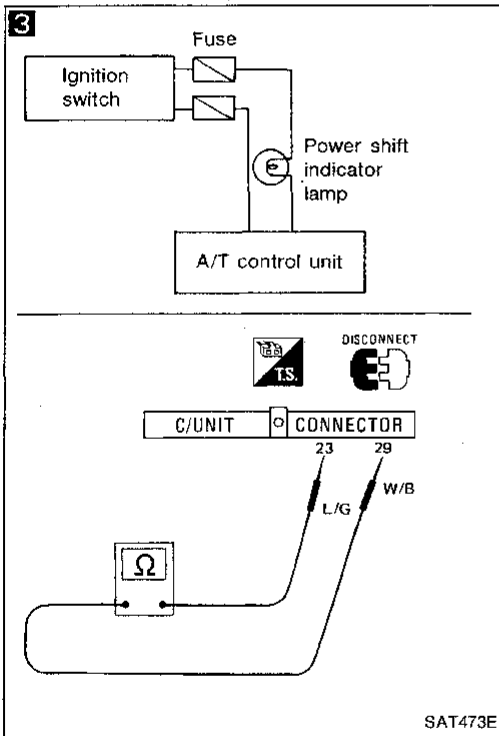
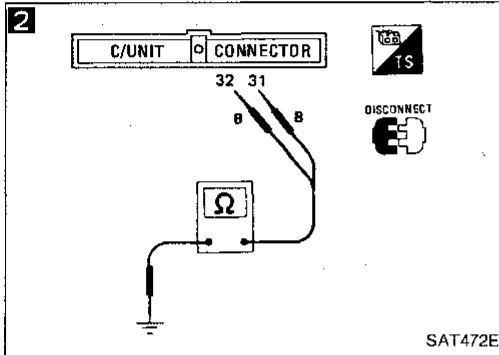
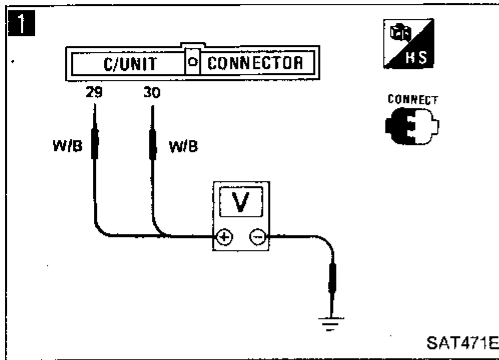

Diagnostic Procedure 1

SYMPTOM: Power shift indicator lamp does not come on for about 2 seconds when turning ignition switch "ON".

1

CHECK A/T CONTROL UNIT POWER SOURCE.

1. Turn ignition switch to "ON" position. (Do not start engine.)
2. Check voltage between A/T control unit terminals ⑳, ㉑ and ground. **Battery voltage should exist.**

NG → Check the following items.

- Harness continuity between ignition switch and A/T control unit (Main harness)
- Ignition switch and fuse — Refer to section EL.

OK ↓

2

CHECK A/T CONTROL UNIT GROUND CIRCUIT.

1. Turn ignition switch to "OFF" position.
2. Disconnect A/T control unit 16-pin connector.
3. Check resistance between A/T control unit terminals ㉑, ㉒ and ground. **Resistance: Approximately 0Ω**

NG → Check harness continuity between A/T control unit and ground.

OK ↓

3

CHECK LAMP CIRCUIT.

1. Turn ignition switch to "OFF" position.
2. Disconnect A/T control unit 16-pin connector.
3. Check resistance between A/T control unit terminals ㉓, ㉔ and ground. **Resistance: 50 - 100Ω**
4. Reinstall any part removed.

NG → Check the following items.

- Power shift indicator lamp — Refer to section EL.
- Harness continuity between ignition switch and power shift indicator lamp (Main harness)
- Harness continuity between power shift indicator lamp and A/T control unit

OK ↓

Check again.

NG →

1. Perform A/T control unit input/output signal inspection.
2. If NG, recheck A/T control unit pin terminals for damage or connection of A/T control unit harness connector.

OK ↓

INSPECTION END

GI
MA
EM
LC
EF & EC
FE
CL
MT
AT
TF
PD
FA
RA
BR
ST
BF
HA
EL

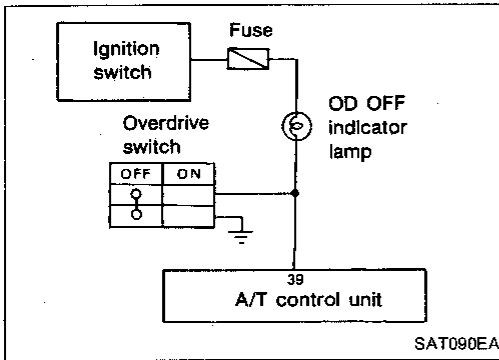

Diagnostic Procedure 2

SYMPTOM: OD OFF indicator lamp does not come on when setting overdrive switch to "OFF" position.

- Check the following items.
- Overdrive switch
 - OD OFF indicator lamp
 - Harness continuity between ignition switch and OD OFF indicator lamp

NG → Repair or replace damaged parts.

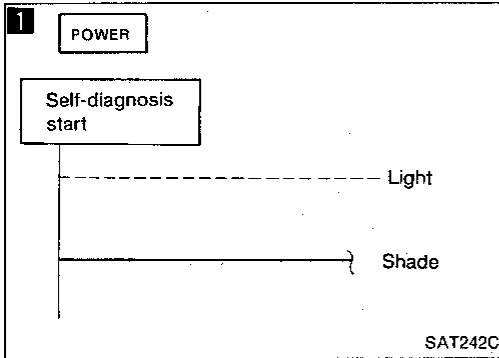

Diagnostic Procedure 3

SYMPTOM: Engine cannot be started with selector lever in "P" or "N" position or engine can be started with selector lever in "D", "2", "1" or "R" position.

1 Does self-diagnosis show damage to inhibitor switch circuit? Yes → Check inhibitor switch circuit. — Refer to "Self-diagnosis" (AT-39). No →

2 Check continuity of inhibitor switch 2-pin connector. — Refer to "Electrical Components Inspection" (AT-68). NG → Repair or replace inhibitor switch. OK →

Check starting system. — Refer to section EL. NG → Repair or replace damaged parts. OK →

INSPECTION END

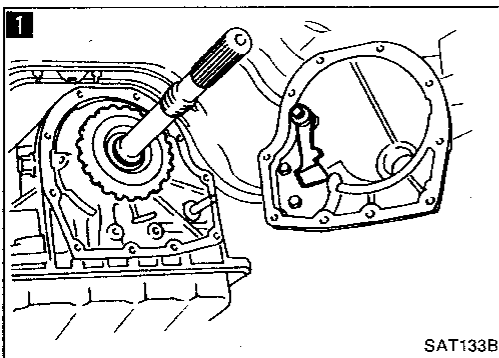
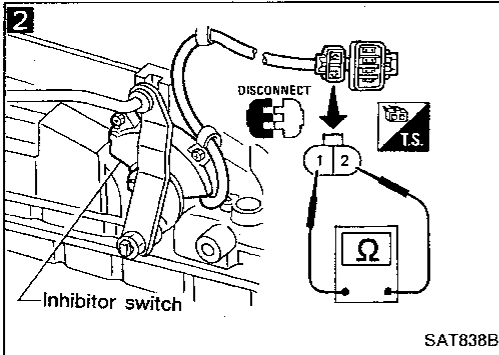

Diagnostic Procedure 4

SYMPTOM: Vehicle moves when it is pushed forward or backward with selector lever in "P" position.

1 Check parking components. — Refer to "ON-VEHICLE SERVICE" (AT-106). NG → Repair or replace damaged parts. OK →

INSPECTION END

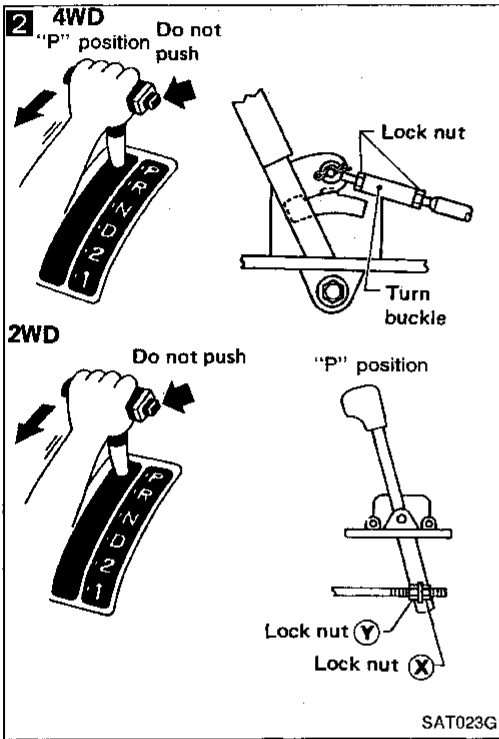
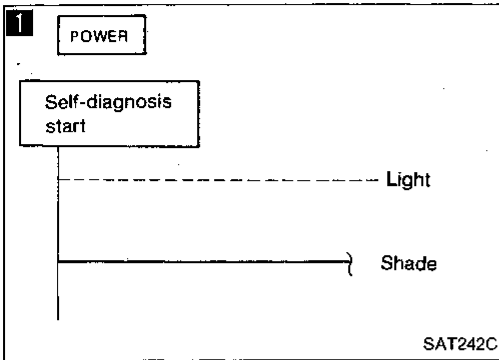

Diagnostic Procedure 5

SYMPTOM: Vehicle moves forward or backward when selecting "N" position.

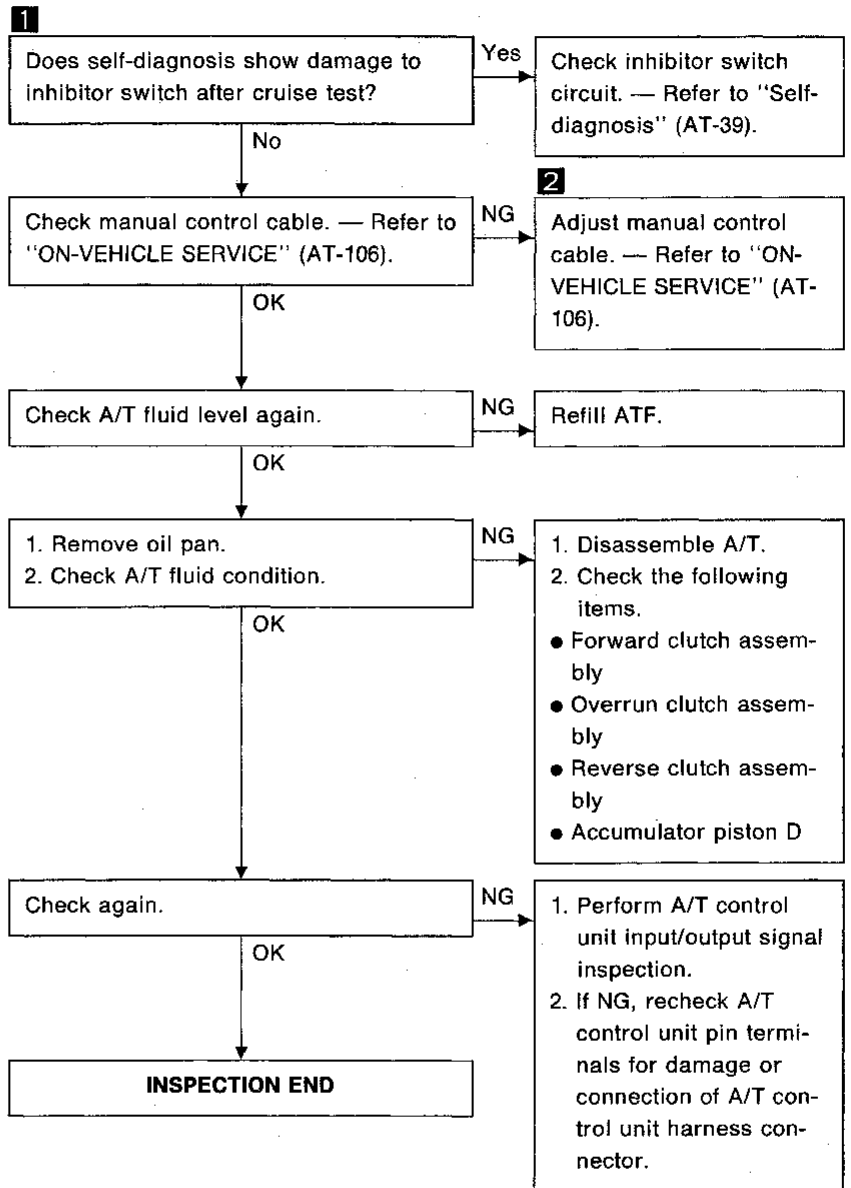

GI
MA
EM
LC
EF & EC
FE
CL
MT
AT
TF
PD
FA
RA
BR
ST
BF
HA
EL
IDX
603

Diagnostic Procedure 6

SYMPTOM: There is large shock when changing from "N" to "R" position.

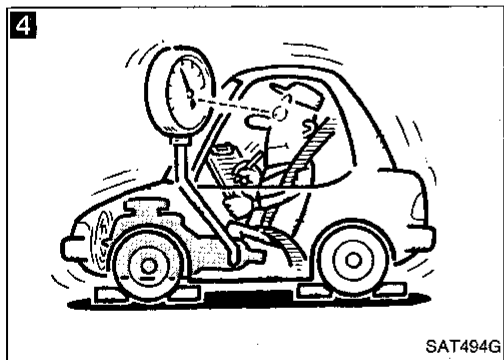
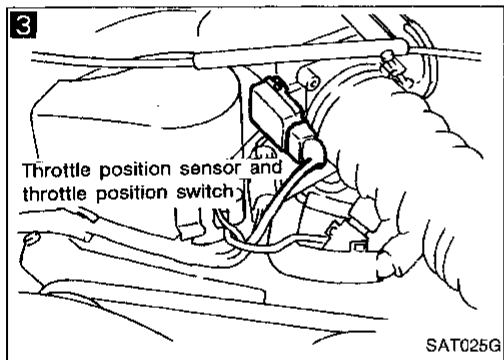
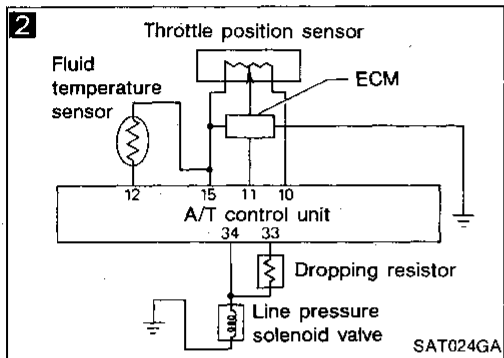
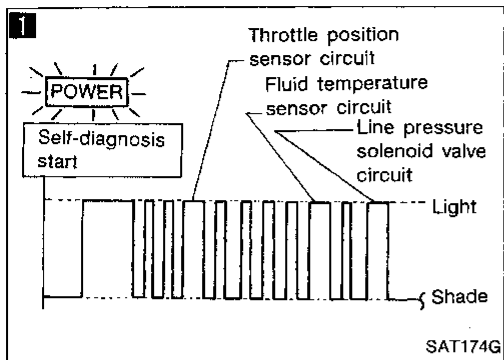

```

    graph TD
        Q1[1 Does self-diagnosis show damage to throttle position sensor, line pressure solenoid valve or fluid temperature sensor circuit?] -- Yes --> A2[2 Check damaged circuit. — Refer to "Self-diagnosis" (AT-39).]
        Q1 -- No --> Q3[3 Check throttle position sensor. — Refer to section EF & EC.]
        Q3 -- NG --> A3[Repair or replace throttle position sensor.]
        Q3 -- OK --> Q4[4 Check line pressure at idle with selector lever in "D" position. — Refer to "PRESSURE TESTING" (AT-75).]
        Q4 -- NG --> A4[1. Remove control valve assembly. — Refer to "ON-VEHICLE SERVICE" (AT-106).  
2. Check the following items:  
• Valves to control line pressure (Pressure regulator valve, modifier valve, pilot valve and pilot filter)  
• Line pressure solenoid valve]
        Q4 -- OK --> Q5[Check again.]
        Q5 -- NG --> A5[1. Perform A/T control unit input/output signal inspection.  
2. If NG, recheck A/T control unit pin terminals for damage or connection of A/T control unit harness connector.]
        Q5 -- OK --> END[INSPECTION END]
    
```

Diagnostic Procedure 7

SYMPTOM: Vehicle does not creep backward when selecting "R" position.

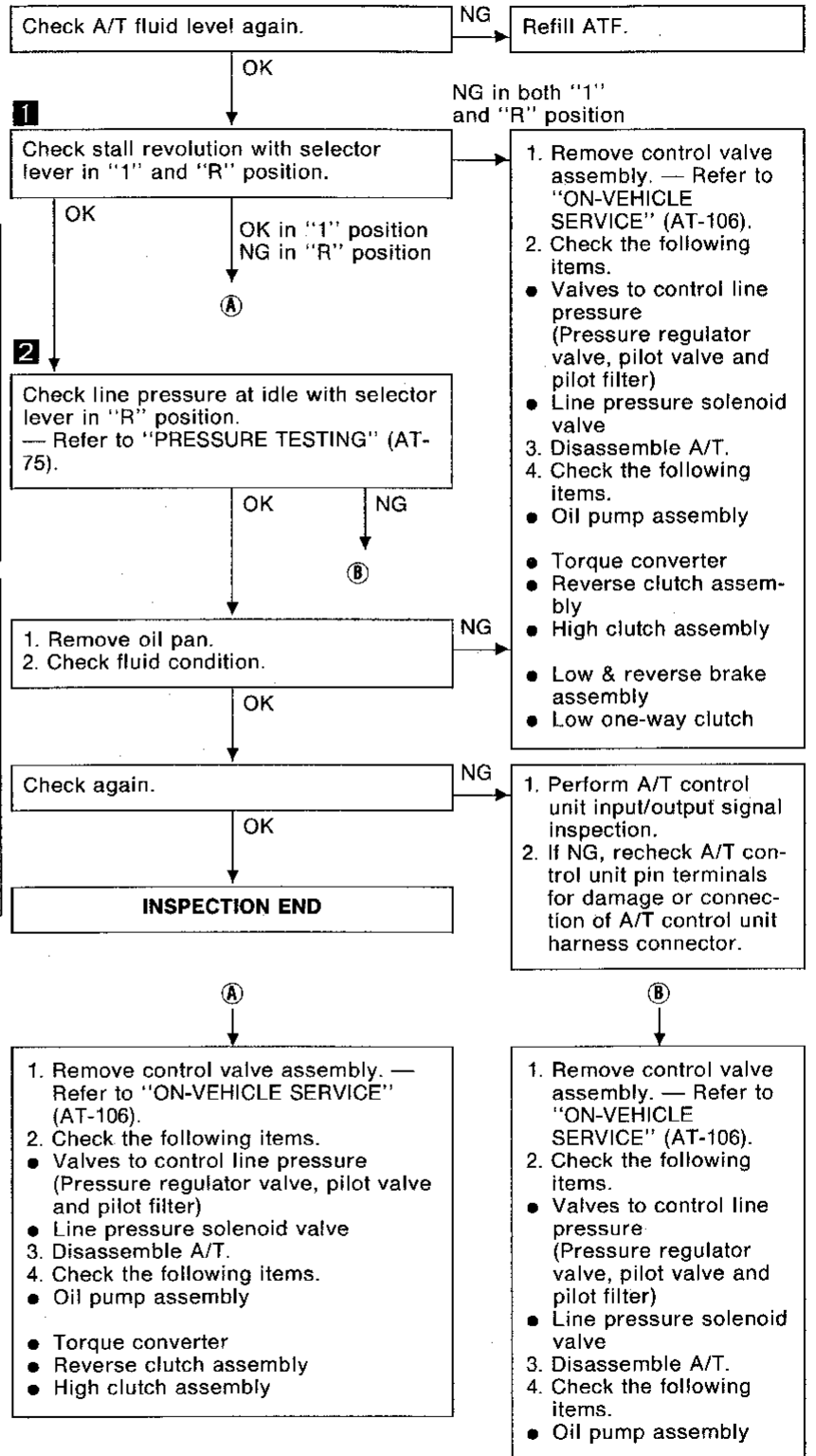
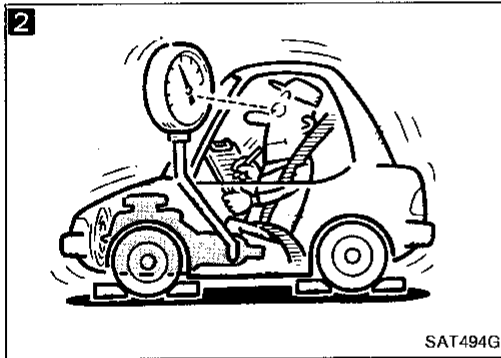
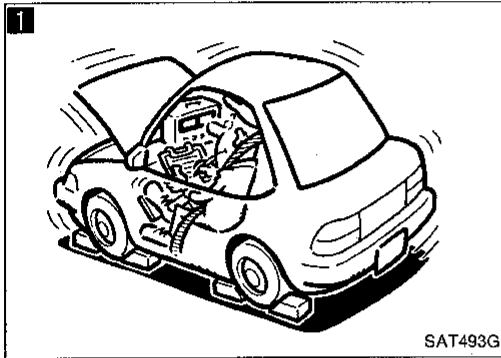

GI
MA
EM
LC
EF & EC
FE
CL
MT
AT
TF
PD
FA
RA
BR
ST
BF
HA
EL

Diagnostic Procedure 8

SYMPTOM: Vehicle does not creep forward when selecting "D", "2" or "1" position.

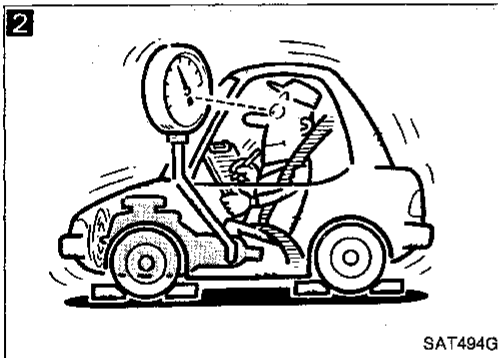
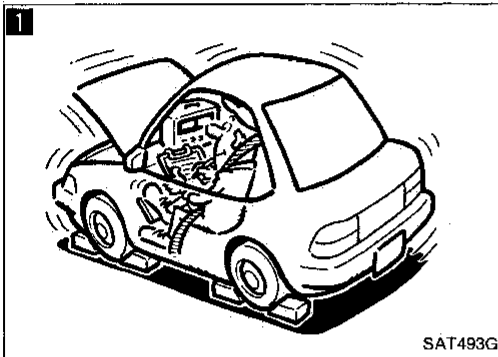
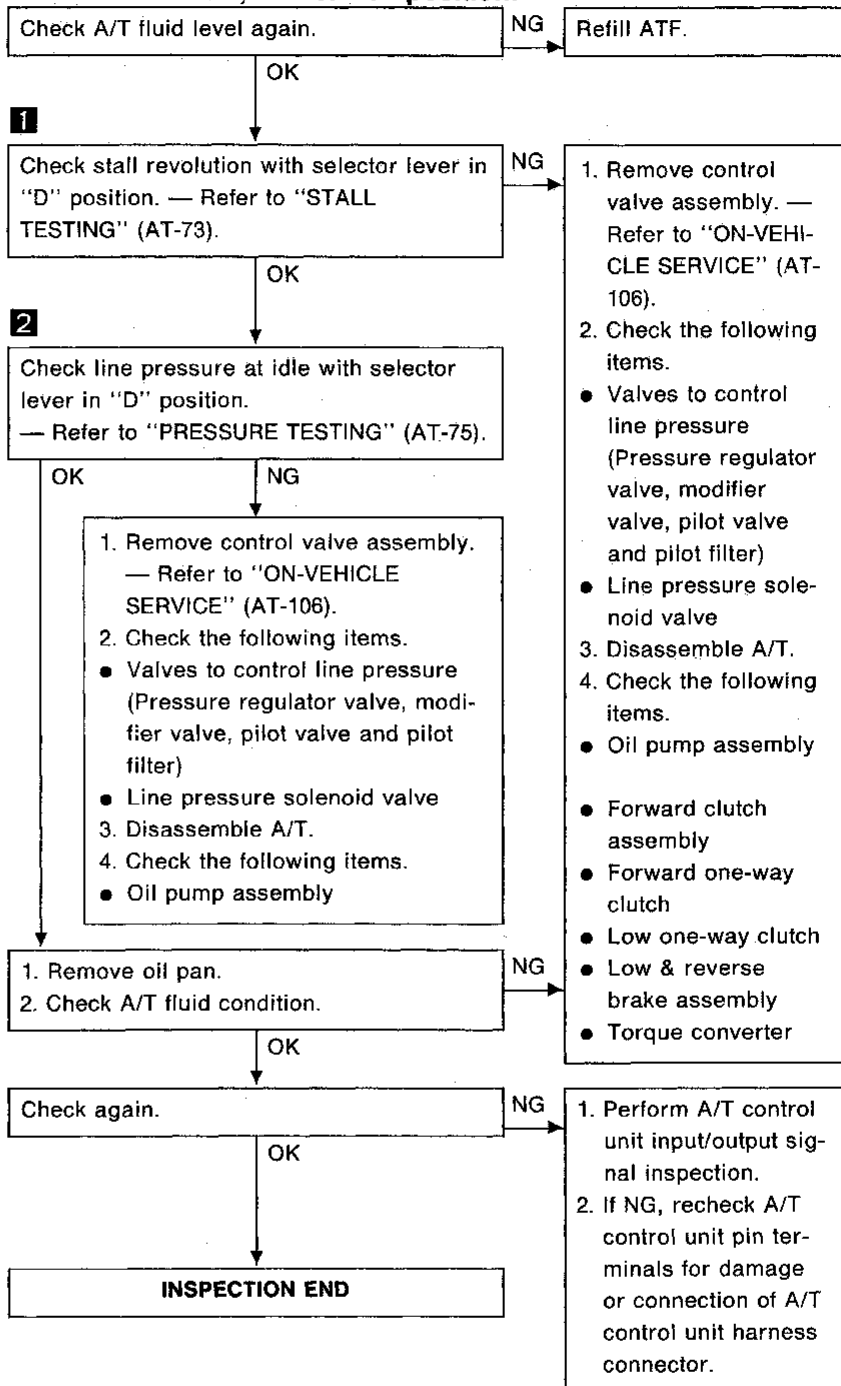

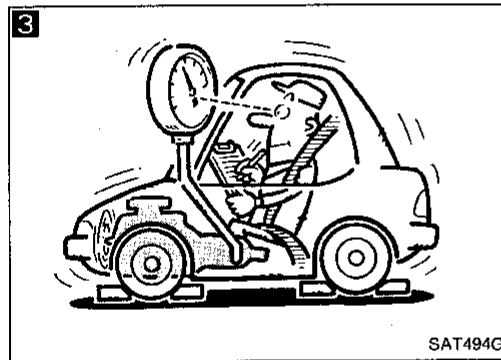
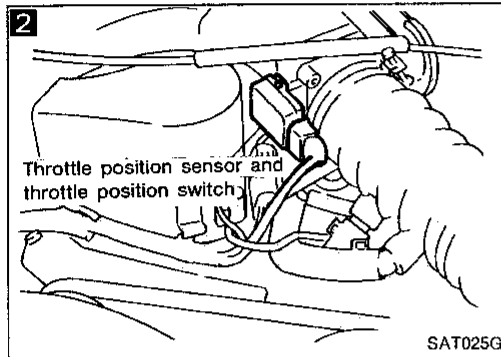
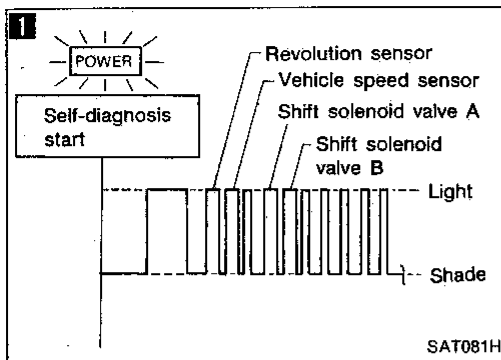

Diagnostic Procedure 9

SYMPTOM: Vehicle cannot be started from D, on Cruise test — Part 1.

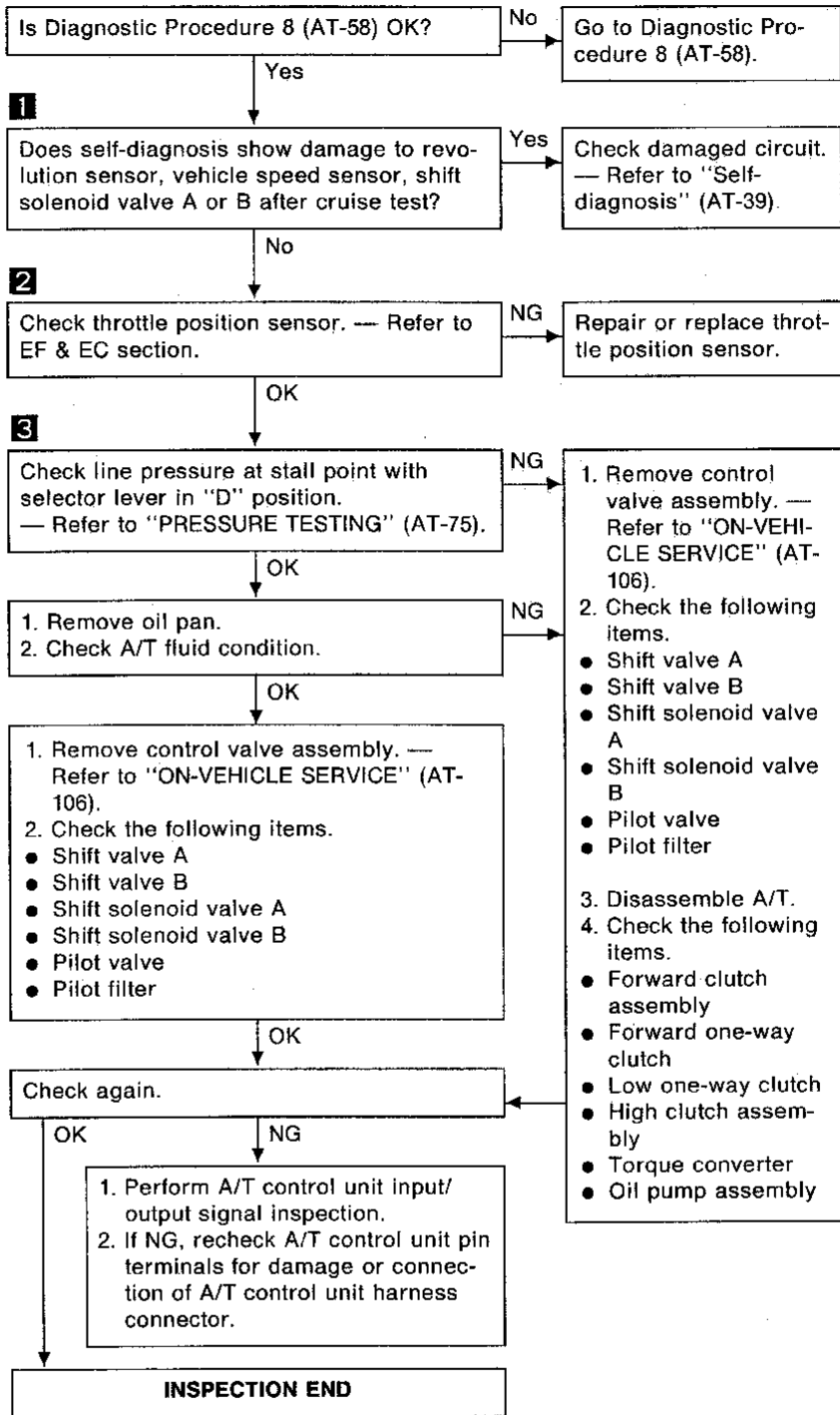

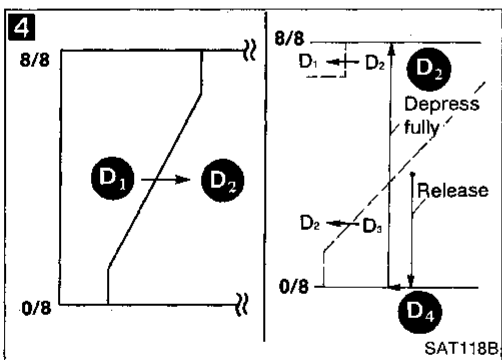
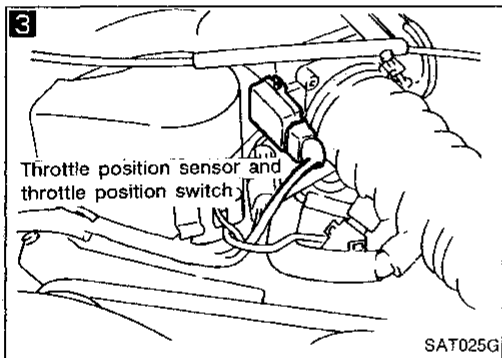
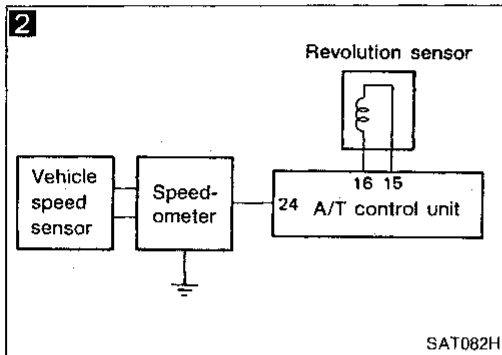
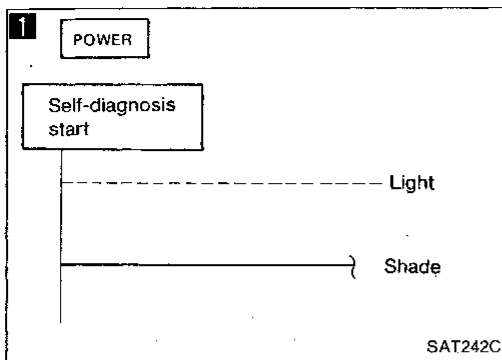

Diagnostic Procedure 10

SYMPTOM: A/T does not shift from D₁ to D₂ at the specified speed.

A/T does not shift from D₄ to D₂ when depressing accelerator pedal fully at the specified speed.

Are Diagnostic Procedures 8 and 9 (AT-58, 59) OK?

No → Go to Diagnostic Procedure 8 or 9 (AT-58, 59).

Yes

1 Does self-diagnosis show damage to inhibitor switch after cruise test?

Yes → Check inhibitor switch circuit. — Refer to "Self-diagnosis" (AT-39).

No

2 Check revolution sensor and vehicle speed sensor circuit. — Refer to "Self-diagnosis" (AT-39).

NG → Repair or replace revolution sensor and vehicle speed sensor circuits.

OK

3 Check throttle position sensor. — Refer to EF & EC section.

NG → Repair or replace throttle position sensor.

OK

1. Remove oil pan.
2. Check A/T fluid condition.

NG → 1. Remove control valve. — Refer to "ON-VEHICLE SERVICE" (AT-106).
2. Check the following items.
● Shift valve A
● Shift solenoid valve A
● Pilot valve
● Pilot filter

OK

1. Remove control valve. — Refer to "ON-VEHICLE SERVICE" (AT-106).
2. Check the following items.
● Shift valve A
● Shift solenoid valve A
● Pilot valve
● Pilot filter

3. Disassemble A/T.
4. Check the following items.
● Servo piston assembly
● Brake band
● Oil pump assembly

OK

4 Check again.

NG → 1. Perform A/T control unit input/output signal inspection.
2. If NG, recheck A/T control unit pin terminals for damage or connection of A/T control unit harness connector.

OK → **INSPECTION END**

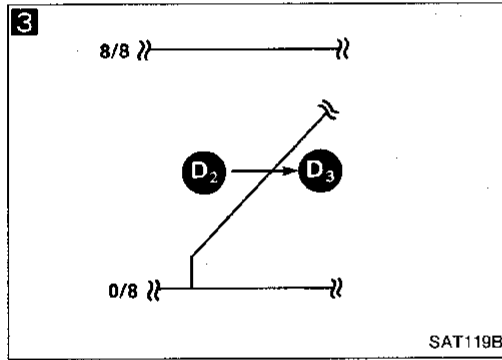
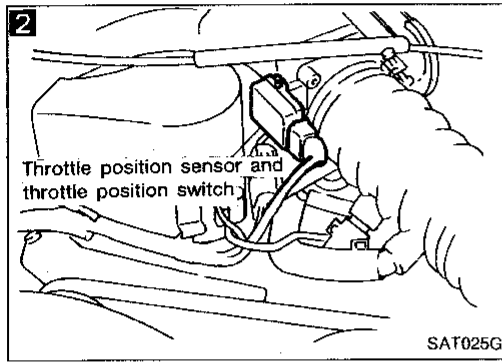
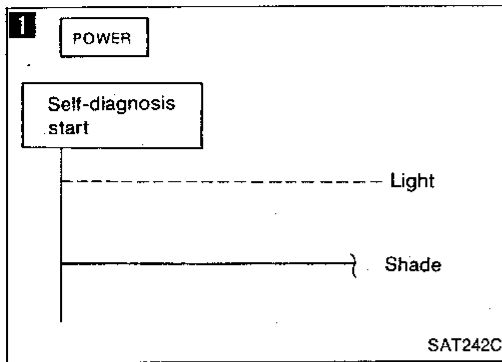

Diagnostic Procedure 11

SYMPTOM: A/T does not shift from D₂ to D₃ at the specified speed.

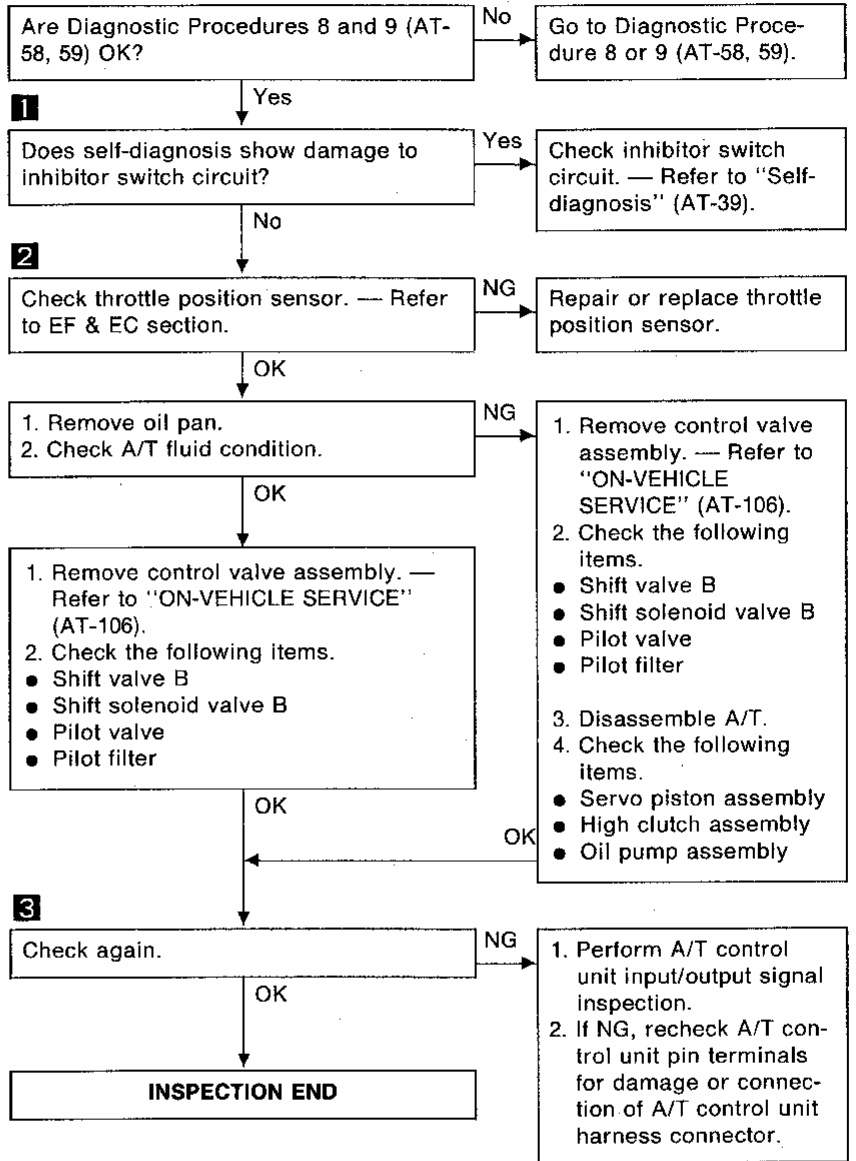

GI
MA
EM
LC
EF & EC
FE
CL
MT
AT
TF
PD
FA
RA
BR
ST
BF
HA
EL
IDX

Diagnostic Procedure 12

SYMPTOM: A/T does not shift from D₃ to D₄ at the specified speed.

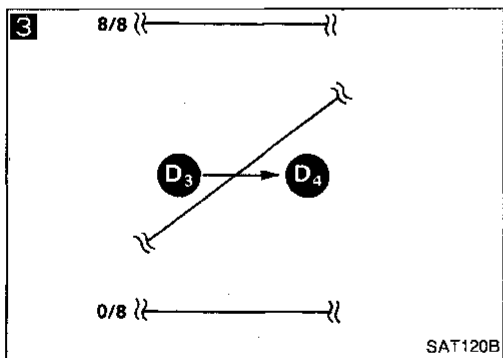
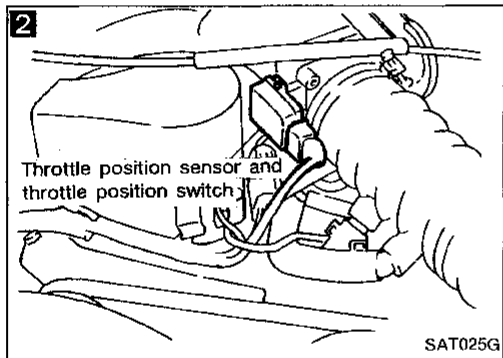
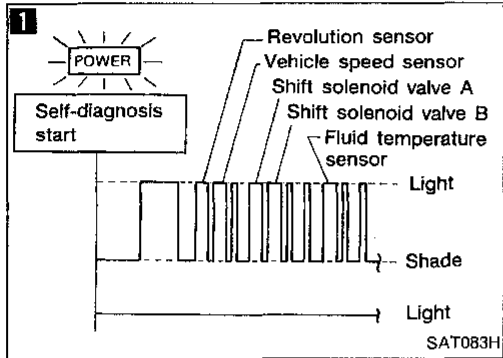

```

    graph TD
        Q1[Are Diagnostic Procedures 8 and 9 (AT-58, 59) OK?] -- No --> A1[Go to Diagnostic Procedure 8 or 9 (AT-58, 59).]
        Q1 -- Yes --> Q2[1 Does self-diagnosis show damage to inhibitor switch, overdrive switch, shift solenoid valve A, B, revolution sensor, vehicle speed sensor or fluid temperature sensor circuit after cruise test?]
        Q2 -- Yes --> A2[Check damaged circuit. — Refer to "Self-diagnosis" (AT-39).]
        Q2 -- No --> Q3[2 Check throttle position sensor. — Refer to EF & EC section.]
        Q3 -- NG --> A3[Repair or replace throttle position sensor.]
        Q3 -- OK --> Q4[1. Remove oil pan.  
2. Check A/T fluid condition.]
        Q4 -- NG --> A4[1. Remove control valve assembly. — Refer to "ON-VEHICLE SERVICE" (AT-106).  
2. Check the following items:  
• Shift valve B  
• Overrun clutch control valve  
• Shift solenoid valve B  
• Pilot valve  
• Pilot filter  
3. Disassemble A/T.  
4. Check the following items:  
• Servo piston assembly  
• Brake band  
• Torque converter  
• Oil pump assembly]
        Q4 -- OK --> Q5[1. Remove control valve assembly. — Refer to "ON-VEHICLE SERVICE" (AT-106).  
2. Check the following items:  
• Shift valve B  
• Overrun clutch control valve  
• Shift solenoid valve B  
• Pilot valve  
• Pilot filter]
        Q5 -- OK --> Q6[3 Check again.]
        Q6 -- NG --> A5[1. Perform A/T control unit input/output signal inspection.  
2. If NG, recheck A/T control unit pin terminals for damage or connection of A/T control unit harness connector.]
        Q6 -- OK --> END[INSPECTION END]
    
```

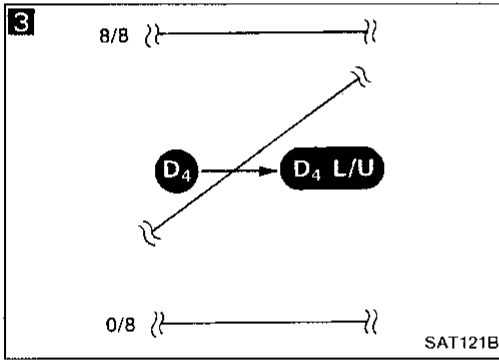
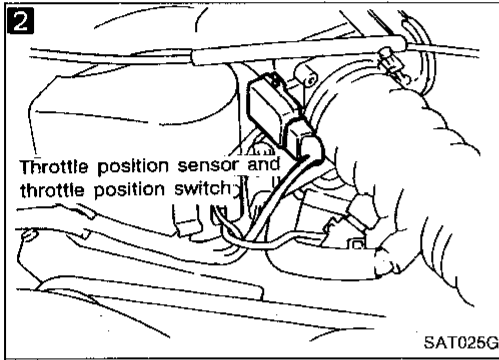
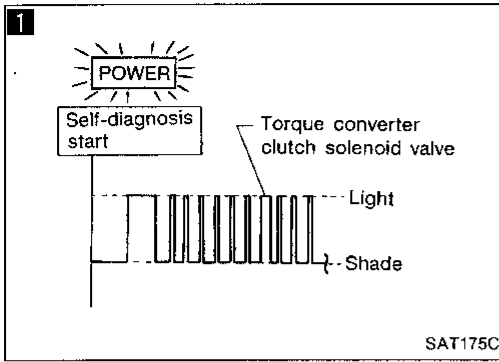

Diagnostic Procedure 13

SYMPTOM: A/T does not perform lock-up at the specified speed.

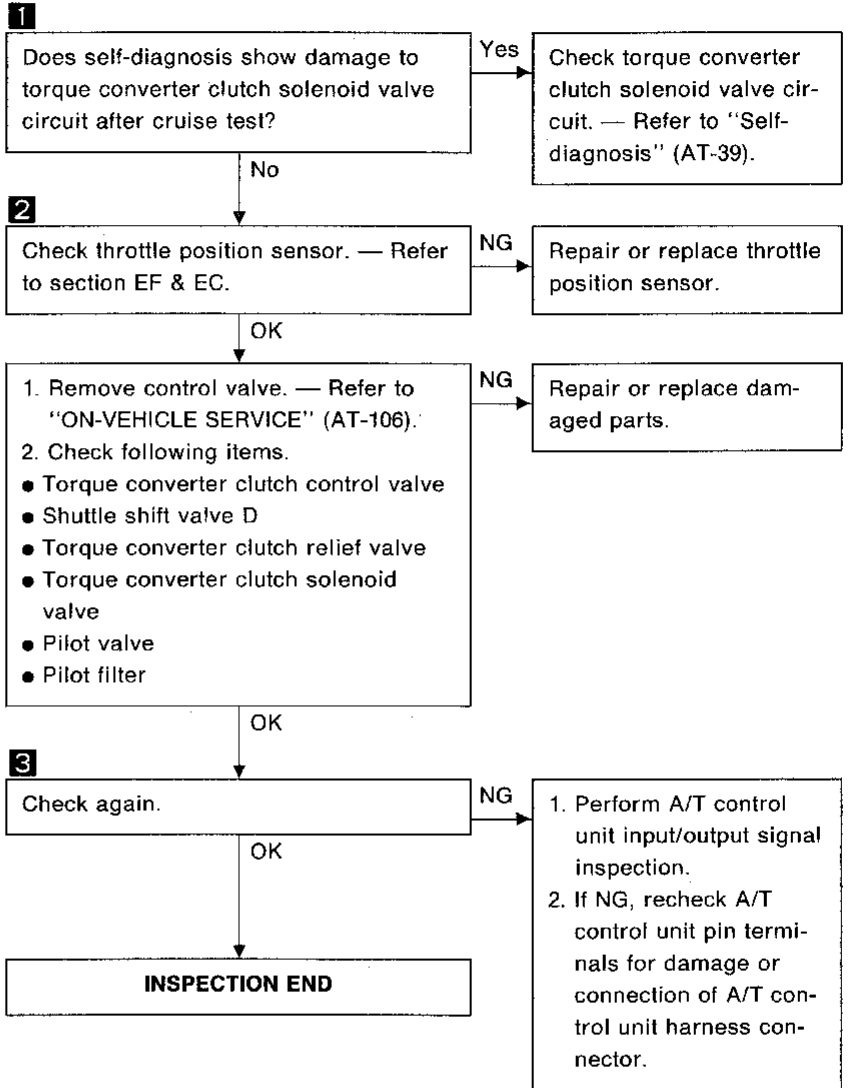

GI

MA

EM

LC

EF & EC

FE

CL

MT

AT

TF

PD

FA

RA

BR

ST

BF

HA

EL

IDX

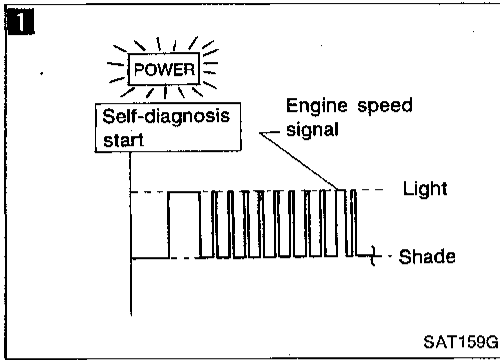

Diagnostic Procedure 14

SYMPTOM: A/T does not hold lock-up condition for more than 30 seconds.

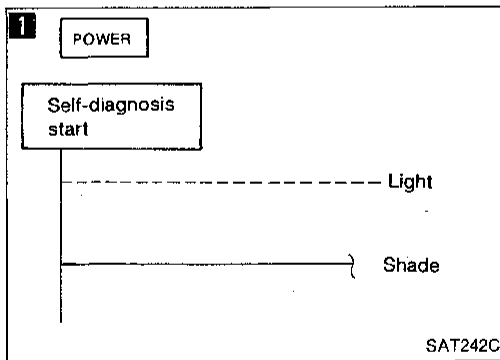
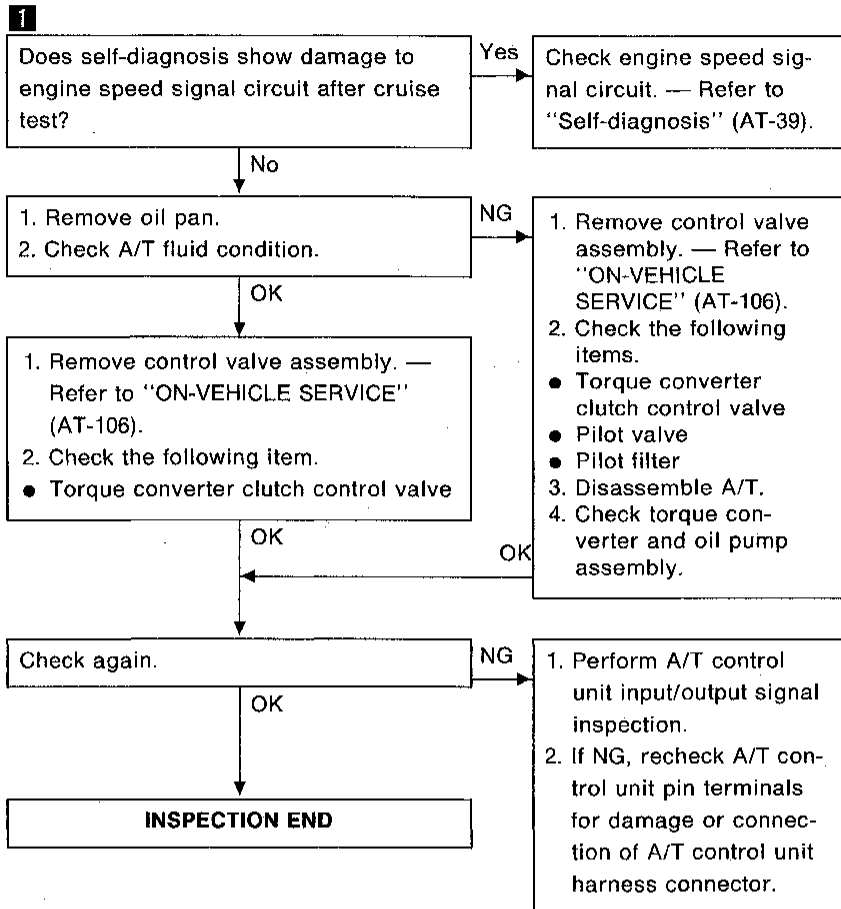

Diagnostic Procedure 15

SYMPTOM: Lock-up is not released when accelerator pedal is released.

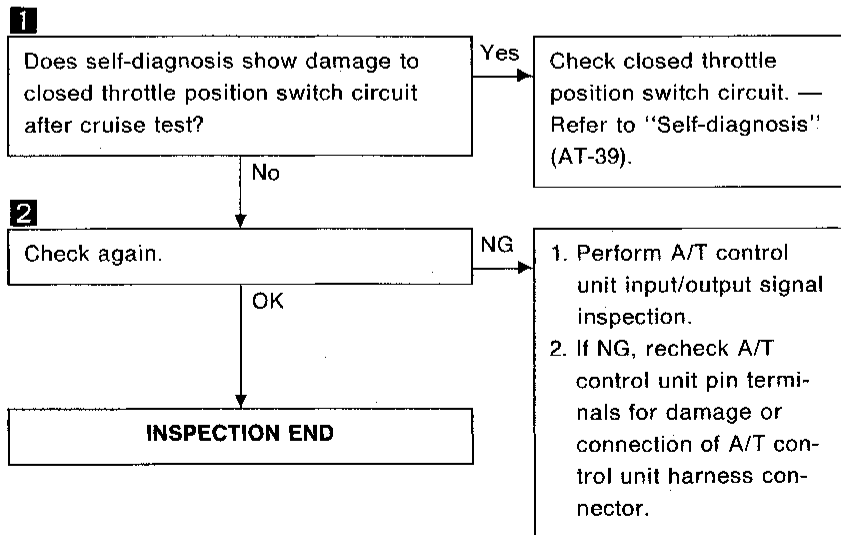
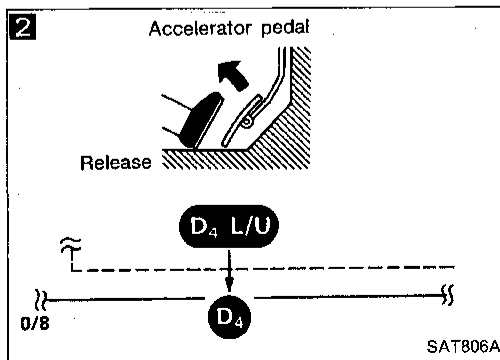

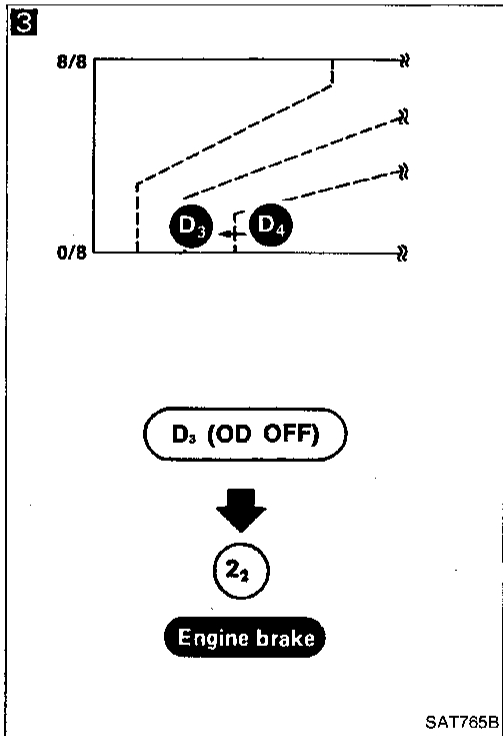
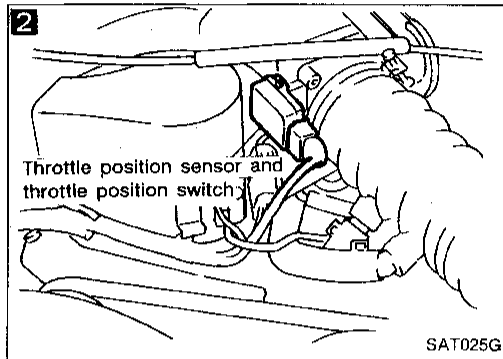
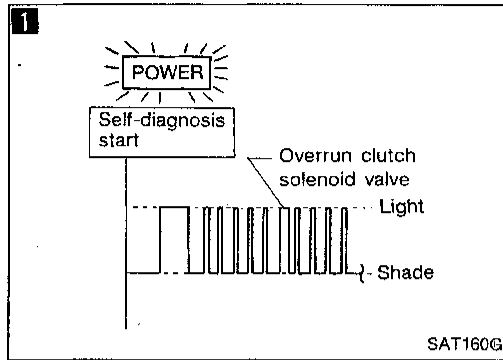

Diagnostic Procedure 16

SYMPTOM: Engine speed does not return to idle smoothly when A/T is shifted from D₄ to D₃ with accelerator pedal released.

Vehicle does not decelerate by engine brake when changing overdrive switch to "OFF" position with accelerator pedal released.

Vehicle does not decelerate by engine brake when changing selector lever from "D" to "2" position with accelerator pedal released.

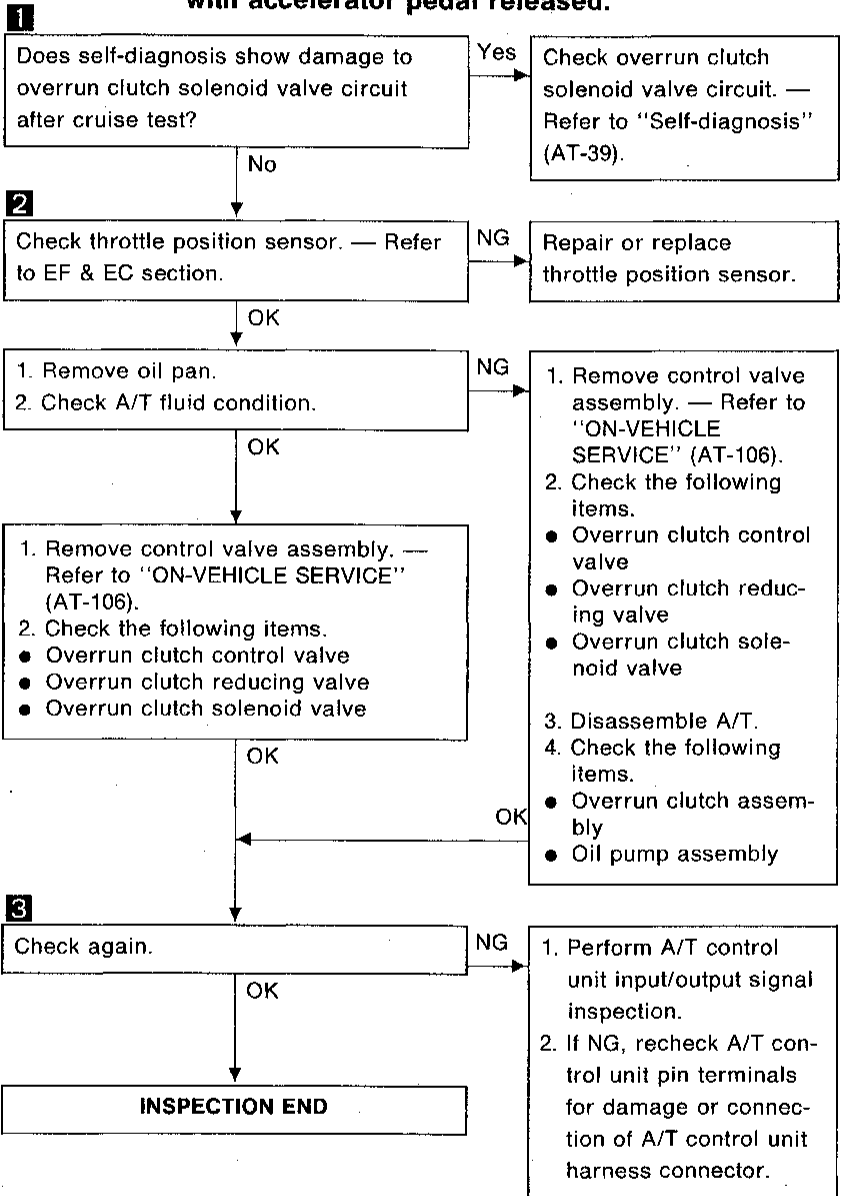

GI
MA
EM
LC
EF & EC
FE
CL
MT
AT
TF
PD
FA
RA
BR
ST
BF
HA
EL
IDX

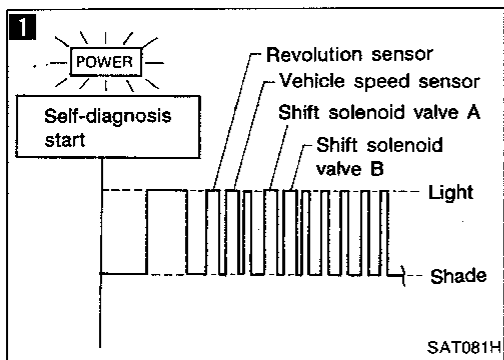

Diagnostic Procedure 17

SYMPTOM: Vehicle does not start from D₁ on Cruise test — Part 2.

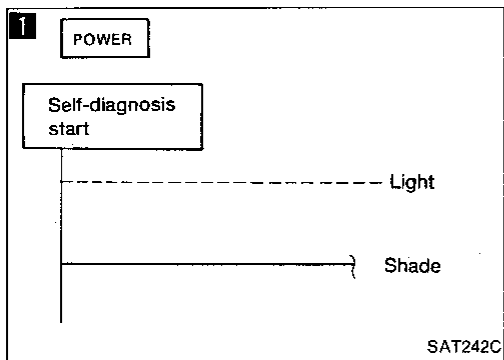
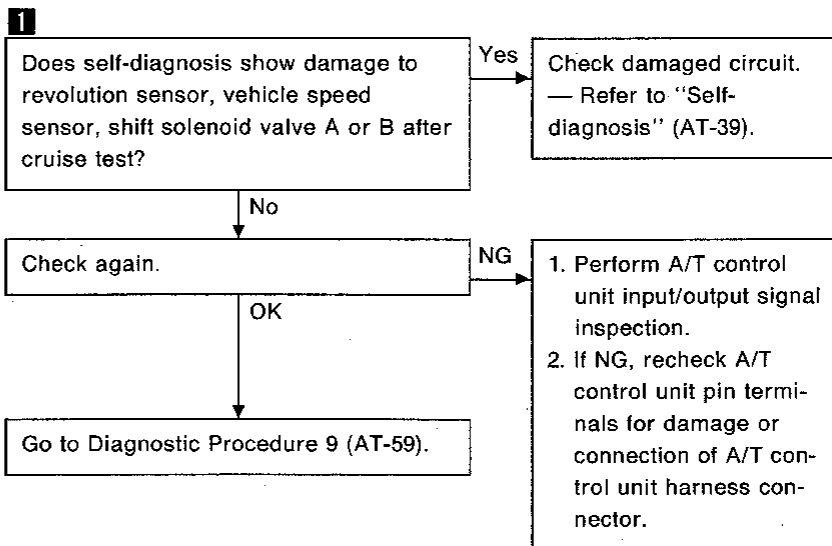

Diagnostic Procedure 18

SYMPTOM: A/T does not shift from D₄ to D₂ when changing overdrive switch to "OFF" position.

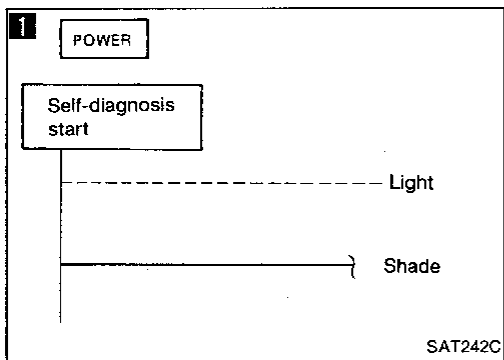
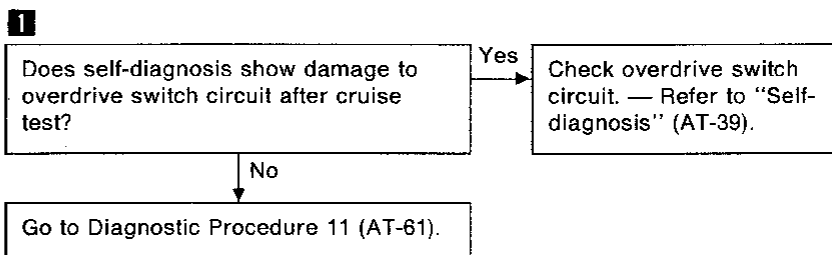

Diagnostic Procedure 19

SYMPTOM: A/T does not shift from D₃ to 2₂ when changing selector lever from "D" to "2" position.

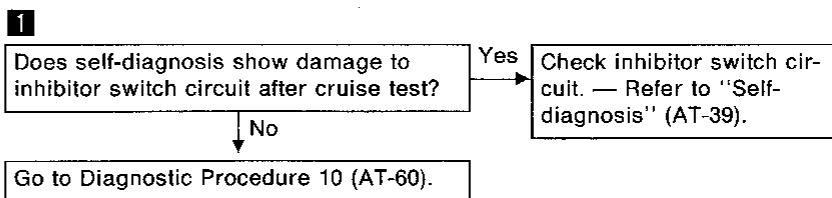

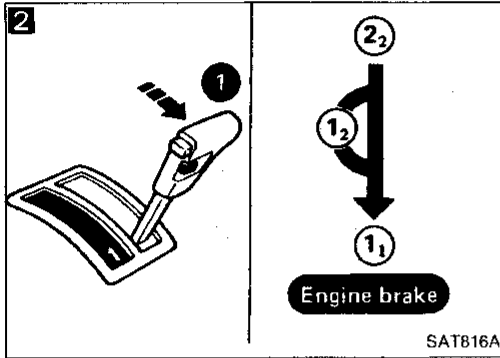
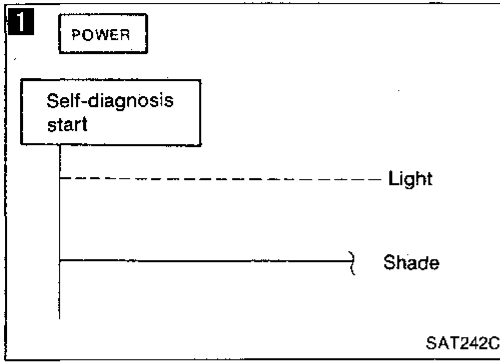

Diagnostic Procedure 20

SYMPTOM: A/T does not shift from 2₂ to 1₁, when changing selector lever from "2" to "1" position.

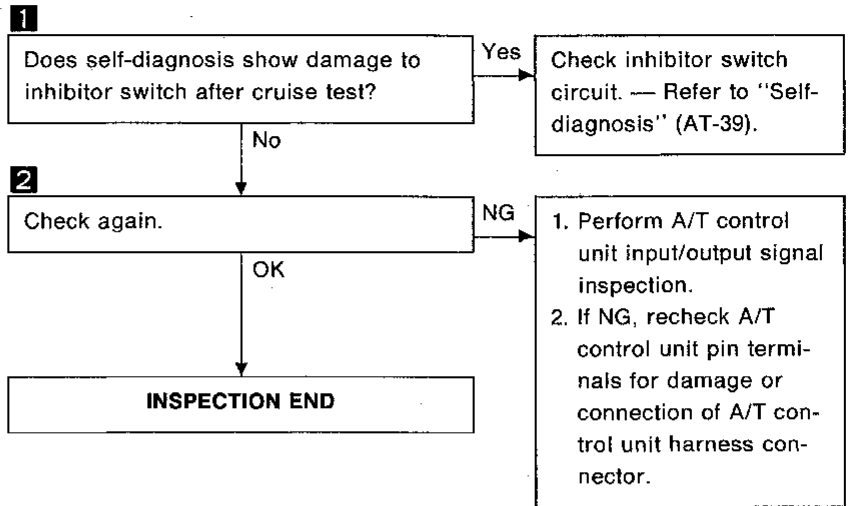

Diagnostic Procedure 21

SYMPTOM: Vehicle does not decelerate by engine brake when shifting from 2₂ (1₂) to 1₁.

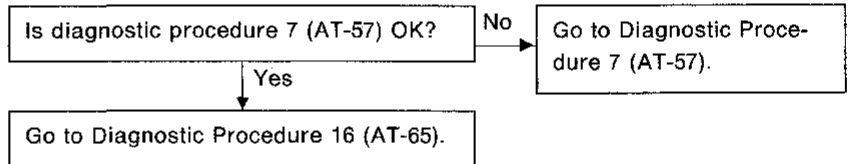

GI
MA
EM
LC
EF & EC
FE
CL
MT
AT
TF
PD
FA
RA
BR
ST
BF
HA
EL
IDX

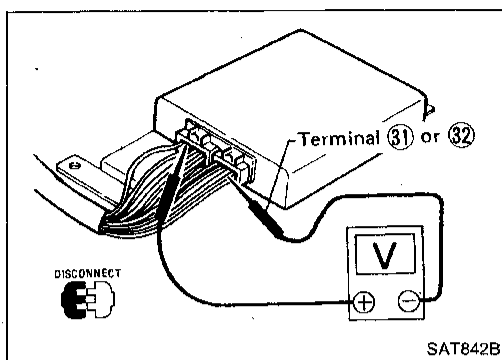

Electrical Components Inspection

INSPECTION OF A/T CONTROL UNIT

- Measure voltage between each terminal and terminal 31 or 32 by following "A/T CONTROL UNIT INSPECTION TABLE".

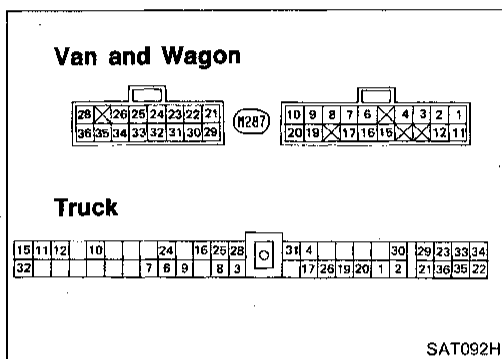















- Pin connector terminal layout.



















A/T CONTROL UNIT INSPECTION TABLE
(Data are reference values.)

Terminal No.	Item	Condition	Judgement standard
1	Inhibitor "2" position switch	When selector lever is set to "2" position.	Battery voltage
		When selector lever is set to other positions.	1V or less
2	Inhibitor "1" position switch	When selector lever is set to "1" position.	Battery voltage
		When selector lever is set to other positions.	1V or less
3	Power shift switch	When power shift switch is set to "POWER" position.	Battery voltage
		When power shift switch is set to "AUTO" position.	1V or less
4	Closed throttle position switch (in throttle position switch)	When accelerator pedal is released after warming up engine.	8 - 15V
		When accelerator pedal is depressed after warming up engine.	1V or less
5	—	—	—
6	ASCD and OD cut signal	When "ACCEL" set switch is released on ASCD cruise.	5 - 8V
		When "ACCEL" set switch is applied on ASCD cruise.	1V or less
7	Kickdown switch	When accelerator pedal is released after warming up engine.	3 - 8V
		When accelerator pedal is depressed fully after warming up engine.	1V or less

Electrical Components Inspection (Cont'd)

Terminal No.	Item	Condition	Judgement standard		
8	ASCD cruise signal		When ASCD cruise is being performed. ("CRUISE" light comes on.)	Battery voltage	GI
			When ASCD cruise is not being performed. ("CRUISE" light does not come on.)	1V or less	MA
9	Overdrive control switch		When overdrive switch is set to "ON" position.	Battery voltage	EM
			When overdrive switch is set to "OFF" position.	1V or less	EM
10	Throttle position sensor (Power source)		—	4.5 - 5.5V	LC
11	Throttle position sensor		When accelerator pedal is depressed slowly after warming up engine.	Fully-closed throttle: 0.2 - 0.6V	EF & EC
			Voltage rises gradually in response to throttle opening angle.	Fully-open throttle: 2.9 - 3.9V	EC
12	Fluid temperature sensor		When ATF temperature is 20°C (68°F).	1.56V	FE
			When ATF temperature is 80°C (176°F).	0.45V	FE
13	—		—	—	
14	—		—	—	
15	Throttle position sensor (Ground)		—	—	CL
16	Revolution sensor (Measure in AC position)		When vehicle is cruising at 30 km/h (19 MPH).	1V or more Voltage rises gradually in response to vehicle speed.	MT
			When vehicle is parked.	0V	AT
17	Wide open throttle position switch		When accelerator pedal is depressed more than half-way after warming up engine.	8 - 15V	TF
			When accelerator pedal is released after warming up engine.	1V or less	PD
18	—		—	—	FA
19	Inhibitor "N" and "P" position switch		When selector lever is set to "N" or "P" position.	Battery voltage	RA
			When selector lever is set to other positions.	1V or less	BR
20	Inhibitor "D" position switch		When selector lever is set to "D" position.	Battery voltage	ST
			When selector lever is set to other positions.	1V or less	BF
21	Overrun clutch solenoid valve		When overrun clutch solenoid valve is operating.	Battery voltage	FA
			When overrun clutch solenoid valve is not operating.	1V or less	EL
22	Torque converter clutch solenoid valve		When A/T is performing lock-up.	8 - 15V	IDX
			When A/T is not performing lock-up.	1V or less	
23	Power shift indicator lamp		When power shift switch is set to "POWER" position.	Battery voltage	
			When power shift switch is set to "AUTO" position.	1V or less	

Electrical Components Inspection (Cont'd)

Terminal No.	Item	Condition	Judgement standard
24	Vehicle speed sensor	 When vehicle is moving at 2 to 3 km/h (1 to 2 MPH) for 1 m (3 ft) or more.	Vary from 0 to 5V
25	Engine speed signal	 When engine is running at idle speed.	9.5 - 12V
		 When engine is running at 2,500 rpm.	Approximately 10V
26	Inhibitor "R" position switch	 When selector lever is set to "R" position.	Battery voltage
		 When selector lever is set to other positions.	1V or less
27	—	 —	—
28	Power source (Back-up)	 When ignition switch is turned to "OFF".	Battery voltage
		 When ignition switch is turned to "ON".	Battery voltage
29 30	Power source	 When ignition switch is turned to "ON".	Battery voltage
		 When ignition switch is turned to "OFF".	1V or less
31 32	Ground	 —	—
33	Line pressure solenoid valve (with dropping resistor)	 When accelerator pedal is released after warming up engine.	5 - 14V
		 When accelerator pedal is depressed fully after warming up engine.	0.5V or less
34	Line pressure solenoid valve	 When accelerator pedal is released after warming up engine.	1.5 - 2.5V
		 When accelerator pedal is depressed fully after warming up engine.	0.5V or less
35	Shift solenoid valve A	 When shift solenoid valve A is operating. (When driving in "D ₁ " or "D ₄ ".)	Battery voltage
		 When shift solenoid valve A is not operating. (When driving in "D ₂ " or "D ₃ ".)	1V or less
36	Shift solenoid valve B	 When shift solenoid valve B is operating. (When driving in "D ₁ " or "D ₂ ".)	Battery voltage
		 When shift solenoid valve B is not operating. (When driving in "D ₃ " or "D ₄ ".)	1V or less

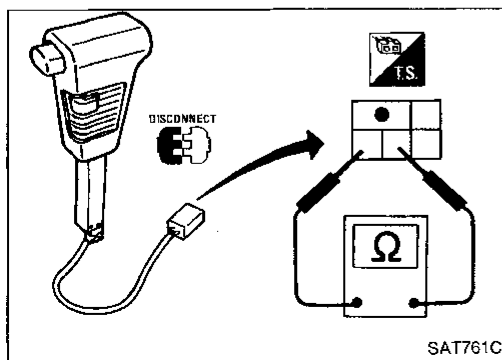

OVERDRIVE SWITCH

- Check continuity between two terminals.

OD switch position	Continuity
ON	No
OFF	Yes

Electrical Components Inspection (Cont'd)

INHIBITOR SWITCH

1. Check continuity between terminals ① and ② and between terminals ③ and ④, ⑤, ⑥, ⑦, ⑧, ⑨ while moving selector lever through each position.

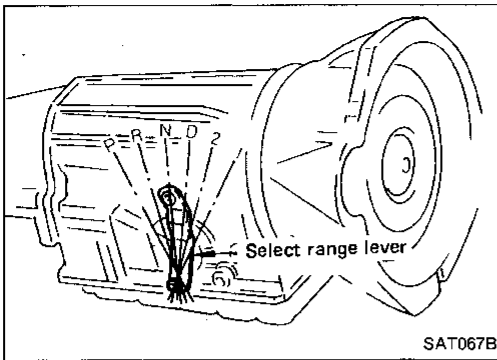

Lever position	Terminal No.								
	①	②	③	④	⑤	⑥	⑦	⑧	⑨
P	○—○		○—○						
R			○—○	○—○					
N	○—○		○—○		○—○				
D			○—○				○—○		
2			○—○					○—○	
1			○—○						○—○

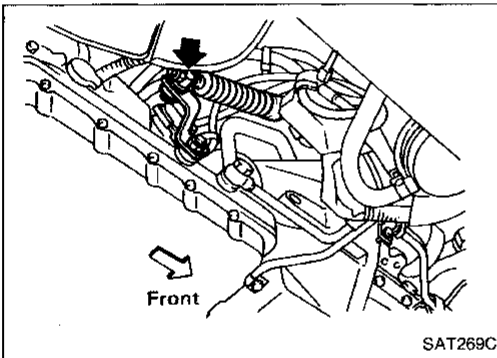
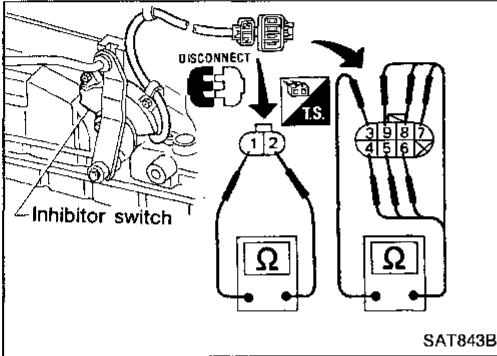

2. If NG, check again with manual control cable disconnected from manual shaft of A/T assembly. — Refer to step 1.
3. If OK on step 2, adjust manual control cable — Refer to "ON-VEHICLE SERVICE" (AT-106).

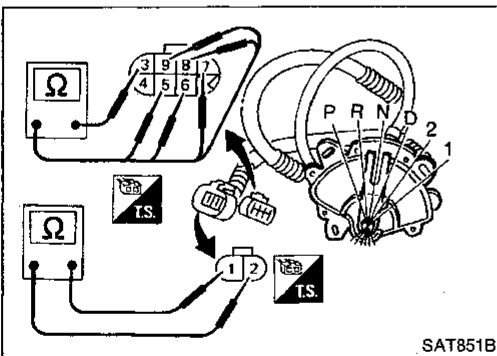

4. If NG on step 2, remove inhibitor switch from A/T and check continuity of inhibitor switch terminal. — Refer to step 1.
5. If OK on step 4, adjust inhibitor switch. — Refer to "ON-VEHICLE SERVICE" (AT-106).
6. If NG on step 4, replace inhibitor switch.

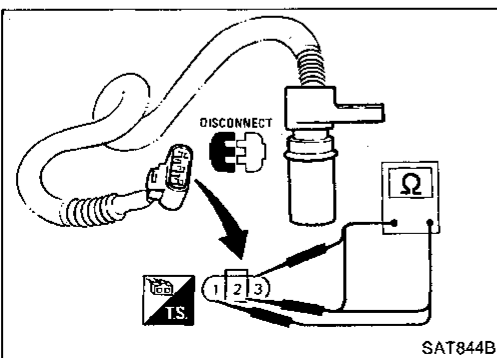

REVOLUTION SENSOR

- For removal and installation, refer to "ON-VEHICLE SERVICE" (AT-106).
- Check resistance between terminals ①, ② and ③.

Terminal No.		Resistance
①	②	500 - 650Ω
②	③	No continuity
①	③	No continuity

GI
MA
EM
LC
EF & EC
FE
CL
MT
AT
TF
PD
FA
RA
BR
ST
BF
HA
EL
IDX

Electrical Components Inspection (Cont'd)

FLUID TEMPERATURE SENSOR

- For removal and installation, refer to "ON-VEHICLE SERVICE" (AT-106).
- Check resistance between two terminals while changing temperature as shown at left.

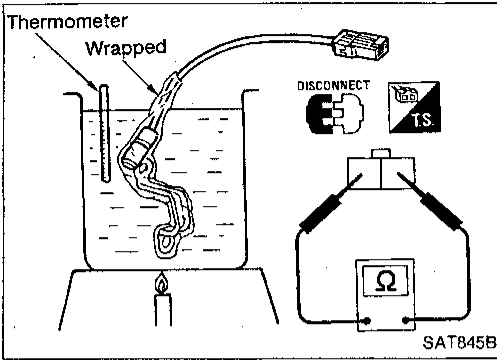

Temperature °C (°F)	Resistance
20 (68)	Approximately 2.5 kΩ
80 (176)	Approximately 0.3 kΩ

TORQUE CONVERTER CLUTCH SOLENOID VALVE

- For removal and installation, refer to "ON-VEHICLE SERVICE" (AT-106).
- Check resistance between two terminals.
Resistance: 10 - 16Ω

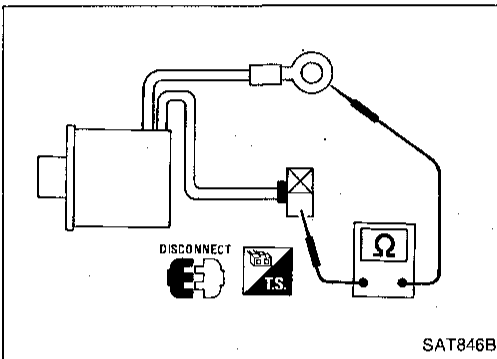

3-UNIT SOLENOID VALVE ASSEMBLY (Shift solenoid valves A, B and overrun clutch solenoid valve) AND LINE PRESSURE SOLENOID VALVE

- For removal and installation, refer to "ON-VEHICLE SERVICE" (AT-106).
- Check resistance between terminals of each solenoid.

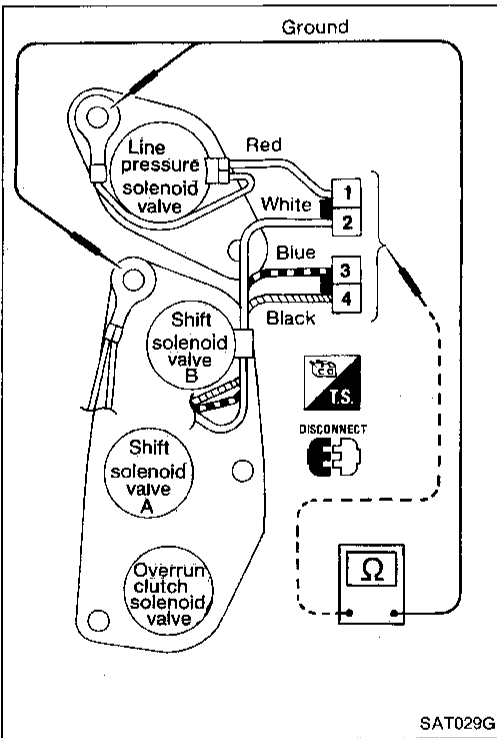

Solenoid	Terminal No.	Resistance
Shift solenoid valve A	③	20 - 30Ω
Shift solenoid valve B	②	
Overrun clutch solenoid valve	④	
Line pressure solenoid valve	①	2.5 - 5Ω

DROPPING RESISTOR

- Check resistance between two terminals.
Resistance: 11.2 - 12.8Ω

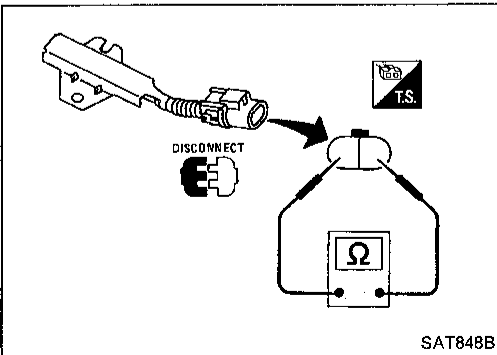

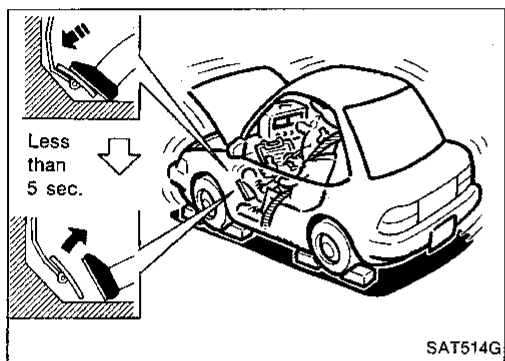
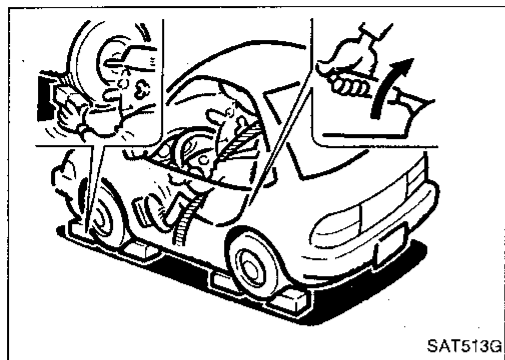

Final Check

STALL TESTING

Stall test procedure

1. Check A/T and engine fluid levels. If necessary, add.
2. Warm up engine until engine oil and ATF reach operating temperature after vehicle has been driven approx. 10 minutes.

ATF operating temperature:

50 - 80°C (122 - 176°F)

3. Set parking brake and block wheels.
4. Install a tachometer where it can be seen by driver during test.
- **It is good practice to put a mark on point of specified engine speed on indicator.**
5. Start engine, apply foot brake, and place selector lever in "D" position.
6. Accelerate to wide-open throttle gradually while applying foot brake.
7. Quickly note the engine stall revolution and immediately release throttle.

- **During test, never hold throttle wide-open for more than 5 seconds.**

Stall revolution:

2,260 - 2,510 rpm

8. Shift selector lever to "N".
9. Cool off ATF
- **Run engine at idle for at least one minute.**
10. Perform stall tests in the same manner as in steps 5 through 9 with selector lever in "2", "1" and "R", respectively.

JUDGEMENT OF STALL TEST

The test result and possible damaged components relating to each result are shown in the illustration. In order to pinpoint the possible damaged components, follow the WORK FLOW shown in AT-15.

Note

Stall revolution is too high in "D" or "2" position:

- Slippage occurs in 1st gear but not in 2nd and 3rd gears. Low one-way clutch slippage
- Slippage occurs in 1st through 3rd gears in "D" position and engine brake functions with power shift switch set to "POWER", or slippage occurs in 1st and 2nd gears in "2" position and engine brake functions with accelerator pedal completely released (fully closed throttle). Forward clutch or forward one-way clutch slippage

Stall revolution is too high in "R" position:

- Engine brake does not function in "1" position. Low & reverse brake slippage
- Engine brake functions in "1" position. Reverse clutch slippage

Stall revolution within specifications:

- Vehicle does not achieve speed of more than 80 km/h. One-way clutch seizure in torque converter housing

CAUTION:

Be careful since automatic fluid temperature increases abnormally.

- Slippage occurs in 3rd and 4th gears in "D" position. High clutch slippage
- Slippage occurs in 2nd and 4th gear in "D" position. Brake band slippage

Stall revolution less than specifications:

- Poor acceleration during starts. One-way clutch seizure in torque converter

Final Check (Cont'd)

Judgement of stall test

Selector lever position	Judgement		
	L	O	H
D	L	O	H
2	L	O	H
1	L	O	O
R	L	H	H

O : Stall revolution is normal.
 H : Stall revolution is higher than specified.
 L : Stall revolution is lower than specified.

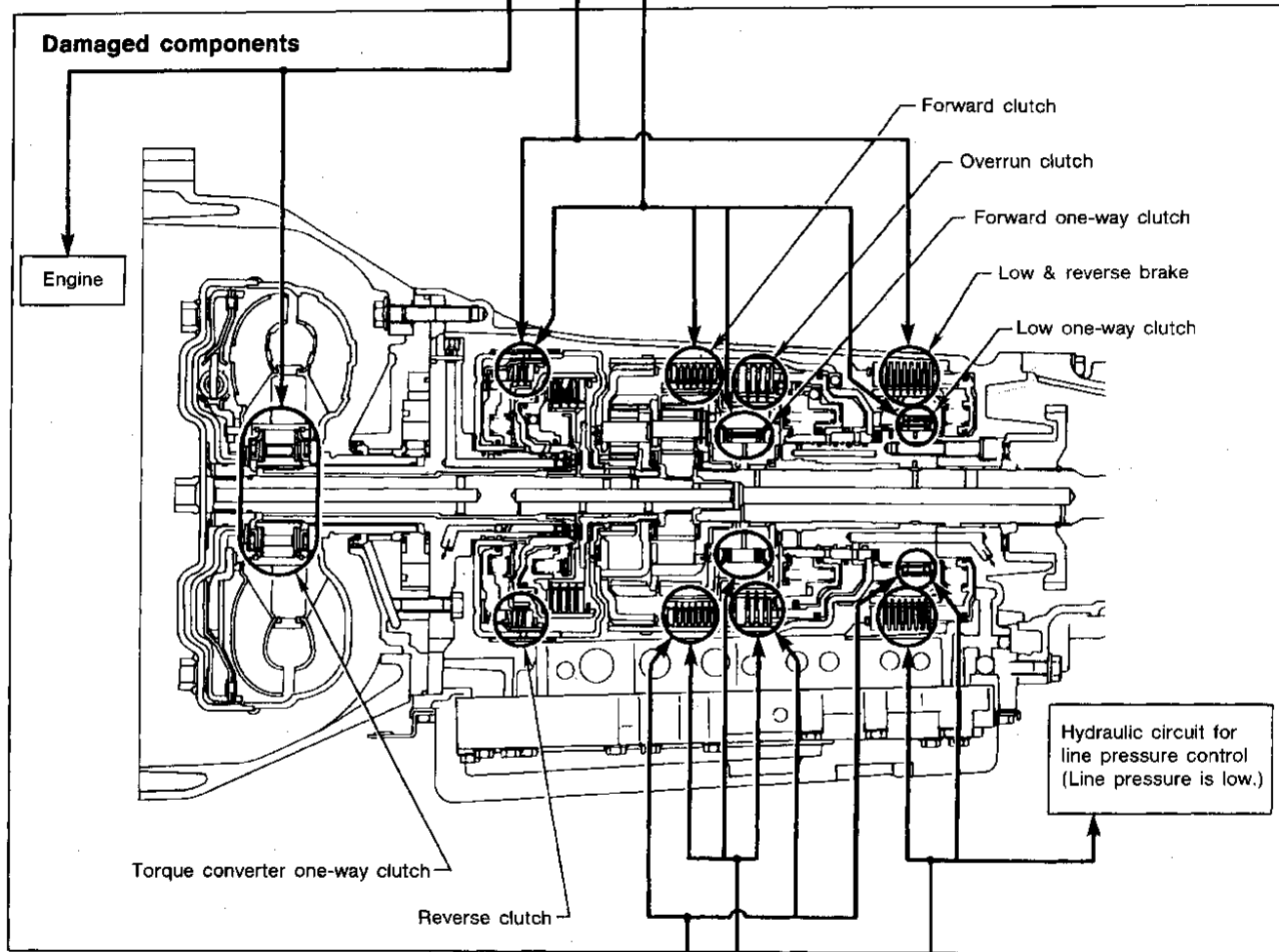

Clutches and brakes except high clutch and brake band are OK. (Condition of high clutch and brake band can not be confirmed by stall test.)

D	H	H	H	O
2	H	H	H	O
1	O	H	H	O
R	O	O	H	O
Selector lever position	Judgement			

Final Check (Cont'd)

PRESSURE TESTING

- Location of line pressure test port
- Line pressure plugs are hexagon headed bolts.
- Always replace line pressure plugs as they are self-sealing bolts.

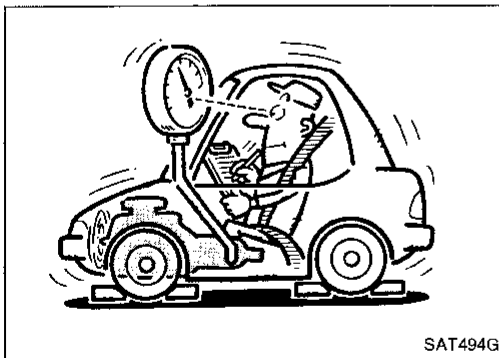
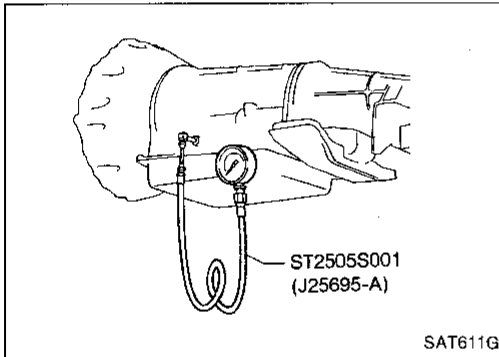
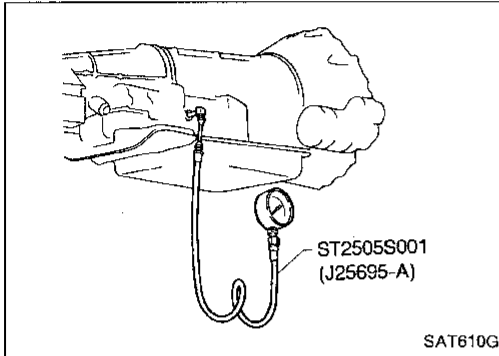
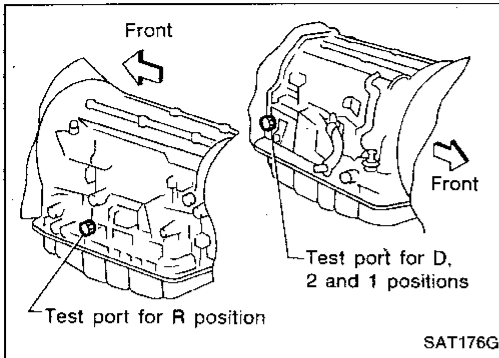

Line pressure test procedure

1. Check A/T and engine fluid levels. If necessary, add.
2. Warm up engine until engine oil and ATF reach operating temperature after vehicle has been driven approx. 10 minutes.

ATF operating temperature:
50 - 80°C (122 - 176°F)

3. Install pressure gauge to line pressure port.

— D, 2 and 1 positions —

— R position —

4. Set parking brake and block wheels.
 - Continue to depress brake pedal fully while line pressure test at stall speed is performed.

5. Start engine and measure line pressure at idle and stall speed.

- When measuring line pressure at stall speed, follow the stall test procedure.

Line pressure:

Engine speed rpm	Line pressure kPa (kg/cm ² , psi)	
	D, 2 and 1 positions	R position
Idle	442 - 461 (4.3 - 4.7, 61 - 67)	667 - 706 (6.8 - 7.2, 97 - 102)
Stall	1,020 - 1,098 (10.4 - 11.2, 148 - 159)	1,422 - 1,500 (14.5 - 15.3, 206 - 218)

GI

MA

EM

LC

EF & EC

FE

CL

MT

AT

TF

PD

FA

RA

BR

ST

BF

HA

EL

IDX

Final Check (Cont'd)

JUDGEMENT OF LINE PRESSURE TEST

Judgement		Suspected parts
At idle	Line pressure is low in all positions.	<ul style="list-style-type: none"> ● Oil pump wear ● Control piston damage ● Pressure regulator valve or plug sticking ● Spring for pressure regulator valve damaged ● Fluid pressure leakage between oil strainer and pressure regulator valve
	Line pressure is low in particular position.	<ul style="list-style-type: none"> ● Fluid pressure leakage between manual valve and particular clutch. ● For example: If line pressure is low in "R" and "1" positions but is normal in "D" and "2" positions, fluid leakage exists at or around low & reverse brake circuit.
	Line pressure is high.	<ul style="list-style-type: none"> ● Mal-adjustment of throttle position sensor ● Fluid temperature sensor damaged ● Line pressure solenoid valve sticking ● Short circuit of line pressure solenoid valve circuit ● Pressure modifier valve sticking ● Pressure regulator valve or plug sticking
At stall speed	Line pressure is low.	<ul style="list-style-type: none"> ● Mal-adjustment of throttle position sensor ● Control piston damaged ● Line pressure solenoid valve sticking ● Short circuit of line pressure solenoid valve circuit ● Pressure regulator valve or plug sticking ● Pressure modifier valve sticking ● Pilot valve sticking

Symptom Chart

Reference page (AT-)		ON vehicle										OFF vehicle																					
		20, 110	71	71	75	140, 72	72	72	72, 106	106	106	122, 136	167, 171	173, 183	173, 181	177	190																
Reference page (AT-)	Numbers are arranged in order of probability. Perform inspections starting with number one and work up. Circled numbers indicate that the transmission must be removed from the vehicle.	Fluid level	Control linkage inhibitor switch	Throttle position sensor (Adjustment)	Revolution sensor and vehicle speed sensor	Engine speed signal	Engine idling speed	Line pressure	Control valve assembly	Shift solenoid valve A	Shift solenoid valve B	Line pressure solenoid valve	Torque converter clutch solenoid valve	Overrun clutch solenoid valve	Fluid temperature sensor	Accumulator N-D	Accumulator 1-2	Accumulator 2-3	Accumulator 3-4 (N-R)	Ignition switch and starter	Torque converter	Oil pump	Reverse clutch	High clutch	Forward clutch	Forward one-way clutch	Overrun clutch	Low one-way clutch	Low & reverse brake	Brake band	Parking components		
		54	Engine does not start in "N", "P" positions.	2	3																	1											
54	Engine starts in position other than "N" and "P".	1	2																														
—	Transmission noise in "P" and "N" positions.	1		3	4	5	2															7	6										
54	Vehicle moves when changing into "P" position or parking gear does not disengage when shifted out of "P" position.	1																													2		
55	Vehicle runs in "N" position.	1																															
57	Vehicle will not run in "R" position (but runs in "D", "2" and "1" positions). Clutch slips. Very poor acceleration.	1					2	4		3														5	6	7	8	9					
—	Vehicle braked when shifting into "R" position.	1	2				3	5		4														6	8	9	9			7			
—	Sharp shock in shifting from "N" to "D" position.			2	5	1	3	7		6			4	8												9							
—	Vehicle will not run in "D" and "2" positions (but runs in "1" and "R" position).	1																										2					
58	Vehicle will not run in "D", "1", "2" positions (but runs in "R" position). Clutch slips. Very poor acceleration.	1					2	4		3			5											6	7	8	9	10					
—	Clutches or brakes slip somewhat in starting.	1	2	3			4	6		5			7										13	12	11	9				11			
—	Excessive creep.					1																											
57, 58	No creep at all.	1					2	3															6	5		4							
—	Failure to change gear from "D ₁ " to "D ₂ ".	2	1	5			4	3																							6		
—	Failure to change gear from "D ₂ " to "D ₃ ".	2	1	5			4	3																	6						7		
—	Failure to change gear from "D ₃ " to "D ₄ ".	2	1	4			3						5																		6		
60, 61, 62	Too high a gear change point from "D ₁ " to "D ₂ ", from "D ₂ " to "D ₃ ", from "D ₃ " to "D ₄ ".			1	2			3	4																								
—	Gear change directly from "D ₁ " to "D ₃ " occurs.	1														2															3		
—	Engine stops when shifting lever into "R", "D", "2" and "1".					1	3			2													4										
—	Too sharp a shock in change from "D ₁ " to "D ₂ ".			1			2	4					5	3																	6		
—	Too sharp a shock in change from "D ₂ " to "D ₃ ".			1			2	4																	5						6		
—	Too sharp a shock in change from "D ₃ " to "D ₄ ".			1			2	4																			5			5			
—	Almost no shock or clutches slipping in change from "D ₁ " to "D ₂ ".	1		2			3	5								4															6		
—	Almost no shock or slipping in change from "D ₂ " to "D ₃ ".	1		2			3	5																		6					7		
—	Almost no shock or slipping in change from "D ₃ " to "D ₄ ".	1		2			3	5																		6					7		
—	Vehicle braked by gear change from "D ₁ " to "D ₂ ".	1																							2	4			5	3			
—	Vehicle braked by gear change from "D ₂ " to "D ₃ ".	1																													2		
—	Vehicle braked by gear change from "D ₃ " to "D ₄ ".	1																							4		3	2					
—	Maximum speed not attained. Acceleration poor.	1	2				5	3	4														11	10	6	7				9	8		
—	Failure to change gear from "D ₄ " to "D ₃ ".	1		2			6	4	5	3																		8		7			
—	Failure to change gear from "D ₃ " to "D ₂ " or from "D ₄ " to "D ₂ ".	1		2			5	3	4																						7		

GI
MA
EM
LC
EF &
EC
FE
CL
WT
AT
TF
PD
FA
RA
BR
ST
BF
HA
EL
IDX

Preliminary Check (Prior to Road Testing)

FLUID LEAKAGE CHECK

1. Clean area suspected of leaking, — for example, mating surface of converter housing and transmission case.
2. Start engine, apply foot brake, place selector lever in "D" position and wait a few minutes.
3. Stop engine.
4. Check for fresh leakage.

FLUID CONDITION CHECK

Fluid color	Suspected problem
Dark or black with burned odor	Wear of frictional material
Milky pink	Water contamination — Road water entering through filler tube or breather
Varnished fluid, light to dark brown and tacky	Oxidation — Over or under filling — Overheating

FLUID LEVEL CHECK — Refer to section MA.

GI

MA

EM

LC

EF &
EC

FE

CL

MT

AT

TF

PD

FA

RA

BR

ST

BF

HA

EL

IDX

Road Testing

Perform road tests using "Symptom" chart. Refer to page (AT-77).

"P" POSITION

1. Place selector lever in "P" position and start the engine. Stop the engine and repeat the procedure in all positions, including neutral position.
2. Stop vehicle on a slight upgrade and place selector lever in "P" position. Release parking brake to make sure vehicle remains locked.

"R" POSITION

1. Manually move selector lever from "P" or "R", and note shift quality.
2. Drive vehicle in reverse long enough to detect slippage or other abnormalities.

"N" POSITION

1. Manually move selector lever from "R" and "D" to "N" and note quality.
2. Release parking brake with selector lever in "N" position. Lightly depress accelerator pedal to make sure vehicle does not move. (When vehicle is new or soon after clutches have been replaced, vehicle may move slightly. This is not a problem.)

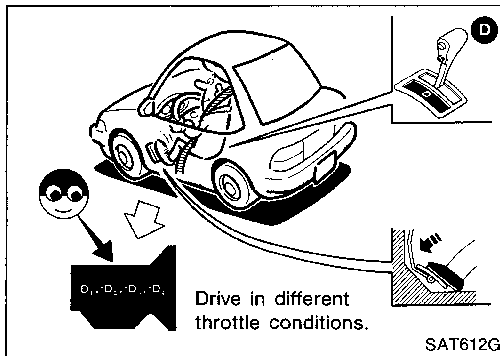

"D" POSITION

1. Manually shift selector lever from "N" to "D" position, and note shift quality.
2. Using the shift schedule as a reference, drive vehicle in "D" position. Record, on symptom chart, respective vehicle speeds, at which up-shifting and down-shifting occur. These speeds are to be read at three different throttle positions (light, half and full), respectively. Also determine the timing at which shocks are encountered during shifting and which clutches are engages.
3. Determine, by observing lock-up pressure, whether lock-up properly occurs while driving vehicle in proper gear position.
4. Check to determine if shifting to overdrive gear cannot be made while OD control switch is "OFF".
5. When vehicle is being driven in the 65 to 80 km/h (40 to 50 MPH) position in "D₃" position at half to light throttle position, fully depress accelerator pedal to make sure it downshifts from 3rd to 2nd gear.
6. When vehicle is being driven in the 35 to 45 km/h (22 to 28 MPH) ("D₂" position) at half to light throttle position, fully depress accelerator pedal to make sure it downshifts from 2nd to 1st gear.

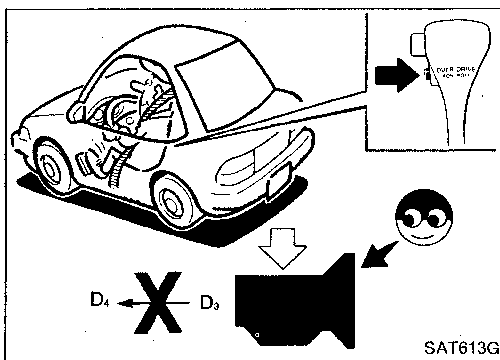

"2" POSITION

1. Shift to "2" position and make sure vehicle begins to move in 1st gear.
2. Increase vehicle speed to make sure it upshifts from 1st to 2nd gear.
3. Further increase vehicle speed. Make sure it does not upshift to 3rd gear.
4. While driving vehicle at the 35 to 45 km/h (22 to 28 MPH) with throttle at half to light position ("2" position), fully depress accelerator pedal to make sure it downshifts from 2nd to 1st gear.
5. Allow vehicle to run idle while in "2" position to make sure that it downshifts to 1st gear.
6. Move selector lever to "D" position and allow vehicle to operate at 40 to 50 km/h (25 to 31 MPH). Then, shift to "2" position to make sure it downshifts to 2nd gear.

Road Testing (Cont'd)

"1" POSITION

1. Place selector lever in "1" position and accelerate vehicle. Make sure it does not shift from 1st to 2nd gear although vehicle speed increases.
2. While vehicle is being driven in "1" position, release accelerator pedal to make sure that engine compression acts as a brake.
3. Place selector lever in "D" or "2" position and allow vehicle to run at 20 to 30 km/h (12 to 19 MPH). Then move selector lever to "1" position to make sure it downshifts to 1st gear.

SHIFT SCHEDULE

KA24E engine model

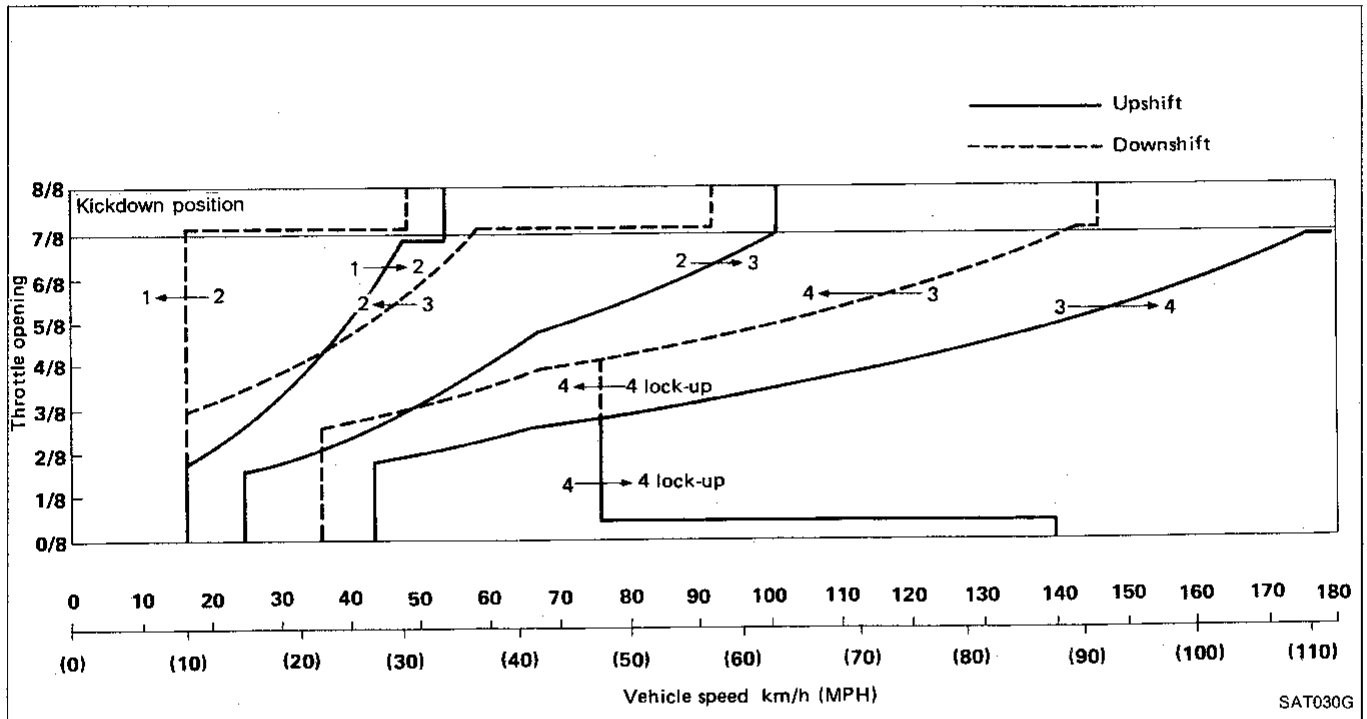

VEHICLE SPEED WHEN SHIFTING GEARS

KA24E engine

Throttle position	Vehicle speed km/h (MPH)						
	D ₁ → D ₂	D ₂ → D ₃	D ₃ → D ₄	D ₄ → D ₃	D ₃ → D ₂	D ₂ → D ₁	1 ₂ → 1 ₁
Full throttle	53 - 57 (33 - 35)	100 - 108 (62 - 67)	—	147 - 157 (91 - 98)	91 - 99 (57 - 62)	47 - 51 (29 - 32)	41 - 45 (25 - 28)
Half throttle	32 - 36 (20 - 22)	57 - 65 (35 - 40)	114 - 124 (71 - 77)	65 - 75 (40 - 47)	28 - 36 (17 - 22)	12 - 16 (7 - 10)	41 - 45 (25 - 28)

VEHICLE SPEED WHEN PERFORMING AND RELEASING LOCK-UP

KA24E engine

Throttle position	D ₄	
	Vehicle speed km/h (MPH)	
	Lock-up "ON"	Lock-up "OFF"
Full throttle	—	—
Half throttle	71 - 79 (44 - 49)	71 - 79 (44 - 49)

NOTE

Road Testing

ROAD TEST SYMPTOM CHART

Numbers are arranged in order of probability.
 Perform inspections starting with number one and work up.
 Circled numbers indicate that the transmission must be removed from the vehicle.

: Valve expected to be malfunctioning

		ON VEHICLE															
		Oil level and oil quality	Control linkage	Inhibitor switch and wiring	Throttle wire	Engine idling speed	Line pressure	Control valve	4th speed cut valve	Pressure regulator valve	Pressure modifier valve	1-2 shift valve	2-3 shift valve	3-4 shift valve	Accumulator control valve	3-2 downshift valve	2-3 throttle modifier valve
Sharp shocks in shifting from "N" to "D" position		1	2	.	5	3	4	8									
Shift shocks	When shifting from 1st to 2nd or 2nd to 3rd	1	2	.	4	.	3	7									
	When shifting from 3rd to 4th	1	2	.	4	.	3	6									
	When shifting from D to 2 and 1 position. When OD switch is set from "ON" to "OFF"	1	2	.	4	.	3	5									
	When shifting from 2nd to 1st in "1" position	1	2	.	4	.	3	5									
Shift slippage when upshifting	When shifting from 1st to 2nd	1	2	.	4	.	3	6									
	When shifting from 2nd to 3rd	1	2	.	4	.	3	6									
	When shifting from 3rd to 4th	1	2	.	4	.	3	6									
Shift slippage with accelerator pedal depressed	When shifting from 4th to 2nd	1	2	.	5	.	3	7									
	When shifting from 4th to 3rd	1	2	.	4	.	3	6									
	When shifting from 4th to 1st and shifting from 3rd to 1st	1	2	.	5	.	3	7									
Poor power/acceleration	When vehicle starts	1	2	.	5	.	3	10									
	When upshifting	1	2	.	4	.	3	8									
No engine braking	When shifting from "D" to "2" and "1" position	1	2	.	4	.	3	6									
	When OD switch is set from "ON" to "OFF"	1	2	.	4	.	3	8									
	When shifting from 2nd to 1st in "1" position	1	2	.	4	.	3	6									
Shift quality	Too low a gear change point from 2nd to 3rd and from 3rd to 2nd.	1	.	.	4	.	2	5									
	Too high a gear change point from 2nd to 3rd and from 3rd to 2nd.	1	.	.	4	.	2	5									
	Too low a gear change point from 2nd to 1st in "1" position.	1	.	.	4	.	2	5									
	Too high a gear change point from 2nd to 1st in "1" position.	1	.	.	4	.	2	5									

GI
 MA
 EM
 LC
 FF & EC
 FE
 CL
 MT
 AT
 TF
 PD
 FA
 RA
 BR
 ST
 BF
 HA
 EL
 IDX

TROUBLE DIAGNOSES

RL4R01A

Road Testing (Cont'd)

Numbers are arranged in order of probability.
 Perform inspections starting with number one and work up.
 Circled numbers indicate that the transmission must be removed from the vehicle.

: Valve expected to be malfunctioning

		← ON VEHICLE →															
		Oil level and oil quality	Control linkage	Inhibitor switch and wiring	Throttle wire	Engine idling speed	Line pressure	Control valve	4th speed cut valve	Pressure regulator valve	Pressure modifier valve	1-2 shift valve	2-3 shift valve	3-4 shift valve	Accumulator control valve	3-2 downshift valve	2-3 throttle modifier valve
Shift quality	Failure to change gear from 4th to 2nd with accelerator pedal depressed.	1	.	.	4	.	2	5									
	Failure to change gear from 3rd to 2nd with accelerator pedal depressed.	1	.	.	4	.	2	5									
	Failure to change gear from 1st to 2nd in "D" and "2" position.	1	.	.	4	.	2	5									
	Vehicle does not start from "1st" in "D" and "2" position.	1	.	.	4	.	2	5									
	Failure to change gear to 3rd to 4th in "D" position.	1	.	.	4	.	2	7									
	Changes gear to 1st directly when selector lever is set from "D" to "1" position.	1	.	.	4	.	2	5									
	Changes gear to 2nd in "1" position.	1	.	.	4	.	2	5									
Lock-up quality	Too high or low a change point when lock-up operates.	1	.	.	4	.	2	5									
	Lock-up point is extremely high or low.	1	.	.	4	.	2	5									
	Torque converter does not lock-up.	1	.	.	4	.	2	5									
	Lock-up is not released when accelerator pedal is released.	1									
	Engine does not start in "P" and "N" positions.	.	2	3									
	Engine starts in positions other than "P" and "N" positions.	.	2	3									

GI
 MA
 EM
 LC
 EF & EC
 FE
 CL
 MT
AT
 TF
 PD
 FA
 RA
 BR
 ST
 BF
 HA
 EL
 IX

Road Testing (Cont'd)

ON VEHICLE										OFF VEHICLE										
4-2 relay valve										Torque converter clutch control valve										
Torque converter clutch control valve										Throttle valve & detent valve										
Throttle valve & detent valve										Manual valve										
Manual valve										Kickdown modifier valve										
Kickdown modifier valve										1st reducing valve										
1st reducing valve										Overrun clutch reducing valve										
Overrun clutch reducing valve										3-2 timing valve										
3-2 timing valve										Torque converter relief valve										
Torque converter relief valve										4-2 sequence valve										
4-2 sequence valve										Governor pressure	3	6								
Governor pressure										Governor valve	3	6								
Governor valve										Primary governor valve										
Primary governor valve										Secondary governor valve ①										
Secondary governor valve ①										Secondary governor valve ②										
Secondary governor valve ②										OD cancel solenoid										
OD cancel solenoid										Torque converter clutch solenoid valve										
Torque converter clutch solenoid valve										Accumulator N-D										
Accumulator N-D										Accumulator 1-2										
Accumulator 1-2										Accumulator 2-3										
Accumulator 2-3										Accumulator 3-4 (N-R)										
Accumulator 3-4 (N-R)										Ignition switch and starter motor										
Ignition switch and starter motor										OD control switch and wiring										
OD control switch and wiring										Torque converter										
Torque converter										Oil pump										
Oil pump										Reverse clutch										
Reverse clutch										High clutch										
High clutch										Forward clutch										
Forward clutch										Forward one-ty clutch										
Forward one-ty clutch										Overrun clutch										
Overrun clutch										Low one-way clutch										
Low one-way clutch										Low & reverse clutch										
Low & reverse clutch										Brake band										
Brake band										Parking components										
Parking components																				

Stall Testing

STALL TEST PROCEDURE

1. Check A/T and engine fluid levels. If necessary, add.
2. Warm up engine until engine oil and ATF reach operating temperature after vehicle has been driven approx. 10 minutes.

**ATF operating temperature:
50 - 80°C (122 - 176°F)**

3. Set parking brake and block wheels.
4. Install a tachometer where it can be seen by driver during test.

It is good practice to put a mark on point of specified engine speed on indicator.

5. Start engine, apply foot brake, and place selector lever in "D" position.

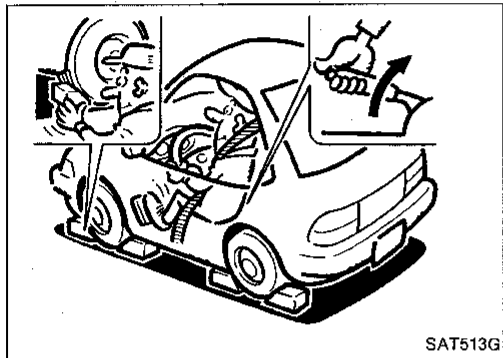

SAT513G

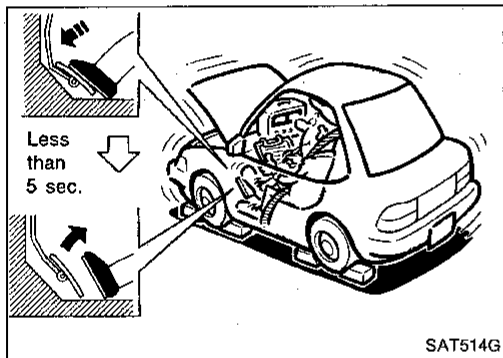

SAT514G

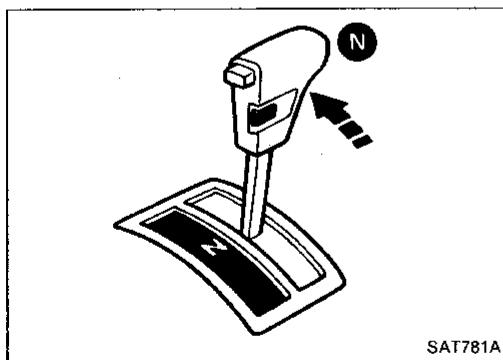

SAT781A

6. Accelerate to wide-open throttle gradually while applying foot brake.
7. Quickly note the engine stall revolution and immediately release throttle.

During test, never hold throttle wide-open for more than 5 seconds.

**Stall revolution:
2,100 - 2,300 rpm**

8. Shift selector lever to "N".
9. Cool off ATF.

Run engine at idle for at least one minute.

10. Perform stall tests in the same manner as in steps 5 through 9 with selector lever in "2", "1" and "R", respectively.

GI

MA

EM

LC

EF &
EC

FE

CL

MT

AT

TF

PD

FA

RA

BR

ST

BF

HA

EL

IDX

Stall Testing (Cont'd)

JUDGEMENT OF STALL TEST

Selector lever position	Judgement		
D	L	O	H
2	L	O	H
1	L	O	O
R	L	H	H

O : Stall revolution is normal.
 H : Stall revolution is higher than specified.
 L : Stall revolution is lower than specified.

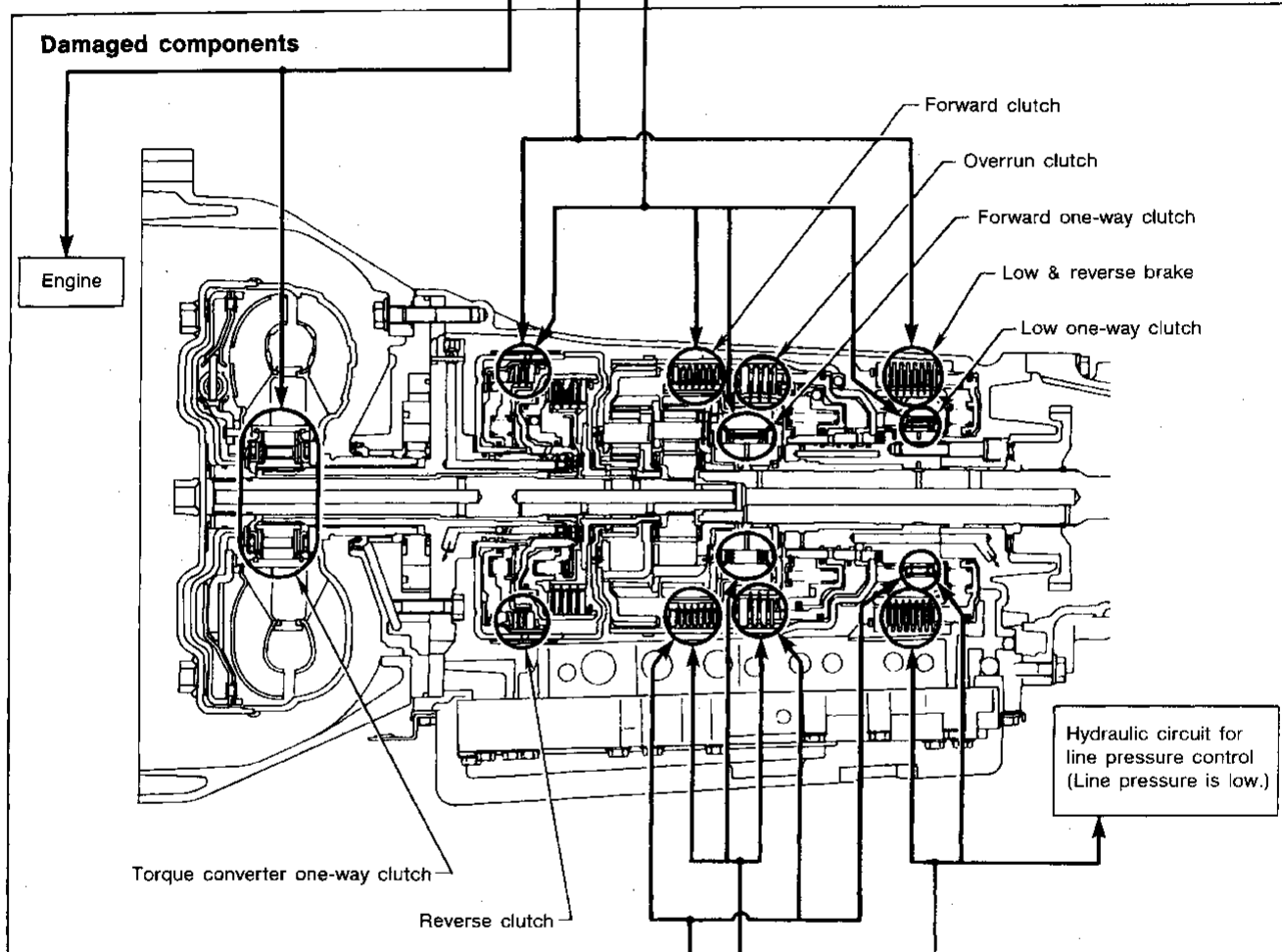

Clutches and brakes except high clutch and brake band are OK. (Condition of high clutch and brake band can not be confirmed by stall test.)

D	H	H	H	O
2	H	H	H	O
1	O	H	H	O
R	O	O	H	O
Selector lever position	Judgement			

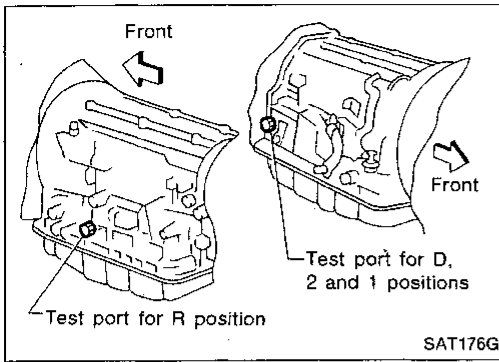

Pressure Testing

- Location of line pressure test port
- Line pressure plugs are hexagon headed bolts.
- Always replace line pressure plugs as they are self-sealing bolts.

LINE PRESSURE TEST PROCEDURE

1. Check A/T and engine fluid levels. If necessary, add.
2. Warm up engine until engine oil and ATF reach operating temperature after vehicle has been driven approx. 10 minutes.

ATF operating temperature:
50 - 80°C (122 - 176°F)

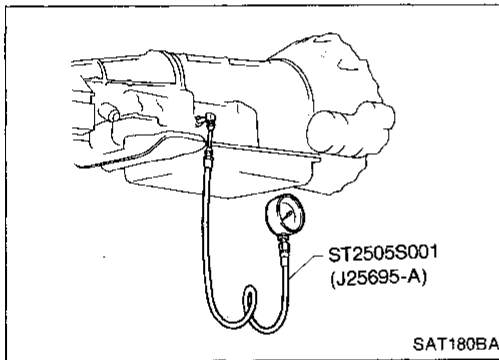

3. Install pressure gauge to line pressure port.
— D, 2 and 1 positions —

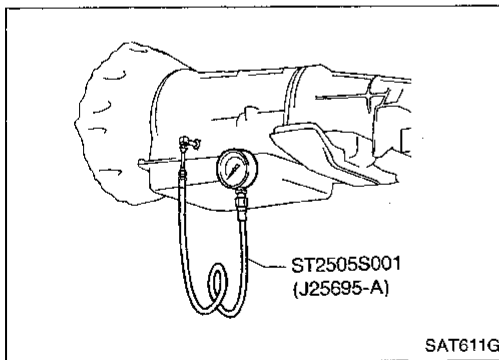

- R position —

4. Set parking brake and block wheels.
- Continue to depress brake pedal fully while line pressure test at stall speed is performed.

GI

MA

EM

LC

EF &
EC

FE

CL

MT

AT

TF

PD

FA

RA

BR

ST

BF

HA

EL

IDX

Pressure Testing (Cont'd)

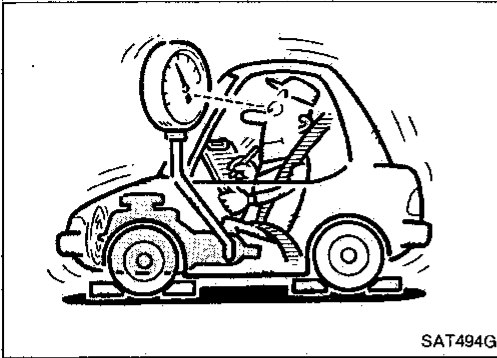

5. Start engine and measure line pressure at idle and stall speed.
- When measuring line pressure at stall speed, follow the stall test procedure.

Line pressure:

Engine speed rpm	Line pressure kPa (kg/cm ² , psi)	
	D, 2 and 1 positions	R position
Idle	422 - 461 (4.3 - 4.7, 61 - 67)	667 - 706 (6.8 - 7.2, 97 - 102)
Stall	883 - 961 (9.0 - 9.8, 128 - 139)	1,393 - 1,471 (14.2 - 15.0, 202 - 213)

JUDGEMENT OF LINE PRESSURE TEST

Judgement		Suspected parts
At idle	Line pressure is low in all positions.	<ul style="list-style-type: none"> ● Oil pump wear ● Control piston damage ● Pressure regulator valve or plug sticking ● Spring for pressure regulator valve damaged ● Fluid pressure leakage between oil strainer and pressure regulator valve
	Line pressure is low in particular position.	<ul style="list-style-type: none"> ● Fluid pressure leakage between manual valve and particular clutch. ● For example: If line pressure is low in "R" and "1" positions but is normal in "D" and "2" position, fluid leakage exists at or around low & reverse brake circuit.
	Line pressure is high.	<ul style="list-style-type: none"> ● Mal-adjustment of throttle position sensor ● Fluid temperature sensor damaged ● Line pressure solenoid valve sticking ● Short circuit of line pressure solenoid valve circuit ● Pressure modifier valve sticking ● Pressure regulator valve or plug sticking
At stall speed	Line pressure is low.	<ul style="list-style-type: none"> ● Mal-adjustment of throttle position sensor ● Control piston damaged ● Line pressure solenoid valve sticking ● Short circuit of line pressure solenoid valve circuit ● Pressure regulator valve or plug sticking ● Pressure modifier valve sticking ● Pilot valve sticking

Circuit Diagram

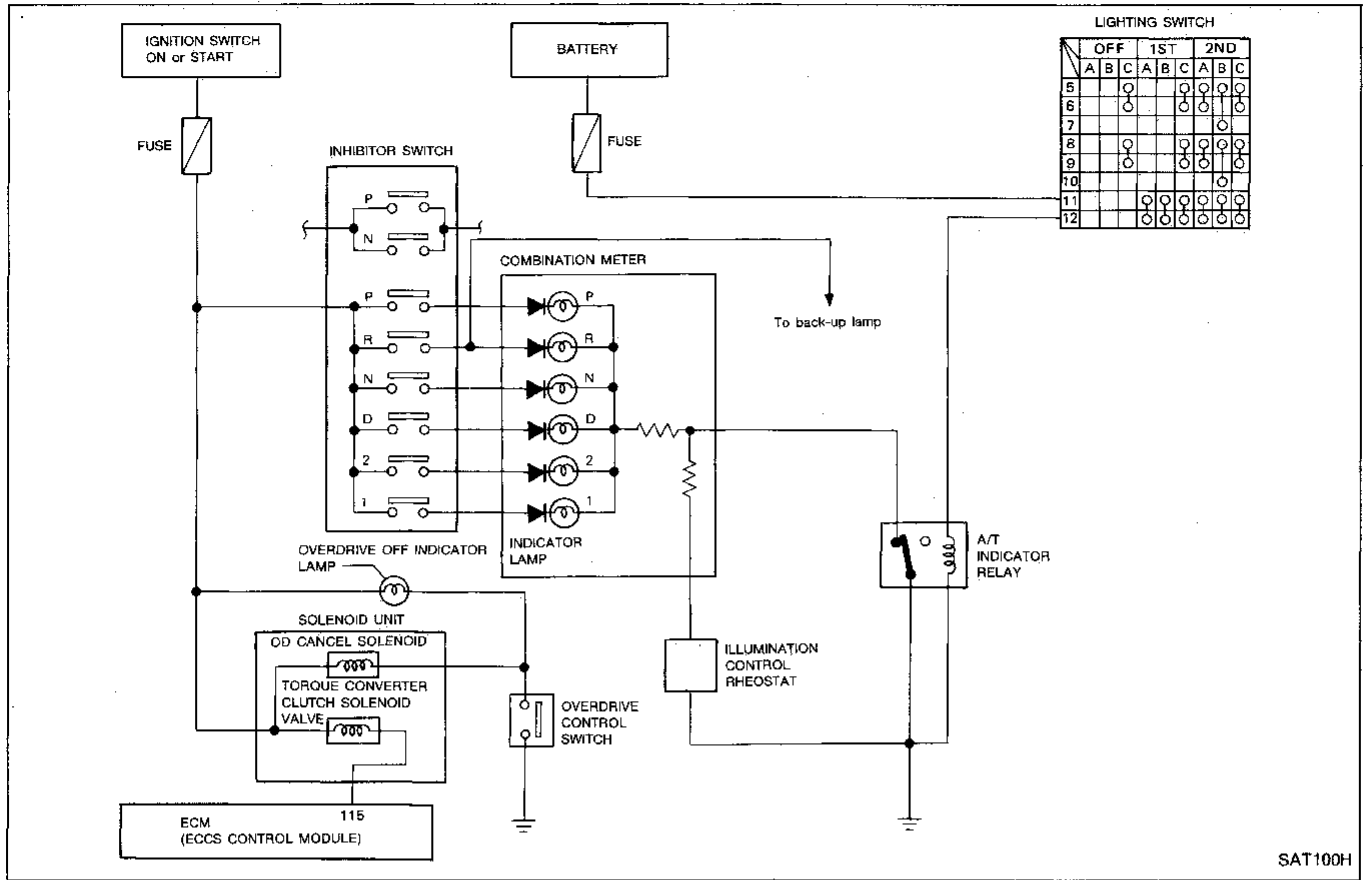

GI
MA
EM
LC
EF & EC
FE
CL
MT
AT

SAT100H

TF
PD
FA
RA
BR
ST
BF
HA
EL
IDX
639

Wiring Diagram

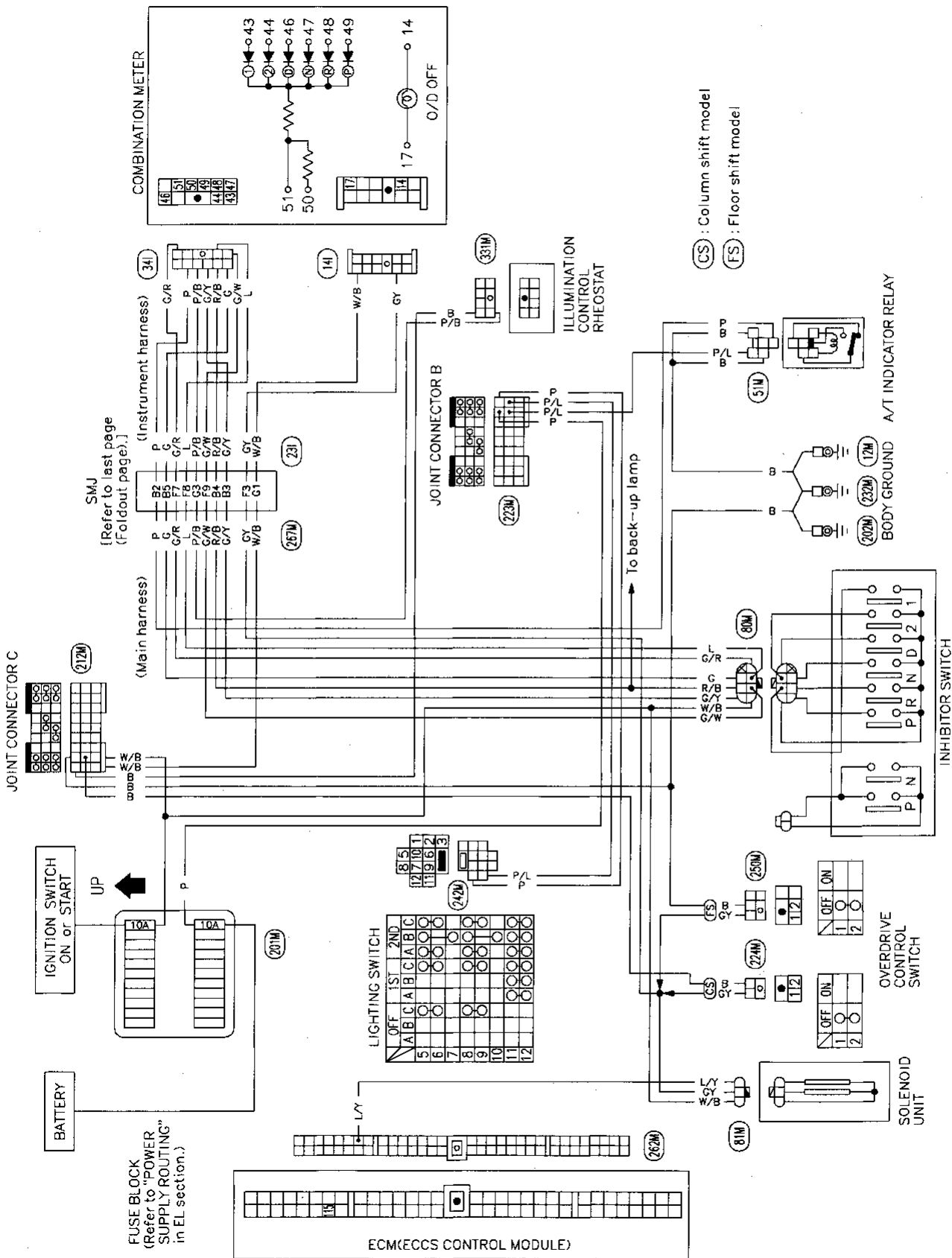

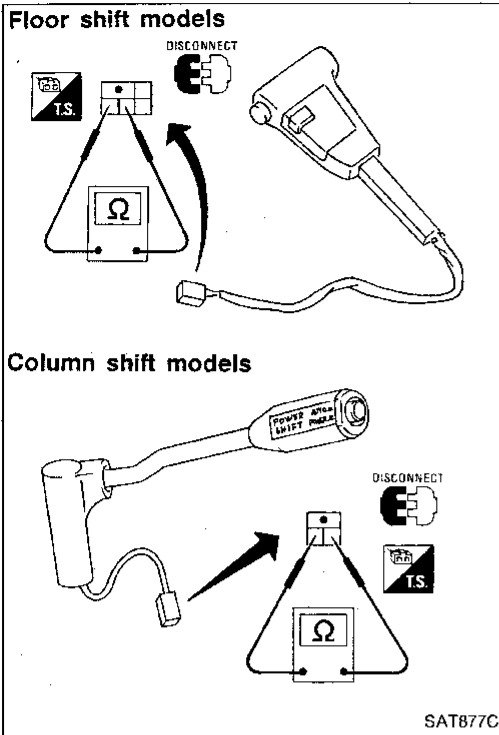

Electrical Components Inspection

OVERDRIVE SWITCH

- Check continuity between two terminals.

OD switch position	Continuity
ON	No
OFF	Yes

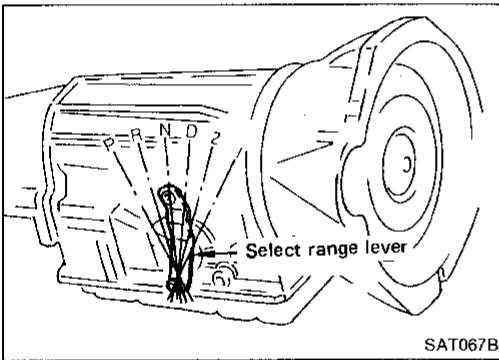

INHIBITOR SWITCH

1. Check continuity between terminals ① and ② and between terminals ③ and ④, ⑤, ⑥, ⑦, ⑧, ⑨ while moving selector lever through each position.

Lever position	Terminal No.								
	①	②	③	④	⑤	⑥	⑦	⑧	⑨
P	○—○		○—○						
R			○—○		○—○				
N	○—○		○—○			○—○			
D			○—○				○—○		
2			○—○					○—○	
1			○—○						○—○

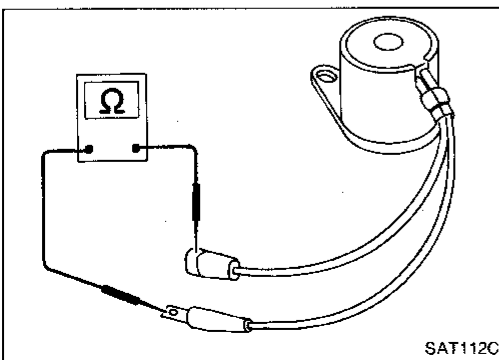
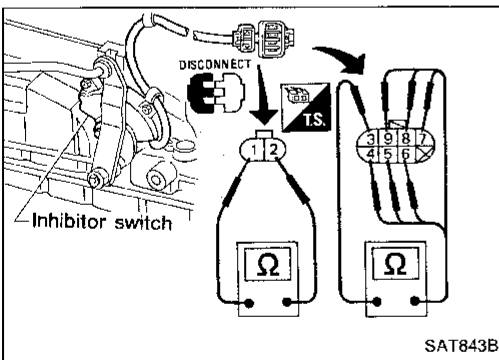

OD CANCEL SOLENOID AND TORQUE CONVERTER CLUTCH SOLENOID VALVE

- Check resistance between terminals of each solenoid.
Resistance: 20 - 30Ω

GI
MA
EM
LC
EF & EC
FE
CL
MT
AT
TF
PD
FA
RA
BR
ST
BF
HA
EL
LDX

Electrical Components Inspection (Cont'd)

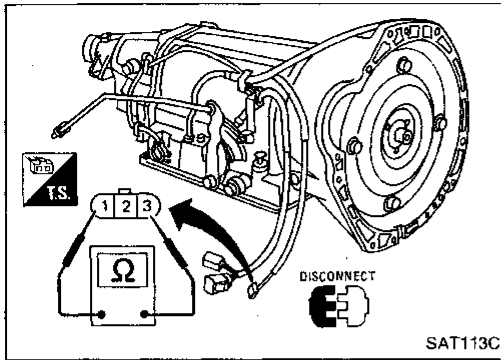

Solenoid	Terminal No.	Resistance
OD cancel solenoid	① - ②	20 - 30Ω
Torque converter clutch solenoid valve	① - ③	

TROUBLE DIAGNOSES — A/T Shift Lock System

Contents

Shift Lock System Electrical Parts Location	AT- 96	
Circuit Diagram for Quick Pinpoint Check	AT- 97	
Wiring Diagram	AT- 98	GI
Diagnostic Procedure	AT- 99	
SYMPTOM 1: Selector lever cannot be moved from "P" position when applying brake pedal or can be moved when releasing brake pedal.		MA
Selector lever can be moved from "P" position when key is removed from key cylinder.		
SYMPTOM 2: Ignition key cannot be removed when selector lever is set to "P" position or can be removed when selector lever is set to any position except "P".		EM
Key Interlock Cable	AT-103	
Shift Lock Control Unit Inspection	AT-104	LC
Shift Lock Control Unit Inspection Table	AT-104	EF & EC
Component Check	AT-105	
		FE
		CL
		MT
		AT
		TF
		PD
		FA
		RA
		BR
		ST
		BF
		HA
		EL
		IDX

Shift Lock System Electrical Parts Location

COLUMN SHIFT

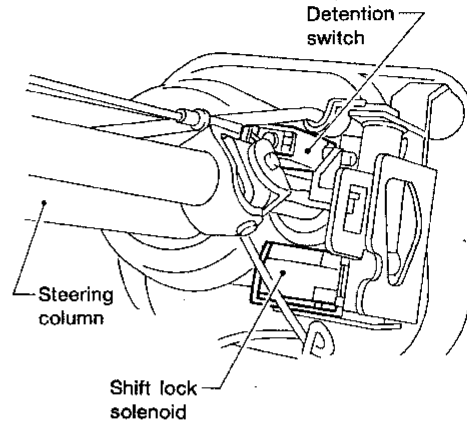
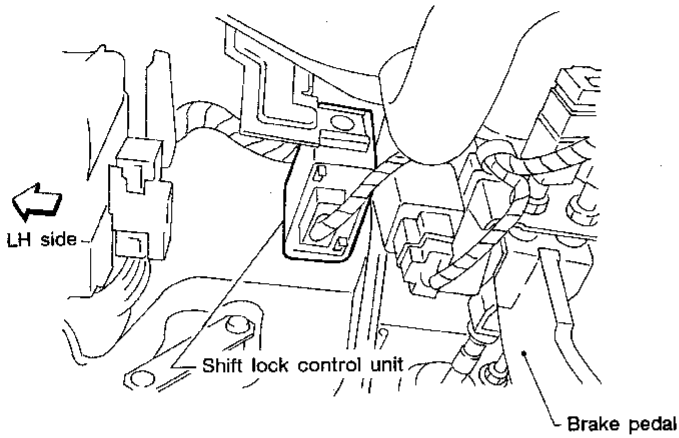

FLOOR SHIFT

2WD

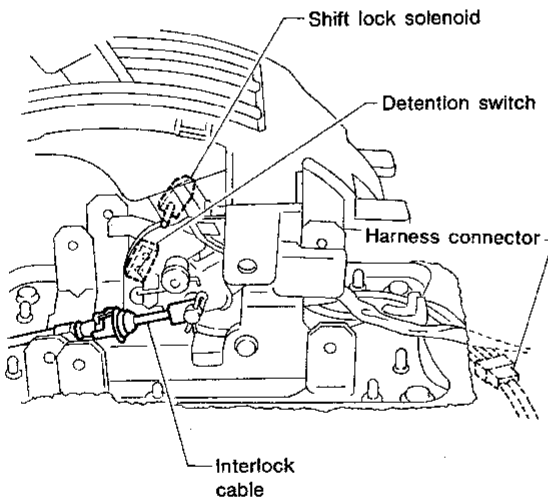

4WD

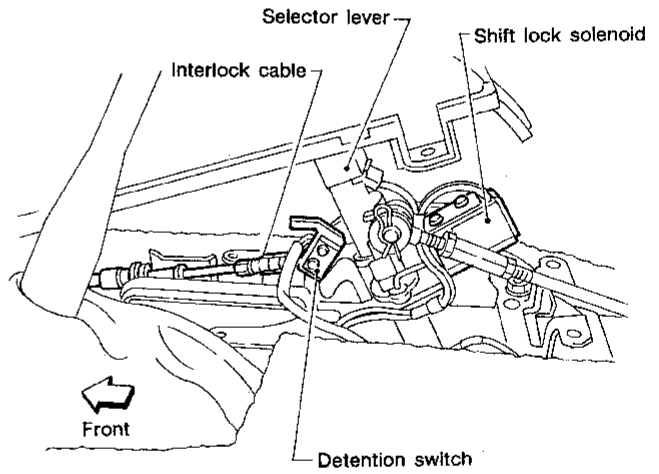

TROUBLE DIAGNOSES — A/T Shift Lock System

Circuit Diagram for Quick Pinpoint Check

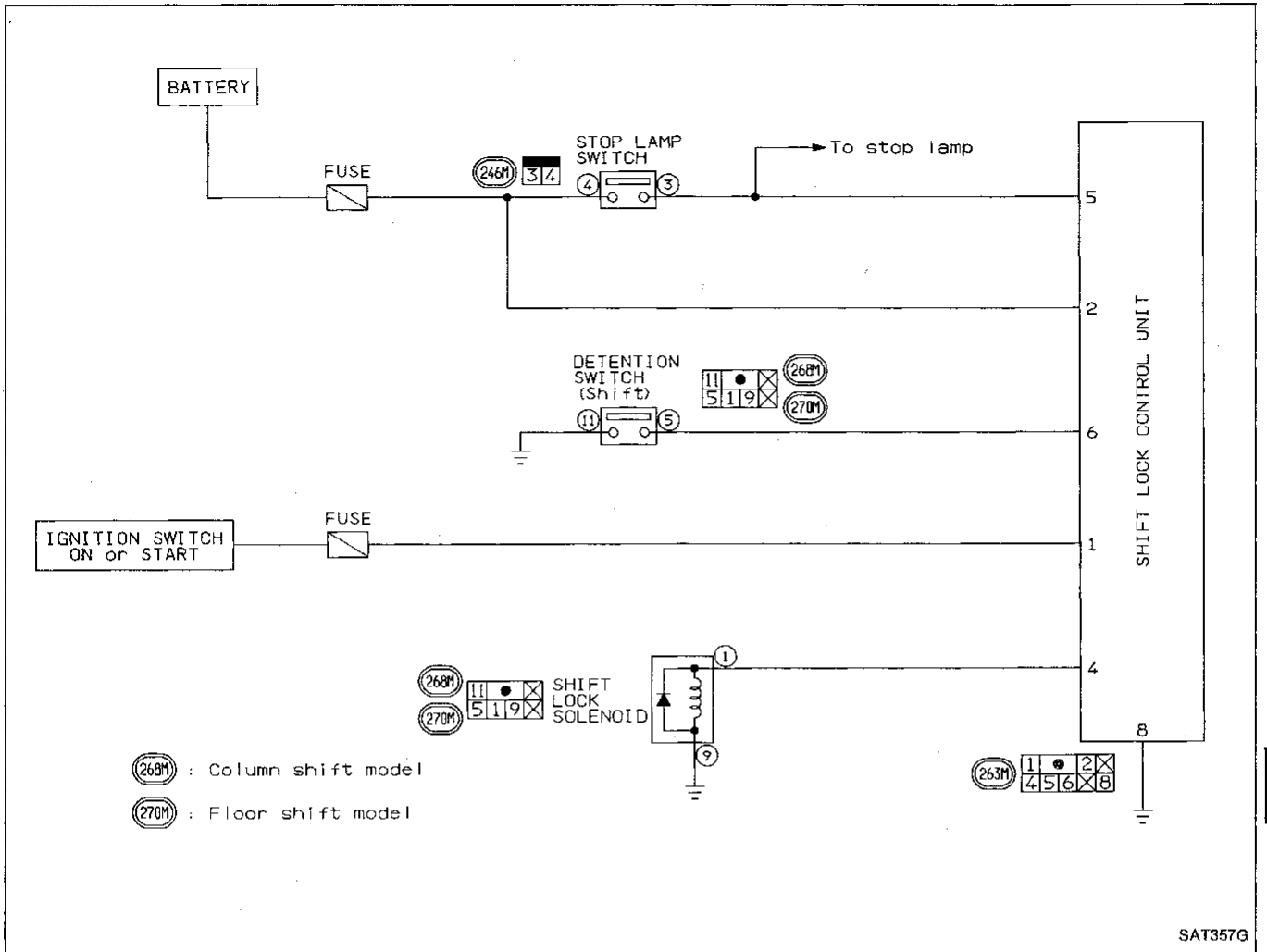

GI
 MA
 EM
 LC
 EF & EC
 FE
 CL
 MT
AT
 TF
 PD
 FA
 RA
 BR
 ST
 BF
 HA
 EL
 IDX

TROUBLE DIAGNOSES — A/T Shift Lock System

Wiring Diagram

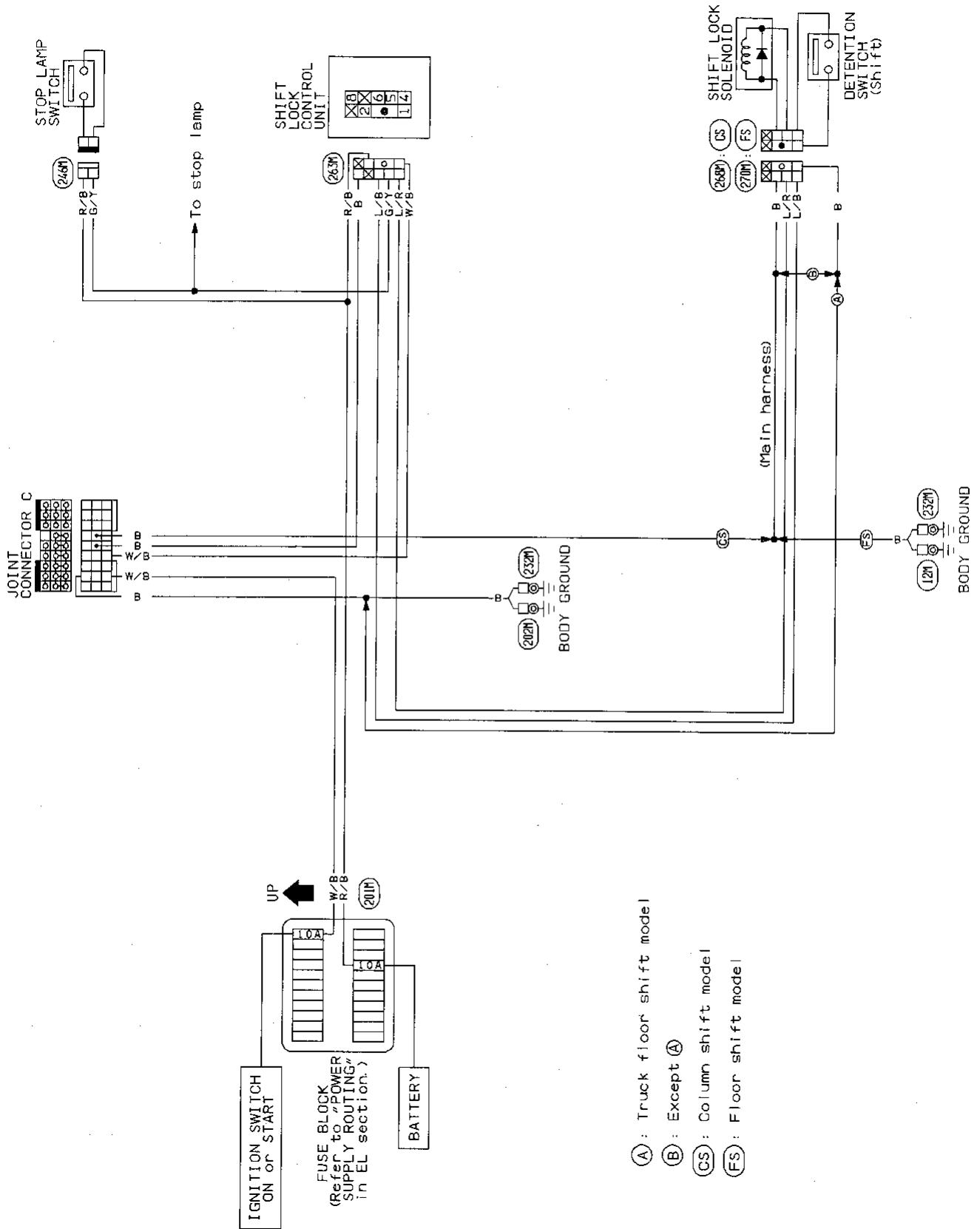

TROUBLE DIAGNOSES — A/T Shift Lock System

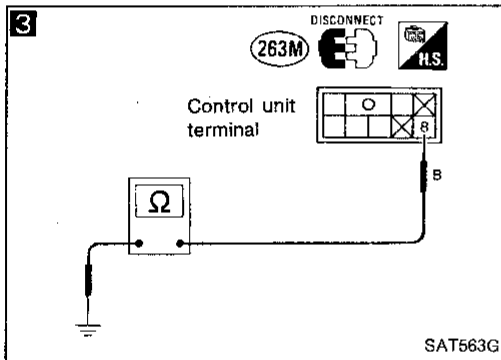
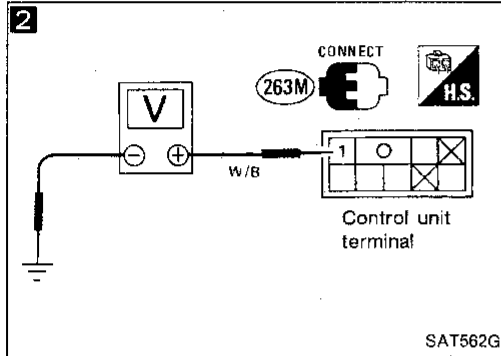
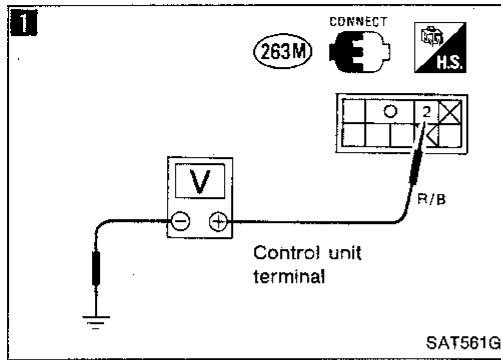

Diagnostic Procedure

SYMPTOM 1:

With key in "ON" position, selector lever cannot be moved from "P" position when applying brake pedal or can be moved when releasing brake pedal.

Selector lever can be moved from "P" position when key is removed from key cylinder.

SYMPTOM 2:

Ignition key cannot be removed when selector lever is set to "P" position or can be removed when selector lever is set to any position except "P".

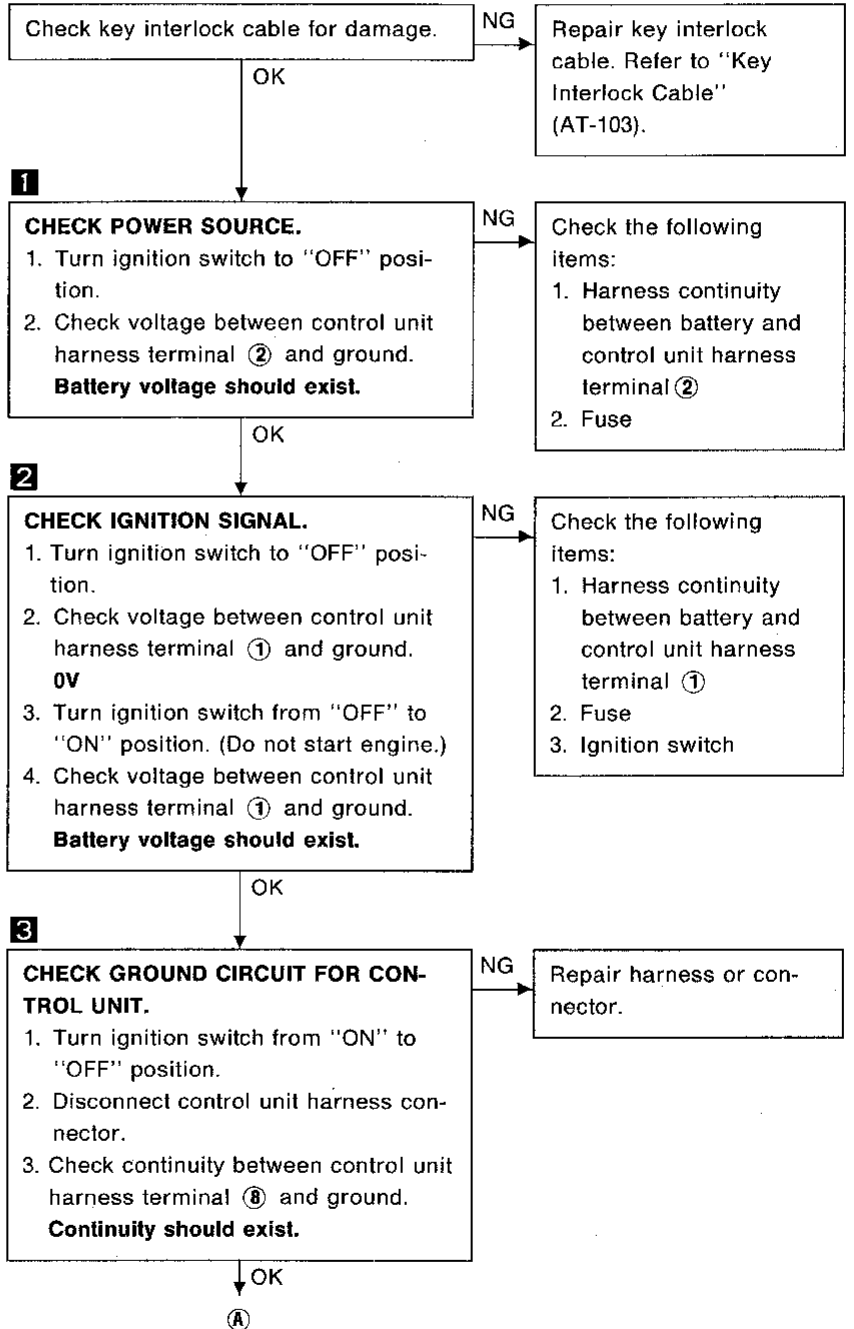

TROUBLE DIAGNOSES — A/T Shift Lock System

Diagnostic Procedure (Cont'd)

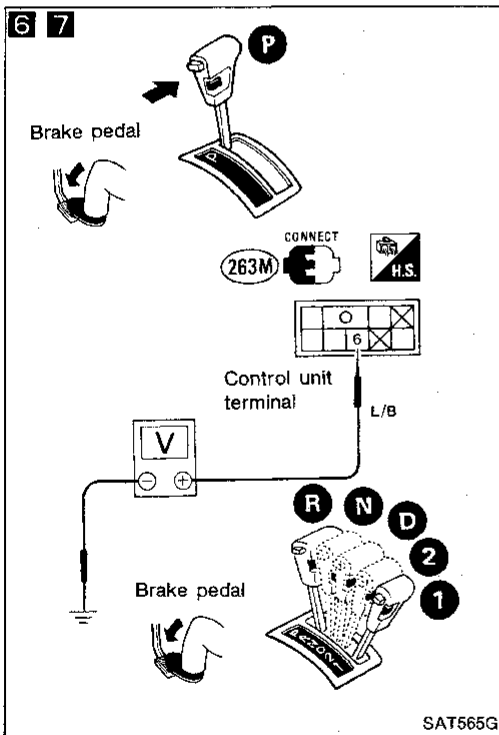
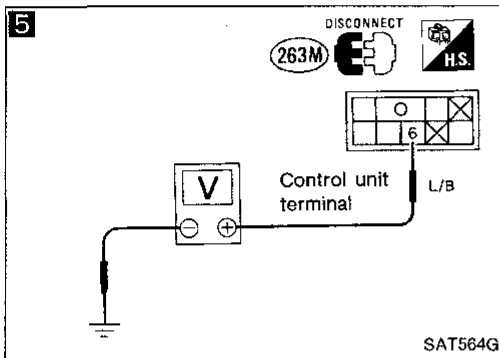
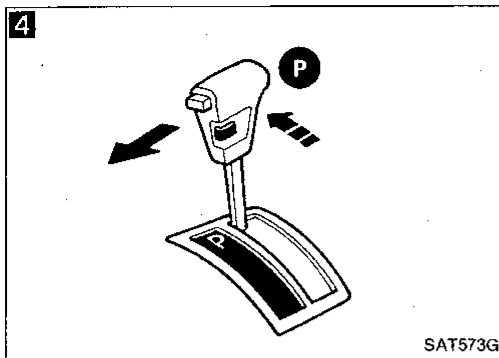

CHECK INPUT SIGNAL (DETENTION SWITCH).

1. Reconnect control unit harness connector.
2. Turn ignition switch from "OFF" to "ON" position. (Do not start engine.)

- 4** 3. Set selector lever in "P" position and release selector lever button.

When selector lever cannot be moved from "P" position with brake pedal depressed, set ignition key to "ACC" position and move lever. Then set ignition key to "ON" position.

- 5** 4. Disconnect control unit harness connector.
5. Check continuity between control unit harness terminal ⑥ and ground.

Continuity should not exist.

NG

Check detention switch—shift.
Refer to "COMPONENT CHECK" (AT-105).

OK

CHECK INPUT SIGNAL (DETENTION SWITCH).

1. Turn ignition switch to "ON" position. (Do not start engine.)

- 6** 2. Check continuity between control unit harness terminal ⑥ and ground with brake pedal depressed and selector lever button pushed.

Continuity should exist.

- 7** 3. Check continuity between control unit harness terminal ⑥ and ground with selector lever set in any position except "P".

Battery voltage should exist.

NG

Check the following items:

1. Harness continuity between control unit harness terminal ⑥ and detention switch harness terminal ⑥
2. Harness continuity between detention switch harness terminal ⑥ and ground
3. Detention switch
Refer to "COMPONENT CHECK" (AT-105).

OK

Ⓑ

TROUBLE DIAGNOSES — A/T Shift Lock System

Diagnostic Procedure (Cont'd)

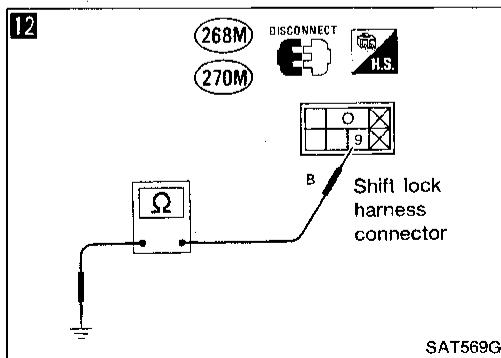
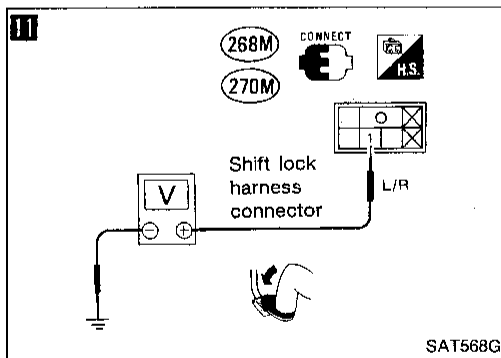
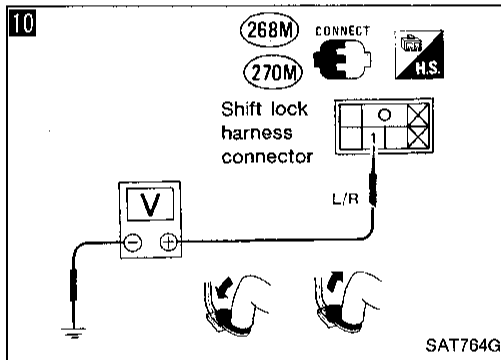
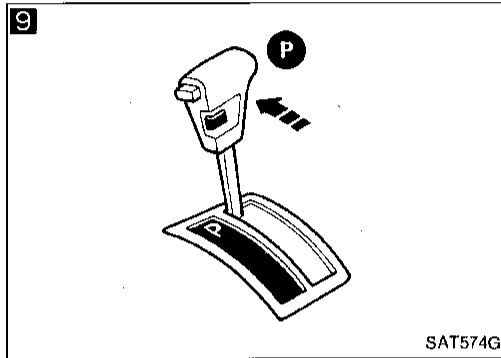
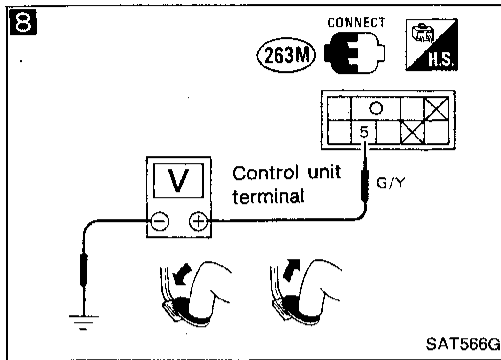

8

CHECK INPUT SIGNAL (STOP LAMP SWITCH).

1. Turn ignition switch to "ON" position. (Do not start engine.)
2. Check voltage between control unit harness terminal ⑤ and ground.

Brake pedal	Voltage
Depressed	Battery voltage
Released	0

NG → Check the following items:

1. Harness continuity between control unit harness terminal ⑤ and stop lamp switch harness terminal ②
2. Harness continuity between stop lamp switch harness terminal ② and fuse
3. Stop lamp switch Refer to "COMPONENT CHECK" (AT-105).

OK →

9

1. Set selector lever in "P" position.

CHECK OUTPUT SIGNAL (SHIFT LOCK SOLENOID).

2. Turn ignition switch to "ON" position. (Do not start engine.)
3. Check voltage between shift lock harness connector terminal ① and body ground.

Brake pedal	Voltage
Depressed	Battery voltage
Released	0

NG → Check harness continuity between control unit harness terminal ① and shift lock solenoid harness terminal ⑨ .

4. Turn ignition switch from "ON" to "OFF" position.
5. Check voltage between shift lock harness connector terminal ① and ground with brake pedal depressed.

0V

OK →

12

CHECK GROUND CIRCUIT FOR SHIFT LOCK SOLENOID.

1. Disconnect shift lock harness connector.
2. Check continuity between shift lock harness terminal ⑨ and ground. **Continuity should exist.**

NG → Repair harness or connector.

OK →

TROUBLE DIAGNOSES — A/T Shift Lock System

Diagnostic Procedure (Cont'd)

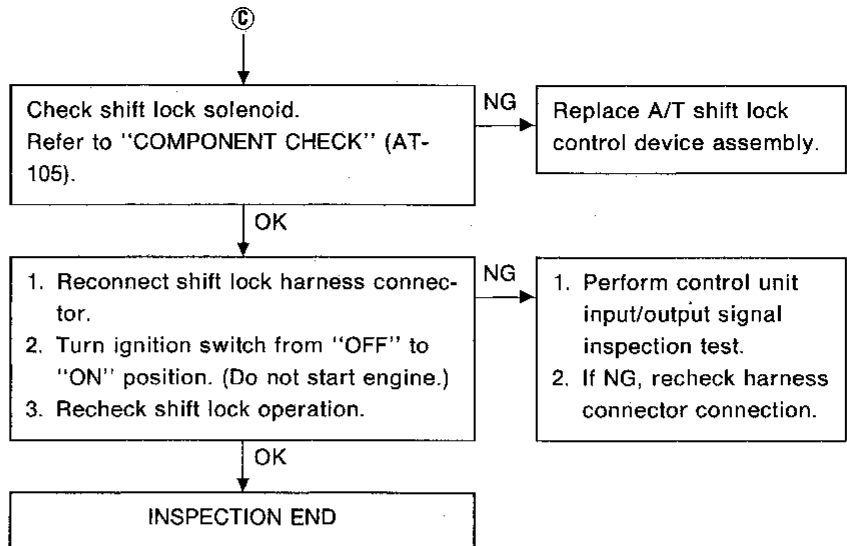

Key Interlock Cable

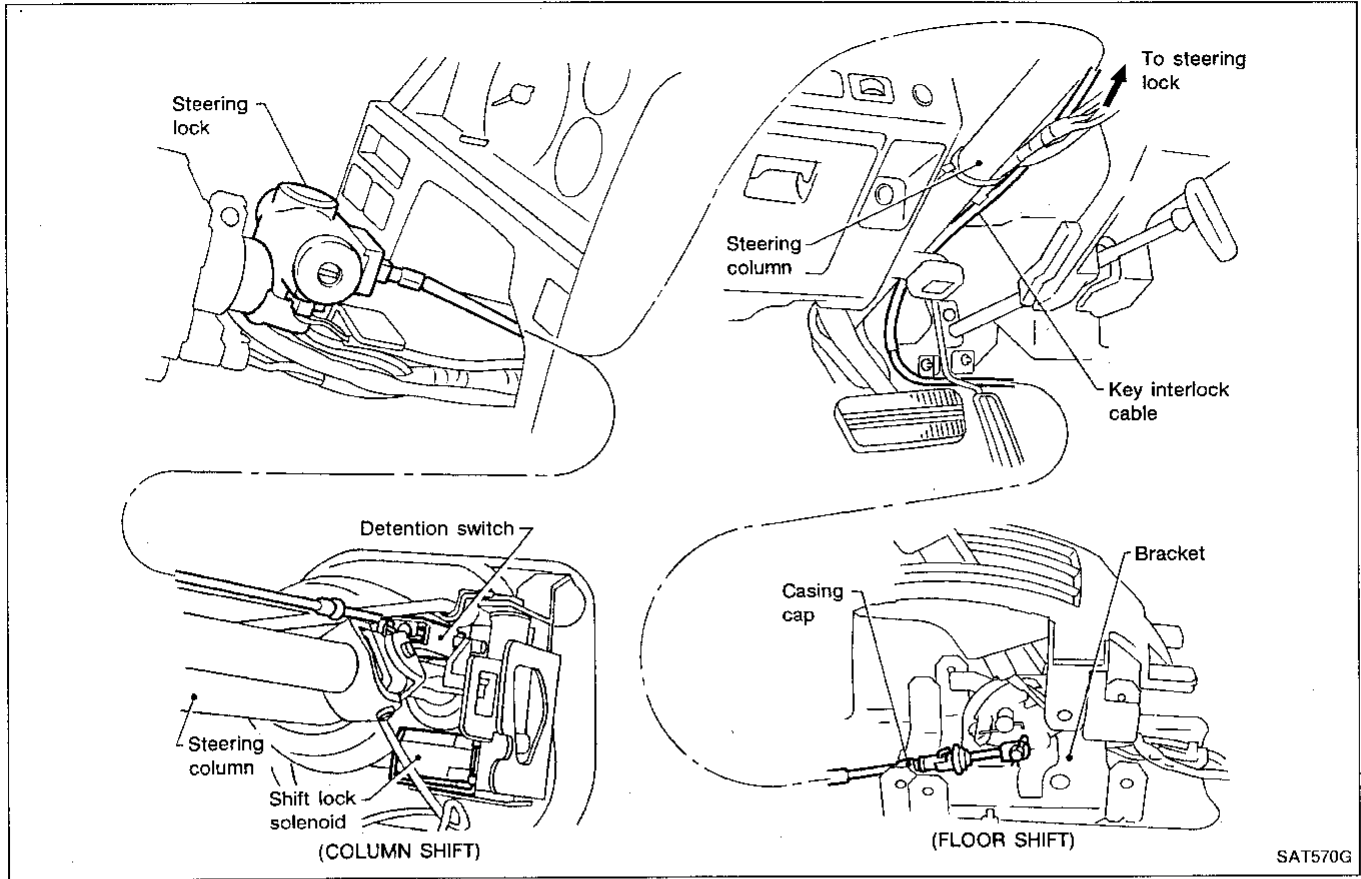

GI
MA
EM
LC
EF &
EC
FE
CL
MT
AT

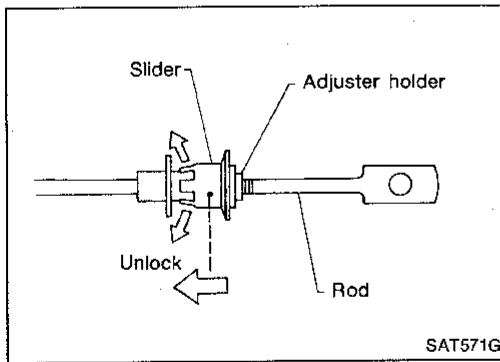

REMOVAL

1. Remove snap pin temporarily and remove key interlock cable from vehicle.
2. Unlock slider from adjuster holder and remove rod from cable.
3. Install rod to control device with snap pin.
4. Remove self-shear type screws. (Tilt type)

TF
PD
FA
RA
BR
ST

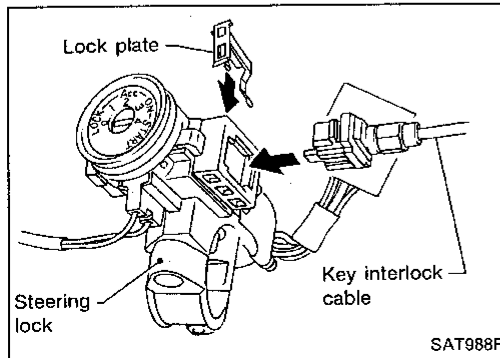

INSTALLATION

1. Set key interlock cable to steering lock assembly and install lock plate.
2. Install steering lock with self-shear type screws and then cut off the screw heads. (Tilt type)
3. Clamp cable to steering column and fix to control cable with band.
4. Set control lever to P position.
5. Insert rod into adjuster holder.
6. Install casing cap to bracket.
7. Move slider in order to fix adjuster holder to rod.

BF
HA
EL
IDX

TROUBLE DIAGNOSES — A/T Shift Lock System

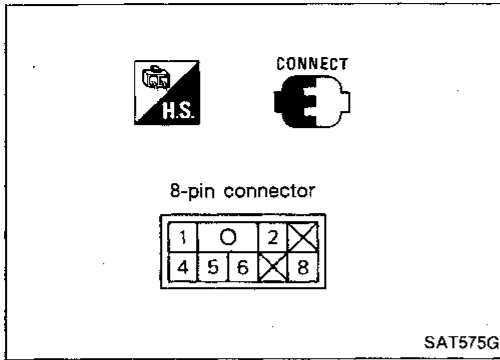



Shift Lock Control Unit Inspection

- Measure voltage between each terminal and terminal ⑧ by following "Shift Lock Control Unit Inspection Table".
- Pin connector terminal layout.

Shift Lock Control Unit Inspection Table

(Data are reference values.)

Terminal No.		Item	Condition	Judgment standard
⊕	⊖			
4	8	Shift lock signal	 When selector lever is set in "P" position and brake pedal is depressed.	Battery voltage
			Except above	0V
2		Power source	Any condition	Battery voltage
5		Stop lamp switch	When brake pedal is depressed.	Battery voltage
			When brake pedal is released.	0V
6		Detention switch	<ul style="list-style-type: none"> ● When key is inserted into key cylinder and selector lever is set in "P" position with selector lever button pushed. ● When selector lever is set in any position except "P". 	Battery voltage
			Except above	0V
1		Ignition signal		Battery voltage
	Except above		0V	
8	—	Ground	—	—

TROUBLE DIAGNOSES — A/T Shift Lock System

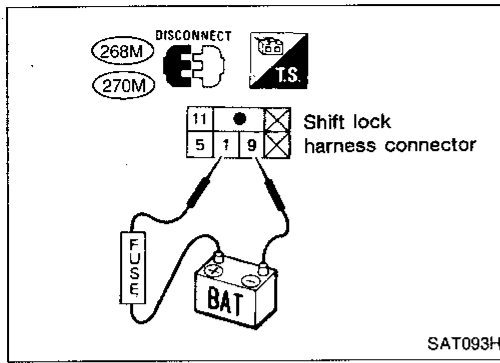

Component Check

SHIFT LOCK SOLENOID

- Check operation by applying battery voltage to shift lock harness connector.

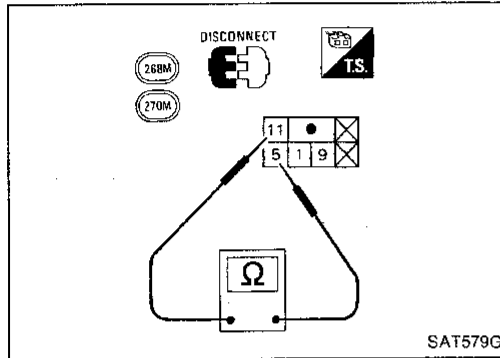

DETENTION SWITCH

- Check continuity between terminals ⑤ and ⑪ of shift lock harness connector.

Condition	Continuity
When selector lever is set in "P" position and selector lever button is released	No
Except above	Yes

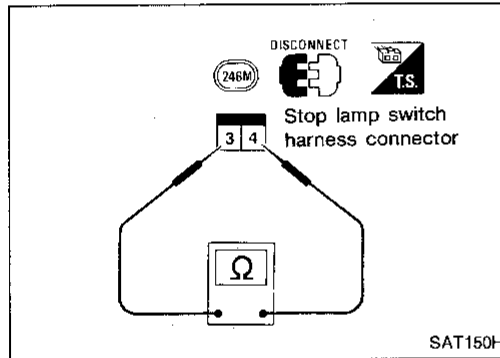

STOP LAMP SWITCH

- Check continuity between terminals ③ and ④ of stop lamp switch harness connector.

Condition	Continuity
When brake pedal is depressed	Yes
When brake pedal is released	No

Check stop lamp switch after adjusting brake pedal — refer to section BR.

GI

MA

EM

LC

EF &
EC

FE

CL

MT

AT

TF

PD

FA

RA

BR

ST

BF

HA

EL

IDX

Control Valve Assembly and Accumulators Inspection

— RE4R01A —

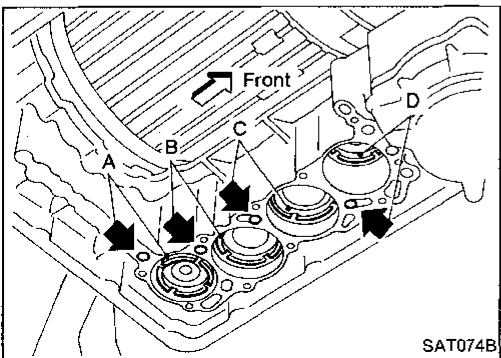
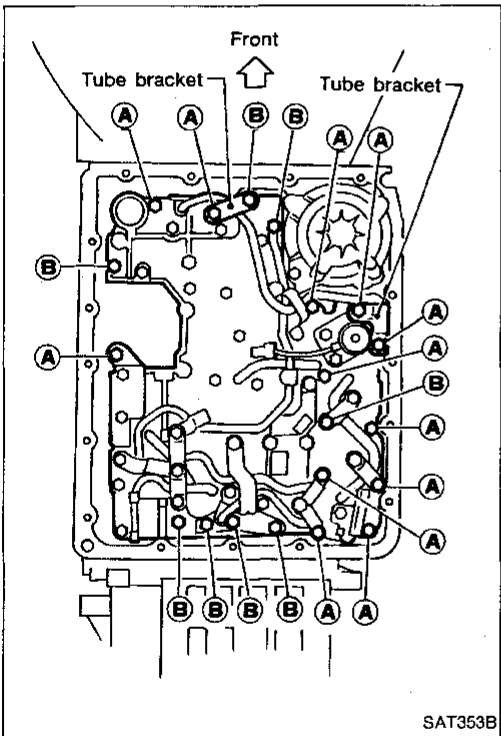
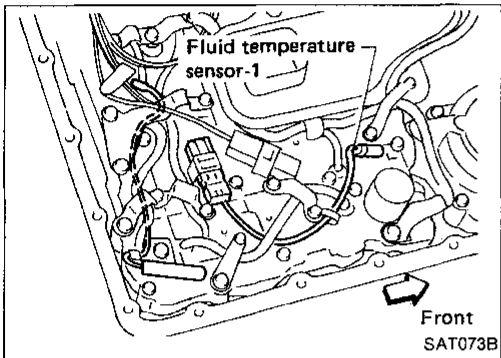
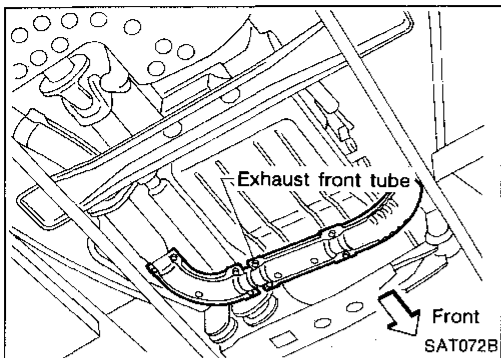

1. Remove exhaust front tube.
2. Remove oil pan and gasket and drain ATF.

3. Remove fluid temperature sensor-1 if necessary.
4. Remove oil strainer.

5. Remove control valve assembly by removing-fixing bolts and disconnecting harness connector.

Bolt length and location

Bolt symbol	ℓ mm (in)	ℓ
Ⓐ	33 (1.30)	
Ⓑ	45 (1.77)	

6. Remove solenoids and valves from valve body if necessary.
7. Remove terminal cord assembly if necessary.

8. Remove accumulator A, B, C and D by applying compressed air if necessary.

- **Hold each piston with rag.**
- 9. Reinstall any part removed.
- **Always use new sealing parts.**

ON-VEHICLE SERVICE

Control Valve Assembly and Accumulators Inspection (Cont'd)

— RL4R01A —

1. Remove oil pan and gasket and drain ATF.
2. Remove oil strainer.
3. Disconnect harness connector.

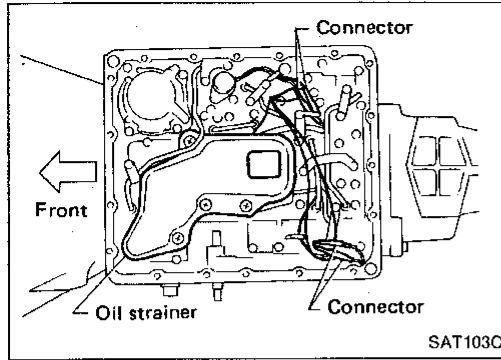

4. Remove control valve assembly by removing fixing bolts.

Bolt length and location

Bolt symbol	ℓ mm (in)
Ⓐ	33 (1.30)
Ⓑ	45 (1.77)

Be careful not to drop manual valve out of valve body.

5. Remove solenoids and valves from valve body if necessary.
6. Remove terminal cord assembly if necessary.

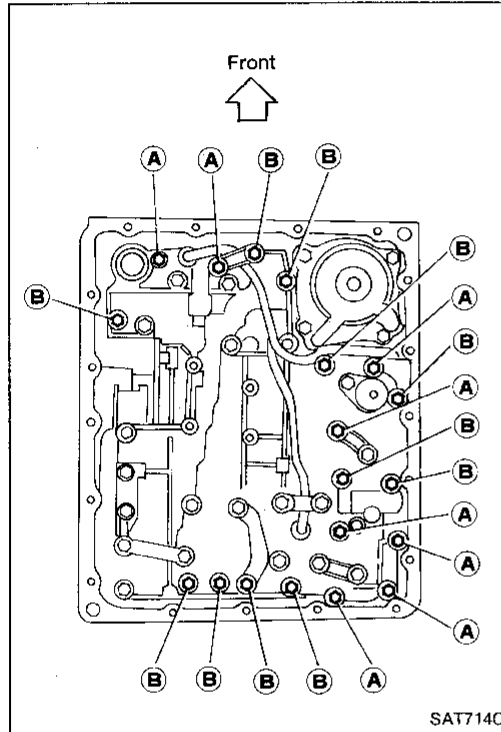

7. Remove accumulator A, B, C and D by applying compressed air if necessary.

Hold each piston with rag.

8. Reinstall any part removed.

Always use new sealing parts.

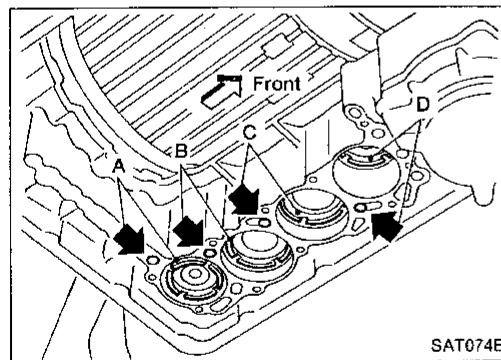

Revolution Sensor Replacement — RE4R01A

— 4WD model —

1. Remove rear engine mounting member from side member while supporting A/T with transfer case with jack.
 2. Lower A/T with transfer case as much as possible.
 3. Remove revolution sensor from A/T.
 4. Reinstall any part removed.
- **Always use new sealing parts.**

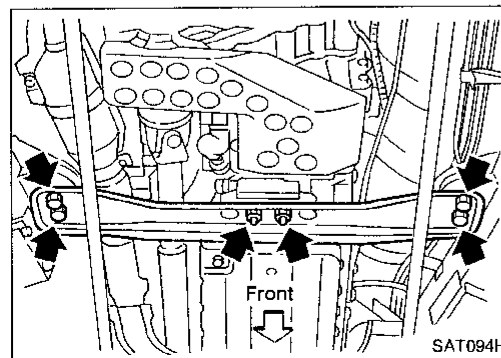

ON-VEHICLE SERVICE

Revolution Sensor Replacement — RE4R01A (Cont'd)

— 2WD model —

- Remove revolution sensor from A/T.
- **Always use new sealing parts.**

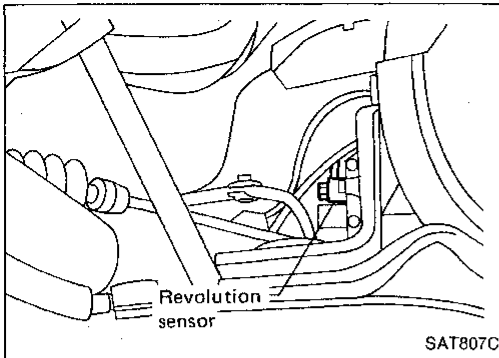

Rear Oil Seal Replacement

— 4WD model —

1. Remove transfer case from vehicle. — Refer to section TF.
 2. Remove rear oil seal.
 3. Install rear oil seal.
- **Apply ATF before installing.**
 - 4. Reinstall any part removed.

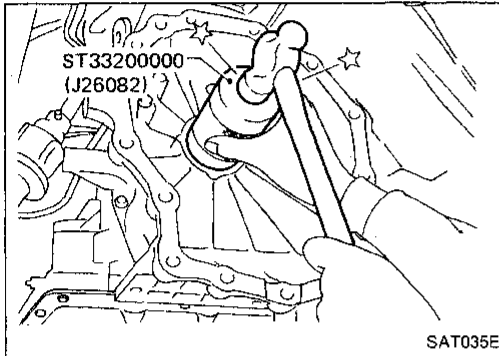

— 2WD model —

1. Remove propeller shaft from vehicle. — Refer to section PD.
 2. Remove rear oil seal.
 3. Install rear oil seal.
- **Apply ATF before installing.**
 - 4. Reinstall any part removed.

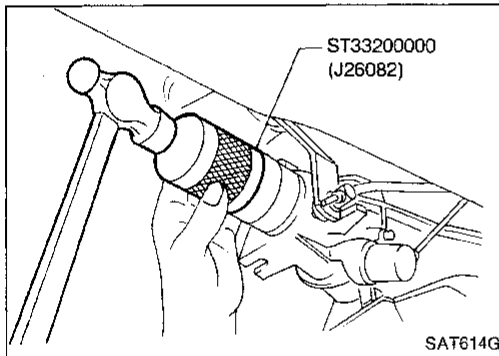

Parking Components Inspection

— 4WD model —

1. Remove propeller shaft. — Refer to section PD.
 2. Remove transfer case from vehicle. — Refer to section TF.
 3. Remove manual control linkage bracket from adapter case.
4. Support A/T assembly with a jack.
 5. Remove adapter case from transmission case.
 6. Replace parking components if necessary.
 7. Reinstall any part removed.
- **Always use new sealing parts.**

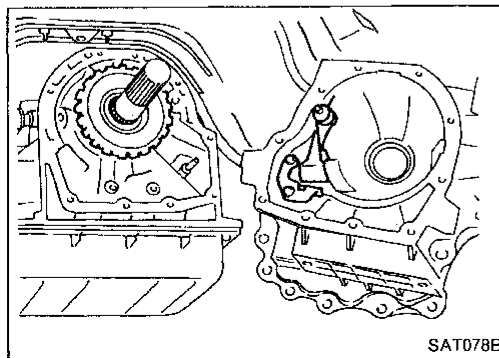
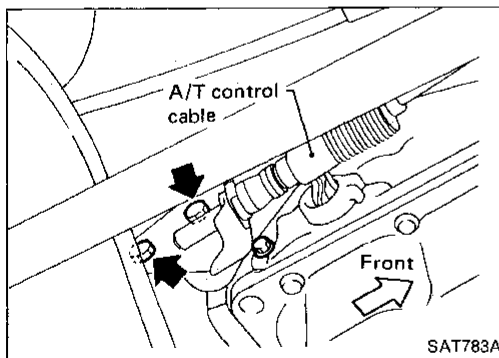

ON-VEHICLE SERVICE

Parking Components Inspection (Cont'd)

— 2WD model —

1. Remove propeller shaft from vehicle. — Refer to section PD.
2. Support A/T assembly with a jack.
3. Remove rear engine mounting member.
4. Remove rear extension from transmission case.
5. Replace parking components if necessary.
6. Reinstall any part removed.

- **Always use new sealing parts.**

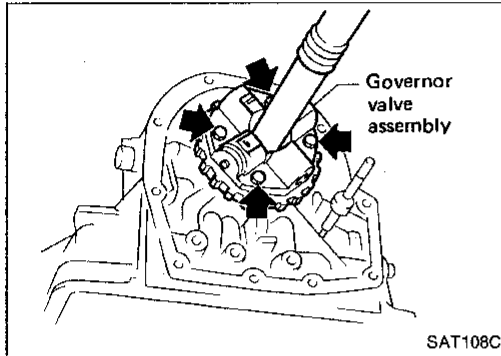
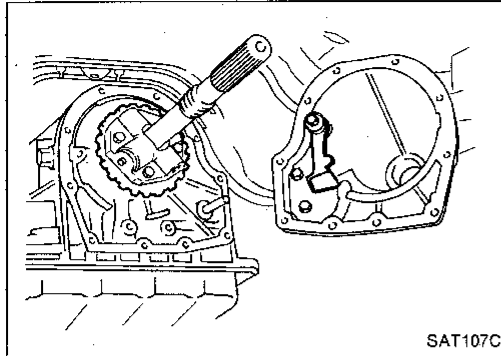

Governor Valve — RL4R01A

1. Remove propeller shaft from vehicle. — Refer to section PD.
2. Support A/T assembly with a jack.
3. Remove rear engine mounting member from A/T assembly.
4. Remove rear extension from transmission case.
5. Remove governor valve assembly.
6. Inspect and repair governor valve assembly. Refer to "REPAIR FOR COMPONENT PARTS" (AT-165).

Throttle Wire Adjustment — RL4R01A

1. While pressing lock plate, move adjusting tube in direction "T".
2. Return lock plate.
3. Move throttle drum from "P₂" to "P₁" quickly.
4. Ensure that throttle wire stroke "L" is within specified position between full throttle and idle.

Throttle wire stroke "L": 38 - 42 mm (1.50 - 1.65 in)

- **Adjust throttle wire stroke when throttle wire/accelerator wire is installed or after carburetor has been adjusted.**
- **Put marks on throttle wire to facilitate measuring wire stroke.**

If throttle wire stroke is improperly adjusted, the following problems may arise.

- When full-open position "P₁" of throttle drum is closer to direction "T", shift schedule will be as shown by ② in figure at left, and kickdown range will greatly increase.
 - When full-open position "P₁" of throttle drum is closer to direction "U", shift schedule will be as shown by ① in figure at left, and kickdown range will not occur.
5. After properly adjusting throttle wire, ensure the parting line is as straight as possible.

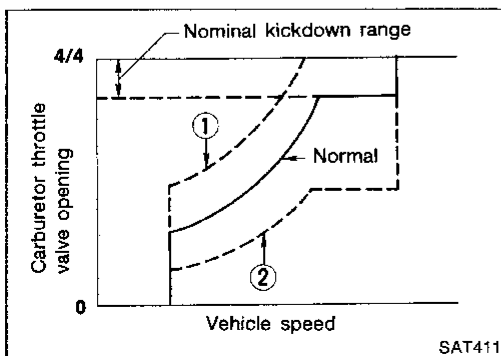
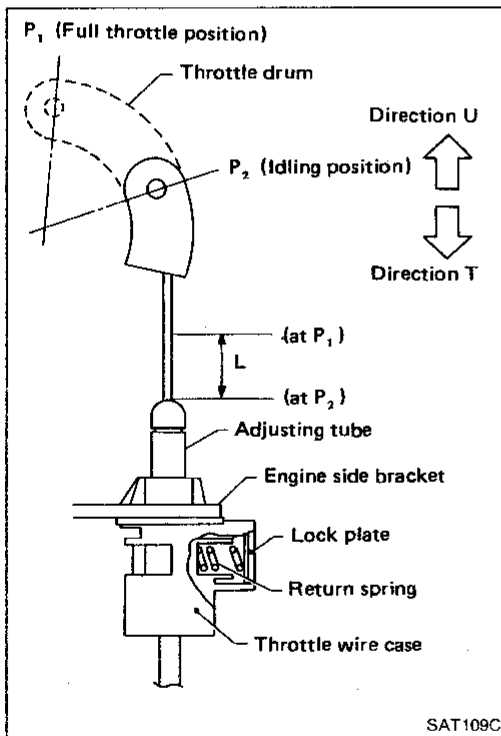

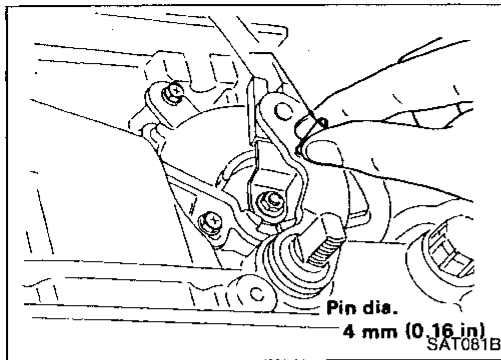

Inhibitor Switch Adjustment

1. Remove manual control linkage from manual shaft of A/T assembly.
2. Set manual shaft of A/T assembly in "N" position.
3. Loosen inhibitor switch fixing bolts.
4. Insert pin into adjustment holes in both inhibitor switch and manual shaft of A/T assembly as near vertical as possible.
5. Reinstall any part removed.
6. Check continuity of inhibitor switch. — Refer to "Electrical System" (AT-71).

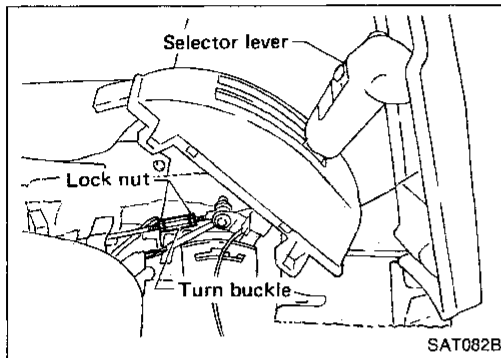

Manual Control Linkage Adjustment

FLOOR SHIFT MODEL — 4WD

Move selector lever from "P" position to "1" position. You should be able to feel the detents in each position. If the detents cannot be felt or the pointer indicating the position is improperly aligned, the linkage needs adjustment.

1. Place selector lever in "P" position.
2. Loosen lock nuts.
3. Tighten turn buckle until aligns with inner cable, pulling selector lever toward "R" position side without pushing button.
4. Back off turn buckle 1 turn and tighten lock nuts to the specified torque.
**ⓐ: Lock nut 4.4 - 5.9 N·m
(0.45 - 0.60 kg-m, 3.3 - 4.3 ft-lb)**
5. Move selector lever from "P" position to "1" position. Make sure that selector lever can move smoothly.

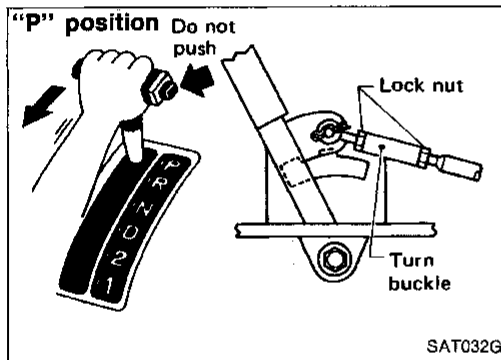

FLOOR SHIFT MODEL — 2WD

Move the selector lever from the "P" position to "1" position. You should be able to feel the detents in each position. If the detents cannot be felt or the pointer indicating the position is improperly aligned, the linkage needs adjustment.

1. Place selector lever in "P" position.
2. Loosen lock nuts.
3. Tighten lock nut ⓧ until it touches trunnion, pulling selector lever toward "R" position side without pushing button.
4. Back off lock nut ⓧ 1 turn and tighten lock nut Ⓨ to the specified torque.
**ⓐ: Lock nut 11 - 15 N·m
(1.1 - 1.5 kg-m, 8 - 11 ft-lb)**
5. Move selector lever from "P" position to "1" position. Make sure that selector lever can move smoothly.

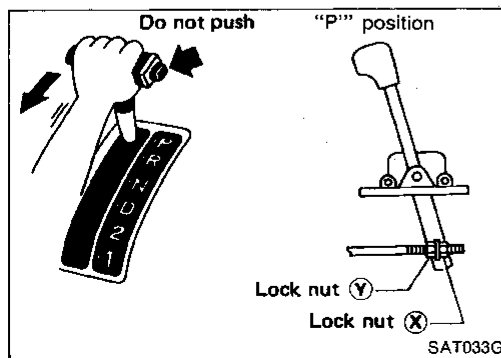

ON-VEHICLE SERVICE

Manual Control Linkage Adjustment (Cont'd)

COLUMN SHIFT MODEL

Move the selector lever from the "P" position to "1" position. You should be able to feel the detents in each position.

If the detents cannot be felt or the pointer indicating the position is improperly aligned, the linkage needs adjustment.

1. Place selector lever in "P" position.
2. Loosen lock nuts.

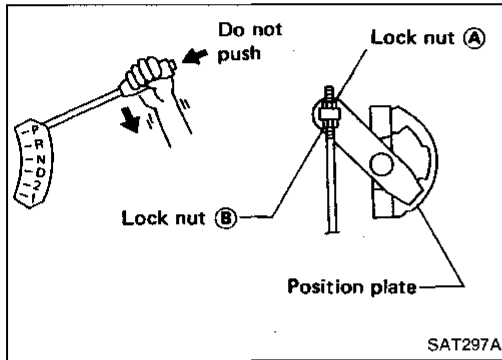

3. Tighten lock nut (A) until it touches trunnion, pulling selector lever toward "R" position side without pushing button.
4. Back off lock nut (A) two turn and tighten lock nut (B) to the specified torque.

: Lock nut 11 - 15 N·m
(1.1 - 1.5 kg-m, 8 - 11 ft-lb)

5. Move selector lever from "P" position to "1" position. Make sure that selector lever can move smoothly.

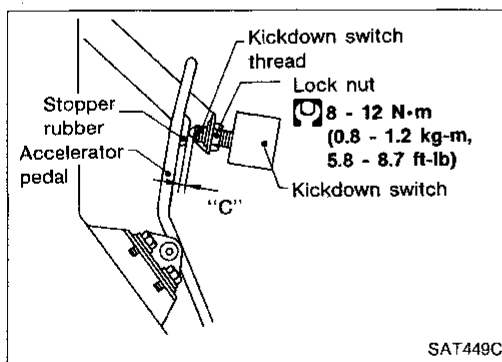

Kickdown Switch Adjustment

1. Adjust accelerator cable — Refer to section FE.
2. Adjust clearance "C" between stopper rubber and end of kickdown switch thread while depressing accelerator pedal fully.

Clearance "C": 0.3 - 1.0 mm (0.012 - 0.039 in)

REMOVAL AND INSTALLATION

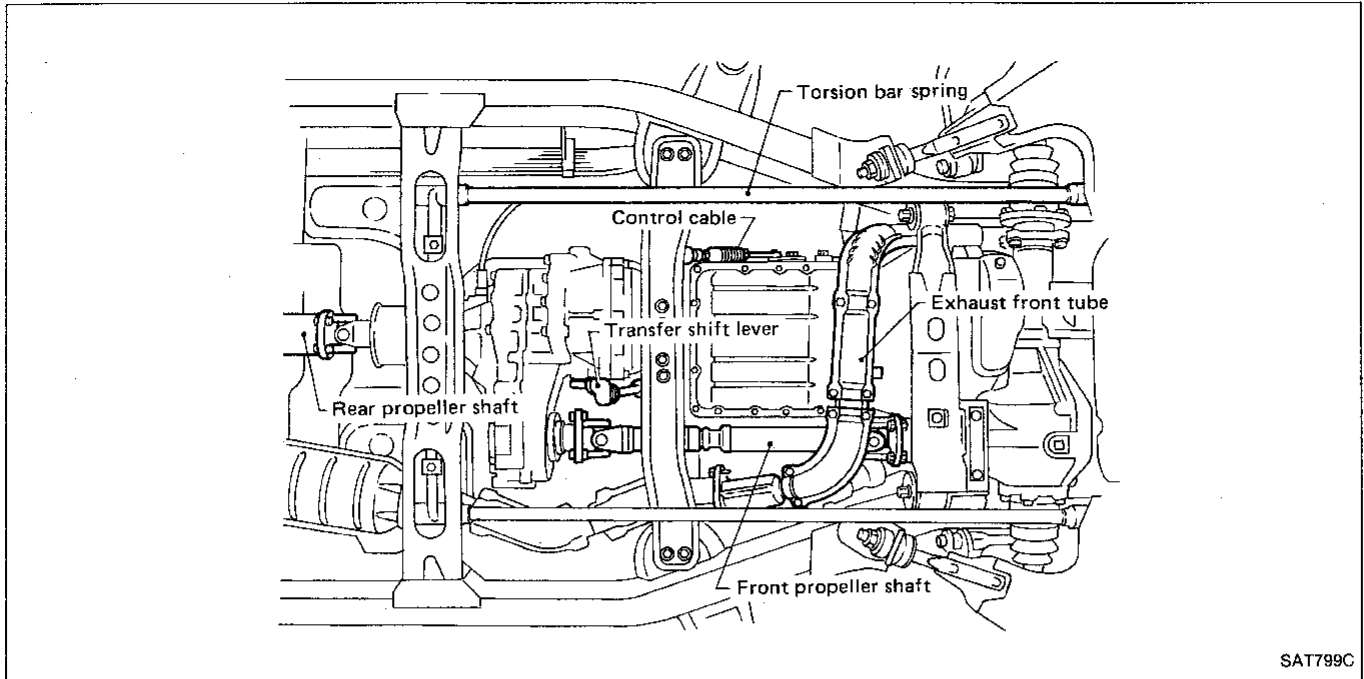

Removal

— 4WD and 2WD model —

- Remove exhaust front tube. (VG30E engine model)
- Remove fluid charging pipe from A/T assembly.
- Remove oil cooler pipe from A/T assembly.
- Plug up openings such as the fluid charging pipe hole, etc.
- Remove propeller shaft.
— Refer to section PD.
- Remove transfer control linkage from transfer.
- **Insert plug into rear oil seal after removing rear propeller shaft.**
- **Be careful not to damage spline, sleeve yoke and rear oil seal.**
- Remove torsion bar springs. — Refer to section FA. Then remove second crossmember. (4WD model)
- Remove speedometer cable from transfer assembly or A/T assembly.
- Remove A/T control cable from A/T assembly. (4WD model)
- Remove A/T control linkage from selector lever. (2WD model)
- Disconnect A/T harness connectors.

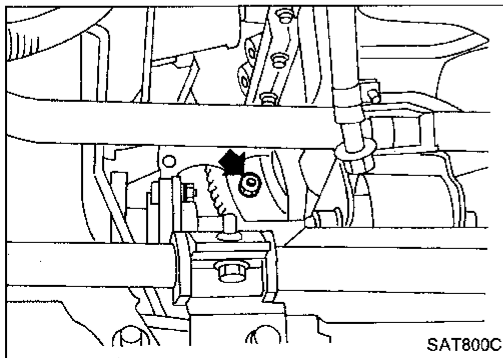

- Remove starter motor.
- Remove gusset securing engine to A/T assembly. (VG30E engine model)
- Remove bolts securing torque converter to drive plate.
Remove the bolts by turning crankshaft.

REMOVAL AND INSTALLATION

Removal (Cont'd)

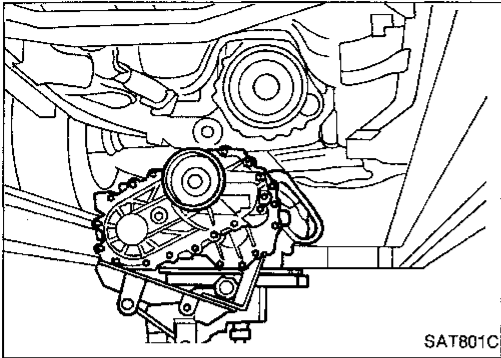

— 4WD model —

- Support A/T and transfer assembly with a jack.
- Remove rear mounting bracket from body and A/T assembly.
- Remove bolts securing A/T assembly to engine.
- Lower A/T assembly with transfer.

GI

MA

EM

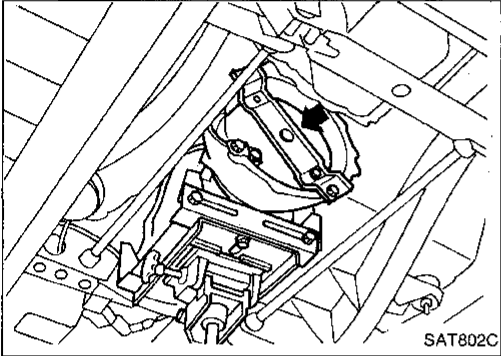

— 2WD model —

- Support A/T assembly with a jack.
- Remove rear mounting bracket from body and A/T assembly.
- Remove bolts securing A/T assembly to engine.
- Pull A/T assembly backwards.
- **Secure torque converter to prevent it from dropping.**
- **Secure A/T assembly to a jack.**

LC

EF &
EC

FE

CL

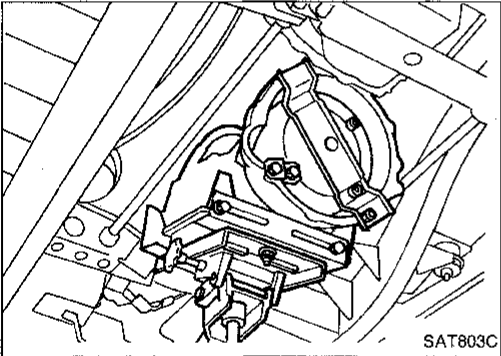

- Slant and lower A/T assembly.

MT

AT

TF

PD

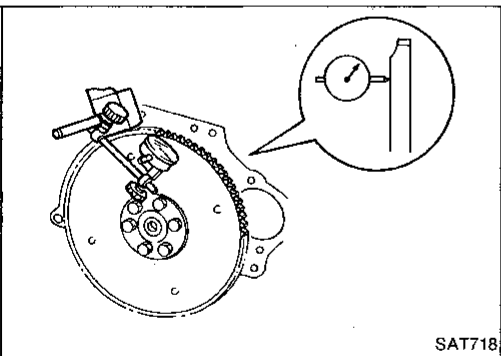

Installation

- Drive plate runout
**Maximum allowable runout:
0.5 mm (0.020 in)**
If this runout is out of specification, replace drive plate with ring gear.

FA

RA

BR

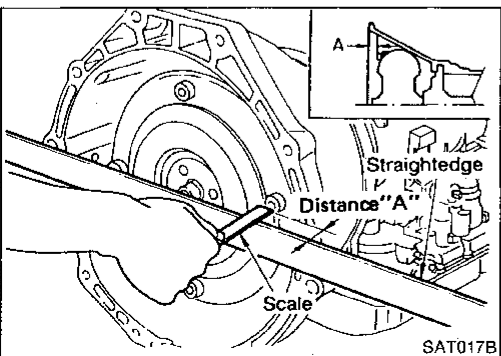

- When connecting torque converter to transmission, measure distance "A" to be certain that they are correctly assembled.

**Distance "A":
26.0 mm (1.024 in) or more**

ST

BF

HA

EL

IDX

REMOVAL AND INSTALLATION

Installation (Cont'd)

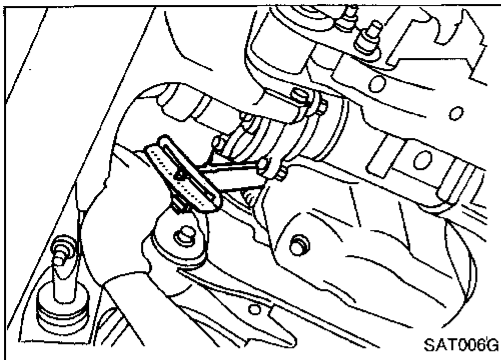

- Install converter to drive plate.
- After converter is installed to drive plate, rotate crankshaft several turns and check to be sure that transmission rotates freely without binding.

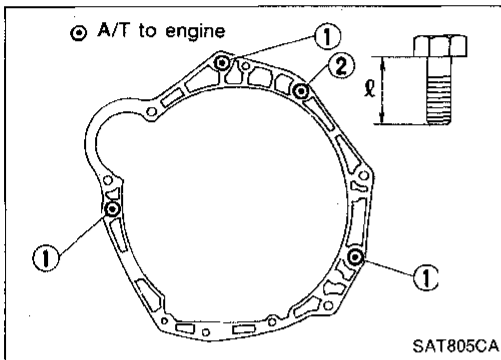

- Tighten bolts securing transmission.

— KA24E engine model —

Tightening torque N·m (kg-m, ft-lb)	Bolt length "ℓ" mm (in)
① 39 - 49 (4.0 - 5.0, 29 - 36)	45 (1.77)
② 39 - 49 (4.0 - 5.0, 29 - 36)	40 (1.57)

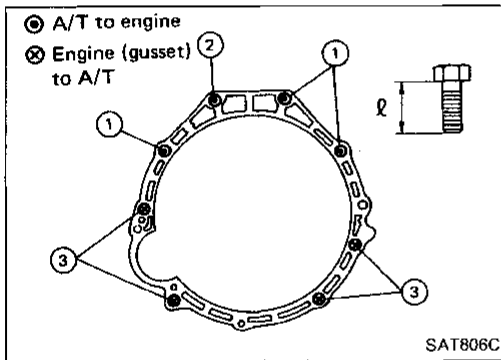

— VG30E engine model —

Bolt No.	Tightening torque N·m (kg-m, ft-lb)	Bolt length "ℓ" mm (in)
①	39 - 49 (4.0 - 5.0, 29 - 36)	45 (1.77)
②	39 - 49 (4.0 - 5.0, 29 - 36)	50 (1.97)
③	29 - 39 (3.0 - 4.0, 22 - 29)	25 (0.98)
Gusset to engine	29 - 39 (3.0 - 4.0, 22 - 29)	20 (0.79)

- Reinstall any part removed.
- Check fluid level in transmission.
- Move selector lever through all position to be sure that transmission operates correctly.
With parking brake applied, rotate engine at idling. Move selector lever through "N" to "D", to "2", to "1" and to "R". A slight shock should be felt by hand gripping selector each time transmission is shifted.
- Perform road test. — Refer to "ROAD TESTING" (AT-20).

MAJOR OVERHAUL RE4R01A (Cont'd)

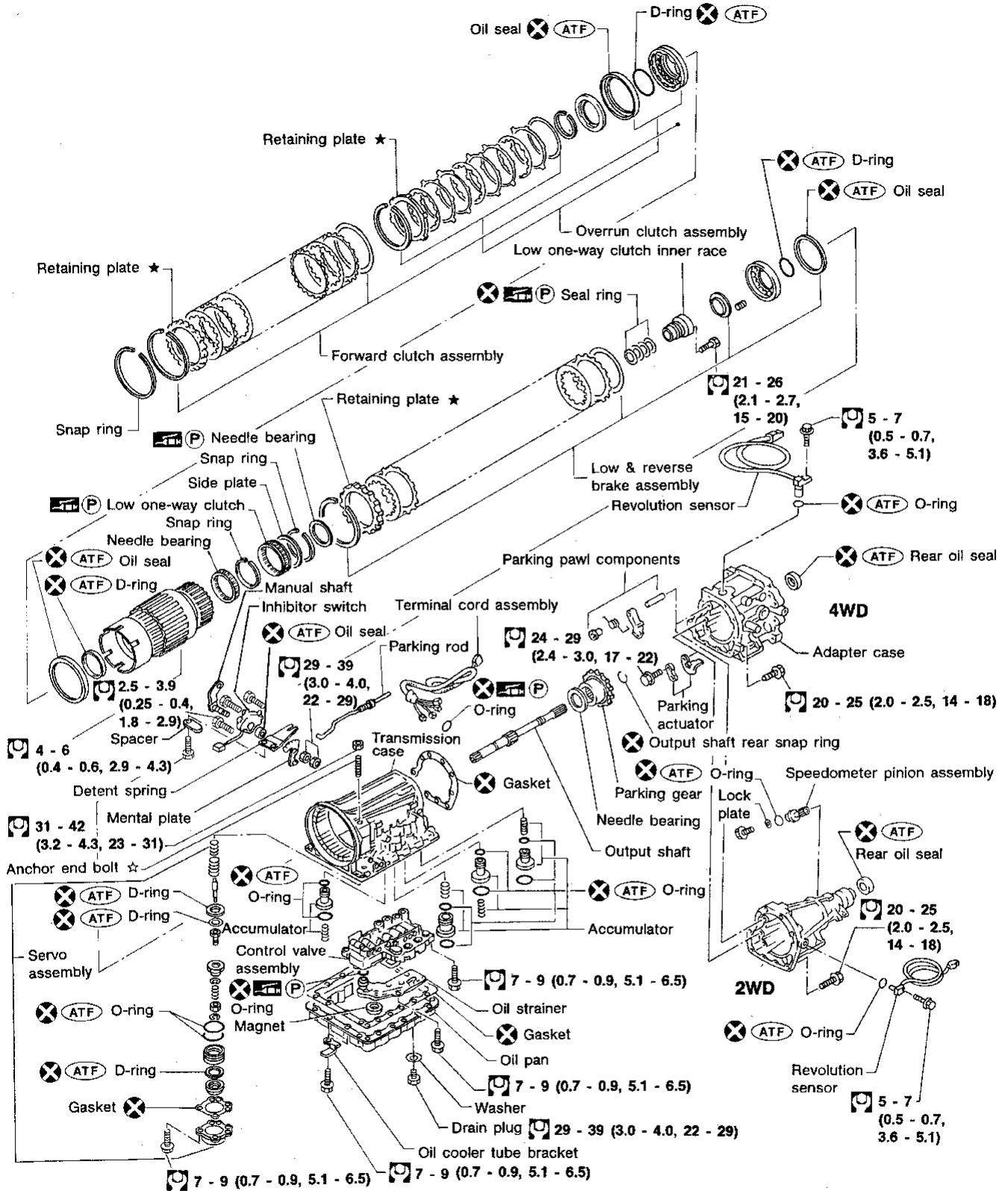

☐ : N·m (kg·m, ft·lb)

MAJOR OVERHAUL

RL4R01A

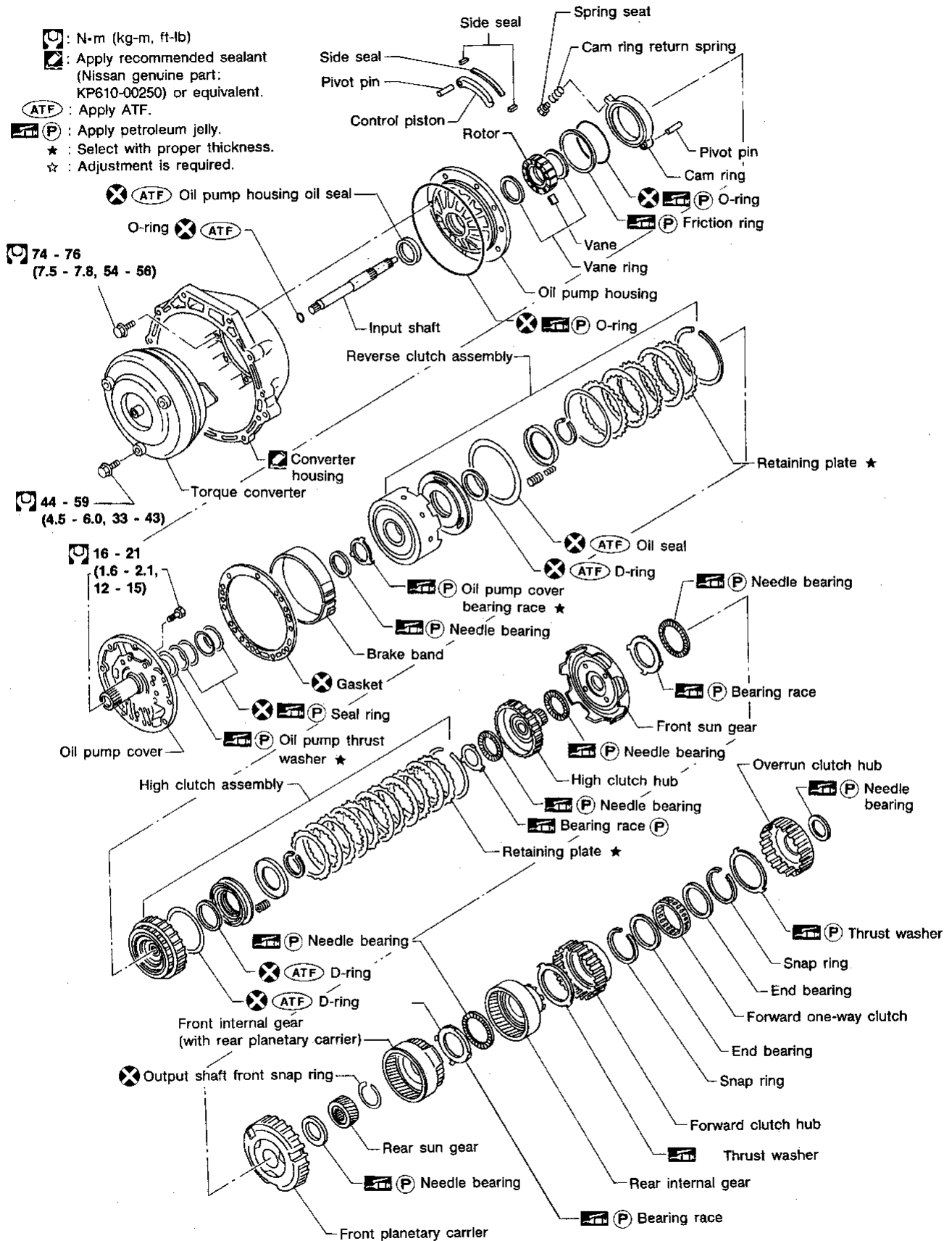

- : N·m (kg·m, ft·lb)
- : Apply recommended sealant (Nissan genuine part: KP610-00250) or equivalent.
- : Apply ATF.
- (P) : Apply petroleum jelly.
- ★ : Select with proper thickness.
- ☆ : Adjustment is required.

74 - 76
(7.5 - 7.8, 54 - 56)

44 - 59
(4.5 - 6.0, 33 - 43)

16 - 21
(1.6 - 2.1, 12 - 15)

GI
MA
EM
LC
EF & EC
FE
CL
MT
AT
TF
PD
FA
RA
BR
ST
BF
HA
EL

MAJOR OVERHAUL RL4R01A (Cont'd)

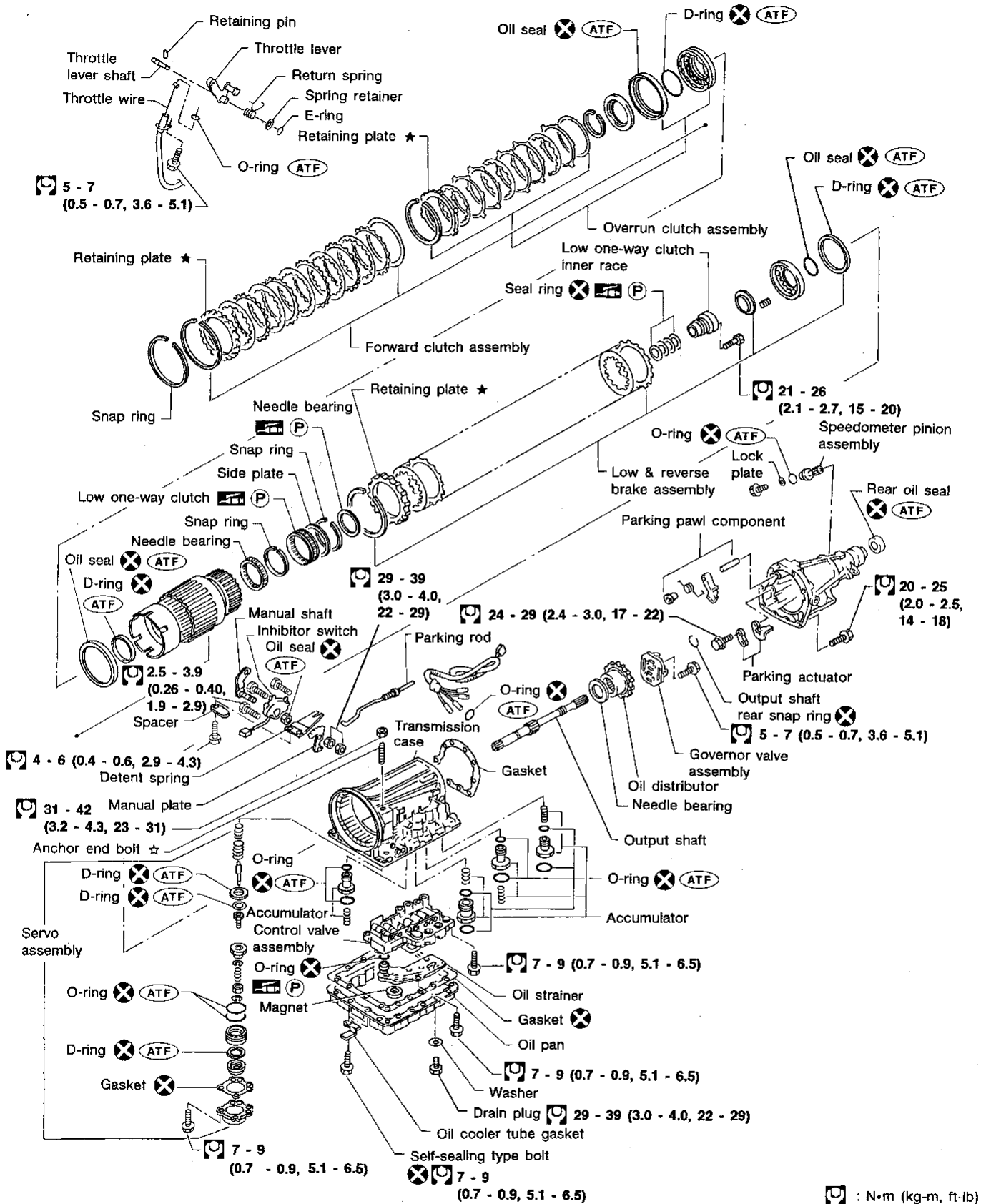

MAJOR OVERHAUL

Oil Channel — RE4R01A

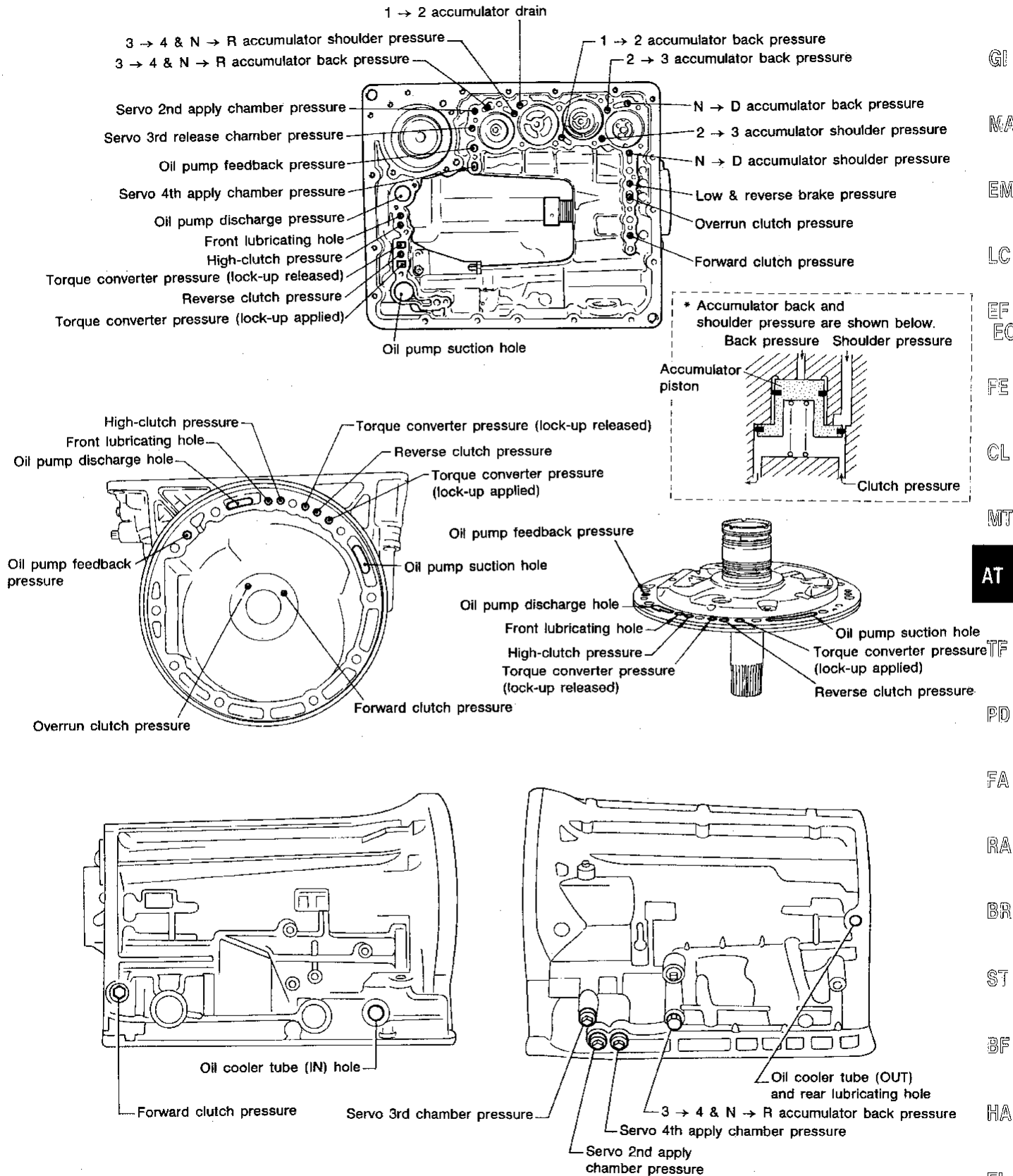

GI
MA
EM
LC
EF & EC
FE
CL
MT
AT
TF
PD
FA
RA
BR
ST
BF
HA
EL

MAJOR OVERHAUL

Oil Channel — RL4R01A

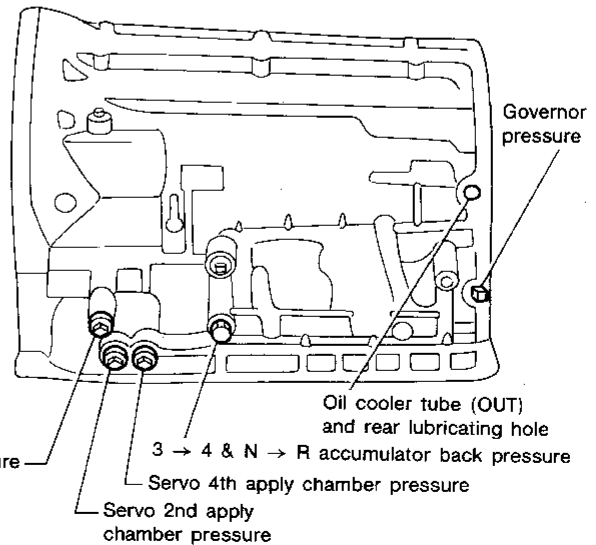
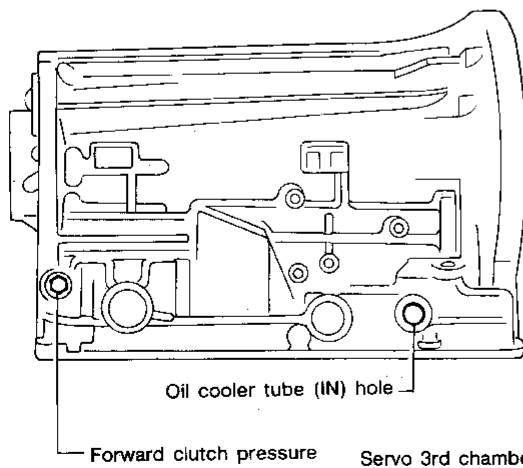
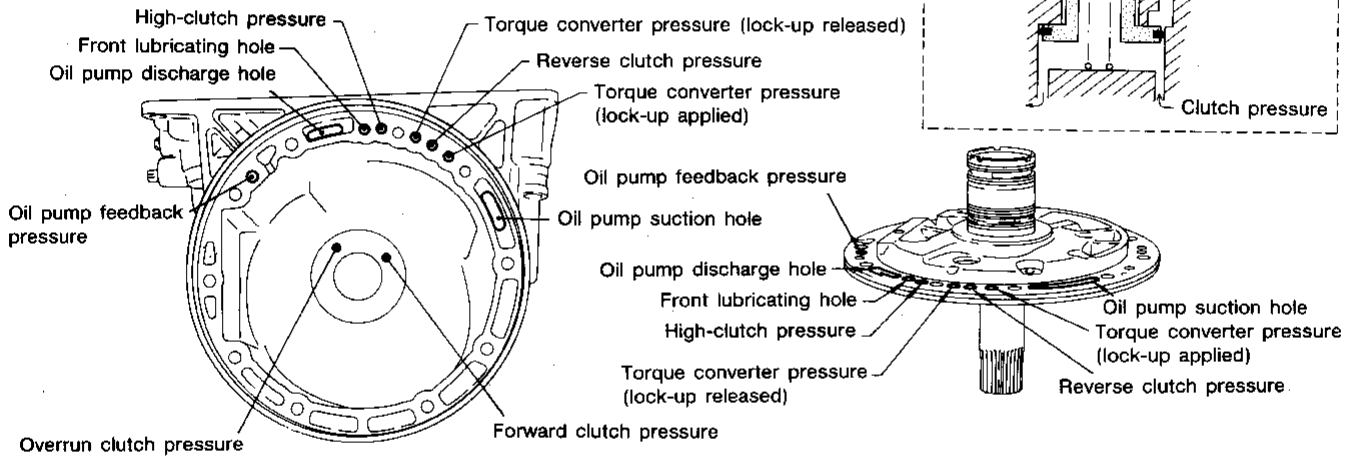
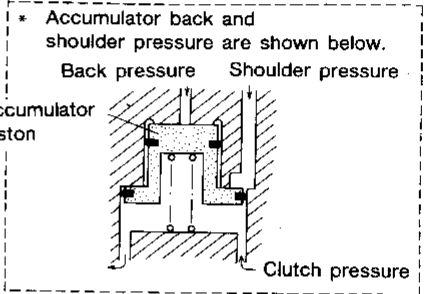
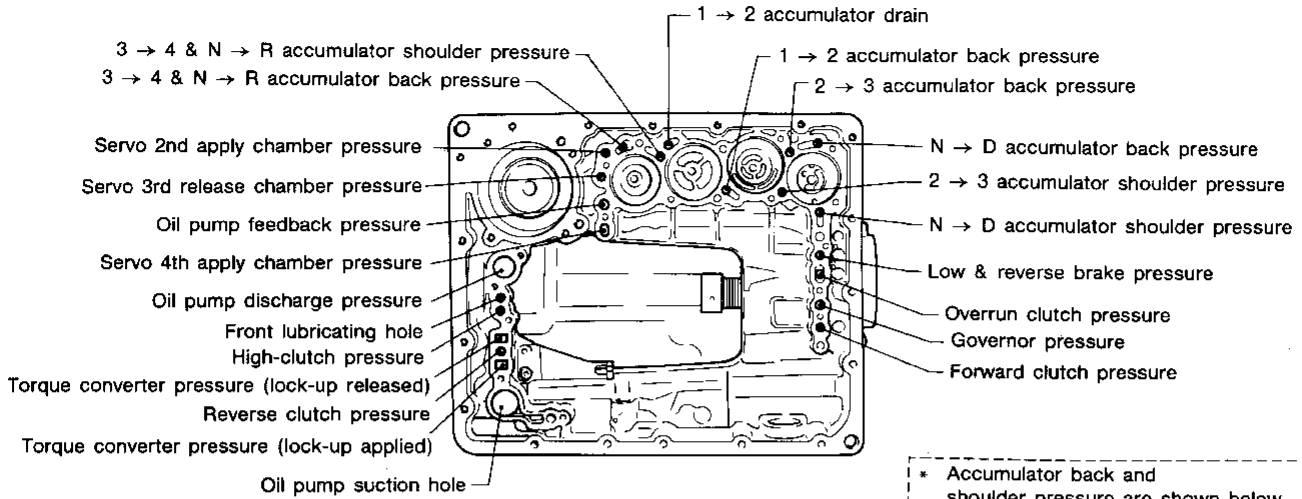

MAJOR OVERHAUL

Locations of Needle Bearings, Thrust Washers and Snap Rings

Outer diameter of snap rings

Item number	Outer diameter mm (in)
②	161.0 (6.34)
③	140.1 (5.52)
④	156.4 (6.16)
⑥	142.0 (5.59)
⑦	159.2 (6.27)

Thrust washers

Item number	Color
①	Black
⑤	White

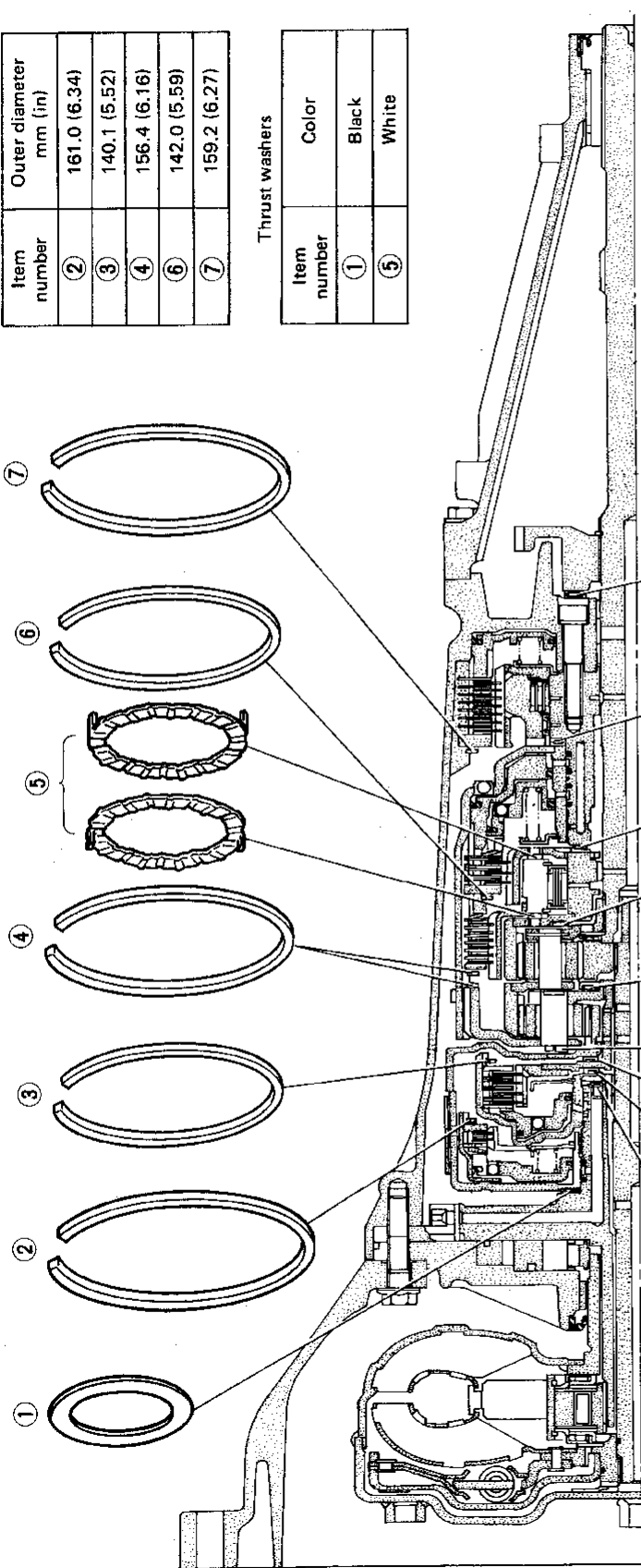

Outer diameter of needle bearings

Item number	Outer diameter mm (in)
⑧	47 (1.85)
⑨	53 (2.09)
⑩	53 (2.09)
⑪	78 (3.07)
⑫	53 (2.09)
⑬	78 (3.07)
⑭	59 (2.32)
⑮	78 (3.07)
⑯	64 (2.52)

Inner diameter of bearing races

Item number	Outer diameter mm (in)
⑪	58 (2.28)
⑬	58.8 (2.315)

Installation of one-piece bearings

Item number	Bearing race (black) location		
	Front	Rear side	Rear side
⑫			
⑮			
⑯			

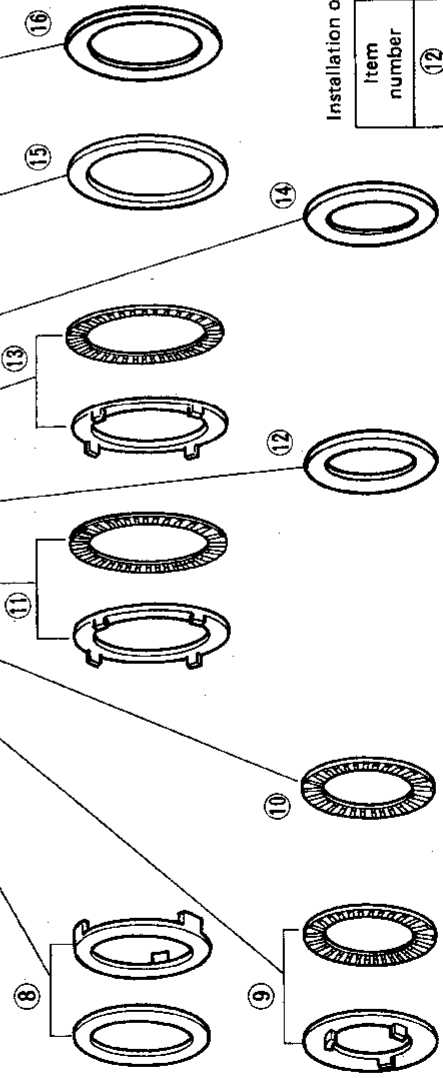

GE
MA
EM
LC
FF & EC
FE
CL
MT
AT
TF
PD
FA
RA
BR
ST
BF
HA
EL

DISASSEMBLY

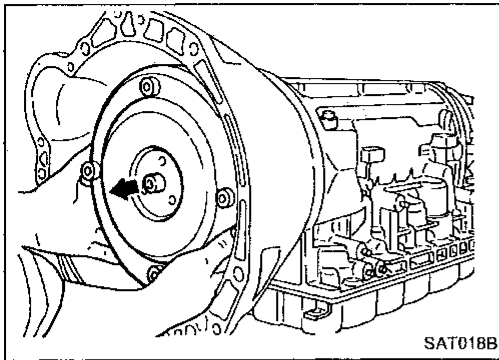

Disassembly

— RE4R01A and RL4R01A —

1. Removing torque converter by holding it firmly and turning while pulling straight out.

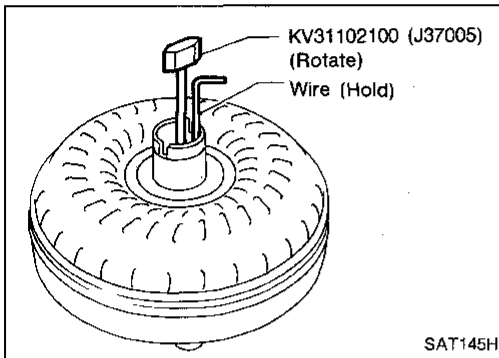

2. Check torque converter one-way clutch.
 - a. Insert Tool into spline of one-way clutch inner race.
 - b. Hook bearing support unitized with one-way clutch outer race with suitable wire.
 - c. Check that one-way clutch inner race rotates only clockwise with Tool while holding bearing support with wire.

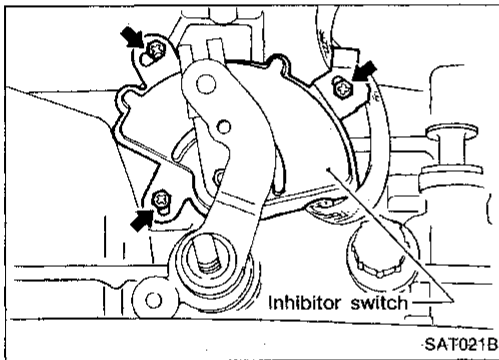

3. Remove inhibitor switch from transmission case.

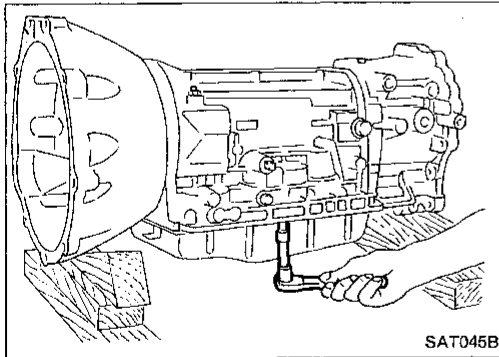

4. Remove oil pan.
 - a. Drain ATF from drain plug.
 - b. Raise oil pan by placing wooden blocks under converter housing and adapter case.
 - c. Separate the oil pan and transmission case.
 - **Always place oil pan straight down so that foreign particles inside will not move.**

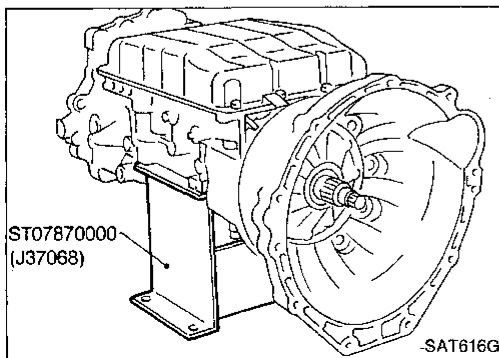

5. Place transmission into Tool with the control valve facing up.
6. Check oil pan and oil strainer for accumulation of foreign particles.
 - If materials of clutch facing are found, clutch plates may be worn.
 - If metal filings are found, clutch plates, brake bands, etc. may be worn.
 - If aluminum filings are found, bushings or aluminum cast parts may be worn.

In above cases, replace torque converter and check unit for cause of particle accumulation.

DISASSEMBLY

Disassembly (Cont'd)

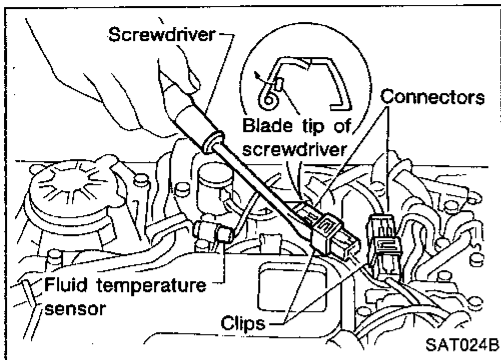

7.

— RE4R01A —

- Remove torque converter clutch solenoid valve and fluid temperature sensor-1 and 2 connectors.
- **Be careful not to damage connector.**

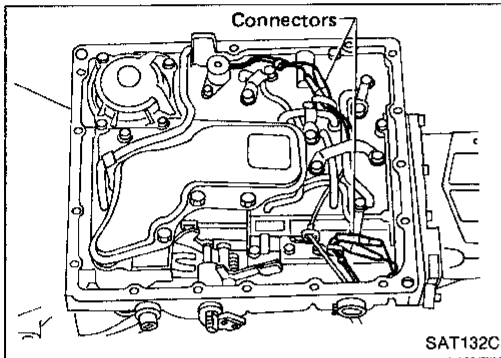

— RL4R01A —

- Remove torque converter clutch solenoid valve and OD cancel solenoid connectors.

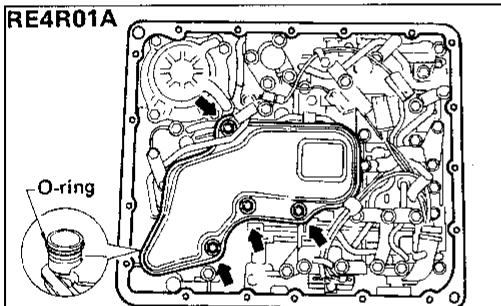

8. Remove oil strainer.

- a. Remove oil strainer from control valve assembly. Then remove O-ring from oil strainer.

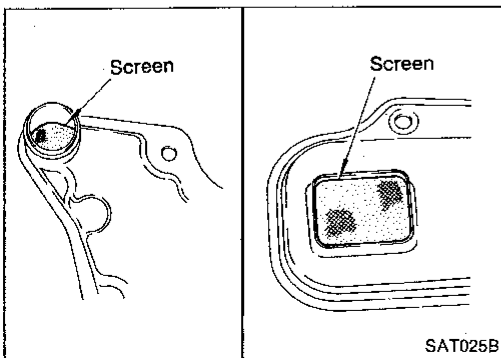
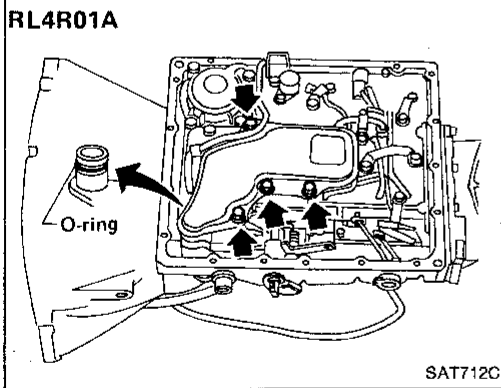

- b. Check oil strainer screen for damage.

GI

MA

EM

LC

EF &
EC

FE

CL

MT

AT

TF

PD

FA

RA

BR

ST

BF

HA

EL

IDX

DISASSEMBLY

Disassembly (Cont'd)

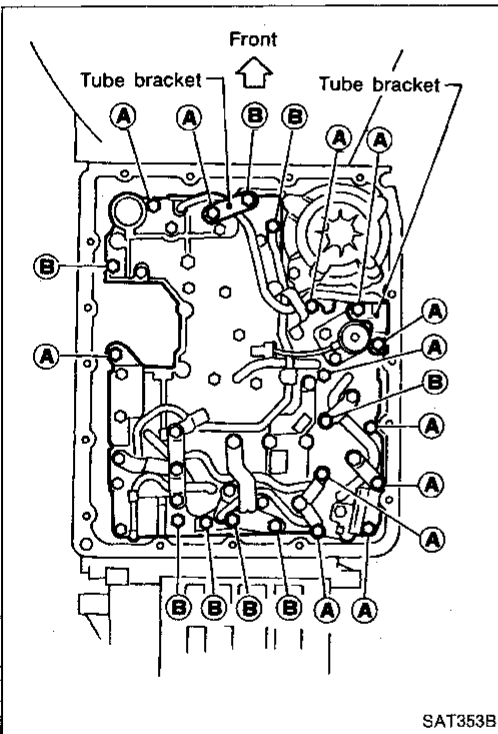
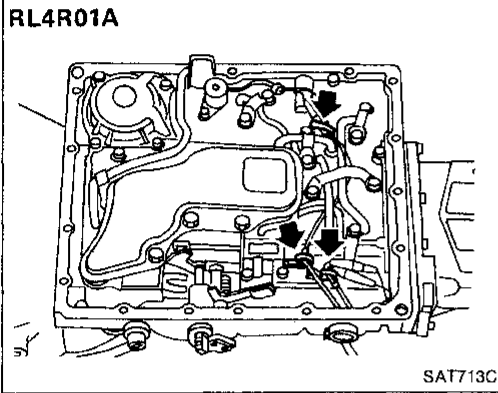
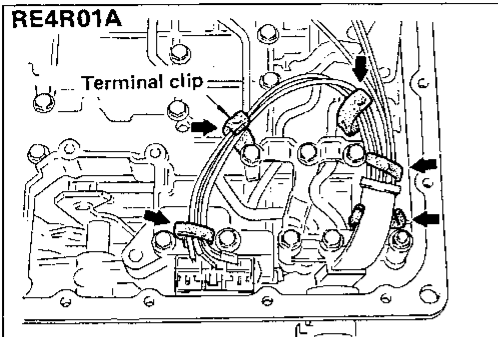

9. Remove control valve assembly.

- a. Straighten terminal clips to free terminal cords then remove terminal clips.

- b. Remove bolts (A) and (B), and remove control valve assembly from transmission.

Bolt	ℓ mm (in)	 ℓ
(A)	33 (1.30)	
(B)	45 (1.77)	

DISASSEMBLY

Disassembly (Cont'd)

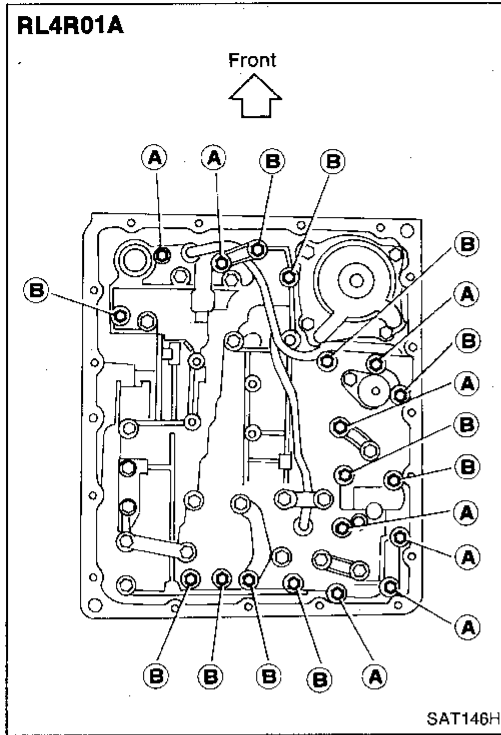

Bolt	ℓ mm (in)	 ℓ
(A)	33 (1.30)	
(B)	45 (1.77)	

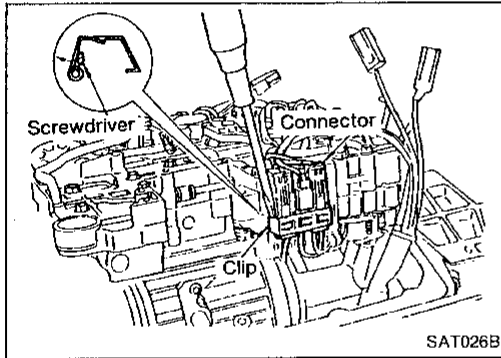

— RE4R01A —

- c. Remove solenoid connector.
- Be careful not to damage connector.

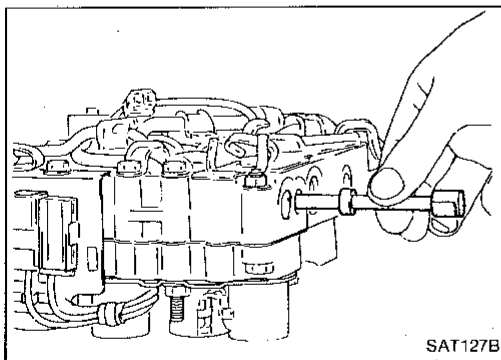

— RE4R01A and RL4R01A —

- d. Remove manual valve from control valve assembly.

GI

MA

EM

LC

EF &
EC

FE

CL

MT

AT

TF

PD

FA

RA

BR

ST

BF

HA

EL

IDX

DISASSEMBLY

Disassembly (Cont'd)

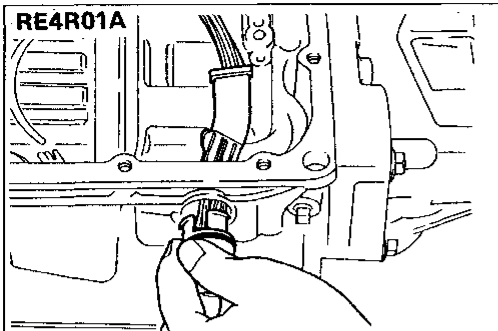

10. Remove terminal cord assembly from transmission case while pushing on stopper.

- Be careful not to damage cord.
- Do not remove terminal cord assembly unless it is damaged.

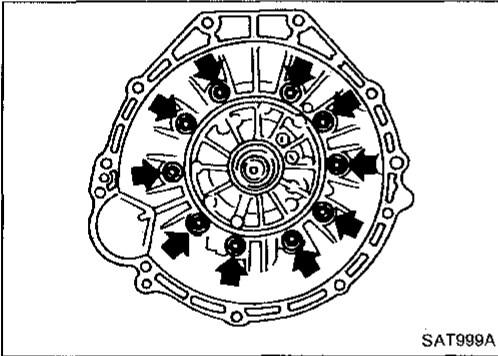
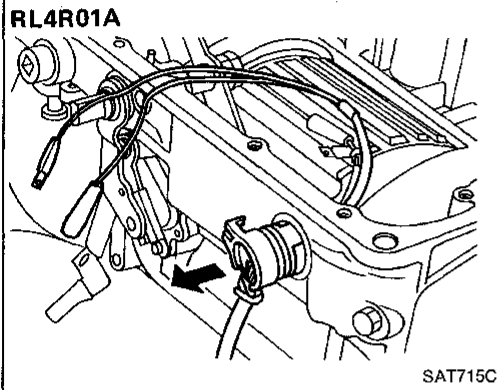

11. Remove converter housing.
a. Remove converter housing from transmission case.
b. Remove traces of sealant.

- Be careful not to scratch converter housing.

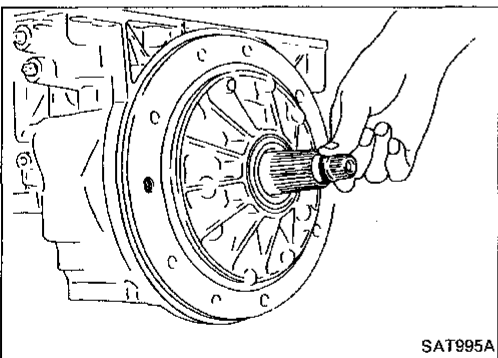

12. Remove O-ring from input shaft.

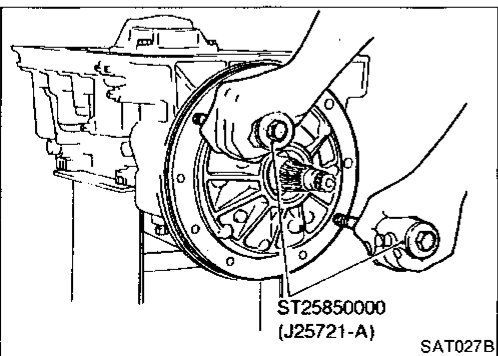

13. Remove oil pump assembly.
a. Attach Tool to oil pump assembly and extract it evenly from transmission case.

DISASSEMBLY

Disassembly (Cont'd)

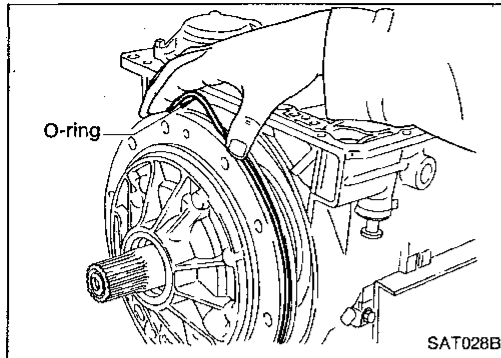

- b. Remove O-ring from oil pump assembly.
- c. Remove traces of sealant from oil pump housing.
- **Be careful not to scratch pump housing.**

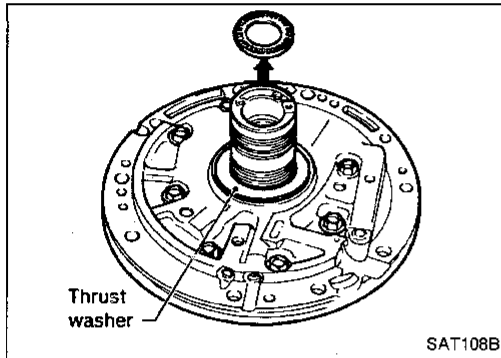

- d. Remove needle bearing and thrust washer from oil pump assembly.

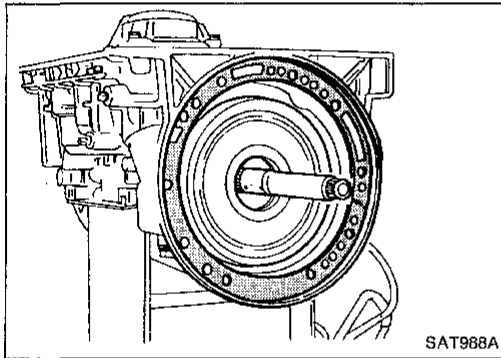

- 14. Remove input shaft and oil pump gasket.

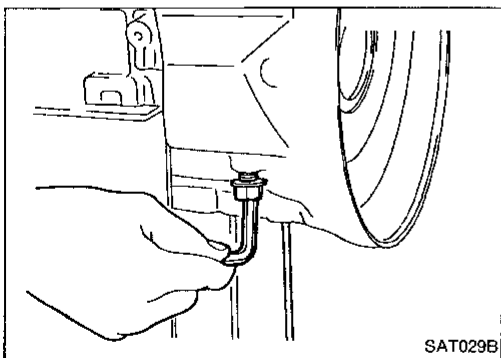

- 15. Remove brake band and band strut.
 - a. Loosen lock nut and remove band servo anchor end pin from transmission case.

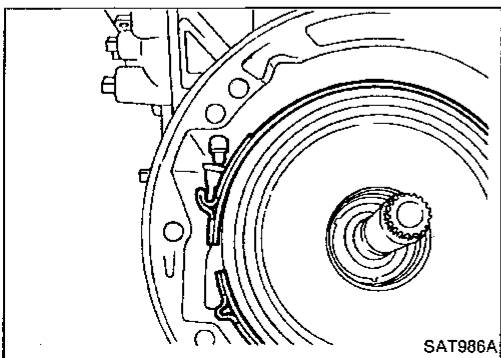

- b. Remove brake band and band strut from transmission case.

GI

MA

EM

LC

EF &
EC

FE

CL

MT

AT

TF

PD

FA

RA

BR

ST

BF

HA

EL

IDX

DISASSEMBLY

Disassembly (Cont'd)

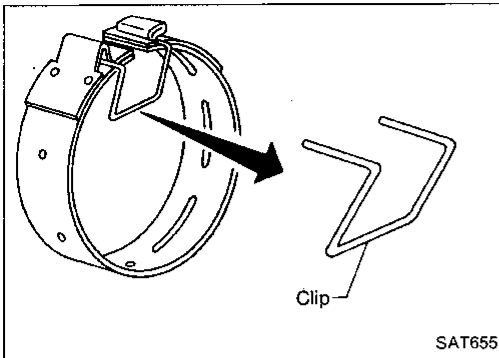

- c. Hold brake band in a circular shape with clip.
Check brake band facing for damage, cracks, wear or burns.

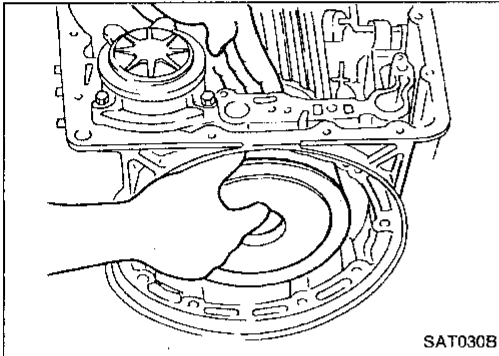

16. Remove front side clutch and gear components.
a. Remove clutch pack (reverse clutch, high clutch and front sun gear) from transmission case.

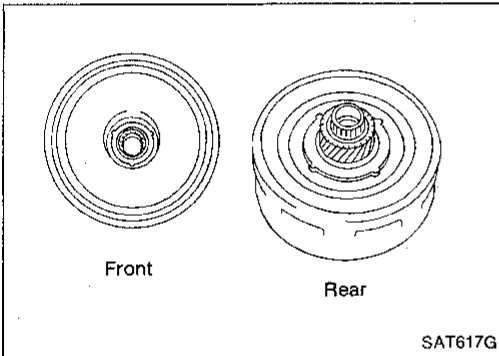

- b. Remove front bearing race from clutch pack.
c. Remove rear bearing race from clutch pack.

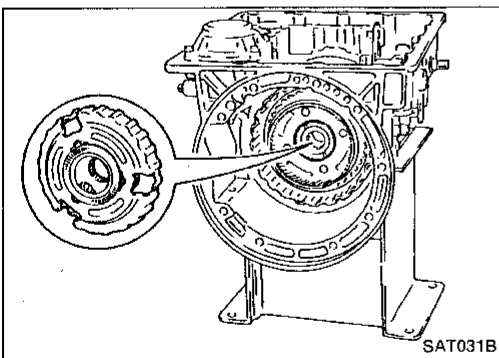

- d. Remove front planetary carrier from transmission case.

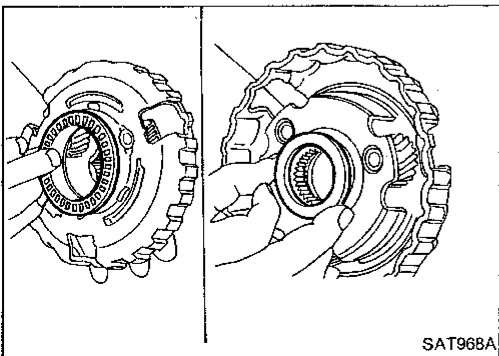

- e. Remove front needle bearing from front planetary carrier.
f. Remove rear bearing from front planetary carrier.

DISASSEMBLY

Disassembly (Cont'd)

- g. Remove rear sun gear from transmission case.

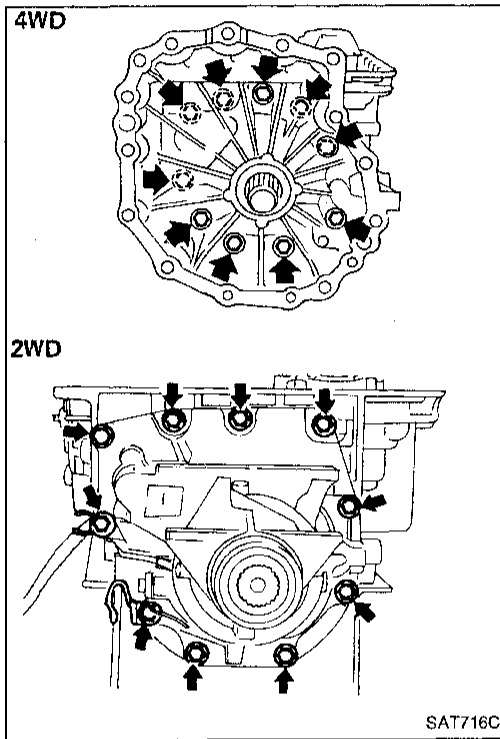
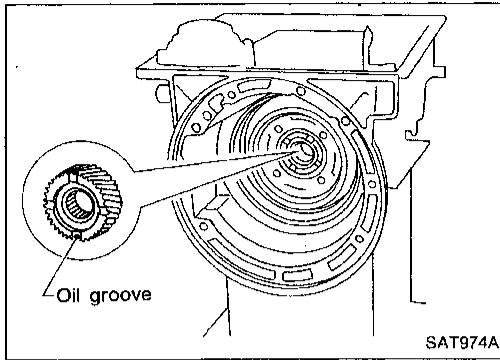

17. Remove rear extension or adapter case.
- Remove rear extension or adapter case from transmission case.
 - Remove rear extension or adapter case gasket from transmission case.

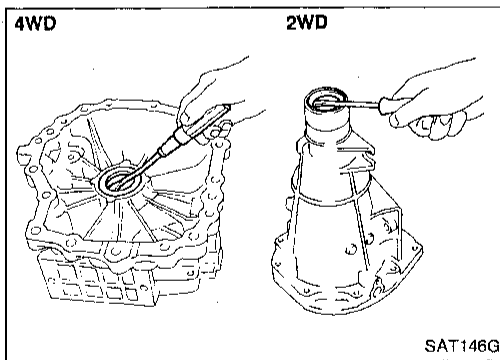

- c. Remove oil seal from rear extension or adapter case.
- Do not remove oil seal unless it is to be replaced.

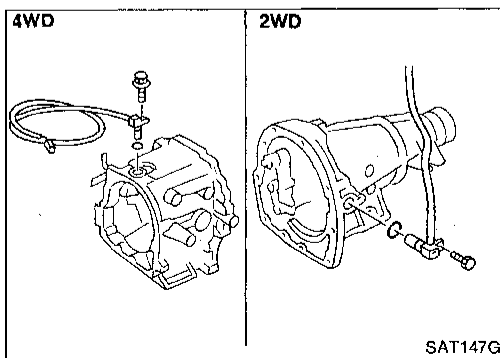

— RE4R01A —

- Remove revolution sensor from rear extension or adapter case.
- Remove O-ring from revolution sensor.

GI

MA

EM

LC

EF &
EC

FE

CL

MT

AT

TF

PD

FA

RA

BR

ST

BF

HA

EL

IDX

DISASSEMBLY

Disassembly (Cont'd)

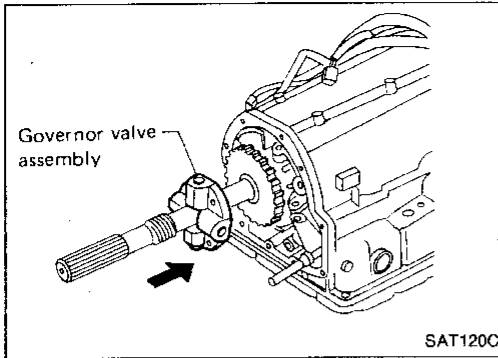

— RE4R01A and RL4R01A —

18. Remove output shaft and parking gear.

— RL4R01A —

a. Remove governor valve assembly.

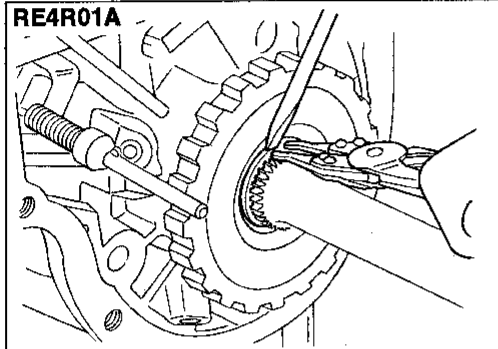

— RE4R01A and RL4R01A —

b. Remove rear snap ring from output shaft.

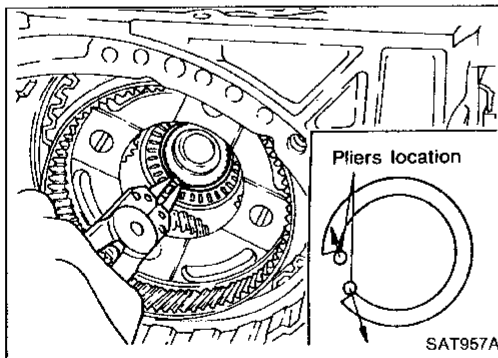
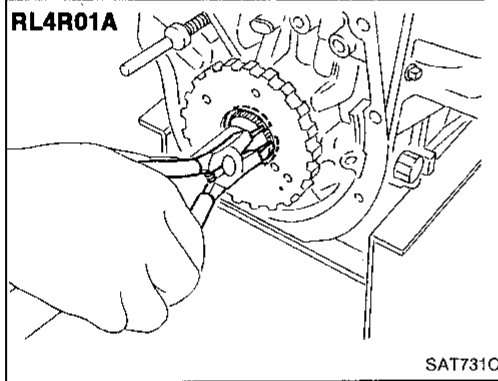

c. Slowly push output shaft all the way forward.

● **Do not use excessive force.**

d. Remove snap ring from output shaft.

DISASSEMBLY

Disassembly (Cont'd)

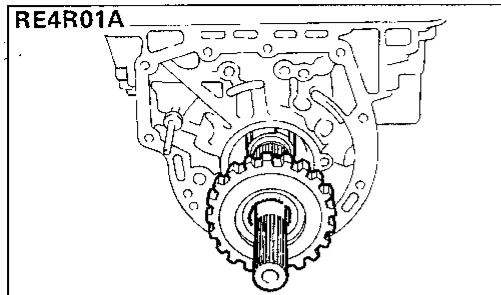

- e. Remove output shaft and parking gear as a unit from transmission case.
- f. Remove parking gear from output shaft.

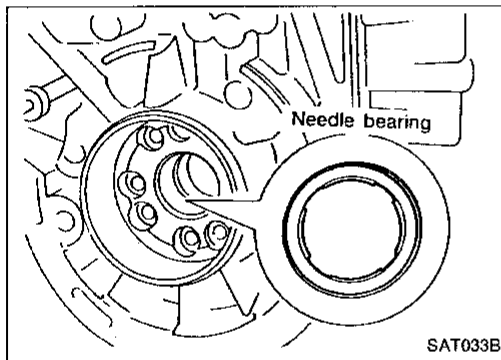
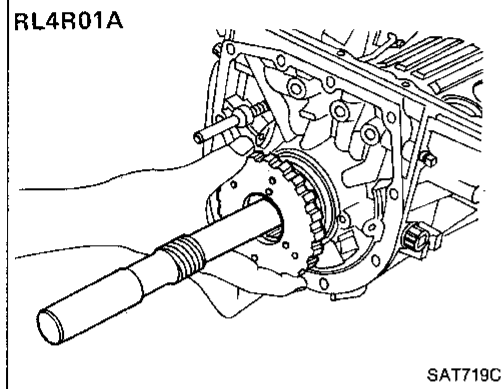

- g. Remove needle bearing from transmission case.

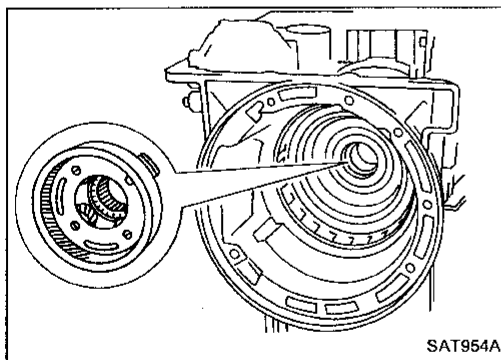

- 19. Remove rear side clutch and gear components.
 - a. Remove front internal gear.

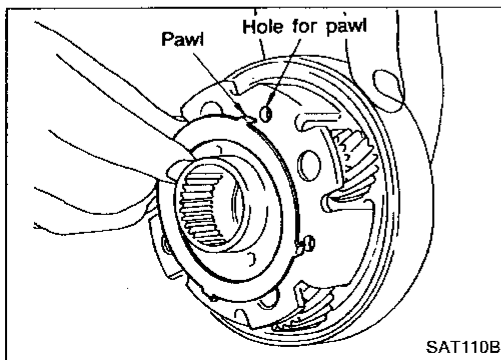

- b. Remove bearing race from front internal gear.

GI

MA

EM

LC

EF &
EC

FE

CL

MT

AT

TF

PD

FA

RA

BR

ST

BF

HA

EL

IDX

DISASSEMBLY

Disassembly (Cont'd)

- c. Remove needle bearing from gear internal gear.

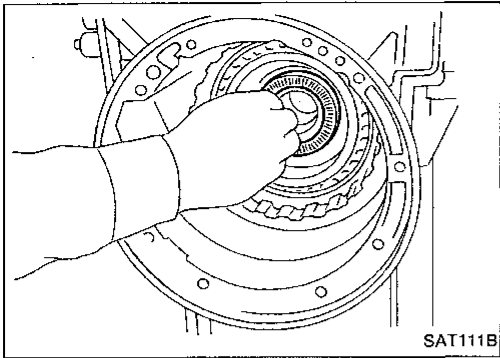

- d. Remove rear internal gear, forward clutch hub and overrun clutch hub as a set from transmission case.

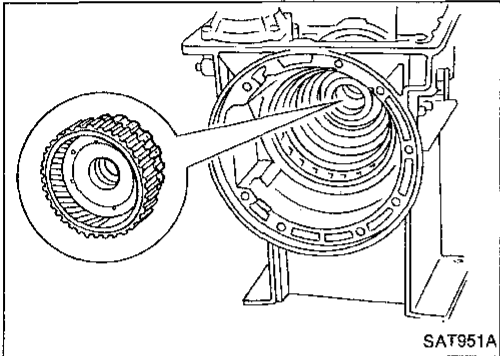

- e. Remove needle bearing from overrun clutch hub.
f. Remove overrun clutch hub from rear internal gear and forward clutch hub.

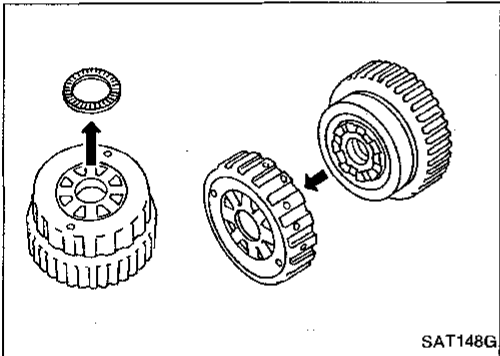

- g. Remove thrust washer from overrun clutch hub.

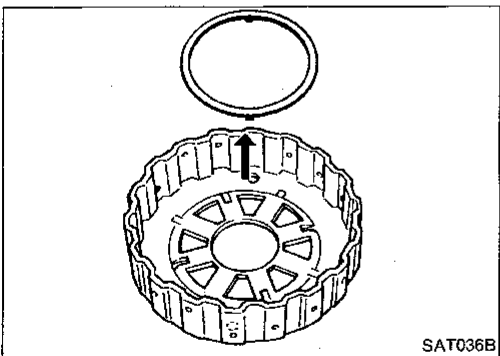

- h. Remove forward clutch assembly from transmission case.

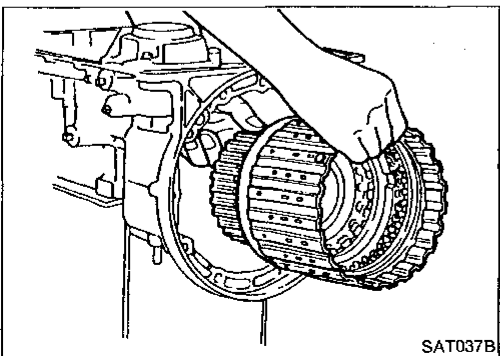

DISASSEMBLY

Disassembly (Cont'd)

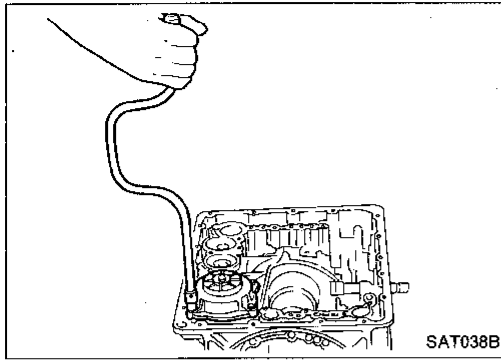

20. Remove band servo and accumulator components.
a. Remove band servo retainer from transmission case.

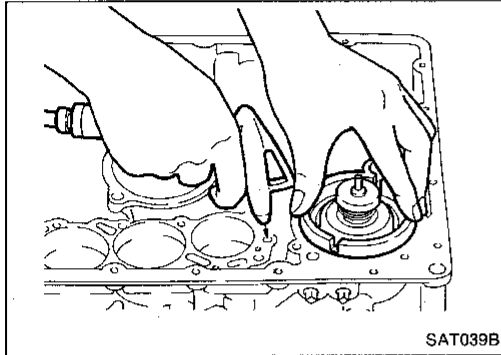

- b. Apply compressed air to oil hole until band servo piston comes out of transmission case.
● **Hold piston with a rag and gradually direct air to oil hole.**
c. Remove return springs.

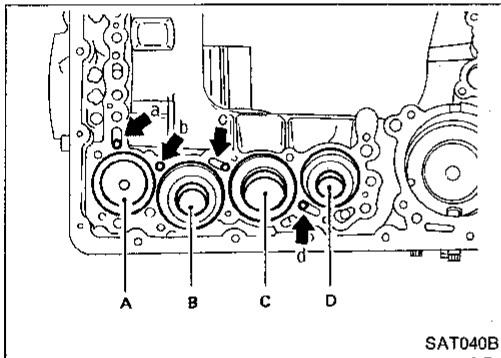

- d. Remove springs from accumulator pistons B, C and D.
e. Apply compressed air to each oil hole until piston comes out.
● **Hold piston with a rag and gradually direct air to oil hole.**

Identification of accumulator pistons	A	B	C	D
Identification of oil holes	a	b	c	d

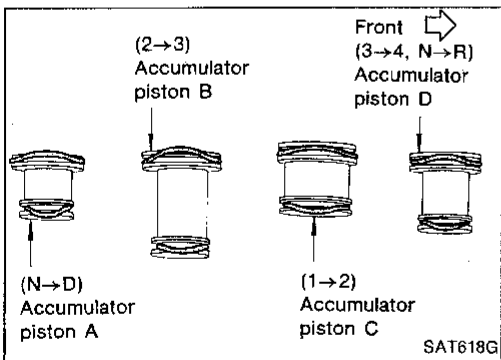

- f. Remove O-ring from each piston.

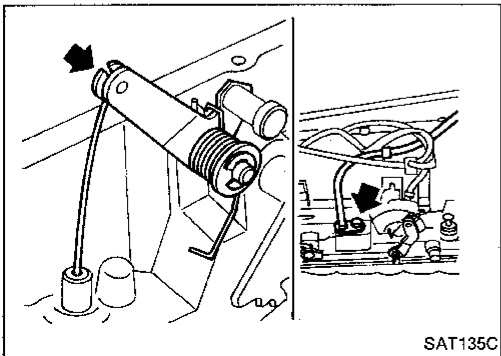

— RL4R01A —

21. Remove throttle wire components if necessary.
a. Remove throttle wire from A/T assembly.

DISASSEMBLY

Disassembly (Cont'd)

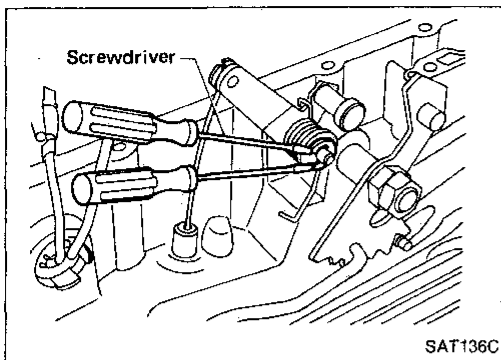

- b. Remove throttle lever shaft E-ring.
- c. Remove return spring.
- d. Remove throttle lever.

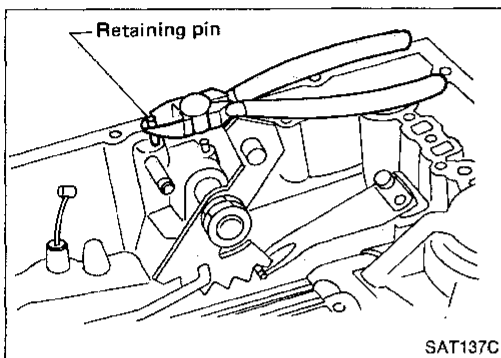

- e. Remove throttle lever shaft retaining pin and throttle lever shaft.

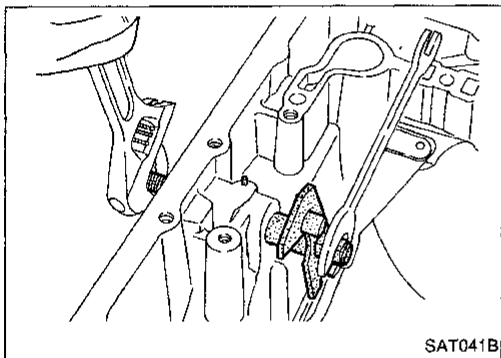

— RE4R01A and RL4R01A —

22. Remove manual shaft components, if necessary.
 - a. Hold width across flats of manual shaft (outside the transmission case) and remove lock nut from shaft.

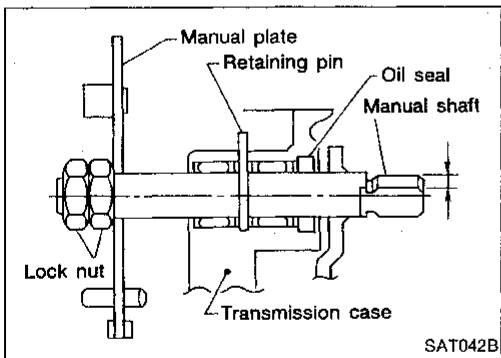

- b. Remove retaining pin from transmission case.

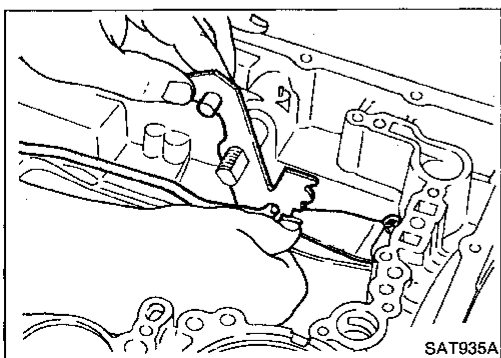

- c. While pushing detent spring down, remove manual plate and parking rod from transmission case.

DISASSEMBLY

Disassembly (Cont'd)

d. Remove manual shaft from transmission case.

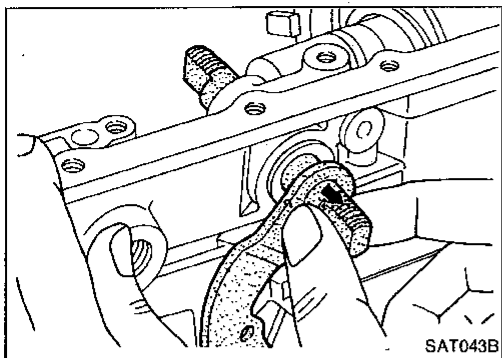

e. Remove spacer and detent spring from transmission case.

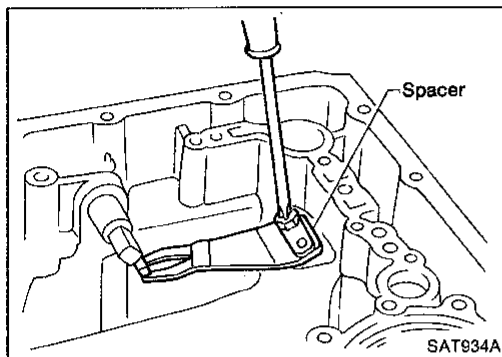

f. Remove oil seal from transmission case.

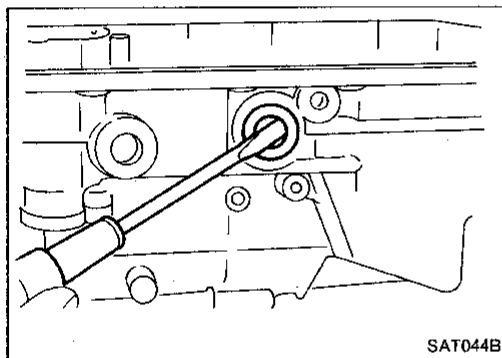

GI

MA

EM

LC

EF &
EC

FE

CL

MT

AT

TF

PD

FA

RA

BR

ST

BF

HA

EL

IDX

Oil Pump — RE4R01A and RL4R01A

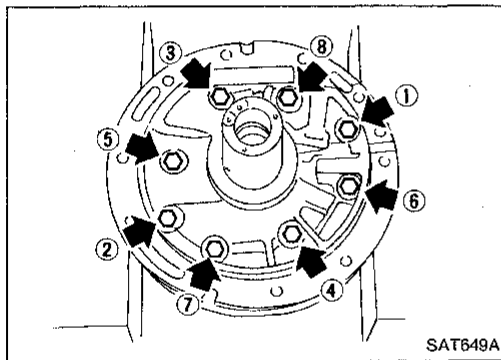
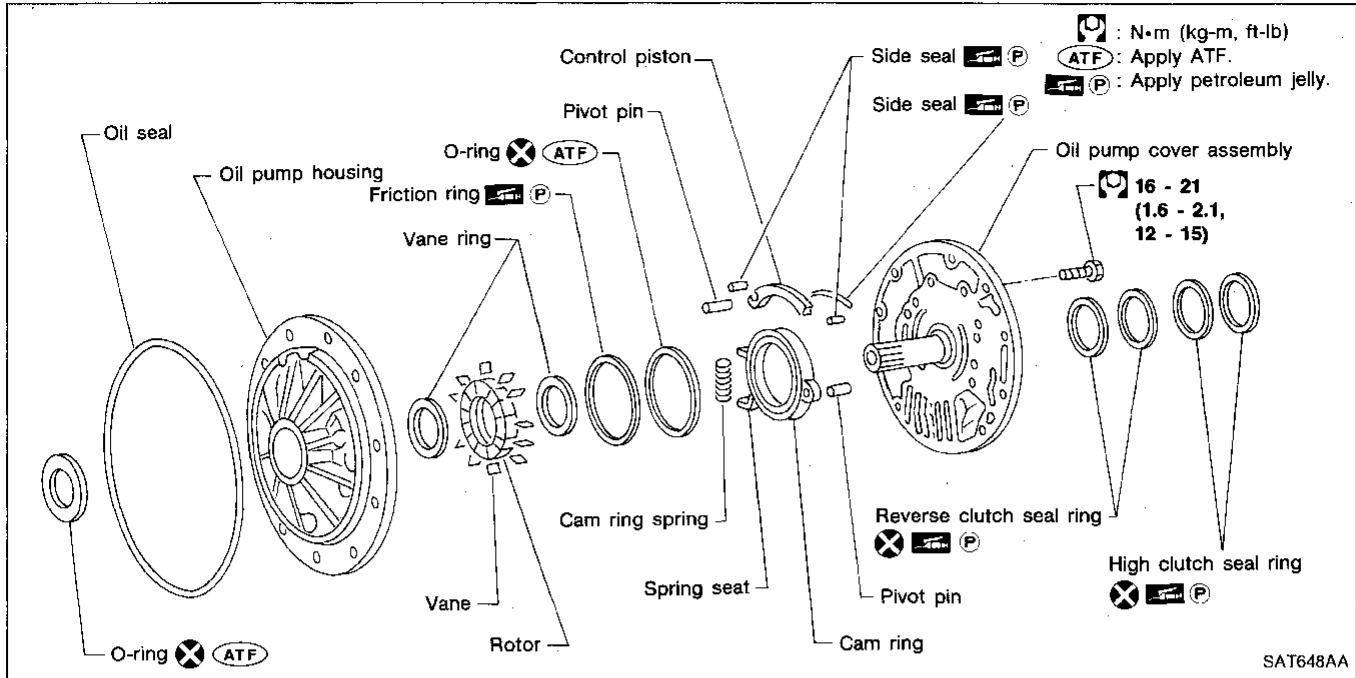

DISASSEMBLY

1. Loosen bolts in numerical order and remove oil pump cover.

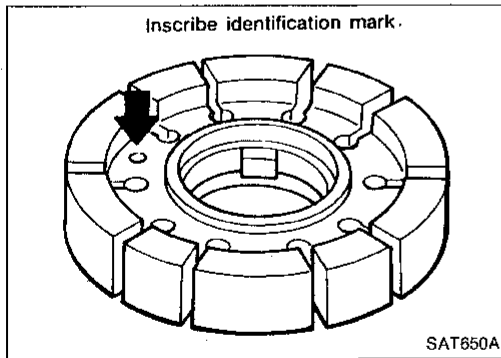

2. Remove rotor, vane rings and vanes.
 - Inscribe a mark on back of rotor for identification of fore-aft direction when reassembling rotor. Then remove rotor.

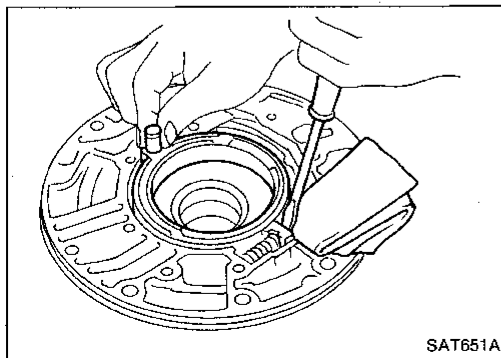

3. While pushing on cam ring remove pivot pin.
 - Be careful not to scratch oil pump housing.

REPAIR FOR COMPONENT PARTS

Oil Pump — RE4R01A and RL4R01A (Cont'd)

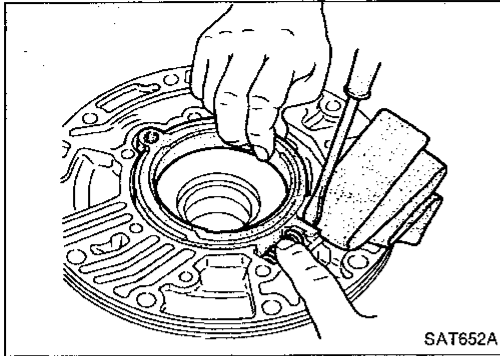

4. While holding cam ring and spring lift out cam ring spring.
 - Be careful not to damage oil pump housing.
 - Hold cam ring spring to prevent it from jumping.

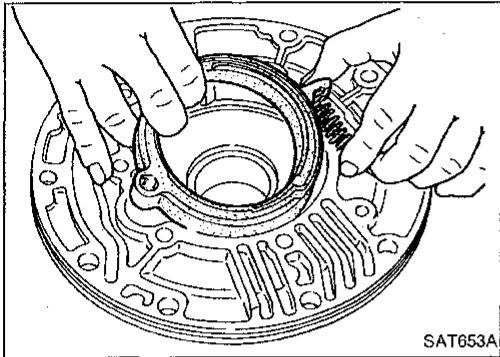

5. Remove cam ring and cam ring spring from oil pump housing.

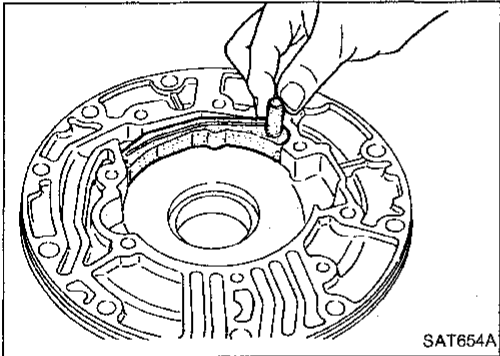

6. Remove pivot pin from control piston and remove control piston assembly.

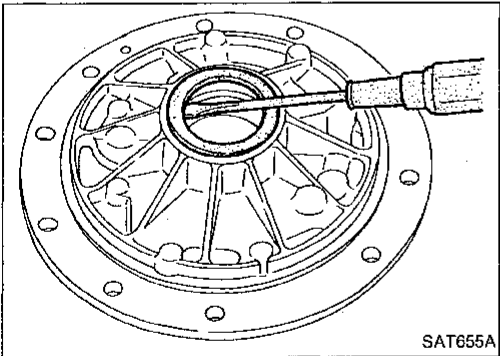

7. Remove oil seal from oil pump housing.
 - Be careful not to scratch oil pump housing.

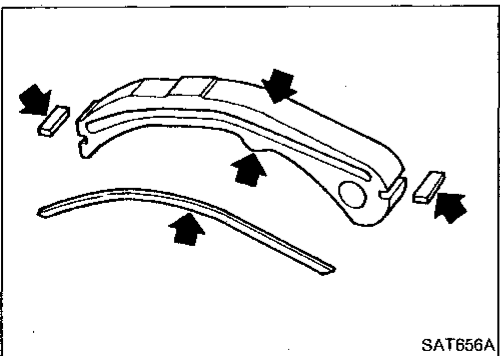

INSPECTION

Oil pump cover, rotor, vanes, control piston, side seals, cam ring and friction ring

- Check for wear or damage.

GI

MA

EM

LC

EF &
EC

FE

CL

MT

AT

TF

PD

FA

RA

BR

ST

BF

HA

EL

IDX

REPAIR FOR COMPONENT PARTS

Oil Pump — RE4R01A and RL4R01A (Cont'd)

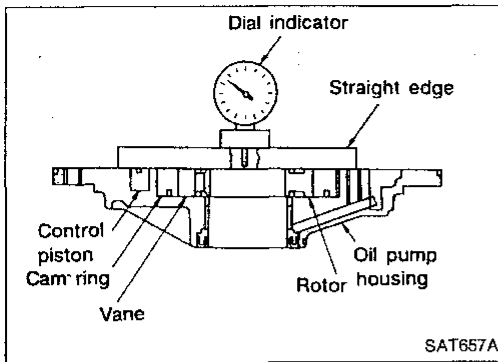

Side clearances

- Measure side clearances between end of oil pump housing and cam ring, rotor, vanes and control piston in at least four places along their circumferences. Maximum measured values should be within specified ranges.

- **Before measuring side clearance, check that friction rings, O-ring, control piston side seals and cam ring spring are removed.**

Standard clearance (Cam ring, rotor, vanes and control piston):

Refer to SDS (AT-217).

- If not within standard clearance, replace oil pump assembly except oil pump cover assembly.

Seal ring clearance

- Measure clearance between seal ring and ring groove.

Standard clearance:

0.10 - 0.25 mm (0.0039 - 0.0098 in)

Wear limit:

0.25 mm (0.0098 in)

- If not within wear limit, replace oil pump cover assembly.

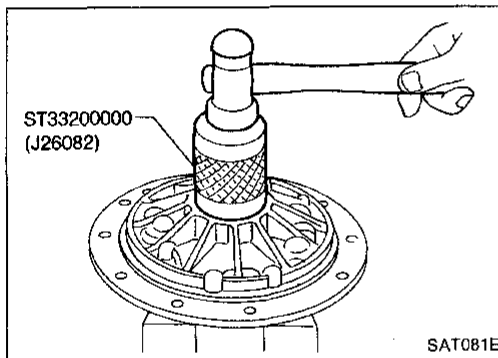
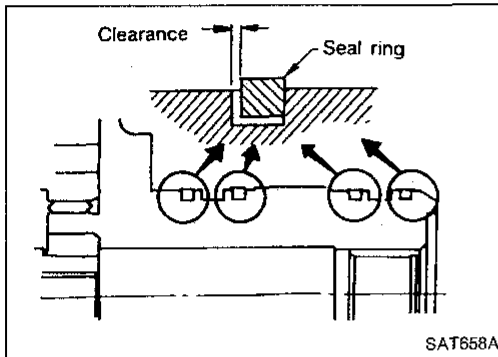

ASSEMBLY

1. Drive oil seal into oil pump housing.

- **Apply ATF to outer periphery and lip surface.**

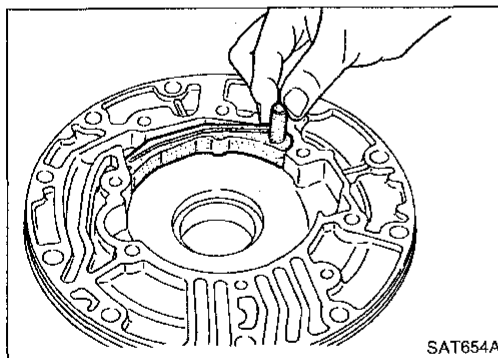

2. Install cam ring in oil pump housing by the following steps.

- a. Install side seal on control piston.

- **Pay attention to its direction — Black surface goes toward control piston.**

- **Apply petroleum jelly to side seal.**

- b. Install control piston on oil pump.

- c. Install O-ring and friction ring on cam ring.

- **Apply petroleum jelly to O-ring.**

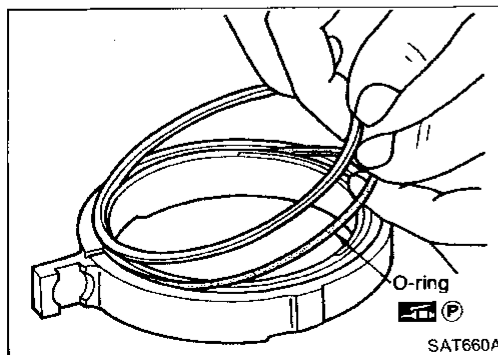

REPAIR FOR COMPONENT PARTS

Oil Pump — RE4R01A and RL4R01A (Cont'd)

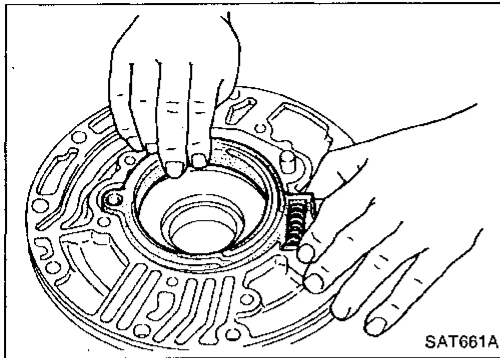

- d. Assemble cam ring, cam ring spring and spring seat. Install spring by pushing it against pump housing.

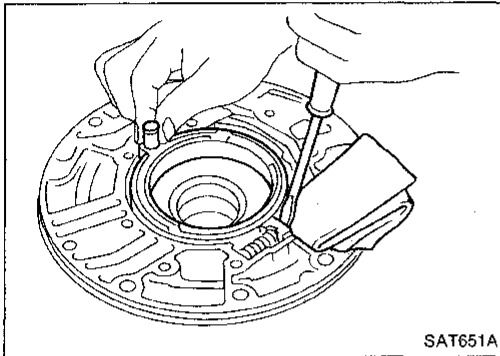

- e. While pushing on cam ring install pivot pin.

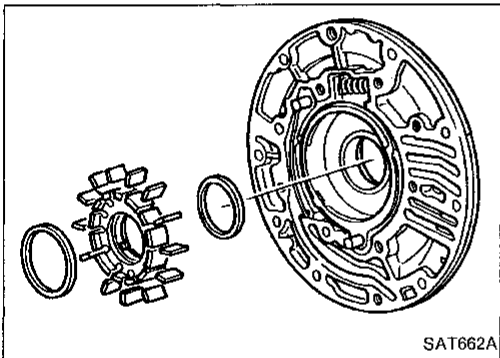

3. Install rotor, vanes and vane rings.
 ● Pay attention to direction of rotor.

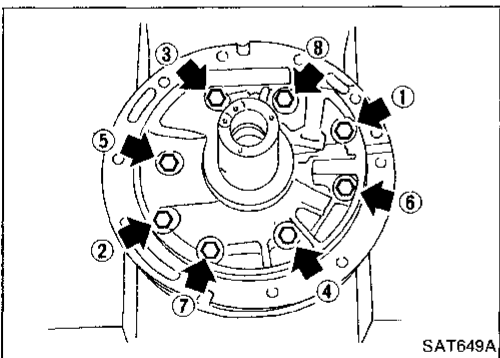

4. Install oil pump housing and oil pump cover.
 a. Wrap masking tape around splines of oil pump cover assembly to protect seal. Position oil pump cover assembly in oil pump housing assembly, then remove masking tape.
 b. Tighten bolts in a criss-cross pattern.

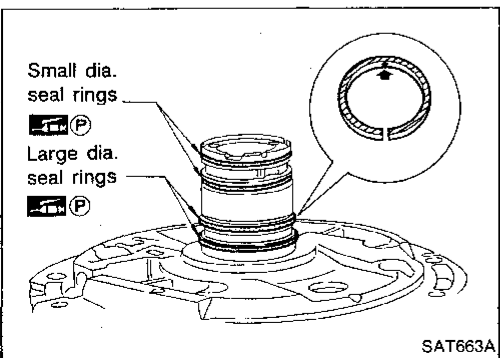

5. Install seal rings carefully after packing ring grooves with petroleum jelly. Press rings down into jelly to a close fit.
 ● Seal rings come in two different diameters. Check fit carefully in each groove.
 Small dia. seal ring:
 No mark
 Large dia. seal ring:
 Yellow mark in area shown by arrow
 ● Do not spread gap of seal ring excessively while installing. It may deform ring.

GI

MA

EM

LC

EF &
EC

FE

CL

MT

AT

TF

PD

FA

RA

BR

ST

BF

HA

EL

IDX

REPAIR FOR COMPONENT PARTS

Control Valve Assembly — RE4R01A

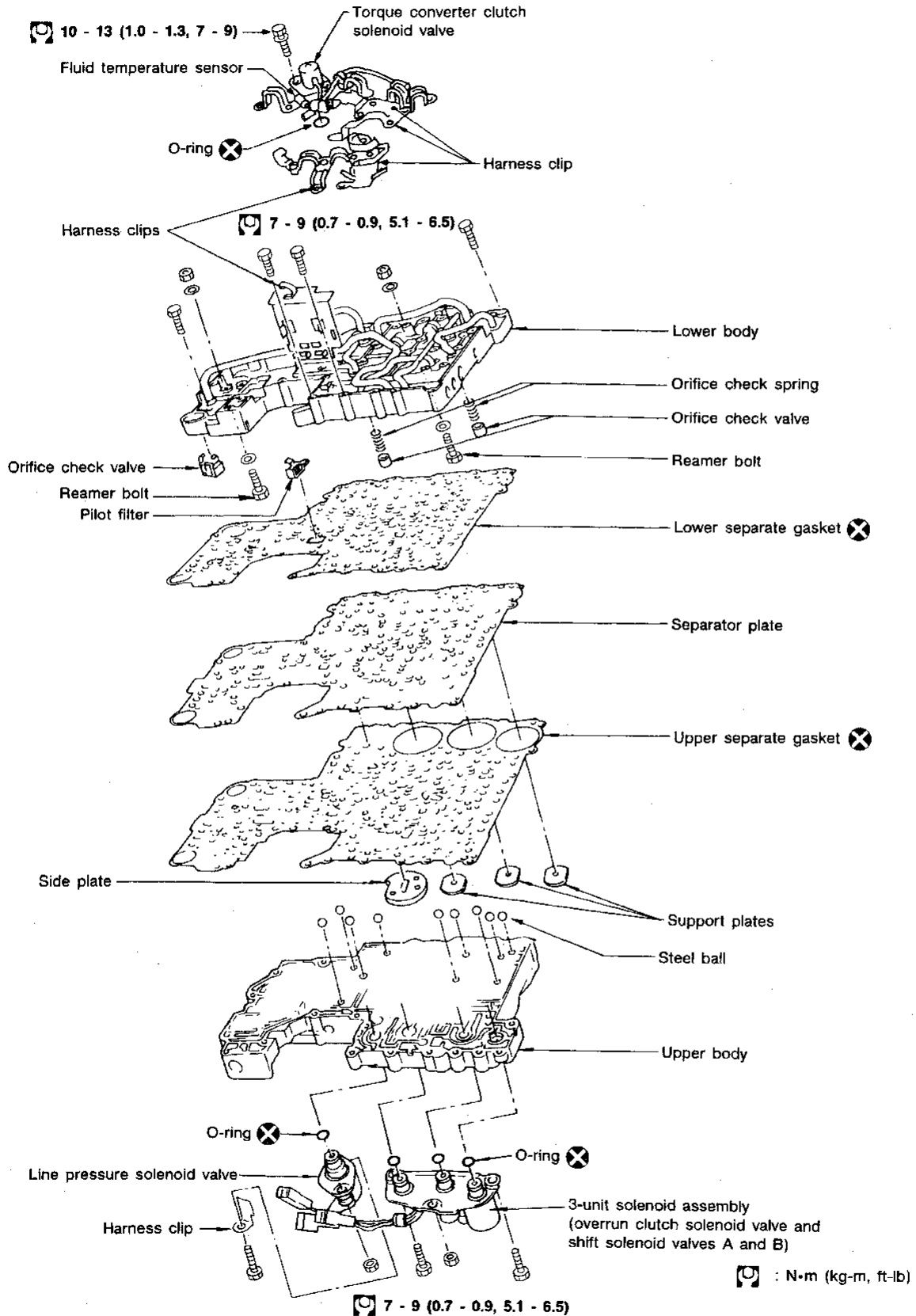

REPAIR FOR COMPONENT PARTS

Control Valve Assembly — RE4R01A (Cont'd)

DISASSEMBLY

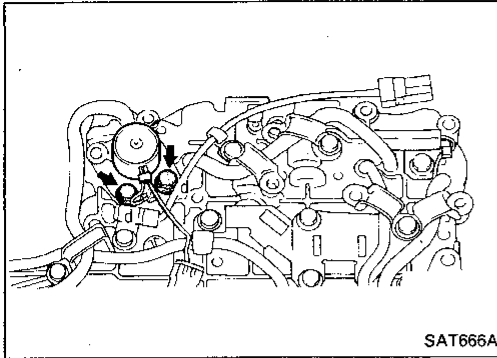

1. Remove solenoid valves.
 - a. Remove torque converter clutch solenoid valve and side plate from lower body.
 - b. Remove O-ring from solenoid valve.

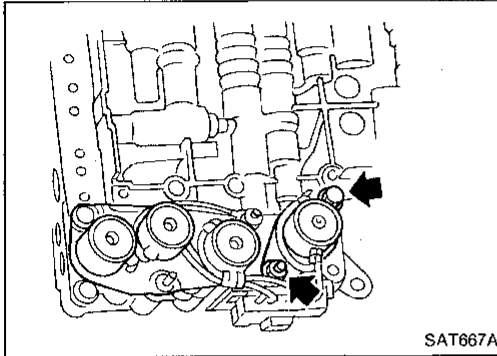

- c. Remove line pressure solenoid valve from upper body.
 - d. Remove O-ring from solenoid valve.

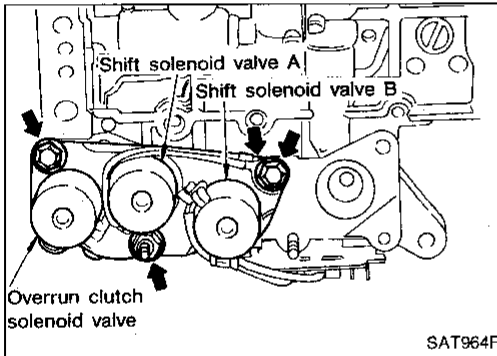

- e. Remove 3-unit solenoid valve assembly from upper body.
 - f. Remove O-rings from solenoid valves.

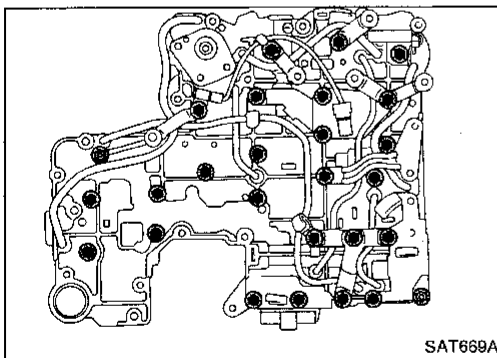

2. Disassemble upper and lower bodies.
 - a. Place upper body facedown, and remove bolts, reamer bolts and support plates.
 - b. Remove lower body, separator plate and separate gasket as a unit from upper body.
- **Be careful not to drop pilot filter, orifice check valve, spring and steel balls.**

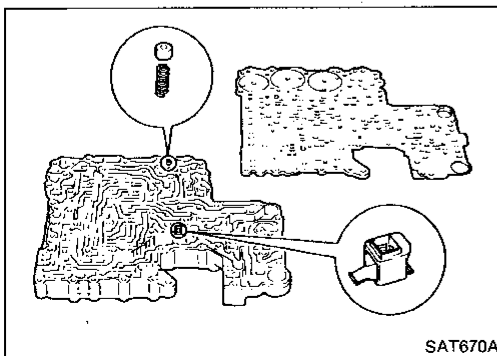

- c. Place lower body facedown, and remove separator gasket and separator plate.
 - d. Remove pilot filter, orifice check valve and orifice check spring.

GI

MA

EM

LC

EF &
EC

FE

CL

MT

AT

TF

PD

FA

RA

BR

ST

BF

KA

EL

IDX

REPAIR FOR COMPONENT PARTS

Control Valve Assembly — RE4R01A (Cont'd)

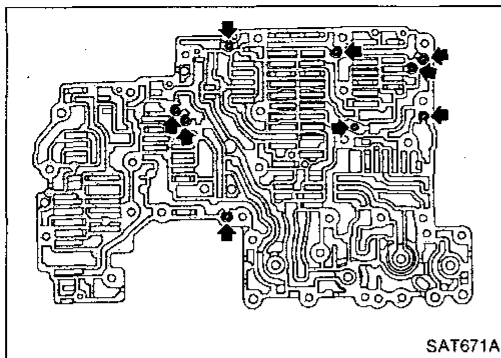

- e. Check to see that steel balls are properly positioned in upper body and then remove them from upper body.

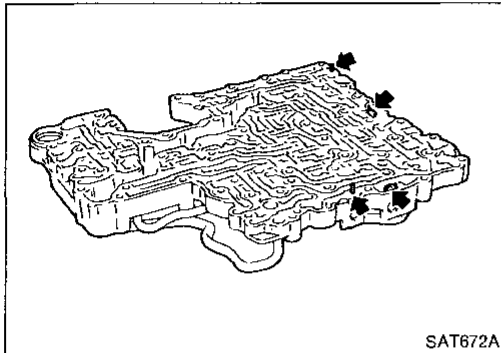

INSPECTION

Lower and upper bodies

- Check to see that there are pins and retainer plates in lower body.

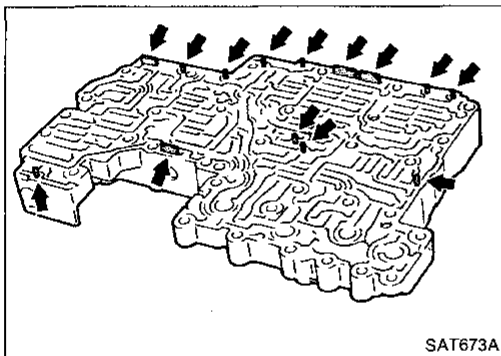

- Check to see that there are pins and retainer plates in upper body.
- **Be careful not to lose these parts.**

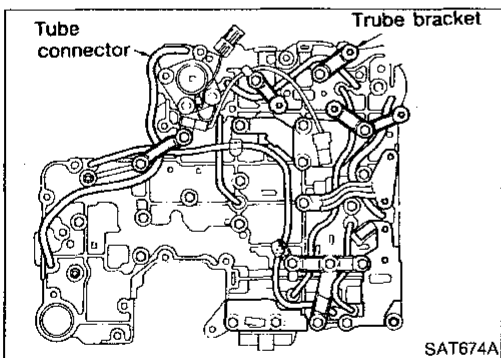

- Check to make sure that oil circuits are clean and free from damage.
- Check tube brackets and tube connectors for damage.

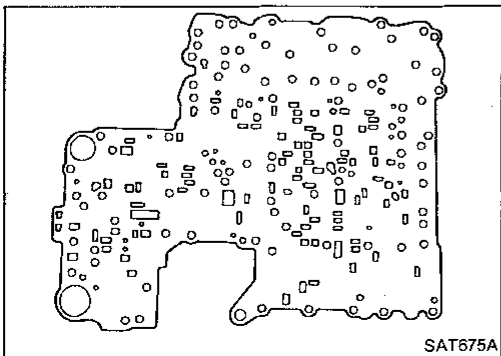

Separator plates

- Check to make sure that separator plate is free of damage and not deformed and oil holes are clean.

REPAIR FOR COMPONENT PARTS

Control Valve Assembly — RE4R01A (Cont'd)

Pilot filter

- Check to make sure that filter is not clogged or damaged.

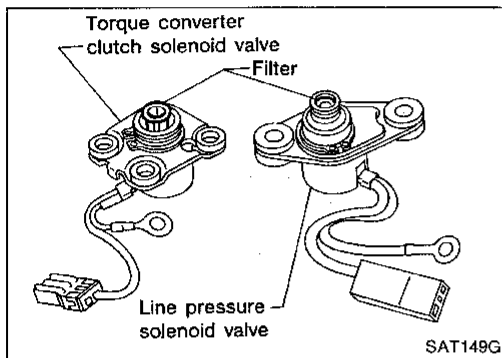
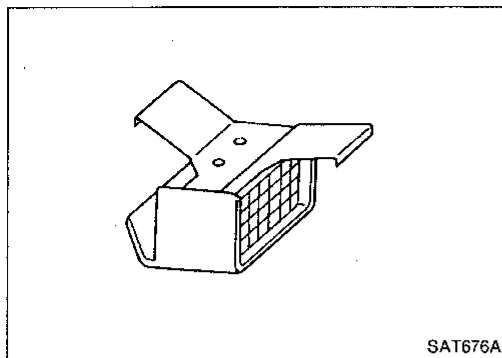

Torque converter clutch solenoid valve

- Check that filter is not clogged or damaged.
- Measure resistance. — Refer to “Electrical Components Inspection” (AT-72).

Line pressure solenoid valve

- Check that filter is not clogged or damaged.
- Measure resistance. — Refer to “Electrical Components Inspection” (AT-72).

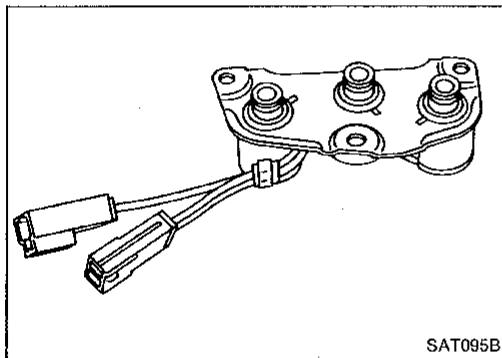

3-unit solenoid valve assembly (Overrun clutch solenoid valve and shift solenoid valves A and B)

- Measure resistance of each solenoid valve. — Refer to “Electrical Components Inspection” (AT-72).

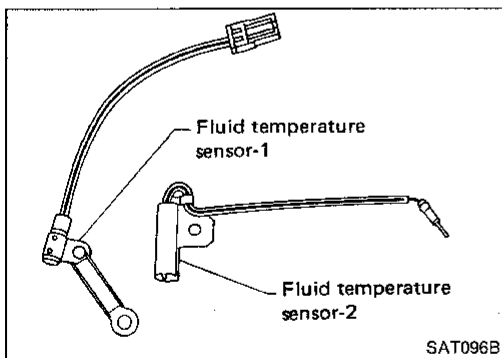

Fluid temperature sensor-1 and -2

- Measure resistance. — Refer to “Electrical Components Inspection” (AT-72).

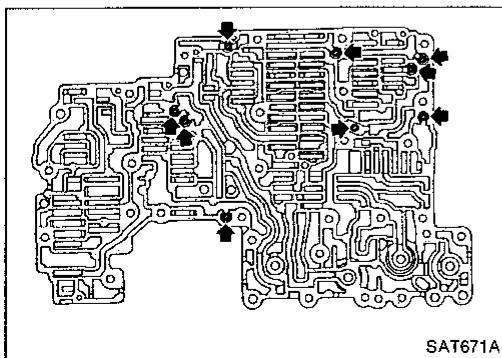

ASSEMBLY

1. Install upper and lower bodies.
 - a. Place oil circuit of upper body face up. Install steel balls in their proper positions.

GI

MA

EM

LC

EF &
EC

FE

CL

MT

AT

TF

PD

FA

RA

BR

ST

BF

HA

EL

IDX

REPAIR FOR COMPONENT PARTS

Control Valve Assembly — RE4R01A (Cont'd)

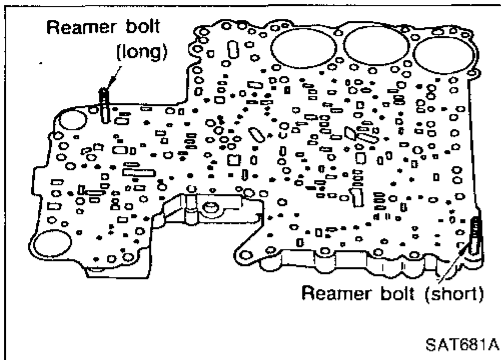

- b. Install reamer bolts from bottom of upper body and install separate gaskets.

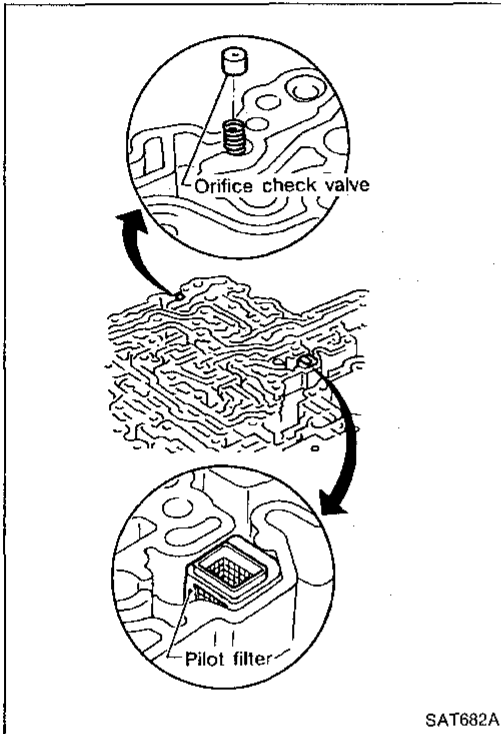

- c. Place oil circuit of lower body face up. Install orifice check spring, orifice check valve and pilot filter.

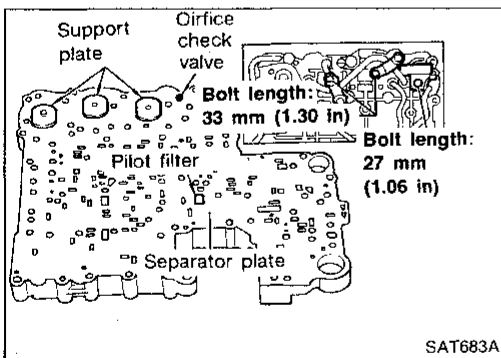

- d. Install lower separate gaskets and separator plates on lower body.
- e. Install and temporarily tighten support plates, fluid temperature sensor-2 and tube brackets.

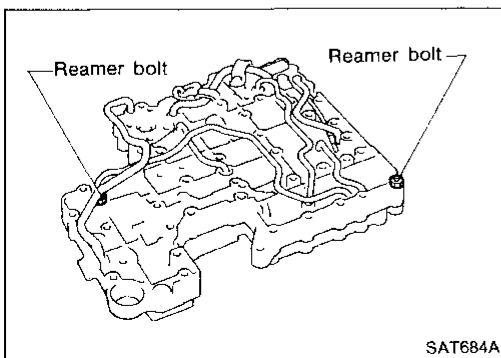

- f. Temporarily assemble lower and upper bodies, using reamer bolt as a guide.
- **Be careful not to dislocate or drop steel balls, orifice check spring, orifice check valve and pilot filter.**

REPAIR FOR COMPONENT PARTS

Control Valve Assembly — RE4R01A (Cont'd)

- g. Install and temporarily tighten bolts and tube brackets in their proper locations.

Bolt length and location

Bolt symbol		a	b	c	d
Bolt length	mm (in)	70 (2.76)	50 (1.97)	33 (1.30)	27 (1.06)

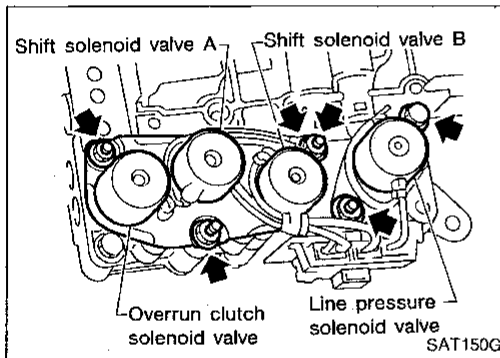
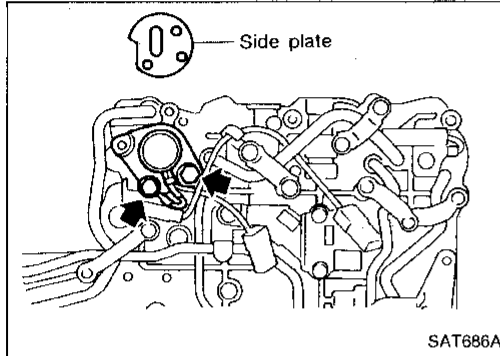
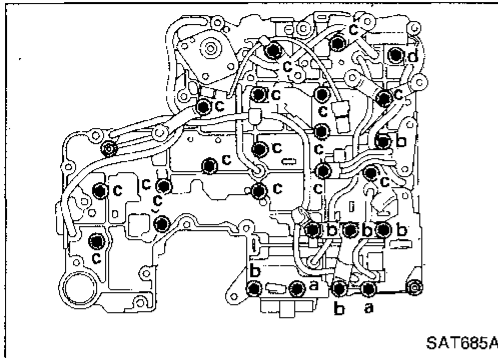

2. Install solenoid valves.
- a. Attach O-ring and install torque converter clutch solenoid valve and side plates onto lower body.

- b. Attach O-rings and install 3-unit solenoid valve assembly onto upper body.
- c. Attach O-ring and install line pressure solenoid valve onto upper body.
3. Tighten all bolts.

GI

MA

EM

LC

EF &
EC

FE

CL

MT

AT

TF

PD

FA

RA

BR

ST

BF

HA

EL

IDX

REPAIR FOR COMPONENT PARTS

Control Valve Assembly — RL4R01A

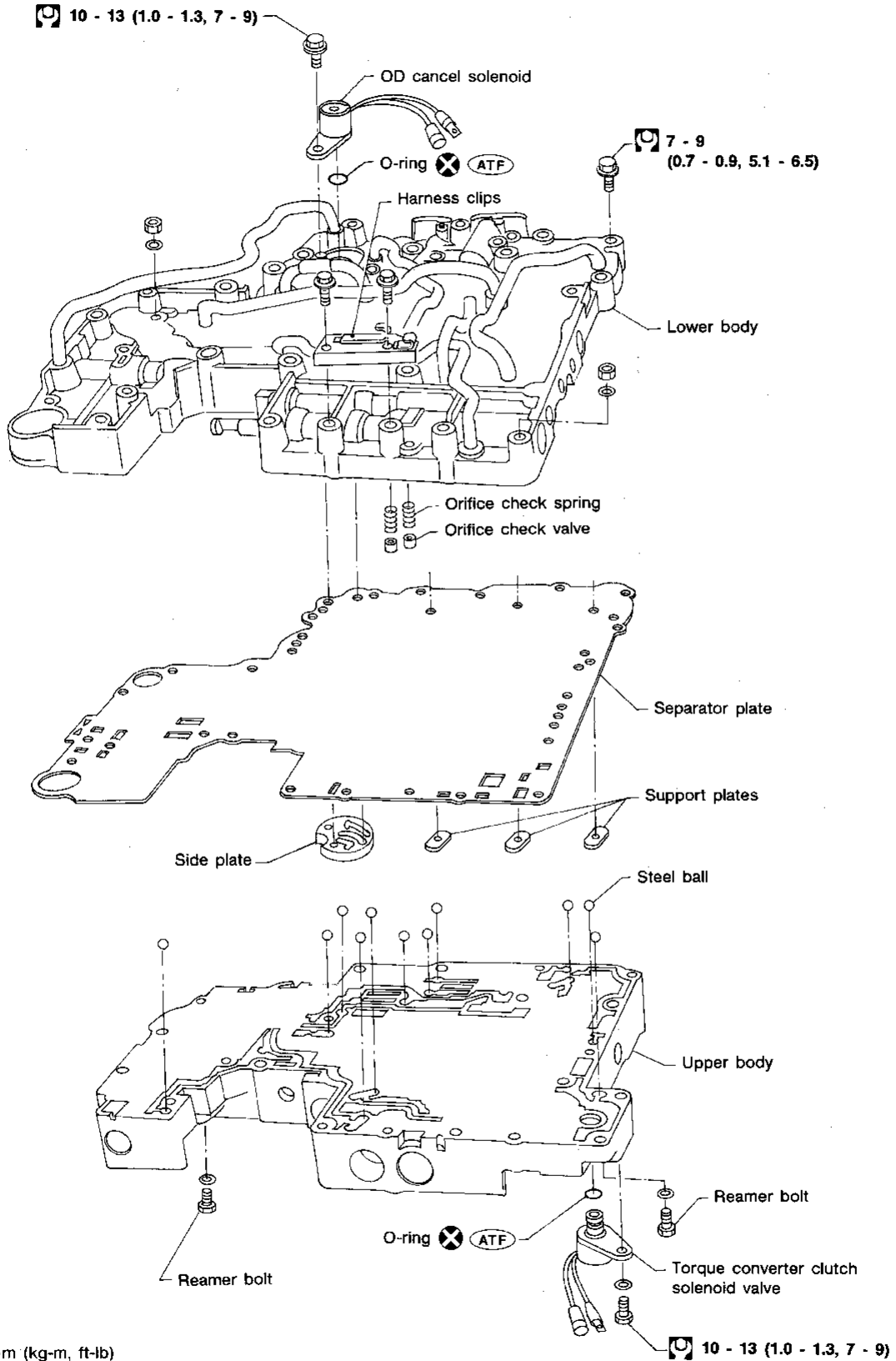

: N·m (kg-m, ft-lb)
 : Apply ATF.

REPAIR FOR COMPONENT PARTS

Control Valve Assembly — RL4R01A (Cont'd)

DISASSEMBLY

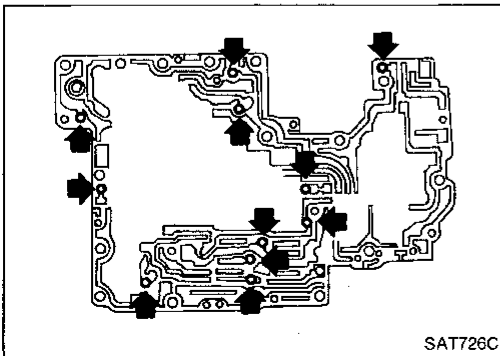
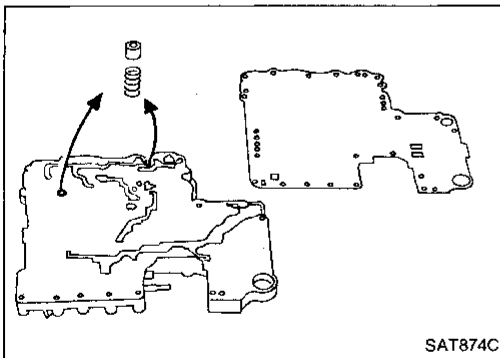
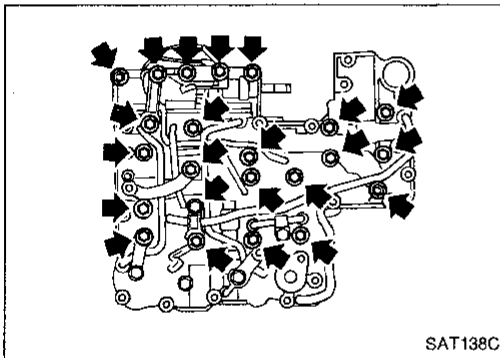
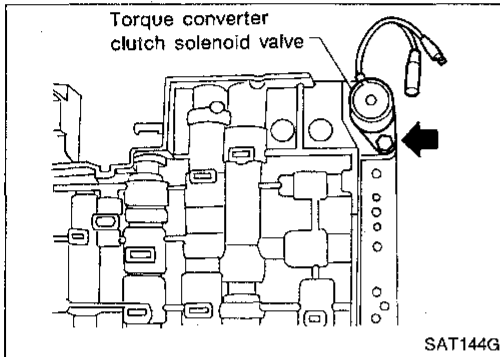
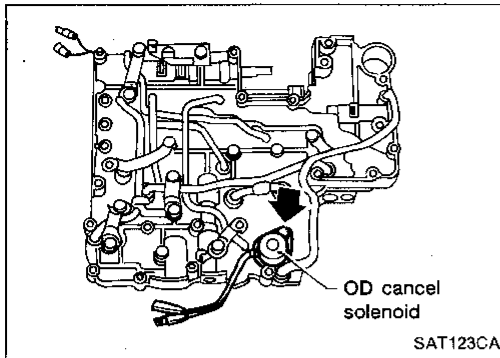

1. Remove solenoids.
 - a. Remove OD cancel solenoid and side plate from lower body.
 - b. Remove O-ring from solenoid.

GI

MA

EM

- c. Remove torque converter clutch solenoid valve from upper body.
 - d. Remove O-ring from solenoid valve.

LC

EF &
EC

FE

CL

2. Disassemble upper and lower bodies.
 - a. Place upper body facedown, and remove bolts, reamer bolts and support plates.
 - b. Remove lower body, separator plate and separate gasket as a unit from upper body.
 - **Be careful not to drop orifice check valve, spring and steel balls.**

MT

AT

TF

PD

- c. Place lower body facedown, and remove separator plate.
 - d. Remove orifice check valve and orifice check spring.

FA

RA

BR

ST

- e. Check to see that steel balls are properly positioned in upper body and then remove them from upper body.

BF

HA

EL

IDX

REPAIR FOR COMPONENT PARTS

Control Valve Assembly — RL4R01A (Cont'd)

INSPECTION

Lower and upper bodies

- Check to see that there are pins and retainer plates in lower body.

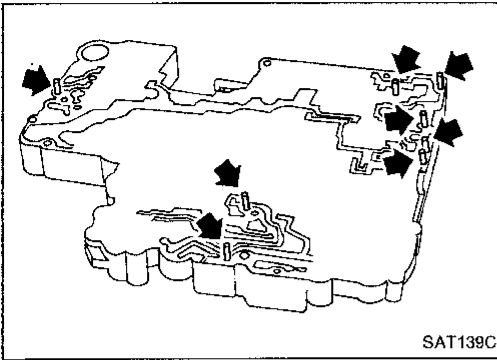

- Check to see that there are pins and retainer plates in upper body.
- **Be careful not to lose these parts.**

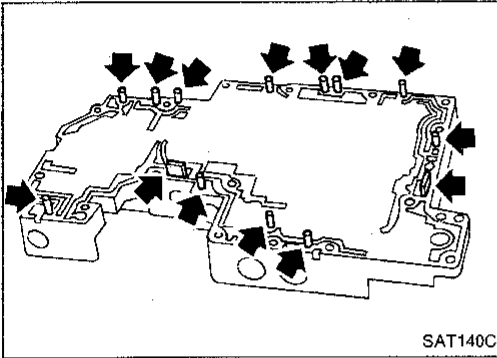

- Check to make sure that oil circuits are clean and free from damage.
- Check tube brackets and tube connectors for damage.

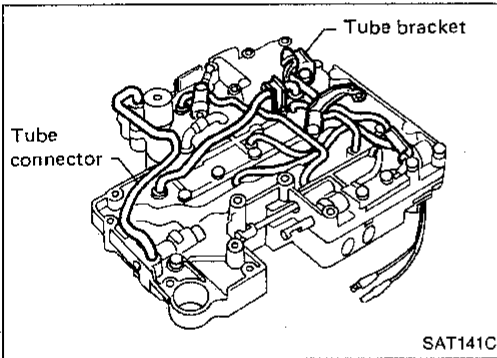

Separator plates

- Check to make sure that separator plate is free of damage and not deformed and oil holes are clean.

OD cancel solenoid and torque converter clutch solenoid valve

- Check that filter is not clogged or damaged.
- Measure resistance. — Refer to "Electrical Components Inspection" (AT-72).

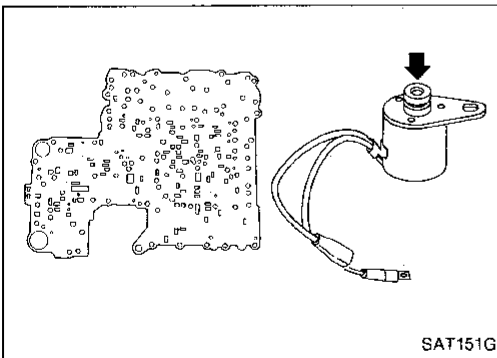

ASSEMBLY

1. Install upper and lower bodies.
 - a. Place oil circuit of upper body face up. Install steel balls in their proper positions.

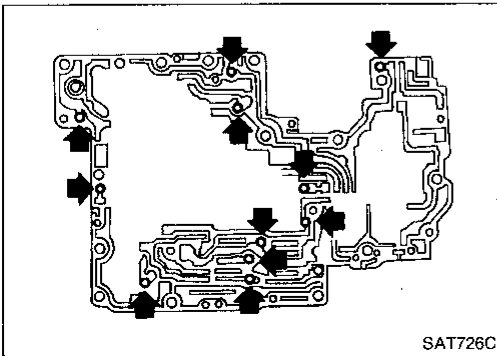

REPAIR FOR COMPONENT PARTS

Control Valve Assembly — RL4R01A (Cont'd)

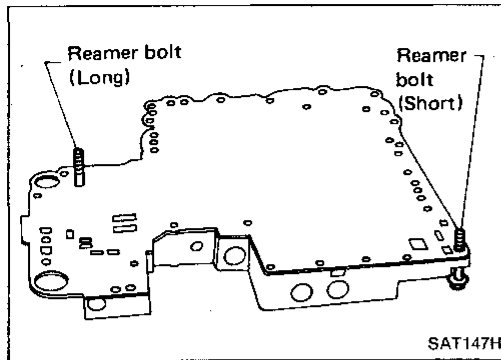

- b. Install reamer bolts from bottom of upper body and install separate gaskets.

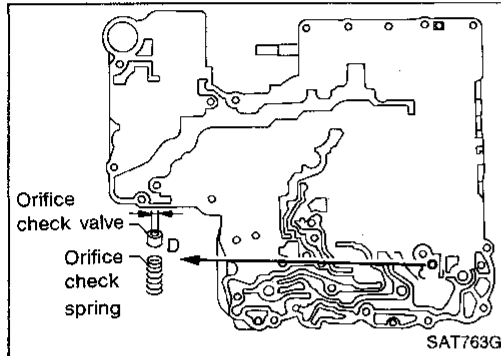

- c. Place oil circuit of lower body face up. Install orifice check spring, orifice check valve.

D: mm (in)
2.0 (0.079)

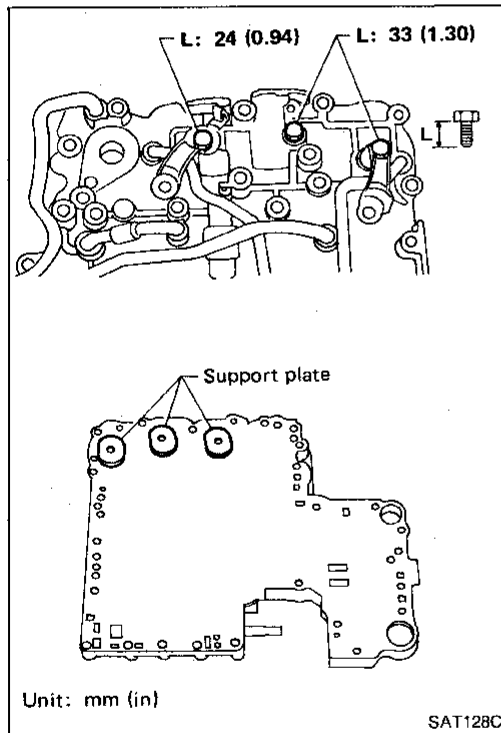

- d. Install separator plates on lower body.
e. Install and temporarily tighten support plates and tube brackets.

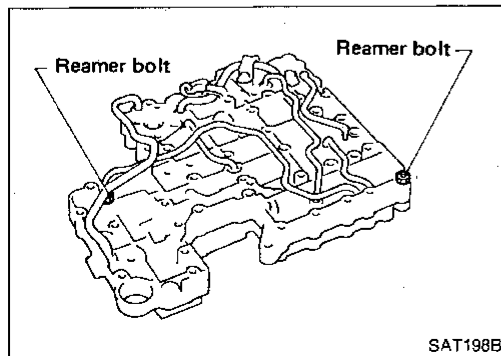

- f. Temporarily assemble lower and upper bodies, using reamer bolt as a guide.
- Be careful not to dislocate or drop steel balls, orifice check spring and orifice check valve.

GI

MA

EM

LC

EF &
EC

FE

CL

MT

AT

TF

PD

FA

RA

BR

ST

BF

HA

EL

IDX

REPAIR FOR COMPONENT PARTS

Control Valve Assembly — RL4R01A (Cont'd)

- g. Install and temporarily tighten bolts and tube brackets in their proper locations.

Bolt length and location:

Item		Bolt symbol	
		a	b
Bolt length	mm (in)	45 (1.77)	33 (1.30)

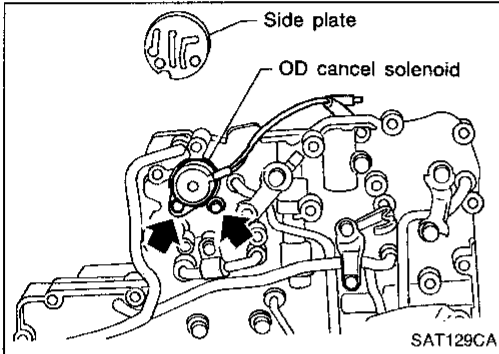
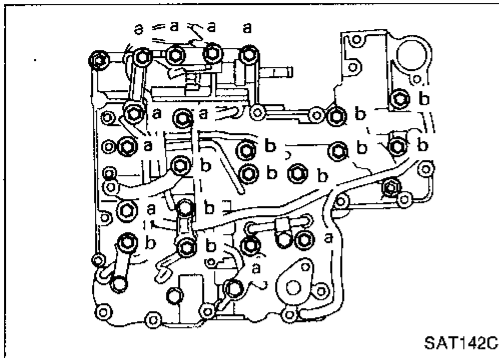

2. Install solenoids.
a. Attach O-ring and install OD cancel solenoid and side plates onto lower body.

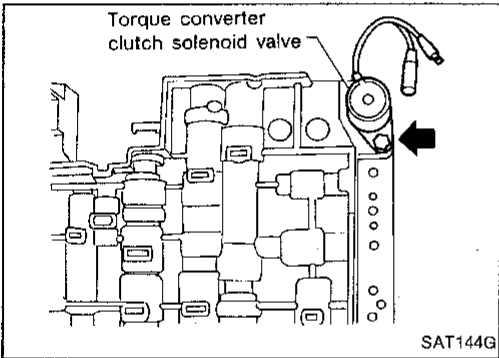

- b. Attach O-ring and install torque converter clutch solenoid valve onto upper body.
3. Tighten bolt.

Control Valve Upper Body — RE4R01A

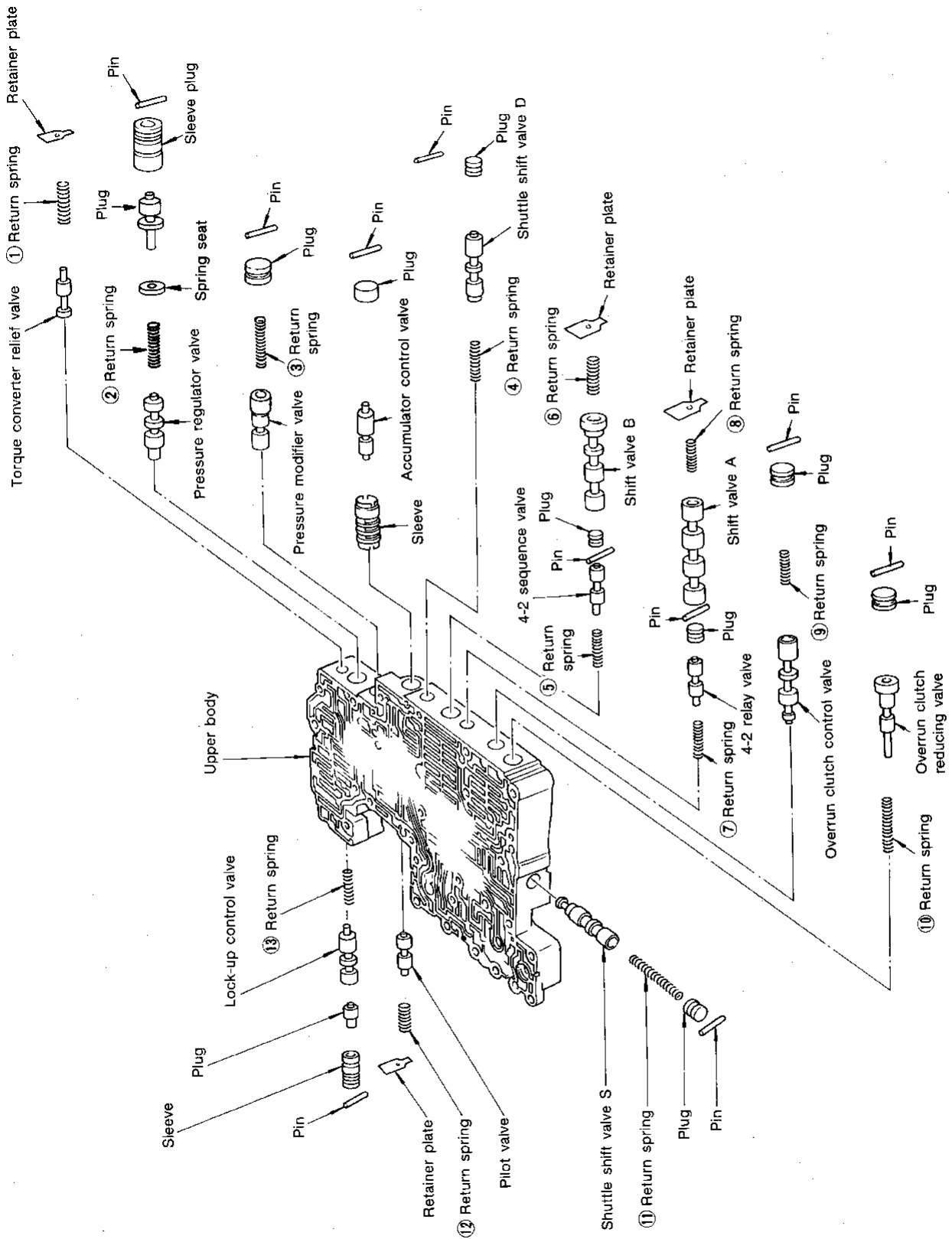

- GI
- MA
- EM
- LC
- EF
- TC
- FE
- CL
- MT
- AT**
- TF
- PD
- FA
- RA
- BR
- ST
- BF
- HA
- EL

Apply ATF to all components before their installation.

Numbers preceding valve springs correspond with those shown in Spring Chart on page AT-154.

REPAIR FOR COMPONENT PARTS

Control Valve Upper Body — RE4R01A (Cont'd)

DISASSEMBLY

1. Remove valves at parallel pins.
 - Do not use a magnetic hand.

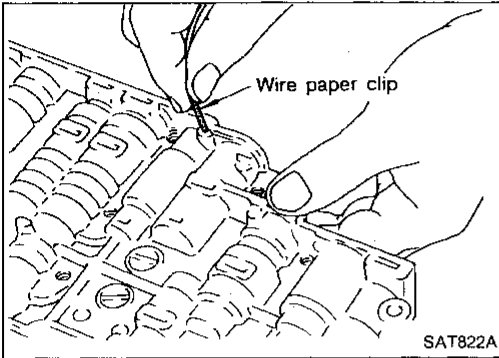
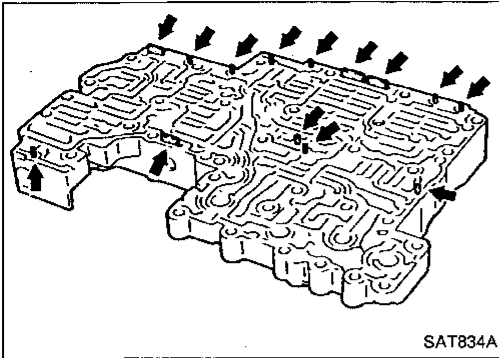

- a. Use a wire paper clip to push out parallel pins.

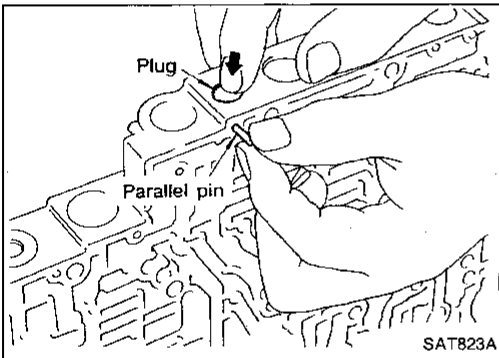

- b. Remove parallel pins while pressing their corresponding plugs and sleeves.
 - Remove plug slowly to prevent internal parts from jumping out.

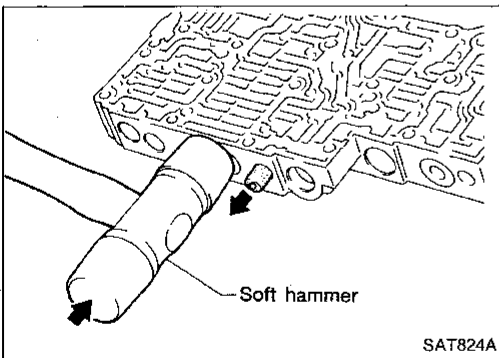

- c. Place mating surface of valve facedown, and remove internal parts.
 - If a valve is hard to remove, place valve body facedown and lightly tap it with a soft hammer.
 - Be careful not to drop or damage valves and sleeves.

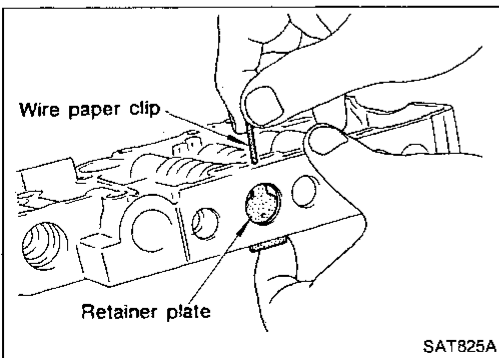

2. Remove valves at retainer plates.
 - a. Pry out retainer plate with wire paper clip.

REPAIR FOR COMPONENT PARTS

Control Valve Upper Body — RE4R01A (Cont'd)

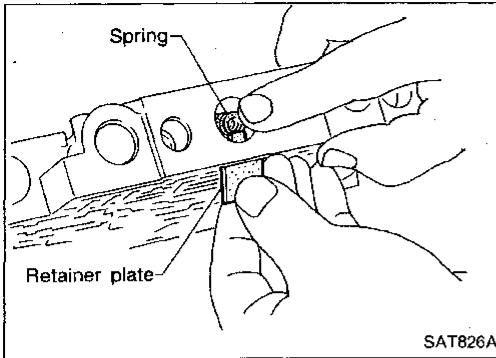

b. Remove retainer plates while holding spring.

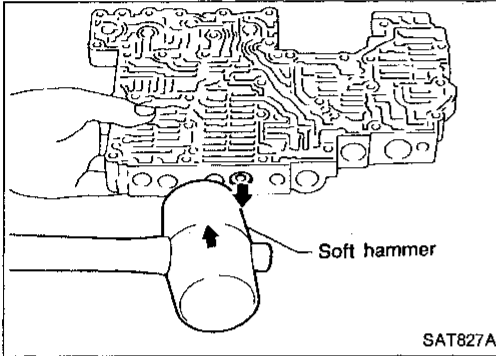

c. Place mating surface of valve facedown, and remove internal parts.

- If a valve is hard to remove, lightly tap valve body with a soft hammer.
- Be careful not to drop or damage valves, sleeves, etc.

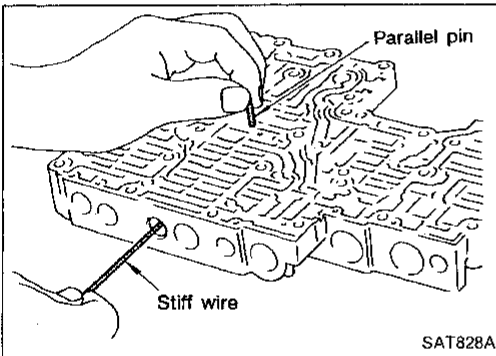

- 4-2 sequence valve and relay valve are located far back in upper body. If they are hard to remove, carefully push them out using stiff wire.
- Be careful not to scratch sliding surface of valve with wire.

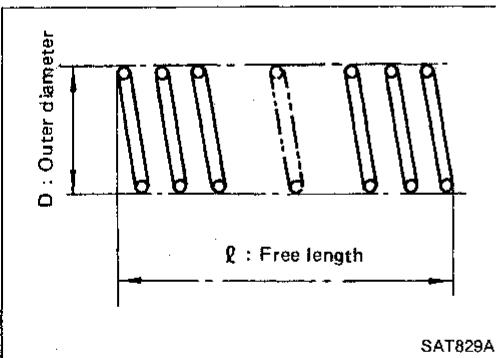

INSPECTION

Valve springs

- Measure free length and outer diameter of each valve spring. Also check for damage or deformation.
- Numbers of each valve spring listed in table below are the same as those in the figure in AT-151.

GI

MA

EM

LC

EF &
EC

FE

CL

MT

AT

TF

PD

FA

RA

BR

ST

BF

HA

EL

IDX

REPAIR FOR COMPONENT PARTS

Control Valve Upper Body — RE4R01A (Cont'd)

Inspection standard

Unit: mm (in)

Parts	Item		
	Part No.	ℓ	D
① Torque converter relief valve spring	31742-41X23	38.0 (1.496)	9.0 (0.354)
② Pressure regulator valve spring	31742-41X24	44.02 (1.7331)	14.0 (0.551)
③ Pressure modifier valve spring	31742-41X19	31.95 (1.2579)	6.8 (0.268)
④ Shuttle shift valve D spring	31762-41X00	26.5 (1.043)	6.0 (0.236)
⑤ 4-2 sequence valve spring	31756-41X00	29.1 (1.146)	6.95 (0.2736)
⑥ Shift valve B spring	31762-41X01	25.0 (0.984)	7.0 (0.276)
⑦ 4-2 relay valve spring	31756-41X00	29.1 (1.146)	6.95 (0.2736)
⑧ Shift valve A spring	31762-41X01	25.0 (0.984)	7.0 (0.276)
⑨ Overrun clutch control valve spring	31762-41X03	23.6 (0.929)	7.0 (0.276)
⑩ Overrun clutch reducing valve spring	31742-41X20	32.5 (1.280)	7.0 (0.276)
⑪ Shuttle shift valve S spring	31762-41X04	51.0 (2.008)	5.65 (0.2224)
⑫ Pilot valve spring	31742-41X13	25.7 (1.012)	9.1 (0.358)
⑬ Lock-up control valve spring	31742-41X22	18.5 (0.728)	13.0 (0.512)

- Replace valve springs if deformed or fatigued.

Control valves

- Check sliding surfaces of valves, sleeves and plugs.

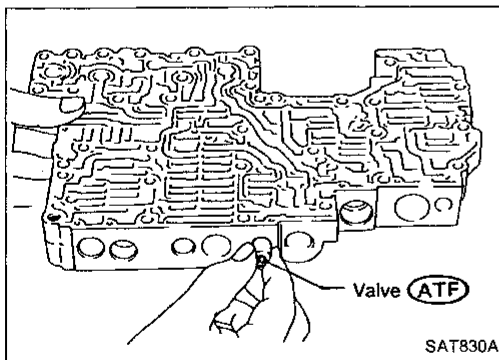

ASSEMBLY

1. Lubricate the control valve body and all valves with ATF. Install control valves by sliding them carefully into their bores.

- Be careful not to scratch or damage valve body.

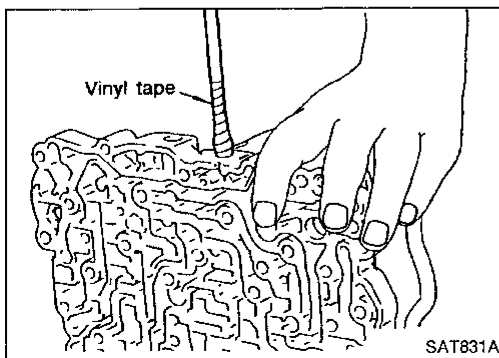

- Wrap a small screwdriver with vinyl tape and use it to insert the valves into proper position.

REPAIR FOR COMPONENT PARTS

Control Valve Upper Body — RE4R01A (Cont'd)

Pressure regulator valve

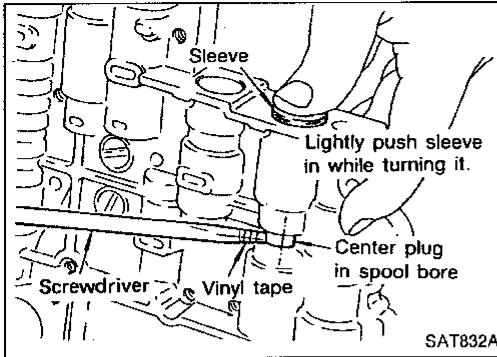

- If pressure regulator plug is not centered properly, sleeve cannot be inserted into bore in upper body. If this happens, use vinyl tape wrapped screwdriver to center sleeve until it can be inserted.
- Turn sleeve slightly while installing.

GI

MA

EM

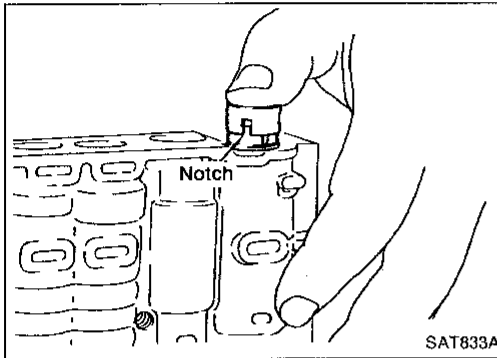

Accumulator control plug

- Align protrusion of accumulator control sleeve with notch in plug.
- Align parallel pin groove in plug with parallel pin, and install accumulator control valve.

LC

EF &
EC

FE

CL

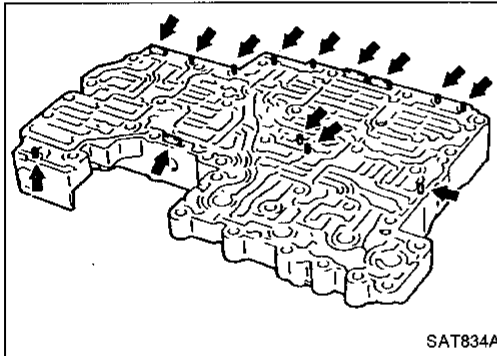

2. Install parallel pins and retainer plates.

MT

AT

TF

PD

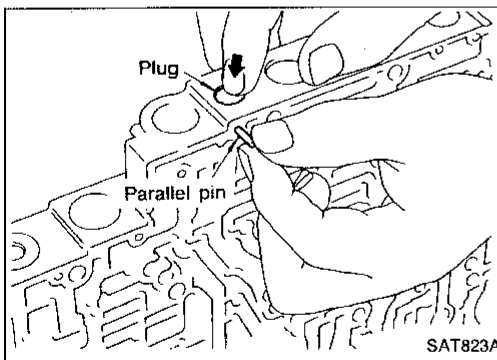

- While pushing plug, install parallel pin.

FA

RA

BR

ST

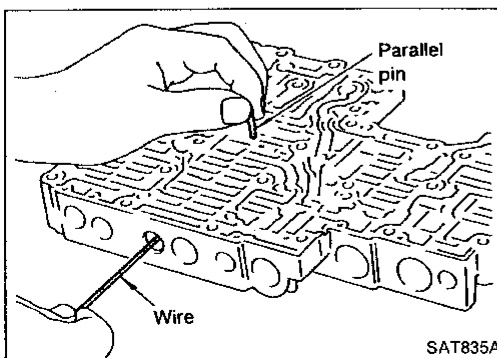

4-2 sequence valve and relay valve

- Push 4-2 sequence valve and relay valve with wire wrapped in vinyl tape to prevent scratching valve body. Install parallel pins.

BF

HA

EL

IDX

REPAIR FOR COMPONENT PARTS

Control Valve Upper Body — RE4R01A (Cont'd)

- Insert retainer plate while pushing spring.

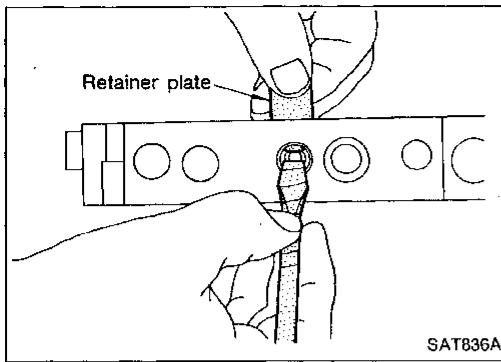

REPAIR FOR COMPONENT PARTS

Control Valve Upper Body — RL4R01A (Cont'd)

DISASSEMBLY

1. Remove valves at parallel pins.

- Do not use a magnetic hand.

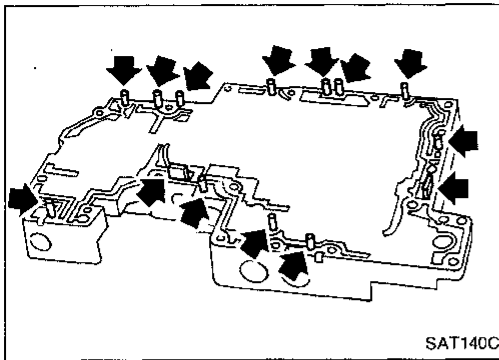

a. Use a wire paper clip to push out parallel pins.

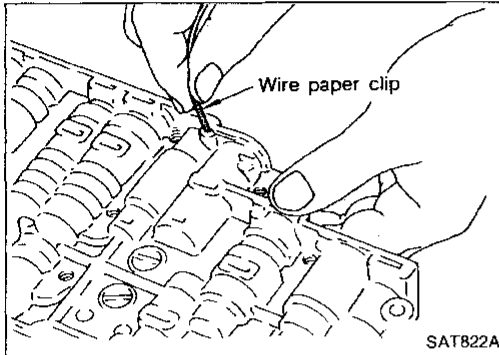

b. Remove parallel pins while pressing their corresponding plugs and sleeves.

- Remove plug slowly to prevent internal parts from jumping out.

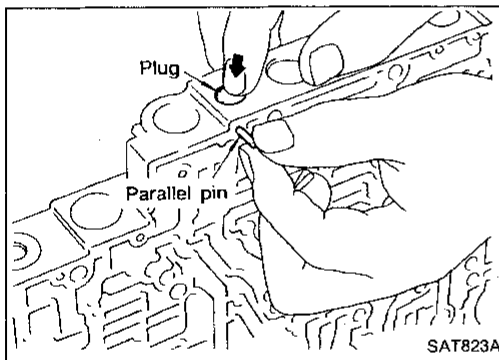

c. Place mating surface of valve facedown, and remove internal parts.

- If a valve is hard to remove, place valve body facedown and lightly tap it with a soft hammer.
- Be careful not to drop or damage valves and sleeves.

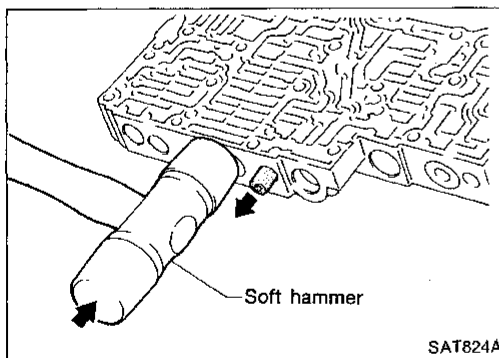

2. Remove valves at retainer plates.

a. Pry out retainer plate with wire paper clip.

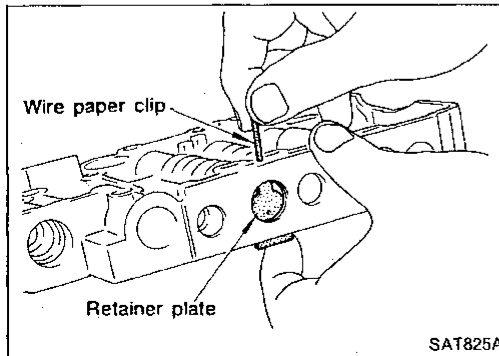

REPAIR FOR COMPONENT PARTS

Control Valve Upper Body — RL4R01A (Cont'd)

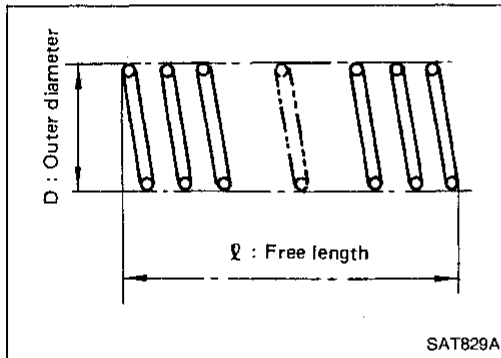
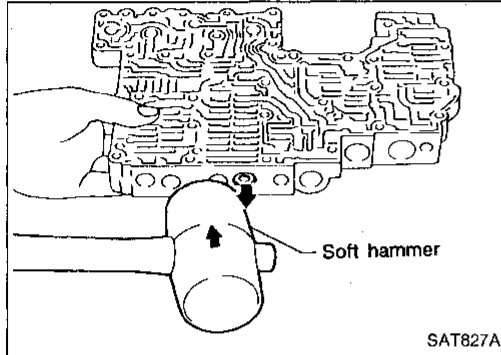
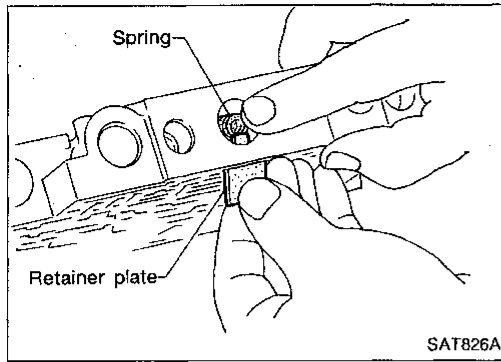

b. Remove retainer plates while holding spring.

c. Place mating surface of valve facedown, and remove internal parts.

- If a valve is hard to remove, lightly tap valve body with a soft hammer.
- Be careful not to drop or damage valves, sleeves, etc.

INSPECTION

Valve springs

- Measure free length and outer diameter of each valve spring. Also check for damage or deformation.
- Numbers of each valve spring listed in table below are the same as those in the figure in AT-157.

Inspection standard

Unit: mm (in)

Parts		Item		
		Part No.	ℓ	D
①	4th speed cut valve spring	31756-48X09	23.5 (0.925)	7.0 (0.276)
②	Pressure regulator valve spring	31742-48X16	48.5 (1.909)	12.1 (0.476)
③	Pressure modifier valve spring	31742-48X13	40.83 (1.6075)	8.0 (0.315)
④	1-2 shift valve spring	31762-48X00	43.4 (1.709)	6.0 (0.236)
⑤	2-3 shift valve spring	31762-48X01	42.7 (1.681)	9.0 (0.354)
⑥	3-4 shift valve spring	31762-48X06	44.03 (1.7335)	8.0 (0.315)
⑦	Accumulator control valve spring	31742-48X02	29.3 (1.154)	8.0 (0.315)
⑧	2-3 throttle modifier valve spring	31742-41X21	33.0 (1.299)	6.5 (0.256)
⑨	4-2 relay valve spring	31756-41X00	29.1 (1.146)	6.95 (0.2736)
⑩	Lock-up control valve spring	31742-48X07	20.0 (0.787)	5.45 (0.2146)

- Replace valve springs if deformed or fatigued.

Control valves

- Check sliding surfaces of valves, sleeves and plugs.

REPAIR FOR COMPONENT PARTS

Control Valve Upper Body — RL4R01A (Cont'd)

ASSEMBLY

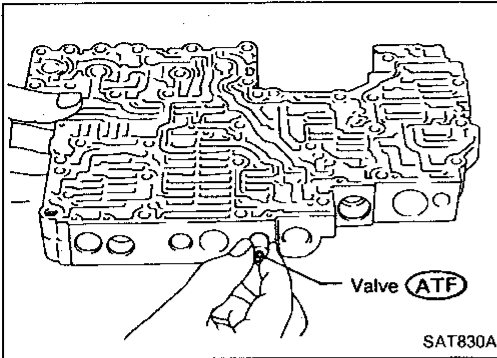

1. Lubricate the control valve body and all valves with ATF. Install control valves by sliding them carefully into their bores.

- Be careful not to scratch or damage valve body.

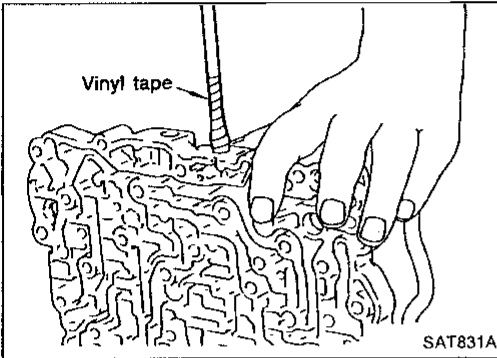

- Wrap a small screwdriver with vinyl tape and use it to insert the valves into proper position.

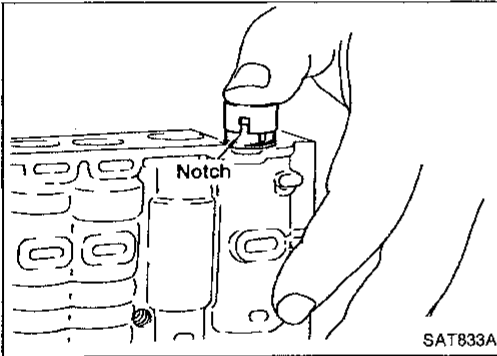

Accumulator control plug

- Align protrusion of accumulator control sleeve with notch in plug.
- Align parallel pin groove in plug with parallel pin, and install accumulator control valve.

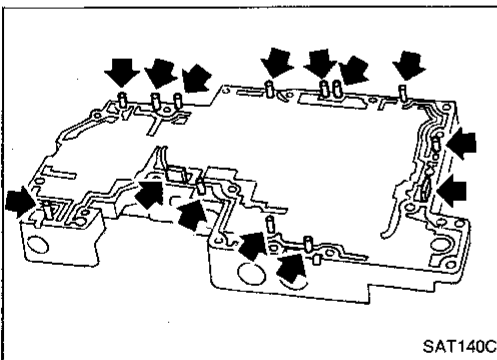

2. Install parallel pins and retainer plates.

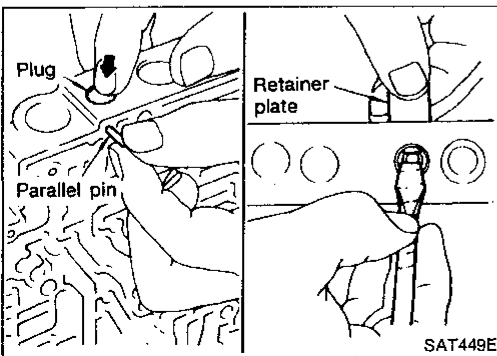

- While pushing plug, install parallel pin.
- Insert retainer plate while pushing spring.

Control Valve Lower Body — RE4R01A

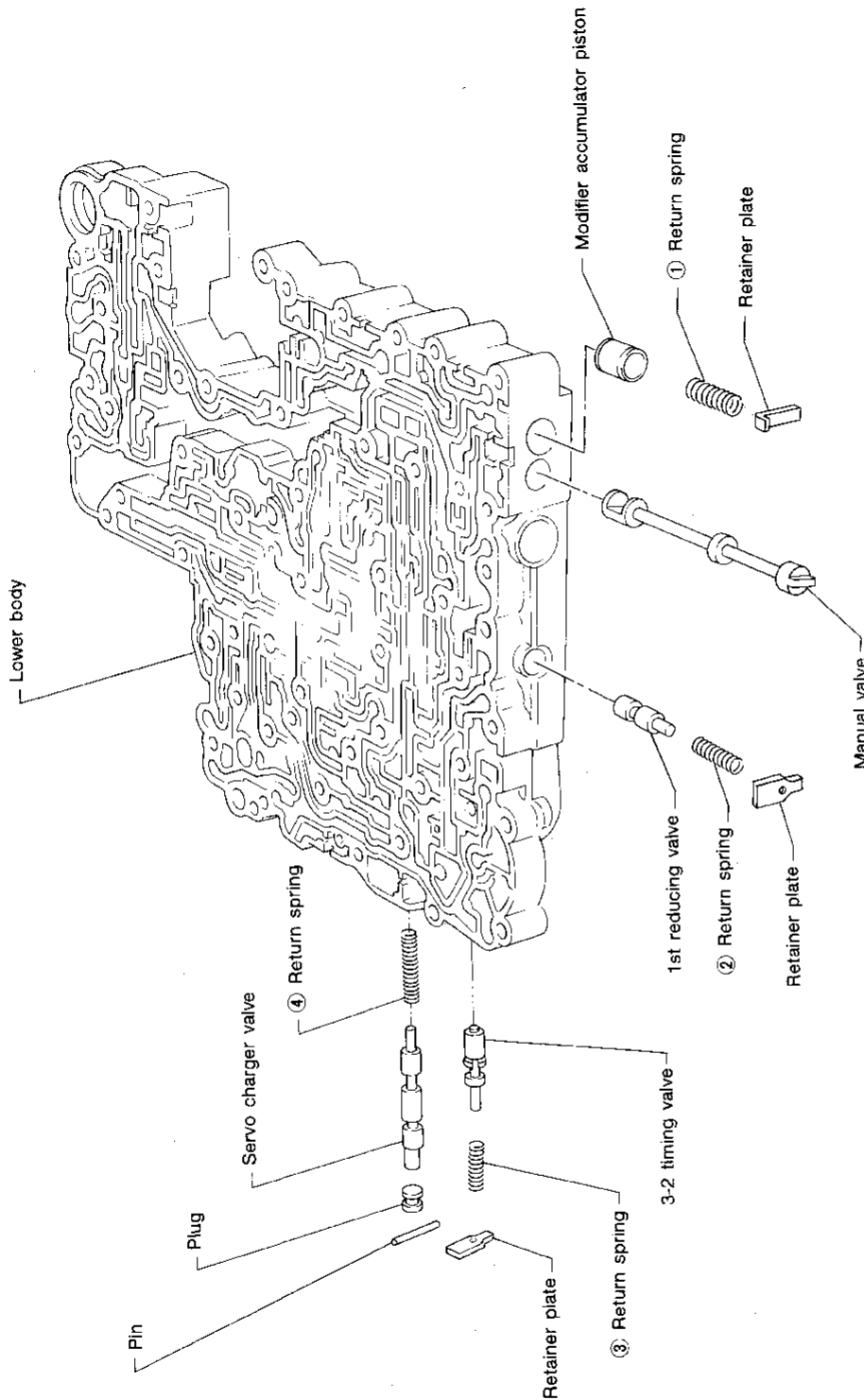

Apply ATF to all components before their installation.

Numbers preceding valve springs correspond with those shown in Spring Chart on page AT-162.

GI
MA
EM
LC
EF &
EC
FE
CL
MT
AT
TF
PD
FA
RA
BR
ST
BF
HA
EL

REPAIR FOR COMPONENT PARTS

Control Valve Lower Body — RE4R01A (Cont'd) DISASSEMBLY

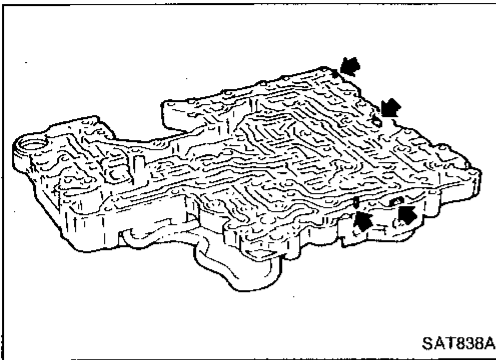

1. Remove valves at parallel pins.
 2. Remove valves at retainer plates.
- For removal procedures, refer to "DISASSEMBLY" of Control Valve Upper Body (AT-152).

INSPECTION

Valve springs

- Check each valve spring for damage or deformation. Also measure free length and outer diameter.
- Numbers of each valve spring listed in table below are the same as those in the figure in AT-161.

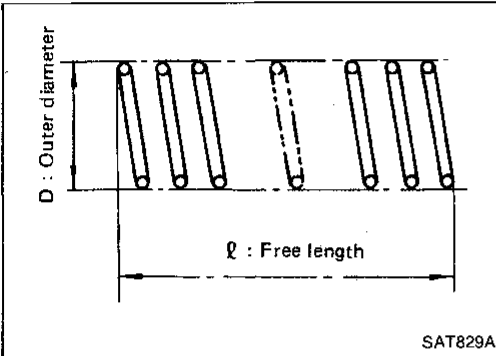

Inspection standard

Unit: mm (in)

	Parts	Item		
		Part No.	ℓ	D
①	Modifier accumulator valve spring	31742-27X70	31.4 (1.236)	9.8 (0.386)
②	1st reducing valve spring	31756-41X05	25.4 (1.000)	6.75 (0.2657)
③	3-2 timing valve spring	31742-41X08	20.55 (0.8091)	6.75 (0.2657)
④	Servo charger valve spring	31742-41X06	23.0 (0.906)	6.7 (0.264)

- Replace valve springs if deformed or fatigued.

Control valves

- Check sliding surfaces of control valves, sleeves and plugs for damage.

ASSEMBLY

- Install control valves.
For installation procedures, refer to "ASSEMBLY" of Control Valve Upper Body (AT-154).

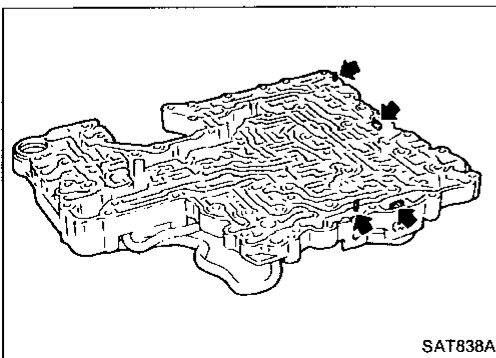

REPAIR FOR COMPONENT PARTS

Control Valve Lower Body — RL4R01A

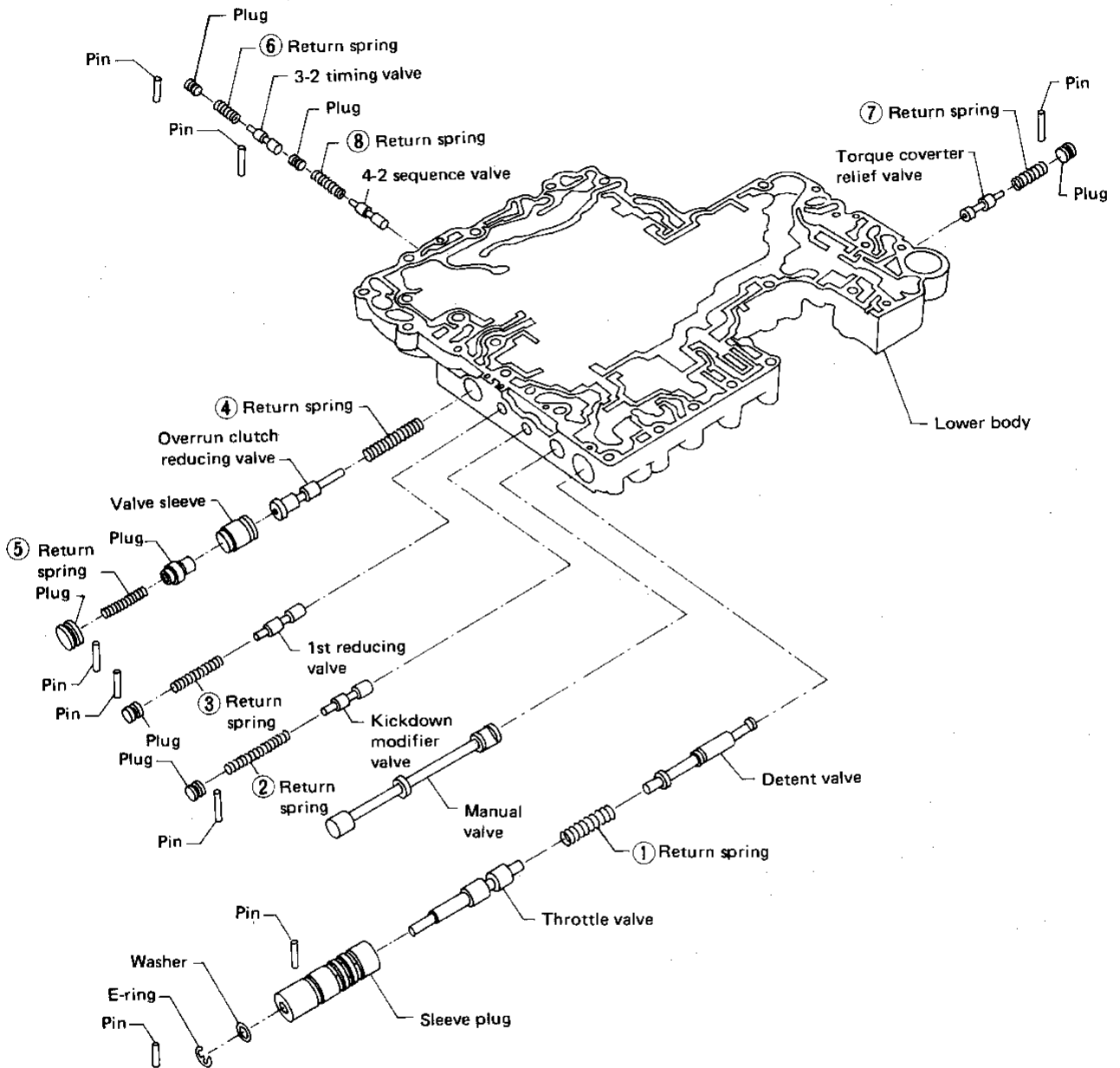

Apply ATF to all components before their installation.

Numbers preceding valve springs correspond with those shown in Spring Chart on page AT-164.

GI
MA
EM
LC
EF & EC
FE
CL
MT
AT
TF
PD
FA
RA
BR
ST
BF
HA
EL

REPAIR FOR COMPONENT PARTS

Control Valve Lower Body — RL4R01A (Cont'd)

DISASSEMBLY

1. Remove valves at parallel pins.
2. Remove valves at retainer plates.
For removal procedures, refer to "DISASSEMBLY" of Control Valve Upper Body (AT-157).

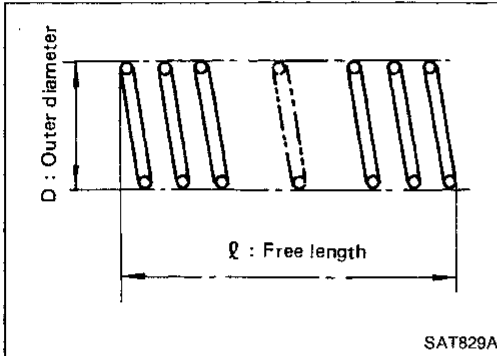
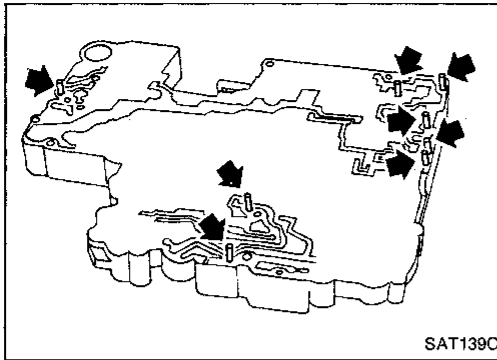

INSPECTION

Valve springs

- Check each valve spring for damage or deformation. Also measure free length and outer diameter.
- Numbers of each valve spring listed in table below are the same as those in the figure in AT-163.

Inspection standard

Unit: mm (in)

Parts		Item		
		Part No.	ℓ	D
①	Throttle valve & detent valve spring	31802-48X02	34.23 (1.3476)	11.0 (0.433)
②	Kickdown modifier valve spring	31756-48X01	45.3 (1.783)	7.0 (0.276)
③	1st reducing valve spring	31756-48X08	29.7 (1.169)	7.2 (0.283)
④	Overrun clutch reducing valve spring	31742-48X04	45.0 (1.772)	7.45 (0.2933)
⑤	Overrun clutch reducing valve spring	31742-48X05	31.0 (1.220)	5.2 (0.205)
⑥	3-2 timing valve spring	31742-48X15	23.0 (0.906)	7.0 (0.276)
⑦	Torque converter relief valve spring	31742-41X23	38.0 (1.496)	9.0 (0.354)
⑧	4-2 sequence valve spring	31756-41X00	29.1 (1.146)	6.95 (0.2736)

- Replace valve springs if deformed or fatigued.

Control valves

- Check sliding surfaces of control valves, sleeves and plugs for damage.

ASSEMBLY

- Install control valves.
For installation procedures, refer to "ASSEMBLY" of Control Valve Upper Body (AT-160).

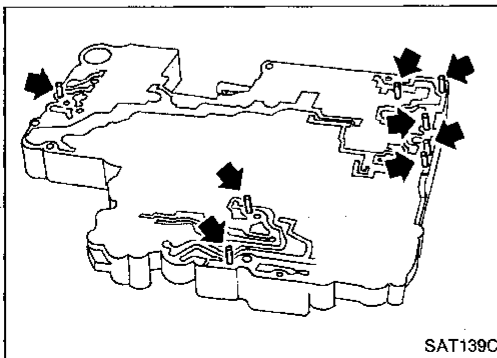

REPAIR FOR COMPONENT PARTS

Governor Valve Assembly — RL4R01A

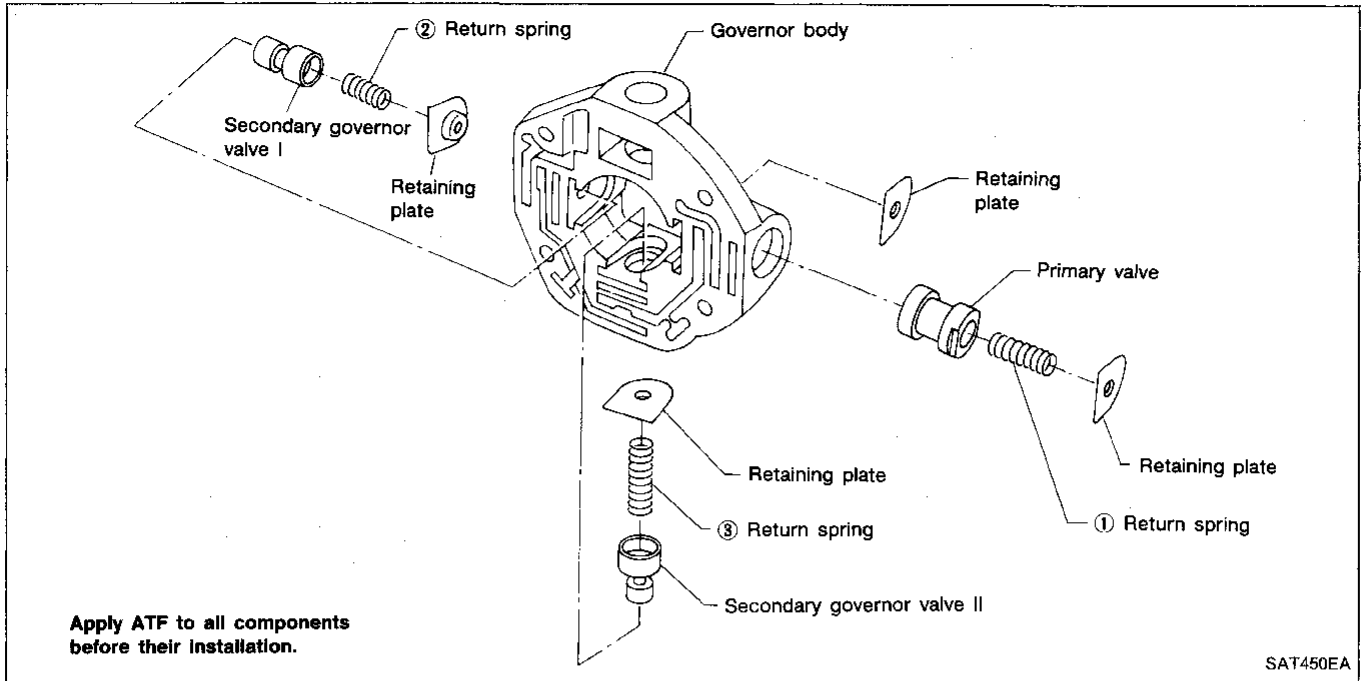

INSPECTION

Governor valves and valve body

- Check governor valves and valve body for indication of burning or scratches.

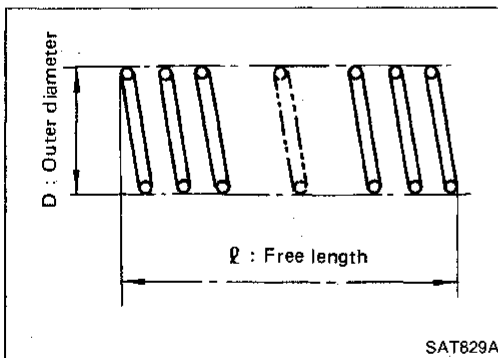

Valve springs

- Measure free length and outer diameter of each valve spring. Also check for damage or deformation.

Inspection standard

Unit: mm (in)

Parts	Item		
	Part No.	ℓ	D
① Governor valve spring	31742-48X11	19.1 (0.752)	9.05 (0.3563)
② Governor valve spring I	31742-48X09	30.58 (1.2039)	9.2 (0.362)
③ Governor valve spring II	31742-48X10	16.79 (0.6610)	9.0 (0.354)

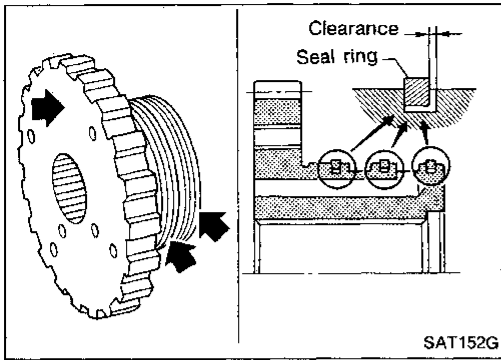

Oil Distributor

INSPECTION

- Check contacting surface of oil distributor and ring groove areas for wear.
- Measure clearance between seal ring and ring groove.

Standard clearance:

0.15 - 0.40 mm (0.0059 - 0.0157 in)

Wear limit:

0.40 mm (0.0157 in)

Reverse Clutch — RE4R01A and RL4R01A

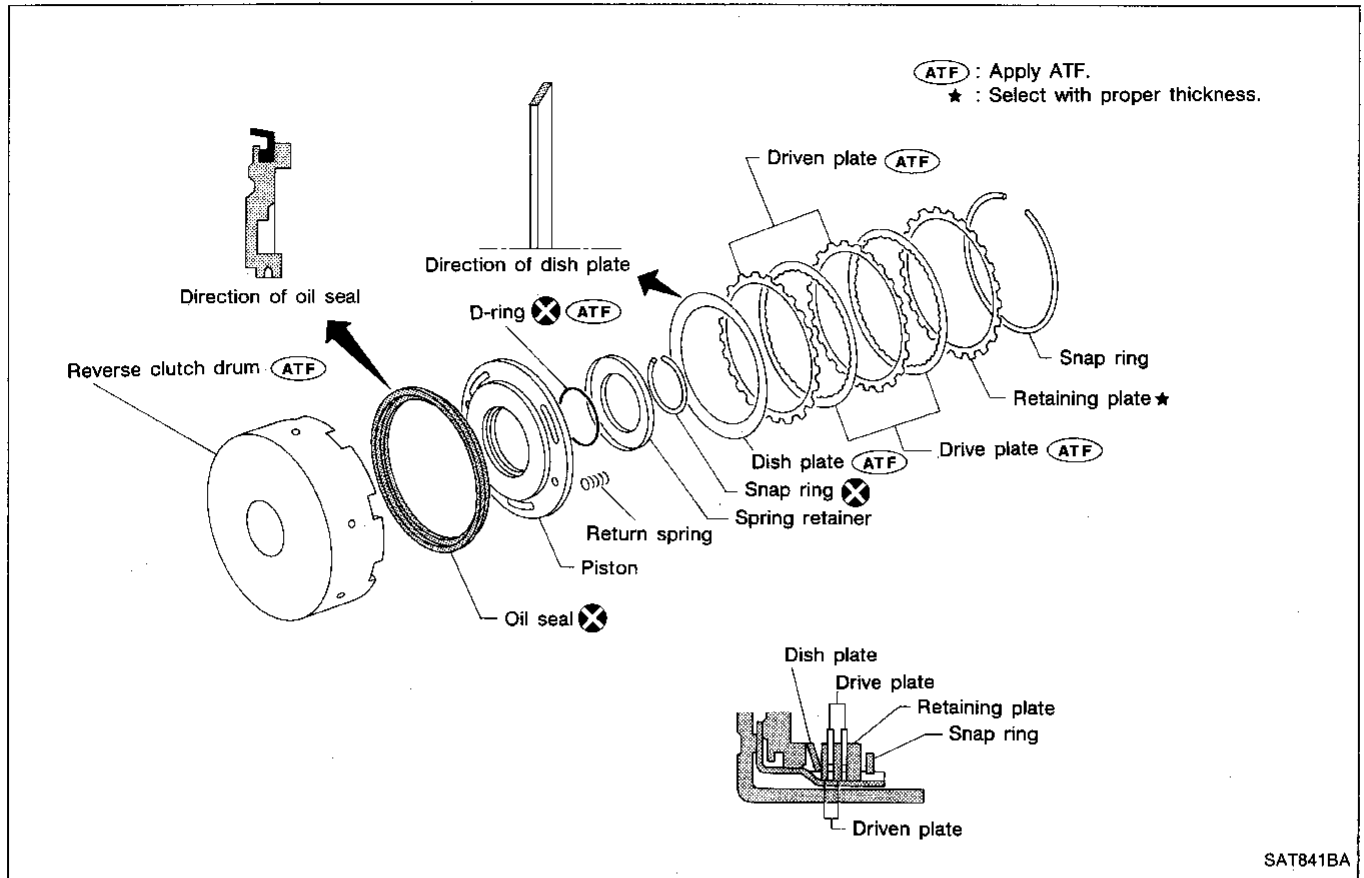

SAT841BA

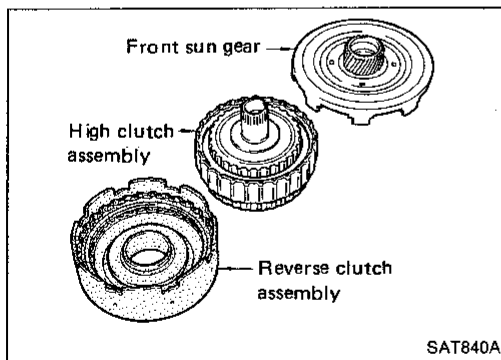

SAT840A

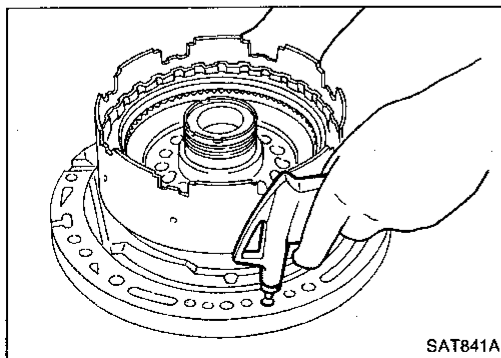

SAT841A

DISASSEMBLY

1. Remove reverse clutch assembly from clutch pack.
2. Check operation of reverse clutch.
 - a. Install seal ring onto oil pump cover and install reverse clutch. Apply compressed air to oil hole.
 - b. Check to see that retaining plate moves to snap ring.
 - c. If retaining plate does not move to snap ring, D-ring or oil seal may be damaged or fluid may be leaking at piston check ball.

GI
MA
EM
LC
EF & EC
FE
CL
MT
AT
TF
PD
FA
RA
BR
ST
BF
HA
EL
IDX

REPAIR FOR COMPONENT PARTS

Reverse Clutch — RE4R01A and RL4R01A (Cont'd)

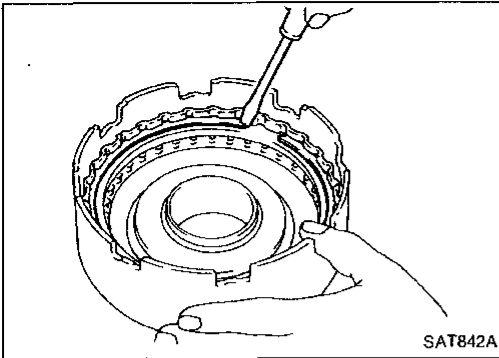

- Remove drive plates, driven plates, retaining plate, dish plate and snap ring.

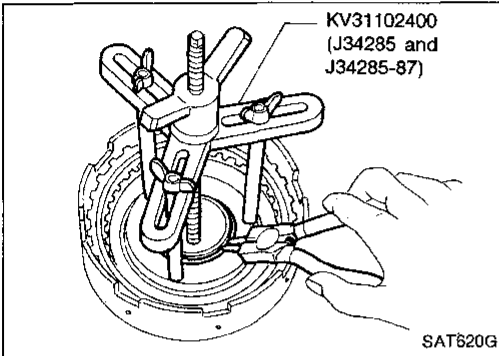

- Remove snap ring from clutch drum while compressing clutch springs.

- Do not expand snap ring excessively.

- Remove spring retainer and return spring.

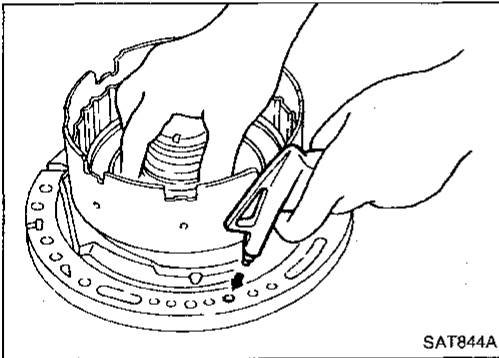

- Install seal ring onto oil pump cover and install reverse clutch drum. While holding piston, gradually apply compressed air to oil hole until piston is removed.

- Do not apply compressed air abruptly.

- Remove D-ring and oil seal from piston.

INSPECTION

Reverse clutch snap ring and spring retainer

- Check for deformation, fatigue or damage.

Reverse clutch return springs

- Check for deformation or damage. Also measure free length and outside diameter.

Inspection standard

Unit: mm (in)

Part No.	ℓ	D
31505-41X02	19.69 (0.7752)	11.6 (0.457)

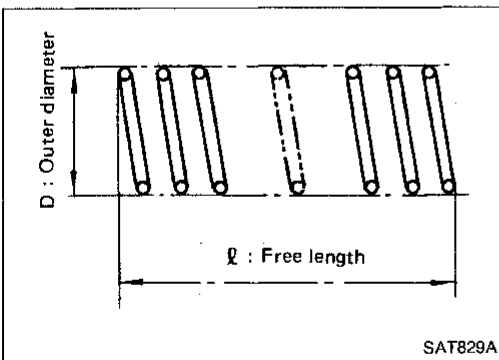

Reverse clutch drive plates

- Check facing for burns, cracks or damage.
- Measure thickness of facing.

Thickness of drive plate:

Standard value 1.90 - 2.05 mm (0.0748 - 0.0807 in)

Wear limit 1.80 mm (0.0709 in)

- If not within wear limit, replace.

Reverse clutch dish plate

- Check for deformation or damage.

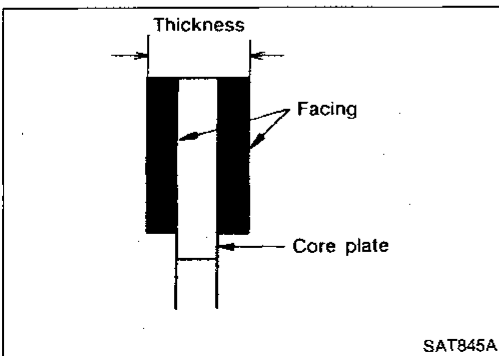

REPAIR FOR COMPONENT PARTS

Reverse Clutch — RE4R01A and RL4R01A (Cont'd)

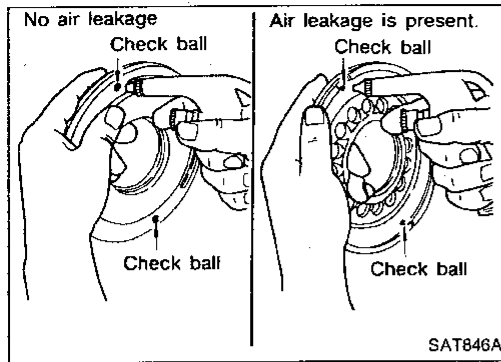

Reverse clutch piston

- Shake piston to assure that balls are not seized.
- Apply compressed air to check ball oil hole opposite the return spring to assure that there is no air leakage.
- Also apply compressed air to oil hole on return spring side to assure that air leaks past ball.

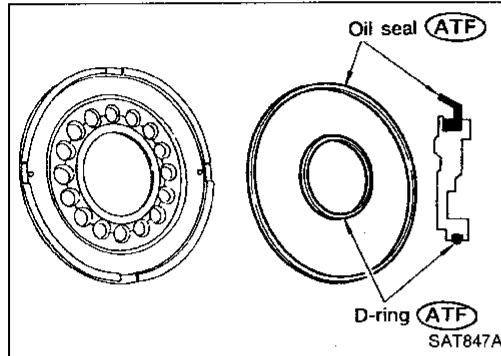

ASSEMBLY

1. Install D-ring and oil seal on piston.
- Apply ATF to both parts.

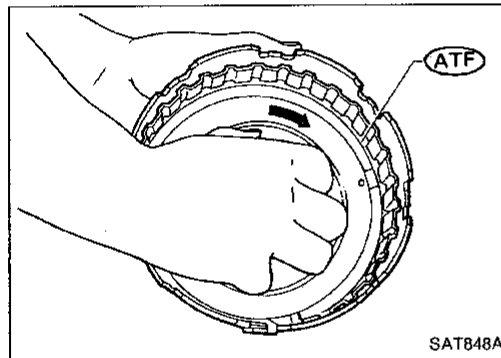

2. Install piston assembly by turning it slowly and evenly.
- Apply ATF to inner surface of drum.

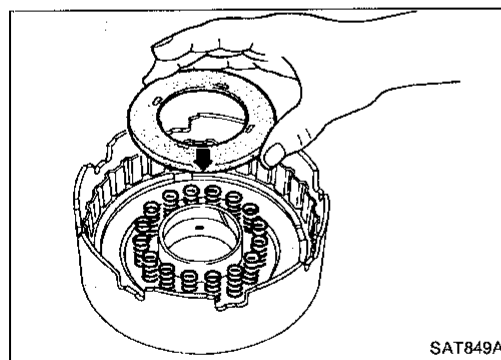

3. Install return springs and spring retainer.

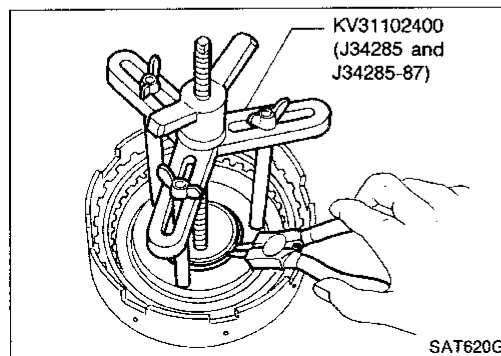

4. Install snap ring while compressing clutch springs.

GI
MA
EM
LC
EF &
EC
FE
CL
MT
AT
TF
PD
FA
RA
BR
ST
BF
HA
EL
IDX

REPAIR FOR COMPONENT PARTS

Reverse Clutch — RE4R01A and RL4R01A (Cont'd)

- Do not align snap ring gap with spring retainer stopper.

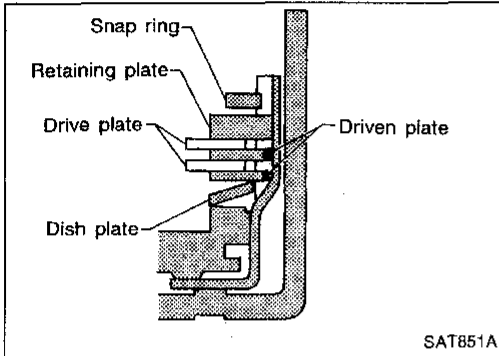
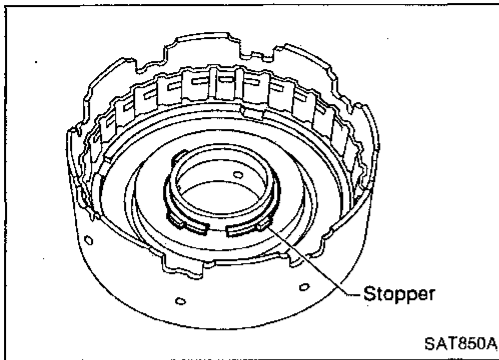

5. Install drive plates, driven plates, retaining plate and dish plate.

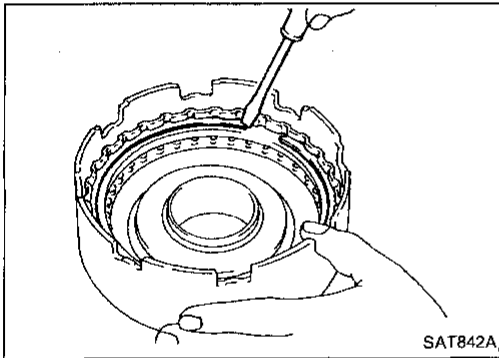

6. Install snap ring.

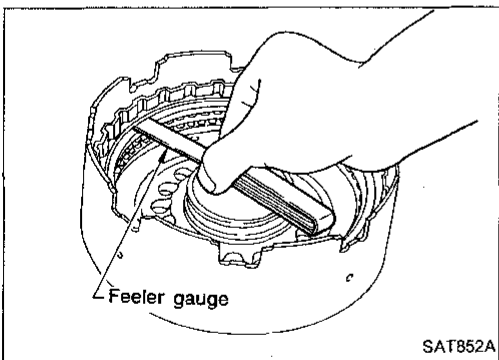

7. Measure clearance between retaining plate and snap ring. If not within allowable limit, select proper retaining plate.

Specified clearance:

Standard

0.5 - 0.8 mm (0.020 - 0.031 in)

Allowable limit

1.2 mm (0.047 in)

Retaining plate:

Refer to SDS (AT-215).

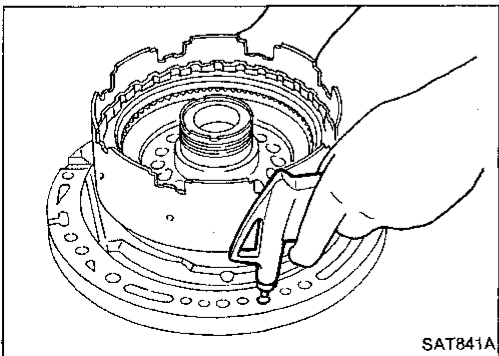

8. Check operation of reverse clutch. Refer to "DISASSEMBLY" of Reverse Clutch (AT-167).

REPAIR FOR COMPONENT PARTS

High Clutch — RE4R01A and RL4R01A

For the number of clutch sheets (drive plate and driven plate), refer to the below cross-section.

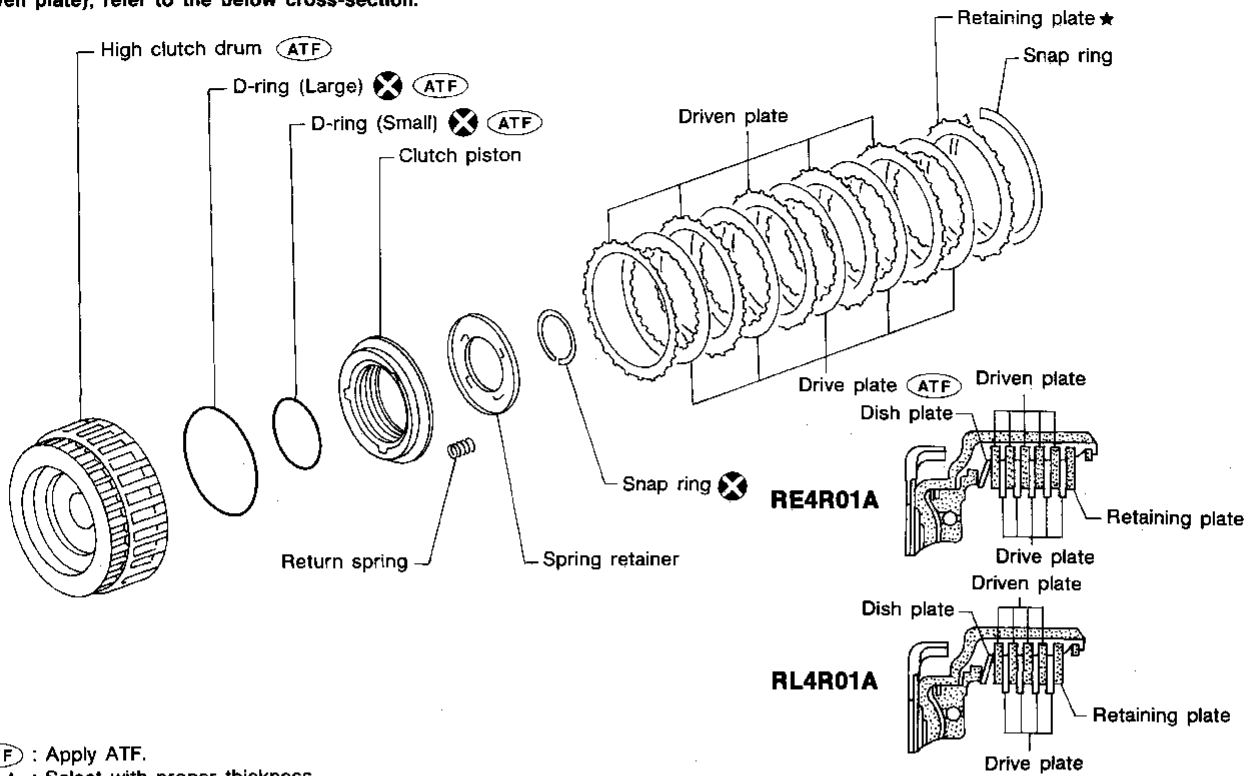

SAT728CA

GI
MA
EM
LC
EF & EC
FE
CL
MT
AT

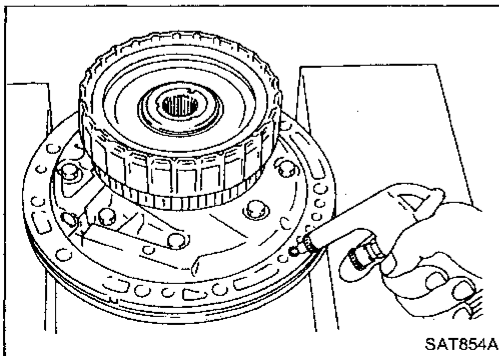
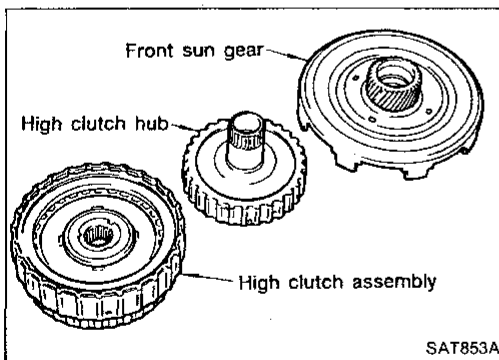

Service procedures for high clutch are essentially the same as those for reverse clutch, with the following exception:

- Check of high clutch operation

TF
PD
FA
RA
BR
ST
BF
HA
EL
IDX

REPAIR FOR COMPONENT PARTS

High Clutch — RE4R01A and RL4R01A (Cont'd)

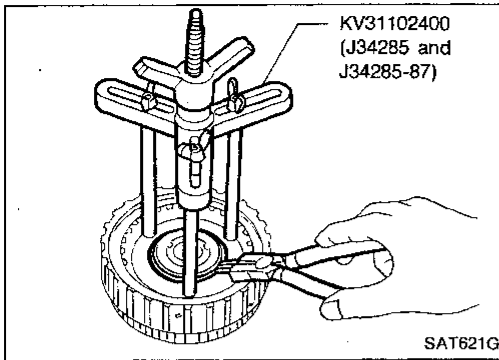

- Removal and installation of return spring

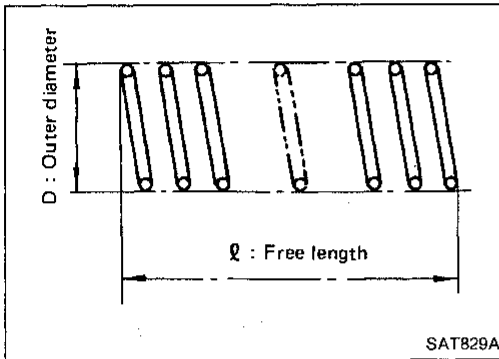

- Inspection of high clutch return springs

Inspection standard

Unit: mm (in)		
Part No.	ℓ	D
31505-21X03	22.06 (0.8685)	11.6 (0.457)

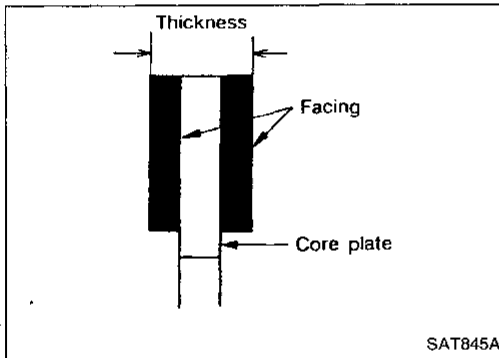

- Inspection of high clutch drive plate

Thickness of drive plate:

Standard

1.52 - 1.67 mm (0.0598 - 0.0657 in)

Wear limit

1.40 mm (0.0551 in)

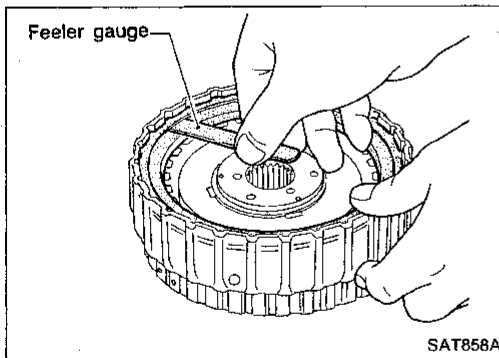

- Measurement of clearance between retaining plate and snap ring

Specified clearance:

Standard

1.8 - 2.2 mm (0.071 - 0.087 in)

Allowable limit

2.8 mm (0.110 in)

Retaining plate:

Refer to SDS (AT-215).

REPAIR FOR COMPONENT PARTS

Forward and Overrun Clutches — RE4R01A and RL4R01A

For the number of clutch sheets (drive plate and driven plate), refer to the below cross-section.

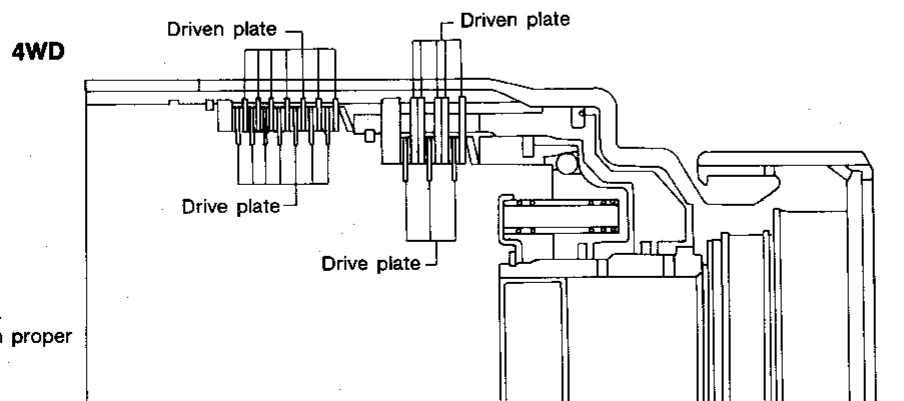
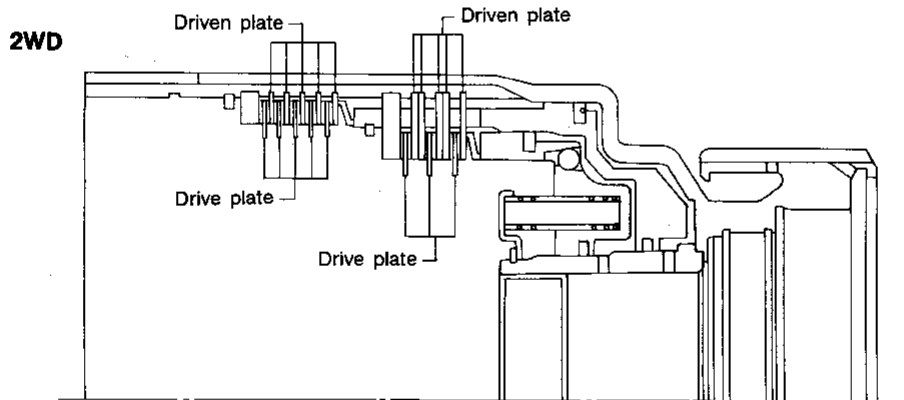
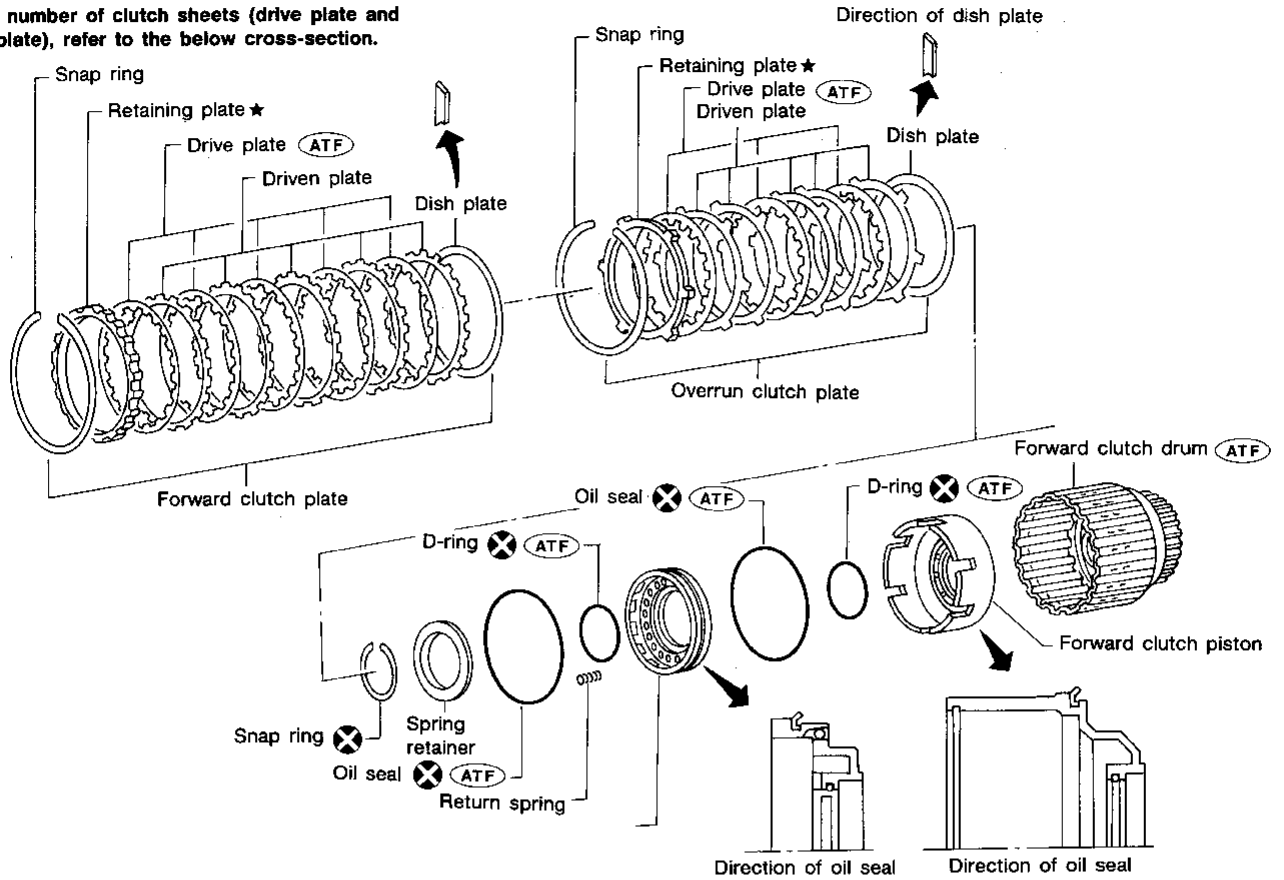

ATF : Apply ATF.
★ : Select with proper thickness.

GI
VA
EM
LC
EF & EC
FE
CL
WT
AT
TF
PD
FA
RA
BR
ST
BF
HA
EL

REPAIR FOR COMPONENT PARTS

Forward and Overrun Clutches — RE4R01A and RL4R01A (Cont'd)

Service procedures for forward and overrun clutches are essentially the same as those for reverse clutch, with the following exception:

- Check of forward clutch operation.
- Check of overrun clutch operation.
- Removal of forward clutch drum
Remove forward clutch drum from transmission case by holding snap ring.
- Removal of forward clutch and overrun clutch pistons
 1. While holding overrun clutch piston, gradually apply compressed air to oil hole.

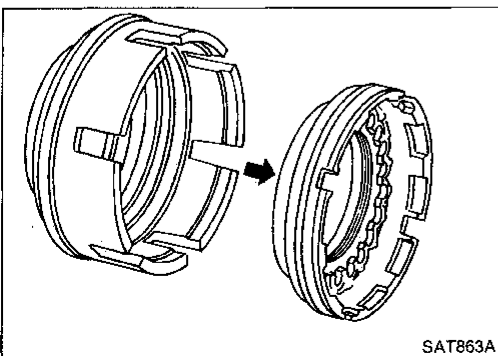
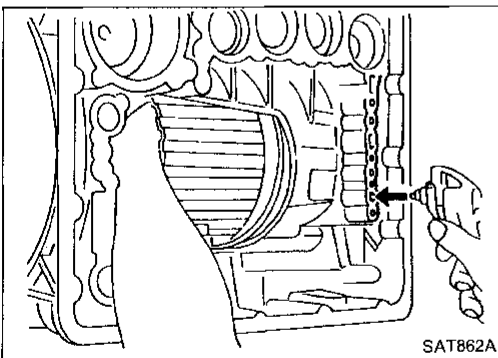
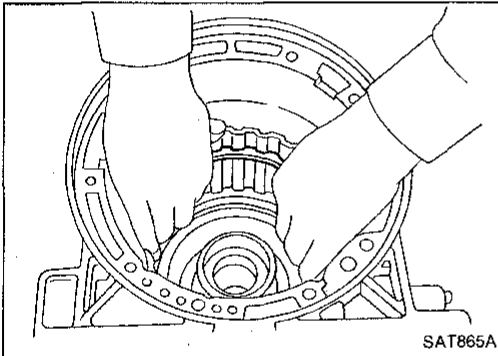
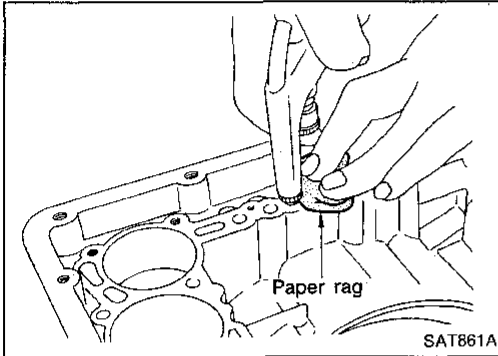
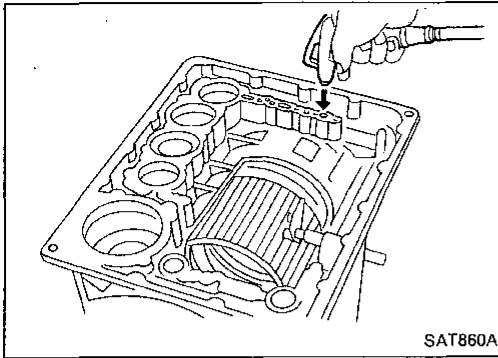

2. Remove overrun clutch from forward clutch.

REPAIR FOR COMPONENT PARTS

Forward and Overrun Clutches — RE4R01A and RL4R01A (Cont'd)

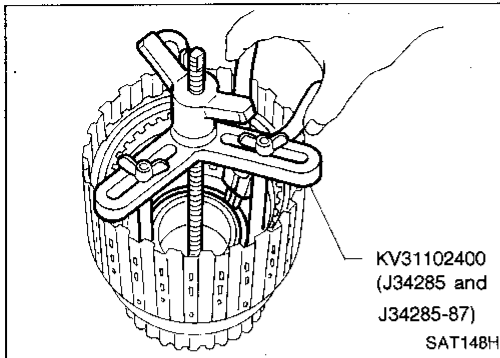

- Removal and installation of return springs

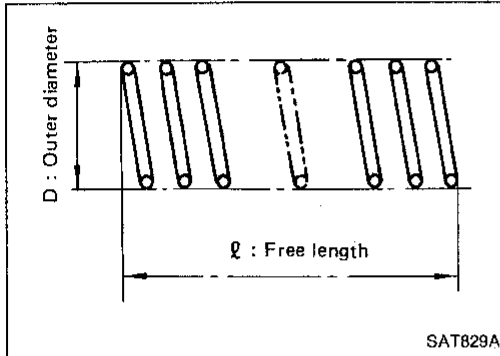

- Inspection of forward clutch and overrun clutch return springs

Inspection standard

Unit: mm (in)		
Part No.	ℓ	D
31505-41X01	35.77 (1.4083)	9.7 (0.382)

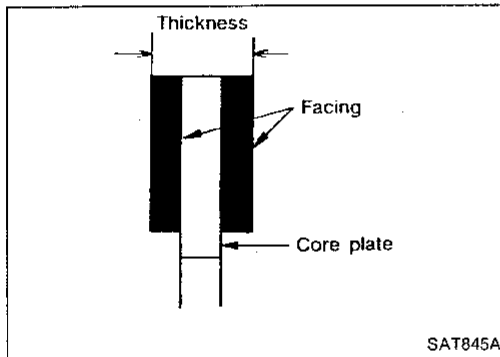

- Inspection of forward clutch drive plates

Thickness of drive plate:

Standard

1.90 - 2.05 mm (0.0748 - 0.0807 in)

Wear limit

1.80 mm (0.0709 in)

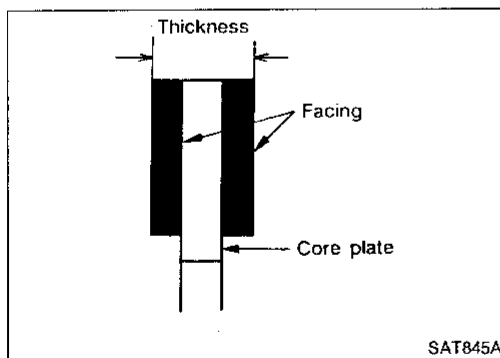

- Inspection of overrun clutch drive plates

Thickness of drive plate:

Standard

1.90 - 2.05 mm (0.0748 - 0.0807 in)

Wear limit

1.80 mm (0.0709 in)

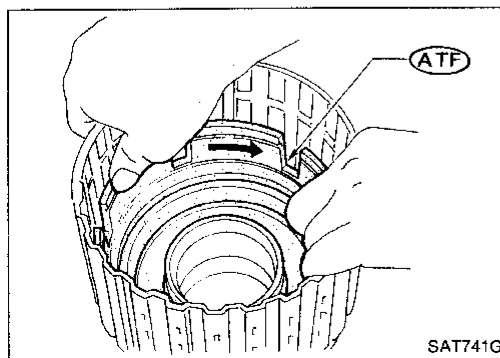

- Installation of forward clutch piston and overrun clutch piston

1. Install forward clutch piston by turning it slowly and evenly.

- Apply ATF to inner surface of clutch drum.

REPAIR FOR COMPONENT PARTS

Forward and Overrun Clutches — RE4R01A and RL4R01A (Cont'd)

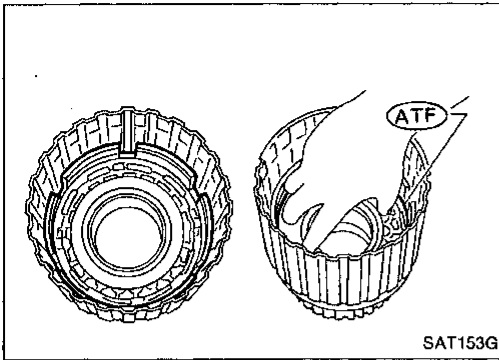

- Align notch in forward clutch piston with groove in forward clutch drum.
- 2. Install overrun clutch by turning it slowly and evenly.
- Apply ATF to inner surface of forward clutch piston.

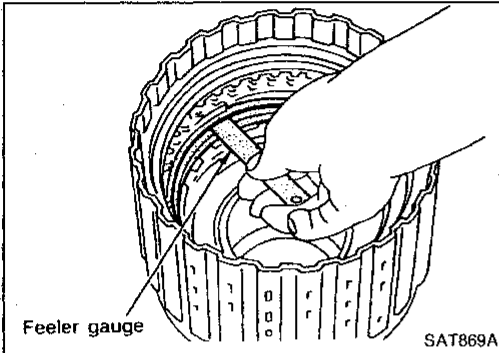

- Measurement of clearance between retaining plate and snap ring of overrun clutch
Specified clearance:
Standard
1.0 - 1.4 mm (0.039 - 0.055 in)
Allowable limit
2.0 mm (0.079 in)
Retaining plate:
Refer to SDS (AT-216).

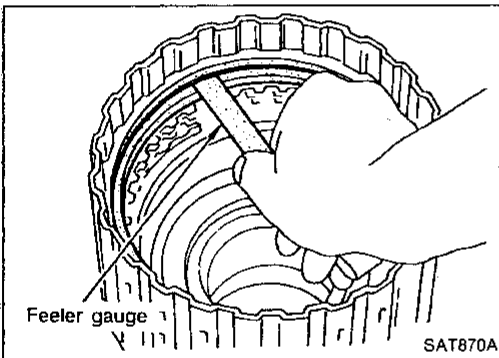

- Measurement of clearance between retaining plate and snap ring of forward clutch
Specified clearance:
Standard
0.45 - 0.85 mm (0.0177 - 0.0335 in)
Allowable limit
Refer to SDS (AT-215).
Retaining plate:
Refer to SDS (AT-215).

REPAIR FOR COMPONENT PARTS

Low & Reverse Brake — RE4R01A and RL4R01A

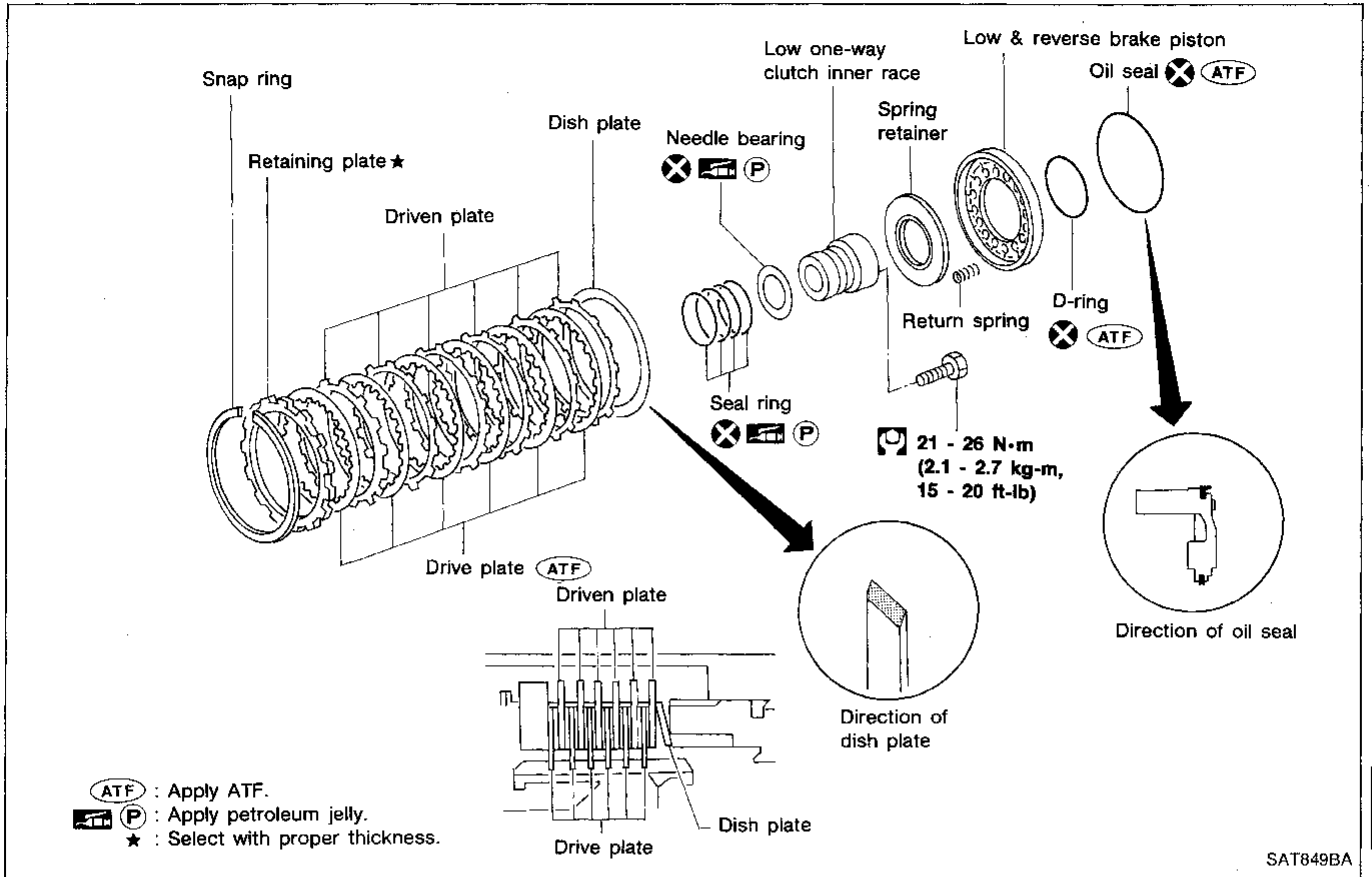

GI
 MA
 EM
 LC
 EF & EC
 FE
 CL
 MT
AT

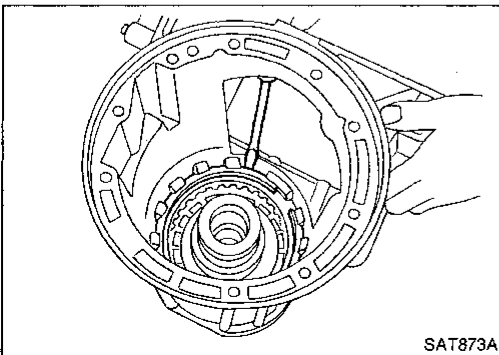
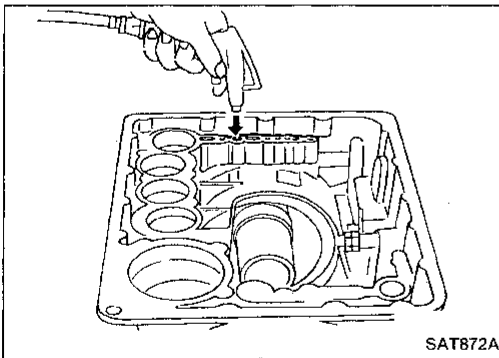

DISASSEMBLY

1. Check operation of low & reverse brake.
 - a. Install seal ring onto oil pump cover and install reverse clutch. Apply compressed air to oil hole.
 - b. Check to see that retaining plate moves to snap ring.
 - c. If retaining plate does not move to snap ring, D-ring or oil seal may be damaged or fluid may be leaking at piston check ball.

2. Remove snap ring, low & reverse brake drive plates, driven plates and dish plate.

TF
 PD
 FA
 RA
 BR
 ST
 BF
 HA
 EL
 IDX

REPAIR FOR COMPONENT PARTS

Low & Reverse Brake — RE4R01A and RL4R01A (Cont'd)

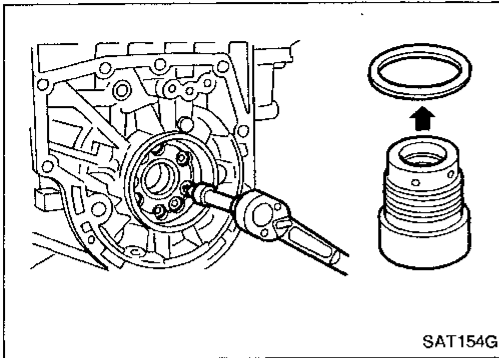

3. Remove low one-way clutch inner race, spring retainer and return spring from transmission case.
4. Remove seal rings from low one-way clutch inner race.
5. Remove needle bearing from low one-way clutch inner race.

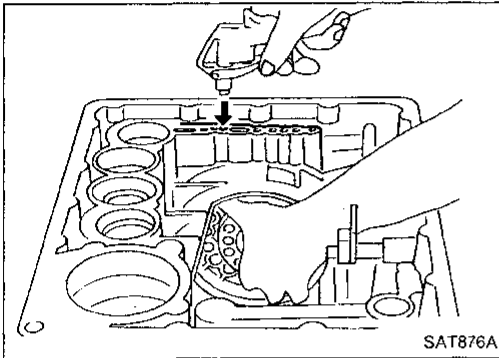

6. Remove low & reverse brake piston using compressed air.
7. Remove oil seal and D-ring from piston.

INSPECTION

Low & reverse brake snap ring and spring retainer

- Check for deformation, or damage.

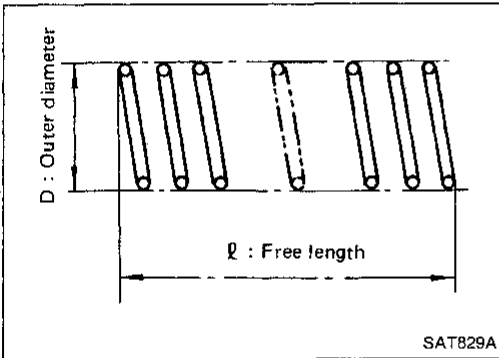

Low & reverse brake return springs

- Check for deformation or damage. Also measure free length and outside diameter.

Inspection standard

Unit: mm (in)		
Part No.	ℓ	D
31521-21X00	23.7 (0.933)	11.6 (0.457)

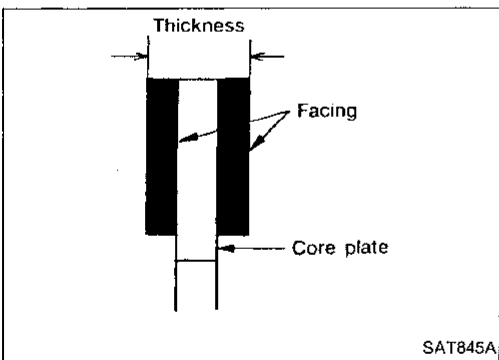

Low & reverse brake drive plates

- Check facing for burns, cracks or damage.
- Measure thickness of facing.

Thickness of drive plate:

Standard value

1.90 - 2.05 mm (0.0748 - 0.0807 in)

Wear limit

1.8 mm (0.071 in)

- If not within wear limit, replace.

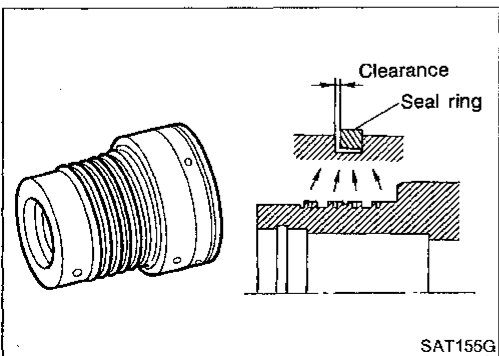

Low one-way clutch inner race

- Check frictional surface of inner race for wear or damage.
- Install a new seal rings onto low one-way clutch inner race.
- **Be careful not to expand seal ring gap excessively.**
- Measure seal ring-to-groove clearance.

Inspection standard:

Standard value 0.10 - 0.25 mm (0.0039 - 0.0098 in)

Allowable limit 0.25 mm (0.0098 in)

- If not within allowable limit, replace low one-way clutch inner race.

REPAIR FOR COMPONENT PARTS

Low & Reverse Brake — RE4R01A and RL4R01A

(Cont'd)

ASSEMBLY

1. Install bearing onto one-way clutch inner race.
 - Pay attention to its direction — Black surface goes to rear side.
 - Apply petroleum jelly to needle bearing.

2. Install oil seal and D-ring onto piston.
 - Apply ATF to oil seal and D-ring.

3. Install piston by rotating it slowly and evenly.
 - Apply ATF to inner surface of transmission case.

4. Install return springs, spring retainer and low one-way clutch inner race onto transmission case.

5. Install dish plate low & reverse brake drive plates, driven plates and retaining plate.
6. Install snap ring on transmission case.

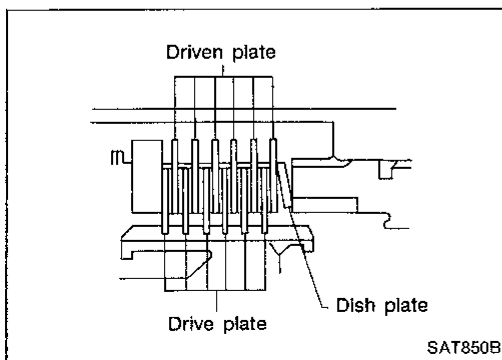
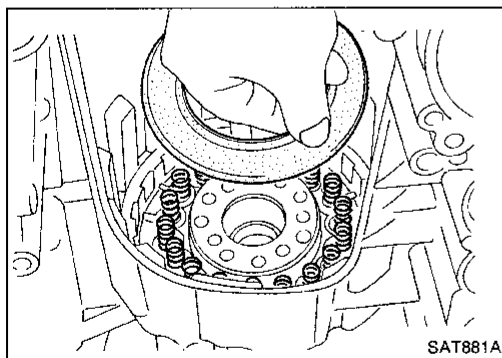
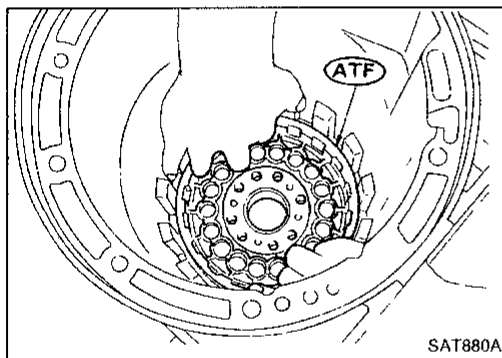
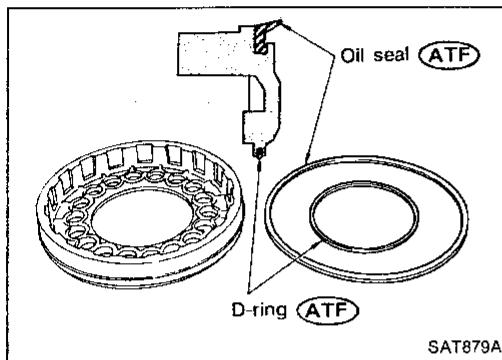
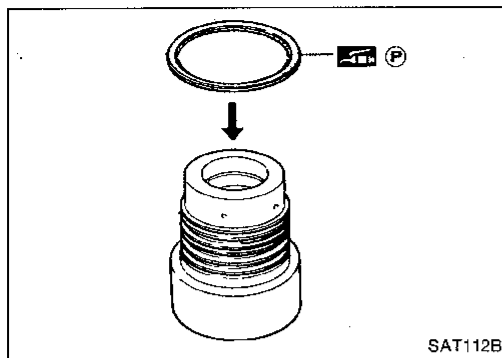

GI

MA

EM

LC

EF &
EC

FE

CL

MT

AT

TF

PD

FA

RA

BR

ST

BF

HA

EL

IDX

REPAIR FOR COMPONENT PARTS

Low & Reverse Brake — RE4R01A and RL4R01A (Cont'd)

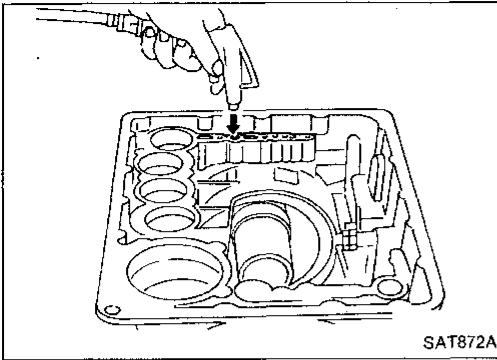

7. Check operation of low & reverse brake clutch piston. Refer to "DISASSEMBLY" (AT-177).

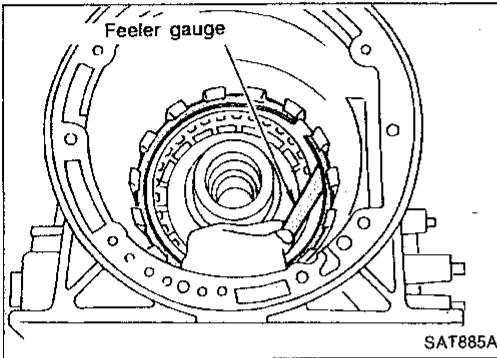

8. Measure clearance between retaining plate and snap ring. If not within allowable limit, select proper retaining plate.

Specified clearance:

Standard

1.1 - 1.5 mm (0.043 - 0.059 in)

Allowable limit

2.3 mm (0.091 in)

Retaining plate:

Refer to SDS (AT-216).

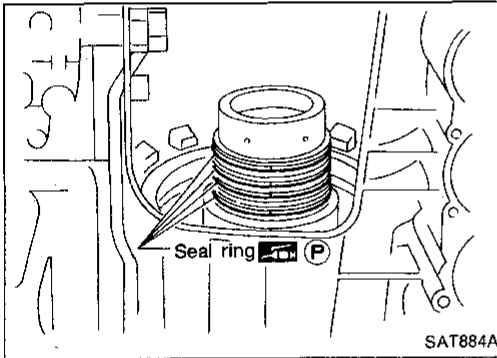

9. Install low one-way clutch inner race seal ring.
 - Apply petroleum jelly to seal ring.
 - Make sure seal rings are pressed firmly into place and held by petroleum jelly.

REPAIR FOR COMPONENT PARTS

Forward Clutch Drum Assembly — RE4R01A and RL4R01A

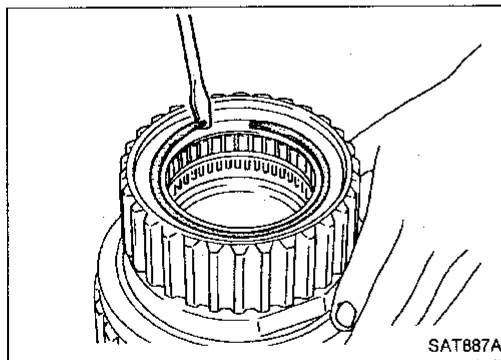
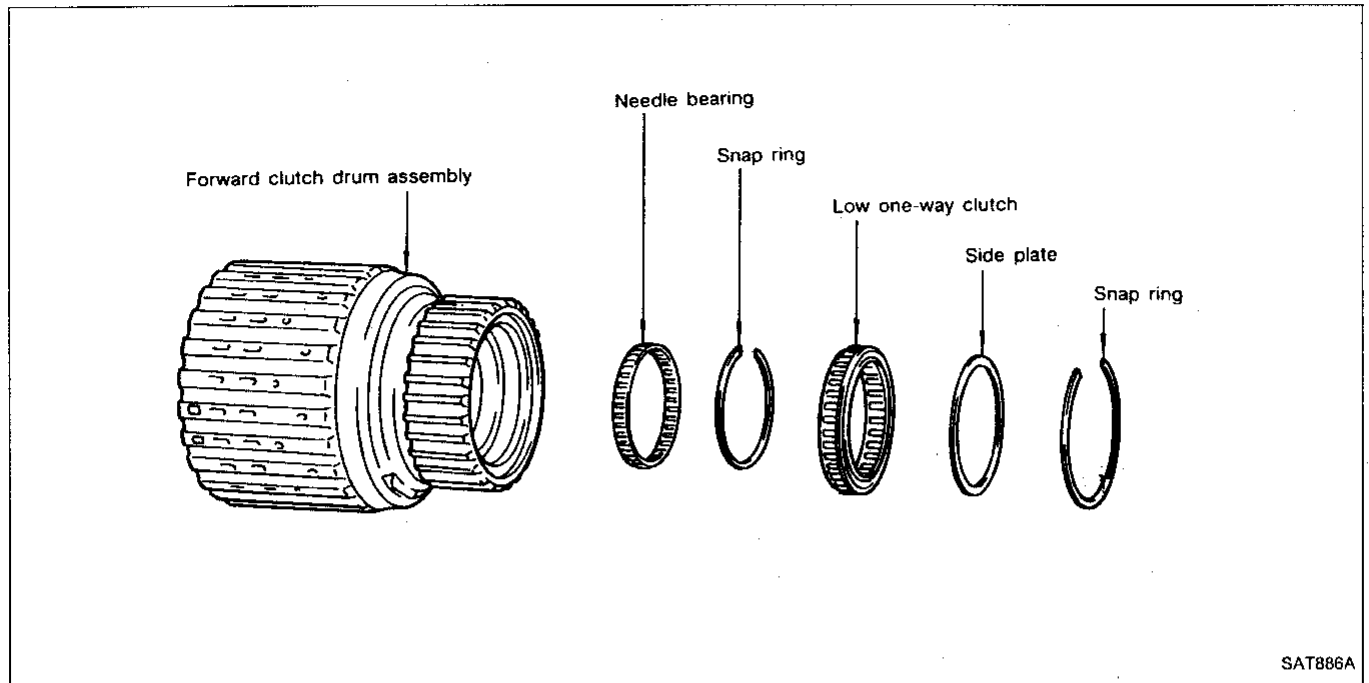

DISASSEMBLY

1. Remove snap ring from forward clutch drum.
2. Remove side plate from forward clutch drum.
3. Remove low one-way clutch from forward clutch drum.
4. Remove snap ring from forward clutch drum.
5. Remove needle bearing from forward clutch drum.

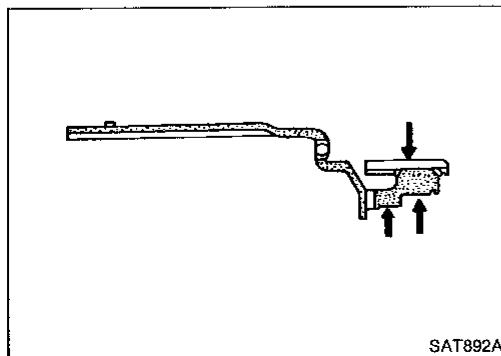

INSPECTION

Forward clutch drum

- Check spline portion for wear or damage.
- Check frictional surfaces of low one-way clutch and needle bearing for wear or damage.

GI
MA
EM
LC
EF &
EC
FE
CL
MT
AT
TF
PD
FA
RA
BR
ST
BF
HA
EL
IDX

REPAIR FOR COMPONENT PARTS

Forward Clutch Drum Assembly — RE4R01A and RL4R01A (Cont'd)

Needle bearing and low one-way clutch

- Check frictional surface for wear or damage.

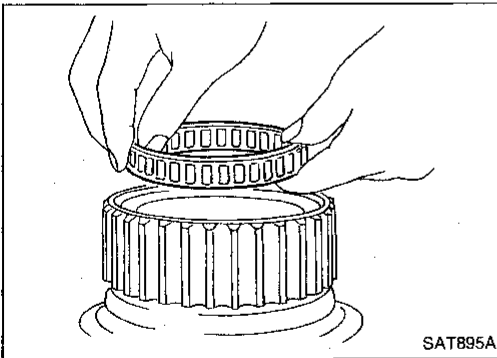
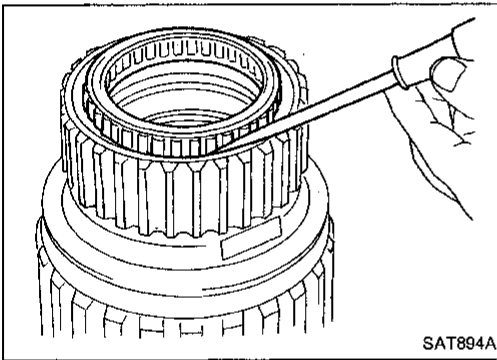
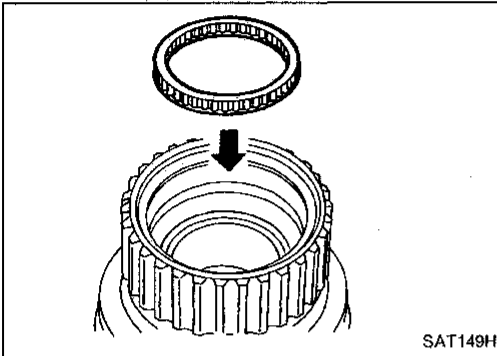
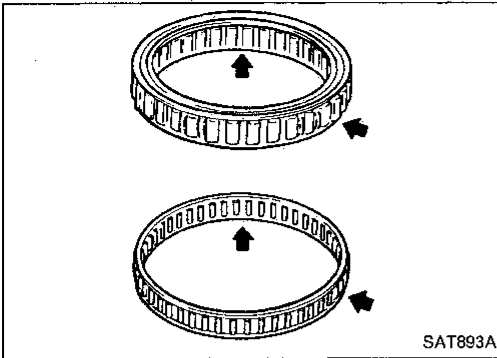

ASSEMBLY

1. Install needle bearing in forward clutch drum.
2. Install snap ring onto forward clutch drum.
3. Install low one-way clutch onto forward clutch drum by pushing the roller in evenly.

- **Install low one-way clutch with flange facing rearward.**
- 4. Install side plate onto forward clutch drum.
- 5. Install snap ring onto forward clutch drum.

Rear Internal Gear and Forward Clutch Hub —
RE4R01A and RL4R01A

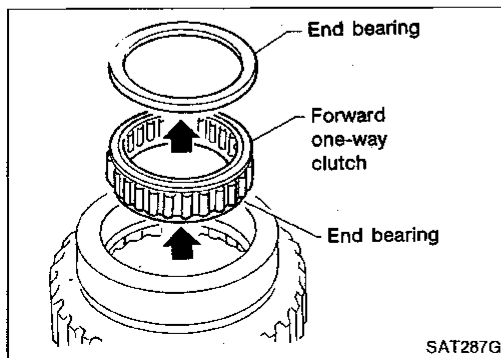
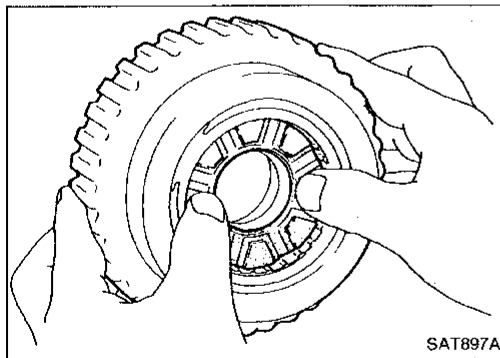
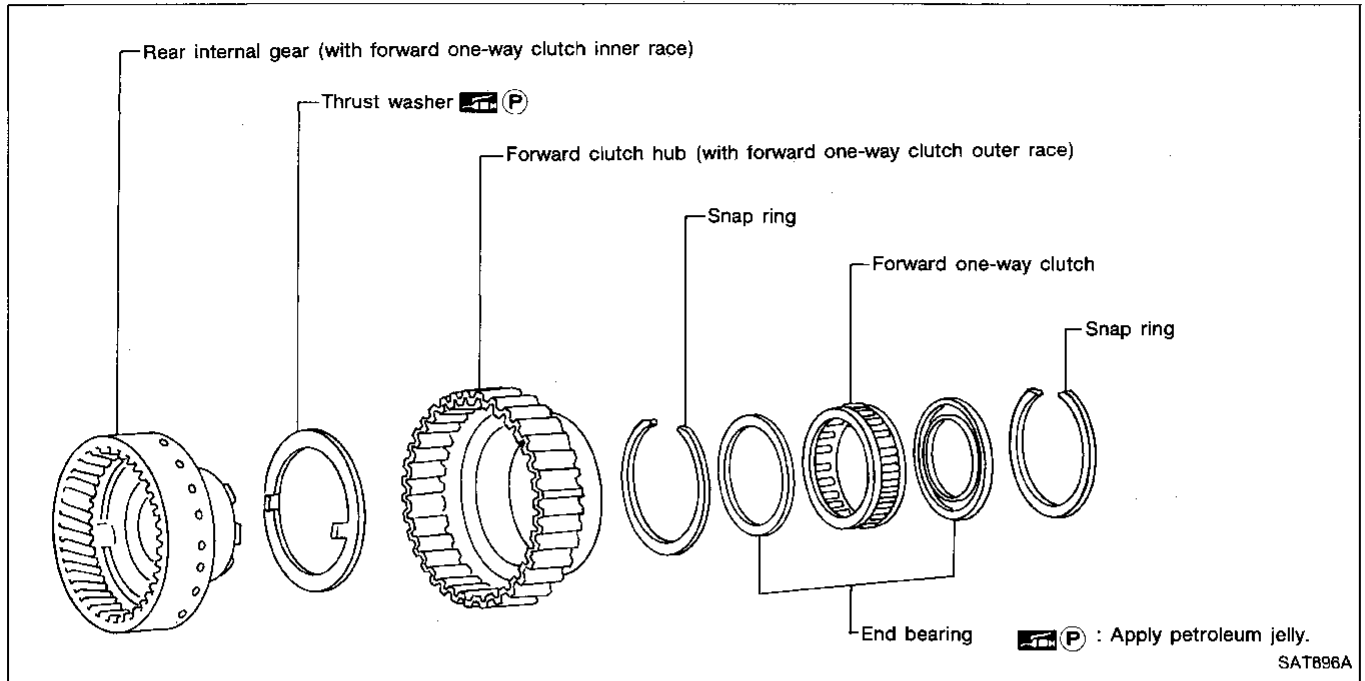

DISASSEMBLY

1. Remove rear internal gear by pushing forward clutch hub forward.
2. Remove thrust washer from rear internal gear.
3. Remove snap ring from forward clutch hub.
4. Remove end bearing
5. Remove forward one-way clutch and end bearing as a unit from forward clutch hub.
6. Remove snap ring from forward clutch hub.

REPAIR FOR COMPONENT PARTS

Rear Internal Gear and Forward Clutch Hub — RE4R01A and RL4R01A (Cont'd)

INSPECTION

Rear internal gear and forward clutch hub

- Check gear for excessive wear, chips or cracks.
- Check frictional surfaces of forward one-way clutch and thrust washer for wear or damage.
- Check spline for wear or damage.

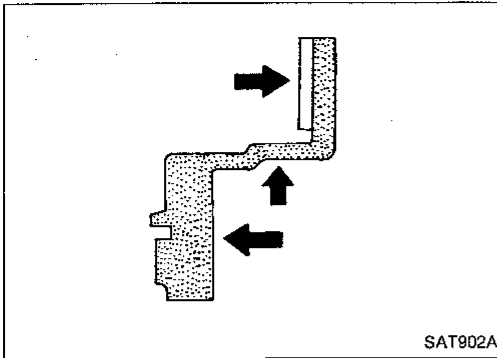

Snap ring and end bearing

- Check for deformation or damage.

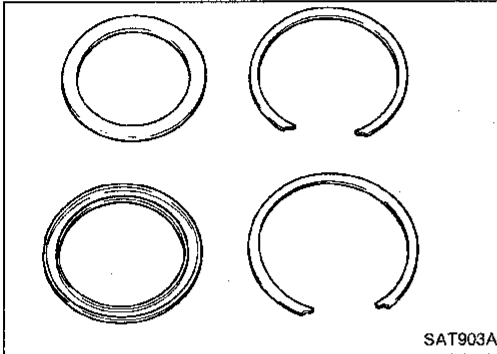

ASSEMBLY

1. Install snap ring onto forward clutch hub.
2. Install end bearing.

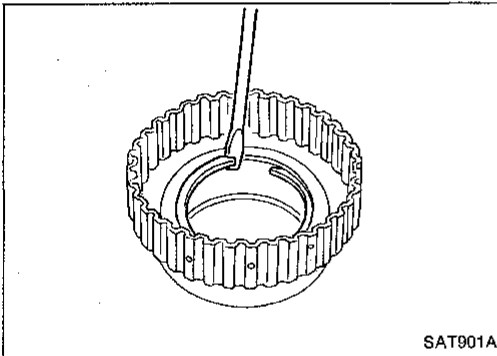

3. Install forward one-way clutch onto clutch hub.
 - **Install forward one-way clutch with flange facing rearward.**
4. Install end bearing.
5. Install snap ring onto forward clutch hub.

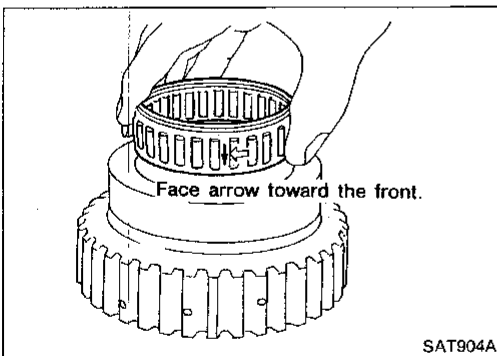

6. Install thrust washer onto rear internal gear.
 - **Apply petroleum jelly to thrust washer.**
 - **Securely insert pawls of thrust washer into holes in rear internal gear.**

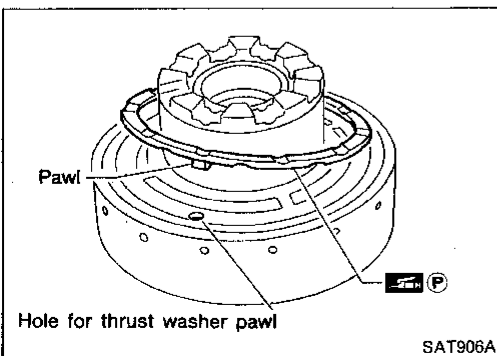

REPAIR FOR COMPONENT PARTS

Rear Internal Gear and Forward Clutch Hub — RE4R01A and RL4R01A (Cont'd)

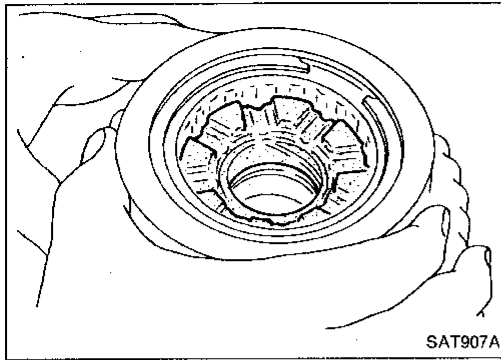

7. Position forward clutch hub in rear internal gear.

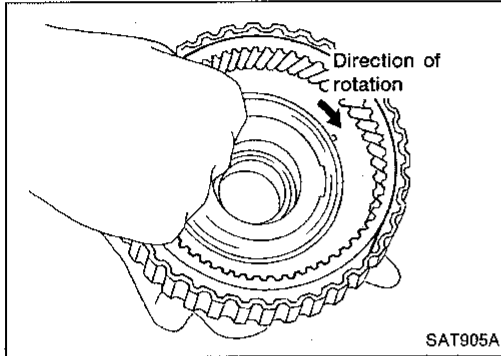

8. After installing, check to assure that forward clutch hub rotates clockwise.

GI

MA

EM

LC

EF &
EC

FE

CL

MT

AT

TF

PD

FA

RA

BR

ST

BF

HA

EL

IDX

REPAIR FOR COMPONENT PARTS

Band Servo Piston Assembly — RE4R01A and RL4R01A

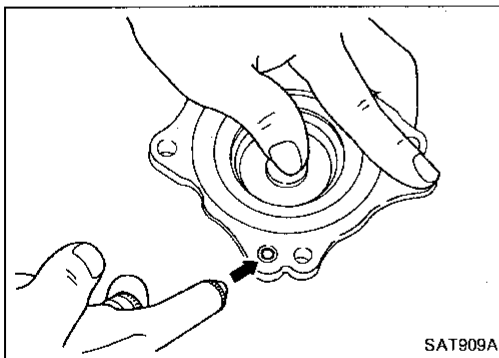
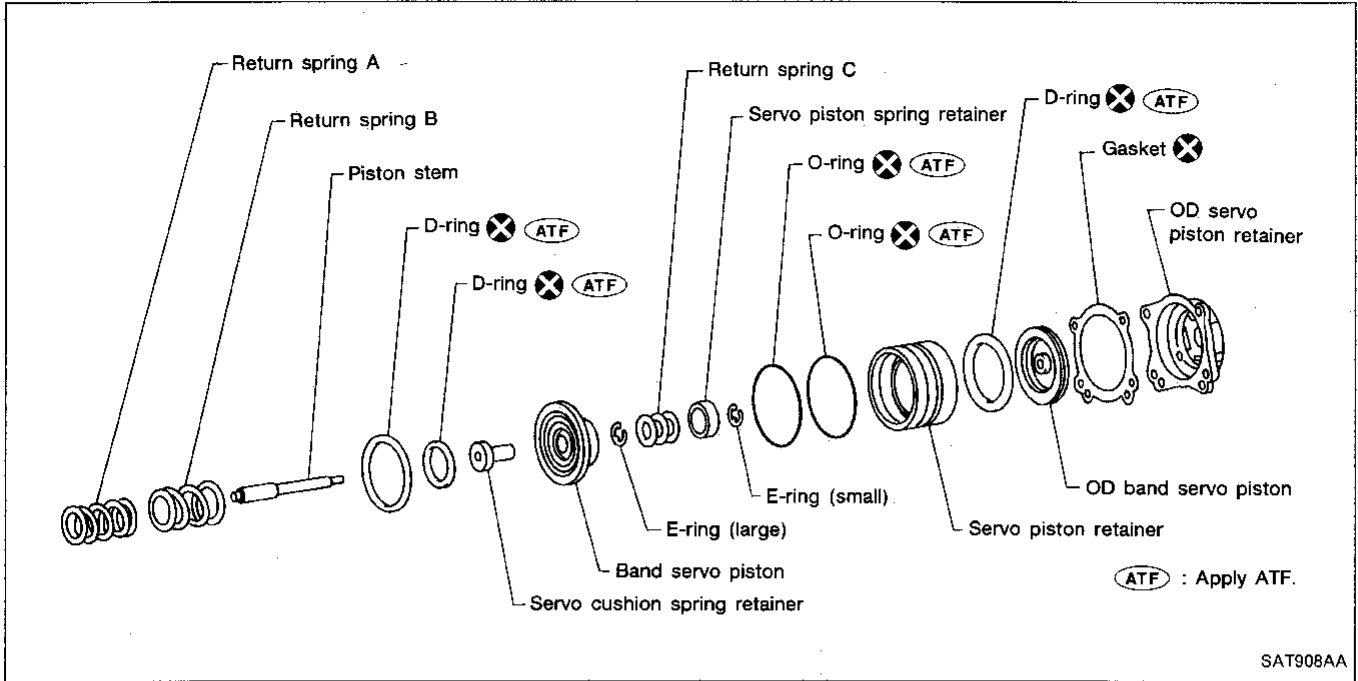

DISASSEMBLY

1. Block one oil hole in OD servo piston retainer and the center hole in OD band servo piston.
2. Apply compressed air to the other oil hole in piston retainer to remove OD band servo piston from retainer.
3. Remove D-ring from OD band servo piston.

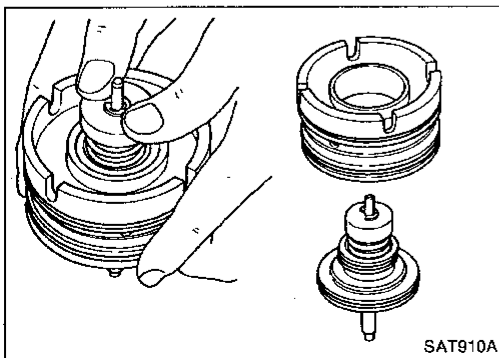

4. Remove band servo piston assembly from servo piston retainer by pushing it forward.

REPAIR FOR COMPONENT PARTS

Band Servo Piston Assembly — RE4R01A and RL4R01A (Cont'd)

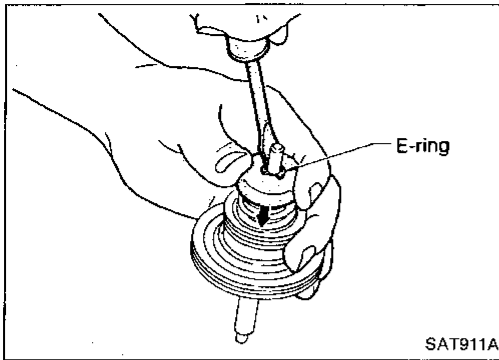

- Place piston stem end on a wooden block. While pushing servo piston spring retainer down, remove E-ring.

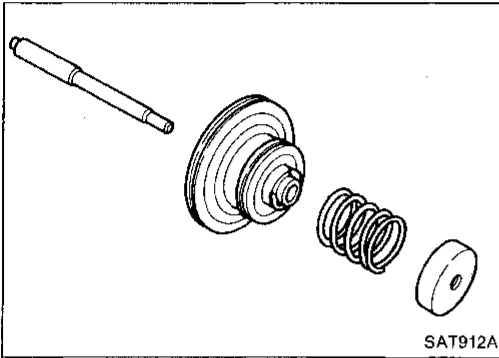

- Remove servo piston spring retainer, return spring C and piston stem from band servo piston.

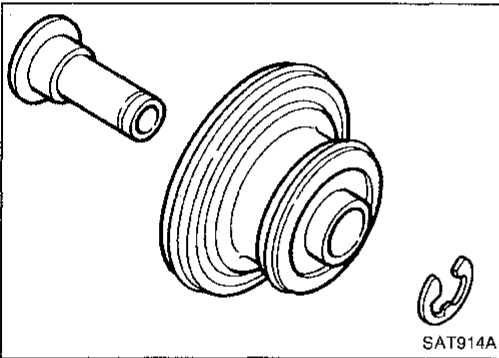

- Remove E-ring from band servo piston.
- Remove servo cushion spring retainer from band servo piston.
- Remove D-rings from band servo piston.
- Remove O-rings from servo piston retainer.

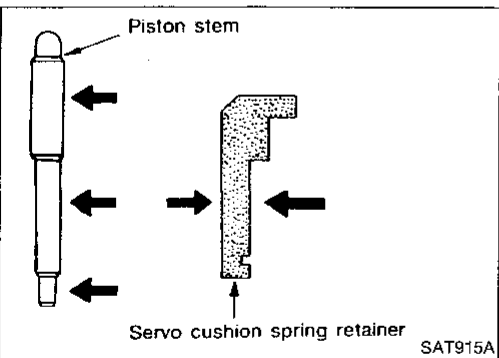

INSPECTION

Pistons, retainers and piston stem

- Check frictional surfaces for abnormal wear or damage.

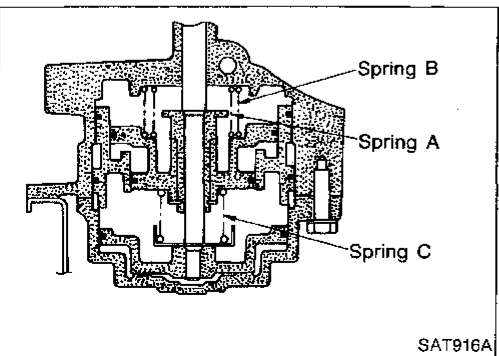

Return springs

- Check for deformation or damage. Measure free length and outer diameter.

Inspection standard

Unit: mm (in)

Parts	Free length	Outer diameter
Spring A	45.6 (1.795)	34.3 (1.350)
Spring B	53.8 (2.118)	40.3 (1.587)
Spring C	29.7 (1.169)	27.6 (1.087)

GI

MA

EM

LC

EF &
EC

FE

CL

MT

AT

TF

PD

FA

RA

BR

ST

BF

HA

EL

IDX

REPAIR FOR COMPONENT PARTS

Band Servo Piston Assembly — RE4R01A and RL4R01A (Cont'd)

ASSEMBLY

1. Install O-rings onto servo piston retainer
 - Apply ATF to O-rings.
 - Pay attention to position of each O-ring.

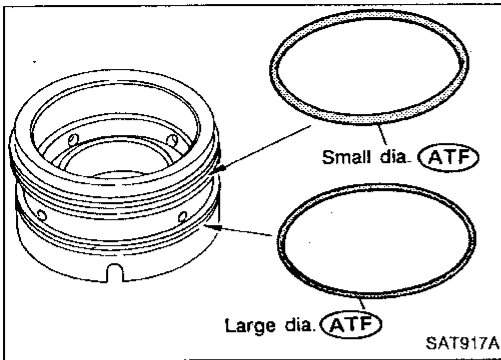

2. Install servo cushion spring retainer onto band servo piston.

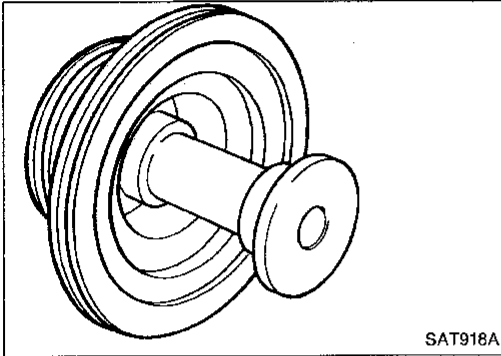

3. Install E-ring onto servo cushion spring retainer.
4. Install D-rings onto band servo piston.
 - Apply ATF to D-rings.

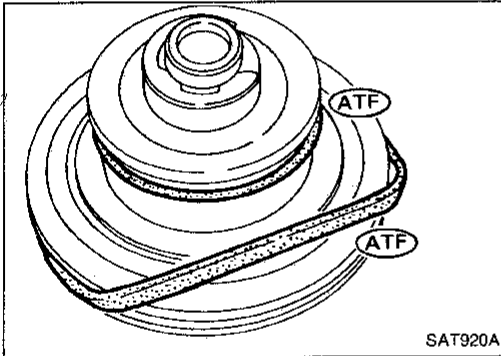

5. Install servo piston spring retainer, return spring C and piston stem onto band servo piston.

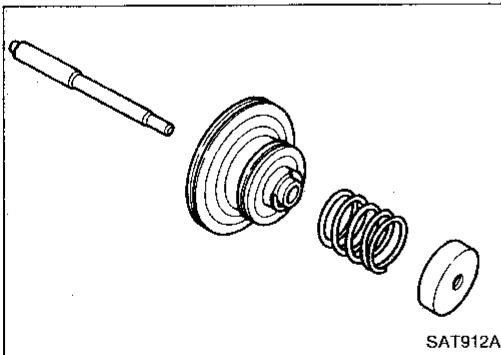

6. Place piston stem end on a wooden block. While pushing servo piston spring retainer down, install E-ring.

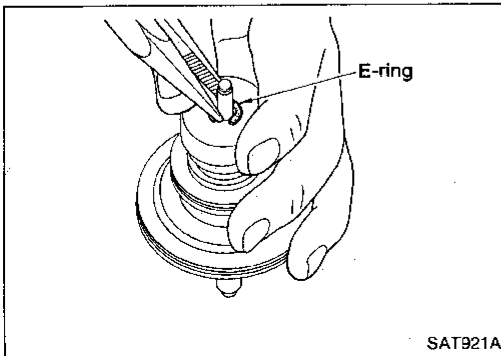

REPAIR FOR COMPONENT PARTS

Band Servo Piston Assembly — RE4R01A and RL4R01A (Cont'd)

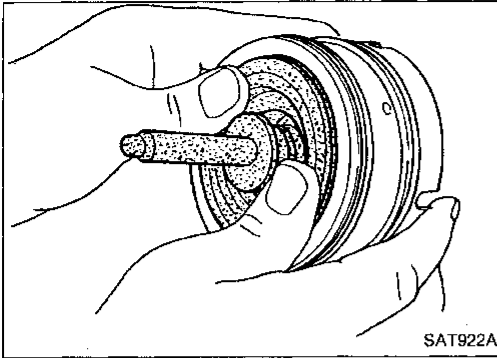

7. Install band servo piston assembly onto servo piston retainer by pushing it inward.

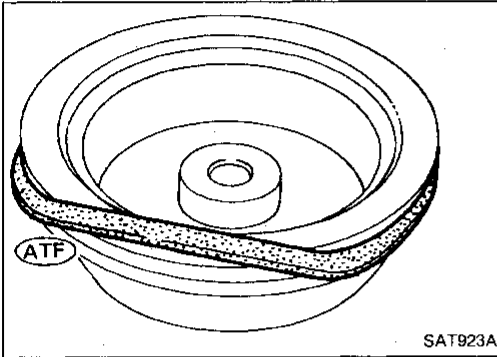

8. Install D-ring on OD band servo piston.
 - Apply ATF to D-ring.

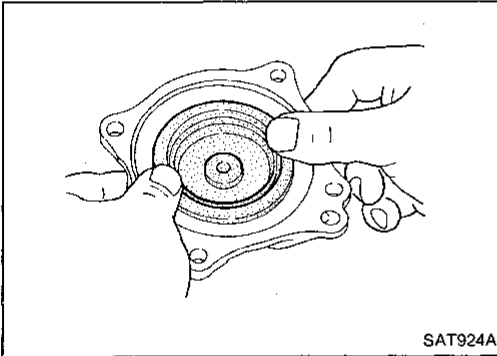

9. Install OD band servo piston onto servo piston retainer by pushing it inward.

GI

MA

EM

LC

EF &
EC

FE

CL

MT

AT

TF

PD

FA

RA

BR

ST

BF

HA

EL

IDX

REPAIR FOR COMPONENT PARTS

Parking Pawl Components — RE4R01A and RL4R01A

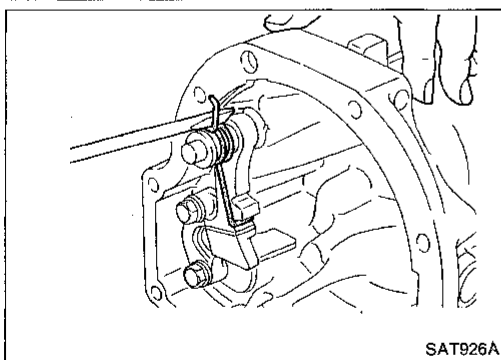
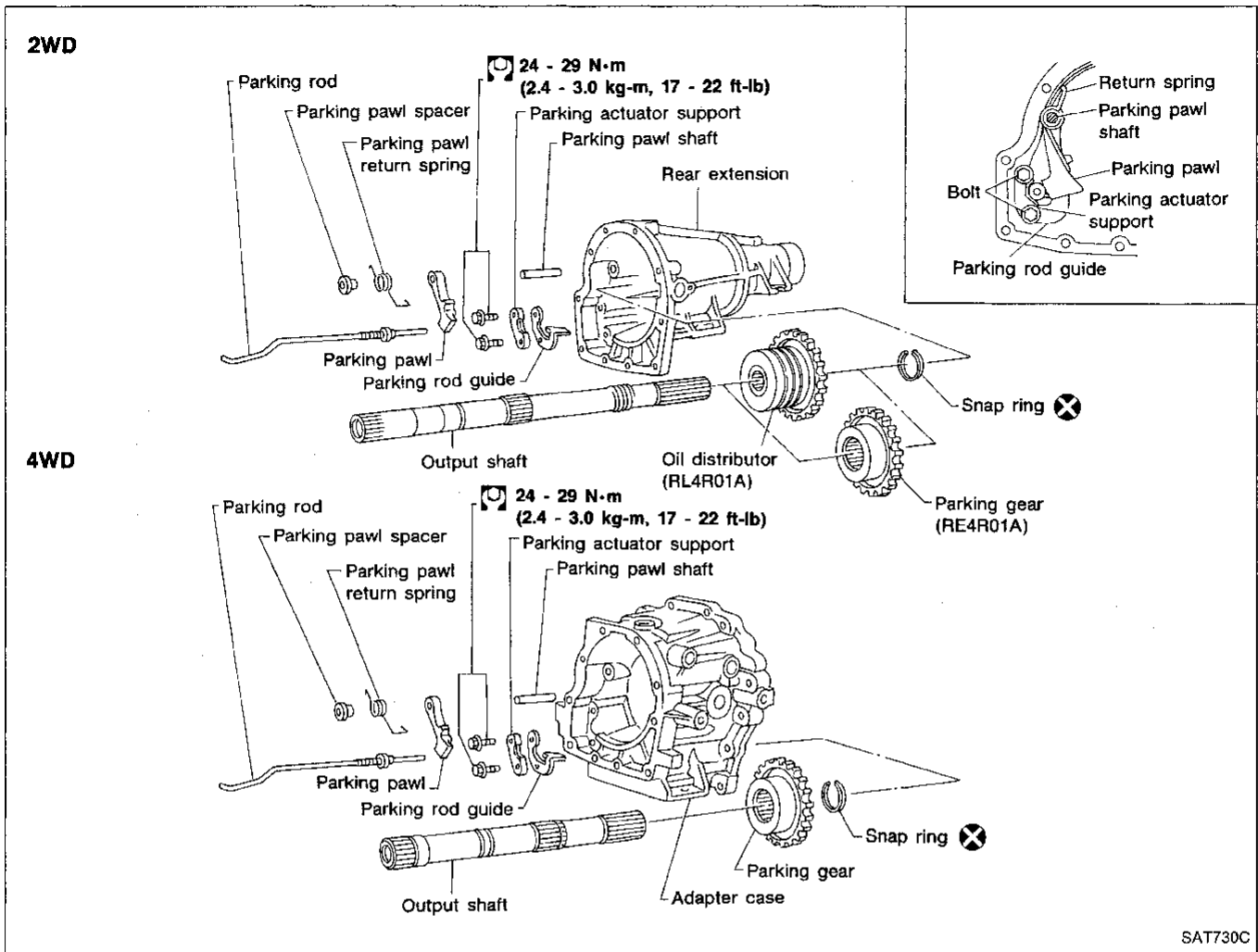

DISASSEMBLY

1. Slide return spring to the front of rear extension case flange or adapter case flange.
2. Remove return spring, pawl spacer and parking pawl from rear extension or adapter case.
3. Remove parking pawl shaft from rear extension or adapter case.

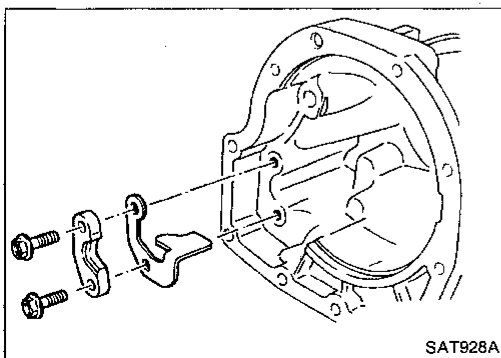

4. Remove parking actuator support and rod guide from rear extension or adapter case.

REPAIR FOR COMPONENT PARTS

Parking Pawl Components — RE4R01A and RL4R01A (Cont'd)

INSPECTION

Parking pawl and parking actuator support

- Check contact surface of parking rod for wear.

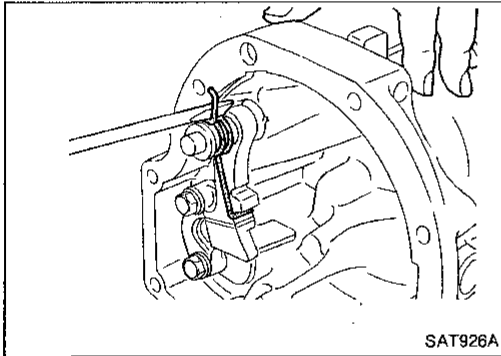
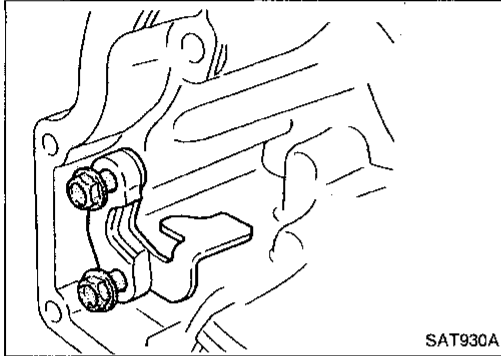
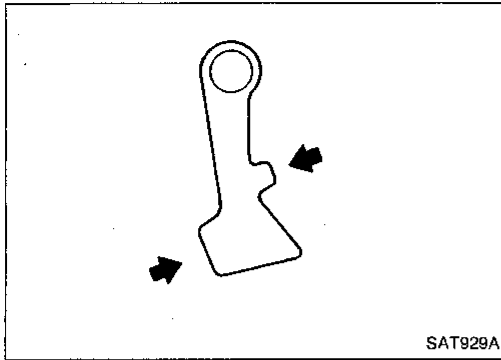

ASSEMBLY

1. Install rod guide and parking actuator support onto rear extension or adapter case.
2. Insert parking pawl shaft into rear extension or adapter case.
3. Install return spring, pawl spacer and parking pawl onto parking pawl shaft.
4. Bend return spring upward and install it onto rear extension or adapter case.

GI

MA

EM

LC

EF &
EC

FE

CL

MT

AT

TF

PD

FA

RA

BR

ST

BF

HA

EL

IDX

ASSEMBLY

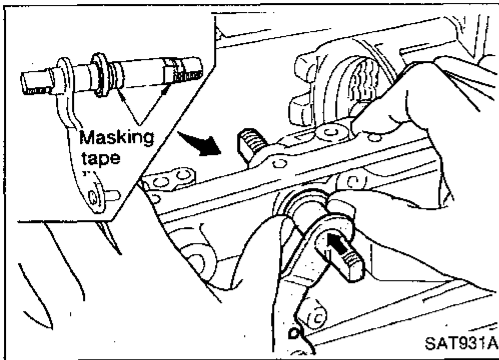

Assembly (1)

— RE4R01A and RL4R01A —

1. Install manual shaft components.
 - a. Install oil seal onto manual shaft.
 - Apply ATF to oil seal.
 - Wrap threads of manual shaft with masking tape.
 - b. Insert manual shaft and oil seal as a unit into transmission case.
 - c. Remove masking tape.

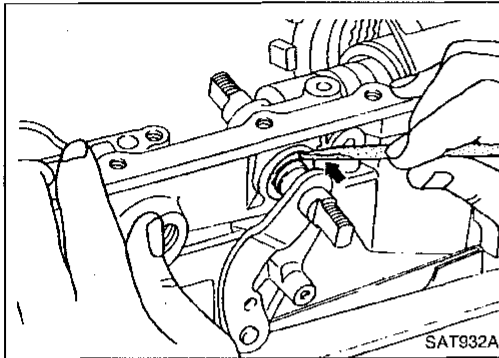

- d. Push oil seal evenly and install it onto transmission case.

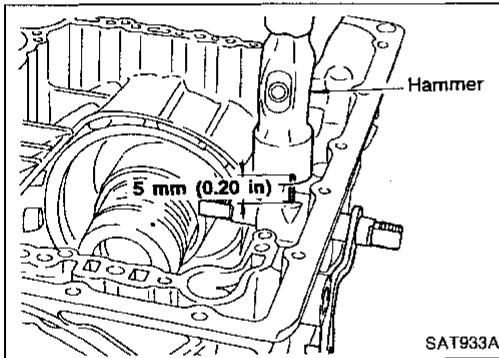

- e. Align groove in shaft with drive pin hole, then drive pin into position as shown in figure at left.

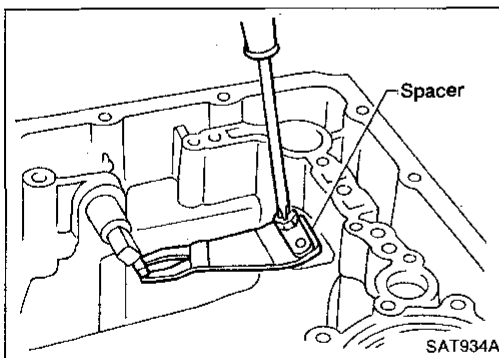

- f. Install detent spring and spacer.

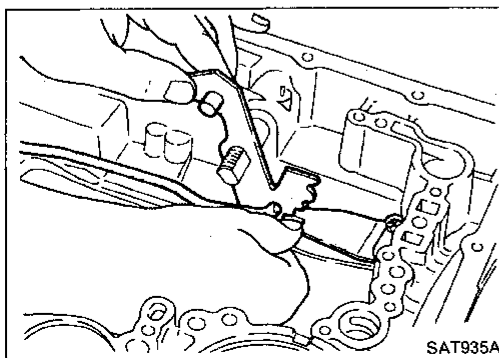

- g. While pushing detent spring down, install manual plate onto manual shaft.

ASSEMBLY

Assembly (1) (Cont'd)

h. Install lock nuts onto manual shaft.

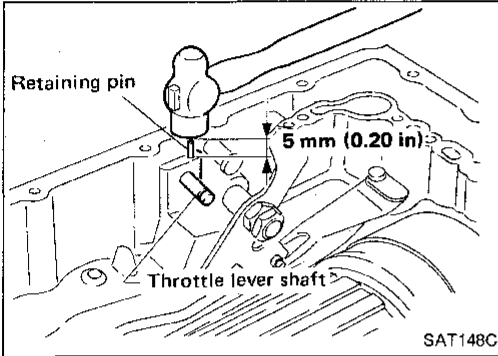
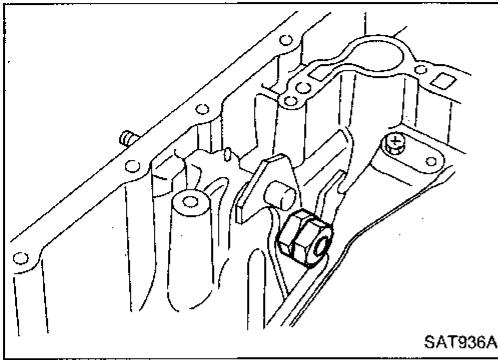

— RL4R01A —

2. Install throttle lever components.

a. Install throttle lever shaft.

b. Align groove in shaft with drive pin hole, then drive pin into position as shown in figure at left.

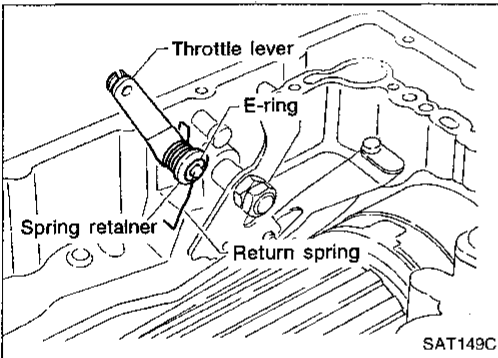

c. Install throttle lever, return spring, spring retainer and E-ring.

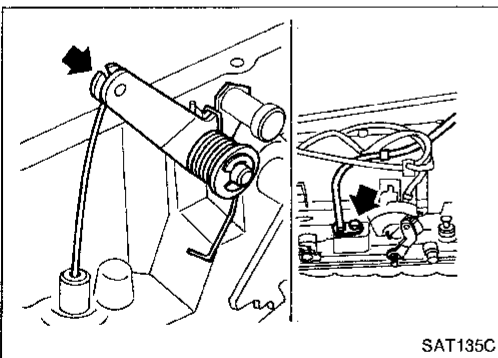

d. Install throttle wire.

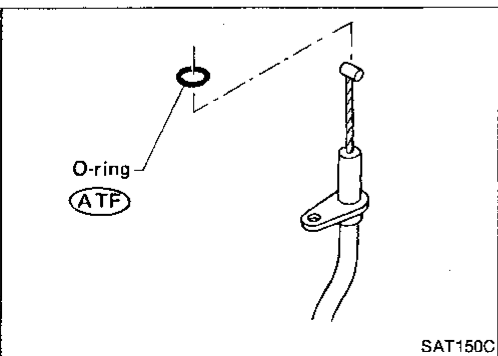

● Apply ATF to O-ring.

GE

WA

EM

LC

EF &
EC

FE

CL

c. Install throttle lever, return spring, spring retainer and E-ring.

MT

AT

TF

PD

FA

RA

BR

ST

BF

HA

EL

IDX

ASSEMBLY

Assembly (1) (Cont'd)

— RE4R01A and RL4R01A —

3. Install accumulator piston.
 - a. Install O-rings onto accumulator piston.
 - **Apply ATF to O-rings.**

Accumulator piston O-rings

Unit: mm (in)

Accumulator	A	B	C	D
Small diameter end	29 (1.14)	32 (1.26)	45 (1.77)	29 (1.14)
Large diameter end	45 (1.77)	50 (1.97)	50 (1.97)	45 (1.77)

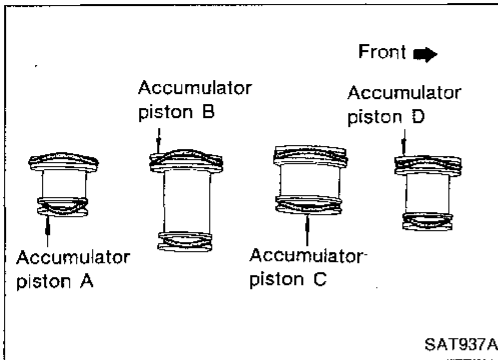

- b. Install return spring for accumulator A onto transmission case.

Free length of return spring

Unit: mm (in)

Accumulator	A
Free length	43 (1.69)

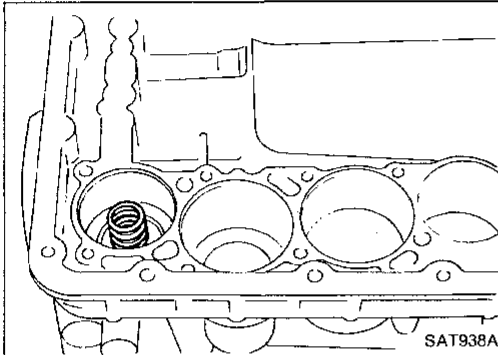

- c. Install accumulator pistons A, B, C and D.
 - **Apply ATF to transmission case.**

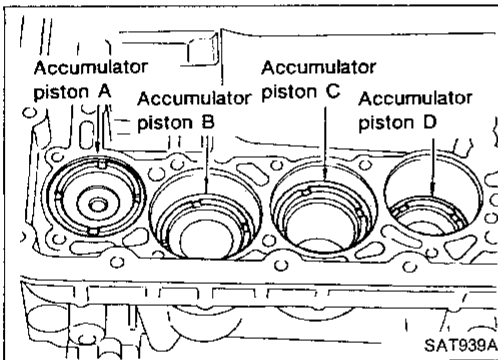

4. Install band servo piston.
 - a. Install return springs onto servo piston.

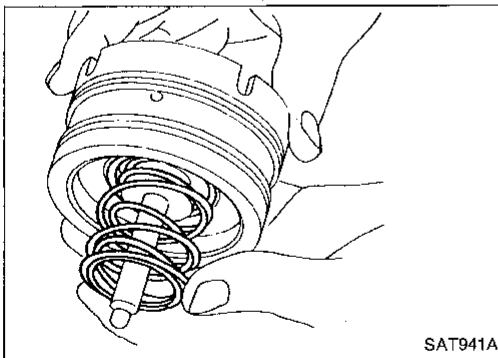

- b. Install band servo piston onto transmission case.
 - **Apply ATF to O-ring of band servo piston and transmission case.**
 - c. Install gasket for band servo onto transmission case.

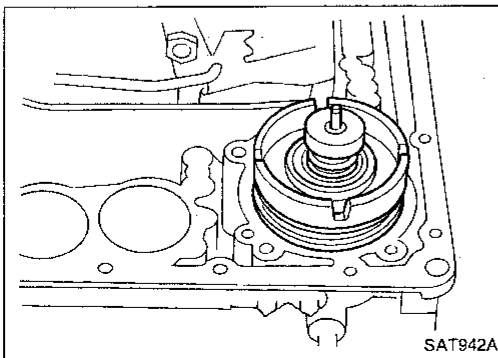

ASSEMBLY

Assembly (1) (Cont'd)

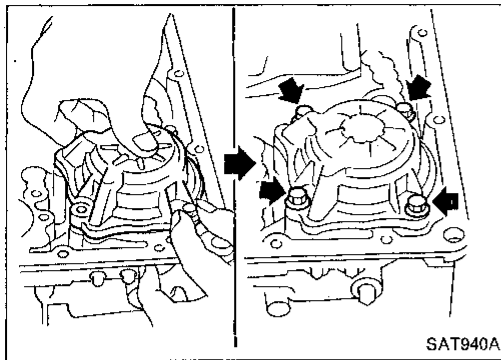

d. Install band servo retainer onto transmission case.

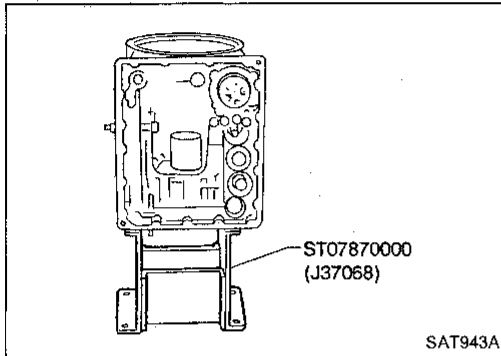

5. Install rear side clutch and gear components.

a. Place transmission case in vertical position.

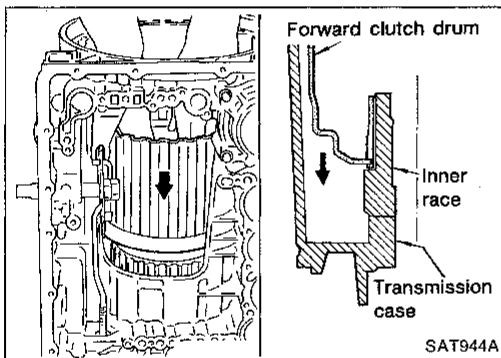

b. Slightly lift forward clutch drum assembly and slowly rotate it clockwise until its hub passes fully over the clutch inner race inside transmission case.

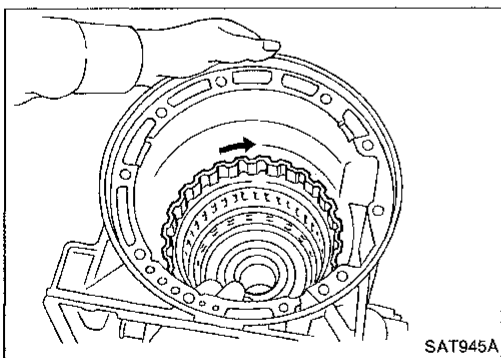

c. Check to be sure that rotation direction of forward clutch assembly is correct.

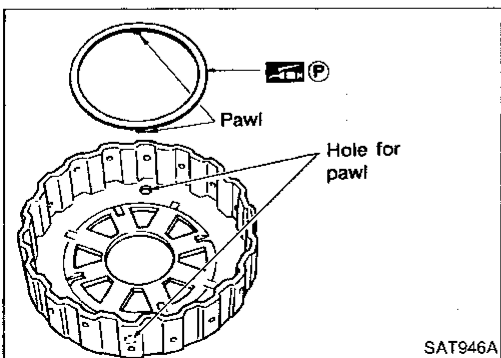

d. Install thrust washer onto front of overrun clutch hub.

- Apply petroleum jelly to the thrust washer.
- Insert pawls of thrust washer securely into holes in overrun clutch hub.

GI

MA

EM

LC

EF &
EC

FE

CL

MT

AT

TF

PD

FA

RA

BR

ST

BF

HA

EL

IDX

ASSEMBLY

Assembly (1) (Cont'd)

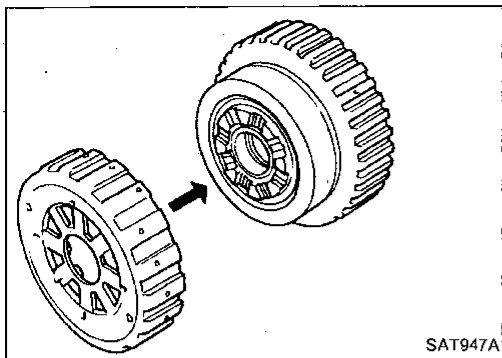

e. Install overrun clutch hub onto rear internal gear assembly.

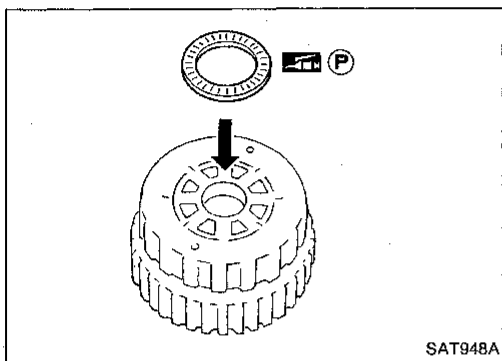

f. Install needle bearing onto rear of overrun clutch hub.

- Apply petroleum jelly to needle bearing.

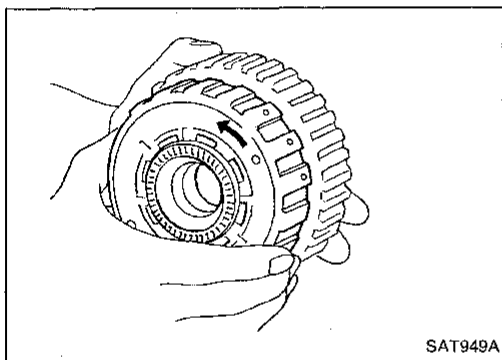

g. Check that overrun clutch hub rotates as shown while holding forward clutch hub.

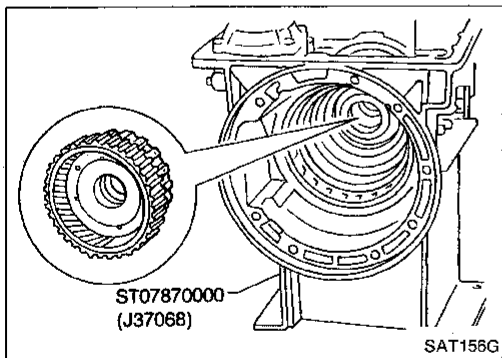

h. Place transmission case into horizontal position.

i. Install rear internal gear, forward clutch hub and overrun clutch hub as a unit onto transmission case.

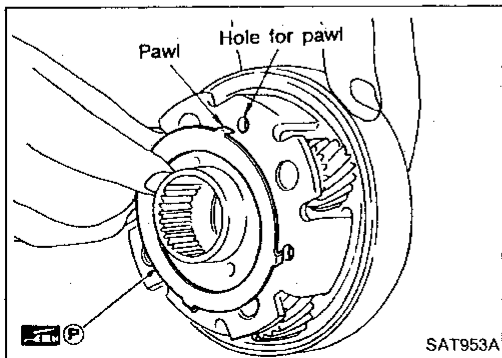

j. Install needle bearing onto rear internal gear.

- Apply petroleum jelly to needle bearing.

k. Install bearing race onto rear of front internal gear.

- Apply petroleum jelly to bearing race.
- Securely engage pawls of bearing race with holes in front internal gear.

ASSEMBLY

Assembly (1) (Cont'd)

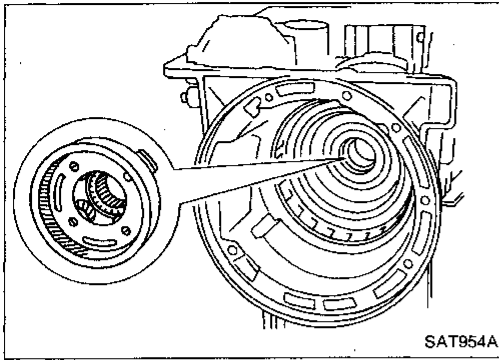

1. Install front internal gear on transmission case.

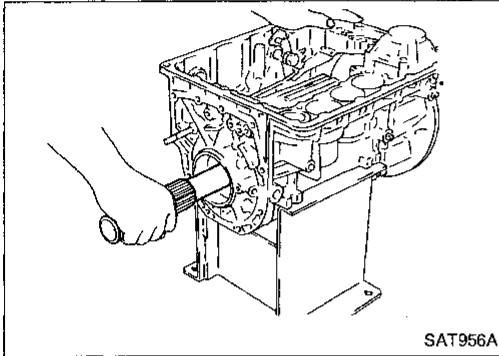

6. Install output shaft and parking gear.
 - a. Insert output shaft from rear of transmission case while slightly lifting front internal gear.
 - **Do not force output shaft against front of transmission case.**

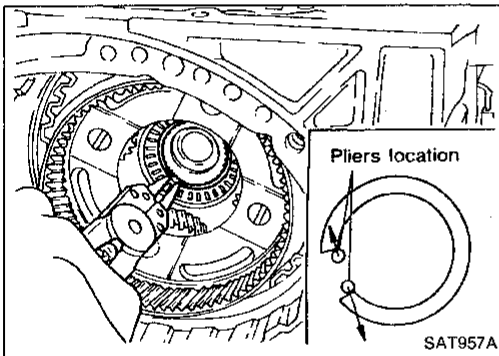

- b. Carefully push output shaft against front of transmission case. Install snap ring on front of output shaft.
 - **Check to be sure output shaft cannot be removed in rear direction.**

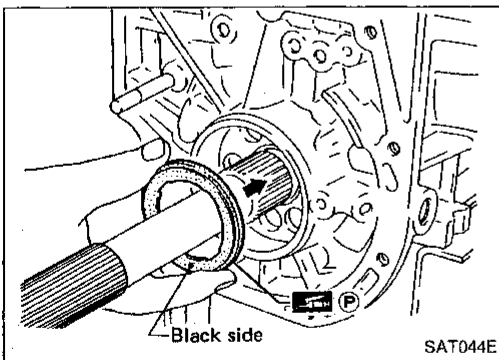

- c. Install needle bearing on transmission case.
 - **Pay attention to its direction — Black side goes to rear.**
 - **Apply petroleum jelly to needle bearing.**

GI

MA

EM

LC

EF &
EC

FE

CL

MT

AT

TF

PD

FA

RA

BR

ST

BF

HA

EL

IDX

ASSEMBLY

Assembly (1) (Cont'd)

d. Install parking gear on transmission case.

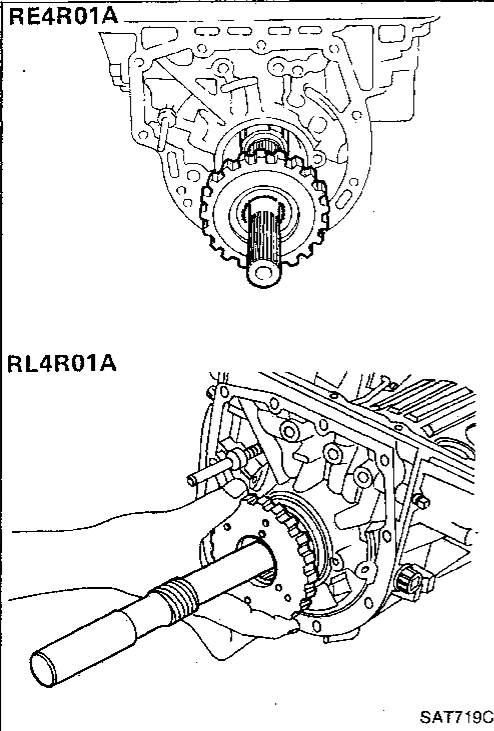

e. Install snap ring on rear of output shaft.

- Check to be sure output shaft cannot be removed in forward direction.

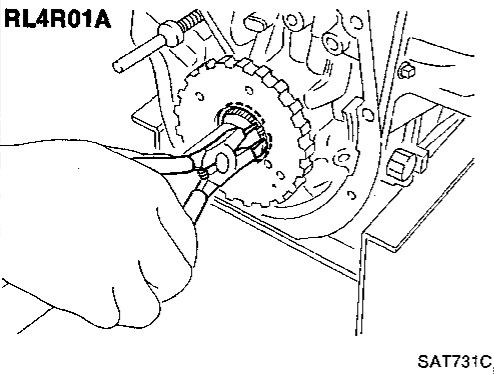
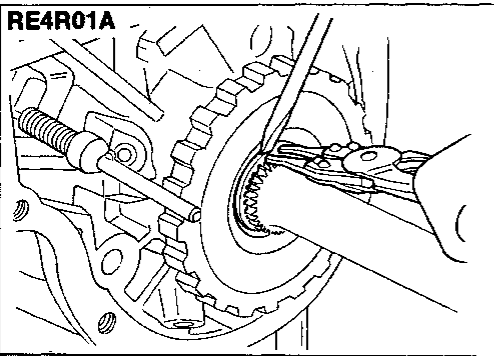

— RL4R01A —

f. Install governor valve assembly on oil distributor.

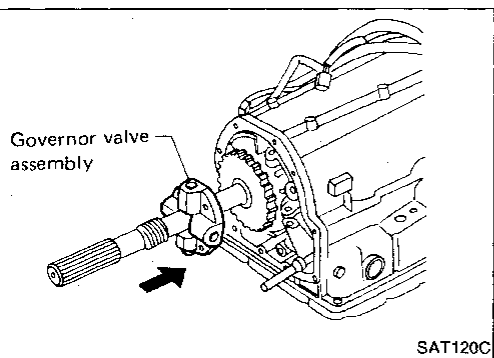

ASSEMBLY

Assembly (1) (Cont'd)

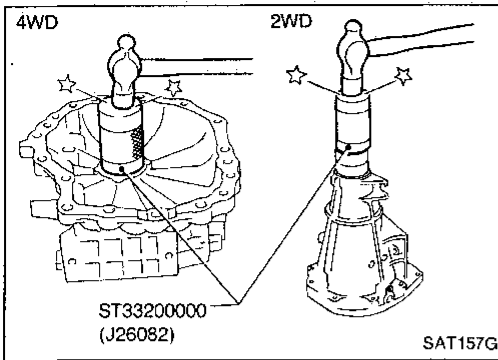

— RE4R01A and RL4R01A —

7. Install rear extension or adapter case.
 - a. Install oil seal on rear extension or adapter case.
 - **Apply ATF to oil seal.**

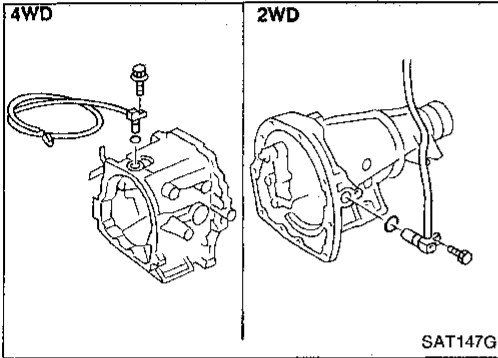

— RE4R01A —

- b. Install O-ring on revolution sensor.
 - **Apply ATF to O-ring.**
- c. Install revolution sensor on rear extension or adapter case.

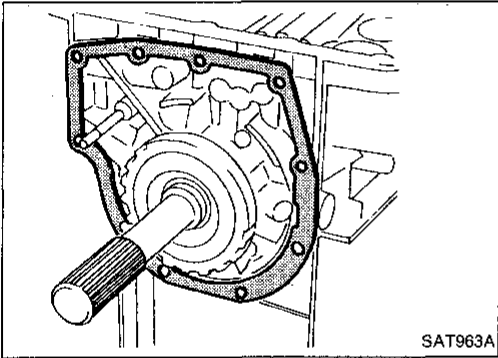

- d. Install adapter case gasket or rear extension case gasket on transmission case.

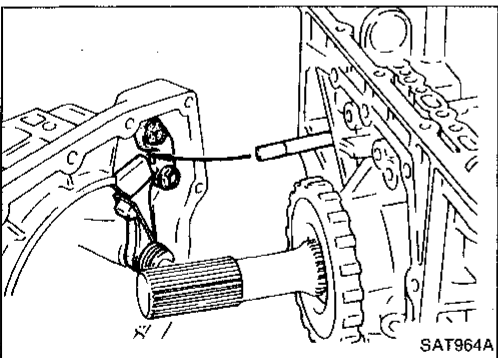

- e. Install parking rod on transmission case.

GI

MA

EM

LC

EF &
EC

FE

CL

MT

AT

TF

PD

FA

RA

BR

ST

BF

HA

EL

IDX

ASSEMBLY

Assembly (1) (Cont'd)

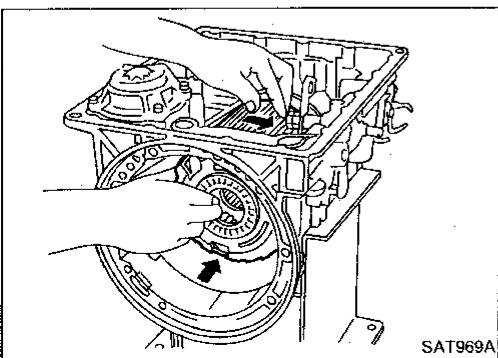
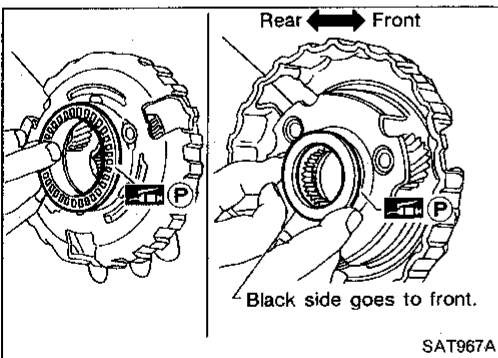
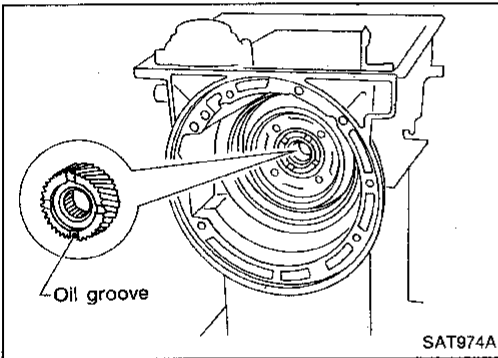
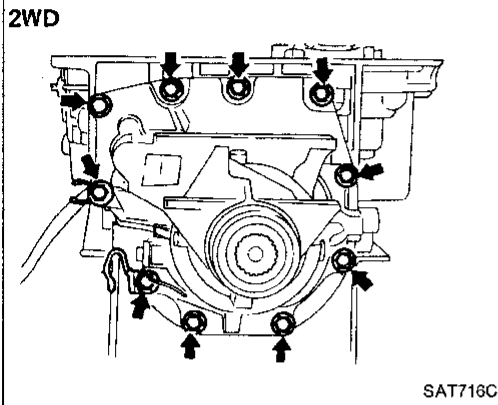
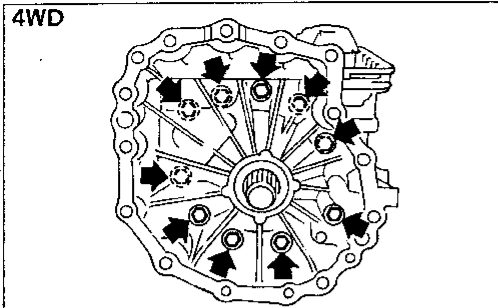

- f. Install rear extension or adapter case on transmission case.

8. Install front side clutch and gear components.
- a. Install rear sun gear on transmission case.
- Pay attention to its direction.

- b. Install needle bearing on front of front planetary carrier.
- Apply petroleum jelly to needle bearing.
- c. Install needle bearing on rear of front planetary carrier.
- Apply petroleum jelly to needle bearing.
 - Pay attention to its direction — Black side goes to front.

- d. While rotating forward clutch drum clockwise, install front planetary carrier on forward clutch drum.

ASSEMBLY

Assembly (1) (Cont'd)

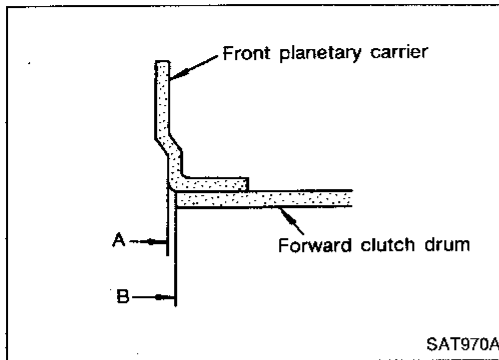

- Check that portion A of front planetary carrier protrudes approximately 2 mm (0.08 in) beyond portion B of forward clutch assembly.

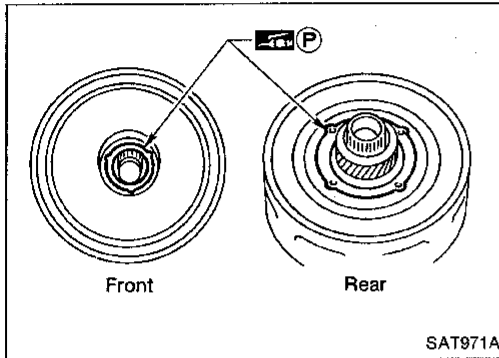

- e. Install bearing races on front and rear of clutch pack.
- Apply petroleum jelly to bearing races.
- Securely engage pawls of bearing races with holes in clutch pack.
- f. Place transmission case in vertical position.

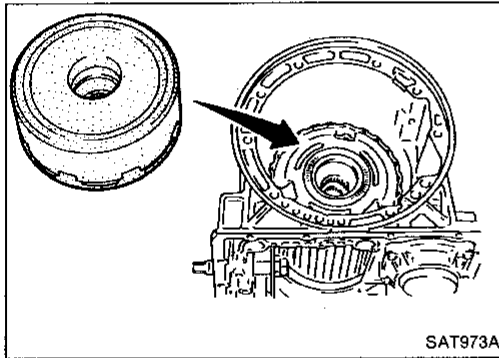

- g. Install clutch pack into transmission case.

Adjustment

When any parts listed in the following table are replaced, total end play or reverse clutch end play must be adjusted.

Part name	Item	
	Total end play	Reverse clutch end play
Transmission case	●	●
Low one-way clutch inner race	●	●
Overrun clutch hub	●	●
Rear internal gear	●	●
Rear planetary carrier	●	●
Rear sun gear	●	●
Front planetary carrier	●	●
Front sun gear	●	●
High clutch hub	●	●
High clutch drum	●	●
Oil pump cover	●	●
Reverse clutch drum	—	●

GI
MA
EM
LC
EF &
EC
FE
CL
MT
AT
TF
PD
FA
RA
BR
ST
BF
HA
EL
IDX

ASSEMBLY

Adjustment (Cont'd)

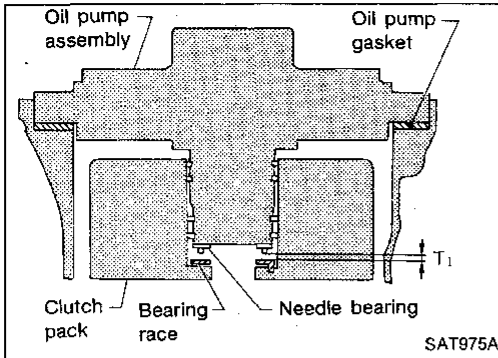

1. Adjust total end play.
Total end play "T₁":
0.25 - 0.55 mm (0.0098 - 0.0217 in)

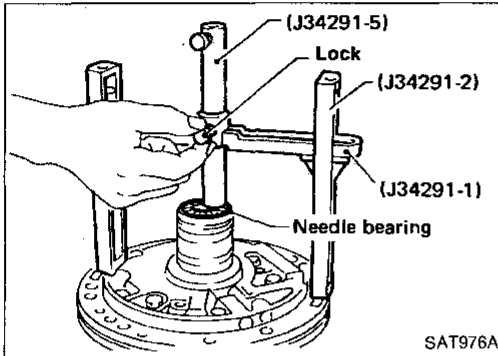

- a. With needle bearing installed, place J34291-1 (bridge), J34291-2 (legs) and the J34291-5 (gauging cylinder) onto oil pump. The long ends of legs should be placed firmly on machined surface of oil pump assembly and gauging cylinder should rest on top of the needle bearing. Lock gauging cylinder in place with set screw.

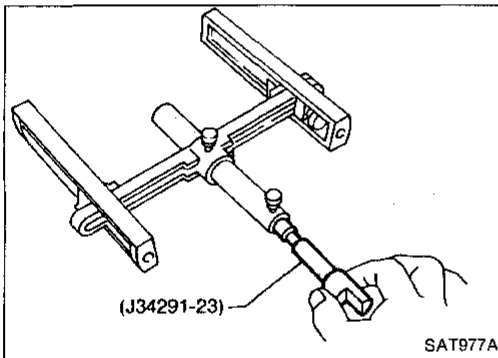

- b. Install J34291-23 (gauging plunger) into gauging cylinder.

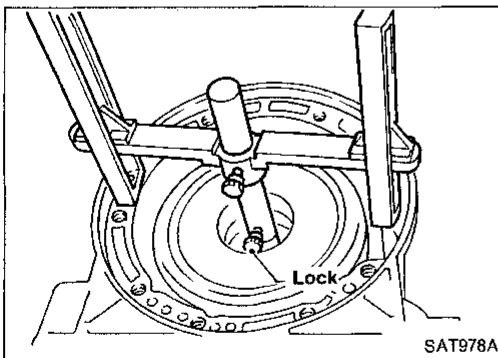

- c. With original bearing race installed inside reverse clutch drum, place shim selecting gauge with its legs on machined surface of transmission case (no gasket) and allow gauging plunger to rest on bearing race. Lock gauging plunger in place with set screw.

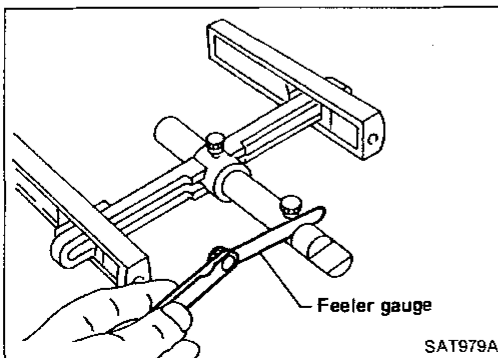

- d. Remove Tool and use feeler gauge to measure gap between gauging cylinder and gauging plunger. This measurement should give exact total end play.

Total end play "T₁":
0.25 - 0.55 mm (0.0098 - 0.0217 in)

- If end play is out of specification, decrease or increase thickness of oil pump cover bearing race as necessary.

Available oil pump cover bearing race:
Refer to SDS (AT-217).

ASSEMBLY

Adjustment (Cont'd)

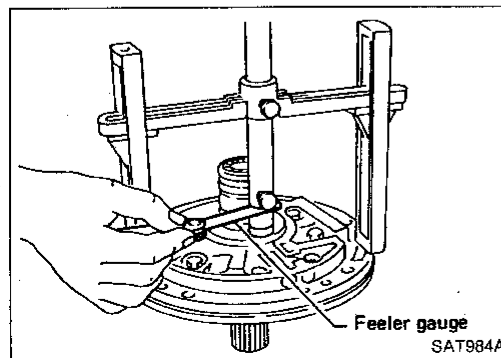
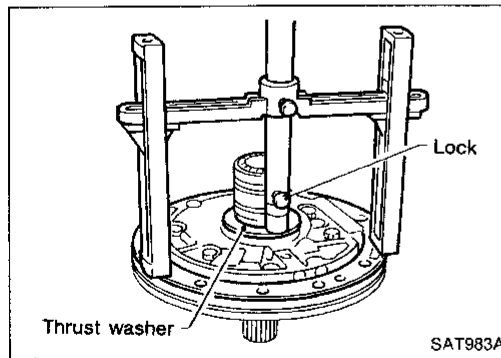
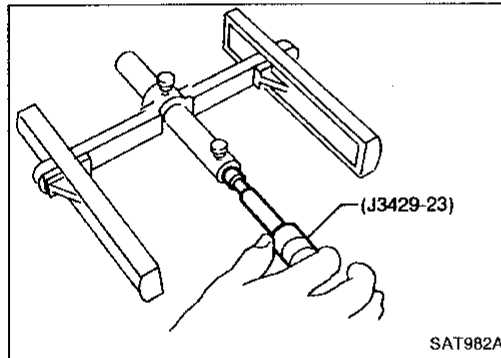
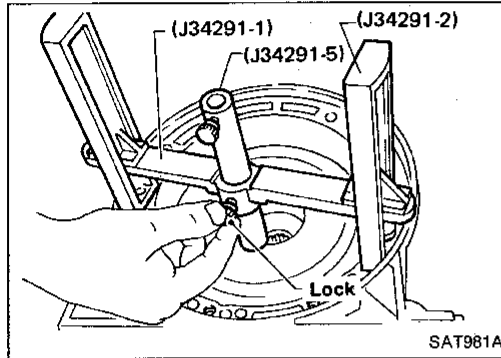
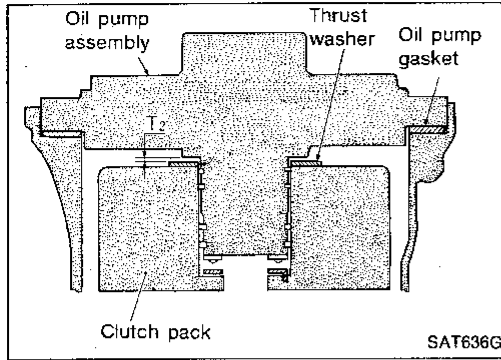

2. Adjust reverse clutch drum end play.
Reverse clutch drum end play " T_2 ":
0.55 - 0.90 mm (0.0217 - 0.0354 in)

- a. Place J34291-1 (bridge), J34291-2 (legs) and J34291-5 (gauging cylinder) on machined surface of transmission case (no gasket) and allow gauging cylinder to rest on front thrust surface of reverse clutch drum. Lock cylinder in place with set screw.

- b. Install J34291-23 (gauging plunger) into gauging cylinder.

- c. With original thrust washer installed on oil pump, place shim setting gauge legs onto machined surface of oil pump assembly and allow gauging plunger to rest on thrust washer. Lock plunger in place with set screw.

- d. Use feeler gauge to measure gap between gauging plunger and gauging cylinder. This measurement should give you exact reverse clutch drum end play.

Reverse clutch drum end play " T_2 ":
0.55 - 0.90 mm (0.0217 - 0.0354 in)

- If end play is out of specification, decrease or increase thickness of oil pump thrust washer as necessary.

Available oil pump thrust washer:
Refer to SDS (AT-217).

GI

MA

EM

LC

EF &
EC

FE

CL

MT

AT

TF

PD

FA

RA

BR

ST

BF

HA

EL

IDX

ASSEMBLY

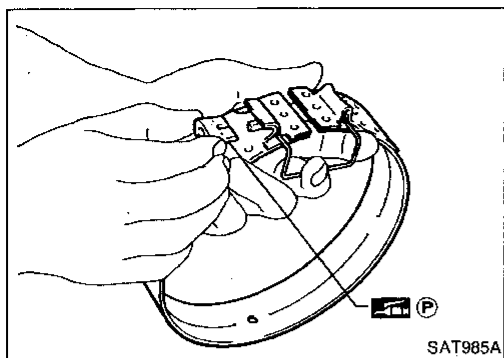

Assembly (2)

1. Place transmission case into horizontal position.
2. Install brake band and band strut.
 - a. Install band strut on brake band.
 - **Apply petroleum jelly to band strut.**
 - b. Place brake band on periphery of reverse clutch drum, and insert band strut into end of band servo piston stem.
 - c. Install anchor end bolt on transmission case. Then, tighten anchor end bolt just enough so that reverse clutch drum (clutch pack) will not tilt forward.

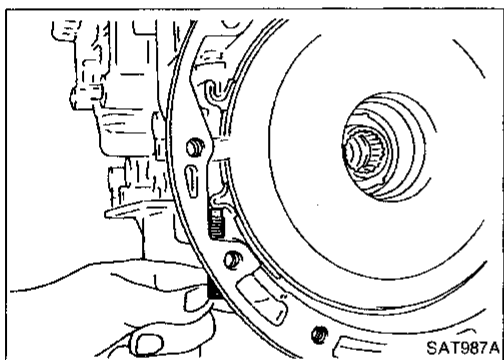
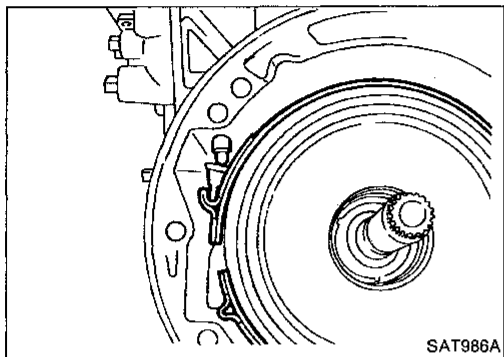

3. Install input shaft on transmission case.
 - **Pay attention to its direction — O-ring groove side is front.**
4. Install gasket on transmission case.

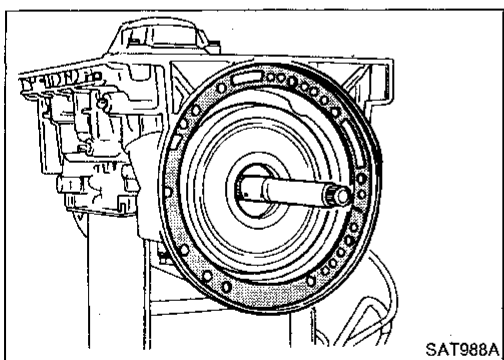

5. Install oil pump assembly.
 - a. Install needle bearing on oil pump assembly.
 - **Apply petroleum jelly to the needle bearing.**
 - b. Install selected thrust washer on oil pump assembly.
 - **Apply petroleum jelly to thrust washer.**

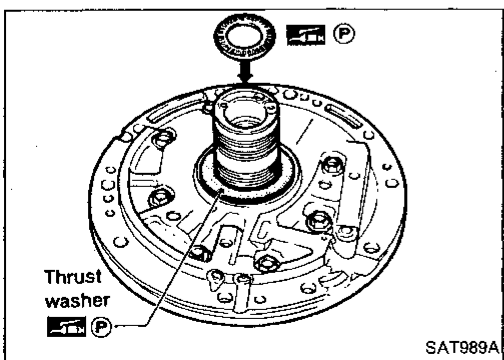

ASSEMBLY

Assembly (2) (Cont'd)

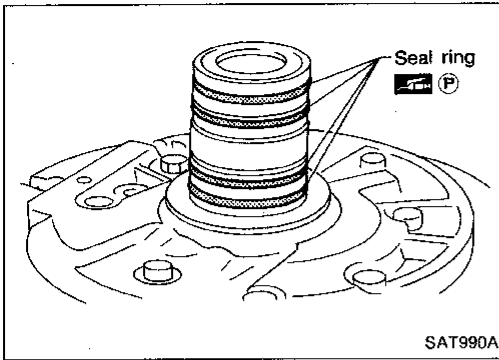

- c. Carefully install seal rings into grooves and press them into the petroleum jelly so that they are a tight fit.

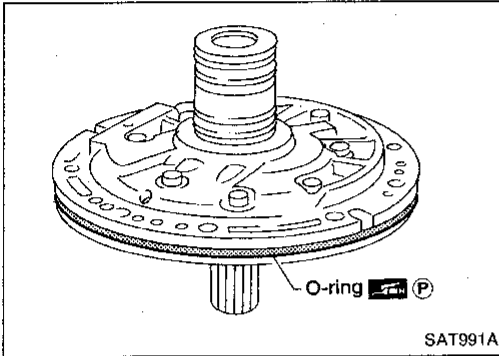

- d. Install O-ring on oil pump assembly.
- **Apply petroleum jelly to O-ring.**

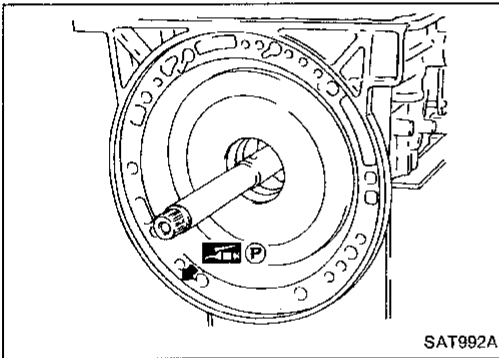

- e. Apply petroleum jelly to mating surface of transmission case and oil pump assembly.

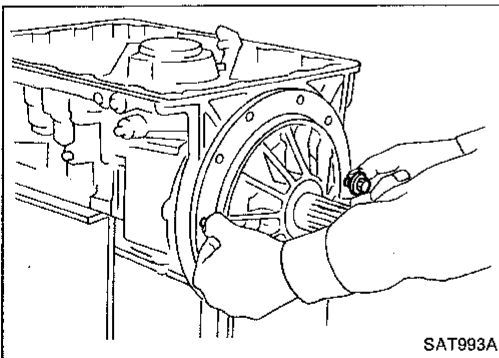

- f. Install oil pump assembly.
- **Install two converter housing securing bolts in bolt holes in oil pump assembly as guides.**

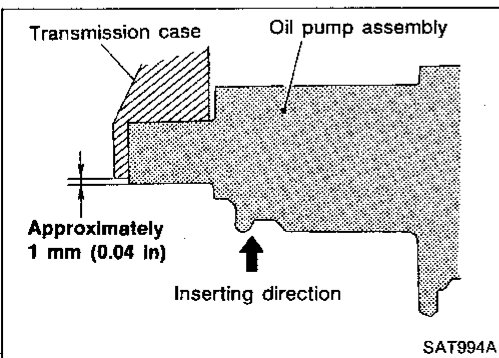

- **Insert oil pump assembly to the specified position in transmission, as shown at left.**

GI

MA

EM

LC

EF &
EC

FE

CL

MT

AT

TF

PD

FA

RA

BR

ST

BF

HA

EL

IDX

ASSEMBLY

Assembly (2) (Cont'd)

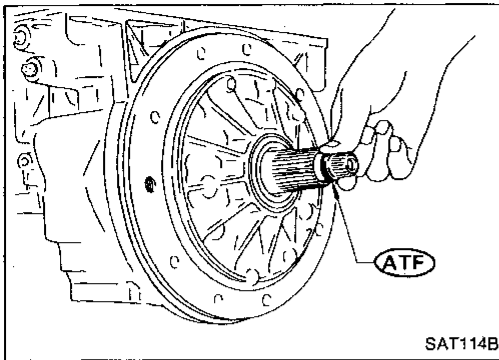

6. Install O-ring on input shaft.
 - **Apply ATF to O-rings.**

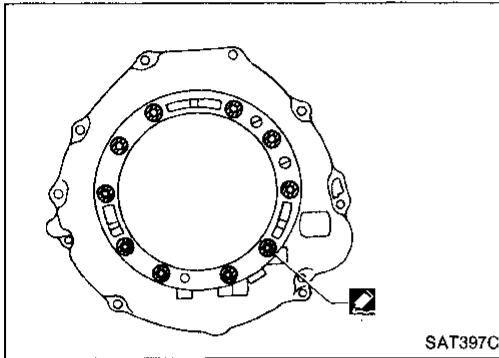

7. Install converter housing.
 - a. Apply recommended sealant (Nissan genuine part: KP610-00250 or equivalent) to outer periphery of bolt holes in converter housing.
 - **Do not apply too much sealant.**

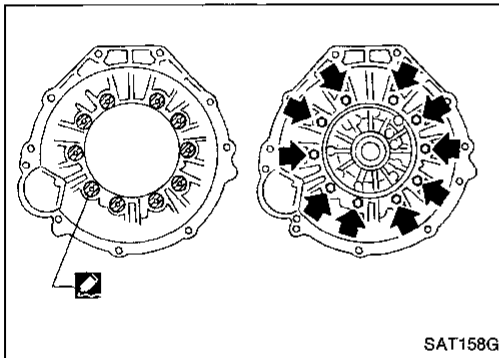

- b. Apply recommended sealant (Nissan genuine part: KP610-00250 or equivalent) to seating surfaces of bolts that secure front of converter housing.
 - c. Install converter housing on transmission case.

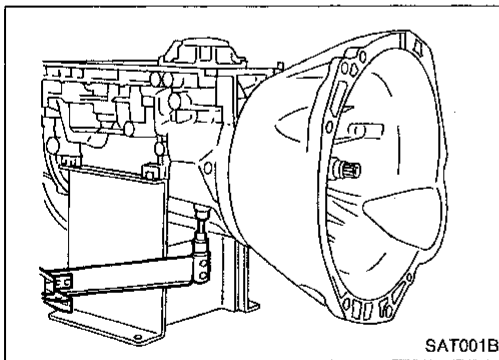

8. Adjust brake band.
 - a. Tighten anchor end bolt to specified torque.
 - ☐: **Anchor end bolt**
4 - 6 N·m
(0.4 - 0.6 kg-m, 2.9 - 4.3 ft-lb)
 - b. Back off anchor end bolt two and a half turns.

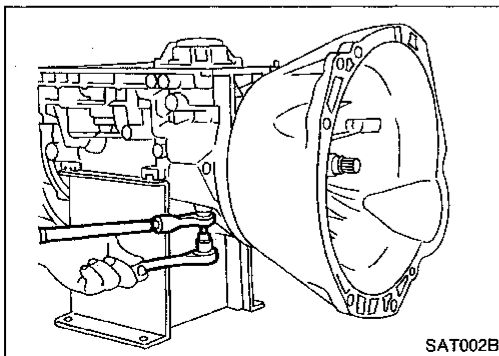

- c. While holding anchor end pin, tighten lock nut.

ASSEMBLY

Assembly (2) (Cont'd)

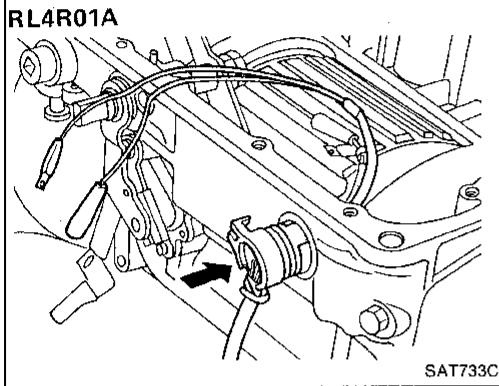
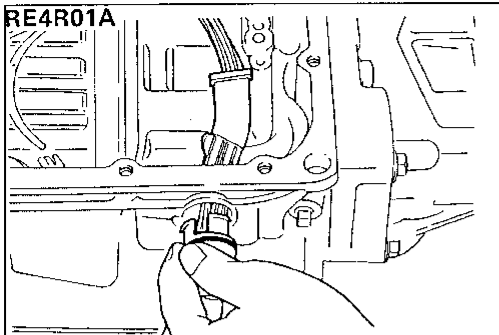

9. Install terminal cord assembly.
 - a. Install O-ring on terminal cord assembly.
 - **Apply petroleum jelly to O-ring.**
 - b. Compress terminal cord assembly stopper and install terminal cord assembly on transmission case.

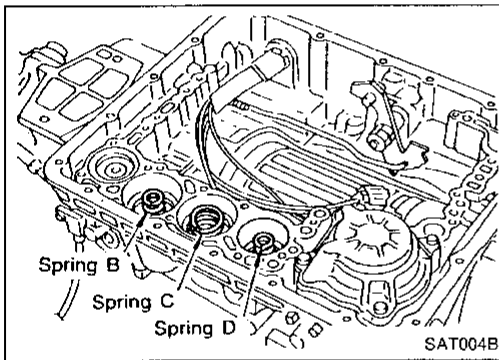

10. Install control valve assembly.
 - a. Install accumulator piston return springs B, C and D.
- Free length of return springs**

Unit: mm (in)

Item	Accumulator		
	B	C	D
Free length	66 (2.60)	45 (1.77)	58.4 (2.299)

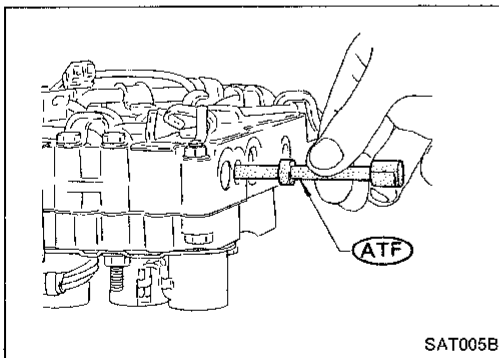

- b. Install manual valve on control valve.
 - **Apply ATF to manual valve.**

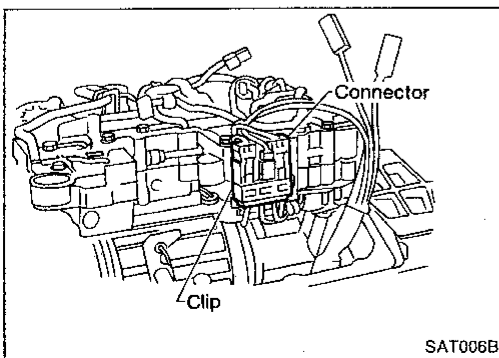

- c. Place control valve assembly on transmission case. Connect solenoid connector for upper body.

— **RE4R01A** —
- d. Install connector clip.

ASSEMBLY

Assembly (2) (Cont'd)

— RE4R01A and RL4R01A —

- e. Install control valve assembly on transmission case.
- f. Install connector tube brackets and tighten bolts **(A)** and **(B)**.

● Check that terminal assembly harness does not catch.

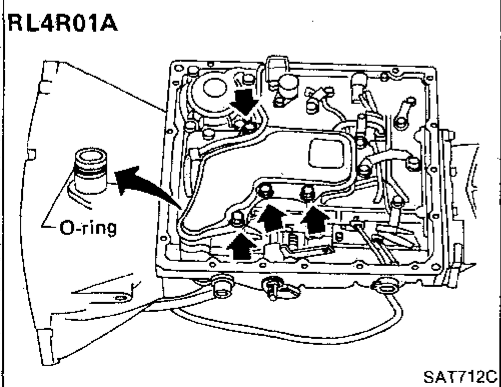
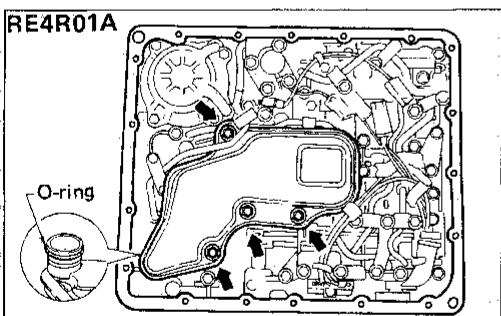
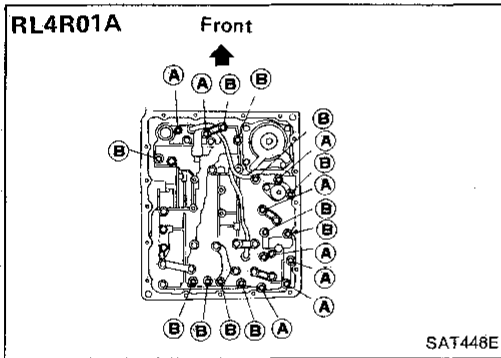
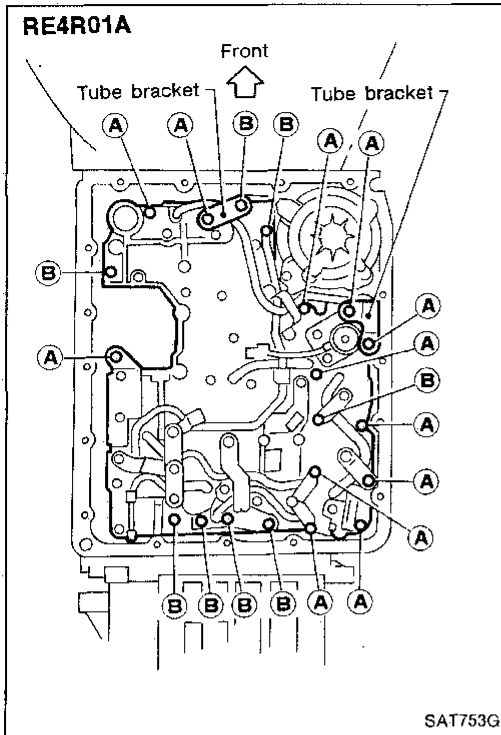

Bolt	ℓ mm (in)	 ℓ
(A)	33 (1.30)	
(B)	45 (1.77)	

- g. Install O-ring on oil strainer.
- Apply petroleum jelly to O-ring.
- h. Install oil strainer on control valve.

ASSEMBLY

Assembly (2) (Cont'd)

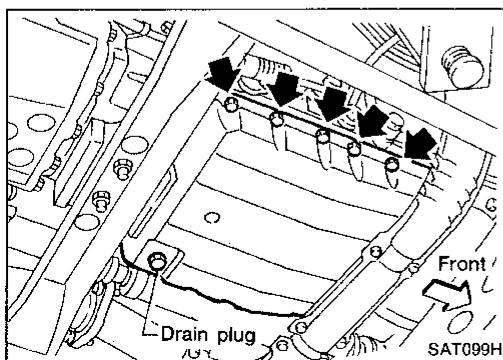
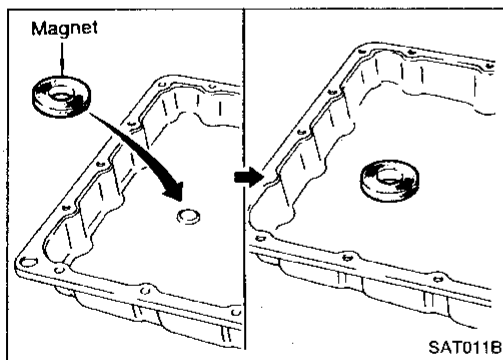
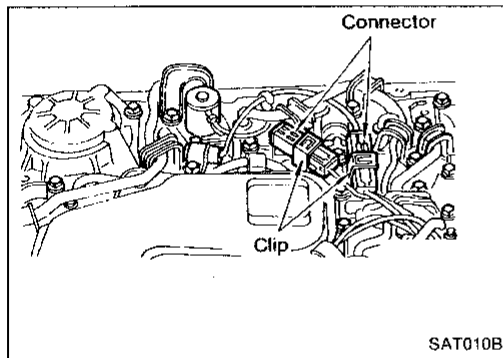
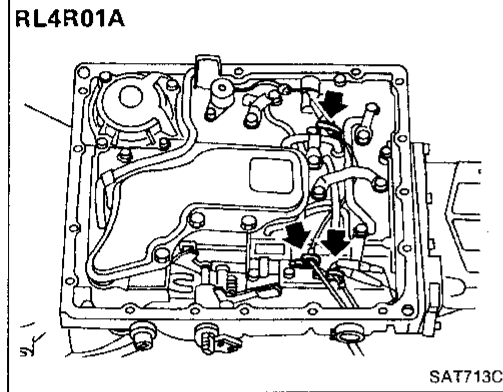
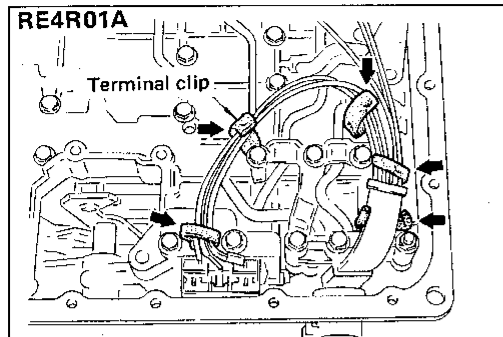

i. Securely fasten terminal harness with clips.

— RE4R01A —

j. Install torque converter clutch solenoid valve and fluid temperature sensor 1 and 2 connectors.

11. Install oil pan.

a. Attach a magnet to oil pan.

b. Install new oil pan gasket on transmission case.

c. Install oil pan and bracket on transmission case.

- Always replace oil pan bolts as they are self-sealing bolts.
- Before installing bolts, remove traces of sealant and oil from mating surface and thread holes.
- Tighten four bolts in a criss-cross pattern to prevent dislocation of gasket.

d. Tighten drain plug.

GI

MA

EM

LC

EF &
EC

FE

CL

— RE4R01A —

j. Install torque converter clutch solenoid valve and fluid temperature sensor 1 and 2 connectors.

MT

AT

TF

PD

FA

RA

BR

ST

b. Install new oil pan gasket on transmission case.

c. Install oil pan and bracket on transmission case.

BF

- Always replace oil pan bolts as they are self-sealing bolts.
- Before installing bolts, remove traces of sealant and oil from mating surface and thread holes.
- Tighten four bolts in a criss-cross pattern to prevent dislocation of gasket.

HA

d. Tighten drain plug.

EL

IDX

ASSEMBLY

Assembly (2) (Cont'd)

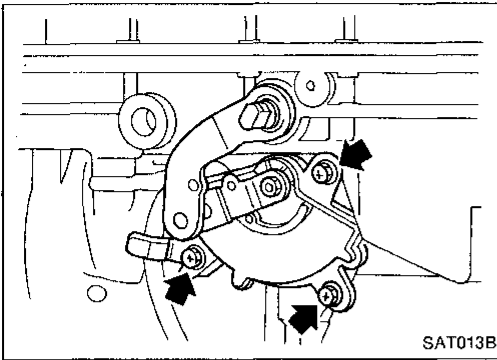

12. Install inhibitor switch.
 - a. Check that manual shaft is in "1" position.
 - b. Temporarily install inhibitor switch on manual shaft.
 - c. Move manual shaft to "N".

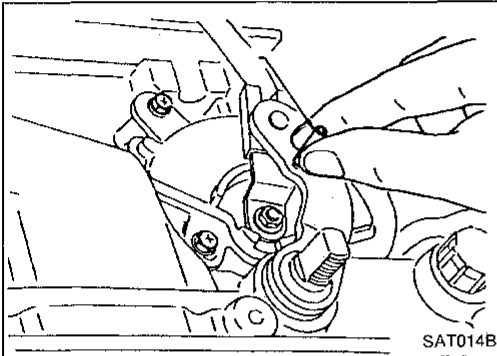

- d. Tighten bolts while inserting 4.0 mm (0.157 in) dia. pin vertically into locating holes in inhibitor switch and manual shaft.

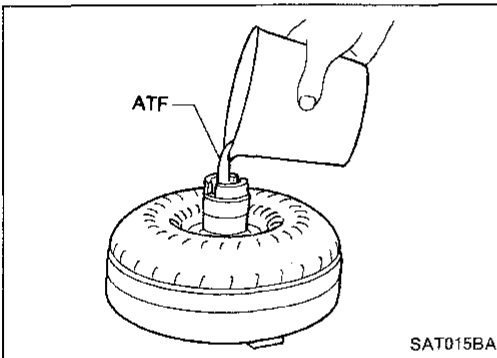

13. Install torque converter.
 - a. Pour ATF into torque converter.
 - **Approximately 2 liters (2-1/8 US qt, 1-3/4 Imp qt) of fluid are required for a new torque converter.**
 - **When reusing old torque converter, add the same amount of fluid as was drained.**

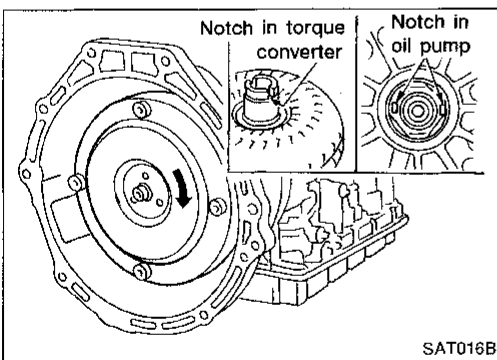

- b. Install torque converter while aligning notches and oil pump.

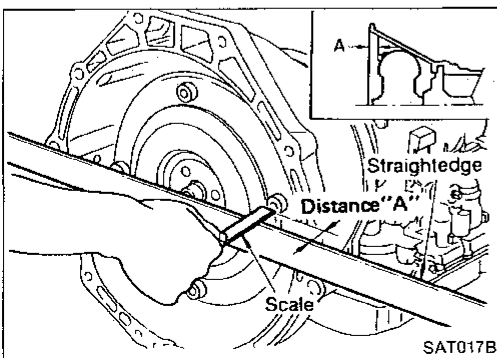

- c. Measure distance A to check that torque converter is in proper position.

Distance "A":

26.0 mm (1.024 in) or more

SERVICE DATA AND SPECIFICATIONS (SDS)

General Specifications

Applied model	KA24E engine		VG30E engine	
	Floor shift	Column shift	2WD	4WD
Automatic transmission model	RL4R01A		RE4R01A	
Transmission model code number	49X02	49X03	45X60	45X72
Stall torque ratio	2.0 : 1			
Transmission gear ratio				
1st	2.785		3.027	
2nd	1.545		1.619	
Top	1.000		1.000	
OD	0.694		0.694	
Reverse	2.272		2.272	
Recommended oil	Genuine Nissan ATF or equivalent type DEXRON™ II			
Oil capacity ℓ (US qt, Imp qt)	7.9 (8-3/8, 7)		8.5 (9, 7-1/2)	

Specifications and Adjustment

VEHICLE SPEED WHEN SHIFTING GEARS

1) KA24E engine

Throttle position	Vehicle speed km/h (MPH)						
	D ₁ → D ₂	D ₂ → D ₃	D ₃ → D ₄	D ₄ → D ₃	D ₃ → D ₂	D ₂ → D ₁	1 ₂ → 1 ₁
Full throttle	53 - 57 (33 - 35)	100 - 108 (62 - 67)	—	147 - 157 (91 - 98)	91 - 99 (57 - 62)	47 - 51 (29 - 32)	41 - 45 (25 - 28)
Half throttle	32 - 36 (20 - 22)	57 - 65 (35 - 40)	114 - 124 (71 - 77)	65 - 75 (40 - 47)	28 - 36 (17 - 22)	12 - 16 (7 - 10)	41 - 45 (25 - 28)

2) VG30E engine 2WD

Throttle position	Vehicle speed km/h (MPH)						
	D ₁ → D ₂	D ₂ → D ₃	D ₃ → D ₄	D ₄ → D ₃	D ₃ → D ₂	D ₂ → D ₁	1 ₂ → 1 ₁
Full throttle	52 - 56 (32 - 35)	99 - 107 (62 - 66)	159 - 169 (99 - 105)	154 - 164 (96 - 102)	91 - 99 (57 - 62)	44 - 48 (27 - 30)	38 - 42 (24 - 26)
Half throttle	32 - 36 (20 - 22)	66 - 72 (41 - 45)	105 - 113 (65 - 70)	69 - 77 (43 - 48)	29 - 35 (18 - 22)	10 - 14 (6 - 9)	38 - 42 (24 - 26)

3) VG30E engine 4WD (Final gear ratio: 4.375)

Throttle position	Vehicle speed km/h (MPH)						
	D ₁ → D ₂	D ₂ → D ₃	D ₃ → D ₄	D ₄ → D ₃	D ₃ → D ₂	D ₂ → D ₁	1 ₂ → 1 ₁
Full throttle	50 - 54 (31 - 34)	97 - 105 (60 - 65)	162 - 172 (101 - 107)	157 - 167 (98 - 104)	92 - 100 (57 - 62)	38 - 42 (24 - 26)	38 - 42 (24 - 26)
Half throttle	32 - 36 (20 - 22)	64 - 70 (40 - 43)	111 - 119 (69 - 74)	65 - 73 (40 - 45)	29 - 35 (18 - 22)	10 - 14 (6 - 9)	38 - 42 (24 - 26)

4) VG30E engine 4WD (Final gear ratio: 4.625)

Throttle position	Vehicle speed km/h (MPH)						
	D ₁ → D ₂	D ₂ → D ₃	D ₃ → D ₄	D ₄ → D ₃	D ₃ → D ₂	D ₂ → D ₁	1 ₂ → 1 ₁
Full throttle	46 - 50 (29 - 31)	90 - 98 (56 - 61)	150 - 160 (93 - 99)	145 - 155 (90 - 96)	86 - 94 (53 - 58)	38 - 42 (24 - 26)	38 - 42 (24 - 26)
Half throttle	30 - 34 (19 - 21)	60 - 66 (37 - 41)	103 - 111 (64 - 69)	60 - 68 (37 - 42)	28 - 34 (17 - 21)	10 - 14 (6 - 9)	38 - 42 (24 - 26)

GI

WA

EM

LC

EF &
EC

FE

CL

MT

AT

TF

PD

FA

RA

BR

ST

BF

HA

EL

IDX

SERVICE DATA AND SPECIFICATIONS (SDS)

Specifications and Adjustment (Cont'd)

VEHICLE SPEED WHEN PERFORMING AND RELEASING LOCK-UP

1) KA24 engine

Throttle position	D ₄	
	Vehicle speed km/h (MPH)	
	Lock-up "ON"	Lock-up "OFF"
Full throttle	—	—
Half throttle	71 - 79 (44 - 49)	71 - 79 (44 - 49)

2) VG30E engine 2WD

Throttle position	OD switch [Shift position]	Vehicle speed km/h (MPH)	
		Lock-up "ON"	Lock-up "OFF"
Full throttle	ON [D ₄]	160 - 168 (99 - 104)	155 - 163 (96 - 101)
	OFF [D ₃]	99 - 107 (62 - 66)	91 - 99 (57 - 62)
Half throttle	ON [D ₄]	101 - 109 (63 - 68)	82 - 90 (51 - 56)
	OFF [D ₃]	76 - 84 (47 - 52)	71 - 79 (44 - 49)

3) VG30E engine 4WD (Final gear ratio: 4.375)

Throttle position	OD switch [Shift position]	Vehicle speed km/h (MPH)	
		Lock-up "ON"	Lock-up "OFF"
		Full throttle	ON [D ₄]
OFF [D ₃]	97 - 105 (60 - 65)		92 - 108 (57 - 67)
Half throttle	ON [D ₄]	110 - 118 (68 - 73)	82 - 90 (51 - 56)
	OFF [D ₃]	76 - 84 (47 - 52)	71 - 79 (44 - 49)

4) VG30E engine 4WD (Final gear ratio: 4.625)

Throttle position	OD switch [Shift position]	Vehicle speed km/h (MPH)	
		Lock-up "ON"	Lock-up "OFF"
Full throttle	ON [D ₄]	151 - 159 (94 - 99)	146 - 154 (91 - 96)
	OFF [D ₃]	90 - 98 (56 - 61)	86 - 94 (53 - 58)
Half throttle	ON [D ₄]	103 - 111 (64 - 69)	83 - 91 (52 - 57)
	OFF [D ₃]	76 - 84 (47 - 52)	71 - 79 (44 - 49)

STALL REVOLUTION

Engine	Stall revolution rpm
KA24E	2,100 - 2,300
VG30E	2,260 - 2,510

LINE PRESSURE

1) VG30E engine

Engine speed rpm	Line pressure kPa (kg/cm ² , psi)	
	D, 2 and 1 positions	R position
Idle	422 - 461 (4.3 - 4.7, 61 - 67)	667 - 706 (6.8 - 7.2, 97 - 102)
Stall	1,020 - 1,098 (10.4 - 11.2, 148 - 159)	1,422 - 1,500 (14.5 - 15.3, 206 - 218)

2) KA24E engine

Engine speed rpm	Line pressure kPa (kg/cm ² , psi)	
	D, 2 and 1 positions	R position
Idle	422 - 461 (4.3 - 4.7, 61 - 67)	667 - 706 (6.8 - 7.2, 97 - 102)
Stall	883 - 961 (9.0 - 9.8, 128 - 139)	1,393 - 1,471 (14.2 - 15.0, 202 - 213)

SERVICE DATA AND SPECIFICATIONS (SDS)

Specifications and Adjustment (Cont'd)

RETURN SPRINGS

1) KA24E engine

Unit: mm (in)

	Parts		Item			
			Part No.	Free length	Outer diameter	
Control valve	4th speed cut valve spring		31756-48X09	23.5 (0.925)	7.0 (0.276)	GI
	Pressure regulator valve spring		31742-48X16	48.5 (1.909)	12.1 (0.476)	MA
	Pressure modifier valve spring		31742-48X13	40.83 (1.6075)	8.0 (0.315)	
	1-2 shift valve spring		31762-48X00	43.4 (1.709)	6.0 (0.236)	EM
	2-3 shift valve spring		31762-48X01	42.7 (1.681)	9.0 (0.354)	
	3-4 shift valve spring		31762-48X06	44.03 (1.7335)	8.0 (0.315)	LC
	Accumulator control valve spring		31742-48X02	29.3 (1.154)	8.0 (0.315)	
	3-2 downshift valve spring		—	—	—	
	2-3 throttle modifier valve spring		31742-41X21	33.0 (1.299)	6.5 (0.256)	EF & EC
	4-2 relay valve spring		31756-41X00	29.1 (1.146)	6.95 (0.2736)	
	Lock-up control valve spring		31742-48X07	20.0 (0.787)	5.45 (0.2146)	FE
	Throttle valve & detent valve spring		31802-48X02	34.23 (1.3476)	11.0 (0.433)	
	Kickdown modifier valve spring		31756-48X01	45.3 (1.783)	7.0 (0.276)	CL
	1st reducing valve spring		31756-48X08	29.7 (1.169)	7.2 (0.283)	
	Overrun clutch reducing valve spring		31742-48X04	45.0 (1.772)	7.45 (0.2933)	
			31742-48X05	31.0 (1.220)	5.2 (0.205)	MT
	3-2 timing valve spring		31742-48X15	23.0 (0.906)	7.0 (0.276)	
Torque converter relief valve spring		31742-41X23	38.0 (1.496)	9.0 (0.354)	AT	
4-2 sequence valve spring		31756-41X00	29.1 (1.146)	6.95 (0.2736)		
Governor valve	Governor valve spring	Primary	31742-48X11	19.1 (0.752)	9.05 (0.3563)	TF
		Secondary ①	31742-48X09	30.58 (1.2039)	9.2 (0.362)	
		Secondary ②	31742-48X10	16.79 (0.6610)	9.0 (0.354)	
Reverse clutch	16 pcs	31505-41X02	19.69 (0.7752)	11.6 (0.457)	PD	
High clutch	16 pcs	31505-21X03	22.06 (0.8685)	11.6 (0.457)		
Forward clutch (Overrun clutch)	20 pcs	31505-41X01	35.77 (1.4083)	9.7 (0.382)	FA	
Low & reverse brake	18 pcs	31521-21X00	23.7 (0.933)	11.6 (0.457)	RA	
Band servo	Spring A		31605-41X05	45.6 (1.795)	34.3 (1.350)	
	Spring B		31605-41X00	53.8 (2.118)	40.3 (1.587)	BR
	Spring C		31605-41X01	29.7 (1.169)	27.6 (1.087)	
Accumulator	Accumulator A		31605-41X02	43.0 (1.693)	—	
	Accumulator B		31605-41X10	66.0 (2.598)	—	ST
	Accumulator C		31605-41X09	45.0 (1.772)	—	
	Accumulator D		31605-41X06	58.4 (2.299)	—	BF

SERVICE DATA AND SPECIFICATIONS (SDS)

Specifications and Adjustment (Cont'd)

2) VG30E engine

Unit: mm (in)

Parts		Item			
		Part No.	Free length	Outer diameter	
Control valve	Upper body	Torque converter relief valve spring	31742-41X23	38.0 (1.496)	9.0 (0.354)
		Pressure regulator valve spring	31742-41X24	44.02 (1.7331)	14.0 (0.551)
		Pressure modifier valve spring	31742-41X19	31.95 (1.2579)	6.8 (0.268)
		Accumulator control valve spring	—	—	—
		Shuttle shift valve D spring	31762-41X00	26.5 (1.043)	6.0 (0.236)
		4-2 sequence valve spring	31756-41X00	29.1 (1.146)	6.95 (0.2736)
		Shift valve B spring	31762-41X01	25.0 (0.984)	7.0 (0.276)
		4-2 relay valve spring	31756-41X00	29.1 (1.146)	6.95 (0.2736)
		Shift valve A spring	31762-41X01	25.0 (0.984)	7.0 (0.276)
		Overrun clutch control valve spring	31762-41X03	23.6 (0.929)	7.0 (0.276)
		Overrun clutch reducing valve spring	31742-41X20	32.5 (1.280)	7.0 (0.276)
		Shuttle shift valve S spring	31762-41X04	51.0 (2.008)	5.65 (0.2224)
		Pilot valve spring	31742-41X13	25.7 (1.012)	9.1 (0.358)
		Lock-up control valve spring	31742-41X22	18.5 (0.728)	13.0 (0.512)
	Lower body	Modifier accumulator valve spring	31742-27X70	31.4 (1.236)	9.8 (0.386)
		1st reducing valve spring	31756-41X05	25.4 (1.000)	6.75 (0.2657)
		3-2 timing valve spring	31742-41X08	20.55 (0.8091)	6.75 (0.2657)
Servo charger valve spring		31742-41X06	23.0 (0.906)	6.7 (0.264)	
Reverse clutch	16 pcs	31505-41X02	19.69 (0.7752)	11.6 (0.457)	
High clutch	16 pcs	31505-21X03	22.06 (0.8685)	11.6 (0.457)	
Forward clutch (Overrun clutch)	20 pcs	31505-41X01	35.77 (1.4083)	9.7 (0.382)	
Low & reverse brake	18 pcs	31521-21X00	23.7 (0.933)	11.6 (0.457)	
Band servo	Spring A	31605-41X05	45.6 (1.795)	34.3 (1.350)	
	Spring B	31605-41X00	53.8 (2.118)	40.3 (1.587)	
	Spring C	31605-41X01	29.7 (1.169)	27.6 (1.087)	
Accumulator	Accumulator A	31605-41X02	43.0 (1.693)	—	
	Accumulator B	31605-41X10	66.0 (2.598)	—	
	Accumulator C	31605-41X09	45.0 (1.772)	—	
	Accumulator D	31605-41X06	58.4 (2.299)	—	

ACCUMULATOR O-RING

Accumulator	Diameter mm (in)			
	A	B	C	D
Small diameter end	29 (1.14)	32 (1.26)	45 (1.77)	29 (1.14)
Large diameter end	45 (1.77)	50 (1.97)	50 (1.97)	45 (1.77)

SERVICE DATA AND SPECIFICATIONS (SDS)

Specifications and Adjustment (Cont'd)

CLUTCHES AND BRAKES

Code number	49X02	49X03	45X60	45X72	
1. Reverse clutch					
Number of drive plates				2	
Number of driven plates				2	
Thickness of drive plate mm (in)	Standard	1.90 - 2.05 (0.0748 - 0.0807)			
	Wear limit	1.80 (0.0709)			
Clearance mm (in)	Standard	0.5 - 0.8 (0.020 - 0.031)			
	Allowable limit	1.2 (0.047)			
Thickness of retaining plate	Thickness mm (in)		Part number		
	4.6 (0.181)		31537-42X01		
	4.8 (0.189)		31537-42X02		
	5.0 (0.197)		31537-42X03		
	5.2 (0.205)		31537-42X04		
	5.4 (0.213)		31537-42X05		
	5.6 (0.220)		31537-42X06		
	5.8 (0.228)		31537-42X07		
2. High clutch					
Number of drive plates	4		5		
Number of driven plates	4		5		
Thickness of drive plate mm (in)	Standard	1.52 - 1.67 (0.0598 - 0.0657)			
	Wear limit	1.40 (0.0551)			
Clearance mm (in)	Standard	1.8 - 2.2 (0.071 - 0.087)			
	Allowable limit	2.8 (0.110)			
Thickness of retaining plate	Thickness mm (in)		Part number	Thickness mm (in)	Part number
	3.6 (0.142)		31537-41X61	3.4 (0.134)	31537-41X71
	3.8 (0.150)		31537-41X62	3.6 (0.142)	31537-41X61
	4.0 (0.157)		31537-41X63	3.8 (0.150)	31537-41X62
	4.2 (0.165)		31537-41X64	4.0 (0.157)	31537-41X63
	4.4 (0.173)		31537-41X65	4.2 (0.165)	31537-41X64
	4.6 (0.181)		31537-41X66	4.4 (0.173)	31537-41X65
	4.8 (0.189)		31537-41X67	4.6 (0.181)	31537-41X66
	5.0 (0.197)		31537-41X68	4.8 (0.189)	31537-41X67
3. Forward clutch					
Number of drive plates	5		7		
Number of driven plates	5		7		
Thickness of drive plate mm (in)	Standard	1.90 - 2.05 (0.0748 - 0.0807)			
	Wear limit	1.80 (0.0709)			
Clearance mm (in)	Standard	0.45 - 0.85 (0.0177 - 0.0335)			
	Allowable limit	1.85 (0.0728)		2.25 (0.0886)	
Thickness of retaining plate	Thickness mm (in)		Part number	Thickness mm (in)	Part number
	8.0 (0.315)		31537-41X00	4.0 (0.157)	31537-41X07
	8.2 (0.323)		31537-41X01	4.2 (0.165)	31537-41X08
	8.4 (0.331)		31537-41X02	4.4 (0.173)	31537-41X09
	8.6 (0.339)		31537-41X03	4.6 (0.181)	31537-41X10
	8.8 (0.346)		31537-41X04	4.8 (0.189)	31537-41X11
	9.0 (0.354)		31537-41X05	5.0 (0.197)	31537-41X12
	9.2 (0.362)		31537-41X06	5.2 (0.205)	31537-41X13

GI
MA
EM
LC
EF & EC
FE
CL
MT
AT
TF
PD
FA
RA
BR
ST
BF
HA
EL

SERVICE DATA AND SPECIFICATIONS (SDS)

Specifications and Adjustment (Cont'd)

Code number	49X02	49X03	45X60	45X72
4. Overrun clutch				
Number of drive plates	3			
Number of driven plates	5			
Thickness of drive plate mm (in)	Standard	1.90 - 2.05 (0.0748 - 0.0807)		
	Wear limit	1.80 (0.0709)		
Clearance mm (in)	Standard	1.0 - 1.4 (0.039 - 0.055)		
	Allowable limit	2.0 (0.079)		
Thickness of retaining plate	Thickness mm (in)		Part number	
	4.0 (0.157)		31537-41X79	
	4.2 (0.165)		31537-41X80	
	4.4 (0.173)		31537-41X81	
	4.6 (0.181)		31537-41X82	
	4.8 (0.189)		31537-41X83	
	5.0 (0.197)		31537-41X84	
5.2 (0.205)		31537-41X20		
<hr/>				
Code number	45X72	45X60	49X02	49X03
5. Low & reverse brake				
Number of drive plates	6			
Number of driven plates	6			
Thickness of drive plate mm (in)	Standard	1.90 - 2.05 (0.0748 - 0.0807)		
	Wear limit	1.80 (0.0709)		
Clearance mm (in)	Standard	0.7 - 1.1 (0.028 - 0.043)		
	Allowable limit	2.3 (0.091)		
Thickness of retaining plate	Thickness mm (in)	Part number	Thickness mm (in)	Part number
	8.6 (0.339)	31667-41X03	9.0 (0.354)	31667-41X05
	8.8 (0.346)	31667-41X04	9.2 (0.362)	31667-41X06
	9.0 (0.354)	31667-41X05	9.4 (0.370)	31667-41X09
	9.2 (0.362)	31667-41X06	9.6 (0.378)	31667-41X10
	9.4 (0.370)	31667-41X09	9.8 (0.386)	31667-41X18
	9.6 (0.378)	31667-41X10	10.0 (0.394)	31667-41X19
<hr/>				
6. Brake band				
Anchor end bolt tightening torque N-m (kg-m, ft-lb)	4 - 6 (0.4 - 0.6, 2.9 - 4.3)			
Number of returning revolution for anchor end bolt	2.5			

SERVICE DATA AND SPECIFICATIONS (SDS)

Specifications and Adjustment (Cont'd)

OIL PUMP AND LOW ONE-WAY CLUTCH

Oil pump clearance	mm (in)	
Cam ring — oil pump housing		
Standard		0.01 - 0.024 (0.0004 - 0.0009)
Rotor, vanes and control piston — oil pump housing		
Standard		0.03 - 0.044 (0.0012 - 0.0017)
Seal ring clearance	mm (in)	
Standard		0.10 - 0.25 (0.0039 - 0.0098)
Allowable limit		0.25 (0.0098)

TOTAL END PLAY

Total end play "T ₁ "	0.25 - 0.55 mm (0.0098 - 0.0217 in)	
	Thickness mm (in)	Part number
Thickness of oil pump cover bearing race	0.8 (0.031)	31429-21X00
	1.0 (0.039)	31429-21X01
	1.2 (0.047)	31429-21X02
	1.4 (0.055)	31429-21X03
	1.6 (0.063)	31429-21X04
	1.8 (0.071)	31429-21X05
	2.0 (0.079)	31429-21X06

OIL DISTRIBUTOR (KA24E engine)

Seal ring — ring groove	mm (in)	
Standard		0.15 - 0.40 (0.0059 - 0.0157)
Allowable limit		0.40 (0.0157)

REVERSE CLUTCH DRUM END PLAY

Reverse clutch drum end play "T ₂ "	0.55 - 0.90 mm (0.0217 - 0.0354 in)	
	Thickness mm (in)	Part number
Thickness of oil pump thrust washer	0.7 (0.028)	31528-21X00
	0.9 (0.035)	31528-21X01
	1.1 (0.043)	31528-21X02
	1.3 (0.051)	31528-21X03
	1.5 (0.059)	31528-21X04
	1.7 (0.067)	31528-21X05
	1.9 (0.075)	31528-21X06

REMOVAL AND INSTALLATION

Manual control linkage	
Number of returning revolutions for lock nut	
Column shift	2
Floor shift	1
Lock nut tightening torque N·m (kg-m, ft-lb)	
2WD	29 - 39 (3.0 - 4.0, 22 - 29)
4WD	29 - 39 (3.0 - 4.0, 22 - 29)
Distance between end of clutch housing and torque converter mm (in)	
2WD	23.5 (0.925)
4WD	26.0 (1.024) or more
Drive plate runout limit	mm (in)
	0.5 (0.020)

GI

MA

EM

LC

EF &
EC

FE

CL

MT

AT

TF

PD

FA

RA

BR

ST

BF

HA

EL

IDX