

STEERING SYSTEM

SECTION **ST**

GI

MA

EM

LC

EF &
EC

CONTENTS

PRECAUTIONS AND PREPARATION	2	POWER STEERING GEAR (Model: PB59K)	18	FE
Precautions.....	2	Removal.....	18	
Special Service Tools.....	2	Power Steering Gear Component.....	18	
Commercial Service Tool.....	3	Inspection and Adjustment.....	19	CL
ON-VEHICLE SERVICE	4	Disassembly.....	20	
Steering System.....	4	Assembly.....	21	MT
Checking Steering Wheel Play.....	4	POWER STEERING SYSTEM (Model: PB48S)	24	
Checking Neutral Position on Steering Wheel.....	4	Description	24	
Checking Front Wheel Turning Angle.....	5	POWER STEERING GEAR (Model: PB48S)	25	AT
Checking and Adjusting Drive Belts.....	5	Removal.....	25	
Checking Fluid Level (Power steering)	5	Power Steering Gear Component.....	25	
Checking Fluid Leakage (Power steering)	5	Inspection and Adjustment.....	26	TF
Bleeding Hydraulic System (Power steering)	6	Disassembly.....	27	
Checking Steering Wheel Turning Torque		Assembly.....	29	PD
(Power steering).....	6	POWER STEERING OIL PUMP	32	
Checking Hydraulic System (Power steering).....	7	Disassembly and Assembly	32	
STEERING WHEEL AND STEERING COLUMN	8	Pre-disassembly Inspection	32	FA
Removal and Installation.....	8	Disassembly.....	33	
Disassembly and Assembly	9	Inspection	33	
Inspection	10	Assembly.....	34	RA
MANUAL STEERING GEAR (Model: VB66K)	11	STEERING LINKAGE	35	
Removal and Installation.....	11	Removal and Installation.....	35	
Disassembly	12	Disassembly.....	36	BR
Assembly and Adjustment.....	12	Inspection	37	
Inspection	15	SERVICE DATA AND SPECIFICATIONS (SDS)	38	ST
POWER STEERING SYSTEM (Model: PB59K)	17	General Specifications.....	38	
Description	17	Inspection and Adjustment.....	38	

BF

HA

EL

IDX



PRECAUTIONS AND PREPARATION

Precautions

- Before disassembly, thoroughly clean the outside of the unit.
- Disassembly should be done in a clean work area. It is important to prevent the internal parts from becoming contaminated by dirt or other foreign matter.
- When disassembling parts, be sure to place them in order on a part rack so they can be reinstalled in their proper positions.
- Use nylon cloths or paper towels to clean the parts; common shop rags can leave lint that might interfere with their operation.
- Before inspection or reassembly, carefully clean all parts with a general purpose, non-flammable solvent.
- Before assembly, apply a coat of recommended ATF* to hydraulic parts. Vaseline may be applied to O-rings and seals. Do not use any grease.
- Replace all gaskets, seals and O-rings. Avoid damaging O-rings, seals and gaskets during installation. Perform functional tests whenever designated.

*: Automatic transmission fluid

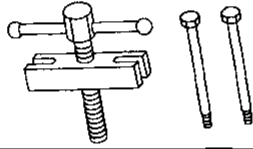
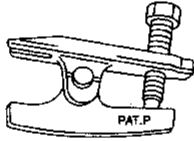
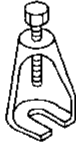
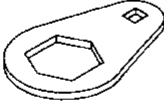
Special Service Tools

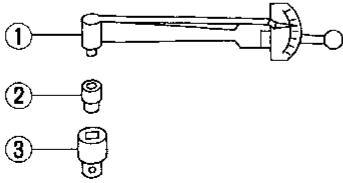
Tool number (Kent-Moore No.) Tool name	Description	Unit application		
		Manual steering	Power steering	
ST27180001 (J25726-A) Steering wheel puller	 NT170	Removing steering wheel	X	X
HT72520000 (J25730-A) Ball joint remover	 NT146	Removing ball joint and swivel joint	X	X
ST29020001 (J24319-01) Steering gear arm puller	 NT143	Removing pitman arm	X	X
KV48101500 (J28802) Lock nut wrench	 NT171		X	—
KV48101400 (J28803) Adjusting plug wrench	 NT172	Adjusting and tightening lock nut	X	—
ST3127S000 (See J25765-A) ① GG91030000 (J25765-A) Torque wrench ② HT62940000 (—) Socket adapter ③ HT62900000 (—) Socket adapter	 NT124	Measuring turning torque	X	X

PRECAUTIONS AND PREPARATION

Special Service Tools (Cont'd)

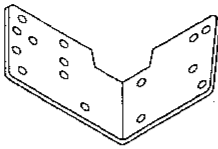
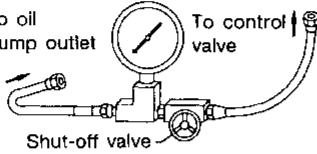
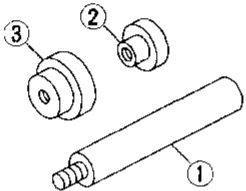
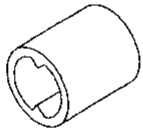
Tool number (Kent-Moore No.) Tool name	Description	Unit application	
		Manual steering	Power steering
KV48100301 (—) Strut & steering gear-box attachment	 Steering gear is installed.	X	X
ST27091000* (J26357) Pressure gauge	 Measuring oil pressure	—	X
KV481009S0 (—) Oil seal drift set ① KV48100910 (—) Drift ② KV48100920 (J26367) Adapter ③ KV48100930 (J26367) Adapter	 Installing oil seal	—	X
KV48100700 (J26364) Torque adapter	 Adjusting worm bearing preload	X	X

Commercial Service Tool

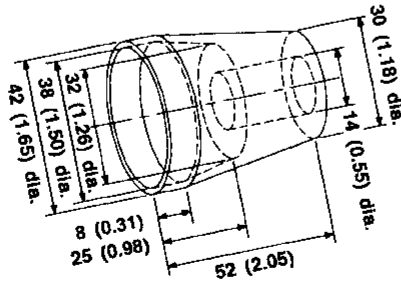
Tool name	Description	Unit application	
		Manual steering	Power steering
Boot band attachment	 Installing boot band Unit: mm (in)	X	X

Steering System

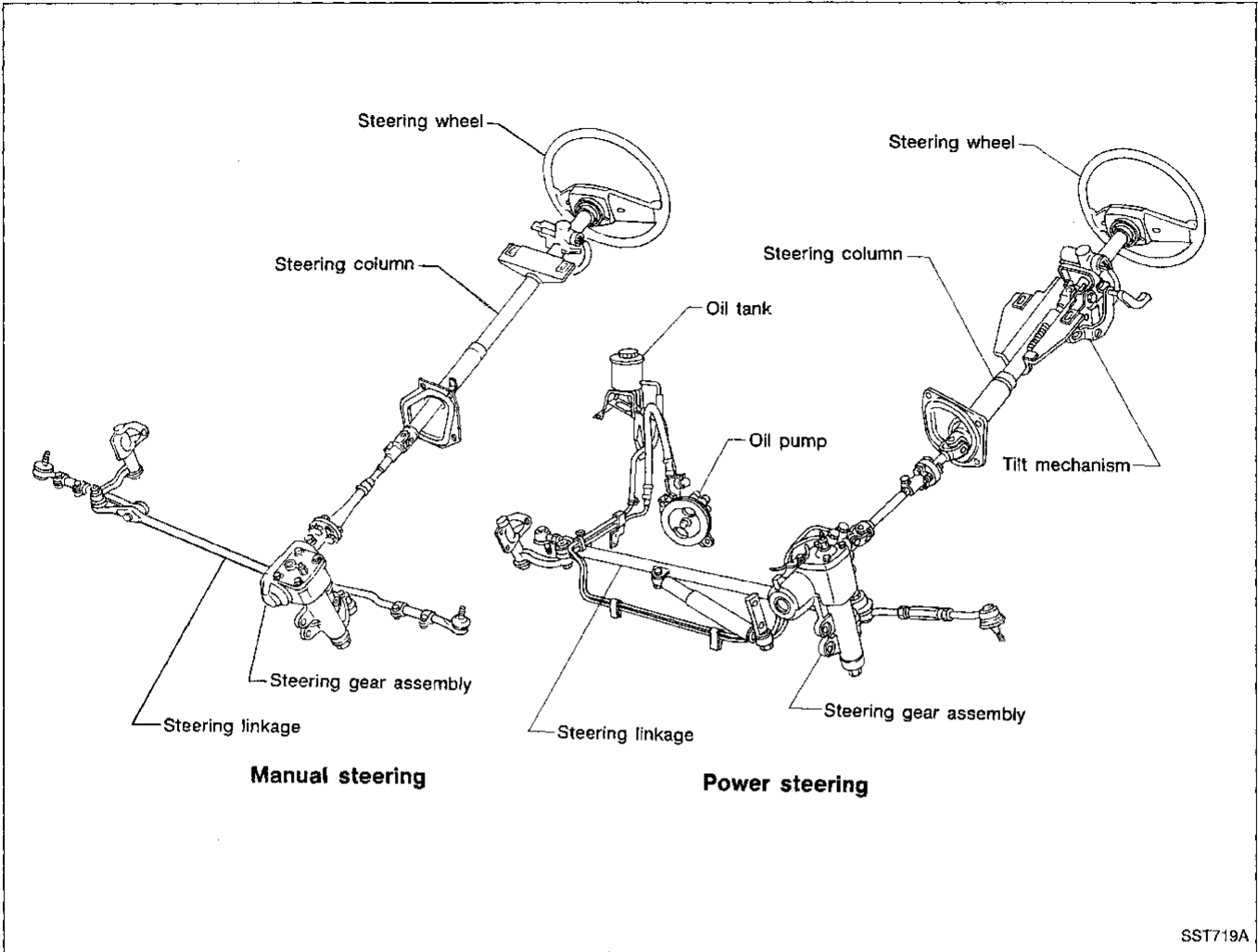

SST719A

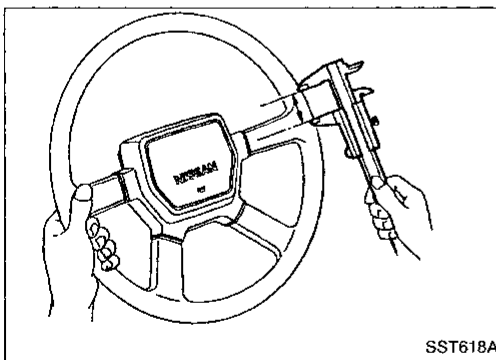

SST618A

Checking Steering Wheel Play

- With wheels in a straight ahead position and check steering wheel play.

Steering wheel play:

35 mm (1.38 in) or less

- If it is not within specification, check backlash of steering gear, tie-rod outer and inner ball joints.

Checking Neutral Position on Steering Wheel
Pre-checking

- Verify that the steering gear is centered before removing the steering wheel.

Checking

- Check that the steering wheel is in the neutral position when driving straight ahead.
- If it is not in the neutral position, remove the steering wheel and reinstall it correctly in the neutral position.
- If the neutral position is between two serrated teeth, loosen tie-rod lock nut and move tie-rod in the opposite direction by the same amount on both left and right sides to compensate for error in the neutral position.

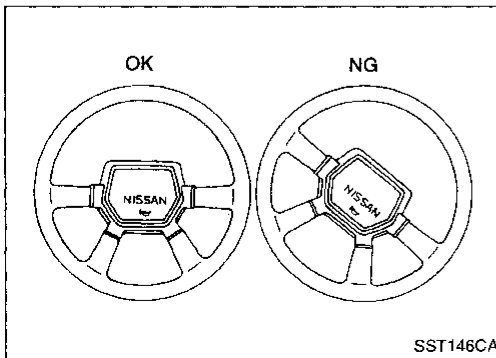

SST146CA

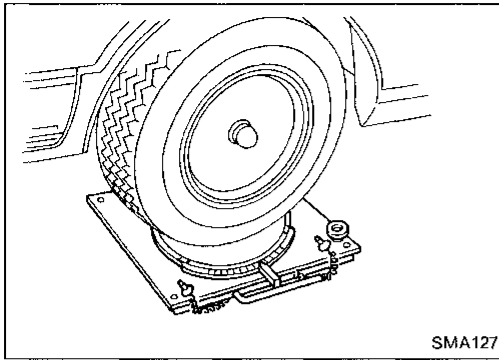

Checking Front Wheel Turning Angle

- Rotate steering wheel all the way right and left; measure turning angle.

Turning angle:

Refer to SDS in FA section.

Checking and Adjusting Drive Belts (Power steering)

- Refer to Drive Belt Inspection in MA section.

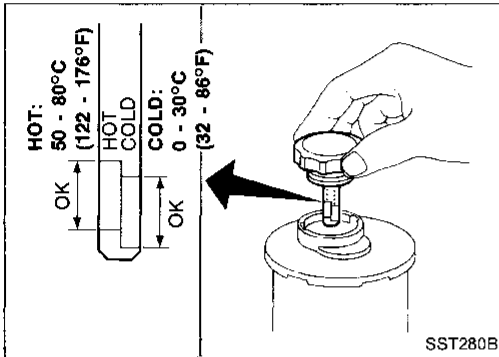

Checking Fluid Level (Power steering)

Check fluid level.

Fluid level should be checked using "HOT" range on dipstick at fluid temperatures of 50 to 80°C (122 to 176°F) or using "COLD" range on dipstick at fluid temperatures of 0 to 30°C (32 to 86°F).

CAUTION:

- Do not overfill.
- Recommended fluid is Automatic Transmission Fluid "DEXRON™ II" type or equivalent.

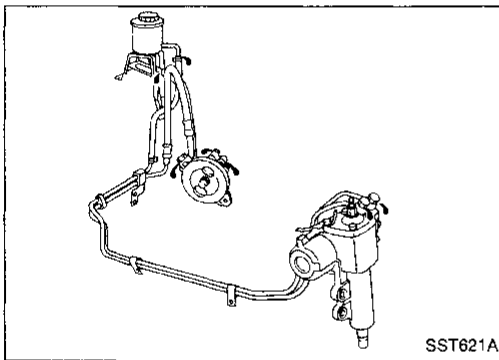

Checking Fluid Leakage (Power steering)

Check lines for proper attachment, cracks, damage, loose connections, chafing and deterioration.

1. Run engine at idle speed or 1,000 rpm.

Make sure temperature of fluid in oil tank rises to 60 to 80°C (140 to 176°F).

2. Turn steering wheel right-to-left several times.
3. Hold steering wheel at each "lock" position for five seconds and carefully check for fluid leakage.

CAUTION:

Do not hold steering wheel at lock position for more than fifteen seconds at a time.

4. If fluid leakage at connectors is noticed, loosen flare nut and then retighten.

Do not overtighten connector as this can damage O-ring, washer and connector.

GI

MA

EM

LC

EF & EC

FE

CL

MT

AT

TF

PD

FA

RA

BR

ST

BF

HA

EL

IDX

Bleeding Hydraulic System (Power steering)

1. Raise front end of vehicle until wheels clear ground.
2. While adding fluid, quickly turn steering wheel fully to right and left until it lightly touches steering stoppers.

CAUTION:

Do not hold steering wheel in lock position for more than fifteen seconds.

Repeat steering wheel operation until fluid level no longer decreases.

3. Start engine.
Repeat step 2 above.
- Incomplete air bleeding will cause the following to occur.
When this happens, bleed air again.
 - ① Generation of air bubbles in reservoir tank
 - ② Generation of clicking noise in oil pump
 - ③ Excessive buzzing in oil pump

In steering while the vehicle is stationary, or when moving wheel slowly, fluid noise may be caused in the valve or oil pump. This type of fluid noise is inherent in an integral power steering system, and it will not affect performance or durability of the system.

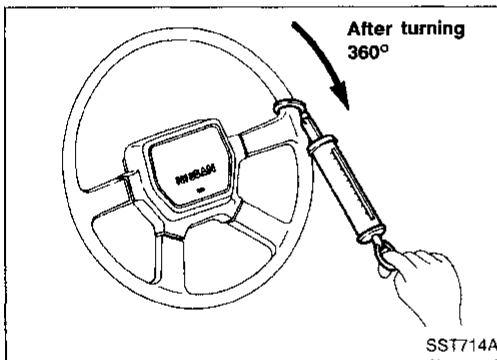

Checking Steering Wheel Turning Torque (Power steering)

1. Park vehicle on a level, dry surface and set parking brake.
2. Bring power steering fluid up to adequate operating temperature. [Make sure temperature of fluid is approximately 60 to 80°C (140 to 176°F).]

Tires need to be inflated to normal pressure.

3. Check steering wheel turning force when steering wheel has been turned 360° from neutral position.

Steering wheel turning force:

PB48S-type

24.5 - 29.4 N (2.5 - 3.0 kg, 5.5 - 6.6 lb)

PB59K-type

39 N (4 kg, 9 lb) or less

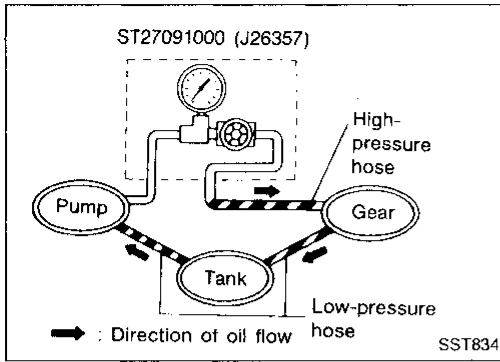

Checking Hydraulic System (Power steering)

Before starting, check belt tension, driving pulley and tire pressure.

1. Set Tool. Open shut-off valve. Then bleed air. (See "Bleeding Hydraulic System".)
2. Run engine.

Make sure temperature of fluid in tank rises to 60 to 80°C (140 to 176°F).

WARNING:

Warm up engine with shut-off valve fully opened. If engine is started with shut-off valve closed, oil pressure in oil pump will increase to relief pressure, resulting in an abnormal rise in oil temperature.

3. Check pressure with steering wheel fully turned to left and right positions.

CAUTION:

Do not hold the steering wheel at lock position for more than fifteen seconds.

Oil pump standard pressure:

7,649 - 8,238 kPa

(78 - 84 kg/cm², 1,109 - 1,194 psi) at idling

4. If oil pressure is below the standard, slowly close shut-off valve and check pressure.
 - When pressure becomes standard, gear is damaged.
 - When pressure remains beyond standard, pump is damaged.
5. If oil pressure is higher than the standard level, pump is damaged.

CAUTION:

Do not close shut-off valve for more than fifteen seconds.

6. After checking hydraulic system, remove Tool and add fluid as necessary, then completely bleed air out of system.

GF

MA

EM

LC

EF &

EC

FE

CL

MT

AT

TF

PD

FA

RA

BR

ST

BF

HA

EL

IDX

STEERING WHEEL AND STEERING COLUMN

Removal and Installation

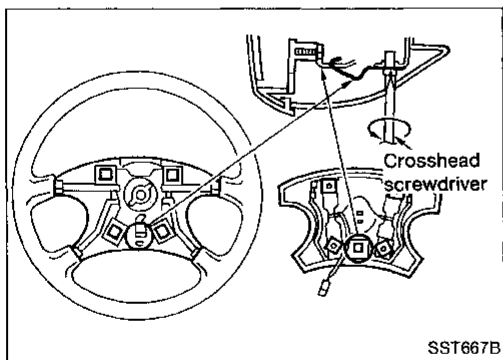
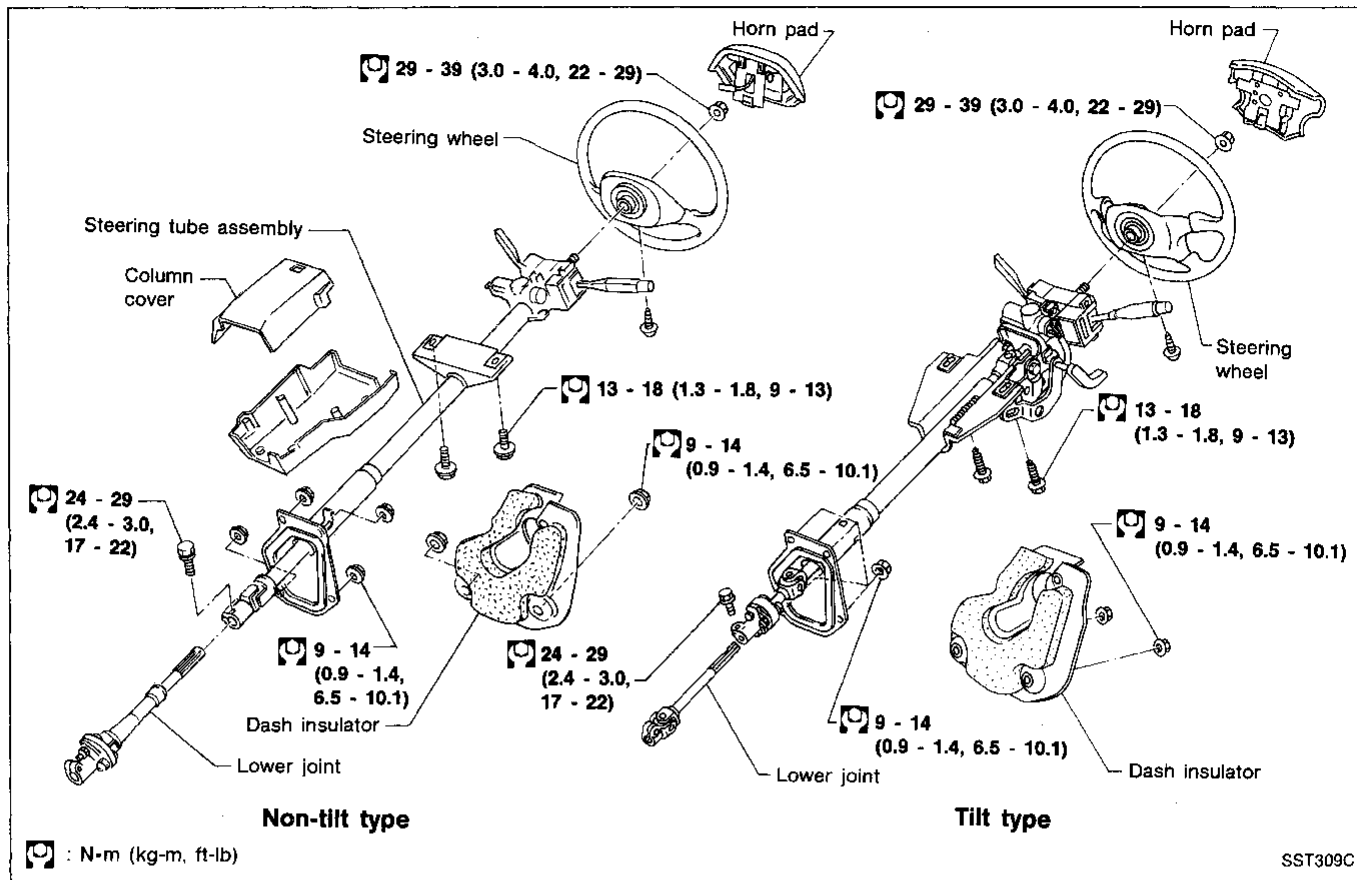

STEERING WHEEL

1. Remove horn pad.
 - Insert a crosshead screwdriver into hole on lower side of spoke and remove screw and clamps. Lift horn pad off by hand.

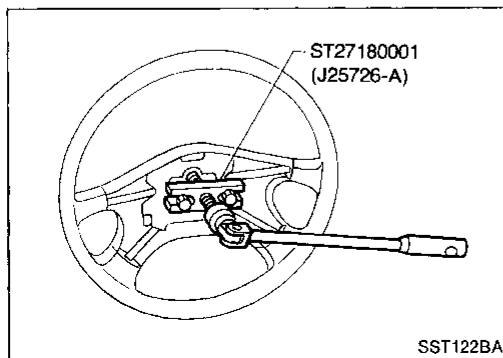

2. Remove steering wheel with Tool.

STEERING WHEEL AND STEERING COLUMN

Removal and Installation (Cont'd)

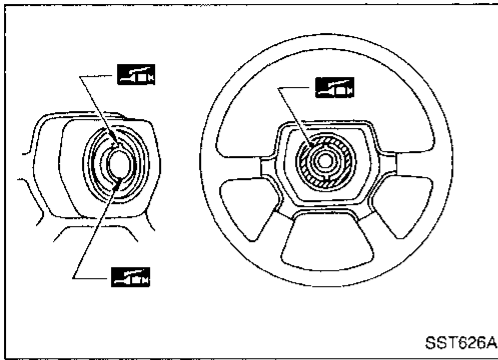

SST626A

- When installing steering wheel, apply multi-purpose grease to entire surface of turn signal cancel pin (both portions) and also to horn contact slip ring.
- Install steering wheel on column shaft in a straight-ahead position.
- After installing, turn steering wheel to make sure it moves smoothly and that the number of turns from the straight forward position to left and right locks are equal.

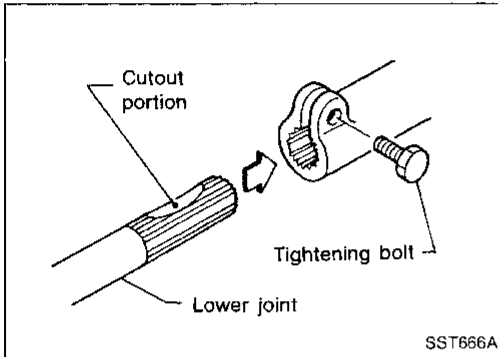

SST666A

STEERING COLUMN

- When installing steering column, finger-tighten all lower bracket and clamp retaining bolts; then tighten them securely. Make sure that undue stress is not applied to steering column.
- When fitting steering lower joint, be sure tightening bolt faces cutout portion perfectly.

Disassembly and Assembly

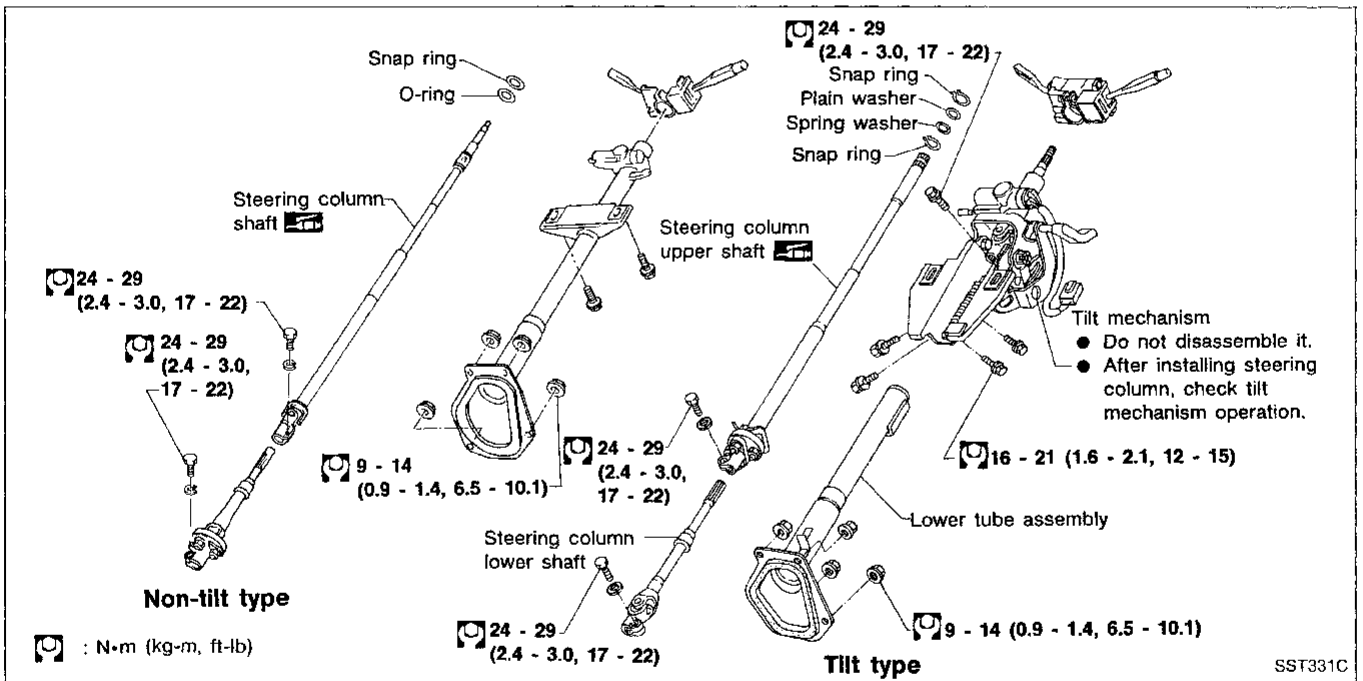

SST331C

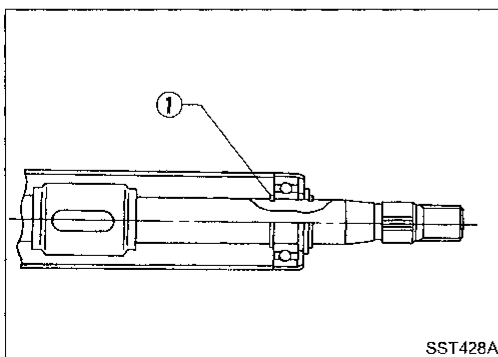

SST428A

- When disassembling and assembling, unlock steering lock with key.
- Ensure that rounded surface of snap ring faces toward bearing when snap ring is installed.
- Install snap ring ① before inserting shaft into jacket tube.

GI
MA
EM
LC
EF & EC
FE
CL
MT
AT
TF
PD
FA
RA
BR
ST
BF
HA
EL
FDX
1035

STEERING WHEEL AND STEERING COLUMN

Disassembly and Assembly (Cont'd)

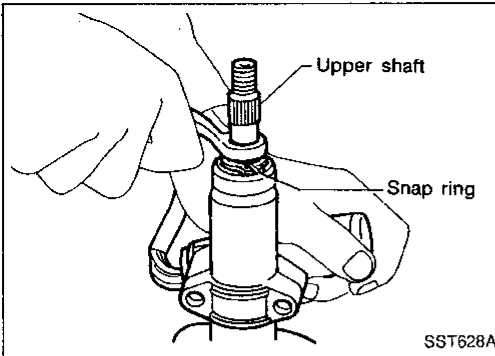

- Install snap ring on upper shaft with tool.

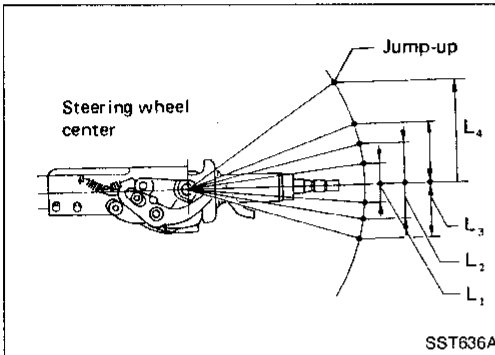

- Tilt type
After installing steering column, check tilt mechanism operation.

- L_1 : 8.7 mm (0.343 in)
- L_2 : 17.3 mm (0.681 in)
- L_3 : 26.0 mm (1.024 in)
- L_4 : 100.0 mm (3.94 in)

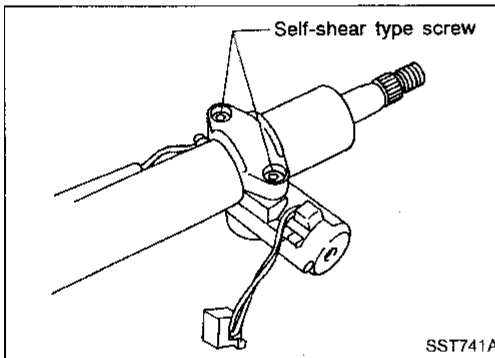

- Steering lock
a) Break self-shear type screws with a drill or other appropriate tool.

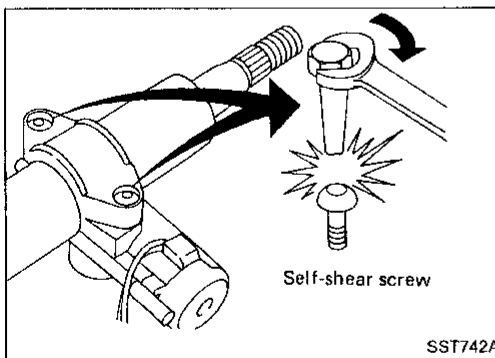

- b) Install self-shear type screws and then cut off self-shear type screw heads.

Inspection

- When steering wheel can not be rotated smoothly, check the steering column for the following matters and replace damaged parts.
 - (1) Check column bearings for damage or unevenness. Lubricate with recommended multi-purpose grease or replace steering column as an assembly, if necessary.
 - (2) Check jacket tube for deformation or breakage. Replace if necessary.
- When the vehicle is involved in a light collision, check dimension "L". If it is not within specifications, replace steering column as an assembly.

Column length "L₁ & L₂":

- $L_1 = 918.0 - 919.6 \text{ mm}$
(36.14 - 36.20 in)
- $L_2 = 886.1 - 887.7 \text{ mm}$
(34.89 - 34.95 in)

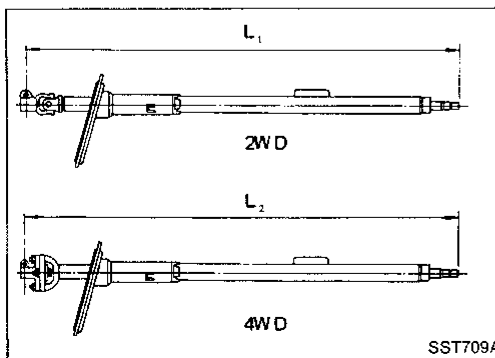

MANUAL STEERING GEAR (Model: VB66K)

Removal and Installation

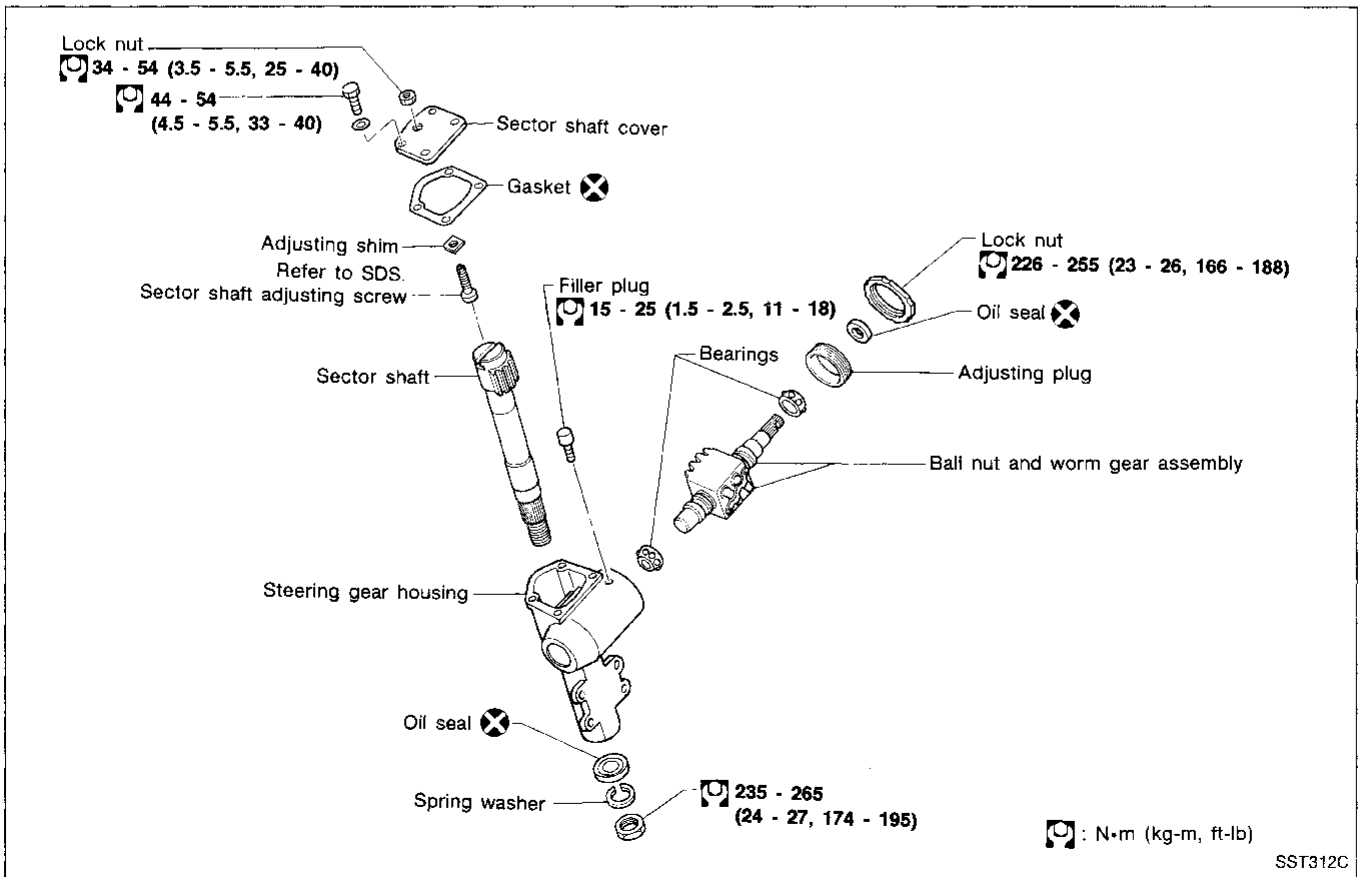
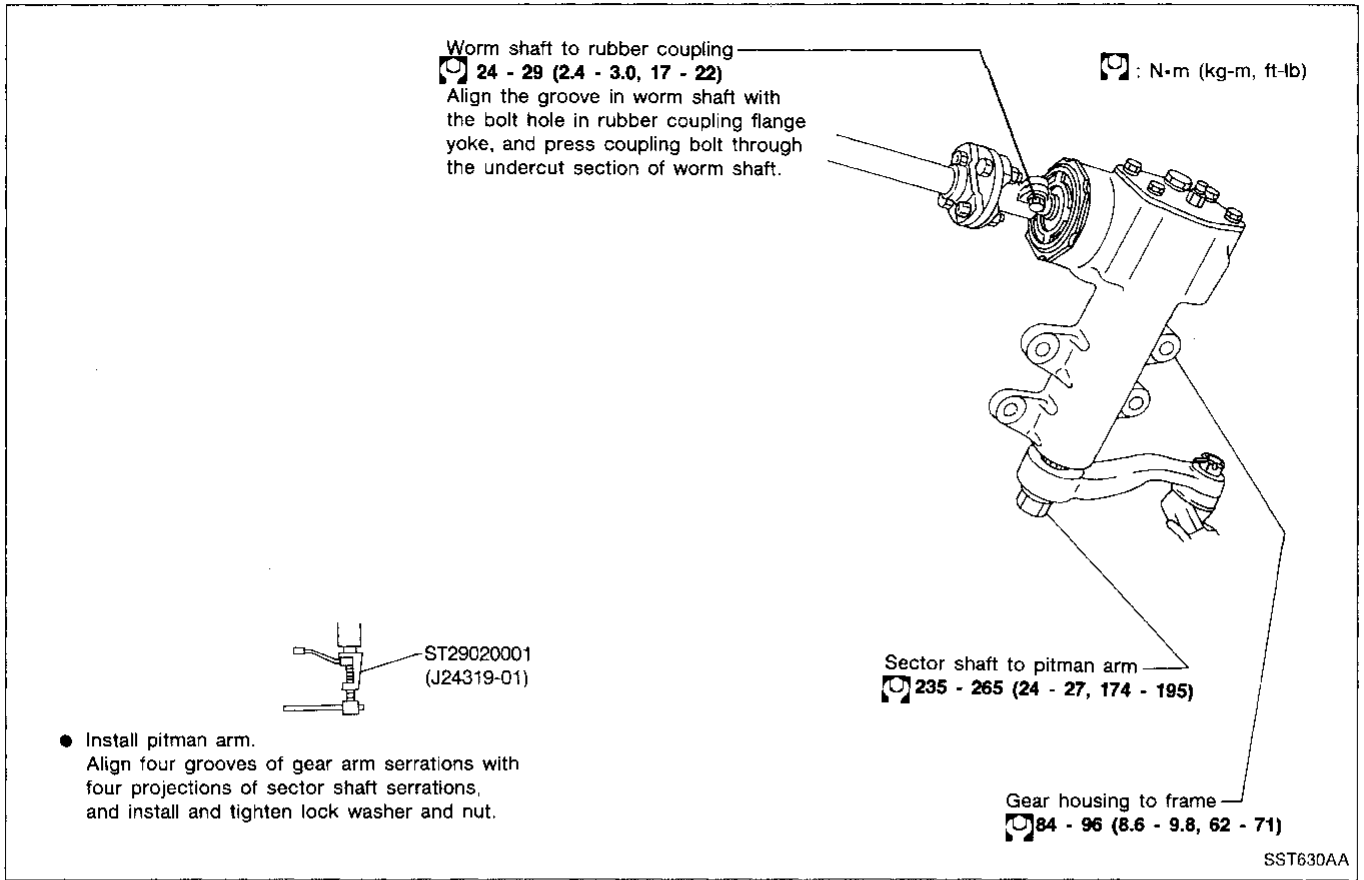

MANUAL STEERING GEAR (Model: VB66K)

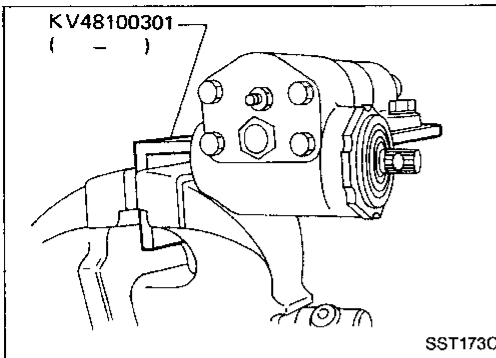

Disassembly

1. Place steering gear in a vise with Tool.

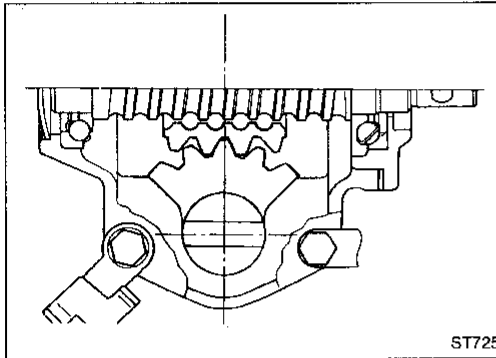

2. Set worm gear in a straight-ahead position.
3. Remove sector shaft with sector shaft cover.

CAUTION:

- a. When pulling sector shaft out, be careful not to damage oil seal or associated parts.
b. Set worm gear in a straight-ahead position.
c. Do not remove sector shaft needle bearings from steering gear housing. If necessary, replace gear housing assembly.

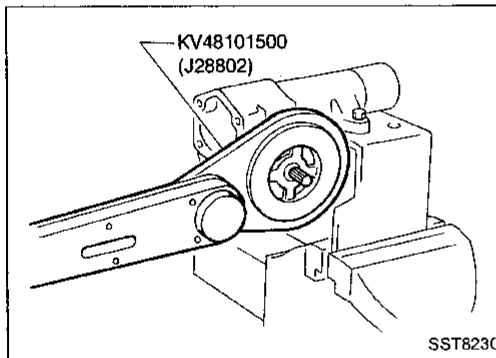

4. Loosen adjusting plug lock nut with Tool.

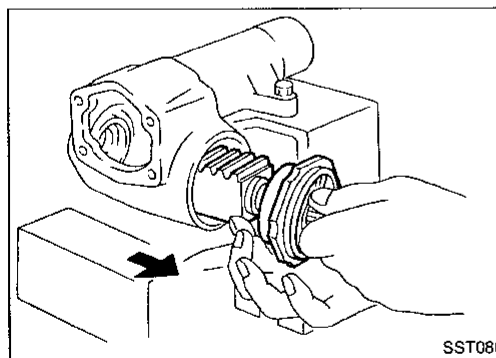

5. Draw out worm gear with worm bearing.

CAUTION:

- a. Be careful not to allow ball nut to run down to either end of worm.
Ends of ball guides will be damaged if nut is rotated until it stops at end of worm.
b. Do not detach ball nut from worm shaft assembly.
If necessary, replace entire unit as an assembly.
c. Do not remove sector shaft needle bearings from steering gear housing.
If necessary, replace entire gear housing as an assembly.

Assembly and Adjustment

Fill space between sealing lips of new sector shaft and adjusting plug oil seals with multi-purpose grease.

WORM BEARING PRELOAD

1. Drive oil seal into place.

Before pressing oil seal, coat seal contacting face of oil seal with gear fluid.

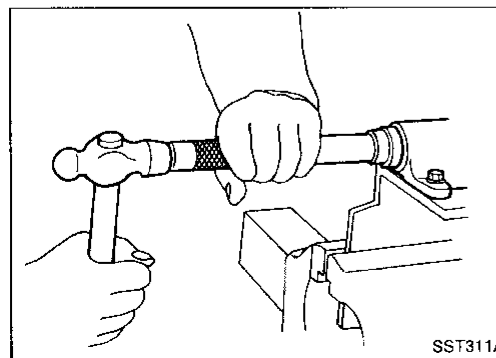

MANUAL STEERING GEAR (Model: VB66K)

Assembly and Adjustment (Cont'd)

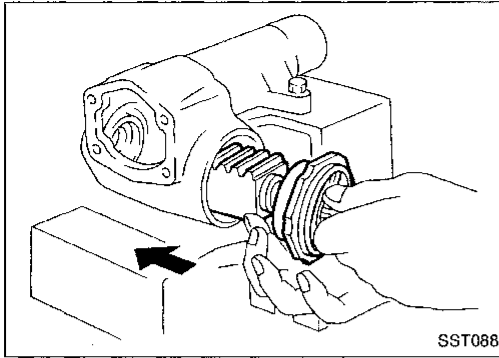

2. Fit worm gear assembly with worm bearing in gear housing.

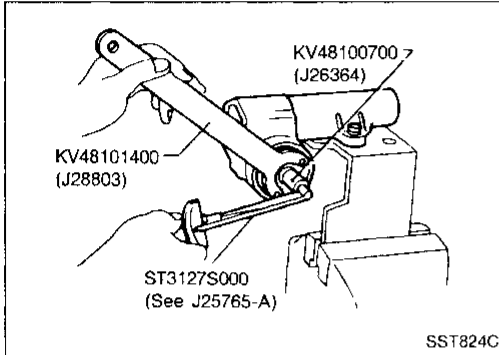

3. Adjust worm bearing preload with Tools.

CAUTION:

- Always adjust worm bearing preload by turning adjusting plug in "tighten" direction.
- Rotate worm shaft a few turns in both directions to settle down worm bearing and measure preload.

Worm bearing preload:

0.69 - 0.88 N·m

(7.0 - 9.0 kg-cm, 6.1 - 7.8 in-lb)

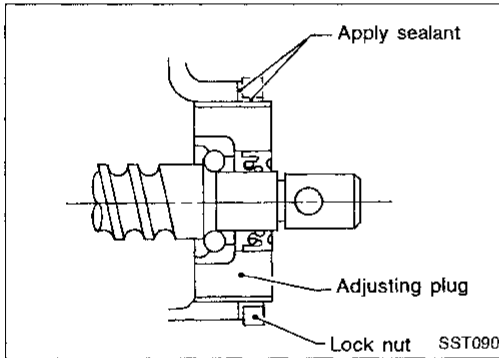

4. Apply suitable sealant around lock nut inner surface.

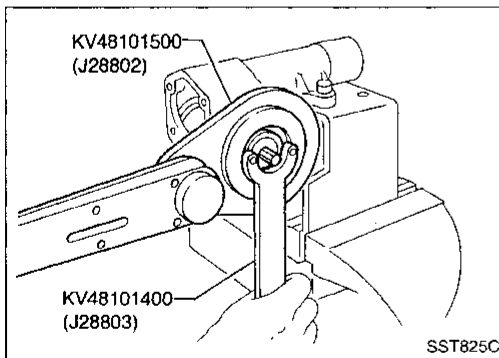

5. Tighten lock nut using Tools.
6. After tightening lock nut, check worm bearing preload to make sure it is within specification.

GI

MA

EM

LC

EF &
EC

FE

CL

MT

AT

TF

PD

FA

RA

BR

ST

BF

HA

EL

FDX

MANUAL STEERING GEAR (Model: VB66K)

Assembly and Adjustment (Cont'd)

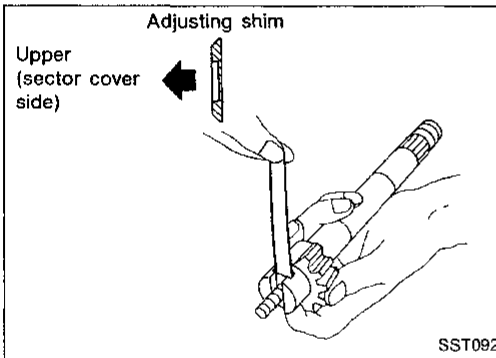
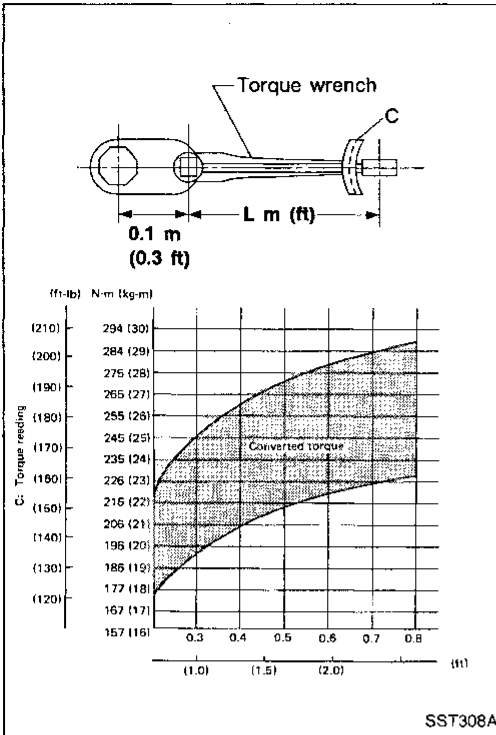

SECTOR SHAFT END PLAY

Select suitable adjusting shim and adjust end play between sector shaft and adjusting screw.

Sector shaft end play:

0.01 - 0.03 mm (0.0004 - 0.0012 in)

Sector shaft adjusting screw shims:

Refer to SDS (ST-39).

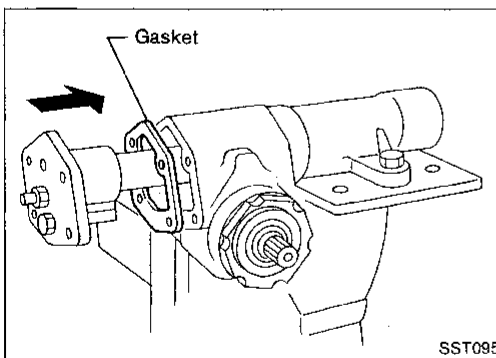

STEERING GEAR PRELOAD AND BACKLASH

1. Set worm gear in a straight-ahead position.
Carefully insert sector shaft in place, using care not to scratch oil seal.
2. Adjust adjusting screw until sector shaft just contacts ball nut. Temporarily tighten lock nut.
3. Lubricate contacting portion of sector shaft and ball nut with gear oil or bearing grease.

4. Adjust steering gear turning torque in a straight-ahead position, and lock with lock nut.

CAUTION:

- Always adjust steering gear preload by turning adjusting screw in "tighten" direction.
- Rotate worm gear a few turns in both directions to settle down steering gear.

- 1) Measure turning torque at 360° position from straight-ahead position with Tools.

Turning torque at 360°:

0.69 - 0.88 N-m (7.0 - 9.0 kg-cm, 6.1 - 7.8 in-lb)

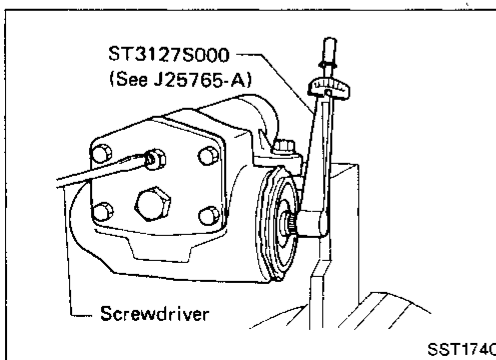

MANUAL STEERING GEAR (Model: VB66K)

Assembly and Adjustment (Cont'd)

2) Measure turning torque at straight-ahead position.

Straight-ahead position is a position where stub shaft is turned 2.14 turns (two full turns and 50°) from lock position.

Turning torque at straight-ahead position:

**0.20 - 0.39 N·m (2.0 - 4.0 kg-cm, 1.7 - 3.5 in-lb)
higher than at 360°**

Maximum turning torque:

1.08 N·m (11.0 kg-cm, 9.5 in-lb)

If they are not within specifications, adjust turning torque by turning sector shaft adjusting screw.

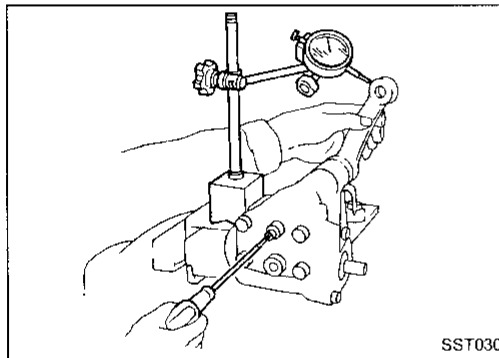
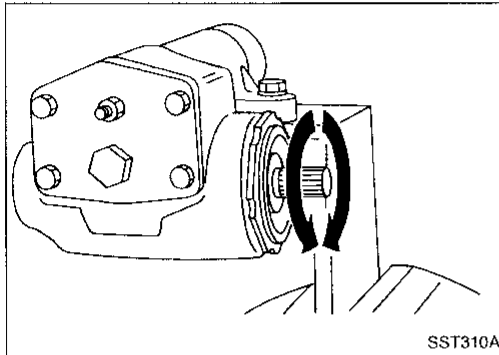

5. Turn worm gear several times by hand to properly break in worm bearing.

6. Check steering gear preload. If not within specification, readjust it.

7. Measure total preload.

8. Check backlash.

Measure backlash at pitman arm top end in straight-ahead position.

Backlash (in straight-ahead position):

0.1 mm (0.004 in) or less

Inspection

Wash clean all the disassembled parts in solvent and check for condition.

SECTOR SHAFT

1. Check gear tooth surface for pitting, burrs, cracks or any other damage, and replace if necessary.

2. Check sector shaft for distortion on its serration, and replace if necessary. Also check gear housing for deformation.

GI

MA

EM

LC

EF &
EC

FE

CL

MT

AT

TF

PD

FA

RA

BR

ST

BF

HA

EL

FOX

MANUAL STEERING GEAR (Model: VB66K)

Inspection (Cont'd)

STEERING WORM ASSEMBLY

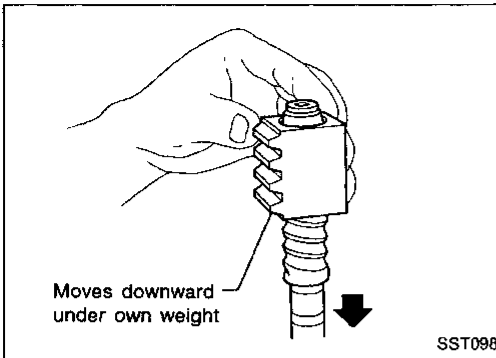

1. Inspect ball nut gear tooth surface, and replace if pitting, burrs, wear or any other damage is found.
2. Ball nut must rotate smoothly on worm gear. If found too tight, assembly should be replaced. Check rotation of ball nut as follows:
 - (1) Move ball nut to either end of worm gear, and gradually stand worm shaft and ball nut assembly until ball nut moves downward on worm gear under its own weight.
 - (2) If ball nut does not move freely over entire stroke, replace assembly.

Be careful not to damage ball nut guide tube while check is being made.

CAUTION:

Be careful not to allow ball nut to run down to either end of worm.

BEARING

1. Inspect worm bearing for wear, pitting or any other damage. Replace as required.

When replacing worm bearing, replace it as a set of bearing and outer race.

2. If sector shaft needle bearings are worn or damaged, replace as an assembly of gear housing and bearings.

OIL SEALS

- Discard any oil seal which has once been removed.
- Replace oil seal if sealing lip is deformed or cracked.
- Discard oil seal if spring is fatigued or dislocated.

POWER STEERING SYSTEM (Model: PB59K)

Description

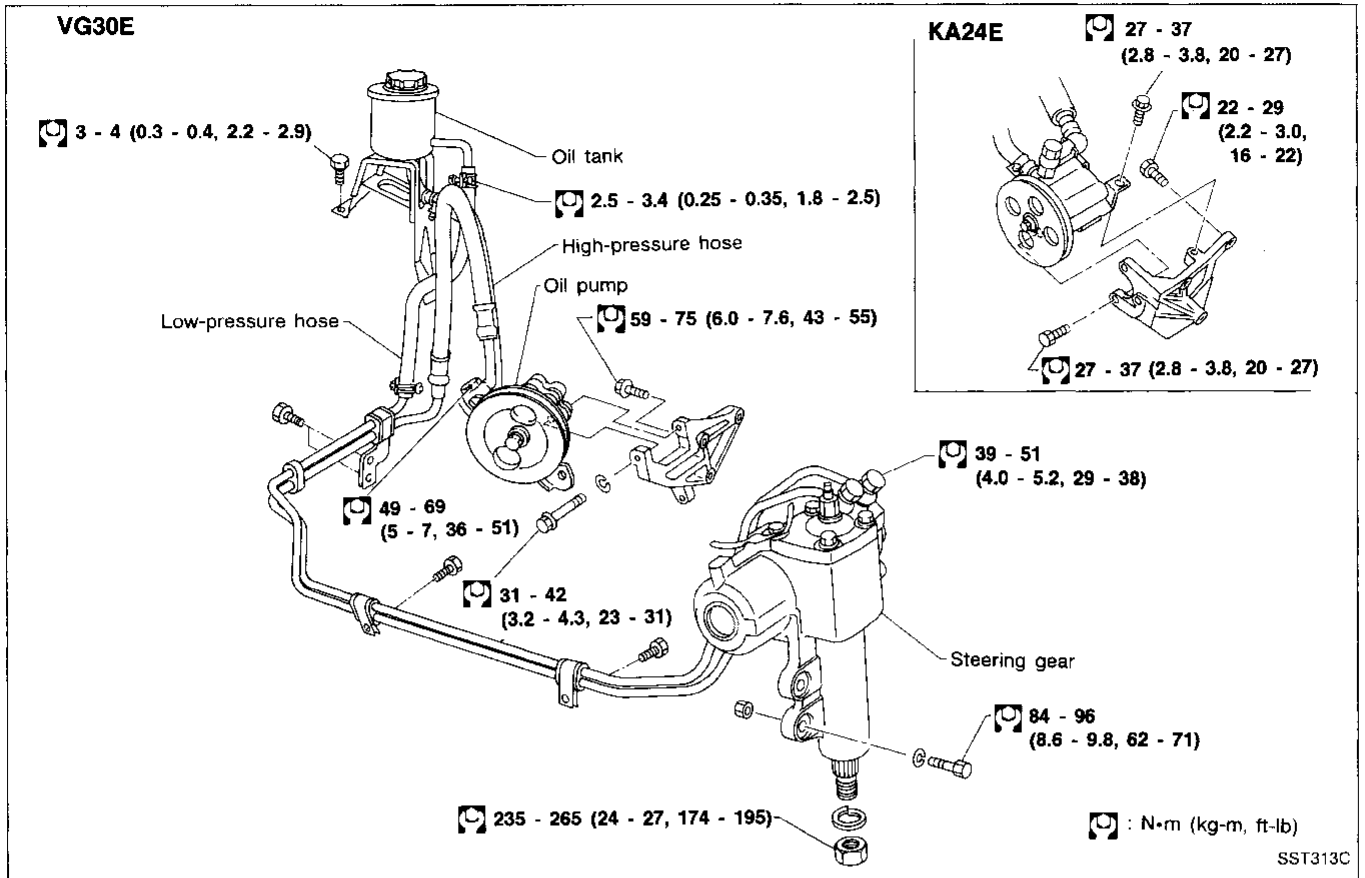

Only the sealing parts can be replaced. The remaining parts must be replaced as an assembly.

CAUTION:

- The parts which can be disassembled are strongly restricted, and never disassemble other parts than the specified ones.
- Disassembly should be performed in a place as clean as possible.
- Hands should be cleaned before disassembly.
- Do not use a rag. Be sure to use nylon or paper cloth.
- Be sure to follow procedures and cautions indicated in the Service Manual.

GI
MA
EM
LC
EF & EC
FE
CL
VT
AT
TF
PD
FA
RA
BR
ST
BF
HA
EL
IDX
1043

POWER STEERING GEAR (Model: PB59K)

Removal

Before removing, clean exteriors of gear housing and oil pump with steam and dry with compressed air.

STEERING GEAR

- Plug openings of gear housing, and securely locate hose connectors at a position higher than oil pump and cover with rag.
- Be extremely careful to prevent entry of foreign matter into hoses through connectors.
- When installing gear arm, align four grooves of gear arm serrations with four projections of sector shaft serrations, and install and tighten lock washer and nut.

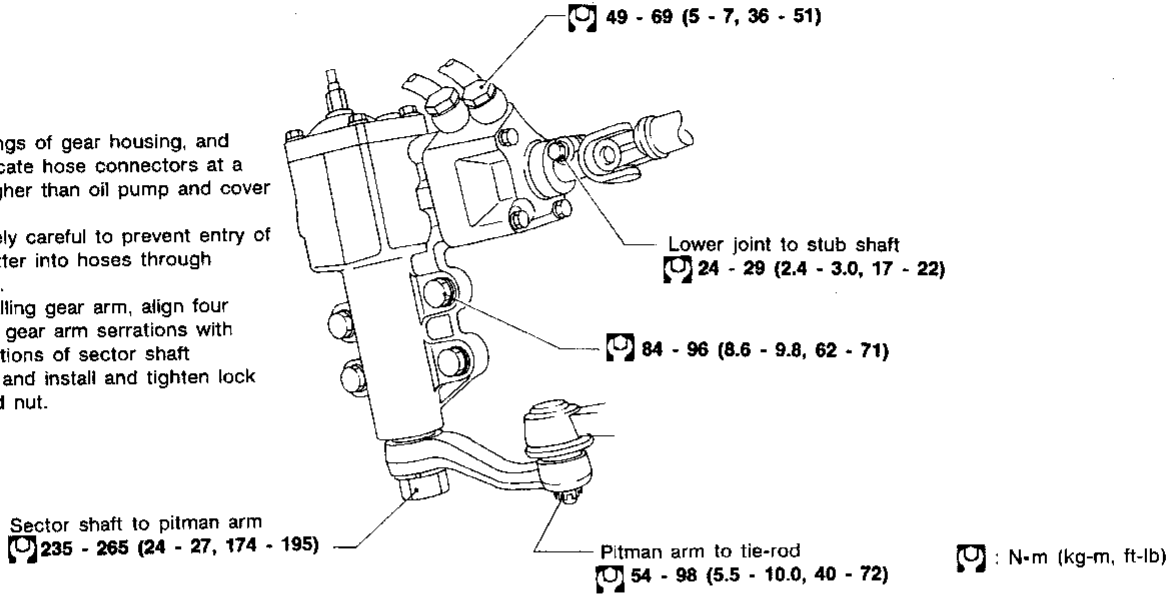

SST123CA

Power Steering Gear Component

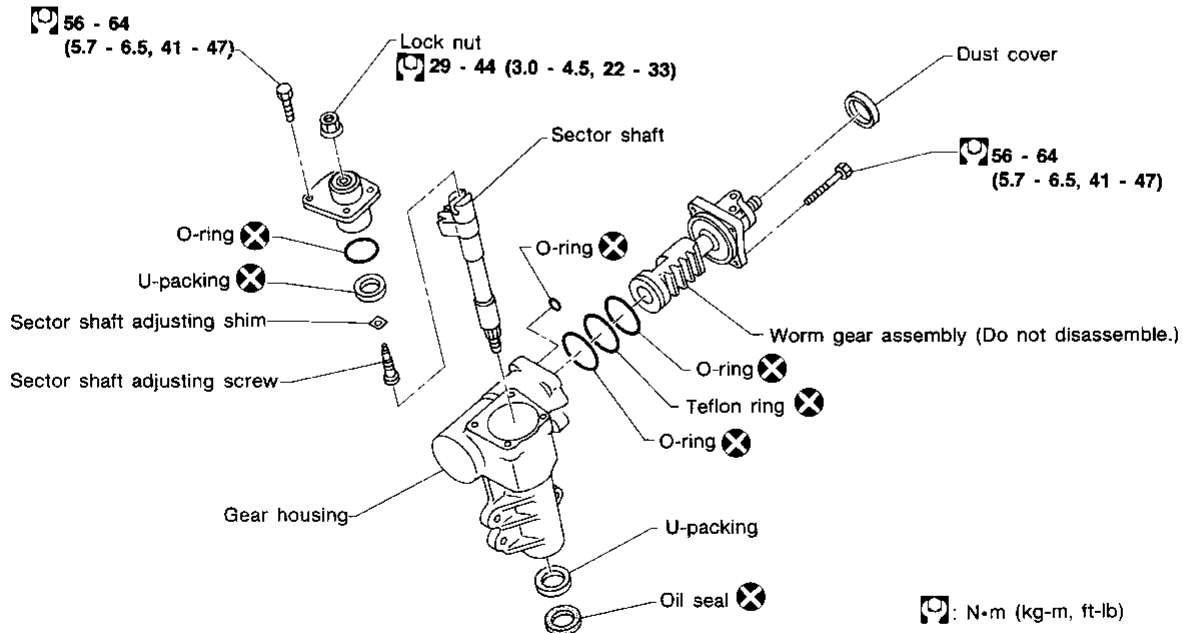

SST314C

Inspection and Adjustment

Before disassembling power steering gear component parts, make sure there is no oil leakage around sealing portion and check steering turning torque as follows:

Check sealing portion.

- Sector shaft cover O-ring
- Sector shaft U-packing
- Sector shaft oil seal
- Rear housing O-ring
- Gear housing O-ring

Discard any oil seal and O-ring which have once been removed. Replace oil seal and O-ring if sealing surface is deformed or cracked.

GI
MA
EM
LC
EF & EC
FE
CL
MT
AT
TF
PD
FA
RA
BR
ST
BF
HA
EL
IDX

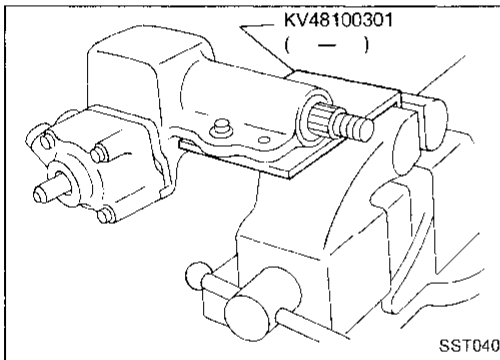

TURNING TORQUE MEASUREMENT

1. Measure turning torque at 360° position.
 - (1) Install steering gear on Tool.

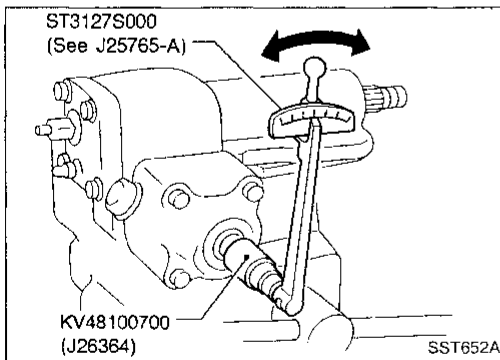

- (2) Turn stub shaft all the way to right and left several times.
 - (3) Measure turning torque at 360° position from straight-ahead position with Tools.

Turning torque at 360°:

0.15 - 0.78 N·m (1.5 - 8.0 kg-cm, 1.3 - 6.9 in-lb)

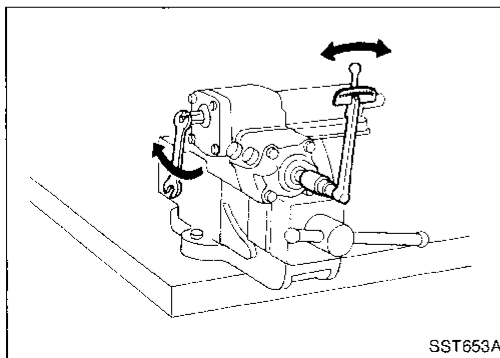

- (4) Measure turning torque at straight-ahead position. Straight-ahead position is a position where stub shaft is turned 2.14 turns (two full turns and 50°) from lock position.

Turning torque at straight-ahead position:

0.25 - 1.32 N·m (2.5 - 13.5 kg-cm, 2.2 - 11.7 in-lb) higher than at 360°

Maximum turning torque:

1.03 - 1.47 N·m (10.5 - 15 kg-cm, 9.1 - 13.0 in-lb)

If they are not within specifications, adjust turning torque by turning sector shaft adjusting screw.

POWER STEERING GEAR (Model: PB59K)

Inspection and Adjustment (Cont'd)

2. Tighten adjusting screw lock nut with tools.

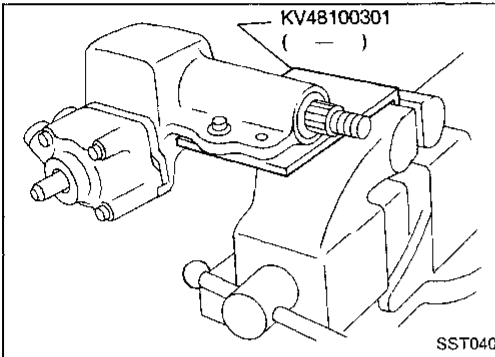
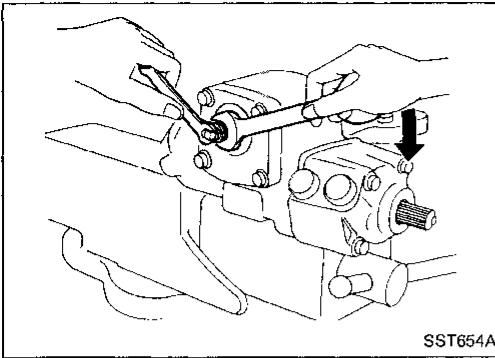

Disassembly

Before disassembly, measure turning torque.

If they are not within specifications, replace steering gear assembly.

CAUTION:

Each oil sealing parts, dust cover, copper washer and snap ring once removed must not be used again.

1. Place steering gear in a vise with Tool.
2. Set worm gear in a straight-ahead position.

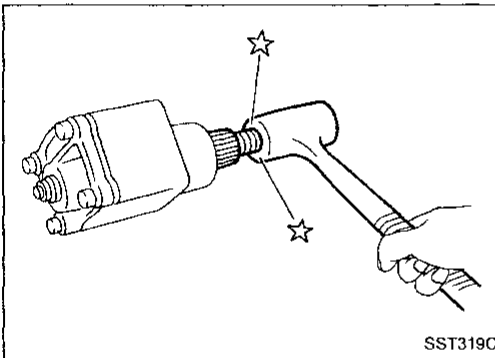

3. Loosen (do not remove) sector shaft cover bolt.
4. Knock out end of sector shaft with plastics hammer.
5. Remove sector shaft by hand.

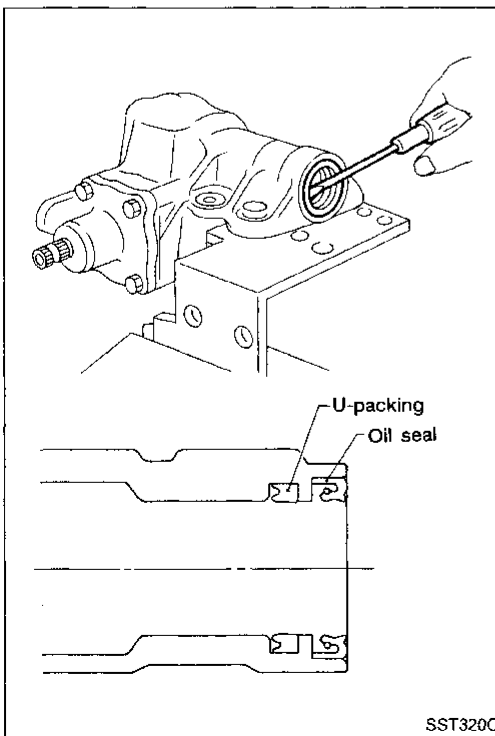

6. Remove oil seal.
7. Remove U-packing.

CAUTION:

When removing oil seal and U-packing, be careful not to scratch gear housing.

POWER STEERING GEAR (Model: PB59K)

Disassembly (Cont'd)

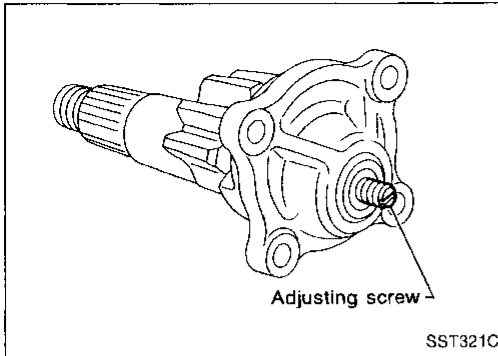

8. Remove lock nut, then loosen adjusting screw using a screwdriver. Separate sector cover and sector shaft.

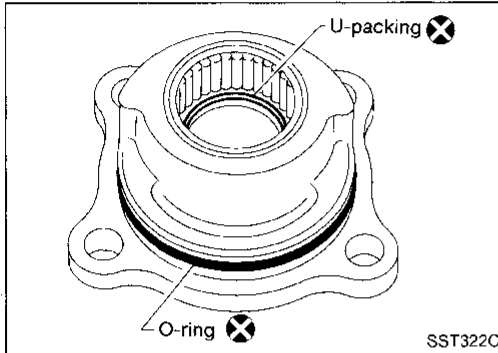

9. Remove O-ring.
10. Remove U-packing.

CAUTION:

- When removing U-packing, be careful not to scratch sector cover, needle bearing, etc.
- Needle bearing cannot be disassembled. If it is damaged, remove sector cover assembly.

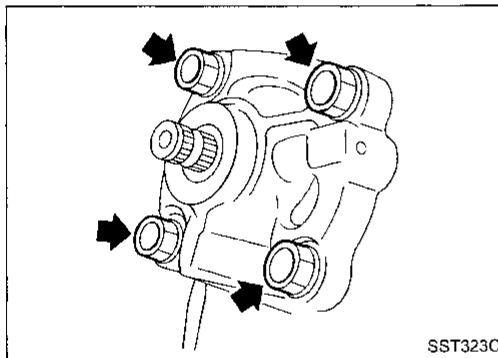

11. Remove dust seal.
12. Remove rear housing bolts.
13. Remove rear housing together with worm gear assembly.

CAUTION:

Worm gear assembly cannot be disassembled. When it is removed, be careful not to disengage worm gear from shaft or allow it to drop.

14. Remove teflon ring and O-ring of worm gear assembly.

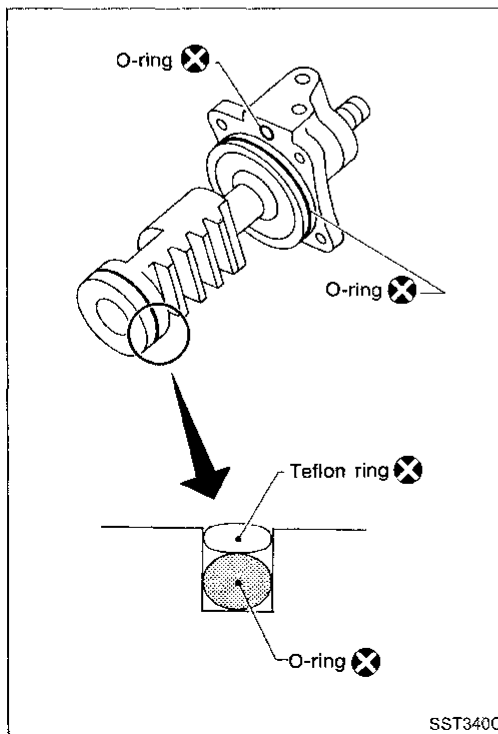

Assembly

1. Install new O-ring on worm gear assembly.
 - Apply a thin coat of ATF to new O-ring.
2. Install new teflon ring on worm gear assembly.
 - Be sure that teflon ring settles in its correct position.
3. Install new O-ring into rear housing.

GI

MA

EM

LC

EF &
EC

FE

CL

MT

AT

TF

PD

FA

RA

BR

ST

BF

HA

EL

FDX

POWER STEERING GEAR (Model: PB59K)

Assembly (Cont'd)

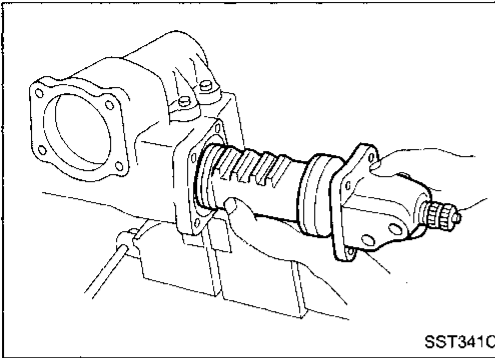

4. Install worm gear assembly with rear housing into the gear housing.

CAUTION:

- Apply a thin coat of ATF inside gear housing and piston before insertion.
- Be sure that teflon ring at piston end is not damaged during insertion of gear housing.

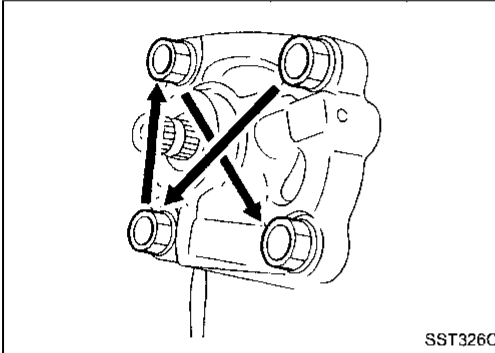

5. Gradually tighten rear housing bolts in a criss-cross fashion.

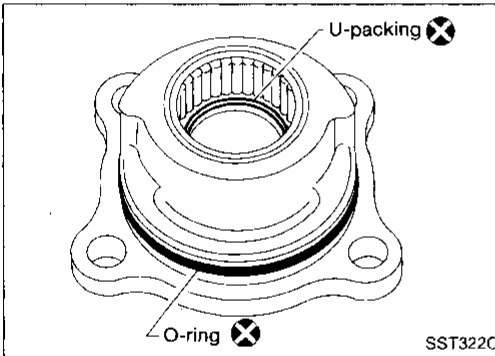

6. Install new O-ring into sector shaft cover.
 - Before installing, apply a thin coat of ATF to O-ring.
7. Install new U-packing into sector shaft cover.
 - Before installing, apply a thin coat of ATF to U-packing.
 - Direct grooved side of U-packing to needle bearing.

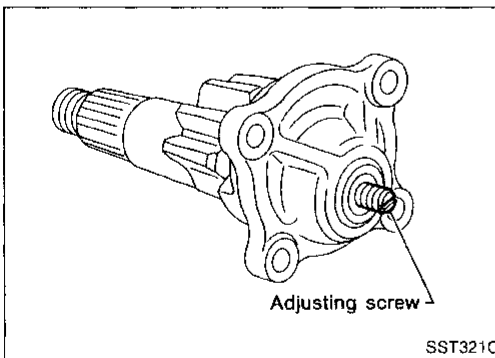

8. Install sector shaft into sector shaft cover.
Set adjusting screw to its outermost position.
 - Before installing sector shaft, apply multi-purpose grease to adjusting screw and adjusting screw shim.

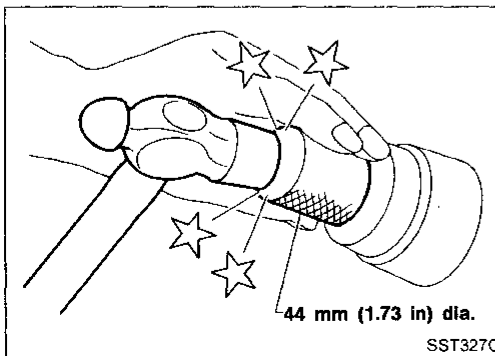

9. Install new oil seal into gear housing with suitable tool.
 - Before installing oil seal, apply multi-purpose grease to oil seal lips.

POWER STEERING GEAR (Model: PB59K)

Assembly (Cont'd)

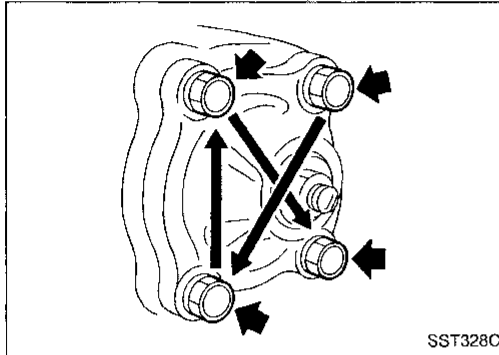
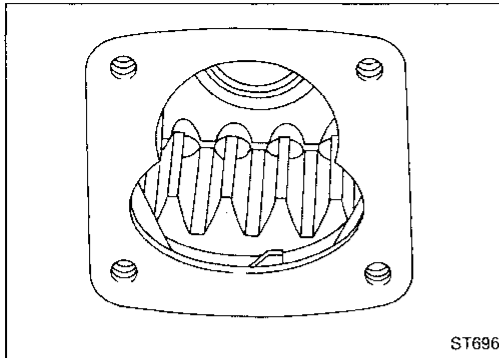

10. Set piston rack at straight-ahead position.
Turn piston rack about 10° to 15° toward yourself with your finger. This is for smooth insertion of sector gear.

11. Gradually insert sector shaft into gear housing.
12. Tighten sector shaft cover bolts.
13. Set worm gear turning torque by turning adjusting screw of sector shaft and locking with lock nut.

Refer to "TURNING TORQUE MEASUREMENT" of Inspection and Adjustment. (ST-19)

- **If there is a great difference between values of turning torque before and after disassembly, it must be assumed that some new problem has occurred. It will be necessary to replace the entire assembly.**

14. Check sector shaft end play in neutral position.
End play: Less than 0.1 mm (0.004 in)
If not within specification, adjust it with adjusting screw.
15. Check worm gear preload. If not within specification, readjust it.

GI

MA

EM

LC

EF &
EC

FE

CL

WT

AT

TF

PD

FA

RA

BR

ST

BF

HA

EL

IDX

POWER STEERING SYSTEM (Model: PB48S)

Description

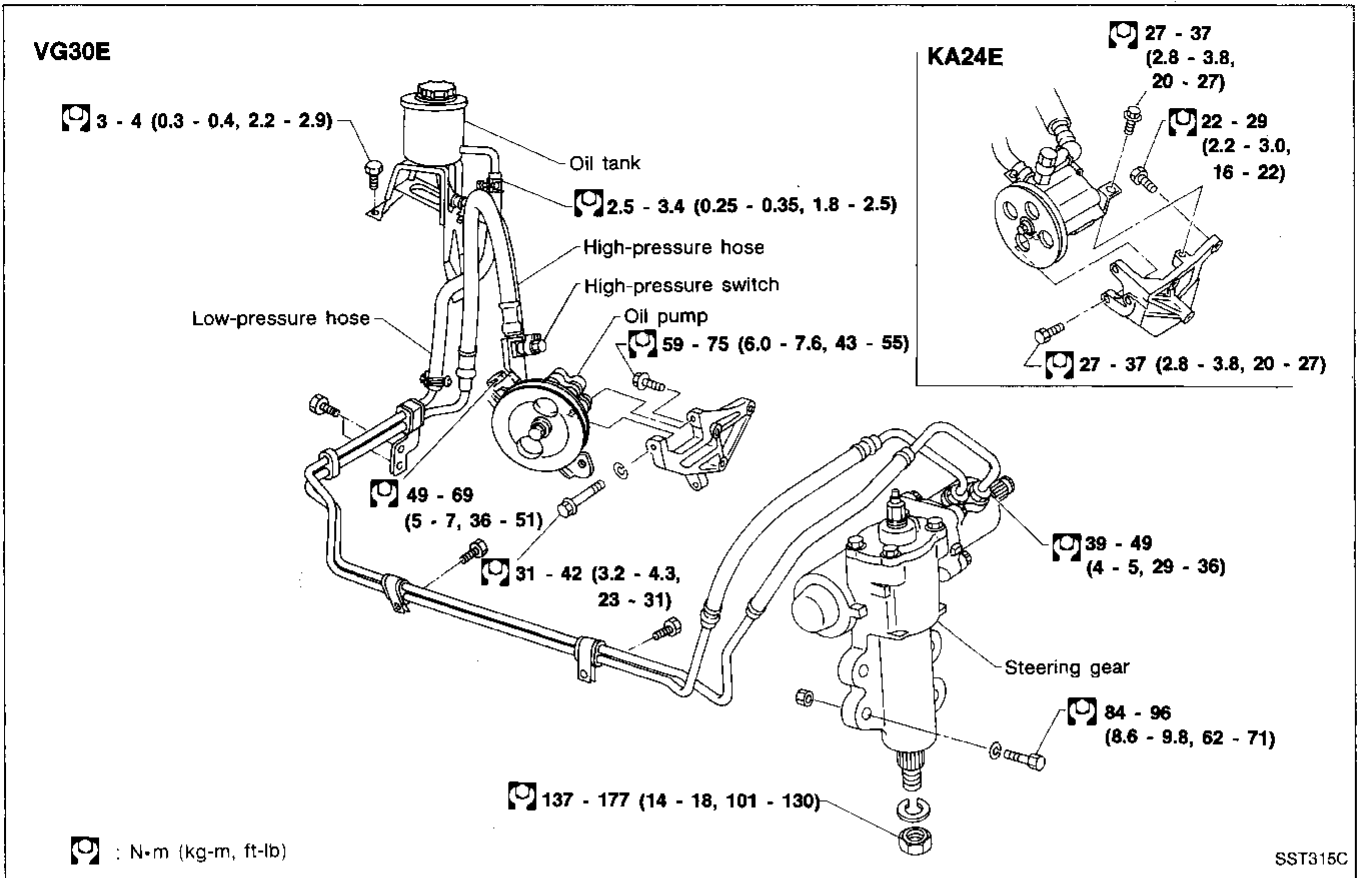

This power steering adopts spool valve control which was developed in a technical tie-up with the ZF Company.

Only the sealing parts can be replaced. The remaining parts must be replaced as an assembly.

CAUTION:

- The parts which can be disassembled are strongly restricted, and never disassemble other parts than the specified ones.
- Disassembly should be performed in a place as clean as possible.
- Hands should be cleaned before disassembly.
- Do not use a rag. Be sure to use nylon or paper cloth.
- Be sure to follow procedures and cautions indicated in the Service Manual.

POWER STEERING GEAR (Model: PB48S)

Removal

Before removing, clean exteriors of gear housing and oil pump with steam and dry with compressed air.

STEERING GEAR

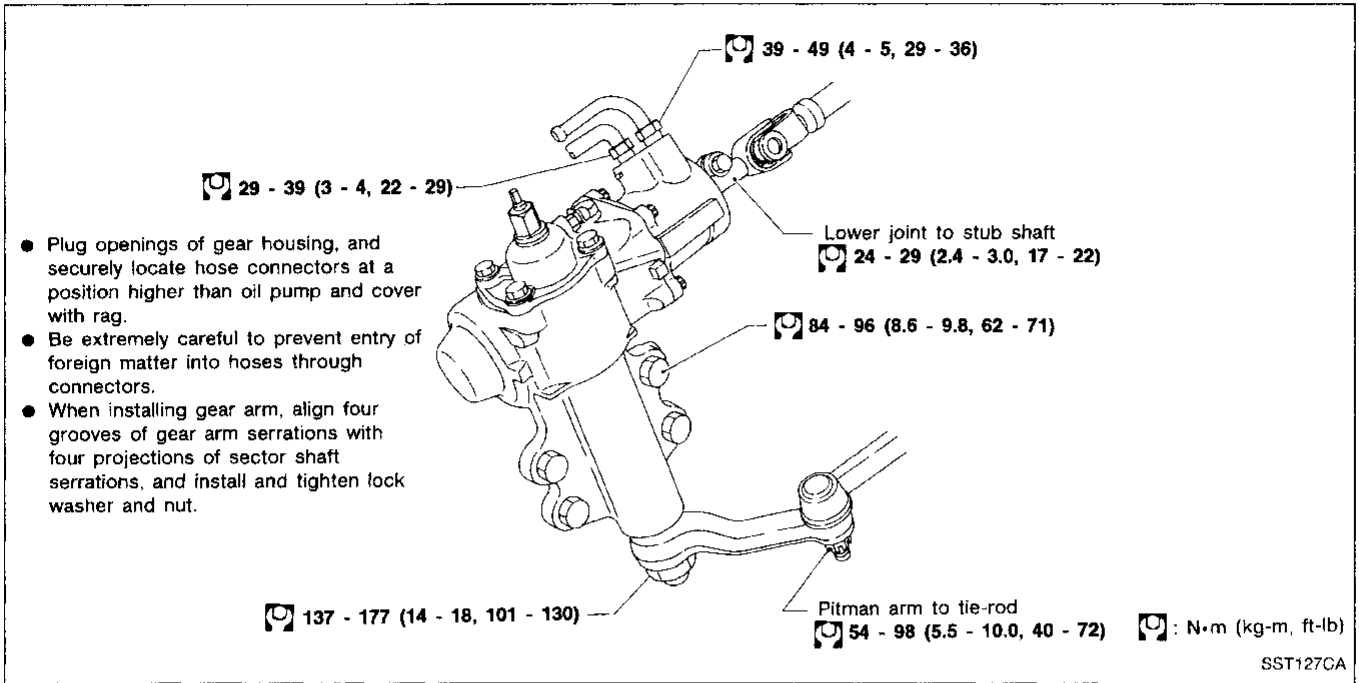

Power Steering Gear Component

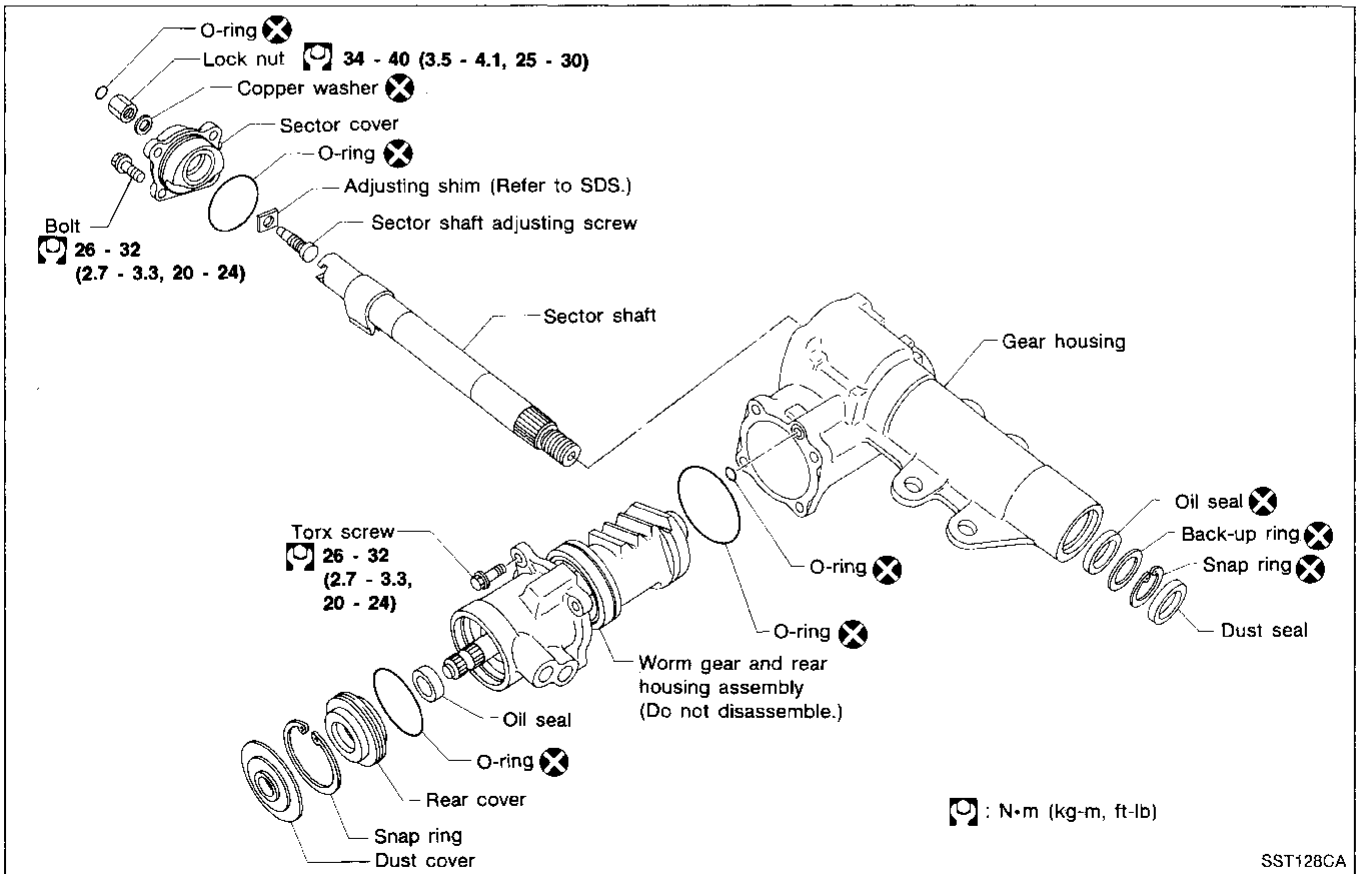

Inspection and Adjustment

Before disassembling power steering gear component parts, make sure there is no oil leakage around sealing portion and check steering turning torque as follows:

Check sealing portion.

- Adjusting screw nut O-ring
- Sector shaft cover O-ring
- Sector shaft oil seal
- Rear cover oil seal and O-ring
- Rear housing O-ring
- Gear housing O-ring

Discard and oil seal and O-ring which have once been removed. Replace oil seal and O-ring if sealing surface is deformed or cracked.

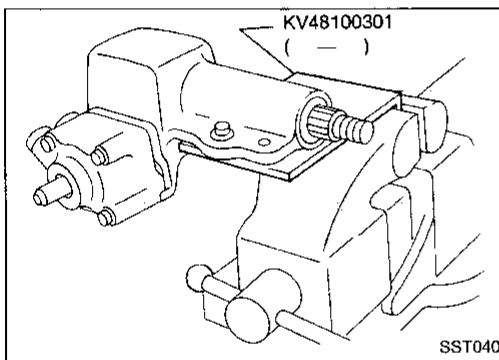

TURNING TORQUE MEASUREMENT

1. Measure turning torque at 360° position.
(1) Install steering gear on Tool.

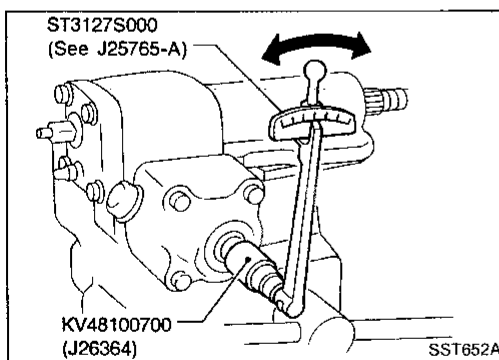

- (2) Turn stub shaft all the way to right and left several times.
- (3) Measure turning torque at 360° position from straight-ahead position with Tools.

Turning torque at 360°:

0.7 - 1.2 N·m

(7 - 12 kg-cm, 6.1 - 10.4 in-lb)

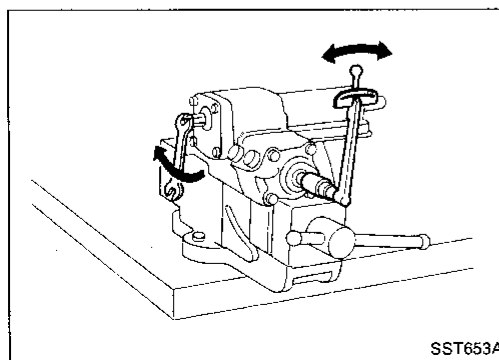

- (4) Measure turning torque at straight-ahead position.
Straight-ahead position is a position where stub shaft is turned 2.14 turns (two full turns and 50°) from lock position.

Turning torque at straight-ahead position:

0.1 - 0.4 N·m

(1 - 4 kg-cm, 0.9 - 3.5 in-lb) higher than at 360°

If they are not within specifications, adjust turning torque by turning sector shaft adjusting screw.

POWER STEERING GEAR (Model: PB48S)

Inspection and Adjustment (Cont'd)

2. Tighten adjusting screw lock nut with tools.

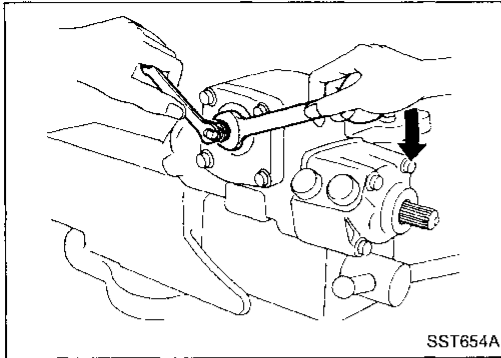

Disassembly

Before disassembly, measure turning torque.

If they are not within specifications, replace steering gear assembly.

CAUTION :

Each oil sealing parts, dust cover, copper washer and snap ring once removed must be used again.

GI

MA

EM

LC

EF &
EC

FE

CL

MT

AT

TF

PD

FA

RA

BR

ST

BF

HA

EL

IDX

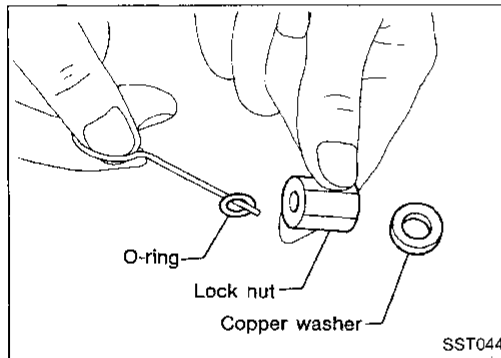

ADJUSTING SCREW LOCK NUT O-RING

Remove adjusting screw lock nut, and replace O-ring.

SECTOR SHAFT OIL SEAL

1. Set stub shaft in a straight-ahead position.

Straight-ahead position is a position where stub shaft is turned 2.14 turns (two full turns and 50°) from lock position.

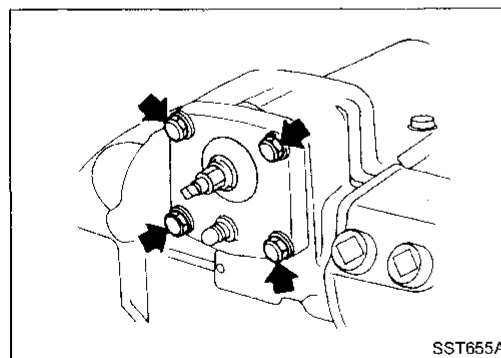

2. Disconnect sector shaft cover bolt.

Do not turn lock nut unless necessary; otherwise it will damage O-ring, resulting in an oil leak.

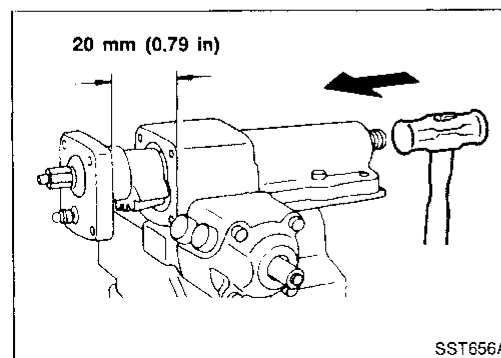

3. Draw out sector shaft.

Knock out end of sector shaft approximately 20 mm (0.79 in).

POWER STEERING GEAR (Model: PB48S)

Disassembly (Cont'd)

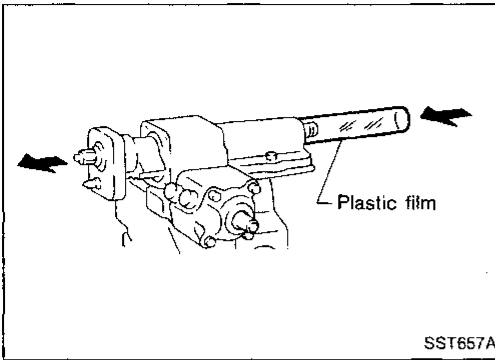

4. Connect a roll of plastic film to sector shaft.

Plastic film:

Thickness 0.1 mm (0.004 in)

Length x width

200 x 200 mm (7.87 x 7.87 in)

5. Pull out sector shaft by hand.

Attach plastic film to needle bearings located at two places inside gear housing while simultaneously pulling out sector shaft so that bearings will not drop into housing.

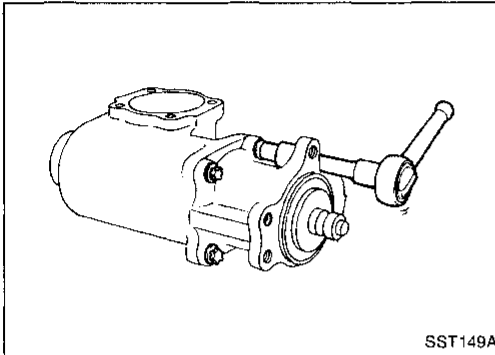

REAR HOUSING O-RING

1. Remove torx screw.

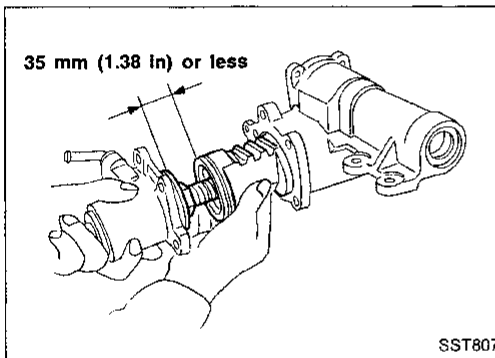

2. Remove rear housing together with worm gear assembly.

CAUTION:

- a. When worm assembly is removed, piston may turn and come off under its own weight. Hold piston to prevent it from turning.

If piston-to-rear housing clearance exceeds 35 mm (1.38 in) by loosening recirculating ball will be out of groove of worm; do not reinstall piston but replace the entire assembly.

- b. Take care not to damage teflon ring at piston end when removing.

3. Remove O-rings.

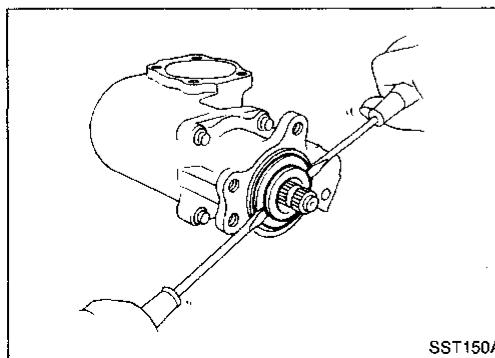
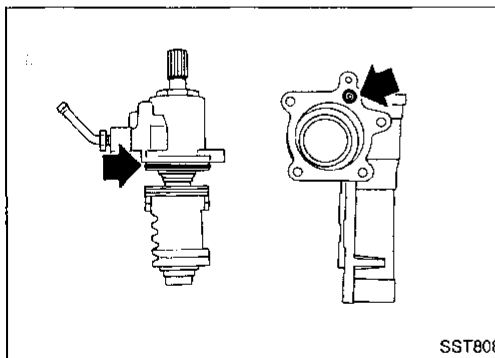

REAR COVER O-RING AND OIL SEAL

1. Remove snap ring, then rear cover.
2. Remove O-ring and oil seal.

POWER STEERING GEAR (Model: PB48S)

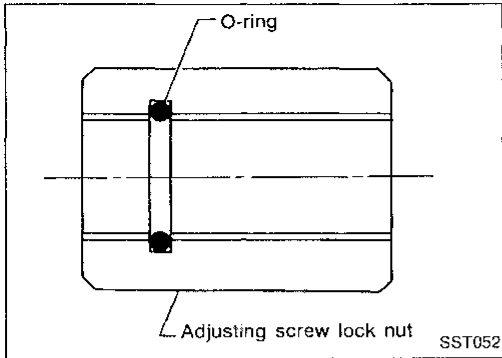

Assembly

ADJUSTING SCREW LOCK NUT O-RING

Insert new O-ring into adjusting screw lock nut.

- Before inserting, apply a thin coat of vaseline to O-ring.
- Insert O-ring to make sure it fits into groove.

GI
MA

EM

LC

EF &
EC

FE

CL

MT

AT

TF

PD

FA

RA

BR

ST

BF

HA

EL

IDX

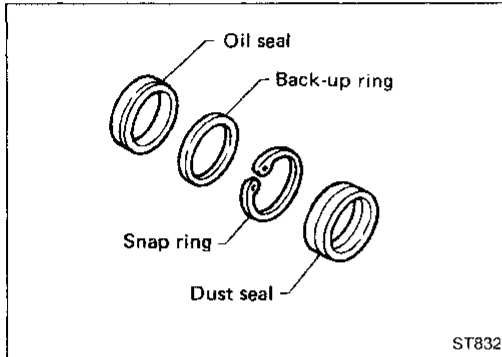

SECTOR SHAFT OIL SEAL

- When installing, be sure to use new oil seal, dust seal, back-up ring and snap ring.
- Before installing, apply a thin coat of vaseline to new oil seal and dust seal.

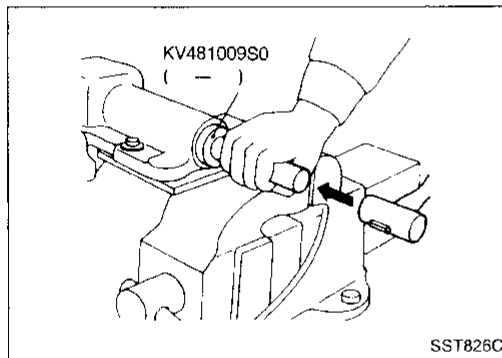

1. Press new oil seal and then install back-up ring with Tool.

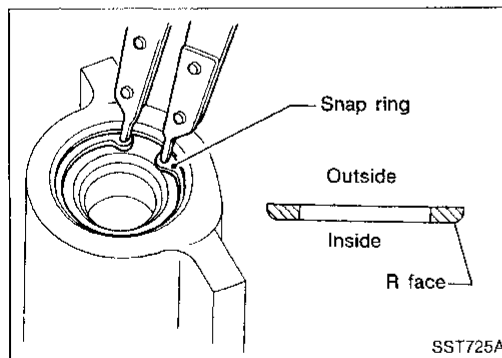

2. Install a new snap ring into gear housing.

CAUTION:

- a. Turn snap ring to make sure it fits into groove.
- b. Always install snap ring with R face facing inward.

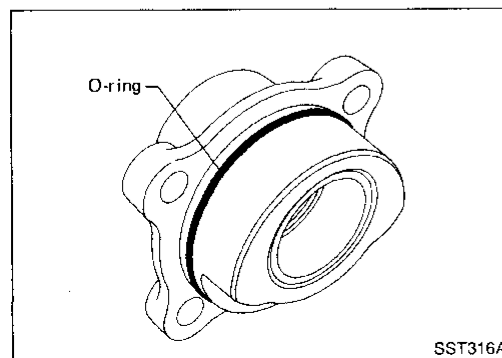

3. Press a new dust seal.

4. Fit new O-ring into sector shaft cover.

- Before installing, apply a thin coat of vaseline to O-ring.
- Make certain that O-ring is installed properly, and not damaged by sector shaft.

POWER STEERING GEAR (Model: PB48S)

Assembly (Cont'd)

SECTOR SHAFT END PLAY

Select suitable adjusting shim and adjust end play between sector shaft and adjusting screw.

Sector shaft end play:

0.01 - 0.03 mm (0.0004 - 0.0012 in)

Sector shaft adjusting screw shims:

Refer to SDS (ST-39).

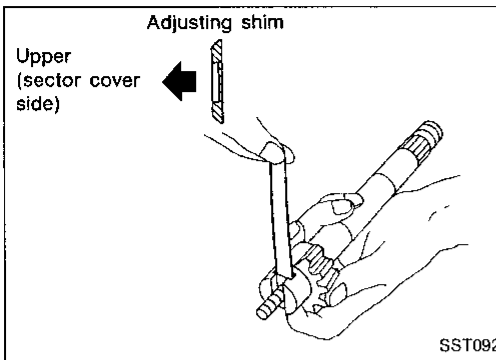

REAR COVER O-RING AND OIL SEAL

1. Install new O-ring and oil seal.
2. Install rear cover, then snap ring.

CAUTION:

- a. Turn snap ring to make sure it fits into grooves.
- b. Always install snap ring with its rounded edge facing rear cover.

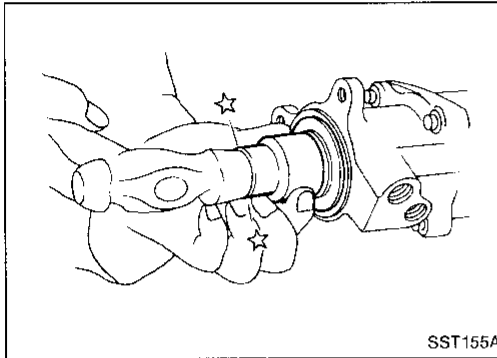

REAR HOUSING O-RING

1. Install new O-rings.
 - a. Before installing, apply a thin coat of vaseline to O-ring.
 - b. Make sure O-ring is installed correctly and is not damaged by worm gear.

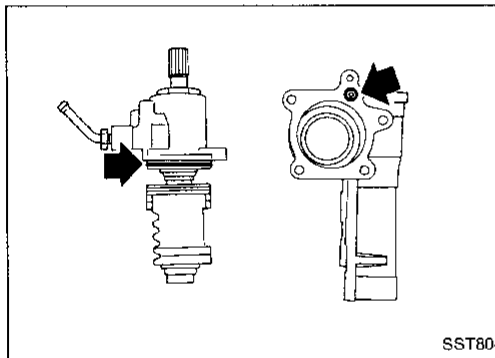

2. Gradually insert worm gear and rear housing assembly into gear housing, being careful not to damage oil seal and O-rings.
3. Install torx screws.

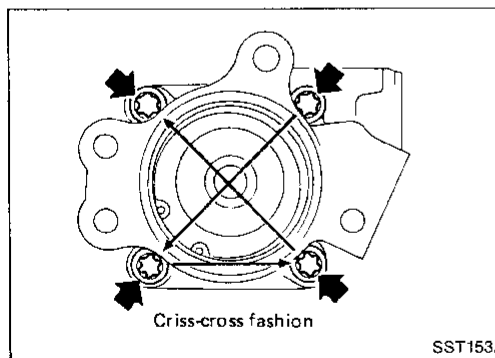

POWER STEERING GEAR (Model: PB48S)

Assembly (Cont'd)

SECTOR SHAFT

1. Set piston rack at straight-ahead position.
Turn piston rack about 10° to 15° toward yourself with your finger. This is for smooth insertion of sector gear.
2. Wrap vinyl tape around serration area of sector shaft.
The reason is that vinyl tape prevents oil seal lip from being damaged during insertion.
3. Gradually insert sector shaft into gear housing, being careful not to damage oil seal.

When inserting sector shaft into gear housing, remove plastic film. Be careful not to drop bearings into gear housing.

4. Tighten sector shaft cover bolts.
5. Check turning torque and steering gear preload.

Refer to Inspection and Adjustment of POWER STEERING GEAR. (ST-26)

- If there is a great difference between values of turning torque before and after disassembly, it must be assumed that some new problem has occurred. It will be necessary to replace the entire assembly.

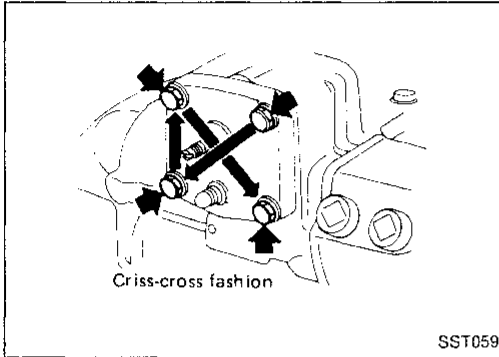
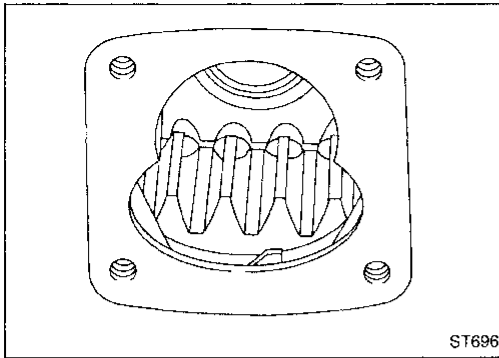

GI
MA
EM
LC
EF & EC
FE
CL
WT
AT
TF
PD
FA
RA
BR
ST
BF
HA
EL
IDX

POWER STEERING OIL PUMP

Disassembly and Assembly

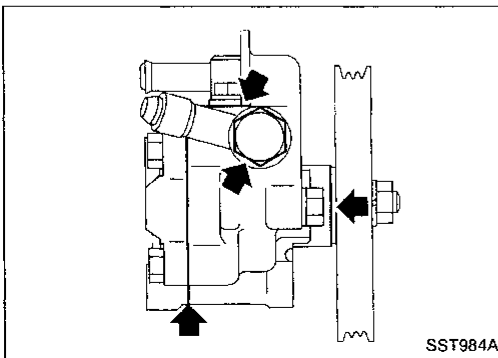
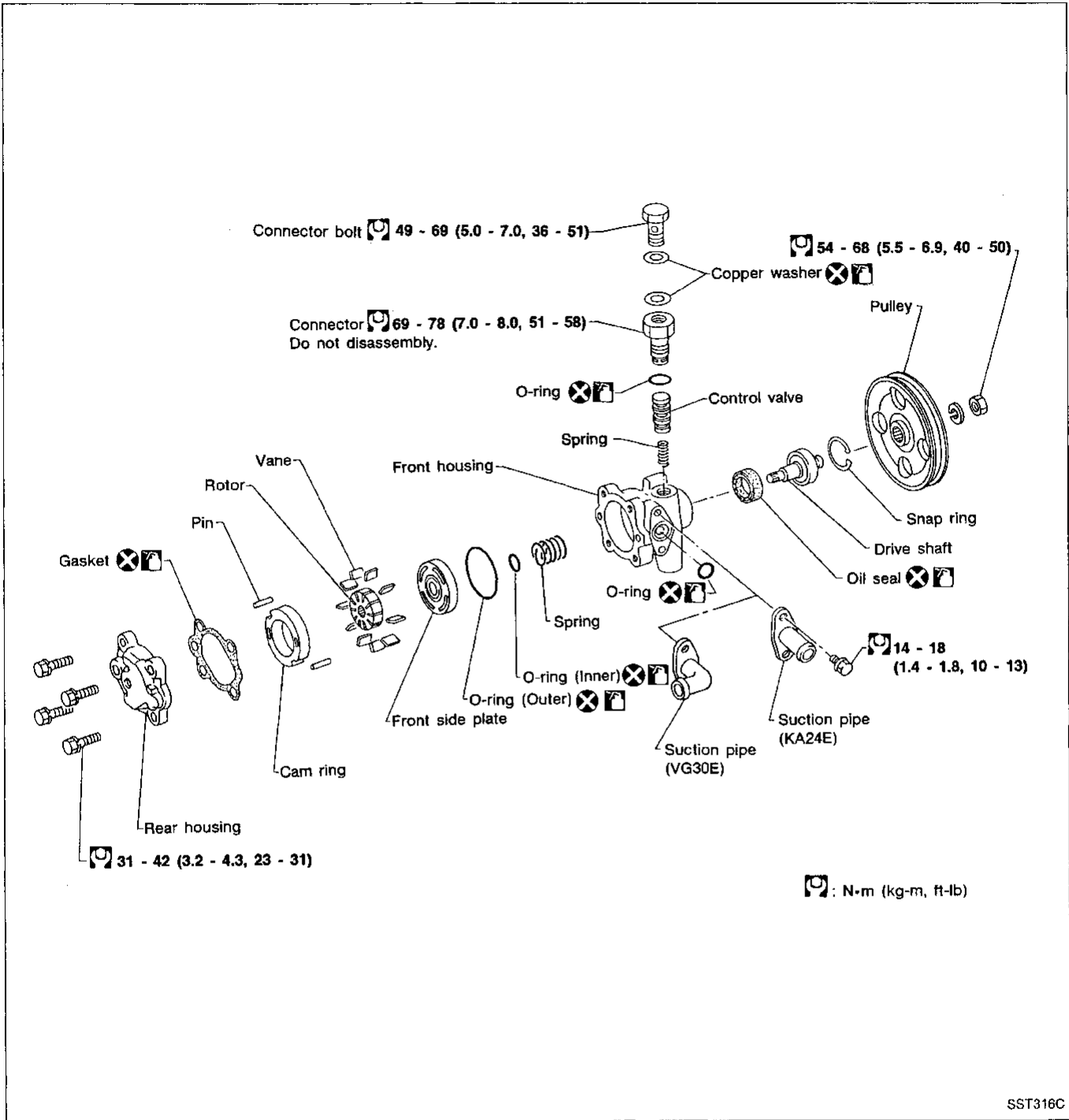

Pre-disassembly Inspection

Disassemble the power steering oil pump only if the following items are found.

- Oil leak from any point shown in the figure.
- Deformed or damaged pulley.
- Poor performance.

POWER STEERING OIL PUMP

Disassembly

CAUTION:

- Parts which can be disassembled are strictly limited. Never disassemble parts other than those specified.
- Disassemble in as clean a place as possible.
- Clean your hands before disassembly.
- Do not use rags; use nylon cloths or paper towels.
- Follow the procedures and cautions in the Service Manual.
- When disassembling and reassembling, do not let foreign matter enter or contact the parts.

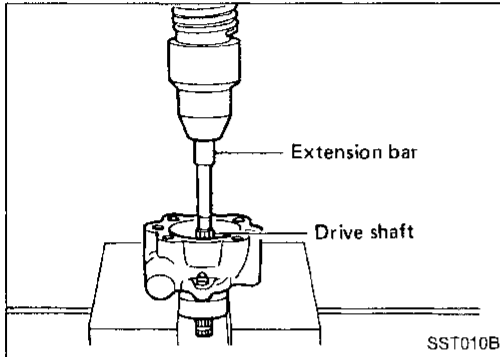

- Remove snap ring, then draw drive shaft out.
Be careful not to drop drive shaft.

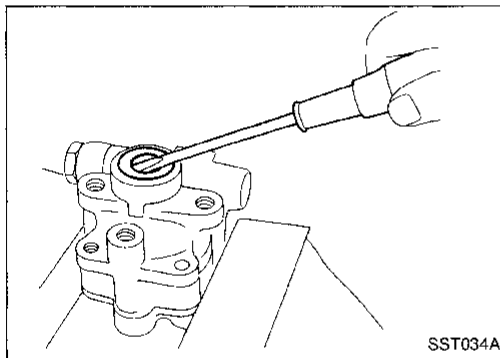

- Remove oil seal.
Be careful not to damage front housing.

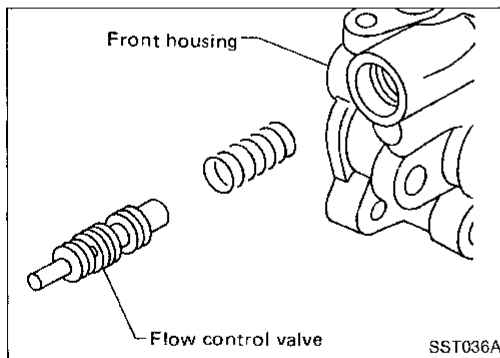

- Remove connector.
Be careful not to drop control valve.

Inspection

Inspect each component part for wear, deformation, scratches, and cracks. If damage is found, replace the part.

GI

MA

EM

LC

EF &
EC

FE

CL

MT

AT

TF

PD

FA

RA

BR

ST

BF

HA

EL

DX

POWER STEERING OIL PUMP

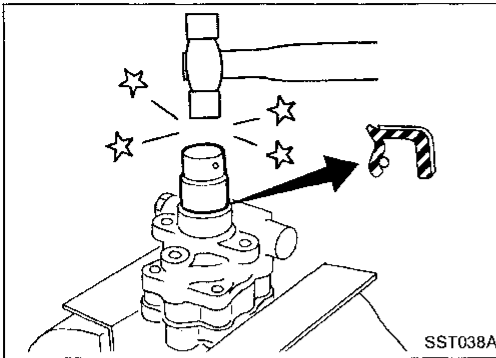

Assembly

Assemble oil pump, noting the following instructions.

- Make sure O-rings and oil seal are properly installed.
- Always install new O-rings and oil seal.
- Be careful of oil seal direction.
- Cam ring, rotor and vanes must be replaced as a set if necessary.
- Coat each part with ATF when assembling.

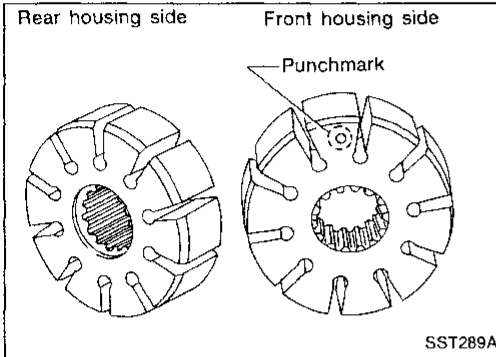

- Pay attention to the direction of rotor.

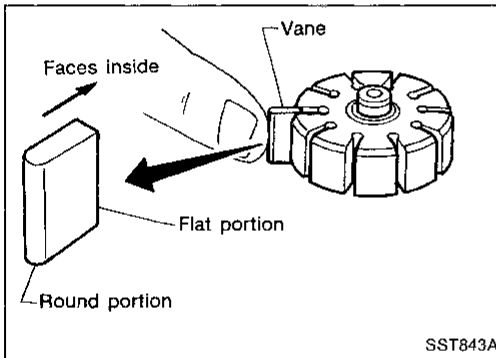

- When assembling vanes to rotor, rounded surfaces of vanes must face cam ring side.

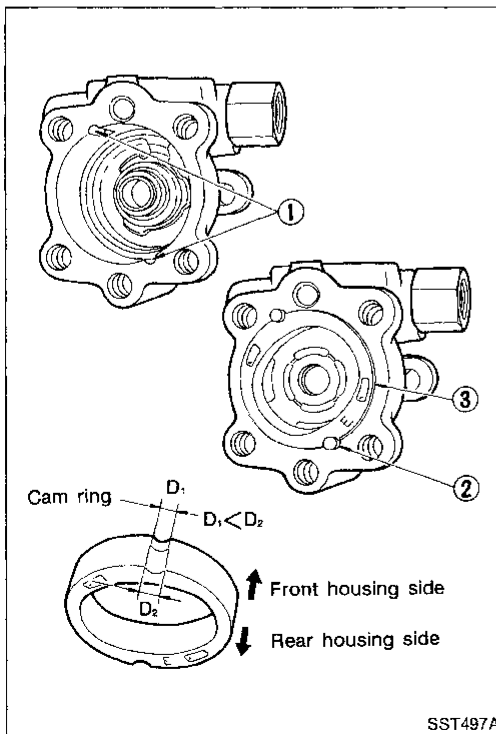

- Insert pin ② into pin groove ① of front housing and front side plate. Then install cam ring ③ as shown at left.

STEERING LINKAGE

Removal and Installation

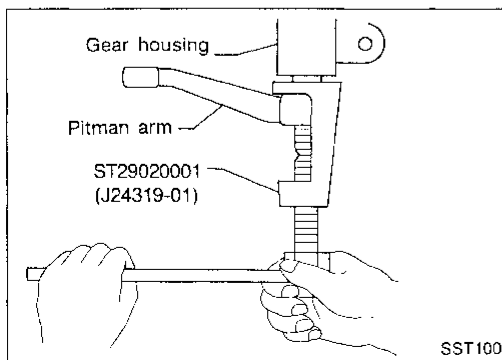
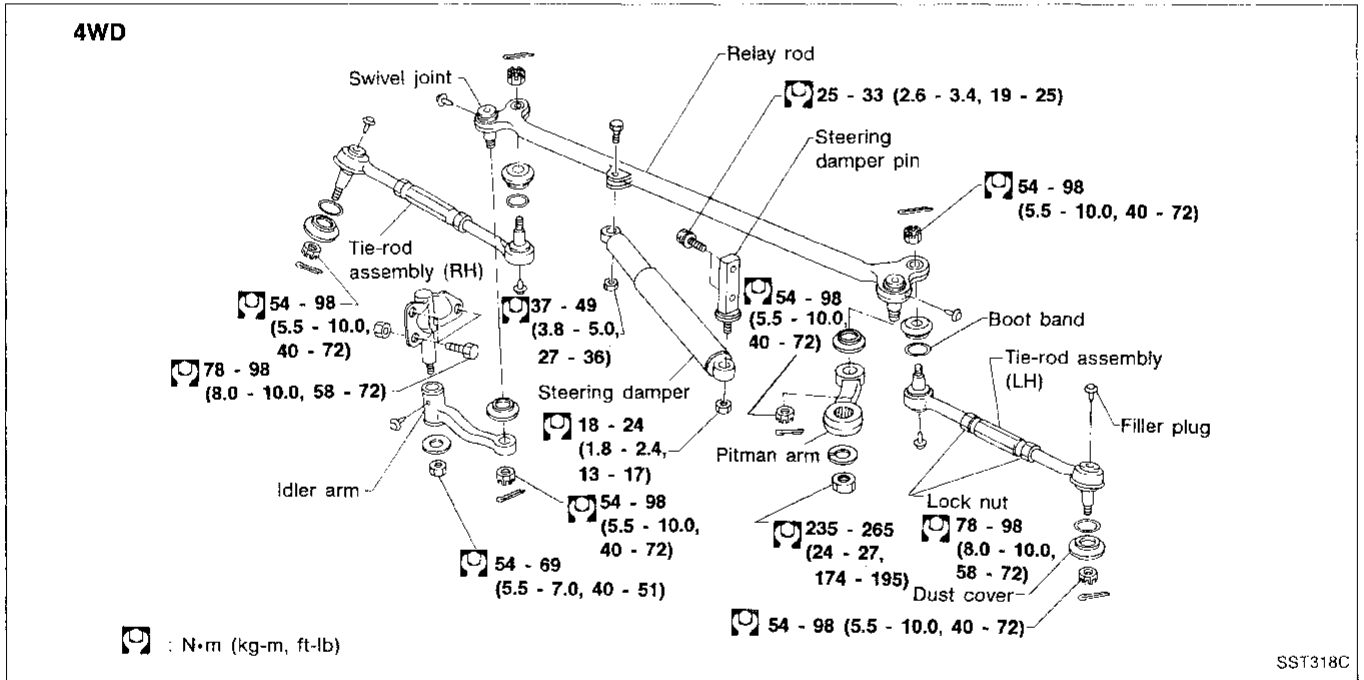
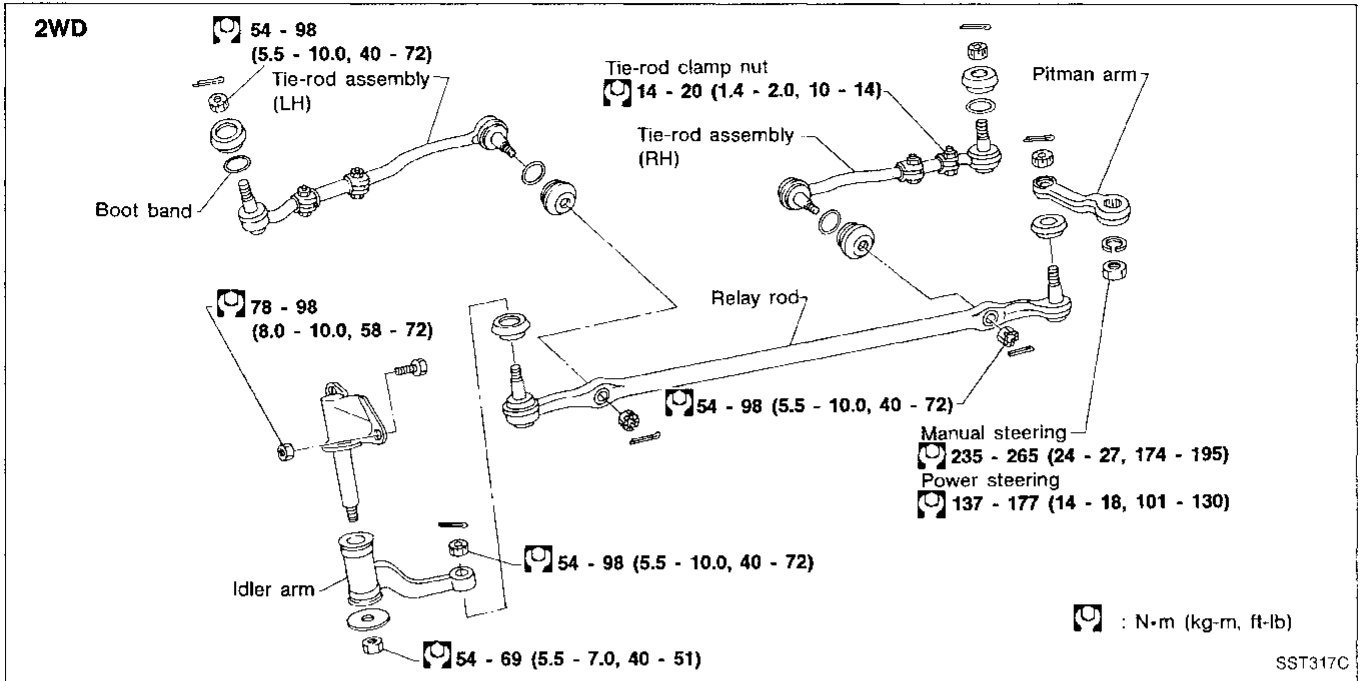

Remove gear arm with Tool.

GI
MA
EM
LC
EF & EC
FE
CL
WT
AT
TF
PD
FA
RA
BR
ST
BF
HA
EL
IDX

STEERING LINKAGE

Removal and Installation (Cont'd)

Remove tie-rod from knuckle arm with Tool.

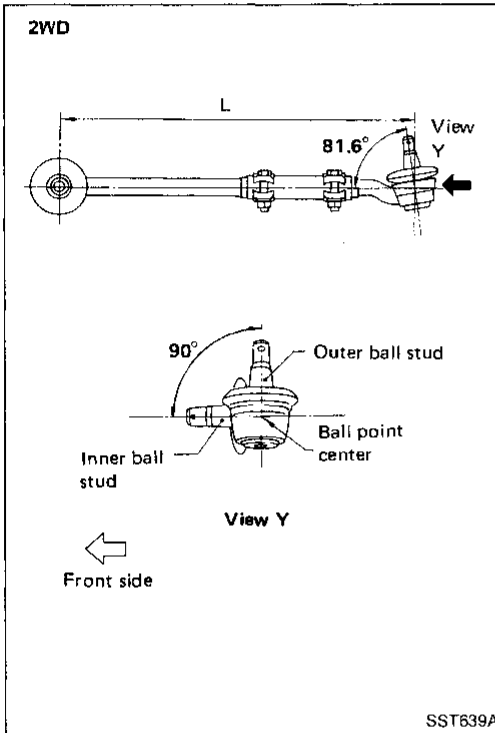
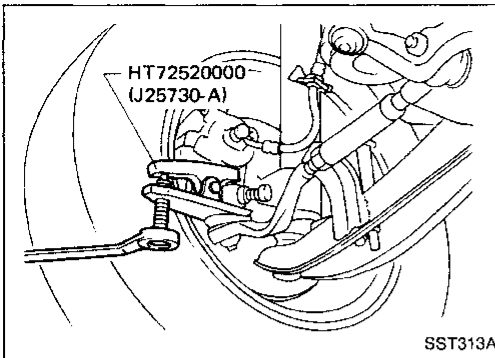

Disassembly

IDLER ARM ASSEMBLY

- Apply coat of multi-purpose grease to bushing.
- Press bushing into idler body, and insert shaft of idler bracket carefully until bushing protrudes.

CROSS ROD AND TIE-ROD

1. When tie-rod ball joints and tie-rod bar are separated, adjust tie-rod length correctly.

Adjustment should be done between ball stud centers.

L: Standard

344 mm (13.54 in) ... 2WD

2. Lock tie-rod clamp nut so that ball joint on outer ball stud is as follows with respect to that on inner ball stud.

CAUTION:

Make sure that tie-rod bars are screwed into tie-rod tube more than 35 mm (1.38 in).

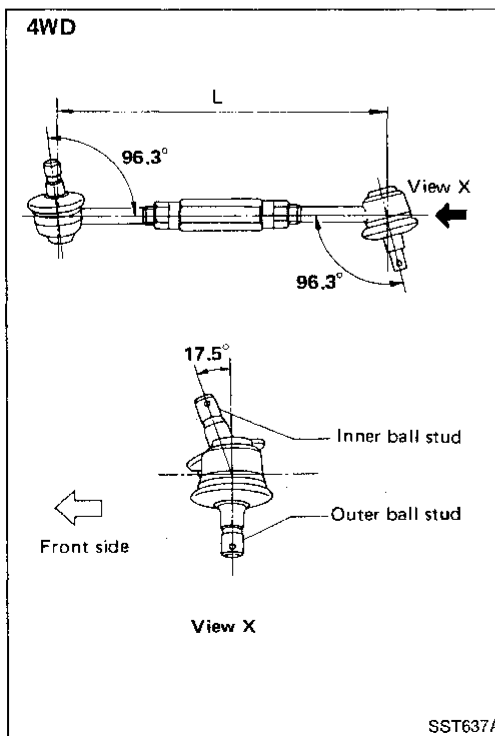

L: Standard

281 mm (11.06 in) ... 4WD

CAUTION:

Make sure that tie-rod bars are screwed into tie-rod tube more than 35 mm (1.38 in).

STEERING LINKAGE

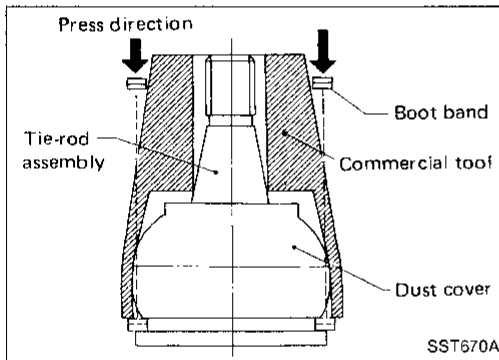
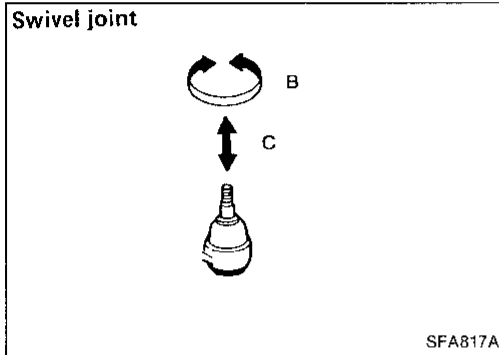
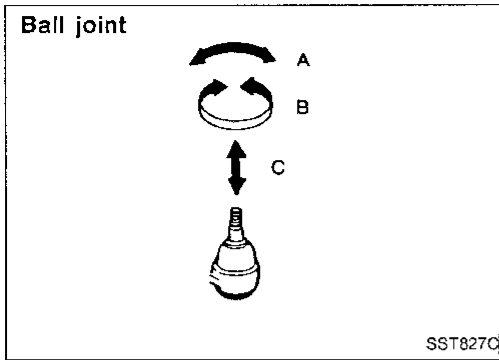

Inspection

BALL JOINT AND SWIVEL JOINT

1. Check joints for play. If ball or swivel stud is worn and play in axial direction is excessive or joint is hard to swing, replace as a complete unit.

Swinging force (Measure point: Cotter pin hole) "A":

Ball joint

10.8 - 107.9 N (1.1 - 11.0 kg, 2.4 - 24.3 lb)

Rotating torque "B":

0.5 - 4.9 N·m (5 - 50 kg-cm, 4.3 - 43.4 in-lb)

Axial end play "C":

Ball joint

0.1 - 0.8 mm (0.004 - 0.031 in)

Swivel joint

0.1 - 1.0 mm (0.004 - 0.039 in)

2. Check condition of dust cover. If it is cracked excessively, replace dust cover.

- When replacing dust cover, be careful not to damage it.
- Lubricate joint with multi-purpose grease, if necessary.
- When installing boot band with *commercial service tool, be careful not to overexpand it.

* Refer to Preparation (ST-3).

CAUTION:

Be careful not to apply grease or oil to taper of joint.

IDLER ARM ASSEMBLY

- Check rubber bushing of idler arm for breakage, wear or play, and if necessary replace.
- Lubricate idler arm assembly with recommended multi-purpose grease, if necessary.

When lubricating, refer to BALL JOINT AND SWIVEL JOINT.

CROSS ROD AND TIE-ROD

Check tie-rod and cross rod for breakage, bend or crack, and replace with a new one if necessary.

STEERING DAMPER

Check for oil leakage of damper, and replace if necessary.

FIXING LOCATION

- Check fixing location (nuts and cotter pins) for looseness, play or breakage.
- When looseness or play is found, check for wear on tapered portion of joints, gear arm of idler arm.
- When reassembling each joint, use new cotter pins.

GI

MA

EM

LC

EF &

EC

FE

CL

VT

AT

TF

PD

FA

RA

BR

ST

BF

HA

EL

IDX

SERVICE DATA AND SPECIFICATIONS (SDS)

General Specifications

Steering column type (Collapsible)	Manual steering	Power steering	
		2WD TRUCK	Except 2WD truck
Steering gear type	VB66K	PB48S	PB59K
Turns of steering wheel on the vehicle (Lock-to-lock)	5.8 (2WD) 5.9 (4WD)	3.7	3.4 2.5*1
Steering gear ratio	24.4 - 26.84	16.5	15

Steering wheel axial play mm (in)	0 (0)
Steering wheel play mm (in)	35 (1.38) or less

*1: 4WD: Tire size ... 10.50R15

Inspection and Adjustment

STEERING COLUMN

Unit: mm (in)

	Dimension "L"
2WD model	918.0 - 919.6 (36.14 - 36.20)
4WD model	886.1 - 887.7 (34.89 - 34.95)

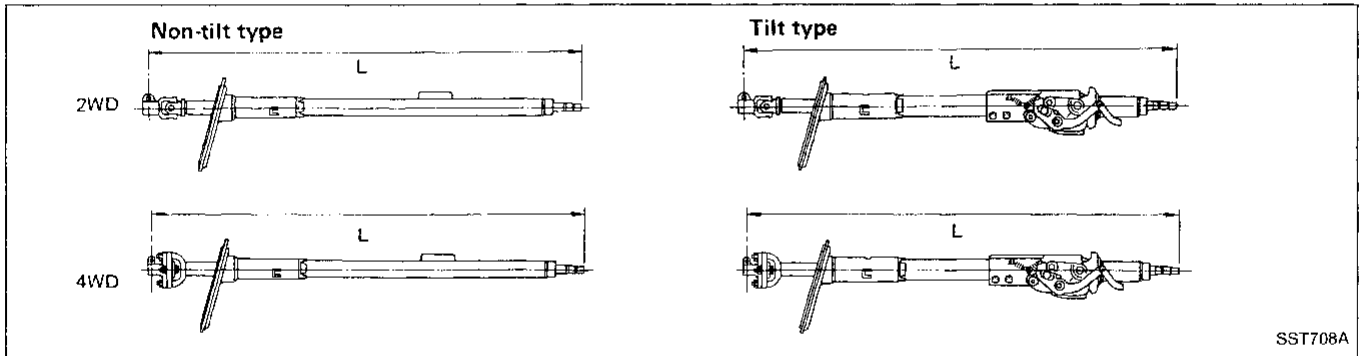

SST708A

SERVICE DATA AND SPECIFICATIONS (SDS)

Inspection and Adjustment (Cont'd)

MANUAL STEERING GEAR (Model: VB66K)

Worm bearing preload N-m (kg-cm, in-lb)	0.69 - 0.88 (7.0 - 9.0, 6.1 - 7.8)	
Steering gear turning torque N-m (kg-cm, in-lb)		
360° position from straight-ahead position	0.69 - 0.88 (7.0 - 9.0, 6.1 - 7.8)	
Straight-ahead position (As compared with steering wheel turned 360°)	0.20 - 0.39 (2.0 - 4.0, 1.7 - 3.5)	
Maximum turning torque	1.08 (11.0, 9.5)	
Backlash at pitman arm top end (in a straight-ahead position) mm (in)	0 - 0.1 (0 - 0.004)	
End play (Between sector shaft and adjusting screw) mm (in)	0.01 - 0.03 (0.0004 - 0.0012)	
Adjusting shim thickness	Thickness mm (in)	Part number
	1.95 (0.0768)	48219-84500
	2.00 (0.0787)	48130-84500
	2.05 (0.0807)	48131-84500
Oil capacity ℓ (US pt, Imp pt)	Approx. 0.62 (1-3/8, 1-1/8)	

STEERING LINKAGE

Applied model	2WD	4WD
Relay-rod swivel joint		
Rotating torque N-m (kg-cm, in-lb)	—	0.5 - 4.9 (5 - 50, 4.3 - 43.4)
Axial end play mm (in)	—	0.1 - 1.0 (0.004 - 0.039)
Tie-rod & relay-rod ball joint		
Swinging force at cotter pin hole N (kg, lb)	10.8 - 107.9 (1.1 - 11.0, 2.4 - 24.3)	
Rotating torque N-m (kg-cm, in-lb)	0.5 - 4.9 (5 - 50, 4.3 - 43.4)	
Axial end play mm (in)	0.1 - 0.8 (0.004 - 0.031)	
Tie-rod standard engine (L) mm (in)	344 (13.54)	281 (11.06)

POWER STEERING SYSTEM (Model: PB48S)

Steering wheel turning force (at 360° from neutral position and circumference of steering wheel) N (kg, lb)	24.5 - 29.4 (2.5 - 3.0, 5.5 - 6.6)	
Oil pump pressure kPa (kg/cm ² , psi)	7,649 - 8,238 (78 - 84, 1,109 - 1,194) at idling	
Fluid capacity mℓ (US fl oz, Imp fl oz)	Approximately 900 - 1,000 (30.4 - 33.8, 31.7 - 35.2)	
Normal operating temperature °C (°F)	60 - 80 (140 - 176)	
Steering gear turning torque N-m (kg-cm, in-lb)		
360° position from straight-ahead position	0.7 - 1.2 (7 - 12, 6.1 - 10.4)	
Straight-ahead position (As compared with steering wheel turned 360°)	0.1 - 0.4 (1 - 4, 0.9 - 3.5) higher	
Backlash at pitman arm top end (in a straight- ahead position) mm (in)	0 - 0.1 (0 - 0.004)	
End play (Between sector shaft and adjusting screw) mm (in)	0.01 - 0.03 (0.0004 - 0.0012)	
Adjusting shim thickness	Thickness mm (in)	Part number
	1.575 - 1.600 (0.0620 - 0.0630)	48213-B0100
	1.550 - 1.575 (0.0610 - 0.0620)	48214-B0100
	1.525 - 1.550 (0.0600 - 0.0610)	48215-B0100
	1.500 - 1.525 (0.0591 - 0.0600)	48216-B0100
	1.475 - 1.500 (0.0581 - 0.0591)	48217-B0100
	1.450 - 1.475 (0.0571 - 0.0581)	48218-B0100

GI

MA

EM

LC

EF &
EC

FE

CL

VT

AT

TF

PD

FA

RA

BR

ST

BF

HA

EL

IDX

SERVICE DATA AND SPECIFICATIONS (SDS)

Inspection and Adjustment (Cont'd)

POWER STEERING SYSTEM (Model: PB59K)

Steering wheel turning force (at 360° from neutral position and circumference of steering wheel) N (kg, lb)	39 (4, 9) or less
Oil pump pressure kPa (kg/cm ² , psi)	7,649 - 8,238 (78 - 84, 1,109 - 1,194) at idling
Fluid capacity ml (US fl oz, Imp fl oz)	Approximately 1,000 - 1,100 (33.8 - 37.2, 35.2 - 38.7)
Normal operating temperature °C (°F)	60 - 80 (140 - 176)
Steering gear turning torque N·m (kg-cm, in-lb)	
360° position from straight-ahead position	0.15 - 0.78 (1.5 - 8.0, 1.3 - 6.9)
Straight-ahead position (As compared with steering wheel turned 360°)	0.25 - 1.32 (2.5 - 13.5, 2.2 - 11.7) higher
Maximum turning torque	1.03 - 1.47 (10.5 - 15, 9.1 - 13.0)
Backlash at pitman arm top end (in a straight-ahead position) mm (in)	0 - 0.1 (0 - 0.004)
End play (at sector shaft end in neutral position) mm (in)	0.1 (0.004) or less