

TRANSFER

SECTION **TF**

GI

MA

EM

LC

FF &
EC

CONTENTS

PREPARATION	2	REPAIR FOR COMPONENT PARTS	16	FE
Special Service Tools.....	2	Mainshaft.....	16	
Commercial Service Tools.....	4	Front Drive Shaft.....	18	
ON-VEHICLE SERVICE	5	Counter Gear.....	19	CL
Checking Transfer Oil.....	5	Main Gear.....	19	
Replacing Oil Seal.....	5	Front Case.....	21	MT
REMOVAL AND INSTALLATION	7	Front Case Cover.....	21	
Removal.....	7	Bearing Retainer.....	22	
Installation.....	7	Rear Case.....	22	AT
TRANSFER GEAR CONTROL	8	Shift Control Components.....	23	
MAJOR OVERHAUL	9	ASSEMBLY	24	TF
Case Components.....	9	SERVICE DATA AND SPECIFICATIONS (SDS)	31	
Gear Components.....	10	General Specifications.....	31	
Shift Control Components.....	11	Inspection and Adjustment.....	31	PD
DISASSEMBLY	12			

FA

RA

BR

ST

BF



HA

EL

IDX

PREPARATION

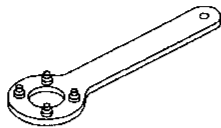
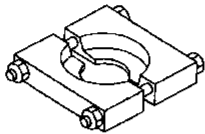
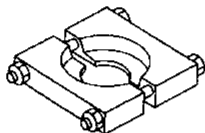
Special Service Tools

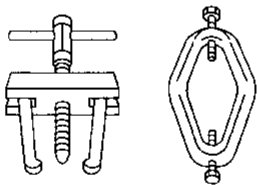
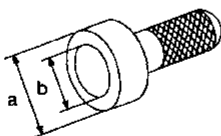
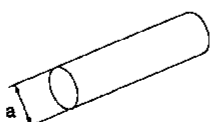
Tool number (Kent-Moore No.) Tool name	Description	
ST38060002 (J34311) Flange wrench	 <p style="text-align: center;">NT113</p>	Removing companion flange nut Installing companion flange nut
ST30021000 (J22912-01) Puller	 <p style="text-align: center;">NT071</p>	Removing counter gear front bearing (Use with ST36710010) Removing L & H hub
ST30031000 (J22912-01) Puller	 <p style="text-align: center;">NT071</p>	Removing counter gear rear bearing (Use with ST36710010)
ST33290001 (J25810-A) Puller	 <p style="text-align: center;">NT076</p>	Removing center case oil seal Removing rear oil seal
ST33051001 (J22888) Puller	 <p style="text-align: center;">NT114</p>	Removing companion flange
ST30720000 ① (J25273) ② (J25405) Drift	 <p style="text-align: center;">NT115</p>	① Installing center case oil seal ② Installing rear oil seal a: 77 mm (3.03 in) dia. b: 55.5 mm (2.185 in) dia.
ST36710010 (—) Drift	 <p style="text-align: center;">NT063</p>	Removing counter gear front bearing (Use with ST30021000) Removing counter gear rear bearing (Use with ST30031000) a: 34.5 mm (1.358 in) dia.

PREPARATION

Special Service Tools (Cont'd)

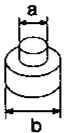
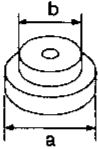
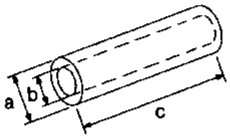
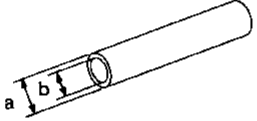
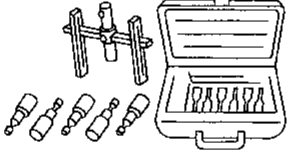
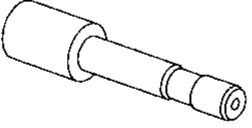
Tool number (Kent-Moore No.) Tool name	Description	
ST33061000 (J8107-2) Drift	 <p style="text-align: center;">NT116</p>	Removing main gear bearing GF MA a: 28.5 mm (1.122 in) dia. b: 38 mm (1.50 in) dia.
ST30613000 ① (J25742-3) ② (J34339) Drift	 <p style="text-align: center;">NT073</p>	① Installing main gear bearing ② Installing cover oil seal EM LC a: 72 mm (2.83 in) dia. b: 48 mm (1.89 in) dia.
(J35864) Drift	 <p style="text-align: center;">NT117</p>	Installing shift shaft oil seal EF & EC FE CL a: 26 mm (1.02 in) dia. b: 20 mm (0.79 in) dia. c: 150 mm (5.91 in)
(J26092) Drift	 <p style="text-align: center;">NT065</p>	Seating counter gear assembly VT AT a: 44.5 mm (1.752 in) dia. b: 38.5 mm (1.516 in) dia.
(J34291) Shim setting gauge set	 <p style="text-align: center;">NT101</p>	Selecting counter gear rear bearing shim TF PD
(J34291-20) Plunger-shim setting gauge	 <p style="text-align: center;">NT118</p>	Selecting counter gear rear bearing shim FA RA BR

PREPARATION

Commercial Service Tools

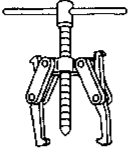
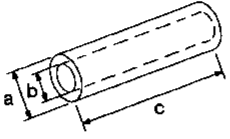
Tool name	Description
Puller	<div style="display: flex; align-items: center; justify-content: center;">  <div style="margin-left: 20px;"> <p>Removing front drive shaft front bearing</p> <p>Removing front drive shaft rear bearing</p> <p>Removing main gear bearing</p> </div> </div> <p style="margin-top: 10px;">NT077</p>
Drift	<div style="display: flex; align-items: center; justify-content: center;">  <div style="margin-left: 20px;"> <p>① Installing mainshaft rear bearing</p> <p>② Installing L & H hub</p> <p>① a: 50 mm (1.97 in) dia.</p> <p> b: 42 mm (1.65 in) dia.</p> <p> c: 180 mm (7.09 in)</p> <p>② a: 60 mm (2.36 in) dia.</p> <p> b: 50 mm (1.97 in) dia.</p> <p> c: 60 mm (2.36 in)</p> </div> </div> <p style="margin-top: 10px;">NT117</p>

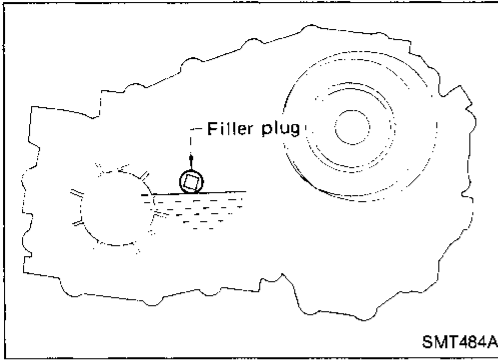

Checking Transfer Oil

- Check transfer for oil leakage.
- Check oil level.

Genuine Nissan ATF or equivalent type DEXRON™II fluid is used for the transfer .

Never add gear oil (75W-90) to Automatic Transmission Fluid.

GI

MA

EM

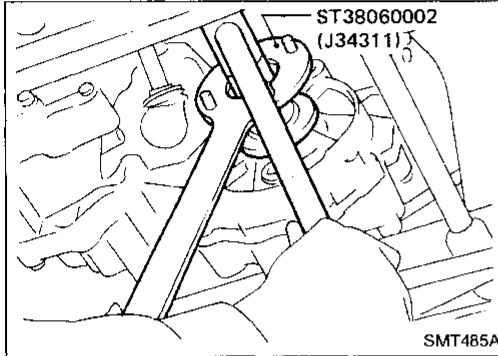

Replacing Oil Seal

CENTER CASE OIL SEAL

1. Remove front propeller shaft. — Refer to PD section.
2. Remove companion flange nut.

LC

EF &
EC

FE

CL

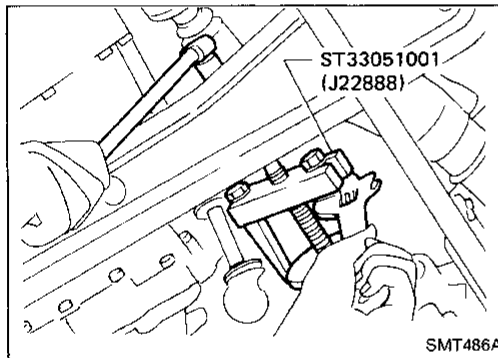

3. Remove companion flange.

MT

AT

TF

PD

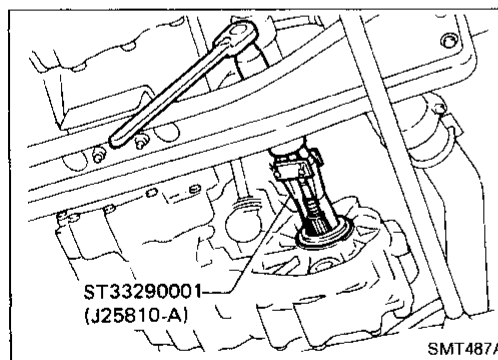

4. Remove center case oil seal.
5. Install center case oil seal.

Before installing, apply multi-purpose grease to seal lip.

6. Install companion flange.

FA

RA

BR

ST

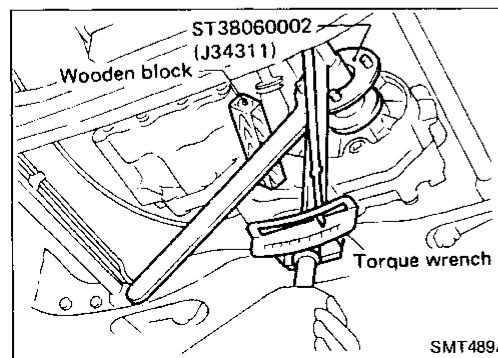

7. Tighten nut to the specified torque.
8. Install front propeller shaft.

BF

HA

EL

IDX

ON-VEHICLE SERVICE

Replacing Oil Seal (Cont'd)

SHIFT SHAFT OIL SEAL

1. Remove front propeller shaft. — Refer to PD section.
2. Remove companion flange. — Refer to center case oil seal service on previous page.
3. Remove transfer control lever from transfer outer shift lever. Then remove outer shift lever.

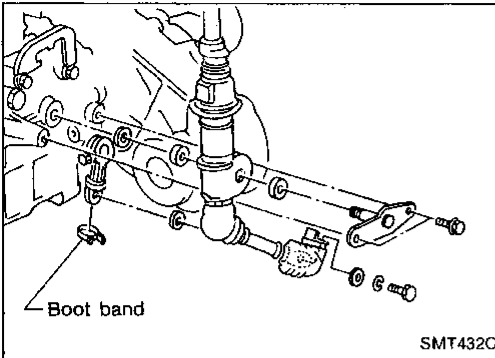

4. Remove shift shaft oil seal.
Be careful not to damage cross shaft.

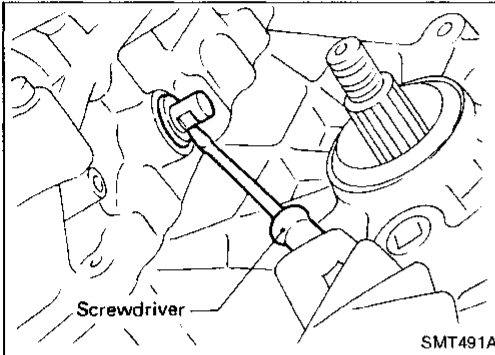

5. Install shift shaft oil seal.
Before installing, apply multi-purpose grease to seal lip.
6. Install transfer control linkage.
7. Install companion flange. — Refer to center case oil seal service on previous page.
8. Install front propeller shaft.

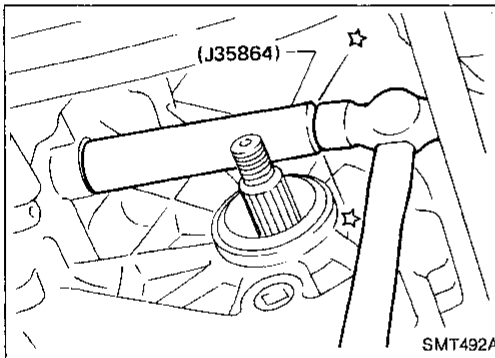

REAR OIL SEAL

1. Remove rear propeller shaft. — Refer to PD section.
2. Remove rear oil seal.

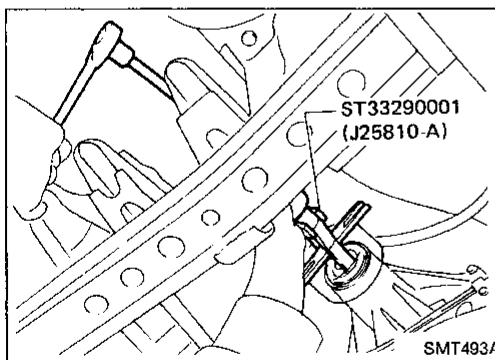

3. Install rear oil seal.
Before installing apply multi-purpose grease to seal lip.
4. Install rear propeller shaft.

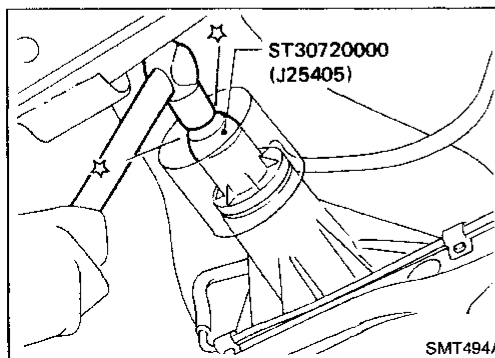

REMOVAL AND INSTALLATION

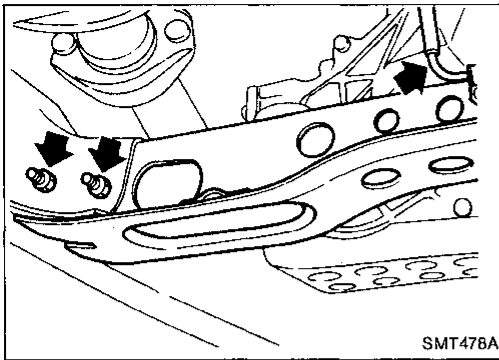

Removal

- Drain oil from transfer and transmission.
- Remove front and rear propeller shaft. — Refer to section PD.
- Insert plug into rear oil seal after removing propeller shaft.

CAUTION:

Be careful not to damage spline, sleeve yoke and rear oil seal, when removing propeller shaft.

- Remove torsion bar spring. — Refer to REMOVAL of Torsion Bar Spring in section FA. Then remove second cross-member.
- Remove transfer control lever from transfer outer shift lever.
- Remove transfer from transmission.

WARNING:

Support transfer while removing it.

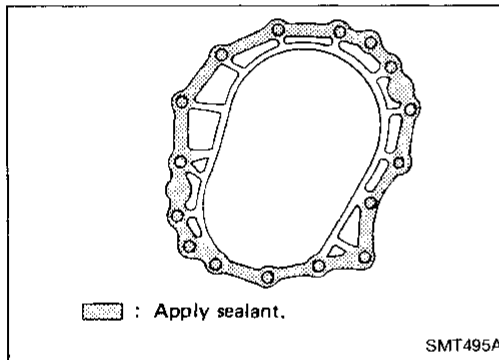
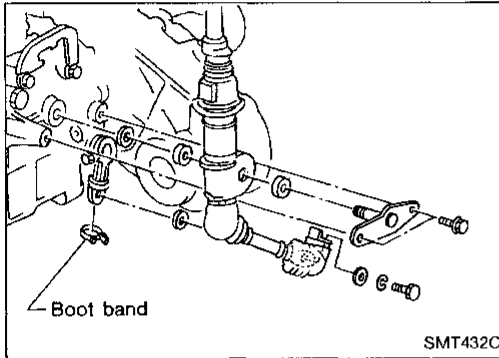

Installation

- Apply recommended sealant to mating surface to transmission. (M/T model only)

Recommended sealant:

Nissan genuine part (KP610-00250) or equivalent

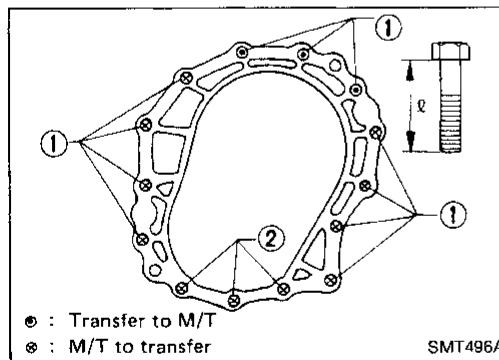

- Tighten bolts securing transfer.

M/T model

Bolt No.	Tightening torque N·m (kg·m, ft·lb)	ℓ mm (in)
①	31 - 41 (3.2 - 4.2, 23 - 30)	45 (1.77)
②	31 - 41 (3.2 - 4.2, 23 - 30)	60 (2.36)

A/T model

Bolt No.	Tightening torque N·m (kg·m, ft·lb)	ℓ mm (in)
①	31 - 41 (3.2 - 4.2, 23 - 30)	60 (2.36)
②	31 - 41 (3.2 - 4.2, 23 - 30)	60 (2.36)

TRANSFER GEAR CONTROL

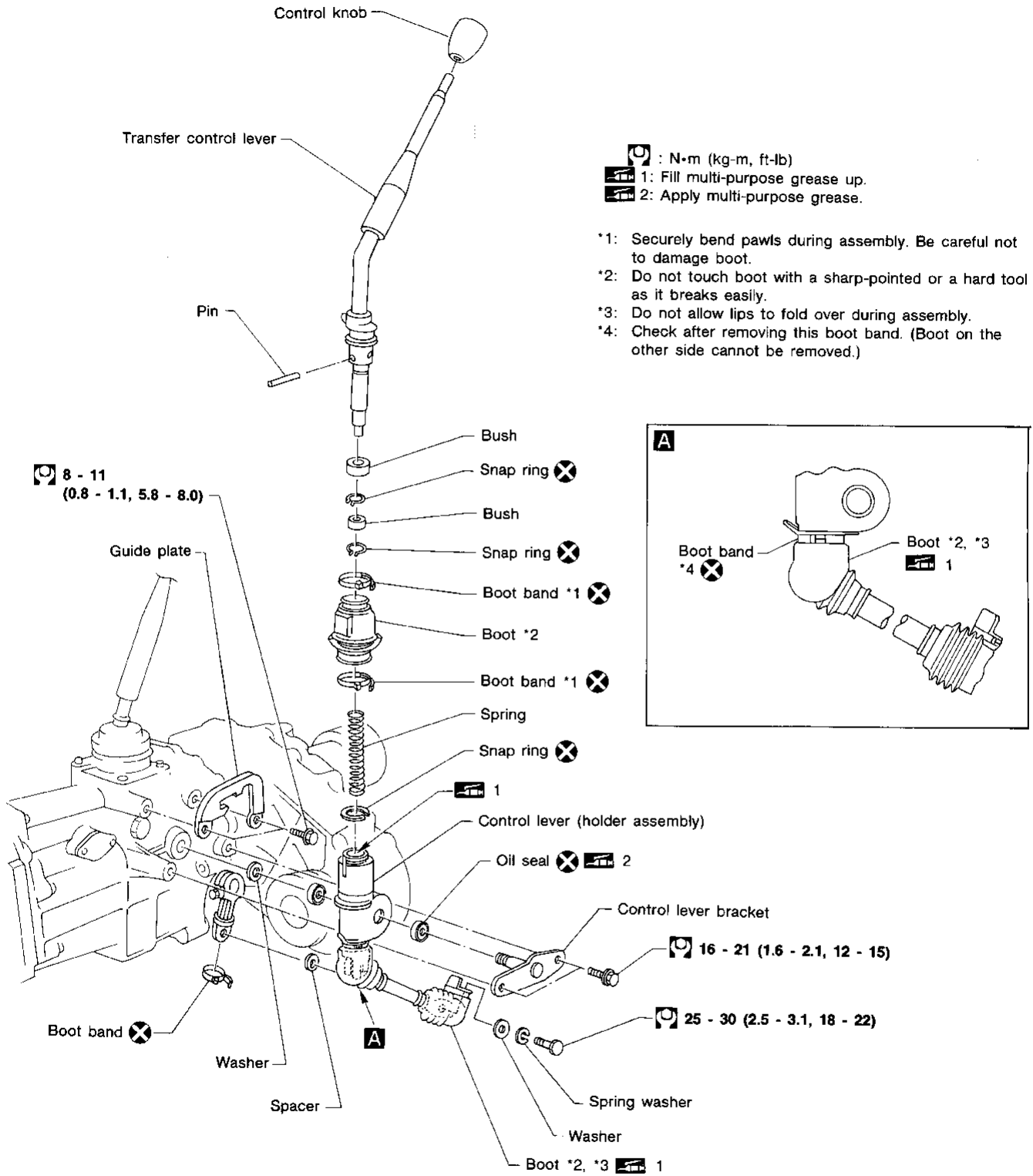

Gear Components

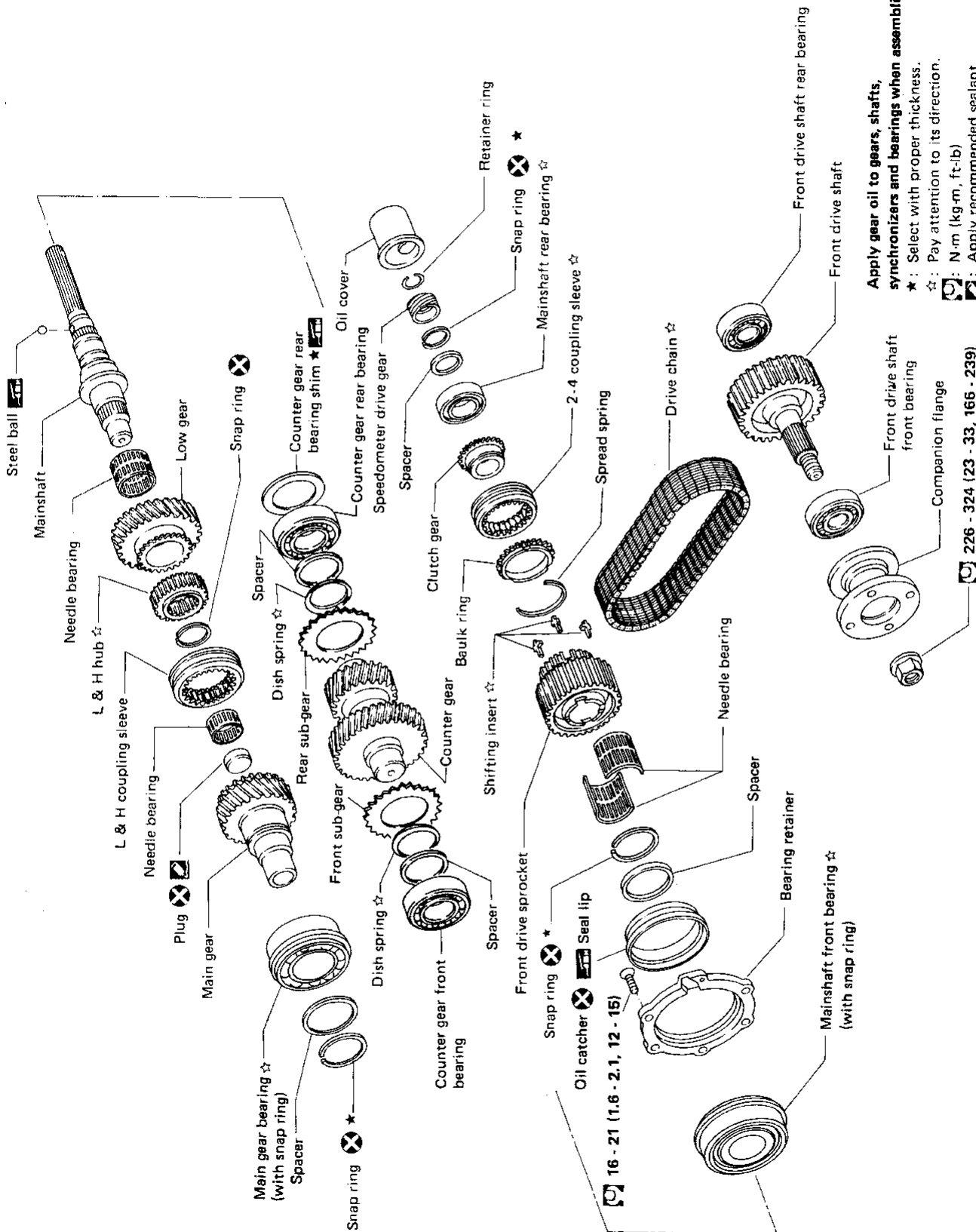

Apply gear oil to gears, shafts, synchronizers and bearings when assembling.

★ : Select with proper thickness.

☆ : Pay attention to its direction.

⊗ : N.m (kg.m, ft.-lb)

⊠ : Apply recommended sealant (Nissan genuine part: KP610-00250) or equivalent.

226 - 324 (23 - 33, 166 - 239)

Shift Control Components

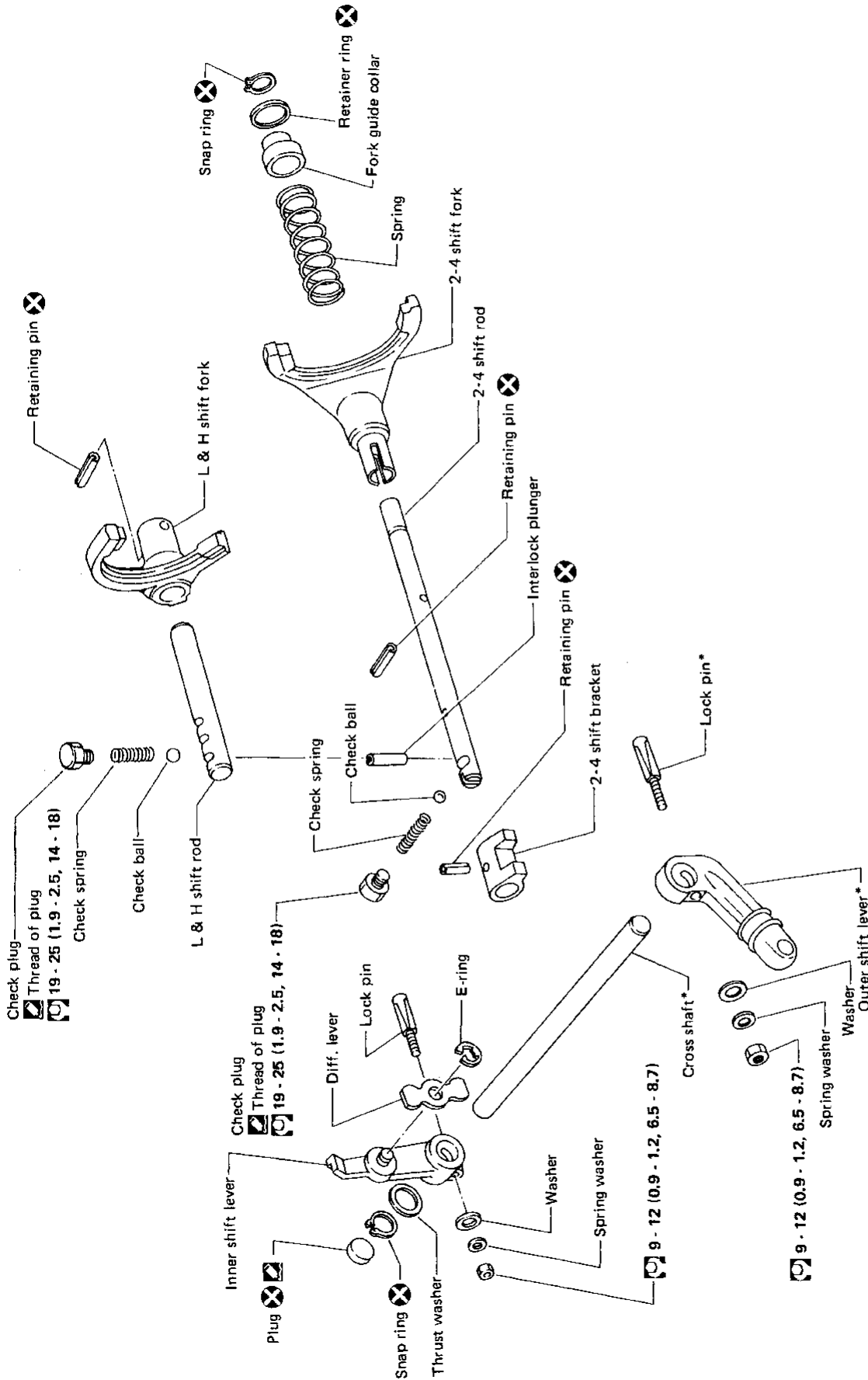

* : If these parts require to be replaced, replace them as a set.
 [] : N·m (kg·m, ft·lb)
 [] : Apply recommended sealant (Nissan genuine part: KP610-00250) or equivalent.

- GI
- MA
- EM
- LC
- EF & EC
- FE
- CL
- MT
- AT
- TF**
- PD
- FA
- RA
- BR
- ST
- BF
- HA
- EL
- IX

DISASSEMBLY

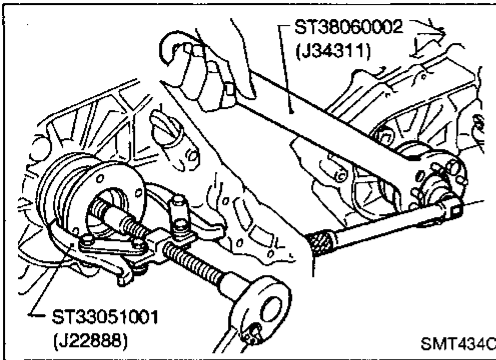

1. Remove nut of companion flange.
2. Remove companion flange.

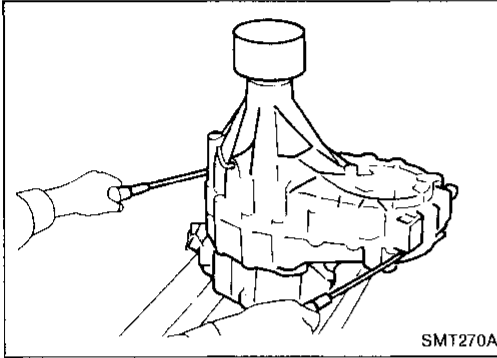

3. Remove 4WD switch.
 4. Remove rear case.
- Be careful not to damage the mating surface.**

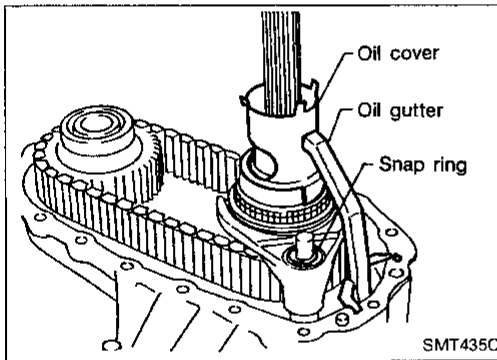

5. Remove oil cover and oil gutter.
6. Remove snap ring from 2-4 shift rod.

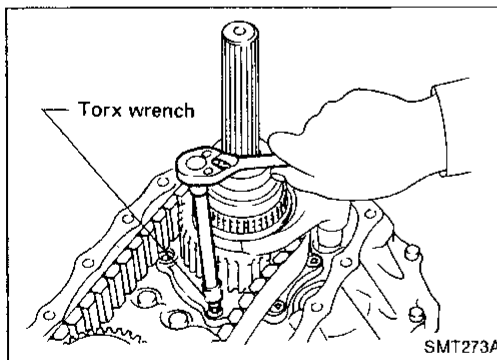

7. Remove bolts securing bearing retainer.
- This step is necessary to remove mainshaft from center case.**

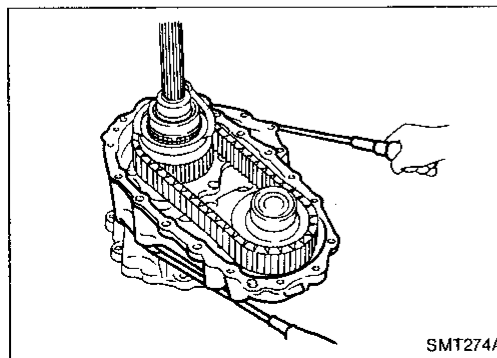

8. Remove bolts securing center case to front case and then separate center case and front case.

DISASSEMBLY

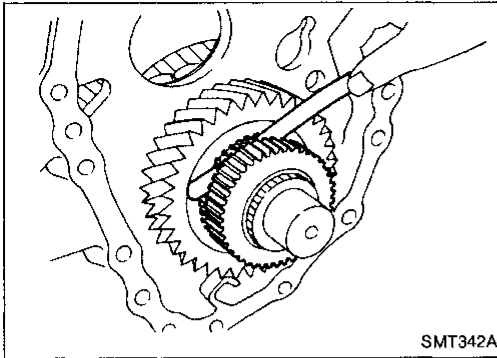

9. Measure end play of low gear.

Standard:

0.2 - 0.35 mm (0.0079 - 0.0138 in)

If end play is beyond the maximum value, check low gear and L & H hub for wear.

GI

MA

EM

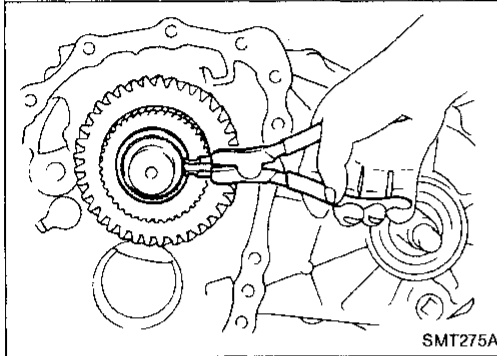

10. Disassemble center case assembly.

a. Remove snap ring from mainshaft.

LC

EF &
EC

FE

CL

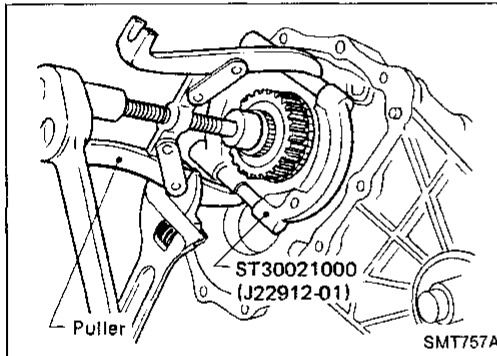

b. Pull out low gear with L & H hub.

MT

AT

TF

PD

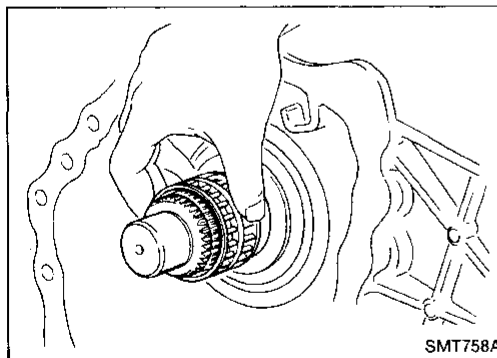

c. Remove needle bearing of low gear.

FA

RA

BR

ST

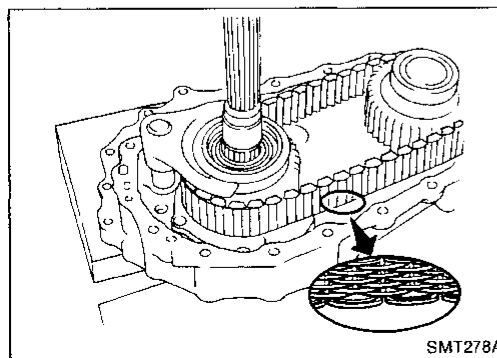

d. Make sure of the direction of the drive chain before removing it. (It must be reinstalled in the same direction.)

Check whether spring part of drive chain is installed on front or rear side.

BF

HA

EL

IDX

DISASSEMBLY

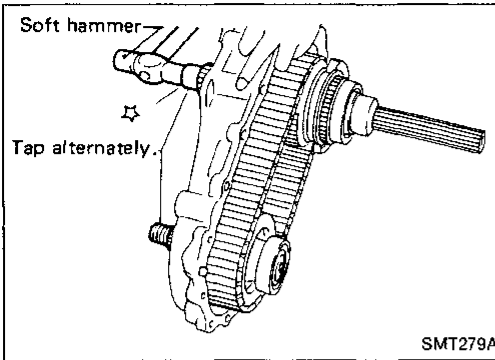

- e. Remove mainshaft, front drive and drive chain as a set by tapping front end of mainshaft and front drive shaft alternately.

Be careful not to bend drive chain.

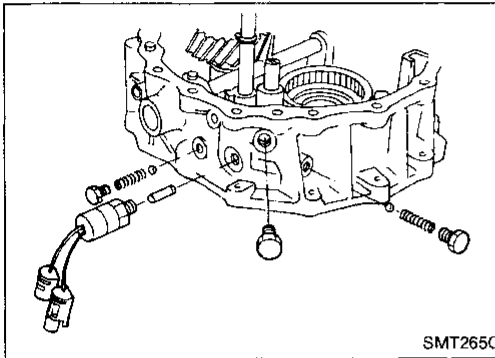

11. Disassemble front case assembly.

- a. Remove switch, plugs, check springs and check balls.

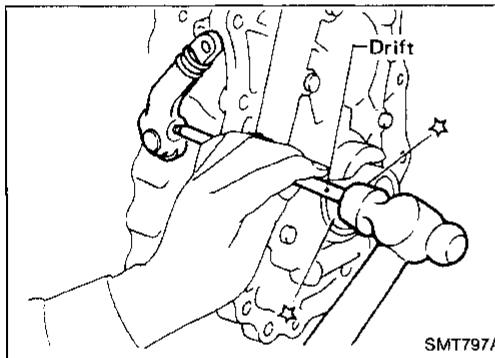

- b. Remove outer shift lever.

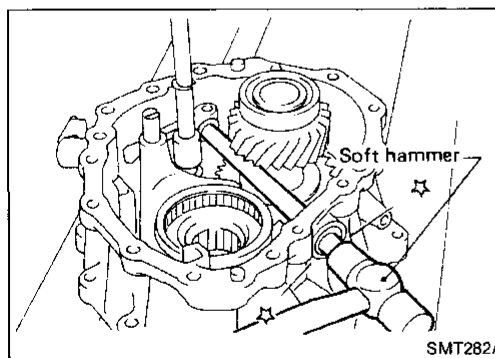

- c. Remove lock pin of inner shift lever and drive out cross shaft with plug.

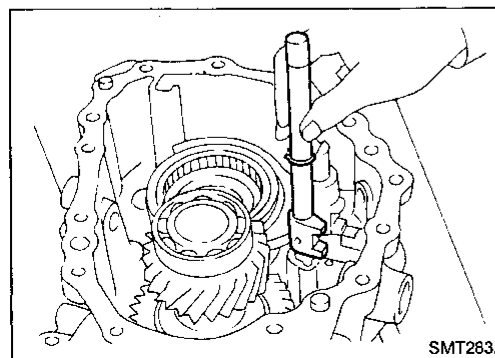

- d. Remove 2-4 shift rod.

DISASSEMBLY

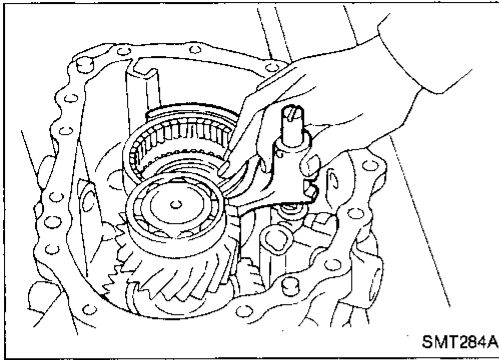

- e. Remove L & H shift rod and fork assembly with coupling sleeve.

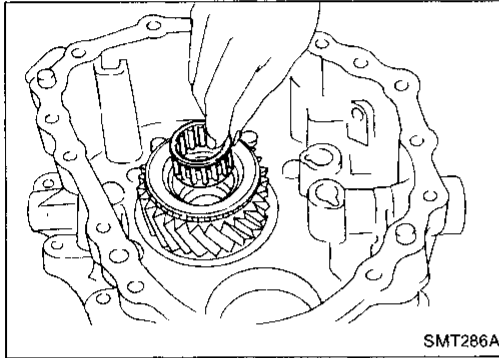

- f. Remove needle bearing from main gear.

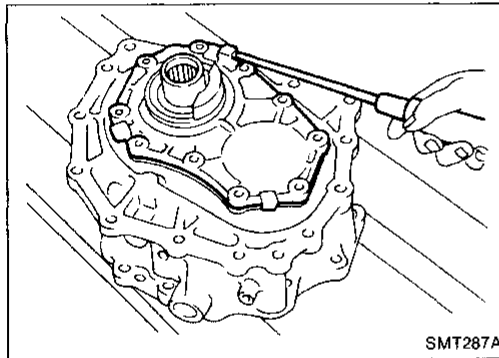

- g. Remove bolts securing front case cover and then remove case.

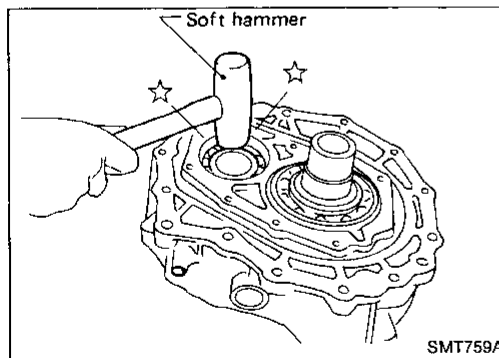

- h. Remove counter gear by tapping lightly.

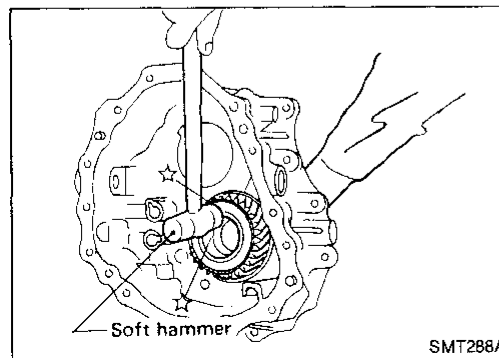

- i. Remove main gear by tapping lightly.

GI

MA

EM

LC

EF &
EC

FE

CL

MT

AT

TF

PD

FA

RA

BR

ST

BF

HA

EL

IDX

REPAIR FOR COMPONENT PARTS

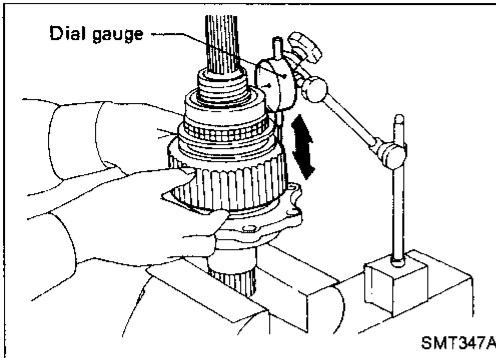

Mainshaft

DISASSEMBLY

1. Check end play of front drive sprocket.

Standard:

0.2 - 0.35 mm (0.0079 - 0.0138 in)

If end play is beyond the maximum value, check front drive sprocket and clutch gear for wear.

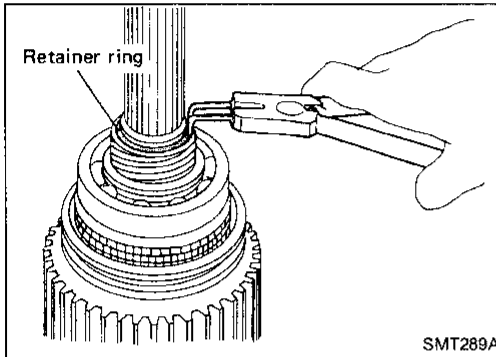

2. Remove retainer ring, speedometer drive gear and steel ball.

Be careful not to lose the steel ball.

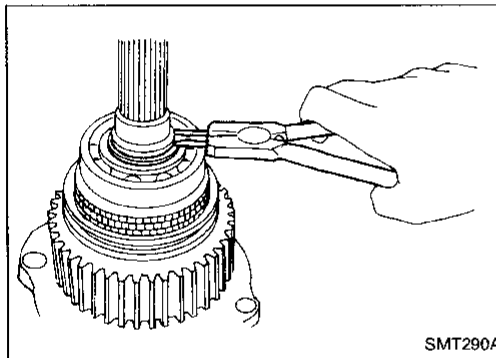

3. Remove snap ring and spacer.

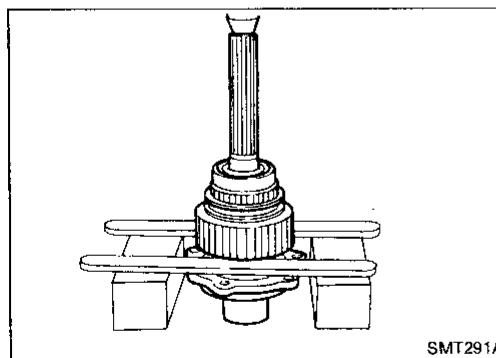

4. Press out front drive sprocket with mainshaft rear bearing and clutch gear together.

5. Remove needle bearing.

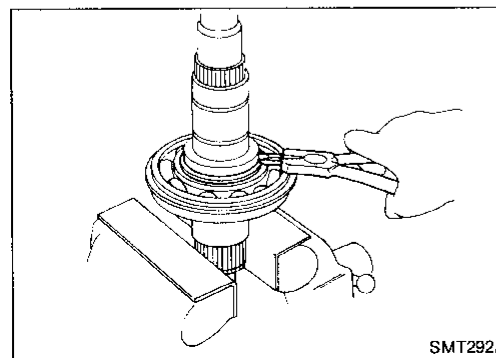

6. Remove bearing retainer and then remove snap ring and spacer.

REPAIR FOR COMPONENT PARTS

Mainshaft (Cont'd)

7. Press out mainshaft front bearing from mainshaft.

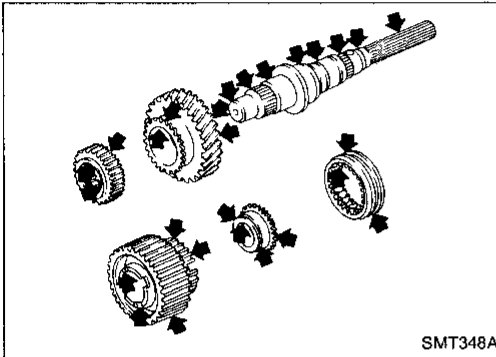
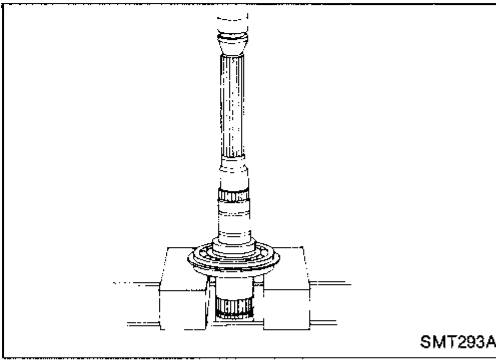

INSPECTION

Gear and shaft

- Check gears for excessive wear, chips or cracks.
- Check shaft for cracks, wear or bending.
- Check coupling sleeve for wear or damage.

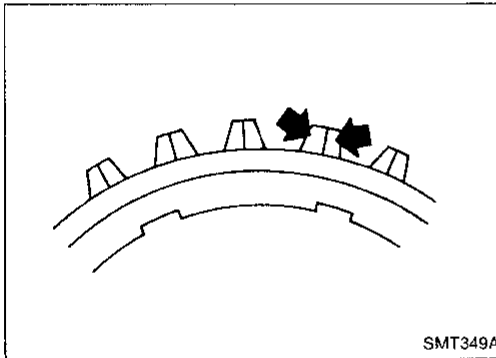

Baulk ring

- Check baulk ring for cracks or deformation.

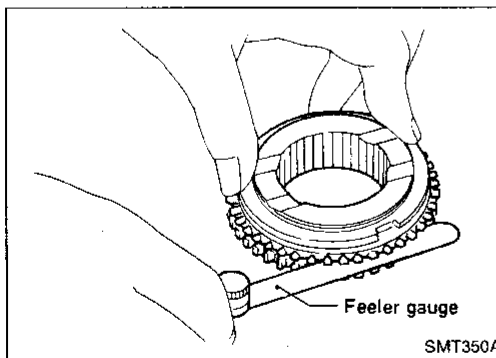

- Measure clearance between baulk ring and gear.

Baulk ring to gear clearance:

Unit: mm (in)

Standard	Wear limit
1.0 - 1.5 (0.039 - 0.059)	0.5 (0.020)

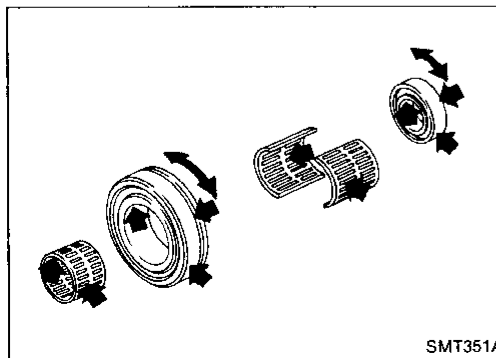

Bearing

- Make sure bearings roll freely and are free from noise, crack, pitting or wear.

GI

MA

EM

LC

EF &
EC

FE

CL

MT

AT

TF

PD

FA

RA

BR

ST

BF

HA

EL

IDX

REPAIR FOR COMPONENT PARTS

Mainshaft (Cont'd)

ASSEMBLY

1. Press mainshaft front bearing onto mainshaft.
Pay special attention to its direction.

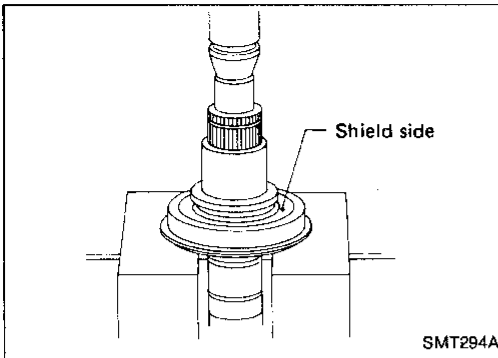

2. Install spacer.
3. Select snap ring with proper thickness and install it.
**Allowable clearance between snap ring and groove:
0 - 0.15 mm (0 - 0.0059 in)**
**Available snap ring for mainshaft front bearing:
Refer to SDS, TF-31.**
4. Regarding to further procedures, refer to "ASSEMBLY", TF-24.

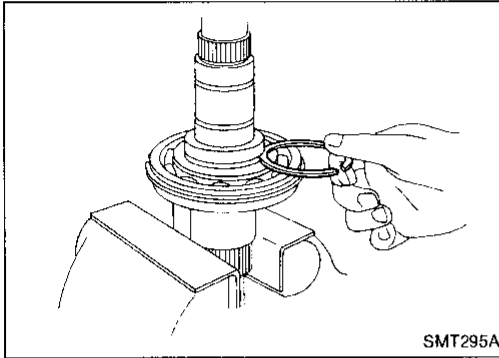

Front Drive Shaft

DISASSEMBLY

- Front drive shaft front bearing and rear bearing

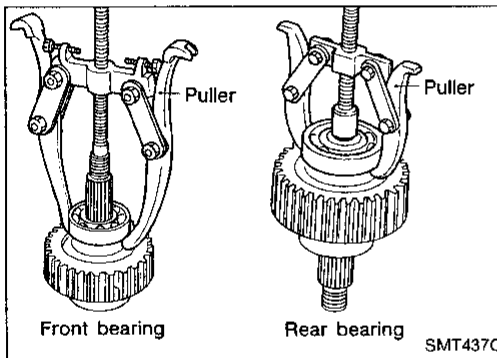

INSPECTION

Sprocket and shaft

- Check sprocket for excessive wear, chips or cracks.
- Check shaft for cracks or wear.

Bearing

- Make sure bearings roll freely and are free from noise, crack, pitting or wear.

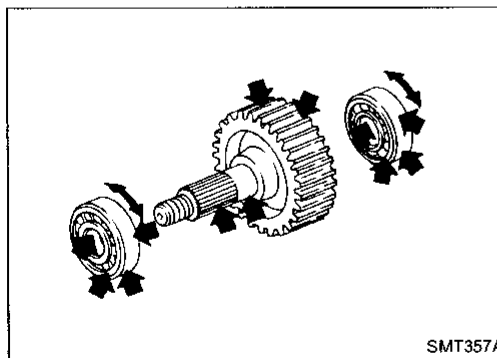

ASSEMBLY

- Press front drive shaft front bearing and rear bearing.

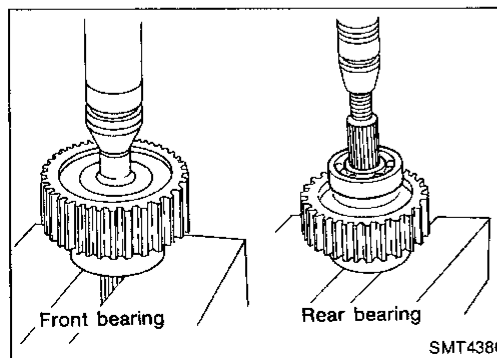

REPAIR FOR COMPONENT PARTS

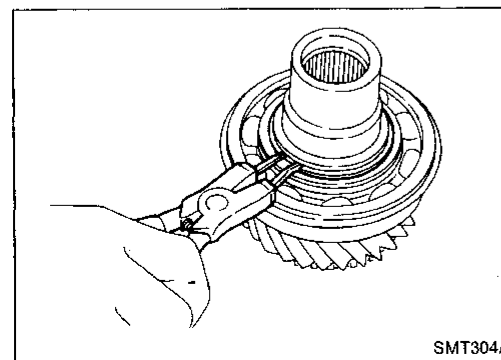
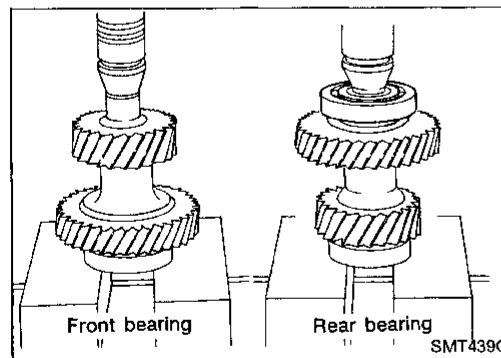
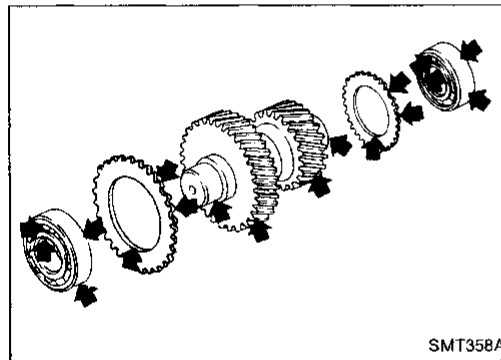
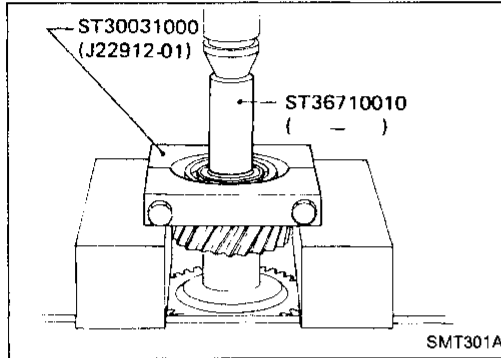
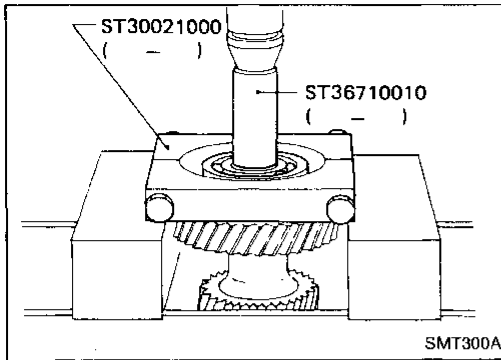

Counter Gear

DISASSEMBLY

1. Press out counter gear front bearing and then remove front sub-gear, spacer and dish spring.
2. Press out counter gear rear bearing and then remove rear sub-gear, spacer and dish spring.

INSPECTION

Gear and shaft

- Check gears for excessive wear, chips or cracks.
- Check shaft for cracks or wear.

Bearing

- Make sure bearings roll freely and are free from noise, crack, pitting or wear.

ASSEMBLY

1. Install front sub-gear, dish spring and spacer, and then press on counter gear front bearing.
2. Install rear sub-gear, dish spring and spacer, and then press on counter gear rear bearing.

Main Gear

DISASSEMBLY

Main gear bearing

1. Remove snap ring and spacer.

GI

MA

EM

LC

EF &
EC

FE

CL

MT

AT

TF

PD

FA

RA

BR

ST

BF

HA

EL

IDX

REPAIR FOR COMPONENT PARTS

Main Gear (Cont'd)

2. Pull out main gear bearing.

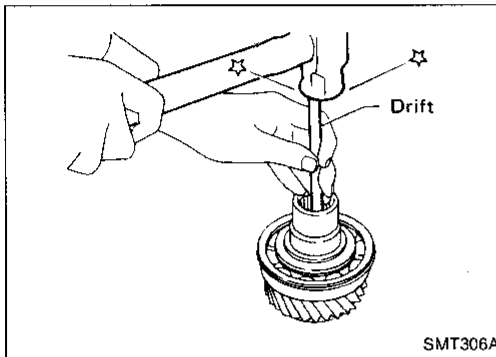
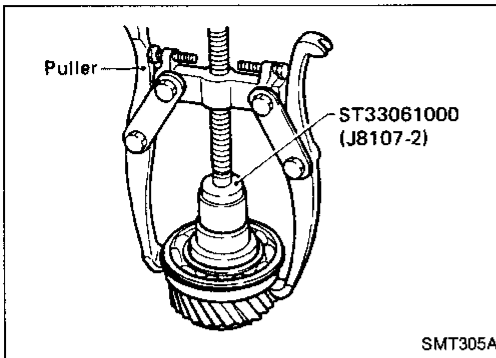

Plug

Always replace it with new one whenever it is removed.

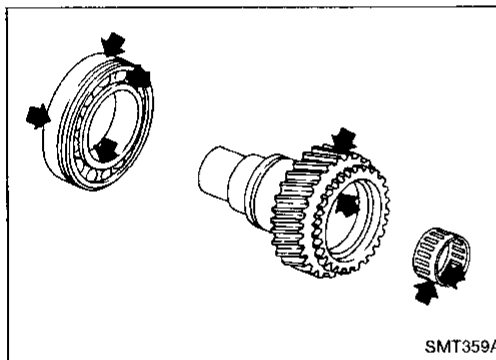

INSPECTION

Gear and shaft

- Check gears for excessive wear, chips or cracks.
- Check shaft for cracks or wear.

Bearing

- Make sure bearings roll freely and are free from noise, crack, pitting or wear.

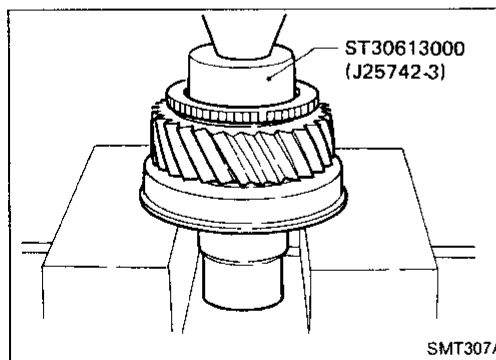

ASSEMBLY

Main gear bearing

1. Press on main gear bearing.
2. Install spacer.

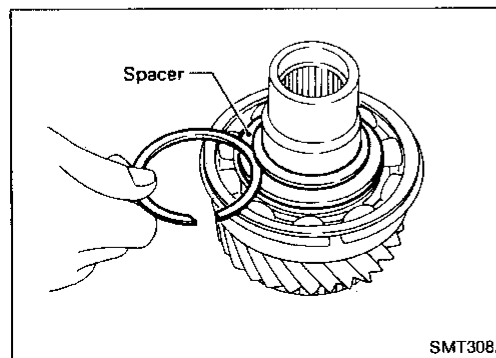

3. Select snap ring with proper thickness and install it.
Allowable clearance between snap ring and groove:
0 - 0.15 mm (0 - 0.0059 in)
Available snap ring for main gear bearing:
Refer to SDS, TF-31.

REPAIR FOR COMPONENT PARTS

Main Gear (Cont'd)

Plug

Apply sealant to plug and install it.

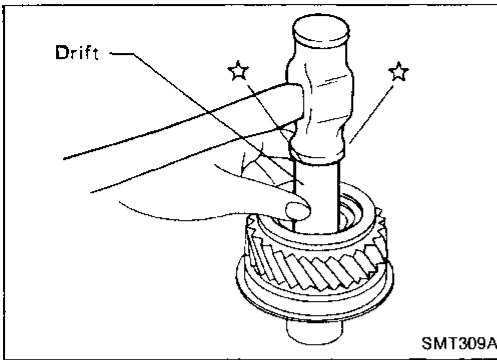

Front Case

SHIFT SHAFT OIL SEAL

Removal

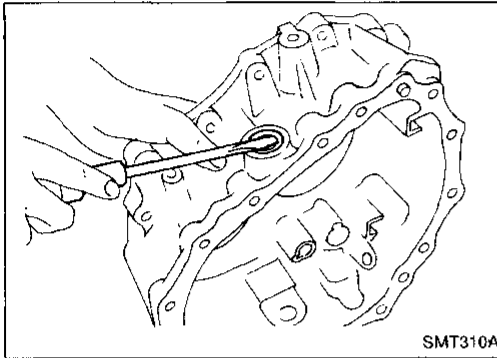

Installation

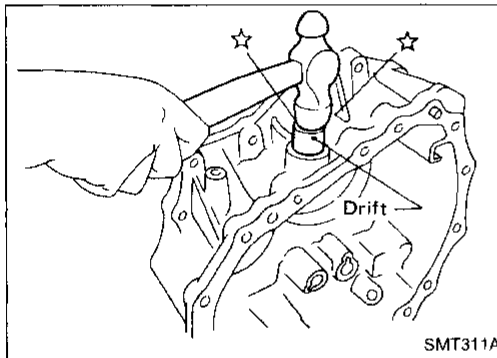

Front Case Cover

COVER OIL SEAL

Removal

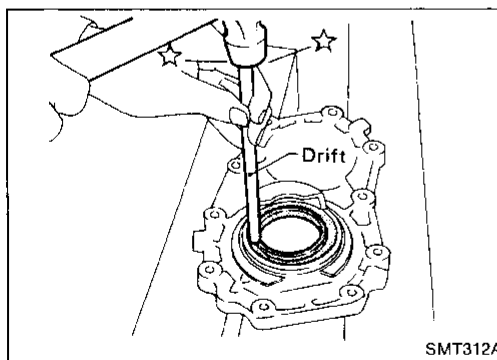

Installation

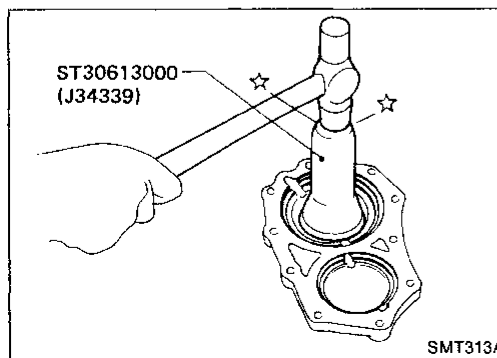

GI

MA

EM

LC

EF &
EC

FE

CL

MT

AT

TF

PD

FA

RA

BR

ST

BF

HA

EL

IDX

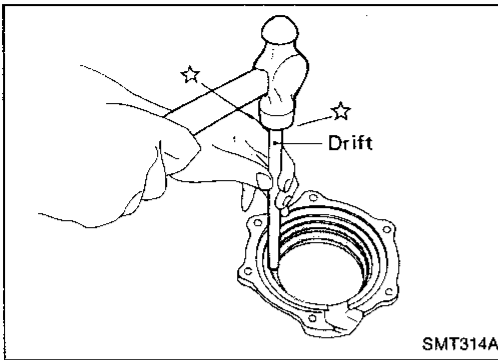

Bearing Retainer
OIL CATCHER
Removal

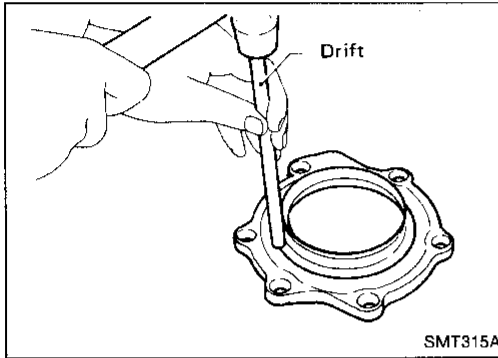

Installation

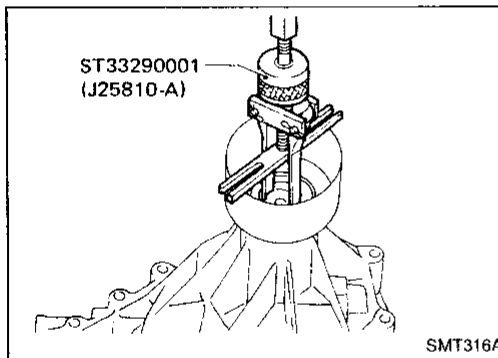

Rear Case
REAR OIL SEAL
Removal

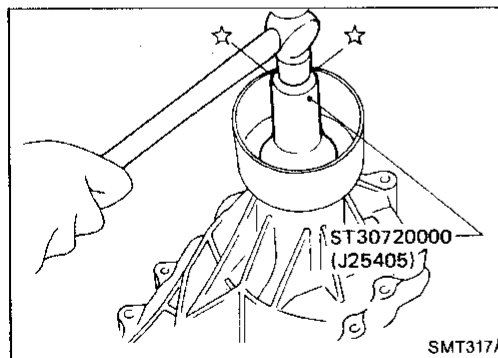

Installation

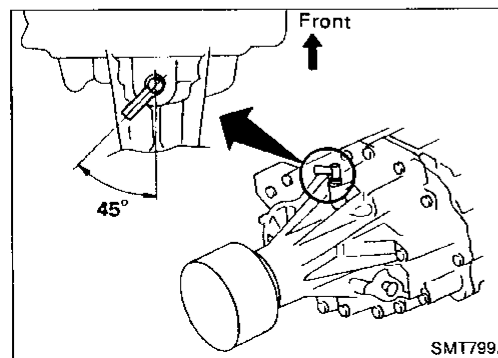

AIR BREATHER
Install as shown in illustration.

Shift Control Components

INSPECTION

- Check contact surface and sliding surface for wear, scratches, projections or other faulty conditions.

GI
MA
EM
LC
EF & EC
FE
CL
MT
AT
TF
PD
FA
RA
BR
ST
BF
HA
EL
IDX

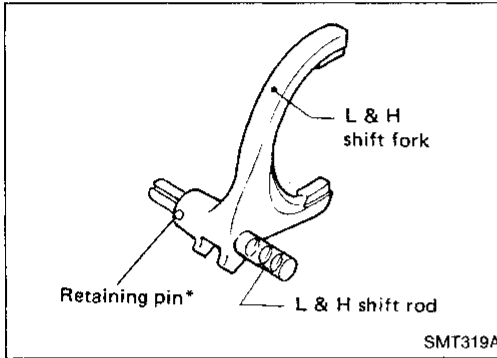
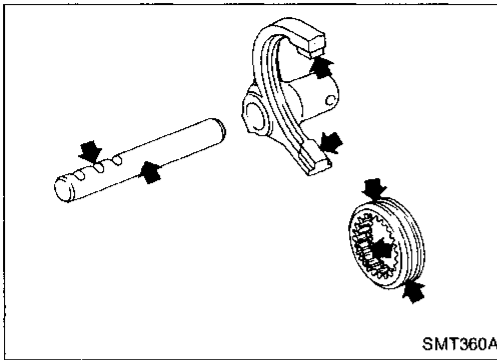

L & H SHIFT ROD & FORK

Assemble as shown in illustration.

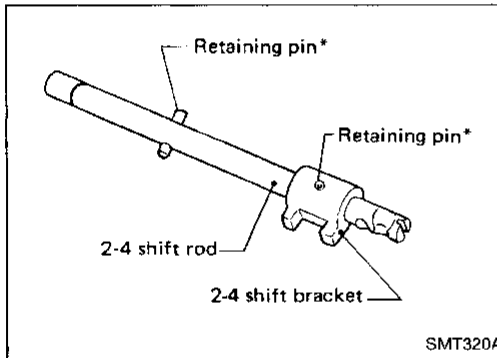

2-4 SHIFT ROD & FORK

Assemble as shown in illustration.

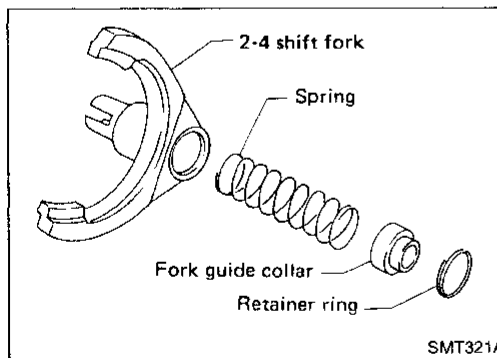

* Retaining pins are the same size.

Pay special attention to the direction of fork guide collar.

ASSEMBLY

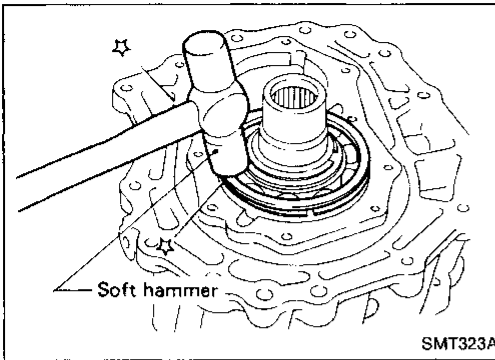

1. Assemble front case.
 - a. Install main gear assembly by tapping lightly.

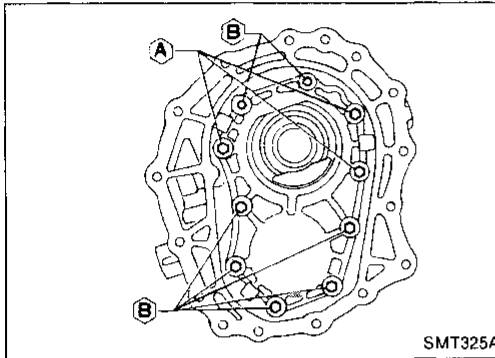

- b. Apply sealant to the mating surface and bolts of front case cover and install it on front case.

- These ten bolts should be coated with sealant.
- Tightening torque
 - A : 16 - 21 N·m
(1.6 - 2.1 kg-m, 12 - 15 ft-lb)
 - B : 19 - 24 N·m
(1.9 - 2.4 kg-m, 14 - 17 ft-lb)

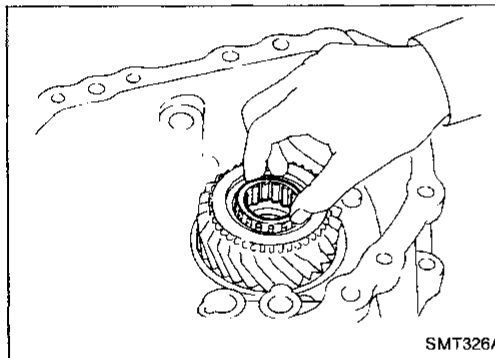

- c. Apply gear oil to needle bearing and install it into main gear.

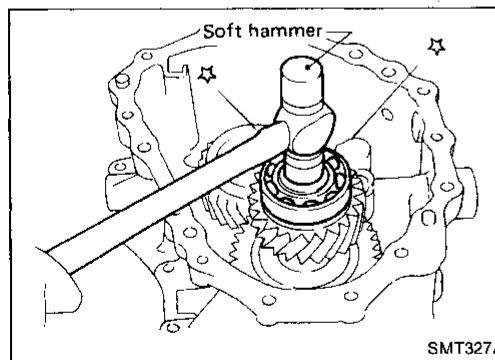

- d. Install counter gear assembly by tapping lightly.

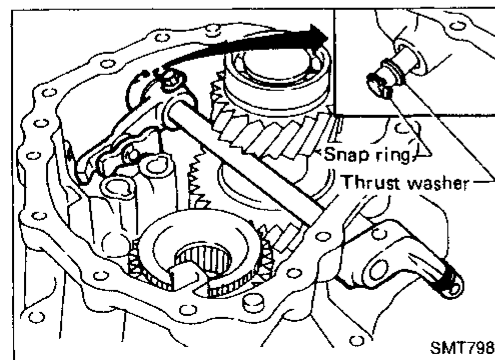

- e. Install cross shaft and inner shift lever.
When replacing cross shaft, outer shift lever or lock pin of outer shift lever, replace them as a set.

ASSEMBLY

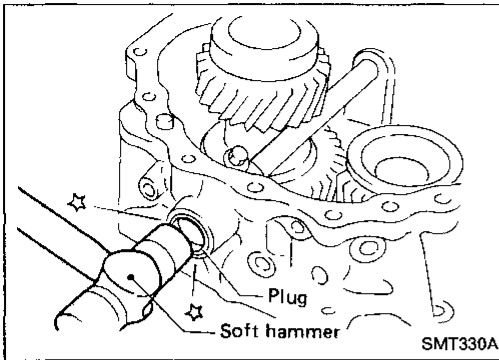

f. Apply sealant to plug and install it into front case.

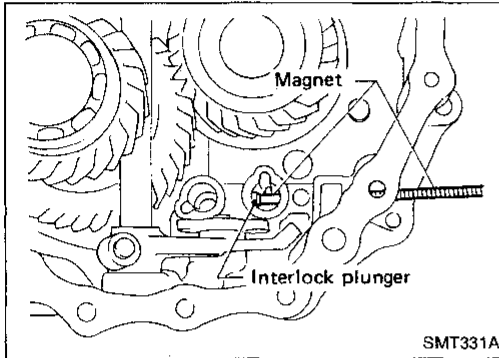

g. Insert interlock plunger into front case.

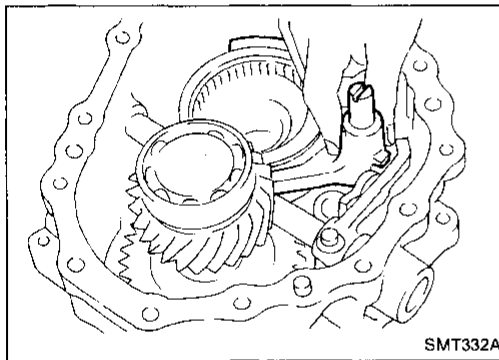

h. Install L & H shift rod and fork assembly with coupling sleeve.

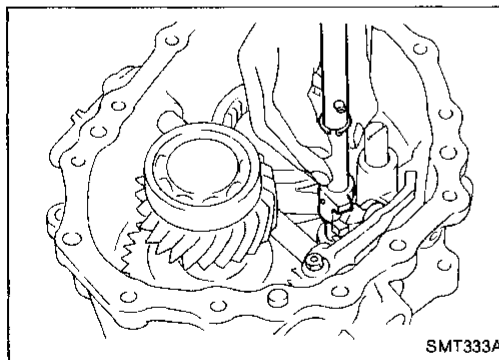

i. Install 2-4 shift rod.

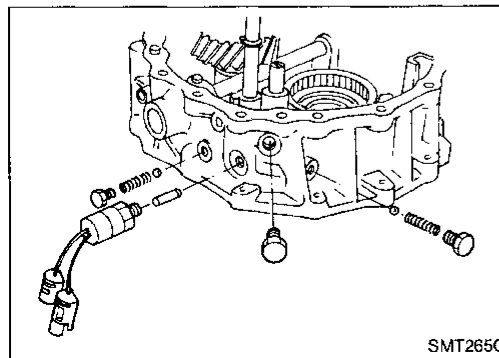

j. Install switches, check balls, check springs and plugs. Apply sealant to switches and plugs.

GI

MA

EM

LC

EF &
EC

FE

CL

MT

AT

TF

PD

FA

RA

BR

ST

BF

HA

EL

IDX

ASSEMBLY

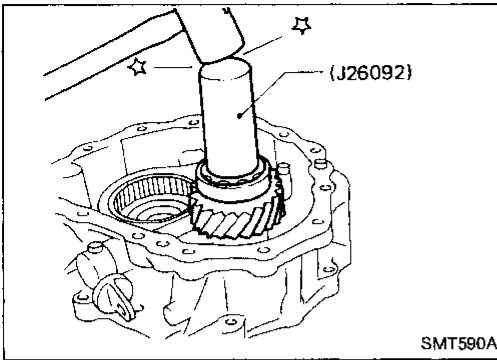

2. Select counter gear rear bearing.
 - a. Seat counter gear assembly.

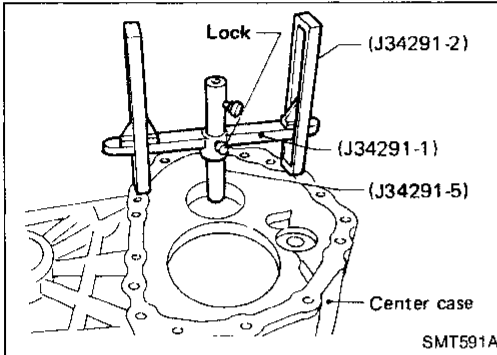

- b. Place J34291-1 (bridge), J34291-2 (legs) and J34291-5 (gauging cylinder) on machined surface of center case and allow gauging cylinder to rest on top outer portion of counter gear rear bearing. Lock gauging cylinder in place.

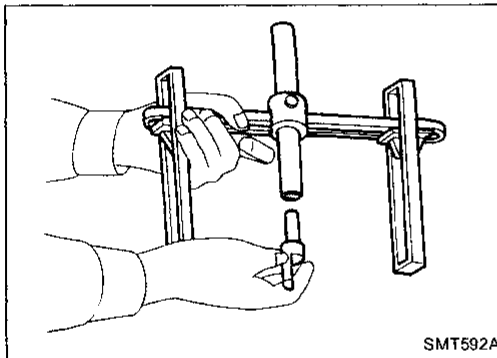

- c. Insert J34291-20 (gauging plunger) into J34291-5 (gauging cylinder).

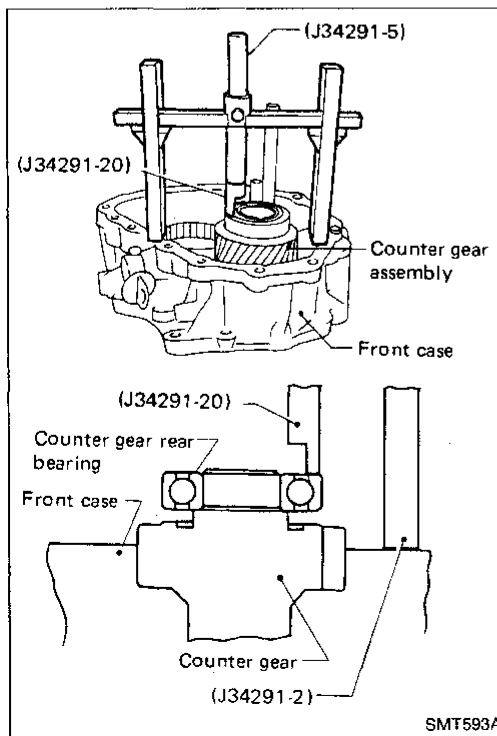

- d. Place bridge, legs, gauging cylinder and gauging plunger onto machined surface of front case assembly, and allow gauging plunger to drop until it contacts counter gear rear bearing mating surface.

ASSEMBLY

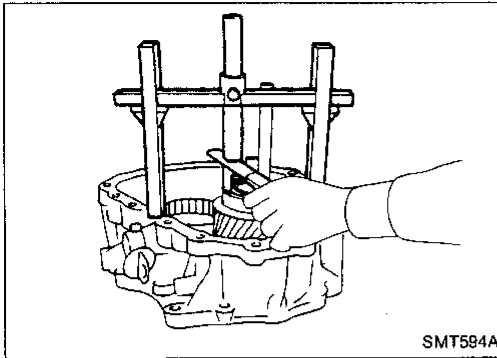

- e. Lock gauging plunger in place and use feeler gauge to measure gap between gauging cylinder and gauging plunger.
- f. Use measured distance and following chart to select correct shim.

Counter gear end play:

0 - 0.2 mm (0 - 0.008 in)

Counter gear rear bearing shim:

Refer to SDS, TF-31.

- g. Select counter gear rear bearing shim.

GI

MA

EM

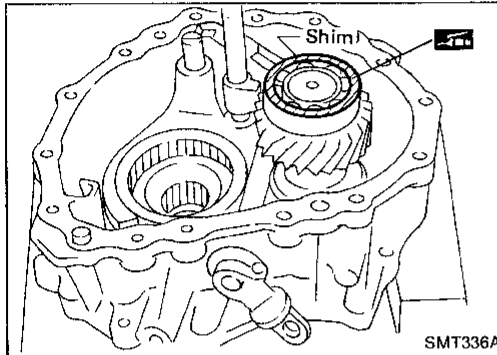

3. Place suitable shim on counter gear rear bearing with grease.
4. Apply gear oil to each part in front case.

LC

EF &
EC

FE

CL

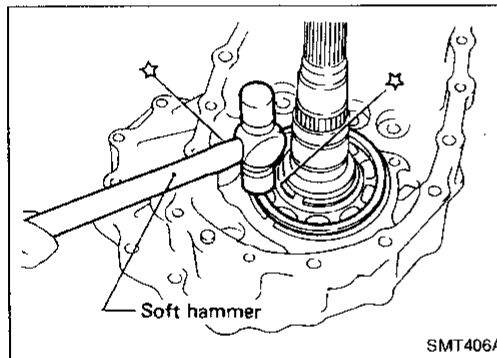

5. Assemble center case assembly.

- a. Install mainshaft on center case by tapping lightly.

Apply gear oil to mainshaft front bearing.

MT

AT

TF

PD

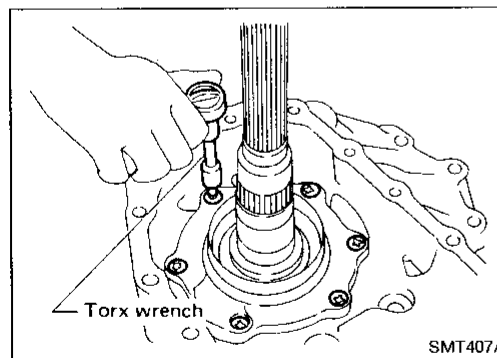

- b. Install bearing retainer.

FA

RA

BR

ST

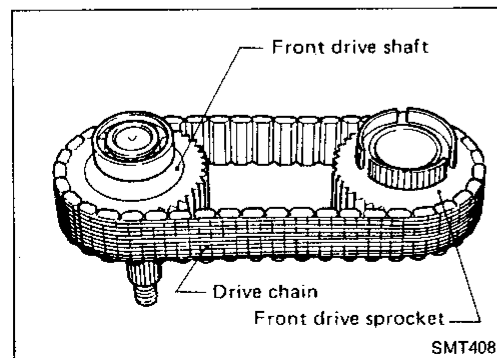

- c. Put drive chain onto the front drive sprocket and front drive shaft, and then put them in center case.

Pay attention to direction of drive chain. Refer to DISASSEMBLY, TF-13.

BF

HA

EL

IDX

ASSEMBLY

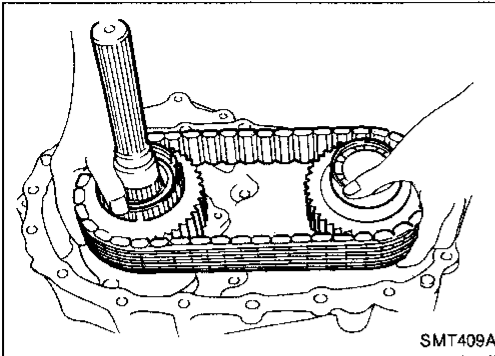

- d. Install front drive shaft by tapping lightly.
Make sure shafts are lined up in the case.

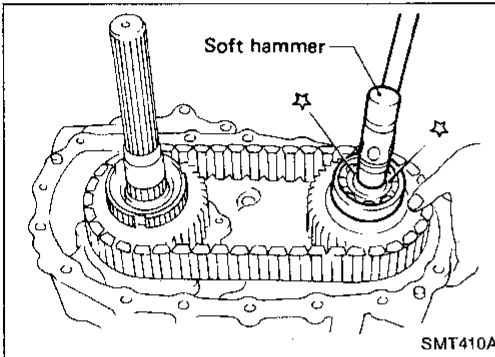

- e. Apply gear oil to needle bearings and install them into front drive sprocket.

These needle bearings will be installed move easily if front drive sprocket is rotated while installing them.

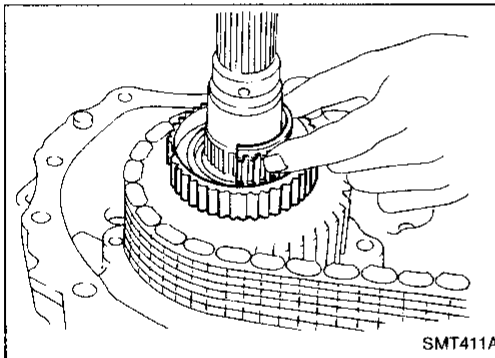

- f. Install 2-4 coupling sleeve with 2-4 shift fork.

Pay special attention to direction of coupling sleeve.

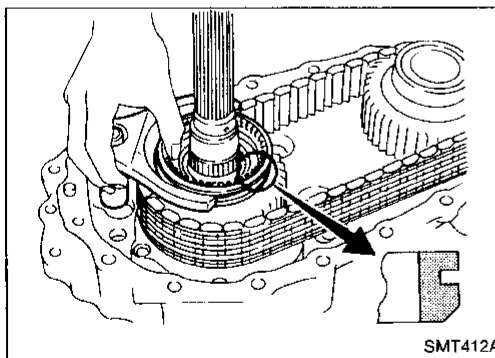

- g. Install shifting inserts and spread spring.

Pay special attention to direction of shifting inserts.

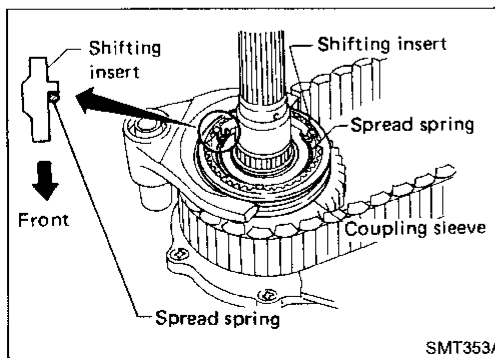

ASSEMBLY

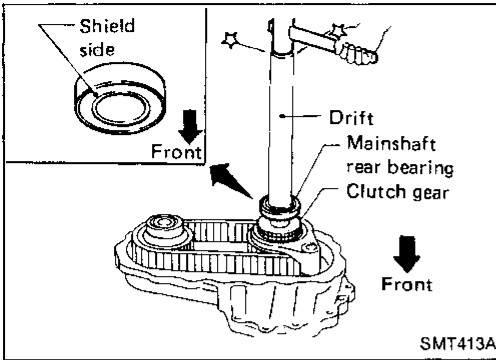

h. Install baulk ring and then install clutch gear and mainshaft rear bearing.

Place wooden block under mainshaft in order to protect mainshaft front bearing.

GI

MA

EM

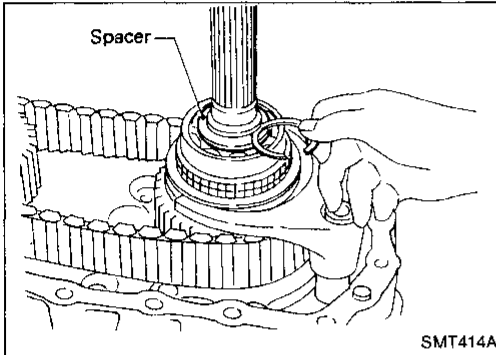

i. Install spacer.

j. Select snap ring with proper thickness and install it.

**Allowable clearance between snap ring and groove:
0 - 0.15 mm (0 - 0.0059 in)**

**Available snap ring for mainshaft rear bearing:
Refer to SDS, TF-31.**

LC

EF &
EC

FE

CL

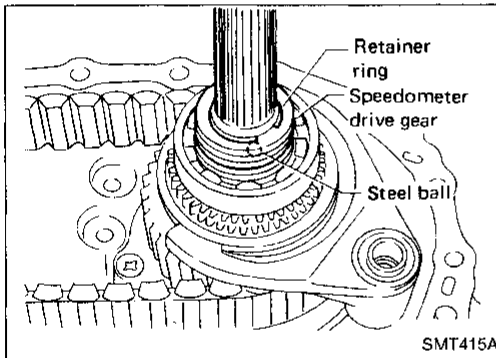

k. Install steel ball, speedometer drive gear and retainer ring.

Steel ball is the smallest of check balls for this unit.

MT

AT

TF

PD

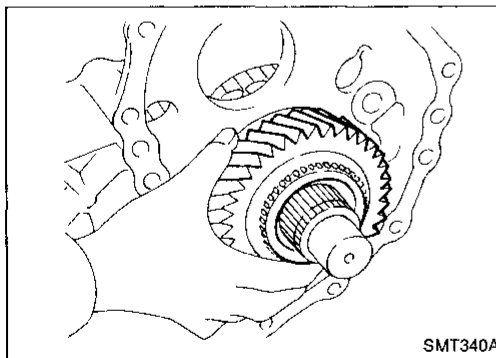

l. Install low gear and its bearing to mainshaft.

Apply gear oil to needle bearing.

FA

RA

BR

ST

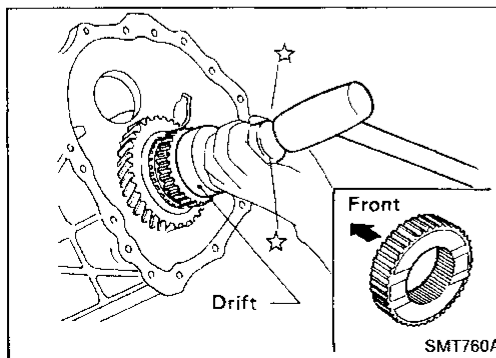

m. Install L & H hub and snap ring to mainshaft.

Pay special attention to direction of L & H hub.

BF

HA

EL

IDX

ASSEMBLY

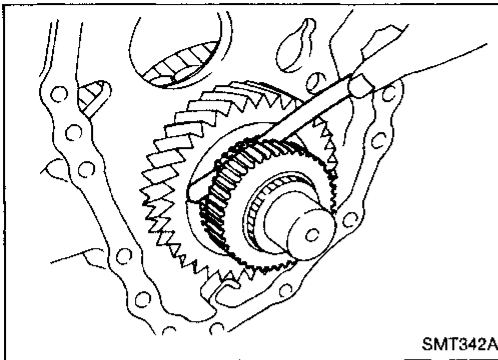

- n. Measure end play of low gear.
Standard: 0.2 - 0.35 mm (0.0079 - 0.0138 in)

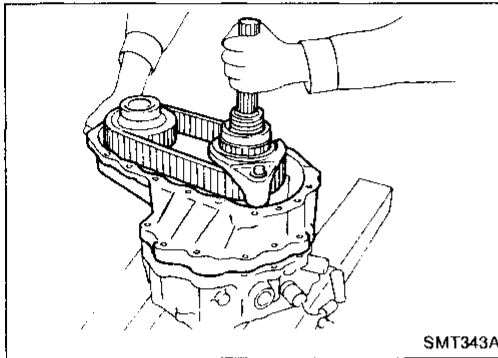

6. Apply sealant to mating surface and put center case assembly onto front case and tighten bolts.

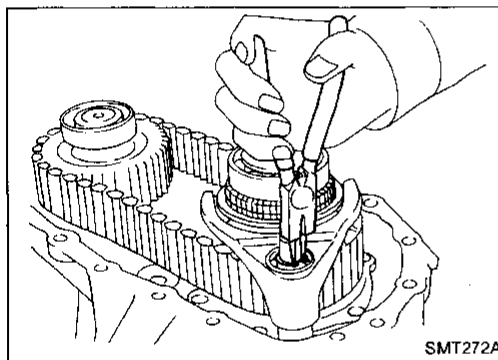

7. Install snap ring to 2-4 shift rod.

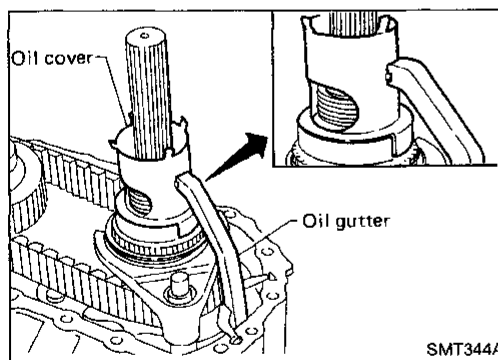

8. Install oil gutter and oil cover.
9. Apply gear oil to each part in center case.

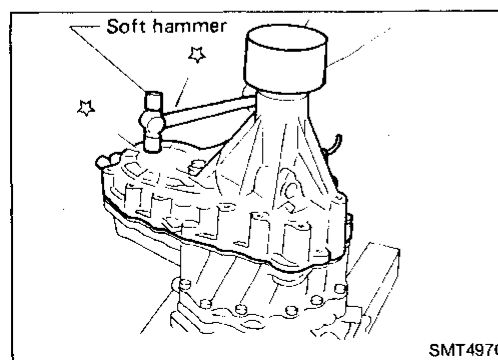

10. Apply sealant to mating surface and install rear case on center case.
11. Install 4WD switch.
Apply sealant to thread of switch.

SERVICE DATA AND SPECIFICATIONS (SDS)

General Specifications

Transfer model		TX10A	
Gear ratio	High	1.000	
	Low	2.020	
Number of teeth	Main gear	29	
	Low gear	37	
	Counter gear	High	38
		Low	24
	Front drive sprocket	41	
Front drive shaft	41		
Oil capacity	ℓ (US qt, Imp qt)	2.2 (2-3/8, 2)	

Inspection and Adjustment

GEAR END PLAY

Unit: mm (in)

Front drive sprocket	0.2 - 0.35 (0.0079 - 0.0138)
Low gear	0.2 - 0.35 (0.0079 - 0.0138)
Counter gear	0 - 0.2 (0 - 0.008)

CLEARANCE BETWEEN BAULK RING AND CLUTCH GEAR

Unit: mm (in)

Standard	Wear limit
1.0 - 1.5 (0.039 - 0.059)	0.5 (0.020)

AVAILABLE SNAP RING

Mainshaft front bearing

Allowable clearance		0 - 0.15 mm (0 - 0.0059 in)	
Thickness mm (in)	Part number	Thickness mm (in)	Part number
3.1 (0.122)	33138-33G10	3.1 (0.122)	33138-33G10
3.2 (0.126)	33138-33G11	3.2 (0.126)	33138-33G11
3.3 (0.130)	33138-33G12	3.3 (0.130)	33138-33G12
3.4 (0.134)	33138-33G13	3.4 (0.134)	33138-33G13

Mainshaft rear bearing

Allowable clearance		0 - 0.15 mm (0 - 0.0059 in)	
Thickness mm (in)	Part number	Thickness mm (in)	Part number
1.8 (0.071)	33138-33G20	1.8 (0.071)	33138-33G20
1.9 (0.075)	33138-33G21	1.9 (0.075)	33138-33G21
2.0 (0.079)	33138-33G22	2.0 (0.079)	33138-33G22
2.1 (0.083)	33138-33G23	2.1 (0.083)	33138-33G23
2.2 (0.087)	33138-33G24	2.2 (0.087)	33138-33G24

Main gear bearing

Allowable clearance		0 - 0.15 mm (0 - 0.0059 in)	
Thickness mm (in)	Part number	Thickness mm (in)	Part number
2.6 (0.102)	33114-33G00	2.6 (0.102)	33114-33G00
2.7 (0.106)	33114-33G01	2.7 (0.106)	33114-33G01
2.8 (0.110)	33114-33G02	2.8 (0.110)	33114-33G02
2.9 (0.114)	33114-33G03	2.9 (0.114)	33114-33G03

AVAILABLE SHIM

Counter gear rear bearing

Allowable clearance		0 - 0.2 mm (0 - 0.008 in)	
Thickness mm (in)	Part number	Thickness mm (in)	Part number
0.1 (0.004)	33112-C6900	0.1 (0.004)	33112-C6900
0.2 (0.008)	33112-C6901	0.2 (0.008)	33112-C6901
0.3 (0.012)	33112-C6902	0.3 (0.012)	33112-C6902
0.4 (0.016)	33112-C6903	0.4 (0.016)	33112-C6903
0.5 (0.020)	33112-33G00	0.5 (0.020)	33112-33G00
0.6 (0.024)	33112-33G01	0.6 (0.024)	33112-33G01