

GI

MA

EM

LC

EC

FE

CL

**MT**

AT

TF

PD

FA

RA

BR

ST

RS

BT

HA

EL

IDX

# SECTION **MT**

## CONTENTS

<b>PREPARATION</b> .....	2	<b>DISASSEMBLY</b> .....	13
Special Service Tools .....	2	Case Components .....	13
Commercial Service Tool.....	3	Shift Control Components .....	14
<b>ON-VEHICLE SERVICE</b> .....	4	Gear Components .....	15
Replacing Rear Oil Seal — 2WD Model .....	4	<b>INSPECTION</b> .....	19
Position Switch Check.....	4	Shift Control Components .....	19
<b>REMOVAL AND INSTALLATION</b> .....	5	Gear Components .....	19
Removal.....	5	<b>ASSEMBLY</b> .....	21
Installation.....	7	Gear Components .....	21
<b>MAJOR OVERHAUL</b> .....	9	Shift Control Components .....	29
Case Components.....	9	Case Components .....	30
Gear Components .....	10	<b>SERVICE DATA AND SPECIFICATIONS (SDS)</b> .....	32
Shift Control Components .....	12	General Specifications.....	32
		Inspection and Adjustment .....	33

# PREPARATION

## Special Service Tools

The actual shapes of Kent-Moore tools may differ from those of special service tools illustrated here.

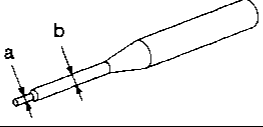
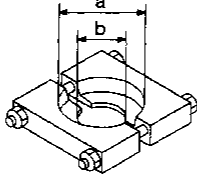
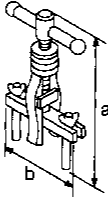
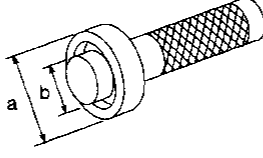
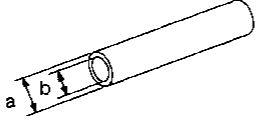
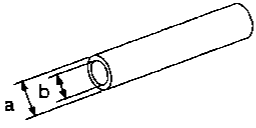
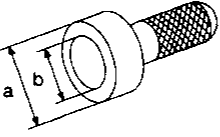
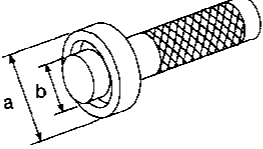
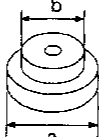
Tool number (Kent-Moore No.) Tool name	Description	
ST23540000 (J25689-A) Pin punch	 NT442	Removing and installing retaining pin  <b>a: 2.3 mm (0.091 in) dia.</b> <b>b: 4 mm (0.16 in) dia.</b>
ST30031000 (J22912-01) Puller	 NT411	Removing 1st & 2nd synchronizer assembly Removing counter gear rear thrust bearing Removing main drive bearing  <b>a: 90 mm (3.54 in) dia.</b> <b>b: 50 mm (1.97 in) dia.</b>
ST33290001 (J25810-A) Puller	 NT414	Removing rear oil seal  <b>a: 250 mm (9.84 in)</b> <b>b: 160 mm (6.30 in)</b>
ST33230000 ( — ) Drift	 NT084	Removing mainshaft and counter gear  <b>a: 51 mm (2.01 in) dia.</b> <b>b: 28.5 mm (1.122 in) dia.</b>
ST22350000 (J25678-01) Drift	 NT065	Removing counter gear front bearing (Use with KV38100300)  <b>a: 34 mm (1.34 in) dia.</b> <b>b: 28 mm (1.10 in) dia.</b>
KV38100300 (J25523) Drift	 NT065	Removing counter gear front bearing (Use with ST22350000) Installing counter gear rear bearing  <b>a: 54 mm (2.13 in) dia.</b> <b>b: 32 mm (1.26 in) dia.</b>
ST30720000 ① (J34286) ② (J34331) Drift	 NT115	① Removing mainshaft front bearing ② Installing mainshaft front bearing  <b>a: 77 mm (3.03 in) dia.</b> <b>b: 55.5 mm (2.185 in) dia.</b>
ST33210000 ① (J25523) ② (J25803-01) Drift	 NT084	① Installing counter gear front bearing ② Installing front cover oil seal  <b>a: 44 mm (1.73 in) dia.</b> <b>b: 24.5 mm (0.965 in) dia.</b>
ST30613000 (J25742-3) Drift	 NT073	Installing main drive gear bearing  <b>a: 72 mm (2.83 in) dia.</b> <b>b: 48 mm (1.89 in) dia.</b>

## PREPARATION

### Special Service Tools (Cont'd)

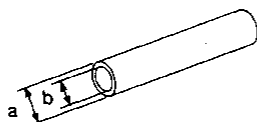
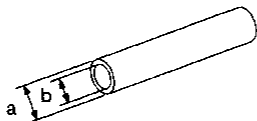
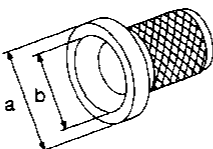
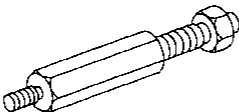
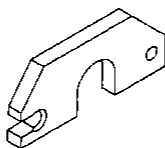
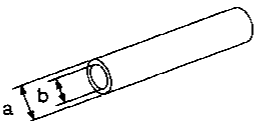
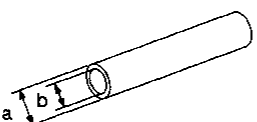
Tool number (Kent-Moore No.) Tool name	Description	
ST37750000 ① (J34286) ② (J34332) ③ (J34334) ④ (J25679-01) Drift	 NT065	① Removing counter gear rear bearing ② Installing OD gear bushing ② Removing and installing mainshaft rear bearing (4WD model) ② Installing reverse cone ③ Installing reverse counter gear ④ Installing counter gear rear end bearing  <b>a: 40 mm (1.57 in) dia.</b> <b>b: 31 mm (1.22 in) dia.</b>
ST22452000 (J34337) Drift	 NT065	Installing reverse hub Installing mainshaft rear bearing (2WD model)  <b>a: 45 mm (1.77 in) dia.</b> <b>b: 36 mm (1.42 in) dia.</b>
ST33400001 (J26082) Drift	 NT086	Installing rear oil seal  <b>a: 60 mm (2.36 in) dia.</b> <b>b: 47 mm (1.85 in) dia.</b>
(J26349-3) Puller leg	 NT078	Installing mainshaft and counter gear (Use with J34328)
(J34328) Puller	 NT079	Installing mainshaft and counter gear (Use with J26349-3)
(J26092) Drift	 NT065	Installing sub-gear snap ring  <b>a: 44.5 mm (1.752 in) dia.</b> <b>b: 38.5 mm (1.516 in) dia.</b>
(J34342) Drift	 NT065	Installing OD main gear Installing reverse gear bushing  <b>a: 44.5 mm (1.752 in) dia.</b> <b>b: 40.5 mm (1.594 in) dia.</b>

### Commercial Service Tool

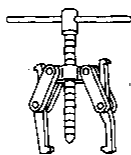
Tool name	Description	
Puller	 NT077	Removing counter gear rear end bearing Removing mainshaft rear bearing (2WD model) Removing reverse synchronizer hub Removing reverse counter gear

**Replacing Rear Oil Seal — 2WD Model**

**REMOVAL**

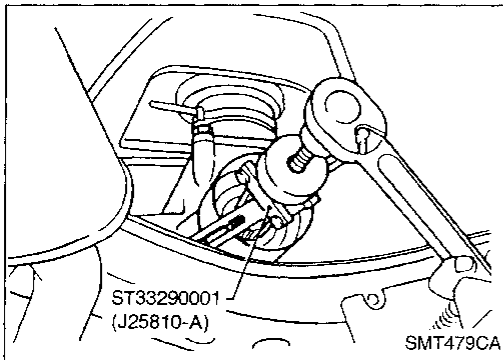

**INSTALLATION**

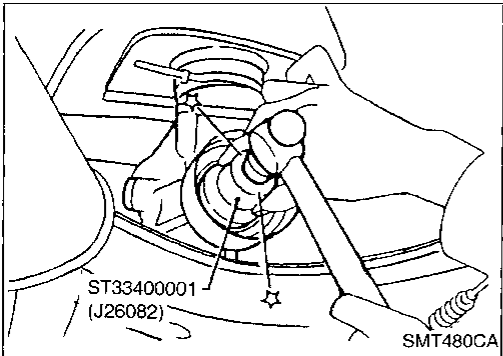

**Position Switch Check**

Switch	Gear position	Continuity
Back-up lamp switch	Reverse	Yes
	Except reverse	No
Neutral position switch	Neutral	Yes
	Except neutral	No

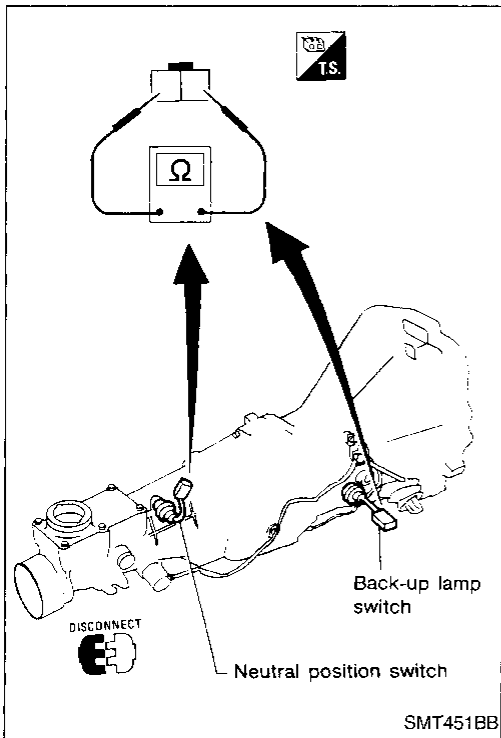

# REMOVAL AND INSTALLATION

## Removal

### CAUTION:

When removing the M/T assembly from engine, first remove the crankshaft position sensor (OBD) from the M/T assembly. Be careful not to damage sensor edge.

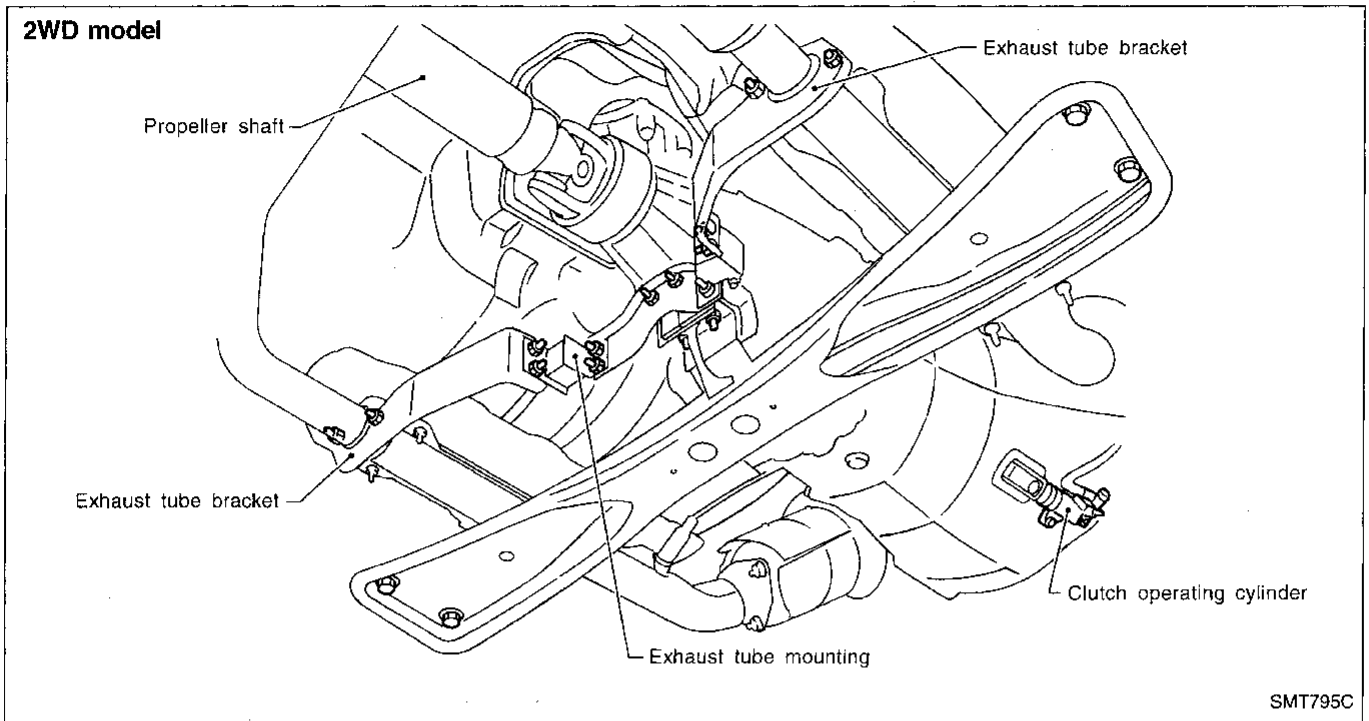

## 2WD MODEL

- Remove crankshaft position sensor (OBD) from transmission upper side.
- Remove propeller shaft. Refer to PD section ("Removal and Installation", "PROPELLER SHAFT").
- **Insert plug into rear oil seal after removing propeller shaft.**
- **Be careful not to damage spline, sleeve yoke and rear oil seal, when removing propeller shaft.**
- Remove clutch operating cylinder.
- Remove exhaust tube mounting and brackets.
- Disconnect vehicle speed sensor, back-up lamp and neutral position switch harness connector.
- Remove shift lever.
- Support engine by placing a jack under oil pan.
- **Do not place jack under the oil pan drain plug.**
- Remove engine rear mounting.
- Remove transmission from engine.

### WARNING:

Support Manual Transmission, while removing it.

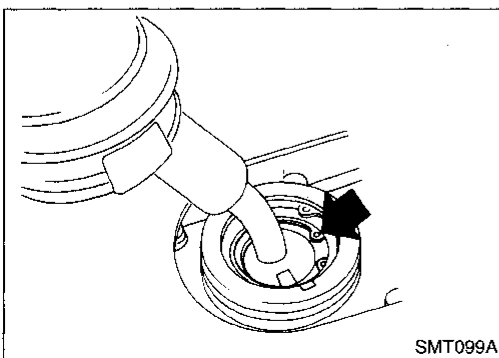

# REMOVAL AND INSTALLATION

## Removal (Cont'd)

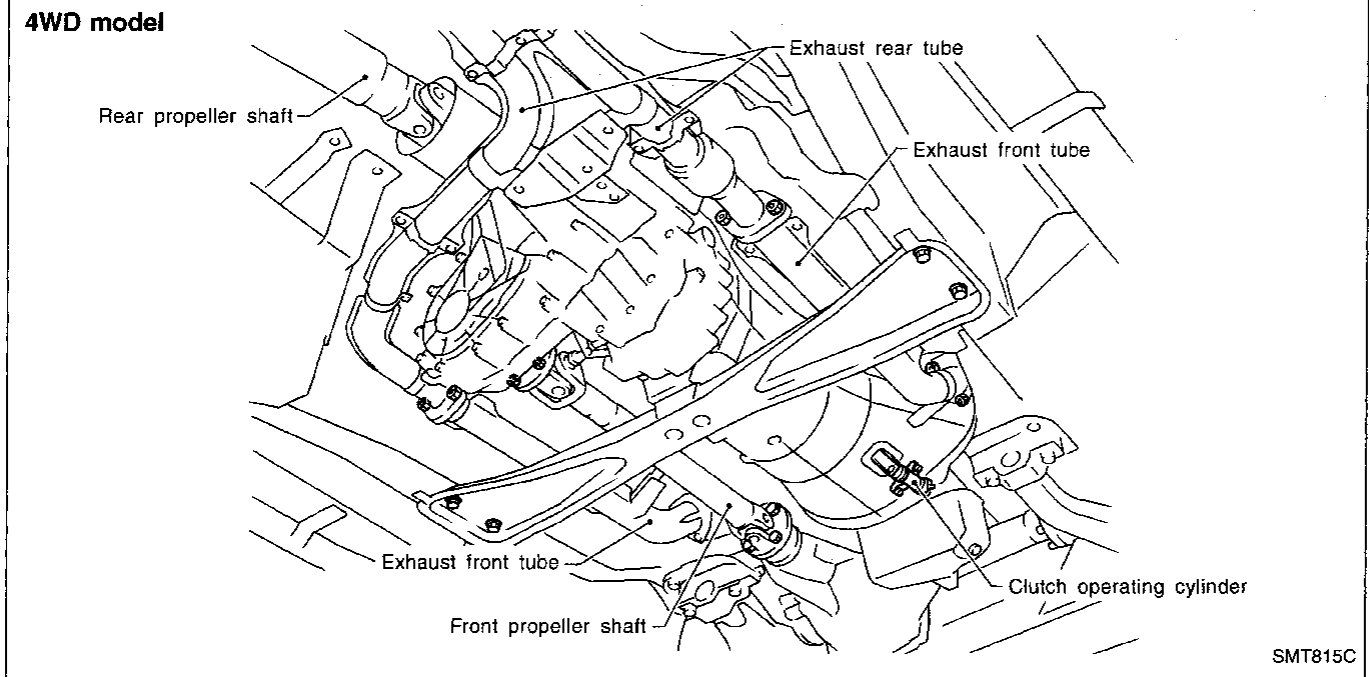

### 4WD MODEL

- Remove crankshaft position sensor (OBD) from transmission upper side.
- Remove front and rear propeller shafts. Refer to PD section ("Removal and Installation"; "PROPELLER SHAFT").
- **Insert plug into rear oil seal of transfer after removing propeller shaft.**
- **Be careful not to damage spline, sleeve yoke and rear oil seal of transfer, when removing propeller shaft.**
- Remove clutch operating cylinder.
- Remove exhaust front and rear tubes. Refer to FE section ("EXHAUST SYSTEM").
- Disconnect vehicle speed sensor, back-up lamp switch, 4WD switch and neutral position switch harness connector.

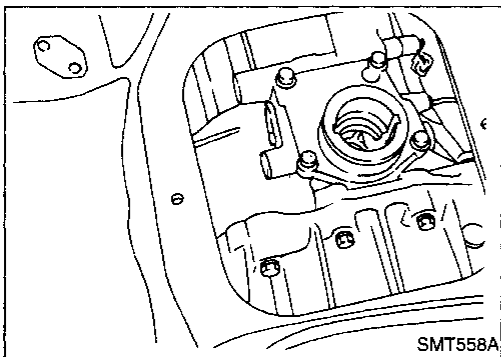

- Remove shift lever of transmission and transfer.
- Support engine by placing a jack under oil pan.
- **Do not place jack under the oil pan drain plug.**
- Remove transmission with transfer from engine.

### WARNING:

**Support Manual Transmission with transfer, while removing it.**

# REMOVAL AND INSTALLATION

## Installation

- Apply sealant as below: — 4WD model

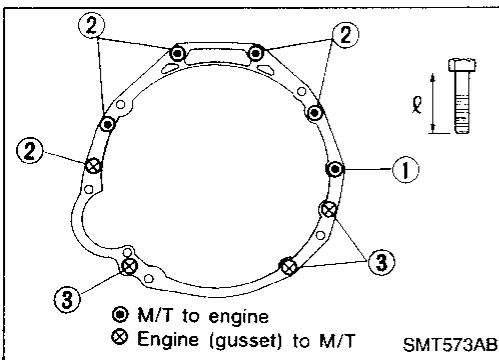
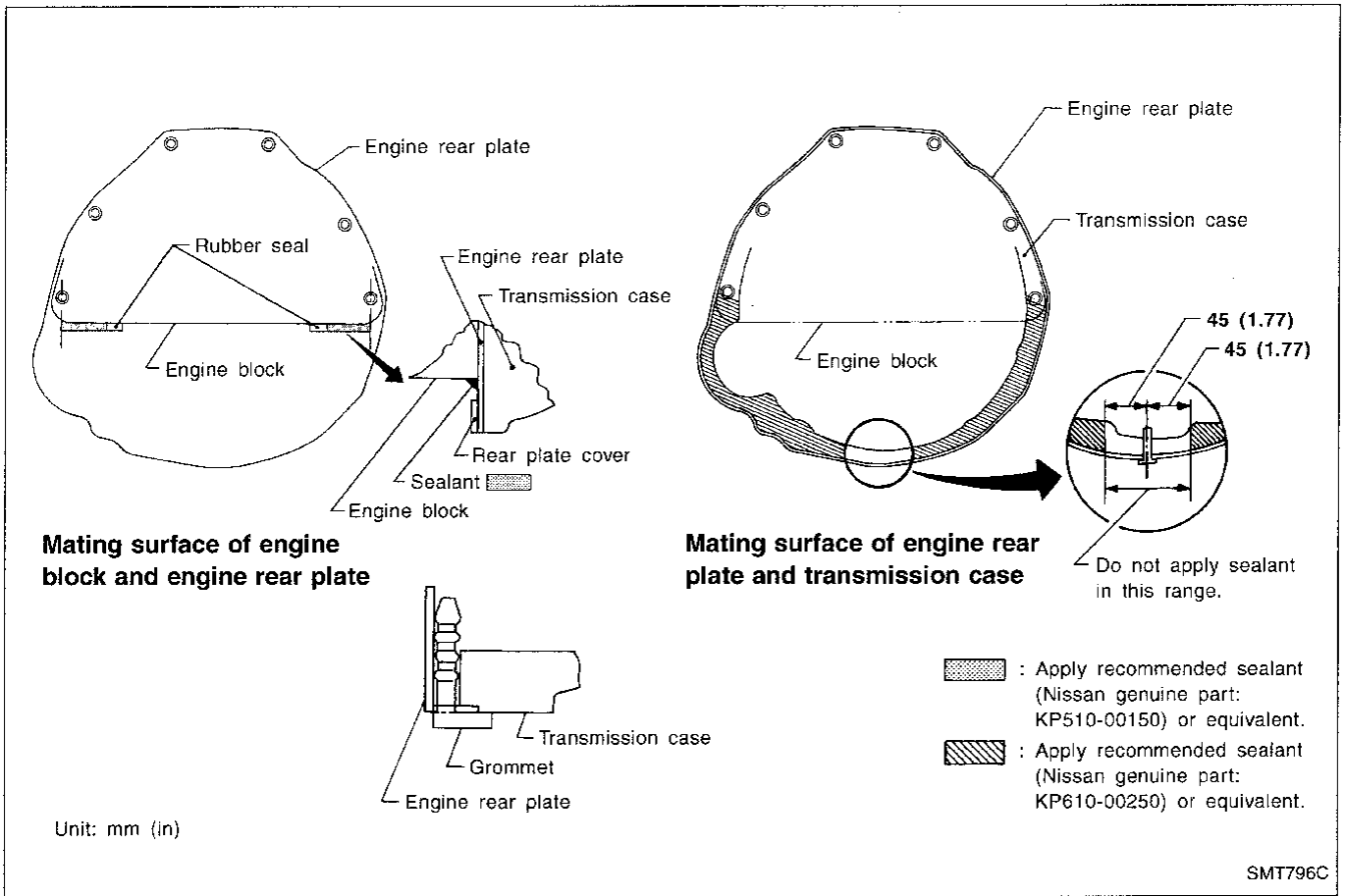

- Tighten bolt securing transmission.

Bolt No.	Tightening torque N·m (kg·m, ft·lb)	r mm (in)
①	39 - 49 (4.0 - 5.0, 29 - 36)	65 (2.56)
②	39 - 49 (4.0 - 5.0, 29 - 36)	58 (2.28)
③	29 - 39 (3.0 - 4.0, 22 - 29)	25 (0.98)
Gusset to engine	29 - 39 (3.0 - 4.0, 22 - 29)	20 (0.79)

CI  
MA  
EM  
LC  
EC  
FE  
CL  
MT  
AT  
TF  
PD  
FA  
RA  
BR  
ST  
RS  
BT  
HA  
EL  
DX

**NOTE**



Case Components

SEC. 320•321

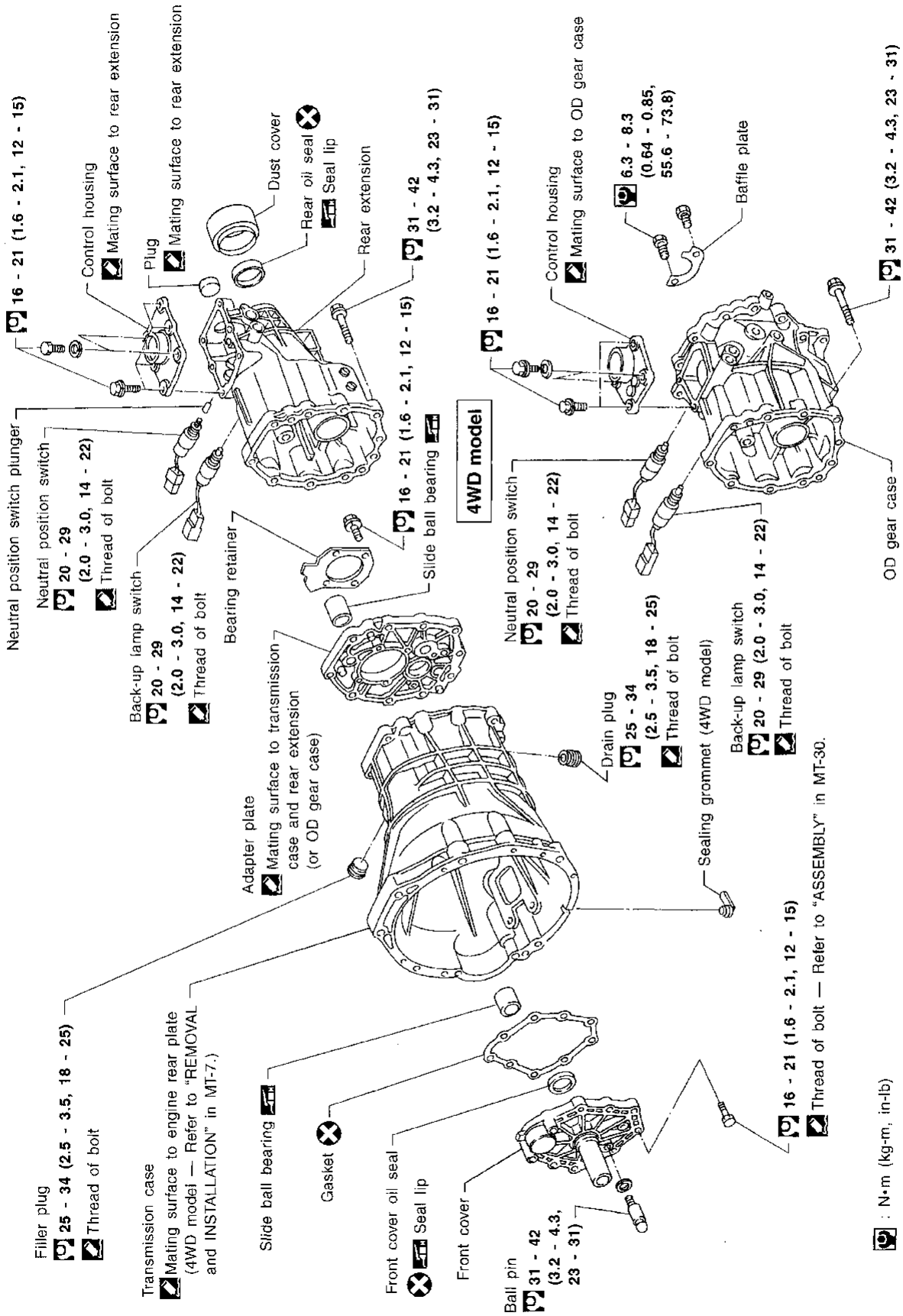

- : N•m (kg-m, in-lb)
- : N•m (kg-m, ft-lb)
- : Apply recommended sealant (Nissan genuine part: KP610-00250) or equivalent.

Thread of bolt — Refer to "ASSEMBLY" in MT-30.

GI  
MA  
EM  
LC  
EC  
FE  
CL  
MT  
AT  
TF  
PD  
FA  
RA  
BR  
ST  
RS  
BT  
HA  
EL  
IDX



# MAJOR OVERHAUL

## Gear Components (Cont'd)

SEC. 322

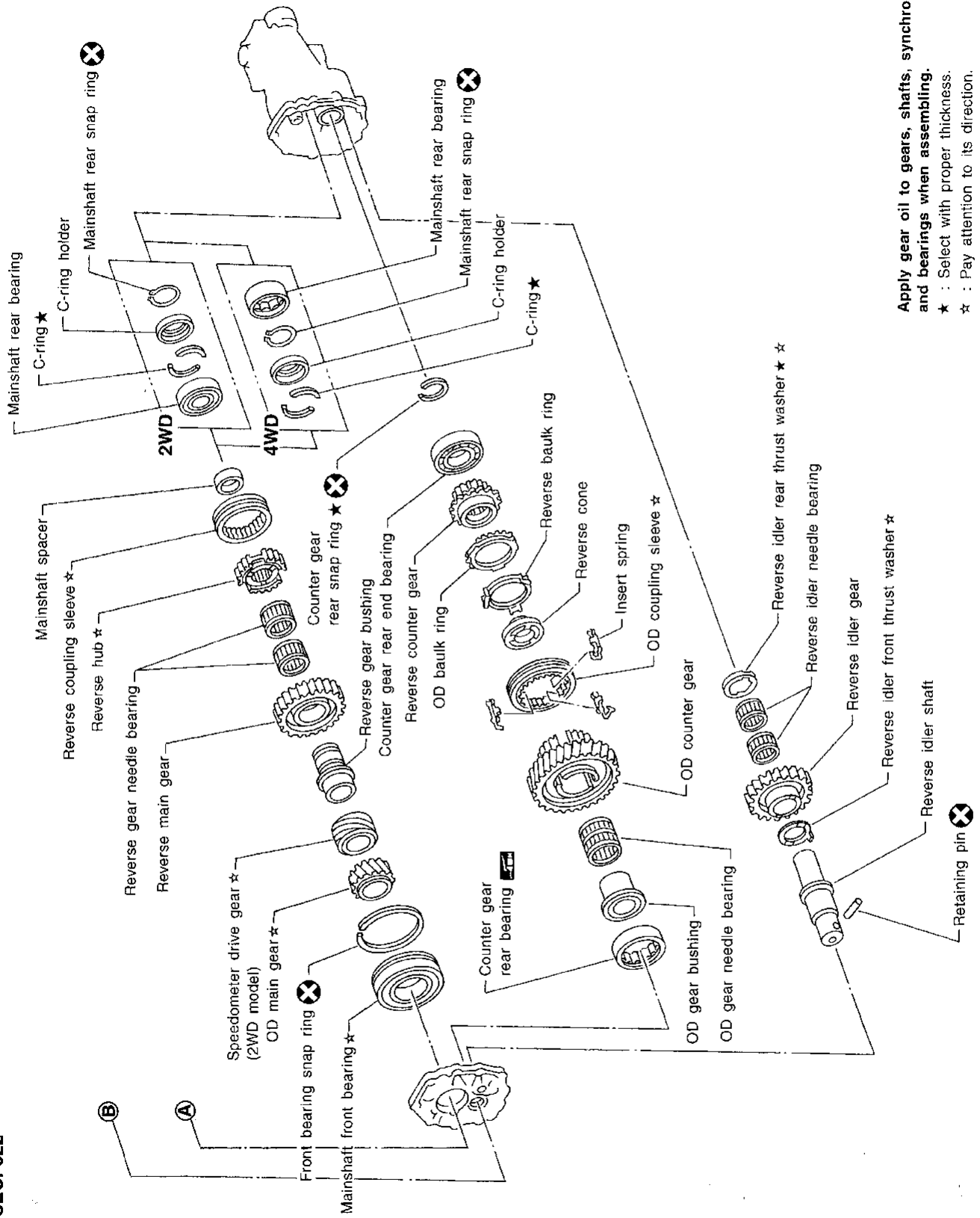

Apply gear oil to gears, shafts, synchronizers and bearings when assembling.  
 ★ : Select with proper thickness.  
 ✕ : Pay attention to its direction.

- GI
- MA
- EM
- LC
- EC
- FE
- CL
- MT
- AT
- TF
- PD
- FA
- RA
- BR
- ST
- RS
- BT
- HA
- EL
- IDX

Shift Control Components

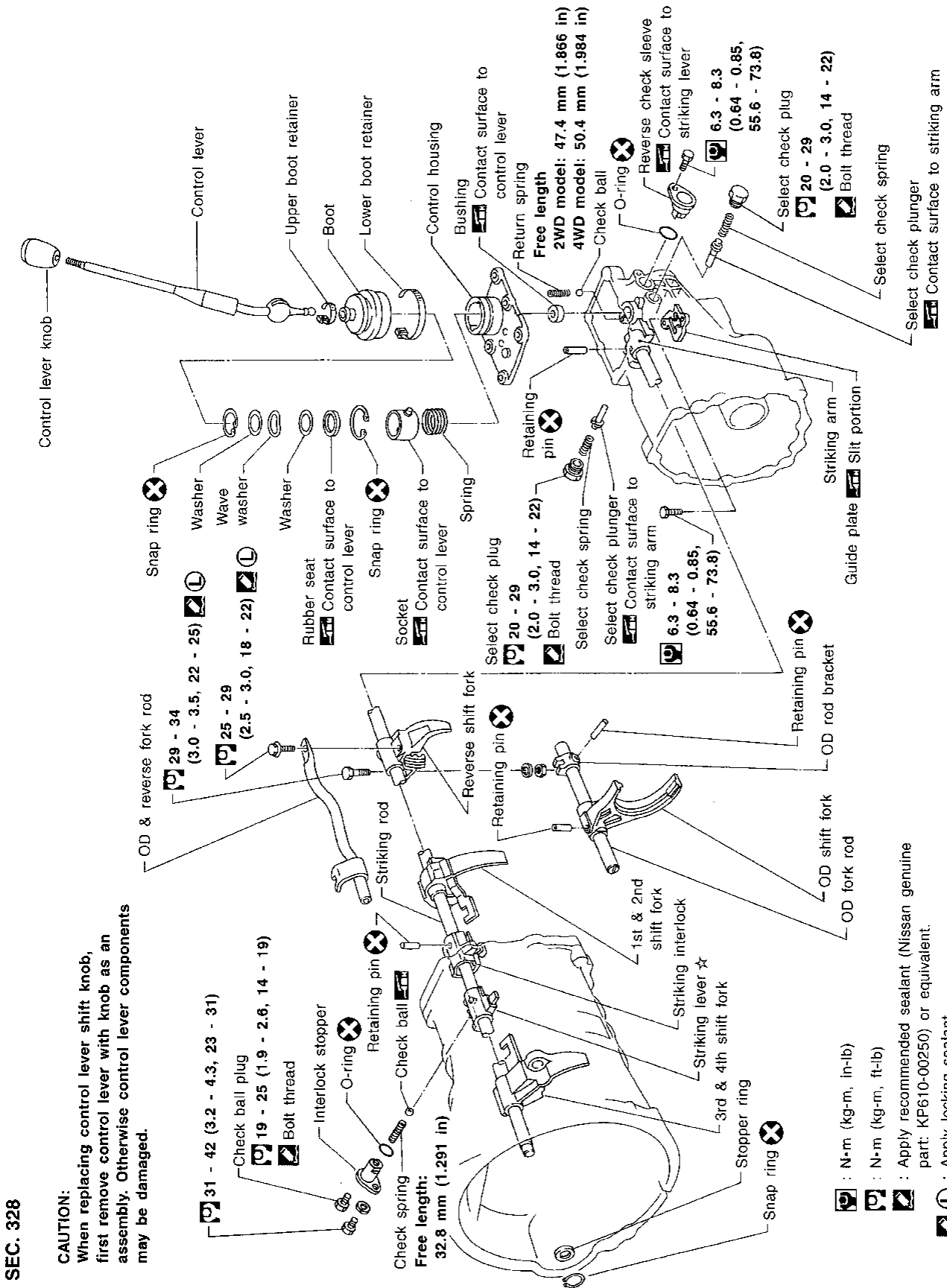

SEC. 328

**CAUTION:**  
When replacing control lever shift knob, first remove control lever with knob as an assembly. Otherwise control lever components may be damaged.

- : N·m (kg-m, in-lb)
- : N-m (kg-m, ft-lb)
- : Apply recommended sealant (Nissan genuine part: KP610-00250) or equivalent.
- : Apply locking sealant.
- ☆ : Pay attention to its direction.

# DISASSEMBLY

## Case Components

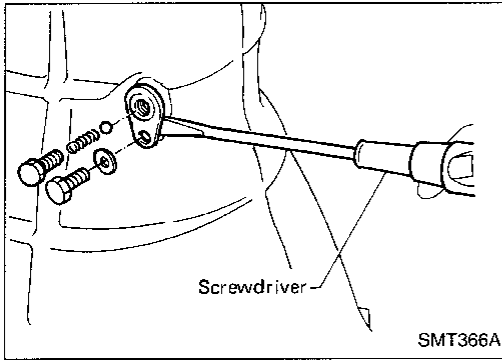

1. Remove check ball plug, check spring and check ball. Then remove interlock stopper.
  - If interlock assembly is removed as a unit, the check ball can fall into transmission case.
  - Be careful not to lose check ball.

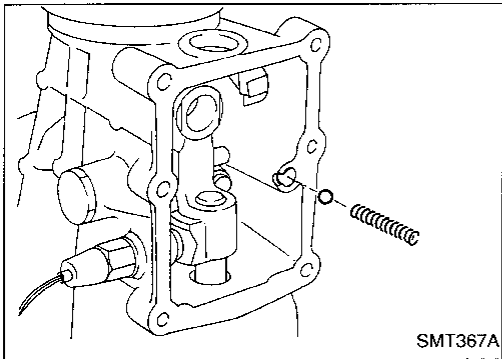

2. Remove control housing, return spring and check ball.
  - Be careful not to lose check ball.

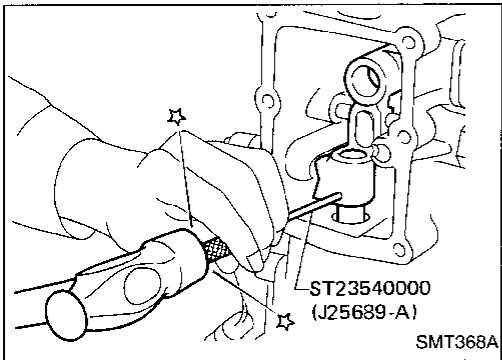

3. Drive out retaining pin from striking arm.

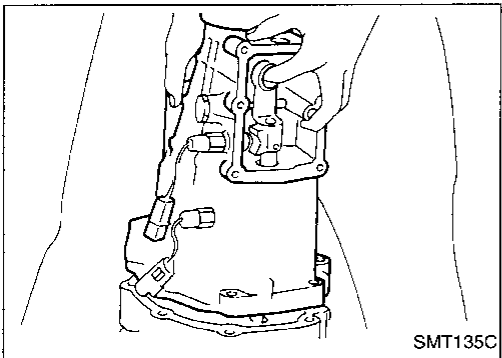

4. Remove rear extension (or OD gear case) together with striking arm by tapping lightly.

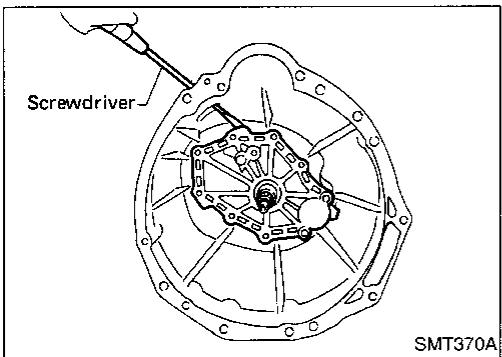

5. Remove front cover and gasket.

GI

MA

EM

LC

EC

FE

CL

MT

AT

TF

PD

FA

RA

BR

ST

RS

BT

HA

EL

IDX

## DISASSEMBLY

### Case Components (Cont'd)

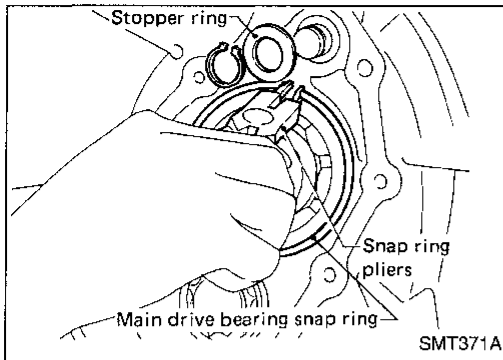

6. Remove stopper ring and main drive bearing snap ring.

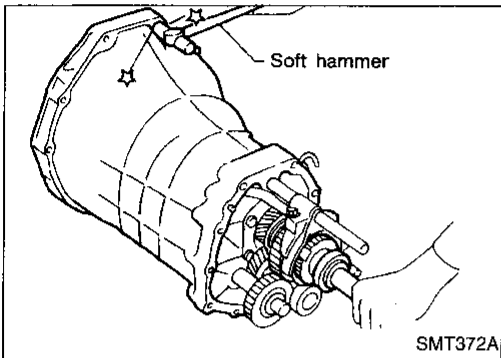

7. Remove transmission case by tapping lightly.

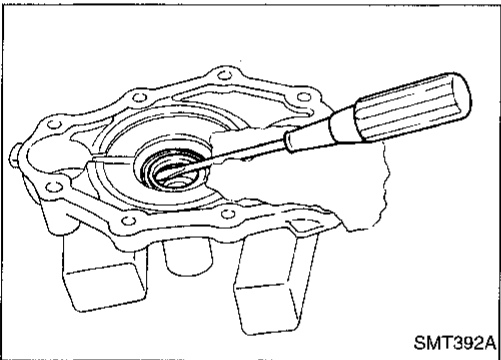

8. Remove front cover oil seal.

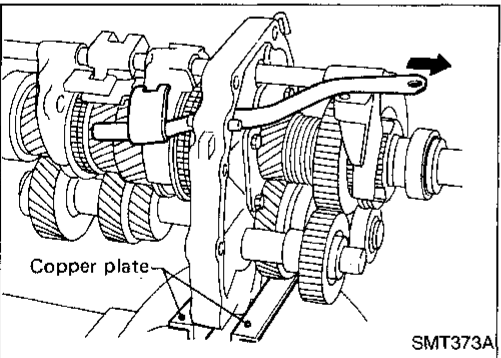

### Shift Control Components

1. Mount adapter plate on vise.
2. Remove OD & reverse fork rod.

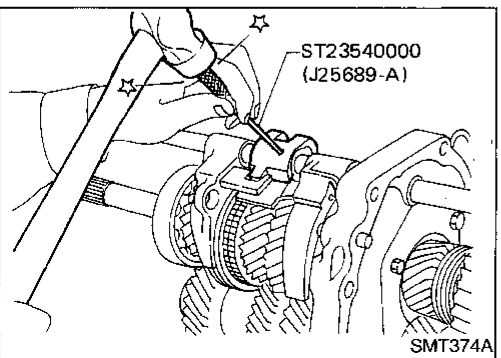

3. Drive out retaining pin from striking lever.
4. While pulling out striking rod, remove striking lever and striking interlock. Then remove 1st & 2nd, 3rd & 4th and reverse shift fork.

## DISASSEMBLY

### Shift Control Components (Cont'd)

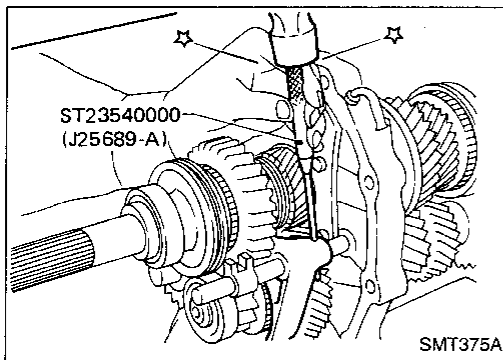

5. Drive out retaining pin from OD shift fork.
6. Pull out OD fork rod and then remove OD shift fork.

GI

MA

EM

LC

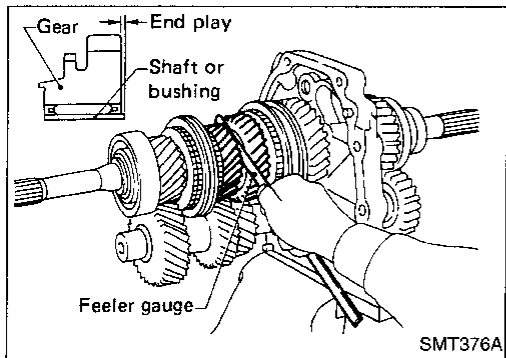

### Gear Components

1. Before removing gears and shafts, measure each gear end play.

#### Gear end play:

Refer to SDS, MT-33.

- If not within specification, disassemble and check contact surface of gear to hub, washer, bushing, needle bearing and shaft.

EC

FE

CL

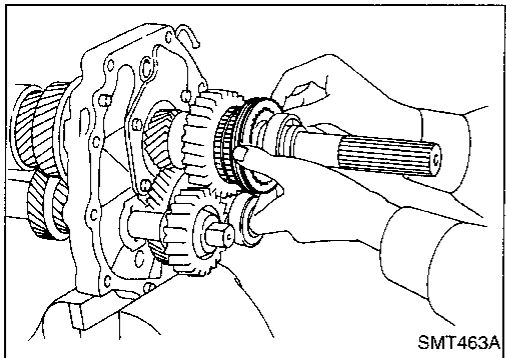

2. Remove rear side components on mainshaft and counter gear.
  - a. Remove reverse coupling sleeve.

MT

AT

TF

PD

FA

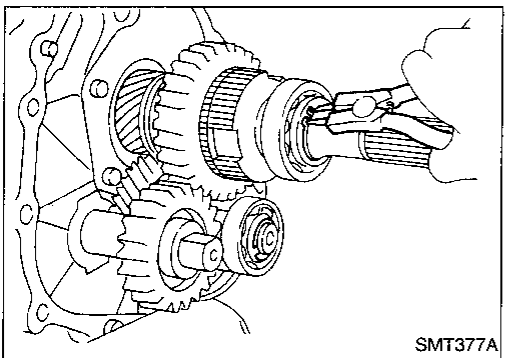

- b. Remove mainshaft rear snap ring and counter gear rear snap ring.
- c. Remove C-ring holder and mainshaft C-rings from mainshaft. Use punch and hammer to remove C-rings.

RA

BR

ST

RS

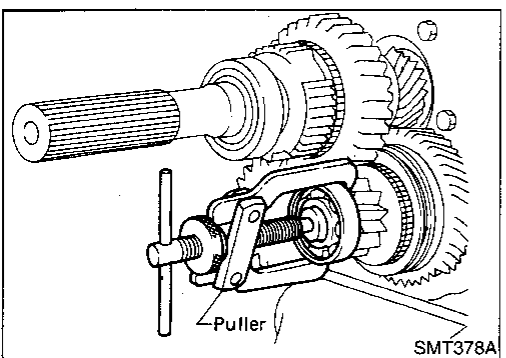

- d. Pull out counter gear rear end bearing.
- e. Remove reverse idler gear and reverse idler thrust washers.

BT

HA

EL

IDX

## DISASSEMBLY

### Gear Components (Cont'd)

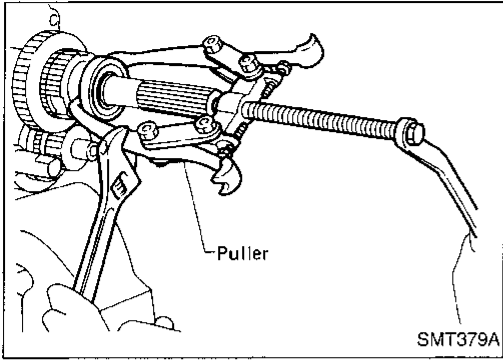

- f. Pull out mainshaft rear bearing (2WD model).

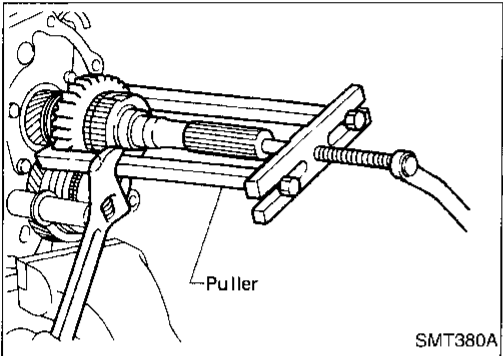

- g. Pull out reverse main gear together with mainshaft spacer and reverse synchronizer hub. Then remove reverse gear needle bearings.

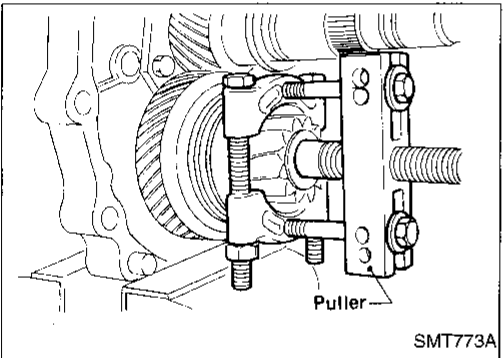

- h. Pull out reverse counter gear.  
i. Remove OD coupling sleeve together with OD baulk ring, reverse baulk ring and spring inserts.

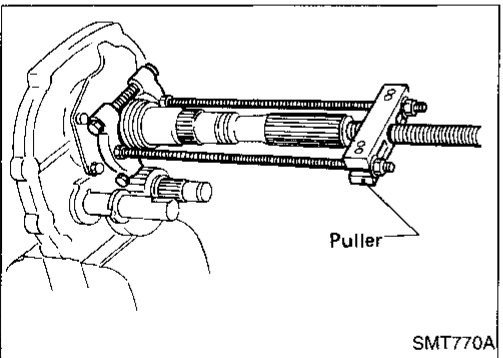

- j. Pull out reverse gear bushing.

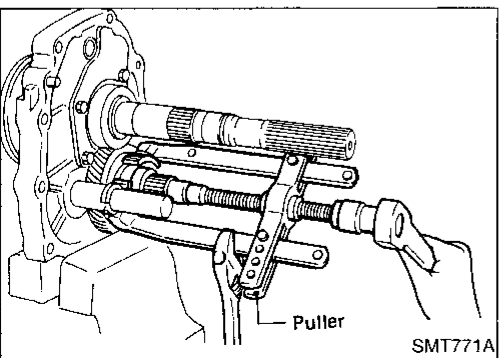

- k. Pull out OD counter gear together with reverse cone.



# DISASSEMBLY

## Gear Components (Cont'd)

3. Press out mainshaft and counter gear alternately.

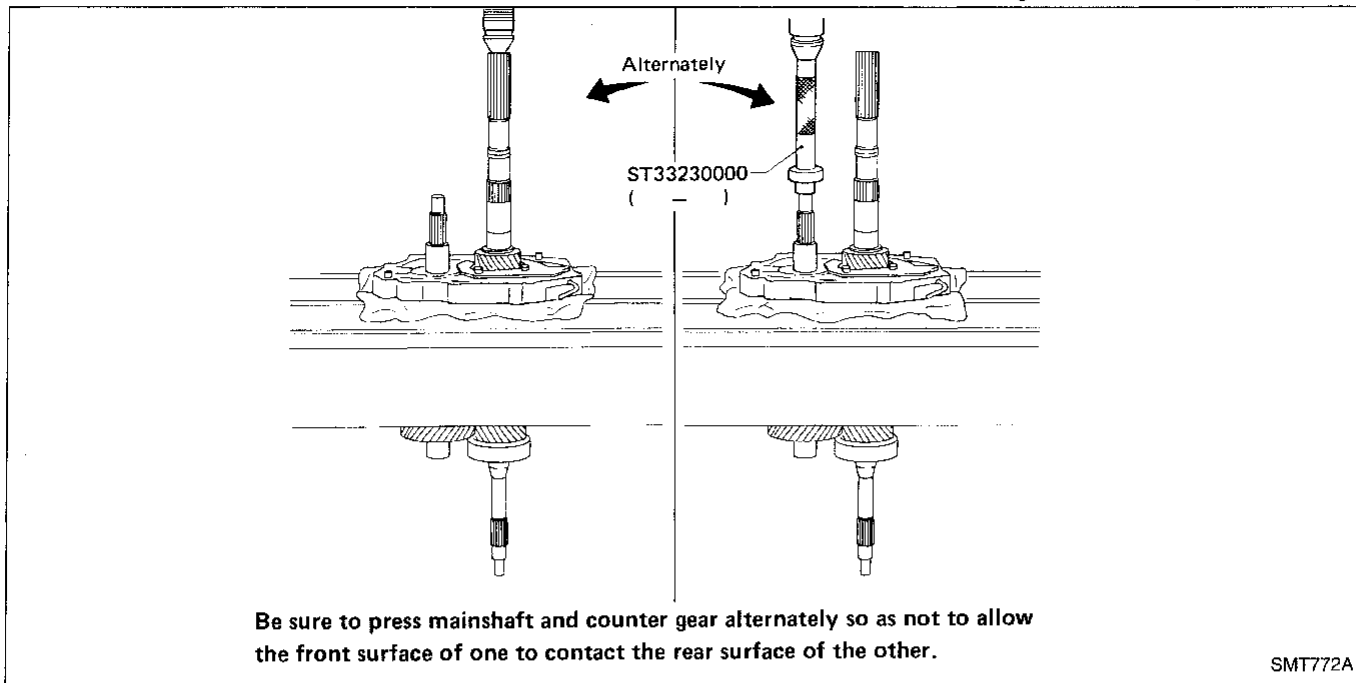

GI  
MA  
EM  
LC  
EC  
FE  
CL  
MT

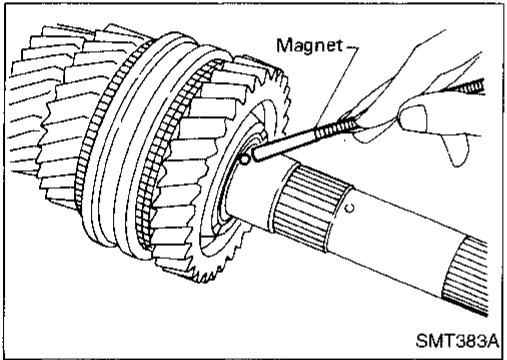

4. Remove front side components on mainshaft.
- a. Remove 1st gear washer and steel ball.
  - b. Remove 1st main gear and 1st gear needle bearing.
- **Be careful not to lose steel ball.**

AT  
TF  
PD  
FA

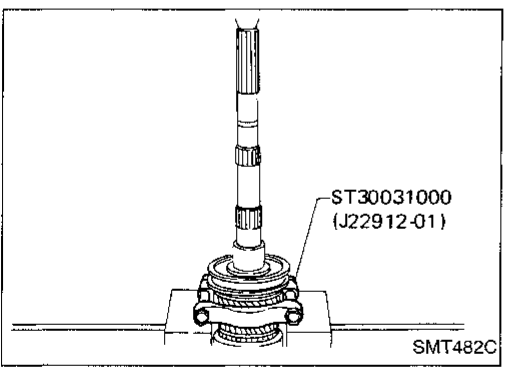

- c. Press out 2nd main gear together with 1st gear bushing and 1st & 2nd synchronizer assembly.
- d. Remove mainshaft front snap ring.

RA  
BR  
ST  
RS

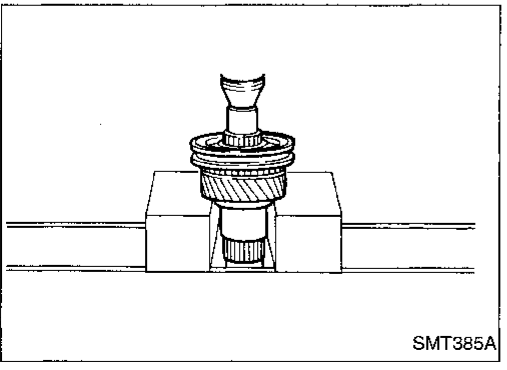

- e. Press out 3rd main gear together with 3rd & 4th synchronizer assembly and 3rd gear needle bearing.

BT  
HA  
EL  
IDX

# DISASSEMBLY

## Gear Components (Cont'd)

5. Remove front side components on counter gear.
  - a. Remove counter gear rear thrust bearing.

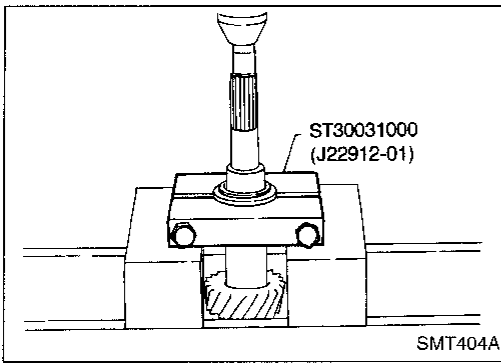

- b. Remove sub gear components.

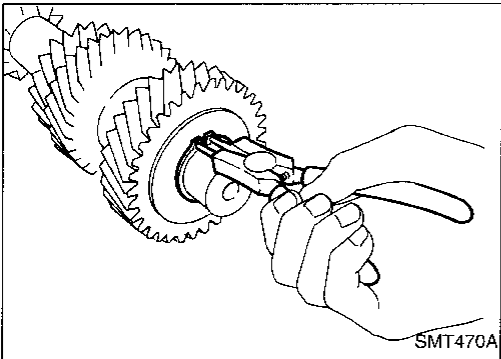

6. Remove main drive gear bearing.
  - a. Remove main drive gear snap ring.
  - b. Press out main drive gear bearing.

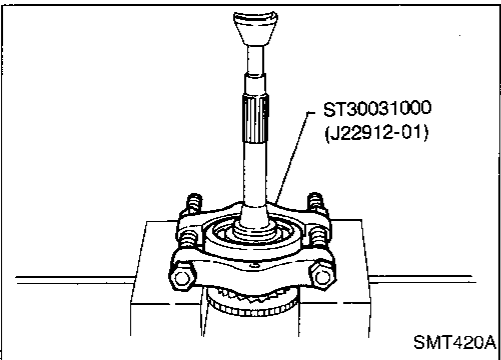

7. Remove bearings from case components.

**Counter gear front bearing in transmission case**

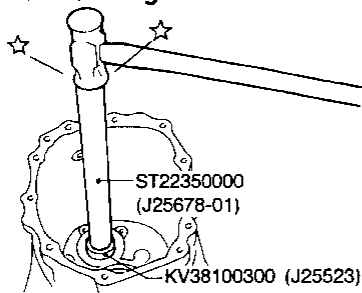

SMT388A

**Mainshaft front bearing in adapter plate**

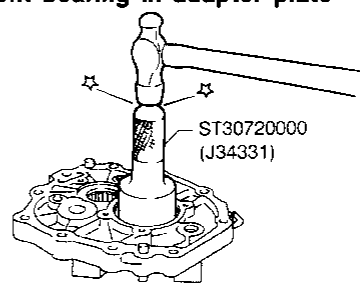

SMT396A

**Mainshaft rear bearing in OD gear case (4WD model)**

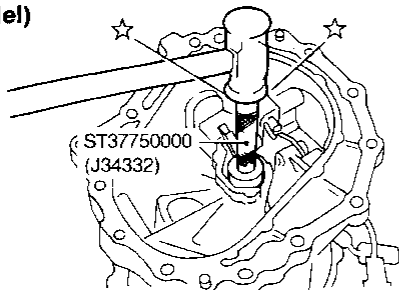

SMT390A

**Counter gear rear bearing in adapter plate**

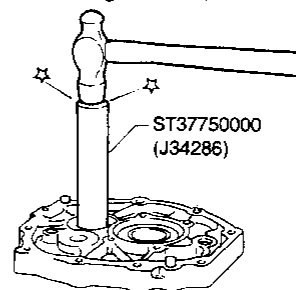

SMT483CC

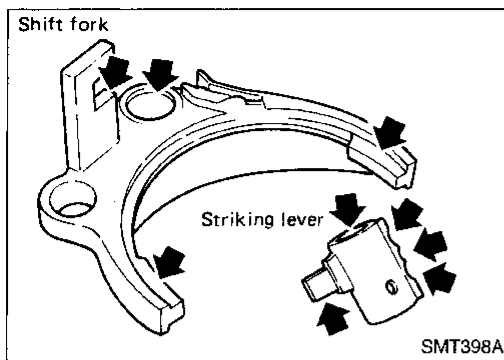

## Shift Control Components

- Check contact surface and sliding surface for wear, scratches, projections or other damage.

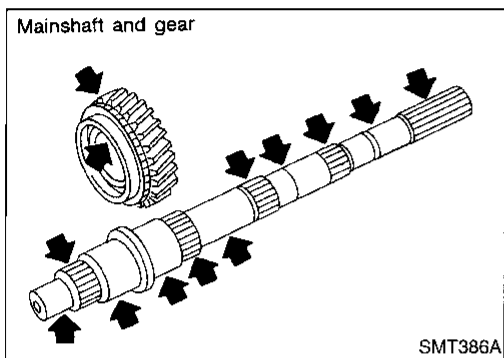

## Gear Components

### GEARS AND SHAFTS

- Check shafts for cracks, wear or bending.
- Check gears for excessive wear, chips or cracks.

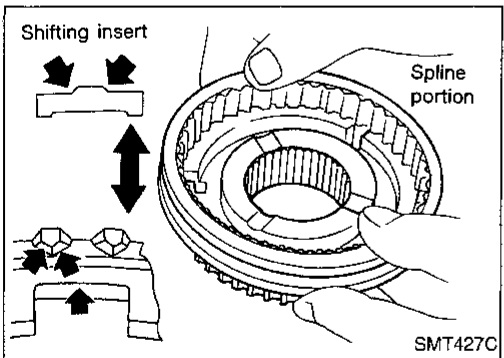
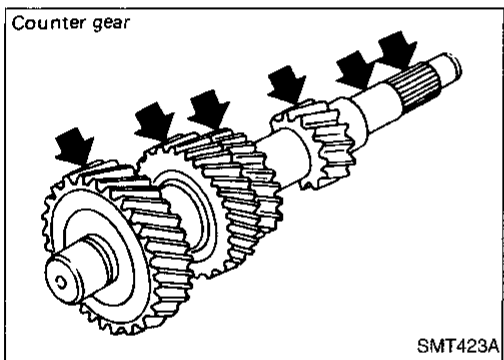

## SYNCHRONIZERS

- Check spline portion of coupling sleeves, hubs, and gears for wear or cracks.
- Check baulk rings for cracks or deformation.
- Check shifting inserts for wear or deformation.
- Check insert springs for deformation.

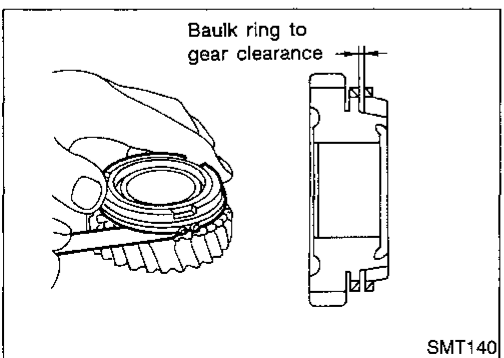

- Measure wear of main drive, 1st and OD baulk rings.  
**Clearance between baulk ring and gear:  
Refer to SDS, MT-33.**
- If the clearance is smaller than the wear limit, replace baulk ring.

GI

MA

EM

LC

EC

FE

CL

MT

AT

TF

PD

FA

RA

BR

ST

RS

BT

HA

EL

IDX

## INSPECTION

### Gear Components (Cont'd)

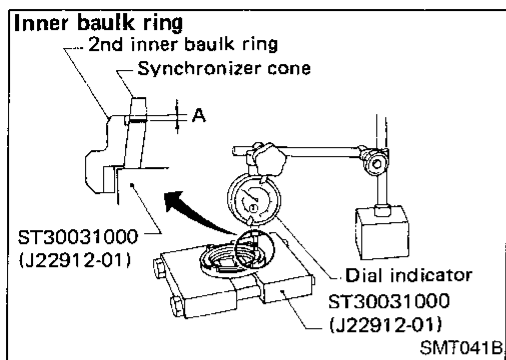

- Measure wear of 2nd and 3rd baulk rings.
- a. Place baulk rings in position on synchronizer cone.
- b. While holding baulk rings against synchronizer cone as far as it will go, measure dimensions "A" and "B".

#### Standard:

**A** 0.7 - 0.9 mm (0.028 - 0.035 in)

**B** 0.6 - 1.1 mm (0.024 - 0.043 in)

#### Wear limit:

**0.2 mm (0.008 in)**

- c. If dimension "A" or "B" is smaller than the wear limit, replace baulk ring.

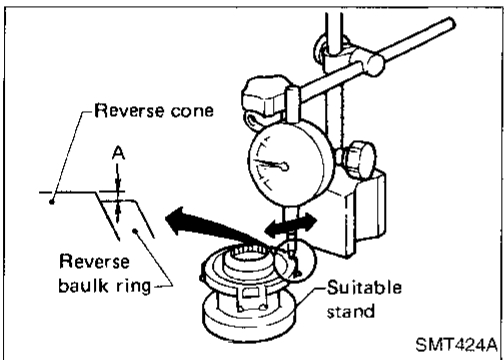
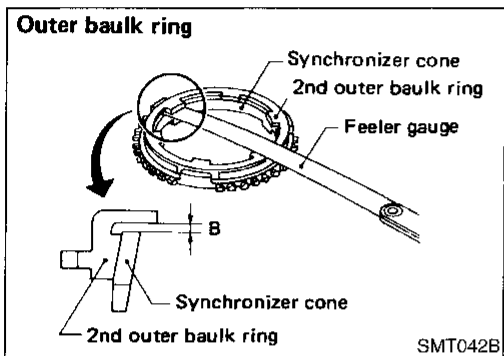

- Measure wear of reverse baulk ring.
- a. Place baulk ring in position on reverse cone.
- b. While holding baulk ring against reverse cone as far as it will go, measure dimension "A" with dial indicator.

#### Dimension "A":

**Standard -0.1 to 0.35 mm (-0.0039 to 0.0138 in)**

**Wear limit 0.7 mm (0.028 in)**

- c. If dimension "A" is larger than the wear limit, replace baulk ring.

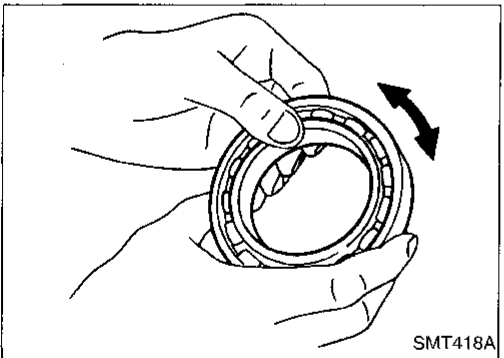

### BEARINGS

- Make sure bearings roll freely and are free from noise, crack, pitting or wear.

## Gear Components

Counter gear front bearing in transmission case

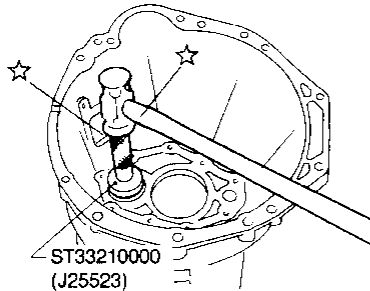

SMT389A

Mainshaft front bearing in adapter plate

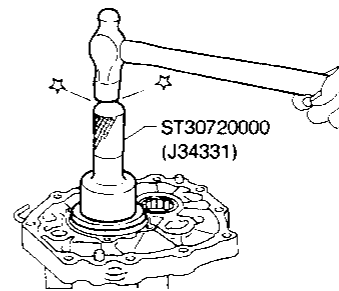

SMT397A

Mainshaft rear bearing in OD gear case (4WD model)

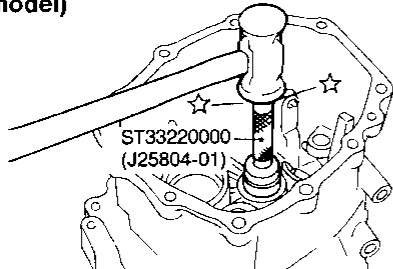

SMT391A

Counter gear rear bearing in adapter plate

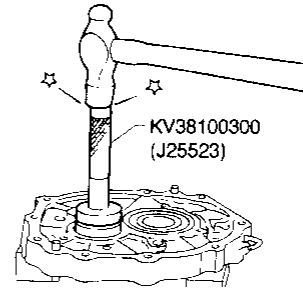

SMT484CC

Be flush with front surface of OD gear case.

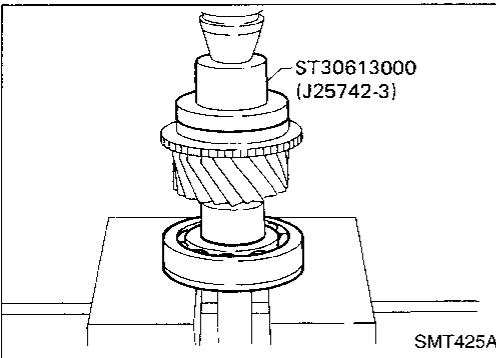

SMT425A

1. Install bearings into case components.

2. Install main drive gear bearing.  
a. Press main drive gear bearing.

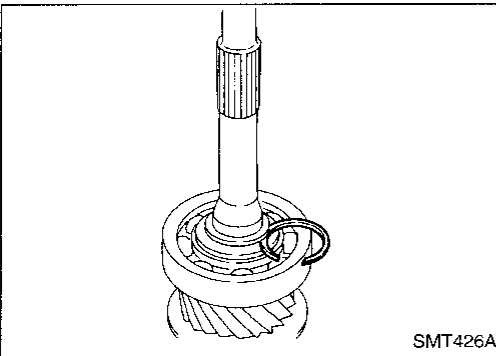

SMT426A

b. Select proper main drive gear snap ring to minimize clearance of groove.

**Allowable clearance of groove:**

**0 - 0.1 mm (0 - 0.004 in)**

**Main drive gear snap ring:**

**Refer to SDS, MT-33.**

c. Install selected snap ring on main drive gear.

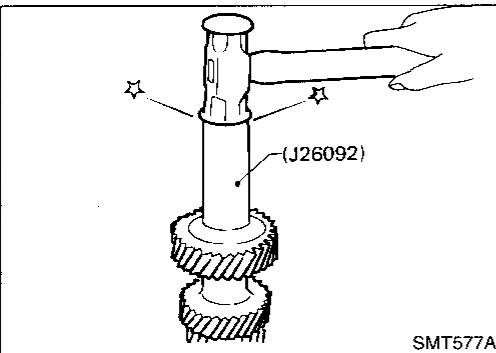

SMT577A

3. Install components on counter gear.

a. Install sub-gear components.

• **When installing sub-gear snap ring, tap sub-gear snap ring into position on counter gear.**

# ASSEMBLY

## Gear Components (Cont'd)

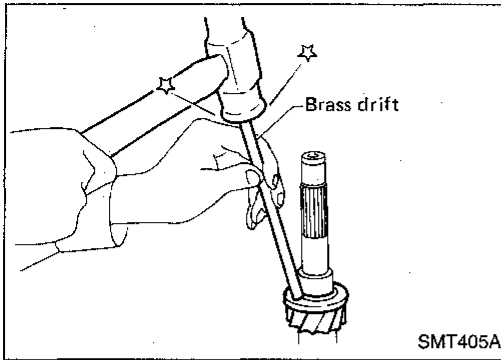

b. Install counter gear rear thrust bearing.

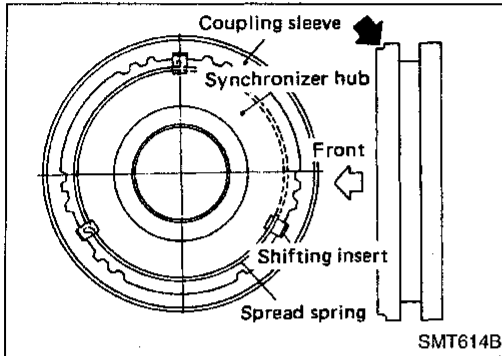

4. Install front side components on mainshaft.  
a. Assemble 1st & 2nd synchronizer.

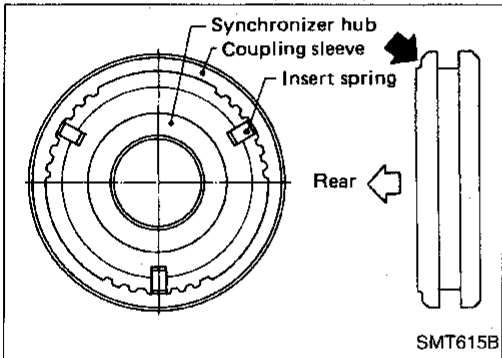

b. Assemble 3rd & 4th synchronizer.

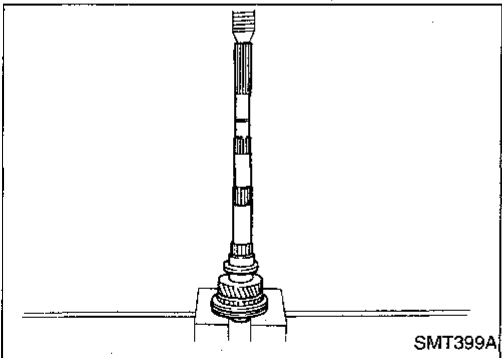

c. Press on 3rd & 4th synchronizer assembly together with 3rd main gear and 3rd gear needle bearing.

• **Pay attention to direction of synchronizer assembly.**

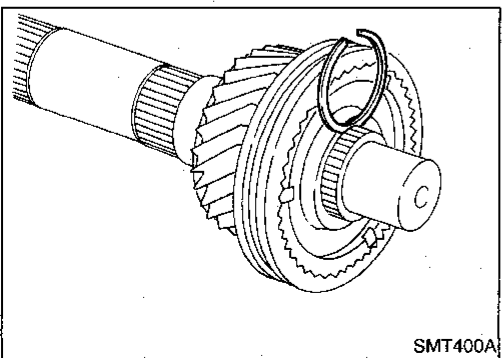

d. Select proper snap ring to minimize clearance of groove.

**Allowable clearance of groove:**

**0 - 0.1 mm (0 - 0.004 in)**

**Mainshaft front snap ring:**

**Refer to SDS, MT-33.**

e. Install selected snap ring on mainshaft.

## ASSEMBLY

### Gear Components (Cont'd)

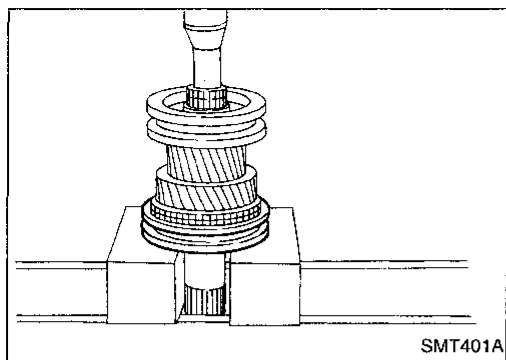

- f. Press on 1st & 2nd synchronizer assembly together with 2nd main gear and 2nd gear needle bearing.

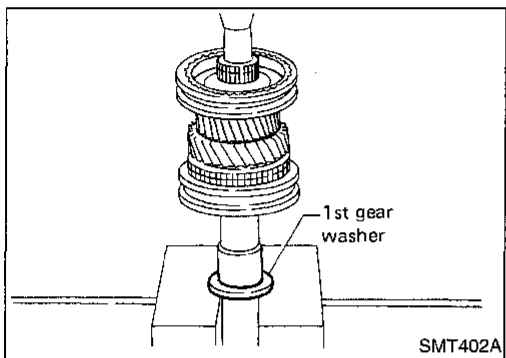

- g. Press on 1st gear bushing using 1st gear washer.  
h. Install 1st main gear and needle bearing.

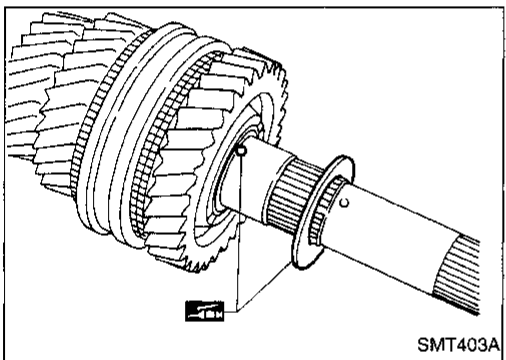

- i. Install steel ball and 1st gear washer.  
• **Apply multi-purpose grease to steel ball and 1st gear washer before installing.**

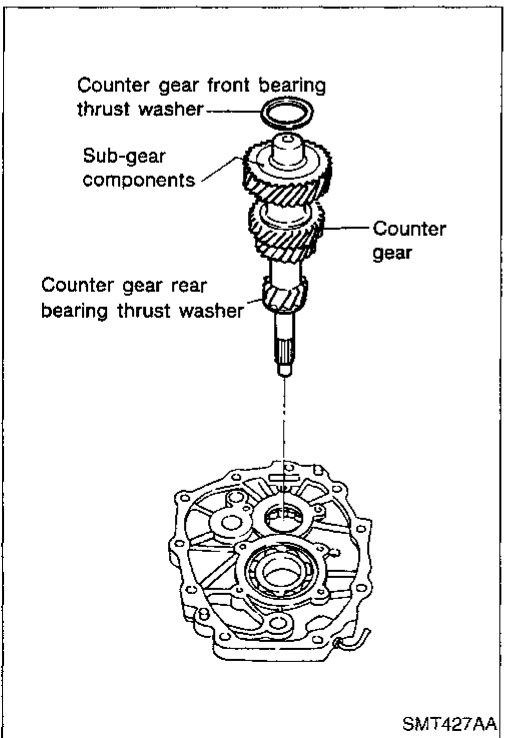

5. Select proper counter gear front bearing thrust washer when replacing transmission case, counter gear, counter gear rear thrust bearing or sub-gear components.  
a. Install counter gear with sub-gear components, counter gear front and rear bearing thrust washer on adapter plate.  
b. Remove counter gear front bearing thrust washer from transmission case.  
c. Place adapter plate and counter gear assembly in transmission case (case inverted).

GI

MA

EM

LC

EC

FE

CL

MT

AT

TF

PD

FA

RA

BR

ST

RS

BT

HA

EL

IDX

## ASSEMBLY

### Gear Components (Cont'd)

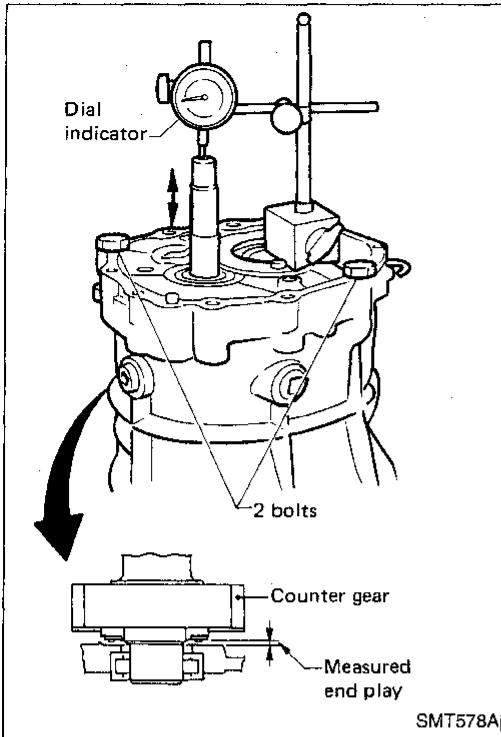

- d. Tighten adapter plate to transmission case using 2 bolts.
- e. Place dial indicator on rear end of counter gear.
- f. Move counter gear up and down and measure dial indicator deflection.
- g. Select proper thrust washer using table below as a guide.

#### Counter gear end play:

0.10 - 0.25 mm (0.0039 - 0.0098 in)

#### Table for selecting proper counter gear front bearing thrust washer:

Refer to SDS, MT-34.

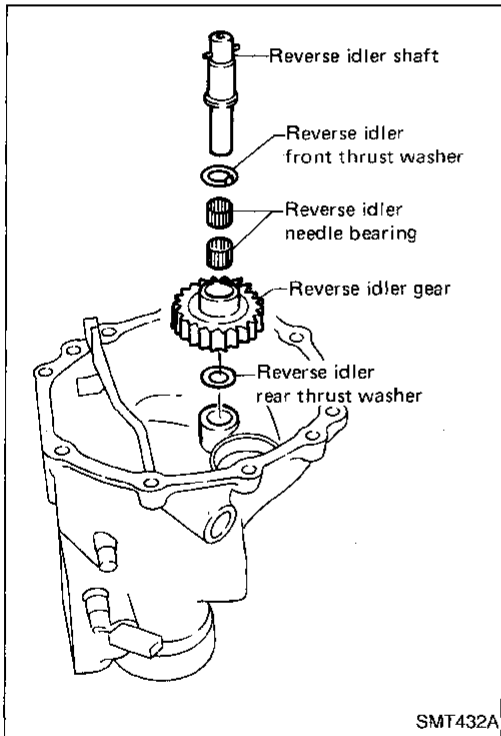

6. Select proper reverse idler rear thrust washer when replacing rear extension (or OD gear case), reverse idler gear, reverse idler shaft or reverse idler front thrust washer.
- a. Install reverse idler gear, reverse idler needle bearings, reverse idler front thrust washers and reverse idler shaft into rear extension (or OD gear case).
- **When replacing reverse idler rear thrust washer, install either A or B.**

#### Reverse idler rear thrust washer:

Refer to SDS, MT-34.



# ASSEMBLY

## Gear Components (Cont'd)

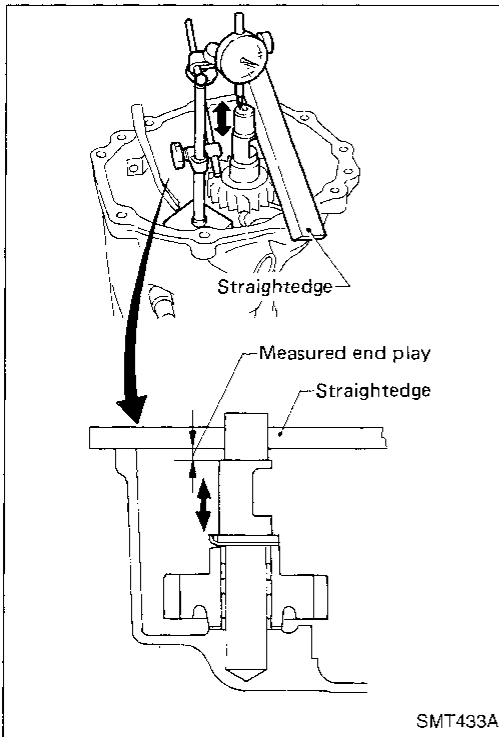

- b. Place dial indicator on front end of reverse idler shaft.
- c. Put straightedge on front surface of rear extension (or OD gear case) as a stopper of reverse idler shaft.
- d. Move reverse idler shaft up and down and measure reverse idler gear end play.

### Reverse idler gear end play:

0.30 - 0.53 mm (0.0118 - 0.0209 in)

- e. If not within specification, replace reverse idler rear thrust washer with the other (A or B) and check again.

GI

MA

EM

LC

EC

FE

CL

MT

AT

TF

PD

FA

RA

BR

ST

RS

ET

HA

EL

IDX

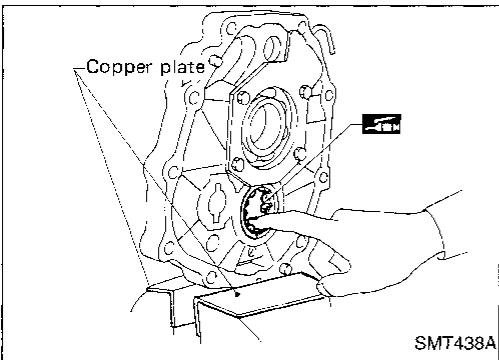

- 7. Install mainshaft and counter gear on adapter plate and main drive gear on mainshaft.

- a. Mount adapter plate on vise and apply multi-purpose grease to counter gear rear bearing.

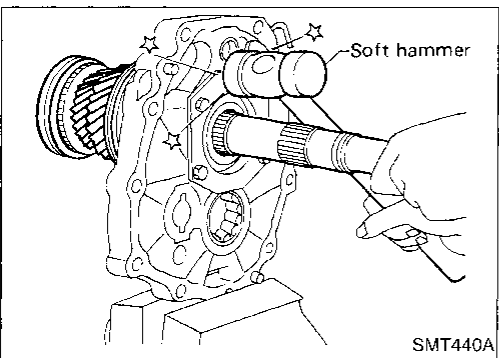

- b. Install mainshaft a little on mainshaft front bearing.

- **To allow for installation of counter gear, do not install mainshaft completely.**

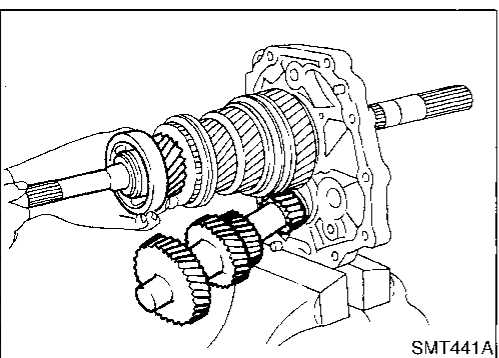

- c. Install counter gear on counter gear rear bearing and install main drive gear, pilot bearing and spacer on mainshaft.

## ASSEMBLY

### Gear Components (Cont'd)

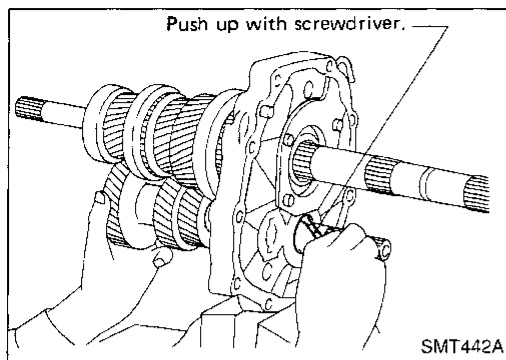

- When installing counter gear into counter gear rear bearing, push up on upper roller of counter gear rear bearing with screwdriver.

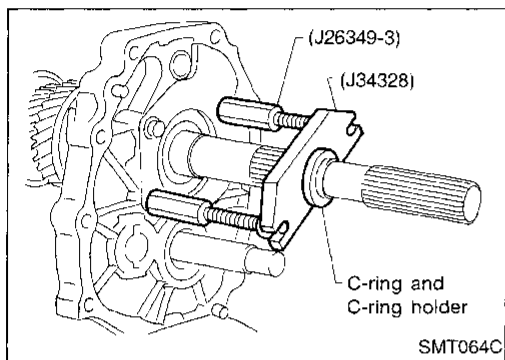

- Install Tools (J26349-3) onto adapter plate and C-ring and C-ring holder on mainshaft.
- Install Tool (J34328) on mainshaft.

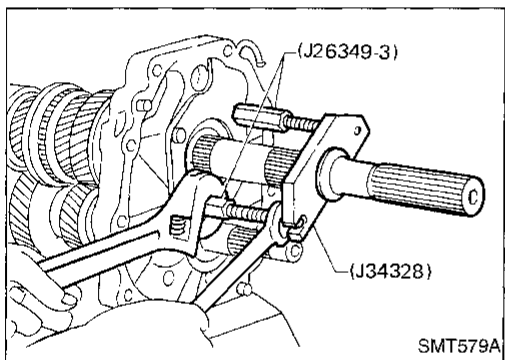

- Install mainshaft and counter gear completely by extending length of (J26349-3).

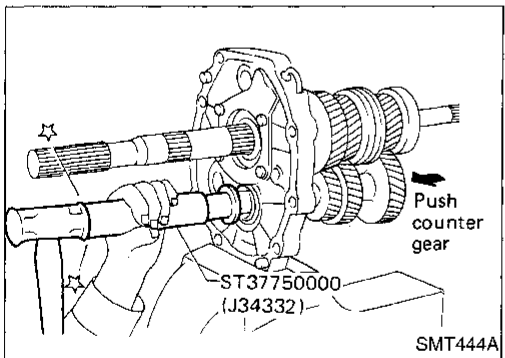

- Install rear side components on mainshaft and counter gear.
  - Install OD gear bushing while pushing on the front of counter gear.

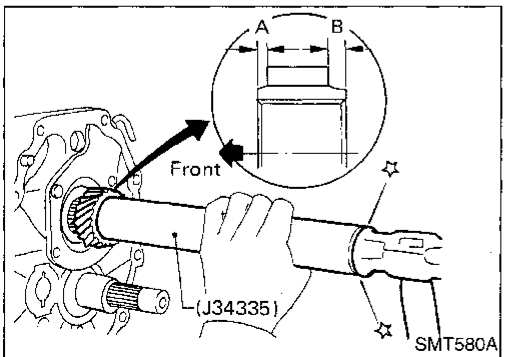

- Install OD main gear.
  - Pay attention to direction of OD main gear. (B is wider than A as shown at left.)
- Install adapter plate with gear assembly onto transmission case.
- Install OD gear needle bearing and then install OD counter gear and reverse idler shaft.

# ASSEMBLY

## Gear Components (Cont'd)

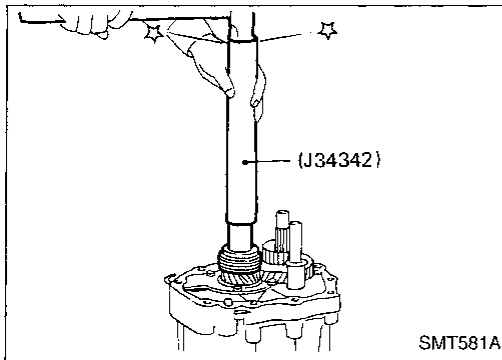

- e. Install reverse gear bushing with speedometer drive gear (2WD model).

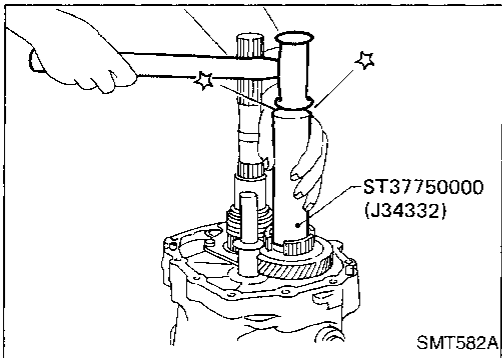

- f. Install reverse cone.

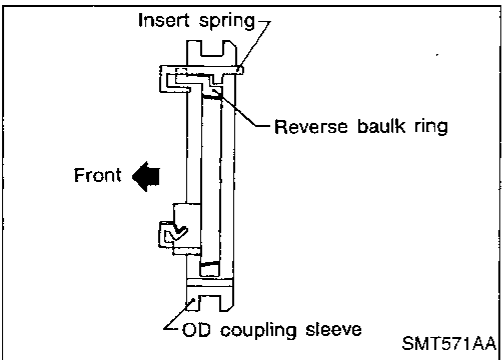

- g. Install insert springs and reverse baulk ring on OD coupling sleeve. Then install them and OD baulk ring on OD counter gear.

- Pay attention to direction of OD coupling sleeve.

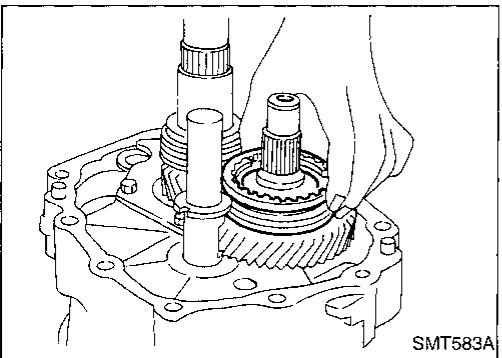

- h. Install reverse counter gear.  
i. Install reverse gear needle bearing and then install reverse main gear, reverse idler gear and reverse idler thrust washers.

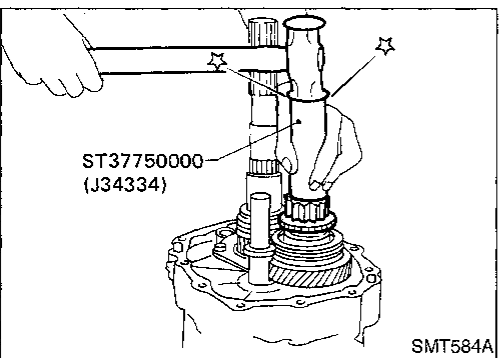

GI  
MA  
EM  
LC  
EC  
FE  
CL  
MT  
AT  
TF  
PD  
FA  
RA  
BR  
ST  
RS  
BT  
HA  
EL  
IDX

## ASSEMBLY

### Gear Components (Cont'd)

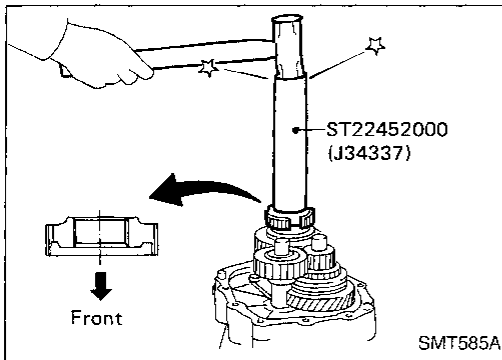

- j. Install reverse hub.
- Pay attention to its direction.

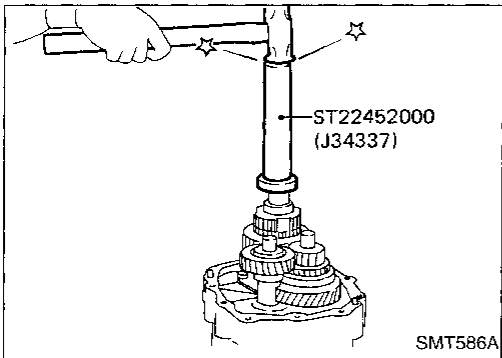

- k. Install mainshaft spacer and mainshaft rear bearing (2WD model).

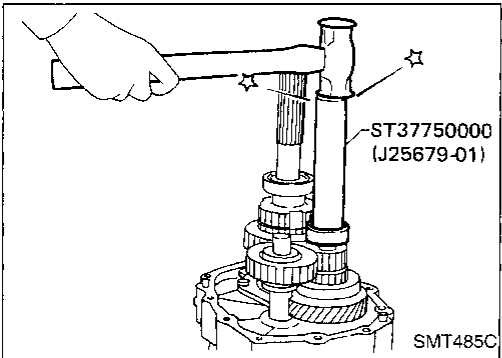

- l. Install counter gear rear end bearing.
- m. Separate adapter plate from transmission case and mount adapter plate on vice again.

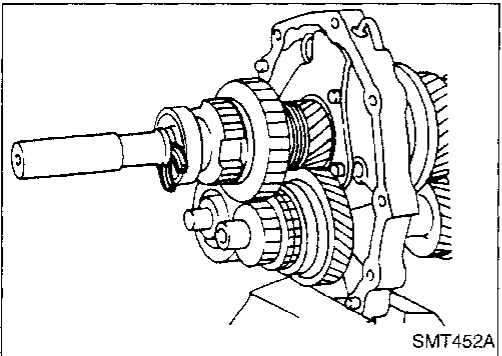

- n. Select proper mainshaft C-ring to minimize clearance of groove.

**Allowable clearance of groove:**

**0 - 0.1 mm (0 - 0.004 in)**

**Mainshaft C-ring:**

**Refer to SDS, MT-34.**

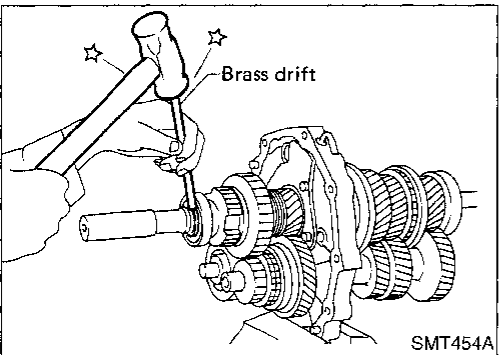

- o. Install selected C-ring, C-ring holder and mainshaft rear snap ring.

# ASSEMBLY

## Gear Components (Cont'd)

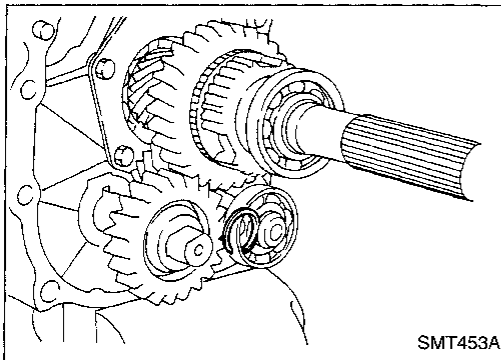

- p. Select proper counter gear rear snap ring to minimize clearance of groove.

**Allowable clearance of groove:**

0 - 0.1 mm (0 - 0.004 in)

**Counter gear rear snap ring:**

**Refer to SDS, MT-34.**

- q. Install selected counter gear rear snap ring.

GI

MA

EM

LC

EC

FE

CL

MT

AT

TF

PD

FA

RA

BR

ST

RS

BT

HA

EL

IDX

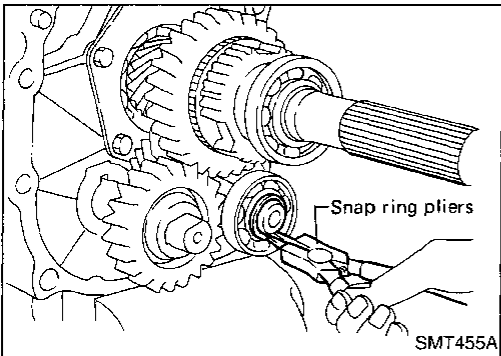

- r. Install reverse coupling sleeve.

• **Pay attention to its direction.**

- s. Measure each gear end play as a final check. Refer to "DISASSEMBLY", MT-15.

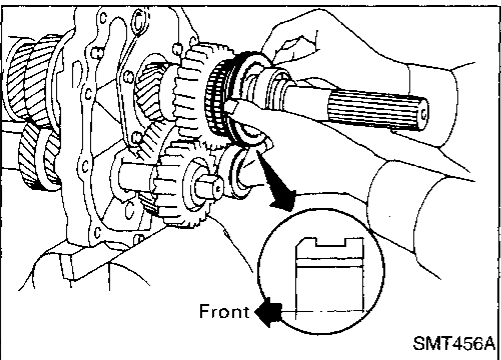

## Shift Control Components

1. Install OD fork rod and OD shift fork. Then install retaining pin into OD shift fork.
2. Install 1st & 2nd, 3rd & 4th and reverse shift fork onto coupling sleeve.

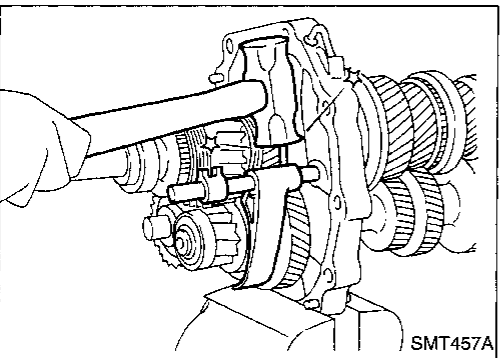

3. Install striking rod into hole of shift forks, striking lever and interlock and then install retaining pin into striking lever.

• **Make sure that striking rod moves smoothly.**

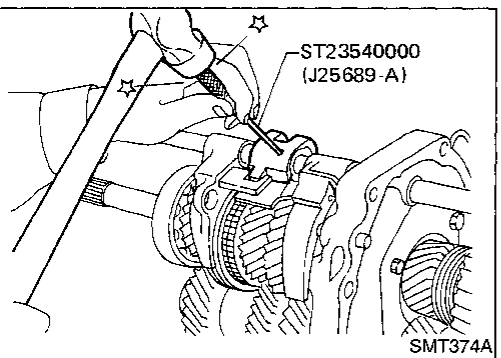

## Case Components

1. Install front cover oil seal.
  - **Apply multi-purpose grease to seal lip.**
2. Install selected counter gear front bearing shim onto transmission case.
  - **Apply multi-purpose grease.**
3. Apply sealant to mating surface of transmission case.
4. Install gear assembly onto transmission case.
5. Install check spring and check ball into interlock stopper.
  - **Apply multi-purpose grease to check ball.**
6. Install interlock stopper assembly and then tighten check ball plug.
  - **Apply sealant to thread of check ball plug.**
7. Install stopper ring and main drive bearing snap ring.
8. Install front cover and gasket.
  - **Apply sealant to thread of 3 bolts shown left.**
9. Apply sealant to mating surface of adapter plate.

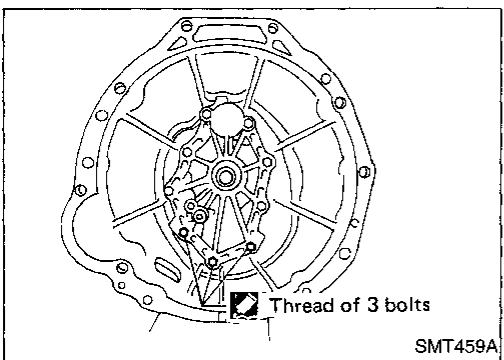
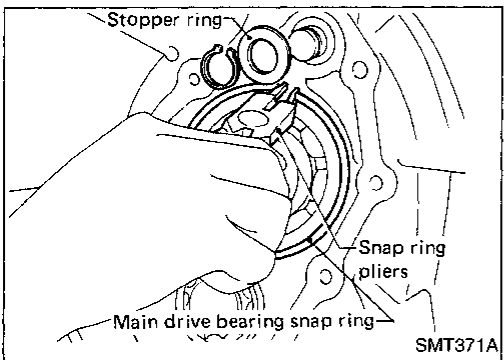
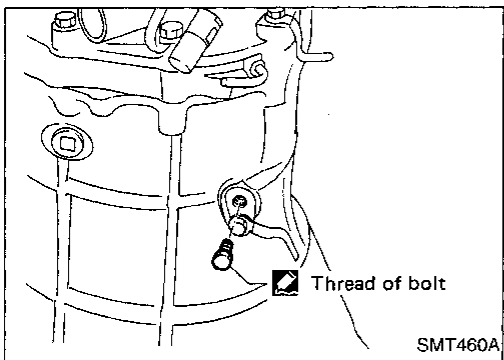
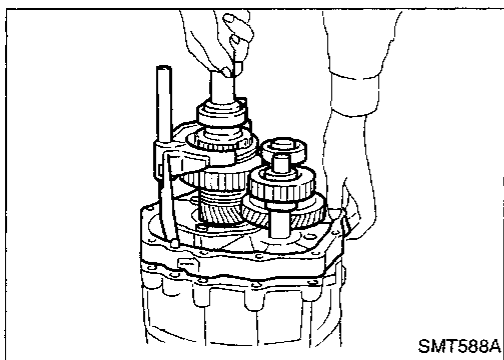
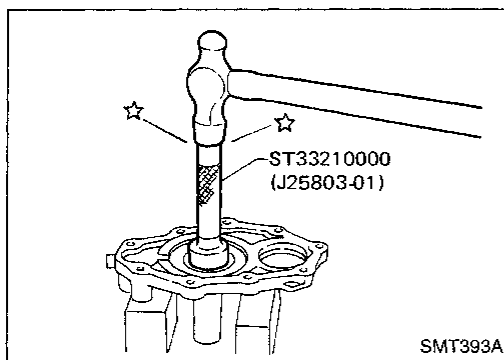

# ASSEMBLY

## Case Components (Cont'd)

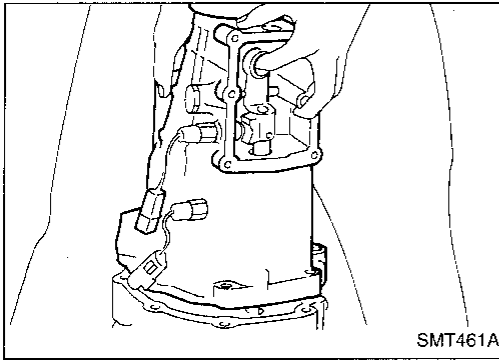

10. Install rear extension (or OD gear case) together with striking arm.

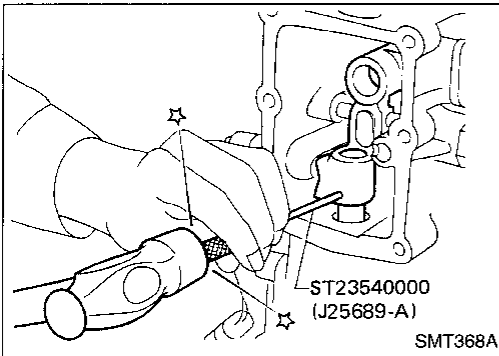

11. Install retaining pin into striking arm.

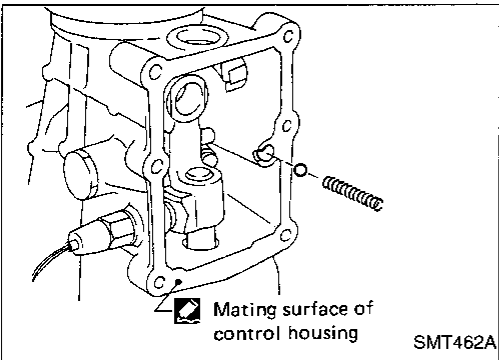

12. Install return spring and check ball and then install control housing.

- **Apply sealant to mating surface of rear extension (or OD gear case).**

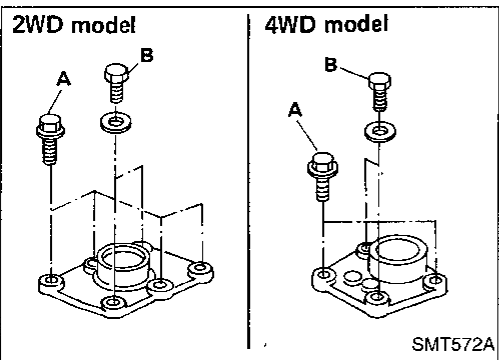

13. Tighten control housing bolts.

**Bolt head size:**

**A bolts 12 mm (0.47 in)**

**B bolts 13 mm (0.51 in)**

GI  
MA  
EM  
LC  
EC  
FE  
CL  
MT  
AT  
TF  
PD  
FA  
RA  
BR  
ST  
RS  
BT  
HA  
EL  
IDX

# SERVICE DATA AND SPECIFICATIONS (SDS)

## General Specifications

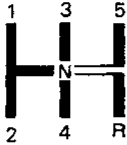
Applied model	VG33E	
	2WD	
	Van	Wagon
	4WD	
Transmission	FS5R30A	
Number of speed	5	
Shift pattern		
Synchronmesh type	Warner	
Gear ratio		
1st	3.580	
2nd	2.077	
3rd	1.360	
4th	1.000	
OD	0.811	
Reverse	3.636	
Number of teeth		
Mainshaft		
Drive	22	
1st	32	
2nd	30	
3rd	29	
OD	24	
Reverse	30	
Countershaft		
Drive	32	
1st	13	
2nd	21	
3rd	31	
OD	43	
Reverse	12	
Reverse idler gear	22	
Oil capacity ℓ (US pt, Imp pt)	2.4 (5-1/8, 4-1/4)	5.1 (10-3/4, 9)
Remarks	2nd & 3rd double baulk ring type synchronizer	



# SERVICE DATA AND SPECIFICATIONS (SDS)

## Inspection and Adjustment

### GEAR END PLAY

Gear	End play mm (in)
1st main gear	0.23 - 0.33 (0.0091 - 0.0130)
2nd main gear	0.23 - 0.33 (0.0091 - 0.0130)
3rd main gear	0.23 - 0.33 (0.0091 - 0.0130)
OD counter gear	0.23 - 0.33 (0.0091 - 0.0130)
Reverse main gear	0.33 - 0.43 (0.0130 - 0.0169)
Counter gear	0.10 - 0.25 (0.0039 - 0.0098)
Reverse idler gear	0.30 - 0.53 (0.0118 - 0.0209)

### CLEARANCE BETWEEN BAULK RING AND GEAR

Unit: mm (in)

	Standard	Wear limit
1st	1.05 - 1.3 (0.0413 - 0.0512)	0.7 (0.028)
Main drive	1.05 - 1.3 (0.0413 - 0.0512)	
OD	1.05 - 1.3 (0.0413 - 0.0512)	

### 2nd and 3rd baulk ring

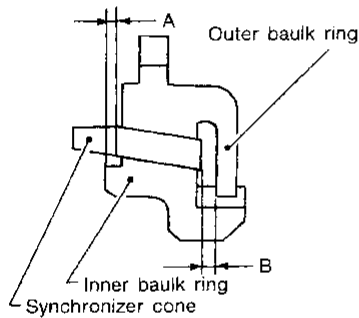

SMT742C

Unit: mm (in)

Dimension	Standard	Wear limit
A	0.7 - 0.9 (0.028 - 0.035)	0.2 (0.008)
B	0.6 - 1.1 (0.024 - 0.043)	

### DISTANCE BETWEEN REAR SURFACE OF REVERSE CONE AND REVERSE BAULK RING

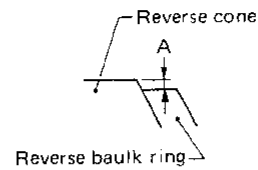

Unit: mm (in)

	Standard	Wear limit
Dimension "A"	-0.1 to 0.35 (-0.0039 to 0.0138)	0.7 (0.028)

### AVAILABLE SNAP RING

#### Main drive gear snap ring

Allowable clearance 0 - 0.1 mm (0 - 0.004 in)

Thickness mm (in)	Part number
1.89 (0.0744)	32204-01G60
1.95 (0.0768)	32204-01G61
1.99 (0.0783)	32204-01G62
2.03 (0.0799)	32204-01G63
2.07 (0.0815)	32204-01G64
2.11 (0.0831)	32204-01G65

#### Mainshaft front snap ring

Allowable clearance 0 - 0.1 mm (0 - 0.004 in)

Thickness mm (in)	Part number
1.99 (0.0783)	32204-01G62
2.03 (0.0799)	32204-01G63
2.07 (0.0815)	32204-01G64
2.11 (0.0831)	32204-01G65
2.15 (0.0846)	32204-01G66
2.19 (0.0862)	32204-01G67

# SERVICE DATA AND SPECIFICATIONS (SDS)

## Inspection and Adjustment (Cont'd)

### Counter gear rear snap ring

Allowable clearance		0 - 0.1 mm (0 - 0.004 in)
Thickness	mm (in)	Part number
1.32	(0.0520)	32236-01G00
1.38	(0.0543)	32236-01G01
1.44	(0.0567)	32236-01G02
1.50	(0.0591)	32236-01G03
1.56	(0.0614)	32236-01G04
1.62	(0.0638)	32236-01G05
1.68	(0.0661)	32236-01G06
1.74	(0.0685)	32236-01G07

### AVAILABLE C-RING

#### Mainshaft C-ring

Allowable clearance		0 - 0.1 mm (0 - 0.004 in)
Thickness	mm (in)	Part number
2.63	(0.1035)	32348-01G15
2.70	(0.1063)	32348-01G00
2.77	(0.1091)	32348-01G01
2.84	(0.1118)	32348-01G02
2.91	(0.1146)	32348-01G03
2.98	(0.1173)	32348-01G04
3.05	(0.1201)	32348-01G05
3.12	(0.1228)	32348-01G06
3.19	(0.1256)	32348-01G07
3.26	(0.1283)	32348-01G08
3.33	(0.1311)	32348-01G09
3.40	(0.1339)	32348-01G10
3.47	(0.1366)	32348-01G11
3.54	(0.1394)	32348-01G12
3.61	(0.1421)	32348-01G13
3.68	(0.1449)	32348-01G14

### AVAILABLE SHIM AND WASHER

#### Table for selecting proper counter gear front bearing thrust washer

Dial indicator deflection	Thickness of proper washer	Part number
mm (in)	mm (in)	
0.93 - 1.02	(0.0366 - 0.0402)	0.80 (0.0315) 32218-01G00
1.01 - 1.10	(0.0398 - 0.0433)	0.88 (0.0346) 32218-01G11
1.09 - 1.18	(0.0429 - 0.0465)	0.96 (0.0378) 32218-01G12
1.17 - 1.26	(0.0461 - 0.0496)	1.04 (0.0409) 32218-01G13
1.25 - 1.34	(0.0492 - 0.0528)	1.12 (0.0441) 32218-01G14
1.33 - 1.42	(0.0524 - 0.0559)	1.20 (0.0472) 32218-01G04
1.41 - 1.50	(0.0555 - 0.0591)	1.28 (0.0504) 32218-01G15
1.49 - 1.58	(0.0587 - 0.0622)	1.36 (0.0535) 32218-01G16
1.57 - 1.66	(0.0618 - 0.0654)	1.44 (0.0567) 32218-01G17

#### Reverse idler rear thrust washer

	Thickness	mm (in)	Part number
A	1.97	(0.0776)	32284-01G10
B	2.07	(0.0815)	32284-01G11