

MANUAL TRANSMISSION

SECTION MT

CONTENTS

PREPARATION	2	INSPECTION.....	20
Special Service Tools	2	Gear Components	20
Commercial Service Tool.....	3	INSPECTION.....	20
NOISE, VIBRATION AND HARSHNESS (NVH)		ASSEMBLY	22
TROUBLESHOOTING	4	Gear Components	22
NVH Troubleshooting Chart.....	4	ASSEMBLY	22
MANUAL TRANSMISSION.....	4	Shift Control Components	30
ON-VEHICLE SERVICE	5	ASSEMBLY	30
Position Switch Check.....	5	Case Components	30
DESCRIPTION	6	ASSEMBLY	30
Cross-sectional View	6	SERVICE DATA AND SPECIFICATIONS (SDS)	33
REMOVAL AND INSTALLATION	7	General Specifications.....	33
Removal.....	7	Gear End Play	33
Installation.....	8	Clearance Between Baulk Ring and Gear	33
OVERHAUL	10	2ND AND 3RD BAULK RING	34
Case Components.....	10	Distance Between Rear Surface of Reverse	
Gear Components	11	Cone and Reverse Baulk Ring.....	34
Shift Control Components	13	Available Snap Ring	34
DISASSEMBLY	14	MAIN DRIVE GEAR SNAP RING	34
Case Components.....	14	MAINSHAFT FRONT SNAP RING.....	34
DISASSEMBLY.....	14	COUNTER GEAR REAR SNAP RING	35
Shift Control Components	15	Available C-ring	35
DISASSEMBLY.....	15	MAINSHAFT C-RING	35
Gear Components	16	Available Shim and Washer	36
DISASSEMBLY.....	16	TABLE FOR SELECTING PROPER COUNTER	
INSPECTION	20	GEAR FRONT BEARING THRUST WASHER	36
Shift Control Components	20	REVERSE IDLER REAR THRUST WASHER	36

GI

MA

EM

LC

EC

FE

CL

MT

AT

TF

PD

AX

SU

BR

ST

RS

BT

HA

SC

EL

IDX

PREPARATION

Special Service Tools

Special Service Tools

NAMT0001

The actual shapes of Kent-Moore tools may differ from those of special service tools illustrated here.

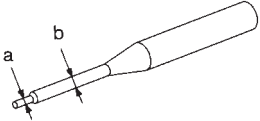
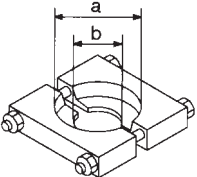
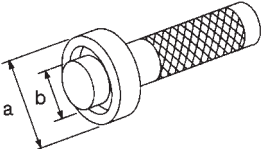
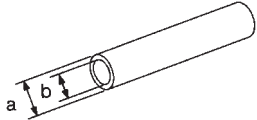
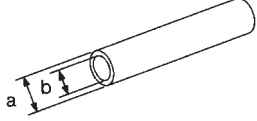
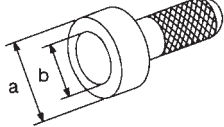
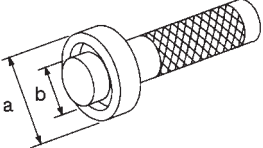
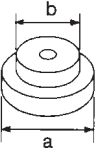
Tool number (Kent-Moore No.) Tool name	Description	
ST23540000 (J25689-A) Pin punch	 <p>NT442</p>	Removing and installing retaining pin a: 2.3 mm (0.091 in) dia. b: 4 mm (0.16 in) dia.
ST30031000 (J22912-01) Puller	 <p>NT411</p>	Removing 1st & 2nd synchronizer assembly Removing counter gear rear thrust bearing Removing main drive bearing a: 90 mm (3.54 in) dia. b: 50 mm (1.97 in) dia.
ST33230000 (—) Drift	 <p>NT084</p>	Removing mainshaft and counter gear a: 51 mm (2.01 in) dia. b: 28.5 mm (1.122 in) dia.
ST22350000 (J25678-01) Drift	 <p>NT065</p>	Removing counter gear front bearing (Use with KV38100300) a: 34 mm (1.34 in) dia. b: 28 mm (1.10 in) dia.
KV38100300 (J25523) Drift	 <p>NT065</p>	Removing counter gear front bearing (Use with ST22350000) Installing counter gear rear bearing a: 54 mm (2.13 in) dia. b: 32 mm (1.26 in) dia.
ST30720000 1 (J34286) 2 (J34331) Drift	 <p>NT115</p>	1 Removing mainshaft front bearing 2 Installing mainshaft front bearing a: 77 mm (3.03 in) dia. b: 55.5 mm (2.185 in) dia.
ST33210000 1 (J25523) 2 (J25803-01) Drift	 <p>NT084</p>	1 Installing counter gear front bearing 2 Installing front cover oil seal a: 44 mm (1.73 in) dia. b: 24.5 mm (0.965 in) dia.
ST30613000 (J25742-3) Drift	 <p>NT073</p>	Installing main drive gear bearing a: 72 mm (2.83 in) dia. b: 48 mm (1.89 in) dia.

PREPARATION

Special Service Tools (Cont'd)

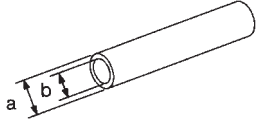
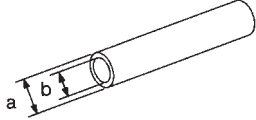
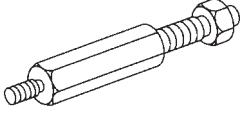
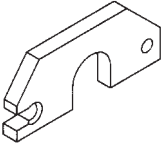
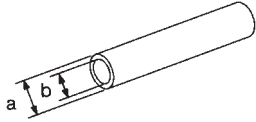
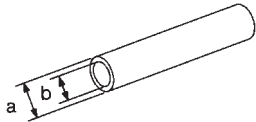
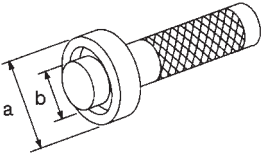
Tool number (Kent-Moore No.) Tool name	Description		
ST37750000 1 (J34286) 2 (J34332) 3 (J34334) 4 (J25679-01) Drift	NT065		1 Removing counter gear rear bearing 2 Installing OD gear bushing 2 Removing and installing mainshaft rear bearing 2 Installing reverse cone 3 Installing reverse counter gear 4 Installing counter gear rear end bearing a: 40 mm (1.57 in) dia. b: 31 mm (1.22 in) dia.
ST22452000 (J34337) Drift	NT065		Installing reverse hub a: 45 mm (1.77 in) dia. b: 36 mm (1.42 in) dia.
(J26349-3) Puller leg	NT078		Installing mainshaft and counter gear (Use with J34328)
(J34328) Puller	NT079		Installing mainshaft and counter gear (Use with J26349-3)
(J26092) Drift	NT065		Installing sub-gear snap ring a: 44.5 mm (1.752 in) dia. b: 38.5 mm (1.516 in) dia.
(J34342) Drift	NT065		Installing OD main gear Installing reverse gear bushing a: 44.5 mm (1.752 in) dia. b: 40.5 mm (1.594 in) dia.
ST33220000 (J25804-01) Drift	NT084		Installing mainshaft rear bearing a: 37 mm (1.46 in) dia. b: 22 mm (0.87 in) dia.

Commercial Service Tool

NAMT0002

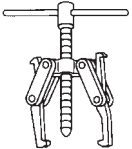
Tool name	Description		
Puller	NT077		Removing counter gear rear end bearing Removing reverse synchronizer hub Removing reverse counter gear

NOISE, VIBRATION AND HARSHNESS (NVH) TROUBLESHOOTING

NVH Troubleshooting Chart

NVH Troubleshooting Chart

NAMT0023S01

Use the chart below to help you find the cause of the problem. The numbers indicate the order of the inspection. If necessary, repair or replace these parts.

MANUAL TRANSMISSION

NAMT0023S0101

Reference page		Refer to MA-22, "Checking M/T Oil".											
SUSPECTED PARTS (Possible cause)		OIL (Level low)	OIL (Wrong)	OIL (Level too high)	GASKET (Damaged)	OIL SEAL (Worn or damaged)	O-RING (Worn or damaged)	CHECK PLUG RETURN SPRING AND CHECK BALL (Worn or damaged)	SHIFT FORK (Worn)	GEAR (Worn or damaged)	BEARING (Worn or damaged)	BAULK RING (Worn or damaged)	INSERT SPRING (Damaged)
		Symptom	Noise	1	2							3	3
Oil leakage			3	1	2	2	2						
Hard to shift or will not shift			1	1								2	2
Jumps out of gear								1	2	2			

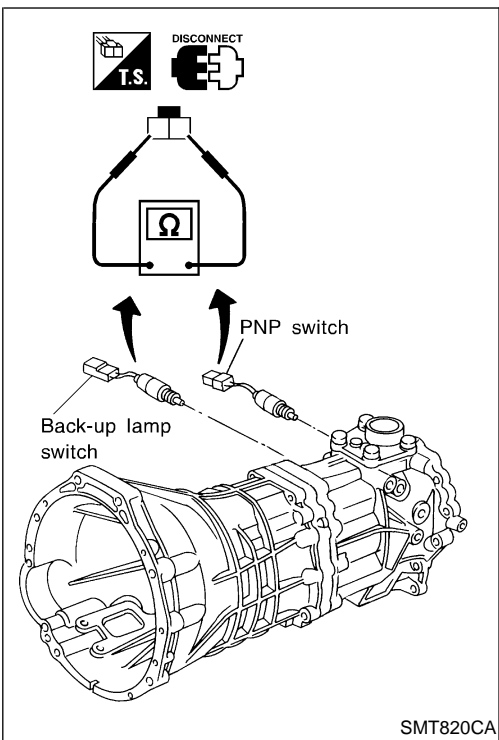

Position Switch Check

NAMT0024

Switch	Gear position	Continuity
Back-up lamp switch	Reverse	Yes
	Except reverse	No
PNP switch	Neutral	Yes
	Except neutral	No

GI
MA
EM
LC
EC
FE
CL
MT
AT
TF
PD
AX
SU
BR
ST
RS
BT
HA
SC
EL
IDX

DESCRIPTION

Cross-sectional View

Cross-sectional View

NAMT0005S02

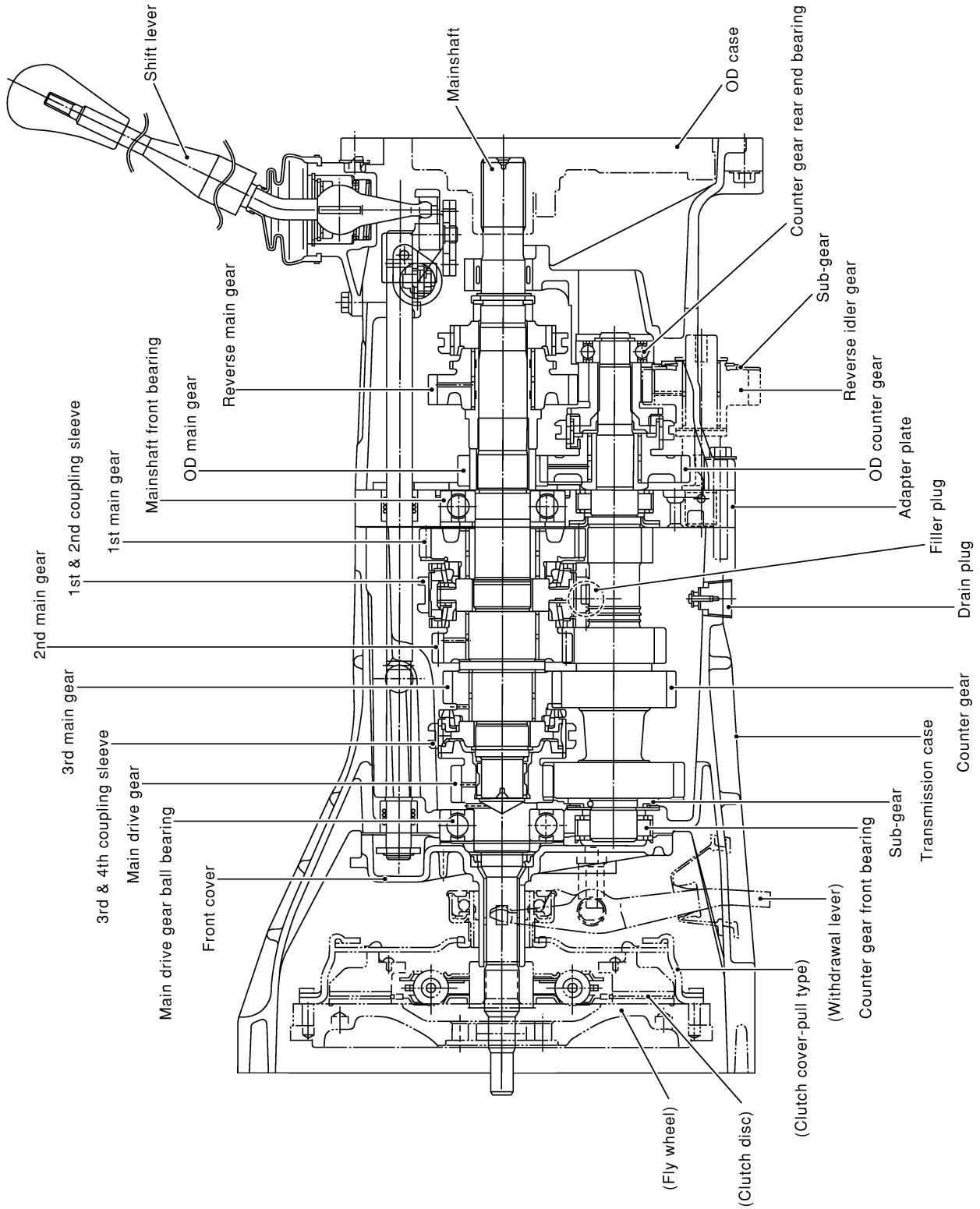

SMT990D

REMOVAL AND INSTALLATION

Removal

Removal

NAMT0006S01

CAUTION:

When removing the M/T assembly from engine, first remove the crankshaft position sensor (OBD) from the M/T assembly. Be careful not to damage sensor edge.

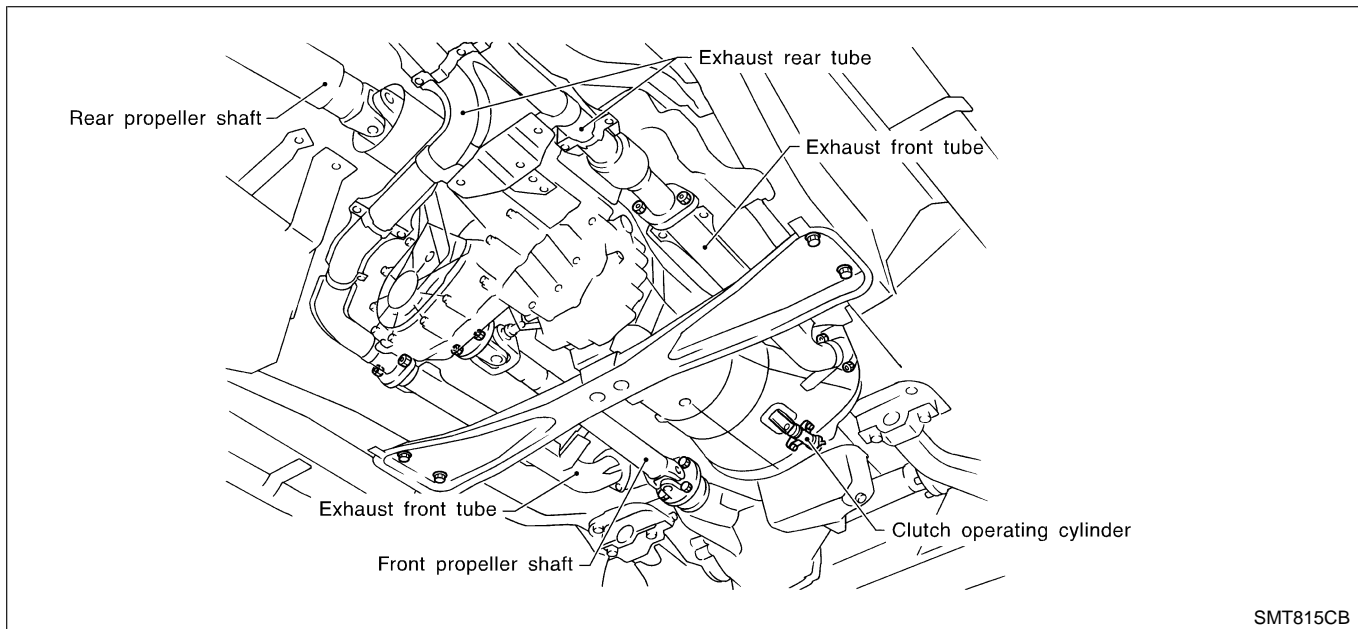

SMT815CB

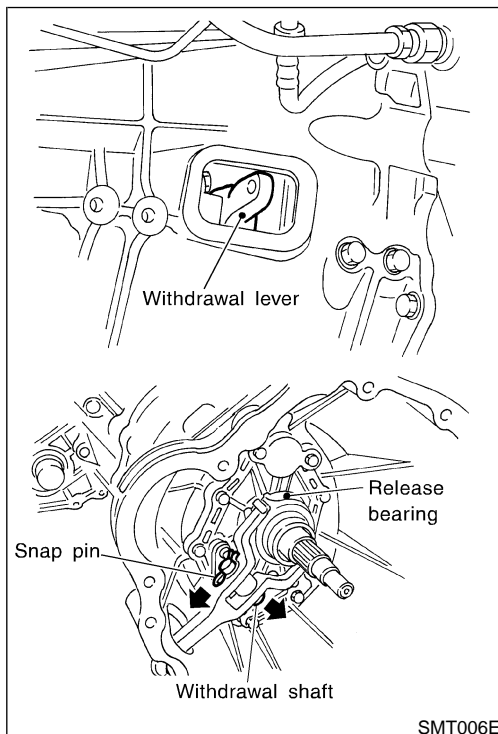

SMT006E

1. Remove battery negative terminal.
2. Remove shift lever from transmission and control lever from transfer.
3. Remove crankshaft position sensor (OBD) from lower side of transmission case.
4. Remove clutch operating cylinder from transmission. Tighten clutch operating cylinder to the specified torque. Refer to CL-5, "CLUTCH SYSTEM".
5. Lower the transmission out of the body with the speed sensor and other harnesses still connected. The harnesses are attached to the body in four places.
6. Remove starter motor from transmission.
⚙️ : 41 - 52 N-m (4.2 - 5.3 kg-m, 30 - 38 ft-lb)
7. Remove front and rear propeller shafts. Refer to PD-8, "Removal and Installation".
 - Insert plug into rear oil seal after removing propeller shaft.
 - Be careful not to damage spline, sleeve yoke and rear oil seal when removing propeller shaft.
8. Remove clutch withdrawal lever and release bearing following the procedures below.
 - a. Remove the dust cover on the withdrawal lever hole from the transmission case.

MT-7

GI

MA

EM

LC

EC

FE

CL

MT

AT

TF

PD

AX

SU

BR

ST

RS

BT

HA

SC

EL

IDX

REMOVAL AND INSTALLATION

Removal (Cont'd)

- b. Pull out snap pin on the withdrawal shaft, and then pull out withdrawal shaft to remove withdrawal lever and release bearing.
9. Remove exhaust tube mounting bracket from transmission. Refer to FE-9, "EXHAUST SYSTEM".
10. Support manual transmission with a jack.
11. Remove rear mounting member. Tighten rear mounting member to the specified torque. Refer to EM-61, "Removal and Installation".
12. Remove bolt securing engine to manual transmission to separate engine from the transmission.
13. Lower manual transmission as much as possible.

WARNING:

Support Manual Transmission together with transfer, while removing it.

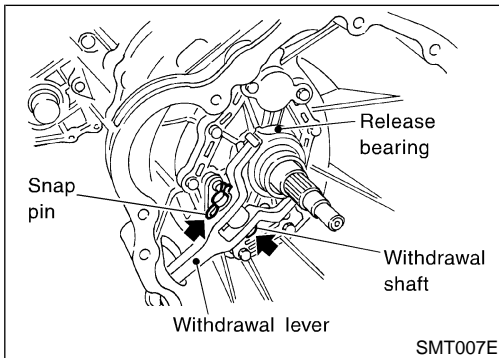

Installation

1. Set withdrawal shaft, washer and snap pin to withdrawal lever and release bearing.
2. Install the manual transmission in reverse order of removal.
- Apply sealant as below

NAMT0006S02

REMOVAL AND INSTALLATION

Installation (Cont'd)

GI
MA
EM
LC
EC
FE
CL
MT
AT
TF
PD
AX
SU
BR
ST
RS
BT
HA
SC
EL
IDX

CAUTION:

- After assembling grommet to crankshaft position sensor, install crankshaft position sensor to the oil pan.
- When assembling grommet to crankshaft position sensor, adjust sensor arm to the positioning rib of grommet.
- The following hole sizes are recommended for sealant ejection nozzle:
4 to 5 mm (0.16 to 0.20 in) dia.
Carefully choose the right hole size to insure that enough sealability is kept but sealant does not run.

After installing, make sure there is no gap at the section "t" (space between oil pan and grommet) by applying recommended sealant all the way around.

Hole for crankshaft position sensor

Crankshaft position sensor

Grommet

Oil pan

Positioning rib

Crankshaft position sensor

Transmission case

Section B-B

View A

Oil pan side

Transmission case side

Apply genuine anaerobic liquid gasket. Refer to GI section.

Always replace after every disassembly.

SMT156EA

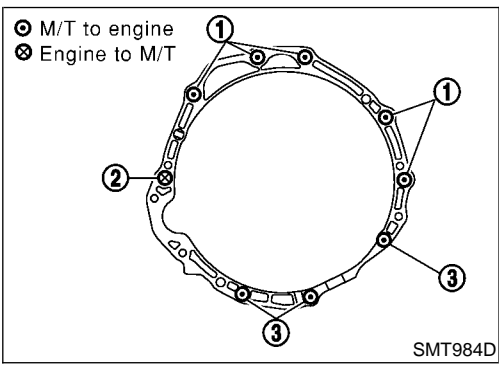

● Tighten bolt securing transmission.

Bolt No.	Tightening torque N-m (kg-m, ft-lb)	ℓ mm (in)
1	70 - 79 (7.1 - 8.1, 52 - 58)	65 (2.56)
2	70 - 79 (7.1 - 8.1, 52 - 58)	55 (2.17)
3	29 - 39 (3.0 - 4.0, 22 - 28)	40 (1.57)

OVERHAUL

Case Components

NAMT0007S01

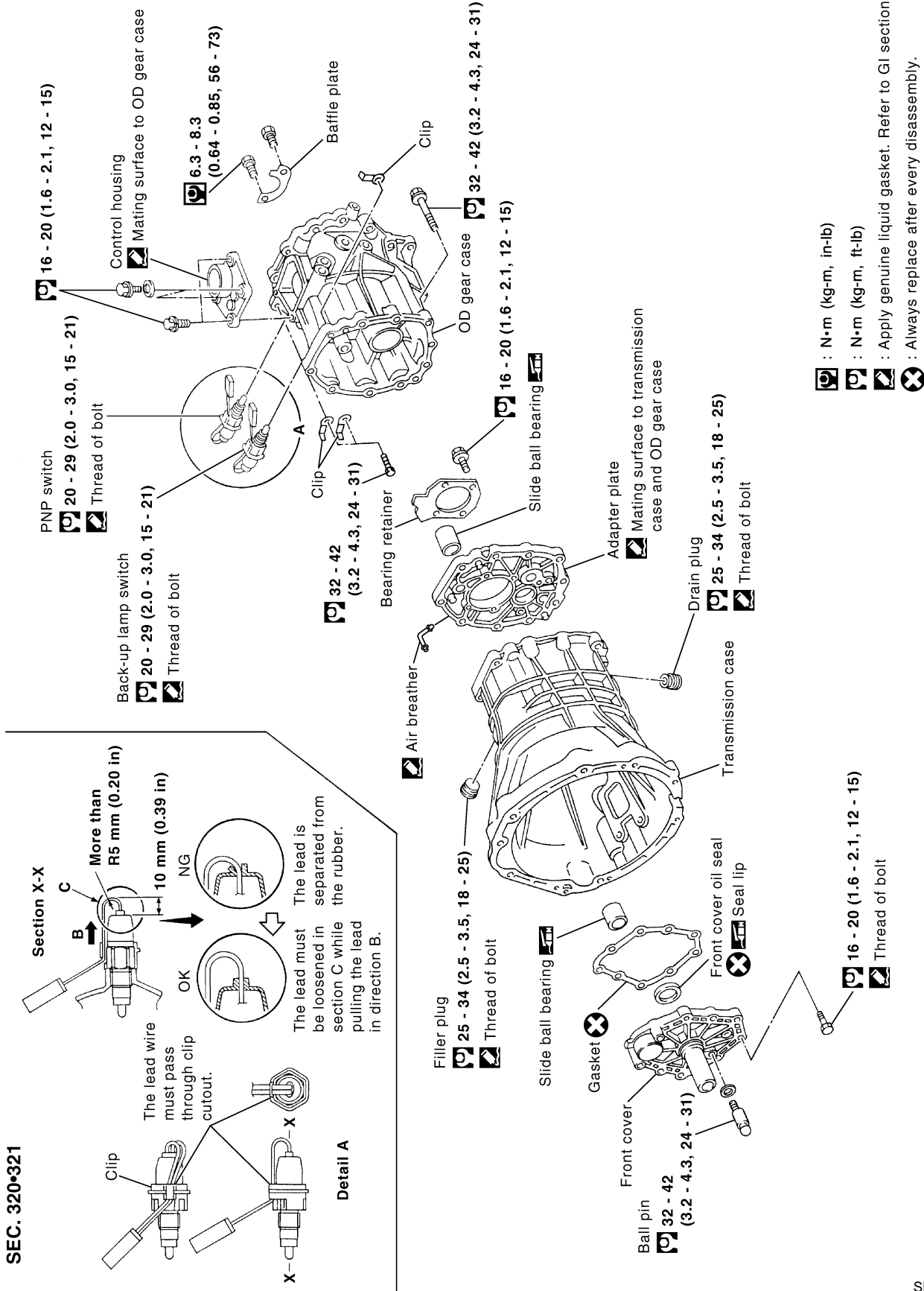

- : N·m (kg-m, in-lb)
- : N·m (kg-m, ft-lb)
- : Apply genuine liquid gasket. Refer to GI section.
- : Always replace after every disassembly.

Gear Components

NAMT0007S02

GI

MA

EM

LC

EC

FE

CL

MT

AT

TF

PD

AX

SU

BR

ST

RS

BT

HA

SC

EL

IDX

SEC. 322

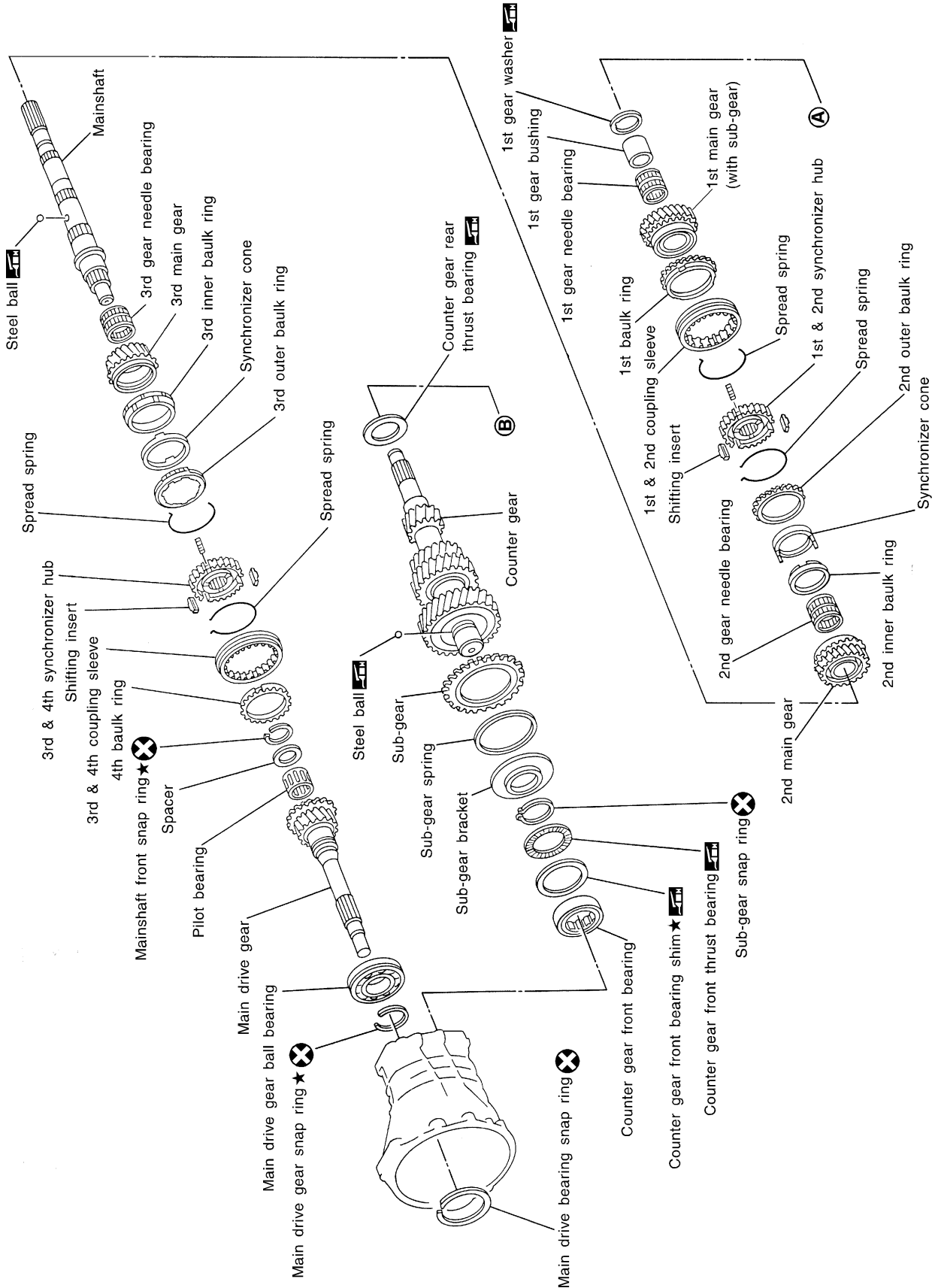

MT-11

SMT049E

OVERHAUL

Gear Components (Cont'd)

SEC. 322

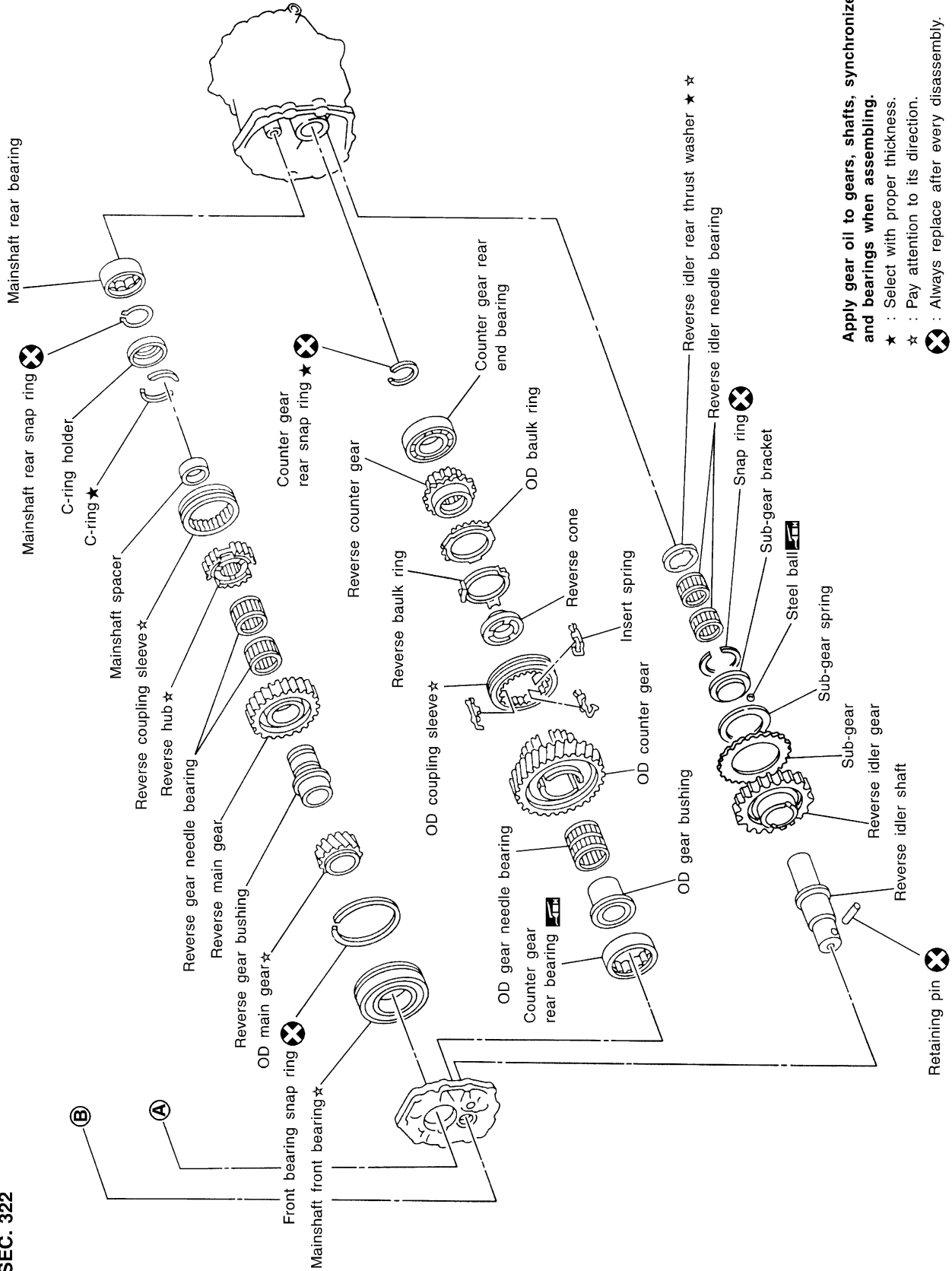

Apply gear oil to gears, shafts, synchronizers and bearings when assembling.

★ : Select with proper thickness.

☆ : Pay attention to its direction.

⊗ : Always replace after every disassembly.

Shift Control Components

GI
MA
EM
LC
EC
FE
CL
MT
AT
TF
PD
AX
SU
BR
ST
RS
BT
HA
SC
EL
IDX

SEC. 328

CAUTION:
When replacing shift knob, first remove shift lever with knob as an assembly. Otherwise shift lever components may be damaged.

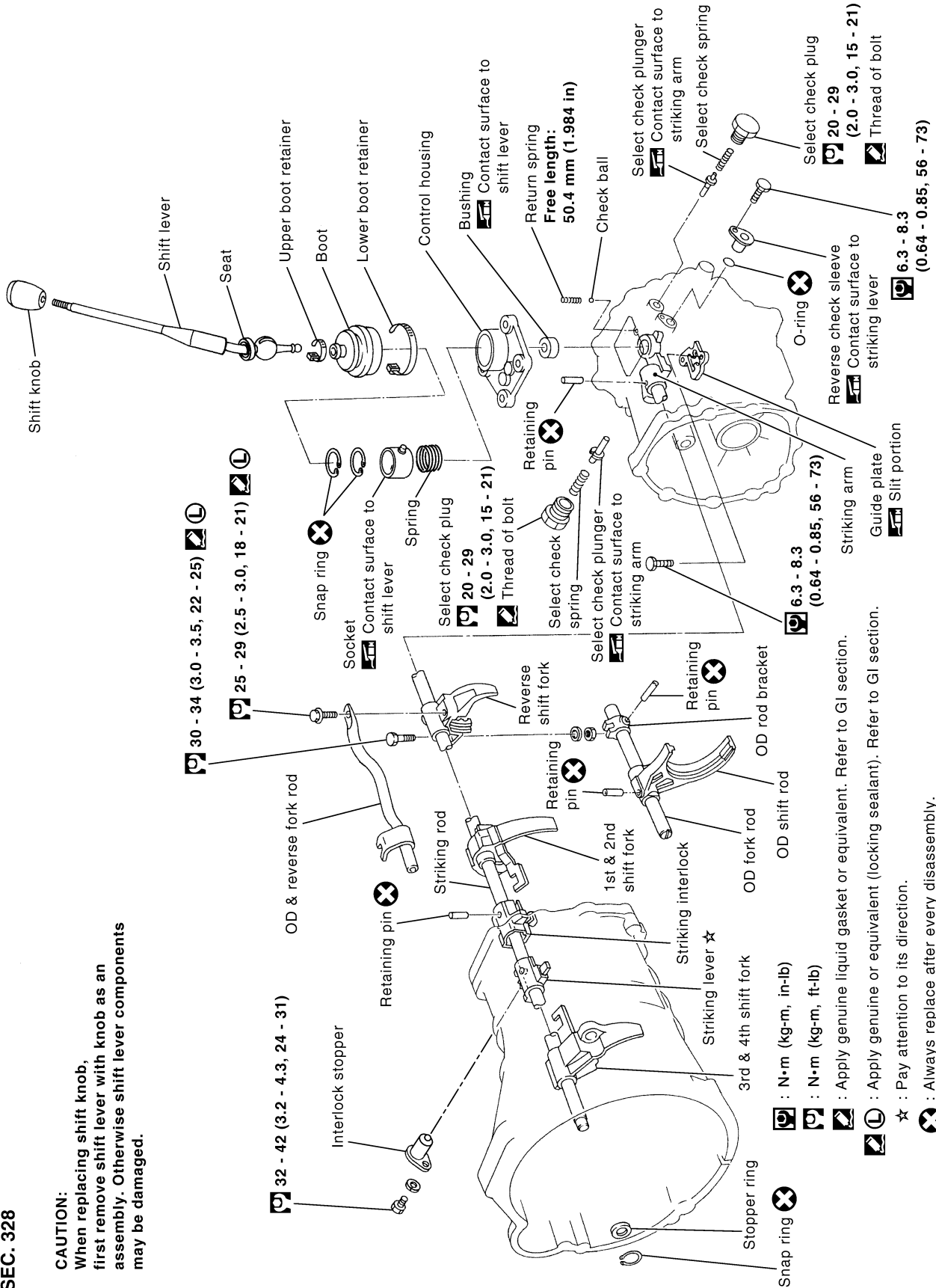

- ☆ : Pay attention to its direction.
- ⊗ : Always replace after every disassembly.
- ⊗ : N•m (kg-m, in-lb)
- ⊗ : N•m (kg-m, ft-lb)
- ⊗ : Apply genuine liquid gasket or equivalent. Refer to GI section.
- ⊗ : Apply genuine or equivalent (locking sealant). Refer to GI section.
- ⊗ : Always replace after every disassembly.

DISASSEMBLY

Case Components

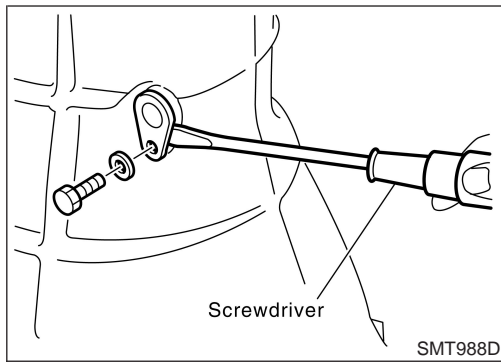

Case Components

DISASSEMBLY

1. Remove check ball plug, check spring and check ball. Then remove interlock stopper. ^{NAMT0008}

- If interlock assembly is removed as a unit, the check ball can fall into transmission case.
- Be careful not to lose check ball.

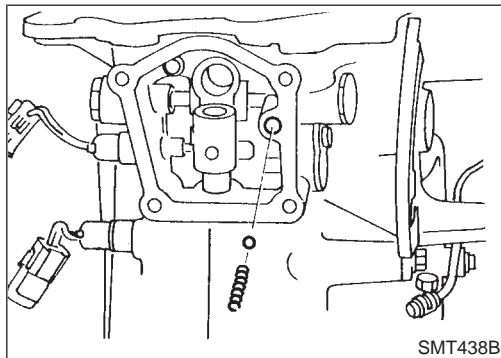

2. Remove control housing, return spring and check ball.

- Be careful not to lose check ball.

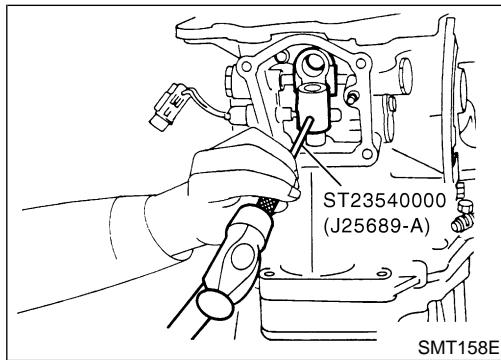

3. Drive out retaining pin from striking arm.

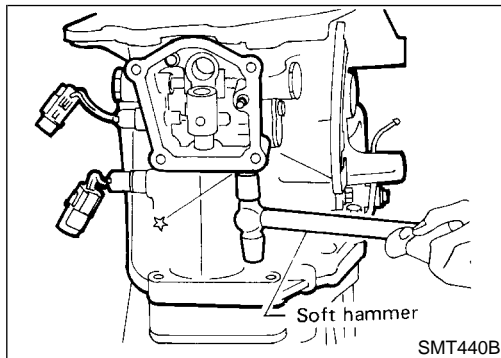

4. Remove OD gear case together with striking arm by tapping lightly.

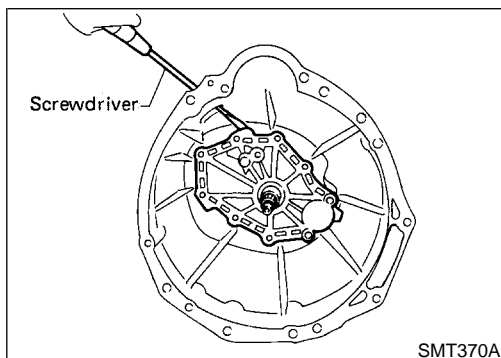

5. Remove front cover and gasket.

DISASSEMBLY

Case Components (Cont'd)

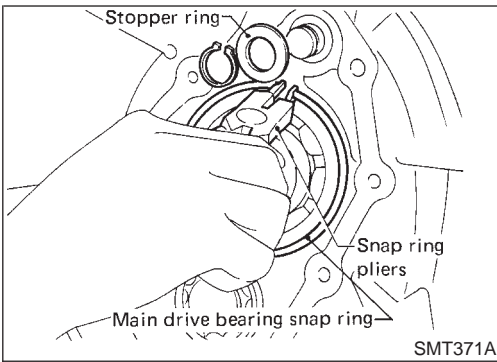

6. Remove stopper ring and main drive bearing snap ring.

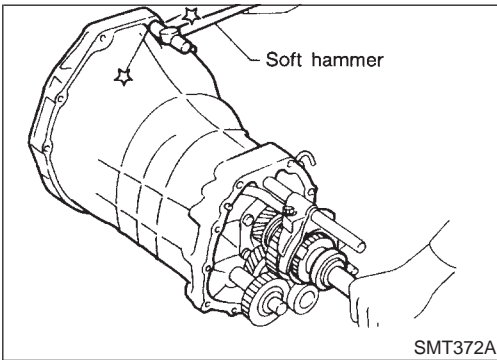

7. Remove transmission case by tapping lightly.

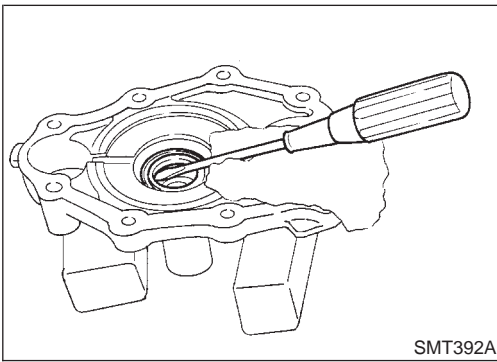

8. Remove front cover oil seal.

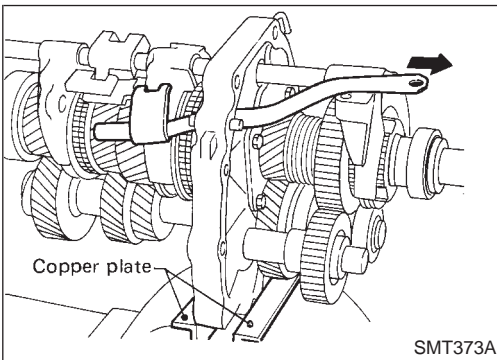

Shift Control Components DISASSEMBLY

1. Mount adapter plate on vise.
2. Remove OD & reverse fork rod.

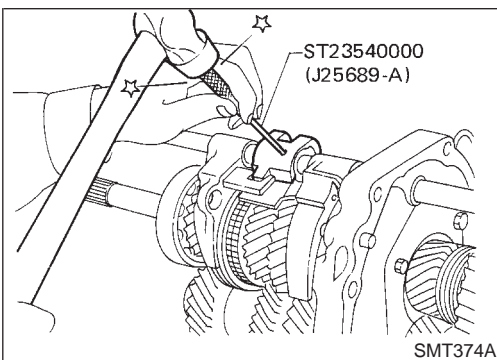

3. Drive out retaining pin from striking lever.
4. While pulling out striking rod, remove striking lever and striking interlock. Then remove 1st & 2nd, 3rd & 4th and reverse shift fork.

GI
MA
EM
LC
EC
FE
CL
MT
AT
TF
PD
AX
SU
BR
ST
RS
BT
HA
SC
EL
IDX

NAMT0009

DISASSEMBLY

Shift Control Components (Cont'd)

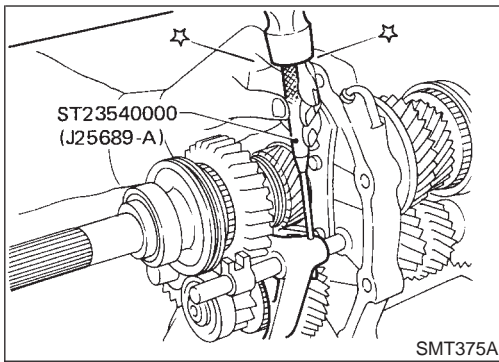

5. Drive out retaining pin from OD shift fork.
6. Pull out OD fork rod and then remove OD shift fork.

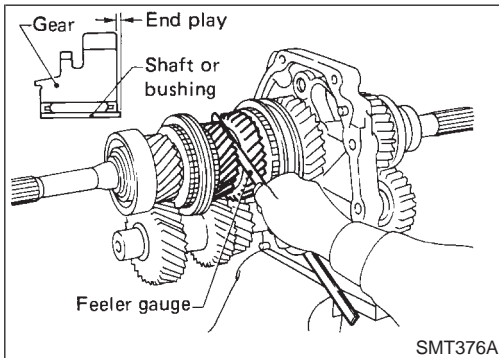

Gear Components DISASSEMBLY

NAMT0010

1. Before removing gears and shafts, measure each gear end play.

Gear end play:

Refer to SDS, MT-33.

- If not within specification, disassemble and check contact surface of gear to hub, washer, bushing, needle bearing and shaft.

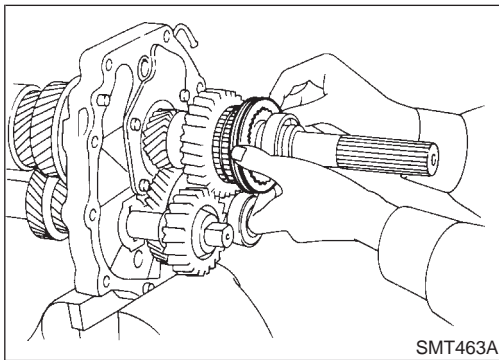

2. Remove rear side components on mainshaft and counter gear.
 - a. Remove reverse coupling sleeve.

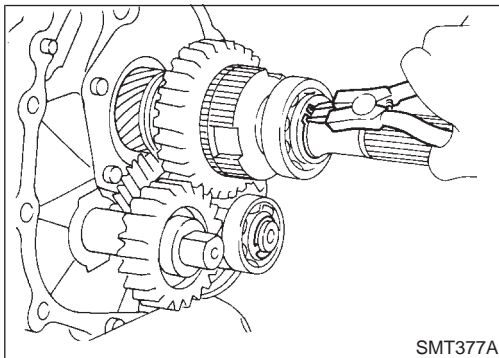

- b. Remove mainshaft rear snap ring and counter gear rear snap ring.
 - c. Remove C-ring holder and mainshaft C-rings from mainshaft. Use punch and hammer to remove C-rings.

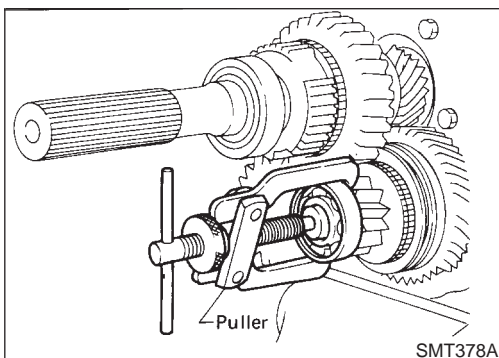

- d. Pull out counter gear rear end bearing.
 - e. Remove reverse idler gear and reverse idler thrust washers.

DISASSEMBLY

Gear Components (Cont'd)

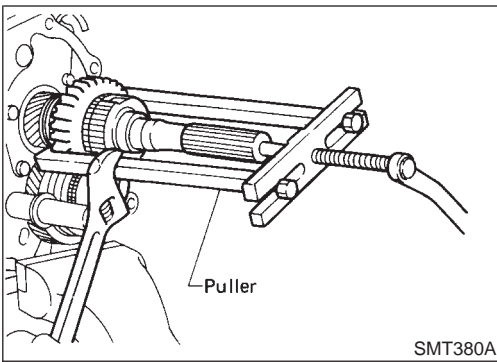

- f. Pull out reverse main gear together with mainshaft spacer and reverse synchronizer hub. Then remove reverse gear needle bearings.

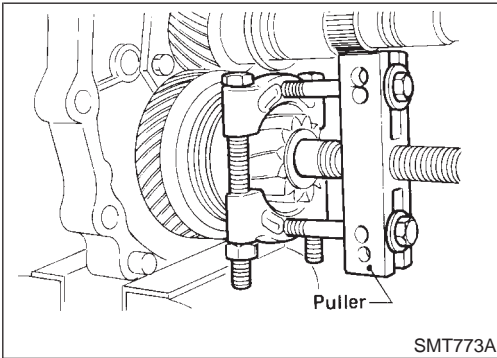

- g. Pull out reverse counter gear.
h. Remove OD coupling sleeve together with OD baulk ring, reverse baulk ring and spring inserts.

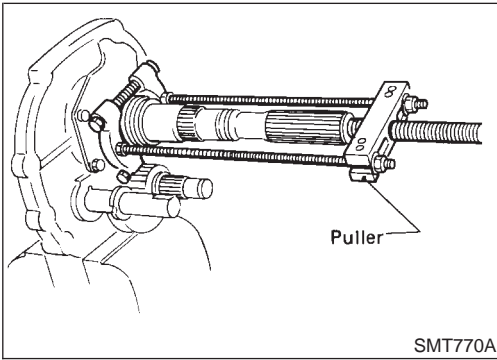

- i. Pull out reverse gear bushing.

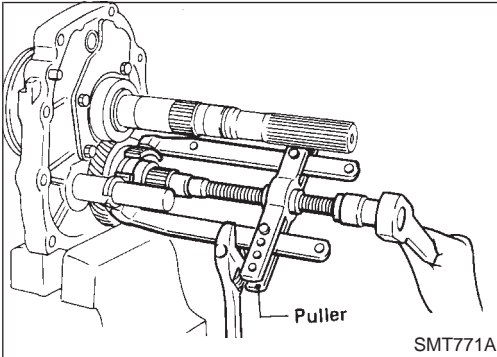

- j. Pull out OD counter gear together with reverse cone.

3. Press out mainshaft and counter gear alternately.

GI

MA

EM

LC

EC

FE

CL

MT

AT

TF

PD

AX

SU

BR

ST

RS

BT

HA

SC

EL

IDX

DISASSEMBLY

Gear Components (Cont'd)

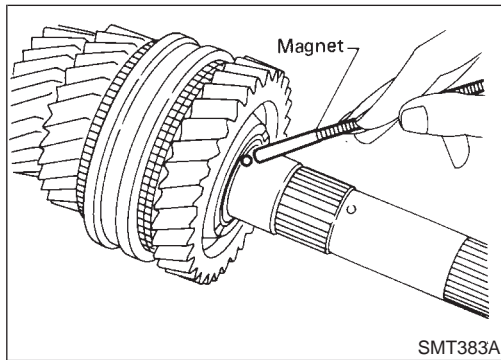
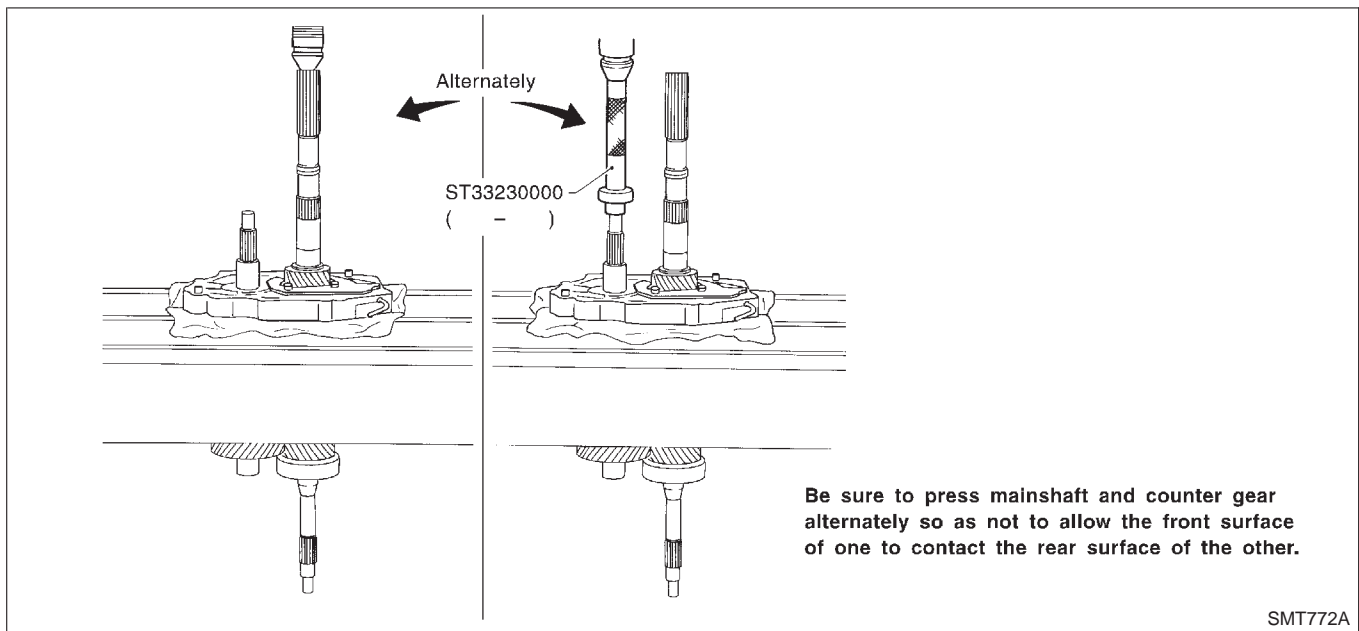

4. Remove front side components on mainshaft.
 - a. Remove 1st gear washer and steel ball.
 - b. Remove 1st main gear and 1st gear needle bearing.
 - **Be careful not to lose steel ball.**

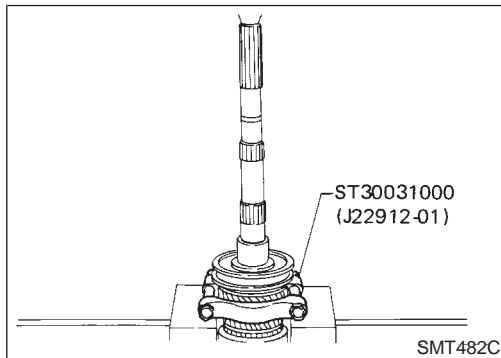

- c. Press out 2nd main gear together with 1st gear bushing and 1st & 2nd synchronizer assembly.
 - d. Remove mainshaft front snap ring.

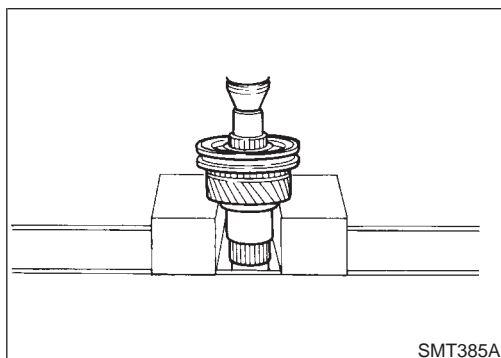

- e. Press out 3rd main gear together with 3rd & 4th synchronizer assembly and 3rd gear needle bearing.

DISASSEMBLY

Gear Components (Cont'd)

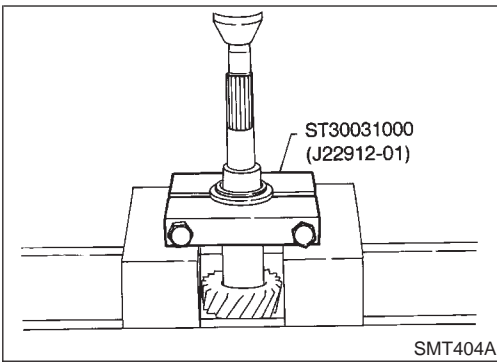

5. Remove front side components on counter gear.
 - a. Remove counter gear rear thrust bearing.

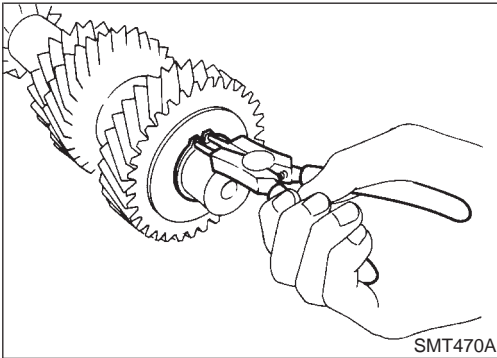

- b. Remove sub-gear components.

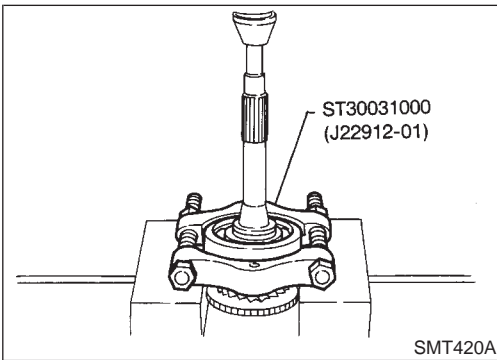

6. Remove main drive gear bearing.
 - a. Remove main drive gear snap ring.
 - b. Press out main drive gear bearing.

7. Remove bearings from case components.

Counter gear front bearing in transmission case

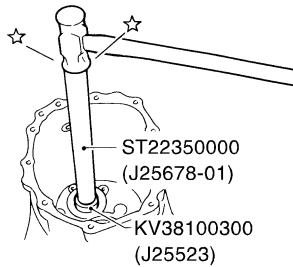

Mainshaft front bearing in adapter plate

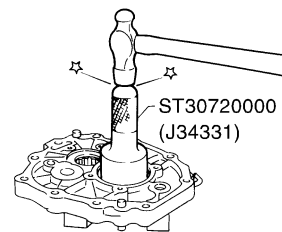

Mainshaft rear bearing in OD gear case

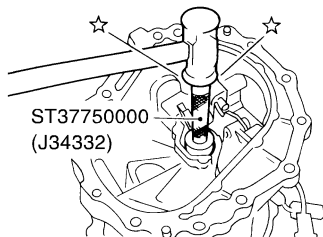

Counter gear rear bearing in adapter plate

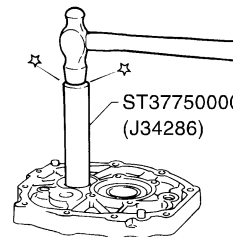

SMT206DA

GI

MA

EM

LC

EC

FE

CL

MT

AT

TF

PD

AX

SU

BR

ST

RS

BT

HA

SC

EL

IDX

INSPECTION

Shift Control Components

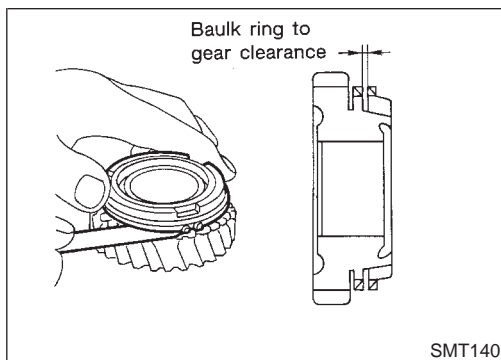
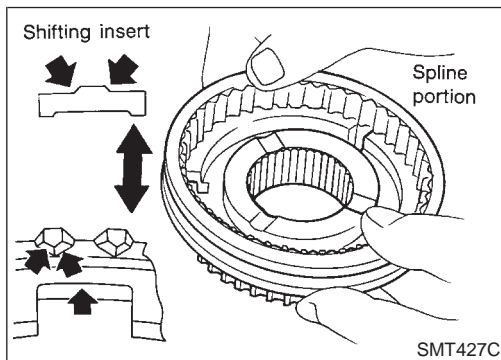
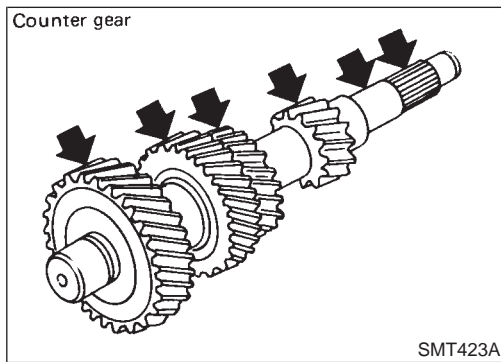
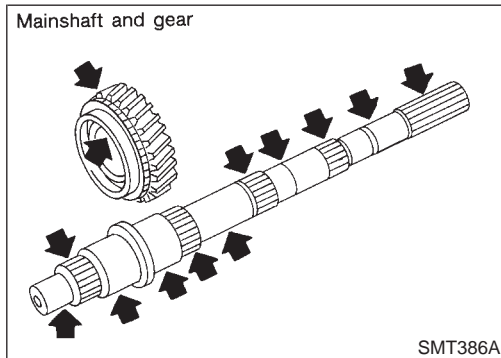
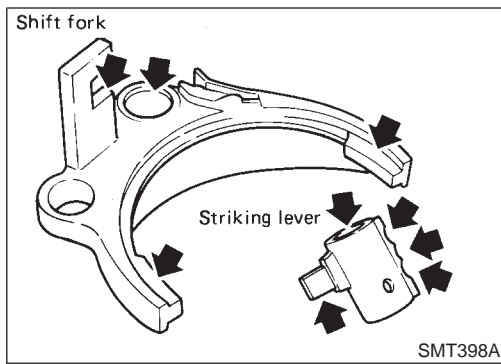

Shift Control Components

INSPECTION

- Check contact surface and sliding surface for wear, scratches, projections or other damage. NAMT0011

Gear Components

INSPECTION

Gears and Shafts

- Check shafts for cracks, wear or bending. NAMT0012
- Check gears for excessive wear, chips or cracks. NAMT0012S01

Synchronizers

- Check spline portion of coupling sleeves, hubs, and gears for wear or cracks. NAMT0012S02
- Check baulk rings for cracks or deformation.
- Check shifting inserts for wear or deformation.
- Check insert springs for deformation.

- Measure wear of main drive, 1st and OD baulk rings.

Clearance between baulk ring and gear:

Refer to SDS, MT-33.

- If the clearance is smaller than the wear limit, replace baulk ring.

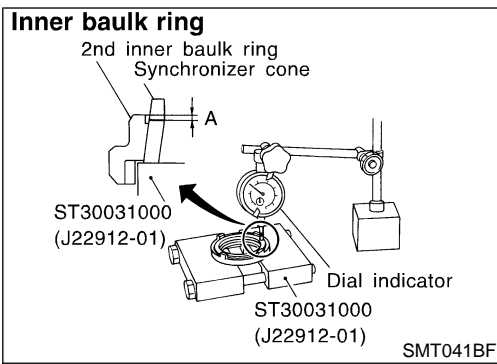

- Measure wear of 2nd and 3rd baulk rings.
 - a) Place baulk rings in position on synchronizer cone.
 - b) While holding baulk rings against synchronizer cone as far as it will go, measure dimensions "A" and "B".

Standard:

A 0.7 - 0.9 mm (0.028 - 0.035 in)

B 0.6 - 1.1 mm (0.024 - 0.043 in)

Wear limit:

0.2 mm (0.008 in)

- If dimension "A" or "B" is smaller than the wear limit, replace outer baulk ring, inner baulk ring and synchronizer cone as a set.

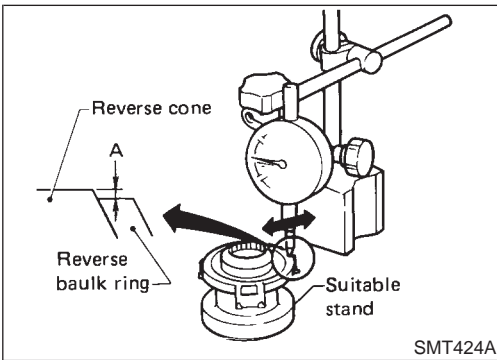
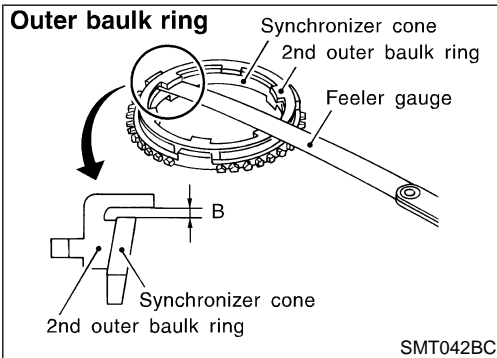

- Measure wear of reverse baulk ring.
 - a) Place baulk ring in position on reverse cone.
 - b) While holding baulk ring against reverse cone as far as it will go, measure dimension "A" with dial indicator.

Dimension "A":

Standard -0.45 to 1.05 mm (-0.0177 to 0.0413 in)

Wear limit 0.7 mm (0.028 in)

- If dimension "A" is larger than the wear limit, replace baulk ring.

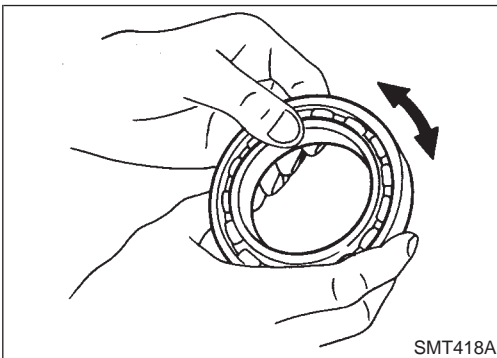

Bearings

- Make sure bearings roll freely and are free from noise, crack, pitting or wear.

NAMT0012S03

GI
MA
EM
LC
EC
FE
CL
MT
AT
TF
PD
AX
SU
BR
ST
RS
BT
HA
SC
EL
IDX

ASSEMBLY

Gear Components ASSEMBLY

NAMT0013

Counter gear front bearing in transmission case

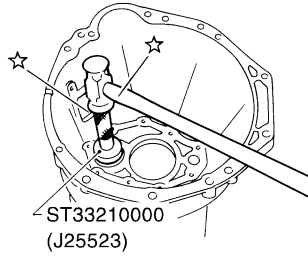

Mainshaft front bearing in adapter plate

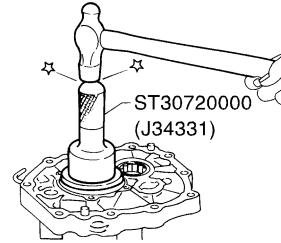

Mainshaft rear bearing in OD gear case

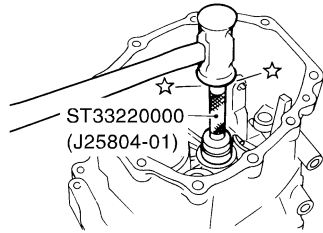

Counter gear rear bearing in adapter plate

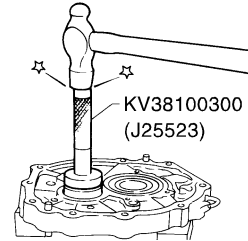

Be flush with front surface of OD gear case.

SMT207DA

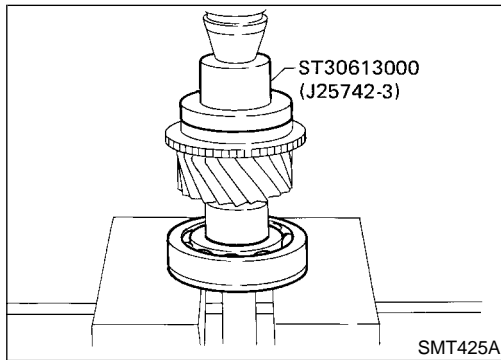

SMT425A

1. Install bearings into case components.
2. Install main drive gear bearing.
 - a. Press main drive gear bearing.

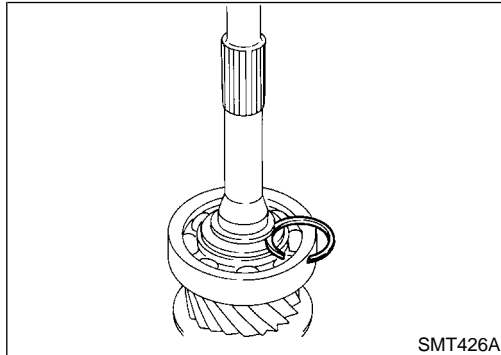

SMT426A

- b. Select proper main drive gear snap ring to minimize clearance of groove.

Allowable clearance of groove:

0 - 0.1 mm (0 - 0.004 in)

Main drive gear snap ring:

Refer to SDS, MT-34.

- c. Install selected snap ring on main drive gear.

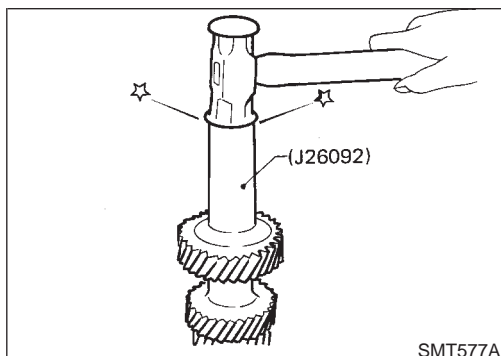

SMT577A

3. Install components on counter gear.
 - a. Install sub-gear components.
 - **When installing sub-gear snap ring, tap sub-gear snap ring into position on counter gear.**

ASSEMBLY

Gear Components (Cont'd)

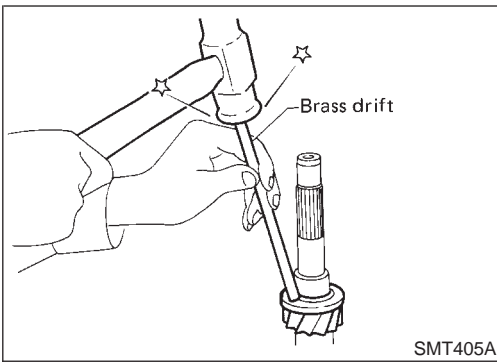

- b. Install counter gear rear thrust bearing.

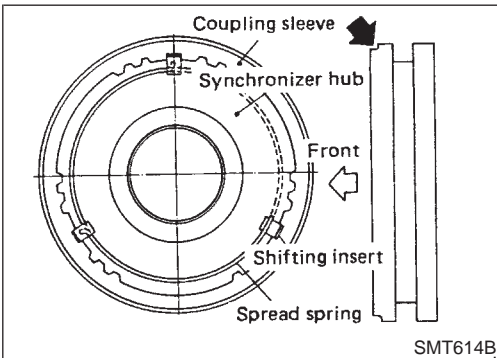

4. Install front side components on mainshaft.
a. Assemble 1st & 2nd synchronizer.

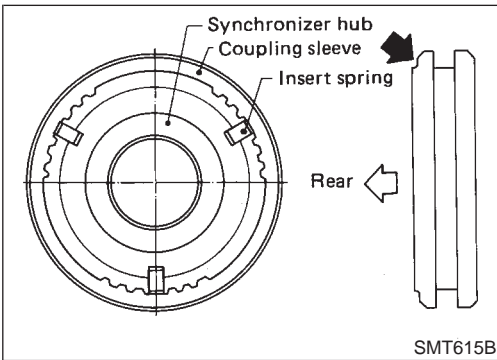

- b. Assemble 3rd & 4th synchronizer.

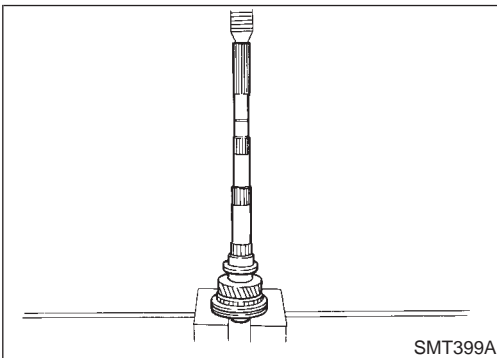

- c. Press on 3rd & 4th synchronizer assembly together with 3rd main gear and 3rd gear needle bearing.
● **Pay attention to direction of synchronizer assembly.**

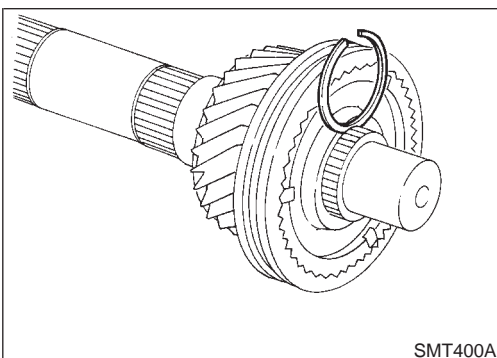

- d. Select proper snap ring to minimize clearance of groove.
Allowable clearance of groove:
0 - 0.1 mm (0 - 0.004 in)
Mainshaft front snap ring:
Refer to SDS, MT-34.
e. Install selected snap ring on mainshaft.

GI

MA

EM

LC

EC

FE

CL

MT

AT

TF

PD

AX

SU

BR

ST

RS

BT

HA

SC

EL

IDX

ASSEMBLY

Gear Components (Cont'd)

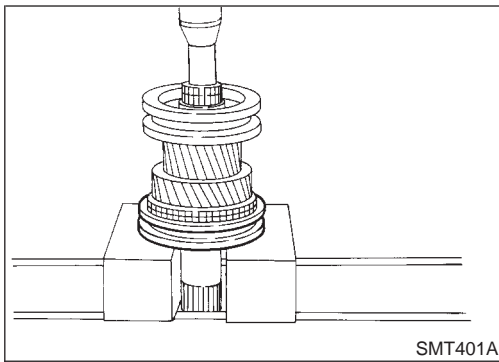

- f. Press on 1st & 2nd synchronizer assembly together with 2nd main gear and 2nd gear needle bearing.

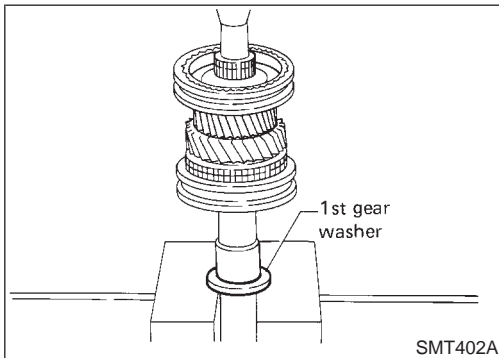

- g. Press on 1st gear bushing using 1st gear washer.
- h. Install 1st main gear and needle bearing.

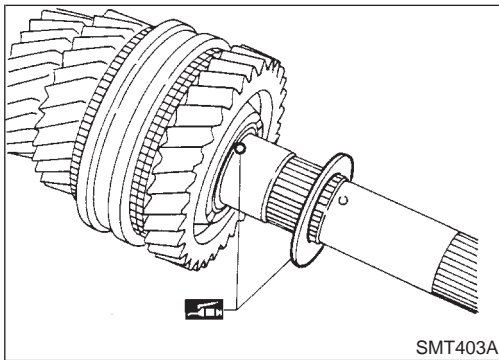

- i. Install steel ball and 1st gear washer.
- **Apply multi-purpose grease to steel ball and 1st gear washer before installing.**

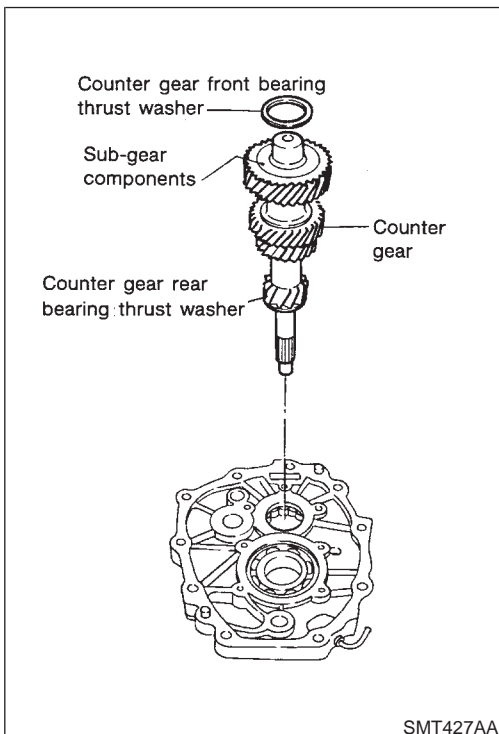

- 5. Select proper counter gear front bearing thrust washer when replacing transmission case, counter gear, counter gear rear thrust bearing or sub-gear components.
 - a. Install counter gear with sub-gear components, counter gear front and rear bearing thrust washer on adapter plate.
 - b. Remove counter gear front bearing thrust washer from transmission case.
 - c. Place adapter plate and counter gear assembly in transmission case (case inverted).

ASSEMBLY

Gear Components (Cont'd)

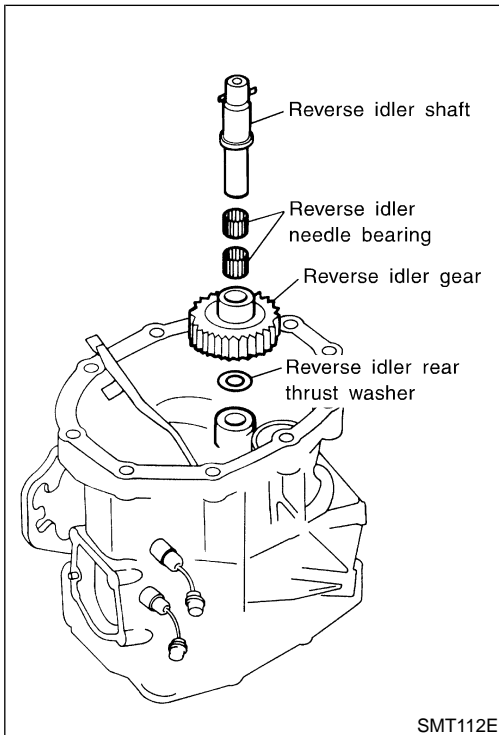
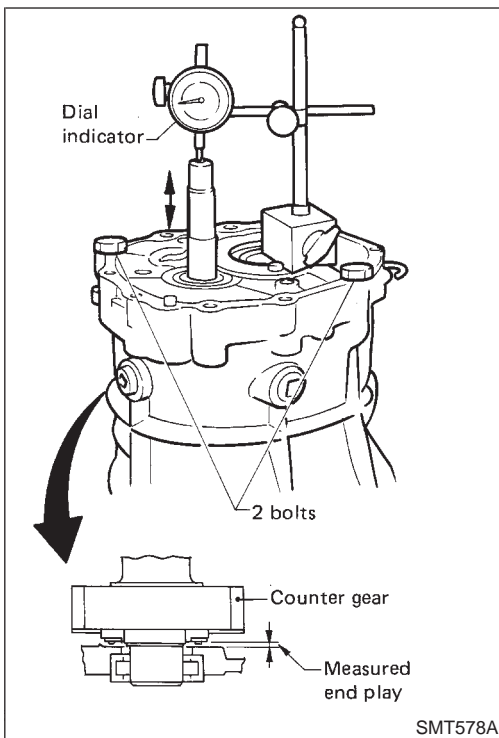

- d. Tighten adapter plate to transmission case using 2 bolts.
- e. Place dial indicator on rear end of counter gear.
- f. Move counter gear up and down and measure dial indicator deflection.
- g. Select proper thrust washer using table below as a guide.

Counter gear end play:

0.10 - 0.25 mm (0.0039 - 0.0098 in)

Table for selecting proper counter gear front bearing thrust washer:

Refer to SDS, MT-36.

6. Select proper reverse idler rear thrust washer when replacing OD gear case, reverse idler gear (with sub-gear components), reverse idler shaft.
- a. Install reverse idler gear (with sub-gear components), reverse idler needle bearings and reverse idler shaft into OD gear case.

- **When replacing reverse idler rear thrust washer, install either A or B.**

Reverse idler rear thrust washer:

Refer to SDS, MT-36.

GI
MA
EM
LC
EC
FE
CL
MT
AT
TF
PD
AX
SU
BR
ST
RS
BT
HA
SC
EL
IDX

ASSEMBLY

Gear Components (Cont'd)

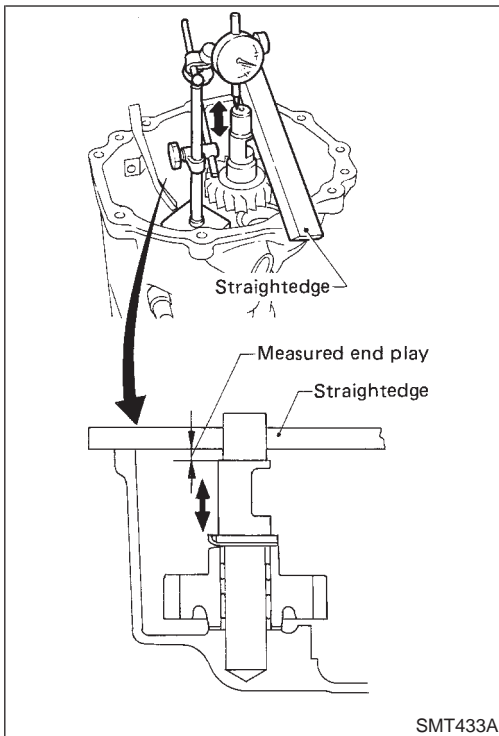

- b. Place dial indicator on front end of reverse idler shaft.
- c. Put straightedge on front surface of rear extension (or OD gear case) as a stopper of reverse idler shaft.
- d. Move reverse idler shaft up and down and measure reverse idler gear end play.

Reverse idler gear end play:

0.30 - 0.53 mm (0.0118 - 0.0209 in)

- e. If not within specification, replace reverse idler rear thrust washer with the other (A or B) and check again.

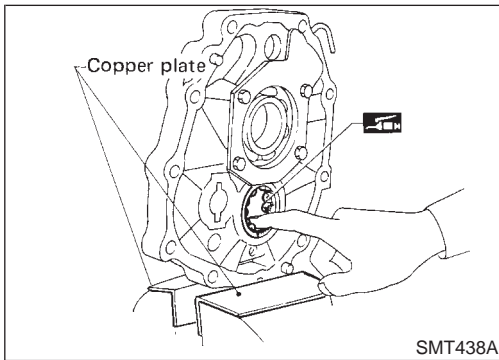

7. Install mainshaft and counter gear on adapter plate and main drive gear on mainshaft.
 - a. Mount adapter plate on vise and apply multi-purpose grease to counter gear rear bearing.

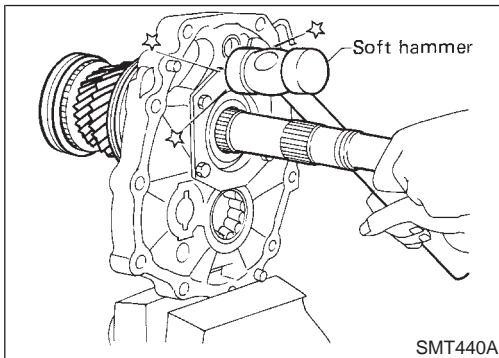

- b. Install mainshaft a little on mainshaft front bearing.
 - **To allow for installation of counter gear, do not install mainshaft completely.**

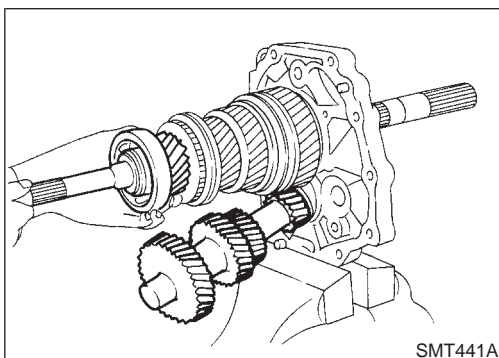

- c. Install counter gear on counter gear rear bearing and install main drive gear, pilot bearing and spacer on mainshaft.

ASSEMBLY

Gear Components (Cont'd)

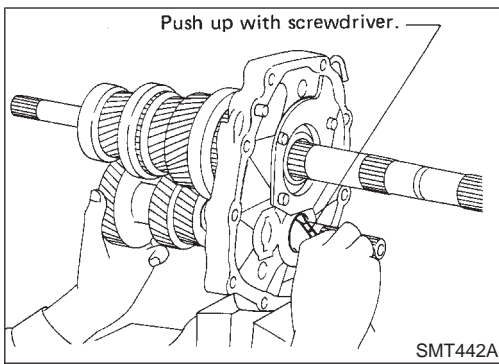

- When installing counter gear into counter gear rear bearing, push up on upper roller of counter gear rear bearing with screwdriver.

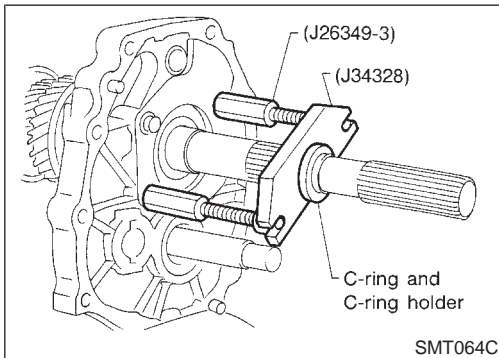

- Install Tools (J26349-3) onto adapter plate and C-ring and C-ring holder on mainshaft.
- Install Tool (J34328) on mainshaft.

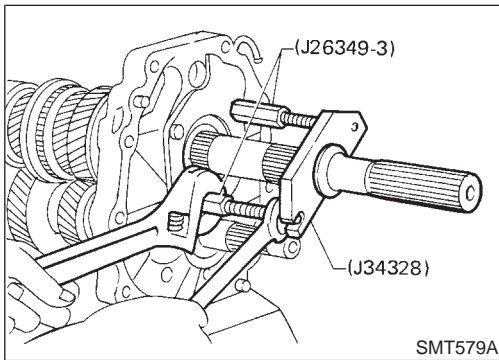

- Install mainshaft and counter gear completely by extending length of (J26349-3).

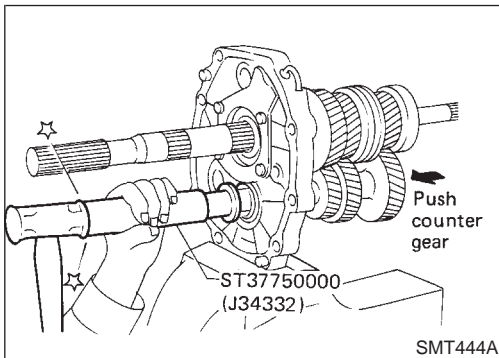

- Install rear side components on mainshaft and counter gear.
 - Install OD gear bushing while pushing on the front of counter gear.

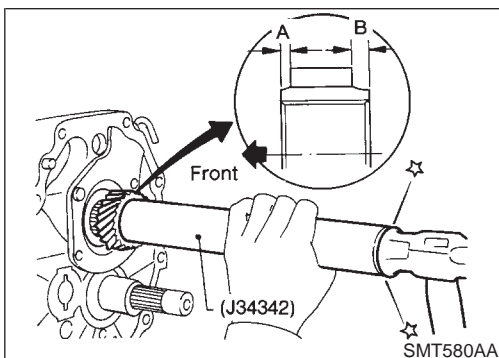

- Install OD main gear.
 - Pay attention to direction of OD main gear. (B is wider than A as shown at left.)
- Install adapter plate with gear assembly onto transmission case.
- Install OD gear needle bearing and then install OD counter gear and reverse idler shaft.

GI
MA
EM
LC
EC
FE
CL
MT
AT
TF
PD
AX
SU
BR
ST
RS
BT
HA
SC
EL
IDX

ASSEMBLY

Gear Components (Cont'd)

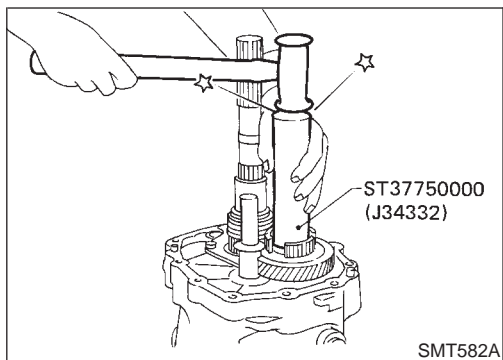

e. Install reverse cone.

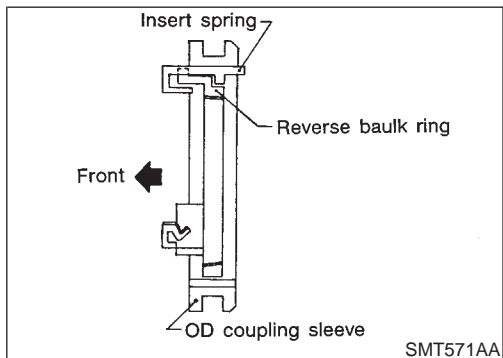

f. Install insert springs and reverse baulk ring on OD coupling sleeve. Then install them and OD baulk ring on OD counter gear.

- Pay attention to direction of OD coupling sleeve.

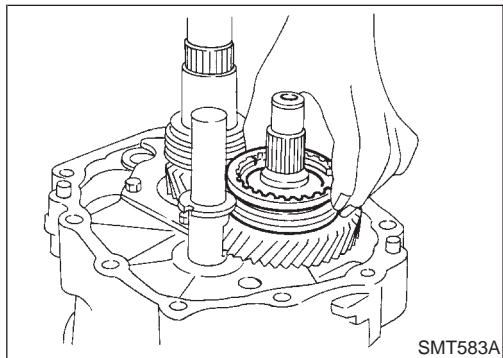

g. Install reverse counter gear.

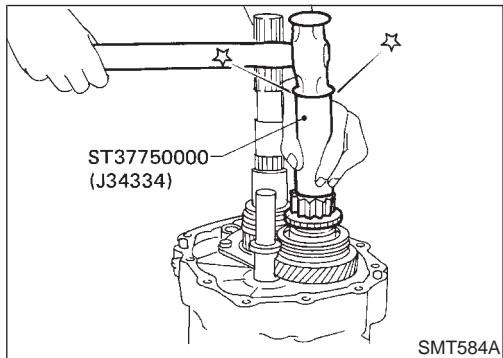

h. Install reverse gear needle bearing and then install reverse main gear, reverse idler gear and reverse idler thrust washers.

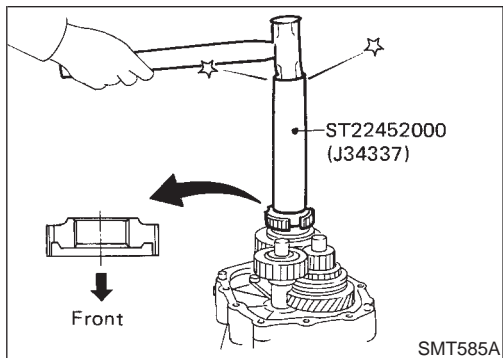

i. Install reverse hub.

- Pay attention to its direction.

ASSEMBLY

Gear Components (Cont'd)

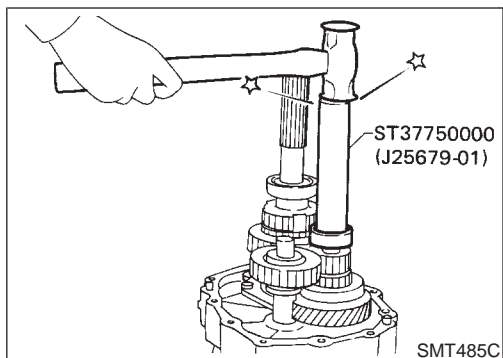

- j. Install counter gear rear end bearing.
- k. Separate adapter plate from transmission case and mount adapter plate on vice again.

GI

MA

EM

LC

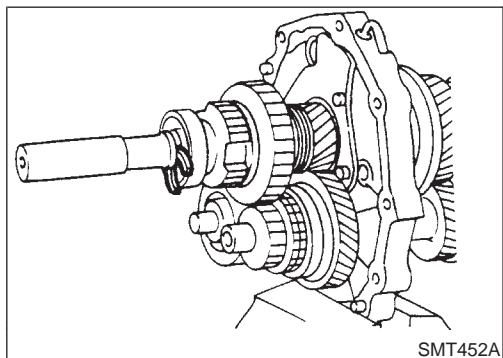

- l. Select proper mainshaft C-ring to minimize clearance of groove.

Allowable clearance of groove:

0 - 0.1 mm (0 - 0.004 in)

Mainshaft C-ring:

Refer to SDS, MT-35.

EC

FE

CL

MT

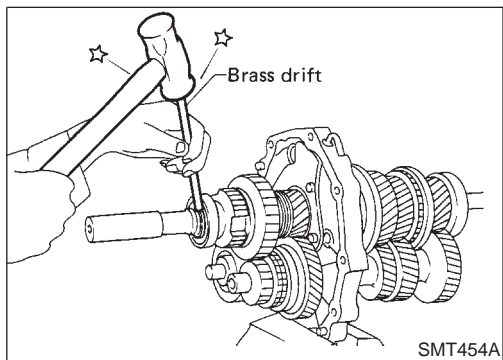

- m. Install selected C-ring, C-ring holder and mainshaft rear snap ring.

AT

TF

PD

AX

SU

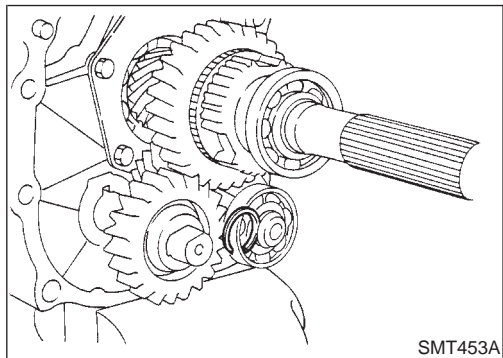

- n. Select proper counter gear rear snap ring to minimize clearance of groove.

Allowable clearance of groove:

0 - 0.1 mm (0 - 0.004 in)

Counter gear rear snap ring:

Refer to SDS, MT-35.

BR

ST

- o. Install selected counter gear rear snap ring.

RS

BT

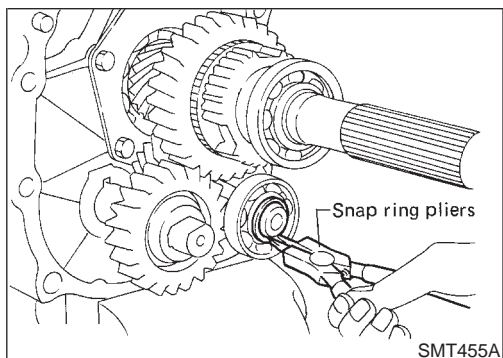

HA

SC

EL

IDX

ASSEMBLY

Gear Components (Cont'd)

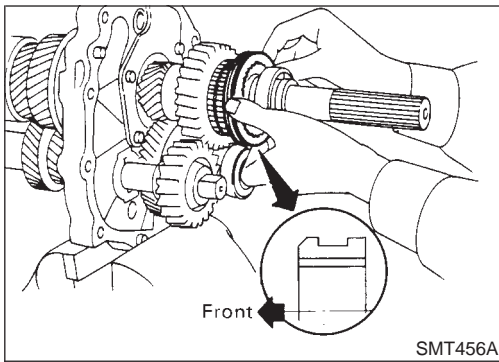

- p. Install reverse coupling sleeve.
- **Pay attention to its direction.**
- q. Measure each gear end play as a final check. Refer to "DISASSEMBLY", MT-16.

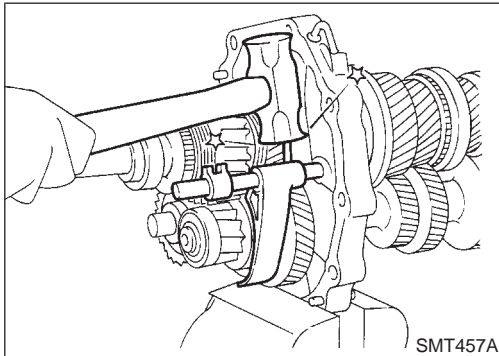

Shift Control Components

ASSEMBLY

NAMT0014

1. Install OD fork rod and OD shift fork. Then install retaining pin into OD shift fork.
2. Install 1st & 2nd, 3rd & 4th and reverse shift fork onto coupling sleeve.

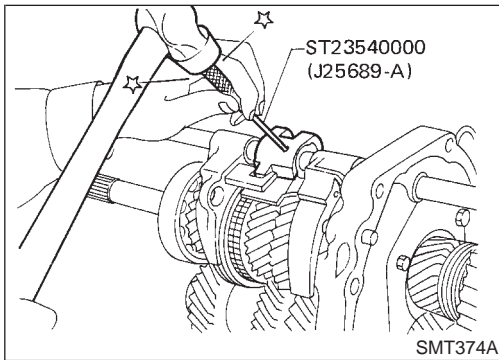

3. Install striking rod into hole of shift forks, striking lever and interlock and then install retaining pin into striking lever.
- **Make sure that striking rod moves smoothly.**

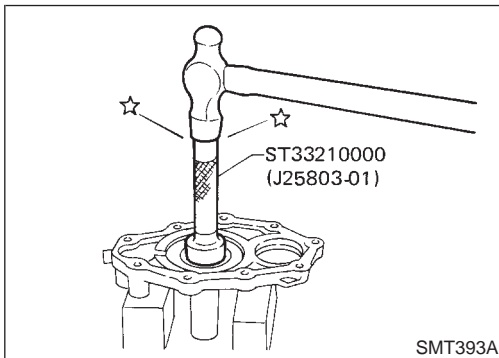

Case Components

ASSEMBLY

NAMT0015

1. Install front cover oil seal.
- **Apply multi-purpose grease to seal lip.**
2. Install selected counter gear front bearing shim onto transmission case.
- **Apply multi-purpose grease.**
3. Apply sealant to mating surface of transmission case.

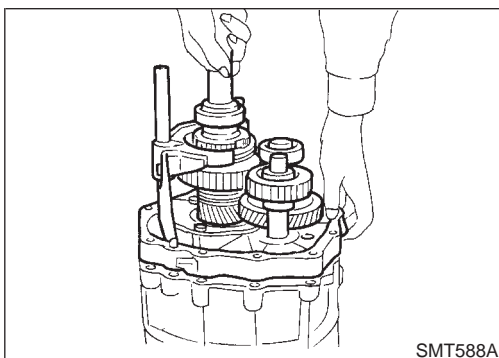

4. Install gear assembly onto transmission case.
 5. Install check spring and check ball into interlock stopper.
- **Apply multi-purpose grease to check ball.**

ASSEMBLY

Case Components (Cont'd)

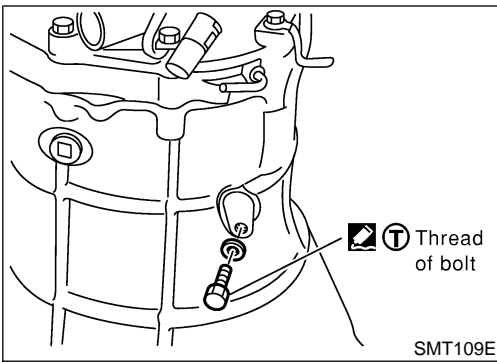

6. Install interlock stopper assembly and then tighten check ball plug.
 - **Apply genuine thread sealant to thread of check ball plug. Refer to Shift Control Components, MT-13.**

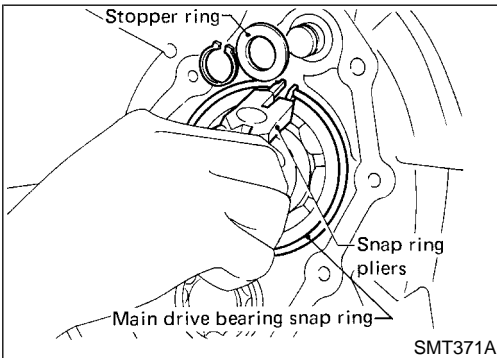

7. Install stopper ring and main drive bearing snap ring.

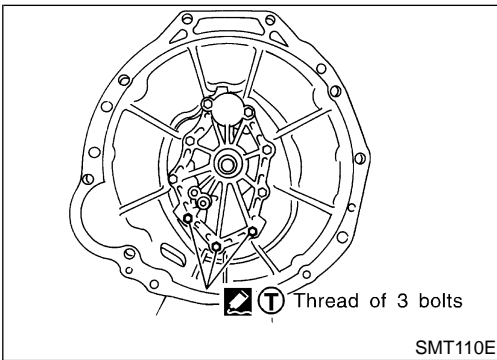

8. Install front cover and gasket.
 - **Apply genuine thread sealant to thread of 3 bolts shown left. Refer to Case Components, MT-10.**
9. Apply sealant to mating surface of adapter plate.

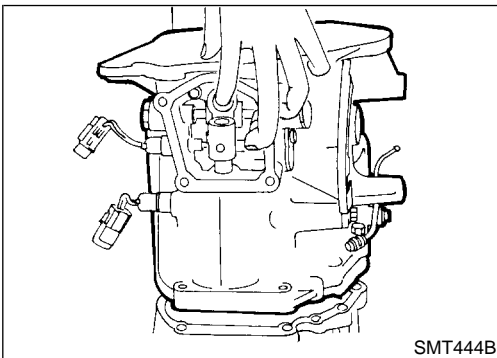

10. Install OD gear case together with striking arm.

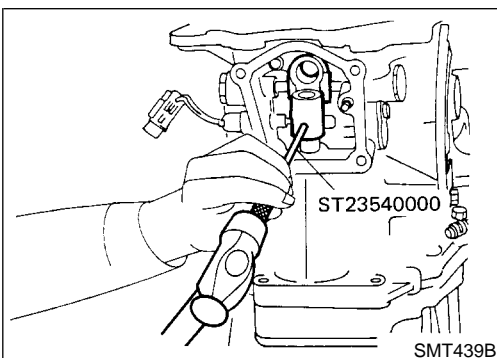

11. Install retaining pin into striking arm.

GI

MA

EM

LC

EC

FE

CL

MT

AT

TF

PD

AX

SU

BR

ST

RS

BT

HA

SC

EL

IDX

ASSEMBLY

Case Components (Cont'd)

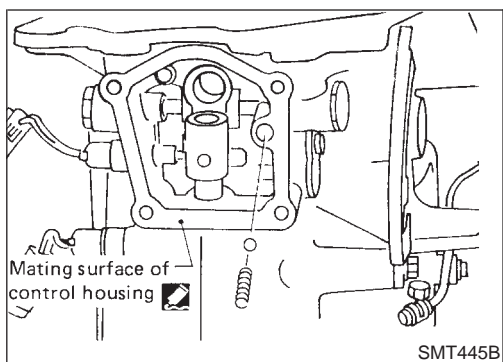

12. Install return spring and check ball and then install control housing.

- **Apply sealant to mating surface of OD gear case. Refer to Case Components, MT-10.**

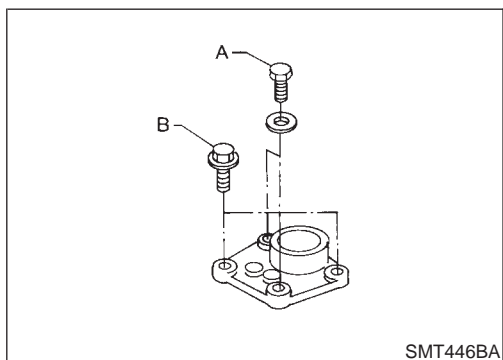

13. Tighten control housing bolts.

Bolt head size:

A bolts 12 mm (0.47 in)

B bolts 13 mm (0.51 in)

SERVICE DATA AND SPECIFICATIONS (SDS)

General Specifications

General Specifications

NAMT0016

Applied model	VQ35DE		
	4WD		
Transmission	FS5R30A		
Model code number	4W120		
Number of speed	5		
Shift pattern			
Synchromesh type	Warner		
	Gear ratio	Number of teeth	
		Mainshaft	Countershaft
Drive	—	22	32
1st	3.580	32	13
2nd	2.077	30	21
3rd	1.360	29	31
4th	1.000	—	—
OD	0.811	24	43
Reverse	3.636	30	12
Reverse idler gear	22		
Oil capacity ℓ (US pt, Imp pt)*	5.1 (10-3/4, 9)		
Remarks	2nd & 3rd double baulk ring type synchronizer		

*: Refer to MA-12, "Fluids and Lubricants".

Gear End Play

NAMT0017
Unit: mm (in)

Gear	End play
1st main gear	0.23 - 0.33 (0.0091 - 0.0130)
2nd main gear	0.23 - 0.33 (0.0091 - 0.0130)
3rd main gear	0.06 - 0.16 (0.0024 - 0.0063)
OD counter gear	0.23 - 0.33 (0.0091 - 0.0130)
Reverse main gear	0.33 - 0.43 (0.0130 - 0.0169)
Counter gear	0.10 - 0.25 (0.0039 - 0.0098)
Reverse idler gear	0.30 - 0.53 (0.0118 - 0.0209)

Clearance Between Baulk Ring and Gear

NAMT0018
Unit: mm (in)

	Standard	Wear limit
1st	1.05 - 1.3 (0.0413 - 0.0512)	0.7 (0.028)
Main drive	1.05 - 1.3 (0.0413 - 0.0512)	
OD	1.05 - 1.3 (0.0413 - 0.0512)	

SERVICE DATA AND SPECIFICATIONS (SDS)

Clearance Between Baulk Ring and Gear (Cont'd)

2ND AND 3RD BAULK RING

NAMT0018S01
Unit: mm (in)

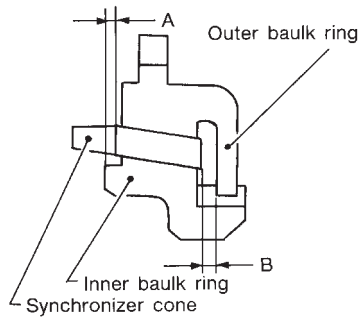

SMT742C

Dimension	Standard	Wear limit
A	0.7 - 0.9 (0.028 - 0.035)	0.2 (0.008)
B	0.6 - 1.1 (0.024 - 0.043)	

Distance Between Rear Surface of Reverse Cone and Reverse Baulk Ring

NAMT0019
Unit: mm (in)

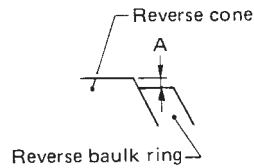

SMT428C

Dimension "A"	Standard	Wear limit
	0.3 to 0.75 (0.012 to 0.0295)	1.1 (0.043)

Available Snap Ring

MAIN DRIVE GEAR SNAP RING

NAMT0020

NAMT0020S01
Unit: mm (in)

Allowable clearance		0 - 0.1 (0 - 0.004)	
Thickness	Part number*	Thickness	Part number*
1.89 (0.0744)	32204-01G60	2.03 (0.0799)	32204-01G63
1.95 (0.0768)	32204-01G61	2.07 (0.0815)	32204-01G64
1.99 (0.0783)	32204-01G62	2.11 (0.0831)	32204-01G65

*: Always check with the Parts Department for the latest parts information.

MAINSHAFT FRONT SNAP RING

NAMT0020S02
Unit: mm (in)

Allowable clearance		0 - 0.1 (0 - 0.004)	
Thickness	Part number*	Thickness	Part number*
1.99 (0.0783)	32204-01G62	2.11 (0.0831)	32204-01G65
2.03 (0.0799)	32204-01G63	2.15 (0.0846)	32204-01G66
2.07 (0.0815)	32204-01G64	2.19 (0.0862)	32204-01G67

*: Always check with the Parts Department for the latest parts information.

SERVICE DATA AND SPECIFICATIONS (SDS)

Available Snap Ring (Cont'd)

COUNTER GEAR REAR SNAP RING

NAMT0020S03
Unit: mm (in)

Allowable clearance		0 - 0.11 (0 - 0.0043)	
Thickness	Part number*	Thickness	Part number*
1.32 (0.0520)	32236-01G00	1.56 (0.0614)	32236-01G04
1.38 (0.0543)	32236-01G01	1.62 (0.0638)	32236-01G05
1.44 (0.0567)	32236-01G02	1.68 (0.0661)	32236-01G06
1.50 (0.0591)	32236-01G03	1.74 (0.0685)	32236-01G07

*: Always check with the Parts Department for the latest parts information.

Available C-ring

MAINSHAFT C-RING

NAMT0021
NAMT0021S01
Unit: mm (in)

Allowable clearance		0 - 0.1 (0 - 0.004)	
Thickness	Part number*	Thickness	Part number*
2.63 (0.1035)	32348-01G15	3.19 (0.1256)	32348-01G07
2.70 (0.1063)	32348-01G00	3.26 (0.1283)	32348-01G08
2.77 (0.1091)	32348-01G01	3.33 (0.1311)	32348-01G09
2.84 (0.1118)	32348-01G02	3.40 (0.1339)	32348-01G10
2.91 (0.1146)	32348-01G03	3.47 (0.1366)	32348-01G11
2.98 (0.1173)	32348-01G04	3.54 (0.1394)	32348-01G12
3.05 (0.1201)	32348-01G05	3.61 (0.1421)	32348-01G13
3.12 (0.1228)	32348-01G06	3.68 (0.1449)	32348-01G14

*: Always check with the Parts Department for the latest parts information.

GI
MA
EM
LC
EC
FE
CL
MT
AT
TF
PD
AX
SU
BR
ST
RS
BT
HA
SC
EL
IDX

SERVICE DATA AND SPECIFICATIONS (SDS)

Available Shim and Washer

Available Shim and Washer

TABLE FOR SELECTING PROPER COUNTER GEAR FRONT BEARING THRUST WASHER

=NAMT0022
NAMT0022S01
Unit: mm (in)

Dial indicator deflection	Thickness of proper washer	Part number*
0.93 - 1.02 (0.0366 - 0.0402)	0.80 (0.0315)	32218-01G00
1.01 - 1.10 (0.0398 - 0.0433)	0.88 (0.0346)	32218-01G11
1.09 - 1.18 (0.0429 - 0.0465)	0.96 (0.0378)	32218-01G12
1.17 - 1.26 (0.0461 - 0.0496)	1.04 (0.0409)	32218-01G13
1.25 - 1.34 (0.0492 - 0.0528)	1.12 (0.0441)	32218-01G14
1.33 - 1.42 (0.0524 - 0.0559)	1.20 (0.0472)	32218-01G04
1.41 - 1.50 (0.0555 - 0.0591)	1.28 (0.0504)	32218-01G15
1.49 - 1.58 (0.0587 - 0.0622)	1.36 (0.0535)	32218-01G16
1.57 - 1.66 (0.0618 - 0.0654)	1.44 (0.0567)	32218-01G17

*: Always check with the Parts Department for the latest parts information.

REVERSE IDLER REAR THRUST WASHER

NAMT0022S02
Unit: mm (in)

	Thickness	Part number*
A	1.97 (0.0776)	32284-01G10
B	2.07 (0.0815)	32284-01G11

*: Always check with the Parts Department for the latest parts information.