

SECTION LAN
LAN SYSTEM

A
B
C

CONTENTS

D
E

CAN

PRECAUTIONS	3	MNTR" SCREEN FOR ABS ACTUATOR AND ELECTRIC UNIT (CONTROL UNIT)	22
Precautions for Supplemental Restraint System (SRS) "AIR BAG" and "SEAT BELT PRE-TENSIONER"	3	DESCRIPTION OF "CAN DIAG SUPPORT MNTR" SCREEN FOR IPDM E/R	23
Precautions When Using CONSULT-II	3	DESCRIPTION OF "CAN DIAG SUPPORT MNTR" SCREEN FOR DISPLAY CONTROL UNIT	24
CHECK POINTS FOR USING CONSULT-II	3	CAN COMMUNICATION	25
Precautions for Trouble Diagnosis	3	System Description	25
CAN SYSTEM	3	Component Parts and Harness Connector Location..	25
Precautions for Harness Repair	4	Schematic	26
CAN SYSTEM	4	Wiring Diagram — CAN —	27
TROUBLE DIAGNOSES WORK FLOW	5	CAN Communication Unit	30
When Displaying CAN Communication System Errors	5	TYPE 1/TYPE 2/TYPE 3/TYPE 4	31
WHEN A MALFUNCTION IS DETECTED BY CAN COMMUNICATION SYSTEM	5	TYPE 5/TYPE 6	35
WHEN A MALFUNCTION IS DETECTED EXCEPT CAN COMMUNICATION SYSTEM	5	TYPE 7/TYPE 8/TYPE 9/TYPE 10	37
TROUBLE DIAGNOSIS FLOW CHART	6	CAN SYSTEM (TYPE 1)	41
Diagnosis Procedure	7	Component Parts and Harness Connector Location..	41
SELECTING CAN SYSTEM TYPE (HOW TO USE SPECIFICATION TABLE)	7	Schematic	41
ACQUISITION OF DATA BY CONSULT-II	8	Wiring Diagram — CAN —	41
HOW TO USE CHECK SHEET TABLE	9	Check Sheet	42
CAN Diagnostic Support Monitor	16	CHECK SHEET RESULTS (EXAMPLE)	44
DESCRIPTION OF "CAN DIAG SUPPORT MNTR" SCREEN FOR ECM	16	CAN SYSTEM (TYPE 2)	55
DESCRIPTION OF "CAN DIAG SUPPORT MNTR" SCREEN FOR TCM	17	Component Parts and Harness Connector Location..	55
DESCRIPTION OF "CAN DIAG SUPPORT MNTR" SCREEN FOR BCM	17	Schematic	55
DESCRIPTION OF "CAN DIAG SUPPORT MNTR" SCREEN FOR METER	18	Wiring Diagram — CAN —	55
DESCRIPTION OF "CAN DIAG SUPPORT MNTR" SCREEN FOR TRANSFER CONTROL UNIT	19	Check Sheet	56
DESCRIPTION OF "CAN DIAG SUPPORT MNTR" SCREEN FOR DRIVER SEAT CONTROL UNIT	21	CHECK SHEET RESULTS (EXAMPLE)	58
DESCRIPTION OF "CAN DIAG SUPPORT		CAN SYSTEM (TYPE 3)	69
MNTR" SCREEN FOR ABS ACTUATOR AND ELECTRIC UNIT (CONTROL UNIT)		Component Parts and Harness Connector Location..	69
DESCRIPTION OF "CAN DIAG SUPPORT MNTR" SCREEN FOR IPDM E/R		Schematic	69
DESCRIPTION OF "CAN DIAG SUPPORT MNTR" SCREEN FOR DISPLAY CONTROL UNIT		Wiring Diagram — CAN —	69
DESCRIPTION OF "CAN DIAG SUPPORT MNTR" SCREEN FOR CAN COMMUNICATION UNIT		Check Sheet	70
TYPE 1/TYPE 2/TYPE 3/TYPE 4		CHECK SHEET RESULTS (EXAMPLE)	72
TYPE 5/TYPE 6		CAN SYSTEM (TYPE 4)	84
TYPE 7/TYPE 8/TYPE 9/TYPE 10		Component Parts and Harness Connector Location..	84
		Schematic	84
		Wiring Diagram — CAN —	84
		Check Sheet	85
		CHECK SHEET RESULTS (EXAMPLE)	87

F
G
H
I
J
K

LAN

L
M

CAN SYSTEM (TYPE 5)	101	Wiring Diagram — CAN —	161
Component Parts and Harness Connector Location	101	Check Sheet	162
Schematic	101	CHECK SHEET RESULTS (EXAMPLE)	164
Wiring Diagram — CAN —	101	CAN SYSTEM (TYPE 10)	177
Check Sheet	102	Component Parts and Harness Connector Location	177
CHECK SHEET RESULTS (EXAMPLE)	104	Schematic	177
CAN SYSTEM (TYPE 6)	116	Wiring Diagram — CAN —	177
Component Parts and Harness Connector Location	116	Check Sheet	178
Schematic	116	CHECK SHEET RESULTS (EXAMPLE)	180
Wiring Diagram — CAN —	116	TROUBLE DIAGNOSIS FOR SYSTEM	195
Check Sheet	117	Inspection Between TCM and Data Link Connector	
CHECK SHEET RESULTS (EXAMPLE)	119	Circuit	195
CAN SYSTEM (TYPE 7)	131	Inspection Between Data Link Connector and ABS	
Component Parts and Harness Connector Location	131	Actuator and Electric Unit (Control Unit) Circuit ...	196
Schematic	131	ECM Circuit Inspection	197
Wiring Diagram — CAN —	131	TCM Circuit Inspection	197
Check Sheet	132	Display Control Unit Circuit Inspection	198
CHECK SHEET RESULTS (EXAMPLE)	134	Front Air Control Circuit Inspection	198
CAN SYSTEM (TYPE 8)	146	Steering Angle Sensor Circuit Inspection	199
Component Parts and Harness Connector Location	146	Data Link Connector Circuit Inspection	199
Schematic	146	BCM Circuit Inspection	200
Wiring Diagram — CAN —	146	Combination Meter Circuit Inspection	200
Check Sheet	147	Transfer Control Unit Circuit Inspection	201
CHECK SHEET RESULTS (EXAMPLE)	149	Driver Seat Control Unit Circuit Inspection	202
CAN SYSTEM (TYPE 9)	161	ABS Actuator and Electric Unit (Control Unit) Circuit	
Component Parts and Harness Connector Location	161	Inspection	202
Schematic	161	IPDM E/R Circuit Inspection	203
		CAN Communication Circuit Inspection	203
		IPDM E/R Ignition Relay Circuit Inspection	204

PRECAUTIONS

Precautions for Supplemental Restraint System (SRS) “AIR BAG” and “SEAT BELT PRE-TENSIONER”

UKS0017I

The Supplemental Restraint System such as “AIR BAG” and “SEAT BELT PRE-TENSIONER”, used along with a front seat belt, helps to reduce the risk or severity of injury to the driver and front passenger for certain types of collision. This system includes seat belt switch inputs and dual stage front air bag modules. The SRS system uses the seat belt switches to determine the front air bag deployment, and may only deploy one front air bag, depending on the severity of a collision and whether the front occupants are belted or unbelted. Information necessary to service the system safely is included in the SRS and SB section of this Service Manual.

WARNING:

- To avoid rendering the SRS inoperative, which could increase the risk of personal injury or death in the event of a collision which would result in air bag inflation, all maintenance must be performed by an authorized NISSAN/INFINITI dealer.
- Improper maintenance, including incorrect removal and installation of the SRS, can lead to personal injury caused by unintentional activation of the system. For removal of Spiral Cable and Air Bag Module, see the SRS section.
- Do not use electrical test equipment on any circuit related to the SRS unless instructed to in this Service Manual. SRS wiring harnesses can be identified by yellow and/or orange harnesses or harness connectors.

Precautions When Using CONSULT-II

UKS0017J

When connecting CONSULT-II to data link connector, connect them through CONSULT-II CONVERTER.

CAUTION:

If CONSULT-II is used with no connection of CONSULT-II CONVERTER, malfunctions might be detected in self-diagnosis depending on control unit which carry out CAN communication.

CHECK POINTS FOR USING CONSULT-II

1. Has CONSULT-II been used without connecting CONSULT-II CONVERTER on this vehicle?
 - If YES, GO TO 2.
 - If NO, GO TO 5.
2. Is there any indication other than indications relating to CAN communication system in the self-diagnosis results?
 - If YES, GO TO 3.
 - If NO, GO TO 4.
3. Based on self-diagnosis results unrelated to CAN communication, carry out the inspection.
4. Malfunctions may be detected in self-diagnosis depending on control units carrying out CAN communication. Therefore, erase the self-diagnosis results.
5. Diagnose CAN communication system. Refer to [LAN-5, "TROUBLE DIAGNOSES WORK FLOW"](#) .

Precautions for Trouble Diagnosis CAN SYSTEM

UKS0017K

- Do not apply voltage of 7.0 V or higher to the measurement terminals.
- Use the tester with its open terminal voltage being 7.0 V or less.
- Be sure to turn ignition switch OFF and disconnect the battery cable from the negative terminal before checking the circuit.

A
B
C
D
E
F
G
H
I
J
L
M

LAN

Precautions for Harness Repair CAN SYSTEM

- Solder the repaired parts, and wrap with tape. [Frays of twisted line must be within 110 mm (4.33 in).]

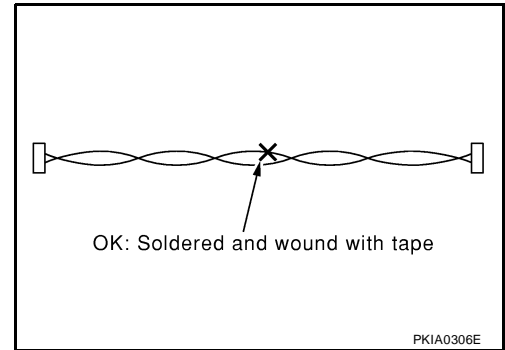

- Do not perform bypass wire connections for the repair parts. (The spliced wire will become separated and the characteristics of twisted line will be lost.)

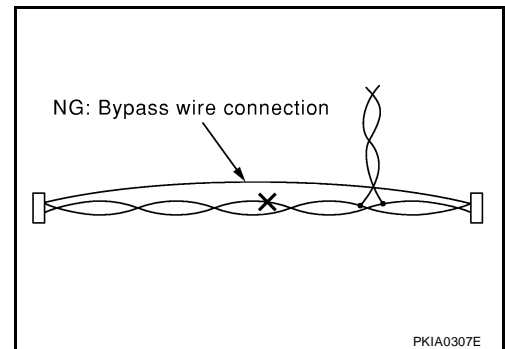

TROUBLE DIAGNOSES WORK FLOW

PFP:00004

**When Displaying CAN Communication System Errors
WHEN A MALFUNCTION IS DETECTED BY CAN COMMUNICATION SYSTEM**

UKS003GH

- CAN communication line is open. (CAN H, CAN L, or both)
- CAN communication line is shorted. (Ground, between CAN lines, or other harnesses)
- The areas related to CAN communication of unit is malfunctioning.

WHEN A MALFUNCTION IS DETECTED EXCEPT CAN COMMUNICATION SYSTEM

- Removal and installation of parts: When the units that perform CAN communication or the sensors related to CAN communication are removed and installed, malfunction may be detected (or DTC other than CAN communication may be detected).
- Fuse blown out (removed): CAN communication of the unit may be stopped at such time.
- Low voltage: If the voltage decreases because of battery discharge when IGN is ON, malfunction may be detected by self-diagnosis according to the units.

A
B
C
D
E
F
G
H
I
J
L
M

LAN

TROUBLE DIAGNOSIS FLOW CHART

Depending on the control unit which performs CAN communication, "U1010" may be indicated as the result of self-diagnosis. Replace the control unit if "U1010" is indicated.

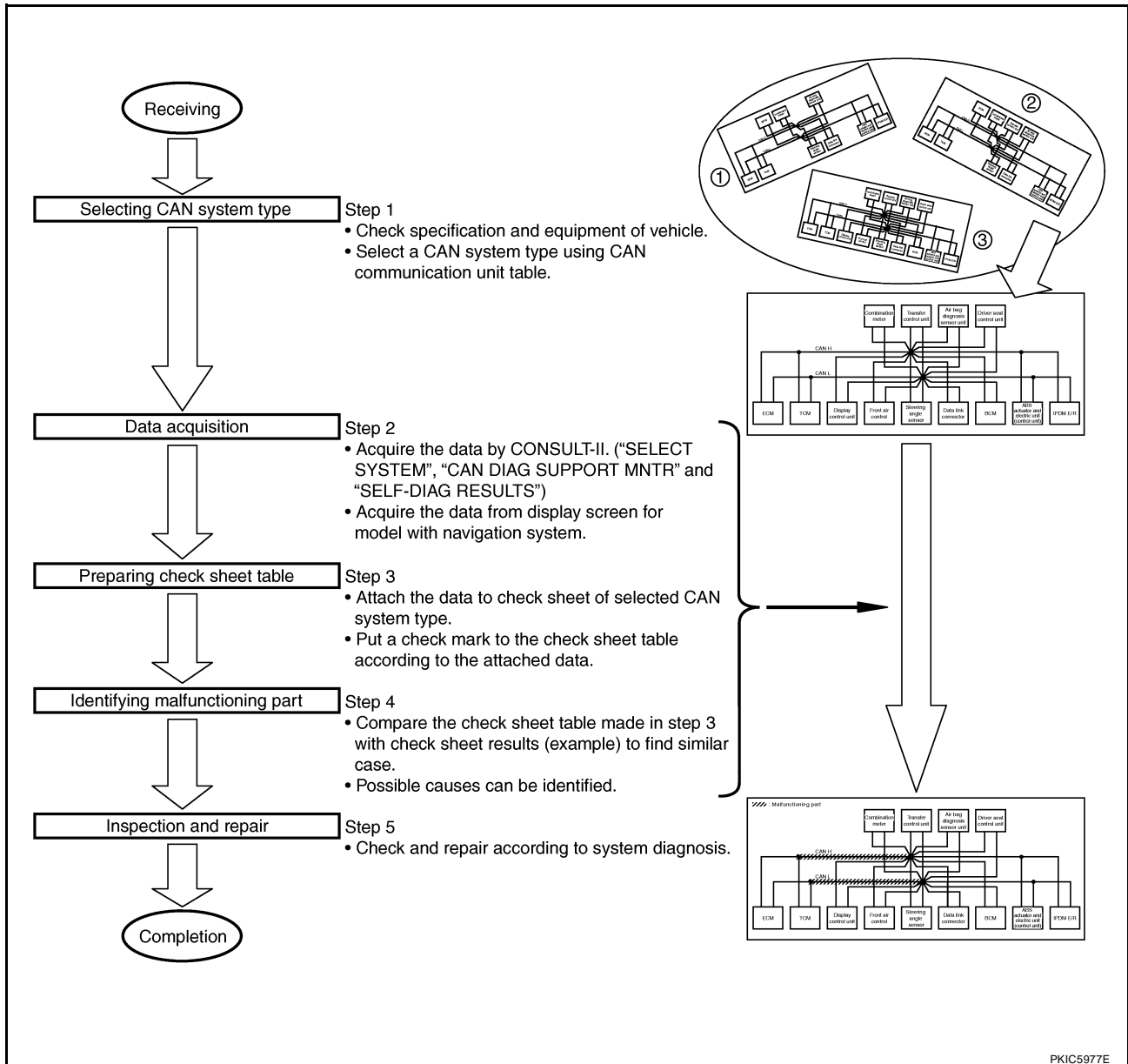

- Step 1: Refer to [LAN-7, "SELECTING CAN SYSTEM TYPE \(HOW TO USE SPECIFICATION TABLE\)"](#) .
- Step 2: Refer to [LAN-8, "ACQUISITION OF DATA BY CONSULT-II"](#) .
- Step 3: Refer to [LAN-9, "HOW TO USE CHECK SHEET TABLE"](#) .
- Step 4: Refer to [LAN-10, "Example of Filling in Check Sheet When Initial Conditions Are Reproduced"](#) .
- Step 5: Refer to [LAN-195, "TROUBLE DIAGNOSIS FOR SYSTEM"](#) .

TROUBLE DIAGNOSES WORK FLOW

[CAN]

UKS003GI

Diagnosis Procedure

SELECTING CAN SYSTEM TYPE (HOW TO USE SPECIFICATION TABLE)

Determine CAN system type from the equipment of the vehicle to select applicable check sheet.

(Example) Wagon/4WD (All-mode)/VQ40DE/AT/VDC/With automatic air conditioner/With automatic drive positioner/With navigation system

CAN Communication Unit

Go to CAN system, when selecting your CAN system type from the following table.

Body type	Wagon									
Axle	2WD			4WD(Part time)			4WD(All-mode)			
Engine	VQ40DE									
Transmission	A/T									
Brake control	VDC									
Automatic air conditioner		x	x	x		x		x	x	x
Automatic drive positioner			x	x					x	x
Navigation system				x						x
CAN system type	1	2	3	4	5	6	7	8	9	10
CAN system trouble diagnosis	XXXX	XXXX	XXXX	XXXX	XXXX	XXXX	XXXX	XXXX	XXXX	XXXX

Check basic specification of the vehicle.

→ Select "x" if it is model with automatic air conditioner.

→ Select "x" if it is model with automatic drive positioner.

→ Select "x" if it is model with navigation system.

Which number is selected when sequentially selecting from the top of the specification table?

The number is "CAN system type" of the applicable vehicle.

In the case of this example:
It corresponds to type 10.

PKIC5978E

x : Applicable

A
B
C
D
E
F
G
H
I
J
L
M

LAN

TROUBLE DIAGNOSES WORK FLOW

[CAN]

ACQUISITION OF DATA BY CONSULT-II

Attach the data acquired by CONSULT-II on the check sheet determined according to CAN system type. (For display control unit, transfer the data from the display screen of the vehicle to "CAN DIAG SUPPORT MONITOR Check Sheet". Refer to [AV-132, "CAN Communication Line Check"](#) .)

Copy "SELECT SYSTEM" screen of CONSULT-II.

SELECT SYSTEM		SELECT SYSTEM	
ENGINE		AIR BAG	
A/T		IPDM E/R	
ABS		BCM	
AIR BAG		METER	
IPDM E/R		AUTO DRIVE POS.	
BCM		ALL MODE AWD/4WD	
Page Down		Page Up	
BACK	LIGHT	COPY	

AV section

Copy "CAN DIAG SUPPORT MONITOR Check Sheet" of CAN Communication Line Check.

Diagnosis Item	Screen display	Diagnosis Item	Screen display
CAN_COMM	OK NG	CAN_CRIC_5	OK UNKWN
CAN_CRIC_1	OK UNKWN	CAN_CRIC_6	OK UNKWN
CAN_CRIC_2	OK UNKWN	CAN_CRIC_7	OK UNKWN
CAN_CRIC_3	OK UNKWN	CAN_CRIC_8	OK UNKWN
CAN_CRIC_4	OK UNKWN	CAN_CRIC_9	OK UNKWN

SELECT SYSTEM screen	CAN DIAG SUPPORT MNTR										SELF-DIAG RESULTS		
	Initial diagnosis	Transmit diagnosis	ECM	TCM	Front air control	STRG	BCM /SEC	METER /M&A	IPDM E/R	DOTCS /ABS	IPDM E/R	CAN COMM CIRCUIT (U1000)	CAN COMM CIRCUIT (U1801)
ENGINE	--	--	UNKWN	--	UNKWN	--	--	UNKWN	UNKWN	UNKWN	UNKWN	--	--
A/T	--	NG	UNKWN	--	UNKWN	--	--	UNKWN	UNKWN	UNKWN	--	--	--
Display control unit	--	NG	UNKWN	--	UNKWN	--	--	UNKWN	UNKWN	UNKWN	--	--	--
BCM	No indicator	NG	UNKWN	--	UNKWN	--	--	UNKWN	UNKWN	UNKWN	--	--	--
METER	No indicator	--	UNKWN	--	UNKWN	--	--	UNKWN	UNKWN	UNKWN	--	--	--
ALL MODE AWD/4WD	No indicator	--	UNKWN	--	UNKWN	--	--	UNKWN	UNKWN	UNKWN	--	--	--
AUTO DRIVE POS.	No indicator	--	UNKWN	--	UNKWN	--	--	UNKWN	UNKWN	UNKWN	--	--	--
ABS	--	NG	UNKWN	--	UNKWN	--	--	UNKWN	UNKWN	UNKWN	--	--	--
IPDM E/R	No indicator	--	UNKWN	--	UNKWN	--	--	UNKWN	UNKWN	UNKWN	--	--	--

Symptoms :

Attach copy of SELECT SYSTEM

Attach copy of SELECT SYSTEM

Display control unit Translation Sheet: Rewrite the following names, and put a check mark on the above check sheet table.

Confirmation/Adjustment Display	Check sheet table Display	Confirmation/Adjustment Display	Check sheet table Display
CAN COMM	Initial diagnosis	CAN CRIC 5	METER/M&A
CAN CRIC 1	Transmit diagnosis	CAN CRIC 6	--
CAN CRIC 2	--	CAN CRIC 7	IPDM E/R
CAN CRIC 3	ECM	CAN CRIC 8	--
CAN CRIC 4	Front air control	CAN CRIC 9	--

Attach copy of display control unit CAN DIAG SUPPORT MONITOR Check Sheet

Copy "SELF-DIAG RESULTS" screen of CONSULT-II.

SELF-DIAG RESULTS	
DTC RESULTS	TIME
NO DTC IS DETECTED. FURTHER TESTING MAY BE REQUIRED.	
ERASE PRINT	
MODE BACK LIGHT COPY	

Attach copy of ENGINE SELF-DIAG RESULTS

Attach copy of A/T SELF-DIAG RESULTS

Attach copy of BCM SELF-DIAG RESULTS

Attach copy of METER SELF-DIAG RESULTS

Attach copy of ALL MODE AWD/4WD SELF-DIAG RESULTS

Attach copy of AUTO DRIVE POS. SELF-DIAG RESULTS

Attach copy of ABS SELF-DIAG RESULTS

Attach copy of IPDM E/R SELF-DIAG RESULTS

Copy "CAN DIAG SUPPORT MNTR" screen of CONSULT-II.

CAN DIAG SUPPORT MNTR	
A/T	
INITIAL DIAG	OK
TRANSMIT DIAG	OK
ECM	OK
VDC/TCS/ABS	UNKWN
METER/M&A	UNKWN
ICC/4WD	UNKWN
AWD/4WD	UNKWN
PRINT	
MODE BACK LIGHT COPY	

CAN DIAG SUPPORT MNTR	
ABS	
INITIAL DIAG	OK
TRANSMIT DIAG	OK
ECM	UNKWN
TCM	UNKWN
METER/M&A	UNKWN
STRG	OK
ICC	UNKWN
AWD/4WD	OK
PRINT	
MODE BACK LIGHT COPY	

Attach copy of ENGINE CAN DIAG SUPPORT MNTR

Attach copy of A/T CAN DIAG SUPPORT MNTR

Attach copy of BCM CAN DIAG SUPPORT MNTR

Attach copy of METER CAN DIAG SUPPORT MNTR

Attach copy of ALL MODE AWD/4WD CAN DIAG SUPPORT MNTR

Attach copy of AUTO DRIVE POS. CAN DIAG SUPPORT MNTR

Attach copy of ABS CAN DIAG SUPPORT MNTR

CAN DIAG SUPPORT MNTR
IPDM E/R
PRNT PAST
TRANSMIT DIAG OK OK
ECM UNKWN 0
BCM UNKWN 0

PKIC5979E

TROUBLE DIAGNOSES WORK FLOW

[CAN]

HOW TO USE CHECK SHEET TABLE

Use when the initial conditions are reproduced													Use when the initial conditions are not reproduced		
Check sheet table													SELF-DIAG RESULTS		
SELECT SYSTEM screen	CAN DIAG SUPPORT MNTR														
	Initial diagnosis	Transmit diagnosis	Receive diagnosis									CAN COMM CIRCUIT (U1000)			CAN COMM CIRCUIT (U1001)
ENGINE	—	—	UNKWN	—	UNKWN	—	—	UNKWN	UNKWN	UNKWN	UNKWN		UNKWN	—	
A/T	—	NG	UNKWN	UNKWN	—	—	—	—	UNKWN	UNKWN	UNKWN	UNKWN	—	CAN COMM CIRCUIT (U1000)	—
Display control unit	—	NG	UNKWN	UNKWN	—	UNKWN	—	UNKWN	UNKWN	—	—	UNKWN	—	—	—
BCM	No indication	NG	UNKWN	UNKWN	—	—	—	—	UNKWN	—	—	UNKWN	—	CAN COMM CIRCUIT (U1000)	—
METER	No indication	—	UNKWN	UNKWN	UNKWN	—	—	UNKWN	—	—	UNKWN	UNKWN	—	CAN COMM CIRCUIT (U1000)	—
ALL MODE AWD/4WD	No indication	—	UNKWN	UNKWN	UNKWN	—	UNKWN	—	—	—	UNKWN	—	—	CAN COMM CIRCUIT (U1000)	—
AUTO DRIVE POS.	No indication	—	—	—	UNKWN	—	—	UNKWN	UNKWN	—	—	—	—	CAN COMM CIRCUIT (U1000)	—
ABS	—	NG	UNKWN	UNKWN	UNKWN	—	UNKWN	—	—	UNKWN	—	—	—	CAN COMM CIRCUIT (U1000)	—
IPDM E/R	No indication	—	UNKWN	UNKWN	—	—	—	UNKWN	—	—	—	—	—	CAN COMM CIRCUIT (U1000)	—

① ② ③ ④ ⑤

Unit that performs CAN communication diagnosis

PKIC5980E

- Unit names displayed on CONSULT-II.
- “No indication”: Put a check mark to it if the unit name described in step 1 is not displayed on “SELECT SYSTEM” screen of CONSULT-II. (Unit communicating with CONSULT-II via CAN communication line)
“—”: Column not used (Unit communicating with CONSULT-II excluding CAN communication line)
- “NG”: Display “NG” when malfunction is detected in the initial diagnosis of the diagnosed unit. Replace the unit if “NG” is displayed.
“—”: Column not used (Initial diagnosis is not performed.)
- “UNKWN”: Display “UNKWN” when the diagnosed unit does not transmit the data normally. Put a check mark to it if “UNKWN” is displayed on CONSULT-II.
“—”: Column not used (Transmit diagnosis is not performed.)
- “UNKWN”: Display “UNKWN” when the diagnosed unit does not receive the data normally. Put a check mark to it if “UNKWN” is displayed on CONSULT-II.
“—”: Column not used (It is not necessary for CAN communication trouble diagnosis.)

NOTE:

CAN communication diagnosis checks if CAN communication works normally. (Contents of data are not diagnosed.)

- When the initial conditions are reproduced, refer to [LAN-10, "Example of Filling in Check Sheet When Initial Conditions Are Reproduced"](#).
- When the initial conditions are not reproduced, refer to [LAN-14, "Example of Filling in Check Sheet When Initial Conditions Are Not Reproduced"](#).

TROUBLE DIAGNOSES WORK FLOW

[CAN]

Example of Filling in Check Sheet When Initial Conditions Are Reproduced

ENGINE	
IPRSNT	PAST
TRANSMIT DIAG	OK OK
VDC/TCS/ABS	UNKWN 0
METER/M&A	UNKWN 0
BCM/SEC	UNKWN 0
ICC	- -
HVAC	- -
TCM	OK OK
EPS	- -
IPDM E/R	UNKWN 0
PRINT	
MODE	BACK LIGHT COPY

ENGINE	
IPRSNT	PAST
METER/M&A	UNKWN 0
BCM/SEC	UNKWN 0
HVAC	- -
TCM	OK OK
EPS	- -
IPDM E/R	UNKWN 0
AWD/4WD	- -
AWD/4WD	UNKWN 0
PRINT	
MODE	BACK LIGHT COPY

SELECT SYSTEM screen	CAN DIAG SUPPORT MNTR										SELF-DIAG RESULTS			
	Initial diagnosis	Transmit diagnosis	ECM	TCM	Front air control	STRG	BCM /SEC	METER /M&A	AWD/4WD	VDC/TCS /ABS			IPDM E/R	
ENGINE	-	-	UNKWN	-	UNKWN	-	-	UNKWN	UNKWN	UNKWN	UNKWN	UNKWN	CAN COMM CIRCUIT (U1000)	CAN COMM CIRCUIT (U1001)
A/T	-	NG	UNKWN	UNKWN	-	-	-	UNKWN	UNKWN	UNKWN	UNKWN	UNKWN	CAN COMM CIRCUIT (U1000)	-
Display control unit	-	NG	UNKWN	UNKWN	-	UNKWN	-	UNKWN	UNKWN	-	-	UNKWN	-	-
BCM	No indication	NG	UNKWN	UNKWN	-	-	-	UNKWN	-	-	UNKWN	UNKWN	CAN COMM CIRCUIT (U1000)	-
METER	No indication	-	UNKWN	UNKWN	UNKWN	-	-	UNKWN	-	-	UNKWN	UNKWN	CAN COMM CIRCUIT (U1000)	-
ALL MODE AWD/4WD	No indication	-	UNKWN	UNKWN	UNKWN	-	UNKWN	-	-	-	UNKWN	-	CAN COMM CIRCUIT (U1000)	-
AUTO DRIVE POS.	No indication	-	-	-	UNKWN	-	-	UNKWN	UNKWN	-	-	-	CAN COMM CIRCUIT (U1000)	-
ABS	-	NG	UNKWN	UNKWN	UNKWN	-	UNKWN	-	-	UNKWN	-	-	CAN COMM CIRCUIT (U1000)	-
IPDM E/R	No indication	-	UNKWN	UNKWN	-	-	-	UNKWN	-	-	-	-	CAN COMM CIRCUIT (U1000)	-

A/T	
IPRSNT	PAST
INITIAL DIAG	OK
TRANSMIT DIAG	OK
ECM	OK
VDC/TCS/ABS	UNKWN
METER/M&A	UNKWN
ICC/e4WD	UNKWN
AWD/4WD	UNKWN
PRINT	
MODE	BACK LIGHT COPY

ENGINE	
A/T	
ABS	
AIR BAG	
IPDM E/R	
BCM	
Page Down	
BACK	LIGHT COPY

AIR BAG	
IPDM E/R	
BCM	
AUTO DRIVE POS.	
METER	
ALL MODE AWD/4WD	
Page Up	
BACK	LIGHT COPY

PKIC5981E

- Put a check mark to "No indication" if some of unit names listed on the column of diagnosis system selection screen of a check sheet table are not displayed on "SELECT SYSTEM" screen attached to the check sheet.

NOTE:

Do not put a check mark on items in the column of "No indication" on the check sheet when displaying all items on "SELECT SYSTEM" screen.

- Confirm the unit name that "UNKWN" is displayed from the copy of "CAN DIAG SUPPORT MNTR" screen of "ENGINE" attached to the check sheet, and then put a check mark to the check sheet table.

NOTE:

In "CAN DIAG SUPPORT MNTR" screen, "UNKWN" is displayed on "VDC/TCS/ABS", "METER/M&A", "BCM/SEC", "IPDM E/R" and "AWD/4WD". Put a check mark to it.

- Confirm the unit name that "UNKWN" is displayed on the copy of "CAN DIAG SUPPORT MNTR" screen of "A/T" as well as "ENGINE". And then, put a check mark to the check sheet table.

NOTE:

- For "A/T", "UNKWN" is displayed on "VDC/TCS/ABS", "METER/M&A", "ICC/e4WD" and "AWD/4WD". But put a check mark to "VDC/TCS/ABS", "METER/M&A" and "AWD/4WD" because "UNKWN" is listed on the column of reception diagnosis of the check sheet table.

TROUBLE DIAGNOSES WORK FLOW

[CAN]

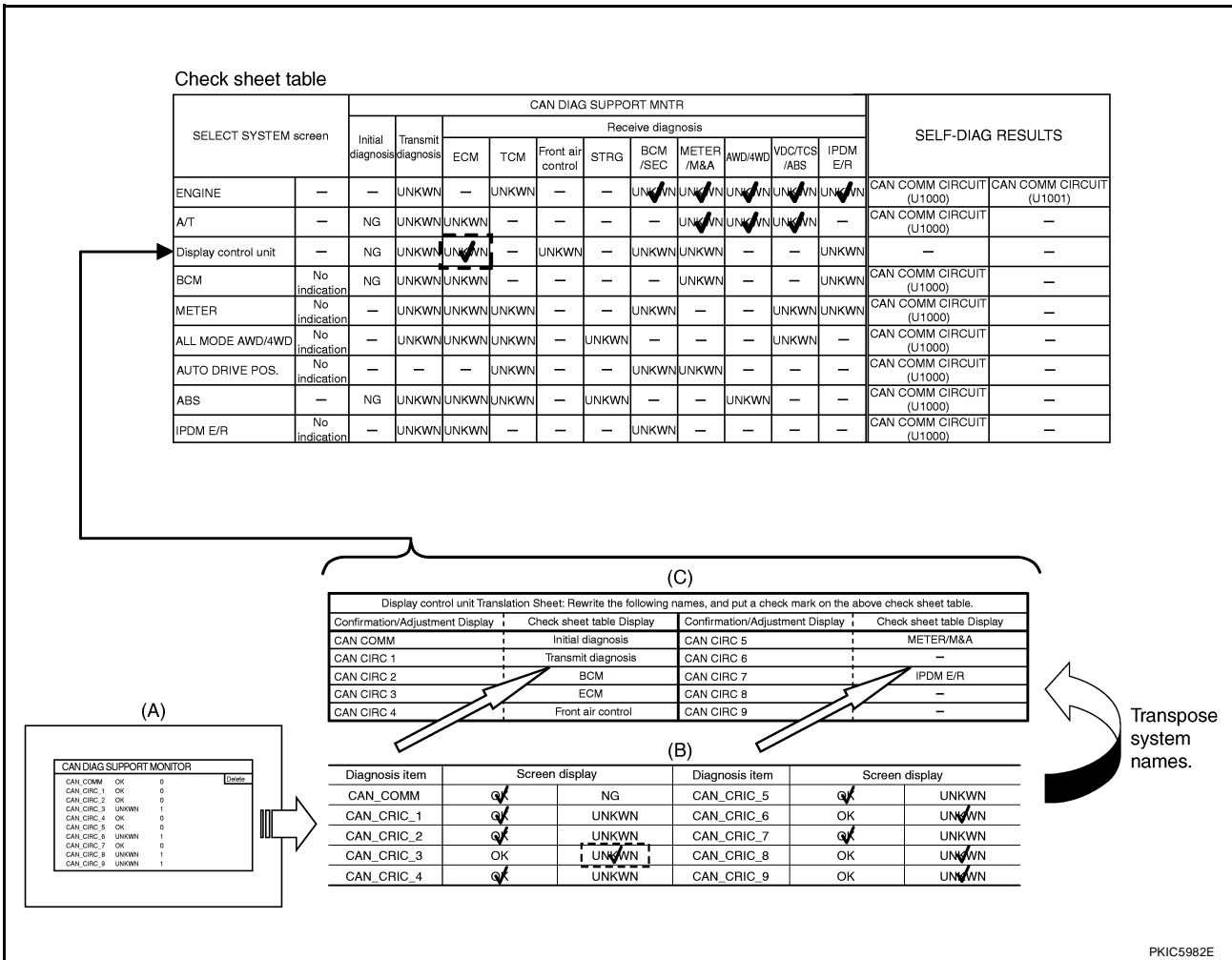

4. For display control unit, put a check mark in the following procedure.
 - a. Copy to "CAN DIAG SUPPORT MONITOR Check Sheet" (B) from the display screen (A). Refer to [AV-132, "CAN Communication Line Check"](#).
 - b. Read "CAN DIAG SUPPORT MONITOR Check Sheet" (B) with "Display control unit Translation Sheet" (C).
 - c. Check "UNKWN" with a check mark. Put a check mark to the check sheet table.

NOTE:

In "CAN DIAG SUPPORT MONITOR Check Sheet" (B), check marks are put to "CAN CIRC 3", "CAN CIRC 6", "CAN CIRC 8" and "CAN CIRC 9". But, in the column of the check sheet table indication in "Display control unit Translation Sheet" (C), "ECM" is listed only for "CAN CIRC 3". Therefore, put a check mark to "ECM" because "UNKWN" is listed on the column of reception diagnosis of the check sheet table.

TROUBLE DIAGNOSES WORK FLOW

[CAN]

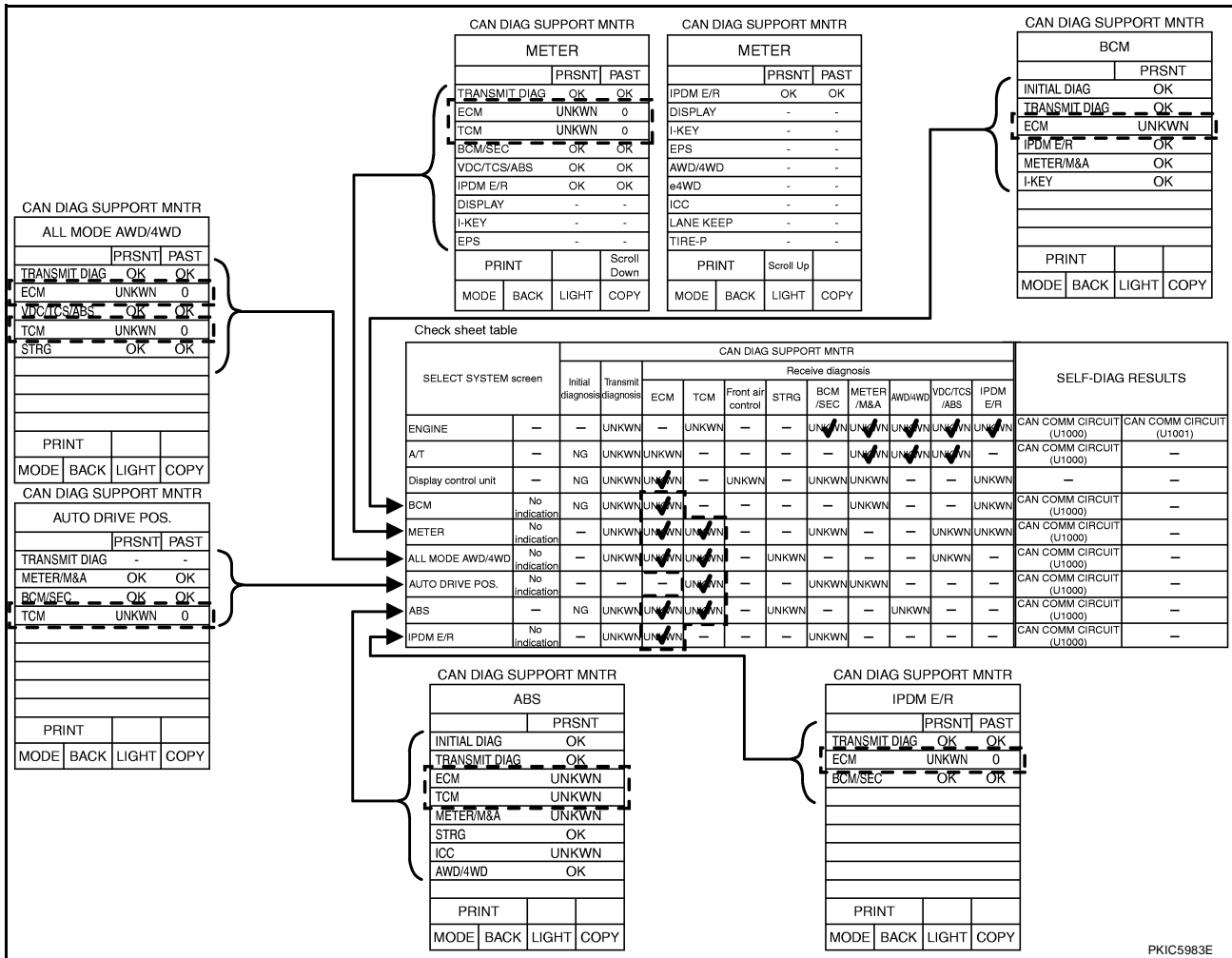

5. Confirm the unit name that “UNKWN” is displayed on the copy of “CAN DIAG SUPPORT MNTR” screen of “BCM”, “METER”, “ALL MODE AWD/4WD”, “AUTO DRIVE POS.”, “ABS” and “IPDM E/R” as well as “ENGINE”. And then, put a check mark to the check sheet table.

NOTE:

- For “BCM”, “UNKWN” is displayed on “ECM”. Put a check mark to it.
- For “METER”, “UNKWN” is displayed on “ECM” and “TCM”. Put a check mark to it.
- For “ALL MODE AWD/4WD”, “UNKWN” is displayed on “ECM” and “TCM”. Put a check mark to it.
- For “AUTO DRIVE POS.”, “UNKWN” is displayed on “TCM”. Put a check mark to it.
- For “ABS”, “UNKWN” is displayed on “ECM”, “TCM”, “METER/M&A” and “ICC”. But put a check mark to “ECM” and “TCM” because “UNKWN” is listed on the column of reception diagnosis of the check sheet table.
- For “IPDM E/R”, “UNKWN” is displayed on “ECM”. Put a check mark to it.

CAUTION:

“ALL MODE AWD/4WD” puts a check mark on the check sheet when “Present” is “UNKWN” and “Past” is “0”.

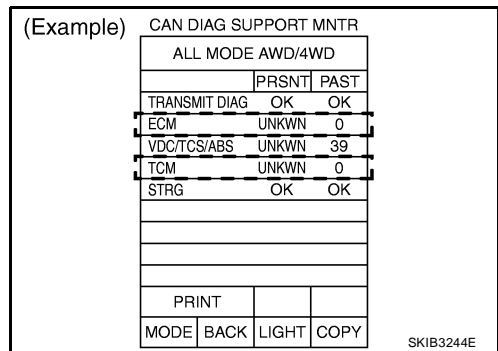

TROUBLE DIAGNOSES WORK FLOW

[CAN]

The arranged results of CAN diagnosis support monitor

Check sheet table

SELECT SYSTEM screen	CAN DIAG SUPPORT MNTR											SELF-DIAG RESULTS					
	Initial diagnosis	Transmit diagnosis	Receive diagnosis														
			ECM	TCM	Front air control	STRG	BCM /SEC	METER /M&A	AWD/4WD	VDC/TC/ABS	IPDM E/R						
ENGINE	—	—	UNKW	—	UNKW	—	—	—	—	—	—	—	—	—	—	CAN COMM CIRCUIT (U1000)	CAN COMM CIRCUIT (U1001)
A/T	—	NG	UNKW	UNKW	—	—	—	—	—	—	—	—	—	—	—	CAN COMM CIRCUIT (U1000)	—
Display control unit	—	NG	UNKW	UNKW	—	UNKW	—	UNKW	UNKW	—	—	—	—	UNKW	—	—	—
BCM	No indication	NG	UNKW	UNKW	—	—	—	—	—	UNKW	—	—	—	UNKW	—	CAN COMM CIRCUIT (U1000)	—
METER	No indication	—	UNKW	UNKW	UNKW	—	—	UNKW	—	—	—	UNKW	UNKW	—	CAN COMM CIRCUIT (U1000)	—	
ALL MODE AWD/4WD	No indication	—	UNKW	UNKW	UNKW	—	UNKW	—	—	—	—	UNKW	—	—	CAN COMM CIRCUIT (U1000)	—	
AUTO DRIVE POS.	No indication	—	—	UNKW	—	—	—	UNKW	UNKW	—	—	—	—	—	CAN COMM CIRCUIT (U1000)	—	
ABS	—	NG	UNKW	UNKW	UNKW	—	UNKW	—	—	UNKW	—	—	—	—	CAN COMM CIRCUIT (U1000)	—	
IPDM E/R	No indication	—	UNKW	UNKW	—	—	—	UNKW	—	—	—	—	—	—	CAN COMM CIRCUIT (U1000)	—	

Choose similar indications between the results of CAN diagnosis support monitor and the results of the check sheet. Malfunctioning parts are found.

Case 1

Check harness between TCM and data link connector.

Check sheet results (example)

SELECT SYSTEM screen	CAN DIAG SUPPORT MNTR											SELF-DIAG RESULTS					
	Initial diagnosis	Transmit diagnosis	Receive diagnosis														
			ECM	TCM	Front air control	STRG	BCM /SEC	METER /M&A	AWD/4WD	VDC/TC/ABS	IPDM E/R						
ENGINE	—	—	UNKW	—	UNKW	—	—	—	—	—	—	—	—	—	—	CAN COMM CIRCUIT (U1000)	CAN COMM CIRCUIT (U1001)
A/T	—	NG	UNKW	UNKW	—	—	—	—	—	—	—	—	—	—	—	CAN COMM CIRCUIT (U1000)	—
Display control unit	—	NG	UNKW	UNKW	—	UNKW	—	UNKW	UNKW	—	—	—	—	UNKW	—	—	—
BCM	No indication	NG	UNKW	UNKW	—	—	—	—	—	UNKW	—	—	—	UNKW	—	CAN COMM CIRCUIT (U1000)	—
METER	No indication	—	UNKW	UNKW	UNKW	—	—	UNKW	—	—	—	UNKW	UNKW	—	CAN COMM CIRCUIT (U1000)	—	
ALL MODE AWD/4WD	No indication	—	UNKW	UNKW	UNKW	—	UNKW	—	—	—	—	UNKW	—	—	CAN COMM CIRCUIT (U1000)	—	
AUTO DRIVE POS.	No indication	—	—	UNKW	—	—	—	UNKW	UNKW	—	—	—	—	—	CAN COMM CIRCUIT (U1000)	—	
ABS	—	NG	UNKW	UNKW	UNKW	—	UNKW	—	—	UNKW	—	—	—	—	CAN COMM CIRCUIT (U1000)	—	
IPDM E/R	No indication	—	UNKW	UNKW	—	—	—	UNKW	—	—	—	—	—	—	CAN COMM CIRCUIT (U1000)	—	

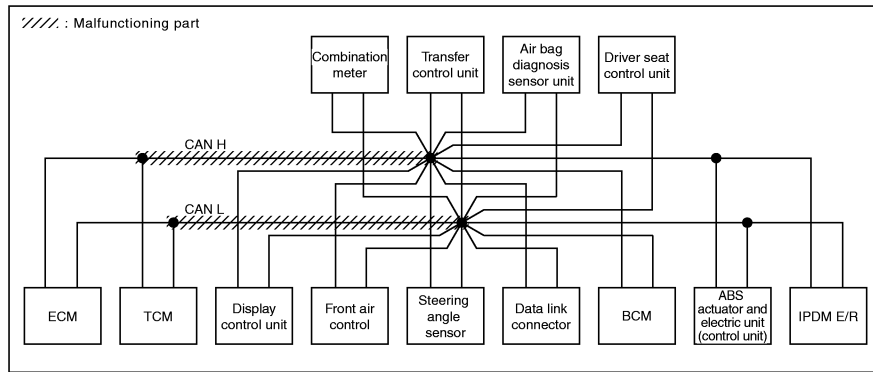

PKIC5984E

NOTE:

There is a case that some of "CAN DIAG SUPPORT MNTR" and "SELF-DIAG RESULTS" are not needed for diagnosis. In the case, "UNKW" and "CAN COMM CIRCUIT [U1000]" in "Check sheet results (example)" change to "—". Then, ignore check marks on the check sheet table.

6. Perform system diagnosis for possible causes identified.
7. Perform diagnosis again after inspection and repair. Make sure that repair is completely performed, and then end the procedure.

Start CAN system trouble diagnosis if this procedure can be confirmed. Refer to [LAN-30, "CAN Communication Unit"](#).

TROUBLE DIAGNOSES WORK FLOW

[CAN]

Example of Filling in Check Sheet When Initial Conditions Are Not Reproduced

Check sheet table

SELECT SYSTEM screen	CAN DIAG SUPPORT MNTR											SELF-DIAG RESULTS	
	Initial diagnosis	Transmit diagnosis	Receive diagnosis										
			ECM	TCM	STRG	BCM /SEC	METER /M&A	AWD/4WD	VDC/TCS /ABS	IPDM E/R			
ENGINE	—	—	UNKWN	—	UNKWN	—	UNKWN	UNKWN	UNKWN	UNKWN	UNKWN	CAN COMM CIRCUIT (U1000)	CAN COMM CIRCUIT (U1001) ✓
A/T	—	NG	UNKWN	UNKWN	—	—	—	UNKWN	UNKWN	UNKWN	—	CAN COMM CIRCUIT (U1000)	—
BCM	No indication	NG	UNKWN	UNKWN	—	—	—	UNKWN	—	—	UNKWN	CAN COMM CIRCUIT (U1000)	—
METER	No indication	—	UNKWN	UNKWN	UNKWN	—	UNKWN	—	—	UNKWN	UNKWN	CAN COMM CIRCUIT (U1000)	—
ALL MODE AWD/4WD	No indication	—	UNKWN	UNKWN	UNKWN	UNKWN	—	—	—	UNKWN	—	CAN COMM CIRCUIT (U1000) ✓	—
ABS	—	NG	UNKWN	UNKWN	UNKWN	UNKWN	—	—	UNKWN	—	—	CAN COMM CIRCUIT (U1000)	—
IPDM E/R	No indication	—	UNKWN	UNKWN	—	—	UNKWN	—	—	—	—	CAN COMM CIRCUIT (U1000) ✓	—

SYSTEM ENGINE

SELF-DIAG RESULTS

DTC RESULTS TIME

CAN COMM CIRCUIT [U1001] 1t

SYSTEM A/T

SELF-DIAG RESULTS

DTC RESULTS

CAN COMM CIRCUIT [U1000]

SYSTEM BCM

SELF-DIAG RESULTS

DTC RESULTS TIME

NO DTC IS DETECTED. FURTHER TESTING MAY BE REQUIRED.

SYSTEM METER

SELF-DIAG RESULTS

DTC RESULTS TIME

CAN COMM CIRCUIT [U1000] 2

SYSTEM ALL MODE AWD/4WD

SELF-DIAG RESULTS

DTC RESULTS TIME

CAN COMM CIRCUIT [U1000] 2

SYSTEM ABS

SELF-DIAG RESULTS

DTC RESULTS TIME

CAN COMM CIRCUIT [U1000] 2

SYSTEM IPDM E/R

SELF-DIAG RESULTS

DTC RESULTS TIME

CAN COMM CIRCUIT [U1000] PAST

PKIC5985E

- See “SELF-DIAG RESULTS” of all units attached to the check sheet. If “CAN COMM CIRCUIT”, “CAN COMM CIRCUIT [U1000]” or “CAN COMM CIRCUIT [U1001]” is displayed, put a check mark to the applicable column of self-diagnostic results of the check sheet table.

NOTE:

- For “ENGINE”, “CAN COMM CIRCUIT [U1001]” is displayed. Put a check mark to it.
- For “A/T”, “CAN COMM CIRCUIT [U1000]” is displayed. Put a check mark to it.
- For “BCM”, “NO DTC IS DETECTED” is displayed. Do not put a check mark to it.
- For “METER”, “CAN COMM CIRCUIT [U1000]” is displayed. Put a check mark to it.
- For “ALL MODE AWD/4WD”, “CAN COMM CIRCUIT [U1000]” is displayed. Put a check mark to it.
- For “ABS”, “CAN COMM CIRCUIT [U1000]” is displayed. Put a check mark to it.
- For “IPDM E/R”, “CAN COMM CIRCUIT [U1000]” is displayed. Put a check mark to it.

TROUBLE DIAGNOSES WORK FLOW

[CAN]

The arranged results of self-diagnosis

Check sheet table

SELECT SYSTEM screen	CAN DIAG SUPPORT MNTR											SELF-DIAG RESULTS			
	Initial diagnosis	Transm diagnosis	Receive diagnosis												
	ECM	TCM	STRG	BCM /SEC	METER /MMA	AWD/WD	VDCTCS /ABS	IPDM E/R	BCM /SEC	METER /MMA	AWD/WD	VDCTCS /ABS	IPDM E/R	CAN COMM CIRCUIT [U1000]	CAN COMM CIRCUIT [U1001]
ENGINE	-	-	UNKWN	-	UNKWN	-	UNKWN	UNKWN	UNKWN	UNKWN	UNKWN	UNKWN	UNKWN	-	-
AT	-	NG	UNKWN	UNKWN	-	-	-	UNKWN	UNKWN	UNKWN	-	-	-	-	-
BCM	-	NG	UNKWN	UNKWN	-	-	-	UNKWN	UNKWN	UNKWN	-	-	-	-	-
METER	-	No indication	UNKWN	UNKWN	UNKWN	-	UNKWN	-	UNKWN	UNKWN	-	-	-	-	-
ALL MODE AWD/WD	-	No indication	UNKWN	UNKWN	UNKWN	UNKWN	-	-	UNKWN	-	-	-	-	-	-
ABS	-	NG	UNKWN	UNKWN	UNKWN	UNKWN	-	-	UNKWN	-	-	-	-	-	-
IPDM E/R	-	No indication	UNKWN	UNKWN	-	-	-	UNKWN	-	-	-	-	-	-	-

When the arranged results of self-diagnosis and check sheet results (example) are corresponding, possible causes can be selected.

Case 1
Check harness between TCM and data link connector.

SELECT SYSTEM screen	CAN DIAG SUPPORT MNTR											SELF-DIAG RESULTS			
	Initial diagnosis	Transm diagnosis	Receive diagnosis												
	ECM	TCM	STRG	BCM /SEC	METER /MMA	AWD/WD	VDCTCS /ABS	IPDM E/R	BCM /SEC	METER /MMA	AWD/WD	VDCTCS /ABS	IPDM E/R	CAN COMM CIRCUIT [U1000]	CAN COMM CIRCUIT [U1001]
ENGINE	-	-	UNKWN	-	UNKWN	-	UNKWN	UNKWN	UNKWN	UNKWN	UNKWN	UNKWN	UNKWN	-	-
AT	-	NG	UNKWN	UNKWN	-	-	-	UNKWN	UNKWN	UNKWN	-	-	-	-	-
BCM	-	NG	UNKWN	UNKWN	-	-	-	UNKWN	UNKWN	UNKWN	-	-	-	-	-
METER	-	No indication	UNKWN	UNKWN	UNKWN	-	UNKWN	-	UNKWN	UNKWN	-	-	-	-	-
ALL MODE AWD/WD	-	No indication	UNKWN	UNKWN	UNKWN	UNKWN	-	-	UNKWN	-	-	-	-	-	-
ABS	-	NG	UNKWN	UNKWN	UNKWN	UNKWN	-	-	UNKWN	-	-	-	-	-	-
IPDM E/R	-	No indication	UNKWN	UNKWN	-	-	-	UNKWN	-	-	-	-	-	-	-

Case 2
Check harness between data link connector and ABS actuator and electric unit (control unit).

SELECT SYSTEM screen	CAN DIAG SUPPORT MNTR											SELF-DIAG RESULTS			
	Initial diagnosis	Transm diagnosis	Receive diagnosis												
	ECM	TCM	STRG	BCM /SEC	METER /MMA	AWD/WD	VDCTCS /ABS	IPDM E/R	BCM /SEC	METER /MMA	AWD/WD	VDCTCS /ABS	IPDM E/R	CAN COMM CIRCUIT [U1000]	CAN COMM CIRCUIT [U1001]
ENGINE	-	-	UNKWN	-	UNKWN	-	UNKWN	UNKWN	UNKWN	UNKWN	UNKWN	UNKWN	UNKWN	-	-
AT	-	NG	UNKWN	UNKWN	-	-	-	UNKWN	UNKWN	UNKWN	-	-	-	-	-
BCM	-	NG	UNKWN	UNKWN	-	-	-	UNKWN	UNKWN	UNKWN	-	-	-	-	-
METER	-	No indication	UNKWN	UNKWN	UNKWN	-	UNKWN	-	UNKWN	UNKWN	-	-	-	-	-
ALL MODE AWD/WD	-	No indication	UNKWN	UNKWN	UNKWN	UNKWN	-	-	UNKWN	-	-	-	-	-	-
ABS	-	NG	UNKWN	UNKWN	UNKWN	UNKWN	-	-	UNKWN	-	-	-	-	-	-
IPDM E/R	-	No indication	UNKWN	UNKWN	-	-	-	UNKWN	-	-	-	-	-	-	-

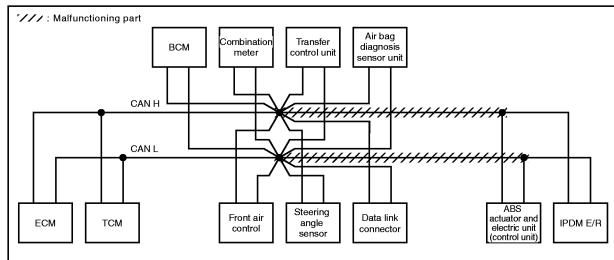
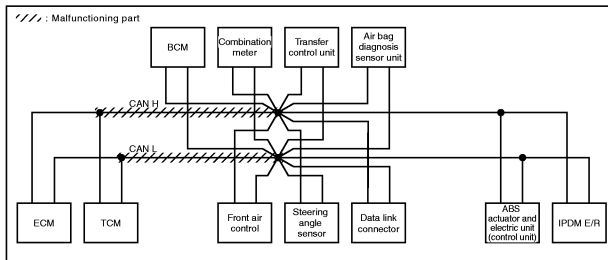

NOTE:

There is a case that some of "CAN DIAG SUPPORT MNTR" and "SELF-DIAG RESULTS" are not needed for diagnosis. In the case, "UNKWN" and "CAN COMM CIRCUIT [U1000]" in "Check sheet results (example)" change to "-". Then, ignore check marks on the check sheet table.

2. For the selected possible causes, it is expected that malfunctions have been found in the past.

TROUBLE DIAGNOSES WORK FLOW

[CAN]

UKS003GJ

CAN Diagnostic Support Monitor

DESCRIPTION OF "CAN DIAG SUPPORT MNTR" SCREEN FOR ECM

(Example)	CAN DIAG SUPPORT MNTR	CAN DIAG SUPPORT MNTR																																																																													
	<table border="1" style="width: 100%; border-collapse: collapse;"> <tr><th colspan="3">ENGINE</th></tr> <tr><td></td><td style="text-align: center;">PRSNT</td><td style="text-align: center;">PAST</td></tr> <tr><td>TRANSMIT DIAG</td><td style="text-align: center;">OK</td><td style="text-align: center;">OK</td></tr> <tr><td>VDC/TCS/ABS</td><td style="text-align: center;">OK</td><td style="text-align: center;">OK</td></tr> <tr><td>METER/M&A</td><td style="text-align: center;">OK</td><td style="text-align: center;">OK</td></tr> <tr><td>BCM/SEC</td><td style="text-align: center;">OK</td><td style="text-align: center;">OK</td></tr> <tr><td>ICC</td><td style="text-align: center;">-</td><td style="text-align: center;">-</td></tr> <tr><td>HVAC</td><td style="text-align: center;">-</td><td style="text-align: center;">-</td></tr> <tr><td>TCM</td><td style="text-align: center;">OK</td><td style="text-align: center;">OK</td></tr> <tr><td>EPS</td><td style="text-align: center;">-</td><td style="text-align: center;">-</td></tr> <tr><td>IPDM E/R</td><td style="text-align: center;">OK</td><td style="text-align: center;">OK</td></tr> <tr><td>PRINT</td><td></td><td style="text-align: center;">Scroll Down</td></tr> <tr><td>MODE</td><td>BACK</td><td>LIGHT COPY</td></tr> </table>	ENGINE				PRSNT	PAST	TRANSMIT DIAG	OK	OK	VDC/TCS/ABS	OK	OK	METER/M&A	OK	OK	BCM/SEC	OK	OK	ICC	-	-	HVAC	-	-	TCM	OK	OK	EPS	-	-	IPDM E/R	OK	OK	PRINT		Scroll Down	MODE	BACK	LIGHT COPY	<table border="1" style="width: 100%; border-collapse: collapse;"> <tr><th colspan="3">ENGINE</th></tr> <tr><td></td><td style="text-align: center;">PRSNT</td><td style="text-align: center;">PAST</td></tr> <tr><td>METER/M&A</td><td style="text-align: center;">OK</td><td style="text-align: center;">OK</td></tr> <tr><td>BCM/SEC</td><td style="text-align: center;">OK</td><td style="text-align: center;">OK</td></tr> <tr><td>ICC</td><td style="text-align: center;">-</td><td style="text-align: center;">-</td></tr> <tr><td>HVAC</td><td style="text-align: center;">-</td><td style="text-align: center;">-</td></tr> <tr><td>TCM</td><td style="text-align: center;">OK</td><td style="text-align: center;">OK</td></tr> <tr><td>EPS</td><td style="text-align: center;">-</td><td style="text-align: center;">-</td></tr> <tr><td>IPDM E/R</td><td style="text-align: center;">OK</td><td style="text-align: center;">OK</td></tr> <tr><td>e4WD</td><td style="text-align: center;">-</td><td style="text-align: center;">-</td></tr> <tr><td>AWD/4WD</td><td style="text-align: center;">OK</td><td style="text-align: center;">OK</td></tr> <tr><td>PRINT</td><td></td><td style="text-align: center;">Scroll Up</td></tr> <tr><td>MODE</td><td>BACK</td><td>LIGHT COPY</td></tr> </table>	ENGINE				PRSNT	PAST	METER/M&A	OK	OK	BCM/SEC	OK	OK	ICC	-	-	HVAC	-	-	TCM	OK	OK	EPS	-	-	IPDM E/R	OK	OK	e4WD	-	-	AWD/4WD	OK	OK	PRINT		Scroll Up	MODE	BACK
ENGINE																																																																															
	PRSNT	PAST																																																																													
TRANSMIT DIAG	OK	OK																																																																													
VDC/TCS/ABS	OK	OK																																																																													
METER/M&A	OK	OK																																																																													
BCM/SEC	OK	OK																																																																													
ICC	-	-																																																																													
HVAC	-	-																																																																													
TCM	OK	OK																																																																													
EPS	-	-																																																																													
IPDM E/R	OK	OK																																																																													
PRINT		Scroll Down																																																																													
MODE	BACK	LIGHT COPY																																																																													
ENGINE																																																																															
	PRSNT	PAST																																																																													
METER/M&A	OK	OK																																																																													
BCM/SEC	OK	OK																																																																													
ICC	-	-																																																																													
HVAC	-	-																																																																													
TCM	OK	OK																																																																													
EPS	-	-																																																																													
IPDM E/R	OK	OK																																																																													
e4WD	-	-																																																																													
AWD/4WD	OK	OK																																																																													
PRINT		Scroll Up																																																																													
MODE	BACK	LIGHT COPY																																																																													

PKIC5987E

"SELECT SYSTEM" screen	"CAN DIAG SUPPORT MNTR" screen	Description	Present	Past
ENGINE	TRANSMIT DIAG	Make sure of normal transmission.	OK/UNKWN/-	OK/0/1 - 39/-
	VDC/TCS/ABS	Make sure of normal reception from ABS actuator and electric unit (control unit).	OK/UNKWN/-	
	METER/M&A	Make sure of normal reception from combination meter.	OK/UNKWN/-	
	BCM/SEC	Make sure of normal reception from BCM.	OK/UNKWN/-	
	ICC	ICC is not diagnosed.	-	
	HVAC	HVAC is not diagnosed.	-	
	TCM	Make sure of normal reception from TCM.	OK/UNKWN/-	
	EPS	EPS is not diagnosed.	-	
	IPDM E/R	Make sure of normal reception from IPDM E/R.	OK/UNKWN/-	
	e4WD	e4WD is not diagnosed.	-	
	AWD/4WD	Make sure of normal reception from transfer control unit.	OK/UNKWN/-	

Display Results (Present)

- OK: Normal
- UNKWN: The diagnosed unit does not transmit or receive the applicable data normally.
- -: There is no received unit or the unit is not in the condition that reception diagnosis is performed.

Display Results (Past)

- OK: Normal
- 0: There is malfunction now.
- 1 - 39: Displays when it is normal at present and finds malfunction in the past. It increases like 0→1→2...38→39 after returning to the normal condition whenever IGN OFF→ON. If it is over 39, it is fixed to 39 until the self-diagnostic results are erased. It returns to 0 when malfunction is detected again in the process.
- -: Undiagnosed

TROUBLE DIAGNOSES WORK FLOW

[CAN]

DESCRIPTION OF “CAN DIAG SUPPORT MNTR” SCREEN FOR TCM

(Example)

CAN DIAG SUPPORT MNTR			
A/T			
		PRSENT	
INITIAL DIAG		OK	
TRANSMIT DIAG		OK	
ECM		OK	
VDC/TCS/ABS		OK	
METER/M&A		OK	
ICC/e4WD		UNKWVN	
AWD/4WD		OK	
PRINT			
MODE	BACK	LIGHT	COPY

SKIB2335E

“SELECT SYSTEM” screen	“CAN DIAG SUPPORT MNTR” screen	Description	Present
A/T	INITIAL DIAG	Make sure that microcomputer in ECU works normally.	OK/NG
	TRANSMIT DIAG	Make sure of normal transmission.	OK/UNKWVN
	ECM	Make sure of normal reception from ECM.	OK/UNKWVN
	VDC/TCS/ABS	Make sure of normal reception from ABS actuator and electric unit (control unit).	OK/UNKWVN
	METER/M&A	Make sure of normal reception from combination meter.	OK/UNKWVN
	ICC/e4WD	ICC/e4WD is not diagnosed.	UNKWVN
	AWD/4WD	Make sure of normal reception from transfer control unit.	OK/UNKWVN

Display Results (Present)

- OK: Normal
- NG: Malfunction
- UNKWVN: The diagnosed unit does not transmit or receive the applicable data normally.

DESCRIPTION OF “CAN DIAG SUPPORT MNTR” SCREEN FOR BCM

(Example)

CAN DIAG SUPPORT MNTR			
BCM			
		PRSENT	
INITIAL DIAG		OK	
TRANSMIT DIAG		OK	
ECM		OK	
IPDM E/R		OK	
METER/M&A		OK	
I-KEY		OK	
PRINT			
MODE	BACK	LIGHT	COPY

SKIB1625E

“SELECT SYSTEM” screen	“CAN DIAG SUPPORT MNTR” screen	Description	Present
BCM	INITIAL DIAG	Make sure that microcomputer in ECU works normally.	OK/NG
	TRANSMIT DIAG	Make sure of normal transmission.	OK/UNKWVN
	ECM	Make sure of normal reception from ECM.	OK/UNKWVN
	IPDM E/R	Make sure of normal reception from IPDM E/R.	OK/UNKWVN
	METER/M&A	Make sure of normal reception from combination meter.	OK/UNKWVN
	I-KEY	I-KEY is not diagnosed.	OK

Display Results (Present)

- OK: Normal
- NG: Malfunction
- UNKWVN: The diagnosed unit does not transmit or receive the applicable data normally.

TROUBLE DIAGNOSES WORK FLOW

[CAN]

DESCRIPTION OF "CAN DIAG SUPPORT MNTR" SCREEN FOR METER

(Example)

<table border="1" style="width: 100%; border-collapse: collapse;"> <tr><th colspan="4">CAN DIAG SUPPORT MNTR</th></tr> <tr><th colspan="4">METER</th></tr> <tr><td></td><th>PRSN</th><th colspan="2">PAST</th></tr> <tr><td>TRANSMIT DIAG</td><td>OK</td><td colspan="2">OK</td></tr> <tr><td>ECM</td><td>OK</td><td colspan="2">OK</td></tr> <tr><td>TCM</td><td>OK</td><td colspan="2">OK</td></tr> <tr><td>BCM/SEC</td><td>OK</td><td colspan="2">OK</td></tr> <tr><td>VDC/TCS/ABS</td><td>OK</td><td colspan="2">OK</td></tr> <tr><td>IPDM E/R</td><td>OK</td><td colspan="2">OK</td></tr> <tr><td>DISPLAY</td><td>-</td><td colspan="2">-</td></tr> <tr><td>I-KEY</td><td>-</td><td colspan="2">-</td></tr> <tr><td>EPS</td><td>-</td><td colspan="2">-</td></tr> <tr><td>PRINT</td><td></td><td colspan="2">Scroll Down</td></tr> <tr><td>MODE</td><td>BACK</td><td>LIGHT</td><td>COPY</td></tr> </table>	CAN DIAG SUPPORT MNTR				METER					PRSN	PAST		TRANSMIT DIAG	OK	OK		ECM	OK	OK		TCM	OK	OK		BCM/SEC	OK	OK		VDC/TCS/ABS	OK	OK		IPDM E/R	OK	OK		DISPLAY	-	-		I-KEY	-	-		EPS	-	-		PRINT		Scroll Down		MODE	BACK	LIGHT	COPY	<table border="1" style="width: 100%; border-collapse: collapse;"> <tr><th colspan="4">CAN DIAG SUPPORT MNTR</th></tr> <tr><th colspan="4">METER</th></tr> <tr><td></td><th>PRSN</th><th colspan="2">PAST</th></tr> <tr><td>IPDM E/R</td><td>OK</td><td colspan="2">OK</td></tr> <tr><td>DISPLAY</td><td>-</td><td colspan="2">-</td></tr> <tr><td>I-KEY</td><td>-</td><td colspan="2">-</td></tr> <tr><td>EPS</td><td>-</td><td colspan="2">-</td></tr> <tr><td>AWD/4WD</td><td>-</td><td colspan="2">-</td></tr> <tr><td>e4WD</td><td>-</td><td colspan="2">-</td></tr> <tr><td>ICC</td><td>-</td><td colspan="2">-</td></tr> <tr><td>LANE KEEP</td><td>-</td><td colspan="2">-</td></tr> <tr><td>TIRE-P</td><td>-</td><td colspan="2">-</td></tr> <tr><td>PRINT</td><td></td><td colspan="2">Scroll Up</td></tr> <tr><td>MODE</td><td>BACK</td><td>LIGHT</td><td>COPY</td></tr> </table>	CAN DIAG SUPPORT MNTR				METER					PRSN	PAST		IPDM E/R	OK	OK		DISPLAY	-	-		I-KEY	-	-		EPS	-	-		AWD/4WD	-	-		e4WD	-	-		ICC	-	-		LANE KEEP	-	-		TIRE-P	-	-		PRINT		Scroll Up		MODE	BACK	LIGHT	COPY
CAN DIAG SUPPORT MNTR																																																																																																																	
METER																																																																																																																	
	PRSN	PAST																																																																																																															
TRANSMIT DIAG	OK	OK																																																																																																															
ECM	OK	OK																																																																																																															
TCM	OK	OK																																																																																																															
BCM/SEC	OK	OK																																																																																																															
VDC/TCS/ABS	OK	OK																																																																																																															
IPDM E/R	OK	OK																																																																																																															
DISPLAY	-	-																																																																																																															
I-KEY	-	-																																																																																																															
EPS	-	-																																																																																																															
PRINT		Scroll Down																																																																																																															
MODE	BACK	LIGHT	COPY																																																																																																														
CAN DIAG SUPPORT MNTR																																																																																																																	
METER																																																																																																																	
	PRSN	PAST																																																																																																															
IPDM E/R	OK	OK																																																																																																															
DISPLAY	-	-																																																																																																															
I-KEY	-	-																																																																																																															
EPS	-	-																																																																																																															
AWD/4WD	-	-																																																																																																															
e4WD	-	-																																																																																																															
ICC	-	-																																																																																																															
LANE KEEP	-	-																																																																																																															
TIRE-P	-	-																																																																																																															
PRINT		Scroll Up																																																																																																															
MODE	BACK	LIGHT	COPY																																																																																																														

PKIC6816E

"SELECT SYSTEM" screen	"CAN DIAG SUPPORT MNTR" screen	Description	Present	Past
METER	TRANSMIT DIAG	Make sure of normal transmission.	OK/UNKWN/-	OK/0/1 - 39/-
	ECM	Make sure of normal reception from ECM.	OK/UNKWN/-	
	TCM	Make sure of normal reception from TCM.	OK/UNKWN/-	
	BCM/SEC	Make sure of normal reception from BCM.	OK/UNKWN/-	
	VDC/TCS/ABS	Make sure of normal reception from ABS actuator and electric unit (control unit).	OK/UNKWN/-	
	IPDM E/R	Make sure of normal reception from IPDM E/R.	OK/UNKWN/-	
	DISPLAY	DISPLAY is not diagnosed.	-	
	I-KEY	I-KEY is not diagnosed.	-	
	EPS	EPS is not diagnosed.	-	
	AWD/4WD	AWD/4WD is not diagnosed.	-	
	e4WD	e4WD is not diagnosed.	-	
	ICC	ICC is not diagnosed.	-	
	LANE KEEP	LANE KEEP is not diagnosed.	-	
TIRE-P	TIRE-P is not diagnosed.	-		

Display Results (Present)

- OK: Normal
- UNKWN: The diagnosed unit does not transmit or receive the applicable data normally.
- -: There is no received unit or the unit is not in the condition that reception diagnosis is performed.

Display Results (Past)

- OK: Normal
- 0: There is malfunction now.
- 1 - 39: Displays when it finds malfunction in the past even if it is normal or there is a malfunction at present. Also, displays when diagnosis is not performed. It increase like 0→1→2...38→39 after returning to the normal condition whenever IGN OFF→ON. If it is over 39, it is fixed to 39 until the self-diagnostic results are erased. Keep this condition until resetting it.
- -: Undiagnosed

TROUBLE DIAGNOSES WORK FLOW

[CAN]

DESCRIPTION OF “CAN DIAG SUPPORT MNTR” SCREEN FOR TRANSFER CONTROL UNIT

All-mode 4WD model

(Example)

CAN DIAG SUPPORT MNTR			
ALL MODE AWD/4WD			
	PRSNT	PAST	
TRANSMIT DIAG	OK	OK	
ECM	OK	OK	
VDC/TCS/ABS	OK	OK	
TCM	OK	OK	
STRG	OK	OK	
PRINT			
MODE	BACK	LIGHT	COPY

PKIB5220E

“SELECT SYSTEM” screen	“CAN DIAG SUPPORT MNTR” screen	Description	Present	Past
ALL MODE AWD/4WD	TRANSMIT DIAG	Make sure of normal transmission.	OK/UNKWN/-	OK/0/1 - 39/-
	ECM	Make sure of normal reception from ECM.	OK/UNKWN/-	
	VDC/TCS/ABS	Make sure of normal reception from ABS actuator and electric unit (control unit).	OK/UNKWN/-	
	TCM	Make sure of normal reception from TCM.	OK/UNKWN/-	
	STRG	Make sure of normal reception from steering angle sensor.	OK/UNKWN/-	

Display Results (Present)

- OK: Normal
- UNKWN: The diagnosed unit does not transmit or receive the applicable data normally.

CAUTION:

“UNKWN” is indicated by erasing the self-diagnosis result when any malfunction was detected in past.

- -: There is no received unit or the unit is not in the condition that reception diagnosis is performed.

Display Results (Past)

- OK: Normal
- 0: There is malfunction now.
- 1 - 39: Displays when it is normal at present and finds malfunction in the past. It increases like 0→1→2...38→39 after returning to the normal condition whenever IGN OFF→ON. If it is over 39, it is fixed to 39 until the self-diagnostic results are erased. It returns to 0 when malfunction is detected again in the process.
- -: Undiagnosed

CAUTION:

- “UNKWN” is indicated in “Present” and “0” is indicated in “Past” when any malfunction is detected at present.
- “UNKWN” is indicated in “Present” and “1 - 39” is indicated in “Past” when any malfunction was detected in past.

(Example)

CAN DIAG SUPPORT MNTR			
ALL MODE AWD/4WD			
	PRSNT	PAST	
TRANSMIT DIAG	OK	OK	
ECM	UNKWN	0	
VDC/TCS/ABS	UNKWN	39	
TCM	UNKWN	0	
STRG	OK	OK	
PRINT			
MODE	BACK	LIGHT	COPY

SKIB3246E

TROUBLE DIAGNOSES WORK FLOW

[CAN]

Part time 4WD model

(Example)

CAN DIAG SUPPORT MNTR			
ALL MODE AWD/4WD			
	PRSNT		
INITIAL DIAG	OK		
TRANSMIT DIAG	OK		
ECM	OK		
VDC/TCS/ABS	OK		
TCM	OK		
METER/M&A	OK		
PRINT			
MODE	BACK	LIGHT	COPY

PKIC2594E

“SELECT SYSTEM” screen	“CAN DIAG SUPPORT MNTR” screen	Description	Present
ALL MODE AWD/ 4WD	INITIAL DIAG	Make sure that microcomputer in ECU works normally.	OK/NG
	TRANSMIT DIAG	Make sure of normal transmission.	OK/UNKWN
	ECM	Make sure of normal reception from ECM.	OK/UNKWN
	VDC/TCS/ABS	Make sure of normal reception from ABS actuator and electric unit (control unit).	OK/UNKWN
	TCM	Make sure of normal reception from TCM.	OK/UNKWN
	METER/M&A	Make sure of normal reception from combination meter.	OK/UNKWN

Display Results (Present)

- OK: Normal
- NG: Malfunction
- UNKWN: The diagnosed unit does not transmit or receive the applicable data normally.

TROUBLE DIAGNOSES WORK FLOW

[CAN]

DESCRIPTION OF “CAN DIAG SUPPORT MNTR” SCREEN FOR ABS ACTUATOR AND ELECTRIC UNIT (CONTROL UNIT)

(Example)

CAN DIAG SUPPORT MNTR			
ABS			
		PRSNT	
INITIAL DIAG		OK	
TRANSMIT DIAG		OK	
ECM		OK	
TCM		OK	
METER/M&A		UNKWVN	
STRG		OK	
ICC		UNKWVN	
AWD/4WD		OK	
PRINT			
MODE	BACK	LIGHT	COPY

PKIB6078E

“SELECT SYSTEM” screen	“CAN DIAG SUPPORT MNTR” screen	Description	Present
ABS	INITIAL DIAG	Make sure that microcomputer in ECU works normally.	OK/NG
	TRANSMIT DIAG	Make sure of normal transmission.	OK/UNKWVN
	ECM	Make sure of normal reception from ECM.	OK/UNKWVN
	TCM	Make sure of normal reception from TCM.	OK/UNKWVN
	METER/M&A	METER/M&A is not diagnosed.	UNKWVN
	STRG	Make sure of normal reception from steering angle sensor.	OK/UNKWVN
	ICC	ICC is not diagnosed.	UNKWVN
	AWD/4WD	Make sure of normal reception from transfer control unit.	OK/UNKWVN

Display Results (Present)

- OK: Normal
- NG: Malfunction
- UNKWVN: The diagnosed unit does not transmit or receive the applicable data normally.

TROUBLE DIAGNOSES WORK FLOW

[CAN]

DESCRIPTION OF “CAN DIAG SUPPORT MNTR” SCREEN FOR DISPLAY CONTROL UNIT

(Example)

CAN DIAG SUPPORT MONITOR			
CAN_COMM	OK	0	Delete
CAN_CIRC_1	OK	0	
CAN_CIRC_2	OK	0	
CAN_CIRC_3	OK	0	
CAN_CIRC_4	OK	0	
CAN_CIRC_5	OK	0	
CAN_CIRC_6	UNKWN	1	
CAN_CIRC_7	OK	0	
CAN_CIRC_8	UNKWN	1	
CAN_CIRC_9	UNKWN	1	

PKIC6981E

Unit name	Diagnosis item	Description	“CAN DIAG SUPPORT MONITOR” screen	Error counter (Reference)
Display control unit	CAN COMM	Make sure that microcomputer in ECU works normally.	OK/NG	0/1 – 50
	CAN CIRC 1	Make sure of normal transmission.	OK/UNKWN	
	CAN CIRC 2	Make sure of normal reception from BCM.	OK/UNKWN	
	CAN CIRC 3	Make sure of normal reception from ECM.	OK/UNKWN	
	CAN CIRC 4	Make sure of normal reception from front air control.	OK/UNKWN	
	CAN CIRC 5	Make sure of normal reception from combination meter.	OK/UNKWN	
	CAN CIRC 6	CAN CIRC 6 is not diagnosed.	UNKWN	
	CAN CIRC 7	Make sure of normal reception from IPDM E/R.	OK/UNKWN	
	CAN CIRC 8	CAN CIRC 8 is not diagnosed.	UNKWN	
	CAN CIRC 9	CAN CIRC 9 is not diagnosed.	UNKWN	

Display Results (Present)

- OK: Normal
- NG: Malfunction
- UNKWN: The diagnosed unit does not transmit or receive the applicable data normally.
- -: There is no received unit or the unit is not in the condition that reception diagnosis is performed.

Display Results: Error Counter (Reference)

- 0: It is normal now.
- 1 – 50: Displays when it finds malfunction in the past even if it is normal or there is a malfunction at present. Also, displays when diagnosis is not performed. It increase like 0→1→2...49→50 after returning to the normal condition whenever IGN OFF→ON. If it is over 50, it is fixed to 50 until the self-diagnostic results are erased. Keep this condition until resetting it.

CAN COMMUNICATION

System Description

CAN (Controller Area Network) is a serial communication line for real time application. It is an on-vehicle multiplex communication line with high data communication speed and excellent error detection ability. Many electronic control units are equipped onto a vehicle, and each control unit shares information and links with other control units during operation (not independent). In CAN communication, control units are connected with 2 communication lines (CAN H line, CAN L line) allowing a high rate of information transmission with less wiring. Each control unit transmits/receives data but selectively reads required data only.

Component Parts and Harness Connector Location

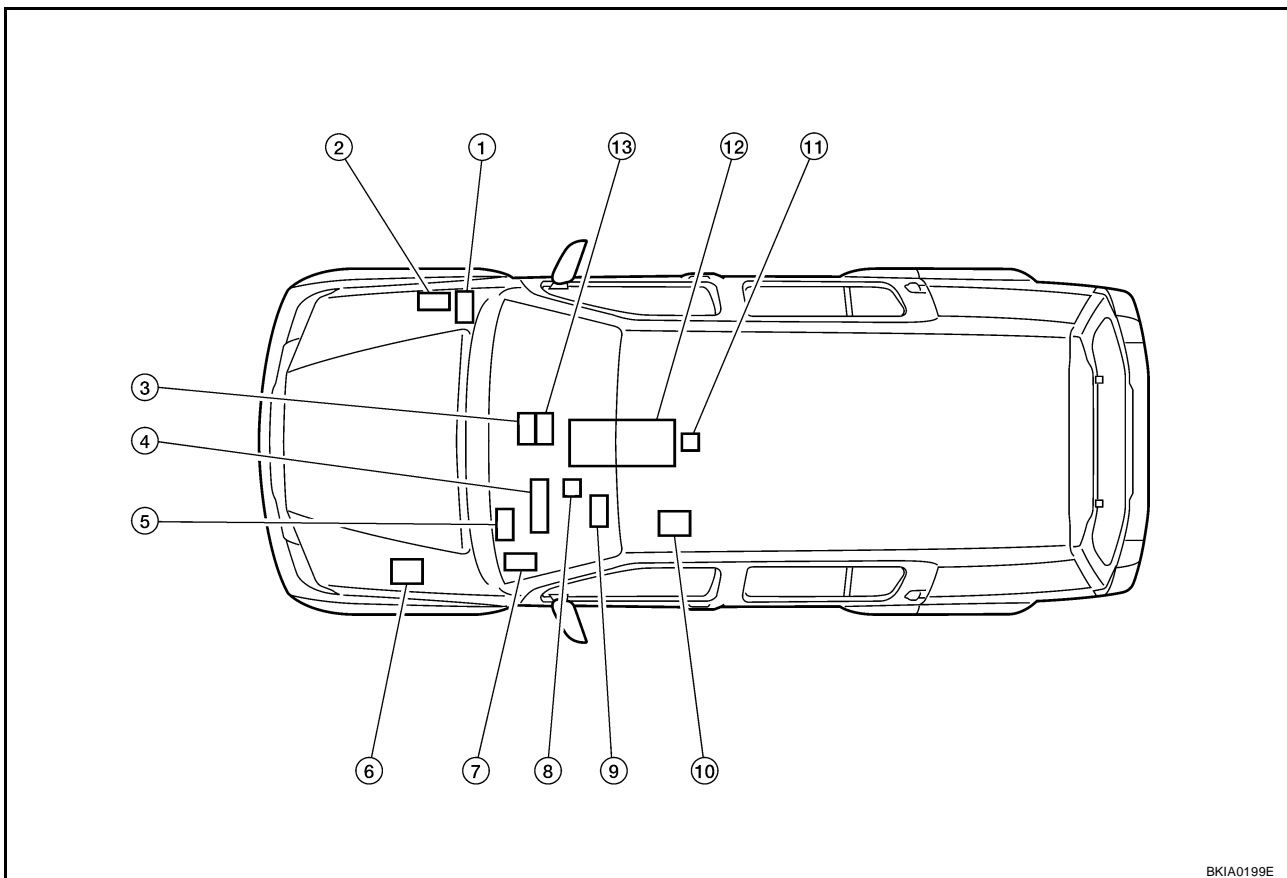

- | | | |
|---|---------------------------------------|---|
| 1. IPDM E/R E122 | 2. ECM E16 | 3. Display control unit M95 (with NAVI) |
| 4. Combination meter M24 | 5. BCM M18 | 6. ABS actuator and electric unit (control unit) E125 |
| 7. Transfer control unit M152 (with 4-wheel drive) | 8. Data link connector M22 | 9. Steering angle sensor M47 |
| 10. Driver seat control unit P2 (with automatic drive positioner) | 11. Air bag diagnosis sensor unit M35 | 12. A/T assembly F9 |
| 13. Front air control M50 (with auto A/C) | | |

BKIA0199E

A
B
C
D
E
F
G
H
I
J
LAN
L
M

Schematic

- (4W) : WITH 4-WHEEL DRIVE
 - (AA) : WITH AUTO A/C
 - (AD) : WITH AUTOMATIC DRIVE POSITIONER
 - (AM) : ALL-MODE 4WD SYSTEM
 - (NV) : WITH NAVI
 - (PT) : PART TIME 4WD SYSTEM
 - (AM) : 7
 - (PT) : 1
 - (AM) : 8
 - (PT) : 2
- *1
- *2

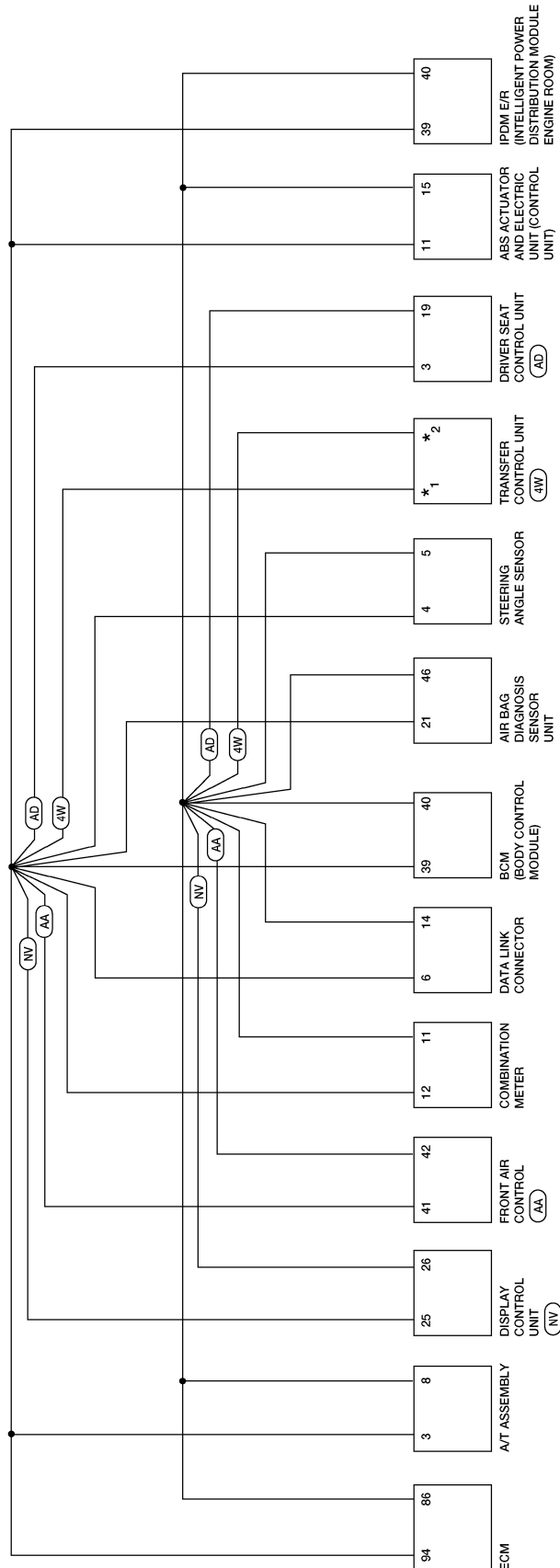

CAN COMMUNICATION

[CAN]

Wiring Diagram — CAN —

UKS0051V

LAN-CAN-01

▬ : DATA LINE

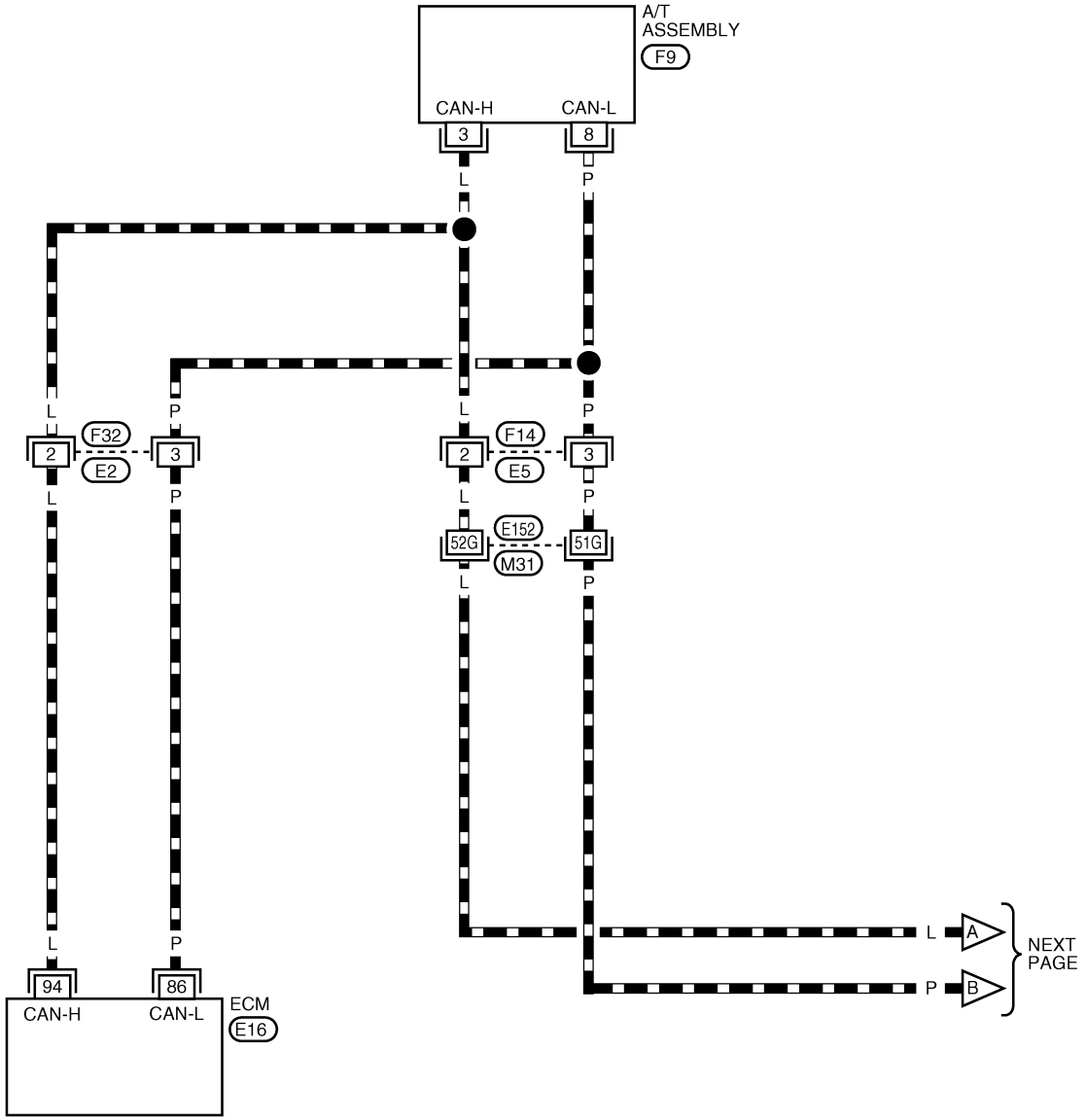

A
B
C
D
E
F
G
H
I
J
K
L
M

LAN

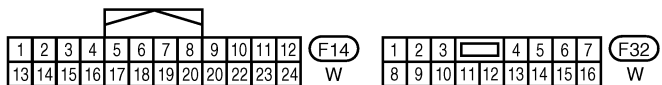
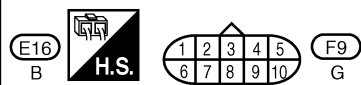
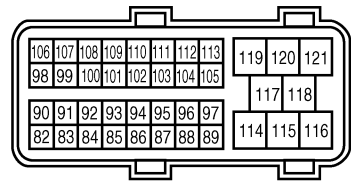

REFER TO THE FOLLOWING.

(M31) - SUPER MULTIPLE JUNCTION (SMJ)

BKWA0660E

CAN COMMUNICATION

[CAN]

LAN-CAN-02

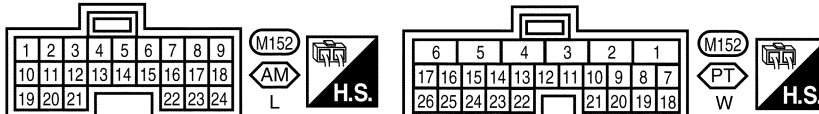
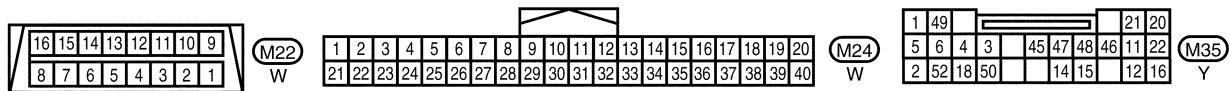
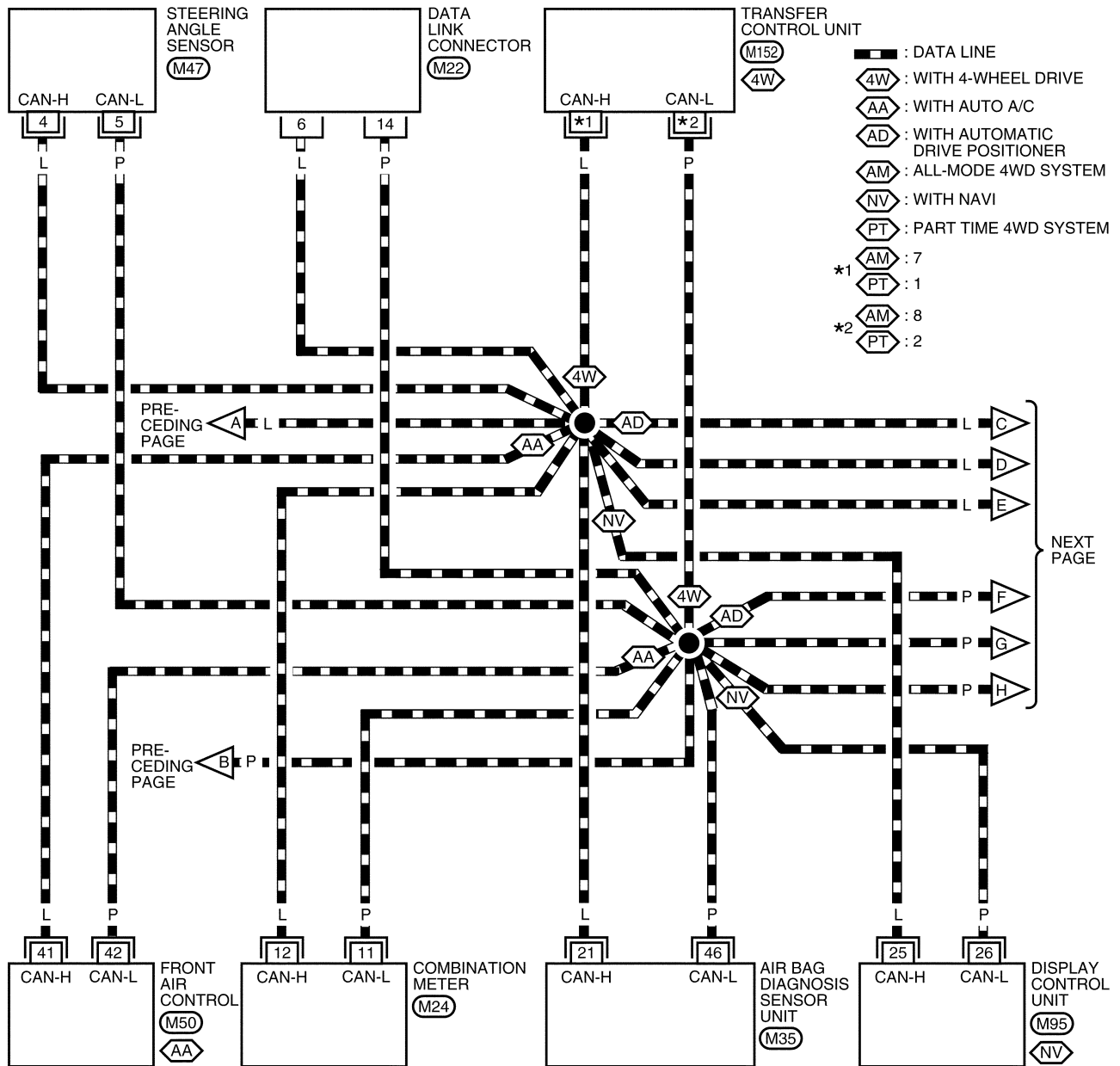

BKWA0661E

CAN COMMUNICATION

[CAN]

LAN-CAN-03

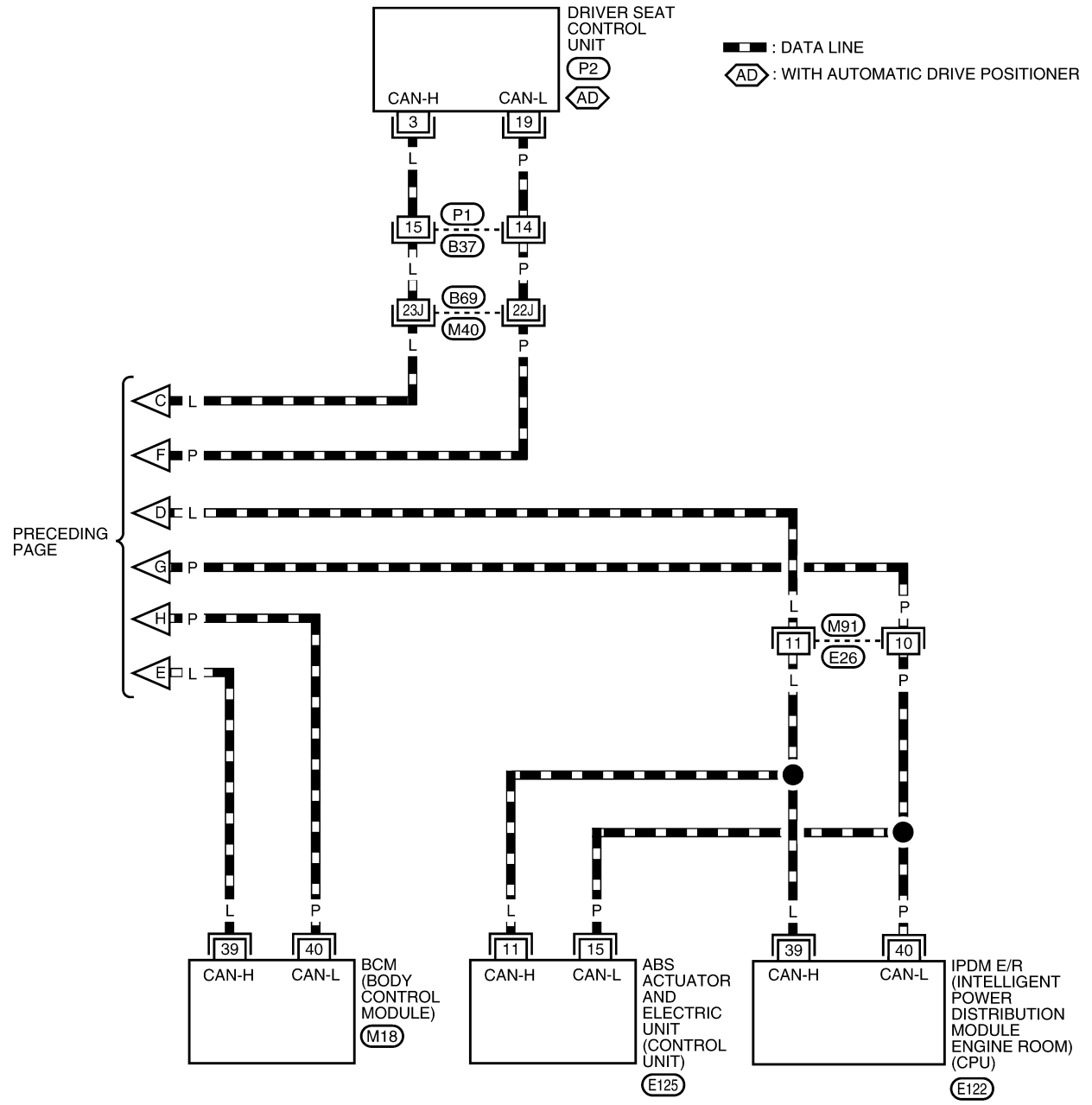

A
B
C
D
E
F
G
H
I
J
LAN
L
M

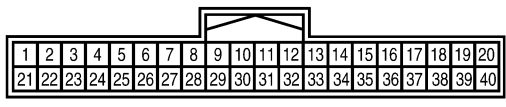

REFER TO THE FOLLOWING.
 (M40) - SUPER MULTIPLE JUNCTION (SMJ)

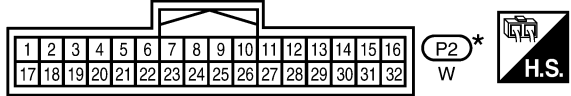
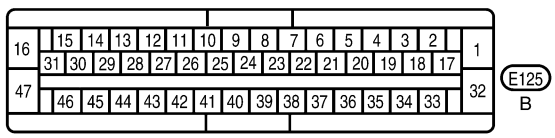
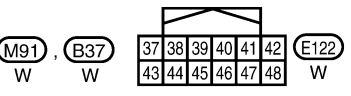
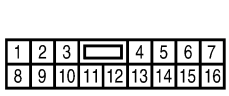

* : THIS CONNECTOR IS NOT SHOWN IN "HARNESS LAYOUT" OF PG SECTION.

BKWA0662E

CAN Communication Unit

Go to CAN system, when selecting your CAN system type from the following table.

Body type	Wagon									
Axle	2WD			4WD(Part time)			4WD(All-mode)			
Engine	VQ40DE									
Transmission	A/T									
Brake control	VDC									
Automatic air conditioner		×	×	×		×		×	×	×
Automatic drive positioner			×	×					×	×
Navigation system				×						×
CAN system type	1	2	3	4	5	6	7	8	9	10
CAN system trouble diagnosis	LAN-41	LAN-55	LAN-69	LAN-84	LAN-101	LAN-116	LAN-131	LAN-146	LAN-161	LAN-177

×: Applicable

NOTE:

Confirming the presence of the following items helps to identify CAN system type.

- With All-mode 4WD

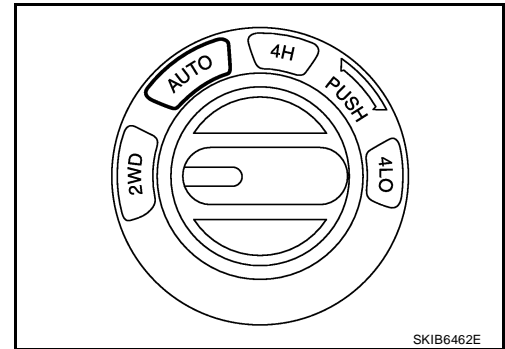

- With automatic air conditioner

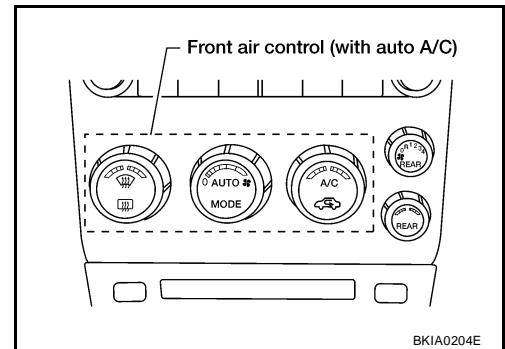

- With automatic drive positioner

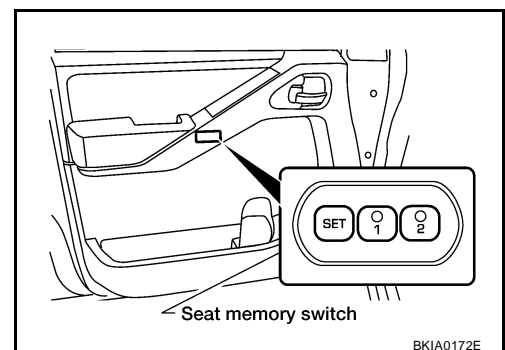

CAN COMMUNICATION

[CAN]

- With navigation system

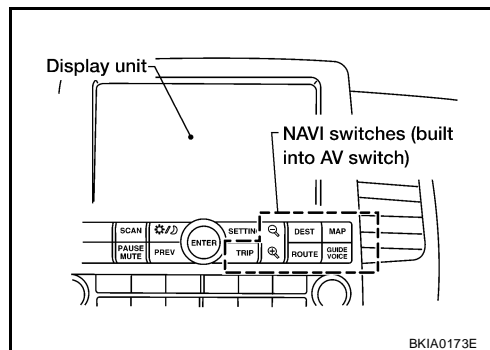

TYPE 1/TYPE 2/TYPE 3/TYPE 4

System diagram

- Type 1

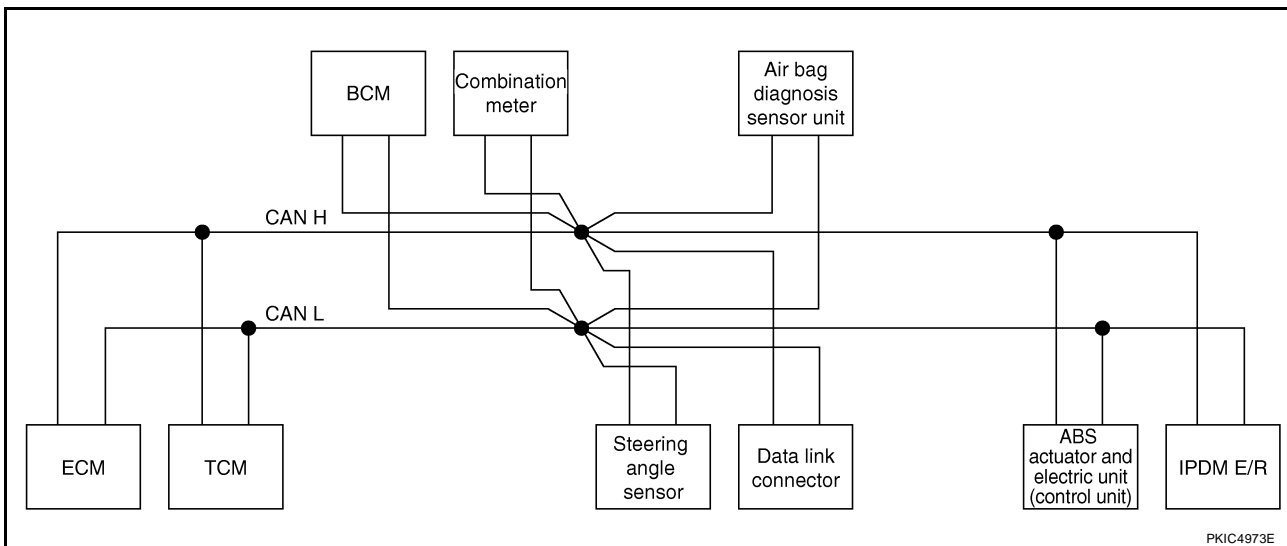

- Type 2

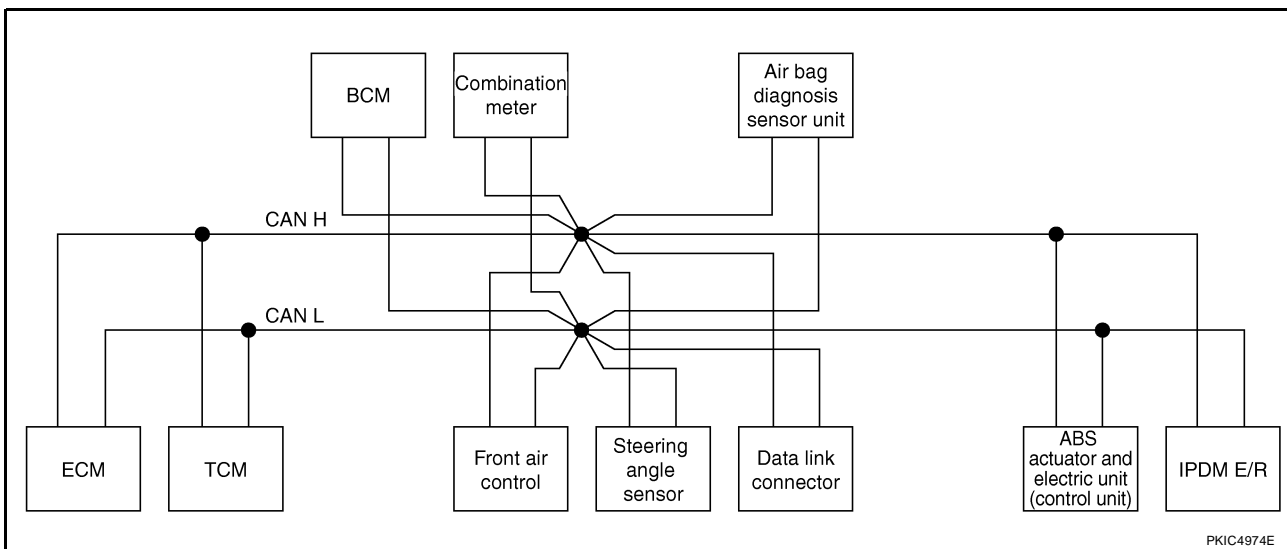

A
B
C
D
E
F
G
H
I
J
LAN
L
M

CAN COMMUNICATION

[CAN]

● Type 3

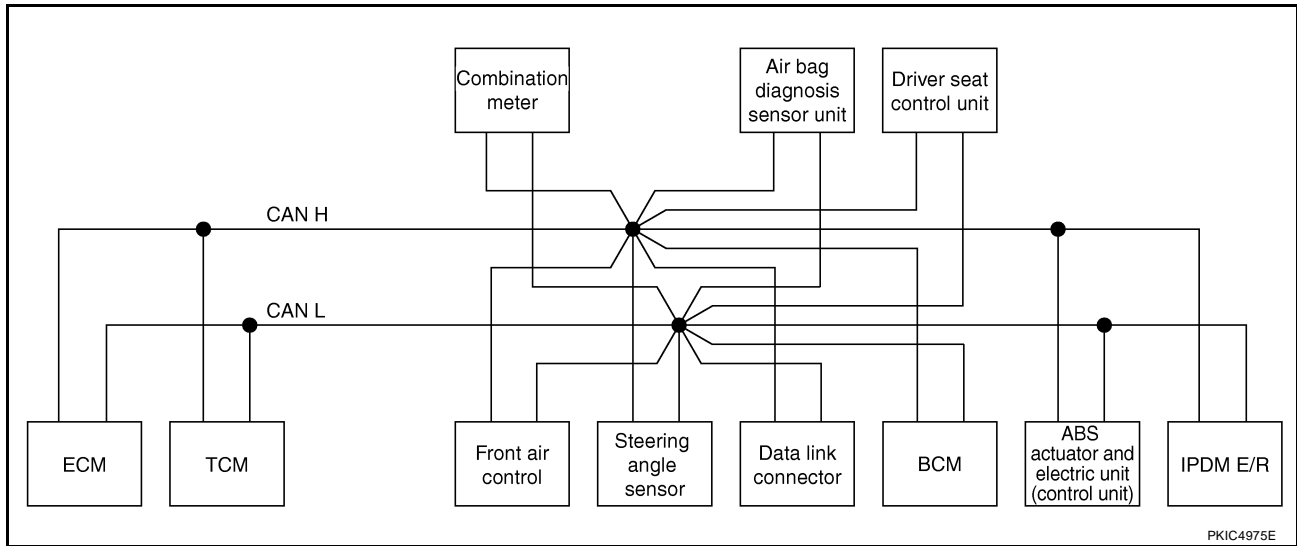

PKIC4975E

● Type 4

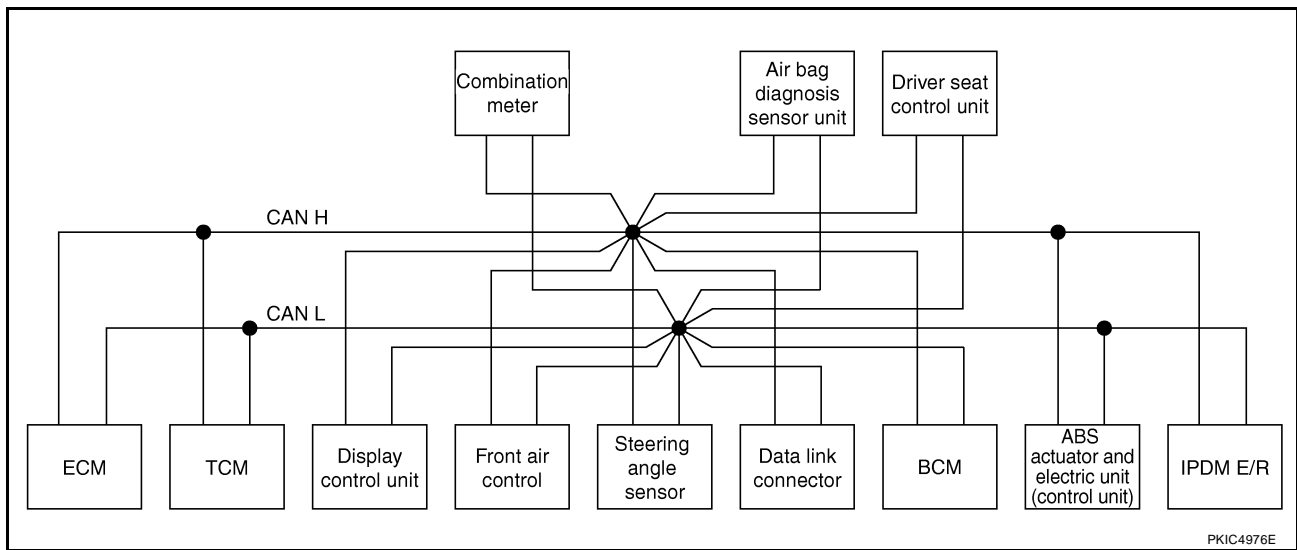

PKIC4976E

Input/output signal chart

T: Transmit R: Receive

Signals	ECM	TCM	Display control unit ^{*1}	Front air control ^{*2}	Steering angle sensor	BCM	Combination meter	Driver seat control unit ^{*3}	ABS actuator and electric unit (control unit)	IPDM E/R
A/C compressor request signal	T									R
Accelerator pedal position signal	T	R							R	
ASCD CRUISE lamp signal	T						R			
ASCD OD cancel request	T	R								
ASCD operation signal	T	R								
ASCD SET lamp signal	T						R			
Battery voltage signal	T	R								
Closed throttle position signal	T	R								
Cooling fan speed request signal	T									R

CAN COMMUNICATION

[CAN]

Signals	ECM	TCM	Display control unit*1	Front air control *2	Steering angle sensor	BCM	Combination meter	Driver seat control unit*3	ABS actuator and electric unit (control unit)	IPDM E/R
Engine coolant temperature signal	T			R			R			
Engine speed signal	T	R	R	R			R		R	
Engine status signal	T					R				
Fuel consumption monitor signal	T						R			
			R				T			
Malfunction indicator lamp signal	T						R			
Power generation command value signal	T									R
Wide open throttle position signal	T	R								
A/T fluid temperature sensor signal		T					R			
A/T position indicator lamp signal		T					R			
A/T self-diagnosis signal	R	T								
O/D OFF indicator signal		T					R			
Output shaft revolution signal	R	T								
P range signal		T					R	R	R	
Turbine revolution signal	R	T								
A/C switch/indicator signal			T	R						
			R	T						
System setting signal			T			R		R		
			R			T		T		
Steering angle sensor signal					T				R	
A/C switch signal	R			R		T				
Blower fan motor switch signal	R					T				
Buzzer output signal						T	R			
Day time running light request signal						T	R			R
Door switch signal			R			T	R	R		R
Front fog light request signal						T	R			R
Front wiper request signal						T				R
High beam request signal						T	R			R
Horn chirp signal						T				R
Ignition switch signal						T		R		
Key fob door unlock signal						T		R		
Key fob ID signal						T		R		
Key switch signal						T		R		
Low beam request signal						T				R
Position light request signal						T	R			R
Rear window defogger switch signal				R		T				R
Sleep wake up signal						T	R	R		R
Theft warning horn request signal						T				R
Tire pressure data signal			R			T				

A

B

C

D

E

F

G

H

I

J

LAN

L

M

CAN COMMUNICATION

[CAN]

Signals	ECM	TCM	Display control unit*1	Front air control*2	Steering angle sensor	BCM	Combination meter	Driver seat control unit*3	ABS actuator and electric unit (control unit)	IPDM E/R
Tire pressure signal			R			T	R			
Turn indicator signal						T	R			
1st position switch signal		R					T			
Distance to empty signal			R				T			
Fuel level low warning signal			R				T			
Fuel level sensor signal	R						T			
Overdrive control switch signal		R					T			
Seat belt buckle switch signal						R	T			
Stop lamp switch signal		R					T			
Vehicle speed signal				R			R		T	
	R	R	R	R		R	T	R		
ABS warning lamp signal							R		T	
Brake warning lamp signal							R		T	
SLIP indicator lamp signal							R		T	
VDC OFF indicator lamp signal							R		T	
Front wiper stop position signal						R				T
High beam status signal	R									T
Low beam status signal	R									T
Rear window defogger control signal	R			R						T

- *1: with navigation system model only.
- *2: with auto air conditioner model only.
- *3: with automatic drive positioner model only.

NOTE:

CAN data of the air bag diagnosis sensor unit is not used by usual service work, thus it is omitted.

TYPE 5/TYPER 6
System diagram

- Type 5

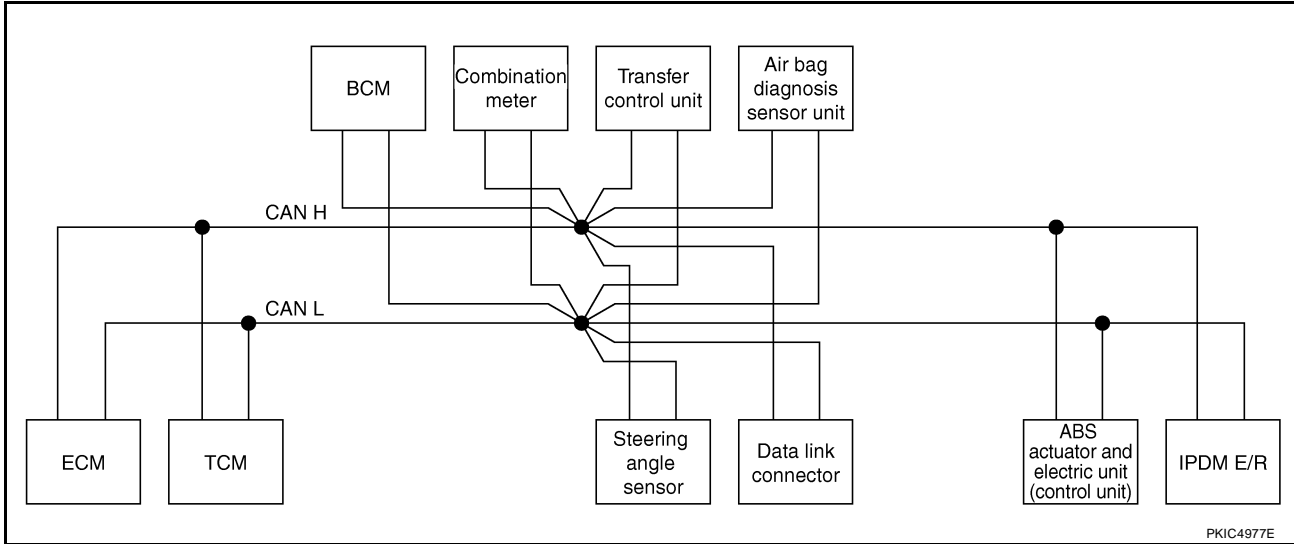

- Type 6

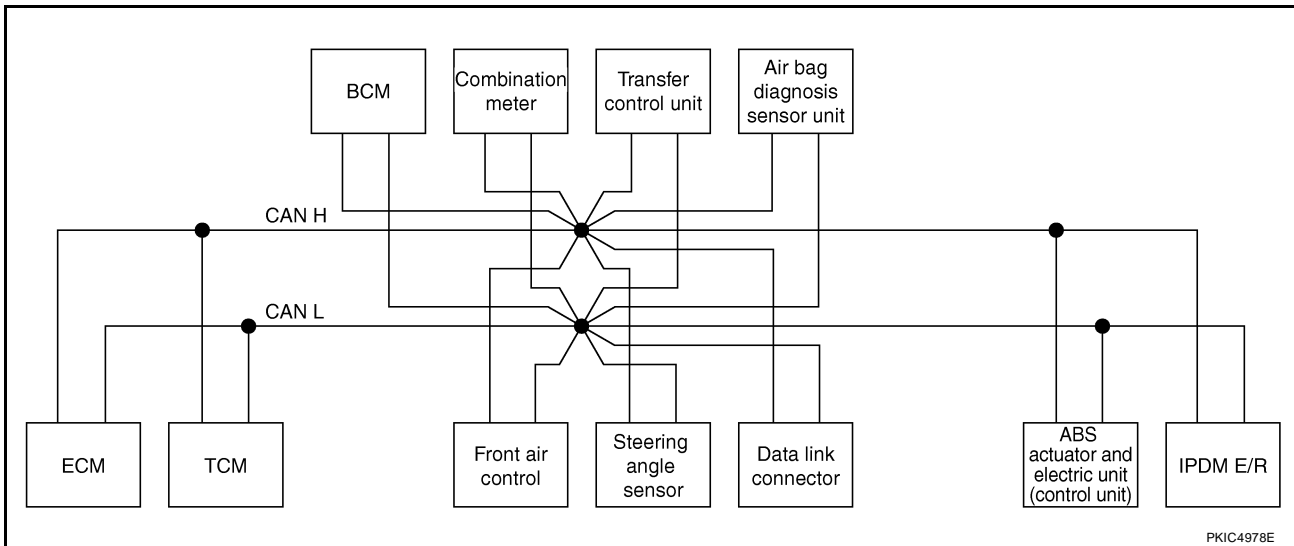

Input/output signal chart

T: Transmit R: Receive

Signals	ECM	TCM	Front air control*	Steering angle sensor	BCM	Combination meter	Transfer control unit	ABS actuator and electric unit (control unit)	IPDM E/R
A/C compressor request signal	T								R
Accelerator pedal position signal	T	R						R	
ASCD CRUISE lamp signal	T					R			
ASCD OD cancel request	T	R							
ASCD operation signal	T	R							
ASCD SET lamp signal	T					R			
Battery voltage signal	T	R							
Closed throttle position signal	T	R							

A
B
C
D
E
F
G
H
I
J
L
M

LAN

CAN COMMUNICATION

[CAN]

Signals	ECM	TCM	Front air control*	Steering angle sensor	BCM	Combi-nation meter	Trans-fer control unit	ABS actua-tor and electric unit (control unit)	IPDM E/R
Cooling fan speed request signal	T								R
Engine coolant temperature signal	T		R			R			
Engine speed signal	T	R	R			R	R	R	
Engine status signal	T				R				
Fuel consumption monitor signal	T					R			
Malfunction indicator lamp signal	T					R			
Power generation command value signal	T								R
Wide open throttle position signal	T	R							
A/T fluid temperature sensor signal		T				R			
A/T position indicator lamp signal		T				R	R		
A/T self-diagnosis signal	R	T							
O/D OFF indicator signal		T				R			
Output shaft revolution signal	R	T					R		
P range signal		T				R		R	
Turbine revolution signal	R	T							
Steering angle sensor signal				T				R	
A/C switch signal	R		R		T				
Blower fan motor switch signal	R				T				
Buzzer output signal					T	R			
Day time running light request signal					T	R			R
Door switch signal					T	R			R
Front fog light request signal					T	R			R
Front wiper request signal					T				R
High beam request signal					T	R			R
Horn chirp signal					T				R
Ignition switch signal					T				R
Low beam request signal					T				R
Position light request signal					T	R			R
Rear window defogger switch signal			R		T				R
Sleep wake up signal					T	R			R
Theft warning horn request signal					T				R
Tire pressure signal					T	R			
Turn indicator signal					T	R			
1st position switch signal		R				T			
Overdrive control switch signal		R				T			
Seat belt buckle switch signal					R	T			
Stop lamp switch signal		R				T	R	T	
Vehicle speed signal	R	R	R		R	T	R	T	

CAN COMMUNICATION

[CAN]

Signals	ECM	TCM	Front air control*	Steering angle sensor	BCM	Combination meter	Transfer control unit	ABS actuator and electric unit (control unit)	IPDM E/R
Fuel level sensor signal	R					T			
ABS warning lamp signal						R		T	
Brake warning lamp signal						R		T	
HDC indicator lamp signal						R		T	
SLIP indicator lamp signal						R		T	
VDC OFF indicator lamp signal						R		T	
Front wiper stop position signal					R				T
High beam status signal	R								T
Low beam status signal	R								T
Rear window defogger control signal	R		R						T

*: with auto air conditioner model only.

NOTE:

CAN data of the air bag diagnosis sensor unit is not used by usual service work, thus it is omitted.

TYPE 7/TYPER 8/TYPER 9/TYPER 10

System diagram

- Type 7

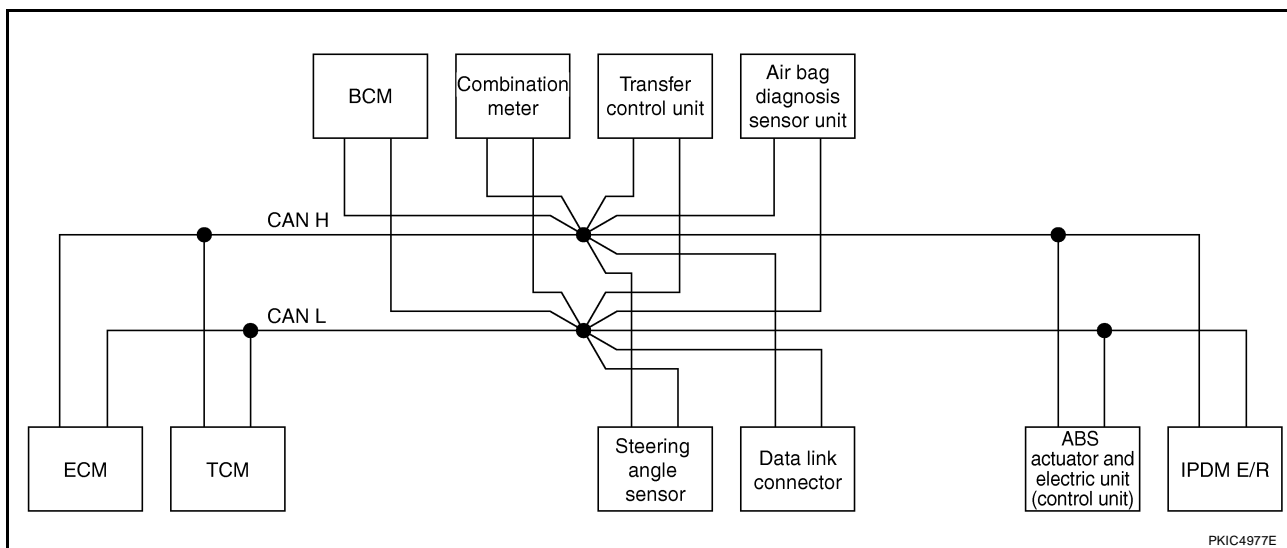

CAN COMMUNICATION

[CAN]

• Type 8

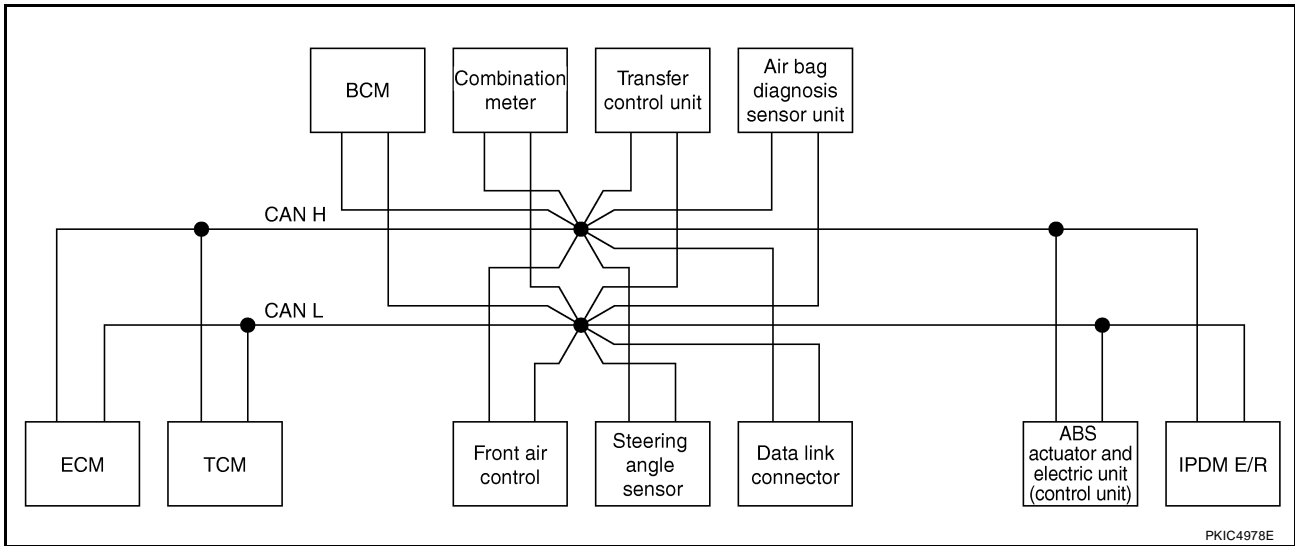

• Type 9

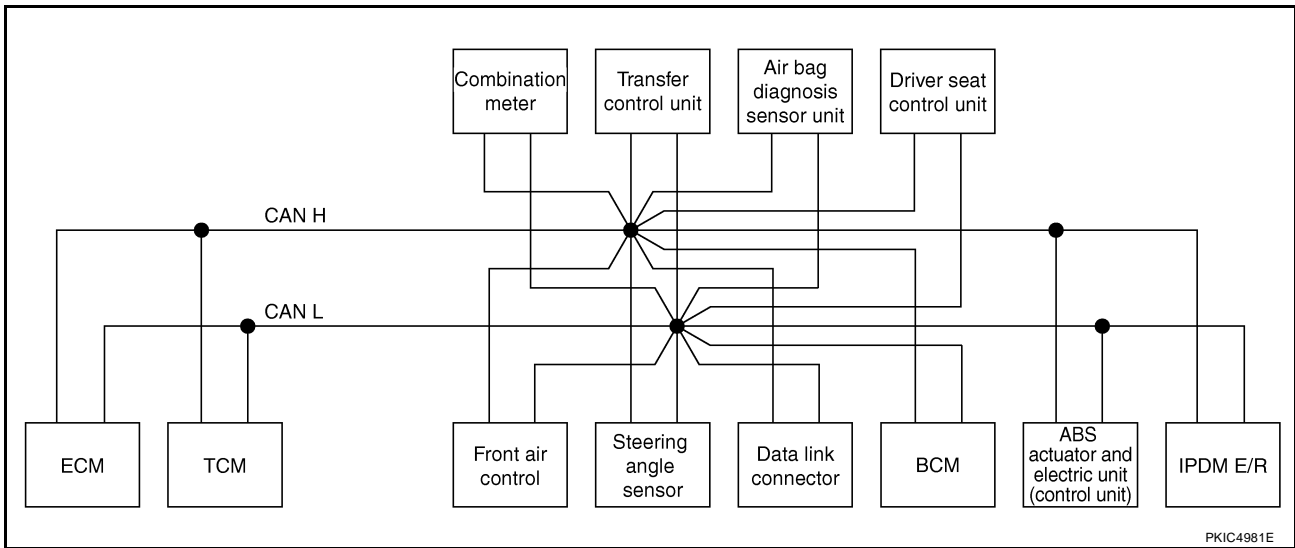

• Type 10

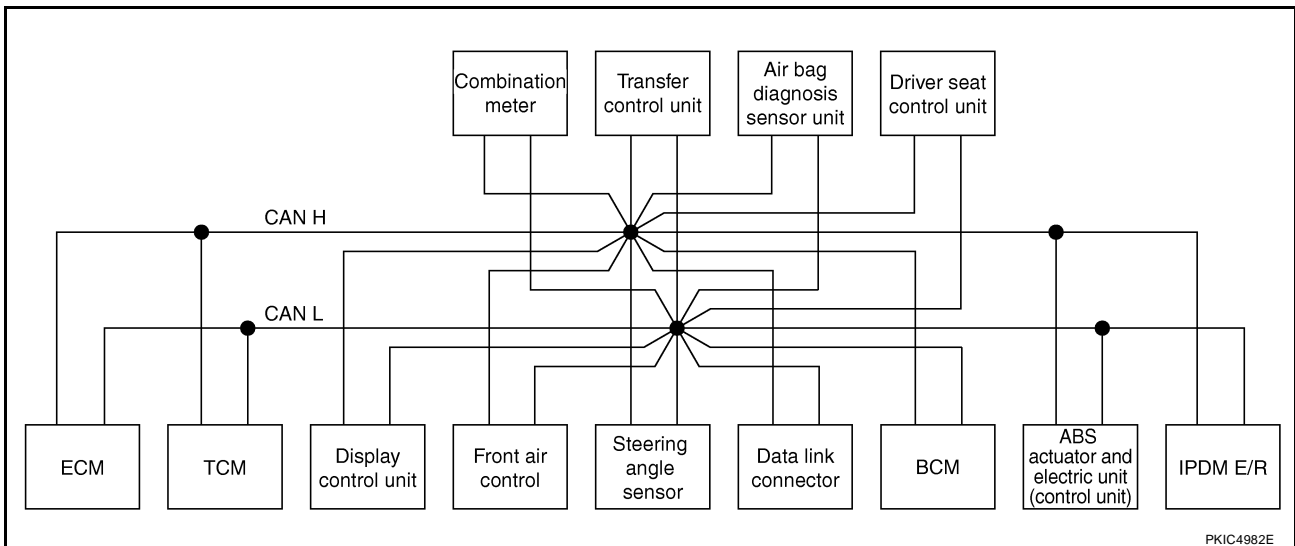

CAN COMMUNICATION

[CAN]

Input/output signal chart

T: Transmit R: Receive

Signals	ECM	TCM	Display control unit*1	Front air control*2	Steering angle sensor	BCM	Combination meter	Transfer control unit	Driver seat control unit*3	ABS actuator and electric unit (control unit)	IPDM E/R
A/C compressor request signal	T										R
Accelerator pedal position signal	T	R						R		R	
ASCD CRUISE lamp signal	T						R				
ASCD OD cancel request	T	R									
ASCD operation signal	T	R									
ASCD SET lamp signal	T						R				
Battery voltage signal	T	R									
Closed throttle position signal	T	R									
Cooling fan speed request signal	T										R
Engine coolant temperature signal	T			R			R				
Engine speed signal	T	R	R	R			R	R		R	
Engine status signal	T					R					
Fuel consumption monitor signal	T						R				
			R				T				
Malfunction indicator lamp signal	T						R				
Power generation command value signal	T										R
Wide open throttle position signal	T	R									
A/T fluid temperature sensor signal		T					R				
A/T position indicator lamp signal		T					R	R			
A/T self-diagnosis signal	R	T									
O/D OFF indicator signal		T					R				
Output shaft revolution signal	R	T						R			
P range signal		T					R		R	R	
Turbine revolution signal	R	T									
A/C switch/indicator signal			T	R							
			R	T							
System setting signal			T			R			R		
			R			T			T		
Steering angle sensor signal					T					R	
A/C switch signal	R			R		T					
Blower fan motor switch signal	R					T					
Buzzer output signal						T	R				
Day time running light request signal						T	R				R
Door switch signal			R			T	R		R		R
Front fog light request signal						T	R				R
Front wiper request signal						T					R

A
B
C
D
E
F
G
H
I
J
LAN
L
M

CAN COMMUNICATION

[CAN]

Signals	ECM	TCM	Display control unit*1	Front air control*2	Steering angle sensor	BCM	Combination meter	Transfer control unit	Driver seat control unit*3	ABS actuator and electric unit (control unit)	IPDM E/R
High beam request signal						T	R				R
Horn chirp signal						T					R
Ignition switch signal						T			R		
Key fob door unlock signal						T			R		
Key fob ID signal						T			R		
Key switch signal						T			R		
Low beam request signal						T					R
Position light request signal						T	R				R
Rear window defogger switch signal				R		T					R
Sleep wake up signal						T	R		R		R
Theft warning horn request signal						T					R
Tire pressure data signal			R			T					
Tire pressure signal			R			T	R				
Turn indicator signal						T	R				
1st position switch signal		R					T				
Distance to empty signal			R				T				
Fuel level low warning signal			R				T				
Fuel level sensor signal	R						T				
Overdrive control switch signal		R					T				
Seat belt buckle switch signal						R	T				
Stop lamp switch signal		R					T				
Vehicle speed signal				R			R	R		T	
	R	R	R	R		R	T		R		
ABS warning lamp signal							R			T	
Brake warning lamp signal							R			T	
SLIP indicator lamp signal							R			T	
VDC OFF indicator lamp signal							R			T	
Front wiper stop position signal						R					T
High beam status signal	R										T
Low beam status signal	R										T
Rear window defogger control signal	R			R							T

- *1: with navigation system model only.
- *2: with auto air conditioner model only.
- *3: with automatic drive positioner model only.

NOTE:

CAN data of the air bag diagnosis sensor unit is not used by usual service work, thus it is omitted.

CAN SYSTEM (TYPE 1)

[CAN]

CAN SYSTEM (TYPE 1)

PF2:23710

Component Parts and Harness Connector Location

UKS0053A

Refer to [LAN-25, "Component Parts and Harness Connector Location"](#) .

Schematic

UKS0053B

Refer to [LAN-26, "Schematic"](#) .

Wiring Diagram — CAN —

UKS0053C

Refer to [LAN-27, "Wiring Diagram — CAN —"](#) .

A

B

C

D

E

F

G

H

I

J

LAN

L

M

CAN SYSTEM (TYPE 1)

[CAN]

UKS0053D

Check Sheet

NOTE:

If a check mark is put on "NG" on "INITIAL DIAG (Initial diagnosis)", replace the control unit.

Check sheet table												
SELECT SYSTEM screen		CAN DIAG SUPPORT MNTR									SELF-DIAG RESULTS	
		Initial diagnosis	Transmit diagnosis	Receive diagnosis								
				ECM	TCM	STRG	BCM /SEC	METER /M&A	VDC/TCS /ABS	IPDM E/R		
ENGINE	—	—	UNKWN	—	UNKWN	—	UNKWN	UNKWN	UNKWN	UNKWN	CAN COMM CIRCUIT (U1000)	CAN COMM CIRCUIT (U1001)
A/T	—	NG	UNKWN	UNKWN	—	—	—	UNKWN	UNKWN	—	CAN COMM CIRCUIT (U1000)	—
BCM	No indication	NG	UNKWN	UNKWN	—	—	—	UNKWN	—	UNKWN	CAN COMM CIRCUIT (U1000)	—
METER	No indication	—	UNKWN	UNKWN	UNKWN	—	UNKWN	—	UNKWN	UNKWN	CAN COMM CIRCUIT (U1000)	—
ABS	—	NG	UNKWN	UNKWN	UNKWN	UNKWN	—	—	—	—	CAN COMM CIRCUIT (U1000)	—
IPDM E/R	No indication	—	UNKWN	UNKWN	—	—	UNKWN	—	—	—	CAN COMM CIRCUIT (U1000)	—

Symptoms :

Attach copy of
SELECT SYSTEM

Attach copy of
SELECT SYSTEM

PKIC5625E

CAN SYSTEM (TYPE 1)

[CAN]

Attach copy of ENGINE SELF-DIAG RESULTS	Attach copy of A/T SELF-DIAG RESULTS	Attach copy of BCM SELF-DIAG RESULTS
Attach copy of METER SELF-DIAG RESULTS	Attach copy of ABS SELF-DIAG RESULTS	Attach copy of IPDM E/R SELF-DIAG RESULTS
Attach copy of ENGINE CAN DIAG SUPPORT MNTR	Attach copy of A/T CAN DIAG SUPPORT MNTR	Attach copy of BCM CAN DIAG SUPPORT MNTR
Attach copy of METER CAN DIAG SUPPORT MNTR	Attach copy of ABS CAN DIAG SUPPORT MNTR	Attach copy of IPDM E/R CAN DIAG SUPPORT MNTR

A
B
C
D
E
F
G
H
I
J
L
M

LAN

PKIC7064E

CHECK SHEET RESULTS (EXAMPLE)

NOTE:

If a check mark is put on "NG" on "INITIAL DIAG (Initial diagnosis)", replace the control unit.

Case 1

Check harness between TCM and data link connector. Refer to [LAN-195, "Inspection Between TCM and Data Link Connector Circuit"](#).

SELECT SYSTEM screen		CAN DIAG SUPPORT MNTR									SELF-DIAG RESULTS	
		Initial diagnosis	Transmit diagnosis	Receive diagnosis								
				ECM	TCM	STRG	BCM /SEC	METER /M&A	VDC/TCS /ABS	IPDM E/R		
ENGINE	—	—	UNKWN	—	UNKWN	—	UNKWN	UNKWN	UNKWN	UNKWN	CAN COMM CIRCUIT (U1000)	CAN COMM CIRCUIT (U1001)
A/T	—	NG	UNKWN	UNKWN	—	—	—	UNKWN	UNKWN	—	CAN COMM CIRCUIT (U1000)	—
BCM	No indication	NG	UNKWN	UNKWN	—	—	—	UNKWN	—	UNKWN	CAN COMM CIRCUIT (U1000)	—
METER	No indication	—	UNKWN	UNKWN	UNKWN	—	UNKWN	—	UNKWN	UNKWN	CAN COMM CIRCUIT (U1000)	—
ABS	—	NG	UNKWN	UNKWN	UNKWN	—	—	—	—	—	CAN COMM CIRCUIT (U1000)	—
IPDM E/R	No indication	—	UNKWN	UNKWN	—	—	UNKWN	—	—	—	CAN COMM CIRCUIT (U1000)	—

PKIC5626E

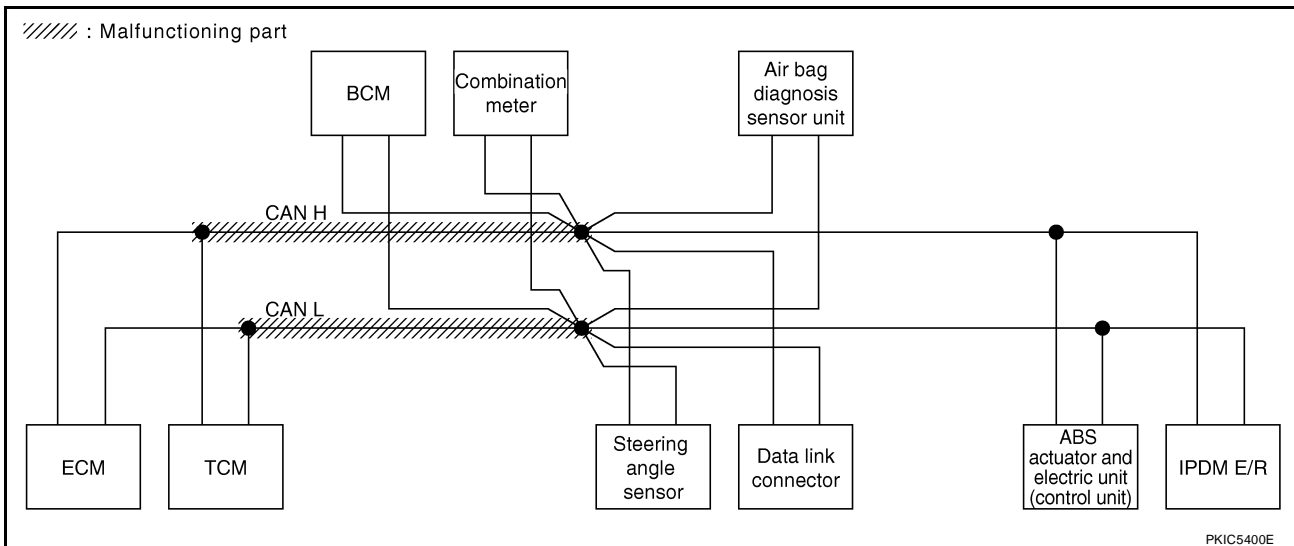

PKIC5400E

CAN SYSTEM (TYPE 1)

[CAN]

Case 2

Check harness between data link connector and ABS actuator and electric unit (control unit). Refer to [LAN-196, "Inspection Between Data Link Connector and ABS Actuator and Electric Unit \(Control Unit\) Circuit"](#).

SELECT SYSTEM screen		CAN DIAG SUPPORT MNTR										SELF-DIAG RESULTS	
		Initial diagnosis	Transmit diagnosis	Receive diagnosis							IPDM E/R		
				ECM	TCM	STRG	BCM /SEC	METER /M&A	VDC/TCS /ABS				
ENGINE	—	—	UNKWN	—	UNKWN	—	UNKWN	UNKWN	UNKWN	UNKWN	UNKWN	CAN COMM CIRCUIT (U1000)	CAN COMM CIRCUIT (U1001)
A/T	—	NG	UNKWN	UNKWN	—	—	—	UNKWN	UNKWN	—	—	CAN COMM CIRCUIT (U1000)	—
BCM	No indication	NG	UNKWN	UNKWN	—	—	—	UNKWN	—	UNKWN	UNKWN	CAN COMM CIRCUIT (U1000)	—
METER	No indication	—	UNKWN	UNKWN	UNKWN	—	UNKWN	—	UNKWN	UNKWN	UNKWN	CAN COMM CIRCUIT (U1000)	—
ABS	—	NG	UNKWN	UNKWN	UNKWN	—	—	—	—	—	—	CAN COMM CIRCUIT (U1000)	—
IPDM E/R	No indication	—	UNKWN	UNKWN	—	—	UNKWN	—	—	—	—	CAN COMM CIRCUIT (U1000)	—

PKIC5627E

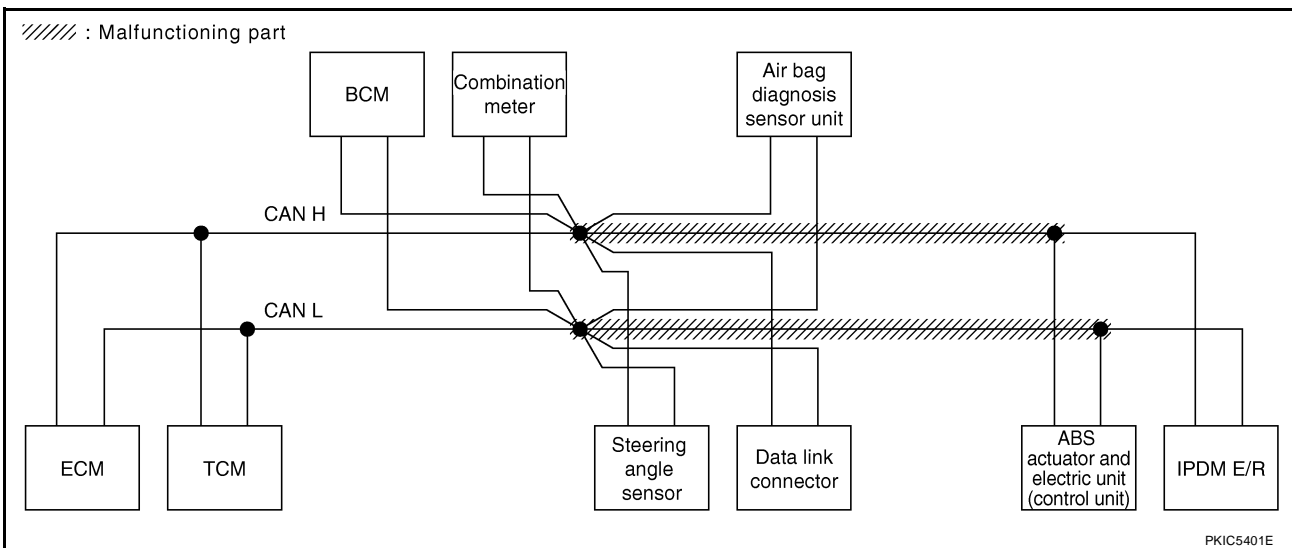

CAN SYSTEM (TYPE 1)

[CAN]

Case 3

Check ECM circuit. Refer to [LAN-197, "ECM Circuit Inspection"](#) .

SELECT SYSTEM screen		CAN DIAG SUPPORT MNTR									SELF-DIAG RESULTS	
		Initial diagnosis	Transmit diagnosis	Receive diagnosis								
				ECM	TCM	STRG	BCM /SEC	METER /M&A	VDC/TCS /ABS	IPDM E/R		
ENGINE	—	—	UNKW [✓]	—	UNKW [✓]	—	UNKW [✓]	UNKW [✓]	UNKW [✓]	UNKW [✓]	CAN COMM CIRCUIT (U100) [✓]	CAN COMM CIRCUIT (U101) [✓]
A/T	—	NG	UNKW [✓]	UNKW [✓]	—	—	—	UNKW [✓]	UNKW [✓]	—	CAN COMM CIRCUIT (U100) [✓]	—
BCM	No indication	NG	UNKW [✓]	UNKW [✓]	—	—	—	UNKW [✓]	—	UNKW [✓]	CAN COMM CIRCUIT (U1000) [✓]	—
METER	No indication	—	UNKW [✓]	UNKW [✓]	—	—	UNKW [✓]	—	UNKW [✓]	UNKW [✓]	CAN COMM CIRCUIT (U100) [✓]	—
ABS	—	NG	UNKW [✓]	UNKW [✓]	UNKW [✓]	—	—	—	—	—	CAN COMM CIRCUIT (U100) [✓]	—
IPDM E/R	No indication	—	UNKW [✓]	UNKW [✓]	—	—	UNKW [✓]	—	—	—	CAN COMM CIRCUIT (U100) [✓]	—

PKIC5628E

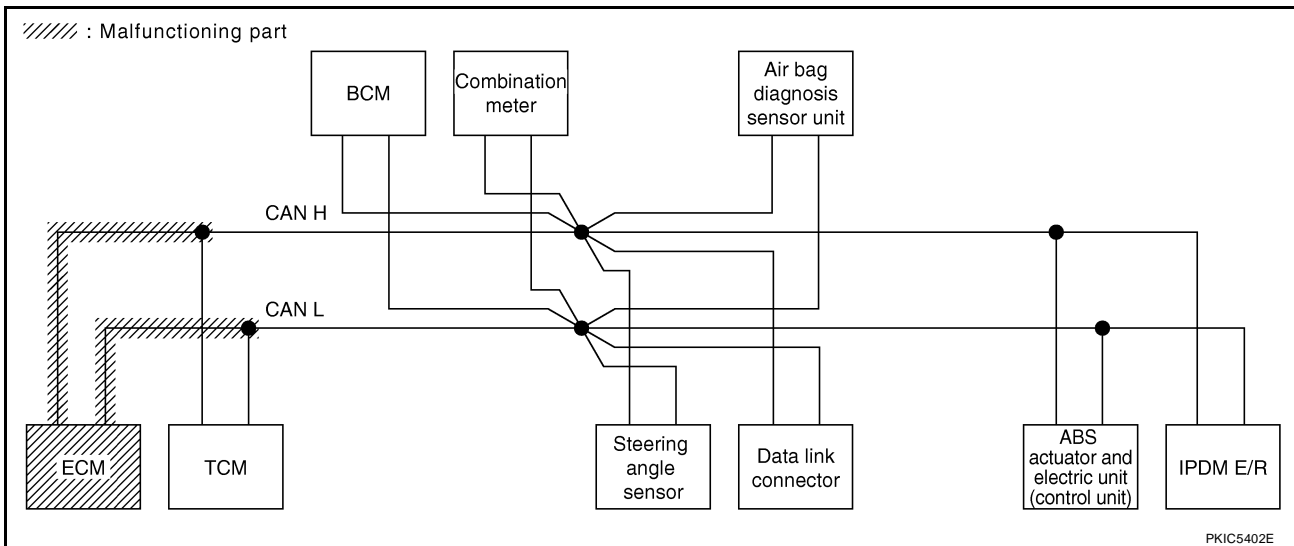

PKIC5402E

CAN SYSTEM (TYPE 1)

[CAN]

Case 4

Check TCM circuit. Refer to [LAN-197, "TCM Circuit Inspection"](#) .

SELECT SYSTEM screen		CAN DIAG SUPPORT MNTR									SELF-DIAG RESULTS	
		Initial diagnosis	Transmit diagnosis	Receive diagnosis						IPDM E/R		
				ECM	TCM	STRG	BCM /SEC	METER /M&A	VDC/TCS /ABS			
ENGINE	—	—	UNKWN	—	UNKWN	—	UNKWN	UNKWN	UNKWN	UNKWN	CAN COMM CIRCUIT (U100)	CAN COMM CIRCUIT (U101)
A/T	—	NG	UNKWN	UNKWN	—	—	—	UNKWN	UNKWN	—	CAN COMM CIRCUIT (U100)	—
BCM	No indication	NG	UNKWN	UNKWN	—	—	—	UNKWN	—	UNKWN	CAN COMM CIRCUIT (U1000)	—
METER	No indication	—	UNKWN	UNKWN	UNKWN	—	UNKWN	—	UNKWN	UNKWN	CAN COMM CIRCUIT (U100)	—
ABS	—	NG	UNKWN	UNKWN	UNKWN	UNKWN	—	—	—	—	CAN COMM CIRCUIT (U100)	—
IPDM E/R	No indication	—	UNKWN	UNKWN	—	—	UNKWN	—	—	—	CAN COMM CIRCUIT (U1000)	—

PKIC5629E

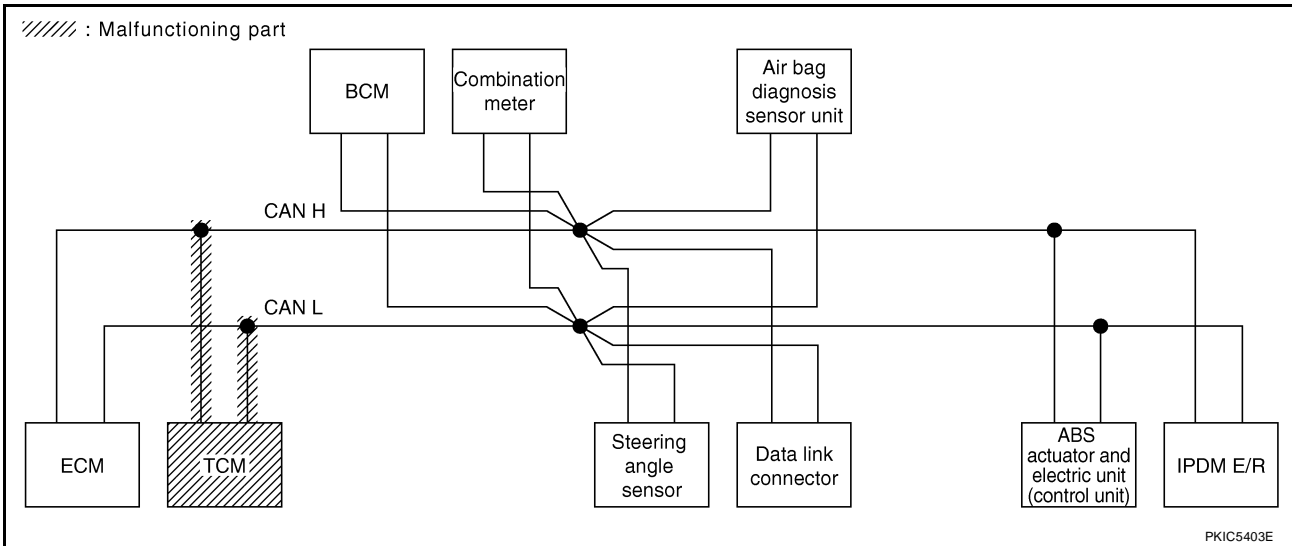

PKIC5403E

CAN SYSTEM (TYPE 1)

[CAN]

Case 5

Check steering angle sensor circuit. Refer to [LAN-199, "Steering Angle Sensor Circuit Inspection"](#) .

SELECT SYSTEM screen		CAN DIAG SUPPORT MNTR									SELF-DIAG RESULTS	
		Initial diagnosis	Transmit diagnosis	Receive diagnosis								
				ECM	TCM	STRG	BCM /SEC	METER /M&A	VDC/TCS /ABS	IPDM E/R		
ENGINE	—	—	UNKWN	—	UNKWN	—	UNKWN	UNKWN	UNKWN	UNKWN	CAN COMM CIRCUIT (U1000)	CAN COMM CIRCUIT (U1001)
A/T	—	NG	UNKWN	UNKWN	—	—	—	UNKWN	UNKWN	—	CAN COMM CIRCUIT (U1000)	—
BCM	No indication	NG	UNKWN	UNKWN	—	—	—	UNKWN	—	UNKWN	CAN COMM CIRCUIT (U1000)	—
METER	No indication	—	UNKWN	UNKWN	UNKWN	—	UNKWN	—	UNKWN	UNKWN	CAN COMM CIRCUIT (U1000)	—
ABS	—	NG	UNKWN	UNKWN	UNKWN	UNKWN	—	—	—	—	CAN COMM CIRCUIT (U1000)	—
IPDM E/R	No indication	—	UNKWN	UNKWN	—	—	UNKWN	—	—	—	CAN COMM CIRCUIT (U1000)	—

PKIC5630E

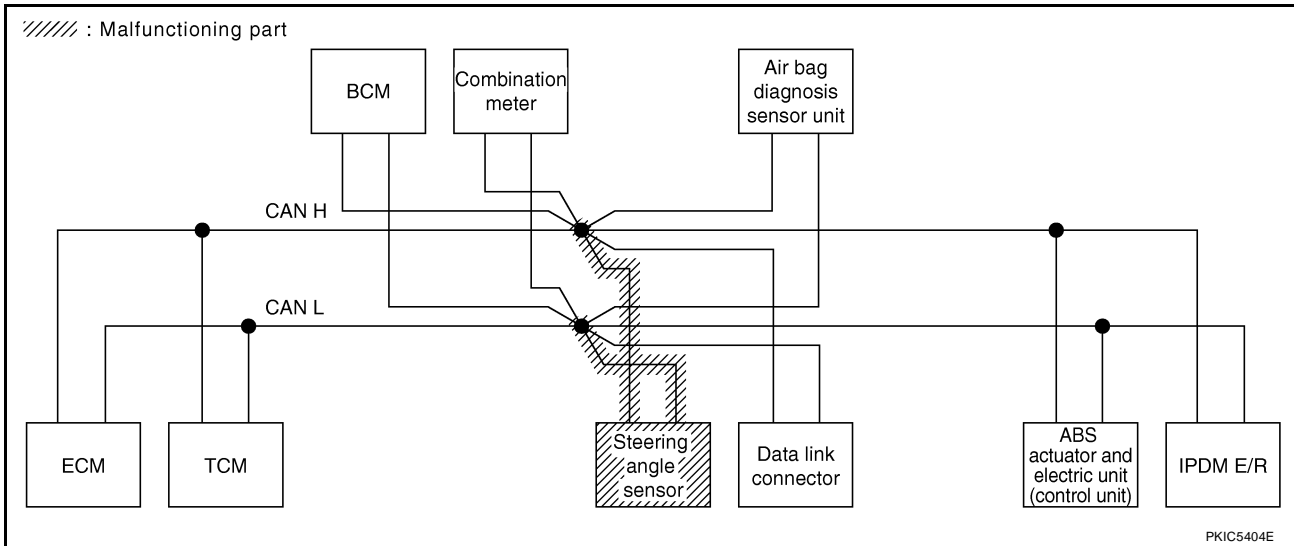

PKIC5404E

CAN SYSTEM (TYPE 1)

[CAN]

Case 6

Check data link connector circuit. Refer to [LAN-199, "Data Link Connector Circuit Inspection"](#) .

SELECT SYSTEM screen		CAN DIAG SUPPORT MNTR									SELF-DIAG RESULTS	
		Initial diagnosis	Transmit diagnosis	Receive diagnosis								
				ECM	TCM	STRG	BCM /SEC	METER /M&A	VDC/TCS /ABS	IPDM E/R		
ENGINE	—	—	UNKWN	—	UNKWN	—	UNKWN	UNKWN	UNKWN	UNKWN	CAN COMM CIRCUIT (U1000)	CAN COMM CIRCUIT (U1001)
A/T	—	NG	UNKWN	UNKWN	—	—	—	UNKWN	UNKWN	—	CAN COMM CIRCUIT (U1000)	—
BCM	No indication	NG	UNKWN	UNKWN	—	—	—	UNKWN	—	UNKWN	CAN COMM CIRCUIT (U1000)	—
METER	No indication	—	UNKWN	UNKWN	UNKWN	—	UNKWN	—	UNKWN	UNKWN	CAN COMM CIRCUIT (U1000)	—
ABS	—	NG	UNKWN	UNKWN	UNKWN	UNKWN	—	—	—	—	CAN COMM CIRCUIT (U1000)	—
IPDM E/R	No indication	—	UNKWN	UNKWN	—	—	UNKWN	—	—	—	CAN COMM CIRCUIT (U1000)	—

PKIC5631E

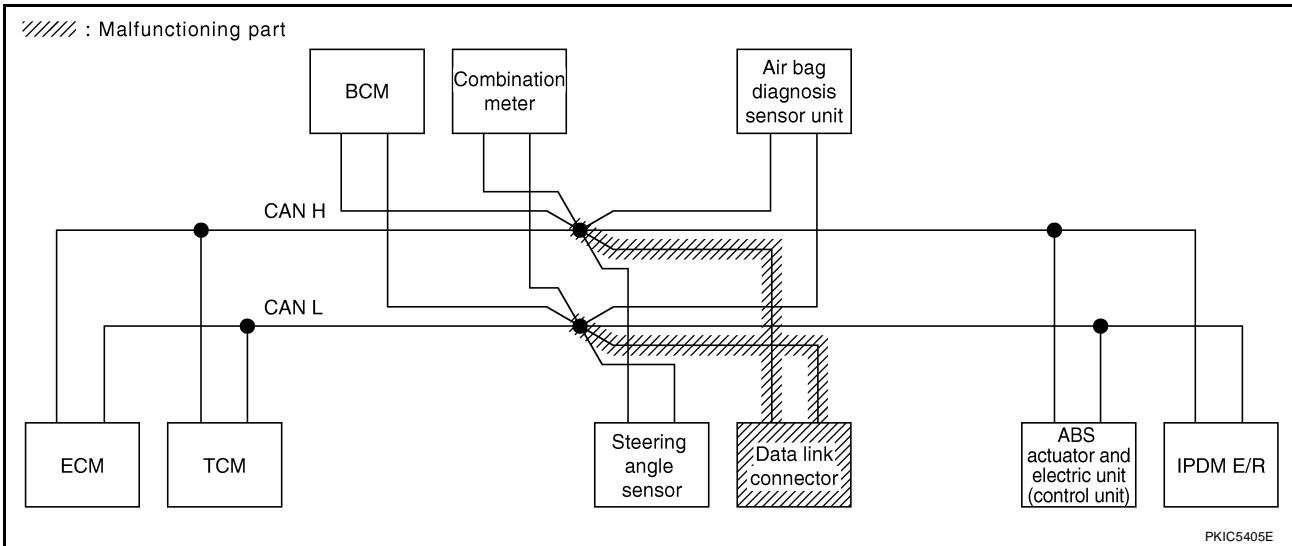

PKIC5405E

CAN SYSTEM (TYPE 1)

[CAN]

Case 7

Check BCM circuit. Refer to [LAN-200, "BCM Circuit Inspection"](#) .

SELECT SYSTEM screen		CAN DIAG SUPPORT MNTR									SELF-DIAG RESULTS	
		Initial diagnosis	Transmit diagnosis	Receive diagnosis								
				ECM	TCM	STRG	BCM /SEC	METER /M&A	VDC/TCS /ABS	IPDM E/R		
ENGINE	—	—	UNKWN	—	UNKWN	—	UNKWN	UNKWN	UNKWN	UNKWN	CAN COMM CIRCUIT (U1000)	CAN COMM CIRCUIT (U1001)
A/T	—	NG	UNKWN	UNKWN	—	—	—	UNKWN	UNKWN	—	CAN COMM CIRCUIT (U1000)	—
BCM	No indication	NG	UNKWN	UNKWN	—	—	—	UNKWN	—	UNKWN	CAN COMM CIRCUIT (U1000)	—
METER	No indication	—	UNKWN	UNKWN	UNKWN	—	UNKWN	—	UNKWN	UNKWN	CAN COMM CIRCUIT (U1000)	—
ABS	—	NG	UNKWN	UNKWN	UNKWN	UNKWN	—	—	—	—	CAN COMM CIRCUIT (U1000)	—
IPDM E/R	No indication	—	UNKWN	UNKWN	—	—	UNKWN	—	—	—	CAN COMM CIRCUIT (U1000)	—

PKIC5632E

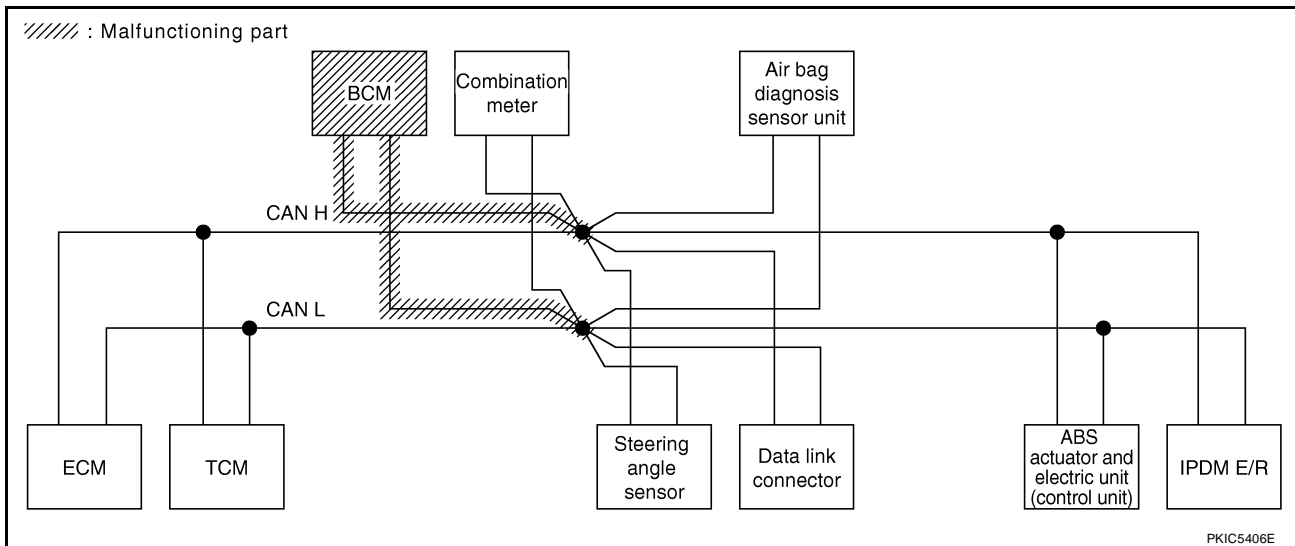

CAN SYSTEM (TYPE 1)

[CAN]

Case 8

Check combination meter circuit. Refer to [LAN-200, "Combination Meter Circuit Inspection"](#).

SELECT SYSTEM screen		CAN DIAG SUPPORT MNTR									SELF-DIAG RESULTS	
		Initial diagnosis	Transmit diagnosis	Receive diagnosis						IPDM E/R		
				ECM	TCM	STRG	BCM /SEC	METER /M&A	VDC/TCS /ABS			
ENGINE	—	—	UNKWN	—	UNKWN	—	UNKWN	UNKWN	UNKWN	UNKWN	CAN COMM CIRCUIT (U1000)	CAN COMM CIRCUIT (U1001)
A/T	—	NG	UNKWN	UNKWN	—	—	—	UNKWN	UNKWN	—	CAN COMM CIRCUIT (U1000)	—
BCM	No indication	NG	UNKWN	UNKWN	—	—	—	UNKWN	—	UNKWN	CAN COMM CIRCUIT (U1000)	—
METER	No indication	—	UNKWN	UNKWN	UNKWN	—	UNKWN	—	UNKWN	UNKWN	CAN COMM CIRCUIT (U1000)	—
ABS	—	NG	UNKWN	UNKWN	UNKWN	UNKWN	—	—	—	—	CAN COMM CIRCUIT (U1000)	—
IPDM E/R	No indication	—	UNKWN	UNKWN	—	—	UNKWN	—	—	—	CAN COMM CIRCUIT (U1000)	—

PKIC5633E

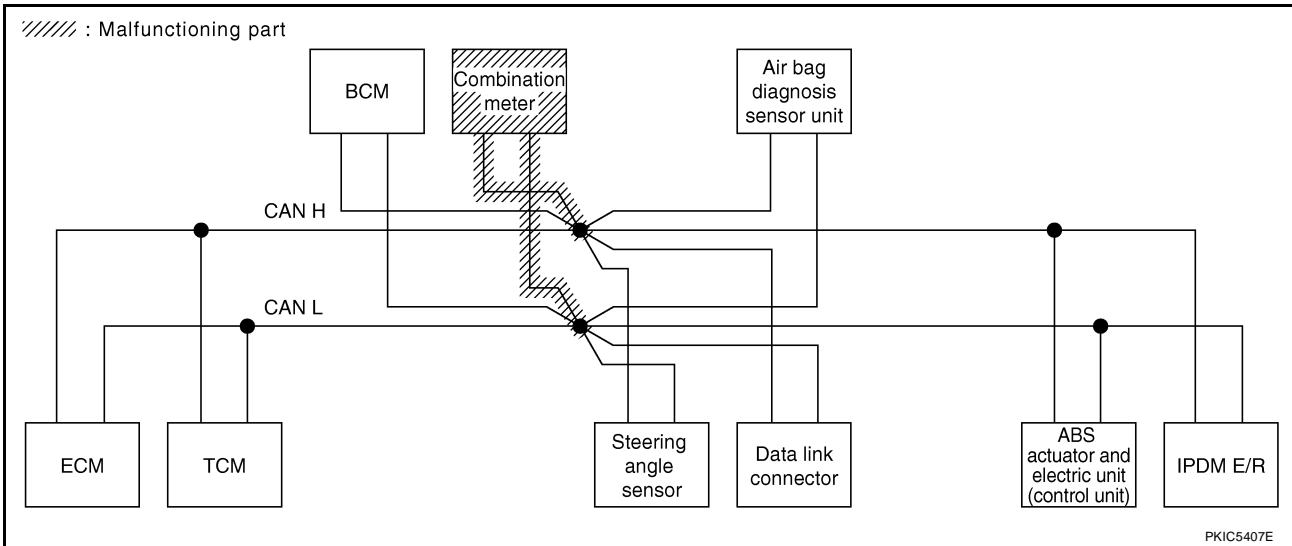

CAN SYSTEM (TYPE 1)

[CAN]

Case 9

Check ABS actuator and electric unit (control unit) circuit. Refer to [LAN-202, "ABS Actuator and Electric Unit \(Control Unit\) Circuit Inspection"](#) .

SELECT SYSTEM screen		CAN DIAG SUPPORT MNTR									SELF-DIAG RESULTS	
		Initial diagnosis	Transmit diagnosis	Receive diagnosis								
				ECM	TCM	STRG	BCM /SEC	METER /M&A	VDC/TCS /ABS	IPDM E/R		
ENGINE	—	—	UNKWN	—	UNKWN	—	UNKWN	UNKWN	UNKWN	UNKWN	CAN COMM CIRCUIT (U1000)	CAN COMM CIRCUIT (U1001)
A/T	—	NG	UNKWN	UNKWN	—	—	—	UNKWN	UNKWN	—	CAN COMM CIRCUIT (U1000)	—
BCM	No indication	NG	UNKWN	UNKWN	—	—	—	UNKWN	—	UNKWN	CAN COMM CIRCUIT (U1000)	—
METER	No indication	—	UNKWN	UNKWN	UNKWN	—	UNKWN	—	UNKWN	UNKWN	CAN COMM CIRCUIT (U1000)	—
ABS	—	✓	UNKWN	UNKWN	UNKWN	UNKWN	—	—	—	—	CAN COMM CIRCUIT (U1000)	—
IPDM E/R	No indication	—	UNKWN	UNKWN	—	—	UNKWN	—	—	—	CAN COMM CIRCUIT (U1000)	—

PKIC5634E

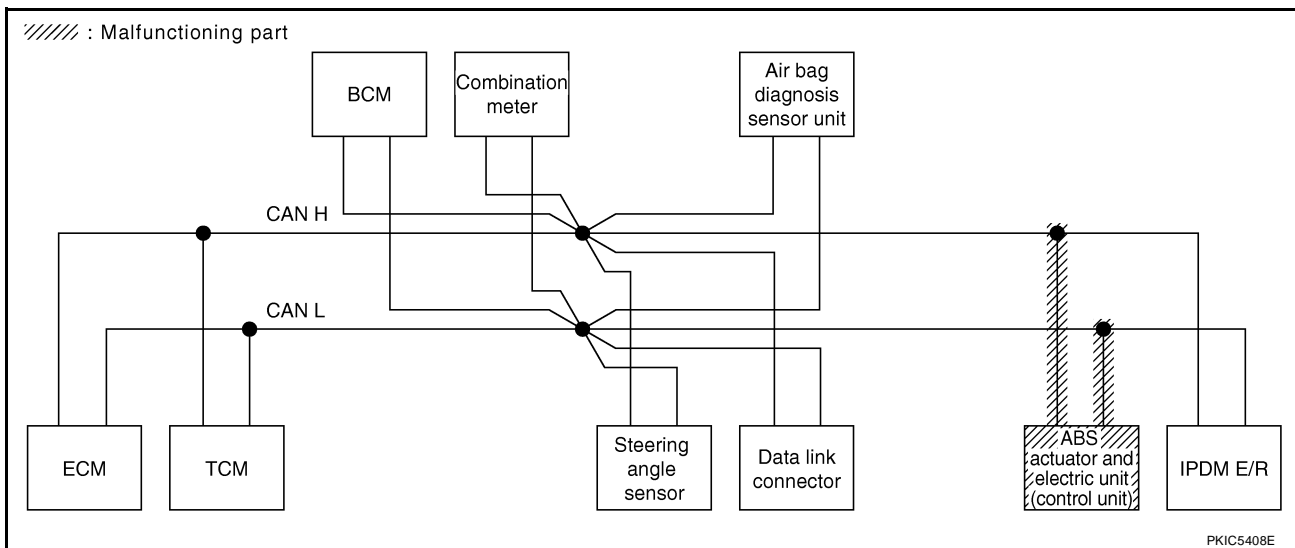

Case 10

Check IPDM E/R circuit. Refer to [LAN-203, "IPDM E/R Circuit Inspection"](#) .

SELECT SYSTEM screen		CAN DIAG SUPPORT MNTR									SELF-DIAG RESULTS		
		Initial diagnosis	Transmit diagnosis	Receive diagnosis									
				ECM	TCM	STRG	BCM /SEC	METER /M&A	VDC/TCS /ABS	IPDM E/R			
ENGINE	—	—	UNKW N	—	UNKW N	—	UNKW N	UNKW N	UNKW N	UNKW N	UNKW N	CAN COMM CIRCUIT (U1000)	CAN COMM CIRCUIT (U1001)
A/T	—	NG	UNKW N	UNKW N	—	—	—	UNKW N	UNKW N	—	—	CAN COMM CIRCUIT (U1000)	—
BCM	No indication	NG	UNKW N	UNKW N	—	—	—	UNKW N	—	UNKW N	UNKW N	CAN COMM CIRCUIT (U1000)	—
METER	No indication	—	UNKW N	UNKW N	UNKW N	—	UNKW N	—	UNKW N	UNKW N	UNKW N	CAN COMM CIRCUIT (U1000)	—
ABS	—	NG	UNKW N	UNKW N	UNKW N	UNKW N	—	—	—	—	—	CAN COMM CIRCUIT (U1000)	—
IPDM E/R	No indication	—	UNKW N	UNKW N	—	—	UNKW N	—	—	—	—	CAN COMM CIRCUIT (U1000)	—

PKIC5635E

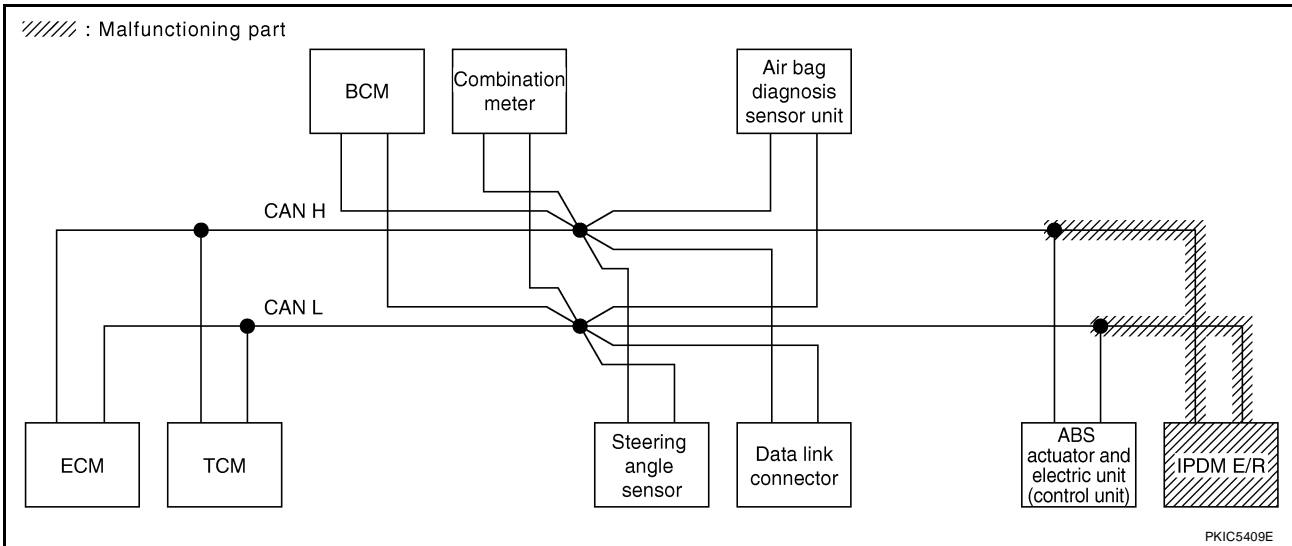

Case 11

Check CAN communication circuit. Refer to [LAN-203, "CAN Communication Circuit Inspection"](#) .

SELECT SYSTEM screen		CAN DIAG SUPPORT MNTR									SELF-DIAG RESULTS		
		Initial diagnosis	Transmit diagnosis	Receive diagnosis									
				ECM	TCM	STRG	BCM /SEC	METER /M&A	VDC/TCS /ABS	IPDM E/R			
ENGINE	—	—	UNKW N	—	UNKW N	—	UNKW N	UNKW N	UNKW N	UNKW N	UNKW N	CAN COMM CIRCUIT (U1000)	CAN COMM CIRCUIT (U1001)
A/T	—	NG	UNKW N	UNKW N	—	—	—	UNKW N	UNKW N	—	—	CAN COMM CIRCUIT (U1000)	—
BCM	No indication	NG	UNKW N	UNKW N	—	—	—	UNKW N	—	UNKW N	UNKW N	CAN COMM CIRCUIT (U1000)	—
METER	No indication	—	UNKW N	UNKW N	UNKW N	—	UNKW N	—	UNKW N	UNKW N	UNKW N	CAN COMM CIRCUIT (U1000)	—
ABS	—	NG	UNKW N	UNKW N	UNKW N	UNKW N	—	—	—	—	—	CAN COMM CIRCUIT (U1000)	—
IPDM E/R	No indication	—	UNKW N	UNKW N	—	—	UNKW N	—	—	—	—	CAN COMM CIRCUIT (U1000)	—

PKIC5636E

CAN SYSTEM (TYPE 1)

[CAN]

Case 12

Check IPDM E/R ignition relay circuit continuously sticks "OFF". Refer to [LAN-204, "IPDM E/R Ignition Relay Circuit Inspection"](#) .

SELECT SYSTEM screen		CAN DIAG SUPPORT MNTR									SELF-DIAG RESULTS	
		Initial diagnosis	Transmit diagnosis	Receive diagnosis								
				ECM	TCM	STRG	BCM /SEC	METER /M&A	VDC/TCS /ABS	IPDM E/R		
ENGINE	—	—	UNKWN	—	UNKWN	—	UNKWN	UNKWN	UNKWN	UNKWN	CAN COMM CIRCUIT (U100)	CAN COMM CIRCUIT (U101)
A/T	—	NG	UNKWN	UNKWN	—	—	—	UNKWN	UNKWN	—	CAN COMM CIRCUIT (U1000)	—
BCM	No indication	NG	UNKWN	UNKWN	—	—	—	UNKWN	—	UNKWN	CAN COMM CIRCUIT (U1000)	—
METER	No indication	—	UNKWN	UNKWN	UNKWN	—	UNKWN	—	UNKWN	UNKWN	CAN COMM CIRCUIT (U1000)	—
ABS	—	NG	UNKWN	UNKWN	UNKWN	UNKWN	—	—	—	—	CAN COMM CIRCUIT (U1000)	—
IPDM E/R	No indication	—	UNKWN	UNKWN	—	—	UNKWN	—	—	—	CAN COMM CIRCUIT (U1000)	—

PKIC5637E

Case 13

Check IPDM E/R ignition relay circuit continuously sticks "ON". Refer to [LAN-204, "IPDM E/R Ignition Relay Circuit Inspection"](#) .

SELECT SYSTEM screen		CAN DIAG SUPPORT MNTR									SELF-DIAG RESULTS	
		Initial diagnosis	Transmit diagnosis	Receive diagnosis								
				ECM	TCM	STRG	BCM /SEC	METER /M&A	VDC/TCS /ABS	IPDM E/R		
ENGINE	—	—	UNKWN	—	UNKWN	—	UNKWN	UNKWN	UNKWN	UNKWN	CAN COMM CIRCUIT (U1000)	CAN COMM CIRCUIT (U1001)
A/T	—	NG	UNKWN	—	—	—	—	—	UNKWN	—	CAN COMM CIRCUIT (U100)	—
BCM	No indication	NG	UNKWN	UNKWN	—	—	—	UNKWN	—	UNKWN	CAN COMM CIRCUIT (U1000)	—
METER	No indication	—	UNKWN	UNKWN	UNKWN	—	UNKWN	—	UNKWN	UNKWN	CAN COMM CIRCUIT (U1000)	—
ABS	—	NG	UNKWN	—	UNKWN	—	—	—	—	—	CAN COMM CIRCUIT (U100)	—
IPDM E/R	No indication	—	UNKWN	UNKWN	—	—	UNKWN	—	—	—	CAN COMM CIRCUIT (U1000)	—

PKIC5638E

CAN SYSTEM (TYPE 2)

[CAN]

CAN SYSTEM (TYPE 2)

PF2:23710

Component Parts and Harness Connector Location

UKS0053E

A

Refer to [LAN-25, "Component Parts and Harness Connector Location"](#) .

Schematic

UKS0053F

B

Refer to [LAN-26, "Schematic"](#) .

Wiring Diagram — CAN —

UKS0053G

C

Refer to [LAN-27, "Wiring Diagram — CAN —"](#) .

D

E

F

G

H

I

J

LAN

L

M

CAN SYSTEM (TYPE 2)

[CAN]

Attach copy of ENGINE SELF-DIAG RESULTS	Attach copy of A/T SELF-DIAG RESULTS	Attach copy of BCM SELF-DIAG RESULTS
Attach copy of METER SELF-DIAG RESULTS	Attach copy of ABS SELF-DIAG RESULTS	Attach copy of IPDM E/R SELF-DIAG RESULTS
Attach copy of ENGINE CAN DIAG SUPPORT MNTR	Attach copy of A/T CAN DIAG SUPPORT MNTR	Attach copy of BCM CAN DIAG SUPPORT MNTR
Attach copy of METER CAN DIAG SUPPORT MNTR	Attach copy of ABS CAN DIAG SUPPORT MNTR	Attach copy of IPDM E/R CAN DIAG SUPPORT MNTR

A
B
C
D
E
F
G
H
I
J
L
M

LAN

PKIC7064E

CHECK SHEET RESULTS (EXAMPLE)

NOTE:

If a check mark is put on "NG" on "INITIAL DIAG (Initial diagnosis)", replace the control unit.

Case 1

Check harness between TCM and data link connector. Refer to [LAN-195, "Inspection Between TCM and Data Link Connector Circuit"](#).

SELECT SYSTEM screen		CAN DIAG SUPPORT MNTR									SELF-DIAG RESULTS	
		Initial diagnosis	Transmit diagnosis	Receive diagnosis								
				ECM	TCM	STRG	BCM /SEC	METER /M&A	VDC/TCS /ABS	IPDM E/R		
ENGINE	—	—	UNKWN	—	UNKWN	—	UNKWN	UNKWN	UNKWN	UNKWN	CAN COMM CIRCUIT (U1000)	CAN COMM CIRCUIT (U1001)
A/T	—	NG	UNKWN	UNKWN	—	—	—	UNKWN	UNKWN	—	CAN COMM CIRCUIT (U1000)	—
BCM	No indication	NG	UNKWN	UNKWN	—	—	—	UNKWN	—	UNKWN	CAN COMM CIRCUIT (U1000)	—
METER	No indication	—	UNKWN	UNKWN	UNKWN	—	UNKWN	—	UNKWN	UNKWN	CAN COMM CIRCUIT (U1000)	—
ABS	—	NG	UNKWN	UNKWN	UNKWN	UNKWN	—	—	—	—	CAN COMM CIRCUIT (U1000)	—
IPDM E/R	No indication	—	UNKWN	UNKWN	—	—	UNKWN	—	—	—	CAN COMM CIRCUIT (U1000)	—

PKIC5626E

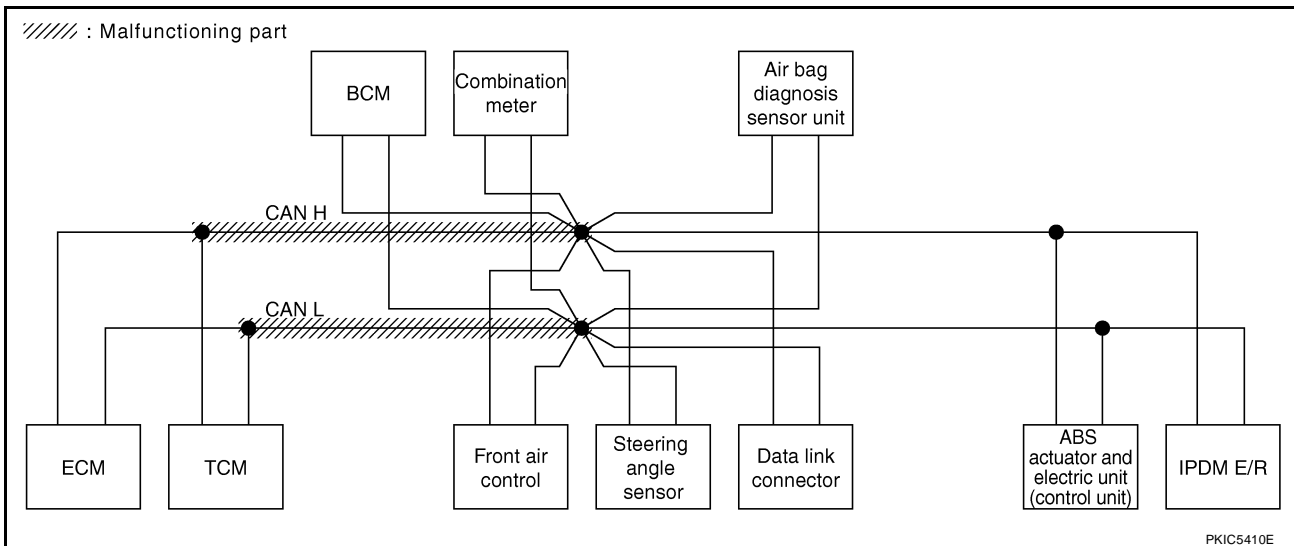

PKIC5410E

Case 2

Check harness between data link connector and ABS actuator and electric unit (control unit). Refer to [LAN-196, "Inspection Between Data Link Connector and ABS Actuator and Electric Unit \(Control Unit\) Circuit"](#).

SELECT SYSTEM screen		CAN DIAG SUPPORT MNTR										SELF-DIAG RESULTS	
		Initial diagnosis	Transmit diagnosis	Receive diagnosis							IPDM E/R		
				ECM	TCM	STRG	BCM /SEC	METER /M&A	VDC/TCS /ABS				
ENGINE	—	—	UNKWN	—	UNKWN	—	UNKWN	UNKWN	UNKWN	UNKWN	UNKWN	CAN COMM CIRCUIT (U1000)	CAN COMM CIRCUIT (U1001)
A/T	—	NG	UNKWN	UNKWN	—	—	—	UNKWN	UNKWN	—	—	CAN COMM CIRCUIT (U1000)	—
BCM	No indication	NG	UNKWN	UNKWN	—	—	—	UNKWN	—	UNKWN	UNKWN	CAN COMM CIRCUIT (U1000)	—
METER	No indication	—	UNKWN	UNKWN	UNKWN	—	UNKWN	—	UNKWN	UNKWN	UNKWN	CAN COMM CIRCUIT (U1000)	—
ABS	—	NG	UNKWN	UNKWN	UNKWN	—	—	—	—	—	—	CAN COMM CIRCUIT (U1000)	—
IPDM E/R	No indication	—	UNKWN	UNKWN	—	—	UNKWN	—	—	—	—	CAN COMM CIRCUIT (U1000)	—

PKIC5627E

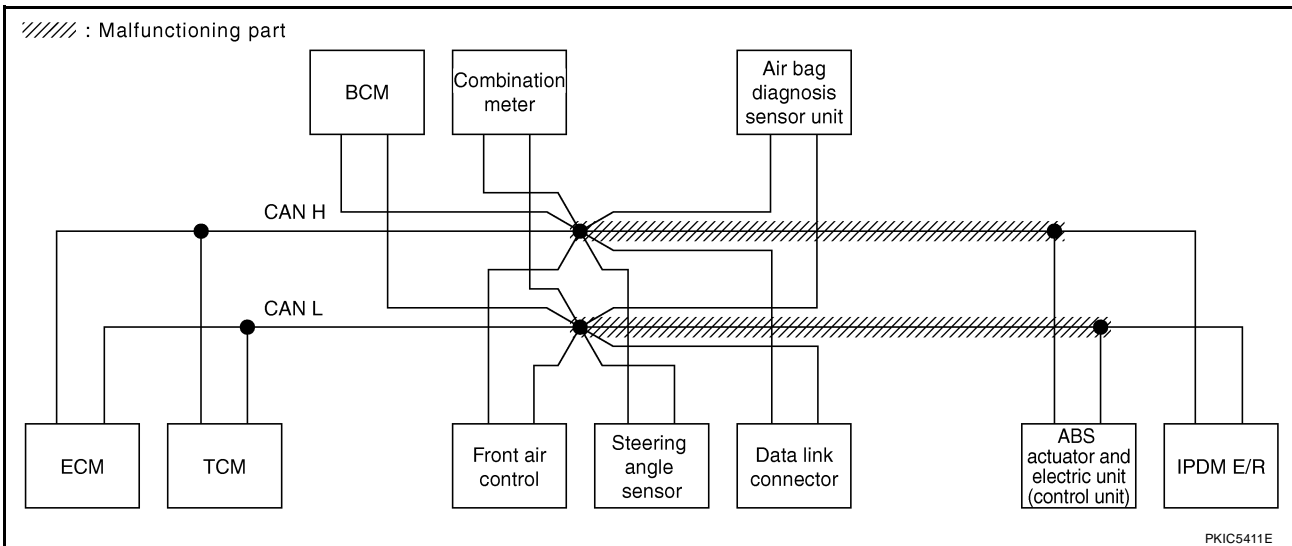

CAN SYSTEM (TYPE 2)

[CAN]

Case 3

Check ECM circuit. Refer to [LAN-197, "ECM Circuit Inspection"](#) .

SELECT SYSTEM screen		CAN DIAG SUPPORT MNTR									SELF-DIAG RESULTS	
		Initial diagnosis	Transmit diagnosis	Receive diagnosis								
				ECM	TCM	STRG	BCM /SEC	METER /M&A	VDC/TCS /ABS	IPDM E/R		
ENGINE	—	—	UNKW [✓]	—	UNKW [✓]	—	UNKW [✓]	UNKW [✓]	UNKW [✓]	UNKW [✓]	CAN COMM CIRCUIT (U100) [✓]	CAN COMM CIRCUIT (U101) [✓]
A/T	—	NG	UNKW [✓]	UNKW [✓]	—	—	—	UNKW [✓]	UNKW [✓]	—	CAN COMM CIRCUIT (U100) [✓]	—
BCM	No indication	NG	UNKW [✓]	UNKW [✓]	—	—	—	UNKW [✓]	—	UNKW [✓]	CAN COMM CIRCUIT (U1000) [✓]	—
METER	No indication	—	UNKW [✓]	UNKW [✓]	—	—	UNKW [✓]	—	UNKW [✓]	UNKW [✓]	CAN COMM CIRCUIT (U100) [✓]	—
ABS	—	NG	UNKW [✓]	UNKW [✓]	UNKW [✓]	—	—	—	—	—	CAN COMM CIRCUIT (U100) [✓]	—
IPDM E/R	No indication	—	UNKW [✓]	UNKW [✓]	—	—	UNKW [✓]	—	—	—	CAN COMM CIRCUIT (U100) [✓]	—

PKIC5628E

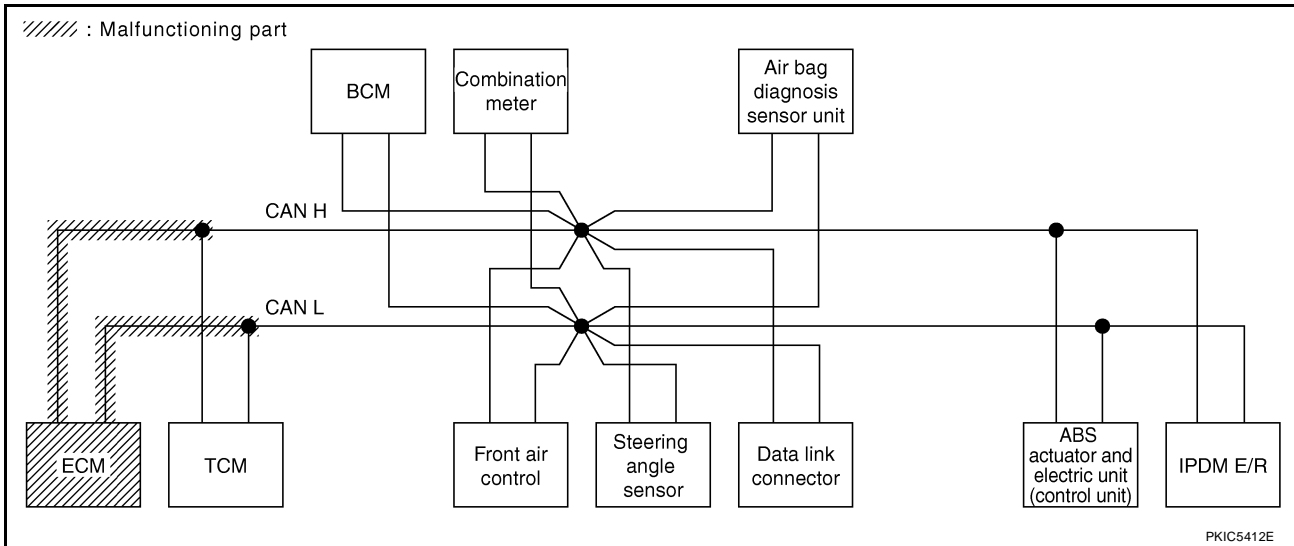

CAN SYSTEM (TYPE 2)

[CAN]

Case 4

Check TCM circuit. Refer to [LAN-197, "TCM Circuit Inspection"](#) .

SELECT SYSTEM screen		CAN DIAG SUPPORT MNTR									SELF-DIAG RESULTS	
		Initial diagnosis	Transmit diagnosis	Receive diagnosis						IPDM E/R		
				ECM	TCM	STRG	BCM /SEC	METER /M&A	VDC/TCS /ABS			
ENGINE	—	—	UNKWN	—	UNKWN	—	UNKWN	UNKWN	UNKWN	UNKWN	CAN COMM CIRCUIT (U100)	CAN COMM CIRCUIT (U101)
A/T	—	NG	UNKWN	UNKWN	—	—	—	UNKWN	UNKWN	—	CAN COMM CIRCUIT (U100)	—
BCM	No indication	NG	UNKWN	UNKWN	—	—	—	UNKWN	—	UNKWN	CAN COMM CIRCUIT (U1000)	—
METER	No indication	—	UNKWN	UNKWN	UNKWN	—	UNKWN	—	UNKWN	UNKWN	CAN COMM CIRCUIT (U100)	—
ABS	—	NG	UNKWN	UNKWN	UNKWN	UNKWN	—	—	—	—	CAN COMM CIRCUIT (U100)	—
IPDM E/R	No indication	—	UNKWN	UNKWN	—	—	UNKWN	—	—	—	CAN COMM CIRCUIT (U1000)	—

PKIC5629E

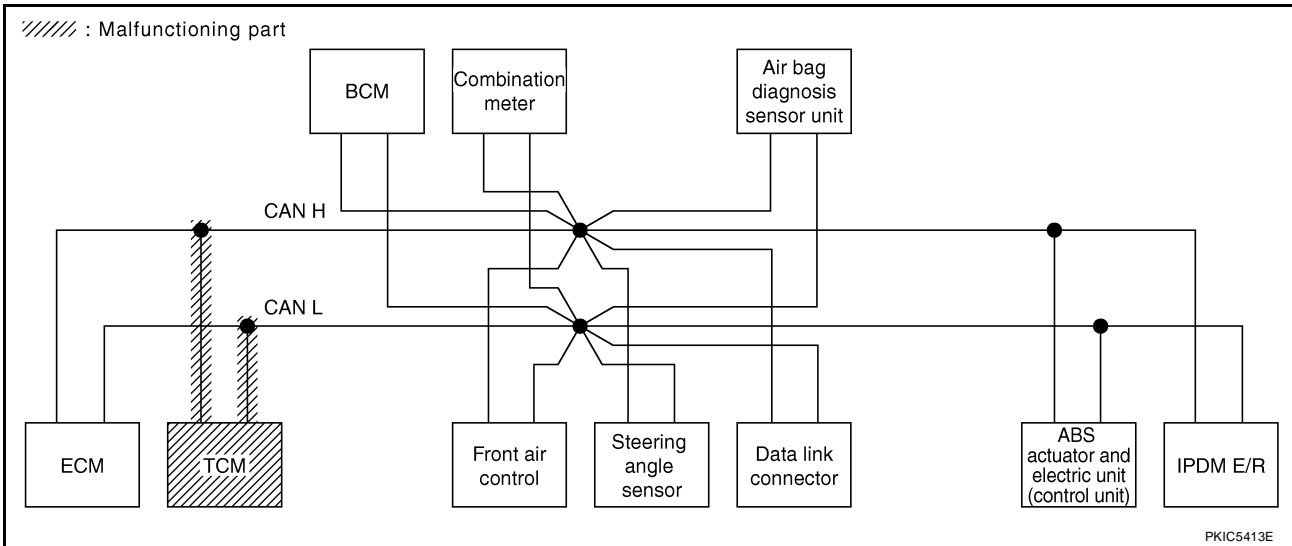

PKIC5413E

CAN SYSTEM (TYPE 2)

[CAN]

Case 5

Check steering angle sensor circuit. Refer to [LAN-199, "Steering Angle Sensor Circuit Inspection"](#) .

SELECT SYSTEM screen		CAN DIAG SUPPORT MNTR									SELF-DIAG RESULTS	
		Initial diagnosis	Transmit diagnosis	Receive diagnosis								
				ECM	TCM	STRG	BCM /SEC	METER /M&A	VDC/TCS /ABS	IPDM E/R		
ENGINE	—	—	UNKWN	—	UNKWN	—	UNKWN	UNKWN	UNKWN	UNKWN	CAN COMM CIRCUIT (U1000)	CAN COMM CIRCUIT (U1001)
A/T	—	NG	UNKWN	UNKWN	—	—	—	UNKWN	UNKWN	—	CAN COMM CIRCUIT (U1000)	—
BCM	No indication	NG	UNKWN	UNKWN	—	—	—	UNKWN	—	UNKWN	CAN COMM CIRCUIT (U1000)	—
METER	No indication	—	UNKWN	UNKWN	UNKWN	—	UNKWN	—	UNKWN	UNKWN	CAN COMM CIRCUIT (U1000)	—
ABS	—	NG	UNKWN	UNKWN	UNKWN	UNKWN	—	—	—	—	CAN COMM CIRCUIT (U1000)	—
IPDM E/R	No indication	—	UNKWN	UNKWN	—	—	UNKWN	—	—	—	CAN COMM CIRCUIT (U1000)	—

PKIC5630E

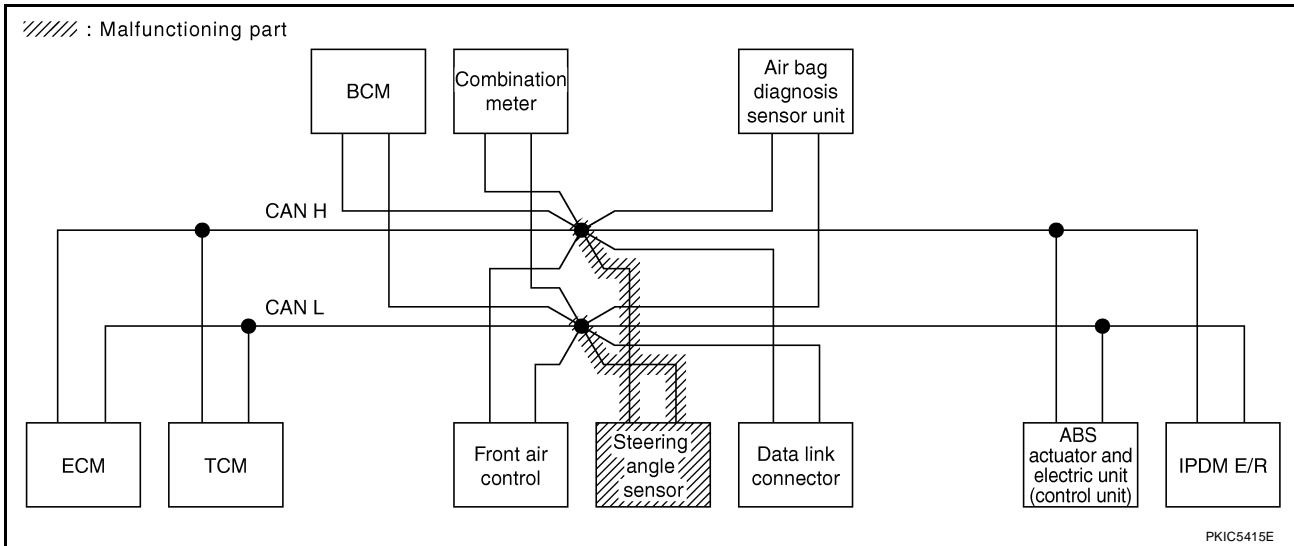

CAN SYSTEM (TYPE 2)

[CAN]

Case 6

Check data link connector circuit. Refer to [LAN-199, "Data Link Connector Circuit Inspection"](#).

SELECT SYSTEM screen		CAN DIAG SUPPORT MNTR									SELF-DIAG RESULTS	
		Initial diagnosis	Transmit diagnosis	Receive diagnosis								
				ECM	TCM	STRG	BCM /SEC	METER /M&A	VDC/TCS /ABS	IPDM E/R		
ENGINE	—	—	UNKWN	—	UNKWN	—	UNKWN	UNKWN	UNKWN	UNKWN	CAN COMM CIRCUIT (U1000)	CAN COMM CIRCUIT (U1001)
A/T	—	NG	UNKWN	UNKWN	—	—	—	UNKWN	UNKWN	—	CAN COMM CIRCUIT (U1000)	—
BCM	No indication	NG	UNKWN	UNKWN	—	—	—	UNKWN	—	UNKWN	CAN COMM CIRCUIT (U1000)	—
METER	No indication	—	UNKWN	UNKWN	UNKWN	—	UNKWN	—	UNKWN	UNKWN	CAN COMM CIRCUIT (U1000)	—
ABS	—	NG	UNKWN	UNKWN	UNKWN	UNKWN	—	—	—	—	CAN COMM CIRCUIT (U1000)	—
IPDM E/R	No indication	—	UNKWN	UNKWN	—	—	UNKWN	—	—	—	CAN COMM CIRCUIT (U1000)	—

PKIC5631E

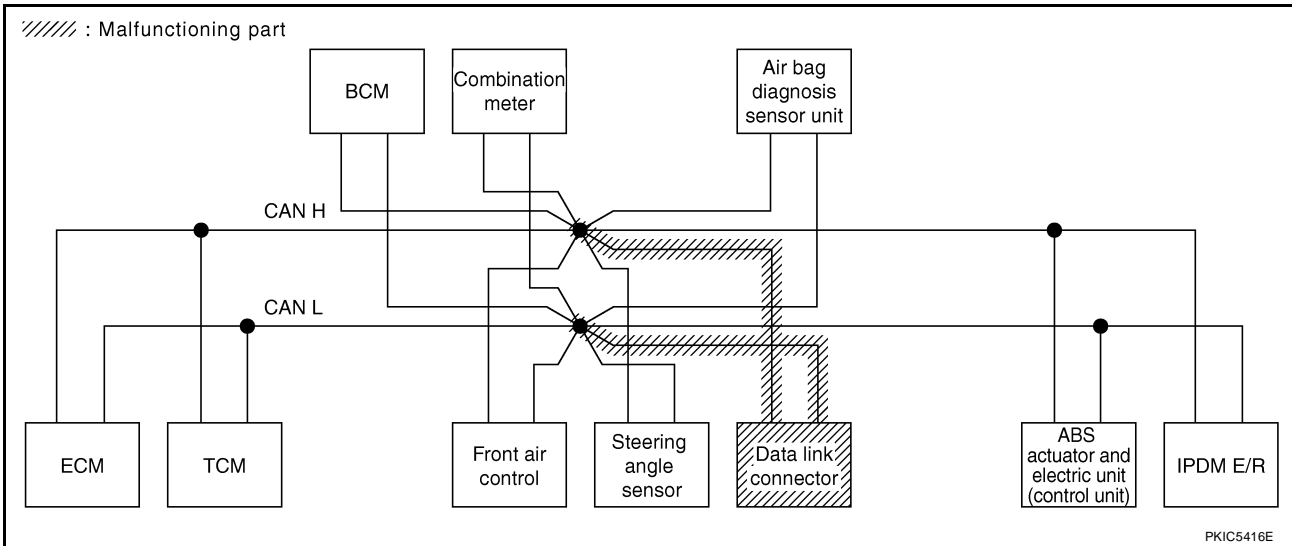

PKIC5416E

CAN SYSTEM (TYPE 2)

[CAN]

Case 7

Check BCM circuit. Refer to [LAN-200, "BCM Circuit Inspection"](#) .

SELECT SYSTEM screen		CAN DIAG SUPPORT MNTR									SELF-DIAG RESULTS	
		Initial diagnosis	Transmit diagnosis	Receive diagnosis								
				ECM	TCM	STRG	BCM /SEC	METER /M&A	VDC/TCS /ABS	IPDM E/R		
ENGINE	—	—	UNKWN	—	UNKWN	—	UNKWN	UNKWN	UNKWN	UNKWN	CAN COMM CIRCUIT (U1000)	CAN COMM CIRCUIT (U1001)
A/T	—	NG	UNKWN	UNKWN	—	—	—	UNKWN	UNKWN	—	CAN COMM CIRCUIT (U1000)	—
BCM	No indication	NG	UNKWN	UNKWN	—	—	—	UNKWN	—	UNKWN	CAN COMM CIRCUIT (U1000)	—
METER	No indication	—	UNKWN	UNKWN	UNKWN	—	UNKWN	—	UNKWN	UNKWN	CAN COMM CIRCUIT (U1000)	—
ABS	—	NG	UNKWN	UNKWN	UNKWN	UNKWN	—	—	—	—	CAN COMM CIRCUIT (U1000)	—
IPDM E/R	No indication	—	UNKWN	UNKWN	—	—	UNKWN	—	—	—	CAN COMM CIRCUIT (U1000)	—

PKIC5632E

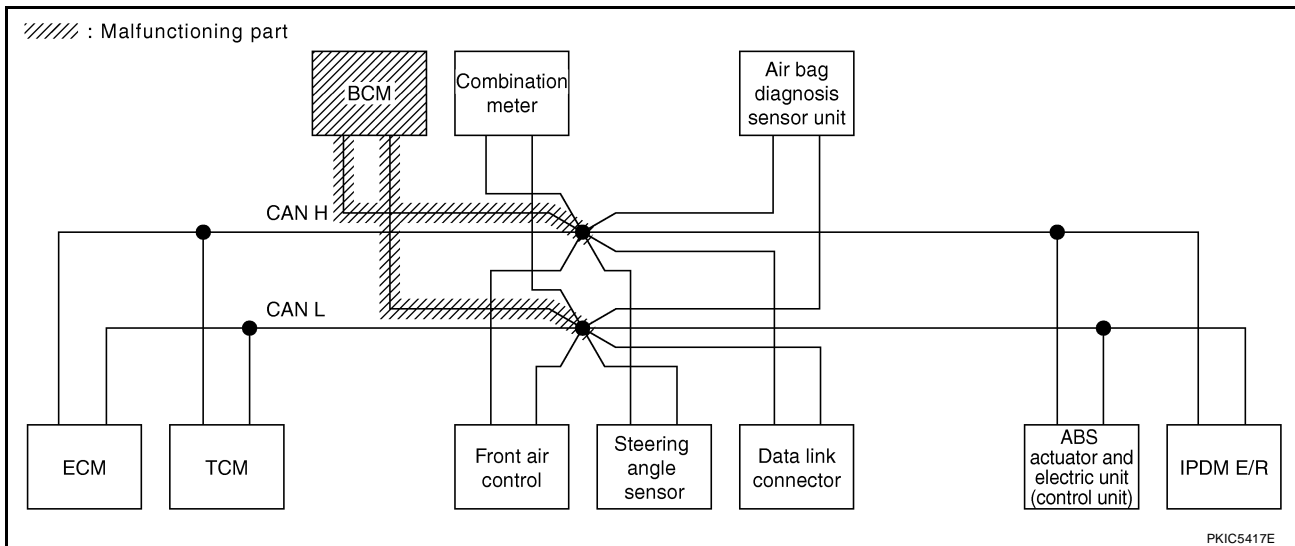

PKIC5417E

CAN SYSTEM (TYPE 2)

[CAN]

Case 8

Check combination meter circuit. Refer to [LAN-200, "Combination Meter Circuit Inspection"](#).

SELECT SYSTEM screen		CAN DIAG SUPPORT MNTR									SELF-DIAG RESULTS	
		Initial diagnosis	Transmit diagnosis	Receive diagnosis						IPDM E/R		
				ECM	TCM	STRG	BCM /SEC	METER /M&A	VDC/TCS /ABS			
ENGINE	—	—	UNKWN	—	UNKWN	—	UNKWN	UNKWN	UNKWN	UNKWN	CAN COMM CIRCUIT (U1000)	CAN COMM CIRCUIT (U1001)
A/T	—	NG	UNKWN	UNKWN	—	—	—	UNKWN	UNKWN	—	CAN COMM CIRCUIT (U1000)	—
BCM	No indication	NG	UNKWN	UNKWN	—	—	—	UNKWN	—	UNKWN	CAN COMM CIRCUIT (U1000)	—
METER	No indication	—	UNKWN	UNKWN	UNKWN	—	UNKWN	—	UNKWN	UNKWN	CAN COMM CIRCUIT (U1000)	—
ABS	—	NG	UNKWN	UNKWN	UNKWN	UNKWN	—	—	—	—	CAN COMM CIRCUIT (U1000)	—
IPDM E/R	No indication	—	UNKWN	UNKWN	—	—	UNKWN	—	—	—	CAN COMM CIRCUIT (U1000)	—

PKIC5633E

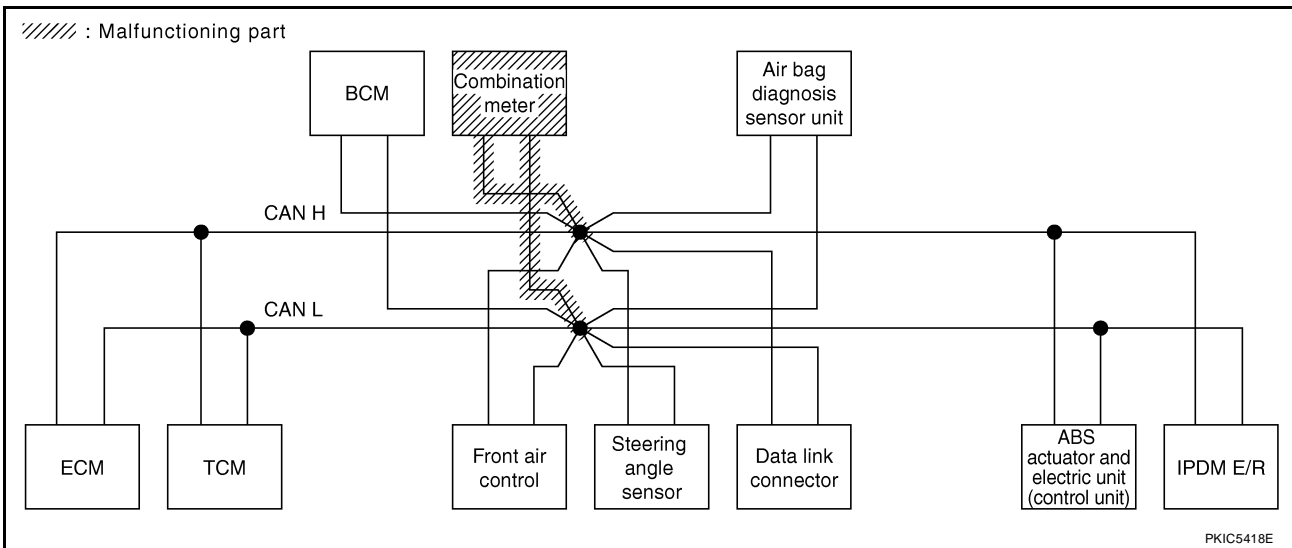

PKIC5418E

CAN SYSTEM (TYPE 2)

[CAN]

Case 9

Check ABS actuator and electric unit (control unit) circuit. Refer to [LAN-202, "ABS Actuator and Electric Unit \(Control Unit\) Circuit Inspection"](#) .

SELECT SYSTEM screen		CAN DIAG SUPPORT MNTR									SELF-DIAG RESULTS	
		Initial diagnosis	Transmit diagnosis	Receive diagnosis								
				ECM	TCM	STRG	BCM /SEC	METER /M&A	VDC/TCS /ABS	IPDM E/R		
ENGINE	—	—	UNKWN	—	UNKWN	—	UNKWN	UNKWN	UNKWN	UNKWN	CAN COMM CIRCUIT (U1000)	CAN COMM CIRCUIT (U1001)
A/T	—	NG	UNKWN	UNKWN	—	—	—	UNKWN	UNKWN	—	CAN COMM CIRCUIT (U1000)	—
BCM	No indication	NG	UNKWN	UNKWN	—	—	—	UNKWN	—	UNKWN	CAN COMM CIRCUIT (U1000)	—
METER	No indication	—	UNKWN	UNKWN	UNKWN	—	UNKWN	—	UNKWN	UNKWN	CAN COMM CIRCUIT (U1000)	—
ABS	—	✓	UNKWN	UNKWN	UNKWN	UNKWN	—	—	—	—	CAN COMM CIRCUIT (U1000)	—
IPDM E/R	No indication	—	UNKWN	UNKWN	—	—	UNKWN	—	—	—	CAN COMM CIRCUIT (U1000)	—

PKIC5634E

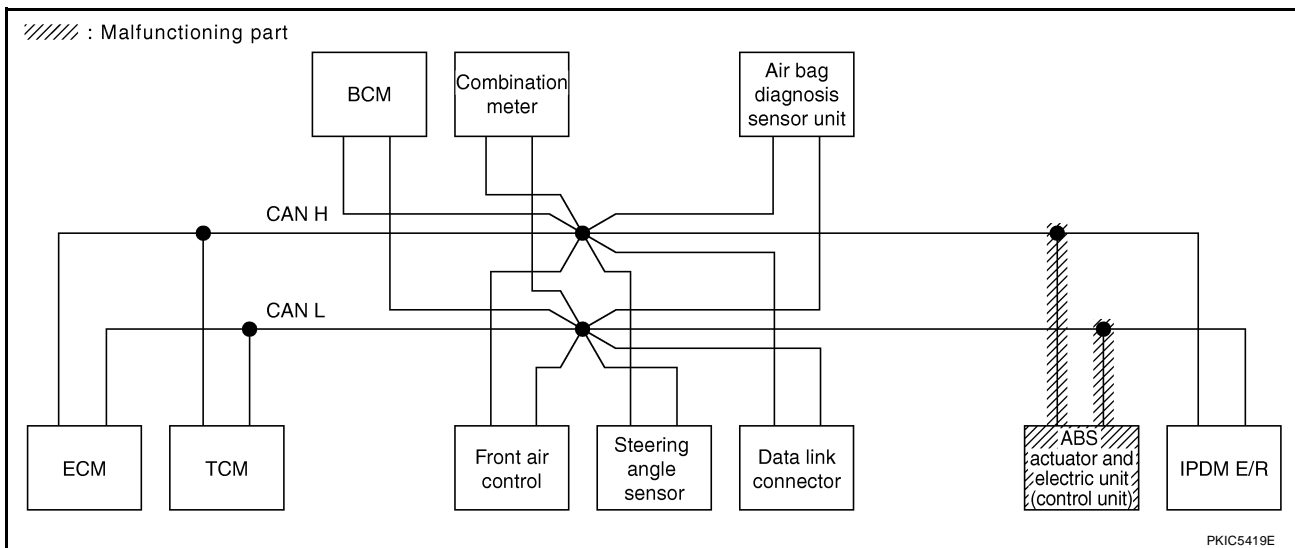

CAN SYSTEM (TYPE 2)

[CAN]

Case 10

Check IPDM E/R circuit. Refer to [LAN-203, "IPDM E/R Circuit Inspection"](#) .

SELECT SYSTEM screen		CAN DIAG SUPPORT MNTR									SELF-DIAG RESULTS		
		Initial diagnosis	Transmit diagnosis	Receive diagnosis									
				ECM	TCM	STRG	BCM /SEC	METER /M&A	VDC/TCS /ABS	IPDM E/R			
ENGINE	—	—	UNKWN	—	UNKWN	—	UNKWN	UNKWN	UNKWN	UNKWN	UNKWN	CAN COMM CIRCUIT (U1000)	CAN COMM CIRCUIT (U1001)
A/T	—	NG	UNKWN	UNKWN	—	—	—	UNKWN	UNKWN	—	—	CAN COMM CIRCUIT (U1000)	—
BCM	No indication	NG	UNKWN	UNKWN	—	—	—	UNKWN	—	UNKWN	UNKWN	CAN COMM CIRCUIT (U1000)	—
METER	No indication	—	UNKWN	UNKWN	UNKWN	—	UNKWN	—	UNKWN	UNKWN	UNKWN	CAN COMM CIRCUIT (U1000)	—
ABS	—	NG	UNKWN	UNKWN	UNKWN	UNKWN	—	—	—	—	—	CAN COMM CIRCUIT (U1000)	—
IPDM E/R	No indication	—	UNKWN	UNKWN	—	—	UNKWN	—	—	—	—	CAN COMM CIRCUIT (U1000)	—

PKIC5635E

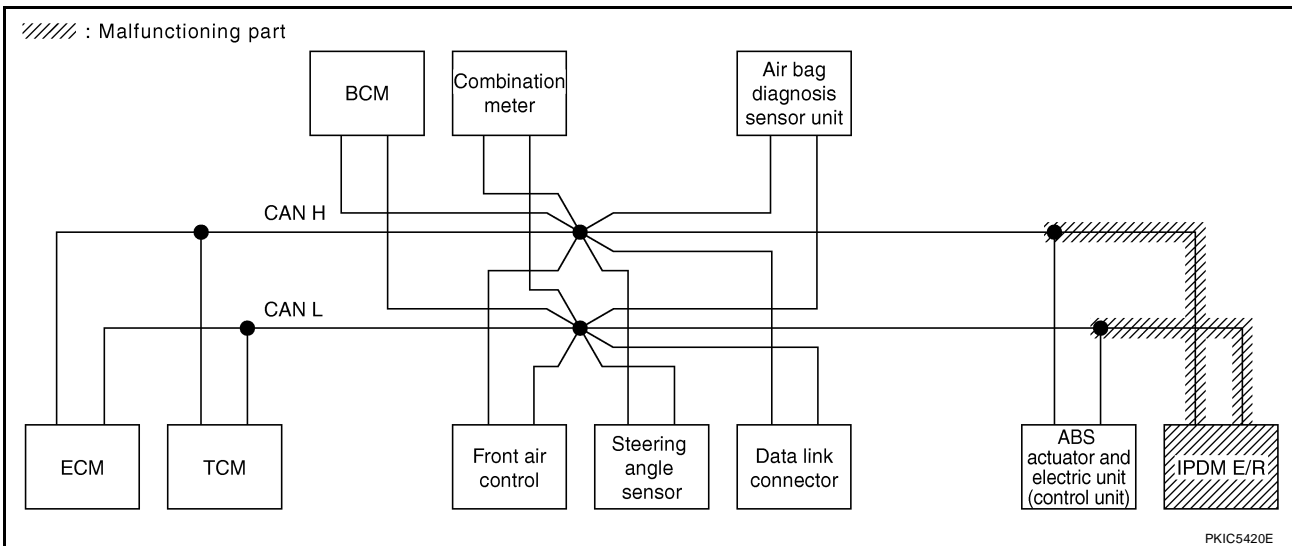

Case 11

Check CAN communication circuit. Refer to [LAN-203, "CAN Communication Circuit Inspection"](#) .

SELECT SYSTEM screen		CAN DIAG SUPPORT MNTR									SELF-DIAG RESULTS		
		Initial diagnosis	Transmit diagnosis	Receive diagnosis									
				ECM	TCM	STRG	BCM /SEC	METER /M&A	VDC/TCS /ABS	IPDM E/R			
ENGINE	—	—	UNKWN	—	UNKWN	—	UNKWN	UNKWN	UNKWN	UNKWN	UNKWN	CAN COMM CIRCUIT (U1000)	CAN COMM CIRCUIT (U1001)
A/T	—	NG	UNKWN	UNKWN	—	—	—	UNKWN	UNKWN	—	—	CAN COMM CIRCUIT (U1000)	—
BCM	No indication	NG	UNKWN	UNKWN	—	—	—	UNKWN	—	UNKWN	UNKWN	CAN COMM CIRCUIT (U1000)	—
METER	No indication	—	UNKWN	UNKWN	UNKWN	—	UNKWN	—	UNKWN	UNKWN	UNKWN	CAN COMM CIRCUIT (U1000)	—
ABS	—	NG	UNKWN	UNKWN	UNKWN	UNKWN	—	—	—	—	—	CAN COMM CIRCUIT (U1000)	—
IPDM E/R	No indication	—	UNKWN	UNKWN	—	—	UNKWN	—	—	—	—	CAN COMM CIRCUIT (U1000)	—

PKIC5636E

CAN SYSTEM (TYPE 2)

[CAN]

Case 12

Check IPDM E/R ignition relay circuit continuously sticks "OFF". Refer to [LAN-204, "IPDM E/R Ignition Relay Circuit Inspection"](#) .

SELECT SYSTEM screen		CAN DIAG SUPPORT MNTR									SELF-DIAG RESULTS	
		Initial diagnosis	Transmit diagnosis	Receive diagnosis								
				ECM	TCM	STRG	BCM /SEC	METER /M&A	VDC/TCS /ABS	IPDM E/R		
ENGINE	—	—	UNKWN	—	UNKWN ✓	—	UNKWN	UNKWN	UNKWN ✓	UNKWN	CAN COMM CIRCUIT (U100) ✓	CAN COMM CIRCUIT (U101) ✓
A/T	—	NG	UNKWN	UNKWN	—	—	—	UNKWN	UNKWN	—	CAN COMM CIRCUIT (U1000)	—
BCM	No indication	NG	UNKWN	UNKWN	—	—	—	UNKWN	—	UNKWN	CAN COMM CIRCUIT (U1000)	—
METER	No indication	—	UNKWN	UNKWN	UNKWN ✓	—	UNKWN	—	UNKWN ✓	UNKWN	CAN COMM CIRCUIT (U1000)	—
ABS	—	NG	UNKWN	UNKWN	UNKWN	UNKWN	—	—	—	—	CAN COMM CIRCUIT (U1000)	—
IPDM E/R	No indication	—	UNKWN	UNKWN	—	—	UNKWN	—	—	—	CAN COMM CIRCUIT (U1000)	—

PKIC5637E

Case 13

Check IPDM E/R ignition relay circuit continuously sticks "ON". Refer to [LAN-204, "IPDM E/R Ignition Relay Circuit Inspection"](#) .

SELECT SYSTEM screen		CAN DIAG SUPPORT MNTR									SELF-DIAG RESULTS	
		Initial diagnosis	Transmit diagnosis	Receive diagnosis								
				ECM	TCM	STRG	BCM /SEC	METER /M&A	VDC/TCS /ABS	IPDM E/R		
ENGINE	—	—	UNKWN	—	UNKWN	—	UNKWN	UNKWN	UNKWN	UNKWN	CAN COMM CIRCUIT (U1000)	CAN COMM CIRCUIT (U1001)
A/T	—	NG	UNKWN	—	—	—	—	—	UNKWN	—	CAN COMM CIRCUIT (U1000) ✓	—
BCM	No indication	NG	UNKWN	UNKWN	—	—	—	UNKWN	—	UNKWN	CAN COMM CIRCUIT (U1000)	—
METER	No indication	—	UNKWN	UNKWN	UNKWN	—	UNKWN	—	UNKWN	UNKWN	CAN COMM CIRCUIT (U1000)	—
ABS	—	NG	UNKWN	—	UNKWN	—	—	—	—	—	CAN COMM CIRCUIT (U1000) ✓	—
IPDM E/R	No indication	—	UNKWN	UNKWN	—	—	UNKWN	—	—	—	CAN COMM CIRCUIT (U1000)	—

PKIC5638E

CAN SYSTEM (TYPE 3)

[CAN]

CAN SYSTEM (TYPE 3)

PF:23710

Component Parts and Harness Connector Location

UKS00536

Refer to [LAN-25, "Component Parts and Harness Connector Location"](#) .

Schematic

UKS00537

Refer to [LAN-26, "Schematic"](#) .

Wiring Diagram — CAN —

UKS00538

Refer to [LAN-27, "Wiring Diagram — CAN —"](#) .

A

B

C

D

E

F

G

H

I

J

LAN

L

M

CAN SYSTEM (TYPE 3)

[CAN]

UKS00539

Check Sheet

NOTE:

If a check mark is put on "NG" on "INITIAL DIAG (Initial diagnosis)", replace the control unit.

Check sheet table												
SELECT SYSTEM screen		CAN DIAG SUPPORT MNTR									SELF-DIAG RESULTS	
		Initial diagnosis	Transmit diagnosis	Receive diagnosis						IPDM E/R		
				ECM	TCM	STRG	BCM /SEC	METER /M&A	VDC/TCS /ABS			
ENGINE	—	—	UNKWN	—	UNKWN	—	UNKWN	UNKWN	UNKWN	UNKWN	CAN COMM CIRCUIT (U1000)	CAN COMM CIRCUIT (U1001)
A/T	—	NG	UNKWN	UNKWN	—	—	—	UNKWN	UNKWN	—	CAN COMM CIRCUIT (U1000)	—
BCM	No indication	NG	UNKWN	UNKWN	—	—	—	UNKWN	—	UNKWN	CAN COMM CIRCUIT (U1000)	—
METER	No indication	—	UNKWN	UNKWN	UNKWN	—	UNKWN	—	UNKWN	UNKWN	CAN COMM CIRCUIT (U1000)	—
AUTO DRIVE POS.	No indication	—	—	—	UNKWN	—	UNKWN	UNKWN	—	—	CAN COMM CIRCUIT (U1000)	—
ABS	—	NG	UNKWN	UNKWN	UNKWN	UNKWN	—	—	—	—	CAN COMM CIRCUIT (U1000)	—
IPDM E/R	No indication	—	UNKWN	UNKWN	—	—	UNKWN	—	—	—	CAN COMM CIRCUIT (U1000)	—

Symptoms :

Attach copy of
SELECT SYSTEM

Attach copy of
SELECT SYSTEM

PKIC5639E

CAN SYSTEM (TYPE 3)

[CAN]

Attach copy of ENGINE SELF-DIAG RESULTS	Attach copy of A/T SELF-DIAG RESULTS	Attach copy of BCM SELF-DIAG RESULTS	Attach copy of METER SELF-DIAG RESULTS
Attach copy of AUTO DRIVE POS. SELF-DIAG RESULTS	Attach copy of ABS SELF-DIAG RESULTS	Attach copy of IPDM E/R SELF-DIAG RESULTS	
Attach copy of ENGINE CAN DIAG SUPPORT MNTR	Attach copy of A/T CAN DIAG SUPPORT MNTR	Attach copy of BCM CAN DIAG SUPPORT MNTR	Attach copy of METER CAN DIAG SUPPORT MNTR
Attach copy of AUTO DRIVE POS. CAN DIAG SUPPORT MNTR	Attach copy of ABS CAN DIAG SUPPORT MNTR	Attach copy of IPDM E/R CAN DIAG SUPPORT MNTR	

A
B
C
D
E
F
G
H
I
J
L
M

LAN

PKIC7065E

CHECK SHEET RESULTS (EXAMPLE)

NOTE:

If a check mark is put on "NG" on "INITIAL DIAG (Initial diagnosis)", replace the control unit.

Case 1

Check harness between TCM and data link connector. Refer to [LAN-195, "Inspection Between TCM and Data Link Connector Circuit"](#).

SELECT SYSTEM screen		CAN DIAG SUPPORT MNTR									SELF-DIAG RESULTS	
		Initial diagnosis	Transmit diagnosis	Receive diagnosis								
				ECM	TCM	STRG	BCM /SEC	METER /M&A	VDC/TCS /ABS	IPDM E/R		
ENGINE	—	—	UNKWN	—	UNKWN	—	UNKWN	UNKWN	UNKWN	UNKWN	CAN COMM CIRCUIT (U1000)	CAN COMM CIRCUIT (U001)
A/T	—	NG	UNKWN	UNKWN	—	—	—	UNKWN	UNKWN	—	CAN COMM CIRCUIT (U000)	—
BCM	No indication	NG	UNKWN	UNKWN	—	—	—	UNKWN	—	UNKWN	CAN COMM CIRCUIT (U1000)	—
METER	No indication	—	UNKWN	UNKWN	UNKWN	—	UNKWN	—	UNKWN	UNKWN	CAN COMM CIRCUIT (U000)	—
AUTO DRIVE POS.	No indication	—	—	—	UNKWN	—	UNKWN	UNKWN	—	—	CAN COMM CIRCUIT (U000)	—
ABS	—	NG	UNKWN	UNKWN	UNKWN	—	—	—	—	—	CAN COMM CIRCUIT (U000)	—
IPDM E/R	No indication	—	UNKWN	UNKWN	—	—	UNKWN	—	—	—	CAN COMM CIRCUIT (U000)	—

PKIC5640E

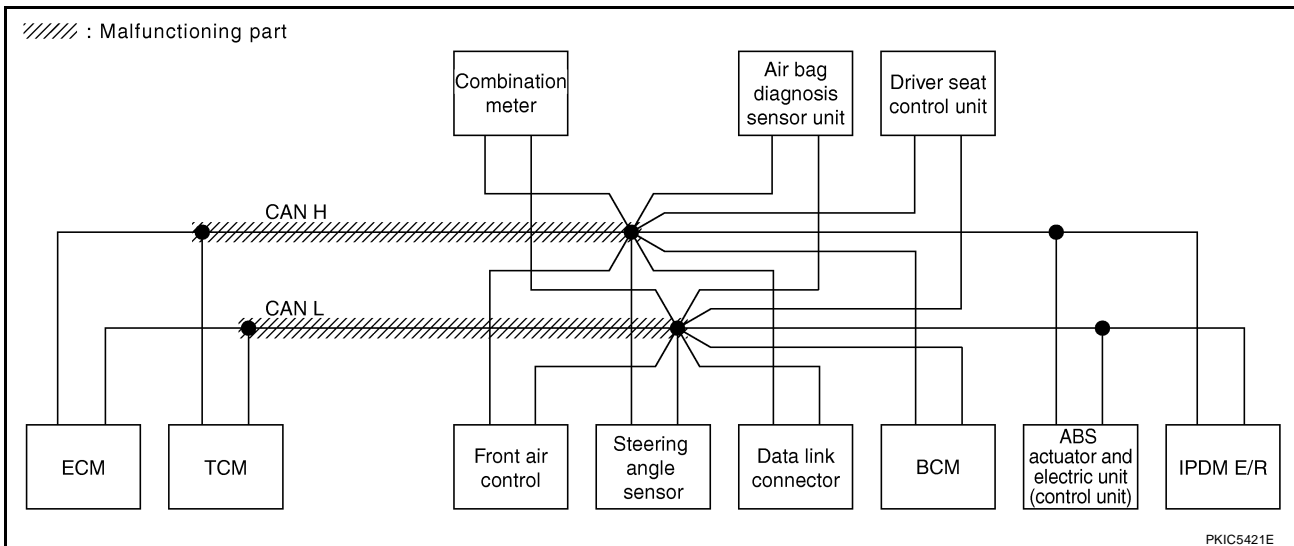

CAN SYSTEM (TYPE 3)

[CAN]

Case 2

Check harness between data link connector and ABS actuator and electric unit (control unit). Refer to [LAN-196, "Inspection Between Data Link Connector and ABS Actuator and Electric Unit \(Control Unit\) Circuit"](#).

SELECT SYSTEM screen		CAN DIAG SUPPORT MNTR									SELF-DIAG RESULTS		
		Initial diagnosis	Transmit diagnosis	Receive diagnosis						IPDM E/R			
				ECM	TCM	STRG	BCM /SEC	METER /M&A	VDC/TCS /ABS				
ENGINE	—	—	UNKWN	—	UNKWN	—	UNKWN	UNKWN	UNKWN	UNKWN	UNKWN	CAN COMM CIRCUIT (U1000)	CAN COMM CIRCUIT (U1001)
A/T	—	NG	UNKWN	UNKWN	—	—	—	UNKWN	UNKWN	—	—	CAN COMM CIRCUIT (U1000)	—
BCM	No indication	NG	UNKWN	UNKWN	—	—	—	UNKWN	—	UNKWN	—	CAN COMM CIRCUIT (U1000)	—
METER	No indication	—	UNKWN	UNKWN	UNKWN	—	UNKWN	—	UNKWN	UNKWN	UNKWN	CAN COMM CIRCUIT (U1000)	—
AUTO DRIVE POS.	No indication	—	—	—	UNKWN	—	UNKWN	UNKWN	—	—	—	CAN COMM CIRCUIT (U1000)	—
ABS	—	NG	UNKWN	UNKWN	UNKWN	—	—	—	—	—	—	CAN COMM CIRCUIT (U1000)	—
IPDM E/R	No indication	—	UNKWN	UNKWN	—	—	UNKWN	—	—	—	—	CAN COMM CIRCUIT (U1000)	—

PKIC5642E

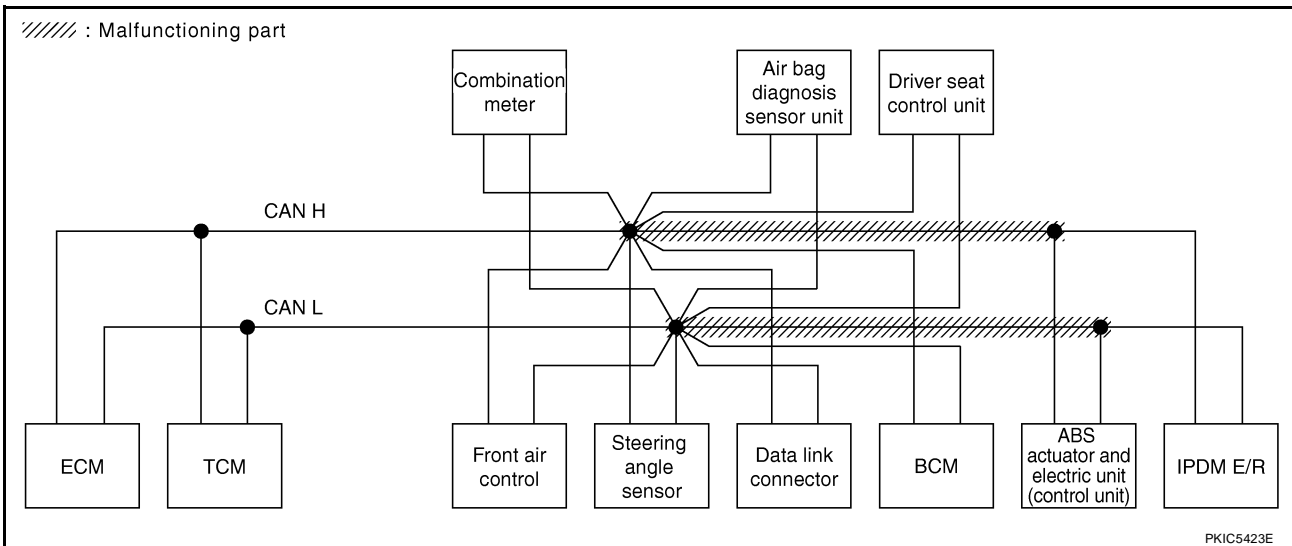

CAN SYSTEM (TYPE 3)

[CAN]

Case 3

Check ECM circuit. Refer to [LAN-197, "ECM Circuit Inspection"](#) .

SELECT SYSTEM screen		CAN DIAG SUPPORT MNTR									SELF-DIAG RESULTS	
		Initial diagnosis	Transmit diagnosis	Receive diagnosis								
				ECM	TCM	STRG	BCM /SEC	METER /M&A	VDC/TCS /ABS	IPDM E/R		
ENGINE	—	—	UNKW [✓]	—	UNKW [✓]	—	UNKW [✓]	UNKW [✓]	UNKW [✓]	UNKW [✓]	CAN COMM CIRCUIT (U1000) [✓]	CAN COMM CIRCUIT (U1001) [✓]
A/T	—	NG	UNKW [✓]	UNKW [✓]	—	—	—	UNKW [✓]	UNKW [✓]	—	CAN COMM CIRCUIT (U1000) [✓]	—
BCM	No indication	NG	UNKW [✓]	UNKW [✓]	—	—	—	UNKW [✓]	—	UNKW [✓]	CAN COMM CIRCUIT (U1000) [✓]	—
METER	No indication	—	UNKW [✓]	UNKW [✓]	—	—	UNKW [✓]	—	UNKW [✓]	UNKW [✓]	CAN COMM CIRCUIT (U1000) [✓]	—
AUTO DRIVE POS.	No indication	—	—	—	UNKW [✓]	—	UNKW [✓]	UNKW [✓]	—	—	CAN COMM CIRCUIT (U1000) [✓]	—
ABS	—	NG	UNKW [✓]	UNKW [✓]	UNKW [✓]	—	—	—	—	—	CAN COMM CIRCUIT (U1000) [✓]	—
IPDM E/R	No indication	—	UNKW [✓]	UNKW [✓]	—	—	UNKW [✓]	—	—	—	CAN COMM CIRCUIT (U1000) [✓]	—

PKIC5643E

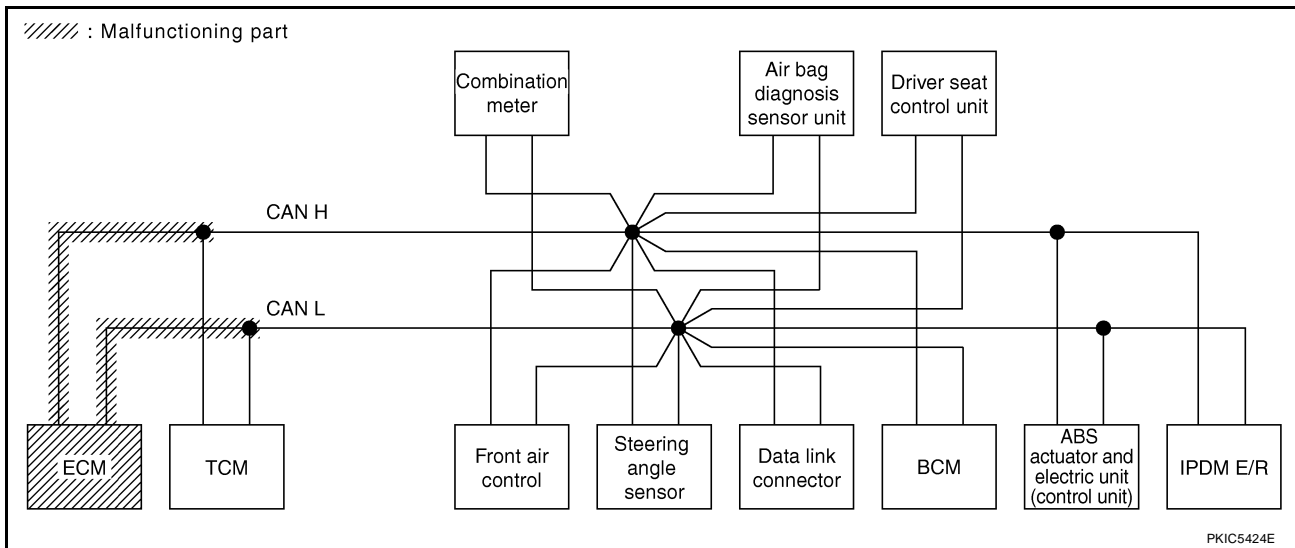

CAN SYSTEM (TYPE 3)

[CAN]

Case 4

Check TCM circuit. Refer to [LAN-197, "TCM Circuit Inspection"](#) .

SELECT SYSTEM screen		CAN DIAG SUPPORT MNTR									SELF-DIAG RESULTS	
		Initial diagnosis	Transmit diagnosis	Receive diagnosis						IPDM E/R		
				ECM	TCM	STRG	BCM /SEC	METER /M&A	VDC/TCS /ABS			
ENGINE	—	—	UNKWN	—	UNKWN ✓	—	UNKWN	UNKWN	UNKWN	UNKWN	CAN COMM CIRCUIT (U100) ✓	CAN COMM CIRCUIT (U101) ✓
A/T	—	NG	UNKWN	UNKWN ✓	—	—	—	UNKWN ✓	UNKWN ✓	—	CAN COMM CIRCUIT (U100) ✓	—
BCM	No indication	NG	UNKWN	UNKWN	—	—	—	UNKWN	—	UNKWN	CAN COMM CIRCUIT (U1000)	—
METER	No indication	—	UNKWN	UNKWN	UNKWN ✓	—	UNKWN	—	UNKWN	UNKWN	CAN COMM CIRCUIT (U100) ✓	—
AUTO DRIVE POS.	No indication	—	—	—	UNKWN ✓	—	UNKWN	UNKWN	—	—	CAN COMM CIRCUIT (U100) ✓	—
ABS	—	NG	UNKWN	UNKWN	UNKWN ✓	UNKWN	—	—	—	—	CAN COMM CIRCUIT (U100) ✓	—
IPDM E/R	No indication	—	UNKWN	UNKWN	—	—	UNKWN	—	—	—	CAN COMM CIRCUIT (U1000)	—

PKIC5644E

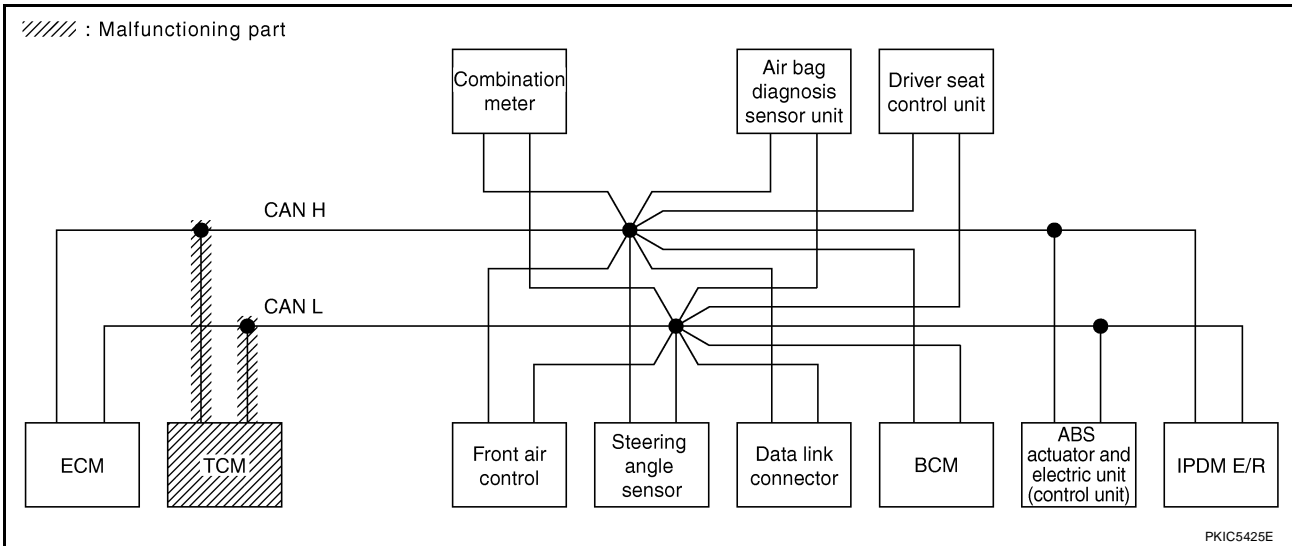

CAN SYSTEM (TYPE 3)

[CAN]

Case 5

Check steering angle sensor circuit. Refer to [LAN-199, "Steering Angle Sensor Circuit Inspection"](#) .

SELECT SYSTEM screen		CAN DIAG SUPPORT MNTR									SELF-DIAG RESULTS	
		Initial diagnosis	Transmit diagnosis	Receive diagnosis								
				ECM	TCM	STRG	BCM /SEC	METER /M&A	VDC/TCS /ABS	IPDM E/R		
ENGINE	—	—	UNKWN	—	UNKWN	—	UNKWN	UNKWN	UNKWN	UNKWN	CAN COMM CIRCUIT (U1000)	CAN COMM CIRCUIT (U1001)
A/T	—	NG	UNKWN	UNKWN	—	—	—	UNKWN	UNKWN	—	CAN COMM CIRCUIT (U1000)	—
BCM	No indication	NG	UNKWN	UNKWN	—	—	—	UNKWN	—	UNKWN	CAN COMM CIRCUIT (U1000)	—
METER	No indication	—	UNKWN	UNKWN	UNKWN	—	UNKWN	—	UNKWN	UNKWN	CAN COMM CIRCUIT (U1000)	—
AUTO DRIVE POS.	No indication	—	—	—	UNKWN	—	UNKWN	UNKWN	—	—	CAN COMM CIRCUIT (U1000)	—
ABS	—	NG	UNKWN	UNKWN	UNKWN	UNKWN	—	—	—	—	CAN COMM CIRCUIT (U1000)	—
IPDM E/R	No indication	—	UNKWN	UNKWN	—	—	UNKWN	—	—	—	CAN COMM CIRCUIT (U1000)	—

PKIC5645E

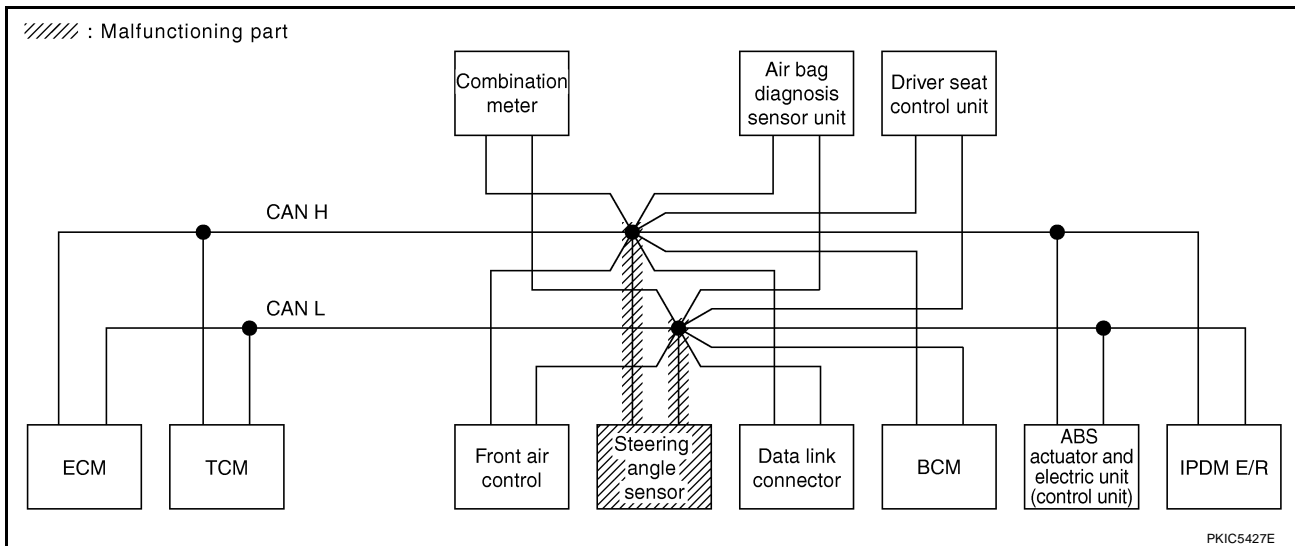

PKIC5427E

CAN SYSTEM (TYPE 3)

[CAN]

Case 6

Check data link connector circuit. Refer to [LAN-199, "Data Link Connector Circuit Inspection"](#) .

SELECT SYSTEM screen		CAN DIAG SUPPORT MNTR									SELF-DIAG RESULTS	
		Initial diagnosis	Transmit diagnosis	Receive diagnosis						IPDM E/R		
				ECM	TCM	STRG	BCM /SEC	METER /M&A	VDC/TCS /ABS			
ENGINE	—	—	UNKWN	—	UNKWN	—	UNKWN	UNKWN	UNKWN	UNKWN	CAN COMM CIRCUIT (U1000)	CAN COMM CIRCUIT (U1001)
A/T	—	NG	UNKWN	UNKWN	—	—	—	UNKWN	UNKWN	—	CAN COMM CIRCUIT (U1000)	—
BCM	No indication	NG	UNKWN	UNKWN	—	—	—	UNKWN	—	UNKWN	CAN COMM CIRCUIT (U1000)	—
METER	No indication	—	UNKWN	UNKWN	UNKWN	—	UNKWN	—	UNKWN	UNKWN	CAN COMM CIRCUIT (U1000)	—
AUTO DRIVE POS.	No indication	—	—	—	UNKWN	—	UNKWN	UNKWN	—	—	CAN COMM CIRCUIT (U1000)	—
ABS	—	NG	UNKWN	UNKWN	UNKWN	UNKWN	—	—	—	—	CAN COMM CIRCUIT (U1000)	—
IPDM E/R	No indication	—	UNKWN	UNKWN	—	—	UNKWN	—	—	—	CAN COMM CIRCUIT (U1000)	—

PKIC5646E

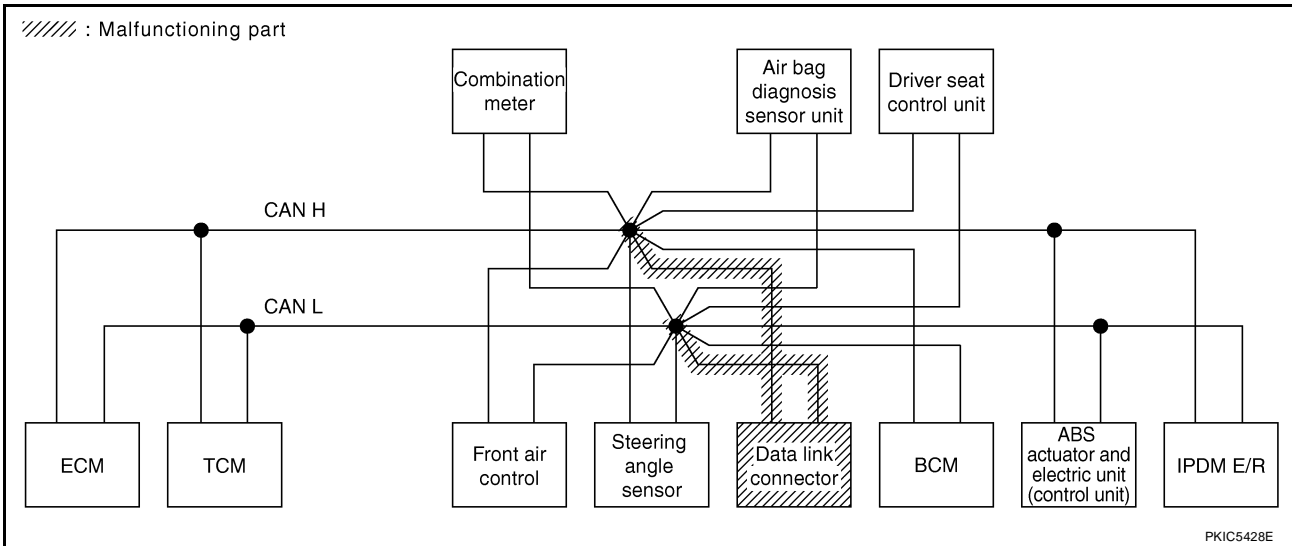

PKIC5428E

CAN SYSTEM (TYPE 3)

[CAN]

Case 7

Check BCM circuit. Refer to [LAN-200, "BCM Circuit Inspection"](#) .

SELECT SYSTEM screen		CAN DIAG SUPPORT MNTR									SELF-DIAG RESULTS	
		Initial diagnosis	Transmit diagnosis	Receive diagnosis								
				ECM	TCM	STRG	BCM /SEC	METER /M&A	VDC/TCS /ABS	IPDM E/R		
ENGINE	—	—	UNKWN	—	UNKWN	—	UNKWN	UNKWN	UNKWN	UNKWN	CAN COMM CIRCUIT (U1000)	CAN COMM CIRCUIT (U1001)
A/T	—	NG	UNKWN	UNKWN	—	—	—	UNKWN	UNKWN	—	CAN COMM CIRCUIT (U1000)	—
BCM	No indication	NG	UNKWN	UNKWN	—	—	—	UNKWN	—	UNKWN	CAN COMM CIRCUIT (U1000)	—
METER	No indication	—	UNKWN	UNKWN	UNKWN	—	UNKWN	—	UNKWN	UNKWN	CAN COMM CIRCUIT (U1000)	—
AUTO DRIVE POS.	No indication	—	—	—	UNKWN	—	UNKWN	UNKWN	—	—	CAN COMM CIRCUIT (U1000)	—
ABS	—	NG	UNKWN	UNKWN	UNKWN	UNKWN	—	—	—	—	CAN COMM CIRCUIT (U1000)	—
IPDM E/R	No indication	—	UNKWN	UNKWN	—	—	UNKWN	—	—	—	CAN COMM CIRCUIT (U1000)	—

PKIC5647E

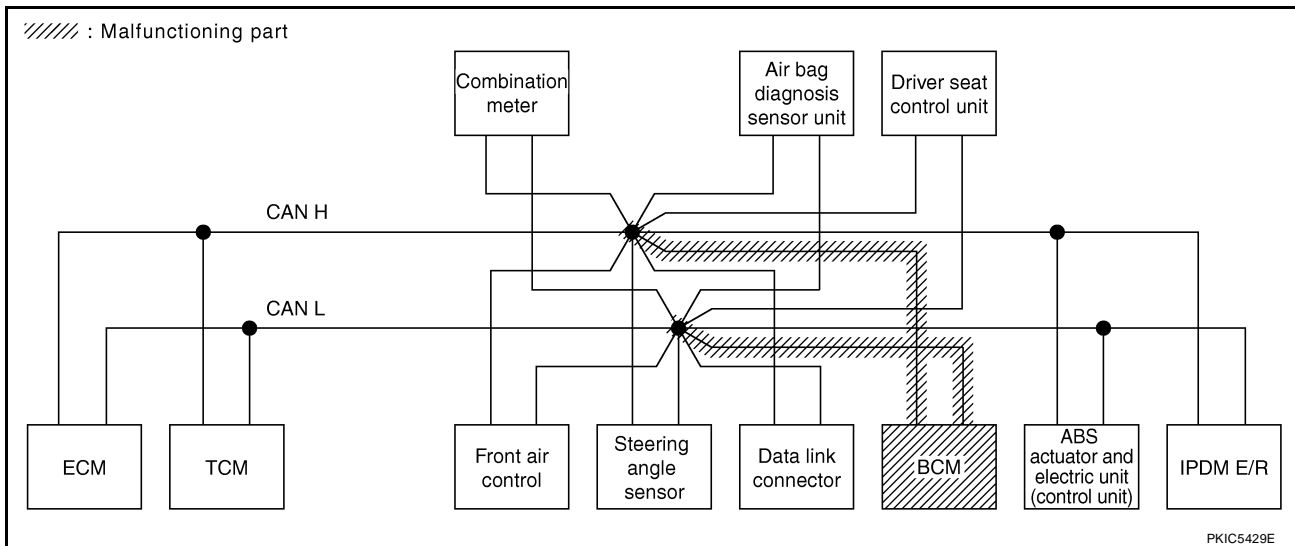

PKIC5429E

Case 8

Check combination meter circuit. Refer to [LAN-200, "Combination Meter Circuit Inspection"](#) .

SELECT SYSTEM screen		CAN DIAG SUPPORT MNTR									SELF-DIAG RESULTS	
		Initial diagnosis	Transmit diagnosis	Receive diagnosis						IPDM E/R		
				ECM	TCM	STRG	BCM /SEC	METER /M&A	VDC/TCS /ABS			
ENGINE	—	—	UNKWN	—	UNKWN	—	UNKWN	UNKWN	UNKWN	UNKWN	CAN COMM CIRCUIT (U1000)	CAN COMM CIRCUIT (U1001)
A/T	—	NG	UNKWN	UNKWN	—	—	—	UNKWN	UNKWN	—	CAN COMM CIRCUIT (U1000)	—
BCM	No indication	NG	UNKWN	UNKWN	—	—	—	UNKWN	—	UNKWN	CAN COMM CIRCUIT (U1000)	—
METER	No indication	—	UNKWN	UNKWN	UNKWN	—	UNKWN	—	UNKWN	UNKWN	CAN COMM CIRCUIT (U1000)	—
AUTO DRIVE POS.	No indication	—	—	—	UNKWN	—	UNKWN	UNKWN	—	—	CAN COMM CIRCUIT (U1000)	—
ABS	—	NG	UNKWN	UNKWN	UNKWN	UNKWN	—	—	—	—	CAN COMM CIRCUIT (U1000)	—
IPDM E/R	No indication	—	UNKWN	UNKWN	—	—	UNKWN	—	—	—	CAN COMM CIRCUIT (U1000)	—

PKIC5648E

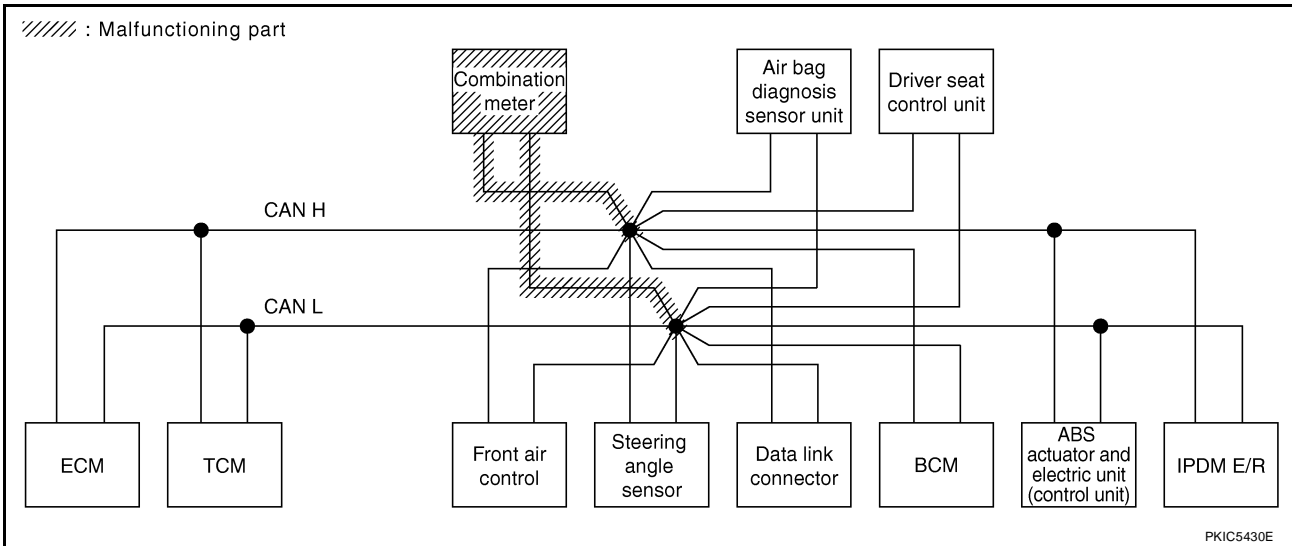

CAN SYSTEM (TYPE 3)

[CAN]

Case 9

Check driver seat control unit circuit. Refer to [LAN-202, "Driver Seat Control Unit Circuit Inspection"](#) .

SELECT SYSTEM screen		CAN DIAG SUPPORT MNTR									SELF-DIAG RESULTS	
		Initial diagnosis	Transmit diagnosis	Receive diagnosis								
				ECM	TCM	STRG	BCM /SEC	METER /M&A	VDC/TCS /ABS	IPDM E/R		
ENGINE	—	—	UNKWN	—	UNKWN	—	UNKWN	UNKWN	UNKWN	UNKWN	CAN COMM CIRCUIT (U1000)	CAN COMM CIRCUIT (U1001)
A/T	—	NG	UNKWN	UNKWN	—	—	—	UNKWN	UNKWN	—	CAN COMM CIRCUIT (U1000)	—
BCM	No indication	NG	UNKWN	UNKWN	—	—	—	UNKWN	—	UNKWN	CAN COMM CIRCUIT (U1000)	—
METER	No indication	—	UNKWN	UNKWN	UNKWN	—	UNKWN	—	UNKWN	UNKWN	CAN COMM CIRCUIT (U1000)	—
AUTO DRIVE POS.	No indication	—	—	—	UNKWN	—	UNKWN	UNKWN	—	—	CAN COMM CIRCUIT (U1000)	—
ABS	—	NG	UNKWN	UNKWN	UNKWN	UNKWN	—	—	—	—	CAN COMM CIRCUIT (U1000)	—
IPDM E/R	No indication	—	UNKWN	UNKWN	—	—	UNKWN	—	—	—	CAN COMM CIRCUIT (U1000)	—

PKIC5649E

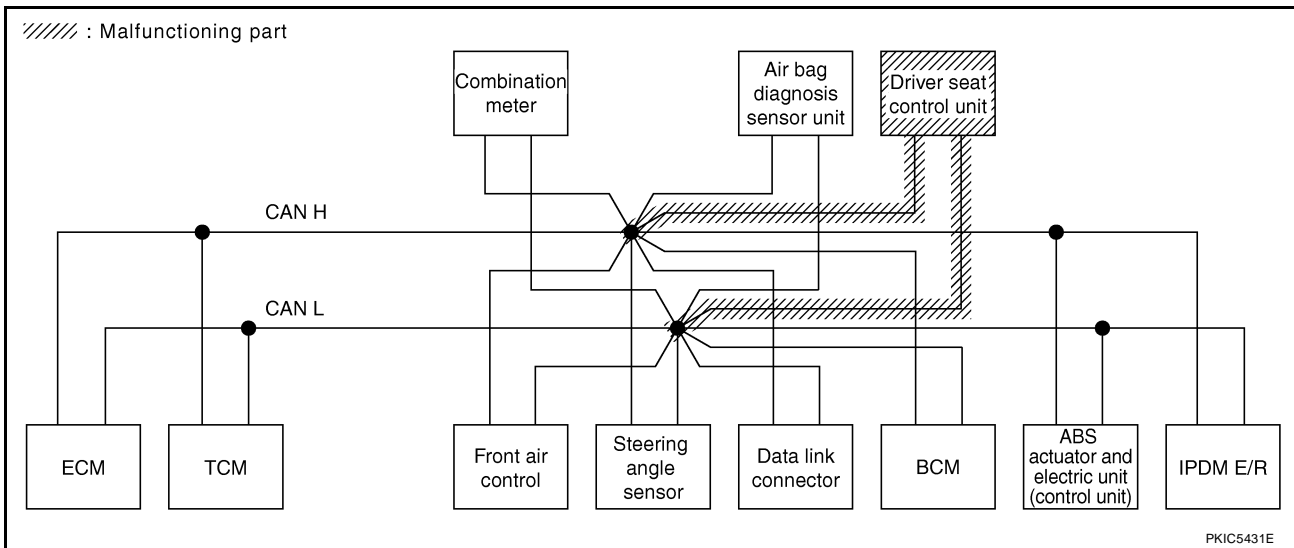

PKIC5431E

CAN SYSTEM (TYPE 3)

[CAN]

Case 10

Check ABS actuator and electric unit (control unit) circuit. Refer to [LAN-202, "ABS Actuator and Electric Unit \(Control Unit\) Circuit Inspection"](#).

SELECT SYSTEM screen		CAN DIAG SUPPORT MNTR									SELF-DIAG RESULTS	
		Initial diagnosis	Transmit diagnosis	Receive diagnosis						IPDM E/R		
				ECM	TCM	STRG	BCM /SEC	METER /M&A	VDC/TCS /ABS			
ENGINE	—	—	UNKWN	—	UNKWN	—	UNKWN	UNKWN	UNKWN	UNKWN	CAN COMM CIRCUIT (U1000)	CAN COMM CIRCUIT (U1001)
A/T	—	NG	UNKWN	UNKWN	—	—	—	UNKWN	UNKWN	—	CAN COMM CIRCUIT (U1000)	—
BCM	No indication	NG	UNKWN	UNKWN	—	—	—	UNKWN	—	UNKWN	CAN COMM CIRCUIT (U1000)	—
METER	No indication	—	UNKWN	UNKWN	UNKWN	—	UNKWN	—	UNKWN	UNKWN	CAN COMM CIRCUIT (U1000)	—
AUTO DRIVE POS.	No indication	—	—	—	UNKWN	—	UNKWN	UNKWN	—	—	CAN COMM CIRCUIT (U1000)	—
ABS	—	NG	UNKWN	UNKWN	UNKWN	UNKWN	—	—	—	—	CAN COMM CIRCUIT (U1000)	—
IPDM E/R	No indication	—	UNKWN	UNKWN	—	—	UNKWN	—	—	—	CAN COMM CIRCUIT (U1000)	—

PKIC5650E

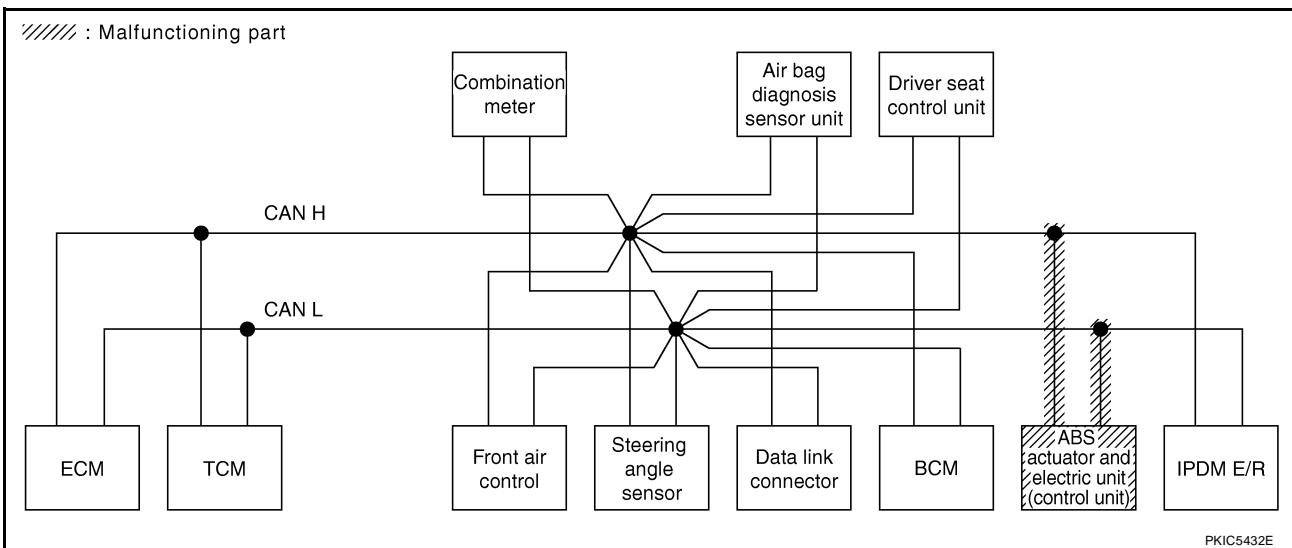

CAN SYSTEM (TYPE 3)

[CAN]

Case 11

Check IPDM E/R circuit. Refer to [LAN-203, "IPDM E/R Circuit Inspection"](#) .

SELECT SYSTEM screen		CAN DIAG SUPPORT MNTR									SELF-DIAG RESULTS		
		Initial diagnosis	Transmit diagnosis	Receive diagnosis									
				ECM	TCM	STRG	BCM /SEC	METER /M&A	VDC/TCS /ABS	IPDM E/R			
ENGINE	—	—	UNKWN	—	UNKWN	—	UNKWN	UNKWN	UNKWN	UNKWN	✓	CAN COMM CIRCUIT (U1000)	CAN COMM CIRCUIT (U1001) ✓
A/T	—	NG	UNKWN	UNKWN	—	—	—	UNKWN	UNKWN	—	—	CAN COMM CIRCUIT (U1000)	—
BCM	No indication	NG	UNKWN	UNKWN	—	—	—	UNKWN	—	UNKWN	✓	CAN COMM CIRCUIT (U1000)	—
METER	No indication	—	UNKWN	UNKWN	UNKWN	—	UNKWN	—	UNKWN	UNKWN	✓	CAN COMM CIRCUIT (U1000)	—
AUTO DRIVE POS.	No indication	—	—	—	UNKWN	—	UNKWN	UNKWN	—	—	—	CAN COMM CIRCUIT (U1000)	—
ABS	—	NG	UNKWN	UNKWN	UNKWN	UNKWN	—	—	—	—	—	CAN COMM CIRCUIT (U1000)	—
IPDM E/R	No indication ✓	—	UNKWN	UNKWN	—	—	UNKWN	—	—	—	—	CAN COMM CIRCUIT (U1000) ✓	—

PKIC5651E

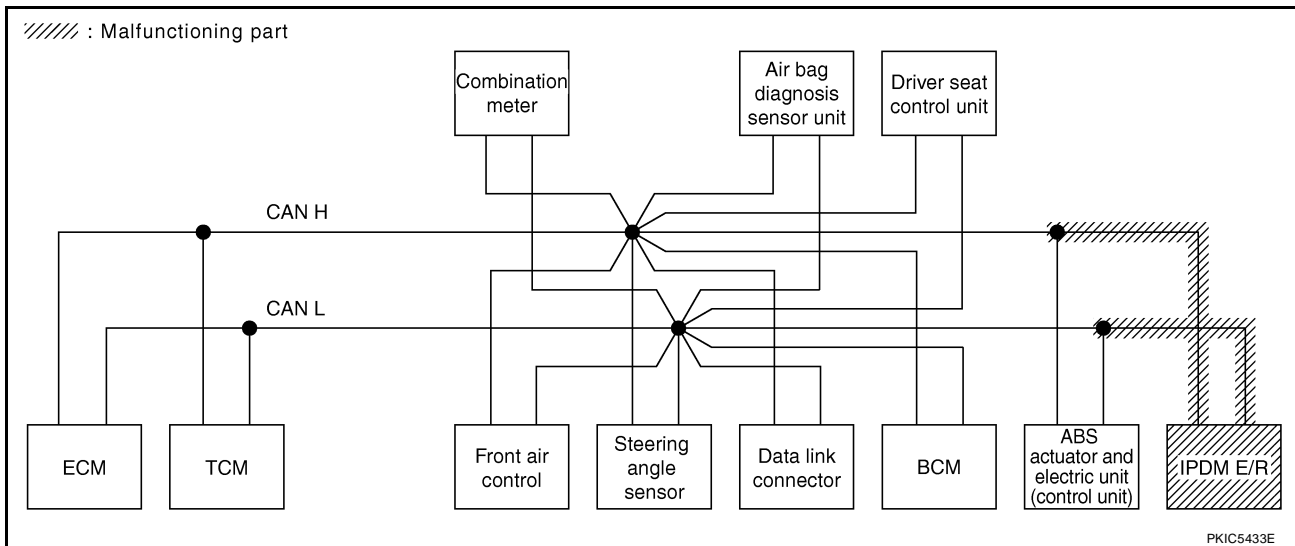

Case 12

Check CAN communication circuit. Refer to [LAN-203, "CAN Communication Circuit Inspection"](#) .

SELECT SYSTEM screen		CAN DIAG SUPPORT MNTR									SELF-DIAG RESULTS		
		Initial diagnosis	Transmit diagnosis	Receive diagnosis									
				ECM	TCM	STRG	BCM /SEC	METER /M&A	VDC/TCS /ABS	IPDM E/R			
ENGINE	—	—	UNKWN ✓	—	UNKWN ✓	—	UNKWN ✓	UNKWN ✓	UNKWN ✓	UNKWN ✓	✓	CAN COMM CIRCUIT (U1000)	CAN COMM CIRCUIT (U1001) ✓
A/T	—	NG	UNKWN	UNKWN ✓	—	—	—	UNKWN ✓	UNKWN ✓	—	—	CAN COMM CIRCUIT (U1000) ✓	—
BCM	No indication ✓	NG	UNKWN	UNKWN	—	—	—	UNKWN	—	UNKWN	—	CAN COMM CIRCUIT (U1000)	—
METER	No indication ✓	—	UNKWN	UNKWN	UNKWN	—	UNKWN	—	UNKWN	UNKWN	—	CAN COMM CIRCUIT (U1000) ✓	—
AUTO DRIVE POS.	No indication ✓	—	—	—	UNKWN	—	UNKWN	UNKWN	—	—	—	CAN COMM CIRCUIT (U1000) ✓	—
ABS	—	NG ✓	UNKWN ✓	UNKWN ✓	UNKWN ✓	UNKWN ✓	—	—	—	—	—	CAN COMM CIRCUIT (U1000) ✓	—
IPDM E/R	No indication ✓	—	UNKWN	UNKWN	—	—	UNKWN	—	—	—	—	CAN COMM CIRCUIT (U1000) ✓	—

PKIC5652E

CAN SYSTEM (TYPE 3)

[CAN]

Case 13

Check IPDM E/R ignition relay circuit continuously sticks "OFF". Refer to [LAN-204, "IPDM E/R Ignition Relay Circuit Inspection"](#) .

SELECT SYSTEM screen		CAN DIAG SUPPORT MNTR									SELF-DIAG RESULTS	
		Initial diagnosis	Transmit diagnosis	Receive diagnosis								
				ECM	TCM	STRG	BCM /SEC	METER /M&A	VDC/TCS /ABS	IPDM E/R		
ENGINE	—	—	UNKWN	—	UNKWN ✓	—	UNKWN	UNKWN	UNKWN ✓	UNKWN	CAN COMM CIRCUIT (U1000) ✓	CAN COMM CIRCUIT (U1001) ✓
A/T	—	NG	UNKWN	UNKWN	—	—	—	UNKWN	UNKWN	—	CAN COMM CIRCUIT (U1000)	—
BCM	No indication	NG	UNKWN	UNKWN	—	—	—	UNKWN	—	UNKWN	CAN COMM CIRCUIT (U1000)	—
METER	No indication	—	UNKWN	UNKWN	UNKWN ✓	—	UNKWN	—	UNKWN ✓	UNKWN	CAN COMM CIRCUIT (U1000) ✓	—
AUTO DRIVE POS.	No indication	—	—	—	UNKWN ✓	—	UNKWN	UNKWN	—	—	CAN COMM CIRCUIT (U1000) ✓	—
ABS	—	NG	UNKWN	UNKWN	UNKWN	UNKWN	—	—	—	—	CAN COMM CIRCUIT (U1000)	—
IPDM E/R	No indication	—	UNKWN	UNKWN	—	—	UNKWN	—	—	—	CAN COMM CIRCUIT (U1000)	—

PKIC5653E

Case 14

Check IPDM E/R ignition relay circuit continuously sticks "ON". Refer to [LAN-204, "IPDM E/R Ignition Relay Circuit Inspection"](#) .

SELECT SYSTEM screen		CAN DIAG SUPPORT MNTR									SELF-DIAG RESULTS	
		Initial diagnosis	Transmit diagnosis	Receive diagnosis								
				ECM	TCM	STRG	BCM /SEC	METER /M&A	VDC/TCS /ABS	IPDM E/R		
ENGINE	—	—	UNKWN	—	UNKWN	—	UNKWN	UNKWN	UNKWN	UNKWN	CAN COMM CIRCUIT (U1000)	CAN COMM CIRCUIT (U1001)
A/T	—	NG	UNKWN	—	—	—	—	—	UNKWN	—	CAN COMM CIRCUIT (U1000) ✓	—
BCM	No indication	NG	UNKWN	UNKWN	—	—	—	UNKWN	—	UNKWN	CAN COMM CIRCUIT (U1000)	—
METER	No indication	—	UNKWN	UNKWN	UNKWN	—	UNKWN	—	UNKWN	UNKWN	CAN COMM CIRCUIT (U1000)	—
AUTO DRIVE POS.	No indication	—	—	—	UNKWN	—	UNKWN	UNKWN	—	—	CAN COMM CIRCUIT (U1000)	—
ABS	—	NG	UNKWN	—	UNKWN	—	—	—	—	—	CAN COMM CIRCUIT (U1000) ✓	—
IPDM E/R	No indication	—	UNKWN	UNKWN	—	—	UNKWN	—	—	—	CAN COMM CIRCUIT (U1000)	—

PKIC5654E

CAN SYSTEM (TYPE 4)

PF2:23710

Component Parts and Harness Connector Location

UKS00532

Refer to [LAN-25, "Component Parts and Harness Connector Location"](#) .

Schematic

UKS00533

Refer to [LAN-26, "Schematic"](#) .

Wiring Diagram — CAN —

UKS00534

Refer to [LAN-27, "Wiring Diagram — CAN —"](#) .

CAN SYSTEM (TYPE 4)

[CAN]

UKS00535

Check Sheet

NOTE:

If a check mark is put on "NG" on "INITIAL DIAG (Initial diagnosis)", replace the control unit.

SELECT SYSTEM screen		CAN DIAG SUPPORT MNTR										SELF-DIAG RESULTS	
		Initial diagnosis	Transmit diagnosis	Receive diagnosis									
				ECM	TCM	Front air control	STRG	BCM /SEC	METER /M&A	VDC/TCS /ABS	IPDM E/R		
ENGINE	—	—	UNKWN	—	UNKWN	—	—	UNKWN	UNKWN	UNKWN	UNKWN	CAN COMM CIRCUIT (U1000)	CAN COMM CIRCUIT (U1001)
A/T	—	NG	UNKWN	UNKWN	—	—	—	—	UNKWN	UNKWN	—	CAN COMM CIRCUIT (U1000)	—
Display control unit	—	NG	UNKWN	UNKWN	—	UNKWN	—	UNKWN	UNKWN	—	UNKWN	—	—
BCM	No indication	NG	UNKWN	UNKWN	—	—	—	—	UNKWN	—	UNKWN	CAN COMM CIRCUIT (U1000)	—
METER	No indication	—	UNKWN	UNKWN	UNKWN	—	—	UNKWN	—	UNKWN	UNKWN	CAN COMM CIRCUIT (U1000)	—
AUTO DRIVE POS.	No indication	—	—	—	UNKWN	—	—	UNKWN	UNKWN	—	—	CAN COMM CIRCUIT (U1000)	—
ABS	—	NG	UNKWN	UNKWN	UNKWN	—	UNKWN	—	—	—	—	CAN COMM CIRCUIT (U1000)	—
IPDM E/R	No indication	—	UNKWN	UNKWN	—	—	—	UNKWN	—	—	—	CAN COMM CIRCUIT (U1000)	—

Symptoms :

Attach copy of
SELECT SYSTEM

Attach copy of
SELECT SYSTEM

Display control unit Translation Sheet: Rewrite the following names, and put a check mark on the above check sheet table.			
Confirmation/Adjustment Display	Check sheet table Display	Confirmation/Adjustment Display	Check sheet table Display
CAN COMM	Initial diagnosis	CAN CIRC 5	METER/M&A
CAN CIRC 1	Transmit diagnosis	CAN CIRC 6	—
CAN CIRC 2	BCM	CAN CIRC 7	IPDM E/R
CAN CIRC 3	ECM	CAN CIRC 8	—
CAN CIRC 4	Front air control	CAN CIRC 9	—

Attach copy of
display control unit
CAN DIAG SUPPORT MONITOR Check Sheet

PKIC5655E

A
B
C
D
E
F
G
H
I
J
L
M

LAN

CAN SYSTEM (TYPE 4)

[CAN]

Attach copy of
ENGINE
SELF-DIAG RESULTS

Attach copy of
A/T
SELF-DIAG RESULTS

Attach copy of
BCM
SELF-DIAG RESULTS

Attach copy of
METER
SELF-DIAG RESULTS

Attach copy of
AUTO DRIVE POS.
SELF-DIAG RESULTS

Attach copy of
ABS
SELF-DIAG RESULTS

Attach copy of
IPDM E/R
SELF-DIAG RESULTS

Attach copy of
ENGINE
CAN DIAG SUPPORT
MNTR

Attach copy of
A/T
CAN DIAG SUPPORT
MNTR

Attach copy of
BCM
CAN DIAG SUPPORT
MNTR

Attach copy of
METER
CAN DIAG SUPPORT
MNTR

Attach copy of
AUTO DRIVE POS.
CAN DIAG SUPPORT
MNTR

Attach copy of
ABS
CAN DIAG SUPPORT
MNTR

Attach copy of
IPDM E/R
CAN DIAG SUPPORT
MNTR

PKIC7065E

CAN SYSTEM (TYPE 4)

[CAN]

CHECK SHEET RESULTS (EXAMPLE)

NOTE:

If a check mark is put on "NG" on "INITIAL DIAG (Initial diagnosis)", replace the control unit.

Case 1

Check harness between TCM and data link connector. Refer to [LAN-195, "Inspection Between TCM and Data Link Connector Circuit"](#).

SELECT SYSTEM screen	CAN DIAG SUPPORT MNTR											SELF-DIAG RESULTS	
	Initial diagnosis	Transmit diagnosis	Receive diagnosis										
			ECM	TCM	Front air control	STRG	BCM /SEC	METER /M&A	VDC/TCS /ABS	IPDM E/R			
ENGINE	—	—	UNKWN	—	UNKWN	—	—	UNKWN	UNKWN	UNKWN	UNKWN	CAN COMM CIRCUIT (U1000)	CAN COMM CIRCUIT (U001)
A/T	—	NG	UNKWN	UNKWN	—	—	—	—	UNKWN	UNKWN	—	CAN COMM CIRCUIT (U000)	—
Display control unit	—	NG	UNKWN	UNKWN	—	UNKWN	—	UNKWN	UNKWN	—	UNKWN	—	—
BCM	No indication	NG	UNKWN	UNKWN	—	—	—	—	UNKWN	—	UNKWN	CAN COMM CIRCUIT (U1000)	—
METER	No indication	—	UNKWN	UNKWN	UNKWN	—	—	UNKWN	—	UNKWN	UNKWN	CAN COMM CIRCUIT (U000)	—
AUTO DRIVE POS.	No indication	—	—	—	UNKWN	—	—	UNKWN	UNKWN	—	—	CAN COMM CIRCUIT (U000)	—
ABS	—	NG	UNKWN	UNKWN	UNKWN	—	UNKWN	—	—	—	—	CAN COMM CIRCUIT (U000)	—
IPDM E/R	No indication	—	UNKWN	UNKWN	—	—	—	UNKWN	—	—	—	CAN COMM CIRCUIT (U000)	—

PKIC5656E

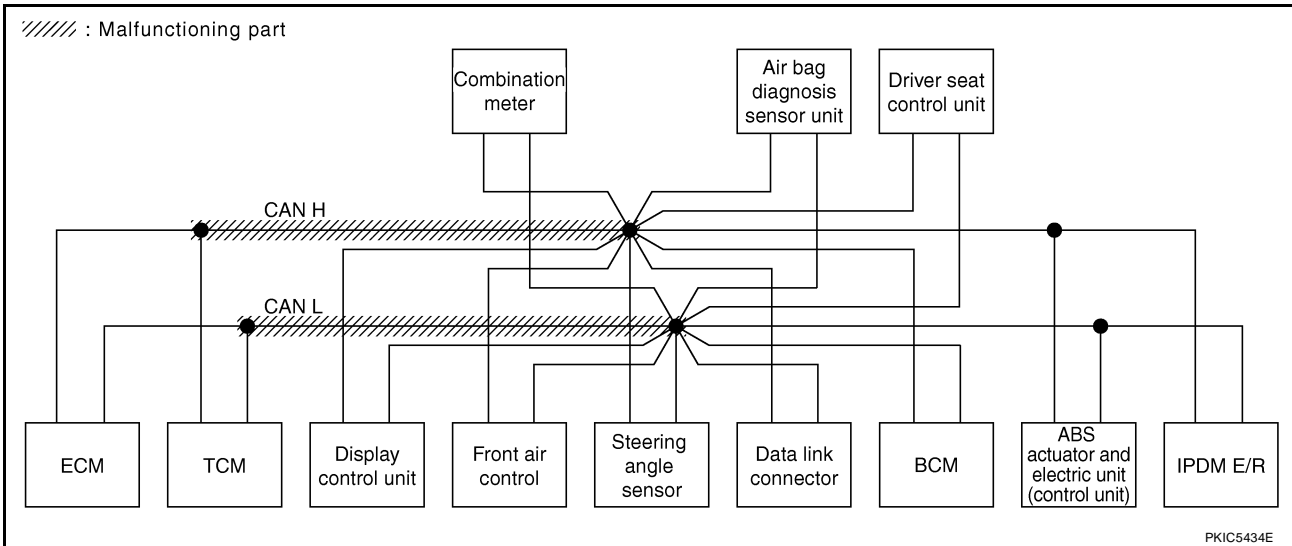

CAN SYSTEM (TYPE 4)

[CAN]

Case 2

Check harness between data link connector and ABS actuator and electric unit (control unit). Refer to [LAN-196, "Inspection Between Data Link Connector and ABS Actuator and Electric Unit \(Control Unit\) Circuit"](#) .

SELECT SYSTEM screen		CAN DIAG SUPPORT MNTR										SELF-DIAG RESULTS		
		Initial diagnosis	Transmit diagnosis	Receive diagnosis										
				ECM	TCM	Front air control	STRG	BCM /SEC	METER /M&A	VDC/TCS /ABS	IPDM E/R			
ENGINE	—	—	UNKWN	—	UNKWN	—	—	UNKWN	UNKWN	UNKWN	UNKWN	UNKWN	CAN COMM CIRCUIT (U1000)	CAN COMM CIRCUIT (U1001)
A/T	—	NG	UNKWN	UNKWN	—	—	—	—	UNKWN	UNKWN	UNKWN	—	CAN COMM CIRCUIT (U1000)	—
Display control unit	—	NG	UNKWN	UNKWN	—	UNKWN	—	UNKWN	UNKWN	—	UNKWN	—	—	—
BCM	No indication	NG	UNKWN	UNKWN	—	—	—	—	UNKWN	—	UNKWN	—	CAN COMM CIRCUIT (U1000)	—
METER	No indication	—	UNKWN	UNKWN	UNKWN	—	—	UNKWN	—	UNKWN	UNKWN	—	CAN COMM CIRCUIT (U1000)	—
AUTO DRIVE POS.	No indication	—	—	—	UNKWN	—	—	UNKWN	UNKWN	—	—	—	CAN COMM CIRCUIT (U1000)	—
ABS	—	NG	UNKWN	UNKWN	UNKWN	—	UNKWN	—	—	—	—	—	CAN COMM CIRCUIT (U1000)	—
IPDM E/R	No indication	—	UNKWN	UNKWN	—	—	—	UNKWN	—	—	—	—	CAN COMM CIRCUIT (U1000)	—

PKIC5658E

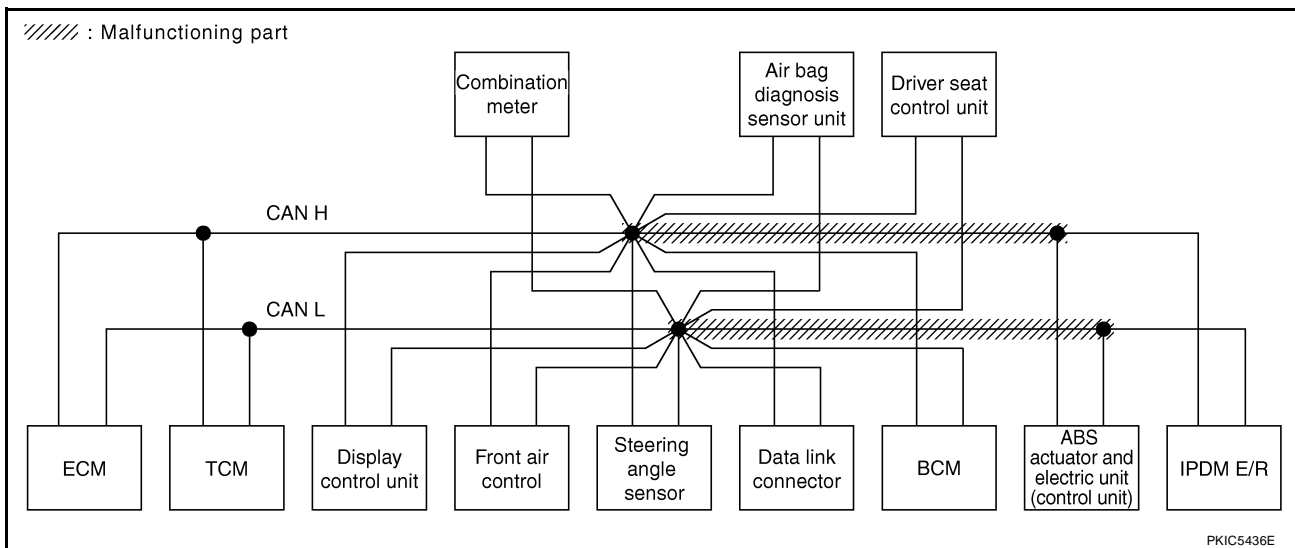

PKIC5436E

CAN SYSTEM (TYPE 4)

[CAN]

Case 3

Check ECM circuit. Refer to [LAN-197, "ECM Circuit Inspection"](#).

SELECT SYSTEM screen		CAN DIAG SUPPORT MNTR										SELF-DIAG RESULTS	
		Initial diagnosis	Transmit diagnosis	Receive diagnosis									
				ECM	TCM	Front air control	STRG	BCM /SEC	METER /M&A	VDC/TCS /ABS	IPDM E/R		
ENGINE	—	—	UNKWN	—	UNKWN	—	—	UNKWN	UNKWN	UNKWN	UNKWN	CAN COMM CIRCUIT (U100)	CAN COMM CIRCUIT (U101)
A/T	—	NG	UNKWN	—	—	—	—	UNKWN	UNKWN	UNKWN	—	CAN COMM CIRCUIT (U100)	—
Display control unit	—	NG	UNKWN	—	UNKWN	—	—	UNKWN	UNKWN	—	UNKWN	—	—
BCM	No indication	NG	UNKWN	—	—	—	—	UNKWN	—	UNKWN	UNKWN	CAN COMM CIRCUIT (U1000)	—
METER	No indication	—	UNKWN	—	UNKWN	—	—	UNKWN	—	UNKWN	UNKWN	CAN COMM CIRCUIT (U100)	—
AUTO DRIVE POS.	No indication	—	—	—	UNKWN	—	—	UNKWN	UNKWN	—	—	CAN COMM CIRCUIT (U1000)	—
ABS	—	NG	UNKWN	—	UNKWN	—	UNKWN	—	—	—	—	CAN COMM CIRCUIT (U100)	—
IPDM E/R	No indication	—	UNKWN	—	—	—	—	UNKWN	—	—	—	CAN COMM CIRCUIT (U100)	—

PKIC5659E

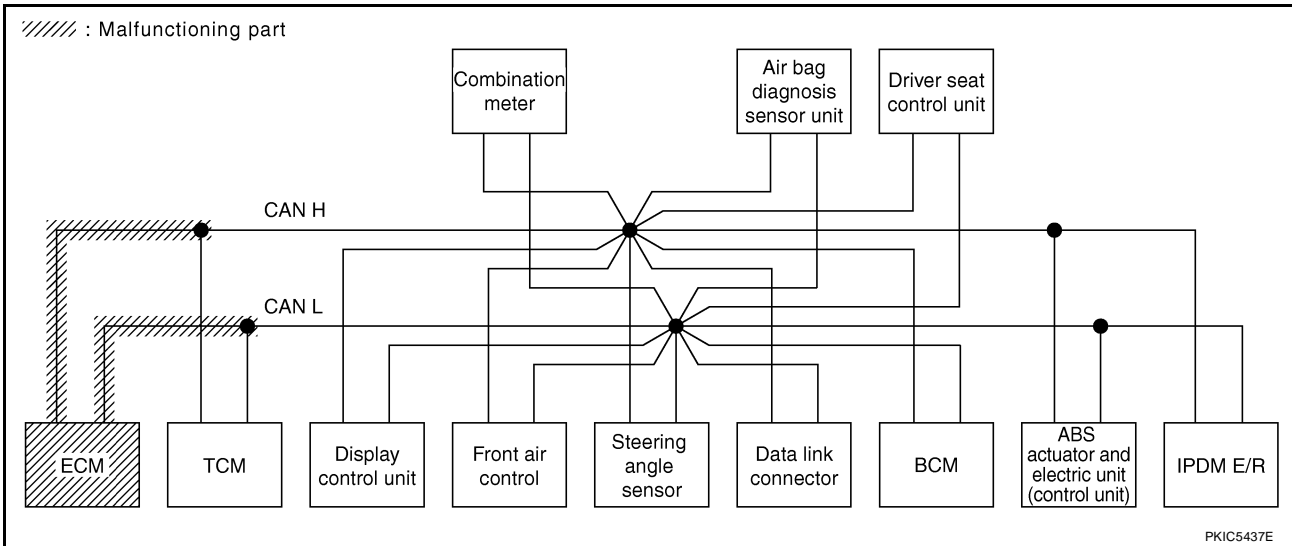

CAN SYSTEM (TYPE 4)

[CAN]

Case 4

Check TCM circuit. Refer to [LAN-197, "TCM Circuit Inspection"](#) .

SELECT SYSTEM screen		CAN DIAG SUPPORT MNTR										SELF-DIAG RESULTS	
		Initial diagnosis	Transmit diagnosis	Receive diagnosis									
				ECM	TCM	Front air control	STRG	BCM /SEC	METER /M&A	VDC/TCS /ABS	IPDM E/R		
ENGINE	—	—	UNKWN	—	UNKWN	—	—	UNKWN	UNKWN	UNKWN	UNKWN	CAN COMM CIRCUIT (U100)	CAN COMM CIRCUIT (U101)
A/T	—	NG	UNKWN	✓	—	—	—	—	UNKWN	UNKWN	—	CAN COMM CIRCUIT (U100)	—
Display control unit	—	NG	UNKWN	UNKWN	—	UNKWN	—	UNKWN	UNKWN	—	UNKWN	—	—
BCM	No indication	NG	UNKWN	UNKWN	—	—	—	—	UNKWN	—	UNKWN	CAN COMM CIRCUIT (U1000)	—
METER	No indication	—	UNKWN	UNKWN	UNKWN	—	—	UNKWN	—	UNKWN	UNKWN	CAN COMM CIRCUIT (U100)	—
AUTO DRIVE POS.	No indication	—	—	—	UNKWN	—	—	UNKWN	UNKWN	—	—	CAN COMM CIRCUIT (U100)	—
ABS	—	NG	UNKWN	UNKWN	UNKWN	—	UNKWN	—	—	—	—	CAN COMM CIRCUIT (U100)	—
IPDM E/R	No indication	—	UNKWN	UNKWN	—	—	—	UNKWN	—	—	—	CAN COMM CIRCUIT (U1000)	—

PKIC5660E

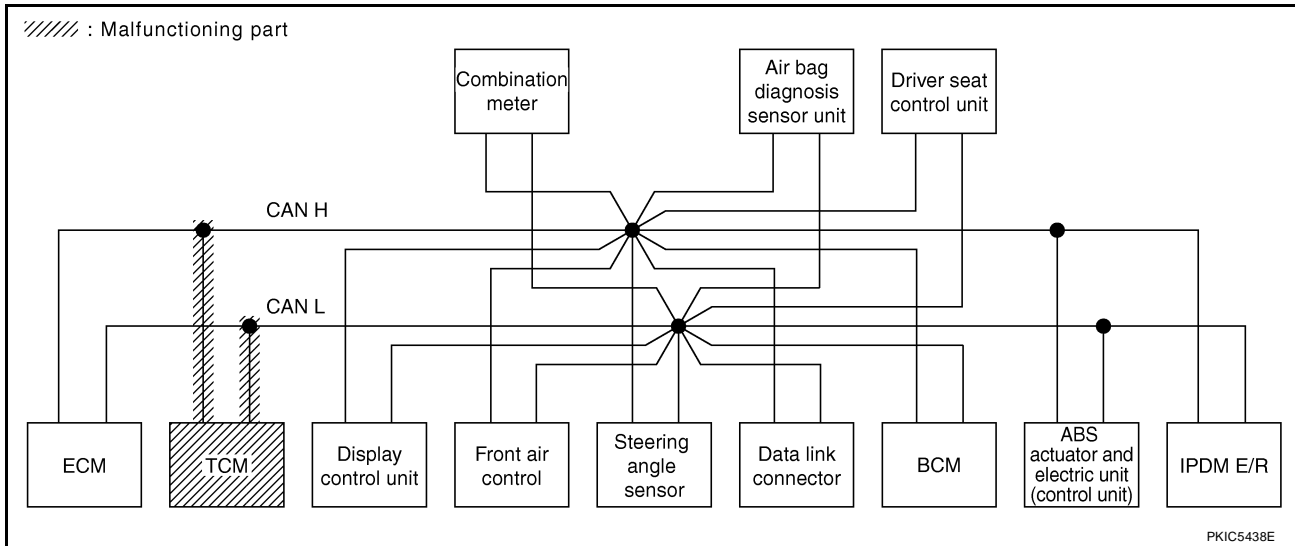

CAN SYSTEM (TYPE 4)

[CAN]

Case 5

Check display control unit circuit. Refer to [LAN-198, "Display Control Unit Circuit Inspection"](#).

SELECT SYSTEM screen		CAN DIAG SUPPORT MNTR										SELF-DIAG RESULTS	
		Initial diagnosis	Transmit diagnosis	Receive diagnosis									
				ECM	TCM	Front air control	STRG	BCM /SEC	METER /M&A	VDC/TCS /ABS	IPDM E/R		
ENGINE	—	—	UNKWN	—	UNKWN	—	—	UNKWN	UNKWN	UNKWN	UNKWN	CAN COMM CIRCUIT (U1000)	CAN COMM CIRCUIT (U1001)
A/T	—	NG	UNKWN	UNKWN	—	—	—	—	UNKWN	UNKWN	—	CAN COMM CIRCUIT (U1000)	—
Display control unit	—	NG	UNKWN	UNKWN	—	UNKWN	—	UNKWN	UNKWN	—	UNKWN	—	—
BCM	No indication	NG	UNKWN	UNKWN	—	—	—	—	UNKWN	—	UNKWN	CAN COMM CIRCUIT (U1000)	—
METER	No indication	—	UNKWN	UNKWN	UNKWN	—	—	UNKWN	—	UNKWN	UNKWN	CAN COMM CIRCUIT (U1000)	—
AUTO DRIVE POS.	No indication	—	—	—	UNKWN	—	—	UNKWN	UNKWN	—	—	CAN COMM CIRCUIT (U1000)	—
ABS	—	NG	UNKWN	UNKWN	UNKWN	—	UNKWN	—	—	—	—	CAN COMM CIRCUIT (U1000)	—
IPDM E/R	No indication	—	UNKWN	UNKWN	—	—	—	UNKWN	—	—	—	CAN COMM CIRCUIT (U1000)	—

PKIC5661E

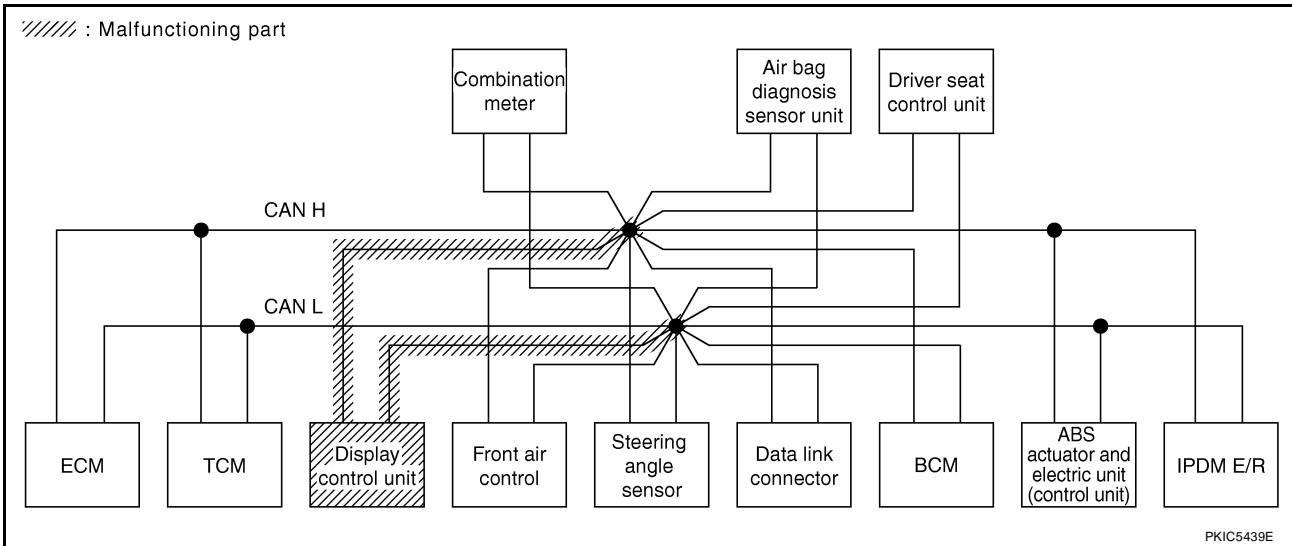

PKIC5439E

CAN SYSTEM (TYPE 4)

[CAN]

Case 6

Check front air control circuit. Refer to [LAN-198, "Front Air Control Circuit Inspection"](#) .

SELECT SYSTEM screen		CAN DIAG SUPPORT MNTR										SELF-DIAG RESULTS	
		Initial diagnosis	Transmit diagnosis	Receive diagnosis									
				ECM	TCM	Front air control	STRG	BCM /SEC	METER /M&A	VDC/TCS /ABS	IPDM E/R		
ENGINE	—	—	UNKWN	—	UNKWN	—	—	UNKWN	UNKWN	UNKWN	UNKWN	CAN COMM CIRCUIT (U1000)	CAN COMM CIRCUIT (U1001)
A/T	—	NG	UNKWN	UNKWN	—	—	—	—	UNKWN	UNKWN	—	CAN COMM CIRCUIT (U1000)	—
Display control unit	—	NG	UNKWN	UNKWN	—	UNKWN	—	UNKWN	UNKWN	—	UNKWN	—	—
BCM	No indication	NG	UNKWN	UNKWN	—	—	—	—	UNKWN	—	UNKWN	CAN COMM CIRCUIT (U1000)	—
METER	No indication	—	UNKWN	UNKWN	UNKWN	—	—	UNKWN	—	UNKWN	UNKWN	CAN COMM CIRCUIT (U1000)	—
AUTO DRIVE POS.	No indication	—	—	—	UNKWN	—	—	UNKWN	UNKWN	—	—	CAN COMM CIRCUIT (U1000)	—
ABS	—	NG	UNKWN	UNKWN	UNKWN	—	UNKWN	—	—	—	—	CAN COMM CIRCUIT (U1000)	—
IPDM E/R	No indication	—	UNKWN	UNKWN	—	—	—	UNKWN	—	—	—	CAN COMM CIRCUIT (U1000)	—

PKIC5662E

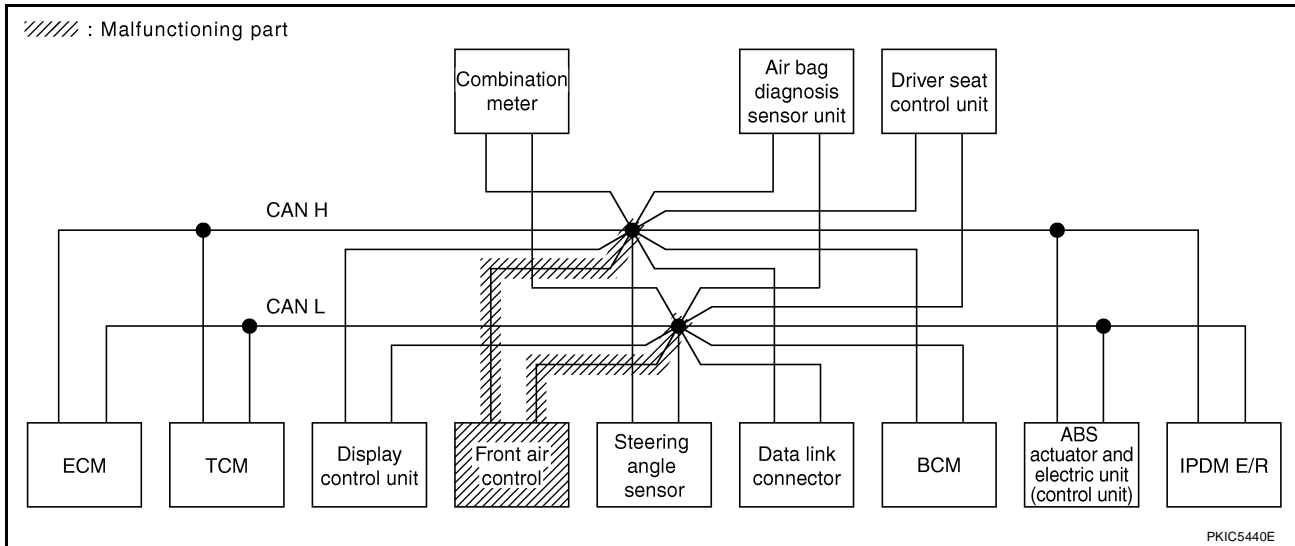

PKIC5440E

CAN SYSTEM (TYPE 4)

[CAN]

Case 7

Check steering angle sensor circuit. Refer to [LAN-199, "Steering Angle Sensor Circuit Inspection"](#).

SELECT SYSTEM screen		CAN DIAG SUPPORT MNTR										SELF-DIAG RESULTS	
		Initial diagnosis	Transmit diagnosis	Receive diagnosis									
				ECM	TCM	Front air control	STRG	BCM /SEC	METER /M&A	VDC/TCS /ABS	IPDM E/R		
ENGINE	—	—	UNKWN	—	UNKWN	—	—	UNKWN	UNKWN	UNKWN	UNKWN	CAN COMM CIRCUIT (U1000)	CAN COMM CIRCUIT (U1001)
A/T	—	NG	UNKWN	UNKWN	—	—	—	—	UNKWN	UNKWN	—	CAN COMM CIRCUIT (U1000)	—
Display control unit	—	NG	UNKWN	UNKWN	—	UNKWN	—	UNKWN	UNKWN	—	UNKWN	—	—
BCM	No indication	NG	UNKWN	UNKWN	—	—	—	—	UNKWN	—	UNKWN	CAN COMM CIRCUIT (U1000)	—
METER	No indication	—	UNKWN	UNKWN	UNKWN	—	—	UNKWN	—	UNKWN	UNKWN	CAN COMM CIRCUIT (U1000)	—
AUTO DRIVE POS.	No indication	—	—	—	UNKWN	—	—	UNKWN	UNKWN	—	—	CAN COMM CIRCUIT (U1000)	—
ABS	—	NG	UNKWN	UNKWN	UNKWN	—	UNKWN	—	—	—	—	CAN COMM CIRCUIT (U1000)	—
IPDM E/R	No indication	—	UNKWN	UNKWN	—	—	—	UNKWN	—	—	—	CAN COMM CIRCUIT (U1000)	—

PKIC5663E

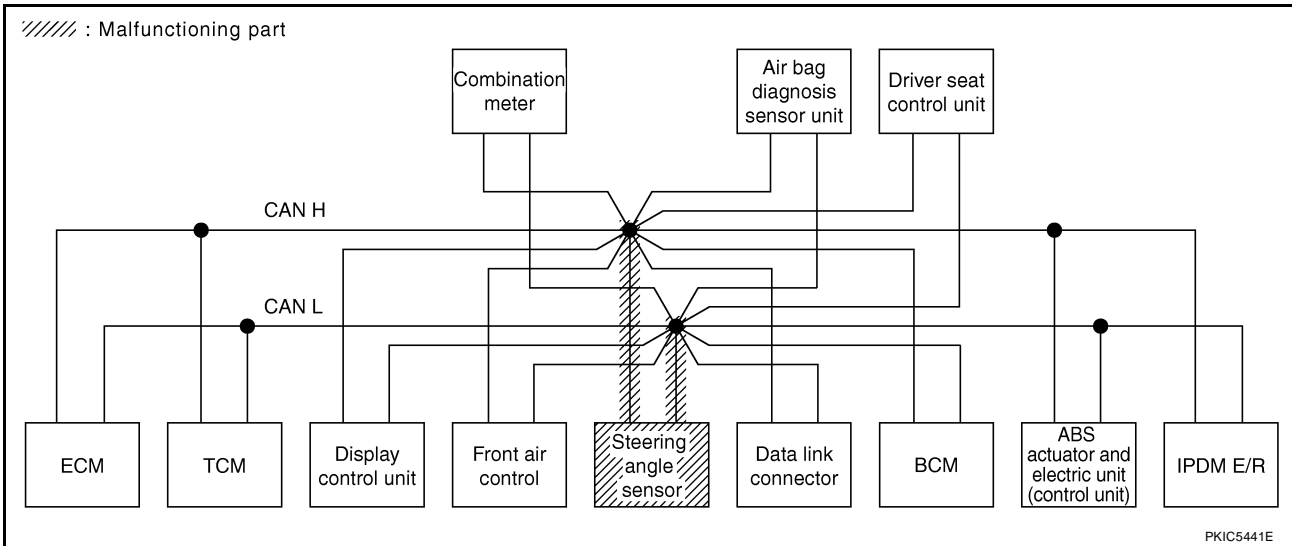

CAN SYSTEM (TYPE 4)

[CAN]

Case 8

Check data link connector circuit. Refer to [LAN-199, "Data Link Connector Circuit Inspection"](#) .

SELECT SYSTEM screen		CAN DIAG SUPPORT MNTR										SELF-DIAG RESULTS	
		Initial diagnosis	Transmit diagnosis	Receive diagnosis									
				ECM	TCM	Front air control	STRG	BCM /SEC	METER /M&A	VDC/TCS /ABS	IPDM E/R		
ENGINE	—	—	UNKWN	—	UNKWN	—	—	UNKWN	UNKWN	UNKWN	UNKWN	CAN COMM CIRCUIT (U1000)	CAN COMM CIRCUIT (U1001)
A/T	—	NG	UNKWN	UNKWN	—	—	—	—	UNKWN	UNKWN	—	CAN COMM CIRCUIT (U1000)	—
Display control unit	—	NG	UNKWN	UNKWN	—	UNKWN	—	UNKWN	UNKWN	—	UNKWN	—	—
BCM	No indication ✓	NG	UNKWN	UNKWN	—	—	—	—	UNKWN	—	UNKWN	CAN COMM CIRCUIT (U1000)	—
METER	No indication ✓	—	UNKWN	UNKWN	UNKWN	—	—	UNKWN	—	UNKWN	UNKWN	CAN COMM CIRCUIT (U1000)	—
AUTO DRIVE POS.	No indication ✓	—	—	—	UNKWN	—	—	UNKWN	UNKWN	—	—	CAN COMM CIRCUIT (U1000)	—
ABS	—	NG	UNKWN	UNKWN	UNKWN	—	UNKWN	—	—	—	—	CAN COMM CIRCUIT (U1000)	—
IPDM E/R	No indication ✓	—	UNKWN	UNKWN	—	—	—	UNKWN	—	—	—	CAN COMM CIRCUIT (U1000)	—

PKIC5664E

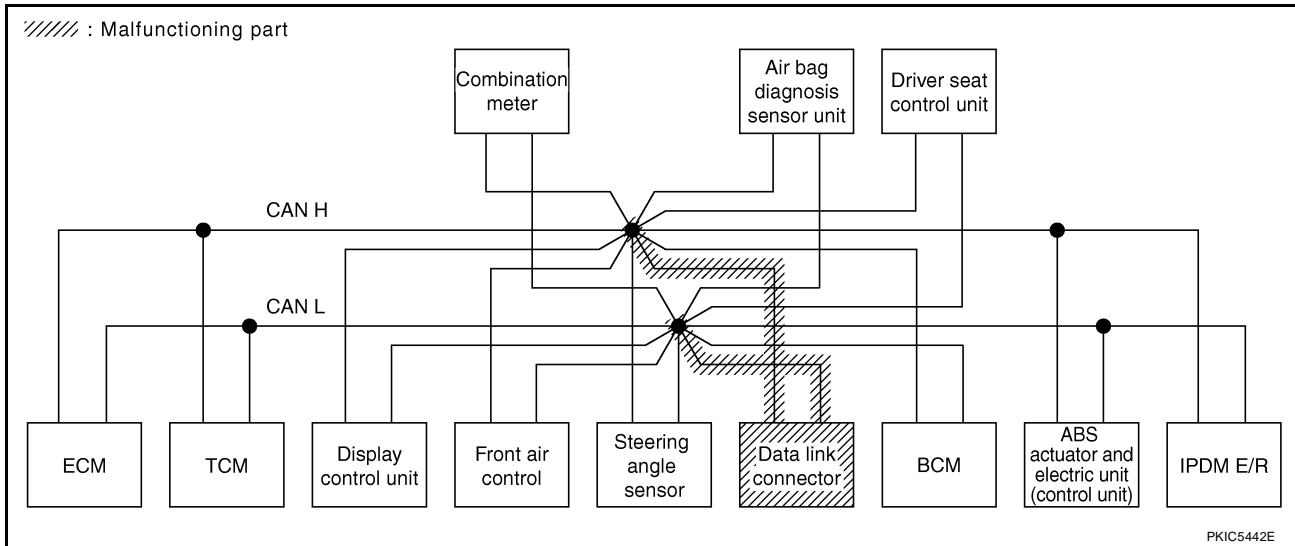

CAN SYSTEM (TYPE 4)

[CAN]

Case 9

Check BCM circuit. Refer to [LAN-200, "BCM Circuit Inspection"](#).

SELECT SYSTEM screen		CAN DIAG SUPPORT MNTR										SELF-DIAG RESULTS	
		Initial diagnosis	Transmit diagnosis	Receive diagnosis									
				ECM	TCM	Front air control	STRG	BCM /SEC	METER /M&A	VDC/TCS /ABS	IPDM E/R		
ENGINE	—	—	UNKWN	—	UNKWN	—	—	UNKWN	UNKWN	UNKWN	UNKWN	CAN COMM CIRCUIT (U1000)	CAN COMM CIRCUIT (U1001)
A/T	—	NG	UNKWN	UNKWN	—	—	—	—	UNKWN	UNKWN	—	CAN COMM CIRCUIT (U1000)	—
Display control unit	—	NG	UNKWN	UNKWN	—	UNKWN	—	UNKWN	UNKWN	—	UNKWN	—	—
BCM	No indication	NG	UNKWN	UNKWN	—	—	—	—	UNKWN	—	UNKWN	CAN COMM CIRCUIT (U1000)	—
METER	No indication	—	UNKWN	UNKWN	UNKWN	—	—	UNKWN	—	UNKWN	UNKWN	CAN COMM CIRCUIT (U1000)	—
AUTO DRIVE POS.	No indication	—	—	—	UNKWN	—	—	UNKWN	UNKWN	—	—	CAN COMM CIRCUIT (U1000)	—
ABS	—	NG	UNKWN	UNKWN	UNKWN	—	UNKWN	—	—	—	—	CAN COMM CIRCUIT (U1000)	—
IPDM E/R	No indication	—	UNKWN	UNKWN	—	—	—	UNKWN	—	—	—	CAN COMM CIRCUIT (U1000)	—

PKIC5665E

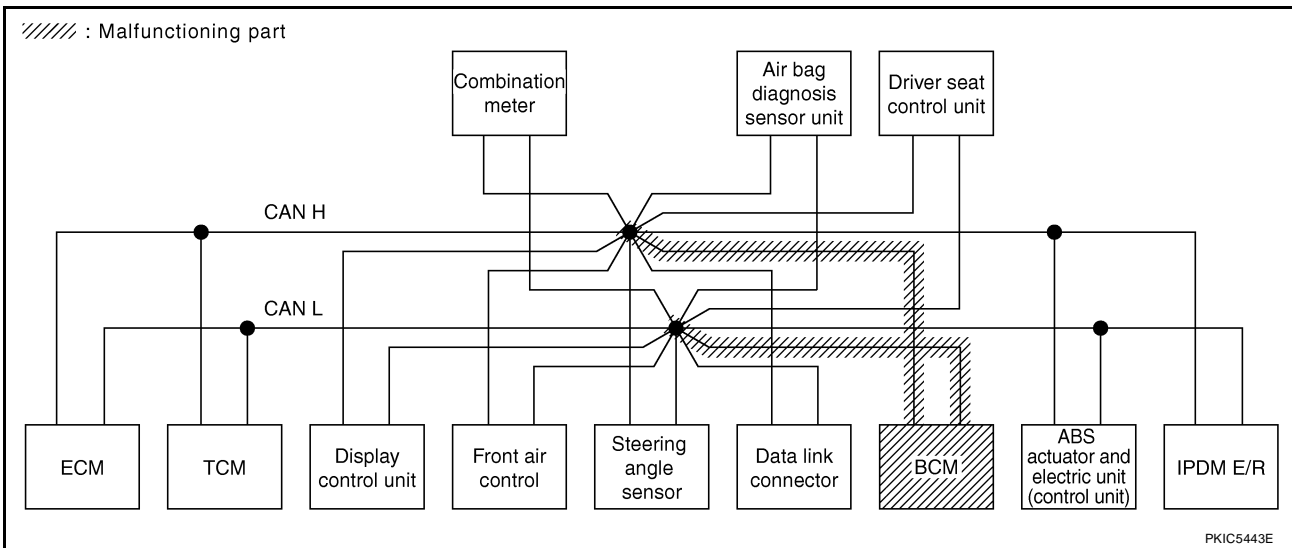

CAN SYSTEM (TYPE 4)

[CAN]

Case 10

Check combination meter circuit. Refer to [LAN-200, "Combination Meter Circuit Inspection"](#) .

SELECT SYSTEM screen		CAN DIAG SUPPORT MNTR										SELF-DIAG RESULTS	
		Initial diagnosis	Transmit diagnosis	Receive diagnosis									
				ECM	TCM	Front air control	STRG	BCM /SEC	METER /M&A	VDC/TCS /ABS	IPDM E/R		
ENGINE	—	—	UNKWN	—	UNKWN	—	—	UNKWN	UNKWN	UNKWN	UNKWN	CAN COMM CIRCUIT (U1000)	CAN COMM CIRCUIT (U1001)
A/T	—	NG	UNKWN	UNKWN	—	—	—	—	UNKWN	UNKWN	—	CAN COMM CIRCUIT (U1000)	—
Display control unit	—	NG	UNKWN	UNKWN	—	UNKWN	—	UNKWN	UNKWN	—	UNKWN	—	—
BCM	No indication	NG	UNKWN	UNKWN	—	—	—	—	UNKWN	—	UNKWN	CAN COMM CIRCUIT (U1000)	—
METER	No indication	—	UNKWN	UNKWN	UNKWN	—	—	UNKWN	—	UNKWN	UNKWN	CAN COMM CIRCUIT (U1000)	—
AUTO DRIVE POS.	No indication	—	—	—	UNKWN	—	—	UNKWN	UNKWN	—	—	CAN COMM CIRCUIT (U1000)	—
ABS	—	NG	UNKWN	UNKWN	UNKWN	—	UNKWN	—	—	—	—	CAN COMM CIRCUIT (U1000)	—
IPDM E/R	No indication	—	UNKWN	UNKWN	—	—	—	UNKWN	—	—	—	CAN COMM CIRCUIT (U1000)	—

PKIC5666E

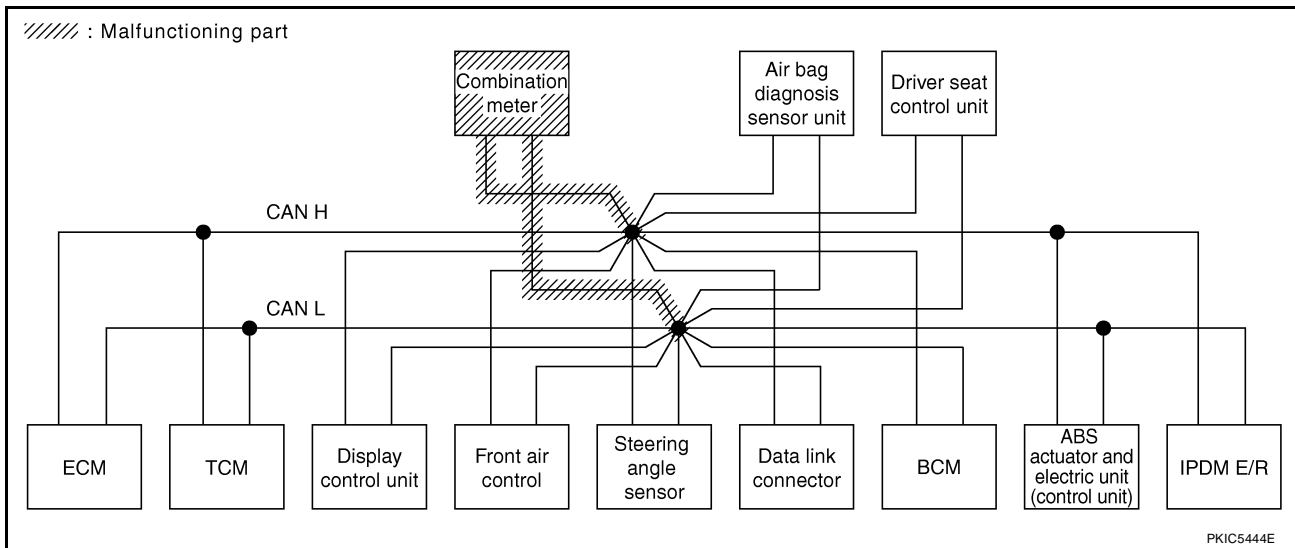

CAN SYSTEM (TYPE 4)

[CAN]

Case 11

Check driver seat control unit circuit. Refer to [LAN-202, "Driver Seat Control Unit Circuit Inspection"](#) .

SELECT SYSTEM screen		CAN DIAG SUPPORT MNTR										SELF-DIAG RESULTS		
		Initial diagnosis	Transmit diagnosis	Receive diagnosis										IPDM E/R
				ECM	TCM	Front air control	STRG	BCM /SEC	METER /M&A	VDC/TCS /ABS				
ENGINE	—	—	UNKWN	—	UNKWN	—	—	UNKWN	UNKWN	UNKWN	UNKWN	CAN COMM CIRCUIT (U1000)	CAN COMM CIRCUIT (U1001)	
A/T	—	NG	UNKWN	UNKWN	—	—	—	—	UNKWN	UNKWN	—	CAN COMM CIRCUIT (U1000)	—	
Display control unit	—	NG	UNKWN	UNKWN	—	UNKWN	—	UNKWN	UNKWN	—	UNKWN	—	—	
BCM	No indication	NG	UNKWN	UNKWN	—	—	—	—	UNKWN	—	UNKWN	CAN COMM CIRCUIT (U1000)	—	
METER	No indication	—	UNKWN	UNKWN	UNKWN	—	—	UNKWN	—	UNKWN	UNKWN	CAN COMM CIRCUIT (U1000)	—	
AUTO DRIVE POS.	No indication	—	—	—	UNKWN	—	—	UNKWN	UNKWN	—	—	CAN COMM CIRCUIT (U1000)	—	
ABS	—	NG	UNKWN	UNKWN	UNKWN	—	UNKWN	—	—	—	—	CAN COMM CIRCUIT (U1000)	—	
IPDM E/R	No indication	—	UNKWN	UNKWN	—	—	—	UNKWN	—	—	—	CAN COMM CIRCUIT (U1000)	—	

PKIC5667E

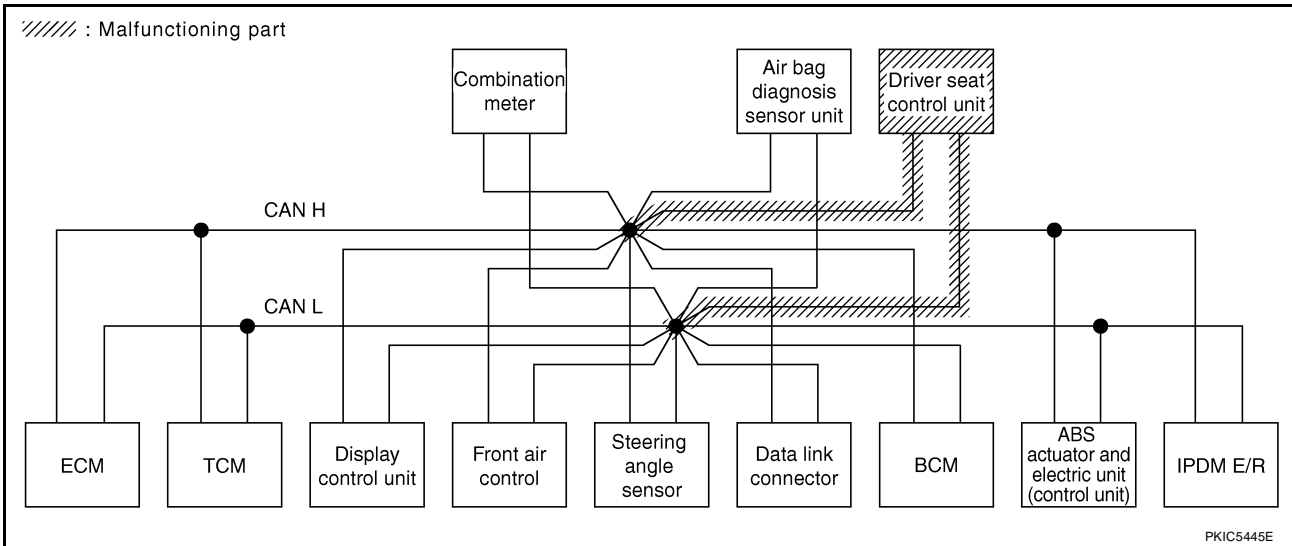

CAN SYSTEM (TYPE 4)

[CAN]

Case 12

Check ABS actuator and electric unit (control unit) circuit. Refer to [LAN-202, "ABS Actuator and Electric Unit \(Control Unit\) Circuit Inspection"](#) .

SELECT SYSTEM screen		CAN DIAG SUPPORT MNTR										SELF-DIAG RESULTS		
		Initial diagnosis	Transmit diagnosis	Receive diagnosis										
				ECM	TCM	Front air control	STRG	BCM /SEC	METER /M&A	VDC/TCS /ABS	IPDM E/R			
ENGINE	—	—	UNKWN	—	UNKWN	—	—	UNKWN	UNKWN	UNKWN	UNKWN	UNKWN	CAN COMM CIRCUIT (U1000)	CAN COMM CIRCUIT (U1001)
A/T	—	NG	UNKWN	UNKWN	—	—	—	—	UNKWN	UNKWN	—	—	CAN COMM CIRCUIT (U1000)	—
Display control unit	—	NG	UNKWN	UNKWN	—	UNKWN	—	UNKWN	UNKWN	—	UNKWN	—	—	—
BCM	No indication	NG	UNKWN	UNKWN	—	—	—	—	UNKWN	—	UNKWN	—	CAN COMM CIRCUIT (U1000)	—
METER	No indication	—	UNKWN	UNKWN	UNKWN	—	—	UNKWN	—	UNKWN	UNKWN	—	CAN COMM CIRCUIT (U1000)	—
AUTO DRIVE POS.	No indication	—	—	—	UNKWN	—	—	UNKWN	UNKWN	—	—	—	CAN COMM CIRCUIT (U1000)	—
ABS	—	✓	✓	✓	✓	—	✓	—	—	—	—	—	CAN COMM CIRCUIT (U1000)	—
IPDM E/R	No indication	—	UNKWN	UNKWN	—	—	—	UNKWN	—	—	—	—	CAN COMM CIRCUIT (U1000)	—

PKIC5668E

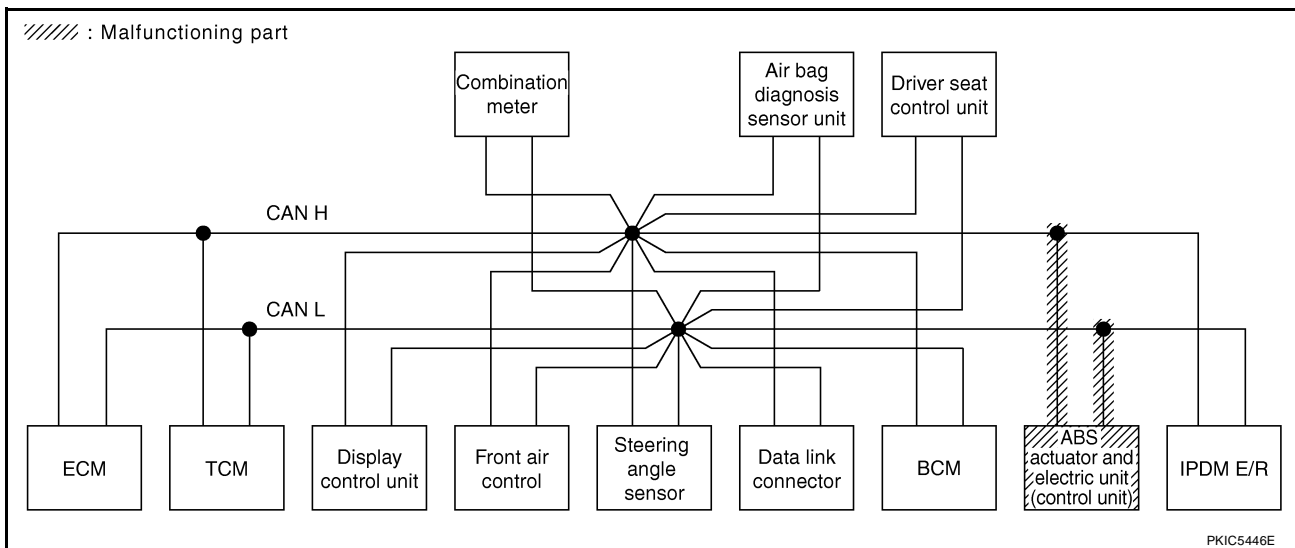

PKIC5446E

CAN SYSTEM (TYPE 4)

[CAN]

Case 13

Check IPDM E/R circuit. Refer to [LAN-203, "IPDM E/R Circuit Inspection"](#).

SELECT SYSTEM screen		CAN DIAG SUPPORT MNTR										SELF-DIAG RESULTS	
		Initial diagnosis	Transmit diagnosis	Receive diagnosis									
				ECM	TCM	Front air control	STRG	BCM /SEC	METER /M&A	VDC/TCS /ABS	IPDM E/R		
ENGINE	—	—	UNKWN	—	UNKWN	—	—	UNKWN	UNKWN	UNKWN	UNKWN	CAN COMM CIRCUIT (U1000)	CAN COMM CIRCUIT (U1001)
A/T	—	NG	UNKWN	UNKWN	—	—	—	—	UNKWN	UNKWN	—	CAN COMM CIRCUIT (U1000)	—
Display control unit	—	NG	UNKWN	UNKWN	—	UNKWN	—	UNKWN	UNKWN	—	UNKWN	—	—
BCM	No indication	NG	UNKWN	UNKWN	—	—	—	—	UNKWN	—	UNKWN	CAN COMM CIRCUIT (U1000)	—
METER	No indication	—	UNKWN	UNKWN	UNKWN	—	—	UNKWN	—	UNKWN	UNKWN	CAN COMM CIRCUIT (U1000)	—
AUTO DRIVE POS.	No indication	—	—	—	UNKWN	—	—	UNKWN	UNKWN	—	—	CAN COMM CIRCUIT (U1000)	—
ABS	—	NG	UNKWN	UNKWN	UNKWN	—	UNKWN	—	—	—	—	CAN COMM CIRCUIT (U1000)	—
IPDM E/R	No indication	—	UNKWN	UNKWN	—	—	—	UNKWN	—	—	—	CAN COMM CIRCUIT (U1000)	—

PKIC5669E

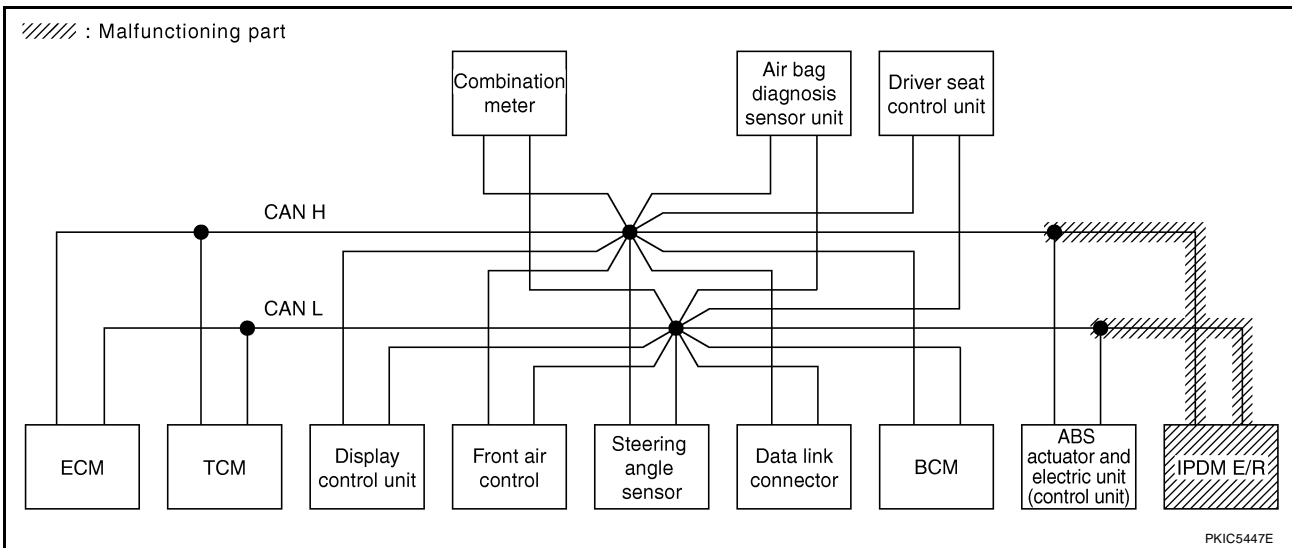

Case 14

Check CAN communication circuit. Refer to [LAN-203, "CAN Communication Circuit Inspection"](#).

SELECT SYSTEM screen		CAN DIAG SUPPORT MNTR										SELF-DIAG RESULTS	
		Initial diagnosis	Transmit diagnosis	Receive diagnosis									
				ECM	TCM	Front air control	STRG	BCM /SEC	METER /M&A	VDC/TCS /ABS	IPDM E/R		
ENGINE	—	—	UNKWN	—	UNKWN	—	—	UNKWN	UNKWN	UNKWN	UNKWN	CAN COMM CIRCUIT (U1000)	CAN COMM CIRCUIT (U1001)
A/T	—	NG	UNKWN	UNKWN	—	—	—	—	UNKWN	UNKWN	—	CAN COMM CIRCUIT (U1000)	—
Display control unit	—	NG	UNKWN	UNKWN	—	UNKWN	—	UNKWN	UNKWN	—	UNKWN	—	—
BCM	No indication	NG	UNKWN	UNKWN	—	—	—	—	UNKWN	—	UNKWN	CAN COMM CIRCUIT (U1000)	—
METER	No indication	—	UNKWN	UNKWN	UNKWN	—	—	UNKWN	—	UNKWN	UNKWN	CAN COMM CIRCUIT (U1000)	—
AUTO DRIVE POS.	No indication	—	—	—	UNKWN	—	—	UNKWN	UNKWN	—	—	CAN COMM CIRCUIT (U1000)	—
ABS	—	NG	UNKWN	UNKWN	UNKWN	—	UNKWN	—	—	—	—	CAN COMM CIRCUIT (U1000)	—
IPDM E/R	No indication	—	UNKWN	UNKWN	—	—	—	UNKWN	—	—	—	CAN COMM CIRCUIT (U1000)	—

PKIC5670E

CAN SYSTEM (TYPE 4)

[CAN]

Case 15

Check IPDM E/R ignition relay circuit continuously sticks "OFF". Refer to [LAN-204, "IPDM E/R Ignition Relay Circuit Inspection"](#) .

SELECT SYSTEM screen		CAN DIAG SUPPORT MNTR										SELF-DIAG RESULTS	
		Initial diagnosis	Transmit diagnosis	Receive diagnosis									
				ECM	TCM	Front air control	STRG	BCM /SEC	METER /M&A	VDC/TCS /ABS	IPDM E/R		
ENGINE	—	—	UNKWN	—	UNKWN	—	—	UNKWN	UNKWN	UNKWN	UNKWN	CAN COMM CIRCUIT (U1000)	CAN COMM CIRCUIT (U1001)
A/T	—	NG	UNKWN	UNKWN	—	—	—	—	UNKWN	UNKWN	—	CAN COMM CIRCUIT (U1000)	—
Display control unit	—	NG	UNKWN	UNKWN	—	UNKWN	—	UNKWN	UNKWN	—	UNKWN	—	—
BCM	No indication	NG	UNKWN	UNKWN	—	—	—	—	UNKWN	—	UNKWN	CAN COMM CIRCUIT (U1000)	—
METER	No indication	—	UNKWN	UNKWN	UNKWN	—	—	UNKWN	—	UNKWN	UNKWN	CAN COMM CIRCUIT (U1000)	—
AUTO DRIVE POS.	No indication	—	—	—	UNKWN	—	—	UNKWN	UNKWN	—	—	CAN COMM CIRCUIT (U1000)	—
ABS	—	NG	UNKWN	UNKWN	UNKWN	—	UNKWN	—	—	—	—	CAN COMM CIRCUIT (U1000)	—
IPDM E/R	No indication	—	UNKWN	UNKWN	—	—	—	UNKWN	—	—	—	CAN COMM CIRCUIT (U1000)	—

PKIC5671E

Case 16

Check IPDM E/R ignition relay circuit continuously sticks "ON". Refer to [LAN-204, "IPDM E/R Ignition Relay Circuit Inspection"](#) .

SELECT SYSTEM screen		CAN DIAG SUPPORT MNTR										SELF-DIAG RESULTS	
		Initial diagnosis	Transmit diagnosis	Receive diagnosis									
				ECM	TCM	Front air control	STRG	BCM /SEC	METER /M&A	VDC/TCS /ABS	IPDM E/R		
ENGINE	—	—	UNKWN	—	UNKWN	—	—	UNKWN	UNKWN	UNKWN	UNKWN	CAN COMM CIRCUIT (U1000)	CAN COMM CIRCUIT (U1001)
A/T	—	NG	UNKWN	—	—	—	—	—	—	UNKWN	—	CAN COMM CIRCUIT (U1000)	—
Display control unit	—	NG	UNKWN	UNKWN	—	UNKWN	—	UNKWN	UNKWN	—	UNKWN	—	—
BCM	No indication	NG	UNKWN	UNKWN	—	—	—	—	UNKWN	—	UNKWN	CAN COMM CIRCUIT (U1000)	—
METER	No indication	—	UNKWN	UNKWN	UNKWN	—	—	UNKWN	—	UNKWN	UNKWN	CAN COMM CIRCUIT (U1000)	—
AUTO DRIVE POS.	No indication	—	—	—	UNKWN	—	—	UNKWN	UNKWN	—	—	CAN COMM CIRCUIT (U1000)	—
ABS	—	NG	UNKWN	—	UNKWN	—	—	—	—	—	—	CAN COMM CIRCUIT (U1000)	—
IPDM E/R	No indication	—	UNKWN	UNKWN	—	—	—	UNKWN	—	—	—	CAN COMM CIRCUIT (U1000)	—

PKIC5672E

CAN SYSTEM (TYPE 5)

[CAN]

CAN SYSTEM (TYPE 5)

PF2:23710

Component Parts and Harness Connector Location

UKS0053I

A

Refer to [LAN-25, "Component Parts and Harness Connector Location"](#) .

Schematic

UKS0053J

B

Refer to [LAN-26, "Schematic"](#) .

Wiring Diagram — CAN —

UKS0053K

C

Refer to [LAN-27, "Wiring Diagram — CAN —"](#) .

D

E

F

G

H

I

J

LAN

L

M

CAN SYSTEM (TYPE 5)

[CAN]

UKS0053L

Check Sheet

NOTE:

If a check mark is put on "NG" on "INITIAL DIAG (Initial diagnosis)", replace the control unit.

Check sheet table														
SELECT SYSTEM screen		CAN DIAG SUPPORT MNTR										SELF-DIAG RESULTS		
		Initial diagnosis	Transmit diagnosis	Receive diagnosis										
				ECM	TCM	STRG	BCM /SEC	METER /M&A	AWD/4WD	VDC/TCS /ABS	IPDM E/R			
ENGINE	—	—	UNKWN	—	UNKWN	—	UNKWN	UNKWN	UNKWN	UNKWN	UNKWN	UNKWN	CAN COMM CIRCUIT (U1000)	CAN COMM CIRCUIT (U1001)
A/T	—	NG	UNKWN	UNKWN	—	—	—	UNKWN	UNKWN	UNKWN	—	—	CAN COMM CIRCUIT (U1000)	—
BCM	No indication	NG	UNKWN	UNKWN	—	—	—	UNKWN	—	—	UNKWN	UNKWN	CAN COMM CIRCUIT (U1000)	—
METER	No indication	—	UNKWN	UNKWN	UNKWN	—	UNKWN	—	—	UNKWN	UNKWN	UNKWN	CAN COMM CIRCUIT (U1000)	—
ALL MODE AWD/4WD	—	NG	UNKWN	UNKWN	UNKWN	—	—	UNKWN	—	UNKWN	—	—	CAN COMM CIRCUIT (U1000)	—
ABS	—	NG	UNKWN	UNKWN	UNKWN	UNKWN	—	—	UNKWN	—	—	—	CAN COMM CIRCUIT (U1000)	—
IPDM E/R	No indication	—	UNKWN	UNKWN	—	—	UNKWN	—	—	—	—	—	CAN COMM CIRCUIT (U1000)	—

Symptoms :

Attach copy of
SELECT SYSTEM

Attach copy of
SELECT SYSTEM

PKIC5673E

CAN SYSTEM (TYPE 5)

[CAN]

Attach copy of ENGINE SELF-DIAG RESULTS	Attach copy of A/T SELF-DIAG RESULTS	Attach copy of BCM SELF-DIAG RESULTS	Attach copy of METER SELF-DIAG RESULTS
Attach copy of ALL MODE AWD/4WD SELF-DIAG RESULTS	Attach copy of ABS SELF-DIAG RESULTS	Attach copy of IPDM E/R SELF-DIAG RESULTS	
Attach copy of ENGINE CAN DIAG SUPPORT MNTR	Attach copy of A/T CAN DIAG SUPPORT MNTR	Attach copy of BCM CAN DIAG SUPPORT MNTR	Attach copy of METER CAN DIAG SUPPORT MNTR
Attach copy of ALL MODE AWD/4WD CAN DIAG SUPPORT MNTR	Attach copy of ABS CAN DIAG SUPPORT MNTR	Attach copy of IPDM E/R CAN DIAG SUPPORT MNTR	

A
B
C
D
E
F
G
H
I
J
L
M

LAN

PKIC7066E

CHECK SHEET RESULTS (EXAMPLE)

NOTE:

If a check mark is put on "NG" on "INITIAL DIAG (Initial diagnosis)", replace the control unit.

Case 1

Check harness between TCM and data link connector. Refer to [LAN-195, "Inspection Between TCM and Data Link Connector Circuit"](#).

SELECT SYSTEM screen		CAN DIAG SUPPORT MNTR										SELF-DIAG RESULTS		
		Initial diagnosis	Transmit diagnosis	Receive diagnosis										
				ECM	TCM	STRG	BCM /SEC	METER /M&A	AWD/4WD	VDC/TCS /ABS	IPDM E/R			
ENGINE	—	—	UNKWN	—	UNKWN	—	UNKWN	UNKWN	UNKWN	UNKWN	UNKWN	UNKWN	CAN COMM CIRCUIT (U1000)	CAN COMM CIRCUIT (U1001)
A/T	—	NG	UNKWN	UNKWN	—	—	—	UNKWN	UNKWN	UNKWN	UNKWN	—	CAN COMM CIRCUIT (U1000)	—
BCM	No indication	NG	UNKWN	UNKWN	—	—	—	UNKWN	—	—	UNKWN	—	CAN COMM CIRCUIT (U1000)	—
METER	No indication	—	UNKWN	UNKWN	UNKWN	—	UNKWN	—	—	UNKWN	UNKWN	—	CAN COMM CIRCUIT (U1000)	—
ALL MODE AWD/4WD	—	NG	UNKWN	UNKWN	UNKWN	—	—	UNKWN	—	UNKWN	—	—	CAN COMM CIRCUIT (U1000)	—
ABS	—	NG	UNKWN	UNKWN	UNKWN	—	—	UNKWN	—	UNKWN	—	—	CAN COMM CIRCUIT (U1000)	—
IPDM E/R	No indication	—	UNKWN	UNKWN	—	—	UNKWN	—	—	—	—	—	CAN COMM CIRCUIT (U1000)	—

PKIC5674E

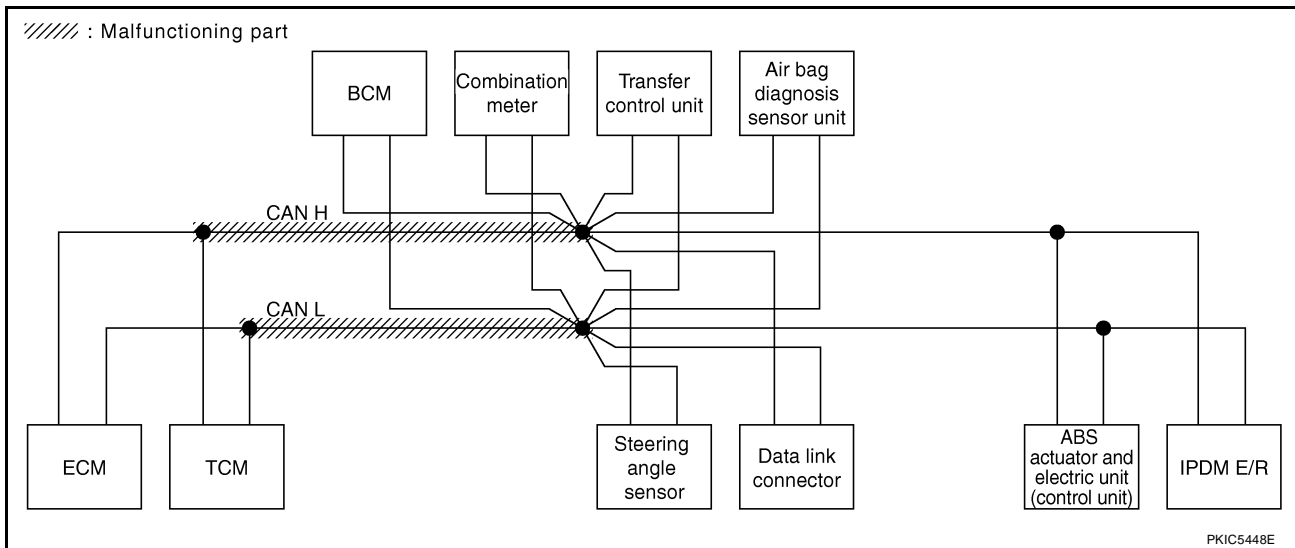

PKIC5448E

Case 2

Check harness between data link connector and ABS actuator and electric unit (control unit). Refer to [LAN-196, "Inspection Between Data Link Connector and ABS Actuator and Electric Unit \(Control Unit\) Circuit"](#).

SELECT SYSTEM screen		CAN DIAG SUPPORT MNTR										SELF-DIAG RESULTS		
		Initial diagnosis	Transmit diagnosis	Receive diagnosis										
				ECM	TCM	STRG	BCM /SEC	METER /M&A	AWD/4WD	VDC/TCS /ABS	IPDM E/R			
ENGINE	—	—	UNKWN	—	UNKWN	—	UNKWN	UNKWN	UNKWN	UNKWN	UNKWN	UNKWN	CAN COMM CIRCUIT (U1000)	CAN COMM CIRCUIT (U1001)
A/T	—	NG	UNKWN	UNKWN	—	—	—	UNKWN	UNKWN	UNKWN	UNKWN	—	CAN COMM CIRCUIT (U1000)	—
BCM	No indication	NG	UNKWN	UNKWN	—	—	—	UNKWN	—	—	UNKWN	UNKWN	CAN COMM CIRCUIT (U1000)	—
METER	No indication	—	UNKWN	UNKWN	UNKWN	—	UNKWN	—	—	UNKWN	UNKWN	UNKWN	CAN COMM CIRCUIT (U1000)	—
ALL MODE AWD/4WD	—	NG	UNKWN	UNKWN	UNKWN	—	—	UNKWN	—	UNKWN	—	—	CAN COMM CIRCUIT (U1000)	—
ABS	—	NG	UNKWN	UNKWN	UNKWN	UNKWN	—	—	UNKWN	—	—	—	CAN COMM CIRCUIT (U1000)	—
IPDM E/R	No indication	—	UNKWN	UNKWN	—	—	UNKWN	—	—	—	—	—	CAN COMM CIRCUIT (U1000)	—

PKIC5675E

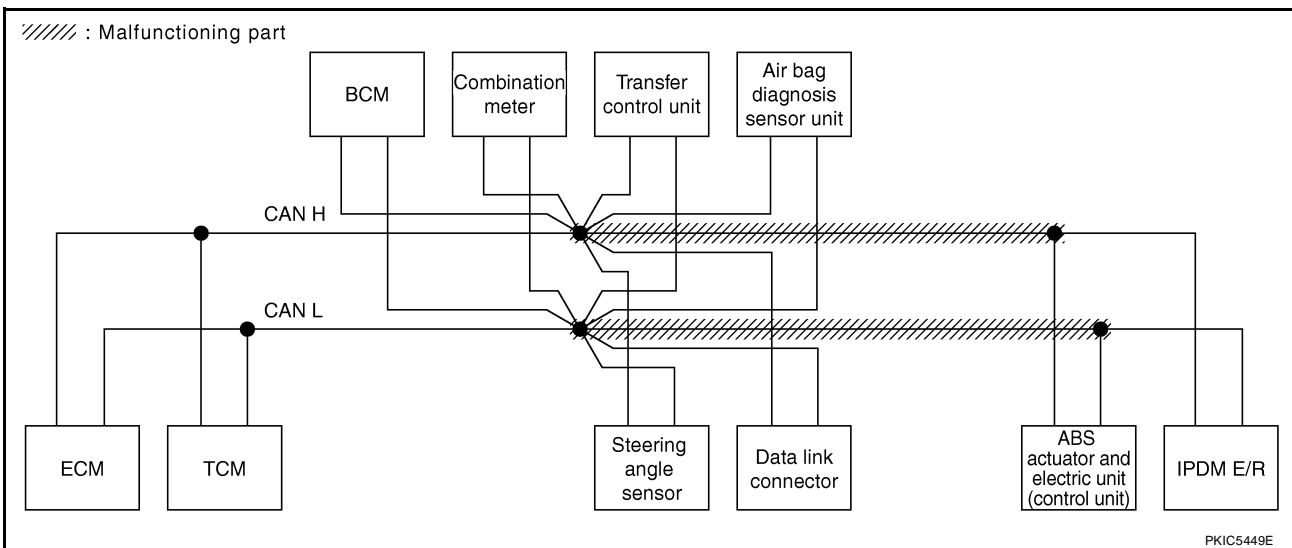

Case 3

Check ECM circuit. Refer to [LAN-197, "ECM Circuit Inspection"](#) .

SELECT SYSTEM screen		CAN DIAG SUPPORT MNTR										SELF-DIAG RESULTS	
		Initial diagnosis	Transmit diagnosis	Receive diagnosis									
				ECM	TCM	STRG	BCM /SEC	METER /M&A	AWD/4WD	VDC/TCS /ABS	IPDM E/R		
ENGINE	—	—	UNKW [√]	—	UNKW [√]	—	UNKW [√]	UNKW [√]	UNKW [√]	UNKW [√]	UNKW [√]	CAN COMM CIRCUIT (U1000) [√]	CAN COMM CIRCUIT (U1001) [√]
A/T	—	NG	UNKW [√]	UNKW [√]	—	—	—	UNKW [√]	UNKW [√]	UNKW [√]	—	CAN COMM CIRCUIT (U1000) [√]	—
BCM	No indication	NG	UNKW [√]	UNKW [√]	—	—	—	UNKW [√]	—	—	UNKW [√]	CAN COMM CIRCUIT (U1000) [√]	—
METER	No indication	—	UNKW [√]	UNKW [√]	—	—	UNKW [√]	—	—	UNKW [√]	UNKW [√]	CAN COMM CIRCUIT (U1000) [√]	—
ALL MODE AWD/4WD	—	NG	UNKW [√]	UNKW [√]	—	—	UNKW [√]	—	UNKW [√]	—	—	CAN COMM CIRCUIT (U1000) [√]	—
ABS	—	NG	UNKW [√]	UNKW [√]	UNKW [√]	—	—	UNKW [√]	—	—	—	CAN COMM CIRCUIT (U1000) [√]	—
IPDM E/R	No indication	—	UNKW [√]	UNKW [√]	—	—	UNKW [√]	—	—	—	—	CAN COMM CIRCUIT (U1000) [√]	—

PKIC5676E

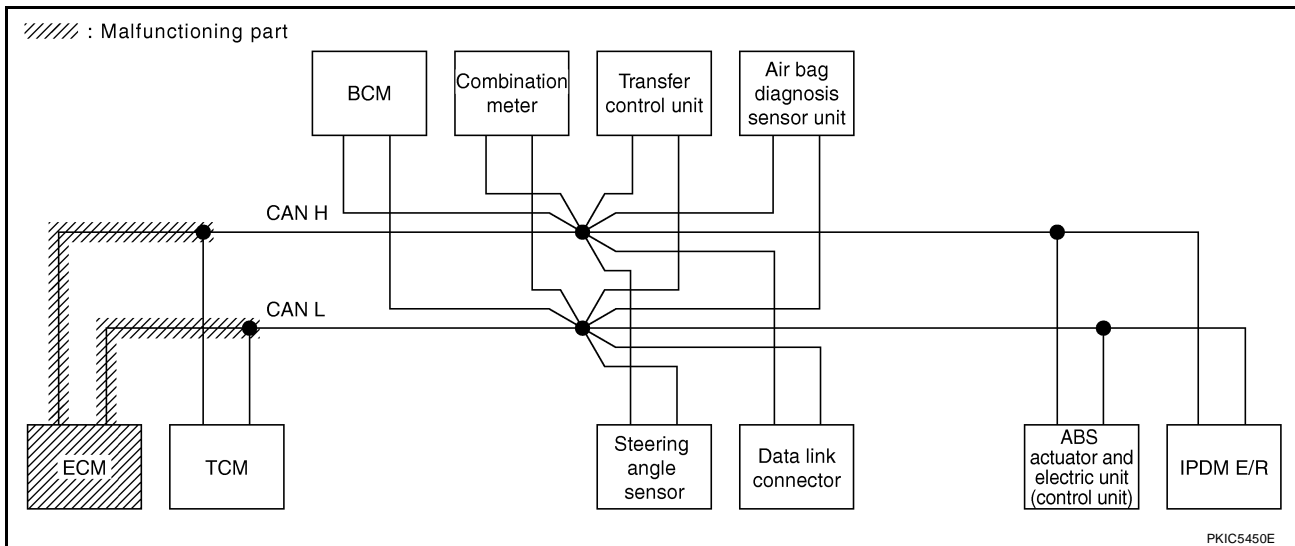

CAN SYSTEM (TYPE 5)

[CAN]

Case 4

Check TCM circuit. Refer to [LAN-197, "TCM Circuit Inspection"](#) .

SELECT SYSTEM screen		CAN DIAG SUPPORT MNTR										SELF-DIAG RESULTS	
		Initial diagnosis	Transmit diagnosis	Receive diagnosis									
				ECM	TCM	STRG	BCM /SEC	METER /M&A	AWD/4WD	VDC/TCS /ABS	IPDM E/R		
ENGINE	—	—	UNKWN	—	UNKWN	—	UNKWN	UNKWN	UNKWN	UNKWN	UNKWN	CAN COMM CIRCUIT (U100)	CAN COMM CIRCUIT (U101)
A/T	—	NG	UNKWN	UNKWN	—	—	—	UNKWN	UNKWN	UNKWN	—	CAN COMM CIRCUIT (U100)	—
BCM	No indication	NG	UNKWN	UNKWN	—	—	—	UNKWN	—	—	UNKWN	CAN COMM CIRCUIT (U100)	—
METER	No indication	—	UNKWN	UNKWN	UNKWN	—	UNKWN	—	—	UNKWN	UNKWN	CAN COMM CIRCUIT (U100)	—
ALL MODE AWD/4WD	—	NG	UNKWN	UNKWN	UNKWN	—	—	UNKWN	—	UNKWN	—	CAN COMM CIRCUIT (U100)	—
ABS	—	NG	UNKWN	UNKWN	UNKWN	UNKWN	—	—	UNKWN	—	—	CAN COMM CIRCUIT (U100)	—
IPDM E/R	No indication	—	UNKWN	UNKWN	—	—	UNKWN	—	—	—	—	CAN COMM CIRCUIT (U100)	—

PKIC5677E

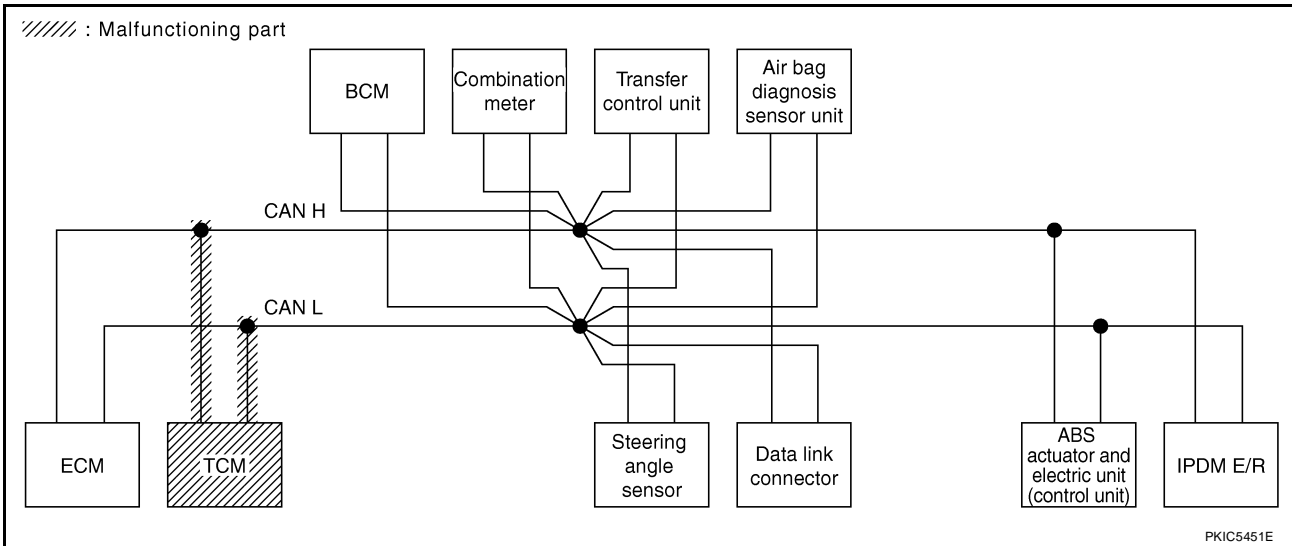

CAN SYSTEM (TYPE 5)

[CAN]

Case 5

Check steering angle sensor circuit. Refer to [LAN-199, "Steering Angle Sensor Circuit Inspection"](#) .

SELECT SYSTEM screen		CAN DIAG SUPPORT MNTR										SELF-DIAG RESULTS	
		Initial diagnosis	Transmit diagnosis	Receive diagnosis									
				ECM	TCM	STRG	BCM /SEC	METER /M&A	AWD/4WD	VDC/TCS /ABS	IPDM E/R		
ENGINE	—	—	UNKWN	—	UNKWN	—	UNKWN	UNKWN	UNKWN	UNKWN	UNKWN	CAN COMM CIRCUIT (U1000)	CAN COMM CIRCUIT (U1001)
A/T	—	NG	UNKWN	UNKWN	—	—	—	UNKWN	UNKWN	UNKWN	—	CAN COMM CIRCUIT (U1000)	—
BCM	No indication	NG	UNKWN	UNKWN	—	—	—	UNKWN	—	—	UNKWN	CAN COMM CIRCUIT (U1000)	—
METER	No indication	—	UNKWN	UNKWN	UNKWN	—	UNKWN	—	—	UNKWN	UNKWN	CAN COMM CIRCUIT (U1000)	—
ALL MODE AWD/4WD	—	NG	UNKWN	UNKWN	UNKWN	—	—	UNKWN	—	UNKWN	—	CAN COMM CIRCUIT (U1000)	—
ABS	—	NG	UNKWN	UNKWN	UNKWN	UNKWN	—	—	UNKWN	—	—	CAN COMM CIRCUIT (U1000)	—
IPDM E/R	No indication	—	UNKWN	UNKWN	—	—	UNKWN	—	—	—	—	CAN COMM CIRCUIT (U1000)	—

PKIC5678E

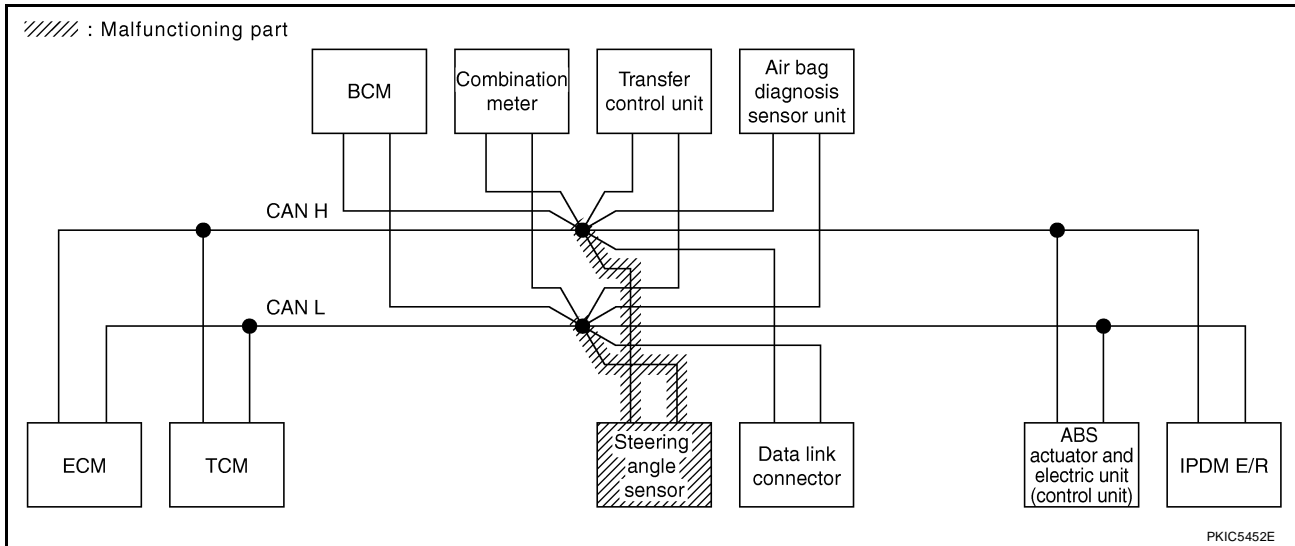

PKIC5452E

CAN SYSTEM (TYPE 5)

[CAN]

Case 6

Check data link connector circuit. Refer to [LAN-199, "Data Link Connector Circuit Inspection"](#) .

SELECT SYSTEM screen	CAN DIAG SUPPORT MNTR										SELF-DIAG RESULTS		
	Initial diagnosis	Transmit diagnosis	Receive diagnosis										
			ECM	TCM	STRG	BCM /SEC	METER /M&A	AWD/4WD	VDC/TCS /ABS	IPDM E/R			
ENGINE	—	—	UNKWN	—	UNKWN	—	UNKWN	UNKWN	UNKWN	UNKWN	UNKWN	CAN COMM CIRCUIT (U1000)	CAN COMM CIRCUIT (U1001)
A/T	—	NG	UNKWN	UNKWN	—	—	—	UNKWN	UNKWN	UNKWN	—	CAN COMM CIRCUIT (U1000)	—
BCM	No indication	NG	UNKWN	UNKWN	—	—	—	UNKWN	—	—	UNKWN	CAN COMM CIRCUIT (U1000)	—
METER	No indication	—	UNKWN	UNKWN	UNKWN	—	UNKWN	—	—	UNKWN	UNKWN	CAN COMM CIRCUIT (U1000)	—
ALL MODE AWD/4WD	—	NG	UNKWN	UNKWN	UNKWN	—	—	UNKWN	—	UNKWN	—	CAN COMM CIRCUIT (U1000)	—
ABS	—	NG	UNKWN	UNKWN	UNKWN	UNKWN	—	—	UNKWN	—	—	CAN COMM CIRCUIT (U1000)	—
IPDM E/R	No indication	—	UNKWN	UNKWN	—	—	UNKWN	—	—	—	—	CAN COMM CIRCUIT (U1000)	—

PKIC5679E

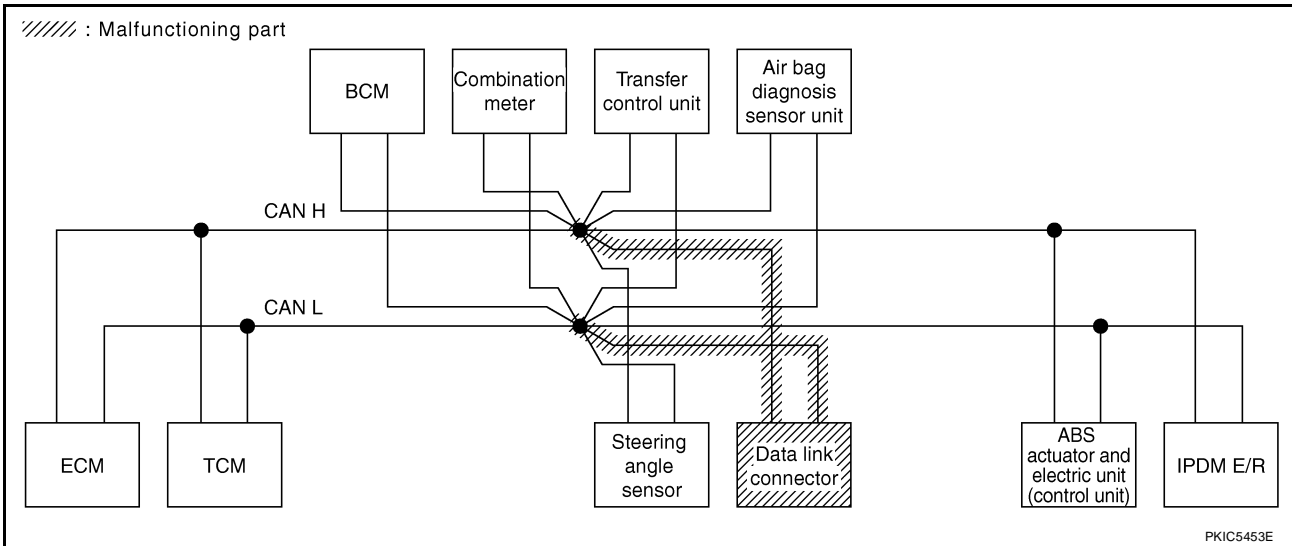

CAN SYSTEM (TYPE 5)

[CAN]

Case 7

Check BCM circuit. Refer to [LAN-200, "BCM Circuit Inspection"](#) .

SELECT SYSTEM screen		CAN DIAG SUPPORT MNTR										SELF-DIAG RESULTS	
		Initial diagnosis	Transmit diagnosis	Receive diagnosis									
				ECM	TCM	STRG	BCM /SEC	METER /M&A	AWD/4WD	VDC/TCS /ABS	IPDM E/R		
ENGINE	—	—	UNKWN	—	UNKWN	—	UNKWN	UNKWN	UNKWN	UNKWN	UNKWN	CAN COMM CIRCUIT (U1000)	CAN COMM CIRCUIT (U1001)
A/T	—	NG	UNKWN	UNKWN	—	—	—	UNKWN	UNKWN	UNKWN	—	CAN COMM CIRCUIT (U1000)	—
BCM	✓ No indication	NG	UNKWN	UNKWN	—	—	—	UNKWN	—	—	UNKWN	CAN COMM CIRCUIT (U1000)	—
METER	—	—	UNKWN	UNKWN	UNKWN	—	UNKWN	—	—	UNKWN	UNKWN	CAN COMM CIRCUIT (U1000)	—
ALL MODE AWD/4WD	—	NG	UNKWN	UNKWN	UNKWN	—	—	UNKWN	—	UNKWN	—	CAN COMM CIRCUIT (U1000)	—
ABS	—	NG	UNKWN	UNKWN	UNKWN	UNKWN	—	—	UNKWN	—	—	CAN COMM CIRCUIT (U1000)	—
IPDM E/R	—	—	UNKWN	UNKWN	—	—	UNKWN	—	—	—	—	CAN COMM CIRCUIT (U1000)	—

PKIC5680E

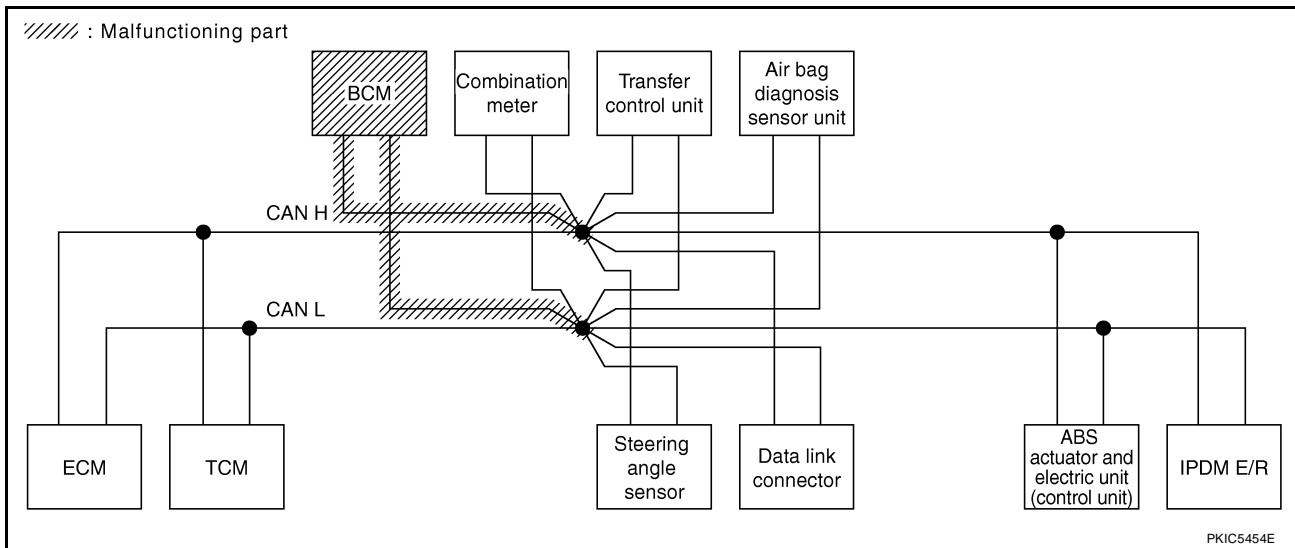

Case 8

Check combination meter circuit. Refer to [LAN-200, "Combination Meter Circuit Inspection"](#) .

SELECT SYSTEM screen		CAN DIAG SUPPORT MNTR										SELF-DIAG RESULTS	
		Initial diagnosis	Transmit diagnosis	Receive diagnosis									
				ECM	TCM	STRG	BCM /SEC	METER /M&A	AWD/4WD	VDC/TCS /ABS	IPDM E/R		
ENGINE	—	—	UNKWN	—	UNKWN	—	UNKWN	UNKWN	UNKWN	UNKWN	UNKWN	CAN COMM CIRCUIT (U1000)	CAN COMM CIRCUIT (U1001)
A/T	—	NG	UNKWN	UNKWN	—	—	—	UNKWN	UNKWN	UNKWN	—	CAN COMM CIRCUIT (U1000)	—
BCM	No indication	NG	UNKWN	UNKWN	—	—	—	UNKWN	—	—	UNKWN	CAN COMM CIRCUIT (U1000)	—
METER	No indication	—	UNKWN	UNKWN	UNKWN	—	UNKWN	—	—	UNKWN	UNKWN	CAN COMM CIRCUIT (U1000)	—
ALL MODE AWD/4WD	—	NG	UNKWN	UNKWN	UNKWN	—	—	UNKWN	—	UNKWN	—	CAN COMM CIRCUIT (U1000)	—
ABS	—	NG	UNKWN	UNKWN	UNKWN	UNKWN	—	—	UNKWN	—	—	CAN COMM CIRCUIT (U1000)	—
IPDM E/R	No indication	—	UNKWN	UNKWN	—	—	UNKWN	—	—	—	—	CAN COMM CIRCUIT (U1000)	—

PKIC5681E

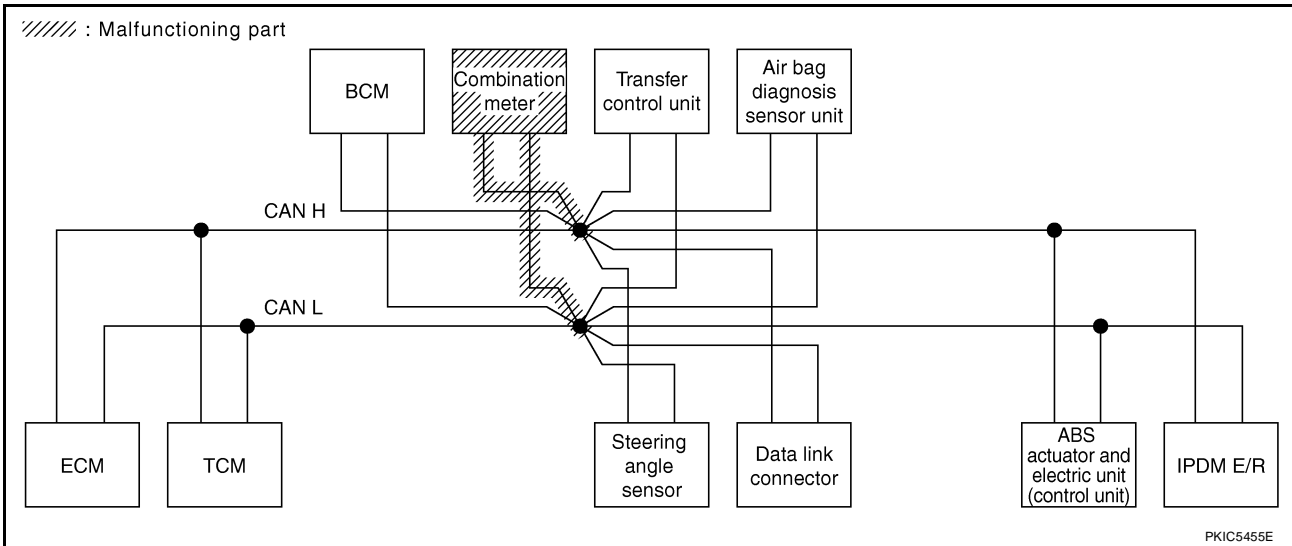

CAN SYSTEM (TYPE 5)

[CAN]

Case 9

Check transfer control unit circuit. Refer to [LAN-201, "Transfer Control Unit Circuit Inspection"](#).

SELECT SYSTEM screen		CAN DIAG SUPPORT MNTR										SELF-DIAG RESULTS	
		Initial diagnosis	Transmit diagnosis	Receive diagnosis									
				ECM	TCM	STRG	BCM /SEC	METER /M&A	AWD/4WD	VDC/TCS /ABS	IPDM E/R		
ENGINE	—	—	UNKWN	—	UNKWN	—	UNKWN	UNKWN	UNKWN	UNKWN	UNKWN	CAN COMM CIRCUIT (U1000)	CAN COMM CIRCUIT (U001)
A/T	—	NG	UNKWN	UNKWN	—	—	—	UNKWN	UNKWN	UNKWN	—	CAN COMM CIRCUIT (U000)	—
BCM	No indication	NG	UNKWN	UNKWN	—	—	—	UNKWN	—	—	UNKWN	CAN COMM CIRCUIT (U1000)	—
METER	No indication	—	UNKWN	UNKWN	UNKWN	—	UNKWN	—	—	UNKWN	UNKWN	CAN COMM CIRCUIT (U1000)	—
ALL MODE AWD/4WD	—	NG	UNKWN	UNKWN	UNKWN	—	—	UNKWN	—	UNKWN	—	CAN COMM CIRCUIT (U000)	—
ABS	—	NG	UNKWN	UNKWN	UNKWN	UNKWN	—	—	UNKWN	—	—	CAN COMM CIRCUIT (U000)	—
IPDM E/R	No indication	—	UNKWN	UNKWN	—	—	UNKWN	—	—	—	—	CAN COMM CIRCUIT (U1000)	—

PKIC5682E

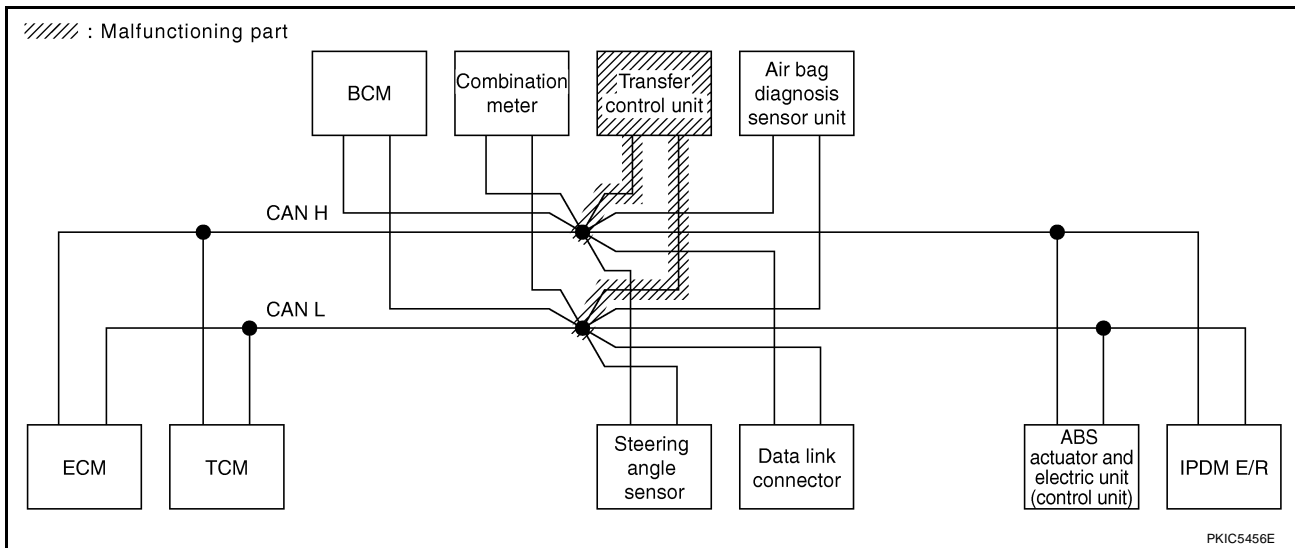

Case 10

Check ABS actuator and electric unit (control unit) circuit. Refer to [LAN-202, "ABS Actuator and Electric Unit \(Control Unit\) Circuit Inspection"](#).

SELECT SYSTEM screen		CAN DIAG SUPPORT MNTR										SELF-DIAG RESULTS		
		Initial diagnosis	Transmit diagnosis	Receive diagnosis										
				ECM	TCM	STRG	BCM /SEC	METER /M&A	AWD/4WD	VDC/TCS /ABS	IPDM E/R			
ENGINE	—	—	UNKWN	—	UNKWN	—	UNKWN	UNKWN	UNKWN	UNKWN	UNKWN	UNKWN	CAN COMM CIRCUIT (U1000)	CAN COMM CIRCUIT (U1001)
A/T	—	NG	UNKWN	UNKWN	—	—	—	UNKWN	UNKWN	UNKWN	UNKWN	—	CAN COMM CIRCUIT (U1000)	—
BCM	No indication	NG	UNKWN	UNKWN	—	—	—	UNKWN	—	—	UNKWN	UNKWN	CAN COMM CIRCUIT (U1000)	—
METER	No indication	—	UNKWN	UNKWN	UNKWN	—	UNKWN	—	—	UNKWN	UNKWN	UNKWN	CAN COMM CIRCUIT (U1000)	—
ALL MODE AWD/4WD	—	NG	UNKWN	UNKWN	UNKWN	—	—	UNKWN	—	UNKWN	UNKWN	—	CAN COMM CIRCUIT (U1000)	—
ABS	—	NG	UNKWN	UNKWN	UNKWN	UNKWN	—	—	UNKWN	—	—	—	CAN COMM CIRCUIT (U1000)	—
IPDM E/R	No indication	—	UNKWN	UNKWN	—	—	UNKWN	—	—	—	—	—	CAN COMM CIRCUIT (U1000)	—

PKIC5683E

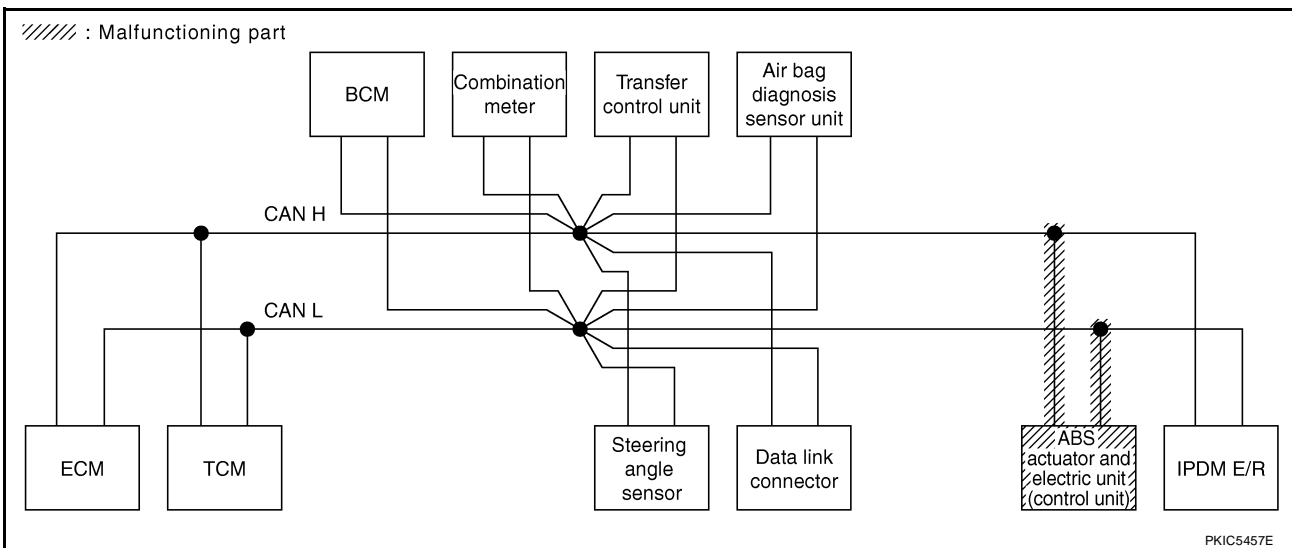

CAN SYSTEM (TYPE 5)

[CAN]

Case 11

Check IPDM E/R circuit. Refer to [LAN-203, "IPDM E/R Circuit Inspection"](#) .

SELECT SYSTEM screen		CAN DIAG SUPPORT MNTR										SELF-DIAG RESULTS		
		Initial diagnosis	Transmit diagnosis	Receive diagnosis										IPDM E/R
				ECM	TCM	STRG	BCM /SEC	METER /M&A	AWD/4WD	VDC/TCS /ABS				
ENGINE	—	—	UNKWN	—	UNKWN	—	UNKWN	UNKWN	UNKWN	UNKWN	UNKWN	UNKWN	CAN COMM CIRCUIT (U1000)	CAN COMM CIRCUIT (U01) ✓
A/T	—	NG	UNKWN	UNKWN	—	—	—	UNKWN	UNKWN	UNKWN	—	—	CAN COMM CIRCUIT (U1000)	—
BCM	No indication	NG	UNKWN	UNKWN	—	—	—	UNKWN	—	—	UNKWN	UNKWN	CAN COMM CIRCUIT (U1000)	—
METER	No indication	—	UNKWN	UNKWN	UNKWN	—	UNKWN	—	—	UNKWN	UNKWN	UNKWN	CAN COMM CIRCUIT (U1000) ✓	—
ALL MODE AWD/4WD	—	NG	UNKWN	UNKWN	UNKWN	—	—	UNKWN	—	UNKWN	—	—	CAN COMM CIRCUIT (U1000)	—
ABS	—	NG	UNKWN	UNKWN	UNKWN	UNKWN	—	—	UNKWN	—	—	—	CAN COMM CIRCUIT (U1000)	—
IPDM E/R	No indication ✓	—	UNKWN	UNKWN	—	—	UNKWN	—	—	—	—	—	CAN COMM CIRCUIT (U1000) ✓	—

PKIC5684E

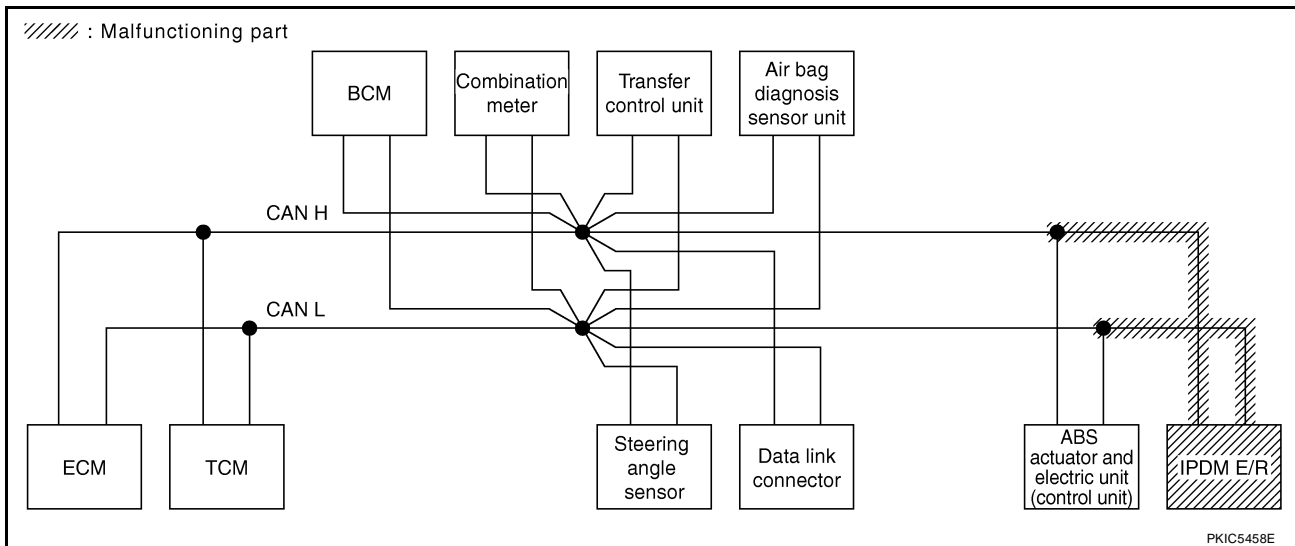

Case 12

Check CAN communication circuit. Refer to [LAN-203, "CAN Communication Circuit Inspection"](#) .

SELECT SYSTEM screen		CAN DIAG SUPPORT MNTR										SELF-DIAG RESULTS		
		Initial diagnosis	Transmit diagnosis	Receive diagnosis										IPDM E/R
				ECM	TCM	STRG	BCM /SEC	METER /M&A	AWD/4WD	VDC/TCS /ABS				
ENGINE	—	—	UNKWN ✓	—	UNKWN ✓	—	UNKWN ✓	UNKWN ✓	UNKWN ✓	UNKWN ✓	UNKWN ✓	UNKWN ✓	CAN COMM CIRCUIT (U1000) ✓	CAN COMM CIRCUIT (U01) ✓
A/T	—	NG	UNKWN	UNKWN ✓	—	—	—	UNKWN ✓	UNKWN ✓	UNKWN ✓	—	—	CAN COMM CIRCUIT (U1000) ✓	—
BCM	No indication ✓	NG	UNKWN	UNKWN	—	—	—	UNKWN	—	—	UNKWN	UNKWN	CAN COMM CIRCUIT (U1000)	—
METER	No indication ✓	—	UNKWN	UNKWN	UNKWN	—	UNKWN	—	—	UNKWN	UNKWN	UNKWN	CAN COMM CIRCUIT (U1000) ✓	—
ALL MODE AWD/4WD	—	NG	UNKWN ✓	UNKWN ✓	UNKWN ✓	—	—	UNKWN ✓	—	UNKWN ✓	—	—	CAN COMM CIRCUIT (U1000) ✓	—
ABS	—	NG ✓	UNKWN ✓	UNKWN ✓	UNKWN ✓	UNKWN ✓	—	—	UNKWN ✓	—	—	—	CAN COMM CIRCUIT (U1000) ✓	—
IPDM E/R	No indication ✓	—	UNKWN	UNKWN	—	—	UNKWN	—	—	—	—	—	CAN COMM CIRCUIT (U1000) ✓	—

PKIC5685E

CAN SYSTEM (TYPE 5)

[CAN]

Case 13

Check IPDM E/R ignition relay circuit continuously sticks "OFF". Refer to [LAN-204, "IPDM E/R Ignition Relay Circuit Inspection"](#) .

SELECT SYSTEM screen		CAN DIAG SUPPORT MNTR										SELF-DIAG RESULTS	
		Initial diagnosis	Transmit diagnosis	Receive diagnosis									
				ECM	TCM	STRG	BCM /SEC	METER /M&A	AWD/4WD	VDC/TCS /ABS	IPDM E/R		
ENGINE	—	—	UNKWN	—	UNKWN	—	UNKWN	UNKWN	UNKWN	UNKWN	UNKWN	CAN COMM CIRCUIT (U1000)	CAN COMM CIRCUIT (U1001)
A/T	—	NG	UNKWN	UNKWN	—	—	—	UNKWN	UNKWN	UNKWN	—	CAN COMM CIRCUIT (U1000)	—
BCM	No indication	NG	UNKWN	UNKWN	—	—	—	UNKWN	—	—	UNKWN	CAN COMM CIRCUIT (U1000)	—
METER	No indication	—	UNKWN	UNKWN	UNKWN	—	UNKWN	—	—	UNKWN	UNKWN	CAN COMM CIRCUIT (U1000)	—
ALL MODE AWD/4WD	—	NG	UNKWN	UNKWN	UNKWN	—	—	UNKWN	—	UNKWN	—	CAN COMM CIRCUIT (U1000)	—
ABS	—	NG	UNKWN	UNKWN	UNKWN	UNKWN	—	—	UNKWN	—	—	CAN COMM CIRCUIT (U1000)	—
IPDM E/R	No indication	—	UNKWN	UNKWN	—	—	UNKWN	—	—	—	—	CAN COMM CIRCUIT (U1000)	—

PKIC5686E

Case 14

Check IPDM E/R ignition relay circuit continuously sticks "ON". Refer to [LAN-204, "IPDM E/R Ignition Relay Circuit Inspection"](#) .

SELECT SYSTEM screen		CAN DIAG SUPPORT MNTR										SELF-DIAG RESULTS	
		Initial diagnosis	Transmit diagnosis	Receive diagnosis									
				ECM	TCM	STRG	BCM /SEC	METER /M&A	AWD/4WD	VDC/TCS /ABS	IPDM E/R		
ENGINE	—	—	UNKWN	—	UNKWN	—	UNKWN	UNKWN	UNKWN	UNKWN	UNKWN	CAN COMM CIRCUIT (U1000)	CAN COMM CIRCUIT (U1001)
A/T	—	NG	UNKWN	—	—	—	—	—	—	UNKWN	—	CAN COMM CIRCUIT (U1000)	—
BCM	No indication	NG	UNKWN	UNKWN	—	—	—	UNKWN	—	—	UNKWN	CAN COMM CIRCUIT (U1000)	—
METER	No indication	—	UNKWN	UNKWN	UNKWN	—	UNKWN	—	—	UNKWN	UNKWN	CAN COMM CIRCUIT (U1000)	—
ALL MODE AWD/4WD	—	NG	UNKWN	UNKWN	UNKWN	—	—	UNKWN	—	UNKWN	—	CAN COMM CIRCUIT (U1000)	—
ABS	—	NG	UNKWN	—	UNKWN	—	—	—	—	—	—	CAN COMM CIRCUIT (U1000)	—
IPDM E/R	No indication	—	UNKWN	UNKWN	—	—	UNKWN	—	—	—	—	CAN COMM CIRCUIT (U1000)	—

PKIC5687E

CAN SYSTEM (TYPE 6)

PF2:23710

Component Parts and Harness Connector Location

UKS0053M

Refer to [LAN-25, "Component Parts and Harness Connector Location"](#) .

Schematic

UKS0053N

Refer to [LAN-26, "Schematic"](#) .

Wiring Diagram — CAN —

UKS0053O

Refer to [LAN-27, "Wiring Diagram — CAN —"](#) .

CAN SYSTEM (TYPE 6)

[CAN]

UKS0053P

Check Sheet

NOTE:

If a check mark is put on "NG" on "INITIAL DIAG (Initial diagnosis)", replace the control unit.

Check sheet table														
SELECT SYSTEM screen		CAN DIAG SUPPORT MNTR										SELF-DIAG RESULTS		
		Initial diagnosis	Transmit diagnosis	Receive diagnosis										
				ECM	TCM	STRG	BCM /SEC	METER /M&A	AWD/4WD	VDC/TCS /ABS	IPDM E/R			
ENGINE	—	—	UNKWN	—	UNKWN	—	UNKWN	UNKWN	UNKWN	UNKWN	UNKWN	UNKWN	CAN COMM CIRCUIT (U1000)	CAN COMM CIRCUIT (U1001)
A/T	—	NG	UNKWN	UNKWN	—	—	—	UNKWN	UNKWN	UNKWN	—	—	CAN COMM CIRCUIT (U1000)	—
BCM	No indication	NG	UNKWN	UNKWN	—	—	—	UNKWN	—	—	UNKWN	UNKWN	CAN COMM CIRCUIT (U1000)	—
METER	No indication	—	UNKWN	UNKWN	UNKWN	—	UNKWN	—	—	UNKWN	UNKWN	UNKWN	CAN COMM CIRCUIT (U1000)	—
ALL MODE AWD/4WD	—	NG	UNKWN	UNKWN	UNKWN	—	—	UNKWN	—	UNKWN	—	—	CAN COMM CIRCUIT (U1000)	—
ABS	—	NG	UNKWN	UNKWN	UNKWN	UNKWN	—	—	UNKWN	—	—	—	CAN COMM CIRCUIT (U1000)	—
IPDM E/R	No indication	—	UNKWN	UNKWN	—	—	UNKWN	—	—	—	—	—	CAN COMM CIRCUIT (U1000)	—

Symptoms :

Attach copy of
SELECT SYSTEM

Attach copy of
SELECT SYSTEM

PKIC5673E

A
B
C
D
E
F
G
H
I
J
LAN
L
M

CAN SYSTEM (TYPE 6)

[CAN]

Attach copy of
ENGINE
SELF-DIAG RESULTS

Attach copy of
A/T
SELF-DIAG RESULTS

Attach copy of
BCM
SELF-DIAG RESULTS

Attach copy of
METER
SELF-DIAG RESULTS

Attach copy of
ALL MODE AWD/4WD
SELF-DIAG RESULTS

Attach copy of
ABS
SELF-DIAG RESULTS

Attach copy of
IPDM E/R
SELF-DIAG RESULTS

Attach copy of
ENGINE
CAN DIAG SUPPORT
MNTR

Attach copy of
A/T
CAN DIAG SUPPORT
MNTR

Attach copy of
BCM
CAN DIAG SUPPORT
MNTR

Attach copy of
METER
CAN DIAG SUPPORT
MNTR

Attach copy of
ALL MODE AWD/4WD
CAN DIAG SUPPORT
MNTR

Attach copy of
ABS
CAN DIAG SUPPORT
MNTR

Attach copy of
IPDM E/R
CAN DIAG SUPPORT
MNTR

PKIC7066E

CHECK SHEET RESULTS (EXAMPLE)

NOTE:

If a check mark is put on "NG" on "INITIAL DIAG (Initial diagnosis)", replace the control unit.

Case 1

Check harness between TCM and data link connector. Refer to [LAN-195, "Inspection Between TCM and Data Link Connector Circuit"](#).

SELECT SYSTEM screen		CAN DIAG SUPPORT MNTR										SELF-DIAG RESULTS		
		Initial diagnosis	Transmit diagnosis	Receive diagnosis										
				ECM	TCM	STRG	BCM /SEC	METER /M&A	AWD/4WD	VDC/TCS /ABS	IPDM E/R			
ENGINE	—	—	UNKWN	—	UNKWN	—	UNKWN	UNKWN	UNKWN	UNKWN	UNKWN	UNKWN	CAN COMM CIRCUIT (U1000)	CAN COMM CIRCUIT (U001)
A/T	—	NG	UNKWN	UNKWN	—	—	—	UNKWN	UNKWN	UNKWN	—	—	CAN COMM CIRCUIT (U1000)	—
BCM	No indication	NG	UNKWN	UNKWN	—	—	—	UNKWN	—	—	UNKWN	—	CAN COMM CIRCUIT (U1000)	—
METER	No indication	—	UNKWN	UNKWN	UNKWN	—	UNKWN	—	—	UNKWN	UNKWN	—	CAN COMM CIRCUIT (U1000)	—
ALL MODE AWD/4WD	—	NG	UNKWN	UNKWN	UNKWN	—	—	UNKWN	—	UNKWN	—	—	CAN COMM CIRCUIT (U1000)	—
ABS	—	NG	UNKWN	UNKWN	UNKWN	UNKWN	—	—	UNKWN	—	—	—	CAN COMM CIRCUIT (U1000)	—
IPDM E/R	No indication	—	UNKWN	UNKWN	—	—	UNKWN	—	—	—	—	—	CAN COMM CIRCUIT (U1000)	—

PKIC5674E

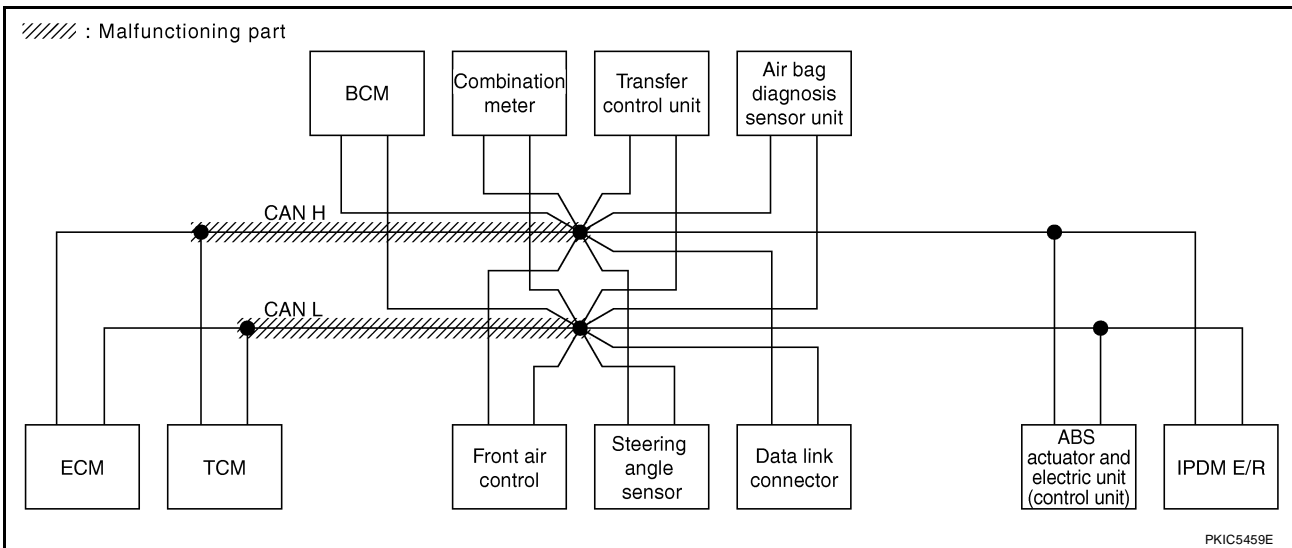

A
B
C
D
E
F
G
H
I
J
LAN
L
M

CAN SYSTEM (TYPE 6)

[CAN]

Case 2

Check harness between data link connector and ABS actuator and electric unit (control unit). Refer to [LAN-196, "Inspection Between Data Link Connector and ABS Actuator and Electric Unit \(Control Unit\) Circuit"](#) .

SELECT SYSTEM screen		CAN DIAG SUPPORT MNTR										SELF-DIAG RESULTS		
		Initial diagnosis	Transmit diagnosis	Receive diagnosis										
				ECM	TCM	STRG	BCM /SEC	METER /M&A	AWD/4WD	VDC/TCS /ABS	IPDM E/R			
ENGINE	—	—	UNKWN	—	UNKWN	—	UNKWN	UNKWN	UNKWN	UNKWN	UNKWN	UNKWN	CAN COMM CIRCUIT (U1000)	CAN COMM CIRCUIT (U001)
A/T	—	NG	UNKWN	UNKWN	—	—	—	UNKWN	UNKWN	UNKWN	UNKWN	—	CAN COMM CIRCUIT (U000)	—
BCM	No indication	NG	UNKWN	UNKWN	—	—	—	UNKWN	—	—	UNKWN	UNKWN	CAN COMM CIRCUIT (U1000)	—
METER	No indication	—	UNKWN	UNKWN	UNKWN	—	UNKWN	—	—	UNKWN	UNKWN	UNKWN	CAN COMM CIRCUIT (U000)	—
ALL MODE AWD/4WD	—	NG	UNKWN	UNKWN	UNKWN	—	—	UNKWN	—	UNKWN	—	—	CAN COMM CIRCUIT (U000)	—
ABS	—	NG	UNKWN	UNKWN	UNKWN	UNKWN	—	—	UNKWN	—	—	—	CAN COMM CIRCUIT (U000)	—
IPDM E/R	No indication	—	UNKWN	UNKWN	—	—	UNKWN	—	—	—	—	—	CAN COMM CIRCUIT (U000)	—

PKIC5675E

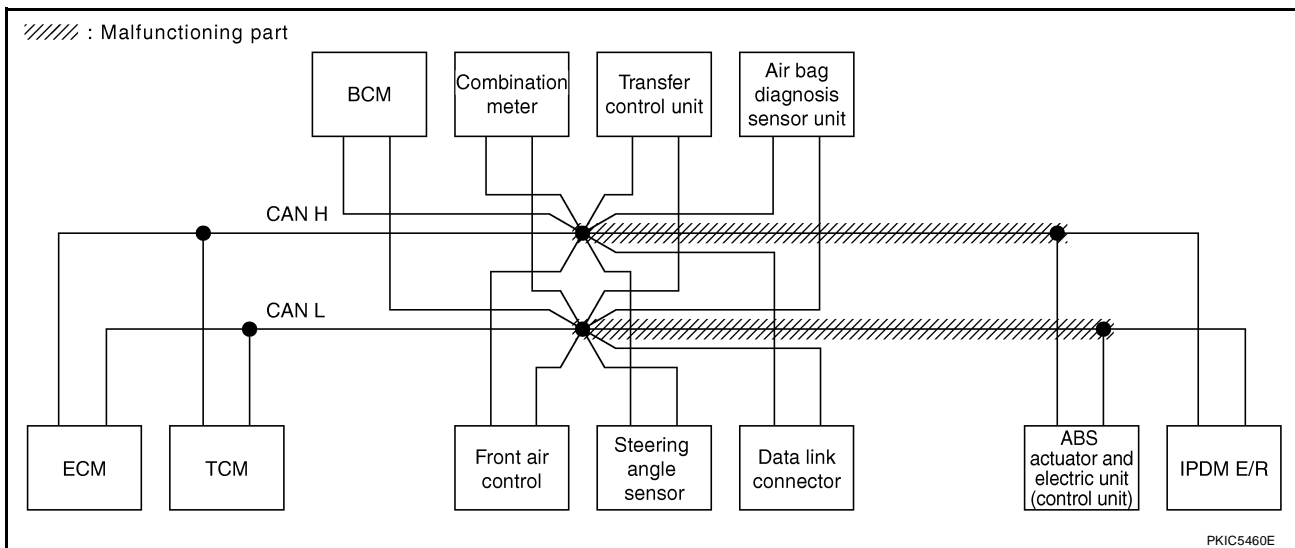

PKIC5460E

CAN SYSTEM (TYPE 6)

[CAN]

Case 3

Check ECM circuit. Refer to [LAN-197, "ECM Circuit Inspection"](#).

SELECT SYSTEM screen		CAN DIAG SUPPORT MNTR										SELF-DIAG RESULTS		
		Initial diagnosis	Transmit diagnosis	Receive diagnosis										
				ECM	TCM	STRG	BCM /SEC	METER /M&A	AWD/4WD	VDC/TCS /ABS	IPDM E/R			
ENGINE	—	—	UNKWN	—	UNKWN	—	UNKWN	UNKWN	UNKWN	UNKWN	UNKWN	UNKWN	CAN COMM CIRCUIT (U100)	CAN COMM CIRCUIT (U101)
A/T	—	NG	UNKWN	UNKWN	—	—	—	UNKWN	UNKWN	UNKWN	UNKWN	—	CAN COMM CIRCUIT (U100)	—
BCM	No indication	NG	UNKWN	UNKWN	—	—	—	UNKWN	—	—	UNKWN	UNKWN	CAN COMM CIRCUIT (U100)	—
METER	No indication	—	UNKWN	UNKWN	UNKWN	—	UNKWN	—	—	UNKWN	UNKWN	UNKWN	CAN COMM CIRCUIT (U100)	—
ALL MODE AWD/4WD	—	NG	UNKWN	UNKWN	UNKWN	—	—	UNKWN	—	UNKWN	—	—	CAN COMM CIRCUIT (U100)	—
ABS	—	NG	UNKWN	UNKWN	UNKWN	—	—	UNKWN	—	UNKWN	—	—	CAN COMM CIRCUIT (U100)	—
IPDM E/R	No indication	—	UNKWN	UNKWN	—	—	UNKWN	—	—	—	—	—	CAN COMM CIRCUIT (U100)	—

PKIC5676E

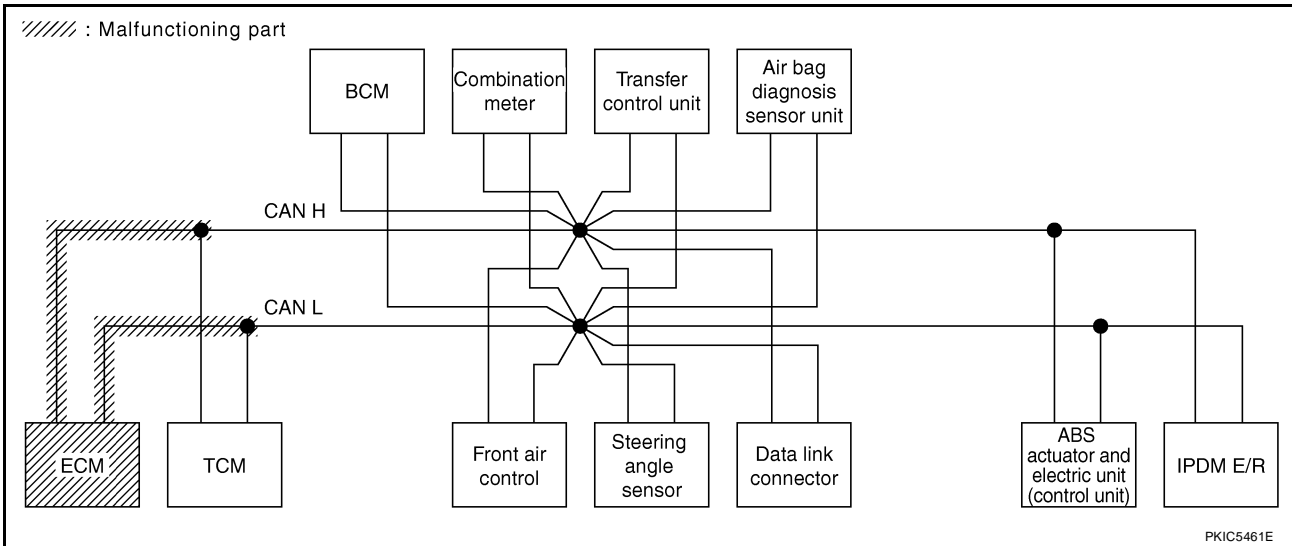

CAN SYSTEM (TYPE 6)

[CAN]

Case 4

Check TCM circuit. Refer to [LAN-197, "TCM Circuit Inspection"](#) .

SELECT SYSTEM screen		CAN DIAG SUPPORT MNTR										SELF-DIAG RESULTS			
		Initial diagnosis	Transmit diagnosis	Receive diagnosis											
				ECM	TCM	STRG	BCM /SEC	METER /M&A	AWD/4WD	VDC/TCS /ABS	IPDM E/R				
ENGINE	—	—	UNKWN	—	✓	—	UNKWN	UNKWN	UNKWN	UNKWN	UNKWN	CAN COMM CIRCUIT (U1000)	✓	CAN COMM CIRCUIT (U1001)	✓
A/T	—	NG	UNKWN	✓	—	—	—	✓	✓	✓	—	CAN COMM CIRCUIT (U1000)	—	—	—
BCM	No indication	NG	UNKWN	UNKWN	—	—	—	UNKWN	—	—	UNKWN	CAN COMM CIRCUIT (U1000)	—	—	—
METER	No indication	—	UNKWN	UNKWN	✓	—	UNKWN	—	—	UNKWN	UNKWN	CAN COMM CIRCUIT (U1000)	—	—	—
ALL MODE AWD/4WD	—	NG	UNKWN	UNKWN	✓	—	—	UNKWN	—	UNKWN	—	CAN COMM CIRCUIT (U1000)	—	—	—
ABS	—	NG	UNKWN	UNKWN	✓	UNKWN	—	—	UNKWN	—	—	CAN COMM CIRCUIT (U1000)	—	—	—
IPDM E/R	No indication	—	UNKWN	UNKWN	—	—	UNKWN	—	—	—	—	CAN COMM CIRCUIT (U1000)	—	—	—

PKIC5677E

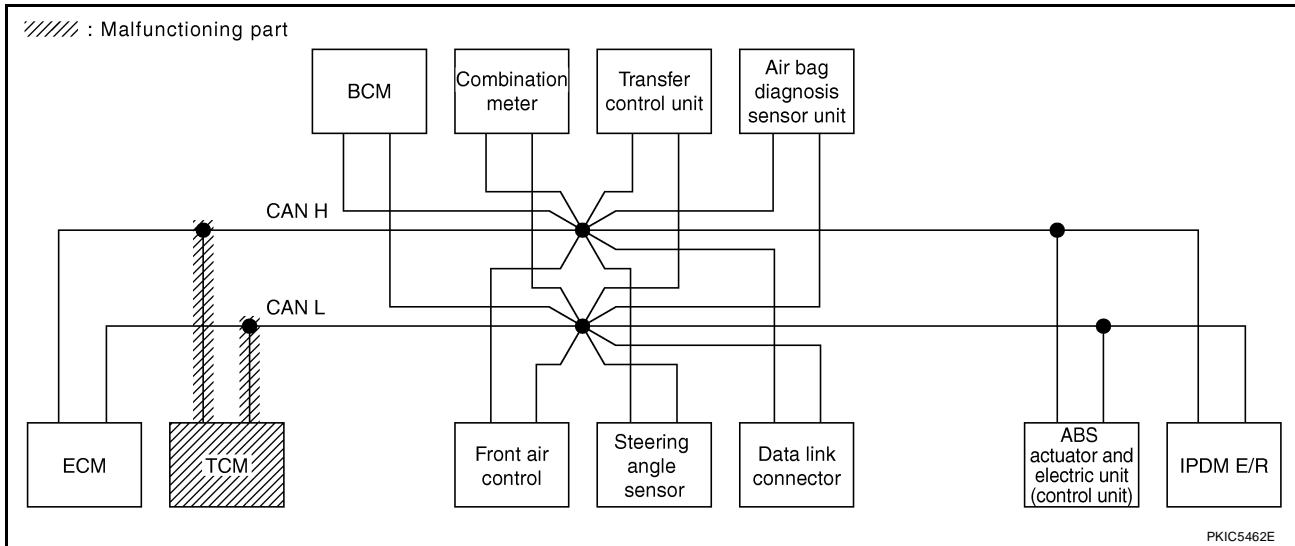

PKIC5462E

CAN SYSTEM (TYPE 6)

[CAN]

Case 5

Check steering angle sensor circuit. Refer to [LAN-199, "Steering Angle Sensor Circuit Inspection"](#).

SELECT SYSTEM screen		CAN DIAG SUPPORT MNTR										SELF-DIAG RESULTS	
		Initial diagnosis	Transmit diagnosis	Receive diagnosis									
				ECM	TCM	STRG	BCM /SEC	METER /M&A	AWD/4WD	VDC/TCS /ABS	IPDM E/R		
ENGINE	—	—	UNKWN	—	UNKWN	—	UNKWN	UNKWN	UNKWN	UNKWN	UNKWN	CAN COMM CIRCUIT (U1000)	CAN COMM CIRCUIT (U1001)
A/T	—	NG	UNKWN	UNKWN	—	—	—	UNKWN	UNKWN	UNKWN	—	CAN COMM CIRCUIT (U1000)	—
BCM	No indication	NG	UNKWN	UNKWN	—	—	—	UNKWN	—	—	UNKWN	CAN COMM CIRCUIT (U1000)	—
METER	No indication	—	UNKWN	UNKWN	UNKWN	—	UNKWN	—	—	UNKWN	UNKWN	CAN COMM CIRCUIT (U1000)	—
ALL MODE AWD/4WD	—	NG	UNKWN	UNKWN	UNKWN	—	—	UNKWN	—	UNKWN	—	CAN COMM CIRCUIT (U1000)	—
ABS	—	NG	UNKWN	UNKWN	UNKWN	UNKWN	—	—	UNKWN	—	—	CAN COMM CIRCUIT (U1000)	—
IPDM E/R	No indication	—	UNKWN	UNKWN	—	—	UNKWN	—	—	—	—	CAN COMM CIRCUIT (U1000)	—

PKIC5678E

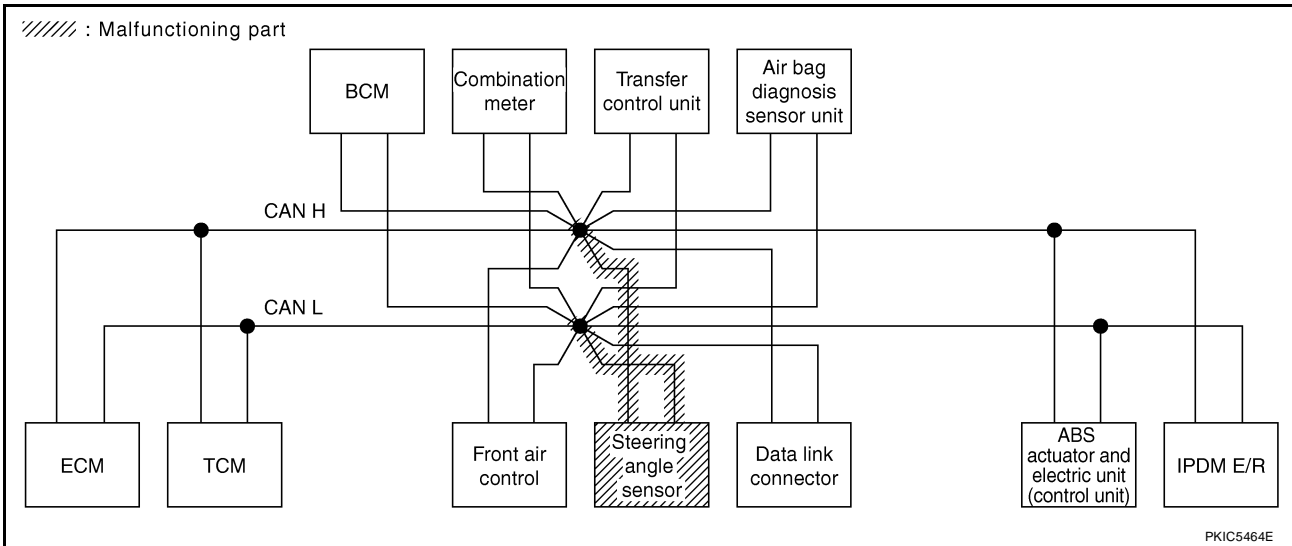

CAN SYSTEM (TYPE 6)

[CAN]

Case 6

Check data link connector circuit. Refer to [LAN-199, "Data Link Connector Circuit Inspection"](#) .

SELECT SYSTEM screen		CAN DIAG SUPPORT MNTR										SELF-DIAG RESULTS	
		Initial diagnosis	Transmit diagnosis	Receive diagnosis									
				ECM	TCM	STRG	BCM /SEC	METER /M&A	AWD/4WD	VDC/TCS /ABS	IPDM E/R		
ENGINE	—	—	UNKWN	—	UNKWN	—	UNKWN	UNKWN	UNKWN	UNKWN	UNKWN	CAN COMM CIRCUIT (U1000)	CAN COMM CIRCUIT (U1001)
A/T	—	NG	UNKWN	UNKWN	—	—	—	UNKWN	UNKWN	UNKWN	—	CAN COMM CIRCUIT (U1000)	—
BCM	No indication	NG	UNKWN	UNKWN	—	—	—	UNKWN	—	—	UNKWN	CAN COMM CIRCUIT (U1000)	—
METER	No indication	—	UNKWN	UNKWN	UNKWN	—	UNKWN	—	—	UNKWN	UNKWN	CAN COMM CIRCUIT (U1000)	—
ALL MODE AWD/4WD	—	NG	UNKWN	UNKWN	UNKWN	—	—	UNKWN	—	UNKWN	—	CAN COMM CIRCUIT (U1000)	—
ABS	—	NG	UNKWN	UNKWN	UNKWN	UNKWN	—	—	UNKWN	—	—	CAN COMM CIRCUIT (U1000)	—
IPDM E/R	No indication	—	UNKWN	UNKWN	—	—	UNKWN	—	—	—	—	CAN COMM CIRCUIT (U1000)	—

PKIC5679E

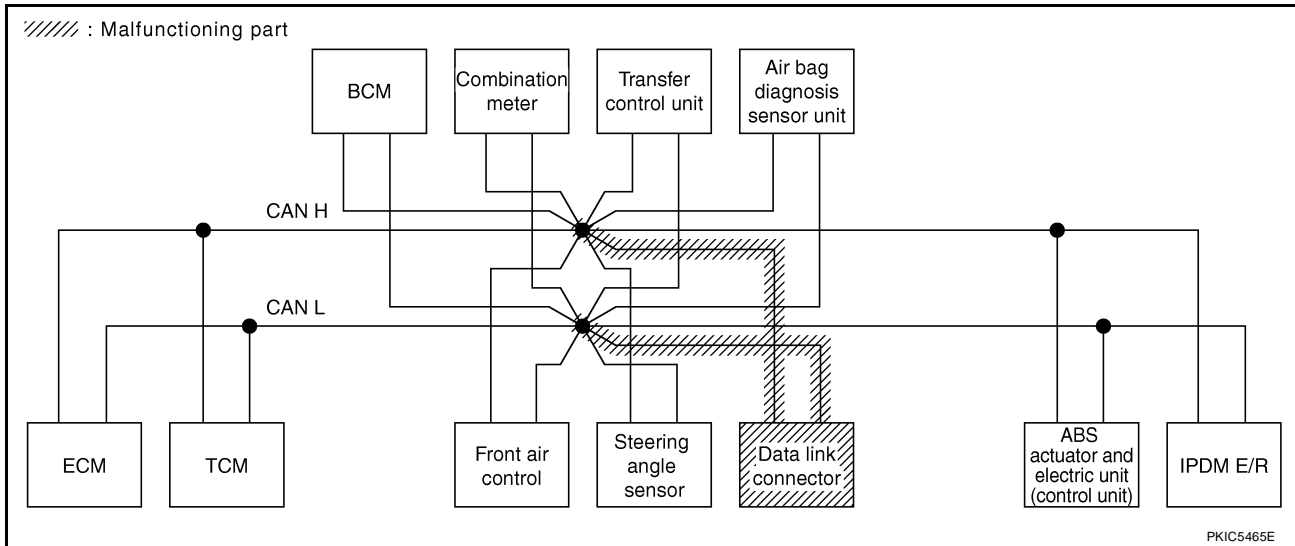

CAN SYSTEM (TYPE 6)

[CAN]

Case 7

Check BCM circuit. Refer to [LAN-200, "BCM Circuit Inspection"](#).

SELECT SYSTEM screen		CAN DIAG SUPPORT MNTR										SELF-DIAG RESULTS	
		Initial diagnosis	Transmit diagnosis	Receive diagnosis									
				ECM	TCM	STRG	BCM /SEC	METER /M&A	AWD/4WD	VDC/TCS /ABS	IPDM E/R		
ENGINE	—	—	UNKWN	—	UNKWN	—	UNKWN	UNKWN	UNKWN	UNKWN	UNKWN	CAN COMM CIRCUIT (U1000)	CAN COMM CIRCUIT (U1001)
A/T	—	NG	UNKWN	UNKWN	—	—	—	UNKWN	UNKWN	UNKWN	—	CAN COMM CIRCUIT (U1000)	—
BCM	No indication	NG	UNKWN	UNKWN	—	—	—	UNKWN	—	—	UNKWN	CAN COMM CIRCUIT (U1000)	—
METER	No indication	—	UNKWN	UNKWN	UNKWN	—	UNKWN	—	—	UNKWN	UNKWN	CAN COMM CIRCUIT (U1000)	—
ALL MODE AWD/4WD	—	NG	UNKWN	UNKWN	UNKWN	—	—	UNKWN	—	UNKWN	—	CAN COMM CIRCUIT (U1000)	—
ABS	—	NG	UNKWN	UNKWN	UNKWN	UNKWN	—	—	UNKWN	—	—	CAN COMM CIRCUIT (U1000)	—
IPDM E/R	No indication	—	UNKWN	UNKWN	—	—	UNKWN	—	—	—	—	CAN COMM CIRCUIT (U1000)	—

PKIC5680E

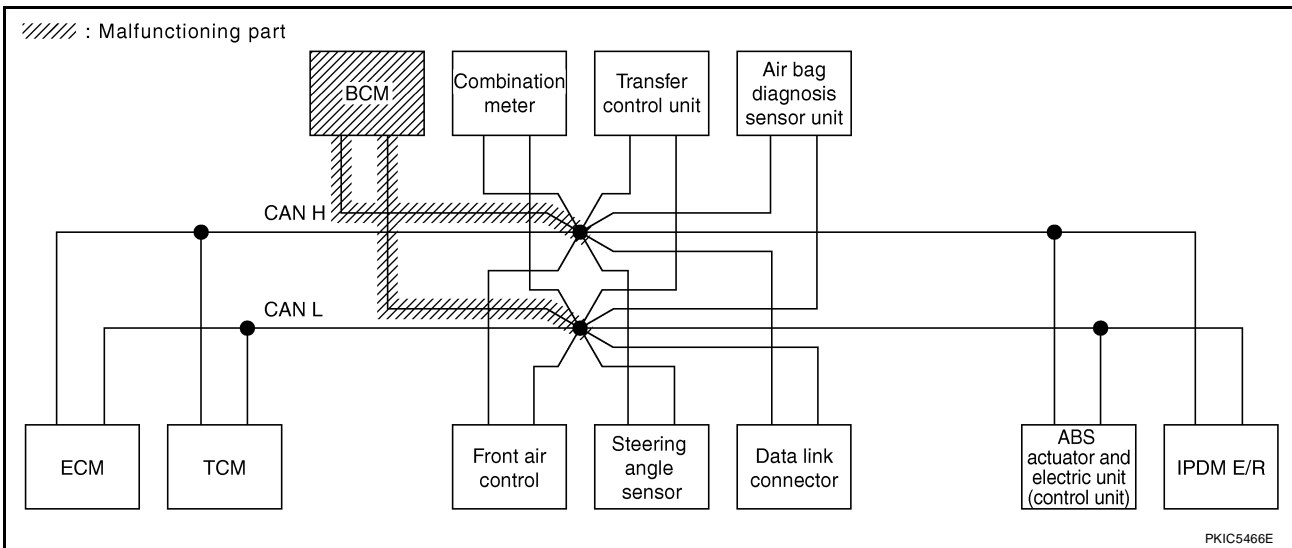

CAN SYSTEM (TYPE 6)

[CAN]

Case 8

Check combination meter circuit. Refer to [LAN-200, "Combination Meter Circuit Inspection"](#) .

SELECT SYSTEM screen	CAN DIAG SUPPORT MNTR										SELF-DIAG RESULTS		
	Initial diagnosis	Transmit diagnosis	Receive diagnosis										
			ECM	TCM	STRG	BCM /SEC	METER /M&A	AWD/4WD	VDC/TCS /ABS	IPDM E/R			
ENGINE	—	—	UNKWN	—	UNKWN	—	UNKWN	UNKWN	UNKWN	UNKWN	UNKWN	CAN COMM CIRCUIT (U1000)	CAN COMM CIRCUIT (U1001)
A/T	—	NG	UNKWN	UNKWN	—	—	—	UNKWN	UNKWN	UNKWN	—	CAN COMM CIRCUIT (U1000)	—
BCM	No indication	NG	UNKWN	UNKWN	—	—	—	UNKWN	—	—	UNKWN	CAN COMM CIRCUIT (U1000)	—
METER	No indication	—	UNKWN	UNKWN	UNKWN	—	UNKWN	—	—	UNKWN	UNKWN	CAN COMM CIRCUIT (U1000)	—
ALL MODE AWD/4WD	—	NG	UNKWN	UNKWN	UNKWN	—	—	UNKWN	—	UNKWN	—	CAN COMM CIRCUIT (U1000)	—
ABS	—	NG	UNKWN	UNKWN	UNKWN	UNKWN	—	—	UNKWN	—	—	CAN COMM CIRCUIT (U1000)	—
IPDM E/R	No indication	—	UNKWN	UNKWN	—	—	UNKWN	—	—	—	—	CAN COMM CIRCUIT (U1000)	—

PKIC5681E

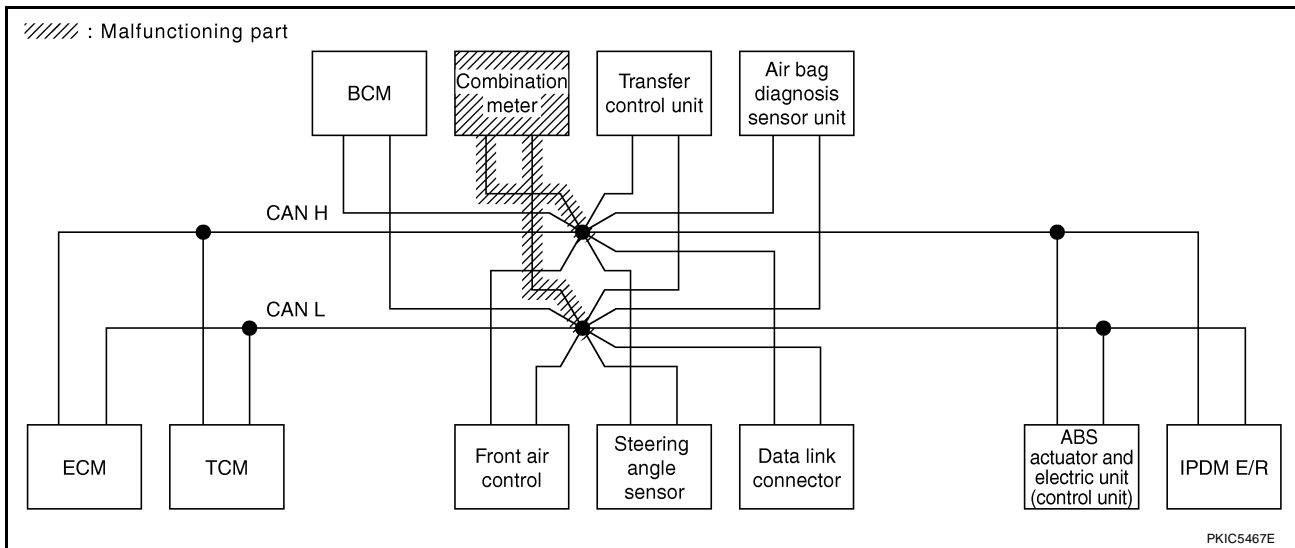

CAN SYSTEM (TYPE 6)

[CAN]

Case 9

Check transfer control unit circuit. Refer to [LAN-201, "Transfer Control Unit Circuit Inspection"](#).

SELECT SYSTEM screen		CAN DIAG SUPPORT MNTR										SELF-DIAG RESULTS		
		Initial diagnosis	Transmit diagnosis	Receive diagnosis										
				ECM	TCM	STRG	BCM /SEC	METER /M&A	AWD/4WD	VDC/TCS /ABS	IPDM E/R			
ENGINE	—	—	UNKWN	—	UNKWN	—	UNKWN	UNKWN	UNKWN	UNKWN	UNKWN	UNKWN	CAN COMM CIRCUIT (U1000)	CAN COMM CIRCUIT (U1001)
A/T	—	NG	UNKWN	UNKWN	—	—	—	UNKWN	UNKWN	UNKWN	—	—	CAN COMM CIRCUIT (U1000)	—
BCM	No indication	NG	UNKWN	UNKWN	—	—	—	UNKWN	—	—	UNKWN	UNKWN	CAN COMM CIRCUIT (U1000)	—
METER	No indication	—	UNKWN	UNKWN	UNKWN	—	UNKWN	—	—	UNKWN	UNKWN	UNKWN	CAN COMM CIRCUIT (U1000)	—
ALL MODE AWD/4WD	—	NG	UNKWN	UNKWN	UNKWN	—	—	UNKWN	—	UNKWN	—	—	CAN COMM CIRCUIT (U1000)	—
ABS	—	NG	UNKWN	UNKWN	UNKWN	UNKWN	—	—	UNKWN	—	—	—	CAN COMM CIRCUIT (U1000)	—
IPDM E/R	No indication	—	UNKWN	UNKWN	—	—	UNKWN	—	—	—	—	—	CAN COMM CIRCUIT (U1000)	—

PKIC5682E

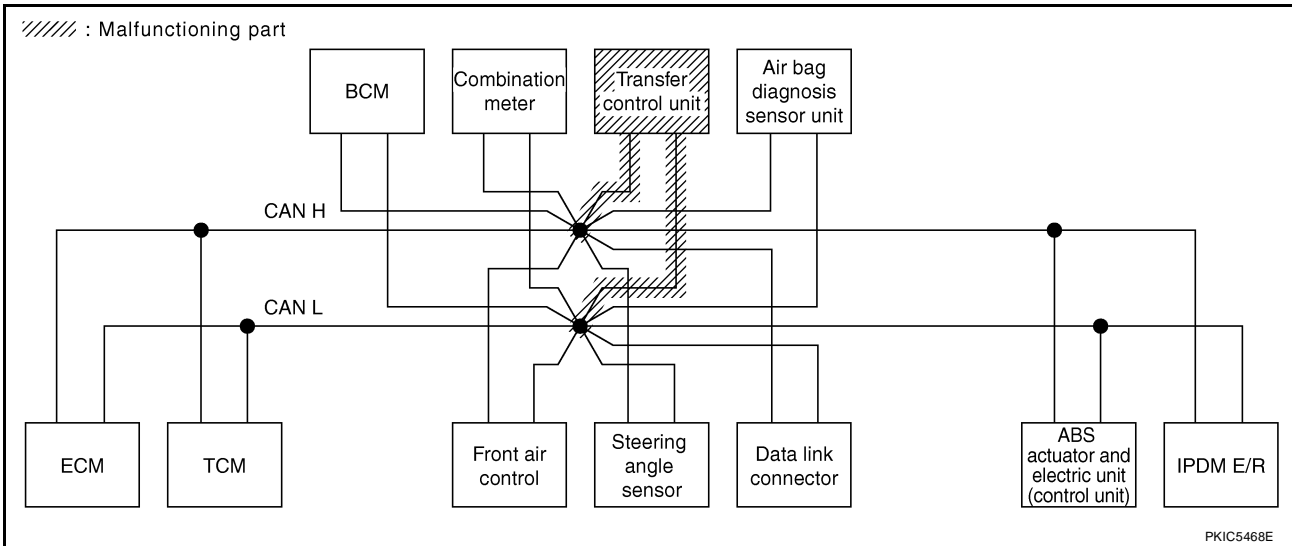

CAN SYSTEM (TYPE 6)

[CAN]

Case 10

Check ABS actuator and electric unit (control unit) circuit. Refer to [LAN-202, "ABS Actuator and Electric Unit \(Control Unit\) Circuit Inspection"](#) .

SELECT SYSTEM screen		CAN DIAG SUPPORT MNTR										SELF-DIAG RESULTS		
		Initial diagnosis	Transmit diagnosis	Receive diagnosis										
				ECM	TCM	STRG	BCM /SEC	METER /M&A	AWD/4WD	VDC/TCS /ABS	IPDM E/R			
ENGINE	—	—	UNKWN	—	UNKWN	—	UNKWN	UNKWN	UNKWN	UNKWN	UNKWN	UNKWN	CAN COMM CIRCUIT (U1000)	CAN COMM CIRCUIT (U001) ✓
A/T	—	NG	UNKWN	UNKWN	—	—	—	UNKWN	UNKWN	UNKWN	UNKWN	—	CAN COMM CIRCUIT (U1000) ✓	—
BCM	No indication	NG	UNKWN	UNKWN	—	—	—	UNKWN	—	—	UNKWN	—	CAN COMM CIRCUIT (U1000)	—
METER	No indication	—	UNKWN	UNKWN	UNKWN	—	UNKWN	—	—	UNKWN	UNKWN	—	CAN COMM CIRCUIT (U1000)	—
ALL MODE AWD/4WD	—	NG	UNKWN	UNKWN	UNKWN	—	—	UNKWN	—	UNKWN	—	—	CAN COMM CIRCUIT (U1000) ✓	—
ABS	—	✓	UNKWN	UNKWN	UNKWN	UNKWN	—	—	UNKWN	—	—	—	CAN COMM CIRCUIT (U1000)	—
IPDM E/R	No indication	—	UNKWN	UNKWN	—	—	UNKWN	—	—	—	—	—	CAN COMM CIRCUIT (U1000)	—

PKIC5683E

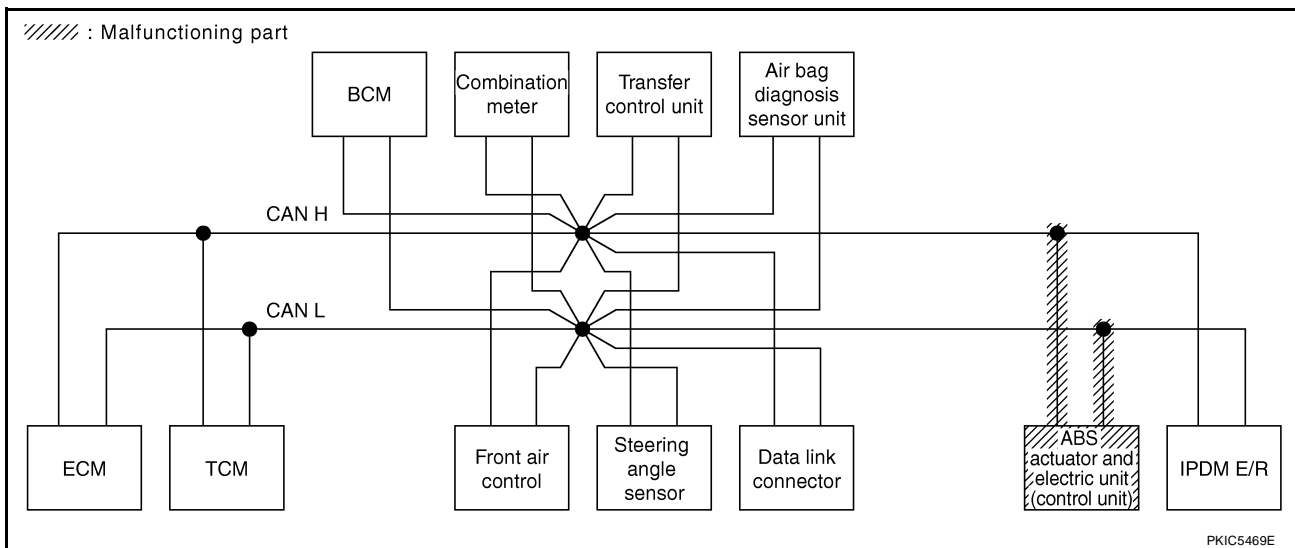

CAN SYSTEM (TYPE 6)

[CAN]

Case 11

Check IPDM E/R circuit. Refer to [LAN-203, "IPDM E/R Circuit Inspection"](#) .

SELECT SYSTEM screen		CAN DIAG SUPPORT MNTR										SELF-DIAG RESULTS		
		Initial diagnosis	Transmit diagnosis	Receive diagnosis										IPDM E/R
				ECM	TCM	STRG	BCM /SEC	METER /M&A	AWD/4WD	VDC/TCS /ABS				
ENGINE	—	—	UNKWN	—	UNKWN	—	UNKWN	UNKWN	UNKWN	UNKWN	UNKWN	UNKWN	CAN COMM CIRCUIT (U1000)	CAN COMM CIRCUIT (U001)
A/T	—	NG	UNKWN	UNKWN	—	—	—	UNKWN	UNKWN	UNKWN	—	—	CAN COMM CIRCUIT (U1000)	—
BCM	No indication	NG	UNKWN	UNKWN	—	—	—	UNKWN	—	—	UNKWN	UNKWN	CAN COMM CIRCUIT (U1000)	—
METER	No indication	—	UNKWN	UNKWN	UNKWN	—	UNKWN	—	—	UNKWN	UNKWN	UNKWN	CAN COMM CIRCUIT (U1000)	—
ALL MODE AWD/4WD	—	NG	UNKWN	UNKWN	UNKWN	—	—	UNKWN	—	UNKWN	—	—	CAN COMM CIRCUIT (U1000)	—
ABS	—	NG	UNKWN	UNKWN	UNKWN	UNKWN	—	—	UNKWN	—	—	—	CAN COMM CIRCUIT (U1000)	—
IPDM E/R	No indication	—	UNKWN	UNKWN	—	—	UNKWN	—	—	—	—	—	CAN COMM CIRCUIT (U1000)	—

PKIC5684E

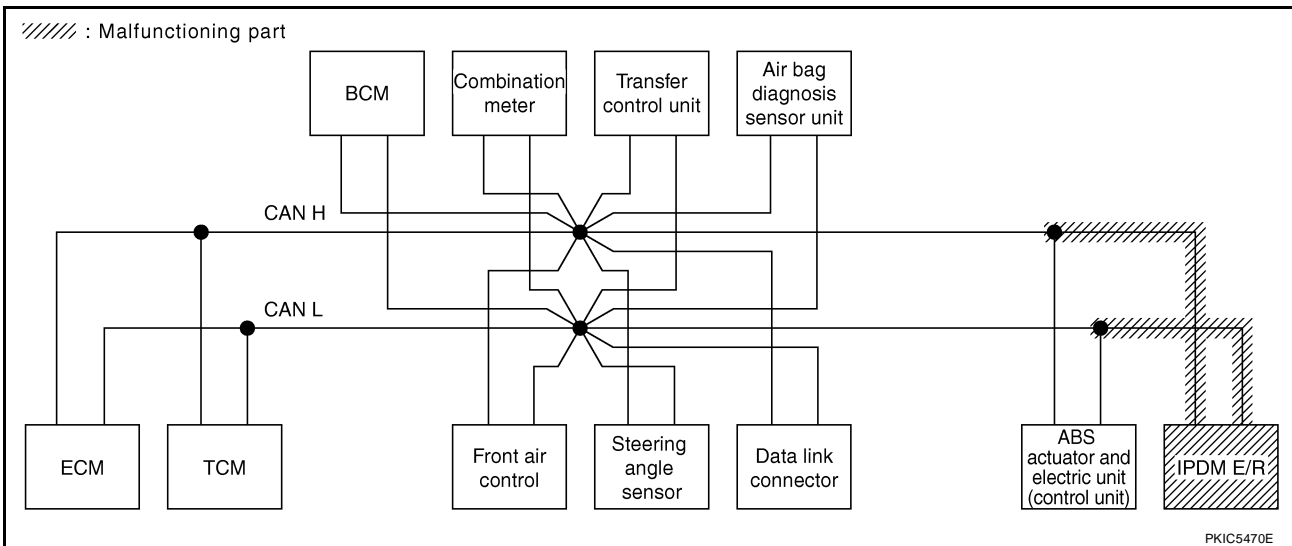

Case 12

Check CAN communication circuit. Refer to [LAN-203, "CAN Communication Circuit Inspection"](#) .

SELECT SYSTEM screen		CAN DIAG SUPPORT MNTR										SELF-DIAG RESULTS		
		Initial diagnosis	Transmit diagnosis	Receive diagnosis										IPDM E/R
				ECM	TCM	STRG	BCM /SEC	METER /M&A	AWD/4WD	VDC/TCS /ABS				
ENGINE	—	—	UNKWN	—	UNKWN	—	UNKWN	UNKWN	UNKWN	UNKWN	UNKWN	UNKWN	CAN COMM CIRCUIT (U1000)	CAN COMM CIRCUIT (U001)
A/T	—	NG	UNKWN	UNKWN	—	—	—	UNKWN	UNKWN	UNKWN	—	—	CAN COMM CIRCUIT (U1000)	—
BCM	No indication	NG	UNKWN	UNKWN	—	—	—	UNKWN	—	—	UNKWN	UNKWN	CAN COMM CIRCUIT (U1000)	—
METER	No indication	—	UNKWN	UNKWN	UNKWN	—	UNKWN	—	—	UNKWN	UNKWN	UNKWN	CAN COMM CIRCUIT (U1000)	—
ALL MODE AWD/4WD	—	NG	UNKWN	UNKWN	UNKWN	—	—	UNKWN	—	UNKWN	—	—	CAN COMM CIRCUIT (U1000)	—
ABS	—	NG	UNKWN	UNKWN	UNKWN	UNKWN	—	—	UNKWN	—	—	—	CAN COMM CIRCUIT (U1000)	—
IPDM E/R	No indication	—	UNKWN	UNKWN	—	—	UNKWN	—	—	—	—	—	CAN COMM CIRCUIT (U1000)	—

PKIC5685E

CAN SYSTEM (TYPE 6)

[CAN]

Case 13

Check IPDM E/R ignition relay circuit continuously sticks "OFF". Refer to [LAN-204, "IPDM E/R Ignition Relay Circuit Inspection"](#) .

SELECT SYSTEM screen		CAN DIAG SUPPORT MNTR										SELF-DIAG RESULTS	
		Initial diagnosis	Transmit diagnosis	Receive diagnosis									
				ECM	TCM	STRG	BCM /SEC	METER /M&A	AWD/4WD	VDC/TCS /ABS	IPDM E/R		
ENGINE	—	—	UNKWN	—	UNKWN	—	UNKWN	UNKWN	UNKWN	UNKWN	UNKWN	CAN COMM CIRCUIT (U1000)	CAN COMM CIRCUIT (U1001)
A/T	—	NG	UNKWN	UNKWN	—	—	—	UNKWN	UNKWN	UNKWN	—	CAN COMM CIRCUIT (U1000)	—
BCM	No indication	NG	UNKWN	UNKWN	—	—	—	UNKWN	—	—	UNKWN	CAN COMM CIRCUIT (U1000)	—
METER	No indication	—	UNKWN	UNKWN	UNKWN	—	UNKWN	—	—	UNKWN	UNKWN	CAN COMM CIRCUIT (U1000)	—
ALL MODE AWD/4WD	—	NG	UNKWN	UNKWN	UNKWN	—	—	UNKWN	—	UNKWN	—	CAN COMM CIRCUIT (U1000)	—
ABS	—	NG	UNKWN	UNKWN	UNKWN	UNKWN	—	—	UNKWN	—	—	CAN COMM CIRCUIT (U1000)	—
IPDM E/R	No indication	—	UNKWN	UNKWN	—	—	UNKWN	—	—	—	—	CAN COMM CIRCUIT (U1000)	—

PKIC5686E

Case 14

Check IPDM E/R ignition relay circuit continuously sticks "ON". Refer to [LAN-204, "IPDM E/R Ignition Relay Circuit Inspection"](#) .

SELECT SYSTEM screen		CAN DIAG SUPPORT MNTR										SELF-DIAG RESULTS	
		Initial diagnosis	Transmit diagnosis	Receive diagnosis									
				ECM	TCM	STRG	BCM /SEC	METER /M&A	AWD/4WD	VDC/TCS /ABS	IPDM E/R		
ENGINE	—	—	UNKWN	—	UNKWN	—	UNKWN	UNKWN	UNKWN	UNKWN	UNKWN	CAN COMM CIRCUIT (U1000)	CAN COMM CIRCUIT (U1001)
A/T	—	NG	UNKWN	—	—	—	—	—	—	UNKWN	—	CAN COMM CIRCUIT (U1000)	—
BCM	No indication	NG	UNKWN	UNKWN	—	—	—	UNKWN	—	—	UNKWN	CAN COMM CIRCUIT (U1000)	—
METER	No indication	—	UNKWN	UNKWN	UNKWN	—	UNKWN	—	—	UNKWN	UNKWN	CAN COMM CIRCUIT (U1000)	—
ALL MODE AWD/4WD	—	NG	UNKWN	UNKWN	UNKWN	—	—	UNKWN	—	UNKWN	—	CAN COMM CIRCUIT (U1000)	—
ABS	—	NG	UNKWN	—	UNKWN	—	—	—	—	—	—	CAN COMM CIRCUIT (U1000)	—
IPDM E/R	No indication	—	UNKWN	UNKWN	—	—	UNKWN	—	—	—	—	CAN COMM CIRCUIT (U1000)	—

PKIC5687E

CAN SYSTEM (TYPE 7)

[CAN]

CAN SYSTEM (TYPE 7)

PF2:23710

Component Parts and Harness Connector Location

UKS0053Q

Refer to [LAN-25, "Component Parts and Harness Connector Location"](#) .

Schematic

UKS0053R

Refer to [LAN-26, "Schematic"](#) .

Wiring Diagram — CAN —

UKS0053S

Refer to [LAN-27, "Wiring Diagram — CAN —"](#) .

A

B

C

D

E

F

G

H

I

J

LAN

L

M

CAN SYSTEM (TYPE 7)

[CAN]

UKS0053T

Check Sheet

NOTE:

If a check mark is put on "NG" on "INITIAL DIAG (Initial diagnosis)", replace the control unit.

Check sheet table														
SELECT SYSTEM screen		CAN DIAG SUPPORT MNTR										SELF-DIAG RESULTS		
		Initial diagnosis	Transmit diagnosis	Receive diagnosis										
				ECM	TCM	STRG	BCM /SEC	METER /M&A	AWD/4WD	VDC/TCS /ABS	IPDM E/R			
ENGINE	—	—	UNKWN	—	UNKWN	—	UNKWN	UNKWN	UNKWN	UNKWN	UNKWN	UNKWN	CAN COMM CIRCUIT (U1000)	CAN COMM CIRCUIT (U1001)
A/T	—	NG	UNKWN	UNKWN	—	—	—	UNKWN	UNKWN	UNKWN	—	—	CAN COMM CIRCUIT (U1000)	—
BCM	No indication	NG	UNKWN	UNKWN	—	—	—	UNKWN	—	—	UNKWN	UNKWN	CAN COMM CIRCUIT (U1000)	—
METER	No indication	—	UNKWN	UNKWN	UNKWN	—	UNKWN	—	—	UNKWN	UNKWN	UNKWN	CAN COMM CIRCUIT (U1000)	—
ALL MODE AWD/4WD	No indication	—	UNKWN	UNKWN	UNKWN	UNKWN	—	—	—	UNKWN	—	—	CAN COMM CIRCUIT (U1000)	—
ABS	—	NG	UNKWN	UNKWN	UNKWN	UNKWN	—	—	UNKWN	—	—	—	CAN COMM CIRCUIT (U1000)	—
IPDM E/R	No indication	—	UNKWN	UNKWN	—	—	UNKWN	—	—	—	—	—	CAN COMM CIRCUIT (U1000)	—

Symptoms :

Attach copy of
SELECT SYSTEM

Attach copy of
SELECT SYSTEM

PKIC5688E

CAN SYSTEM (TYPE 7)

[CAN]

Attach copy of ENGINE SELF-DIAG RESULTS	Attach copy of A/T SELF-DIAG RESULTS	Attach copy of BCM SELF-DIAG RESULTS	Attach copy of METER SELF-DIAG RESULTS
Attach copy of ALL MODE AWD/4WD SELF-DIAG RESULTS	Attach copy of ABS SELF-DIAG RESULTS	Attach copy of IPDM E/R SELF-DIAG RESULTS	
Attach copy of ENGINE CAN DIAG SUPPORT MNTR	Attach copy of A/T CAN DIAG SUPPORT MNTR	Attach copy of BCM CAN DIAG SUPPORT MNTR	Attach copy of METER CAN DIAG SUPPORT MNTR
Attach copy of ALL MODE AWD/4WD CAN DIAG SUPPORT MNTR	Attach copy of ABS CAN DIAG SUPPORT MNTR	Attach copy of IPDM E/R CAN DIAG SUPPORT MNTR	

A
B
C
D
E
F
G
H
I
J
L
M

LAN

PKIC7066E

CAN SYSTEM (TYPE 7)

[CAN]

CHECK SHEET RESULTS (EXAMPLE)

NOTE:

If a check mark is put on "NG" on "INITIAL DIAG (Initial diagnosis)", replace the control unit.

Case 1

Check harness between TCM and data link connector. Refer to [LAN-195, "Inspection Between TCM and Data Link Connector Circuit"](#).

SELECT SYSTEM screen		CAN DIAG SUPPORT MNTR										SELF-DIAG RESULTS		
		Initial diagnosis	Transmit diagnosis	Receive diagnosis										
				ECM	TCM	STRG	BCM /SEC	METER /M&A	AWD/4WD	VDC/TCS /ABS	IPDM E/R			
ENGINE	—	—	UNKWN	—	UNKWN	—	UNKWN	UNKWN	UNKWN	UNKWN	UNKWN	UNKWN	CAN COMM CIRCUIT (U1000)	CAN COMM CIRCUIT (U001)
A/T	—	NG	UNKWN	UNKWN	—	—	—	UNKWN	UNKWN	UNKWN	UNKWN	—	CAN COMM CIRCUIT (U000)	—
BCM	No indication	NG	UNKWN	UNKWN	—	—	—	UNKWN	—	—	UNKWN	UNKWN	CAN COMM CIRCUIT (U1000)	—
METER	No indication	—	UNKWN	UNKWN	UNKWN	—	UNKWN	—	—	UNKWN	UNKWN	UNKWN	CAN COMM CIRCUIT (U000)	—
ALL MODE AWD/4WD	No indication	—	UNKWN	UNKWN	UNKWN	—	—	—	—	UNKWN	—	—	CAN COMM CIRCUIT (U000)	—
ABS	—	NG	UNKWN	UNKWN	UNKWN	—	—	UNKWN	—	—	—	—	CAN COMM CIRCUIT (U000)	—
IPDM E/R	No indication	—	UNKWN	UNKWN	—	—	UNKWN	—	—	—	—	—	CAN COMM CIRCUIT (U000)	—

PKIC5689E

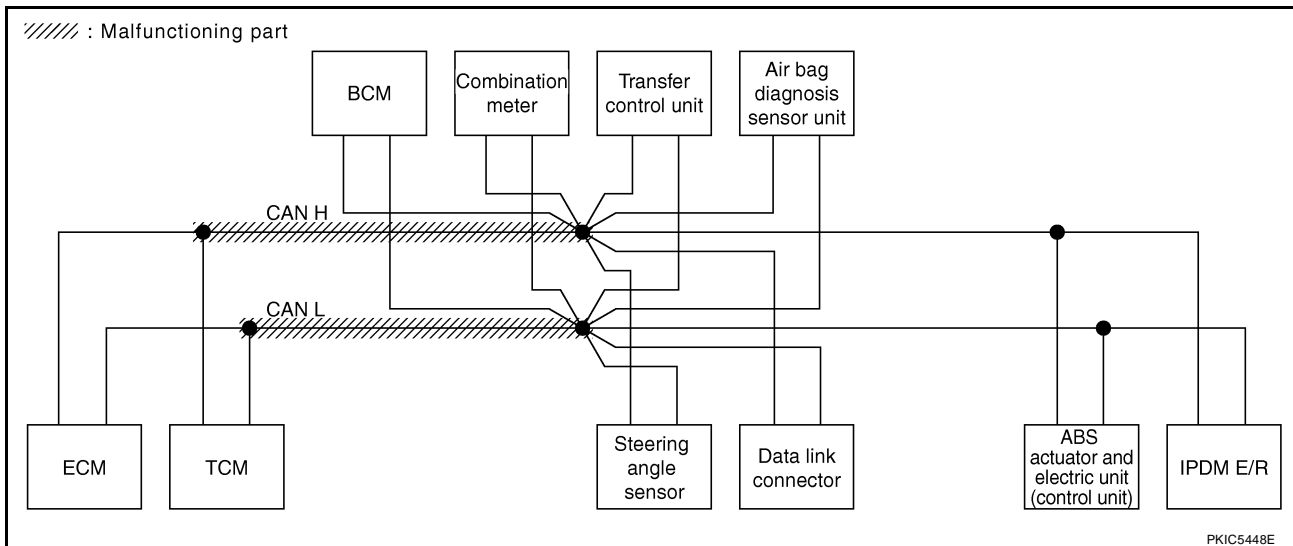

PKIC5448E

CAN SYSTEM (TYPE 7)

[CAN]

Case 2

Check harness between data link connector and ABS actuator and electric unit (control unit). Refer to [LAN-196, "Inspection Between Data Link Connector and ABS Actuator and Electric Unit \(Control Unit\) Circuit"](#).

SELECT SYSTEM screen		CAN DIAG SUPPORT MNTR										SELF-DIAG RESULTS			
		Initial diagnosis	Transmit diagnosis	Receive diagnosis											
				ECM	TCM	STRG	BCM /SEC	METER /M&A	AWD/4WD	VDC/TCS /ABS	IPDM E/R				
ENGINE	—	—	UNKWN	—	UNKWN	—	UNKWN	UNKWN	UNKWN	UNKWN	UNKWN	UNKWN	UNKWN	CAN COMM CIRCUIT (U1000)	CAN COMM CIRCUIT (U1001)
A/T	—	NG	UNKWN	UNKWN	—	—	—	UNKWN	UNKWN	UNKWN	UNKWN	UNKWN	—	CAN COMM CIRCUIT (U1000)	—
BCM	No indication	NG	UNKWN	UNKWN	—	—	—	UNKWN	—	—	UNKWN	UNKWN	—	CAN COMM CIRCUIT (U1000)	—
METER	No indication	—	UNKWN	UNKWN	UNKWN	—	UNKWN	—	—	UNKWN	UNKWN	UNKWN	—	CAN COMM CIRCUIT (U1000)	—
ALL MODE AWD/4WD	No indication	—	UNKWN	UNKWN	UNKWN	UNKWN	—	—	—	UNKWN	UNKWN	UNKWN	—	CAN COMM CIRCUIT (U1000)	—
ABS	—	NG	UNKWN	UNKWN	UNKWN	UNKWN	—	—	UNKWN	—	—	—	—	CAN COMM CIRCUIT (U1000)	—
IPDM E/R	No indication	—	UNKWN	UNKWN	—	—	UNKWN	—	—	—	—	—	—	CAN COMM CIRCUIT (U1000)	—

PKIC5690E

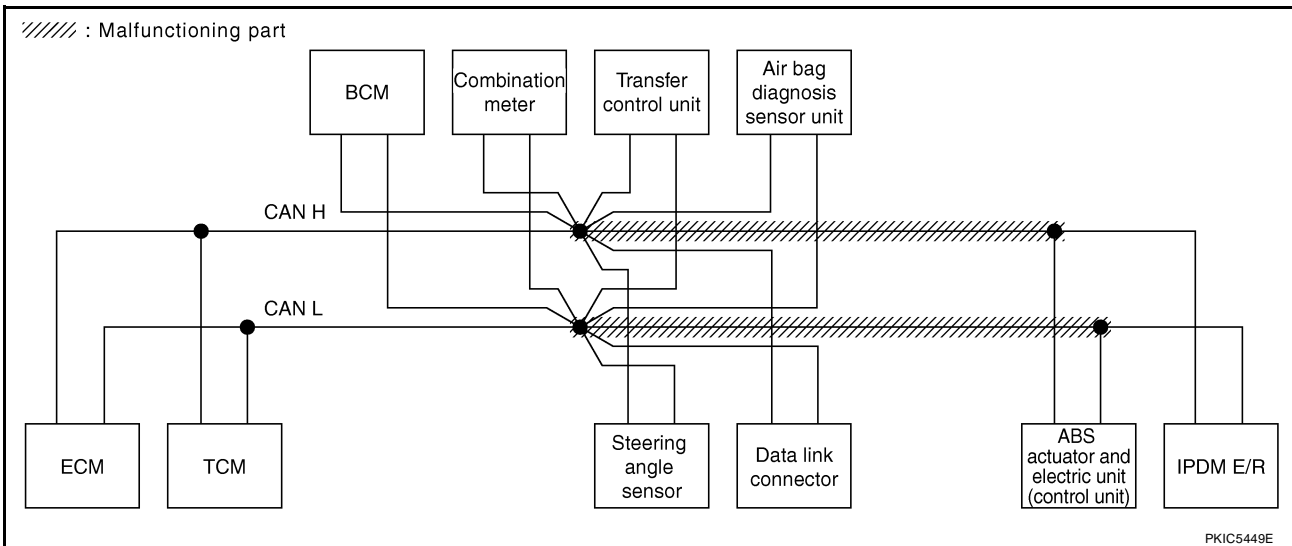

CAN SYSTEM (TYPE 7)

[CAN]

Case 3

Check ECM circuit. Refer to [LAN-197, "ECM Circuit Inspection"](#) .

SELECT SYSTEM screen		CAN DIAG SUPPORT MNTR										SELF-DIAG RESULTS		
		Initial diagnosis	Transmit diagnosis	Receive diagnosis										
				ECM	TCM	STRG	BCM /SEC	METER /M&A	AWD/4WD	VDC/TCS /ABS	IPDM E/R			
ENGINE	—	—	UNKWN	—	UNKWN	—	UNKWN	UNKWN	UNKWN	UNKWN	UNKWN	UNKWN	CAN COMM CIRCUIT (U000)	CAN COMM CIRCUIT (U001)
A/T	—	NG	UNKWN	UNKWN	—	—	—	UNKWN	UNKWN	UNKWN	—	—	CAN COMM CIRCUIT (U000)	—
BCM	No indication	NG	UNKWN	UNKWN	—	—	—	UNKWN	—	—	UNKWN	UNKWN	CAN COMM CIRCUIT (U1000)	—
METER	No indication	—	UNKWN	UNKWN	—	—	—	UNKWN	—	—	UNKWN	UNKWN	CAN COMM CIRCUIT (U000)	—
ALL MODE AWD/4WD	No indication	—	UNKWN	UNKWN	UNKWN	—	—	—	—	—	UNKWN	—	CAN COMM CIRCUIT (U000)	—
ABS	—	NG	UNKWN	UNKWN	UNKWN	—	—	—	—	—	UNKWN	—	CAN COMM CIRCUIT (U000)	—
IPDM E/R	No indication	—	UNKWN	UNKWN	—	—	—	—	—	—	—	—	CAN COMM CIRCUIT (U000)	—

PKIC5691E

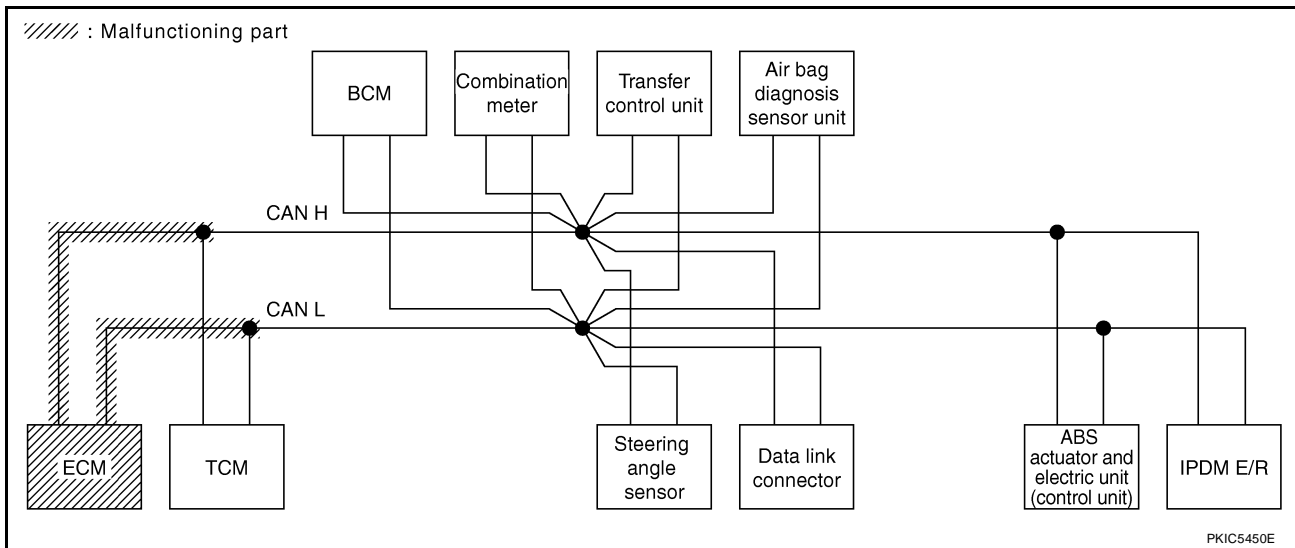

PKIC5450E

CAN SYSTEM (TYPE 7)

[CAN]

Case 4

Check TCM circuit. Refer to [LAN-197, "TCM Circuit Inspection"](#) .

SELECT SYSTEM screen		CAN DIAG SUPPORT MNTR										SELF-DIAG RESULTS	
		Initial diagnosis	Transmit diagnosis	Receive diagnosis									
				ECM	TCM	STRG	BCM /SEC	METER /M&A	AWD/4WD	VDC/TCS /ABS	IPDM E/R		
ENGINE	—	—	UNKWN	—	UNKWN	—	UNKWN	UNKWN	UNKWN	UNKWN	UNKWN	CAN COMM CIRCUIT (U1000)	CAN COMM CIRCUIT (U1001)
A/T	—	NG	UNKWN	UNKWN	—	—	—	UNKWN	UNKWN	UNKWN	—	CAN COMM CIRCUIT (U1000)	—
BCM	No indication	NG	UNKWN	UNKWN	—	—	—	UNKWN	—	—	UNKWN	CAN COMM CIRCUIT (U1000)	—
METER	No indication	—	UNKWN	UNKWN	UNKWN	—	UNKWN	—	—	UNKWN	UNKWN	CAN COMM CIRCUIT (U1000)	—
ALL MODE AWD/4WD	No indication	—	UNKWN	UNKWN	UNKWN	—	—	—	—	UNKWN	—	CAN COMM CIRCUIT (U1000)	—
ABS	—	NG	UNKWN	UNKWN	UNKWN	—	—	UNKWN	—	—	—	CAN COMM CIRCUIT (U1000)	—
IPDM E/R	No indication	—	UNKWN	UNKWN	—	—	UNKWN	—	—	—	—	CAN COMM CIRCUIT (U1000)	—

PKIC5692E

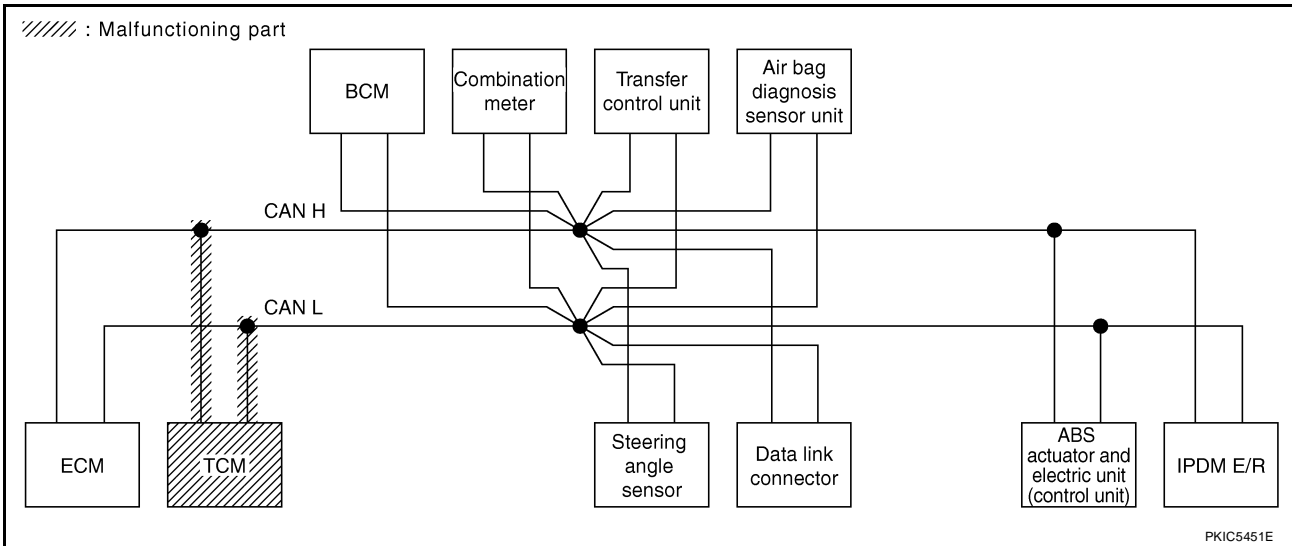

CAN SYSTEM (TYPE 7)

[CAN]

Case 5

Check steering angle sensor circuit. Refer to [LAN-199, "Steering Angle Sensor Circuit Inspection"](#) .

SELECT SYSTEM screen		CAN DIAG SUPPORT MNTR										SELF-DIAG RESULTS		
		Initial diagnosis	Transmit diagnosis	Receive diagnosis										
				ECM	TCM	STRG	BCM /SEC	METER /M&A	AWD/4WD	VDC/TCS /ABS	IPDM E/R			
ENGINE	—	—	UNKWN	—	UNKWN	—	UNKWN	UNKWN	UNKWN	UNKWN	UNKWN	UNKWN	CAN COMM CIRCUIT (U1000)	CAN COMM CIRCUIT (U1001)
A/T	—	NG	UNKWN	UNKWN	—	—	—	UNKWN	UNKWN	UNKWN	—	—	CAN COMM CIRCUIT (U1000)	—
BCM	No indication	NG	UNKWN	UNKWN	—	—	—	UNKWN	—	—	UNKWN	UNKWN	CAN COMM CIRCUIT (U1000)	—
METER	No indication	—	UNKWN	UNKWN	UNKWN	—	UNKWN	—	—	UNKWN	UNKWN	UNKWN	CAN COMM CIRCUIT (U1000)	—
ALL MODE AWD/4WD	No indication	—	UNKWN	UNKWN	UNKWN	UNKWN	—	—	—	UNKWN	—	—	CAN COMM CIRCUIT (U1000)	—
ABS	—	NG	UNKWN	UNKWN	UNKWN	UNKWN	—	—	UNKWN	—	—	—	CAN COMM CIRCUIT (U1000)	—
IPDM E/R	No indication	—	UNKWN	UNKWN	—	—	UNKWN	—	—	—	—	—	CAN COMM CIRCUIT (U1000)	—

PKIC5693E

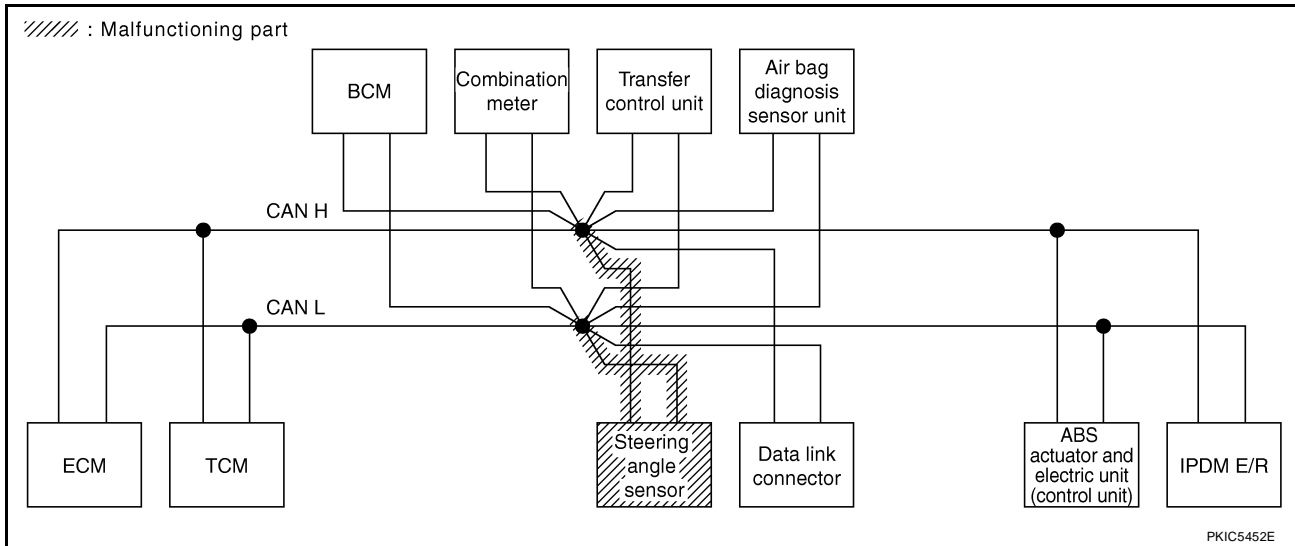

CAN SYSTEM (TYPE 7)

[CAN]

Case 6

Check data link connector circuit. Refer to [LAN-199, "Data Link Connector Circuit Inspection"](#) .

SELECT SYSTEM screen		CAN DIAG SUPPORT MNTR										SELF-DIAG RESULTS		
		Initial diagnosis	Transmit diagnosis	Receive diagnosis										
				ECM	TCM	STRG	BCM /SEC	METER /M&A	AWD/4WD	VDC/TCS /ABS	IPDM E/R			
ENGINE	—	—	UNKWN	—	UNKWN	—	UNKWN	UNKWN	UNKWN	UNKWN	UNKWN	UNKWN	CAN COMM CIRCUIT (U1000)	CAN COMM CIRCUIT (U1001)
A/T	—	NG	UNKWN	UNKWN	—	—	—	UNKWN	UNKWN	UNKWN	—	—	CAN COMM CIRCUIT (U1000)	—
BCM	No indication	NG	UNKWN	UNKWN	—	—	—	UNKWN	—	—	UNKWN	UNKWN	CAN COMM CIRCUIT (U1000)	—
METER	No indication	—	UNKWN	UNKWN	UNKWN	—	UNKWN	—	—	UNKWN	UNKWN	UNKWN	CAN COMM CIRCUIT (U1000)	—
ALL MODE AWD/4WD	No indication	—	UNKWN	UNKWN	UNKWN	UNKWN	—	—	—	UNKWN	—	—	CAN COMM CIRCUIT (U1000)	—
ABS	—	NG	UNKWN	UNKWN	UNKWN	UNKWN	—	—	UNKWN	—	—	—	CAN COMM CIRCUIT (U1000)	—
IPDM E/R	No indication	—	UNKWN	UNKWN	—	—	UNKWN	—	—	—	—	—	CAN COMM CIRCUIT (U1000)	—

PKIC5694E

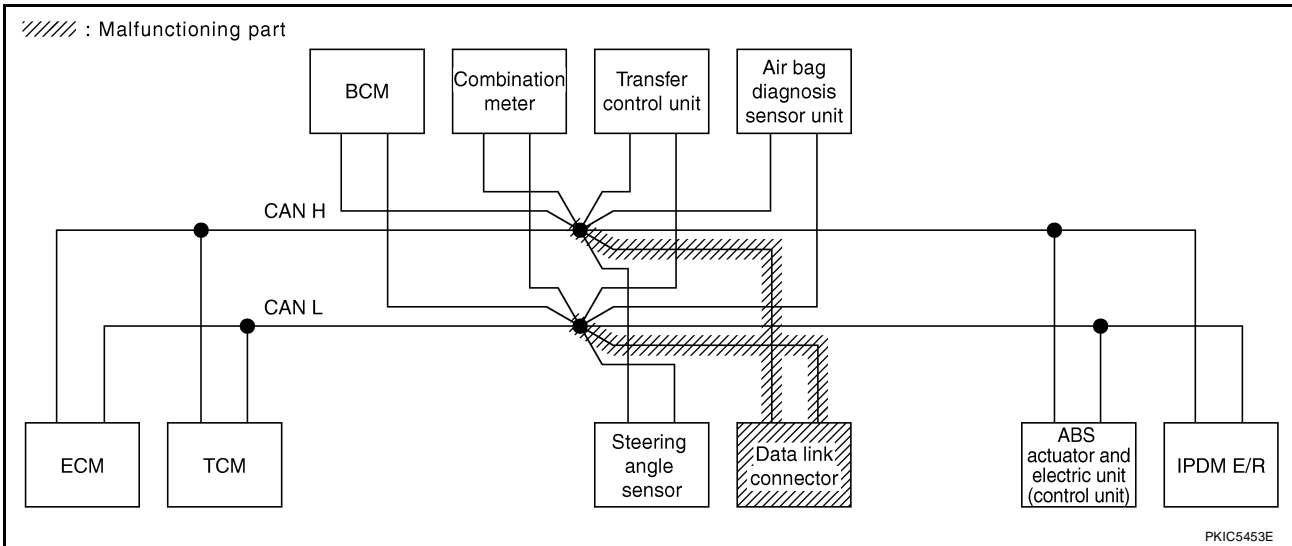

PKIC5453E

CAN SYSTEM (TYPE 7)

[CAN]

Case 7

Check BCM circuit. Refer to [LAN-200, "BCM Circuit Inspection"](#) .

SELECT SYSTEM screen		CAN DIAG SUPPORT MNTR										SELF-DIAG RESULTS		
		Initial diagnosis	Transmit diagnosis	Receive diagnosis										
				ECM	TCM	STRG	BCM /SEC	METER /M&A	AWD/4WD	VDC/TCS /ABS	IPDM E/R			
ENGINE	—	—	UNKWN	—	UNKWN	—	✓	UNKWN	UNKWN	UNKWN	UNKWN	UNKWN	CAN COMM CIRCUIT (U1000)	CAN COMM CIRCUIT (U001) ✓
A/T	—	NG	UNKWN	UNKWN	—	—	—	UNKWN	UNKWN	UNKWN	—	—	CAN COMM CIRCUIT (U1000)	—
BCM	No indication ✓	NG	UNKWN	UNKWN	—	—	—	UNKWN	—	—	UNKWN	UNKWN	CAN COMM CIRCUIT (U1000)	—
METER	No indication	—	UNKWN	UNKWN	UNKWN	—	✓	—	—	—	UNKWN	UNKWN	CAN COMM CIRCUIT (U1000) ✓	—
ALL MODE AWD/4WD	No indication	—	UNKWN	UNKWN	UNKWN	UNKWN	—	—	—	—	UNKWN	—	CAN COMM CIRCUIT (U1000)	—
ABS	—	NG	UNKWN	UNKWN	UNKWN	UNKWN	—	—	UNKWN	—	—	—	CAN COMM CIRCUIT (U1000)	—
IPDM E/R	No indication	—	UNKWN	UNKWN	—	—	✓	—	—	—	—	—	CAN COMM CIRCUIT (U1000) ✓	—

PKIC5695E

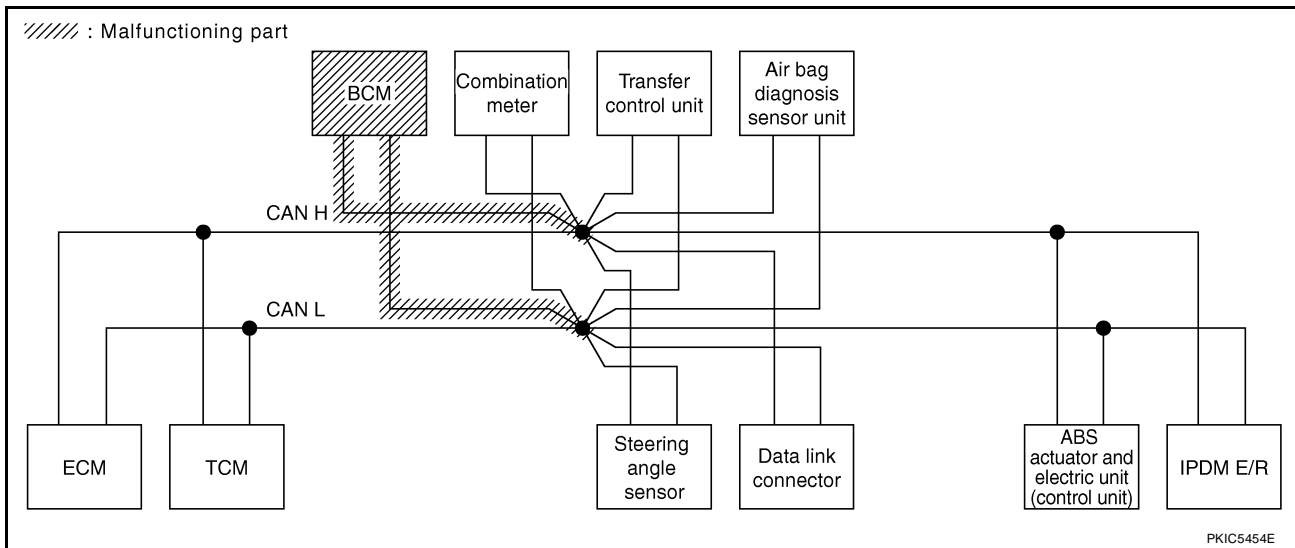

CAN SYSTEM (TYPE 7)

[CAN]

Case 8

Check combination meter circuit. Refer to [LAN-200, "Combination Meter Circuit Inspection"](#).

SELECT SYSTEM screen		CAN DIAG SUPPORT MNTR										SELF-DIAG RESULTS	
		Initial diagnosis	Transmit diagnosis	Receive diagnosis									
				ECM	TCM	STRG	BCM /SEC	METER /M&A	AWD/4WD	VDC/TCS /ABS	IPDM E/R		
ENGINE	—	—	UNKWN	—	UNKWN	—	UNKWN	UNKWN	UNKWN	UNKWN	UNKWN	CAN COMM CIRCUIT (U1000)	CAN COMM CIRCUIT (U1001)
A/T	—	NG	UNKWN	UNKWN	—	—	—	UNKWN	UNKWN	UNKWN	—	CAN COMM CIRCUIT (U1000)	—
BCM	No indication	NG	UNKWN	UNKWN	—	—	—	UNKWN	—	—	UNKWN	CAN COMM CIRCUIT (U1000)	—
METER	No indication	—	UNKWN	UNKWN	UNKWN	—	UNKWN	—	—	UNKWN	UNKWN	CAN COMM CIRCUIT (U1000)	—
ALL MODE AWD/4WD	No indication	—	UNKWN	UNKWN	UNKWN	UNKWN	—	—	—	UNKWN	—	CAN COMM CIRCUIT (U1000)	—
ABS	—	NG	UNKWN	UNKWN	UNKWN	UNKWN	—	—	UNKWN	—	—	CAN COMM CIRCUIT (U1000)	—
IPDM E/R	No indication	—	UNKWN	UNKWN	—	—	UNKWN	—	—	—	—	CAN COMM CIRCUIT (U1000)	—

PKIC5696E

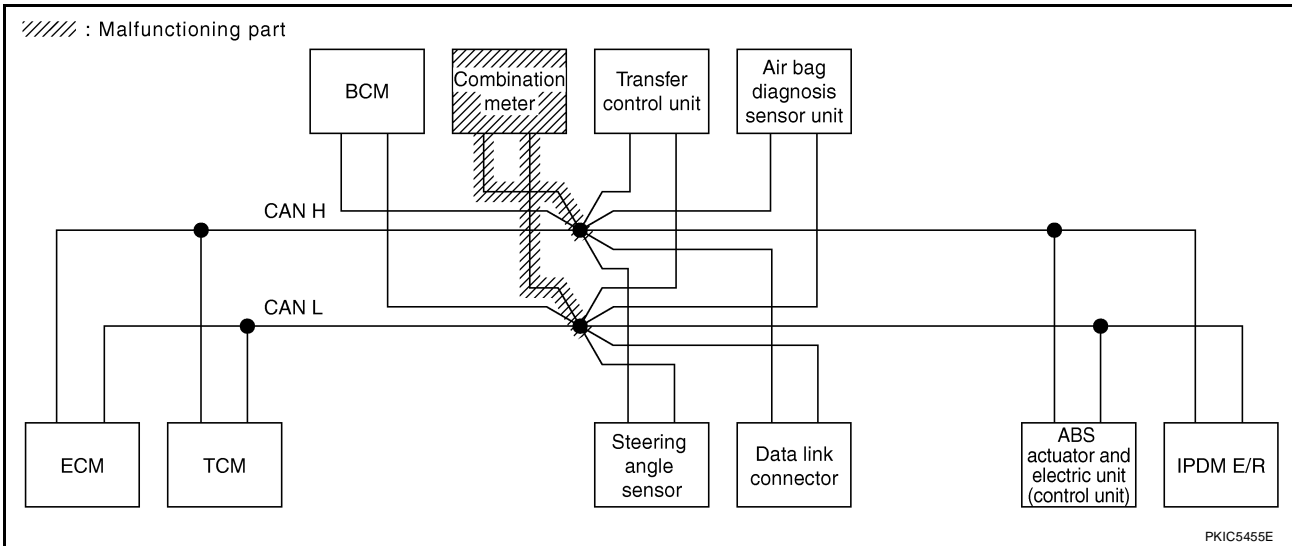

Case 9

Check transfer control unit circuit. Refer to [LAN-201, "Transfer Control Unit Circuit Inspection"](#) .

SELECT SYSTEM screen		CAN DIAG SUPPORT MNTR										SELF-DIAG RESULTS		
		Initial diagnosis	Transmit diagnosis	Receive diagnosis										IPDM E/R
				ECM	TCM	STRG	BCM /SEC	METER /M&A	AWD/4WD	VDC/TCS /ABS				
ENGINE	—	—	UNKWN	—	UNKWN	—	UNKWN	UNKWN	UNKWN	UNKWN	UNKWN	UNKWN	CAN COMM CIRCUIT (U1000)	CAN COMM CIRCUIT (U001) ✓
A/T	—	NG	UNKWN	UNKWN	—	—	—	UNKWN	UNKWN	UNKWN	—	—	CAN COMM CIRCUIT (U1000) ✓	—
BCM	No indication	NG	UNKWN	UNKWN	—	—	—	UNKWN	—	—	UNKWN	UNKWN	CAN COMM CIRCUIT (U1000)	—
METER	No indication	—	UNKWN	UNKWN	UNKWN	—	UNKWN	—	—	UNKWN	UNKWN	UNKWN	CAN COMM CIRCUIT (U1000)	—
ALL MODE AWD/4WD	No indication ✓	—	UNKWN	UNKWN	UNKWN	UNKWN	—	—	—	UNKWN	—	—	CAN COMM CIRCUIT (U1000) ✓	—
ABS	—	NG	UNKWN	UNKWN	UNKWN	UNKWN	—	—	UNKWN	—	—	—	CAN COMM CIRCUIT (U1000) ✓	—
IPDM E/R	No indication	—	UNKWN	UNKWN	—	—	UNKWN	—	—	—	—	—	CAN COMM CIRCUIT (U1000)	—

PKIC5697E

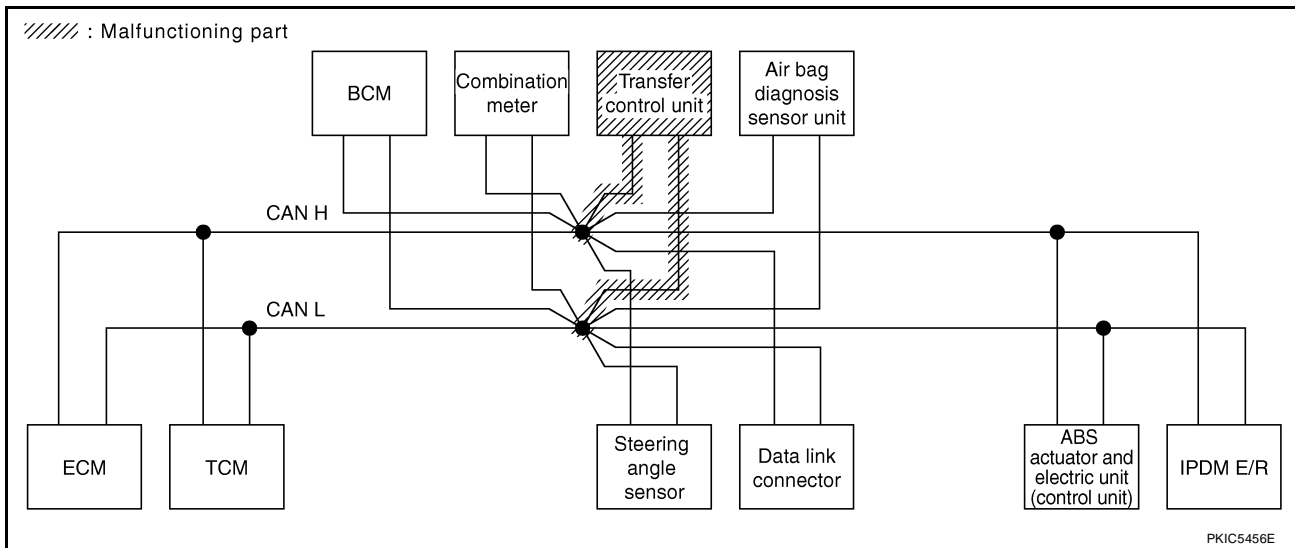

CAN SYSTEM (TYPE 7)

[CAN]

Case 10

Check ABS actuator and electric unit (control unit) circuit. Refer to [LAN-202, "ABS Actuator and Electric Unit \(Control Unit\) Circuit Inspection"](#).

SELECT SYSTEM screen		CAN DIAG SUPPORT MNTR										SELF-DIAG RESULTS		
		Initial diagnosis	Transmit diagnosis	Receive diagnosis										
				ECM	TCM	STRG	BCM /SEC	METER /M&A	AWD/4WD	VDC/TCS /ABS	IPDM E/R			
ENGINE	—	—	UNKWN	—	UNKWN	—	UNKWN	UNKWN	UNKWN	UNKWN	UNKWN	UNKWN	CAN COMM CIRCUIT (U1000)	CAN COMM CIRCUIT (U1001)
A/T	—	NG	UNKWN	UNKWN	—	—	—	UNKWN	UNKWN	UNKWN	UNKWN	UNKWN	CAN COMM CIRCUIT (U1000)	—
BCM	No indication	NG	UNKWN	UNKWN	—	—	—	UNKWN	—	—	—	UNKWN	CAN COMM CIRCUIT (U1000)	—
METER	No indication	—	UNKWN	UNKWN	UNKWN	—	UNKWN	—	—	—	UNKWN	UNKWN	CAN COMM CIRCUIT (U1000)	—
ALL MODE AWD/4WD	No indication	—	UNKWN	UNKWN	UNKWN	UNKWN	—	—	—	—	UNKWN	UNKWN	CAN COMM CIRCUIT (U1000)	—
ABS	—	NG	UNKWN	UNKWN	UNKWN	UNKWN	—	—	UNKWN	—	—	—	CAN COMM CIRCUIT (U1000)	—
IPDM E/R	No indication	—	UNKWN	UNKWN	—	—	UNKWN	—	—	—	—	—	CAN COMM CIRCUIT (U1000)	—

PKIC5698E

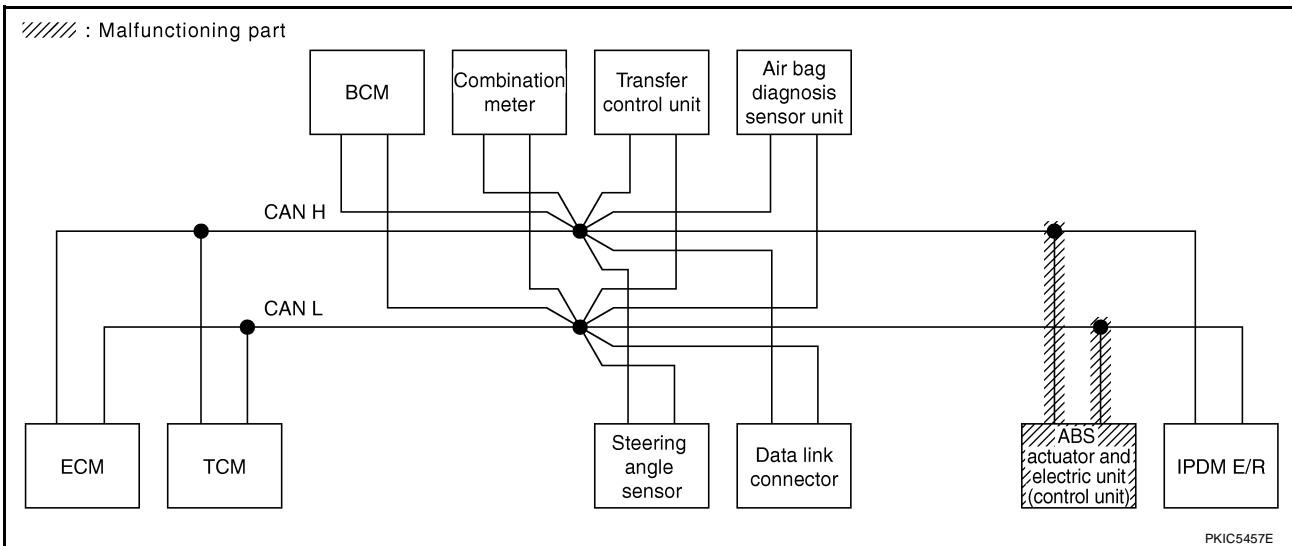

CAN SYSTEM (TYPE 7)

[CAN]

Case 11

Check IPDM E/R circuit. Refer to [LAN-203, "IPDM E/R Circuit Inspection"](#) .

SELECT SYSTEM screen		CAN DIAG SUPPORT MNTR										SELF-DIAG RESULTS		
		Initial diagnosis	Transmit diagnosis	Receive diagnosis										
				ECM	TCM	STRG	BCM /SEC	METER /M&A	AWD/4WD	VDC/TCS /ABS	IPDM E/R			
ENGINE	—	—	UNKWN	—	UNKWN	—	UNKWN	UNKWN	UNKWN	UNKWN	UNKWN	UNKWN	CAN COMM CIRCUIT (U1000)	CAN COMM CIRCUIT (U001) ✓
A/T	—	NG	UNKWN	UNKWN	—	—	—	UNKWN	UNKWN	UNKWN	—	—	CAN COMM CIRCUIT (U1000)	—
BCM	No indication	NG	UNKWN	UNKWN	—	—	—	UNKWN	—	—	UNKWN	UNKWN	CAN COMM CIRCUIT (U1000)	—
METER	No indication	—	UNKWN	UNKWN	UNKWN	—	UNKWN	—	—	UNKWN	UNKWN	UNKWN	CAN COMM CIRCUIT (U1000)	—
ALL MODE AWD/4WD	No indication	—	UNKWN	UNKWN	UNKWN	UNKWN	—	—	—	UNKWN	—	—	CAN COMM CIRCUIT (U1000)	—
ABS	—	NG	UNKWN	UNKWN	UNKWN	UNKWN	—	—	UNKWN	—	—	—	CAN COMM CIRCUIT (U1000)	—
IPDM E/R	No indication ✓	—	UNKWN	UNKWN	—	—	UNKWN	—	—	—	—	—	CAN COMM CIRCUIT (U1000)	—

PKIC5699E

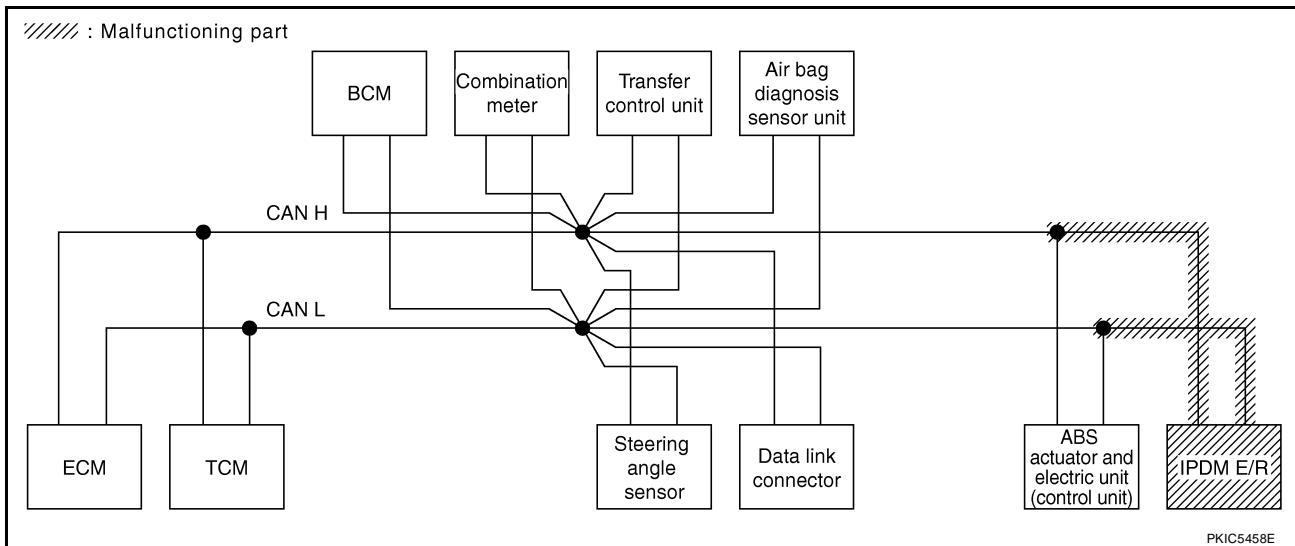

Case 12

Check CAN communication circuit. Refer to [LAN-203, "CAN Communication Circuit Inspection"](#) .

SELECT SYSTEM screen		CAN DIAG SUPPORT MNTR										SELF-DIAG RESULTS		
		Initial diagnosis	Transmit diagnosis	Receive diagnosis										
				ECM	TCM	STRG	BCM /SEC	METER /M&A	AWD/4WD	VDC/TCS /ABS	IPDM E/R			
ENGINE	—	—	UNKWN ✓	—	UNKWN ✓	—	UNKWN ✓	UNKWN ✓	UNKWN ✓	UNKWN ✓	UNKWN ✓	UNKWN ✓	CAN COMM CIRCUIT (U1000) ✓	CAN COMM CIRCUIT (U001) ✓
A/T	—	NG	UNKWN	UNKWN ✓	—	—	—	UNKWN ✓	UNKWN ✓	UNKWN ✓	—	—	CAN COMM CIRCUIT (U1000)	—
BCM	No indication ✓	NG	UNKWN	UNKWN	—	—	—	UNKWN	—	—	UNKWN	UNKWN	CAN COMM CIRCUIT (U1000)	—
METER	No indication ✓	—	UNKWN	UNKWN	UNKWN	—	UNKWN	—	—	UNKWN	UNKWN	UNKWN	CAN COMM CIRCUIT (U1000)	—
ALL MODE AWD/4WD	No indication ✓	—	UNKWN	UNKWN	UNKWN	UNKWN	—	—	—	UNKWN	—	—	CAN COMM CIRCUIT (U1000)	—
ABS	—	NG ✓	UNKWN ✓	UNKWN ✓	UNKWN ✓	UNKWN ✓	—	—	UNKWN ✓	—	—	—	CAN COMM CIRCUIT (U1000)	—
IPDM E/R	No indication ✓	—	UNKWN	UNKWN	—	—	UNKWN	—	—	—	—	—	CAN COMM CIRCUIT (U1000)	—

PKIC5700E

CAN SYSTEM (TYPE 7)

[CAN]

Case 13

Check IPDM E/R ignition relay circuit continuously sticks "OFF". Refer to [LAN-204, "IPDM E/R Ignition Relay Circuit Inspection"](#).

SELECT SYSTEM screen		CAN DIAG SUPPORT MNTR										SELF-DIAG RESULTS		
		Initial diagnosis	Transmit diagnosis	Receive diagnosis										
				ECM	TCM	STRG	BCM /SEC	METER /M&A	AWD/4WD	VDC/TCS /ABS	IPDM E/R			
ENGINE	—	—	UNKWN	—	UNKWN	—	UNKWN	UNKWN	UNKWN	UNKWN	UNKWN	UNKWN	CAN COMM CIRCUIT (U1000)	CAN COMM CIRCUIT (U1001)
A/T	—	NG	UNKWN	UNKWN	—	—	—	UNKWN	UNKWN	UNKWN	—	—	CAN COMM CIRCUIT (U1000)	—
BCM	No indication	NG	UNKWN	UNKWN	—	—	—	UNKWN	—	—	UNKWN	—	CAN COMM CIRCUIT (U1000)	—
METER	No indication	—	UNKWN	UNKWN	UNKWN	—	UNKWN	—	—	UNKWN	UNKWN	—	CAN COMM CIRCUIT (U1000)	—
ALL MODE AWD/4WD	No indication	—	UNKWN	UNKWN	UNKWN	—	—	—	—	UNKWN	—	—	CAN COMM CIRCUIT (U1000)	—
ABS	—	NG	UNKWN	UNKWN	UNKWN	UNKWN	—	—	UNKWN	—	—	—	CAN COMM CIRCUIT (U1000)	—
IPDM E/R	No indication	—	UNKWN	UNKWN	—	—	UNKWN	—	—	—	—	—	CAN COMM CIRCUIT (U1000)	—

PKIC5701E

Case 14

Check IPDM E/R ignition relay circuit continuously sticks "ON". Refer to [LAN-204, "IPDM E/R Ignition Relay Circuit Inspection"](#).

SELECT SYSTEM screen		CAN DIAG SUPPORT MNTR										SELF-DIAG RESULTS		
		Initial diagnosis	Transmit diagnosis	Receive diagnosis										
				ECM	TCM	STRG	BCM /SEC	METER /M&A	AWD/4WD	VDC/TCS /ABS	IPDM E/R			
ENGINE	—	—	UNKWN	—	UNKWN	—	UNKWN	UNKWN	UNKWN	UNKWN	UNKWN	UNKWN	CAN COMM CIRCUIT (U1000)	CAN COMM CIRCUIT (U1001)
A/T	—	NG	UNKWN	—	—	—	—	—	—	UNKWN	—	—	CAN COMM CIRCUIT (U1000)	—
BCM	No indication	NG	UNKWN	UNKWN	—	—	—	UNKWN	—	—	UNKWN	—	CAN COMM CIRCUIT (U1000)	—
METER	No indication	—	UNKWN	UNKWN	UNKWN	—	UNKWN	—	—	UNKWN	UNKWN	—	CAN COMM CIRCUIT (U1000)	—
ALL MODE AWD/4WD	No indication	—	UNKWN	UNKWN	UNKWN	UNKWN	—	—	—	UNKWN	—	—	CAN COMM CIRCUIT (U1000)	—
ABS	—	NG	UNKWN	—	UNKWN	—	—	—	—	—	—	—	CAN COMM CIRCUIT (U1000)	—
IPDM E/R	No indication	—	UNKWN	UNKWN	—	—	UNKWN	—	—	—	—	—	CAN COMM CIRCUIT (U1000)	—

PKIC5702E

CAN SYSTEM (TYPE 8)

PF2:23710

Component Parts and Harness Connector Location

UKS0053U

Refer to [LAN-25, "Component Parts and Harness Connector Location"](#) .

Schematic

UKS0053V

Refer to [LAN-26, "Schematic"](#) .

Wiring Diagram — CAN —

UKS0053W

Refer to [LAN-27, "Wiring Diagram — CAN —"](#) .

CAN SYSTEM (TYPE 8)

[CAN]

UKS0053X

Check Sheet

NOTE:

If a check mark is put on "NG" on "INITIAL DIAG (Initial diagnosis)", replace the control unit.

SELECT SYSTEM screen		CAN DIAG SUPPORT MNTR										SELF-DIAG RESULTS	
		Initial diagnosis	Transmit diagnosis	Receive diagnosis									
				ECM	TCM	STRG	BCM /SEC	METER /M&A	AWD/4WD	VDC/TCS /ABS	IPDM E/R		
ENGINE	—	—	UNKWN	—	UNKWN	—	UNKWN	UNKWN	UNKWN	UNKWN	UNKWN	CAN COMM CIRCUIT (U1000)	CAN COMM CIRCUIT (U1001)
A/T	—	NG	UNKWN	UNKWN	—	—	—	UNKWN	UNKWN	UNKWN	—	CAN COMM CIRCUIT (U1000)	—
BCM	No indication	NG	UNKWN	UNKWN	—	—	—	UNKWN	—	—	UNKWN	CAN COMM CIRCUIT (U1000)	—
METER	No indication	—	UNKWN	UNKWN	UNKWN	—	UNKWN	—	—	UNKWN	UNKWN	CAN COMM CIRCUIT (U1000)	—
ALL MODE AWD/4WD	No indication	—	UNKWN	UNKWN	UNKWN	UNKWN	—	—	—	UNKWN	—	CAN COMM CIRCUIT (U1000)	—
ABS	—	NG	UNKWN	UNKWN	UNKWN	UNKWN	—	—	UNKWN	—	—	CAN COMM CIRCUIT (U1000)	—
IPDM E/R	No indication	—	UNKWN	UNKWN	—	—	UNKWN	—	—	—	—	CAN COMM CIRCUIT (U1000)	—

Symptoms :

Attach copy of
SELECT SYSTEM

Attach copy of
SELECT SYSTEM

PKIC5688E

A
B
C
D
E
F
G
H
I
J
LAN
L
M

CAN SYSTEM (TYPE 8)

[CAN]

Attach copy of
ENGINE
SELF-DIAG RESULTS

Attach copy of
A/T
SELF-DIAG RESULTS

Attach copy of
BCM
SELF-DIAG RESULTS

Attach copy of
METER
SELF-DIAG RESULTS

Attach copy of
ALL MODE AWD/4WD
SELF-DIAG RESULTS

Attach copy of
ABS
SELF-DIAG RESULTS

Attach copy of
IPDM E/R
SELF-DIAG RESULTS

Attach copy of
ENGINE
CAN DIAG SUPPORT
MNTR

Attach copy of
A/T
CAN DIAG SUPPORT
MNTR

Attach copy of
BCM
CAN DIAG SUPPORT
MNTR

Attach copy of
METER
CAN DIAG SUPPORT
MNTR

Attach copy of
ALL MODE AWD/4WD
CAN DIAG SUPPORT
MNTR

Attach copy of
ABS
CAN DIAG SUPPORT
MNTR

Attach copy of
IPDM E/R
CAN DIAG SUPPORT
MNTR

PKIC7066E

CHECK SHEET RESULTS (EXAMPLE)

NOTE:

If a check mark is put on "NG" on "INITIAL DIAG (Initial diagnosis)", replace the control unit.

Case 1

Check harness between TCM and data link connector. Refer to [LAN-195, "Inspection Between TCM and Data Link Connector Circuit"](#).

SELECT SYSTEM screen		CAN DIAG SUPPORT MNTR										SELF-DIAG RESULTS		
		Initial diagnosis	Transmit diagnosis	Receive diagnosis										
				ECM	TCM	STRG	BCM /SEC	METER /M&A	AWD/4WD	VDC/TCS /ABS	IPDM E/R			
ENGINE	—	—	UNKWN	—	UNKWN	—	UNKWN	UNKWN	UNKWN	UNKWN	UNKWN	UNKWN	CAN COMM CIRCUIT (U1000)	CAN COMM CIRCUIT (U001) ✓
A/T	—	NG	UNKWN	UNKWN	—	—	—	UNKWN	UNKWN	UNKWN	UNKWN	—	CAN COMM CIRCUIT (U1000) ✓	—
BCM	No indication	NG	UNKWN	UNKWN	—	—	—	UNKWN	—	—	UNKWN	UNKWN	CAN COMM CIRCUIT (U1000)	—
METER	No indication	—	UNKWN	UNKWN	UNKWN	—	UNKWN	—	—	UNKWN	UNKWN	UNKWN	CAN COMM CIRCUIT (U1000) ✓	—
ALL MODE AWD/4WD	No indication	—	UNKWN	UNKWN	UNKWN	—	—	—	—	UNKWN	—	—	CAN COMM CIRCUIT (U1000) ✓	—
ABS	—	NG	UNKWN	UNKWN	UNKWN	—	—	UNKWN	—	—	—	—	CAN COMM CIRCUIT (U1000) ✓	—
IPDM E/R	No indication	—	UNKWN	UNKWN	—	—	UNKWN	—	—	—	—	—	CAN COMM CIRCUIT (U1000) ✓	—

PKIC5689E

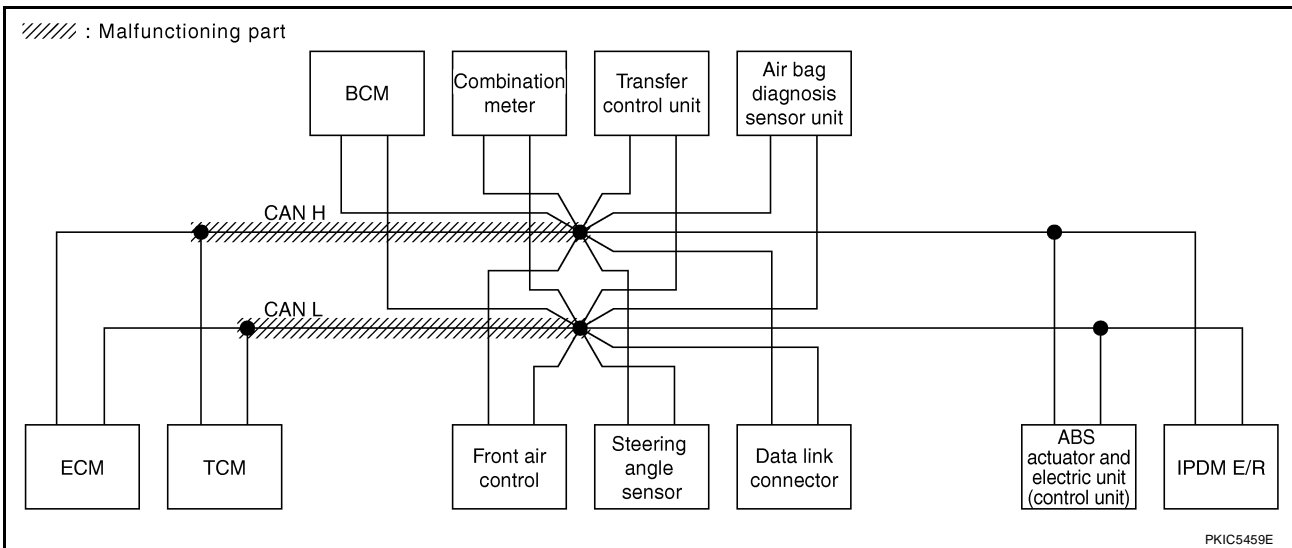

A
B
C
D
E
F
G
H
I
J
L
M

LAN

CAN SYSTEM (TYPE 8)

[CAN]

Case 2

Check harness between data link connector and ABS actuator and electric unit (control unit). Refer to [LAN-196, "Inspection Between Data Link Connector and ABS Actuator and Electric Unit \(Control Unit\) Circuit"](#) .

SELECT SYSTEM screen		CAN DIAG SUPPORT MNTR										SELF-DIAG RESULTS			
		Initial diagnosis	Transmit diagnosis	Receive diagnosis											
				ECM	TCM	STRG	BCM /SEC	METER /M&A	AWD/4WD	VDC/TCS /ABS	IPDM E/R				
ENGINE	—	—	UNKWN	—	UNKWN	—	UNKWN	UNKWN	UNKWN	UNKWN	UNKWN	UNKWN	UNKWN	CAN COMM CIRCUIT (U1000)	CAN COMM CIRCUIT (U1001)
A/T	—	NG	UNKWN	UNKWN	—	—	—	UNKWN	UNKWN	UNKWN	UNKWN	UNKWN	UNKWN	CAN COMM CIRCUIT (U1000)	—
BCM	No indication	NG	UNKWN	UNKWN	—	—	—	UNKWN	—	—	UNKWN	UNKWN	UNKWN	CAN COMM CIRCUIT (U1000)	—
METER	No indication	—	UNKWN	UNKWN	UNKWN	—	UNKWN	—	—	UNKWN	UNKWN	UNKWN	UNKWN	CAN COMM CIRCUIT (U1000)	—
ALL MODE AWD/4WD	No indication	—	UNKWN	UNKWN	UNKWN	UNKWN	—	—	—	UNKWN	UNKWN	UNKWN	UNKWN	CAN COMM CIRCUIT (U1000)	—
ABS	—	NG	UNKWN	UNKWN	UNKWN	UNKWN	—	—	UNKWN	—	—	—	—	CAN COMM CIRCUIT (U1000)	—
IPDM E/R	No indication	—	UNKWN	UNKWN	—	—	UNKWN	—	—	—	—	—	—	CAN COMM CIRCUIT (U1000)	—

PKIC5690E

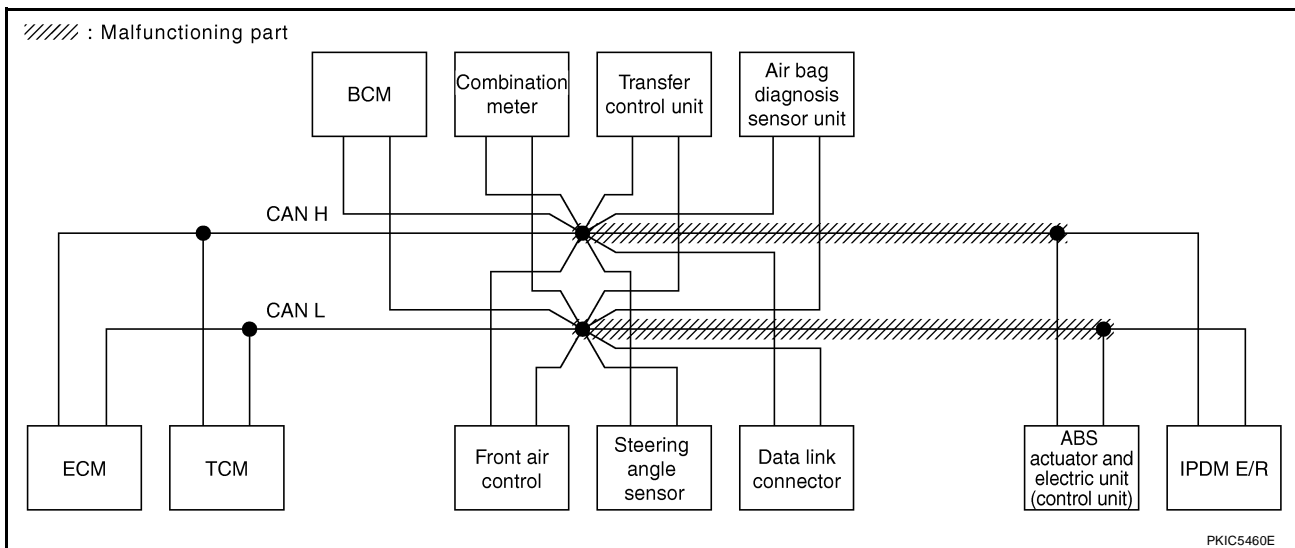

PKIC5460E

CAN SYSTEM (TYPE 8)

[CAN]

Case 3

Check ECM circuit. Refer to [LAN-197, "ECM Circuit Inspection"](#).

SELECT SYSTEM screen		CAN DIAG SUPPORT MNTR										SELF-DIAG RESULTS		
		Initial diagnosis	Transmit diagnosis	Receive diagnosis										
				ECM	TCM	STRG	BCM /SEC	METER /M&A	AWD/4WD	VDC/TCS /ABS	IPDM E/R			
ENGINE	—	—	UNKWN	UNKWN	UNKWN	—	UNKWN	UNKWN	UNKWN	UNKWN	UNKWN	UNKWN	CAN COMM CIRCUIT (U100)	CAN COMM CIRCUIT (U101)
A/T	—	NG	UNKWN	UNKWN	—	—	—	UNKWN	UNKWN	UNKWN	—	—	CAN COMM CIRCUIT (U100)	—
BCM	No indication	NG	UNKWN	UNKWN	—	—	—	UNKWN	—	—	UNKWN	—	CAN COMM CIRCUIT (U100)	—
METER	No indication	—	UNKWN	UNKWN	UNKWN	—	UNKWN	—	—	UNKWN	UNKWN	—	CAN COMM CIRCUIT (U100)	—
ALL MODE AWD/4WD	No indication	—	UNKWN	UNKWN	UNKWN	—	—	—	—	UNKWN	—	—	CAN COMM CIRCUIT (U100)	—
ABS	—	NG	UNKWN	UNKWN	UNKWN	—	—	UNKWN	—	—	—	—	CAN COMM CIRCUIT (U100)	—
IPDM E/R	No indication	—	UNKWN	UNKWN	—	—	UNKWN	—	—	—	—	—	CAN COMM CIRCUIT (U100)	—

PKIC5691E

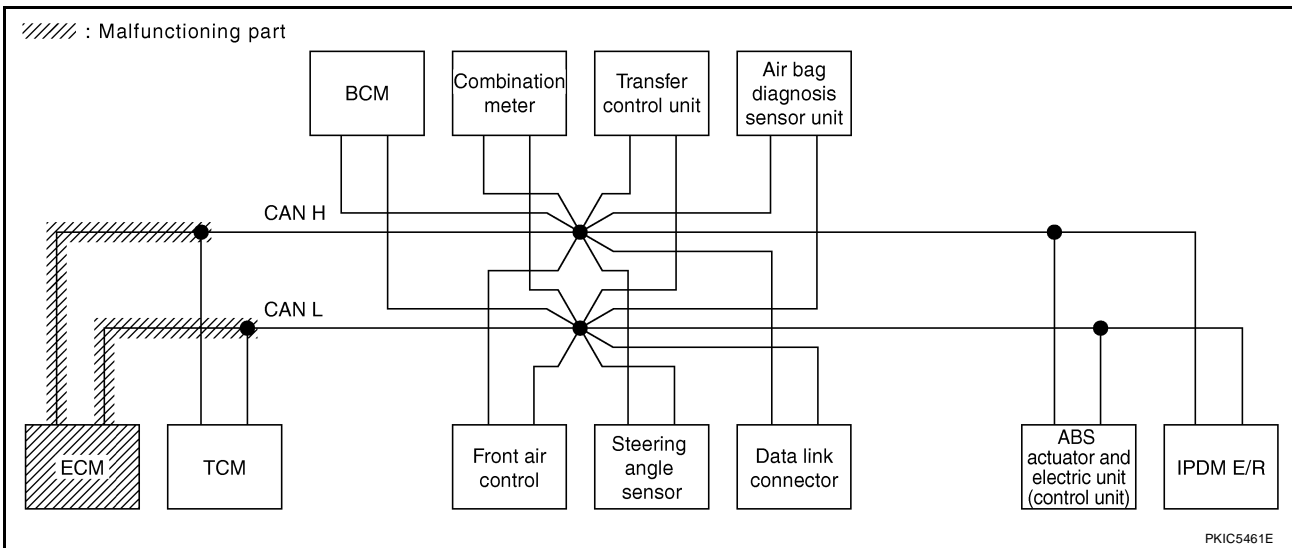

PKIC5461E

CAN SYSTEM (TYPE 8)

[CAN]

Case 4

Check TCM circuit. Refer to [LAN-197, "TCM Circuit Inspection"](#) .

SELECT SYSTEM screen		CAN DIAG SUPPORT MNTR										SELF-DIAG RESULTS		
		Initial diagnosis	Transmit diagnosis	Receive diagnosis										
				ECM	TCM	STRG	BCM /SEC	METER /M&A	AWD/4WD	VDC/TCS /ABS	IPDM E/R			
ENGINE	—	—	UNKWN	—	UNKWN ✓	—	UNKWN	UNKWN	UNKWN	UNKWN	UNKWN	UNKWN	CAN COMM CIRCUIT (U100) ✓	CAN COMM CIRCUIT (U101) ✓
A/T	—	NG	UNKWN	UNKWN ✓	—	—	—	UNKWN ✓	UNKWN ✓	UNKWN ✓	—	—	CAN COMM CIRCUIT (U100) ✓	—
BCM	No indication	NG	UNKWN	UNKWN	—	—	—	UNKWN	—	—	UNKWN	UNKWN	CAN COMM CIRCUIT (U1000)	—
METER	No indication	—	UNKWN	UNKWN	UNKWN ✓	—	UNKWN	—	—	UNKWN	UNKWN	UNKWN	CAN COMM CIRCUIT (U100) ✓	—
ALL MODE AWD/4WD	No indication	—	UNKWN	UNKWN	UNKWN ✓	UNKWN	—	—	—	UNKWN	—	—	CAN COMM CIRCUIT (U100) ✓	—
ABS	—	NG	UNKWN	UNKWN	UNKWN ✓	UNKWN	—	—	UNKWN	—	—	—	CAN COMM CIRCUIT (U100) ✓	—
IPDM E/R	No indication	—	UNKWN	UNKWN	—	—	UNKWN	—	—	—	—	—	CAN COMM CIRCUIT (U1000)	—

PKIC5692E

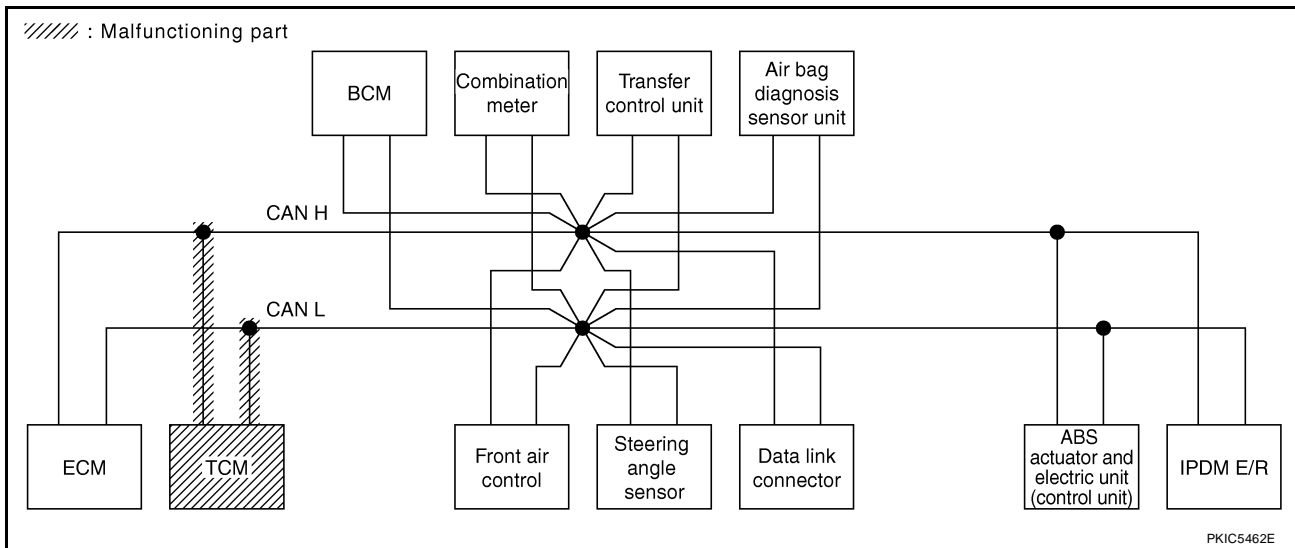

Case 5

Check steering angle sensor circuit. Refer to [LAN-199, "Steering Angle Sensor Circuit Inspection"](#).

SELECT SYSTEM screen		CAN DIAG SUPPORT MNTR										SELF-DIAG RESULTS	
		Initial diagnosis	Transmit diagnosis	Receive diagnosis									
				ECM	TCM	STRG	BCM /SEC	METER /M&A	AWD/4WD	VDC/TCS /ABS	IPDM E/R		
ENGINE	—	—	UNKWN	—	UNKWN	—	UNKWN	UNKWN	UNKWN	UNKWN	UNKWN	CAN COMM CIRCUIT (U1000)	CAN COMM CIRCUIT (U1001)
A/T	—	NG	UNKWN	UNKWN	—	—	—	UNKWN	UNKWN	UNKWN	—	CAN COMM CIRCUIT (U1000)	—
BCM	No indication	NG	UNKWN	UNKWN	—	—	—	UNKWN	—	—	UNKWN	CAN COMM CIRCUIT (U1000)	—
METER	No indication	—	UNKWN	UNKWN	UNKWN	—	UNKWN	—	—	UNKWN	UNKWN	CAN COMM CIRCUIT (U1000)	—
ALL MODE AWD/4WD	No indication	—	UNKWN	UNKWN	UNKWN	✓	—	—	—	UNKWN	—	CAN COMM CIRCUIT (U1000)	—
ABS	—	NG	UNKWN	UNKWN	UNKWN	✓	—	—	UNKWN	—	—	CAN COMM CIRCUIT (U1000)	—
IPDM E/R	No indication	—	UNKWN	UNKWN	—	—	UNKWN	—	—	—	—	CAN COMM CIRCUIT (U1000)	—

PKIC5693E

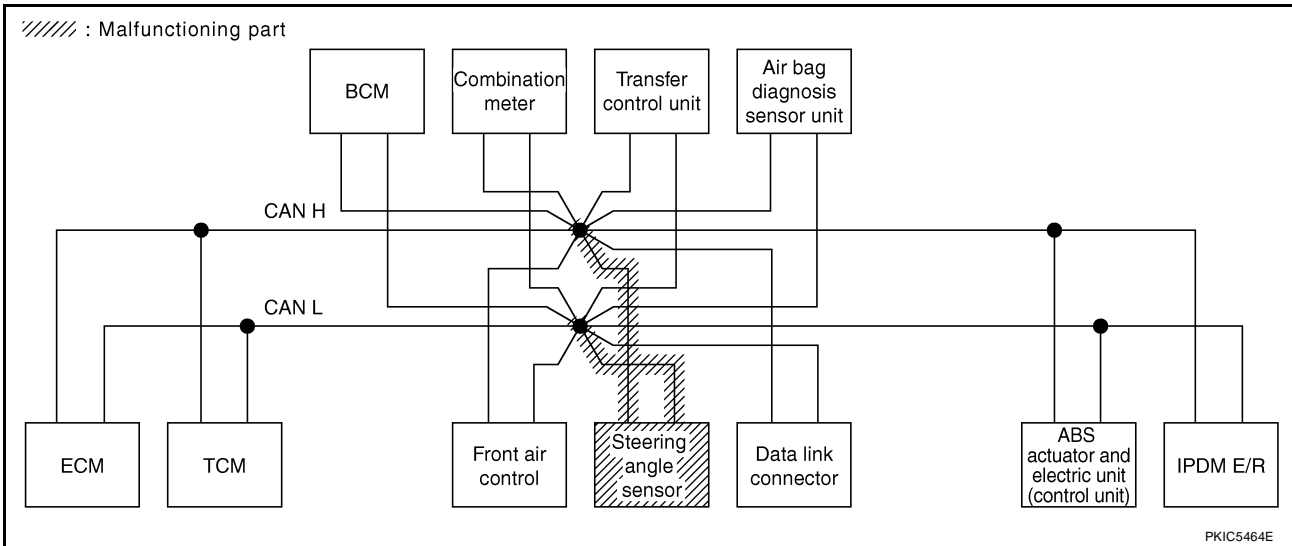

CAN SYSTEM (TYPE 8)

[CAN]

Case 6

Check data link connector circuit. Refer to [LAN-199, "Data Link Connector Circuit Inspection"](#) .

SELECT SYSTEM screen		CAN DIAG SUPPORT MNTR										SELF-DIAG RESULTS		
		Initial diagnosis	Transmit diagnosis	Receive diagnosis										
				ECM	TCM	STRG	BCM /SEC	METER /M&A	AWD/4WD	VDC/TCS /ABS	IPDM E/R			
ENGINE	—	—	UNKWN	—	UNKWN	—	UNKWN	UNKWN	UNKWN	UNKWN	UNKWN	UNKWN	CAN COMM CIRCUIT (U1000)	CAN COMM CIRCUIT (U1001)
A/T	—	NG	UNKWN	UNKWN	—	—	—	UNKWN	UNKWN	UNKWN	—	—	CAN COMM CIRCUIT (U1000)	—
BCM	No indication	NG	UNKWN	UNKWN	—	—	—	UNKWN	—	—	UNKWN	UNKWN	CAN COMM CIRCUIT (U1000)	—
METER	No indication	—	UNKWN	UNKWN	UNKWN	—	UNKWN	—	—	UNKWN	UNKWN	UNKWN	CAN COMM CIRCUIT (U1000)	—
ALL MODE AWD/4WD	No indication	—	UNKWN	UNKWN	UNKWN	UNKWN	—	—	—	UNKWN	—	—	CAN COMM CIRCUIT (U1000)	—
ABS	—	NG	UNKWN	UNKWN	UNKWN	UNKWN	—	—	UNKWN	—	—	—	CAN COMM CIRCUIT (U1000)	—
IPDM E/R	No indication	—	UNKWN	UNKWN	—	—	UNKWN	—	—	—	—	—	CAN COMM CIRCUIT (U1000)	—

PKIC5694E

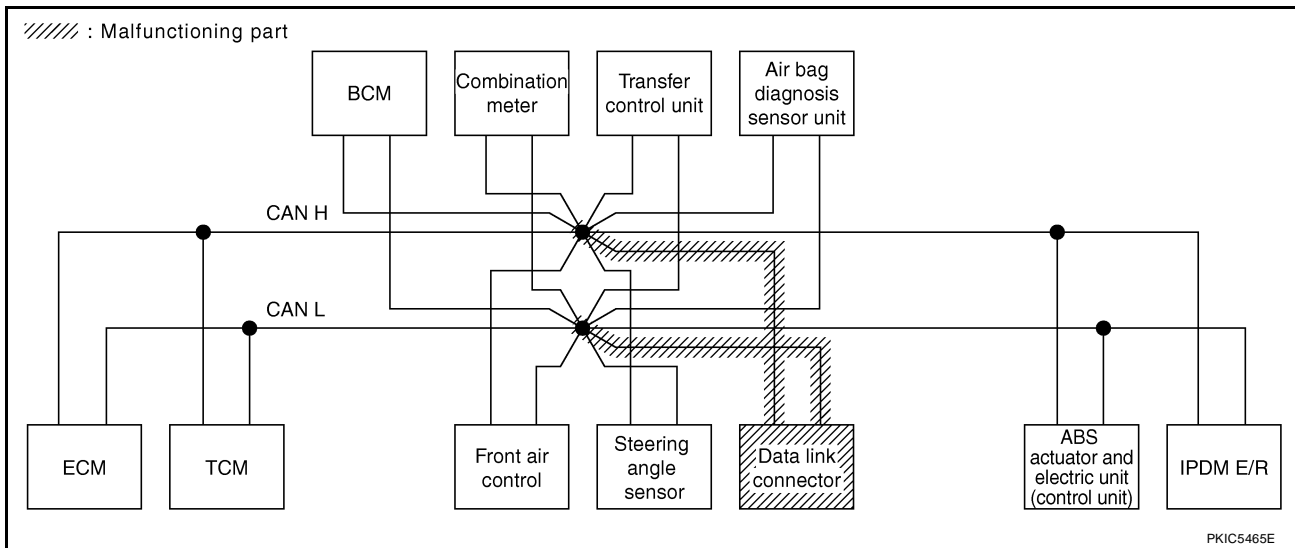

Case 7

Check BCM circuit. Refer to [LAN-200, "BCM Circuit Inspection"](#) .

SELECT SYSTEM screen		CAN DIAG SUPPORT MNTR										SELF-DIAG RESULTS	
		Initial diagnosis	Transmit diagnosis	Receive diagnosis									
				ECM	TCM	STRG	BCM /SEC	METER /M&A	AWD/4WD	VDC/TCS /ABS	IPDM E/R		
ENGINE	—	—	UNKWN	—	UNKWN	—	UNKWN	UNKWN	UNKWN	UNKWN	UNKWN	CAN COMM CIRCUIT (U1000)	CAN COMM CIRCUIT (U1001)
A/T	—	NG	UNKWN	UNKWN	—	—	—	UNKWN	UNKWN	UNKWN	—	CAN COMM CIRCUIT (U1000)	—
BCM	No indication	NG	UNKWN	UNKWN	—	—	—	UNKWN	—	—	UNKWN	CAN COMM CIRCUIT (U1000)	—
METER	No indication	—	UNKWN	UNKWN	UNKWN	—	UNKWN	—	—	UNKWN	UNKWN	CAN COMM CIRCUIT (U1000)	—
ALL MODE AWD/4WD	No indication	—	UNKWN	UNKWN	UNKWN	UNKWN	—	—	—	UNKWN	—	CAN COMM CIRCUIT (U1000)	—
ABS	—	NG	UNKWN	UNKWN	UNKWN	UNKWN	—	—	UNKWN	—	—	CAN COMM CIRCUIT (U1000)	—
IPDM E/R	No indication	—	UNKWN	UNKWN	—	—	UNKWN	—	—	—	—	CAN COMM CIRCUIT (U1000)	—

PKIC5695E

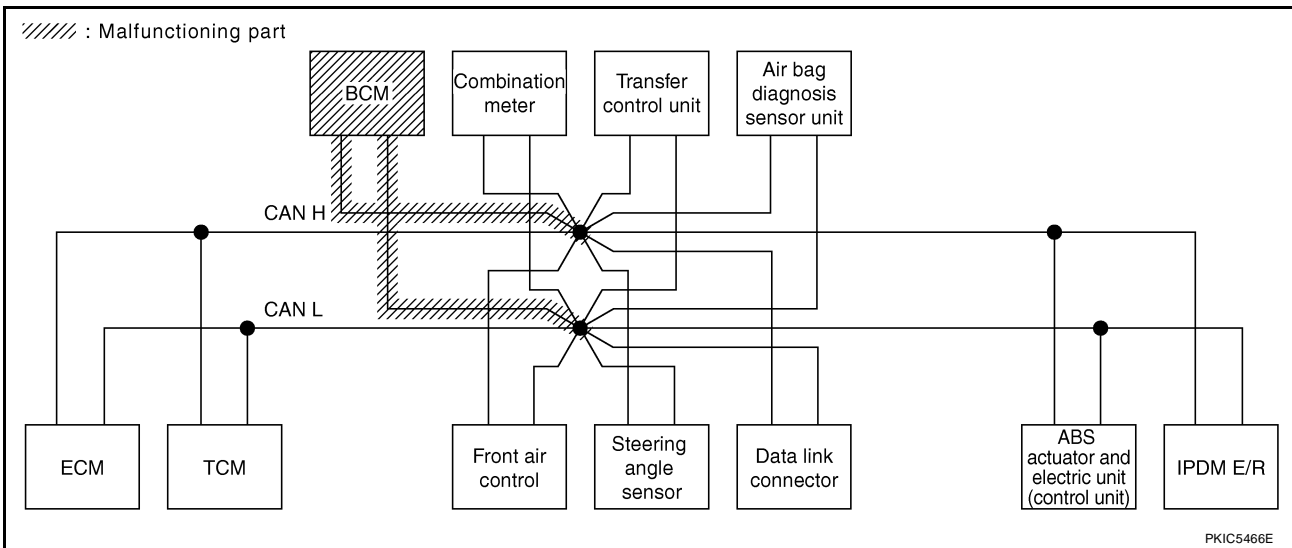

Case 8

Check combination meter circuit. Refer to [LAN-200, "Combination Meter Circuit Inspection"](#) .

SELECT SYSTEM screen		CAN DIAG SUPPORT MNTR										SELF-DIAG RESULTS		
		Initial diagnosis	Transmit diagnosis	Receive diagnosis										
				ECM	TCM	STRG	BCM /SEC	METER /M&A	AWD/4WD	VDC/TCS /ABS	IPDM E/R			
ENGINE	—	—	UNKWN	—	UNKWN	—	UNKWN	UNKWN	UNKWN	UNKWN	UNKWN	UNKWN	CAN COMM CIRCUIT (U1000)	CAN COMM CIRCUIT (U001) ✓
A/T	—	NG	UNKWN	UNKWN	—	—	—	UNKWN	UNKWN	UNKWN	—	—	CAN COMM CIRCUIT (U1000) ✓	—
BCM	No indication	NG	UNKWN	UNKWN	—	—	—	UNKWN	—	—	UNKWN	UNKWN	CAN COMM CIRCUIT (U1000)	—
METER	No indication ✓	—	UNKWN	UNKWN	UNKWN	—	UNKWN	—	—	UNKWN	UNKWN	UNKWN	CAN COMM CIRCUIT (U1000) ✓	—
ALL MODE AWD/4WD	No indication	—	UNKWN	UNKWN	UNKWN	UNKWN	—	—	—	UNKWN	—	—	CAN COMM CIRCUIT (U1000)	—
ABS	—	NG	UNKWN	UNKWN	UNKWN	UNKWN	—	—	UNKWN	—	—	—	CAN COMM CIRCUIT (U1000)	—
IPDM E/R	No indication	—	UNKWN	UNKWN	—	—	UNKWN	—	—	—	—	—	CAN COMM CIRCUIT (U1000)	—

PKIC5696E

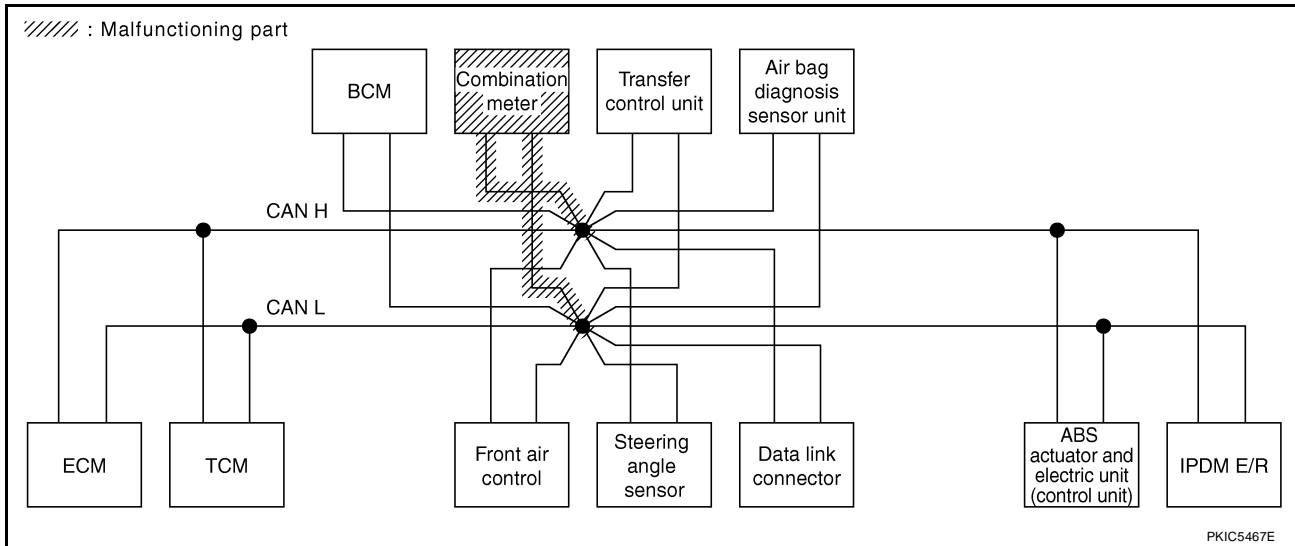

Case 9

Check transfer control unit circuit. Refer to [LAN-201, "Transfer Control Unit Circuit Inspection"](#).

SELECT SYSTEM screen		CAN DIAG SUPPORT MNTR										SELF-DIAG RESULTS		
		Initial diagnosis	Transmit diagnosis	Receive diagnosis										
				ECM	TCM	STRG	BCM /SEC	METER /M&A	AWD/4WD	VDC/TCS /ABS	IPDM E/R			
ENGINE	—	—	UNKWN	—	UNKWN	—	UNKWN	UNKWN	UNKWN	UNKWN	UNKWN	UNKWN	CAN COMM CIRCUIT (U1000)	CAN COMM CIRCUIT (U1001)
A/T	—	NG	UNKWN	UNKWN	—	—	—	UNKWN	UNKWN	UNKWN	—	—	CAN COMM CIRCUIT (U1000)	—
BCM	No indication	NG	UNKWN	UNKWN	—	—	—	UNKWN	—	—	UNKWN	UNKWN	CAN COMM CIRCUIT (U1000)	—
METER	No indication	—	UNKWN	UNKWN	UNKWN	—	UNKWN	—	—	UNKWN	UNKWN	UNKWN	CAN COMM CIRCUIT (U1000)	—
ALL MODE AWD/4WD	No indication	—	UNKWN	UNKWN	UNKWN	UNKWN	—	—	—	UNKWN	—	—	CAN COMM CIRCUIT (U1000)	—
ABS	—	NG	UNKWN	UNKWN	UNKWN	UNKWN	—	—	UNKWN	—	—	—	CAN COMM CIRCUIT (U1000)	—
IPDM E/R	No indication	—	UNKWN	UNKWN	—	—	UNKWN	—	—	—	—	—	CAN COMM CIRCUIT (U1000)	—

PKIC5697E

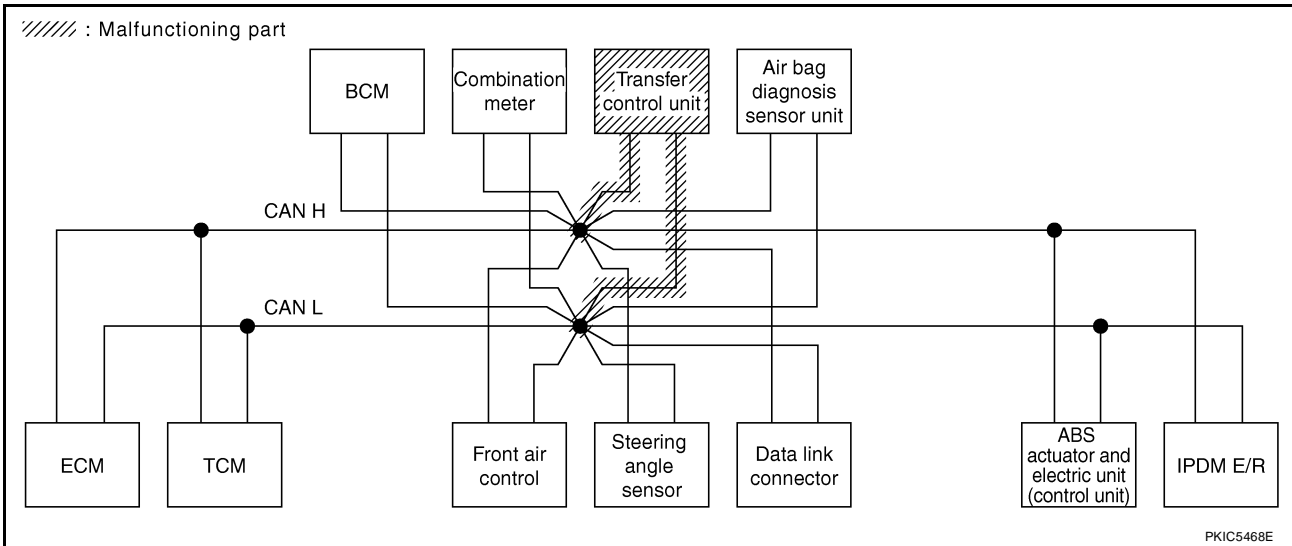

CAN SYSTEM (TYPE 8)

[CAN]

Case 10

Check ABS actuator and electric unit (control unit) circuit. Refer to [LAN-202, "ABS Actuator and Electric Unit \(Control Unit\) Circuit Inspection"](#) .

SELECT SYSTEM screen		CAN DIAG SUPPORT MNTR										SELF-DIAG RESULTS			
		Initial diagnosis	Transmit diagnosis	Receive diagnosis											
				ECM	TCM	STRG	BCM /SEC	METER /M&A	AWD/4WD	VDC/TCS /ABS	IPDM E/R				
ENGINE	—	—	UNKWN	—	UNKWN	—	UNKWN	UNKWN	UNKWN	UNKWN	UNKWN	UNKWN	UNKWN	CAN COMM CIRCUIT (U1000)	CAN COMM CIRCUIT (U1001)
A/T	—	NG	UNKWN	UNKWN	—	—	—	UNKWN	UNKWN	UNKWN	UNKWN	UNKWN	UNKWN	CAN COMM CIRCUIT (U1000)	—
BCM	No indication	NG	UNKWN	UNKWN	—	—	—	UNKWN	—	—	UNKWN	UNKWN	UNKWN	CAN COMM CIRCUIT (U1000)	—
METER	No indication	—	UNKWN	UNKWN	UNKWN	—	UNKWN	—	—	UNKWN	UNKWN	UNKWN	UNKWN	CAN COMM CIRCUIT (U1000)	—
ALL MODE AWD/4WD	No indication	—	UNKWN	UNKWN	UNKWN	UNKWN	—	—	—	UNKWN	UNKWN	UNKWN	UNKWN	CAN COMM CIRCUIT (U1000)	—
ABS	—	✓	✓	✓	✓	✓	—	—	UNKWN	—	—	—	CAN COMM CIRCUIT (U1000)	—	
IPDM E/R	No indication	—	UNKWN	UNKWN	—	—	UNKWN	—	—	—	—	—	—	CAN COMM CIRCUIT (U1000)	—

PKIC5698E

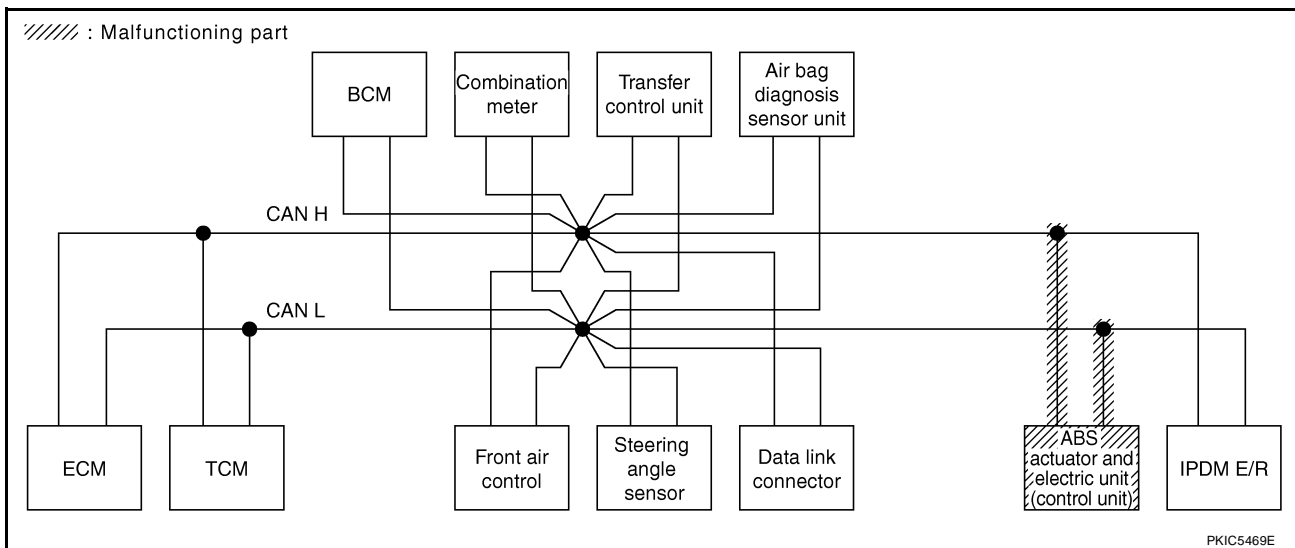

Case 11

Check IPDM E/R circuit. Refer to [LAN-203, "IPDM E/R Circuit Inspection"](#) .

SELECT SYSTEM screen		CAN DIAG SUPPORT MNTR										SELF-DIAG RESULTS			
		Initial diagnosis	Transmit diagnosis	Receive diagnosis											
				ECM	TCM	STRG	BCM /SEC	METER /M&A	AWD/4WD	VDC/TCS /ABS	IPDM E/R				
ENGINE	—	—	UNKWN	—	UNKWN	—	UNKWN	UNKWN	UNKWN	UNKWN	UNKWN	UNKWN	✓	CAN COMM CIRCUIT (U1000)	CAN COMM CIRCUIT (U1001)
A/T	—	NG	UNKWN	UNKWN	—	—	—	UNKWN	UNKWN	UNKWN	—	—	—	CAN COMM CIRCUIT (U1000)	—
BCM	No indication	NG	UNKWN	UNKWN	—	—	—	UNKWN	—	—	UNKWN	✓	✓	CAN COMM CIRCUIT (U1000)	—
METER	No indication	—	UNKWN	UNKWN	UNKWN	—	UNKWN	—	—	UNKWN	UNKWN	✓	✓	CAN COMM CIRCUIT (U1000)	—
ALL MODE AWD/4WD	No indication	—	UNKWN	UNKWN	UNKWN	UNKWN	—	—	—	UNKWN	—	—	—	CAN COMM CIRCUIT (U1000)	—
ABS	—	NG	UNKWN	UNKWN	UNKWN	UNKWN	—	—	UNKWN	—	—	—	—	CAN COMM CIRCUIT (U1000)	—
IPDM E/R	No indication	—	UNKWN	UNKWN	—	—	UNKWN	—	—	—	—	—	—	CAN COMM CIRCUIT (U1000)	—

PKIC5699E

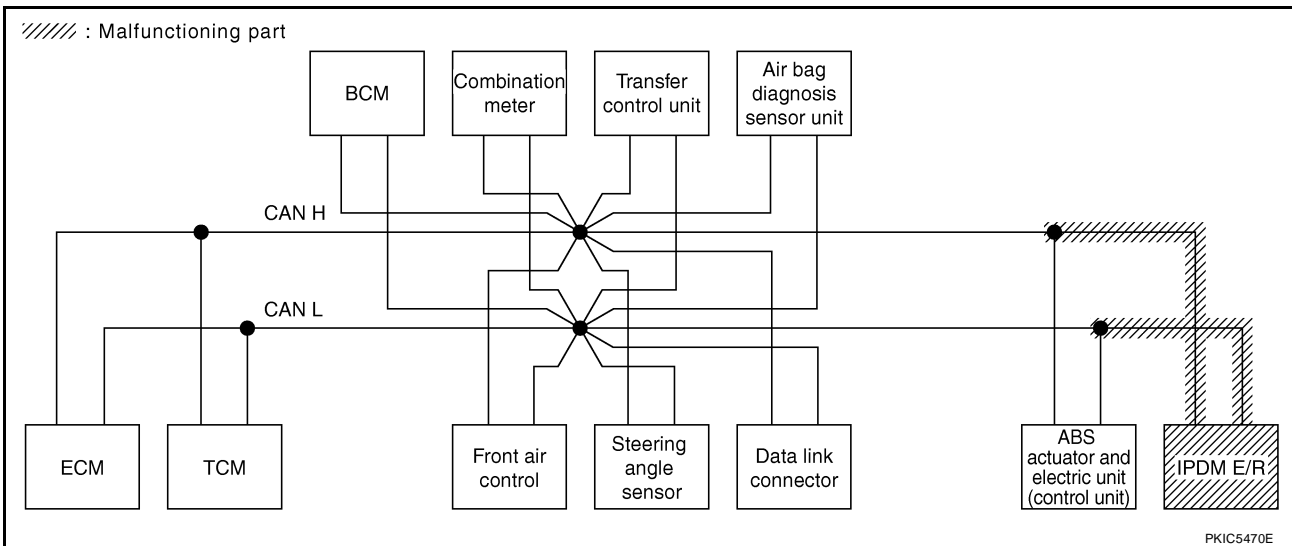

Case 12

Check CAN communication circuit. Refer to [LAN-203, "CAN Communication Circuit Inspection"](#) .

SELECT SYSTEM screen		CAN DIAG SUPPORT MNTR										SELF-DIAG RESULTS			
		Initial diagnosis	Transmit diagnosis	Receive diagnosis											
				ECM	TCM	STRG	BCM /SEC	METER /M&A	AWD/4WD	VDC/TCS /ABS	IPDM E/R				
ENGINE	—	—	✓	—	✓	—	✓	✓	✓	✓	✓	✓	✓	CAN COMM CIRCUIT (U1000)	CAN COMM CIRCUIT (U1001)
A/T	—	NG	UNKWN	✓	—	—	—	UNKWN	UNKWN	UNKWN	—	—	—	CAN COMM CIRCUIT (U1000)	—
BCM	No indication	NG	UNKWN	UNKWN	—	—	—	UNKWN	—	—	UNKWN	UNKWN	—	CAN COMM CIRCUIT (U1000)	—
METER	No indication	—	UNKWN	UNKWN	UNKWN	—	UNKWN	—	—	UNKWN	UNKWN	—	—	CAN COMM CIRCUIT (U1000)	—
ALL MODE AWD/4WD	No indication	—	UNKWN	UNKWN	UNKWN	UNKWN	—	—	—	UNKWN	—	—	—	CAN COMM CIRCUIT (U1000)	—
ABS	—	NG	✓	✓	✓	✓	—	—	UNKWN	—	—	—	—	CAN COMM CIRCUIT (U1000)	—
IPDM E/R	No indication	—	UNKWN	UNKWN	—	—	UNKWN	—	—	—	—	—	—	CAN COMM CIRCUIT (U1000)	—

PKIC5700E

CAN SYSTEM (TYPE 8)

[CAN]

Case 13

Check IPDM E/R ignition relay circuit continuously sticks "OFF". Refer to [LAN-204, "IPDM E/R Ignition Relay Circuit Inspection"](#) .

SELECT SYSTEM screen		CAN DIAG SUPPORT MNTR										SELF-DIAG RESULTS		
		Initial diagnosis	Transmit diagnosis	Receive diagnosis										IPDM E/R
				ECM	TCM	STRG	BCM /SEC	METER /M&A	AWD/4WD	VDC/TCS /ABS				
ENGINE	—	—	UNKWN	—	UNKWN	—	UNKWN	UNKWN	UNKWN	UNKWN	UNKWN	UNKWN	CAN COMM CIRCUIT (U1000)	CAN COMM CIRCUIT (U1001)
A/T	—	NG	UNKWN	UNKWN	—	—	—	UNKWN	UNKWN	UNKWN	—	—	CAN COMM CIRCUIT (U1000)	—
BCM	No indication	NG	UNKWN	UNKWN	—	—	—	UNKWN	—	—	UNKWN	—	CAN COMM CIRCUIT (U1000)	—
METER	No indication	—	UNKWN	UNKWN	UNKWN	—	UNKWN	—	—	UNKWN	UNKWN	UNKWN	CAN COMM CIRCUIT (U1000)	—
ALL MODE AWD/4WD	No indication	—	UNKWN	UNKWN	UNKWN	—	—	—	—	UNKWN	—	—	CAN COMM CIRCUIT (U1000)	—
ABS	—	NG	UNKWN	UNKWN	UNKWN	UNKWN	—	—	UNKWN	—	—	—	CAN COMM CIRCUIT (U1000)	—
IPDM E/R	No indication	—	UNKWN	UNKWN	—	—	UNKWN	—	—	—	—	—	CAN COMM CIRCUIT (U1000)	—

PKIC5701E

Case 14

Check IPDM E/R ignition relay circuit continuously sticks "ON". Refer to [LAN-204, "IPDM E/R Ignition Relay Circuit Inspection"](#) .

SELECT SYSTEM screen		CAN DIAG SUPPORT MNTR										SELF-DIAG RESULTS		
		Initial diagnosis	Transmit diagnosis	Receive diagnosis										IPDM E/R
				ECM	TCM	STRG	BCM /SEC	METER /M&A	AWD/4WD	VDC/TCS /ABS				
ENGINE	—	—	UNKWN	—	UNKWN	—	UNKWN	UNKWN	UNKWN	UNKWN	UNKWN	UNKWN	CAN COMM CIRCUIT (U1000)	CAN COMM CIRCUIT (U1001)
A/T	—	NG	UNKWN	—	—	—	—	—	—	UNKWN	—	—	CAN COMM CIRCUIT (U1000)	—
BCM	No indication	NG	UNKWN	UNKWN	—	—	—	UNKWN	—	—	UNKWN	—	CAN COMM CIRCUIT (U1000)	—
METER	No indication	—	UNKWN	UNKWN	UNKWN	—	UNKWN	—	—	UNKWN	UNKWN	UNKWN	CAN COMM CIRCUIT (U1000)	—
ALL MODE AWD/4WD	No indication	—	UNKWN	UNKWN	UNKWN	UNKWN	—	—	—	UNKWN	—	—	CAN COMM CIRCUIT (U1000)	—
ABS	—	NG	UNKWN	—	UNKWN	—	—	—	—	—	—	—	CAN COMM CIRCUIT (U1000)	—
IPDM E/R	No indication	—	UNKWN	UNKWN	—	—	UNKWN	—	—	—	—	—	CAN COMM CIRCUIT (U1000)	—

PKIC5702E

CAN SYSTEM (TYPE 9)

[CAN]

CAN SYSTEM (TYPE 9)

PF2:23710

Component Parts and Harness Connector Location

UKS0051W

A

Refer to [LAN-25, "Component Parts and Harness Connector Location"](#) .

Schematic

UKS0051X

B

Refer to [LAN-26, "Schematic"](#) .

Wiring Diagram — CAN —

UKS0051Y

C

Refer to [LAN-27, "Wiring Diagram — CAN —"](#) .

D

E

F

G

H

I

J

LAN

L

M

CAN SYSTEM (TYPE 9)

[CAN]

UKS0051Z

Check Sheet

NOTE:

If a check mark is put on "NG" on "INITIAL DIAG (Initial diagnosis)", replace the control unit.

Check sheet table														
SELECT SYSTEM screen		CAN DIAG SUPPORT MNTR										SELF-DIAG RESULTS		
		Initial diagnosis	Transmit diagnosis	Receive diagnosis										IPDM E/R
				ECM	TCM	STRG	BCM /SEC	METER /M&A	AWD/4WD	VDC/TCS /ABS				
ENGINE	—	—	UNKWN	—	UNKWN	—	UNKWN	UNKWN	UNKWN	UNKWN	UNKWN	UNKWN	CAN COMM CIRCUIT (U1000)	CAN COMM CIRCUIT (U1001)
A/T	—	NG	UNKWN	UNKWN	—	—	—	UNKWN	UNKWN	UNKWN	—	—	CAN COMM CIRCUIT (U1000)	—
BCM	No indication	NG	UNKWN	UNKWN	—	—	—	UNKWN	—	—	UNKWN	—	CAN COMM CIRCUIT (U1000)	—
METER	No indication	—	UNKWN	UNKWN	UNKWN	—	UNKWN	—	—	UNKWN	UNKWN	—	CAN COMM CIRCUIT (U1000)	—
ALL MODE AWD/4WD	No indication	—	UNKWN	UNKWN	UNKWN	UNKWN	—	—	—	UNKWN	—	—	CAN COMM CIRCUIT (U1000)	—
AUTO DRIVE POS.	No indication	—	—	—	UNKWN	—	UNKWN	UNKWN	—	—	—	—	CAN COMM CIRCUIT (U1000)	—
ABS	—	NG	UNKWN	UNKWN	UNKWN	UNKWN	—	—	UNKWN	—	—	—	CAN COMM CIRCUIT (U1000)	—
IPDM E/R	No indication	—	UNKWN	UNKWN	—	—	UNKWN	—	—	—	—	—	CAN COMM CIRCUIT (U1000)	—

Symptoms :

Attach copy of
SELECT SYSTEM

Attach copy of
SELECT SYSTEM

PKIC5703E

CAN SYSTEM (TYPE 9)

[CAN]

Attach copy of ENGINE SELF-DIAG RESULTS	Attach copy of A/T SELF-DIAG RESULTS	Attach copy of BCM SELF-DIAG RESULTS	Attach copy of METER SELF-DIAG RESULTS
Attach copy of ALL MODE AWD/4WD SELF-DIAG RESULTS	Attach copy of AUTO DRIVE POS. SELF-DIAG RESULTS	Attach copy of ABS SELF-DIAG RESULTS	Attach copy of IPDM E/R SELF-DIAG RESULTS
Attach copy of ENGINE CAN DIAG SUPPORT MNTR	Attach copy of A/T CAN DIAG SUPPORT MNTR	Attach copy of BCM CAN DIAG SUPPORT MNTR	Attach copy of METER CAN DIAG SUPPORT MNTR
Attach copy of ALL MODE AWD/4WD CAN DIAG SUPPORT MNTR	Attach copy of AUTO DRIVE POS. CAN DIAG SUPPORT MNTR	Attach copy of ABS CAN DIAG SUPPORT MNTR	Attach copy of IPDM E/R CAN DIAG SUPPORT MNTR

A
B
C
D
E
F
G
H
I
J
L
M

LAN

PKIC7067E

CAN SYSTEM (TYPE 9)

[CAN]

CHECK SHEET RESULTS (EXAMPLE)

NOTE:

If a check mark is put on "NG" on "INITIAL DIAG (Initial diagnosis)", replace the control unit.

Case 1

Check harness between TCM and data link connector. Refer to [LAN-195, "Inspection Between TCM and Data Link Connector Circuit"](#).

SELECT SYSTEM screen		CAN DIAG SUPPORT MNTR										SELF-DIAG RESULTS		
		Initial diagnosis	Transmit diagnosis	Receive diagnosis										
				ECM	TCM	STRG	BCM /SEC	METER /M&A	AWD/4WD	VDC/TCS /ABS	IPDM E/R			
ENGINE	—	—	UNKWN	—	UNKWN	—	UNKWN	UNKWN	UNKWN	UNKWN	UNKWN	UNKWN	CAN COMM CIRCUIT (U1000)	CAN COMM CIRCUIT (U001)
A/T	—	NG	UNKWN	UNKWN	—	—	—	UNKWN	UNKWN	UNKWN	UNKWN	—	CAN COMM CIRCUIT (U1000)	—
BCM	No indication	NG	UNKWN	UNKWN	—	—	—	UNKWN	—	—	UNKWN	UNKWN	CAN COMM CIRCUIT (U1000)	—
METER	No indication	—	UNKWN	UNKWN	UNKWN	—	UNKWN	—	—	—	UNKWN	UNKWN	CAN COMM CIRCUIT (U1000)	—
ALL MODE AWD/4WD	No indication	—	UNKWN	UNKWN	UNKWN	—	—	—	—	—	UNKWN	—	CAN COMM CIRCUIT (U1000)	—
AUTO DRIVE POS.	No indication	—	—	—	UNKWN	—	UNKWN	UNKWN	—	—	—	—	CAN COMM CIRCUIT (U1000)	—
ABS	—	NG	UNKWN	UNKWN	UNKWN	—	—	UNKWN	—	—	UNKWN	—	CAN COMM CIRCUIT (U1000)	—
IPDM E/R	No indication	—	UNKWN	UNKWN	—	—	UNKWN	—	—	—	—	—	CAN COMM CIRCUIT (U1000)	—

PKIC5704E

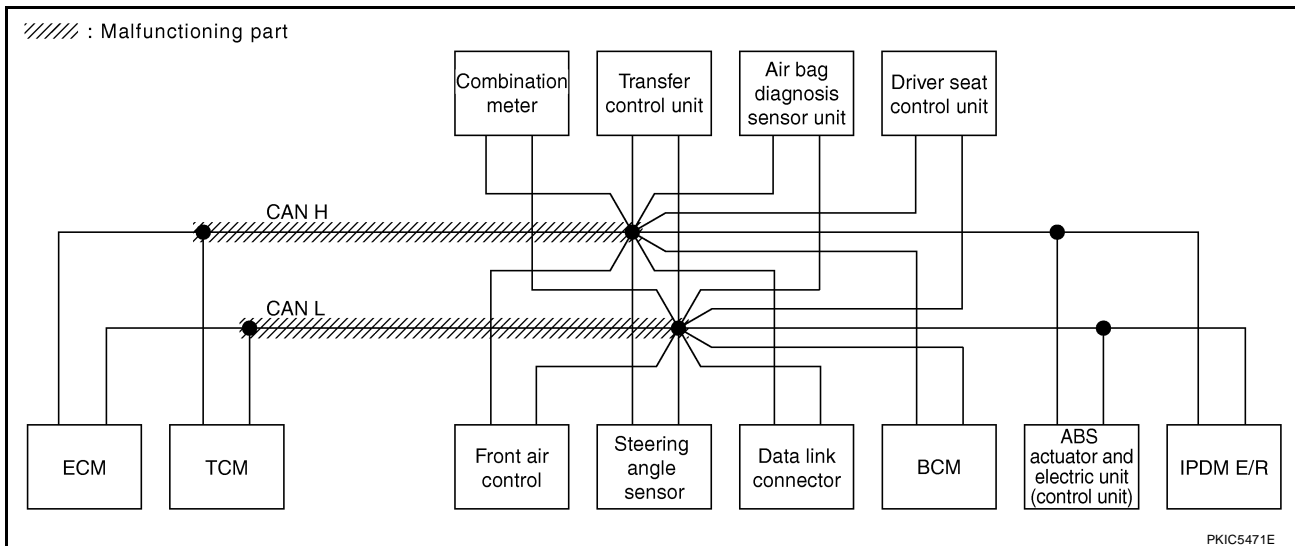

PKIC5471E

CAN SYSTEM (TYPE 9)

[CAN]

Case 2

Check harness between data link connector and ABS actuator and electric unit (control unit). Refer to [LAN-196, "Inspection Between Data Link Connector and ABS Actuator and Electric Unit \(Control Unit\) Circuit"](#).

SELECT SYSTEM screen		CAN DIAG SUPPORT MNTR										SELF-DIAG RESULTS		
		Initial diagnosis	Transmit diagnosis	Receive diagnosis										
				ECM	TCM	STRG	BCM /SEC	METER /M&A	AWD/4WD	VDC/TCS /ABS	IPDM E/R			
ENGINE	—	—	UNKWN	—	UNKWN	—	UNKWN	UNKWN	UNKWN	UNKWN	UNKWN	UNKWN	CAN COMM CIRCUIT (U1000)	CAN COMM CIRCUIT (U1001)
A/T	—	NG	UNKWN	UNKWN	—	—	—	UNKWN	UNKWN	UNKWN	UNKWN	UNKWN	CAN COMM CIRCUIT (U1000)	—
BCM	No indication	NG	UNKWN	UNKWN	—	—	—	UNKWN	—	—	—	UNKWN	CAN COMM CIRCUIT (U1000)	—
METER	No indication	—	UNKWN	UNKWN	UNKWN	—	UNKWN	—	—	—	UNKWN	UNKWN	CAN COMM CIRCUIT (U1000)	—
ALL MODE AWD/4WD	No indication	—	UNKWN	UNKWN	UNKWN	UNKWN	—	—	—	—	UNKWN	—	CAN COMM CIRCUIT (U1000)	—
AUTO DRIVE POS.	No indication	—	—	—	UNKWN	—	UNKWN	UNKWN	—	—	—	—	CAN COMM CIRCUIT (U1000)	—
ABS	—	NG	UNKWN	UNKWN	UNKWN	UNKWN	—	—	UNKWN	—	—	—	CAN COMM CIRCUIT (U1000)	—
IPDM E/R	No indication	—	UNKWN	UNKWN	—	—	UNKWN	—	—	—	—	—	CAN COMM CIRCUIT (U1000)	—

PKIC5706E

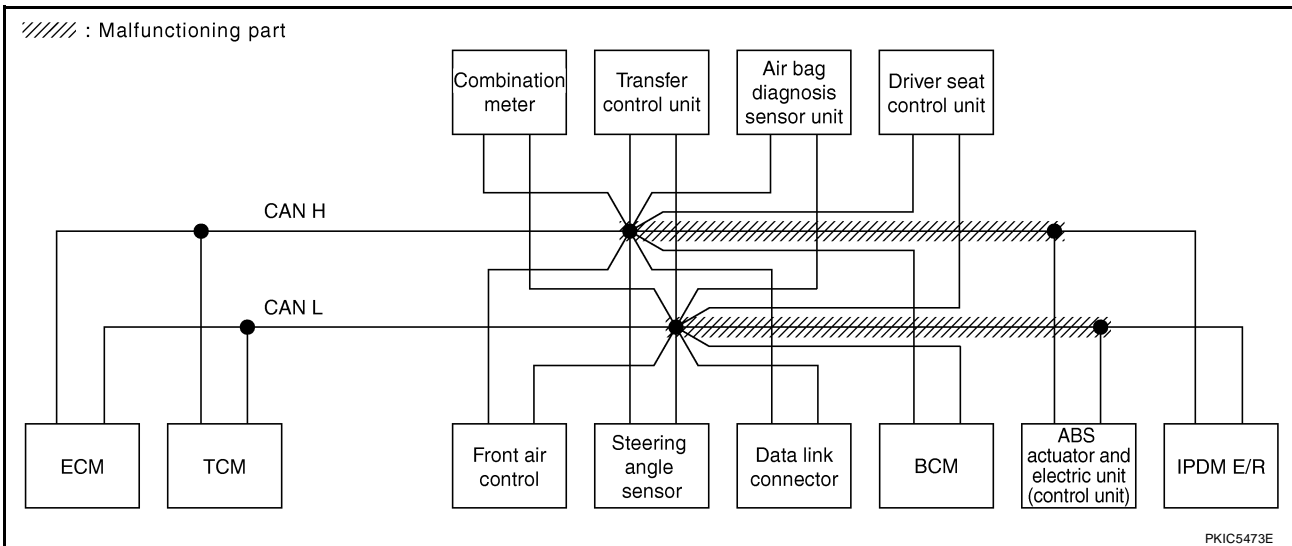

CAN SYSTEM (TYPE 9)

[CAN]

Case 3

Check ECM circuit. Refer to [LAN-197, "ECM Circuit Inspection"](#) .

SELECT SYSTEM screen		CAN DIAG SUPPORT MNTR										SELF-DIAG RESULTS		
		Initial diagnosis	Transmit diagnosis	Receive diagnosis										
				ECM	TCM	STRG	BCM /SEC	METER /M&A	AWD/4WD	VDC/TCS /ABS	IPDM E/R			
ENGINE	—	—	UNKWN	—	UNKWN	—	UNKWN	UNKWN	UNKWN	UNKWN	UNKWN	UNKWN	CAN COMM CIRCUIT (U000)	CAN COMM CIRCUIT (U001)
A/T	—	NG	UNKWN	UNKWN	—	—	—	UNKWN	UNKWN	UNKWN	—	—	CAN COMM CIRCUIT (U000)	—
BCM	No indication	NG	UNKWN	UNKWN	—	—	—	UNKWN	—	—	UNKWN	—	CAN COMM CIRCUIT (U1000)	—
METER	No indication	—	UNKWN	UNKWN	—	—	—	UNKWN	—	—	UNKWN	UNKWN	CAN COMM CIRCUIT (U000)	—
ALL MODE AWD/4WD	No indication	—	UNKWN	UNKWN	UNKWN	—	—	—	—	—	UNKWN	—	CAN COMM CIRCUIT (U000)	—
AUTO DRIVE POS.	No indication	—	—	—	UNKWN	—	—	UNKWN	UNKWN	—	—	—	CAN COMM CIRCUIT (U1000)	—
ABS	—	NG	UNKWN	UNKWN	UNKWN	—	—	—	—	UNKWN	—	—	CAN COMM CIRCUIT (U000)	—
IPDM E/R	No indication	—	UNKWN	UNKWN	—	—	—	—	—	—	—	—	CAN COMM CIRCUIT (U000)	—

PKIC5707E

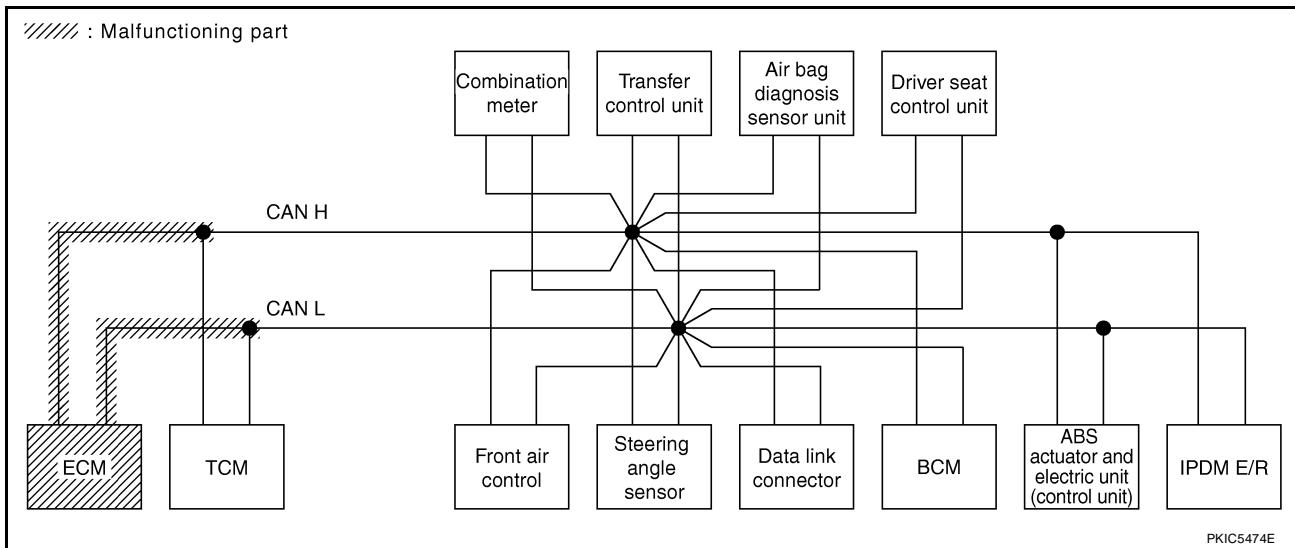

PKIC5474E

CAN SYSTEM (TYPE 9)

[CAN]

Case 4

Check TCM circuit. Refer to [LAN-197, "TCM Circuit Inspection"](#) .

SELECT SYSTEM screen		CAN DIAG SUPPORT MNTR										SELF-DIAG RESULTS		
		Initial diagnosis	Transmit diagnosis	Receive diagnosis										
				ECM	TCM	STRG	BCM /SEC	METER /M&A	AWD/4WD	VDC/TCS /ABS	IPDM E/R			
ENGINE	—	—	UNKWN	—	UNKWN	—	UNKWN	UNKWN	UNKWN	UNKWN	UNKWN	UNKWN	CAN COMM CIRCUIT (U100)	CAN COMM CIRCUIT (U101)
A/T	—	NG	UNKWN	UNKWN	—	—	—	UNKWN	UNKWN	UNKWN	—	—	CAN COMM CIRCUIT (U100)	—
BCM	No indication	NG	UNKWN	UNKWN	—	—	—	UNKWN	—	—	UNKWN	UNKWN	CAN COMM CIRCUIT (U1000)	—
METER	No indication	—	UNKWN	UNKWN	UNKWN	—	UNKWN	—	—	UNKWN	UNKWN	UNKWN	CAN COMM CIRCUIT (U100)	—
ALL MODE AWD/4WD	No indication	—	UNKWN	UNKWN	UNKWN	UNKWN	—	—	—	UNKWN	—	—	CAN COMM CIRCUIT (U100)	—
AUTO DRIVE POS.	No indication	—	—	—	UNKWN	—	UNKWN	UNKWN	—	—	—	—	CAN COMM CIRCUIT (U100)	—
ABS	—	NG	UNKWN	UNKWN	UNKWN	UNKWN	—	—	UNKWN	—	—	—	CAN COMM CIRCUIT (U100)	—
IPDM E/R	No indication	—	UNKWN	UNKWN	—	—	UNKWN	—	—	—	—	—	CAN COMM CIRCUIT (U1000)	—

PKIC5708E

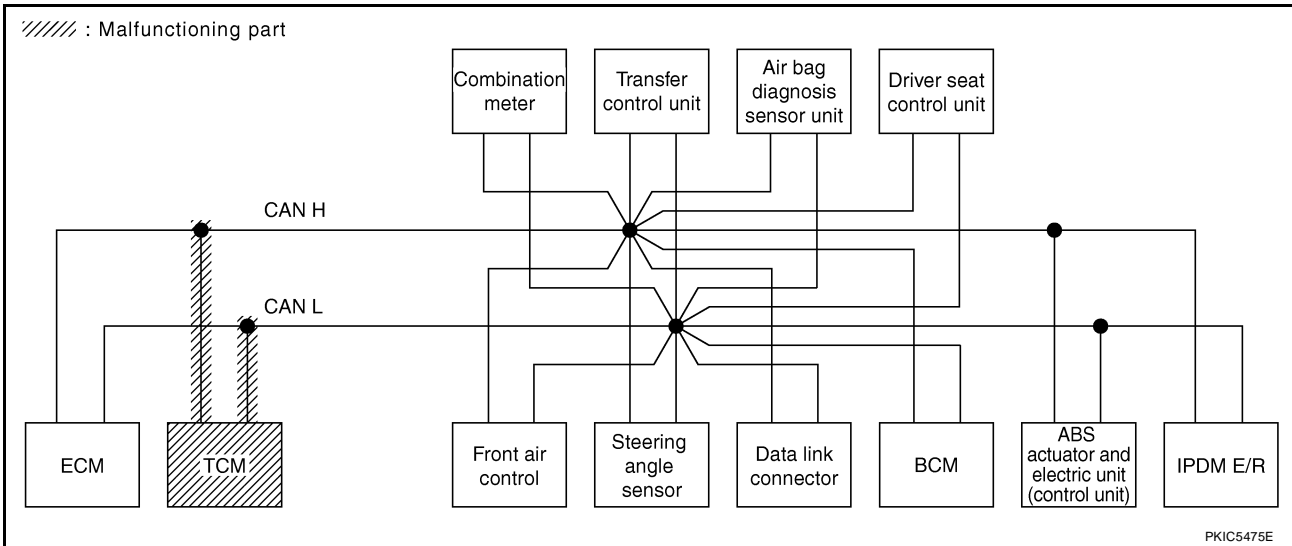

CAN SYSTEM (TYPE 9)

[CAN]

Case 5

Check steering angle sensor circuit. Refer to [LAN-199, "Steering Angle Sensor Circuit Inspection"](#) .

SELECT SYSTEM screen		CAN DIAG SUPPORT MNTR										SELF-DIAG RESULTS	
		Initial diagnosis	Transmit diagnosis	Receive diagnosis									
				ECM	TCM	STRG	BCM /SEC	METER /M&A	AWD/4WD	VDC/TCS /ABS	IPDM E/R		
ENGINE	—	—	UNKWN	—	UNKWN	—	UNKWN	UNKWN	UNKWN	UNKWN	UNKWN	CAN COMM CIRCUIT (U1000)	CAN COMM CIRCUIT (U1001)
A/T	—	NG	UNKWN	UNKWN	—	—	—	UNKWN	UNKWN	UNKWN	—	CAN COMM CIRCUIT (U1000)	—
BCM	No indication	NG	UNKWN	UNKWN	—	—	—	UNKWN	—	—	UNKWN	CAN COMM CIRCUIT (U1000)	—
METER	No indication	—	UNKWN	UNKWN	UNKWN	—	UNKWN	—	—	UNKWN	UNKWN	CAN COMM CIRCUIT (U1000)	—
ALL MODE AWD/4WD	No indication	—	UNKWN	UNKWN	UNKWN	✓	—	—	—	UNKWN	—	CAN COMM CIRCUIT (U1000)	—
AUTO DRIVE POS.	No indication	—	—	—	UNKWN	—	UNKWN	UNKWN	—	—	—	CAN COMM CIRCUIT (U1000)	—
ABS	—	NG	UNKWN	UNKWN	UNKWN	✓	—	—	UNKWN	—	—	CAN COMM CIRCUIT (U1000)	—
IPDM E/R	No indication	—	UNKWN	UNKWN	—	—	UNKWN	—	—	—	—	CAN COMM CIRCUIT (U1000)	—

PKIC5709E

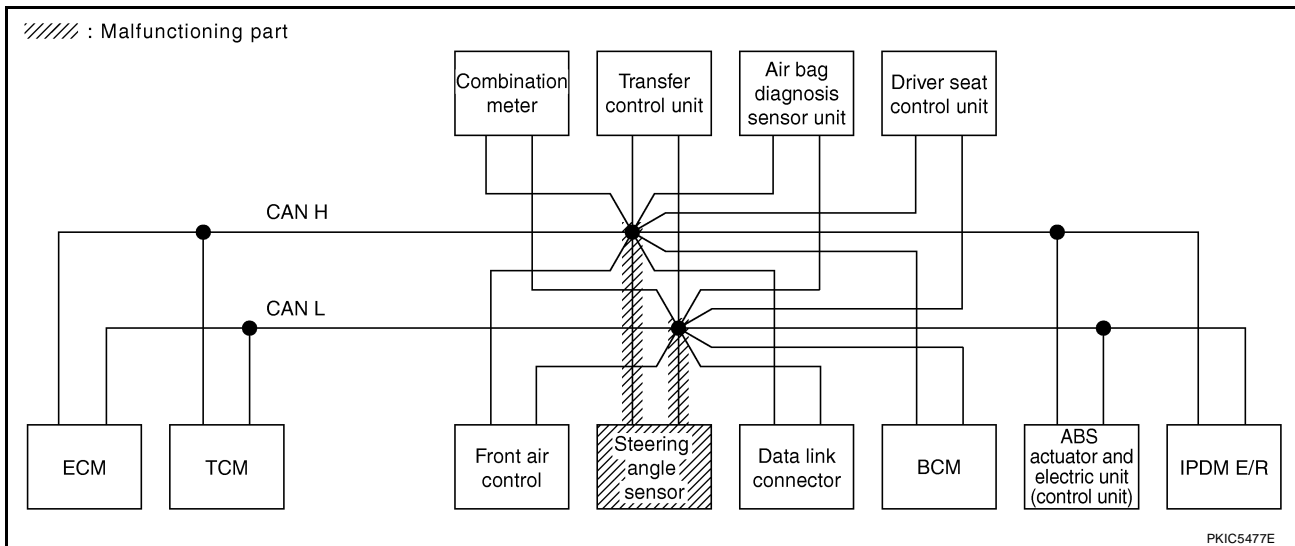

PKIC5477E

CAN SYSTEM (TYPE 9)

[CAN]

Case 6

Check data link connector circuit. Refer to [LAN-199, "Data Link Connector Circuit Inspection"](#) .

SELECT SYSTEM screen		CAN DIAG SUPPORT MNTR										SELF-DIAG RESULTS	
		Initial diagnosis	Transmit diagnosis	Receive diagnosis									
				ECM	TCM	STRG	BCM /SEC	METER /M&A	AWD/4WD	VDC/TCS /ABS	IPDM E/R		
ENGINE	—	—	UNKWN	—	UNKWN	—	UNKWN	UNKWN	UNKWN	UNKWN	UNKWN	CAN COMM CIRCUIT (U1000)	CAN COMM CIRCUIT (U1001)
A/T	—	NG	UNKWN	UNKWN	—	—	—	UNKWN	UNKWN	UNKWN	—	CAN COMM CIRCUIT (U1000)	—
BCM	No indication	NG	UNKWN	UNKWN	—	—	—	UNKWN	—	—	UNKWN	CAN COMM CIRCUIT (U1000)	—
METER	No indication	—	UNKWN	UNKWN	UNKWN	—	UNKWN	—	—	UNKWN	UNKWN	CAN COMM CIRCUIT (U1000)	—
ALL MODE AWD/4WD	No indication	—	UNKWN	UNKWN	UNKWN	UNKWN	—	—	—	UNKWN	—	CAN COMM CIRCUIT (U1000)	—
AUTO DRIVE POS.	No indication	—	—	—	UNKWN	—	UNKWN	UNKWN	—	—	—	CAN COMM CIRCUIT (U1000)	—
ABS	—	NG	UNKWN	UNKWN	UNKWN	UNKWN	—	—	UNKWN	—	—	CAN COMM CIRCUIT (U1000)	—
IPDM E/R	No indication	—	UNKWN	UNKWN	—	—	UNKWN	—	—	—	—	CAN COMM CIRCUIT (U1000)	—

PKIC5710E

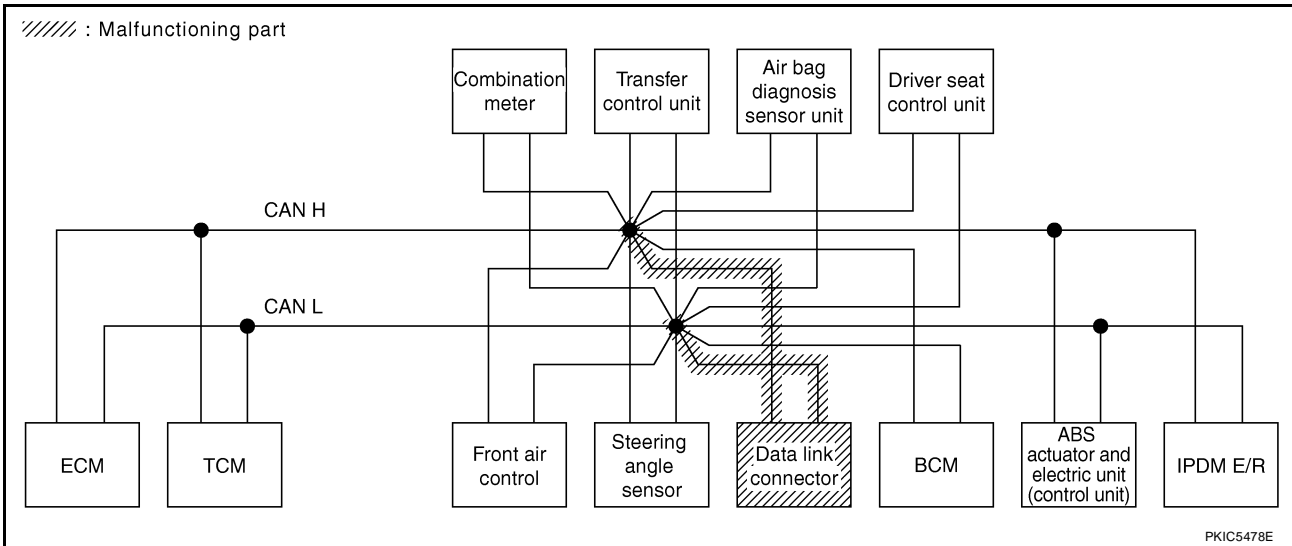

PKIC5478E

CAN SYSTEM (TYPE 9)

[CAN]

Case 7

Check BCM circuit. Refer to [LAN-200, "BCM Circuit Inspection"](#) .

SELECT SYSTEM screen		CAN DIAG SUPPORT MNTR										SELF-DIAG RESULTS	
		Initial diagnosis	Transmit diagnosis	Receive diagnosis									
				ECM	TCM	STRG	BCM /SEC	METER /M&A	AWD/4WD	VDC/TCS /ABS	IPDM E/R		
ENGINE	—	—	UNKWN	—	UNKWN	—	UNKWN	UNKWN	UNKWN	UNKWN	UNKWN	CAN COMM CIRCUIT (U1000)	CAN COMM CIRCUIT (U1001) ✓
A/T	—	NG	UNKWN	UNKWN	—	—	—	UNKWN	UNKWN	UNKWN	—	CAN COMM CIRCUIT (U1000)	—
BCM	No indication ✓	NG	UNKWN	UNKWN	—	—	—	UNKWN	—	—	UNKWN	CAN COMM CIRCUIT (U1000)	—
METER	No indication	—	UNKWN	UNKWN	UNKWN	—	UNKWN	—	—	UNKWN	UNKWN	CAN COMM CIRCUIT (U1000)	—
ALL MODE AWD/4WD	No indication	—	UNKWN	UNKWN	UNKWN	UNKWN	—	—	—	UNKWN	—	CAN COMM CIRCUIT (U1000)	—
AUTO DRIVE POS.	No indication	—	—	—	UNKWN	—	UNKWN	UNKWN	—	—	—	CAN COMM CIRCUIT (U1000)	—
ABS	—	NG	UNKWN	UNKWN	UNKWN	UNKWN	—	—	UNKWN	—	—	CAN COMM CIRCUIT (U1000)	—
IPDM E/R	No indication	—	UNKWN	UNKWN	—	—	UNKWN	—	—	—	—	CAN COMM CIRCUIT (U1000)	—

PKIC5711E

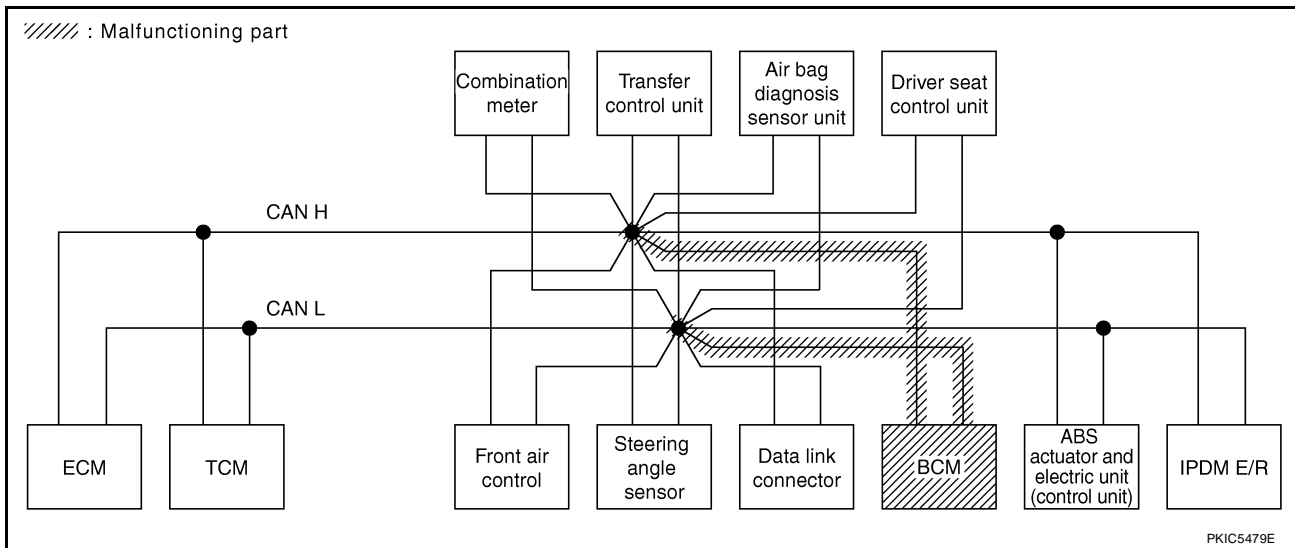

CAN SYSTEM (TYPE 9)

[CAN]

Case 8

Check combination meter circuit. Refer to [LAN-200, "Combination Meter Circuit Inspection"](#).

SELECT SYSTEM screen		CAN DIAG SUPPORT MNTR										SELF-DIAG RESULTS	
		Initial diagnosis	Transmit diagnosis	Receive diagnosis									
				ECM	TCM	STRG	BCM /SEC	METER /M&A	AWD/4WD	VDC/TCS /ABS	IPDM E/R		
ENGINE	—	—	UNKWN	—	UNKWN	—	UNKWN	UNKWN	UNKWN	UNKWN	UNKWN	CAN COMM CIRCUIT (U1000)	CAN COMM CIRCUIT (U1001)
A/T	—	NG	UNKWN	UNKWN	—	—	—	UNKWN	UNKWN	UNKWN	—	CAN COMM CIRCUIT (U1000)	—
BCM	No indication	NG	UNKWN	UNKWN	—	—	—	UNKWN	—	—	UNKWN	CAN COMM CIRCUIT (U1000)	—
METER	No indication	—	UNKWN	UNKWN	UNKWN	—	UNKWN	—	—	UNKWN	UNKWN	CAN COMM CIRCUIT (U1000)	—
ALL MODE AWD/4WD	No indication	—	UNKWN	UNKWN	UNKWN	UNKWN	—	—	—	UNKWN	—	CAN COMM CIRCUIT (U1000)	—
AUTO DRIVE POS.	No indication	—	—	—	UNKWN	—	UNKWN	UNKWN	—	—	—	CAN COMM CIRCUIT (U1000)	—
ABS	—	NG	UNKWN	UNKWN	UNKWN	UNKWN	—	—	UNKWN	—	—	CAN COMM CIRCUIT (U1000)	—
IPDM E/R	No indication	—	UNKWN	UNKWN	—	—	UNKWN	—	—	—	—	CAN COMM CIRCUIT (U1000)	—

PKIC5712E

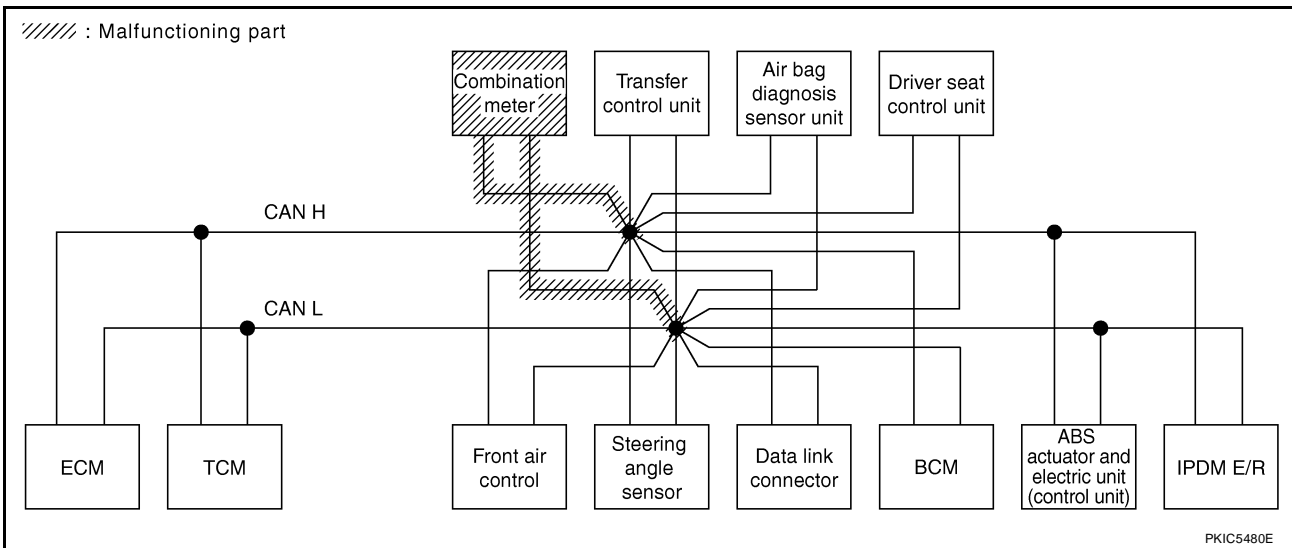

CAN SYSTEM (TYPE 9)

[CAN]

Case 9

Check transfer control unit circuit. Refer to [LAN-201, "Transfer Control Unit Circuit Inspection"](#) .

SELECT SYSTEM screen		CAN DIAG SUPPORT MNTR										SELF-DIAG RESULTS	
		Initial diagnosis	Transmit diagnosis	Receive diagnosis									
				ECM	TCM	STRG	BCM /SEC	METER /M&A	AWD/4WD	VDC/TCS /ABS	IPDM E/R		
ENGINE	—	—	UNKWN	—	UNKWN	—	UNKWN	UNKWN	UNKWN	UNKWN	UNKWN	CAN COMM CIRCUIT (U1000)	CAN COMM CIRCUIT (U001)
A/T	—	NG	UNKWN	UNKWN	—	—	—	UNKWN	UNKWN	UNKWN	—	CAN COMM CIRCUIT (U000)	—
BCM	No indication	NG	UNKWN	UNKWN	—	—	—	UNKWN	—	—	UNKWN	CAN COMM CIRCUIT (U1000)	—
METER	No indication	—	UNKWN	UNKWN	UNKWN	—	UNKWN	—	—	UNKWN	UNKWN	CAN COMM CIRCUIT (U1000)	—
ALL MODE AWD/4WD	No indication	—	UNKWN	UNKWN	UNKWN	UNKWN	—	—	—	UNKWN	—	CAN COMM CIRCUIT (U000)	—
AUTO DRIVE POS.	No indication	—	—	—	UNKWN	—	UNKWN	UNKWN	—	—	—	CAN COMM CIRCUIT (U1000)	—
ABS	—	NG	UNKWN	UNKWN	UNKWN	UNKWN	—	—	UNKWN	—	—	CAN COMM CIRCUIT (U000)	—
IPDM E/R	No indication	—	UNKWN	UNKWN	—	—	UNKWN	—	—	—	—	CAN COMM CIRCUIT (U1000)	—

PKIC5713E

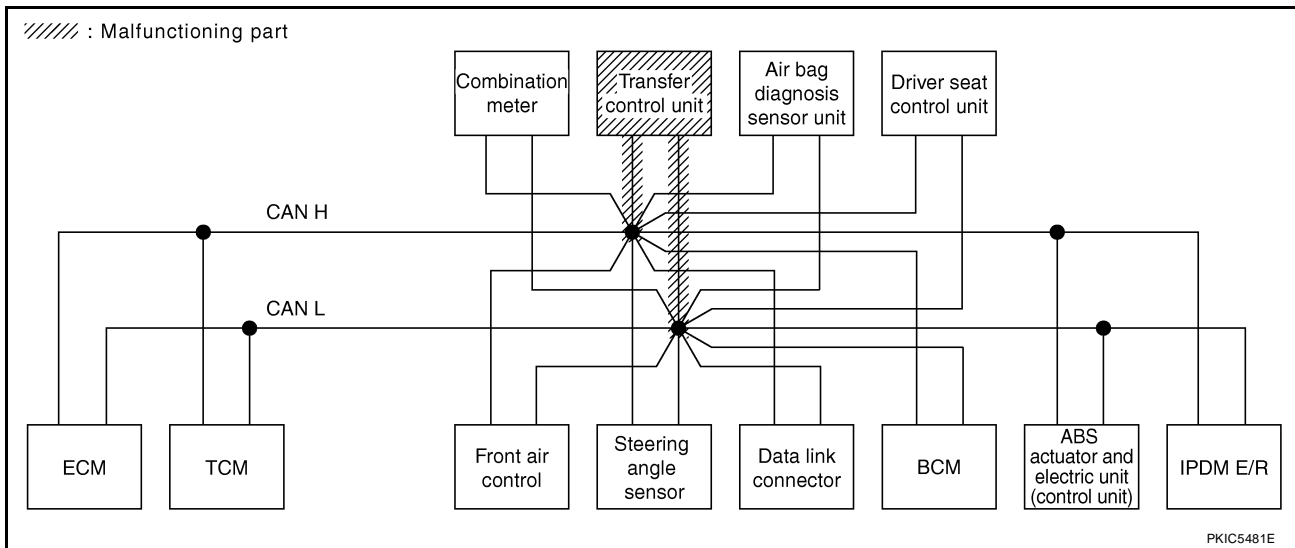

Case 10

Check driver seat control unit circuit. Refer to [LAN-202, "Driver Seat Control Unit Circuit Inspection"](#) .

SELECT SYSTEM screen		CAN DIAG SUPPORT MNTR										SELF-DIAG RESULTS	
		Initial diagnosis	Transmit diagnosis	Receive diagnosis									
				ECM	TCM	STRG	BCM /SEC	METER /M&A	AWD/4WD	VDC/TCS /ABS	IPDM E/R		
ENGINE	—	—	UNKWN	—	UNKWN	—	UNKWN	UNKWN	UNKWN	UNKWN	UNKWN	CAN COMM CIRCUIT (U1000)	CAN COMM CIRCUIT (U1001)
A/T	—	NG	UNKWN	UNKWN	—	—	—	UNKWN	UNKWN	UNKWN	—	CAN COMM CIRCUIT (U1000)	—
BCM	No indication	NG	UNKWN	UNKWN	—	—	—	UNKWN	—	—	UNKWN	CAN COMM CIRCUIT (U1000)	—
METER	No indication	—	UNKWN	UNKWN	UNKWN	—	UNKWN	—	—	UNKWN	UNKWN	CAN COMM CIRCUIT (U1000)	—
ALL MODE AWD/4WD	No indication	—	UNKWN	UNKWN	UNKWN	UNKWN	—	—	—	UNKWN	—	CAN COMM CIRCUIT (U1000)	—
AUTO DRIVE POS.	No indication	—	—	—	UNKWN	—	UNKWN	UNKWN	—	—	—	CAN COMM CIRCUIT (U1000)	—
ABS	—	NG	UNKWN	UNKWN	UNKWN	UNKWN	—	—	UNKWN	—	—	CAN COMM CIRCUIT (U1000)	—
IPDM E/R	No indication	—	UNKWN	UNKWN	—	—	UNKWN	—	—	—	—	CAN COMM CIRCUIT (U1000)	—

PKIC5714E

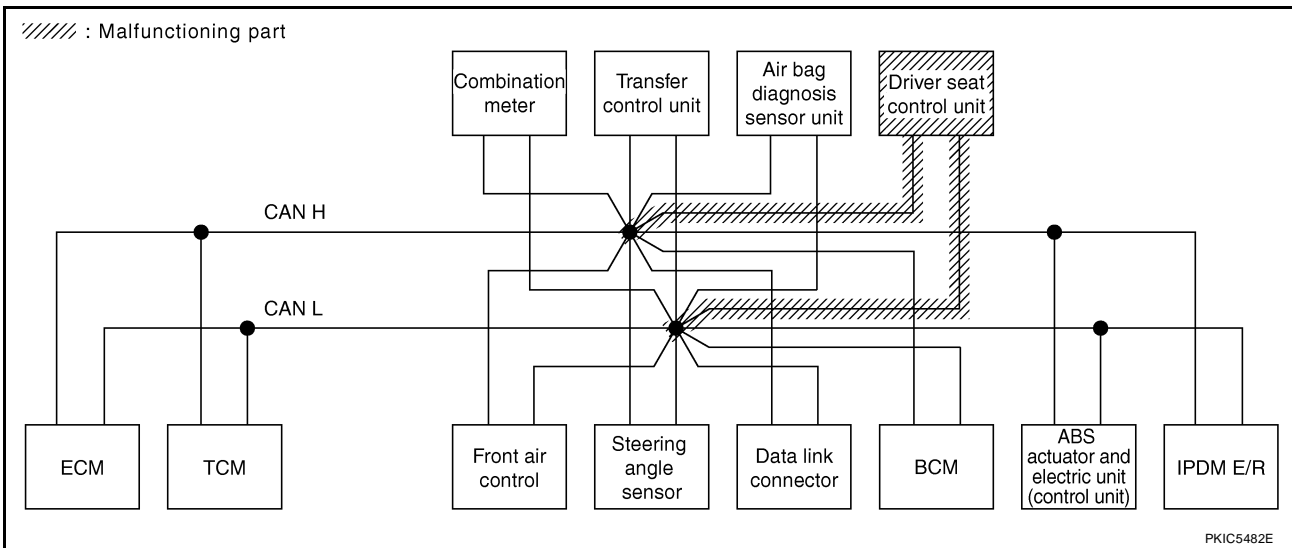

CAN SYSTEM (TYPE 9)

[CAN]

Case 11

Check ABS actuator and electric unit (control unit) circuit. Refer to [LAN-202, "ABS Actuator and Electric Unit \(Control Unit\) Circuit Inspection"](#) .

SELECT SYSTEM screen		CAN DIAG SUPPORT MNTR										SELF-DIAG RESULTS		
		Initial diagnosis	Transmit diagnosis	Receive diagnosis										IPDM E/R
				ECM	TCM	STRG	BCM /SEC	METER /M&A	AWD/4WD	VDC/TCS /ABS				
ENGINE	—	—	UNKWN	—	UNKWN	—	UNKWN	UNKWN	UNKWN	UNKWN	UNKWN	UNKWN	CAN COMM CIRCUIT (U1000)	CAN COMM CIRCUIT (U1001)
A/T	—	NG	UNKWN	UNKWN	—	—	—	UNKWN	UNKWN	UNKWN	UNKWN	—	CAN COMM CIRCUIT (U1000)	—
BCM	No indication	NG	UNKWN	UNKWN	—	—	—	UNKWN	—	—	UNKWN	UNKWN	CAN COMM CIRCUIT (U1000)	—
METER	No indication	—	UNKWN	UNKWN	UNKWN	—	UNKWN	—	—	UNKWN	UNKWN	UNKWN	CAN COMM CIRCUIT (U1000)	—
ALL MODE AWD/4WD	No indication	—	UNKWN	UNKWN	UNKWN	UNKWN	—	—	—	UNKWN	UNKWN	UNKWN	CAN COMM CIRCUIT (U1000)	—
AUTO DRIVE POS.	No indication	—	—	—	UNKWN	—	UNKWN	UNKWN	—	—	—	—	CAN COMM CIRCUIT (U1000)	—
ABS	—	✓	✓	✓	✓	✓	—	—	—	✓	—	—	CAN COMM CIRCUIT (U1000)	—
IPDM E/R	No indication	—	UNKWN	UNKWN	—	—	UNKWN	—	—	—	—	—	CAN COMM CIRCUIT (U1000)	—

PKIC5715E

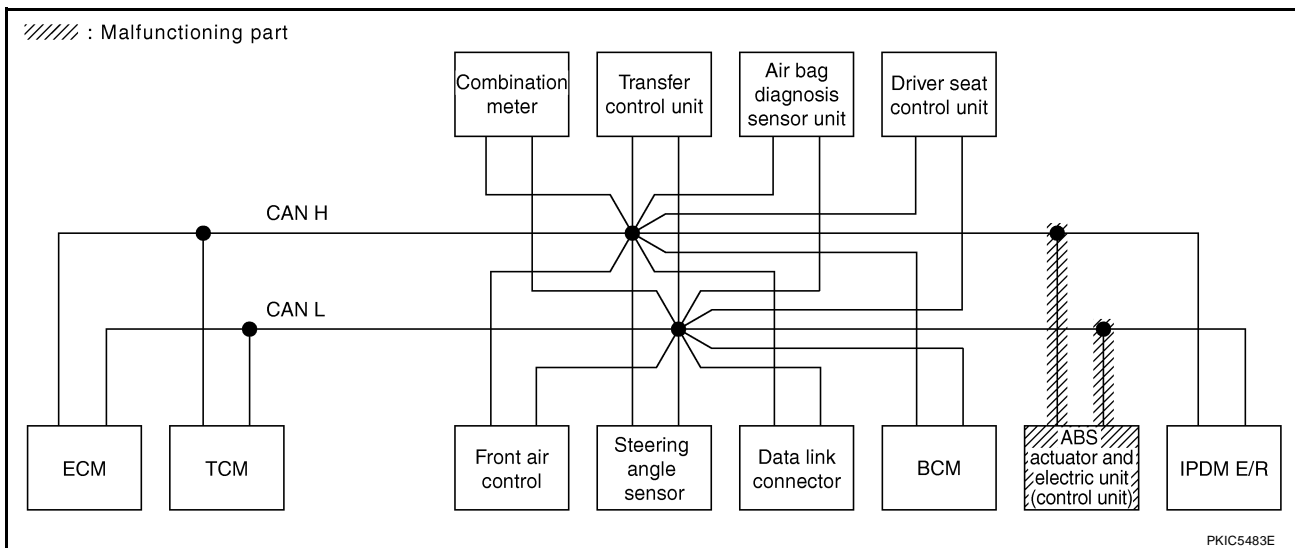

Case 12

Check IPDM E/R circuit. Refer to [LAN-203, "IPDM E/R Circuit Inspection"](#) .

SELECT SYSTEM screen		CAN DIAG SUPPORT MNTR										SELF-DIAG RESULTS		
		Initial diagnosis	Transmit diagnosis	Receive diagnosis										
				ECM	TCM	STRG	BCM /SEC	METER /M&A	AWD/4WD	VDC/TCS /ABS	IPDM E/R			
ENGINE	—	—	UNKWN	—	UNKWN	—	UNKWN	UNKWN	UNKWN	UNKWN	UNKWN	UNKWN	CAN COMM CIRCUIT (U1000)	CAN COMM CIRCUIT (U1001)
A/T	—	NG	UNKWN	UNKWN	—	—	—	UNKWN	UNKWN	UNKWN	—	—	CAN COMM CIRCUIT (U1000)	—
BCM	No indication	NG	UNKWN	UNKWN	—	—	—	UNKWN	—	—	UNKWN	UNKWN	CAN COMM CIRCUIT (U1000)	—
METER	No indication	—	UNKWN	UNKWN	UNKWN	—	UNKWN	—	—	UNKWN	UNKWN	UNKWN	CAN COMM CIRCUIT (U1000)	—
ALL MODE AWD/4WD	No indication	—	UNKWN	UNKWN	UNKWN	UNKWN	—	—	—	UNKWN	—	—	CAN COMM CIRCUIT (U1000)	—
AUTO DRIVE POS.	No indication	—	—	—	UNKWN	—	UNKWN	UNKWN	—	—	—	—	CAN COMM CIRCUIT (U1000)	—
ABS	—	NG	UNKWN	UNKWN	UNKWN	UNKWN	—	—	UNKWN	—	—	—	CAN COMM CIRCUIT (U1000)	—
IPDM E/R	No indication	—	UNKWN	UNKWN	—	—	UNKWN	—	—	—	—	—	CAN COMM CIRCUIT (U1000)	—

PKIC5716E

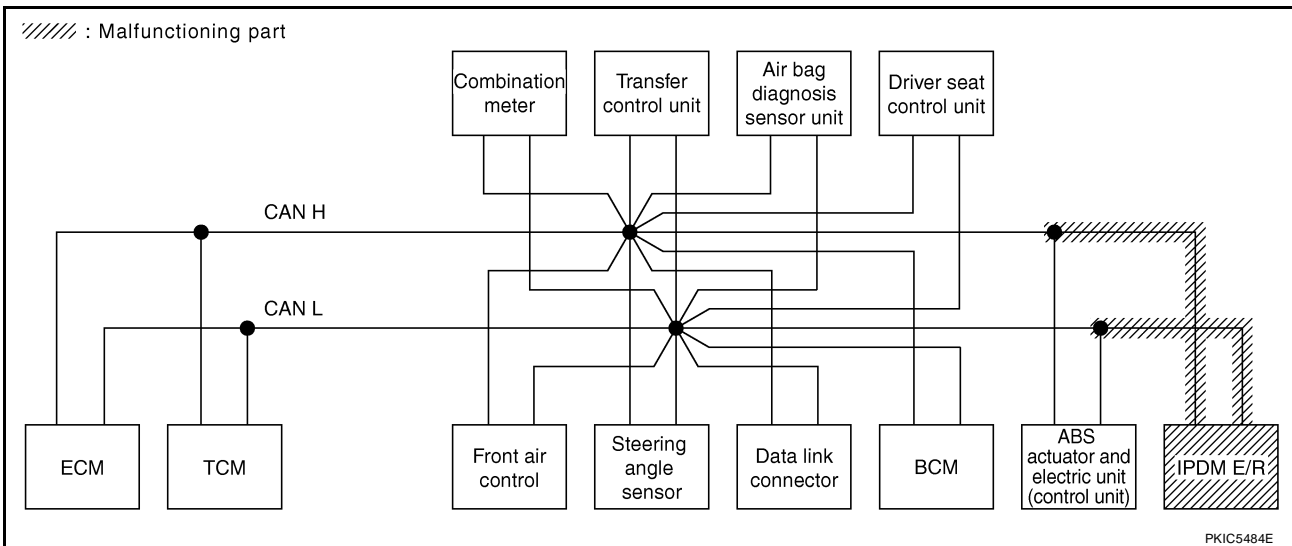

Case 13

Check CAN communication circuit. Refer to [LAN-203, "CAN Communication Circuit Inspection"](#) .

SELECT SYSTEM screen		CAN DIAG SUPPORT MNTR										SELF-DIAG RESULTS		
		Initial diagnosis	Transmit diagnosis	Receive diagnosis										
				ECM	TCM	STRG	BCM /SEC	METER /M&A	AWD/4WD	VDC/TCS /ABS	IPDM E/R			
ENGINE	—	—	UNKWN	—	UNKWN	—	UNKWN	UNKWN	UNKWN	UNKWN	UNKWN	UNKWN	CAN COMM CIRCUIT (U1000)	CAN COMM CIRCUIT (U1001)
A/T	—	NG	UNKWN	UNKWN	—	—	—	UNKWN	UNKWN	UNKWN	—	—	CAN COMM CIRCUIT (U1000)	—
BCM	No indication	NG	UNKWN	UNKWN	—	—	—	UNKWN	—	—	UNKWN	UNKWN	CAN COMM CIRCUIT (U1000)	—
METER	No indication	—	UNKWN	UNKWN	UNKWN	—	UNKWN	—	—	UNKWN	UNKWN	UNKWN	CAN COMM CIRCUIT (U1000)	—
ALL MODE AWD/4WD	No indication	—	UNKWN	UNKWN	UNKWN	UNKWN	—	—	—	UNKWN	—	—	CAN COMM CIRCUIT (U1000)	—
AUTO DRIVE POS.	No indication	—	—	—	UNKWN	—	UNKWN	UNKWN	—	—	—	—	CAN COMM CIRCUIT (U1000)	—
ABS	—	NG	UNKWN	UNKWN	UNKWN	UNKWN	—	—	UNKWN	—	—	—	CAN COMM CIRCUIT (U1000)	—
IPDM E/R	No indication	—	UNKWN	UNKWN	—	—	UNKWN	—	—	—	—	—	CAN COMM CIRCUIT (U1000)	—

PKIC5717E

CAN SYSTEM (TYPE 9)

[CAN]

Case 14

Check IPDM E/R ignition relay circuit continuously sticks "OFF". Refer to [LAN-204, "IPDM E/R Ignition Relay Circuit Inspection"](#) .

SELECT SYSTEM screen		CAN DIAG SUPPORT MNTR										SELF-DIAG RESULTS		
		Initial diagnosis	Transmit diagnosis	Receive diagnosis										IPDM E/R
				ECM	TCM	STRG	BCM /SEC	METER /M&A	AWD/4WD	VDC/TCS /ABS				
ENGINE	—	—	UNKWN	—	UNKWN	—	UNKWN	UNKWN	UNKWN	UNKWN	UNKWN	UNKWN	CAN COMM CIRCUIT (U1000)	CAN COMM CIRCUIT (U1001)
A/T	—	NG	UNKWN	UNKWN	—	—	—	UNKWN	UNKWN	UNKWN	—	—	CAN COMM CIRCUIT (U1000)	—
BCM	No indication	NG	UNKWN	UNKWN	—	—	—	UNKWN	—	—	UNKWN	UNKWN	CAN COMM CIRCUIT (U1000)	—
METER	No indication	—	UNKWN	UNKWN	UNKWN	—	UNKWN	—	—	UNKWN	UNKWN	UNKWN	CAN COMM CIRCUIT (U1000)	—
ALL MODE AWD/4WD	No indication	—	UNKWN	UNKWN	UNKWN	UNKWN	—	—	—	UNKWN	—	—	CAN COMM CIRCUIT (U1000)	—
AUTO DRIVE POS.	No indication	—	—	—	UNKWN	—	UNKWN	UNKWN	—	—	—	—	CAN COMM CIRCUIT (U1000)	—
ABS	—	NG	UNKWN	UNKWN	UNKWN	UNKWN	—	—	UNKWN	—	—	—	CAN COMM CIRCUIT (U1000)	—
IPDM E/R	No indication	—	UNKWN	UNKWN	—	—	UNKWN	—	—	—	—	—	CAN COMM CIRCUIT (U1000)	—

PKIC5718E

Case 15

Check IPDM E/R ignition relay circuit continuously sticks "ON". Refer to [LAN-204, "IPDM E/R Ignition Relay Circuit Inspection"](#) .

SELECT SYSTEM screen		CAN DIAG SUPPORT MNTR										SELF-DIAG RESULTS		
		Initial diagnosis	Transmit diagnosis	Receive diagnosis										IPDM E/R
				ECM	TCM	STRG	BCM /SEC	METER /M&A	AWD/4WD	VDC/TCS /ABS				
ENGINE	—	—	UNKWN	—	UNKWN	—	UNKWN	UNKWN	UNKWN	UNKWN	UNKWN	UNKWN	CAN COMM CIRCUIT (U1000)	CAN COMM CIRCUIT (U1001)
A/T	—	NG	UNKWN	—	—	—	—	—	—	UNKWN	—	—	CAN COMM CIRCUIT (U1000)	—
BCM	No indication	NG	UNKWN	UNKWN	—	—	—	UNKWN	—	—	UNKWN	UNKWN	CAN COMM CIRCUIT (U1000)	—
METER	No indication	—	UNKWN	UNKWN	UNKWN	—	UNKWN	—	—	UNKWN	UNKWN	UNKWN	CAN COMM CIRCUIT (U1000)	—
ALL MODE AWD/4WD	No indication	—	UNKWN	UNKWN	UNKWN	UNKWN	—	—	—	UNKWN	—	—	CAN COMM CIRCUIT (U1000)	—
AUTO DRIVE POS.	No indication	—	—	—	UNKWN	—	UNKWN	UNKWN	—	—	—	—	CAN COMM CIRCUIT (U1000)	—
ABS	—	NG	UNKWN	—	UNKWN	—	—	—	—	—	—	—	CAN COMM CIRCUIT (U1000)	—
IPDM E/R	No indication	—	UNKWN	UNKWN	—	—	UNKWN	—	—	—	—	—	CAN COMM CIRCUIT (U1000)	—

PKIC5719E

CAN SYSTEM (TYPE 10)

[CAN]

CAN SYSTEM (TYPE 10)

PF2:23710

Component Parts and Harness Connector Location

UKS00520

Refer to [LAN-25, "Component Parts and Harness Connector Location"](#) .

Schematic

UKS00521

Refer to [LAN-26, "Schematic"](#) .

Wiring Diagram — CAN —

UKS00522

Refer to [LAN-27, "Wiring Diagram — CAN —"](#) .

A

B

C

D

E

F

G

H

I

J

LAN

L

M

CAN SYSTEM (TYPE 10)

[CAN]

UKS00523

Check Sheet

NOTE:

If a check mark is put on "NG" on "INITIAL DIAG (Initial diagnosis)", replace the control unit.

Check sheet table													SELF-DIAG RESULTS		
SELECT SYSTEM screen		CAN DIAG SUPPORT MNTR													
		Initial diagnosis	Transmit diagnosis	Receive diagnosis											IPDM E/R
ECM	TCM			Front air control	STRG	BCM /SEC	METER /M&A	AWD/4WD	VDC/TCS /ABS						
ENGINE	—	—	UNKWN	—	UNKWN	—	—	—	UNKWN	UNKWN	UNKWN	UNKWN	UNKWN	CAN COMM CIRCUIT (U1000)	CAN COMM CIRCUIT (U1001)
A/T	—	NG	UNKWN	UNKWN	—	—	—	—	UNKWN	UNKWN	UNKWN	—	—	CAN COMM CIRCUIT (U1000)	—
Display control unit	—	NG	UNKWN	UNKWN	—	UNKWN	—	—	UNKWN	UNKWN	—	—	UNKWN	—	—
BCM	No indication	NG	UNKWN	UNKWN	—	—	—	—	UNKWN	—	—	—	UNKWN	CAN COMM CIRCUIT (U1000)	—
METER	No indication	—	UNKWN	UNKWN	UNKWN	—	—	—	UNKWN	—	—	UNKWN	UNKWN	CAN COMM CIRCUIT (U1000)	—
ALL MODE AWD/4WD	No indication	—	UNKWN	UNKWN	UNKWN	—	UNKWN	—	—	—	—	UNKWN	—	CAN COMM CIRCUIT (U1000)	—
AUTO DRIVE POS.	No indication	—	—	—	UNKWN	—	—	—	UNKWN	UNKWN	—	—	—	CAN COMM CIRCUIT (U1000)	—
ABS	—	NG	UNKWN	UNKWN	UNKWN	—	UNKWN	—	—	—	UNKWN	—	—	CAN COMM CIRCUIT (U1000)	—
IPDM E/R	No indication	—	UNKWN	UNKWN	—	—	—	—	UNKWN	—	—	—	—	CAN COMM CIRCUIT (U1000)	—

Symptoms :

Attach copy of
SELECT SYSTEM

Attach copy of
SELECT SYSTEM

Display control unit Translation Sheet: Rewrite the following names, and put a check mark on the above check sheet table.			
Confirmation/Adjustment Display	Check sheet table Display	Confirmation/Adjustment Display	Check sheet table Display
CAN COMM	Initial diagnosis	CAN CIRC 5	METER/M&A
CAN CIRC 1	Transmit diagnosis	CAN CIRC 6	—
CAN CIRC 2	BCM	CAN CIRC 7	IPDM E/R
CAN CIRC 3	ECM	CAN CIRC 8	—
CAN CIRC 4	Front air control	CAN CIRC 9	—

Attach copy of
display control unit
CAN DIAG SUPPORT MONITOR Check Sheet

PKIC5720E

CAN SYSTEM (TYPE 10)

[CAN]

Attach copy of ENGINE SELF-DIAG RESULTS	Attach copy of A/T SELF-DIAG RESULTS	Attach copy of BCM SELF-DIAG RESULTS	Attach copy of METER SELF-DIAG RESULTS
Attach copy of ALL MODE AWD/4WD SELF-DIAG RESULTS	Attach copy of AUTO DRIVE POS. SELF-DIAG RESULTS	Attach copy of ABS SELF-DIAG RESULTS	Attach copy of IPDM E/R SELF-DIAG RESULTS
Attach copy of ENGINE CAN DIAG SUPPORT MNTR	Attach copy of A/T CAN DIAG SUPPORT MNTR	Attach copy of BCM CAN DIAG SUPPORT MNTR	Attach copy of METER CAN DIAG SUPPORT MNTR
Attach copy of ALL MODE AWD/4WD CAN DIAG SUPPORT MNTR	Attach copy of AUTO DRIVE POS. CAN DIAG SUPPORT MNTR	Attach copy of ABS CAN DIAG SUPPORT MNTR	Attach copy of IPDM E/R CAN DIAG SUPPORT MNTR

A
B
C
D
E
F
G
H
I
J
L
M

LAN

PKIC7067E

CHECK SHEET RESULTS (EXAMPLE)

NOTE:

If a check mark is put on "NG" on "INITIAL DIAG (Initial diagnosis)", replace the control unit.

Case 1

Check harness between TCM and data link connector. Refer to [LAN-195, "Inspection Between TCM and Data Link Connector Circuit"](#).

SELECT SYSTEM screen	CAN DIAG SUPPORT MNTR											SELF-DIAG RESULTS			
	Initial diagnosis	Transmit diagnosis	Receive diagnosis												
			ECM	TCM	Front air control	STRG	BCM /SEC	METER /M&A	AWD/4WD	VDC/TCS /ABS	IPDM E/R				
ENGINE	—	—	UNKWN	—	UNKWN	—	—	UNKWN	UNKWN	UNKWN	UNKWN	UNKWN	UNKWN	CAN COMM CIRCUIT (U1000)	CAN COMM CIRCUIT (U001) ✓
A/T	—	NG	UNKWN	UNKWN	—	—	—	—	UNKWN	UNKWN	UNKWN	UNKWN	—	CAN COMM CIRCUIT (U000)	—
Display control unit	—	NG	UNKWN	UNKWN	—	UNKWN	—	UNKWN	UNKWN	—	—	UNKWN	—	—	—
BCM	No indication	NG	UNKWN	UNKWN	—	—	—	—	UNKWN	—	—	UNKWN	—	CAN COMM CIRCUIT (U1000)	—
METER	No indication	—	UNKWN	UNKWN	UNKWN	—	—	UNKWN	—	—	UNKWN	UNKWN	—	CAN COMM CIRCUIT (U000)	—
ALL MODE AWD/4WD	No indication	—	UNKWN	UNKWN	UNKWN	—	UNKWN	—	—	—	UNKWN	—	—	CAN COMM CIRCUIT (U000)	—
AUTO DRIVE POS.	No indication	—	—	—	UNKWN	—	—	UNKWN	UNKWN	—	—	—	—	CAN COMM CIRCUIT (U000)	—
ABS	—	NG	UNKWN	UNKWN	UNKWN	—	UNKWN	—	—	UNKWN	—	—	—	CAN COMM CIRCUIT (U000)	—
IPDM E/R	No indication	—	UNKWN	UNKWN	—	—	—	UNKWN	—	—	—	—	—	CAN COMM CIRCUIT (U000)	—

PKIC5721E

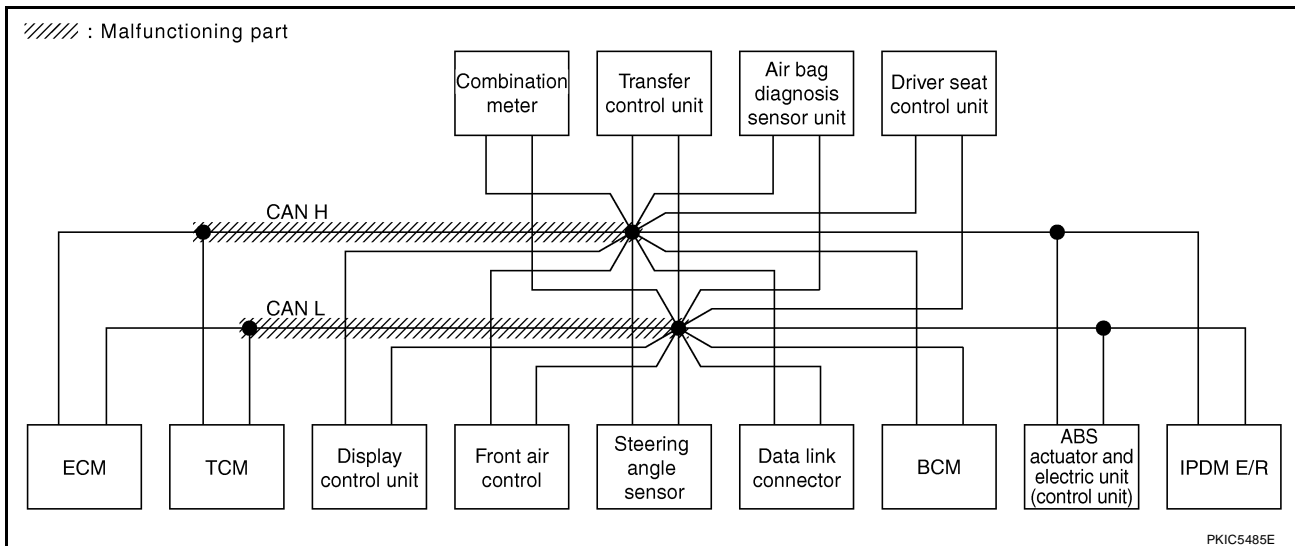

CAN SYSTEM (TYPE 10)

[CAN]

Case 2

Check harness between data link connector and ABS actuator and electric unit (control unit). Refer to [LAN-196, "Inspection Between Data Link Connector and ABS Actuator and Electric Unit \(Control Unit\) Circuit"](#).

SELECT SYSTEM screen		CAN DIAG SUPPORT MNTR										SELF-DIAG RESULTS			
		Initial diagnosis	Transmit diagnosis	Receive diagnosis										CAN COMM CIRCUIT (U1000)	CAN COMM CIRCUIT (U1001)
				ECM	TCM	Front air control	STRG	BCM /SEC	METER /M&A	AWD/4WD	VDC/TCS /ABS				
ENGINE	—	—	UNKWN	—	UNKWN	—	—	UNKWN	UNKWN	UNKWN	UNKWN	UNKWN	UNKWN	CAN COMM CIRCUIT (U1000)	CAN COMM CIRCUIT (U1001)
A/T	—	NG	UNKWN	UNKWN	—	—	—	—	UNKWN	UNKWN	UNKWN	UNKWN	—	CAN COMM CIRCUIT (U1000)	—
Display control unit	—	NG	UNKWN	UNKWN	—	UNKWN	—	UNKWN	UNKWN	—	—	UNKWN	—	—	—
BCM	No indication	NG	UNKWN	UNKWN	—	—	—	—	UNKWN	—	—	UNKWN	—	CAN COMM CIRCUIT (U1000)	—
METER	No indication	—	UNKWN	UNKWN	UNKWN	—	—	UNKWN	—	—	UNKWN	UNKWN	—	CAN COMM CIRCUIT (U1000)	—
ALL MODE AWD/4WD	No indication	—	UNKWN	UNKWN	UNKWN	—	UNKWN	—	—	—	UNKWN	—	—	CAN COMM CIRCUIT (U1000)	—
AUTO DRIVE POS.	No indication	—	—	—	UNKWN	—	—	UNKWN	UNKWN	—	—	—	—	CAN COMM CIRCUIT (U1000)	—
ABS	—	NG	UNKWN	UNKWN	UNKWN	—	UNKWN	—	—	UNKWN	—	—	—	CAN COMM CIRCUIT (U1000)	—
IPDM E/R	No indication	—	UNKWN	UNKWN	—	—	—	UNKWN	—	—	—	—	—	CAN COMM CIRCUIT (U1000)	—

PKIC5723E

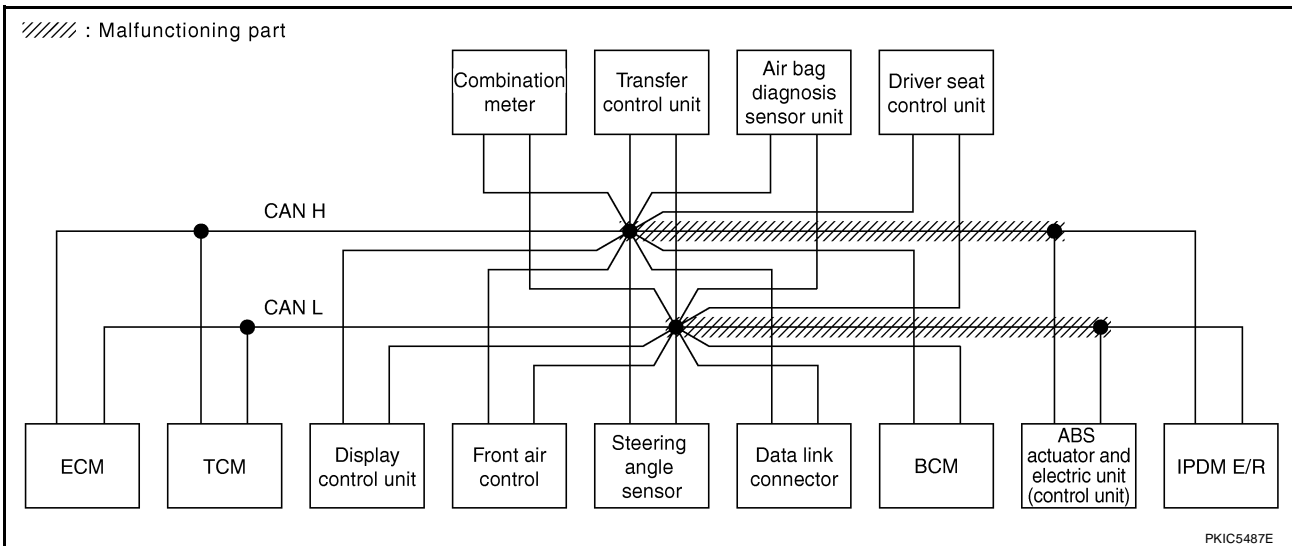

PKIC5487E

CAN SYSTEM (TYPE 10)

[CAN]

Case 3

Check ECM circuit. Refer to [LAN-197, "ECM Circuit Inspection"](#) .

SELECT SYSTEM screen	CAN DIAG SUPPORT MNTR											SELF-DIAG RESULTS			
	Initial diagnosis	Transmit diagnosis	Receive diagnosis												
			ECM	TCM	Front air control	STRG	BCM /SEC	METER /M&A	AWD/4WD	VDC/TCS /ABS	IPDM E/R				
ENGINE	—	—	UNKWN	UNKWN	UNKWN	—	—	UNKWN	UNKWN	UNKWN	UNKWN	UNKWN	UNKWN	CAN COMM CIRCUIT (U100)	CAN COMM CIRCUIT (U101)
A/T	—	NG	UNKWN	UNKWN	—	—	—	—	UNKWN	UNKWN	UNKWN	—	—	CAN COMM CIRCUIT (U100)	—
Display control unit	—	NG	UNKWN	UNKWN	—	UNKWN	—	UNKWN	UNKWN	—	—	UNKWN	—	—	—
BCM	No indication	NG	UNKWN	UNKWN	—	—	—	—	UNKWN	—	—	UNKWN	—	CAN COMM CIRCUIT (U1000)	—
METER	No indication	—	UNKWN	UNKWN	UNKWN	—	—	UNKWN	—	—	UNKWN	UNKWN	—	CAN COMM CIRCUIT (U100)	—
ALL MODE AWD/4WD	No indication	—	UNKWN	UNKWN	UNKWN	—	UNKWN	—	—	—	UNKWN	—	—	CAN COMM CIRCUIT (U100)	—
AUTO DRIVE POS.	No indication	—	—	—	UNKWN	—	—	UNKWN	UNKWN	—	—	—	—	CAN COMM CIRCUIT (U1000)	—
ABS	—	NG	UNKWN	UNKWN	UNKWN	—	UNKWN	—	—	UNKWN	—	—	—	CAN COMM CIRCUIT (U100)	—
IPDM E/R	No indication	—	UNKWN	UNKWN	—	—	—	UNKWN	—	—	—	—	—	CAN COMM CIRCUIT (U100)	—

PKIC5724E

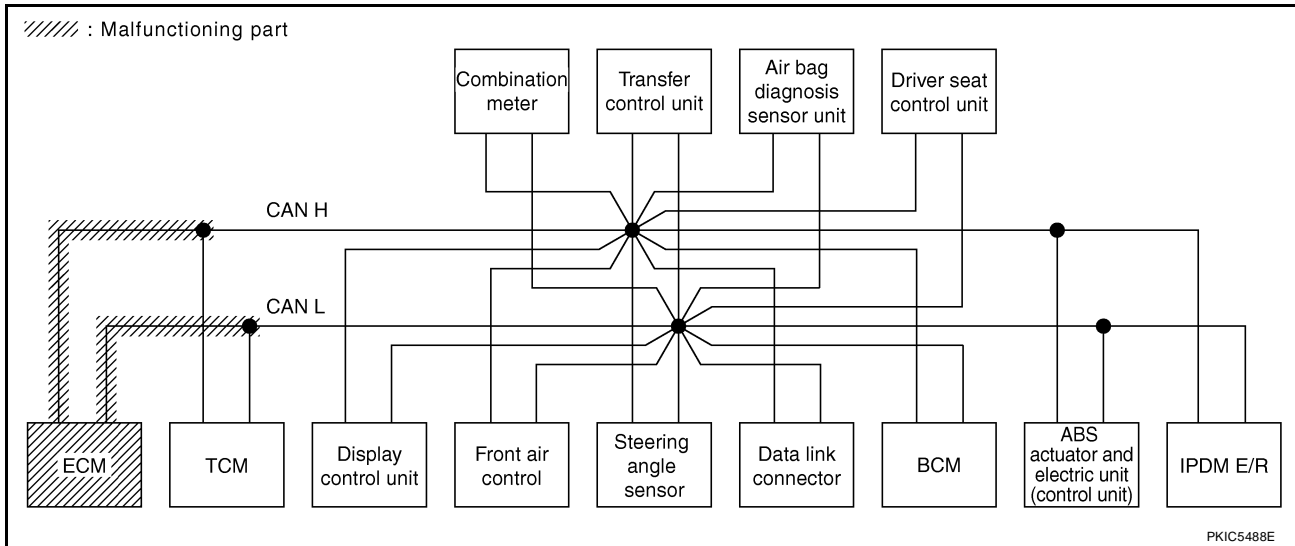

CAN SYSTEM (TYPE 10)

[CAN]

Case 4

Check TCM circuit. Refer to [LAN-197, "TCM Circuit Inspection"](#).

SELECT SYSTEM screen		CAN DIAG SUPPORT MNTR											SELF-DIAG RESULTS		
		Initial diagnosis	Transmit diagnosis	Receive diagnosis											IPDM E/R
				ECM	TCM	Front air control	STRG	BCM /SEC	METER /M&A	AWD/4WD	VDC/TCS /ABS				
ENGINE	—	—	UNKWN	UNKWN	—	—	—	UNKWN	UNKWN	UNKWN	UNKWN	UNKWN	UNKWN	CAN COMM CIRCUIT (U1000)	CAN COMM CIRCUIT (U1001)
AT	—	NG	UNKWN	UNKWN	—	—	—	—	UNKWN	UNKWN	UNKWN	—	—	CAN COMM CIRCUIT (U1000)	—
Display control unit	—	NG	UNKWN	UNKWN	—	UNKWN	—	UNKWN	UNKWN	—	—	UNKWN	—	—	—
BCM	No indication	NG	UNKWN	UNKWN	—	—	—	—	UNKWN	—	—	UNKWN	UNKWN	CAN COMM CIRCUIT (U1000)	—
METER	No indication	—	UNKWN	UNKWN	UNKWN	—	—	UNKWN	—	—	UNKWN	UNKWN	—	CAN COMM CIRCUIT (U1000)	—
ALL MODE AWD/4WD	No indication	—	UNKWN	UNKWN	UNKWN	—	UNKWN	—	—	—	UNKWN	—	—	CAN COMM CIRCUIT (U1000)	—
AUTO DRIVE POS.	No indication	—	—	—	UNKWN	—	—	UNKWN	UNKWN	—	—	—	—	CAN COMM CIRCUIT (U1000)	—
ABS	—	NG	UNKWN	UNKWN	UNKWN	—	UNKWN	—	—	UNKWN	—	—	—	CAN COMM CIRCUIT (U1000)	—
IPDM E/R	No indication	—	UNKWN	UNKWN	—	—	—	UNKWN	—	—	—	—	—	CAN COMM CIRCUIT (U1000)	—

PKIC5725E

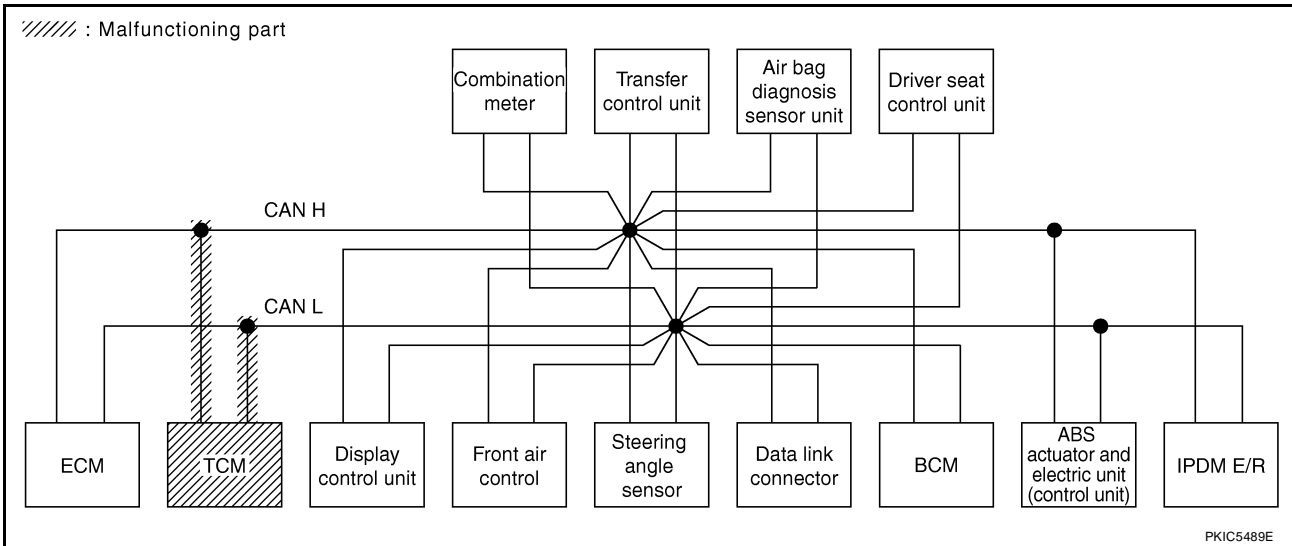

Case 5

Check display control unit circuit. Refer to [LAN-198, "Display Control Unit Circuit Inspection"](#) .

SELECT SYSTEM screen	CAN DIAG SUPPORT MNTR											SELF-DIAG RESULTS		
	Initial diagnosis	Transmit diagnosis	Receive diagnosis											
			ECM	TCM	Front air control	STRG	BCM /SEC	METER /M&A	AWD/4WD	VDC/TCS /ABS	IPDM E/R			
ENGINE	—	—	UNKWN	—	UNKWN	—	—	UNKWN	UNKWN	UNKWN	UNKWN	UNKWN	CAN COMM CIRCUIT (U1000)	CAN COMM CIRCUIT (U1001)
A/T	—	NG	UNKWN	UNKWN	—	—	—	—	UNKWN	UNKWN	UNKWN	—	CAN COMM CIRCUIT (U1000)	—
Display control unit	—	NG	UNKWN ✓	UNKWN ✓	—	UNKWN ✓	—	UNKWN ✓	UNKWN ✓	—	—	UNKWN ✓	—	—
BCM	No indication	NG	UNKWN	UNKWN	—	—	—	—	UNKWN	—	—	UNKWN	CAN COMM CIRCUIT (U1000)	—
METER	No indication	—	UNKWN	UNKWN	UNKWN	—	—	UNKWN	—	—	UNKWN	UNKWN	CAN COMM CIRCUIT (U1000)	—
ALL MODE AWD/4WD	No indication	—	UNKWN	UNKWN	UNKWN	—	UNKWN	—	—	—	UNKWN	—	CAN COMM CIRCUIT (U1000)	—
AUTO DRIVE POS.	No indication	—	—	—	UNKWN	—	—	UNKWN	UNKWN	—	—	—	CAN COMM CIRCUIT (U1000)	—
ABS	—	NG	UNKWN	UNKWN	UNKWN	—	UNKWN	—	—	UNKWN	—	—	CAN COMM CIRCUIT (U1000)	—
IPDM E/R	No indication	—	UNKWN	UNKWN	—	—	—	UNKWN	—	—	—	—	CAN COMM CIRCUIT (U1000)	—

PKIC5726E

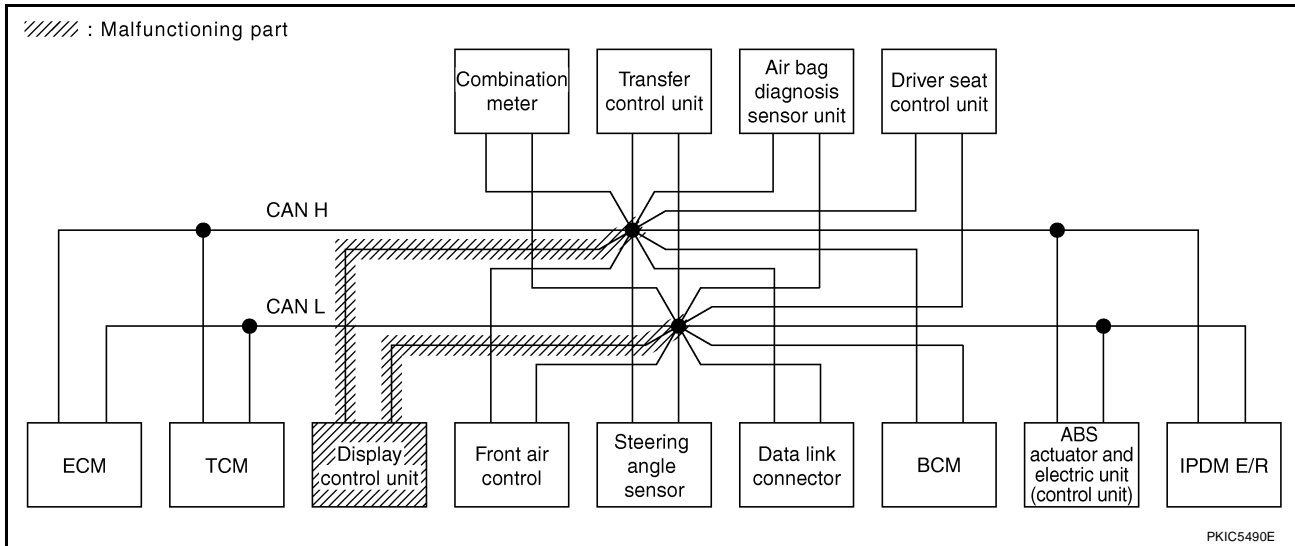

CAN SYSTEM (TYPE 10)

[CAN]

Case 6

Check front air control circuit. Refer to [LAN-198, "Front Air Control Circuit Inspection"](#) .

SELECT SYSTEM screen	CAN DIAG SUPPORT MNTR											SELF-DIAG RESULTS		
	Initial diagnosis	Transmit diagnosis	Receive diagnosis											
			ECM	TCM	Front air control	STRG	BCM /SEC	METER /M&A	AWD/4WD	VDC/TCS /ABS	IPDM E/R			
ENGINE	—	—	UNKWN	—	UNKWN	—	—	UNKWN	UNKWN	UNKWN	UNKWN	UNKWN	CAN COMM CIRCUIT (U1000)	CAN COMM CIRCUIT (U1001)
A/T	—	NG	UNKWN	UNKWN	—	—	—	—	UNKWN	UNKWN	UNKWN	—	CAN COMM CIRCUIT (U1000)	—
Display control unit	—	NG	UNKWN	UNKWN	—	UNKWN	—	—	UNKWN	UNKWN	—	—	—	—
BCM	No indication	NG	UNKWN	UNKWN	—	—	—	—	UNKWN	—	—	UNKWN	CAN COMM CIRCUIT (U1000)	—
METER	No indication	—	UNKWN	UNKWN	UNKWN	—	—	—	UNKWN	—	—	UNKWN	CAN COMM CIRCUIT (U1000)	—
ALL MODE AWD/4WD	No indication	—	UNKWN	UNKWN	UNKWN	—	UNKWN	—	—	—	—	UNKWN	CAN COMM CIRCUIT (U1000)	—
AUTO DRIVE POS.	No indication	—	—	—	UNKWN	—	—	—	UNKWN	UNKWN	—	—	CAN COMM CIRCUIT (U1000)	—
ABS	—	NG	UNKWN	UNKWN	UNKWN	—	UNKWN	—	—	—	—	—	CAN COMM CIRCUIT (U1000)	—
IPDM E/R	No indication	—	UNKWN	UNKWN	—	—	—	—	UNKWN	—	—	—	CAN COMM CIRCUIT (U1000)	—

PKIC5727E

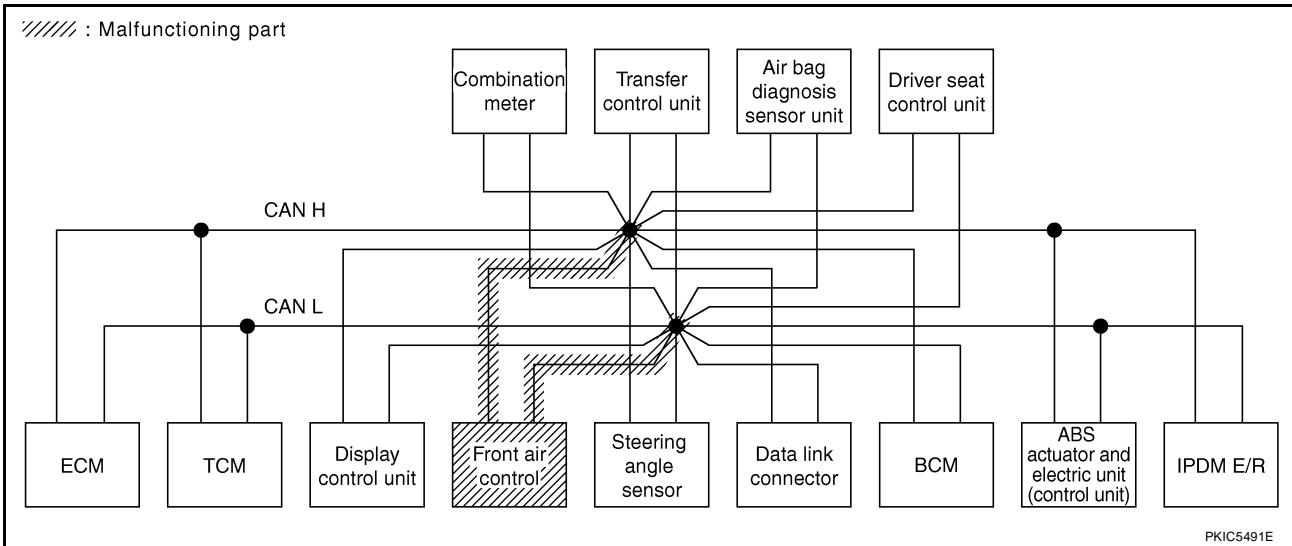

CAN SYSTEM (TYPE 10)

[CAN]

Case 7

Check steering angle sensor circuit. Refer to [LAN-199, "Steering Angle Sensor Circuit Inspection"](#) .

SELECT SYSTEM screen	CAN DIAG SUPPORT MNTR											SELF-DIAG RESULTS		
	Initial diagnosis	Transmit diagnosis	Receive diagnosis											
			ECM	TCM	Front air control	STRG	BCM /SEC	METER /M&A	AWD/4WD	VDC/TCS /ABS	IPDM E/R			
ENGINE	—	—	UNKWN	—	UNKWN	—	—	UNKWN	UNKWN	UNKWN	UNKWN	UNKWN	CAN COMM CIRCUIT (U1000)	CAN COMM CIRCUIT (U1001)
A/T	—	NG	UNKWN	UNKWN	—	—	—	—	UNKWN	UNKWN	UNKWN	—	CAN COMM CIRCUIT (U1000)	—
Display control unit	—	NG	UNKWN	UNKWN	—	UNKWN	—	UNKWN	UNKWN	—	—	UNKWN	—	—
BCM	No indication	NG	UNKWN	UNKWN	—	—	—	—	UNKWN	—	—	UNKWN	CAN COMM CIRCUIT (U1000)	—
METER	No indication	—	UNKWN	UNKWN	UNKWN	—	—	UNKWN	—	—	UNKWN	UNKWN	CAN COMM CIRCUIT (U1000)	—
ALL MODE AWD/4WD	No indication	—	UNKWN	UNKWN	UNKWN	—	✓	—	—	—	UNKWN	—	CAN COMM CIRCUIT (U1000)	—
AUTO DRIVE POS.	No indication	—	—	—	UNKWN	—	—	UNKWN	UNKWN	—	—	—	CAN COMM CIRCUIT (U1000)	—
ABS	—	NG	UNKWN	UNKWN	UNKWN	—	✓	—	—	UNKWN	—	—	CAN COMM CIRCUIT (U1000)	—
IPDM E/R	No indication	—	UNKWN	UNKWN	—	—	—	UNKWN	—	—	—	—	CAN COMM CIRCUIT (U1000)	—

PKIC5728E

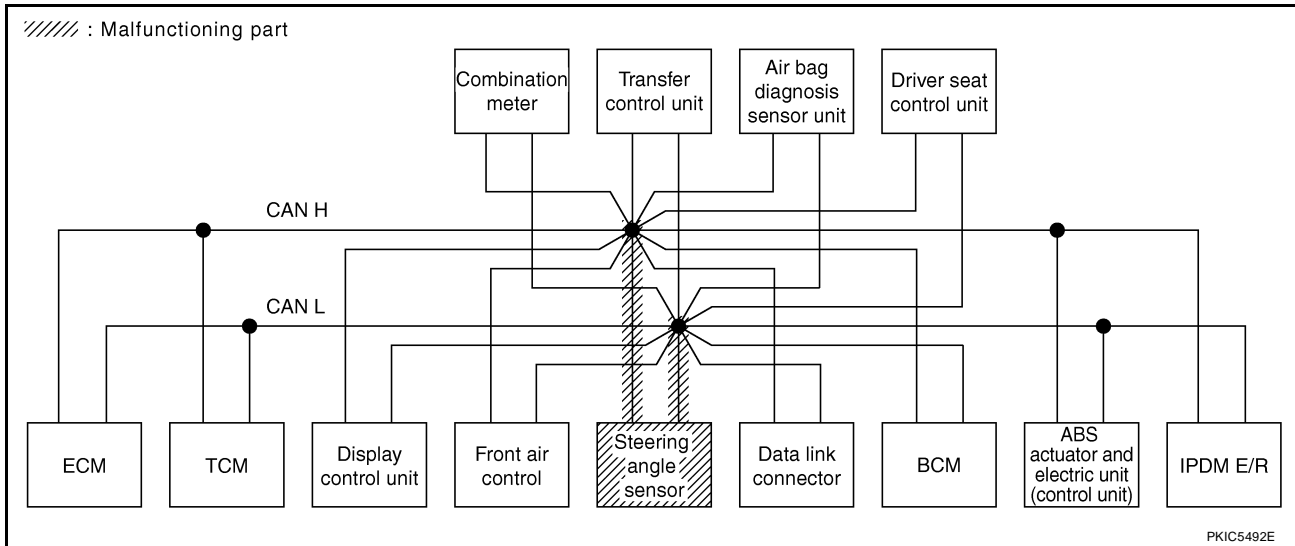

CAN SYSTEM (TYPE 10)

[CAN]

Case 8

Check data link connector circuit. Refer to [LAN-199, "Data Link Connector Circuit Inspection"](#) .

SELECT SYSTEM screen	CAN DIAG SUPPORT MNTR											SELF-DIAG RESULTS		
	Initial diagnosis	Transmit diagnosis	Receive diagnosis											
			ECM	TCM	Front air control	STRG	BCM /SEC	METER /M&A	AWD/4WD	VDC/TCS /ABS	IPDM E/R			
ENGINE	—	—	UNKWN	—	UNKWN	—	—	UNKWN	UNKWN	UNKWN	UNKWN	UNKWN	CAN COMM CIRCUIT (U1000)	CAN COMM CIRCUIT (U1001)
AT	—	NG	UNKWN	UNKWN	—	—	—	—	UNKWN	UNKWN	UNKWN	—	CAN COMM CIRCUIT (U1000)	—
Display control unit	—	NG	UNKWN	UNKWN	—	UNKWN	—	UNKWN	UNKWN	—	—	UNKWN	—	—
BCM	N indication	NG	UNKWN	UNKWN	—	—	—	—	UNKWN	—	—	UNKWN	CAN COMM CIRCUIT (U1000)	—
METER	N indication	—	UNKWN	UNKWN	UNKWN	—	—	UNKWN	—	—	UNKWN	UNKWN	CAN COMM CIRCUIT (U1000)	—
ALL MODE AWD/4WD	N indication	—	UNKWN	UNKWN	UNKWN	—	UNKWN	—	—	—	UNKWN	—	CAN COMM CIRCUIT (U1000)	—
AUTO DRIVE POS.	N indication	—	—	—	UNKWN	—	—	UNKWN	UNKWN	—	—	—	CAN COMM CIRCUIT (U1000)	—
ABS	—	NG	UNKWN	UNKWN	UNKWN	—	UNKWN	—	—	UNKWN	—	—	CAN COMM CIRCUIT (U1000)	—
IPDM E/R	N indication	—	UNKWN	UNKWN	—	—	—	UNKWN	—	—	—	—	CAN COMM CIRCUIT (U1000)	—

PKIC5729E

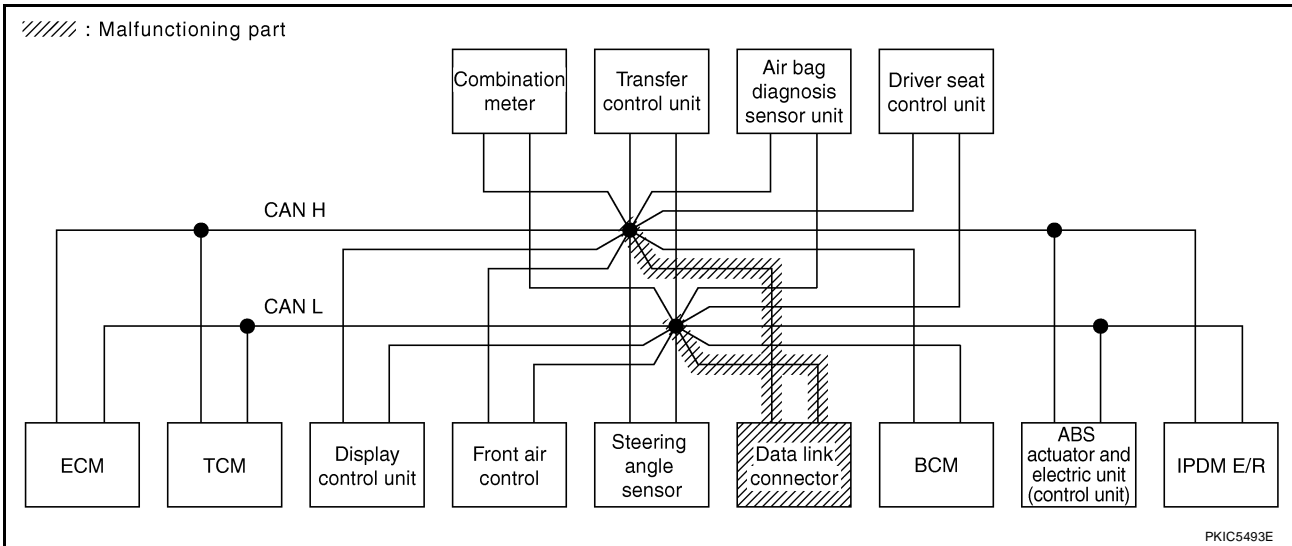

A
B
C
D
E
F
G
H
I
J
L
M

LAN

CAN SYSTEM (TYPE 10)

[CAN]

Case 9

Check BCM circuit. Refer to [LAN-200, "BCM Circuit Inspection"](#) .

SELECT SYSTEM screen	CAN DIAG SUPPORT MNTR											SELF-DIAG RESULTS		
	Initial diagnosis	Transmit diagnosis	Receive diagnosis											
			ECM	TCM	Front air control	STRG	BCM /SEC	METER /M&A	AWD/4WD	VDC/TCS /ABS	IPDM E/R			
ENGINE	—	—	UNKWN	—	UNKWN	—	—	UNKWN	UNKWN	UNKWN	UNKWN	UNKWN	CAN COMM CIRCUIT (U1000)	CAN COMM CIRCUIT (U001) ✓
A/T	—	NG	UNKWN	UNKWN	—	—	—	—	UNKWN	UNKWN	UNKWN	—	CAN COMM CIRCUIT (U1000)	—
Display control unit	—	NG	UNKWN	UNKWN	—	UNKWN	—	UNKWN	UNKWN	—	—	UNKWN	—	—
BCM	No indication ✓	NG	UNKWN	UNKWN	—	—	—	—	UNKWN	—	—	UNKWN	CAN COMM CIRCUIT (U1000)	—
METER	No indication	—	UNKWN	UNKWN	UNKWN	—	—	UNKWN	—	—	UNKWN	UNKWN	CAN COMM CIRCUIT (U1000)	—
ALL MODE AWD/4WD	No indication	—	UNKWN	UNKWN	UNKWN	—	UNKWN	—	—	—	UNKWN	—	CAN COMM CIRCUIT (U1000)	—
AUTO DRIVE POS.	No indication	—	—	—	UNKWN	—	—	UNKWN	UNKWN	—	—	—	CAN COMM CIRCUIT (U1000)	—
ABS	—	NG	UNKWN	UNKWN	UNKWN	—	UNKWN	—	—	UNKWN	—	—	CAN COMM CIRCUIT (U1000)	—
IPDM E/R	No indication	—	UNKWN	UNKWN	—	—	—	UNKWN	—	—	—	—	CAN COMM CIRCUIT (U1000)	—

PKIC5730E

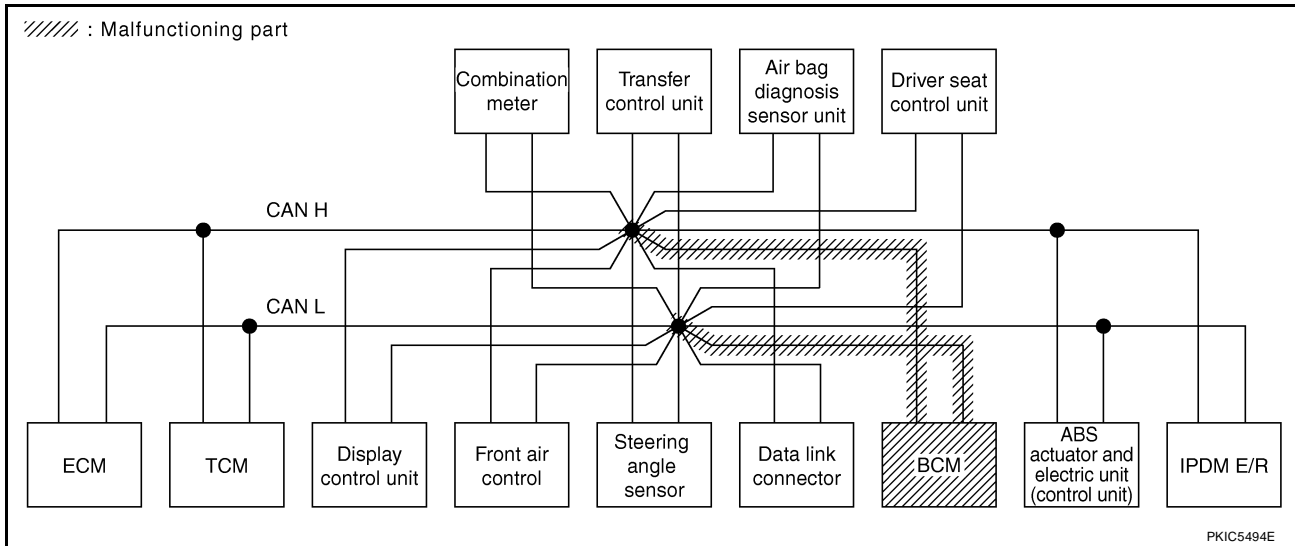

CAN SYSTEM (TYPE 10)

[CAN]

Case 10

Check combination meter circuit. Refer to [LAN-200, "Combination Meter Circuit Inspection"](#).

SELECT SYSTEM screen	CAN DIAG SUPPORT MNTR											SELF-DIAG RESULTS			
	Initial diagnosis	Transmit diagnosis	Receive diagnosis												
			ECM	TCM	Front air control	STRG	BCM /SEC	METER /M&A	AWD/4WD	VDC/TCS /ABS	IPDM E/R				
ENGINE	—	—	UNKWN	—	UNKWN	—	—	UNKWN	UNKWN	UNKWN	UNKWN	UNKWN	UNKWN	CAN COMM CIRCUIT (U1000)	CAN COMM CIRCUIT (U1001)
AT	—	NG	UNKWN	UNKWN	—	—	—	—	UNKWN	UNKWN	UNKWN	—	—	CAN COMM CIRCUIT (U1000)	—
Display control unit	—	NG	UNKWN	UNKWN	—	UNKWN	—	UNKWN	UNKWN	—	—	UNKWN	—	—	—
BCM	No indication	NG	UNKWN	UNKWN	—	—	—	—	UNKWN	—	—	UNKWN	—	CAN COMM CIRCUIT (U1000)	—
METER	No indication	—	UNKWN	UNKWN	UNKWN	—	—	UNKWN	—	—	UNKWN	UNKWN	—	CAN COMM CIRCUIT (U1000)	—
ALL MODE AWD/4WD	No indication	—	UNKWN	UNKWN	UNKWN	—	UNKWN	—	—	—	UNKWN	—	—	CAN COMM CIRCUIT (U1000)	—
AUTO DRIVE POS.	No indication	—	—	—	UNKWN	—	—	UNKWN	UNKWN	—	—	—	—	CAN COMM CIRCUIT (U1000)	—
ABS	—	NG	UNKWN	UNKWN	UNKWN	—	UNKWN	—	—	UNKWN	—	—	—	CAN COMM CIRCUIT (U1000)	—
IPDM E/R	No indication	—	UNKWN	UNKWN	—	—	—	UNKWN	—	—	—	—	—	CAN COMM CIRCUIT (U1000)	—

PKIC5731E

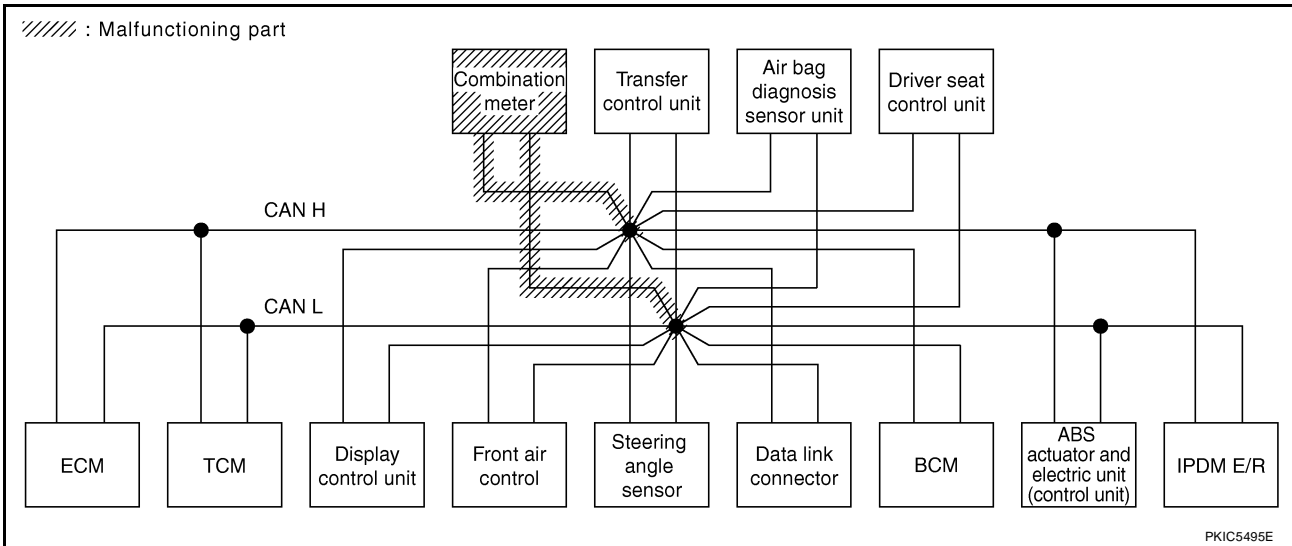

PKIC5495E

CAN SYSTEM (TYPE 10)

[CAN]

Case 11

Check transfer control unit circuit. Refer to [LAN-201, "Transfer Control Unit Circuit Inspection"](#) .

SELECT SYSTEM screen	CAN DIAG SUPPORT MNTR											SELF-DIAG RESULTS			
	Initial diagnosis	Transmit diagnosis	Receive diagnosis												
			ECM	TCM	Front air control	STRG	BCM /SEC	METER /M&A	AWD/4WD	VDC/TCS /ABS	IPDM E/R				
ENGINE	—	—	UNKWN	—	UNKWN	—	—	UNKWN	UNKWN	UNKWN	UNKWN	UNKWN	UNKWN	CAN COMM CIRCUIT (U1000)	CAN COMM CIRCUIT (U001) ✓
A/T	—	NG	UNKWN	UNKWN	—	—	—	—	UNKWN	UNKWN	UNKWN	UNKWN	—	CAN COMM CIRCUIT (U1000) ✓	—
Display control unit	—	NG	UNKWN	UNKWN	—	UNKWN	—	UNKWN	UNKWN	—	—	UNKWN	—	—	—
BCM	No indication	NG	UNKWN	UNKWN	—	—	—	—	UNKWN	—	—	UNKWN	UNKWN	CAN COMM CIRCUIT (U1000)	—
METER	No indication	—	UNKWN	UNKWN	UNKWN	—	—	UNKWN	—	—	UNKWN	UNKWN	UNKWN	CAN COMM CIRCUIT (U1000)	—
ALL MODE AWD/4WD	No indication ✓	—	UNKWN	UNKWN	UNKWN	—	UNKWN	—	—	—	UNKWN	—	—	CAN COMM CIRCUIT (U1000) ✓	—
AUTO DRIVE POS.	No indication	—	—	—	UNKWN	—	—	UNKWN	UNKWN	—	—	—	—	CAN COMM CIRCUIT (U1000)	—
ABS	—	NG	UNKWN	UNKWN	UNKWN	—	UNKWN	—	—	UNKWN	—	—	—	CAN COMM CIRCUIT (U1000) ✓	—
IPDM E/R	No indication	—	UNKWN	UNKWN	—	—	—	UNKWN	—	—	—	—	—	CAN COMM CIRCUIT (U1000)	—

PKIC5732E

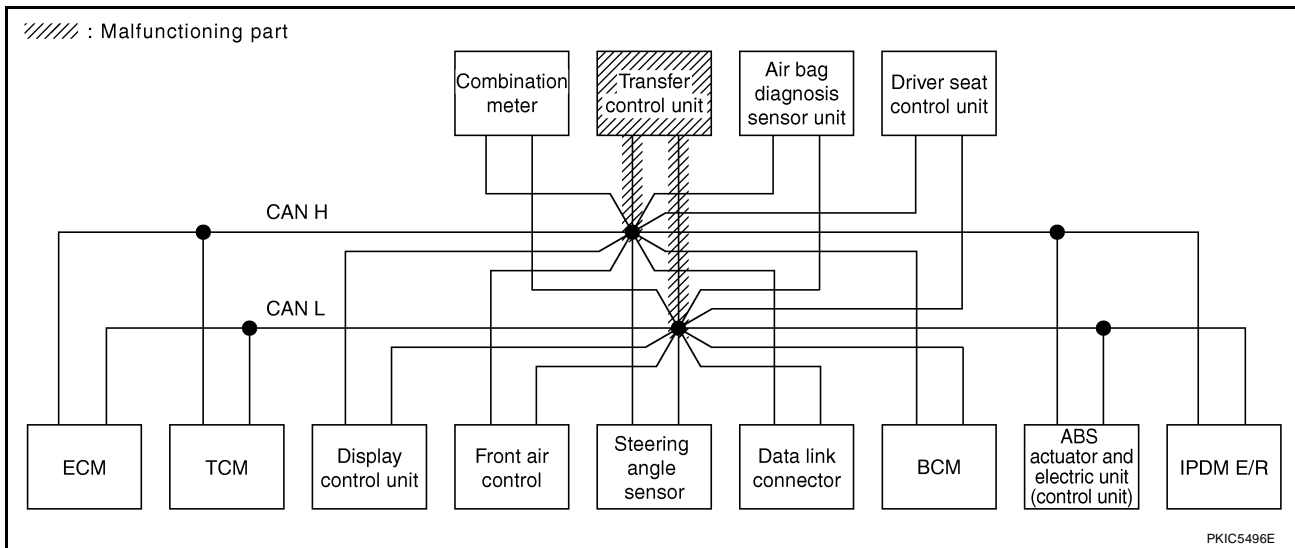

CAN SYSTEM (TYPE 10)

[CAN]

Case 12

Check driver seat control unit circuit. Refer to [LAN-202, "Driver Seat Control Unit Circuit Inspection"](#) .

SELECT SYSTEM screen	CAN DIAG SUPPORT MNTR											SELF-DIAG RESULTS		
	Initial diagnosis	Transmit diagnosis	Receive diagnosis											
			ECM	TCM	Front air control	STRG	BCM /SEC	METER /M&A	AWD/4WD	VDC/TCS /ABS	IPDM E/R			
ENGINE	—	—	UNKWN	—	UNKWN	—	—	UNKWN	UNKWN	UNKWN	UNKWN	UNKWN	CAN COMM CIRCUIT (U1000)	CAN COMM CIRCUIT (U1001)
AT	—	NG	UNKWN	UNKWN	—	—	—	—	UNKWN	UNKWN	UNKWN	—	CAN COMM CIRCUIT (U1000)	—
Display control unit	—	NG	UNKWN	UNKWN	—	UNKWN	—	UNKWN	UNKWN	—	—	UNKWN	—	—
BCM	No indication	NG	UNKWN	UNKWN	—	—	—	—	UNKWN	—	—	UNKWN	CAN COMM CIRCUIT (U1000)	—
METER	No indication	—	UNKWN	UNKWN	UNKWN	—	—	UNKWN	—	—	UNKWN	UNKWN	CAN COMM CIRCUIT (U1000)	—
ALL MODE AWD/4WD	No indication	—	UNKWN	UNKWN	UNKWN	—	UNKWN	—	—	—	UNKWN	—	CAN COMM CIRCUIT (U1000)	—
AUTO DRIVE POS.	✓ No indication	—	—	—	UNKWN	—	—	UNKWN	UNKWN	—	—	—	CAN COMM CIRCUIT (U1000)	—
ABS	—	NG	UNKWN	UNKWN	UNKWN	—	UNKWN	—	—	UNKWN	—	—	CAN COMM CIRCUIT (U1000)	—
IPDM E/R	No indication	—	UNKWN	UNKWN	—	—	—	UNKWN	—	—	—	—	CAN COMM CIRCUIT (U1000)	—

PKIC5733E

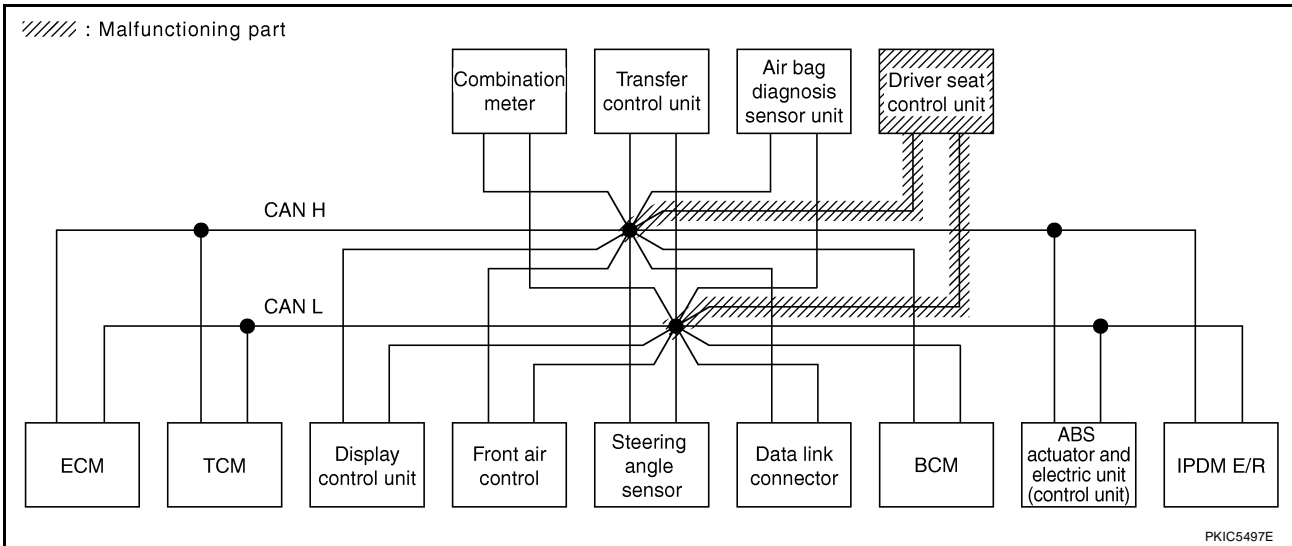

Case 13

Check ABS actuator and electric unit (control unit) circuit. Refer to [LAN-202, "ABS Actuator and Electric Unit \(Control Unit\) Circuit Inspection"](#) .

SELECT SYSTEM screen		CAN DIAG SUPPORT MNTR										SELF-DIAG RESULTS			
		Initial diagnosis	Transmit diagnosis	Receive diagnosis											
				ECM	TCM	Front air control	STRG	BCM /SEC	METER /M&A	AWD/4WD	VDC/TCS /ABS			IPDM E/R	
ENGINE	—	—	UNKWN	—	UNKWN	—	—	UNKWN	UNKWN	UNKWN	UNKWN	UNKWN	UNKWN	CAN COMM CIRCUIT (U1000)	CAN COMM CIRCUIT (U001)
A/T	—	NG	UNKWN	UNKWN	—	—	—	—	UNKWN	UNKWN	UNKWN	UNKWN	—	CAN COMM CIRCUIT (U000)	—
Display control unit	—	NG	UNKWN	UNKWN	—	UNKWN	—	UNKWN	UNKWN	—	—	UNKWN	—	—	—
BCM	No indication	NG	UNKWN	UNKWN	—	—	—	—	UNKWN	—	—	UNKWN	—	CAN COMM CIRCUIT (U1000)	—
METER	No indication	—	UNKWN	UNKWN	UNKWN	—	—	UNKWN	—	—	UNKWN	UNKWN	—	CAN COMM CIRCUIT (U000)	—
ALL MODE AWD/4WD	No indication	—	UNKWN	UNKWN	UNKWN	—	UNKWN	—	—	—	UNKWN	—	—	CAN COMM CIRCUIT (U000)	—
AUTO DRIVE POS.	No indication	—	—	—	UNKWN	—	—	UNKWN	UNKWN	—	—	—	—	CAN COMM CIRCUIT (U1000)	—
ABS	—	✓	UNKWN	UNKWN	UNKWN	—	UNKWN	—	—	UNKWN	—	—	—	CAN COMM CIRCUIT (U000)	—
IPDM E/R	No indication	—	UNKWN	UNKWN	—	—	—	UNKWN	—	—	—	—	—	CAN COMM CIRCUIT (U1000)	—

PKIC5734E

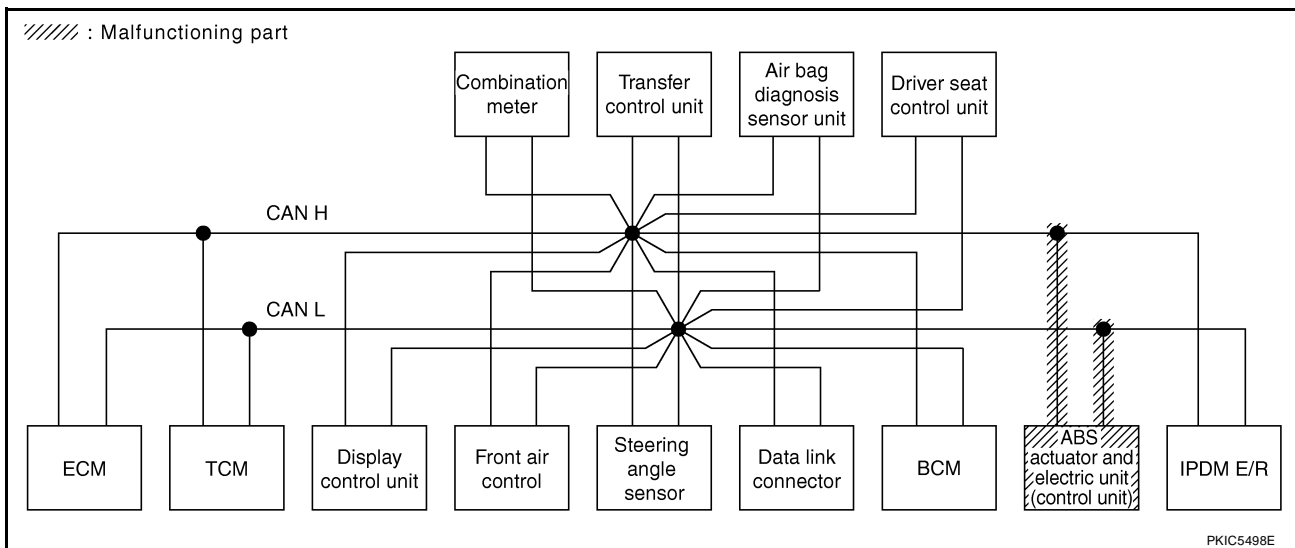

CAN SYSTEM (TYPE 10)

[CAN]

Case 14

Check IPDM E/R circuit. Refer to [LAN-203, "IPDM E/R Circuit Inspection"](#).

SELECT SYSTEM screen	CAN DIAG SUPPORT MNTR											SELF-DIAG RESULTS			
	Initial diagnosis	Transmit diagnosis	Receive diagnosis												
			ECM	TCM	Front air control	STRG	BCM /SEC	METER /M&A	AWD/4WD	VDC/TCS /ABS	IPDM E/R				
ENGINE	—	—	UNKWN	—	UNKWN	—	—	UNKWN	UNKWN	UNKWN	UNKWN	UNKWN	UNKWN	CAN COMM CIRCUIT (U1000)	CAN COMM CIRCUIT (U1001)
A/T	—	NG	UNKWN	UNKWN	—	—	—	—	UNKWN	UNKWN	UNKWN	—	—	CAN COMM CIRCUIT (U1000)	—
Display control unit	—	NG	UNKWN	UNKWN	—	UNKWN	—	UNKWN	UNKWN	—	—	UNKWN	—	—	—
BCM	No indication	NG	UNKWN	UNKWN	—	—	—	—	UNKWN	—	—	UNKWN	UNKWN	CAN COMM CIRCUIT (U1000)	—
METER	No indication	—	UNKWN	UNKWN	UNKWN	—	—	UNKWN	—	—	UNKWN	UNKWN	UNKWN	CAN COMM CIRCUIT (U1000)	—
ALL MODE AWD/4WD	No indication	—	UNKWN	UNKWN	UNKWN	—	UNKWN	—	—	—	UNKWN	—	—	CAN COMM CIRCUIT (U1000)	—
AUTO DRIVE POS.	No indication	—	—	—	UNKWN	—	—	UNKWN	UNKWN	—	—	—	—	CAN COMM CIRCUIT (U1000)	—
ABS	—	NG	UNKWN	UNKWN	UNKWN	—	UNKWN	—	—	UNKWN	—	—	—	CAN COMM CIRCUIT (U1000)	—
IPDM E/R	No indication	—	UNKWN	UNKWN	—	—	—	UNKWN	—	—	—	—	—	CAN COMM CIRCUIT (U1000)	—

PKIC5735E

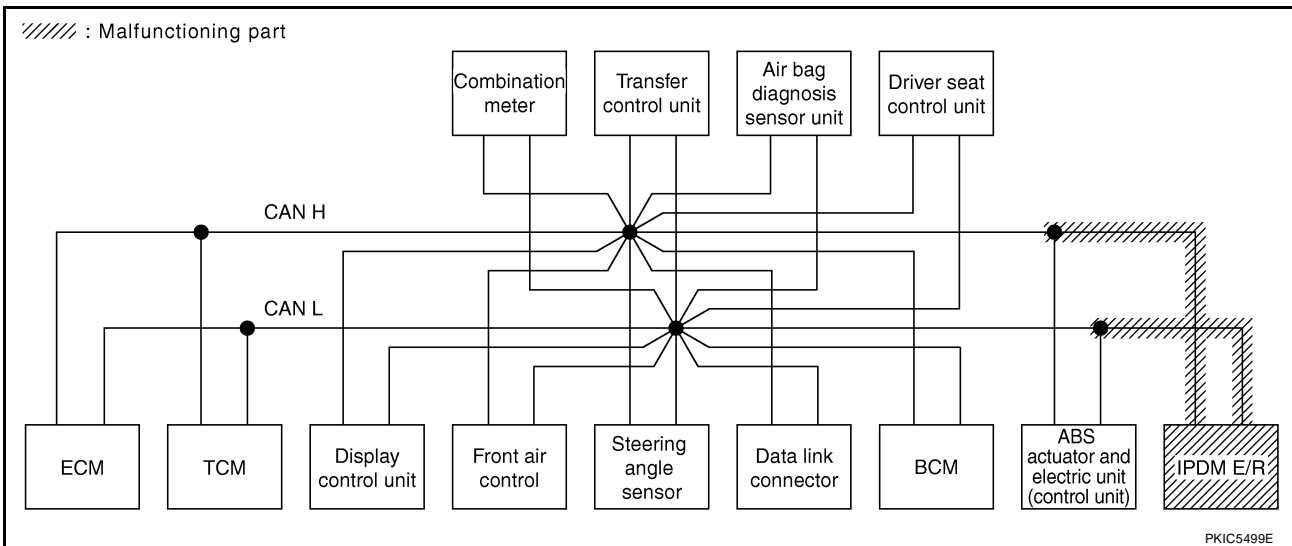

Case 15

Check CAN communication circuit. Refer to [LAN-203, "CAN Communication Circuit Inspection"](#).

SELECT SYSTEM screen	CAN DIAG SUPPORT MNTR											SELF-DIAG RESULTS			
	Initial diagnosis	Transmit diagnosis	Receive diagnosis												
			ECM	TCM	Front air control	STRG	BCM /SEC	METER /M&A	AWD/4WD	VDC/TCS /ABS	IPDM E/R				
ENGINE	—	—	UNKWN	UNKWN	UNKWN	—	—	UNKWN	UNKWN	UNKWN	UNKWN	UNKWN	UNKWN	CAN COMM CIRCUIT (U1000)	CAN COMM CIRCUIT (U1001)
A/T	—	NG	UNKWN	UNKWN	—	—	—	—	UNKWN	UNKWN	UNKWN	—	—	CAN COMM CIRCUIT (U1000)	—
Display control unit	—	NG	UNKWN	UNKWN	—	UNKWN	—	UNKWN	UNKWN	—	—	UNKWN	—	—	—
BCM	No indication	NG	UNKWN	UNKWN	—	—	—	—	UNKWN	—	—	UNKWN	UNKWN	CAN COMM CIRCUIT (U1000)	—
METER	No indication	—	UNKWN	UNKWN	UNKWN	—	—	UNKWN	—	—	UNKWN	UNKWN	UNKWN	CAN COMM CIRCUIT (U1000)	—
ALL MODE AWD/4WD	No indication	—	UNKWN	UNKWN	UNKWN	—	UNKWN	—	—	—	UNKWN	—	—	CAN COMM CIRCUIT (U1000)	—
AUTO DRIVE POS.	No indication	—	—	—	UNKWN	—	—	UNKWN	UNKWN	—	—	—	—	CAN COMM CIRCUIT (U1000)	—
ABS	—	NG	UNKWN	UNKWN	UNKWN	—	UNKWN	—	—	UNKWN	—	—	—	CAN COMM CIRCUIT (U1000)	—
IPDM E/R	No indication	—	UNKWN	UNKWN	—	—	—	UNKWN	—	—	—	—	—	CAN COMM CIRCUIT (U1000)	—

PKIC5736E

CAN SYSTEM (TYPE 10)

[CAN]

Case 16

Check IPDM E/R ignition relay circuit continuously sticks "OFF". Refer to [LAN-204, "IPDM E/R Ignition Relay Circuit Inspection"](#) .

SELECT SYSTEM screen		CAN DIAG SUPPORT MNTR										SELF-DIAG RESULTS			
		Initial diagnosis	Transmit diagnosis	Receive diagnosis											
				ECM	TCM	Front air control	STRG	BCM /SEC	METER /M&A	AWD/4WD	VDC/TCS /ABS			IPDM E/R	
ENGINE	—	—	UNKWN	—	✓	—	—	UNKWN	UNKWN	UNKWN	UNKWN	UNKWN	UNKWN	CAN COMM CIRCUIT (U1000)	CAN COMM CIRCUIT (U1001)
A/T	—	NG	UNKWN	UNKWN	—	—	—	—	UNKWN	UNKWN	UNKWN	—	—	CAN COMM CIRCUIT (U1000)	—
Display control unit	—	NG	UNKWN	UNKWN	—	UNKWN	—	UNKWN	UNKWN	—	—	UNKWN	—	—	—
BCM	No indication	NG	UNKWN	UNKWN	—	—	—	—	UNKWN	—	—	UNKWN	—	CAN COMM CIRCUIT (U1000)	—
METER	No indication	—	UNKWN	UNKWN	✓	—	—	UNKWN	—	—	✓	UNKWN	UNKWN	CAN COMM CIRCUIT (U1000)	—
ALL MODE AWD/4WD	No indication	—	UNKWN	UNKWN	✓	—	UNKWN	—	—	—	✓	UNKWN	—	CAN COMM CIRCUIT (U1000)	—
AUTO DRIVE POS.	No indication	—	—	—	✓	—	—	UNKWN	UNKWN	—	—	—	—	CAN COMM CIRCUIT (U1000)	—
ABS	—	NG	UNKWN	UNKWN	UNKWN	—	UNKWN	—	—	UNKWN	—	—	—	CAN COMM CIRCUIT (U1000)	—
IPDM E/R	No indication	—	UNKWN	UNKWN	—	—	—	UNKWN	—	—	—	—	—	CAN COMM CIRCUIT (U1000)	—

PKIC5737E

Case 17

Check IPDM E/R ignition relay circuit continuously sticks "ON". Refer to [LAN-204, "IPDM E/R Ignition Relay Circuit Inspection"](#) .

SELECT SYSTEM screen		CAN DIAG SUPPORT MNTR										SELF-DIAG RESULTS			
		Initial diagnosis	Transmit diagnosis	Receive diagnosis											
				ECM	TCM	Front air control	STRG	BCM /SEC	METER /M&A	AWD/4WD	VDC/TCS /ABS			IPDM E/R	
ENGINE	—	—	UNKWN	—	UNKWN	—	—	UNKWN	UNKWN	UNKWN	UNKWN	UNKWN	UNKWN	CAN COMM CIRCUIT (U1000)	CAN COMM CIRCUIT (U1001)
A/T	—	NG	UNKWN	—	—	—	—	—	—	—	UNKWN	—	—	CAN COMM CIRCUIT (U1000)	—
Display control unit	—	NG	UNKWN	UNKWN	—	UNKWN	—	UNKWN	UNKWN	—	—	UNKWN	—	—	—
BCM	No indication	NG	UNKWN	UNKWN	—	—	—	—	UNKWN	—	—	UNKWN	—	CAN COMM CIRCUIT (U1000)	—
METER	No indication	—	UNKWN	UNKWN	UNKWN	—	—	UNKWN	—	—	UNKWN	UNKWN	—	CAN COMM CIRCUIT (U1000)	—
ALL MODE AWD/4WD	No indication	—	UNKWN	UNKWN	UNKWN	—	UNKWN	—	—	—	UNKWN	—	—	CAN COMM CIRCUIT (U1000)	—
AUTO DRIVE POS.	No indication	—	—	—	UNKWN	—	—	UNKWN	UNKWN	—	—	—	—	CAN COMM CIRCUIT (U1000)	—
ABS	—	NG	UNKWN	—	UNKWN	—	—	—	—	—	—	—	—	CAN COMM CIRCUIT (U1000)	—
IPDM E/R	No indication	—	UNKWN	UNKWN	—	—	—	UNKWN	—	—	—	—	—	CAN COMM CIRCUIT (U1000)	—

PKIC5738E

TROUBLE DIAGNOSIS FOR SYSTEM

Inspection Between TCM and Data Link Connector Circuit

1. CHECK CONNECTOR

1. Turn ignition switch OFF.
2. Disconnect the battery cable from the negative terminal.
3. Check following terminals and connectors for damage, bend and loose connection (connector side and harness side).
 - Harness connector F14
 - Harness connector E5
 - Harness connector E152
 - Harness connector M31

OK or NG

- OK >> GO TO 2.
 NG >> Repair terminal or connector.

2. CHECK HARNESS FOR OPEN CIRCUIT

1. Disconnect A/T assembly connector and harness connector F14.
2. Check continuity between A/T assembly harness connector and harness connector.

A/T assembly connector		Harness connector		Continuity
Connector	Terminal	Connector	Terminal	
F9	3	F14	2	Yes
	8		3	Yes

OK or NG

- OK >> GO TO 3.
 NG >> Repair harness.

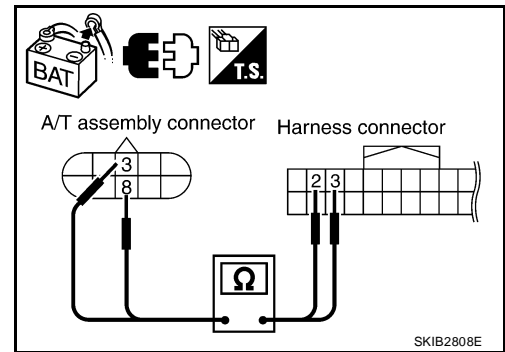

3. CHECK HARNESS FOR OPEN CIRCUIT

1. Disconnect harness connector E152.
2. Check continuity between harness connector and SMJ harness connector.

Harness connector		SMJ harness connector		Continuity
Connector	Terminal	Connector	Terminal	
E5	2	E152	52G	Yes
	3		51G	Yes

OK or NG

- OK >> GO TO 4.
 NG >> Repair harness.

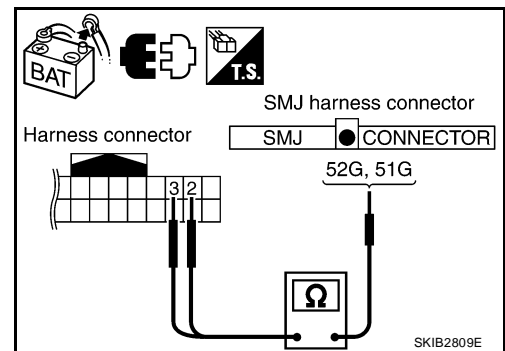

4. CHECK HARNESS FOR OPEN CIRCUIT

Check continuity between SMJ harness connector and data link connector.

SMJ harness connector		Data link connector		Continuity
Connector	Terminal	Connector	Terminal	
M31	52G	M22	6	Yes
	51G		14	Yes

OK or NG

- OK >> Connect all the connectors and diagnose again. Refer to [LAN-5, "TROUBLE DIAGNOSES WORK FLOW"](#).
- NG >> Repair harness.

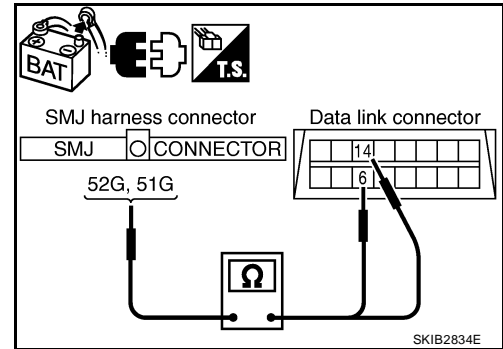

Inspection Between Data Link Connector and ABS Actuator and Electric Unit (Control Unit) Circuit

UKS0051D

1. CHECK CONNECTOR

- Turn ignition switch OFF.
- Disconnect the battery cable from the negative terminal.
- Check following terminals and connectors for damage, bend and loose connection (connector side and harness side).
 - Harness connector M91
 - Harness connector E26

OK or NG

- OK >> GO TO 2.
- NG >> Repair terminal or connector.

2. CHECK HARNESS FOR OPEN CIRCUIT

- Disconnect harness connector M91.
- Check continuity between data link connector and harness connector.

Data link connector		Harness connector		Continuity
Connector	Terminal	Connector	Terminal	
M22	6	M91	11	Yes
	14		10	Yes

OK or NG

- OK >> GO TO 3.
- NG >> Repair harness.

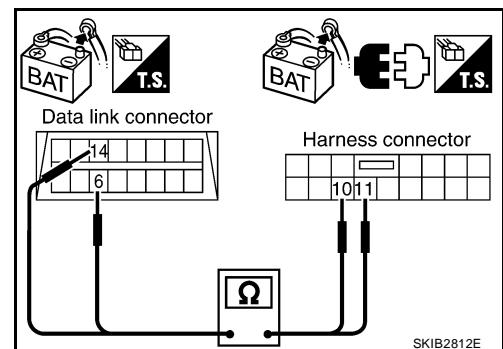

3. CHECK HARNESS FOR OPEN CIRCUIT

1. Disconnect ABS actuator and electric unit (control unit) connector.
2. Check continuity between harness connector and ABS actuator and electric unit (control unit) harness connector.

Harness connector		ABS actuator and electric unit (control unit) connector		Continuity
Connector	Terminal	Connector	Terminal	
E26	11	E125	11	Yes
	10		15	Yes

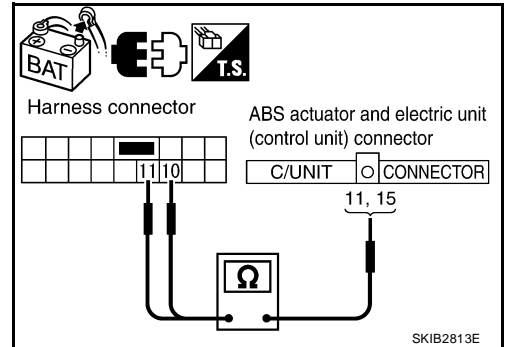

OK or NG

- OK >> Connect all the connectors and diagnose again. Refer to [LAN-5, "TROUBLE DIAGNOSES WORK FLOW"](#).
- NG >> Repair harness.

ECM Circuit Inspection

UKS0051F

1. CHECK CONNECTOR

1. Turn ignition switch OFF.
2. Disconnect the battery cable from the negative terminal.
3. Check following terminals and connectors for damage, bend and loose connection (control module side and harness side).
 - ECM connector
 - Harness connector E2
 - Harness connector F32

OK or NG

- OK >> GO TO 2.
- NG >> Repair terminal or connector.

2. CHECK HARNESS FOR OPEN CIRCUIT

1. Disconnect ECM connector.
2. Check resistance between ECM harness connector terminals.

ECM connector	Terminal		Resistance (Approx.)
E16	94	86	108 – 132 Ω

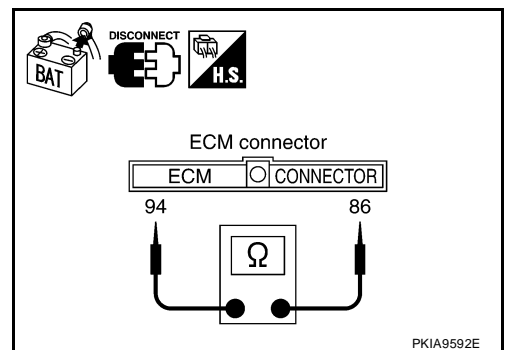

OK or NG

- OK >> Replace ECM.
- NG >> Repair harness between ECM and A/T assembly.

TCM Circuit Inspection

UKS0051G

1. CHECK CONNECTOR

1. Turn ignition switch OFF.
2. Disconnect the battery cable from the negative terminal.
3. Check terminals and connector of A/T assembly for damage, bend and loose connection (control module side and harness side).

OK or NG

- OK >> GO TO 2.
- NG >> Repair terminal or connector.

2. CHECK HARNESS FOR OPEN CIRCUIT

1. Disconnect A/T assembly connector.
2. Check resistance between A/T assembly harness connector terminals.

A/T assembly connector	Terminal		Resistance (Approx.)
F9	3	8	54 – 66 Ω

OK or NG

- OK >> Replace control valve with TCM.
- NG >> Repair harness between A/T assembly and harness connector F14.

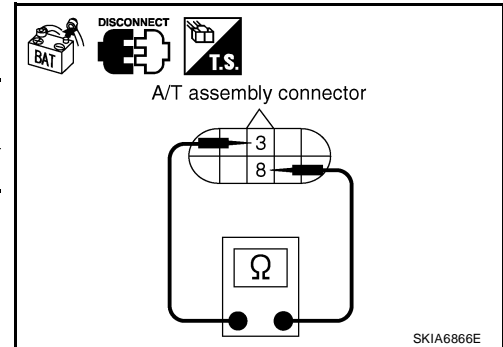

SKIA6866E

UKS0051H

Display Control Unit Circuit Inspection

1. CHECK CONNECTOR

1. Turn ignition switch OFF.
2. Disconnect the battery cable from the negative terminal.
3. Check terminals and connector of display control unit for damage, bend and loose connection (control unit side and harness side).

OK or NG

- OK >> GO TO 2.
- NG >> Repair terminal or connector.

2. CHECK HARNESS FOR OPEN CIRCUIT

1. Disconnect display control unit connector.
2. Check resistance between display control unit harness connector terminals.

Display control unit connector	Terminal		Resistance (Approx.)
M95	25	26	54 – 66 Ω

OK or NG

- OK >> Replace display control unit.
- NG >> Repair harness between display control unit and data link connector.

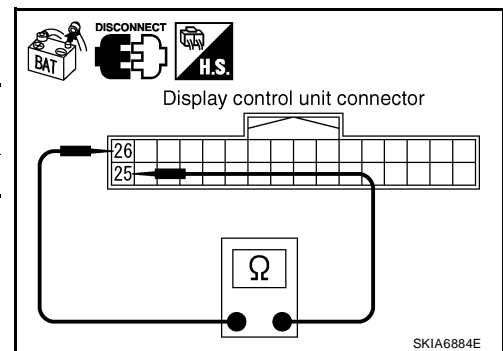

SKIA6884E

UKS0051I

Front Air Control Circuit Inspection

1. CHECK CONNECTOR

1. Turn ignition switch OFF.
2. Disconnect the battery cable from the negative terminal.
3. Check terminals and connector of front air control for damage, bend and loose connection (unit side and harness side).

OK or NG

- OK >> GO TO 2.
- NG >> Repair terminal or connector.

2. CHECK HARNESS FOR OPEN CIRCUIT

1. Disconnect front air control connector.
2. Check resistance between front air control harness connector terminals.

Front air control connector	Terminal		Resistance (Approx.)
	41	42	
M50	41	42	54 – 66 Ω

OK or NG

- OK >> Replace front air control.
- NG >> Repair harness between front air control and data link connector.

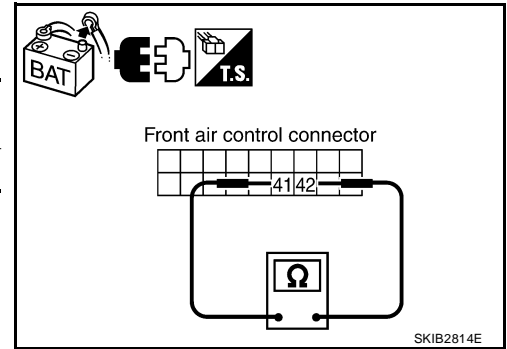

UKS0051J

Steering Angle Sensor Circuit Inspection

1. CHECK CONNECTOR

1. Turn ignition switch OFF.
2. Disconnect the battery cable from the negative terminal.
3. Check terminals and connector of steering angle sensor for damage, bend and loose connection (sensor side and harness side).

OK or NG

- OK >> GO TO 2.
- NG >> Repair terminal or connector.

2. CHECK HARNESS FOR OPEN CIRCUIT

1. Disconnect steering angle sensor connector.
2. Check resistance between steering angle sensor harness connector terminals.

Steering angle sensor connector	Terminal		Resistance (Approx.)
	4	5	
M47	4	5	54 – 66 Ω

OK or NG

- OK >> Replace steering angle sensor.
- NG >> Repair harness between steering angle sensor and data link connector.

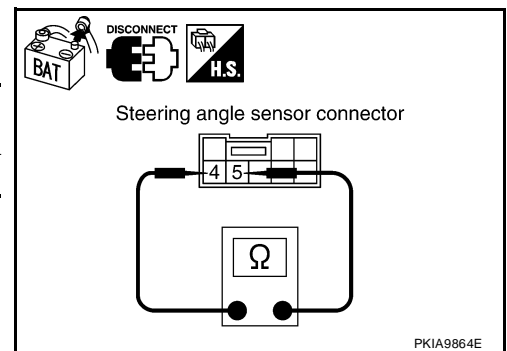

UKS0051K

Data Link Connector Circuit Inspection

1. CHECK CONNECTOR

1. Turn ignition switch OFF.
2. Disconnect the battery cable from the negative terminal.
3. Check data link connector and terminals for damage, bend and loose connection (connector side and harness side).

OK or NG

- OK >> GO TO 2.
- NG >> Repair terminal or connector.

A
B
C
D
E
F
G
H
I
J
LAN
L
M

2. CHECK HARNESS FOR OPEN CIRCUIT

Check resistance between data link connector terminals.

Data link connector	Terminal		Resistance (Approx.)
M22	6	14	54 – 66 Ω

OK or NG

- OK >> Diagnose again. Refer to [LAN-5, "TROUBLE DIAGNOSES WORK FLOW"](#).
- NG >> Repair harness between data link connector and BCM.

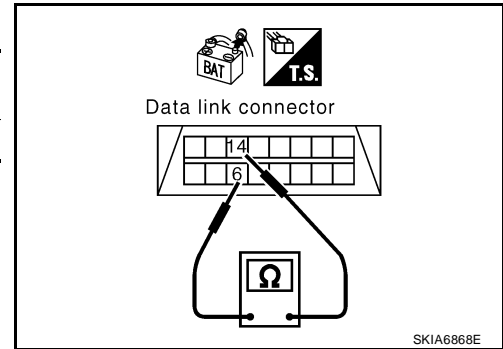

UKS0051L

BCM Circuit Inspection

1. CHECK CONNECTOR

1. Turn ignition switch OFF.
2. Disconnect the battery cable from the negative terminal.
3. Check terminals and connector of BCM for damage, bend and loose connection (control module side and harness side).

OK or NG

- OK >> GO TO 2.
- NG >> Repair terminal or connector.

2. CHECK HARNESS FOR OPEN CIRCUIT

1. Disconnect BCM connector.
2. Check resistance between BCM harness connector terminals.

BCM connector	Terminal		Resistance (Approx.)
M18	39	40	54 – 66 Ω

OK or NG

- OK >> Replace BCM. Refer to [BCS-27, "Removal and Installation"](#).
- NG >> Repair harness between BCM and data link connector.

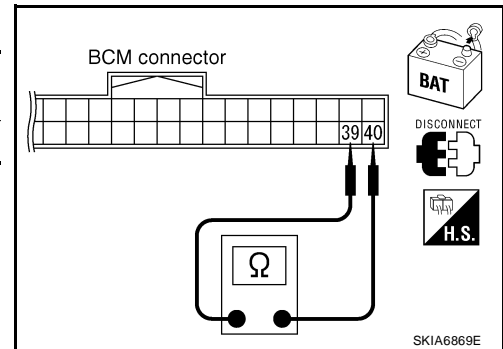

UKS0051M

Combination Meter Circuit Inspection

1. CHECK CONNECTOR

1. Turn ignition switch OFF.
2. Disconnect the battery cable from the negative terminal.
3. Check terminals and connector of combination meter for damage, bend and loose connection (meter side and harness side).

OK or NG

- OK >> GO TO 2.
- NG >> Repair terminal or connector.

2. CHECK HARNESS FOR OPEN CIRCUIT

1. Disconnect combination meter connector.
2. Check resistance between combination meter harness connector terminals.

Combination meter connector	Terminal		Resistance (Approx.)
M24	12	11	54 – 66 Ω

OK or NG

- OK >> Replace combination meter.
- NG >> Repair harness between combination meter and data link connector.

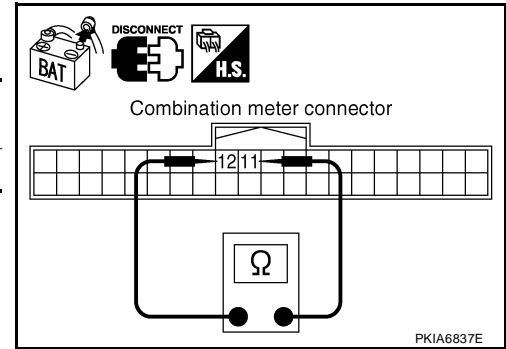

UKS0051N

Transfer Control Unit Circuit Inspection

1. CHECK CONNECTOR

1. Turn ignition switch OFF.
2. Disconnect the battery cable from the negative terminal.
3. Check terminals and connector of transfer control unit for damage, bend and loose connection (control unit side and harness side).

OK or NG

- OK >> GO TO 2.
- NG >> Repair terminal or connector.

2. CHECK HARNESS FOR OPEN CIRCUIT

All-mode 4WD system

1. Disconnect transfer control unit connector.
2. Check resistance between transfer control unit harness connector terminals.

Transfer control unit connector	Terminal		Resistance (Approx.)
M152	7	8	54 – 66 Ω

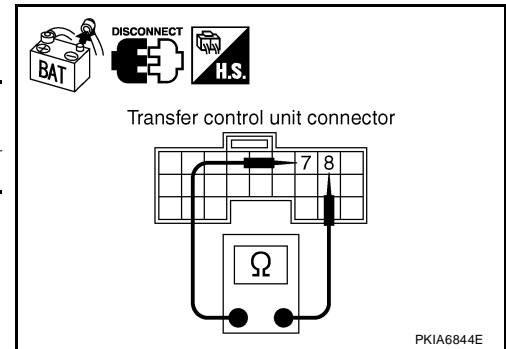

Part time 4WD system

1. Disconnect transfer control unit connector.
2. Check resistance between transfer control unit harness connector terminals.

Transfer control unit connector	Terminal		Resistance (Approx.)
M152	1	2	54 – 66 Ω

OK or NG

- OK >> Replace transfer control unit.
- NG >> Repair harness between transfer control unit and data link connector.

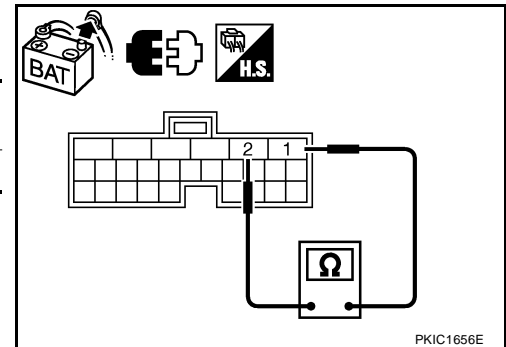

Driver Seat Control Unit Circuit Inspection

1. CHECK CONNECTOR

1. Turn ignition switch OFF.
2. Disconnect the battery cable from the negative terminal.
3. Check following terminals and connectors for damage, bend and loose connection (control unit side and harness side).
 - Driver seat control unit connector
 - Harness connector P1
 - Harness connector B37
 - Harness connector B69
 - Harness connector M40

OK or NG

- OK >> GO TO 2.
- NG >> Repair terminal or connector.

2. CHECK HARNESS FOR OPEN CIRCUIT

1. Disconnect driver seat control unit connector.
2. Check resistance between driver seat control unit harness connector terminals.

Transfer control unit connector	Terminal		Resistance (Approx.)
P2	3	19	54 – 66 Ω

OK or NG

- OK >> Replace driver seat control unit.
- NG >> Repair harness between driver seat control unit and data link connector.

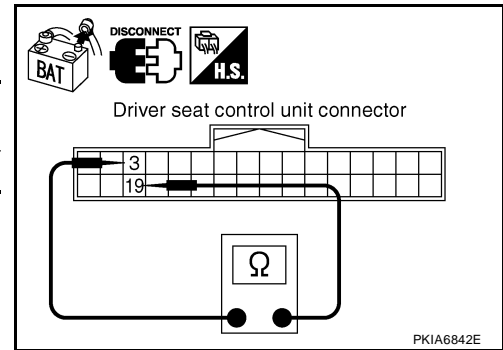

ABS Actuator and Electric Unit (Control Unit) Circuit Inspection

1. CHECK CONNECTOR

1. Turn ignition switch OFF.
2. Disconnect the battery cable from the negative terminal.
3. Check terminals and connector of ABS actuator and electric unit (control unit) for damage, bend and loose connection (control unit side and harness side).

OK or NG

- OK >> GO TO 2.
- NG >> Repair terminal or connector.

2. CHECK HARNESS FOR OPEN CIRCUIT

1. Disconnect ABS actuator and electric unit (control unit) connector.
2. Check resistance between ABS actuator and electric unit (control unit) harness connector terminals.

ABS actuator and electric unit (control unit) connector	Terminal		Resistance (Approx.)
E125	11	15	54 – 66 Ω

OK or NG

- OK >> Replace ABS actuator and electric unit (control unit).
- NG >> Repair harness between ABS actuator and electric unit (control unit) and IPDM E/R.

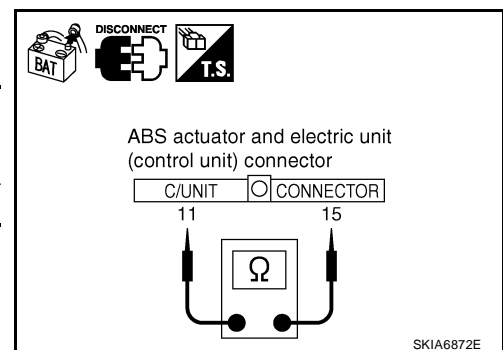

IPDM E/R Circuit Inspection

1. CHECK CONNECTOR

1. Turn ignition switch OFF.
2. Disconnect the battery cable from the negative terminal.
3. Check terminals and connector of IPDM E/R for damage, bend and loose connection (control module side and harness side).

OK or NG

- OK >> GO TO 2.
- NG >> Repair terminal or connector.

2. CHECK HARNESS FOR OPEN CIRCUIT

1. Disconnect IPDM E/R connector.
2. Check resistance between IPDM E/R harness connector terminals.

IPDM E/R connector	Terminal		Resistance (Approx.)
E122	39	40	108 – 132 Ω

OK or NG

- OK >> Replace IPDM E/R.
- NG >> Repair harness between IPDM E/R and ABS actuator and electric unit (control unit).

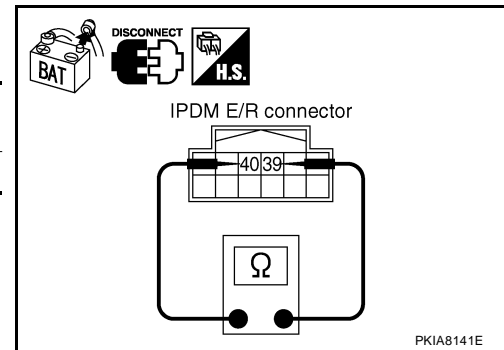

CAN Communication Circuit Inspection

1. CHECK CONNECTOR

1. Turn ignition switch OFF.
2. Disconnect the battery cable from the negative terminal.
3. Disconnect the harness connector for each unit on the CAN network and check terminals for deformation, disconnection, looseness or damage.

OK or NG

- OK >> GO TO 2.
- NG >> Repair terminal or connector as necessary.

2. CHECK HARNESS FOR SHORT CIRCUIT

With all module and control unit connectors disconnected, check continuity between data link connector terminals.

Data link connector	Terminal		Continuity
M22	6	14	No

OK or NG

- OK >> GO TO 3.
- NG >>
 - Repair harness.
 - Replace harness if shielded lines are used for the harness.

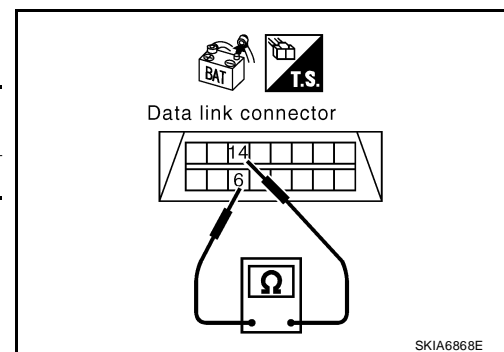

A
B
C
D
E
F
G
H
I
J
L
M

LAN

3. CHECK HARNESS FOR SHORT CIRCUIT

Check continuity between data link connector terminals and ground.

Data link connector	Terminal	Ground	Continuity
M22	6	Ground	No
	14		No

OK or NG

OK >> GO TO 4.

NG >> ● Repair harness.

- Replace harness if shielded lines are used for the harness.

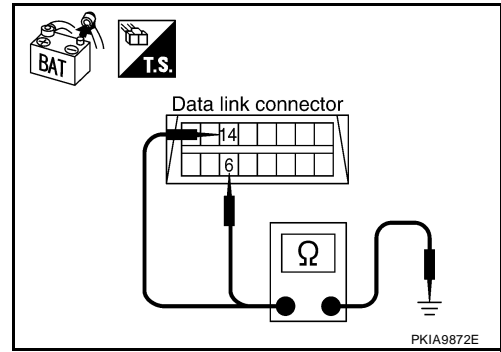

4. ECM AND IPDM E/R INTERNAL CIRCUIT INSPECTION

1. Remove ECM and IPDM E/R from vehicle.
2. Check resistance between ECM terminals.

Terminal	Terminal	Resistance (Approx.)
94	86	108 – 132 Ω

3. Check resistance between IPDM E/R terminals.

Terminal	Terminal	Resistance (Approx.)
39	40	108 – 132 Ω

OK or NG

OK >> GO TO 5.

NG >> Replace ECM and/or IPDM E/R.

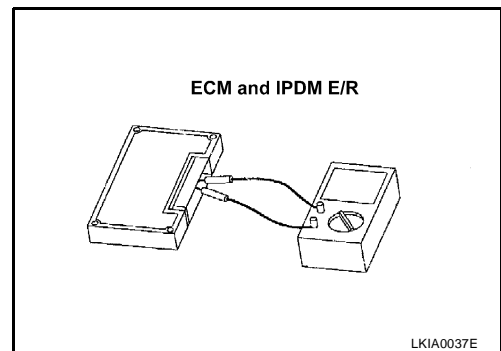

5. CHECK SYMPTOM

1. Fill in described symptoms on the column “Symptom” in the check sheet.
2. Connect all connectors, and then make sure that the symptom is reproduced.

Check results

Reproduced>>GO TO 6.

Not reproduced>>Refer to [LAN-14, "Example of Filling in Check Sheet When Initial Conditions Are Not Reproduced"](#) .

6. UNIT REPRODUCIBILITY INSPECTION

Perform the following procedure for each unit on the CAN network, and then perform reproducibility test.

1. Turn ignition switch OFF.
2. Disconnect the battery cable from the negative terminal.
3. Disconnect the unit connector.
4. Connect the battery cable to the negative terminal.
5. Make sure that the symptom filled in the “Symptom” of the check sheet is reproduced.

NOTE:

Malfunction (related to a unit that the connector is disconnected) is reproduced. Do not confuse the malfunction with the symptom filled in the column of “Symptom” on the check sheet.

Inspection results

Reproduced>>Connect the disconnected connector. Check other units applying the above procedure.

Not reproduced>>Replace the unit that the connector is disconnected.

IPDM E/R Ignition Relay Circuit Inspection

UKS0051S

Check the following. If no malfunction is found, replace the IPDM E/R.

TROUBLE DIAGNOSIS FOR SYSTEM

[CAN]

- IPDM E/R power supply circuit. Refer to [PG-31, "IPDM E/R Power/Ground Circuit Inspection"](#) .
- Ignition power supply circuit. Refer to [PG-14, "IGNITION POWER SUPPLY — IGNITION SW. IN ON AND/OR START"](#) .

A

B

C

D

E

F

G

H

I

J

LAN

L

M

