

SECTION HAC

HEATER & AIR CONDITIONING CONTROL SYSTEM

CONTENTS

AUTOMATIC AIR CONDITIONER	COMPONENT DIAGNOSIS	25	F
BASIC INSPECTION	MODE DOOR MOTOR	25	G
DIAGNOSIS AND REPAIR WORKFLOW	System Description	25	H
How to Perform Trouble Diagnosis For Quick And Accurate Repair	Mode Door Motor (Front) Component Function Check	26	H
INSPECTION AND ADJUSTMENT	Mode Door Motor (Front) Diagnosis Procedure	27	H
Operational Check (Front)	AIR MIX DOOR MOTOR	31	HAC
Operational Check (Rear)	System Description	31	J
FUNCTION DIAGNOSIS	Air Mix Door Motor Component Function Check	32	K
FUNCTION INFORMATION	Air Mix Door Motor (Driver) Diagnosis Procedure.....	33	L
Component Part Location	Air Mix Door Motor (Passenger) Diagnosis Proce- dure	37	M
Symptom Table	INTAKE DOOR MOTOR	41	N
REFRIGERATION SYSTEM	System Description	41	O
Refrigerant Cycle	Intake Door Motor Component Function Check	42	P
Refrigerant System Protection	Intake Door Motor Diagnosis Procedure	43	
AUTOMATIC AIR CONDITIONER SYSTEM	BLOWER MOTOR CONTROL SYSTEM	45	
Control System Diagram	System Description	45	
Control System Description	Front Blower Motor Component Function Check	46	
Discharge Air Flow (Front)	Front Blower Motor Diagnosis Procedure	47	
Switches And Their Control Function (Front)	Front Blower Motor Component Inspection	50	
Switches And Their Control Function (Rear)	Rear Blower Motor Description	51	
CAN COMMUNICATION SYSTEM	Rear Blower motor Component Function Check	52	
System Description	Rear Air Control (Front) Diagnosis Procedure #1	53	
DIAGNOSIS SYSTEM (HVAC)	Rear Air Control (Rear) Diagnosis Procedure #2	54	
CONSULT-III Function (HVAC)	Rear Air Control (Rear) Diagnosis Procedure #3	55	
DIAGNOSIS SYSTEM (BCM)	Rear Air Control (Rear) Diagnosis Procedure #4	58	
CONSULT-III Function (BCM)	Rear Blower Motor And Relay Component Inspec- tion	59	
SELF-DIAGNOSIS FUNCTION	REAR AIR CONTROL SYSTEM	61	
A/C Auto Amp. Self-Diagnosis	Rear Air Control System Description	61	
A/C and AV Switch Assembly Self-Diagnosis	Rear Air Control Component Function Check	61	
A/C System Self-Diagnosis Code Chart	Rear Air Control (Front) Diagnosis Procedure	62	
	Rear Air Control (Rear) Diagnosis Procedure	64	
	MAGNET CLUTCH	67	
	System Description	67	

Magnet Clutch Component Function Check	67	MEMORY FUNCTION DOES NOT OPERATE.	119
Magnet Clutch Diagnosis Procedure	68	Memory Function Check	119
WATER VALVE CIRCUIT	72	PRECAUTION	120
Water Valve Description (VK56DE)	72	PRECAUTIONS	120
Water Valve Diagnosis Procedure (VK56DE)	72	Supplemental Restraint System (SRS) "AIR BAG" and "SEAT BELT PRE-TENSIONER"	120
HEATER PUMP	74	Working with HFC-134a (R-134a)	120
System Description (VQ40DE)	74	Precaution for Service Equipment	121
Diagnosis Procedure (VQ40DE)	74	MANUAL AIR CONDITIONER	
Component Inspection (VQ40DE)	76	BASIC INSPECTION	122
AMBIENT SENSOR	77	DIAGNOSIS AND REPAIR WORKFLOW	122
Component Description	77	How to Perform Trouble Diagnosis For Quick And Accurate Repair	122
Ambient Sensor Diagnosis Procedure	77	INSPECTION AND ADJUSTMENT	123
Ambient Sensor Component Inspection	78	Operational Check	123
IN-VEHICLE SENSOR	80	FUNCTION DIAGNOSIS	125
Component Description	80	FUNCTION INFORMATION	125
In-Vehicle Sensor Diagnosis Procedure	80	Component Part Location	125
In-Vehicle Sensor Component Inspection	82	Symptom Table	127
OPTICAL SENSOR	83	REFRIGERATION SYSTEM	128
Component Description	83	Refrigerant Cycle	128
Optical Sensor Diagnosis Procedure	83	Refrigerant System Protection	128
INTAKE SENSOR	85	MANUAL AIR CONDITIONER SYSTEM	129
System Description	85	Control System Diagram	129
Intake Sensor Diagnosis Procedure	85	Control System Description	129
Intake Sensor Component Inspection	86	Discharge Air Flow	131
POWER SUPPLY AND GROUND CIRCUIT FOR CONTROLLER	87	Switches And Their Control Function	131
Component Description	87	CAN COMMUNICATION SYSTEM	133
A/C Auto Amp. Component Function Check	87	System Description	133
A/C Auto Amp Power and Ground Diagnosis Pro- cedure	88	DIAGNOSIS SYSTEM (BCM)	134
ECU DIAGNOSIS	89	CONSULT-III Function (BCM)	134
AIR CONDITIONER CONTROL	89	COMPONENT DIAGNOSIS	135
A/C Auto Amp. Terminals Reference Values	89	MODE DOOR MOTOR	135
Wiring Diagram	91	System Description	135
SYMPTOM DIAGNOSIS	106	Mode Door Motor (Front) Component Function Check	135
AIR CONDITIONER CONTROL	106	Mode Door Motor (Front) Diagnosis Procedure ...	136
Symptom Matrix Chart	106	AIR MIX DOOR MOTOR	139
INSUFFICIENT COOLING	107	System Description	139
Component Function Check	107	Air Mix Door Motor Component Function Check .	140
Performance Test Diagnoses	108	Air Mix Door Motor Diagnosis Procedure	141
Performance Chart	110	INTAKE DOOR MOTOR	143
Test Reading	111	System Description	143
Trouble Diagnoses for Unusual Pressure	112	Intake Door Motor Component Function Check ...	143
INSUFFICIENT HEATING	115	Intake Door Motor Diagnosis Procedure	144
Component Function Check	115	BLOWER MOTOR	146
NOISE	117		
Component Function Check	117		

System Description	146	Wiring Diagram	164
Front Blower Motor Component Function Check ..	146	SYMPTOM DIAGNOSIS	171
Front Blower Motor Diagnosis Procedure	147	AIR CONDITIONER CONTROL	171
Front Blower Motor Component Inspection	151	Symptom Matrix Chart	171
MAGNET CLUTCH	152	INSUFFICIENT COOLING	172
System Description	152	Component Function Check	172
Magnet Clutch Component Function Check	152	Performance Test Diagnoses	173
Magnet Clutch Diagnosis Procedure	152	Performance Chart	175
INTAKE SENSOR	157	Test Reading	176
System Description	157	Trouble Diagnoses for Unusual Pressure	177
Intake Sensor Diagnosis Procedure	157	INSUFFICIENT HEATING	181
Intake Sensor Component Inspection	158	Component Function Check	181
POWER SUPPLY AND GROUND CIRCUIT		NOISE	183
FOR CONTROLLER	159	Component Function Check	183
Component Description	159	PRECAUTION	185
Front Air Control Component Function Check	159	PRECAUTIONS	185
Front Air Control Power and Ground Diagnosis		Supplemental Restraint System (SRS) "AIR BAG"	
Procedure	160	and "SEAT BELT PRE-TENSIONER"	185
ECU DIAGNOSIS	161	Working with HFC-134a (R-134a)	185
AIR CONDITIONER CONTROL	161	Precaution for Service Equipment	186
System Description	161		
System Operation	161		
Front Air Control Terminals Reference Values	162		

A
B
C
D
E
F
G
H
HAC
J
K
L
M
N
O
P

BASIC INSPECTION

DIAGNOSIS AND REPAIR WORKFLOW

How to Perform Trouble Diagnosis For Quick And Accurate Repair

INFOID:00000000136682

WORK FLOW

1. LISTEN TO CUSTOMER COMPLAINT

Listen to customer complaint. Get detailed information about the conditions and environment when the symptom occurs.

>> GO TO 2

2. CHECK FOR SERVICE BULLETINS

Check for any service bulletins.

>> GO TO 3.

3. VERIFY THE SYMPTOM WITH OPERATIONAL CHECK

Verify the symptom with operational check. Refer to [HAC-123, "Operational Check"](#).

Can a symptom be duplicated?

YES >> GO TO 4

NO >> GO TO 5

4. GO TO APPROPRIATE TROUBLE DIAGNOSIS

Go to appropriate trouble diagnosis. Refer to [HAC-171, "Symptom Matrix Chart"](#).

Can a symptom be duplicated?

>> GO TO 5.

5. PERFORM THE A/C AUTO AMP SELF-DIAGNOSIS

Perform A/C auto amp. self-diagnosis. Refer to [HAC-23, "A/C Auto Amp. Self-Diagnosis"](#).

>> If any diagnostic trouble codes set. Refer to [HAC-24, "A/C System Self-Diagnosis Code Chart"](#).

>> Confirm the repair by performing operational check. Refer to [HAC-123, "Operational Check"](#).

INSPECTION AND ADJUSTMENT

< BASIC INSPECTION >

[AUTOMATIC AIR CONDITIONER]

INSPECTION AND ADJUSTMENT

Operational Check (Front)

INFOID:000000001366683

The purpose of the operational check is to confirm that the system operates properly.

Conditions : Engine running and at normal operating temperature

CHECKING MEMORY FUNCTION

1. Set the temperature to 32°C (90°F).
2. Press the OFF switch.
3. Turn ignition switch OFF.
4. Turn ignition switch ON.
5. Press the AUTO switch.
6. Confirm that the set temperature remains at previous temperature.

7. Press the OFF switch.

If NG, go to trouble diagnosis procedure for [HAC-119, "Memory Function Check"](#).

If OK, continue with next check.

CHECKING BLOWER

1. Press the blower speed control switch (+) once, blower should operate on low speed. The fan display should have one bar lit (on display).
2. Press the blower speed control switch (+) again, and continue checking blower speed and fan display until all speeds are checked.
3. Leave blower on maximum speed.

If NG, go to trouble diagnosis procedure for [HAC-147, "Front Blower Motor Diagnosis Procedure"](#).

If OK, continue with next check.

CHECKING DISCHARGE AIR

1. Press MODE switch four times and the DEF  switch.
2. Each position indicator should change shape (on display).
3. Confirm that discharge air comes out according to the air distribution table. Refer to [HAC-17, "Discharge Air Flow \(Front\)"](#).

Mode door position is checked in the next step.



If NG, go to trouble diagnosis procedure for [HAC-136, "Mode Door Motor \(Front\) Diagnosis Procedure"](#).

If OK, continue the check.

NOTE:

Confirm that the compressor clutch is engaged (sound or visual inspection) and intake door position is at fresh when the FOOT, DEF or D/F is selected.





CHECKING RECIRCULATION (, ONLY)

1. Press recirculation () switch one time. Recirculation indicator should illuminate.
2. Press recirculation () switch one more time. Recirculation indicator should go off.
3. Listen for intake door position change (blower sound should change slightly).

If NG, go to trouble diagnosis procedure for [HAC-144, "Intake Door Motor Diagnosis Procedure"](#).

If OK, continue the check.

NOTE:

Confirm that the compressor clutch is engaged (sound or visual inspection) and intake door position is at fresh when the FOOT, DEF or D/F is selected. REC () is not allowed in DEF () D/F () or FOOT ().

CHECKING TEMPERATURE DECREASE

1. Rotate temperature control dial (drive or passenger) counterclockwise until 18°C (60°F) is displayed.
2. Check for cold air at appropriate discharge air outlets.

INSPECTION AND ADJUSTMENT

< BASIC INSPECTION >

[AUTOMATIC AIR CONDITIONER]

If NG, listen for sound of air mix door motor operation. If OK, go to trouble diagnosis procedure for [HAC-172, "Component Function Check"](#). If air mix door motor appears to be malfunctioning, go to [HAC-32, "Air Mix Door Motor Component Function Check"](#).

If OK, continue the check.

CHECKING TEMPERATURE INCREASE

1. Rotate temperature control dial clockwise (drive or passenger) until 32°C (90°F) is displayed.
2. Check for hot air at appropriate discharge air outlets.

If NG, listen for sound of air mix door motor operation. If OK, go to trouble diagnosis procedure for [HAC-181, "Component Function Check"](#). If air mix door motor appears to be malfunctioning, go to [HAC-32, "Air Mix Door Motor Component Function Check"](#).

If OK, continue with next check.

CHECK A/C SWITCH

1. Press A/C switch when AUTO switch is ON, or in manual mode.
2. A/C switch indicator will turn ON.
 - Confirm that the compressor clutch engages (sound or visual inspection).

NOTE:

If current mode setting is DEF or D/F, compressor clutch will already be engaged and cannot be turned off.

If NG, go to trouble diagnosis procedure for [HAC-152, "Magnet Clutch Diagnosis Procedure"](#).

If OK, continue with next check.

CHECKING AUTO MODE

1. Press AUTO switch.
2. Display should indicate AUTO.
 - If ambient temperature is warm, and selected temperature is cool, confirm that the compressor clutch engages (sound or visual inspection). (Discharge air and blower speed will depend on ambient, in-vehicle, and set temperatures.)

If NG, go to trouble diagnosis procedure for [HAC-160, "Front Air Control Power and Ground Diagnosis Procedure"](#), then if necessary, trouble diagnosis procedure for [HAC-152, "Magnet Clutch Diagnosis Procedure"](#).

If all operational checks are OK (symptom cannot be duplicated), go to malfunction Simulation Tests in [HAC-122, "How to Perform Trouble Diagnosis For Quick And Accurate Repair"](#) and perform tests as outlined to simulate driving conditions environment. If symptom appears. Refer to [HAC-171, "Symptom Matrix Chart"](#), and perform applicable trouble diagnosis procedures.

Operational Check (Rear)

INFOID:00000000136684

The purpose of the operational check is to confirm that the system operates properly.

Conditions : Engine running and at normal operating temperature

CHECKING REAR BLOWER MOTOR

1. Turn the ignition switch ON.
2. Rotate rear air control (front) blower control dial to low speed.
3. Rotate the blower control dial clockwise and continue checking blower speed until all speeds are checked.
4. Leave blower on maximum speed.
5. Press the REAR CTRL switch from the rear air control (front).
6. Rotate rear air control (rear) blower control dial to low speed.
7. Rotate the blower control dial clockwise and continue checking blower speed until all speeds are checked.
8. Leave blower on maximum speed.

If NG, go to trouble diagnosis procedure for [HAC-52, "Rear Blower motor Component Function Check"](#).

If OK, continue with next check.

CHECKING REAR TEMPERATURE DECREASE

1. Press the REAR CTRL switch (indicator off).
2. Rotate the rear air control (front) temperature control dial counterclockwise to maximum cold.
3. Check for cold air at appropriate discharge air outlets.

INSPECTION AND ADJUSTMENT

< BASIC INSPECTION >

[AUTOMATIC AIR CONDITIONER]

4. Press the REAR CTRL switch (indicator on) from the rear air control (front).
5. Rotate the rear air control (rear) temperature control dial counterclockwise to maximum cold.
6. Check for cold air at appropriate discharge air outlets.

If NG, listen for sound of air mix door motor operation. If OK, go to trouble diagnosis procedure for [HAC-140, "Air Mix Door Motor Component Function Check"](#). If air mix door motor appears to be malfunctioning, go to [HAC-64, "Rear Air Control \(Rear\) Diagnosis Procedure"](#).

If OK, continue with next check.

CHECKING REAR TEMPERATURE INCREASE

1. Press the REAR CTRL switch (indicator off).
2. Rotate the rear air control (front) temperature control dial clockwise to maximum heat.
3. Check for hot air at appropriate discharge air outlets.
4. Press the REAR CTRL switch (indicator on) from the rear air control (front).
5. Rotate the rear air control (rear) temperature control dial clockwise to maximum heat.
6. Check for hot air at appropriate discharge air outlets.

If NG, listen for sound of air mix door motor operation. If OK, go to trouble diagnosis procedure for [HAC-115, "Component Function Check"](#). If air mix door motor appears to be malfunctioning, go to [HAC-64, "Rear Air Control \(Rear\) Diagnosis Procedure"](#).

If NG, go to trouble diagnosis procedure for [HAC-181, "Component Function Check"](#).

If all operational checks are OK (symptom cannot be duplicated), go to [HAC-122, "How to Perform Trouble Diagnosis For Quick And Accurate Repair"](#) and perform tests as outlined. If symptom appears, refer to [HAC-171, "Symptom Matrix Chart"](#) and perform applicable trouble diagnosis procedures.

A
B
C
D
E
F
G
H
J
K
L
M
N
O
P

HAC

FUNCTION INFORMATION

< FUNCTION DIAGNOSIS >

[AUTOMATIC AIR CONDITIONER]

FUNCTION DIAGNOSIS

FUNCTION INFORMATION

Component Part Location

INFOID:00000000136685

ENGINE COMPARTMENT

VQ40DE

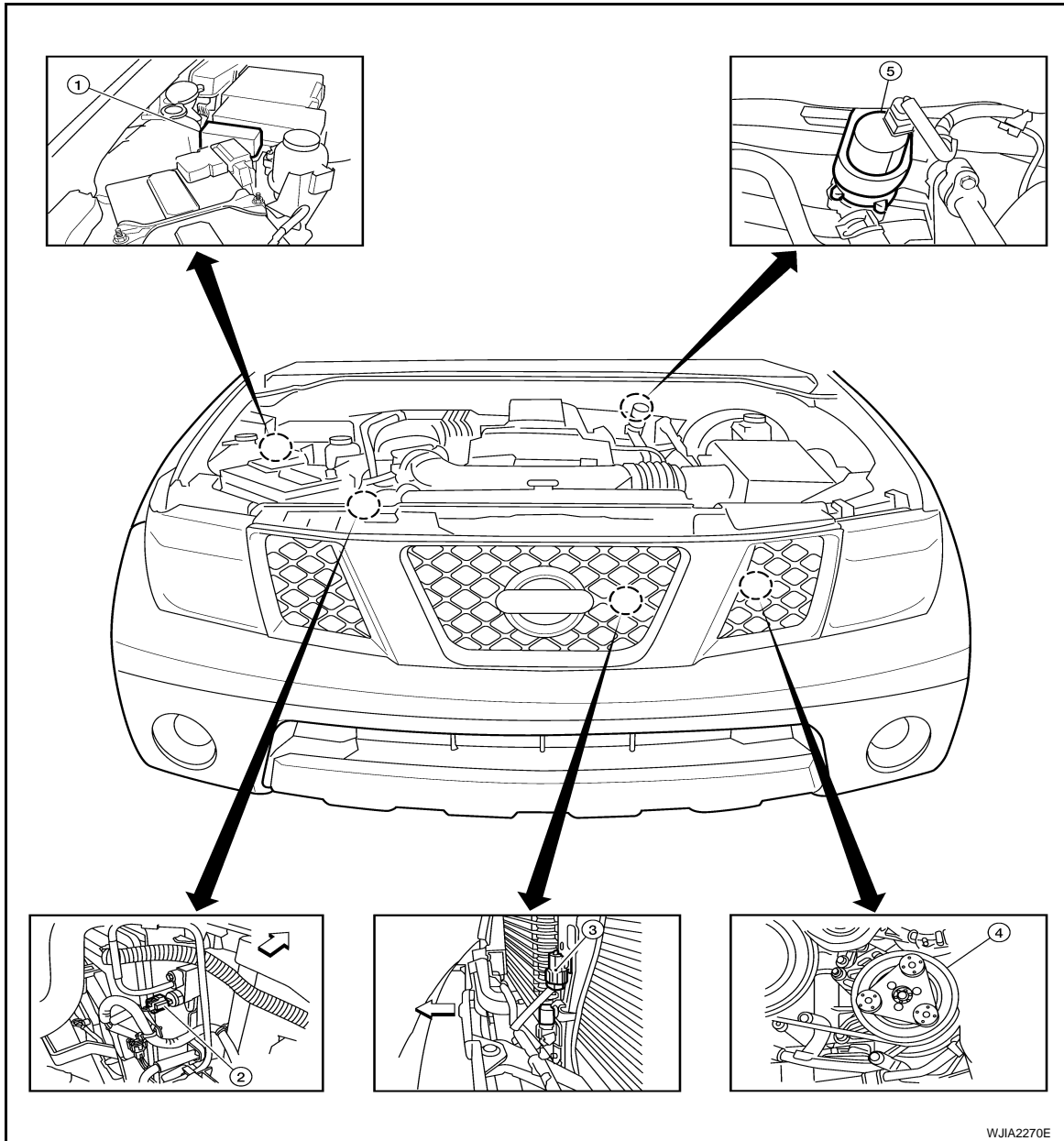

1. Heater pump relay E144
2. Refrigerant pressure sensor E48
(View with battery removed)
←: Front
3. Ambient sensor E1 (View with grille removed)
4. A/C Compressor F3
5. Heater pump E141

FUNCTION INFORMATION

< FUNCTION DIAGNOSIS >

[AUTOMATIC AIR CONDITIONER]

VK56DE

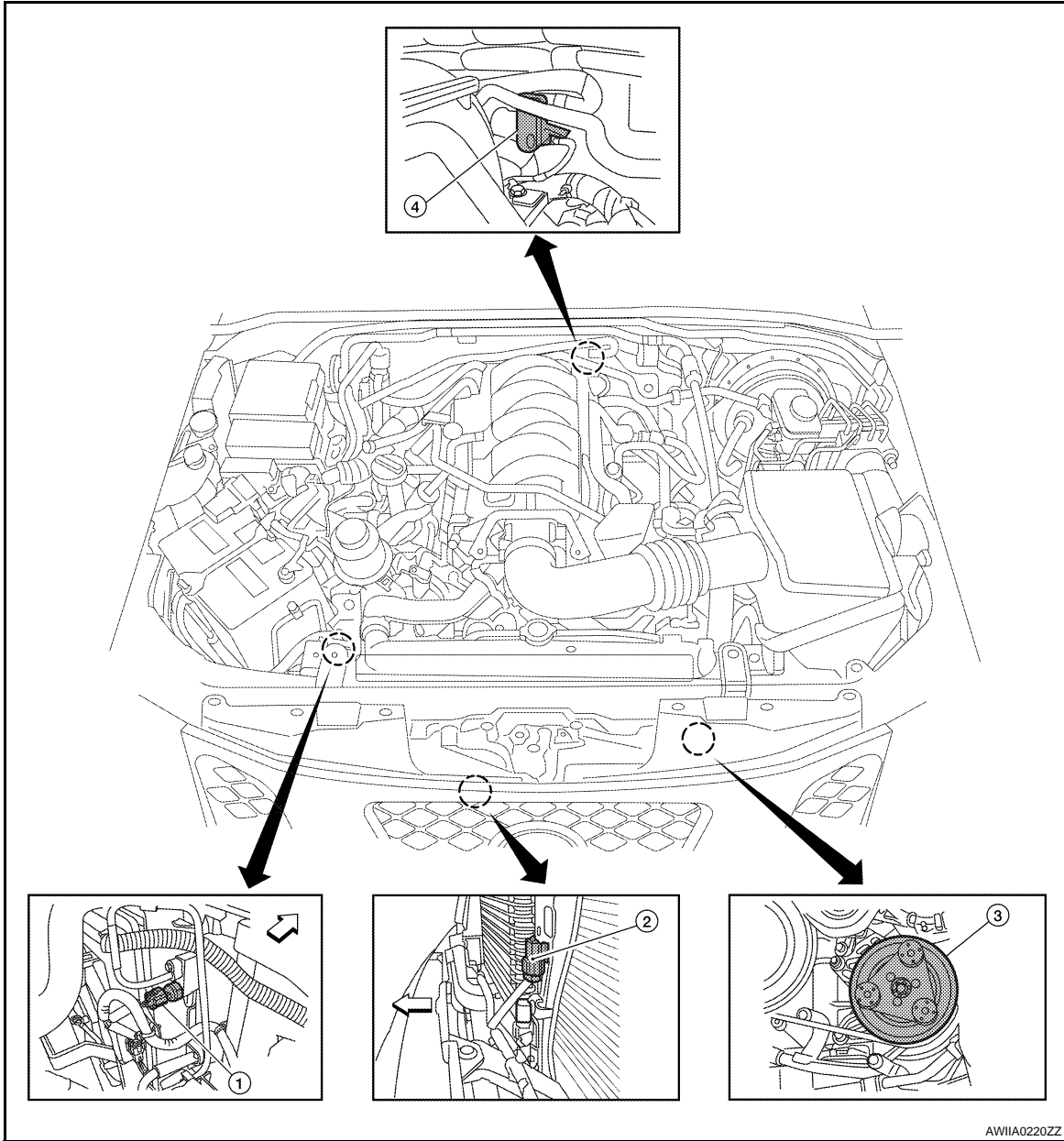

1. Refrigerant pressure sensor E48
(View with battery removed)

←: Front

4. Water valve F68

2. Ambient sensor E1 (View with grille removed)

3. A/C Compressor F3

PASSENGER COMPARTMENT

A
B
C
D
E
F
G
H
HAC
J
K
L
M
N
O
P

FUNCTION INFORMATION

< FUNCTION DIAGNOSIS >

[AUTOMATIC AIR CONDITIONER]

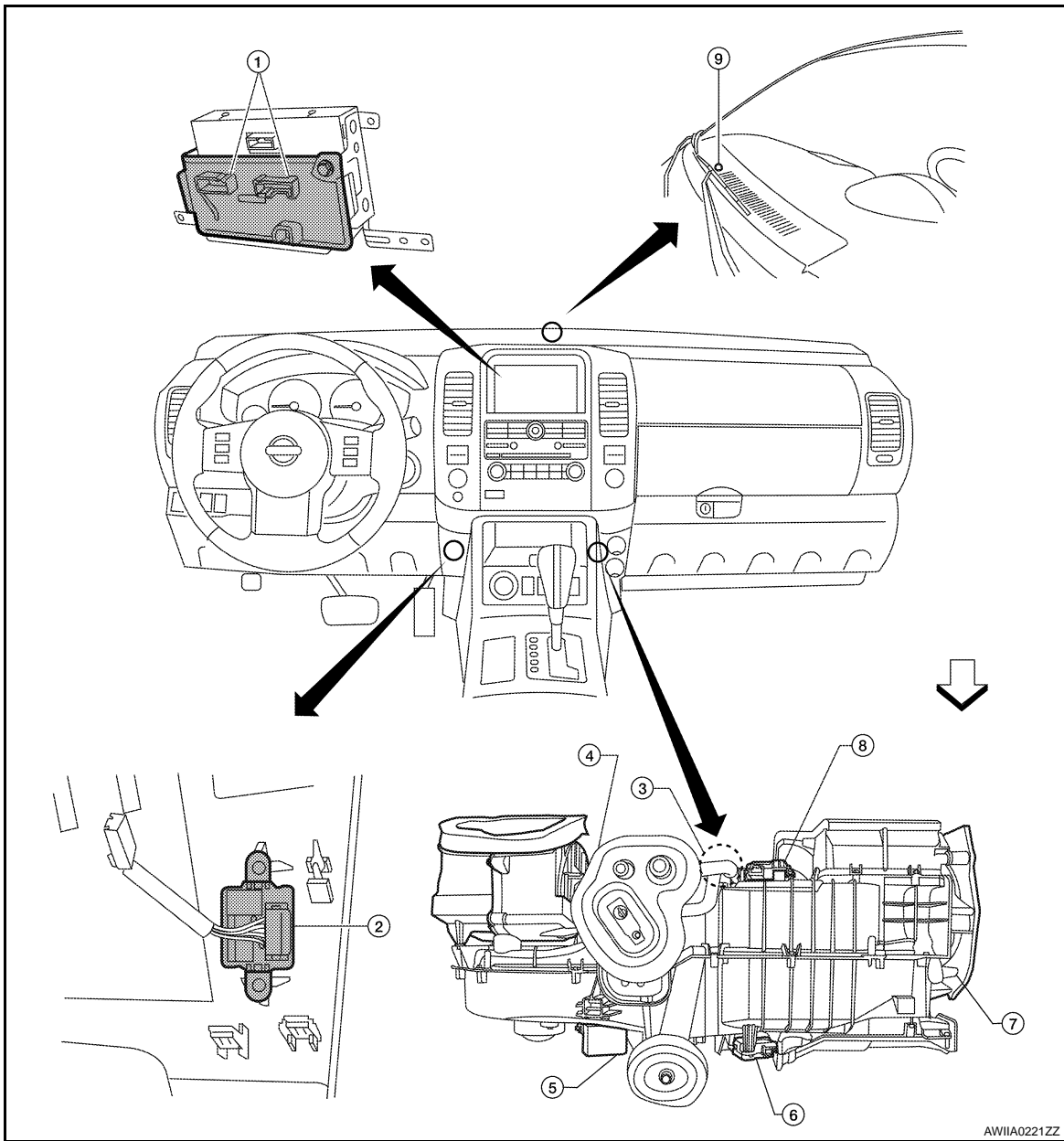

- | | | |
|---------------------------------|---|-------------------------------------|
| 1. A/C Auto amp. M49, M50 | 2. In-vehicle sensor M32 | 3. Intake sensor M146 |
| 4. Intake door motor M58 | 5. Variable blower control (front) M122 | 6. Air mix door motor (driver) M147 |
| 7. Mode door motor (front) M142 | 8. Air mix door motor (passenger) M143 | 9. Optical sensor M145 |

← :Front

←

FUNCTION INFORMATION

< FUNCTION DIAGNOSIS >

[AUTOMATIC AIR CONDITIONER]

REAR PASSENGER COMPARTMENT

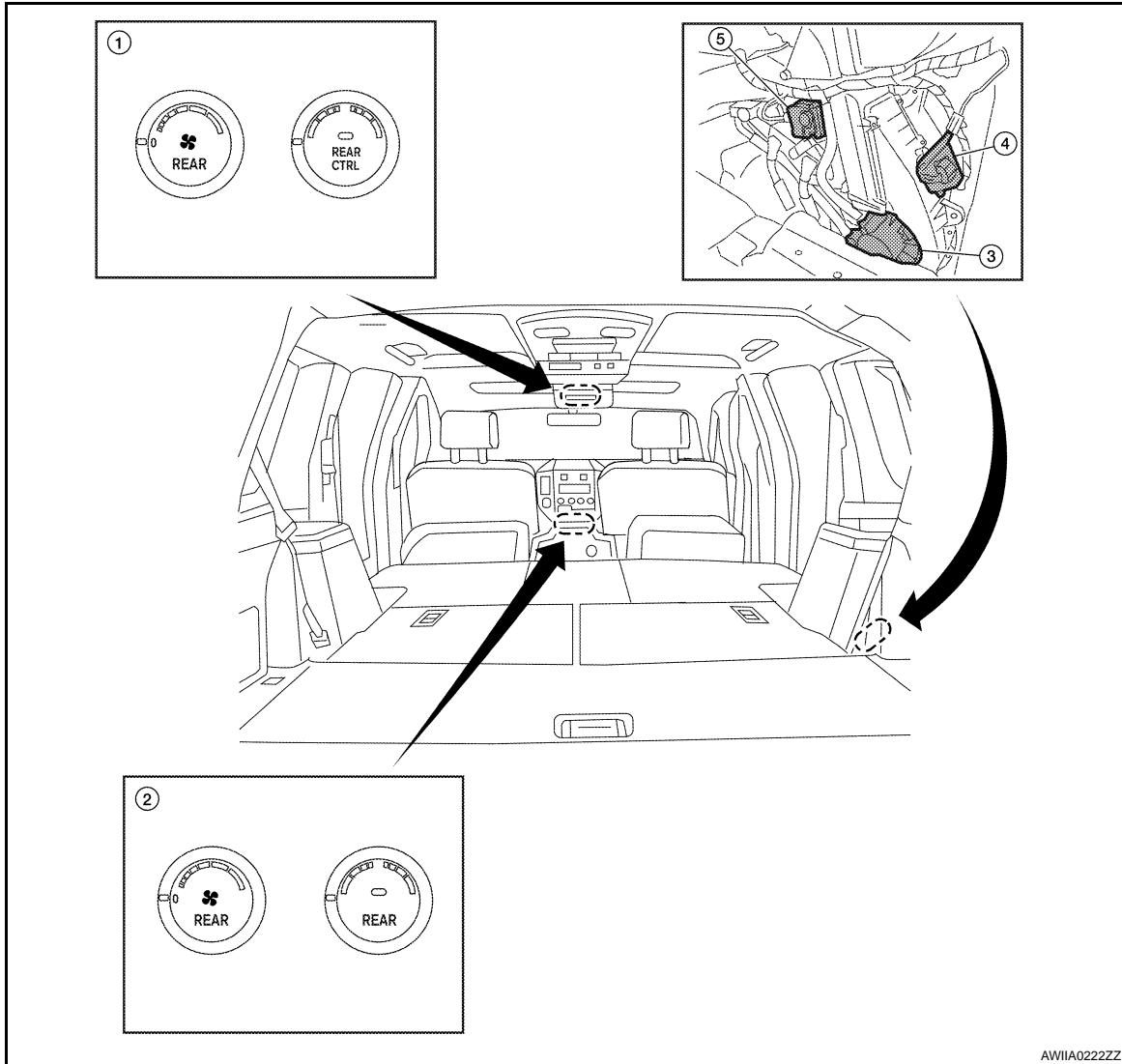

1. Rear air control (front) R2
2. Air mix door motor (rear) B155
3. Rear blower motor B501
4. Variable blower control (rear) B133
5. Rear air control (rear) M208

Symptom Table

INFOID:000000001366686

Symptom	Reference Page
A/C system does not come on.	Go to Trouble Diagnosis Procedure for A/C System. HAC-87
A/C system display is malfunctioning (with NAVI).	Go to Navigation System. AV-337
A/C system display is malfunctioning (without NAVI).	Go to Mid-level Audio System. AV-179
A/C system cannot be controlled.	Go to Self-diagnosis Function. HAC-23
Air outlet does not change.	Go to Trouble Diagnosis Procedure for Mode Door Motor. HAC-27
Mode door motor is malfunctioning.	
Discharge air temperature does not change.	Go to Trouble Diagnosis Procedure for Air Mix Door Motor. HAC-32
Air mix door motor is malfunctioning.	

FUNCTION INFORMATION

< FUNCTION DIAGNOSIS >

[AUTOMATIC AIR CONDITIONER]

Symptom	Reference Page	
Intake door does not change.	Go to Trouble Diagnosis Procedure for Intake Door Motor.	HAC-43
Intake door motor is malfunctioning.		
Front blower motor operation is malfunctioning.	Go to Trouble Diagnosis Procedure for Front Blower Motor.	HAC-47
Rear blower motor operation is malfunctioning.	Go to Trouble Diagnosis Procedure for Rear Blower Motor.	HAC-52
Rear discharge air temperature and/or air outlet does not change.	Go to Trouble Diagnosis Procedure for Rear Air Control circuit.	HAC-61
Magnet clutch does not engage.	Go to Trouble Diagnosis Procedure for Magnet Clutch.	HAC-68
Insufficient cooling	Go to Trouble Diagnosis Procedure for Insufficient Cooling.	HAC-107
Insufficient heating	Go to Trouble Diagnosis Procedure for Insufficient Heating.	HAC-115
Noise	Go to Trouble Diagnosis Procedure for Noise.	HAC-117
Self-diagnosis cannot be performed.	Go to Trouble Diagnosis Procedure for Self-diagnosis.	HAC-87
Memory function does not operate.	Go to Trouble Diagnosis Procedure for Memory Function.	HAC-119

REFRIGERATION SYSTEM

< FUNCTION DIAGNOSIS >

[AUTOMATIC AIR CONDITIONER]

REFRIGERATION SYSTEM

Refrigerant Cycle

INFOID:000000001366687

Refer to [HAC-13. "Refrigerant Cycle"](#).

Refrigerant System Protection

INFOID:000000001366688

Refer to [HAC-13. "Refrigerant System Protection"](#).

A

B

C

D

E

F

G

H

HAC

J

K

L

M

N

O

P

AUTOMATIC AIR CONDITIONER SYSTEM

< FUNCTION DIAGNOSIS >

[AUTOMATIC AIR CONDITIONER]

AUTOMATIC AIR CONDITIONER SYSTEM

Control System Diagram

INFOID:00000000136689

CONTROL SYSTEM

The control system consists of input sensors, switches, the A/C auto amp. (microcomputer) and outputs. The relationship of these components is shown in the figure below:

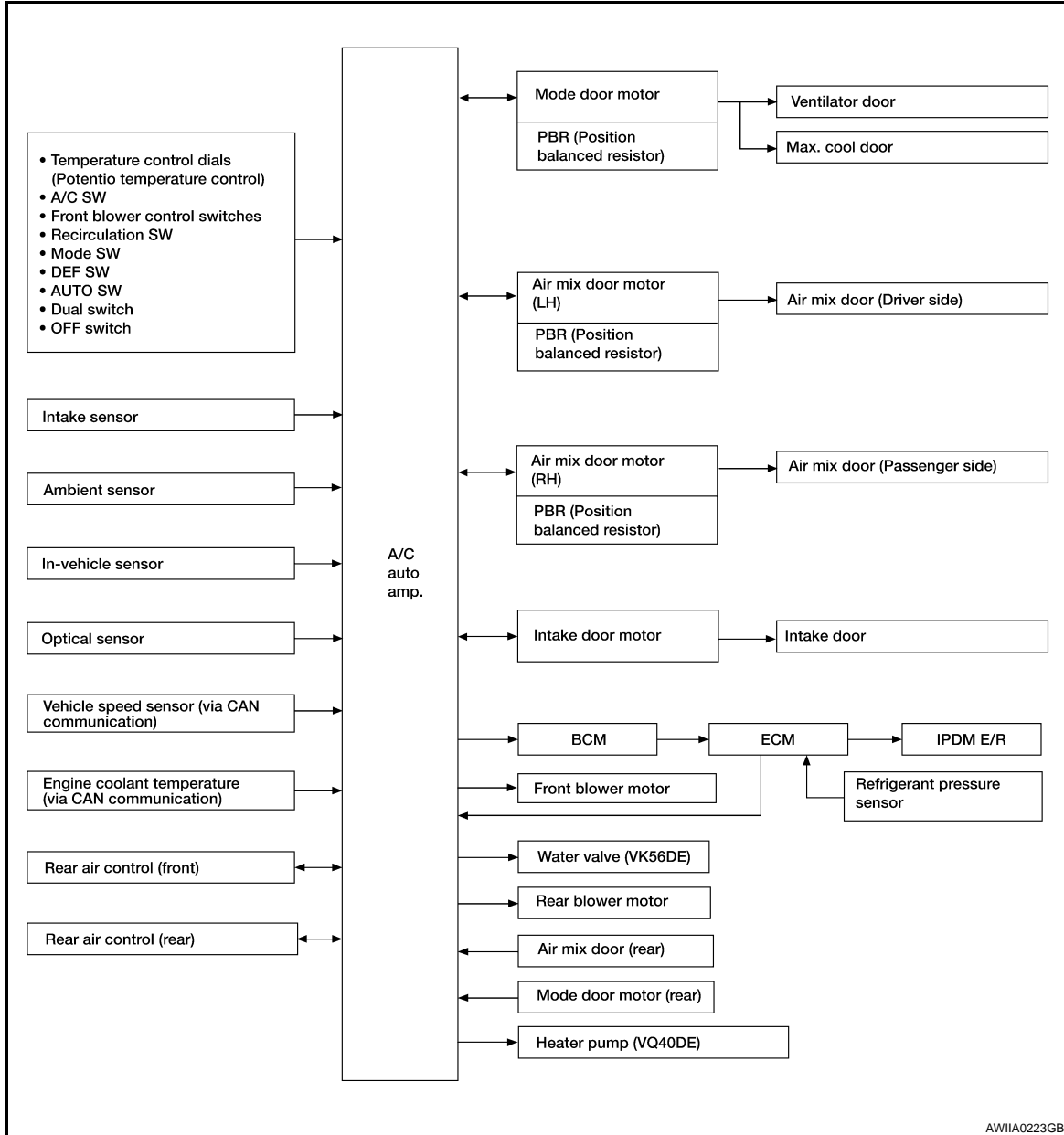

Control System Description

INFOID:00000000136690

CONTROL OPERATION

AUTOMATIC AIR CONDITIONER SYSTEM

< FUNCTION DIAGNOSIS >

[AUTOMATIC AIR CONDITIONER]

A/C Auto Amp.

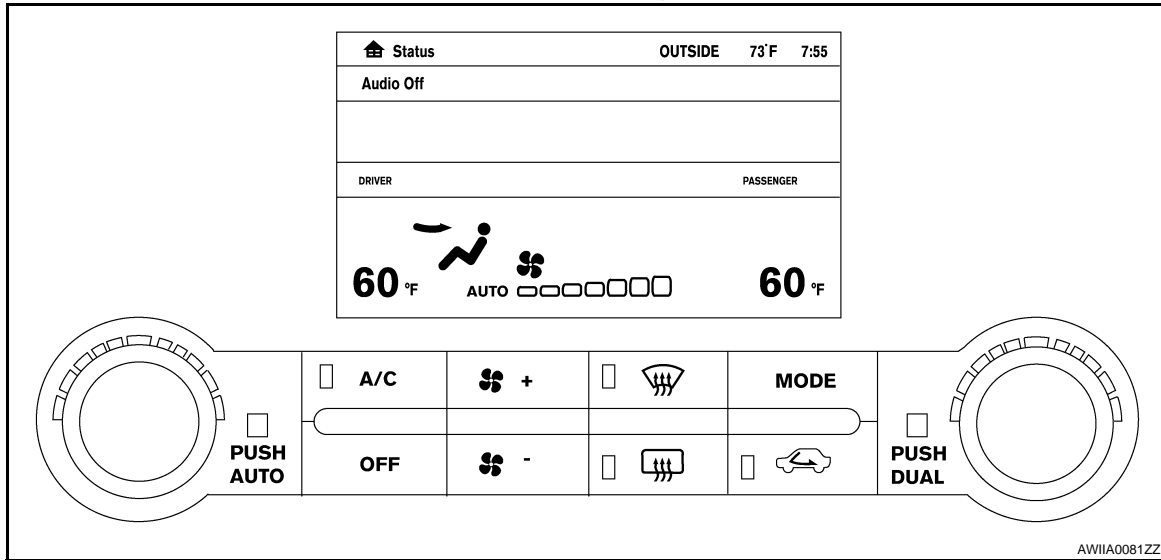

DISPLAY SCREEN

Displays the operational status of the system.

AUTO SWITCH

- Pressing the AUTO switch will illuminate the LED and "Auto" will be visible on the display. The A/C indicator will illuminate.
- The A/C compressor, intake door, air mix doors, outlet doors and blower speed are automatically controlled so that the in-vehicle temperature will reach, and be maintained at the set temperature selected by the operator.
- When pressing AUTO switch, air inlet, air outlet, blower speed, and discharge air temperature are automatically controlled.
- A partial AUTO mode can be achieved by only changing the blower speed or by changing the mode position. If both the blower speed and the mode positions are changed, the AUTO mode will be cancelled.

TEMPERATURE CONTROL DIAL (DRIVER)

Increases or decreases the set temperature.

TEMPERATURE CONTROL DIAL (PASSENGER)

Increases or decreases the set temperature.

RECIRCULATION () SWITCH

- When REC switch is ON, REC switch indicator turns ON, and air inlet is set to REC.
- When REC switch is turned OFF, or when compressor is turned from ON to OFF, REC switch is automatically turned OFF. REC mode can be re-entered by pressing REC switch again.
- REC switch is not operated when DEF switch is turned ON, at the D/F position, or in floor position.

DEFROSTER () SWITCH

Positions the air outlet doors to the defrost position. Also positions the intake doors to the outside air position, and turns A/C compressor ON.

REAR WINDOW DEFOGGER SWITCH

When switch is ON, rear window and door mirrors are defogged.

OFF SWITCH

The A/C compressor and blower are OFF, the intake doors are set to the outside air position, and the air outlet doors are set to the foot (75% foot and 25% defrost) position.

A/C SWITCH

The compressor is ON or OFF.

(Pressing the A/C switch when the AUTO switch is ON will turn off the A/C switch and compressor.)

MODE SWITCH

Controls the air discharge outlets.

A
B
C
D
E
F

G

H

HAC

J

K

L

M

N

O

P

AUTOMATIC AIR CONDITIONER SYSTEM

< FUNCTION DIAGNOSIS >

[AUTOMATIC AIR CONDITIONER]

FRONT BLOWER CONTROL SWITCHES

Manually control the blower speed.

Rear Air Controls

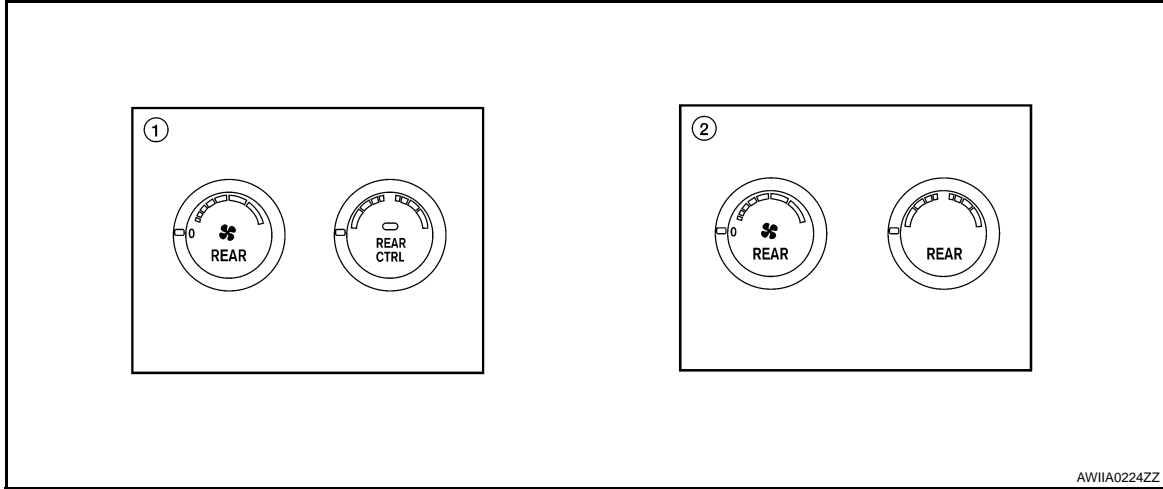

1. Rear air control (front)

2. Rear air control (rear)

TEMPERATURE CONTROL DIAL (TEMPERATURE AND MODE CONTROL)

The temperature increases or decreases the set temperature. The mode also changes from foot at full hot setting, to foot/vent at mid-range (warm) setting, and then to vent at full cold setting.

REAR BLOWER CONTROL DIAL (FRONT)

When the REAR CTRL switch is in the off (indicator off) the rear air control (front) controls the rear blower motor speed regardless of the rear air control (rear) blower control dial (rear) position. The rear air control (front) controls the blower motor speed.

REAR BLOWER CONTROL DIAL (REAR)

When the REAR CTRL switch is on (indicator on) the rear air control (rear) controls the rear blower motor speed regardless of the rear air control (front) blower control dial (front) position. The rear air control (rear) controls the blower motor speed.

MAGNET CLUTCH CONTROL

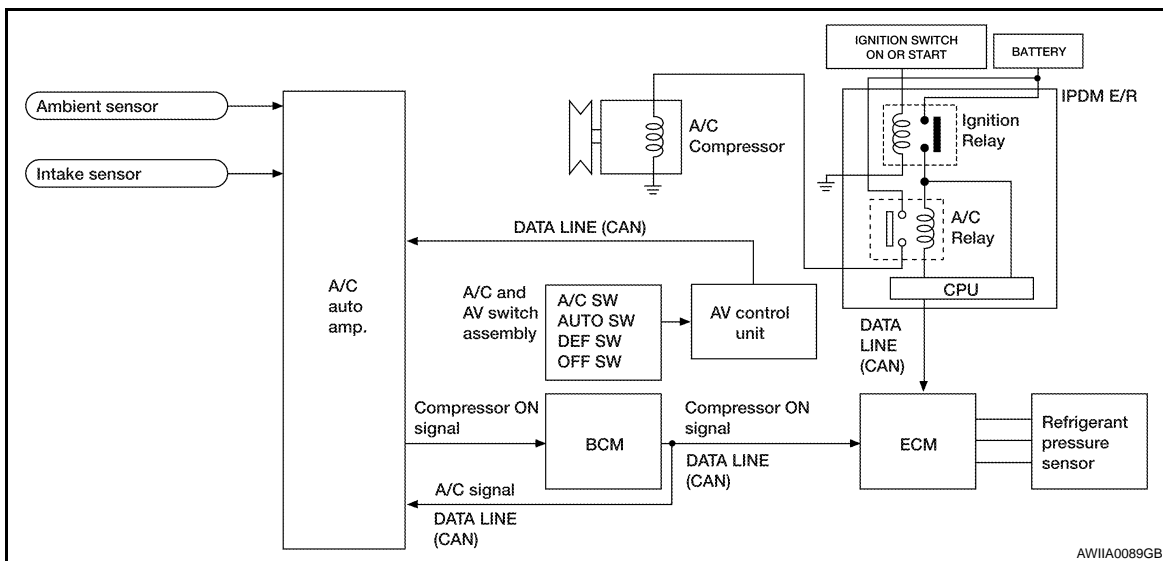

When A/C switch or DEF switch is pressed, A/C auto amp. inputs compressor ON signal to BCM. BCM sends compressor ON signal to ECM and A/C auto amp., via CAN communication line.

AUTOMATIC AIR CONDITIONER SYSTEM

[AUTOMATIC AIR CONDITIONER]

< FUNCTION DIAGNOSIS >





ECM judges whether compressor can be turned ON, based on each sensor status (refrigerant pressure sensor signal, throttle angle sensor, etc.). If it judges compressor can be turned ON, it sends compressor ON signal to IPDM E/R, via CAN communication line.

Upon receipt of compressor ON signal from ECM, IPDM E/R turns air conditioner relay ON to operate compressor.

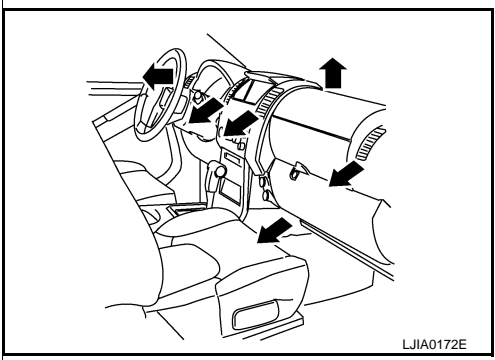
Discharge Air Flow (Front)

INFOID:000000001366691



Mode door position	Air outlet/distribution		
	Vent	Foot	Defroster
	100%	0%	—
	60%	40%	—
	18%	64%	18%
	14%	53%	33%
	—	13%	87%

A
B
C
D
E
F
G
H
J
K
L
M
N
O
P

HAC

AUTOMATIC AIR CONDITIONER SYSTEM

< FUNCTION DIAGNOSIS >

[AUTOMATIC AIR CONDITIONER]

Switches And Their Control Function (Front)

INFOID:00000000136693

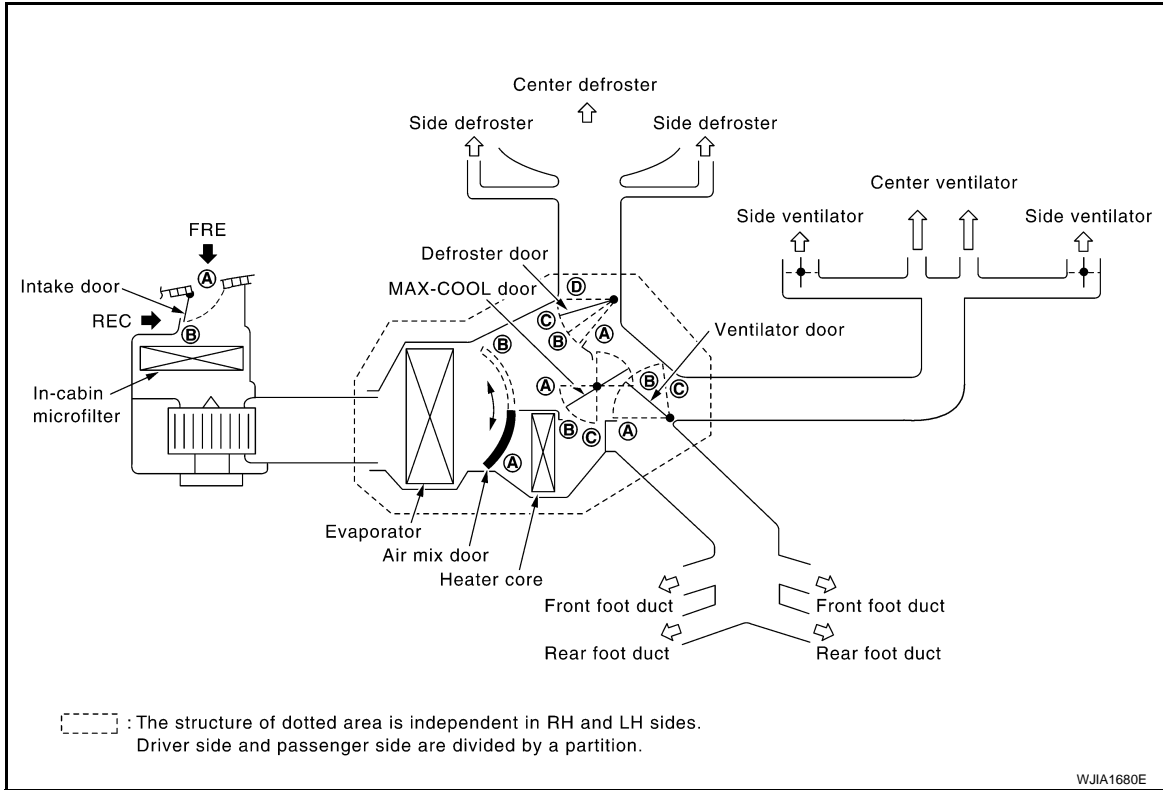

Position or switch	MODE SW				DEF SW		REC SW		Temperature control dial			OFF SW
	VENT	B/L	FOOT	D/F	ON	OFF	ON	OFF				OFF
												COLD
Ventilator door	(A)	(B)	(C)	(C)	(C)	—	—	—	—	—	—	(C)
MAX-COOL door	(A)	(B)	(B)	(B)	(C)	—	—	—	—	—	—	(B)
Defroster door	(D)	(D)	(D _o or C)	(B)	(A)	—	—	—	—	—	—	(C)
Intake door	—				(B)	—	(A)	(B)	—			(B)
Air mix door	—				—	—	—	—	(A)	AUTO	(B)	—

AWIA0236GB

AUTOMATIC AIR CONDITIONER SYSTEM

< FUNCTION DIAGNOSIS >

[AUTOMATIC AIR CONDITIONER]

Switches And Their Control Function (Rear)

INFOID:000000001366694

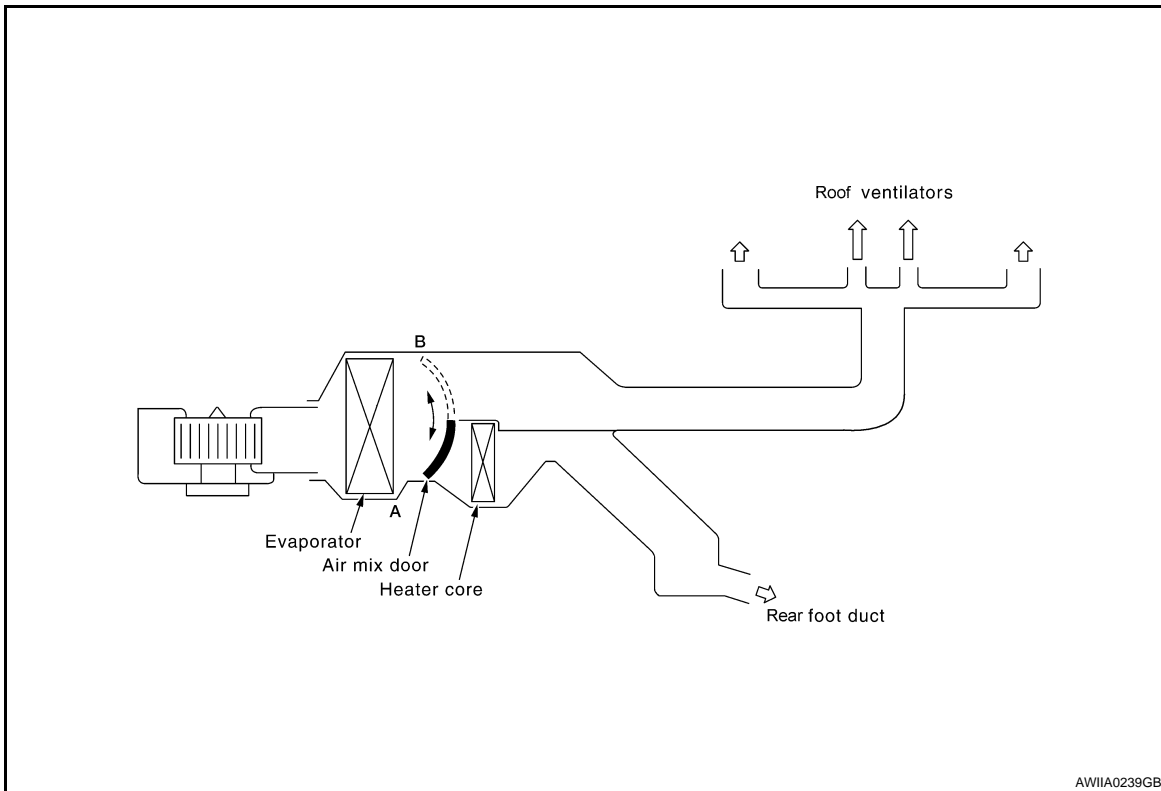

A
B
C
D
E
F
G
H

HAC

	Rear Temp Control Dial (Front)			OFF SW
Door	COLD	~	HOT	
Mode door	Fixed Position			
Air mix door	(A)		(B)	—

J
K
L
M
N
O
P

AWIA0240GB

CAN COMMUNICATION SYSTEM

< FUNCTION DIAGNOSIS >

[AUTOMATIC AIR CONDITIONER]

CAN COMMUNICATION SYSTEM

System Description

INFOID:000000001366695

Refer to [LAN-4. "System Description"](#).

DIAGNOSIS SYSTEM (HVAC)

< FUNCTION DIAGNOSIS >

[AUTOMATIC AIR CONDITIONER]

DIAGNOSIS SYSTEM (HVAC)

CONSULT-III Function (HVAC)

INFOID:000000001366696

CONSULT-III can display each diagnostic item using the diagnostic test modes shown following.

Diagnostic mode	Description
SELF-DIAG RESULTS	Displays A/C auto amp. self-diagnosis results.
DATA MONITOR	Displays A/C auto amp. input/output data in real time.
CAN DIAG SUPPORT MNTR	The result of transmit/receive diagnosis of CAN communication can be read.
ECU PART NUMBER	A/C auto amp. part number can be read.

SELF-DIAGNOSIS

Display Item List

DTC	Description	Reference page
B2573	Battery voltage out of range	CHG-4, "Work Flow"
B2578	In-vehicle sensor circuit out of range (low)	HAC-80, "In-Vehicle Sensor Diagnosis Procedure"
B2579	In-vehicle sensor circuit out of range (high)	
B257B	Ambient sensor circuit short	HAC-77, "Ambient Sensor Diagnosis Procedure"
B257C	Ambient sensor circuit open	
B257F	Optical sensor (Driver) circuit open or short	HAC-83, "Optical Sensor Diagnosis Procedure"
B2580	Optical sensor (Passenger) circuit open or short	
B2581	Intake sensor circuit short	HAC-85, "Intake Sensor Diagnosis Procedure"
B2582	Intake sensor circuit open	
U1000	CAN bus fault	LAN-4, "System Description"

DATA MONITOR

Display Item List

Monitor item	Value	Contents
BATT VIA CAN	"V"	Displays battery voltage signal.
IGN VIA CAN	"ON/OFF"	Displays ignition switch signal.
DVR SUNLD SEN	"w/m2"	Displays optical sensor (driver) signal.
PAS SUNLD SEN	"w/m2"	Displays optical sensor (passenger) signal.
AMB TEMP SEN	"°C/°F"	Displays ambient sensor signal.
EVAP TEMP SEN	"°C/°F"	Displays intake sensor signal.
INCAR TMP SEN	"°C/°F"	Displays in-vehicle sensor signal.
RR TEMPSET FR	"V"	Displays air mix door (front) set point signal.
RR TEMPSET RR	"V"	Displays air mix door (rear) set point signal.
MODE FDBCK	"V"	Displays mode door motor feedback signal.
DVR MIX FDBCK	"V"	Displays air mix door motor (driver) feedback signal.
PAS MIX FDBCK	"V"	Displays air mix door motor (passenger) feedback signal.
RR FDBCK	"V"	Displays air mix door motor (rear) feedback signal.

DIAGNOSIS SYSTEM (BCM)

< FUNCTION DIAGNOSIS >

[AUTOMATIC AIR CONDITIONER]

DIAGNOSIS SYSTEM (BCM)

CONSULT-III Function (BCM)

INFOID:000000001366697

CONSULT-II can display each diagnostic item using the diagnostic test modes shown following.

BCM diagnostic test item	Diagnostic mode	Description
Inspection by part	WORK SUPPORT	Supports inspections and adjustments. Commands are transmitted to the BCM for setting the status suitable for required operation, input/output signals are received from the BCM and received data is displayed.
	DATA MONITOR	Displays BCM input/output data in real time.
	ACTIVE TEST	Operation of electrical loads can be checked by sending drive signal to them.
	SELF-DIAG RESULTS	Displays BCM self-diagnosis results.
	CAN DIAG SUPPORT MNTR	The result of transmit/receive diagnosis of CAN communication can be read.
	ECU PART NUMBER	BCM part number can be read.
	CONFIGURATION	Performs BCM configuration read/write functions.

DATA MONITOR

Display Item List

Monitor item name "operation or unit"	Contents
IGN ON SW "ON/OFF"	Displays "IGN Position (ON)/OFF, ACC Position (OFF)" status as judged from ignition switch signal.
COMP ON SIG "ON/OFF"	Displays "COMP (ON)/COMP (OFF)" status as judged from air conditioner switch signal.
FAN ON SIG "ON/OFF"	Displays "FAN (ON)/FAN (OFF)" status as judged from blower motor switch signal.

SELF-DIAGNOSIS FUNCTION

< FUNCTION DIAGNOSIS >

[AUTOMATIC AIR CONDITIONER]

SELF-DIAGNOSIS FUNCTION

A/C Auto Amp. Self-Diagnosis

INFOID:000000001366698

A/C SYSTEM SELF-DIAGNOSIS FUNCTION

The self-diagnosis function is built into the A/C auto amp. to quickly locate the cause of malfunctions.

DESCRIPTION

The self-diagnostic system diagnoses sensors, CAN system, and battery voltage on A/C auto amp. Refer to applicable sections (items) for details. Fault codes (if any are present) will be displayed in the ambient temperature display area. Refer to [HAC-24, "A/C System Self-Diagnosis Code Chart"](#).

SELF-DIAGNOSTIC MODE

NOTE:

Radio must be OFF.

1. Turn the ignition switch ON.
2. On the A/C and AV switch assembly, press the "SETTING" button and twist the volume knob clockwise and counterclockwise until the Self-Diagnosis screen shows on the display.
3. Scroll down to "Confirmation/Adjustment" and press the "ENTER" button.
4. Scroll down to "Climate Control" and press the "ENTER" button.
5. The fan bars will flash on the display during the self-test, and then the fault codes will display in the ambient temperature area. They will continue scrolling until diagnostic mode is exited.
6. Exit by pressing the "BACK" button on A/C and AV switch assembly until display returns to its normal operation screen. HVAC system will be OFF or by turning the ignition switch OFF.

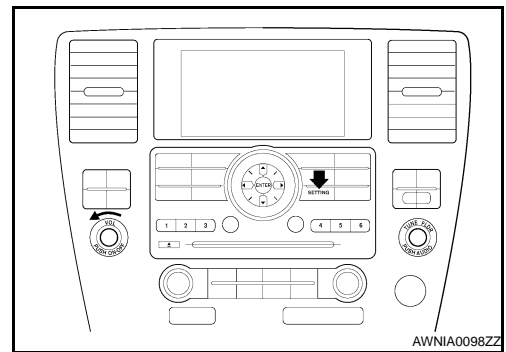

The self-diagnostic system diagnoses sensors, CAN system, and battery voltage on A/C auto amp. Refer to applicable sections (items) for details. Fault codes (if any are present) will be displayed in the ambient temperature display area. Refer to [HAC-24, "A/C System Self-Diagnosis Code Chart"](#).

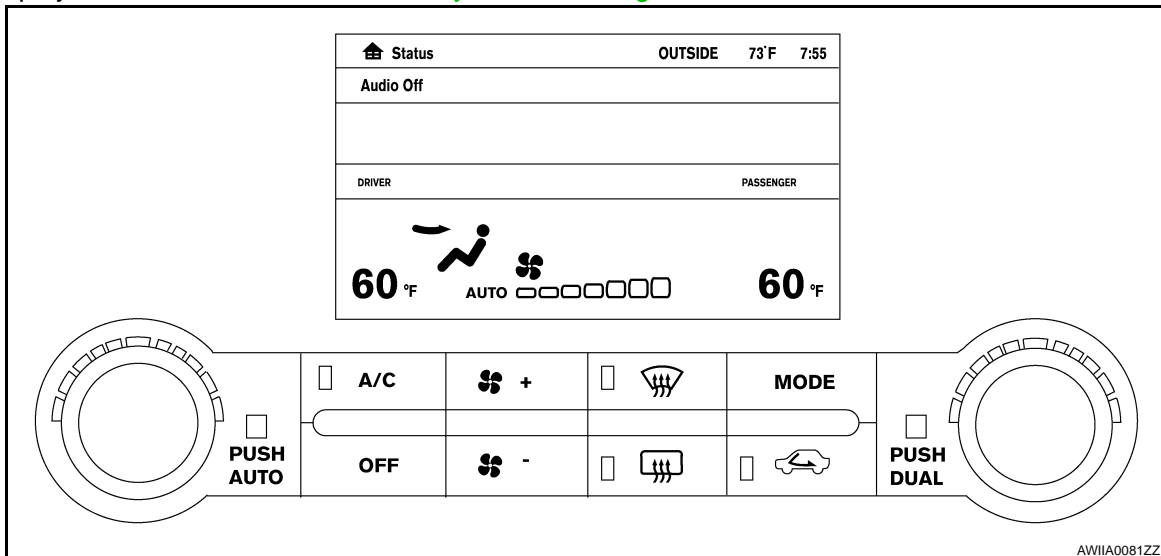

A/C and AV Switch Assembly Self-Diagnosis

INFOID:000000001366699

A/C and AV switch assembly self-diagnosis function

The ON/OFF operation (continuity) of each switch in the A/C and AV switch assembly can be checked.

Self-diagnosis mode

SELF-DIAGNOSIS FUNCTION

[AUTOMATIC AIR CONDITIONER]

< FUNCTION DIAGNOSIS >

- Press the “BACK” switch and the “UP” switch within 10 seconds after turning the ignition switch from OFF to ACC and hold them for 3 seconds or more. Then the buzzer sounds, all indicators of the preset switch illuminate, and the self-diagnosis mode starts.
- The continuity of each switch and control dials (A/C and AV switch assembly only) at the ON position can be checked by pressing each switch and turning each control dial. The buzzer sounds and LED's will illuminate if the switch is normal.

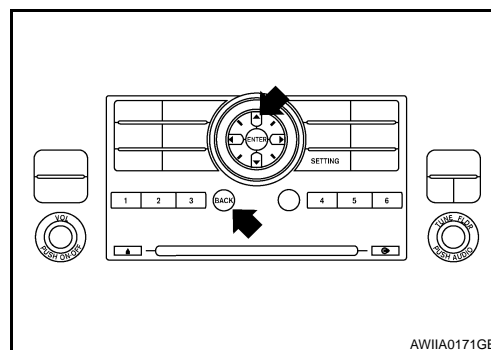

Finishing self-diagnosis mode

Self-diagnosis mode is canceled when turning the ignition switch OFF.

A/C System Self-Diagnosis Code Chart

INFOID:000000001366700

SELF-DIAGNOSTIC CODE CHART

Code No.	Reference page	
02	EE changed by calibration	VTL-8, "Removal and Installation"
03	Battery voltage out of range	CHG-10, "Inspection Procedure"
12	Passenger air mix door open/short/out of limits	HAC-37, "Air Mix Door Motor (Passenger) Diagnosis Procedure"
22	Driver air mix door open/short	HAC-33, "Air Mix Door Motor (Driver) Diagnosis Procedure"
30	In-vehicle sensor circuit out of range (low)	HAC-80, "In-Vehicle Sensor Diagnosis Procedure"
31	In-vehicle sensor circuit out of range (high)	
38	Air mix door motor (rear) circuit failure	HAC-61, "Rear Air Control Component Function Check"
40	Ambient sensor circuit short	HAC-77, "Ambient Sensor Diagnosis Procedure"
41	Ambient sensor circuit open	
44	Intake door motor open	HAC-43, "Intake Door Motor Diagnosis Procedure"
46	Intake door motor short	
50	Optical sensor (Driver) circuit open or short	HAC-83, "Optical Sensor Diagnosis Procedure"
52	Optical sensor (Passenger) circuit open or short	
56	Intake sensor circuit short	HAC-157, "Intake Sensor Diagnosis Procedure"
57	Intake sensor circuit open	
80	CAN bus fault	LAN-14, "Trouble Diagnosis Flow Chart"
81	BCM message missing	
82	Intake door motor circuit malfunction	HAC-43, "Intake Door Motor Diagnosis Procedure"
90	Stuck button	VTL-8, "Removal and Installation"
92	Mode door motor circuit malfunction	HAC-26, "Mode Door Motor (Front) Component Function Check"

COMPONENT DIAGNOSIS

MODE DOOR MOTOR

System Description

INFOID:000000001366701

SYSTEM DESCRIPTION

Component Parts

Mode door control system components are:

- A/C auto amp.
- A/C and AV switch assembly
- Mode door motor (front)
- PBR (built into mode door motor)
- In-vehicle sensor
- Ambient sensor
- Optical sensor
- Intake sensor

System Operation

The mode door position (vent, B/L, foot, D/F, and defrost) is set by the A/C auto amp. by means of the mode door motor (front). When a mode door position is selected on the A/C auto amp., voltage is applied to one circuit of the mode door motor (front) while ground is applied to the other circuit, causing the mode door motor (front) to rotate. The direction of rotation is determined by which circuit has voltage applied to it, and which one has ground applied to it. The A/C auto amp. monitors the mode door position by measuring the voltage signal on the PBR circuit.

In AUTO mode the mode door position is set by the A/C auto amp. which determines the proper position based on inputs from the in-vehicle sensor, ambient sensor, optical sensor, intake sensor, and the temperature selected by the driver or passenger.

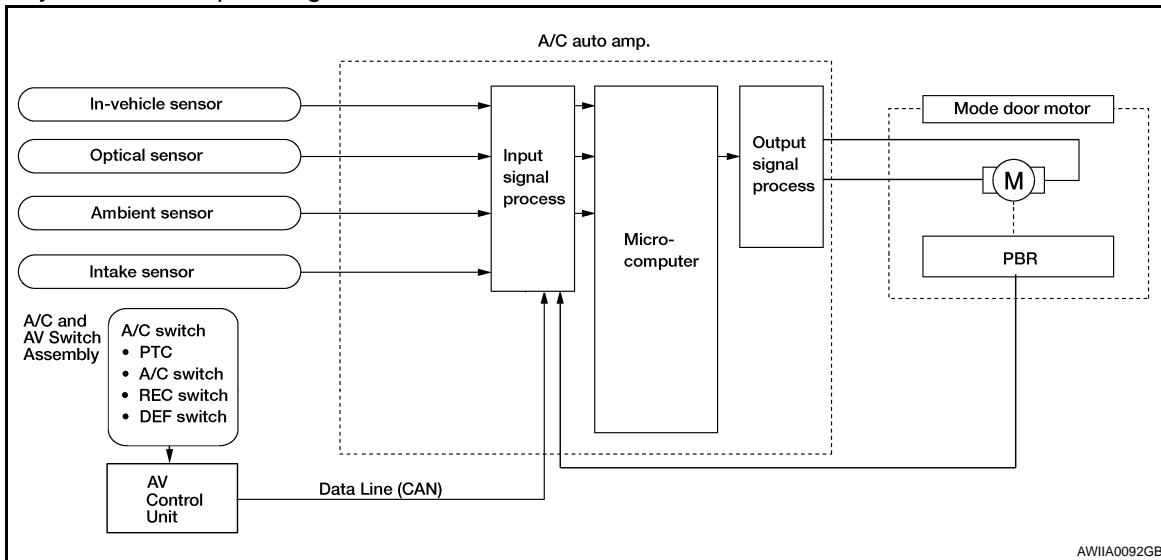

Mode Door Control Specification

COMPONENT DESCRIPTION

Mode Door Motor (Front)

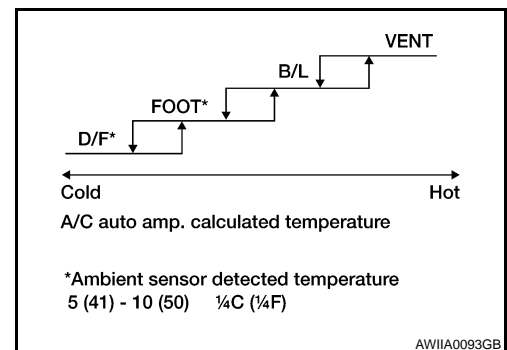

MODE DOOR MOTOR

< COMPONENT DIAGNOSIS >

[AUTOMATIC AIR CONDITIONER]

The mode door motor (front) is attached to the heater & cooling unit assembly. It rotates so that air is discharged from the outlet as indicated by the A/C auto amp. Motor rotation is conveyed to a link which activates the mode door.

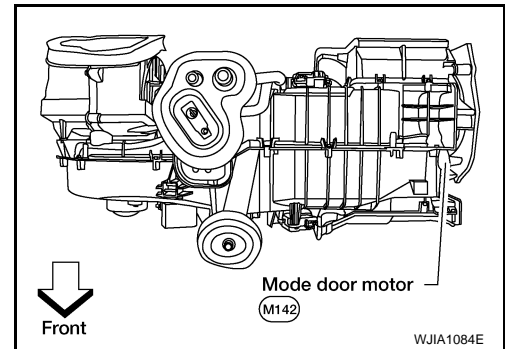

Mode Door Motor (Front) Component Function Check





INFOID:000000001366702

INSPECTION FLOW

1. CONFIRM SYMPTOM BY PERFORMING OPERATIONAL CHECK - DISCHARGE AIR

1. Press mode switch four times and then press the  (DEF) switch. Each position indicator should change shape (on display).
2. Confirm that discharge air comes out according to the air distribution table. Refer to [HAC-131. "Discharge Air Flow"](#).

NOTE:

Confirm that the compressor clutch is engaged (visual inspection) and intake door position is at FRESH  when FOOT () , DEF () or D/F () is selected.

Can a symptom be duplicated?

- YES >> GO TO 3.
- NO >> GO TO 2.

2. PERFORM COMPLETE OPERATIONAL CHECK

Perform a complete operational check and check for any symptoms. Refer to [HAC-123. "Operational Check"](#).

Can a symptom be duplicated?

- YES >> Refer to [HAC-122. "How to Perform Trouble Diagnosis For Quick And Accurate Repair"](#).
- NO >> System OK.

3. CHECK FOR SERVICE BULLETINS

Check for any service bulletins.

>> GO TO 4.

4. CHECK MODE DOOR OPERATION

Check and verify mode door mechanism for smooth operation in each mode.

Is the inspection result normal?

- YES >> GO TO 5.
- NO >> Repair as necessary.

5. PERFORM A/C AUTO AMP. SELF-DIAGNOSIS

Perform self-diagnosis to check for any codes. Refer to [HAC-23. "A/C Auto Amp. Self-Diagnosis"](#).

Are any self-diagnosis codes present?

- YES >> Refer to [HAC-24. "A/C System Self-Diagnosis Code Chart"](#).
- NO >> GO TO 6.

6. PERFORM A/C AND AV SWITCH ASSEMBLY SELF-DIAGNOSIS

Perform self-diagnosis to check the A/C and AV switch assembly. Refer to [HAC-23. "A/C and AV Switch Assembly Self-Diagnosis"](#).

Is the inspection result normal?

- YES >> Replace A/C and AV switch assembly. Refer to [VTL-8. "Removal and Installation"](#).
- NO >> GO TO 6.

MODE DOOR MOTOR

[AUTOMATIC AIR CONDITIONER]

< COMPONENT DIAGNOSIS >

7. CHECK THE MODE DOOR MOTOR (FRONT) PBR CIRCUIT

Perform diagnostic procedure for the mode door motor (front). Refer to [HAC-135. "Mode Door Motor \(Front\) Component Function Check"](#).

Is the inspection result normal?

YES >> GO TO 8.

NO >> Repair PBR circuit or replace motor. Refer to [HAC-136. "Mode Door Motor \(Front\) Diagnosis Procedure"](#).

8. RECHECK FOR CODES

Perform A/C auto amp. self-diagnosis. Refer to [HAC-23. "A/C Auto Amp. Self-Diagnosis"](#).

Are any self-diagnostic codes present?

YES >> Refer to [HAC-24. "A/C System Self-Diagnosis Code Chart"](#).

NO >> GO TO 9.

9. RECHECK FOR SYMPTOMS

Perform a complete operational check and check for any symptoms. Refer to [HAC-123. "Operational Check"](#).

Does another symptom exist?

YES >> Repair as necessary.

NO >> Replace A/C auto amp. Refer to [VTL-8. "Removal and Installation"](#).

Mode Door Motor (Front) Diagnosis Procedure

INFOID:000000001366703

SYMPTOM:

- Air outlet does not change.
- Mode door motor does not operate normally.

1. CHECK A/C AUTO AMP. FOR POWER AND GROUND

1. Turn ignition switch ON.
2. Press the mode switch to the B/L (↺) mode.
3. Check voltage between A/C auto amp. harness connector M49 terminal 19 and terminal 20 while pressing the mode switch to the floor (↵) mode.

Connector	Terminals		Condition	Voltage (Approx.)
	(+)	(-)		
A/C auto amp.: M49	20	19	Press mode switch	Battery voltage

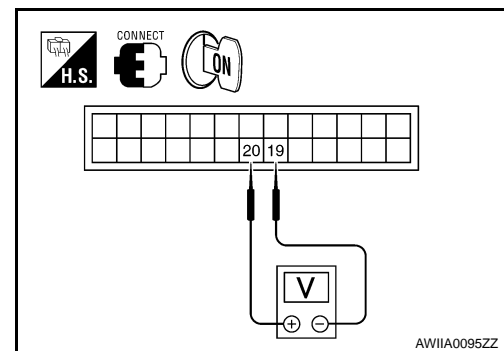

Is the inspection result normal?

YES >> GO TO 4.

NO >> GO TO 3.

2. CHECK MODE DOOR MOTOR CIRCUITS FOR SHORT TO GROUND

1. Turn ignition switch OFF.
2. Disconnect the A/C auto amp. harness connector.
3. Check continuity between A/C auto amp. harness connector M49 terminal 19, 20 and ground.

19 - Ground : Continuity should not exist.

20 - Ground : Continuity should not exist.

Is the inspection result normal?

YES >> Replace A/C auto amp. Refer to [VTL-8. "Removal and Installation"](#).

NO >> Repair or replace harness as necessary.

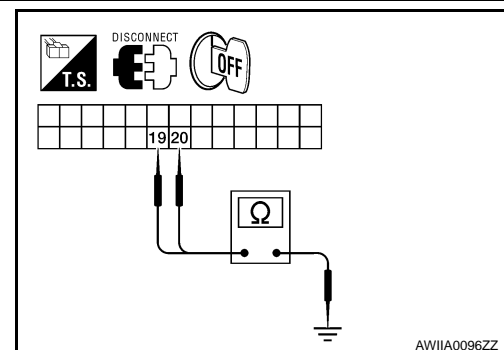

MODE DOOR MOTOR

[AUTOMATIC AIR CONDITIONER]

< COMPONENT DIAGNOSIS >

3. CHECK A/C AUTO AMP. FOR GROUND AND POWER

1. Press the mode switch to the D/F () mode.
2. Check voltage between A/C auto amp. harness connector M49 terminal 19 and terminal 20 while pressing the mode switch to the vent () mode.

Connector	Terminals		Condition	Voltage (Approx.)
	(+)	(-)		
A/C auto amp.: M49	19	20	Press mode switch	Battery voltage

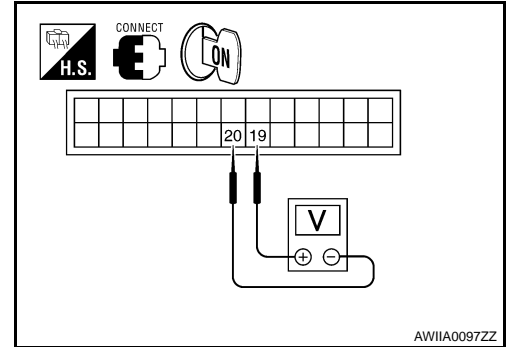

Is the inspection result normal?

- YES >> GO TO 5.
 NO >> Replace A/C auto amp. Refer to [VTL-8. "Removal and Installation"](#).

4. CHECK MODE DOOR MOTOR AND CIRCUITS FOR OPEN

1. Turn ignition switch OFF.
2. Disconnect the A/C auto amp. harness connector.
3. Check continuity between A/C auto amp. harness connector M49 terminal 19 and terminal 20.

Continuity should exist.

Is the inspection result normal?

- YES >> GO TO 7.
 NO >> GO TO 6.

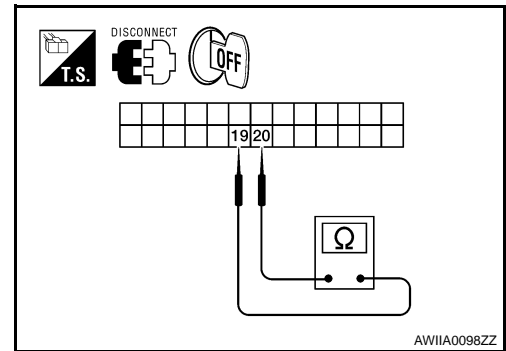

5. CHECK MODE DOOR MOTOR CIRCUITS FOR OPEN

1. Disconnect the mode door motor harness connector.
2. Check continuity between A/C auto amp. harness connector M49 (A) terminal 19, 20 and the mode door motor harness connector M142 (B) terminal 1, 6.

6 - 19 : Continuity should exist.
1 - 20 : Continuity should exist.

Is the inspection result normal?

- YES >> Replace mode door motor. Refer to [VTL-28. "Removal and Installation"](#).
 NO >> Repair or replace harness as necessary.

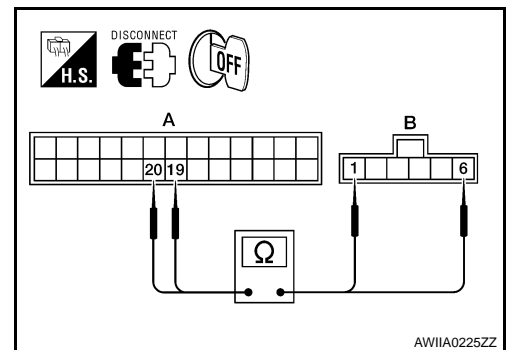

6. CHECK A/C AUTO AMP. FOR PBR POWER AND GROUND

1. Reconnect A/C auto amp. harness connector.
2. Turn ignition switch ON.
3. Check voltage between A/C auto amp. harness connector M50 (A) terminal 28 and M49 (B) terminal 3.

Connector	Terminals		Voltage (Approx.)
	(+)	(-)	
A/C auto amp.: M49, M50	28	3	5V

Is the inspection result normal?

- YES >> GO TO 9.
 NO >> GO TO 8.

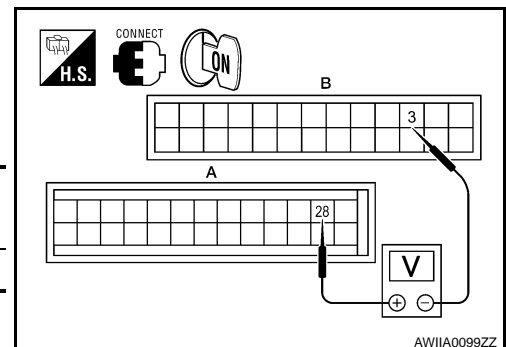

7. CHECK PBR REFERENCE VOLTAGE CIRCUIT FOR SHORT TO GROUND

MODE DOOR MOTOR

[AUTOMATIC AIR CONDITIONER]

< COMPONENT DIAGNOSIS >

1. Turn ignition switch OFF.
2. Disconnect the A/C auto amp. harness connector.
3. Check continuity between A/C auto amp. harness connector M50 terminal 28 and ground.

Continuity should not exist.

Is the inspection result normal?

- YES >> Replace A/C auto amp. Refer to [VTL-8, "Removal and Installation"](#).
- NO >> Repair or replace harness as necessary.

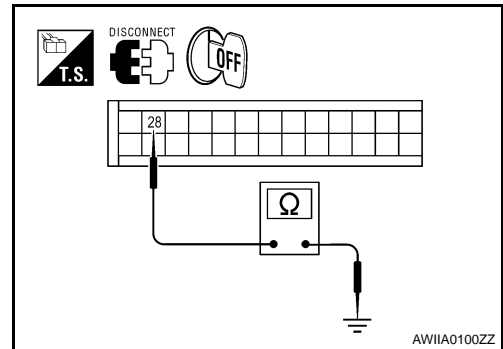

8. CHECK PBR REFERENCE VOLTAGE AND GROUND CIRCUITS

1. Turn ignition switch OFF.
2. Disconnect the A/C auto amp. harness connector.
3. Check continuity between A/C auto amp. harness connector M50 (A) terminal 28 and M49 (B) terminal 3.

Continuity should exist.

Is the inspection result normal?

- YES >> GO TO 11.
- NO >> GO TO 10

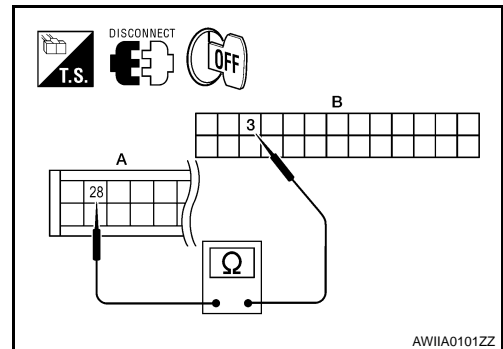

9. CHECK PBR REFERENCE VOLTAGE CIRCUIT FOR OPEN

1. Disconnect the mode door motor harness connector.
2. Check continuity between mode door motor harness connector M142 (B) terminal 3, 1 and A/C auto amp. harness connector M49 (C) terminal 3, M50 (A) terminal 28.

28 - 3 : Continuity should exist.

3 - 2 : Continuity should exist.

Is the inspection result normal?

- YES >> Replace mode door motor. Refer to [VTL-28, "Removal and Installation"](#).
- NO >> Repair or replace harness as necessary.

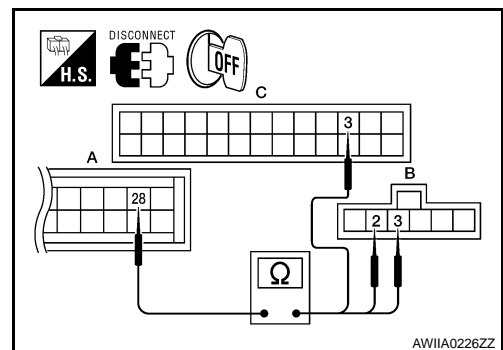

10. CHECK PBR FEEDBACK VOLTAGE

1. Reconnect the A/C auto amp. harness connector.
2. Turn ignition switch ON.
3. Check voltage between A/C auto amp. harness connector M49 terminal 7 and ground while cycling mode switch through all modes.

Voltage : Approx. 1V - 4.5V

Is the inspection result normal?

- YES >> GO TO 13.
- NO >> GO TO 12.

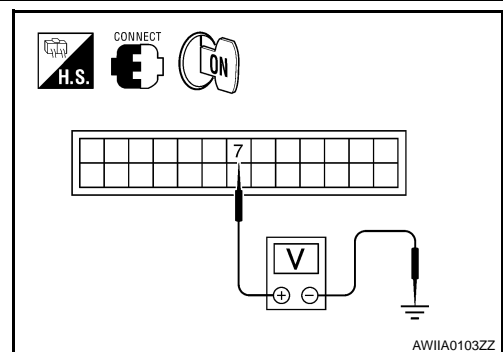

11. CHECK PBR FEEDBACK SIGNAL CIRCUIT FOR SHORT TO GROUND

A
B
C
D
E
F
G
H
HAC
J
K
L
M
N
O
P

MODE DOOR MOTOR

[AUTOMATIC AIR CONDITIONER]

< COMPONENT DIAGNOSIS >

1. Turn ignition switch OFF.
2. Disconnect A/C auto amp. harness connector.
3. Check continuity between A/C auto amp. harness connector M49 terminal 7 and ground.

Continuity should not exist.

Is the inspection result normal?

YES >> Replace A/C auto amp. Refer to [VTL-8, "Removal and Installation"](#).

NO >> Repair or replace harness as necessary.

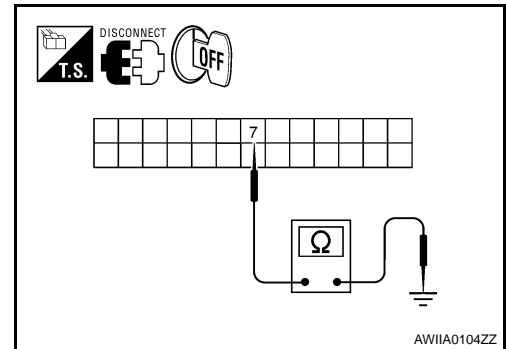

12.CHECK PBR FEEDBACK CIRCUIT FOR OPEN

1. Turn ignition switch OFF.
2. Disconnect the mode door motor harness connector and A/C auto amp. harness connector.
3. Check continuity between mode door motor harness connector M142 terminal 4 and A/C auto amp. harness connector M49 terminal 7.

Continuity should exist.

Is the inspection result normal?

YES >> Replace mode door motor. Refer to [VTL-28, "Removal and Installation"](#).

NO >> Repair or replace harness as necessary.

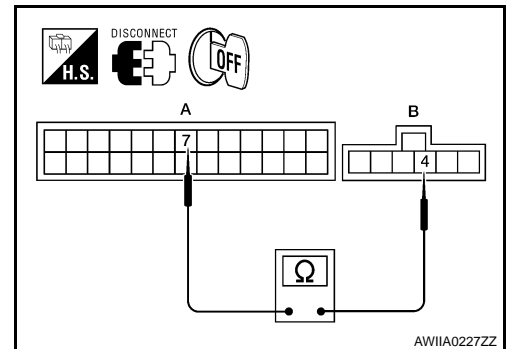

AIR MIX DOOR MOTOR

< COMPONENT DIAGNOSIS >

[AUTOMATIC AIR CONDITIONER]

AIR MIX DOOR MOTOR

System Description

INFOID:000000001366704

SYSTEM DESCRIPTION

SYMPTOM:

- Discharge air temperature does not change.
- Air mix door motor does not operate.

SYSTEM DESCRIPTION

Component Parts

Air mix door control system components are:

- A/C auto amp.
- A/C and AV switch assembly
- Air mix door motors (driver, passenger, and rear)
- PBR (built-into air mix door motors)
- In-vehicle sensor
- Ambient sensor
- Optical sensor
- Intake sensor

System Operation

The A/C auto amp. receives data from the temperature selected by the driver side, passenger side, and rear. The A/C auto amp. then applies a voltage to one circuit of the appropriate air mix door motor, while ground is applied to the other circuit, causing the appropriate air mix door motor to rotate. The direction of rotation is determined by which circuit has voltage applied to it, and which one has ground applied to it. The A/C auto amp. monitors the air mix door positions by measuring the voltage signal on the PBR circuits of each door.

In AUTO mode the air mix, intake, mode door, and defrost door positions are set by the A/C auto amp. which determines the proper position based on inputs from the in-vehicle sensor, ambient sensor, optical sensor, intake sensor, and the temperature selected by the driver and front and rear passengers.

Subsequently, HOT/COLD or DEFROST/VENT or FRESH/RECIRCULATION operation is selected. The new door position data is returned to the A/C auto amp.

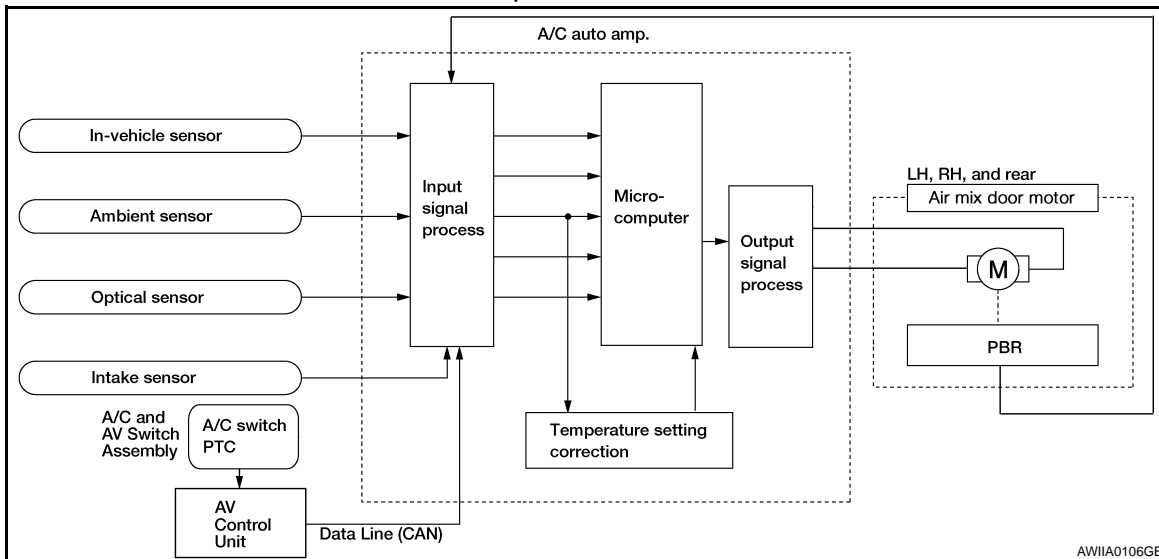

AIR MIX DOOR MOTOR

< COMPONENT DIAGNOSIS >

[AUTOMATIC AIR CONDITIONER]

Air Mix Door Control Specification

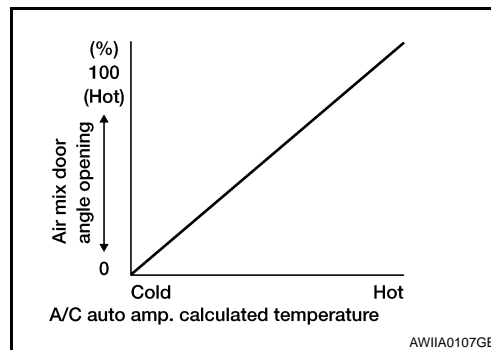

COMPONENT DESCRIPTION

Air Mix Door Motors (front)

The driver (2) and passenger (1) air mix door motors are attached to the front heater & cooling unit assembly. These motors rotate so that the air mix door is opened or closed to a position set by the A/C auto amp. Motor rotation is then conveyed through a shaft and the air mix door position is then fed back to the A/C auto amp. by the PBR built into the air mix door motors.

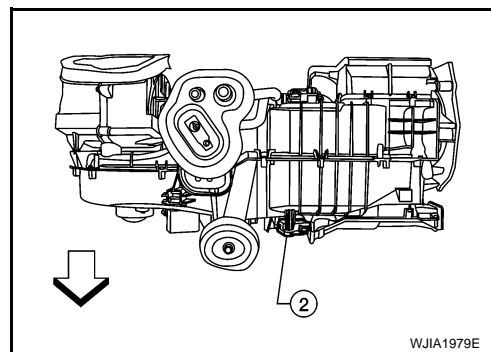
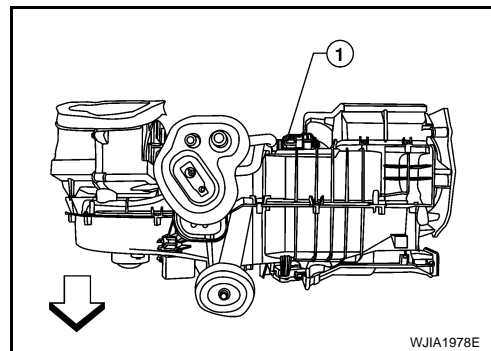

Air Mix Door Motor (rear)

The air mix door motor (rear) (1) is attached to the rear heater & cooling unit assembly. These motors rotate so that the air mix door is opened or closed to a position set by the front (or rear) air control. Motor rotation is then conveyed through a shaft and the air mix door position is then fed back to the A/C auto amp. by the PBR built into the air mix door motors.

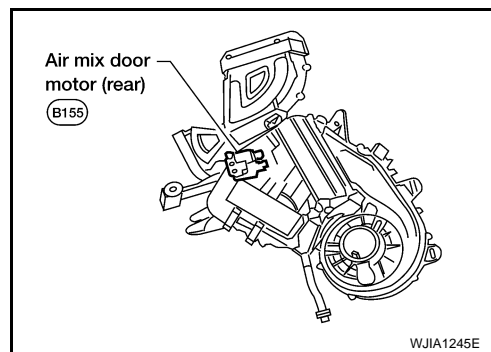

Air Mix Door Motor Component Function Check

INFOID:000000001366705

INSPECTION FLOW

1. CONFIRM SYMPTOM BY PERFORMING OPERATIONAL CHECK - TEMPERATURE INCREASE

1. Turn the temperature control dial (driver) clockwise until 32°C (90°F) is displayed.
2. Check for hot air at discharge air outlets.

AIR MIX DOOR MOTOR

< COMPONENT DIAGNOSIS >

[AUTOMATIC AIR CONDITIONER]

>> GO TO 2.

2. CONFIRM SYMPTOM BY PERFORMING OPERATIONAL CHECK - TEMPERATURE DECREASE

1. Turn the temperature control dial (driver) counterclockwise until 18°C (60°F) is displayed.
2. Check for cold air at discharge air outlets.

Can a symptom be duplicated?

YES >> GO TO 4.

NO >> GO TO 3.

3. PERFORM COMPLETE OPERATIONAL CHECK

Perform a complete operational check and check for any symptoms. Refer to [HAC-123, "Operational Check"](#).

Can a symptom be duplicated?

YES >> Refer to [HAC-122, "How to Perform Trouble Diagnosis For Quick And Accurate Repair"](#).

NO >> System OK.

4. CHECK FOR SERVICE BULLETINS

Check for any service bulletins.

>> GO TO 5.

5. CHECK AIR MIX DOOR OPERATION

Check and verify air mix door mechanism for smooth operation from 18°C (60°F) to 32°C (90°F) in each mode.

Is the inspection result normal?

YES >> GO TO 6.

NO >> Repair as necessary.

6. PERFORM SELF-DIAGNOSIS

Perform self-diagnosis to check for any codes. Refer to [HAC-23, "A/C Auto Amp. Self-Diagnosis"](#).

Are any self-diagnosis codes present?

YES >> Refer to [HAC-24, "A/C System Self-Diagnosis Code Chart"](#).

NO >> GO TO 7.

7. CHECK THE AIR MIX DOOR MOTOR PBR CIRCUIT

Perform diagnostic procedure for the air mix door motors. Refer to [HAC-140, "Air Mix Door Motor Component Function Check"](#).

Is the inspection result normal?

YES >> GO TO 8.

NO >> Repair PBR circuit or replace air mix door motor. Refer to [VTL-29, "Removal and Installation"](#).

8. RECHECK FOR CODES

Perform self-diagnosis. Refer to [HAC-23, "A/C and AV Switch Assembly Self-Diagnosis"](#).

Are any self-diagnostic codes present?

YES >> Refer to [HAC-24, "A/C System Self-Diagnosis Code Chart"](#).

NO >> GO TO 9.

9. RECHECK FOR ANY SYMPTOMS

Perform a complete operational check for any symptoms. Refer to [HAC-123, "Operational Check"](#).

Does another symptom exist?

YES >> Refer to [HAC-122, "How to Perform Trouble Diagnosis For Quick And Accurate Repair"](#).

NO >> Replace A/C auto amp. Refer to [VTL-8, "Removal and Installation"](#).

Air Mix Door Motor (Driver) Diagnosis Procedure

INFOID:000000001366706

SYMPTOM:

- Discharge air temperature does not change.

AIR MIX DOOR MOTOR

[AUTOMATIC AIR CONDITIONER]

< COMPONENT DIAGNOSIS >

- Air mix door motor does not operate.

DIAGNOSTIC PROCEDURE FOR AIR MIX DOOR MOTOR (DRIVER)

1. CHECK A/C AUTO AMP. FOR POWER AND GROUND

1. Turn ignition switch ON.
2. Rotate temperature control dial (driver) to 32°C (90°F).
3. Check voltage between A/C auto amp. harness connector M49 terminal 17 and terminal 18 while rotating temperature control dial (driver) to 18°C (60°F).

Connector	Terminals		Condition	Voltage (Approx.)
	(+)	(-)		
A/C auto amp.: M49	17	18	Rotate temp control dial	Battery voltage

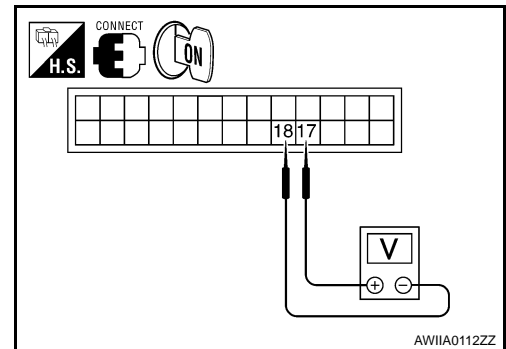

Is the inspection result normal?

- YES >> GO TO 4.
NO >> GO TO 3.

2. CHECK AIR MIX DOOR MOTOR (DRIVER) CIRCUITS FOR SHORT TO GROUND

1. Turn ignition switch OFF.
2. Disconnect the A/C auto amp. harness connector.
3. Check continuity between A/C auto amp. harness connector M49 terminal 17, 18 and ground.

- 17 - Ground : Continuity should not exist.**
18 - Ground : Continuity should not exist.

Is the inspection result normal?

- YES >> Replace A/C auto amp. Refer to [VTL-8, "Removal and Installation"](#).
NO >> Repair or replace harness as necessary.

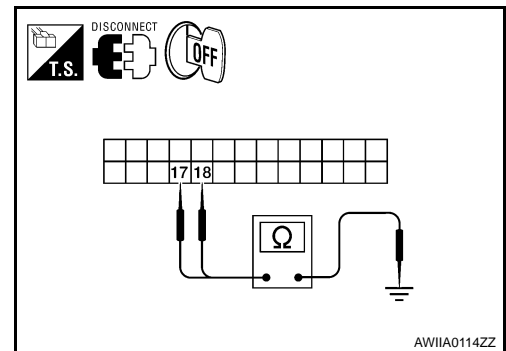

3. CHECK A/C AUTO AMP. FOR POWER AND GROUND

1. Turn ignition switch ON.
2. Rotate temperature control dial (driver) to 32°C (90°F).
3. Check voltage between A/C auto amp. harness connector M49 terminal 17 and terminal 18 while rotating temperature control dial (driver) to 18°C (60°F).

Connector	Terminals		Condition	Voltage (Approx.)
	(+)	(-)		
A/C auto amp.: M49	18	17	Rotate temp control dial	Battery voltage

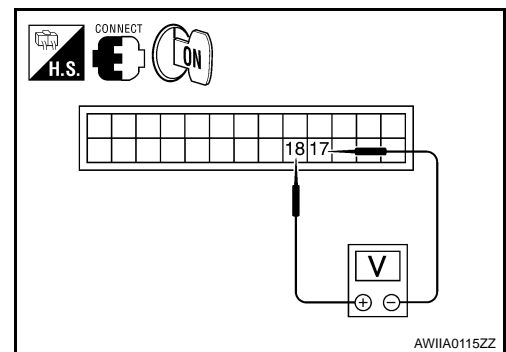

Is the inspection result normal?

- YES >> GO TO 5.
NO >> Replace A/C auto amp. Refer to [VTL-8, "Removal and Installation"](#).

4. CHECK AIR MIX DOOR MOTOR (DRIVER) CIRCUITS FOR OPEN

AIR MIX DOOR MOTOR

[AUTOMATIC AIR CONDITIONER]

< COMPONENT DIAGNOSIS >

1. Turn ignition switch OFF.
2. Disconnect the A/C auto amp. harness connector.
3. Check continuity between A/C auto amp. harness connector M49 terminal 17 and terminal 18.

Continuity should exist.

Is the inspection result normal?

- YES >> GO TO 7.
NO >> GO TO 6.

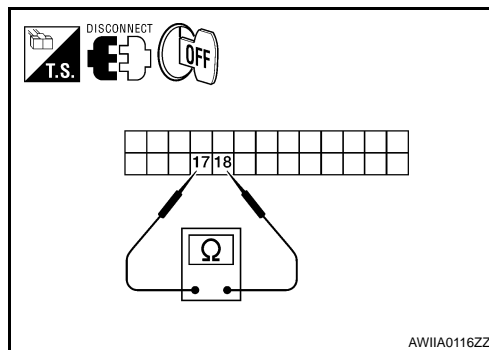

AWIIA0116ZZ

5. CHECK AIR MIX DOOR MOTOR (DRIVER) CIRCUITS FOR OPEN

1. Disconnect the air mix door motor (driver) harness connector.
2. Check continuity between A/C auto amp. harness connector M49 (A) terminal 17, 18 and the air mix door motor (driver) harness connector M147 (B) terminal 5, 6.

17 - 6 : Continuity should exist.

18 - 5 : Continuity should exist.

Is the inspection result normal?

- YES >> Replace air mix door motor (driver). Refer to [VTL-29. "Removal and Installation"](#).
NO >> Repair or replace harness as necessary.

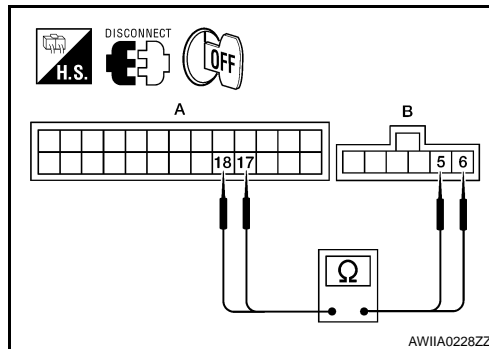

AWIIA0228ZZ

6. CHECK A/C AUTO AMP. FOR PBR POWER AND GROUND

1. Reconnect A/C auto amp. harness connector.
2. Turn ignition switch ON.
3. Check voltage between A/C auto amp. harness connector M50 (A) terminal 28 and M49 (B) terminal 3.

Connector	Terminals		Voltage (Approx.)
	(+)	(-)	
A/C auto amp.: M50, M49	28	3	5V

Is the inspection result normal?

- YES >> GO TO 9.
NO >> GO TO 8.

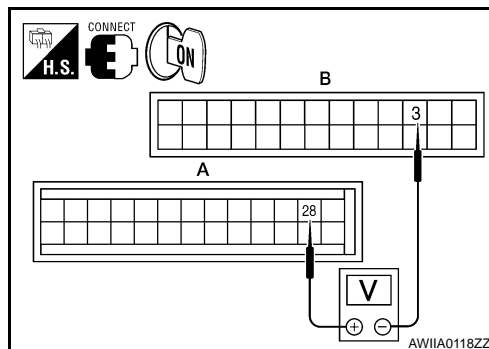

AWIIA0118ZZ

7. CHECK PBR REFERENCE VOLTAGE CIRCUIT FOR SHORT TO GROUND

1. Turn ignition switch OFF.
2. Disconnect the A/C auto amp. harness connector.
3. Check continuity between A/C auto amp. harness connector M50 terminal 28 and ground.

Continuity should not exist.

Is the inspection result normal?

- YES >> Replace A/C auto amp. Refer to [VTL-8. "Removal and Installation"](#).
NO >> Repair or replace harness as necessary.

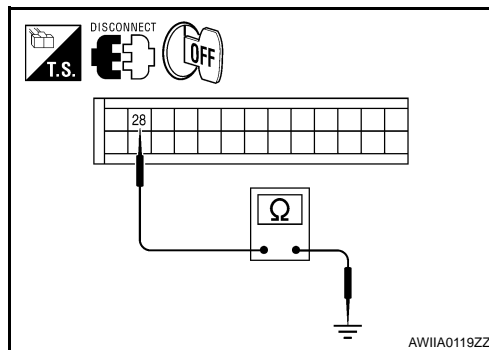

AWIIA0119ZZ

8. CHECK PBR REFERENCE VOLTAGE AND GROUND CIRCUITS

AIR MIX DOOR MOTOR

[AUTOMATIC AIR CONDITIONER]

< COMPONENT DIAGNOSIS >

1. Turn ignition switch OFF.
2. Disconnect the A/C auto amp. harness connector.
3. Check continuity between A/C auto amp. harness connector M50 (A) terminal 28 and M49 (B) terminal 3.

Continuity should exist.

Is the inspection result normal?

- YES >> GO TO 11.
NO >> GO TO 10.

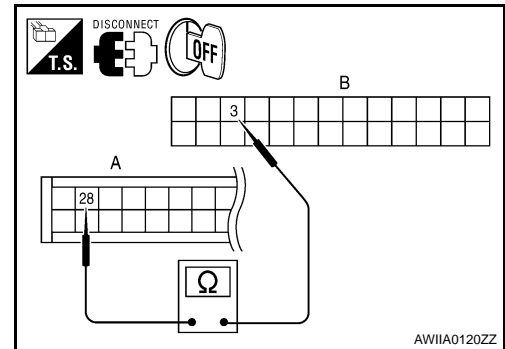

AWHIA0120ZZ

9. CHECK PBR REFERENCE VOLTAGE CIRCUIT FOR OPEN

1. Disconnect the air mix door motor (driver) harness connector.
2. Check continuity between air mix door motor (driver) harness connector M147 (B) terminal 3, 1 and A/C auto amp. harness connector M49 (C) terminal 3 and M50 (A) terminal 28.

28 - 1 : Continuity should exist.

3 - 3 : Continuity should exist.

Is the inspection result normal?

- YES >> Replace air mix door motor (driver). Refer to [VTL-29. "Removal and Installation"](#).
NO >> Repair or replace harness as necessary.

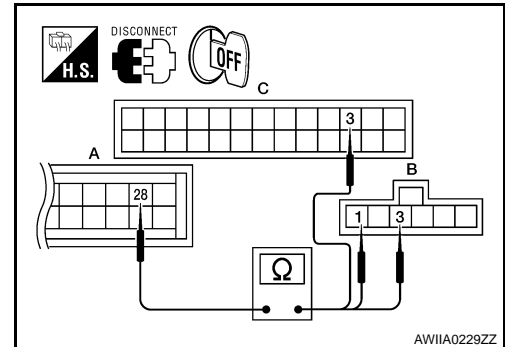

AWHIA0229ZZ

10. CHECK PBR FEEDBACK VOLTAGE

1. Reconnect the A/C auto amp. harness connector.
2. Turn ignition switch ON.
3. Check voltage between A/C auto amp. harness connector M49 terminal 6 and ground while rotating temperature control dial from 32°C (90°F) to 18°C (60°F).

Voltage : Approx. .5V - 4.5V

Is the inspection result normal?

- YES >> GO TO 13.
NO >> GO TO 12.

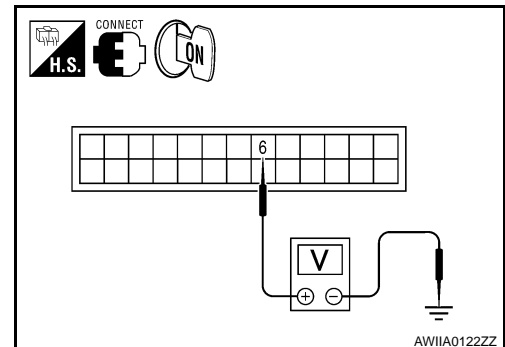

AWHIA0122ZZ

11. CHECK PBR FEEDBACK SIGNAL CIRCUIT FOR SHORT TO GROUND

1. Turn ignition switch OFF.
2. Disconnect A/C auto amp. harness connector.
3. Check continuity between A/C auto amp. harness connector M49 terminal 6 and ground.

Continuity should not exist.

Is the inspection result normal?

- YES >> Replace A/C auto amp. Refer to [VTL-8. "Removal and Installation"](#).
NO >> Repair or replace harness as necessary.

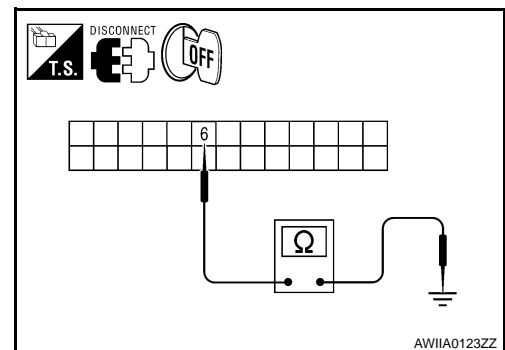

AWHIA0123ZZ

12. CHECK PBR FEEDBACK CIRCUIT FOR OPEN

AIR MIX DOOR MOTOR

< COMPONENT DIAGNOSIS >

[AUTOMATIC AIR CONDITIONER]

1. Turn ignition switch OFF.
2. Disconnect the air mix door motor (driver) harness connector and A/C auto amp. harness connector.
3. Check continuity between air mix door motor (driver) harness connector M147 (B) terminal 2 and A/C auto amp. harness connector M49 (A) terminal 6.

Continuity should exist.

Is the inspection result normal?

YES >> Replace air mix door motor (driver). Refer to [VTL-29, "Removal and Installation"](#).

NO >> Repair or replace harness as necessary.

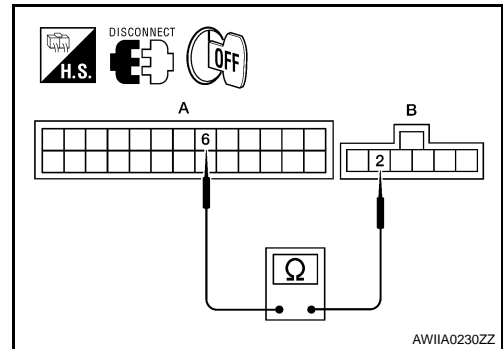

Air Mix Door Motor (Passenger) Diagnosis Procedure

INFOID:000000001366707

SYMPTOM:

- Discharge air temperature does not change.
- Air mix door motor does not operate.

DIAGNOSTIC PROCEDURE FOR AIR MIX DOOR MOTOR (PASSENGER)

1. CHECK A/C AUTO AMP. FOR POWER AND GROUND

1. Turn ignition switch ON.
2. Rotate temperature control dial (passenger) to 32°C (90°F).
3. Check voltage between A/C auto amp. harness connector M49 terminal 14 and terminal 2 while rotating temperature control dial (passenger) to 18° C (60° F).

Connector	Terminals		Condition	Voltage (Approx.)
	(+)	(-)		
A/C auto amp.: M49	2	14	Rotate temp control dial	Battery voltage

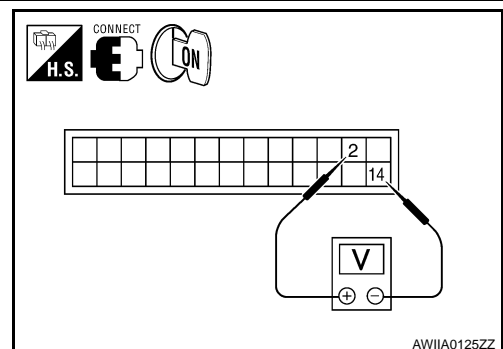

Is the inspection result normal?

OK >> GO TO 4.

NG >> GO TO 3.

2. CHECK AIR MIX DOOR MOTOR (PASSENGER) CIRCUITS FOR SHORT TO GROUND

1. Turn ignition switch OFF.
2. Disconnect the A/C auto amp. harness connector.
3. Check continuity between A/C auto amp. harness connector M49 terminal 14, 2 and ground.

14 - Ground : Continuity should not exist.

2 - Ground : Continuity should not exist.

Is the inspection result normal?

YES >> Replace A/C auto amp. Refer to [VTL-8, "Removal and Installation"](#).

NO >> Repair or replace harness as necessary.

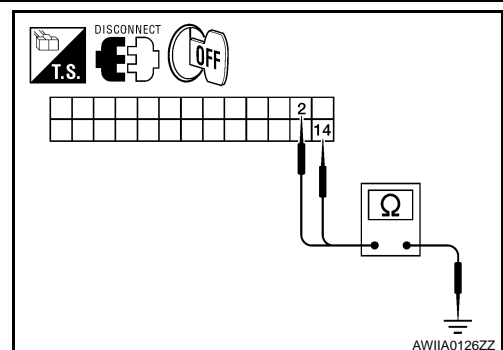

3. CHECK A/C AUTO AMP. FOR POWER AND GROUND

AIR MIX DOOR MOTOR

[AUTOMATIC AIR CONDITIONER]

< COMPONENT DIAGNOSIS >

1. Turn ignition switch ON.
2. Rotate temperature control dial (passenger) to 16°C (60°F).
3. Check voltage between A/C auto amp. harness connector M49 terminal 14 and terminal 2 while rotating temperature control dial (passenger) to 32°C (90°F).

Connector	Terminals		Condition	Voltage (Approx.)
	(+)	(-)		
A/C auto amp.: M49	14	2	Rotate temp control dial	Battery voltage

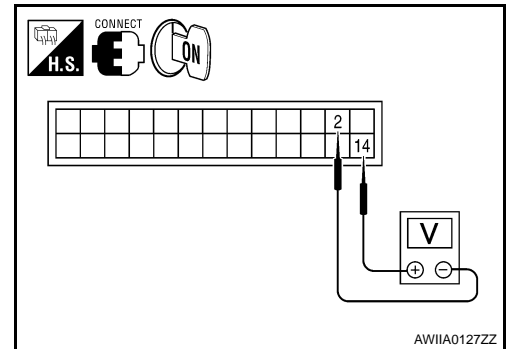

Is the inspection result normal?

YES >> GO TO 5.

NO >> Replace A/C auto amp. Refer to [VTL-8, "Removal and Installation"](#).

4. CHECK AIR MIX DOOR MOTOR (PASSENGER) CIRCUITS FOR OPEN

1. Turn ignition switch OFF.
2. Disconnect the A/C auto amp. harness connector.
3. Check continuity between A/C auto amp. harness connector M50 terminal 14 and terminal 2.

Continuity should exist.

Is the inspection result normal?

YES >> GO TO 7.

NO >> GO TO 6.

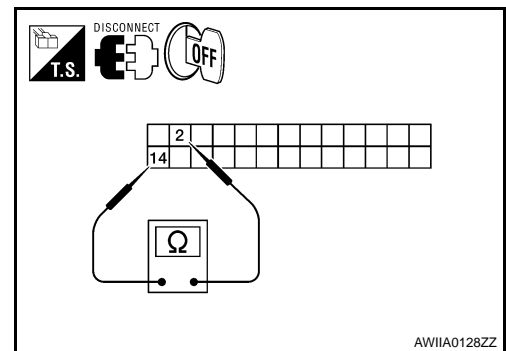

5. CHECK AIR MIX DOOR MOTOR (PASSENGER) CIRCUITS FOR OPEN

1. Disconnect the air mix door motor (passenger) harness connector.
2. Check continuity between A/C auto amp. harness connector M49 terminal 14, 2 and the air mix door motor (passenger) harness connector M143 terminal 5, 6.

14 - 6 : Continuity should exist.

2 - 5 : Continuity should exist.

Is the inspection result normal?

YES >> Replace air mix door motor (passenger). Refer to [VTL-29, "Removal and Installation"](#).

NO >> Repair or replace harness as necessary.

6. CHECK A/C AUTO AMP. FOR PBR POWER AND GROUND

1. Reconnect A/C auto amp. harness connector.
2. Turn ignition switch ON.
3. Check voltage between A/C auto amp. harness connector M50 (A) terminal 28 and M49 (B) terminal 3.

Connector	Terminals		Voltage (Approx.)
	(+)	(-)	
A/C auto amp.: M49	28	3	5V

Is the inspection result normal?

YES >> GO TO 9.

NO >> GO TO 8.

7. CHECK PBR REFERENCE VOLTAGE CIRCUIT FOR SHORT TO GROUND

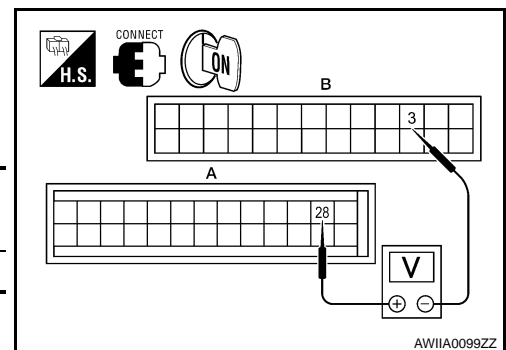

AIR MIX DOOR MOTOR

[AUTOMATIC AIR CONDITIONER]

< COMPONENT DIAGNOSIS >

1. Turn ignition switch OFF.
2. Disconnect the A/C auto amp. harness connector.
3. Check continuity between A/C auto amp. harness connector M49 terminal 29 and ground.

Continuity should not exist.

Is the inspection result normal?

- YES >> Replace A/C auto amp. Refer to [VTL-8. "Removal and Installation"](#).
- NO >> Repair or replace harness as necessary.

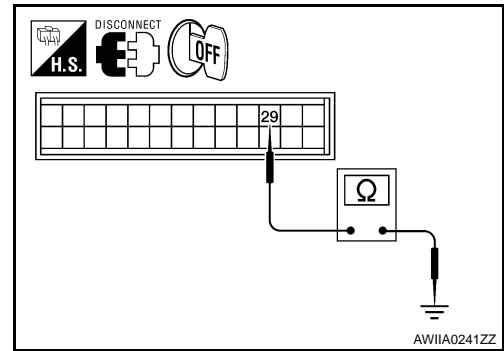

8. CHECK PBR REFERENCE VOLTAGE AND GROUND CIRCUITS

1. Turn ignition switch OFF.
2. Disconnect the A/C auto amp. harness connector.
3. Check continuity between A/C auto amp. harness connector M50 (A) terminal 28 and M49 (B) terminal 3.

Continuity should exist.

Is the inspection result normal?

- YES >> GO TO 11.
- NO >> GO TO 10.

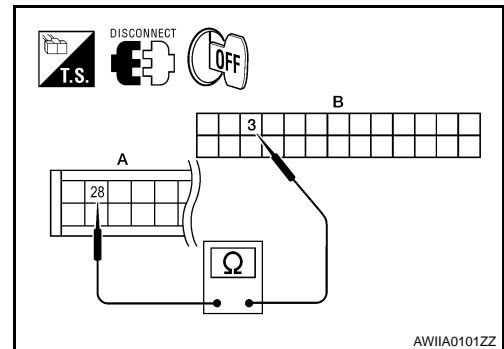

9. CHECK PBR REFERENCE VOLTAGE CIRCUIT FOR OPEN

1. Disconnect the air mix door motor (passenger) harness connector.
2. Check continuity between air mix door motor (passenger) harness connector M143 (B) terminal 3, 1 and A/C auto amp. harness connector M49 (C) terminal 3 and M50 terminal 28.

28 - 1 : Continuity should exist.

3 - 3 : Continuity should exist.

Is the inspection result normal?

- YES >> Replace air mix door motor (passenger). Refer to [VTL-29. "Removal and Installation"](#).
- NO >> Repair or replace harness as necessary.

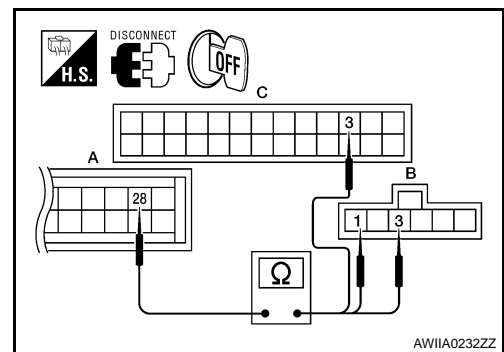

10. CHECK PBR FEEDBACK VOLTAGE

1. Reconnect the A/C auto amp. harness connector.
2. Turn ignition switch ON.
3. Check voltage between A/C auto amp. harness connector M50 terminal 29 and ground while rotating temperature control dial (passenger) from 32°C (90° F) to 18° (60° F).

Voltage : Approx. .5V - 4.5V

Is the inspection result normal?

- YES >> GO TO 13.
- NO >> GO TO 12.

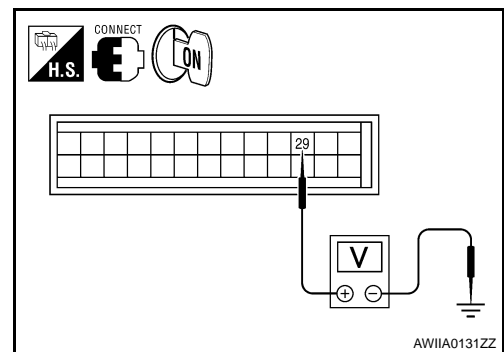

11. CHECK PBR FEEDBACK SIGNAL CIRCUIT FOR SHORT TO GROUND

A
B
C
D
E
F
G
H
HAC
J
K
L
M
N
O
P

AIR MIX DOOR MOTOR

[AUTOMATIC AIR CONDITIONER]

< COMPONENT DIAGNOSIS >

1. Turn ignition switch OFF.
2. Disconnect A/C auto amp. harness connector.
3. Check continuity between A/C auto amp. harness connector M50 terminal 29 and ground.

Continuity should not exist.

Is the inspection result normal?

YES >> Replace A/C auto amp. Refer to [VTL-8, "Removal and Installation"](#).

NO >> Repair or replace harness as necessary.

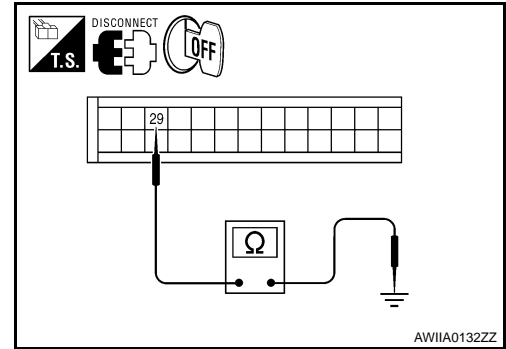

12.CHECK PBR FEEDBACK CIRCUIT FOR OPEN

1. Turn ignition switch OFF.
2. Disconnect the air mix door motor (passenger) harness connector and A/C auto amp. harness connector.
3. Check continuity between air mix door motor (passenger) harness connector M143 terminal 2 and A/C auto amp. harness connector M50 terminal 29.

Continuity should exist.

Is the inspection result normal?

YES >> Replace air mix door motor (passenger). Refer to [VTL-29, "Removal and Installation"](#).

NO >> Repair or replace harness as necessary.

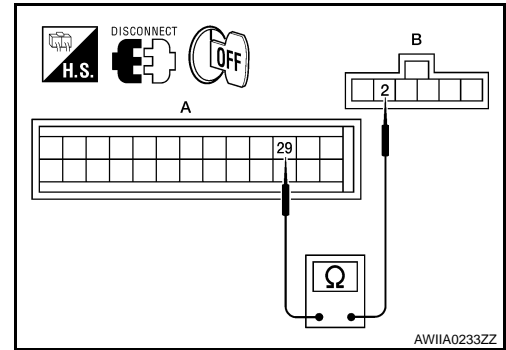

INTAKE DOOR MOTOR

< COMPONENT DIAGNOSIS >

[AUTOMATIC AIR CONDITIONER]

INTAKE DOOR MOTOR

System Description

INFOID:000000001366708

SYSTEM DESCRIPTION

SYMptom:

- Intake door motor does not operate normally.
- Intake door does not change.

SYSTEM DESCRIPTION

Component Parts

Intake door control system components are:

- A/C auto amp.
- A/C and AV switch assembly
- Intake door motor (PRB built into the intake door motor)
- In-vehicle sensor
- Ambient sensor
- Optical sensor
- Intake sensor

System Operation

The intake door control determines the intake door position based on the position of the recirculation switch. When the recirculation switch is depressed the intake door motor rotates closing off the fresh air inlet and recirculating the cabin air. If the recirculation switch is depressed again, the intake door motor rotates in the opposite direction, again allowing fresh air into the cabin.

In the AUTO mode, the A/C auto amp. determines the intake door position based on the ambient temperature, the intake air temperature and the in-vehicle temperature. When the DEF, D/F, FLOOR or OFF switches are pushed, the A/C auto amp. sets the intake door at the fresh position.

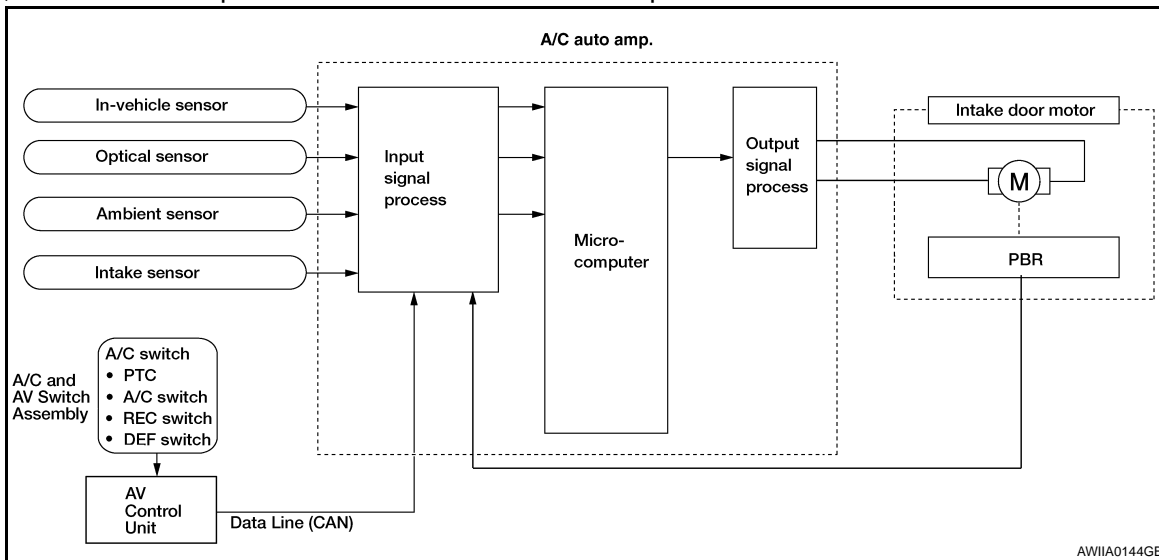

Intake Door Control Specification

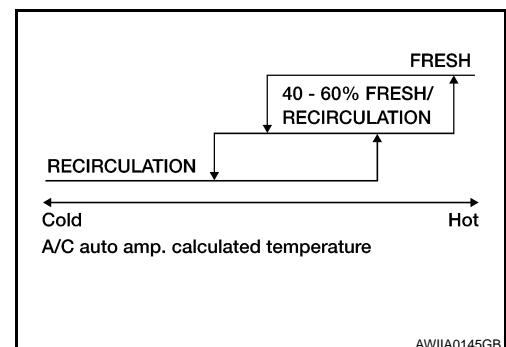

INTAKE DOOR MOTOR

[AUTOMATIC AIR CONDITIONER]

< COMPONENT DIAGNOSIS >

COMPONENT DESCRIPTION

Intake door motor

The intake door motor is attached to the intake unit. It rotates so that air is drawn from inlets set by the A/C auto amp. Motor rotation is conveyed to a lever which activates the intake door.

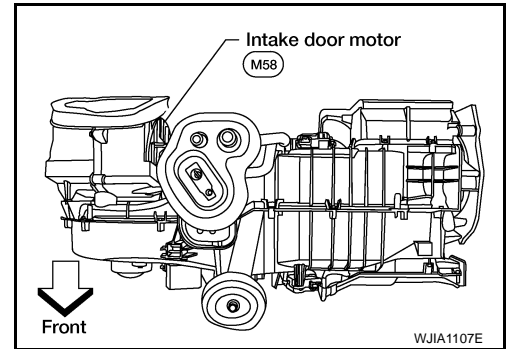





INFOID:000000001366709

Intake Door Motor Component Function Check

INSPECTION FLOW

1. CONFIRM SYMPTOM BY PERFORMING OPERATIONAL CHECK - REC ()

1. Press the mode switch to vent mode().
2. Press REC () switch. The REC () indicator should illuminate.
3. Press REC () switch again. The REC () indicator should go out.
4. Listen for intake door position change (you should hear blower sound changes slightly).

Can a symptom be duplicated?

- YES >> GO TO 3.
- NO >> GO TO 2.

2. PERFORM COMPLETE OPERATIONAL CHECK

Perform a complete operational check and check for any symptoms. Refer to [HAC-123, "Operational Check"](#).

Can a symptom be duplicated?

- YES >> Refer to [HAC-122, "How to Perform Trouble Diagnosis For Quick And Accurate Repair"](#).
- NO >> System OK.

3. CHECK FOR SERVICE BULLETINS

Check for any service bulletins.

>> GO TO 4.

4. CHECK INTAKE DOOR OPERATION

Check and verify intake door mechanism for smooth operation.

Is the inspection result normal?

- YES >> GO TO 5.
- NO >> Repair intake door mechanism.

5. PERFORM SELF-DIAGNOSIS

Perform self-diagnosis to check for any codes. Refer to [HAC-23, "A/C Auto Amp. Self-Diagnosis"](#).

Are any self-diagnosis codes present?

- YES >> Refer to [HAC-24, "A/C System Self-Diagnosis Code Chart"](#).
- NO >> GO TO 6.

6. RECHECK FOR ANY SYMPTOMS

Perform a complete operational check for any symptoms. Refer to [HAC-123, "Operational Check"](#).

Does another symptom exist?

- YES >> Refer to [HAC-122, "How to Perform Trouble Diagnosis For Quick And Accurate Repair"](#).
- NO >> Replace A/C auto amp. Refer to [VTL-8, "Removal and Installation"](#).

INTAKE DOOR MOTOR

[AUTOMATIC AIR CONDITIONER]

< COMPONENT DIAGNOSIS >

INFOID:000000001366710

Intake Door Motor Diagnosis Procedure

SYMPTOM:

- Intake door does not change.
- Intake door motor does not operate normally.

DIAGNOSTIC PROCEDURE FOR INTAKE DOOR MOTOR

1. CHECK A/C AUTO AMP. FOR POWER AND GROUND

1. Turn ignition switch ON.
2. Check voltage between A/C auto amp. harness connector M49 terminal 21 and terminal 22 while placing the HVAC system into self-diagnostic mode.

Connector	Terminals		Condition	Voltage (Approx.)
	(+)	(-)		
A/C auto amp.: M49	21	22	Self-diagnostic mode	Battery voltage

Is the inspection result normal?

- OK >> GO TO 4.
NO >> GO TO 3.

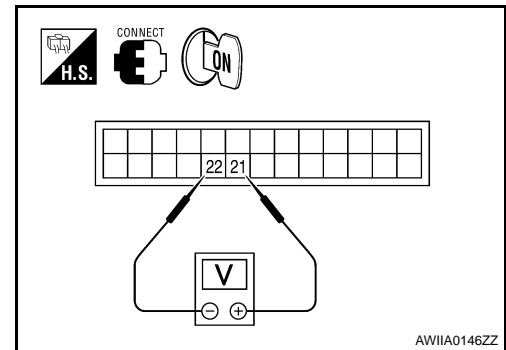

2. CHECK INTAKE DOOR MOTOR CIRCUITS FOR SHORT TO GROUND

1. Turn ignition switch OFF.
2. Disconnect the A/C auto amp. harness connector.
3. Check continuity between A/C auto amp. harness connector M49 terminal 21, 22 and ground.

- 21 - Ground : Continuity should not exist.**
22 - Ground : Continuity should not exist.

Is the inspection result normal?

- OK >> Replace A/C auto amp. Refer to [VTL-8. "Removal and Installation"](#).
NO >> Repair or replace harness as necessary.

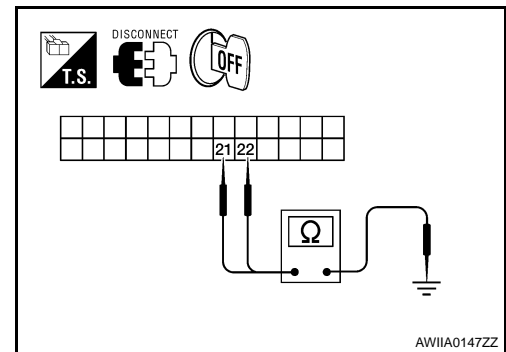

3. CHECK A/C AUTO AMP. FOR GROUND AND POWER

1. Press the BACK button to back out of self-diagnostic mode.
2. Check voltage between A/C auto amp. harness connector M49 terminal 21 and terminal 22 while placing the HVAC system into self-diagnostic mode.

Connector	Terminals		Condition	Voltage (Approx.)
	(+)	(-)		
A/C auto amp.: M49	22	21	Self-diagnostic mode	Battery voltage

Is the inspection result normal?

- OK >> GO TO 5.
NO >> Replace A/C auto amp. Refer to [VTL-8. "Removal and Installation"](#).

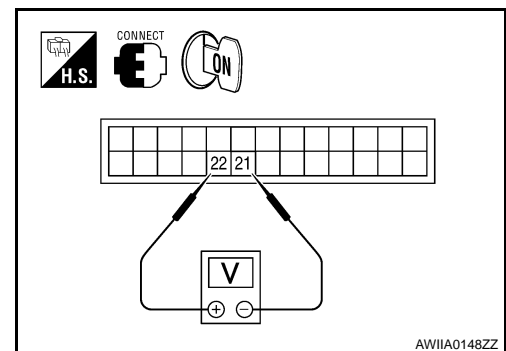

4. CHECK INTAKE DOOR MOTOR AND CIRCUITS FOR OPEN

A
B
C
D
E
F
G
H
HAC
J
K
L
M
N
O
P

INTAKE DOOR MOTOR

[AUTOMATIC AIR CONDITIONER]

< COMPONENT DIAGNOSIS >

1. Turn ignition switch OFF.
2. Disconnect the A/C auto amp. harness connector.
3. Check continuity between A/C auto amp. harness connector M49 terminal 21 and terminal 22.

Continuity should exist.

Is the inspection result normal?

- OK >> Replace intake door motor. Refer to [VTL-27, "Removal and Installation"](#).
- NO >> GO TO 6.

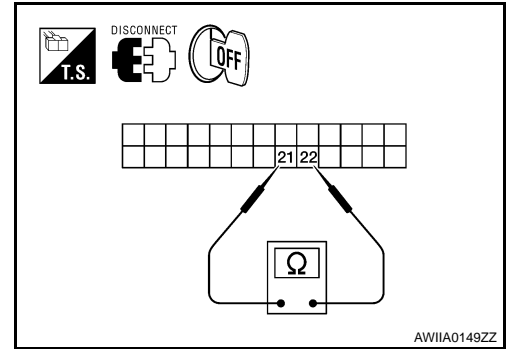

5. CHECK INTAKE DOOR MOTOR CIRCUITS FOR OPEN

1. Disconnect the intake door motor harness connector.
2. Check continuity between A/C auto amp. harness connector M49 (A) terminal 21, 22 and the intake door motor harness connector M58 (B) terminal 1, 6.

21 - 6 : Continuity should exist.

22 - 1 : Continuity should exist.

Is the inspection result normal?

- YES >> Replace intake door motor. Refer to [VTL-27, "Removal and Installation"](#).
- NO >> Repair or replace harness as necessary.

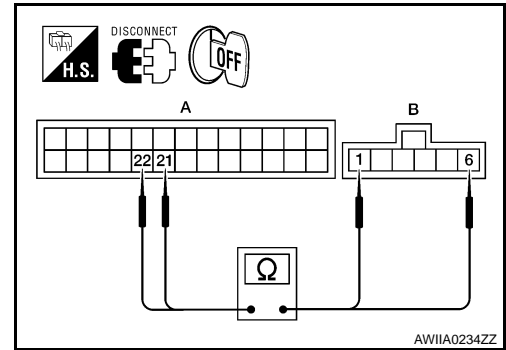

BLOWER MOTOR CONTROL SYSTEM

< COMPONENT DIAGNOSIS >

[AUTOMATIC AIR CONDITIONER]

BLOWER MOTOR CONTROL SYSTEM

System Description

INFOID:000000001366714

SYSTEM DESCRIPTION

Component Parts

Blower speed control system components are:

- A/C auto amp.
- A/C and AV switch assembly
- Variable blower control
- Front blower motor relay
- Front blower motor
- In-vehicle sensor
- Ambient sensor
- Optical sensor
- Intake sensor

System Operation

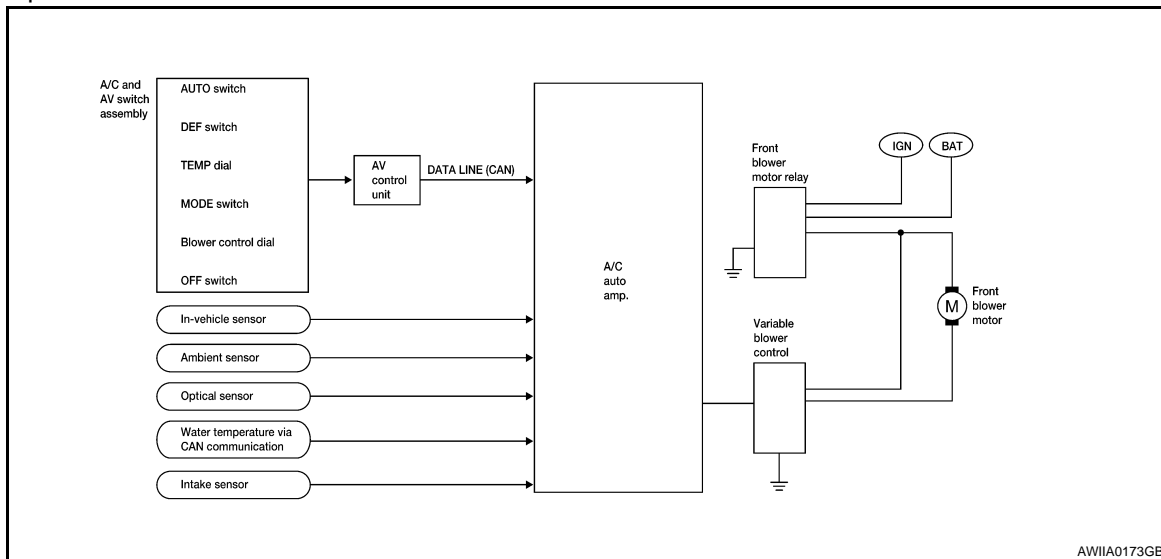

Automatic Mode

In the automatic mode, the blower motor speed is calculated by the A/C auto amp. and variable blower control based on input from the in-vehicle sensor, optical sensor, intake sensor and ambient sensor, and potentiometer temperature control (PTC).

When the air flow is increased, the blower motor speed is adjusted gradually to prevent a sudden increase in air flow.

In addition to manual air flow control and the usual automatic air flow control, starting air flow control, low water temperature starting control and high passenger compartment temperature starting control are available.

Starting Blower Speed Control

Start up from cold soak condition (Automatic mode).

In a cold start up condition where the engine coolant temperature is below 50°C (122°F), the blower will not operate at blower speed 1 for a short period of time (up to 210 seconds). The exact start delay time varies depending on the ambient and engine coolant temperatures.

In the most extreme case (very low ambient temperature) the blower starting delay will be 210 seconds as described above. After the coolant temperature reaches 50°C (122°F), or the 210 seconds has elapsed, the blower speed will increase to the objective blower speed.

Start up from usual operating or hot soak condition (Automatic mode).

The blower will begin operation momentarily after the AUTO switch is pushed. The blower speed will gradually rise to the objective speed over a time period of 3 seconds or less (actual time depends on the objective blower speed).

A

B

C

D

E

F

G

H

HAC

J

K

L

M

N

O

P

BLOWER MOTOR CONTROL SYSTEM

[AUTOMATIC AIR CONDITIONER]

< COMPONENT DIAGNOSIS >

Blower Speed Compensation - Sunload

When the in-vehicle temperature and the set temperature are very close, the blower will be operating at low speed. The speed will vary depending on the sunload. During conditions of low or no sunload, the blower operates at low speed. During high sunload conditions, the A/C auto amp. causes the blower speed to increase.

Blower Speed Control Specification

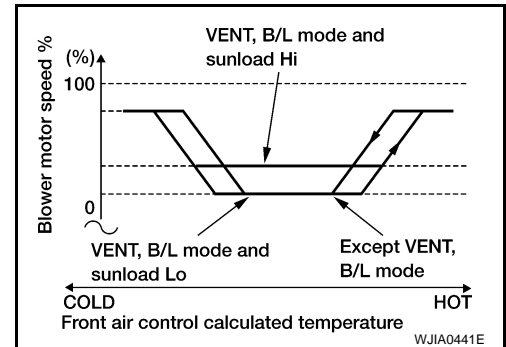

COMPONENT DESCRIPTION

Variable Blower Control

The variable blower control is located on the cooling unit. The variable blower control receives a gate voltage from the A/C auto amp. to steplessly maintain the blower motor voltage in the 0 to 5 volt range (approx.).

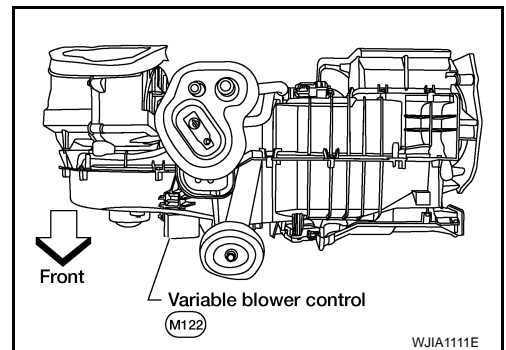

Front Blower Motor Component Function Check

INFOID:000000001366715

INSPECTION FLOW

1. CONFIRM SYMPTOM BY PERFORMING OPERATIONAL CHECK - FRONT BLOWER

1. Press the blower (+) switch. Blower should operate.
2. Rotate the front blower control dial clockwise, and continue checking blower speed and fan symbol until all speeds are checked.

Can the symptom be duplicated?

- YES >> GO TO 3.
- NO >> GO TO 2.

2. CHECK FOR ANY SYMPTOMS

Perform a complete operational check for any symptoms. Refer to [HAC-123, "Operational Check"](#).

Does another symptom exist?

- YES >> Refer to [HAC-122, "How to Perform Trouble Diagnosis For Quick And Accurate Repair"](#).
- NO >> System OK.

3. CHECK FOR SERVICE BULLETINS

Check for any service bulletins.

>> GO TO 4.

4. PERFORM A/C AUTO AMP. SELF-DIAGNOSIS

Perform self-diagnosis to check for any codes. Refer to [HAC-23, "A/C Auto Amp. Self-Diagnosis"](#).

Are any self-diagnosis codes present?

BLOWER MOTOR CONTROL SYSTEM

[AUTOMATIC AIR CONDITIONER]

< COMPONENT DIAGNOSIS >

- YES >> Refer to [HAC-24. "A/C System Self-Diagnosis Code Chart"](#).
- NO >> GO TO 5.

5. PERFORM A/C AND AV SWITCH ASSEMBLY SELF-DIAGNOSIS

Perform self-diagnosis to check the A/C and AV switch assembly. Refer to [HAC-23. "A/C and AV Switch Assembly Self-Diagnosis"](#).

Is the inspection results normal?

- YES >> GO TO 6.
- NO >> Replace A/C and AV switch assembly. Refer to [VTL-8. "Removal and Installation"](#).

6. CHECK BLOWER MOTOR OPERATION

Check and verify blower motor operates manually in all speeds.

Does blower motor operate in all speeds?

- YES >> GO TO 7.
- NO >> Refer to [HAC-147. "Front Blower Motor Diagnosis Procedure"](#).

7. CHECK ENGINE COOLANT TEMPERATURE SENSOR CIRCUIT

Check engine coolant temperature sensor circuit. Refer to [EC-127. "Diagnosis Procedure"](#) (VQ40DE) or [EC-600. "Diagnosis Procedure"](#) (VK56DE).

Is the inspection results normal?

- YES >> GO TO 8.
- NO >> Replace engine coolant temperature sensor.

8. RECHECK FOR ANY SYMPTOMS

Perform a complete operational check for any symptoms. Refer to [HAC-123. "Operational Check"](#).

Does another symptom exist?

- YES >> Refer to [HAC-122. "How to Perform Trouble Diagnosis For Quick And Accurate Repair"](#).
- NO >> Replace A/C auto amp. Refer to [VTL-8. "Removal and Installation"](#).

Front Blower Motor Diagnosis Procedure

INFOID:000000001366716

SYMPTOM: Blower motor operation is malfunctioning.

DIAGNOSTIC PROCEDURE FOR BLOWER MOTOR

SYMPTOM: Blower motor operation is malfunctioning under starting blower speed control.

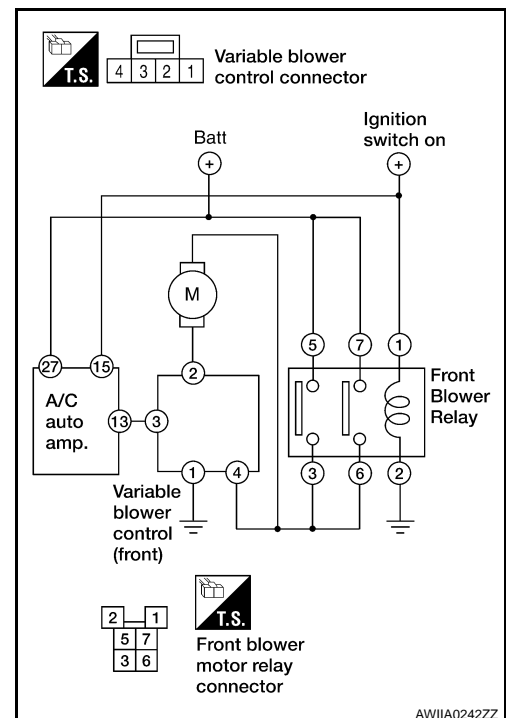

1. CHECK FUSES

BLOWER MOTOR CONTROL SYSTEM

[AUTOMATIC AIR CONDITIONER]

< COMPONENT DIAGNOSIS >

Check 15A fuses [No. 24 and 27 (Located in the fuse and fusible link box)].

Fuses are good.

Is the inspection result normal?

YES >> GO TO 3.

NO >> GO TO 9.

2. CHECK FRONT BLOWER MOTOR POWER SUPPLY CIRCUIT

1. Turn ignition switch OFF.
2. Disconnect front blower motor connector.
3. Turn ignition switch ON.
4. Press the A/C switch.
5. Press the front blower control "+" switch to maximum speed.
6. Check voltage between front blower motor harness connector M62 terminal 2 and ground.

2 - Ground

: Battery voltage

Is the inspection result normal?

YES >> GO TO 10.

NO >> GO TO 3.

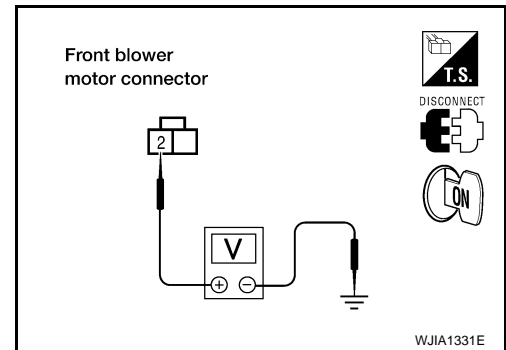

3. CHECK FRONT BLOWER MOTOR RELAY (SWITCH SIDE) POWER SUPPLY CIRCUIT

1. Turn ignition switch OFF.
2. Disconnect front blower motor relay.
3. Check voltage between front blower motor relay harness connector E22 terminals 5, 7 and ground.

5 - Ground

: Battery voltage

7 - Ground

: Battery voltage

Is the inspection result normal?

YES >> GO TO 4.

NO >> Repair harness or connector.

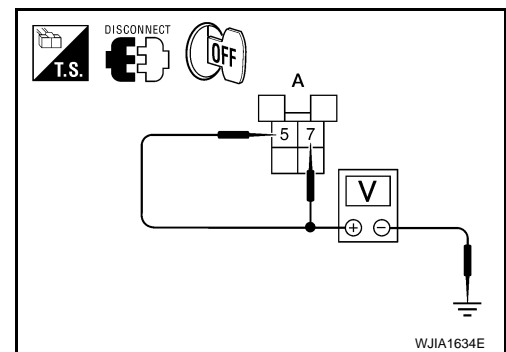

4. CHECK FRONT BLOWER MOTOR RELAY

Turn ignition switch OFF.

Check front blower motor relay. Refer to [HAC-151, "Front Blower Motor Component Inspection"](#).

Is the inspection result normal?

YES >> GO TO 5.

NO >> Replace front blower motor relay.

5. CHECK FRONT BLOWER MOTOR RELAY (SWITCH SIDE) CIRCUIT FOR OPEN

Check continuity between front blower motor relay harness connector E22 terminals 3, 6 and front blower motor harness connector M62 terminal 2.

3, 6 - 2

: Continuity should exist.

Is the inspection result normal?

YES >> GO TO 6.

NO >> Repair harness or connector.

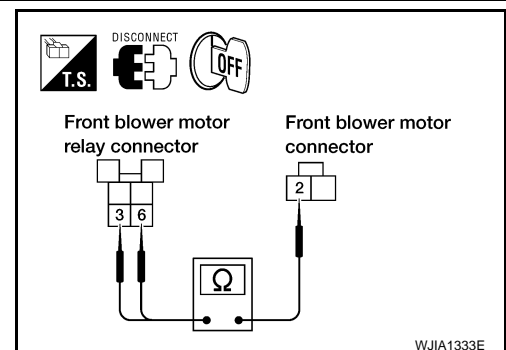

6. CHECK VARIABLE BLOWER CONTROL POWER SUPPLY CIRCUIT FOR OPEN

BLOWER MOTOR CONTROL SYSTEM

[AUTOMATIC AIR CONDITIONER]

< COMPONENT DIAGNOSIS >

1. Disconnect variable blower control harness connector.
2. Check continuity between front blower motor relay harness connector E22 (A) terminals 3, 6 and variable blower control harness connector M122 (B) terminal 4.

3, 6 - 4 : Continuity should exist.

Is the inspection result normal?

- YES >> GO TO 7.
NO >> Repair harness or connector.

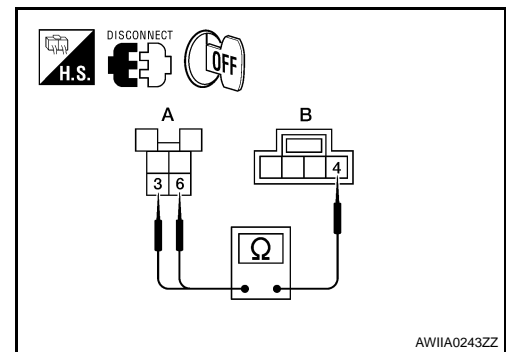

7. CHECK VARIABLE BLOWER CONTROL SIGNAL CIRCUIT

1. Disconnect A/C auto amp. connector.
2. Check continuity between A/C auto amp. harness connector M49 (B) terminal 13 and variable blower control harness connector M122 (A) terminal 3.

13 - 3 : Continuity should exist.

Is the inspection result normal?

- YES >> GO TO 8.
NO >> Repair harness or connector.

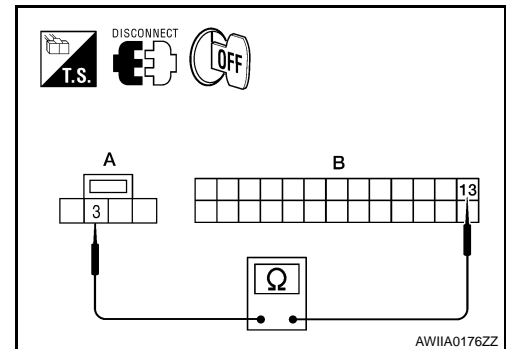

8. CHECK FRONT BLOWER MOTOR RELAY (COIL SIDE) POWER SUPPLY

1. Turn ignition switch ON.
2. Check voltage between front blower motor relay harness connector E22 terminal 1 and ground.

1 - Ground : Battery voltage

Is the inspection result normal?

- YES >> GO TO 9.
NO >> Repair front blower motor ground circuit or connector.

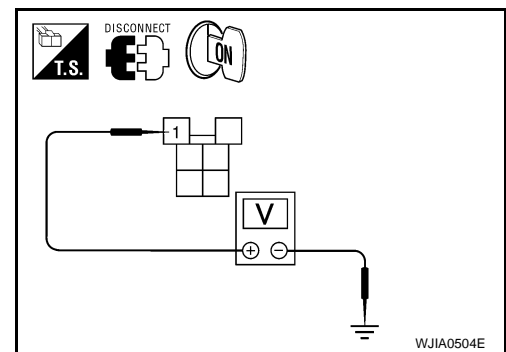

9. REPLACE FUSES

1. Replace fuses.
2. Activate the front blower motor.

Does the fuse blow?

- YES >> GO TO 10.
NO >> Inspection End.

10. CHECK FRONT BLOWER MOTOR POWER SUPPLY CIRCUIT FOR SHORT

1. Turn ignition switch OFF.
2. Disconnect front blower motor connector and variable blower control connector.
3. Check continuity between variable blower control harness connector M122 terminal 4 and ground.

4 - Ground : Continuity should not exist.

Is the inspection result normal?

- YES >> GO TO 11.
NO >> Repair harness or connector.

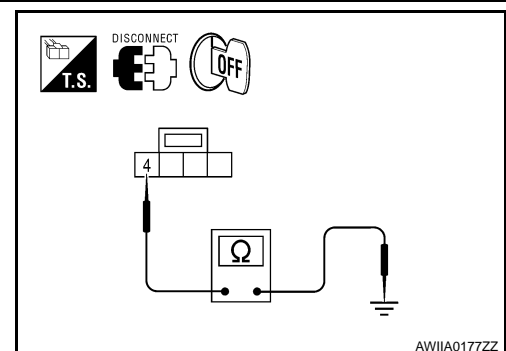

11. CHECK VARIABLE BLOWER CONTROL SIGNAL CIRCUIT

A
B
C
D
E
F
G
H
HAC
J
K
L
M
N
O
P

BLOWER MOTOR CONTROL SYSTEM

[AUTOMATIC AIR CONDITIONER]

< COMPONENT DIAGNOSIS >

1. Disconnect A/C auto amp. connector.
2. Check continuity between A/C auto amp. harness connector M49 (B) terminal 13 and variable blower control harness connector M122 (A) terminal 3.

13 - 3 : Continuity should exist.

Is the inspection result normal?

YES >> GO TO 12.

NO >> Repair harness or connector.

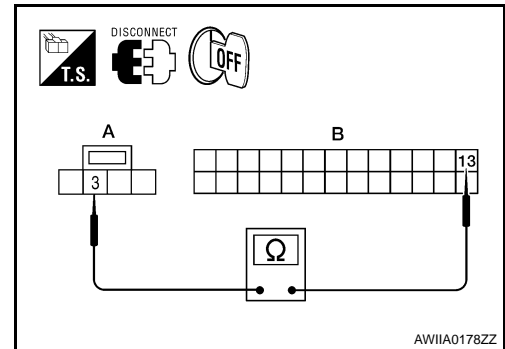

12. CHECK FRONT BLOWER MOTOR

Check front blower motor. Refer to [HAC-151, "Front Blower Motor Component Inspection"](#).

Is the inspection result normal?

YES >> GO TO 13.

NO >> Replace front blower motor. Refer to [VTL-13, "Removal and Installation"](#).

13. CHECK BLOWER MOTOR GROUND CIRCUIT

Check continuity between front blower motor harness connector M62 terminal 1 and variable blower control harness connector M122 terminal 2.

1 - 2 : Continuity should exist.

Is the inspection result normal?

YES >> GO TO 14.

NO >> Repair harness or connector.

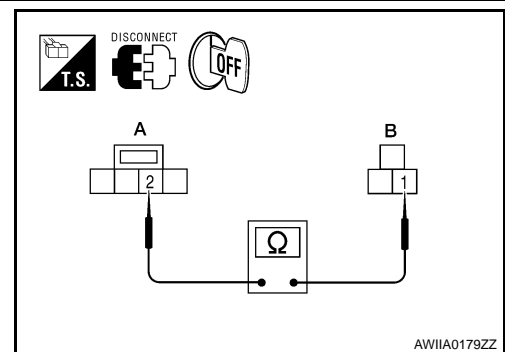

14. CHECK VARIABLE BLOWER CONTROL GROUND CIRCUIT

Check continuity between variable blower control harness connector M122 terminal 1 and ground.

1 - Ground : Continuity should exist.

Is the inspection result normal?

YES >> Replace variable blower control. Refer to [VTL-15, "Removal and Installation"](#).

NO >> Repair harness or connector.

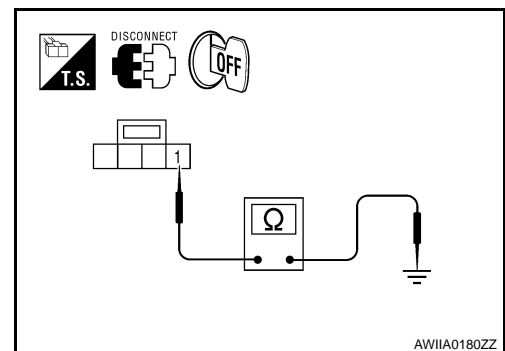

Front Blower Motor Component Inspection

INFOID:000000001366717

COMPONENT INSPECTION

Front Blower Relay

BLOWER MOTOR CONTROL SYSTEM

[AUTOMATIC AIR CONDITIONER]

< COMPONENT DIAGNOSIS >

Check continuity between terminals 6-7 and 3-5 by supplying 12 volts to terminal 1 and ground to terminal 2 of relay.

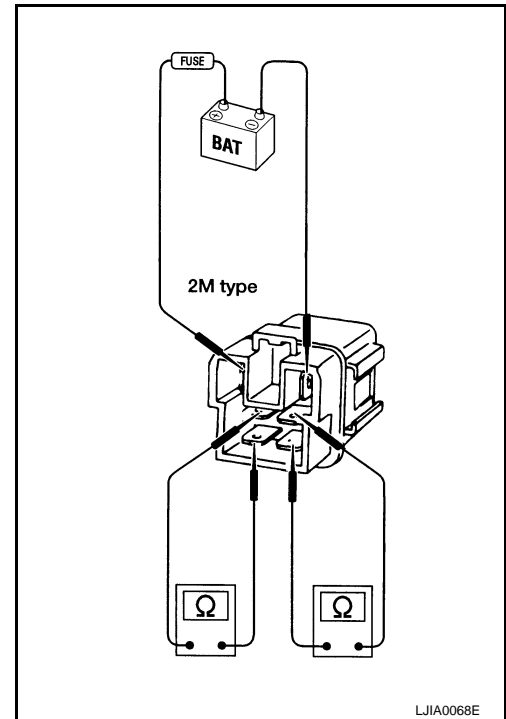

Front Blower Motor

Confirm smooth rotation of the blower motor.

- Ensure that there are no foreign particles inside the blower unit.
- Apply 12 volts to terminal 2 and ground to terminal 1 and verify that the motor operates freely and quietly.

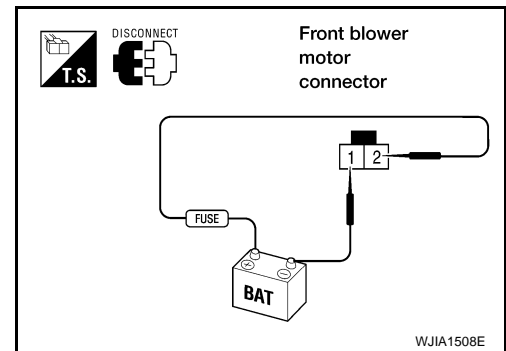

Rear Blower Motor Description

SYSTEM DESCRIPTION

Component Parts

Rear blower speed control system components are:

- A/C auto amp.
- A/C and AV switch assembly
- Rear air control (front)
- Rear air control (rear)
- Variable blower control (rear)
- Rear blower motor
- Rear blower motor relay

A
B
C
D
E
F
G
H
HAC
J
K
L
M
N
O
P

BLOWER MOTOR CONTROL SYSTEM

< COMPONENT DIAGNOSIS >

[AUTOMATIC AIR CONDITIONER]

System Operation

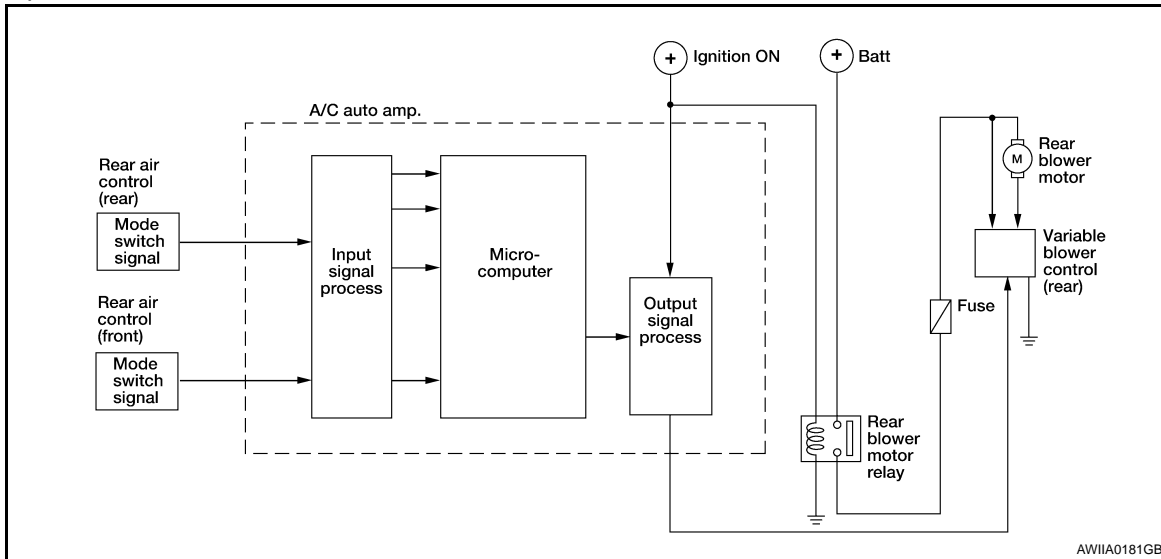

Rear Blower Control

When the rear blower control dial (front) REAR CTRL switch is pressed (indicator on), it allows the rear air control (rear) to control the rear blower motor speed. If the REAR CTRL switch is off (indicator off), the rear air control (front) controls the rear blower motor speed regardless of the rear air control (rear) position.

Rear Blower motor Component Function Check

INFOID:000000001366719

SYMPTOM:

- Rear blower motor does not operate from the rear air control (front) and the rear air control (rear).
- Rear blower motor operates from rear air control (front) only.
- Rear blower motor operates from rear air control (rear) only.
- Rear blower motor speed does not match the rear air control (front) speed selected.
- Rear blower motor speed does not match the rear air control (rear) speed selected.
- Rear blower motor operates in high all the time when controlled from the rear air control (front).
- Rear blower motor operates in high all the time when controlled from the rear air control (rear).

INSPECTION FLOW

1. CONFIRM SYMPTOM BY PERFORMING OPERATIONAL CHECK - REAR AIR CONTROL (FRONT)

1. Press AUTO switch.
2. Turn the rear air control (front) blower control dial to the lowest speed and check for rear blower operation (REAR CTRL indicator off).
3. Continue checking that rear blower speed increases as the rear blower control dial is rotated clockwise.

Does the rear blower motor operate correctly?

YES >> GO TO 3.

NO >> GO TO 2.

2. CONFIRM SYMPTOM BY PERFORMING OPERATIONAL CHECK - REAR AIR CONTROL (REAR)

1. Press the REAR CTRL switch (indicator on) on the rear air control (front) to send control of the rear blower motor back the rear air control (rear).
2. Turn the rear air control (rear) blower control dial to the lowest speed and check for rear blower operation.
3. Continue checking that rear blower speed increases as the rear blower control dial is rotated clockwise.

Does the rear blower motor operate correctly?

YES >> • Rear blower motor does not operate at any speed from the rear air control (front). Refer to [HAC-53. "Rear Air Control \(Front\) Diagnosis Procedure #1"](#).

• Rear blower motor operates in high speed all the time or does not match the rear air control (front) speed selected. Refer to [HAC-54. "Rear Air Control \(Rear\) Diagnosis Procedure #2"](#).

NO >> • Rear blower motor does not operate from the rear air control (front) and the rear air control (rear). Refer to [HAC-55. "Rear Air Control \(Rear\) Diagnosis Procedure #3"](#)

3. CONFIRM SYMPTOM BY PERFORMING OPERATIONAL CHECK - REAR AIR CONTROL (REAR)

BLOWER MOTOR CONTROL SYSTEM

[AUTOMATIC AIR CONDITIONER]

< COMPONENT DIAGNOSIS >

1. Press the REAR CTRL switch (indicator on) on the rear air control (front) to send control of the rear blower motor back the rear air control (rear).
2. Turn the rear air control (rear) blower control dial to the lowest speed and check for rear blower operation.
3. Continue checking that rear blower speed increases as the rear blower control dial is rotated clockwise.

Does the rear blower motor operate correctly?

YES >> GO TO 4.

NO >> Check rear air control (rear). Refer to [HAC-58. "Rear Air Control \(Rear\) Diagnosis Procedure #4"](#).

4. CHECK FOR SERVICE BULLETINS

Check for any service bulletins.

>> GO TO 5.

5. RECHECK FOR ANY SYMPTOMS

Perform a complete operational check for any symptoms. Refer to [HAC-5. "Operational Check \(Front\)"](#).

Does another symptom exist?

YES >> Refer to [HAC-4. "How to Perform Trouble Diagnosis For Quick And Accurate Repair"](#).

NO >> INSPECTION END.

Rear Air Control (Front) Diagnosis Procedure #1

INFOID:000000001366720

TROUBLE DIAGNOSIS PROCEDURE

1. CHECK REAR AIR CONTROL (FRONT) POWER SUPPLY

1. Disconnect rear air control (front) harness connector.
2. Turn ignition switch ON.
3. Check voltage between rear air control (front) harness connector R2 terminal 10 and ground.

Battery voltage should exist.

Is the inspection result normal?

YES >> GO TO 2.

NO >> Repair harness or connector.

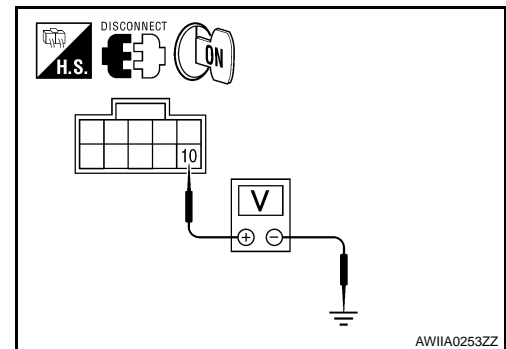

2. CHECK REAR AIR CONTROL (FRONT) FRONT AUX BLOWER POT REFERENCE VOLTAGE

1. Disconnect rear air control (front) harness connector.
2. Turn ignition switch ON.
3. Check voltage between rear air control (front) harness connector R2 terminal 6 and ground.

Connector	Terminals		Voltage (Approx.)
	(+)	(-)	
Rear air control (front): R2	6	Ground	5V

Is the inspection result normal?

YES >> GO TO 3.

NO >> Repair harness or connector.

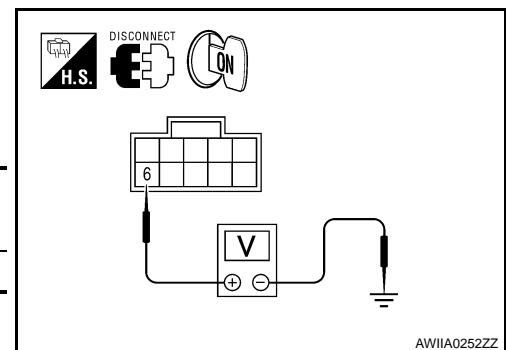

3. CHECK REAR AIR CONTROL (FRONT) GROUND CIRCUIT

BLOWER MOTOR CONTROL SYSTEM

[AUTOMATIC AIR CONDITIONER]

< COMPONENT DIAGNOSIS >

Check continuity between rear air control (front) harness connector R2 terminal 1 and ground.

Continuity should exist.

Is the inspection result normal?

YES >> Replace A/C auto amp. Refer to [VTL-8, "Removal and Installation"](#).

NO >> Repair harness or connector.

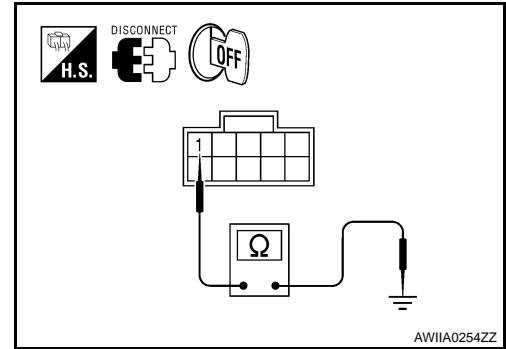

INFOID:000000001366721

Rear Air Control (Rear) Diagnosis Procedure #2

TROUBLE DIAGNOSIS PROCEDURE

1. CHECK REAR AIR CONTROL (FRONT) POWER SUPPLY

1. Disconnect rear air control (front) harness connector.
2. Turn ignition switch ON.
3. Check voltage between rear air control (front) harness connector R2 terminal 10 and ground.

Battery voltage should exist.

Is the inspection result normal?

YES >> GO TO 2.

NO >> Repair harness or connector.

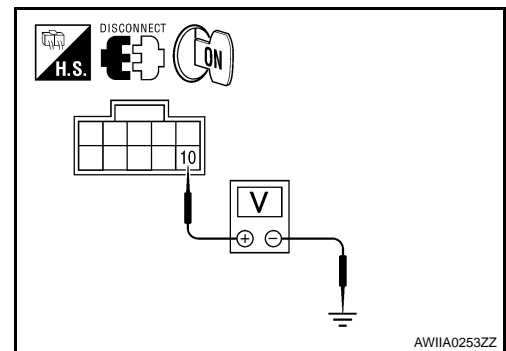

2. CHECK REAR AIR CONTROL (FRONT) FRONT AUX BLOWER POT REFERENCE VOLTAGE

1. Disconnect rear air control (front) harness connector.
2. Turn ignition switch ON.
3. Check voltage between rear air control (front) harness connector R2 terminal 6 and ground.

Connector	Terminals		Voltage (Approx.)
	(+)	(-)	
Rear air control (front): R2	6	Ground	5V

Is the inspection result normal?

YES >> GO TO 3.

NO >> GO TO 4.

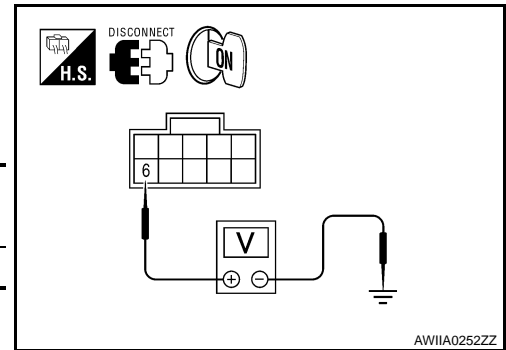

3. CHECK REAR AIR CONTROL (FRONT) GROUND CIRCUIT

1. Turn ignition switch OFF.
2. Check continuity between rear air control (front) harness connector R2 terminal 1 and ground.

Continuity should exist.

Is the inspection result normal?

YES >> Replace rear air control (front).

NO >> Repair harness or connector.

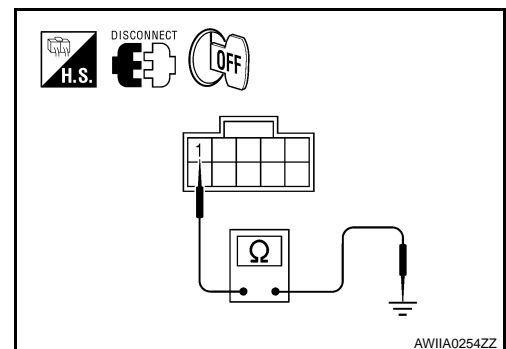

4. CHECK REAR AIR CONTROL (FRONT) BLOWER POT CIRCUIT FOR OPEN

BLOWER MOTOR CONTROL SYSTEM

[AUTOMATIC AIR CONDITIONER]

< COMPONENT DIAGNOSIS >

1. Turn ignition switch OFF.
2. Disconnect A/C auto amp. connector.
3. Check continuity between A/C auto amp. harness connector M50 (A) terminal 38 and rear air control (front) harness connector R2 (B) terminal 6.

Continuity should exist.

Is the inspection result normal?

- YES >> Replace A/C auto amp. Refer to [VTL-8, "Removal and Installation"](#).
- NO >> Repair harness or connector.

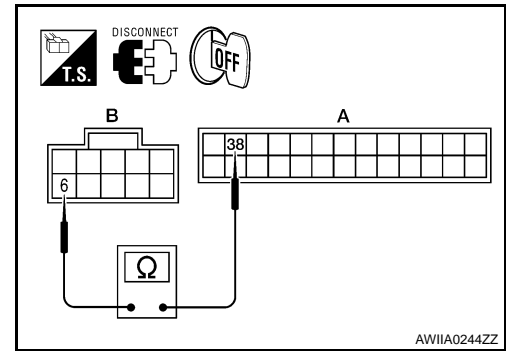

Rear Air Control (Rear) Diagnosis Procedure #3

INFOID:000000001430753

TROUBLE DIAGNOSIS PROCEDURE

1. CHECK REAR AIR CONTROL (FRONT)

1. Disconnect rear air control (front) connector.
2. Turn ignition switch ON.
3. Press AUTO switch.

Does rear blower motor operate in high speed?

- YES >> GO TO 17.
- NO >> GO TO 2.

2. CHECK REAR BLOWER MOTOR POWER SUPPLY

1. Turn ignition switch OFF.
2. Disconnect rear blower motor harness connector.
3. Turn ignition switch ON.
4. Press AUTO switch.
5. Rotate rear air control (front) blower speed control dial to maximum speed (REAR CTRL indicator off).
6. Check voltage between rear blower motor harness connector B201 terminal 2 and ground.

Battery voltage should exist.

Is the inspection result normal?

- YES >> GO TO 3.
- NO >> GO TO 9.

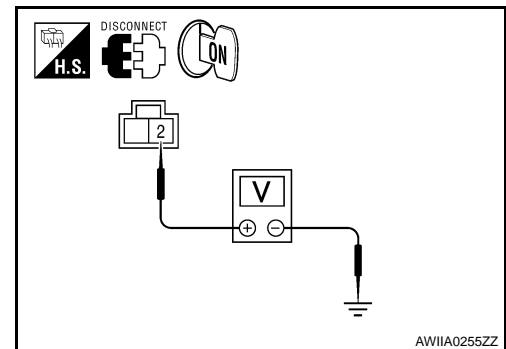

3. CHECK VARIABLE BLOWER CONTROL (REAR) POWER SUPPLY

1. Turn ignition switch OFF.
2. Disconnect variable blower control (rear) connector.
3. Turn ignition switch ON.
4. Check voltage between variable blower control connector B133 terminal 4 and ground.

Battery voltage should exist.

Is the inspection result normal?

- YES >> GO TO 4.
- NO >> Repair harness or connector.

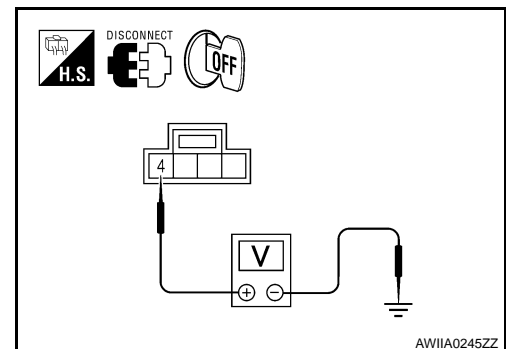

4. CHECK VARIABLE BLOWER CONTROL (REAR) AUX BLOWER SPEED SIGNAL CIRCUIT FOR SHORT

A
B
C
D
E
F
G
H
HAC
J
K
L
M
N
O
P

BLOWER MOTOR CONTROL SYSTEM

[AUTOMATIC AIR CONDITIONER]

< COMPONENT DIAGNOSIS >

Check voltage between variable blower control (rear) harness connector B133 terminal 3 and ground.

Connector	Terminals		Voltage (Approx.)
	(+)	(-)	
Variable blower control: B133	3	Ground	4.5 V

Is the inspection result normal?

- YES >> GO TO 5.
- NO >> GO TO 8.

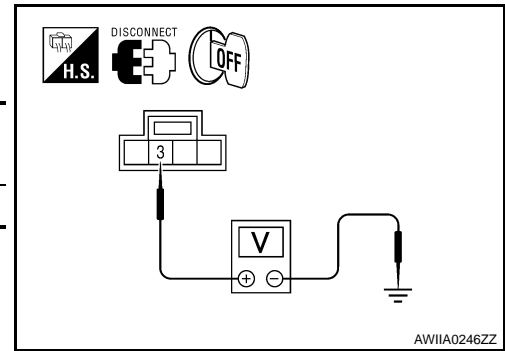

5. CHECK VARIABLE BLOWER CONTROL (REAR) GROUND CIRCUIT

1. Turn ignition switch OFF.
2. Check continuity between variable blower control (rear) harness connector B133 terminal 1 and ground.

Continuity should exist.

Is the inspection result normal?

- YES >> GO TO 6.
- NO >> Repair harness or connector.

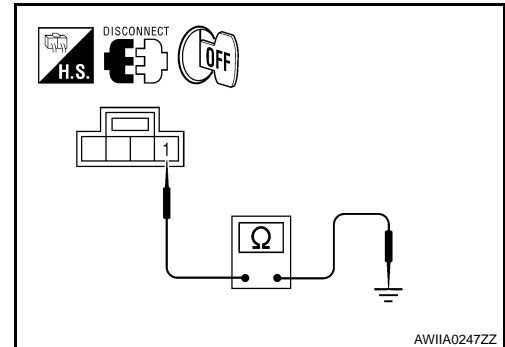

6. CHECK REAR BLOWER MOTOR

Check rear blower motor. Refer to [HAC-59, "Rear Blower Motor And Relay Component Inspection"](#).

Is the inspection result normal?

- YES >> GO TO 7.
- NO >> Replace rear blower motor. Refer to [VTL-13, "Removal and Installation"](#).

7. CHECK VARIABLE BLOWER CONTROL (REAR) BLOWER MOTOR GROUND CIRCUIT

Check continuity between rear blower motor connector B501 (B) terminal 1 and variable blower control (rear) connector B133 (A) terminal 2.

Continuity should exist.

Is the inspection result normal?

- YES >> Replace A/C auto amp. Refer to [VTL-8, "Removal and Installation"](#).
- NO >> Repair harness or connector.

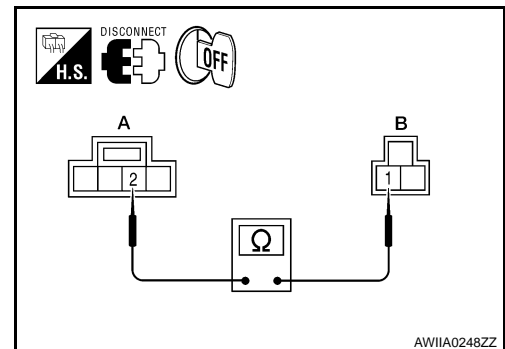

8. CHECK VARIABLE BLOWER CONTROL (REAR) AUX BLOWER SPEED CIRCUIT FOR OPEN

1. Turn ignition switch OFF.
2. Disconnect A/C auto amp. connector.
3. Check continuity between A/C auto amp. harness connector M49 (A) terminal 12 and variable blower control (rear) harness connector B133 (B) terminal 3.

Continuity should exist.

Is the inspection result normal?

- YES >> Replace A/C auto amp. Refer to [VTL-8, "Removal and Installation"](#).
- NO >> Repair harness or connector.

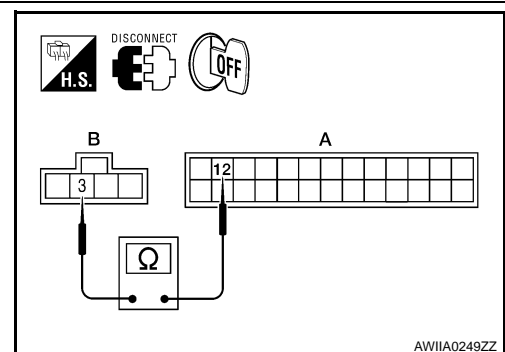

9. CHECK FUSES

Check 15A fuses [Nos. 10 and 11, located in the fuse block (J/B)].

BLOWER MOTOR CONTROL SYSTEM

[AUTOMATIC AIR CONDITIONER]

< COMPONENT DIAGNOSIS >

Is the inspection result normal?

YES >> GO TO 10.

NO >> GO TO 14.

10. CHECK REAR BLOWER MOTOR RELAY

Check rear blower motor relay. Refer to [HAC-59. "Rear Blower Motor And Relay Component Inspection"](#).

Is the inspection result normal?

YES >> GO TO 11.

NO >> Replace rear blower motor relay.

11. CHECK REAR BLOWER MOTOR CIRCUIT BETWEEN REAR BLOWER MOTOR AND FUSE BLOCK (J/B)

1. Turn ignition switch OFF.
2. Disconnect fuse block (J/B) M3 harness connector.
3. Check continuity between fuse block (J/B) harness connector M3 terminal 3N and 8N and rear blower motor harness connector B501 terminal 2.

Continuity should exist.

Is the inspection result normal?

YES >> GO TO 12.

NO >> Repair harness or connector.

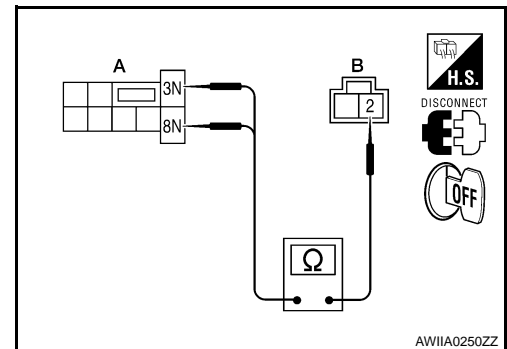

12. CHECK REAR BLOWER MOTOR RELAY (COIL SIDE) GROUND CIRCUIT

Check continuity between fuse block (J/B) harness connector M3 terminal 7N and ground.

Continuity should exist.

Is the inspection result normal?

YES >> GO TO 13.

NO >> Repair harness or connector.

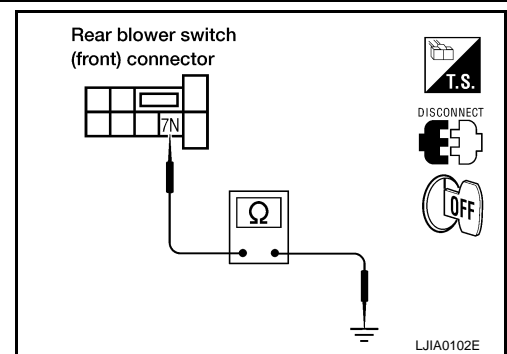

13. CHECK REAR BLOWER MOTOR RELAY (COIL SIDE) POWER SUPPLY CIRCUIT FOR OPEN

1. Turn ignition switch ON.
2. Check voltage between rear blower motor relay harness connector J-1 terminal 1 and ground.

Battery voltage should exist.

Is the inspection result normal?

YES >> Replace fuse block (J/B).

NO >> Repair harness or connector.

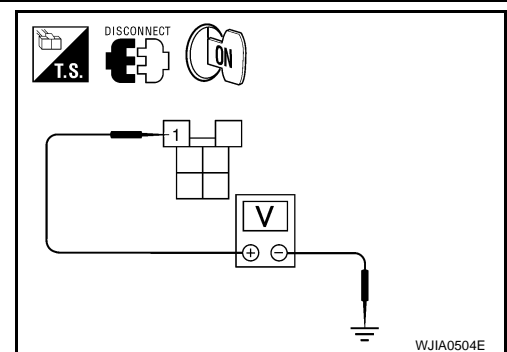

14. REPLACE FUSE

1. Turn ignition switch OFF.
2. Replace fuses.
3. Reconnect all disconnected parts.
4. Turn ignition switch ON.
5. Activate the rear blower motor from the rear air control (front).

Does the fuse blow?

YES >> GO TO 15.

A
B
C
D
E
F
G
H
HAC
J
K
L
M
N
O
P

BLOWER MOTOR CONTROL SYSTEM

[AUTOMATIC AIR CONDITIONER]

< COMPONENT DIAGNOSIS >

NO >> Inspection End.

15. CHECK REAR BLOWER MOTOR

Check rear blower motor. Refer to [HAC-59, "Rear Blower Motor And Relay Component Inspection"](#).

Is the inspection result normal?

YES >> GO TO 16.

NO >> Replace rear blower motor. Refer to [VTL-13, "Removal and Installation"](#).

16. CHECK REAR BLOWER MOTOR POWER SUPPLY CIRCUIT FOR SHORT

1. Turn ignition switch OFF.
2. Disconnect fuse block (J/B) M3 harness connector and variable blower control (rear).
3. Check continuity between rear blower motor harness connector B501 terminal 2 and ground.

Continuity should not exist.

Is the inspection result normal?

YES >> Replace variable blower control (rear). Refer to [VTL-15, "Removal and Installation"](#).

NO >> Repair harness or connector.

17. CHECK REAR AIR CONTROL (FRONT) POWER SUPPLY

Check voltage between rear air control (front) harness connector R2 terminal 10 and ground.

Battery voltage should exist.

Is the inspection result normal?

YES >> GO TO 18.

NO >> Repair harness or connector.

18. CHECK A/C AUTO AMP. FRONT AUX BLOWER POT CIRCUIT FOR SHORT

1. Turn ignition switch OFF.
2. Disconnect A/C auto amp. harness connector M50.
3. Check continuity between rear air control (front) harness connector R2 terminal 6 and ground.

Continuity should not exist.

Is the inspection result normal?

YES >> Replace rear air control (front) Refer to [VTL-8, "Removal and Installation"](#).

NO >> Repair harness or connector.

Rear Air Control (Rear) Diagnosis Procedure #4

INFOID:000000001430754

TROUBLE DIAGNOSIS PROCEDURE

1. CHECK REAR AIR CONTROL (REAR) REAR AUX BLOWER POT REFERENCE VOLTAGE

1. Turn ignition switch OFF.

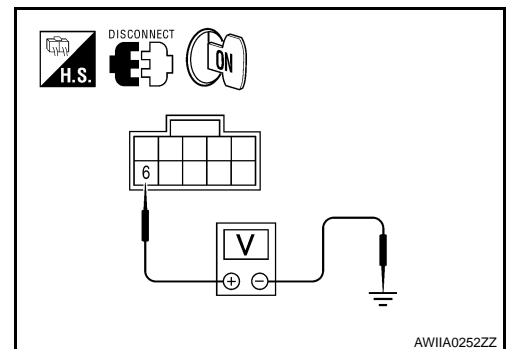
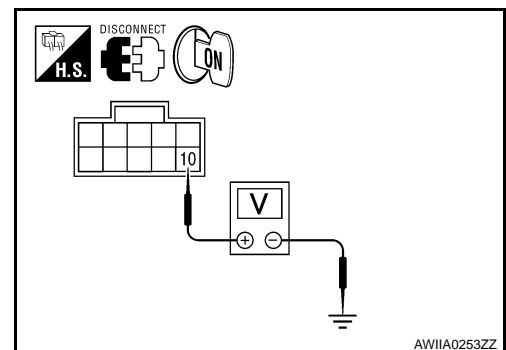
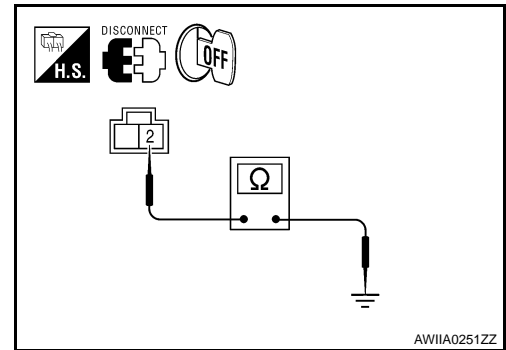

BLOWER MOTOR CONTROL SYSTEM

[AUTOMATIC AIR CONDITIONER]

< COMPONENT DIAGNOSIS >

- Disconnect rear air control (rear) harness connector.
- Turn ignition switch ON.
- Check voltage between rear air control (rear) harness connector M208 terminal 6 and ground.

Connector	Terminals		Voltage (Approx.)
	(+)	(-)	
Rear air control (rear): M208	6	Ground	5V

OK or NG

- OK >> GO TO 2.
NG >> GO TO 3.

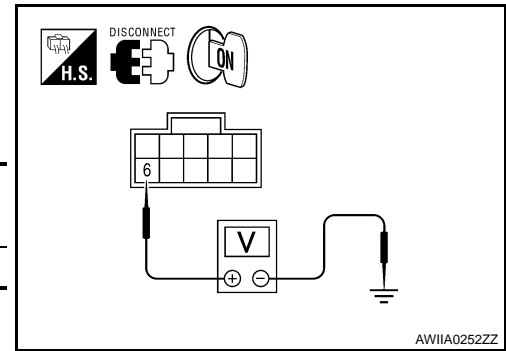

2. CHECK REAR AIR CONTROL (REAR) GROUND CIRCUIT

- Turn ignition switch OFF.
- Check continuity between rear air control (rear) harness connector M208 terminal 1 and ground.

Continuity should exist.

OK or NG

- OK >> Replace rear air control (rear). Refer to [VTL-8, "Removal and Installation"](#).
NG >> Repair harness or connector.

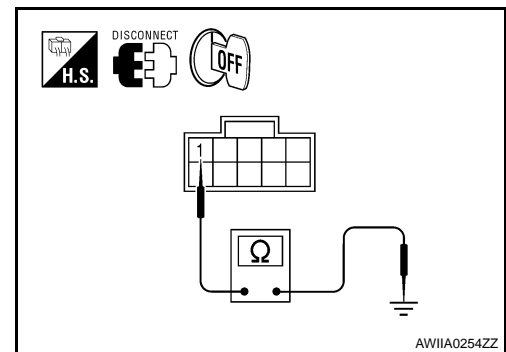

3. CHECK REAR AIR CONTROL (REAR) REAR AUX BLOWER POT FOR SHORT

- Turn ignition switch OFF.
- Check continuity between rear air control (rear) harness connector M208 terminal 6 and ground.

Continuity should not exist.

OK or NG

- OK >> GO TO 4.
NG >> Repair harness or connector.

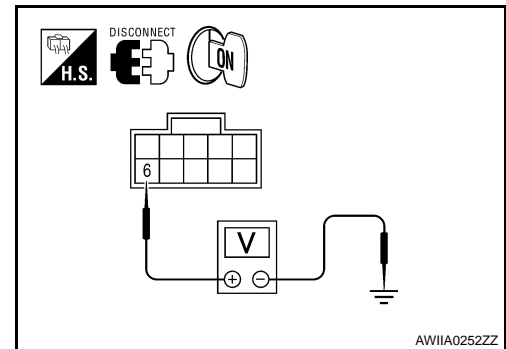

4. CHECK REAR AIR CONTROL (REAR) REAR AUX BLOWER POT BETWEEN A/C AUTO AMP. AND REAR AIR CONTROL REAR

- Disconnect A/C auto amp. harness connector.
- Check continuity between A/C auto amp. harness connector M50 (A) terminal 52 and rear air control (rear) harness connector M208 (B) terminal 6.

Continuity should exist.

OK or NG

- OK >> Replace A/C auto amp. Refer to [VTL-8, "Removal and Installation"](#).
NG >> Repair harness or connector.

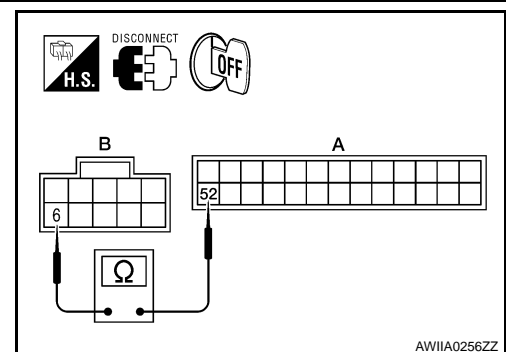

Rear Blower Motor And Relay Component Inspection

INFOID:000000001366722

COMPONENT INSPECTION

Rear Blower Motor Relay

BLOWER MOTOR CONTROL SYSTEM

[AUTOMATIC AIR CONDITIONER]

< COMPONENT DIAGNOSIS >

Check circuit continuity between terminals by supplying 12 volts and ground to coil side terminals of relays.

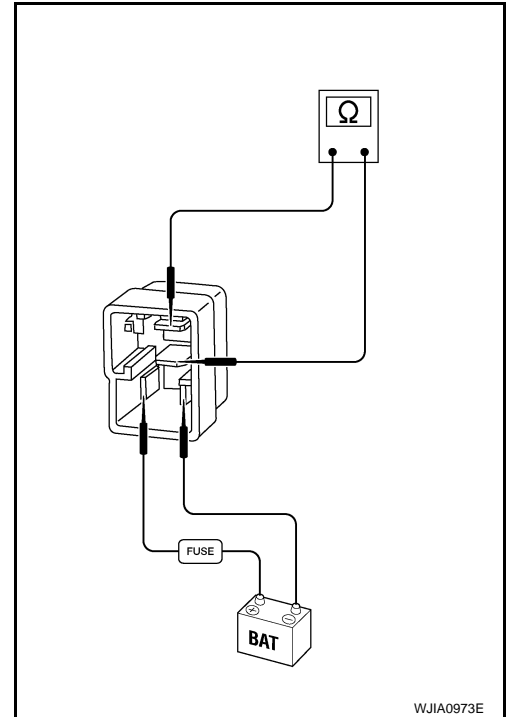

Rear Blower Motor

Check that there are no foreign particles inside the intake unit.
Apply 12 volts to terminal 2 and ground to terminal 1 and ensure that the blower motor rotates freely and quietly.

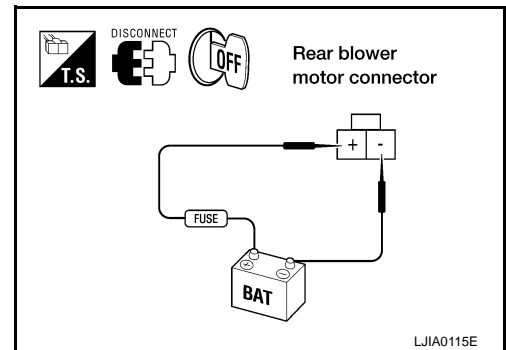

REAR AIR CONTROL SYSTEM

< COMPONENT DIAGNOSIS >

[AUTOMATIC AIR CONDITIONER]

REAR AIR CONTROL SYSTEM

Rear Air Control System Description

INFOID:000000001366723

SYSTEM DESCRIPTION

Component Parts

Rear air control system components are:

- A/C auto amp.
- Rear air control (front)
- Rear air control (rear)
- Air mix door motor (rear)

System Operation

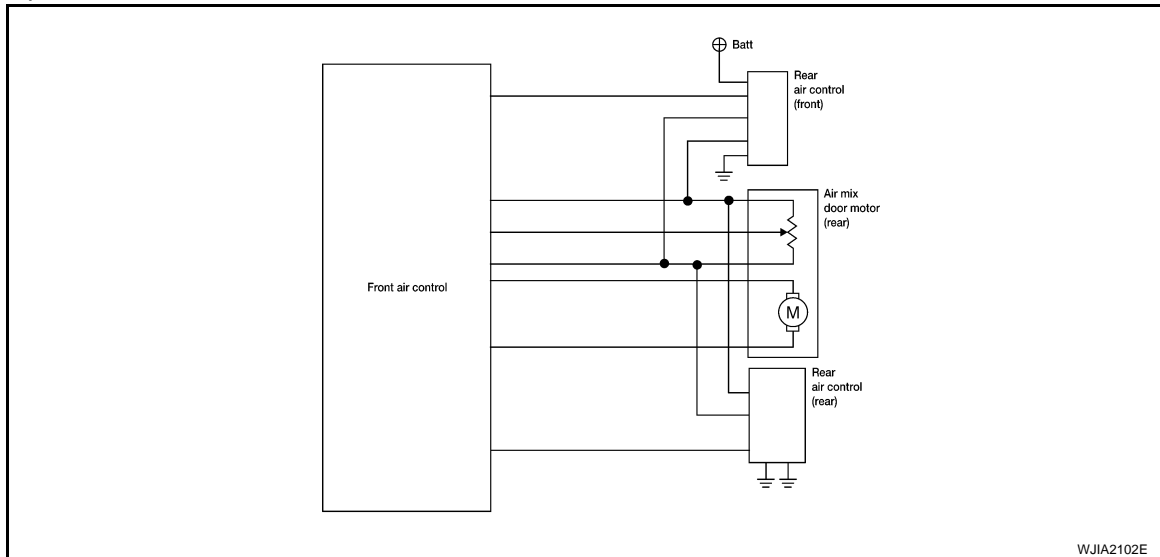

Rear Air Control

When the REAR CTRL indicator is off the rear air control (front) will control all rear blower motor speeds and the rear temperature/mode operations. When the REAR CTRL switch is pressed (indicator on), the rear air control (rear) will control all the rear blower motor speeds and the rear temperature/mode operations.

Rear Air Control Component Function Check

INFOID:000000001366724

SYMPTOM:

- Temperature cannot be adjusted from the rear air control.

INSPECTION FLOW

1. CONFIRM SYMPTOM BY PERFORMING REAR AIR CONTROL (FRONT) OPERATIONAL CHECK

1. Press AUTO switch (rear air controls only operate when front blower is on).
2. Turn the rear blower motor to maximum speed from the rear air control (front).
3. Turn rear air control (front) temperature/mode control dial clockwise and then counterclockwise (REAR CTRL indicator off).
4. Check for hot air at rear floor discharge air outlets in the maximum heat position and cold air at rear roof discharge air outlets in the maximum cold position.

Does the rear air control (front) operate properly?

YES >> GO TO 2.

NO >> Check rear air control (front). Refer to [HAC-62, "Rear Air Control \(Front\) Diagnosis Procedure"](#).

2. CONFIRM SYMPTOM BY PERFORMING REAR AIR CONTROL (REAR) OPERATIONAL CHECK

1. Press the REAR CTRL switch on rear air control (front) to send control to the rear air control (rear).
2. Turn the rear blower motor to maximum speed from the rear air control (rear).
3. Turn rear air control (rear) temperature/mode control dial slowly clockwise and then counterclockwise (REAR CTRL indicator on).

REAR AIR CONTROL SYSTEM

[AUTOMATIC AIR CONDITIONER]

< COMPONENT DIAGNOSIS >

4. Check for hot air at rear floor discharge air outlets in the maximum heat position and cold air at rear roof discharge air outlets in the maximum cold position.

Does the rear air control (rear) operate properly?

YES >> GO TO 3.

NO >> Check rear air control (rear). Refer to [HAC-64, "Rear Air Control \(Rear\) Diagnosis Procedure"](#).

3.CHECK FOR ANY SYMPTOMS

Perform a complete operational check (rear) for any symptoms.

Does another symptom exist?

YES >> Refer to [HAC-4, "How to Perform Trouble Diagnosis For Quick And Accurate Repair"](#).

NO >> System OK.

4.CHECK FOR SERVICE BULLETINS

Check for any service bulletins.

>> GO TO 5.

5.CONFIRM SYMPTOM BY PERFORMING REAR AIR CONTROL (REAR) OPERATIONAL CHECK

Perform rear air control operation diagnosis to check for any codes. Refer to [HAC-6, "Operational Check \(Rear\)"](#).

Are any symptoms present?

YES >> Refer to [HAC-106, "Symptom Matrix Chart"](#).

NO >> System OK.

Rear Air Control (Front) Diagnosis Procedure

INFOID:000000001366725

DIAGNOSTIC PROCEDURE FOR REAR AIR CONTROL (FRONT)

SYMPTOM:

- Temperature/mode operation is malfunctioning.

1.CHECK REAR AIR CONTROL (FRONT) POWER SUPPLY

1. Disconnect rear air control (front) harness connector.
2. Turn ignition switch ON.
3. Check voltage between rear air control (front) harness connector R2 terminal 10 and ground.

Battery voltage should exist.

Is the inspection result normal?

YES >> GO TO 2.

NO >> Repair harness or connector.

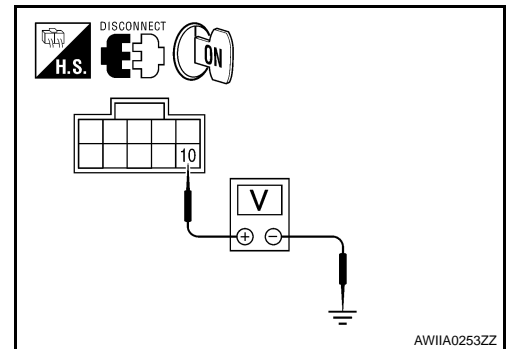

2.CHECK REAR AIR CONTROL (FRONT) REFERENCE VOLTAGE

Check voltage between rear air control (front) harness connector R2 terminal 3 and ground.

Connector	Terminals		Voltage (Approx.)
	(+)	(-)	
Rear air control (front): R2	3	Ground	4.5V

Is the inspection result normal?

YES >> GO TO 3.

NO >> GO TO 6.

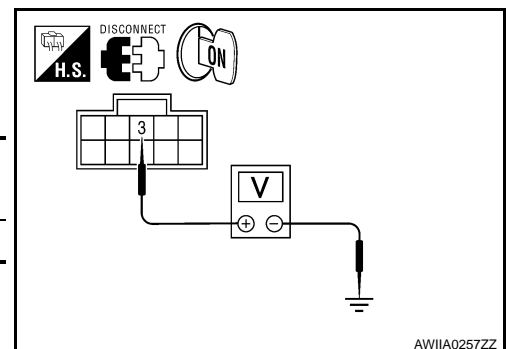

3.CHECK REAR AIR CONTROL (FRONT) AUX TEMP POT VOLTAGE

REAR AIR CONTROL SYSTEM

[AUTOMATIC AIR CONDITIONER]

< COMPONENT DIAGNOSIS >

Check voltage between rear air control (front) harness connector R2 terminal 7 and ground.

Connector	Terminals		Voltage (Approx.)
	(+)	(-)	
Rear air control (front): R2	7	Ground	4.5V

Is the inspection result normal?

- YES >> GO TO 4.
NO >> GO TO 7.

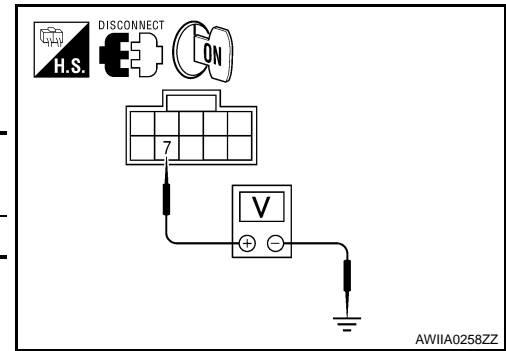

4. CHECK REAR AIR CONTROL (FRONT) GROUND CIRCUIT

- Turn ignition switch OFF.
- Check continuity between rear air control (front) harness connector R2 terminal 1 and ground.

Continuity should exist.

Is the inspection result normal?

- YES >> GO TO 5.
NO >> Repair harness or connector.

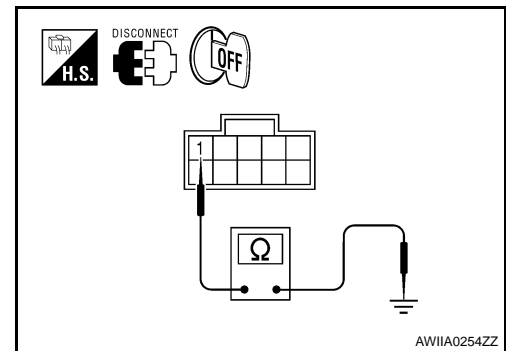

5. CHECK REAR AIR CONTROL (FRONT) REFERENCE GROUND CIRCUIT

Check continuity between rear air control (front) harness connector R2 terminal 8 and ground.

Continuity should exist.

Is the inspection result normal?

- YES >> Replace rear air control (front). Refer to [VTL-8, "Removal and Installation"](#).
NO >> GO TO 8.

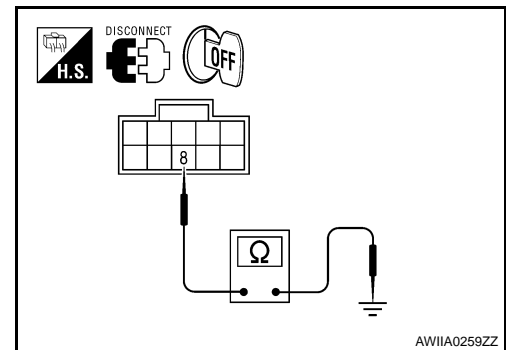

6. CHECK REAR AIR CONTROL (FRONT) REFERENCE VOLTAGE CIRCUIT

- Turn ignition switch OFF.
- Disconnect A/C auto amp. connector.
- Check continuity between A/C auto amp. harness connector M50 (A) terminal 28 and rear air control (front) harness connector R2 (B) terminal 3.

Continuity should exist.

Is the inspection result normal?

- YES >> Replace A/C auto amp. Refer to [VTL-8, "Removal and Installation"](#).
NO >> Repair harness or connector.

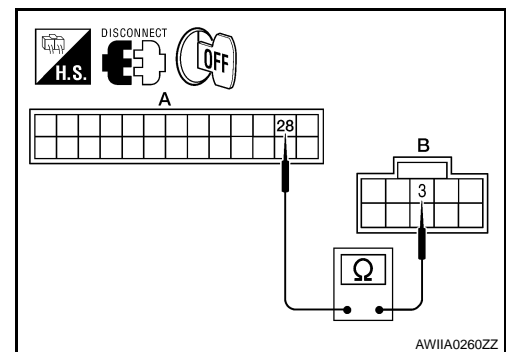

7. CHECK REAR AIR CONTROL (FRONT) AUX TEMP POT CIRCUIT

REAR AIR CONTROL SYSTEM

[AUTOMATIC AIR CONDITIONER]

< COMPONENT DIAGNOSIS >

1. Turn ignition switch OFF.
2. Disconnect A/C auto amp. connector.
3. Check continuity between A/C auto amp. harness connector M50 (A) terminal 37 and rear air control (front) harness connector R2 (B) terminal 7.

Continuity should exist.

Is the inspection result normal?

YES >> Replace A/C auto amp. Refer to [VTL-8, "Removal and Installation"](#).

NO >> Repair harness or connector.

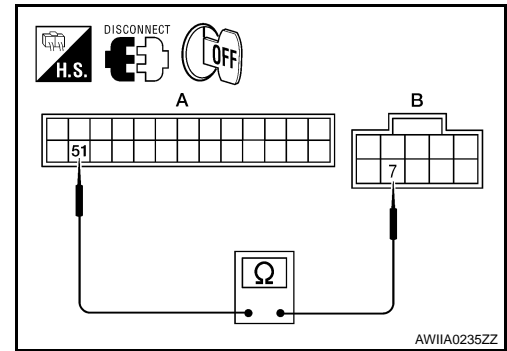

8.CHECK REAR AIR CONTROL (FRONT) REFERENCE GROUND CIRCUIT FOR OPEN

1. Disconnect A/C auto amp. connector.
2. Check continuity between A/C auto amp. harness connector M49 (A) terminal 3 and rear air control (front) harness connector R2 (B) terminal 8.

Continuity should exist.

Is the inspection result normal?

YES >> Replace A/C auto amp. Refer to [VTL-8, "Removal and Installation"](#).

NO >> Repair harness or connector.

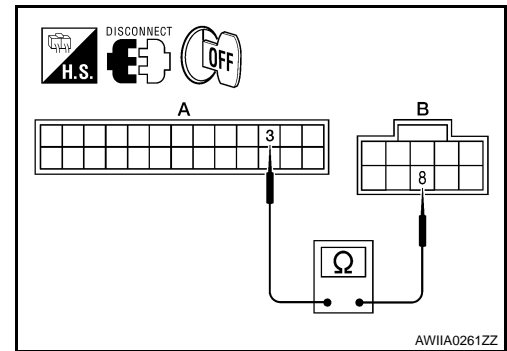

Rear Air Control (Rear) Diagnosis Procedure

INFOID:000000001366726

DIAGNOSTIC PROCEDURE FOR REAR AIR CONTROL (REAR)

1.CHECK REAR AIR CONTROL (REAR) AUX TEMPERATURE POT VOLTAGE

1. Turn ignition switch OFF.
2. Disconnect rear air control (rear).
3. Turn ignition switch ON.
4. Check voltage between rear air control (rear) harness connector M208 terminal 7 and ground.

Connector	Terminals		Voltage (Approx.)
	(+)	(-)	
Rear air control (rear): M208	7	Ground	4.5V

Is the inspection result normal?

YES >> GO TO 2.

NO >> GO TO 5.

2.CHECK REAR AIR CONTROL (REAR) REFERENCE VOLTAGE

Check voltage between rear air control (rear) harness connector M208 terminal 3 and ground.

Connector	Terminals		Voltage (Approx.)
	(+)	(-)	
Rear air control (rear): M208	3	Ground	4.5V

Is the inspection result normal?

YES >> GO TO 3.

NO >> GO TO 6

3.CHECK REAR AIR CONTROL (REAR) REFERENCE RETURN GROUND

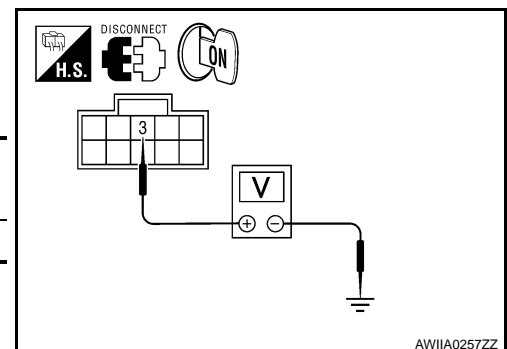
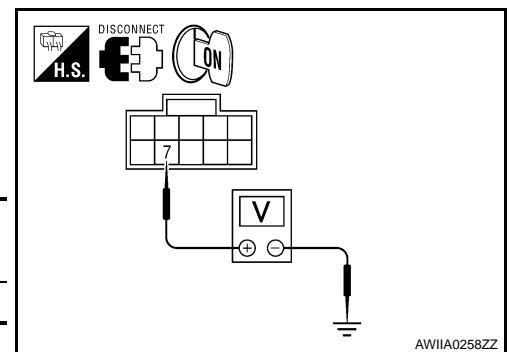

REAR AIR CONTROL SYSTEM

[AUTOMATIC AIR CONDITIONER]

< COMPONENT DIAGNOSIS >

1. Turn ignition switch OFF.
2. Check continuity between rear air control (rear) harness connector M208 terminal 8 and ground.

Continuity should exist.

Is the inspection result normal?

YES >> GO TO 4.

NO >> GO TO 7.

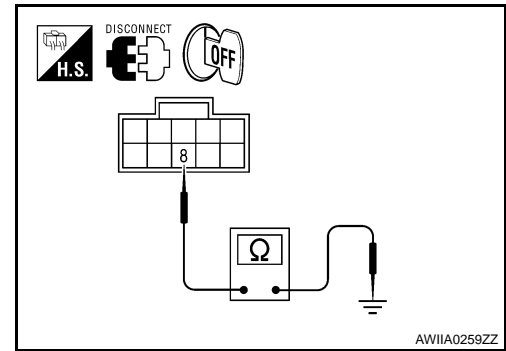

4. CHECK REAR AIR CONTROL (REAR) GROUND CIRCUIT

1. Check continuity between rear air control (rear) harness connector M208 terminal 1 and ground.

Continuity should exist.

Is the inspection result normal?

YES >> Replace rear air control (rear). Refer to [VTL-8, "Removal and Installation"](#).

NO >> Repair harness or connector.

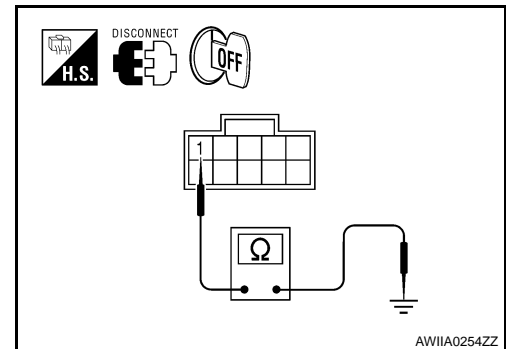

5. CHECK REAR AUX TEMP CIRCUIT BETWEEN REAR AIR CONTROL (REAR) AND A/C AUTO AMP. FOR OPEN

1. Turn ignition switch OFF.
2. Disconnect A/C auto amp. connector.
3. Check continuity between rear air control (rear) harness connector M50 (A) terminal 51 and rear air control (rear) harness connector M208 (B) terminal 7.

Continuity should exist.

Is the inspection result normal?

YES >> Replace A/C auto amp. Refer to [VTL-8, "Removal and Installation"](#).

NO >> Repair harness or connector.

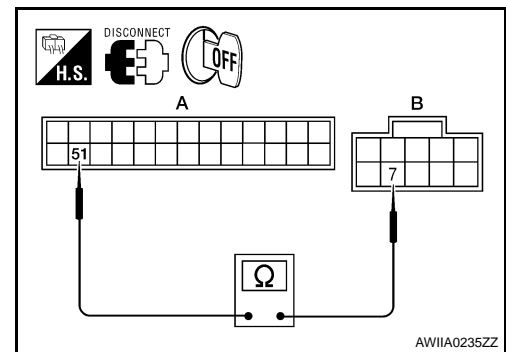

6. CHECK REFERENCE VOLTAGE CIRCUIT BETWEEN REAR AIR CONTROL (REAR) AND A/C AUTO AMP. FOR OPEN

1. Turn ignition switch OFF.
2. Disconnect A/C auto amp. connector.
3. Check continuity between rear air control (rear) harness connector M50 (A) terminal 28 and rear air control (rear) harness connector M208 (B) terminal 3.

Continuity should exist.

Is the inspection result normal?

YES >> Replace A/C auto amp. Refer to [VTL-8, "Removal and Installation"](#).

NO >> Repair harness or connector.

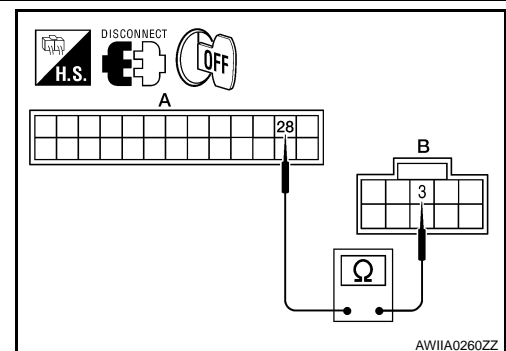

7. CHECK REFERENCE RETURN GROUND CIRCUIT BETWEEN REAR AIR CONTROL (REAR) AND A/C AUTO AMP. FOR OPEN

A
B
C
D
E
F
G
H
J
K
L
M
N
O
P

HAC

REAR AIR CONTROL SYSTEM

[AUTOMATIC AIR CONDITIONER]

< COMPONENT DIAGNOSIS >

1. Turn ignition switch OFF.
2. Disconnect A/C auto amp. connector.
3. Check continuity between rear air control (rear) harness connector M49 (A) terminal 3 and rear air control (rear) harness connector M208 (B) terminal 8.

Continuity should exist.

Is the inspection result normal?

- YES >> Replace A/C auto amp. Refer to [VTL-8, "Removal and Installation"](#).
- NO >> Repair harness or connector.

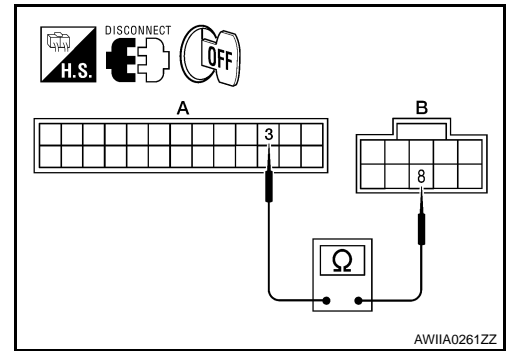

MAGNET CLUTCH

< COMPONENT DIAGNOSIS >

[AUTOMATIC AIR CONDITIONER]

MAGNET CLUTCH

System Description

INFOID:000000001366727

SYSTEM DESCRIPTION

The A/C auto amp. controls compressor operation based on ambient and intake temperature and a signal from ECM.

Low Temperature Protection Control

The A/C auto amp. will turn the compressor ON or OFF as determined by a signal detected by the intake sensor and the ambient sensor.

When intake air temperature is higher than the preset value, the compressor turns ON. The compressor turns OFF when intake air temperature is lower than the preset value. That preset value is dependent on the ambient temperature, refer to the following table.



Ambient temperature °C (°F)	VK56DE Model		VQ40DE Model	
	Compressor ON intake temperature °C (°F)	Compressor OFF intake temperature °C (°F)	Compressor ON intake temperature °C (°F)	Compressor OFF intake temperature °C (°F)
0 (32)	6.0 (43)	5.5 (42)	5.5 (42)	5.0 (41)
10 (50)	5.0 (41)	5.0 (41)	4.5 (40)	4.5 (40)
20 (68)	3.5 (38)	3.0 (37)	3.0 (37)	2.5 (37)
30 (86)	3.0 (37)	2.5 (37)	2.5 (37)	1.5 (35)
40 (104)	3.0 (37)	2.5 (37)	2.0 (36)	1.0 (34)
50 (122)	3.0 (37)	2.5 (37)	2.0 (36)	1.0 (34)

Magnet Clutch Component Function Check

INFOID:000000001366728

INSPECTION FLOW

1. CONFIRM SYMPTOM BY PERFORMING OPERATIONAL CHECK - MAGNET CLUTCH

1. Turn ignition switch ON.
2. Press the A/C switch.
3. Press vent switch ().
4. Display shows  , A/C. Confirm that the compressor clutch engages (sound or visual inspection). (Discharge air and blower speed will depend on ambient, in-vehicle and set temperatures.)

Can the symptom be duplicated?

- YES >> GO TO 3.
NO >> GO TO 2.

2. CHECK FOR ANY SYMPTOMS

Perform a complete operational check for any symptoms. Refer to [HAC-123. "Operational Check"](#).

Does another symptom exist?

- YES >> Refer to [HAC-122. "How to Perform Trouble Diagnosis For Quick And Accurate Repair"](#).
NO >> System OK.

3. CHECK FOR SERVICE BULLETINS

Check for any service bulletins.

>> GO TO 4.

4. PERFORM SELF-DIAGNOSIS

Perform self-diagnosis to check for any codes. Refer to [HAC-23. "A/C Auto Amp. Self-Diagnosis"](#).

Are any self-diagnosis codes present?

- YES >> Refer to [HAC-24. "A/C System Self-Diagnosis Code Chart"](#).

MAGNET CLUTCH

[AUTOMATIC AIR CONDITIONER]

< COMPONENT DIAGNOSIS >

NO >> GO TO 5.

5. CHECK AMBIENT SENSOR

Check and verify ambient sensor circuit. Refer to [HAC-77, "Ambient Sensor Diagnosis Procedure"](#).

>> GO TO 6.

6. CHECK INTAKE SENSOR

Check and verify intake sensor circuit. Refer to [HAC-157, "Intake Sensor Diagnosis Procedure"](#).

>> GO TO 7.

7. RECHECK FOR ANY SYMPTOMS

Perform a complete operational check for any symptoms. Refer to [HAC-123, "Operational Check"](#).

Does another symptom exist?

YES >> Refer to [HAC-122, "How to Perform Trouble Diagnosis For Quick And Accurate Repair"](#).

NO >> Replace A/C auto amp. Refer to [VTL-8, "Removal and Installation"](#).

Magnet Clutch Diagnosis Procedure

INFOID:000000001366729

DIAGNOSTIC PROCEDURE FOR MAGNET CLUTCH

SYMPTOM: Magnet clutch does not engage when A/C switch is ON.

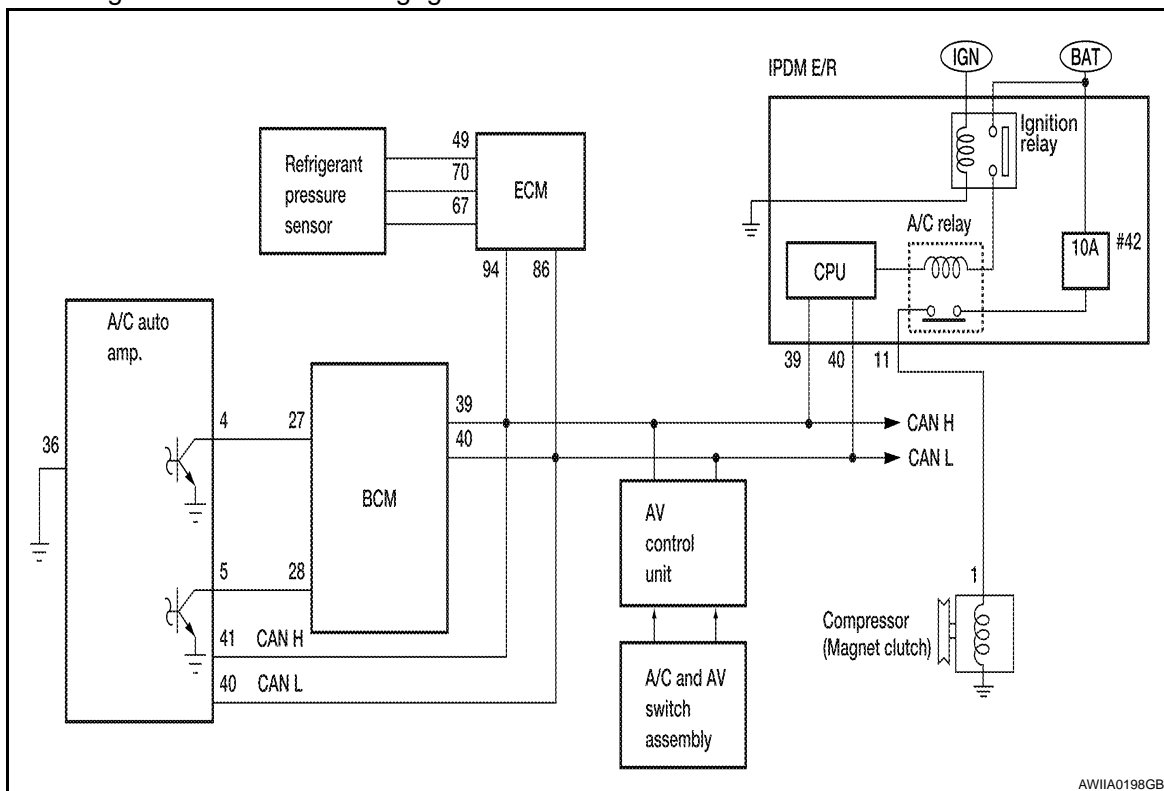

1. CHECK INTAKE AND AMBIENT SENSOR CIRCUITS

Check intake and ambient sensors. Refer to [HAC-23, "A/C Auto Amp. Self-Diagnosis"](#).

Is the inspection result normal?

YES >> GO TO 2.

NO >> • Malfunctioning intake sensor. Refer to [HAC-157, "Intake Sensor Diagnosis Procedure"](#).
• Malfunctioning ambient sensor. Refer to [HAC-77, "Ambient Sensor Diagnosis Procedure"](#).

2. PERFORM AUTO ACTIVE TEST

Refer to [PCS-10, "Diagnosis Description"](#).

Does magnet clutch operate?

MAGNET CLUTCH

[AUTOMATIC AIR CONDITIONER]

< COMPONENT DIAGNOSIS >

- YES >> • WITH CONSULT-III
GO TO 5.
• WITHOUT CONSULT-III
GO TO 6.

NO >> Check 10A fuse (No. 42, located in IPDM E/R), and GO TO 3.

3. CHECK CIRCUIT CONTINUITY BETWEEN IPDM E/R AND COMPRESSOR

1. Turn ignition switch OFF.
2. Disconnect IPDM E/R connector and compressor (magnet clutch) connector.
3. Check continuity between IPDM E/R harness connector E119 terminal 11 and A/C compressor harness connector F3 terminal 1.

11 - 1 : Continuity should exist.

Is the inspection result normal?

- YES >> GO TO 4.
NO >> Repair harness or connector.

4. CHECK MAGNET CLUTCH CIRCUIT

Check for operation sound when applying battery voltage direct current to terminal.

Is the inspection result normal?

- YES >> Replace IPDM E/R. Refer to [PCS-30, "Removal and Installation of IPDM E/R"](#).
NO >> Replace magnet clutch. Refer to [HA-41, "Removal and Installation for Compressor Clutch"](#).

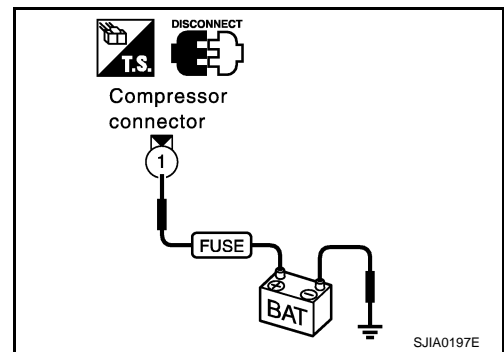
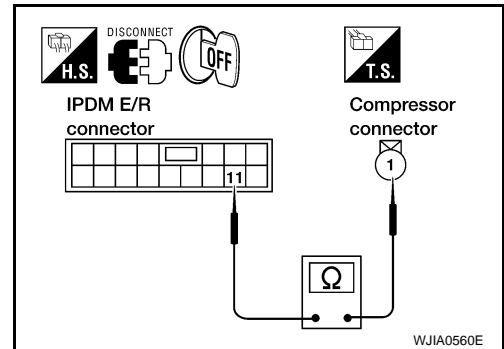

5. CHECK BCM INPUT (COMPRESSOR ON) SIGNAL

Check compressor ON/OFF signal. Refer to [HAC-21, "CONSULT-III Function \(HVAC\)"](#).

A/C SW ON : COMP ON SIG ON
A/C SW OFF : COMP ON SIG OFF

Is the inspection result normal?

- YES >> GO TO 8.
NO >> GO TO 6.

6. CHECK CIRCUIT CONTINUITY BETWEEN BCM AND A/C AUTO AMP.

1. Turn ignition switch OFF.
2. Disconnect BCM connector and A/C auto amp. connector.
3. Check continuity between BCM harness connector M18 (A) terminal 27 and A/C auto amp. harness connector M49 (B) terminal 4.

27 - 4 Continuity should exist.

Is the inspection result normal?

- YES >> GO TO 7.
NO >> Repair harness or connector.

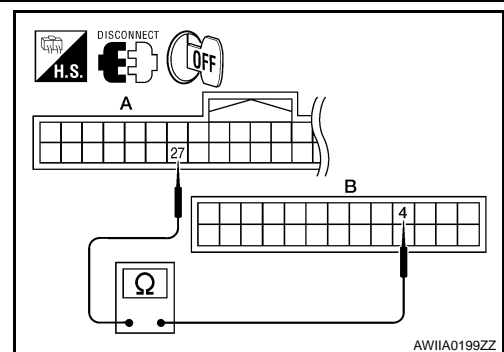

7. CHECK VOLTAGE FOR A/C AUTO AMP. (A/C COMPRESSOR ON SIGNAL)

MAGNET CLUTCH

[AUTOMATIC AIR CONDITIONER]

< COMPONENT DIAGNOSIS >

1. Reconnect BCM connector and A/C auto amp. connector.
2. Turn ignition switch ON.
3. Check voltage between A/C auto amp. harness connector M49 terminal 4 and ground.

Terminals			Condition	Voltage
(+)		(-)		
A/C auto amp. connector	Terminal No.			
M49	4	Ground	A/C switch: ON	Approx. 0V
			A/C switch: OFF	Approx. 5V

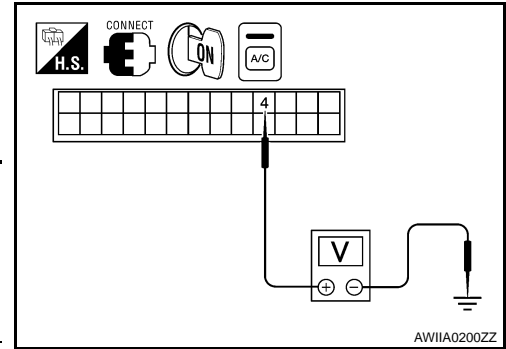

Is the inspection result normal?

YES >> GO TO 8.

NO-1 >> If the voltage is approx. 5V when A/C switch is ON, replace A/C auto amp. Refer to [VTL-8, "Removal and Installation"](#).

NO-2 >> If the voltage is approx. 0V when A/C switch is OFF, replace BCM. Refer to [PCS-41, "Removal and Installation"](#).

8. CHECK REFRIGERANT PRESSURE SENSOR

1. Start engine.
2. Check voltage between ECM harness connector F54 terminal 70 and ground.

Terminals			Condition	Voltage
(+)		(-)		
ECM connector	Terminal No.			
F54	70	Ground	A/C switch: ON	Approx. 0.36 - 3.88V

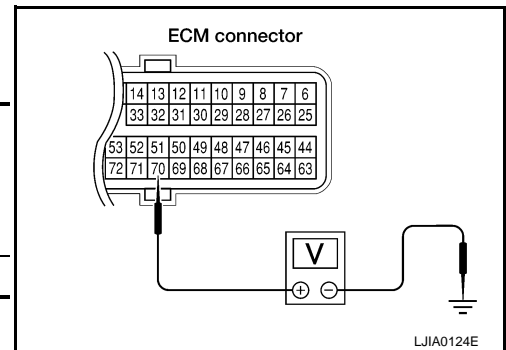

Is the inspection result normal?

YES >> GO TO 9.

NO >> Refer to [EC-412, "Diagnosis Procedure"](#).

9. CHECK BCM INPUT (FAN ON) SIGNAL

Check FAN ON/OFF signal. Refer to [HAC-21, "CONSULT-III Function \(HVAC\)"](#).

**FRONT BLOWER CONTROL : FAN ON SIG ON
DIAL ON**

**FRONT BLOWER CONTROL : FAN ON SIG OFF
DIAL OFF**

Is the inspection result normal?

YES >> GO TO 12.

NO >> GO TO 10.

10. CHECK CIRCUIT CONTINUITY BETWEEN BCM AND A/C AUTO AMP.

MAGNET CLUTCH

[AUTOMATIC AIR CONDITIONER]

< COMPONENT DIAGNOSIS >

1. Turn ignition switch OFF.
2. Disconnect BCM connector and A/C auto amp. connector.
3. Check continuity between BCM harness connector M18 (A) terminal 28 and A/C auto amp. harness connector M49 terminal 5.

28 - 5

Continuity should exist.

Is the inspection result normal?

YES >> GO TO 11.

NO >> Repair harness or connector.

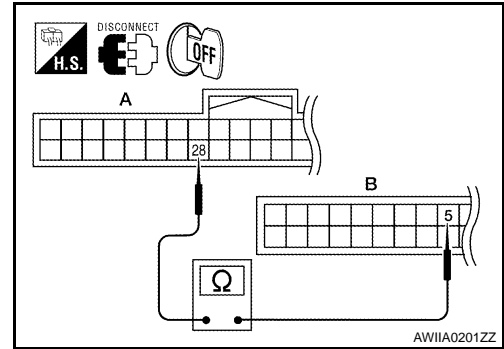

11. CHECK VOLTAGE FOR A/C AUTO AMP. (FAN ON SIGNAL)

1. Reconnect BCM connector and A/C auto amp. connector.
2. Turn ignition switch ON.
3. Check voltage between A/C auto amp. harness connector M49 terminal 5 and ground.

Terminals		(-)	Condition	Voltage
(+) A/C auto amp. connector				
A/C auto amp. connector	Terminal No.			
M49	5	Ground	A/C switch: ON Blower motor operates	Approx. 0V
			A/C switch: OFF	Approx. 5V

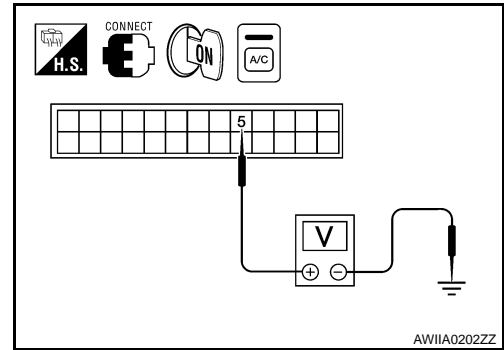

Is the inspection result normal?

YES >> GO TO 12.

NO-1 >> If the voltage is approx. 5V when blower motor is ON, replace A/C auto amp. Refer to [VTL-8, "Removal and Installation"](#).

NO-2 >> If the voltage is approx. 0V when blower motor is OFF, replace BCM. Refer to [PCS-41, "Removal and Installation"](#).

12. CHECK CAN COMMUNICATION

Check CAN communication. Refer to [LAN-14, "Trouble Diagnosis Flow Chart"](#).

- BCM – ECM
- ECM – IPDM E/R
- ECM – A/C auto amp.

Is the inspection result normal?

YES >> Inspection End.

NO >> Repair or replace malfunctioning part(s).

A
B
C
D
E
F
G
H
J
K
L
M
N
O
P

HAC

WATER VALVE CIRCUIT

< COMPONENT DIAGNOSIS >

[AUTOMATIC AIR CONDITIONER]

WATER VALVE CIRCUIT

Water Valve Description (VK56DE)

INFOID:000000001366730

COMPONENT DESCRIPTION

Water Valve

The water valve (1) cuts the flow of engine coolant to the front and rear heater cores to allow for maximum cooling during A/C operation. It is controlled by the A/C auto amp.

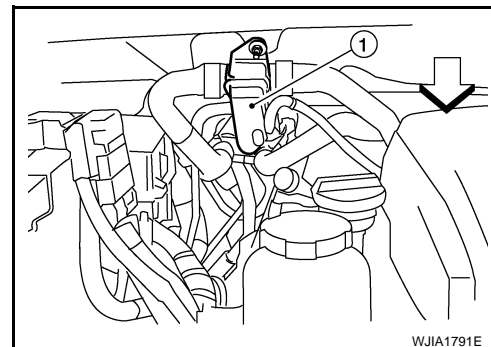

Water Valve Diagnosis Procedure (VK56DE)

INFOID:000000001366731

DIAGNOSTIC PROCEDURE FOR WATER VALVE

1. CHECK WATER VALVE POWER AND GROUND CIRCUITS

1. Disconnect water valve connector F68.
2. Turn ignition switch ON.
3. Rotate temperature control dial (driver) to 32°C (90°F).
4. Check voltage between water valve harness connector F68 terminal 1 and terminal 2 while rotating temperature control dial (driver) to 18°C (60°F).

Connector	Terminals		Condition	Voltage (Approx.)
	(+)	(-)		
Water valve: F68	2	1	Rotate temperature control dial	Battery voltage

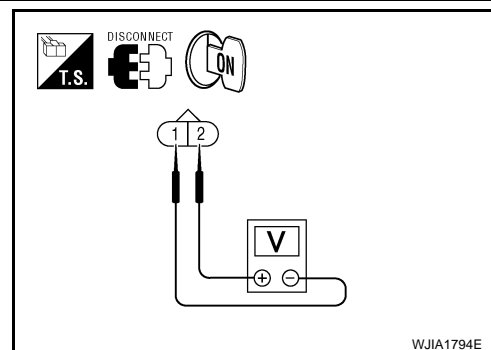

Is the inspection result normal?

- YES >> GO TO 3.
NO >> GO TO 2.

2. CHECK WATER VALVE CONTROL OUTPUT CIRCUIT

1. Turn ignition switch OFF.
2. Disconnect A/C auto amp. connector M50.
3. Check continuity between water valve harness connector F68 (A) terminal 2 and A/C auto amp. harness connector M50 (B) terminal 46.

2 - 46 : Continuity should exist.

4. Check continuity between water valve harness connector F68 terminal 2 and ground.

2 - Ground : Continuity should not exist.

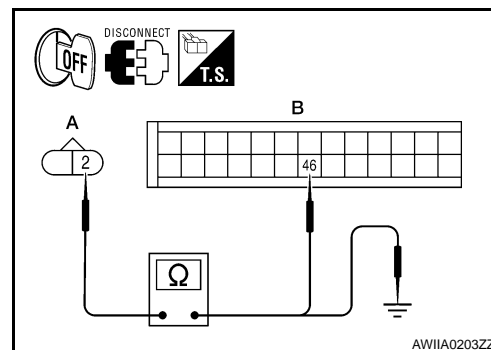

Is the inspection result normal?

- YES >> Replace A/C auto amp. Refer to [VTL-8, "Removal and Installation"](#).
NO >> Repair harness or connector.

3. CHECK WATER VALVE POWER AND GROUND CIRCUITS

WATER VALVE CIRCUIT

[AUTOMATIC AIR CONDITIONER]

< COMPONENT DIAGNOSIS >

1. Rotate temperature control dial (driver) to 18°C (60°F).
2. Check voltage between water valve harness connector F68 terminal 1 and terminal 2 while rotating temperature control dial (driver) to 32°C (90°F).

Connector	Terminals		Condition	Voltage (Approx.)
	(+)	(-)		
Water valve: F68	1	2	Rotate temperature control dial	Battery voltage

Is the inspection result normal?

- YES >> Replace the water valve.
 NO >> GO TO 4.

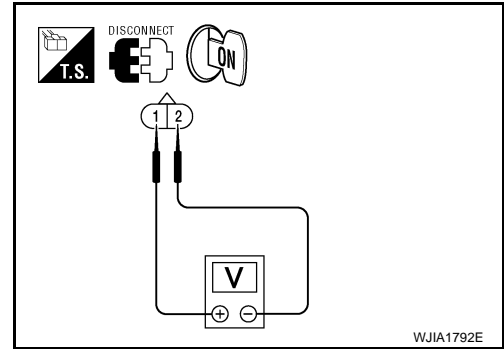

4. CHECK WATER VALVE CONTROL OUTPUT CIRCUIT

1. Turn ignition switch OFF.
2. Disconnect A/C auto amp. connector M50.
3. Check continuity between water valve harness connector F68 (A) terminal 1 and A/C auto amp. harness connector M50 (B) terminal 45.

1 - 45 : Continuity should exist.

4. Check continuity between water valve harness connector F68 (A) terminal 1 and ground.

1 - Ground : Continuity should not exist.

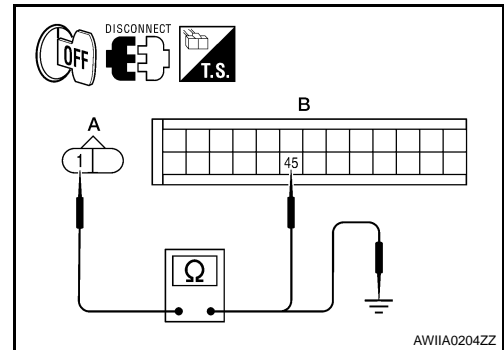

Is the inspection result normal?

- YES >> Replace A/C auto amp. Refer to [VTL-8, "Removal and Installation"](#).
 NO >> Repair harness or connector.

A
B
C
D
E
F
G
H
J
K
L
M
N
O
P

HAC

HEATER PUMP

< COMPONENT DIAGNOSIS >

[AUTOMATIC AIR CONDITIONER]

HEATER PUMP

System Description (VQ40DE)

INFOID:000000001404888

SYSTEM DESCRIPTION

Component Parts

Heater pump control system components are:

- A/C auto amp.
- Heater pump relay
- Heater pump
- Intake sensor

System Operation

The heater pump improves heater performance specifically at idle conditions. It is designed to operate in either of the following 2 situations:

1. Front blower motor set to maximum speed and temperature control dial (driver or passenger) set to full hot 32° C (90° F) or
2. Engine coolant temperature (signal via CAN communication) minus heater core outlet temperature (intake sensor input to A/C auto amp.) is greater than 20° C (68° F). If the difference is less than 16° C (61° F), the heater pump will not operate unless the conditions in item No. 1 above are met.

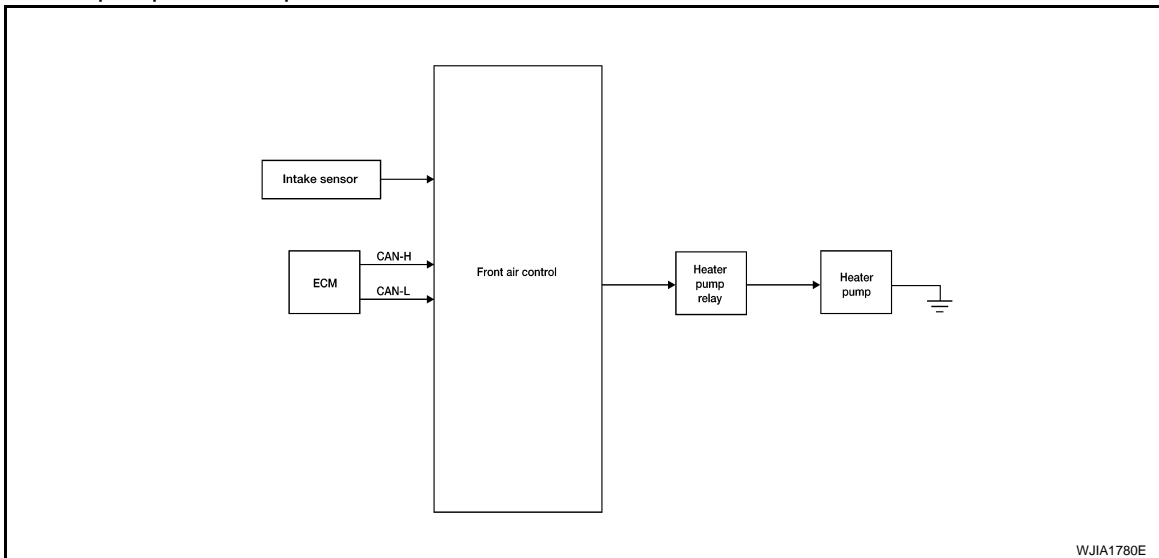

Diagnosis Procedure (VQ40DE)

INFOID:000000001404889

DIAGNOSTIC PROCEDURE FOR HEATER PUMP CIRCUIT

1. CHECK POWER SUPPLY TO HEATER PUMP

1. Disconnect heater pump connector.
2. Turn ignition switch ON.
3. Set front blower motor to maximum speed.
4. Turn temperature control dial (passenger or driver) to full hot 32° C (90° F).
5. Check voltage between heater pump harness connector E141 terminal 1 and ground.

1 - Ground

: Battery voltage

Is the inspection result normal?

- YES >> GO TO 2.
NO >> GO TO 3.

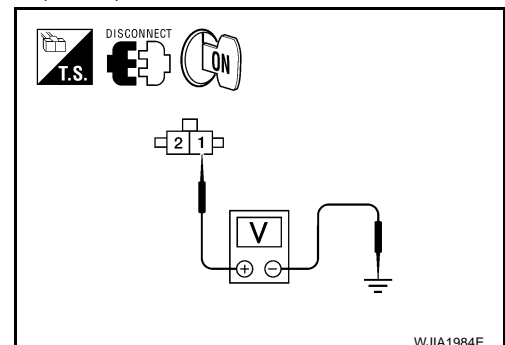

HEATER PUMP

< COMPONENT DIAGNOSIS >

[AUTOMATIC AIR CONDITIONER]

2. CHECK HEATER PUMP GROUND

1. Turn ignition switch OFF.
2. Check continuity between heater pump harness connector E141 terminal 2 and ground.

2 - Ground : Continuity should exist.

Is the inspection result normal?

- YES >> Replace heater pump. Refer to [HA-58. "Removal and Installation"](#).
- NO >> Repair harness or connector.

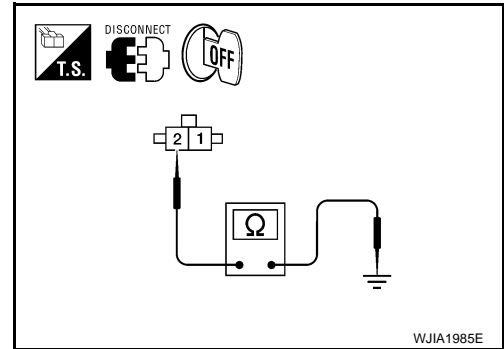

3. CHECK HEATER PUMP RELAY

1. Turn ignition switch OFF.
2. Check heater pump relay. Refer to [HAC-76. "Component Inspection \(VQ40DE\)"](#).

Is the inspection result normal?

- YES >> GO TO 4.
- NO >> Replace heater pump relay.

4. CHECK RELAY POWER SUPPLY

1. Turn ignition switch ON.
2. Check voltage between heater pump relay harness connector E144 terminals 2, 5 and ground.

2 - Ground : Battery voltage
5 - Ground : Battery voltage

Is the inspection result normal?

- YES >> GO TO 5.
- NO >> Repair harness or connector.

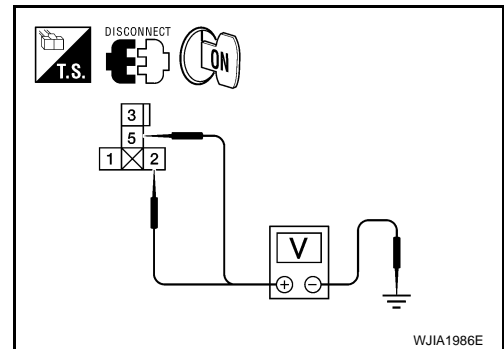

5. CHECK HEATER PUMP MOTOR POWER CIRCUIT

1. Turn ignition switch OFF.
2. Check continuity between heater pump relay harness connector (A) E144 terminal 3 and heater pump harness connector (B) E141 terminal 1.

3 - 1 : Continuity should exist.

3. Check continuity between heater pump relay harness connector (A) E144 terminal 3 and ground.

3 - Ground : Continuity should not exist.

Is the inspection result normal?

- YES >> GO TO 6.
- NO >> Repair harness or connector.

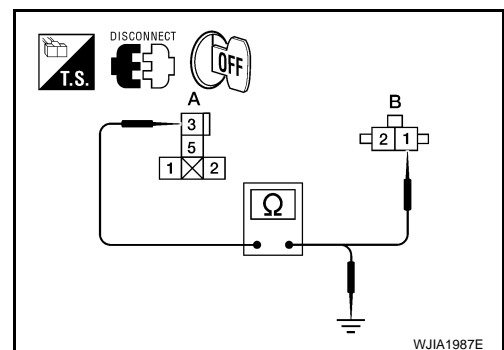

6. CHECK CIRCUIT BETWEEN HEATER PUMP RELAY AND A/C AUTO AMP.

HEATER PUMP

< COMPONENT DIAGNOSIS >

[AUTOMATIC AIR CONDITIONER]

1. Disconnect A/C auto amp. connector.
2. Check continuity between A/C auto amp. harness connector (A) M50 terminal 50 and heater pump relay harness connector (B) E144 terminal 1.

1 - 50 : Continuity should exist.

3. Check continuity between heater pump relay harness connector (B) E144 terminal 1 and ground.

1 - Ground : Continuity should not exist.

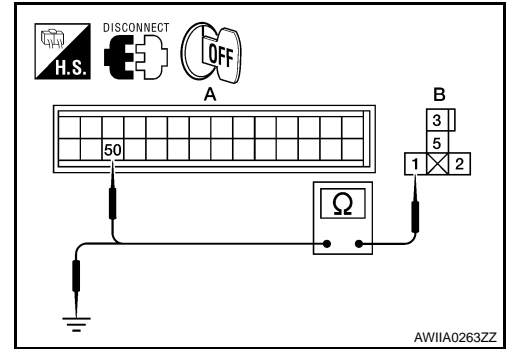

Is the inspection result normal?

- YES >> Replace A/C auto amp. Refer to [VTL-8. "Removal and Installation"](#).
 NO >> Repair harness or connector.

Component Inspection (VQ40DE)

INFOID:000000001404928

COMPONENT INSPECTION

Heater Pump Relay

Check continuity between terminals 3 and 5.

Conditions	Continuity
12V direct current supply between terminals 1 and 2	Yes
No current supply	No

If NG, replace relay.

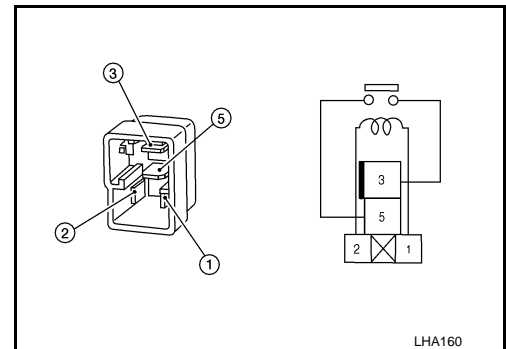

AMBIENT SENSOR

Component Description

INFOID:000000001366732

COMPONENT DESCRIPTION

Ambient Sensor

Ambient sensor (1) is attached to the radiator core support (left side). It detects ambient temperature and converts it into a value which is then input into the A/C auto amp.

- ←: Front

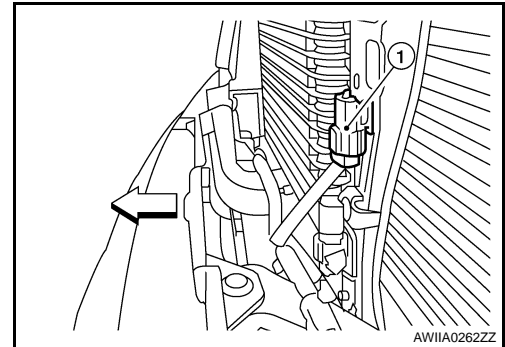

AMBIENT TEMPERATURE INPUT PROCESS

The A/C auto amp. includes a processing circuit for the ambient sensor input. However, when the temperature detected by the ambient sensor increases quickly, the processing circuit retards the A/C auto amp. function. It only allows the A/C auto amp. to recognize an ambient temperature increase of 0.33°C (0.6°F) per 100 seconds.

This prevents constant adjustments due to momentary conditions, such as stopping after high speed driving. Although the actual ambient temperature has not changed, the temperature detected by the ambient sensor will increase. This is because the heat from the engine compartment can radiate to the front grille area, location of the ambient sensor.

Ambient Sensor Diagnosis Procedure

INFOID:000000001366733

DIAGNOSTIC PROCEDURE FOR AMBIENT SENSOR

SYMPTOM: Ambient sensor circuit is open or shorted. (40 or 41 is indicated on A/C auto amp. as a result of conducting the A/C auto amp. self-diagnosis)

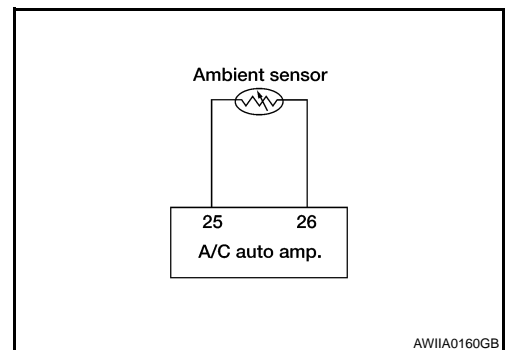

1. CHECK VOLTAGE BETWEEN AMBIENT SENSOR AND GROUND

1. Disconnect ambient sensor connector.
2. Turn ignition switch ON.
3. Check voltage between ambient sensor harness connector E1 terminal 1 and ground.

1 - Ground

: Approx. 5V

Is the inspection result normal?

- YES >> GO TO 3.
NO >> GO TO 5.

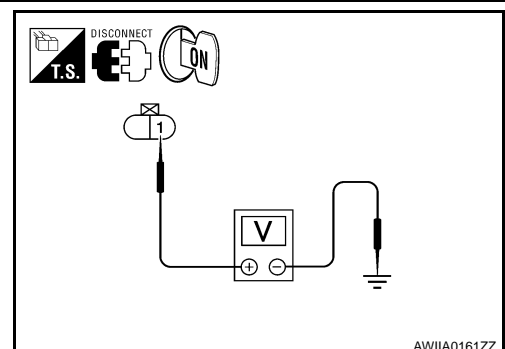

AMBIENT SENSOR

< COMPONENT DIAGNOSIS >

[AUTOMATIC AIR CONDITIONER]

2. CHECK CIRCUIT CONTINUITY BETWEEN AMBIENT SENSOR AND A/C AUTO AMP.

1. Turn ignition switch OFF.
2. Disconnect A/C auto amp. connector.
3. Check continuity between ambient sensor harness connector E1 (B) terminal 1 and A/C auto amp. harness connector M49 (A) terminal 25.

1 - 25 : Continuity should exist.

Is the inspection result normal?

- YES >> GO TO 4.
NO >> Repair harness or connector.

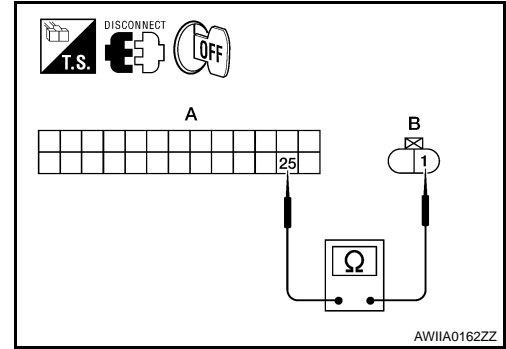

3. CHECK AMBIENT SENSOR

Check the Ambient Sensor Circuit. Refer to [HAC-78, "Ambient Sensor Component Inspection"](#).

Is the inspection result normal?

- YES >> 1. Replace A/C auto amp. Refer to [VTL-8, "Removal and Installation"](#).
2. GO TO [HAC-23, "A/C Auto Amp. Self-Diagnosis"](#) and perform self-diagnosis.
NO >> 1. Replace ambient sensor.
2. GO TO [HAC-23, "A/C Auto Amp. Self-Diagnosis"](#) and perform self-diagnosis.

4. CHECK CIRCUIT CONTINUITY BETWEEN AMBIENT SENSOR AND A/C AUTO AMP.

1. Turn ignition switch OFF.
2. Disconnect A/C auto amp. connector.
3. Check continuity between ambient sensor harness connector E1 (B) terminal 2 and A/C auto amp. harness connector M49 (A) terminal 26.

2 - 26 : Continuity should exist.

4. Check continuity between ambient sensor harness connector E1 (B) terminal 2 and ground.

2 - Ground : Continuity should not exist.

Is the inspection result normal?

- YES >> 1. Replace A/C auto amp. Refer to [VTL-8, "Removal and Installation"](#).
2. GO TO [HAC-23, "A/C Auto Amp. Self-Diagnosis"](#) and perform self-diagnosis.
NO >> Repair harness or connector.

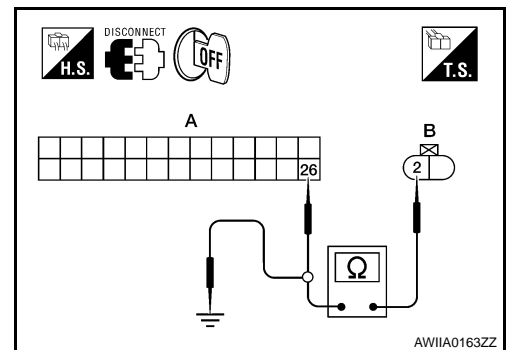

Ambient Sensor Component Inspection

INFOID:000000001366734

COMPONENT INSPECTION

Ambient Sensor

AMBIENT SENSOR

[AUTOMATIC AIR CONDITIONER]

< COMPONENT DIAGNOSIS >

After disconnecting ambient sensor (1) connector E1, measure resistance between terminals 1 and 2 at sensor component side, using the table below.

- ←: Front

NOTE:

The ambient sensor is located behind the front grille, below the hood latch. The ambient sensor (1) provides input for the automatic A/C system.

Temperature °C (°F)	Resistance kΩ
-15 (5)	12.73
-10 (14)	9.92
-5 (23)	7.80
0 (32)	6.19
5 (41)	4.95
10 (50)	3.99
15 (59)	3.24
20 (68)	2.65
25 (77)	2.19
30 (86)	1.81
35 (95)	1.51
40 (104)	1.27
45 (113)	1.07

If NG, replace ambient sensor. Refer to XXXX

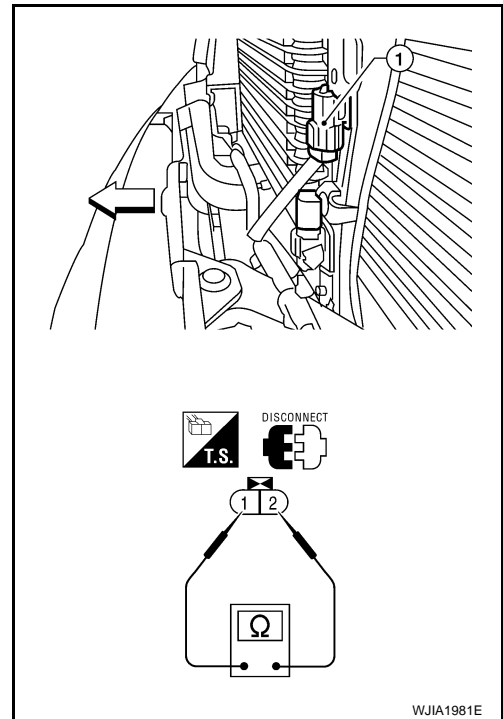

A
B
C
D
E
F
G
H
HAC
J
K
L
M
N
O
P

IN-VEHICLE SENSOR

Component Description

INFOID:000000001366735

COMPONENT DESCRIPTION

In-vehicle Sensor

The in-vehicle sensor (1) is located on the lower instrument panel LH. It converts variations in temperature of passenger compartment air (drawn in through the integrated fan) into a resistance value. It is then input into the A/C auto amp.

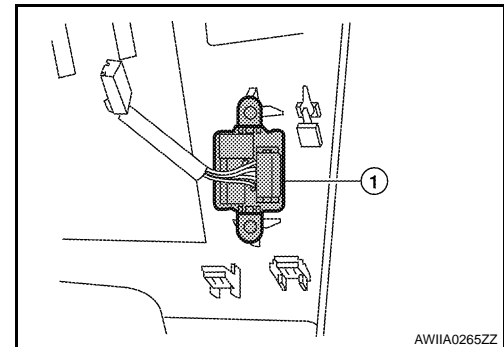
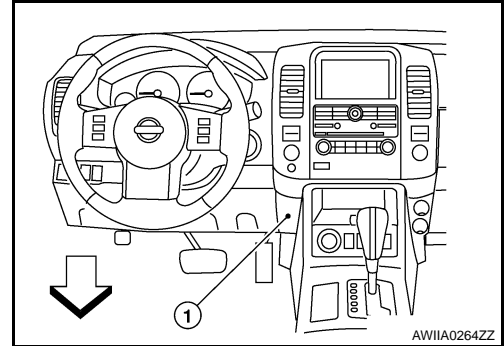

In-Vehicle Sensor Diagnosis Procedure

INFOID:000000001366736

DIAGNOSTIC PROCEDURE FOR IN-VEHICLE SENSOR

SYMPTOM: In-vehicle sensor circuit is open or shorted. Using the CONSULT-III, DTC B2578 or B2579 is displayed. Without a CONSULT-III, code 30, 31, 44 or 46 is indicated on A/C auto amp. as a result of conducting self-diagnosis.

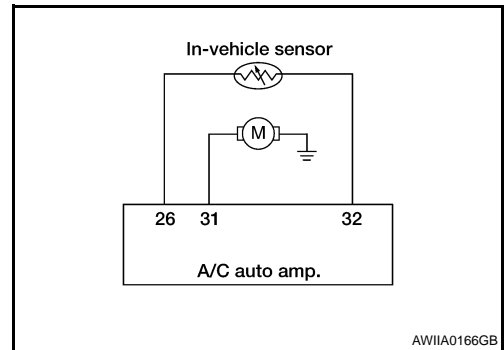

1. CHECK IN-VEHICLE SENSOR CIRCUIT

Is self-diagnosis DTC B2578 or B2579 (with CONSULT-III) or code 30, 31 44 or 46 (without CONSULT-III) present?

YES or NO?

- YES >> GO TO 6.
- NO >> GO TO 2.

2. CHECK VOLTAGE BETWEEN IN-VEHICLE SENSOR AND GROUND

IN-VEHICLE SENSOR

[AUTOMATIC AIR CONDITIONER]

< COMPONENT DIAGNOSIS >

1. Disconnect in-vehicle sensor connector.
2. Turn ignition switch ON.
3. Check voltage between in-vehicle sensor harness connector M32 terminal 1 and ground.

1 - Ground : Approx. 5V.

Is the inspection result normal?

- YES >> GO TO 3.
NO >> GO TO 5.

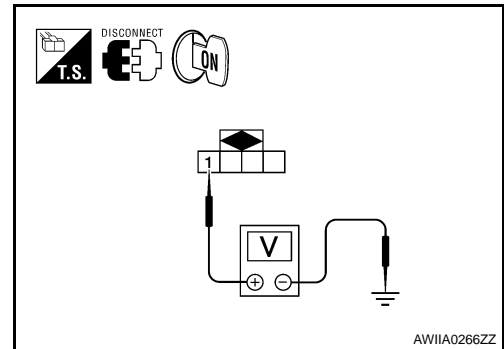

3. CHECK CIRCUIT CONTINUITY BETWEEN IN-VEHICLE SENSOR AND A/C AUTO AMP.

1. Turn ignition switch OFF.
2. Disconnect A/C auto amp. connector M49.
3. Check continuity between in-vehicle sensor harness connector M32 (B) terminal 1 and A/C auto amp. harness connector M50 (A) terminal 32.

1 - 32 : Continuity should exist.

Is the inspection result normal?

- YES >> GO TO 4.
NO >> Repair harness or connector.

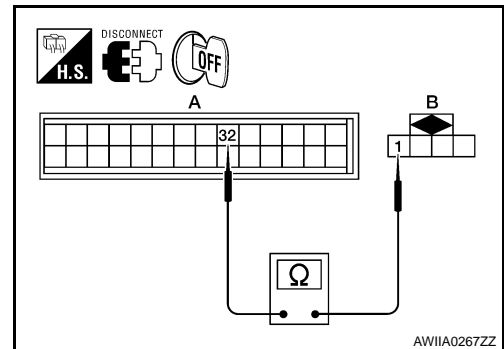

4. CHECK IN-VEHICLE SENSOR

Check in-vehicle sensor. Refer to [HAC-82, "In-Vehicle Sensor Component Inspection"](#).

Is the inspection result normal?

- YES >> 1. Replace A/C auto amp. Refer to [VTL-8, "Removal and Installation"](#).
2. Go to [HAC-23, "A/C Auto Amp. Self-Diagnosis"](#) and perform self-diagnosis.
NO >> 1. Replace in-vehicle sensor. Refer to [VTL-10, "Removal and Installation"](#).
2. Go to [HAC-23, "A/C Auto Amp. Self-Diagnosis"](#) and perform self-diagnosis.

5. CHECK CIRCUIT CONTINUITY BETWEEN IN-VEHICLE SENSOR AND A/C AUTO AMP.

1. Turn ignition switch OFF.
2. Disconnect A/C auto amp. connector.
3. Check continuity between in-vehicle sensor harness connector M32 (B) terminal 4 and A/C auto amp. harness connector M49 (A) terminal 26.

4 - 26 : Continuity should exist.

4. Check continuity between in-vehicle sensor harness connector M32 (B) terminal 4 and ground.

4 - Ground Continuity should not exist.

Is the inspection result normal?

- YES >> 1. Replace A/C auto amp. Refer to [VTL-8, "Removal and Installation"](#).
2. Go to [HAC-23, "A/C Auto Amp. Self-Diagnosis"](#) and perform self-diagnosis.
NO >> Repair harness or connector.

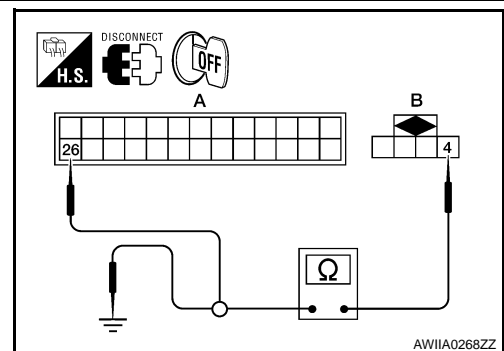

6. CHECK CIRCUIT CONTINUITY BETWEEN IN-VEHICLE SENSOR MOTOR AND A/C AUTO AMP. (SELF-DIAGNOSIS CODES 30, 31, 44, 46 OR DTC B2578, B2579)

IN-VEHICLE SENSOR

[AUTOMATIC AIR CONDITIONER]

< COMPONENT DIAGNOSIS >

1. Turn ignition switch OFF.
2. Disconnect A/C auto amp. connector and in-vehicle sensor connector.
3. Check continuity between in-vehicle sensor harness connector M32 (B) terminal 3 and A/C auto amp. harness connector M50 (A) terminal 31.

3 - 31 : Continuity should exist.

4. Check continuity between in-vehicle sensor harness connector M32 (B) terminal 3 and ground.

2 - Ground : Continuity should exist.

3 - Ground : Continuity should not exist.

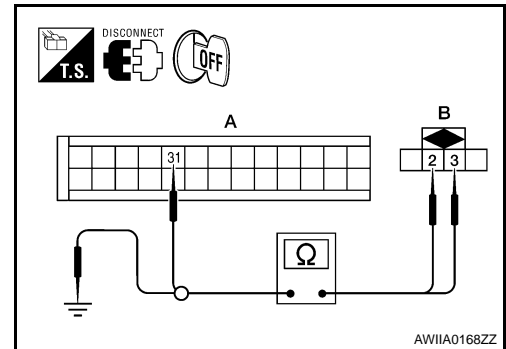

Is the inspection result normal?

- YES >> 1. Replace A/C auto amp. Refer to [VTL-8, "Removal and Installation"](#).
 2. Go to [HAC-23, "A/C Auto Amp. Self-Diagnosis"](#) and perform self-diagnosis.
- NO >> Repair harness or connector.

In-Vehicle Sensor Component Inspection

INFOID:000000001366737

COMPONENT INSPECTION

In-vehicle Sensor

After disconnecting in-vehicle sensor connector M32, measure resistance between terminals 1 and 4 at sensor component side, using the table below.

Temperature °C (°F)	Resistance kΩ
-15 (5)	21.40
-10 (14)	16.15
-5 (23)	12.29
0 (32)	9.41
5 (41)	7.27
10 (50)	5.66
15 (59)	4.45
20 (68)	3.51
25 (77)	2.79
30 (86)	2.24
35 (95)	1.80
40 (104)	1.45
45 (113)	1.18

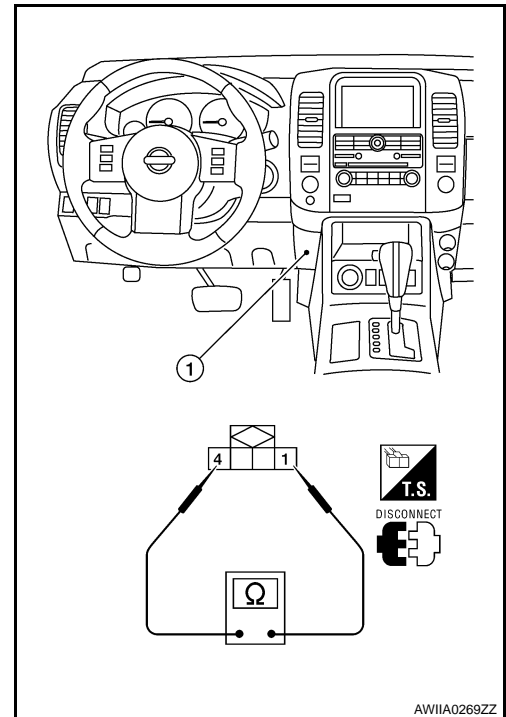

If NG, replace in-vehicle sensor. Refer to [VTL-10, "Removal and Installation"](#).

OPTICAL SENSOR

Component Description

INFOID:000000001366738

COMPONENT DESCRIPTION

The optical sensor is located in the center of the defroster grille. It detects sunload entering through windshield by means of a photo diode. The sensor converts the sunload into a current value which is then input into the A/C auto amp.

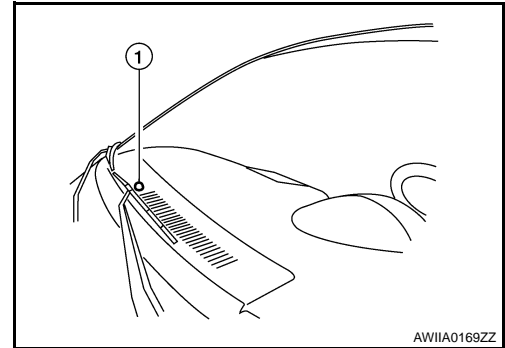

OPTICAL INPUT PROCESS

The A/C auto amp. includes a processing circuit which averages the variations in detected sunload over a period of time. This prevents adjustments in the ATC system operation due to small or quick variations in detected sunload.

For example, consider driving along a road bordered by an occasional group of large trees. The sunload detected by the optical sensor will vary whenever the trees obstruct the sunlight. The processing circuit averages the detected sunload over a period of time, so that the (insignificant) effect of the trees momentarily obstructing the sunlight does not cause any change in the ATC system operation. On the other hand, shortly after entering a long tunnel, the system will recognize the change in sunload, and the system will react accordingly.

Optical Sensor Diagnosis Procedure

INFOID:000000001366739

DIAGNOSTIC PROCEDURE FOR OPTICAL SENSOR

SYMPTOM: Optical sensor circuit is open or shorted. Using the CONSULT-III, DTC B257F or B2580 is displayed. Without a CONSULT-III, code 50 or 52 is indicated on A/C auto amp. as a result of conducting self-diagnosis.

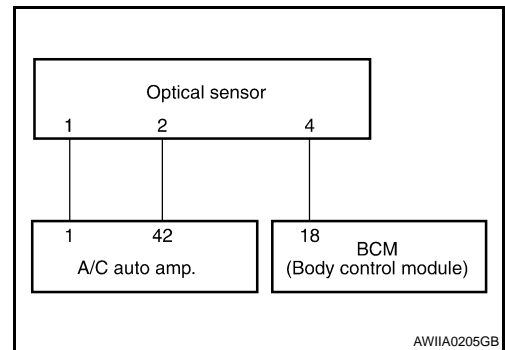

1. CHECK CIRCUIT CONTINUITY BETWEEN OPTICAL SENSOR AND A/C AUTO AMP.

1. Turn ignition switch OFF.
2. Disconnect A/C auto amp. connector and optical sensor connector.
3. Check continuity between optical sensor harness connector M145 (B) terminals 1 and 2 and A/C auto amp. harness connector M50 (C) terminal 42 and M49 (A) terminal 1.

- 1 - 1** : Continuity should exist.
- 2 - 42** : Continuity should exist.

4. Check continuity between optical sensor harness connector M145 terminal 1 and 2 and ground.

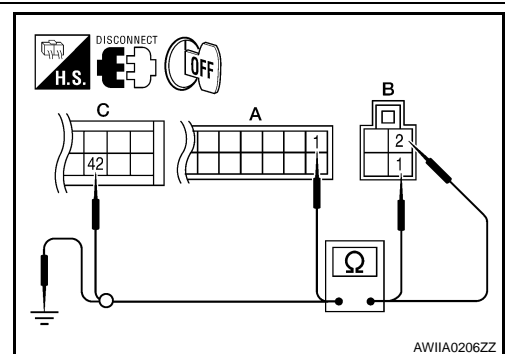

OPTICAL SENSOR

< COMPONENT DIAGNOSIS >

[AUTOMATIC AIR CONDITIONER]

1, 2 - Ground. : **Continuity should not exist.**

Is the inspection result normal?

YES >> GO TO 2.

NO >> Repair harness or connector.

2. CHECK CIRCUIT CONTINUITY BETWEEN OPTICAL SENSOR AND BCM

1. Disconnect BCM connector.
2. Check continuity between optical sensor harness connector M145 (B) terminal 3 and 4 and BCM harness connector M18 (A) terminal 18 and M20 (C) terminal 58.

3 - 18 : **Continuity should exist.**

4 - 58 : **Continuity should exist.**

3. Check continuity between optical sensor harness connector M145 (A) terminal 4 and ground.

3, 4 - Ground : **Continuity should not exist.**

Is the inspection result normal?

YES >> Replace optical sensor. Refer to [VTL-11, "Removal and Installation"](#).

NO >> Repair harness or connector.

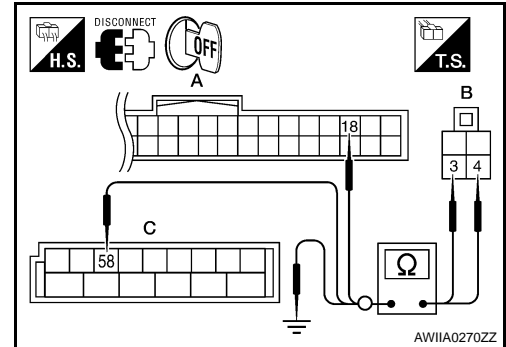

INTAKE SENSOR

< COMPONENT DIAGNOSIS >

[AUTOMATIC AIR CONDITIONER]

INTAKE SENSOR

System Description

INFOID:000000001366740

COMPONENT DESCRIPTION

Intake Sensor

The intake sensor is located on the heater & cooling unit assembly. It converts temperature of air after it passes through the evaporator into a resistance value which is then input to the A/C auto amp.

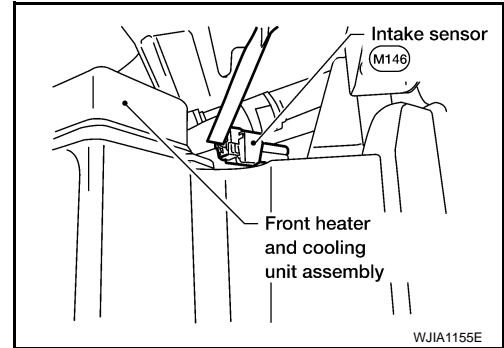

Intake Sensor Diagnosis Procedure

INFOID:000000001366741

DIAGNOSTIC PROCEDURE FOR INTAKE SENSOR

SYMPTOM: Intake sensor circuit is open or shorted. Using the CONSULT-III, DTC B2581 or B2582 is displayed. Without a CONSULT-III, code 56 or 57 is indicated on A/C auto amp. as a result of conducting self-diagnosis.

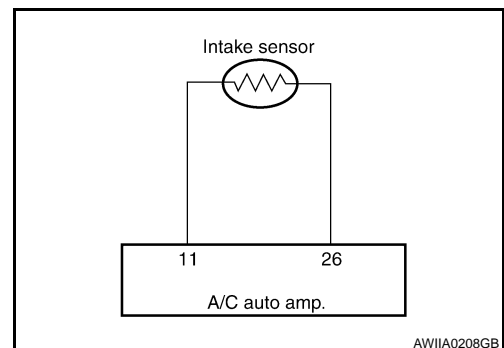

1. CHECK VOLTAGE BETWEEN INTAKE SENSOR AND GROUND

1. Disconnect intake sensor connector.
2. Turn ignition switch ON.
3. Check voltage between intake sensor harness connector M146 terminal 2 and ground.

2 - Ground : Approx. 5V

Is the inspection result normal?

- YES >> GO TO 3.
NO >> GO TO 4.

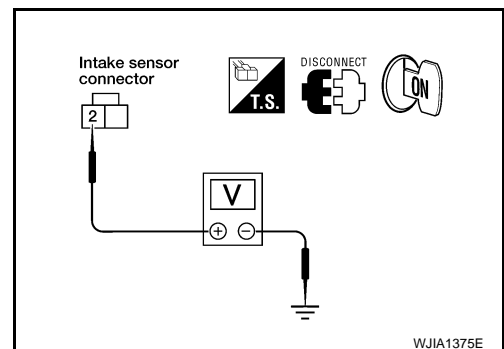

2. CHECK CIRCUIT CONTINUITY BETWEEN INTAKE SENSOR AND A/C AUTO AMP.

1. Turn ignition switch OFF.
2. Disconnect A/C auto amp. connector.
3. Check continuity between intake sensor harness connector M146 (B) terminal 1 and A/C auto amp. harness connector M49 (A) terminal 26.

1 - 26 : Continuity should exist.

Is the inspection result normal?

- YES >> GO TO 4.
NO >> Repair harness or connector.

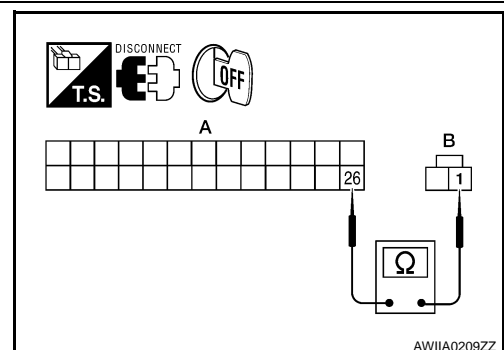

A
B
C
D
E
F
G
H
HAC
J
K
L
M
N
O
P

INTAKE SENSOR

< COMPONENT DIAGNOSIS >

[AUTOMATIC AIR CONDITIONER]

3. CHECK INTAKE SENSOR

Check intake sensor. Refer to [HAC-86, "Intake Sensor Component Inspection"](#).

Is the inspection result normal?

- YES >> 1. Replace A/C auto amp. Refer to [VTL-8, "Removal and Installation"](#).
 2. Go to [HAC-23, "A/C Auto Amp. Self-Diagnosis"](#) and perform self-diagnosis.
- NO >> 1. Replace intake sensor. Refer to XXXX.
 2. Go to [HAC-23, "A/C Auto Amp. Self-Diagnosis"](#) and perform self-diagnosis.

4. CHECK CIRCUIT CONTINUITY BETWEEN INTAKE SENSOR AND A/C AUTO AMP.

- Turn ignition switch OFF.
- Disconnect A/C auto amp. connector.
- Check continuity between intake sensor harness connector M146 (B) terminal 2 and A/C auto amp. harness connector M49 (A) terminal 11.

2 - 11 : Continuity should exist.

- Check continuity between intake sensor harness connector M146 terminal 2 and ground.

2 - Ground : Continuity should not exist.

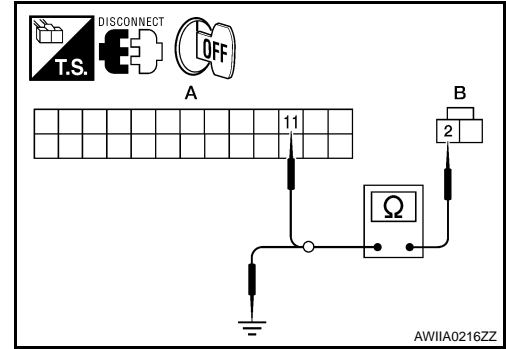

Is the inspection result normal?

- YES >> 1. Replace A/C auto amp. Refer to [VTL-8, "Removal and Installation"](#).
 2. Go to [HAC-23, "A/C Auto Amp. Self-Diagnosis"](#) and perform self-diagnosis.
- NO >> Repair harness or connector.

Intake Sensor Component Inspection

INFOID:000000001366742

COMPONENT INSPECTION

Intake Sensor

After disconnecting intake sensor connector, measure resistance between terminals 1 and 2 at sensor harness side, using the table below.

Temperature °C (°F)	Resistance kΩ
-15 (5)	209.0
-10 (14)	160.0
-5 (23)	123.0
0 (32)	95.8
5 (41)	74.9
10 (50)	58.9
15 (59)	46.7
20 (68)	37.3
25 (77)	30.0
30 (86)	24.2
35 (95)	19.7
40 (104)	16.1
45 (113)	13.2

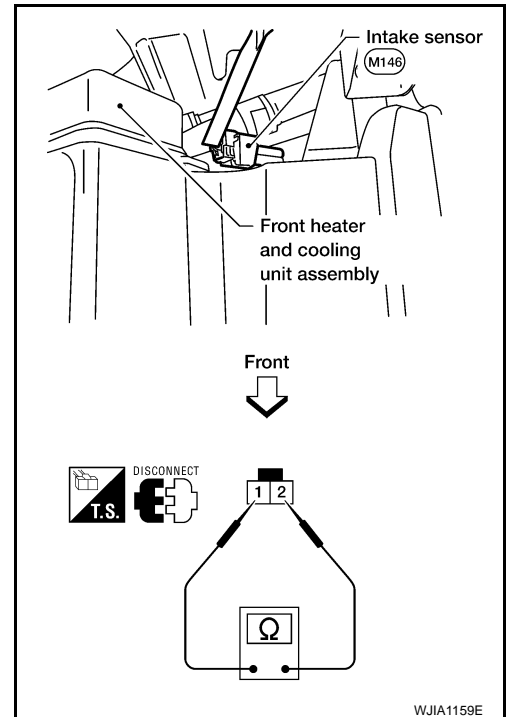

If NG, replace intake sensor. Refer to [VTL-12, "Removal and Installation"](#).

POWER SUPPLY AND GROUND CIRCUIT FOR CONTROLLER

< COMPONENT DIAGNOSIS >

[AUTOMATIC AIR CONDITIONER]

POWER SUPPLY AND GROUND CIRCUIT FOR CONTROLLER

Component Description

INFOID:000000001366743

COMPONENT DESCRIPTION

A/C auto amp.

The A/C auto amp. (1) has a built-in microcomputer which processes information sent from various sensors needed for air conditioner operation. The air mix door motors, mode door motor, intake door motor, defroster door motor, blower motor and compressor are then controlled.

The A/C auto amp. is unitized with control mechanisms. When the various switches and temperature dials are operated, data is input to the A/C auto amp.

Self-diagnostic functions are also built into the A/C auto amp. to provide quick check of malfunctions in the auto air conditioner system.

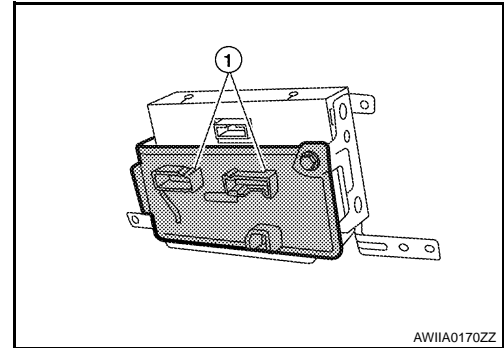

Potential Temperature Control (PTC)

There are two PTCs (driver and passenger) built into the A/C auto amp. They can be set at an interval of 0.5°C (1.0°F) in the 18°C (60°F) to 32°C (90°F) temperature range by rotating the temperature dial. The set temperature is displayed.

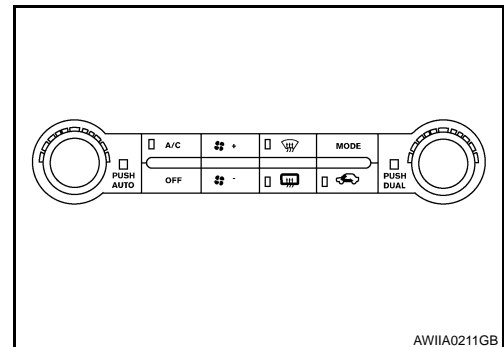

A/C Auto Amp. Component Function Check

INFOID:000000001366744

SYMPTOM: A/C system does not come on.

INSPECTION FLOW

1. CONFIRM SYMPTOM BY PERFORMING OPERATIONAL CHECK - AUTO MODE

1. Press AUTO switch.
2. Display should indicate AUTO. Confirm that the compressor clutch engages (sound or visual inspection). (Discharge air and blower speed will depend on ambient, in-vehicle and set temperatures.)

Can a symptom be duplicated?

- YES >> GO TO 3.
NO >> GO TO 2.

2. PERFORM COMPLETE OPERATIONAL CHECK

Perform a complete operational check and check for any symptoms. Refer to [HAC-123, "Operational Check"](#).

Can a symptom be duplicated?

- YES >> Refer to [HAC-122, "How to Perform Trouble Diagnosis For Quick And Accurate Repair"](#).
NO >> System OK.

3. CHECK FOR SERVICE BULLETINS

Check for any service bulletins.

>> GO TO 4.

4. CHECK POWER AND GROUND CIRCUIT

Check main power supply and ground circuit. Refer to [HAC-160, "Front Air Control Power and Ground Diagnosis Procedure"](#).

A
B
C
D
E
F
G
H
HAC
J
K
L
M
N
O
P

POWER SUPPLY AND GROUND CIRCUIT FOR CONTROLLER

[AUTOMATIC AIR CONDITIONER]

< COMPONENT DIAGNOSIS >

Is the inspection result normal?

YES >> System OK.

NO >> Replace A/C auto amp. Refer to [VTL-8. "Removal and Installation"](#).

A/C Auto Amp Power and Ground Diagnosis Procedure

INFOID:000000001366745

DIAGNOSTIC PROCEDURE FOR A/C SYSTEM

SYMPTOM: A/C system does not come on.

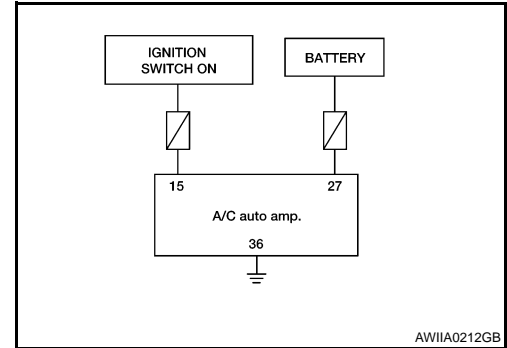

1. CHECK POWER SUPPLY CIRCUITS FOR A/C AUTO AMP.

1. Disconnect A/C auto amp. connectors.
2. Check voltage between A/C auto amp. harness connector M49 (B) terminal 15 and M50 (A) terminal 27, and ground.

Terminals		Ignition switch position			
(+)		(-)	OFF	ACC	ON
A/C auto amp. connector	Terminal No.				
M49	15	Ground	Approx. 0V	Approx. 0V	Battery voltage
M50	27		Battery voltage	Battery voltage	Battery voltage

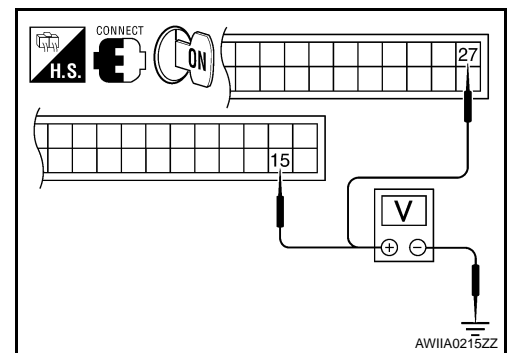

Is the inspection result normal?

YES >> GO TO 3.

NO >> Check 10A fuses [Nos. 8 and 19, located in the fuse block (J/B)]. Refer to [HAC-89. "A/C Auto Amp. Terminals Reference Values"](#).

- If fuses are OK, check harness for open circuit. Repair or replace as necessary.
- If fuses are NG, replace fuse and check harness for short circuit. Repair or replace as necessary.

2. CHECK GROUND CIRCUIT FOR A/C AUTO AMP.

1. Turn ignition switch OFF.
2. Check continuity between A/C auto amp. harness connector M50 terminal 36 and ground.

36 - Ground : Continuity should exist.

Is the inspection result normal?

OK >> Replace A/C auto amp. Refer to [VTL-8. "Removal and Installation"](#).

NG >> Repair harness or connector.

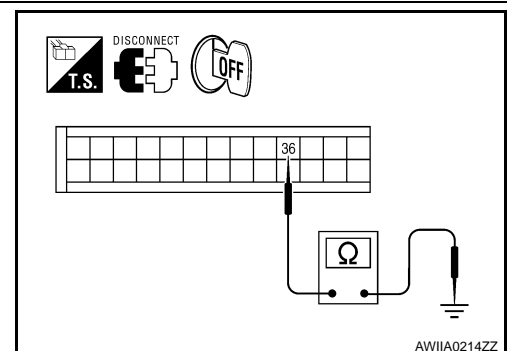

AIR CONDITIONER CONTROL

[AUTOMATIC AIR CONDITIONER]

< ECU DIAGNOSIS >

ECU DIAGNOSIS

AIR CONDITIONER CONTROL

A/C Auto Amp. Terminals Reference Values

INFOID:000000001366746

Measure voltage between each terminal and ground by following Terminals and Reference Value for A/C auto amp. (1).

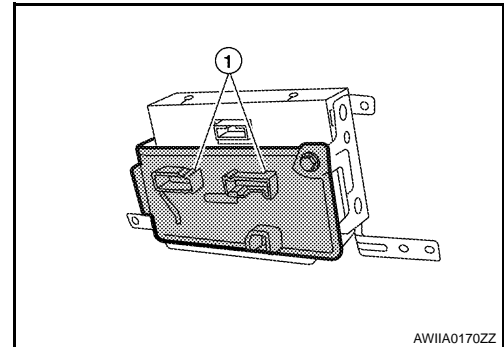

A/C AUTO AMP. HARNESS CONNECTOR TERMINAL LAYOUT

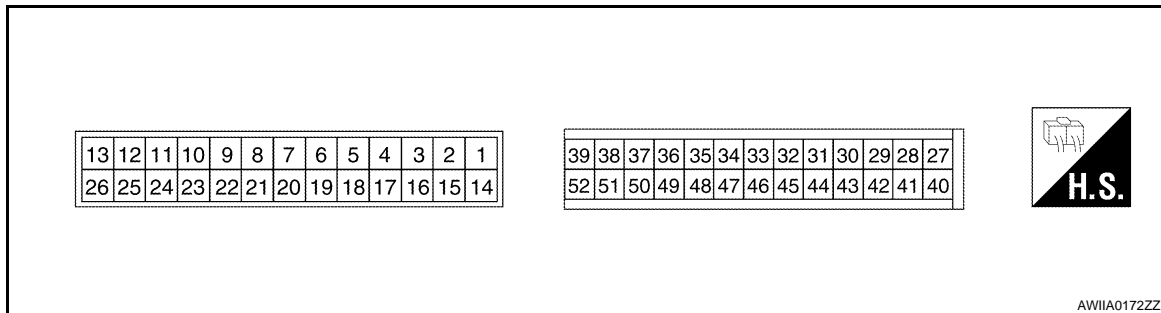

TERMINALS AND RERERENCE VALUES FOR A/C AUTO AMP.

Terminal No.	Wire color	Item	Ignition switch	Condition	Voltage (V) (Approx.)
1	G	Optical sensor (driver)	ON	-	0 - 5V
2	L	Air mix door motor (passenger) CCW	ON	-	0 - 5V
3	G	V ref ACTR (ground)	ON	-	5V
4	W	Compressor ON signal	ON	A/C switch OFF	5V
			ON	A/C switch ON	0V
5	R	Fan ON signal	ON	Blower switch OFF	5V
			ON	Blower switch ON	0V
6	SB	Air mix door motor (driver) feedback	ON	-	0 - 5V
7	V	Mode door motor (front) feedback	ON	-	0 - 5V
8	G	Illumination +	ON	Park lamps ON	Battery voltage
9	BR	Illumination -	-	Park lamps ON	<p>PIA2344E</p>
11	L	Intake sensor	ON	-	0 - 5V
12	P	Variable blower control (rear)	ON	-	0 - 5V
13	R	Variable blower control (front)	ON	-	0 - 5V
14	LG	Air mix door motor (passenger) CW	ON	Clockwise rotation	Battery voltage

AIR CONDITIONER CONTROL

< ECU DIAGNOSIS >

[AUTOMATIC AIR CONDITIONER]

Terminal No.	Wire color	Item	Ignition switch	Condition	Voltage (V) (Approx.)
15	W/G	Power supply for IGN	ON	-	Battery voltage
17	GR	Air mix door motor (driver) CW	ON	Clockwise rotation	Battery voltage
18	BR	Air mix door motor (driver) CCW	ON	Counterclockwise rotation	Battery voltage
19	L	Mode door motor CW (front)	ON	Clockwise rotation	Battery voltage
20	B/R	Mode door motor CCW	ON	Counterclockwise rotation	Battery voltage
21	O	Intake door motor CCW	ON	Counterclockwise rotation	Battery voltage
22	O	Intake door motor CW	ON	Clockwise rotation	Battery voltage
25	W	Ambient sensor	ON	-	0 - 5V
26	V	Sensor ground	ON	-	0V
27	R/Y	Power supply for BAT	-	-	Battery voltage
28	P	V ref ACTR (5V)	ON	-	0 - 5V
29	SB	Air mix door motor (passenger) feed-back	ON	-	0 - 5V
30	R	Air mix door motor (Rear) feedback	ON	-	0 - 5V
31	BR	In-vehicle sensor motor (+)	ON	-	Battery voltage
32	LG	In-vehicle sensor signal	ON	-	0 - 5V
34	GY	Front aux backlight dim	ON	Headlamps OFF	Battery voltage
35	W/G	Front aux tell tale LED	ON	Tell tale OFF	Battery voltage
36	B	Ground	-	-	0V
37	GR	Front aux temp pot	ON	Rear air control (front) temperature control dial	0 - 5V
38	P	Front aux blower pot	ON	Rear air control (front) blower motor	0 - 5V
39	SB	Front AUX (rear)	ON	-	0 - 5V
40	P	CAN-L	ON	-	0 - 5V
41	L	CAN-H	ON	-	0 - 5V
42	GR	Optical sensor (passenger)	ON	-	0 - 5V
43	V	Air mix door motor (Rear) CW	ON	Clockwise rotation	Battery voltage
44	O	Air mix door motor (Rear) CCW	ON	Counterclockwise rotation	Battery voltage
45	P	Water valve (VK56DE)	ON	Water valve open	Battery voltage
				Water valve closed	0V
46	R	Water valve (VK56DE)	ON	Water valve open	0V
				Water valve closed	Battery voltage
50	GR	Heater pump request (VQ40DE)	ON	Heater pump on	0V
				Heater pump off	Battery voltage
51	L	Rear aux temp pot	ON	Rear air control (rear) temperature control dial	0 - 5V
52	W	Rear aux blower pot	ON	Rear blower motor	0 - 5V

AIR CONDITIONER CONTROL

[AUTOMATIC AIR CONDITIONER]

< ECU DIAGNOSIS >

Wiring Diagram

INFOID:000000001366747

AIR CONDITIONER CONTROL - AUTOMATIC

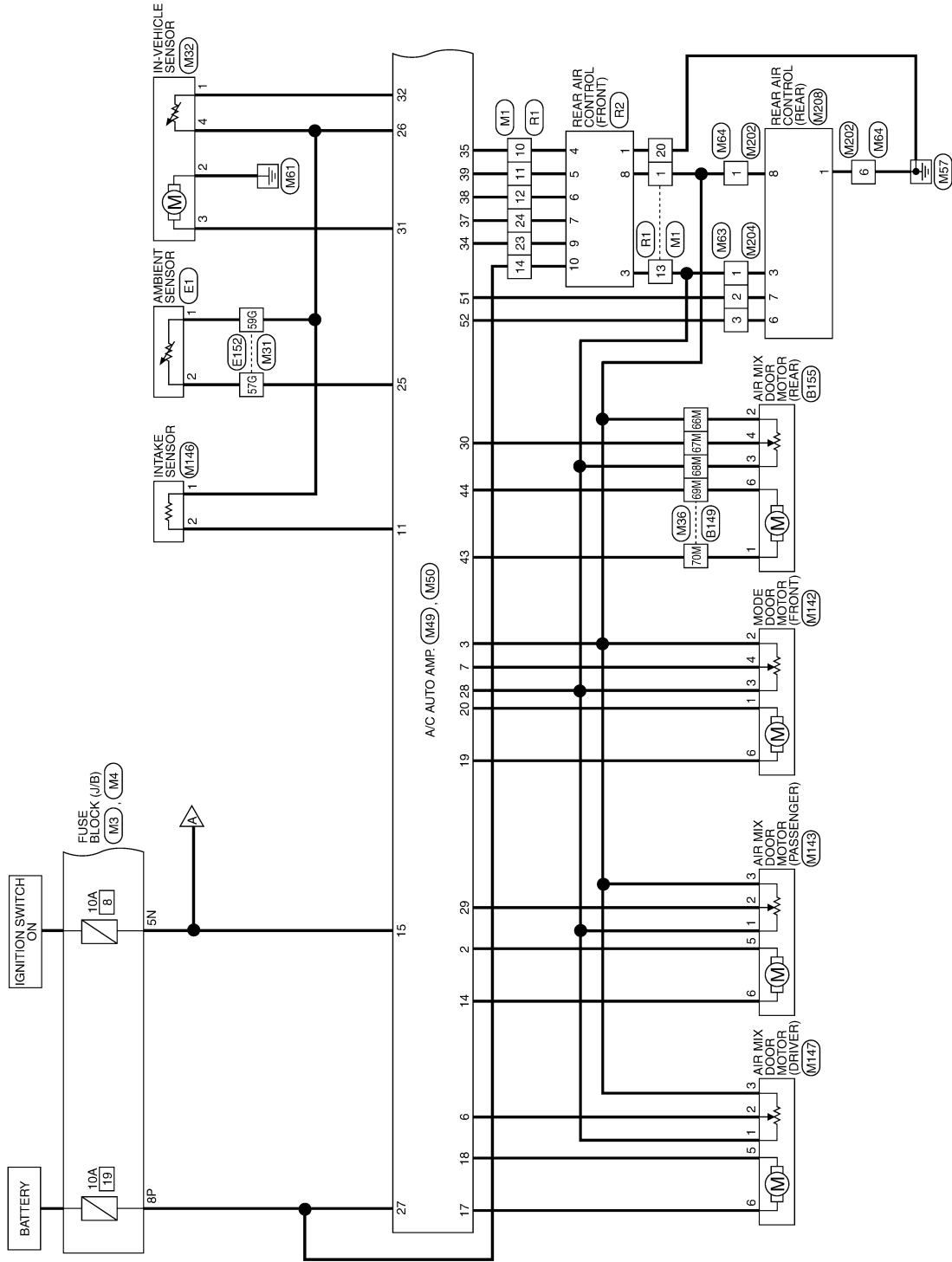

A
B
C
D
E
F
G
H
I
J
K
L
M
N
O
P

HAC

ALIWA0028GB

AIR CONDITIONER CONTROL

[AUTOMATIC AIR CONDITIONER]

< ECU DIAGNOSIS >

ZB : WITH VK56DE
ZV : WITH VQ40DE

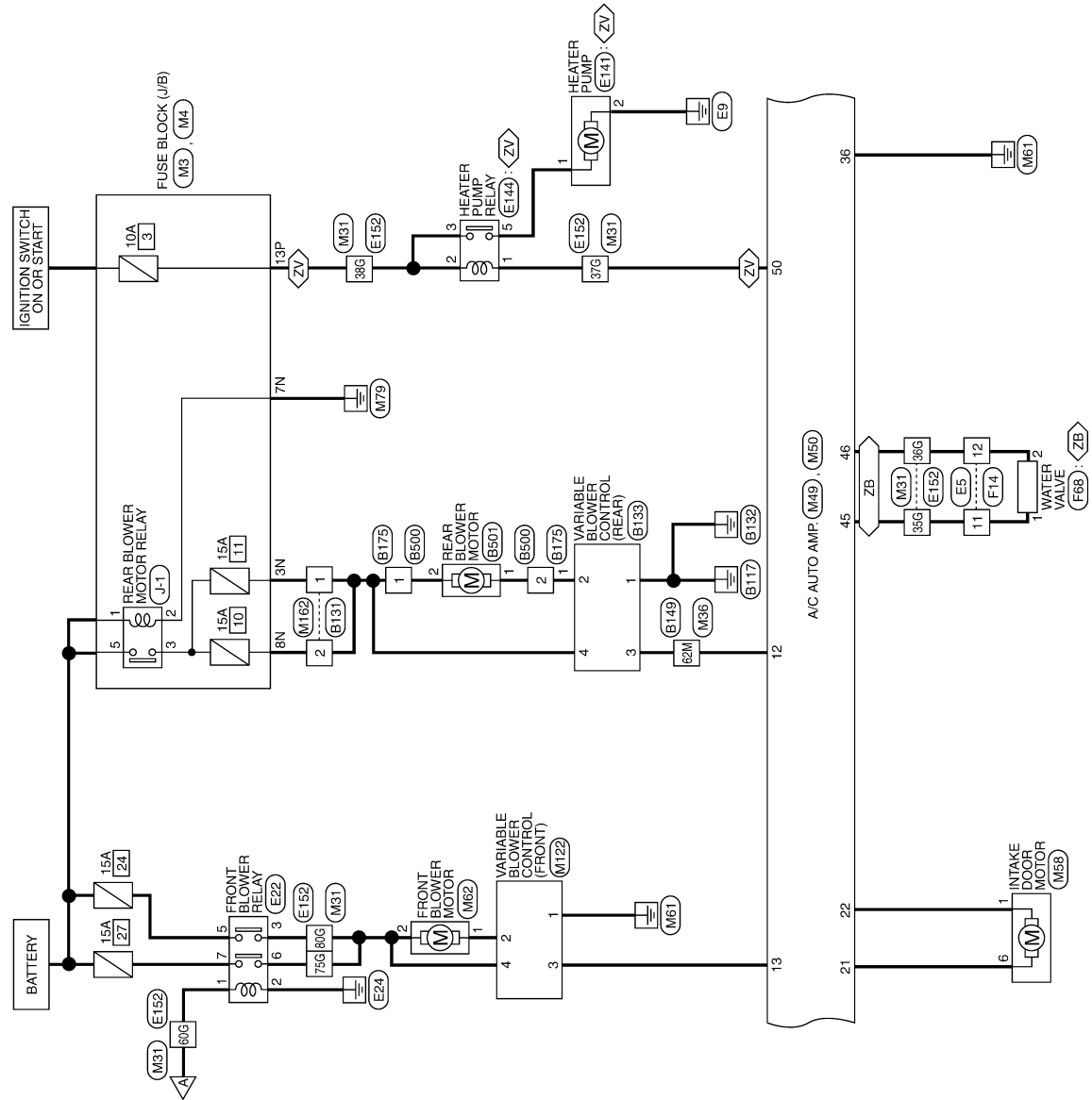

ALIWA0029GB

AIR CONDITIONER CONTROL

[AUTOMATIC AIR CONDITIONER]

< ECU DIAGNOSIS >

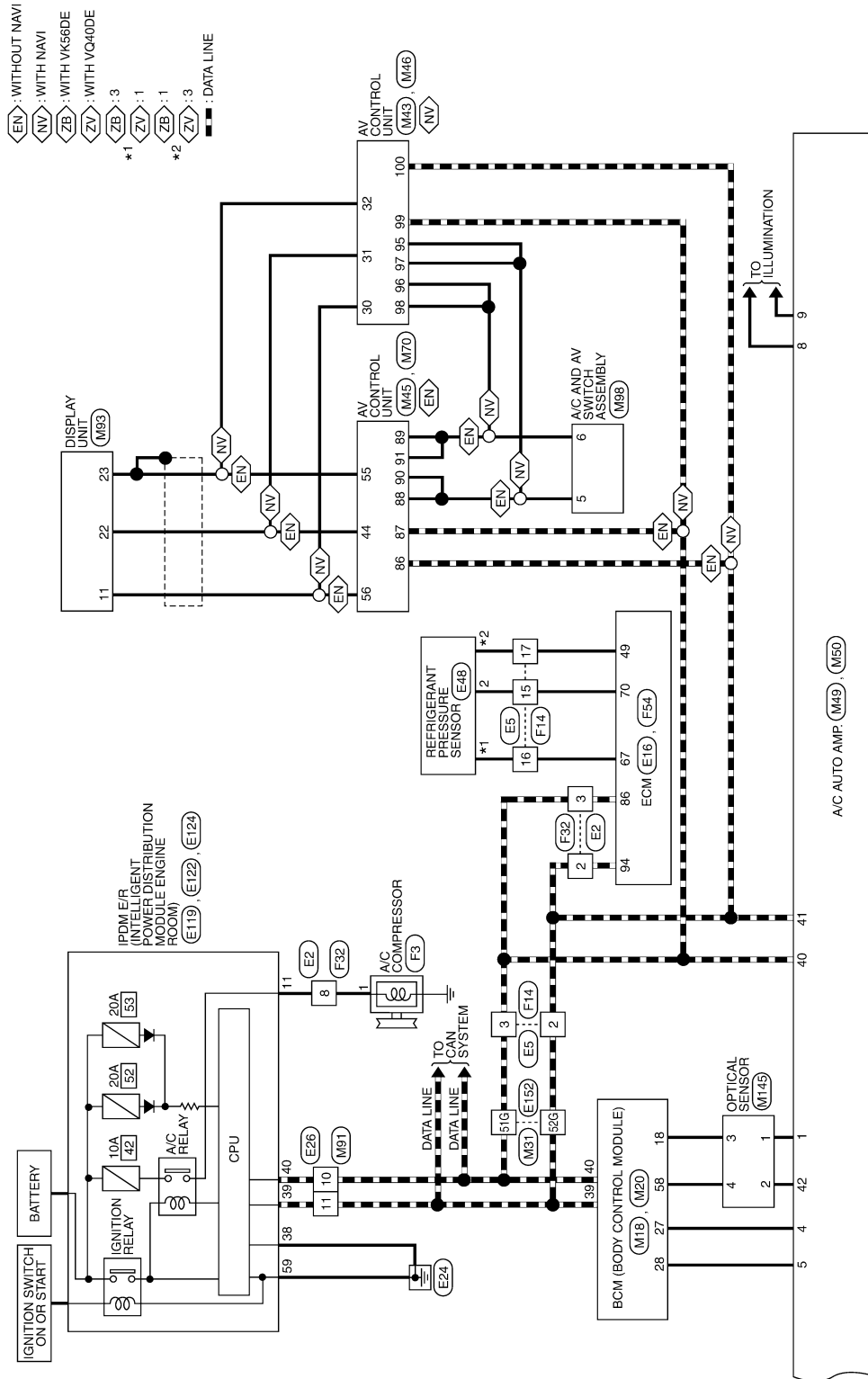

ALIWA0030GB

A
B
C
D
E
F
G
H
I
J
K
L
M
N
O
P

HAC

AIR CONDITIONER CONTROL

[AUTOMATIC AIR CONDITIONER]

< ECU DIAGNOSIS >

AIR CONDITIONER CONTROL - AUTOMATIC CONNECTORS

Connector No.	M1
Connector Name	WIRE TO WIRE
Connector Color	WHITE

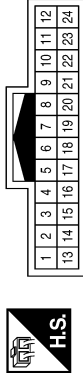

Terminal No.	Color of Wire	Signal Name
1	LG	—
10	W/G	—
11	SB	—
12	P	—
13	R	—
14	R/Y	—
20	B	—
23	G	—
24	GR	—

Connector No.	M3
Connector Name	FUSE BLOCK (J/B)
Connector Color	WHITE

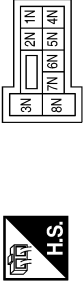

Terminal No.	Color of Wire	Signal Name
3N	R/B	—
5N	W/G	—
7N	B	—
8N	R/B	—

Connector No.	M4
Connector Name	FUSE BLOCK (J/B)
Connector Color	WHITE

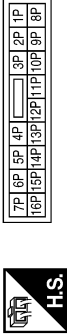

Terminal No.	Color of Wire	Signal Name
8P	R/Y	—
13P	W/G	—

Connector No.	M18
Connector Name	BCM
Connector Color	WHITE

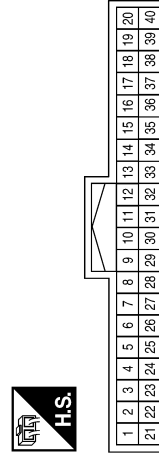

Terminal No.	Color of Wire	Signal Name
18	BR	KEYLESS & AUTO LIGHT_SENSOR_GND
27	W	AIRCON_SW
28	LG	BLOWER_FAN_SW
39	L	CAN-H
40	P	CAN-L

Connector No.	M20
Connector Name	BCM
Connector Color	WHITE



Terminal No.	Color of Wire	Signal Name
58	W	AUTO_LIGHT_SEN

ALIA0079GB

AIR CONDITIONER CONTROL

[AUTOMATIC AIR CONDITIONER]

< ECU DIAGNOSIS >

Connector No.	M32
Connector Name	IN-VEHICLE SENSOR
Connector Color	WHITE

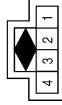

Terminal No.	Color of Wire	Signal Name
1	LG	-
2	O	-
3	BR	-
4	V	-

Terminal No.	Color of Wire	Signal Name
35G	P	-
36G	R	-
37G	GR	-
38G	W/G	-
51G	P	-
52G	L	-
57G	W	-
59G	V	-
60G	W/G	-
75G	W/G	-
80G	W/G	-

Connector No.	M31
Connector Name	WIRE TO WIRE
Connector Color	WHITE

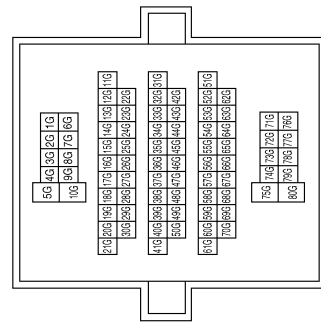

Connector No.	M43
Connector Name	AV CONTROL UNIT
Connector Color	WHITE

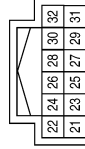

Terminal No.	Color of Wire	Signal Name
30	V	IT_DISP
31	LG	DISP_IT
32	-	SHIELD

Terminal No.	Color of Wire	Signal Name
62M	P	-
66M	P	-
67M	R	-
68M	Y	-
69M	O	-
70M	V	-

Connector No.	M36
Connector Name	WIRE TO WIRE
Connector Color	WHITE

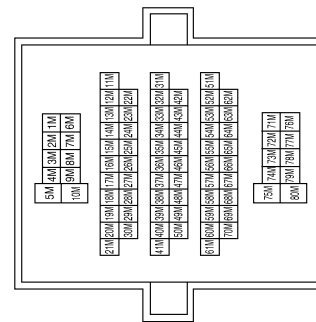

ALIIA0080GB

A
B
C
D
E
F
G
H
HAC
J
K
L
M
N
O
P

AIR CONDITIONER CONTROL

[AUTOMATIC AIR CONDITIONER]

< ECU DIAGNOSIS >

Connector No.	M45
Connector Name	AV CONTROL UNIT
Connector Color	WHITE



47	46	45	44	43	42	41	40	39	38	37	36
59	58	57	56	55	54	53	52	51	50	49	48

Connector No.	M46
Connector Name	AV CONTROL UNIT
Connector Color	WHITE



69	71	73	75	77	79	81	83	85	87	89	91	93	95	97	99	101	103	105	107
68	70	72	74	76	78	80	82	84	86	88	90	92	94	96	98	100	102	104	106

Terminal No.	Color of Wire	Signal Name
95	L	M-CAN2-H
96	P	M-CAN2-L
97	L	M-CAN1-H
98	P	M-CAN1-L
99	L	CAN-H
100	P	CAN-L

Terminal No.	Color of Wire	Signal Name
44	LG	DISP_IT
55	-	SHIELD
56	V	IT_DISP

Connector No.	M49
Connector Name	FRONT AIR CONTROL
Connector Color	BLACK



13	12	11	10	9	8	7	6	5	4	3	2	1
26	25	24	23	22	21	20	19	18	17	16	15	14

Terminal No.	Color of Wire	Signal Name
1	G	SUNLOAD SEN LEFT
2	L	PASS BLEND DR B
3	G	V REF RETURN
4	W	A/C REQUEST
5	R	FAN ON
6	SB	DR BLEND DOOR FEED BACK
7	V	MODE FEED BACK
8	G	-
9	BR	-
10	-	-
11	L	DISCHARGE AIR TEM SENS
12	P	AUX BLOWER VBC
13	R	FRONT BLOWER VBC

Terminal No.	Color of Wire	Signal Name
14	LG	PASS BLEND DOOR A
15	W/G	IGN
16	-	-
17	GR	DR BLEND DOOR A
18	BR	DR BLEND DOOR B
19	L	MODE A
20	BR	MODE B
21	O	INTAKE A
22	Y	INTAKE B
23	-	-
24	-	-
25	W	AMB TEMP SENS
26	V	SENSOR RETURN

ALIIA0081GB

AIR CONDITIONER CONTROL

[AUTOMATIC AIR CONDITIONER]

< ECU DIAGNOSIS >

Terminal No.	Color of Wire	Signal Name
43	V	AUX BLEND A
44	O	BLEND B
45	P	WATER VALVE A
46	R	WATER VALVE B
47	-	-
48	-	-
49	-	-
50	GR	COOLANT PUMP REQUEST
51	L	REAR AUX TEMP POT
52	W	REAR AUX BLOWER POT

Terminal No.	Color of Wire	Signal Name
30	R	AUX BLEND FEED BACK
31	BR	IN CAR MTR+
32	LG	IN CAR TEMP SEN
33	-	-
34	G	FRONT AUX BACKLIGHT DIMMING
35	W/G	REAR TELLTALE
36	B	GND
37	GR	FRONT AUX TEMP POT
38	P	FRONT AUX BLOWER POT
39	SB	REAR BUTTON
40	P	CAN-L
41	L	CAN-H
42	GR	SUNLOAD SEN RIGHT

Connector No.	M50
Connector Name	FRONT AIR CONTROL
Connector Color	BLUE

13	12	11	10	9	8	7	6	5	4	3	2	1
26	25	24	23	22	21	20	19	18	17	16	15	14



Terminal No.	Color of Wire	Signal Name
27	R/Y	B
28	P	V REF ACTR
29	SB	PASS BLEND DR FEED BACK

Connector No.	M63
Connector Name	WIRE TO WIRE
Connector Color	WHITE

3	2	1
6	5	4



Connector No.	M62
Connector Name	FRONT BLOWER MOTOR
Connector Color	BLACK

1	2
---	---



Terminal No.	Color of Wire	Signal Name
1	R	-
2	L	-
3	W	-

Terminal No.	Color of Wire	Signal Name
1	L	-
2	W/G	-

Connector No.	M58
Connector Name	INTAKE DOOR MOTOR
Connector Color	BLACK

1	2	3	4	5	6
---	---	---	---	---	---



Terminal No.	Color of Wire	Signal Name
1	Y	-
6	O	-

ALIIA0082GB

A
B
C
D
E
F
G
H
HAC
J
K
L
M
N
O
P

AIR CONDITIONER CONTROL

[AUTOMATIC AIR CONDITIONER]

< ECU DIAGNOSIS >

Terminal No.	Color of Wire	Signal Name
86	L	CAN_H
87	P	CAN_L
88	L	M_CAN1_H
89	P	M_CAN1_H
90	L	M_CAN2_H
91	P	M_CAN2_L

Connector No.	M70
Connector Name	AV CONTROL UNIT
Connector Color	WHITE



91	90	89	88	87	86	85	84	83	82	81	80	79	78	77	76
107	106	105	104	103	102	101	100	99	98	97	96	95	94	93	92

Connector No.	M64
Connector Name	WIRE TO WIRE
Connector Color	WHITE



2	1		
6	5	4	3

Terminal No.	Color of Wire	Signal Name
1	LG	-
6	B	-

Connector No.	M98
Connector Name	A/C AND AV SWITCH ASSEMBLY
Connector Color	WHITE



2	4	6	8	10	12	14	16
1	3	5	7	9	11	13	15

Connector No.	M93
Connector Name	DISPLAY UNIT
Connector Color	BLACK



12	11	10	9	8	7	6	5	4	3	2	1
24	23	22	21	20	19	18	17	16	15	14	13

Connector No.	M91
Connector Name	WIRE TO WIRE
Connector Color	WHITE



7	6	5	4	3	2	1		
16	15	14	13	12	11	10	9	8

Terminal No.	Color of Wire	Signal Name
5	L	M_CAN1-L
6	P	M_CAN1-H

Terminal No.	Color of Wire	Signal Name
11	V	IT_DISP
22	LG	DISP_IT
23	-	SHIELD

Terminal No.	Color of Wire	Signal Name
10	P	-
11	L	-

ALIIA0083GB

AIR CONDITIONER CONTROL

[AUTOMATIC AIR CONDITIONER]

< ECU DIAGNOSIS >

Connector No.	M143
Connector Name	AIR MIX DOOR MOTOR (PASSENGER)
Connector Color	BLACK



Terminal No.	Color of Wire	Signal Name
1	Y	-
2	SB	-
3	R	-
4	-	-
5	L	-
6	LG	-

Connector No.	M142
Connector Name	MODE DOOR MOTOR (FRONT)
Connector Color	BLACK



Terminal No.	Color of Wire	Signal Name
1	BR	-
2	P	-
3	G	-
4	V	-
5	-	-
6	L	-

Connector No.	M122
Connector Name	VARIABLE BLOWER CONTROL (FRONT)
Connector Color	WHITE

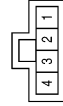

Terminal No.	Color of Wire	Signal Name
1	B	GND
2	L	MOTOR -
3	R	SET_POINT
4	W/G	MOTOR +

Connector No.	M147
Connector Name	AIR MIX DOOR MOTOR (DRIVER)
Connector Color	BLACK



Terminal No.	Color of Wire	Signal Name
1	P	-
2	SB	-
3	G	-
4	-	-
5	BR	-
6	GR	-

Connector No.	M146
Connector Name	INTAKE SENSOR
Connector Color	WHITE



Terminal No.	Color of Wire	Signal Name
1	V	-
2	L	-

Connector No.	M145
Connector Name	OPTICAL SENSOR
Connector Color	BLACK



Terminal No.	Color of Wire	Signal Name
1	G	-
2	GR	-
3	P	-
4	W	-

ALIIA0084GB

A
B
C
D
E
F
G
H
HAC
J
K
L
M
N
O
P

AIR CONDITIONER CONTROL

[AUTOMATIC AIR CONDITIONER]

< ECU DIAGNOSIS >

Connector No.	M204
Connector Name	WIRE TO WIRE
Connector Color	WHITE



Terminal No.	Color of Wire	Signal Name
1	R	-
2	L	-
3	W	-

Connector No.	M202
Connector Name	WIRE TO WIRE
Connector Color	WHITE

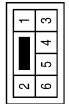

Terminal No.	Color of Wire	Signal Name
1	LG	-
6	B	-

Connector No.	M162
Connector Name	WIRE TO WIRE
Connector Color	WHITE



Terminal No.	Color of Wire	Signal Name
1	GR	-
2	L	-

Connector No.	E2
Connector Name	WIRE TO WIRE
Connector Color	WHITE

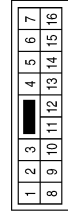

Terminal No.	Color of Wire	Signal Name
2	L	-
3	P	-
8	Y	-

Connector No.	E1
Connector Name	AMBIENT SENSOR
Connector Color	BLACK



Terminal No.	Color of Wire	Signal Name
1	W	-
2	V	-

Connector No.	M208
Connector Name	REAR AIR CONTROL (REAR)
Connector Color	BLACK

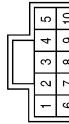

Terminal No.	Color of Wire	Signal Name
1	B	GND
3	R	VREF_5V
6	W	BLOWER_SPEED_POT
7	L	TEMP_POT
8	LG	VREF_RETURN

ALIIA0085GB

AIR CONDITIONER CONTROL

[AUTOMATIC AIR CONDITIONER]

< ECU DIAGNOSIS >

Connector No.	E22
Connector Name	FRONT BLOWER RELAY
Connector Color	BROWN



Terminal No.	Color of Wire	Signal Name
1	W/G	-
2	B	-
3	W/G	-
5	L	-
6	W/G	-
7	GR	-

Connector No.	E16
Connector Name	ECM
Connector Color	BLACK

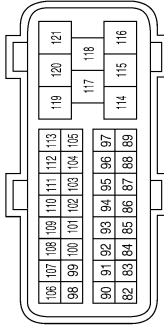

Terminal No.	Color of Wire	Signal Name
86	P	CAN-L
94	L	CAN-H

Connector No.	E5
Connector Name	WIRE TO WIRE
Connector Color	WHITE

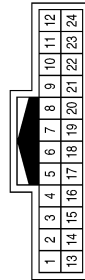

Terminal No.	Color of Wire	Signal Name
2	L	-
3	P	-
11	P	-
12	R	-
15	BR	-
16	B	-
17	P	-

Connector No.	E48
Connector Name	REFRIGERANT PRESSURE SENSOR (VK56DE)
Connector Color	BLACK



Terminal No.	Color of Wire	Signal Name
1	P	POWER_SUPPLY
2	BR	SIGNAL
3	B	GND

Connector No.	E48
Connector Name	REFRIGERANT PRESSURE SENSOR (VQ40DE)
Connector Color	BLACK



Terminal No.	Color of Wire	Signal Name
1	B	GND
2	BR	SIGNAL
3	P	POWER_SUPPLY

Connector No.	E26
Connector Name	WIRE TO WIRE
Connector Color	WHITE

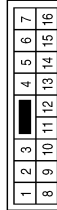

Terminal No.	Color of Wire	Signal Name
10	P	-
11	L	-

ALIIA0086GB

A
B
C
D
E
F
G
H
HAC
J
K
L
M
N
O
P

AIR CONDITIONER CONTROL

[AUTOMATIC AIR CONDITIONER]

< ECU DIAGNOSIS >

Connector No.	E124
Connector Name	IPDM E/R (INTELLIGENT POWER DISTRIBUTION MODULE ENGINE ROOM)
Connector Color	BLACK



59	58	57
62	61	60

Terminal No.	Color of Wire	Signal Name
59	B	POWER_GND

Connector No.	E122
Connector Name	IPDM E/R (INTELLIGENT POWER DISTRIBUTION MODULE ENGINE ROOM)
Connector Color	WHITE



42	41	40	39	38	37
48	47	46	45	44	43

Terminal No.	Color of Wire	Signal Name
38	B	SIGNAL_GND
39	L	CAN-H
40	P	CAN-L

Connector No.	E119
Connector Name	AV CONTROL UNIT (WITHOUT NAVI)
Connector Color	WHITE



9	8	7	6	5	4	3		
18	17	16	15	14	13	12	11	10

Terminal No.	Color of Wire	Signal Name
11	Y	A/C_COMPRESSOR

Connector No.	E144
Connector Name	FRONT AIR CONTROL (WITH MANUAL A/C)
Connector Color	BLACK



3	5
2	1

Terminal No.	Color of Wire	Signal Name
1	GR	-
2	W/G	-
3	W/G	-
5	V	-

Connector No.	E141
Connector Name	HEATER PUMP
Connector Color	BLACK



1	2
---	---

Terminal No.	Color of Wire	Signal Name
1	V	-
2	B	-

ALIIA0087GB

AIR CONDITIONER CONTROL

[AUTOMATIC AIR CONDITIONER]

< ECU DIAGNOSIS >

Connector No.	F3
Connector Name	A/C COMPRESSOR
Connector Color	BLACK



Terminal No.	Color of Wire	Signal Name
1	Y	-

Terminal No.	Color of Wire	Signal Name
35G	P	-
36G	R	-
37G	GR	-
38G	W/G	-
51G	P	-
52G	L	-
57G	W	-
59G	V	-
60G	W/G	-
75G	W/G	-
80G	W/G	-

Connector No.	E152
Connector Name	WIRE TO WIRE
Connector Color	WHITE

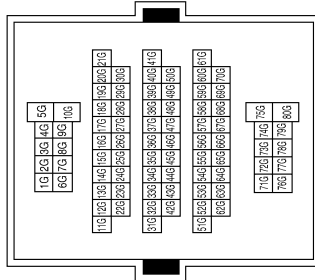

Connector No.	F54
Connector Name	ECM
Connector Color	BLACK

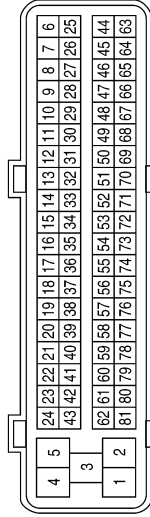

Terminal No.	Color of Wire	Signal Name
49	P	AVCC (PDPRES)
67	B	GND-A
70	BR	PDPRESS

Connector No.	F32
Connector Name	WIRE TO WIRE
Connector Color	WHITE

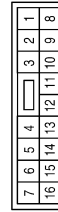

Terminal No.	Color of Wire	Signal Name
2	L	-
3	P	-
8	Y	-

Connector No.	F14
Connector Name	WIRE TO WIRE
Connector Color	WHITE

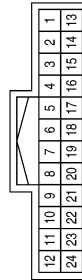

Terminal No.	Color of Wire	Signal Name
2	L	-
3	P	-
11	P	-
12	R	-
15	BR	-
16	B	-
17	P	-

ALIIA0088GB

A
B
C
D
E
F
G
H
HAC
J
K
L
M
N
O
P

AIR CONDITIONER CONTROL

[AUTOMATIC AIR CONDITIONER]

< ECU DIAGNOSIS >

Connector No.	B133
Connector Name	VARIABLE BLOWER CONTROL (REAR)
Connector Color	WHITE

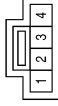

Terminal No.	Color of Wire	Signal Name
1	B	GND
2	O	MOTOR -
3	P	SET_POINT
4	L	MOTOR +

Connector No.	B131
Connector Name	WIRE TO WIRE
Connector Color	WHITE



Terminal No.	Color of Wire	Signal Name
1	L	-
2	L	-

Connector No.	F68
Connector Name	WATER VALVE
Connector Color	GRAY



Terminal No.	Color of Wire	Signal Name
1	P	-
2	R	-

Connector No.	B155
Connector Name	AIR MIX DOOR MOTOR (REAR)
Connector Color	BLACK



Terminal No.	Color of Wire	Signal Name
1	V	-
2	P	-
3	Y	-
4	R	-
6	G	-

Terminal No.	Color of Wire	Signal Name
62M	P	-
66M	P	-
67M	R	-
68M	Y	-
69M	O	-
70M	V	-

Connector No.	B149
Connector Name	WIRE TO WIRE
Connector Color	WHITE

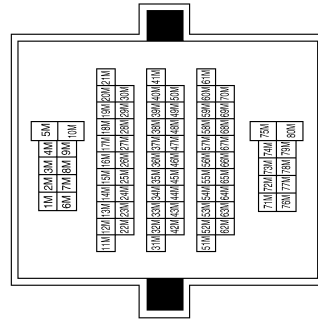

ALIIA0089GB

AIR CONDITIONER CONTROL

[AUTOMATIC AIR CONDITIONER]

< ECU DIAGNOSIS >

Connector No.	B501
Connector Name	REAR BLOWER MOTOR
Connector Color	BLACK



Terminal No.	Color of Wire	Signal Name
1	G	-
2	R	-

Connector No.	B500
Connector Name	WIRE TO WIRE
Connector Color	WHITE



Terminal No.	Color of Wire	Signal Name
1	L	-
2	G	-

Connector No.	B175
Connector Name	WIRE TO WIRE
Connector Color	WHITE



Terminal No.	Color of Wire	Signal Name
1	L	-
2	G	-

Connector No.	R1
Connector Name	WIRE TO WIRE
Connector Color	WHITE

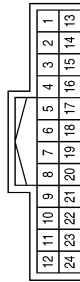

Terminal No.	Color of Wire	Signal Name
1	G	-
10	W/G	-
11	SB	-
12	P	-
13	P	-
14	R/Y	-
20	B	-
23	G	-
24	GR	-

ALIIA0090GB

A
B
C
D
E
F
G
H
HAC
J
K
L
M
N
O
P

AIR CONDITIONER CONTROL

< SYMPTOM DIAGNOSIS >

[AUTOMATIC AIR CONDITIONER]

SYMPTOM DIAGNOSIS

AIR CONDITIONER CONTROL

Symptom Matrix Chart

INFOID:000000001366748

SYMPTOM TABLE

Symptom	Reference Page	
A/C system does not come on.	Go to Trouble Diagnosis Procedure for A/C System.	HAC-159
A/C system display is malfunctioning.	Go to AV System.	AV-178 , AV-66
A/C system cannot be controlled.	Go to Self-diagnosis Function.	HAC-23
Air outlet does not change.	Go to Trouble Diagnosis Procedure for Mode Door Motor.	HAC-135
Mode door motor is malfunctioning.		
Discharge air temperature does not change.	Go to Trouble Diagnosis Procedure for Air Mix Door Motor.	HAC-140
Air mix door motor is malfunctioning.		
Intake door does not change.	Go to Trouble Diagnosis Procedure for Intake Door Motor.	HAC-143
Intake door motor is malfunctioning.		
Front blower motor operation is malfunctioning.	Go to Trouble Diagnosis Procedure for Front Blower Motor.	HAC-146
Rear blower motor operation is malfunctioning.	Go to Trouble Diagnosis Procedure for Rear Blower Motor.	HAC-52
Rear discharge air temperature and/or air outlet does not change.	Go to Trouble Diagnosis Procedure for Rear Air Control system.	HAC-61
Magnet clutch does not engage.	Go to Trouble Diagnosis Procedure for Magnet Clutch.	HAC-152
Insufficient cooling	Go to Trouble Diagnosis Procedure for Insufficient Cooling.	HAC-172
Insufficient heating	Go to Trouble Diagnosis Procedure for Insufficient Heating.	HAC-181
Noise	Go to Trouble Diagnosis Procedure for Noise.	HAC-183
Self-diagnosis cannot be performed.	Go to Trouble Diagnosis Procedure for Self-diagnosis.	HAC-159
Memory function does not operate.	Go to Trouble Diagnosis Procedure for Memory Function.	HAC-119

INSUFFICIENT COOLING

< SYMPTOM DIAGNOSIS >

[AUTOMATIC AIR CONDITIONER]

INSUFFICIENT COOLING

Component Function Check

INFOID:000000001366749

SYMPTOM: Insufficient cooling

INSPECTION FLOW

1. CONFIRM SYMPTOM BY PERFORMING OPERATIONAL CHECK - TEMPERATURE DECREASE

1. Press the AUTO switch.
2. Turn temperature control dial (driver) counterclockwise until 16° C (60° F) is displayed.
3. Check for cold air at discharge air outlets.

Can the symptom be duplicated?

YES >> GO TO 3.

NO >> GO TO 2.

2. CHECK FOR ANY SYMPTOMS

Perform a complete operational check for any symptoms. Refer to [HAC-123, "Operational Check"](#).

Does another symptom exist?

YES >> Refer to [HAC-171, "Symptom Matrix Chart"](#).

NO >> System OK.

3. CHECK FOR SERVICE BULLETINS

Check for any service bulletins.

>> GO TO 3.

4. PERFORM SELF-DIAGNOSIS

Perform self-diagnosis Refer to [HAC-23, "A/C Auto Amp. Self-Diagnosis"](#).

Is the inspection result normal?

YES >> GO TO 5.

NO >> Refer to [HAC-24, "A/C System Self-Diagnosis Code Chart"](#).

5. CHECK DRIVE BELTS

Check compressor belt tension. Refer to [EM-13, "Checking Drive Belts"](#) (VQ40DE) or [EM-153, "Checking Drive Belts"](#) (VK56DE).

Is the inspection result normal?

OK >> GO TO 6.

NG >> Adjust or replace compressor belt. Refer to [EM-13, "Tension Adjustment"](#), [EM-13, "Removal and Installation"](#) (VQ40DE) or [EM-153, "Removal and Installation"](#) (VK56DE).

6. CHECK AIR MIX DOOR OPERATION

Check and verify air mix door mechanism for smooth operation. Refer to [HAC-140, "Air Mix Door Motor Component Function Check"](#)

Does air mix door operate correctly?

YES >> GO TO 7.

NO >> Check air mix door motor circuit. Refer to [HAC-141, "Air Mix Door Motor Diagnosis Procedure"](#) or [HAC-37, "Air Mix Door Motor \(Passenger\) Diagnosis Procedure"](#).

7. CHECK COOLING FAN MOTOR OPERATION

Check and verify cooling fan motor for smooth operation.

Does cooling fan motor operate correctly?

YES >> GO TO 8.

NO >> Check cooling fan motor.

8. CHECK WATER VALVE OPERATION (VK56DE ONLY)

Check and verify water valve for smooth operation. Refer to [HAC-72, "Water Valve Description \(VK56DE\)"](#).

Does water valve operate correctly?

A

B

C

D

E

F

G

H

HAC

J

K

L

M

N

O

P

INSUFFICIENT COOLING

[AUTOMATIC AIR CONDITIONER]

< SYMPTOM DIAGNOSIS >

YES >> GO TO 8.

NO >> Check water valve circuit. Refer to [HAC-72, "Water Valve Diagnosis Procedure \(VK56DE\)"](#).

9.CHECK RECOVERY/RECYCLING EQUIPMENT BEFORE USAGE

Check recovery/recycling equipment before connecting to vehicle. Verify there is no pressure in the recovery/recycling equipment by checking the gauges. If pressure exists, recover refrigerant from equipment lines.

>> GO TO 9.

10.CHECK REFRIGERANT PURITY

1. Connect recovery/recycling equipment to vehicle.

2. Confirm refrigerant purity in supply tank using recovery/recycling and refrigerant identifier.

Is the inspection result normal?

YES >> GO TO 10.

NO >> Check contaminated refrigerant. Refer to [HAC-185, "Working with HFC-134a \(R-134a\)"](#).

11.CHECK FOR EVAPORATOR FREEZE UP

Start engine and run A/C. Check for evaporator freeze up.

Does evaporator freeze up?

YES >> Perform performance test diagnoses. Refer to [HAC-173, "Performance Test Diagnoses"](#).

NO >> GO TO 11.

12.CHECK REFRIGERANT PRESSURE

Check refrigerant pressure with manifold gauge connected. Refer to [HAC-176, "Test Reading"](#).

Is the inspection result normal?

YES >> Perform performance test diagnoses. Refer to [HAC-173, "Performance Test Diagnoses"](#).

NO >> GO TO 12.

13.CHECK AIR DUCTS

Check ducts for air leaks.

Is the inspection result normal?

YES >> System OK.

NO >> Repair air leaks.

Performance Test Diagnoses

INFOID:000000001366750

INSUFFICIENT COOLING

< SYMPTOM DIAGNOSIS >

[AUTOMATIC AIR CONDITIONER]

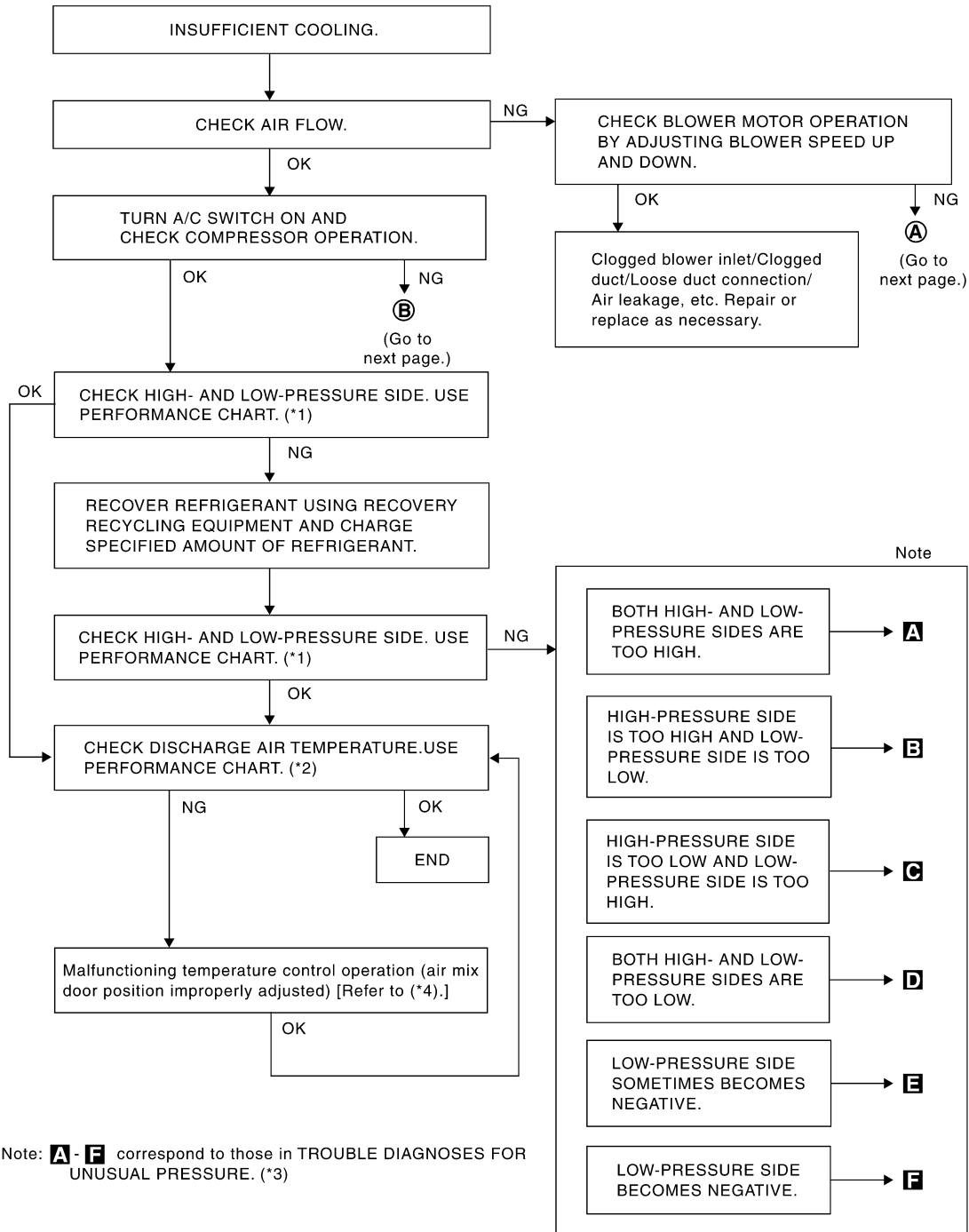

RJA1601E

*1 [HAC-175. "Performance Chart"](#)

*2 [HAC-176. "Test Reading"](#)

*3 [HAC-177. "Trouble Diagnoses for Unusual Pressure"](#)

*4 [HAC-140. "Air Mix Door Motor Component Function Check"](#)

A
B
C
D
E
F
G
H
HAC
J
K
L
M
N
O
P

INSUFFICIENT COOLING

< SYMPTOM DIAGNOSIS >

[AUTOMATIC AIR CONDITIONER]

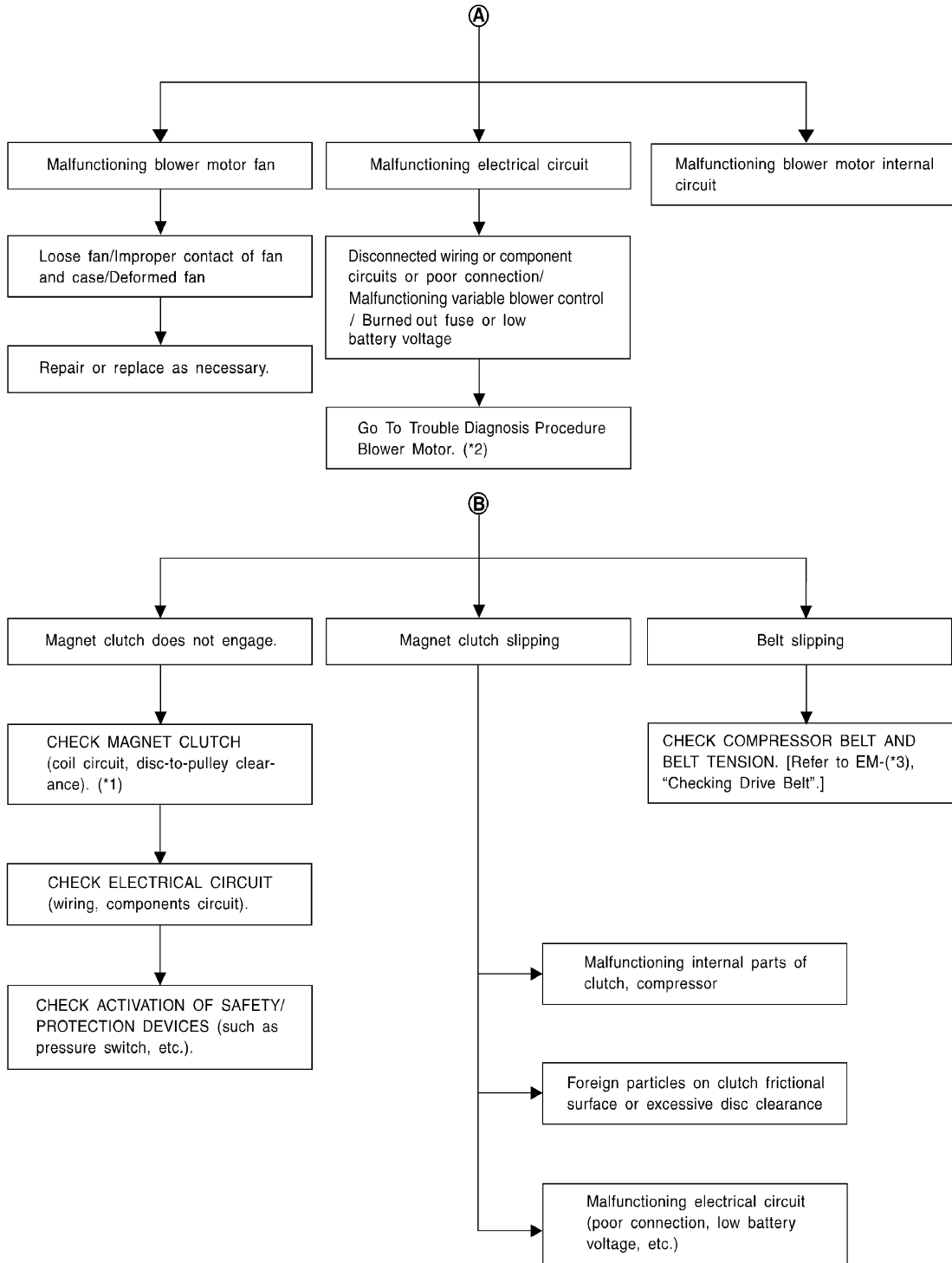

WJIA1371E

*1 XXX REMOVAL FOR COMPRESSOR CLUTCH

*2 [HAC-146. "Front Blower Motor Component Function Check"](#)

*3 CHECK A/C COMPRESSOR BELT XXXX

Performance Chart

INFOID:000000001366751

Test Condition



HAC-110

INSUFFICIENT COOLING

< SYMPTOM DIAGNOSIS >

[AUTOMATIC AIR CONDITIONER]

Testing must be performed as follows:

Vehicle location	Indoors or in the shade (in a well-ventilated place)
Doors	Closed
Door window	Open
Hood	Open
TEMP.	Max. COLD
Mode switch	 (Ventilation) set
Recirculation (REC) switch	 (Recirculation) set
 Blower speed	Max. speed set
Engine speed	Idle speed

Operate the air conditioning system for 10 minutes before taking measurements.

Test Reading

INFOID:000000001366752

Recirculating-to-discharge Air Temperature Table

Inside air (Recirculating air) at blower assembly inlet		Discharge air temperature at center ventilator °C (°F)
Relative humidity %	Air temperature °C (°F)	
50 - 60	20 (68)	5.3 - 6.5 (42 - 44)
	25 (77)	9.7 - 11.5 (49 - 53)
	30 (86)	13.8 - 16.3 (57 - 61)
	35 (95)	18.0 - 21.2 (64 - 70)
	40 (104)	22.2 - 25.7 (72 - 78)
60 - 70	20 (68)	6.5 - 7.7 (44 - 46)
	25 (77)	11.5 - 13.3 (53 - 56)
	30 (86)	16.3 - 18.8 (61 - 66)
	35 (95)	21.2 - 24.0 (70 - 75)
	40 (104)	25.7 - 29.2 (78 - 85)

Ambient Air Temperature-to-operating Pressure Table

Ambient air		High-pressure (Discharge side) kPa (kg/cm ² , psi)	Low-pressure (Suction side) kPa (kg/cm ² , psi)
Relative humidity %	Air temperature °C (°F)		
50 - 70	20 (68)	680 - 840 (6.94 - 8.57, 98.6 - 121.8)	160 - 198 (1.63 - 2.02, 23.2 - 28.7)
	25 (77)	800 - 985 (8.16 - 10.05, 116.0 - 142.8)	198 - 245 (2.02 - 2.50, 28.7 - 35.5)
	30 (86)	940 - 1,150 (9.59 - 11.73, 136.3 - 166.8)	225 - 278 (2.30 - 2.84, 32.6 - 40.3)
	35 (95)	1,160 - 1,410 (11.83 - 14.38, 168.2 - 204.5)	273 - 335 (2.78 - 3.42, 39.6 - 48.6)
	40 (104)	1,325 - 1,620 (13.52 - 16.52, 192.1 - 234.9)	325 - 398 (3.32 - 4.06, 47.1 - 57.7)

INSUFFICIENT COOLING

< SYMPTOM DIAGNOSIS >

[AUTOMATIC AIR CONDITIONER]

Trouble Diagnoses for Unusual Pressure

INFOID:000000001366753

Whenever system's high and/or low side pressure is unusual, diagnose using a manifold gauge. The marker above the gauge scale in the following tables indicates the standard (usual) pressure range. Since the standard (usual) pressure, however, differs from vehicle to vehicle, refer to above table (Ambient air temperature-to-operating pressure table).

Both High- and Low-pressure Sides are Too High

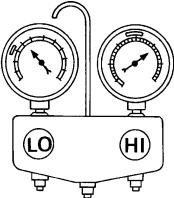
Gauge indication	Refrigerant cycle	Probable cause	Corrective action
<p>Both high- and low-pressure sides are too high.</p>  <p>AC359A</p>	Pressure is reduced soon after water is splashed on condenser.	Excessive refrigerant charge in refrigeration cycle	Reduce refrigerant until specified pressure is obtained.
	Air suction by cooling fan is insufficient.	Insufficient condenser cooling performance ↓ 1. Condenser fins are clogged. 2. Improper fan rotation of cooling fan	<ul style="list-style-type: none"> Clean condenser. Check and repair cooling fan if necessary.
	<ul style="list-style-type: none"> Low-pressure pipe is not cold. When compressor is stopped high-pressure value quickly drops by approximately 196 kPa (2 kg/cm², 28 psi). It then decreases gradually thereafter. 	Poor heat exchange in condenser (After compressor operation stops, high-pressure decreases too slowly.) ↓ Air in refrigeration cycle	Evacuate and recharge system.
	Engine tends to overheat.	Engine cooling systems malfunction.	Check and repair engine cooling system.
	<ul style="list-style-type: none"> An area of the low-pressure pipe is colder than areas near the evaporator outlet. Plates are sometimes covered with frost. 	<ul style="list-style-type: none"> Excessive liquid refrigerant on low-pressure side Excessive refrigerant discharge flow Expansion valve is open a little compared with the specification. ↓ Improper expansion valve adjustment	Replace expansion valve.

High-pressure Side is Too High and Low-pressure Side is Too Low

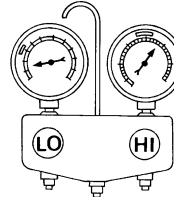
Gauge indication	Refrigerant cycle	Probable cause	Corrective action
<p>High-pressure side is too high and low-pressure side is too low.</p>  <p>AC360A</p>	Upper side of condenser and high-pressure side are hot, however, liquid tank is not so hot.	High-pressure tube or parts located between compressor and condenser are clogged or crushed.	<ul style="list-style-type: none"> Check and repair or replace malfunctioning parts. Check oil for contamination.

High-pressure Side is Too Low and Low-pressure Side is Too High

INSUFFICIENT COOLING

< SYMPTOM DIAGNOSIS >

[AUTOMATIC AIR CONDITIONER]

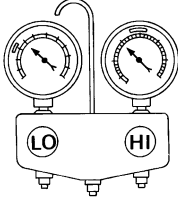
Gauge indication	Refrigerant cycle	Probable cause	Corrective action
High-pressure side is too low and low-pressure side is too high. 	High- and low-pressure sides become equal soon after compressor operation stops.	Compressor pressure operation is improper. ↓ Damaged inside compressor packings.	Replace compressor.
	No temperature difference between high- and low-pressure sides.	Compressor pressure operation is improper. ↓ Damaged inside compressor packings.	Replace compressor.

A
B
C
D

Both High- and Low-pressure Sides are Too Low

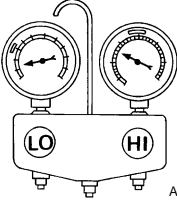
Gauge indication	Refrigerant cycle	Probable cause	Corrective action
Both high- and low-pressure sides are too low. 	<ul style="list-style-type: none"> There is a big temperature difference between liquid tank outlet and inlet. Outlet temperature is extremely low. Liquid tank inlet and expansion valve are frosted. 	Liquid tank inside is slightly clogged.	<ul style="list-style-type: none"> Replace liquid tank. Check oil for contamination.
	<ul style="list-style-type: none"> Temperature of expansion valve inlet is extremely low as compared with areas near liquid tank. Expansion valve inlet may be frosted. Temperature difference occurs somewhere in high-pressure side. 	High-pressure pipe located between liquid tank and expansion valve is clogged.	<ul style="list-style-type: none"> Check and repair malfunctioning parts. Check oil for contamination.
	Expansion valve and liquid tank are warm or only cool when touched.	Low refrigerant charge. ↓ Leaking fittings or components.	Check refrigerant system for leaks. Refer to HA-29, "Checking System for Leaks Using the Fluorescent Dye Leak Detector" or HA-31, "Electronic Refrigerant Leak Detector" .
	There is a big temperature difference between expansion valve inlet and outlet while the valve itself is frosted.	Expansion valve closes a little compared with the specification. ↓ 1. Improper expansion valve adjustment. 2. Malfunctioning expansion valve. 3. Outlet and inlet may be clogged.	<ul style="list-style-type: none"> Remove foreign particles by using compressed air. Check oil for contamination.
	An area of the low-pressure pipe is colder than areas near the evaporator outlet.	Low-pressure pipe is clogged or crushed.	<ul style="list-style-type: none"> Check and repair malfunctioning parts. Check oil for contamination.
	Air flow volume is too low.	Evaporator is frozen.	<ul style="list-style-type: none"> Check intake sensor circuit. Refer to HAC-157, "Intake Sensor Diagnosis Procedure". Repair evaporator fins. Replace evaporator. Refer to HAC-146, "Front Blower Motor Component Function Check".

E
F
G
H
J
K
L
M
N
O
P

HAC

Low-pressure Side Sometimes Becomes Negative

INSUFFICIENT COOLING

< SYMPTOM DIAGNOSIS >

[AUTOMATIC AIR CONDITIONER]

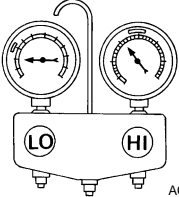
Gauge indication	Refrigerant cycle	Probable cause	Corrective action
<p>Low-pressure side sometimes becomes negative.</p>  <p style="text-align: right; font-size: small;">AC354A</p>	<ul style="list-style-type: none"> • Air conditioning system does not function and does not cyclically cool the compartment air. • The system constantly functions for a certain period of time after compressor is stopped and restarted. 	<p>Refrigerant does not discharge cyclically.</p> <p>↓</p> <p>Moisture is frozen at expansion valve outlet and inlet.</p> <p>↓</p> <p>Water is mixed with refrigerant.</p>	<ul style="list-style-type: none"> • Drain water from refrigerant or replace refrigerant. • Replace liquid tank.

Low-pressure Side Becomes Negative

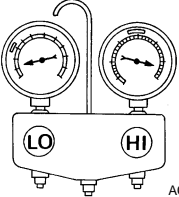
Gauge indication	Refrigerant cycle	Probable cause	Corrective action
<p>Low-pressure side becomes negative.</p>  <p style="text-align: right; font-size: small;">AC362A</p>	<p>Liquid tank or front/rear side of expansion valve's pipe is frosted or dewed.</p>	<p>High-pressure side is closed and refrigerant does not flow.</p> <p>↓</p> <p>Expansion valve or liquid tank is frosted.</p>	<p>Leave the system at rest until no frost is present. Start it again to check whether or not the malfunction is caused by water or foreign particles.</p> <ul style="list-style-type: none"> • If water is the cause, initially cooling is okay. Then the water freezes causing a blockage. Drain water from refrigerant or replace refrigerant. • If due to foreign particles, remove expansion valve and remove the particles with dry and compressed air (not shop air). • If either of the above methods cannot correct the malfunction, replace expansion valve. • Replace liquid tank. • Check oil for contamination.

INSUFFICIENT HEATING

< SYMPTOM DIAGNOSIS >

[AUTOMATIC AIR CONDITIONER]

INSUFFICIENT HEATING

Component Function Check

INFOID:000000001366754

SYMPTOM: Insufficient heating

INSPECTION FLOW

1. CONFIRM SYMPTOM BY PERFORMING OPERATIONAL CHECK - TEMPERATURE INCREASE

1. Press the AUTO switch.
2. Turn the temperature control dial (driver) clockwise until 32° C (90° F) is displayed.
3. Check for hot air at discharge air outlets.

Can this symptom be duplicated?

YES >> GO TO 2.

NO >> Perform complete system operational check. Refer to [HAC-123, "Operational Check"](#).

2. CHECK FOR SERVICE BULLETINS

Check for any service bulletins.

>> GO TO 3.

3. PERFORM SELF-DIAGNOSIS

Perform self-diagnosis. Refer to [HAC-23, "A/C Auto Amp. Self-Diagnosis"](#).

Is the inspection results normal?

YES >> GO TO 4.

NO >> Refer to [HAC-24, "A/C System Self-Diagnosis Code Chart"](#).

4. CHECK ENGINE COOLING SYSTEM

1. Check for proper engine coolant level. Refer to [CO-11, "System Inspection"](#) (VQ40DE) or [CO-38, "System Inspection"](#) (VK56DE).
2. Check hoses for leaks or kinks.
3. Check radiator cap. Refer to [CO-18, "Checking Radiator"](#) (VQ40DE) or [CO-45, "Checking Radiator"](#) (VK56DE).
4. Check for air in cooling system.

>> GO TO 5.

5. CHECK AIR MIX DOOR OPERATION

Check the operation of the air mix door.

Is the inspection result normal?

YES >> GO TO 6.

NO >> Check the air mix door motor circuit. Refer to [HAC-140, "Air Mix Door Motor Component Function Check"](#).

6. CHECK AIR DUCTS

Check for disconnected or leaking air ducts.

Is the inspection result normal?

YES >> GO TO 7.

NO >> Repair all disconnected or leaking air ducts.

7. CHECK HEATER HOSE TEMPERATURES

1. Start engine and warm it up to normal operating temperature.
2. Touch both the inlet and outlet heater hoses.

Is the inspection result normal?

YES >> Hot inlet hose and a warm outlet hose: GO TO 8.

NO >> • Inlet hose cold: GO TO 11.
• Both hoses warm: GO TO 9.

A
B
C
D
E
F
G
H
HAC
J
K
L
M
N
O
P

INSUFFICIENT HEATING

< SYMPTOM DIAGNOSIS >

[AUTOMATIC AIR CONDITIONER]

8. CHECK ENGINE COOLANT SYSTEM

Check engine control temperature sensor.

Is the inspection result normal?

YES >> System OK.

NO >> Repair or replace as necessary. Retest.

9. CHECK HEATER HOSES

Check heater hoses for proper installation.

Is the inspection result normal?

YES >> System OK.

NO >> 1. Back flush heater core.

2. Drain the water from the system.

3. Refill system with new engine coolant. Refer to [CO-12, "Changing Engine Coolant"](#) (VQ40DE) or [CO-39, "Changing Engine Coolant"](#) (VK56DE).

4. GO TO 10 to retest.

10. CHECK HEATER HOSE TEMPERATURES

1. Start engine and warm it up to normal operating temperature.

2. Touch both the inlet and outlet heater hoses.

Is the inspection result normal?

YES >> System OK.

NO >> Replace heater core. Refer to [VTL-26, "Removal and Installation"](#).

11. CHECK HEATER PUMP (VQ40DE ONLY)

Check the operation of the heater pump valve. Refer to [HAC-76, "Component Inspection \(VQ40DE\)"](#).

Is the inspection result normal?

YES >> System OK.

NO >> Replace heater pump. Refer to [HA-58, "Removal and Installation"](#).

NOISE

Component Function Check

INFOID:000000001366755

SYMPTOM: Noise

INSPECTION FLOW

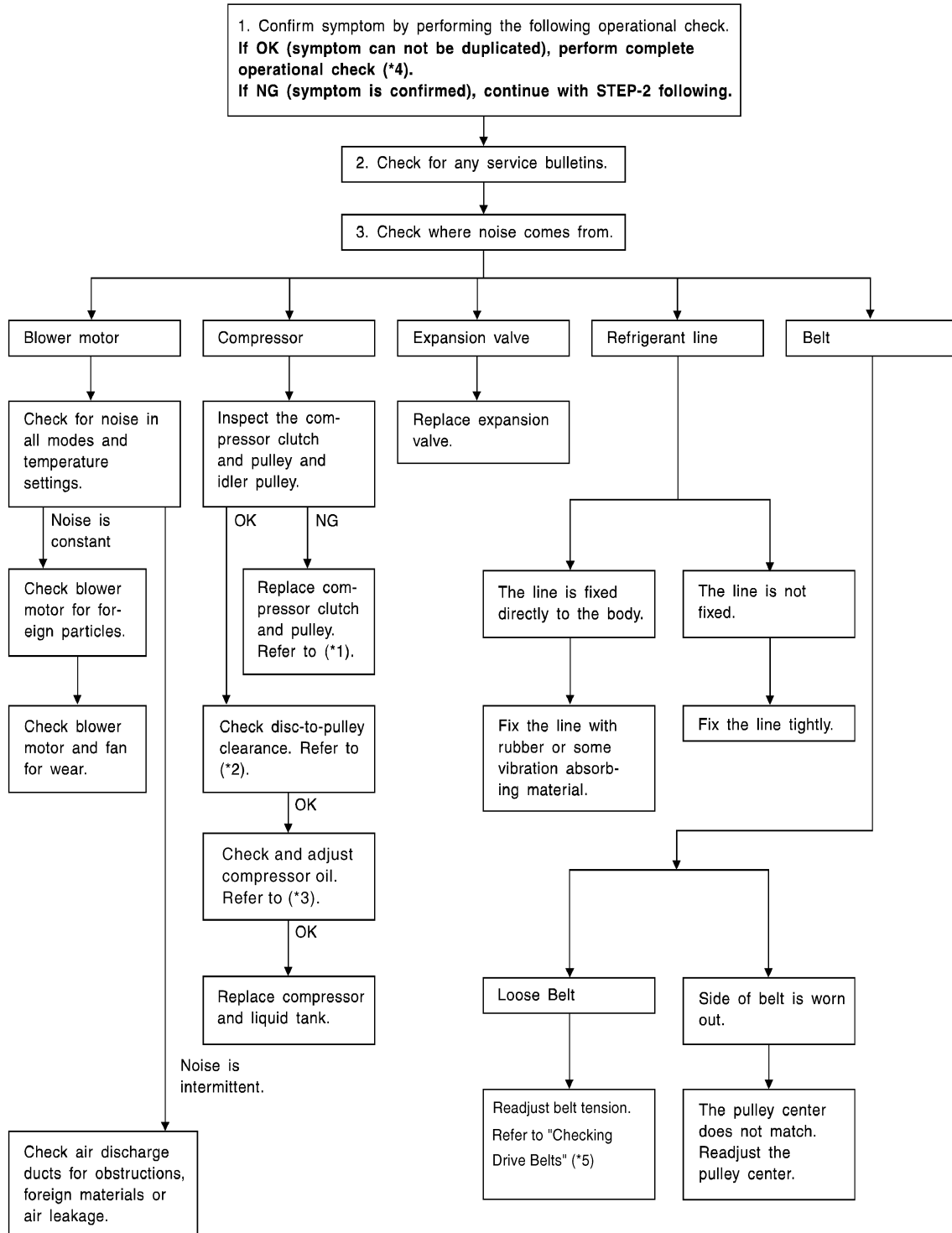

A
B
C
D
E
F
G
H
HAC
J
K
L
M
N
O
P

NOISE

< SYMPTOM DIAGNOSIS >

[AUTOMATIC AIR CONDITIONER]

- | | | |
|--|-----------------------------------|--|
| *1 XXXX REMOVAL FOR COMPRESSOR CLUTCH | *2 XXXX REMOVAL COMPRESSOR CLUTCH | *3 XXXX MAINTANENCE OF OIL IN COMPRESSOR |
| *4 HAC-5. "Operational Check (Front)" or HAC-6. "Operational Check (Rear)" | *5 CHECK DRIVE BELTS XXXX | |

MEMORY FUNCTION DOES NOT OPERATE

< SYMPTOM DIAGNOSIS >

[AUTOMATIC AIR CONDITIONER]

MEMORY FUNCTION DOES NOT OPERATE

Memory Function Check

INFOID:000000001366756

SYMPTOM: Memory function does not operate.

INSPECTION FLOW

1. CONFIRM SYMPTOM BY PERFORMING OPERATIONAL CHECK - MEMORY FUNCTION

1. Set the temperature to 32°C (90°F).
2. Press the OFF switch.
3. Turn ignition switch OFF.
4. Turn ignition switch ON.
5. Press the AUTO switch.
6. Confirm that the set temperature remains at previous temperature.
7. Press the OFF switch.

Can the symptom be duplicated?

- YES >> GO TO 3.
NO >> GO TO 2.

2. PERFORM COMPLETE OPERATIONAL CHECK

Perform a complete operational check and check for any symptoms. Refer to [HAC-123, "Operational Check"](#).

Can a symptom be duplicated?

- YES >> Refer to [HAC-122, "How to Perform Trouble Diagnosis For Quick And Accurate Repair"](#).
NO >> System OK.

3. CHECK FOR SERVICE BULLETINS

Check for any service bulletins.

>> GO TO 4.

4. PERFORM SELF-DIAGNOSIS

Perform self-diagnosis to check for any codes. Refer to [HAC-23, "A/C Auto Amp. Self-Diagnosis"](#).

Are any self-diagnosis codes present?

- YES >> Refer to [HAC-24, "A/C System Self-Diagnosis Code Chart"](#).
NO >> GO TO 5.

5. CHECK POWER AND GROUND CIRCUIT

Check main power supply and ground circuit. Refer to [HAC-159, "Front Air Control Component Function Check"](#).

Is the inspection result normal?

- YES >> GO TO 6.
NO >> Repair or replace as necessary.

6. RECHECK FOR SYMPTOMS

Perform a complete operational check for any symptoms. Refer to [HAC-123, "Operational Check"](#).

Does another symptom exist?

- YES >> Refer to [HAC-122, "How to Perform Trouble Diagnosis For Quick And Accurate Repair"](#).
NO >> Replace A/C auto amp. Refer to [VTL-8, "Removal and Installation"](#).

PRECAUTION

PRECAUTIONS

Supplemental Restraint System (SRS) "AIR BAG" and "SEAT BELT PRE-TENSIONER"

INFOID:000000001366757

The Supplemental Restraint System such as "AIR BAG" and "SEAT BELT PRE-TENSIONER", used along with a front seat belt, helps to reduce the risk or severity of injury to the driver and front passenger for certain types of collision. This system includes seat belt switch inputs and dual stage front air bag modules. The SRS system uses the seat belt switches to determine the front air bag deployment, and may only deploy one front air bag, depending on the severity of a collision and whether the front occupants are belted or unbelted. Information necessary to service the system safely is included in the SR and SB section of this Service Manual.

WARNING:

- To avoid rendering the SRS inoperative, which could increase the risk of personal injury or death in the event of a collision which would result in air bag inflation, all maintenance must be performed by an authorized NISSAN/INFINITI dealer.
- Improper maintenance, including incorrect removal and installation of the SRS, can lead to personal injury caused by unintentional activation of the system. For removal of Spiral Cable and Air Bag Module, see the SR section.
- Do not use electrical test equipment on any circuit related to the SRS unless instructed to in this Service Manual. SRS wiring harnesses can be identified by yellow and/or orange harnesses or harness connectors.

Working with HFC-134a (R-134a)

INFOID:000000001366758

WARNING:

- CFC-12 (R-12) refrigerant and HFC-134a (R-134a) refrigerant are not compatible. If the refrigerants are mixed compressor failure is likely to occur. Refer to [HA-3, "Contaminated Refrigerant"](#). To determine the purity of HFC-134a (R-134a) in the vehicle and recovery tank, use Refrigerant Recovery/Recycling Recharging equipment and Refrigerant Identifier.
- Use only specified oil for the HFC-134a (R-134a) A/C system and HFC-134a (R-134a) components. If oil other than that specified is used, compressor failure is likely to occur.
- The specified HFC-134a (R-134a) oil rapidly absorbs moisture from the atmosphere. The following handling precautions must be observed:
 - When removing refrigerant components from a vehicle, immediately cap (seal) the component to minimize the entry of moisture from the atmosphere.
 - When installing refrigerant components to a vehicle, do not remove the caps (unseal) until just before connecting the components. Connect all refrigerant loop components as quickly as possible to minimize the entry of moisture into system.
 - Only use the specified oil from a sealed container. Immediately reseal containers of oil. Without proper sealing, oil will become moisture saturated and should not be used.
 - Avoid breathing A/C refrigerant and oil vapor or mist. Exposure may irritate eyes, nose and throat. Remove HFC-134a (R-134a) from the A/C system using certified service equipment meeting requirements of SAE J2210 [HFC-134a (R-134a) recycling equipment], or J2209 [HFC-134a (R-134a) recycling equipment], If accidental system discharge occurs, ventilate work area before resuming service. Additional health and safety information may be obtained from refrigerant and oil manufacturers.
 - Do not allow A/C oil to come in contact with styrofoam parts. Damage may result.

CONTAMINATED REFRIGERANT

If a refrigerant other than pure HFC-134a (R-134a) is identified in a vehicle, your options are:

- Explain to the customer that environmental regulations prohibit the release of contaminated refrigerant into the atmosphere.
- Explain that recovery of the contaminated refrigerant could damage your service equipment and refrigerant supply.
- Suggest the customer return the vehicle to the location of previous service where the contamination may have occurred.
- If you choose to perform the repair, recover the refrigerant using only **dedicated equipment and containers. Do not recover contaminated refrigerant into your existing service equipment.** If your facility does

PRECAUTIONS

[AUTOMATIC AIR CONDITIONER]

< PRECAUTION >

- not have dedicated recovery equipment, you may contact a local refrigerant product retailer for available service. This refrigerant must be disposed of in accordance with all federal and local regulations. In addition, replacement of all refrigerant system components on the vehicle is recommended.
- If the vehicle is within the warranty period, the air conditioner warranty is void. Please contact NISSAN Customer Affairs for further assistance.

Precaution for Service Equipment

INFOID:000000001366759

MANIFOLD GAUGE SET

Be certain that the gauge face indicates R-134a or 134a. Make sure the gauge set has 1/2"-16 ACME threaded connections for service hoses. Confirm the set has been used only with refrigerant HFC-134a (R-134a) along with specified oil.

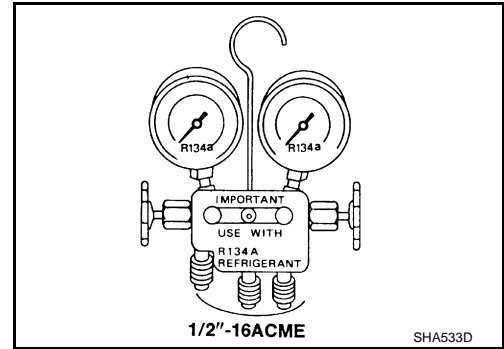

SERVICE HOSES

Be certain that the service hoses display the markings described (colored hose with black stripe). All hoses must include positive shut-off devices (either manual or automatic) near the end of the hoses opposite the manifold gauge.

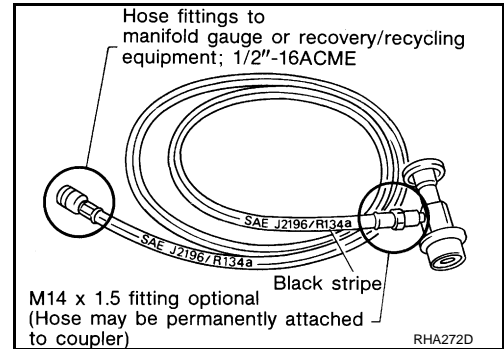

SERVICE COUPLERS

Never attempt to connect HFC-134a (R-134a) service couplers to a CFC-12 (R-12) A/C system. The HFC-134a (R-134a) couplers will not properly connect to the CFC-12 (R-12) system. However, if an improper connection is attempted, discharging and contamination may occur.

Shut-off valve rotation	A/C service valve
Clockwise	Open
Counterclockwise	Close

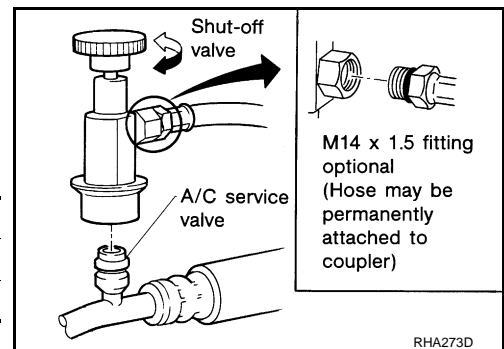

BASIC INSPECTION

DIAGNOSIS AND REPAIR WORKFLOW

How to Perform Trouble Diagnosis For Quick And Accurate Repair

INFOID:000000001366764

WORK FLOW

1. LISTEN TO CUSTOMER COMPLAINT

Listen to customer complaint. Get detailed information about the conditions and environment when the symptom occurs.

>> GO TO 2

2. CHECK FOR SERVICE BULLETINS

Check for any service bulletins.

>> GO TO 3.

3. VERIFY THE SYMPTOM WITH OPERATIONAL CHECK

Verify the symptom with operational check. Refer to [HAC-123, "Operational Check"](#).

Can a symptom be duplicated?

- YES >> Go to trouble diagnosis. Refer to [HAC-171, "Symptom Matrix Chart"](#)
- NO >> System OK.

INSPECTION AND ADJUSTMENT

Operational Check

INFOID:000000001366765

The purpose of the operational check is to confirm that the system operates properly.

Conditions : Engine running and at normal operating temperature

CHECKING BLOWER

1. Turn blower control dial clockwise. Blower should operate on low speed.
2. Turn the blower control dial again, and continue checking each blower speed until all speeds are checked.
3. Leave blower on speed 4.

If NG, go to trouble diagnosis procedure for [HAC-147, "Front Blower Motor Diagnosis Procedure"](#).

If OK, continue with next check.

CHECKING DISCHARGE AIR



1. Turn the mode switch to each position.
2. Confirm that discharge air comes out according to the air distribution table. Refer to [HAC-131, "Discharge Air Flow"](#).

Mode door position is checked in the next step.



If NG, go to trouble diagnosis procedure for [HAC-136, "Mode Door Motor \(Front\) Diagnosis Procedure"](#).

If OK, continue with next check.

NOTE:

Confirm that the A/C compressor clutch is engaged (sound or visual inspection) and intake door position is at fresh when the DEF () or D/F () is selected.

CHECKING RECIRCULATION

1. Press recirculation () switch one time. Recirculation indicator should illuminate.
2. Press recirculation () switch one more time. Recirculation indicator should go off.
3. Listen for intake door position change (blower sound should change slightly).

If NG, go to trouble diagnosis procedure for [HAC-144, "Intake Door Motor Diagnosis Procedure"](#).

If OK, continue with next check.

NOTE:

Confirm that the compressor clutch is engaged (sound or visual inspection) and intake door position is at fresh when the DEF or D/F is selected.

CHECKING TEMPERATURE DECREASE

1. Rotate temperature control dial counterclockwise.
2. Check for cold air at appropriate discharge air outlets.

If NG, listen for sound of air mix door motor operation if OK, go to trouble diagnosis procedure for [HAC-172, "Component Function Check"](#). If air mix door motor appears to be malfunctioning, go to [HAC-140, "Air Mix Door Motor Component Function Check"](#).

If OK, continue with next check.

CHECKING TEMPERATURE INCREASE

1. Rotate temperature control dial clockwise.
2. Check for hot air at appropriate discharge air outlets.

If NG, listen for sound of air mix door motor operation. If OK, go to trouble diagnosis procedure for [HAC-181, "Component Function Check"](#). If air mix door motor (front) appears to be malfunctioning, go to [HAC-140, "Air Mix Door Motor Component Function Check"](#).

If OK, continue with next check.

CHECK A/C SWITCH

1. Press A/C switch with the blower switch ON.
2. A/C switch indicator will turn ON.
 - Confirm that the compressor clutch engages (sound or visual inspection).

INSPECTION AND ADJUSTMENT

< BASIC INSPECTION >

[MANUAL AIR CONDITIONER]

If NG, go to trouble diagnosis procedure for [HAC-152. "Magnet Clutch Diagnosis Procedure"](#).
If OK, continue with next check.

FUNCTION DIAGNOSIS

FUNCTION INFORMATION

Component Part Location

ENGINE COMPARTMENT

INFOID:000000001366827

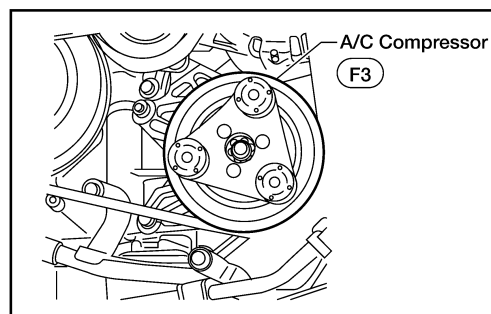
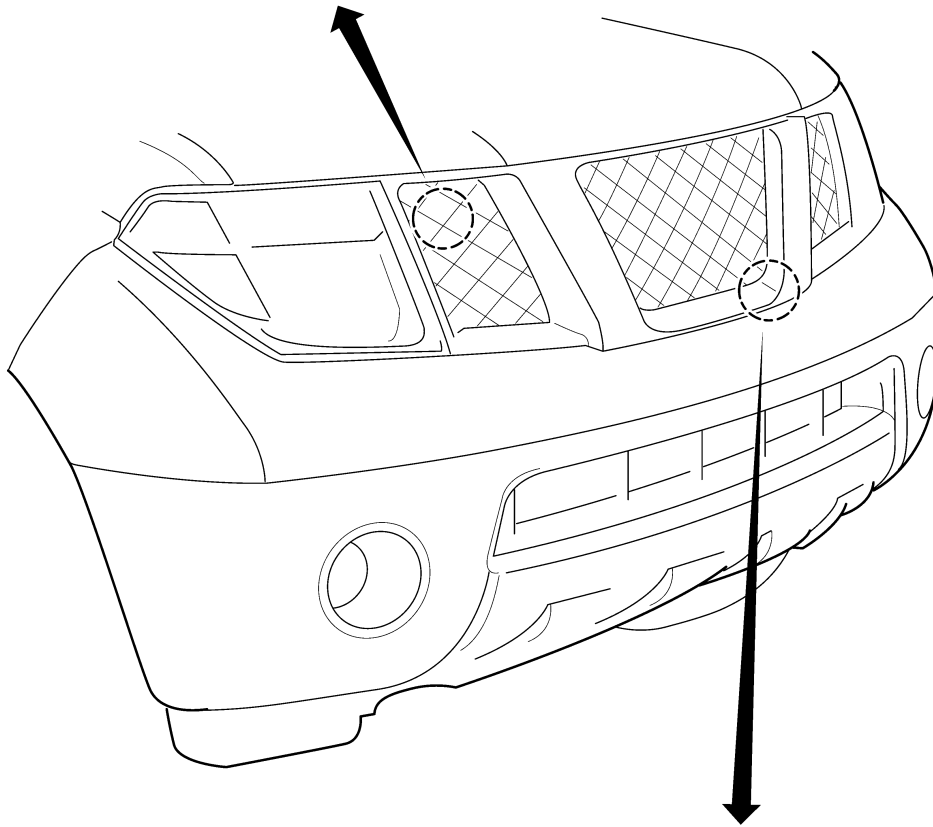
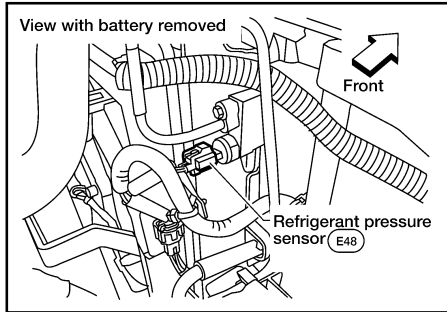

A
B
C
D
E
F
G
H
I
J
K
L
M
N
O
P

HAC

FUNCTION INFORMATION

< FUNCTION DIAGNOSIS >

[MANUAL AIR CONDITIONER]

PASSENGER COMPARTMENT

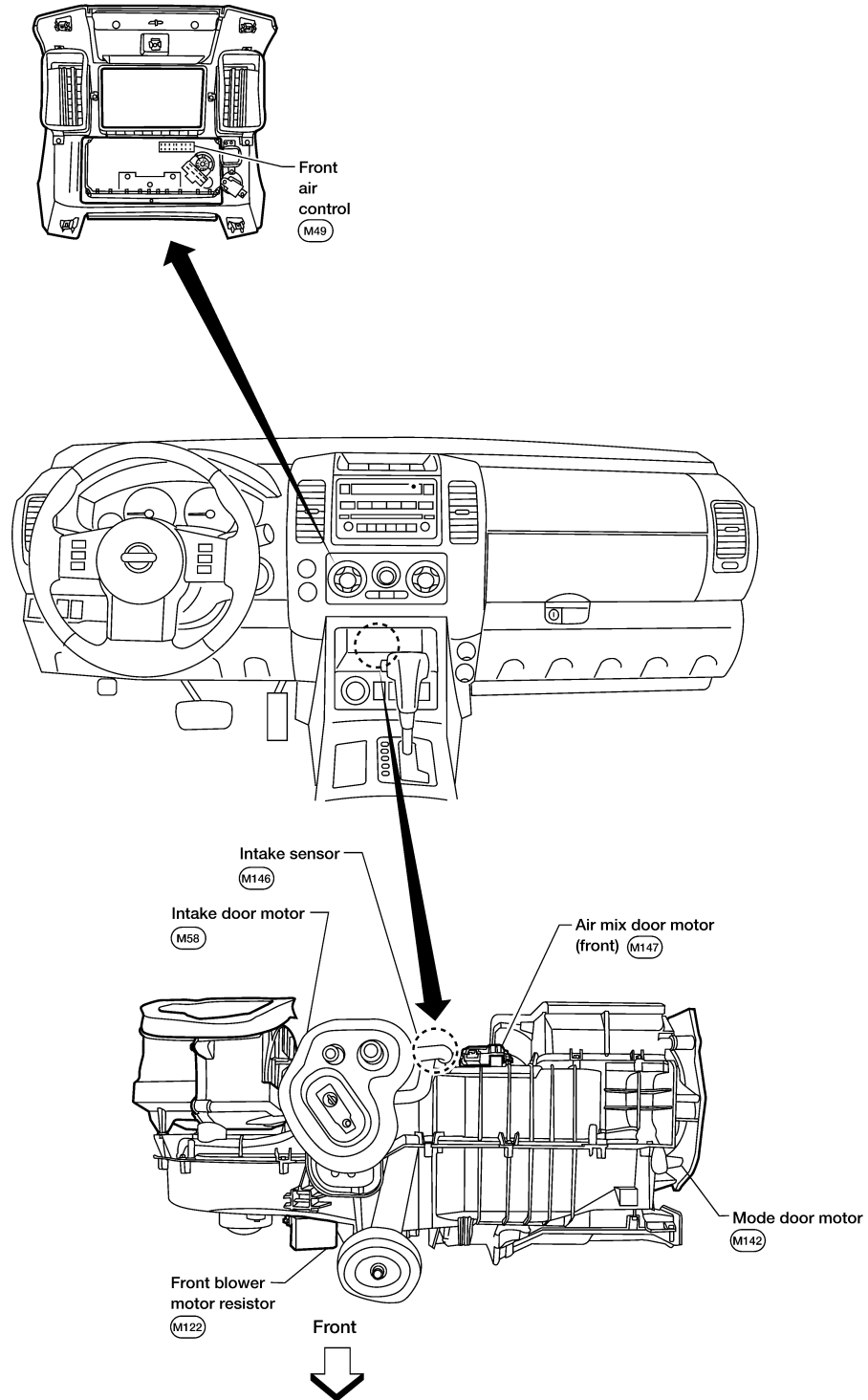

WJIA1301E

FUNCTION INFORMATION

< FUNCTION DIAGNOSIS >

[MANUAL AIR CONDITIONER]

Symptom Table

INFOID:000000001366828

Symptom	Reference Page	
A/C system does not come on.	Go to Trouble Diagnosis Procedure for A/C System.	HAC-159
Air outlet does not change.	Go to Trouble Diagnosis Procedure for Mode Door Motor.	HAC-135
Mode door motor is malfunctioning.		
Discharge air temperature does not change.	Go to Trouble Diagnosis Procedure for Air Mix Door Motor.	HAC-140
Air mix door motor is malfunctioning.		
Intake door does not change.	Go to Trouble Diagnosis Procedure for Intake Door Motor.	HAC-143
Intake door motor is malfunctioning.		
Front blower motor operation is malfunctioning.	Go to Trouble Diagnosis Procedure for Front Blower Motor.	HAC-146
Magnet clutch does not engage.	Go to Trouble Diagnosis Procedure for Magnet Clutch.	HAC-152
Insufficient cooling	Go to Trouble Diagnosis Procedure for Insufficient Cooling.	HAC-172
Insufficient heating	Go to Trouble Diagnosis Procedure for Insufficient Heating.	HAC-181
Noise	Go to Trouble Diagnosis Procedure for Noise.	HAC-183

A
B
C
D
E
F
G
H
J
K
L
M
N
O
P

HAC

REFRIGERATION SYSTEM

Refrigerant Cycle

INFOID:000000001366829

Refer to [HAC-128. "Refrigerant Cycle"](#).

Refrigerant System Protection

INFOID:000000001366830

Refer to [HAC-128. "Refrigerant System Protection"](#).

MANUAL AIR CONDITIONER SYSTEM

< FUNCTION DIAGNOSIS >

[MANUAL AIR CONDITIONER]

MANUAL AIR CONDITIONER SYSTEM

Control System Diagram

INFOID:000000001366831

CONTROL SYSTEM

The control system consists of input sensors, switches, the front air control (microcomputer) and outputs. The relationship of these components is shown in the figure below:

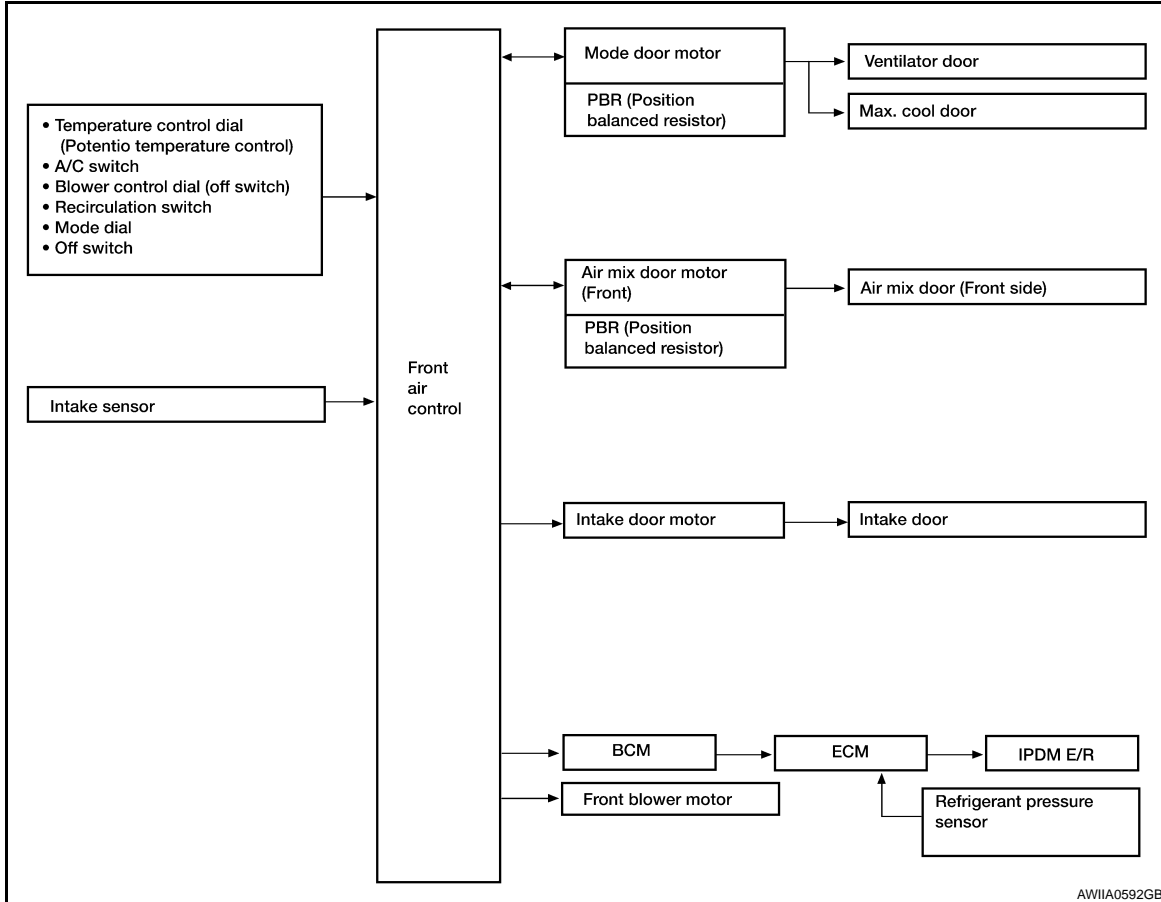

AWIA0592GB

Control System Description

INFOID:000000001366832

CONTROL OPERATION

Front air control

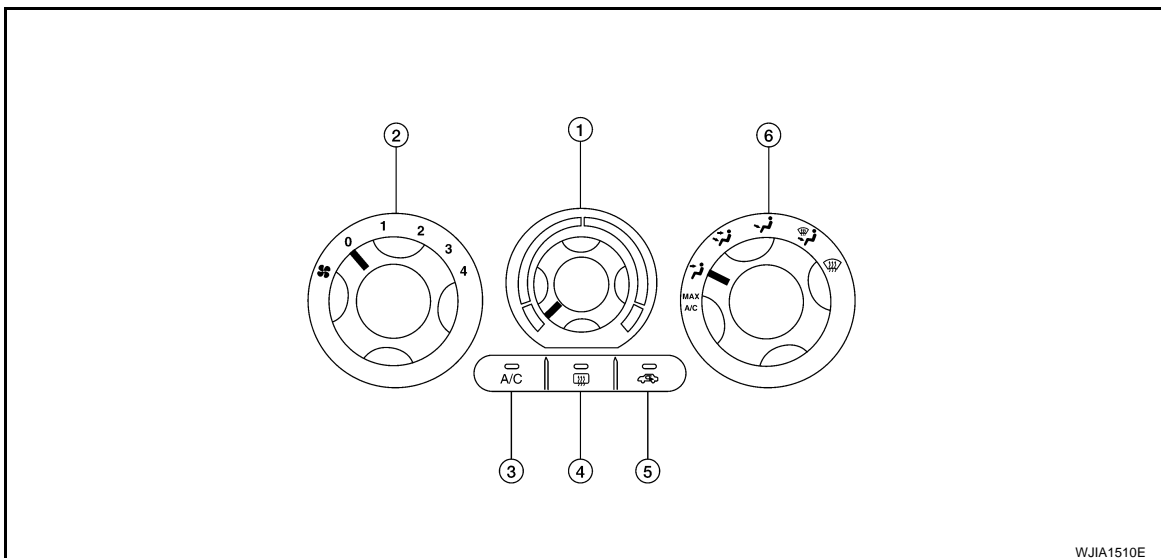

WJIA1510E

A
B
C
D
E
F
G
H
HAC
J
K
L
M
N
O
P

MANUAL AIR CONDITIONER SYSTEM

< FUNCTION DIAGNOSIS >

[MANUAL AIR CONDITIONER]

1. Temperature control dial
2. Blower control dial
3. A/C switch
4. Rear window defogger switch
5. Recirculation switch
6. Mode dial

TEMPERATURE CONTROL DIAL (TEMPERATURE CONTROL)

Increases or decreases the set temperature.

RECIRCULATION () SWITCH

- When REC switch is ON, REC switch indicator turns ON, and air inlet is set to REC.
- When REC switch is turned OFF, or when compressor is turned from ON to OFF, REC switch is automatically turned OFF. REC mode can be re-entered by pressing REC switch again.
- REC switch is not operated when DEF switch is turned ON, or at the D/F or FOOT position.

DEFROSTER () SWITCH

Positions the air outlet doors to the defrost position. Also positions the intake doors to the outside air position.

REAR WINDOW DEFOGGER SWITCH

When switch is ON, rear window is defogged.

OFF SWITCH (BLOWER SPEED SET TO 0)

The compressor and blower are OFF.

A/C SWITCH

The compressor is ON or OFF.

(Pressing the A/C switch will turn off the A/C switch and compressor.)

MODE DIAL

Controls the air discharge outlets.

FRONT BLOWER CONTROL DIAL

Manually controls the four blower speeds.

MAGNET CLUTCH CONTROL

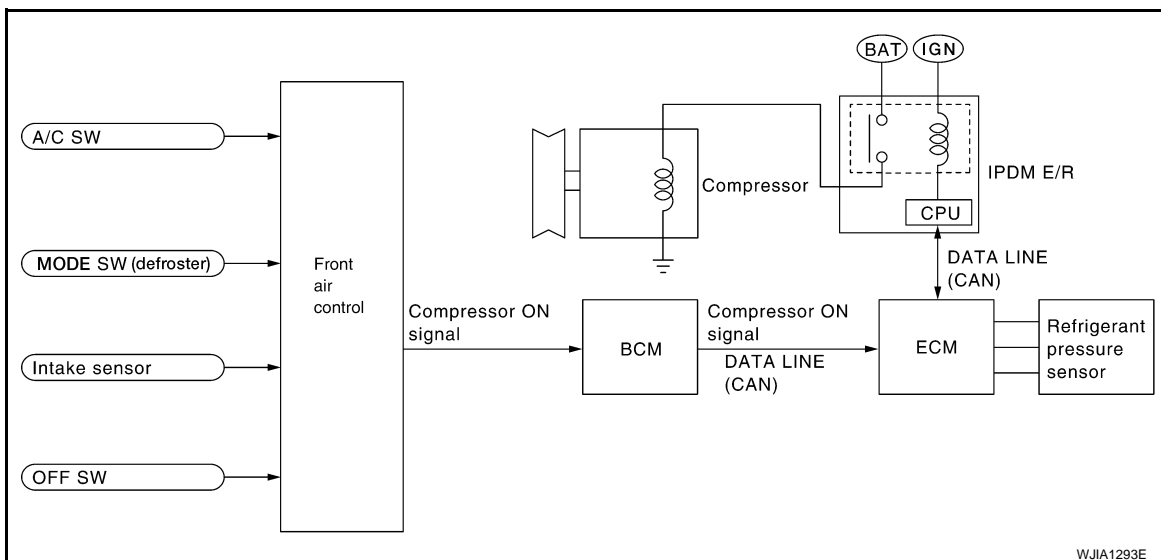

When the A/C switch is pressed, or the mode dial is turned to the DEF or D/F position, the front air control outputs a compressor ON signal to BCM.

The BCM then sends a compressor ON signal to ECM, via CAN communication line.

ECM judges whether compressor can be turned ON, based on each sensor status (refrigerant pressure sensor signal, throttle angle sensor, etc.). If it judges compressor can be turned ON, it sends compressor ON signal to IPDM E/R, via CAN communication line.

Upon receipt of compressor ON signal from ECM, IPDM E/R turns air conditioner relay ON to operate compressor.

MANUAL AIR CONDITIONER SYSTEM

< FUNCTION DIAGNOSIS >

[MANUAL AIR CONDITIONER]

Discharge Air Flow

INFOID:000000001366833

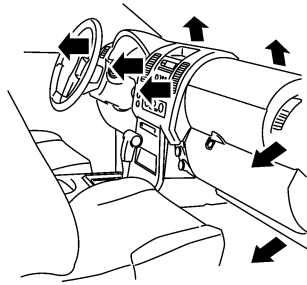

WJIA1296E

Mode door position	Air outlet/distribution		
	Vent	Foot	Defroster
	95%	5%	—
	60%	40%	—
	20%	55%	25%
	15%	50%	35%
	7%	15%	78%

Airflow always present at driver and passenger side demisters

Switches And Their Control Function

INFOID:000000001366835

SWITCHES AND THEIR CONTROL FUNCTION

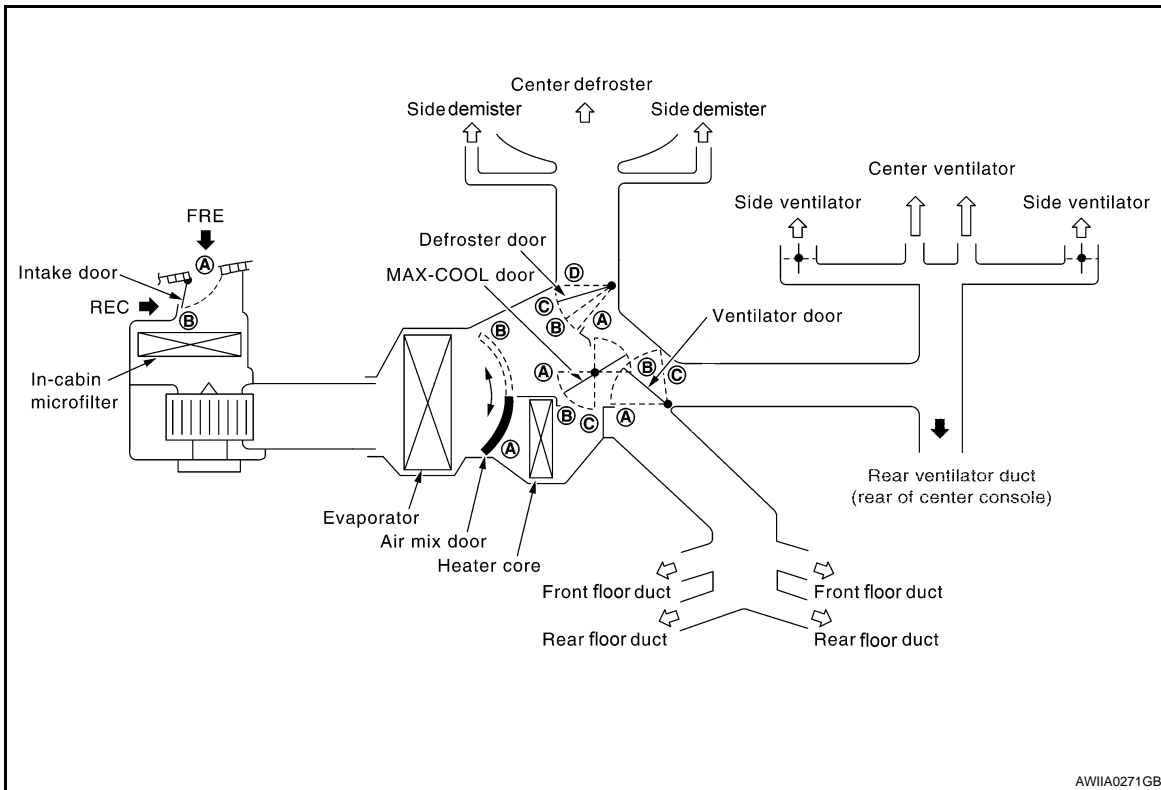







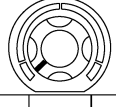

AWIA0271GB

MANUAL AIR CONDITIONER SYSTEM

< FUNCTION DIAGNOSIS >

[MANUAL AIR CONDITIONER]

Door	Position or switch	MODE SW				DEF SW		REC SW		Temperature dial			OFF SW
		VENT	B/L	FOOT	D/F	ON	OFF	ON	OFF				
										COLD	~	HOT	
Ventilator door		(A)	(B)	(C)	(C)	(C)	—	—	—	—	—	(C)	
MAX-COOL door		(A)	(B)	(B)	(B)	(C)	—	—	—	—	—	(B)	
Defroster door		(D)	(D)	(D _{or} C)	(B)	(A)	—	—	—	—	—	(C)	
Intake door		—				(B)	—	(A)	(B)	—			(B)
Air mix door		—				—	—	—		(A)		(B)	—

WJIA1497E

CAN COMMUNICATION SYSTEM

System Description

INFOID:000000001366837

Refer to [LAN-4. "System Description"](#).

A

B

C

D

E

F

G

H

HAC

J

K

L

M

N

O

P

DIAGNOSIS SYSTEM (BCM)

< FUNCTION DIAGNOSIS >

[MANUAL AIR CONDITIONER]

DIAGNOSIS SYSTEM (BCM)

CONSULT-III Function (BCM)

INFOID:000000001366839

CONSULT-II can display each diagnostic item using the diagnostic test modes shown following.

BCM diagnostic test item	Diagnostic mode	Description
Inspection by part	WORK SUPPORT	Supports inspections and adjustments. Commands are transmitted to the BCM for setting the status suitable for required operation, input/output signals are received from the BCM and received data is displayed.
	DATA MONITOR	Displays BCM input/output data in real time.
	ACTIVE TEST	Operation of electrical loads can be checked by sending drive signal to them.
	SELF-DIAG RESULTS	Displays BCM self-diagnosis results.
	CAN DIAG SUPPORT MNTR	The result of transmit/receive diagnosis of CAN communication can be read.
	ECU PART NUMBER	BCM part number can be read.
	CONFIGURATION	Performs BCM configuration read/write functions.

DATA MONITOR

Display Item List

Monitor item name "operation or unit"	Contents
IGN ON SW "ON/OFF"	Displays "IGN Position (ON)/OFF, ACC Position (OFF)" status as judged from ignition switch signal.
COMP ON SIG "ON/OFF"	Displays "COMP (ON)/COMP (OFF)" status as judged from air conditioner switch signal.
FAN ON SIG "ON/OFF"	Displays "FAN (ON)/FAN (OFF)" status as judged from blower motor switch signal.

COMPONENT DIAGNOSIS

MODE DOOR MOTOR

System Description

INFOID:000000001366782

SYSTEM DESCRIPTION

Component Parts

Mode door control system components are:

- Front air control
- Mode door motor
- PBR (built into mode door motor)
- Intake sensor

System Operation

The mode door position (vent, B/L, foot, D/F, and defrost) is set by the front air control by means of the mode door motor. When a mode door position is selected on the front air control, voltage is applied to one circuit of the mode door motor while ground is applied to the other circuit, causing the mode door motor to rotate. The direction of rotation is determined by which circuit has voltage applied to it, and which one has ground applied to it. The front air control monitors the mode door position by measuring the voltage signal on the PBR circuit.

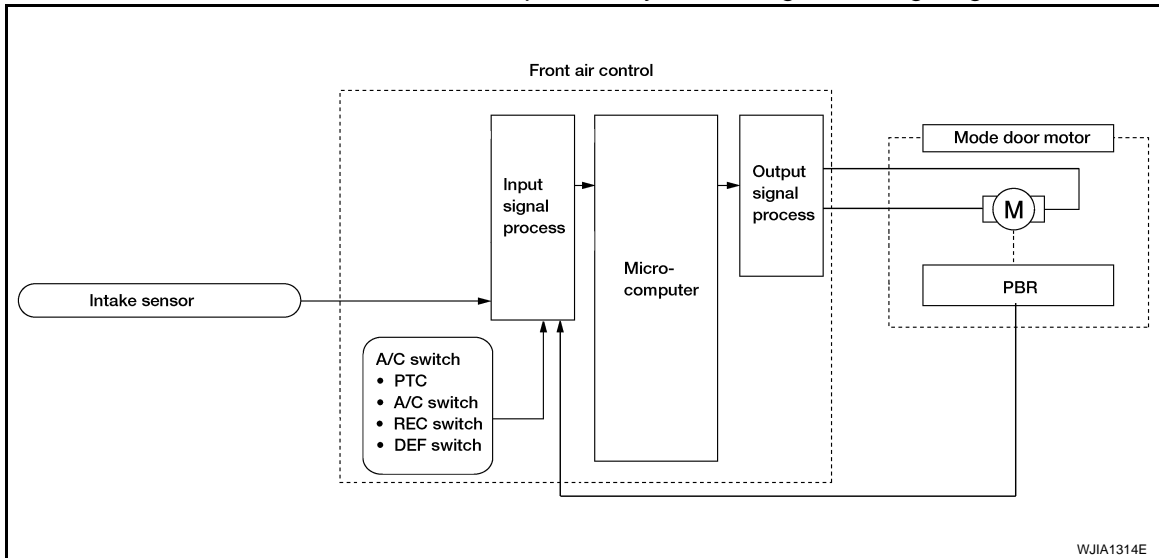

COMPONENT DESCRIPTION

Mode Door Motor

The mode door motor is attached to the heater and cooling unit assembly. It rotates so that air is discharged from the outlet as indicated by the front air control. Motor rotation is conveyed to a link which activates the mode door.

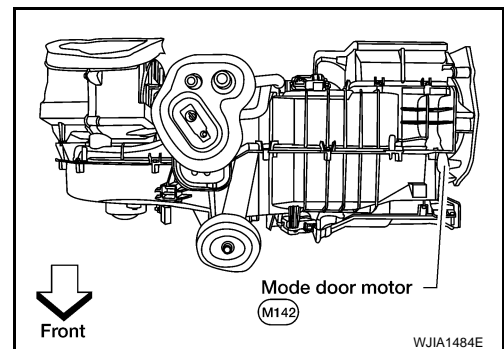

Mode Door Motor (Front) Component Function Check

INFOID:000000001366783

SYMPTOM:

- Air outlet does not change.
- Mode door motor does not operate normally.

A
B
C
D
E
F
G
H
J
K
L
M
N
O
P

HAC

MODE DOOR MOTOR

[MANUAL AIR CONDITIONER]



< COMPONENT DIAGNOSIS >

INSPECTION FLOW

1. CONFIRM SYMPTOM BY PERFORMING OPERATIONAL CHECK - DISCHARGE AIR

1. Turn blower control dial to 4.
2. Turn the mode dial and check all positions.
3. Confirm that discharge air comes out according to the air distribution table. Refer to [HAC-131, "Discharge Air Flow"](#).

NOTE:

Confirm that the compressor clutch is engaged (visual inspection) and intake door position is at FRESH when DEF () or D/F () is selected.

Can a symptom be duplicated?

- YES >> GO TO 3.
NO >> GO TO 2.

2. PERFORM COMPLETE OPERATIONAL CHECK

Perform a complete operational check and check for any symptoms. Refer to [HAC-123, "Operational Check"](#).

Can a symptom be duplicated?

- YES >> Refer to [HAC-171, "Symptom Matrix Chart"](#).
NO >> System OK.

3. CHECK FOR SERVICE BULLETINS

Check for any service bulletins.

>> GO TO 4.

4. CHECK MODE DOOR OPERATION

Check and verify mode door mechanism for smooth operation in each mode.

Is inspection result normal?

- YES >> GO TO 5.
NO >> Repair as necessary.

5. CHECK THE MODE DOOR MOTOR PBR CIRCUIT

Perform diagnostic procedure for the mode door motor. Refer to XX-XX, "*****".

Is inspection result normal?

- YES >> GO TO 6.
NO >> Repair PBR circuit or replace motor.

6. RECHECK FOR SYMPTOMS

Perform a complete operational check and check for any symptoms. Refer to [HAC-123, "Operational Check"](#).

Does another symptom exist?

- YES >> Repair as necessary.
NO >> Replace front air control. Refer to XX-XX, "*****".

Mode Door Motor (Front) Diagnosis Procedure

INFOID:000000001366784

MODE DOOR MOTOR DIAGNOSTIC PROCEDURE

1. CHECK POWER SUPPLY AND GROUND CIRCUITS FOR MODE DOOR MOTOR

MODE DOOR MOTOR

[MANUAL AIR CONDITIONER]

< COMPONENT DIAGNOSIS >

1. Turn ignition switch OFF.
2. Disconnect front air control connector and mode door motor connector.
3. Check continuity between front air control harness connector M49 terminal 1 and mode door motor harness connector M142 terminal 1 and between front air control harness connector M49 terminal 14 and mode door motor harness connector M142 terminal 6.

1 - 1 : Continuity should exist.
14 - 6 : Continuity should exist.

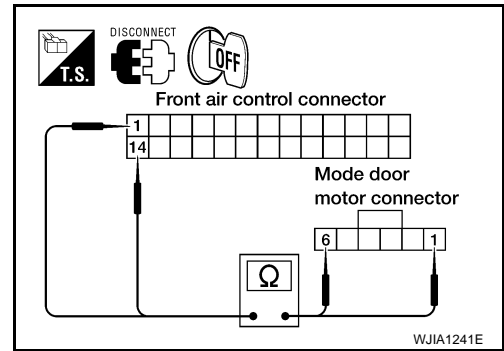

Is inspection result normal?

- YES >> GO TO 2.
NO >> Repair or replace harness as necessary.

2.CHECK PBR REFERENCE SIGNAL VOLTAGE

1. Reconnect the front air control connector.
2. Turn ignition switch ON.
3. Check voltage between mode door motor harness connector M142 terminal 3 and ground.

3 - Ground : Approx. 5V

Is inspection result normal?

- YES >> GO TO 4.
NO >> GO TO 3.

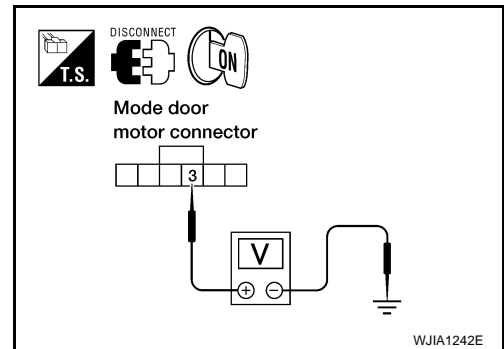

3.CHECK PBR REFERENCE VOLTAGE CIRCUIT BETWEEN MODE DOOR AND FRONT AIR CONTROL

1. Turn ignition switch OFF.
2. Disconnect the front air control connector.
3. Check continuity between mode door motor harness connector M142 terminal 3 and front air control harness connector M49 terminal 23.

3 - 23 : Continuity should exist.

Is inspection result normal?

- YES >> Replace front air control. Refer to XX-XX.
NO >> Repair or replace harness as necessary.

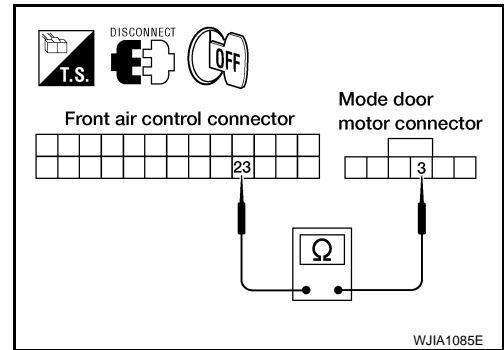

4.CHECK PBR GROUND REFERENCE CIRCUIT

1. Turn ignition switch OFF.
2. Disconnect the front air control connector.
3. Check continuity between mode door motor harness connector M142 terminal 2 and front air control harness connector M49 terminal 26.

2 - 26 : Continuity should exist.

Is inspection result normal?

- YES >> GO TO 5.
NO >> Repair or replace harness as necessary.

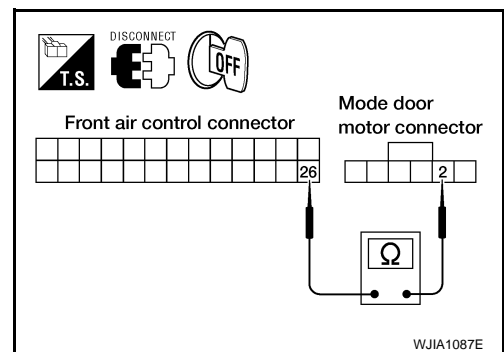

5.CHECK PBR FEEDBACK SIGNAL

A
B
C
D
E
F
G
H
HAC
J
K
L
M
N
O
P

MODE DOOR MOTOR

[MANUAL AIR CONDITIONER]

< COMPONENT DIAGNOSIS >

1. Reconnect the front air control connector and mode door motor connector.
2. Turn ignition switch ON.
3. Check voltage between front air control harness connector M49 terminal 21 and ground.
4. Press mode switch through all modes.

21 - Ground

: Approx. 0 - 5V

Is inspection result normal?

- YES >> Replace front air control. Refer to XX-XX.
NO >> GO TO 6.

6. CHECK PBR FEEDBACK CIRCUIT

1. Turn ignition switch OFF.
2. Disconnect the mode door motor connector and front air control harness connector.
3. Check continuity between mode door motor harness connector M142 terminal 4 and front air control harness connector M49 terminal 21.

4 - 21

: Continuity should exist.

Is inspection result normal?

- YES >> Replace mode door motor. Refer to XX-XX.
NO >> Repair or replace harness as necessary.

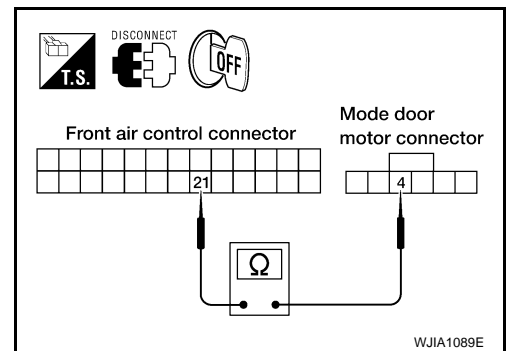
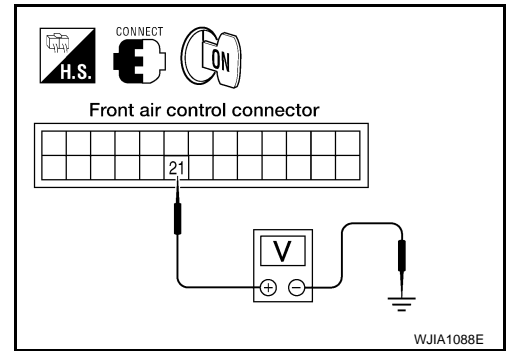

AIR MIX DOOR MOTOR

System Description

INFOID:000000001366785

SYSTEM DESCRIPTION

Component Parts

Air mix door control system components are:

- Front air control
- Air mix door motor
- PBR (built into air mix door motor)
- Intake sensor

System Operation

The front air control receives data from the temperature selected by the driver. The front air control then applies a voltage to one circuit of the air mix door motor, while ground is applied to the other circuit, causing the air mix door motor to rotate. The direction of rotation is determined by which circuit has voltage applied to it, and which one has ground applied to it. The front air control monitors the air mix door positions by measuring the voltage signal on the PBR circuits of each door.

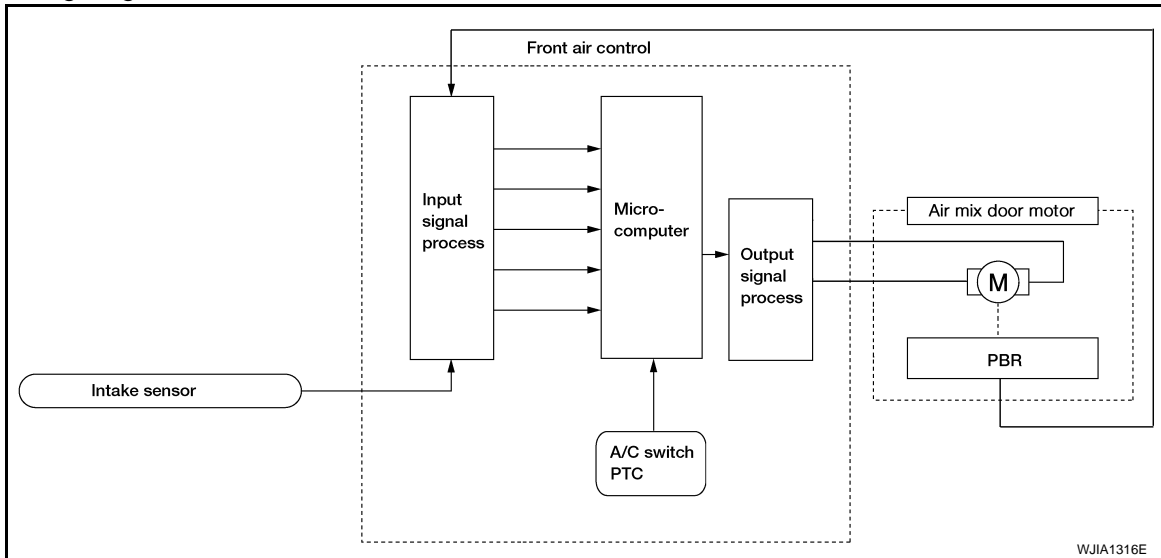

Air Mix Door Control Specification

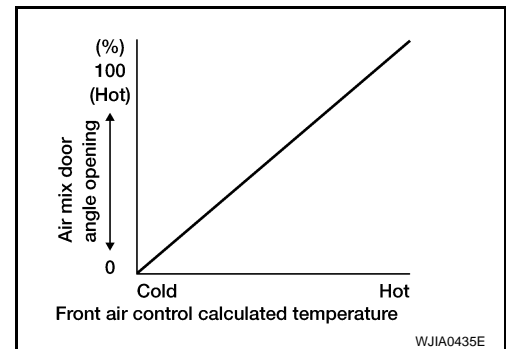

COMPONENT DESCRIPTION

Air Mix Door Motors

AIR MIX DOOR MOTOR

[MANUAL AIR CONDITIONER]

< COMPONENT DIAGNOSIS >

The air mix door motor is attached to the front heater and cooling unit assembly. This motor rotates so that the air mix door is opened or closed to a position set by the front air control. Motor rotation is then conveyed through a shaft and the air mix door position is then fed back to the front air control by the PBR built into the air mix door motor.

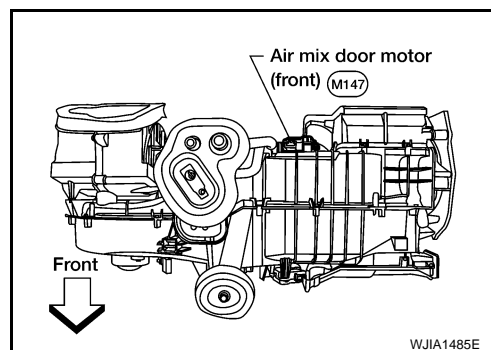

Air Mix Door Motor Component Function Check

INFOID:000000001366786

INSPECTION FLOW

1. CONFIRM SYMPTOM BY PERFORMING OPERATIONAL CHECK - TEMPERATURE INCREASE

1. Blower must be on (1, 2, 3, 4).
2. Turn the temperature control dial clockwise to maximum heat.
3. Check for hot air at discharge air outlets.

>> GO TO 2.

2. CONFIRM SYMPTOM BY PERFORMING OPERATIONAL CHECK - TEMPERATURE DECREASE

1. Turn the temperature control dial counterclockwise to maximum cold.
2. Check for cold air at discharge air outlets.

Can a symptom be duplicated?

- YES >> GO TO 4.
NO >> GO TO 3.

3. PERFORM COMPLETE OPERATIONAL CHECK

Perform a complete operational check and check for any symptoms. Refer to [HAC-123, "Operational Check"](#).

Can a symptom be duplicated?

- YES >> Refer to [HAC-171, "Symptom Matrix Chart"](#).
NO >> System OK.

4. CHECK FOR SERVICE BULLETINS

Check for any service bulletins.

>> GO TO 5.

5. CHECK AIR MIX DOOR OPERATION

Check and verify air mix door mechanism for smooth operation from maximum cold to maximum heat in each mode.

OK or NG

- OK >> GO TO 6.
NG >> Repair as necessary.

6. CHECK THE AIR MIX DOOR MOTOR PBR CIRCUIT

Perform diagnostic procedure for the air mix door motor. Refer to [HAC-141, "Air Mix Door Motor Diagnosis Procedure"](#).

OK or NG

- OK >> GO TO 7.
NG >> Repair PBR circuit or replace air mix door motor. Refer to XX-XX, "*****".

7. RECHECK FOR ANY SYMPTOMS

Perform a complete operational check for any symptoms. Refer to [HAC-123, "Operational Check"](#).

AIR MIX DOOR MOTOR

[MANUAL AIR CONDITIONER]

< COMPONENT DIAGNOSIS >

Does another symptom exist?

- YES >> Refer to [HAC-171, "Symptom Matrix Chart"](#).
- NO >> Replace front air control. Refer to XX-XX, "*****".

Air Mix Door Motor Diagnosis Procedure

INFOID:000000001366787

DIAGNOSTIC PROCEDURE FOR AIR MIX DOOR MOTOR

1. CHECK POWER SUPPLY CIRCUITS FOR AIR MIX DOOR MOTOR

1. Turn ignition switch OFF.
2. Disconnect front air control connector and air mix door motor (front) connector.
3. Check continuity between front air control harness connector M49 terminal 2 and 3 and air mix door motor (front) harness connector M147 terminal 6 and 5.

- 2 - 6** : Continuity should exist.
- 3 - 5** : Continuity should exist.

Is inspection result normal?

- YES >> GO TO 2.
- NO >> Repair or replace harness as necessary.

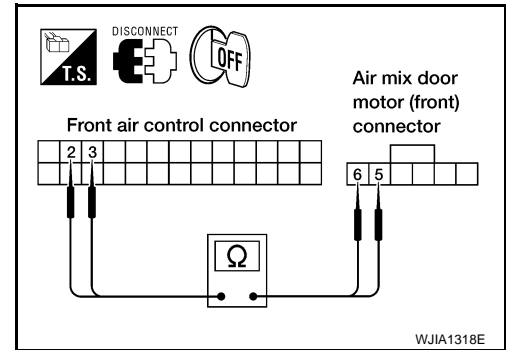

2. CHECK PBR REFERENCE SIGNAL VOLTAGE

1. Reconnect the front air control connector.
2. Turn ignition switch ON.
3. Check voltage between air mix door motor (front) harness connector M147 terminal 1 and ground.

- 1 - Ground** : Approx. 5V

Is inspection result normal?

- YES >> GO TO 4.
- NO >> GO TO 3.

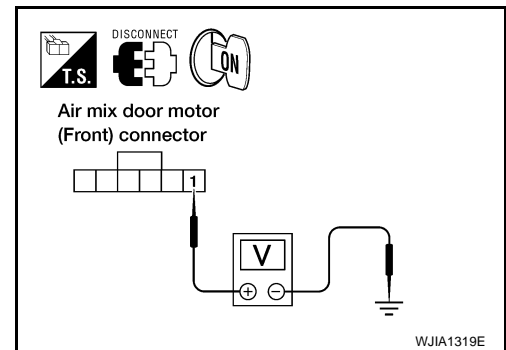

3. CHECK PBR REFERENCE VOLTAGE CIRCUIT BETWEEN AIR MIX DOOR MOTOR (FRONT) AND FRONT AIR CONTROL

1. Turn ignition switch OFF.
2. Disconnect the front air control connector.
3. Check continuity between air mix door motor (front) harness connector M147 (B) terminal 1 and front air control harness connector M49 (A) terminal 23.

A		B		Continuity
Connector	Terminal	Connector	Terminal	
Front air control: M49	23	Air mix door motor (front): M143	1	Yes

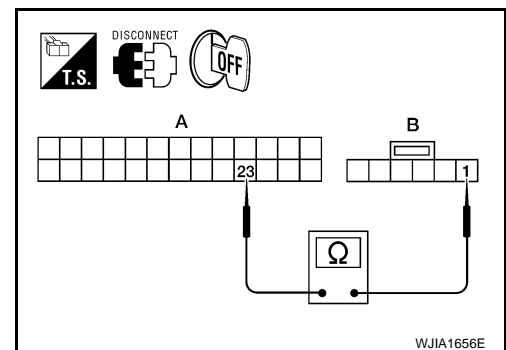

Is inspection result normal?

- YES >> Replace front air control. Refer to XX-XX, "*****".
- NO >> Repair or replace harness as necessary.

4. CHECK PBR GROUND REFERENCE CIRCUIT

AIR MIX DOOR MOTOR

[MANUAL AIR CONDITIONER]

< COMPONENT DIAGNOSIS >

1. Turn ignition switch OFF.
2. Disconnect the front air control connector.
3. Check continuity between air mix door motor (front) harness connector M147 terminal 3 and front air control harness connector M49 terminal 26.

3 - 26

: Continuity should exist.

Is inspection result normal?

YES >> GO TO 5.

NO >> Repair or replace harness as necessary.

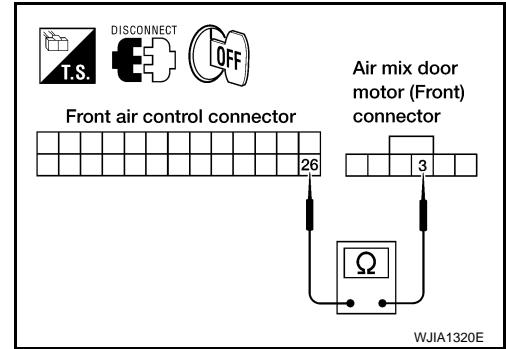

5. CHECK PBR FEEDBACK SIGNAL

1. Reconnect the front air control connector and air mix door motor (front) connector.
2. Turn ignition switch ON.
3. Check voltage between front air control harness connector M49 terminal 22 and ground.
4. Rotate temperature control dial through complete range.

22 - Ground

: Approx. 0V - 5V

Is inspection result normal?

YES >> Replace front air control. Refer to XX-XX, "*****".

NO >> GO TO 6.

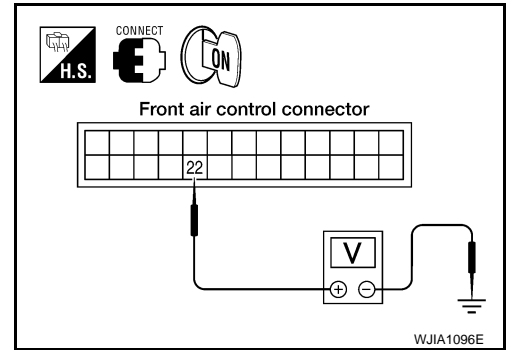

6. CHECK PBR FEEDBACK CIRCUIT

1. Turn ignition switch OFF.
2. Disconnect the air mix door motor (front) connector and front air control connector.
3. Check continuity between air mix door motor (front) harness connector M147 terminal 2 and front air control harness connector M49 terminal 22.

2 - 22

: Continuity should exist.

Is inspection result normal?

YES >> Replace air mix door motor (front). Refer to XXXX.

NO >> Repair or replace harness as necessary.

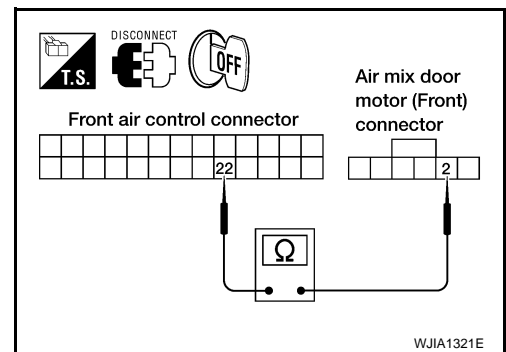

INTAKE DOOR MOTOR

< COMPONENT DIAGNOSIS >

[MANUAL AIR CONDITIONER]

INTAKE DOOR MOTOR

System Description

INFOID:000000001366789

SYSTEM DESCRIPTION

Component Parts

Intake door control system components are:

- Front air control
- Intake door motor
- Intake sensor

System Operation

The intake door control determines the intake door position based on the position of the recirculation switch. When the recirculation switch is depressed the intake door motor rotates closing off the fresh air inlet and recirculating the cabin air. If the recirculation switch is depressed again, the intake door motor rotates in the opposite direction, again allowing fresh air into the cabin.

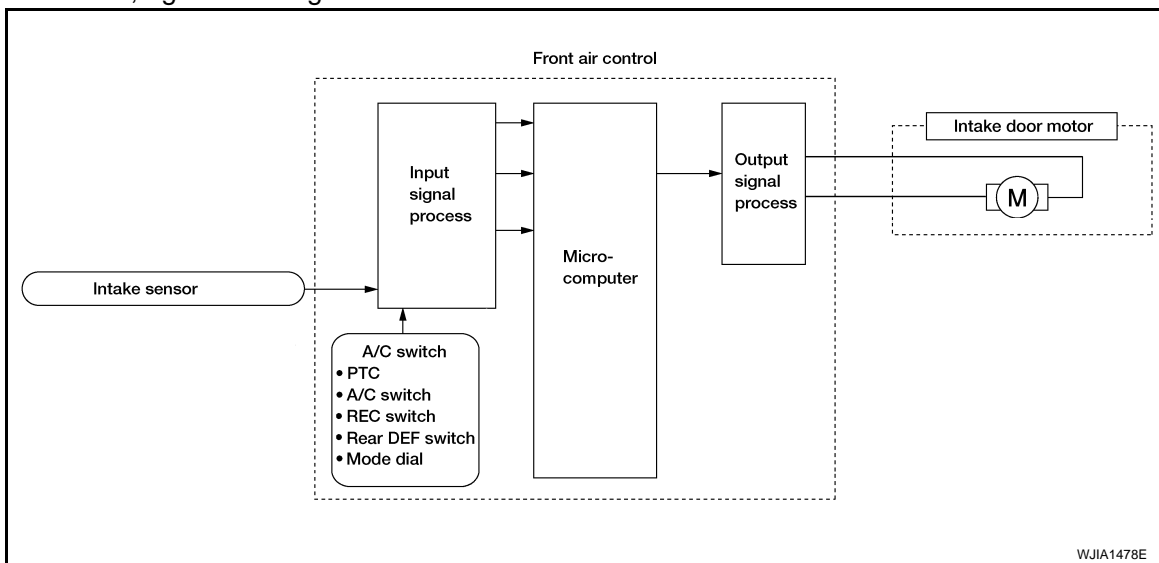

COMPONENT DESCRIPTION

Intake door motor

The intake door motor is attached to the intake unit. It rotates so that air is drawn from inlets set by the front air control. Motor rotation is conveyed to a lever which activates the intake door.

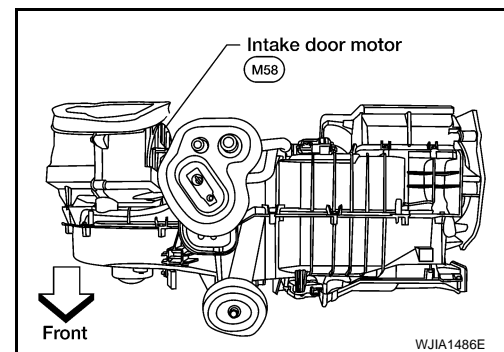

Intake Door Motor Component Function Check

INFOID:000000001366790

SYMPTOM:

- Intake door does not change.
- Intake door motor does not operate normally.

INSPECTION FLOW

1. CONFIRM SYMPTOM BY PERFORMING OPERATIONAL CHECK - REC (🔧)

1. Turn blower control dial to 4.



A
B
C
D
E
F
G
H
J
K
L
M
N
O
P

HAC

INTAKE DOOR MOTOR

[MANUAL AIR CONDITIONER]

< COMPONENT DIAGNOSIS >

2. Turn mode dial to vent mode ().
3. Press REC () switch.
4. Press REC () switch again.
5. Listen for intake door position change (you should hear blower sound change slightly).

Can a symptom be duplicated?

- YES >> GO TO 3.
NO >> GO TO 2.

2.PERFORM COMPLETE OPERATIONAL CHECK

Perform a complete operational check and check for any symptoms. Refer to [HAC-123. "Operational Check"](#).

Can a symptom be duplicated?

- YES >> Refer to [HAC-171. "Symptom Matrix Chart"](#).
NO >> System OK.

3.CHECK FOR SERVICE BULLETINS

Check for any service bulletins.

>> GO TO 4.

4.CHECK INTAKE DOOR OPERATION

Check and verify intake door mechanism for smooth operation.

Is inspection result normal?

- YES >> GO TO 5.
NO >> Repair intake door mechanism.

5.RECHECK FOR ANY SYMPTOMS

Perform a complete operational check for any symptoms. Refer to [HAC-123. "Operational Check"](#).

Does another symptom exist?

- YES >> Refer to [HAC-171. "Symptom Matrix Chart"](#).
NO >> Replace front air control. Refer to XX-XX, "*****".

Intake Door Motor Diagnosis Procedure

INFOID:000000001366791

DIAGNOSTIC PROCEDURE FOR INTAKE DOOR MOTOR

1.CHECK INTAKE DOOR MOTOR CIRCUIT VOLTAGE

1. Turn ignition switch OFF.
2. Disconnect intake door motor connector.
3. Turn ignition switch ON.
4. Rotate the temperature control dial counterclockwise.
5. Check voltage between intake door motor harness connector M58 terminal 6 and ground.

6 - Ground : **Battery voltage**

Is inspection result normal?

- OK >> GO TO 3.
NG >> GO TO 2.

2.CHECK INTAKE DOOR MOTOR CIRCUIT FOR OPEN

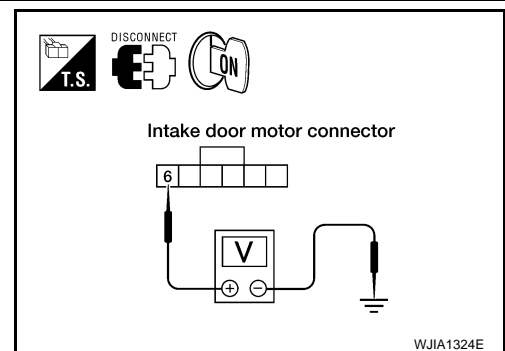

INTAKE DOOR MOTOR

[MANUAL AIR CONDITIONER]

< COMPONENT DIAGNOSIS >

1. Turn ignition switch OFF.
2. Disconnect front air control connector.
3. Check continuity between front air control harness connector M49 terminal 5 and intake door motor harness connector M58 terminal 6.

5 - 6 : Continuity should exist.

Is inspection result normal?

- OK >> Replace front air control connector. Refer to XXXX.
 NG >> Repair or replace harness as necessary.

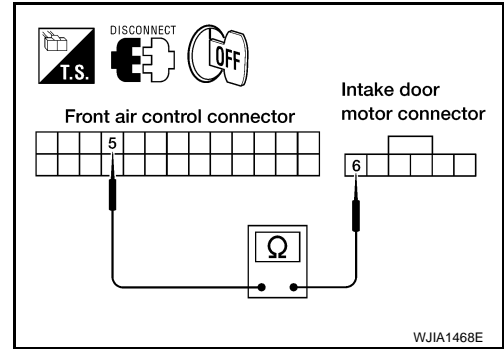

3.CHECK INTAKE DOOR MOTOR CIRCUIT VOLTAGE

1. Rotate the temperature control dial clockwise.
2. Check voltage between intake door motor harness connector M58 terminal 1 and ground.

1 - Ground :Battery voltage

Is inspection result normal?

- YES >> Replace intake door motor. Refer to XX-XX, "*****".
 NO >> GO TO 4.

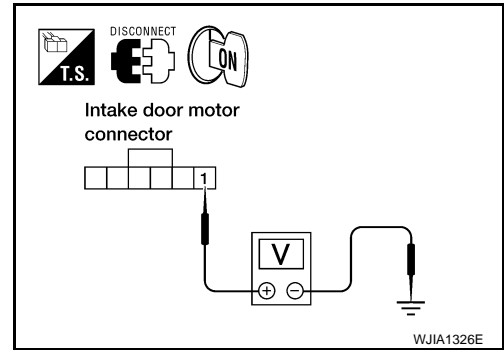

4.CHECK INTAKE DOOR MOTOR CIRCUIT FOR OPEN

1. Turn ignition switch OFF.
2. Disconnect front air control connector.
3. Check continuity between front air control harness connector M49 (A) terminal 4 and intake door motor harness connector M58 (B) terminal 1.

A		B		Continuity
Connector	Terminal	Connector	Terminal	
Front air control: M49	4	Intake door motor: M58	1	Yes

Is inspection result normal?

- YES >> Replace front air control connector. Refer to XXXX.
 NO >> Repair or replace harness as necessary.

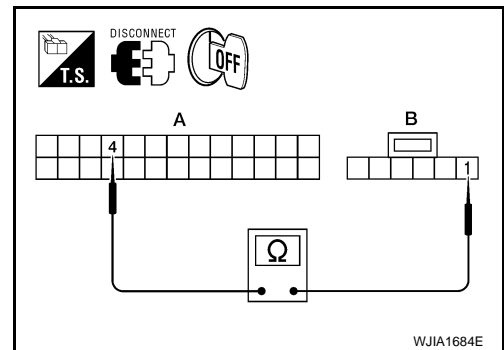

A
B
C
D
E
F
G
H
J
K
L
M
N
O
P

HAC

BLOWER MOTOR

System Description

INFOID:000000001366795

Component Parts

Blower speed control system components are:

- Front air control
- Front blower motor resistor
- Front blower motor
- Front blower relay

System Operation

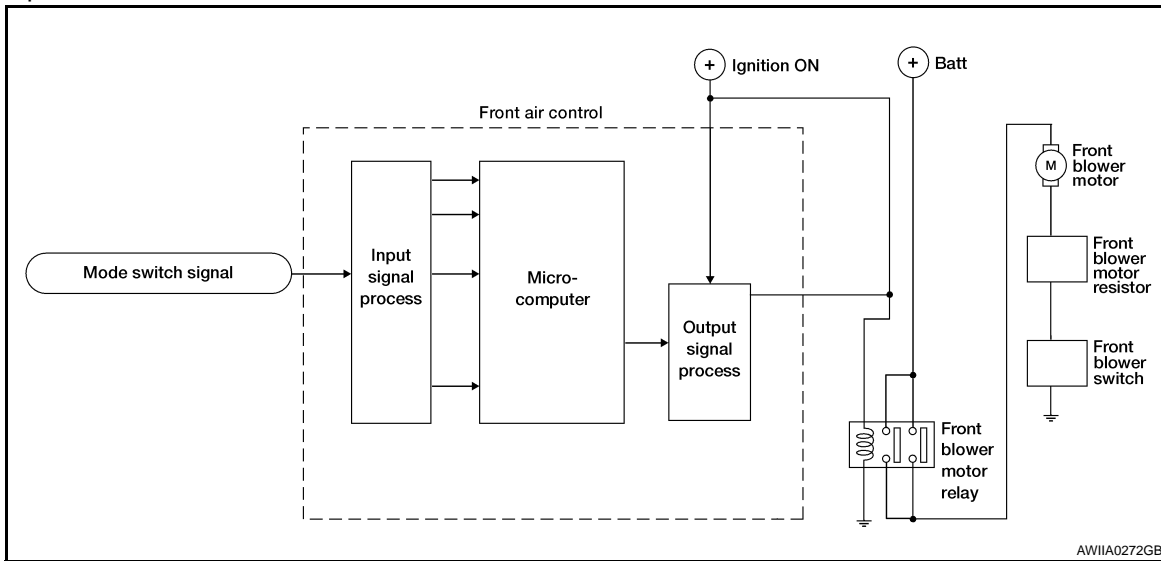

COMPONENT DESCRIPTION

Blower Motor Resistor

The front blower motor resistor is located on the heater and cooling unit assembly. The front blower motor resistor grounds the front blower motor through a series of 1, 2, or 3 resistors, depending upon speed selected. For high speed operation the front blower motor resistor is circumvented and the front blower motor grounds directly.

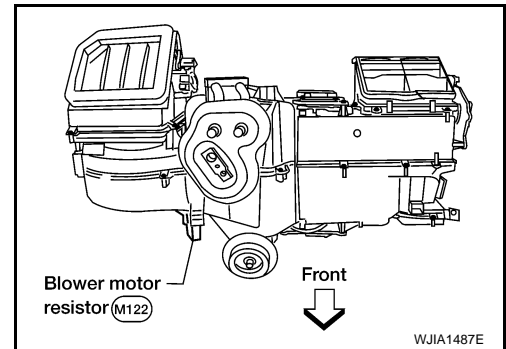

Front Blower Motor Component Function Check

INFOID:000000001366796

INSPECTION FLOW

1. CONFIRM SYMPTOM BY PERFORMING OPERATIONAL CHECK - FRONT BLOWER

1. Rotate the blower control dial clockwise. Blower should operate.
2. Rotate the blower control dial clockwise, and continue checking blower speed until all speeds are checked.

Can the symptom be duplicated?

- YES >> GO TO 3.
NO >> GO TO 2.

BLOWER MOTOR

[MANUAL AIR CONDITIONER]

< COMPONENT DIAGNOSIS >

2.CHECK FOR ANY SYMPTOMS

Perform a complete operational check for any symptoms. Refer to [HAC-123, "Operational Check"](#).

Does another symptom exist?

- YES >> Refer to XX-XX, "*****".
- NO >> System OK.

3.CHECK FOR SERVICE BULLETINS

Check for any service bulletins.

>> GO TO 4.

4.CHECK BLOWER MOTOR OPERATION

Check and verify blower motor operates in all speeds.

Does blower motor operate in all speeds?

- YES >> GO TO 5.
- NO >> Refer to [HAC-147, "Front Blower Motor Diagnosis Procedure"](#).

5.CHECK ENGINE COOLANT TEMPERATURE SENSOR CIRCUIT

Perform diagnostic procedure for the coolant temperature sensor circuit. Refer to XX-XX, "*****".

Is the inspection result normal?

- YES >> GO TO 6.
- NO >> Repair or replace harness as necessary.

6.RECHECK FOR ANY SYMPTOMS

Perform a complete operational check for any symptoms. Refer to [HAC-123, "Operational Check"](#).

Does another symptom exist?

- YES >> Refer to [HAC-171, "Symptom Matrix Chart"](#).
- NO >> Replace front air control. Refer to XX-XX.

Front Blower Motor Diagnosis Procedure

INFOID:000000001366797

SYMPTOM: Blower motor operation is malfunctioning under starting blower speed control.

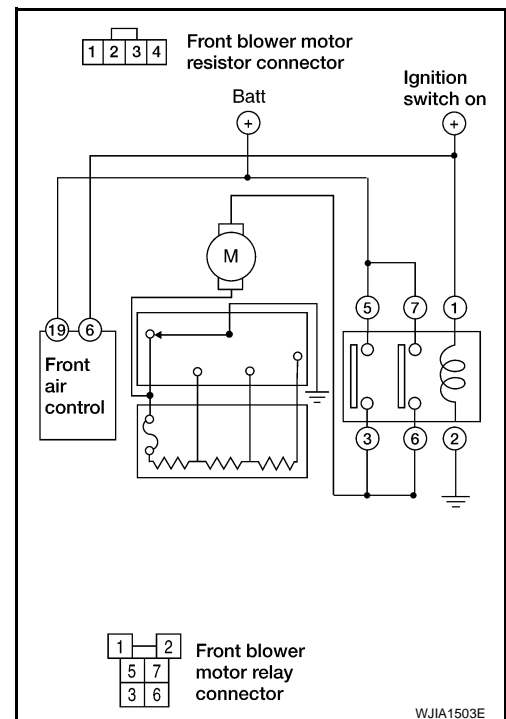

1.DIAGNOSTIC PROCEDURE

1. Turn ignition switch ON.
2. Turn the front blower switch to each of its four speeds.

BLOWER MOTOR

[MANUAL AIR CONDITIONER]

< COMPONENT DIAGNOSIS >

Does blower motor rotate normally at each speed?

YES or NO

- YES >> Inspection End.
 NO >> 1. Does not rotate at any speed, GO TO 2.
 2. Does not rotate at 1 - 3 speed, GO TO 13.
 3. Does not rotate at 4 speed, GO TO 16.

2.CHECK FUSES

1. Check 15A fuses (Nos. 24 and 27, located in the fuse and fusible link box). Refer to XX-XX.
2. Check 10A fuse [No. 8, located in the fuse block (JB)]. Refer to XX-XX.

Is inspection result normal?

- YES >> GO TO 3.
 NO >> GO TO 8.

3.CHECK FRONT BLOWER MOTOR POWER SUPPLY

1. Turn ignition switch OFF.
2. Disconnect front blower motor harness connector.
3. Turn ignition switch ON.
4. Select any front blower speed except OFF.
5. Check voltage between front blower motor harness connector M62 terminal 2 and ground.

2 - Ground : Battery voltage

Is inspection result normal?

- YES >> GO TO 12.
 NO >> GO TO 4.

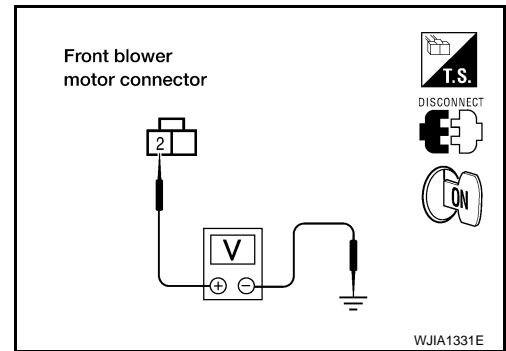

4.CHECK FRONT BLOWER MOTOR RELAY

1. Turn Ignition switch OFF.
2. Check front blower motor relay. Refer to [HAC-151. "Front Blower Motor Component Inspection"](#).

Is inspection result normal?

- YES >> GO TO 5.
 NO >> Replace front blower motor relay.

5.CHECK FRONT BLOWER MOTOR RELAY POWER SUPPLY (SWITCH SIDE)

Check voltage between front blower motor relay harness connector E54 terminals 7 and 5 and ground.

A		Condition	Voltage (Approx.)
(+)	(-)		
Front air control connector	Terminal		
M54	5	Blower motor relay power supply	Battery voltage
M54	7	Blower motor relay power supply	Battery voltage

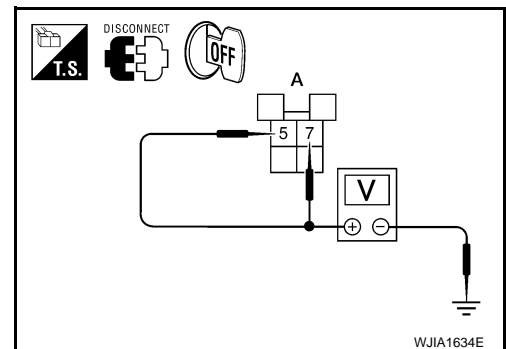

Is inspection result normal?

- YES >> GO TO 6.
 NO >> Repair harness or connector.

6.CHECK FRONT BLOWER MOTOR RELAY POWER SUPPLY (COIL SIDE)

BLOWER MOTOR

[MANUAL AIR CONDITIONER]

< COMPONENT DIAGNOSIS >

1. Turn ignition switch ON.
2. Check voltage between front blower motor relay harness connector E54 terminal 1 and ground.

A			Condition	Voltage (Approx.)
(+)		(-)		
Front air control connector	Terminal			
M54	1	Ground	Blower motor relay power supply (coil side)	Battery voltage

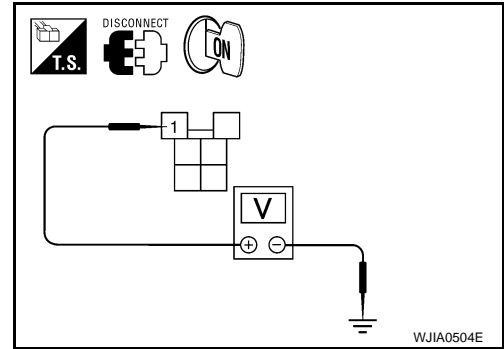

Is inspection result normal?

- YES >> GO TO 7.
NO >> Repair or replace harness as necessary.

7. CHECK FRONT BLOWER MOTOR POWER FROM RELAY TO FRONT BLOWER MOTOR

1. Turn ignition switch OFF.
2. Check continuity between front blower motor relay harness connector E54 terminals 6 and 3 and front blower motor harness connector M62 terminal 2.

3, 6 - 2 : Continuity should exist.

Is inspection result normal?

- YES >> Repair or replace harness as necessary.
NO >> Repair harness or connector between the front blower motor relay and the front blower motor.

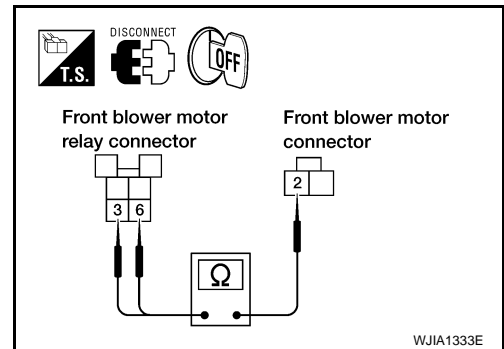

8. REPLACE FUSE

Refer to XX-XX, "*****".

Does fuse No. 24 or 27 open when the front blower motor is turned on?

YES or NO

- YES >> GO TO 10.
NO >> GO TO 9.

9. REPLACE FUSE

Refer to XX-XX, "*****".

Does fuse No. 8 open when the ignition switch is turned ON?

YES or NO

- YES >> Repair or replace harness as necessary.
NO >> Inspection End.

10. CHECK FRONT BLOWER MOTOR POWER SUPPLY CIRCUIT FOR SHORT

1. Turn ignition switch OFF.
2. Disconnect front blower motor connector.
3. Check continuity between front blower motor harness connector M62 terminal 2 and ground.

2 - Ground : Continuity should not exist.

Is inspection result normal?

- YES >> GO TO 11.
NO >> Repair or replace harness as necessary.

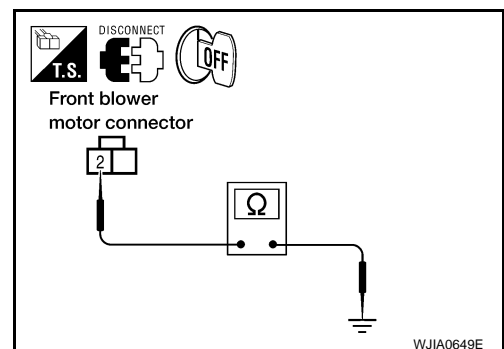

BLOWER MOTOR

< COMPONENT DIAGNOSIS >

[MANUAL AIR CONDITIONER]

11. CHECK FRONT BLOWER MOTOR RELAY (SWITCH SIDE) POWER SUPPLY CIRCUIT FOR SHORT

1. Disconnect front blower motor relay connector.
2. Check continuity between the front blower motor relay harness connector E54 terminal 7 and terminal 5 and ground.

7, 5 - Ground : Continuity should not exist.

Is inspection result normal?

- YES >> Check front blower motor. Refer to [HAC-147. "Front Blower Motor Diagnosis Procedure"](#).
- NO >> Repair harness or connector.

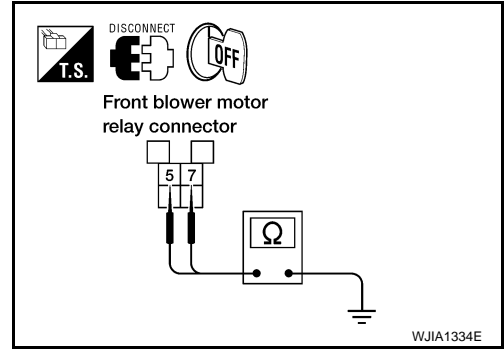

12. CHECK FRONT BLOWER MOTOR

1. Turn ignition switch OFF.
2. Check front blower motor. Refer to [HAC-151. "Front Blower Motor Component Inspection"](#).

Is inspection result normal?

- YES >> GO TO 13.
- NO >> Replace front blower motor. Refer to XXXX.

13. CHECK FRONT BLOWER MOTOR RESISTOR

Check front blower motor resistor. Refer to [HAC-151. "Front Blower Motor Component Inspection"](#).

Is inspection result normal?

- YES >> GO TO 14.
- NO >> Replace front blower motor resistor. Refer to XXXX.

14. CHECK FRONT BLOWER SWITCH

Check front blower switch. Refer to [HAC-151. "Front Blower Motor Component Inspection"](#).

Is inspection result normal?

- YES >> GO TO 15.
- NO >> Replace front blower switch. Refer to XXXX.

15. CHECK FRONT BLOWER MOTOR GROUND CIRCUIT TO FRONT BLOWER MOTOR RESISTOR

1. Disconnect front blower motor resistor harness connector.
2. Check continuity between front blower motor connector M62 (A) terminal 1 and front blower motor resistor harness connector M122 (B) terminal 3.

A		B		Continuity
Connector	Terminal	Connector	Terminal	
Front blower motor: M62	1	Front blower motor resistor: M122	3	Yes

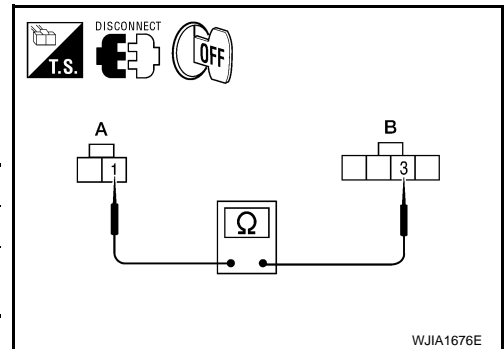

Is inspection result normal?

- YES >> Repair harness or connector between front blower switch connector M51 terminal 8 and ground.
- NO >> Repair harness or connector between front blower motor resistor and front blower motor.

16. CHECK FRONT BLOWER SWITCH

Check front blower switch. Refer to [HAC-151. "Front Blower Motor Component Inspection"](#).

Is inspection result normal?

- YES >> Repair harness or connector between front blower motor switch connector M51 terminal 8 and front blower motor resistor connector M122 terminal 3.
- NO >> Replace front blower switch. Refer to XXXX.

SYMPTOM: Blower motor operation is malfunctioning.

Front Blower Motor Component Inspection

INFOID:000000001366798

COMPONENT INSPECTION

Front Blower Motor Relay

Check continuity between terminals by supplying 12 volts and ground to coil side terminals of relay.

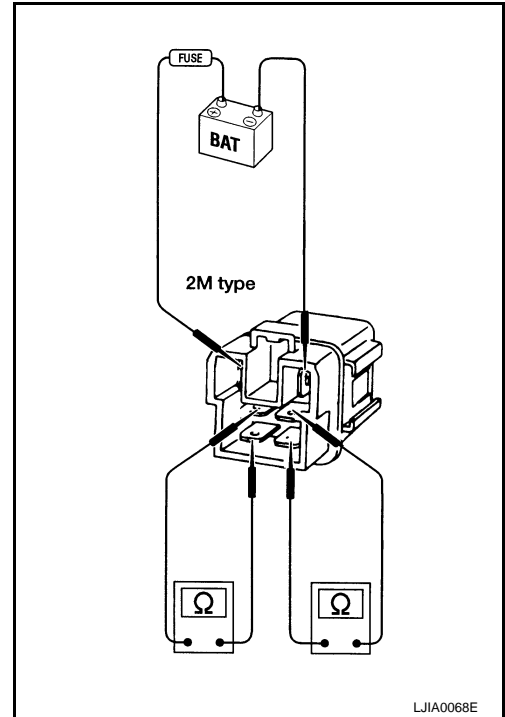

Front Blower Motor

Confirm smooth rotation of the blower motor.

- Ensure that there are no foreign particles inside the blower unit.
- Apply 12 volts to terminal 2 and ground to terminal 1 and verify that the motor operates freely and quietly.

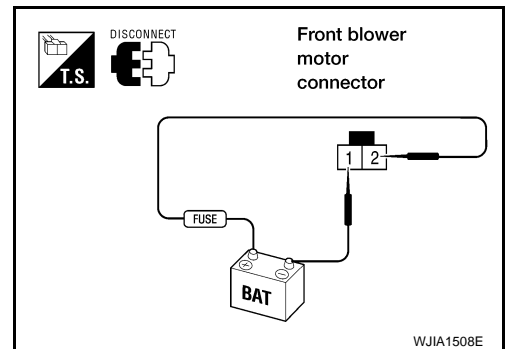

Front Blower Switch

Check continuity between terminals at each switch position.

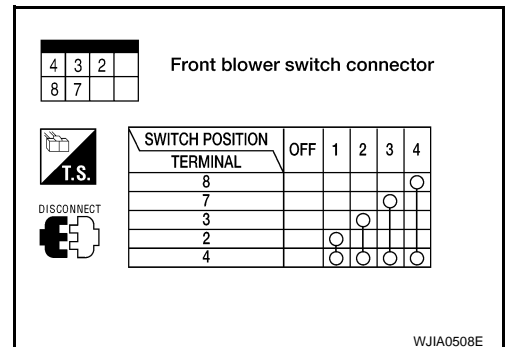

A
B
C
D
E
F
G
H
HAC
J
K
L
M
N
O
P

MAGNET CLUTCH

System Description

INFOID:000000001366808

SYSTEM DESCRIPTION

The front air control controls compressor operation based on ambient and intake temperature and a signal from ECM.

Low Temperature Protection Control

The front air control will turn the compressor ON or OFF as determined by a signal detected by the intake sensor and the ambient sensor.

When intake air temperature is higher than 3.5° C (38.3° F), the compressor turns ON. The compressor turns OFF when intake air temperature is lower than 2.5° C (36.5° F).

Magnet Clutch Component Function Check

INFOID:000000001366809

SYMPTOM: Magnet clutch does not engage.

INSPECTION FLOW

1. CONFIRM SYMPTOM BY PERFORMING OPERATIONAL CHECK - MAGNET CLUTCH

1. Rotate blower control dial clockwise.
2. Rotate mode dial to vent (☼) position.
3. Press A/C switch. Confirm that the compressor clutch engages (sound or visual inspection).

Can the symptom be duplicated?

- YES >> GO TO 3.
NO >> GO TO 2.

2. CHECK FOR ANY SYMPTOMS

Perform a complete operational check for any symptoms. Refer to [HAC-123, "Operational Check"](#).

Does another symptom exist?

- YES >> Refer to [HAC-171, "Symptom Matrix Chart"](#).
NO >> System OK.

3. CHECK FOR SERVICE BULLETINS

Check for any service bulletins.

>> GO TO 4.

4. CHECK INTAKE SENSOR

Check and verify intake sensor circuit. Refer to [HAC-158, "Intake Sensor Component Inspection"](#).

>> GO TO 5.

5. RECHECK FOR ANY SYMPTOMS

Perform a complete operational check for any symptoms. Refer to [HAC-123, "Operational Check"](#).

Does another symptom exist?

- YES >> Refer to [HAC-171, "Symptom Matrix Chart"](#).
NO >> Replace front air control. Refer to XX-XX, "*****".

Magnet Clutch Diagnosis Procedure

INFOID:000000001366810

DIAGNOSTIC PROCEDURE FOR MAGNET CLUTCH

MAGNET CLUTCH

< COMPONENT DIAGNOSIS >

[MANUAL AIR CONDITIONER]

SYMPTOM: Magnet clutch does not engage when A/C switch is ON.

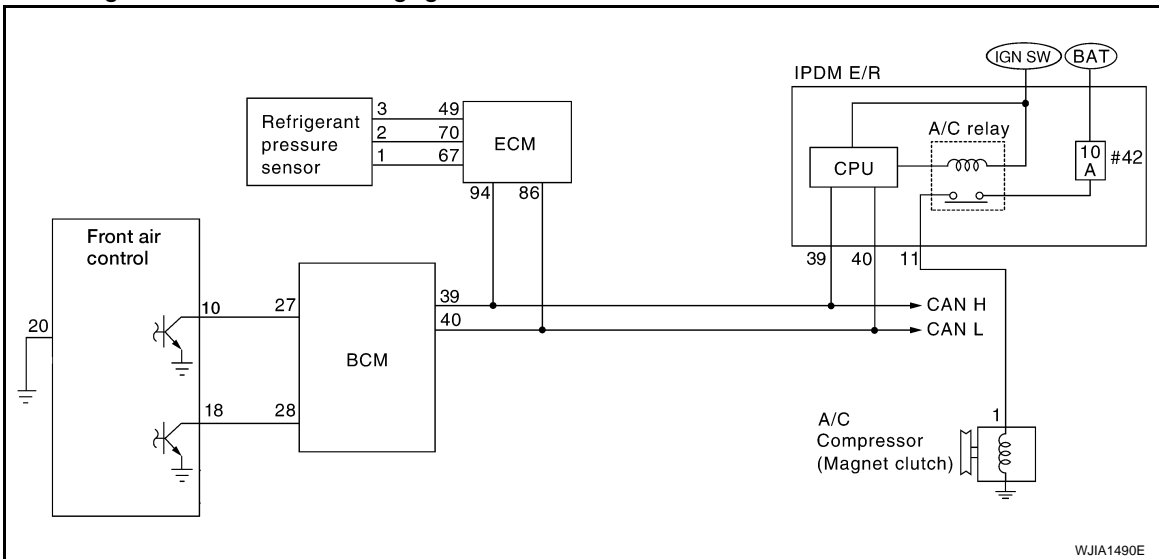

1. PERFORM AUTO ACTIVE TEST

Refer to XX-XX.

Does magnet clutch operate?

YES or NO

- YES >> • WITH CONSULT-II
GO TO 2.
• WITHOUT CONSULT-II
GO TO 8.

NO >> Check 10A fuse (No. 42, located in IPDM E/R), and GO TO 12.

2. CHECK BCM INPUT (A/C COMPRESSOR ON) SIGNAL

Check A/C compressor ON/OFF signal. Refer to [HAC-134, "CONSULT-III Function \(BCM\)"](#).

A/C SW ON : COMP ON SIG ON
A/C SW OFF : COMP ON SIG OFF

OK or NG

- OK >> GO TO 3.
NG >> GO TO 8.

3. CHECK REFRIGERANT PRESSURE SENSOR

Check refrigerant pressure sensor. Refer to [EC-412, "Diagnosis Procedure"](#).

OK or NG

- OK >> GO TO 4.
NG >> Replace refrigerant pressure sensor. Refer to XX-XX, .

4. CHECK BCM INPUT (FAN ON) SIGNAL

Check FAN ON/OFF signal. Refer to [HAC-134, "CONSULT-III Function \(BCM\)"](#)

BLOWER CONTROL DIAL ON : FAN ON SIG ON
BLOWER CONTROL DIAL OFF : FAN ON SIG OFF

OK or NG

- OK >> GO TO 7.
NG >> GO TO 5.

DATA MONITOR			
MONITOR			
FAN ON SIG	ON		
COMP ON SIG	ON		
IGN ON SW	ON		
RECORD			
MODE	BACK	LIGHT	COPY

WJIA0469E

MAGNET CLUTCH

< COMPONENT DIAGNOSIS >

[MANUAL AIR CONDITIONER]

5. CHECK CIRCUIT CONTINUITY BETWEEN BCM AND FRONT AIR CONTROL

1. Turn ignition switch OFF.
2. Disconnect BCM connector and front air control connector.
3. Check continuity between BCM harness connector M18 (A) terminal 28 and front air control harness connector M49 (B) terminal 18.

A		B		Continuity
Connector	Terminal	Connector	Terminal	
BCM: M18	28	Front air control: M49	18	Yes

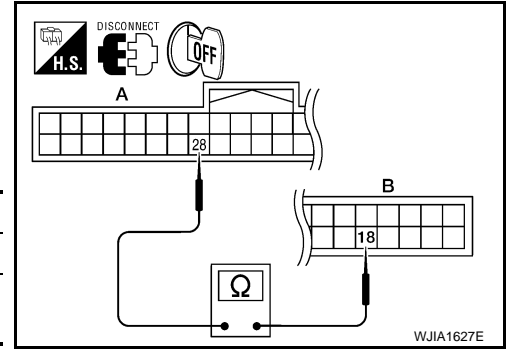

OK or NG

- OK >> GO TO 6.
 NG >> Repair harness or connector.

6. CHECK VOLTAGE FOR FRONT AIR CONTROL (FAN ON SIGNAL)

1. Reconnect BCM connector and front air control connector.
2. Turn ignition switch ON.
3. Turn A/C switch ON.
4. Check voltage between front air control harness connector M49 terminal 18 and ground.

Terminals		Condition	Voltage (Approx.)
(+)	(-)		
Front air control connector	Terminal No.		
M49	18	A/C switch: ON Blower motor operates	0V
		A/C switch: OFF	5V

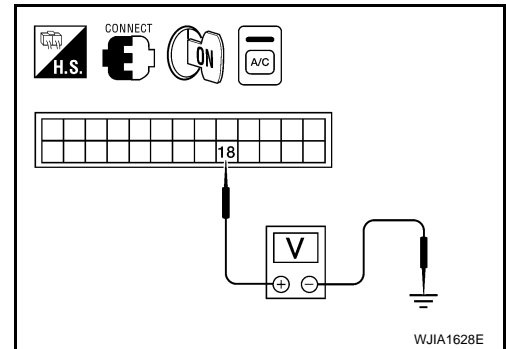

OK or NG

- OK >> Replace BCM. Refer to XX-XX.
 NG-1 >> If the voltage is approx. 5V when blower motor is ON, replace front air control. Refer to XXXX.
 NG-2 >> If the voltage is approx. 0V when blower motor is OFF, replace BCM. Refer to XX-XX.

7. CHECK CAN COMMUNICATION

Check CAN communication. Refer to [LAN-14. "Trouble Diagnosis Flow Chart"](#).

OK or NG

- OK >> Inspection End.
 NG >> Repair or replace malfunctioning part(s).

8. CHECK VOLTAGE FOR FRONT AIR CONTROL (A/C COMPRESSOR ON SIGNAL)

1. Reconnect BCM connector and front air control connector.
2. Turn ignition switch ON.
3. Check voltage between front air control harness connector M49 terminal 10 and ground.

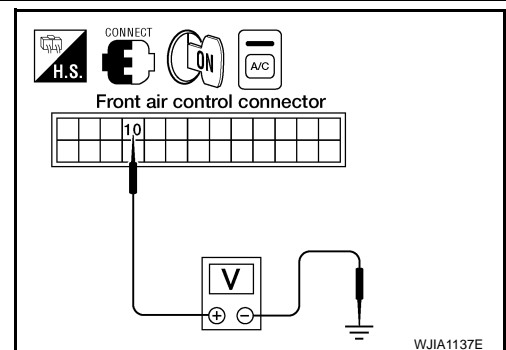

MAGNET CLUTCH

< COMPONENT DIAGNOSIS >

[MANUAL AIR CONDITIONER]

Terminals		Condition	Voltage (Approx.)
(+)	(-)		
Front air control connector	Terminal No.		
M49	10	A/C switch: ON	0V
		A/C switch: OFF	Battery voltage

OK or NG

OK >> GO TO 9.

NG-1 >> If the voltage is approx. 5V when A/C switch is ON, replace front air control. Refer to XXX.

NG-2 >> If the voltage is approx. 0V when A/C switch is OFF, replace BCM. Refer to XX-XX, "*****".

9. CHECK CIRCUIT CONTINUITY BETWEEN BCM AND FRONT AIR CONTROL

1. Disconnect BCM connector and front air control connector.
2. Check continuity between BCM harness connector M18 terminal 27 and front air control harness connector M49 terminal 10.

27 - 10 : Continuity should exist.

OK or NG

OK >> GO TO 10.

NG >> Repair harness or connector.

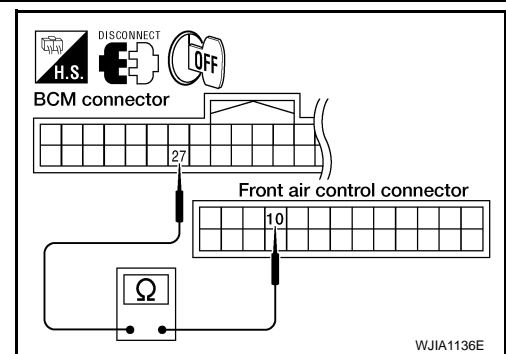

10. CHECK INTAKE SENSOR CIRCUITS

Check intake sensor. Refer to XXXX.

OK or NG

OK >> GO TO 11.

NG >> Replace intake sensor. Refer to XXXX.

11. CHECK CAN COMMUNICATION

Check CAN communication. Refer to [LAN-14, "Trouble Diagnosis Flow Chart"](#).

OK or NG

OK >> Replace BCM. Refer to XX-XX, "*****".

NG >> Repair or replace malfunctioning part(s).

12. CHECK MAGNET CLUTCH CIRCUIT

Check for operation sound when applying battery voltage to terminal.

OK or NG

OK >> GO TO 13.

NG >> Replace magnet clutch. Refer to XXX.

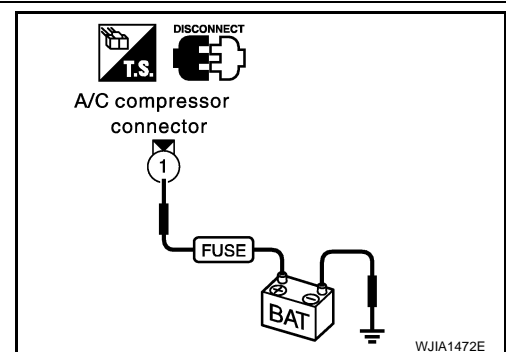

13. CHECK CIRCUIT CONTINUITY BETWEEN IPDM E/R AND A/C COMPRESSOR

MAGNET CLUTCH

[MANUAL AIR CONDITIONER]

< COMPONENT DIAGNOSIS >

1. Turn ignition switch OFF.
2. Disconnect IPDM E/R connector and A/C compressor (magnet clutch) connector.
3. Check continuity between IPDM E/R harness connector E119 terminal 11 and A/C compressor harness connector F3 terminal 1.

11 - 1

: Continuity should exist.

OK or NG

- OK >> Replace IPDM E/R. Refer to XX-XX, "*****".
NG >> Repair harness or connector.

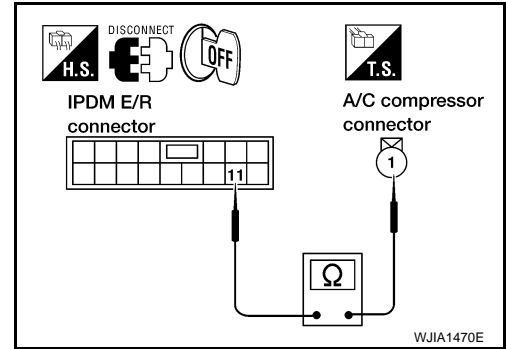

INTAKE SENSOR

System Description

INFOID:000000001366821

COMPONENT DESCRIPTION

Intake Sensor

The intake sensor is located on top of the heater and cooling unit assembly next to the A/C evaporator cover. It converts temperature of air after it passes through the evaporator into a resistance value which is then input to the front air control.

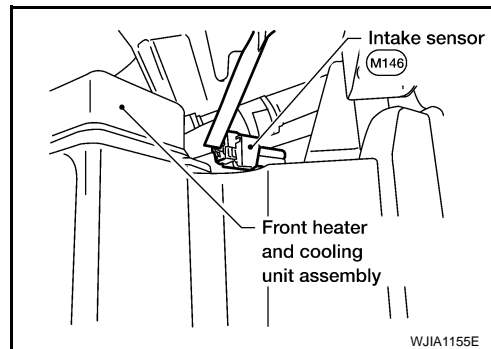

Intake Sensor Diagnosis Procedure

INFOID:000000001366822

DIAGNOSTIC PROCEDURE FOR INTAKE SENSOR

SYMPTOM: Intake sensor circuit is open or shorted.

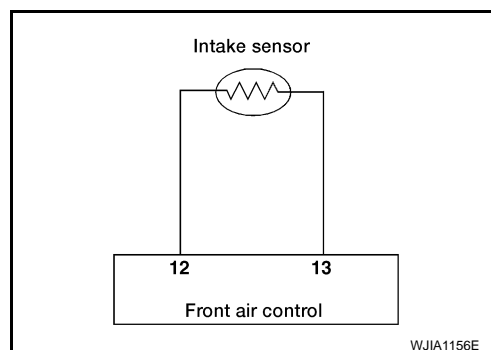

1. CHECK VOLTAGE BETWEEN INTAKE SENSOR AND GROUND

1. Disconnect intake sensor connector.
2. Turn ignition switch ON.
3. Check voltage between intake sensor harness connector M146 terminal 2 and ground.

2 - Ground : Approx. 5V

Is the inspection result normal?

- YES >> GO TO 2.
NO >> GO TO 4.

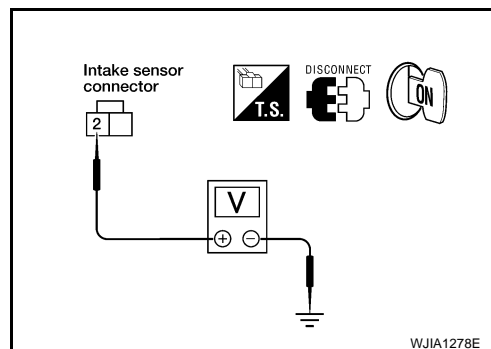

2. CHECK CIRCUIT CONTINUITY BETWEEN INTAKE SENSOR AND FRONT AIR CONTROL

1. Turn ignition switch OFF.
2. Disconnect front air control connector.
3. Check continuity between intake sensor harness connector M146 terminal 1 and front air control harness connector M49 terminal 13.

1 - 13 : Continuity should exist.

Is the inspection result normal?

- YES >> GO TO 3.
NO >> Repair harness or connector.

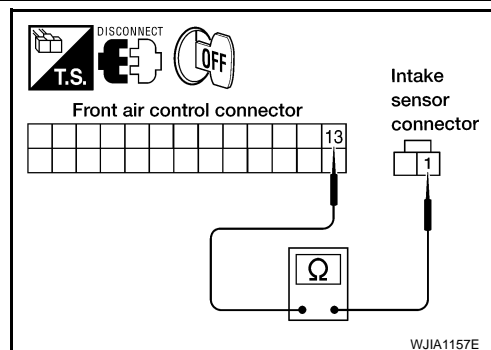

A
B
C
D
E
F
G
H
HAC
J
K
L
M
N
O
P

INTAKE SENSOR

[MANUAL AIR CONDITIONER]

< COMPONENT DIAGNOSIS >

3. CHECK INTAKE SENSOR

Refer to [HAC-158. "Intake Sensor Component Inspection"](#).

Is the inspection result normal?

- YES >> Replace front air control. Refer to XXXX.
- NO >> Replace intake sensor. Refer to XXXX.

4. CHECK CIRCUIT CONTINUITY BETWEEN INTAKE SENSOR AND FRONT AIR CONTROL

1. Turn ignition switch OFF.
2. Disconnect front air control connector.
3. Check continuity between intake sensor harness connector M146 terminal 2 and front air control harness connector M146 terminal 12.

2 - 12 : Continuity should exist.

4. Check continuity between intake sensor harness connector M146 terminal 2 and ground.

2 - Ground : Continuity should not exist.

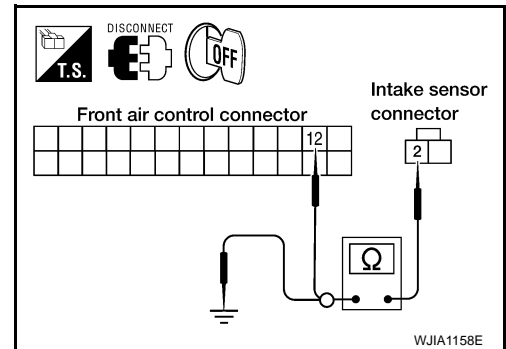

Is the inspection result normal?

- YES >> Replace front air control. Refer to XXXX.
- NO >> Repair harness or connector.

Intake Sensor Component Inspection

INFOID:000000001366823

COMPONENT INSPECTION

Intake Sensor

After disconnecting intake sensor connector, measure resistance between terminals 1 and 2 at sensor harness side, using the table below.

Temperature °C (°F)	Resistance kΩ
-15 (5)	209.0
-10 (14)	160.0
-5 (23)	123.0
0 (32)	95.8
5 (41)	74.9
10 (50)	58.9
15 (59)	46.7
20 (68)	37.3
25 (77)	30.0
30 (86)	24.2
35 (95)	19.7
40 (104)	16.1
45 (113)	13.2

If NG, replace intake sensor. Refer to XXXX.

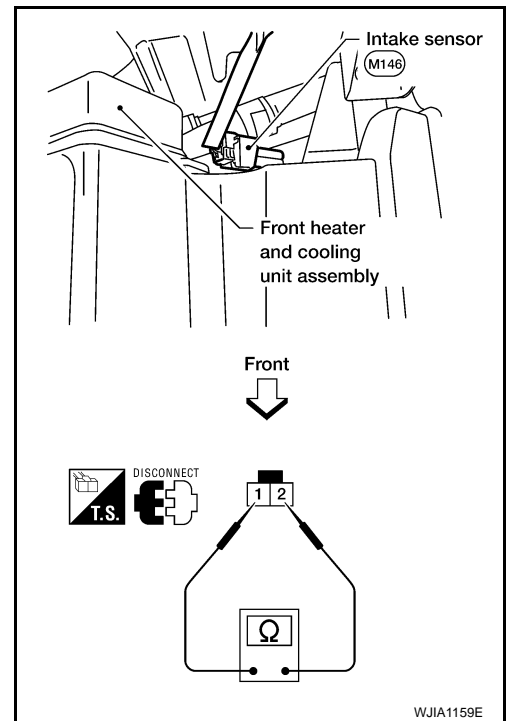

POWER SUPPLY AND GROUND CIRCUIT FOR CONTROLLER

< COMPONENT DIAGNOSIS >

[MANUAL AIR CONDITIONER]

POWER SUPPLY AND GROUND CIRCUIT FOR CONTROLLER

Component Description

INFOID:000000001366824

COMPONENT DESCRIPTION

Front Air Control

The front air control has a built-in microcomputer which processes information sent from various sensors needed for air conditioner operation. The air mix door motor, mode door motor, intake door motor, defroster door motor, blower motor and compressor are then controlled.

The front air control is unitized with control mechanisms. When the various switches and temperature dials are operated, data is input to the front air control.

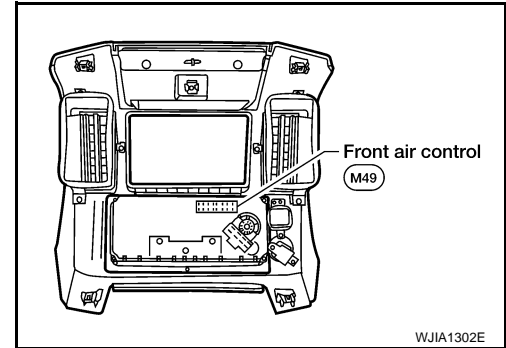

Potential Temperature Control (PTC)

The PTC is built into the front air control. It can be set from cold to hot or any intermediate position by rotating the temperature dial.

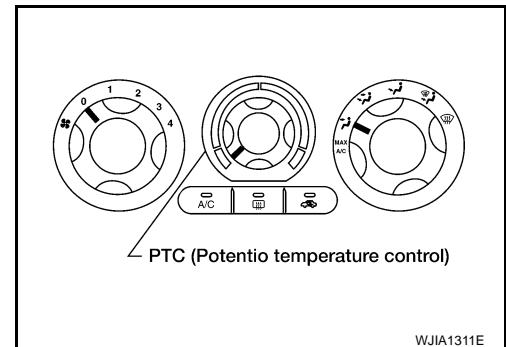

Front Air Control Component Function Check

INFOID:000000001366825

SYMPTOM: A/C system does not come on.

INSPECTION FLOW

1. CONFIRM SYMPTOM BY PERFORMING OPERATIONAL CHECK

1. Turn blower control dial to position 1-4, then press A/C switch.
2. Confirm that the compressor clutch engages (sound or visual inspection).

Can a symptom be duplicated?

- YES >> GO TO 3.
- NO >> GO TO 2.

2. PERFORM COMPLETE OPERATIONAL CHECK

Perform a complete operational check and check for any symptoms. Refer to [HAC-123, "Operational Check"](#).

Can a symptom be duplicated?

- YES >> Refer to [HAC-171, "Symptom Matrix Chart"](#).
- NO >> System OK.

3. CHECK FOR SERVICE BULLETINS

Check for any service bulletins.

>> GO TO 4.

4. CHECK POWER AND GROUND CIRCUIT

Check main power supply and ground circuit. Refer to [HAC-160, "Front Air Control Power and Ground Diagnosis Procedure"](#).

A
B
C
D
E
F
G
H
HAC
J
K
L
M
N
O
P

POWER SUPPLY AND GROUND CIRCUIT FOR CONTROLLER

[MANUAL AIR CONDITIONER]

< COMPONENT DIAGNOSIS >

Is the inspection result normal?

YES >> System OK.

NO >> Replace front air control. Refer to XX-XX, "*****".

Front Air Control Power and Ground Diagnosis Procedure

INFOID:000000001366826

DIAGNOSTIC PROCEDURE FOR A/C SYSTEM

SYMPTOM: A/C system does not come on.

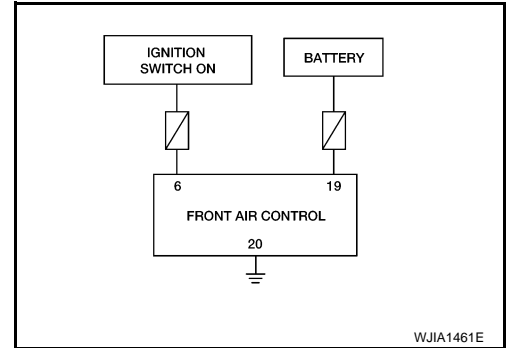

1. CHECK POWER SUPPLY CIRCUITS FOR FRONT AIR CONTROL

1. Turn ignition switch OFF.
2. Disconnect front air control connector.
3. Turn ignition switch ON.
4. Check voltage between front air control harness connector M49 terminals 6 and 19, and ground.

Terminals		Ignition switch position			
(+)		(-)	OFF	ACC	ON
Front air control connector	Terminal No.				
M49	6	Ground	Approx. 0V	Approx. 0V	Battery voltage
M49	19		Battery voltage	Battery voltage	Battery voltage

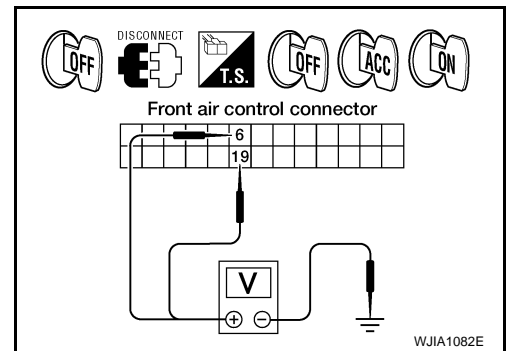

Is the inspection result normal?

YES >> GO TO 2.

NO >> Check 10A fuses [Nos. 8 and 19, located in the fuse block (J/B)]. Refer to XX-XX, "*****".

- If fuses are OK, check harness for open circuit. Repair or replace as necessary.
- If fuses are NG, replace fuse and check harness for short circuit. Repair or replace as necessary.

2. CHECK GROUND CIRCUIT FOR FRONT AIR CONTROL

1. Turn ignition switch OFF.
2. Check continuity between front air control harness connector M49 terminal 20 and ground.

20 - Ground : Continuity should exist.

Is the inspection result normal?

YES >> Replace front air control. Refer to XX-XX, "*****".

NO >> Repair harness or connector.

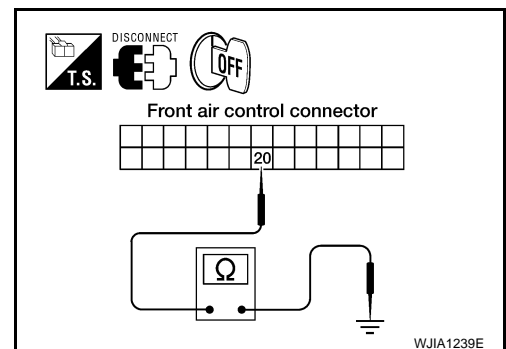

ECU DIAGNOSIS

AIR CONDITIONER CONTROL

System Description

INFOID:000000001381668

The front air control provides regulation of the vehicle's interior temperature. The system is based on the position of the front air controls temperature switch selected by the driver. This is done by utilizing a microcomputer, also referred to as the front air control, which receives input signals from the following two sensors:

- Intake sensor
- PBR (position balanced resistor)

The front air control uses these signals (including the set position of the temperature switch) to control:

- Outlet air volume
- Air temperature
- Air distribution

System Operation

INFOID:000000001381717

AIR MIX DOOR CONTROL

The air mix door is controlled so that in-vehicle temperature changed based on the position of the temperature control dial.

BLOWER SPEED CONTROL

Blower speed is controlled based on front blower switch settings.

When blower switch is turned, the blower motor starts and increases air flow volume each time the blower switch is turned counterclockwise, and decreases air flow volume each time the blower switch is turned clockwise.

When engine coolant temperature is low, the blower motor operation is delayed to prevent cool air from flowing.

INTAKE DOORS CONTROL

The intake doors are controlled by the recirculation switch setting, and the mode (defroster) switch setting.

MODE DOOR CONTROL

The mode door is controlled by the position of the mode dial.

DEFROSTER DOOR CONTROL

The defroster door is controlled by the defroster dial set to defroster.

MAGNET CLUTCH CONTROL

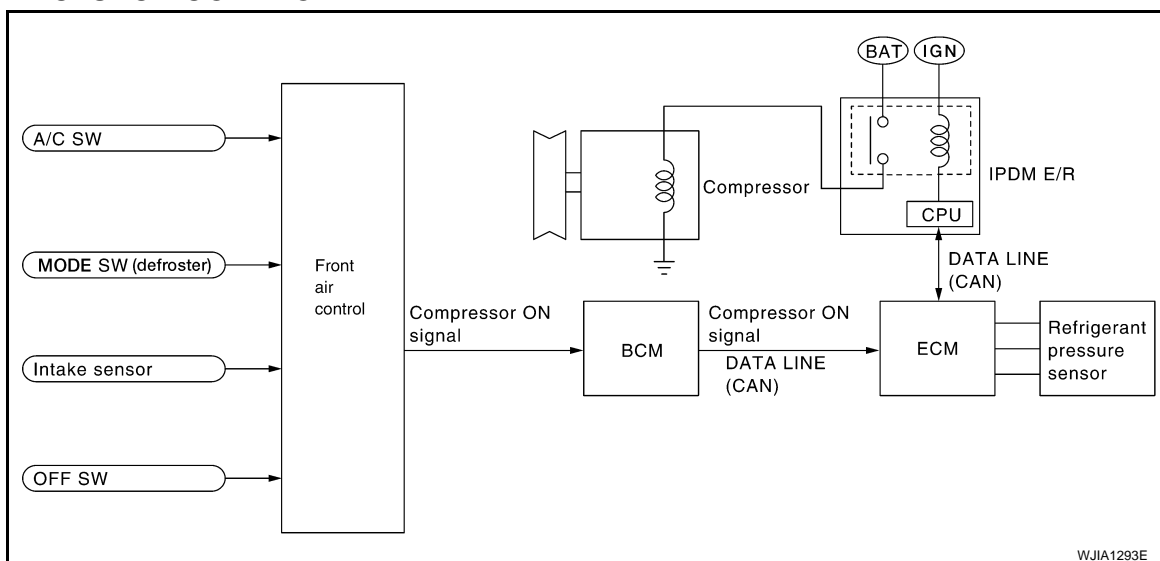

When the A/C switch is pressed, or the mode dial is turned to the defroster position, the front air control outputs a compressor ON signal to BCM.

The BCM then sends a compressor ON signal to ECM, via CAN communication line.

AIR CONDITIONER CONTROL

< ECU DIAGNOSIS >

[MANUAL AIR CONDITIONER]

ECM judges whether compressor can be turned ON, based on each sensor status (refrigerant pressure sensor signal, throttle angle sensor, etc.). If it judges compressor can be turned ON, it sends compressor ON signal to IPDM E/R, via CAN communication line.

Upon receipt of compressor ON signal from ECM, IPDM E/R turns air conditioner relay ON to operate compressor.

Front Air Control Terminals Reference Values

INFOID:000000001366779

Measure voltage between each terminal and ground by following Terminals and Reference Values for front air control.

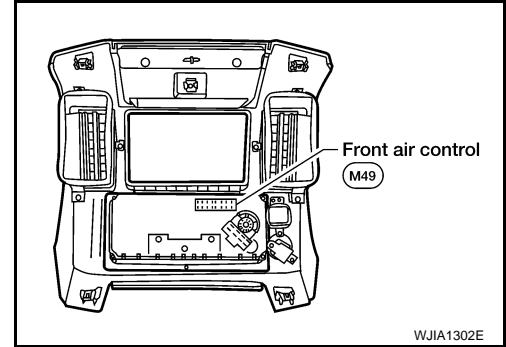

FRONT AIR CONTROL HARNESS CONNECTOR TERMINAL LAYOUT

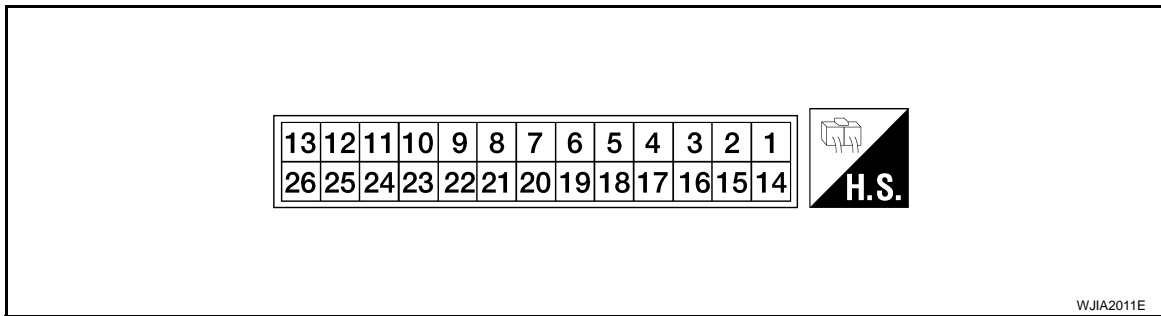

TERMINALS AND REFERENCE VALUES FOR FRONT AIR CONTROL

Terminal No.	Wire color	Item	Ignition switch	Condition	Voltage (V) (Approx.)
1	BR	Mode door motor CW	ON	Clockwise rotation	Battery voltage
2	W	Air mix door motor (Driver) CW	ON	Clockwise rotation	Battery voltage
3	GR	Air mix door motor (Driver) CCW	ON	Counterclockwise rotation	Battery voltage
4	Y	Intake door motor CW	ON	Clockwise rotation	Battery voltage
5	O	Intake door motor CCW	ON	Counterclockwise rotation	Battery voltage
6	W/G	Power supply for IGN	ON	-	Battery voltage
8	G	Illumination +	ON	Park lamps ON	Battery voltage
9	BR	Illumination -	-	Park lamps ON	<p>The diagram shows a square wave pulse train. The vertical axis is labeled '(V)' with markings at 0, 5, 10, and 15. The horizontal axis is labeled '200 ms' with a double-headed arrow indicating the pulse width. The pulses reach a peak voltage of approximately 10V. The diagram is labeled 'PIIA2344E' in the bottom right corner.</p>
10	W	Compressor ON signal	ON	A/C switch OFF	5V
			ON	A/C switch ON	0V
11	Y	Rear defrost request	ON	-	Battery voltage
12	L	Intake sensor	ON	-	0 - 5V
13	V	Sensor ground	ON	-	0 - 5V
14	R	Mode door motor CCW	ON	Counterclockwise rotation	Battery voltage

AIR CONDITIONER CONTROL

< ECU DIAGNOSIS >

[MANUAL AIR CONDITIONER]

Terminal No.	Wire color	Item	Ignition switch	Condition	Voltage (V) (Approx.)
18	BR	Front blower monitor	ON	Front blower motor OFF	Battery voltage
				Front blower motor ON	0V
19	R/Y	Power supply for BAT	-	-	Battery voltage
20	B	Ground	-	-	0V
21	V	Mode door motor feedback	ON	-	0 - 5V
22	SB	Air mix door motor (Front) feedback	ON	-	0 - 5V
23	G	Power supply for mode door motor and air mix door motor (Front) PBR	ON	-	5V
25	R	Rear defroster request	ON	-	Battery voltage
26	P	Ground for mode door motor and air mix door motor (Front) PBR	ON	-	0V

A
B
C
D
E
F
G
H
J
K
L
M
N
O
P

HAC

AIR CONDITIONER CONTROL

[MANUAL AIR CONDITIONER]

< ECU DIAGNOSIS >

Wiring Diagram

INFOID:000000001366780

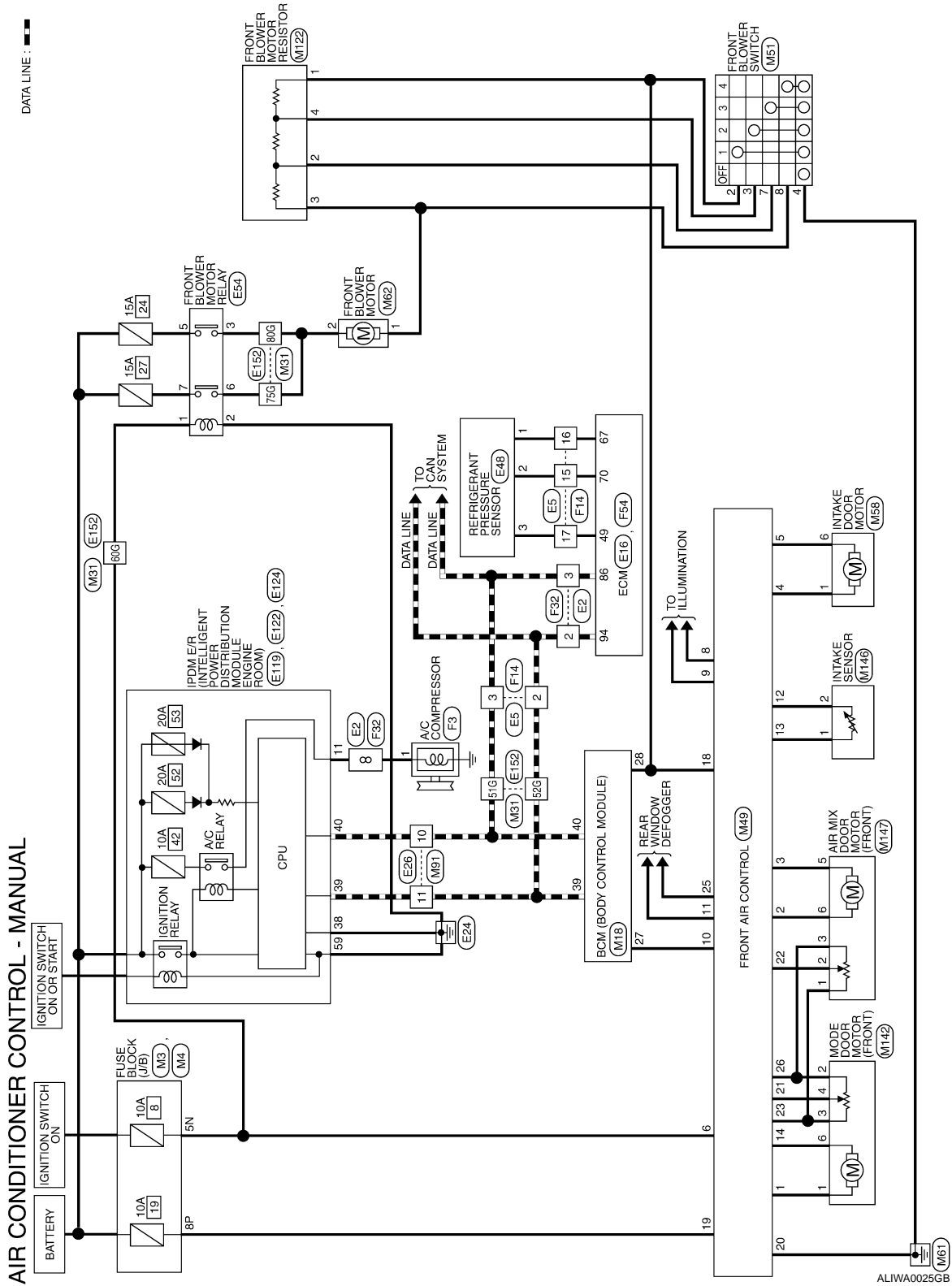

ALIWA0025GB

AIR CONDITIONER CONTROL CONNECTORS - MANUAL

Connector No.	M3
Connector Name	FUSE BLOCK (J/B)
Connector Color	WHITE

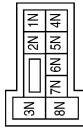

Terminal No.	Color of Wire	Signal Name
5N	W/G	-

Connector No.	M4
Connector Name	FUSE BLOCK (J/B)
Connector Color	WHITE



Terminal No.	Color of Wire	Signal Name
8P	R/Y	-

Connector No.	M18
Connector Name	BCM
Connector Color	WHITE

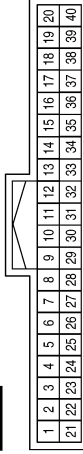

Terminal No.	Color of Wire	Signal Name
27	W	AIRCON_SW
28	LG	BLOWER_FAN_SW
39	L	CAN-H
40	P	CAN-L

Connector No.	M31
Connector Name	WIRE TO WIRE
Connector Color	WHITE

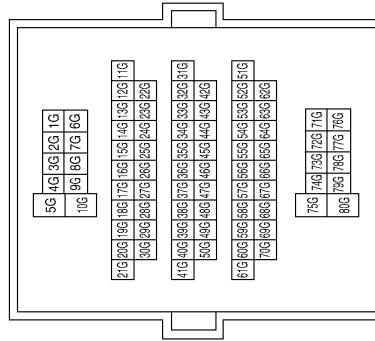

Terminal No.	Color of Wire	Signal Name
51G	P	-
52G	L	-
60G	W/G	-
75G	W/G	-
80G	W/G	-

A
B
C
D
E
F
G
H
HAC
J
K
L
M
N
O
P

AIR CONDITIONER CONTROL

< ECU DIAGNOSIS >

[MANUAL AIR CONDITIONER]

Terminal No.	Color of Wire	Signal Name
25	R	REAR DEFROST STATUS
26	P	V_REF_RETURN

Terminal No.	Color of Wire	Signal Name
8	G	-
9	BR	-
10	W	A/C_REQUEST
11	Y	REAR DEFROST REQUEST
12	L	EVAP_AIR_TEMP_SENS
13	V	SENS_RETURN
14	R	PANEL/FLOOR_CCW
18	BR	FR_BLOWER_MONITOR
19	R/Y	VB
20	B	GND
21	V	PANEL/FLOOR_FEED_BACK
22	SB	DR_BLEND_DR_FEED_BACK
23	G	V_REF.ACTR(5V)

Connector No.	M49
Connector Name	FRONT AIR CONTROL
Connector Color	BLACK

13	12	11	10	9	8	7	6	5	4	3	2	1
26	25	24	23	22	21	20	19	18	17	16	15	14



Terminal No.	Color of Wire	Signal Name
1	BR	PANEL/FLOOR_CW
2	W	DR_BLEND_DR_CW
3	GR	DR_BLEND_DR_CCW
4	Y	RECIRC_DOOR_CW
5	O	RECIRC_DOOR_CCW
6	W/G	IGN

Connector No.	M62
Connector Name	FRONT BLOWER MOTOR
Connector Color	BLACK



Terminal No.	Color of Wire	Signal Name
1	L	-
2	W/G	-

Connector No.	M58
Connector Name	INTAKE DOOR MOTOR
Connector Color	BLACK

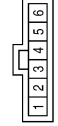

Terminal No.	Color of Wire	Signal Name
1	Y	-
6	O	-

Connector No.	M51
Connector Name	FRONT BLOWER SWITCH
Connector Color	WHITE



Terminal No.	Color of Wire	Signal Name
2	BR	-
3	SB	-
4	B	-
7	Y	-
8	W	-

ALIIA0073GB

AIR CONDITIONER CONTROL

[MANUAL AIR CONDITIONER]

< ECU DIAGNOSIS >

Connector No.	M142
Connector Name	MODE DOOR MOTOR
Connector Color	BLACK

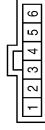

Terminal No.	Color of Wire	Signal Name
1	BR	-
2	P	-
3	G	-
4	V	-
6	R	-

Connector No.	M122
Connector Name	FRONT BLOWER MOTOR RESISTOR
Connector Color	WHITE

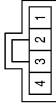

Terminal No.	Color of Wire	Signal Name
1	R	-
2	Y	-
3	L	-
4	SB	-

Connector No.	M91
Connector Name	WIRE TO WIRE
Connector Color	WHITE

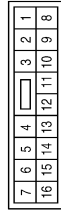

Terminal No.	Color of Wire	Signal Name
10	P	-
11	L	-

Connector No.	E2
Connector Name	WIRE TO WIRE
Connector Color	WHITE



Terminal No.	Color of Wire	Signal Name
2	L	-
3	P	-
8	Y	-

Connector No.	M147
Connector Name	AIR MIX DOOR (FRONT)
Connector Color	BLACK

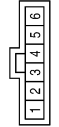

Terminal No.	Color of Wire	Signal Name
1	Y	-
2	SB	-
3	P	-
5	GR	-
6	W	-

Connector No.	M146
Connector Name	INTAKE SENSOR
Connector Color	WHITE



Terminal No.	Color of Wire	Signal Name
1	V	-
2	L	-

ALIIA0074GB

A
B
C
D
E
F
G
H
HAC
J
K
L
M
N
O
P

AIR CONDITIONER CONTROL

[MANUAL AIR CONDITIONER]

< ECU DIAGNOSIS >

Connector No.	E5
Connector Name	WIIRE TO WIRE
Connector Color	WHITE

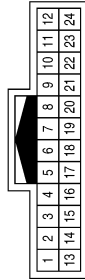

Terminal No.	Color of Wire	Signal Name
2	L	-
3	P	-
15	BR	-
16	B	-
17	P	-

Connector No.	E16
Connector Name	ECM
Connector Color	BLACK

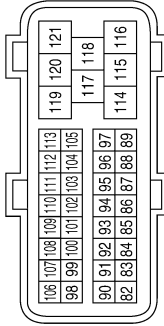

Terminal No.	Color of Wire	Signal Name
86	P	CAN-L
94	L	CAN-H

Connector No.	E26
Connector Name	WIIRE TO WIRE
Connector Color	WHITE

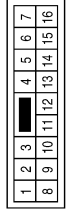

Terminal No.	Color of Wire	Signal Name
10	P	-
11	L	-

Connector No.	E48
Connector Name	REFRIGERANT PRESSURE SENSOR
Connector Color	BLACK



Terminal No.	Color of Wire	Signal Name
1	B	GND
2	BR	SIGNAL
3	P	POWER_SUPPLY

Connector No.	E54
Connector Name	FRONT BLOWER MOTOR RELAY
Connector Color	BROWN



Terminal No.	Color of Wire	Signal Name
1	W/G	-
2	B	-
3	W/G	-
5	L	-
6	W/G	-
7	GR	-

Connector No.	E119
Connector Name	IPDM E/R (INTELLIGENT POWER DISTRIBUTION MODULE ENGINE ROOM)
Connector Color	WHITE

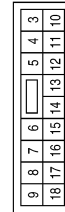

Terminal No.	Color of Wire	Signal Name
11	Y	A/C_COMPRESSOR

ALIIA0075GB

AIR CONDITIONER CONTROL

[MANUAL AIR CONDITIONER]

< ECU DIAGNOSIS >

Connector No.	E124
Connector Name	IPDM E/R (INTELLIGENT POWER DISTRIBUTION MODULE ENGINE ROOM)
Connector Color	WHITE



Terminal No.	Color of Wire	Signal Name
59	B	GROUND

Connector No.	E122
Connector Name	IPDM E/R (INTELLIGENT POWER DISTRIBUTION MODULE ENGINE ROOM)
Connector Color	WHITE

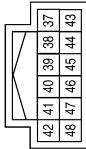

Terminal No.	Color of Wire	Signal Name
38	B	SIGNAL_GND
39	L	CAN-H
40	P	CAN-L

Connector No.	F3
Connector Name	A/C COMPRESSOR
Connector Color	BLACK



Terminal No.	Color of Wire	Signal Name
1	Y	-

Terminal No.	Color of Wire	Signal Name
51G	P	-
52G	L	-
60G	W/G	-
75G	W/G	-
80G	W/G	-

Connector No.	E152
Connector Name	WIRING TO WIRING
Connector Color	BLACK

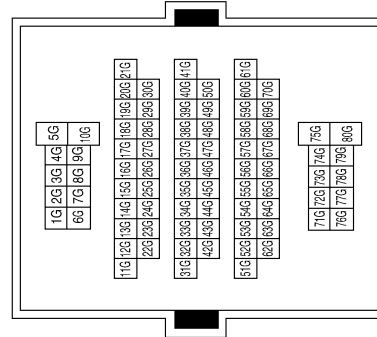

ALIIA0076GB

A
B
C
D
E
F
G
H
HAC
J
K
L
M
N
O
P

AIR CONDITIONER CONTROL

< ECU DIAGNOSIS >

[MANUAL AIR CONDITIONER]

Connector No.	F54
Connector Name	ECM
Connector Color	BLACK



63	64	65	66	67	68	69	70	71	72	73	74	75	76	77	78	79	80	81	2	1
44	45	46	47	48	49	50	51	52	53	54	55	56	57	58	59	60	61	62		
25	26	27	28	29	30	31	32	33	34	35	36	37	38	39	40	41	42	43	3	
6	7	8	9	10	11	12	13	14	15	16	17	18	19	20	21	22	23	24	5	4

Terminal No.	Color of Wire	Signal Name
49	P	AVCC(PDPRES)
67	B	GND-A
70	BR	PDPRES

Connector No.	F32
Connector Name	WIRE TO WIRE
Connector Color	WHITE



7	6	5	4	3	2	1		
16	15	14	13	12	11	10	9	8

Terminal No.	Color of Wire	Signal Name
2	L	-
3	P	-
8	Y	-

Connector No.	F14
Connector Name	WIRE TO WIRE
Connector Color	WHITE



12	11	10	9	8	7	6	5	4	3	2	1
24	23	22	21	20	19	18	17	16	15	14	13

Terminal No.	Color of Wire	Signal Name
2	L	-
3	P	-
15	BR	-
16	B	-
17	P	-

ALIA0077GB

SYMPTOM DIAGNOSIS

AIR CONDITIONER CONTROL

Symptom Matrix Chart

INFOID:000000001366770

SYMPTOM TABLE

Symptom	Reference Page	
A/C system does not come on.	Go to Trouble Diagnosis Procedure for A/C System.	HAC-159
Air outlet does not change.	Go to Trouble Diagnosis Procedure for Mode Door Motor.	HAC-135
Mode door motor is malfunctioning.		
Discharge air temperature does not change.	Go to Trouble Diagnosis Procedure for Air Mix Door Motor.	HAC-140
Air mix door motor is malfunctioning.		
Intake door does not change.	Go to Trouble Diagnosis Procedure for Intake Door Motor.	HAC-143
Intake door motor is malfunctioning.		
Front blower motor operation is malfunctioning.	Go to Trouble Diagnosis Procedure for Front Blower Motor.	HAC-146
Magnet clutch does not engage.	Go to Trouble Diagnosis Procedure for Magnet Clutch.	HAC-152
Insufficient cooling	Go to Trouble Diagnosis Procedure for Insufficient Cooling.	HAC-172
Insufficient heating	Go to Trouble Diagnosis Procedure for Insufficient Heating.	HAC-181
Noise	Go to Trouble Diagnosis Procedure for Noise.	HAC-183

A
B
C
D
E
F
G
H
J
K
L
M
N
O
P

HAC

< SYMPTOM DIAGNOSIS >

INSUFFICIENT COOLING

Component Function Check

INFOID:000000001366771

SYMPTOM: Insufficient cooling

INSPECTION FLOW

1. CONFIRM SYMPTOM BY PERFORMING OPERATIONAL CHECK - TEMPERATURE DECREASE

1. Turn temperature control dial counterclockwise to maximum cold.
2. Check for cold air at discharge air outlets.

Can the symptom be duplicated?

- YES >> GO TO 3.
NO >> GO TO 2.

2. CHECK FOR ANY SYMPTOMS

Perform a complete operational check for any symptoms. Refer to XX-XX, "*****".

Does another symptom exist?

- YES >> Refer to XX-XX, "*****".
NO >> System OK.

3. CHECK FOR SERVICE BULLETINS

Check for any service bulletins.

>> GO TO 4.

4. CHECK DRIVE BELTS

Check compressor belt tension. Refer to XX-XX, "*****".

Is the inspection result normal?

- YES >> GO TO 5.
NO >> Adjust or replace compressor belt. Refer to XX-XX, "*****".

5. CHECK AIR MIX DOOR OPERATION

Check and verify air mix door mechanism for smooth operation.

Does air mix door operate correctly?

- YES >> GO TO 6.
NO >> Repair or replace air mix door control linkage.

6. CHECK COOLING FAN MOTOR OPERATION

Check and verify cooling fan motor for smooth operation. Refer to XX-XX, "*****".

Does cooling fan motor operate correctly?

- YES >> GO TO 7.
NO >> Check cooling fan motor. Refer to XX-XX, "*****".

7. CHECK RECOVERY/RECYCLING EQUIPMENT BEFORE USAGE

Check recovery/recycling equipment before connecting to vehicle. Verify there is no pressure in the recovery/recycling equipment by checking the gauges. If pressure exists, recover refrigerant from equipment lines.

>> GO TO 8.

8. CHECK REFRIGERANT PURITY

1. Connect recovery/recycling equipment to vehicle.
2. Confirm refrigerant purity in supply tank using recovery/recycling and refrigerant identifier.

Is the inspection result normal?

- YES >> GO TO 9.
NO >> Check contaminated refrigerant. Refer to XX-XX, "*****".

INSUFFICIENT COOLING

< SYMPTOM DIAGNOSIS >

[MANUAL AIR CONDITIONER]

9.CHECK FOR EVAPORATOR FREEZE UP

Start engine and run A/C. Check for evaporator freeze up.

Does evaporator freeze up?

YES >> Perform performance test diagnoses. Refer to XX-XX, "*****".

NO >> GO TO 10.

10.CHECK REFRIGERANT PRESSURE

Check refrigerant pressure with manifold gauge connected. Refer to XX-XX, "*****".

OK or NG

OK >> Perform performance test diagnoses. Refer to XX-XX, "*****".

NG >> GO TO 11.

11.CHECK AIR DUCTS

Check ducts for air leaks.

Is the inspection result normal?

YES >> System OK.

NO >> Repair air leaks.

Performance Test Diagnoses

INFOID:000000001366772

PERFORMANCE TEST DIAGNOSES

A
B
C
D
E
F
G
H
J
K
L
M
N
O
P

HAC

INSUFFICIENT COOLING

< SYMPTOM DIAGNOSIS >

[MANUAL AIR CONDITIONER]

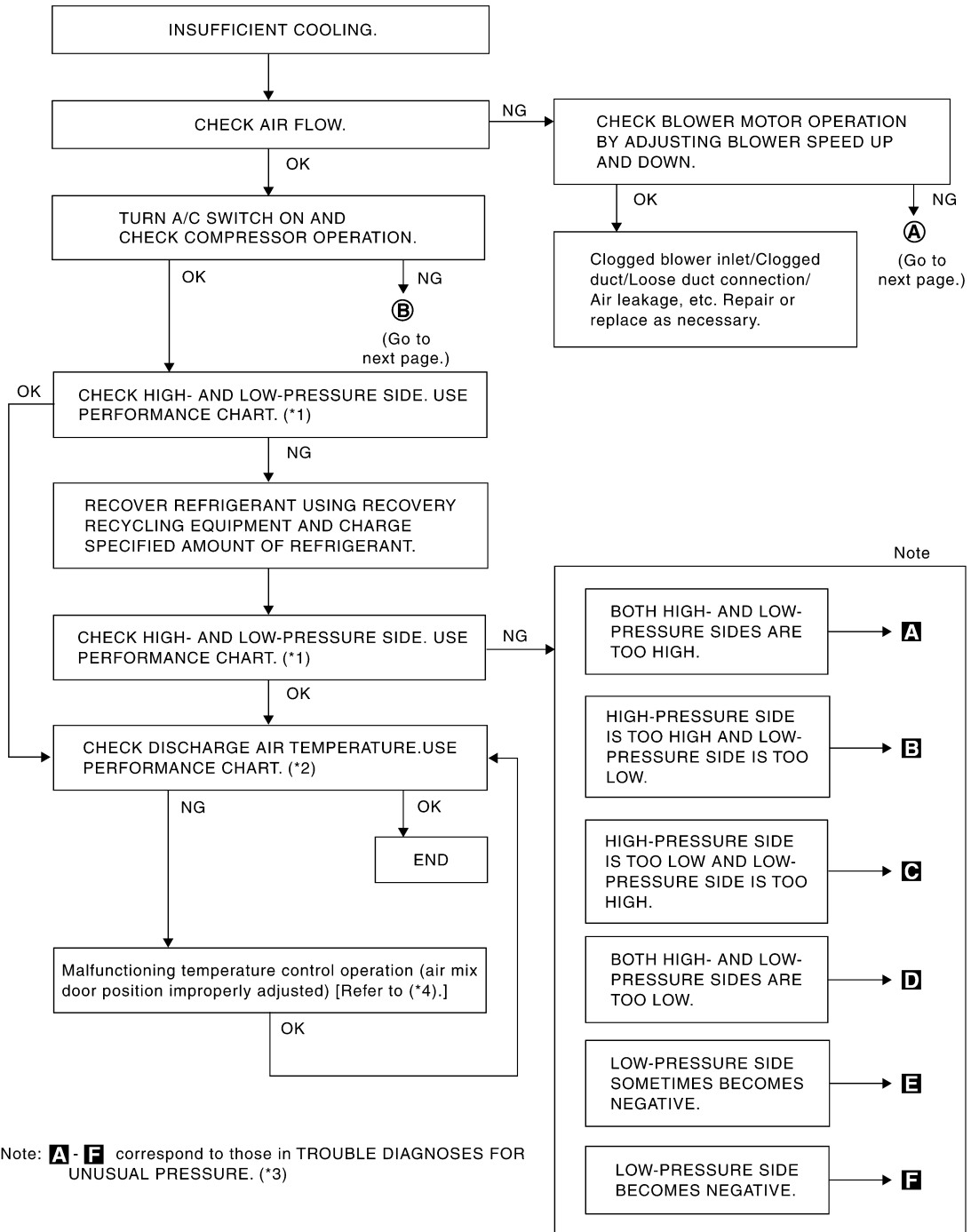

Note: **A - F** correspond to those in TROUBLE DIAGNOSES FOR UNUSUAL PRESSURE. (*3)

RJIA1601E

*1 XX-XX, "*****"

*2 "Test Reading"

*3 XX-XX, "*****"

*4 XX-XX, "*****"

INSUFFICIENT COOLING

< SYMPTOM DIAGNOSIS >

[MANUAL AIR CONDITIONER]

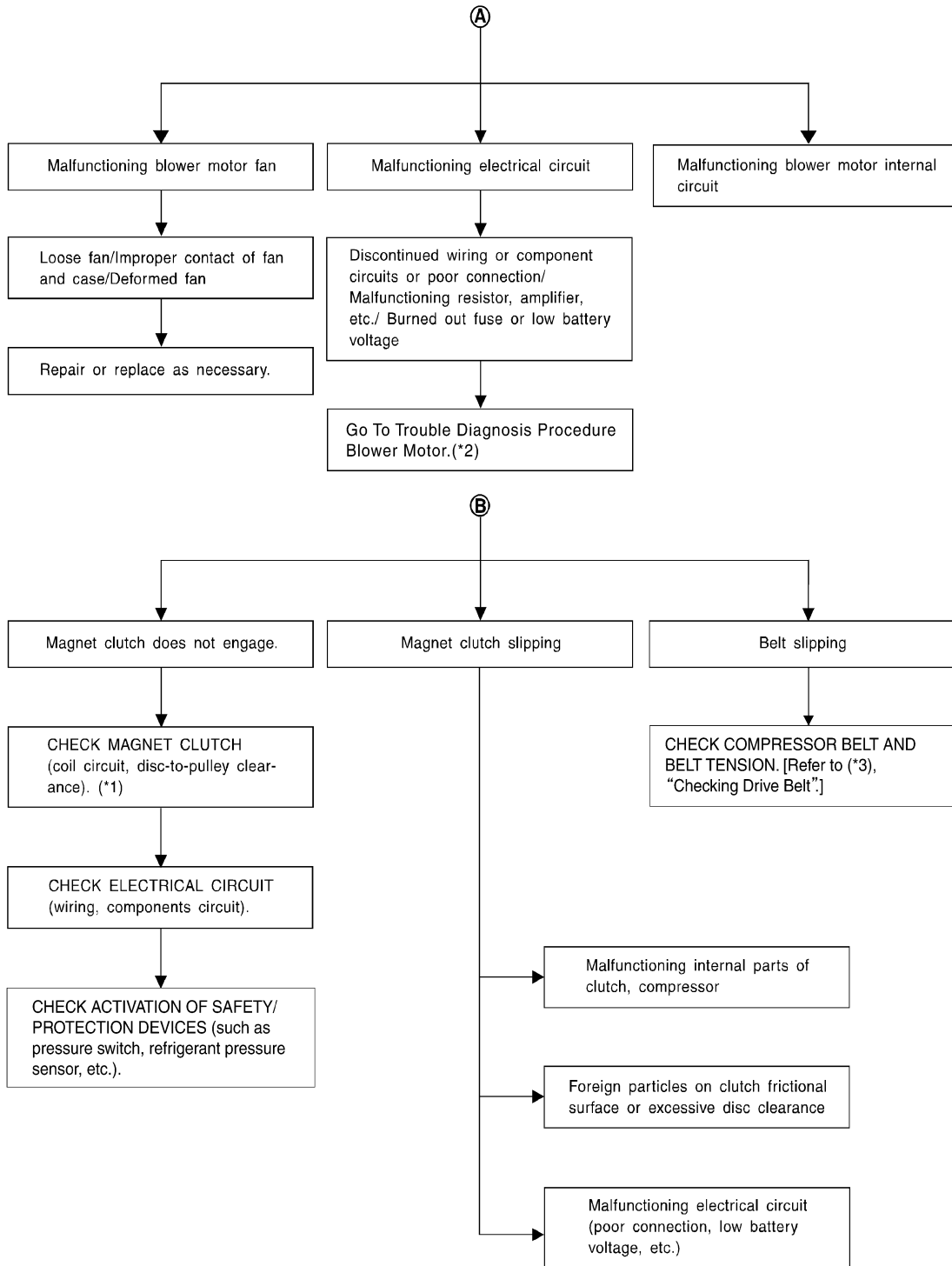

A
B
C
D
E
F
G
H
I
J
K
L
M
N
O
P

HAC

RJA3107E

*1 XX-XX, "*****"

*2 XX-XX, "*****"

*3 XX-XX, "*****"

Performance Chart

PERFORMANCE CHART

Test Condition



INFOID:000000001366773

INSUFFICIENT COOLING

< SYMPTOM DIAGNOSIS >

[MANUAL AIR CONDITIONER]

Testing must be performed as follows:

Vehicle location	Indoors or in the shade (in a well-ventilated place)
Doors	Closed
Door window	Open
Hood	Open
TEMP.	Max. COLD
Mode switch	 (Ventilation) set
Recirculation (REC) switch	 (Recirculation) set
 Blower speed	Max. speed set
Engine speed	Idle speed

Operate the air conditioning system for 10 minutes before taking measurements.

Test Reading

INFOID:000000001366774

Inside air (Recirculating air) at blower assembly inlet		Discharge air temperature at center ventilator °C (°F)
Relative humidity %	Air temperature °C (°F)	
50 - 60	20 (68)	5.3 - 6.5 (42 - 44)
	25 (77)	9.7 - 11.5 (49 - 53)
	30 (86)	13.8 - 16.3 (57 - 61)
	35 (95)	18.0 - 21.2 (64 - 70)
	40 (104)	22.2 - 25.7 (72 - 78)
60 - 70	20 (68)	6.5 - 7.7 (44 - 46)
	25 (77)	11.5 - 13.3 (53 - 56)
	30 (86)	16.3 - 18.8 (61 - 66)
	35 (95)	21.2 - 24.0 (70 - 75)
	40 (104)	25.7 - 29.2 (78 - 85)

Ambient Air Temperature-to-operating Pressure Table

Ambient air		High-pressure (Discharge side) kPa (kg/cm ² , psi)	Low-pressure (Suction side) kPa (kg/cm ² , psi)
Relative humidity %	Air temperature °C (°F)		
50 - 70	20 (68)	680 - 840 (6.94 - 8.57, 98.6 - 121.8)	160 - 198 (1.63 - 2.02, 23.2 - 28.7)
	25 (77)	800 - 985 (8.16 - 10.05, 116.0 - 142.8)	198 - 245 (2.02 - 2.50, 28.7 - 35.5)
	30 (86)	940 - 1,150 (9.59 - 11.73, 136.3 - 166.8)	225 - 278 (2.30 - 2.84, 32.6 - 40.3)
	35 (95)	1,160 - 1,410 (11.83 - 14.38, 168.2 - 204.5)	273 - 335 (2.78 - 3.42, 39.6 - 48.6)
	40 (104)	1,325 - 1,620 (13.52 - 16.52, 192.1 - 234.9)	325 - 398 (3.32 - 4.06, 47.1 - 57.7)

Recirculating-to-discharge Air Temperature Table

INSUFFICIENT COOLING

< SYMPTOM DIAGNOSIS >

[MANUAL AIR CONDITIONER]

Inside air (Recirculating air) at blower assembly inlet		Discharge air temperature at center ventilator °C (°F)
Relative humidity %	Air temperature °C (°F)	
50 - 60	20 (68)	9.9 - 13.9 (50 - 57)
	25 (77)	14.6 - 18.6 (58 - 65)
	30 (86)	16.8 - 21.8 (62 - 71)
	35 (95)	21.1 - 27.1 (70 - 81)
	40 (104)	25.3 - 31.5 (78 - 89)
60 - 70	20 (68)	11.4 - 15.2 (53 - 59)
	25 (77)	15.5 - 20.0 (60 - 68)
	30 (86)	19.9 - 25.0 (68 - 77)
	35 (95)	24.5 - 29.6 (76 - 85)
	40 (104)	28.7 - 34.9 (84 - 95)

Ambient Air Temperature-to-operating Pressure Table

Ambient air		High-pressure (Discharge side) kPa (kg/cm ² , psi)	Low-pressure (Suction side) kPa (kg/cm ² , psi)
Relative humidity %	Air temperature °C (°F)		
50 - 70	20 (68)	1020 - 1250 (10.4 - 12.7, 147.9 - 181.3)	160 - 190 (1.63 - 1.94, 23.2 - 27.6)
	25 (77)	1236 - 1510 (12.6 - 15.4, 179.2 - 219)	206 - 245 (2.1 - 2.5, 29.9 - 35.6)
	30 (86)	1569 - 1,922 (16.0 - 19.6, 227.6 - 278.8)	265 - 324 (2.7 - 3.3, 38.4 - 46.9)
	35 (95)	1,697 - 2079 (17.3 - 21.2, 246.1 - 301.5)	304 - 363 (3.1 - 3.7, 44.1 - 52.6)
	40 (104)	1971 - 2403 (20.1 - 24.5, 285.9 - 348.5)	373 - 451 (3.8 - 4.6, 54.0 - 65.4)

Trouble Diagnoses for Unusual Pressure

INFOID:000000001366775

Trouble Diagnoses for Unusual Pressure

Whenever system's high and/or low side pressure is unusual, diagnose using a manifold gauge. The marker above the gauge scale in the following tables indicates the standard (usual) pressure range. Since the standard (usual) pressure, however, differs from vehicle to vehicle, refer to above table (Ambient air temperature-to-operating pressure table).

Both High- and Low-pressure Sides are Too High

INSUFFICIENT COOLING

< SYMPTOM DIAGNOSIS >

[MANUAL AIR CONDITIONER]

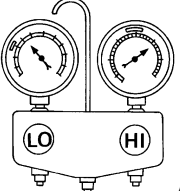
Gauge indication	Refrigerant cycle	Probable cause	Corrective action
<p>Both high- and low-pressure sides are too high.</p>  <p style="text-align: right; font-size: small;">AC359A</p>	<p>Pressure is reduced soon after water is splashed on condenser.</p>	<p>Excessive refrigerant charge in refrigeration cycle</p>	<p>Reduce refrigerant until specified pressure is obtained.</p>
	<p>Air suction by cooling fan is insufficient.</p>	<p>Insufficient condenser cooling performance ↓ 1. Condenser fins are clogged. 2. Improper fan rotation of cooling fan</p>	<ul style="list-style-type: none"> • Clean condenser. • Check and repair cooling fan if necessary.
	<ul style="list-style-type: none"> • Low-pressure pipe is not cold. • When compressor is stopped high-pressure value quickly drops by approximately 196 kPa (2 kg/cm², 28 psi). It then decreases gradually thereafter. 	<p>Poor heat exchange in condenser (After compressor operation stops, high-pressure decreases too slowly.) ↓ Air in refrigeration cycle</p>	<p>Evacuate and recharge system.</p>
	<p>Engine tends to overheat.</p>	<p>Engine cooling systems malfunction.</p>	<p>Check and repair engine cooling system.</p>
	<ul style="list-style-type: none"> • An area of the low-pressure pipe is colder than areas near the evaporator outlet. • Plates are sometimes covered with frost. 	<ul style="list-style-type: none"> • Excessive liquid refrigerant on low-pressure side • Excessive refrigerant discharge flow • Expansion valve is open a little compared with the specification. <p>↓ Improper expansion valve adjustment</p>	<p>Replace expansion valve.</p>

High-pressure Side is Too High and Low-pressure Side is Too Low

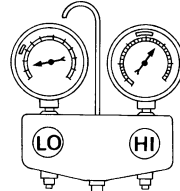
Gauge indication	Refrigerant cycle	Probable cause	Corrective action
<p>High-pressure side is too high and low-pressure side is too low.</p>  <p style="text-align: right; font-size: small;">AC360A</p>	<p>Upper side of condenser and high-pressure side are hot, however, liquid tank is not so hot.</p>	<p>High-pressure tube or parts located between compressor and condenser are clogged or crushed.</p>	<ul style="list-style-type: none"> • Check and repair or replace malfunctioning parts. • Check oil for contamination.

High-pressure Side is Too Low and Low-pressure Side is Too High

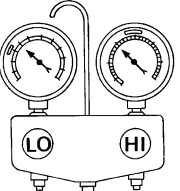
Gauge indication	Refrigerant cycle	Probable cause	Corrective action
<p>High-pressure side is too low and low-pressure side is too high.</p>  <p style="text-align: right; font-size: small;">AC356A</p>	<p>High- and low-pressure sides become equal soon after compressor operation stops.</p>	<p>Compressor pressure operation is improper. ↓ Damaged inside compressor packings.</p>	<p>Replace compressor.</p>
	<p>No temperature difference between high- and low-pressure sides.</p>	<p>Compressor pressure operation is improper. ↓ Damaged inside compressor packings.</p>	<p>Replace compressor.</p>

Both High- and Low-pressure Sides are Too Low

INSUFFICIENT COOLING

< SYMPTOM DIAGNOSIS >

[MANUAL AIR CONDITIONER]

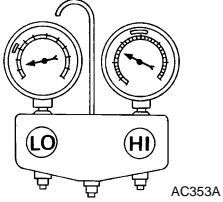
Gauge indication	Refrigerant cycle	Probable cause	Corrective action
<p>Both high- and low-pressure sides are too low.</p>  <p style="text-align: right; font-size: small;">AC353A</p>	<ul style="list-style-type: none"> There is a big temperature difference between liquid tank outlet and inlet. Outlet temperature is extremely low. Liquid tank inlet and expansion valve are frosted. 	Liquid tank inside is slightly clogged.	<ul style="list-style-type: none"> Replace liquid tank. Check oil for contamination.
	<ul style="list-style-type: none"> Temperature of expansion valve inlet is extremely low as compared with areas near liquid tank. Expansion valve inlet may be frosted. Temperature difference occurs somewhere in high-pressure side. 	High-pressure pipe located between liquid tank and expansion valve is clogged.	<ul style="list-style-type: none"> Check and repair malfunctioning parts. Check oil for contamination.
	Expansion valve and liquid tank are warm or only cool when touched.	Low refrigerant charge. ↓ Leaking fittings or components.	Check refrigerant system for leaks. Refer to XX-XX, "*****".
	There is a big temperature difference between expansion valve inlet and outlet while the valve itself is frosted.	Expansion valve closes a little compared with the specification. ↓ 1. Improper expansion valve adjustment. 2. Malfunctioning expansion valve. 3. Outlet and inlet may be clogged.	<ul style="list-style-type: none"> Remove foreign particles by using compressed air. Check oil for contamination.
	An area of the low-pressure pipe is colder than areas near the evaporator outlet.	Low-pressure pipe is clogged or crushed.	<ul style="list-style-type: none"> Check and repair malfunctioning parts. Check oil for contamination.
	Air flow volume is too low.	Evaporator is frozen.	<ul style="list-style-type: none"> Check intake sensor circuit. Refer to XX-XX, "*****". Replace compressor. Repair evaporator fins. Replace evaporator. Refer to XX-XX, "*****".

Low-pressure Side Sometimes Becomes Negative

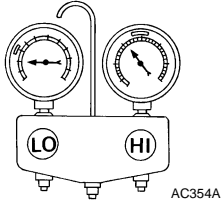
Gauge indication	Refrigerant cycle	Probable cause	Corrective action
<p>Low-pressure side sometimes becomes negative.</p>  <p style="text-align: right; font-size: small;">AC354A</p>	<ul style="list-style-type: none"> Air conditioning system does not function and does not cyclically cool the compartment air. The system constantly functions for a certain period of time after compressor is stopped and restarted. 	Refrigerant does not discharge cyclically. ↓ Moisture is frozen at expansion valve outlet and inlet. ↓ Water is mixed with refrigerant.	<ul style="list-style-type: none"> Drain water from refrigerant or replace refrigerant. Replace liquid tank.

Low-pressure Side Becomes Negative

INSUFFICIENT COOLING

< SYMPTOM DIAGNOSIS >

[MANUAL AIR CONDITIONER]

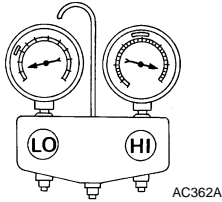
Gauge indication	Refrigerant cycle	Probable cause	Corrective action
<p>Low-pressure side becomes negative.</p> 	<p>Liquid tank or front/rear side of expansion valve's pipe is frosted or dewed.</p>	<p>High-pressure side is closed and refrigerant does not flow. ↓ Expansion valve or liquid tank is frosted.</p>	<p>Leave the system at rest until no frost is present. Start it again to check whether or not the malfunction is caused by water or foreign particles.</p> <ul style="list-style-type: none"> • If water is the cause, initially cooling is okay. Then the water freezes causing a blockage. Drain water from refrigerant or replace refrigerant. • If due to foreign particles, remove expansion valve and remove the particles with dry and compressed air (not shop air). • If either of the above methods cannot correct the malfunction, replace expansion valve. • Replace liquid tank. • Check oil for contamination.

INSUFFICIENT HEATING**Component Function Check**

INFOID:000000001366776

SYMPTOM: Insufficient heating

INSPECTION FLOW**1.CONFIRM SYMPTOM BY PERFORMING OPERATIONAL CHECK - TEMPERATURE INCREASE**

1. Rotate blower control dial clockwise.
2. Turn the temperature control dial clockwise to maximum heat.
3. Check for hot air at discharge air outlets.

Can the symptom be duplicated?

YES >> GO TO 2.

NO >> Perform complete operational check (front). Refer to XX-XX, "*****".

2.CHECK FOR SERVICE BULLETINS

Check for any service bulletins.

>> GO TO 3.

3.CHECK ENGINE COOLING SYSTEM

1. Check for proper engine coolant level. Refer to XX-XX, "*****".
2. Check hoses for leaks or kinks.
3. Check radiator cap. Refer to XX-XX, "*****".
4. Check for air in cooling system.

>> GO TO 4.

4.CHECK AIR MIX DOOR OPERATION

Check the operation of the air mix door.

OK or NG

OK >> GO TO 5.

NG >> Check the air mix door motor circuit. Refer to XX-XX, "*****".

5.CHECK AIR DUCTS

Check for disconnected or leaking air ducts.

OK or NG

OK >> GO TO 6.

NG >> Repair all disconnected or leaking air ducts.

6.CHECK HEATER HOSE TEMPERATURES

1. Start engine and warm it up to normal operating temperature.
2. Touch both the inlet and outlet heater hoses.

OK or NG

OK >> Hot inlet hose and a warm outlet hose: GO TO 7.

NG >> Both hoses warm: GO TO 8.

7.CHECK ENGINE COOLANT SYSTEM

Check engine coolant temperature sensor. Refer to XX-XX, "*****".

OK or NG

OK >> System OK.

NG >> Repair or replace as necessary. Retest.

8.CHECK HEATER HOSES

Check heater hoses for proper installation.

OK or NG

A

B

C

D

E

F

G

H

HAC

J

K

L

M

N

O

P

INSUFFICIENT HEATING

[MANUAL AIR CONDITIONER]

< SYMPTOM DIAGNOSIS >

OK >> System OK.

- NG >> 1. Back flush heater core.
2. Drain the water from the system.
3. Refill system with new engine coolant. Refer to XX-XX, "*****".
4. GO TO 9 to retest.

9. CHECK HEATER HOSE TEMPERATURES

1. Start engine and warm it up to normal operating temperature.
2. Touch both the inlet and outlet heater hoses.

OK or NG

OK >> System OK.

NG >> Replace heater core. Refer to XX-XX, "*****".

NOISE

Component Function Check

INFOID:000000001366777

SYMPTOM: Noise

INSPECTION FLOW

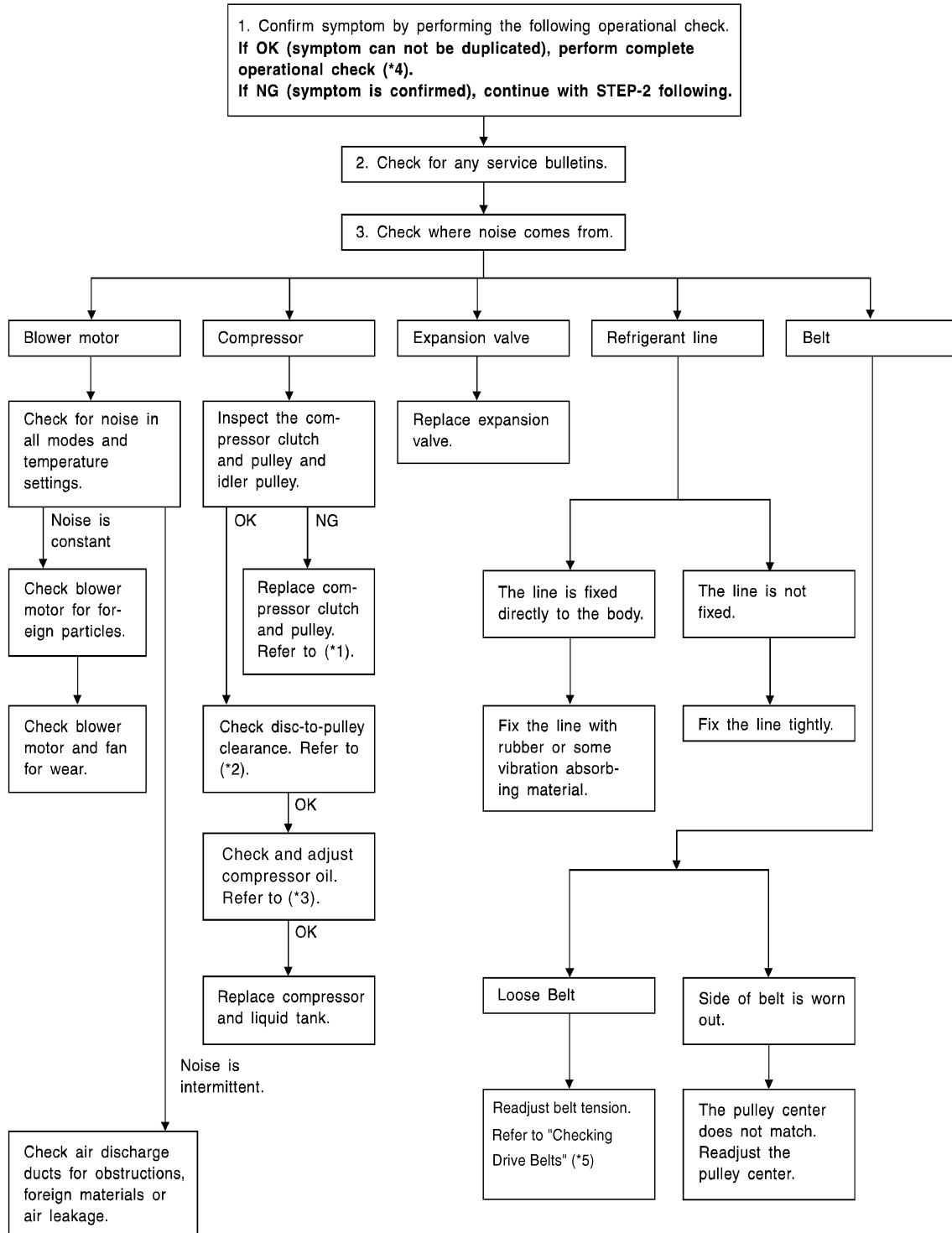

A
B
C
D
E
F
G
H
HAC
J
K
L
M
N
O
P

NOISE

< SYMPTOM DIAGNOSIS >

[MANUAL AIR CONDITIONER]

*1 XX-XX, "*****"

*2 XX-XX, "*****"

*3 XX-XX, "*****"

*4 XX-XX, "*****"

*5 XX-XX, "*****"

PRECAUTION

PRECAUTIONS

Supplemental Restraint System (SRS) "AIR BAG" and "SEAT BELT PRE-TENSIONER"

INFOID:000000001366767

The Supplemental Restraint System such as "AIR BAG" and "SEAT BELT PRE-TENSIONER", used along with a front seat belt, helps to reduce the risk or severity of injury to the driver and front passenger for certain types of collision. This system includes seat belt switch inputs and dual stage front air bag modules. The SRS system uses the seat belt switches to determine the front air bag deployment, and may only deploy one front air bag, depending on the severity of a collision and whether the front occupants are belted or unbelted. Information necessary to service the system safely is included in the SR and SB section of this Service Manual.

WARNING:

- To avoid rendering the SRS inoperative, which could increase the risk of personal injury or death in the event of a collision which would result in air bag inflation, all maintenance must be performed by an authorized NISSAN/INFINITI dealer.
- Improper maintenance, including incorrect removal and installation of the SRS, can lead to personal injury caused by unintentional activation of the system. For removal of Spiral Cable and Air Bag Module, see the SR section.
- Do not use electrical test equipment on any circuit related to the SRS unless instructed to in this Service Manual. SRS wiring harnesses can be identified by yellow and/or orange harnesses or harness connectors.

Working with HFC-134a (R-134a)

INFOID:000000001366768

WARNING:

- CFC-12 (R-12) refrigerant and HFC-134a (R-134a) refrigerant are not compatible. If the refrigerants are mixed compressor failure is likely to occur. Refer to HA-3, "[Contaminated Refrigerant](#)". To determine the purity of HFC-134a (R-134a) in the vehicle and recovery tank, use Refrigerant Recovery/Recycling Recharging equipment and Refrigerant Identifier.
- Use only specified oil for the HFC-134a (R-134a) A/C system and HFC-134a (R-134a) components. If oil other than that specified is used, compressor failure is likely to occur.
- The specified HFC-134a (R-134a) oil rapidly absorbs moisture from the atmosphere. The following handling precautions must be observed:
 - When removing refrigerant components from a vehicle, immediately cap (seal) the component to minimize the entry of moisture from the atmosphere.
 - When installing refrigerant components to a vehicle, do not remove the caps (unseal) until just before connecting the components. Connect all refrigerant loop components as quickly as possible to minimize the entry of moisture into system.
 - Only use the specified oil from a sealed container. Immediately reseal containers of oil. Without proper sealing, oil will become moisture saturated and should not be used.
 - Avoid breathing A/C refrigerant and oil vapor or mist. Exposure may irritate eyes, nose and throat. Remove HFC-134a (R-134a) from the A/C system using certified service equipment meeting requirements of SAE J2210 [HFC-134a (R-134a) recycling equipment], or J2209 [HFC-134a (R-134a) recycling equipment], If accidental system discharge occurs, ventilate work area before resuming service. Additional health and safety information may be obtained from refrigerant and oil manufacturers.
 - Do not allow A/C oil to come in contact with styrofoam parts. Damage may result.

CONTAMINATED REFRIGERANT

If a refrigerant other than pure HFC-134a (R-134a) is identified in a vehicle, your options are:

- Explain to the customer that environmental regulations prohibit the release of contaminated refrigerant into the atmosphere.
- Explain that recovery of the contaminated refrigerant could damage your service equipment and refrigerant supply.
- Suggest the customer return the vehicle to the location of previous service where the contamination may have occurred.
- If you choose to perform the repair, recover the refrigerant using only **dedicated equipment and containers. Do not recover contaminated refrigerant into your existing service equipment.** If your facility does

A
B
C
D
E
F
G
H
HAC
J
K
L
M
N
O
P

PRECAUTIONS

[MANUAL AIR CONDITIONER]

< PRECAUTION >

not have dedicated recovery equipment, you may contact a local refrigerant product retailer for available service. This refrigerant must be disposed of in accordance with all federal and local regulations. In addition, replacement of all refrigerant system components on the vehicle is recommended.

- If the vehicle is within the warranty period, the air conditioner warranty is void. Please contact NISSAN Customer Affairs for further assistance.

Precaution for Service Equipment

INFOID:000000001366769

MANIFOLD GAUGE SET

Be certain that the gauge face indicates R-134a or 134a. Make sure the gauge set has 1/2"-16 ACME threaded connections for service hoses. Confirm the set has been used only with refrigerant HFC-134a (R-134a) along with specified oil.

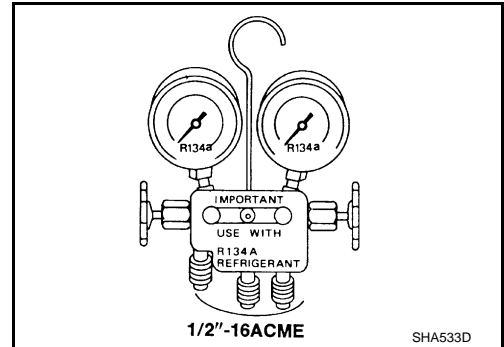

SERVICE HOSES

Be certain that the service hoses display the markings described (colored hose with black stripe). All hoses must include positive shut-off devices (either manual or automatic) near the end of the hoses opposite the manifold gauge.

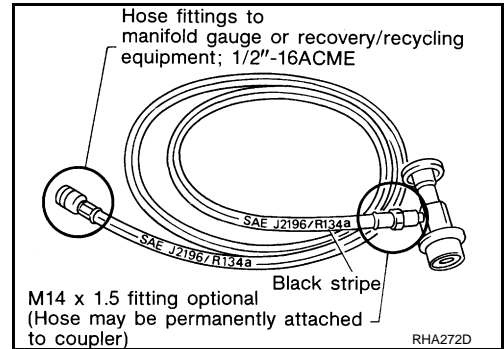

SERVICE COUPLERS

Never attempt to connect HFC-134a (R-134a) service couplers to a CFC-12 (R-12) A/C system. The HFC-134a (R-134a) couplers will not properly connect to the CFC-12 (R-12) system. However, if an improper connection is attempted, discharging and contamination may occur.

Shut-off valve rotation	A/C service valve
Clockwise	Open
Counterclockwise	Close

