

CLUTCH

1990 Nissan 240SX

1990 Clutch

Pathfinder, Pickup, 240SX, 300ZX

DESCRIPTION

Clutch is of dry, single disc type, with a diaphragm spring type pressure plate. Clutch release bearing is prelubricated. The clutch master cylinder is on firewall with a nonadjustable slave cylinder on clutch housing.

PEDAL HEIGHT & FREE PLAY ADJUST

Adjust pedal height by turning pedal stopper adjusting nut or clutch switch. See Fig. 1. See CLUTCH PEDAL HEIGHT ADJUSTMENT SPECIFICATIONS TABLE. Adjust free play to .04-.12" (1-3 mm) by turning clutch master cylinder push rod in or out.

CLUTCH PEDAL HEIGHT ADJUSTMENT SPECIFICATIONS TABLE

Application	In. (mm)
Pathfinder & Pickup	
V6	8.9-9.3 (226-236)
Pickup 4-Cyl.	9.3-9.7 (236-246)
240SX	7.3-8.0 (185-203)
300ZX	7.7-8.0 (196-203)

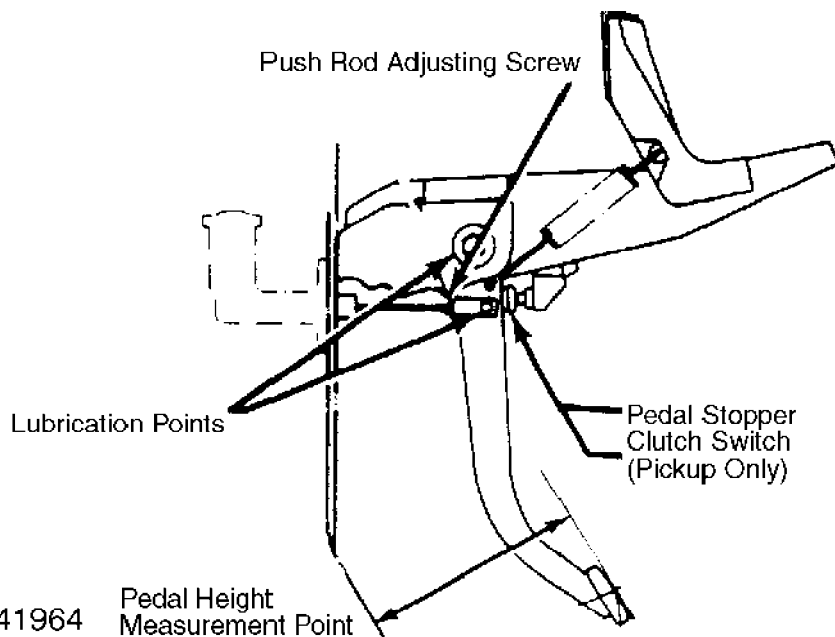

Fig. 1: Adjusting Clutch Pedal Height & Free Play
 Courtesy of Nissan Motor Co., U.S.A.

CLUTCH ASSEMBLY R & I

Removal

- 1) Disconnect battery terminals and accelerator linkage. Place shift lever in Neutral. Remove shift lever boot, snap ring or nut, shift lever pin and shift lever. Raise and support vehicle.
- 2) Disconnect exhaust pipe from manifold. Remove bolts mounting exhaust pipe bracket to extension housing or rear engine crossmember (if necessary). Remove exhaust pipe insulator. Disconnect all electrical connectors from transmission. Disconnect speedometer cable.
- 3) Mark drive shafts and companion flanges for installation reference. On 4WD models, remove front and rear drive shafts. Remove front differential carrier crossmember. Remove slave cylinder.
- 4) On 2WD models, separate center support bearing from crossmember. Remove drive shaft. On all models, plug rear of transmission to prevent fluid loss. Support engine and transmission with jacks. Loosen rear engine mount attaching bolt.
- 5) Remove rear engine mount bracket. Remove starter and engine-to-transmission bolts. Slide transmission rearward and remove. Loosen pressure plate bolts using a crisscross pattern to relieve spring pressure. Remove pressure plate and clutch disc.

Inspection

- 1) Check clutch disc for wear. Minimum height of lining above rivet heads is .012" (.3 mm). Check disc runout by mounting disc onto input shaft. Mount dial indicator to transmission case with indicator plunger on face of disc.
- 2) Measure runout from hub center. See CLUTCH DISC RUNOUT SPECIFICATIONS table. Backlash at outer edge of disc must not exceed .035" (.90 mm) on 240SX or .039" (1.0 mm) on Pathfinder, Pickup and 300ZX. Check disc hub fit on input shaft splines. Disc should slide smoothly.
- 3) Check end surface of pressure plate diaphragm springs for wear. Inspect thrust springs by shaking pressure plate assembly. Tap lightly on rivets. Replace complete assembly if noise is heard.
- 4) Inspect flywheel and pressure plate for scoring, grooves or warpage. Light roughness may be dressed with fine emery cloth. Machine flywheel surface if necessary. If surface is deeply scored, replace flywheel or pressure plate.

CLUTCH DISC RUNOUT SPECIFICATIONS

Application	Radius	In. (mm)	Runout	In. (mm)
Pathfinder & Pickup	4.53	(115)	.039	(1.0)
240SX	4.23	(107)	.039	(1.0)
300ZX	4.53	(115)	.039	(1.0)

Installation

- 1) Lubricate clutch disc splines with molybdenum grease. Slide onto mainshaft splines. Remove disc and wipe off excess grease. Slip clutch assembly over guide dowels. Use clutch aligning tool to center disc and pressure plate.
- 2) Tighten bolts evenly one turn at a time in a crisscross pattern. To complete transmission installation, reverse removal procedure. Adjust linkage and clutch pedal. Refill transmission and bleed clutch hydraulic system.

CLUTCH MASTER CYLINDER R & I

Removal & Installation

1) Disconnect clutch master cylinder push rod at clevis by removing snap ring. Disconnect hydraulic line.

2) Remove clutch master cylinder mount bolts and remove cylinder. Remove master cylinder dust cover (if equipped). To install, reverse removal procedure. Bleed hydraulic system. Adjust pedal free play.

CLUTCH DAMPER R & I

Removal & Installation

Remove hydraulic lines from clutch damper. Remove clutch damper from bracket. To install, reverse removal procedure and bleed hydraulic clutch system.

CLUTCH SLAVE CYLINDER R & I

Removal & Installation

Remove clutch fork return spring (if equipped). Disconnect hydraulic line. Remove bolts attaching cylinder to clutch housing and remove slave cylinder. To install, reverse removal procedure. Bleed hydraulic system at slave cylinder.

CLUTCH RELEASE BEARING & LEVER R & I

Removal

With transmission out of vehicle, remove dust boot from clutch housing. Disconnect release lever return spring and retaining clips holding release bearing to lever. Remove bearing and lever as an assembly through front of clutch housing. Remove bearing from collar using puller.

Installation

Assemble bearing onto inner sleeve using a press. Do not press on outer race. Apply molybdenum grease to inside surface of bearing collar, release bearing contact points, release bearing, ball pin in clutch housing and ball contact points on release lever. To complete installation, reverse removal procedure.

CLUTCH MASTER CYLINDER OVERHAUL

NOTE: Master cylinders are supplied by several manufacturers. Do not interchange parts. Ensure overhaul kit matches cylinder.

Disassembly & Reassembly

1) Remove clutch master cylinder. Remove dust cover and stopper ring. Remove push rod and stopper. Remove supply valve stopper, piston, spring seat and return spring. See Fig. 2. Inspect for excessive wear or damage.

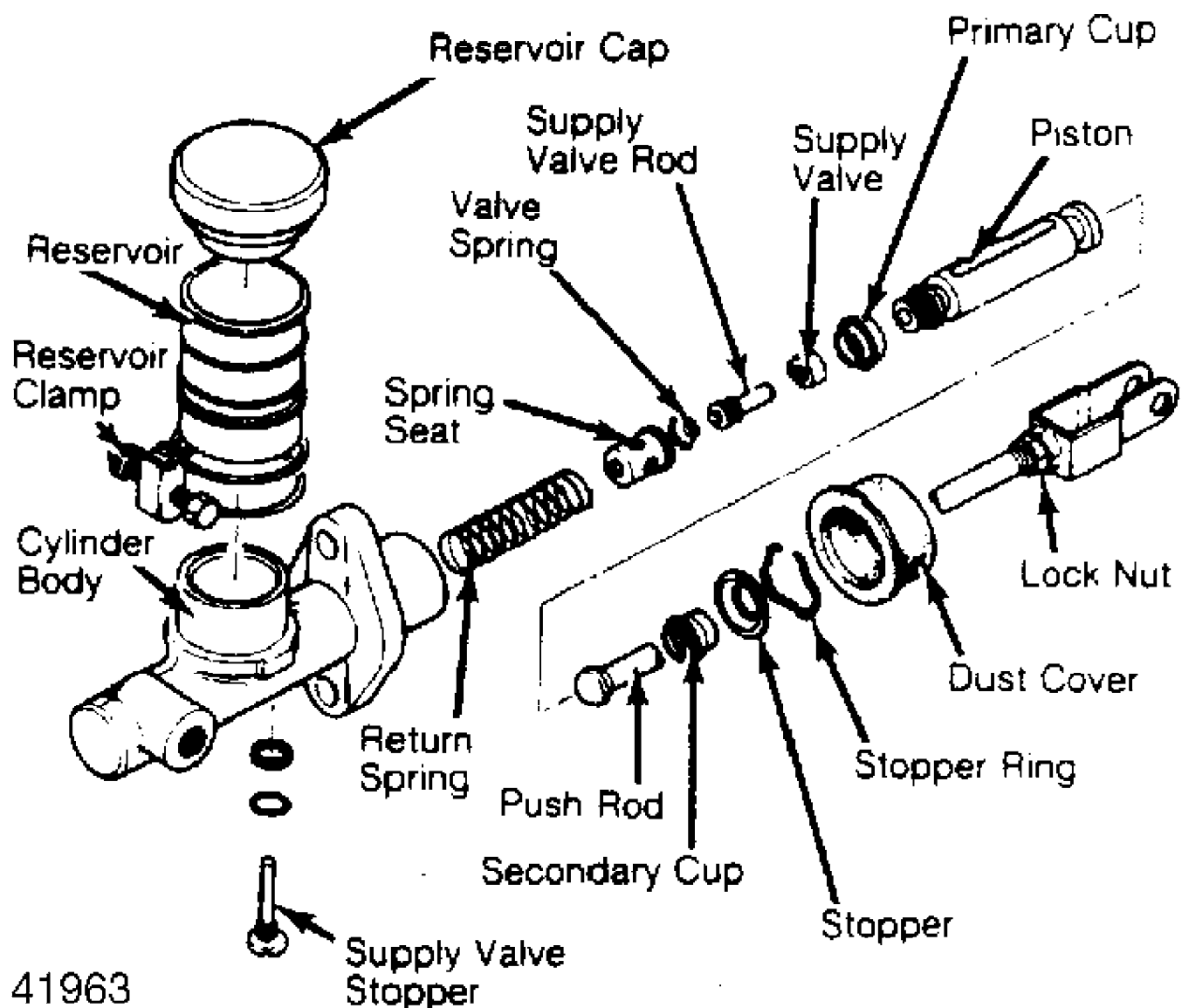

Fig. 2: Exploded View of Clutch Master Cylinder
 Courtesy of Nissan Motor Co., U.S.A.

2) Replace rubber piston cup and dust cover. Ensure internal passages are clear. To reassemble, coat parts with brake fluid and reverse disassembly procedure. Bleed hydraulic system.

CLUTCH SLAVE CYLINDER

NOTE: Slave cylinders are supplied by several manufacturers. Do not interchange parts. Ensure overhaul kit matches cylinder.

Disassembly & Reassembly

1) Remove cylinder. Remove push rod and dust cover. Remove piston, cup and spring as an assembly. Remove bleeder screw. See Fig. 3. Clean parts and inspect for wear or damage.

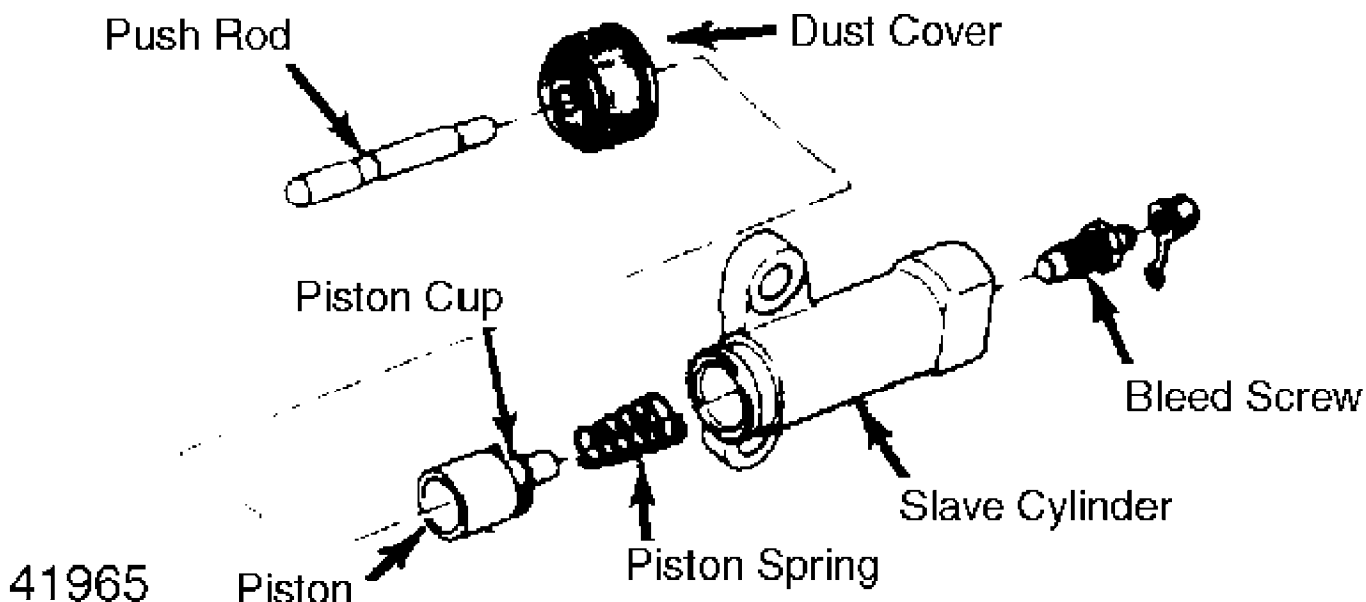

Fig. 3: Exploded View of Clutch Slave Cylinder Assembly
Courtesy of Nissan Motor Co., U.S.A.

2) Replace piston cup and dust cover. To reassemble, coat parts with brake fluid and reverse disassembly procedure. Ensure piston cup is installed properly. Bleed hydraulic system.

CLUTCH DAMPER OVERHAUL

Disassembly & Reassembly

1) Remove clutch damper assembly. Remove damper rubber, piston and cup. Clean parts in brake fluid. Check cylinder bore and piston for wear or damage.

2) Replace piston cup if overhauling. Check damper rubber for cracks, deformation and elasticity. Replace as necessary. To reassemble, reverse disassembly procedure. Lubricate parts in brake fluid. Bleed hydraulic system.

HYDRAULIC SYSTEM BLEEDING

NOTE: On models with clutch damper, bleed hydraulic system in sequence of slave cylinder, clutch damper and clutch master cylinder.

1) Fill reservoir and place hose on bleeder screw. Place opposite end of hose into container partially filled with brake fluid. Have assistant apply clutch pedal and hold.

2) Open bleeder screw until pedal reaches floor. Close bleeder screw. Allow pedal to return. Repeat bleeding procedure until air bubbles are evacuated. Do not let fluid reservoir run dry during bleeding operation.

TORQUE SPECIFICATIONS

TORQUE SPECIFICATIONS

Application	Ft. Lbs. (N.m)
Clutch Cover-to-Flywheel Bolt (1)	

Pathfinder & Pickup	16-22	(22-30)
240SX	16-22	(22-30)
300ZX	25-33	(34-45)
Crossmember-to-Body Bolt	23-31	(31-42)
Engine-to-Transmission Bolt	29-36	(39-49)
Flex Hose-to-Slave Cylinder Nut	12-15	(17-21)
Flywheel Bolt		
Pathfinder & Pickup	101-116	(137-157)
240SX & 300ZX	72-80	(98-108)
Slave Cylinder Mount Bolt	22-30	(30-40)
Starter Motor-to-Housing Bolt	22-27	(30-36)

(1) - Tighten bolts evenly in a diagonal pattern.
