

M - VACUUM DIAGRAMS

1990 Nissan 240SX

1990 ENGINE PERFORMANCE
Vacuum Diagrams

Nissan; 240SX, 300ZX, Axxess, Maxima, Pathfinder,
Pickup, Pulsar, Sentra, Stanza, Van

INTRODUCTION

This article contains underhood views of vacuum hose routing. Use these vacuum diagrams during the visual inspection portion of F - BASIC TESTING article. This will assist in identifying improperly routed vacuum hoses which cause driveability and/or computer-indicated malfunctions.

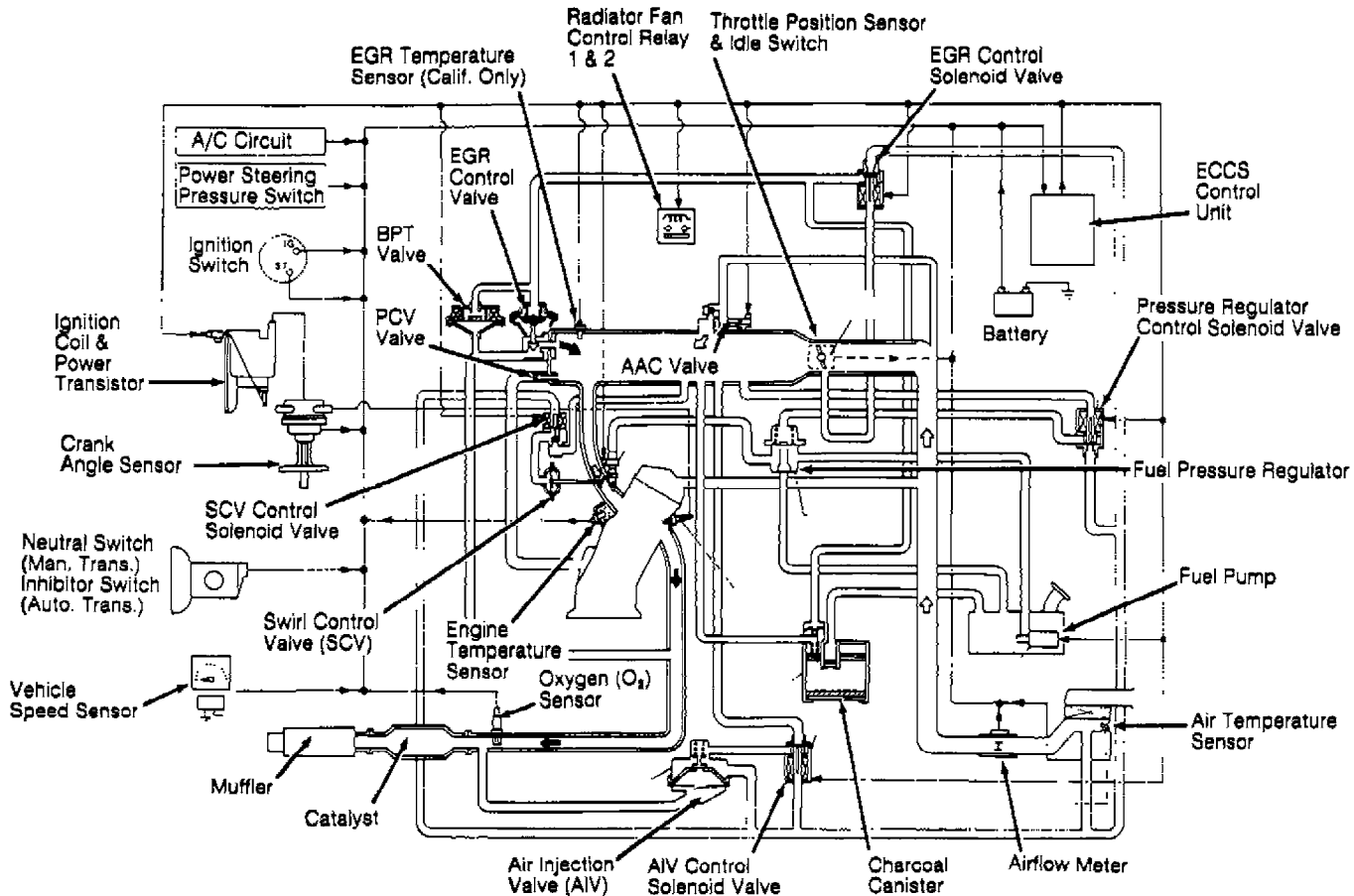

Fig. 1: Axxess Vacuum Diagram
Courtesy of Nissan Motor Co., U.S.A.

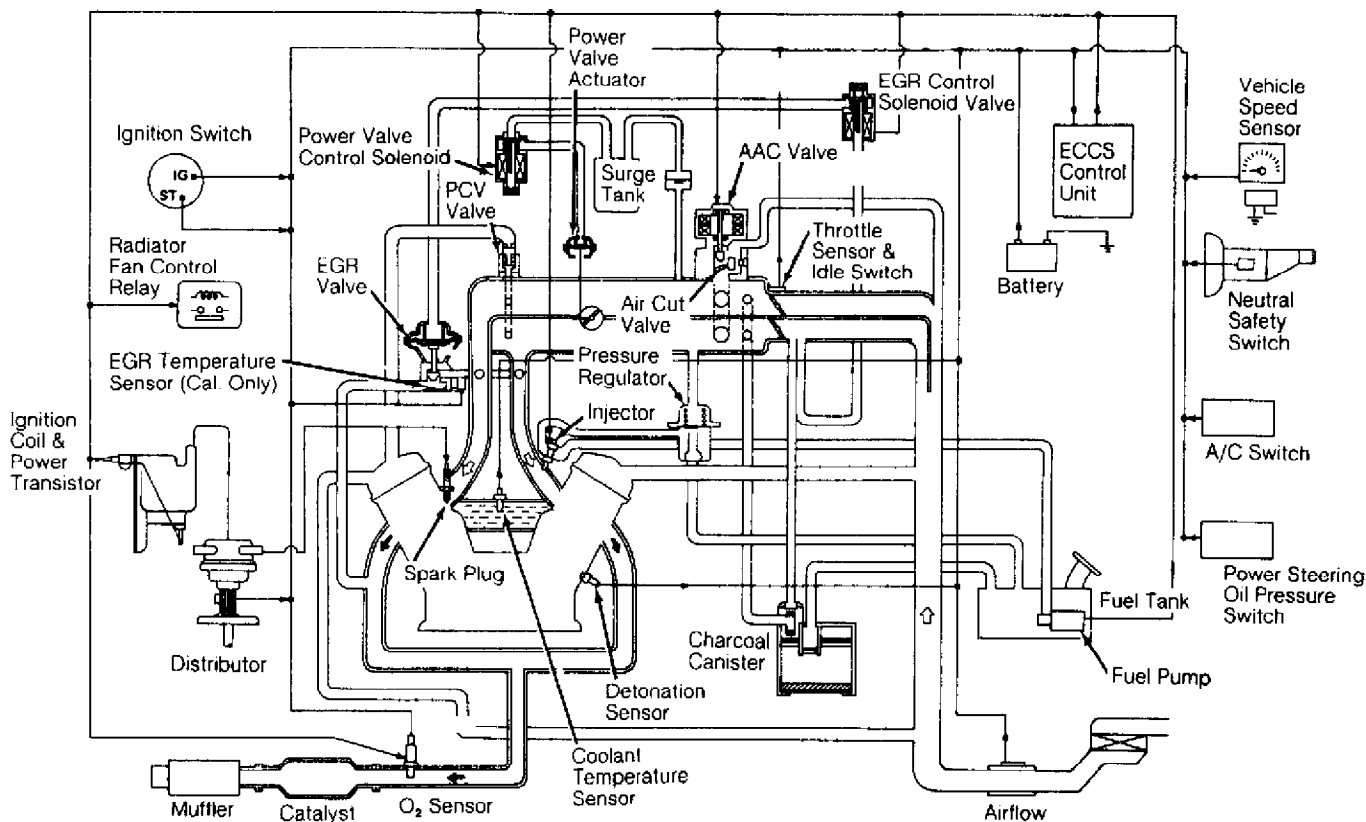

Fig. 2: Maxima Vacuum Diagram
Courtesy of Nissan Motor Co., U.S.A.

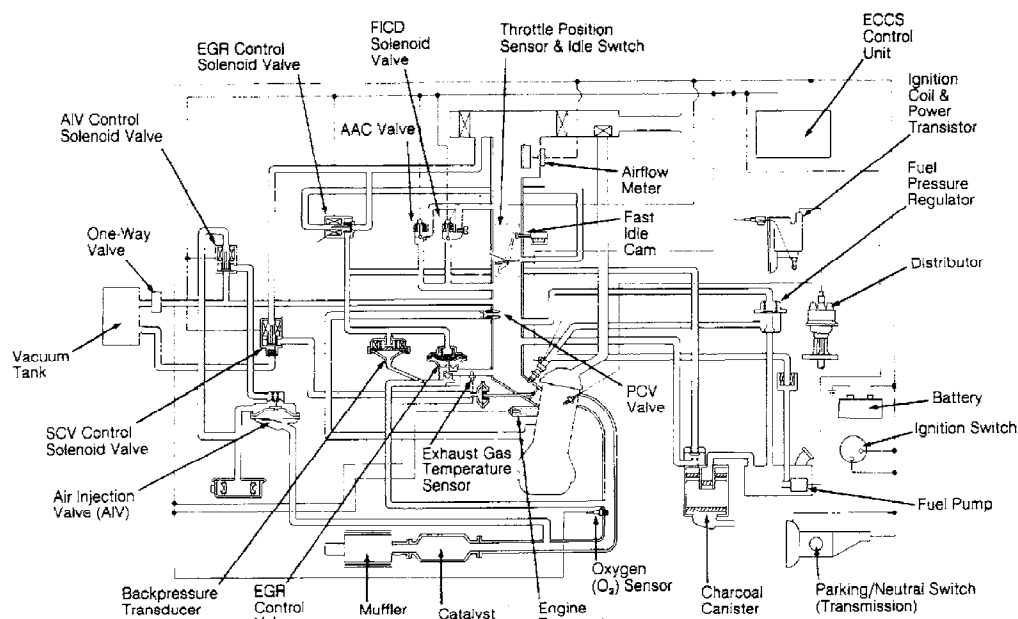

Fig. 3: Pickup (4-Cylinder) Vacuum Diagram
Courtesy of Nissan Motor Co., U.S.A.

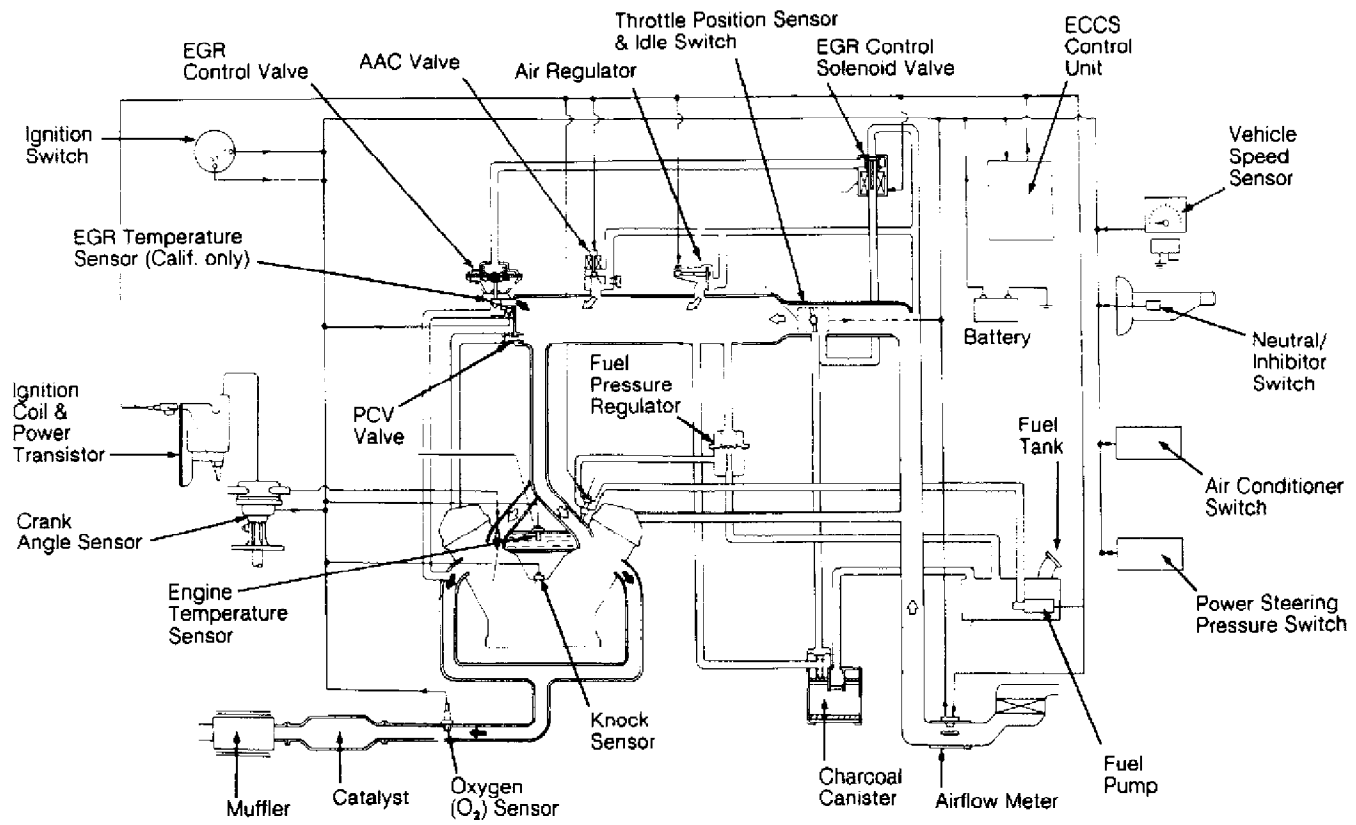

Fig. 4: Pathfinder & Pickup (V6) Vacuum Diagram
Courtesy of Nissan Motor Co., U.S.A.

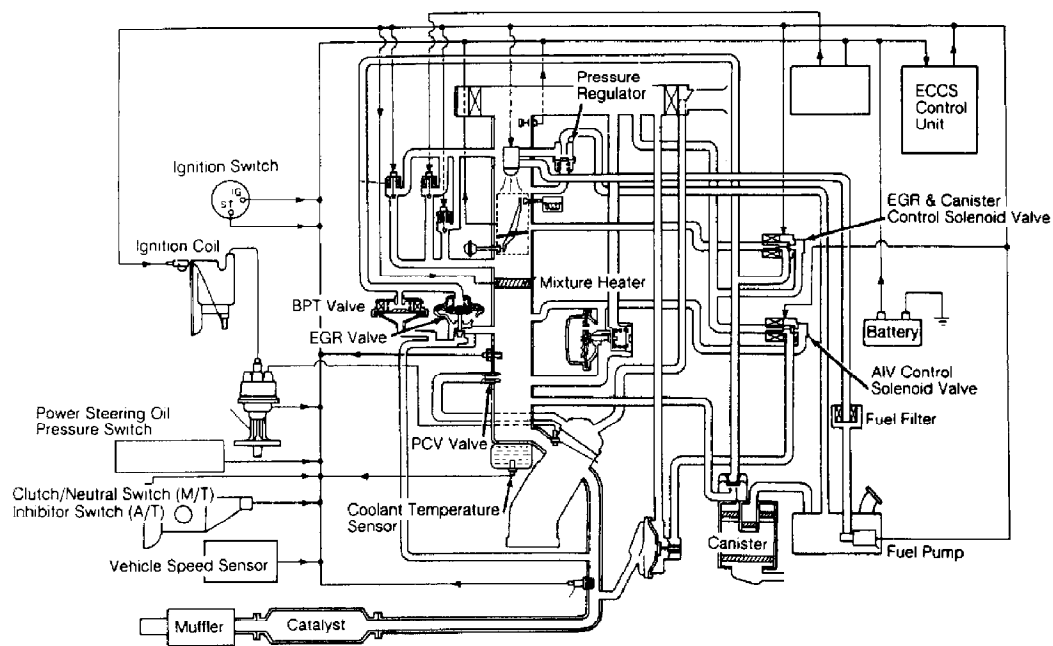

Fig. 5: Pulsar NX Vacuum Diagram
Courtesy of Nissan Motor Co., U.S.A.

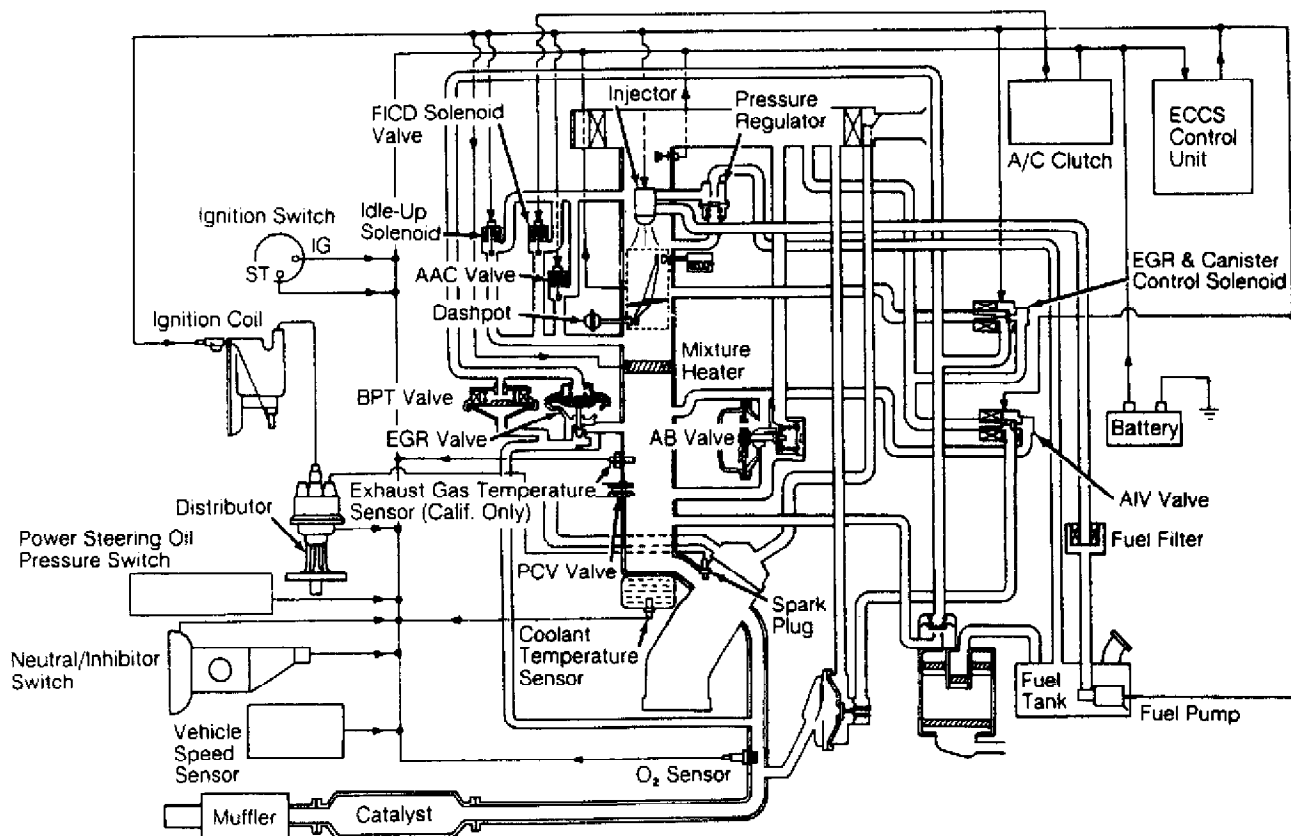

Fig. 6: Sentra Vacuum Diagram
 Courtesy of Nissan Motor Co., U.S.A.

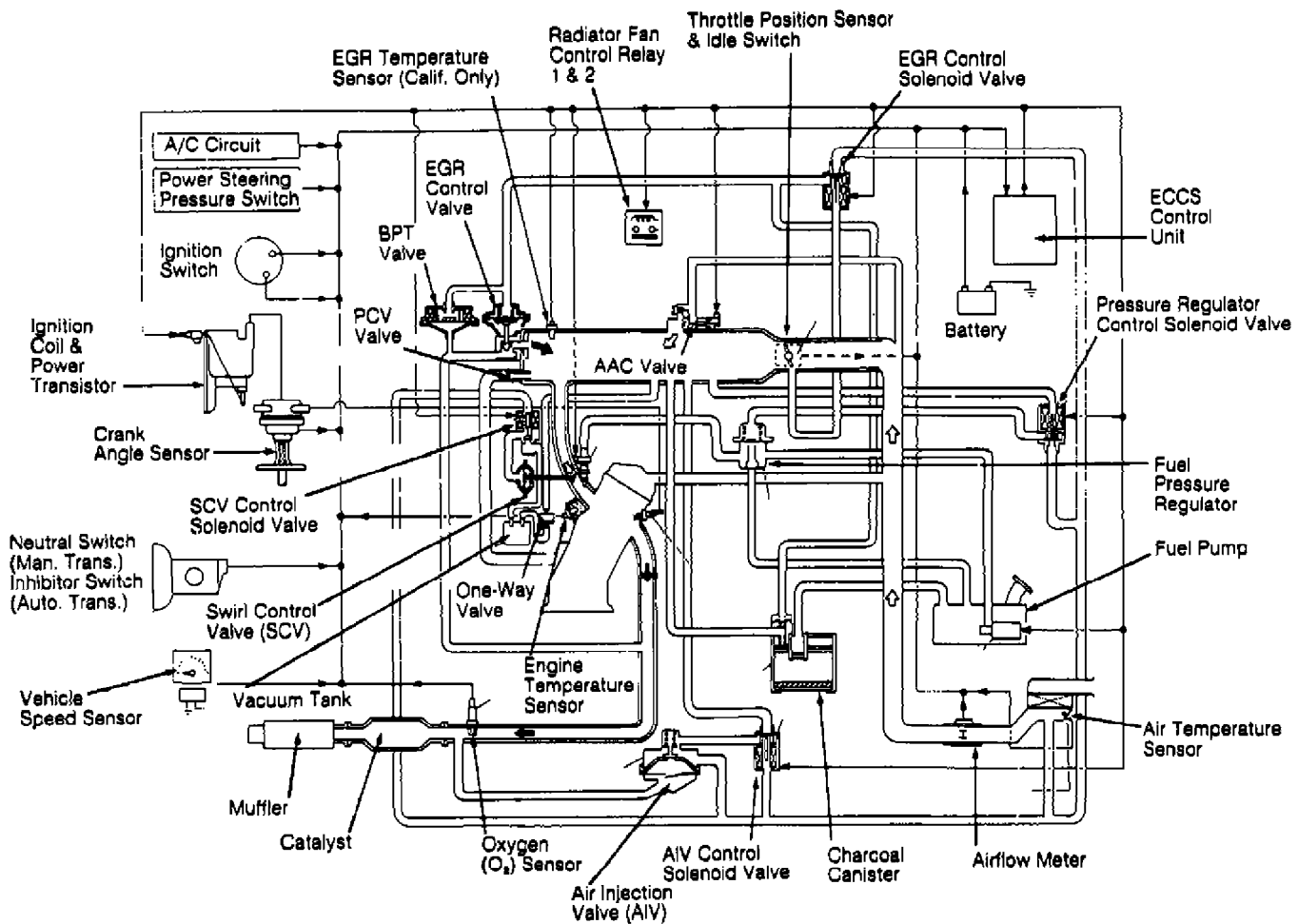

Fig. 7: Stanza Vacuum Diagram
 Courtesy of Nissan Motor Co., U.S.A.

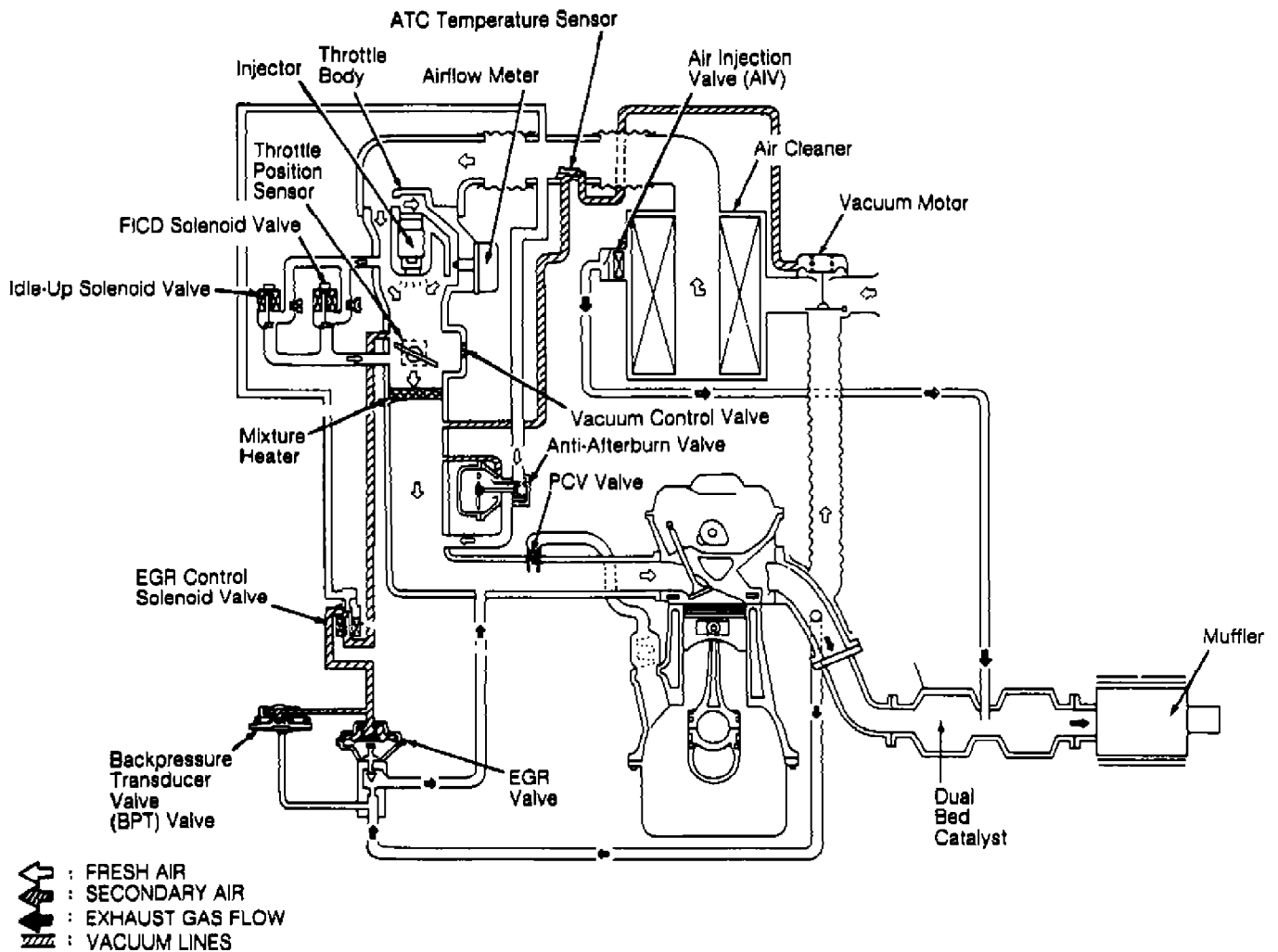

Fig. 8: Van Vacuum Diagram
 Courtesy of Nissan Motor Co., U.S.A.

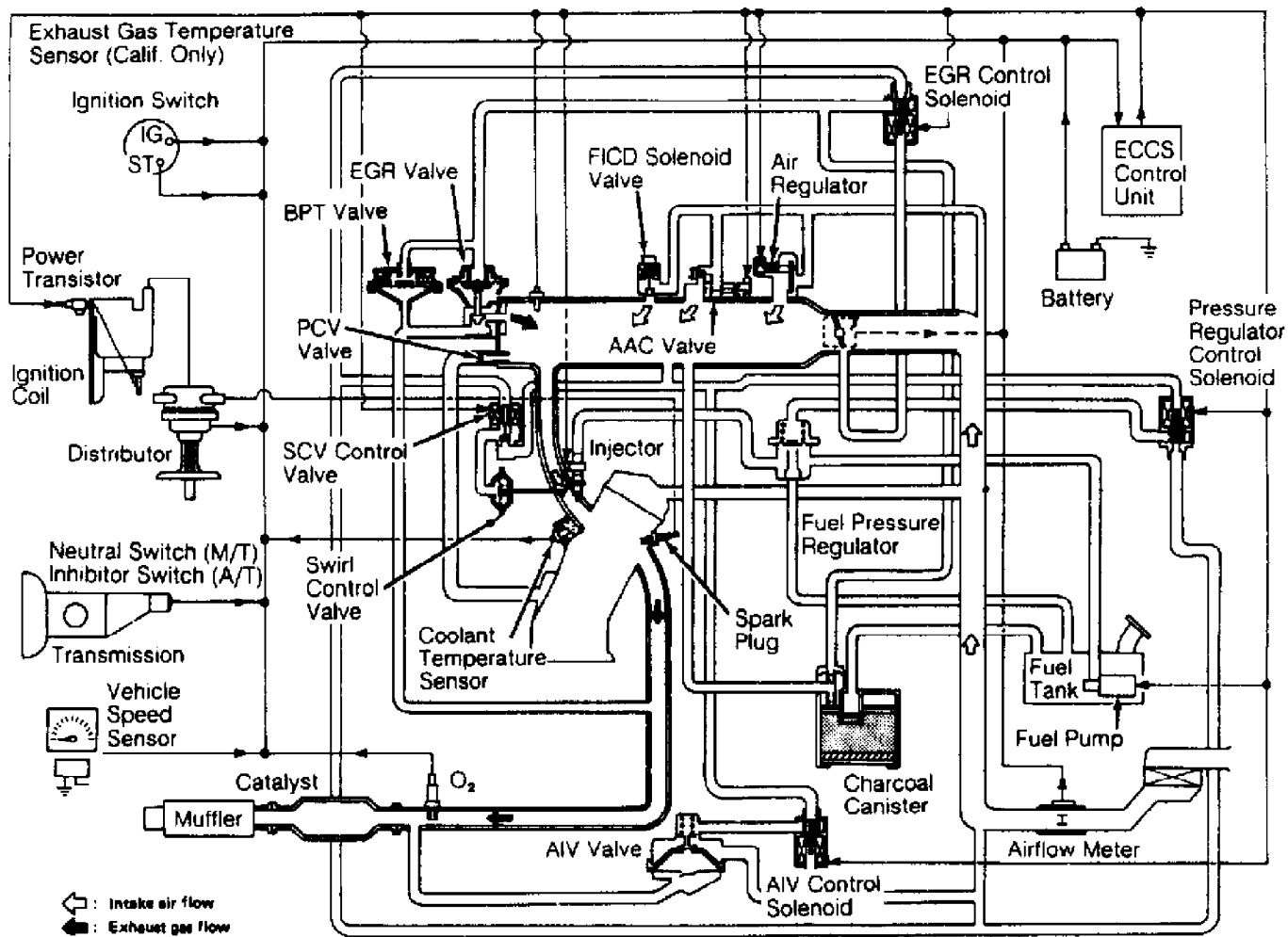

Fig. 9: 240SX Vacuum Diagram
Courtesy of Nissan Motor Co., U.S.A.

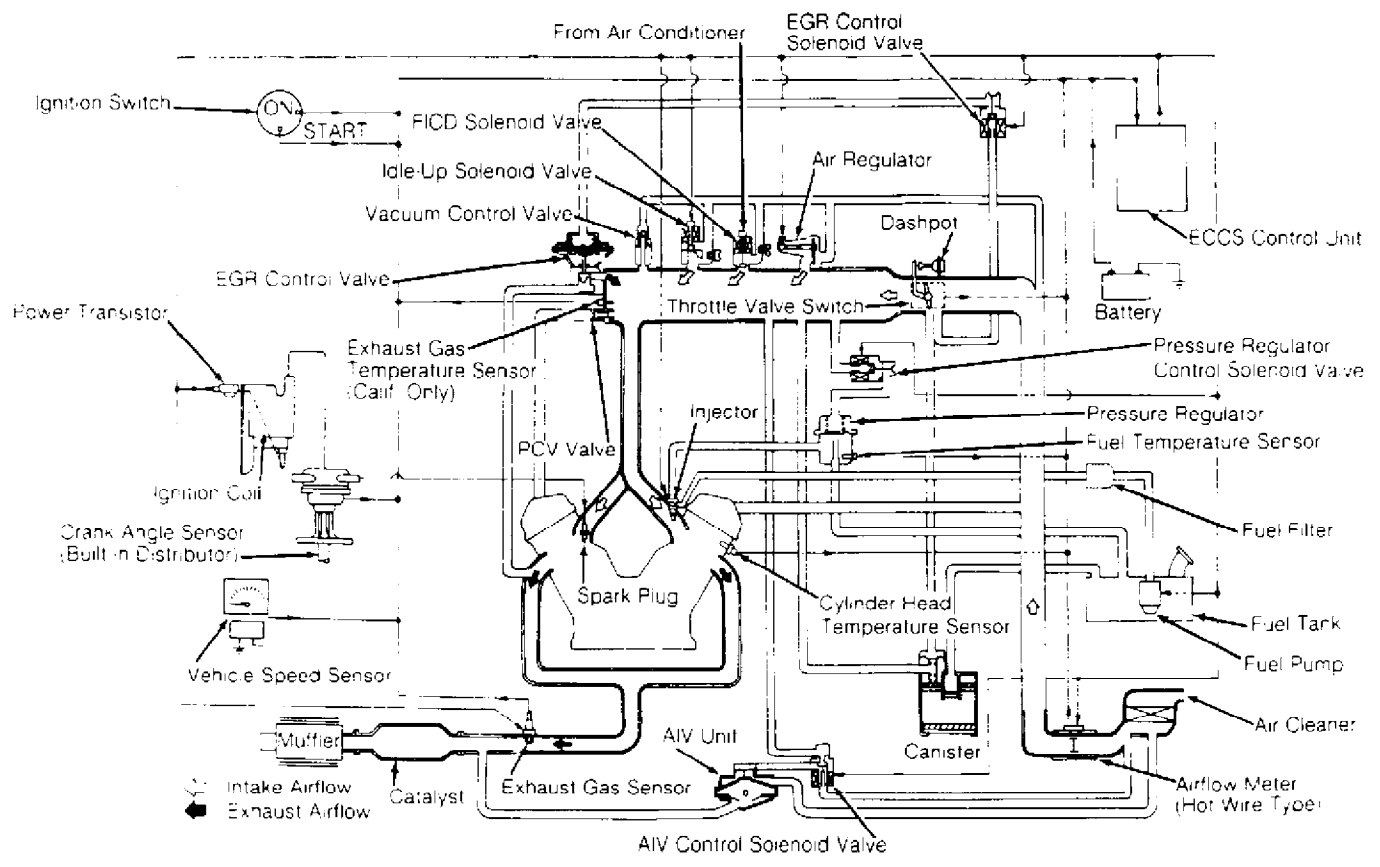

Fig. 10: 300ZX Vacuum Diagram
 Courtesy of Nissan Motor Co., U.S.A.