

SEAT BELTS - AUTOMATIC

1990 Nissan 240SX

1990 ACCESSORIES/SAFETY EQUIPMENT
Nissan Automatic Seat Belt

Nissan; 240SX

DESCRIPTION

OPERATION

Shoulder belt buckle mainly operates while ignition is ON.

IGNITION SWITCH IS ON

When door is opened, shoulder buckle is moved forward and when door is closed, buckle is moved rearward.

IGNITION SWITCH IS OFF

When door is opened, shoulder buckle is moved forward. When door is closed, buckle will remain in this position.

(Voltage of output signal is approximate value.)

		Input signal															
		Ignition switch	Door latch switch	Front limit switch	Rear limit switch	Ignition switch	Door latch switch	Front limit switch	Rear limit switch	Ignition switch	Door latch switch	Front limit switch	Rear limit switch	Ignition switch	Door latch switch	Front limit switch	Rear limit switch
Output signal	Drive motor power source for forward operation	0V	0V	0V	0V	12V	12V	0V	0V	0V	0V	12V	12V	0V	0V	0V	0V
	Drive motor power source for rearward operation	0V	0V	12V	12V	0V	0V	0V	0V	12V	12V	0V	0V	0V	0V	0V	0V
Shoulder belt buckle	Function	Stop	Stop	Start to move	Moving	Stop	Start to move	Moving	Stop	Start to move	Moving	Stop	Stop	Start to move	Moving	Stop	Stop
	Position	Front	Front	Front	Between Front & Rear	Rear	Rear	Between Front & Rear	Front	Front	Between Front & Rear	Rear	Rear	Rear	Between Front & Rear	Front	Front

50A07073

Fig. 1: Automatic Seat Belt Quick Test

TIMER (IGNITION SWITCH EITHER ON OR OFF)

If limit switch does not operate (when accomplishing forward operation, front limit switch cannot be turned OFF or when accomplishing rearward operation, rear limit switch cannot be turned OFF, control unit will continue to supply power to drive motor for 15 seconds and control unit will stop supplying power.

QUICK WARNING (IGNITION SWITCH ON)

If front limit switch is not turned OFF after accomplishing forward operation, control unit will stop supplying power 15 seconds later and warning lamp will flash and chime will operate rapidly for approximately 6 seconds.

REAR LOCK

If quick warning functions twice successively while ignition switch is ON, shoulder belt buckle will move to rear position when door is closed as normal but will remain in rear position even if door is opened. This function is canceled when ignition switch is OFF.

HARNESS LAYOUT

Harness Layout

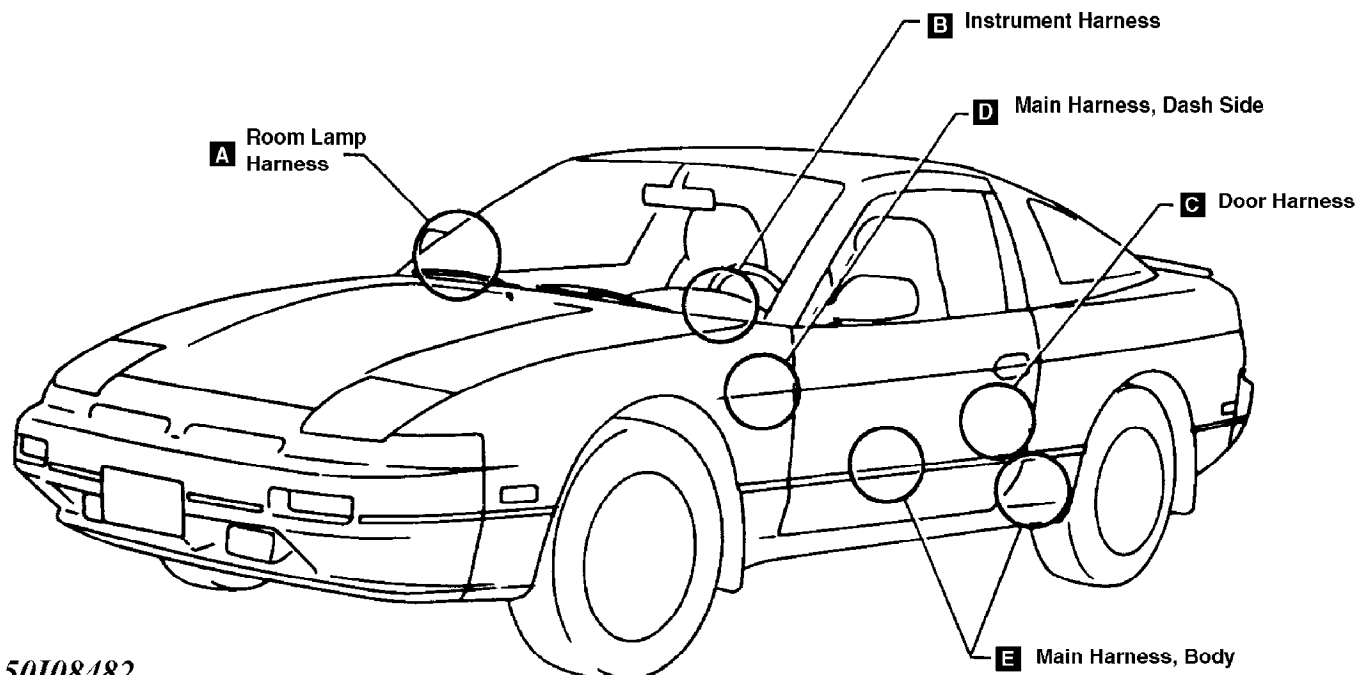

50108482

Fig. 2: Harness Layout Location

(R8)
**RH Front
Limit Switch**

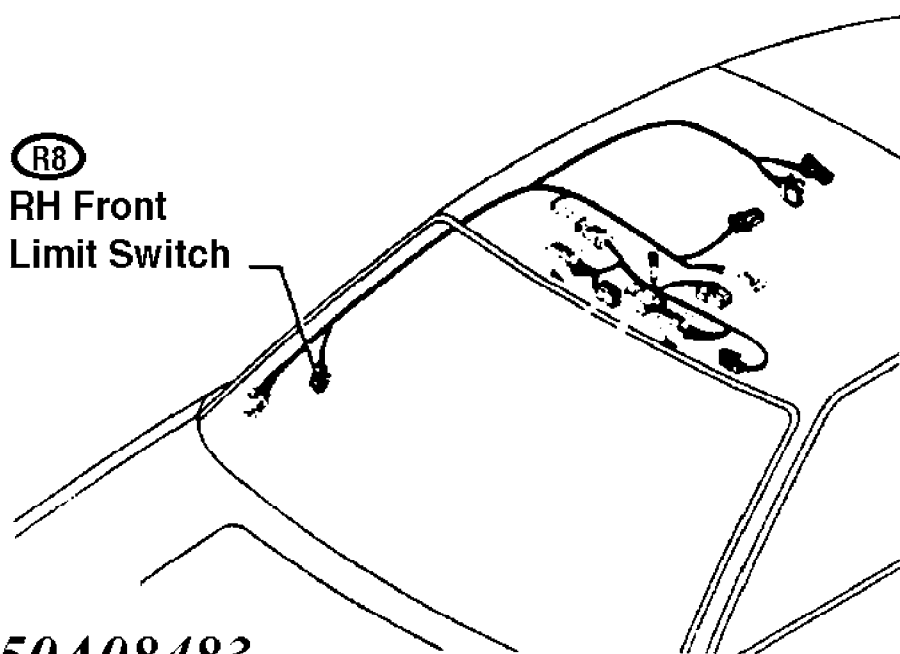

50A08483

Fig. 3: Right Hand Front Limit Switch

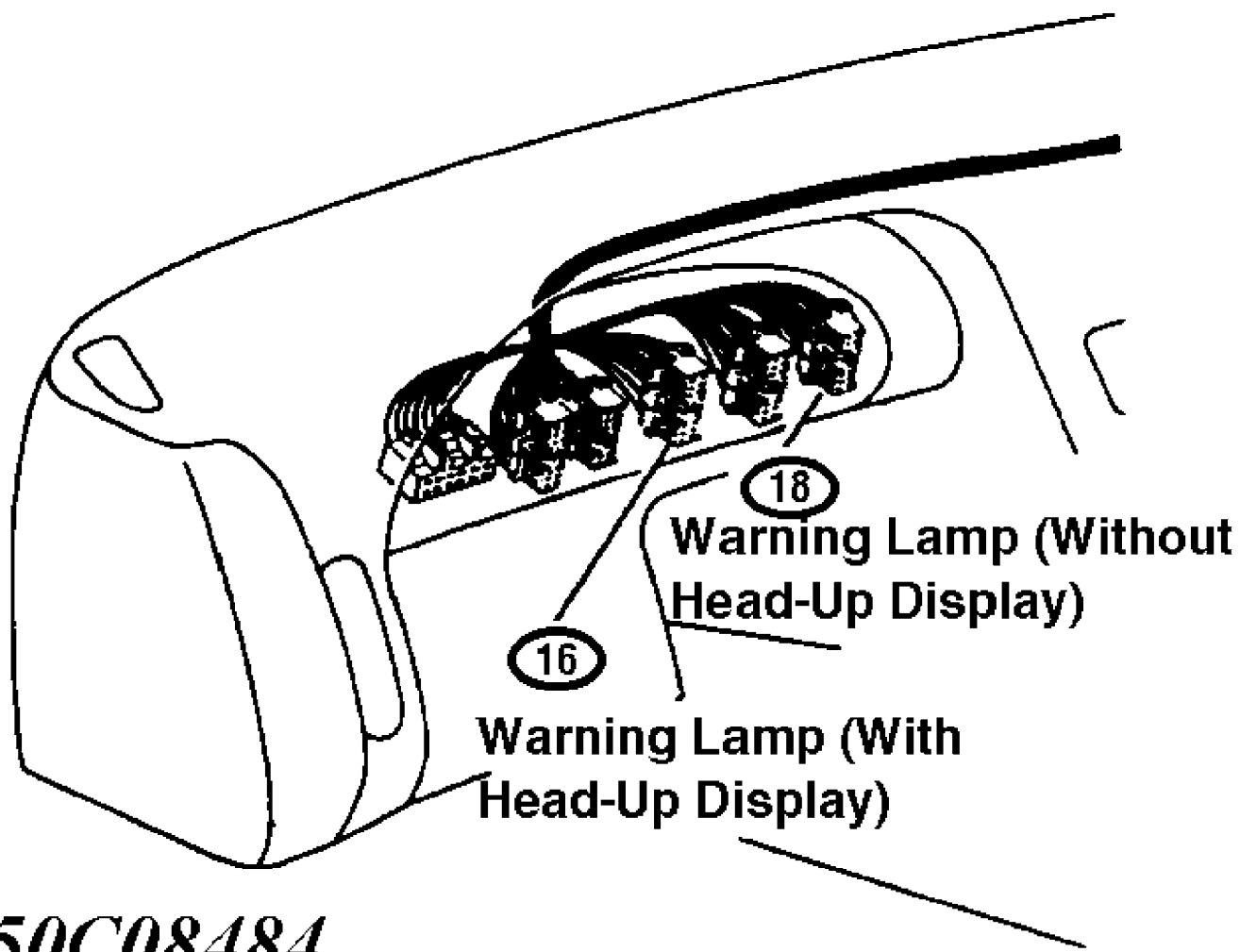

50C08484

Fig. 4: Warning Lamp

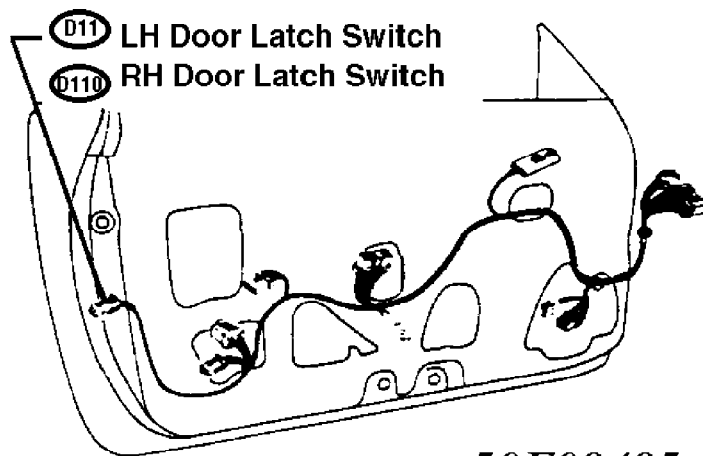

50F08485

Fig. 5: Door Latch Switch

D

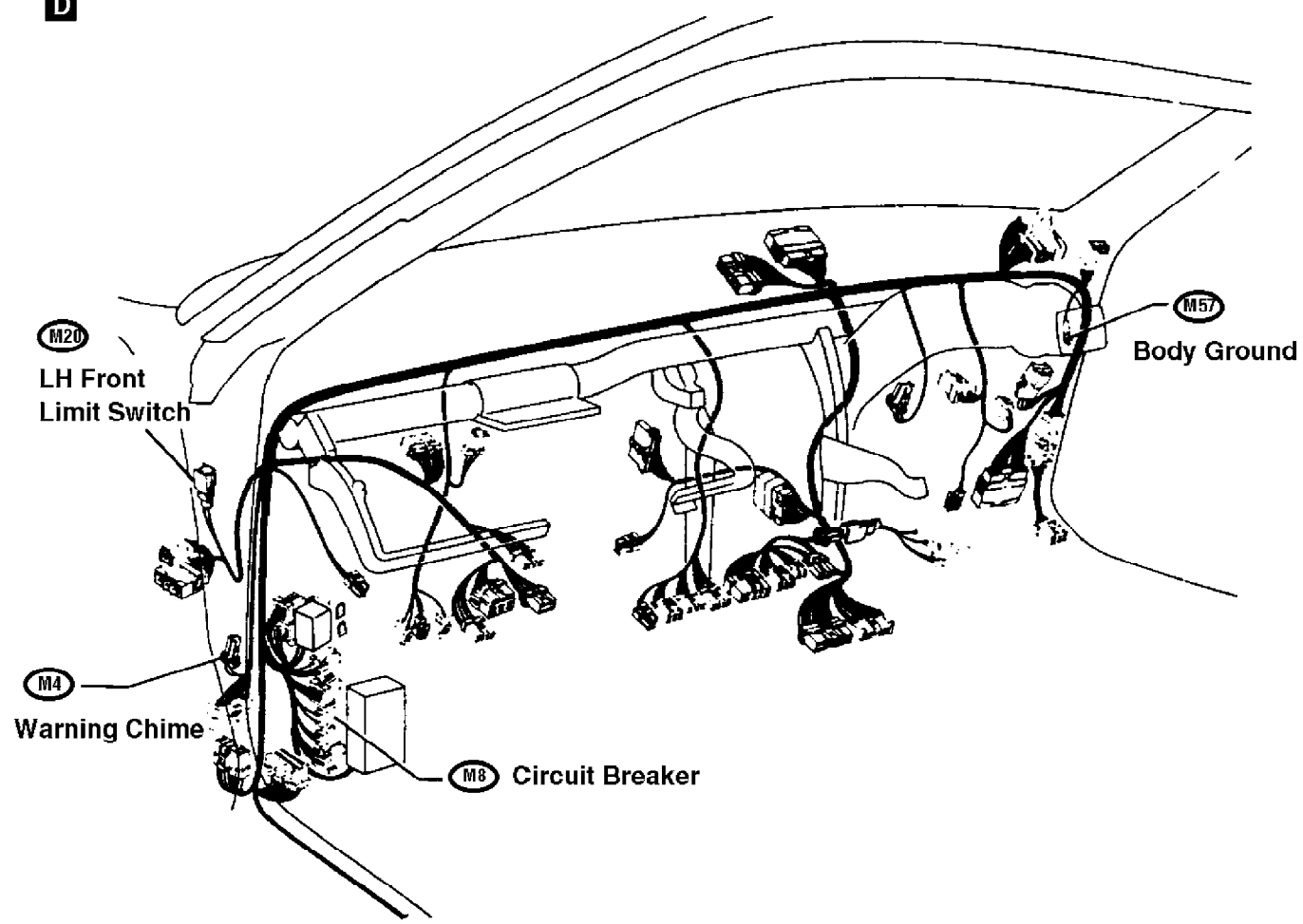

50H08486

Fig. 6: Warning Chime & Left Hand Front Limit Switch

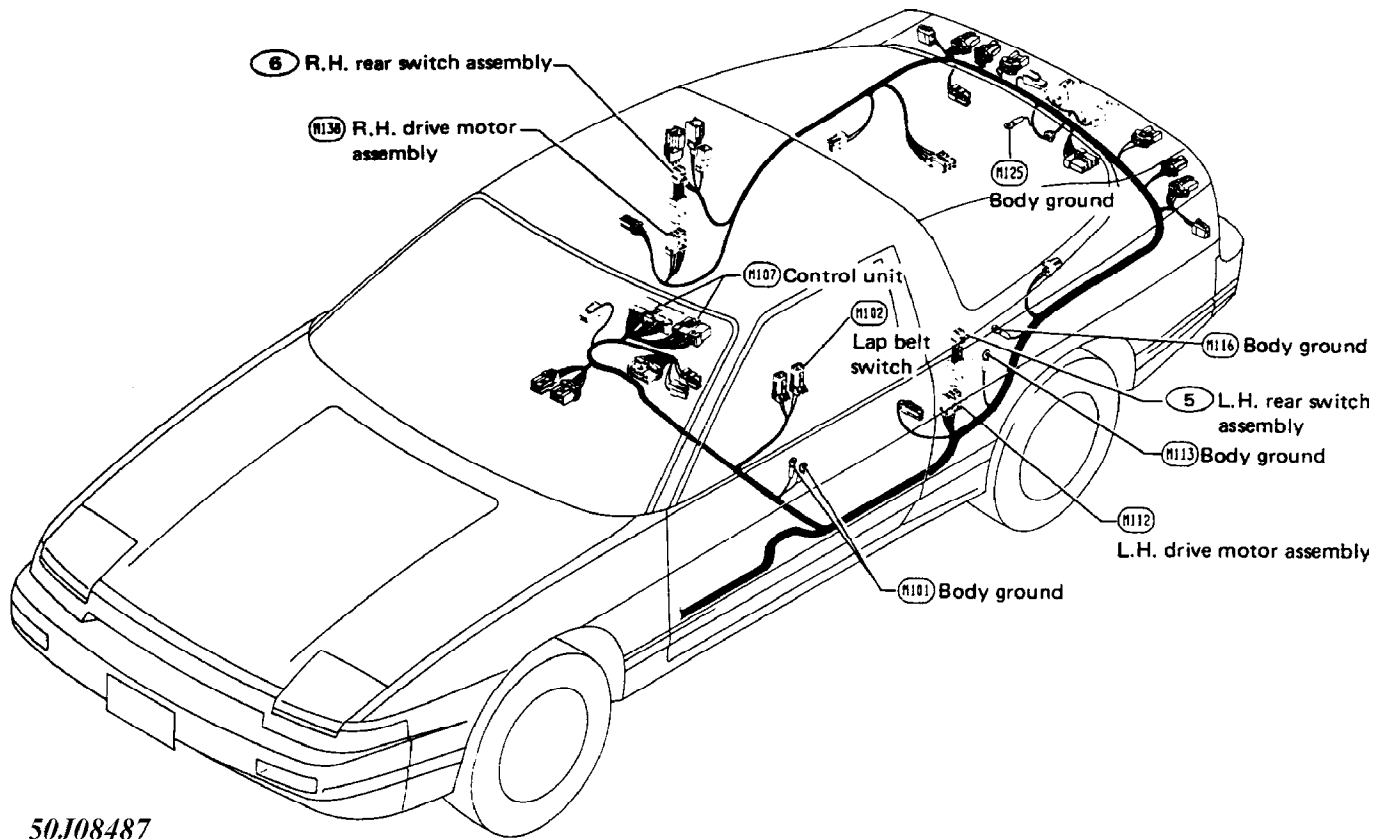

50J08487
Fig. 7: Driver's Side Wiring Harness Layout

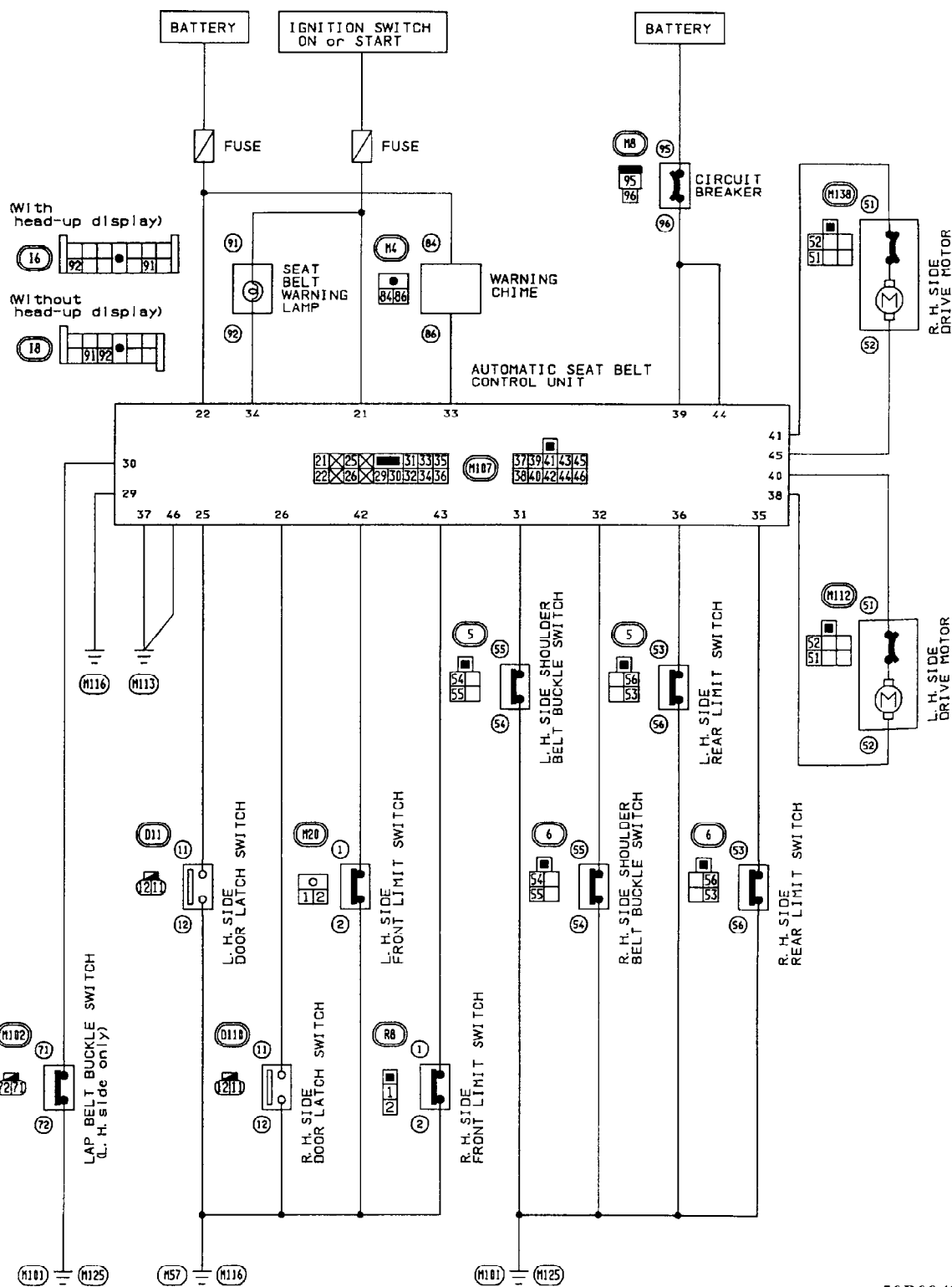
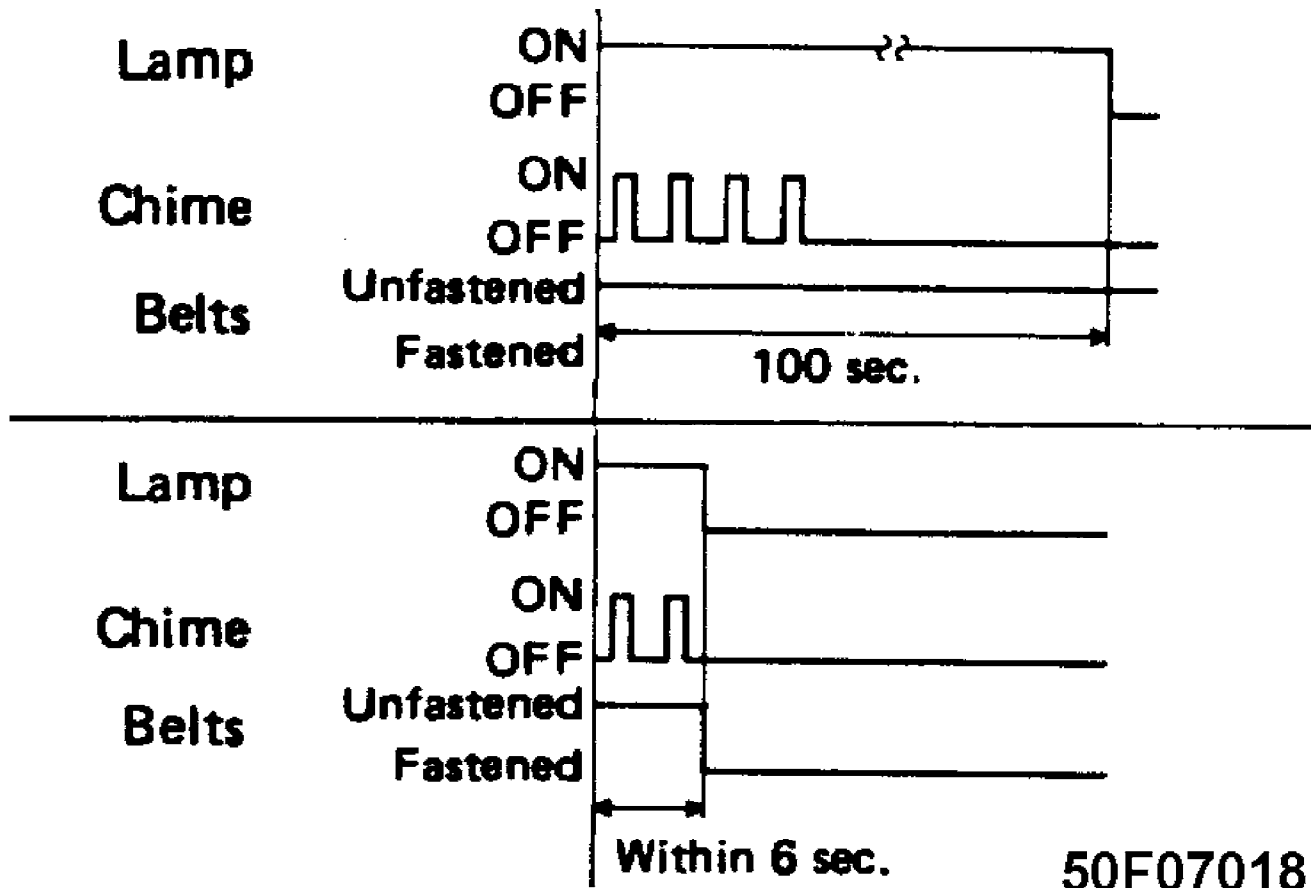

Fig. 8: Quick Pinpoint Check Circuit Diagram

50B08488

SEAT BELT WARNING



50F07018

Fig. 11: Shoulder Belts Are Not Fastened; Ignition Sw. ON

DRIVER SIDE LAP BELT IS NOT FASTENED

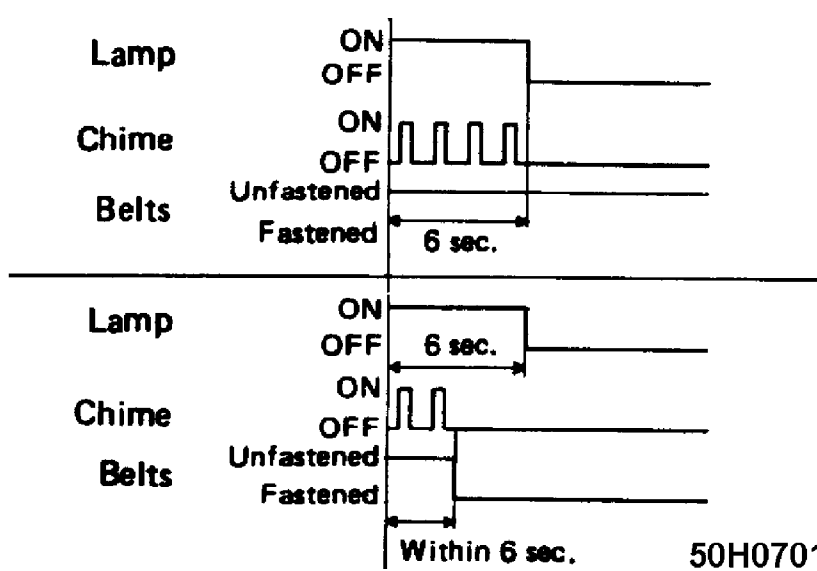

50H07019

Fig. 12: Driver Side Lap Belt Is Not Fastened; Ignition Sw. OFF to ON

NORMAL (ALL BELTS ARE FASTENED & SHOULDER ANCHORS ARE IN REAR LOCK POSITION)

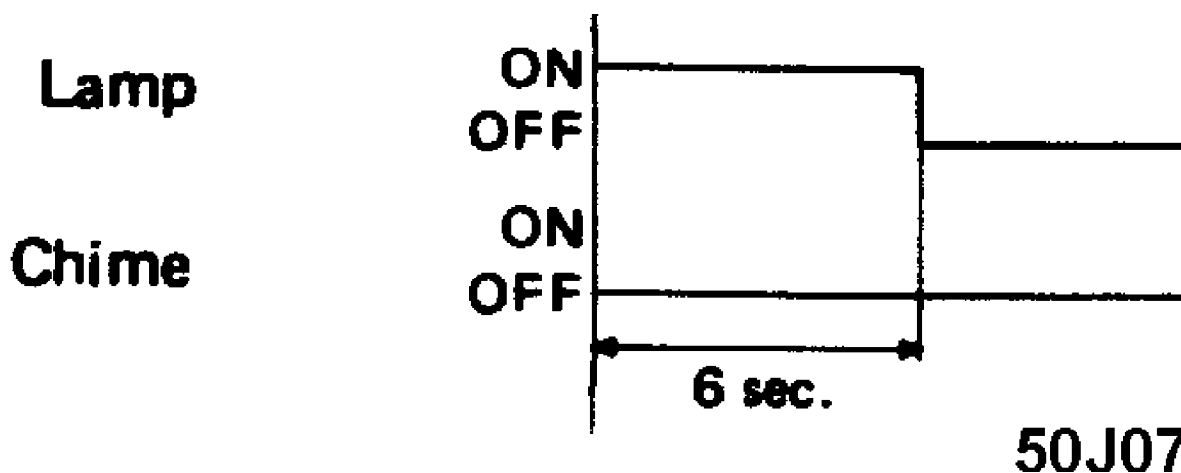

Fig. 13: NORMAL (All Belts Fastened & Shoulder Anchors In Rear Lock Position); Ignition Sw. OFF to ON

TROUBLE SHOOTING

DESCRIPTION

Since left and right component parts are basically the same, harness layout and methods for electrical components inspection are shown for one side only.

Although methods for checking component parts on both sides are described in the flow chart, making it easier to troubleshoot, apply checking procedures to either side that have malfunction during trouble diagnosis. For those methods enclosed by double rectangulars, however, component parts on both sides must be checked as problems occurring on either side cannot be easily determined by a symptom.

SYMPTOMS

No Operation Has Made. No Warning Indicated & No Buckles Movement Performed

- * Main Power Supply & Ground Circuit Check (Diagnostic Procedure 1)
- * Diagnostic Procedures 1, 3 & 4
- * The following Electrical Components Inspection: Warning Lamp, Warning Chime, LEFT SIDE (Front Limit Switch, Rear Limit Switch, Door Latch Switch, Shoulder Belt Buckles Switch, Motor, Lap Belt Switch), RIGHT SIDE (Front Limit Switch, Rear Limit Switch, Door Latch Switch, Shoulder Belt Buckles Switch, Motor)

Shoulder Belt Buckle In L.H. or R.H. Side Does Not Move

- * Preliminary Check (Diagnostic Procedure 1)
- * Main Power Supply & Ground Circuit Check (Diagnostic Procedure 2)
- * Diagnostic Procedures 1, 3 & 4
- * The following Electrical Components Inspection: Warning Lamp, Warning Chime, LEFT & RIGHT Side (Front & Rear Limit Switch, Motor)

Shoulder Belt Buckle Moves FORWARD Only

- * Preliminary Check (Diagnostic Procedure 1)
- * Diagnostic Procedures 2 & 4
- * The following Electrical Components Inspection: LEFT & RIGHT Side (Rear Limit & Door Latch Switch)

- Shoulder Belt Buckle Moves REARWARD Only
- * Preliminary Check (Diagnostic Procedure 1)
- * Diagnostic Procedures 2 & 3
- * The following Electrical Components Inspection: LEFT & RIGHT Side (Front Limit & Door Latch Switch)

- Warnings Indicate Incorrectly Or Do Not Function
- * Preliminary Check (Diagnostic Procedure 2)
- * Diagnostic Procedures 4-8
- * The following Electrical Components Inspection: Warning Lamp & Chime, LEFT SIDE (Rear Limit & Shoulder Belt Buckle Switch, Lap Belt Switch), RIGHT SIDE (Rear Limit & Shoulder Belt Buckle Switch)

- Quick Warning Operates
- * Diagnostic Procedure 3
- * The following Electrical Components Inspection: LEFT & RIGHT Side (Front Limit Switch)

PROCEDURE 1 (PRELIMINARY CHECK)

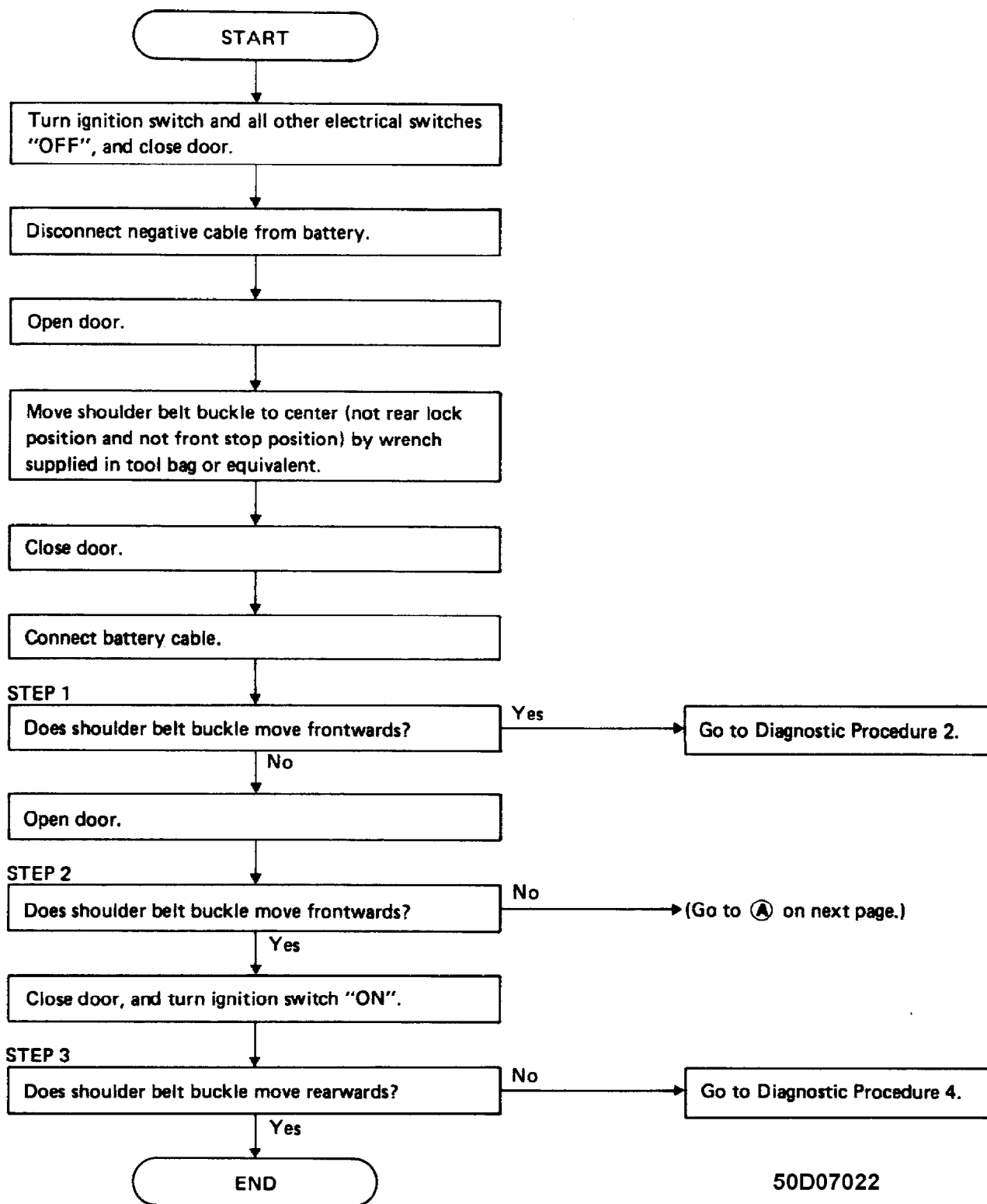

50D07022

Fig. 14: Diagnostic Procedure 1 (Preliminary Check - 1 of 2)

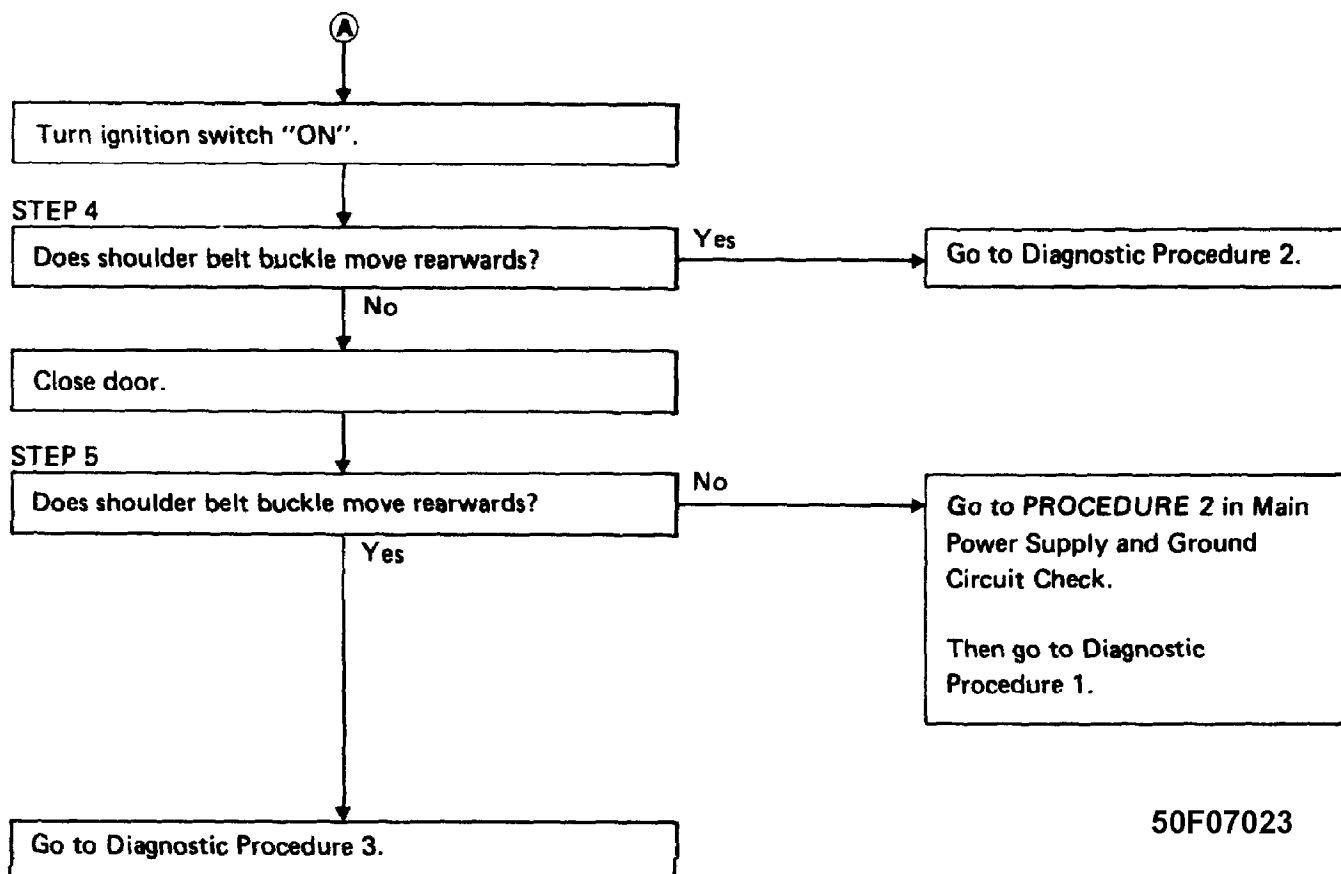

50F07023

Fig. 15: Diagnostic Procedure 1 (Preliminary Check - 2 of 2)

MAIN POWER SUPPLY TABLE

Terminals	Does Battery Voltage Exist?	
	With Ignition Switch ON	Other Than Ignition Switch ON
21 & Ground	Yes	No
22 & Ground	Yes	Yes
39 & Ground	Yes	Yes
44 & Ground	Yes	Yes

GROUND CIRCUIT TABLE

Terminals	Continuity
29 & Ground	Yes
37 & Ground	Yes
46 & Ground	Yes

PROCEDURE 2 (PRELIMINARY CHECK)

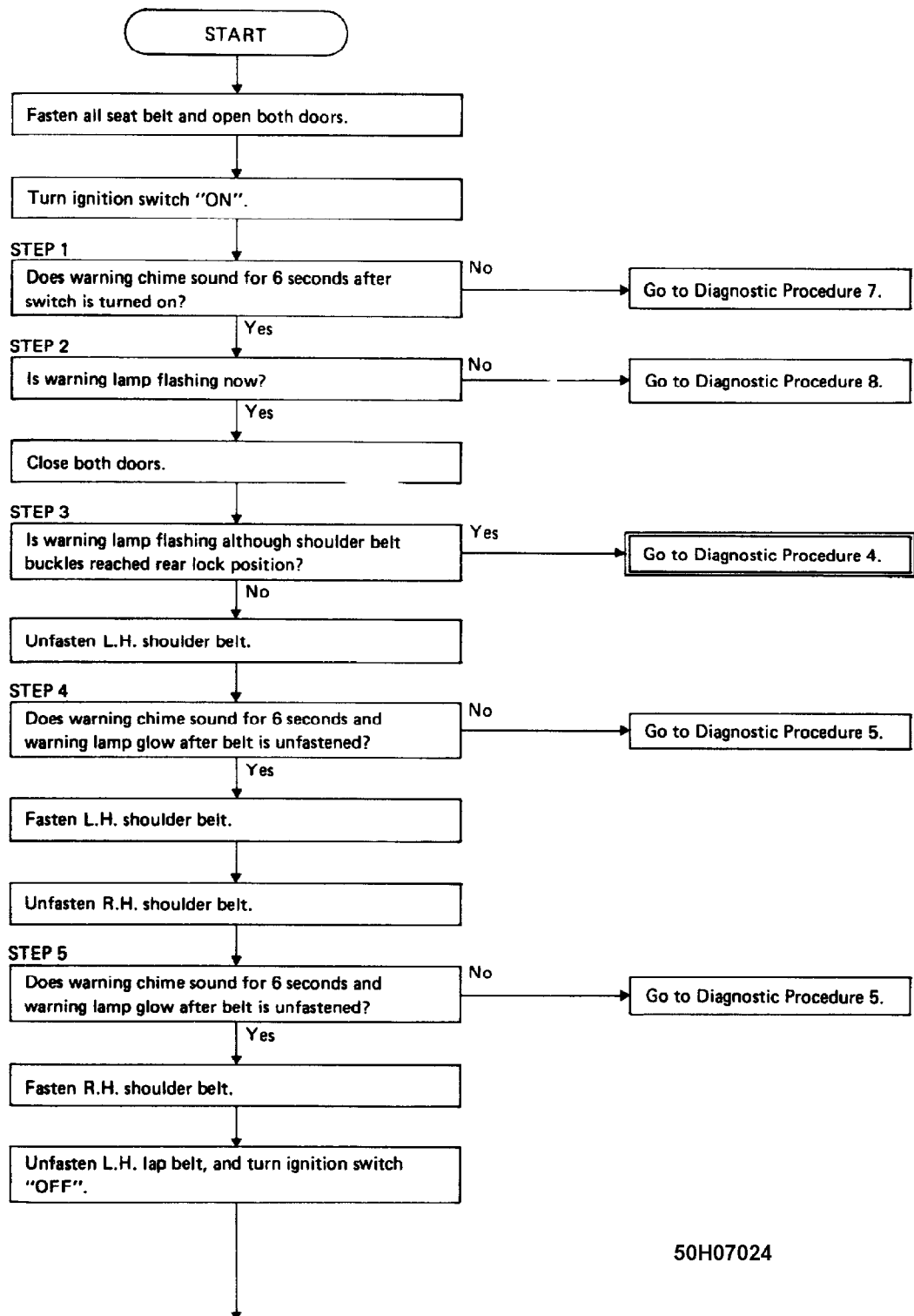

(Go to (A) on next graphic)

Fig. 16: Diagnostic Procedure 2 (Preliminary Check - 1 of 2)

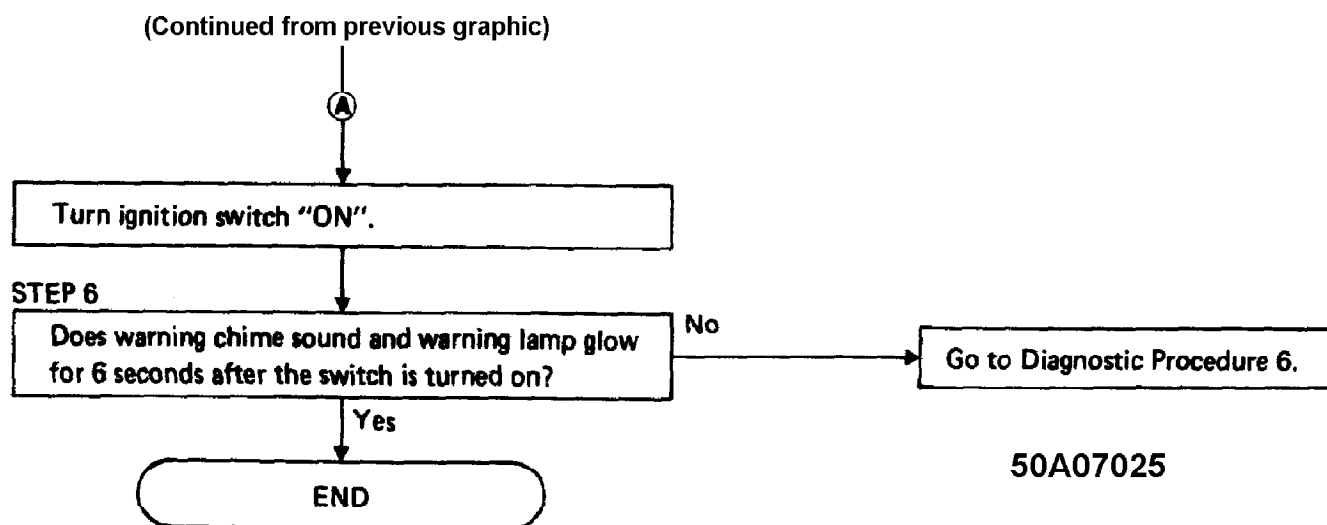

Fig. 17: Diagnostic Procedure 2 (Preliminary Check - 2 of 2)

POWER SUPPLY FOR MOTOR DRIVE TABLE

Terminals	Application	Continuity
39 & Ground	Left Hand Side	Yes
44 & Ground	Right Hand Side	Yes

GROUND CIRCUIT FOR MOTOR DRIVE TABLE

Terminals	Application	Continuity
37 & Ground	Left Hand Side	Yes
46 & Ground	Right Hand Side	Yes

DIAGNOSTIC PROCEDURE CHARTS

DIAGNOSTIC PROCEDURE 1

(Continued from previous graphic.)

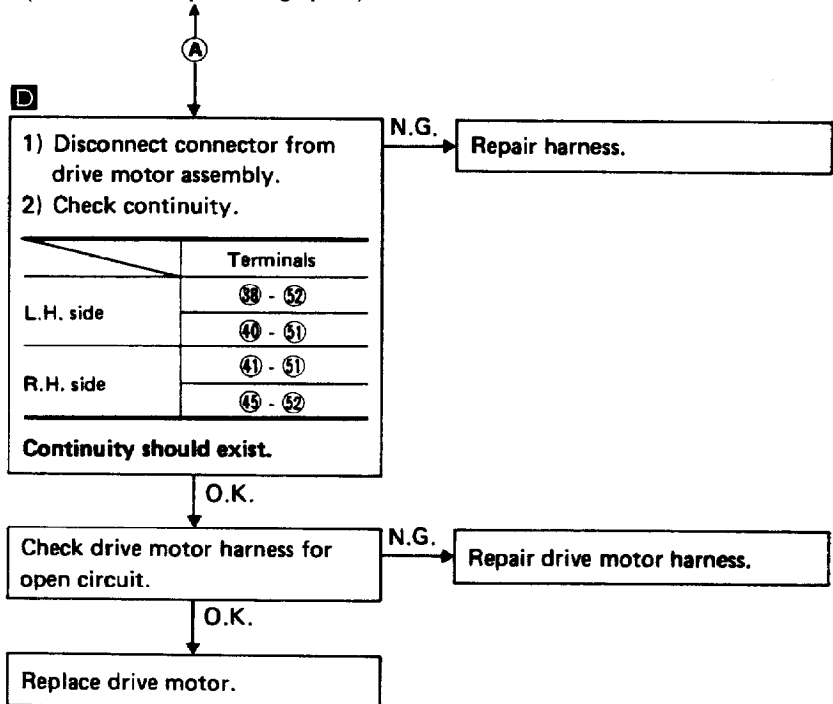

(Continued from previous graphic.)

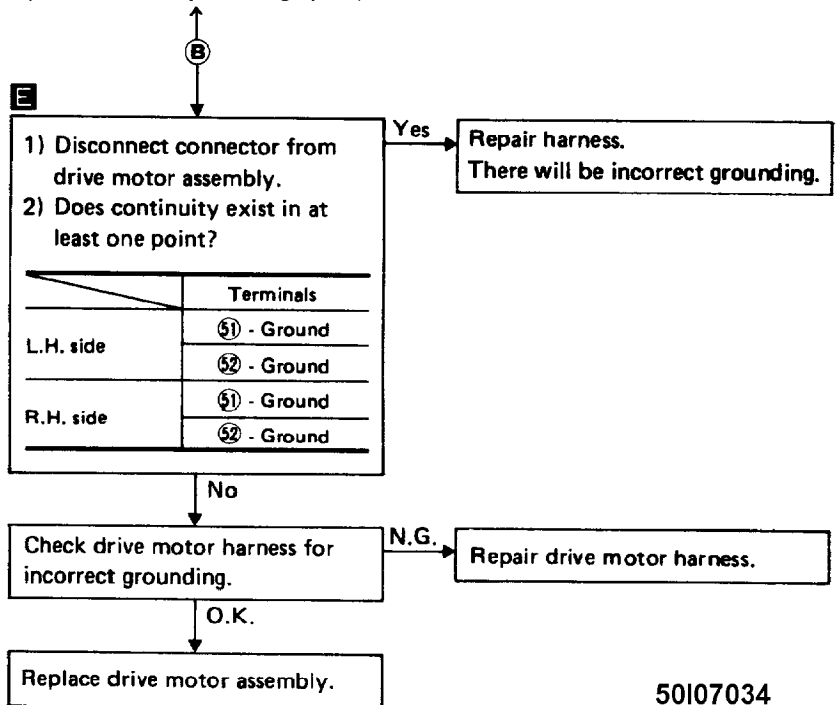

50I07034

Fig. 19: Diagnostic Procedure 1 (2 of 3)

(Continued from graphic (1 of 3).)

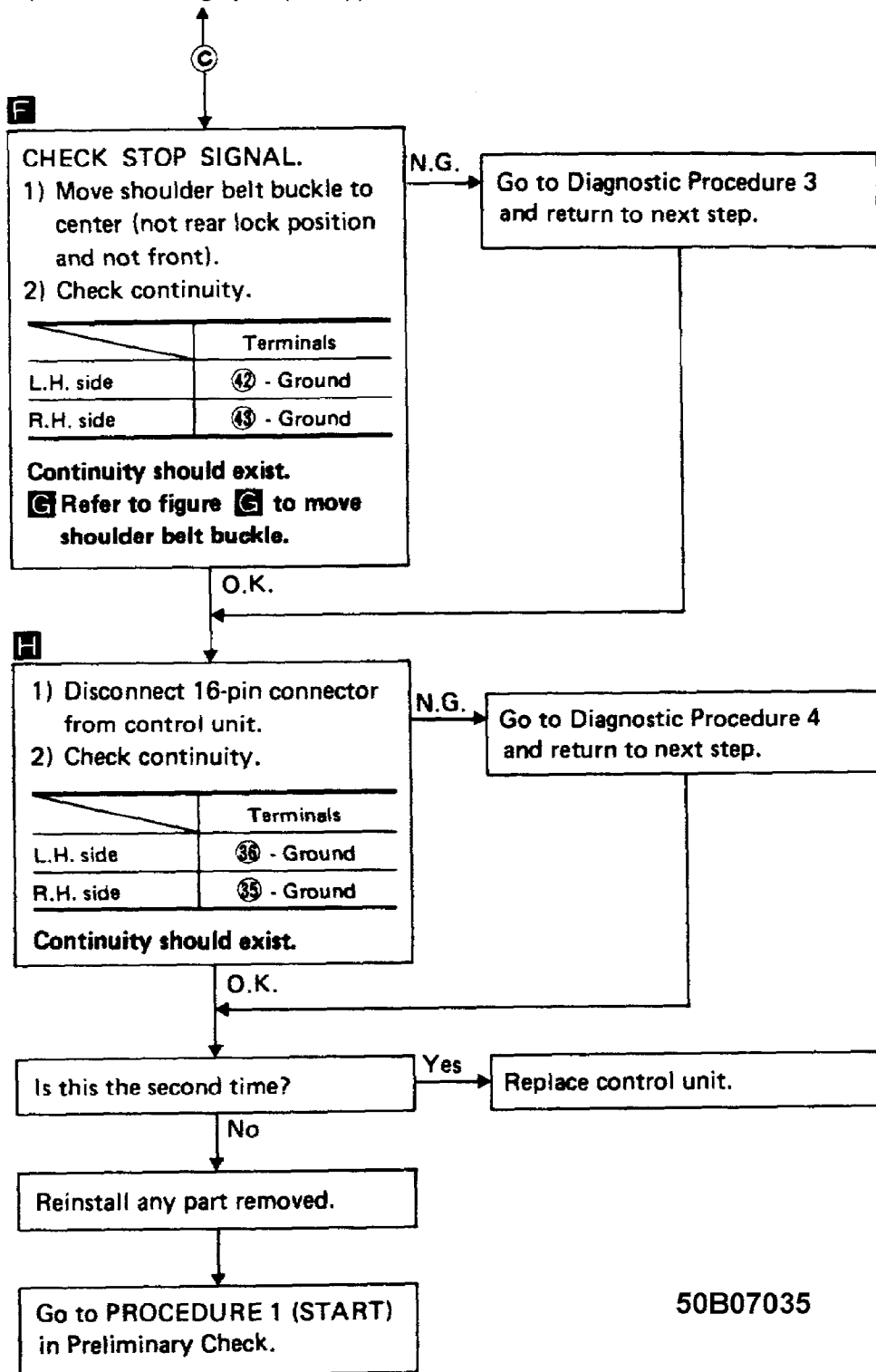

50B07035

Fig. 20: Diagnostic Procedure 1 (3 of 3)

DIAGNOSTIC PROCEDURE 2

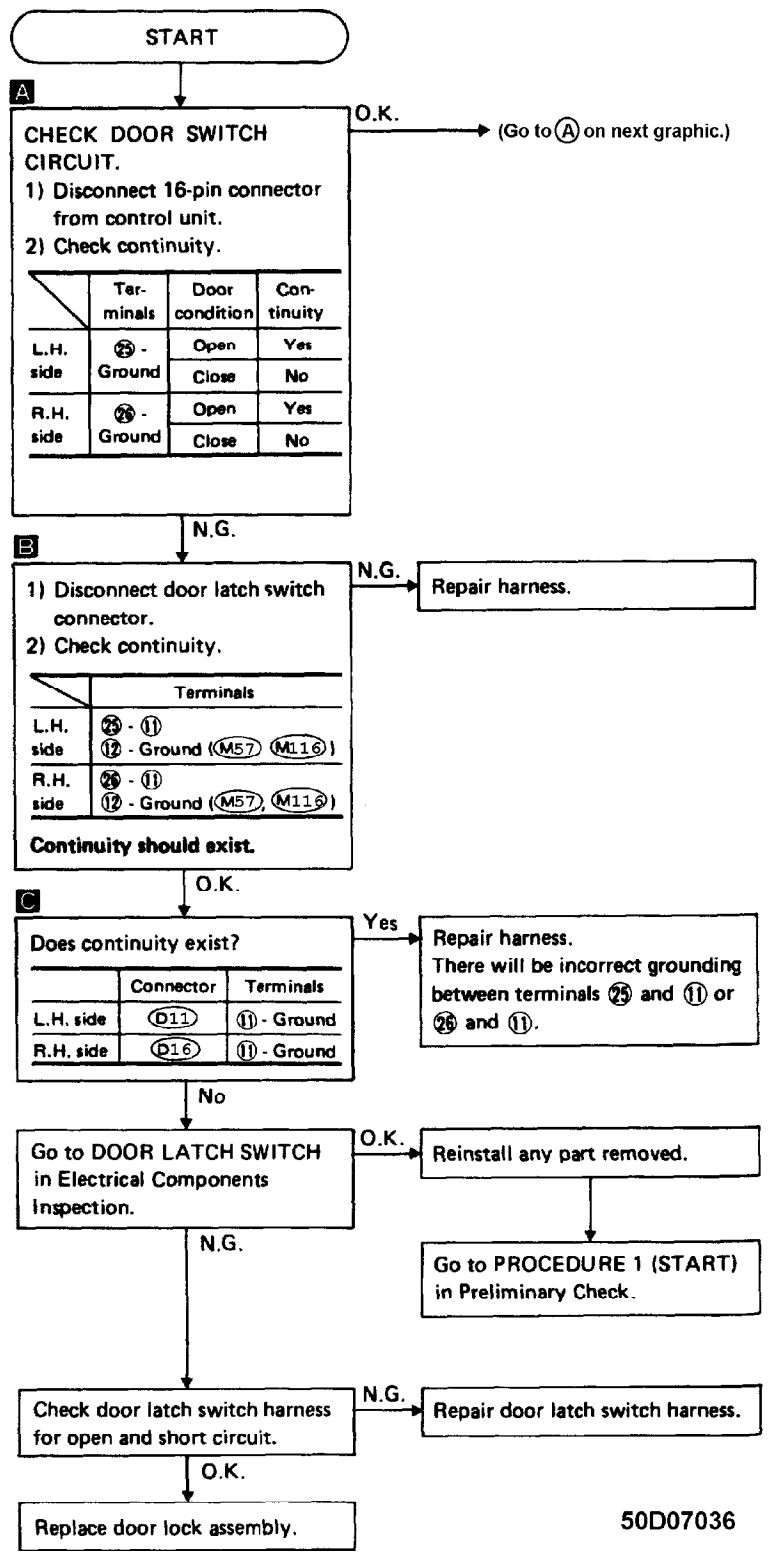

50D07036

Fig. 21: Diagnostic Procedure 2 (1 of 2)

(Continued from previous graphic.)

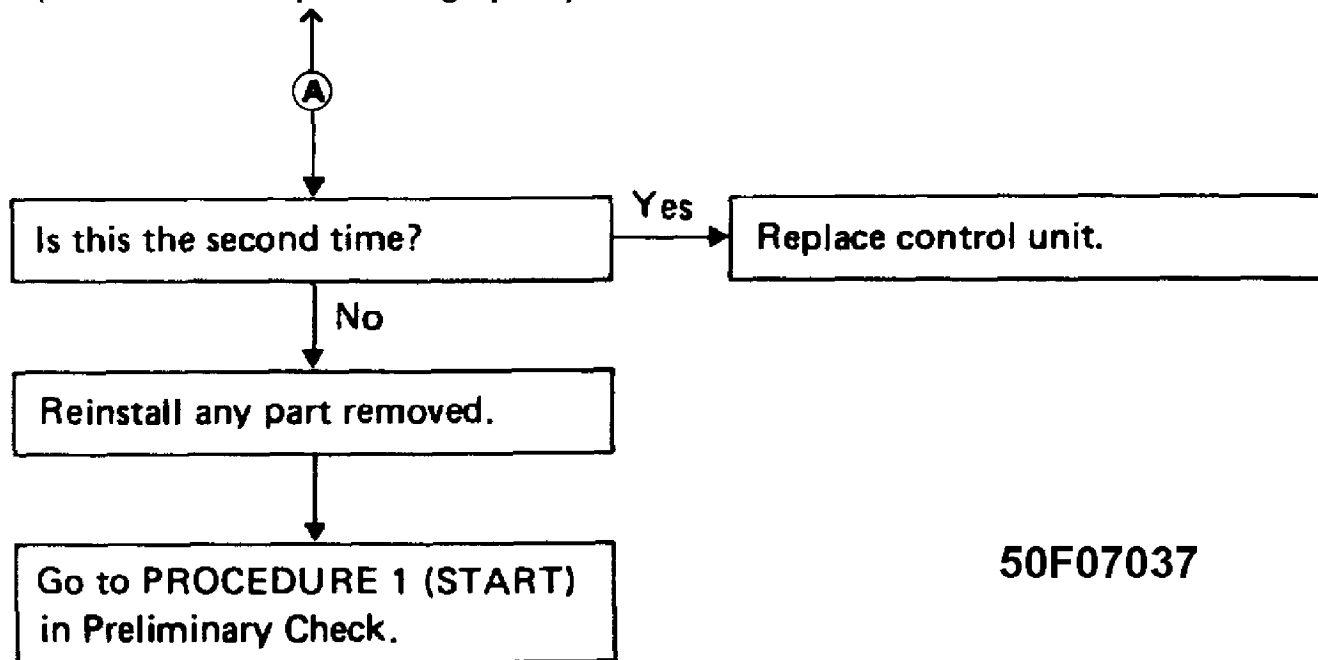

50F07037

Fig. 22: Diagnostic Procedure 2 (2 of 2)

DIAGNOSTIC PROCEDURE 3

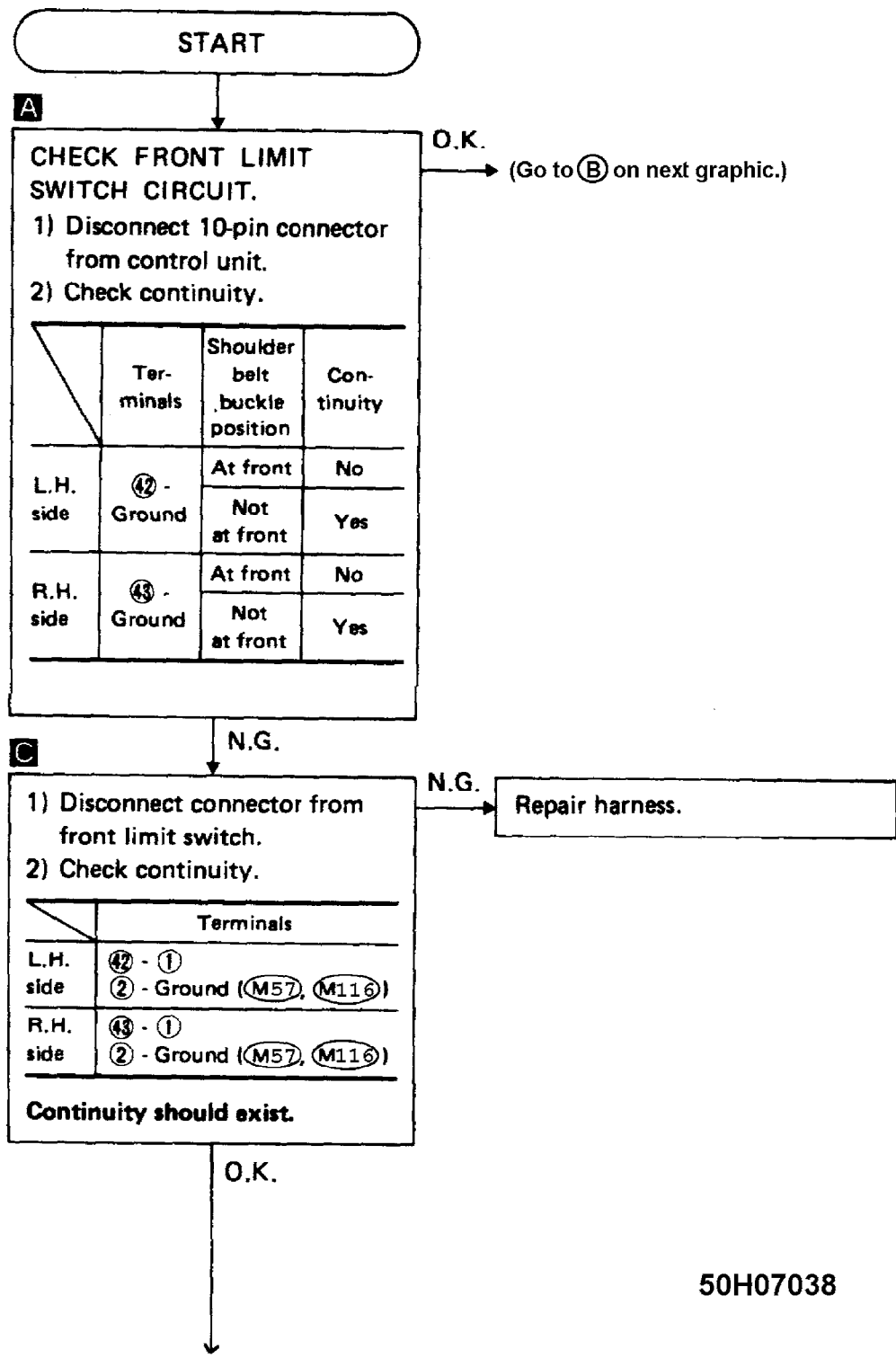

50H07038

Fig. 23: Diagnostic Procedure 3 (1 of 2)

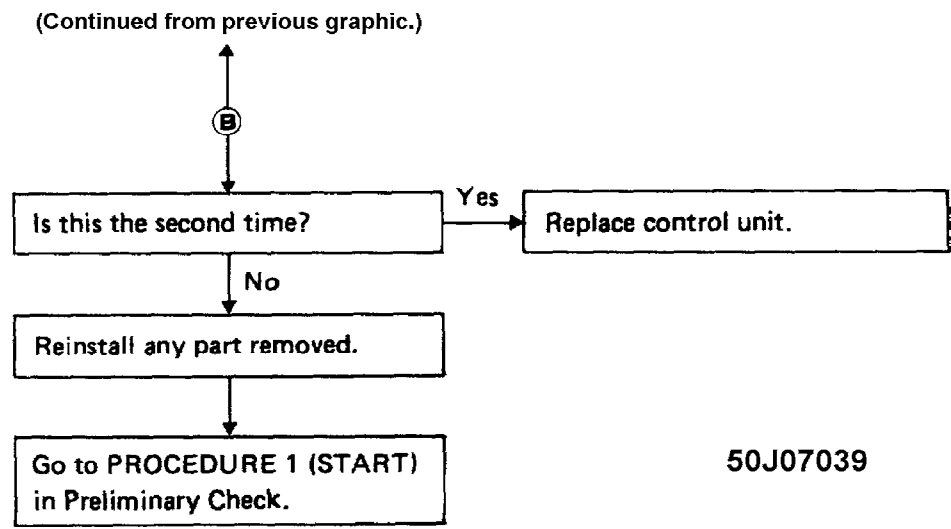
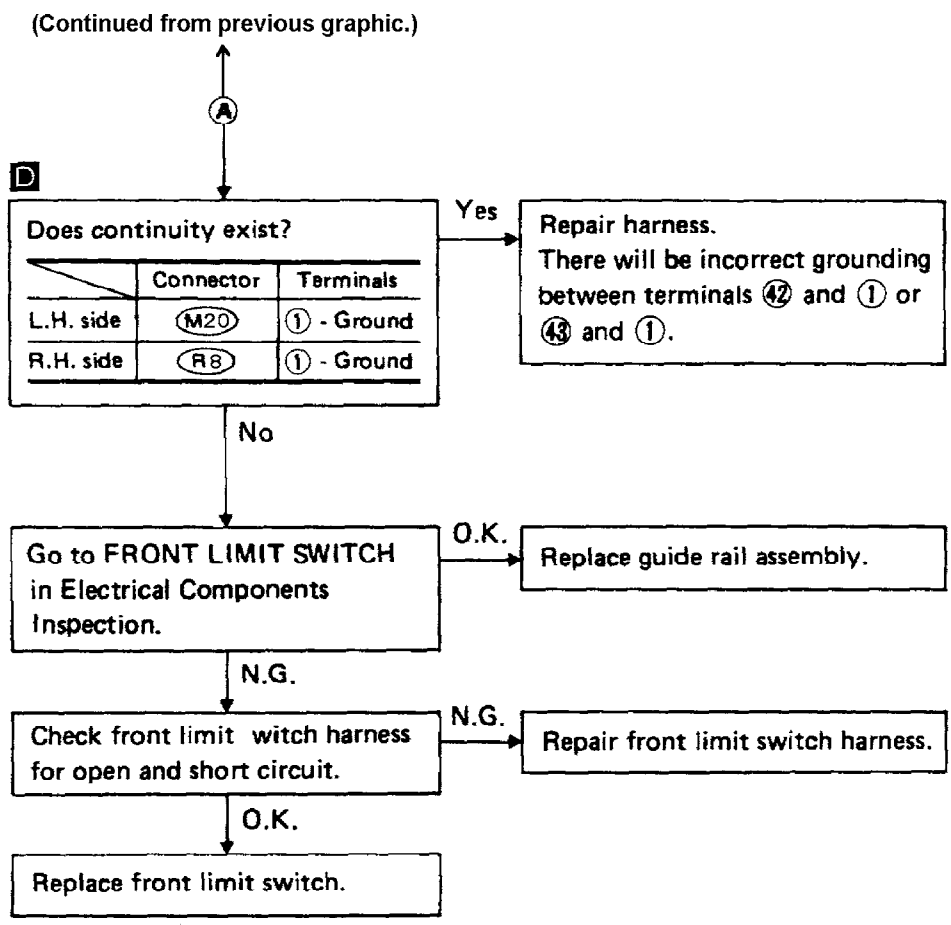

50J07039

Fig. 24: Diagnostic Procedure 3 (2 of 2)

DIAGNOSTIC PROCEDURE 4

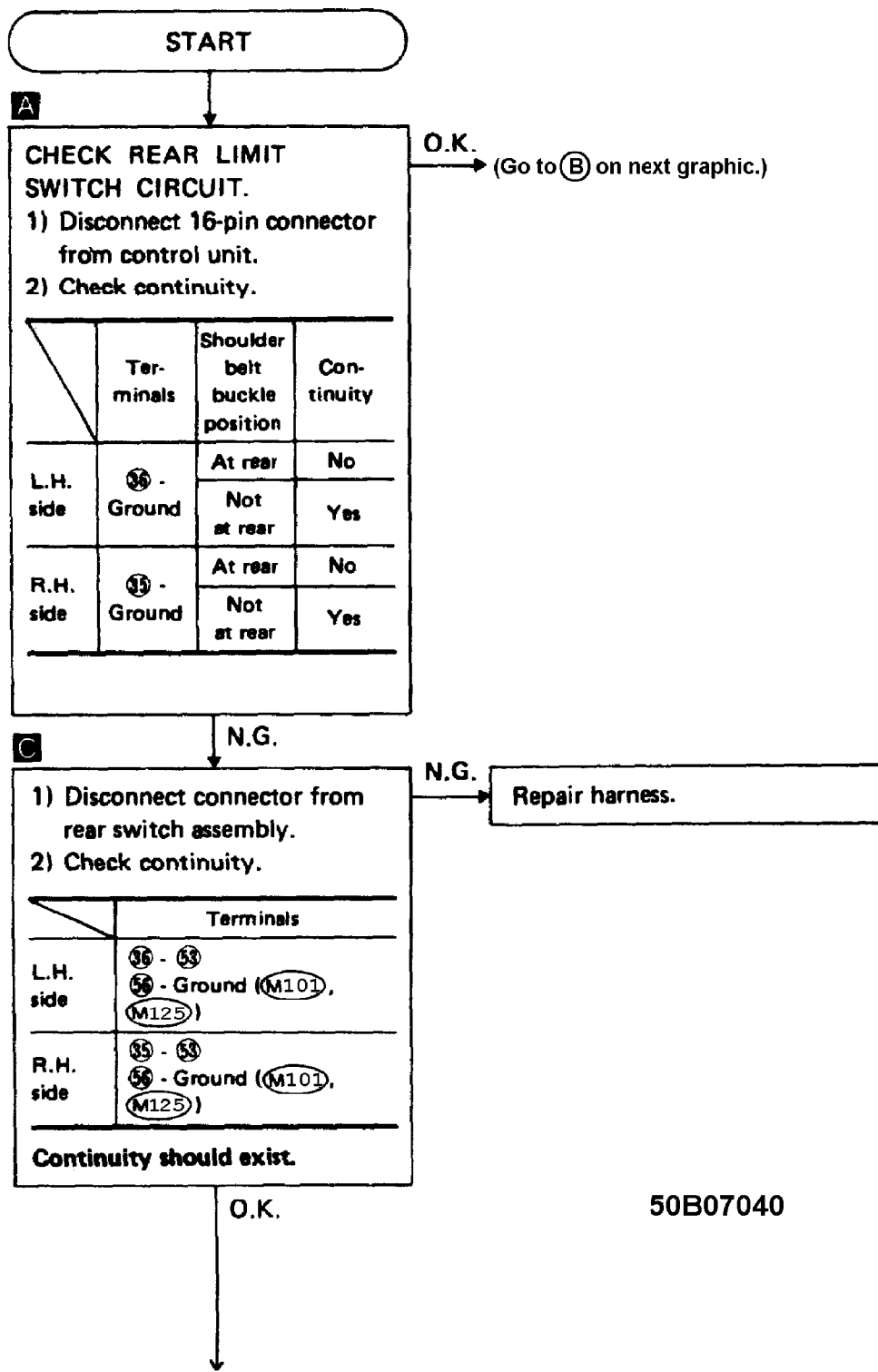

50B07040

Fig. 25: Diagnostic Procedure 4 (1 of 2)

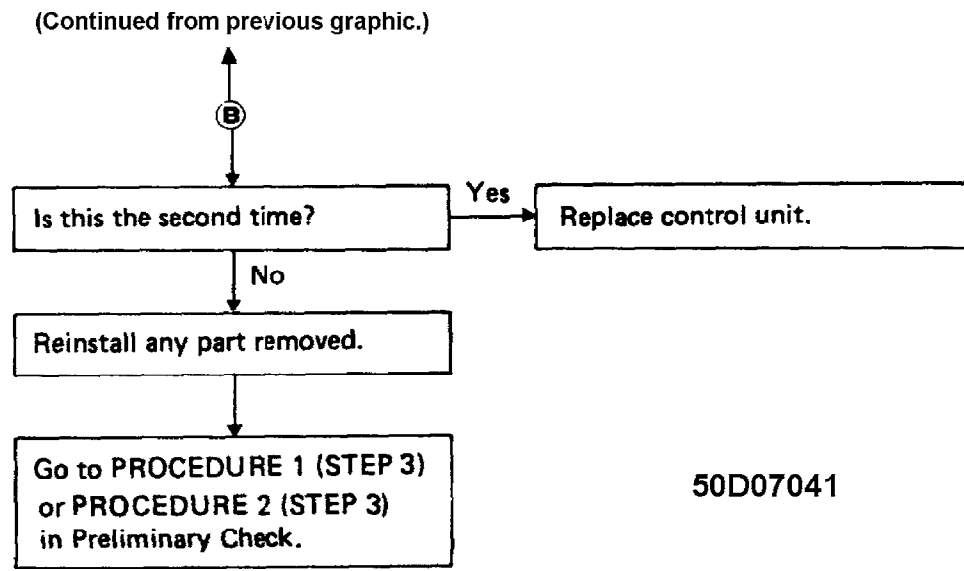
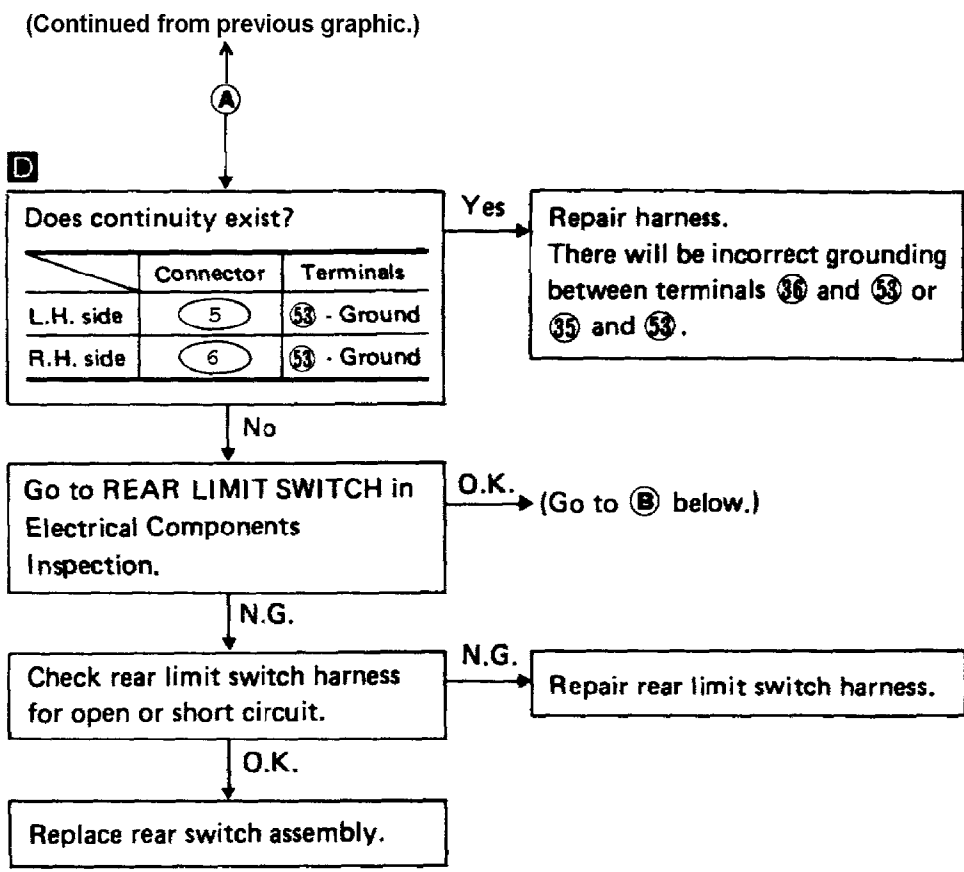

50D07041

Fig. 26: Diagnostic Procedure 4 (2 of 2)

DIAGNOSTIC PROCEDURE 5

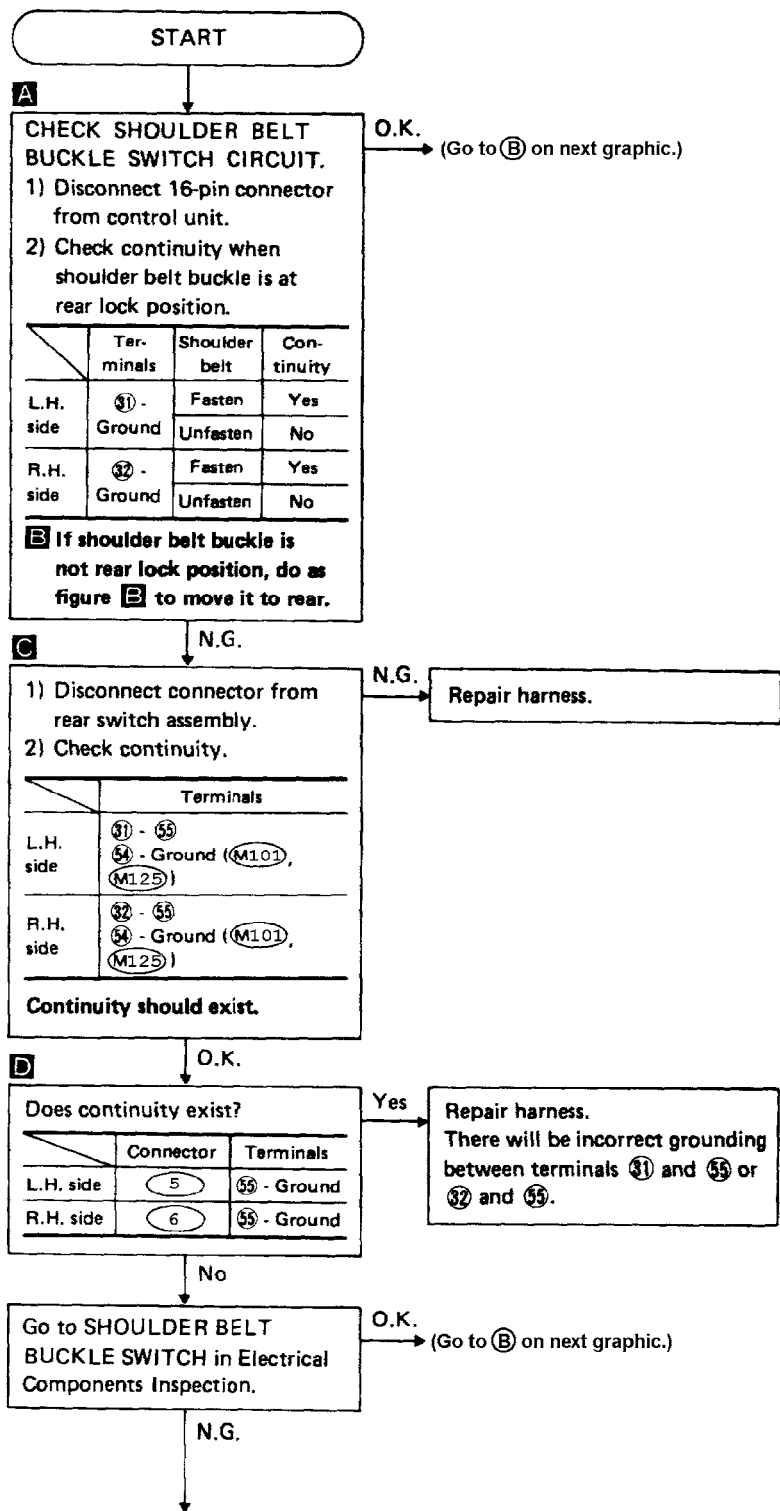

(Go to A on next graphic.)

50F07042

Fig. 27: Diagnostic Procedure 5 (1 of 2)

(Continued from previous graphic.)

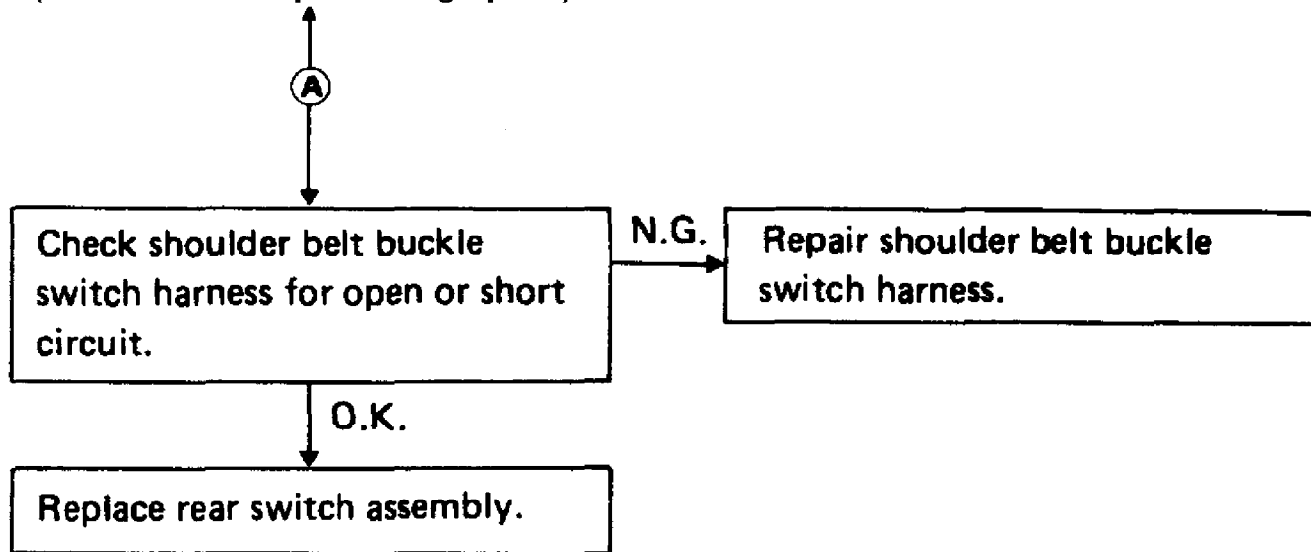

(Continued from previous graphic.)

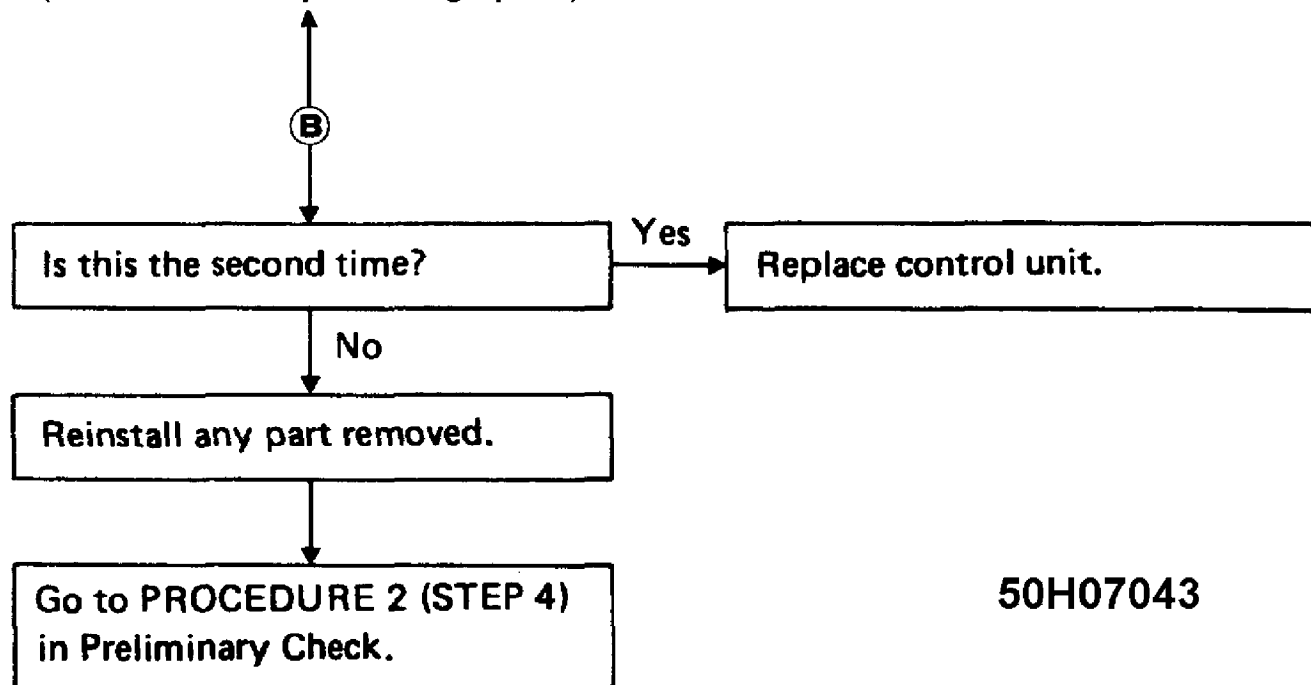

50H07043

Fig. 28: Diagnostic Procedure 5 (2 of 2)

DIAGNOSTIC PROCEDURE 6

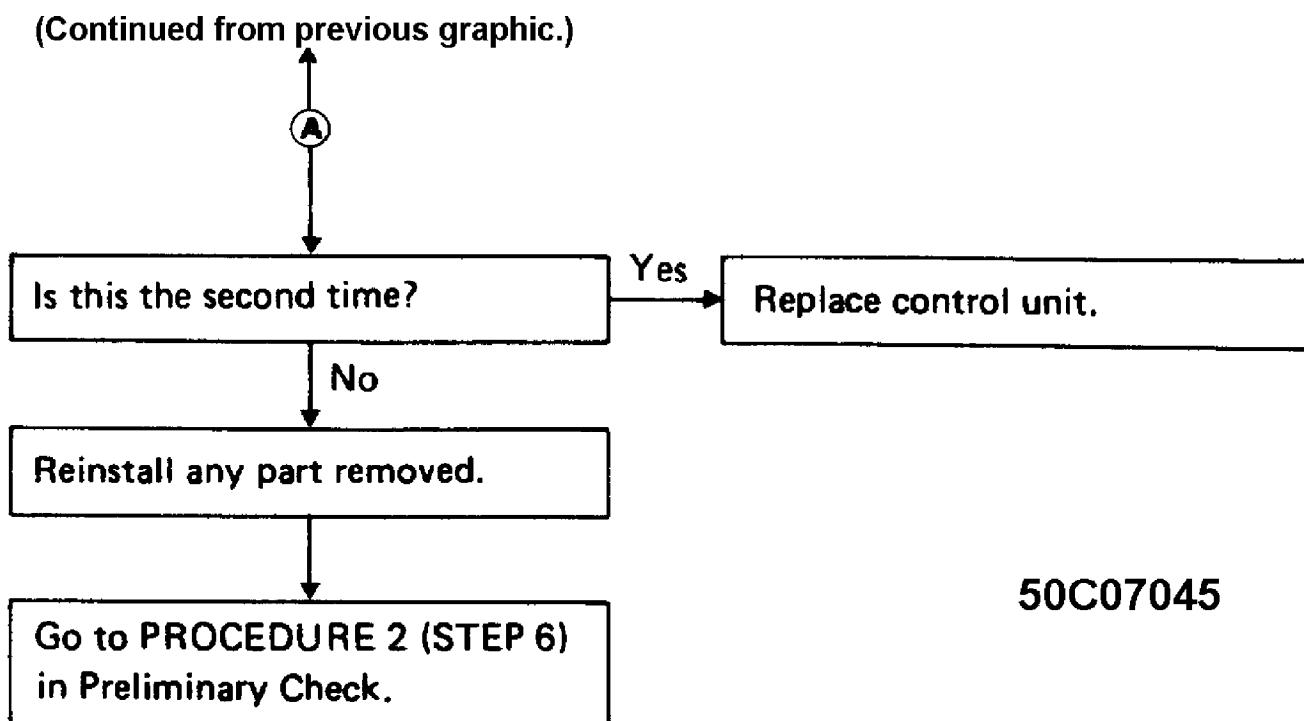
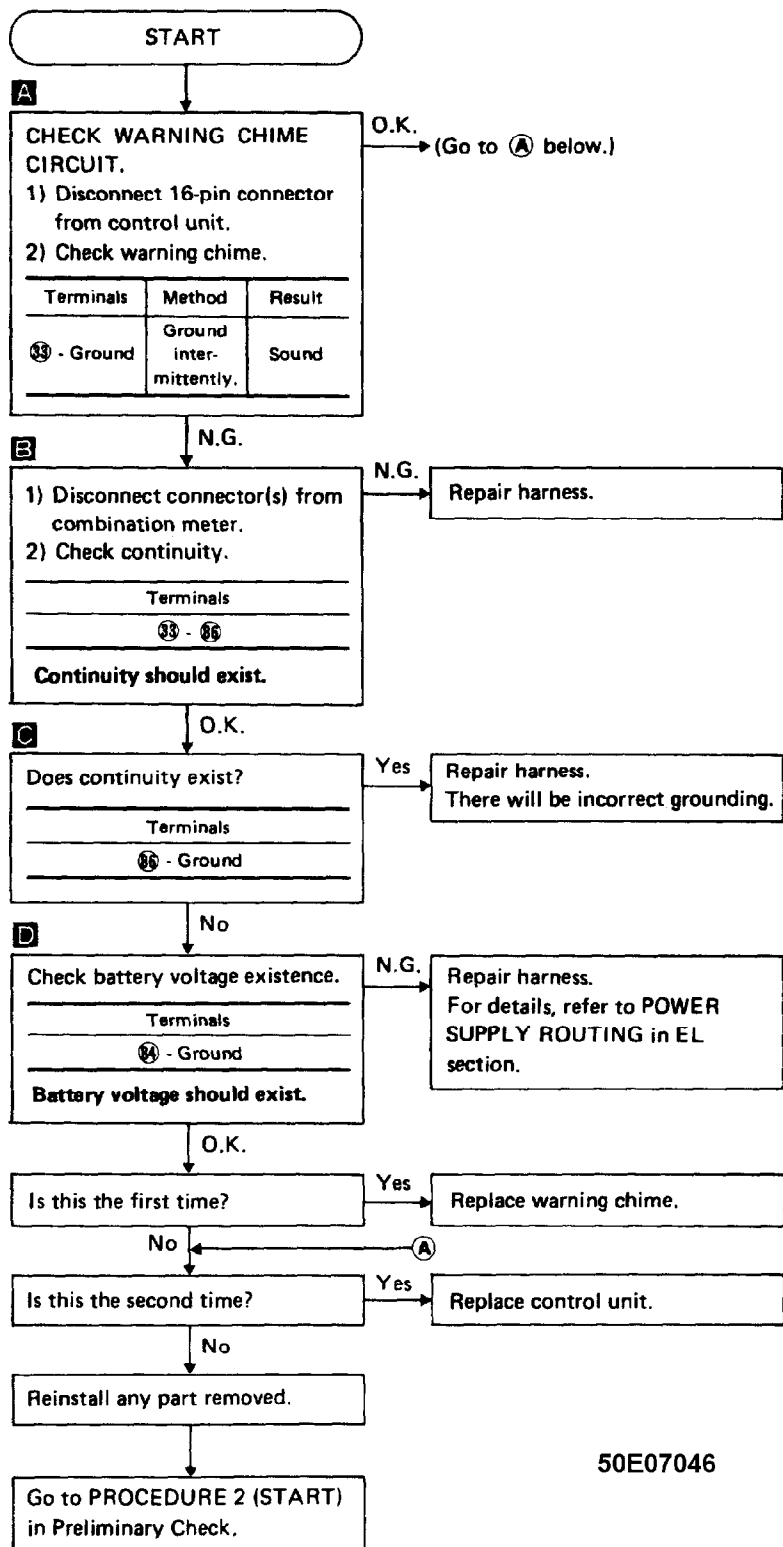

Fig. 30: Diagnostic Procedure 6 (2 of 2)

DIAGNOSTIC PROCEDURE 7



50E07046

Fig. 31: Diagnostic Procedure 7

DIAGNOSTIC PROCEDURE 8

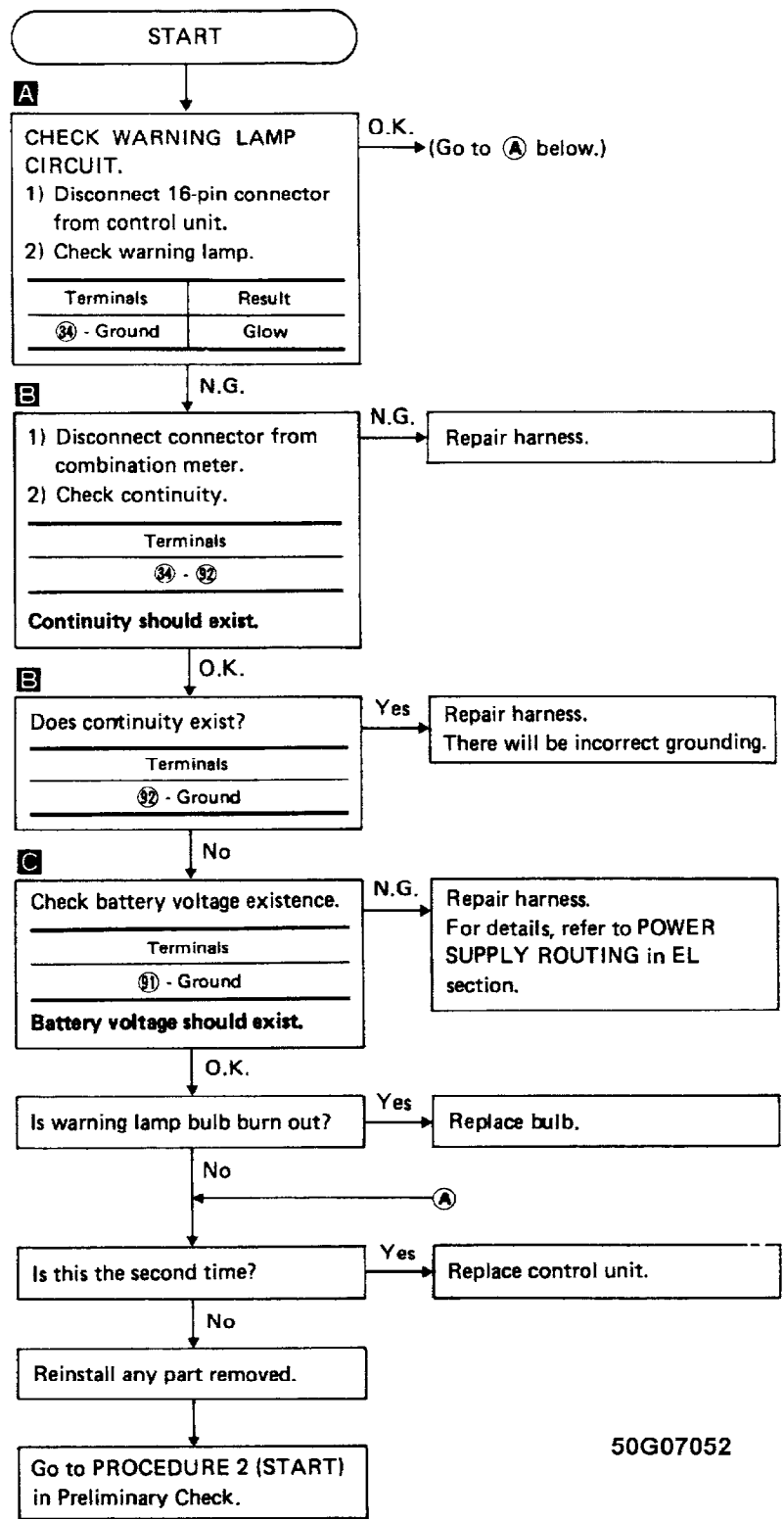

50G07052

Fig. 32: Diagnostic Procedure 8

ELECTRICAL COMPONENTS INSPECTION

FRONT LIMIT SWITCH

FRONT LIMIT SWITCH

Condition	Continuity
Pushed	No
Released	Yes

REAR LIMIT SWITCH

REAR LIMIT SWITCH

Condition	Continuity
Pushed	No
Released	Yes

SHOULDER BELT BUCKLE SWITCH

SHOULDER BELT BUCKLE SWITCH

Condition	Continuity
Move magnet toward buckle switch.	Yes
Move magnet away from buckle switch.	No

DOOR LATCH SWITCH

DOOR LATCH SWITCH (BUILT IN DOOR LOCK ASSEMBLY)

Door Condition	Continuity
Open	Yes
Closed	No

DRIVE MOTOR ASSEMBLY

DRIVE MOTOR ASSEMBLY

Terminals		Drive Belt Operation
+	-	
52	51	Lengthen
51	52	Shorten

LAP BELT BUCKLE SWITCH

LAP BELT BUCKLE SWITCH

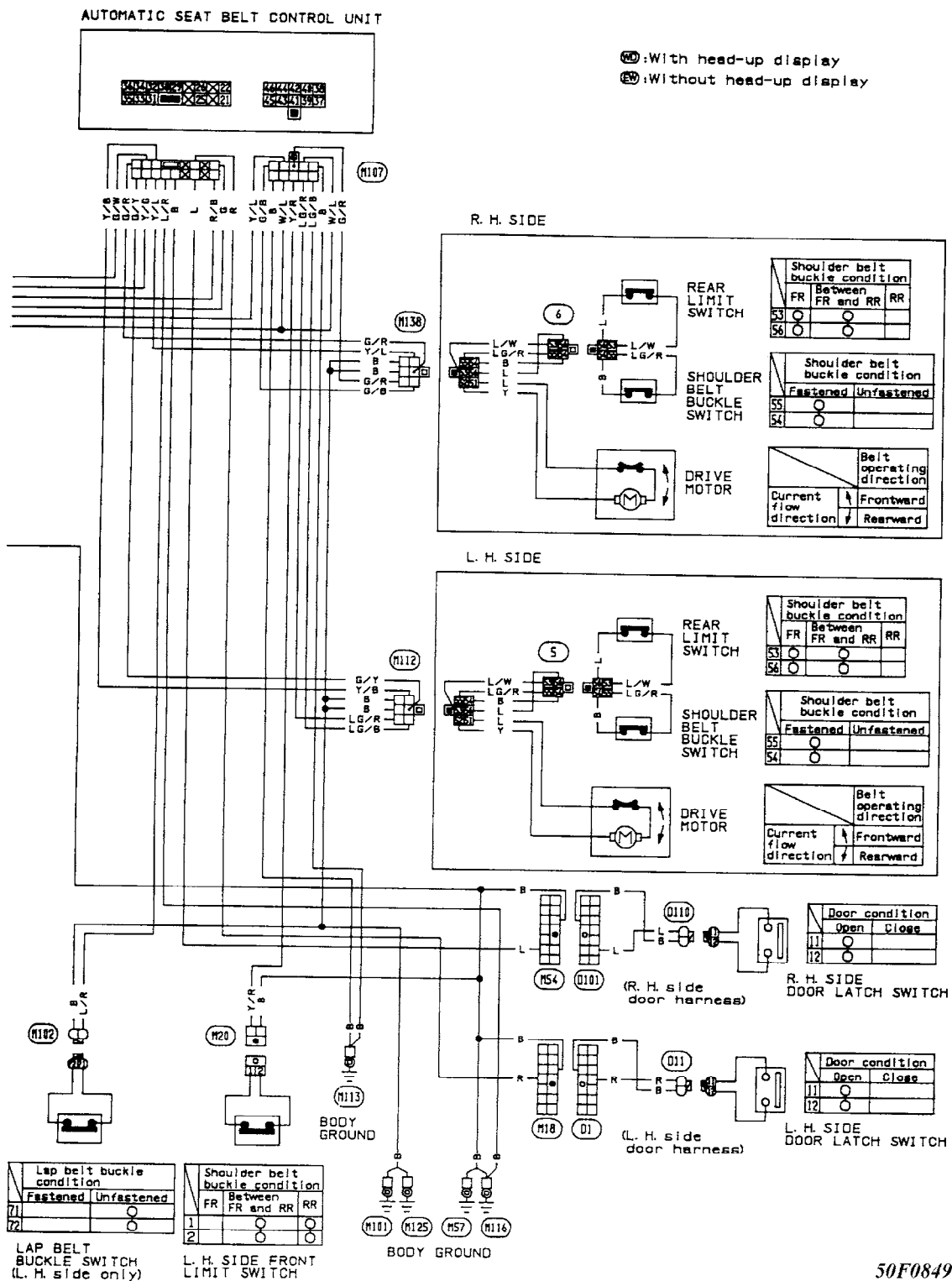

Fig. 34: Automatic Seat Belt Wiring Diagram (2 of 2)
Print For Best Results

50F08490