

SECTION **EX**
EXHAUST SYSTEM

A
EX
C
D
E
F
G
H
I
J
K
L
M
N
O
P

CONTENTS

PRECAUTION	2	ON-VEHICLE MAINTENANCE	4
PRECAUTIONS	2	EXHAUST SYSTEM	4
Removal and Installation	2	Inspection	4
PREPARATION	3	ON-VEHICLE REPAIR	5
PREPARATION	3	EXHAUST SYSTEM	5
Special Service Tool	3	Exploded View	5
Commercial Service Tool	3	Removal and Installation	5
		Inspection	6

PRECAUTIONS

< PRECAUTION >

PRECAUTION

PRECAUTIONS

Removal and Installation

INFOID:000000004231601

CAUTION:

- Be sure to use genuine exhaust system parts or equivalents which are specially designed for heat resistance, corrosion resistance, and shape.
- Perform the operation with the exhaust system fully cooled down because the system will be hot just after engine stops.
- Be careful not to cut your hand on the heat insulator edge.

PREPARATION

< PREPARATION >

PREPARATION

PREPARATION

Special Service Tool

INFOID:000000004231602

A

EX

The actual shapes of Kent-Moore tools may differ from those of special service tools illustrated here.

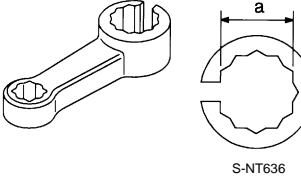
Tool number (Kent-Moore No.) Tool name	Description
KV10114400 (J-38365) Heated oxygen sensor wrench 	Loosening or tightening heated oxygen sensor 3 For 22 mm (0.87 in) (a) width hexagon nut



C

D

E

Commercial Service Tool

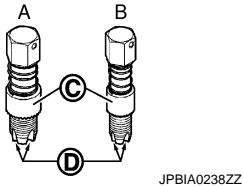
INFOID:000000004231603

(Kent-Moore No.) Tool name	Description
A: (J-43897-18) B: (J-43897-12) Heated oxygen sensor thread cleaner 	Reconditioning the exhaust system threads before installing a heated oxygen sensor (Use with anti-seize lubricant shown below.) A: J-43897-18 [18 mm (0.71 in) dia.] for zirconia heated oxygen sensor B: J-43897-12 [12 mm (0.47 in) dia.] for titania heated oxygen sensor C: Mating surface shave cylinder D: Flutes
(—) Anti-seize lubricant (Permatex 133AR or equivalent meeting MIL specification MIL-A-907) 	Lubricating air fuel ratio sensor and heated oxygen sensor thread cleaner when reconditioning exhaust system threads

F

G

H

I

J

K

L

M

N

O

P

EXHAUST SYSTEM

< ON-VEHICLE MAINTENANCE >

ON-VEHICLE MAINTENANCE

EXHAUST SYSTEM

Inspection

INFOID:000000004231604

Check exhaust pipes, muffler, and mounting for improper attachment, leakage, cracks, damage or deterioration.

- If anything is found, repair or replace damaged parts.

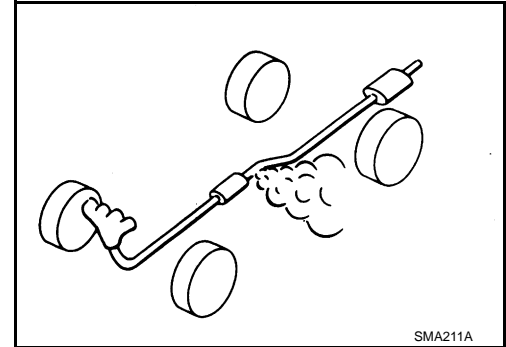

EXHAUST SYSTEM

< ON-VEHICLE REPAIR >

ON-VEHICLE REPAIR

EXHAUST SYSTEM

Exploded View

INFOID:000000004231605

A

EX

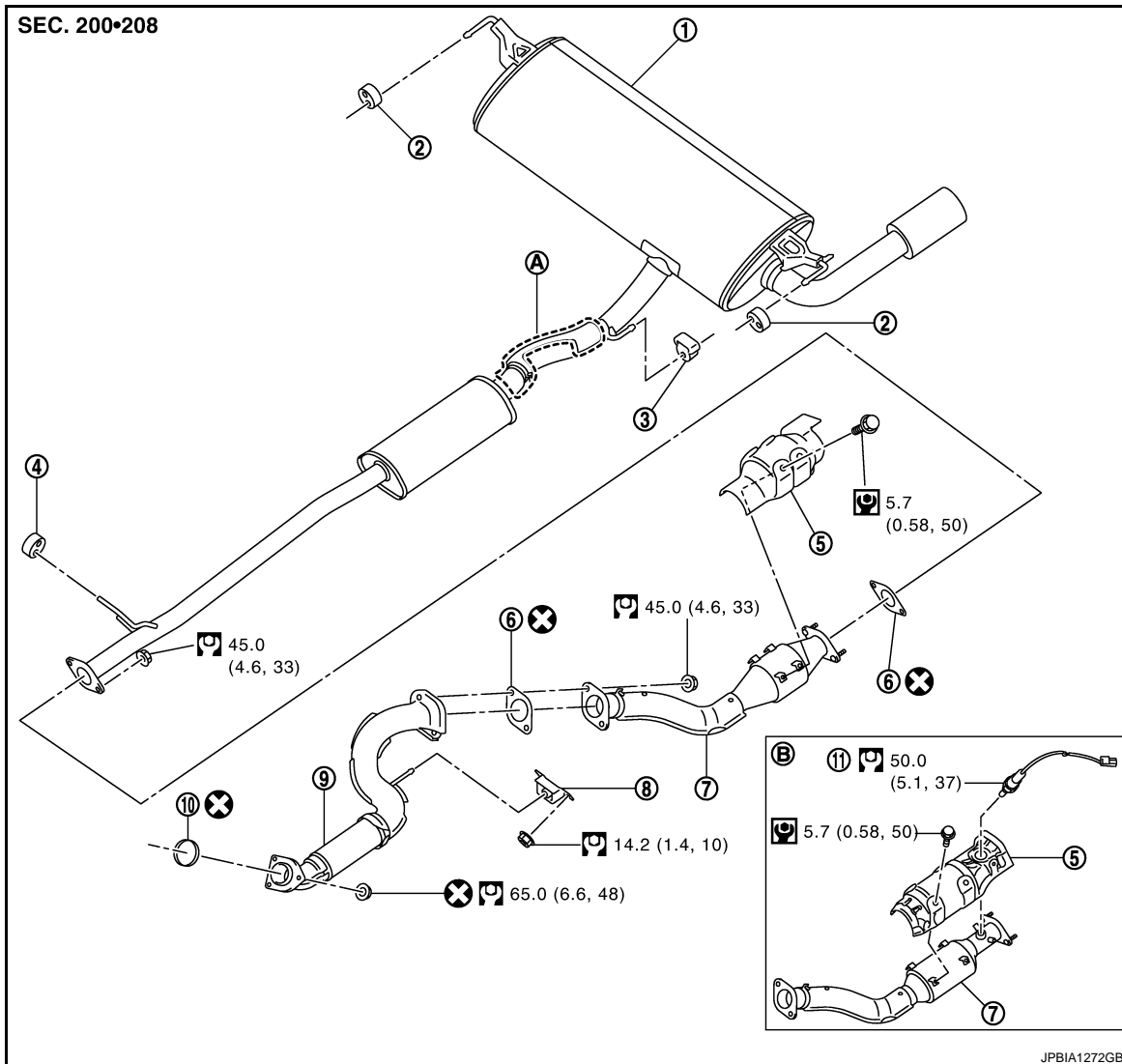

C

D

E

F

G

H

I

J

K

L

M

- | | | |
|---------------------------|----------------------------|-----------------------|
| 1. Muffer assembly | 2. Mounting rubber | 3. Mounting rubber |
| 4. Mounting rubber | 5. Insulator | 6. Gasket |
| 7. Exhaust center tube | 8. Mounting rubber | 9. Exhaust front tube |
| 10. Gasket | 11. Heated oxygen sensor 3 | |
| A. Insulator (AWD models) | B. For California | |

Refer to [GI-4, "Components"](#) for symbols in the figure.

Removal and Installation

INFOID:000000004231606

REMOVAL

- Disconnect each joint and mounting.
- Remove heated oxygen sensor 3 with following procedure. (For California)

N

O

P

EXHAUST SYSTEM

< ON-VEHICLE REPAIR >

- Using heated oxygen sensor wrench [SST: KV10114400 (J-38365)] (A), removal heated oxygen sensor 3 (1).

CAUTION:

Be careful not to damage heated oxygen sensor 3.

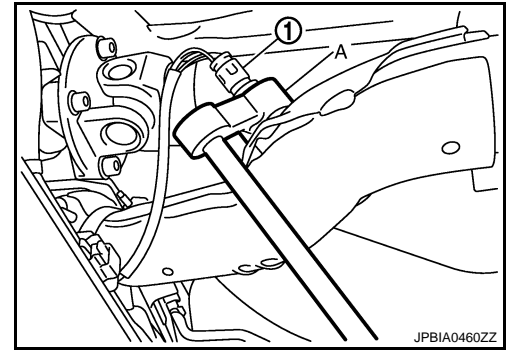

INSTALLATION

Note the following, and install in the reverse order of removal.

CAUTION:

- Always replace exhaust gasket with new ones when reassembling.
- Discard any heated oxygen sensor 3 which has been dropped onto a hard surface such as a concrete floor. Use a new one. (For California)
- Before installing a new heated oxygen sensor 3, clean exhaust system threads using the heated oxygen sensor thread cleaner (commercial service tool: J-43897-18 or J-43897-12), and apply the anti-seize lubricant (commercial service tool). (For California)
- Never over torque heated oxygen sensor 3. Doing so may cause damage to heated oxygen sensor 3, resulting in the “MIL” coming on. (For California)
- If heat insulator is badly deformed, repair or replace it. If deposits such as mud pile up on the heat insulator, remove them.
- When installing heat insulator avoid large gaps or interference between heat insulator and each exhaust pipe.
- Remove deposits from the sealing surface of each connection. Connect them securely to avoid gas leakage.
- If it is difficult to install mounting rubber, use mild detergent for smooth installation.
- When installing each mounting rubber, avoid twisting or unusual extension in up/down and right/left directions.
- Temporarily tighten mounting nuts and bolts. Check each part for unusual interference, and then tighten them to the specified torque.

Inspection

INFOID:000000004231607

INSPECTION AFTER INSTALLATION

- Check clearance between tail tube and rear bumper is even.
- With engine running, check exhaust tube joints for gas leakage and unusual noises.
- Check to ensure that mounting brackets and mounting rubbers are installed properly and free from undue stress. Improper installation could result in excessive noise and vibration.