

SECTION **RSU**
 REAR SUSPENSION

A
 B
 C
 D

RSU

CONTENTS

SYMPTOM DIAGNOSIS	2	SUSPENSION ARM	12	F
NOISE, VIBRATION AND HARSHNESS (NVH) TROUBLESHOOTING	2	Exploded View	12	
NVH Troubleshooting Chart	2	Removal and Installation	12	
PRECAUTION	3	Inspection	13	G
PRECAUTIONS	3	LOWER LINK	14	
Precautions for Suspension	3	Exploded View	14	H
PREPARATION	4	Removal and Installation	14	
PREPARATION	4	Inspection	15	I
Commercial Service Tool	4	UPPER LINK	16	
ON-VEHICLE MAINTENANCE	5	Exploded View	16	J
REAR SUSPENSION ASSEMBLY	5	Removal and Installation	16	
Inspection and Adjustment	5	Inspection	17	K
WHEEL ALIGNMENT	6	REAR STABILIZER	18	
Inspection	6	Exploded View	18	L
Adjustment	6	Removal and Installation	18	
ON-VEHICLE REPAIR	8	Inspection	19	M
COIL SPRING	8	REMOVAL AND INSTALLATION	20	
Exploded View	8	REAR SUSPENSION MEMBER	20	N
Removal and Installation	8	Exploded View	20	
Inspection	9	Removal and Installation	20	O
REAR SHOCK ABSORBER	10	Inspection	21	
Exploded View	10	SERVICE DATA AND SPECIFICATIONS (SDS)	22	P
Removal and Installation	10	SERVICE DATA AND SPECIFICATIONS (SDS)	22	
Inspection	11	Wheel Alignment	22	
Disposal	11	Wheelarch Height	22	

NOISE, VIBRATION AND HARSHNESS (NVH) TROUBLESHOOTING

< SYMPTOM DIAGNOSIS >

SYMPTOM DIAGNOSIS

NOISE, VIBRATION AND HARSHNESS (NVH) TROUBLESHOOTING

NVH Troubleshooting Chart

INFOID:000000004235720

Use chart below to find the cause of the symptom. If necessary, repair or replace these parts.

Symptom		Possible cause and SUSPECTED PARTS													Reference page		
		Improper installation, looseness	Shock absorber deformation, damage or deflection	Bushing or mounting deterioration	Parts interference	Spring fatigue	Suspension looseness	Incorrect wheel alignment	Stabilizer bar fatigue	PROPELLER SHAFT (AWD)	DIFFERENTIAL (AWD)	REAR AXLE AND REAR SUSPENSION	TIRE	ROAD WHEEL		DRIVE SHAFT (AWD)	BRAKE
REAR SUSPENSION	Noise	x	x	x	x	x	x			x	x	x	x	x	x	x	RSU-8, RSU-10, RSU-12, RSU-14, RSU-16, RSU-18
	Shake	x	x	x	x		x			x		x	x	x	x		RSU-11
	Vibration	x	x	x	x	x				x		x	x		x		—
	Shimmy	x	x	x	x			x				x	x	x			—
	Judder	x	x	x								x	x	x			—
	Poor quality ride or handling	x	x	x	x	x		x	x			x	x	x			RSU-8, RSU-10, RSU-12, RSU-14, RSU-16, RSU-18
																	RSU-6
																	RSU-19
																	NVH in DLN section
																	NVH in DLN section
																	NVH in RAX and RSU sections
																	NVH in WT section
																	NVH in WT section
																	NVH in RAX section
																	NVH in BR section

x: Applicable

PRECAUTIONS

< PRECAUTION >

PRECAUTION

PRECAUTIONS

Precautions for Suspension

INFOID:000000004467727

- When installing rubber bushings, the final tightening must be carried out under unladen conditions with tires on ground. Spilled oil might shorten the life of rubber bushings. Be sure to wipe off any spilled oil.
- Unladen conditions mean that fuel, engine coolant and lubricant are full. Spare tire, jack, hand tools and mats are in designated positions.
- After servicing suspension parts, be sure to check wheel alignment.
- Self-lock nuts are not reusable. Always use new ones when installing. Since new self-lock nuts are pre-oiled, tighten as they are.

A

B

C

D

RSU

F

G

H

I

J

K

L

M

N

O

P

PREPARATION

< PREPARATION >

PREPARATION

PREPARATION

Commercial Service Tool

INFOID:000000004235722

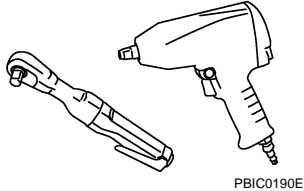
Tool name	Description
Power tool 	Loosening bolts and nuts

REAR SUSPENSION ASSEMBLY

< ON-VEHICLE MAINTENANCE >

ON-VEHICLE MAINTENANCE

REAR SUSPENSION ASSEMBLY

Inspection and Adjustment

INFOID:000000004235723

MOUNTING INSPECTION

Make sure the mounting conditions (looseness, backlash) of each component and component conditions (wear, damage) are normal.

SHOCK ABSORBER

Check for oil leakage and damage, and replace if necessary.

A

B

C

D

RSU

F

G

H

I

J

K

L

M

N

O

P

WHEEL ALIGNMENT

< ON-VEHICLE MAINTENANCE >

WHEEL ALIGNMENT

Inspection

INFOID:000000004235724

DESCRIPTION

- Measure wheel alignment under unladen conditions.

NOTE:

“Unladen conditions” means that fuel, engine coolant, and lubricant are full. Spare tire, jack, hand tools and mats are in designated positions.

PRELIMINARY CHECK

Check the following:

- Tires for improper air pressure and wear.
- Road wheels for runout. Refer to [WT-75, "Inspection"](#).
- Wheel bearing axial end play. Refer to [RAX-6, "Inspection"](#) (2WD), [RAX-14, "Inspection"](#) (AWD).
- Shock absorber operation.
- Each mounting point of axle and suspension for looseness and deformation.
- Each of front lower link, rear lower link, radius rod, rear suspension member, suspension arm and shock absorber for cracks, deformation, and other damage.
- Vehicle height (posture).

GENERAL INFORMATION AND RECOMMENDATIONS

- A four-wheel thrust alignment should be performed.
- This type of alignment is recommended for any NISSAN/INFINITI vehicle.
- The four-wheel “thrust” process helps ensure that the vehicle is properly aligned and the steering wheel is centered.
- The alignment rack itself should be capable of accepting any NISSAN/INFINITI vehicle.
- The rack should be checked to ensure that it is level.
- Make sure the machine is properly calibrated.
- Your alignment equipment should be regularly calibrated in order to give correct information.
- Check with the manufacturer of your specific equipment for their recommended Service/Calibration Schedule.

ALIGNMENT PROCESS

IMPORTANT:

Use only the alignment specifications listed in this Service Manual.

- When displaying the alignment settings, many alignment machines use “indicators”: (Green/red, plus or minus, Go/No Go). **Do not use these indicators.**
- The alignment specifications programmed into your machine that operate these indicators may not be correct.
- This may result in an ERROR.
- Some newer alignment machines are equipped with an optional “Rolling Compensation” method to “compensate” the sensors (alignment targets or head units). **Do not use this “Rolling Compensation” method.**
- Use the “Jacking Compensation Method”. After installing the alignment targets or head units, raise the vehicle and rotate the wheels 1/2 turn both ways.
- See Instructions in the alignment machine you're using for more information on this.

Adjustment

INFOID:000000004235725

CAMBER

If camber is outside the standard value, adjust with adjusting bolt (1) in lower link (2).

Standard

Camber: Refer to [RSU-22, "Wheel Alignment"](#).

CAUTION:

After adjusting camber, be sure to check toe-in.

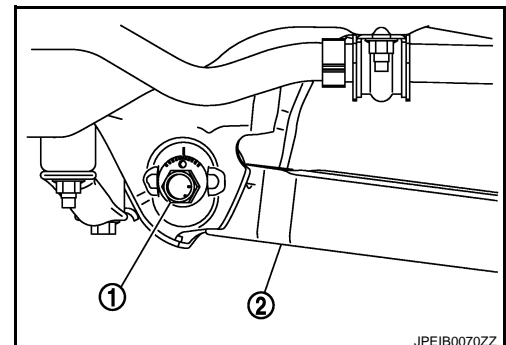

JPEIB0070ZZ

WHEEL ALIGNMENT

< ON-VEHICLE MAINTENANCE >

TOE-IN

- If toe-in is not within the specification, adjust with adjusting bolt (1) in suspension arm (2).

Standard

Toe-In: Refer to [RSU-22, "Wheel Alignment"](#).

CAUTION:

- Be sure to adjust equally on RH and LH side with adjusting bolt.
 - When tightening the nut firmly and checking the torque, use a wrench to prevent the turning of the bolt.
- If toe-in is not still within the specification, inspect and replace any damaged or worn suspension parts.

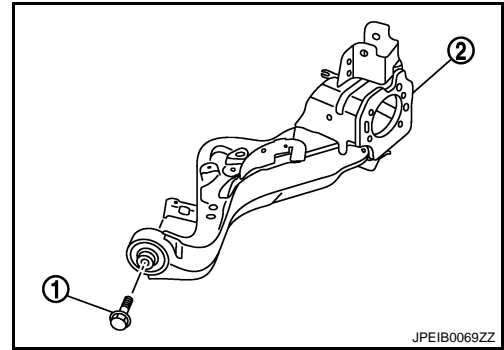

A
B
C
D

RSU

F
G
H
I
J
K
L
M
N
O
P

COIL SPRING

< ON-VEHICLE REPAIR >

ON-VEHICLE REPAIR

COIL SPRING

Exploded View

INFOID:000000004235726

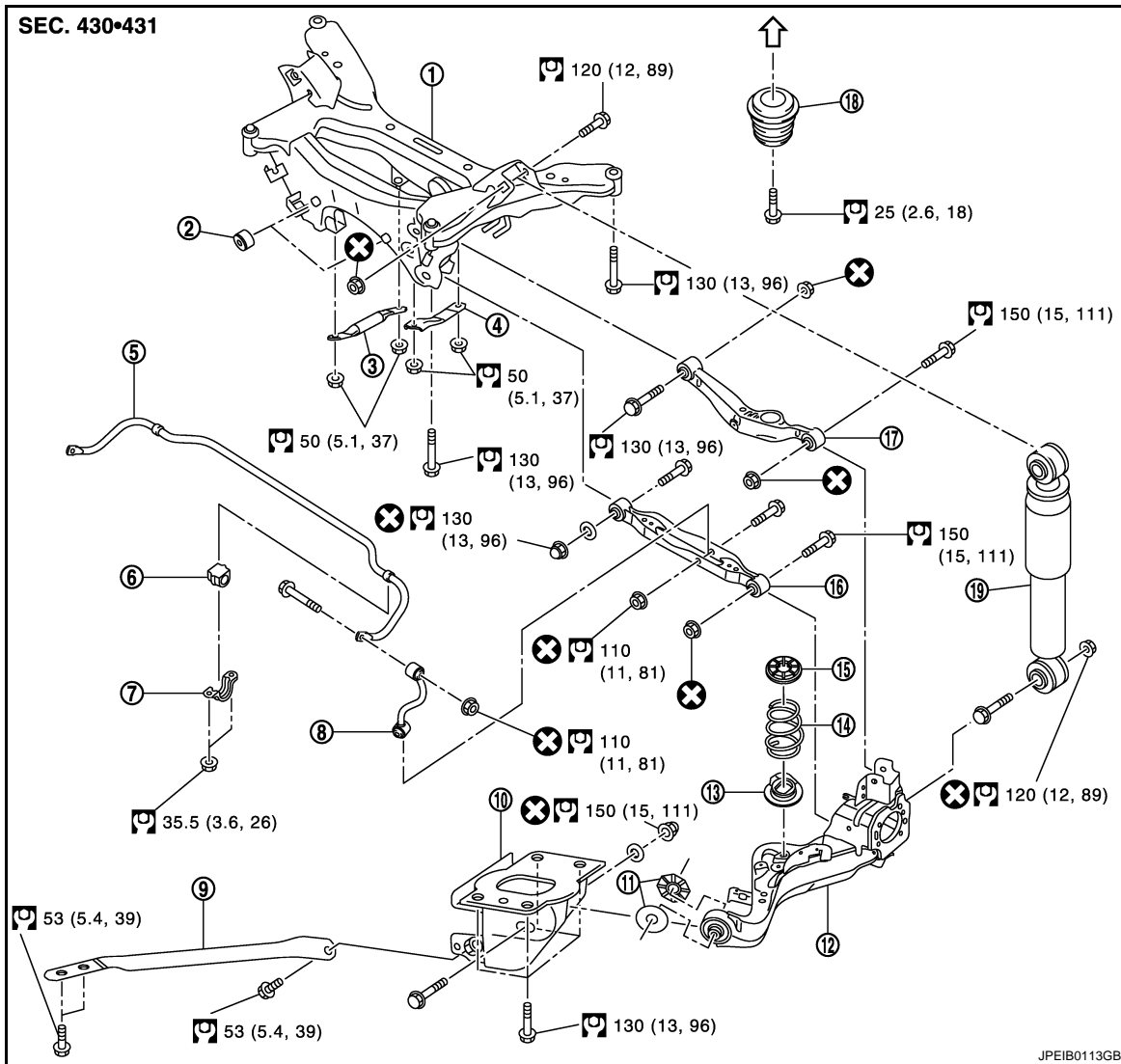

- | | | |
|---------------------------------------|--------------------------------------|--|
| 1. Rear suspension member | 2. Suspension member protector (2WD) | 3. Suspension member stay (right side) |
| 4. Suspension member stay (left side) | 5. Stabilizer bar | 6. Stabilizer bushing |
| 7. Stabilizer clamp | 8. Stabilizer link | 9. Suspension bar |
| 10. Suspension arm bracket | 11. Arm stopper | 12. Suspension arm |
| 13. Low rubber seat | 14. Coil spring | 15. Upper rubber seat |
| 16. Lower link | 17. Upper link | 18. Bound bumper |
| 19. Shock absorber | | |

◁ : Vehicle body

Refer to [GI-4. "Components"](#) for symbols in the figure.

Removal and Installation

INFOID:000000004235727

REMOVAL

1. Remove tires with power tool.

COIL SPRING

< ON-VEHICLE REPAIR >

2. Remove torque member mounting bolts with power tool. Hang torque member where it does not interfere with work. Refer to [BR-42, "BRAKE CALIPER ASSEMBLY : Exploded View"](#).
CAUTION:
 - Fix the disc rotor for wheel hub and bearing assembly with wheel nuts.
 - Never depress brake pedal while brake caliper is removed.
3. Remove wheel sensor from axle housing. Refer to [BRC-66, "REAR WHEEL SENSOR : Exploded View"](#) (without VDC), [BRC-169, "REAR WHEEL SENSOR : Exploded View"](#) (with VDC).
CAUTION:
Never pull on wheel sensor harness.
4. Set suitable jack under suspension arm.
5. Remove shock absorber from suspension arm.
6. Remove lower link from suspension arm.
7. Remove upper link from suspension arm.
8. Remove drive shaft (AWD). Refer to [RAX-15, "Exploded View"](#).
9. Remove coil spring and rubber seat (upper/lower).

INSTALLATION

Note the following, and install in the reverse order of removal.

- Match up lower rubber seat indentions and suspension arm grooves and attach.

CAUTION:

The lower rubber seat protrusion shall be securely inserted into the hole of suspension arm.

- Install coil spring by aligning lower end of the large diameter side to step between lower rubber seat and suspension arm.

CAUTION:

Assemble coil spring so that spring lower end is located spring end holding section of lower rubber seat.

- Perform the final tightening of rear suspension member and axle installation position (rubber bushing) under unladen condition with tires on level ground.

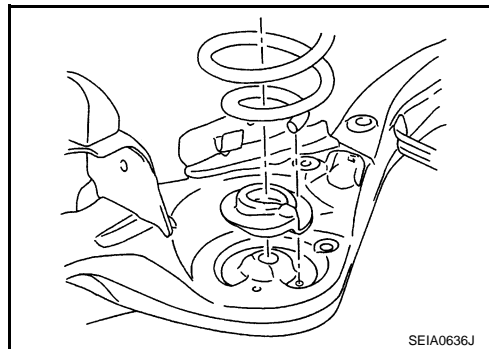

INFOID:000000004235728

Inspection

INSPECTION AFTER REMOVAL

Check lower link, bushing and coil spring for deformation, crack, and damage. Replace it if necessary.

INSPECTION AFTER INSTALLATION

1. Check wheel alignment. Refer to [RSU-6, "Inspection"](#).
2. Adjust neutral position of steering angle sensor. Refer to [BRC-75, "ADJUSTMENT OF STEERING ANGLE SENSOR NEUTRAL POSITION : Special Repair Requirement"](#) (with VDC).

REAR SHOCK ABSORBER

< ON-VEHICLE REPAIR >

REAR SHOCK ABSORBER

Exploded View

INFOID:000000004235729

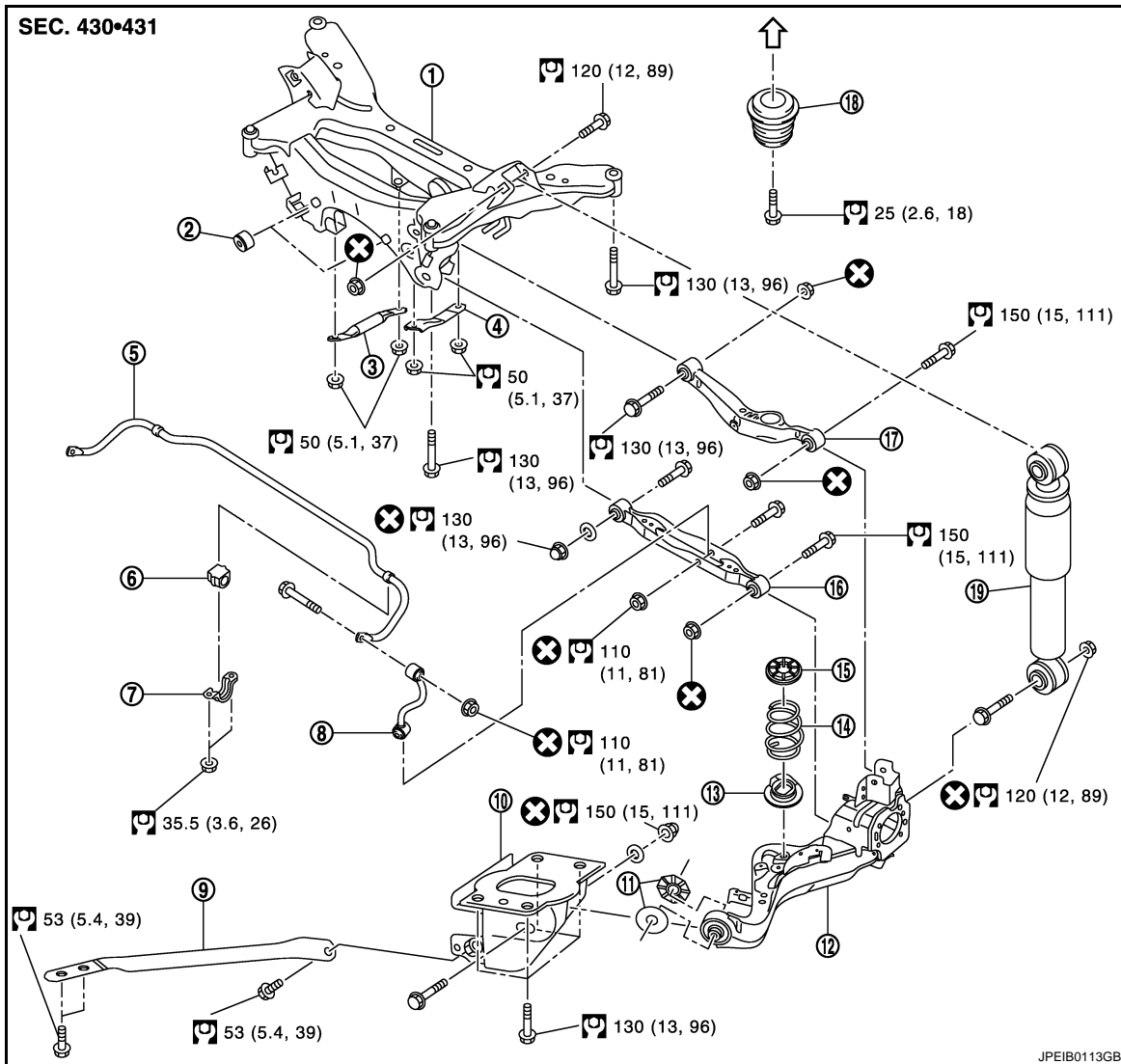

- | | | |
|---------------------------------------|--------------------------------------|--|
| 1. Rear suspension member | 2. Suspension member protector (2WD) | 3. Suspension member stay (right side) |
| 4. Suspension member stay (left side) | 5. Stabilizer bar | 6. Stabilizer bushing |
| 7. Stabilizer clamp | 8. Stabilizer link | 9. Suspension bar |
| 10. Suspension arm bracket | 11. Arm stopper | 12. Suspension arm |
| 13. Low rubber seat | 14. Coil spring | 15. Upper rubber seat |
| 16. Lower link | 17. Upper link | 18. Bound bumper |
| 19. Shock absorber | | |

↳ : Vehicle body

Refer to [GI-4, "Components"](#) for symbols in the figure.

Removal and Installation

INFOID:000000004235730

REMOVAL

1. Remove tires with power tool.
2. Set suitable jack under suspension arm to relieve the coil spring tension.

REAR SHOCK ABSORBER

< ON-VEHICLE REPAIR >

3. Remove shock absorber.

INSTALLATION

Note the following, and install in the reverse order of removal.

- Perform final tightening of bolts and nuts at the shock absorber lower side (rubber bushing), under unladen conditions with tires on level ground.

Inspection

INFOID:000000004235731

INSPECTION AFTER REMOVAL

- Check shock absorber for deformation, cracks, damage. Replace it if necessary.
- Check welded and sealed areas for oil leakage. Replace it if necessary.

INSPECTION AFTER INSTALLATION

1. Check wheel alignment. Refer to [RSU-6, "Inspection"](#).
2. Adjust neutral position of steering angle sensor. Refer to [BRC-75, "ADJUSTMENT OF STEERING ANGLE SENSOR NEUTRAL POSITION : Special Repair Requirement"](#) (with VDC).

RSU

Disposal

INFOID:000000004466885

1. Set shock absorber horizontally to the ground with the piston rod fully extracted.
2. Drill 2 – 3 mm (0.08 – 0.12 in) hole at the position (●) from top as shown in the figure to release gas gradually.

NOTE:

- Drill vertically in this direction (←).
- Directly to the outer tube avoiding brackets.

A: 20 – 30 mm (0.79 – 1.18 in)

3. Position the drilled hole downward and drain oil by moving the piston rod several times.

CAUTION:

- **Wear eye protection (safety glasse).**
- **Wear gloves.**
- **Be careful with metal chips or oil blown out by the compressed gas.**
- **Handle drained oil appropriately to the law and other local regulations.**

NOTE:

The gas is clear, colorless, odorless, and harmless.

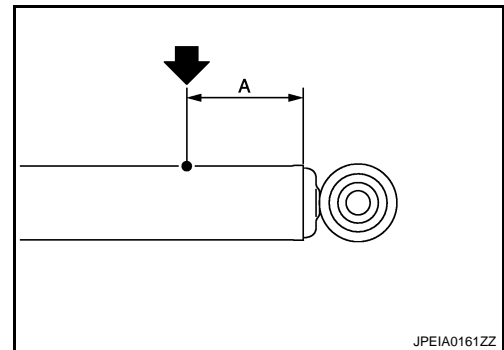

JPEIA0161ZZ

SUSPENSION ARM

< ON-VEHICLE REPAIR > SUSPENSION ARM

Exploded View

INFOID:000000004235732

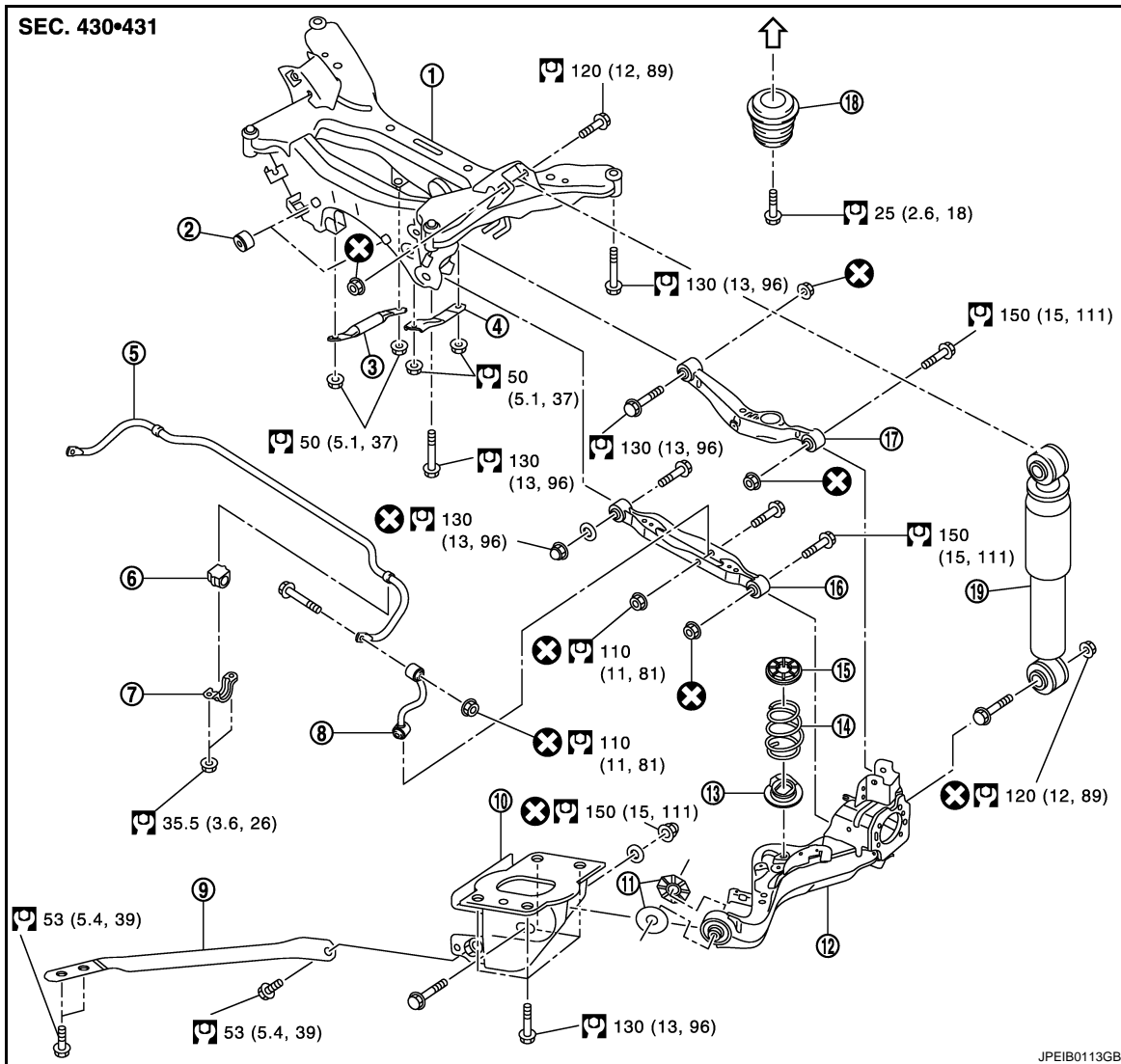

- | | | |
|---------------------------------------|--------------------------------------|--|
| 1. Rear suspension member | 2. Suspension member protector (2WD) | 3. Suspension member stay (right side) |
| 4. Suspension member stay (left side) | 5. Stabilizer bar | 6. Stabilizer bushing |
| 7. Stabilizer clamp | 8. Stabilizer link | 9. Suspension bar |
| 10. Suspension arm bracket | 11. Arm stopper | 12. Suspension arm |
| 13. Low rubber seat | 14. Coil spring | 15. Upper rubber seat |
| 16. Lower link | 17. Upper link | 18. Bound bumper |
| 19. Shock absorber | | |

□ : Vehicle body

Refer to [GI-4, "Components"](#) for symbols in the figure.

Removal and Installation

INFOID:000000004235733

REMOVAL

1. Remove tires with power tool.
2. Drain brake fluid. Refer to [BR-12, "Draining"](#).

SUSPENSION ARM

< ON-VEHICLE REPAIR >

3. Remove torque member mounting bolts. Hang torque member where it does not interfere with work. Refer to [BR-42, "BRAKE CALIPER ASSEMBLY : Exploded View"](#). A
4. Remove disc rotor. Refer to [BR-42, "BRAKE CALIPER ASSEMBLY : Removal and Installation"](#). B
CAUTION:
 - Put matching marks on the wheel hub and bearing assembly and the disc rotor before removing the disc rotor.
 - Never drop disc rotor.
5. Remove wheel sensor and sensor harness from axle housing and lower link. Refer to [BRC-66, "REAR WHEEL SENSOR : Exploded View"](#) (without VDC), [BRC-169, "REAR WHEEL SENSOR : Exploded View"](#) (with VDC). C
CAUTION:
Never pull on wheel sensor harness. D
6. Remove parking brake cable mounting bolt. Refer to [PB-6, "Exploded View"](#).
7. Separate the brake tube from the brake hose, and remove lock plate. Refer to [BR-23, "REAR : Exploded View"](#). RSU
8. Remove stabilizer link.
9. Set suitable jack under suspension arm to relieve the coil spring tension.
10. Remove coil spring from suspension arm.
11. Remove suspension arm and arm stopper from vehicle.

INSTALLATION

Note the following and, install in the reverse order of removal.

- Align the matching marks (A) made during removal when reusing the disc rotor.
- After installation, perform the air bleeding. Refer to [BR-13, "Bleeding Brake System"](#).
- Perform final tightening of rear suspension member installation position (rubber bussing), under unladen conditions with tires on level ground.

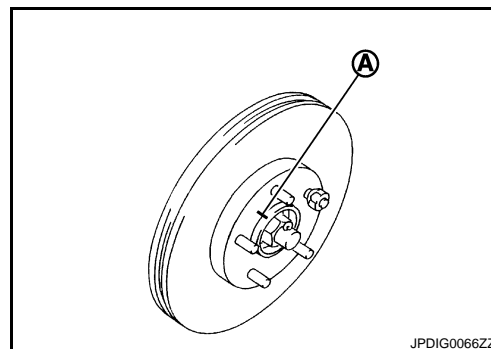

INFOID:000000004235734

Inspection

INSPECTION AFTER REMOVAL

Visual Inspection

Check suspension arm and bushing for deformation, cracks or damage. Replace it if necessary.

INSPECTION AFTER INSTALLATION

1. Adjust parking brake operation (stroke). Refer to [PB-3, "Inspection and Adjustment"](#).
 2. Check wheel alignment. Refer to [RSU-6, "Inspection"](#).
 3. Adjust neutral position of steering angle sensor. Refer to [BRC-75, "ADJUSTMENT OF STEERING ANGLE SENSOR NEUTRAL POSITION : Special Repair Requirement"](#) (with VDC). N
- O
- P

LOWER LINK

< ON-VEHICLE REPAIR >

LOWER LINK

Exploded View

INFOID:000000004235735

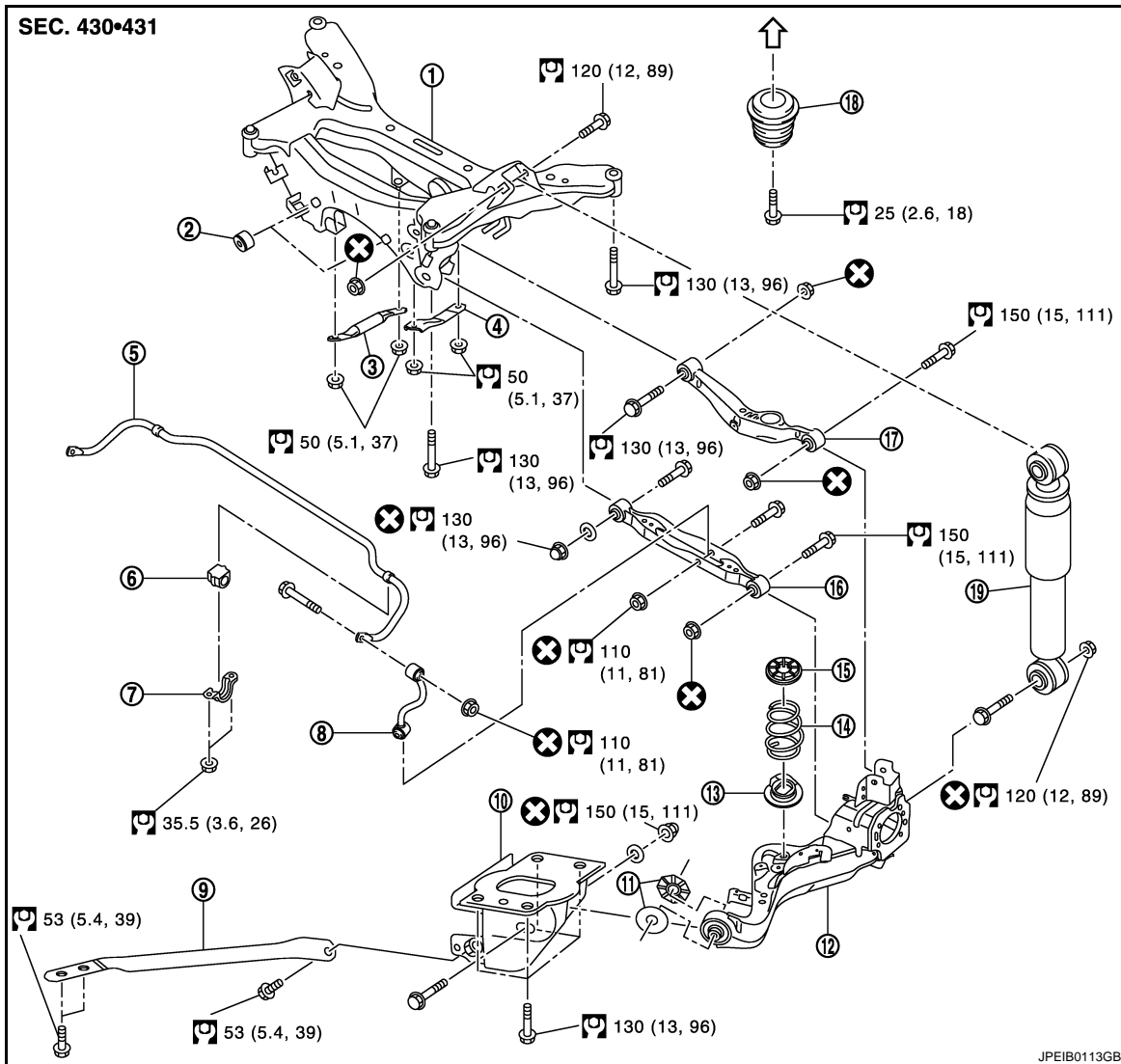

- | | | |
|---------------------------------------|--------------------------------------|--|
| 1. Rear suspension member | 2. Suspension member protector (2WD) | 3. Suspension member stay (right side) |
| 4. Suspension member stay (left side) | 5. Stabilizer bar | 6. Stabilizer bushing |
| 7. Stabilizer clamp | 8. Stabilizer link | 9. Suspension bar |
| 10. Suspension arm bracket | 11. Arm stopper | 12. Suspension arm |
| 13. Low rubber seat | 14. Coil spring | 15. Upper rubber seat |
| 16. Lower link | 17. Upper link | 18. Bound bumper |
| 19. Shock absorber | | |

↳ : Vehicle body

Refer to [GI-4, "Components"](#) for symbols in the figure.

Removal and Installation

INFOID:000000004235736

REMOVAL

1. Remove tires with power tool.
2. Remove stabilizer link.

LOWER LINK

< ON-VEHICLE REPAIR >

3. Set suitable jack under suspension arm to relieve the coil spring tension.
4. Remove lower link from suspension arm with power tool.
5. Remove lower link from suspension member with power tool.

INSTALLATION

Note the following, and install in the reverse order of removal.

- Perform final tightening of rear suspension member and axle installation position (rubber bushing), under unladen conditions with tires on level ground.

Inspection

INFOID:000000004235737

INSPECTION AFTER REMOVAL

Check lower link and bushing for any deformation, cracks, or damage. Replace it if necessary.

INSPECTION AFTER INSTALLATION

1. Check wheel alignment. Refer to [RSU-6, "Inspection"](#).
2. Adjust neutral position of steering angle sensor. Refer to [BRC-75, "ADJUSTMENT OF STEERING ANGLE SENSOR NEUTRAL POSITION : Special Repair Requirement"](#) (with VDC).

A
B
C
D
E
F
G
H
I
J
K
L
M
N
O
P

RSU

UPPER LINK

< ON-VEHICLE REPAIR >

UPPER LINK

Exploded View

INFOID:000000004235738

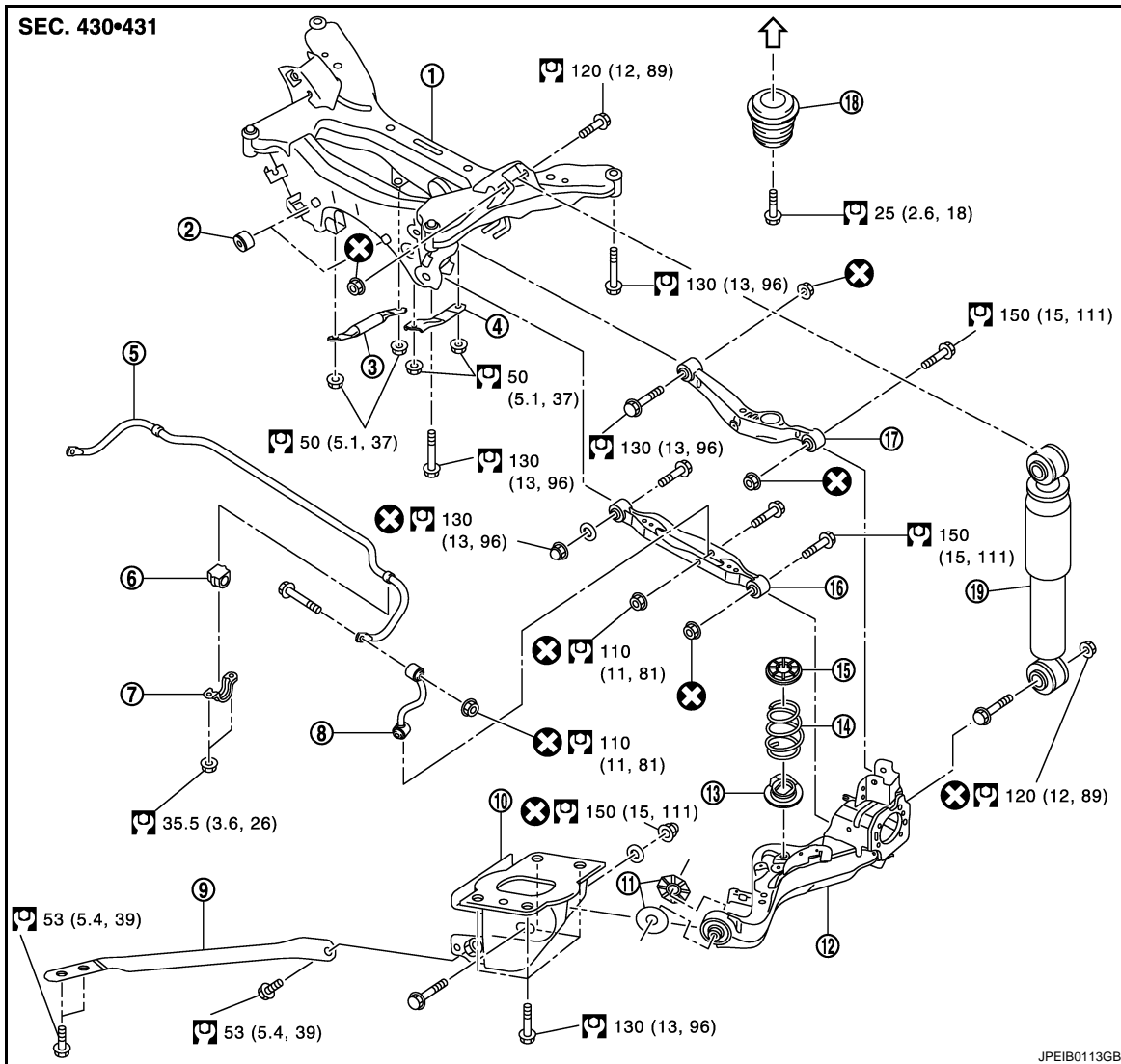

- | | | |
|---------------------------------------|--------------------------------------|--|
| 1. Rear suspension member | 2. Suspension member protector (2WD) | 3. Suspension member stay (right side) |
| 4. Suspension member stay (left side) | 5. Stabilizer bar | 6. Stabilizer bushing |
| 7. Stabilizer clamp | 8. Stabilizer link | 9. Suspension bar |
| 10. Suspension arm bracket | 11. Arm stopper | 12. Suspension arm |
| 13. Low rubber seat | 14. Coil spring | 15. Upper rubber seat |
| 16. Lower link | 17. Upper link | 18. Bound bumper |
| 19. Shock absorber | | |

↙ : Vehicle body

Refer to [GI-4, "Components"](#) for symbols in the figure.

Removal and Installation

INFOID:000000004235739

REMOVAL

1. Remove tires with power tool.
2. Remove wheel sensor harness from suspension arm. Refer to [BRC-66, "REAR WHEEL SENSOR : Exploded View"](#) (without VDC), [BRC-169, "REAR WHEEL SENSOR : Exploded View"](#) (with VDC).

UPPER LINK

< ON-VEHICLE REPAIR >

CAUTION:

Never pull on wheel sensor harness.

3. Set suitable jack under suspension arm to relieve the coil spring tension.
4. Remove upper link from suspension arm with power tool.
5. Remove upper link from suspension member with power tool.

INSTALLATION

Note the following, and install in the reverse order of removal.

- Perform final tightening of rear suspension member and axle installation position (rubber bushing), under unladen conditions with tires on level ground.

Inspection

INFOID:000000004235740

INSPECTION AFTER REMOVAL

Check upper link and bushing for any deformation, cracks, or damage. Replace it if necessary.

INSPECTION AFTER INSTALLATION

1. Check wheel alignment. Refer to [RSU-6, "Inspection"](#).
2. Adjust neutral position of steering angle sensor. Refer to [BRC-75, "ADJUSTMENT OF STEERING ANGLE SENSOR NEUTRAL POSITION : Special Repair Requirement"](#) (with VDC).

A
B
C
D
F
G
H
I
J
K
L
M
N
O
P

RSU

REAR STABILIZER

< ON-VEHICLE REPAIR >

REAR STABILIZER

Exploded View

INFOID:000000004235741

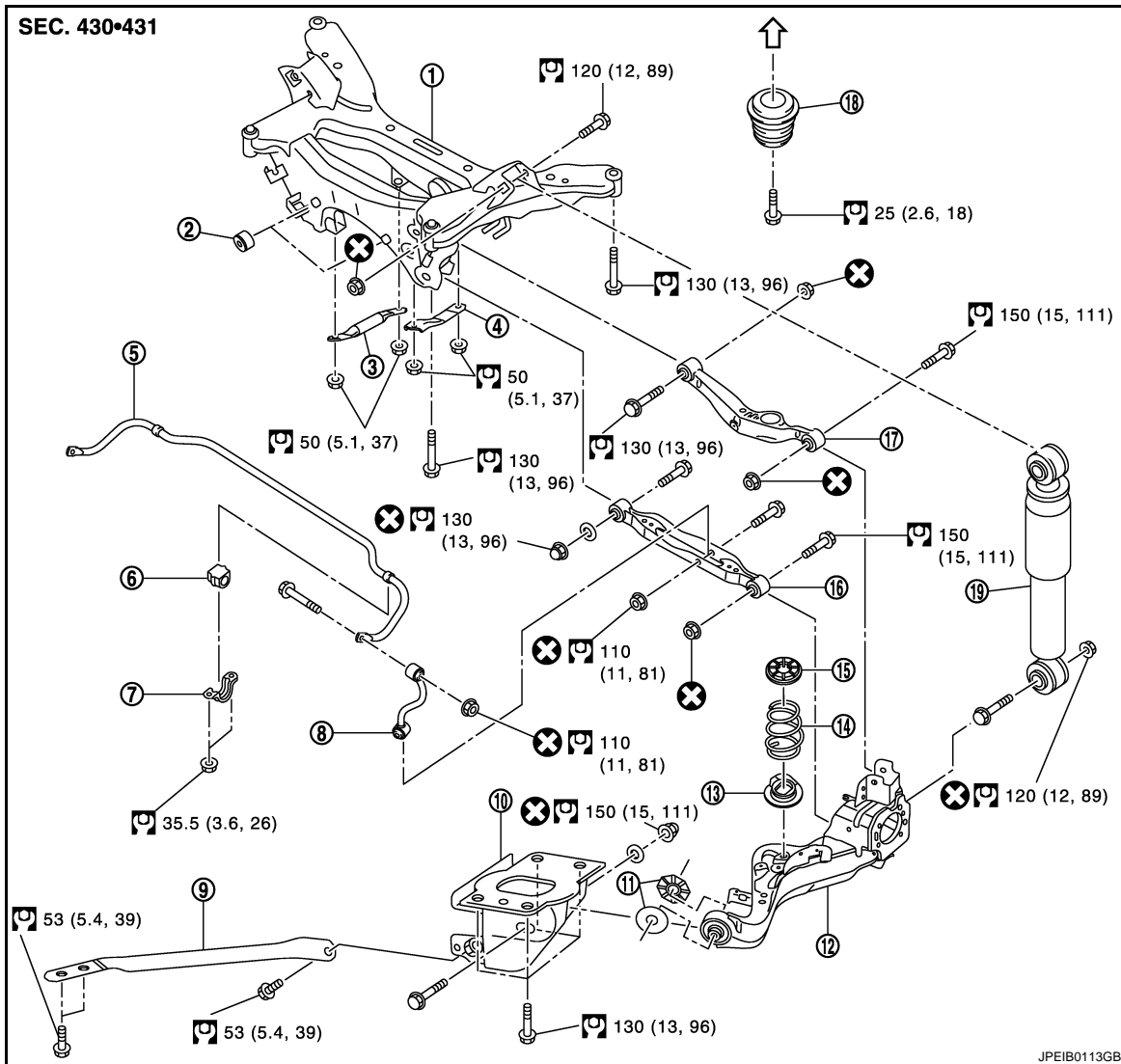

- | | | |
|---------------------------------------|--------------------------------------|--|
| 1. Rear suspension member | 2. Suspension member protector (2WD) | 3. Suspension member stay (right side) |
| 4. Suspension member stay (left side) | 5. Stabilizer bar | 6. Stabilizer bushing |
| 7. Stabilizer clamp | 8. Stabilizer link | 9. Suspension bar |
| 10. Suspension arm bracket | 11. Arm stopper | 12. Suspension arm |
| 13. Low rubber seat | 14. Coil spring | 15. Upper rubber seat |
| 16. Lower link | 17. Upper link | 18. Bound bumper |
| 19. Shock absorber | | |

← : Vehicle body

Refer to [GI-4, "Components"](#) for symbols in the figure.

Removal and Installation

INFOID:000000004235742

REMOVAL

1. Remove stabilizer link.
2. Remove main muffler. Refer to [EX-5, "Exploded View"](#).

REAR STABILIZER

< ON-VEHICLE REPAIR >

3. Remove mounting nuts on stabilizer clamp and stabilizer bar from suspension member with power tool.

INSTALLATION

Install in the reverse order of removal.

Inspection

INFOID:000000004235743

INSPECTION AFTER REMOVAL

Check stabilizer bar, stabilizer link, stabilizer bushing and stabilizer clamp for deformation, cracks or damage. Replace it if necessary.

A

B

C

D

RSU

F

G

H

I

J

K

L

M

N

O

P

REAR SUSPENSION MEMBER

< REMOVAL AND INSTALLATION >

REMOVAL AND INSTALLATION

REAR SUSPENSION MEMBER

Exploded View

INFOID:000000004235744

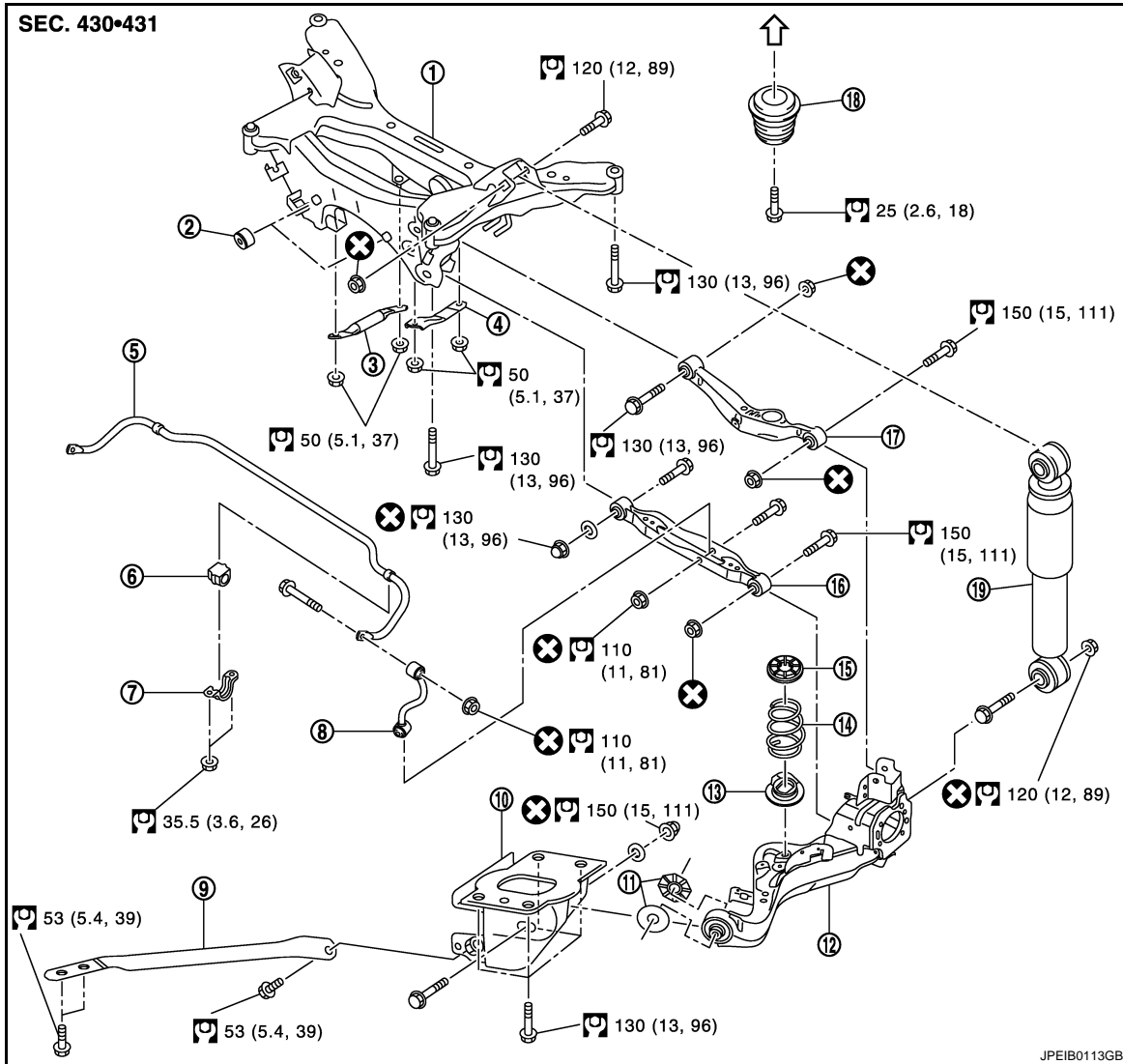

- | | | |
|---------------------------------------|--------------------------------------|--|
| 1. Rear suspension member | 2. Suspension member protector (2WD) | 3. Suspension member stay (right side) |
| 4. Suspension member stay (left side) | 5. Stabilizer bar | 6. Stabilizer bushing |
| 7. Stabilizer clamp | 8. Stabilizer link | 9. Suspension bar |
| 10. Suspension arm bracket | 11. Arm stopper | 12. Suspension arm |
| 13. Low rubber seat | 14. Coil spring | 15. Upper rubber seat |
| 16. Lower link | 17. Upper link | 18. Bound bumper |
| 19. Shock absorber | | |

◁ : Vehicle body

Refer to [GI-4. "Components"](#) for symbols in the figure.

Removal and Installation

INFOID:000000004235745

REMOVAL

1. Remove tires with power tool.

REAR SUSPENSION MEMBER

< REMOVAL AND INSTALLATION >

2. Remove torque member mounting bolts. Hang torque member where it does not interfere with work. Refer to [BR-42, "BRAKE CALIPER ASSEMBLY : Exploded View"](#).
CAUTION:
Never depressing brake pedal while brake caliper is removed.
3. Remove disc rotor. Refer to [BR-42, "BRAKE CALIPER ASSEMBLY : Removal and Installation"](#).
CAUTION:
 - Put matching marks on the wheel hub and bearing assembly and the disc rotor before removing the disc rotor.
 - Never drop disc rotor.
4. Remove wheel sensor and sensor harness from axle housing and lower link. Refer to [BRC-66, "REAR WHEEL SENSOR : Exploded View"](#) (without VDC), [BRC-169, "REAR WHEEL SENSOR : Exploded View"](#) (with VDC).
CAUTION:
Never pull on wheel sensor harness.
5. Remove parking brake cable mounting bolts and separate parking brake cable from suspension arm. Refer to [PB-6, "Exploded View"](#).
6. Remove main muffler. Refer to [EX-5, "Exploded View"](#).
7. Remove stabilizer bar.
8. Remove drive shaft (AWD). Refer to [RAX-15, "Exploded View"](#).
9. Remove propeller shaft (AWD). Refer to [DLN-85, "Exploded View"](#).
10. Remove rear final drive (AWD). Refer to [DLN-103, "Exploded View"](#).
11. Remove shock absorber.
12. Remove coil spring.
13. Set suitable jack under rear suspension member.
14. Remove mounting nuts and bolts from rear suspension member.
15. Slowly lower jack, then remove rear suspension member, lower link and upper link from vehicle as a unit.
CAUTION:
Secure suspension assembly to a suitable jack while removing it.
16. Remove mounting bolts and nuts, then remove lower link, upper link and suspension member protector (2WD) from rear suspension member.

INSTALLATION

Note the following, and install in the reverse order of the removal.

- Align the matching marks (A) made during removal when reusing the disc rotor.
- Perform the final tightening of each parts removed when removing rear suspension assembly under unladen conditions.
- Check wheel sensor harness for proper connection. Refer to [BRC-66, "REAR WHEEL SENSOR : Exploded View"](#) (without VDC), [BRC-169, "REAR WHEEL SENSOR : Exploded View"](#) (with VDC).

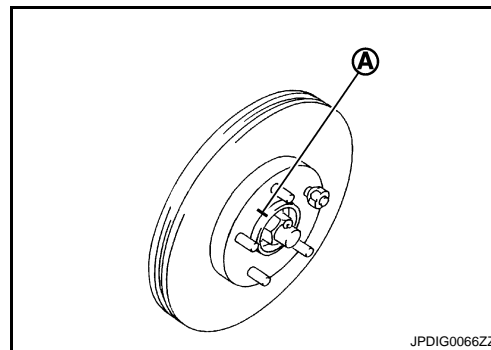

Inspection

INFOID:000000004235746

INSPECTION AFTER REMOVAL

Check rear suspension member for deformation, cracks, or any other damage. Replace it if necessary.

INSPECTION AFTER INSTALLATION

1. Adjust parking brake operation. Refer to [PB-3, "Inspection and Adjustment"](#).
2. Check wheel alignment. Refer to [RSU-6, "Inspection"](#).
3. Adjust neutral position of steering angle sensor. Refer to [BRC-75, "ADJUSTMENT OF STEERING ANGLE SENSOR NEUTRAL POSITION : Special Repair Requirement"](#) (with VDC).

SERVICE DATA AND SPECIFICATIONS (SDS)

< SERVICE DATA AND SPECIFICATIONS (SDS)

SERVICE DATA AND SPECIFICATIONS (SDS)

SERVICE DATA AND SPECIFICATIONS (SDS)

Wheel Alignment

INFOID:000000004235750

Item		Standard	
Camber Degree minute (Decimal degree)	Minimum	-1° 25' (-1.42°)	
	Nominal	-0° 55' (-0.92°)	
	Maximum	-0° 25' (-0.42°)	
Total toe-in	Distance	Minimum	0 mm (0 in)
		Nominal	In 2 mm (0.08 in)
		Maximum	In 4 mm (0.16 in)
	Angle (left wheel or right wheel) Degree minute (Decimal degree)	Minimum	0° 00' (0.00°)
		Nominal	In 0° 05' (0.08°)
		Maximum	In 0° 10' (0.16°)

Measure value under unladen* conditions.

*: Fuel, engine coolant and lubricant are full. Spare tire, jack, hand tools and mats are in designated positions.

Wheelarch Height

INFOID:000000004235751

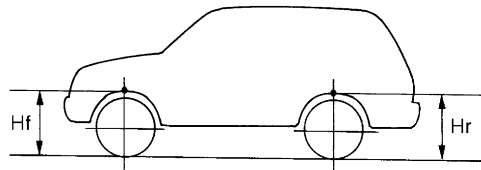

SFA746B

Tire size	Front (Hf)	Rear (Hr)
215/70R16	789 mm (31.06 in)	811 mm (31.93 in)
225/60R17	788 mm (31.02 in)	810 mm (31.89 in)

Measure value under unladen* conditions.

*: Fuel, engine coolant and lubricant are full. Spare tire, jack, hand tools and mats are in designated positions.