

# BRC

## SECTION

### BRAKE CONTROL SYSTEM

A  
B  
C  
D  
E  
**BRC**  
G  
H  
I  
J  
K  
L  
M

## CONTENTS

<b>VDC/TCS/ABS</b>		... 26
<b>PRECAUTIONS</b> .....	<b>3</b>	
Precautions for Supplemental Restraint System (SRS) "AIR BAG" and "SEAT BELT PRE-TENSIONER" .....	3	
Precautions for Brake System .....	3	
Precautions for Brake Control .....	3	
<b>PREPARATION</b> .....	<b>5</b>	
Special Service Tools .....	5	
Commercial Service Tools .....	5	
<b>ON-VEHICLE SERVICE</b> .....	<b>6</b>	
Adjustment of Steering Angle Sensor Neutral Position .....	6	
Calibration of Decel G-sensor (AWD Model) .....	6	
<b>SYSTEM DESCRIPTION</b> .....	<b>8</b>	
System Diagram .....	8	
VDC Function .....	8	
TCS Function .....	8	
ABS Function .....	8	
EBD Function .....	9	
Fail-Safe Function .....	9	
VDC / TCS SYSTEM .....	9	
ABS, EBD SYSTEM .....	9	
Hydraulic Circuit Diagram .....	10	
<b>CAN COMMUNICATION</b> .....	<b>11</b>	
System Description .....	11	
<b>TROUBLE DIAGNOSIS</b> .....	<b>12</b>	
How to Proceed With Diagnosis .....	12	
BASIC CONCEPT .....	12	
DIAGNOSIS FLOWCHART .....	13	
ASKING COMPLAINTS .....	14	
EXAMPLE OF DIAGNOSIS SHEET .....	14	
Component Installation Location .....	15	
Schematic .....	16	
Wiring Diagram — VDC — .....	17	
Control Unit Input/Output Signal Standard .....	23	
REFERENCE VALUE FROM CONSULT-II .....	23	
CONSULT-II Functions .....	25	
CONSULT-II MAIN FUNCTION .....	25	
CONSULT-II BASIC OPERATION PROCEDURE		
SELF-DIAGNOSIS .....	27	
DATA MONITOR .....	30	
ACTIVE TEST .....	33	
For Fast and Accurate Diagnosis .....	35	
PRECAUTIONS FOR DIAGNOSIS .....	35	
Basic Inspection .....	36	
BASIC INSPECTION 1: BRAKE FLUID AMOUNT, LEAKS, AND BRAKE PADS INSPECTION .....	36	
BASIC INSPECTION 2: POWER SYSTEM TERMINAL LOOSENESS AND BATTERY INSPECTION .....	36	
BASIC INSPECTION 3: ABS WARNING LAMP, VDC OFF INDICATOR LAMP, SLIP INDICATOR LAMP AND BRAKE WARNING LAMP INSPECTION .....	37	
Inspection 1: Wheel Sensor System .....	37	
Inspection 2: Engine System .....	39	
Inspection 3: VDC/TCS/ABS Control Unit System .....	40	
Inspection 4: Pressure Sensor System .....	40	
Inspection 5: Steering Angle Sensor System .....	42	
Inspection 6: Yaw Rate/Side G-Sensor (2WD model), Yaw Rate/Side/Decel G-sensor (AWD models) System .....	44	
Inspection 7: Solenoid and VDC Change-Over Valve System .....	46	
Inspection 8: Actuator Motor System .....	47	
Inspection 9: ABS Actuator and Electric Unit (Control Unit) Power Supply and Ground System .....	48	
Inspection 10: Stop Lamp Switch System .....	50	
Inspection 11: Brake Fluid Level Switch System .....	51	
Inspection 12: When "ST ANG SEN SIGNAL" Appears on Self-Diagnosis Results Display .....	52	
Inspection 13: When "DECEL G SENSE" Appears on Self-Diagnosis Results Display (AWD Model) .....	52	
Inspection 14: CAN Communication System .....	53	
Component Inspection .....	53	
VDC OFF SWITCH .....	53	
Symptom 1: Excessive ABS Function Operation		

Frequency .....	53	<b>ACTUATOR AND ELECTRIC UNIT (ASSEMBLY) ...</b>	<b>60</b>
Symptom 2: Unexpected Pedal Reaction .....	54	Removal and Installation .....	60
Symptom 3: The Braking Distance Is Long .....	54	REMOVAL .....	60
Symptom 4: The ABS Function Does Not Operate..	54	INSTALLATION .....	60
Symptom 5: Pedal Vibration or ABS Operation		<b>G SENSOR .....</b>	<b>62</b>
Sound Occurs .....	55	Removal and Installation .....	62
Symptom 6: Vehicle Jerks During VDC/TCS/ABS		REMOVAL .....	62
Control .....	55	INSTALLATION .....	62
<b>WHEEL SENSORS .....</b>	<b>57</b>	<b>STEERING ANGLE SENSOR .....</b>	<b>63</b>
Removal and Installation .....	57	Removal and Installation .....	63
REMOVAL .....	57	REMOVAL .....	63
INSTALLATION .....	57	INSTALLATION .....	63
<b>SENSOR ROTOR .....</b>	<b>59</b>		
Removal and Installation .....	59		
REMOVAL .....	59		
INSTALLATION .....	59		

**PRECAUTIONS**

PF0:00001

**Precautions for Supplemental Restraint System (SRS) “AIR BAG” and “SEAT BELT PRE-TENSIONER”**

AFS00289

The Supplemental Restraint System such as “AIR BAG” and “SEAT BELT PRE-TENSIONER”, used along with a front seat belt, helps to reduce the risk or severity of injury to the driver and front passenger for certain types of collision. This system includes seat belt switch inputs and dual stage front air bag modules. The SRS system uses the seat belt switches to determine the front air bag deployment, and may only deploy one front air bag, depending on the severity of a collision and whether the front occupants are belted or unbelted. Information necessary to service the system safely is included in the SRS and SB section of this Service Manual.

**WARNING:**

- To avoid rendering the SRS inoperative, which could increase the risk of personal injury or death in the event of a collision which would result in air bag inflation, all maintenance must be performed by an authorized NISSAN/INFINITI dealer.
- Improper maintenance, including incorrect removal and installation of the SRS, can lead to personal injury caused by unintentional activation of the system. For removal of Spiral Cable and Air Bag Module, see the SRS section.
- Do not use electrical test equipment on any circuit related to the SRS unless instructed to in this Service Manual. SRS wiring harnesses can be identified by yellow and/or orange harnesses or harness connectors.

**Precautions for Brake System**

AFS001S3

- Recommended fluid is brake fluid “DOT 3”.
- Do not reuse drained brake fluid.
- Be careful not to splash brake fluid on painted areas such as body. If brake fluid is splashed, wipe it off and flush area with water immediately.
- Do not use mineral oils such as gasoline or kerosene to clean. They will ruin rubber parts and cause improper operation.
- Using a flare nut crowfoot and torque wrench, securely tighten brake tube flare nuts.
- Brake system is an important safety part. If a brake fluid leak is detected, always disassemble the affected part. If a malfunction is detected, replace part with a new one.
- Before working, turn ignition switch OFF and disconnect electrical connectors of ABS actuator and electric unit (control unit) or battery negative terminal.
- When installing brake piping, be sure to check torque.

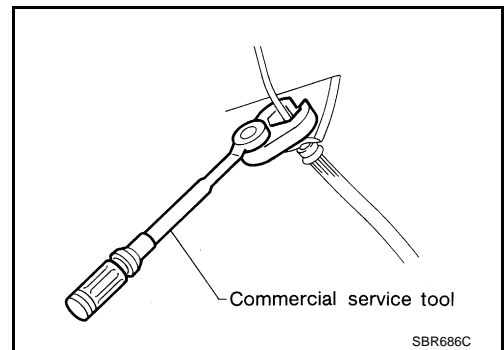

**Precautions for Brake Control**

AFS001S4

- During VDC/TCS/ABS operation, brake pedal lightly vibrates and a mechanical noise may be heard. This is normal.
- Just after starting vehicle after ignition switch ON, brake pedal may vibrate or motor operating noise may be heard from engine room. This is a normal status of operation check.
- Stopping distance may be longer than that of vehicles without ABS when vehicle drives on rough, gravel, or snow-covered (fresh, deep snow) roads.
- When an error is indicated by ABS or another warning lamp, collect all necessary information from customer (what symptoms are present under what conditions) and check for simple causes before starting diagnostic servicing. Besides electrical system inspection, check booster operation, brake fluid level, and fluid leaks.
- If tire size and type are used in an improper combination, or brake pads are not Genuine NISSAN parts, stopping distance or steering stability may deteriorate.
- If there is a radio, antenna, or antenna lead-in wire (including wiring) near control module, VDC/TCS/ABS function may have a malfunction or error.

A  
B  
C  
D  
E  
BRC  
G  
H  
I  
J  
K  
L  
M

## PRECAUTIONS

[VDC/TCS/ABS]

- If aftermarket parts (car stereo, CD player, etc.) have been installed, check for incidents such as harness pinches, open circuits, and improper wiring.
- If the following components are replaced with non-genuine components or converted, VDC OFF indicator lamp and SLIP indicator lamp may turn on or the VDC system may not operate properly. Components related to suspension (Shock Absorber, Strut, Spring, Bush, etc.), Tires, wheels (exclude specified size), components related to brake (Pad, Rotor, Caliper, etc.), components related to engine (Muffler, ECM, etc.), components related to body reinforcement (Roll bar, Tower bar, etc.).
- Driving in the condition of breakage or excessive wear of suspension, tires or components related to the brakes may cause VDC OFF indicator lamp and SLIP indicator lamp turn on, and the VDC system may not operate properly.
- When the TCS or VDC is activated by sudden acceleration or sudden turn, some noise may occur. The noise is a result of the normal operation of the TCS and VDC.
- When driving on roads which have extreme slopes (such as mountainous roads) or high banks (such as sharp curves on a freeway), the VDC may not operate normally, or VDC OFF indicator lamp and SLIP indicator lamp may turn on. However, this is not a malfunction, if normal operation can be resumed after restarting engine.
- Sudden turns (such as spin turns, acceleration turns), drifting, etc. When VDC function is OFF (VDC SW ON) may cause the G -sensor system indicate a malfunction. However, this is not a malfunction, if normal operation can be resumed after restarting engine.

# PREPARATION

[VDC/TCS/ABS]

## PREPARATION

PF0:00002

### Special Service Tools

AFS001S7

The actual shapes of Kent-Moore tools may differ from those of special service tools illustrated here.

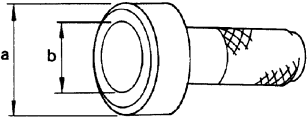
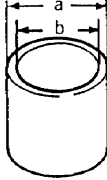
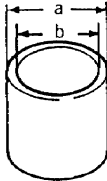
Tool number (Kent-Moore No.) Tool name	Description
ST30720000 (J 25405) Drift a: 77 mm (0.03 in) dia. b: 55 mm (2.17 in) dia.	 <p style="text-align: right;">ZZA0701D</p>
ST27863000 (—) Drift a: 75 mm (2.95 in) dia. b: 62 mm (2.44 in) dia.	 <p style="text-align: right;">ZZA0832D</p>
KV40104710 (—) Drift a: 76 mm (2.99 in) dia. b: 68.5 mm (2.697 in) dia.	 <p style="text-align: right;">ZZA0832D</p>

A  
B  
C  
D  
E  
F  
G  
H  
I  
J  
K  
L  
M

**BRC**

### Commercial Service Tools

AFS001S8

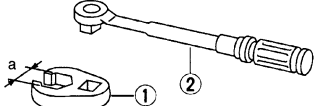
Tool name	Description
1: Flare nut crowfoot a: 10 mm (0.39 in) : 12 mm (0.47 in) 2: Torque wrench	 <p style="text-align: right;">S-NT360</p>

## ON-VEHICLE SERVICE

PFP:00000

### Adjustment of Steering Angle Sensor Neutral Position

AFS001S9

In case of doing work that applies to the list below, make sure to adjust neutral position of steering angle sensor before running vehicle.

Situation	Adjustment of Steering Angle Sensor Neutral Position
Removing/Installing ABS actuator and electric unit (control unit)	-
Replacing ABS actuator and electric unit (control unit)	×
Removing/Installing steering angle sensor	×
Removing/Installing steering components	×
Removing/Installing suspension components	×
Change 4 tires to new ones	-
Tire rotation	-
Adjusting wheel alignment	×

×: Required

-: Not required

**CAUTION:**

**To adjust neutral position of steering angle sensor, make sure to use CONSULT-II. (Adjustment cannot be done without CONSULT-II.)**

1. Stop vehicle with front wheels in straight-ahead position.
2. Connect CONSULT-II and CONSULT-II CONVERTER to data link connector on vehicle, and turn ignition switch ON (do not start engine).

**CAUTION:**

**If CONSULT-II is used with no connection of CONSULT-II CONVERTER, malfunctions might be detected in self-diagnosis depending on control unit which carry out CAN communication.**

3. Touch "ABS", "WORK SUPPORT" and "ST ANGLE SENSOR ADJUSTMENT" on CONSULT-II screen in this order. Refer to [BRC-26, "CONSULT-II BASIC OPERATION PROCEDURE"](#) .

4. Touch "START".

**CAUTION:**

**Do not touch steering wheel while adjusting steering angle sensor.**

5. After approximately 10 seconds, touch "END". (After approximately 60 seconds, it ends automatically.)
6. Turn ignition switch OFF, then turn it ON again.

**CAUTION:**

**Be sure to carry out above operation.**

7. Run vehicle with front wheels in straight-ahead position, then stop.
8. Select "DATA MONITOR", "SELECTION FROM MENU", and "STR ANGLE SIG" on CONSULT-II screen. Then make sure "STR ANGLE SIG" is within  $0 \pm 3.5$  deg. If value is more than specification, repeat steps 3 to 7.
9. Erase memory of ABS actuator and electric unit (control unit) and ECM.
10. Turn ignition switch OFF.

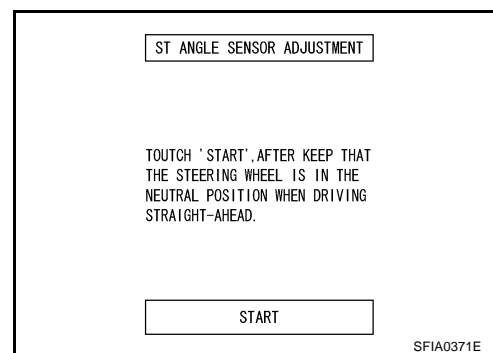

### Calibration of Decel G-sensor (AWD Model)

AFS001TQ

**NOTE:**

After removing/installing or replacing yaw rate/side/decel G-sensor, ABS actuator and electric unit (control unit), suspension components, or after adjusting wheel alignment make sure to calibrate of decel G-sensor before running vehicle.

**CAUTION:**

**To calibrate decel G-sensor, make sure to use CONSULT-II. (Adjustment cannot be done without CONSULT-II.)**

1. Stop vehicle with front wheels in straight-ahead position.
  - CAUTION:**
  - The work should be done at a horizontal place when vehicle is in the unloaded vehicle condition.
  - Keep all tires inflated to correct pressures. Adjust the tire pressure to the specified pressure value.
2. Connect CONSULT-II and CONSULT-II CONVERTER to data link connector on vehicle, and turn ignition switch ON (do not start engine).
  - CAUTION:**
  - If CONSULT-II is used with no connection of CONSULT-II CONVERTER, malfunctions might be detected in self-diagnosis depending on control unit which carry out CAN communication.
3. Touch "ABS", "WORK SUPPORT" and "DECEL G-SEN CALIBRATION" on CONSULT-II screen in this order. Refer to [BRC-26, "CONSULT-II BASIC OPERATION PROCEDURE"](#) .
4. Touch "START".
  - CAUTION:**
  - Set vehicle as shown in the display.
5. After approximately 10 seconds, touch "END". (After approximately 60 seconds, it ends automatically.)
6. Turn ignition switch OFF, then turn it ON again.
  - CAUTION:**
  - Be sure to carry out above operation.
7. Run vehicle with front wheels in straight-ahead position, then stop.
8. Select "DATA MONITOR", "SELECTION FROM MENU", and "DECEL G-SEN" on CONSULT-II screen. Then make sure "DECEL G-SEN" is within  $0 \pm 0.08$  G. If value is more than specification, repeat steps 3 to 7.
9. Erase memory of ABS actuator and electric unit (control unit) and ECM.
10. Turn ignition switch OFF.

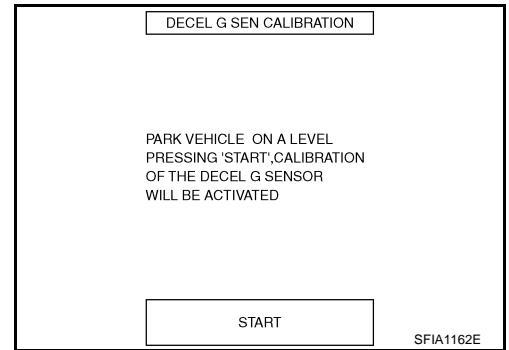

A  
B  
C  
D  
E  
F  
G  
H  
I  
J  
K  
L  
M

BRC

## SYSTEM DESCRIPTION

PFP:00000

### System Diagram

AFS001SB

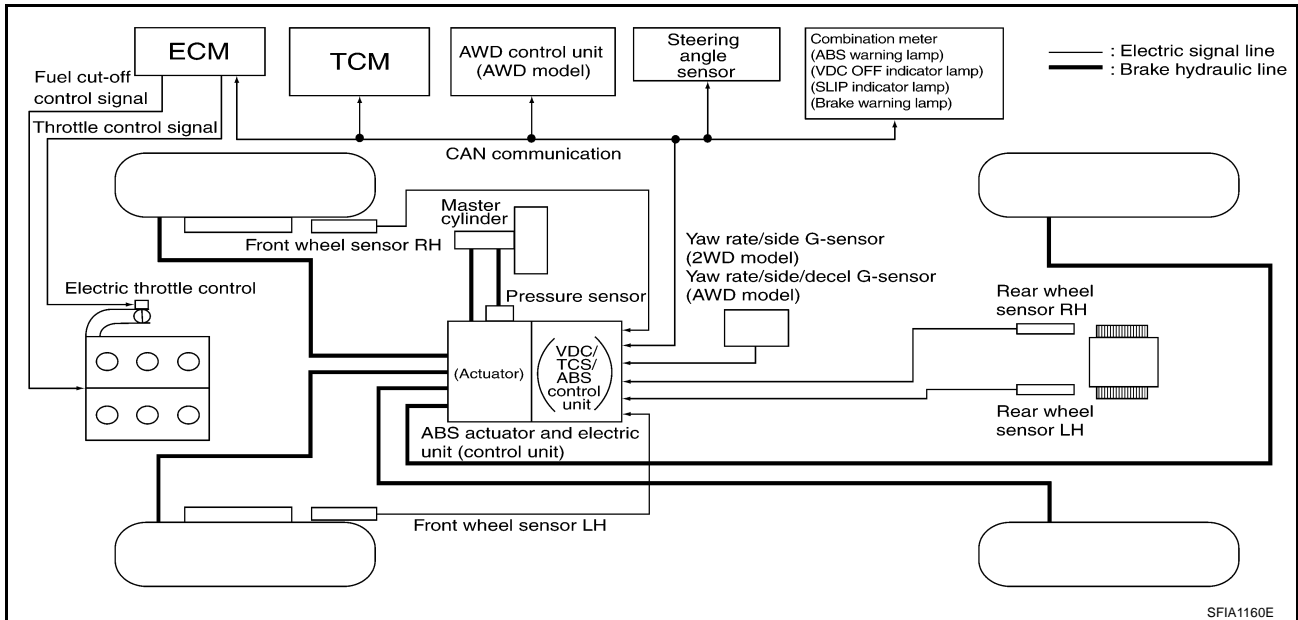

### VDC Function

AFS001SC

- In addition to the TCS/ABS function, the driver steering amount and brake operation amount are detected from steering angle sensor and pressure sensor, and the vehicle's driving status (amount of under steering / over steering) is determined from information from G-sensor, wheel sensor, etc., and this information is used to improve vehicle stability by controlling the braking and engine power to all four wheels.
- SLIP indicator lamp flashes to inform the driver of VDC operation.
- During VDC operation, body and brake pedal lightly vibrate and mechanical noises may be heard. This is normal.
- ABS warning lamp, VDC OFF indicator lamp, and SLIP indicator lamp might turn on when vehicle is subject to strong shaking or large vibration, such as when vehicle is on a turn table, a ship or a steep slope such as bank while engine is running. In this case, restart engine on a normal road, and if ABS warning lamp, VDC OFF indicator lamp, and SLIP indicator lamp turn off, there is no problem.

### TCS Function

AFS001SD

- The wheel spin of the drive wheels is detected by ABS actuator and electric unit (control unit) from the wheel speed signals from four wheels, so if wheel spin occurs, drive wheel right and left brake fluid pressure control and engine fuel cut are performed while throttle value is restricted to reduce the engine torque and decrease the amount of wheel spin. In addition, the degree throttle is opened is controlled to achieve the optimum engine torque.
- Depending on road circumstances, the driver may have a sluggish feel. This is normal, because the optimum traction has the highest priority under TCS operation.
- TCS may be activated any time vehicle suddenly accelerates, suddenly down/upshifts, or is driven on a road with a varying surface friction coefficient.
- During TCS operation, it informs a driver of system operation by flashing SLIP indicator lamp.

### ABS Function

AFS001SE

- The anti-lock brake system is a function that detects wheel revolution while braking, and it improves handling stability during sudden braking by electrically preventing 4 wheel lock. Maneuverability is also improved for avoiding obstacles.
- If the electrical system breaks down, then the fail-safe function starts, the ABS becomes inoperative, and ABS warning lamp turns on.
- Electrical system diagnosis by CONSULT-II is available.
- During ABS operation, brake pedal lightly vibrates and a mechanical noise may be heard. This is normal.



# SYSTEM DESCRIPTION

[VDC/TCS/ABS]

- When starting engine, or just after starting vehicle, brake pedal may vibrate or motor operating noises may be heard from engine compartment. This is a normal status of operation check.
- Stopping distance may be longer than that of vehicles without ABS when vehicle drives on rough, gravel, or snow-covered (fresh, deep snow) roads.

A

B

## EBD Function

AFS001SF

- Electronic brake distributor is a function that detects subtle slippages between front and rear wheels during braking, and it improves handling stability by electronically controlling the brake fluid pressure which results in reduced rear wheel slippage.
- In case of electrical system break down, the fail-safe function is activated, EBD and ABS becomes inoperative, and ABS warning lamp and brake warning lamp are turned on.
- Electrical system diagnosis by CONSULT-II is available.
- During EBD operation, brake pedal lightly vibrates and a mechanical noise may be heard. This is normal.
- When starting engine, or just after starting vehicle, brake pedal may vibrate or motor operating noises may be heard from engine compartment. This is a normal status of operation check.
- Stopping distance may be longer than that of vehicles without EBD when vehicle drives on rough, gravel, or snow-covered (fresh, deep snow) roads.

C

D

E

BRC

## Fail-Safe Function VDC / TCS SYSTEM

AFS001SG

In case of malfunction in the VDC/TCS system, VDC OFF indicator lamp and SLIP indicator lamp are turned on, and the condition of vehicle is the same as the condition of vehicles without VDC/TCS system. In case of malfunction in the VDC/TCS system, the ABS control continues to operate normally without VDC/TCS control.

G

### CAUTION:

**If the fail-safe function is activated, then perform the self-diagnosis for VDC/TCS/ABS control system.**

H

## ABS, EBD SYSTEM

In case of electrical malfunctions with the ABS, ABS warning lamp, VDC OFF indicator lamp and SLIP indicator lamp will turn on. In case of electrical malfunctions with the EBD, brake warning lamp, ABS warning lamp, VDC OFF indicator lamp and SLIP indicator lamp will turn on. Simultaneously, the VDC/TCS/ABS become one of the following conditions of the fail-safe function.

I

J

1. For malfunction of ABS, only the EBD is activated and the condition of vehicle is the same condition of vehicles without TCS/ABS system.
2. For malfunction of EBD, EBD and ABS become inoperative, and the condition of vehicle is the same as the condition of vehicles without TCS/ABS, EBD system.

K

### NOTE:

In condition 1 described above, an ABS self-diagnosis sound may be heard. That is a normal condition because a self-diagnosis for "Key Switch ON" and "the First Starting" are being performed.

L

M

Hydraulic Circuit Diagram

AFS001SH

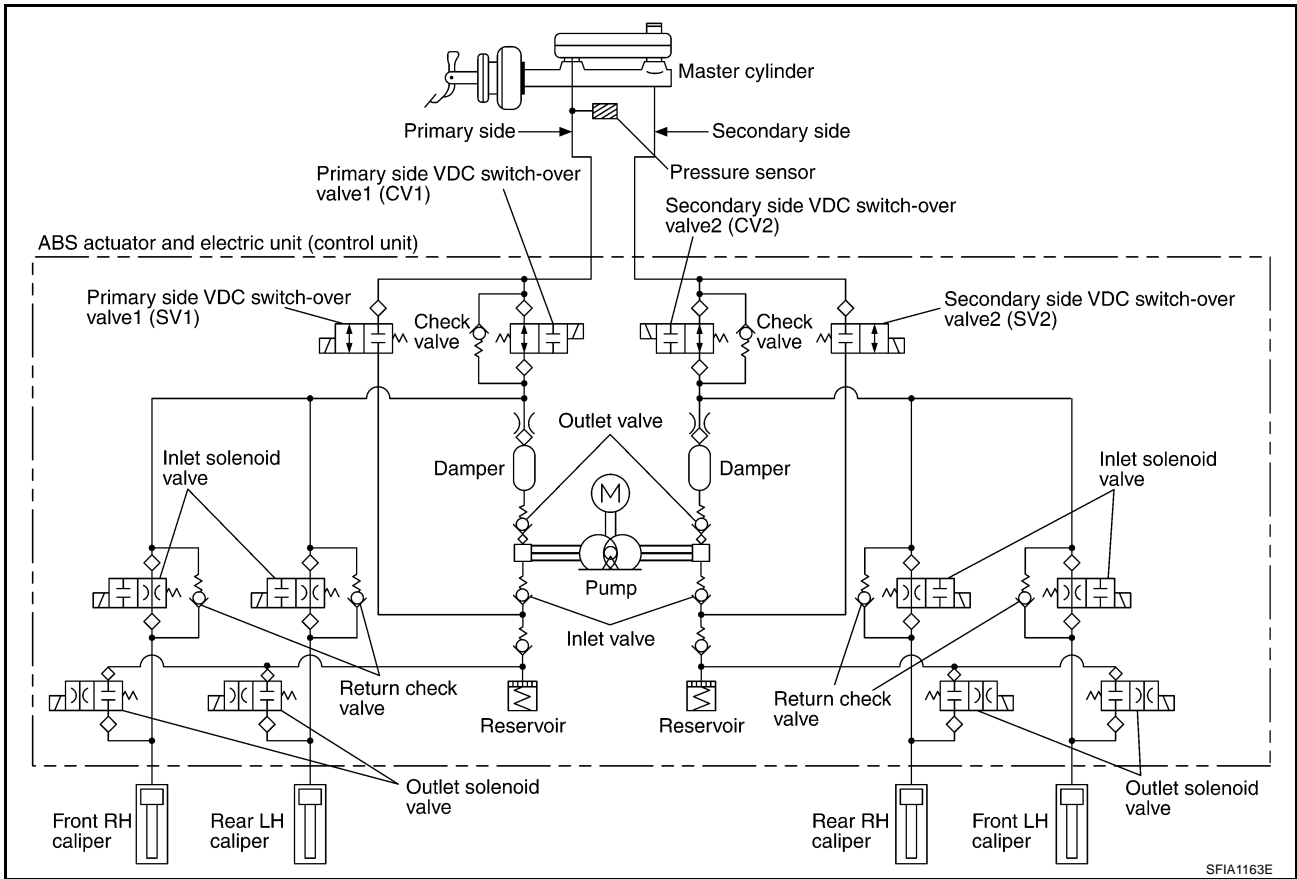

SFIA1163E

### CAN COMMUNICATION

PF2:23710

#### System Description

AFS002Q7

CAN (Controller Area Network) is a serial communication line for real time application. It is an on-vehicle multiplex communication line with high data communication speed and excellent error detection ability. Many electronic control units are equipped onto a vehicle, and each control unit shares information and links with other control units during operation (not independent). In CAN communication, control units are connected with 2 communication lines (CAN H line, CAN L line) allowing a high rate of information transmission with less wiring. Each control unit transmits/receives data but selectively reads required data only. Refer to [LAN-6, "CAN Communication Unit"](#).

A  
B  
C  
D  
E  
G  
H  
I  
J  
K  
L  
M

**BRC**

## TROUBLE DIAGNOSIS

PFP:00004

## How to Proceed With Diagnosis

### BASIC CONCEPT

AFS001SL

- Most important point to perform diagnosis is to understand systems (control and mechanism) in vehicle thoroughly.
- It is also important to clarify customer complaints before inspection.  
First of all, reproduce symptom, and understand it fully.  
Ask customer about his/her complaints carefully. In some cases, it will be necessary to check symptom by driving vehicle with customer.

**NOTE:**

Customers are not professionals. Do not assume “maybe customer means...” or “maybe customer mentioned this symptom”.

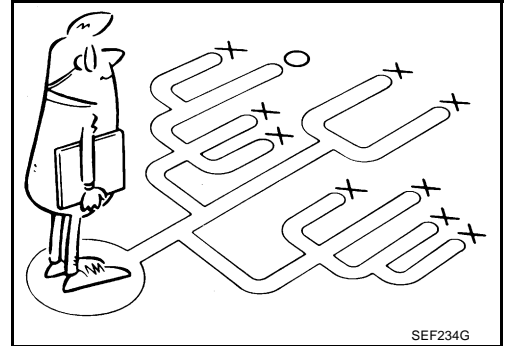

- It is essential to check symptoms right from beginning in order to repair a malfunction completely.  
For an intermittent malfunction, it is important to reproduce symptom based on interview with customer and past examples. Do not perform inspection on ad hoc basis. Most intermittent malfunctions are caused by poor contacts. In this case, it will be effective to shake suspected harness or connector by hand. When repairs are performed without any symptom check, no one can judge if malfunction has actually been eliminated.
- After diagnosis, make sure to carry out “erase memory”. Refer to [BRC-27, "SELF-DIAGNOSIS"](#).
- For an intermittent malfunction, move harness or harness connector by hand to check poor contact or false open circuit.
- Always read “GI General Information” to confirm general precautions. Refer to [GI-4, "General Precautions"](#).

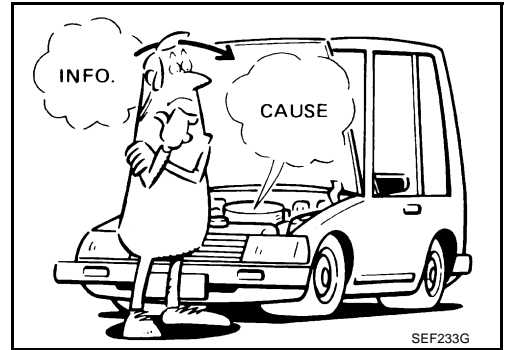

## DIAGNOSIS FLOWCHART

A  
B  
C  
D  
E  
F  
**BRC**  
G  
H  
I  
J  
K  
L  
M

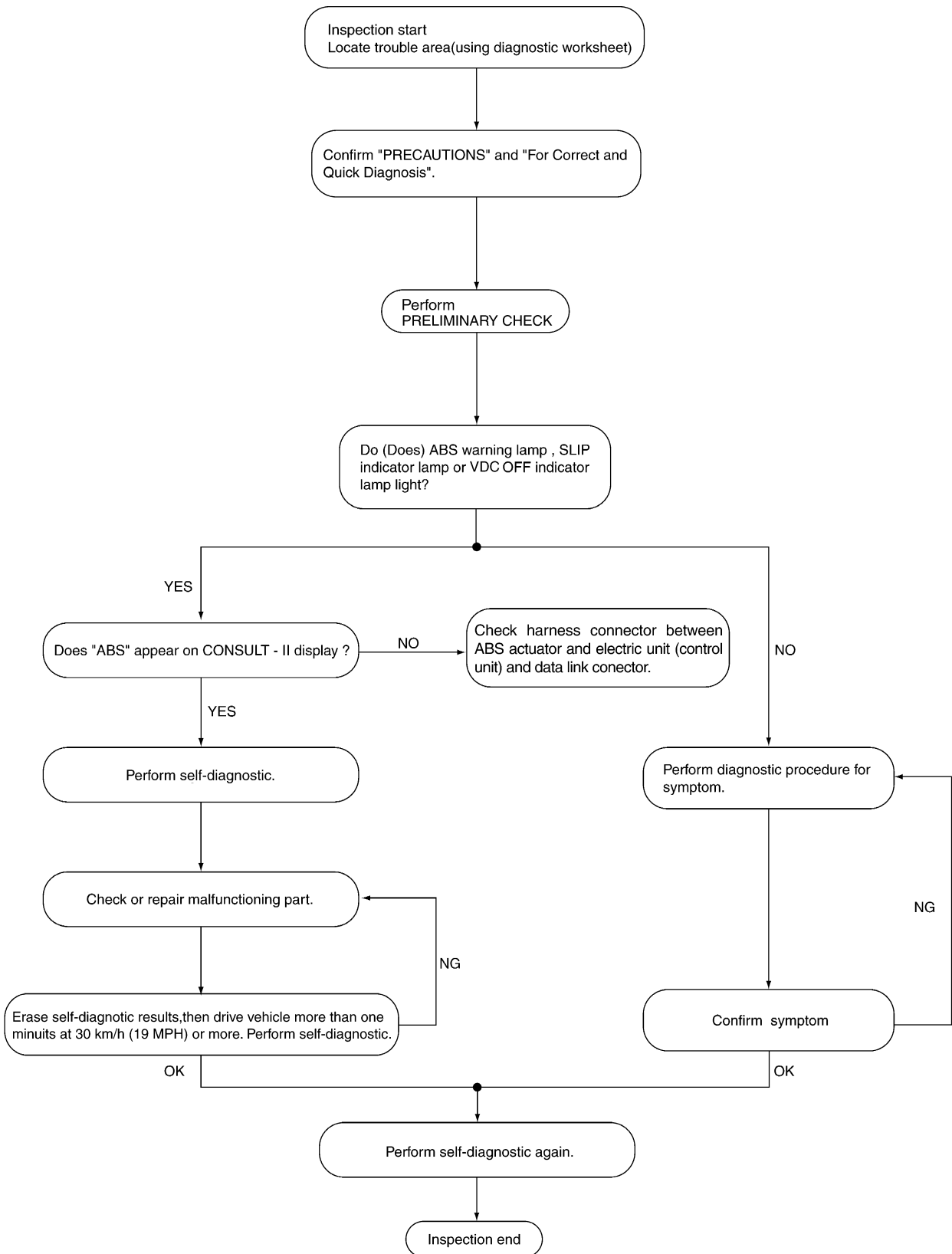

SFIA1164E

# TROUBLE DIAGNOSIS

[VDC/TCS/ABS]

## ASKING COMPLAINTS

- Complaints against malfunction vary depending on each person. It is important to clarify customer complaints.
- Ask customer about what symptoms are present and under what conditions. Use information to reproduce symptom while driving.
- It is also important to use diagnosis sheet so as not to miss information.

### KEY POINTS

**WHAT** ..... Vehicle model  
**WHEN** ..... Date, Frequencies  
**WHERE** ..... Road conditions  
**HOW** ..... Operating conditions,  
 Weather conditions,  
 Symptoms

SBR339B

## EXAMPLE OF DIAGNOSIS SHEET

Customer name MR/MS	Model & Year	VIN	
Engine #	Trans.	Mileage	
Incident Date	Manuf. Date	In Service Date	
Symptoms	<input type="checkbox"/> Noise and vibration (from engine compartment) <input type="checkbox"/> Noise and vibration (from axle)	<input type="checkbox"/> Warning / Indicator activate	<input type="checkbox"/> Firm pedal operation <input type="checkbox"/> Large stroke pedal operation
	<input type="checkbox"/> VDC/TCS does not work (Drive wheels slip when accelerating, etc.)	<input type="checkbox"/> ABS does not work. (wheels slip when braking)	<input type="checkbox"/> Lack of sense of acceleration
Engine conditions	<input type="checkbox"/> When starting <input type="checkbox"/> After starting		
Road conditions	<input type="checkbox"/> Low friction road ( <input type="checkbox"/> Snow <input type="checkbox"/> Gravel <input type="checkbox"/> Other ) <input type="checkbox"/> Bumps / potholes		
Driving conditions	<input type="checkbox"/> Full-acceleration <input type="checkbox"/> High speed cornering <input type="checkbox"/> Vehicle speed: Greater than 10 km/h (6 MPH) <input type="checkbox"/> Vehicle speed: 10 km/h (6 MPH) or less <input type="checkbox"/> Vehicle is stopped		
Applying brake conditions	<input type="checkbox"/> Suddenly <input type="checkbox"/> Gradually		
Other conditions	<input type="checkbox"/> Operation of electrical equipment <input type="checkbox"/> Shift change <input type="checkbox"/> Other descriptions		

SFIA1425E

### Component Installation Location

AFS001SM

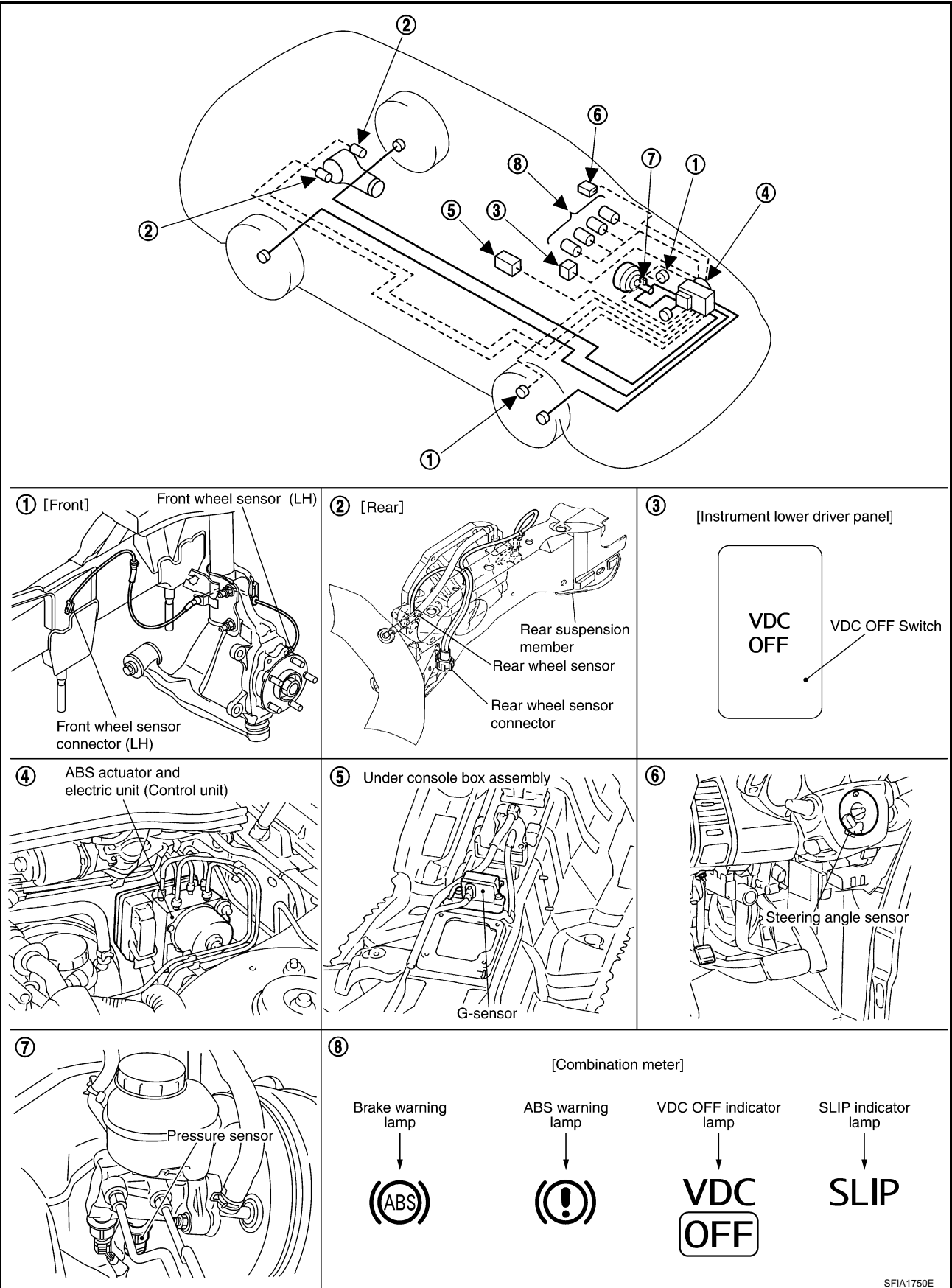

SFIA1750E

A  
B  
C  
D  
E  
BRC  
G  
H  
I  
J  
K  
L  
M

### Schematic

AFS001SN

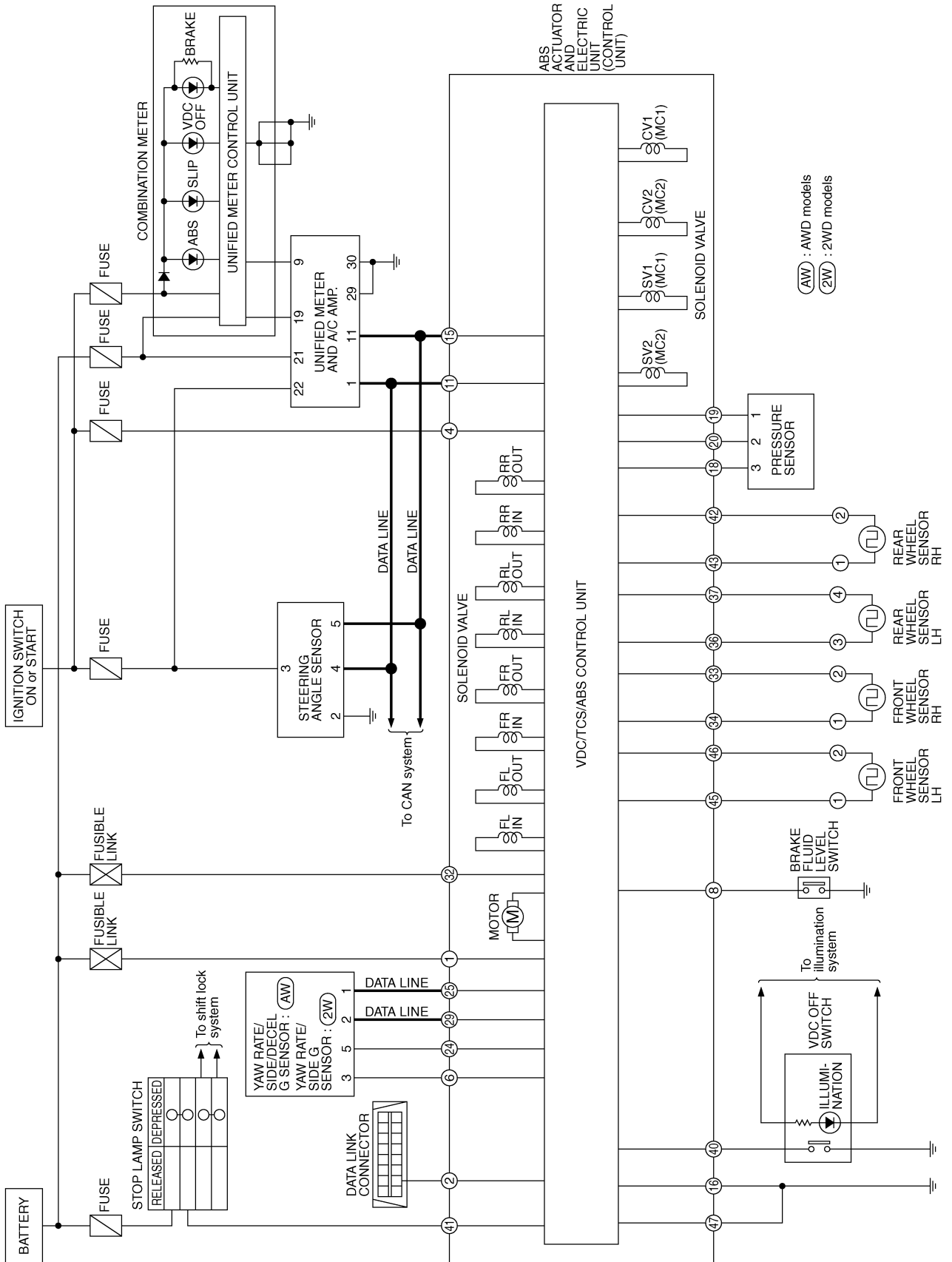

TFWH0009E



# TROUBLE DIAGNOSIS

[VDC/TCS/ABS]

## Wiring Diagram — VDC —

AFS00150

### BRC-VDC-01

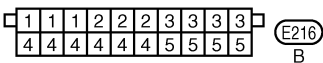
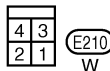
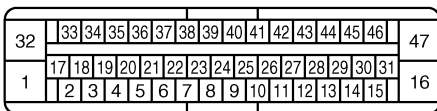
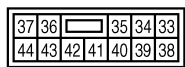
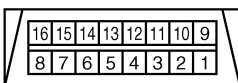
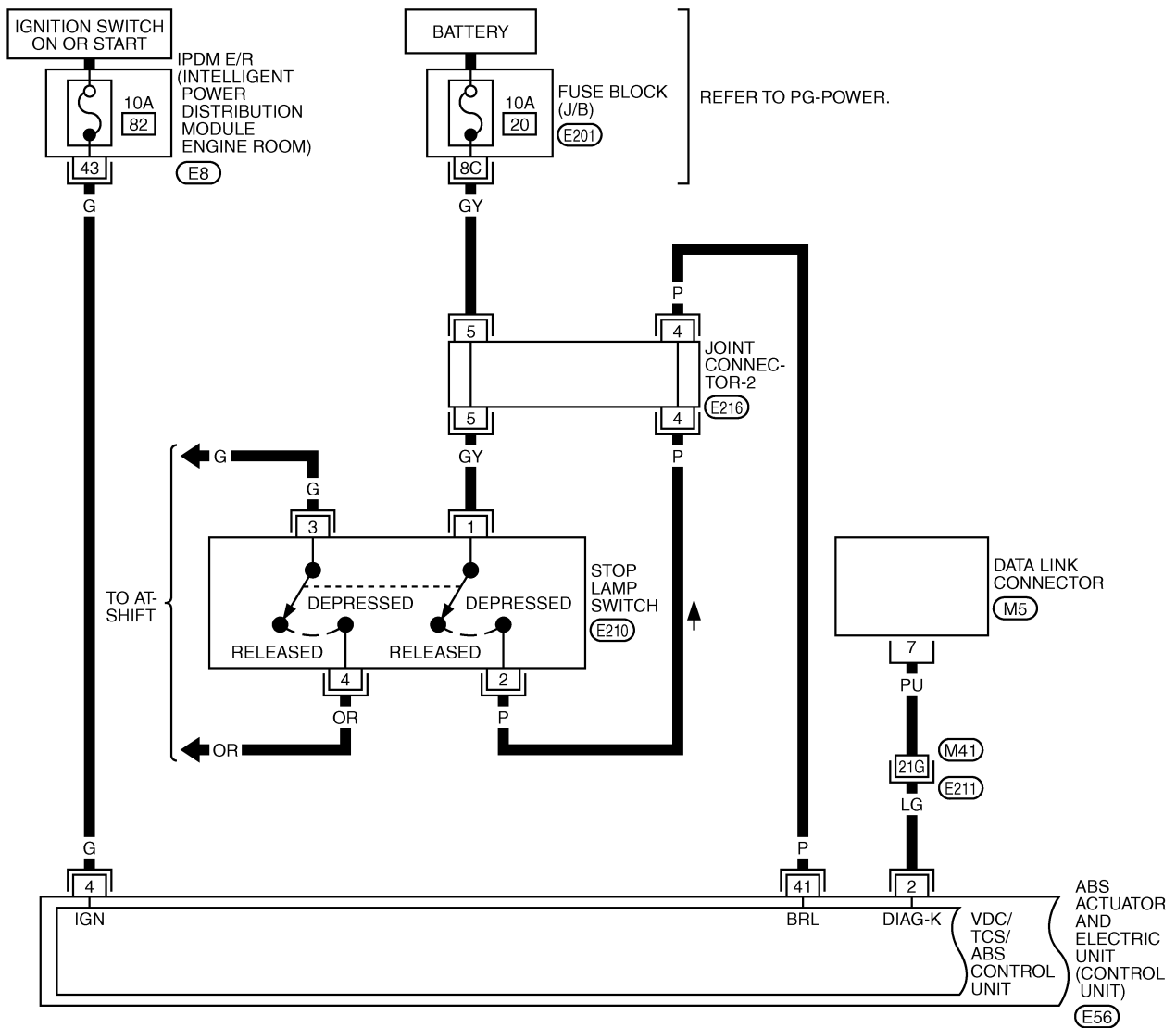

REFER TO THE FOLLOWING.

- (E211) -SUPER MULTIPLE JUNCTION (SMJ)
- (E201) -FUSE BLOCK-JUNCTION BOX (J/B)

TFWM0056E

# TROUBLE DIAGNOSIS

[VDC/TCS/ABS]

BRC-VDC-02

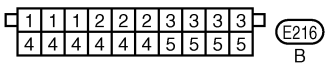
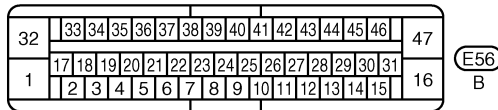
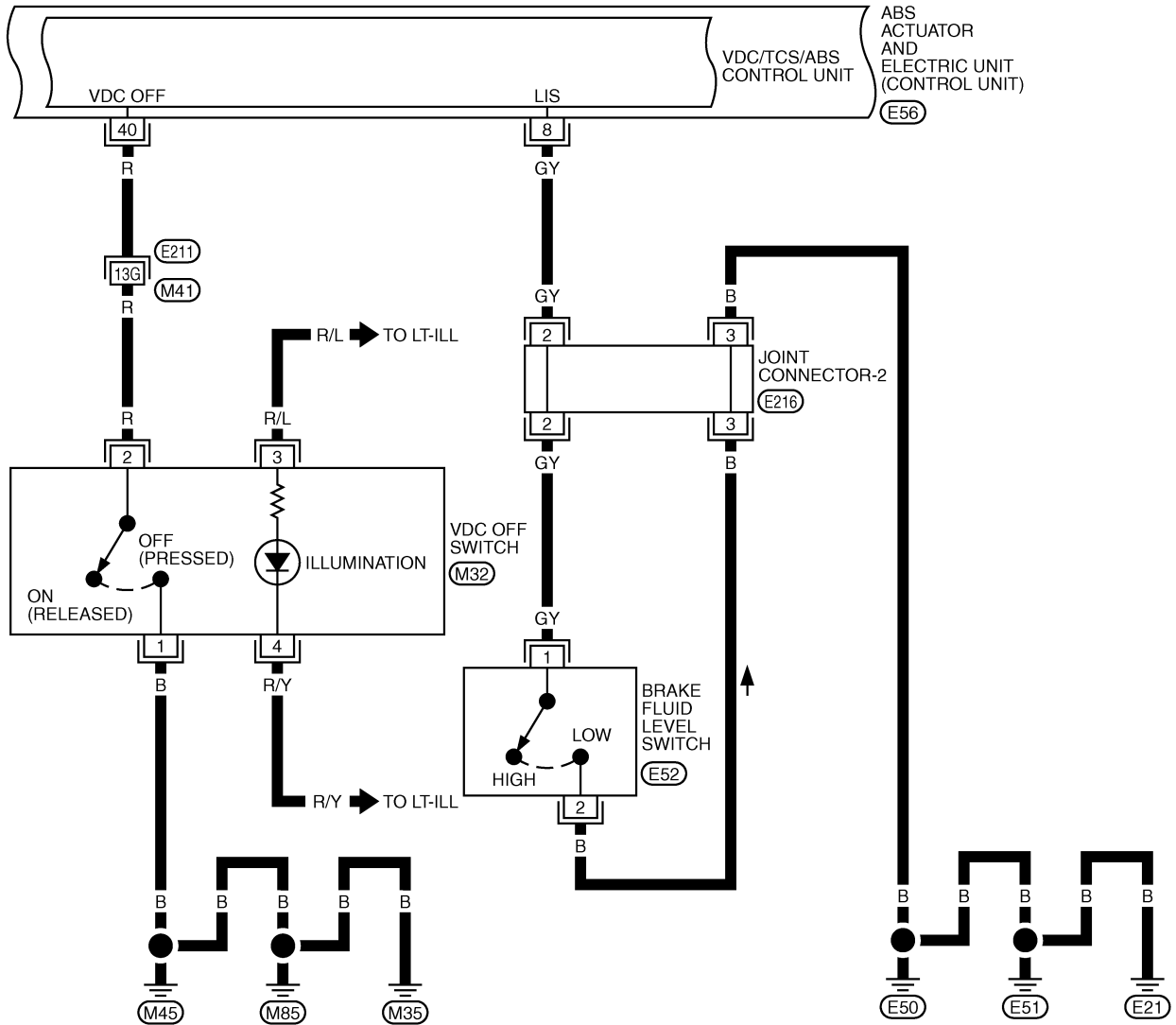

REFER TO THE FOLLOWING.  
 (E211) -SUPER MULTIPLE JUNCTION (SMJ)

TFWM0057E

# TROUBLE DIAGNOSIS

[VDC/TCS/ABS]

## BRC-VDC-03

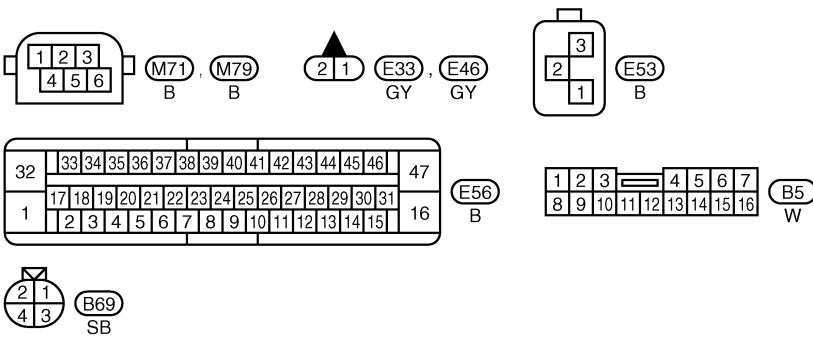
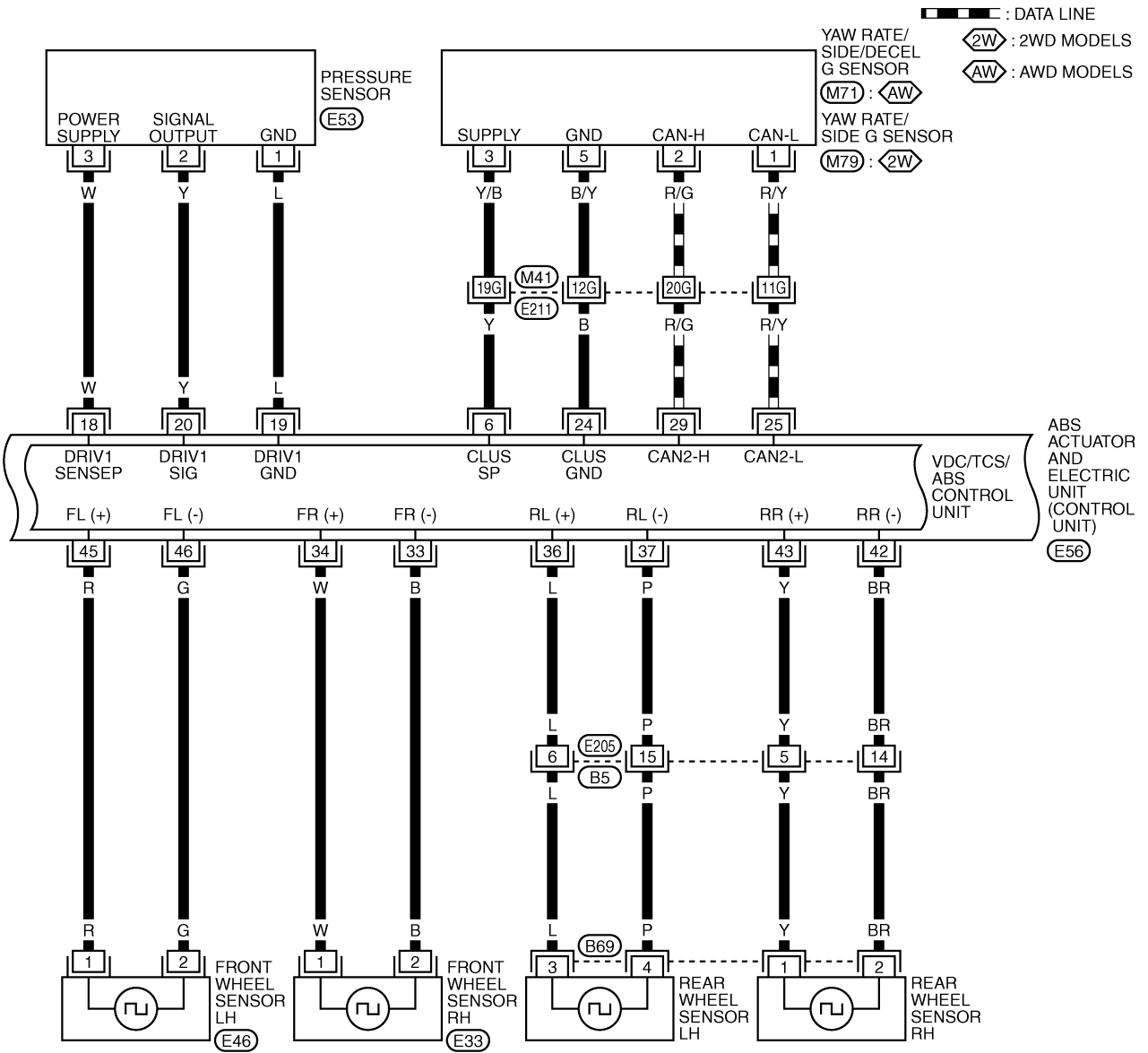

REFER TO THE FOLLOWING.

(E211) -SUPER MULTIPLE JUNCTION (SMJ)

TFWM0058E

# TROUBLE DIAGNOSIS

[VDC/TCS/ABS]

BRC-VDC-04

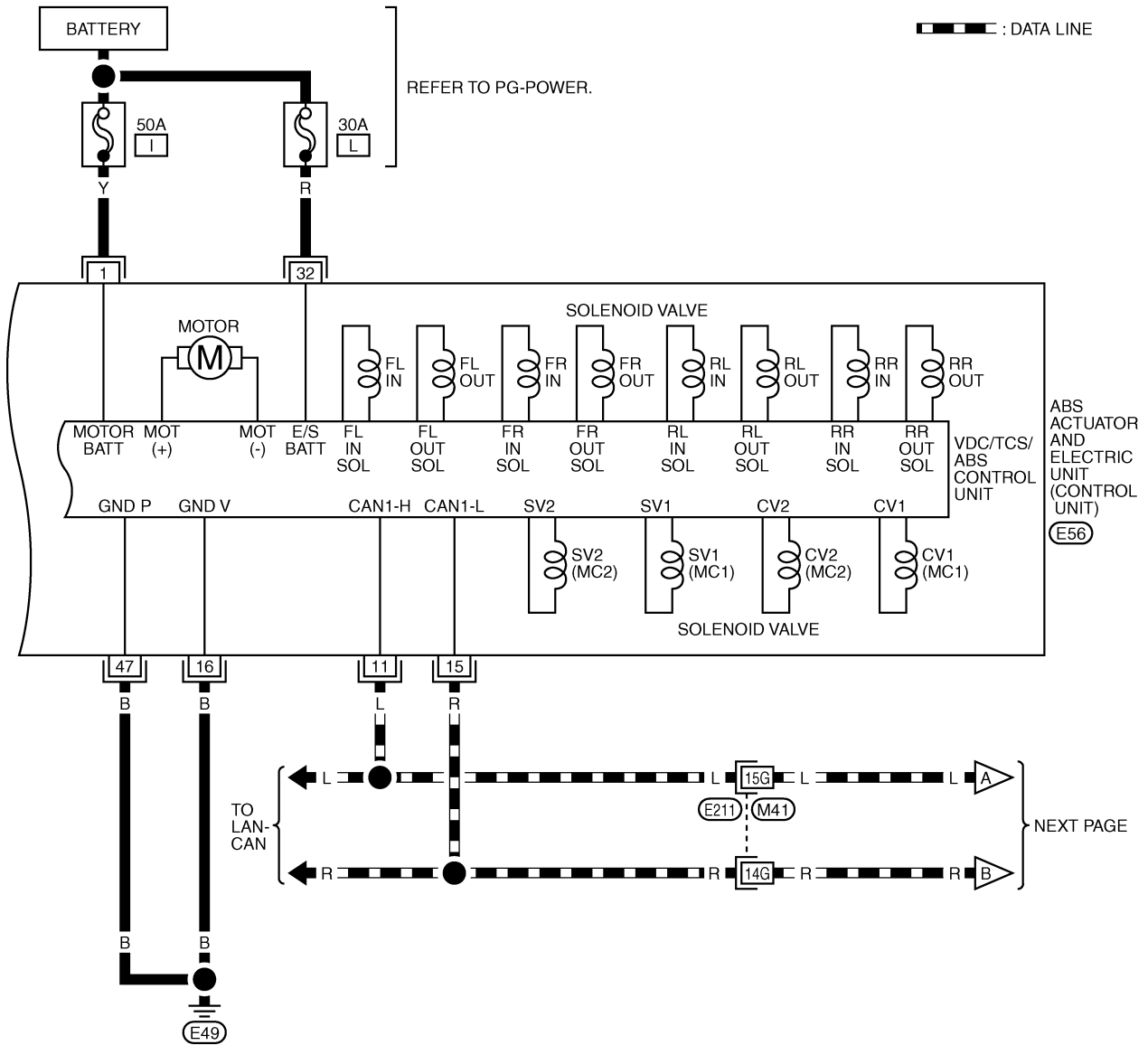

32	33	34	35	36	37	38	39	40	41	42	43	44	45	46	47
1	17	18	19	20	21	22	23	24	25	26	27	28	29	30	31
	2	3	4	5	6	7	8	9	10	11	12	13	14	15	16

(E56)  
B

REFER TO THE FOLLOWING.

(E211) -SUPER MULTIPLE JUNCTION (SMJ)

TFWM0059E

# TROUBLE DIAGNOSIS

[VDC/TCS/ABS]

BRC-VDC-05

A  
B  
C  
D  
E  
G  
H  
I  
J  
K  
L  
M

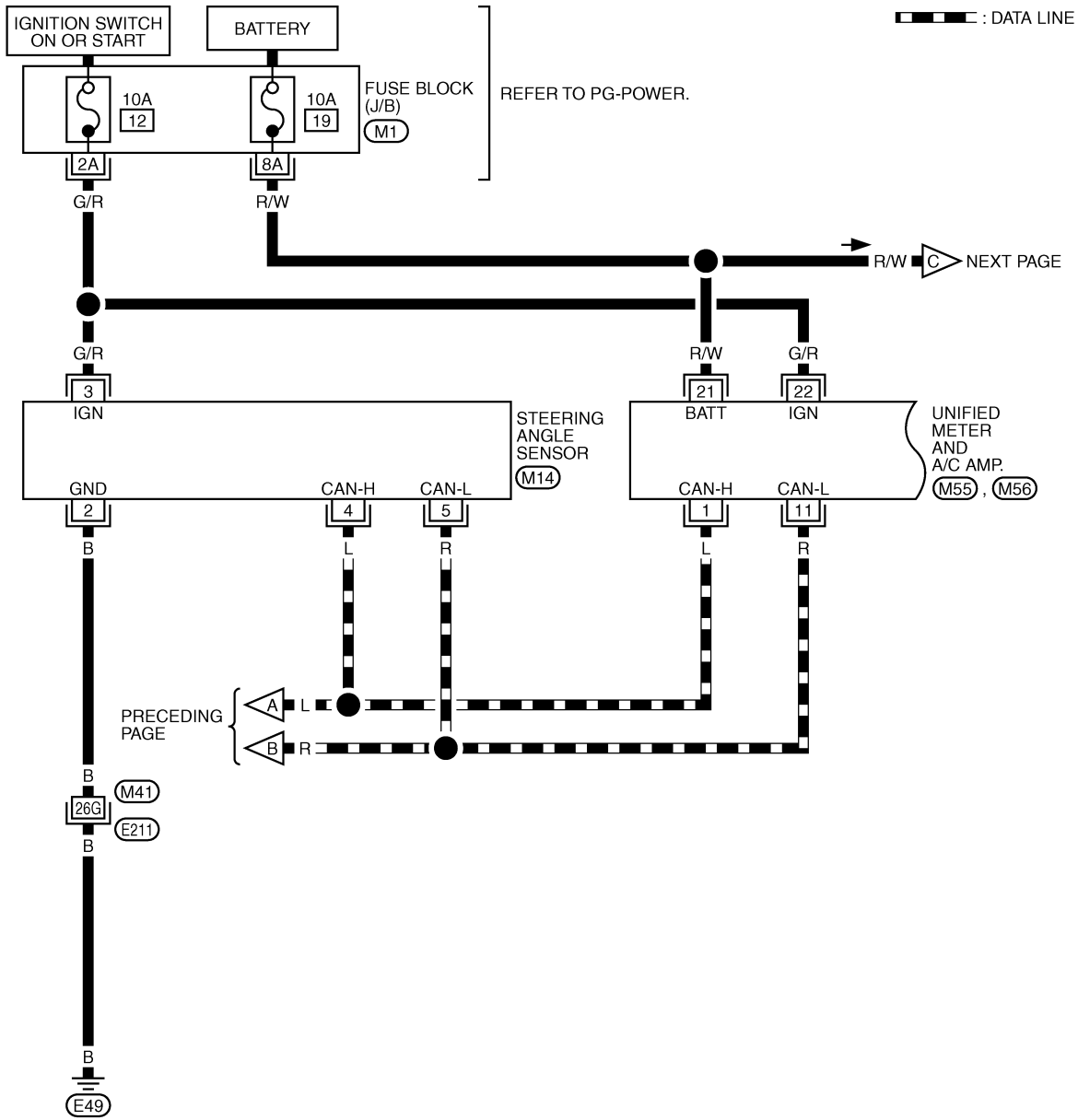

BRC

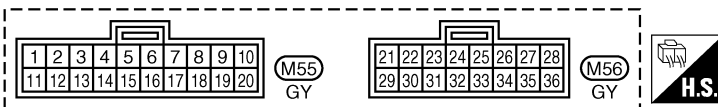
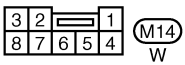

REFER TO THE FOLLOWING.  
 (E21) -SUPER MULTIPLE JUNCTION (SMJ)  
 (M1) -FUSE BLOCK-JUNCTION BOX (J/B)

TFWM0060E

# TROUBLE DIAGNOSIS

[VDC/TCS/ABS]

BRC-VDC-06

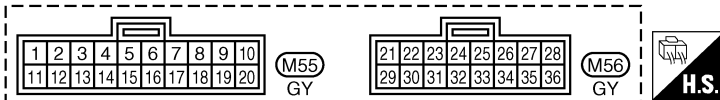
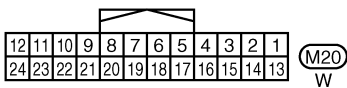
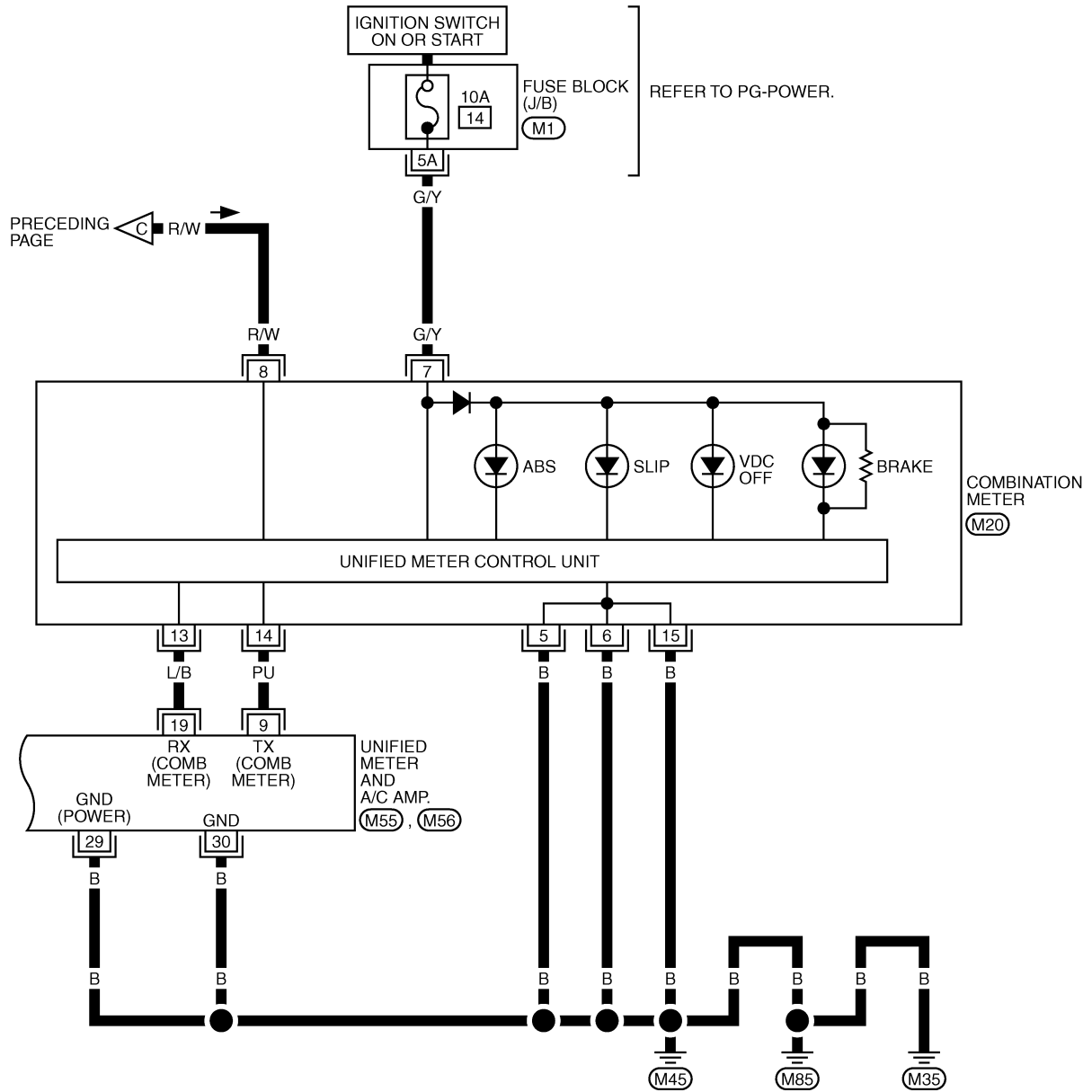

REFER TO THE FOLLOWING.  
 (M1) - FUSE BLOCK-JUNCTION BOX (J/B)

TFWM0061E

# TROUBLE DIAGNOSIS

[VDC/TCS/ABS]

## Control Unit Input/Output Signal Standard REFERENCE VALUE FROM CONSULT-II

AFS001SP

### CAUTION:

The display shows ABS actuator and electric unit (control unit) calculation data, so a normal value might be displayed even in the event the output circuit (harness) is open or short-circuited.

Monitor item	Display content	Data monitor		Note: Error inspection checklist
		Condition	Reference value in normal operation	
SLCT LVR POSI	A/T shift position	P: P position R: R position N: N position D: D position		—
GEAR	A/T gear position	1: 1st gear 2: 2nd gear 3: 3rd gear 4: 4th gear 5: 5th gear		
FR RH SENSOR FR LH SENSOR RR RH SENSOR RR LH SENSOR	Wheel speed	Vehicle stopped	0 [km/h (MPH)]	<a href="#">BRC-37, "Inspection 1: Wheel Sensor System"</a>
		Vehicle running (Note 1)	Almost in accordance with speedometer display (within ±10 %)	
ACCEL POS SIG	Open/close condition of throttle valve (linked with accelerator pedal).	Accelerator pedal not depressed (ignition switch is ON)	0 %	Communication circuit between VDC/TCS/ABS control unit and ECM
		Depress accelerator pedal (ignition switch is ON)	0 to 100 %	
ENGINE SPEED	With engine running	With engine stopped	0 rpm	EC section
		Engine running	Almost in accordance with tachometer display	
STR ANGLE SIG	Steering angle detected by steering angle sensor	Straight-ahead	Approx. 0 deg	<a href="#">BRC-42, "Inspection 5: Steering Angle Sensor System"</a>
		Steering wheel turned	-756 to 756 deg	
YAW RATE SEN	Yaw rate detected by yaw rate sensor	Vehicle stopped	Approx. 0 d/s	<a href="#">BRC-44, "Inspection 6: Yaw Rate/Side G-Sensor (2WD model), Yaw Rate/Side/Decel G-sensor (AWD models) System"</a>
		Vehicle running	-100 to 100 d/s	
SIDE G-SENSOR	Transverse G detected by side G-sensor	Vehicle stopped	Approx. 0 m/s <sup>2</sup>	<a href="#">BRC-44, "Inspection 6: Yaw Rate/Side G-Sensor (2WD model), Yaw Rate/Side/Decel G-sensor (AWD models) System"</a>
		Vehicle running	-16.7 to 16.7 m/s <sup>2</sup>	
PRESS SENSOR	Brake fluid pressure detected by pressure sensor	With ignition switch turned ON and brake pedal released	Approx. 0 bar	<a href="#">BRC-40, "Inspection 4: Pressure Sensor System"</a>
		With ignition switch turned ON and brake pedal depressed	0 to 170 bar	
BATTERY VOLT	Battery voltage supplied to ABS actuator and electric unit (control unit)	Ignition switch ON	10 to 16 V	<a href="#">BRC-48, "Inspection 9: ABS Actuator and Electric Unit (Control Unit) Power Supply and Ground System"</a>
STOP LAMP SW	Brake pedal operation	Brake pedal depressed	ON	<a href="#">BRC-50, "Inspection 10: Stop Lamp Switch System"</a>
		Brake pedal not depressed	OFF	

# TROUBLE DIAGNOSIS

**[VDC/TCS/ABS]**

Monitor item	Display content	Data monitor		Note: Error inspection checklist
		Condition	Reference value in normal operation	
OFF SW	VDC OFF switch ON/OFF status	VDC OFF switch ON (When VDC OFF indicator lamp is ON)	ON	<a href="#">BRC-53. "VDC OFF SWITCH"</a>
		VDC OFF switch OFF (When VDC OFF indicator lamp is OFF)	OFF	
ABS WARN LAMP	ABS warning lamp ON condition (Note 2)	ABS warning lamp ON	ON	<a href="#">BRC-37. "BASIC INSPECTION 3: ABS WARNING LAMP, VDC OFF INDICATOR LAMP, SLIP INDICATOR LAMP and BRAKE WARNING LAMP INSPECTION"</a>
		ABS warning lamp OFF	OFF	
MOTOR RELAY	Operation status of motor and motor relay	Ignition switch ON or engine running (ABS not operated)	OFF	<a href="#">BRC-47. "Inspection 8: Actuator Motor System"</a>
		Ignition switch ON or engine running (ABS operated)	ON	
ACTUATOR RLY	Actuator relay operation status	Actuator (solenoid) is active ("ACTIVE TEST" with CONSULT-II)	ON	<a href="#">BRC-47. "Inspection 8: Actuator Motor System"</a>
		When actuator relay is inactive (in fail-safe mode)	OFF	
OFF LAMP	VDC OFF indicator lamp status (Note 3)	When VDC OFF indicator lamp is ON	ON	<a href="#">BRC-37. "BASIC INSPECTION 3: ABS WARNING LAMP, VDC OFF INDICATOR LAMP, SLIP INDICATOR LAMP and BRAKE WARNING LAMP INSPECTION"</a>
		When VDC OFF indicator lamp is OFF	OFF	
SLIP LAMP	SLIP indicator lamp status (Note 4)	When SLIP indicator lamp is ON	ON	<a href="#">BRC-37. "BASIC INSPECTION 3: ABS WARNING LAMP, VDC OFF INDICATOR LAMP, SLIP INDICATOR LAMP and BRAKE WARNING LAMP INSPECTION"</a>
		When SLIP indicator lamp is OFF	OFF	
FR LH IN SOL FR LH OUT SOL FR RH IN SOL FR RH OUT SOL RR RH IN SOL RR RH OUT SOL RR LH IN SOL RR LH OUT SOL	Solenoid valve operation	Actuator (solenoid) is active ("ACTIVE TEST" with CONSULT-II) and actuator relay is active (ignition switch ON)	ON	<a href="#">BRC-46. "Inspection 7: Solenoid and VDC Change-Over Valve System"</a>
		When actuator (solenoid) is not active or actuator relay is inactive (in fail-safe mode)	OFF	
CV1 CV2 SV1 SV2	VDC/TCS switch-over valve status	When actuator (switch-over valve) is active ("ACTIVE TEST" with CONSULT-II) and actuator relay is active (ignition switch ON)	ON	<a href="#">BRC-46. "Inspection 7: Solenoid and VDC Change-Over Valve System"</a>
		When actuator (switch-over valve) is not active or actuator relay is inactive (in fail-safe mode)	OFF	
DECEL G-SEN (AWD model)	Longitudinal acceleration detected by Decel G-Sensor [Note 5]	Vehicle stopped	approx. 0 G	<a href="#">BRC-44. "Inspection 6: Yaw Rate/Side G-Sensor (2WD model), Yaw Rate/Side/Decel G-sensor (AWD models) System"</a>
		Vehicle running	-1.7 to +1.7 G	



# TROUBLE DIAGNOSIS

[VDC/TCS/ABS]

Monitor item	Display content	Data monitor		Note: Error inspection checklist
		Condition	Reference value in normal operation	
FLUID LEV SW	ON/OFF status of brake fluid level switch	When brake fluid level switch ON	ON	<a href="#">BRC-51, "Inspection 11: Brake Fluid Level Switch System"</a>
		When brake fluid level switch OFF	OFF	
VDC FAIL SIG TCS FAIL SIG ABS FAIL SIG EBD FAIL SIG	Fail signal status	VDC fail TCS fail ABS fail EBD fail	ON	VDC system TCS system ABS system EBD system
		VDC normal TCS normal ABS normal EBD normal	OFF	
EBD WARN LAMP	Brake warning lamp on condition (Note 6)	Brake warning lamp ON	ON	<a href="#">BRC-37, "BASIC INSPECTION 3: ABS WARNING LAMP, VDC OFF INDICATOR LAMP, SLIP INDICATOR LAMP and BRAKE WARNING LAMP INSPECTION"</a>
		Brake warning lamp OFF	OFF	
EBD SIGNAL	EBD operation	EBD active	ON	
		EBD not active	OFF	
ABS SIGNAL	ABS operation	ABS active	ON	
		ABS not active	OFF	
TCS SIGNAL	TCS operation	TCS active	ON	
		TCS not active	OFF	
VDC SIGNAL	VDC operation	VDC active	ON	—
		VDC not active	OFF	
CRANKING SIG	CRANKING status	Cranking	ON	
		Not cranking	OFF	
4WD FAIL REQ	ETS fail status (Note 5)	ETS fail	ON	
		ETS normal	OFF	
2WD/4WD	Drive axle	2WD model	2WD	
		AWD model	AWD	

Note 1: Confirm tire pressure is normal.

Note 2: ON/OFF timing of ABS warning lamp

ON: Approx. Within 2 seconds after ignition switch is turned ON, or when a malfunction is detected.

OFF: Approx. 2 seconds after ignition switch is turned ON (when system is in normal operation) and VDC/TCS function is not activated.

Note 3: ON/OFF timing of VDC OFF indicator lamp

ON: Approx. Within 2 seconds after ignition switch is turned ON, or when a malfunction is detected and VDC OFF switch is ON.

OFF: Approx. 2 seconds after ignition switch is turned ON (when system is in normal operation.) And when VDC OFF switch is OFF.

Note 4: SLIP indicator lamp ON/OFF timing

ON: Approx. Within 2 seconds after ignition switch is turned ON, or when a malfunction is detected and VDC/TCS function is activated while driving.

OFF: Approx. 2 seconds after ignition switch is turned ON (when system is in normal operation) and VDC/TCS function is not activated.

Blinking: VDC/TCS function is active during driving

Note 5: Only AWD model.

Note 6: Serves as EBD warning lamp.

## CONSULT-II Functions CONSULT-II MAIN FUNCTION

AFS00208

In a diagnosis function (main function), there are "WORK SUPPORT", "SELF-DIAGNOSTIC RESULTS", "DATA MONITOR", "CAN DIAG SUPPORT MNTR", "ACTIVE TEST", "FUNCTION TEST", "ECU PART NUMBER".

# TROUBLE DIAGNOSIS

[VDC/TCS/ABS]

Diagnostic test mode	Function	Reference
WORK SUPPORT	This mode enables a technician to adjust some devices faster and more accurately by following the indications on CONSULT-II.	<a href="#">BRC-6. "Adjustment of Steering Angle Sensor Neutral Position"</a>
SELF-DIAGNOSTIC RESULTS	Self-diagnostic results can be read and erased quickly.	<a href="#">BRC-27. "SELF-DIAGNOSIS"</a>
DATA MONITOR	Input/Output data in the ABS actuator and electric unit (control unit) can be read.	<a href="#">BRC-30. "DATA MONITOR"</a>
CAN DIAG SUPPORT MNTR	The results of transmit/receive diagnosis of communication can be read.	—
ACTIVE TEST	Diagnostic Test Mode in which CONSULT-II drives some actuators apart from the ABS actuator and electric unit (control unit) and also shifts some parameters in a specified range.	<a href="#">BRC-33. "ACTIVE TEST"</a>
FUNCTION TEST	Conducted by CONSULT-II instead of a technician to determine whether each system is "OK" or "NG".	—
ECU PART NUMBER	ABS actuator and electric unit (control unit) part number can be read.	—

## CONSULT-II BASIC OPERATION PROCEDURE

1. Turn ignition switch OFF.
2. Connect CONSULT-II and CONSULT-II CONVERTER to data link connector.

**CAUTION:**

If CONSULT-II is used with no connection of CONSULT-II CONVERTER, malfunctions might be detected in self-diagnosis depending on control unit which carry out CAN communication.

3. Turn ignition switch ON.
4. Touch "START (NISSAN BASED VHCL)".

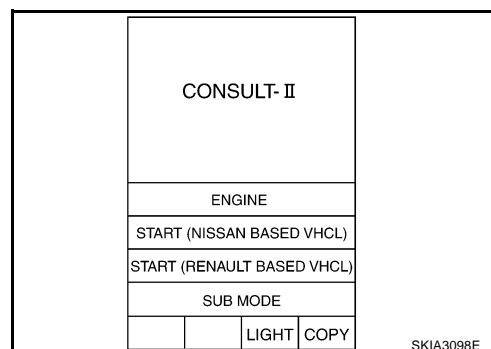

5. Touch "ABS" in the "SELECT SYSTEM" screen.  
If "ABS" is not indicated, go to [GI-40. "CONSULT-II Data Link Connector \(DLC\) Circuit"](#).

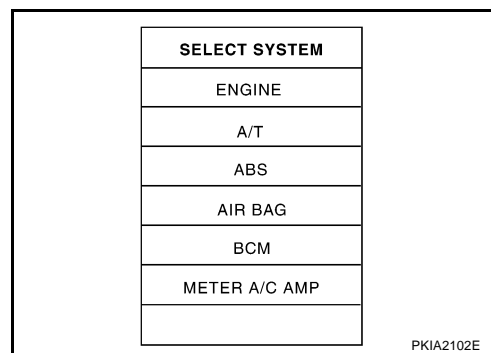

6. Select the required diagnostic location from the "SELECT DIAG MODE" screen.  
For further information, see CONSULT-II Operation Manual.

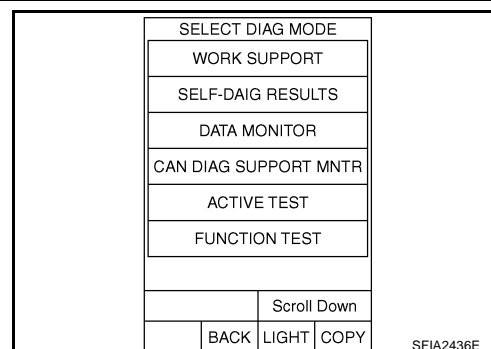

## SELF-DIAGNOSIS

### Description

- If an error is detected in the system, ABS warning lamp, VDC OFF indicator lamp and SLIP indicator lamp on the combination meter turn on. In this case, perform self-diagnosis as follows:
- While CONSULT-II is used, ABS warning lamp, VDC OFF indicator lamp, SLIP indicator lamp may be turned on in a case of no malfunctioning.

### Operation Procedure

1. Turn ignition switch OFF.
2. Connect CONSULT-II and CONSULT-II CONVERTER to data link connector.
 

**CAUTION:**  
If CONSULT-II is used with no connection of CONSULT-II CONVERTER, malfunctions might be detected in self-diagnosis depending on control unit which carry out CAN communication.
3. Turn ignition switch ON.
4. Start engine and drive at approximately 30 km/h (19 MPH) or more for approximately 1 minute.
5. After stopping vehicle, with the engine running, touch "START (NISSAN BASED VHCL)", "ABS", "SELF-DIAG RESULTS" in order on the CONSULT-II screen.
 

**CAUTION:**  
If "START (NISSAN BASED VHCL)" is touched immediately after starting engine or turning on the ignition switch, "ABS" might not be displayed in the System Selection screen. In this case, repeat the operation from step 1. If it cannot be shown after several attempts, ABS actuator and electric unit (control unit) may have malfunctioned.
6. The self-diagnostic results are displayed. (If necessary, the self-diagnostic results can be printed out by touching "PRINT".)
  - When "NO FAILURE" is displayed, check ABS warning lamp, VDC OFF indicator lamp and SLIP indicator lamp.
7. Perform the appropriate inspection from the display item list, and repair or replace the malfunctioning component.
8. Drive the vehicle at approximately 30 km/h (19 MPH) or more for approximately 1 minute.
 

**CAUTION:**  
• In a case that a wheel sensor is malfunctioning, ABS warning lamp, VDC OFF indicator lamp, SLIP indicator lamp will turn on. If vehicle is not driven at approximately 30 km/h (19 MPH) or more for at least approximately 1 minute after repair of the wheel sensor system, ABS warning lamp, VDC OFF indicator lamp and SLIP indicator lamp may not turn off even if everything is normal. Check again to make sure that there is no malfunction on other parts.
9. Turn ignition switch OFF to prepare for erasing the memory.
10. Start engine and touch "START (NISSAN BASED VHCL)", "ABS", "SELF-DIAG RESULTS", "ERASE MEMORY" in order on the CONSULT-II screen to erase the error memory.  
If "ABS" is not indicated, go to [GI-40, "CONSULT-II Data Link Connector \(DLC\) Circuit"](#) .
 

**CAUTION:**  
If the error memory is not erased, re-perform the operation from step 5.
11. For the final inspection, drive at approximately 30 km/h (19 MPH) or more for approximately 1 minute and confirm that ABS warning lamp, VDC OFF indicator lamp and SLIP indicator lamp are OFF.

# TROUBLE DIAGNOSIS

[VDC/TCS/ABS]

## Display Item List

Self-diagnostic item	Malfunction detecting condition	Check system
FR LH SENSOR- 1 [C1104]	Circuit of front LH wheel sensor is open, shorted or sensor power voltage is unusual.	<a href="#">BRC-37. "Inspection 1: Wheel Sensor System"</a> (Note 1)
RR RH SENSOR- 1 [C1101]	Circuit of rear RH wheel sensor is open, shorted or sensor power voltage is unusual.	
FR RH SENSOR- 1 [C1103]	Circuit of front RH wheel sensor is open, shorted or sensor power voltage is unusual.	
RR LH SENSOR- 1 [C1102]	Circuit of rear LH wheel sensor is open, shorted or sensor power voltage is unusual.	
FR LH SENSOR- 2 [C1108]	ABS actuator and electric unit (control unit) cannot identify sensor pulses, because of large gap between wheel sensor and sensor rotor.	
RR RH SENSOR- 2 [C1105]	ABS actuator and electric unit (control unit) cannot identify sensor pulses, because of large gap between wheel sensor and sensor rotor.	
FR RH SENSOR- 2 [C1107]	ABS actuator and electric unit (control unit) cannot identify sensor pulses, because of large gap between wheel sensor and sensor rotor.	
RR LH SENSOR- 2 [C1106]	ABS actuator and electric unit (control unit) cannot identify sensor pulses, because of large gap between wheel sensor and sensor rotor.	
STOP LAMP SW [C1116]	Stop lamp switch circuit is open or shorted.	<a href="#">BRC-50. "Inspection 10: Stop Lamp Switch System"</a>
PRESS SEN CIRCUIT [C1142]	Pressure sensor signal line is open or shorted, or sensor power voltage is unusual, or pressure sensor is malfunctioning.	<a href="#">BRC-40. "Inspection 4: Pressure Sensor System"</a>
ST ANG SEN CIRCUIT [C1143]	Neutral position of steering angle sensor is dislocated, or steering angle sensor is malfunctioning.	<a href="#">BRC-42. "Inspection 5: Steering Angle Sensor System"</a>
YAW RATE SENSOR [C1145]	Yaw rate sensor has generated an error, or yaw rate sensor signal line is open or shorted.	<a href="#">BRC-44. "Inspection 6: Yaw Rate/Side G-Sensor (2WD model), Yaw Rate/Side/Decel G-sensor (AWD models) System"</a>

# TROUBLE DIAGNOSIS

[VDC/TCS/ABS]

Self-diagnostic item	Malfunction detecting condition	Check system	
FR LH IN ABS SOL [C1120]	Circuit of front LH IN ABS solenoid is open or shorted, or control line is open or shorted to power supply or ground.	<a href="#">BRC-46. "Inspection 7: Solenoid and VDC Change-Over Valve System"</a>	
FR LH OUT ABS SOL [C1121]	Circuit of front LH OUT ABS solenoid is open or shorted, or control line is open or shorted to power supply or ground.		
RR RH IN ABS SOL [C1126]	Circuit of rear RH IN ABS solenoid is open or shorted, or control line is open or shorted to power supply or ground.		
RR RH OUT ABS SOL [C1127]	Circuit of rear RH OUT ABS solenoid is open or shorted, or control line is open or shorted to power supply or ground.		
FR RH IN ABS SOL [C1122]	Circuit of front RH IN ABS solenoid is open or shorted, or control line is open or shorted to power supply or ground.		
FR RH OUT ABS SOL [C1123]	Circuit of front RH OUT ABS solenoid is open or shorted, or control line is open or shorted to power supply or ground.		
RR LH IN ABS SOL [C1124]	Circuit of rear LH IN ABS solenoid is open or shorted, or control line is open or shorted to power supply or ground.		
RR LH OUT ABS SOL [C1125]	Circuit of rear LH OUT ABS solenoid is open or shorted, or control line is open or shorted to power supply or ground.		
CV1 [C1164]	Primary side VDC switch-over solenoid valve 1 (cut valve 1) is open or shorted, or control line is open or shorted to power supply or ground.		
CV2 [C1165]	Secondary side VDC switch-over solenoid valve 2 (cut valve 2) is open or shorted, or control line is open or shorted to power supply or ground.		
SV1 [C1166]	Primary side VDC switch-over solenoid valve 1 (suction valve 1) is open or shorted, or control line is open or shorted to power supply or ground.		
SV2 [C1167]	Secondary side VDC switch-over solenoid valve 2 (suction valve 2) is open or shorted, or control line is open or shorted to power supply or ground.		
PUMP MOTOR (Note 3) [C1111]	During actuator motor operation with ON, when actuator motor turns OFF or when control line for actuator motor relay is open.		<a href="#">BRC-47. "Inspection 8: Actuator Motor System"</a>
	During actuator motor operation with OFF, when actuator motor turns ON or when control line for relay is shorted to ground.		
ABS SENSOR [ABNORMAL SIGNAL] [C1115]	Wheel sensor input is malfunction.	<a href="#">BRC-37. "Inspection 1: Wheel Sensor System"</a> (Note 1)	
BATTERY VOLTAGE [ABNORMAL] [C1109]	ABS actuator and electric unit (control unit) power voltage is too low.	<a href="#">BRC-48. "Inspection 9: ABS Actuator and Electric Unit (Control Unit) Power Supply and Ground System"</a>	
ST ANG SEN SIGNAL [C1144]	Neutral position correction of steering angle sensor is not finished.	<a href="#">BRC-42. "Inspection 5: Steering Angle Sensor System"</a>	
ST ANG SEN COM CIR [C1156]	CAN communication line or steering angle sensor has generated an error.		
SIDE G-SEN CIRCUIT [C1146]	Side G-sensor is malfunctioning, or signal line of side G-sensor is open or shorted.	<a href="#">BRC-44. "Inspection 6: Yaw Rate/Side G-Sensor (2WD model), Yaw Rate/Side/Decel G-sensor (AWD models) System"</a>	
CONTROLLER FAILURE [C1110]	Internal malfunction of ABS actuator and electric unit (control unit)	<a href="#">BRC-40. "Inspection 3: VDC/TCS/ABS Control Unit System"</a>	

A  
B  
C  
D  
E  
BRC  
G  
H  
I  
J  
K  
L  
M

# TROUBLE DIAGNOSIS

[VDC/TCS/ABS]

Self-diagnostic item	Malfunction detecting condition	Check system
CAN COMM CIRCUIT [U1000]	<ul style="list-style-type: none"> <li>● CAN communication line is open or shorted.</li> <li>● ABS actuator and electric unit (control unit) internal malfunction</li> <li>● Battery voltage for EMC is suddenly interrupted for approximately 0.5 seconds or more.</li> </ul>	<a href="#">BRC-53. "Inspection 14: CAN Communication System" (Note 2)</a>
BR FLUID LEVEL LOW [C1155]	Brake fluid level drops or circuit between ABS actuator and electric unit (control unit) and brake fluid level switch is open or shorted.	<a href="#">BRC-51. "Inspection 11: Brake Fluid Level Switch System"</a>
VARIANT CODING [C1170]	V coding is not functioning.	ABS actuator and electric unit (control unit) and circuit
G - SENSOR (AWD model) [C1113]	Decel G sensor is malfunctioning, or signal line of Decel G sensor is open or shorted.	<a href="#">BRC-44. "Inspection 6: Yaw Rate/Side G-Sensor (2WD model), Yaw Rate/Side/Decel G-sensor (AWD models) System"</a>
ENGINE SIGNAL 1 [C1130]	Based on the signal from ECM, ABS actuator and electric unit (control unit) judges that engine fuel cut system is malfunctioning.	—
ENGINE SIGNAL 2 [C1131]	Based on the signal from ECM, ABS actuator and electric unit (control unit) judges that engine ETC system is malfunctioning.	—
ENGINE SIGNAL 3 [C1132]	Based on the signal from ECM, ABS actuator and electric unit (control unit) judges that engine CAN system is malfunctioning.	—
ENGINE SIGNAL 4 [C1133]	Based on the signal from ECM, ABS actuator and electric unit (control unit) judges that engine torque down system is malfunctioning.	—
ENGINE SIGNAL 6 [C1136]	Based on the signal from ECM, ABS actuator and electric unit (control unit) judges that engine control system is malfunctioning.	—
ACTUATOR RLY [C1140] (Note 3)	<ul style="list-style-type: none"> <li>● Actuator solenoid valve relay is ON, even if control unit sends off signal.</li> <li>● Actuator solenoid valve relay is OFF, even if control unit sends on signal.</li> </ul>	<a href="#">BRC-47. "Inspection 8: Actuator Motor System"</a>
DECEL G SEN SET (AWD model) [C1160]	Neutral position correction of Decel G -sensor is not finished.	<a href="#">BRC-52. "Inspection 13: When "DECEL G SEN SET" Appears on Self-Diagnosis Results Display (AWD Model)"</a>

Note 1: After completing repairs of shorted sensor circuit, when turn ignition switch ON, ABS warning lamp turned on. Check that ABS warning lamp turned off while driving vehicle at approximately 30 km/h (19 MPH) or more for approximately 1 minute according to self-diagnosis procedure. In addition, if wheel sensor 2 is displayed for wheels, check wheel sensor circuit and also check ABS actuator and electric unit (control unit) power voltage.

Note 2: If multiple malfunctions are detected including CAN communication line [U1000], perform diagnosis for CAN communication line first.

Note 3: "ACTUATOR RLY" on the CONSULT-II self-diagnostic results indicates the malfunction of actuator relay or circuit. Actuator relay is imbedded in ABS actuator and electric unit (control unit).

## DATA MONITOR

### Operation Procedure

1. After turning OFF ignition switch, connect CONSULT-II and CONVERTER to data link connector.

#### CAUTION:

**If CONSULT-II is used with no connection of CONSULT-II CONVERTER, malfunctions might be detected in self-diagnosis depending on control unit which carry out CAN communication.**

2. Turn ignition switch ON.
3. Touch "START (NISSAN BASED VHCL)", "ABS", "DATA MONITOR" in order on the CONSULT-II screen. If "ABS" is not indicated, go to [GI-40. "CONSULT-II Data Link Connector \(DLC\) Circuit"](#).

# TROUBLE DIAGNOSIS

[VDC/TCS/ABS]

**CAUTION:**

When “START (NISSAN BASED VHCL)” is touched immediately after starting engine or turning on ignition switch, “ABS” might not be displayed in the system selection screen. In this case, repeat the operation from step 1.

4. Return to the Monitor Item Selection screen, and touch “ECU INPUT SIGNALS”, “MAIN SIGNALS” or “SELECTION FROM MENU”. Refer to the following information.
5. When “START” is touched, the data monitor screen is displayed.

## Display Item List

Item (Unit)	Data monitor item selection			Remarks
	ECU INPUT SIGNALS	MAIN SIGNALS	SELECTION FROM MENU	
GEAR	×	×	×	Gear position judged by PNP switch signal is displayed.
FR RH SENSOR (km/h, MPH)	×	×	×	Wheel speed calculated by front RH wheel sensor signal is displayed.
FR LH SENSOR (km/h, MPH)	×	×	×	Wheel speed calculated by front LH wheel sensor signal is displayed.
RR RH SENSOR (km/h, MPH)	×	×	×	Wheel speed calculated by rear RH wheel sensor signal is displayed.
RR LH SENSOR (km/h, MPH)	×	×	×	Wheel speed calculated by rear LH wheel sensor signal is displayed.
BATTERY VOLT (V)	×	×	×	Voltage supplied to ABS actuator and electric unit (control unit) is displayed.
SLCT LVR POSI	×	×	×	Shift position judged by PNP switch signal.
ACCEL POS SIG (%)	×	–	–	Throttle valve open/close status judged by CAN communication signal is displayed.
ENGINE SPEED (rpm)	×	×	×	Engine speed judged by CAN communication signal is displayed.
STR ANGLE SIG (deg)	×	–	–	Steering angle detected by steering angle sensor is displayed.
YAW RATE SEN (d/s)	×	×	–	Yaw rate detected by yaw rate sensor is displayed.
DECEL G-SEN (AWD model) (G)	×	×	×	Longitudinal acceleration detected by decel G-sensor is displayed.
SIDE G-SENSOR (m/s <sup>2</sup> )	×	–	–	Lateral acceleration detected by side G-sensor is displayed.
PRESS SENSOR (bar)	×	–	–	Brake fluid pressure detected by pressure sensor is displayed.
STOP LAMP SW (ON/OFF)	×	×	×	Stop lamp switch (ON/OFF) status is displayed.
OFF SW (ON/OFF)	×	×	×	VDC OFF switch (ON/OFF) status is displayed.
ABS WARN LAMP (ON/OFF)	–	×	×	ABS warning lamp (ON/OFF) status is displayed.
SLIP LAMP (ON/OFF)	–	×	×	SLIP indicator lamp (ON/OFF) status is displayed.
FR LH IN SOL (ON/OFF)	–	×	×	Front LH IN ABS solenoid (ON/OFF) status is displayed.

A  
B  
C  
D  
E  
BRC  
G  
H  
I  
J  
K  
L  
M

# TROUBLE DIAGNOSIS

**[VDC/TCS/ABS]**

Item (Unit)	Data monitor item selection			Remarks
	ECU INPUT SIGNALS	MAIN SIGNALS	SELECTION FROM MENU	
FR LH OUT SOL (ON/OFF)	-	×	×	Front LH OUT ABS solenoid (ON/OFF) status is displayed.
RR RH IN SOL (ON/OFF)	-	×	×	Rear RH IN ABS solenoid (ON/OFF) status is displayed.
RR RH OUT SOL (ON/OFF)	-	×	×	Rear RH OUT ABS solenoid (ON/OFF) status is displayed.
FR RH IN SOL (ON/OFF)	-	×	×	Front RH IN ABS solenoid (ON/OFF) status is displayed.
FR RH OUT SOL (ON/OFF)	-	×	×	Front RH OUT ABS solenoid (ON/OFF) status is displayed.
RR LH IN SOL (ON/OFF)	-	×	×	Rear LH IN ABS solenoid (ON/OFF) status is displayed.
RR LH OUT SOL (ON/OFF)	-	×	×	Rear LH OUT ABS solenoid (ON/OFF) status is displayed.
OFF LAMP (ON/OFF)	-	×	×	OFF Lamp (ON/OFF) status is displayed.
MOTOR RELAY (ON/OFF)	-	×	×	ABS motor relay signal (ON/OFF) status is displayed.
ACTUATOR RLY (ON/OFF)	-	×	×	ABS actuator relay signal (ON/OFF) status is displayed.
CV1 (ON/OFF)	-	-	×	Primary side switch-over solenoid valve 1 (cut valve 1) (ON/OFF) status is displayed.
CV2 (ON/OFF)	-	-	×	Secondary side switch-over solenoid valve 2 (cut-valve 2) (ON/OFF) status is displayed.
SV1 (ON/OFF)	-	-	×	Primary side switch-over solenoid valve 1 (suction valve 1) (ON/OFF) status is displayed.
SV2 (ON/OFF)	-	-	×	Secondary side switch-over solenoid valve 2 (suction valve 2) (ON/OFF) status is displayed.
VDC FAIL SIG (ON/OFF)	-	-	×	VDC fail signal (ON/OFF) status is displayed.
TCS FAIL SIG (ON/OFF)	-	-	×	TCS fail signal (ON/OFF) status is displayed.
ABS FAIL SIG (ON/OFF)	-	-	×	ABS fail signal (ON/OFF) status is displayed.
EBD FAIL SIG (ON/OFF)	-	-	×	EBD fail signal (ON/OFF) status is displayed.
FLUID LEV SW (ON/OFF)	×	-	-	Brake fluid level switch (ON/OFF) status is displayed.
EBD SIGNAL (ON/OFF)	-	-	×	EBD operation (ON/OFF) status is displayed.
ABS SIGNAL (ON/OFF)	-	-	×	ABS operation (ON/OFF) status is displayed.
TCS SIGNAL (ON/OFF)	-	-	×	TCS operation (ON/OFF) status is displayed.
VDC SIGNAL (ON/OFF)	-	-	×	VDC operation (ON/OFF) status is displayed.
EBD WARN LAMP (ON/OFF)	-	-	×	Brake warning lamp (ON/OFF) status is displayed. (Note)



# TROUBLE DIAGNOSIS

[VDC/TCS/ABS]

Item (Unit)	Data monitor item selection			Remarks
	ECU INPUT SIGNALS	MAIN SIGNALS	SELECTION FROM MENU	
CRANKING SIG (ON/OFF)	-	-	×	Cranking condition (ON/OFF) status is displayed.
4WD FAIL REQ (ON/OFF)	-	-	×	AWD fail-safe signal (ON/OFF) status is displayed.
2WD/4WD (2WD/4WD)	-	-	×	Distinguish 2WD and AWD

×:Applicable

-:Not applicable

Note: Serves as EBD warning lamp.

## ACTIVE TEST

### CAUTION:

- Do not perform active test while driving.
- Make sure to completely bleed air from the brake system.
- Active test cannot be performed when EBD, ABS, TCS or VDC operation is malfunction.
- ABS and brake warning lamps turn on during the active test.

## Operation Procedure

1. Connect CONSULT-II and CONVERTER to data link connector and start engine.

### CAUTION:

If CONSULT-II is used with no connection of CONSULT-II CONVERTER, malfunctions might be detected in self-diagnosis depending on control unit which carry out CAN communication.

2. Touch "START (NISSAN BASED VHCL)" on the display screen.
3. Touch "ABS".  
If "ABS" is not indicated, go to [GI-40. "CONSULT-II Data Link Connector \(DLC\) Circuit"](#).
4. Touch "ACTIVE TEST".
5. The test item selection screen is displayed.
6. Touch necessary test item.

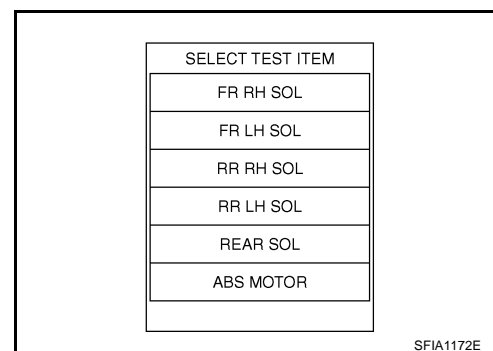

7. With the "MAIN SIGNALS" display shown in reverse, touch "START".
8. The "ACTIVE TEST" screen will be displayed, so perform the following test.

## Solenoid Valve Operation Chart

Operation	ABS solenoid valve			ABS solenoid valve (ACT)		
	UP	KEEP	DOWN	UP	ACTUATOR UP	ACTUATOR KEEP
FR RH IN SOL	OFF	ON	ON	OFF	OFF	OFF
FR RH OUT SOL	OFF	OFF	ON*	OFF	OFF	OFF
FR LH IN SOL	OFF	ON	ON	OFF	OFF	OFF
FR LH OUT SOL	OFF	OFF	ON*	OFF	OFF	OFF
RR RH IN SOL	OFF	ON	ON	OFF	OFF	OFF
RR RH OUT SOL	OFF	OFF	ON*	OFF	OFF	OFF

# TROUBLE DIAGNOSIS

**[VDC/TCS/ABS]**

Operation	ABS solenoid valve			ABS solenoid valve (ACT)		
	UP	KEEP	DOWN	UP	ACTUATOR UP	ACTUATOR KEEP
RR LH IN SOL	OFF	ON	ON	OFF	OFF	OFF
RR LH OUT SOL	OFF	OFF	ON*	OFF	OFF	OFF
PRIMARY SIDE VDC SWITCH OVER VALVE 1 (SV 1)	OFF	OFF	OFF	OFF	ON*	OFF
PRIMARY SIDE VDC SWITCH OVER VALVE 1 (CV 1)	OFF	OFF	OFF	OFF	ON	ON
SECONDARY SIDE VDC SWITCH OVER VALVE 2 (SV 2)	OFF	OFF	OFF	OFF	ON*	OFF
SECONDARY SIDE VDC SWITCH OVER VALVE 2 (CV 2)	OFF	OFF	OFF	OFF	ON	ON

\*: ON for 1 to 2 seconds after the touch, and then OFF

**NOTE:**

- If active test is performed with brake pedal depressed, pedal stroke may change. This is normal.
- "TEST IS STOPPED" is displayed approximately 10 seconds after operation starts.
- After "TEST IS STOPPED" is displayed, touch "BACK" and conduct the test from the Step 8.

**ABS Motor**

Touch "ON" and "OFF" on the screen. Make sure ABS motor relay operates as shown in table below.

Operation	ON	OFF
MOTOR RELAY	ON	OFF
ACTUATOR RELAY	ON	ON

**NOTE:**

- If active test is performed with brake pedal depressed, pedal stroke may change. This is normal.
- "TEST IS STOPPED" is displayed approximately 10 seconds after operation starts.

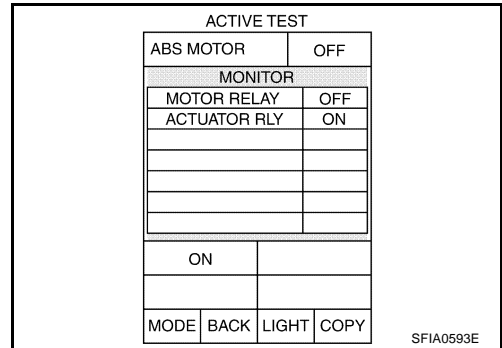

### For Fast and Accurate Diagnosis

#### PRECAUTIONS FOR DIAGNOSIS

- Before performing diagnosis, always read precautions. Refer to [BRC-12, "How to Proceed With Diagnosis"](#).
- If ABS actuator and electric unit (control unit), steering angle sensor, steering system parts or suspension system parts have been replaced, or if alignment has been adjusted, be sure to adjust neutral position of steering angle sensor before driving. Refer to [BRC-6, "Adjustment of Steering Angle Sensor Neutral Position"](#).
- After diagnosis is finished, be sure to erase memory. Refer to [BRC-27, "SELF-DIAGNOSIS"](#).
- When checking continuity and voltage between units, be sure to check for disconnection, looseness, bend, or collapse of connector terminals. If any malfunction is found, repair or replace connector terminals.
- For intermittent symptoms, possible cause is malfunction in harness, harness connector, or terminals. Move harness, harness connector, and terminals to check for poor connections.
- If a circuit tester is used for the check, be careful not to forcibly extend any connector terminal.
- To use CONSULT-II to perform self-diagnosis of ABS actuator and electric unit (control unit), active tests, or work support, first stop work, then connect CONSULT-II and select "ABS".
- While self-diagnostic results of CONSULT-II shows malfunction, if CONSULT-II active test is performed, an engine system error may be indicated. In this case, start engine to resume the normal screen.
- VDC/TCS/ABS system electronically controls brake operation and engine output. The following symptoms may be caused by normal operations:

Symptom	Symptom description	Result
Motor operation noise	This is noise of motor inside ABS actuator and electric unit (control unit). Slight noise may occur during VDC, TCS, and ABS operation.	Normal
	When the vehicle speed goes over 20 km/h (12.5 MPH), motor and valves operating noise may be heard. It happens only once after IGN (ignition) is ON. This is a normal status of the system operation check.	
System operation check noise	When engine starts, slight "click" noise may be heard from engine room. This is normal and is part of system operation check.	Normal
VDC/TCS operation (SLIP indicator lamp blinking)	TCS may activate momentarily if wheel speed changes when driving over location where friction coefficient varies, when up/downshifting, or when fully depressing accelerator pedal.	Normal Cancel the VDC/TCS function for the inspection on a chassis dynamometer.
	For inspection of speedometer or other instruments, press VDC OFF SW to turn VDC/TCS function off.	
	When accelerator pedal is depressed on a chassis dynamometer (fixed front-wheel type), vehicle speed will not increase. This is not normal. It is result of TCS being activated by stationary front wheels. Warning lamp may also illuminate to indicate "sensor system error". This is also normal, and is the result of the stationary front wheels being detected. To be certain, restart engine, and drive vehicle at 30 km/h (19 MPH) or more. Make sure warning lamp does not illuminate.	
ABS operation (Longer stopping distance)	On roads with low friction coefficients, such as snowy roads or gravel roads, vehicles with ABS may require a longer stopping distance. Therefore, when driving on such roads, avoid overconfidence and keep speed sufficiently low.	Normal
Insufficient feeling of acceleration	Depending on road conditions, driver may feel that feeling of acceleration is insufficient. This is because traction control, which controls engine and brakes to achieve optimal traction, has the highest priority (for safety). As a result, there may be times when acceleration is slightly less than usual for the same accelerator pedal operation.	Normal

# TROUBLE DIAGNOSIS

[VDC/TCS/ABS]

## ON and OFF Timing for ABS Warning Lamp, VDC OFF Indicator Lamp, SLIP Indicator Lamp, Brake Warning Lamp

×: ON –: OFF

Condition	ABS warning lamp	VDC OFF indicator lamp	SLIP indicator lamp	Brake warning lamp [Note 1]	Remarks
Ignition SW OFF.	–	–	–	—	—
Approx. 2 seconds after ignition switch is turned ON.	×	×	×	× [Note 2]	—
Approx. 2 seconds later after ignition switch ON.	–	–	–	× [Note 2]	Go out 2 seconds after ignition switch is turned ON.
VDC OFF SW is turned ON. (VDC/TCS function is OFF.)	–	×	–	—	—
VDC/TCS/ABS error.	×	×	×	—	There is an ABS actuator and electric unit (control unit) error. (Power, ground or system malfunction)
When VDC/TCS is not functioning normally.	–	×	×	—	—
EBD error.	×	×	×	×	—

### NOTE:

1. Brake warning lamp will turn on in case of operating parking brake (switch turned on) or of actuating brake fluid level switch (brake fluid is insufficient).
2. After starting engine, turn OFF.

## Basic Inspection

AFS001SS

### BASIC INSPECTION 1: BRAKE FLUID AMOUNT, LEAKS, AND BRAKE PADS INSPECTION

1. Check fluid level in the brake reservoir tank. If fluid level is low, refill brake fluid.
2. Check brake piping and around ABS actuator and electric unit (control unit) for leaks. If there is leaking or oozing fluid, check the following items.
  - If ABS actuator and electric unit (control unit) connection is loose, tighten piping to the specified torque and re-perform the leak inspection to make sure there are no leaks.
  - If there is damage to the connection flare nut or ABS actuator and electric unit (control unit) screw, replace the damaged part and re-perform the leak inspection to make sure there are no leaks.
  - When there is fluid leaking or oozing from a part other than ABS actuator and electric unit (control unit) connection, if fluid is just oozing out, use a clean cloth to wipe off the oozing fluid and re-check for leaks. If fluid is still oozing out, replace the damaged part.
  - When there is fluid leaking or oozing at ABS actuator and electric unit (control unit), if fluid is just oozing out, use a clean cloth to wipe off oozing fluid and re-check for leaks. If fluid is still oozing out, replace ABS actuator and electric unit (control unit) body.

#### CAUTION:

**ABS actuator and electric unit (control unit) body cannot be disassembled.**

3. Check brake pad degree of wear. Refer to [BR-20, "PAD WEAR INSPECTION"](#) in "Front Disc Brake" and [BR-25, "PAD WEAR INSPECTION"](#) in "Rear Disc Brake"

### BASIC INSPECTION 2: POWER SYSTEM TERMINAL LOOSENESS AND BATTERY INSPECTION

Make sure battery positive cable, negative cable and ground connection are not loose. If looseness is detected, tighten the cables. In addition, check the battery voltage to make sure it has not dropped and alternator is normal.

**BASIC INSPECTION 3: ABS WARNING LAMP, VDC OFF INDICATOR LAMP, SLIP INDICATOR LAMP AND BRAKE WARNING LAMP INSPECTION**

1. Make sure ABS warning lamp, VDC OFF indicator lamp (when VDC OFF switch is OFF), and SLIP indicator lamp turns on approximately 2 second, and brake warning lamp turns on when ignition switch is turned ON. If they do not, check VDC OFF indicator lamp and then VDC OFF switch. Refer to [BRC-53, "VDC OFF SWITCH"](#) . Check CAN communications. Refer to "CAN Communication Inspection". If there are no errors with VDC OFF switch and CAN communication system, check combination meter. Refer to [DI-4, "COMBINATION METERS"](#) .
2. Make sure ABS warning lamp, VDC OFF indicator lamp, SLIP indicator lamp turn off approximately 2 second after turn ignition switch ON, and brake warning lamp turns off after engine starts. If lamps do not turn off, perform self-diagnosis.
3. With engine running, make sure VDC OFF indicator lamp turns on and off when VDC OFF switch is turned ON and OFF. If indicator lamp status does not correspond to switch operation, check the VDC OFF switch system. Refer to [BRC-53, "VDC OFF SWITCH"](#) .
4. Make sure ABS warning lamp, VDC OFF indicator lamp, and SLIP indicator lamp turn off 2 seconds after engine is started. If ABS warning lamp, VDC OFF indicator lamp, and SLIP indicator lamp have not turned off 10 seconds after engine has been started, perform self-diagnosis of ABS actuator and electric unit (control unit).
5. After performing the self-diagnosis, be sure to erase the error memory. Refer to [BRC-27, "SELF-DIAGNOSIS"](#) .

**CAUTION:**

**Brake warning lamp turns on when parking brake is operated (switch on) and brake fluid level switch is activated (leak of brake fluid).**

**Inspection 1: Wheel Sensor System**

AFS001ST

**DTC C1101-C1108**

After using the CONSULT-II SELF-DIAG RESULTS to determine the location of the malfunctioning wheel sensor, check all areas to determine the component to be replaced.

**CAUTION:**

- **Do not measure the resistance value and also voltage between sensor terminal with tester etc., because sensor is an active sensor.**
- **Do not expand terminal of connector with a tester terminal stick, when it does the inspection with tester.**

## INSPECTION PROCEDURE

**1. CHECK TIRE**

Check air pressure, wear and size.

Are air pressure, wear, and size within the standard values?

YES >> GO TO 2.

NO >> Adjust air pressure, or replace tire.

**2. CHECK SENSOR AND SENSOR ROTOR**

- Check the condition of the sensor mount (for looseness, etc.).
- Check the surface of front sensor rotor rubber for damage.
- Check rear sensor rotor for damage.

## OK or NG

OK >> GO TO 3.

NG >> Repair sensor mount or replace sensor rotor.

## 3. CHECK SELF-DIAGNOSTIC RESULTS

---

Check the self-diagnostic results.

Self-diagnosis results
FR RH SENSOR-1,-2
FR LH SENSOR- 1,-2
RR RH SENSOR-1,-2
RR LH SENSOR-1,- 2

Is the above displayed in the self-diagnosis display items?

YES >> GO TO 4.

NO >> INSPECTION END.

## 4. CHECK CONNECTOR

---

1. Disconnect ABS actuator and electric unit (control unit) connector and malfunctioning wheel sensor connector E46 (FR-LH), E33 (FR-RH) or B69 (RR). Check terminal for deformation, open circuit, poor contact, etc., and repair or replace if any malfunctioning condition is found.
2. Reconnect connectors, drive at a speed of approximately 30 km/h (19 MPH) or more for approximately 1minute, and perform self-diagnosis.

OK or NG

OK >> Connector terminal contact is loose, damaged, open or shorted.

NG >> GO TO 5.

## 5. CHECK WHEEL SENSOR HARNESS

1. Turn ignition switch OFF and disconnect malfunctioning wheel sensor connector E46 (FR-LH), E33 (FR-RH) or B69 (RR) and ABS actuator and electric unit (control unit) connector.
2. Check continuity between terminals. (Also check the continuity when steering wheel is turned right and left and when sensor harness inside wheel well is moved.)

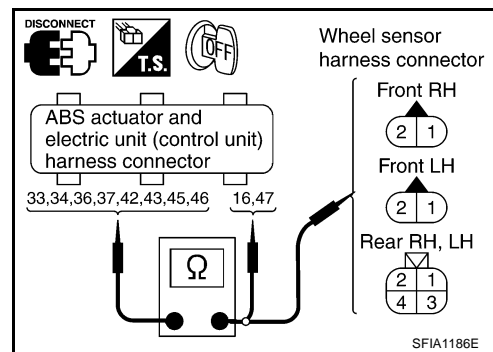

Wheel	Power system		Signal system		Ground system	
	ABS actuator and electric unit (control unit) harness connector E56	Wheel sensor harness connector E46, E33 or B69	ABS actuator and electric unit (control unit) harness connector E56	Wheel sensor harness connector E46, E33 or B69	ABS actuator and electric unit (control unit) harness connector E56 (signal)	ABS actuator and electric unit (control unit) harness connector E56 (ground)
Front RH (E33)	34 (W)	1 (W)	33 (B)	2 (B)	33 (B), 34 (W)	16 (B), 47 (B)
Front LH (E46)	45 (R)	1 (R)	46 (G)	2 (G)	45 (R), 46 (G)	
Rear RH (B69)	43 (Y)	1 (Y)	42 (BR)	2 (BR)	43 (Y), 42 (BR)	
Rear LH (B69)	36 (L)	3 (L)	37 (P)	4 (P)	36 (L), 37 (P)	

- Power system** : Continuity should exist.
- Signal system** : Continuity should exist.
- Ground system** : Continuity should not exist.

### OK or NG

- OK >> GO TO 6.
- NG >> Repair or replace harness and connector that have malfunction.

## 6. CHECK WHEEL SENSOR

1. Replace wheel sensor that resulted in malfunction by self-diagnosis.
2. Reconnect connectors, drive vehicle at 30 km/h (19 MPH) or more for approximately 1 minute, and then perform self-diagnosis.

### Is above displayed on self-diagnosis display?

- OK >> Wheel sensor has malfunction.
- NG >>
  - Replace ABS actuator and electric unit (control unit).
  - Perform to self-diagnosis again, and make sure that the result shows "NO DTC IS DETECTED. FURTHER TESTING MAY BE REQUIRED".

## Inspection 2: Engine System

AFS001SU

**DTC C1130-C1133, C1136**

## INSPECTION PROCEDURE

**1. CHECK SELF-DIAGNOSTIC RESULTS**

Check the self-diagnostic results.

Self-diagnostic results
ENGINE SIGNAL 1
ENGINE SIGNAL 2
ENGINE SIGNAL 3
ENGINE SIGNAL 4
ENGINE SIGNAL 6

Is the above displayed in the self-diagnosis display items?

- YES >> GO TO 2.  
NO >> INSPECTION END

**2. CHECK ENGINE SYSTEM**

1. Perform an ECM self-diagnosis and repair or replace malfunctioning items. Re-perform ECM self-diagnosis.
2. Re-perform ABS actuator and electric unit (control unit) self-diagnosis.

OK or NG

- OK >> INSPECTION END  
NG >> Repair or replace malfunctioning items. Re-perform the self-diagnosis.

**Inspection 3: VDC/TCS/ABS Control Unit System**

AFS001SV

**DTC C1110**

## INSPECTION PROCEDURE

**1. CHECK SELF-DIAGNOSTIC RESULTS**

Check the self-diagnostic results.

Self-diagnostic results
CONTROLLER FAILURE

Is the above displayed in the self-diagnosis display items?

- YES >> Replace ABS actuator and electric unit (control unit). Re-perform the self-diagnosis.  
NO >> INSPECTION END

**Inspection 4: Pressure Sensor System**

AFS001SW

**DTC C1142**

## INSPECTION PROCEDURE

**1. CHECK SELF-DIAGNOSTIC RESULTS**

Check the self-diagnostic results.

Self-diagnostic results
PRESS SEN CIRCUIT

Is the above displayed in the self-diagnosis display items?

- YES >> GO TO 2.  
NO >> INSPECTION END



## 2. CHECK CONNECTOR

1. Disconnect pressure sensor connector and ABS actuator and electric unit (control unit) connector, check terminals for deformation, disconnection, looseness, and so on. If any malfunction is found, repair or replace terminal.
2. Reconnect connectors and Re-perform ABS actuator and electric unit (control unit) self-diagnosis.

OK or NG

- OK >> Connector terminal contact is loose, damaged, open or shorted.  
 NG >> GO TO 3.

## 3. CHECK PRESSURE SENSOR HARNESS

1. Turn ignition switch OFF and disconnect pressure sensor connector and ABS actuator and electric unit (control unit) connector.
2. Check continuity between ABS actuator and electric unit (control unit) harness connector E56 and pressure sensor harness connector E53.

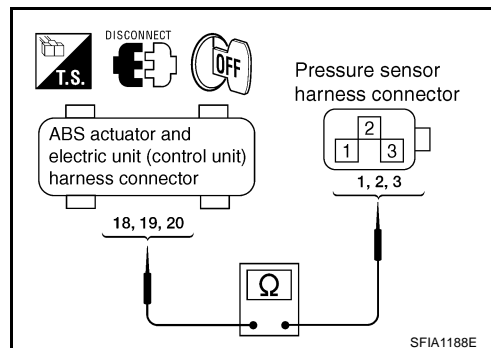

ABS actuator and electric unit (control unit) (Harness connector E56)	Pressure sensor (Harness connector E53)	Continuity
19 (L)	1 (L)	Yes
20 (Y)	2 (Y)	Yes
18 (W)	3 (W)	Yes

OK or NG

- OK >> GO TO 4.  
 NG >> If the open or short in harness, repair or replace harness.

## 4. PRESSURE SENSOR INSPECTION

1. Connect pressure sensor connector and ABS actuator and electric unit (control unit) connector.
2. Use CONSULT-II "Data Monitor" to check pressure sensor value.

Condition	Data monitor display
When brake pedal is depressed.	Positive value
When brake pedal is released.	Approx. 0 bar

OK or NG

- OK >> INSPECTION END  
 NG >> Pressure sensor is damaged or malfunctioning, replace pressure sensor.

---

## Inspection 5: Steering Angle Sensor System

DTC C1143

INSPECTION PROCEDURE

### 1. CHECK SELF-DIAGNOSTIC RESULTS

---

Check the self-diagnostic results.

Self-diagnosis results

ST ANG SEN CIRCUIT

Is the above displayed in the self-diagnosis item?

YES >> GO TO 2.

NO >> INSPECTION END

### 2. CHECK CONNECTOR

---

1. Disconnect steering angle sensor connector and ABS actuator and electric unit (control unit) connector and check terminals for deformation, disconnection, looseness, and so on. If any malfunction is found, repair or replace terminal.
2. Reconnect connectors and Re-perform a ABS actuator and electric unit (control unit) self-diagnosis.

OK or NG

OK >> Connector terminal contact is loose, damaged, open or shorted.

NG >> GO TO 3.

**3. CHECK STEERING ANGLE SENSOR HARNESS**

1. Check CAN communication system. Refer to [BRC-53, "Inspection 14: CAN Communication System"](#) .
2. Turn ignition switch OFF and disconnect steering angle sensor connector.
3. Check continuity between steering angle sensor harness connector M14 and ground.

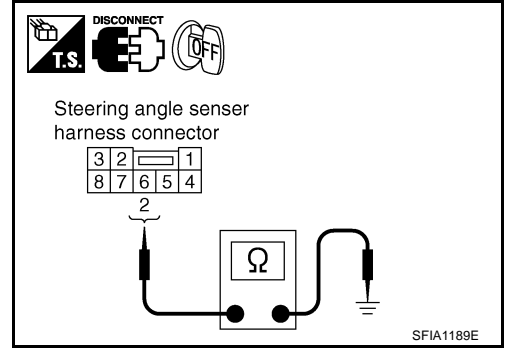

Steering angle sensor (Harness connector M14)	Ground	Continuity
2 (B)	—	Yes

4. Check voltage between steering angle sensor harness connector M14 and ground.

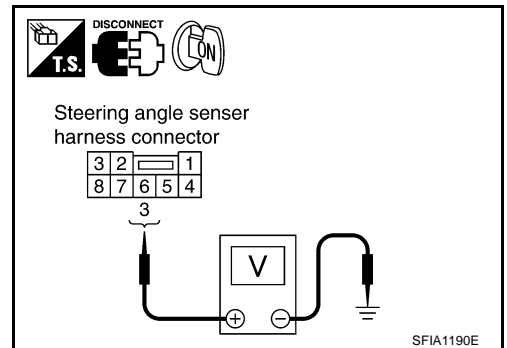

Steering angle sensor (Harness connector M14)	Ground	Voltage (V) (Approx.)
3 (G/R)	—	12V

OK or NG

- OK >> GO TO 4.
- NG >> If the open or short in harness, repair or replace harness.

**4. CHECK STEERING WHEEL PLAY**

Check steering wheel play. Refer to [PS-10, "CHECKING STEERING WHEEL PLAY"](#) .

OK or NG

- OK >> GO TO 5
- NG >> Adjustment steering wheel play.

## 5. PERFORM DATA MONITOR

1. Connect steering angle sensor and ABS actuator and electric unit (control unit) connectors.
2. Perform "DATA MONITOR" of the "STEERING ANGLE SIGNAL" to check if the status is normal.

Steering condition	Data monitor
Straight-ahead	-3.5 deg - +3.5 deg
Turn wheel to the right by 90°.	Approx. -90 deg
Turn wheel to the left by 90°.	Approx. +90 deg

### OK or NG

- OK >> Re-perform ABS actuator and electric unit (control unit) self-diagnosis.  
 NG >> Replace steering angle sensor and adjust neutral position of steering angle sensor. Refer to [BRC-6. "Adjustment of Steering Angle Sensor Neutral Position"](#).

## Inspection 6: Yaw Rate/Side G-Sensor (2WD model), Yaw Rate/Side/Decel G-sensor (AWD models) System

AFS001SY

DTC C1145, C1146, C1113

### CAUTION:

Sudden turns (such as spin turns, acceleration turns), drifting, etc. May cause the G-sensor system indicate a malfunction. However, this is not a malfunction, if normal operation can be resumed after restarting engine.

### INSPECTION PROCEDURE

#### 1. CHECK SELF-DIAGNOSTIC RESULTS

Check the self-diagnostic results.

Self-diagnostic results
YAW RATE SENSOR
SIDE G-SEN CIRCUIT
G-SENSOR (AWD model)

### CAUTION:

When on a turntable, such as at a parking structure entrance, or when on a moving object with engine running, VDC OFF indicator lamp might turn on and self-diagnosis using CONSULT-II the yaw rate sensor system might be displayed, but in this case there is no malfunction in yaw rate sensor system. As soon as vehicle leaves turntable or moving object, restart engine to return the system to normal.

Is the above displayed in the self-diagnosis display items?

- YES >> GO TO 2.  
 NO >> INSPECTION END

#### 2. CHECK CONNECTOR

1. Disconnect G-sensor connector and ABS actuator and electric unit (control unit) connector and check terminals for deformation, disconnection, looseness, and so on. If any malfunction is found, repair or replace terminal.
2. Reconnect connectors and re-perform a ABS actuator and electric unit (control unit) self-diagnosis.

### OK or NG

- OK >> Connector terminal contact is loose, damaged, open or shorted.  
 NG >> GO TO 3.

### 3. CHECK G-SENSOR HARNESS

1. Turn ignition switch OFF and disconnect G-sensor connector and ABS actuator and electric unit (control unit) connector.
2. Check continuity between ABS actuator and electric unit (control unit) harness connector E56 and G-sensor harness connector M79 (2WD model) or M71 (AWD model).

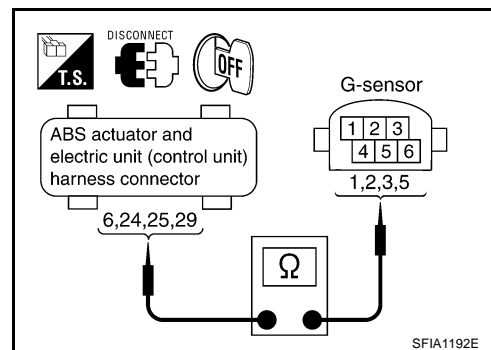

ABS actuator and electric unit (control unit) (Harness connector E56)	G-sensor (Harness connector M79 or M71)	Continuity
6 (Y)	3 (Y/B)	Yes
24 (B)	5 (B/Y)	Yes
25 (R/Y)	1 (R/Y)	Yes
29 (R/G)	2 (R/G)	Yes

OK or NG

OK >> GO TO 4.

NG >> If the open or short in harness, repair or replace harness.

### 4. CHECK G-SENSOR

1. Connect G-sensor connector and ABS actuator and electric unit (control unit) connector.
2. Use CONSULT-II "DATA MONITOR" to check if G-sensor are normal.

Vehicle status	Yaw rate sensor (Data monitor standard)	Side G sensor (Data monitor standard)	Decel G sensor (Data monitor standard) (AWD model)
When stopped	-4 to +4 deg/s	-1.1 to +1.1 m/s <sup>2</sup>	-0.11 to +0.11 G
Right turn	Negative value	Negative value	-
Left turn	Positive value	Positive value	-
Speed up	-	-	Negative value
Speed down	-	-	Positive value

OK or NG

OK >> Re-perform ABS actuator and electric unit (control unit) self-diagnosis.

NG >> Replace malfunctioning G-sensor, and then re-perform self-diagnosis for ABS actuator and electric unit (control unit).

**Inspection 7: Solenoid and VDC Change-Over Valve System**

DTC C1120-C1127, C1164-C1167

INSPECTION PROCEDURE

**1. CHECK SELF-DIAGNOSTIC RESULTS**

Check the self-diagnostic results.

Self-diagnostic results
FR LH IN ABS SOL
FR LH OUT ABS SOL
RR RH IN ABS SOL
RR RH OUT ABS SOL
FR RH IN ABS SOL
FR RH OUT ABS SOL
RR LH IN ABS SOL
RR LH OUT ABS SOL
CV 1
CV 2
SV 1
SV 2

Is the above displayed in the self-diagnosis display items?

- YES >> GO TO 2.
- NO >> INSPECTION END

**2. CHECK CONNECTOR**

1. Disconnect ABS actuator and electric unit (control unit) connector check terminals for deformation, disconnection, looseness, and so on. If any malfunction is found, repair or replace terminal.
2. Securely reconnect connector and perform self-diagnosis.

OK or NG

- OK >> Connector terminal contact is loose, damaged, open or shorted.
- NG >> GO TO 3.

**3. CHECKING SOLENOID POWER AND GROUND**

1. Disconnect ABS actuator and electric unit (control unit) connector.
2. Check voltage between ABS actuator and electric unit (control unit) harness connector E56 and ground.

ABS actuator and electric unit (control unit) (Harness connector E56)	Ground	Voltage (V) (Approx.)
32 (R)	—	12 V

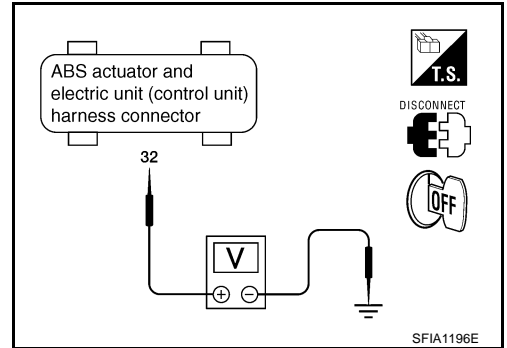

3. Check continuity between ABS actuator and electric unit (control unit) harness connector E56 and ground.

ABS actuator and electric unit (control unit) (Harness connector E56)	Ground	Continuity
16 (B)	—	Yes
47 (B)	—	Yes

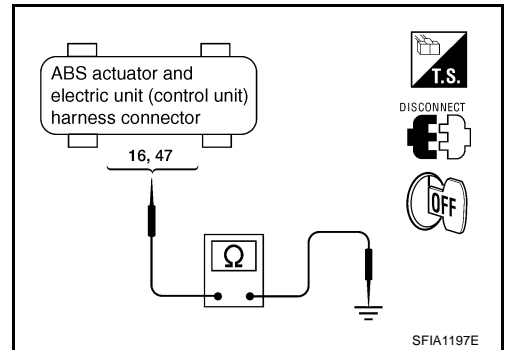

OK or NG

- OK >> Perform self-diagnosis again. If the same results appear, replace ABS actuator and electric unit (control unit). Refer to [BRC-60, "ACTUATOR AND ELECTRIC UNIT \(ASSEMBLY\)"](#).
- NG >> Repair or replace harness or connectors.

**Inspection 8: Actuator Motor System**

AFS001T0

**DTC C1111, C1140**

Inspection Procedure

**1. CHECK SELF-DIAGNOSIS RESULTS (1)**

Check the self-diagnostic results.

Self-diagnostic results
PUMP MOTOR
ACTUATOR RLY

Is the above displayed in the self-diagnostic display items?

- YES >> GO TO 2.
- NO >> Inspection is completed.

**2. CHECK SELF-DIAGNOSIS RESULTS (2)**

1. Disconnect ABS actuator and electric unit (control unit) connector. Then reconnect it securely.
2. Perform self-diagnosis again.

Do any self-diagnosis item appear?

- YES >> GO TO 3.
- NO >> Poor connection. Repair or replace the applicable connector.

### 3. CHECK ABS MOTOR AND MOTOR RELAY POWER SYSTEM

1. Disconnect ABS actuator and electric unit (control unit) connector.
2. Check voltage between ABS actuator and electric unit (control unit) harness connector E56 and ground.

ABS actuator and electric unit (control unit) (Harness connector E56)	Ground	Voltage (V) (Approx.)
1 (Y) 32 (R)	—	12 V

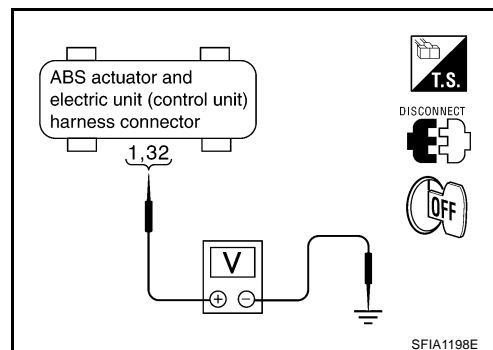

3. Check continuity between ABS actuator and electric unit (control unit) harness connector E56 and ground.

ABS actuator and electric unit (control unit) (Harness connector E56)	Ground	Continuity
16 (B)	—	Yes
47 (B)	—	Yes

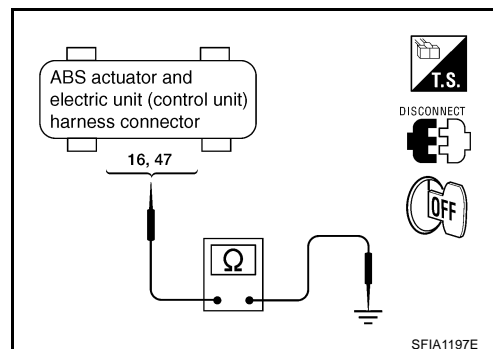

OK or NG

- OK >> Perform self-diagnosis again. If the same result appears, replace ABS actuator and electric unit (control unit). Refer to [BRC-60, "ACTUATOR AND ELECTRIC UNIT \(ASSEMBLY\)"](#).
- NG >> Repair harness or connectors.

## Inspection 9: ABS Actuator and Electric Unit (Control Unit) Power Supply and Ground System

AFS001T1

### DTC C1109

Inspection Procedure

#### 1. CHECK SELF-DIAGNOSTIC RESULTS

Check the self-diagnostic results.

Self-diagnostic results
BATTERY VOLTAGE

Does "BATTERY VOLTAGE" appear in self-diagnostic results display?

- YES >> GO TO 2.  
NO >> INSPECTION END

#### 2. STARTING INSPECTION

1. Disconnect ABS actuator and electric unit (control unit) connector. Then reconnect it securely.
2. Perform self-diagnosis.

Do any self-diagnosis item appear?

- YES >> GO TO 3.  
NO >> Poor connection. Repair or replace connector.



## 3. CHECK ABS ACTUATOR AND ELECTRIC UNIT (CONTROL UNIT) POWER SUPPLY (1)

1. Disconnect ABS actuator and electric unit (control unit) connector.
2. Turn ignition switch OFF. Check voltage between ABS actuator and electric unit (control unit) harness connector E56 and ground.

ABS actuator and electric unit (control unit) (Harness connector E56)	Ground	Voltage (V) (Approx.)
32 (R)	—	12 V

3. Turn ignition switch ON (but do not start engine). Check voltage between ABS actuator and electric unit (control unit) harness connector E56 and ground.

ABS actuator and electric unit (control unit) (Harness connector E56)	Ground	Voltage (V) (Approx.)
4 (G)	—	12 V

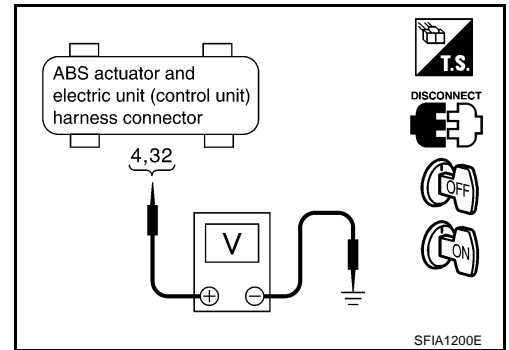

OK or NG

- OK >> GO TO 4.
- NG >> GO TO 5.

## 4. CHECK ABS ACTUATOR AND ELECTRIC UNIT (CONTROL UNIT) GROUND SYSTEM

Check ABS actuator and electric unit (control unit) ground system.

ABS actuator and electric unit (control unit) (Harness connector E56)	Ground	Continuity
16 (B)	—	Yes

OK or NG

- OK >> Perform ABS actuator and electric unit (control unit) self-diagnosis again.
- NG >> Repair or replace harness or connectors.

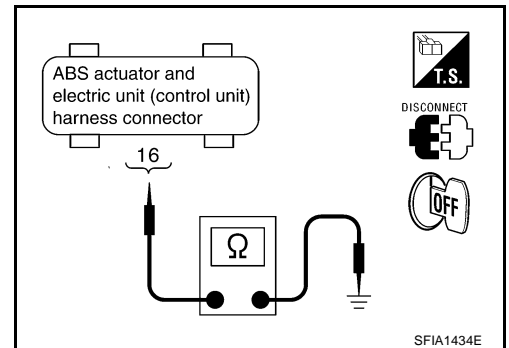

## 5. CHECK ABS ACTUATOR AND ELECTRIC UNIT (CONTROL UNIT) POWER SUPPLY (2)

1. Check fuse 10A (terminal 4) and 30A (terminal 32).
2. Turn ignition switch OFF and check continuity between battery positive terminal and ABS actuator and electric unit (control unit) harness connector E56.

ABS actuator and electric unit (control unit) (Harness connector E56)	Battery positive terminal	Continuity
4 (G), 32 (R)	—	Yes

OK or NG

- OK >> Check for non-standard conditions in battery (terminal looseness, low voltage, etc.) and alternator.
- NG >>
  - Replace fuse 10A or 30A.
  - Open or short in harness.

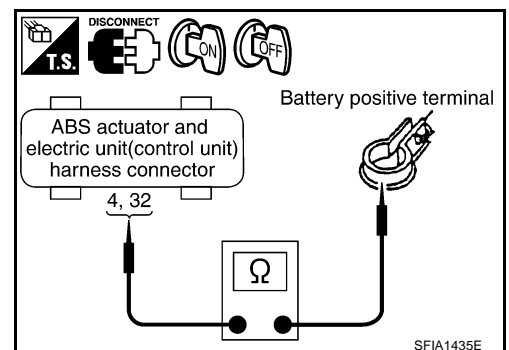

## Inspection 10: Stop Lamp Switch System

**DTC C1116**

INSPECTION PROCEDURE

### 1. CHECK SELF-DIAGNOSTIC RESULTS

Check the self-diagnostic results.

Self-diagnostic results

STOP LAMP SW

Is the above displayed in the self-diagnosis display item?

YES >> GO TO 2.

NO >> INSPECTION END

### 2. CHECK CONNECTOR

1. Disconnect stop lamp switch connector and ABS actuator and electric unit (control unit) connector E56 and check terminals for deformation, disconnection, looseness, and so on. If any malfunction is found, repair or replace terminal.
2. Securely reconnect connectors.
3. perform self-diagnosis again.

OK or NG

OK >> Connector terminal contact is loose, damaged, open or shorted.

NG >> GO TO 3.

### 3. CHECK STOP LAMP SWITCH CIRCUIT

1. Turn ignition switch OFF and disconnect stop lamp switch connector and ABS actuator and electric unit (control unit) connector.
2. Check continuity between stop lamp switch harness connector E210 and ABS actuator and electric unit (control unit) harness connector E56.

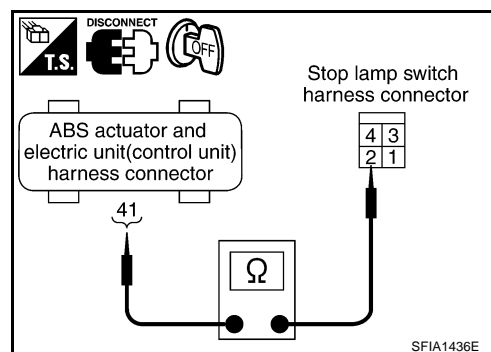

ABS actuator and electric unit (control unit) (Harness connector E56)	Stop lamp switch (Harness connector E210)	Continuity
41 (P)	2 (P)	Yes

OK or NG

OK >> Connect connectors and conduct a ABS actuator and electric unit (control unit) self-diagnosis.

NG >> Open or short in harness between stop lamp switch and ABS actuator and electric unit (control unit). Repair or replace applied harness.

## Inspection 11: Brake Fluid Level Switch System

AFS001T4

**DTC C1155**

### INSPECTION PROCEDURE

#### 1. CHECK SELF-DIAGNOSTIC RESULTS

1. Check fluid level in brake fluid reservoir tank. If the level is low, add brake fluid.
2. Clear the stored self-diagnostic results and check self-diagnosis results.

Self-diagnostic results

BR FLUID LEVEL LOW

Is the above displayed in the self-diagnosis display item?

YES >> GO TO 2.

NO >> INSPECTION END

#### 2. CHECK CONNECTOR

1. Disconnect brake fluid level switch connector and ABS actuator and electric unit (control unit) connector and check terminal for deformation, disconnection, looseness, and so on. If any malfunction is found, repair or replace terminal.
2. Securely reconnect connectors and Re-perform self-diagnosis.

OK or NG

OK >> Connector terminal contact is loose, damaged, open or shorted.

NG >> GO TO 3.

#### 3. CHECK HARNESS BETWEEN BRAKE FLUID LEVEL SWITCH AND ABS ACTUATOR AND ELECTRIC UNIT (CONTROL UNIT)

1. Turn ignition switch OFF and disconnect brake fluid level switch connector and ABS actuator and electric unit (control unit) connector.
2. Check continuity between brake fluid level switch harness connector and ABS actuator and electric unit (control unit) harness connector E56.

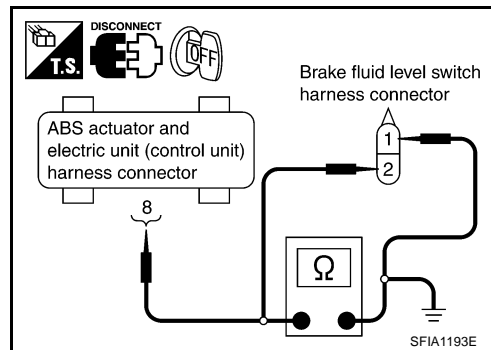

ABS actuator and electric unit (control unit) (Harness connector E56)	Brake fluid level switch (Harness connector E52)	Continuity
8 (GY)	1 (GY)	Yes
8 (GY)	Ground	No
Ground	2 (B)	Yes

OK or NG

OK >> Connect connectors and perform a ABS actuator and electric unit (control unit) self-diagnosis.

NG >> If open or short in harness, repair or replace applied harness.

## Inspection 12: When “ST ANG SEN SIGNAL” Appears on Self-Diagnosis Results Display

AFS0021V

DTC C1144

INSPECTION PROCEDURE

### 1. CHECK SELF DIAGNOSIS RESULTS (1)

Check self-diagnosis results.

Self-diagnosis results
------------------------

ST ANG SEN SIGNAL
-------------------

Dose anything besides “ST ANG SEN SIGNAL” appear on self-diagnosis results display?

- YES >> Inspect and repair the indicated items. Then perform self-diagnosis again.  
 NO >> Perform adjustment of steering angle sensor neutral position. Then GO TO 2.

### 2. CHECK SELF DIAGNOSIS RESULTS (2)

Turn ignition switch OFF and ON to erase self-diagnosis results, and perform ABS actuator and electric unit (control unit) self-diagnosis again.

Dose anything appear on self-diagnosis results display?

- YES >> Replace steering angle sensor. Then perform adjustment of neutral position and perform self-diagnosis again.  
 NO >> INSPECTION END.

## Inspection 13: When “DECEL G SEN SET” Appears on Self-Diagnosis Results Display (AWD Model)

AFS0021W

DTC C1160

INSPECTION PROCEDURE

### 1. CHECK SELF DIAGNOSIS RESULTS (1)

Check self-diagnosis results.

Self-diagnosis results
------------------------

DECEL G SEN SET
-----------------

Dose anything besides “DECEL G SEN SET” appear on self-diagnosis results display?

- YES >> Inspect and repair the indicated items. Then perform self-diagnosis again.  
 NO >> Perform calibration of Decel G Sensor. Then GO TO 2.

### 2. CHECK SELF-DIAGNOSIS RESULTS (2)

Turn ignition switch OFF and ON to erase self-diagnosis results, and perform ABS actuator and electric unit (control unit) self-diagnosis again.

Dose anything appear on self-diagnosis results display?

- YES >> Replace Yaw rate/side/decel G sensor. Then perform adjustments of neutral position and perform self-diagnosis again.  
 NO >> INSPECTION END.

**Inspection 14: CAN Communication System**

AFS002Q9

DTC U1000, C1156

## INSPECTION PROCEDURE

**1. CHECK CONNECTOR**

1. Turn ignition switch OFF, disconnect the ABS actuator and electric unit (control unit) connector, and check the terminal for deformation, disconnection, looseness, and so on. If there is a malfunction, repair or replace the terminal.
2. Reconnect connector to perform self-diagnosis.

Is "CAN COMM CIRCUIT" or "ST ANG SEN COM CIR" displayed in the self-diagnosis display items?

- YES >> Print out the self-diagnostic results, and refer to [LAN-4, "Precautions When Using CONSULT-II"](#) .
- NO >> Connector terminal connection is loose, damaged, open, or shorted.

**Component Inspection**  
**VDC OFF SWITCH**

AFS001T6

- Turn ignition switch OFF and disconnect VDC OFF switch connector, and check continuity between VDC OFF switch connector M32 terminals 1 and 2.

- 1-2 :Continuity should exist when pushing switch.**  
**continuity should not exist when releasing switch.**

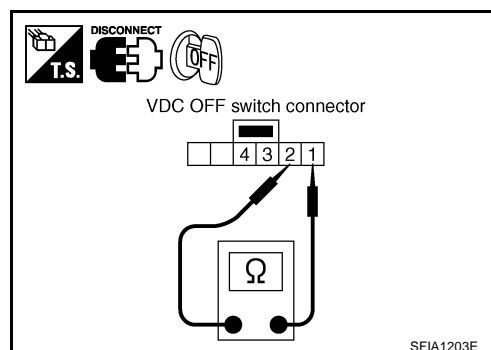
**Symptom 1: Excessive ABS Function Operation Frequency**

AFS001T7

**1. FRONT AND REAR AXLE INSPECTION**

Make sure there is no excessive looseness in the front and rear axles.

OK or NG

- OK >> GO TO 2.
- NG >> Check front or rear axle system.

**2. WHEEL SENSOR INSPECTION**

Perform following inspection for wheel sensor:

- Sensor mount and damage inspection
- Sensor rotor mount and damage inspection
- Sensor connector connection inspection
- Sensor harness inspection

OK or NG

- OK >> GO TO 3.
- NG >> Sensor or sensor rotor replacement

**3. ABS WARNING LAMP DISPLAY CHECK**

Make sure warning lamp turns off approximately 2 sec. After turn ignition switch ON or when driving.

OK or NG

- OK >> Normal
- NG >> Perform self-diagnosis. Refer to [BRC-27, "SELF-DIAGNOSIS"](#) .

**Symptom 2: Unexpected Pedal Reaction**

AFS001T8

**1. CHECK BRAKE PEDAL STROKE**

Check brake pedal stroke.

Is the stroke too long?

YES >> ● Bleed air from brake piping.

- Check brake pedal, brake booster, and master cylinder mount for play, looseness, and brake system for fluid leaks, etc. If any malfunctions are found, make repair.

NO >> GO TO 2.

**2. CHECK FUNCTION**

Disconnect ABS actuator and electric unit (control unit) connector E56 and make sure that braking force is sufficient when ABS is not operating. After the inspection, reconnect connector.

OK or NG

OK >> GO TO symptom 1 "Step 2". Refer to [BRC-53, "Symptom 1: Excessive ABS Function Operation Frequency"](#).

NG >> Check brake system.

**Symptom 3: The Braking Distance Is Long**

AFS001T9

**CAUTION:**

**On slippery road surfaces, the stopping distance might be longer with the ABS operating than when the ABS is not operating.**

**1. CHECK FUNCTION**

Disconnect ABS actuator and electric unit (control unit) connector E56 to deactivate ABS. In this condition, check stopping distance. After inspection, connect connector.

OK or NG

OK >> ● Bleed air from brake piping.

- Check brake system.

NG >> GO TO symptom 1 "Step 2". Refer to [BRC-53, "Symptom 1: Excessive ABS Function Operation Frequency"](#).

**Symptom 4: The ABS Function Does Not Operate**

AFS001TA

**CAUTION:**

**The ABS does not operate when the speed is 10 km/h (6 MPH) or less.**

**1. CHECK ABS WARNING LAMP DISPLAY**

Make sure warning lamp turns off approximately 2 second after the ignition switch is turned on or when driving.

OK or NG

OK >> GO TO symptom 1 "Step 2". Refer to [BRC-53, "Symptom 1: Excessive ABS Function Operation Frequency"](#).

NG >> Perform self-diagnosis. Refer to [BRC-27, "SELF-DIAGNOSIS"](#).

**Symptom 5: Pedal Vibration or ABS Operation Sound Occurs**

AFS001TB

**CAUTION:**

Under the following conditions, when brake pedal is lightly depressed (just place a foot on it), ABS is activated and vibration is felt. However, this is normal.

- When shifting gears
- When driving on slippery road
- During cornering at high speed
- When passing over bumps or grooves
- When pulling away just after starting engine [at approximately 10 km/h (6MPH) or higher]

**1. SYMPTOM CHECK 1**

Check if pedal vibration or operation sound occurs when engine is started.

OK or NG

- OK >> Perform self-diagnosis. Refer to [BRC-27, "SELF-DIAGNOSIS"](#) .  
 NG >> GO TO 2.

**2. SYMPTOM CHECK 2**

Check symptom when electrical component (headlamps, etc.) switches are operated.

Does the symptom occur when the electrical component (head lamp, etc.) switches are operated?

- YES >> Check if there is a radio, antenna, antenna lead wire, or wiring close to ABS actuator and electric unit (control unit) (or its wiring), and if there is, move it farther away.  
 NO >> GO TO symptom 1 "Step 2". Refer to [BRC-53, "Symptom 1: Excessive ABS Function Operation Frequency"](#) .

**Symptom 6: Vehicle Jerks During VDC/TCS/ABS Control**

AFS001TC

**1. CHECK ENGINE SPEED SIGNAL**

Perform CONSULT-II "DATA MONITOR" to check engine speed.

Is engine speed at idle 400 rpm or higher?

- YES >> GO TO 3.  
 NO >> GO TO 2.

**2. ABS WARNING LAMP DISPLAY CHECK**

Make sure warning lamp turns off approximately 2 sec. After turn ignition switch ON or when driving.

OK or NG

- OK >> System is normal.  
 NG >> GO TO 3.

**3. CHECK ECM SELF-DIAGNOSTIC RESULTS**

Perform ECM self-diagnosis.

Are self-diagnosis items displayed?

- YES >> Check the corresponding items. Refer to [EC-77, "TROUBLE DIAGNOSIS"](#) (VQ35DE), [EC-726, "TROUBLE DIAGNOSIS"](#) (VK45DE) in "Engine Control (EC section)".  
 NO >> GO TO 4.

**4. CHECK A/T SELF-DIAGNOSTIC RESULTS**

Perform A/T self-diagnosis.

OK or NG

- OK >> GO TO 5.  
 NG >> Check the corresponding items. Refer to [AT-42, "TROUBLE DIAGNOSIS"](#) in "A/T".

---

### 5. CHECK SELF-DIAGNOSTIC RESULTS 1

---

Perform self-diagnosis of ABS actuator and electric unit (control unit).

Are self-diagnosis items displayed?

- YES >> Check the corresponding items, make repairs, and re-perform ABS actuator and electric unit (control unit) self-diagnosis.  
NO >> GO TO 6.

---

### 6. CHECK CONNECTOR

---

1. Disconnect ABS actuator and electric unit (control unit) connector E56 and ECM connector, check terminals for deformation, disconnection, looseness, and so on. If any malfunction is found, repair or replace connector.
2. Securely reconnect connector and perform self-diagnosis.

OK or NG

- OK >> If poor connect, damaged, open or short circuit is found, repair or replace connector terminal.  
NG >> GO TO 7.

---

### 7. CHECK SELF-DIAGNOSTIC RESULTS 2

---

Re-perform ABS actuator and electric unit (control unit) self-diagnosis.

Are self-diagnosis items displayed?

- YES >> Repair or replace malfunctioning items.  
NO >> GO TO 8.

---

### 8. CHECK CIRCUIT BETWEEN ABS ACTUATOR AND ELECTRIC UNIT (CONTROL UNIT) AND ECM

---

Check CAN communication system. Refer to [BRC-53, "Inspection 14: CAN Communication System"](#) .

OK or NG

- OK >> INSPECTION END  
NG >> Connect connectors, and re-perform ABS actuator and electric unit (control unit) self-diagnosis.



## WHEEL SENSORS

PFP:47910

### Removal and Installation

AFS001Z3

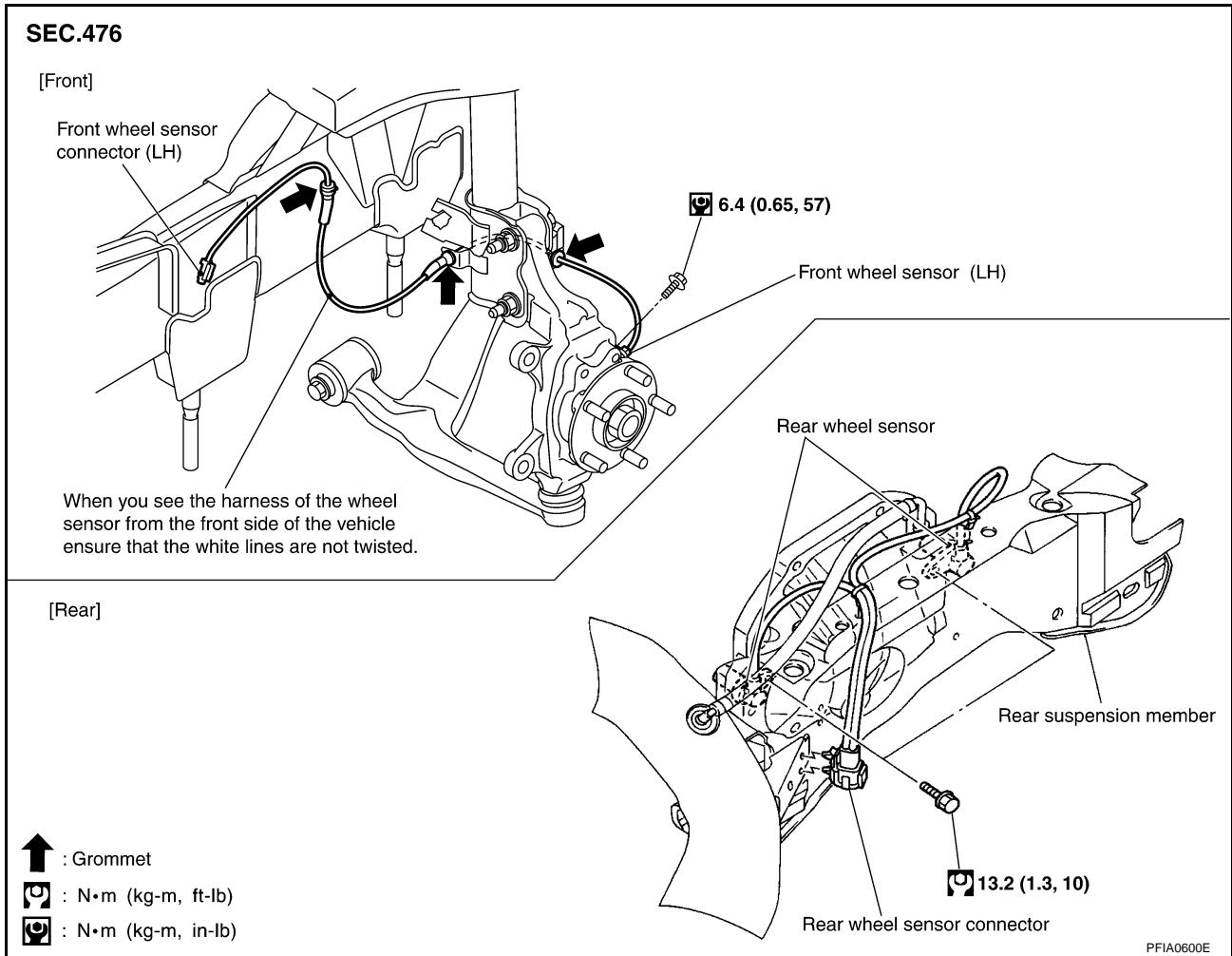

### REMOVAL

1. Disconnect wheel sensor connector.
2. Remove wheel sensor mounting bolts, grommets (front sensor) and clip.
3. Remove wheel sensor.

### CAUTION:

Be careful of the following when installing sensor.

- As much as possible, avoid rotating sensor when removing it. Pull sensors out without pulling on sensor harness.
- Take care to avoid damaging sensor edges or rotor teeth. Remove wheel sensor first before removing front wheel hub and bearing assembly and rear final drive. This is to avoid damage to sensor wiring and loss of sensor function.

### INSTALLATION

To install, follow procedure for removal in reverse order.

### CAUTION:

Be careful of the following when installing sensor. Tighten installation bolts to specified torques.

- When installing, make sure there is no foreign material such as iron chips on pick-up and mounting hole of sensor. Make sure no foreign material has been caught in the sensor rotor. Remove any foreign material and clean the mount.
- When installing front sensor, be sure to press rubber grommets in until they lock at the three locations shown in the figure (2 at shock absorbers and 1 at body panel). When installed, harness must not be twisted. White line on harness must be visible from front.

A  
B  
C  
D  
E  
BRC  
G  
H  
I  
J  
K  
L  
M

## WHEEL SENSORS

[VDC/TCS/ABS]

- 
- When installing rear sensor, attach harness at rear suspension member securely. Besides, harness must not be twisted when installed.

## SENSOR ROTOR

PFP:47970

### Removal and Installation

AFS001Z4

#### REMOVAL

##### Front

Sensor rotor cannot be disassembled. To replace sensor rotor, replace wheel hub and bearing assembly. Refer to [FAX-4, "Removal and Installation"](#) (2WD model), [FAX-10, "Removal and Installation"](#) (AWD model).

##### Rear

- Follow procedure below to remove rear sensor rotor.
  - Remove side flange. Refer to [RFD-9, "SIDE OIL SEAL"](#) .
  - Using a bearing replacer and puller, remove sensor rotor from side flange.

#### INSTALLATION

##### Front

Sensor rotor cannot be disassembled. To replace sensor rotor, replace wheel hub and bearing assembly. Refer to [FAX-4, "Removal and Installation"](#) (2WD model), [FAX-10, "Removal and Installation"](#) (AWD model).

##### Rear

- Follow procedure below to install rear sensor rotor.
  - Using a drift (special service tool), press rear sensor rotor onto side flange.
  - Install side flange. Refer to [RFD-9, "SIDE OIL SEAL"](#) .

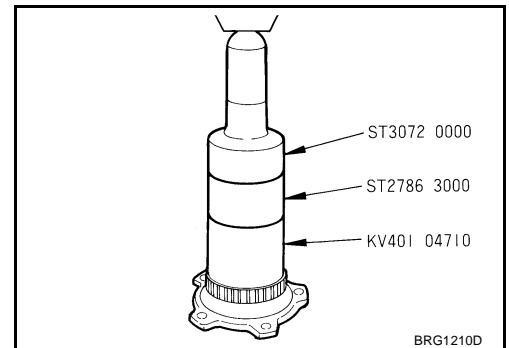

A

B

C

D

E

BRC

G

H

I

J

K

L

M

## ACTUATOR AND ELECTRIC UNIT (ASSEMBLY)

PF4:47660

### Removal and Installation

AFS001Z5

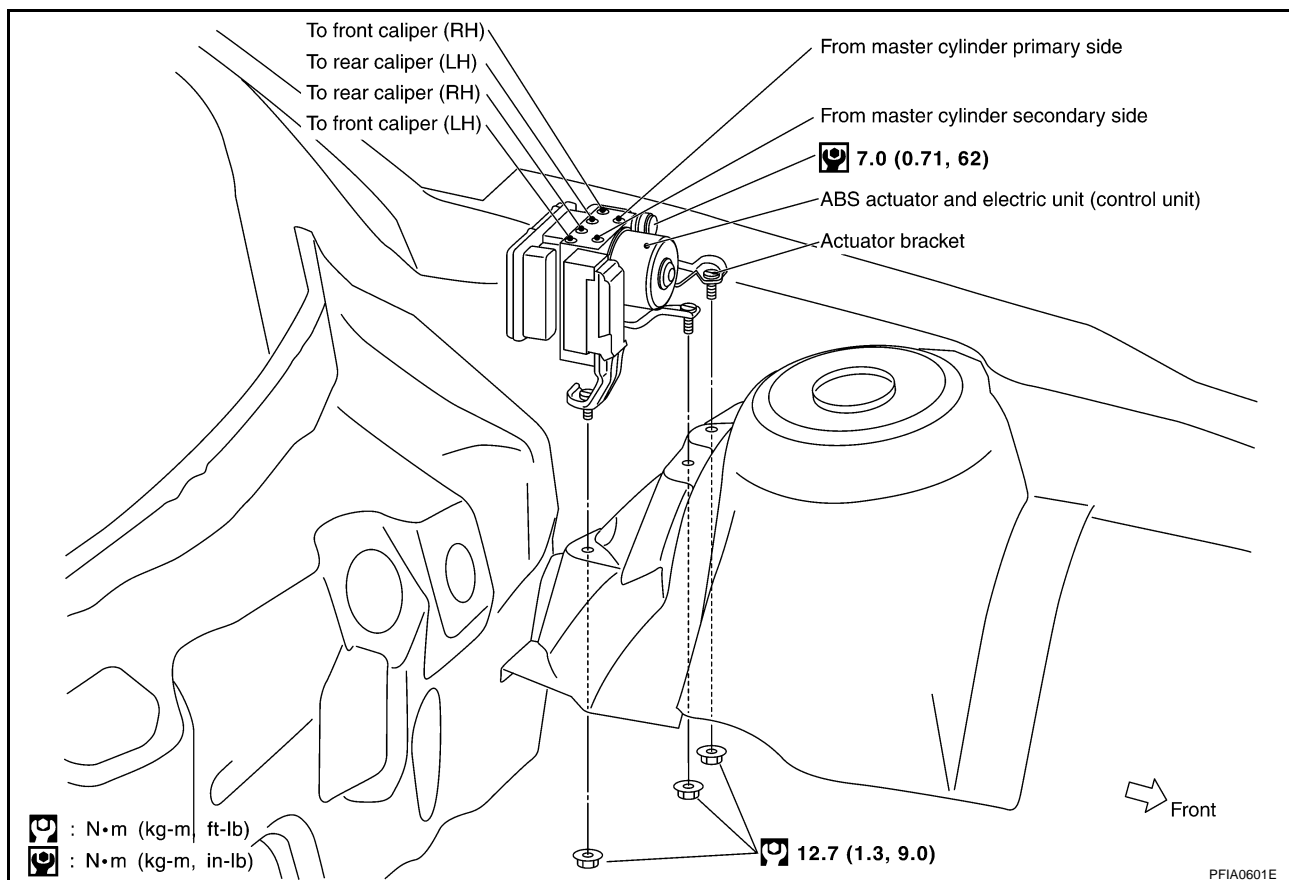

### REMOVAL

1. Disconnect ABS actuator and electric unit (control unit) connector.
2. Loosen brake tube flare nuts, then remove brake tubes from ABS actuator and electric unit (control unit).
3. Remove LH side fender protector. Refer to [EI-25, "FENDER PROTECTOR"](#).
4. Remove ABS actuator and electric unit (control unit) mounting nuts.
5. Remove ABS actuator and electric unit (control unit) from vehicle.

### CAUTION:

Be careful of the following when removing ABS actuator and electric unit (control unit).

- If the part number on the part number label (pasted on actuator upper surface) is the same, ABS actuator and electric unit (control unit) cannot be used on another vehicle. If it is used on another vehicle, ABS warning lamp, SLIP indicator lamp and VDC OFF indicator lamp may turn ON or VDC/TCS/ABS may not operate normally. When replacing ABS actuator and electric unit (control unit), must use new service parts.
- Before servicing, disconnect battery cables.
- To remove brake tube, use a flare nut wrench to prevent flare nuts and brake tube from being damaged. To install, use a flare nut torque wrench (commercial service tool) and tighten to the specified torque.
- Do not apply excessive impact to actuator, such as dropping it.
- Do not remove and install ABS actuator and electric unit (control unit) by holding harness.

### INSTALLATION

To install, follow procedure for removal in reverse order.

### CAUTION:

Be careful of the following when installing ABS actuator and electric unit (control unit).

- Tighten the mounting bolts and nuts to the specified torque.
- After the work, bleed air from brake piping. Refer to [BR-10, "Bleeding Brake System"](#).

# ACTUATOR AND ELECTRIC UNIT (ASSEMBLY)

[VDC/TCS/ABS]

- After installing vehicle harness connector in the actuator, make sure connector is securely locked.
- When replacing ABS actuator and electric unit (control unit), calibrate Steering angle sensor neutral position and Decel G sensor. Refer to [BRC-6, "ON-VEHICLE SERVICE"](#) .

## NOTE:

- After performing above works, calibrate decel G-sensor (AWD model). Refer to [BRC-6, "Calibration of Decel G-sensor \(AWD Model\)"](#) .
- In the case that ABS actuator and electric unit (control unit) are replaced, make sure to adjust position of steering angle sensor. Refer to [BRC-6, "Adjustment of Steering Angle Sensor Neutral Position"](#) .

A

B

C

D

E

BRC

G

H

I

J

K

L

M

**G SENSOR****Removal and Installation****REMOVAL**

1. Remove center console. Refer to [IP-12, "\(H\) Center Console"](#) .
2. Disconnect G-sensor harness connector.
3. Remove G-sensor mounting bolts. Then remove G-sensor from vehicle.

**CAUTION:**

- Do not drop or strike G-sensor, because it has little endurance to impact.
- Do not use power tool etc., because G-sensor is weak for the impact.

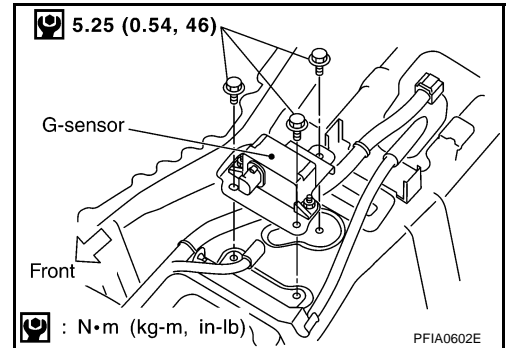
**INSTALLATION**

To install, follow procedure for removal in reverse order.

**CAUTION:**

- Do not drop or strike G-sensor, because it has little endurance to impact.

**NOTE:**

- After performing above works, calibrate decel G-sensor (AWD model). Refer to [BRC-6, "Calibration of Decel G-sensor \(AWD Model\)"](#) .

## STEERING ANGLE SENSOR

PF2:25554

### Removal and Installation

AFS002/1

#### REMOVAL

1. Remove spiral cable assembly. Refer to [SRS-38, "SPIRAL CABLE"](#) .
2. Remove steering angle sensor from spiral cable assembly.

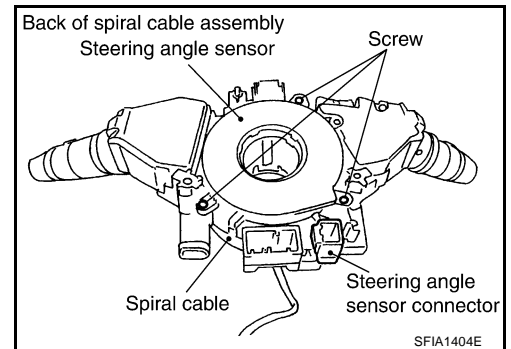

#### INSTALLATION

Install in the reverse order of removal.

#### NOTE:

After work, make sure to adjust neutral position of steering angle sensor. Refer to [BRC-6, "Adjustment of Steering Angle Sensor Neutral Position"](#) .

A  
B  
C  
D  
E  
G  
H  
I  
J  
K  
L  
M

**BRC**

