

SECTION **SE**
SEAT

A
B
C
D
E
F
G
H
I
SE
K
L
M
N
O
P

CONTENTS

FUNCTION DIAGNOSIS	2	PRECAUTION	32
POWER SEAT	2	PRECAUTIONS	32
System Description	2	Precaution for Supplemental Restraint System (SRS) "AIR BAG" and "SEAT BELT PRE-TENSIONER"	32
Component Parts Location	2	Service Notice	32
Component Description	2	Precaution for Work	32
HEATED SEAT	3	PREPARATION	33
System Description	3	PREPARATION	33
Component Parts Location	3	Commercial Service Tool	33
Component Description	3	ON-VEHICLE REPAIR	34
COMPONENT DIAGNOSIS	4	FRONT SEAT	34
POWER SEAT	4	Exploded View	34
Wiring Diagram - POWER SEAT (LHD MODELS)	4	Removal and Installation	36
-	4	Disassembly and Assembly	36
Wiring Diagram - POWER SEAT (RHD MODELS)	9	REAR SEAT	45
-	9	Exploded View	45
HEATED SEAT	14	Removal and Installation	47
Wiring Diagram - HEATED SEAT (LHD MODELS WITH POWER SEAT) -	14	Disassembly and Assembly	48
Wiring Diagram - HEATED SEAT (RHD MODELS WITH POWER SEAT) -	18	POWER SEAT SWITCH	51
Wiring Diagram - HEATED SEAT (WITHOUT POWER SEAT) -	22	Exploded View	51
SYMPTOM DIAGNOSIS	26	Removal and Installation	51
SQUEAK AND RATTLE TROUBLE DIAGNOSIS	26	HEATED SEAT SWITCH	52
Work Flow	26	Exploded View	52
Inspection Procedure	28	Removal and Installation	52
Diagnostic Worksheet	30		

POWER SEAT

< FUNCTION DIAGNOSIS >

FUNCTION DIAGNOSIS

POWER SEAT

System Description

INFOID:000000001278449

BCM can operate regardless of the ignition switch position, because battery power is supplied at all times to power seat switch and side support unit.

SLIDING OPERATION

While operating the sliding switch located in power seat switch, sliding motor operates and makes possible the seat front and back position adjustment.

RECLINING OPERATION

While operating the reclining switch located in power seat switch, reclining motor operates and makes possible the seat back forward and backward position adjustment.

LIFTING OPERATION

While operating the lifting switch located in power seat switch, lifting motor operates and makes possible the seat cushion up and down position adjustment.

Component Parts Location

INFOID:000000001278450

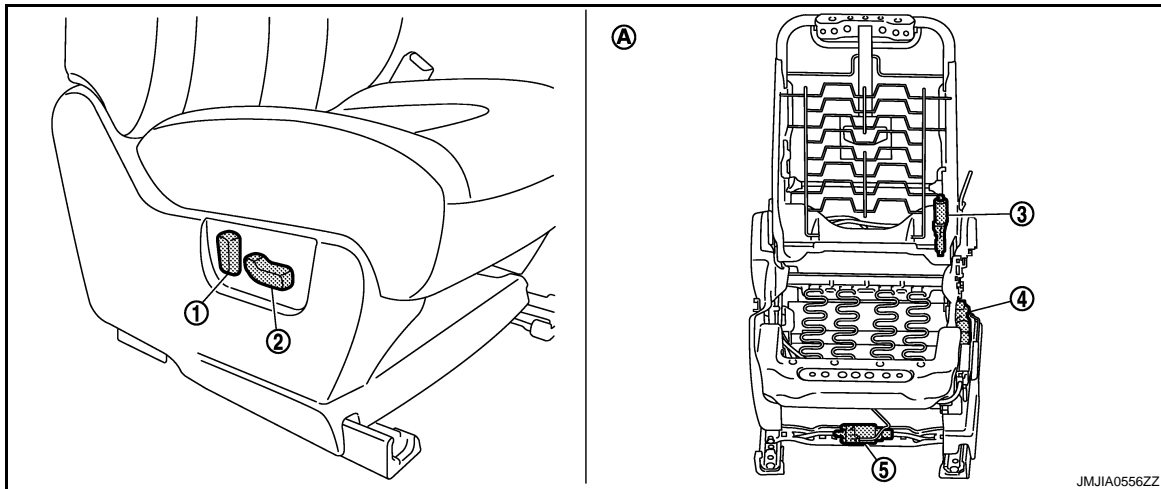

1. Sliding switch and lifting switch B414 2. Reclining switch B414 3. Side support switch (seat back) B414
 4. Side support switch (seat cushion) B414 5. Side support (seat cushion) B414
 A. View with seat cushion pad and seat back pad are removed.

Component Description

INFOID:000000001278451

Item	Function
BCM	Supplies at all times the power received from battery to power seat switch and side support unit.
Power seat switch	Built-in reclining switch, sliding switch and lifting switch, controls the power supplied to each motor.
Reclining motor	With the power supplied to power seat switch, operates the forward and backward movement of seatback.
Sliding motor	With the power supplied to power seat switch, operates the forward and backward slide of seat.
Lifting motor (front/rear)	With the power supplied to power seat switch, operates the up and down movement of seat cushion.
Side support switch	With a built-in cushion side and seat back side, controls the power supplied to pump and to each solenoid.
Side support unit	Built-in pump, pump relay and solenoid, operates when pressing ON/OFF on side support switch.

HEATED SEAT

< FUNCTION DIAGNOSIS >

HEATED SEAT

System Description

INFOID:000000001278416

Heated seat is a system that operates when ignition switch is in ON or START position.

HEATER OPERATION

- While operating the heated seat switch, seat cushion heater and seat back heater operate.
- Temperature of seat can be adjusted by operating on heated seat switch.

Component Parts Location

INFOID:000000001278417

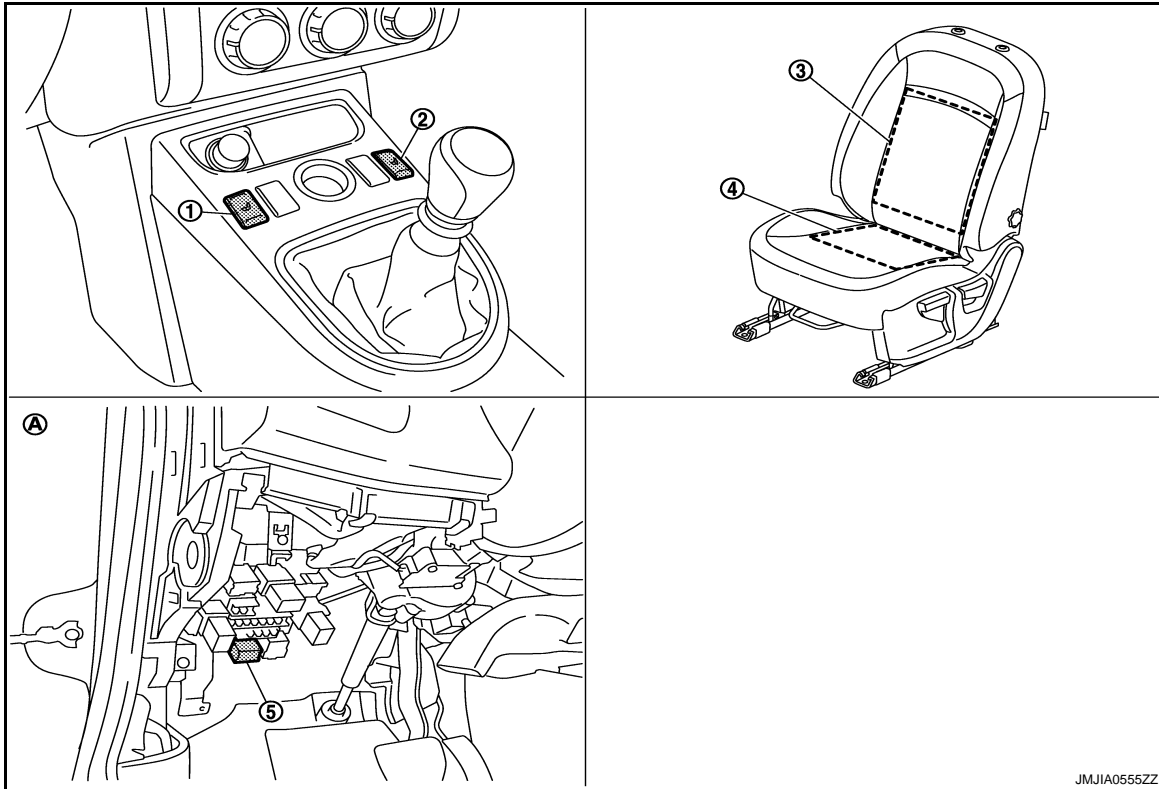

- | | | |
|--|--------------------------------|--------------------------|
| 1. Heated seat switch (LH) M56 | 2. Heated seat switch (RH) M55 | 3. Seat back heater unit |
| 4. Seat cushion heater unit | 5. Heated seat relay | |
| A. Over the instrument lower panel (driver side) | | |

Component Description

INFOID:000000001278418

Item	Function
Heated seat switch	<ul style="list-style-type: none"> • Power is supplied to each heater. • Depending on LOW/HIGH position of switch, operating heater number is changeable.
Seat cushion heater	Built-in seat cushion, the heater operates with the power supplied by heater seat switch.
Seat back heater	Built-in seatback, the heater operates with the power supplied by heater seat switch.

POWER SEAT

< COMPONENT DIAGNOSIS >

COMPONENT DIAGNOSIS

POWER SEAT

Wiring Diagram - POWER SEAT (LHD MODELS) -

INFOID:000000001485217

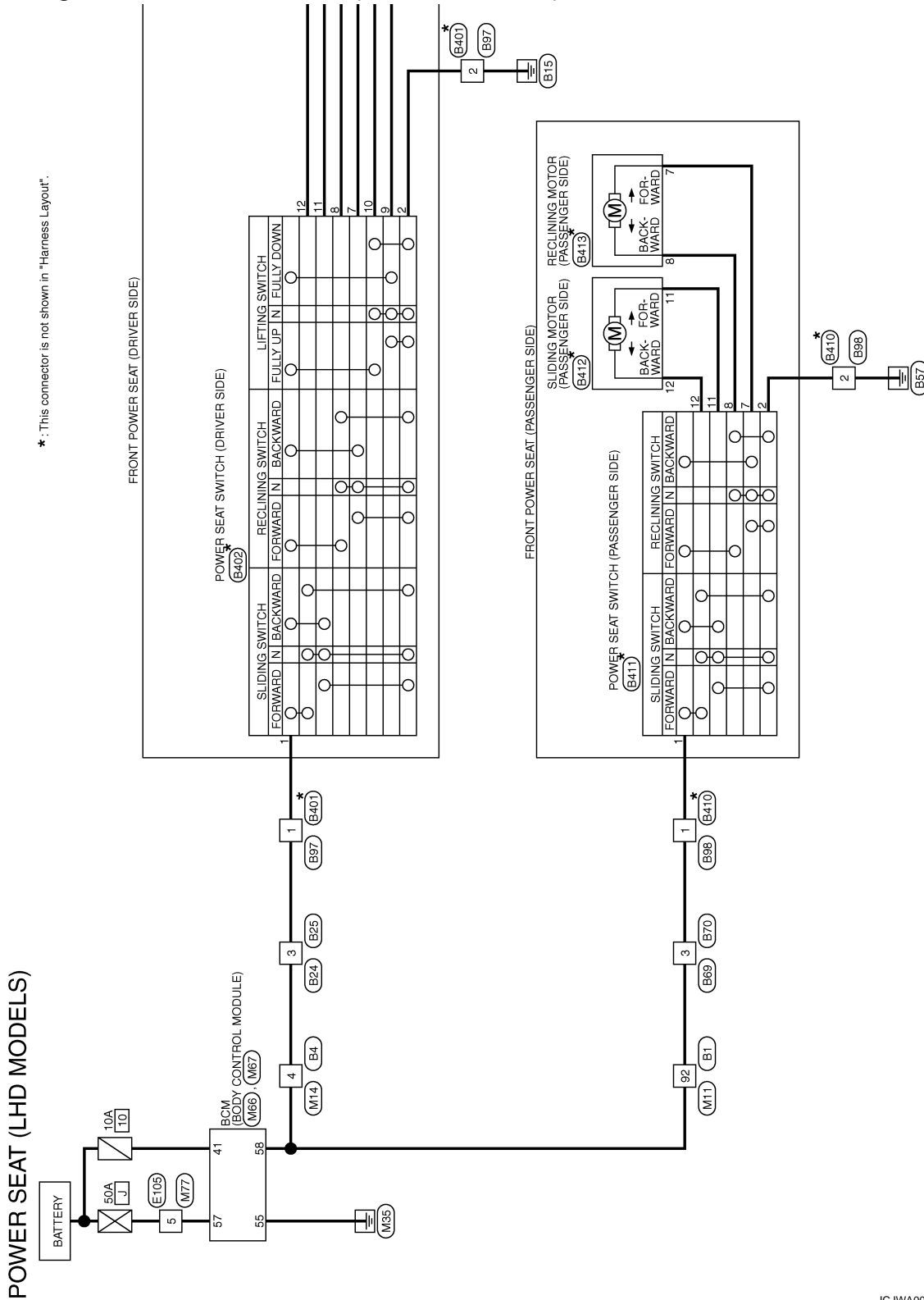

2007/02/28

JCJWA0082GB

POWER SEAT

< COMPONENT DIAGNOSIS >

A

B

C

D

E

F

G

H

I

SE

K

L

M

N

O

P

* : This connector is not shown in "Harness Layout".

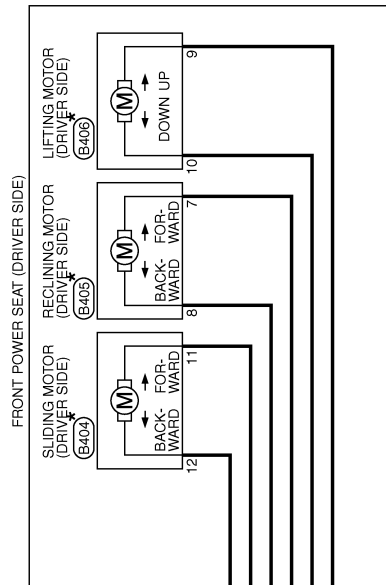



JCJWA0083GB

POWER SEAT

< COMPONENT DIAGNOSIS >

POWER SEAT (LHD MODELS)

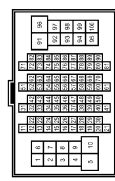
Connector No.	B1	Connector No.	B23
Connector Name	WIRE TO WIRE	Connector Name	WIRE TO WIRE
Connector Type	TH80MW-CS16-TM4	Connector Type	NS04MW-CS



Terminal No.	92	Color of Wire	P	Signal Name [Specification]	-
--------------	----	---------------	---	-----------------------------	---

Terminal No.	3	Color of Wire	P	Signal Name [Specification]	-
--------------	---	---------------	---	-----------------------------	---

Terminal No.	3	Color of Wire	P	Signal Name [Specification]	-
--------------	---	---------------	---	-----------------------------	---

Terminal No.	3	Color of Wire	P	Signal Name [Specification]	-
--------------	---	---------------	---	-----------------------------	---

Connector No.	B69	Connector No.	B98
Connector Name	WIRE TO WIRE	Connector Name	WIRE TO WIRE
Connector Type	NS04FW-CS	Connector Type	NS08FW-CS

Terminal No.	3	Color of Wire	P	Signal Name [Specification]	-
--------------	---	---------------	---	-----------------------------	---

Terminal No.	3	Color of Wire	P	Signal Name [Specification]	-
--------------	---	---------------	---	-----------------------------	---

Terminal No.	3	Color of Wire	P	Signal Name [Specification]	-
--------------	---	---------------	---	-----------------------------	---

Terminal No.	3	Color of Wire	P	Signal Name [Specification]	-
--------------	---	---------------	---	-----------------------------	---

POWER SEAT

< COMPONENT DIAGNOSIS >

POWER SEAT (LHD MODELS)

Connector No.	B401
Connector Name	WIRE TO WIRE
Connector Type	NS308MW-CS



Terminal No.	Color of Wire	Signal Name [Specification]
1	Y	-
2	B	-

Connector No.	B402
Connector Name	POWER SEAT SWITCH (DRIVER SIDE)
Connector Type	Delphi 15326931



Terminal No.	Color of Wire	Signal Name [Specification]
1	Y	-
2	B	-
7	G	-
8	B/Y	-
9	L/R	-
10	B/W	-
11	W/B	-
12	BR	-

Connector No.	B404
Connector Name	SLIDING MOTOR (DRIVER SIDE)
Connector Type	TB02FW-TV



Terminal No.	Color of Wire	Signal Name [Specification]
11	W/B	-
12	BR	-

Connector No.	B405
Connector Name	RECLINING MOTOR (DRIVER SIDE)
Connector Type	M02FW-GY-LC



Terminal No.	Color of Wire	Signal Name [Specification]
7	G	-
8	B/Y	-

Connector No.	B406
Connector Name	LIFTING MOTOR (DRIVER SIDE)
Connector Type	M02MW-LC



Terminal No.	Color of Wire	Signal Name [Specification]
9	L/R	-
10	B/W	-

Connector No.	B410
Connector Name	WIRE TO WIRE
Connector Type	NS308MW-CS

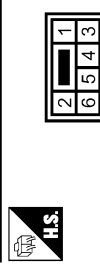

Terminal No.	Color of Wire	Signal Name [Specification]
1	Y	-
2	B	-

Connector No.	B411
Connector Name	POWER SEAT SWITCH (PASSENGER SIDE)
Connector Type	Delphi 15326931



Terminal No.	Color of Wire	Signal Name [Specification]
1	Y	-
2	B	-
7	G	-
8	B/Y	-
11	W/B	-
12	BR	-

Connector No.	B412
Connector Name	SLIDING MOTOR (PASSENGER SIDE)
Connector Type	TB02FW-TV



Terminal No.	Color of Wire	Signal Name [Specification]
11	W/B	-
12	BR	-

A
B
C
D
E
F
G
H
I
SE
K
L
M
N
O
P

POWER SEAT

< COMPONENT DIAGNOSIS >

POWER SEAT (LHD MODELS)

Connector No.	B413
Connector Name	RECLINING MOTOR (PASSENGER SIDE)
Connector Type	M02FW-GY-LC



Terminal No.	Color of Wire	Signal Name [Specification]
7	G	-
8	B/Y	-

Connector No.	E105
Connector Name	WIRE TO WIRE
Connector Type	T180FW-CS1E-TM4



Terminal No.	Color of Wire	Signal Name [Specification]
5	Y	-

Connector No.	M11
Connector Name	WIRE TO WIRE
Connector Type	T180FW-CS16-TM4



Terminal No.	Color of Wire	Signal Name [Specification]
92	P	-

Connector No.	M14
Connector Name	WIRE TO WIRE
Connector Type	NS18FW-CS



Terminal No.	Color of Wire	Signal Name [Specification]
4	P	-

Connector No.	M66
Connector Name	BCM (BODY CONTROL MODULE)
Connector Type	FEA12FBR



Terminal No.	Color of Wire	Signal Name [Specification]
41	LG	BAT(FUSE)

Connector No.	M67
Connector Name	BCM (BODY CONTROL MODULE)
Connector Type	FHA08FB



Terminal No.	Color of Wire	Signal Name [Specification]
55	B	GND
57	Y	BAT(F/L)
58	P	P/W POWER SUPPLY(BAT)

Connector No.	M77
Connector Name	WIRE TO WIRE
Connector Type	T180MW-CS16-TM4



Terminal No.	Color of Wire	Signal Name [Specification]
5	Y	-

POWER SEAT

< COMPONENT DIAGNOSIS >

Wiring Diagram - POWER SEAT (RHD MODELS) -

INFOID:000000001534742

POWER SEAT (RHD MODELS)

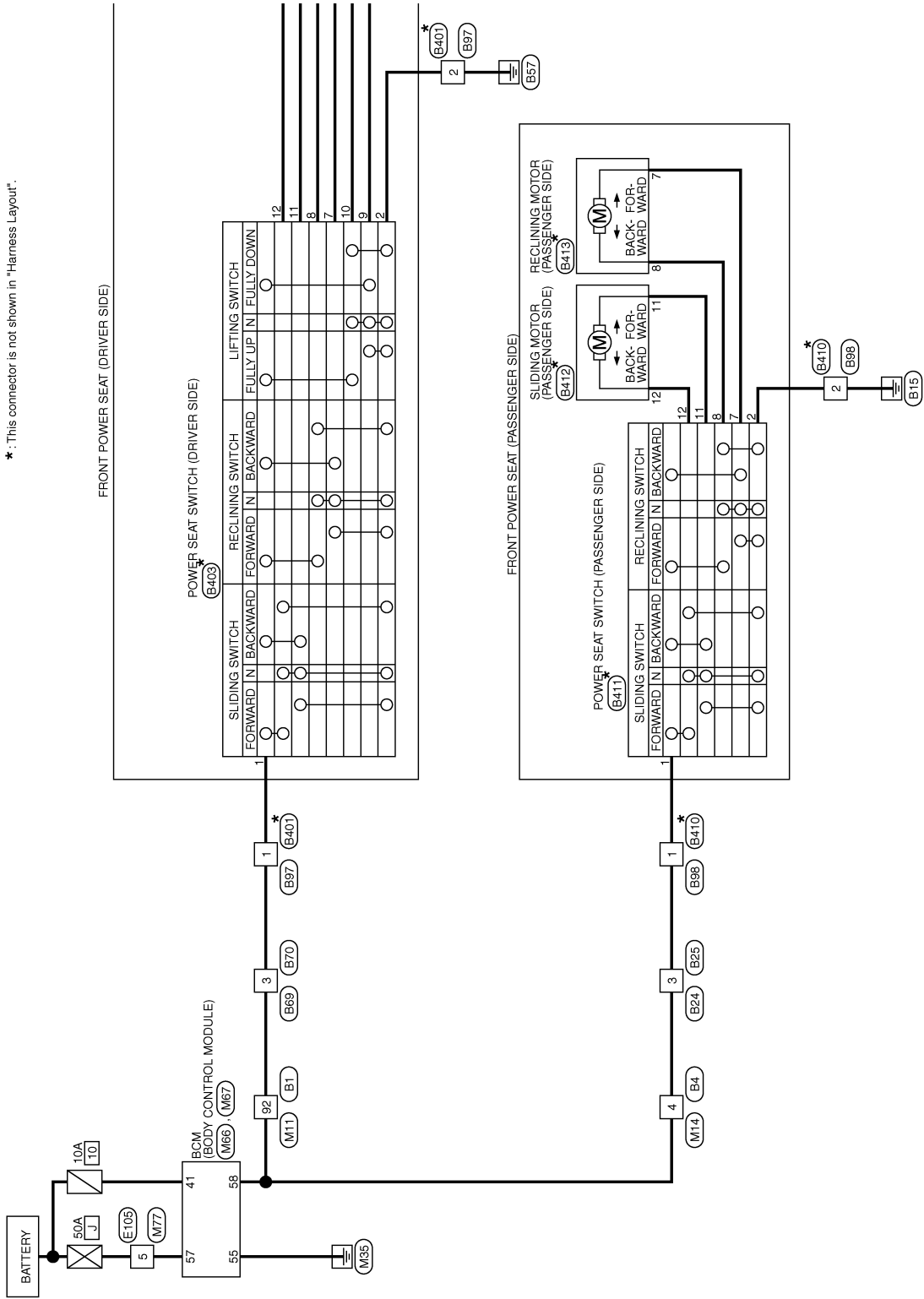

*: This connector is not shown in "Harness Layout".

A
B
C
D
E
F
G
H
I
SE
K
L
M
N
O
P

2007/2/28

JCJWA0087GB

POWER SEAT

< COMPONENT DIAGNOSIS >

* : This connector is not shown in "Harness Layout".

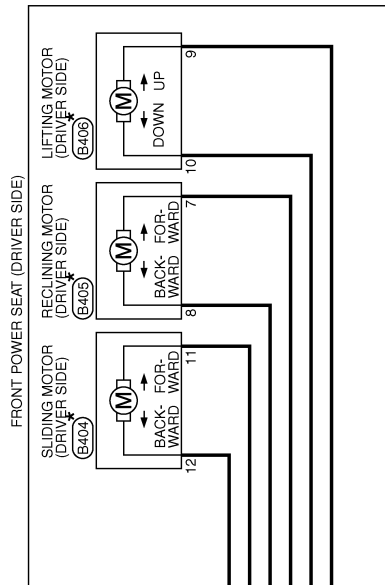

JCJWA0088GB

POWER SEAT

< COMPONENT DIAGNOSIS >

POWER SEAT (RHD MODELS)

Connector No.	B1
Connector Name	WIRE TO WIRE
Connector Type	THROW-CS16-TM4

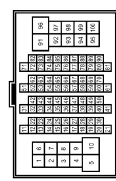

Terminal No.	92	P	
Color of Wire			
Signal Name [Specification]			

Connector No.	B4
Connector Name	WIRE TO WIRE
Connector Type	NS16MW-CS



Terminal No.	4	P	
Color of Wire			
Signal Name [Specification]			

Connector No.	B24
Connector Name	WIRE TO WIRE
Connector Type	NSD4FW-CS



Terminal No.	3	P	
Color of Wire			
Signal Name [Specification]			

Connector No.	B23
Connector Name	WIRE TO WIRE
Connector Type	NSD4MW-CS



Terminal No.	3	P	
Color of Wire			
Signal Name [Specification]			

Connector No.	B69
Connector Name	WIRE TO WIRE
Connector Type	NSD4FW-CS



Terminal No.	3	P	
Color of Wire			
Signal Name [Specification]			

Connector No.	B70
Connector Name	WIRE TO WIRE
Connector Type	NSD4MW-CS



Terminal No.	3	P	
Color of Wire			
Signal Name [Specification]			

Connector No.	B87
Connector Name	WIRE TO WIRE
Connector Type	NSD8FW-CS

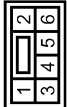

Terminal No.	2	B	
Color of Wire			
Signal Name [Specification]			

Connector No.	B98
Connector Name	WIRE TO WIRE
Connector Type	NSD8FW-CS

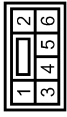

Terminal No.	2	B	
Color of Wire			
Signal Name [Specification]			

JCJWA0089GB

A
B
C
D
E
F
G
H
I
SE
K
L
M
N
O
P

POWER SEAT

< COMPONENT DIAGNOSIS >

POWER SEAT (RHD MODELS)

Connector No.	B401
Connector Name	WIRE TO WIRE
Connector Type	NS306MW-CS



Terminal No.	Color of Wire	Signal Name [Specification]
1	Y	-
2	B	-

Connector No.	B403
Connector Name	POWER SEAT SWITCH (DRIVER SIDE)
Connector Type	Delphi 15326931

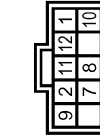

Terminal No.	Color of Wire	Signal Name [Specification]
1	Y	-
2	B	-
7	G	-
8	B/Y	-
9	L/R	-
10	B/W	-
11	W/B	-
12	BR	-

Connector No.	B404
Connector Name	SLIDING MOTOR (DRIVER SIDE)
Connector Type	TB02FW-TV



Terminal No.	Color of Wire	Signal Name [Specification]
11	W/B	-
12	BR	-

Connector No.	B405
Connector Name	RECLINING MOTOR (DRIVER SIDE)
Connector Type	M02FW-GY-LC



Terminal No.	Color of Wire	Signal Name [Specification]
7	G	-
8	B/Y	-

Connector No.	B406
Connector Name	LIFTING MOTOR (DRIVER SIDE)
Connector Type	M02MW-LC



Terminal No.	Color of Wire	Signal Name [Specification]
9	L/R	-
10	B/W	-

Connector No.	B410
Connector Name	WIRE TO WIRE
Connector Type	NS306MW-CS

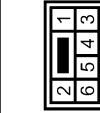

Terminal No.	Color of Wire	Signal Name [Specification]
1	Y	-
2	B	-

Connector No.	B411
Connector Name	POWER SEAT SWITCH (PASSENGER SIDE)
Connector Type	Delphi 15326931

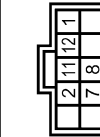

Terminal No.	Color of Wire	Signal Name [Specification]
1	Y	-
2	B	-
7	G	-
8	B/Y	-
11	W/B	-
12	BR	-

Connector No.	B412
Connector Name	SLIDING MOTOR (PASSENGER SIDE)
Connector Type	TB02FW-TV





Terminal No.	Color of Wire	Signal Name [Specification]
11	W/B	-
12	BR	-

POWER SEAT

< COMPONENT DIAGNOSIS >



POWER SEAT (RHD MODELS)

Connector No.	B413
Connector Name	RECLINING MOTOR (PASSENGER SIDE)
Connector Type	M02EW-GY-LC



Terminal No.	Color of Wire	Signal Name [Specification]
7	G	
8	B/Y	

Connector No.	E105
Connector Name	WIRE TO WIRE
Connector Type	TH80FW-CS1E-TM4



Terminal No.	Color of Wire	Signal Name [Specification]
5	Y	

Connector No.	M11
Connector Name	WIRE TO WIRE
Connector Type	TH80FW-CS1E-TM4



Terminal No.	Color of Wire	Signal Name [Specification]
92	P	

Connector No.	M14
Connector Name	WIRE TO WIRE
Connector Type	NS18FW-CS



Terminal No.	Color of Wire	Signal Name [Specification]
4	P	

Connector No.	M66
Connector Name	BCM (BODY CONTROL MODULE)
Connector Type	FEA12FBR

Terminal No.	Color of Wire	Signal Name [Specification]
41	LG	BAT(FUSE)

Connector No.	M67
Connector Name	BCM (BODY CONTROL MODULE)
Connector Type	FHA08FB

Terminal No.	Color of Wire	Signal Name [Specification]
55	B	GND
57	Y	BAT(F/L)
58	P	P/W POWER SUPPLY(BAT)

Connector No.	M77
Connector Name	WIRE TO WIRE
Connector Type	TH80MW-CS1E-TM4

Terminal No.	Color of Wire	Signal Name [Specification]
5	Y	

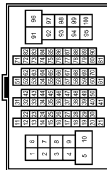
A
B
C
D
E
F
G
H
I
SE
K
L
M
N
O
P

HEATED SEAT

< COMPONENT DIAGNOSIS >

HEATED SEAT

Wiring Diagram - HEATED SEAT (LHD MODELS WITH POWER SEAT) - INFOID:0000000014852.19

HEATED SEAT (LHD MODELS WITH POWER SEAT)

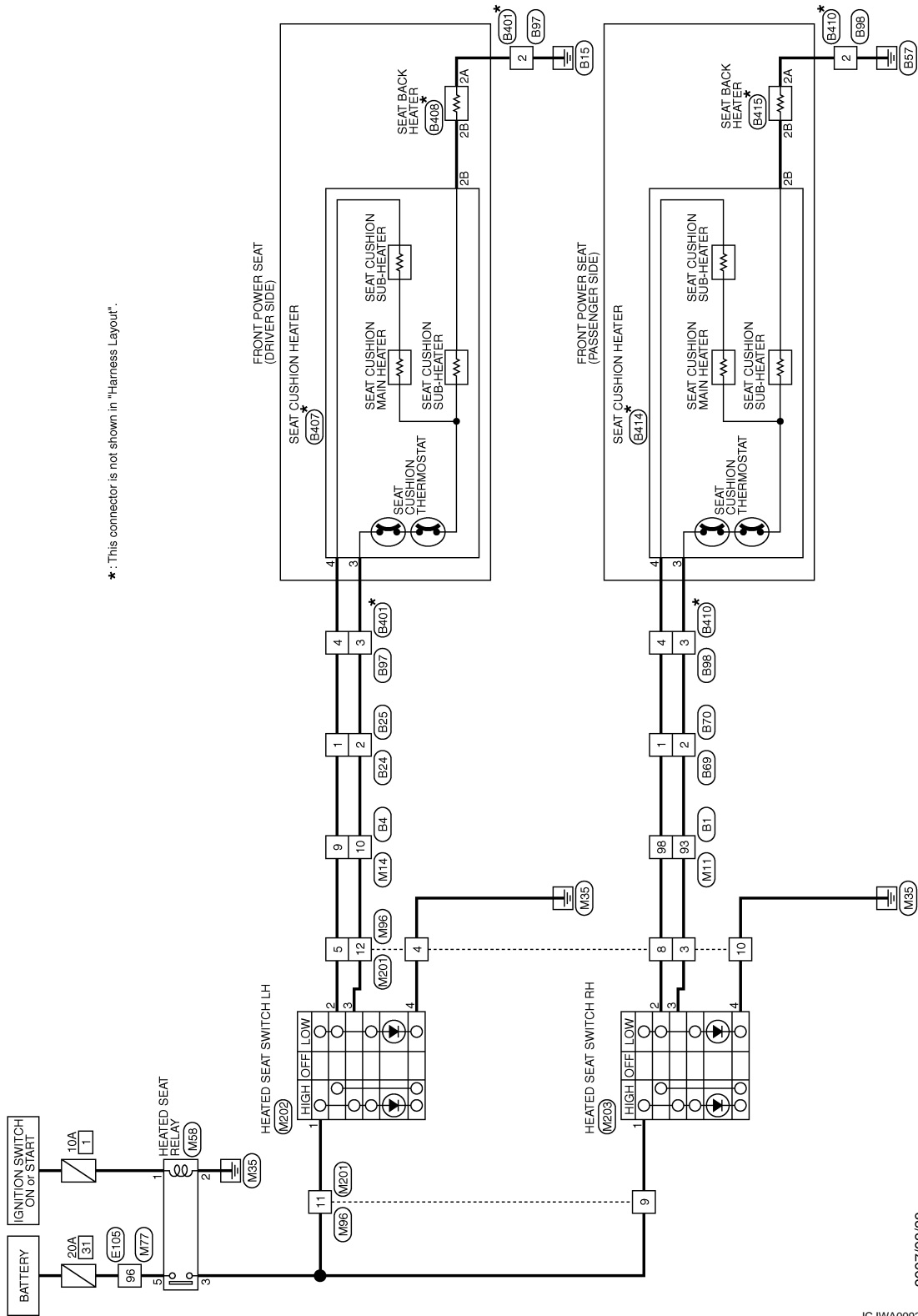

*: This connector is not shown in "Harness Layout".

2007/02/28

JCJWA0092GB

HEATED SEAT

< COMPONENT DIAGNOSIS >

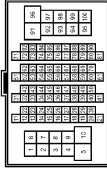

HEATED SEAT (LHD MODELS WITH POWER SEAT)

Connector No.	B1
Connector Name	WIRE TO WIRE
Connector Type	TH80MW-CS16-TM4



Terminal No.	Color of Wire	Signal Name [Specification]
93	Y	-
96	SB	-

Connector No.	B4
Connector Name	WIRE TO WIRE
Connector Type	NS16MW-CS



Terminal No.	Color of Wire	Signal Name [Specification]
9	W	-
10	O	-

Connector No.	B24
Connector Name	WIRE TO WIRE
Connector Type	NS24FW-CS



Terminal No.	Color of Wire	Signal Name [Specification]
1	W	-
2	O	-

Connector No.	B23
Connector Name	WIRE TO WIRE
Connector Type	NS24MW-CS



Terminal No.	Color of Wire	Signal Name [Specification]
1	W	-
2	O	-

Connector No.	B69
Connector Name	WIRE TO WIRE
Connector Type	NS24FW-CS



Terminal No.	Color of Wire	Signal Name [Specification]
1	SB	-
2	Y	-

Connector No.	B70
Connector Name	WIRE TO WIRE
Connector Type	NS24MW-CS



Terminal No.	Color of Wire	Signal Name [Specification]
1	SB	-
2	Y	-

Connector No.	B87
Connector Name	WIRE TO WIRE
Connector Type	NS26FW-CS

Terminal No.	Color of Wire	Signal Name [Specification]
2	B	-
3	O	- [LHD models]
4	W	- [LHD models]

Connector No.	B99
Connector Name	WIRE TO WIRE
Connector Type	NS26FW-CS

Terminal No.	Color of Wire	Signal Name [Specification]
2	B	-
3	GR	- [LHD models]
4	SB	- [LHD models]

A
B
C
D
E
F
G
H
I
SE
K
L
M
N
O
P

HEATED SEAT

< COMPONENT DIAGNOSIS >

HEATED SEAT (LHD MODELS WITH POWER SEAT)

Connector No.	B401
Connector Name	WIRE TO WIRE
Connector Type	NSC8MW-CS

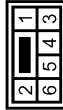

Terminal No.	Color of Wire	Signal Name [Specification]
2	B	-
3	V	-
4	L	-

Connector No.	B407
Connector Name	SEAT CUSHION HEATER
Connector Type	M03MW-LC



Terminal No.	Color of Wire	Signal Name [Specification]
2B	GR	-
3	V	-
4	L	-

Connector No.	B408
Connector Name	SEAT BACK HEATER
Connector Type	M02MW-GY-LC



Terminal No.	Color of Wire	Signal Name [Specification]
2A	B	-
2B	GR	-

Connector No.	B410
Connector Name	WIRE TO WIRE
Connector Type	NSC8MW-CS

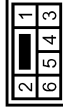

Terminal No.	Color of Wire	Signal Name [Specification]
2	B	-
3	V	-
4	L	-

Connector No.	B414
Connector Name	SEAT CUSHION HEATER
Connector Type	M03MW-LC



Terminal No.	Color of Wire	Signal Name [Specification]
2B	GR	-
3	V	-
4	L	-

Connector No.	B415
Connector Name	SEAT BACK HEATER
Connector Type	M02MW-GY-LC



Terminal No.	Color of Wire	Signal Name [Specification]
2A	B	-
2B	GR	-

Connector No.	E105
Connector Name	WIRE TO WIRE
Connector Type	TH80FY-CS16-TM4

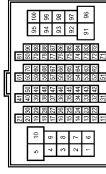

Terminal No.	Color of Wire	Signal Name [Specification]
95	BR	-

Connector No.	M11
Connector Name	WIRE TO WIRE
Connector Type	TH80FY-CS16-TM4

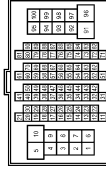

Terminal No.	Color of Wire	Signal Name [Specification]
93	GR	-
98	SB	-

HEATED SEAT

< COMPONENT DIAGNOSIS >

HEATED SEAT (LHD MODELS WITH POWER SEAT)

Connector No.	M14
Connector Name	WIRE TO WIRE
Connector Type	NS16FW-CS

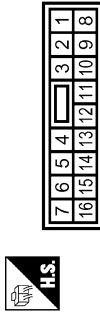

Terminal No.	Color of Wire	Signal Name [Specification]
9	W	-
10	O	-

Connector No.	M88
Connector Name	HEATED SEAT RELAY
Connector Type	MS30FL-M2-LC



Terminal No.	Color of Wire	Signal Name [Specification]
1	LG	-
2	B	-
3	G	-
5	BR	-

Connector No.	M77
Connector Name	WIRE TO WIRE
Connector Type	TH80MW-CS16-TM4

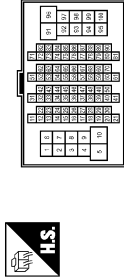

Terminal No.	Color of Wire	Signal Name [Specification]
9f	BR	-

Connector No.	M96
Connector Name	WIRE TO WIRE
Connector Type	NS12MW-CS



Terminal No.	Color of Wire	Signal Name [Specification]
3	GR	-
4	B	-
5	W	-
8	SB	-
9	G	-
10	B	-
11	G	-
12	O	-

Connector No.	M201
Connector Name	WIRE TO WIRE
Connector Type	NS12FW-CS

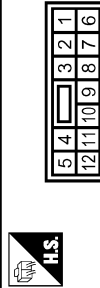

Terminal No.	Color of Wire	Signal Name [Specification]
3	GR	-
4	B	-
5	W	-
8	SB	-
9	G	-
10	B	-
11	V	-
12	O	-

Connector No.	M202
Connector Name	HEATED SEAT SWITCH LH
Connector Type	NS306FW-CS



Terminal No.	Color of Wire	Signal Name [Specification]
1	V	-
2	W	-
3	O	-
4	B	-

Connector No.	M203
Connector Name	HEATED SEAT SWITCH RH
Connector Type	NS306BR-CS

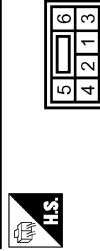

Terminal No.	Color of Wire	Signal Name [Specification]
1	G	-
2	SR	-
3	GR	-
4	B	-

JCJWA0095GB

HEATED SEAT

< COMPONENT DIAGNOSIS >

Wiring Diagram - HEATED SEAT (RHD MODELS WITH POWER SEAT) - INFOID:000000001534738

HEATED SEAT (RHD MODELS WITH POWER SEAT)

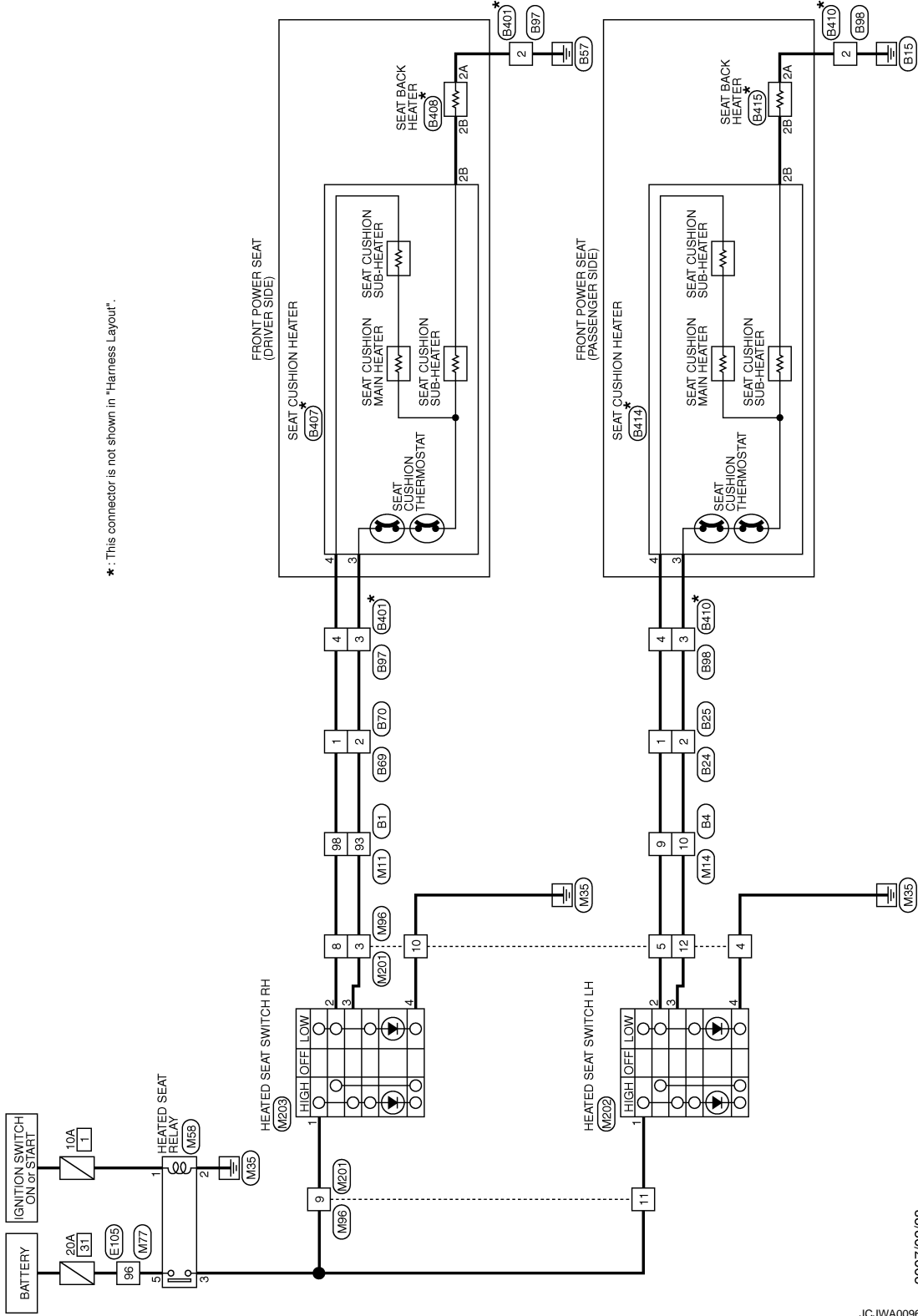

*: This connector is not shown in "Harness Layout".

2007/02/28

JCJWA0096GB

HEATED SEAT

< COMPONENT DIAGNOSIS >

HEATED SEAT (RHD MODELS WITH POWER SEAT)

Connector No.	B1
Connector Name	WIRE TO WIRE
Connector Type	TH80MW-CS16-TM4



Terminal No.	Color of Wire	Signal Name [Specification]
93	Y	-
96	SB	-

Connector No.	B4
Connector Name	WIRE TO WIRE
Connector Type	NS16MW-CS



Terminal No.	Color of Wire	Signal Name [Specification]
9	W	-
10	O	-

Connector No.	B24
Connector Name	WIRE TO WIRE
Connector Type	NS24FW-CS



Terminal No.	Color of Wire	Signal Name [Specification]
1	W	-
2	O	-

Connector No.	B23
Connector Name	WIRE TO WIRE
Connector Type	NS24MW-CS



Terminal No.	Color of Wire	Signal Name [Specification]
1	W	-
2	O	-

Connector No.	B69
Connector Name	WIRE TO WIRE
Connector Type	NS24FW-CS



Terminal No.	Color of Wire	Signal Name [Specification]
1	SB	-
2	Y	-

Connector No.	B70
Connector Name	WIRE TO WIRE
Connector Type	NS24MW-CS



Terminal No.	Color of Wire	Signal Name [Specification]
1	SB	-
2	Y	-

Connector No.	B87
Connector Name	WIRE TO WIRE
Connector Type	NS24FW-CS



Terminal No.	Color of Wire	Signal Name [Specification]
2	B	-
3	Y	-[RHD models]
4	SB	-[RHD models]

Connector No.	B99
Connector Name	WIRE TO WIRE
Connector Type	NS24FW-CS



Terminal No.	Color of Wire	Signal Name [Specification]
2	B	-
3	Y	-[RHD models]
4	W	-[RHD models]

JCJWA0097GB

HEATED SEAT

< COMPONENT DIAGNOSIS >

HEATED SEAT (RHD MODELS WITH POWER SEAT)

Connector No.	B401
Connector Name	WIRE TO WIRE
Connector Type	NSC8MW-CS

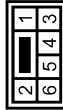

Terminal No.	Color of Wire	Signal Name [Specification]
2	B	-
3	V	-
4	L	-

Connector No.	B407
Connector Name	SEAT CUSHION HEATER
Connector Type	M03MW-LC



Terminal No.	Color of Wire	Signal Name [Specification]
2B	GR	-
3	V	-
4	L	-

Connector No.	B408
Connector Name	SEAT BACK HEATER
Connector Type	M02MW-GY-LC



Terminal No.	Color of Wire	Signal Name [Specification]
2A	B	-
2B	GR	-

Connector No.	B410
Connector Name	WIRE TO WIRE
Connector Type	NSC8MW-CS

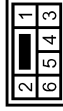

Terminal No.	Color of Wire	Signal Name [Specification]
2	B	-
3	V	-
4	L	-

Connector No.	B414
Connector Name	SEAT CUSHION HEATER
Connector Type	M03MW-LC



Terminal No.	Color of Wire	Signal Name [Specification]
2B	GR	-
3	V	-
4	L	-

Connector No.	B415
Connector Name	SEAT BACK HEATER
Connector Type	M02MW-GY-LC



Terminal No.	Color of Wire	Signal Name [Specification]
2A	B	-
2B	GR	-

Connector No.	E105
Connector Name	WIRE TO WIRE
Connector Type	TH80FW-CS16-TM4

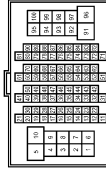

Terminal No.	Color of Wire	Signal Name [Specification]
95	BR	-

Connector No.	M11
Connector Name	WIRE TO WIRE
Connector Type	TH80FW-CS16-TM4

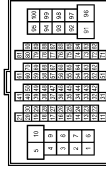

Terminal No.	Color of Wire	Signal Name [Specification]
93	GR	-
98	SB	-

HEATED SEAT

< COMPONENT DIAGNOSIS >

HEATED SEAT (RHD MODELS WITH POWER SEAT)

Connector No.	M14
Connector Name	WIRE TO WIRE
Connector Type	NS16FW-CS

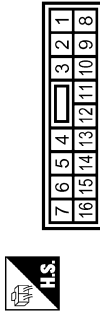

Terminal No.	Color of Wire	Signal Name [Specification]
9	W	-
10	O	-

Connector No.	M88
Connector Name	HEATED SEAT RELAY
Connector Type	MS30FL-M2-LC



Terminal No.	Color of Wire	Signal Name [Specification]
1	LG	-
2	B	-
3	G	-
5	BR	-

Connector No.	M77
Connector Name	WIRE TO WIRE
Connector Type	TH80MW-CS16-TM4

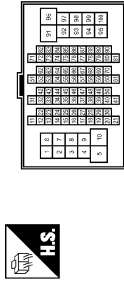

Terminal No.	Color of Wire	Signal Name [Specification]
9f	BR	-

Connector No.	M96
Connector Name	WIRE TO WIRE
Connector Type	NS12MW-CS



Terminal No.	Color of Wire	Signal Name [Specification]
3	GR	-
4	B	-
5	W	-
8	SB	-
9	G	-
10	B	-
11	G	-
12	O	-

Connector No.	M201
Connector Name	WIRE TO WIRE
Connector Type	NS12FW-CS

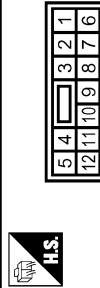

Terminal No.	Color of Wire	Signal Name [Specification]
3	GR	-
4	B	-
5	W	-
8	SB	-
9	G	-
10	B	-
11	V	-
12	O	-

Connector No.	M202
Connector Name	HEATED SEAT SWITCH-LH
Connector Type	NS306FW-CS

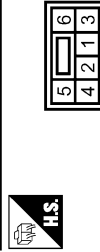

Terminal No.	Color of Wire	Signal Name [Specification]
1	V	-
2	W	-
3	O	-
4	B	-

Connector No.	M203
Connector Name	HEATED SEAT SWITCH-RH
Connector Type	NS306BR-CS



Terminal No.	Color of Wire	Signal Name [Specification]
1	G	-
2	SR	-
3	GR	-
4	B	-

JCJWA0099GB

HEATED SEAT

< COMPONENT DIAGNOSIS >

Wiring Diagram - HEATED SEAT (WITHOUT POWER SEAT) -

INFOID:000000001534741

HEATED SEAT (WITHOUT POWER SEAT)

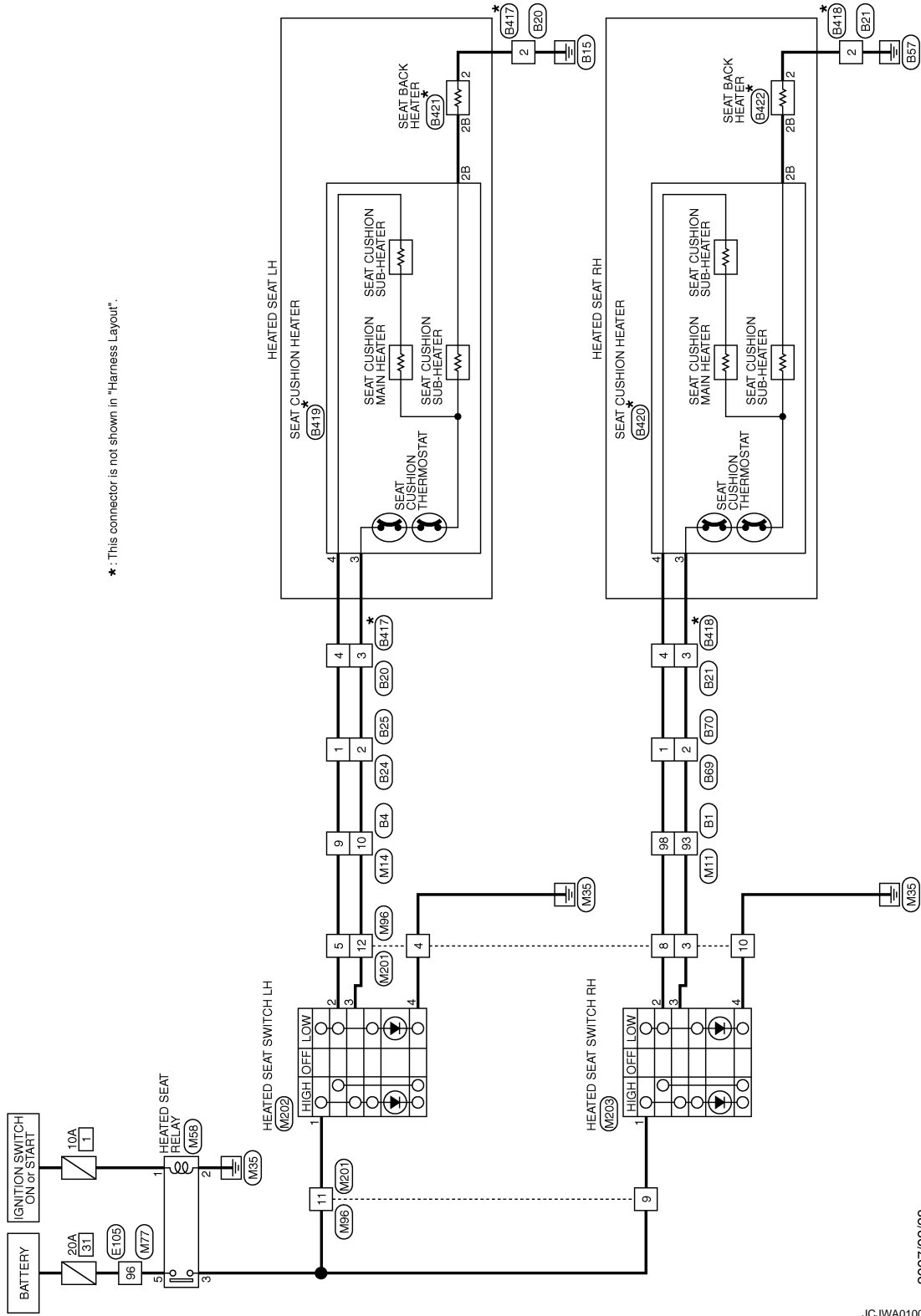

*: This connector is not shown in "Harness Layout".

2007/02/28

JCJWA0100GB

HEATED SEAT

< COMPONENT DIAGNOSIS >

HEATED SEAT (WITHOUT POWER SEAT)

Connector No.	B1
Connector Name	WIRE TO WIRE
Connector Type	TH80MW-CS16-TM4

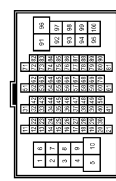

Terminal No.	Color of Wire	Signal Name [Specification]
93	Y	-
96	SB	-

Connector No.	B4
Connector Name	WIRE TO WIRE
Connector Type	NS16MW-CS



Terminal No.	Color of Wire	Signal Name [Specification]
9	W	-
10	O	-

Connector No.	B20
Connector Name	WIRE TO WIRE
Connector Type	M03FW-GY-LC



Terminal No.	Color of Wire	Signal Name [Specification]
2	B	-
3	O	-
4	W	-

Connector No.	B21
Connector Name	WIRE TO WIRE
Connector Type	M03FW-GY-LC



Terminal No.	Color of Wire	Signal Name [Specification]
2	B	-
3	GR	-
4	SB	-

Connector No.	B24
Connector Name	WIRE TO WIRE
Connector Type	NS04FW-CS



Terminal No.	Color of Wire	Signal Name [Specification]
1	W	-
2	O	-

Connector No.	B25
Connector Name	WIRE TO WIRE
Connector Type	NS04MW-CS



Terminal No.	Color of Wire	Signal Name [Specification]
1	W	-
2	O	-

Connector No.	B69
Connector Name	WIRE TO WIRE
Connector Type	NS04FW-CS



Terminal No.	Color of Wire	Signal Name [Specification]
1	SB	-
2	Y	-

Connector No.	B70
Connector Name	WIRE TO WIRE
Connector Type	NS04MW-CS



Terminal No.	Color of Wire	Signal Name [Specification]
1	SB	-
2	Y	-

JCJWA0101GB

HEATED SEAT

< COMPONENT DIAGNOSIS >

HEATED SEAT (WITHOUT POWER SEAT)

Connector No.	B417
Connector Name	WIRE TO WIRE
Connector Type	M03MW-GY-LC



Terminal No.	Color of Wire	Signal Name [Specification]
2	Y	-
3	V	-
4	L	-

Connector No.	B418
Connector Name	WIRE TO WIRE
Connector Type	M03MW-GY-LC



Terminal No.	Color of Wire	Signal Name [Specification]
2	Y	-
3	V	-
4	L	-

Connector No.	B419
Connector Name	SEAT CUSHION HEATER
Connector Type	M03MW-LC



Terminal No.	Color of Wire	Signal Name [Specification]
2B	GR	-
3	V	-
4	L	-

Connector No.	B420
Connector Name	SEAT CUSHION HEATER
Connector Type	M03MW-LC



Terminal No.	Color of Wire	Signal Name [Specification]
2B	GR	-
3	V	-
4	L	-

Connector No.	B421
Connector Name	SEAT BACK HEATER
Connector Type	M02MW-GY-LC



Terminal No.	Color of Wire	Signal Name [Specification]
2	Y	-
2B	GR	-

Connector No.	B422
Connector Name	SEAT BACK HEATER
Connector Type	M02MW-GY-LC



Terminal No.	Color of Wire	Signal Name [Specification]
2	Y	-
2B	GR	-

Connector No.	E105
Connector Name	WIRE TO WIRE
Connector Type	TH80FW-GS16-TM4

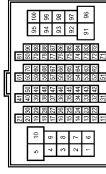

Terminal No.	Color of Wire	Signal Name [Specification]
95	BR	-

Connector No.	M11
Connector Name	WIRE TO WIRE
Connector Type	TH80FW-GS16-TM4

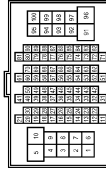

Terminal No.	Color of Wire	Signal Name [Specification]
93	GR	-
98	SB	-

HEATED SEAT

< COMPONENT DIAGNOSIS >

HEATED SEAT (WITHOUT POWER SEAT)

Connector No.	M14
Connector Name	WIRE TO WIRE
Connector Type	NS16FW-CS

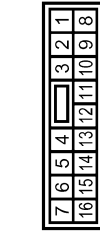

Terminal No.	Color of Wire	Signal Name [Specification]
9	W	-
10	O	-

Connector No.	M88
Connector Name	HEATED SEAT RELAY
Connector Type	MS30FL-M2-LC

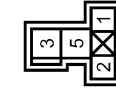

Terminal No.	Color of Wire	Signal Name [Specification]
1	LG	-
2	B	-
3	G	-
5	BR	-

Connector No.	M77
Connector Name	WIRE TO WIRE
Connector Type	TH80MW-CS16-TM4

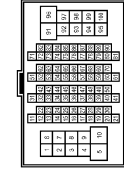

Terminal No.	Color of Wire	Signal Name [Specification]
9f	BR	-

Connector No.	M96
Connector Name	WIRE TO WIRE
Connector Type	NS12MW-CS

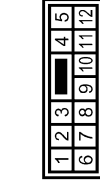

Terminal No.	Color of Wire	Signal Name [Specification]
3	GR	-
4	B	-
5	W	-
8	SB	-
9	G	-
10	B	-
11	G	-
12	O	-

Connector No.	M201
Connector Name	WIRE TO WIRE
Connector Type	NS12FW-CS

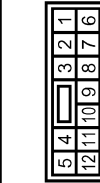

Terminal No.	Color of Wire	Signal Name [Specification]
3	GR	-
4	B	-
5	W	-
8	SB	-
9	G	-
10	B	-
11	V	-
12	O	-

Connector No.	M202
Connector Name	HEATED SEAT SWITCH LH
Connector Type	NS306FW-CS

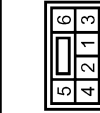

Terminal No.	Color of Wire	Signal Name [Specification]
1	V	-
2	W	-
3	O	-
4	B	-

Connector No.	M203
Connector Name	HEATED SEAT SWITCH RH
Connector Type	NS306BR-CS

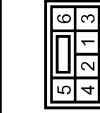

Terminal No.	Color of Wire	Signal Name [Specification]
1	G	-
2	SR	-
3	GR	-
4	B	-

JCJWA0103GB

SQUEAK AND RATTLE TROUBLE DIAGNOSIS

< SYMPTOM DIAGNOSIS >

SYMPTOM DIAGNOSIS

SQUEAK AND RATTLE TROUBLE DIAGNOSIS

Work Flow

INFOID:000000001278433

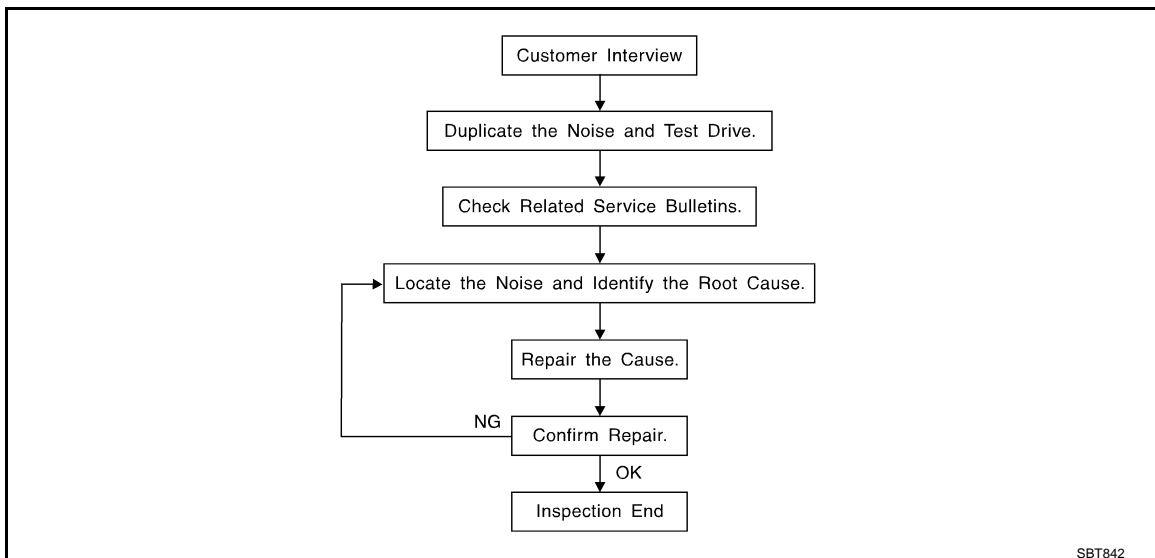

CUSTOMER INTERVIEW

Interview the customer if possible, to determine the conditions that exist when the noise occurs. Use the Diagnostic Worksheet during the interview to document the facts and conditions when the noise occurs and any of the customer's comments; refer to [SE-30, "Diagnostic Worksheet"](#). This information is necessary to duplicate the conditions that exist when the noise occurs.

- The customer may not be able to provide a detailed description or the location of the noise. Attempt to obtain all the facts and conditions that exist when the noise occurs (or does not occur).
- If there is more than one noise in the vehicle, be sure to diagnose and repair the noise that the customer is concerned about. This can be accomplished by a test drive with the customer.
- After identifying the type of noise, isolate the noise in terms of its characteristics. The noise characteristics are provided so the customer, service adviser and technician are all speaking the same language when defining the noise.
- Squeak – (Like tennis shoes on a clean floor)
Squeak characteristics include the light contact/fast movement/brought on by road conditions/hard surfaces = higher pitch noise/softer surfaces = lower pitch noises/edge to surface = chirping
- Creak – (Like walking on an old wooden floor)
Creak characteristics include firm contact/slow movement/twisting with a rotational movement/pitch dependent on materials/often brought on by activity.
- Rattle – (Like shaking a baby rattle)
Rattle characteristics include the fast repeated contact/vibration or similar movement/loose parts/missing clip or fastener/incorrect clearance.
- Knock – (Like a knock on a door)
Knock characteristics include hollow sounding/sometimes repeating/often brought on by driver action.
- Tick – (Like a clock second hand)
Tick characteristics include gentle contacting of light materials/loose components/can be caused by driver action or road conditions.
- Thump – (Heavy, muffled knock noise)
Thump characteristics include softer knock/dead sound often brought on by activity.
- Buzz – (Like a bumble bee)
Buzz characteristics include high frequency rattle/firm contact.
- Often the degree of acceptable noise level will vary depending upon the person. A noise that you may judge as acceptable may be very irritating to the customer.
- Weather conditions, especially humidity and temperature, may have a great effect on noise level.

DUPLICATE THE NOISE AND TEST DRIVE

SQUEAK AND RATTLE TROUBLE DIAGNOSIS

< SYMPTOM DIAGNOSIS >

If possible, drive the vehicle with the customer until the noise is duplicated. Note any additional information on the Diagnostic Worksheet regarding the conditions or location of the noise. This information can be used to duplicate the same conditions when you confirm the repair.

If the noise can be duplicated easily during the test drive, to help identify the source of the noise, try to duplicate the noise with the vehicle stopped by doing one or all of the following:

- 1) Close a door.
 - 2) Tap or push/pull around the area where the noise appears to be coming from.
 - 3) Rev the engine.
 - 4) Use a floor jack to recreate vehicle "twist".
 - 5) At idle, apply engine load (electrical load, half-clutch on M/T model, drive position on A/T model).
 - 6) Raise the vehicle on a hoist and hit a tire with a rubber hammer.
- Drive the vehicle and attempt to duplicate the conditions the customer states exist when the noise occurs.
 - If it is difficult to duplicate the noise, drive the vehicle slowly on an undulating or rough road to stress the vehicle body.

LOCATE THE NOISE AND IDENTIFY THE ROOT CAUSE

1. Narrow down the noise to a general area. To help pinpoint the source of the noise, use a listening tool (Engine Ear or mechanics stethoscope).
2. Narrow down the noise to a more specific area and identify the cause of the noise by:
 - removing the components in the area that you suspect the noise is coming from.
Do not use too much force when removing clips and fasteners, otherwise clips and fastener can be broken or lost during the repair, resulting in the creation of new noise.
 - tapping or pushing/pulling the component that you suspect is causing the noise.
Do not tap or push/pull the component with excessive force, otherwise the noise will be eliminated only temporarily.
 - feeling for a vibration with your hand by touching the component(s) that you suspect is (are) causing the noise.
 - placing a piece of paper between components that you suspect are causing the noise.
 - looking for loose components and contact marks.
Refer to [SE-28. "Inspection Procedure"](#).

REPAIR THE CAUSE

- If the cause is a loose component, tighten the component securely.
- If the cause is insufficient clearance between components:
 - separate components by repositioning or loosening and retightening the component, if possible.
 - insulate components with a suitable insulator such as urethane pads, foam blocks, felt cloth tape or urethane tape are available through your authorized Nissan Parts Department.

CAUTION:

Do not use excessive force as many components are constructed of plastic and may be damaged.

NOTE:

- URETHANE PADS
Insulates connectors, harness, etc.
- INSULATOR (Foam blocks)
Insulates components from contact. Can be used to fill space behind a panel.
- INSULATOR (Light foam block)
- FELT CLOTHTAPE
Used to insulate where movement does not occur. Ideal for instrument panel applications.
The following materials, not available through NISSAN Parts Department, can also be used to repair squeaks and rattles.
- UHMW(TEFLON) TAPE
Insulates where slight movement is present. Ideal for instrument panel applications.
- SILICONE GREASE
Used in place of UHMW tape that will be visible or not fit.
Note: Will only last a few months.
- SILICONE SPRAY
Use when grease cannot be applied.
- DUCT TAPE
Use to eliminate movement.

CONFIRM THE REPAIR

SQUEAK AND RATTLE TROUBLE DIAGNOSIS

< SYMPTOM DIAGNOSIS >

Confirm that the cause of a noise is repaired by test driving the vehicle. Operate the vehicle under the same conditions as when the noise originally occurred. Refer to the notes on the Diagnostic Worksheet.

Inspection Procedure

INFOID:000000001278434

Refer to Table of Contents for specific component removal and installation information.

INSTRUMENT PANEL

Most incidents are caused by contact and movement between:

1. Cluster lid A and instrument panel
2. Acrylic lens and combination meter housing
3. Instrument panel to front pillar garnish
4. Instrument panel to windshield
5. Instrument panel mounting pins
6. Wiring harnesses behind the combination meter
7. A/C defroster duct and duct joint

These incidents can usually be located by tapping or moving the components to duplicate the noise or by pressing on the components while driving to stop the noise. Most of these incidents can be repaired by applying felt cloth tape or silicon spray (in hard to reach areas). Urethane pads can be used to insulate wiring harness.

CAUTION:

Do not use silicone spray to isolate a squeak or rattle. If you saturate the area with silicone, you will not be able to recheck the repair.

CENTER CONSOLE

Components to pay attention to include:

1. Shifter assembly cover to finisher
2. A/C control unit and cluster lid C
3. Wiring harnesses behind audio and A/C control unit

The instrument panel repair and isolation procedures also apply to the center console.

DOORS

Pay attention to the:

1. Finisher and inner panel making a slapping noise
2. Inside handle escutcheon to door finisher
3. Wiring harnesses tapping
4. Door striker out of alignment causing a popping noise on starts and stops

Tapping or moving the components or pressing on them while driving to duplicate the conditions can isolate many of these incidents. You can usually insulate the areas with felt cloth tape or insulator foam blocks to repair the noise.

TRUNK

Trunk noises are often caused by a loose jack or loose items put into the trunk by the owner.

In addition look for:

1. Trunk lid dumpers out of adjustment
2. Trunk lid striker out of adjustment
3. Trunk lid torsion bars knocking together
4. A loose license plate or bracket

Most of these incidents can be repaired by adjusting, securing or insulating the item(s) or component(s) causing the noise.

SUNROOF/HEADLINING

Noises in the sunroof/headlining area can often be traced to one of the following:

1. Sunroof lid, rail, linkage or seals making a rattle or light knocking noise
2. Sunvisor shaft shaking in the holder
3. Front or rear windshield touching headlining and squeaking

SQUEAK AND RATTLE TROUBLE DIAGNOSIS

< SYMPTOM DIAGNOSIS >

Again, pressing on the components to stop the noise while duplicating the conditions can isolate most of these incidents. Repairs usually consist of insulating with felt cloth tape.

A

SEATS

When isolating seat noise it is important to note the position the seat is in and the load placed on the seat when the noise is present. These conditions should be duplicated when verifying and isolating the cause of the noise.

B

Cause of seat noise include:

1. Headrest rods and holder
2. A squeak between the seat pad cushion and frame
3. Rear seatback lock and bracket

C

These noises can be isolated by moving or pressing on the suspected components while duplicating the conditions under which the noise occurs. Most of these incidents can be repaired by repositioning the component or applying urethane tape to the contact area.

D

UNDERHOOD

Some interior noise may be caused by components under the hood or on the engine wall. The noise is then transmitted into the passenger compartment.

E

Causes of transmitted underhood noise include:

1. Any component mounted to the engine wall
2. Components that pass through the engine wall
3. Engine wall mounts and connectors
4. Loose radiator mounting pins
5. Hood bumpers out of adjustment
6. Hood striker out of adjustment

F

G

H

These noises can be difficult to isolate since they cannot be reached from the interior of the vehicle. The best method is to secure, move or insulate one component at a time and test drive the vehicle. Also, engine RPM or load can be changed to isolate the noise. Repairs can usually be made by moving, adjusting, securing, or insulating the component causing the noise.

I

SE

K

L

M

N

O

P

SQUEAK AND RATTLE TROUBLE DIAGNOSIS

< SYMPTOM DIAGNOSIS >

Diagnostic Worksheet

INFOID:000000001278435



SQUEAK & RATTLE DIAGNOSTIC WORKSHEET

Dear Nissan Customer:

We are concerned about your satisfaction with your Nissan vehicle. Repairing a squeak or rattle sometimes can be very difficult. To help us fix your Nissan right the first time, please take a moment to note the area of the vehicle where the squeak or rattle occurs and under what conditions. You may be asked to take a test drive with a service advisor or technician to ensure we confirm the noise you are hearing.

I. WHERE DOES THE NOISE COME FROM? (circle the area of the vehicle)

The illustrations are for reference only, and may not reflect the actual configuration of your vehicle.

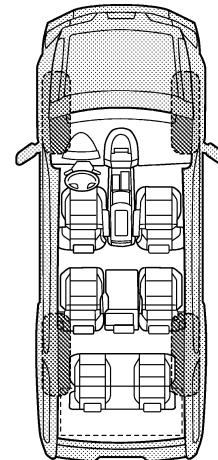
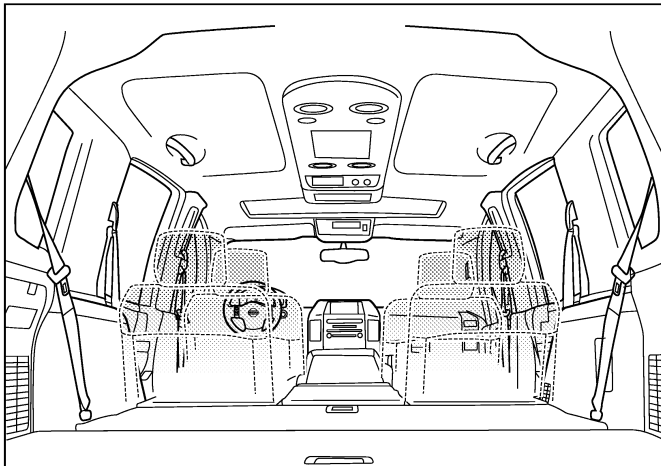
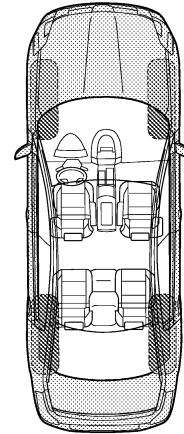
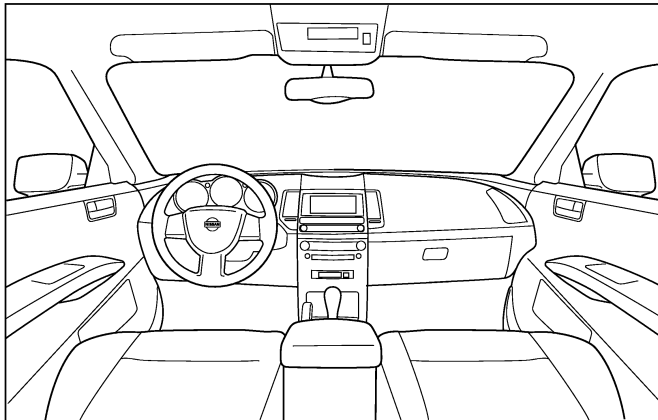

Continue to page 2 of the worksheet and briefly describe the location of the noise or rattle. In addition, please indicate the conditions which are present when the noise occurs.

PIIB8740E

SQUEAK AND RATTLE TROUBLE DIAGNOSIS

< SYMPTOM DIAGNOSIS >

SQUEAK & RATTLE DIAGNOSTIC WORKSHEET - page 2

Briefly describe the location where the noise occurs:

II. WHEN DOES IT OCCUR? (please check the boxes that apply)

- | | |
|---|--|
| <input type="checkbox"/> anytime | <input type="checkbox"/> after sitting out in the rain |
| <input type="checkbox"/> 1st time in the morning | <input type="checkbox"/> when it is raining or wet |
| <input type="checkbox"/> only when it is cold outside | <input type="checkbox"/> dry or dusty conditions |
| <input type="checkbox"/> only when it is hot outside | <input type="checkbox"/> other: |

III. WHEN DRIVING:

- through driveways
- over rough roads
- over speed bumps
- only about ____ mph
- on acceleration
- coming to a stop
- on turns: left, right or either (circle)
- with passengers or cargo
- other: _____
- after driving ____ miles or ____ minutes

IV. WHAT TYPE OF NOISE

- squeak (like tennis shoes on a clean floor)
- creak (like walking on an old wooden floor)
- rattle (like shaking a baby rattle)
- knock (like a knock at the door)
- tick (like a clock second hand)
- thump (heavy, muffled knock noise)
- buzz (like a bumble bee)

TO BE COMPLETED BY DEALERSHIP PERSONNEL

Test Drive Notes:

	YES	NO	Initials of person performing
Vehicle test driven with customer	<input type="checkbox"/>	<input type="checkbox"/>	_____
- Noise verified on test drive	<input type="checkbox"/>	<input type="checkbox"/>	_____
- Noise source located and repaired	<input type="checkbox"/>	<input type="checkbox"/>	_____
- Follow up test drive performed to confirm repair	<input type="checkbox"/>	<input type="checkbox"/>	_____

VIN: _____ Customer Name: _____
W.O.# _____ Date: _____

This form must be attached to Work Order

PIIB8742E

A
B
C
D
E
F
G
H
I
SE
K
L
M
N
O
P

PRECAUTIONS

< PRECAUTION >

PRECAUTION

PRECAUTIONS

Precaution for Supplemental Restraint System (SRS) "AIR BAG" and "SEAT BELT PRE-TENSIONER"

INFOID:000000001558902

The Supplemental Restraint System such as "AIR BAG" and "SEAT BELT PRE-TENSIONER", used along with a front seat belt, helps to reduce the risk or severity of injury to the driver and front passenger for certain types of collision. Information necessary to service the system safely is included in the "SRS AIRBAG" and "SEAT BELT" of this Service Manual.

WARNING:

- **To avoid rendering the SRS inoperative, which could increase the risk of personal injury or death in the event of a collision which would result in air bag inflation, all maintenance must be performed by an authorized NISSAN/INFINITI dealer.**
- **Improper maintenance, including incorrect removal and installation of the SRS, can lead to personal injury caused by unintentional activation of the system. For removal of Spiral Cable and Air Bag Module, see the "SRS AIRBAG".**
- **Do not use electrical test equipment on any circuit related to the SRS unless instructed to in this Service Manual. SRS wiring harnesses can be identified by yellow and/or orange harnesses or harness connectors.**

Service Notice

INFOID:000000001485181

- When removing or installing various parts, place a cloth or padding onto the vehicle body to prevent scratches.
- Handle trim, molding, instruments, grille, etc. carefully during removing or installing. Be careful not to oil or damage them.
- Apply sealing compound where necessary when installing parts.
- When applying sealing compound, be careful that the sealing compound does not protrude from parts.
- When replacing any metal parts (for example body outer panel, members, etc.), be sure to take rust prevention measures.

Precaution for Work

INFOID:000000001485182

- When removing or disassembling each component, be careful not to damage or deform it. If a component may be subject to interference, be sure to protect it with a shop cloth.
- When removing (disengaging) components with a screwdriver or similar tool, be sure to wrap the component with a shop cloth or vinyl tape to protect it.
- Protect the removed parts with a shop cloth and keep them.
- Replace a deformed or damaged clip.
- If a part is specified as a non-reusable part, always replace it with new one.
- Be sure to tighten bolts and nuts securely to the specified torque.
- After re-installation is completed, be sure to check that each part works normally.
- Follow the steps below to clean components.
 - Water soluble foul: Dip a soft cloth into lukewarm water, and wring the water out of the cloth to wipe the fouled area.
Then rub with a soft and dry cloth.
 - Oily foul: Dip a soft cloth into lukewarm water with mild detergent (concentration: within 2 to 3%), and wipe the fouled area.
Then dip a cloth into fresh water, and wring the water out of the cloth to wipe the detergent off. Then rub with a soft and dry cloth.
- Do not use organic solvent such as thinner, benzene, alcohol, and gasoline.
- For genuine leather seats, use a genuine leather seat cleaner.

PREPARATION

< PREPARATION >

PREPARATION

PREPARATION

Commercial Service Tool

INFOID:000000001278439

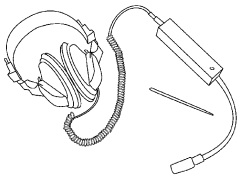
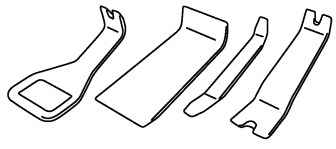
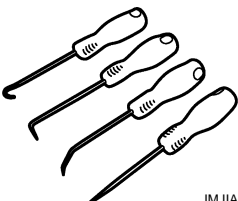
Tool name	Description
<p>Engine ear</p>  <p>SIIA0995E</p>	<p>Locating the noise</p>
<p>Remover tool</p>  <p>PIIB7923J</p>	<p>Remove the clips, pawls and metal clips</p>
<p>Hook and pick tool</p>  <p>JMJA0490ZZ</p>	<p>Remove the snap pins.</p>

A

B

C

D

E

F

G

H

I

SE

K

L

M

N

O

P

FRONT SEAT

< ON-VEHICLE REPAIR >

ON-VEHICLE REPAIR

FRONT SEAT

Exploded View

INFOID:000000001278441

CAUTION:

Do not disassemble the component parts of only front passenger seat in the dotted lines shown in the figure below.

MANUAL SEAT

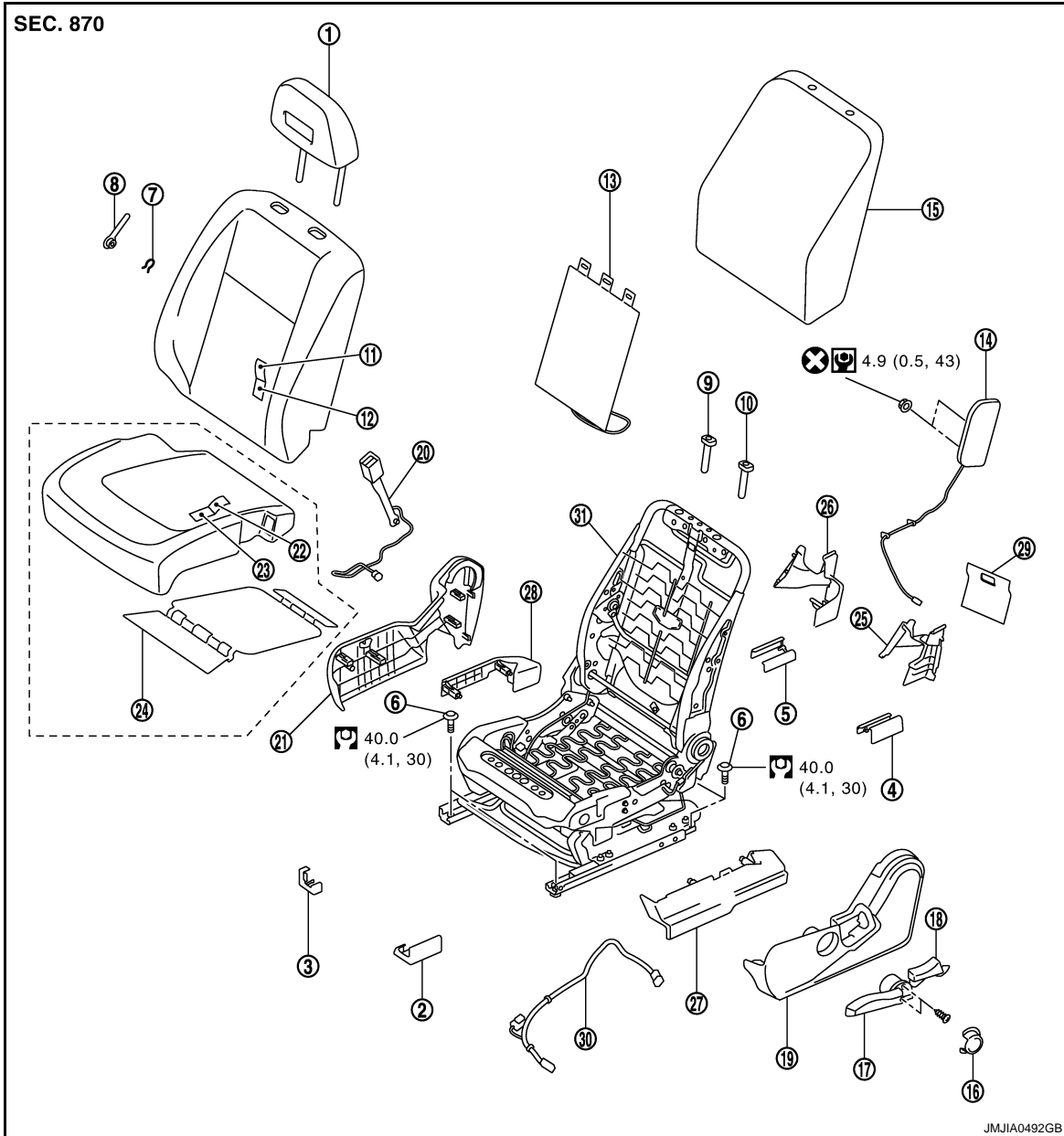

- | | | |
|---------------------------------|------------------------------|---------------------------------|
| 1. Headrest | 2. Front outer slide cover | 3. Front inner slide cover |
| 4. Rear outer slide cover | 5. Rear inner slide cover | 6. TORX bolt |
| 7. Snap ring | 8. Lumbar support lever knob | 9. Headrest holder (free) |
| 10. Headrest holder (locked) | 11. Seatback trim | 12. Seatback pad |
| 13. Seatback heater unit | 14. Side air bag module | 15. Seatback silencer |
| 16. Lifter lever knob finisher | 17. Lifter lever knob | 18. Reclining lever knob |
| 19. Seat cushion outer finisher | 20. Seat belt buckle | 21. Seat cushion inner finisher |

FRONT SEAT

< ON-VEHICLE REPAIR >

- | | | |
|----------------------------------|----------------------------------|-------------------------------|
| 22. Seat cushion trim | 23. Seat cushion pad | 24. Seat cushion heater unit |
| 25. Reclining device outer cover | 26. Reclining device inner cover | 27. Seat slide outer finisher |
| 28. Seat slide inner finisher | 29. Seatback protector | 30. Seat harness |
| 31. Seat frame assembly | | |

Refer to [GI-4. "Components"](#) for symbols in the figure.

POWER SEAT

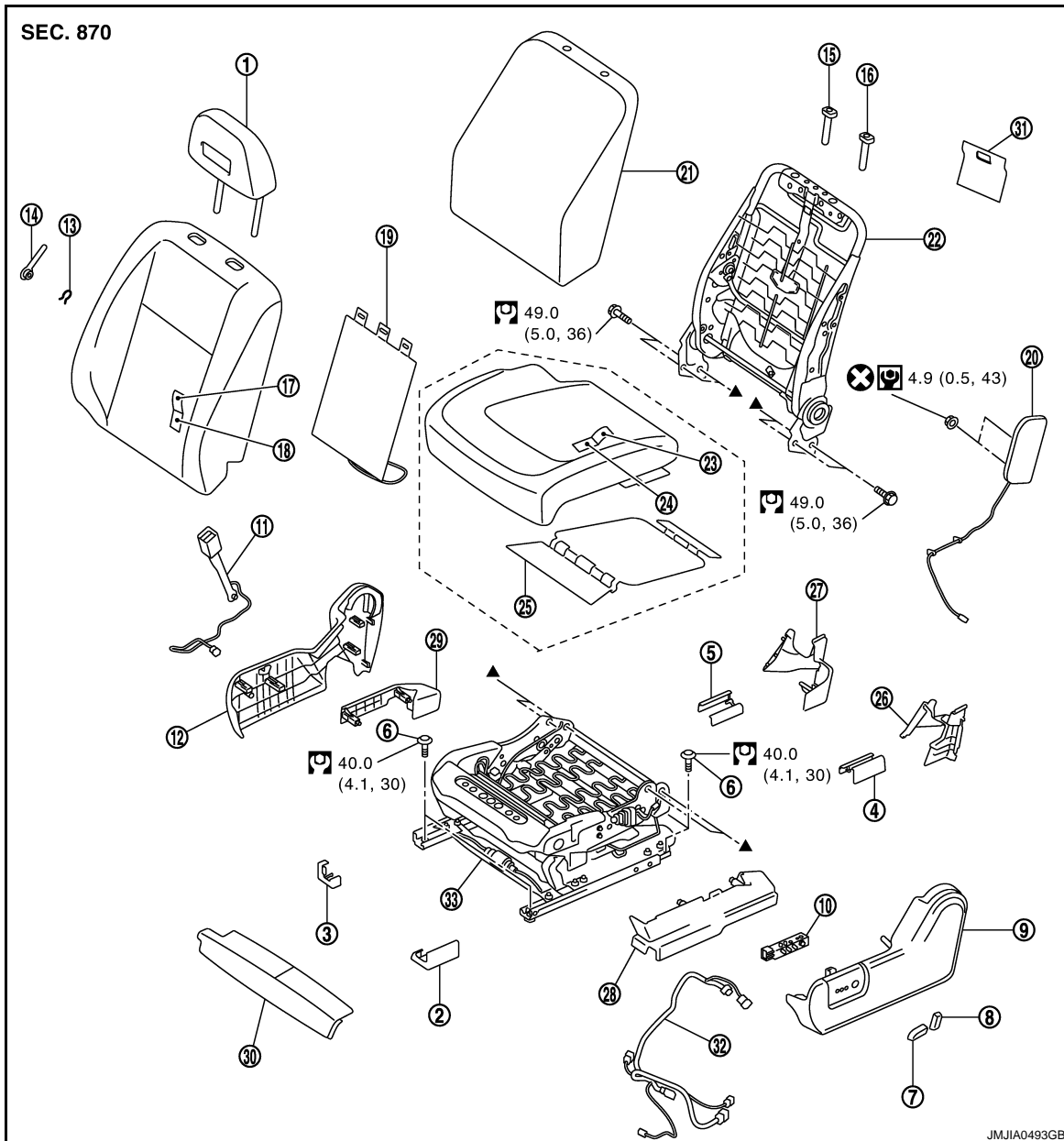

- | | | |
|--------------------------------------|----------------------------------|----------------------------------|
| 1. Headrest | 2. Front outer slide cover | 3. Front inner slide cover |
| 4. Rear outer slide cover | 5. Rear inner slide cover | 6. TORX bolt |
| 7. Seat slide and lifter switch knob | 8. Reclining switch knob | 9. Seat cushion outer finisher |
| 10. Power seat switch | 11. Seat belt buckle | 12. Seat cushion inner finisher |
| 13. Snap ring | 14. Lumbar support lever knob | 15. Headrest holder (free) |
| 16. Headrest holder (locked) | 17. Seatback trim | 18. Seatback pad |
| 19. Seatback heater unit | 20. Side air bag module | 21. Seatback silencer |
| 22. Seatback frame | 23. Seat cushion trim | 24. Seat cushion pad |
| 25. Seat cushion heater unit | 26. Reclining device outer cover | 27. Reclining device inner cover |

A
B
C
D
E
F
G
H
I
SE
K
L
M
N
O
P

FRONT SEAT

< ON-VEHICLE REPAIR >

- | | | |
|-------------------------------|-------------------------------|---------------------------------|
| 28. Seat slide outer finisher | 29. Seat slide inner finisher | 30. Seat cushion front finisher |
| 31. Seatback protector | 32. Seat harness | 33. Seat cushion frame |
- Refer to [GI-4. "Components"](#) for symbols in the figure.

Removal and Installation

INFOID:000000001278442

REMOVAL

CAUTION:

- When removing and installing, use shop cloths to protect parts from damage.
- Before removal, turn ignition switch OFF, disconnect both battery cables, and then wait for at least 3 minutes.

NOTE:

Confirming a position of connector before work.

1. Remove the headrest.
2. Remove the rear outer and inner slide cover.
3. Remove the rear inner mounting TORX bolt.
4. Remove the rear outer mounting TORX bolt.
5. Remove the front outer and inner slide cover.
6. Remove the front outer mounting TORX bolt.
7. Remove the front inner mounting TORX bolt.
8. Set seatback in a standing position.
9. Disconnect harness connector under the seat and remove harness clamps.
10. Remove seat from the vehicle.

INSTALLATION

Install in the reverse order of removal.

CAUTION:

- Before installation, turn ignition switch OFF, disconnect both battery cables, and then wait for at least 3 minutes.
- Clamp the harness in position.

Disassembly and Assembly

INFOID:000000001278443

SEATBACK (MANUAL SEAT)

Disassembly

1. Remove the lumbar support lever knob. (Driver's seat only)
Pull snap ring (1) upward, and remove lumbar support lever knob (2) from seatback frame. Using a hook and pick tool.

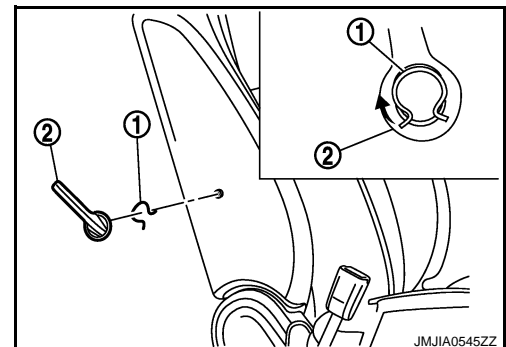

2. Remove the seatback trim and seatback pad.

FRONT SEAT

< ON-VEHICLE REPAIR >

- Remove the seatback retainer (1) on the back side of the seatback.
- Unfasten fastener (2) on the back side of the seatback.

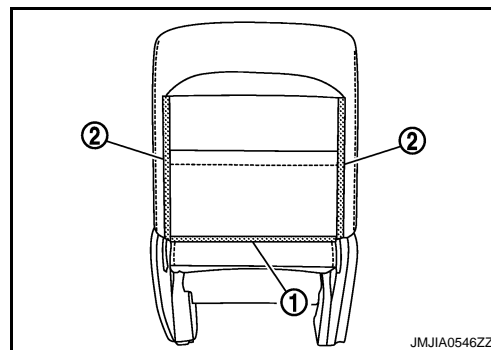

- Remove the seatback retainer (3).
- Disconnect the harness connectors (A) and remove the harness clamp.

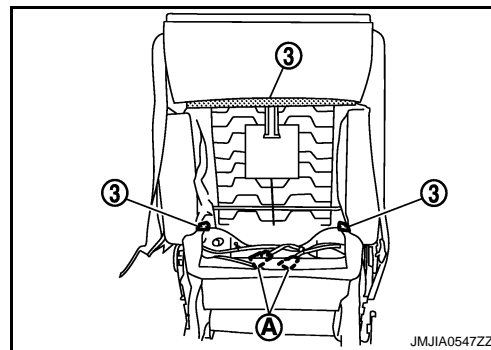

- Remove the air bag module mounting nut (B).

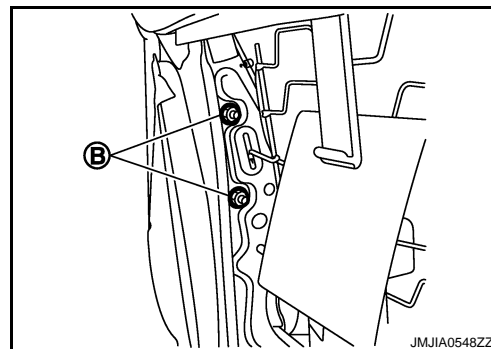

- Remove the headrest holder.
CAUTION:
Before installing headrest holder, check its orientation.
(front/rear and right/left)

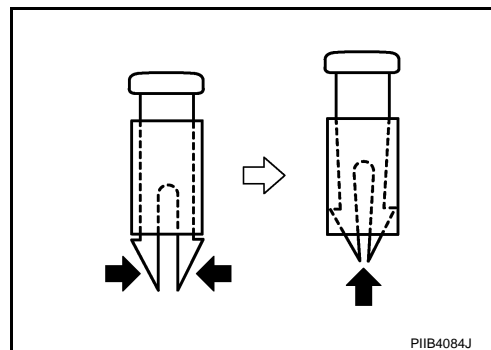

- Remove the seatback trim and seatback pad from the seat frame assembly.
- Remove the air bag module. Refer to [SR-13, "Removal and Installation"](#).
- Remove the hog rings to separate the seatback trim and seatback pad.

3. Remove the seatback silencer.

Assembly

Assemble in the reverse order of disassembly.

CAUTION:

Install the hog rings of seatback trim in position, and then securely connect the trim or trim cord with the pad side wire.

A
B
C
D
E
F
G
H
I
SE
K
L
M
N
O
P

FRONT SEAT

< ON-VEHICLE REPAIR >

SEAT CUSHION (MANUAL SEAT)

Disassembly

CAUTION:

Do not disassemble front passenger seat cushion. Always replace as an assembly. For front passenger seat service parts, refer to the service part catalogue.

1. Remove the seat cushion outer finisher.
 - Remove the pawls, and then remove lifter lever knob finisher (1). (Driver's seat only)

 : Pawl

- Remove the mounting screws, and remove lifter lever knob (2). (Driver's seat only)

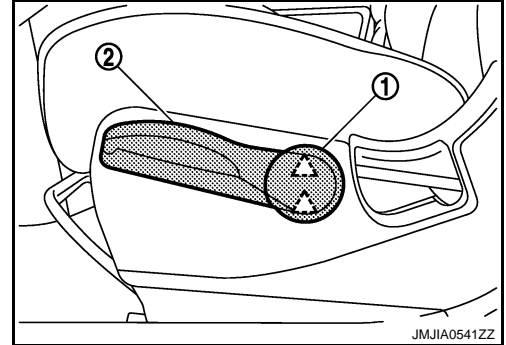

- Pull out the reclining lever knob while holding and raising the pawls.

 : Pawl

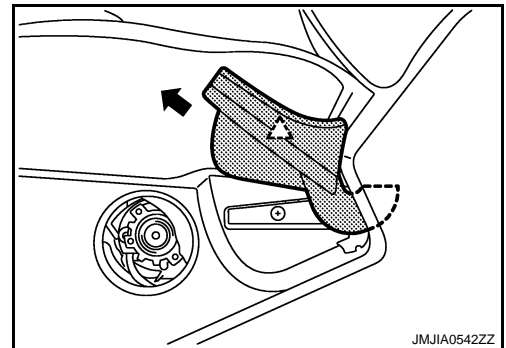

- Remove the screw (A).
- Remove the metal clips and pawls, and then pull out seat cushion outer finisher.

 : Metal clip

 : Pawl

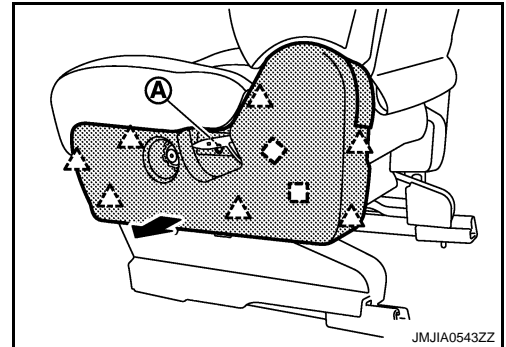

2. Remove the seat belt buckle. Refer to [SB-7. "SEAT BELT BUCKLE : Removal and Installation"](#).
3. Remove the seat cushion inner finisher.
Remove the metal clips and pawls, and then pull out seat cushion inner finisher.

 : Metal clip

 : Pawl

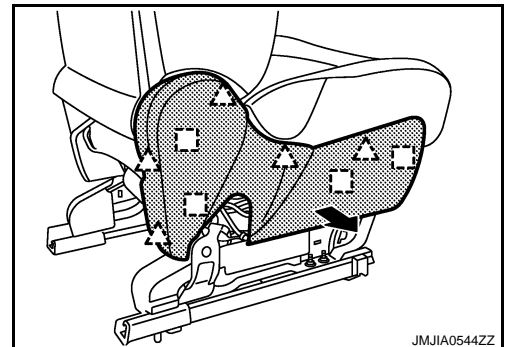

4. Remove the seat cushion trim and seat cushion pad.

FRONT SEAT

< ON-VEHICLE REPAIR >

- Remove the seat cushion retainer.
- Disconnect the heater unit harness connector (A).
- Disconnect the occupant detection unit harness connector (B). (Passenger's seat only)

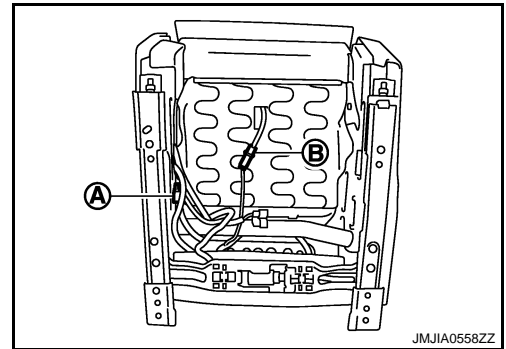

- Remove the seat cushion trim and seat cushion pad from the seat frame assembly.
- Remove the hog rings, and separate the seat cushion trim and seat cushion pad. (Driver's seat only)

5. Remove the reclining device outer cover and inner cover.
6. Remove the seat slide outer finisher. (Driver's seat only)
Remove the metal clips, and then pull out seat slide outer finisher.

 : Metal clip

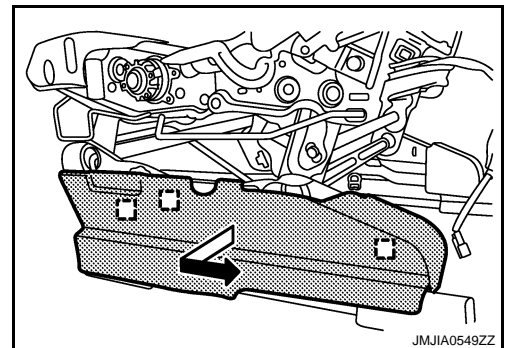

7. Remove seat slide inner finisher. (Driver's seat only)
Remove the metal clips, and then pull out seat slide inner finisher.

 : Metal clip

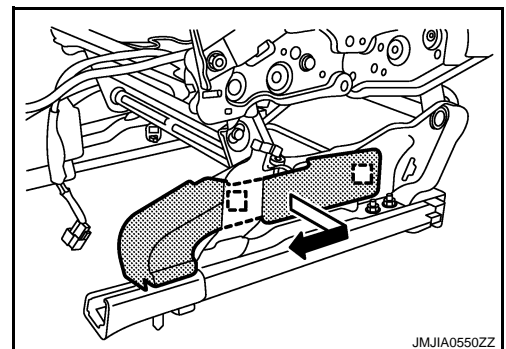

Assembly

Assemble in the reverse order of disassembly.

CAUTION:

Install the hog rings of seat cushion trim in position, and then securely connect the trim or trim cord with the pad side wire.

SEATBACK (POWER SEAT)

Disassembly

1. Remove the seat cushion outer finisher.

FRONT SEAT

< ON-VEHICLE REPAIR >

- Remove the seat slide and lifter switch knob (1) and seat reclining switch knob (2). Using a remover tool (A).

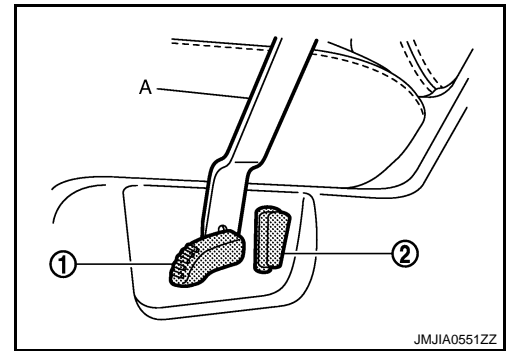

- Remove the metal clips and pawls, and then pull out seat cushion outer finisher.

□ : Metal clip

△ : Pawl

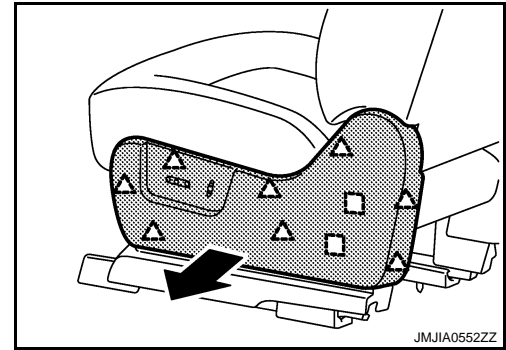

- Remove the power seat switch. Refer to [SE-51. "Removal and Installation"](#).

- Remove the seat belt buckle. Refer to [SB-7. "SEAT BELT BUCKLE : Removal and Installation"](#).

- Remove the seat cushion inner finisher.
Remove the metal clips and pawls, and then pull out seat cushion inner finisher.

□ : Metal clip

△ : Pawl

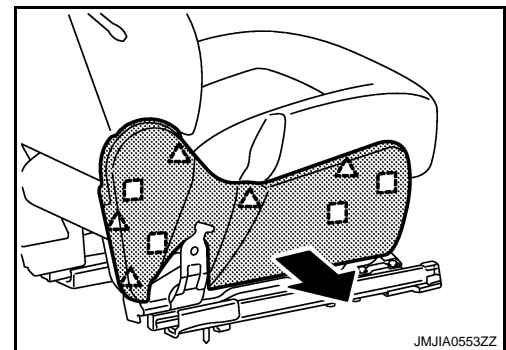

- Remove the lumbar support lever knob. (Driver's seat only)
Pull snap ring (1) upward, and remove lumbar support lever knob (2) from seatback frame. Using a hook and pick tool.

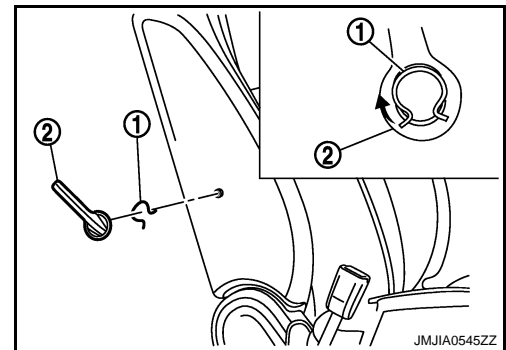

- Remove the seatback trim and seatback pad.

FRONT SEAT

< ON-VEHICLE REPAIR >

- Remove the seatback retainer (1) on the back side of the seatback.
- Unfasten fastener (2) on the back side of the seatback.

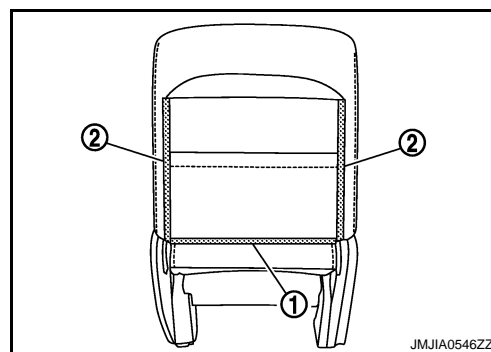

- Remove the seatback retainer (3).
- Disconnect the harness connectors (A) and remove the harness clamp.

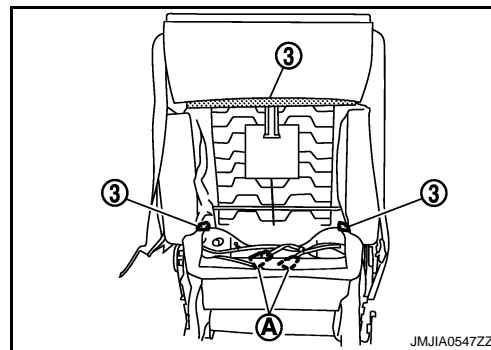

- Remove the air bag module mounting nut (B).

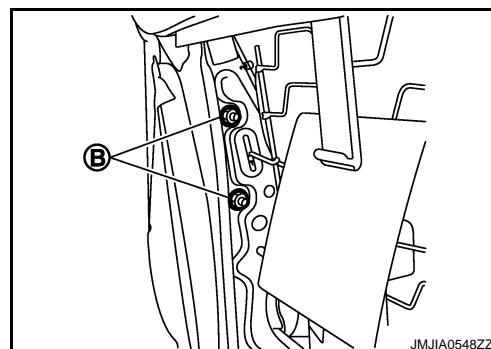

- Remove the headrest holder.
CAUTION:
Before installing headrest holder, check its orientation.
(front/rear and right/left)

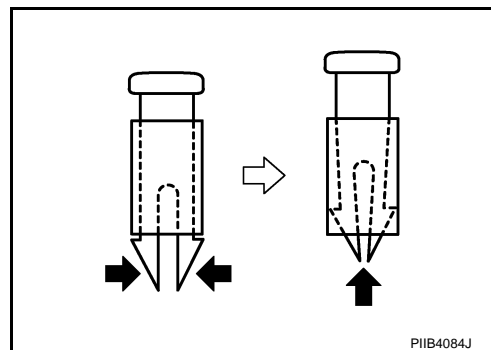

- Remove the seatback trim and seatback pad from the seat frame assembly.
 - Remove the air bag module. Refer to [SR-13, "Removal and Installation"](#).
 - Remove the hog rings to separate the seatback trim and seatback pad.
6. Remove the seatback silencer.
 7. Remove the seatback frame.

A
B
C
D
E
F
G
H
I
SE
K
L
M
N
O
P

FRONT SEAT

< ON-VEHICLE REPAIR >

Remove the seatback frame mounting bolt (A).

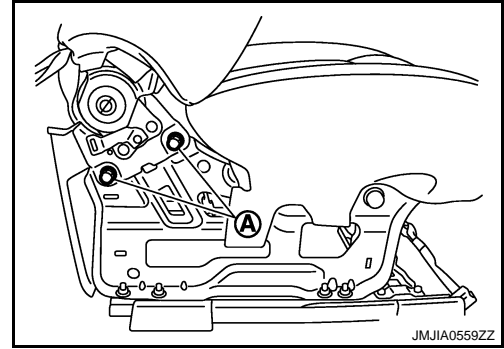

Assembly

Assemble in the reverse order of disassembly.

CAUTION:

Install the hog rings of seatback trim in position, and then securely connect the trim or trim cord with the pad side wire.

SEAT CUSHION (POWER SEAT)

Disassembly

CAUTION:

Do not disassemble front passenger seat cushion. Always replace as an assembly. For front passenger seat service parts, refer to the service part catalogue.

1. Remove the seat cushion outer finisher.
 - Remove the seat slide and lifter switch knob (1) and seat reclining switch knob (2). Using a remover tool (A).

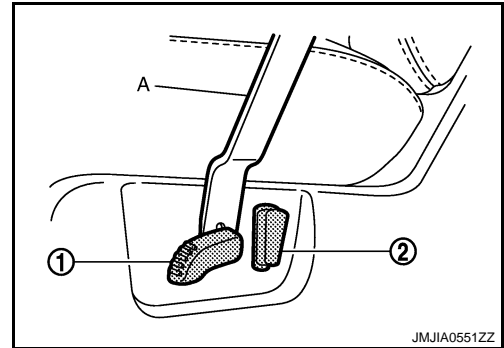

- Remove the metal clips and pawls, and then pull out seat cushion outer finisher.

□ : Metal clip

△ : Pawl

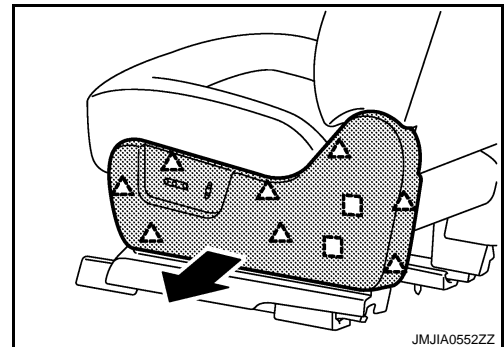

- Remove the power seat switch. Refer to [SE-51. "Removal and Installation"](#).

2. Remove the seat belt buckle. Refer to [SB-7. "SEAT BELT BUCKLE : Removal and Installation"](#).
3. Remove the seat cushion inner finisher.

FRONT SEAT

< ON-VEHICLE REPAIR >

Remove the metal clips and pawls, and then pull out seat cushion outer finisher.

□ : Metal clip

△ : Pawl

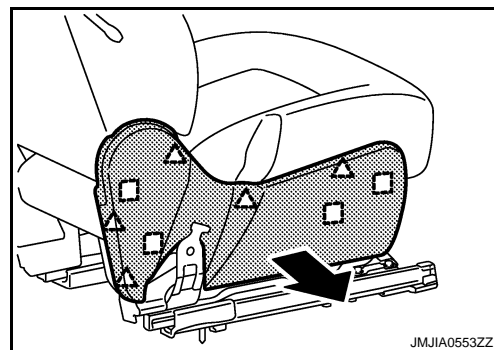

4. Remove the seatback assembly.
Remove the seatback frame mounting bolt (A).

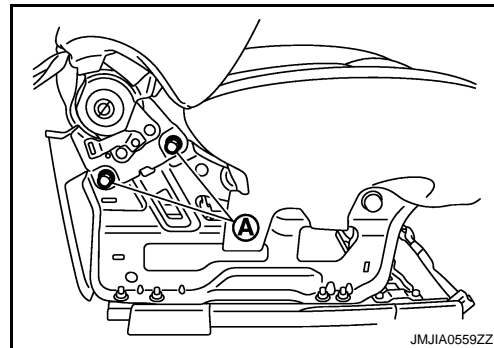

5. Remove the seat cushion trim and seat cushion pad.
- Remove the seat cushion retainer.
 - Disconnect the heater unit harness connector (A).
 - Disconnect the occupant detection unit harness connector (B). (Passenger's seat only)

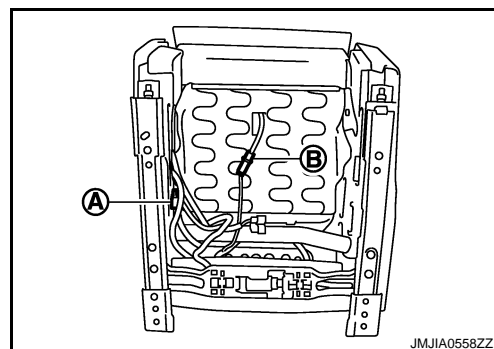

- Remove the seat cushion trim and seat cushion pad from the seat cushion assembly.
- Remove the hog rings, and separate the seat cushion trim and seat cushion pad. (Driver's seat only)

6. Remove the reclining device outer cover and inner cover.
7. Remove the seat slide outer finisher. (Driver's seat only)
Remove the metal clips, and then pull out seat slide outer finisher.

□ : Metal clip

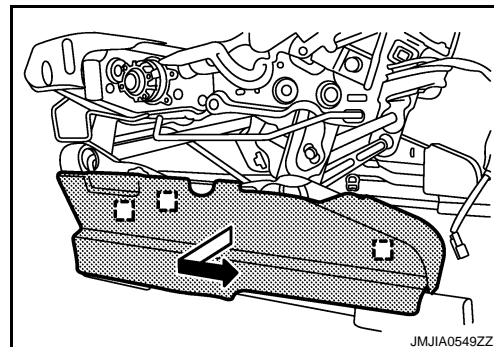

8. Remove seat slide inner finisher. (Driver's seat only)

A
B
C
D
E
F
G
H
I
SE
K
L
M
N
O
P

FRONT SEAT

< ON-VEHICLE REPAIR >

Remove the metal clips, and then pull out seat slide inner finisher.

 : Metal clip

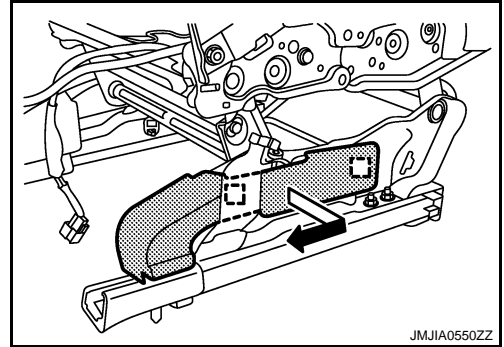

9. Remove the seat cushion front finisher.

Assembly

Assemble in the reverse order of disassembly.

CAUTION:

Install the hog rings of seat cushion trim in position, and then securely connect the trim or trim cord with the pad side wire.

REAR SEAT

< ON-VEHICLE REPAIR >

- | | | |
|-------------------------------------|-----------------------------|---------------------------------|
| 13. Armrest lid | 14. Seatback lock protector | 15. Headrest holder (free) |
| 16. Headrest holder (locked) | 17. Seatback lock knob | 18. Seatback lock knob finisher |
| 19. Seatback pad | 20. Seatback trim | 21. TORX bolt |
| 22. Seatback lock assembly | 23. Seatback side bracket | 24. Reclining device cover |
| 25. Seatback frame | 26. Seatback center bracket | 27. Seat striker |
| 28. Seatback mounting outer bracket | 29. Seatback lower support | |

Refer to [GI-4. "Components"](#) for symbols in the figure.

Removal and Installation

INFOID:000000001278445

REMOVAL

CAUTION:

When removing and installing, use shop cloths to protect parts from damage.

- Remove the seat cushion.
 - Lift to fold seat cushion up.
 - Compress the seat cushion hinge (1) to remove it through the body side hook.
 - Remove the seat cushion assembly (RH/LH) from the vehicle.

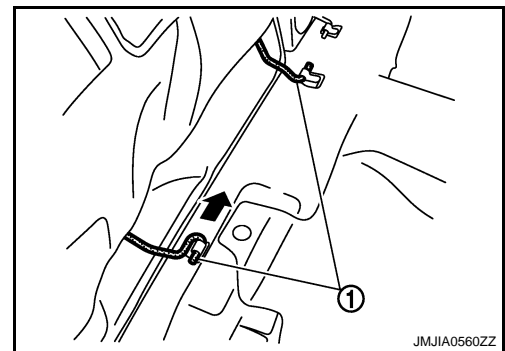

- Remove the headrest.
- Remove the seatback.
 - Remove the center seat belt anchor nut. Refer to [SB-10. "SEAT BELT RETRACTOR : Removal and Installation"](#).
 - Remove the pawl, and then remove the seatback center bracket cover.

 : Pawl

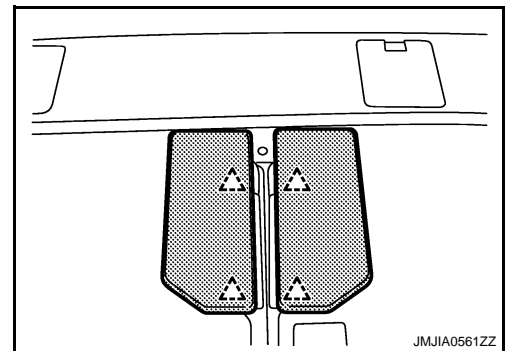

- Remove the seatback center bracket mounting bolt (A).

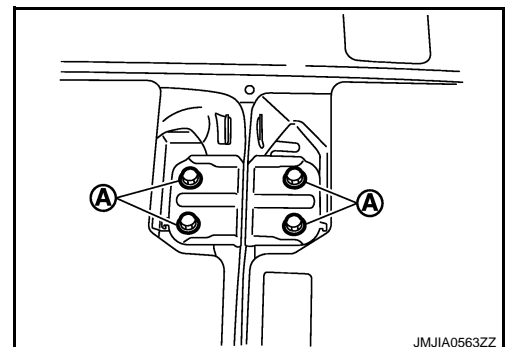

- Remove the luggage finisher mask. Refer to [INT-28. "Removal and Installation"](#).

A
B
C
D
E
F
G
H
I
SE
K
L
M
N
O
P

REAR SEAT

< ON-VEHICLE REPAIR >

- Remove the seatback side bracket mounting nut (B) and bolt (C).
- Remove the seatback assembly (RH/LH) from the vehicle.

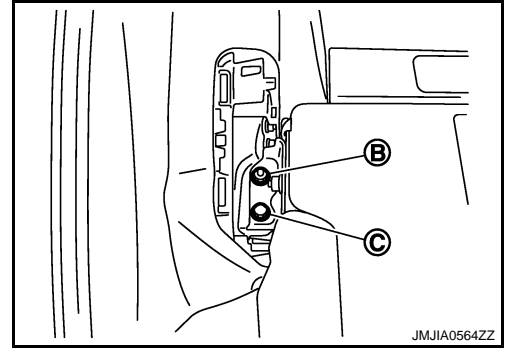

4. Remove the seatback center bracket.
 - Remove the luggage floor center finisher. Refer to [INT-28, "Removal and Installation"](#).
 - Remove the seatback center bracket mounting bolt.
 - Remove the seatback center bracket from the vehicle.
5. Remove the seat striker.
 - Remove the luggage side lower finisher. Refer to [INT-28, "Removal and Installation"](#).
 - Remove the seat striker mounting bolt.
 - Remove the seat striker from the vehicle.
6. Remove the seatback mounting outer bracket.
 - Remove the seatback mounting outer bracket mounting bolts and nuts.
 - Remove the seatback mounting outer bracket from the vehicle.
7. Remove the seatback lower support.
 - Remove the seatback lower support mounting bolt.
 - Remove the seatback lower support from the vehicle.

INSTALLATION

Install in the reverse order of removal.

CAUTION:

When removing and installing, use shop cloths to protect parts from damage.

Disassembly and Assembly

INFOID:000000001278446

SEATBACK

Disassembly

1. Remove the seatback board.
 - a. 6:4 SEAT
Remove the clip, disengage the pawl while pulling downward the seatback board to remove it.

- : Clip
△ : Pawl

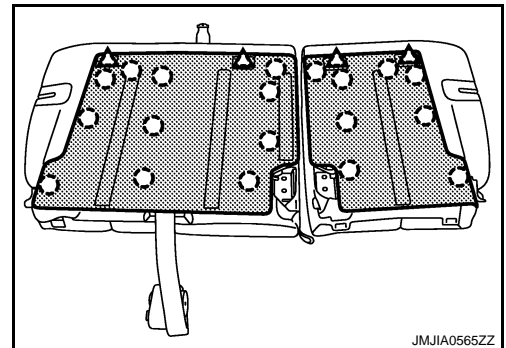



- b. 4:2:4 SEAT

REAR SEAT

< ON-VEHICLE REPAIR >

Remove the clip, disengage the pawl while pulling downward the seatback board to remove it.

-  : Clip
-  : Pawl

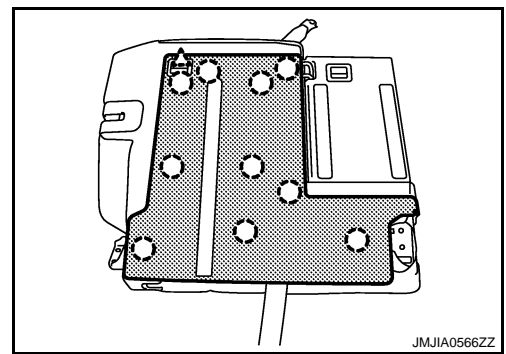

2. Remove the center seat belt retractor. Refer to [SB-10. "SEAT BELT RETRACTOR : Removal and Installation"](#).
3. Remove the armrest assembly. (4:2:4 SEAT only)
 - Remove the metal clip, and then armrest hinge cover.

-  : Metal clip

- Remove the hog ring from the back side of the seatback, fold the armrest lower side seatback trim to remove the seatback pad (center).

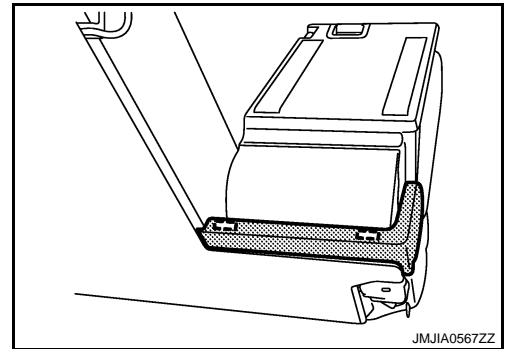

- Remove the mounting bolt (A) and mounting bolt (B), and then remove armrest lid and armrest assembly.

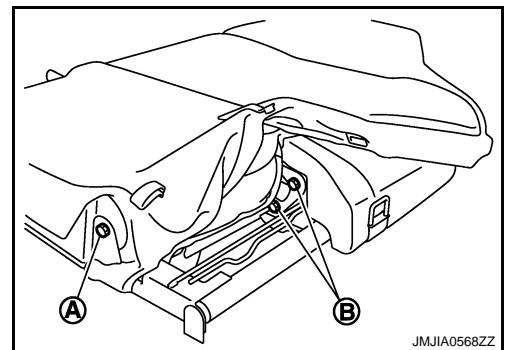

4. Remove the seatback trim and seatback pad.
 - Remove the mounting screw, and then remove seatback lock protector.
 - Remove the seatback retainer on the back side of the seatback.
 - Remove the headrest holder.

CAUTION:
 Before installing headrest holder, check its orientation.
 (front/rear and right/left)

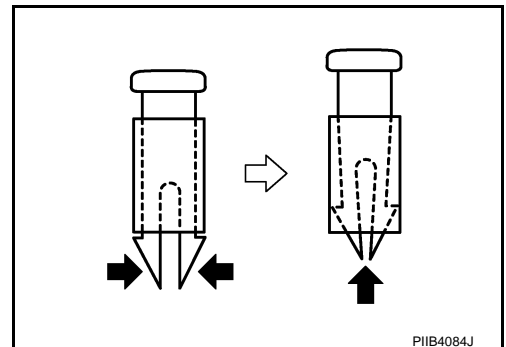

- Turn seatback lock knob counterclockwise to remove.

A
B
C
D
E
F
G
H
I
SE
K
L
M
N
O
P

REAR SEAT

< ON-VEHICLE REPAIR >

- Push the seatback lock knob finisher pawl upward through the seatback pad and the seatback frame to remove it.

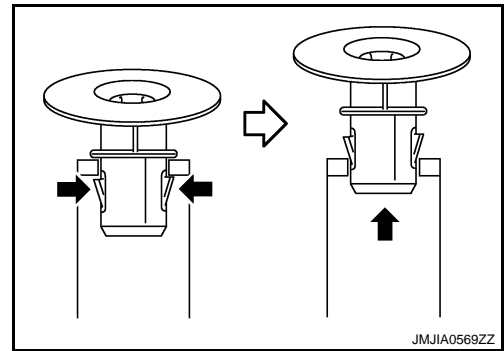

- Remove the seatback trim and seatback pad from the seatback frame.
 - Remove the hog rings to separate the seatback trim and seatback pad.
5. Remove the seatback lock assembly.
Remove the mounting bolt (A) and TORX bolt (B), and then remove seatback lock assembly.

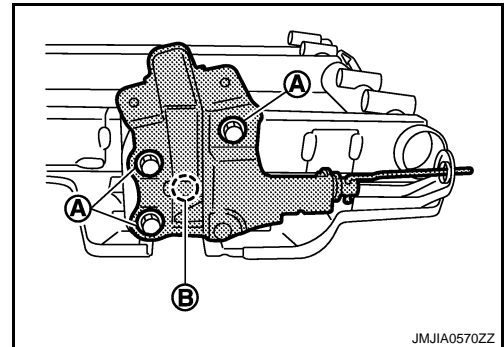

6. Remove the seatback side bracket.
Remove the mounting bolt (A), and then remove seatback side bracket.

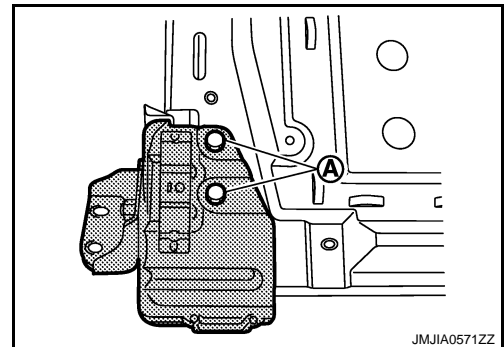

Assembly

Assemble in the reverse order of disassembly.

CAUTION:

Install the hog rings of seatback trim in position, and then securely connect the trim or trim cord with the seatback frame and pad wire.

SEAT CUSHION

Disassembly

1. Remove the fastener and fold the seatback trim.
2. Remove the hog rings to separate the seat cushion trim and seat cushion pad.

Assembly

Assemble in the reverse order of disassembly.

CAUTION:

Install the hog rings of seat cushion trim in position, and then securely connect the trim cord with the seat cushion frame and pad wire,

POWER SEAT SWITCH

< ON-VEHICLE REPAIR >

POWER SEAT SWITCH

Exploded View

INFOID:000000001365639

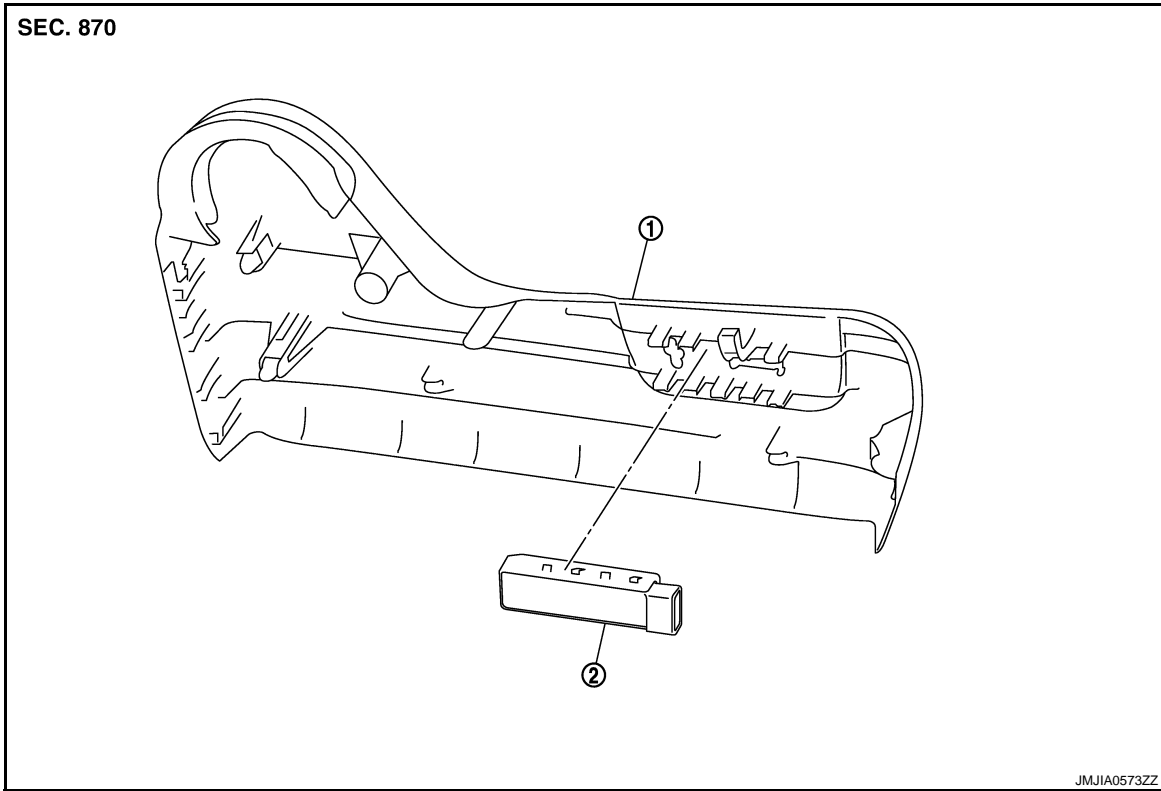

1. Seat cushion outer finisher
2. Power seat switch

Removal and Installation

INFOID:000000001278485

REMOVAL

CAUTION:

When removing and installing, use shop cloths to protect parts from damage.

1. Remove the seat cushion outer finisher (1). Refer to [SE-36](#). "[Removal and Installation](#)".
2. Remove the power seat switch (2) from the seat cushion outer finisher (1).



: Pawl

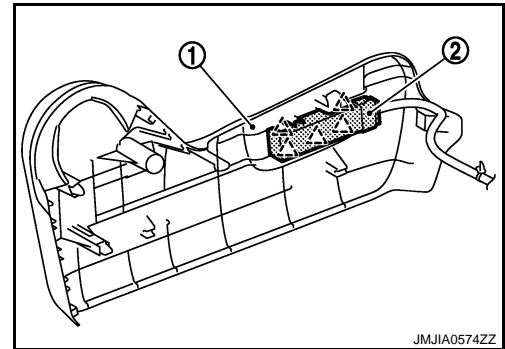

INSTALLATION

Install in the reverse order of removal.

HEATED SEAT SWITCH

< ON-VEHICLE REPAIR >

HEATED SEAT SWITCH

Exploded View

INFOID:000000001278447

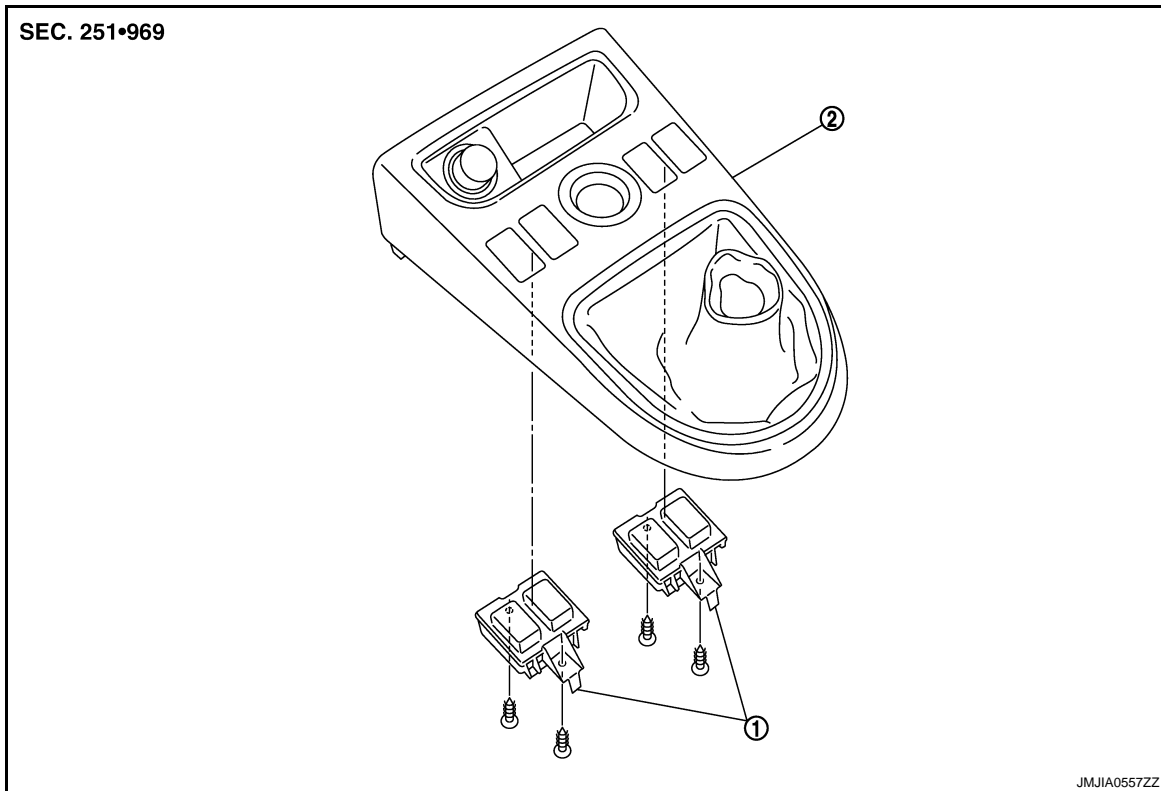

1. Heated seat switch
2. Console switch panel

Removal and Installation

INFOID:000000001278448

REMOVAL

1. Remove the console switch panel (1). Refer to [IP-21. "Removal and Installation"](#)
2. Remove the mounting screw (A).
3. Remove heated seat switch bracket (2) from console switch panel(1).

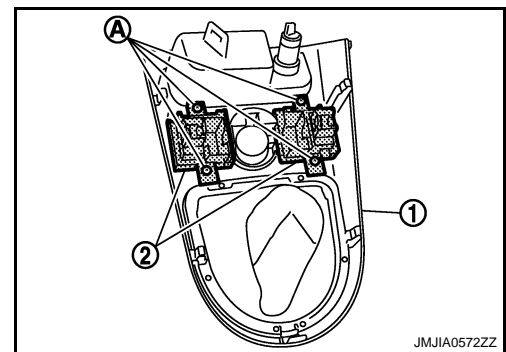

4. Remove heated seat switch (1) from heated seat switch bracket (2). Using minus driver (A).

 : Pawl

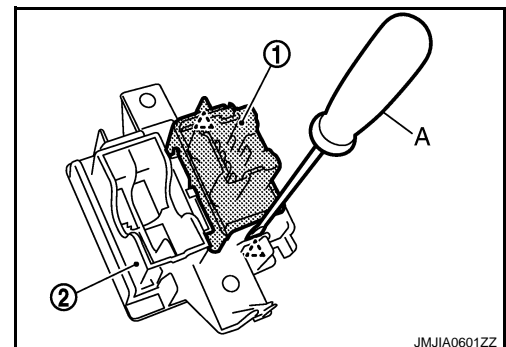

HEATED SEAT SWITCH

< ON-VEHICLE REPAIR >

INSTALLATION

Install in the reverse order of removal.

A

B

C

D

E

F

G

H

I

SE

K

L

M

N

O

P