

SECTION **STR**  
STARTING SYSTEM

CONTENTS

<b>BASIC INSPECTION</b> .....	2	<b>ON-VEHICLE REPAIR</b> .....	22
<b>DIAGNOSIS AND REPAIR WORKFLOW</b> .....	2	<b>STARTER MOTOR</b> .....	22
Work Flow .....	2	<b>M9R MODELS</b> .....	22
<b>FUNCTION DIAGNOSIS</b> .....	5	M9R MODELS : Exploded View .....	22
<b>STARTING SYSTEM</b> .....	5	M9R MODELS : Removal and Installation .....	23
System Diagram .....	5	M9R MODELS : Disassembly and Assembly .....	24
System Description .....	5	M9R MODELS : Inspection .....	24
Component Parts Location .....	6	<b>MR20DE MODELS</b> .....	27
Component Description .....	7	MR20DE MODELS : Exploded View .....	27
<b>COMPONENT DIAGNOSIS</b> .....	8	MR20DE MODELS : Removal and Installation .....	28
<b>B TERMINAL CIRCUIT</b> .....	8	MR20DE MODELS : Disassembly and Assembly.....	28
Description .....	8	MR20DE MODELS : Inspection .....	29
Diagnosis Procedure .....	8	<b>QR25DE (M/T) MODELS</b> .....	32
<b>S TERMINAL CIRCUIT</b> .....	9	QR25DE (M/T) MODELS : Exploded View .....	32
Description .....	9	QR25DE (M/T) MODELS : Removal and Installa- tion .....	33
Diagnosis Procedure .....	9	QR25DE (M/T) MODELS : Disassembly and As- sembly .....	34
<b>STARTING SYSTEM</b> .....	10	QR25DE (M/T) MODELS : Inspection .....	34
Wiring Diagram - STARTING SYSTEM (WITH M/ T) - .....	10	<b>QR25DE (CVT) MODELS</b> .....	37
Wiring Diagram - STARTING SYSTEM (WITH A/ T) - .....	13	QR25DE (CVT) MODELS : Exploded View .....	37
Wiring Diagram - STARTING SYSTEM (WITH CVT) - .....	16	QR25DE (CVT) MODELS : Removal and Installa- tion .....	38
<b>SYMPTOM DIAGNOSIS</b> .....	20	QR25DE (CVT) MODELS : Disassembly and As- sembly .....	39
<b>STARTING SYSTEM</b> .....	20	QR25DE (CVT) MODELS : Inspection .....	39
Symptom Table .....	20	<b>SERVICE DATA AND SPECIFICATIONS</b> <b>(SDS)</b> .....	43
<b>PRECAUTION</b> .....	21	<b>SERVICE DATA AND SPECIFICATIONS</b> <b>(SDS)</b> .....	43
<b>PRECAUTIONS</b> .....	21	Starter Motor .....	43
Precaution for Supplemental Restraint System (SRS) "AIR BAG" and "SEAT BELT PRE-TEN- SIONER" .....	21		

# DIAGNOSIS AND REPAIR WORKFLOW

< BASIC INSPECTION >

## BASIC INSPECTION

### DIAGNOSIS AND REPAIR WORKFLOW

Work Flow

INFOID:000000001208669

#### OVERALL SEQUENCE

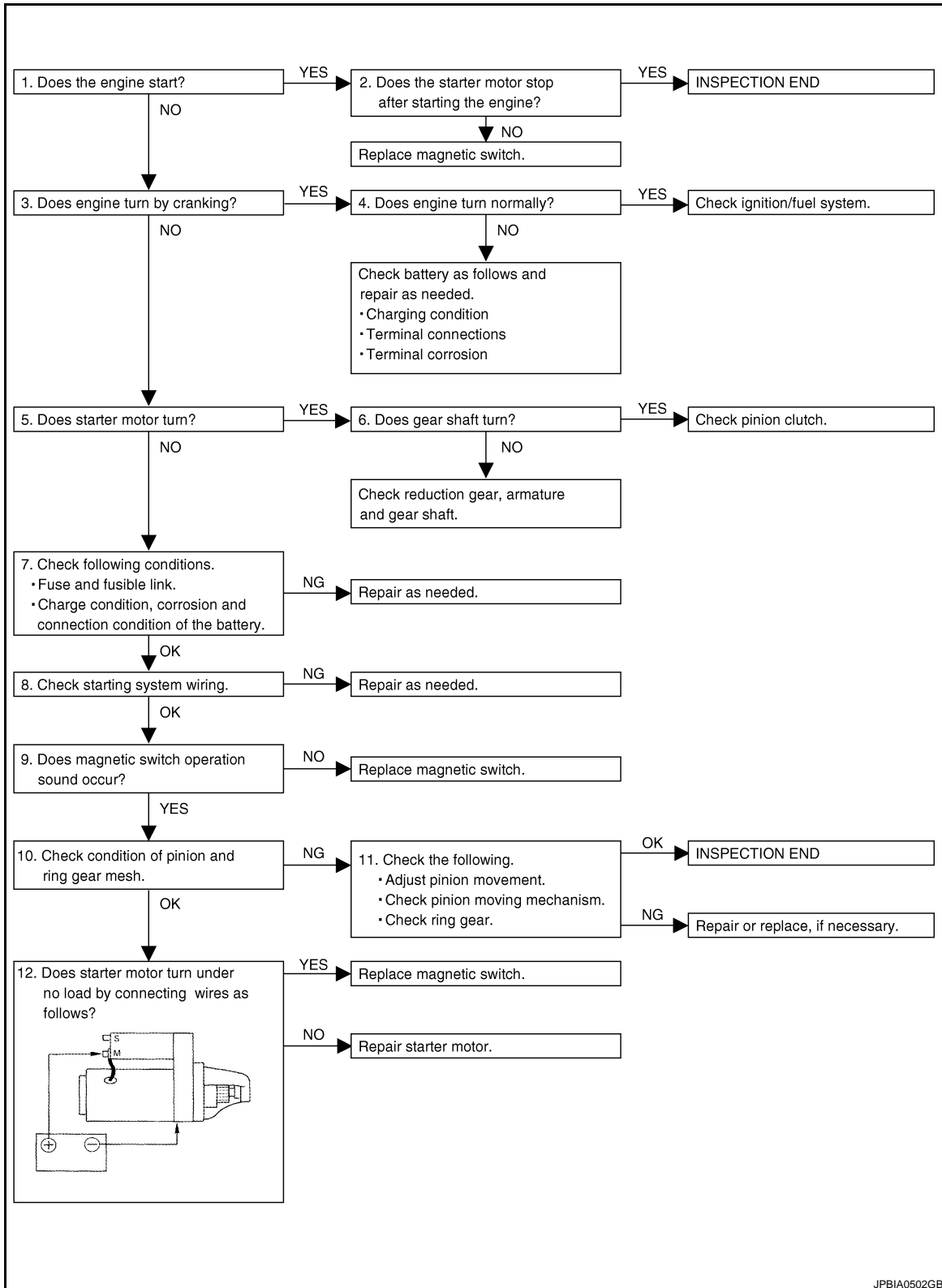

JPBIA0502GB

DETAILED FLOW

# DIAGNOSIS AND REPAIR WORKFLOW

## < BASIC INSPECTION >

### NOTE:

If any malfunction is found, immediately disconnect the battery cable from the negative terminal.

### 1.CHECK ENGINE START

Crank the engine and check that the engine starts.

#### Does the engine start?

YES >> GO TO 2.

NO >> GO TO 3.

### 2.CHECK THAT THE STARTER MOTOR STOPS

Check that the starter motor stops after starting the engine.

#### Does the starter motor stop?

YES >> INSPECTION END

NO >> Replace magnetic switch.

### 3.CHECK THE ENGINE SPEED WITH CRANKING

Check that the engine runs at cranking.

#### Does engine turn by cranking?

YES >> GO TO 4.

NO >> GO TO 5.

### 4.CHECK THE ENGINE SPEED WITH CRANKING

Check that the engine speed is not low at cranking.

#### Does engine turn normally?

YES >> Check ignition/fuel system.

NO >> Check charge condition, corrosion and connection condition of the battery. Refer to [PG-5, "Work Flow"](#).

### 5.CHECK STARTER MOTOR ACTIVATION

Check that the starter motor runs at cranking.

#### Does starter motor turn?

YES >> GO TO 6.

NO >> GO TO 7.

### 6.CHECK STARTER MOTOR UNIT

1. Remove starter motor.
2. Check that the gear shaft of starter motor rotates.

#### Does gear shaft turn?

YES >> Check pinion clutch. Refer to the following.

- M9R models: [STR-24, "M9R MODELS : Inspection"](#)

- MR20DE models: [STR-29, "MR20DE MODELS : Inspection"](#).

- QR25DE (M/T) models: [STR-34, "QR25DE \(M/T\) MODELS : Inspection"](#).

- QR25DE (CVT) models: [STR-39, "QR25DE \(CVT\) MODELS : Inspection"](#)

NO >> Check reduction gear, armature and gear shaft.

### 7.CHECK POWER SUPPLY CIRCUIT

Check the following conditions.

- Fuse and fusible link
- Charge condition, corrosion and connection condition of the battery. Refer to [PG-5, "Work Flow"](#).

#### Are these inspection results normal?

YES >> GO TO 8.

NO >> Repair as needed.

### 8.CHECK STARTING SYSTEM WIRING

Check the following.

- "B" terminal circuit. Refer to [STR-8, "Diagnosis Procedure"](#).
- "S" terminal circuit. Refer to [STR-9, "Diagnosis Procedure"](#).

A

STR

C

D

E

F

G

H

I

J

K

L

M

N

O

P

# DIAGNOSIS AND REPAIR WORKFLOW

## < BASIC INSPECTION >

Are these inspection results normal?

YES >> GO TO 9.

NO >> Repair as needed.

## 9. CHECK MAGNETIC SWITCH OPERATION SOUND

Check that a magnetic switch operation sound can be heard when the ignition switch is set at the starting position.

Does magnetic switch operation sound occur?

YES >> GO TO 10.

NO >> Replace magnetic switch.

## 10. PINION AND RING GEAR ENGAGEMENT CHECK

Check condition of pinion and ring gear mesh.

Is the inspection result normal?

YES >> GO TO 12.

NO >> GO TO 11.

## 11. CHECK STARTER MOTOR UNIT

Check the following.

- Adjust pinion movement. Refer to the following.

### NOTE:

Regarding starter motor for M9R models, adjustment is not required for pinion movement.

- MR20DE models: [STR-28, "MR20DE MODELS : Disassembly and Assembly"](#)
- QR25DE (M/T) models: [STR-34, "QR25DE \(M/T\) MODELS : Disassembly and Assembly"](#)
- QR25DE (CVT) models: [STR-39, "QR25DE \(CVT\) MODELS : Disassembly and Assembly"](#)
- Check pinion moving mechanism.
- Check ring gear.

Are these inspection results normal?

YES >> INSPECTION END

NO >> Repair or replace, if necessary.

## 12. CHECK STARTER MOTOR UNIT

Check that the starter motor runs when connecting the positive terminal (12 V) to starter motor terminal M and the negative terminal (ground) to starter motor body.

Does the starter motor run?

YES >> Replace magnetic switch.

NO >> Repair starter motor.

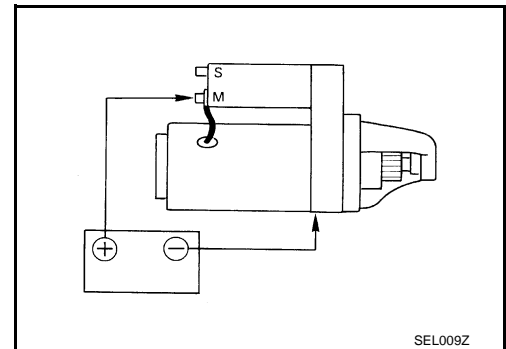

# STARTING SYSTEM

< FUNCTION DIAGNOSIS >

## FUNCTION DIAGNOSIS

### STARTING SYSTEM

#### System Diagram

INFOID:000000001208670

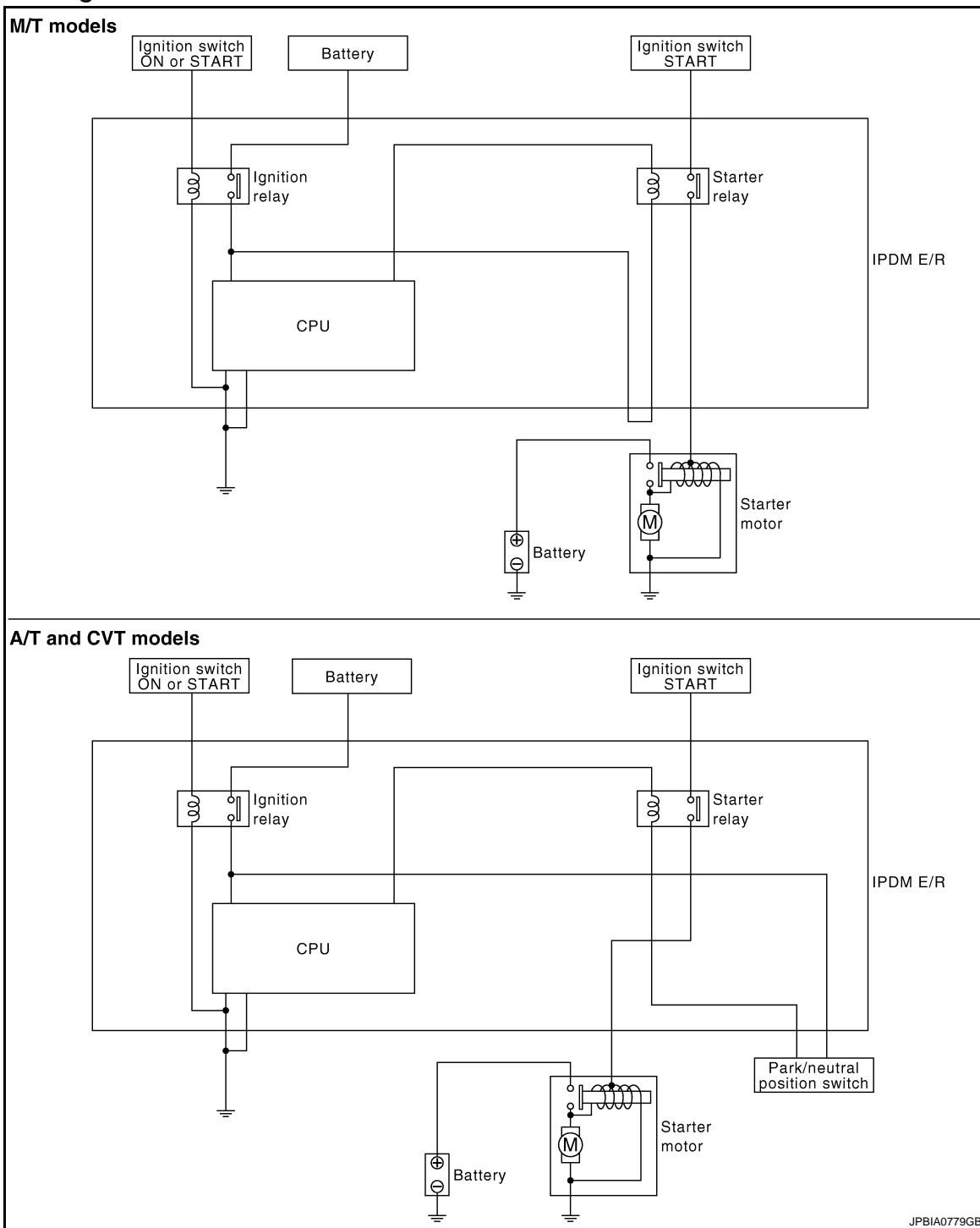

JPBIA0779GB

#### System Description

INFOID:000000001208671

The starter motor plunger closes and provides a closed circuit between the battery and starter motor. The starter motor is grounded to the engine block. With power and ground supplied, cranking occurs and the engine starts.

A  
C  
D  
E  
F  
G  
H  
I  
J  
K  
L  
M  
N  
O  
P

STR

# STARTING SYSTEM

< FUNCTION DIAGNOSIS >

## Component Parts Location

INFOID:000000001208672

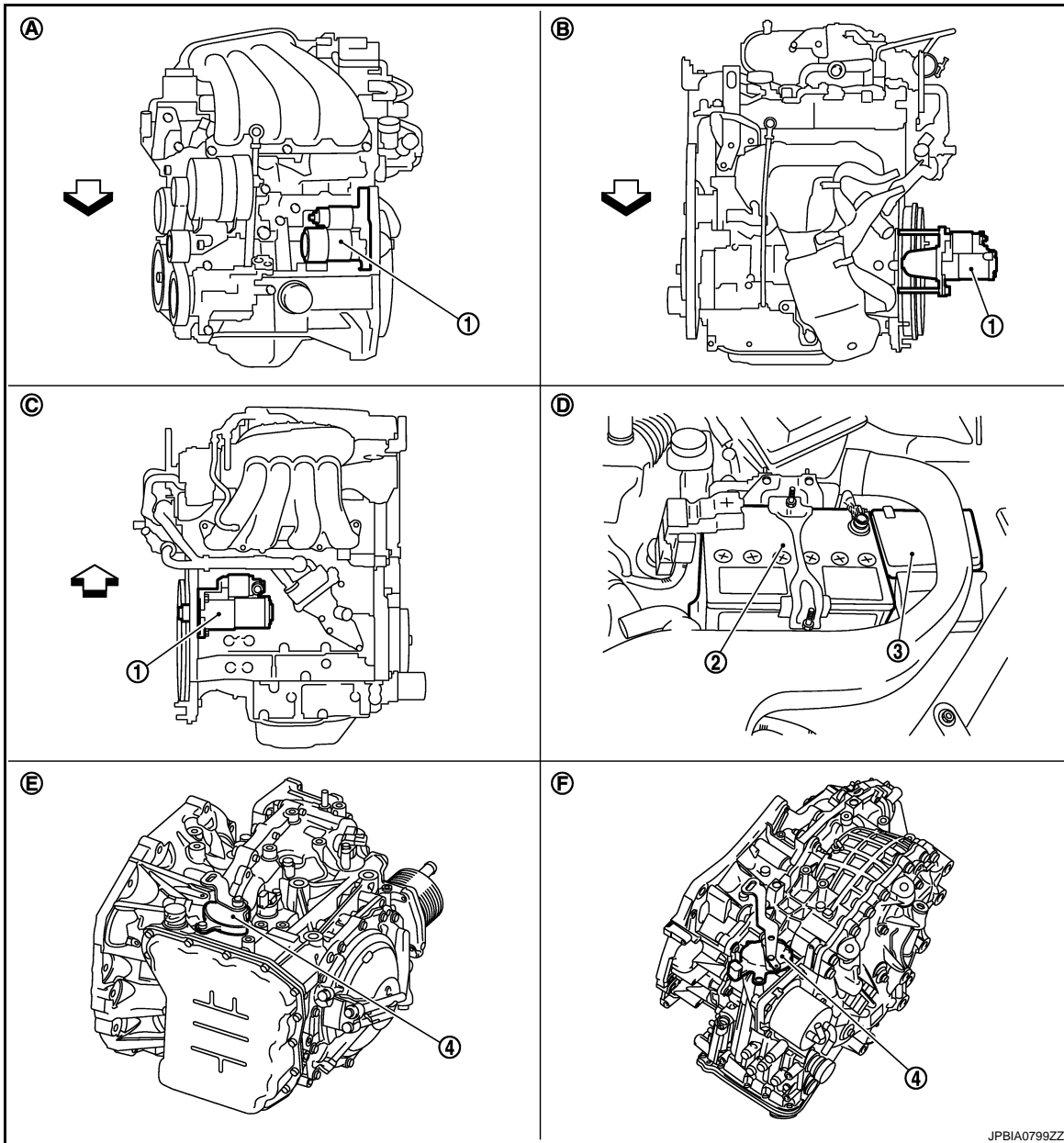

JPBIA0799ZZ

1. Starter motor

2. Battery

3. IPDM E/R

4. Park/neutral position switch

A. M9R/MR20DE engine

B. QR25DE engine (M/T models)

C. QR25DE engine (CVT models)

D. Engine room (left side)

E. A/T assembly

F. CVT assembly

↶ : Vehicle front

# STARTING SYSTEM

< FUNCTION DIAGNOSIS >

## Component Description

INFOID:000000001208673

Component part	Description
Park/neutral position switch (A/T and CVT models)	Park/neutral position switch supplies power to the starter relay inside IPDM E/R when the selector lever is shifted to the P or N position.
IPDM E/R	CPU inside IPDM E/R controls the starter relay. Ignition relay inside IPDM E/R supplies power to the park/neutral position switch when ignition switch is ON or START.
Starter motor	The starter motor plunger closes and the motor is supplied with battery power, which in turn cranks the engine, when the "S" terminal is supplied with electric power.

A

STR

C

D

E

F

G

H

I

J

K

L

M

N

O

P

# B TERMINAL CIRCUIT

< COMPONENT DIAGNOSIS >

## COMPONENT DIAGNOSIS

### B TERMINAL CIRCUIT

#### Description

INFOID:000000001208674

The "B" terminal is constantly supplied with battery power.

#### Diagnosis Procedure

INFOID:000000001208675

#### CAUTION:

Perform diagnosis under the condition that engine cannot start by the following procedure.

1. Remove fuel pump fuse.
2. Crank or start the engine (where possible) until the fuel pressure is released.

#### 1. CHECK "B" TERMINAL CIRCUIT

1. Turn ignition switch OFF.
2. Check that starter motor "B" terminal connection is clean and tight.
3. Check voltage between starter motor "B" terminal and ground.

Terminals		Voltage (Approx.)
(+)	(-)	
Starter motor "B" terminal	Terminal	Battery voltage
F10 (M9R) F52 (MR20DE) F49 (QR25DE)	2	
	Ground	

Is the inspection result normal?

YES >> GO TO 2.

NO >> Check harness between battery and starter motor for open circuit.

#### 2. CHECK BATTERY CABLE CONNECTION STATUS (VOLTAGE DROP TEST)

1. Shift A/T or CVT selector lever to "P" or "N" position. (A/T or CVT models)
2. Check voltage between battery positive terminal and starter motor "B" terminal.

Terminals		Condition	Voltage (Approx.)
(+)	(-)		
Battery positive terminal	Starter motor "B" terminal	When the ignition switch is in START position	Less than 0.5 V
	F10 (M9R) F52 (MR20DE) F49 (QR25DE)		

Is the inspection result normal?

YES >> GO TO 3.

NO >> Check harness between the battery and the starter motor for poor continuity.

#### 3. CHECK GROUND CIRCUIT STATUS (VOLTAGE DROP TEST)

1. Shift A/T or CVT selector lever to "P" or "N" position. (A/T or CVT models)
2. Check voltage between starter motor case and battery negative terminal.

Terminals		Condition	Voltage (Approx.)
(+)	(-)		
Starter motor case	Battery negative terminal	When the ignition switch is in START position	Less than 0.2 V

Is the inspection result normal?

YES >> "B" terminal circuit is OK. Further inspection is necessary. Refer to [STR-2, "Work Flow"](#).

NO >> Check the starter motor case and ground for poor continuity.



# S TERMINAL CIRCUIT

< COMPONENT DIAGNOSIS >

## S TERMINAL CIRCUIT

### Description

INFOID:000000001208676

The starter motor magnetic switch is supplied with power when the ignition switch is turned to START with the selector lever "P" or "N" for A/T or CVT models.

A  
STR

### Diagnosis Procedure

INFOID:000000001208677

#### CAUTION:

Perform diagnosis under the condition that engine cannot start by the following procedure.

1. Remove fuel pump fuse.
2. Crank or start the engine (where possible) until the fuel pressure is released.

#### 1.CHECK "S" CONNECTOR CIRCUIT

1. Turn ignition switch OFF.
2. Disconnect "S" terminal.
3. Shift A/T or CVT selector lever to "P" or "N" position. (A/T or CVT models)
4. Check voltage between starter motor harness connector and ground.

Terminals		Condition	Voltage (Approx.)
(+)	(-)		
Starter motor harness connector	Terminal		
F11 (M9R) F53 (MR20DE) F50 [QR25DE (M/T)] F47 [QR25DE (CVT)]	1	Ground	Battery voltage

Is the inspection result normal?

- YES >> "S" terminal circuit is OK. Further inspection is necessary. Refer to [STR-2. "Work Flow"](#).  
 NO >> GO TO 2.

#### 2.CHECK CONNECTOR

1. Turn ignition switch OFF.
2. Check the following terminals and connectors for damage, bend and loose connection.
  - Harness connector E8
  - Harness connector F122

Is the inspection result normal?

- YES >> GO TO 3.  
 NO >> Repair the terminal and connector.

#### 3.CHECK HARNESS CONTINUITY (OPEN CIRCUIT)

1. Disconnect IPDM E/R connector.
2. Check continuity between starter motor "S" terminal and IPDM E/R harness connector.

Starter motor "S" terminal		IPDM E/R harness connector		Continuity
Connector No.	Terminal No.	Connector No.	Terminal No.	
F11 (M9R) F53 (MR20DE) F50 [QR25DE (M/T)] F47 [QR25DE (CVT)]	1	E10	3	Existed

Is the inspection result normal?

- YES >> Inspect IPDM E/R and power supply circuit. Refer to [SEC-7. "Work Flow"](#).  
 NO >> Repair the harness.

C  
D  
E  
F  
G  
H  
I  
J  
K  
L  
M  
N  
O  
P

# STARTING SYSTEM

< COMPONENT DIAGNOSIS >

## STARTING SYSTEM

Wiring Diagram - STARTING SYSTEM (WITH M/T) -

INFOID:000000001208678

### STARTING SYSTEM (WITH M/T)

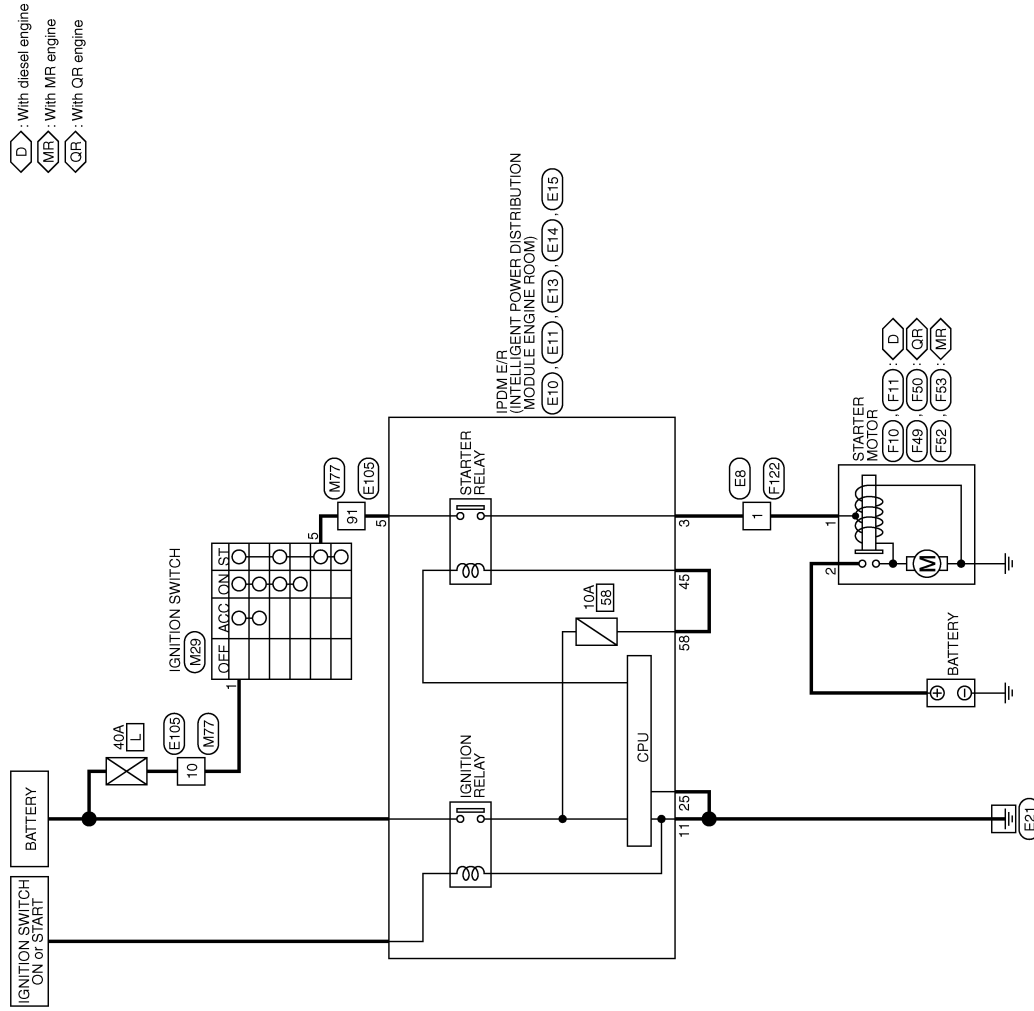

(D) : With diesel engine  
 (MF) : With MF engine  
 (OR) : With OR engine

IPDM/IR  
 (INTELLIGENT POWER DISTRIBUTION  
 MODULE ENGINE ROOM)  
 (E10) (E11) (E13) (E14) (E15)

(D) (MF) (OR)  
 (F10) (F11) (F49) (F50) (F52) (F53)

2007/02/28

JCBWA0256GE

# STARTING SYSTEM

## < COMPONENT DIAGNOSIS >

### STARTING SYSTEM (WITH M/T)

Connector No.	E8
Connector Name	WIRE TO WIRE
Connector Type	M02MW-LC



Terminal No.	1	Color of Wire	O	Signal Name [Specification]	-
2					

Connector No.	E10
Connector Name	IPDM E/R INTELLIGENT POWER DISTRIBUTION MODULE (ENGINE ROOM)
Connector Type	M08FW-LC



Terminal No.	3	Color of Wire	O	Signal Name [Specification]	-
5					

Connector No.	E11
Connector Name	IPDM E/R INTELLIGENT POWER DISTRIBUTION MODULE (ENGINE ROOM)
Connector Type	M08FB-LC



Terminal No.	11	Color of Wire	B	Signal Name [Specification]	-
--------------	----	---------------	---	-----------------------------	---

Connector No.	E13
Connector Name	IPDM E/R INTELLIGENT POWER DISTRIBUTION MODULE (ENGINE ROOM)
Connector Type	TH12FW-NH



Terminal No.	25	Color of Wire	B	Signal Name [Specification]	-
--------------	----	---------------	---	-----------------------------	---

Connector No.	E14
Connector Name	IPDM E/R INTELLIGENT POWER DISTRIBUTION MODULE (ENGINE ROOM)
Connector Type	NS12FB-CS



Terminal No.	45	Color of Wire	Y	Signal Name [Specification]	-
--------------	----	---------------	---	-----------------------------	---

Connector No.	E15
Connector Name	IPDM E/R INTELLIGENT POWER DISTRIBUTION MODULE (ENGINE ROOM)
Connector Type	NS16FW-CS



Terminal No.	58	Color of Wire	Y	Signal Name [Specification]	-[With M/T]
--------------	----	---------------	---	-----------------------------	-------------

Connector No.	E105
Connector Name	WIRE TO WIRE
Connector Type	TH88FW-CS16-TM4

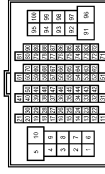

Terminal No.	10	Color of Wire	L	Signal Name [Specification]	-
81					

Connector No.	F10
Connector Name	STARTER MOTOR
Connector Type	-



Terminal No.	2	Color of Wire	B/R	Signal Name [Specification]	-
--------------	---	---------------	-----	-----------------------------	---

A

STR

C

D

E

F

G

H

I

J

K

L

M

N

O

P

# STARTING SYSTEM

## < COMPONENT DIAGNOSIS >

### STARTING SYSTEM (WITH M/T)

Connector No.	F11	Connector No.	F49	Connector No.	F50	Connector No.	F52
Connector Name	STARTER MOTOR	Connector Name	STARTER MOTOR	Connector Name	STARTER MOTOR	Connector Name	STARTER MOTOR
Connector Type	-	Connector Type	-	Connector Type	-	Connector Type	-

Terminal No.	1	Terminal No.	2	Terminal No.	1	Terminal No.	2
Color of Wire	O	Color of Wire	B/R	Color of Wire	O	Color of Wire	B/R
Signal Name [Specification]	-	Signal Name [Specification]	-	Signal Name [Specification]	-	Signal Name [Specification]	-

Terminal No.	1	Terminal No.	2
Color of Wire	O	Color of Wire	B/R
Signal Name [Specification]	-	Signal Name [Specification]	-

Terminal No.	1	Terminal No.	2
Color of Wire	O	Color of Wire	B/R
Signal Name [Specification]	-	Signal Name [Specification]	-

Connector No.	F53	Connector No.	F122	Connector No.	M29	Connector No.	M77
Connector Name	STARTER MOTOR	Connector Name	WIRE TO WIRE	Connector Name	IGNITION SWITCH	Connector Name	WIRE TO WIRE
Connector Type	-	Connector Type	IM2FW-LC	Connector Type	M06FW-LC	Connector Type	TH80MW-GS16-TM4

Terminal No.	1	Terminal No.	1	Terminal No.	1	Terminal No.	10
Color of Wire	O	Color of Wire	O	Color of Wire	L	Color of Wire	L
Signal Name [Specification]	-	Signal Name [Specification]	-	Signal Name [Specification]	-	Signal Name [Specification]	-

Terminal No.	1	Terminal No.	2
Color of Wire	O	Color of Wire	B/R
Signal Name [Specification]	-	Signal Name [Specification]	-

Terminal No.	1	Terminal No.	5
Color of Wire	O	Color of Wire	R
Signal Name [Specification]	-	Signal Name [Specification]	-

Terminal No.	1	Terminal No.	81
Color of Wire	O	Color of Wire	R
Signal Name [Specification]	-	Signal Name [Specification]	-

# STARTING SYSTEM

< COMPONENT DIAGNOSIS >

## Wiring Diagram - STARTING SYSTEM (WITH A/T) -

INFOID:000000001532448

### STARTING SYSTEM (WITH A/T)

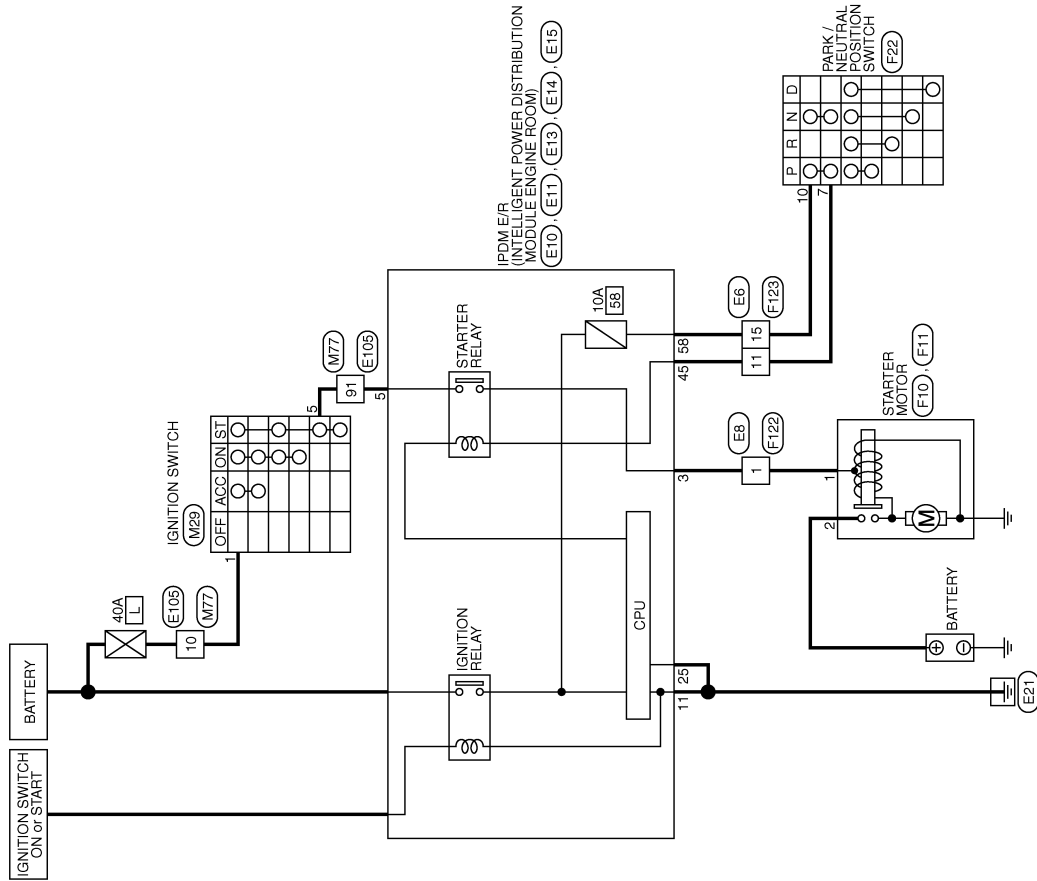

2007/02/28







JCBWA0259GE

A  
STR  
C  
D  
E  
F  
G  
H  
I  
J  
K  
L  
M  
N  
O  
P

# STARTING SYSTEM

## < COMPONENT DIAGNOSIS >

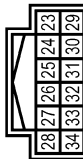
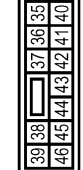
### STARTING SYSTEM (WITH A/T)













Connector No. EB	WIRE TO WIRE	TK24MW-1V		Terminal No. 11	Y	Signal Name [Specification]	
Connector No. EB	WIRE TO WIRE	M02MW-LC		Terminal No. 1	O	Signal Name [Specification]	
Connector No. E10	IPDM E/R (INTELLIGENT POWER DISTRIBUTION MODULE ENGINE ROOM)	M06FW-LC		Terminal No. 3	O	Signal Name [Specification]	
Connector No. E11	IPDM E/R (INTELLIGENT POWER DISTRIBUTION MODULE ENGINE ROOM)	M06FEB-LC		Terminal No. 11	B	Signal Name [Specification]	
Connector No. E13	IPDM E/R (INTELLIGENT POWER DISTRIBUTION MODULE ENGINE ROOM)	TH12FW-NH		Terminal No. 25	B	Signal Name [Specification]	
Connector No. E14	IPDM E/R (INTELLIGENT POWER DISTRIBUTION MODULE ENGINE ROOM)	NS12FBR-CS		Terminal No. 45	Y	Signal Name [Specification]	
Connector No. E15	IPDM E/R (INTELLIGENT POWER DISTRIBUTION MODULE ENGINE ROOM)	NS10FW-CS		Terminal No. 58	LG	Signal Name [Specification]	- [Except M/T]
Connector No. E105	WIRE TO WIRE	TH06FW-CS16-TM4		Terminal No. 10	L	Signal Name [Specification]	

JCBWA0260GE

# STARTING SYSTEM

## < COMPONENT DIAGNOSIS >

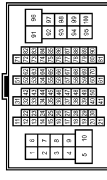
### STARTING SYSTEM (WITH A/T)

<table border="1"> <tr><td>Connector No.</td><td>F10</td></tr> <tr><td>Connector Name</td><td>STARTER MOTOR</td></tr> <tr><td>Connector Type</td><td>-</td></tr> </table>  	Connector No.	F10	Connector Name	STARTER MOTOR	Connector Type	-	<table border="1"> <tr><td>Terminal No.</td><td>2</td></tr> <tr><td>Color of Wire</td><td>B/R</td></tr> <tr><td>Signal Name [Specification]</td><td>-</td></tr> </table>	Terminal No.	2	Color of Wire	B/R	Signal Name [Specification]	-						
Connector No.	F10																		
Connector Name	STARTER MOTOR																		
Connector Type	-																		
Terminal No.	2																		
Color of Wire	B/R																		
Signal Name [Specification]	-																		
<table border="1"> <tr><td>Connector No.</td><td>F11</td></tr> <tr><td>Connector Name</td><td>STARTER MOTOR</td></tr> <tr><td>Connector Type</td><td>-</td></tr> </table>  	Connector No.	F11	Connector Name	STARTER MOTOR	Connector Type	-	<table border="1"> <tr><td>Terminal No.</td><td>1</td></tr> <tr><td>Color of Wire</td><td>O</td></tr> <tr><td>Signal Name [Specification]</td><td>-</td></tr> </table>	Terminal No.	1	Color of Wire	O	Signal Name [Specification]	-						
Connector No.	F11																		
Connector Name	STARTER MOTOR																		
Connector Type	-																		
Terminal No.	1																		
Color of Wire	O																		
Signal Name [Specification]	-																		
<table border="1"> <tr><td>Connector No.</td><td>F22</td></tr> <tr><td>Connector Name</td><td>PARK / NEUTRAL POSITION SWITCH</td></tr> <tr><td>Connector Type</td><td>YAZAKI 7283-8700-30</td></tr> </table>  	Connector No.	F22	Connector Name	PARK / NEUTRAL POSITION SWITCH	Connector Type	YAZAKI 7283-8700-30	<table border="1"> <tr><td>Terminal No.</td><td>7</td></tr> <tr><td>Color of Wire</td><td>Y</td></tr> <tr><td>Signal Name [Specification]</td><td>-</td></tr> <tr><td>Terminal No.</td><td>10</td></tr> <tr><td>Color of Wire</td><td>GR</td></tr> <tr><td>Signal Name [Specification]</td><td>-</td></tr> </table>	Terminal No.	7	Color of Wire	Y	Signal Name [Specification]	-	Terminal No.	10	Color of Wire	GR	Signal Name [Specification]	-
Connector No.	F22																		
Connector Name	PARK / NEUTRAL POSITION SWITCH																		
Connector Type	YAZAKI 7283-8700-30																		
Terminal No.	7																		
Color of Wire	Y																		
Signal Name [Specification]	-																		
Terminal No.	10																		
Color of Wire	GR																		
Signal Name [Specification]	-																		
<table border="1"> <tr><td>Connector No.</td><td>F122</td></tr> <tr><td>Connector Name</td><td>WIRE TO WIRE</td></tr> <tr><td>Connector Type</td><td>M02FW-LC</td></tr> </table>  	Connector No.	F122	Connector Name	WIRE TO WIRE	Connector Type	M02FW-LC	<table border="1"> <tr><td>Terminal No.</td><td>1</td></tr> <tr><td>Color of Wire</td><td>O</td></tr> <tr><td>Signal Name [Specification]</td><td>-</td></tr> </table>	Terminal No.	1	Color of Wire	O	Signal Name [Specification]	-						
Connector No.	F122																		
Connector Name	WIRE TO WIRE																		
Connector Type	M02FW-LC																		
Terminal No.	1																		
Color of Wire	O																		
Signal Name [Specification]	-																		
<table border="1"> <tr><td>Connector No.</td><td>M29</td></tr> <tr><td>Connector Name</td><td>IGNITION SWITCH</td></tr> <tr><td>Connector Type</td><td>M06FW-LC</td></tr> </table>  	Connector No.	M29	Connector Name	IGNITION SWITCH	Connector Type	M06FW-LC	<table border="1"> <tr><td>Terminal No.</td><td>1</td></tr> <tr><td>Color of Wire</td><td>L</td></tr> <tr><td>Signal Name [Specification]</td><td>-</td></tr> <tr><td>Terminal No.</td><td>5</td></tr> <tr><td>Color of Wire</td><td>R</td></tr> <tr><td>Signal Name [Specification]</td><td>-</td></tr> </table>	Terminal No.	1	Color of Wire	L	Signal Name [Specification]	-	Terminal No.	5	Color of Wire	R	Signal Name [Specification]	-
Connector No.	M29																		
Connector Name	IGNITION SWITCH																		
Connector Type	M06FW-LC																		
Terminal No.	1																		
Color of Wire	L																		
Signal Name [Specification]	-																		
Terminal No.	5																		
Color of Wire	R																		
Signal Name [Specification]	-																		
<table border="1"> <tr><td>Connector No.</td><td>M77</td></tr> <tr><td>Connector Name</td><td>WIRE TO WIRE</td></tr> <tr><td>Connector Type</td><td>TH80MW-GS16-TM4</td></tr> </table>  	Connector No.	M77	Connector Name	WIRE TO WIRE	Connector Type	TH80MW-GS16-TM4	<table border="1"> <tr><td>Terminal No.</td><td>10</td></tr> <tr><td>Color of Wire</td><td>L</td></tr> <tr><td>Signal Name [Specification]</td><td>-</td></tr> <tr><td>Terminal No.</td><td>81</td></tr> <tr><td>Color of Wire</td><td>R</td></tr> <tr><td>Signal Name [Specification]</td><td>-</td></tr> </table>	Terminal No.	10	Color of Wire	L	Signal Name [Specification]	-	Terminal No.	81	Color of Wire	R	Signal Name [Specification]	-
Connector No.	M77																		
Connector Name	WIRE TO WIRE																		
Connector Type	TH80MW-GS16-TM4																		
Terminal No.	10																		
Color of Wire	L																		
Signal Name [Specification]	-																		
Terminal No.	81																		
Color of Wire	R																		
Signal Name [Specification]	-																		
<table border="1"> <tr><td>Connector No.</td><td>F123</td></tr> <tr><td>Connector Name</td><td>WIRE TO WIRE</td></tr> <tr><td>Connector Type</td><td>TK2FW-TV</td></tr> </table>  	Connector No.	F123	Connector Name	WIRE TO WIRE	Connector Type	TK2FW-TV	<table border="1"> <tr><td>Terminal No.</td><td>11</td></tr> <tr><td>Color of Wire</td><td>LG</td></tr> <tr><td>Signal Name [Specification]</td><td>-</td></tr> <tr><td>Terminal No.</td><td>15</td></tr> <tr><td>Color of Wire</td><td>GR</td></tr> <tr><td>Signal Name [Specification]</td><td>-</td></tr> </table>	Terminal No.	11	Color of Wire	LG	Signal Name [Specification]	-	Terminal No.	15	Color of Wire	GR	Signal Name [Specification]	-
Connector No.	F123																		
Connector Name	WIRE TO WIRE																		
Connector Type	TK2FW-TV																		
Terminal No.	11																		
Color of Wire	LG																		
Signal Name [Specification]	-																		
Terminal No.	15																		
Color of Wire	GR																		
Signal Name [Specification]	-																		

JCBWA0261GE

# STARTING SYSTEM

< COMPONENT DIAGNOSIS >

## Wiring Diagram - STARTING SYSTEM (WITH CVT) -

INFOID:000000001208679

### STARTING SYSTEM (WITH CVT)

ME : With MR engine  
 OR : With OR engine

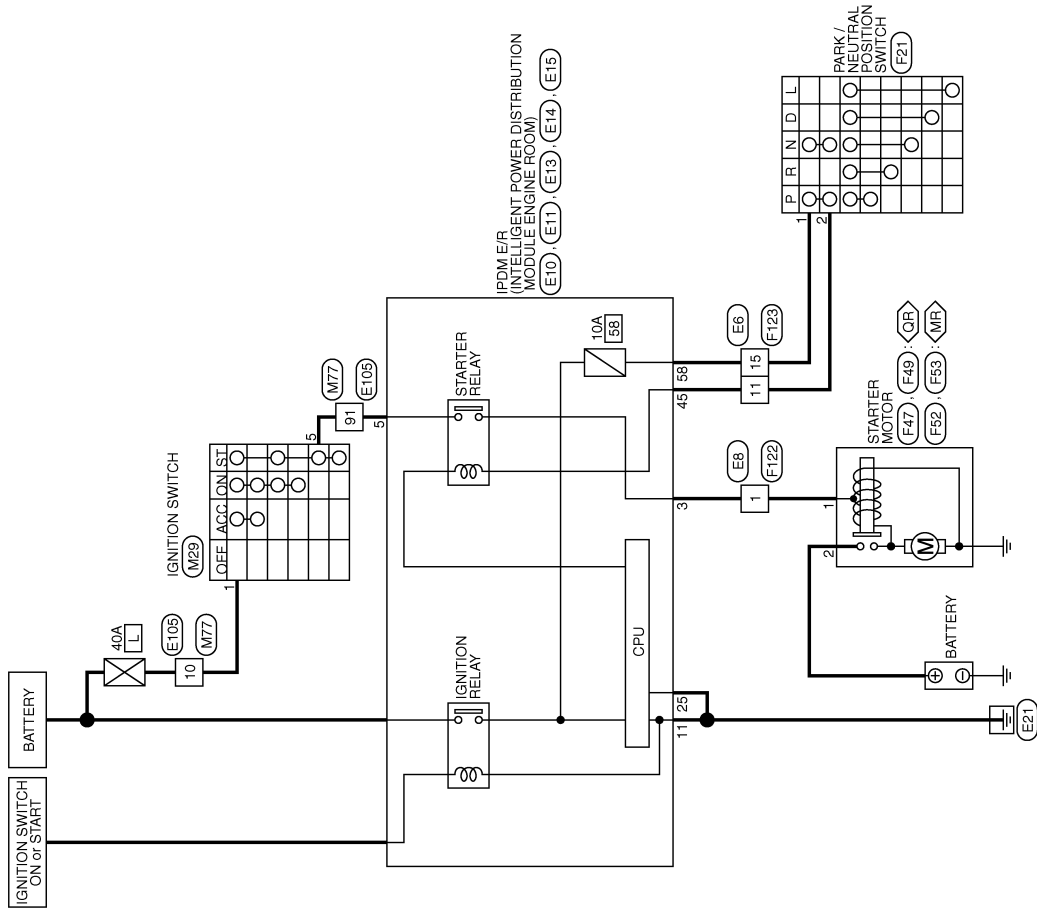

2007/02/28

JCBWA0262GE



# STARTING SYSTEM

< COMPONENT DIAGNOSIS >

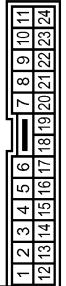

## STARTING SYSTEM (WITH CVT)

Connector No.	E6
Connector Name	WIRE TO WIRE
Connector Type	TK24MW-1V



Terminal No.	Color of Wire	Signal Name [Specification]
11	Y	-
15	LG	-

Connector No.	E8
Connector Name	WIRE TO WIRE
Connector Type	M02MW-LC



Terminal No.	Color of Wire	Signal Name [Specification]
1	O	-

Connector No.	E10
Connector Name	IPDM E/R (INTELLIGENT POWER DISTRIBUTION MODULE ENGINE ROOM)
Connector Type	M06FW-LC



Terminal No.	Color of Wire	Signal Name [Specification]
3	O	-
5	R	-

Connector No.	E11
Connector Name	IPDM E/R (INTELLIGENT POWER DISTRIBUTION MODULE ENGINE ROOM)
Connector Type	M06FB-LC

Terminal No.	Color of Wire	Signal Name [Specification]
11	B	-

Connector No.	E13
Connector Name	IPDM E/R (INTELLIGENT POWER DISTRIBUTION MODULE ENGINE ROOM)
Connector Type	TH12FW-RH

Terminal No.	Color of Wire	Signal Name [Specification]
25	B	-

Connector No.	E14
Connector Name	IPDM E/R (INTELLIGENT POWER DISTRIBUTION MODULE ENGINE ROOM)
Connector Type	NS12FBR-CS

Terminal No.	Color of Wire	Signal Name [Specification]
45	Y	-

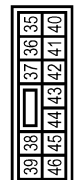
Connector No.	E15
Connector Name	IPDM E/R (INTELLIGENT POWER DISTRIBUTION MODULE ENGINE ROOM)
Connector Type	NS18FW-CS

Terminal No.	Color of Wire	Signal Name [Specification]
58	LG	-[Except M/T]

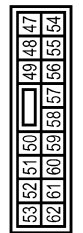
Connector No.	E105
Connector Name	WIRE TO WIRE
Connector Type	TH80FW-GS16-TM4

Terminal No.	Color of Wire	Signal Name [Specification]
10	L	-
91	R	-

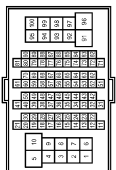
JCBWA0263GE

A  
STR  
C  
D  
E  
F  
G  
H  
I  
J  
K  
L  
M  
N  
O  
P

# STARTING SYSTEM

## < COMPONENT DIAGNOSIS >

### STARTING SYSTEM (WITH CVT)

Connector No.	F21
Connector Name	PARK / NEUTRAL POSITION SWITCH
Connector Type	RCQ8FG



Terminal No.	Color of Wire	Signal Name [Specification]
1	GR	-
2	Y	-

Connector No.	F47
Connector Name	STARTER MOTOR
Connector Type	XQ1MGY



Terminal No.	Color of Wire	Signal Name [Specification]
1	O	-

Connector No.	F49
Connector Name	STARTER MOTOR
Connector Type	-



Terminal No.	Color of Wire	Signal Name [Specification]
2	B/R	-

Connector No.	F52
Connector Name	STARTER MOTOR
Connector Type	-



Terminal No.	Color of Wire	Signal Name [Specification]
2	B/R	-

Connector No.	F53
Connector Name	STARTER MOTOR
Connector Type	-



Terminal No.	Color of Wire	Signal Name [Specification]
1	O	-

Connector No.	F122
Connector Name	WIRE TO WIRE
Connector Type	IMQ2FW-LC



Terminal No.	Color of Wire	Signal Name [Specification]
1	O	-

Connector No.	F123
Connector Name	WIRE TO WIRE
Connector Type	TK24FW-IV

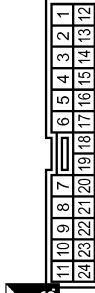

Terminal No.	Color of Wire	Signal Name [Specification]
11	LG	-
15	GR	-

Connector No.	M29
Connector Name	IGNITION SWITCH
Connector Type	MO6FW-LC



Terminal No.	Color of Wire	Signal Name [Specification]
1	L	-
5	R	-

# STARTING SYSTEM

## < COMPONENT DIAGNOSIS >

A

**STR**

C

D

E

F

G

H

I

J

K

L

M

N

O

P

**STARTING SYSTEM (WITH CVT)**

Connector No.	M77
Connector Name	WIRE TO WIRE
Connector Type	THROW-CSI6-TM4

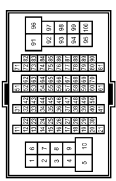

Terminal No.	Color of Wire	Signal Name (Specification)
10	L	-
9	R	-



JCBWA0265GE

# STARTING SYSTEM

< SYMPTOM DIAGNOSIS >

## SYMPTOM DIAGNOSIS

### STARTING SYSTEM

#### Symptom Table

INFOID:000000001208680

Symptom	Reference
No normal cranking	Refer to <a href="#">STR-2, "Work Flow"</a> .
Starter motor does not rotate	

# PRECAUTIONS

< PRECAUTION >

## PRECAUTION

### PRECAUTIONS

#### Precaution for Supplemental Restraint System (SRS) "AIR BAG" and "SEAT BELT PRE-TENSIONER"

INFOID:000000001308689

The Supplemental Restraint System such as "AIR BAG" and "SEAT BELT PRE-TENSIONER", used along with a front seat belt, helps to reduce the risk or severity of injury to the driver and front passenger for certain types of collision. Information necessary to service the system safely is included in the "SRS AIRBAG" and "SEAT BELT" of this Service Manual.

**WARNING:**

- To avoid rendering the SRS inoperative, which could increase the risk of personal injury or death in the event of a collision which would result in air bag inflation, all maintenance must be performed by an authorized NISSAN/INFINITI dealer.
- Improper maintenance, including incorrect removal and installation of the SRS, can lead to personal injury caused by unintentional activation of the system. For removal of Spiral Cable and Air Bag Module, see the "SRS AIRBAG".
- Do not use electrical test equipment on any circuit related to the SRS unless instructed to in this Service Manual. SRS wiring harnesses can be identified by yellow and/or orange harnesses or harness connectors.

A

STR

C

D

E

F

G

H

I

J

K

L

M

N

O

P

# STARTER MOTOR

< ON-VEHICLE REPAIR >

## ON-VEHICLE REPAIR

### STARTER MOTOR

#### M9R MODELS

#### M9R MODELS : Exploded View

INFOID:000000001208682

#### REMOVAL

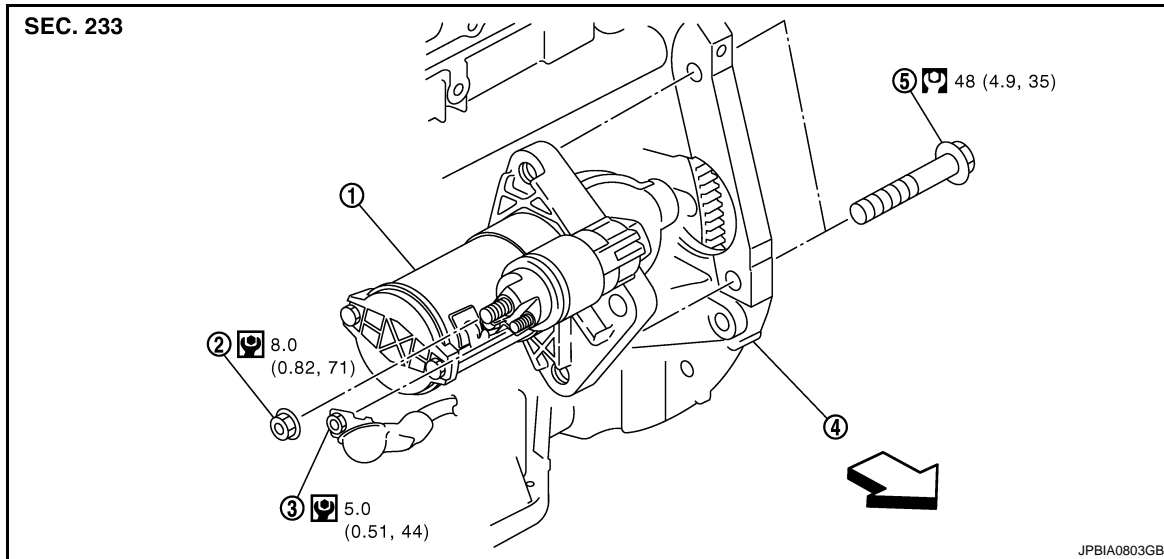

1. Starter motor
2. "B" terminal nut
3. "S" terminal nut
4. Cylinder block
5. Starter motor mounting bolt

↔ : Vehicle front

Refer to [GI-4, "Components"](#) for symbols in the figure.

#### DISASSEMBLY

Type: 194262

# STARTER MOTOR

< ON-VEHICLE REPAIR >

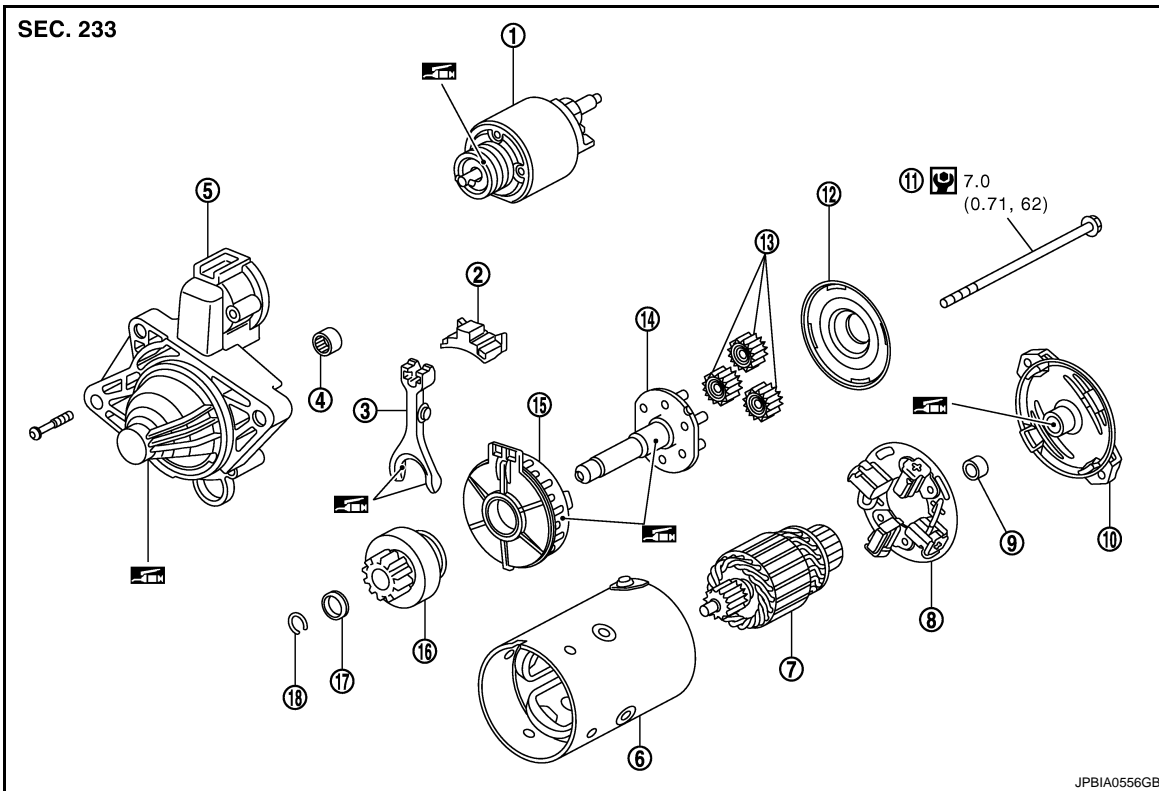

- |                             |                          |                   |
|-----------------------------|--------------------------|-------------------|
| 1. Solenoid switch assembly | 2. Lever holder          | 3. Shift lever    |
| 4. Needle bearing           | 5. Front bracket         | 6. Yoke           |
| 7. Armature                 | 8. Brush holder assembly | 9. Needle bearing |
| 10. Rear cover              | 11. Through bolt         | 12. Cover         |
| 13. Planetary gear          | 14. Pinion shaft         | 15. Internal gear |
| 16. Pinion assembly         | 17. Stopper              | 18. Stop ring     |

 : High-temperature grease point

Refer to [GI-4, "Components"](#) for symbols not described on the above.

## M9R MODELS : Removal and Installation

INFOID:000000001208683

### REMOVAL

1. Disconnect the battery cable from the negative terminal.
2. Remove air duct (inlet). Refer to [EM-263, "Exploded View"](#).
3. Remove clip (A).

1 : Harness bracket

 : Vehicle front

4. Remove harness bracket bolt (B).
5. Remove "S" terminal nut (C) and "S" terminal harness.
6. Remove "B" terminal nut (D) and "B" terminal harness.

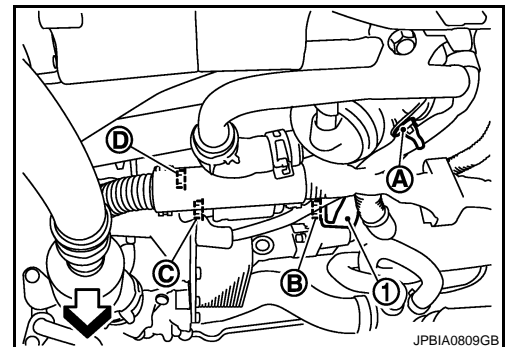

7. Remove starter motor mounting bolts.
8. Remove starter motor upward from the vehicle.

### INSTALLATION

# STARTER MOTOR

## < ON-VEHICLE REPAIR >

Install in the reverse order of removal.

### CAUTION:

Be sure to tighten "B" terminal nut carefully.

## M9R MODELS : Disassembly and Assembly

INFOID:000000001208920

### ASSEMBLY

Apply high-temperature grease to lubricate the bearing, gears and frictional surface when assembling the starter.

## M9R MODELS : Inspection

INFOID:000000001208921

### INSPECTION

#### Solenoid Switch Check

- Before starting to check, disconnect the battery cable from the negative terminal.
- Disconnect "M" terminal of starter motor.

#### 1. Continuity test [between "S" terminal (A) and switch body]

B : "B" terminal

C : "M" terminal

- Replace solenoid switch if continuity does not exist.

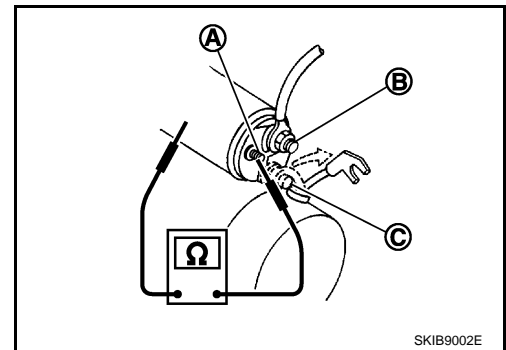

#### 2. Continuity test [between "S" terminal (A) and "M" terminal (C)]

B : "B" terminal

- Replace solenoid switch if continuity does not exist.

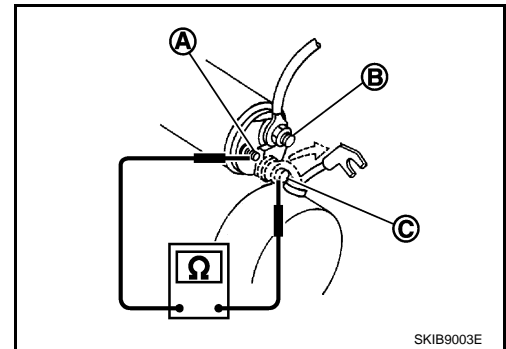

#### Pinion/Clutch Check

1. Inspect pinion teeth.
  - Replace pinion if teeth are worn or damaged. (Also check condition of ring gear teeth.)
2. Inspect reduction gear teeth (If equipped).
  - Replace reduction gear if teeth are worn or damaged. (Also check condition of armature shaft gear teeth.)
3. Check to see if pinion locks in one direction and rotates smoothly in the opposite direction.
  - Replace pinion assembly if it is locked or rotated in both directions or unusual resistance is evident.

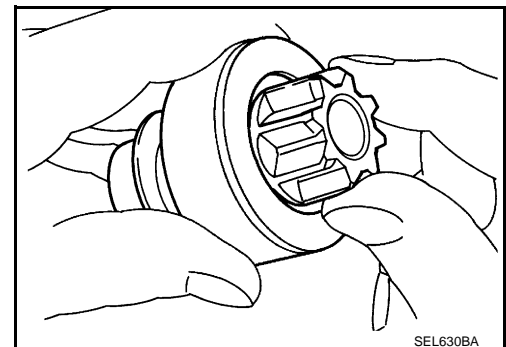

#### Brush Check



# STARTER MOTOR

## < ON-VEHICLE REPAIR >

- Check wear of brush.

**Minimum length of brush** : Refer to SDS [STR-43, "Starter Motor"](#).

- Replace brush if the measurement value is less than the specified value.

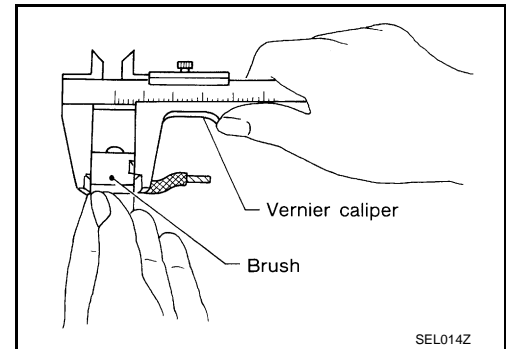

### Brush Spring Check

- Check brush spring tension with brush spring detached from brush.

**Spring tension (with new brush)** : Refer to SDS [STR-43, "Starter Motor"](#).

- Replace brush spring if the measurement value is less than the specified value.

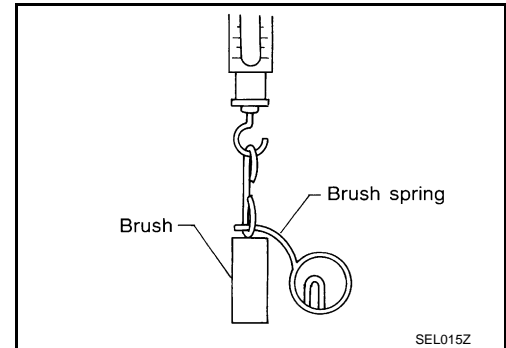

### Brush Holder Check

1. Perform insulation test between brush holder (positive side) and its base (negative side).
  - Replace brush holder assembly if continuity does not exist.
2. Check brush to see if it moves smoothly.
  - If brush holder is bent, replace it; if sliding surface is dirty, clean.

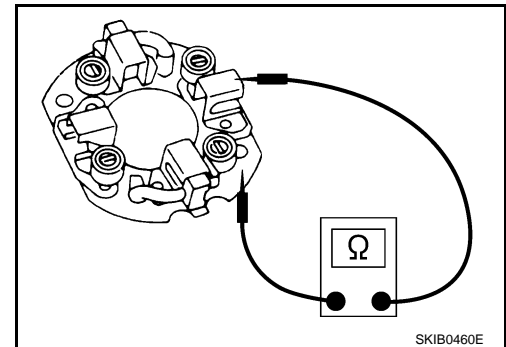

### Yoke Check

Magnet is secured to yoke by bonding agent. Check magnet to see that it is secured to yoke and for any cracks. Replace malfunctioning parts as an assembly.

**CAUTION:**

**Never clamp yoke in a vise or strike it with a hammer.**

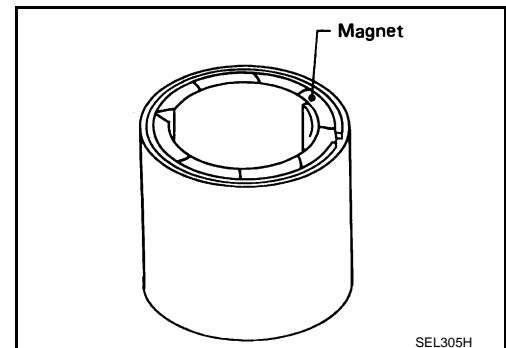

### Armature Check

# STARTER MOTOR

## < ON-VEHICLE REPAIR >

1. Continuity test (between two segments side by side)
  - Replace armature assembly if continuity does not exist.
2. Insulation test (between each commutator bar and shaft)
  - Replace armature assembly if continuity exists.

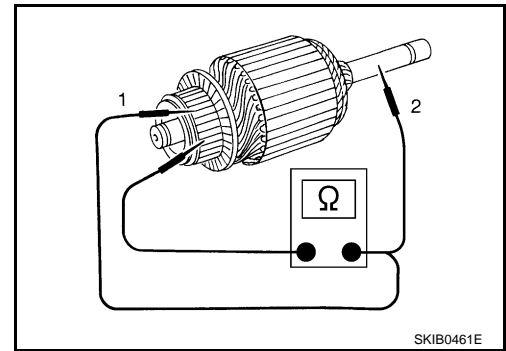

3. Check commutator surface.
  - Grind with No. 500 - 600 emery paper if it has a rough surface.

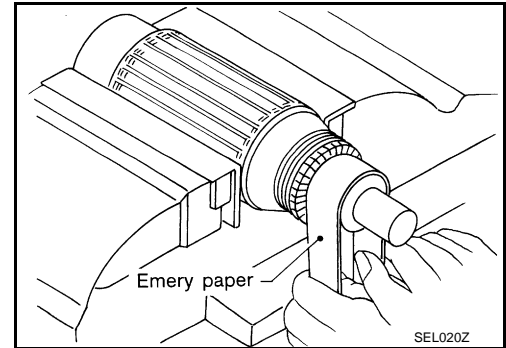

4. Check diameter of commutator.

**Commutator minimum diameter** : Refer to SDS [STR-43](#), "[Starter Motor](#)".

- Replace armature assembly if the measurement value is less than the specified value.

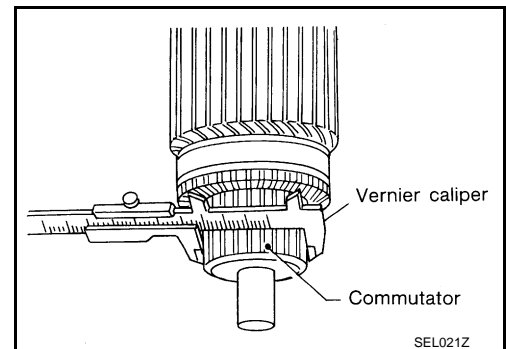

# STARTER MOTOR

## < ON-VEHICLE REPAIR >

5. Check depth of insulating mold from commutator surface.
  - Undercut to 0.5 to 0.8 mm (0.020 to 0.031 in) if the depth is 0.2 mm (0.008 in) or less.

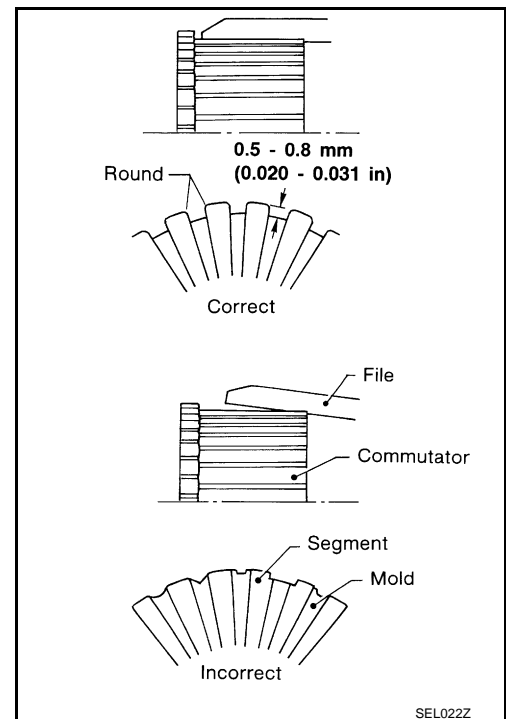

## MR20DE MODELS

### MR20DE MODELS : Exploded View

INFOID:000000001208684

### REMOVAL

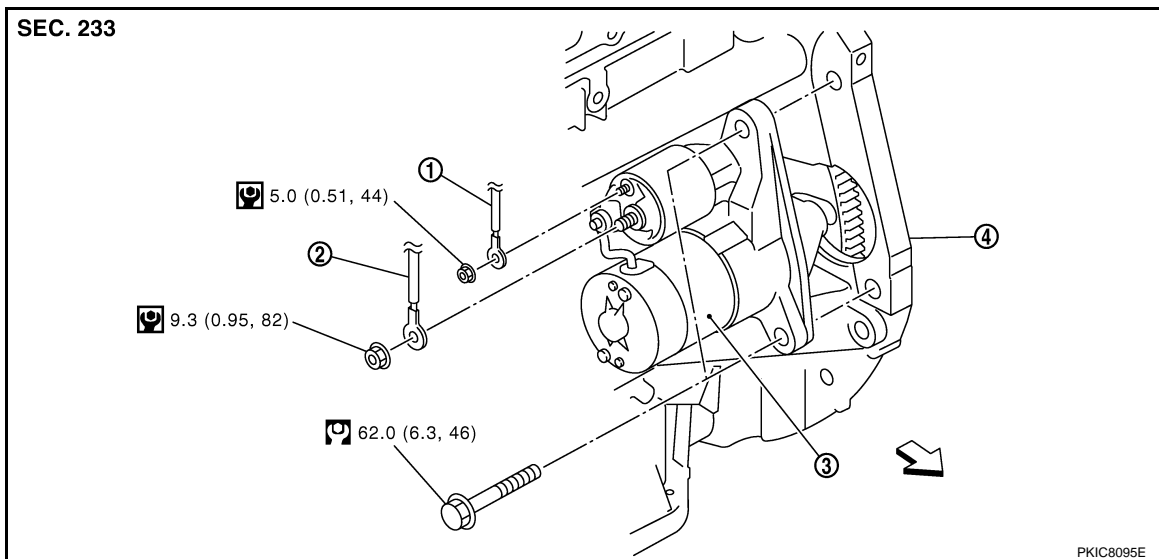

1. "S" terminal harness
2. "B" terminal harness
3. Starter motor
4. Cylinder block

← : Vehicle front

Refer to [GI-4. "Components"](#) for symbols in the figure.

### DISASSEMBLY

Type: S114-902A

# STARTER MOTOR

< ON-VEHICLE REPAIR >

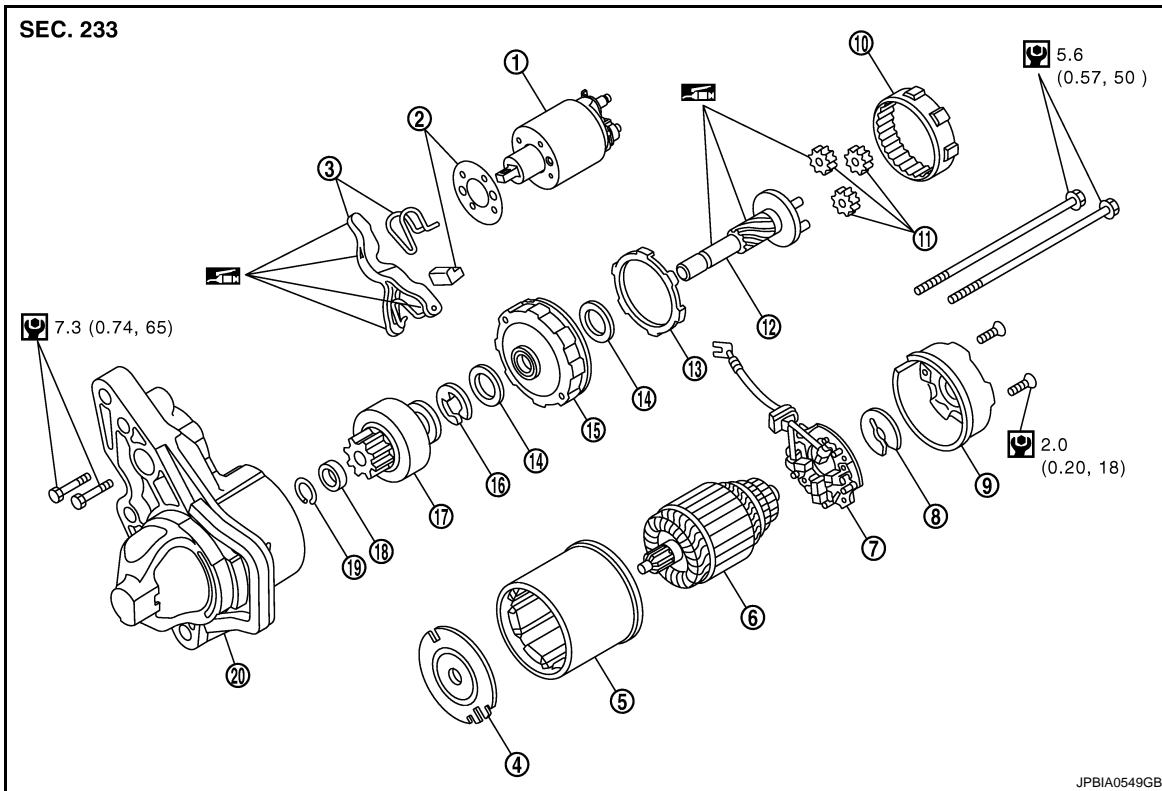

- |                             |                        |                        |
|-----------------------------|------------------------|------------------------|
| 1. Magnetic switch assembly | 2. Dust cover kit      | 3. Shift lever set     |
| 4. Center bracket (A)       | 5. Yoke assembly       | 6. Armature assembly   |
| 7. Brush holder assembly    | 8. Thrust washer       | 9. Rear cover assembly |
| 10. Internal gear           | 11. Planetary gear     | 12. Pinion shaft       |
| 13. Packing                 | 14. Thrust washer      | 15. Center bracket (P) |
| 16. E-ring                  | 17. Pinion assembly    | 18. Pinion stopper     |
| 19. Pinion stopper clip     | 20. Gear case assembly |                        |

 : High-temperature grease point

Refer to [GI-4, "Components"](#) for symbols not described on the above.

## MR20DE MODELS : Removal and Installation

INFOID:000000001208685

### REMOVAL

1. Disconnect the battery cable from the negative terminal.
2. Remove air duct (inlet). Refer to [EM-25, "Exploded View"](#).
3. Disconnect oil pressure switch connector.
4. Remove "B" terminal nut and "B" terminal harness.
5. Remove "S" terminal nut and "S" terminal harness.
6. Remove starter motor mounting bolts.
7. Remove starter motor upward from the vehicle.

### INSTALLATION

Install in the reverse order of removal.

#### **CAUTION:**

**Be sure to tighten "B" terminal nut carefully.**

## MR20DE MODELS : Disassembly and Assembly

INFOID:000000001208686

### ASSEMBLY

# STARTER MOTOR

## < ON-VEHICLE REPAIR >

Apply high-temperature grease to lubricate the bearing, gears and frictional surface when assembling the starter.

Carefully observe the following instructions.

### Pinion Protrusion Length Adjustment

#### CLEARANCE

- With pinion driven out by magnetic switch, push pinion back to remove slack and measure clearance "L" between the front edge of the pinion and the pinion stopper.

Clearance "L"

: Refer to SDS [STR-43](#),  
["Starter Motor"](#).

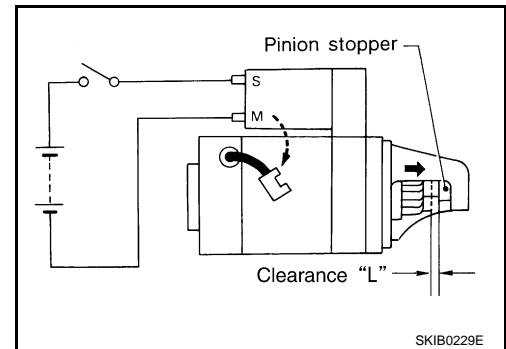

- Adjust with the adjusting plate if the measurement value is not in the specified area.

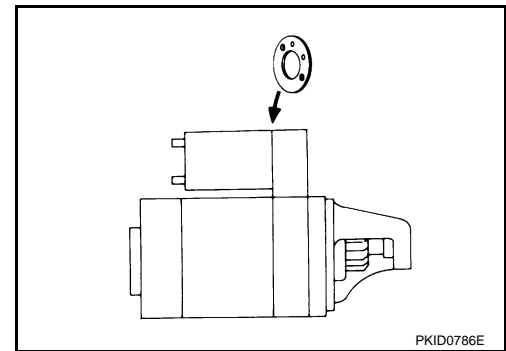

INFOID:000000001208687

## MR20DE MODELS : Inspection

### INSPECTION

#### Magnetic Switch Check

- Before starting to check, disconnect the battery cable from the negative terminal.
- Disconnect "M" terminal of starter motor.

1. Continuity test [between "S" terminal (A) and switch body]

B : "B" terminal  
C : "M" terminal

- Replace magnetic switch if continuity does not exist.

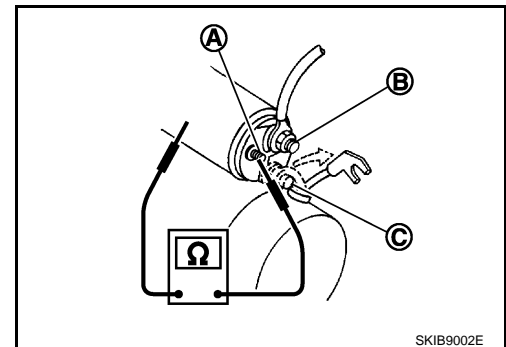

# STARTER MOTOR

## < ON-VEHICLE REPAIR >

### 2. Continuity test [between "S" terminal (A) and "M" terminal (C)]

B : "B" terminal

- Replace magnetic switch if continuity does not exist.

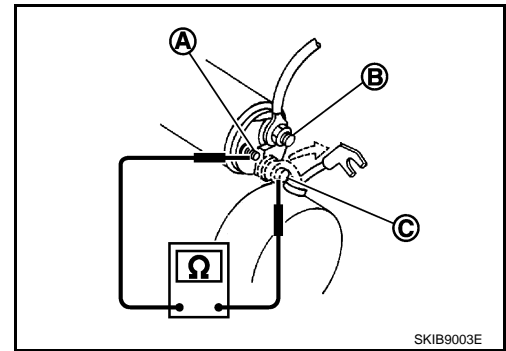

### Pinion/Clutch Check

1. Inspect pinion teeth.
  - Replace pinion if teeth are worn or damaged. (Also check condition of ring gear teeth.)
2. Inspect reduction gear teeth (If equipped).
  - Replace reduction gear if teeth are worn or damaged. (Also check condition of armature shaft gear teeth.)
3. Check to see if pinion locks in one direction and rotates smoothly in the opposite direction.
  - Replace pinion assembly if it is locked or rotated in both directions or unusual resistance is evident.

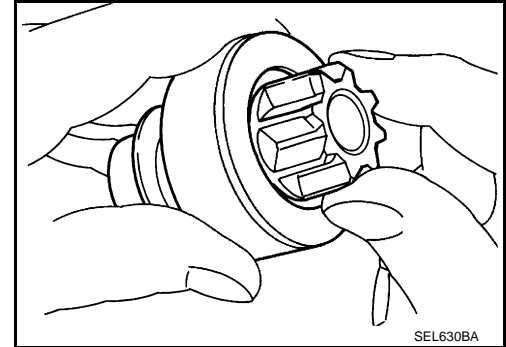

### Brush Check

- Check wear of brush.

**Minimum length of brush** : Refer to SDS [STR-43](#), "[Starter Motor](#)".

- Replace brush if the measurement value is less than the specified value.

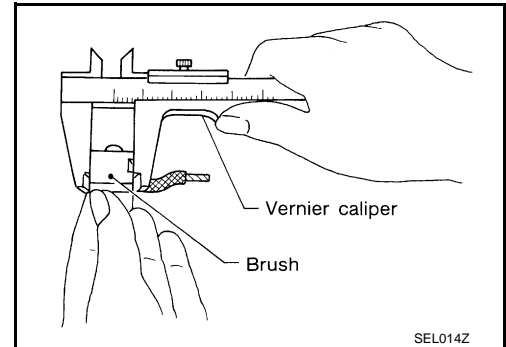

### Brush Spring Check

- Check brush spring tension with brush spring detached from brush.

**Spring tension (with new brush)** : Refer to SDS [STR-43](#), "[Starter Motor](#)".

- Replace brush spring if the measurement value is less than the specified value.

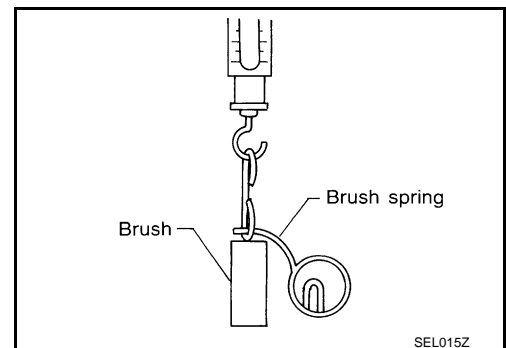

### Brush Holder Check

# STARTER MOTOR

## < ON-VEHICLE REPAIR >

1. Perform insulation test between brush holder (positive side) and its base (negative side).
  - Replace brush holder assembly if continuity does not exist.
2. Check brush to see if it moves smoothly.
  - If brush holder is bent, replace it; if sliding surface is dirty, clean.

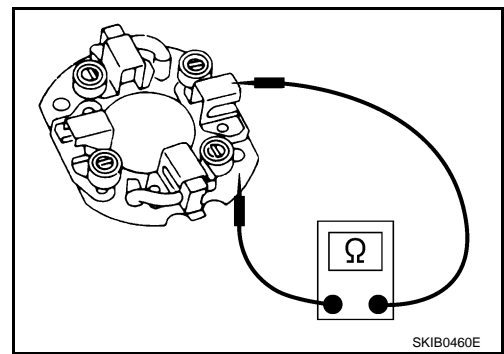

### Yoke Check

Magnet is secured to yoke by bonding agent. Check magnet to see that it is secured to yoke and for any cracks. Replace malfunctioning parts as an assembly.

### **CAUTION:**

**Never clamp yoke in a vise or strike it with a hammer.**

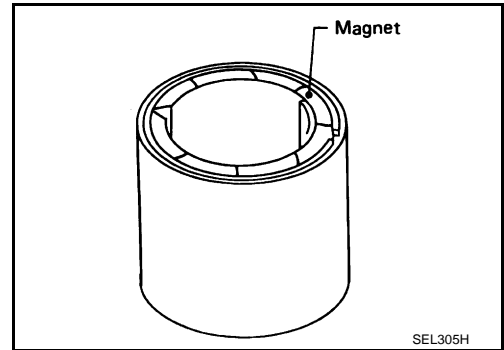

### Armature Check

1. Continuity test (between two segments side by side)
  - Replace armature assembly if continuity does not exist.
2. Insulation test (between each commutator bar and shaft)
  - Replace armature assembly if continuity exists.

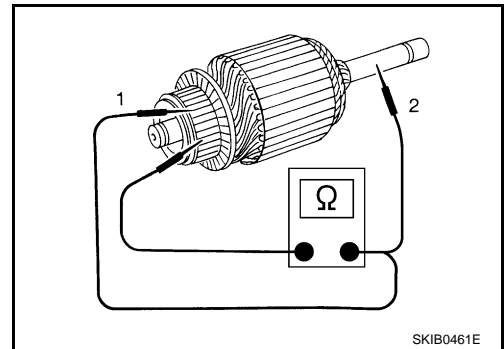

3. Check commutator surface.
  - Grind with No. 500 - 600 emery paper if it has a rough surface.

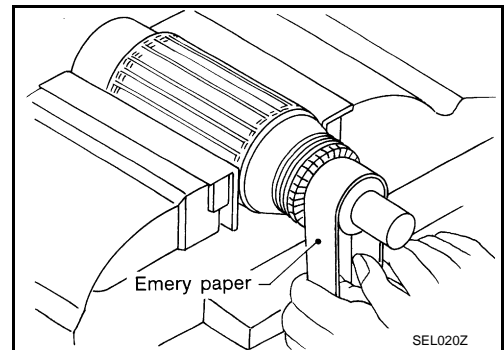

A

STR

C

D

E

F

G

H

I

J

K

L

M

N

O

P

# STARTER MOTOR

## < ON-VEHICLE REPAIR >

4. Check diameter of commutator.

**Commutator minimum diameter** : Refer to SDS [STR-43](#), "[Starter Motor](#)".

- Replace armature assembly if the measurement value is less than the specified value.

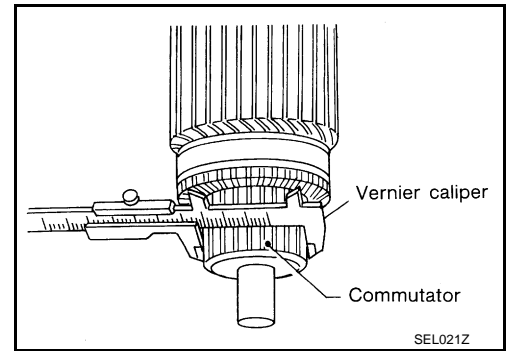

5. Check depth of insulating mold from commutator surface.

- Undercut to 0.5 to 0.8 mm (0.020 to 0.031 in) if the depth is 0.2 mm (0.008 in) or less.

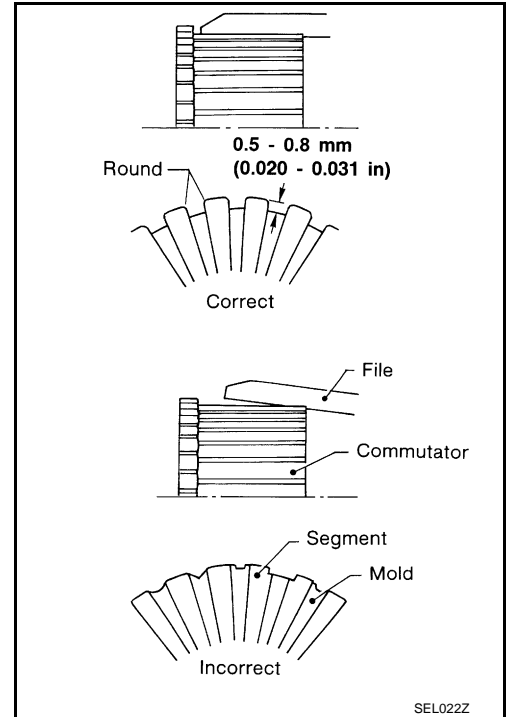

## QR25DE (M/T) MODELS

### QR25DE (M/T) MODELS : Exploded View

INFOID:000000001208688

## REMOVAL

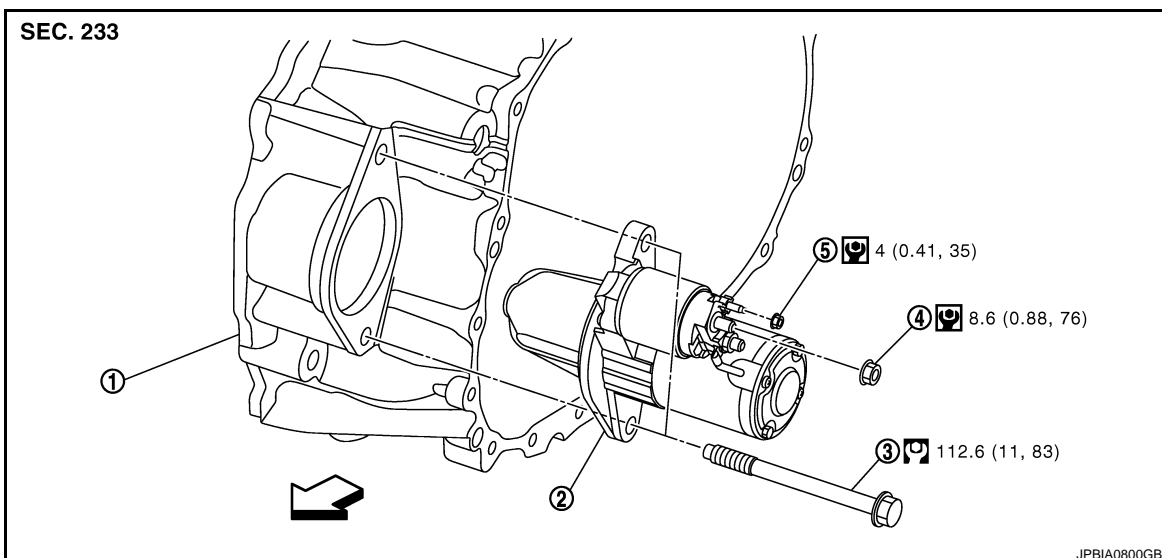



# STARTER MOTOR

## < ON-VEHICLE REPAIR >

- |                     |                     |                                |
|---------------------|---------------------|--------------------------------|
| 1. Clutch housing   | 2. Starter motor    | 3. Starter motor mounting bolt |
| 4. "B" terminal nut | 5. "S" terminal nut |                                |

↔ : Vehicle front

Refer to [GI-4, "Components"](#) for symbols in the figure.

## DISASSEMBLY

Type: M000T22271

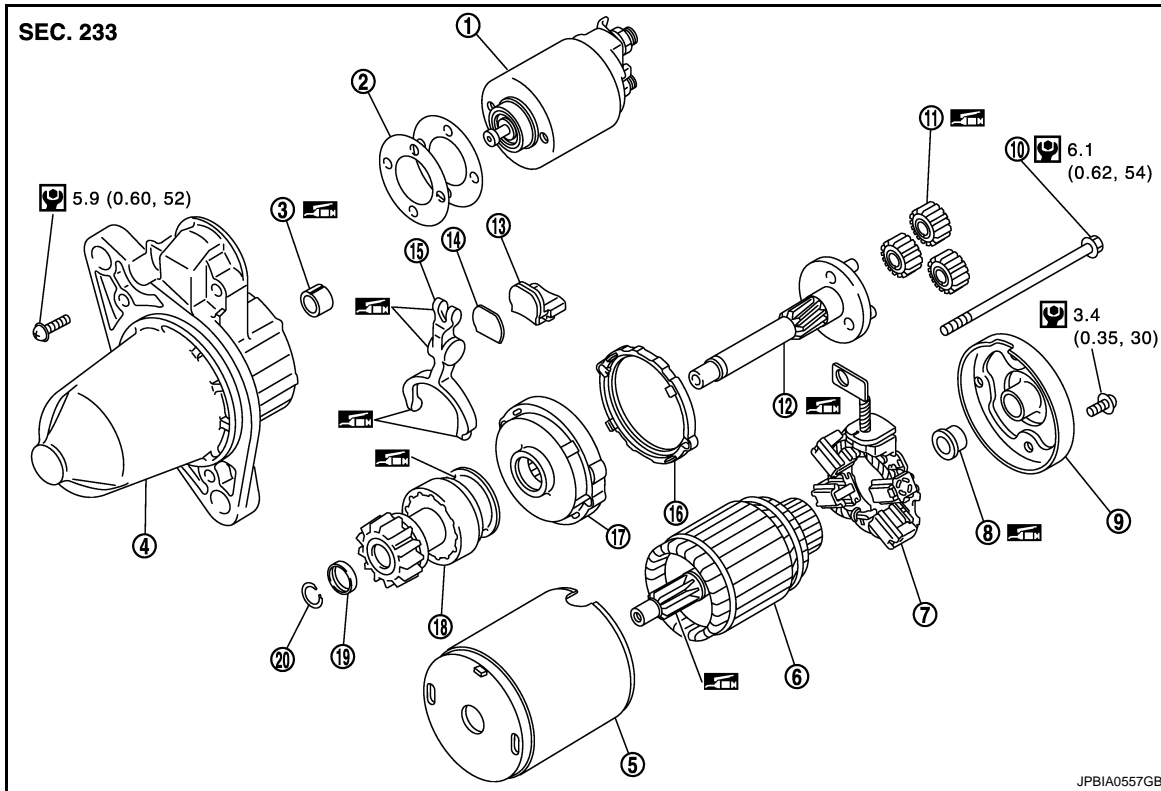

- |                             |                    |                     |
|-----------------------------|--------------------|---------------------|
| 1. Magnetic switch assembly | 2. Adjusting plate | 3. Metal FR         |
| 4. Gear case                | 5. Yoke            | 6. Armature         |
| 7. Brush holder assembly    | 8. Metal RR        | 9. Rear cover       |
| 10. Through bolt            | 11. Planetary gear | 12. Gear shaft      |
| 13. Packing                 | 14. Plate          | 15. Shift lever     |
| 16. Packing                 | 17. Internal gear  | 18. Pinion assembly |
| 19. Stopper                 | 20. Stopper ring   |                     |

: High-temperature grease point

Refer to [GI-4, "Components"](#) for symbols not described on the above.

## QR25DE (M/T) MODELS : Removal and Installation

INFOID:000000001208689

### REMOVAL

1. Disconnect the battery cable from the negative terminal.
2. Remove air duct (inlet). Refer to [EM-150, "Exploded View"](#).
3. Remove "B" terminal nut and "B" terminal harness.
4. Remove "S" terminal nut and "S" terminal harness.
5. Remove starter motor mounting bolts.
6. Remove starter motor upward from the vehicle.

### INSTALLATION

# STARTER MOTOR

## < ON-VEHICLE REPAIR >

Install in the reverse order of removal.

### CAUTION:

Be sure to tighten "B" terminal nut carefully.

## QR25DE (M/T) MODELS : Disassembly and Assembly

INFOID:000000001208690

### ASSEMBLY

Apply high-temperature grease to lubricate the bearing, gears and frictional surface when assembling the starter.

Carefully observe the following instructions.

#### Pinion Protrusion Length Adjustment

#### CLEARANCE

- With pinion driven out by magnetic switch, push pinion back to remove slack and measure clearance "L" between the front edge of the pinion and the pinion stopper.

Clearance "L"

: Refer to SDS [STR-43](#),  
["Starter Motor"](#).

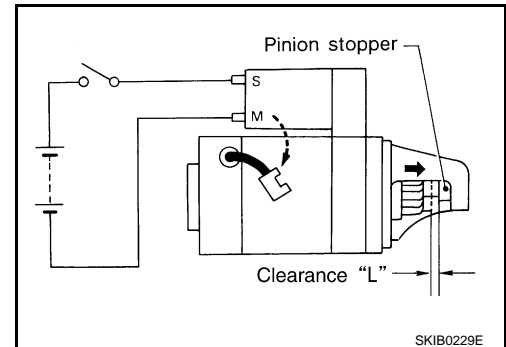

- Adjust with the adjusting plate if the measurement value is not in the specified area.

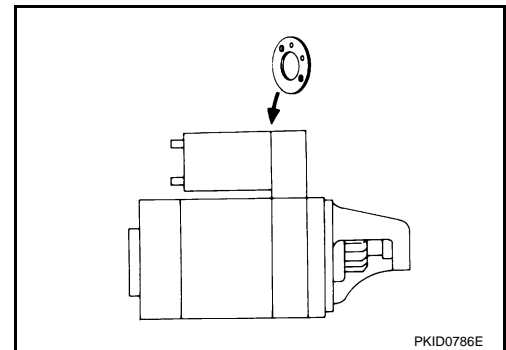

## QR25DE (M/T) MODELS : Inspection

INFOID:000000001208691

### INSPECTION

#### Magnetic Switch Check

- Before starting to check, disconnect the battery cable from the negative terminal.
- Disconnect "M" terminal of starter motor.

#### 1. Continuity test [between "S" terminal (A) and switch body]

B : "B" terminal

C : "M" terminal

- Replace magnetic switch if continuity does not exist.

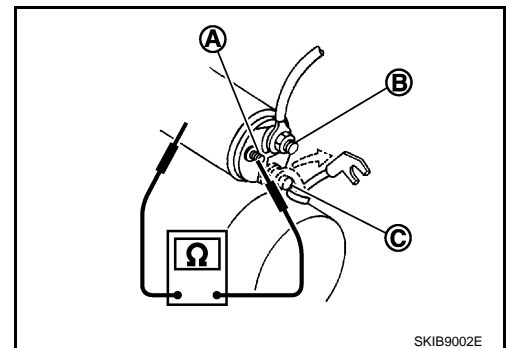

# STARTER MOTOR

## < ON-VEHICLE REPAIR >

### 2. Continuity test [between "S" terminal (A) and "M" terminal (C)]

B : "B" terminal

- Replace magnetic switch if continuity does not exist.

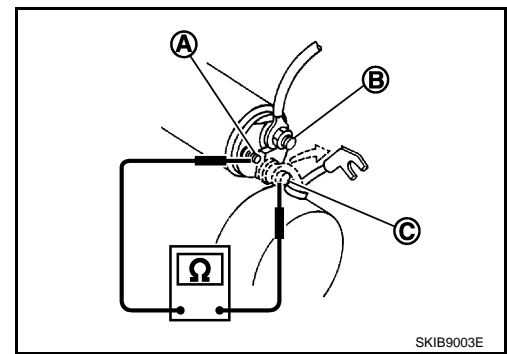

### Pinion/Clutch Check

1. Inspect pinion teeth.
  - Replace pinion if teeth are worn or damaged. (Also check condition of ring gear teeth.)
2. Inspect reduction gear teeth (If equipped).
  - Replace reduction gear if teeth are worn or damaged. (Also check condition of armature shaft gear teeth.)
3. Check to see if pinion locks in one direction and rotates smoothly in the opposite direction.
  - Replace pinion assembly if it is locked or rotated in both directions or unusual resistance is evident.

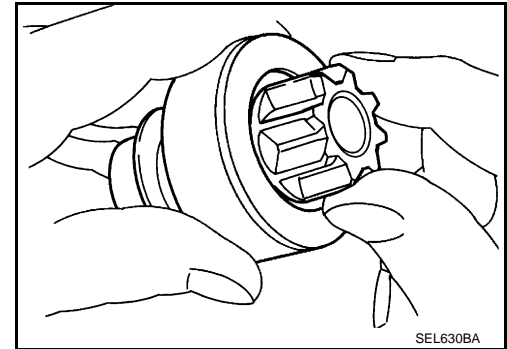

### Brush Check

- Check wear of brush.

**Minimum length of brush** : Refer to SDS [STR-43, "Starter Motor"](#).

- Replace brush if the measurement value is less than the specified value.

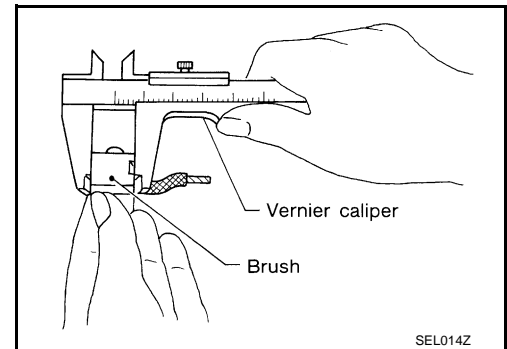

### Brush Spring Check

- Check brush spring tension with brush spring detached from brush.

**Spring tension (with new brush)** : Refer to SDS [STR-43, "Starter Motor"](#).

- Replace brush spring if the measurement value is less than the specified value.

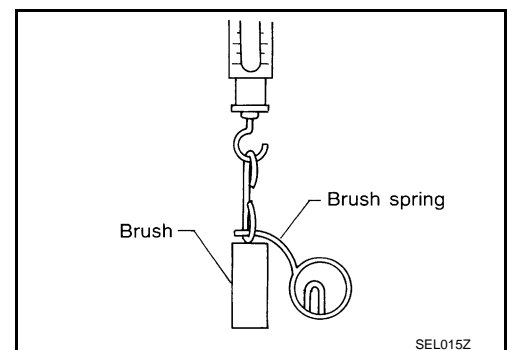

### Brush Holder Check

# STARTER MOTOR

## < ON-VEHICLE REPAIR >

1. Perform insulation test between brush holder (positive side) and its base (negative side).
  - Replace brush holder assembly if continuity does not exist.
2. Check brush to see if it moves smoothly.
  - If brush holder is bent, replace it; if sliding surface is dirty, clean.

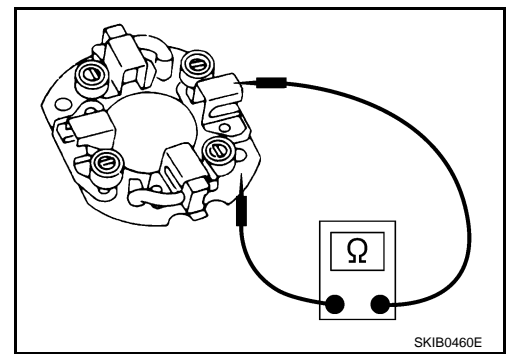

### Yoke Check

Magnet is secured to yoke by bonding agent. Check magnet to see that it is secured to yoke and for any cracks. Replace malfunctioning parts as an assembly.

### **CAUTION:**

**Never clamp yoke in a vise or strike it with a hammer.**

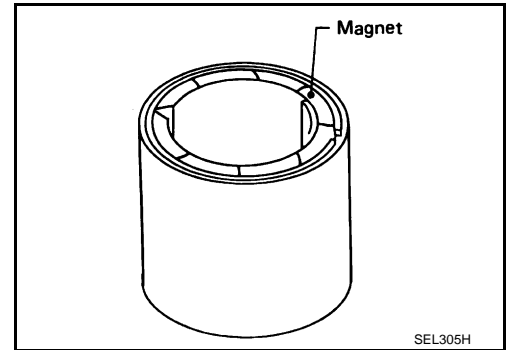

### Armature Check

1. Continuity test (between two segments side by side)
  - Replace armature assembly if continuity does not exist.
2. Insulation test (between each commutator bar and shaft)
  - Replace armature assembly if continuity exists.

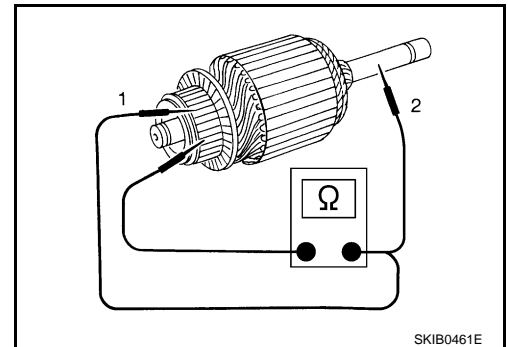

3. Check commutator surface.
  - Grind with No. 500 - 600 emery paper if it has a rough surface.

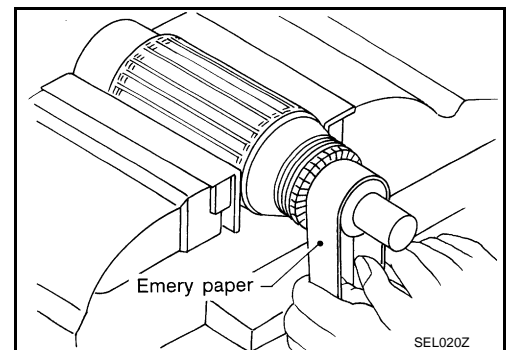

# STARTER MOTOR

## < ON-VEHICLE REPAIR >

4. Check diameter of commutator.

**Commutator minimum diameter** : Refer to SDS [STR-43](#), "[Starter Motor](#)".

- Replace armature assembly if the measurement value is less than the specified value.

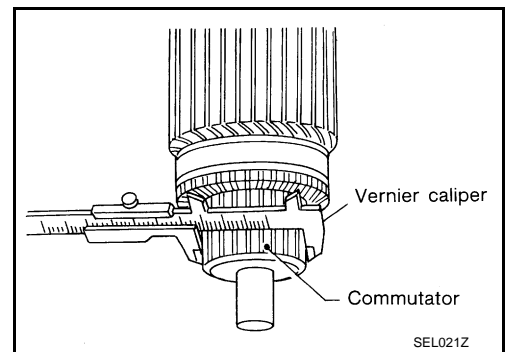

5. Check depth of insulating mold from commutator surface.

- Undercut to 0.5 to 0.8 mm (0.020 to 0.031 in) if the depth is 0.2 mm (0.008 in) or less.

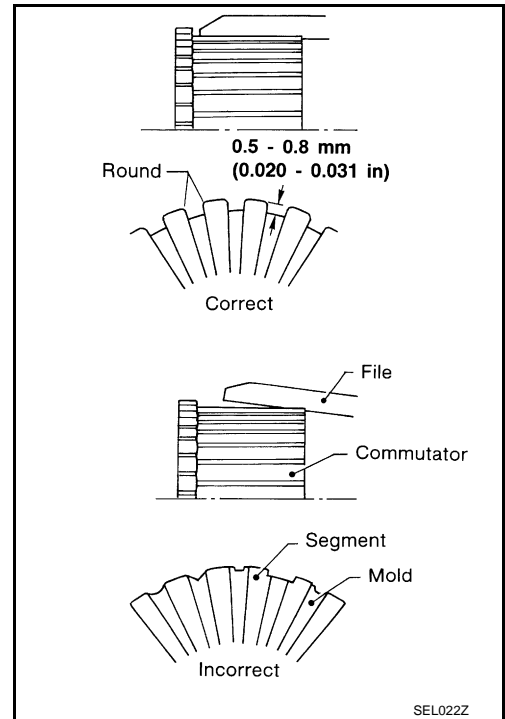

## QR25DE (CVT) MODELS

### QR25DE (CVT) MODELS : Exploded View

INFOID:000000001283152

## REMOVAL

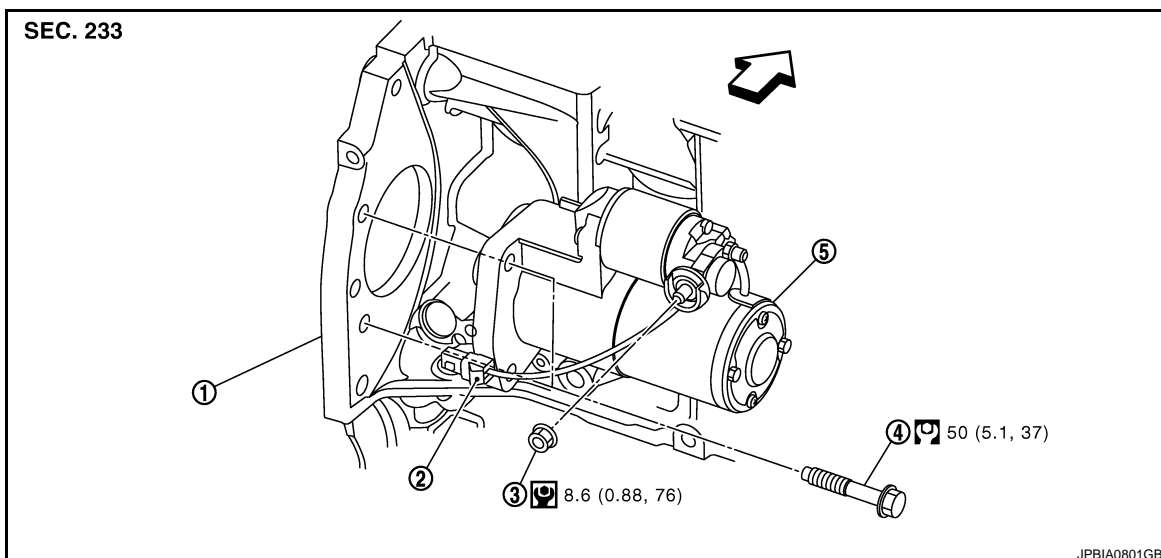

# STARTER MOTOR

## < ON-VEHICLE REPAIR >

- |                                |                  |                     |
|--------------------------------|------------------|---------------------|
| 1. Cylinder block              | 2. "S" connector | 3. "B" terminal nut |
| 4. Starter motor mounting bolt | 5. Starter motor |                     |

↶ : Vehicle front

Refer to [GI-4, "Components"](#) for symbols in the figure.

## DISASSEMBLY

Type: M000TA0271

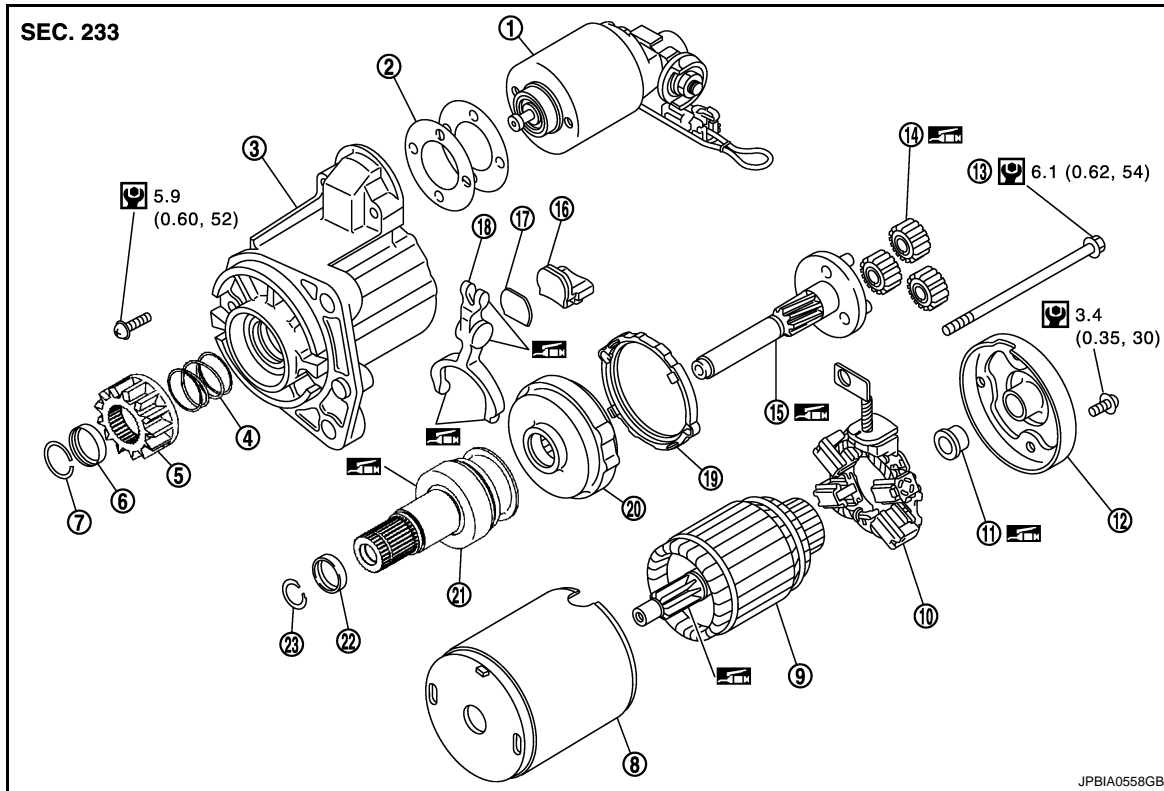

- |                             |                    |                         |
|-----------------------------|--------------------|-------------------------|
| 1. Magnetic switch assembly | 2. Adjusting plate | 3. Gear case            |
| 4. Spring                   | 5. Pinion          | 6. Pinion stopper       |
| 7. Stopper clip             | 8. Yoke            | 9. Armature             |
| 10. Brush holder assembly   | 11. Metal RR       | 12. Rear cover          |
| 13. Through bolt            | 14. Planetary gear | 15. Gear shaft          |
| 16. Packing                 | 17. Plate          | 18. Shift lever         |
| 19. Packing                 | 20. Internal gear  | 21. Over running clutch |
| 22. Retainer ring           | 23. Snap ring      |                         |

: High-temperature grease point

Refer to [GI-4, "Components"](#) for symbols not described on the above.

## QR25DE (CVT) MODELS : Removal and Installation

INFOID:000000001283153

### REMOVAL

1. Disconnect the battery cable from the negative terminal.
2. Remove exhaust front tube. Refer to [EX-10, "Exploded View"](#).

# STARTER MOTOR

## < ON-VEHICLE REPAIR >

3. Remove "B" terminal nut (A) and "B" terminal harness.

↔ : Vehicle front

4. Disconnect "S" connector (B).
5. Remove starter motor mounting bolts (C).

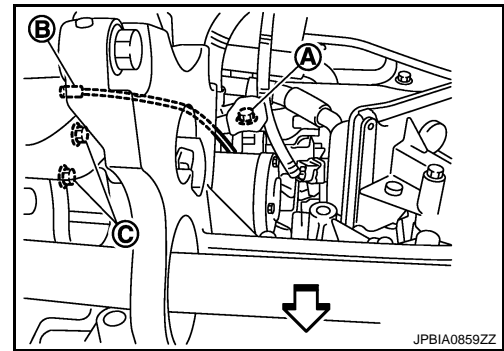

6. Remove starter motor downward from the vehicle.

## INSTALLATION

Install in the reverse order of removal.

### CAUTION:

Be sure to tighten "B" terminal nut carefully.

## QR25DE (CVT) MODELS : Disassembly and Assembly

INFOID:000000001283154

## ASSEMBLY

Apply high-temperature grease to lubricate the bearing, gears and frictional surface when assembling the starter.

Carefully observe the following instructions.

### Pinion Protrusion Length Adjustment

## MOVEMENT

- Compare movement "L" in height of pinion when it is pushed out with magnetic switch energized and when it is pulled out by hand until it touches stopper.

**Movement "L"**

**: Refer to SDS [STR-43](#),  
"Starter Motor".**

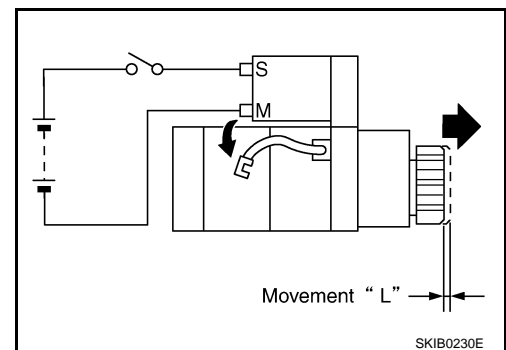

- Adjust with the adjusting plate if the measurement value is not in the specified area.

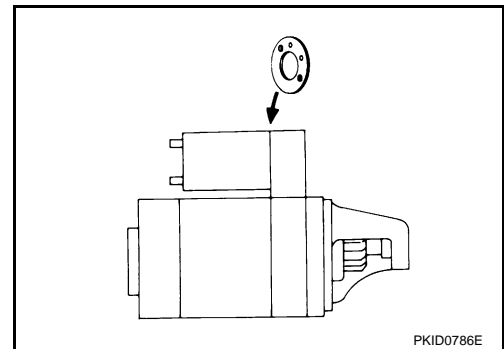

## QR25DE (CVT) MODELS : Inspection

INFOID:000000001283155

## INSPECTION

### Magnetic Switch Check

- Before starting to check, disconnect the battery cable from the negative terminal.
- Disconnect "M" terminal of starter motor.

# STARTER MOTOR

## < ON-VEHICLE REPAIR >

### 1. Continuity test [between "S" terminal (A) and switch body]

B : "B" terminal

C : "M" terminal

- Replace magnetic switch if continuity does not exist.

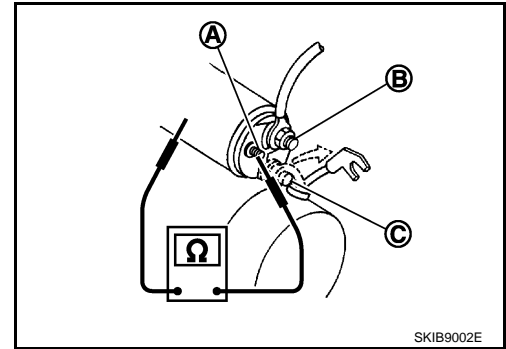

### 2. Continuity test [between "S" terminal (A) and "M" terminal (C)]

B : "B" terminal

- Replace magnetic switch if continuity does not exist.

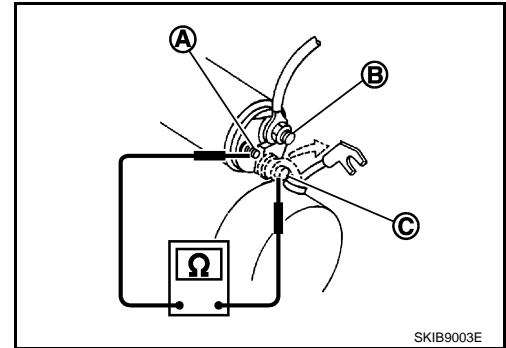

### Pinion/Clutch Check

#### 1. Inspect pinion teeth.

- Replace pinion if teeth are worn or damaged. (Also check condition of ring gear teeth.)

#### 2. Inspect reduction gear teeth (If equipped).

- Replace reduction gear if teeth are worn or damaged. (Also check condition of armature shaft gear teeth.)

#### 3. Check to see if pinion locks in one direction and rotates smoothly in the opposite direction.

- Replace pinion assembly if it is locked or rotated in both directions or unusual resistance is evident.

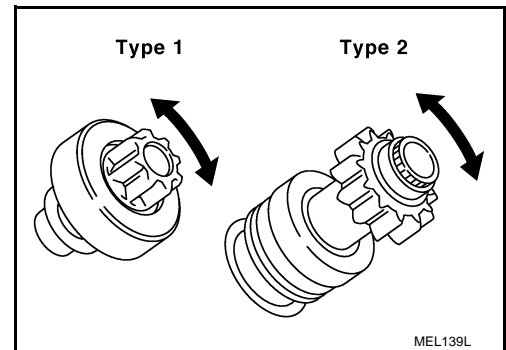

### Brush Check

- Check wear of brush.

**Minimum length of brush** : Refer to SDS [STR-43](#), "[Starter Motor](#)".

- Replace brush if the measurement value is less than the specified value.

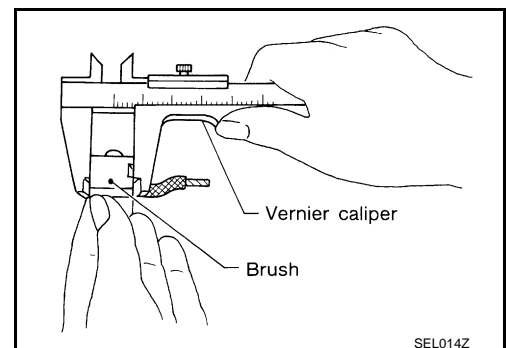

### Brush Spring Check



# STARTER MOTOR

## < ON-VEHICLE REPAIR >

- Check brush spring tension with brush spring detached from brush.

**Spring tension (with new brush) : Refer to SDS STR-43, "Starter Motor".**

- Replace brush spring if the measurement value is less than the specified value.

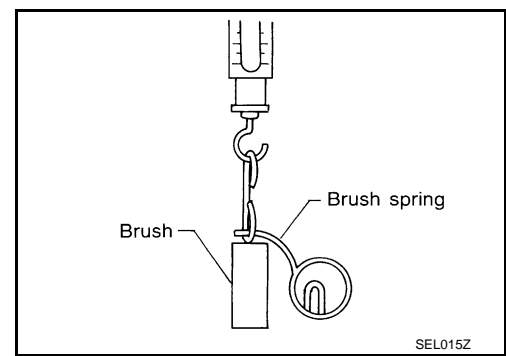

### Brush Holder Check

1. Perform insulation test between brush holder (positive side) and its base (negative side).
  - Replace brush holder assembly if continuity does not exist.
2. Check brush to see if it moves smoothly.
  - If brush holder is bent, replace it; if sliding surface is dirty, clean.

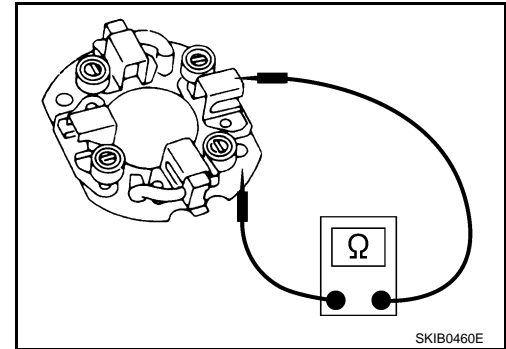

### Yoke Check

Magnet is secured to yoke by bonding agent. Check magnet to see that it is secured to yoke and for any cracks. Replace malfunctioning parts as an assembly.

**CAUTION:**

**Never clamp yoke in a vise or strike it with a hammer.**

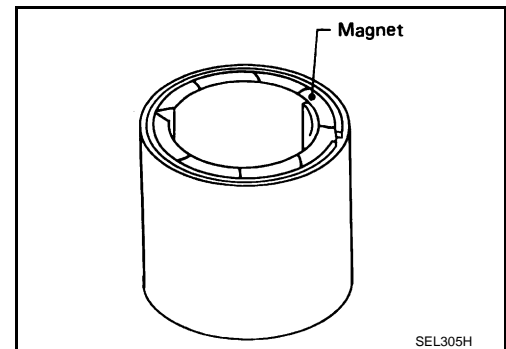

### Armature Check

1. Continuity test (between two segments side by side)
  - Replace armature assembly if continuity does not exist.
2. Insulation test (between each commutator bar and shaft)
  - Replace armature assembly if continuity exists.

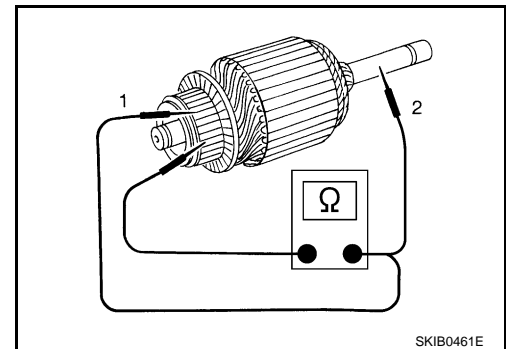

A

STR

C

D

E

F

G

H

I

J

K

L

M

N

O

P

# STARTER MOTOR

## < ON-VEHICLE REPAIR >

3. Check commutator surface.
  - Grind with No. 500 - 600 emery paper if it has a rough surface.

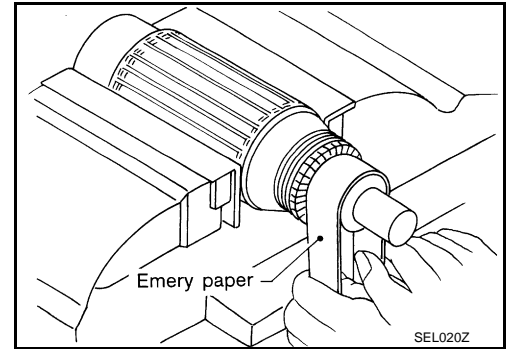

4. Check diameter of commutator.

**Commutator minimum diameter** : Refer to SDS [STR-43](#), "[Starter Motor](#)".

- Replace armature assembly if the measurement value is less than the specified value.

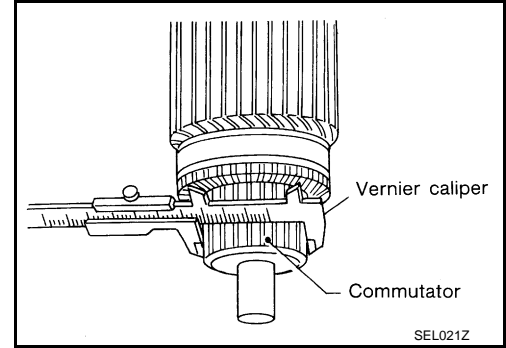

5. Check depth of insulating mold from commutator surface.
  - Undercut to 0.5 to 0.8 mm (0.020 to 0.031 in) if the depth is 0.2 mm (0.008 in) or less.

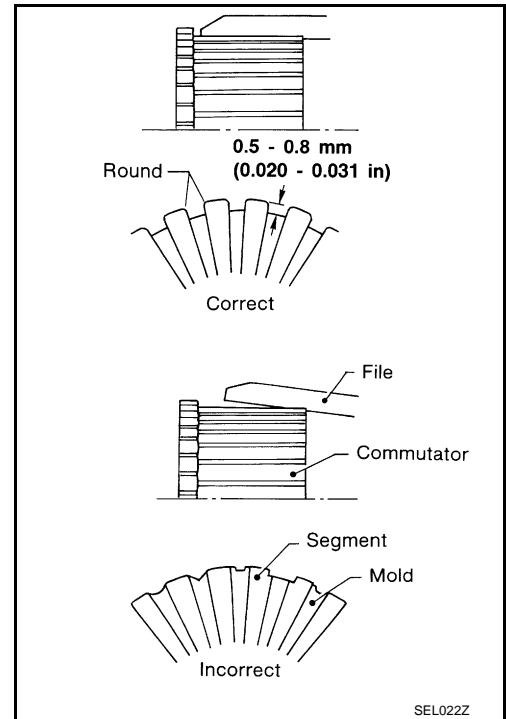

# SERVICE DATA AND SPECIFICATIONS (SDS)

< SERVICE DATA AND SPECIFICATIONS (SDS)

## SERVICE DATA AND SPECIFICATIONS (SDS)

### SERVICE DATA AND SPECIFICATIONS (SDS)

#### Starter Motor

INFOID:000000001208692

A

STR

Applied model		M9R	MR20DE	QR25DE (M/T)	QR25DE (CVT)
		194262	S114-902A	M000T22271	M000TA0271
Type		VALEO make	HITACHI make	MITSUBISHI make	
		Reduction gear type			
System voltage [V]		12			
No-load	Terminal voltage [V]	10.8	11		
	Current [A]	Less than 115	Less than 110	Less than 90	
	Revolution [rpm]	More than 5,704	More than 3,000	More than 2,000	More than 2,400
Minimum diameter of commutator [mm (in)]		28.8 (1.134)	28.0 (1.102)	28.8 (1.134)	
Minimum length of brush [mm (in)]		8.0 (0.315)	10.5 (0.413)	5.5 (0.217)	
Brush spring tension [N (kg, lb)]		24 (2.45, 5.40)	16.2 (1.65, 3.64)	15.0 - 20.4 (1.53 - 2.08, 3.4 - 4.6)	
Clearance between bearing metal and armature shaft [mm (in)]		—	Less than 0.2 (0.008)	Less than 0.2 (0.008)	
Clearance "L" between pinion front edge and pinion stopper [mm (in)]		—	0.3 - 2.5 (0.012 - 0.098)	—	0.5 - 2.0 (0.020 - 0.079)
Movement "L" in height of pinion assembly [mm (in)]		—	—	0.5 - 2.0 (0.020 - 0.079)	—

C

D

E

F

G

H

I

J

K

L

M

N

O

P