

**SECTION**  
TF  
**TRANSFER**

A  
B  
C

TF

**CONTENTS**

E

|   |   |                                      |
|---|---|--------------------------------------|
| <b>PRECAUTIONS</b> ..... 4  |   |                                      |
| Precautions for Supplemental Restraint System (SRS) "AIR BAG" and "SEAT BELT PRE-TENSIONER" ..... 4 |   |                                      |
| Precautions for Transfer Assembly and Transfer Control Unit Replacement ..... 4                     |   |                                      |
| METHOD FOR POSITION ADJUSTMENT ..... 4  |   |                                      |
| Precautions ..... 4   |   |                                      |
| Service Notice ..... 5  |   |                                      |
| <b>PREPARATION</b> ..... 6  |   |                                      |
| Special Service Tools ..... 6   |   |                                      |
| Commercial Service Tools ..... 9  |   |                                      |
| <b>NOISE, VIBRATION AND HARSHNESS (NVH)</b>   |   |                                      |
| <b>TROUBLESHOOTING</b> ..... 10   |   |                                      |
| NVH Troubleshooting Chart ..... 10  |   |                                      |
| <b>TRANSFER FLUID</b> ..... 11  |   |                                      |
| Replacement ..... 11  |   |                                      |
| DRAINING ..... 11   |   |                                      |
| FILLING ..... 11  |   |                                      |
| Inspection ..... 11   |   |                                      |
| FLUID LEAKAGE AND FLUID LEVEL ..... 11  |   |                                      |
| <b>ALL-MODE 4WD SYSTEM</b> ..... 12   |   |                                      |
| Cross-section View ..... 12   |   |                                      |
| Power Transfer ..... 13   |   |                                      |
| POWER TRANSFER DIAGRAM ..... 13   |   |                                      |
| POWER TRANSFER FLOW ..... 14  |   |                                      |
| System Description ..... 15   |   |                                      |
| CONTROL SYSTEM ..... 15   |   |                                      |
| TRANSFER MOTOR ..... 16   |   |                                      |
| WAIT DETECTION SWITCH ..... 17  |   |                                      |
| NEUTRAL-4LO SWITCH ..... 17   |   |                                      |
| ATP SWITCH ..... 17   |   |                                      |
| 2-4WD SHIFT SOLENOID VALVE ..... 17   |   |                                      |
| CLUTCH PRESSURE SOLENOID VALVE ..... 18   |   |                                      |
| LINE PRESSURE SWITCH ..... 18   |   |                                      |
| CLUTCH PRESSURE SWITCH ..... 18   |   |                                      |
| TRANSFER FLUID TEMPERATURE SENSOR.. 18  |   |                                      |
| TRANSFER CONTROL UNIT ..... 18  |   |                                      |
| TRANSFER CONTROL DEVICE ..... 18  |   |                                      |
| 4WD SHIFT SWITCH AND INDICATOR LAMP.. 18  |   |                                      |
|   | 4WD WARNING LAMP ..... 19<br>ATP WARNING LAMP ..... 19<br>System Diagram ..... 19<br>COMPONENTS FUNCTION ..... 20<br>CAN Communication ..... 20<br>SYSTEM DESCRIPTION ..... 20<br><b>TROUBLE DIAGNOSIS</b> ..... 21<br>How to Perform Trouble Diagnosis ..... 21<br>BASIC CONCEPT ..... 21<br>Location of Electrical Parts ..... 22<br>Schematic ..... 23<br>Wiring Diagram — T/F — ..... 24<br>Inspections Before Trouble Diagnosis ..... 32<br>TRANSFER FLUID CHECK ..... 32<br>PREPARATION FOR ROAD TEST ..... 32<br>CHECK BEFORE ENGINE IS STARTED ..... 32<br>CHECK AT IDLE ..... 32<br>CRUISE TEST ..... 33<br>Trouble Diagnosis Chart for Symptoms ..... 34<br>Transfer Control Unit Input/Output Signal Reference Values ..... 35<br>TRANSFER CONTROL UNIT INSPECTION TABLE ..... 35<br>CONSULT-II Function (ALL MODE AWD/4WD) ... 44<br>FUNCTION ..... 44<br>CONSULT-II SETTING PROCEDURE ..... 44<br>SELF-DIAG RESULT MODE ..... 45<br>DATA MONITOR MODE ..... 47<br>WORK SUPPORT ..... 49<br>Self-diagnostic Procedure ..... 50<br>SELF-DIAGNOSTIC PROCEDURE (WITH CONSULT-II) ..... 50<br>SELF-DIAGNOSTIC PROCEDURE (WITHOUT CONSULT-II) ..... 50<br>ERASE SELF-DIAGNOSIS ..... 53<br><b>TROUBLE DIAGNOSIS FOR SYSTEM</b> ..... 54<br>Power Supply Circuit For Transfer Control Unit .... 54<br>CONSULT-II REFERENCE VALUE IN DATA MONITOR MODE ..... 54<br>TRANSFER CONTROL UNIT TERMINALS AND | F<br>G<br>H<br>I<br>J<br>K<br>L<br>M |

|  |    |   |            |
|--|----|---|------------|
| REFERENCE VALUE .....                      | 54 | DIAGNOSTIC PROCEDURE .....                      | 86         |
| DIAGNOSTIC PROCEDURE .....                 | 55 | COMPONENT INSPECTION .....                      | 89         |
| COMPONENT INSPECTION .....                 | 57 | 2-4WD Solenoid .....                            | 90         |
| Transfer Control Unit .....                | 57 | CONSULT-II REFERENCE VALUE IN DATA              |            |
| DIAGNOSTIC PROCEDURE .....                 | 57 | MONITOR MODE .....                              | 90         |
| Output Shaft Revolution Signal (TCM) ..... | 58 | TRANSFER CONTROL UNIT TERMINALS AND             |            |
| DIAGNOSTIC PROCEDURE .....                 | 58 | REFERENCE VALUE .....                           | 90         |
| Vehicle Speed Sensor (ABS) .....           | 58 | DIAGNOSTIC PROCEDURE .....                      | 90         |
| DIAGNOSTIC PROCEDURE .....                 | 58 | COMPONENT INSPECTION .....                      | 93         |
| Neutral-4LO Switch .....                   | 59 | Transfer Motor .....                            | 94         |
| CONSULT-II REFERENCE VALUE IN DATA         |    | CONSULT-II REFERENCE VALUE IN DATA              |            |
| MONITOR MODE .....                         | 59 | MONITOR MODE .....                              | 94         |
| TRANSFER CONTROL UNIT TERMINALS AND        |    | TRANSFER CONTROL UNIT TERMINALS AND             |            |
| REFERENCE VALUE .....                      | 59 | REFERENCE VALUE .....                           | 95         |
| DIAGNOSTIC PROCEDURE .....                 | 60 | DIAGNOSTIC PROCEDURE .....                      | 96         |
| COMPONENT INSPECTION .....                 | 62 | COMPONENT INSPECTION .....                      | 101        |
| 4WD Shift Switch .....                     | 62 | Transfer Fluid Temperature .....                | 101        |
| CONSULT-II REFERENCE VALUE IN DATA         |    | CONSULT-II REFERENCE VALUE IN DATA              |            |
| MONITOR MODE .....                         | 62 | MONITOR MODE .....                              | 101        |
| TRANSFER CONTROL UNIT TERMINALS AND        |    | TRANSFER CONTROL UNIT TERMINALS AND             |            |
| REFERENCE VALUE .....                      | 62 | REFERENCE VALUE .....                           | 101        |
| DIAGNOSTIC PROCEDURE .....                 | 63 | DIAGNOSTIC PROCEDURE .....                      | 102        |
| COMPONENT INSPECTION .....                 | 66 | COMPONENT INSPECTION .....                      | 103        |
| Wait Detection Switch .....                | 66 | Clutch Pressure Switch .....                    | 104        |
| CONSULT-II REFERENCE VALUE IN DATA         |    | CONSULT-II REFERENCE VALUE IN DATA              |            |
| MONITOR MODE .....                         | 66 | MONITOR MODE .....                              | 104        |
| TRANSFER CONTROL UNIT TERMINALS AND        |    | TRANSFER CONTROL UNIT TERMINALS AND             |            |
| REFERENCE VALUE .....                      | 66 | REFERENCE VALUE .....                           | 104        |
| DIAGNOSTIC PROCEDURE .....                 | 67 | DIAGNOSTIC PROCEDURE .....                      | 105        |
| COMPONENT INSPECTION .....                 | 69 | COMPONENT INSPECTION .....                      | 106        |
| PNP Switch Signal (TCM) .....              | 69 | Line Pressure Switch .....                      | 107        |
| DIAGNOSTIC PROCEDURE .....                 | 69 | CONSULT-II REFERENCE VALUE IN DATA              |            |
| Actuator Motor .....                       | 70 | MONITOR MODE .....                              | 107        |
| CONSULT-II REFERENCE VALUE IN DATA         |    | TRANSFER CONTROL UNIT TERMINALS AND             |            |
| MONITOR MODE .....                         | 70 | REFERENCE VALUE .....                           | 107        |
| TRANSFER CONTROL UNIT TERMINALS AND        |    | DIAGNOSTIC PROCEDURE .....                      | 108        |
| REFERENCE VALUE .....                      | 70 | COMPONENT INSPECTION .....                      | 109        |
| DIAGNOSTIC PROCEDURE .....                 | 71 | Throttle Position Signal (ECM) .....            | 110        |
| COMPONENT INSPECTION .....                 | 76 | DIAGNOSTIC PROCEDURE .....                      | 110        |
| Actuator Position Switch .....             | 77 | ABS Operation Signal (ABS) .....                | 110        |
| CONSULT-II REFERENCE VALUE IN DATA         |    | DIAGNOSTIC PROCEDURE .....                      | 110        |
| MONITOR MODE .....                         | 77 | VDC Operation Signal (ABS) .....                | 111        |
| TRANSFER CONTROL UNIT TERMINALS AND        |    | DIAGNOSTIC PROCEDURE .....                      | 111        |
| REFERENCE VALUE .....                      | 77 | TCS Operation Signal (ABS) .....                | 111        |
| DIAGNOSTIC PROCEDURE .....                 | 78 | DIAGNOSTIC PROCEDURE .....                      | 111        |
| COMPONENT INSPECTION .....                 | 80 | CAN Communication Line .....                    | 112        |
| Transfer Control Device .....              | 81 | DIAGNOSTIC PROCEDURE .....                      | 112        |
| CONSULT-II REFERENCE VALUE IN DATA         |    | ATP Switch .....                                | 112        |
| MONITOR MODE .....                         | 81 | CONSULT-II REFERENCE VALUE IN DATA              |            |
| TRANSFER CONTROL UNIT TERMINALS AND        |    | MONITOR MODE .....                              | 112        |
| REFERENCE VALUE .....                      | 81 | TRANSFER CONTROL UNIT TERMINALS AND             |            |
| DIAGNOSTIC PROCEDURE .....                 | 82 | REFERENCE VALUE .....                           | 112        |
| Engine Speed Signal (ECM) .....            | 85 | DIAGNOSTIC PROCEDURE .....                      | 113        |
| DIAGNOSTIC PROCEDURE .....                 | 85 | COMPONENT INSPECTION .....                      | 114        |
| Clutch Pressure Solenoid .....             | 85 | <b>TROUBLE DIAGNOSIS FOR SYMPTOMS</b> .....     | <b>116</b> |
| CONSULT-II REFERENCE VALUE IN DATA         |    | 4WD Shift Indicator Lamp and 4LO Indicator Lamp |            |
| MONITOR MODE .....                         | 85 | Do Not Turn ON .....                            | 116        |
| TRANSFER CONTROL UNIT TERMINALS AND        |    | SYMPTOM: .....                                  | 116        |
| REFERENCE VALUE .....                      | 85 | DIAGNOSTIC PROCEDURE .....                      | 116        |

|  |            |  |            |    |
|--|------------|--|------------|----|
| 4WD Warning Lamp Does Not Turn ON .....        | 120        | <b>SIDE OIL SEAL .....</b>                       | <b>136</b> |    |
| SYMPTOM: .....                                 | 120        | Removal and Installation .....                   | 136        | A  |
| DIAGNOSTIC PROCEDURE .....                     | 120        | REMOVAL .....                                    | 136        |    |
| 4WD Shift Indicator Lamp or 4LO Indicator Lamp |            | INSTALLATION .....                               | 136        |    |
| Does Not Change .....                          | 122        | <b>TRANSFER CONTROL DEVICE .....</b>             | <b>137</b> | B  |
| SYMPTOM: .....                                 | 122        | Removal and Installation .....                   | 137        |    |
| DIAGNOSTIC PROCEDURE .....                     | 123        | <b>AIR BREATHER HOSE .....</b>                   | <b>138</b> |    |
| ATP Warning Lamp Turns ON .....                | 124        | Removal and Installation .....                   | 138        | C  |
| SYMPTOM: .....                                 | 124        | <b>TRANSFER MOTOR .....</b>                      | <b>141</b> |    |
| DIAGNOSTIC PROCEDURE .....                     | 124        | Removal and Installation .....                   | 141        |    |
| 4LO Indicator Lamp Repeats Flashing .....      | 126        | REMOVAL .....                                    | 141        |    |
| SYMPTOM: .....                                 | 126        | INSTALLATION .....                               | 141        | TF |
| DIAGNOSTIC PROCEDURE .....                     | 126        | <b>TRANSFER OIL FILTER .....</b>                 | <b>142</b> |    |
| 4WD Warning Lamp Flashes Rapidly .....         | 127        | Removal and Installation .....                   | 142        |    |
| SYMPTOM: .....                                 | 127        | REMOVAL .....                                    | 142        | E  |
| DIAGNOSTIC PROCEDURE .....                     | 127        | INSTALLATION .....                               | 142        |    |
| 4WD Warning Lamp Flashes Slowly .....          | 128        | <b>TRANSFER ASSEMBLY .....</b>                   | <b>144</b> |    |
| SYMPTOM: .....                                 | 128        | Removal and Installation .....                   | 144        | F  |
| DIAGNOSTIC PROCEDURE .....                     | 128        | REMOVAL .....                                    | 144        |    |
| Heavy Tight-corner Braking Symptom Occurs .... | 129        | INSTALLATION .....                               | 144        |    |
| SYMPTOM: .....                                 | 129        | Disassembly and Assembly .....                   | 145        | G  |
| DIAGNOSTIC PROCEDURE .....                     | 129        | COMPONENTS .....                                 | 145        |    |
| 4WD System Does Not Operate .....              | 130        | DISASSEMBLY .....                                | 147        |    |
| SYMPTOM: .....                                 | 130        | INSPECTION AFTER DISASSEMBLY .....               | 162        |    |
| DIAGNOSTIC PROCEDURE .....                     | 130        | ASSEMBLY .....                                   | 166        | H  |
| <b>TRANSFER CONTROL UNIT .....</b>             | <b>131</b> | <b>SERVICE DATA AND SPECIFICATIONS (SDS) ...</b> | <b>182</b> |    |
| Removal and Installation .....                 | 131        | General Specifications .....                     | 182        |    |
| REMOVAL .....                                  | 131        | Inspection and Adjustment .....                  | 182        | I  |
| INSTALLATION .....                             | 131        | CLEARANCE BETWEEN INNER GEAR AND                 |            |    |
| <b>FRONT OIL SEAL .....</b>                    | <b>132</b> | OUTER GEAR .....                                 | 182        |    |
| Removal and Installation .....                 | 132        | CLUTCH .....                                     | 182        | J  |
| REMOVAL .....                                  | 132        | PINION GEAR END PLAY .....                       | 182        |    |
| INSTALLATION .....                             | 133        | CLEARANCE BETWEEN SHIFT FORK AND                 |            |    |
| <b>REAR OIL SEAL .....</b>                     | <b>134</b> | SLEEVE .....                                     | 182        |    |
| Removal and Installation .....                 | 134        | SELECTIVE PARTS .....                            | 182        | K  |
| REMOVAL .....                                  | 134        |  |            |    |
| INSTALLATION .....                             | 134        |  |            | L  |
|  |            |  |            | M  |

# PRECAUTIONS

## PRECAUTIONS

PF:00001

### Precautions for Supplemental Restraint System (SRS) “AIR BAG” and “SEAT BELT PRE-TENSIONER”

EDS001XW

The Supplemental Restraint System such as “AIR BAG” and “SEAT BELT PRE-TENSIONER”, used along with a front seat belt, helps to reduce the risk or severity of injury to the driver and front passenger for certain types of collision. This system includes seat belt switch inputs and dual stage front air bag modules. The SRS system uses the seat belt switches to determine the front air bag deployment, and may only deploy one front air bag, depending on the severity of a collision and whether the front occupants are belted or unbelted. Information necessary to service the system safely is included in the SRS and SB section of this Service Manual.

#### **WARNING:**

- To avoid rendering the SRS inoperative, which could increase the risk of personal injury or death in the event of a collision which would result in air bag inflation, all maintenance must be performed by an authorized NISSAN/INFINITI dealer.
- Improper maintenance, including incorrect removal and installation of the SRS, can lead to personal injury caused by unintentional activation of the system. For removal of Spiral Cable and Air Bag Module, see the SRS section.
- Do not use electrical test equipment on any circuit related to the SRS unless instructed to in this Service Manual. SRS wiring harnesses can be identified by yellow and/or orange harnesses or harness connectors.

### Precautions for Transfer Assembly and Transfer Control Unit Replacement

EDS001XX

When replacing transfer assembly or transfer control unit, check the 4WD shift indicator lamp as follows.

1. Turn ignition switch “ON”.
2. Check 4WD shift indicator lamp is turned ON for approx. 1 second.
- If OK, the position between transfer assembly and transfer control unit is correct.
- If NG, the position is different between transfer assembly and transfer control unit. Adjust the position between transfer assembly and transfer control unit. Refer to [TF-4, "METHOD FOR POSITION ADJUSTMENT"](#).

#### **METHOD FOR POSITION ADJUSTMENT**

1. Start engine. Run the engine for at least 10 seconds.
2. Stop vehicle and move A/T selector lever to “N” position with brake pedal depressed. Stay in “N” for at least 2 seconds.
3. Turn 4WD shift switch to “2WD” position. Stay in “2WD” for at least 2 seconds.
4. Turn ignition switch “OFF”.
5. Start engine.
6. Erase self-diagnosis. Refer to [TF-47, "How to Erase Self-diagnostic Results"](#) (with CONSULT-II) or [TF-53, "ERASE SELF-DIAGNOSIS"](#) (without CONSULT-II).
7. Check 4WD shift indicator lamp. Refer to [TF-32, "CHECK BEFORE ENGINE IS STARTED"](#). If 4WD shift indicator lamp does not indicate “2WD”, install new transfer control unit and retry the above check.

#### **Precautions**

EDS001XY

- Before connecting or disconnecting the transfer control unit harness connector, turn ignition switch “OFF” and disconnect battery ground cable. Failure to do so may damage the transfer control unit. Battery voltage is applied to transfer control unit even if ignition switch is turned “OFF”.

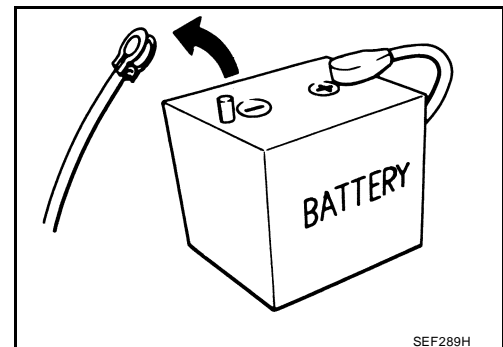

SEF289H

# PRECAUTIONS

- When connecting or disconnecting pin connectors into or from transfer control unit, take care not to damage pin terminals (bend or break). When connecting pin connectors make sure that there are not any bends or breaks on transfer control unit pin terminals.

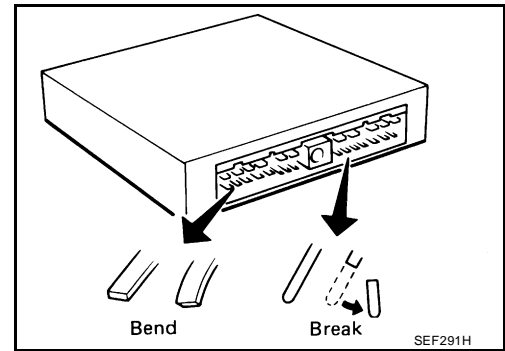

- Before replacing transfer control unit, perform transfer control unit input/output signal inspection and make sure whether transfer control unit functions properly or not. Refer to [TF-35, "Transfer Control Unit Input/Output Signal Reference Values"](#)

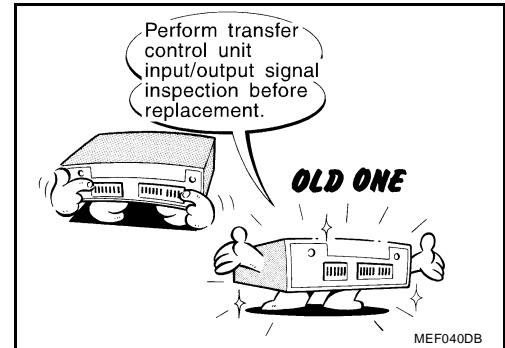

## Service Notice

- After overhaul refill the transfer with new transfer fluid.
- Check the fluid level or replace the fluid only with the vehicle parked on level ground.
- During removal or installation, keep inside of transfer clear of dust or dirt.
- Disassembly should be done in a clean work area.
- Before proceeding with disassembly, thoroughly clean the transfer. It is important to prevent the internal parts from becoming contaminated by dirt or other foreign matter.
- Check for the correct installation status prior to removal or disassembly. If matchmarks are required, be certain they do not interfere with the function of the parts when applied.
- All parts should be carefully cleaned with a general purpose, non-flammable solvent before inspection or reassembly.
- Check appearance of the disassembled parts for damage, deformation, and unusual wear. Replace them with new ones if necessary.
- Gaskets, seals and O-rings should be replaced any time the transfer is disassembled.
- In principle, tighten bolts or nuts gradually in several steps working diagonally from inside to outside. If tightening sequence is specified, use it.
- Observe the specified torque when assembling.
- Clean and flush the parts sufficiently and blow-dry them.
- Be careful not to damage sliding surfaces and mating surfaces.
- Use lint-free cloth or towels for wiping parts clean. Common shop rags can leave fibers that could interfere with the operation of the transfer.

# PREPARATION

## PREPARATION

PF0:00002

### Special Service Tools

EDS001Y1

The actual shapes of Kent-Moore tools may differ from those of special service tools illustrated here.

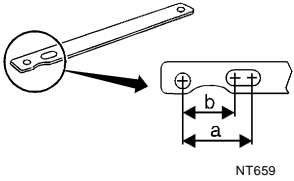
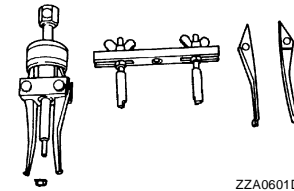
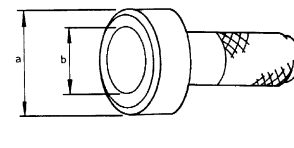
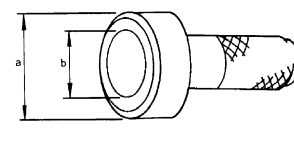
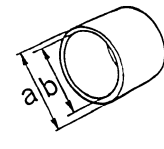
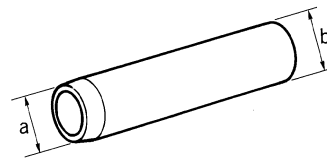
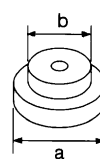
| Tool number<br>(Kent-Moore No.)<br>Tool name | Description  |
|--|--|
| KV40104000<br>( — )<br>Flange wrench         |  <ul style="list-style-type: none"> <li>● Removing self-lock nut</li> <li>● Installing self-lock nut</li> </ul> <p><b>a: 85 mm (3.35 in)</b><br/><b>b: 65 mm (2.56 in)</b></p>  |
| KV381054S0<br>(J-34286)<br>Puller            |  <ul style="list-style-type: none"> <li>● Removing front oil seal</li> <li>● Removing rear oil seal</li> <li>● Removing metal bushing</li> </ul>  |
| KV38100500<br>( — )<br>Drift                 |  <ul style="list-style-type: none"> <li>● Installing front oil seal</li> </ul> <p><b>a: 80 mm (3.15 in) dia.</b><br/><b>b: 60 mm (2.36 in) dia.</b></p>  |
| ST30720000<br>(J-25405)<br>Drift             |  <ul style="list-style-type: none"> <li>● Installing rear oil seal</li> <li>● Installing mainshaft front bearing and oil seal</li> </ul> <p><b>a: 77 mm (3.03 in) dia.</b><br/><b>b: 55.5 mm (2.185 in) dia.</b></p>  |
| KV40105310<br>( — )<br>Drift                 |  <ul style="list-style-type: none"> <li>● Installing dust cover</li> </ul> <p><b>a: 89 mm (3.50 in) dia.</b><br/><b>b: 80.7 mm (3.17 in) dia.</b></p>   |
| ST22360002<br>(J-25679-01)<br>Drift          |  <ul style="list-style-type: none"> <li>● Installing side oil seal</li> </ul> <p><b>a: 23 mm (0.91 in) dia.</b><br/><b>b: 32 mm (1.26 in) dia.</b></p>  |
| ST35300000<br>( — )<br>Drift                 |  <ul style="list-style-type: none"> <li>● Removing sun gear assembly and planetary carrier assembly</li> <li>● Removing carrier bearing</li> <li>● Installing metal bushing</li> </ul> <p><b>a: 59 mm (2.32 in) dia.</b><br/><b>b: 45 mm (1.77 in) dia.</b></p> |

# PREPARATION

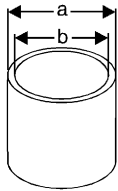
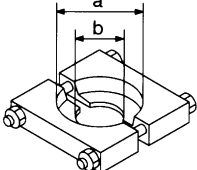
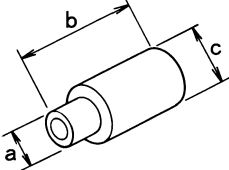
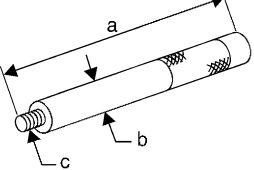
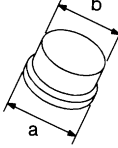
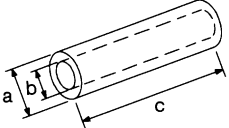
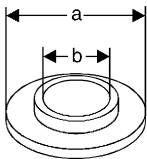
| Tool number<br>(Kent-Moore No.)<br>Tool name   | Description   |             |
|--|---|-------------|
| ST33200000<br>(J-26082)<br>Drift <div style="text-align: center;">  <p>NT661</p> </div>   | <ul style="list-style-type: none"> <li>● Removing mainshaft front bearing</li> <li>● Installing sun gear assembly and planetary carrier assembly</li> <li>● Installing mainshaft front bearing and oil seal</li> </ul> <p><b>a: 74.5 mm (2.933 in) dia.</b><br/><b>b: 62.5 mm (2.461 in) dia.</b></p> | A<br>B<br>C |
| ST30031000<br>( — )<br>Puller <div style="text-align: center;">  <p>NT411</p> </div>      | <ul style="list-style-type: none"> <li>● Removing carrier bearing</li> <li>● Removing front drive shaft front bearing</li> <li>● Removing front drive shaft rear bearing</li> </ul> <p><b>a: 90 mm (3.54 in) dia.</b><br/><b>b: 50 mm (1.97 in) dia.</b></p>  | TF<br>E     |
| ST33710000<br>( — )<br>Drift <div style="text-align: center;">  <p>ZZA1057D</p> </div>    | <ul style="list-style-type: none"> <li>● Removing needle bearing</li> <li>● Removing metal bushing</li> </ul> <p><b>a: 24 mm (0.94 in) dia.</b><br/><b>b: 89 mm (3.5 in)</b><br/><b>c: 30 mm (1.18 in) dia.</b></p>   | F<br>G<br>H |
| ST35325000<br>( — )<br>Drift bar <div style="text-align: center;">  <p>NT663</p> </div>  | <ul style="list-style-type: none"> <li>● Removing metal bushing</li> </ul> <p><b>a: 215 mm (8.46 in)</b><br/><b>b: 25 mm (0.98 in) dia.</b><br/><b>c: M12 × 1.5P</b></p>  | I<br>J      |
| ST33052000<br>( — )<br>Adapter <div style="text-align: center;">  <p>NT431</p> </div>   | <ul style="list-style-type: none"> <li>● Removing front drive shaft front bearing</li> <li>● Removing front drive shaft rear bearing</li> <li>● Installing mainshaft</li> </ul> <p><b>a: 28 mm (1.10 in) dia.</b><br/><b>b: 22 mm (0.87 in) dia.</b></p>  | K<br>L      |
| ST22452000<br>(J-34335)<br>Drift <div style="text-align: center;">  <p>NT117</p> </div> | <ul style="list-style-type: none"> <li>● Removing press flange snap ring</li> <li>● Installing press flange snap ring</li> </ul> <p><b>a: 45 mm (1.77 in) dia.</b><br/><b>b: 36 mm (1.42 in) dia.</b><br/><b>c: 400 mm (15.76 in) dia.</b></p>  | M           |
| ST30911000<br>( — )<br>Puller <div style="text-align: center;">  <p>NT664</p> </div>    | <ul style="list-style-type: none"> <li>● Removing press flange snap ring</li> <li>● Installing press flange snap ring</li> <li>● Installing mainshaft</li> <li>● Installing carrier bearing</li> </ul> <p><b>a: 98 mm (3.86 in) dia.</b><br/><b>b: 40.5 mm (1.594 in) dia.</b></p>                    |             |

# PREPARATION

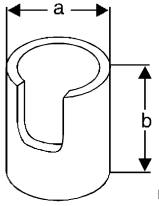
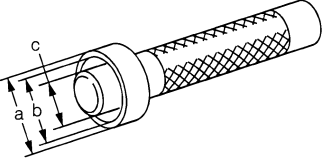
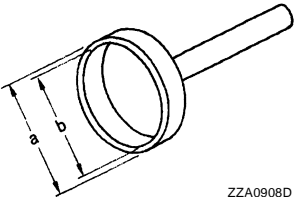
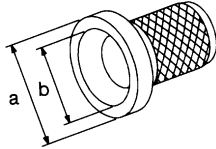
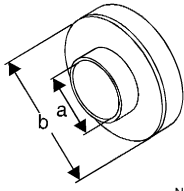
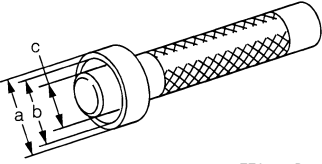
| Tool number<br>(Kent-Moore No.)<br>Tool name | Description   |
|--|---|
| KV31103300<br>( — )<br>Drift                 |  <p style="text-align: right; margin-right: 50px;">NT668</p> <ul style="list-style-type: none"> <li>● Removing press flange snap ring</li> <li>● Installing press flange snap ring</li> <li>● Installing carrier bearing</li> </ul> <p><b>a: 76.3 mm (3.004 in) dia.</b><br/> <b>b: 130 mm (5.12 in)</b></p> |
| KV38100300<br>(J-25523)<br>Drift             |  <p style="text-align: right; margin-right: 50px;">ZZA1046D</p> <ul style="list-style-type: none"> <li>● Removing mainshaft rear bearing</li> </ul> <p><b>a: 54 mm (2.13 in) dia.</b><br/> <b>b: 46 mm (1.81 in) dia.</b><br/> <b>c: 32 mm (1.26 in) dia.</b></p>  |
| ST15310000<br>(J-25640-B)<br>Drift           |  <p style="text-align: right; margin-right: 50px;">ZZA0908D</p> <ul style="list-style-type: none"> <li>● Installing mainshaft rear bearing</li> </ul> <p><b>a: 96 mm (3.78 in) dia.</b><br/> <b>b: 84 mm (3.31 in) dia.</b></p>  |
| KV40100621<br>(J-25273)<br>Drift             |  <p style="text-align: right; margin-right: 50px;">NT086</p> <ul style="list-style-type: none"> <li>● Installing front drive shaft front bearing</li> <li>● Installing front drive shaft rear bearing</li> </ul> <p><b>a: 76 mm (2.99 in) dia.</b><br/> <b>b: 69 mm (2.72 in) dia.</b></p>                  |
| ST30032000<br>(J-26010-01)<br>Base           |  <p style="text-align: right; margin-right: 50px;">NT660</p> <ul style="list-style-type: none"> <li>● Installing front drive shaft front bearing</li> <li>● Installing front drive shaft rear bearing</li> </ul> <p><b>a: 38 mm (1.50 in) dia.</b><br/> <b>b: 80 mm (3.15 in) dia.</b></p>                 |
| ST33220000<br>( — )<br>Drift                 |  <p style="text-align: right; margin-right: 50px;">ZZA1046D</p> <ul style="list-style-type: none"> <li>● Installing needle bearing</li> </ul> <p><b>a: 37 mm (1.46 in) dia.</b><br/> <b>b: 31 mm (1.22 in) dia.</b><br/> <b>b: 22 mm (0.87 in) dia.</b></p>  |



# PREPARATION

## Commercial Service Tools

EDS001Y2

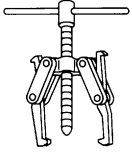
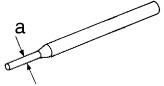
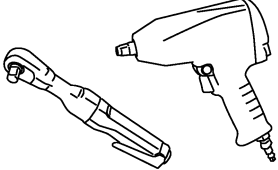
| Tool name  | Description   |
|--|---|
| <p>Puller</p>  <p>NT077</p>         | <ul style="list-style-type: none"> <li>● Removing companion flange</li> </ul>   |
| <p>Pin punch</p>  <p>NT410</p>      | <ul style="list-style-type: none"> <li>● Removing retainer pin</li> <li>● Installing retainer pin</li> </ul> <p><b>a: 6 mm (0.24 in) dia.</b></p> |
| <p>Power tool</p>  <p>PBIC0190E</p> | <ul style="list-style-type: none"> <li>● Removing transfer case assembly</li> </ul>   |

A  
B  
C  
TF  
E  
F  
G  
H  
I  
J  
K  
L  
M

# NOISE, VIBRATION AND HARSHNESS (NVH) TROUBLESHOOTING

## NOISE, VIBRATION AND HARSHNESS (NVH) TROUBLESHOOTING

PF0:00003

### NVH Troubleshooting Chart

EDS001Y3

Use the chart below to help you find the cause of the symptom. The numbers indicate the order of the inspection. If necessary, repair or replace these parts.

| Reference page                      |                                 | IF-11                      |                        |                                 | IF-145                  |                          |                            | IF-162                       | IF-162                 | IF-162                    |
|-------------------------------------|---------------------------------|----------------------------|------------------------|---------------------------------|-------------------------|--------------------------|----------------------------|------------------------------|------------------------|---------------------------|
| SUSPECTED PARTS<br>(Possible cause) |                                 | TRANSFER FLUID (Level low) | TRANSFER FLUID (Wrong) | TRANSFER FLUID (Level too high) | LIQUID GASKET (Damaged) | O-RING (Worn or damaged) | OIL SEAL (Worn or damaged) | SHIFT FORK (Worn or damaged) | GEAR (Worn or damaged) | BEARING (Worn or damaged) |
| Symptom                             | Noise                           | 1                          | 2                      |                                 |                         |                          |                            |                              | 3                      | 3                         |
|                                     | Transfer fluid leakage          |                            | 3                      | 1                               | 2                       | 2                        | 2                          |                              |                        |                           |
|                                     | Hard to shift or will not shift |                            | 1                      | 1                               |                         |                          |                            | 2                            |                        |                           |

# TRANSFER FLUID

PFP:31001

EDS001Y4

## TRANSFER FLUID

### Replacement DRAINING

1. Stop the engine.
2. Remove the drain plug and gasket to drain the transfer fluid as shown.
3. Install the new gasket on the drain plug and install the drain plug in the transfer. Tighten the drain plug to specification.

**Drain plug** : Refer to [TF-145, "COMPONENTS"](#) .

**CAUTION:**  
Do not reuse the gasket.

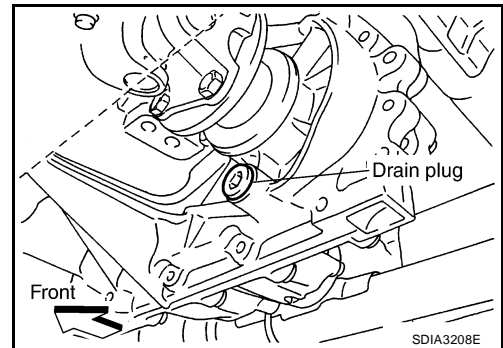

### FILLING

1. Remove the filler plug and gasket.
2. Fill with new specified fluid until the fluid level reaches the specified limit near the filler plug hole as shown.

**Fluid capacity and grade** : Refer to [MA-11, "Fluids and Lubricants"](#) .

**CAUTION:**  
Carefully fill the transfer with fluid. Filling should take approximately three minutes.

3. Leave the vehicle for three minutes and then check the fluid level again as shown.
4. Install the new gasket on the filler plug and install the filler plug in the transfer. Tighten the filler plug to specification.

**Filler plug** : Refer to [TF-145, "COMPONENTS"](#) .

**CAUTION:**  
Do not reuse the gasket.

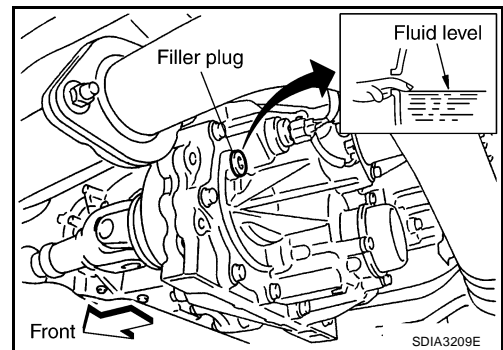

### Inspection

#### FLUID LEAKAGE AND FLUID LEVEL

1. Check for any fluid leaks from the transfer assembly or around it and correct as necessary.
2. Remove the filler plug to check the fluid level at the filler plug hole as shown.

**CAUTION:**  
Do not start the engine while checking the fluid level.

3. Install the new gasket on the filler plug and install the filler plug in the transfer. Tighten the filler plug to specification.

**Filler plug** : Refer to [TF-145, "COMPONENTS"](#) .

**CAUTION:**  
Do not reuse the gasket.

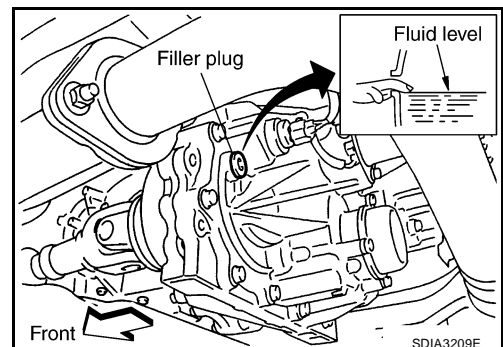

EDS001Y5

# ALL-MODE 4WD SYSTEM

## ALL-MODE 4WD SYSTEM

PFP:00000

### Cross-section View

EDS001Y6

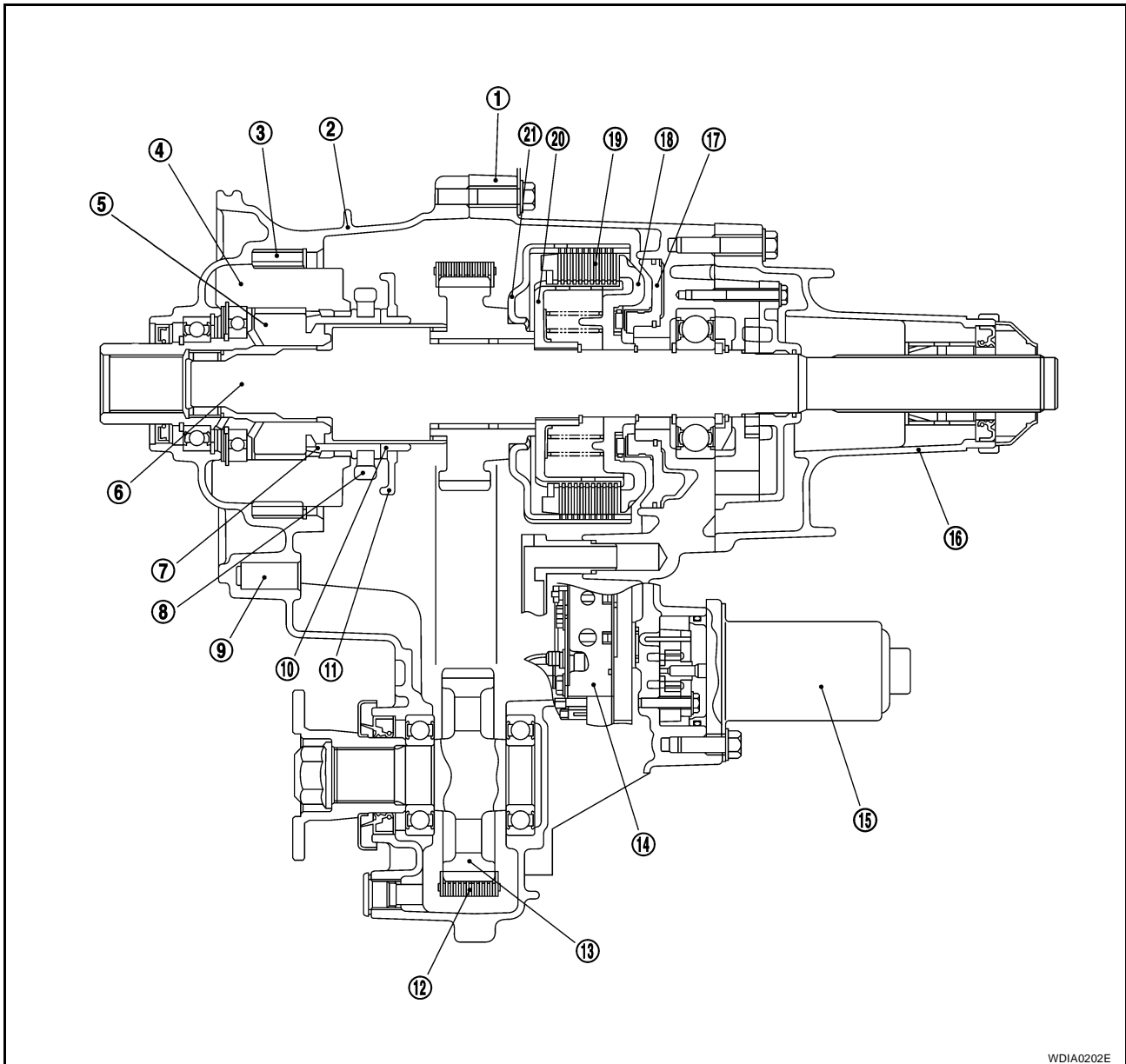

WDIA0202E

- |                               |                            |                          |
|-------------------------------|----------------------------|--------------------------|
| 1. Center case                | 2. Front case              | 3. Internal gear         |
| 4. Planetary carrier assembly | 5. Sun gear assembly       | 6. Main shaft            |
| 7. L-H sleeve                 | 8. L-H fork                | 9. Shift rod             |
| 10. 2-4 sleeve                | 11. 2-4 fork               | 12. Drive chain          |
| 13. Front drive shaft         | 14. Control valve assembly | 15. Transfer motor       |
| 16. Rear case                 | 17. Clutch piston          | 18. Press flange         |
| 19. Multiple disc clutch      | 20. Clutch hub assembly    | 21. Clutch drum assembly |

# ALL-MODE 4WD SYSTEM

EDS001Y7

## Power Transfer POWER TRANSFER DIAGRAM

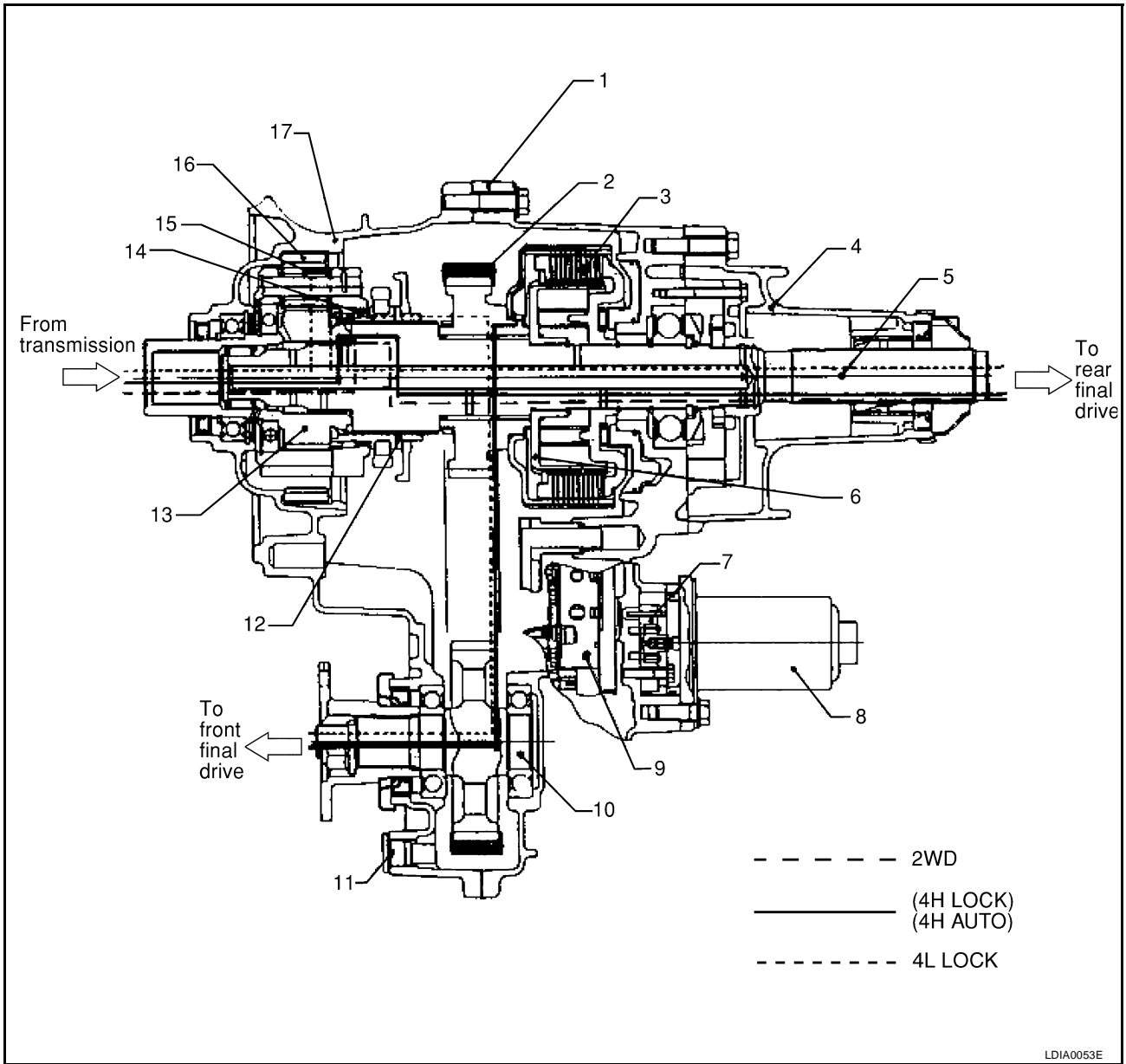

- |                       |                   |                                |
|-----------------------|-------------------|--------------------------------|
| 1. Center case        | 2. Chain          | 3. Multiple disc clutch        |
| 4. Rear case          | 5. Mainshaft      | 6. Clutch hub assembly         |
| 7. Sub oil pump       | 8. Transfer motor | 9. Control valve               |
| 10. Front drive shaft | 11. Drain plug    | 12. 2-4 sleeve                 |
| 13. Sun gear assembly | 14. L-H sleeve    | 15. Planetary carrier assembly |
| 16. Internal gear     | 17. Front case    |                                |

# ALL-MODE 4WD SYSTEM

## POWER TRANSFER FLOW

2WD

From transmisson → Sun gear → L-H sleeve → Mainshaft → To rear final drive

AUTO 4H (LOCK)

From transmisson → Sun gear → L-H sleeve → Mainshaft → To rear final drive

Clutch hub → Multiple disc clutch → Clutch drum → Drive chain → Front drive shaft → To front final drive

Clutch piston → press flange → Multiple disc clutch

4LO

From transmisson → Sun gear → Planetary carrier → L-H sleeve → Mainshaft → To rear final drive

2-4 sleeve → Clutch drum → Drive chain → Front drive shaft → To front final drive

SDIA3327E



# ALL-MODE 4WD SYSTEM

## ALL-MODE 4WD Transfer Basic Control

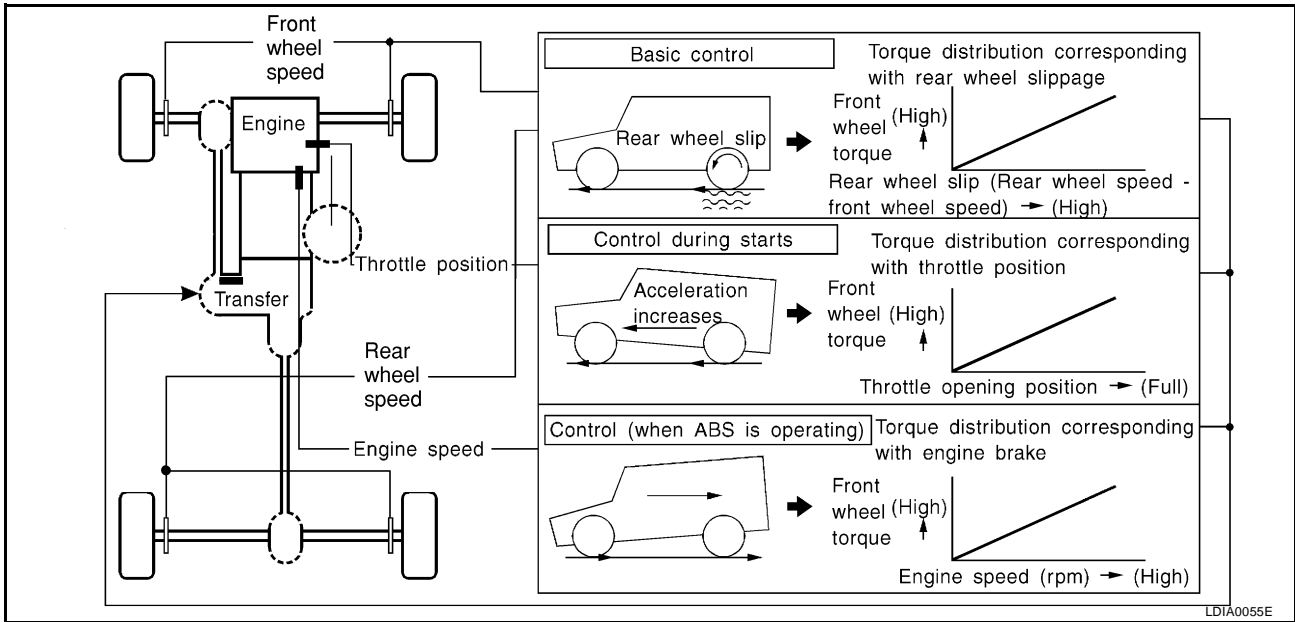

LDIA0055E

## Hydraulic Control Circuits

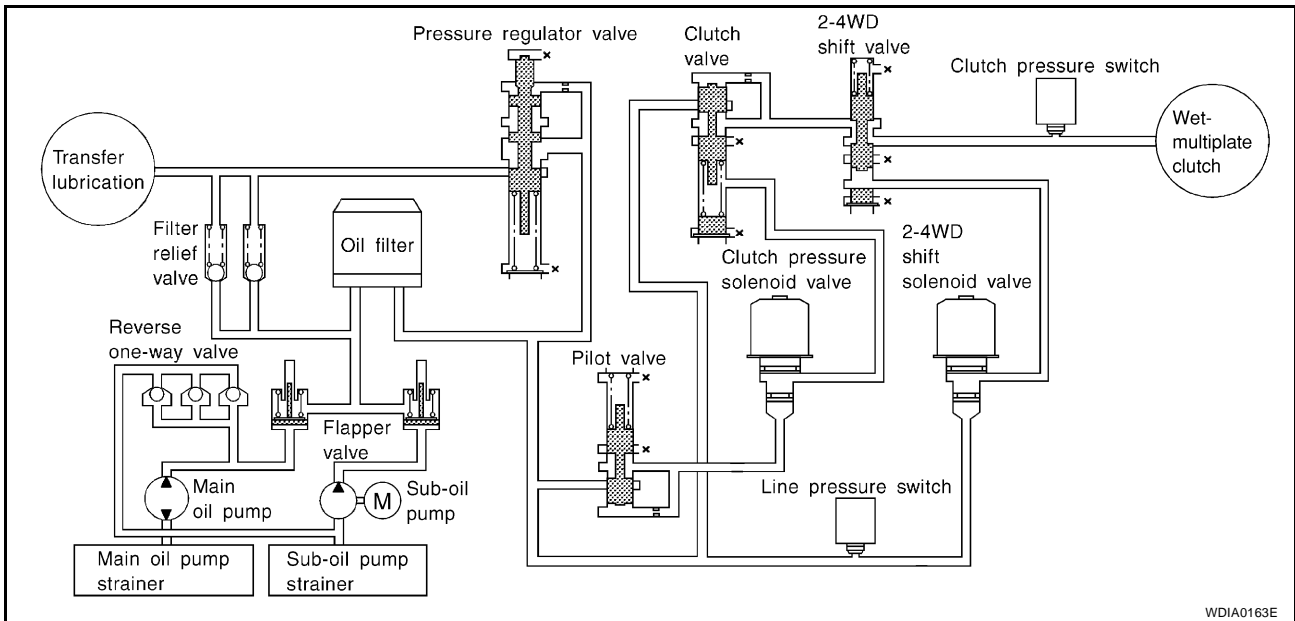

WDIA0163E

## TRANSFER MOTOR

- The transfer motor drives the sub-oil pump to provide proper lubrication and oil pressure control when the vehicle is at standstill, during low-speed operations or is being driven in reverse.
- The main oil pump is operated by the driving force of the mainshaft. In other words, sufficient oil pressure buildup does not occur when the vehicle is at standstill or during low-speed operations. While the vehicle is being driven in reverse, the main oil pump rotates in the reverse direction. Therefore the main oil pump does not discharge oil pressure. During any of the above vehicle operations, the transfer motor drives the sub-oil pump to compensate for insufficient oil pressure.
- The transfer motor operates as follows.
  - The motor relay turns OFF in the 2WD mode.
  - The motor relay operates as described in the table below in modes other than the 2WD mode.



# ALL-MODE 4WD SYSTEM

## Transfer Motor Relay Operation

| 4WD shift switch  | A/T selector lever position          | Vehicle speed (VSS)   | Accelerator pedal position                                  | Motor relay drive command |
|-------------------|--------------------------------------|---|---|---------------------------|
| 2WD               | —                                    | —   | —   | OFF                       |
| 4H (LOCK) and 4LO | "N" position                         | 0   | —   | ON                        |
|                   | "P" position                         | 0   | 0 - 0.07/8  | OFF*                      |
|                   |                                      |   | 0.07/8 - 1/8  | HOLD                      |
|                   |                                      |   | 1/8 - MAX   | ON                        |
|                   | Other than "R" position              | $0 < VSS \leq 50 \text{ km/h (31 MPH)}$<br>$50 \text{ km/h (31 MPH)} < VSS < 55 \text{ km/h (34 MPH)}$<br>$55 \text{ km/h (34 MPH)} \leq VSS$ | —   | ON                        |
|                   |                                      |   |   | HOLD                      |
|                   |                                      |   |   | OFF                       |
| "R" position      | —                                    | —   | —   | ON                        |
| AUTO              | "R" position                         | —   | —   | ON                        |
|                   | "P" or "N" position                  | 0   | 0 - 0.07/8  | OFF*                      |
|                   |                                      |   | 0.07/8 - 1/8  | HOLD                      |
|                   |                                      |   | 1/8 - MAX   | ON                        |
|                   |                                      |   | $0 < VSS \leq 50 \text{ km/h (31 MPH)}$                     | ON                        |
|                   |                                      |   | $50 \text{ km/h (31 MPH)} < VSS < 55 \text{ km/h (34 MPH)}$ | HOLD                      |
|                   |                                      |   | $55 \text{ km/h (34 MPH)} \leq VSS$                         | OFF                       |
|                   | Other than "R", "P" and "N" position | $0 < VSS \leq 50 \text{ km/h (31 MPH)}$<br>$50 \text{ km/h (31 MPH)} < VSS < 55 \text{ km/h (34 MPH)}$<br>$55 \text{ km/h (34 MPH)} \leq VSS$ | —   | ON                        |
|                   |                                      |   |   | HOLD                      |
|                   |                                      |   |   | OFF                       |

\*: After 2.5 seconds have elapsed.

- 4WD shift switch, PNP switch, Neutral-4LO switch, vehicle speed sensor and throttle position sensor are used in conjunction with the transfer motor.

### WAIT DETECTION SWITCH

- The wait detection switch operates when there is "circulating" torque produced in the propeller shaft (L→H) or when there is a phase difference between 2-4 sleeve and clutch drum (H→L). After the release of the "circulating" torque, the wait detection switch helps provide the 4WD lock gear (clutch drum) shifts. A difference may occur between the operation of the 4WD shift switch and actual drive mode. At this point, the wait detection switch senses an actual drive mode.
- The wait detection switch operates as follows.
  - 4WD lock gear (clutch drum) locked: ON
  - 4WD lock gear (clutch drum) released: OFF
- The wait detection switch senses an actual drive mode and the 4WD shift indicator lamp indicates the vehicle drive mode.

### NEUTRAL-4LO SWITCH

The neutral-4LO switch detects that transfer gear is in neutral or 4LO (or shifting from neutral to 4LO) condition by L-H shift fork position.

### ATP SWITCH

It detects that transfer gear is under neutral condition by L-H shift fork position.

#### NOTE:

Transfer gear may be under neutral condition in 4H-4LO.

### 2-4WD SHIFT SOLENOID VALVE

The 2-4WD shift solenoid valve operates to apply oil pressure to the wet-multiplate clutch, depending on the drive mode. The driving force is transmitted to the front wheels through the clutch so the vehicle is set in the

# ALL-MODE 4WD SYSTEM

4WD mode. Setting the vehicle in the 2WD mode requires no pressure buildup. In other words, pressure force applied to the wet-multiplate clutch becomes zero.

## CLUTCH PRESSURE SOLENOID VALVE

The clutch pressure solenoid valve distributes each of torque (front and rear) with AUTO mode.

## LINE PRESSURE SWITCH

- With the transfer system design, control of the oil pressure provides the transmission of drive torque to the front wheels. The main pressure to control the oil pressure is referred to as the line pressure.
- The line pressure switch determines whether or not adequate line pressure has built up under different operating conditions.
- The line pressure switch turns ON when line pressure is produced.
- The line pressure switch senses line pressure abnormalities and turns the 4WD warning lamp ON.

## CLUTCH PRESSURE SWITCH

- The clutch pressure switch determines whether or not adequate clutch pressure has built up under different operating conditions.
- The clutch pressure switch turns ON when clutch pressure is produced.
- The clutch pressure switch senses clutch pressure abnormalities and turns the 4WD warning lamp ON.

## TRANSFER FLUID TEMPERATURE SENSOR

The transfer temperature sensor detects the transfer fluid temperature and sends a signal to the transfer control unit.

## TRANSFER CONTROL UNIT

- Transfer control unit controls transfer control device by input signals of each sensor and each switch.
- Self-diagnosis can be done.

## TRANSFER CONTROL DEVICE

The transfer control device changes the state of transfer assembly between 2WD, AUTO, 4H⇔4LO with the 2WD, AUTO, 4H and 4LO signals of 4WD shift switch.

### NOTE:

- To shift between 4H⇔4LO, stop the vehicle, depress the brake pedal and shift the transmission selector to the "N" position. Depress and turn the 4WD shift switch. The shift switch will not shift to the desired mode if the transmission is not in "N" or the vehicle is moving. The 4LO indicator lamp will be lit when the 4LO is engaged.
- Actuator motor and actuator position switch are integrated.

## 4WD SHIFT SWITCH AND INDICATOR LAMP

### 4WD Shift Switch

Able to select from 2WD, AUTO, 4H or 4LO.

### 4WD Shift Indicator Lamp

- Displays driving conditions selected by 4WD shift switch with 2WD, AUTO and 4H indicators while engine is running. (When 4WD warning lamp is turned on, all 4WD shift indicator lamps are turned off.)
- Turns ON for approximately 1 second when ignition switch is turned ON, for purpose of lamp check.

### 4LO Indicator Lamp

- Displays 4LO condition while engine is running. 4LO indicator lamp flashes if transfer gear does not shift completely under 2WD, AUTO, 4H⇔4LO. (When 4WD warning lamp is turned on, 4LO indicator lamp is turned off.)
- Turns ON for approximately 1 second when ignition switch is turned ON, for purpose of lamp check.

# ALL-MODE 4WD SYSTEM

## 4WD WARNING LAMP

Turns ON or FLASH when there is a malfunction in 4WD system.

Also turns ON when ignition switch is turned ON, for purpose of lamp check. Turns OFF for approximately 1 second after the engine starts if system is normal.

## 4WD Warning Lamp Indication

| Condition   | Content   | 4WD warning lamp               |
|---|---|--------------------------------|
| During self-diagnosis   | Indicates the malfunction position by number of flickers.   | Flickers at malfunction mode.  |
| Lamp check*   | Checks the lamp by turning ON during engine starting. After engine starts, it turns OFF if there are no malfunctions.   | ON                             |
| Malfunction in 4WD system*  | Turns ON to indicate malfunction. When ignition switch is turned to "OFF" or the malfunction is corrected, it turns OFF.  | ON                             |
| When vehicle is driven with different diameters of front and rear tires | Flickers once every 2 seconds.<br>Turns OFF when ignition switch is "OFF".  | Flickers once every 2 seconds. |
| High fluid temperature in transfer unit                                 | When fluid temperature is high or fluid temperature sensor circuit is shorted, it flickers twice every second.<br>It turns OFF when fluid temperature becomes normal. | Flickers twice a second.       |
| Other than above (System is normal.)                                    | Lamp is OFF.  | OFF                            |

\*: When 4WD warning lamp is ON, all the 4WD shift indicator lamps turn OFF.

## ATP WARNING LAMP

Even if A/T selector lever is in "P" position, vehicle may move because A/T parking mechanism does not operate when transfer is under neutral condition. ATP warning lamp is turned on so as to indicate this condition to the driver.

## System Diagram

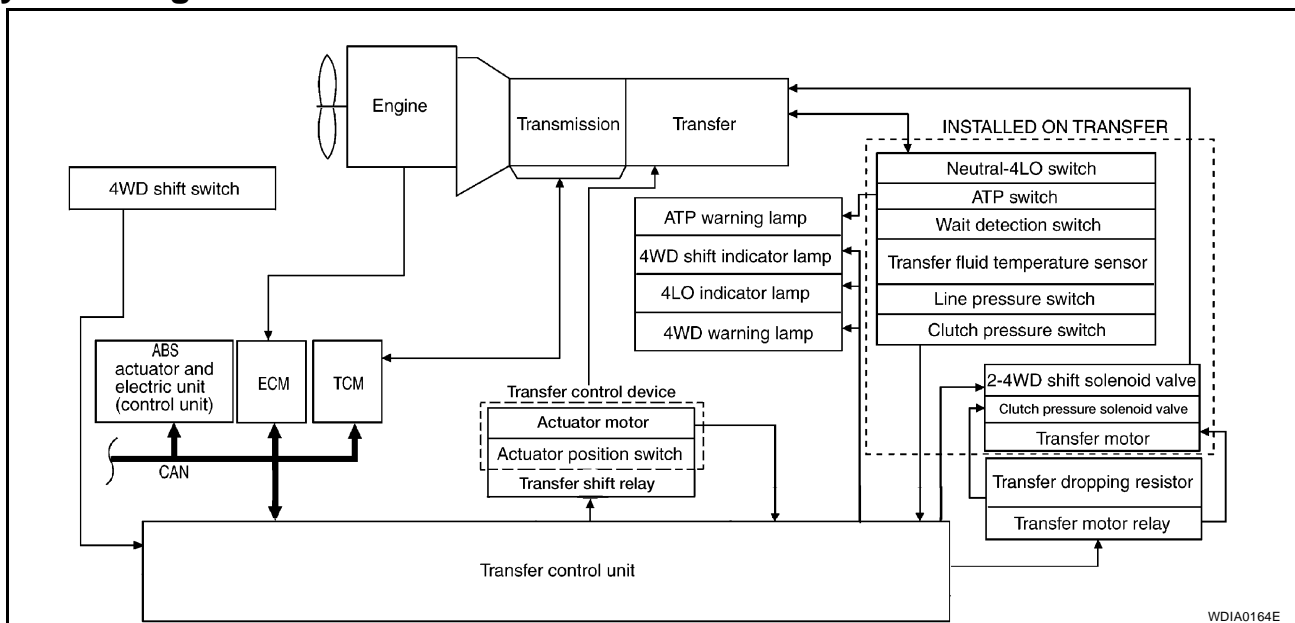

# ALL-MODE 4WD SYSTEM

## COMPONENTS FUNCTION

| Component parts                               | Function  |
|---|---|
| Transfer control unit                         | Controls transfer control device and control valves.  |
| Transfer control device                       | Actuator motor and actuator position switch are integrated so as to switch driving types.   |
| 2-4WD shift solenoid valve                    | Controls oil pressure and allows selection between 2WD and 4WD.   |
| Clutch pressure solenoid valve                | Controls oil pressure and distributes torque (front and rear).  |
| Line pressure switch                          | Detects line pressure.  |
| Clutch pressure switch                        | Detects clutch pressure.  |
| Transfer fluid temperature sensor             | Detects transfer fluid temperature.   |
| Wait detection switch                         | Detects whether or not 4WD lock gear is locked.   |
| Neutral-4LO switch                            | Detects that transfer is under neutral-4LO condition (or shifting through neutral).   |
| ATP switch                                    | Detects that transfer is under neutral condition.   |
| 4WD shift switch                              | Allows selection from 2WD, AUTO, 4H or 4LO.   |
| 4WD warning lamp                              | <ul style="list-style-type: none"> <li>● Illuminates if malfunction is detected in electrical system of 4WD system.</li> <li>● There is 1 blink every 2 seconds if rotation difference of front wheels and rear wheels is large.</li> <li>● There is 2 blinks every 1 second if high transfer fluid temperature is detected.</li> </ul> |
| ATP warning lamp                              | Indicates that A/T parking mechanism does not operate when A/T selector lever is in "P" position and transfer is under neutral condition.   |
| 4WD shift indicator lamp                      | Displays driving condition selected by 4WD shift switch.  |
| 4LO indicator lamp                            | Displays 4LO condition.   |
| ABS actuator and electric unit (control unit) | Transmits vehicle speed signal via CAN communication to transfer control unit.  |
| TCM   | Transmits the following signals via CAN communication to transfer control unit. <ul style="list-style-type: none"> <li>● Output shaft revolution signal</li> <li>● A/T position indicator signal (PNP switch signal)</li> </ul>   |
| ECM   | Transmits the following signals via CAN communication to transfer control unit. <ul style="list-style-type: none"> <li>● Engine speed signal</li> <li>● Accelerator pedal position signal</li> </ul>  |

## CAN Communication SYSTEM DESCRIPTION

EDS001YA

Refer to [LAN-30, "CAN Communication Unit"](#) .

## TROUBLE DIAGNOSIS

### How to Perform Trouble Diagnosis BASIC CONCEPT

EDS001YB

- To perform trouble diagnosis, it is the most important to have understanding about vehicle systems (control and mechanism) thoroughly.
- It is also important to clarify customer complaints before inspection.  
First of all, reproduce symptoms, and understand them fully. Ask customer about his/her complaints carefully. In some cases, it will be necessary to check symptoms by driving vehicle with customer.

**CAUTION:**

**Customers are not professional. It is dangerous to make an easy guess like "maybe the customer means that...," or "maybe the customer mentions this symptom".**

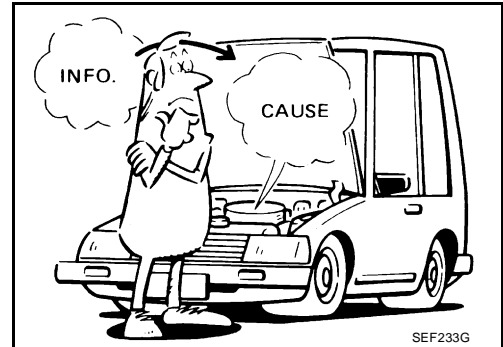

- It is essential to check symptoms right from the beginning in order to repair malfunctions completely. For intermittent malfunctions, reproduce symptoms based on interview with customer and past examples. Do not perform inspection on ad hoc basis. Most intermittent malfunctions are caused by poor contacts. In this case, it will be effective to shake suspected harness or connector by hand. When repairing without any symptom diagnosis, you cannot judge if malfunctions have actually been eliminated.
- After completing diagnosis, always erase diagnostic memory. Refer to [TF-53, "ERASE SELF-DIAGNOSIS"](#).
- For intermittent malfunctions, move harness or harness connector by hand. Then check for poor contact or reproduced open circuit.

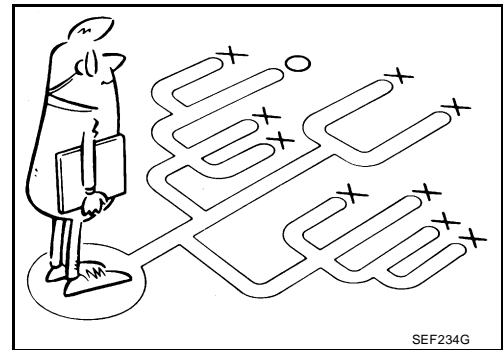

A  
B  
C  
TF  
E  
F  
G  
H  
I  
J  
K  
L  
M

# TROUBLE DIAGNOSIS

## Location of Electrical Parts

EDS001YC

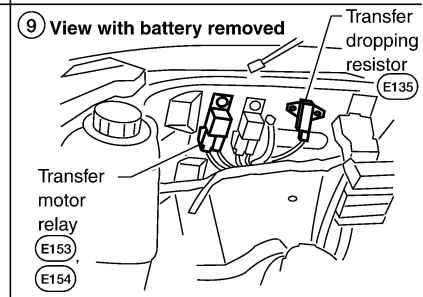
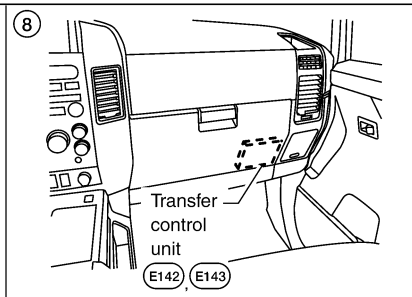
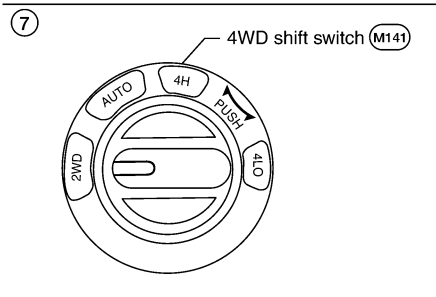
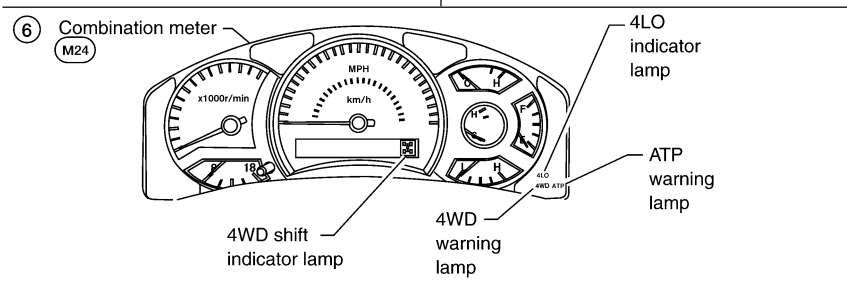
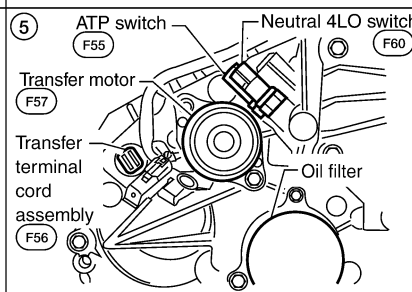
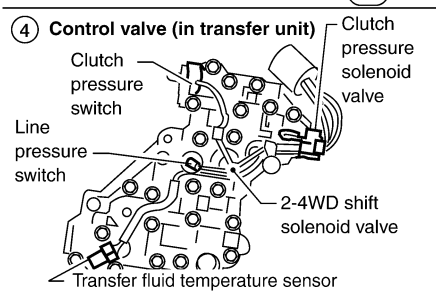
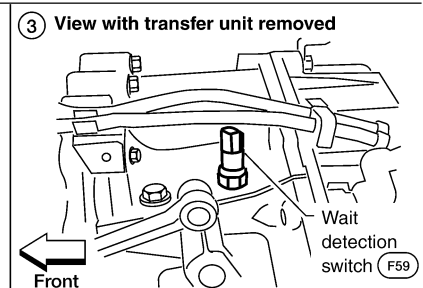
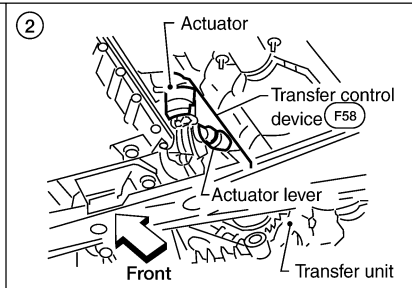
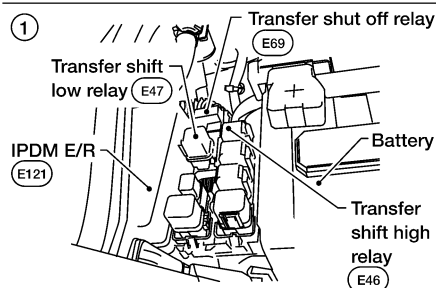
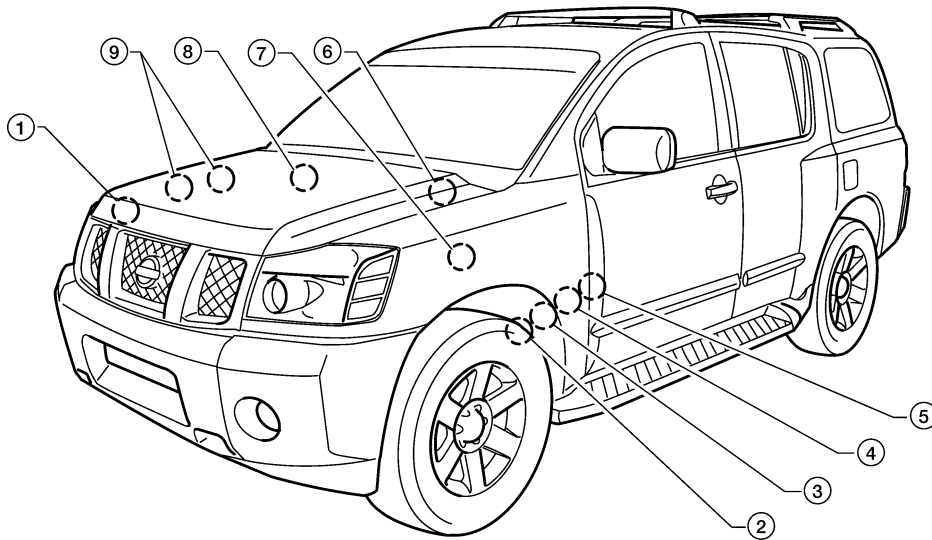

WDIA0153E

# TROUBLE DIAGNOSIS

## Schematic

EDS001YD

A  
B  
C  
TF  
E  
F  
G  
H  
I  
J  
K  
L  
M

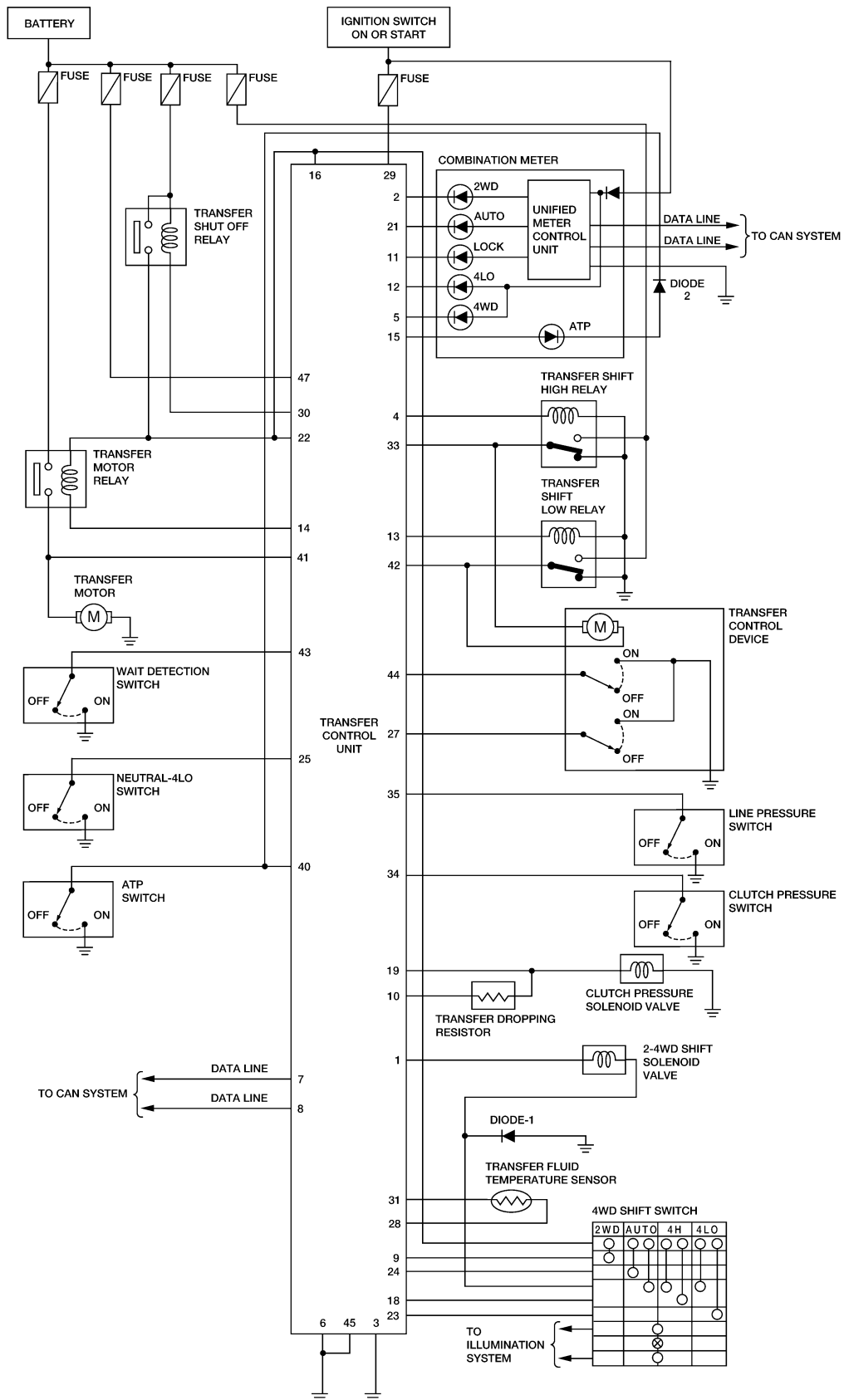

BDWA0089E

# TROUBLE DIAGNOSIS

## Wiring Diagram — T/F —

EDS001YE

### TF-T/F-01

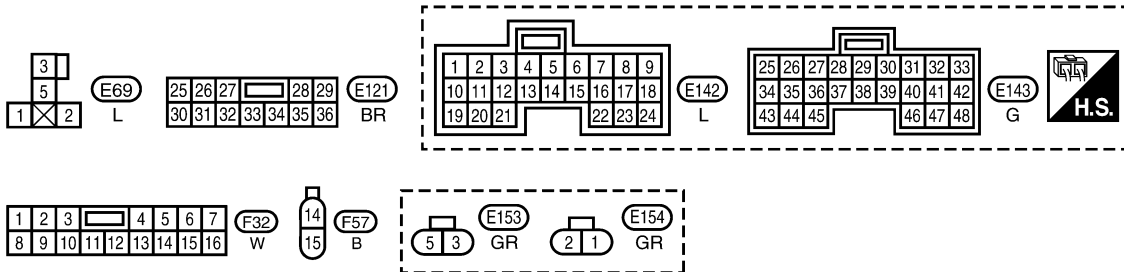
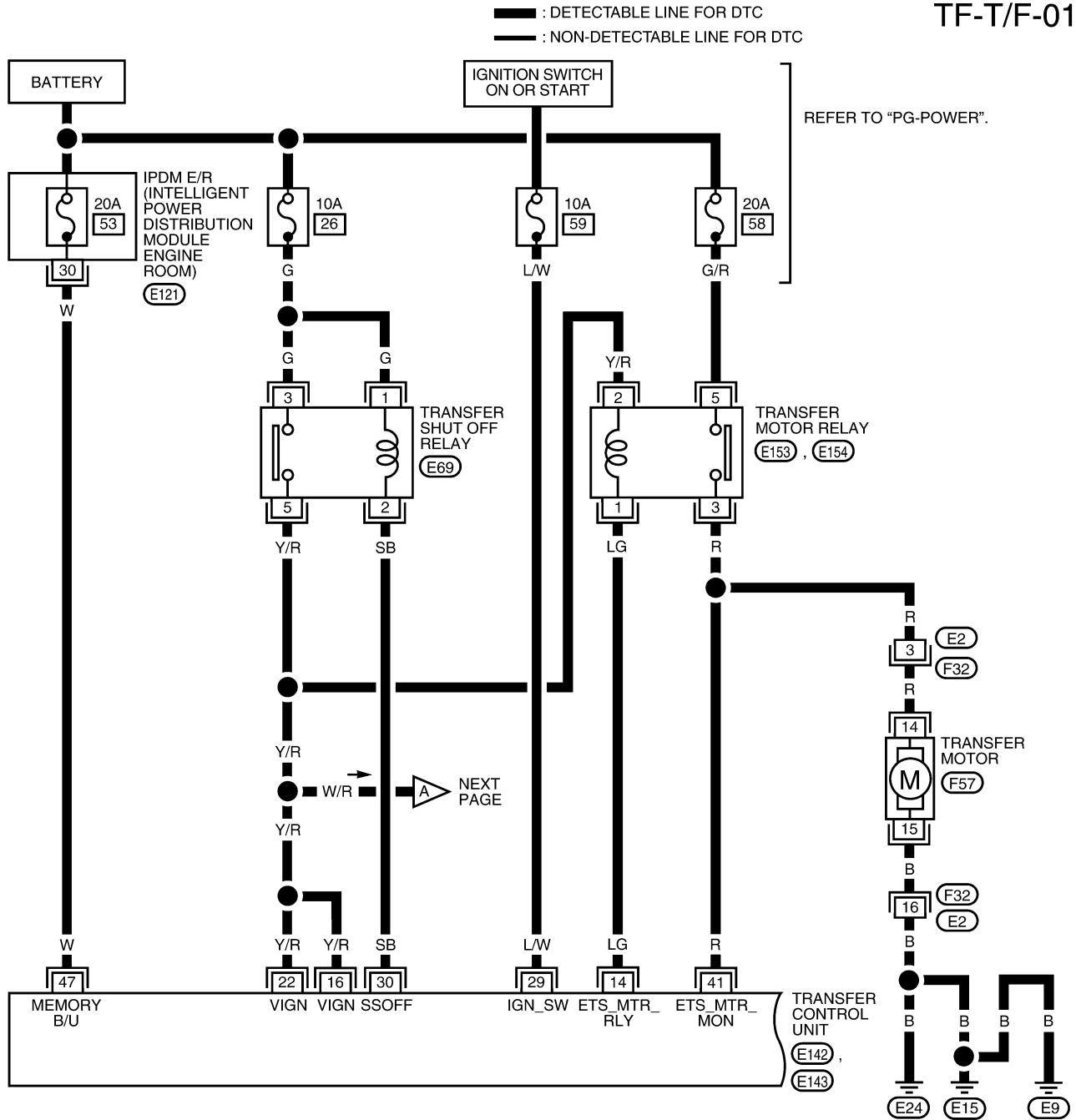

WDWA0016E



# TROUBLE DIAGNOSIS

TF-T/F-02

PRECEDING PAGE

**—** : DETECTABLE LINE FOR DTC  
**—** : NON-DETECTABLE LINE FOR DTC

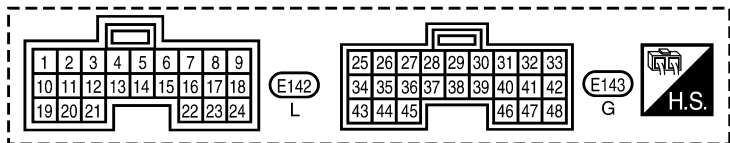
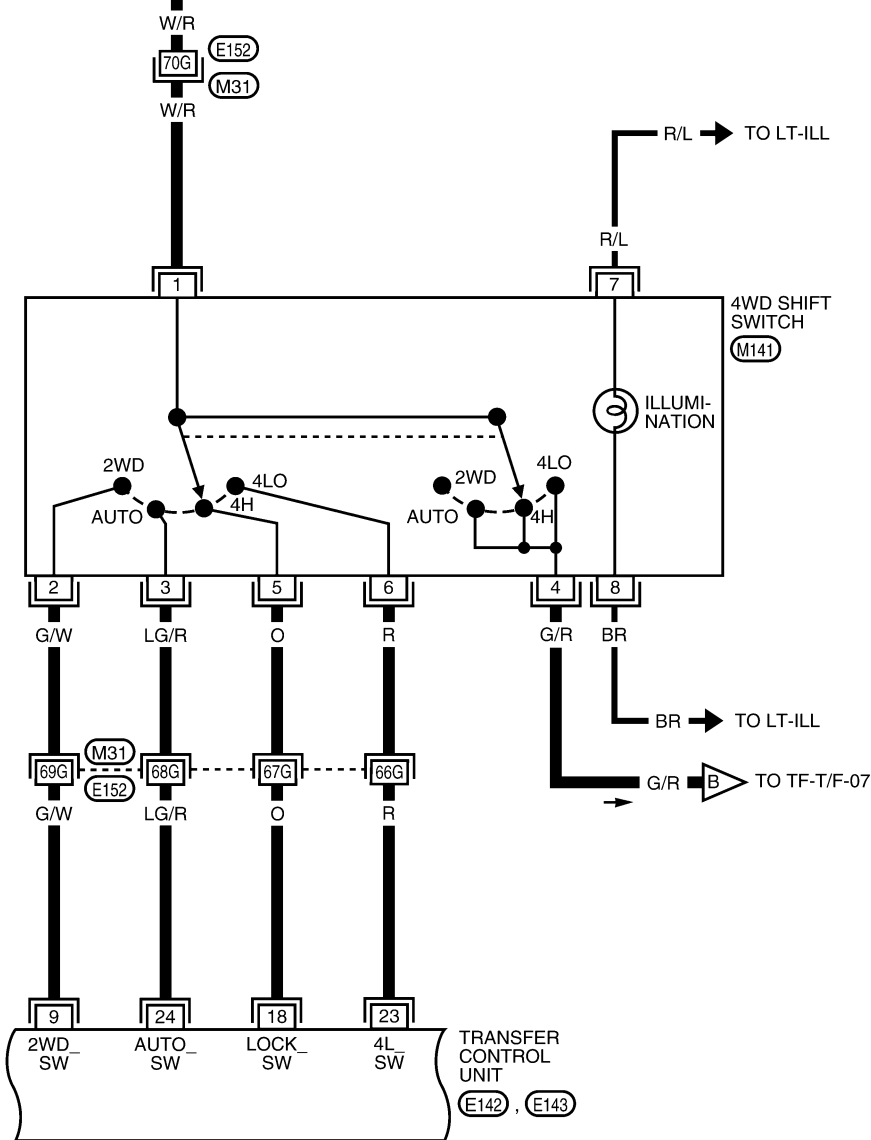

REFER TO THE FOLLOWING.  
**(M31)** - SUPER MULTIPLE JUNCTION (SMJ)

WDA0017E

# TROUBLE DIAGNOSIS

TF-T/F-03

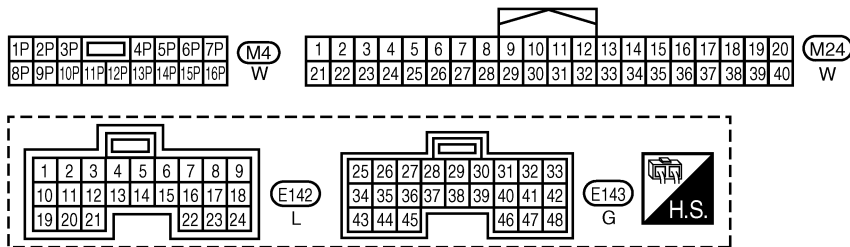
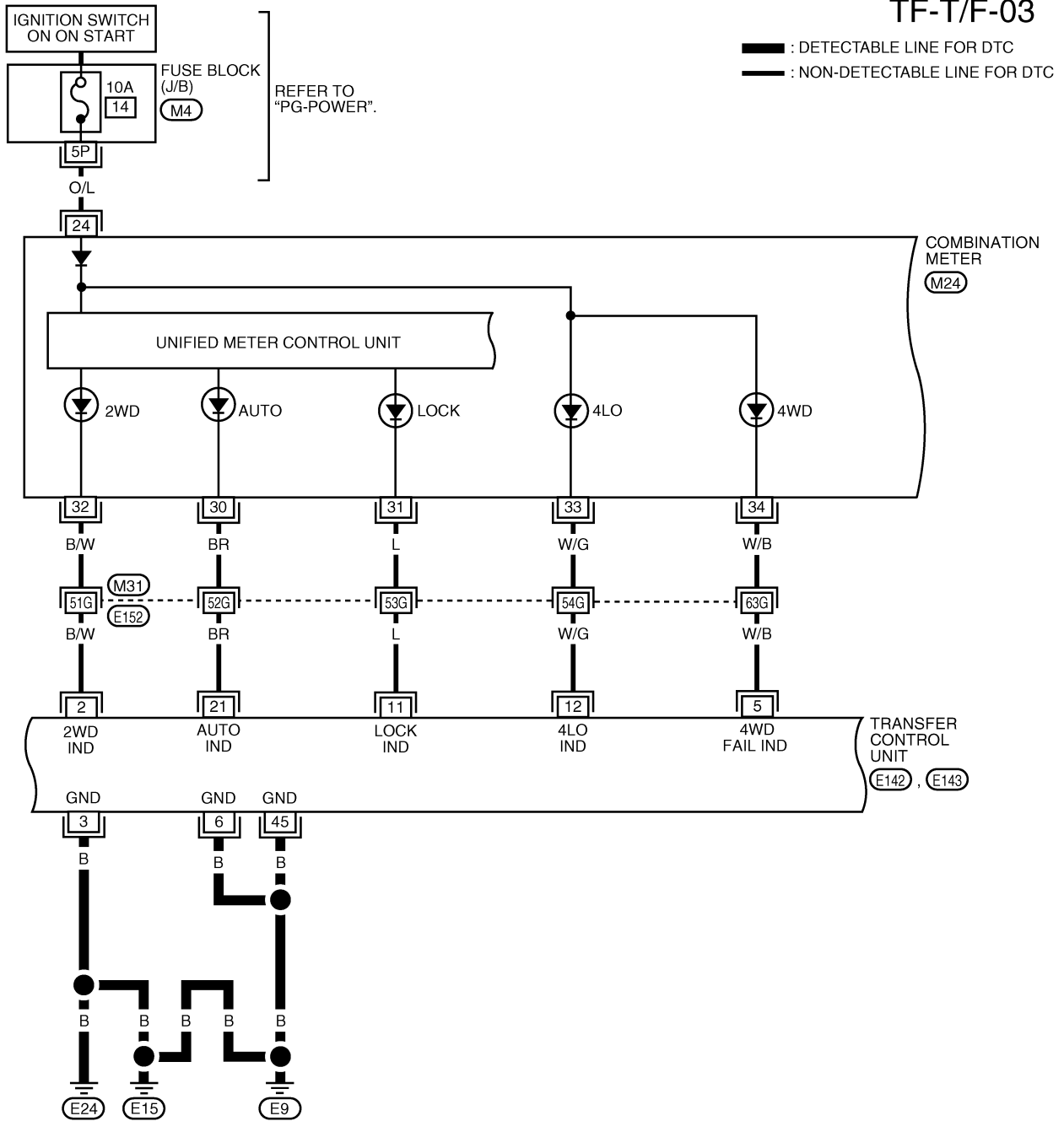

BDWA0090E

# TROUBLE DIAGNOSIS

TF-T/F-04

: DETECTABLE LINE FOR DTC  
 : NON-DETECTABLE LINE FOR DTC  
 : DATA LINE

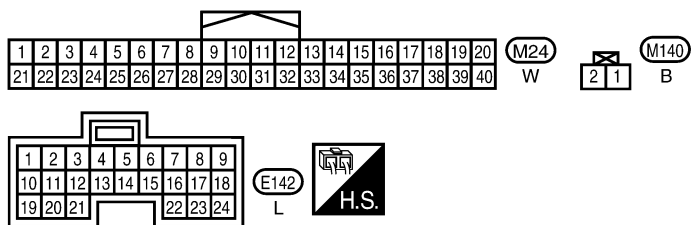
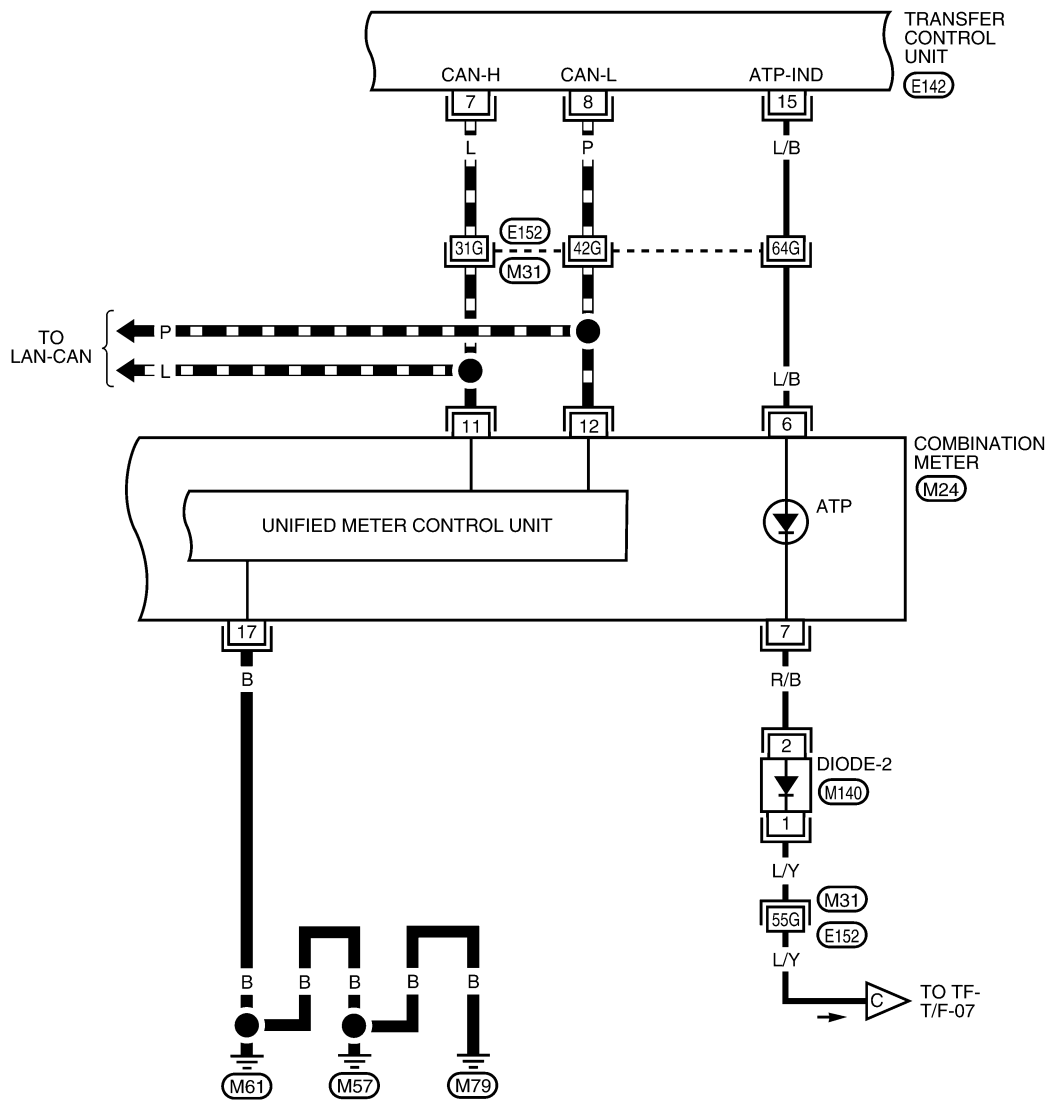

REFER TO THE FOLLOWING.  
 (M31) - SUPER MULTIPLE JUNCTION (SMJ)

WDWA0043E

# TROUBLE DIAGNOSIS

TF-T/F-05

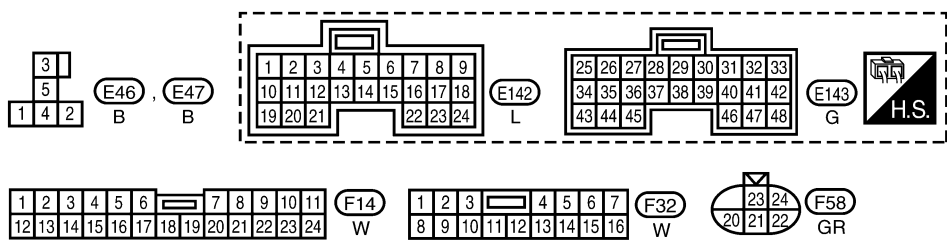
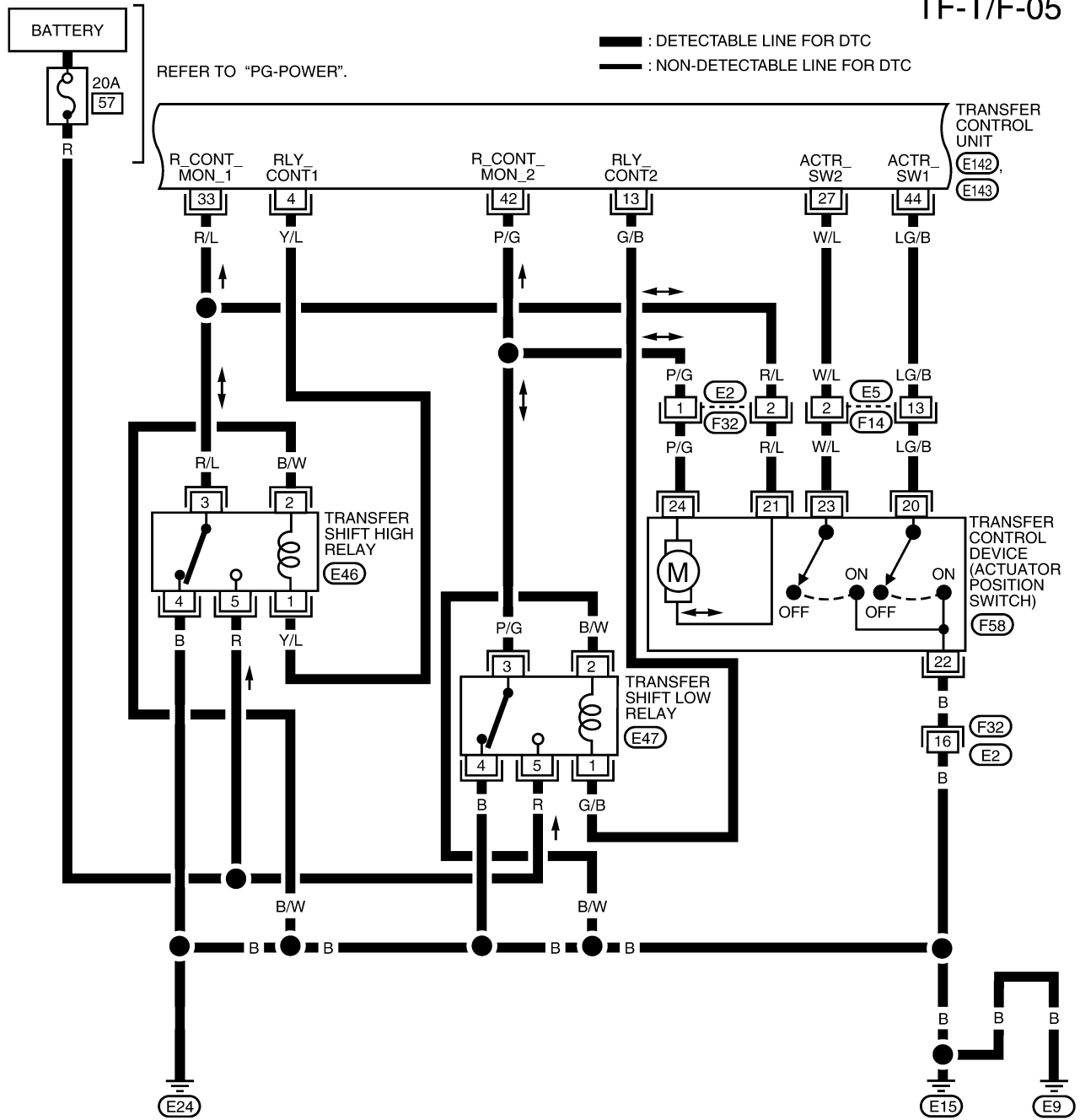

BDWA0100E

# TROUBLE DIAGNOSIS

TF-T/F-06

: DETECTABLE LINE FOR DTC  
 : NON-DETECTABLE LINE FOR DTC

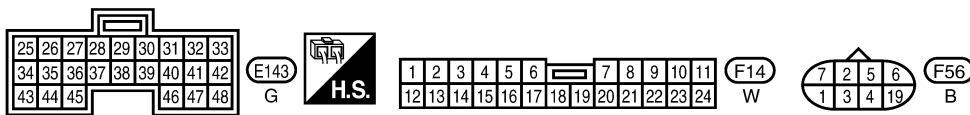
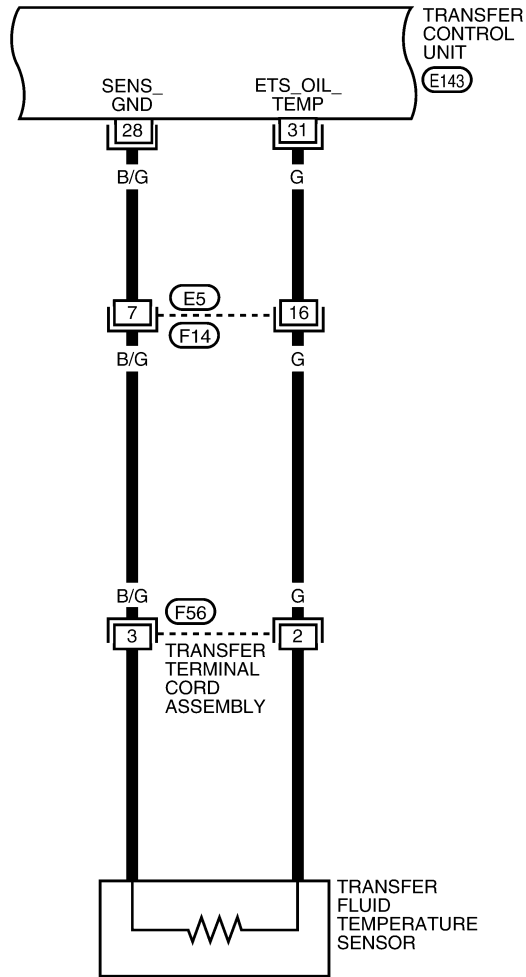

WDA0021E

# TROUBLE DIAGNOSIS

TF-T/F-07

— : DETECTABLE LINE FOR DTC  
 — : NON-DETECTABLE LINE FOR DTC

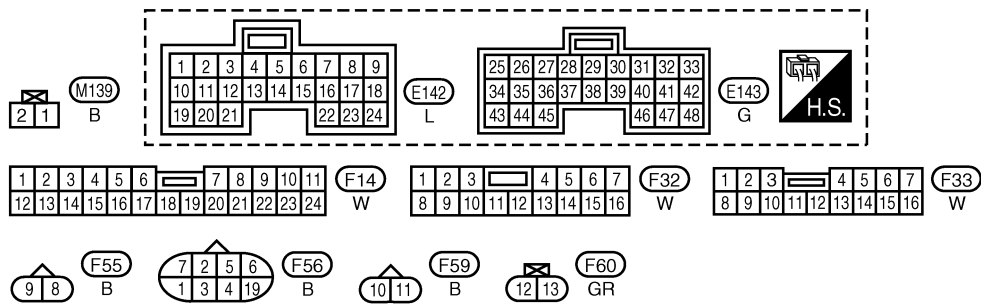
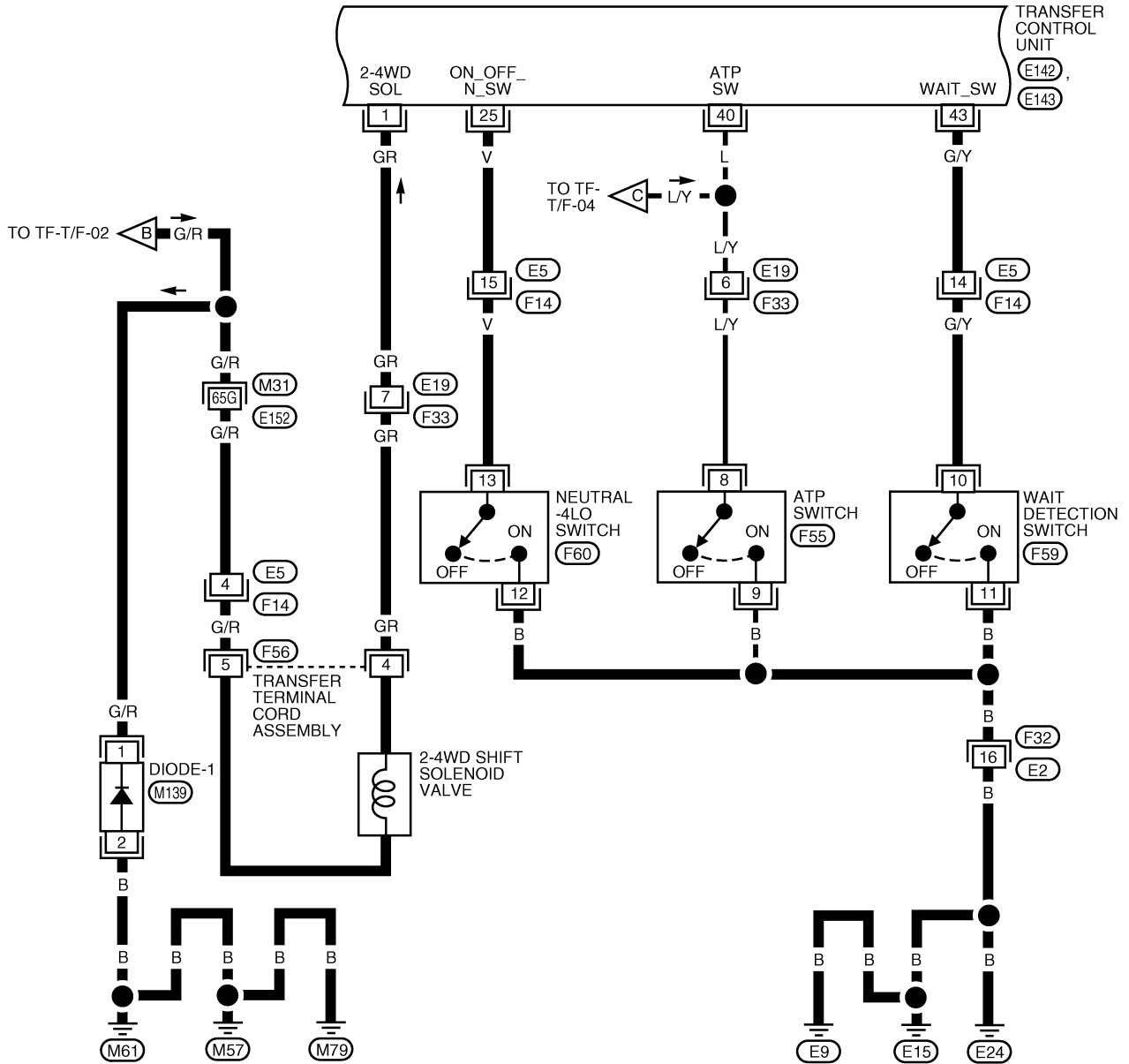

REFER TO THE FOLLOWING.

(M31) - SUPER MULTIPLE JUNCTION (SMJ)

BDWA0092E

# TROUBLE DIAGNOSIS

TF-T/F-08

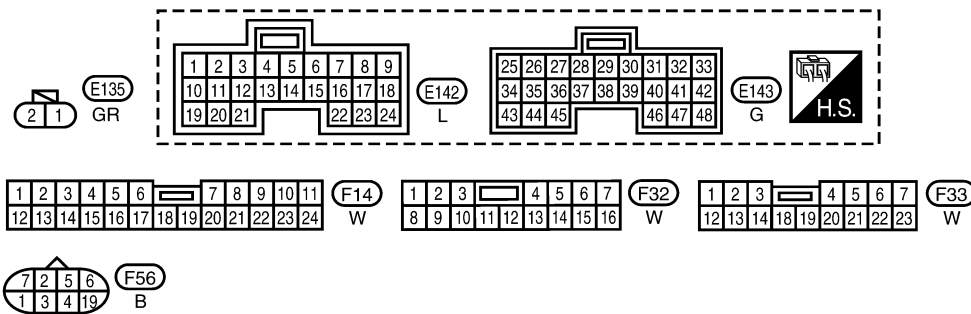
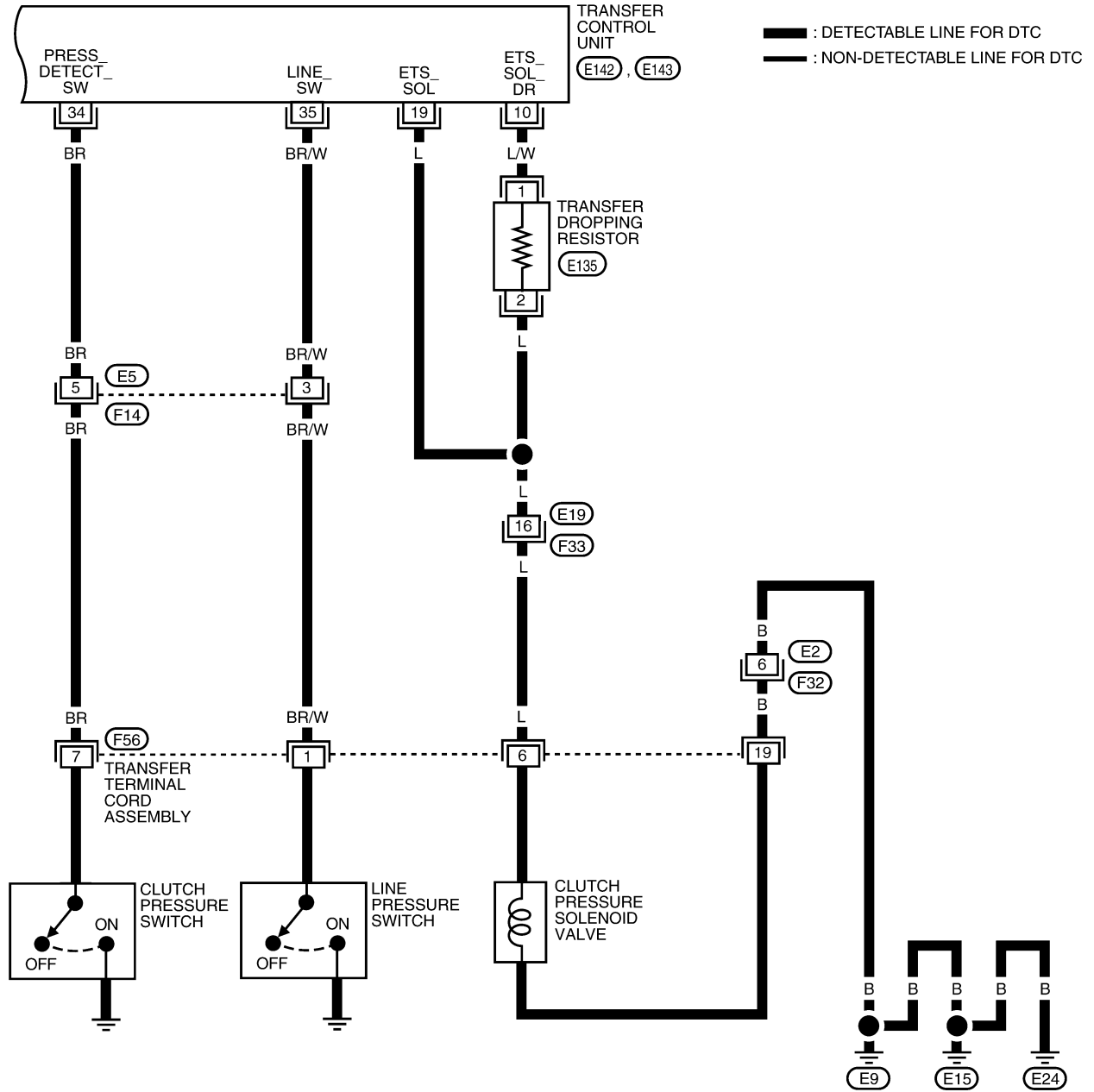

BDWA0093E

# TROUBLE DIAGNOSIS

EDS002GE

## Inspections Before Trouble Diagnosis

### TRANSFER FLUID CHECK

Check fluid for leaks and fluid level. Refer to [TF-11, "Inspection"](#) .

### PREPARATION FOR ROAD TEST

- The purpose of the test is to determine overall performance of transfer and analyze causes of problems.
- When a malfunction is found in any part of transfer, perform the road test to locate the malfunction area and repair the malfunction parts.
- The road test consists of the following three parts.
  - Check before engine is started. Refer to [TF-32, "CHECK BEFORE ENGINE IS STARTED"](#) .
  - Check at idle. Refer to [TF-32, "CHECK AT IDLE"](#) .
  - Cruise test. Refer to [TF-33, "CRUISE TEST"](#) .

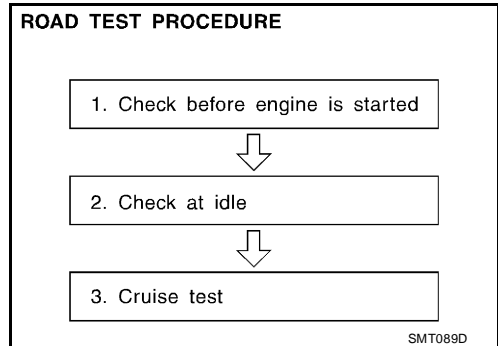

### CHECK BEFORE ENGINE IS STARTED

#### 1. CHECK 4WD SHIFT INDICATOR LAMP

1. Park vehicle on flat surface.
2. Turn ignition switch to "OFF" position.
3. Move A/T selector lever to "P" position.
4. Set 4WD shift switch to "2WD" position.
5. Turn ignition switch to "ON" position. (Do not start engine.)

Does 4WD shift indicator lamp turn ON for approximately 1 second?

YES >> GO TO 2.

NO >> Go to [TF-116, "4WD Shift Indicator Lamp and 4LO Indicator Lamp Do Not Turn ON"](#) .

#### 2. CHECK 4WD WARNING LAMP

1. Turn ignition switch to "OFF" position.
2. Move A/T selector lever to "P" position.
3. Set 4WD shift switch to "2WD" position.
4. Turn ignition switch to "ON" position. (Do not start engine.)

Does 4WD warning lamp turn ON?

YES >> GO TO [TF-32, "CHECK AT IDLE"](#) .

NO >> GO TO [TF-120, "4WD Warning Lamp Does Not Turn ON"](#) .

### CHECK AT IDLE

#### 1. CHECK 4WD SHIFT INDICATOR LAMP

1. Park vehicle on flat surface and engage the parking brake.
2. Turn ignition switch to "OFF" position.
3. Move A/T selector lever to "P" position.
4. Set 4WD shift switch to "2WD" position.
5. Start engine.

Does 4WD shift indicator lamp turn ON?

YES >> GO TO 3.

NO >> GO TO 2.



# TROUBLE DIAGNOSIS

## 2. CHECK 4WD WARNING LAMP

Check 4WD warning lamp state?

Is 4WD warning lamp turned ON?

YES >> Perform the self-diagnosis. Refer to [TF-50, "SELF-DIAGNOSTIC PROCEDURE \(WITH CONSULT-II\)"](#) (with CONSULT-II) or [TF-50, "SELF-DIAGNOSTIC PROCEDURE \(WITHOUT CONSULT-II\)"](#) (without CONSULT-II).

NO >> Go to [TF-122, "4WD Shift Indicator Lamp or 4LO Indicator Lamp Does Not Change"](#) .

## 3. CHECK 4WD SHIFT INDICATOR AND 4LO INDICATOR OPERATION

1. Brake pedal depressed.
2. Move A/T selector lever to "N" position.
3. Set 4WD shift switch to "2WD", "AUTO", "4H", "4LO", "4H", "AUTO" and "2WD" in order. (Stay at each switch position for at least 1 second.)

Do 4WD shift indicator and 4LO indicator lamps change properly?

Does buzzer sound?

YES >> GO TO [TF-33, "CRUISE TEST"](#) .

NO >> GO TO [TF-122, "4WD Shift Indicator Lamp or 4LO Indicator Lamp Does Not Change"](#) .

| 4WD shift switch | 4WD shift indicator lamp | 4LO indicator lamp | Buzzer sound |
|------------------|--------------------------|--------------------|--------------|
| 2WD              |                          | 4LO OFF            |              |
|                  | ↓                        |                    | "Pip"        |
| AUTO             |                          | 4LO OFF            |              |
|                  | ↓                        |                    | "Pip"        |
| 4H               |                          | 4LO OFF            |              |
|                  | ↓                        | Lamp flasher       | "Pip"        |
| 4LO              |                          | 4LO ON             |              |
|                  | ↓                        | Lamp flasher       | "Pip"        |
| 4H               |                          | 4LO OFF            |              |
|                  | ↓                        |                    | "Pip"        |
| AUTO             |                          | 4LO OFF            |              |
|                  | ↓                        |                    | "Pip"        |
| 2WD              |                          | 4LO OFF            |              |

WDIA0136E

## CRUISE TEST

### 1. CHECK INPUT SIGNAL

1. Warm up engine to normal operating temperature.
2. Park vehicle on flat surface.
3. Move A/T selector lever to "P" position.
4. Set 4WD shift switch to "AUTO" position.
5. Start engine.
6. Drive vehicle for at least 30 seconds at a speed higher than 20 km/h (12 MPH).

Check 4WD warning lamp turned ON?

On steady>>Perform the self-diagnosis. Refer to [TF-50, "SELF-DIAGNOSTIC PROCEDURE \(WITH CONSULT-II\)"](#) (with CONSULT-II) or [TF-50, "SELF-DIAGNOSTIC PROCEDURE \(WITHOUT CONSULT-II\)"](#) (without CONSULT-II).

Flash rapidly>>GO TO [TF-127, "4WD Warning Lamp Flashes Rapidly"](#) .

Flash slowly>>GO TO [TF-128, "4WD Warning Lamp Flashes Slowly"](#) .

NO >> GO TO 2.

# TROUBLE DIAGNOSIS

## 2. CHECK TIGHT CORNER BRAKING SYMPTOM (1)

1. Set 4WD shift switch to "AUTO" position.
2. Drive vehicle at speed lower than 20 km/h (12 MPH) with steering wheel fully turned.

Does tight corner braking symptom occur?

- YES >> GO TO [TF-129, "Heavy Tight-corner Braking Symptom Occurs"](#) .  
 NO >> GO TO 3.

## 3. CHECK TIGHT CORNER BRAKING SYMPTOM (2)

1. Set 4WD shift switch to "4HI" position.
2. Drive vehicle at speed lower than 20 km/h (12 MPH) with steering wheel fully turned.

Does tight corner braking symptom occur?

- YES >> Inspection End.  
 NO >> GO TO [TF-130, "4WD System Does Not Operate"](#) .

## Trouble Diagnosis Chart for Symptoms

EDS002GF

If 4WD warning lamp turns ON, perform self-diagnosis. Refer to [TF-50, "Self-diagnostic Procedure"](#) .

| Symptom   | Condition           | Check item   | Reference page         |
|---|---------------------|--|------------------------|
| 4WD shift indicator lamp and 4LO indicator lamp do not turn ON<br>(4WD shift indicator lamp and 4LO indicator lamp check) | Ignition switch: ON | Power supply and ground for transfer control unit        | <a href="#">TF-116</a> |
|   |                     | Transfer shut off relay                                  |                        |
|   |                     | Combination meter  |                        |
| 4WD warning lamp does not turn ON<br>(4WD warning lamp check)   | Ignition switch: ON | Power supply and ground for transfer control unit        | <a href="#">TF-120</a> |
|   |                     | Transfer shut off relay                                  |                        |
|   |                     | Combination meter  |                        |
| 4WD shift indicator lamp or 4LO indicator lamp does not change  | Engine running      | 4WD shift switch   | <a href="#">TF-122</a> |
|   |                     | Wait detection switch                                    |                        |
|   |                     | Neutral-4LO switch                                       |                        |
|   |                     | ATP switch   |                        |
|   |                     | 2-4WD solenoid   |                        |
|   |                     | Transfer control device                                  |                        |
|   |                     | Actuator motor   |                        |
|   |                     | Actuator position switch                                 |                        |
| Transfer inner parts  |                     |  |                        |
| ATP warning lamp turns ON   | Engine running      | CAN communication line                                   | <a href="#">TF-124</a> |
|   |                     | 4WD shift switch   |                        |
|   |                     | PNP switch signal  |                        |
|   |                     | ATP switch   |                        |
|   |                     | Combination meter  |                        |
|   |                     | Transfer inner parts                                     |                        |
| 4LO indicator lamp repeats flashing   | Engine running      | Wait detection switch                                    | <a href="#">TF-126</a> |
|   |                     | Neutral-4LO switch                                       |                        |
|   |                     | Transfer inner parts                                     |                        |
| 4WD warning lamp flashes rapidly (2 times/second)   | While driving       | Transfer fluid temperature                               | <a href="#">TF-127</a> |
|   |                     | Tire size is different between front and rear of vehicle |                        |

# TROUBLE DIAGNOSIS

| Symptom  | Condition   | Check item  | Reference page         |
|--|---|---|------------------------|
| 4WD warning lamp flashes slowly<br>(1 time/2 seconds)    | While driving   | Tire size is different between front and rear of vehicle. | <a href="#">TF-128</a> |
|  |   | Transfer fluid temperature                                |                        |
|  |   | Clutch pressure switch                                    |                        |
| Heavy tight-corner braking symptom occurs<br>(See NOTE.) | <ul style="list-style-type: none"> <li>● While driving</li> <li>● AUTO mode</li> <li>● Steering wheel is turned fully to either side</li> </ul> | CAN communication line                                    | <a href="#">TF-129</a> |
|  |   | 4WD shift switch  |                        |
|  |   | Accelerator pedal position signal                         |                        |
|  |   | Clutch pressure solenoid                                  |                        |
|  |   | Transfer inner parts                                      |                        |
| 4WD system does not operate                              | While driving   | 4WD shift switch  | <a href="#">TF-130</a> |
|  |   | Clutch pressure switch                                    |                        |
|  |   | Transfer inner parts                                      |                        |

## NOTE:

- Light tight-corner braking symptom may occur depending on driving conditions in AUTO mode. This is not a malfunction.
- Heavy tight-corner braking symptom occurs when vehicle is driven in the following conditions: 4WD shift switch is "4H" or "4LO", steering wheel is turned fully to either side.

## Transfer Control Unit Input/Output Signal Reference Values

EDS001YH

### TRANSFER CONTROL UNIT INSPECTION TABLE

#### Specifications with CONSULT-II

| Monitored item [Unit]            | Content  | Condition  | Display value   |
|----------------------------------|--|--|---|
| VHCL/S SEN-FR [km/h]<br>or [mph] | Front wheel speed                                      | Vehicle stopped  | 0 km/h (0 MPH)  |
|                                  |  | Vehicle running<br><b>CAUTION:</b><br>Check air pressure of tire under standard condition. | Approximately equal to the indication on speedometer (Inside of ±10%) |
| VHCL/S SEN-RR [km/h]<br>or [mph] | Rear wheel speed                                       | Vehicle stopped  | 0 km/h (0 MPH)  |
|                                  |  | Vehicle running<br><b>CAUTION:</b><br>Check air pressure of tire under standard condition. | Approximately equal to the indication on speedometer (Inside of ±10%) |
| ENGINE SPEED [rpm]               | Engine speed   | Engine stopped<br>(Engine speed: Less than 400 rpm)  | 0 rpm   |
|                                  |  | Engine running<br>(Engine speed: 400 rpm or more)  | Approximately equal to the indication on tachometer                   |
| THRTL POS SEN [V]                | Accelerator pedal position (APP) sensor signal voltage | Accelerator pedal: Release   | Approx. 0.5V  |
|                                  |  | Accelerator pedal: Fully depressed   | Approx. 4.0V  |
| FLUID TEMP SE [V]                | Transfer fluid temperature signal voltage              | Transfer fluid temperature approx. 20 - 80°C (68 - 176°F)                                  | Approx. 1.1 - 0.3V  |
| BATTERY VOLT [V]                 | Power supply voltage for transfer control unit         | Ignition switch: ON  | Battery voltage   |
| 2WD SWITCH [ON/OFF]              | Input condition from 4WD shift switch                  | 4WD shift switch: 2WD  | ON  |
|                                  |  | 4WD shift switch: AUTO, 4H or 4LO  | OFF   |
| AUTO SWITCH [ON/OFF]             | Input condition from 4WD shift switch                  | 4WD shift switch: AUTO   | ON  |
|                                  |  | 4WD shift switch: 2WD, 4H or 4LO   | OFF   |

# TROUBLE DIAGNOSIS

| Monitored item [Unit]  | Content                               | Condition  |   | Display value |
|------------------------|---------------------------------------|--|---|---------------|
| LOCK SWITCH [ON/OFF]   | Input condition from 4WD shift switch | 4WD shift switch: 4H   |   | ON            |
|                        |                                       | 4WD shift switch: 2WD, AUTO or 4LO   |   | OFF           |
| 4L SWITCH [ON/OFF]     | Input condition from 4WD shift switch | 4WD shift switch: 4LO  |   | ON            |
|                        |                                       | 4WD shift switch: 2WD, AUTO or 4H  |   | OFF           |
| N POSI SW TF [ON/OFF]  | Condition of neutral-4LO switch       | <ul style="list-style-type: none"> <li>● Vehicle stopped</li> <li>● Engine running</li> <li>● A/T selector lever "N" position</li> <li>● Brake pedal depressed</li> </ul>  | 4WD shift switch: 2WD, AUTO or 4H   | OFF           |
|                        |                                       |  | 4WD shift switch: 4H to 4LO (While actuator motor is operating.)  | OFF → ON      |
|                        |                                       |  | 4WD shift switch: 4LO to 4H (While actuator motor is operating.)  | ON → OFF      |
|                        |                                       |  | 4WD shift switch: 4LO   | ON            |
| ATP SWITCH [ON/OFF]    | Condition of ATP switch               | <ul style="list-style-type: none"> <li>● Vehicle stopped</li> <li>● Engine running</li> <li>● A/T selector lever "N"</li> <li>● Brake pedal depressed</li> </ul>   | 4WD shift switch : 4H to 4LO or 4LO to 4H (While actuator motor is operating.)  | ON            |
|                        |                                       |  | Except the above  | OFF           |
| WAIT DETCT SW [ON/OFF] | Condition of wait detection switch    | <ul style="list-style-type: none"> <li>● Vehicle stopped</li> <li>● Engine running</li> <li>● A/T selector lever "N" position</li> <li>● Brake pedal depressed</li> </ul>  | 4WD shift switch: 2WD, AUTO or 4H   | OFF           |
|                        |                                       |  | 4WD shift switch: 4H to 4LO (While actuator motor is operating.)  | OFF → ON      |
|                        |                                       |  | 4WD shift switch: 4LO to 4H (While actuator motor is operating.)  | ON → OFF      |
|                        |                                       |  | 4WD shift switch: 4LO   | ON            |
| LINE PRES SW [ON/OFF]  | Condition of line pressure switch     | <ul style="list-style-type: none"> <li>● A/T selector lever "D" position</li> <li>● 4WD shift switch: 2WD, AUTO or 4H</li> </ul>   |   | ON            |
|                        |                                       | <ul style="list-style-type: none"> <li>● Except the above</li> <li>● The vehicle has been left at room temperature for 5 minutes and more with ignition switch in "OFF" position.</li> </ul>                         | <ul style="list-style-type: none"> <li>● Ignition switch: ON</li> <li>● A/T selector lever: "P" or "N" position</li> <li>● 4WD shift switch: other than AUTO</li> </ul> | OFF           |
| CL PRES SW [ON / OFF]  | Condition of clutch pressure switch   | <ul style="list-style-type: none"> <li>● Vehicle stopped</li> <li>● Engine running</li> <li>● A/T selector lever "D" position</li> <li>● 4WD shift switch: AUTO or 4H ("Wait" function is not operating.)</li> </ul> |   | ON            |
|                        |                                       | <ul style="list-style-type: none"> <li>● Vehicle stopped</li> <li>● Engine running</li> <li>● 4WD shift switch: 2WD ("Wait" function is not operating.)</li> </ul>   |   | OFF           |
| N POSI SW AT [ON/OFF]  | Input condition from A/T PNP switch   | <ul style="list-style-type: none"> <li>● Vehicle stopped</li> <li>● Engine running</li> <li>● Brake pedal depressed</li> </ul>   | A/T selector lever position: N  | ON            |
|                        |                                       |  | Except the above  | OFF           |
| R POSI SW AT [ON/OFF]  | Input condition from A/T PNP switch   | <ul style="list-style-type: none"> <li>● Vehicle stopped</li> <li>● Engine running</li> <li>● Brake pedal depressed</li> </ul>   | A/T selector lever position: R  | ON            |
|                        |                                       |  | Except the above  | OFF           |

# TROUBLE DIAGNOSIS

| Monitored item [Unit]       | Content   | Condition   |  | Display value   |
|-----------------------------|---|---|--|---|
| P POSI SW AT [ON/OFF]       | Input condition from A/T PNP switch   | <ul style="list-style-type: none"> <li>● Vehicle stopped</li> <li>● Engine running</li> <li>● Brake pedal depressed</li> </ul>  | A/T selector lever position: P                         | ON  |
|                             |   |   | Except the above                                       | OFF   |
| ABS OPER SW [ON/OFF]        | Condition of ABS operating  | ABS is operating.   |  | ON  |
|                             |   | ABS is not operating.   |  | OFF   |
| VDC OPER SW [ON/OFF]        | Condition of VDC operating  | VDC is operating.   |  | ON  |
|                             |   | VDC is not operating.   |  | OFF   |
| TCS OPER SW [ON/OFF]        | Condition of TCS operating  | TCS is operating.   |  | ON  |
|                             |   | TCS is not operating.   |  | OFF   |
| THROTTLE POSI [0.0/8]       | Condition of throttle opening   | When depressing accelerator pedal (Value rises gradually in response to throttle position.)   |  | 0.0/8 - 8.0/8   |
| 4WD MODE [AUTO/LOCK/2WD/4L] | Control status of 4WD (Output condition of 4WD shift indicator lamp and 4LO indicator lamp) | <ul style="list-style-type: none"> <li>● Vehicle stopped</li> <li>● Engine running</li> <li>● A/T selector lever "N" position</li> <li>● Brake pedal depressed</li> </ul> | 4WD shift switch: 2WD                                  | 2WD   |
|                             |   |   | 4WD shift switch: AUTO                                 | AUTO  |
|                             |   |   | 4WD shift switch: 4H                                   | LOCK  |
|                             |   |   | 4WD shift switch: 4LO                                  | 4L  |
| VHCL/S COMP [km/h] or [mph] | Vehicle speed   | Vehicle stopped   |  | 0 km/h (0 MPH)  |
|                             |   | Vehicle running<br><b>CAUTION:</b><br><b>Check air pressure of tire under standard condition.</b>   |  | Approximately equal to the indication on speedometer (Inside of ±10%) |
| COMP CL TORQ [kgm]          | Condition of control torque   | <ul style="list-style-type: none"> <li>● Vehicle stopped</li> <li>● Engine running</li> <li>● A/T selector lever "N" position</li> <li>● Brake pedal depressed</li> </ul> | 4WD shift switch: 2WD                                  | 0 kg-m  |
|                             |   |   | 4WD shift switch: AUTO                                 | 39 - 1,353 N-m (4 - 138 kg-m, 29 - 998 ft-lb)                         |
|                             |   |   | 4WD shift switch: 4H or 4LO                            | 1,353 N-m (138 kg-m, 998 ft-lb)                                       |
| DUTY SOLENOID [%]           | Condition of clutch pressure solenoid   | <ul style="list-style-type: none"> <li>● Vehicle stopped</li> <li>● Engine running</li> <li>● A/T selector lever "N" position</li> <li>● Brake pedal depressed</li> </ul> | 4WD shift switch: 2WD                                  | 4%  |
|                             |   |   | 4WD shift switch: AUTO                                 | 96 - 4%   |
|                             |   |   | 4WD shift switch: 4H or 4LO                            | 4%  |
| 2-4WD SOL [ON/OFF]          | Condition of 2-4WD shift solenoid valve   | <ul style="list-style-type: none"> <li>● Vehicle stopped</li> <li>● Engine running</li> <li>● A/T selector lever "N" position</li> <li>● Brake pedal depressed</li> </ul> | 4WD shift switch: 2WD                                  | OFF   |
|                             |   |   | 4WD shift switch: AUTO                                 | ON  |
|                             |   |   | 4WD shift switch: 4H                                   |   |
|                             |   |   | 4WD shift switch: 4LO                                  |   |
|                             |   |   | 4WD shift switch: AUTO ("Wait" function is operating.) | OFF   |
|                             |   |   | 4WD shift switch: 4H ("Wait" function is operating.)   | OFF   |

# TROUBLE DIAGNOSIS

| Monitored item [Unit]    | Content   | Condition   | Display value   |   |
|--------------------------|---|---|---|---|
| 2-4WD SOL MON [ON/OFF]   | Check signal for transfer control unit signal output        | <ul style="list-style-type: none"> <li>● Vehicle stopped</li> <li>● Engine running</li> <li>● A/T selector lever "N" position</li> <li>● Brake pedal depressed</li> </ul> | 4WD shift switch: 2WD   | OFF   |
|                          |   |   | 4WD shift switch: AUTO  | ON  |
|                          |   |   | 4WD shift switch: 4H  |   |
|                          |   |   | 4WD shift switch: 4LO   | OFF   |
|                          |   |   | 4WD shift switch: AUTO ("Wait" function is operating.)                            |   |
|                          |   |   | 4WD shift switch: 4H ("Wait" function is operating.)                              |   |
| MOTOR RELAY [ON/OFF]     | Condition of transfer motor relay                           | <ul style="list-style-type: none"> <li>● Accelerator pedal depressed</li> <li>● Vehicle stopped</li> <li>● Engine running</li> <li>● Brake pedal depressed</li> </ul>     | 4WD shift switch: 2WD   | OFF   |
|                          |   |   | 4WD shift switch: AUTO or 4LO (A/T selector lever "P" or "N" position)            | OFF<br>("ON" for approx. 2 sec. after shifting to "P" and "N".) |
|                          |   |   | 4WD shift switch: AUTO or 4LO (Except for A/T selector lever "P" or "N" position) | ON  |
|                          |   |   | 4WD shift switch: 4H (A/T selector lever "P" position)                            | OFF<br>("ON" for approx. 2 sec. after shifting to "P".)         |
|                          |   |   | 4WD shift switch: 4H (Except for A/T selector lever "P" position)                 | ON  |
| MOTOR RELAY MON [ON/OFF] | Check signal for transfer control unit signal output        | <ul style="list-style-type: none"> <li>● Accelerator pedal depressed</li> <li>● Vehicle stopped</li> <li>● Engine running</li> <li>● Brake pedal depressed</li> </ul>     | 4WD shift switch: 2WD   | OFF   |
|                          |   |   | 4WD shift switch: AUTO or 4LO (A/T selector lever "P" or "N" position)            | OFF<br>("ON" for approx. 2 sec. after shifting to "P" and "N".) |
|                          |   |   | 4WD shift switch: AUTO or 4LO (Except for A/T selector lever "P" or "N" position) | ON  |
|                          |   |   | 4WD shift switch: 4H (A/T selector lever "P" position)                            | OFF<br>("ON" for approx. 2 sec. after shifting to "P".)         |
|                          |   |   | 4WD shift switch: 4H (Except for A/T selector lever "P" position)                 | ON  |
| 4WD FAIL LAMP [ON/OFF]   | Condition of 4WD warning lamp                               | 4WD warning lamp: ON  | ON  |   |
|                          |   | 4WD warning lamp: OFF   | OFF   |   |
| 2WD IND [ON/OFF]         | Condition of 4WD shift indicator lamp (2WD indicator lamp)  | 2WD indicator lamp of 4WD shift indicator lamp: OFF   | OFF   |   |
|                          |   | 2WD indicator lamp of 4WD shift indicator lamp: ON  | ON  |   |
| AUTO IND [ON/OFF]        | Condition of 4WD shift indicator lamp (AUTO indicator lamp) | AUTO indicator lamp of 4WD shift indicator lamp: OFF  | OFF   |   |
|                          |   | AUTO indicator lamp of 4WD shift indicator lamp: ON   | ON  |   |
| LOCK IND [ON/OFF]        | Condition of 4WD shift indicator lamp (Lock indicator lamp) | Lock indicator lamp of 4WD shift indicator lamp: OFF  | OFF   |   |
|                          |   | Lock indicator lamp of 4WD shift indicator lamp: ON   | ON  |   |
| 4L IND [ON/OFF]          | Condition of 4LO indicator lamp condition                   | 4LO indicator lamp: OFF   | OFF   |   |
|                          |   | 4LO indicator lamp: ON  | ON  |   |

# TROUBLE DIAGNOSIS

| Monitored item [Unit]       | Content   | Condition   | Display value   |
|-----------------------------|---|---|---|
| ATP IND [ON/OFF]            | Condition of ATP indicator lamp                           | ATP indicator lamp: ON  | ON  |
|                             |   | ATP indicator lamp: OFF   | OFF   |
| SHIFT POS SW1 [ON/OFF]      | Condition of actuator position switch 1 (Low)             | <ul style="list-style-type: none"> <li>● Vehicle stopped</li> <li>● Engine running</li> <li>● A/T selector lever "N" position</li> <li>● Brake pedal depressed</li> </ul> | 4WD shift switch: 4LO<br>ON                                       |
|                             |   |   | 4WD shift switch: 2WD, AUTO or 4H<br>OFF                          |
| SHIFT POS SW2 [ON/OFF]      | Condition of actuator position switch 2 (High)            | <ul style="list-style-type: none"> <li>● Vehicle stopped</li> <li>● Engine running</li> <li>● A/T selector lever "N" position</li> <li>● Brake pedal depressed</li> </ul> | 4WD shift switch: 4H, AUTO or 2WD<br>ON                           |
|                             |   |   | 4WD shift switch: 4LO<br>OFF                                      |
| SHIFT ACT1 [ON/OFF]         | Output condition to actuator motor (High)                 | <ul style="list-style-type: none"> <li>● Vehicle stopped</li> <li>● Engine running</li> <li>● A/T selector lever "N" position</li> <li>● Brake pedal depressed</li> </ul> | 4WD shift switch: 4H to 4LO ("Wait" function is operating.)<br>ON |
|                             |   |   | Except the above<br>OFF   |
| SHIFT AC MON1 [ON/OFF]      | Check signal for transfer control unit signal output      | <ul style="list-style-type: none"> <li>● Vehicle stopped</li> <li>● Engine running</li> <li>● A/T selector lever "N" position</li> <li>● Brake pedal depressed</li> </ul> | 4WD shift switch: 4H to 4LO ("Wait" function is operating.)<br>ON |
|                             |   |   | Except the above<br>OFF   |
| SHIFT ACT2 [ON/OFF]         | Output condition to actuator motor (Low)                  | <ul style="list-style-type: none"> <li>● Vehicle stopped</li> <li>● Engine running</li> <li>● A/T selector lever "N" position</li> <li>● Brake pedal depressed</li> </ul> | 4WD shift switch: 4LO to 4H ("Wait" function is operating.)<br>ON |
|                             |   |   | Except the above<br>OFF   |
| SHIFT AC MON2 [ON/OFF]      | Check signal for transfer control unit signal output      | <ul style="list-style-type: none"> <li>● Vehicle stopped</li> <li>● Engine running</li> <li>● A/T selector lever "N" position</li> <li>● Brake pedal depressed</li> </ul> | 4WD shift switch: 4LO to 4H ("Wait" function is operating.)<br>ON |
|                             |   |   | Except the above<br>OFF   |
| T/F SPEED [km/h] or [mph]   | Displayed, but do not use.                                |   |   |
| A/T R SPEED [km/h] or [mph] | Condition of vehicle speed sensor A/T (Revolution sensor) | During driving  | Approximately matches the output shaft speed.                     |
| AT GEAR POSI [1/2/3/4/5]    | Condition of A/T selector lever position                  | Displays actual A/T gear position.  | 1/2/3/4/5   |

## Specifications Between Transfer Control Unit Terminals

### TRANSFER CONTROL UNIT TERMINAL CONNECTOR LAYOUT

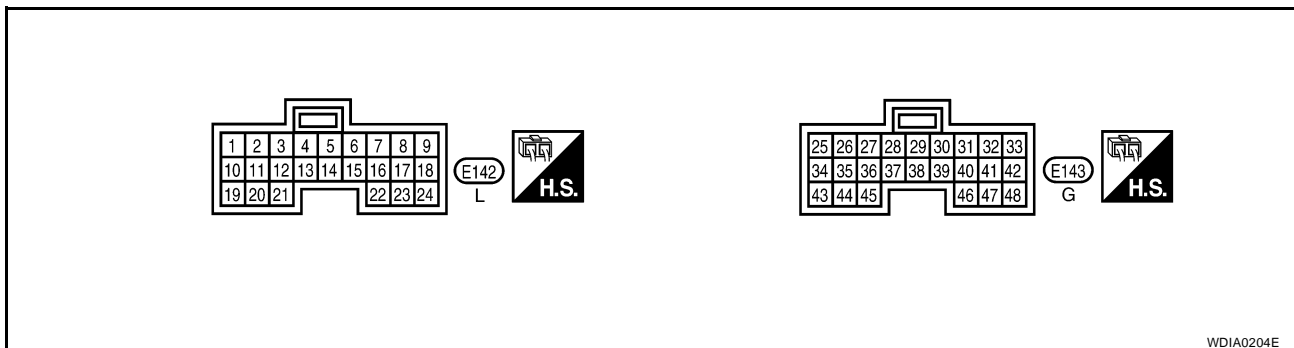

WDIA0204E

# TROUBLE DIAGNOSIS

**NOTE:**

Data are reference value and are measured between each terminal and ground.

| Terminal | Wire color | Item   | Condition   |   | Data (Approx.)  |
|----------|------------|--|---|---|-----------------|
| 1        | GR         | 2-4WD shift solenoid valve                     | <ul style="list-style-type: none"> <li>● Vehicle stopped</li> <li>● Engine running</li> <li>● A/T selector lever "N" position</li> <li>● Brake pedal depressed</li> </ul> | 4WD shift switch: 2WD                                       | 0V              |
|          |            |  |   | 4WD shift switch: AUTO, 4H or 4LO                           | Battery voltage |
| 2        | B/W        | 4WD shift indicator lamp (2WD indicator lamp)  | 2WD indicator lamp: OFF   |   | Battery voltage |
|          |            |  | 2WD indicator lamp: ON  |   | 0V              |
| 3        | B          | Ground   | Always  |   | 0V              |
| 4        | Y/L        | Transfer shift high relay                      | <ul style="list-style-type: none"> <li>● Vehicle stopped</li> <li>● Engine running</li> <li>● A/T selector lever "N" position</li> <li>● Brake pedal depressed</li> </ul> | 4WD shift switch: 4H to 4LO ("Wait" function is operating.) | Battery voltage |
|          |            |  |   | Except the above  | 0V              |
| 5        | W/B        | 4WD warning lamp                               | 4WD warning lamp: ON  |   | 0V              |
|          |            |  | 4WD warning lamp: OFF   |   | Battery voltage |
| 6        | B          | Ground   | Always  |   | 0V              |
| 7        | L          | CAN-H  | —   |   | —               |
| 8        | P          | CAN-L  | —   |   | —               |
| 9        | G/W        | 4WD shift switch (2WD)                         | Ignition switch: ON   | 4WD shift switch: 2WD                                       | Battery voltage |
|          |            |  |   | 4WD shift switch: AUTO, 4H or 4LO                           | 0V              |
| 10       | LW         | Transfer dropping resistor                     | <ul style="list-style-type: none"> <li>● Vehicle stopped</li> <li>● Engine running</li> <li>● A/T selector lever "N" position</li> <li>● Brake pedal depressed</li> </ul> | 4WD shift switch: AUTO                                      | 4 - 14V         |
|          |            |  |   | 4WD shift switch: 2WD, 4H or 4LO                            | Less than 1V    |
| 11       | L          | 4WD shift indicator lamp (Lock indicator lamp) | Lock indicator lamp of 4WD shift indicator lamp: OFF  |   | Battery voltage |
|          |            |  | Lock indicator lamp of 4WD shift indicator lamp: ON   |   | 0V              |
| 12       | W/G        | 4LO indicator lamp                             | 4LO indicator lamp: OFF   |   | Battery voltage |
|          |            |  | 4LO indicator lamp: ON  |   | 0V              |
| 13       | G/B        | Transfer shift low relay                       | <ul style="list-style-type: none"> <li>● Vehicle stopped</li> <li>● Engine running</li> <li>● A/T selector lever "N" position</li> <li>● Brake pedal depressed</li> </ul> | 4WD shift switch: 4LO to 4H ("Wait" function is operating.) | Battery voltage |
|          |            |  |   | Except the above  | 0V              |



# TROUBLE DIAGNOSIS

| Terminal | Wire color | Item   | Condition   | Data (Approx.)  |  |
|----------|------------|--|---|---|--|
| 14       | LG         | Transfer motor relay                           | <ul style="list-style-type: none"> <li>● Accelerator pedal depressed</li> <li>● Vehicle stopped</li> <li>● Engine running</li> <li>● Brake pedal depressed</li> </ul>     | 4WD shift switch: 2WD   | Battery voltage  |
|          |            |  |   | 4WD shift switch: AUTO or 4LO (A/T selector lever "P" or "N" position)            | Battery voltage (0V for approx. 2 sec. after shifting to "P" and "N".) |
|          |            |  |   | 4WD shift switch: AUTO or 4LO (Except for A/T selector lever "P" or "N" position) | 0V   |
|          |            |  |   | 4WD shift switch: 4H (A/T selector lever "P" position)                            | Battery voltage (0V for approx. 2 sec. after shifting to "P".)         |
|          |            |  |   | 4WD shift switch: 4H (Except for A/T selector lever "P" position)                 | 0V   |
| 15       | L/B        | ATP warning lamp                               | ATP indicator lamp: ON  | 0V  |  |
|          |            |  | ATP indicator lamp: OFF   | Battery voltage   |  |
| 16       | Y/R        | Power supply                                   | Ignition switch: ON   | Battery voltage   |  |
|          |            |  | Ignition switch: OFF  | 0V  |  |
| 18       | O          | 4WD shift switch (4H)                          | Ignition switch: ON   | 4WD shift switch: 4H  | Battery voltage  |
|          |            |  |   | 4WD shift switch: 2WD, AUTO or 4LO  | 0V   |
| 19       | L          | Clutch pressure solenoid valve                 | <ul style="list-style-type: none"> <li>● Vehicle stopped</li> <li>● Engine running</li> <li>● A/T selector lever "N" position</li> <li>● Brake pedal depressed</li> </ul> | 4WD shift switch: AUTO  | 1.5 - 3V   |
|          |            |  |   | 4WD shift switch: 2WD, 4H or 4LO  | Less than 1V   |
| 21       | BR         | 4WD shift indicator lamp (AUTO indicator lamp) | ● AUTO indicator lamp of 4WD shift indicator lamp: OFF  | Battery voltage   |  |
|          |            |  | AUTO indicator lamp of 4WD shift indicator lamp: ON   | 0V  |  |
| 22       | Y/R        | Power supply                                   | Ignition switch: ON   | Battery voltage   |  |
|          |            |  | Ignition switch: OFF  | 0V  |  |
| 23       | R          | 4WD shift switch (4LO)                         | Ignition switch: ON   | 4WD shift switch: 4LO   | Battery voltage  |
|          |            |  |   | 4WD shift switch: 2WD, AUTO or 4H   | 0V   |
| 24       | LG/R       | 4WD shift switch (AUTO)                        | Ignition switch: ON   | 4WD shift switch: AUTO  | Battery voltage  |
|          |            |  |   | 4WD shift switch: 2WD, 4H or 4LO  | 0V   |
| 25       | V          | Neutral-4LO switch                             | <ul style="list-style-type: none"> <li>● Vehicle stopped</li> <li>● Engine running</li> <li>● A/T selector lever "N" position</li> <li>● Brake pedal depressed</li> </ul> | 4WD shift switch: 2WD, AUTO or 4H   | Battery voltage  |
|          |            |  |   | 4WD shift switch: 4H to 4LO (While actuator motor is operating.)                  | Battery voltage → 0V   |
|          |            |  |   | 4WD shift switch: 4LO to 4H (While actuator motor is operating.)                  | 0V → Battery voltage   |
|          |            |  |   | 4WD shift switch: 4LO   | 0V   |
| 27       | W/L        | Actuator position switch 2 (High)              | <ul style="list-style-type: none"> <li>● Vehicle stopped</li> <li>● Engine running</li> <li>● A/T selector lever "N" position</li> <li>● Brake pedal depressed</li> </ul> | 4WD shift switch: 4H, AUTO or 2WD   | 0V   |
|          |            |  |   | 4WD shift switch: 4LO   | Battery voltage  |
| 28       | B/G        | Sensor ground                                  | Always  | 0V  |  |
| 29       | L/W        | Ignition switch monitor                        | Ignition switch: ON   | Battery voltage   |  |
|          |            |  | Ignition switch: OFF  | 0V  |  |

## TROUBLE DIAGNOSIS

| Terminal | Wire color | Item                              | Condition   |   | Data (Approx.)   |
|----------|------------|-----------------------------------|---|---|--|
| 30       | SB         | Shut off relay                    | Ignition switch: ON   |   | 0V   |
|          |            |                                   | Ignition switch: OFF  |   | Battery voltage  |
| 31       | G          | Transfer fluid temperature sensor | Ignition switch: ON   | Transfer fluid temperature approx. 20°C (68°F)  | 1.1V   |
|          |            |                                   |   | Transfer fluid temperature approx. 80°C (176°F)   | 0.3V   |
| 33       | R/L        | Transfer shift high relay monitor | <ul style="list-style-type: none"> <li>● Vehicle stopped</li> <li>● Engine running</li> <li>● A/T selector lever "N" position</li> <li>● Brake pedal depressed</li> </ul> | 4WD shift switch: 4H to 4LO ("Wait" function is operating.)   | Battery voltage  |
|          |            |                                   |   | Except the above  | 0V   |
| 34       | BR         | Clutch pressure switch            | <ul style="list-style-type: none"> <li>● Vehicle stopped</li> <li>● Engine running</li> <li>● A/T selector lever "D" position</li> </ul>                                  | 4WD shift switch: AUTO or 4H ("Wait" function is not operating.)  | 0V   |
|          |            |                                   |   | <ul style="list-style-type: none"> <li>● Vehicle stopped</li> <li>● Engine running</li> </ul>   | 4WD shift switch: 2WD ("Wait" function is not operating.)              |
| 35       | BR/W       | Line pressure switch              | <ul style="list-style-type: none"> <li>● Ignition switch: ON</li> <li>● A/T selector lever "D" position</li> <li>● 4WD shift switch: AUTO</li> </ul>                      |   | 0V   |
|          |            |                                   | <ul style="list-style-type: none"> <li>● After the vehicle has been left at room temperature for 5 minutes and more with ignition switch in "OFF" position.</li> </ul>    | <ul style="list-style-type: none"> <li>● Ignition switch: ON</li> <li>● A/T selector lever: "P" or "N" position</li> <li>● 4WD shift switch: other than AUTO</li> </ul> | Battery voltage  |
| 40       | L          | ATP switch                        | <ul style="list-style-type: none"> <li>● Vehicle stopped</li> <li>● Engine running</li> <li>● A/T selector lever "N"</li> <li>● Brake pedal depressed</li> </ul>          | 4WD shift switch: 4H to 4LO or 4LO to 4H (While actuator motor is operating.)   | 0V   |
|          |            |                                   |   | Except the above  | Battery voltage  |
| 41       | R          | Transfer motor relay monitor      | <ul style="list-style-type: none"> <li>● Accelerator pedal depressed</li> <li>● Vehicle stopped</li> <li>● Engine running</li> <li>● Brake pedal depressed</li> </ul>     | 4WD shift switch: 2WD   | 0V   |
|          |            |                                   |   | 4WD shift switch: AUTO or 4LO (A/T selector lever "P" or "N" position)  | 0V (Battery voltage for approx. 2 sec. after shifting to "P" and "N".) |
|          |            |                                   |   | 4WD shift switch: AUTO or 4LO (Except for A/T selector lever "P" or "N" position)   | Battery voltage  |
|          |            |                                   |   | 4WD shift switch: 4H (A/T selector lever "P" position)  | 0V (Battery voltage for approx. 2 sec. after shifting to "P".)         |
|          |            |                                   |   | 4WD shift switch: 4H (Except for A/T selector lever "P" position)   | Battery voltage  |

# TROUBLE DIAGNOSIS

| Terminal | Wire color | Item                             | Condition  | Data (Approx.)   |                      |
|----------|------------|----------------------------------|--|--|----------------------|
| 42       | P/G        | Transfer shift low relay monitor | <ul style="list-style-type: none"> <li>● Vehicle stopped</li> <li>● Engine running</li> </ul>                        | 4WD shift switch: 4LO to 4H ("Wait" function is operating.)      | Battery voltage      |
|          |            |                                  | <ul style="list-style-type: none"> <li>● A/T selector lever "N" position</li> <li>● Brake pedal depressed</li> </ul> | Except the above   | 0V                   |
| 43       | G/Y        | Wait detection switch            | <ul style="list-style-type: none"> <li>● Vehicle stopped</li> <li>● Engine running</li> </ul>                        | 4WD shift switch: 2WD, AUTO or 4H                                | Battery voltage      |
|          |            |                                  | <ul style="list-style-type: none"> <li>● A/T selector lever "N" position</li> </ul>                                  | 4WD shift switch: 4H to 4LO (While actuator motor is operating.) | Battery voltage → 0V |
|          |            |                                  | <ul style="list-style-type: none"> <li>● Brake pedal depressed</li> </ul>  | 4WD shift switch: 4LO to 4H (While actuator motor is operating.) | 0V → Battery voltage |
|          |            |                                  |  | 4WD shift switch: 4LO  | 0V                   |
| 44       | LG/B       | Actuator position switch 1 (Low) | <ul style="list-style-type: none"> <li>● Vehicle stopped</li> <li>● Engine running</li> </ul>                        | 4WD shift switch: 4LO  | 0V                   |
|          |            |                                  | <ul style="list-style-type: none"> <li>● A/T selector lever "N" position</li> <li>● Brake pedal depressed</li> </ul> | 4WD shift switch: 2WD, AUTO or 4H                                | Battery voltage      |
| 45       | B          | Ground                           | Always   | 0V   |                      |
| 47       | W          | Power supply (Memory back-up)    | Ignition switch: ON  | Battery voltage  |                      |
|          |            |                                  | Ignition switch: OFF   | Battery voltage  |                      |

**CAUTION:**

When using a circuit tester to measure voltage for inspection, be sure not to extend forcibly any connector terminals.

# TROUBLE DIAGNOSIS

EDS001Y1

## CONSULT-II Function (ALL MODE AWD/4WD) FUNCTION

CONSULT-II can display each diagnostic item using the diagnostic test modes shown following.

| ALL MODE AWD/4WD diagnostic mode | Description  |
|----------------------------------|--|
| SELF-DIAG RESULTS                | Displays transfer control unit self-diagnosis results.   |
| DATA MONITOR                     | Displays transfer control unit input/output data in real time.   |
| WORK SUPPORT                     | Supports inspections and adjustments. Commands are transmitted to the transfer control unit for setting the status suitable for required operation, input/output signals are received from the transfer control unit and received data is displayed. |
| CAN DIAG SUPPORT MNTR            | The results of transmit/receive diagnosis of CAN communication can be read.  |
| ECU PART NUMBER                  | Transfer control unit part number can be read.   |

## CONSULT-II SETTING PROCEDURE

### CAUTION:

If CONSULT-II is used with no connection of CONSULT-II CONVERTER, malfunctions might be detected in self-diagnosis depending on which control unit carries out CAN communication.

### NOTE:

For details, refer to the separate "CONSULT-II Operations Manual".

1. Turn ignition switch "OFF".
2. Connect CONSULT-II and CONSULT-II CONVERTER to data link connector on vehicle.
3. Turn ignition switch "ON".
4. Touch "START (NISSAN BASED VHCL)".

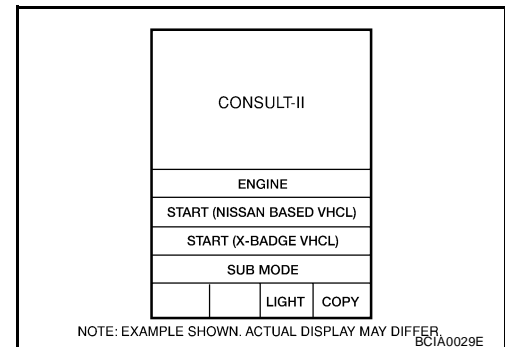

5. Touch "ALL MODE AWD/4WD".  
If "ALL MODE AWD/4WD" is not indicated, go to [GI-39, "CONSULT-II Data Link Connector \(DLC\) Circuit"](#).
6. Perform each diagnostic test mode according to each service procedure.

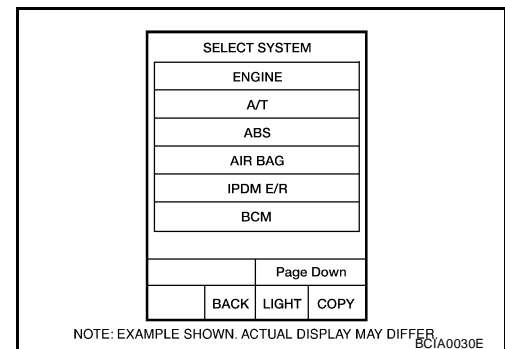

# TROUBLE DIAGNOSIS

## SELF-DIAG RESULT MODE

### Operation Procedure

1. Perform "CONSULT-II SETTING PROCEDURE". Refer to [TF-44, "CONSULT-II SETTING PROCEDURE"](#).
2. With engine at idle, touch "SELF-DIAG RESULTS".  
Display shows malfunction experienced since the last erasing operation.

#### NOTE:

- The details for "TIME" are as follow:
  - "0": Error currently detected with transfer control unit.
  - Except for "0": Error detected in the past and memorized with transfer control unit.  
Detects frequency of driving after DTC occurs (frequency of turning ignition switch "ON/OFF").

| SELF-DIAG RESULTS         |       |
|---------------------------|-------|
| DTC RESULTS               | TIME  |
| CAN COMM CIRCUIT [U1000]  | 0     |
| SHIFT ACT POSI SW [P1818] | 1     |
|                           |       |
|                           |       |
| ERASE                     | PRINT |

SDIA2687E

### Display Item List

| Items (CONSULT-II screen terms) | Diagnostic item is detected when...  | Check item  |
|---------------------------------|--|---|
| CONTROL UNIT 1 [P1802]          | <ul style="list-style-type: none"> <li>● Malfunction is detected in the memory (RAM) system of transfer control unit.</li> </ul>   | <a href="#">TF-57, "Transfer Control Unit"</a>                          |
| CONTROL UNIT 2 [P1803]          | <ul style="list-style-type: none"> <li>● Malfunction is detected in the memory (ROM) system of transfer control unit.</li> </ul>   | <a href="#">TF-57, "Transfer Control Unit"</a>                          |
| CONTROL UNIT 3 [P1804]          | <ul style="list-style-type: none"> <li>● Malfunction is detected in the memory (EEPROM) system of transfer control unit.</li> </ul>  | <a href="#">TF-57, "Transfer Control Unit"</a>                          |
| VHCL SPEED SEN-AT [P1807]       | <ul style="list-style-type: none"> <li>● Malfunction is detected in output shaft revolution signal that is output from TCM through CAN communication.</li> <li>● Improper signal is input while driving.</li> </ul>  | <a href="#">TF-58, "Output Shaft Revolution Signal (TCM)"</a>           |
| VHCL SPEED SEN-ABS [P1808]      | <ul style="list-style-type: none"> <li>● Malfunction is detected in vehicle speed signal that is output from ABS actuator and electric unit (control unit) through CAN communication.</li> <li>● Improper signal is input while driving.</li> </ul>  | <a href="#">TF-58, "Vehicle Speed Sensor (ABS)"</a>                     |
| CONTROL UNIT 4 [P1809]          | <ul style="list-style-type: none"> <li>● AD converter system of transfer control unit is malfunctioning.</li> </ul>  | <a href="#">TF-57, "Transfer Control Unit"</a>                          |
| 4L POSI SW TF [P1810]           | <ul style="list-style-type: none"> <li>● Improper signal from neutral-4LO switch is input due to open or short circuit.</li> </ul>   | <a href="#">TF-59, "Neutral-4LO Switch"</a>                             |
| BATTERY VOLTAGE [P1811]         | <ul style="list-style-type: none"> <li>● Power supply voltage for transfer control unit is abnormally low while driving.</li> </ul>  | <a href="#">TF-54, "Power Supply Circuit For Transfer Control Unit"</a> |
| 4WD MODE SW [P1813]             | <ul style="list-style-type: none"> <li>● More than two switch inputs are simultaneously detected due to short circuit of 4WD shift switch.</li> </ul>  | <a href="#">TF-62, "4WD Shift Switch"</a>                               |
| 4WD DETECT SWITCH [P1814]       | <ul style="list-style-type: none"> <li>● Improper signal from wait detection switch is input due to open or short circuit.</li> </ul>  | <a href="#">TF-66, "Wait Detection Switch"</a>                          |
| PNP SW/CIRC [P1816]             | <ul style="list-style-type: none"> <li>● When A/T PNP switch signal is malfunction or communication error between the vehicles.</li> </ul>   | <a href="#">TF-69, "PNP Switch Signal (TCM)"</a>                        |
| SHIFT ACTUATOR [P1817]          | <ul style="list-style-type: none"> <li>● Motor does not operate properly due to open or short circuit in actuator motor.</li> <li>● Malfunction is detected in the actuator motor. (When 4WD shift switch is operated and actuator motor is not operated)</li> <li>● Malfunction is detected in transfer shift high relay and transfer shift low relay.</li> </ul> | <a href="#">TF-70, "Actuator Motor"</a>                                 |
| SHIFT ACT POSI SW [P1818]       | <ul style="list-style-type: none"> <li>● Improper signal from actuator position switch is input due to open or short circuit.</li> <li>● Malfunction is detected in the actuator position switch.</li> </ul>   | <a href="#">TF-77, "Actuator Position Switch"</a>                       |

# TROUBLE DIAGNOSIS

| Items (CONSULT-II screen terms)                            | Diagnostic item is detected when...   | Check item  |
|--|---|---|
| SHIFT ACT CIR<br>[P1819]                                   | <ul style="list-style-type: none"> <li>● Transfer control device actuator circuit is shorted or open. (Malfunctions are detected when transfer shift relay circuit is open/shorted or relay monitor circuit is open/shorted.)</li> <li>● Malfunction occurs in transfer control device drive circuit.</li> <li>● Malfunction is detected in transfer shut off relay.</li> </ul> | <a href="#">TF-81, "Transfer Control Device"</a>                        |
|  | Malfunction is detected in transfer shut off relay.   | <a href="#">TF-54, "Power Supply Circuit For Transfer Control Unit"</a> |
| ENGINE SPEED SIG<br>[P1820]                                | <ul style="list-style-type: none"> <li>● Malfunction is detected in engine speed signal that is output from ECM through CAN communication.</li> <li>● Improper signal is input while driving.</li> </ul>  | <a href="#">TF-85, "Engine Speed Signal (ECM)"</a>                      |
| DUTY SOLENOID<br>[P1822]                                   | <ul style="list-style-type: none"> <li>● Proper voltage is not applied to clutch pressure solenoid valve due to open or short circuit.</li> </ul>   | <a href="#">TF-85, "Clutch Pressure Solenoid"</a>                       |
| 2-4WD SOLENOID<br>[P1823]                                  | <ul style="list-style-type: none"> <li>● Proper voltage is not applied to 2-4WD solenoid valve due to open or short circuit.</li> </ul>   | <a href="#">TF-90, "2-4WD Solenoid"</a>                                 |
| MOTOR RELAY<br>[P1824]                                     | <ul style="list-style-type: none"> <li>● Motor does not operate properly due to open or short circuit in transfer motor or motor relay.</li> </ul>  | <a href="#">TF-94, "Transfer Motor"</a>                                 |
| OIL TEMP SEN<br>[P1826]                                    | <ul style="list-style-type: none"> <li>● Signal voltage from fluid temperature sensor is abnormally high (Transfer fluid temperature is abnormally low) while driving.</li> </ul>   | <a href="#">TF-101, "Transfer Fluid Temperature"</a>                    |
| CLUTCH PRES SW<br>[P1827]                                  | <ul style="list-style-type: none"> <li>● Improper signal from clutch pressure switch is input due to open or short circuit.</li> <li>● Malfunction occurs in clutch pressure switch or hydraulic circuit.</li> </ul>  | <a href="#">TF-104, "Clutch Pressure Switch"</a>                        |
| LINE PRES SW<br>[P1828]                                    | <ul style="list-style-type: none"> <li>● Improper signal from line pressure switch is input due to open or short circuit.</li> <li>● Malfunction occurs in line pressure switch or hydraulic circuit.</li> </ul>  | <a href="#">TF-107, "Line Pressure Switch"</a>                          |
| THROTTLE POSI SEN<br>[P1829]                               | <ul style="list-style-type: none"> <li>● Malfunction is detected in accelerator pedal position signal that is output from ECM through CAN communication.</li> <li>● Signal voltage from accelerator pedal position sensor is abnormally high or low.</li> </ul>   | <a href="#">TF-110, "Throttle Position Signal (ECM)"</a>                |
| ABS OP SIG<br>[P1830]                                      | <ul style="list-style-type: none"> <li>● Malfunction is detected in ABS operation signal that is output from ABS actuator and electric unit (control unit) through CAN communication.</li> </ul>  | <a href="#">TF-110, "ABS Operation Signal (ABS)"</a>                    |
| VDC OP SIG<br>[P1831]                                      | <ul style="list-style-type: none"> <li>● Malfunction is detected in VDC operation signal that is output from ABS actuator and electric unit (control unit) through CAN communication.</li> </ul>  | <a href="#">TF-111, "VDC Operation Signal (ABS)"</a>                    |
| TCS OP SIG<br>[P1832]                                      | <ul style="list-style-type: none"> <li>● Malfunction is detected in TCS operation signal that is output from ABS through CAN communication.</li> </ul>  | <a href="#">TF-111, "TCS Operation Signal (ABS)"</a>                    |
| CAN COMM CIRCUIT<br>[U1000]                                | <ul style="list-style-type: none"> <li>● Malfunction has been detected from CAN communication line.</li> </ul>  | <a href="#">TF-112, "CAN Communication Line"</a>                        |
| NO DTC IS DETECTED.<br>FURTHER TESTING MAY<br>BE REQUIRED. | <ul style="list-style-type: none"> <li>● No NG item has been detected.</li> </ul>   | —   |

**CAUTION:**

- If "CAN COMM CIRCUIT [U1000]" is displayed with other DTCs, first perform the trouble diagnosis for CAN communication line.
- If "VHCL SPEED SEN-AT [P1808]", "ABS OP SIG [P1830]", "VDC OP SIG [P1831]" or "TCS OP SIG [P1832]" is displayed, first perform the trouble diagnosis for ABS system.
- If "VHCL SPEED SEN-AT [P1808]", is displayed, first perform the trouble diagnosis for A/T system.

**NOTE:**

- If "SHIFT ACT POSI SW [P1818]" or "SHIFT ACT CIR [P1819]" is displayed, first erase self-diagnostic results. ("SHIFT ACT POSI SW [P1818]" or "SHIFT ACT CIR [P1819]" may be displayed after installing transfer control unit or transfer assembly.)
- If "CL PRES SW [P1827]" or "LINE PRES SW [P1828]" is displayed only while driving in reverse, check the continuity of "R" position on A/T PNP switch. When there is nothing wrong with the electrical system, check the hydraulic system.

# TROUBLE DIAGNOSIS

## How to Erase Self-diagnostic Results

1. Perform applicable inspection of malfunctioning item and then repair or replace.
2. Start engine and select "SELF-DIAG RESULTS" mode for "ALL MODE AWD/4WD" with CONSULT-II.
3. Touch "ERASE" on CONSULT-II screen to erase DTC memory.

### CAUTION:

If memory cannot be erased, perform applicable diagnosis.

## DATA MONITOR MODE

### Operation Procedure

1. Perform "CONSULT-II SETTING PROCEDURE". Refer to [TF-44, "CONSULT-II SETTING PROCEDURE"](#).
2. Touch "DATA MONITOR".
3. Select from "SELECT MONITOR ITEM", screen of data monitor mode is displayed.

### NOTE:

When malfunction is detected, CONSULT-II performs REAL-TIME DIAGNOSIS.

Also, any malfunction detected while in this mode will be displayed at real time.

## Display Item List

×: Standard –: Not applicable

| Monitored item (Unit)         | Monitor item selection |              |                     | Remarks   |
|-------------------------------|------------------------|--------------|---------------------|---|
|                               | ECU INPUT SIGNALS      | MAIN SIGNALS | SELECTION FROM MENU |   |
| VHCL/S SEN-FR [km/h] or [mph] | ×                      | –            | ×                   | Wheel speed calculated by ABS actuator and electric unit (control unit).<br>Signal input with CAN communication line. |
| VHCL/S SEN-RR [km/h] or [mph] | ×                      | –            | ×                   | Wheel speed calculated by TCM.<br>Signal input with CAN communication line.   |
| ENGINE SPEED [rpm]            | ×                      | –            | ×                   | Engine speed calculated by ECM.<br>Signal input with CAN communication line.  |
| THRTL POS SEN [V]             | ×                      | –            | ×                   | Accelerator pedal position (APP) sensor signal voltage is displayed.<br>Signal input with CAN communication line.     |
| FLUID TEMP SE [V]             | ×                      | –            | ×                   | Transfer fluid temperature sensor signal voltage is displayed.  |
| BATTERY VOLT [V]              | ×                      | –            | ×                   | Power supply voltage for transfer control unit.   |
| 2WD SWITCH [ON/OFF]           | ×                      | –            | ×                   | 4WD shift switch status is displayed.   |
| AUTO SWITCH [ON/OFF]          | ×                      | –            | ×                   | 4WD shift switch status is displayed.   |
| LOCK SWITCH [ON/OFF]          | ×                      | –            | ×                   | 4WD shift switch status is displayed.<br>(LOCK means 4H of 4WD shift switch.)   |
| 4L SW [ON/OFF]                | ×                      | –            | ×                   | 4WD shift switch status is displayed.<br>(4L means 4LO of 4WD shift switch.)  |
| N POSI SW TF [ON/OFF]         | ×                      | –            | ×                   | Neutral-4LO switch signal status is displayed.  |
| ATP SWITCH [ON/OFF]           | ×                      | –            | ×                   | ATP switch signal status is displayed.  |
| WAIT DETCT SW [ON/OFF]        | ×                      | –            | ×                   | Wait detection switch status is displayed.  |
| LINE PRES SW [ON/OFF]         | ×                      | –            | ×                   | Line pressure switch status is displayed.   |
| CL PRES SW [ON / OFF]         | ×                      | –            | ×                   | Clutch pressure switch status is displayed.   |
| N POSI SW AT [ON/OFF]         | ×                      | –            | ×                   | "N" position signal of A/T PNP switch status is displayed.<br>Signal input with CAN communication line.               |
| R POSI SW AT [ON/OFF]         | ×                      | –            | ×                   | "R" position signal of A/T PNP switch status is displayed.<br>Signal input with CAN communication line.               |

# TROUBLE DIAGNOSIS

| Monitored item (Unit)       | Monitor item selection |              |                     | Remarks   |
|-----------------------------|------------------------|--------------|---------------------|---|
|                             | ECU INPUT SIGNALS      | MAIN SIGNALS | SELECTION FROM MENU |   |
| P POSI SW AT [ON/OFF]       | ×                      | -            | ×                   | "P" position signal of A/T PNP switch status is displayed.<br>Signal input with CAN communication line. |
| ABS OPER SW [ON/OFF]        | ×                      | -            | ×                   | ABS operation signal status is displayed.<br>Signal input with CAN communication line.                  |
| VDC OPER SW [ON/OFF]        | ×                      | -            | ×                   | VDC operation signal status is displayed.<br>Signal input with CAN communication line.                  |
| TCS OPER SW [ON/OFF]        | ×                      | -            | ×                   | TCS operation signal status is displayed.<br>Signal input with CAN communication line.                  |
| THROTTLE POSI [0.0/8]       | -                      | ×            | ×                   | Throttle position status is displayed.<br>Signal input with CAN communication line.                     |
| 4WD MODE [AUTO/LOCK/2WD/4L] | -                      | ×            | ×                   | Control status of 4WD recognized by transfer control unit. (AUTO, 4H, 2WD or 4LO)                       |
| VHLC/S COMP [km/h] or [mph] | -                      | ×            | ×                   | Vehicle speed recognized by transfer control unit.  |
| COMP CL TORQ [kgm]          | -                      | ×            | ×                   | Calculated torque recognized by transfer control unit.  |
| DUTY SOLENOID [%]           | -                      | ×            | ×                   | Control value of clutch pressure solenoid.  |
| 2-4WD SOL [ON/OFF]          | -                      | ×            | ×                   | Output condition to 2-4WD solenoid.   |
| 2-4WD SOL MON [ON/OFF]      | -                      | -            | ×                   | Check signal for transfer control unit signal output.   |
| MOTOR RELAY [ON/OFF]        | -                      | ×            | ×                   | Transfer motor relay signal status is displayed.  |
| MOTOR RELAY MON [ON/OFF]    | -                      | -            | ×                   | Check signal for transfer control unit signal output.   |
| 4WD FAIL LAMP [ON/OFF]      | -                      | ×            | ×                   | Control status of 4WD warning lamp is displayed.  |
| 2WD IND [ON/OFF]            | -                      | -            | ×                   | Control status of 4WD shift indicator lamp (2WD indicator lamp) is displayed.                           |
| AUTO IND [ON/OFF]           | -                      | -            | ×                   | Control status of 4WD shift indicator lamp (2WD and AUTO indicator lamp) is displayed.                  |
| LOCK IND [ON/OFF]           | -                      | -            | ×                   | Control status of 4WD shift indicator lamp (2WD, AUTO and Lock indicator) is displayed.                 |
| 4L IND [ON/OFF]             | -                      | -            | ×                   | Control status of 4LO indicator lamp is displayed.  |
| ATP IND [ON/OFF]            | -                      | -            | ×                   | Control status of ATP warning lamp is displayed.  |
| SHIFT POS SW1 [ON/OFF]      | ×                      | -            | ×                   | Actuator position switch 1 (Low) signal status is displayed.  |
| SHIFT POS SW2 [ON/OFF]      | ×                      | -            | ×                   | Actuator position switch 2 (high) signal status is displayed.   |
| SHIFT ACT1 [ON/OFF]         | -                      | ×            | ×                   | Output condition to actuator motor (clockwise)  |
| SHIFT AC MON1 [ON/OFF]      | ×                      | -            | ×                   | Check signal for transfer control unit signal output  |
| SHIFT ACT2 [ON/OFF]         | -                      | ×            | ×                   | Output condition to actuator motor (counterclockwise)   |
| SHIFT AC MON2 [ON/OFF]      | ×                      | -            | ×                   | Check signal for transfer control unit signal output  |



# TROUBLE DIAGNOSIS

| Monitored item (Unit)       | Monitor item selection |              |                     | Remarks  |
|-----------------------------|------------------------|--------------|---------------------|--|
|                             | ECU INPUT SIGNALS      | MAIN SIGNALS | SELECTION FROM MENU |  |
| T/F F SPEED [km/h] or [mph] | ×                      | –            | ×                   | Displayed, but do not use.   |
| A/T R SPEED [km/h] or [mph] | ×                      | –            | ×                   | Output shaft revolution signal (Revolution sensor) calculated by TCM.<br>Signal input with CAN communication line. |
| AT GEAR POSI [1/2/3/4/5]    | ×                      | –            | ×                   | A/T actual gear position is displayed.   |
| Voltage [V]                 | –                      | –            | ×                   | The value measured by the voltage probe is displayed.  |
| Frequency [Hz]              | –                      | –            | ×                   | The value measured by the pulse probe is displayed.  |
| DUTY-HI (high) [%]          | –                      | –            | ×                   |  |
| DUTY-LOW (low) [%]          | –                      | –            | ×                   |  |
| PLS WIDTH-HI [msec]         | –                      | –            | ×                   |  |
| PLS WIDTH-LOW [msec]        | –                      | –            | ×                   |  |

## WORK SUPPORT

When there is no problem with transfer and 4WD system, following symptom in “AUTO” mode may be claimed by a customer.

- Vibration when accelerating on a low  $\mu$  road (snow-covered or icy road)  
It is possible to deal with these symptoms by changing “CLUTCH FORCE RELEASE LIMIT VALUE”.  
However, be careful when changing the values because it may adversely affect driving performance.

### NOTE:

A slight shock is felt at a few hertz as if it were being pushed lightly from behind.

## Operation Procedure

1. Perform “CONSULT-II SETTING PROCEDURE”. Refer to [TF-44, "CONSULT-II SETTING PROCEDURE"](#).
2. Touch “WORK SUPPORT”.
3. Select from “CLUTCH/F RLS LIM ADJ”, screen of data monitor mode is displayed.

# TROUBLE DIAGNOSIS

## Clutch Force Release Limit Adjustment

- Current CLUTCH FORCE RELEASE LIMIT value "0.3 kgm" appears under "CONDITION SETTING" on CONSULT-II display.

**1.2 kg-m** : Tight corner braking symptom is alleviated. However, vibration may occur when accelerating on a low  $\mu$  road (icy road, etc.).

**0.3 kg-m** : Initial set value.

**0.2 kg-m** : Do not set to this value because the tight corner braking symptom will get worse.

- Touch "1.2" on the display.
- Display changes to "NOW ADJUSTING" in a short time.

|                      |         |     |
|----------------------|---------|-----|
| CLUTCH/F RLS LIM ADJ |         |     |
|                      |         |     |
| ADJ MONITOR          |         |     |
| CL/F RLS LIM         | 0.3 kgm |     |
|                      |         |     |
|                      |         |     |
|                      |         |     |
|                      |         |     |
| 0.2                  | 0.3     | 1.2 |

SMT968D

|                      |  |  |
|----------------------|--|--|
| CLUTCH/F RLS LIM ADJ |  |  |
| NOW ADJUSTING        |  |  |
| ADJ MONITOR          |  |  |
|                      |  |  |
|                      |  |  |
|                      |  |  |
|                      |  |  |
|                      |  |  |
|                      |  |  |

SMT969D

- When clutch force release limit value is set to "1.2 kgm", current value "0.3 kgm" shown on display will be replaced by "1.2 kgm" and "ADJUSTMENT COMPLETE" will appear at the same time. Clutch force release limit value setting is now complete.

|                      |         |     |
|----------------------|---------|-----|
| CLUTCH/F RLS LIM ADJ |         |     |
| ADJUSTMENT COMPLETE  |         |     |
| ADJ MONITOR          |         |     |
| CL/F RLS LIM         | 1.2 kgm |     |
|                      |         |     |
|                      |         |     |
|                      |         |     |
|                      |         |     |
| 0.2                  | 0.3     | 1.2 |

SMT970D

## Self-diagnostic Procedure

EDS001YJ

### Ⓟ SELF-DIAGNOSTIC PROCEDURE (WITH CONSULT-II)

Refer to [TF-50, "SELF-DIAGNOSTIC PROCEDURE \(WITH CONSULT-II\)"](#) .

### ⓧ SELF-DIAGNOSTIC PROCEDURE (WITHOUT CONSULT-II)

#### Description

If the engine starts when there is something wrong with the 4WD system, the 4WD warning lamp turns ON or flickers in the combination meter. When the system functions properly, the warning lamp turns ON when the ignition switch is turned to "ON", and it turns OFF after engine starts. To locate the cause of a problem, start the self-diagnosis function. The 4WD warning lamp in the combination meter will indicate the problem area by flickering according to the self-diagnostic results. As for the details of the 4WD warning lamp flickering patterns, refer to [TF-50, "SELF-DIAGNOSTIC PROCEDURE \(WITHOUT CONSULT-II\)"](#) .

# TROUBLE DIAGNOSIS

## Diagnostic Procedure

1. Warn up engine.
2. Move A/T selector lever to "P" position.
3. Turn 4WD shift switch to "2WD" position.
4. Turn ignition switch "ON" and "OFF" at least twice, and then turn ignition switch "OFF".
5. Turn 4WD shift switch to "AUTO" position.
6. Turn ignition switch "ON". (Do not start engine.)
7. 4WD warning lamp ON.  
If 4WD warning lamp does not turn ON, refer to [TF-120, "4WD Warning Lamp Does Not Turn ON"](#).
8. Move A/T selector lever to "R" position.
9. Turn 4WD shift switch to "2WD", "AUTO" and "2WD" in order.
10. Move A/T selector lever to "D" position.
11. Turn 4WD shift switch to "4H", "AUTO" and "4H" in order.
12. Move A/T selector lever to "N" position.
13. Turn 4WD shift switch to "AUTO" position.
14. Move A/T selector lever to "P" position.
15. Read the flickering of 4WD warning lamp.  
Refer to [TF-51, "Judgement Self-diagnosis"](#).

## Judgement Self-diagnosis

When a malfunction is detected, the malfunction route is indicated by flickering of the 4WD warning lamp.

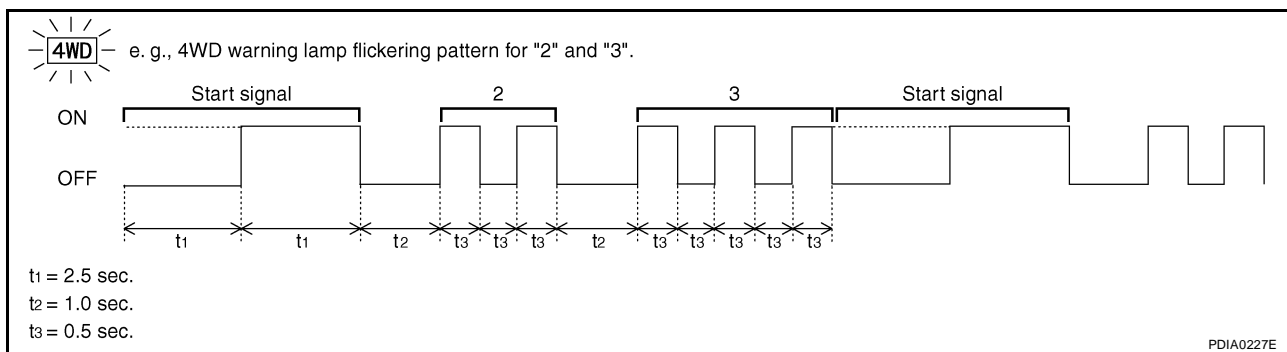

| Flickering pattern or flickering condition | Items                                     | Malfunction   | Check items   |
|--|---|---|---|
| 2  | Output shaft revolution signal (from TCM) | <ul style="list-style-type: none"> <li>● Malfunction is detected in output shaft revolution signal that is output from TCM through CAN communication.</li> <li>● Improper signal is input while driving.</li> </ul>                                 | <a href="#">TF-58, "Output Shaft Revolution Signal (TCM)"</a>           |
| 3  | Clutch pressure solenoid signal           | <ul style="list-style-type: none"> <li>● Proper voltage is not applied to clutch pressure solenoid valve due to open or short circuit.</li> </ul>   | <a href="#">TF-85, "Clutch Pressure Solenoid"</a>                       |
| 4  | 2-4WD solenoid signal                     | <ul style="list-style-type: none"> <li>● Proper voltage is not applied to 2-4WD solenoid valve due to open or short circuit.</li> </ul>   | <a href="#">TF-90, "2-4WD Solenoid"</a>                                 |
| 5  | Transfer motor                            | <ul style="list-style-type: none"> <li>● Motor does not operate properly due to open or short circuit in transfer motor or motor relay.</li> </ul>  | <a href="#">TF-94, "Transfer Motor"</a>                                 |
| 6  | Vehicle speed signal (from ABS)           | <ul style="list-style-type: none"> <li>● Malfunction is detected in vehicle speed signal that is output from ABS actuator and electric unit (control unit) through CAN communication.</li> <li>● Improper signal is input while driving.</li> </ul> | <a href="#">TF-58, "Vehicle Speed Sensor (ABS)"</a>                     |
| 7  | CAN communication                         | <ul style="list-style-type: none"> <li>● Malfunction has been detected from CAN communication line.</li> </ul>  | <a href="#">TF-112, "CAN Communication Line"</a>                        |
| 8  | AD converter                              | <ul style="list-style-type: none"> <li>● AD converter system of transfer control unit is malfunctioning.</li> </ul>   | <a href="#">TF-54, "Power Supply Circuit For Transfer Control Unit"</a> |

# TROUBLE DIAGNOSIS

| Flickering pattern or flickering condition | Items                               | Malfunction  | Check items  |
|--|-------------------------------------|--|--|
| 9  | Transfer fluid temperature          | <ul style="list-style-type: none"> <li>● Signal voltage from fluid temperature sensor is abnormally high (Transfer fluid temperature is abnormally low) while driving.</li> </ul>  | <a href="#">TF-101, "Transfer Fluid Temperature"</a>   |
| 10   | Neutral-4LO switch                  | <ul style="list-style-type: none"> <li>● Improper signal from neutral-4LO switch is input due to open or short circuit.</li> </ul>   | <a href="#">TF-59, "Neutral-4LO Switch"</a>  |
| 11   | Clutch pressure switch              | <ul style="list-style-type: none"> <li>● Improper signal from clutch pressure switch is input due to open or short circuit.</li> <li>● Malfunction occurs in clutch pressure switch or hydraulic circuit.</li> </ul>   | <a href="#">TF-104, "Clutch Pressure Switch"</a>   |
| 12   | Line pressure switch                | <ul style="list-style-type: none"> <li>● Improper signal from line pressure switch is input due to open or short circuit.</li> <li>● Malfunction occurs in line pressure switch or hydraulic circuit.</li> </ul>   | <a href="#">TF-107, "Line Pressure Switch"</a>   |
| 13   | Engine speed signal (from ECM)      | <ul style="list-style-type: none"> <li>● Malfunction is detected in engine speed signal that is output from ECM through CAN communication.</li> <li>● Improper signal is input while driving.</li> </ul>   | <a href="#">TF-85, "Engine Speed Signal (ECM)"</a>   |
| 14   | Throttle position sensor (from ECM) | <ul style="list-style-type: none"> <li>● Malfunction is detected in accelerator pedal position signal that is output from ECM through CAN communication.</li> <li>● Signal voltage from accelerator pedal position sensor is abnormally high or low.</li> </ul>  | <a href="#">TF-110, "Throttle Position Signal (ECM)"</a>   |
| 15   | Power supply                        | <ul style="list-style-type: none"> <li>● Power supply voltage for transfer control unit is abnormally low while driving.</li> </ul>  | <a href="#">TF-54, "Power Supply Circuit For Transfer Control Unit"</a>                          |
| 16   | 4WD shift switch                    | <ul style="list-style-type: none"> <li>● More than two switch inputs are simultaneously detected due to short circuit of 4WD shift switch.</li> </ul>  | <a href="#">TF-62, "4WD Shift Switch"</a>  |
| 17   | ABS operation signal (from ABS)     | <ul style="list-style-type: none"> <li>● Malfunction is detected in ABS operation signal that is output from ABS actuator and electric unit (control unit) through CAN communication.</li> </ul>   | <a href="#">TF-110, "ABS Operation Signal (ABS)"</a>   |
| 18   | Wait detection switch               | <ul style="list-style-type: none"> <li>● Improper signal from wait detection switch is input due to open or short circuit.</li> </ul>  | <a href="#">TF-66, "Wait Detection Switch"</a>   |
| 19   | Actuator motor                      | <ul style="list-style-type: none"> <li>● Motor does not operate properly due to open or short circuit in actuator motor.</li> <li>● Malfunction is detected in the actuator motor. (When 4WD shift switch is operated and actuator motor is not operated)</li> <li>● Malfunction is detected in transfer shift high relay and transfer shift low relay.</li> </ul> | <a href="#">TF-70, "Actuator Motor", TF-54, "Power Supply Circuit For Transfer Control Unit"</a> |
| 20   | Actuator position switch            | <ul style="list-style-type: none"> <li>● Improper signal from actuator position switch is input due to open or short circuit.</li> <li>● Malfunction is detected in the actuator position switch.</li> </ul>   | <a href="#">TF-77, "Actuator Position Switch"</a>  |
| 21   | Actuator circuit                    | <ul style="list-style-type: none"> <li>● Transfer control device actuator circuit is shorted or open. (Malfunctions are detected when motor relay circuit is open/shorted or relay transfer shift circuit is open/shorted.)</li> <li>● Malfunction occurs in transfer control device drive circuit.</li> </ul>   | <a href="#">TF-81, "Transfer Control Device"</a>   |
|  |                                     | <ul style="list-style-type: none"> <li>● Malfunction is detected in transfer shut off relay.</li> </ul>  | <a href="#">TF-54, "Power Supply Circuit For Transfer Control Unit"</a>                          |
| 22   | VDC operation signal (from VDC)     | <ul style="list-style-type: none"> <li>● Malfunction is detected in VDC operation signal that is output from ABS actuator and electric unit (control unit) through CAN communication.</li> </ul>   | <a href="#">TF-111, "VDC Operation Signal (ABS)"</a>   |
| 23   | TCS operation signal (from TCS)     | <ul style="list-style-type: none"> <li>● Malfunction is detected in TCS operation signal that is output from ABS actuator and electric unit (control unit) through CAN communication.</li> </ul>   | <a href="#">TF-111, "TCS Operation Signal (ABS)"</a>   |

# TROUBLE DIAGNOSIS

| Flickering pattern or flickering condition | Items                          | Malfunction   | Check items  |
|--|--------------------------------|---|--|
| 24   | PNP switch signal (from TCM)   | <ul style="list-style-type: none"> <li>When A/T PNP switch signal is malfunctioning or communication error between the vehicles.</li> </ul> | <a href="#">TF-69, "PNP Switch Signal (TCM)"</a>   |
| Repeats flickering every 2 to 5 sec.       | —                              | Circuits that the self-diagnosis covers have no malfunction.  | —  |
| Repeats flickering every 0.25 sec.         | Data erase display             | <ul style="list-style-type: none"> <li>Power supply failure of memory back-up.</li> <li>Battery performance is poor.</li> </ul>             | <a href="#">TF-54, "Power Supply Circuit For Transfer Control Unit"</a>                      |
| No flickering                              | PNP switch or 4WD shift switch | <ul style="list-style-type: none"> <li>PNP switch or 4WD shift switch circuit is shorted or open.</li> </ul>                                | <a href="#">TF-69, "PNP Switch Signal (TCM)"</a> , <a href="#">TF-62, "4WD Shift Switch"</a> |

**CAUTION:**

- If “CAN communication” is displayed with other DTCs, first perform the trouble diagnosis for CAN communication line.
- If “ABS operation signal”, “VDC operation signal” or “TCS operation signal” is displayed, first perform the trouble diagnosis for ABS system.
- If “Output shaft revolution signal” is displayed, first perform the trouble diagnosis for A/T system.

**NOTE:**

- If “actuator position switch” or “actuator circuit” is displayed, first erase self-diagnostic results. (“Actuator position switch” or “actuator circuit” may be displayed after installing transfer control unit or transfer assembly.)
- If “clutch pressure switch” or “line pressure switch” is displayed only while driving in reverse, check the continuity of “R” position on A/T PNP switch. When there is nothing wrong with the electrical system, check the hydraulic system.

**ERASE SELF-DIAGNOSIS**

- In order to make it easier to find the cause of hard-to-duplicate malfunctions, malfunction information is stored into the control unit as necessary during use by the user. This memory is not erased no matter how many times the ignition switch is turned ON and OFF.
- However, this information is erased by turning ignition switch “OFF” after performing self-diagnostics or by erasing the memory using the CONSULT-II.

# TROUBLE DIAGNOSIS FOR SYSTEM

## TROUBLE DIAGNOSIS FOR SYSTEM

PFP:00000

### Power Supply Circuit For Transfer Control Unit CONSULT-II REFERENCE VALUE IN DATA MONITOR MODE

EDS001YK

Data are reference value.

| Monitored item [Unit] | Content  | Condition           | Display value   |
|-----------------------|--|---------------------|-----------------|
| BATTERY VOLT [V]      | Power supply voltage for transfer control unit | Ignition switch: ON | Battery voltage |

### TRANSFER CONTROL UNIT TERMINALS AND REFERENCE VALUE

Data are reference value and are measured between each terminal and ground.

| Terminal | Wire color | Item                             | Condition   | Data (Approx.)  |
|----------|------------|----------------------------------|---|-----------------|
| 3        | B          | Ground                           | Always  | 0V              |
| 6        | B          | Ground                           | Always  | 0V              |
| 16       | Y/R        | Power supply                     | Ignition switch: ON   | Battery voltage |
|          |            |                                  | Ignition switch: OFF<br>(5 seconds after ignition switch is turned OFF) | 0V              |
| 22       | Y/R        | Power supply                     | Ignition switch: ON   | Battery voltage |
|          |            |                                  | Ignition switch: OFF<br>(5 seconds after ignition switch is turned OFF) | 0V              |
| 29       | L/W        | Ignition switch monitor          | Ignition switch: ON   | Battery voltage |
|          |            |                                  | Ignition switch: OFF  | 0V              |
| 30       | SB         | Shut off relay                   | Ignition switch: ON   | 0V              |
|          |            |                                  | Ignition switch: OFF<br>(5 seconds after ignition switch is turned OFF) | Battery voltage |
| 45       | B          | Ground                           | Always  | 0V              |
| 47       | W          | Power supply<br>(Memory back-up) | Ignition switch: ON   | Battery voltage |
|          |            |                                  | Ignition switch: OFF  | Battery voltage |

**CAUTION:**

When using a circuit tester to measure voltage for inspection, be sure not to extend forcibly any connector terminals.

# TROUBLE DIAGNOSIS FOR SYSTEM

## DIAGNOSTIC PROCEDURE

### 1. CHECK POWER SUPPLY

1. Turn ignition switch "OFF". (Stay for at least 5 seconds.)
2. Connect transfer control unit harness connector.
3. Check voltage between transfer control unit harness connector terminals and ground.

| Connector | Terminal    | Voltage (Approx.) |
|-----------|-------------|-------------------|
| E142      | 16 - Ground | 0V                |
|           | 22 - Ground |                   |
| E143      | 29 - Ground | Battery voltage   |
|           | 30 - Ground |                   |
|           | 47 - Ground |                   |

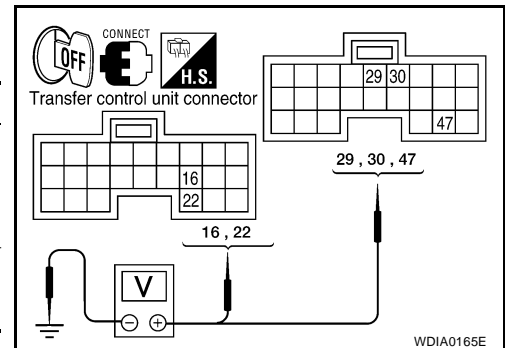

4. Turn ignition switch "ON". (Do not start engine.)
5. Check voltage between transfer control unit harness connector terminals and ground.

| Connector | Terminal    | Voltage (Approx.) |
|-----------|-------------|-------------------|
| E142      | 16 - Ground | Battery voltage   |
|           | 22 - Ground |                   |
| E143      | 29 - Ground | 0V                |
|           | 30 - Ground |                   |
|           | 47 - Ground |                   |

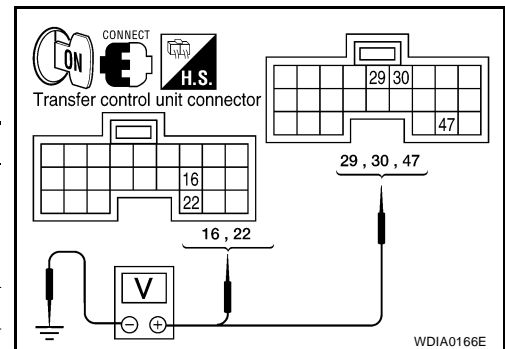

OK or NG

OK >> GO TO 2.

NG >> Check the following. If any items are damaged, repair or replace damaged parts.

- 10A fuses No. 26 located in fuse and fusible link box and No. 59 located in the fuse and relay box. Refer to [PG-4, "POWER SUPPLY ROUTING CIRCUIT"](#).
- 20A fuse No. 53 located in the IPDM E/R. Refer to [PG-4, "POWER SUPPLY ROUTING CIRCUIT"](#).
- Harness for short or open between battery and transfer control unit harness connector terminals 47.
- Harness for short or open between battery and transfer control unit harness connector terminal 29.
- Harness for short or open between battery and transfer shut off relay harness connector E69 terminal 1, and 3.
- Harness for short or open between transfer shut off relay harness connector E69 terminal 2 and transfer control unit harness connector terminal 30.
- Harness for short or open between transfer shut off relay harness connector E69 terminal 5 and transfer control unit harness connector terminals 16 and 22.
- Battery and ignition switch. Refer to [PG-4, "POWER SUPPLY ROUTING CIRCUIT"](#).
- Transfer shut off relay. Refer to [TF-57, "COMPONENT INSPECTION"](#).

# TROUBLE DIAGNOSIS FOR SYSTEM

## 2. CHECK GROUND CIRCUIT

1. Turn ignition switch "OFF". (Stay for at least 5 seconds.)
2. Disconnect transfer control unit harness connector.
3. Check continuity between transfer control unit harness connector E142 terminals 3, 6, E143 terminal 45 and ground.

**Continuity should exist.**

Also check harness for short to ground and short to power.

OK or NG

OK >> GO TO 3.

NG >> Repair open circuit or short to ground or short to power in harness or connectors.

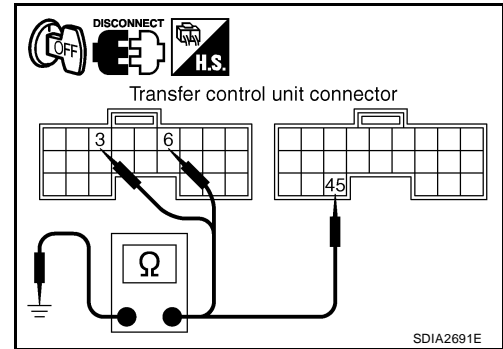

## 3. CHECK TRANSFER CONTROL UNIT

Check transfer control unit input/output signal. Refer to [TF-35, "Transfer Control Unit Input/Output Signal Reference Values"](#) .

OK or NG

OK >> GO TO 4.

NG >> Check transfer control unit pin terminals for damage or loose connection with harness connector. If any items are damaged, repair or replace damaged parts.

## 4. CHECK DTC

Perform the self-diagnosis, after driving a vehicle for a while.

OK or NG

OK >> Inspection End.

NG >> Replace transfer control unit. Refer to [TF-131, "Removal and Installation"](#) .



# TROUBLE DIAGNOSIS FOR SYSTEM

## COMPONENT INSPECTION

1. Turn ignition switch "OFF". (Stay for at least 5 seconds.)
2. Remove transfer shut off relay. Refer to [TF-22, "Location of Electrical Parts"](#).
3. Apply 12V direct current between transfer shut off relay terminals 1 and 2.
4. Check continuity between relay terminals 3 and 5.

| Condition   | Continuity |
|---|------------|
| 12V direct current supply between terminals 1 and 2 | Yes        |
| OFF   | No         |

5. If NG, replace the transfer shut off relay.

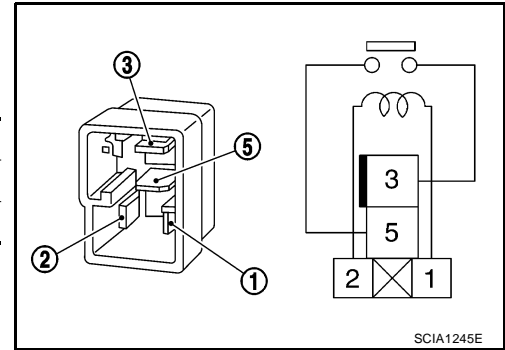

EDS001YL

## Transfer Control Unit DIAGNOSTIC PROCEDURE

### 1. INSPECTION START

Do you have CONSULT-II?

YES or NO

- YES >> GO TO 2.  
NO >> GO TO 3.

### 2. PERFORM SELF-DIAGNOSIS (WITH CONSULT-II)

#### With CONSULT-II

1. Turn ignition switch "ON". (Do not start engine.)
2. Select "SELF-DIAG RESULTS" mode for "ALL MODE AWD/4WD" with CONSULT-II.
3. Touch "ERASE".
4. Turn ignition switch "OFF" and wait at least 10 seconds.
5. Perform the self-diagnosis again.

Is the "CONTROL UNIT 1 [P1802]", "CONTROL UNIT 2 [P1803]", "CONTROL UNIT 3 [P1804]" or "CONTROL UNIT 4 [P1809]" displayed?

- YES >> Replace transfer control unit. Refer to [TF-131, "Removal and Installation"](#).  
NO >> Inspection End.

### 3. PERFORM SELF-DIAGNOSIS (WITHOUT CONSULT-II)

#### Without CONSULT-II

1. Perform the self-diagnosis and then erase self-diagnostic results. Refer to [TF-50, "SELF-DIAGNOSTIC PROCEDURE \(WITHOUT CONSULT-II\)"](#) and [TF-53, "ERASE SELF-DIAGNOSIS"](#).
2. Perform the self-diagnosis again.

Do the self-diagnostic results indicate AD converter?

- YES >> Replace transfer control unit. Refer to [TF-131, "Removal and Installation"](#).  
NO >> Inspection End.

# TROUBLE DIAGNOSIS FOR SYSTEM

## Output Shaft Revolution Signal (TCM)

EDS001YM

### DIAGNOSTIC PROCEDURE

#### 1. CHECK DTC WITH TCM

Perform self-diagnosis with TCM. Refer to [TF-50, "SELF-DIAGNOSTIC PROCEDURE \(WITH CONSULT-II\)"](#) .

Is any malfunction detected by self-diagnosis?

- YES >> Check the malfunctioning system.
- NO >> GO TO 2.

#### 2. CHECK TRANSFER CONTROL UNIT

Check transfer control unit input/output signal. Refer to [TF-35, "Transfer Control Unit Input/Output Signal Reference Values"](#) .

OK or NG

- OK >> GO TO 3.
- NG >> Check transfer control unit pin terminals for damage or loose connection with harness connector. If any items are damaged, repair or replace damaged parts.

#### 3. CHECK DTC

Perform the self-diagnosis, after driving a vehicle for a while.

OK or NG

- OK >> Inspection End.
- NG >> Perform self-diagnosis with TCM again. Refer to [TF-50, "SELF-DIAGNOSTIC PROCEDURE \(WITH CONSULT-II\)"](#) .

## Vehicle Speed Sensor (ABS)

EDS001YN

### DIAGNOSTIC PROCEDURE

#### 1. CHECK DTC WITH ABS ACTUATOR AND ELECTRIC UNIT (CONTROL UNIT)

Perform self-diagnosis with ABS actuator and electric unit (control unit). Refer to [BRC-30, "SELF-DIAGNOSIS"](#) .

Is any malfunction detected by self-diagnosis?

- YES >> Check the malfunctioning system.
- NO >> GO TO 2.

#### 2. CHECK TRANSFER CONTROL UNIT

Check transfer control unit input/output signal. Refer to [TF-35, "Transfer Control Unit Input/Output Signal Reference Values"](#) .

OK or NG

- OK >> GO TO 3.
- NG >> Check transfer control unit pin terminals for damage or loose connection with harness connector. If any items are damaged, repair or replace damaged parts.

#### 3. CHECK DTC

Perform the self-diagnosis, after driving a vehicle for a while.

OK or NG

- OK >> Inspection End.
- NG >> Perform self-diagnosis with ABS actuator and electric unit (control unit) again. Refer to [BRC-30, "SELF-DIAGNOSIS"](#) .

# TROUBLE DIAGNOSIS FOR SYSTEM

## Neutral-4LO Switch

EDS001YO

### CONSULT-II REFERENCE VALUE IN DATA MONITOR MODE

Data are reference value.

| Monitored item        | Content                         | Condition   | Display value                            |
|-----------------------|---------------------------------|---|--|
| N POSI SW TF [ON/OFF] | Condition of neutral-4LO switch | <ul style="list-style-type: none"> <li>● Vehicle stopped</li> <li>● Engine running</li> <li>● A/T selector lever "N" position</li> <li>● Brake pedal depressed</li> </ul> | 4WD shift switch: 2WD, AUTO or 4H<br>OFF |
|                       |                                 | 4WD shift switch: 4H to 4LO (While actuator motor is operating.)<br>OFF → ON  |  |
|                       |                                 | 4WD shift switch: 4LO to 4H (While actuator motor is operating.)<br>ON → OFF  |  |
|                       |                                 | 4WD shift switch: 4LO<br>ON   |  |

### TRANSFER CONTROL UNIT TERMINALS AND REFERENCE VALUE

Data are reference value and are measured between each terminal and ground.

| Terminal | Wire color | Item               | Condition   | Data (Approx.)                                       |
|----------|------------|--------------------|---|--|
| 25       | V          | Neutral-4LO switch | <ul style="list-style-type: none"> <li>● Vehicle stopped</li> <li>● Engine running</li> <li>● A/T selector lever "N" position</li> <li>● Brake pedal depressed</li> </ul> | 4WD shift switch: 2WD, AUTO or 4H<br>Battery voltage |
|          |            |                    | 4WD shift switch: 4H to 4LO (While actuator motor is operating.)<br>Battery voltage → 0V  |  |
|          |            |                    | 4WD shift switch: 4LO to 4H (While actuator motor is operating.)<br>0V → Battery voltage  |  |
|          |            |                    | 4WD shift switch: 4LO<br>0V   |  |

**CAUTION:**

When using a circuit tester to measure voltage for inspection, be sure not to extend forcibly any connector terminals.

# TROUBLE DIAGNOSIS FOR SYSTEM

## DIAGNOSTIC PROCEDURE

### 1. CHECK 4LO POSITION SWITCH SIGNAL

#### ④ With CONSULT-II

1. Start engine.
2. Select "DATA MONITOR" mode for "ALL MODE AWD/4WD" with CONSULT-II.
3. Read out the value of "N POSI SW TF".

| Condition   |  | Display value |
|---|--|---------------|
| <ul style="list-style-type: none"> <li>● Vehicle stopped</li> <li>● Engine running</li> <li>● A/T selector lever "N" position</li> <li>● Brake pedal depressed</li> </ul> | 4WD shift switch: 2WD, AUTO or 4H                                | OFF           |
|   | 4WD shift switch: 4H to 4LO (While actuator motor is operating.) | OFF → ON      |
|   | 4WD shift switch: 4LO to 4H (While actuator motor is operating.) | ON → OFF      |
|   | 4WD shift switch: 4LO  | ON            |

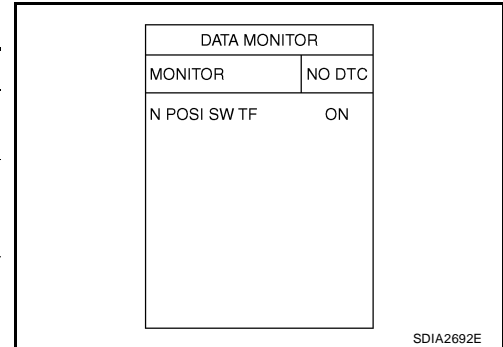

#### ⊗ Without CONSULT-II

1. Start engine.
2. Check voltage between transfer control unit harness connector terminal and ground.

| Connector | Terminal (Wire color) | Condition   | Voltage (Approx.)                                    |
|-----------|-----------------------|---|--|
| E143      | 25 - Ground           | <ul style="list-style-type: none"> <li>● Vehicle stopped</li> <li>● Engine running</li> <li>● A/T selector lever "N" position</li> <li>● Brake pedal depressed</li> </ul> | 4WD shift switch: 2WD, AUTO or 4H<br>Battery voltage |
|           |                       | 4WD shift switch: 4H to 4LO (While actuator motor is operating.)  | Battery voltage → 0V                                 |
|           |                       | 4WD shift switch: 4LO to 4H (While actuator motor is operating.)  | 0V → Battery voltage                                 |
|           |                       | 4WD shift switch: 4LO   | 0V   |

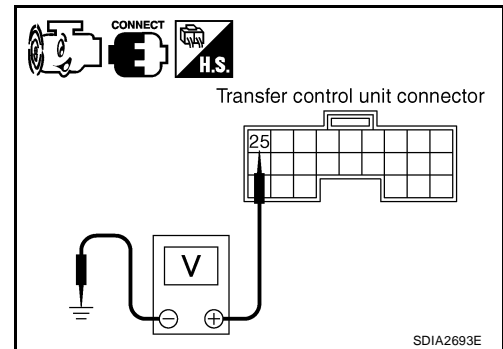

OK or NG

- OK    >> GO TO 5.  
 NG    >> GO TO 2.

### 2. CHECK HARNESS BETWEEN TRANSFER CONTROL UNIT AND NEUTRAL-4LO SWITCH

1. Turn ignition switch "OFF". (Stay for at least 5 seconds.)
2. Disconnect transfer control unit harness connector and the neutral-4LO switch harness connector.
3. Check continuity between transfer control unit harness connector E143 terminal 25 and neutral-4LO switch harness connector F60 terminal 13.

**Continuity should exist.**

Also check harness for short to ground and short to power.

OK or NG

- OK    >> GO TO 3.  
 NG    >> Repair or replace damaged parts.

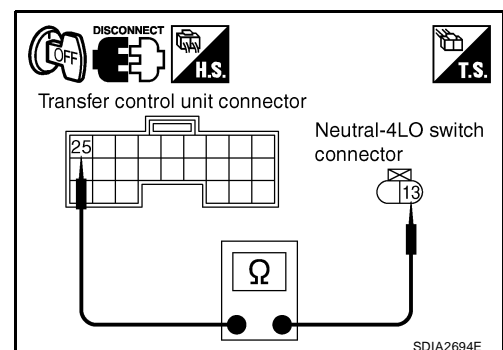

# TROUBLE DIAGNOSIS FOR SYSTEM

## 3. CHECK GROUND CIRCUIT

1. Turn ignition switch "OFF". (Stay for at least 5 seconds.)
2. Disconnect neutral-4LO switch harness connector.
3. Check continuity between neutral-4LO switch harness connector F60 terminal 12 and ground.

**Continuity should exist.**

Also check harness for short to ground and short to power.

OK or NG

OK >> GO TO 4.

NG >> Repair open circuit or short to ground or short to power in harness or connectors.

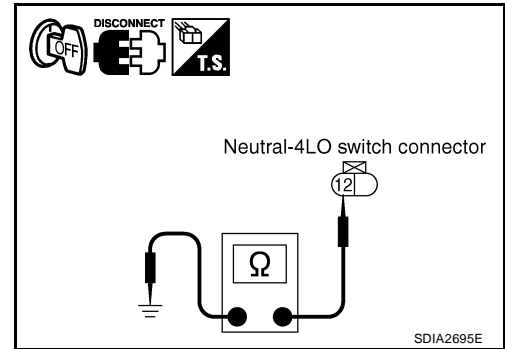

## 4. CHECK 4LO SWITCH

1. Turn ignition switch "OFF".
2. Disconnect neutral-4LO switch harness connector.
3. Remove neutral-4LO switch.
4. Push and release neutral-4LO switch and check continuity between neutral-4LO switch terminals 12 and 13.

| Terminal | Condition                  | Continuity |
|----------|----------------------------|------------|
| 12 - 13  | Push neutral-4LO switch    | Yes        |
|          | Release neutral-4LO switch | No         |

OK or NG

OK >> GO TO 5.

NG >> Replace neutral-4LO switch. Refer to [TF-22, "Location of Electrical Parts"](#) .

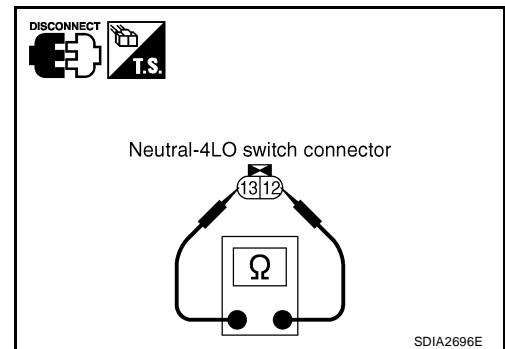

## 5. CHECK TRANSFER CONTROL UNIT

Check transfer control unit input/output signal. Refer to [TF-35, "Transfer Control Unit Input/Output Signal Reference Values"](#) .

OK or NG

OK >> GO TO 6.

NG >> Check transfer control unit pin terminals for damage or loose connection with harness connector. If any items are damaged, repair or replace damaged parts.

## 6. CHECK DTC

Perform the self-diagnosis, after driving a vehicle for a while.

OK or NG

OK >> Inspection End.

NG >> Replace transfer control unit. Refer to [TF-131, "Removal and Installation"](#) .

# TROUBLE DIAGNOSIS FOR SYSTEM

## COMPONENT INSPECTION

1. Turn ignition switch "OFF". (Stay for at least 5 seconds.)
2. Disconnect neutral-4LO switch harness connector.
3. Remove neutral-4LO switch. Refer to [TF-22, "Location of Electrical Parts"](#) .
4. Push and release neutral-4LO switch and check continuity between neutral-4LO switch terminals 12 and 13.

| Terminal | Condition                  | Continuity |
|----------|----------------------------|------------|
| 12 - 13  | Push neutral-4LO switch    | Yes        |
|          | Release neutral-4LO switch | No         |

5. If NG, replace the neutral-4LO switch. Refer to [TF-22, "Location of Electrical Parts"](#) .

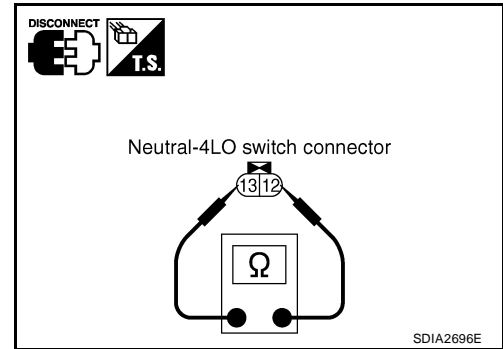

## 4WD Shift Switch

### CONSULT-II REFERENCE VALUE IN DATA MONITOR MODE

Data are reference value.

| Monitored item [Unit]       | Content   | Condition                          | Display value          |      |
|-----------------------------|---|------------------------------------|------------------------|------|
| 2WD SWITCH [ON/OFF]         | Input condition from 4WD shift switch   | 4WD shift switch: 2WD              | ON                     |      |
|                             |   | 4WD shift switch: AUTO, 4H or 4LO  | OFF                    |      |
| AUTO SWITCH [ON/OFF]        | Input condition from 4WD shift switch   | 4WD shift switch: AUTO             | ON                     |      |
|                             |   | 4WD shift switch: 2WD, 4H or 4LO   | OFF                    |      |
| LOCK SWITCH [ON/OFF]        | Input condition from 4WD shift switch   | 4WD shift switch: 4H               | ON                     |      |
|                             |   | 4WD shift switch: 2WD, AUTO or 4LO | OFF                    |      |
| 4L SWITCH [ON/OFF]          | Input condition from 4WD shift switch   | 4WD shift switch: 4LO              | ON                     |      |
|                             |   | 4WD shift switch: 2WD, AUTO or 4H  | OFF                    |      |
| 4WD MODE [AUTO/LOCK/2WD/4L] | Control status of 4WD (Output condition of 4WD shift indicator lamp and 4LO indicator lamp) | ● Vehicle stopped                  | 4WD shift switch: 2WD  | 2WD  |
|                             |   | ● Engine running                   | 4WD shift switch: AUTO | AUTO |
|                             |   | ● A/T selector lever "N" position  | 4WD shift switch: 4H   | LOCK |
|                             |   | ● Brake pedal depressed            | 4WD shift switch: 4LO  | 4L   |

## TRANSFER CONTROL UNIT TERMINALS AND REFERENCE VALUE

Data are reference value and are measured between each terminal and ground.

| Terminal | Wire color | Item                    | Condition           | Data (Approx.)                     |                 |
|----------|------------|-------------------------|---------------------|------------------------------------|-----------------|
| 9        | G/W        | 4WD shift switch (2WD)  | Ignition switch: ON | 4WD shift switch: 2WD              | Battery voltage |
|          |            |                         |                     | 4WD shift switch: AUTO, 4H or 4LO  | 0V              |
| 18       | O          | 4WD shift switch (4H)   | Ignition switch: ON | 4WD shift switch: 4H               | Battery voltage |
|          |            |                         |                     | 4WD shift switch: 2WD, AUTO or 4LO | 0V              |
| 23       | R          | 4WD shift switch (4LO)  | Ignition switch: ON | 4WD shift switch: 4LO              | Battery voltage |
|          |            |                         |                     | 4WD shift switch: 2WD, AUTO or 4H  | 0V              |
| 24       | LG/R       | 4WD shift switch (AUTO) | Ignition switch: ON | 4WD shift switch: AUTO             | Battery voltage |
|          |            |                         |                     | 4WD shift switch: 2WD, 4H or 4LO   | 0V              |

### CAUTION:

When using a circuit tester to measure voltage for inspection, be sure not to extend forcibly any connector terminals.

# TROUBLE DIAGNOSIS FOR SYSTEM

## DIAGNOSTIC PROCEDURE

### 1. CHECK 4WD SHIFT SWITCH SIGNAL

#### Ⓜ With CONSULT-II

1. Turn ignition switch "ON". (Do not start engine.)
2. Select "DATA MONITOR" mode for "ALL MODE AWD/4WD" with CONSULT-II.
3. Read out ON/OFF switching action of the "2WD SWITCH", "AUTO SWITCH", "LOCK SWITCH", "4L SWITCH" with operating 4WD shift switch.

| DATA MONITOR |        |
|--------------|--------|
| MONITOR      | NO DTC |
| 2WD SWITCH   | OFF    |
| AUTO SWITCH  | ON     |
| LOCK SWITCH  | OFF    |
| 4L SWITCH    | OFF    |

SDIA2697E

#### ⓧ Without CONSULT-II

1. Turn ignition switch "ON". (Do not start engine.)
2. Check voltage between transfer control unit harness connector terminals and ground.

| Connector   | Terminal                         | Condition                          | Voltage (Approx.) |
|-------------|----------------------------------|------------------------------------|-------------------|
| E142        | 9 - ground                       | 4WD shift switch: 2WD              | Battery voltage   |
|             |                                  | 4WD shift switch: AUTO, 4H or 4LO  | 0V                |
|             | 18 - ground                      | 4WD shift switch: 4H               | Battery voltage   |
|             |                                  | 4WD shift switch: 2WD, AUTO or 4LO | 0V                |
|             | 23 - ground                      | 4WD shift switch: 4LO              | Battery voltage   |
|             |                                  | 4WD shift switch: 2WD, AUTO or 4H  | 0V                |
| 24 - ground | 4WD shift switch: AUTO           | Battery voltage                    |                   |
|             | 4WD shift switch: 2WD, 4H or 4LO | 0V                                 |                   |

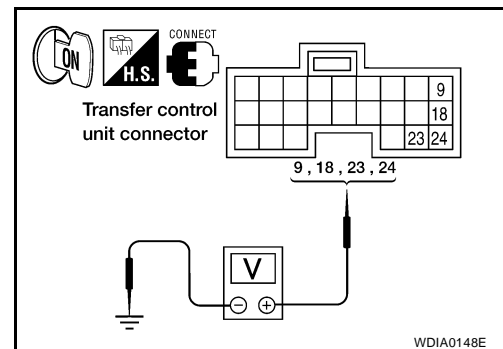

#### OK or NG

- OK    >> GO TO 5.  
 NG    >> GO TO 2.

# TROUBLE DIAGNOSIS FOR SYSTEM

## 2. CHECK 4WD SHIFT SWITCH POWER SUPPLY CIRCUIT

1. Turn ignition switch "OFF". (Stay for at least 5 seconds.)
2. Disconnect 4WD shift switch harness connector.
3. Check voltage between 4WD shift switch harness connector terminal 1 and ground.

| Connector | Terminal   | Voltage (Approx.) |
|-----------|------------|-------------------|
| M141      | 1 - Ground | 0V                |

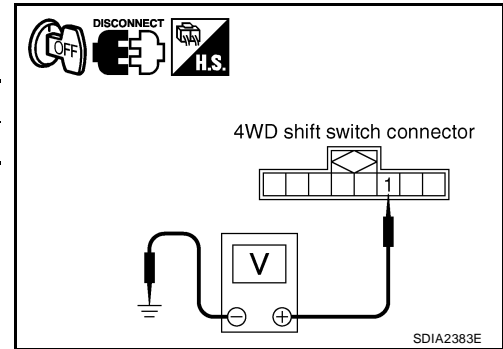

4. Turn ignition switch "ON". (Do not start engine.)
5. Check voltage between 4WD shift switch harness connector terminal 1 and ground.

| Connector | Terminal   | Voltage (Approx.) |
|-----------|------------|-------------------|
| M141      | 1 - Ground | Battery voltage   |

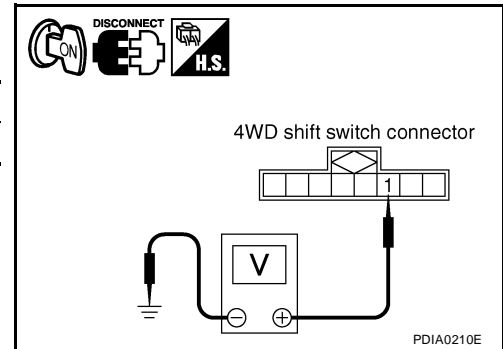

**OK or NG**

- OK >> GO TO 3.
- NG >> Go to [TF-54, "Power Supply Circuit For Transfer Control Unit"](#).

## 3. CHECK HARNESS BETWEEN 4WD SHIFT SWITCH AND TRANSFER CONTROL UNIT

1. Turn ignition switch "OFF". (Stay for at least 5 seconds.)
2. Disconnect transfer control unit harness connector and the 4WD shift switch harness connector.
3. Check continuity between the following terminals.
  - Transfer control unit harness connector E142 terminal 9 and 4WD shift switch harness connector M141 terminal 2.
  - Transfer control unit harness connector E142 terminal 18 and 4WD shift switch harness connector M141 terminal 5.
  - Transfer control unit harness connector E142 terminal 23 and 4WD shift switch harness connector M141 terminal 6.
  - Transfer control unit harness connector E142 terminal 24 and 4WD shift switch harness connector M141 terminal 3.

**Continuity should exist.**

Also check harness for short to ground and short to power.

**OK or NG**

- OK >> GO TO 4.
- NG >> Check the following. If any items are damaged, repair or replace damaged parts.
  - Harness for short or open between battery and transfer shut off relay harness connector E69 terminal 3.
  - Power supply circuit for transfer control unit. Refer to [TF-54, "Power Supply Circuit For Transfer Control Unit"](#).

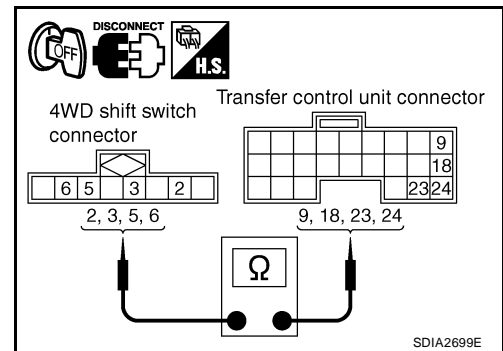



# TROUBLE DIAGNOSIS FOR SYSTEM

## 4. CHECK 4WD SHIFT SWITCH

1. Turn ignition switch "OFF". (Stay for at least 5 seconds.)
2. Disconnect 4WD shift switch harness connector.
3. Operate 4WD shift switch and check continuity between 4WD shift switch terminals.

| Connector | Terminal | Condition                            | Continuity |
|-----------|----------|--------------------------------------|------------|
| M141      | 1 - 2    | 4WD shift switch: 2WD                | Yes        |
|           |          | 4WD shift switch: AUTO, 4H and 4LO   | No         |
|           | 1 - 3    | 4WD shift switch: AUTO               | Yes        |
|           |          | 4WD shift switch: 2WD, 4H and 4LO    | No         |
|           | 1 - 4    | 4WD shift switch: 2WD                | No         |
|           |          | 4WD shift switch: AUTO, 4H and 4LO   | Yes        |
|           | 1 - 5    | 4WD shift switch: 4H                 | Yes        |
|           |          | 4WD shift switch: 2WD, AUTO, and 4LO | No         |
|           | 1 - 6    | 4WD shift switch: 4LO                | Yes        |
|           |          | 4WD shift switch: 2WD, AUTO and 4H   | No         |

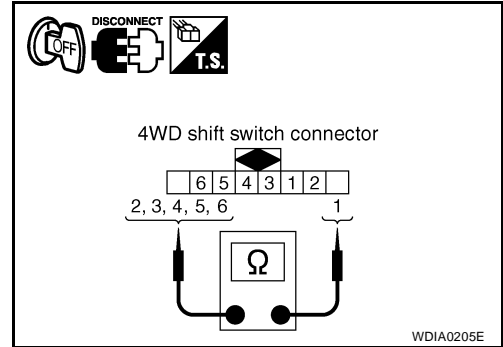

OK or NG

- OK >> GO TO 5.
- NG >> Replace 4WD shift switch.

## 5. CHECK TRANSFER CONTROL UNIT

Check transfer control unit input/output signal. Refer to [TF-35, "Transfer Control Unit Input/Output Signal Reference Values"](#) .

OK or NG

- OK >> GO TO 6.
- NG >> Check transfer control unit pin terminals for damage or loose connection with harness connector. If any items are damaged, repair or replace damaged parts.

## 6. CHECK DTC

Perform the self-diagnosis, after driving a vehicle for a while.

OK or NG

- OK >> Inspection End.
- NG >> Replace transfer control unit. Refer to [TF-131, "Removal and Installation"](#) .

# TROUBLE DIAGNOSIS FOR SYSTEM

## COMPONENT INSPECTION

1. Turn ignition switch "OFF". (Stay for at least 5 second.)
2. Disconnect 4WD shift switch harness connector.
3. Operate 4WD shift switch and check continuity between 4WD shift switch terminals.

| Connector | Terminal | Condition                            | Continuity |
|-----------|----------|--------------------------------------|------------|
| M141      | 1 - 2    | 4WD shift switch: 2WD                | Yes        |
|           |          | 4WD shift switch: AUTO, 4H and 4LO   | No         |
|           | 1 - 3    | 4WD shift switch: AUTO               | Yes        |
|           |          | 4WD shift switch: 2WD, 4H and 4LO    | No         |
|           | 1 - 4    | 4WD shift switch: 2WD                | No         |
|           |          | 4WD shift switch: AUTO, 4H and 4LO   | Yes        |
|           | 1 - 5    | 4WD shift switch: 4H                 | Yes        |
|           |          | 4WD shift switch: 2WD, AUTO, and 4LO | No         |
|           | 1 - 6    | 4WD shift switch: 4LO                | Yes        |
|           |          | 4WD shift switch: 2WD, AUTO and 4H   | No         |

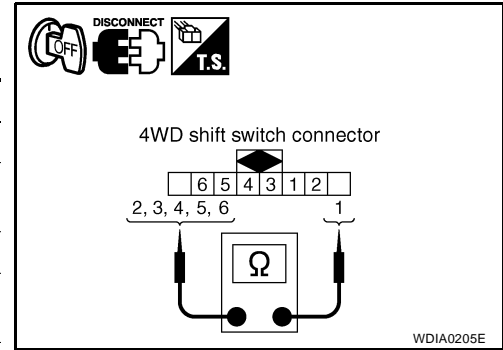

4. If NG, replace the 4WD shift switch.

## Wait Detection Switch

EDS001YQ

### CONSULT-II REFERENCE VALUE IN DATA MONITOR MODE

Data are reference value.

| Monitored item         | Content                            | Condition   | Display value                            |
|------------------------|------------------------------------|---|--|
| WAIT DETCT SW [ON/OFF] | Condition of wait detection switch | <ul style="list-style-type: none"> <li>● Vehicle stopped</li> <li>● Engine running</li> <li>● A/T selector lever "N" position</li> <li>● Brake pedal depressed</li> </ul> | 4WD shift switch: 2WD, AUTO or 4H<br>OFF |
|                        |                                    | 4WD shift switch: 4H to 4LO (While actuator motor is operating.)<br>OFF → ON  |  |
|                        |                                    | 4WD shift switch: 4LO to 4H (While actuator motor is operating.)<br>ON → OFF  |  |
|                        |                                    | 4WD shift switch: 4LO<br>ON   |  |

### TRANSFER CONTROL UNIT TERMINALS AND REFERENCE VALUE

Data are reference value and are measured between each terminal and ground.

| Terminal | Wire color | Item                  | Condition   | Data (Approx.)                                       |
|----------|------------|-----------------------|---|--|
| 43       | G/Y        | Wait detection switch | <ul style="list-style-type: none"> <li>● Vehicle stopped</li> <li>● Engine running</li> <li>● A/T selector lever "N" position</li> <li>● Brake pedal depressed</li> </ul> | 4WD shift switch: 2WD, AUTO or 4H<br>Battery voltage |
|          |            |                       | 4WD shift switch: 4H to 4LO (While actuator motor is operating.)<br>Battery voltage → 0V  |  |
|          |            |                       | 4WD shift switch: 4LO to 4H (While actuator motor is operating.)<br>0V → Battery voltage  |  |
|          |            |                       | 4WD shift switch: 4LO<br>0V   |  |

**CAUTION:**

When using a circuit tester to measure voltage for inspection, be sure not to extend forcibly any connector terminals.

# TROUBLE DIAGNOSIS FOR SYSTEM

## DIAGNOSTIC PROCEDURE

### 1. CHECK WAIT DETECTION SWITCH SIGNAL

#### ④ With CONSULT-II

1. Start engine.
2. Select "DATA MONITOR" mode for "ALL MODE AWD/4WD" with CONSULT-II.
3. Read out the value of "WAIT DETCT SW".

| Condition   |  | Display value |
|---|--|---------------|
| <ul style="list-style-type: none"> <li>● Vehicle stopped</li> <li>● Engine running</li> <li>● A/T selector lever "N" position</li> <li>● Brake pedal depressed</li> </ul> | 4WD shift switch: 2WD, AUTO or 4H                                | OFF           |
|   | 4WD shift switch: 4H to 4LO (While actuator motor is operating.) | OFF → ON      |
|   | 4WD shift switch: 4LO to 4H (While actuator motor is operating.) | ON → OFF      |
|   | 4WD shift switch: 4LO  | ON            |

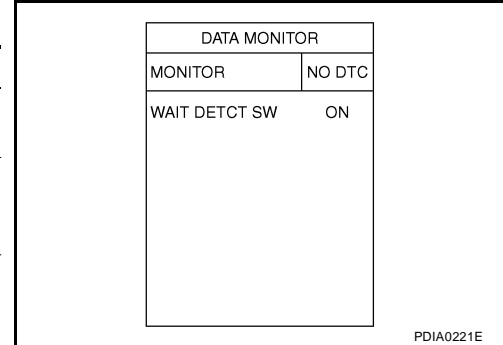

#### ⊗ Without CONSULT-II

1. Start engine.
2. Check voltage between transfer control unit harness connector terminal and ground.

| Connector | Terminal    | Condition   | Voltage (Approx.)                                    |
|-----------|-------------|---|--|
| E143      | 43 - Ground | <ul style="list-style-type: none"> <li>● Vehicle stopped</li> <li>● Engine running</li> <li>● A/T selector lever "N" position</li> <li>● Brake pedal depressed</li> </ul> | 4WD shift switch: 2WD, AUTO or 4H<br>Battery voltage |
|           |             | 4WD shift switch: 4H to 4LO (While actuator motor is operating.)  | Battery voltage → 0V                                 |
|           |             | 4WD shift switch: 4LO to 4H (While actuator motor is operating.)  | 0V → Battery voltage                                 |
|           |             | 4WD shift switch: 4LO   | 0V   |

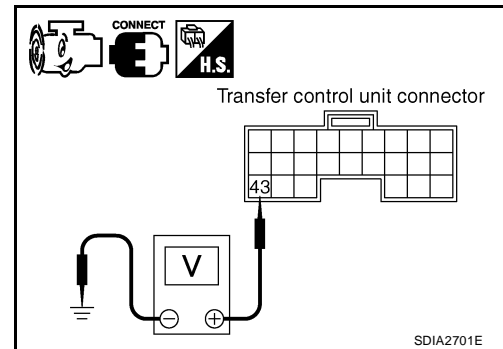

OK or NG

- OK    >> GO TO 5.  
 NG    >> GO TO 2.

### 2. CHECK HARNESS BETWEEN TRANSFER CONTROL UNIT AND WAIT DETECTION SWITCH

1. Turn ignition switch "OFF". (Stay for at least 5 seconds.)
2. Disconnect transfer control unit harness connector and the wait detection switch harness connector.
3. Check continuity between transfer control unit harness connector E143 terminal 43 and wait detection switch harness connector F59 terminal 10.

**Continuity should exist.**

Also check harness for short to ground and short to power.

OK or NG

- OK    >> GO TO 3.  
 NG    >> Repair or replace damaged parts.

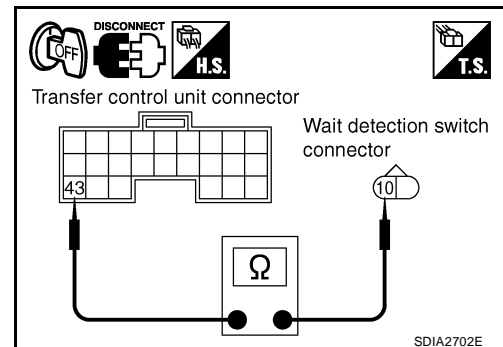

# TROUBLE DIAGNOSIS FOR SYSTEM

## 3. CHECK GROUND CIRCUIT

1. Turn ignition switch "OFF". (Stay for at least 5 seconds.)
2. Disconnect wait detection switch harness connector.
3. Check continuity between wait detection switch harness connector F59 terminal 11 and ground.

**Continuity should exist.**

Also check harness for short to ground and short to power.

OK or NG

OK >> GO TO 4.

NG >> Repair open circuit or short to ground or short to power in harness or connectors.

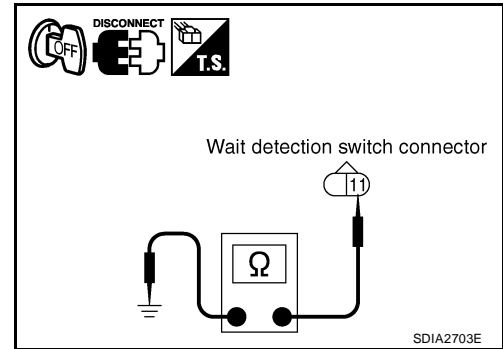

## 4. CHECK WAIT DETECTION SWITCH

1. Turn ignition switch "OFF". (Stay for at least 5 seconds.)
2. Disconnect wait detection switch harness connector.
3. Remove wait detection switch. Refer to [TF-22, "Location of Electrical Parts"](#) .
4. Push and release wait detection switch and check continuity between wait detection switch terminals 10 and 11.

| Terminal | Condition                     | Continuity |
|----------|-------------------------------|------------|
| 10 - 11  | Push wait detection switch    | Yes        |
|          | Release wait detection switch | No         |

OK or NG

OK >> GO TO 5.

NG >> Replace wait detection switch. Refer to [TF-22, "Location of Electrical Parts"](#) .

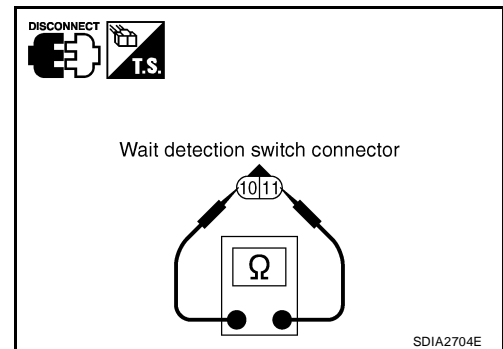

## 5. CHECK TRANSFER CONTROL UNIT

Check transfer control unit input/output signal. Refer to [TF-35, "Transfer Control Unit Input/Output Signal Reference Values"](#) .

OK or NG

OK >> GO TO 6.

NG >> Check transfer control unit pin terminals for damage or loose connection with harness connector. If any items are damaged, repair or replace damaged parts.

## 6. CHECK DTC

Perform the self-diagnosis, after driving a vehicle for a while.

OK or NG

OK >> Inspection End.

NG >> Replace transfer control unit. Refer to [TF-131, "Removal and Installation"](#) .

# TROUBLE DIAGNOSIS FOR SYSTEM

## COMPONENT INSPECTION

1. Turn ignition switch "OFF". (Stay for at least 5 seconds.)
2. Disconnect wait detection switch harness connector.
3. Remove wait detection switch. Refer to [TF-22, "Location of Electrical Parts"](#) .
4. Push and release wait detection switch and check continuity between wait detection switch terminals 10 and 11.

| Terminal | Condition                     | Continuity |
|----------|-------------------------------|------------|
| 10 - 11  | Push wait detection switch    | Yes        |
|          | Release wait detection switch | No         |

5. If NG, replace the wait detection switch. Refer to [TF-22, "Location of Electrical Parts"](#) .

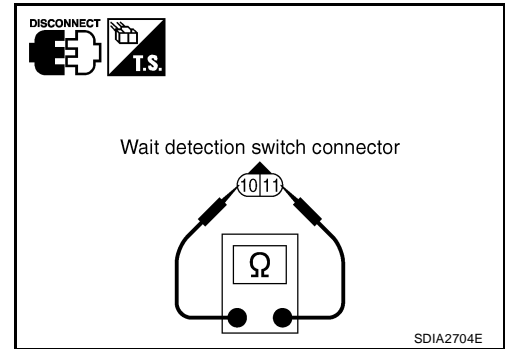

EDS001YR

## PNP Switch Signal (TCM) DIAGNOSTIC PROCEDURE

### 1. CHECK DTC WITH TCM

Perform self-diagnosis with TCM. Refer to [TF-50, "SELF-DIAGNOSTIC PROCEDURE \(WITH CONSULT-II\)"](#) .  
Is any malfunction detected by self-diagnosis?

- YES >> Check the malfunctioning system.  
NO >> GO TO 2.

### 2. CHECK TRANSFER CONTROL UNIT

Check transfer control unit input/output signal. Refer to [TF-35, "Transfer Control Unit Input/Output Signal Reference Values"](#) .

OK or NG

- OK >> GO TO 3.  
NG >> Check transfer control unit pin terminals for damage or loose connection with harness connector.  
If any items are damaged, repair or replace damaged parts.

### 3. CHECK DTC

Perform the self-diagnosis, after driving a vehicle for a while.

OK or NG

- OK >> Inspection End.  
NG >> Perform self-diagnosis with TCM again. Refer to [TF-50, "SELF-DIAGNOSTIC PROCEDURE \(WITH CONSULT-II\)"](#) .

# TROUBLE DIAGNOSIS FOR SYSTEM

## Actuator Motor

EDS001YS

### CONSULT-II REFERENCE VALUE IN DATA MONITOR MODE

Data are reference value.

| Monitored item         | Content  | Condition   | Display value   |     |
|------------------------|--|---|---|-----|
| SHIFT ACT1 [ON/OFF]    | Output condition to actuator motor (High)            | <ul style="list-style-type: none"> <li>● Vehicle stopped</li> <li>● Engine running</li> <li>● A/T selector lever "N" position</li> <li>● Brake pedal depressed</li> </ul> | 4WD shift switch: 4H to 4LO ("Wait" function is operating.) | ON  |
|                        |  |   | Except the above  | OFF |
| SHIFT AC MON1 [ON/OFF] | Check signal for transfer control unit signal output | <ul style="list-style-type: none"> <li>● Vehicle stopped</li> <li>● Engine running</li> <li>● A/T selector lever "N" position</li> <li>● Brake pedal depressed</li> </ul> | 4WD shift switch: 4H to 4LO ("Wait" function is operating.) | ON  |
|                        |  |   | Except the above  | OFF |
| SHIFT ACT2 [ON/OFF]    | Output condition to actuator motor (Low)             | <ul style="list-style-type: none"> <li>● Vehicle stopped</li> <li>● Engine running</li> <li>● A/T selector lever "N" position</li> <li>● Brake pedal depressed</li> </ul> | 4WD shift switch: 4LO to 4H ("Wait" function is operating.) | ON  |
|                        |  |   | Except the above  | OFF |
| SHIFT AC MON2 [ON/OFF] | Check signal for transfer control unit signal output | <ul style="list-style-type: none"> <li>● Vehicle stopped</li> <li>● Engine running</li> <li>● A/T selector lever "N" position</li> <li>● Brake pedal depressed</li> </ul> | 4WD shift switch: 4LO to 4H ("Wait" function is operating.) | ON  |
|                        |  |   | Except the above  | OFF |

### TRANSFER CONTROL UNIT TERMINALS AND REFERENCE VALUE

Data are reference value and are measured between each terminal and ground.

| Terminal | Wire color | Item                              | Condition   | Data (Approx.)  |                 |
|----------|------------|-----------------------------------|---|---|-----------------|
| 4        | Y/L        | Transfer shift high relay         | <ul style="list-style-type: none"> <li>● Vehicle stopped</li> <li>● Engine running</li> <li>● A/T selector lever "N" position</li> <li>● Brake pedal depressed</li> </ul> | 4WD shift switch: 4H to 4LO ("Wait" function is operating.) | Battery voltage |
|          |            |                                   |   | Except the above  | 0V              |
| 13       | G/B        | Transfer shift low relay          | <ul style="list-style-type: none"> <li>● Vehicle stopped</li> <li>● Engine running</li> <li>● A/T selector lever "N" position</li> <li>● Brake pedal depressed</li> </ul> | 4WD shift switch: 4LO to 4H ("Wait" function is operating.) | Battery voltage |
|          |            |                                   |   | Except the above  | 0V              |
| 33       | R/L        | Transfer shift high relay monitor | <ul style="list-style-type: none"> <li>● Vehicle stopped</li> <li>● Engine running</li> <li>● A/T selector lever "N" position</li> <li>● Brake pedal depressed</li> </ul> | 4WD shift switch: 4H to 4LO ("Wait" function is operating.) | Battery voltage |
|          |            |                                   |   | Except the above  | 0V              |
| 42       | P/G        | Transfer shift low relay monitor  | <ul style="list-style-type: none"> <li>● Vehicle stopped</li> <li>● Engine running</li> <li>● A/T selector lever "N" position</li> <li>● Brake pedal depressed</li> </ul> | 4WD shift switch: 4LO to 4H ("Wait" function is operating.) | Battery voltage |
|          |            |                                   |   | Except the above  | 0V              |

**CAUTION:**

When using a circuit tester to measure voltage for inspection, be sure not to extend forcibly any connector terminals.

# TROUBLE DIAGNOSIS FOR SYSTEM

## DIAGNOSTIC PROCEDURE

### 1. CHECK ACTUATOR MOTOR SIGNAL

#### ④ With CONSULT-II

1. Start engine.
2. Select "DATA MONITOR" mode for "ALL MODE AWD/4WD" with CONSULT-II.
3. Read out the value of "SHIFT ACT1", "SHIFT AC MON1", "SHIFT ACT2" and "SHIFT AC MON2".

| Monitored item | Condition  | Display value   |
|----------------|--|---|
| SHIFT ACT1     | <ul style="list-style-type: none"> <li>● Vehicle stopped</li> <li>● Engine running</li> <li>● A/T selector lever "N" position</li> </ul> | 4WD shift switch: 4H to 4LO ("Wait" function is operating.) |
|                | ● Brake pedal depressed  | Except the above  |
| SHIFT AC MON1  | <ul style="list-style-type: none"> <li>● Vehicle stopped</li> <li>● Engine running</li> <li>● A/T selector lever "N" position</li> </ul> | 4WD shift switch: 4H to 4LO ("Wait" function is operating.) |
|                | ● Brake pedal depressed  | Except the above  |
| SHIFT ACT2     | <ul style="list-style-type: none"> <li>● Vehicle stopped</li> <li>● Engine running</li> <li>● A/T selector lever "N" position</li> </ul> | 4WD shift switch: 4LO to 4H ("Wait" function is operating.) |
|                | ● Brake pedal depressed  | Except the above  |
| SHIFT AC MON2  | <ul style="list-style-type: none"> <li>● Vehicle stopped</li> <li>● Engine running</li> <li>● A/T selector lever "N" position</li> </ul> | 4WD shift switch: 4LO to 4H ("Wait" function is operating.) |
|                | ● Brake pedal depressed  | Except the above  |

| DATA MONITOR  |        |
|---------------|--------|
| MONITOR       | NO DTC |
| SHIFT ACT1    | OFF    |
| SHIFT AC MON1 | OFF    |
| SHIFT ACT2    | OFF    |
| SHIFT AC MON2 | OFF    |

PDIA0223E

#### ⊗ Without CONSULT-II

1. Start engine.
2. Check voltage between transfer control unit harness connector terminal and ground.

| Connector | Terminal    | Condition  | Voltage (Approx.)   |
|-----------|-------------|--|---|
| E142      | 4 - Ground  | <ul style="list-style-type: none"> <li>● Vehicle stopped</li> <li>● Engine running</li> <li>● A/T selector lever "N" position</li> </ul> | 4WD shift switch: 4H to 4LO ("Wait" function is operating.) |
|           |             | ● Brake pedal depressed  | Except the above  |
|           | 13 - Ground | <ul style="list-style-type: none"> <li>● Vehicle stopped</li> <li>● Engine running</li> <li>● A/T selector lever "N" position</li> </ul> | 4WD shift switch: 4LO to 4H ("Wait" function is operating.) |
|           |             | ● Brake pedal depressed  | Except the above  |

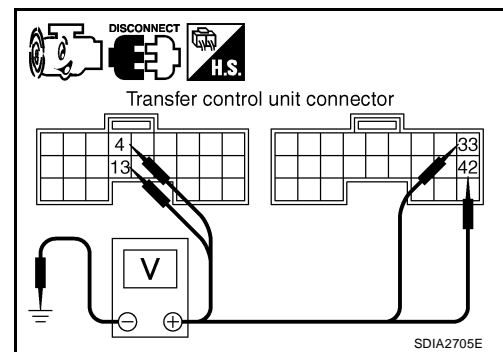

# TROUBLE DIAGNOSIS FOR SYSTEM

| Connector | Terminal    | Condition  |   | Voltage (Approx.) |
|-----------|-------------|--|---|-------------------|
| E143      | 33 - Ground | <ul style="list-style-type: none"> <li>● Vehicle stopped</li> <li>● Engine running</li> <li>● A/T selector lever "N" position</li> </ul> | 4WD shift switch: 4H to 4LO ("Wait" function is operating.) | Battery voltage   |
|           |             |  | Except the above  | 0V                |
|           | 42 - Ground | <ul style="list-style-type: none"> <li>● Vehicle stopped</li> <li>● Engine running</li> <li>● A/T selector lever "N" position</li> </ul> | 4WD shift switch: 4LO to 4H ("Wait" function is operating.) | Battery voltage   |
|           |             |  | Except the above  | 0V                |

**OK or NG**

- OK >> GO TO 7.
- NG >> GO TO 2.

## 2. CHECK ACTUATOR MOTOR POWER SUPPLY CIRCUIT

1. Turn ignition switch "OFF". (Stay for at least 5 seconds.)
2. Remove transfer shift high relay and transfer shift low relay.
3. Check voltage between transfer shift high relay harness connector E46 terminal 5 (A), transfer shift low relay harness connector E47 terminal 5 (B) and ground.

| Connector | Terminal   | Voltage (Approx.) |
|-----------|------------|-------------------|
| A: E46    | 5 - Ground | Battery voltage   |
| B: E47    | 5 - Ground |                   |

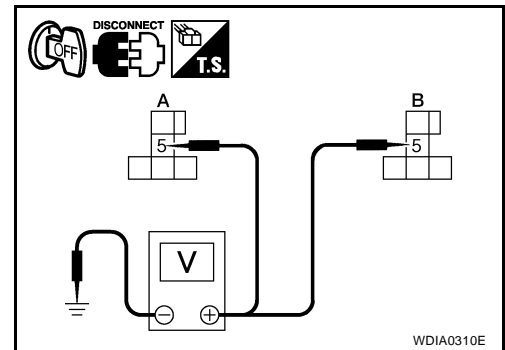

4. Turn ignition switch "ON". (Do not start engine.)
5. Check voltage between transfer shift high relay harness connector E46 terminal 5 (A), transfer shift low relay harness connector E47 terminal 5 (B) and ground.

| Connector | Terminal   | Voltage (Approx.) |
|-----------|------------|-------------------|
| A: E46    | 5 - Ground | Battery voltage   |
| B: E47    | 5 - Ground |                   |

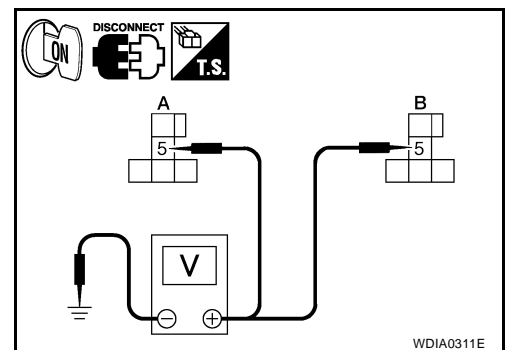

**OK or NG**

- OK >> GO TO 3.
- NG >> Check the following. If any items are damaged, repair or replace damaged parts.
  - 20A fuse (No. 57, located in the fuse and relay box). Refer to [PG-4, "POWER SUPPLY ROUTING CIRCUIT"](#) .
  - Harness for short or open between battery, transfer shift high relay harness connector terminal 5 and transfer shift low relay harness connector terminal 5.



# TROUBLE DIAGNOSIS FOR SYSTEM

## 3. CHECK ACTUATOR MOTOR GROUND CIRCUIT

1. Turn ignition switch "OFF". (Stay for at least 5 seconds.)
2. Remove transfer shift high relay and transfer shift low relay. Refer to [TF-22, "Location of Electrical Parts"](#).
3. Check continuity between transfer shift high relay harness connector E46 terminals 2, 4 (A) and transfer shift low relay harness connector E47 terminals 2, 4 (B) and ground.

**Continuity should exist.**

Also check harness for short to ground and short to power.

OK or NG

OK >> GO TO 4.

NG >> Repair open circuit or short to ground or short to power in harness or connectors.

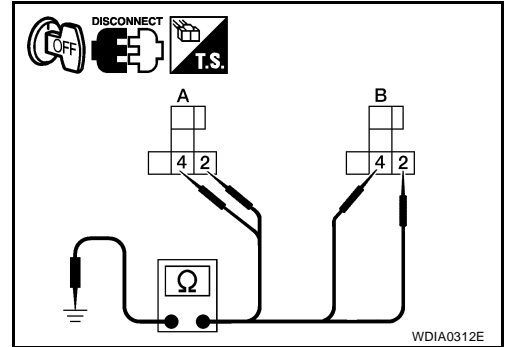

## 4. CHECK TRANSFER SHIFT RELAY

1. Turn ignition switch "OFF".
2. Remove transfer shift high relay and transfer shift low relay. Refer to [TF-22, "Location of Electrical Parts"](#).
3. Apply 12V direct current between transfer shift relay terminals 1 and 2.
4. Check continuity between relay terminals 3 and 4, 3 and 5.

| Terminal | Condition   | Continuity |
|----------|---|------------|
| 3 - 4    | 12V direct current supply between terminals 1 and 2 | No         |
|          | OFF   | Yes        |
| 3 - 5    | 12V direct current supply between terminals 1 and 2 | Yes        |
|          | OFF   | No         |

OK or NG

OK >> GO TO 5.

NG >> Replace the transfer shut off relay. Refer to [TF-22, "Location of Electrical Parts"](#).

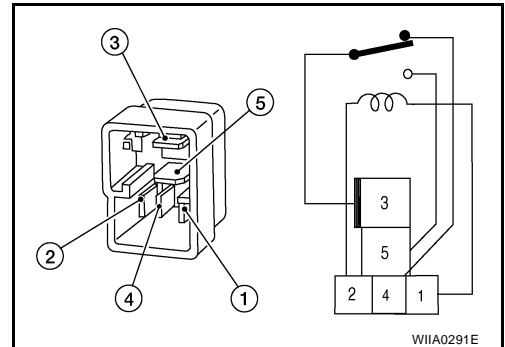

# TROUBLE DIAGNOSIS FOR SYSTEM

## 5. CHECK HARNESS BETWEEN TRANSFER CONTROL UNIT AND TRANSFER SHIFT RELAY

1. Turn ignition switch "OFF". (Stay for at least 5 seconds.)
2. Disconnect transfer control unit harness connector and the transfer control device (actuator motor) harness connector.
3. Remove transfer shift high relay and transfer shift low relay.
4. Check continuity between the following terminals.
  - Transfer control unit harness connector E143 terminal 33 and transfer control device (actuator motor) harness connector F58 terminal 21.
  - Transfer control unit harness connector E143 terminal 42 and transfer control device (actuator motor) harness connector F58 terminal 24.

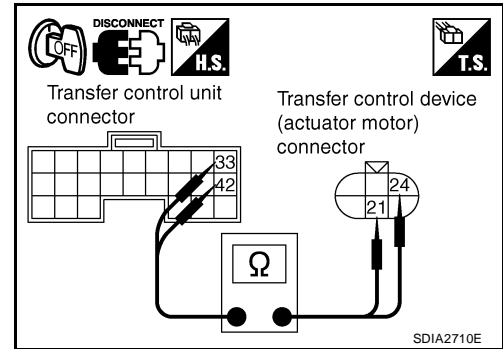

- Transfer control unit harness connector E142 terminal 4 and transfer shift high relay harness connector E46 terminal 1 (A).
- Transfer control unit harness connector E142 terminal 13 and transfer shift low relay harness connector E47 terminal 1 (B).

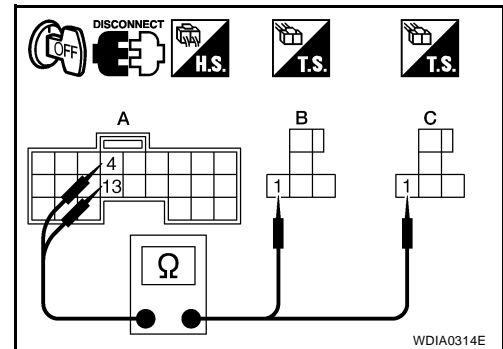

- Transfer control unit harness connector E143 terminal 33 and transfer shift high relay harness connector E46 terminal 3 (A).
- Transfer control unit harness connector E143 terminal 42 and transfer shift low relay harness connector E47 terminal 3 (B).

**Continuity should exist.**

Also check harness for short to ground and short to power.

OK or NG

- OK >> GO TO 6.
- NG >> Repair or replace damaged parts.

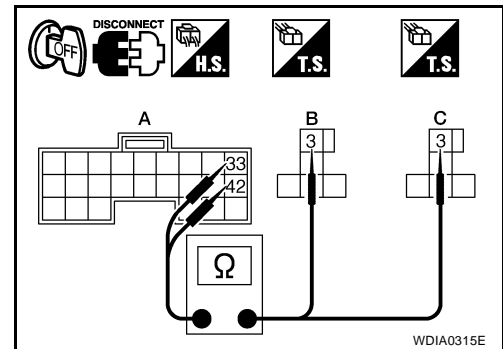

# TROUBLE DIAGNOSIS FOR SYSTEM

## 6. CHECK ACTUATOR MOTOR

1. Remove transfer control device. Refer to [TF-137, "Removal and Installation"](#) .
2. Check operation by applying battery voltage to transfer control device (actuator motor) terminals 21 and 24.

**CAUTION:**

- Do not operate actuator motor for more than 1 second.
- Change the actuator motor position to "HIGH" when installing.
- Be careful not to overheat the harness.

| Terminal                           | Actuator motor            |
|------------------------------------|---------------------------|
| 21 (Battery voltage) - 24 (Ground) | Clockwise rotation        |
| 24 (Battery voltage) - 21 (Ground) | Counterclockwise rotation |

3. Check resistance between transfer control device (actuator motor) terminals 21 and 24.

**21 - 24 : Approx. 0.2 Ω**

OK or NG

- OK >> GO TO 7.
- NG >> Replace transfer control device (actuator motor). Refer to [TF-137, "Removal and Installation"](#) .

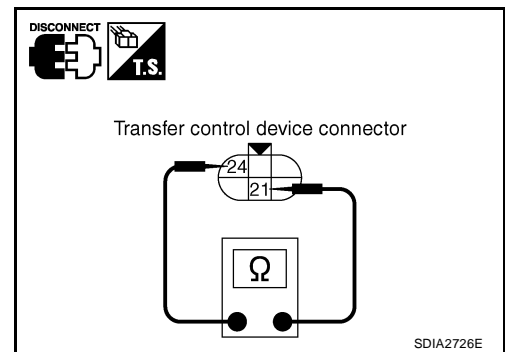
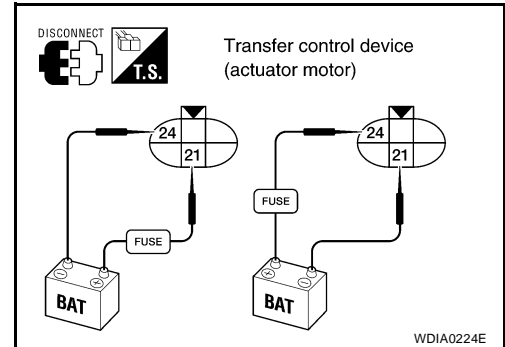

## 7. CHECK TRANSFER CONTROL UNIT

Check transfer control unit input/output signal. Refer to [TF-35, "Transfer Control Unit Input/Output Signal Reference Values"](#) .

OK or NG

- OK >> GO TO 8.
- NG >> Check transfer control unit pin terminals for damage or loose connection with harness connector. If any items are damaged, repair or replace damaged parts.

## 8. CHECK DTC

Perform the self-diagnosis, after driving a vehicle for a while.

OK or NG

- OK >> Inspection End.
- NG >> Replace transfer control unit. Refer to [TF-131, "Removal and Installation"](#) .

# TROUBLE DIAGNOSIS FOR SYSTEM

## COMPONENT INSPECTION

### Transfer Shift Relay

1. Turn ignition switch "OFF". (Stay for at least 5 seconds.)
2. Remove transfer shift high relay and transfer shift low relay. Refer to [TF-22, "Location of Electrical Parts"](#) .
3. Apply 12V direct current between transfer shift relay terminals 1 and 2.
4. Check continuity between relay terminals 3 and 4, 3 and 5.

| Terminal | Condition   | Continuity |
|----------|---|------------|
| 3 - 4    | 12V direct current supply between terminals 1 and 2 | No         |
|          | OFF   | Yes        |
| 3 - 5    | 12V direct current supply between terminals 1 and 2 | Yes        |
|          | OFF   | No         |

5. If NG, replace transfer shift relay.

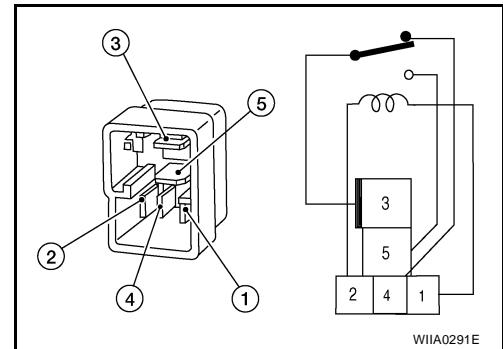

### Transfer Control Device

1. Remove transfer control device. Refer to [TF-137, "Removal and Installation"](#) .
2. Check operation by applying battery voltage to transfer control device (actuator motor) terminals 21 and 24.

**CAUTION:**

- Do not operate actuator motor for more than 1 second.
- Change the actuator motor position to "HIGH" when installing.
- Be careful not to overheat the harness.

| Terminal                           | Actuator motor          |
|------------------------------------|-------------------------|
| 21 (Battery voltage) - 24 (Ground) | Clockwise rotate        |
| 24 (Battery voltage) - 21 (Ground) | Counterclockwise rotate |

3. Check resistance between transfer control device (actuator motor) terminals 21 and 24.

**21 - 24 : Approx. 0.2 Ω**

4. If NG, replace transfer control device (actuator motor). Refer to [TF-137, "Removal and Installation"](#) .

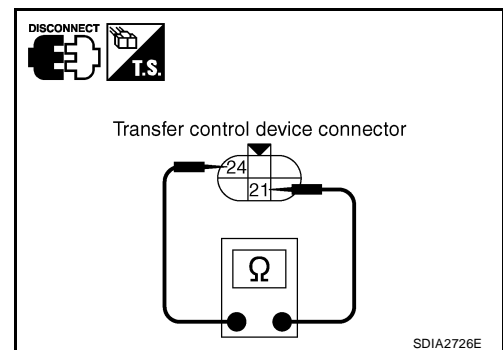
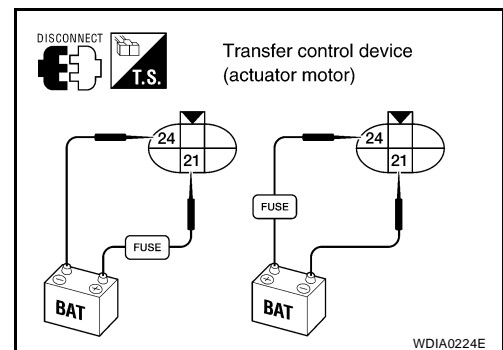

# TROUBLE DIAGNOSIS FOR SYSTEM

## Actuator Position Switch

EDS001YT

### CONSULT-II REFERENCE VALUE IN DATA MONITOR MODE

Data are reference value.

| Monitored item [Unit]  | Content  | Condition   | Display value                            |
|------------------------|--|---|--|
| SHIFT POS SW1 [ON/OFF] | Condition of actuator position switch 1 (Low)  | <ul style="list-style-type: none"> <li>● Vehicle stopped</li> <li>● Engine running</li> <li>● A/T selector lever "N" position</li> <li>● Brake pedal depressed</li> </ul> | 4WD shift switch: 4LO<br>ON              |
|                        |  |   | 4WD shift switch: 2WD, AUTO or 4H<br>OFF |
| SHIFT POS SW2 [ON/OFF] | Condition of actuator position switch 2 (High) | <ul style="list-style-type: none"> <li>● Vehicle stopped</li> <li>● Engine running</li> <li>● A/T selector lever "N" position</li> <li>● Brake pedal depressed</li> </ul> | 4WD shift switch: 4H, AUTO or 2WD<br>ON  |
|                        |  |   | 4WD shift switch: 4LO<br>OFF             |

### TRANSFER CONTROL UNIT TERMINALS AND REFERENCE VALUE

Data are reference value and are measured between each terminal and ground.

| Terminal | Wire color | Item                              | Condition   | Data (Approx.)                                       |
|----------|------------|-----------------------------------|---|--|
| 27       | W/L        | Actuator position switch 2 (High) | <ul style="list-style-type: none"> <li>● Vehicle stopped</li> <li>● Engine running</li> <li>● A/T selector lever "N" position</li> <li>● Brake pedal depressed</li> </ul> | 4WD shift switch: 4H, AUTO or 2WD<br>0V              |
|          |            |                                   |   | 4WD shift switch: 4LO<br>Battery voltage             |
| 44       | LG/B       | Actuator position switch 1 (Low)  | <ul style="list-style-type: none"> <li>● Vehicle stopped</li> <li>● Engine running</li> <li>● A/T selector lever "N" position</li> <li>● Brake pedal depressed</li> </ul> | 4WD shift switch: 4LO<br>0V                          |
|          |            |                                   |   | 4WD shift switch: 2WD, AUTO or 4H<br>Battery voltage |

**CAUTION:**

When using a circuit tester to measure voltage for inspection, be sure not to extend forcibly any connector terminals.

# TROUBLE DIAGNOSIS FOR SYSTEM

## DIAGNOSTIC PROCEDURE

### 1. CHECK ACTUATOR POSITION SWITCH SIGNAL

#### ④ With CONSULT-II

1. Start engine.
2. Select "DATA MONITOR" mode for "ALL MODE AWD/4WD" with CONSULT-II.
3. Read out the value of "SHIFT POS SW1" and "SHIFT POS SW2".

| Monitored item | Condition   | Display value                           |
|----------------|---|---|
| SHIFT POS SW1  | <ul style="list-style-type: none"> <li>● Vehicle stopped</li> <li>● Engine running</li> <li>● A/T selector lever "N" position</li> <li>● Brake pedal depressed</li> </ul> | 4WD shift switch: 4LO<br>ON             |
|                | 4WD shift switch: 2WD, AUTO or 4H   | OFF                                     |
| SHIFT POS SW2  | <ul style="list-style-type: none"> <li>● Vehicle stopped</li> <li>● Engine running</li> <li>● A/T selector lever "N" position</li> <li>● Brake pedal depressed</li> </ul> | 4WD shift switch: 4H, AUTO or 2WD<br>ON |
|                | 4WD shift switch: 4LO   | OFF                                     |

| DATA MONITOR  |        |
|---------------|--------|
| MONITOR       | NO DTC |
| SHIFT POS SW1 | ON     |
| SHIFT POS SW2 | OFF    |

SDIA2714E

#### ⊗ Without CONSULT-II

1. Start engine.
2. Check voltage between transfer control unit harness connector terminal and ground.

| Connector | Terminal    | Condition   | Voltage (Approx.)                       |
|-----------|-------------|---|---|
| E143      | 27 - Ground | <ul style="list-style-type: none"> <li>● Vehicle stopped</li> <li>● Engine running</li> <li>● A/T selector lever "N" position</li> <li>● Brake pedal depressed</li> </ul> | 4WD shift switch: 4H, AUTO or 2WD<br>0V |
|           |             | 4WD shift switch: 4LO   | Battery voltage                         |
|           | 44 - Ground | <ul style="list-style-type: none"> <li>● Vehicle stopped</li> <li>● Engine running</li> <li>● A/T selector lever "N" position</li> <li>● Brake pedal depressed</li> </ul> | 4WD shift switch: 4LO<br>0V             |
|           |             | 4WD shift switch: 2WD, AUTO or 4H   | Battery voltage                         |

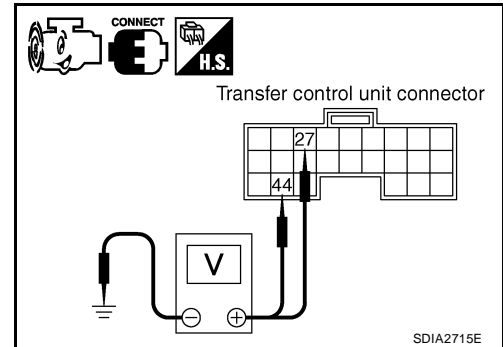

#### OK or NG

- OK    >> GO TO 5.  
 NG    >> GO TO 2.

# TROUBLE DIAGNOSIS FOR SYSTEM

## 2. CHECK HARNESS BETWEEN TRANSFER CONTROL UNIT AND ACTUATOR POSITION SWITCH

1. Turn ignition switch "OFF". (Stay for at least 5 seconds.)
2. Disconnect transfer control unit harness connector and the transfer control device (actuator position switch) harness connector.
3. Check continuity between the following terminals.
  - Transfer control unit harness connector E143 terminal 27 and transfer control device (actuator position switch) harness connector F58 terminal 23.
  - Transfer control unit harness connector E143 terminal 44 and transfer control device (actuator position switch) harness connector F58 terminal 20.

**Continuity should exist.**

Also check harness for short to ground and short to power.

OK or NG

- OK >> GO TO 3.
- NG >> Repair or replace damaged parts.

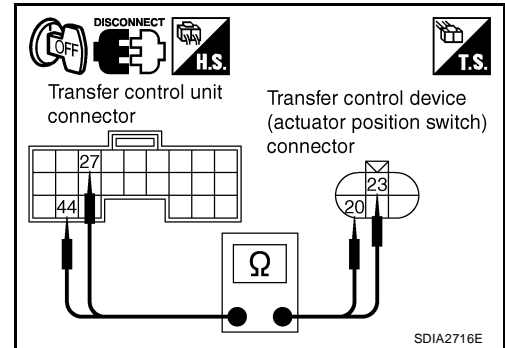

## 3. CHECK GROUND CIRCUIT

1. Turn ignition switch "OFF". (Stay for at least 5 seconds.)
2. Disconnect transfer control device (actuator position switch) harness connector.
3. Check continuity between transfer control device (actuator position switch) harness connector F58 terminal 22 and ground.

**Continuity should exist.**

Also check harness for short to ground and short to power.

OK or NG

- OK >> GO TO 4.
- NG >> Repair open circuit or short to ground or short to power in harness or connectors.

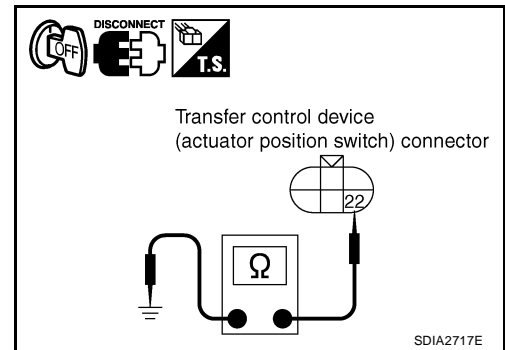

## 4. CHECK ACTUATOR POSITION SWITCH

1. Remove transfer control device. Refer to [TF-137, "Removal and Installation"](#).
2. Check operation by applying battery voltage to transfer control device (actuator motor) terminals 21 and 24.

**CAUTION:**

- Do not operate actuator motor for more than 1 second.
- Change the actuator motor position to "HIGH" when installing.
- Be careful not to overheat the harness.

| Terminal                           | Continuity | Continuity |
|------------------------------------|------------|------------|
| 24 (Battery voltage) - 21 (Ground) | 20 - 22    | Yes        |
|                                    | 22 - 23    | No         |
| 21 (Battery voltage) - 24 (Ground) | 22 - 23    | Yes        |
|                                    | 20 - 22    | No         |

OK or NG

- YES >> GO TO 5.
- NO >> Replace transfer control device (actuator motor). Refer to [TF-137, "Removal and Installation"](#).

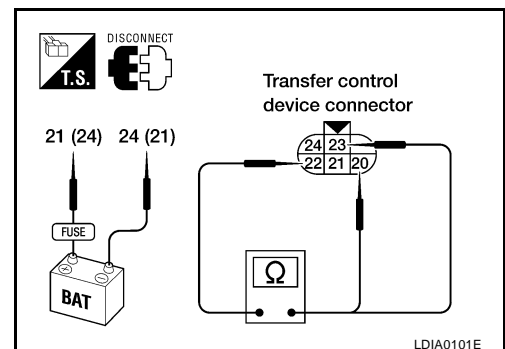

# TROUBLE DIAGNOSIS FOR SYSTEM

## 5. CHECK TRANSFER CONTROL UNIT

Check transfer control unit input/output signal. Refer to [TF-35, "Transfer Control Unit Input/Output Signal Reference Values"](#) .

### OK or NG

OK >> GO TO 6.

NG >> Check transfer control unit pin terminals for damage or loose connection with harness connector.  
If any items are damaged, repair or replace damaged parts.

## 6. CHECK DTC

Perform the self-diagnosis, after driving a vehicle for a while.

### OK or NG

OK >> Inspection End.

NG >> Replace transfer control device. Refer to [TF-137, "Removal and Installation"](#) .

## COMPONENT INSPECTION

1. Remove transfer control device. Refer to [TF-137, "Removal and Installation"](#) .
2. Check operation by applying battery voltage to transfer control device (actuator motor) terminals 21 and 24.

### CAUTION:

- Do not operate actuator motor for more than 1 second.
- Change the actuator motor position to "HIGH" when installing.
- Be careful not to overheat the harness.

| Terminal                              | Continuity | Continuity |
|---------------------------------------|------------|------------|
| 24 (Battery voltage) - 21<br>(Ground) | 20 - 22    | Yes        |
|                                       | 22 - 23    | No         |
| 21 (Battery voltage) - 24<br>(Ground) | 22 - 23    | Yes        |
|                                       | 20 - 22    | No         |

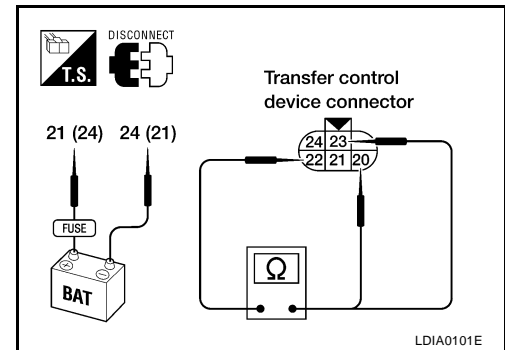

3. If NG, replace transfer control device (actuator motor). Refer to [TF-137, "Removal and Installation"](#) .



# TROUBLE DIAGNOSIS FOR SYSTEM

## Transfer Control Device

EDS001YU

### CONSULT-II REFERENCE VALUE IN DATA MONITOR MODE

Data are reference value.

| Monitored item [Unit]  | Content  | Condition   | Display value   |
|------------------------|--|---|---|
| SHIFT AC MON1 [ON/OFF] | Check signal for transfer control unit signal output | <ul style="list-style-type: none"> <li>● Vehicle stopped</li> <li>● Engine running</li> <li>● A/T selector lever "N" position</li> <li>● Brake pedal depressed</li> </ul> | 4WD shift switch: 4H to 4LO ("Wait" function is operating.) |
|                        |  |   | Except the above  |
| SHIFT AC MON2 [ON/OFF] | Check signal for transfer control unit signal output | <ul style="list-style-type: none"> <li>● Vehicle stopped</li> <li>● Engine running</li> <li>● A/T selector lever "N" position</li> <li>● Brake pedal depressed</li> </ul> | 4WD shift switch: 4LO to 4H ("Wait" function is operating.) |
|                        |  |   | Except the above  |

### TRANSFER CONTROL UNIT TERMINALS AND REFERENCE VALUE

Data are reference value and are measured between each terminal and ground.

| Terminal | Wire color | Item                              | Condition   | Data (Approx.)  |
|----------|------------|-----------------------------------|---|---|
| 16       | Y/R        | Power supply                      | Ignition switch: ON   | Battery voltage   |
|          |            |                                   | Ignition switch: OFF  | 0V  |
| 22       | Y/R        | Power supply                      | Ignition switch: ON   | Battery voltage   |
|          |            |                                   | Ignition switch: OFF  | 0V  |
| 30       | SB         | Shut off relay                    | Ignition switch: ON   | 0V  |
|          |            |                                   | Ignition switch: OFF  | Battery voltage   |
| 33       | R/L        | Transfer shift high relay monitor | <ul style="list-style-type: none"> <li>● Vehicle stopped</li> <li>● Engine running</li> <li>● A/T selector lever "N" position</li> <li>● Brake pedal depressed</li> </ul> | 4WD shift switch: 4H to 4LO ("Wait" function is operating.) |
|          |            |                                   |   | Except the above  |
| 42       | P/G        | Transfer shift low relay monitor  | <ul style="list-style-type: none"> <li>● Vehicle stopped</li> <li>● Engine running</li> <li>● A/T selector lever "N" position</li> <li>● Brake pedal depressed</li> </ul> | 4WD shift switch: 4LO to 4H ("Wait" function is operating.) |
|          |            |                                   |   | Except the above  |

**CAUTION:**

When using a circuit tester to measure voltage for inspection, be sure not to extend forcibly any connector terminals.

# TROUBLE DIAGNOSIS FOR SYSTEM

## DIAGNOSTIC PROCEDURE

### 1. CHECK POWER SUPPLY

1. Turn ignition switch "OFF". (Stay for at least 5 seconds.)
2. Connect transfer control unit harness connector.
3. Check voltage between transfer control unit harness connector terminal and ground.

| Connector | Terminal    | Voltage (Approx.) |
|-----------|-------------|-------------------|
| E142      | 16 - Ground | 0V                |
|           | 22 - Ground |                   |
| E143      | 30 - Ground | Battery voltage   |

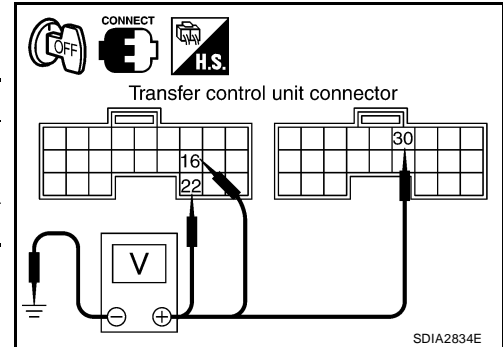

4. Turn ignition switch "ON". (Do not start engine.)
5. Check voltage between transfer control unit harness connector terminals and ground.

| Connector | Terminal    | Voltage (Approx.) |
|-----------|-------------|-------------------|
| E142      | 16 - Ground | Battery voltage   |
|           | 22 - Ground |                   |
| E143      | 30 - Ground | 0V                |

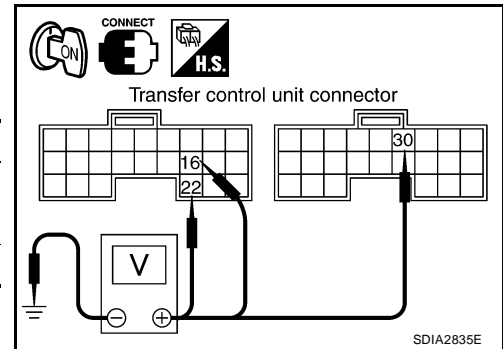

**OK or NG**

OK >> GO TO 2.

NG >> Check the following. If any items are damaged, repair or replace damaged parts.

- 10A fuse (No. 26 located in the fuse and fusible link box). Refer to [PG-4, "POWER SUPPLY ROUTING CIRCUIT"](#).
- Harness for short or open between battery and transfer shut off relay harness connector E69 terminal 1.
- Harness for short or open between transfer shut off relay harness connector E69 terminal 2 and transfer control unit harness connector E143 terminal 30.
- Harness for short or open between battery and transfer shut off relay harness connector E69 terminal 3.
- Harness for short or open between transfer shut off relay harness connector E69 terminal 5 and transfer control unit harness connector E142 terminal 22.
- Transfer shut off relay. Refer to [TF-57, "COMPONENT INSPECTION"](#).

# TROUBLE DIAGNOSIS FOR SYSTEM

## 2. CHECK GROUND CIRCUIT

1. Turn ignition switch "OFF". (Stay for at least 5 seconds.)
2. Disconnect transfer control unit harness connector.
3. Check continuity between transfer control unit harness connector E142 terminals 3, 6, E143 terminal 45 and ground.

**Continuity should exist.**

Also check harness for short to ground and short to power.

**OK or NG**

OK >> GO TO 3.

NG >> Repair open circuit or short to ground or short to power in harness or connectors.

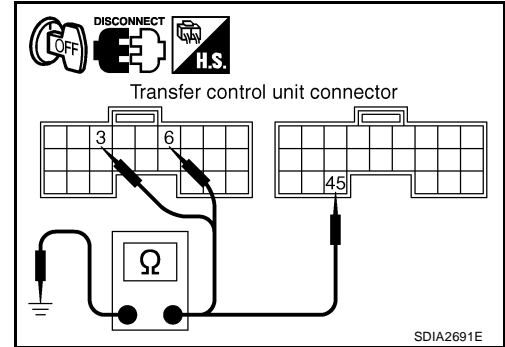

## 3. CHECK ACTUATOR MOTOR POWER SUPPLY CIRCUIT

1. Turn ignition switch "OFF". (Stay for at least 5 seconds.)
2. Remove transfer shift high relay and transfer shift low relay. Refer to [TF-22, "Location of Electrical Parts"](#).
3. Check voltage between transfer shift high relay harness connector E46 terminal 5 (A), transfer shift low relay harness connector E47 terminal 5 (B) and ground.

| Connector | Terminal   | Voltage (Approx.) |
|-----------|------------|-------------------|
| A: E46    | 5 - Ground | Battery voltage   |
| B: E47    | 5 - Ground |                   |

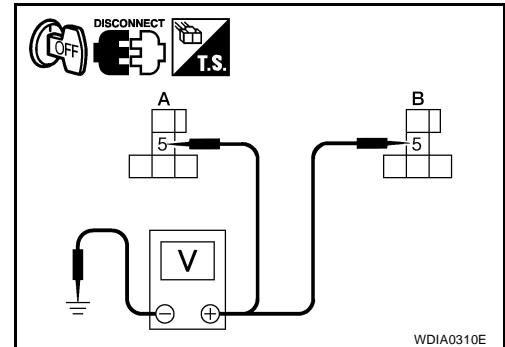

4. Turn ignition switch "ON". (Do not start engine.)
5. Check voltage between transfer shift high relay harness connector E46 terminal 5 (A), transfer shift low relay harness connector E47 terminal 5 (B) and ground.

| Connector | Terminal   | Voltage (Approx.) |
|-----------|------------|-------------------|
| A: E46    | 5 - Ground | Battery voltage   |
| B: E47    | 5 - Ground |                   |

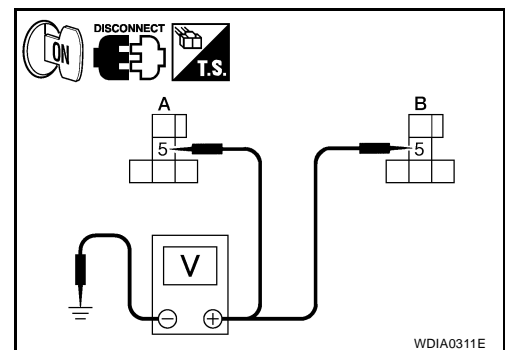

**OK or NG**

OK >> GO TO 4.

NG >> Check the following. If any items are damaged, repair or replace damaged parts.

- 20A fuse (No. 57 located in the fuse and relay box). Refer to [PG-4, "POWER SUPPLY ROUTING CIRCUIT"](#).
- Harness for short or open between battery, transfer shift high relay harness connector E46 terminal 5 and transfer shift low relay harness connector E47 terminal 5.

# TROUBLE DIAGNOSIS FOR SYSTEM

## 4. CHECK HARNESS BETWEEN TRANSFER CONTROL UNIT AND TRANSFER SHIFT RELAY

1. Turn ignition switch "OFF". (Stay for at least 5 seconds.)
2. Disconnect transfer control unit harness connector and transfer control device (actuator motor) harness connector.
3. Remove transfer shift high relay and transfer shift low relay. Refer to [TF-22, "Location of Electrical Parts"](#) .
4. Check continuity between the following terminals.
  - Transfer control unit harness connector E143 terminal 33 and transfer shift high relay harness connector E46 terminal 3.
  - Transfer control unit harness connector E143 terminal 42 and transfer shift low relay harness connector E47 terminal 3.

**Continuity should exist.**

Also check harness for short to ground and short to power.

OK or NG

- OK >> GO TO 5.
- NG >> Repair or replace damaged parts.

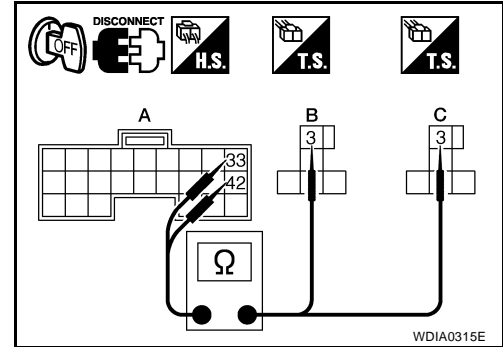

## 5. CHECK TRANSFER SHIFT RELAY GROUND CIRCUIT

1. Turn ignition switch "OFF". (Stay for at least 5 seconds.)
2. Remove transfer shift high relay and transfer shift low relay.
3. Check continuity between transfer shift high relay harness connector E46 terminals 2, 4, transfer shift low relay harness connector E47 terminals 2, 4 and ground.

**Continuity should exist.**

Also check harness for short to ground and short to power.

OK or NG

- OK >> GO TO 6.
- NG >> Repair open circuit or short to ground or short to power in harness or connectors.

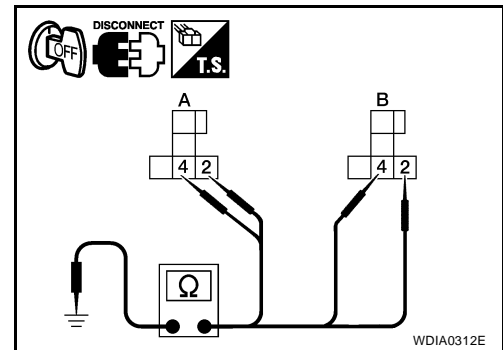

## 6. CHECK TRANSFER CONTROL UNIT

Check transfer control unit input/output signal. Refer to [TF-35, "Transfer Control Unit Input/Output Signal Reference Values"](#) .

OK or NG

- OK-1 >> With CONSULT-II: GO TO 7.
- OK-2 >> Without CONSULT-II: GO TO 8.
- NG >> Check transfer control unit pin terminals for damage or loose connection with harness connector. If any items are damaged, repair or replace damaged parts.

## 7. PERFORM SELF-DIAGNOSIS (WITH CONSULT-II)

**With CONSULT-II**

1. Turn ignition switch "ON". (Do not start engine.)
2. Select "SELF-DIAG RESULTS" mode for "ALL MODE AWD/4WD" with CONSULT-II.
3. Touch "ERASE".
4. Turn ignition switch "OFF" and wait at least 10 seconds.
5. Perform the self-diagnosis again.

Is the "SHIFT ACT CIR [P1819]" displayed?

- YES >> Replace transfer control unit. Refer to [TF-131, "Removal and Installation"](#) .
- NO >> Inspection End.

# TROUBLE DIAGNOSIS FOR SYSTEM

## 8. PERFORM SELF-DIAGNOSIS (WITHOUT CONSULT-II)

### ⊗ Without CONSULT-II

1. Perform the self-diagnosis and then erase self-diagnostic results. Refer to [TF-50, "SELF-DIAGNOSTIC PROCEDURE \(WITHOUT CONSULT-II\)"](#) and [TF-53, "ERASE SELF-DIAGNOSIS"](#) .

2. Perform the self-diagnosis again.

Do the self-diagnostic results indicate transfer control device?

- YES >> Replace transfer control unit. Refer to [TF-131, "Removal and Installation"](#) .  
 NO >> Inspection End.

### Engine Speed Signal (ECM) DIAGNOSTIC PROCEDURE

EDS001YV

#### 1. CHECK DTC WITH ECM

Perform self-diagnosis with ECM. Refer to [EC-116, "SELF-DIAG RESULTS MODE"](#) .

Is any malfunction detected by self-diagnosis?

- YES >> Check the malfunctioning system.  
 NO >> GO TO 2.

#### 2. CHECK TRANSFER CONTROL UNIT

Check transfer control unit input/output signal. Refer to [TF-35, "Transfer Control Unit Input/Output Signal Reference Values"](#) .

OK or NG

- OK >> GO TO 3.  
 NG >> Check transfer control unit pin terminals for damage or loose connection with harness connector. If any items are damaged, repair or replace damaged parts.

#### 3. CHECK DTC

Perform the self-diagnosis, after driving a vehicle for a while.

OK or NG

- OK >> Inspection End.  
 NG >> Perform self-diagnosis with ECM again. Refer to [EC-116, "SELF-DIAG RESULTS MODE"](#) .

### Clutch Pressure Solenoid CONSULT-II REFERENCE VALUE IN DATA MONITOR MODE

EDS001YW

Data are reference value.

| Monitored item    | Content                               | Condition   | Display value                     |
|-------------------|---------------------------------------|---|-----------------------------------|
| DUTY SOLENOID [%] | Condition of clutch pressure solenoid | <ul style="list-style-type: none"> <li>● Vehicle stopped</li> <li>● Engine running</li> <li>● A/T selector lever "N" position</li> <li>● Brake pedal depressed</li> </ul> | 4WD shift switch: 2WD<br>4%       |
|                   |                                       |   | 4WD shift switch: AUTO<br>96 - 4% |
|                   |                                       |   | 4WD shift switch: 4H or 4LO<br>4% |

#### TRANSFER CONTROL UNIT TERMINALS AND REFERENCE VALUE

Data are reference value and are measured between each terminal and ground.

| Terminal | Wire color | Item                       | Condition   | Data (Approx.)                                   |
|----------|------------|----------------------------|---|--|
| 10       | L/W        | Transfer dropping resistor | <ul style="list-style-type: none"> <li>● Vehicle stopped</li> <li>● Engine running</li> <li>● A/T selector lever "N" position</li> <li>● Brake pedal depressed</li> </ul> | 4WD shift switch: AUTO<br>4 - 14V                |
|          |            |                            |   | 4WD shift switch: 2WD, 4H or 4LO<br>Less than 1V |

# TROUBLE DIAGNOSIS FOR SYSTEM

| Terminal | Wire color | Item                           | Condition  | Data (Approx.)                   |              |
|----------|------------|--------------------------------|--|----------------------------------|--------------|
| 19       | L          | Clutch pressure solenoid valve | <ul style="list-style-type: none"> <li>● Vehicle stopped</li> <li>● Engine running</li> </ul>                        | 4WD shift switch: AUTO           | 1.5 - 3V     |
|          |            |                                | <ul style="list-style-type: none"> <li>● A/T selector lever "N" position</li> <li>● Brake pedal depressed</li> </ul> | 4WD shift switch: 2WD, 4H or 4LO | Less than 1V |

**CAUTION:**

When using a circuit tester to measure voltage for inspection, be sure not to extend forcibly any connector terminals.

## DIAGNOSTIC PROCEDURE

### 1. CHECK CLUTCH PRESSURE SIGNAL

**With CONSULT-II**

1. Start engine.
2. Select "DATA MONITOR" mode for "ALL MODE AWD/4WD" with CONSULT-II.
3. Read out the value of "DUTY SOLENOID".

| Condition  | Display value                     |
|--|-----------------------------------|
| <ul style="list-style-type: none"> <li>● Vehicle stopped</li> </ul>  | 4WD shift switch: 2WD<br>4%       |
| <ul style="list-style-type: none"> <li>● Engine running</li> </ul>   | 4WD shift switch: AUTO<br>96 - 4% |
| <ul style="list-style-type: none"> <li>● A/T selector lever "N" position</li> <li>● Brake pedal depressed</li> </ul> | 4WD shift switch: 4H or 4LO<br>4% |

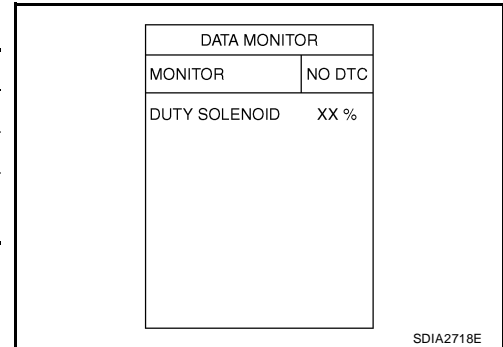

**Without CONSULT-II**

1. Start engine.
2. Check voltage between transfer control unit harness connector terminal and ground.

| Connector | Terminal    | Condition  | Voltage (Approx.)                                |
|-----------|-------------|--|--|
| E142      | 10 - Ground | <ul style="list-style-type: none"> <li>● Vehicle stopped</li> </ul>  | 4WD shift switch: AUTO<br>4 - 14V                |
|           |             | <ul style="list-style-type: none"> <li>● Engine running</li> <li>● A/T selector lever "N" position</li> <li>● Brake pedal depressed</li> </ul> | 4WD shift switch: 2WD, 4H or 4LO<br>Less than 1V |
|           | 19 - Ground | <ul style="list-style-type: none"> <li>● Vehicle stopped</li> <li>● Engine running</li> </ul>  | 4WD shift switch: AUTO<br>1.5 - 3V               |
|           |             | <ul style="list-style-type: none"> <li>● A/T selector lever "N" position</li> <li>● Brake pedal depressed</li> </ul>                           | 4WD shift switch: 2WD, 4H or 4LO<br>Less than 1V |

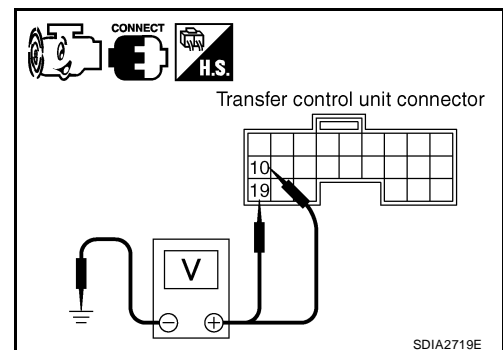

**OK or NG**

- OK >> GO TO 7.  
NG >> GO TO 2.

# TROUBLE DIAGNOSIS FOR SYSTEM

## 2. CHECK HARNESS BETWEEN TRANSFER CONTROL UNIT AND CLUTCH PRESSURE SOLENOID VALVE

1. Turn ignition switch "OFF". (Stay for at least 5 seconds.)
2. Disconnect transfer control unit harness connector, transfer terminal cord assembly harness connector and transfer dropping resistor.
3. Check continuity between transfer control unit harness connector E142 terminal 19 and transfer terminal cord assembly harness connector F56 terminal 6.

**Continuity should exist.**

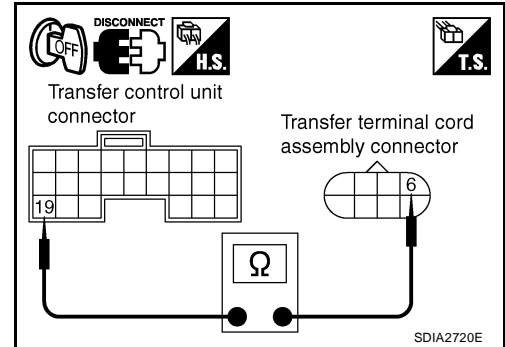

4. Check continuity between transfer dropping resistor harness connector E135 terminal 2 and transfer terminal cord assembly harness connector F56 terminal 6.

**Continuity should exist.**

Also check harness for short to ground and short to power.

OK or NG

- OK >> GO TO 3.
- NG >> Repair or replace damaged parts.

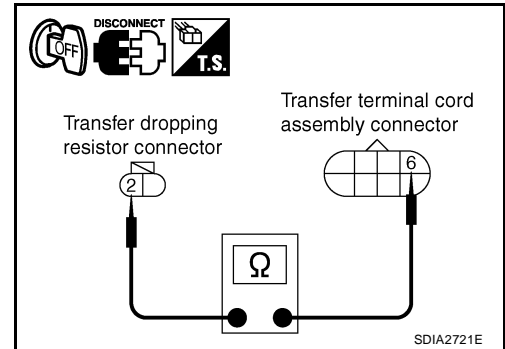

## 3. CHECK HARNESS BETWEEN TRANSFER CONTROL UNIT AND TRANSFER DROPPING RESISTOR

1. Turn ignition switch "OFF". (Stay for at least 5 seconds.)
2. Disconnect transfer control unit harness connector and transfer dropping resistor harness connector.
3. Check continuity between transfer control unit harness connector E142 terminal 10 and transfer dropping resistor harness connector E135 terminal 1.

**Continuity should exist.**

Also check harness for short to ground and short to power.

OK or NG

- OK >> GO TO 4.
- NG >> Repair or replace damaged parts.

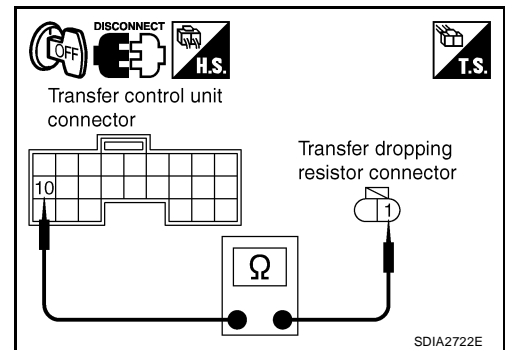

# TROUBLE DIAGNOSIS FOR SYSTEM

## 4. CHECK GROUND CIRCUIT

1. Turn ignition switch "OFF". (Stay for at least 5 seconds.)
2. Disconnect transfer terminal cord assembly harness connector.
3. Check continuity between transfer terminal cord assembly harness connector F56 terminal 19 and ground.

**Continuity should exist.**

Also check harness for short to ground and short to power.

OK or NG

OK >> GO TO 5.

NG >> Repair open circuit or short to ground or short to power in harness or connectors.

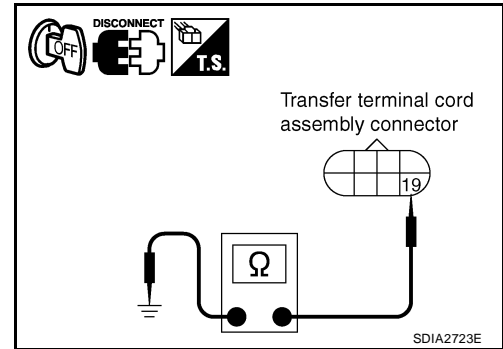

## 5. CHECK CLUTCH PRESSURE SOLENOID

1. Turn ignition switch "OFF". (Stay for at least 5 seconds.)
2. Disconnect transfer terminal cord assembly harness connector.
3. Check resistance between transfer terminal cord assembly harness connector F56 terminals 6 and 19.

**6 - 19 : Approx. 3.0 - 3.4  $\Omega$**

OK or NG

OK >> GO TO 6.

NG >> Replace clutch pressure solenoid. Refer to [TF-22](#), "[Location of Electrical Parts](#)".

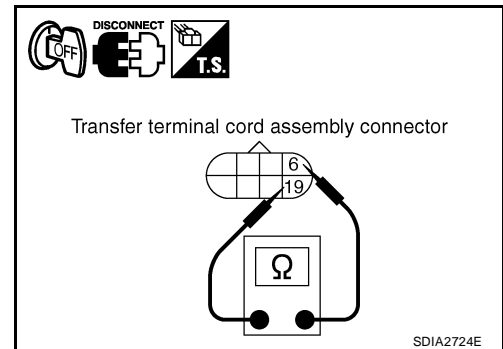

## 6. CHECK TRANSFER DROPPING RESISTOR

1. Turn ignition switch "OFF". (Stay for at least 5 seconds.)
2. Disconnect transfer dropping resistor harness connector.
3. Check resistance between transfer dropping resistor terminals 1 and 2.

**1 - 2 : Approx. 11.2 - 12.8  $\Omega$**

OK or NG

OK >> GO TO 7.

NG >> Replace transfer dropping resistor.

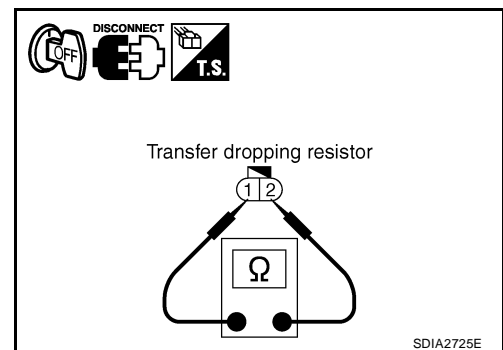

## 7. CHECK TRANSFER CONTROL UNIT

Check transfer control unit input/output signal. Refer to [TF-35](#), "[Transfer Control Unit Input/Output Signal Reference Values](#)".

OK or NG

OK >> GO TO 8.

NG >> Check transfer control unit pin terminals for damage or loose connection with harness connector. If any items are damaged, repair or replace damaged parts.



# TROUBLE DIAGNOSIS FOR SYSTEM

## 8. CHECK DTC

Perform the self-diagnosis, after driving a vehicle for a while.

OK or NG

OK >> Inspection End.

NG >> Replace transfer control unit. Refer to [TF-131, "Removal and Installation"](#).

### COMPONENT INSPECTION

#### Clutch Pressure Solenoid

1. Turn ignition switch "OFF". (Stay for at least 5 seconds.)
2. Disconnect transfer terminal cord assembly harness connector.
3. Check resistance between transfer terminal cord assembly terminals 6 and 19.

**6 - 19 : Approx. 3.0 - 3.4  $\Omega$**

4. If NG, replace clutch pressure solenoid. Refer to [TF-22, "Location of Electrical Parts"](#).

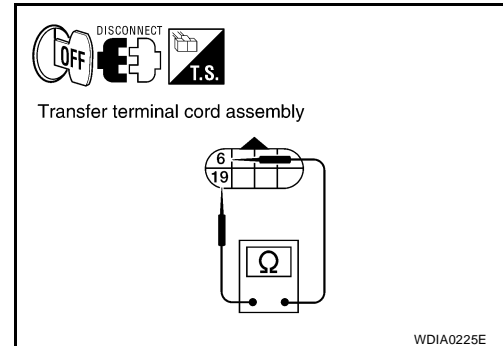

#### Transfer Dropping Resistor

1. Turn ignition switch "OFF". (Stay for at least 5 seconds.)
2. Disconnect transfer dropping resistor harness connector.
3. Check resistance between transfer dropping resistor terminals 1 and 2.

**1 - 2 : Approx. 11.2 - 12.8  $\Omega$**

4. If NG, replace transfer dropping resistor. Refer to [TF-22, "Location of Electrical Parts"](#).

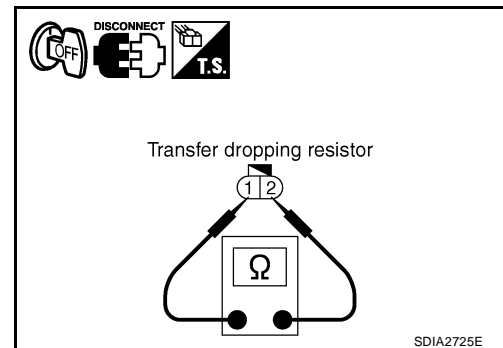

# TROUBLE DIAGNOSIS FOR SYSTEM

EDS001YX

## 2-4WD Solenoid

### CONSULT-II REFERENCE VALUE IN DATA MONITOR MODE

Data are reference value.

| Monitored item         | Content  | Condition  | Display value |
|------------------------|--|--|---------------|
| 2-4WD SOL [ON/OFF]     | Condition of 2-4WD shift solenoid valve              | 4WD shift switch: 2WD                                  | OFF           |
|                        |  | 4WD shift switch: AUTO                                 | ON            |
|                        |  | 4WD shift switch: 4H                                   |               |
|                        |  | 4WD shift switch: 4LO                                  |               |
|                        |  | 4WD shift switch: AUTO ("Wait" function is operating.) | OFF           |
|                        |  | 4WD shift switch: 4H ("Wait" function is operating.)   | OFF           |
| 2-4WD SOL MON [ON/OFF] | Check signal for transfer control unit signal output | 4WD shift switch: 2WD                                  | OFF           |
|                        |  | 4WD shift switch: AUTO                                 | ON            |
|                        |  | 4WD shift switch: 4H                                   |               |
|                        |  | 4WD shift switch: 4LO                                  |               |
|                        |  | 4WD shift switch: AUTO ("Wait" function is operating.) | OFF           |
|                        |  | 4WD shift switch: 4H ("Wait" function is operating.)   | OFF           |

### TRANSFER CONTROL UNIT TERMINALS AND REFERENCE VALUE

Data are reference value and are measured between each terminal and ground.

| Terminal | Wire color | Item                       | Condition  | Data (Approx.)  |
|----------|------------|----------------------------|--|-----------------|
| 1        | GR         | 2-4WD shift solenoid valve | <ul style="list-style-type: none"> <li>● Vehicle stopped</li> <li>● Engine running</li> </ul> 4WD shift switch: 2WD                                    | 0V              |
|          |            |                            | <ul style="list-style-type: none"> <li>● A/T selector lever "N" position</li> <li>● Brake pedal depressed</li> </ul> 4WD shift switch: AUTO, 4H or 4LO | Battery voltage |

**CAUTION:**

When using a circuit tester to measure voltage for inspection, be sure not to extend forcibly any connector terminals.

### DIAGNOSTIC PROCEDURE

#### 1. CHECK 4WD SHIFT SWITCH SYSTEM

Perform self-diagnosis. Refer to [TF-50, "Self-diagnostic Procedure"](#).

Is the "4WD MOD SW [P1814]" (with CONSULT-II) or "Flickering pattern: 16 (without CONSULT-II) detected?"

- YES >> Perform trouble diagnosis for 4WD shift switch. Refer to [TF-62, "4WD Shift Switch"](#).
- NO >> GO TO 2.

# TROUBLE DIAGNOSIS FOR SYSTEM

## 2. CHECK 2-4WD SHIFT SOLENOID SIGNAL

### With CONSULT-II

1. Start engine.
2. Select "DATA MONITOR" mode for "ALL MODE AWD/4WD" with CONSULT-II.
3. Read out the value of "2-4WD SOL" and "2-4WD SOL MON".

| Monitored item | Condition  | Display value  |     |
|----------------|--|--|-----|
| 2-4WD SOL      | 4WD shift switch: 2WD  | OFF  |     |
|                | <ul style="list-style-type: none"> <li>● Vehicle stopped</li> <li>● Engine running</li> <li>● A/T selector lever "N" position</li> </ul> | 4WD shift switch: AUTO                                 | ON  |
|                |  | 4WD shift switch: 4H                                   |     |
|                |  | 4WD shift switch: 4LO                                  |     |
|                | <ul style="list-style-type: none"> <li>● Brake pedal depressed</li> </ul>  | 4WD shift switch: AUTO ("Wait" function is operating.) | OFF |
|                |  | 4WD shift switch: 4H ("Wait" function is operating.)   | OFF |
| 2-4WD SOL MON  | 4WD shift switch: 2WD  | OFF  |     |
|                | <ul style="list-style-type: none"> <li>● Vehicle stopped</li> <li>● Engine running</li> <li>● A/T selector lever "N" position</li> </ul> | 4WD shift switch: AUTO                                 | ON  |
|                |  | 4WD shift switch: 4H                                   |     |
|                |  | 4WD shift switch: 4LO                                  |     |
|                | <ul style="list-style-type: none"> <li>● Brake pedal depressed</li> </ul>  | 4WD shift switch: AUTO ("Wait" function is operating.) | OFF |
|                |  | 4WD shift switch: 4H ("Wait" function is operating.)   | OFF |

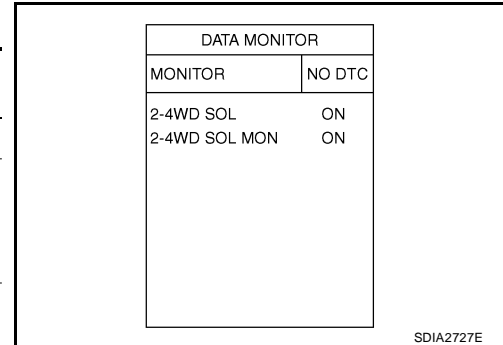

### Without CONSULT-II

1. Start engine.
2. Check voltage between transfer control unit harness connector terminal and ground.

| Connector | Terminal   | Condition  | Voltage (Approx.)                 |                 |
|-----------|------------|--|-----------------------------------|-----------------|
| E142      | 1 - Ground | <ul style="list-style-type: none"> <li>● Vehicle stopped</li> <li>● Engine running</li> </ul>                        | 4WD shift switch: 2WD             | 0V              |
|           |            | <ul style="list-style-type: none"> <li>● A/T selector lever "N" position</li> <li>● Brake pedal depressed</li> </ul> | 4WD shift switch: AUTO, 4H or 4LO | Battery voltage |

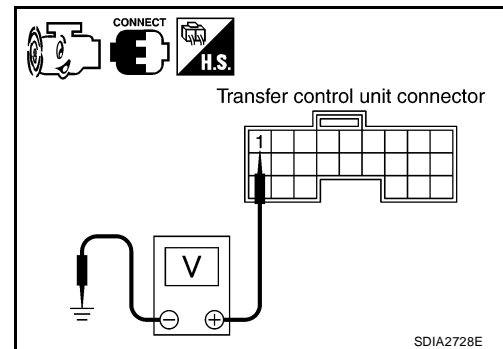

### OK or NG

- OK >> GO TO 7.  
 NG >> GO TO 3.

# TROUBLE DIAGNOSIS FOR SYSTEM

## 3. CHECK 4WD SHIFT SWITCH SIGNAL

1. Turn ignition switch "ON". (Do not start engine.)
2. Check voltage between transfer control unit harness connector terminals and ground.

| Connector | Terminal   | Condition                         | Voltage (Approx.) |
|-----------|------------|-----------------------------------|-------------------|
| M141      | 4 - ground | 4WD shift switch: AUTO, 4H or 4LO | Battery voltage   |
|           |            | 4WD shift switch: 2WD             | 0V                |

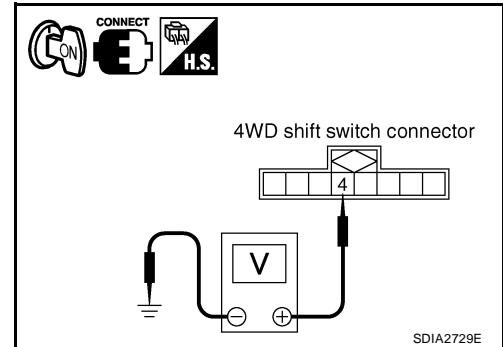

OK or NG

OK >> GO TO 4.

NG >> Check 4WD shift switch. Refer to [TF-66, "COMPONENT INSPECTION"](#).

## 4. CHECK HARNESS BETWEEN 4WD SHIFT SWITCH AND TRANSFER TERMINAL CORD ASSEMBLY

1. Turn ignition switch "OFF". (Stay for at least 5 seconds.)
2. Disconnect 4WD shift switch harness connector and transfer terminal cord assembly harness connector.
3. Check continuity between 4WD shift switch harness connector M141 terminal 4 and transfer terminal cord assembly harness connector F56 terminal 5.

**Continuity should exist.**

Also check harness for short to ground and short to power.

OK or NG

OK >> GO TO 5.

NG >> Repair or replace damaged parts.

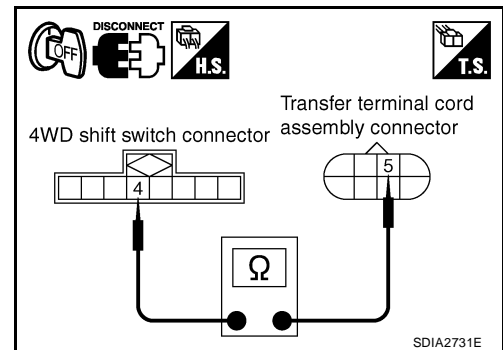

## 5. CHECK HARNESS BETWEEN TRANSFER CONTROL UNIT AND TRANSFER TERMINAL CORD ASSEMBLY

1. Turn ignition switch "OFF". (Stay for at least 5 seconds.)
2. Disconnect transfer control unit harness connector and transfer terminal cord assembly harness connector.
3. Check continuity between transfer control unit harness connector E142 terminal 1 and transfer terminal cord assembly harness connector F56 terminal 4.

**Continuity should exist.**

Also check harness for short to ground and short to power.

OK or NG

OK >> GO TO 6.

NG >> Repair or replace damaged parts.

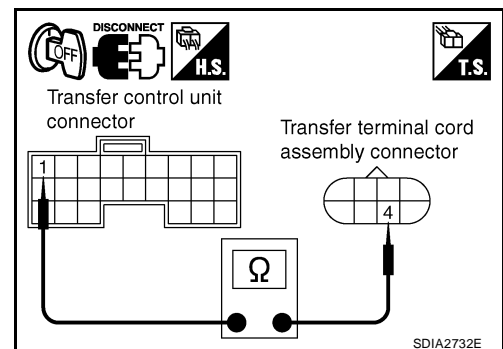

# TROUBLE DIAGNOSIS FOR SYSTEM

## 6. CHECK 2-4WD SOLENOID

1. Turn ignition switch "OFF". (Stay for at least 5 seconds.)
2. Disconnect transfer terminal cord assembly harness connector.
3. Check resistance between transfer terminal cord assembly terminals 4 and 5.

**4 - 5 : Approx. 22.8 - 25.2  $\Omega$**

OK or NG

OK >> GO TO 7.

NG >> Replace 2-4WD solenoid. Refer to [TF-22, "Location of Electrical Parts"](#).

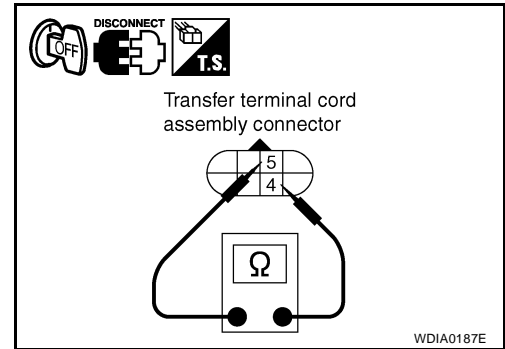

## 7. CHECK TRANSFER CONTROL UNIT

Check transfer control unit input/output signal. Refer to [TF-35, "Transfer Control Unit Input/Output Signal Reference Values"](#).

OK or NG

OK >> GO TO 8.

NG >> Check transfer control unit pin terminals for damage or loose connection with harness connector. If any items are damaged, repair or replace damaged parts.

## 8. CHECK DTC

Perform the self-diagnosis, after driving a vehicle for a while.

OK or NG

OK >> Inspection End.

NG >> Replace transfer control unit. Refer to [TF-131, "Removal and Installation"](#).

## COMPONENT INSPECTION

1. Turn ignition switch "OFF". (Stay for at least 5 seconds.)
2. Disconnect transfer terminal cord assembly harness connector.
3. Check resistance between transfer terminal cord assembly terminals 4 and 5.

**4 - 5 : Approx. 22.8 - 25.2  $\Omega$**

4. If NG, replace the 2-4WD solenoid. Refer to [TF-22, "Location of Electrical Parts"](#).

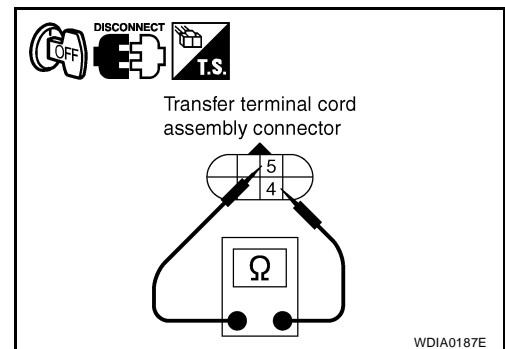

# TROUBLE DIAGNOSIS FOR SYSTEM

EDS001YY

## Transfer Motor

### CONSULT-II REFERENCE VALUE IN DATA MONITOR MODE

Data are reference value.

| Monitored item           | Content  | Condition   | Display value   |   |
|--------------------------|--|---|---|---|
| MOTOR RELAY [ON/OFF]     | Condition of transfer motor relay                    | <ul style="list-style-type: none"> <li>● Accelerator pedal depressed</li> <li>● Vehicle stopped</li> <li>● Engine running</li> <li>● Brake pedal depressed</li> </ul> | 4WD shift switch: 2WD   | OFF   |
|                          |  |   | 4WD shift switch: AUTO or 4LO (A/T selector lever "P" or "N" position)            | OFF<br>("ON" for approx. 2 sec. after shifting to "P" and "N".) |
|                          |  |   | 4WD shift switch: AUTO or 4LO (Except for A/T selector lever "P" or "N" position) | ON  |
|                          |  |   | 4WD shift switch: 4H (A/T selector lever "P" position)                            | OFF<br>("ON" for approx. 2 sec. after shifting to "P".)         |
|                          |  |   | 4WD shift switch: 4H (Except for A/T selector lever "P" position)                 | ON  |
| MOTOR RELAY MON [ON/OFF] | Check signal for transfer control unit signal output | <ul style="list-style-type: none"> <li>● Accelerator pedal depressed</li> <li>● Vehicle stopped</li> <li>● Engine running</li> <li>● Brake pedal depressed</li> </ul> | 4WD shift switch: 2WD   | OFF   |
|                          |  |   | 4WD shift switch: AUTO or 4LO (A/T selector lever "P" or "N" position)            | OFF<br>("ON" for approx. 2 sec. after shifting to "P" and "N".) |
|                          |  |   | 4WD shift switch: AUTO or 4LO (Except for A/T selector lever "P" or "N" position) | ON  |
|                          |  |   | 4WD shift switch: 4H (A/T selector lever "P" position)                            | OFF<br>("ON" for approx. 2 sec. after shifting to "P".)         |
|                          |  |   | 4WD shift switch: 4H (Except for A/T selector lever "P" position)                 | ON  |

# TROUBLE DIAGNOSIS FOR SYSTEM

## TRANSFER CONTROL UNIT TERMINALS AND REFERENCE VALUE

Data are reference value and are measured between each terminal and ground.

| Terminal | Wire color | Item                         | Condition   | Data (Approx.)  |  |
|----------|------------|------------------------------|---|---|--|
| 14       | LG         | Transfer motor relay         | <ul style="list-style-type: none"> <li>● Accelerator pedal depressed</li> <li>● Vehicle stopped</li> <li>● Engine running</li> <li>● Brake pedal depressed</li> </ul> | 4WD shift switch: 2WD   | Battery voltage  |
|          |            |                              |   | 4WD shift switch: AUTO or 4LO (A/T selector lever "P" or "N" position)            | Battery voltage (0V for approx. 2 sec. after shifting to "P" and "N".) |
|          |            |                              |   | 4WD shift switch: AUTO or 4LO (Except for A/T selector lever "P" or "N" position) | 0V   |
|          |            |                              |   | 4WD shift switch: 4H (A/T selector lever "P" position)                            | Battery voltage (0V for approx. 2 sec. after shifting to "P".)         |
|          |            |                              |   | 4WD shift switch: 4H (Except for A/T selector lever "P" position)                 | 0V   |
| 41       | R          | Transfer motor relay monitor | <ul style="list-style-type: none"> <li>● Accelerator pedal depressed</li> <li>● Vehicle stopped</li> <li>● Engine running</li> <li>● Brake pedal depressed</li> </ul> | 4WD shift switch: 2WD   | 0V   |
|          |            |                              |   | 4WD shift switch: AUTO or 4LO (A/T selector lever "P" or "N" position)            | 0V (Battery voltage for approx. 2 sec. after shifting to "P" and "N".) |
|          |            |                              |   | 4WD shift switch: AUTO or 4LO (Except for A/T selector lever "P" or "N" position) | Battery voltage  |
|          |            |                              |   | 4WD shift switch: 4H (A/T selector lever "P" position)                            | 0V (Battery voltage for approx. 2 sec. after shifting to "P".)         |
|          |            |                              |   | 4WD shift switch: 4H (Except for A/T selector lever "P" position)                 | Battery voltage  |

**CAUTION:**

When using a circuit tester to measure voltage for inspection, be sure not to extend forcibly any connector terminals.

A  
B  
C  
TF  
E  
F  
G  
H  
I  
J  
K  
L  
M

# TROUBLE DIAGNOSIS FOR SYSTEM

## DIAGNOSTIC PROCEDURE

### 1. CHECK TRANSFER MOTOR RELAY SIGNAL

**④ With CONSULT-II**

1. Start engine.
2. Select "DATA MONITOR" mode for "ALL MODE AWD/4WD" with CONSULT-II.
3. Read out the value of "MOTOR RELAY" and "MOTOR RELAY MON".

| DATA MONITOR    |        |
|-----------------|--------|
| MONITOR         | NO DTC |
| MOTOR RELAY     | ON     |
| MOTOR RELAY MON | ON     |
|                 |        |

SDIA2734E

| Monitored item  |   | Condition   | Display value (Approx.)                                      |
|-----------------|---|---|--|
| MOTOR RELAY     | <ul style="list-style-type: none"> <li>● Accelerator pedal depressed</li> <li>● Vehicle stopped</li> <li>● Engine running</li> <li>● Brake pedal depressed</li> </ul> | 4WD shift switch: 2WD   | OFF  |
|                 |   | 4WD shift switch: AUTO or 4LO (A/T selector lever "P" or "N" position)            | OFF ("ON" for approx. 2 sec. after shifting to "P" and "N".) |
|                 |   | 4WD shift switch: AUTO or 4LO (Except for A/T selector lever "P" or "N" position) | ON   |
|                 |   | 4WD shift switch: 4H (A/T selector lever "P" position)                            | OFF ("ON" for approx. 2 sec. after shifting to "P".)         |
|                 |   | 4WD shift switch: 4H (Except for A/T selector lever "P" position)                 | ON   |
| MOTOR RELAY MON | <ul style="list-style-type: none"> <li>● Accelerator pedal depressed</li> <li>● Vehicle stopped</li> <li>● Engine running</li> <li>● Brake pedal depressed</li> </ul> | 4WD shift switch: 2WD   | OFF  |
|                 |   | 4WD shift switch: AUTO or 4LO (A/T selector lever "P" or "N" position)            | OFF ("ON" for approx. 2 sec. after shifting to "P" and "N".) |
|                 |   | 4WD shift switch: AUTO or 4LO (Except for A/T selector lever "P" or "N" position) | ON   |
|                 |   | 4WD shift switch: 4H (A/T selector lever "P" position)                            | OFF ("ON" for approx. 2 sec. after shifting to "P".)         |
|                 |   | 4WD shift switch: 4H (Except for A/T selector lever "P" position)                 | ON   |

**⊗ Without CONSULT-II**

1. Start engine.



# TROUBLE DIAGNOSIS FOR SYSTEM

2. Check voltage between transfer control unit harness connector terminal and ground.

| Connector | Terminal    | Condition   | Voltage (Approx.)  |
|-----------|-------------|---|--|
| E142      | 14 - Ground | 4WD shift switch: 2WD   | Battery voltage  |
|           |             | 4WD shift switch: AUTO or 4LO (A/T selector lever "P" or "N" position)            | Battery voltage (0V for approx. 2 sec. after shifting to "P" and "N".) |
|           |             | 4WD shift switch: AUTO or 4LO (Except for A/T selector lever "P" or "N" position) | 0V   |
|           |             | 4WD shift switch: 4H (A/T selector lever "P" position)                            | Battery voltage (0V for approx. 2 sec. after shifting to "P".)         |
|           |             | 4WD shift switch: 4H (Except for A/T selector lever "P" position)                 | 0V   |
| E143      | 41 - Ground | 4WD shift switch: 2WD   | 0V   |
|           |             | 4WD shift switch: AUTO or 4LO (A/T selector lever "P" or "N" position)            | 0V (Battery voltage for approx. 2 sec. after shifting to "P" and "N".) |
|           |             | 4WD shift switch: AUTO or 4LO (Except for A/T selector lever "P" or "N" position) | Battery voltage  |
|           |             | 4WD shift switch: 4H (A/T selector lever "P" position)                            | 0V (Battery voltage for approx. 2 sec. after shifting to "P".)         |
|           |             | 4WD shift switch: 4H (Except for A/T selector lever "P" position)                 | Battery voltage  |

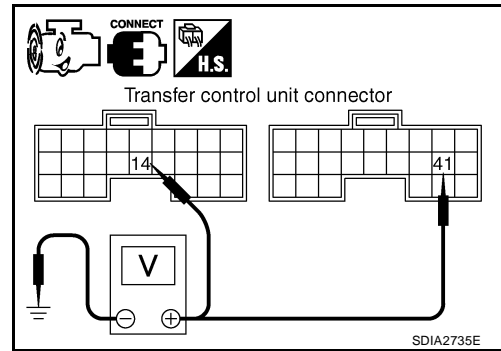

**OK or NG**

- OK >> GO TO 7.
- NG >> GO TO 2.

A  
B  
C  
TF  
E  
F  
G  
H  
I  
J  
K  
L  
M

# TROUBLE DIAGNOSIS FOR SYSTEM

## 2. CHECK TRANSFER MOTOR RELAY POWER SUPPLY CIRCUIT

1. Turn ignition switch "OFF". (Stay for at least 5 seconds.)
2. Connect transfer control unit harness connector.
3. Disconnect transfer motor relay.
4. Check voltage between transfer motor relay harness connector terminals and ground.

| Connector | Terminal   | Voltage (Approx.) |
|-----------|------------|-------------------|
| E153      | 2 - Ground | 0V                |
| E154      | 5 - Ground | Battery voltage   |

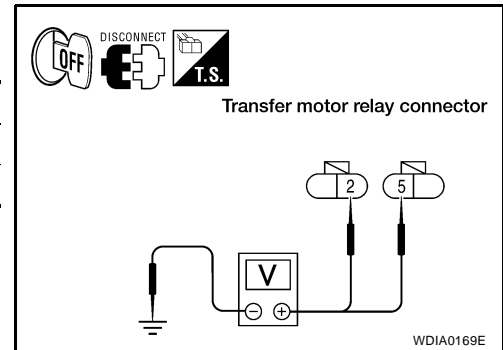

5. Turn ignition switch "ON". (Do not start engine.)
6. Check voltage between transfer motor relay harness connector terminals and ground.

| Connector | Terminal   | Voltage (Approx.) |
|-----------|------------|-------------------|
| E153      | 2 - Ground | Battery voltage   |
| E154      | 5 - Ground |                   |

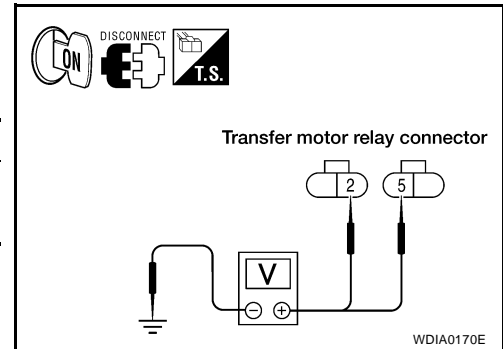

### OK or NG

OK >> GO TO 3.

NG >> Check the following. If any items are damaged, repair or replace damaged parts.

- 20A fuse (No. 58 located in the fuse and relay box). Refer to [PG-4, "POWER SUPPLY ROUTING CIRCUIT"](#) .
- 10A fuse (No. 26 located in the fuse and fusible link box). Refer to [PG-4, "POWER SUPPLY ROUTING CIRCUIT"](#) .
- Harness for short or open between battery and transfer motor relay harness connector E154 terminal 5.
- Harness for short or open between transfer shut off relay harness connector E69 terminal 5 and transfer motor relay harness connector E153 terminal 2.
- Battery and ignition switch. Refer to [PG-4, "POWER SUPPLY ROUTING CIRCUIT"](#) .

## 3. CHECK TRANSFER MOTOR RELAY

1. Turn ignition switch "OFF".
2. Remove transfer motor relay. Refer to [TF-22, "Location of Electrical Parts"](#) .
3. Apply 12V direct current between transfer motor relay terminals 1 and 2.
4. Check continuity between relay terminals 3 and 5.

| Condition   | Continuity |
|---|------------|
| 12V direct current supply between terminals 1 and 2 | Yes        |
| OFF   | No         |

### OK or NG

OK >> GO TO 4.

NG >> Replace the transfer motor relay.

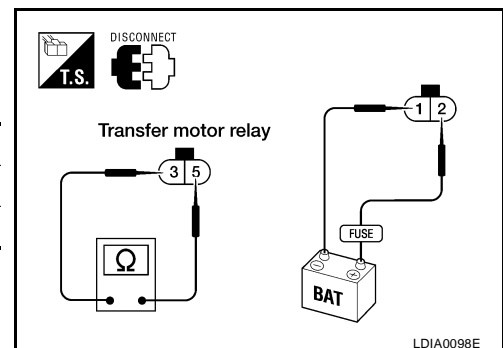

# TROUBLE DIAGNOSIS FOR SYSTEM

## 4. CHECK TRANSFER MOTOR CONTROL CIRCUIT

1. Turn ignition switch "OFF". (Stay for at least 5 seconds.)
2. Remove transfer motor relay. Refer to [.TF-22, "Location of Electrical Parts"](#) .
3. Disconnect transfer control unit harness connector and transfer motor.
4. Check continuity between the following terminals.
  - Transfer control unit harness connector E142 terminal 14 and transfer motor relay harness connector E153 terminal 1.

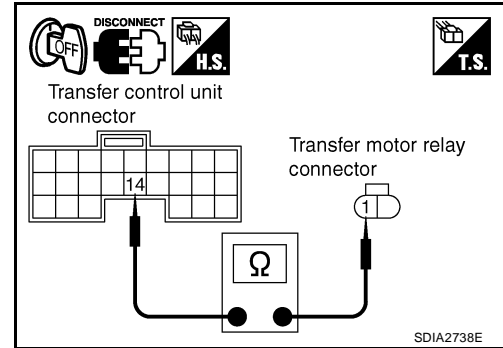

- Transfer control unit harness connector E142 terminal 41 and transfer motor relay harness connector E154 terminal 3.
- Transfer control unit harness connector E142 terminal 41 and transfer motor harness connector F57 terminal 14.

**Continuity should exist.**

Also check harness for short to ground and short to power.

OK or NG

- OK >> GO TO 5.
- NG >> Repair or replace damaged parts.

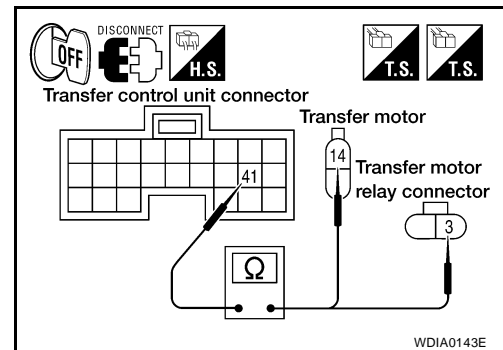

## 5. CHECK TRANSFER MOTOR GROUND CIRCUIT

1. Turn ignition switch "OFF". (Stay for at least 5 seconds.)
2. Disconnect transfer motor harness connector.
3. Check continuity between transfer motor harness connector F57 terminal 15 and ground.

**Continuity should exist.**

Also check harness for short to ground and short to power.

OK or NG

- OK >> GO TO 6.
- NG >> Repair open circuit or short to ground or short to power in harness or connectors.

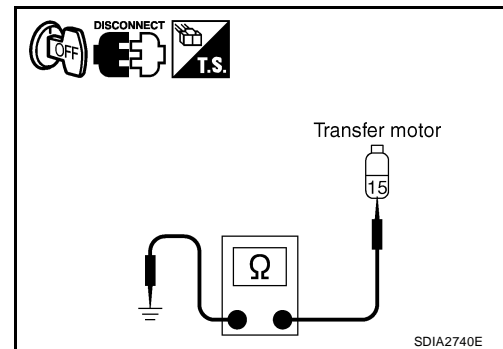

# TROUBLE DIAGNOSIS FOR SYSTEM

## 6. CHECK TRANSFER MOTOR

1. Turn ignition switch "OFF". (Stay for at least 5 seconds.)
2. Disconnect transfer motor harness connector.
3. Apply 12V direct current between transfer motor terminals 14 and 15.

Does transfer motor operate?

YES >> GO TO 7.

NO >> Replace transfer motor. Refer to [TF-141, "Removal and Installation"](#).

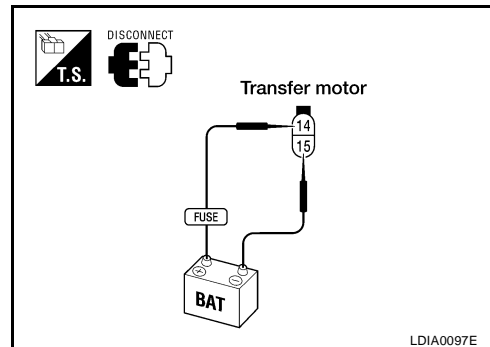

## 7. CHECK TRANSFER CONTROL UNIT

Check transfer control unit input/output signal. Refer to [TF-35, "Transfer Control Unit Input/Output Signal Reference Values"](#).

OK or NG

OK >> GO TO 8.

NG >> Check transfer control unit pin terminals for damage or loose connection with harness connector. If any items are damaged, repair or replace damaged parts.

## 8. CHECK DTC

Perform the self-diagnosis, after driving a vehicle for a while.

OK or NG

OK >> Inspection End.

NG >> Replace transfer control unit. Refer to [TF-131, "Removal and Installation"](#).

# TROUBLE DIAGNOSIS FOR SYSTEM

## COMPONENT INSPECTION

### Transfer Motor Relay

1. Turn ignition switch "OFF". (Stay for at least 5 seconds.)
2. Remove transfer motor relay. Refer to [TF-22, "Location of Electrical Parts"](#) .
3. Apply 12V direct current between transfer motor relay terminals 1 and 2.
4. Check continuity between relay terminals 3 and 5.

| Condition   | Continuity |
|---|------------|
| 12V direct current supply between terminals 1 and 2 | Yes        |
| OFF   | No         |

5. If NG, replace transfer motor relay [TF-22, "Location of Electrical Parts"](#) .

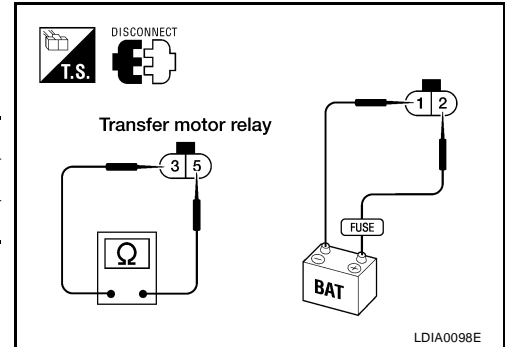

### Transfer Motor

1. Turn ignition switch "OFF". (Stay for at least 5 seconds.)
2. Remove transfer motor. Refer to [TF-141, "TRANSFER MOTOR"](#) .
3. Apply 12V direct current between transfer motor terminals 14 and 15.
4. If transfer motor does not operate, replace transfer motor.

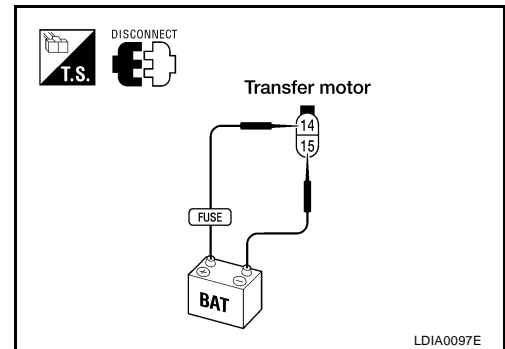

### Transfer Fluid Temperature

#### CONSULT-II REFERENCE VALUE IN DATA MONITOR MODE

Data are reference value.

| Monitored item [Unit] | Content                                 | Condition   | Display value (Approx.) |
|-----------------------|---|---|-------------------------|
| FLUID TEMP SE [V]     | Condition of transfer fluid temperature | Transfer fluid temperature approx. 20 - 80°C (68 - 176°F) | 1.1 - 0.3V              |

EDS001YZ

#### TRANSFER CONTROL UNIT TERMINALS AND REFERENCE VALUE

Data are reference value and are measured between each terminal and ground.

| Terminal | Wire color | Item                              | Condition           | Data (Approx.)                                  |      |
|----------|------------|-----------------------------------|---------------------|---|------|
| 28       | B/G        | Sensor ground                     | Always              | 0V  |      |
| 31       | G          | Transfer fluid temperature sensor | Ignition switch: ON | Transfer fluid temperature approx. 20°C (68°F)  | 1.1V |
|          |            |                                   |                     | Transfer fluid temperature approx. 80°C (176°F) | 0.3V |

**CAUTION:**

When using a circuit tester to measure voltage for inspection, be sure not to extend forcibly any connector terminals.

# TROUBLE DIAGNOSIS FOR SYSTEM

## DIAGNOSTIC PROCEDURE

### 1. CHECK TRANSFER FLUID TEMPERATURE SENSOR SIGNAL

#### Ⓜ With CONSULT-II

1. Start engine.
2. Select "DATA MONITOR" mode for "ALL MODE AWD/4WD" with CONSULT-II.
3. Read out the value of "FLUID TEMP SE".

| Condition   | Display value<br>(Approx.) |
|---|----------------------------|
| Transfer fluid temperature approx. 20 - 80°C (68 - 176°F) | 1.1 - 0.3V                 |

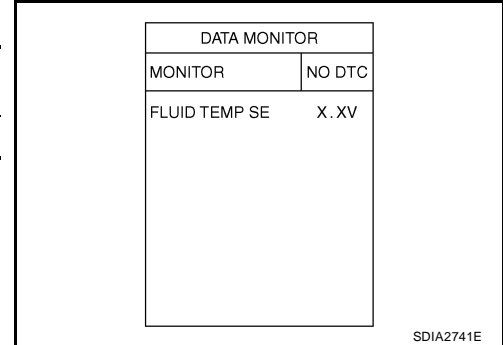

#### ⊗ Without CONSULT-II

1. Start engine.
2. Check voltage between transfer control unit harness connector terminals and ground.

| Connector | Terminal       | Condition              | Data<br>(Approx.)                                  |      |
|-----------|----------------|------------------------|--|------|
| E143      | 28 -<br>Ground | Always                 | 0V   |      |
|           | 31 -<br>Ground | Ignition switch:<br>ON | Transfer fluid temperature<br>approx. 20°C (68°F)  | 1.1V |
|           |                |                        | Transfer fluid temperature<br>approx. 80°C (176°F) | 0.3V |

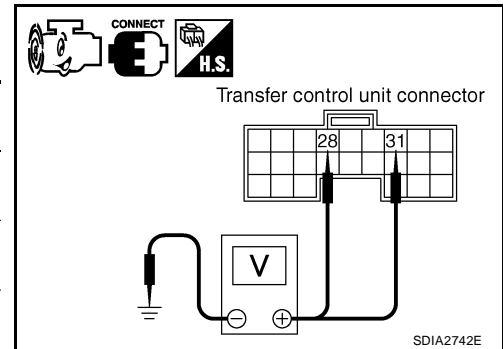

#### OK or NG

- OK >> GO TO 4.
- NG >> GO TO 2.

### 2. CHECK HARNESS BETWEEN TRANSFER CONTROL UNIT AND TRANSFER TERMINAL CORD ASSEMBLY

1. Turn ignition switch "OFF". (Stay for at least 5 seconds.)
2. Disconnect transfer control unit harness connector and transfer terminal cord assembly harness connector.
3. Check continuity between the following terminals.
  - Transfer control unit harness connector E143 terminal 28 and transfer terminal cord assembly harness connector F56 terminal 3.
  - Transfer control unit harness connector E143 terminal 31 and transfer terminal cord assembly harness connector F56 terminal 2.

**Continuity should exist.**

Also check harness for short to ground and short to power.

#### OK or NG

- OK >> GO TO 3.
- NG >> Repair or replace damaged parts.

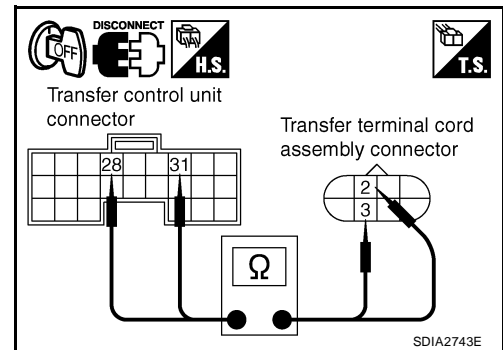

# TROUBLE DIAGNOSIS FOR SYSTEM

## 3. CHECK TRANSFER FLUID TEMPERATURE SENSOR

1. Turn ignition switch "OFF". (Stay for at least 5 seconds.)
2. Disconnect transfer terminal cord assembly harness connector.
3. Check resistance between transfer terminal cord assembly terminals 2 and 3.

| Temperature °C (°F) | Resistance (Approx.) |
|---------------------|----------------------|
| 20 (68)             | 2.5 kΩ               |
| 80 (176)            | 0.3 kΩ               |

### OK or NG

- OK >> GO TO 4.
- NG >> Replace transfer fluid temperature sensor. Refer to [TF-22, "Location of Electrical Parts"](#).

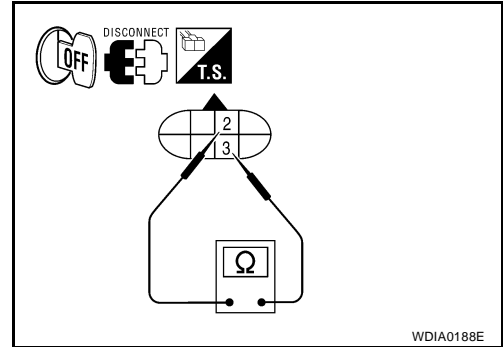

## 4. CHECK TRANSFER CONTROL UNIT

Check transfer control unit input/output signal. Refer to [TF-35, "Transfer Control Unit Input/Output Signal Reference Values"](#).

### OK or NG

- OK >> GO TO 5.
- NG >> Check transfer control unit pin terminals for damage or loose connection with harness connector. If any items are damaged, repair or replace damaged parts.

## 5. CHECK DTC

Perform the self-diagnosis, after driving a vehicle for a while.

### OK or NG

- OK >> Inspection End.
- NG >> Replace transfer control unit. Refer to [TF-131, "Removal and Installation"](#).

## COMPONENT INSPECTION

1. Turn ignition switch "OFF". (Stay for at least 5 seconds.)
2. Disconnect transfer terminal cord assembly harness connector.
3. Check resistance between transfer terminal cord assembly terminals 2 and 3.

| Temperature °C (°F) | Resistance (Approx.) |
|---------------------|----------------------|
| 20 (68)             | 2.5 kΩ               |
| 80 (176)            | 0.3 kΩ               |

4. If NG, replace the transfer fluid temperature sensor. Refer to [TF-22, "Location of Electrical Parts"](#).

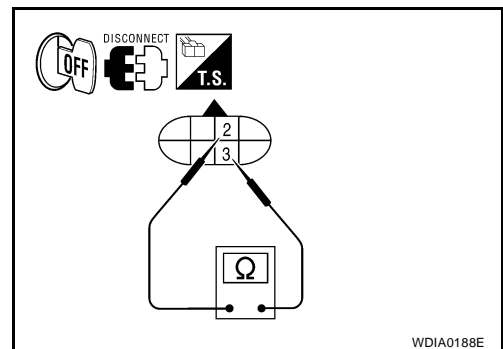

# TROUBLE DIAGNOSIS FOR SYSTEM

EDS001Z0

## Clutch Pressure Switch

### CONSULT-II REFERENCE VALUE IN DATA MONITOR MODE

Data are reference value.

| Monitored item [Unit] | Content                             | Condition  | Display value |
|-----------------------|-------------------------------------|--|---------------|
| CL PRES SW [ON / OFF] | Condition of clutch pressure switch | <ul style="list-style-type: none"> <li>● Vehicle stopped</li> <li>● Engine running</li> <li>● A/T selector lever "D" position</li> <li>● 4WD shift switch: AUTO or 4H ("Wait" function is not operating.)</li> </ul> | ON            |
|                       |                                     | <ul style="list-style-type: none"> <li>● Vehicle stopped</li> <li>● Engine running</li> <li>● 4WD shift switch: 2WD ("Wait" function is not operating.)</li> </ul>   | OFF           |

### TRANSFER CONTROL UNIT TERMINALS AND REFERENCE VALUE

Data are reference value and are measured between each terminal and ground.

| Terminal | Wire color | Item                   | Condition   | Data (Approx.)  |
|----------|------------|------------------------|---|-----------------|
| 34       | BR         | Clutch pressure switch | <ul style="list-style-type: none"> <li>● Vehicle stopped</li> <li>● Engine running</li> <li>● A/T selector lever "D" position</li> </ul> 4WD shift switch: AUTO or 4H ("Wait" function is not operating.) | 0V              |
|          |            |                        | <ul style="list-style-type: none"> <li>● Vehicle stopped</li> <li>● Engine running</li> </ul> 4WD shift switch: 2WD ("Wait" function is not operating.)   | Battery voltage |

**CAUTION:**

When using a circuit tester to measure voltage for inspection, be sure not to extend forcibly any connector terminals.



# TROUBLE DIAGNOSIS FOR SYSTEM

## DIAGNOSTIC PROCEDURE

### 1. CHECK CLUTCH PRESSURE SWITCH SIGNAL

#### With CONSULT-II

1. Start engine.
2. Select "DATA MONITOR" mode for "ALL MODE AWD/4WD" with CONSULT-II.
3. Read out ON/OFF switching action of the "CL PRES SW" while operating 4WD shift switch.

| Condition  | Display value  |
|--|--|
| <ul style="list-style-type: none"> <li>● Ignition switch: ON</li> <li>● A/T selector lever "D" position</li> </ul> | 4WD shift switch: AUTO or 4H ("Wait" function is not operating.)<br>ON |
| Ignition switch: ON  | 4WD shift switch: 2WD ("Wait" function is not operating.)<br>OFF       |

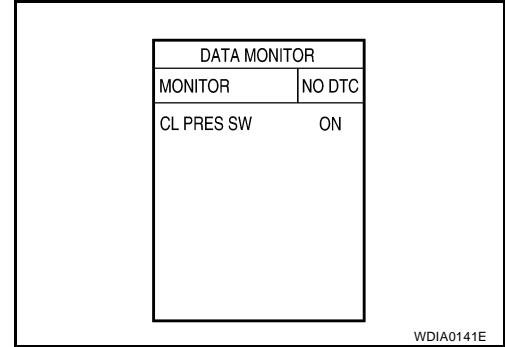

#### Without CONSULT-II

1. Start engine.
2. Check voltage between transfer control unit harness connector terminals and ground.

| Connector | Terminal    | Condition  | Voltage (Approx.)  |
|-----------|-------------|--|--|
| E143      | 34 - Ground | <ul style="list-style-type: none"> <li>● Ignition switch: ON</li> <li>● A/T selector lever "D" position</li> </ul> | 4WD shift switch: AUTO or 4H ("Wait" function is not operating.)<br>0V       |
|           |             | Ignition switch: ON  | 4WD shift switch: 2WD ("Wait" function is not operating.)<br>Battery voltage |

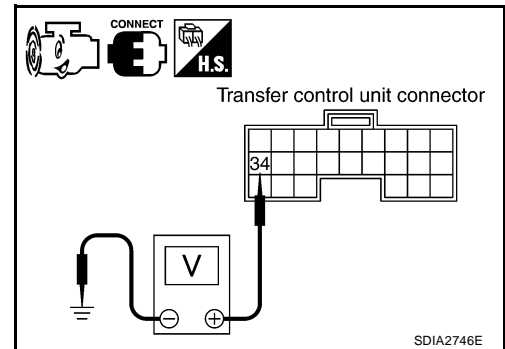

#### OK or NG

- OK >> GO TO 5.  
NG >> GO TO 2.

### 2. CHECK HARNESS BETWEEN TRANSFER CONTROL UNIT AND CLUTCH PRESSURE SWITCH

1. Turn ignition switch "OFF". (Stay for at least 5 seconds.)
2. Disconnect transfer control unit harness connector and the transfer terminal cord assembly harness connector.
3. Check continuity between transfer control unit harness connector E143 terminal 34 and transfer terminal cord assembly harness connector F56 terminal 7

**Continuity should exist.**

Also check harness for short to ground and short to power.

#### OK or NG

- OK >> GO TO 3.  
NG >> Repair or replace damaged parts.

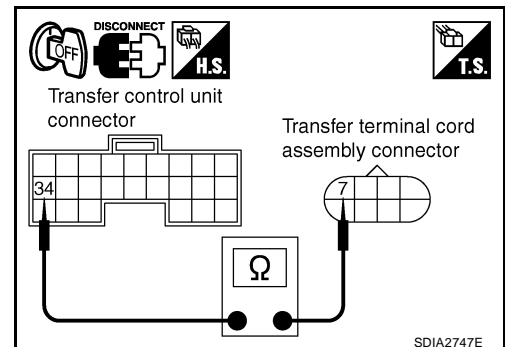

# TROUBLE DIAGNOSIS FOR SYSTEM

## 3. CHECK TRANSFER CONTROL UNIT

Check transfer control unit input/output signal. Refer to [TF-35, "Transfer Control Unit Input/Output Signal Reference Values"](#) .

### OK or NG

- OK >> GO TO 4.
- NG >> Check transfer control unit pin terminals for damage or loose connection with the harness connector. If any items are damaged, repair or replace damaged parts.

## 4. CHECK CLUTCH PRESSURE SWITCH

1. Turn ignition switch "OFF". (Stay for at least 5 seconds.)
2. Remove clutch pressure switch. Refer to [TF-22, "Location of Electrical Parts"](#) .
3. Push and release clutch pressure switch and check continuity between terminal 7 and ground.

| Terminal | Condition                      | Continuity |
|----------|--------------------------------|------------|
| 7 -      | Push clutch pressure switch    | Yes        |
| Ground   | Release clutch pressure switch | No         |

### OK or NG

- OK >> GO TO 5.
- NG >> Replace clutch pressure switch.

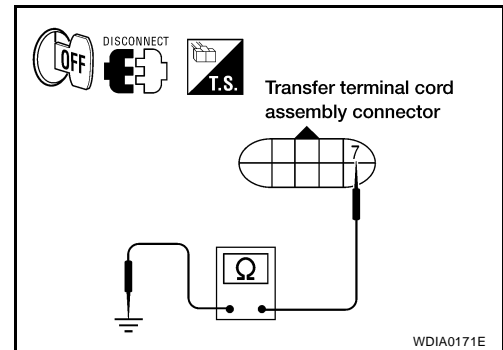

## 5. CHECK DTC

Perform the self-diagnosis, after driving a vehicle for a while.

### OK or NG

- OK >> GO TO 6.
- NG >> Replace transfer control unit. Refer to [TF-131, "Removal and Installation"](#) .

## 6. CRUISE TEST

Perform cruise test. Refer to [TF-33, "CRUISE TEST"](#) .

### OK or NG

- OK >> Inspection End.
- NG >> Perform the applicable trouble diagnosis.

### COMPONENT INSPECTION

1. Turn ignition switch "OFF". (Stay for at least 5 seconds.)
2. Remove clutch pressure switch. Refer to [TF-22, "Location of Electrical Parts"](#) .
3. Push and release clutch pressure switch and check continuity between terminal 7 and ground.

| Terminal   | Condition                      | Continuity |
|------------|--------------------------------|------------|
| 7 - Ground | Push clutch pressure switch    | Yes        |
|            | Release clutch pressure switch | No         |

4. If NG, replace the clutch pressure switch. Refer to [TF-22, "Location of Electrical Parts"](#) .

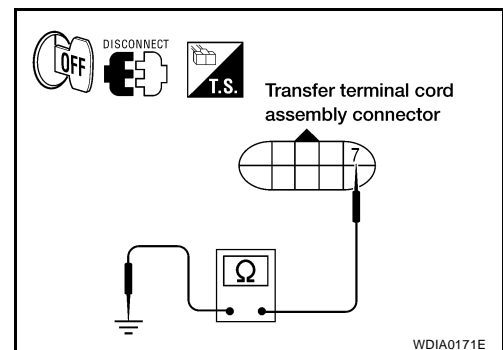

# TROUBLE DIAGNOSIS FOR SYSTEM

## Line Pressure Switch

EDS001Z1

### CONSULT-II REFERENCE VALUE IN DATA MONITOR MODE

Data are reference value.

| Monitored item [Unit] | Content                           | Condition  | Display value   |
|-----------------------|-----------------------------------|--|---|
| LINE PRES SW [ON/OFF] | Condition of line pressure switch | <ul style="list-style-type: none"> <li>● A/T selector lever "D" position</li> <li>● 4WD shift switch: 2WD, AUTO or 4H</li> </ul>   | ON  |
|                       |                                   | <ul style="list-style-type: none"> <li>● Except the above</li> <li>● The vehicle has been left at room temperature for 5 minutes and more with ignition switch in "OFF" position.</li> </ul> | <ul style="list-style-type: none"> <li>● Ignition switch: ON</li> <li>● A/T selector lever: "P" or "N" position</li> <li>● 4WD shift switch: other than AUTO</li> </ul> |

### TRANSFER CONTROL UNIT TERMINALS AND REFERENCE VALUE

Data are reference value and are measured between each terminal and ground.

| Terminal | Wire color | Item                 | Condition  | Data (Approx.)  |                 |
|----------|------------|----------------------|--|---|-----------------|
| 35       | BR/W       | Line pressure switch | <ul style="list-style-type: none"> <li>● Ignition switch: ON</li> <li>● A/T selector lever "D" position</li> </ul>   | <ul style="list-style-type: none"> <li>● 4WD shift switch: AUTO</li> </ul>  | 0V              |
|          |            |                      | <ul style="list-style-type: none"> <li>● Except the above</li> <li>● The vehicle has been left at room temperature for 5 minutes and more with ignition switch in "OFF" position.</li> </ul> | <ul style="list-style-type: none"> <li>● Ignition switch: ON</li> <li>● A/T selector lever: "P" or "N" position</li> <li>● 4WD shift switch: other than AUTO</li> </ul> | Battery voltage |

**CAUTION:**

When using a circuit tester to measure voltage for inspection, be sure not to extend forcibly any connector terminals.

# TROUBLE DIAGNOSIS FOR SYSTEM

## DIAGNOSTIC PROCEDURE

### 1. CHECK LINE PRESSURE SWITCH SIGNAL

#### ④ With CONSULT-II

1. Start engine.
2. Select "DATA MONITOR" mode for "ALL MODE AWD/4WD" with CONSULT-II.
3. Read out ON/OFF switching action of "LINE PRES SW" while operating 4WD shift switch.

| Condition  | Display value |
|--|---------------|
| <ul style="list-style-type: none"> <li>● A/T selector lever "D" position</li> <li>● 4WD shift switch: AUTO</li> </ul>  | ON            |
| <ul style="list-style-type: none"> <li>● Except the above</li> <li>● The vehicle has been left at room temperature for 5 minutes and more with ignition switch in "OFF" position.</li> </ul> | OFF           |

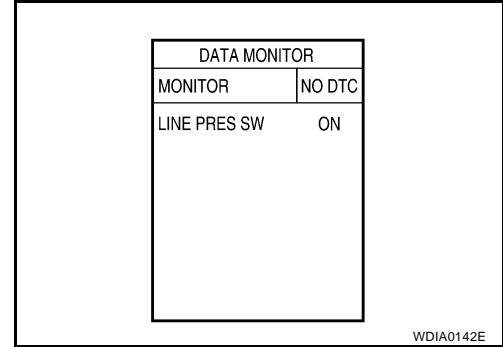

#### ⊗ Without CONSULT-II

1. Start engine.
2. Check voltage between transfer control unit harness connector terminals and ground.

| Connector | Terminal    | Condition  | Voltage (Approx.) |
|-----------|-------------|--|-------------------|
| E143      | 35 - Ground | <ul style="list-style-type: none"> <li>● A/T selector lever "D" position</li> </ul>  | 0V                |
|           |             | <ul style="list-style-type: none"> <li>● Except the above</li> <li>● The vehicle has been left at room temperature for 5 minutes and more with ignition switch in "OFF" position.</li> </ul> | Battery voltage   |

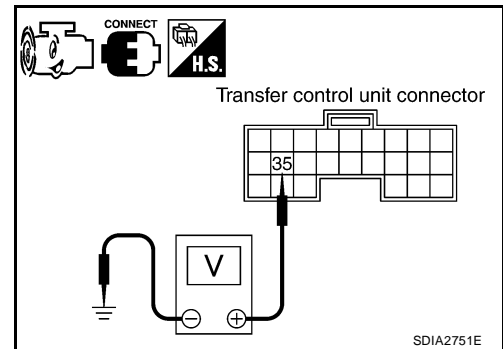

#### OK or NG

- OK >> GO TO 5.
- NG >> GO TO 2.

### 2. CHECK HARNESS BETWEEN TRANSFER CONTROL UNIT AND LINE PRESSURE SWITCH

1. Turn ignition switch "OFF". (Stay for at least 5 seconds.)
2. Disconnect transfer control unit harness connector and the transfer terminal cord assembly harness connector.
3. Check continuity between transfer control unit harness connector E143 terminal 35 and transfer terminal cord assembly harness connector F56 terminal 1.

**Continuity should exist.**

Also check harness for short to ground and short to power.

#### OK or NG

- OK >> GO TO 3.
- NG >> Repair or replace damaged parts.

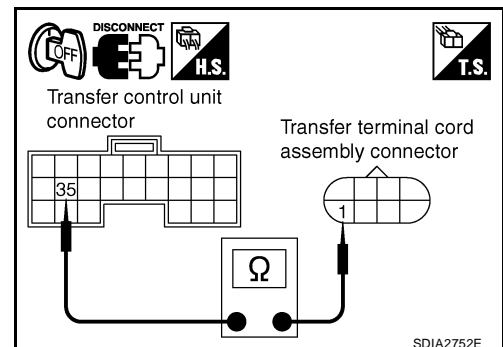

# TROUBLE DIAGNOSIS FOR SYSTEM

## 3. CHECK TRANSFER CONTROL UNIT

Check transfer control unit input/output signal. Refer to [TF-35, "Transfer Control Unit Input/Output Signal Reference Values"](#) .

OK or NG

OK >> GO TO 4.

NG >> Check the following. If any items are damaged, repair or replace damaged parts.

- Transfer control unit pin terminals for damage or loose connection with harness connector.
- Transfer control unit. Refer to [TF-131, "Removal and Installation"](#) .

## 4. CHECK LINE PRESSURE SWITCH

1. Turn ignition switch "OFF". (Stay for at least 5 seconds.)
2. Remove line pressure switch. Refer to [TF-22, "Location of Electrical Parts"](#) .
3. Push and release line pressure switch and check continuity between terminal 1 and ground.

| Terminal | Condition                    | Continuity |
|----------|------------------------------|------------|
| 1 -      | Push line pressure switch    | Yes        |
| Ground   | Release line pressure switch | No         |

OK or NG

OK >> GO TO 5.

NG >> Replace line pressure switch.

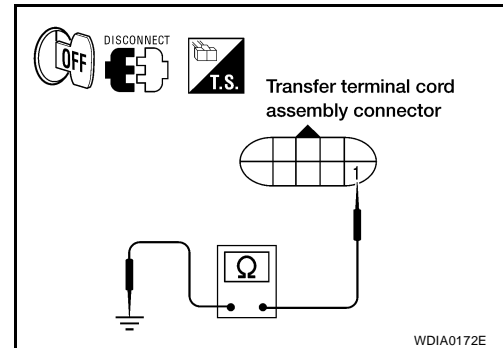

## 5. CHECK DTC

Perform the self-diagnosis, after driving a vehicle for a while.

OK or NG

OK >> GO TO 6.

NG >> Replace transfer control unit. Refer to [TF-131, "Removal and Installation"](#) .

## 6. CRUISE TEST

Perform cruise test. Refer to [TF-33, "CRUISE TEST"](#) .

OK or NG

OK >> Inspection End.

NG >> Perform the applicable trouble diagnosis.

## COMPONENT INSPECTION

1. Turn ignition switch "OFF". (Stay for at least 5 seconds.)
2. Remove line pressure switch. Refer to [TF-22, "Location of Electrical Parts"](#) .
3. Push and release line pressure switch and check continuity between terminal 1 and ground.

| Terminal   | Condition                    | Continuity |
|------------|------------------------------|------------|
| 1 - Ground | Push line pressure switch    | Yes        |
|            | Release line pressure switch | No         |

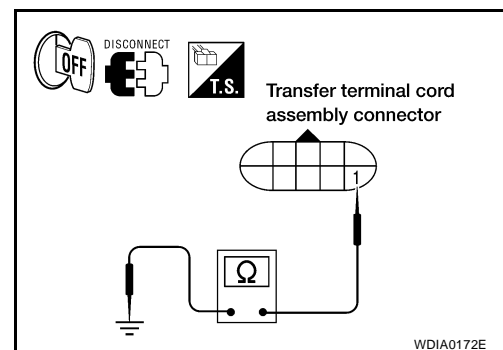

# TROUBLE DIAGNOSIS FOR SYSTEM

EDS001Z2

## Throttle Position Signal (ECM) DIAGNOSTIC PROCEDURE

### 1. CHECK DTC WITH ECM

Perform self-diagnosis with ECM. Refer to [EC-116, "SELF-DIAG RESULTS MODE"](#) .

Is any malfunction detected by self-diagnosis?

- YES >> Check the malfunctioning system.
- NO >> GO TO 2.

### 2. CHECK TRANSFER CONTROL UNIT

Check transfer control unit input/output signal. Refer to [TF-35, "Transfer Control Unit Input/Output Signal Reference Values"](#) .

OK or NG

- OK >> GO TO 3.
- NG >> Check transfer control unit pin terminals for damage or loose connection with harness connector. If any items are damaged, repair or replace damaged parts.

### 3. CHECK DTC

Perform the self-diagnosis, after driving a vehicle for a while.

OK or NG

- OK >> Inspection End.
- NG >> Perform self-diagnosis with ECM again. Refer to [EC-116, "SELF-DIAG RESULTS MODE"](#) .

## ABS Operation Signal (ABS) DIAGNOSTIC PROCEDURE

EDS001Z3

### 1. CHECK DTC WITH ABS ACTUATOR AND ELECTRIC UNIT (CONTROL UNIT)

Perform self-diagnosis with ABS actuator and electric unit (control unit). Refer to [BRC-30, "SELF-DIAGNOSIS"](#) .

Is any malfunction detected by self-diagnosis?

- YES >> Check the malfunctioning system.
- NO >> GO TO 2.

### 2. CHECK TRANSFER CONTROL UNIT

Check transfer control unit input/output signal. Refer to [TF-35, "Transfer Control Unit Input/Output Signal Reference Values"](#) .

OK or NG

- OK >> GO TO 3.
- NG >> Check transfer control unit pin terminals for damage or loose connection with harness connector. If any items are damaged, repair or replace damaged parts.

### 3. CHECK DTC

Perform the self-diagnosis, after driving a vehicle for a while.

OK or NG

- OK >> Inspection End.
- NG >> Perform self-diagnosis with ABS actuator and electric unit (control unit) again. Refer to [BRC-30, "SELF-DIAGNOSIS"](#) .

# TROUBLE DIAGNOSIS FOR SYSTEM

## VDC Operation Signal (ABS) DIAGNOSTIC PROCEDURE

EDS001Z4

### 1. CHECK DTC WITH ABS ACTUATOR AND ELECTRIC UNIT

Perform self-diagnosis with ABS actuator and electric unit (control unit). Refer to [BRC-30, "SELF-DIAGNOSIS"](#).

Is any malfunction detected by self-diagnosis?

- YES >> Check the malfunctioning system.
- NO >> GO TO 2.

### 2. CHECK TRANSFER CONTROL UNIT

Check transfer control unit input/output signal. Refer to [TF-35, "Transfer Control Unit Input/Output Signal Reference Values"](#).

OK or NG

- OK >> GO TO 3.
- NG >> Check transfer control unit pin terminals for damage or loose connection with harness connector. If any items are damaged, repair or replace damaged parts.

### 3. CHECK DTC

Perform the self-diagnosis, after driving a vehicle for a while.

OK or NG

- OK >> Inspection End.
- NG >> Perform self-diagnosis with ABS actuator electric unit (control unit) again. Refer to [BRC-30, "SELF-DIAGNOSIS"](#).

## TCS Operation Signal (ABS) DIAGNOSTIC PROCEDURE

EDS001Z5

### 1. CHECK DTC WITH ABS ACTUATOR AND ELECTRIC UNIT (CONTROL UNIT)

Perform self-diagnosis with ABS actuator and electric unit (control unit). Refer to [BRC-30, "SELF-DIAGNOSIS"](#).

Is any malfunction detected by self-diagnosis?

- YES >> Check the malfunctioning system.
- NO >> GO TO 2.

### 2. CHECK TRANSFER CONTROL UNIT

Check transfer control unit input/output signal. Refer to [TF-35, "Transfer Control Unit Input/Output Signal Reference Values"](#).

OK or NG

- OK >> GO TO 3.
- NG >> Check transfer control unit pin terminals for damage or loose connection with harness connector. If any items are damaged, repair or replace damaged parts.

### 3. CHECK DTC

Perform the self-diagnosis, after driving a vehicle for a while.

OK or NG

- OK >> Inspection End.
- NG >> Perform self-diagnosis with ABS actuator and electric unit (control unit) again. Refer to [BRC-30, "SELF-DIAGNOSIS"](#).

# TROUBLE DIAGNOSIS FOR SYSTEM

EDS001Z6

## CAN Communication Line DIAGNOSTIC PROCEDURE

### 1. CHECK CAN COMMUNICATION CIRCUIT

④ With CONSULT-II

1. Turn ignition switch "ON" and start engine.
2. Select "SELF-DIAG RESULTS" mode for "ALL MODE AWD/4WD" within CONSULT-II.
3. Perform the self-diagnosis.

Is the "CAN COMM CIRCUIT [U1000]" displayed?

- YES >> Print CONSULT-II screen and go to [LAN-3, "Precautions When Using CONSULT-II"](#) .
- NO >> Inspection End.

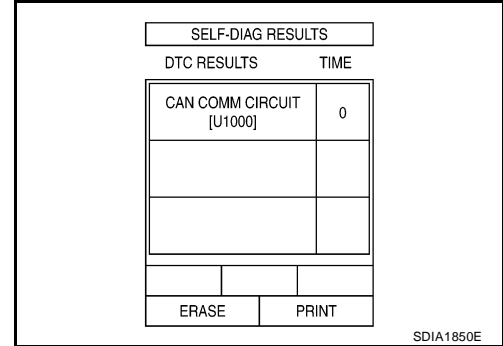

## ATP Switch

### CONSULT-II REFERENCE VALUE IN DATA MONITOR MODE

EDS001Z7

Data are reference value.

| Monitored item [Unit] | Content                 | Condition  | Display value  |
|-----------------------|-------------------------|--|--|
| ATP SWITCH [ON/OFF]   | Condition of ATP switch | <ul style="list-style-type: none"> <li>● Vehicle stopped</li> <li>● Engine running</li> <li>● A/T selector lever "N"</li> <li>● Brake pedal depressed</li> </ul> | 4WD shift switch : 4H to 4LO or 4LO to 4H (While actuator motor is operating.) |
|                       |                         | Except the above   | OFF  |

### TRANSFER CONTROL UNIT TERMINALS AND REFERENCE VALUE

Data are reference value and are measured between each terminal and ground.

| Terminal | Wire color | Item       | Condition  | Data (Approx.)  |
|----------|------------|------------|--|---|
| 40       | L          | ATP switch | <ul style="list-style-type: none"> <li>● Vehicle stopped</li> <li>● Engine running</li> <li>● A/T selector lever "N"</li> <li>● Brake pedal depressed</li> </ul> | 4WD shift switch: 4H to 4LO or 4LO to 4H (While actuator motor is operating.) |
|          |            |            | Except the above   | Battery voltage   |

**CAUTION:**

When using a circuit tester to measure voltage for inspection, be sure not to extend forcibly any connector terminals.



# TROUBLE DIAGNOSIS FOR SYSTEM

## DIAGNOSTIC PROCEDURE

### 1. CHECK ATP SWITCH SIGNAL

#### ☑ With CONSULT-II

1. Start engine.
2. Select "DATA MONITOR" mode for "ALL MODE AWD/4WD" with CONSULT-II.
3. Read out the value of "ATP SWITCH".

| Condition   |  | Display value |
|---|--|---------------|
| <ul style="list-style-type: none"> <li>● Vehicle stopped</li> <li>● Engine running</li> <li>● A/T selector lever "N"</li> </ul> | 4WD shift switch : 4H to 4LO or 4LO to 4H (While actuator motor is operating.) | ON            |
| <ul style="list-style-type: none"> <li>● Brake pedal depressed</li> </ul>   | Except the above   | OFF           |

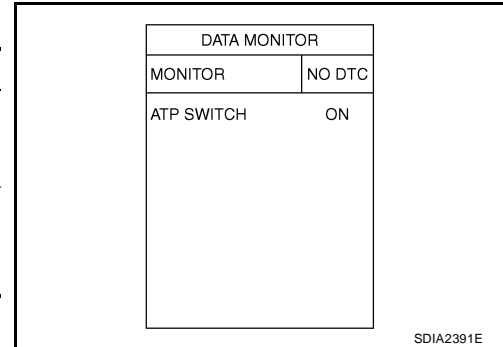

#### ☒ Without CONSULT-II

1. Start engine.
2. Check voltage between transfer control unit harness connector terminal and ground.

| Connector | Terminal    | Condition   | Voltage (Approx.)   |
|-----------|-------------|---|---|
| E143      | 40 - Ground | <ul style="list-style-type: none"> <li>● Vehicle stopped</li> <li>● Engine running</li> <li>● A/T selector lever "N"</li> </ul> | 4WD shift switch: 4H to 4LO or 4LO to 4H (While actuator motor is operating.) |
|           |             | <ul style="list-style-type: none"> <li>● Brake pedal depressed</li> </ul>   | Except the above  |

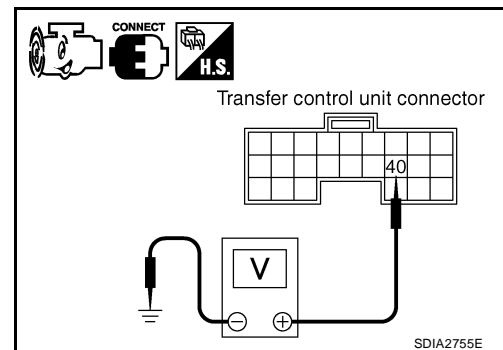

OK or NG

- OK >> GO TO 5.
- NG >> GO TO 2.

### 2. CHECK HARNESS BETWEEN TRANSFER CONTROL UNIT AND ATP SWITCH

1. Turn ignition switch "OFF". (Stay for at least 5 seconds.)
2. Disconnect transfer control unit harness connector and the ATP switch harness connector.
3. Check continuity between transfer control unit harness connector E143 terminal 40 and ATP switch harness connector F55 terminal 8.

**Continuity should exist.**

Also check harness for short to ground and short to power.

OK or NG

- OK >> GO TO 3.
- NG >> Repair or replace damaged parts.

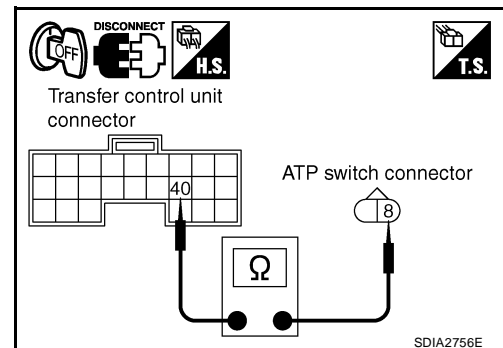

# TROUBLE DIAGNOSIS FOR SYSTEM

## 3. CHECK GROUND CIRCUIT

1. Turn ignition switch "OFF". (Stay for at least 5 seconds.)
2. Disconnect ATP switch harness connector.
3. Check continuity between ATP switch harness connector F55 terminal 9 and ground.

**Continuity should exist.**

Also check harness for short to ground and short to power.

OK or NG

OK >> GO TO 4.

NG >> Repair open circuit or short to ground or short to power in harness or connectors.

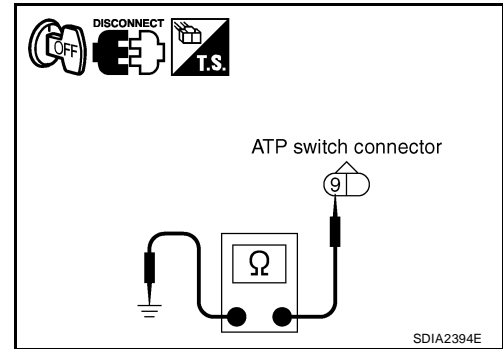

## 4. CHECK ATP SWITCH

1. Turn ignition switch "OFF". (Stay for at least 5 seconds.)
2. Disconnect ATP switch harness connector.
3. Remove ATP switch. Refer to [TF-22, "Location of Electrical Parts"](#).
4. Push and release ATP switch and check continuity between ATP switch terminals 8 and 9.

| Terminal | Condition          | Continuity |
|----------|--------------------|------------|
| 8 - 9    | Push ATP switch    | Yes        |
|          | Release ATP switch | No         |

OK or NG

OK >> GO TO 5.

NG >> Replace ATP switch.

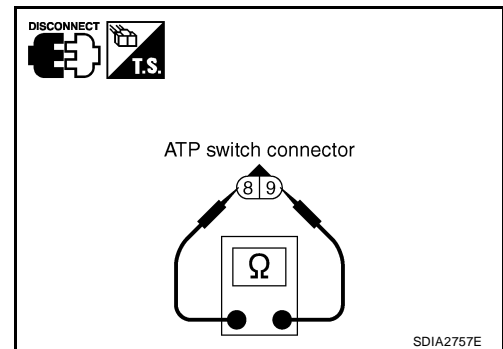

## 5. CHECK TRANSFER CONTROL UNIT

Check transfer control unit input/output signal. Refer to [TF-35, "Transfer Control Unit Input/Output Signal Reference Values"](#).

OK or NG

OK >> GO TO 6.

NG >> Check transfer control unit pin terminals for damage or loose connection with harness connector. If any items are damaged, repair or replace damaged parts.

## 6. CHECK ATP WARNING LAMP

1. Turn ignition switch "ON". (Do not start engine.)
2. Move A/T selector lever to "P" position.
3. Set 4WD shift switch from "4H" to "4LO" or "4LO" to "4H".

Does ATP warning lamp turn ON while switching?

YES >> GO TO [TF-124, "ATP Warning Lamp Turns ON"](#).

NO >> Inspection End.

### COMPONENT INSPECTION

1. Turn ignition switch "OFF". (Stay for at least 5 seconds.)
2. Disconnect ATP switch harness connector.
3. Remove ATP switch. Refer to [TF-22, "Location of Electrical Parts"](#).

# TROUBLE DIAGNOSIS FOR SYSTEM

4. Push and release ATP switch and check continuity between ATP switch terminals 8 and 9.

| Terminal | Condition          | Continuity |
|----------|--------------------|------------|
| 8 - 9    | Push ATP switch    | Yes        |
|          | Release ATP switch | No         |

5. If NG, replace the ATP switch.

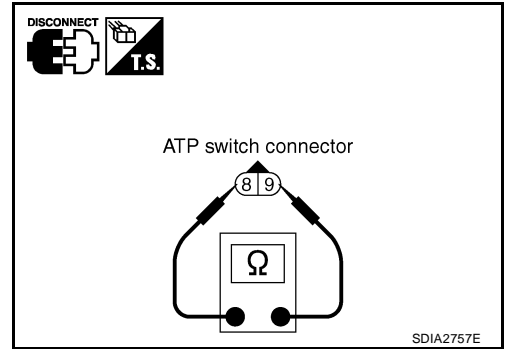

A

B

C

TF

E

F

G

H

I

J

K

L

M

# TROUBLE DIAGNOSIS FOR SYMPTOMS

PF0:00007

EDS001ZA

## TROUBLE DIAGNOSIS FOR SYMPTOMS

### 4WD Shift Indicator Lamp and 4LO Indicator Lamp Do Not Turn ON SYMPTOM:

4WD shift indicator lamp and 4LO indicator lamp do not turn ON for approx. 1 second when turning ignition switch to "ON".

### DIAGNOSTIC PROCEDURE

#### 1. CHECK TRANSFER CONTROL UNIT POWER SUPPLY CIRCUIT

1. Turn ignition switch "OFF". (Stay for at least 5 seconds.)
2. Connect transfer control unit harness connector.
3. Check voltage between transfer control unit harness connector terminals and ground.

| Connector | Terminal    | Voltage (Approx.) |
|-----------|-------------|-------------------|
| E142      | 16 - Ground | 0V                |
|           | 22 - Ground |                   |
| E143      | 29 - Ground | Battery voltage   |
|           | 30 - Ground |                   |
|           | 47 - Ground |                   |

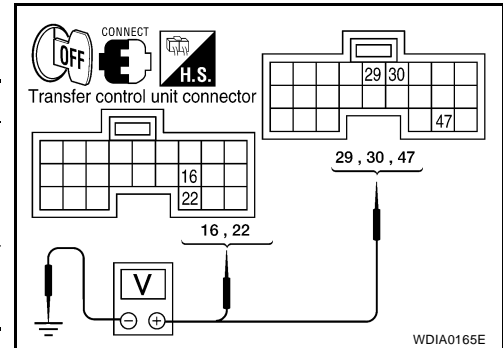

4. Turn ignition switch "ON". (Do not start engine.)
5. Check voltage between transfer control unit harness connector terminals and ground.

| Connector | Terminal    | Voltage (Approx.) |
|-----------|-------------|-------------------|
| E142      | 16 - Ground | Battery voltage   |
|           | 22 - Ground |                   |
| E143      | 29 - Ground | 0V                |
|           | 30 - Ground |                   |
|           | 47 - Ground |                   |

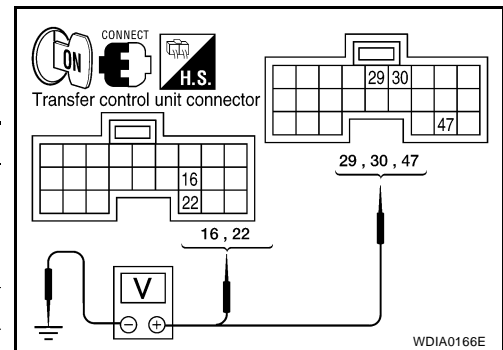

#### OK or NG

OK >> GO TO 2.

NG >> Check the following. If any items are damaged, repair or replace damaged parts.

- 10A fuses (No. 26 located in fuse and fusible link box and No. 59 located in the fuse and relay box). Refer to [PG-4, "POWER SUPPLY ROUTING CIRCUIT"](#) .
- 20A fuse (No. 53 located in the IPDM E/R). Refer to [PG-4, "POWER SUPPLY ROUTING CIRCUIT"](#) .
- Harness for short or open between battery and transfer control unit harness connector terminals 47.
- Harness for short or open between battery and transfer control unit harness connector terminal 29.
- Harness for short or open between battery and transfer shut off relay harness connector E69 terminal 1, and 3.
- Harness for short or open between transfer shut off relay harness connector E69 terminal 2 and transfer control unit harness connector terminal 30.
- Harness for short or open between transfer shut off relay harness connector E69 terminal 5 and transfer control unit harness connector terminals 16 and 22.
- Battery and ignition switch. Refer to [PG-4, "POWER SUPPLY ROUTING CIRCUIT"](#) .
- Transfer shut off relay. Refer to [TF-57, "COMPONENT INSPECTION"](#) .

# TROUBLE DIAGNOSIS FOR SYMPTOMS

## 2. CHECK TRANSFER CONTROL UNIT GROUND CIRCUIT

1. Turn ignition switch "OFF". (Stay for at least 5 seconds.)
2. Disconnect transfer control unit harness connector.
3. Check continuity between transfer control unit harness connector E142 terminals 3, 6, E143 terminal 45 and ground.

**Continuity should exist.**

Also check harness for short to ground and short to power.

OK or NG

OK >> GO TO 3.

NG >> Repair open circuit or short to ground or short to power in harness or connectors.

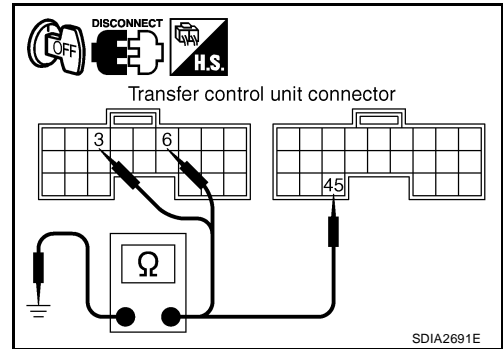

## 3. CHECK COMBINATION METER POWER SUPPLY CIRCUIT

1. Turn ignition switch "OFF". (Stay for at least 5 seconds.)
2. Disconnect transfer control unit harness connector.
3. Check voltage between combination meter harness connector terminal and ground.

| Connector | Terminal    | Voltage (Approx.) |
|-----------|-------------|-------------------|
| M24       | 24 - Ground | 0V                |

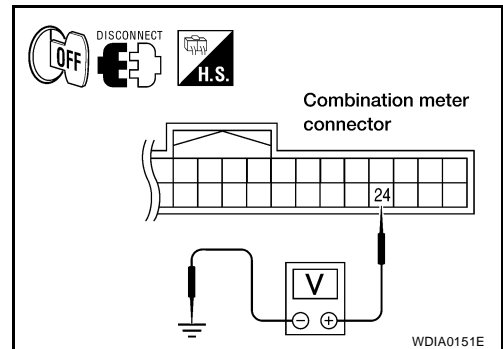

4. Turn ignition switch "ON". (Do not start engine.)
5. Check voltage between combination meter harness connector terminal and ground.

| Connector | Terminal    | Voltage (Approx.) |
|-----------|-------------|-------------------|
| M24       | 24 - Ground | Battery voltage   |

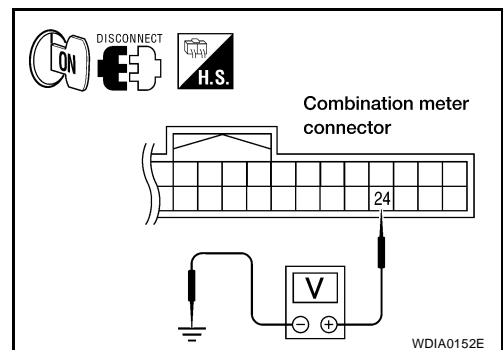

OK or NG

OK >> GO TO 4.

NG >> Check the following. If any items are damaged, repair or replace damaged parts.

- 10A fuse [No. 14 located in the fuse block (J/B)]. Refer to [PG-4, "POWER SUPPLY ROUTING CIRCUIT"](#).
- Harness for short or open between battery and combination meter harness connector M24 terminal 24.
- Ignition switch. Refer to [PG-4, "POWER SUPPLY ROUTING CIRCUIT"](#).

# TROUBLE DIAGNOSIS FOR SYMPTOMS

## 4. CHECK HARNESS BETWEEN TRANSFER CONTROL UNIT AND COMBINATION METER

1. Turn ignition switch "OFF". (Stay for at least 5 seconds.)
2. Disconnect transfer control unit harness connector and combination meter harness connector.
3. Check continuity between the following terminals.
  - Transfer control unit harness connector E142 terminal 2 and combination meter harness connector M24 terminal 32.
  - Transfer control unit harness connector E142 terminal 11 and combination meter harness connector M24 terminal 31.
  - Transfer control unit harness connector E142 terminal 12 and combination meter harness connector M24 terminal 33.
  - Transfer control unit harness connector E142 terminal 21 and combination meter harness connector M24 terminal 30.

**Continuity should exist.**

Also check harness for short to ground and short to power.

OK or NG

- OK >> GO TO 5.
- NG >> Repair or replace damaged parts.

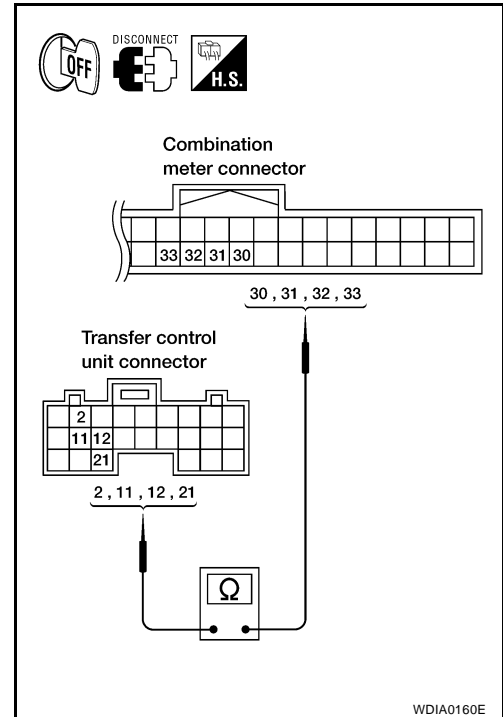

## 5. CHECK INDICATOR LAMP CIRCUIT

1. Connect combination meter harness connector.
2. Disconnect transfer control unit harness connector.
3. Turn ignition switch "ON".
4. Ground the following terminals using suitable wiring.
  - Transfer control unit harness connector E142 terminal 2 and ground.
  - Transfer control unit harness connector E142 terminal 11 and ground.
  - Transfer control unit harness connector E142 terminal 12 and ground.
  - Transfer control unit harness connector E142 terminal 21 and ground.

Do indicator lamps turn on?

- OK >> GO TO 6.
- NG >> Replace combination meter. Refer to [IP-13, "COMBINATION METER"](#) .

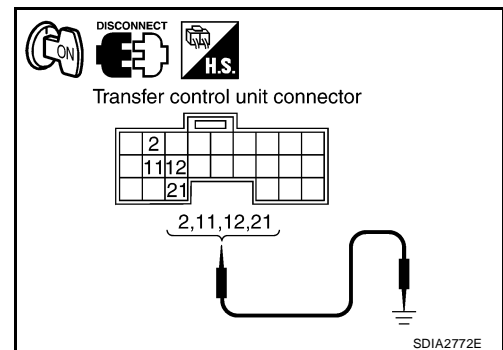

## 6. SYMPTOM CHECK

Check again.

OK or NG

- OK >> Inspection End.
- NG >> GO TO 7.

# TROUBLE DIAGNOSIS FOR SYMPTOMS

---

## 7. CHECK TRANSFER CONTROL UNIT

---

Check transfer control unit input/output signal. Refer to [TF-35, "Transfer Control Unit Input/Output Signal Reference Values"](#) .

### OK or NG

OK >> Inspection End.

NG >> Check transfer control unit pin terminals for damage or loose connection with harness connector.  
If any items are damaged, repair or replace damaged parts.

A  
B  
C  
E  
F  
G  
H  
I  
J  
K  
L  
M

TF

# TROUBLE DIAGNOSIS FOR SYMPTOMS

EDS001ZB

## 4WD Warning Lamp Does Not Turn ON

### SYMPTOM:

4WD warning lamp does not turn ON when turning ignition switch to "ON".

### DIAGNOSTIC PROCEDURE

#### 1. CHECK TRANSFER CONTROL UNIT POWER SUPPLY CIRCUIT

1. Turn ignition switch "OFF". (Stay for at least 5 seconds.)
2. Connect transfer control unit harness connector.
3. Check voltage between transfer control unit harness connector terminals and ground.

| Connector | Terminal    | Voltage (Approx.) |
|-----------|-------------|-------------------|
| E142      | 16 - Ground | 0V                |
|           | 22 - Ground |                   |
| E143      | 29 - Ground | Battery voltage   |
|           | 30 - Ground |                   |
|           | 47 - Ground |                   |

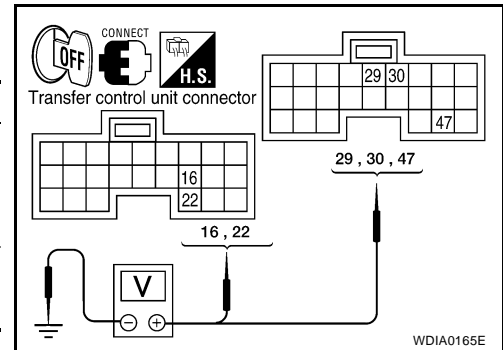

4. Turn ignition switch "ON". (Do not start engine.)
5. Check voltage between transfer control unit harness connector terminals and ground.

| Connector | Terminal    | Voltage (Approx.) |
|-----------|-------------|-------------------|
| E142      | 16 - Ground | Battery voltage   |
|           | 22 - Ground |                   |
| E143      | 29 - Ground | 0V                |
|           | 30 - Ground |                   |
|           | 47 - Ground |                   |

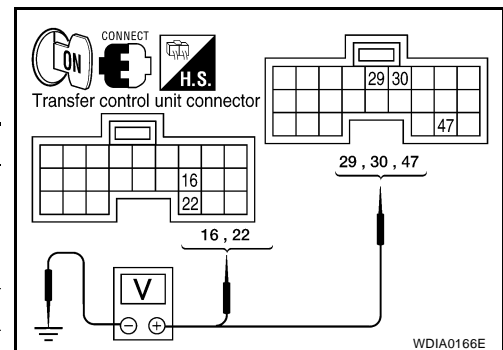

### OK or NG

OK >> GO TO 4.

NG >> Check the following. If any items are damaged, repair or replace damaged parts.

- 10A fuses (No. 26 located in fuse and fusible link box and No. 59 located in the fuse and relay box). Refer to [PG-4, "POWER SUPPLY ROUTING CIRCUIT"](#) .
- 20A fuse (No. 53 located in the IPDM E/R). Refer to [PG-4, "POWER SUPPLY ROUTING CIRCUIT"](#) .
- Harness for short or open between battery and transfer control unit harness connector terminals 47.
- Harness for short or open between battery and transfer control unit harness connector terminal 29.
- Harness for short or open between battery and transfer shut off relay harness connector E69 terminal 1 and 3.
- Harness for short or open between transfer shut off relay harness connector E69 terminal 2 and transfer control unit harness connector terminal 30.
- Harness for short or open between transfer shut off relay harness connector E69 terminal 5 and transfer control unit harness connector terminals 16 and 22.
- Battery and ignition switch. Refer to [PG-4, "POWER SUPPLY ROUTING CIRCUIT"](#) .
- Transfer shut off relay. Refer to [TF-57, "COMPONENT INSPECTION"](#) .



# TROUBLE DIAGNOSIS FOR SYMPTOMS

## 2. CHECK TRANSFER CONTROL UNIT GROUND CIRCUIT

1. Turn ignition switch "OFF". (Stay for at least 5 seconds.)
2. Disconnect transfer control unit harness connector.
3. Check continuity between transfer control unit harness connector E142 terminals 3, 6, E143 terminal 45 and ground.

**Continuity should exist.**

Also check harness for short to ground and short to power.

OK or NG

OK >> GO TO 3.

NG >> Repair open circuit or short to ground or short to power in harness or connectors.

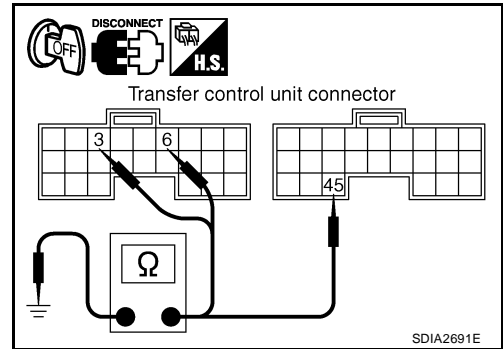

## 3. CHECK COMBINATION METER POWER SUPPLY CIRCUIT

1. Turn ignition switch "OFF". (Stay for at least 5 seconds.)
2. Disconnect transfer control unit harness connector.
3. Check voltage between combination meter harness connector terminal and ground.

| Connector | Terminal    | Voltage (Approx.) |
|-----------|-------------|-------------------|
| M24       | 24 - Ground | 0V                |

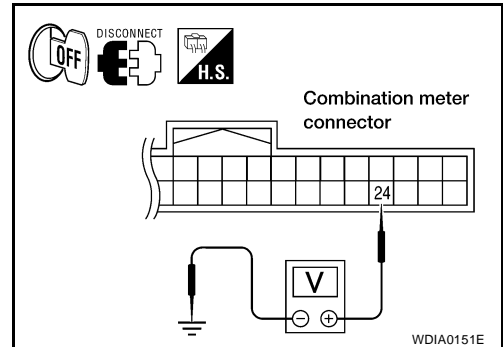

4. Turn ignition switch "ON". (Do not start engine.)
5. Check voltage between combination meter harness connector terminal and ground.

| Connector | Terminal    | Voltage (Approx.) |
|-----------|-------------|-------------------|
| M24       | 24 - Ground | Battery voltage   |

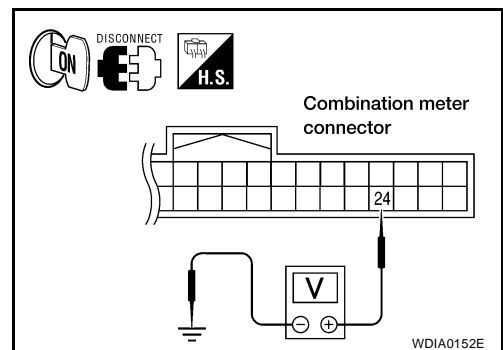

OK or NG

OK >> GO TO 4.

NG >> Check the following. If any items are damaged, repair or replace damaged parts.

- 10A fuse [No. 14 located in the fuse block (J/B)]. Refer to [PG-4, "POWER SUPPLY ROUTING CIRCUIT"](#).
- Harness for short or open between battery and combination meter harness connector M24 terminal 24.
- Ignition switch. Refer to [PG-4, "POWER SUPPLY ROUTING CIRCUIT"](#).

# TROUBLE DIAGNOSIS FOR SYMPTOMS

## 4. CHECK HARNESS BETWEEN TRANSFER CONTROL UNIT AND COMBINATION METER

1. Turn ignition switch "OFF". (Stay for at least 5 seconds.)
2. Disconnect transfer control unit harness connector and combination meter harness connector.
3. Check continuity between the following terminals.
  - Transfer control unit harness connector E142 terminal 5 and combination meter harness connector M24 terminal 34.

**Continuity should exist.**

Also check harness for short to ground and short to power.

OK or NG

- OK >> GO TO 5.
- NG >> Repair or replace damaged parts.

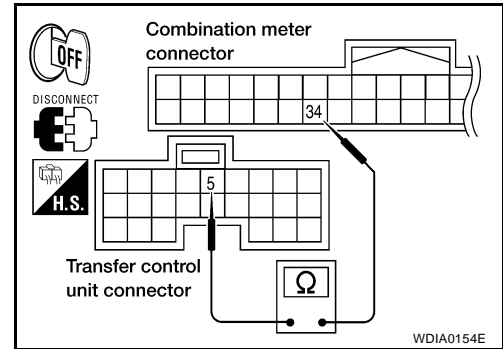

## 5. CHECK INDICATOR LAMP CIRCUIT

1. Connect combination meter harness connector.
2. Disconnect transfer control unit harness connector.
3. Turn ignition switch "ON". (Do not start engine.)
4. Ground the following terminal using suitable wiring.
  - Transfer control unit harness connector E142 terminal 5 and ground.

Does 4WD warning lamp turn on?

- OK >> GO TO 6.
- NG >> Replace combination meter. Refer to [IP-13, "COMBINATION METER"](#).

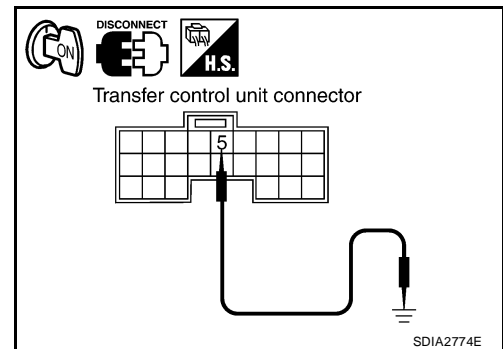

## 6. SYMPTOM CHECK

Check again.

OK or NG

- OK >> Inspection End.
- NG >> GO TO 7.

## 7. CHECK TRANSFER CONTROL UNIT

Check transfer control unit input/output signal. Refer to [TF-35, "Transfer Control Unit Input/Output Signal Reference Values"](#).

OK or NG

- OK >> Inspection End.
- NG >> Check transfer control unit pin terminals for damage or loose connection with harness connector. If any items are damaged, repair or replace damaged parts.

## 4WD Shift Indicator Lamp or 4LO Indicator Lamp Does Not Change

EDS001ZC

**SYMPTOM:**

4WD shift indicator lamp or 4LO indicator lamp does not change when switching 4WD shift switch.

# TROUBLE DIAGNOSIS FOR SYMPTOMS

---

## DIAGNOSTIC PROCEDURE

### 1. CONFIRM THE SYMPTOM

---

Confirm 4WD shift indicator lamp and 4LO indicator lamp turn on when ignition switch is turned to ON.  
Do 4WD shift indicator lamp and 4LO indicator lamp turn on?

YES >> GO TO 2.

NO >> Go to [TF-116, "4WD Shift Indicator Lamp and 4LO Indicator Lamp Do Not Turn ON"](#) .

### 2. CHECK SYSTEM FOR 4WD SHIFT SWITCH

---

Perform trouble diagnosis for 4WD shift switch system. Refer to [TF-62, "4WD Shift Switch"](#) .

OK or NG

OK >> GO TO 3.

NG >> Repair or replace damaged parts.

### 3. CHECK SYSTEM FOR WAIT DETECTION SWITCH

---

Perform trouble diagnosis for wait detection switch system. Refer to [TF-66, "Wait Detection Switch"](#) .

OK or NG

OK >> GO TO 4.

NG >> Repair or replace damaged parts.

### 4. CHECK SYSTEM FOR NEUTRAL-4LO SWITCH

---

Perform trouble diagnosis for neutral-4LO switch system. Refer to [TF-59, "Neutral-4LO Switch"](#) .

OK or NG

OK >> GO TO 5.

NG >> Repair or replace damaged parts.

### 5. CHECK SYSTEM FOR ATP SWITCH

---

Perform trouble diagnosis for ATP switch system. Refer to [TF-112, "ATP Switch"](#) .

OK or NG

OK >> GO TO 6.

NG >> Repair or replace damaged parts.

### 6. CHECK SYSTEM FOR 2-4WD SOLENOID

---

Perform trouble diagnosis for 2-4WD solenoid system. Refer to [TF-90, "2-4WD Solenoid"](#) .

OK or NG

OK >> GO TO 7.

NG >> Repair or replace damaged parts.

### 7. CHECK SYSTEM FOR TRANSFER CONTROL DEVICE

---

Perform trouble diagnosis for transfer control device system. Refer to [TF-81, "Transfer Control Device"](#) .

OK or NG

OK >> GO TO 8.

NG >> Repair or replace damaged parts.

### 8. CHECK SYSTEM FOR ACTUATOR MOTOR

---

Perform trouble diagnosis for actuator motor system. Refer to [TF-70, "Actuator Motor"](#) .

OK or NG

OK >> GO TO 9.

NG >> Repair or replace damaged parts.

# TROUBLE DIAGNOSIS FOR SYMPTOMS

---

## 9. CHECK SYSTEM FOR ACTUATOR POSITION SWITCH

---

Perform trouble diagnosis for actuator position switch system. Refer to [TF-77, "Actuator Position Switch"](#) .

### OK or NG

- OK >> GO TO 10.
- NG >> Repair or replace damaged parts.

---

## 10. SYMPTOM CHECK

---

Check again.

### OK or NG

- OK >> Inspection End.
- NG >> GO TO 11.

---

## 11. CHECK TRANSFER CONTROL UNIT

---

Check transfer control unit input/output signal. Refer to [TF-35, "Transfer Control Unit Input/Output Signal Reference Values"](#) .

### OK or NG

- OK >> GO TO 12.
- NG >> Check transfer control unit pin terminals for damage or loose connection with harness connector. If any items are damaged, repair or replace damaged parts.

---

## 12. CHECK TRANSFER INNER PARTS

---

1. Disassemble transfer assembly. Refer to [TF-145, "Disassembly and Assembly"](#) .
2. Check transfer inner parts.

### OK or NG

- OK >> Inspection End.
- NG >> Repair or replace damaged parts.

## ATP Warning Lamp Turns ON

### SYMPTOM:

EDS001ZD

ATP warning lamp turns ON when 4WD shift switch from "4H" to "4LO" or "4LO" to "4H" with A/T selector lever "N" to "P" position.

### DIAGNOSTIC PROCEDURE

---

## 1. CHECK SYSTEM FOR CAN COMMUNICATION LINE

---

Perform self-diagnosis. Refer to [TF-50, "Self-diagnostic Procedure"](#) .

Do the self-diagnostic results indicate CAN communication?

- YES >> Perform trouble diagnosis for CAN communication line. Refer to [TF-112, "CAN Communication Line"](#) .
- NO >> GO TO 2.

---

## 2. CHECK SYSTEM FOR 4WD SHIFT SWITCH

---

Perform trouble diagnosis for 4WD shift switch system. Refer to [TF-62, "4WD Shift Switch"](#) .

### OK or NG

- OK >> GO TO 3.
- NG >> Repair or replace damaged parts.

---

## 3. CHECK SYSTEM FOR PNP SWITCH SIGNAL

---

Perform trouble diagnosis for PNP switch signal system. Refer to [TF-69, "PNP Switch Signal \(TCM\)"](#) .

### OK or NG

- OK >> GO TO 4.
- NG >> Repair or replace damaged parts.

# TROUBLE DIAGNOSIS FOR SYMPTOMS

## 4. CHECK SYSTEM FOR ATP SWITCH

Perform trouble diagnosis for ATP switch system. Refer to [TF-112, "ATP Switch"](#).

OK or NG

- OK >> GO TO 5.
- NG >> Repair or replace damaged parts.

## 5. CHECK HARNESS BETWEEN TRANSFER CONTROL UNIT AND COMBINATION METER

1. Turn ignition switch "OFF". (Stay for at least 5 seconds.)
2. Disconnect transfer control unit harness connector and combination meter harness connector.
3. Check continuity between the following terminals.
  - Transfer control unit harness connector E142 terminal 15 and combination meter harness connector M24 terminal 6.

**Continuity should exist.**

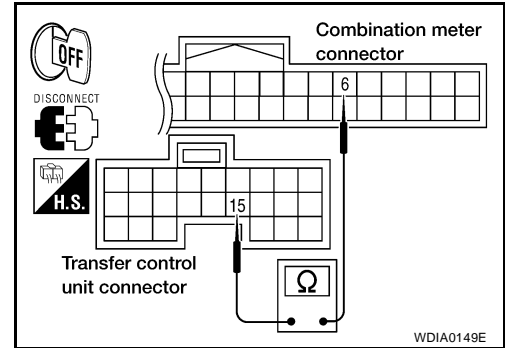

- Transfer control unit harness connector E142 terminal 40 and combination meter harness connector M24 terminal 7.

**40 to 7: Continuity should not exist.**

**7 to 40: Continuity should exist.**

Also check harness for short to ground and short to power.

OK or NG

- OK >> GO TO 6.
- NG >> Repair or replace damaged parts.

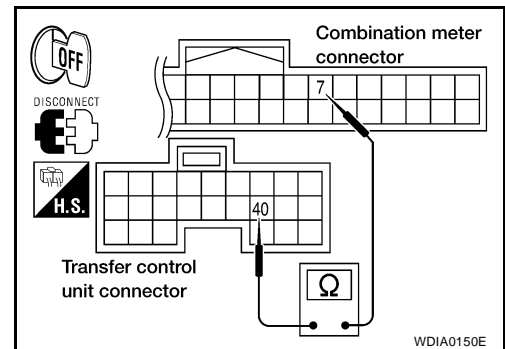

## 6. CHECK ATP WARNING LAMP CIRCUIT

1. A/T selector lever in "P" position.
2. Connect combination meter harness connector and transfer control unit harness connector.
3. Disconnect ATP switch harness connector.
4. Ground the following terminal using suitable wiring.
  - ATP switch harness connector F55 terminal 8 and ground.
5. Turn ignition switch "ON". (Do not start engine.)

Does indicator lamp turn on?

- OK >> GO TO 7.
- NG >> Replace combination meter. Refer to [IP-13, "COMBINATION METER"](#).

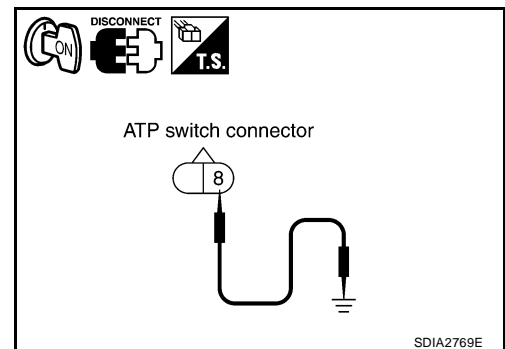

# TROUBLE DIAGNOSIS FOR SYMPTOMS

---

## 7. SYMPTOM CHECK

---

Check again.

OK or NG

- OK >> Inspection End.
- NG >> GO TO 8.

---

## 8. CHECK TRANSFER CONTROL UNIT

---

Check transfer control unit input/output signal. Refer to [TF-35, "Transfer Control Unit Input/Output Signal Reference Values"](#) .

OK or NG

- OK >> GO TO 9.
- NG >> Check transfer control unit pin terminals for damage or loose connection with harness connector. If any items are damaged, repair or replace damaged parts.

---

## 9. CHECK TRANSFER INNER PARTS

---

1. Disassemble transfer assembly. Refer to [TF-145, "Disassembly and Assembly"](#) .
2. Check transfer inner parts.

OK or NG

- OK >> Inspection End.
- NG >> Repair or replace damaged parts.

### 4LO Indicator Lamp Repeats Flashing

**SYMPTOM:**

EDS001ZE

4LO lamp keeps flashing.

#### DIAGNOSTIC PROCEDURE

### 1. CONFIRM THE SYMPTOM

---

1. Set 4WD shift switch to "2WD".
  2. Move vehicle forward and backward, or drive straight increasing or decreasing under 20 km/h (12 MPH).
- Dose 4WD shift indicator lamp keep flashing?

- YES >> GO TO 2.
- NO >> Inspection End.

---

### 2. CHECK SYSTEM FOR WAIT DETECTION SWITCH

---

Perform trouble diagnosis for wait detection switch system. Refer to [TF-66, "Wait Detection Switch"](#) .

OK or NG

- OK >> GO TO 3.
- NG >> Repair or replace damaged parts.

---

### 3. CHECK SYSTEM FOR NEUTRAL-4LO SWITCH

---

Perform trouble diagnosis for neutral-4LO switch system. Refer to [TF-59, "Neutral-4LO Switch"](#) .

OK or NG

- OK >> GO TO 4.
- NG >> Repair or replace damaged parts.

---

## 4. SYMPTOM CHECK

---

Check again.

OK or NG

- OK >> Inspection End.
- NG >> GO TO 5.

# TROUBLE DIAGNOSIS FOR SYMPTOMS

---

## 5. CHECK TRANSFER CONTROL UNIT

---

Check transfer control unit input/output signal. Refer to [TF-35, "Transfer Control Unit Input/Output Signal Reference Values"](#) .

OK or NG

OK >> GO TO 6.

NG >> Check transfer control unit pin terminals for damage or loose connection with harness connector. If any items are damaged, repair or replace damaged parts.

---

## 6. CHECK TRANSFER INNER PARTS

---

1. Disassemble transfer assembly. Refer to [TF-145, "Disassembly and Assembly"](#) .

2. Check transfer inner parts.

OK or NG

OK >> Inspection End.

NG >> Repair or replace damaged parts.

### 4WD Warning Lamp Flashes Rapidly

EDS002G5

#### SYMPTOM:

While driving, 4WD warning lamp flashes rapidly.

#### NOTE:

Rapid flashing: 2 times/second

#### DIAGNOSTIC PROCEDURE

---

### 1. CHECK TIRE

---

Check the following.

- Tire pressure
- Wear condition
- Longitudinal tire size (There is no difference between longitudinal tires.)

OK or NG

OK >> GO TO 2.

NG >> Repair or replace damaged parts.

---

### 2. CHECK 4WD WARNING LAMP

---

Stop the vehicle and allow it to idle for a short period of time.

Does flashing stop?

YES >> Inspection End.

NO >> GO TO 3.

---

### 3. CHECK TRANSFER FLUID TEMPERATURE

---

Perform trouble diagnosis for transfer fluid temperature system. Refer to [TF-101, "Transfer Fluid Temperature"](#) .

OK or NG

OK >> GO TO 4.

NG >> Repair or replace damaged parts.

---

### 4. SYMPTOM CHECK

---

Check again.

OK or NG

OK >> Inspection End.

NG >> GO TO 5.

# TROUBLE DIAGNOSIS FOR SYMPTOMS

---

## 5. CHECK TRANSFER CONTROL UNIT

---

Check transfer control unit input/output signal. Refer to [TF-35, "Transfer Control Unit Input/Output Signal Reference Values"](#) .

### OK or NG

- OK >> Inspection End.
- NG >> Check transfer control unit pin terminals for damage or loose connection with harness connector.  
If any items are damaged, repair or replace damaged parts.

## 4WD Warning Lamp Flashes Slowly

EDS001ZF

### SYMPTOM:

While driving, 4WD warning lamp flashes slowly. (When continuing to flash until turning ignition switch OFF.)

### NOTE:

Slow flashing: 1 time/2 seconds

### DIAGNOSTIC PROCEDURE

#### 1. CHECK TIRE

---

Check the following.

- Tire pressure
- Wear condition
- Longitudinal tire size (There is no difference between longitudinal tires.)

### OK or NG

- OK >> GO TO 2.
- NG >> Repair or replace damaged parts.

#### 2. CHECK TRANSFER FLUID TEMPERATURE

---

Perform trouble diagnosis for transfer fluid temperature system. Refer to [TF-101, "Transfer Fluid Temperature"](#) .

### OK or NG

- OK >> GO TO 3.
- NG >> Repair or replace damaged parts.

#### 3. CHECK CLUTCH PRESSURE SWITCH

---

Perform trouble diagnosis for clutch pressure switch system. Refer to [TF-104, "Clutch Pressure Switch"](#) .

### OK or NG

- OK >> GO TO 4.
- NG >> Repair or replace damaged parts.

#### 4. SYMPTOM CHECK

---

Check again.

### OK or NG

- OK >> Inspection End.
- NG >> GO TO 5.

## 5. CHECK TRANSFER CONTROL UNIT

---

Check transfer control unit input/output signal. Refer to [TF-35, "Transfer Control Unit Input/Output Signal Reference Values"](#) .

### OK or NG

- OK >> Inspection End.
- NG >> Check transfer control unit pin terminals for damage or loose connection with harness connector.  
If any items are damaged, repair or replace damaged parts.



# TROUBLE DIAGNOSIS FOR SYMPTOMS

## Heavy Tight-corner Braking Symptom Occurs

EDS002GG

### SYMPTOM:

Heavy tight-corner braking symptom occurs when vehicle is driven in AUTO mode and steering wheel is turned fully to either side.

### DIAGNOSTIC PROCEDURE

#### NOTE:

- Light tight-corner braking symptom may occur depending on driving conditions in AUTO mode. This is not a malfunction.
- Heavy tight-corner braking symptom occurs when vehicle is driven in the following conditions: 4WD shift switch is "4H" or "4LO", steering wheel is turned fully to either side.

### 1. CHECK SYSTEM FOR CAN COMMUNICATION LINE

Perform self-diagnosis. Refer to [TF-50, "Self-diagnostic Procedure"](#) .

Is "CAN COMM CIRCUIT [U1000]" displayed?

- YES >> Perform trouble diagnosis for CAN communication line. Refer to [TF-112, "CAN Communication Line"](#) .
- NO >> GO TO 2.

### 2. CHECK SYSTEM FOR 4WD SHIFT SWITCH

Perform trouble diagnosis for 4WD shift switch system. Refer to [TF-62, "4WD Shift Switch"](#) .

OK or NG

- OK >> GO TO 3.
- NG >> Repair or replace damaged parts.

### 3. CHECK ACCELERATOR PEDAL POSITION SIGNAL CIRCUIT

Perform self diagnosis for ECM. Refer to [EC-49, "Emission-related Diagnostic Information"](#) .

Is any malfunction detected by self-diagnosis?

- YES >> Check the malfunctioning system.
- NO >> GO TO 4.

### 4. CHECK SYSTEM FOR CLUTCH PRESSURE SOLENOID

Perform trouble diagnosis for clutch pressure solenoid system. Refer to [TF-104, "Clutch Pressure Switch"](#) .

OK or NG

- OK >> GO TO 5.
- NG >> Repair or replace damaged parts.

### 5. SYMPTOM CHECK

Check again.

OK or NG

- OK >> Inspection End.
- NG >> GO TO 6.

### 6. CHECK TRANSFER CONTROL UNIT

Check transfer control unit input/output signal. Refer to [TF-35, "Transfer Control Unit Input/Output Signal Reference Values"](#) .

OK or NG

- OK >> GO TO 7.
- NG >> Check transfer control unit pin terminals for damage or loose connection with harness connector. If any items are damaged, repair or replace damaged parts.

# TROUBLE DIAGNOSIS FOR SYMPTOMS

---

## 7. CHECK TRANSFER INNER PARTS

---

1. Disassemble transfer assembly. Refer to [TF-145, "Disassembly and Assembly"](#) .
2. Check transfer inner parts.

### OK or NG

- OK >> Inspection End.
- NG >> Repair or replace damaged parts.

## 4WD System Does Not Operate

EDS001ZG

### SYMPTOM:

The vehicle cannot be put into 4WD mode. (Hydraulic system failure)

### DIAGNOSTIC PROCEDURE

## 1. CHECK SYSTEM FOR 4WD SHIFT SWITCH

---

Perform trouble diagnosis for 4WD shift switch system. Refer to [TF-62, "4WD Shift Switch"](#) .

### OK or NG

- OK >> GO TO 2.
- NG >> Repair or replace damaged parts.

## 2. CHECK SYSTEM FOR CLUTCH PRESSURE SWITCH

---

Perform trouble diagnosis for clutch pressure switch system. Refer to [TF-104, "Clutch Pressure Switch"](#) .

### OK or NG

- OK >> GO TO 3.
- NG >> Repair or replace damaged parts.

## 3. SYMPTOM CHECK

---

Check again.

### OK or NG

- OK >> Inspection End.
- NG >> GO TO 4.

## 4. CHECK TRANSFER CONTROL UNIT

---

Check transfer control unit input/output signal. Refer to [TF-35, "Transfer Control Unit Input/Output Signal Reference Values"](#) .

### OK or NG

- OK >> GO TO 5.
- NG >> Check transfer control unit pin terminals for damage or loose connection with harness connector. If any items are damaged, repair or replace damaged parts.

## 5. CHECK TRANSFER INNER PARTS

---

1. Disassemble transfer assembly. Refer to [TF-145, "Disassembly and Assembly"](#) .
2. Check transfer inner parts.

### OK or NG

- OK >> Inspection End.
- NG >> Repair or replace damaged parts.

# TRANSFER CONTROL UNIT

PFP:33084

## TRANSFER CONTROL UNIT

EDS001ZH

### Removal and Installation

#### REMOVAL

1. Set transfer state as 2WD when 4WD shift switch is at 2WD, or as AUTO when 4WD shift switch is at AUTO.

**CAUTION:**

**When removing transfer control unit, transfer state must be at 2WD or AUTO.**

2. Turn the ignition switch OFF and disconnect negative battery terminal.
3. Remove the glove box assembly. Refer to [IP-14, "LOWER INSTRUMENT PANEL RH AND GLOVE BOX"](#).
4. Disconnect the two transfer control unit connectors.
5. Remove the transfer control unit bolts.
6. Remove the transfer control unit.

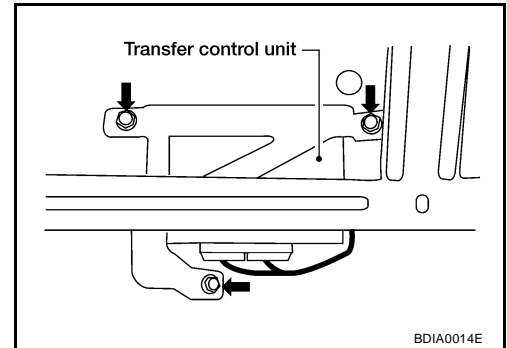

#### INSTALLATION

Installation is in the reverse order of removal.

- When installing the transfer control unit, tighten bolts to the specified torque.

**Transfer control unit bolts : 5.1 N-m (0.52 kg-m, 45 in-lb)**

**CAUTION:**

**Do not connect harness connector to transfer control unit when 4WD shift switch is at 4LO.**

- After the installation, check perform self-diagnosis. Refer to [TF-50, "Self-diagnostic Procedure"](#). If NG, adjust position between transfer assembly and transfer control unit. Refer to [TF-4, "Precautions for Transfer Assembly and Transfer Control Unit Replacement"](#).

# FRONT OIL SEAL

PFP:38189

EDS001ZI

## FRONT OIL SEAL

### Removal and Installation REMOVAL

1. Partially drain the transfer fluid. Refer to [TF-11, "DRAINING"](#) .
2. Remove the front propeller shaft. Refer to [PR-5, "REMOVAL"](#) .
3. Remove the companion flange self-lock nut using Tool.

**Tool number** : KV40104000 ( — )

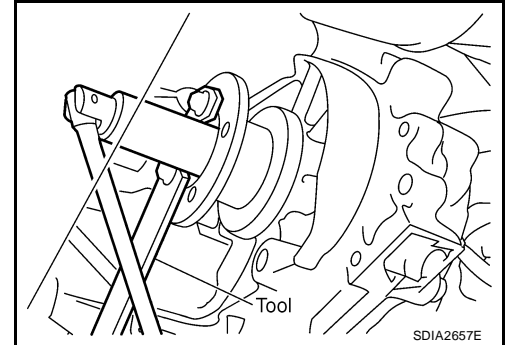

4. Put a matching mark on top of the front drive shaft in line with the mark on the companion flange.

**CAUTION:**

**Use paint to make the matching mark on the front drive shaft. Do not damage the front drive shaft.**

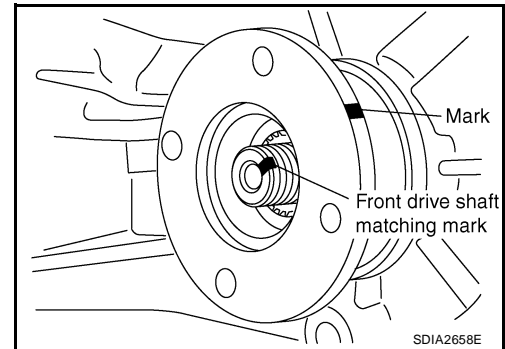

5. Remove the companion flange using suitable tool.

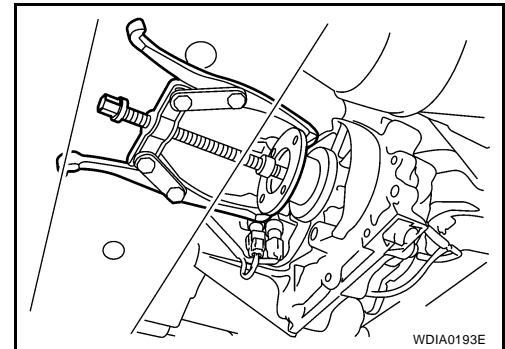

6. Remove the oil seal from the front case using Tool.

**Tool number** : KV381054S0 (J-34286)

**CAUTION:**

**Do not damage front case.**

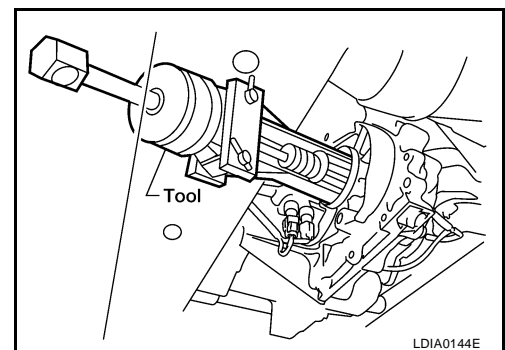

# FRONT OIL SEAL

## INSTALLATION

1. Install the new oil seal until it is flush with the end face of the front case using Tool.

**Tool number** : KV38100500 ( — )

### CAUTION:

- Do not reuse oil seal.
- Apply petroleum jelly to oil seal.

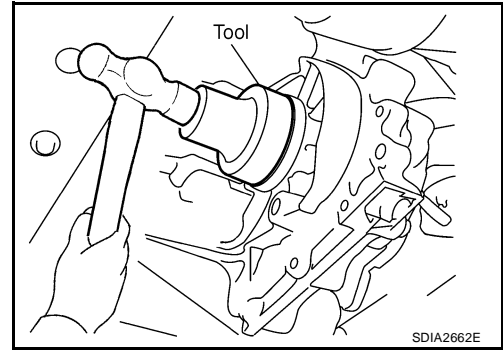

2. Align the matching mark of the front drive shaft with the matching mark of the companion flange, then install the companion flange.

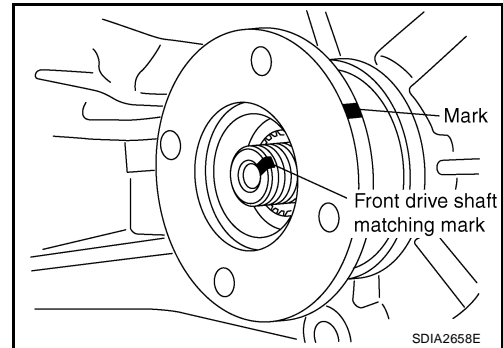

3. Install the new self-lock nut. Tighten to the specified torque using Tool. Refer to [TF-145, "COMPONENTS"](#).

**Tool number** : KV40104000 ( — )

### CAUTION:

**Do not reuse self-lock nut.**

4. Install the front propeller shaft. Refer to [PR-5, "INSTALLATION"](#).
5. Refill the transfer with fluid and check fluid level. Refer to [TF-11, "TRANSFER FLUID"](#).
6. Check the transfer for fluid leakage. Refer to [TF-11, "FLUID LEAKAGE AND FLUID LEVEL"](#).

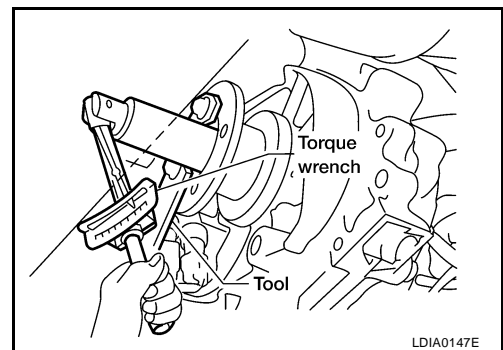

# REAR OIL SEAL

## REAR OIL SEAL

PF3:33140

### Removal and Installation

EDS001ZJ

#### REMOVAL

1. Partially drain the transfer fluid. Refer to [TF-11, "DRAINING"](#).
2. Remove the rear propeller shaft. Refer to [PR-9, "REMOVAL"](#).
3. Remove the dust cover from the rear case.

**CAUTION:**

Do not damage the rear case.

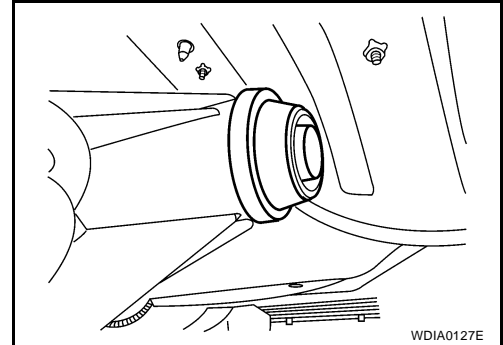

4. Remove the rear oil seal from the rear case using Tool.

**CAUTION:**

Do not damage the rear case.

Tool number : KV381054S0 (J-34286)

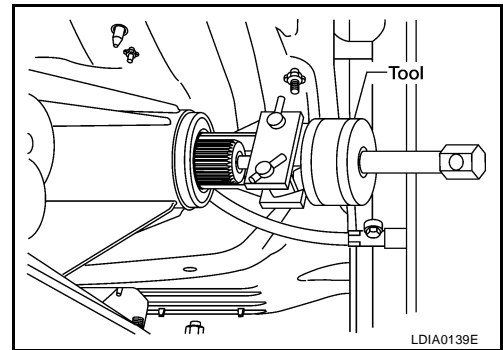

#### INSTALLATION

1. Install the new oil seal until it is flush with the end face of the rear case using Tool.

Tool number : ST30720000 (J-25405)

**CAUTION:**

- Do not reuse oil seal.
- Apply petroleum jelly to oil seal.

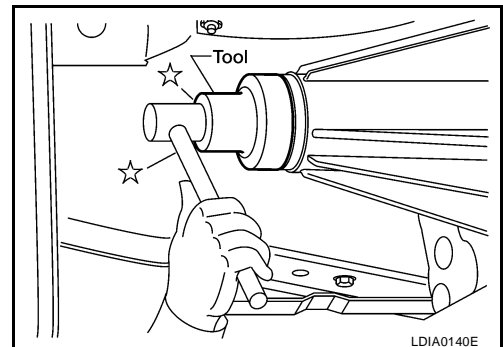

2. Apply petroleum jelly to the circumference of the new dust cover. Position the new dust cover using the identification mark as shown.

**CAUTION:**

- Do not reuse dust cover.
- Position the identification mark at the position shown.

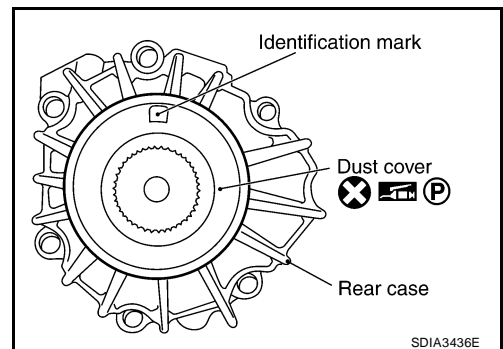

## REAR OIL SEAL

3. Install the new dust cover to the rear case using Tool.

**Tool number** : KV40105310 ( — )

**CAUTION:**

- Do not reuse dust cover.
  - Apply petroleum jelly to dust cover.
4. Install the rear propeller shaft. Refer to [PR-9, "INSTALLATION"](#) .
  5. Refill the transfer with fluid and check fluid level. Refer to [TF-11, "FILLING"](#) .
  6. Check the transfer for fluid leakage. Refer to [TF-11, "FLUID LEAKAGE AND FLUID LEVEL"](#) .

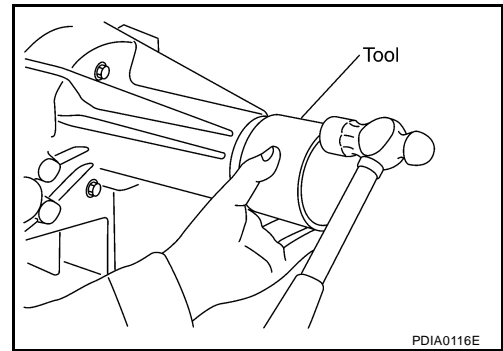

PDIA0116E

A  
B  
C

TF

E  
F  
G  
H  
I  
J  
K  
L  
M

# SIDE OIL SEAL

## SIDE OIL SEAL

PFP:33142

### Removal and Installation

EDS001ZK

#### REMOVAL

1. Remove the front propeller shaft. Refer to [PR-5, "REMOVAL"](#) .
2. Remove the companion flange. Refer to [TF-132, "REMOVAL"](#) .
3. Remove the transfer control device from the transfer assembly. Refer to [TF-137, "Removal and Installation"](#) .
4. Remove the side oil seal using suitable tool.

**CAUTION:**

**Do not damage shift cross.**

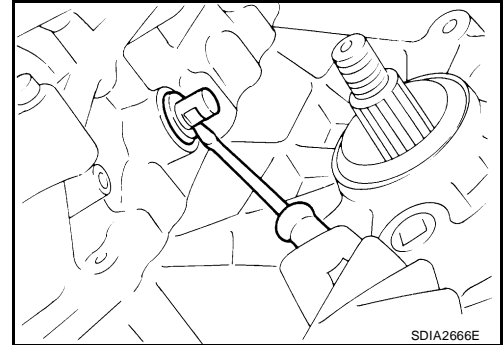

#### INSTALLATION

1. Install the new side oil seal until it is flush with the end face of case using Tool.

**Tool number : ST22360002 (J-25679-01)**

**CAUTION:**

- Do not reuse oil seal.
  - Apply petroleum jelly to oil seal.
2. Install the transfer control device to the transfer assembly. Refer to [TF-137, "Removal and Installation"](#) .
  3. Install the companion flange. Refer to [TF-132, "Removal and Installation"](#) .
  4. Install the front propeller shaft. Refer to [PR-4, "Removal and Installation"](#) .

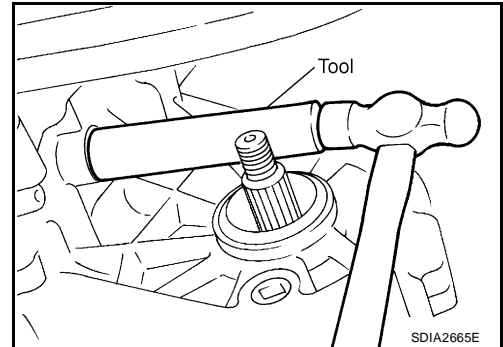



# TRANSFER CONTROL DEVICE

## TRANSFER CONTROL DEVICE

PFP:33251

### Removal and Installation

EDS001ZL

SEC.333

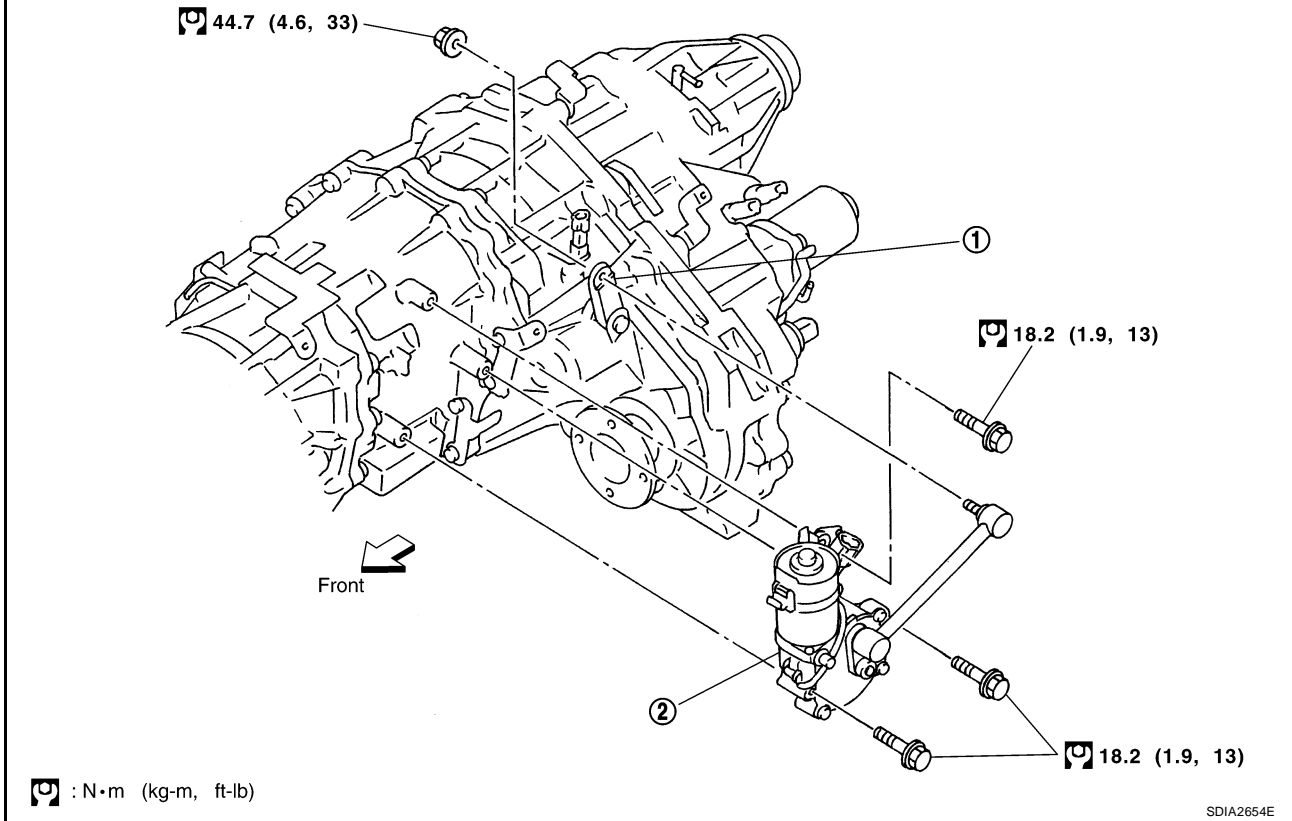

1. Shift lever

2. Transfer control device

#### CAUTION:

- Change vehicle state to 2WD, and then remove and install transfer control device.
- Check 4WD shift indicator after installation. Refer to [TF-4. "Precautions for Transfer Assembly and Transfer Control Unit Replacement"](#).

A  
B  
C  
TF  
E  
F  
G  
H  
I  
J  
K  
L  
M

# AIR BREATHER HOSE

## AIR BREATHER HOSE

PF3:31098

### Removal and Installation

EDS001ZM

SEC.310

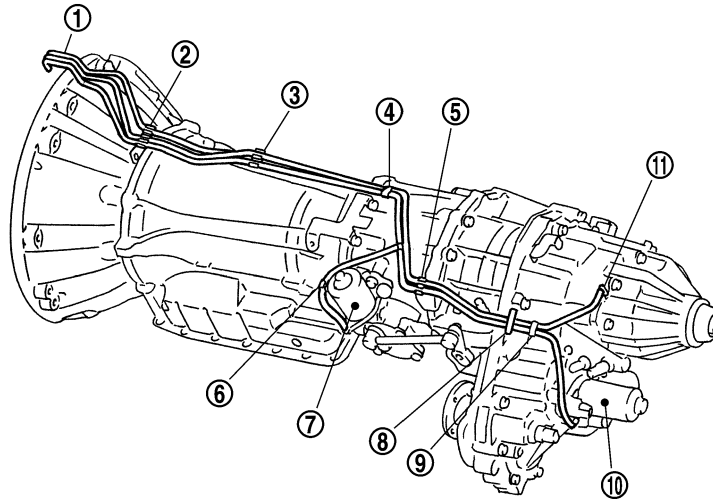

SDIA3339E

- |                    |                              |           |
|--------------------|------------------------------|-----------|
| 1. Breather tube   | 2. Clip A                    | 3. Clip B |
| 4. Clip C          | 5. Clip D                    | 6. Clip E |
| 7. Actuator        | 8. Air breather hose clamp   | 9. Clip F |
| 10. Transfer motor | 11. Breather tube (transfer) |           |

#### CAUTION:

- Make sure there are no pinched or restricted areas on each air breather hose caused by bending or winding when installing it.
- Install each air breather hose into the breather tube (metal connector) until the hose end reaches the end of the curve section. Set each air breather hose with paint mark facing upward.

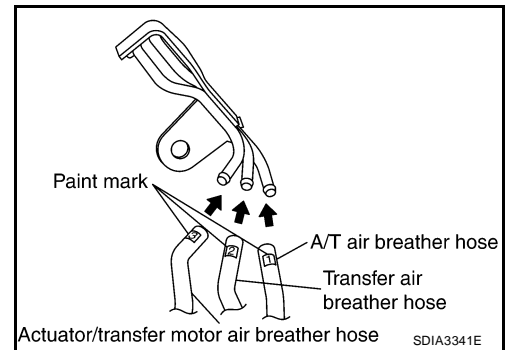

SDIA3341E

- Install actuator/transfer motor air breather hose and transfer air breather hose on clip A and clip B with the paint mark facing upward.

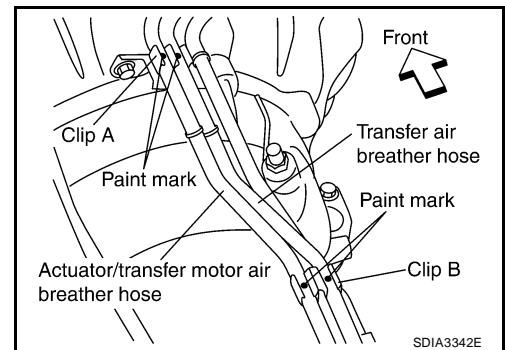

SDIA3342E

# AIR BREATHER HOSE

- Install clip C on actuator/transfer motor air breather hose and transfer air breather hose with the paint mark matched.

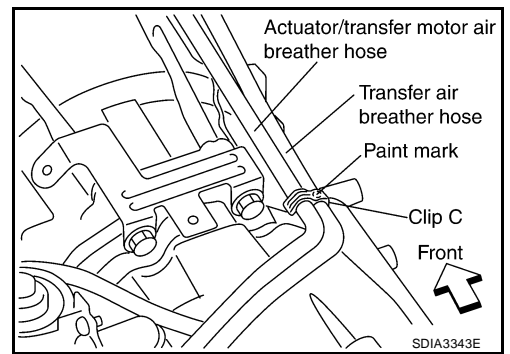

- Install actuator/transfer motor air breather hose and transfer air breather hose on clip D and clip E with the paint mark facing upward.

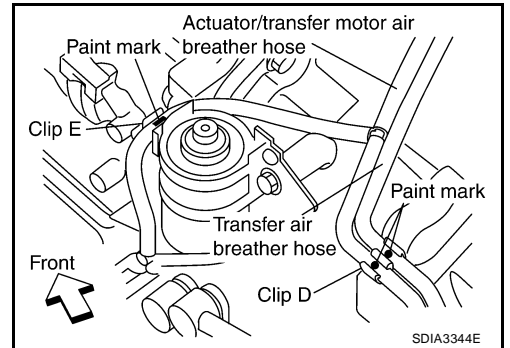

- Install the actuator air breather hose into the actuator (case connector) until the hose end reaches the base of the tube. Set actuator air breather hose with paint mark facing leftward.

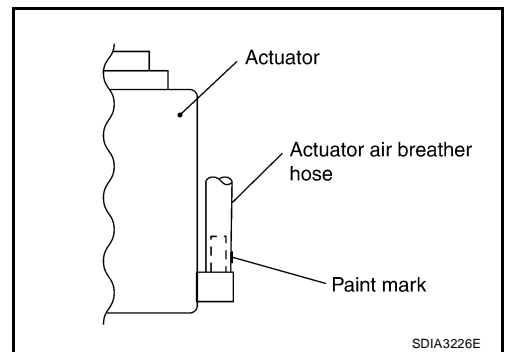

- Install clip F on transfer motor air breather hose and transfer air breather hose with the paint mark matched.

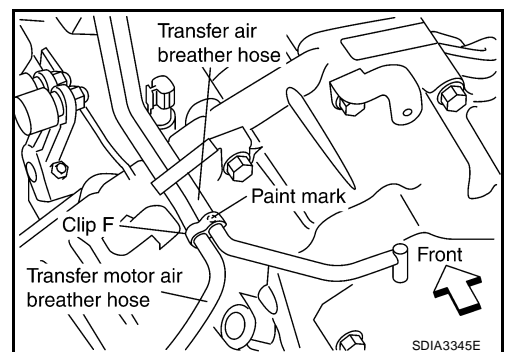

- Install the transfer air breather hose into the breather tube (transfer, metal connector) until the hose end reaches the base of the tube. Set transfer air breather hose with paint mark facing upwards.

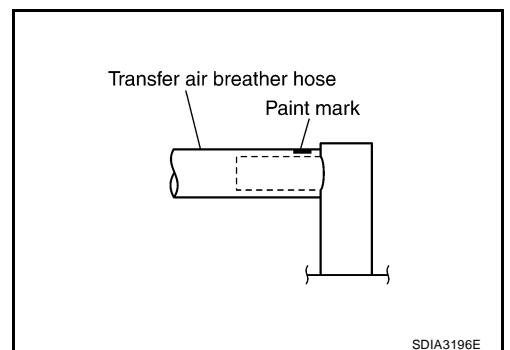

A  
B  
C  
TF  
E  
F  
G  
H  
I  
J  
K  
L  
M

## AIR BREATHER HOSE

- Install the transfer motor air breather hose into the transfer motor (case connector) until the hose end reaches the end of the curved section. Set transfer motor air breather hose with paint mark facing leftward.

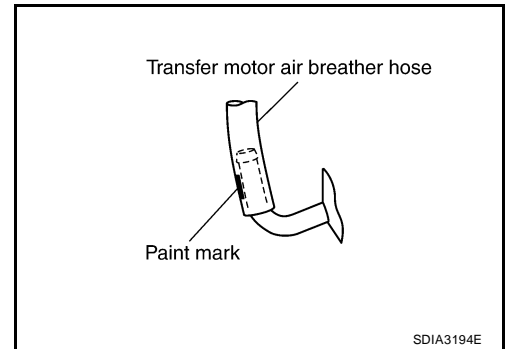

# TRANSFER MOTOR

PFP:00000

EDS001ZN

## TRANSFER MOTOR

### Removal and Installation

#### REMOVAL

1. Disconnect the transfer motor connector.
2. Remove the transfer motor air breather hose from the transfer motor. Refer to [TF-138, "Removal and Installation"](#) .
3. Remove the transfer motor bolts.
4. Remove the transfer motor.

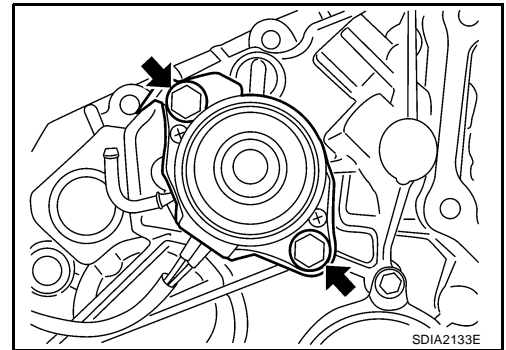

#### INSTALLATION

1. Apply ATF to the new O-ring and install it to the transfer motor.  
**CAUTION:**  
**Do not reuse O-rings.**
2. Fit the double-flat end of the transfer motor shaft into the slot of the sub-oil pump assembly. Then tighten to the specified torque. Refer to [TF-145, "COMPONENTS"](#) .  
**CAUTION:**  
**Be sure to install connector bracket.**
3. Install the transfer motor air breather hose to the transfer motor. Refer to [TF-138, "Removal and Installation"](#) .
4. Connect the transfer motor connector.
5. Check the transfer fluid. Refer to [TF-11, "FILLING"](#) .
6. Start the engine for one minute. Then stop the engine and recheck the transfer fluid. Refer to [TF-11, "FLUID LEAKAGE AND FLUID LEVEL"](#) .

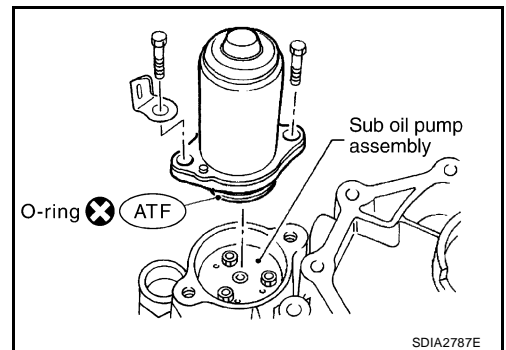

# TRANSFER OIL FILTER

PFP:00000

EDS001Z0

## TRANSFER OIL FILTER

### Removal and Installation

#### REMOVAL

1. Remove the oil filter bolts and oil filter.

**CAUTION:**

- Do not damage center case and oil filter.
- Loosen bolts and detach oil filter evenly.

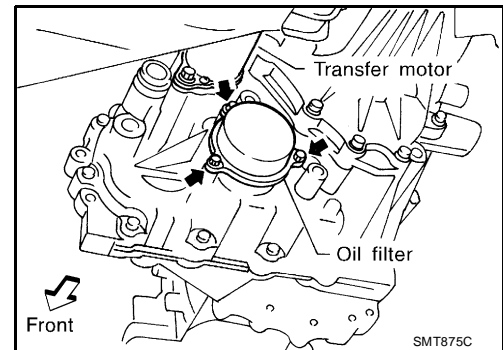

2. Remove the O-rings (1) from the oil filter (2).

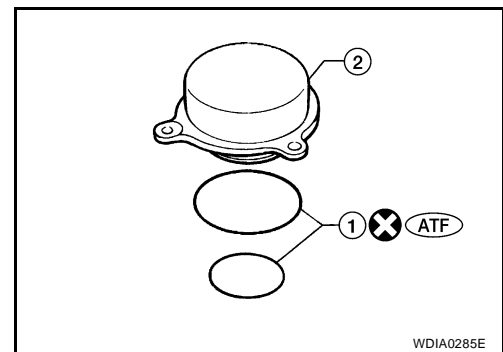

3. Remove the oil filter stud from the oil filter.
4. Remove the O-ring from the oil filter stud.

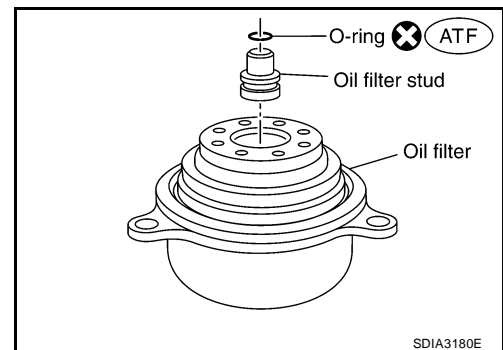

#### INSTALLATION

1. Apply ATF to the new O-ring, and install it on the oil filter stud.

**CAUTION:**

**Do not reuse O-ring.**

2. Install the oil filter stud to the oil filter.

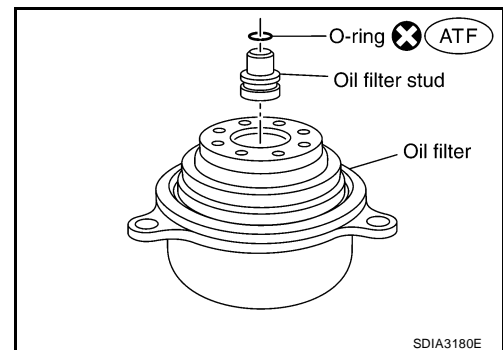

# TRANSFER OIL FILTER

3. Apply ATF to the two new O-rings (1), and install them on the oil filter (2).

**CAUTION:**

**Do not reuse O-rings.**

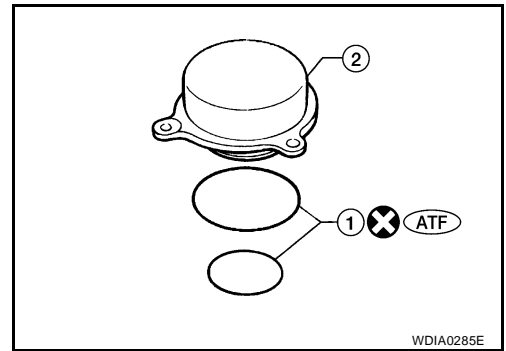

4. Install the oil filter to the transfer assembly. Tighten the bolts to the specified torque. Refer to [TF-145, "COMPONENTS"](#).

**CAUTION:**

- Do not damage oil filter.
- Attach oil filter and tighten bolts evenly.

5. Check the transfer fluid. Refer to [TF-11, "TRANSFER FLUID"](#).
6. Start the engine and let it run for one minute. Then stop the engine and recheck the transfer fluid. Refer to [TF-11, "TRANSFER FLUID"](#).

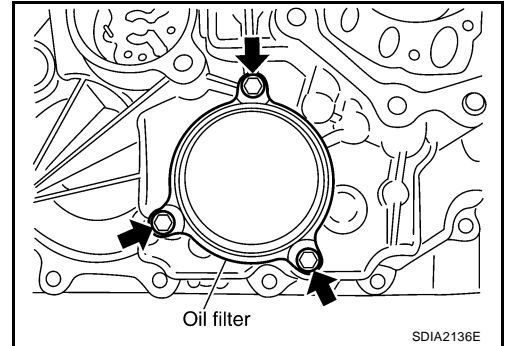

A  
B  
C  
TF  
E  
F  
G  
H  
I  
J  
K  
L  
M

# TRANSFER ASSEMBLY

PFP:33100

EDS001ZP

## TRANSFER ASSEMBLY

### Removal and Installation

#### REMOVAL

1. Remove the drain plug and gasket. Drain the fluid. Refer to [TF-11, "DRAINING"](#) .
2. Remove the A/T undercover using power tool.
3. Remove the center exhaust tube and main muffler. Refer to [EX-4, "REMOVAL"](#) .
4. Remove the front and rear propeller shafts. Refer to [PR-5, "REMOVAL"](#) (front), [PR-9, "REMOVAL"](#) (rear).

#### CAUTION:

**Do not damage spline, sleeve yoke and rear oil seal when removing rear propeller shaft.**

#### NOTE:

Insert a plug into the rear oil seal after removing the rear propeller shaft.

5. Remove the A/T nuts from the A/T crossmember.
6. Position two suitable jacks under the A/T and transfer assembly.
7. Remove the crossmember. Refer to [AT-246, "COMPONENTS"](#) .

#### WARNING:

**Support A/T and transfer assembly using two suitable jacks while removing crossmember.**

8. Disconnect the electrical connectors from the following:
  - ATP switch
  - Neutral 4LO switch
  - Wait detection switch
  - Transfer motor
  - Transfer control device
  - Transfer terminal cord assembly
9. Disconnect each air breather hose from the following. Refer to [TF-138, "Removal and Installation"](#) .
  - Actuator
  - Breather tube (transfer)
  - Transfer motor (case connector)
10. Remove the transfer control device from the extension housing.
11. Remove the transfer to A/T and A/T to transfer bolts.

#### WARNING:

**Support transfer assembly with suitable jack while removing it.**

12. Remove the transfer assembly.

#### INSTALLATION

Installation is in the reverse order of removal.

- Tighten the bolts to specification.

**Bolt length : 45 mm (1.77 in)**

**Transfer bolt torque : 36 N·m (3.7 kg·m, 27 ft·lb)**

- After installation check the transfer fluid level and for fluid leakage. Refer to [TF-11, "TRANSFER FLUID"](#) .
- After filling, start the engine and let it run for one minute. Then stop the engine and recheck the transfer fluid.

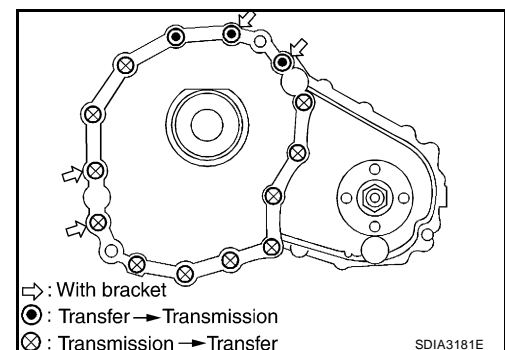



# TRANSFER ASSEMBLY

EDS001ZQ

## Disassembly and Assembly COMPONENTS

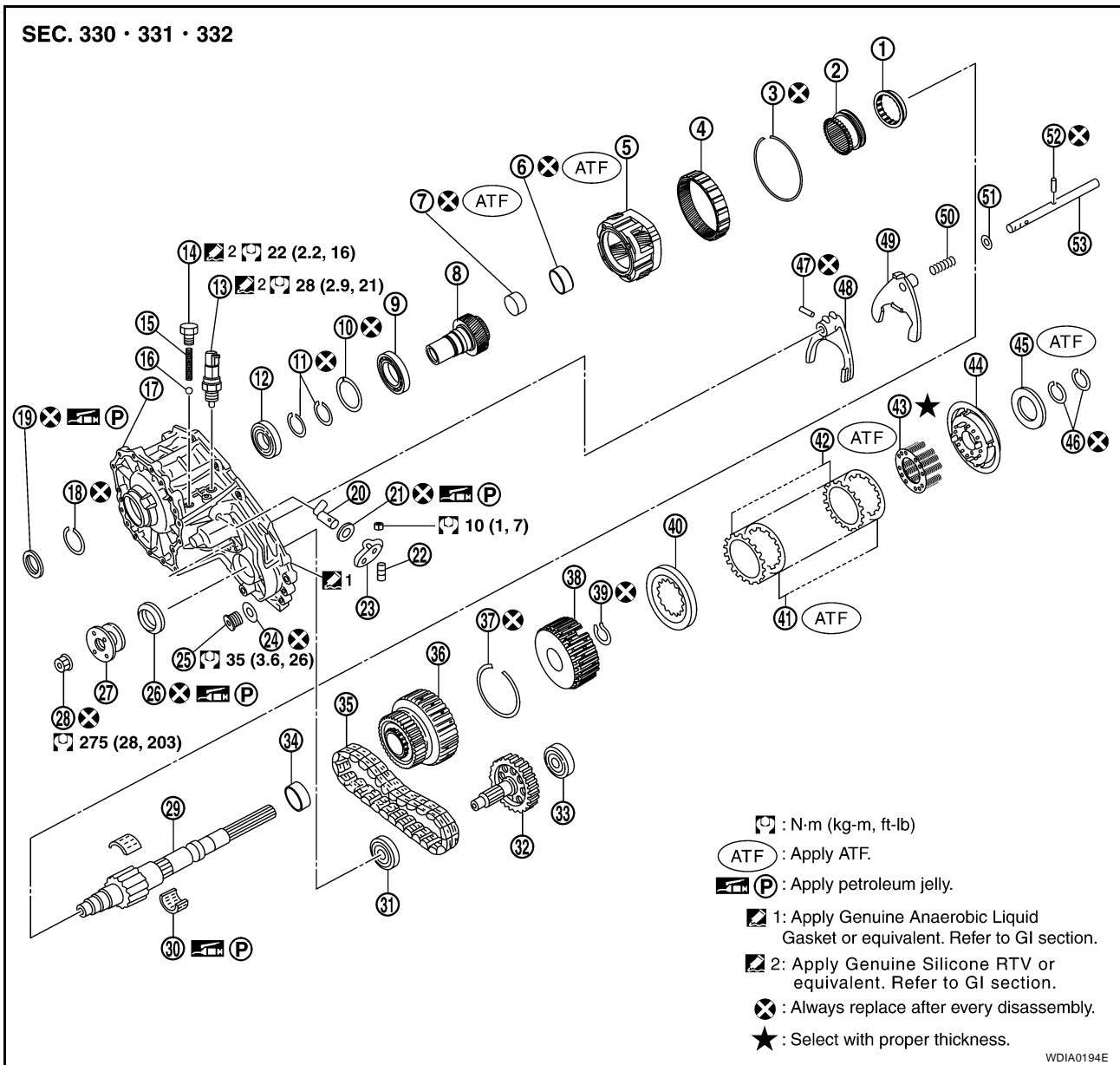

- |                            |                               |                            |
|----------------------------|-------------------------------|----------------------------|
| 1. 2-4 sleeve              | 2. L-H sleeve                 | 3. Snap ring               |
| 4. Internal gear           | 5. Planetary carrier assembly | 6. Metal bushing           |
| 7. Needle bearing          | 8. Sun gear                   | 9. Carrier bearing         |
| 10. Snap ring              | 11. Snap ring                 | 12. Input bearing          |
| 13. Wait detection switch  | 14. Check plug                | 15. Check spring           |
| 16. Check ball             | 17. Front case                | 18. Snap ring              |
| 19. Input oil seal         | 20. Shift cross               | 21. Side oil seal          |
| 22. Lock pin               | 23. Shift lever               | 24. Gasket                 |
| 25. Drain plug             | 26. Front oil seal            | 27. Companion flange       |
| 28. Self-lock nut          | 29. Mainshaft                 | 30. Needle bearing         |
| 31. Front bearing          | 32. Front drive shaft         | 33. Rear bearing           |
| 34. Spacer                 | 35. Drive chain               | 36. Clutch drum            |
| 37. Snap ring              | 38. Clutch hub                | 39. Snap ring              |
| 40. Retaining plate        | 41. Driven plate (10 sheet)   | 42. Drive plate (10 sheet) |
| 43. Return spring assembly | 44. Press flange              | 45. Thrust needle bearing  |
| 46. Snap ring              | 47. Retaining pin             | 48. L-H fork               |

A  
B  
C  
TF  
E  
F  
G  
H  
I  
J  
K  
L  
M

# TRANSFER ASSEMBLY

- 49. 2-4 fork
- 52. Retainer pin

- 50. Shift fork spring
- 53. Shift rod

- 51. Fork guide

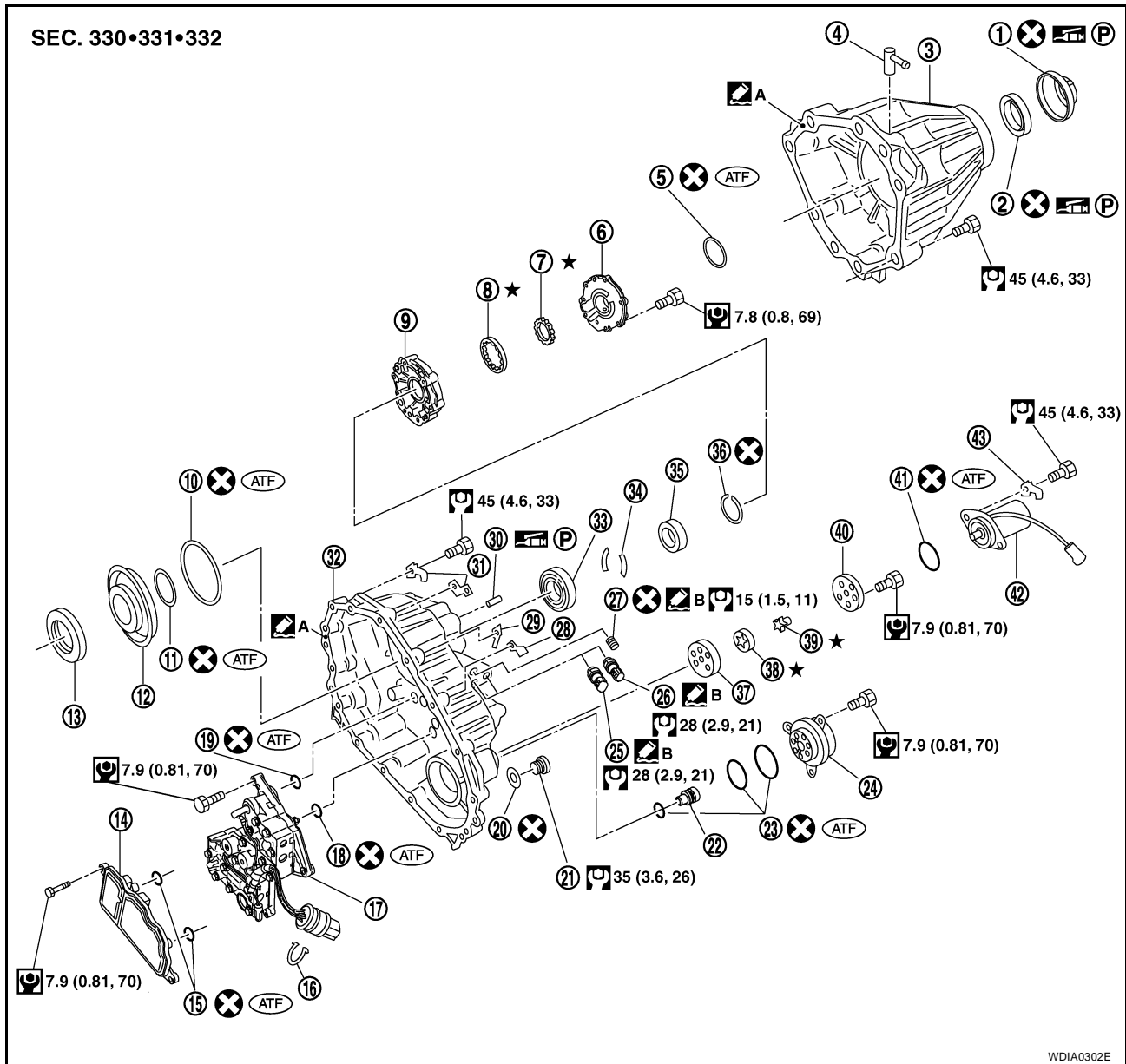

WDIA0302E

- |                                |                             |                               |
|--------------------------------|-----------------------------|-------------------------------|
| 1. Dust cover                  | 2. Rear oil seal            | 3. Rear case                  |
| 4. Breather tube               | 5. Seal ring                | 6. Main oil pump cover        |
| 7. Inner gear                  | 8. Outer gear               | 9. Main oil pump housing      |
| 10. D-ring                     | 11. D-ring                  | 12. Clutch piston             |
| 13. Thrust needle bearing race | 14. Oil strainer            | 15. O-ring                    |
| 16. Snap ring                  | 17. Control valve assembly  | 18. Lip seal (large 5 pieces) |
| 19. Lip seal (small 2 pieces)  | 20. Gasket                  | 21. Filler plug               |
| 22. Oil filter stud            | 23. O-ring                  | 24. Oil filter                |
| 25. ATP switch                 | 26. Neutral-4LO switch      | 27. Oil pressure check plug   |
| 28. Harness bracket            | 29. Air breather hose clamp | 30. Stem bleeder              |
| 31. Harness bracket            | 32. Center case             | 33. Mainshaft rear bearing    |
| 34. C-ring                     | 35. Washer holder           | 36. Snap ring                 |
| 37. Sub oil pump housing       | 38. Outer gear              | 39. Inner gear                |

# TRANSFER ASSEMBLY

- 40. Sub oil pump cover
- 43. Connector bracket

- 41. O-ring
- A. Apply Genuine Anaerobic Liquid Gasket, Three Bond TB1133C or equivalent.

- 42. Transfer motor
- B. Apply Genuine Liquid Gasket, Three Bond TB1215 or equivalent.

## DISASSEMBLY

### Rear Case

1. Remove the rear case bolts.

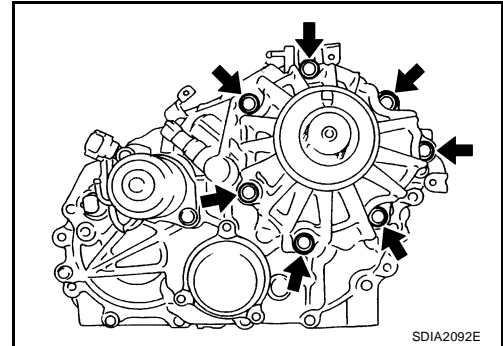

2. Remove the rear case from the center case.

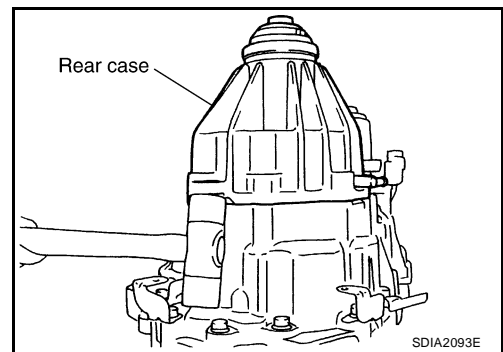

3. Remove the dust cover using suitable tool.

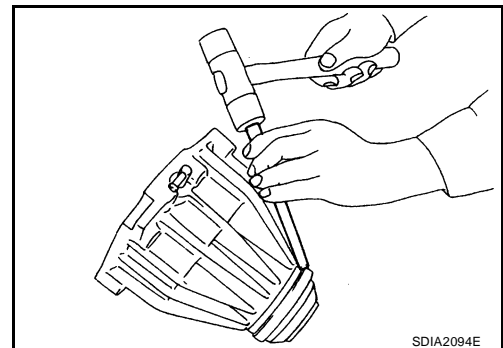

4. Remove the rear oil seal using suitable tool.

**CAUTION:**  
**Do not damage rear case.**

5. Remove the breather tube.

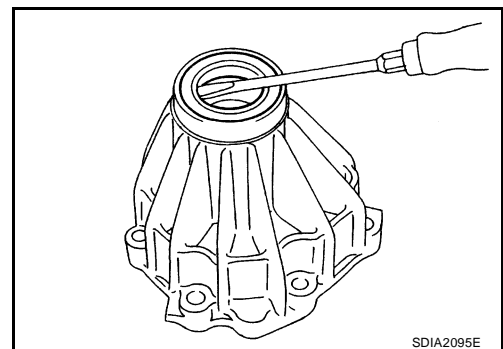

A  
B  
C  
TF  
E  
F  
G  
H  
I  
J  
K  
L  
M

# TRANSFER ASSEMBLY

## Front Case

1. Remove the rear case assembly. Refer to [TF-147, "Rear Case"](#).
2. Remove the lock pin nut.
3. Remove the lock pin using suitable tool.
4. Remove the shift lever.

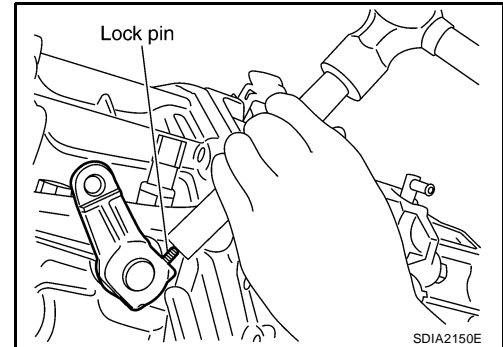

5. Remove the side oil seal from the front case using suitable tool.  
**CAUTION:**  
**Do not damage front case or shift cross.**

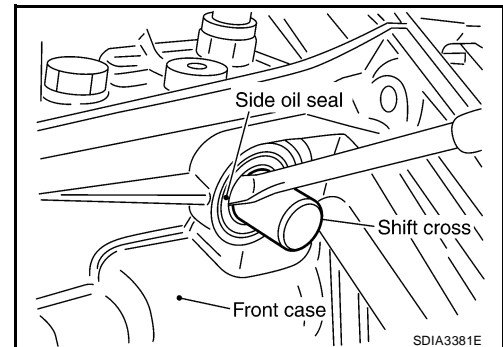

6. Remove the check plug, check spring and check ball.
7. Remove the wait detection switch.

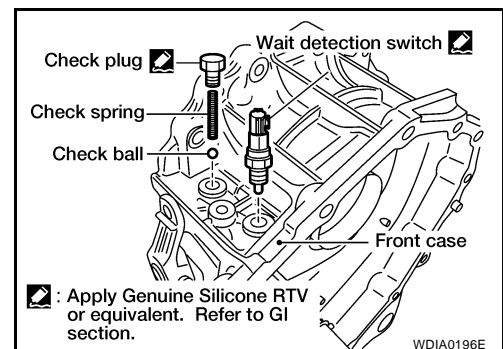

8. Remove the self-lock nut from the companion flange using Tool.  
**Tool number : KV40104000 ( — )**

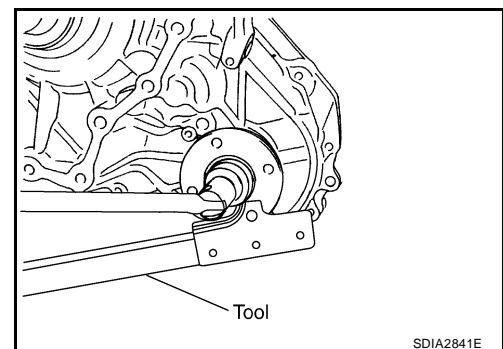

# TRANSFER ASSEMBLY

9. Put a matching mark on top of the front drive shaft thread in line with the mark on the companion flange.

**CAUTION:**

Use paint to make the matching mark on the front drive shaft thread. Never damage the front drive shaft.

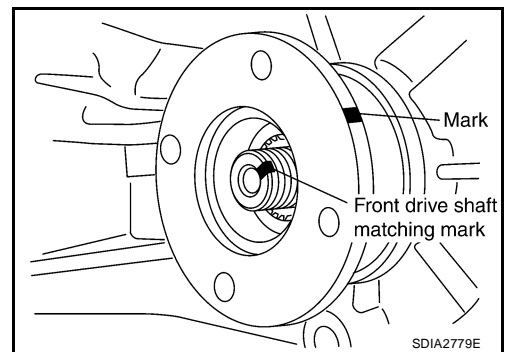

10. Remove the companion flange using suitable tool.

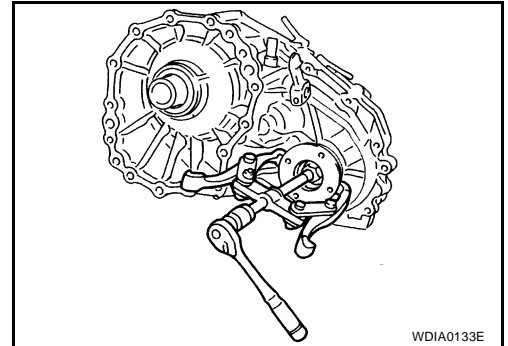

11. Remove the center case bolts, harness bracket and air breather hose clamp.  
12. Remove the filler plug and gasket.

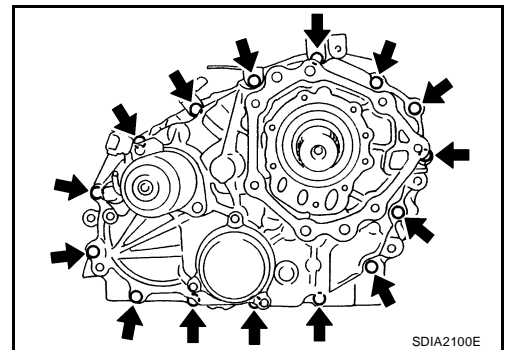

13. Separate the center case from the front case. Then remove the center case from the front case by prying it up using suitable tools.

**CAUTION:**

Do not damage the mating surfaces.

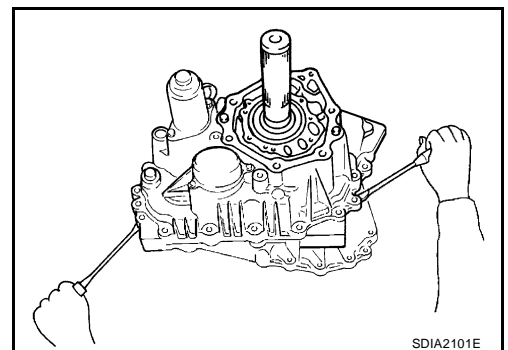

14. Remove the shift rod components together with the 2-4 sleeve and L-H sleeve.  
15. Remove the shift cross from the front case.

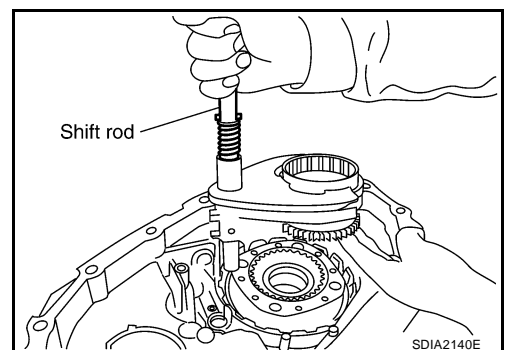

A  
B  
C  
TF  
E  
F  
G  
H  
I  
J  
K  
L  
M

## TRANSFER ASSEMBLY

16. Remove the 2-4 sleeve and L-H sleeve from the 2-4 fork and L-H fork respectively.

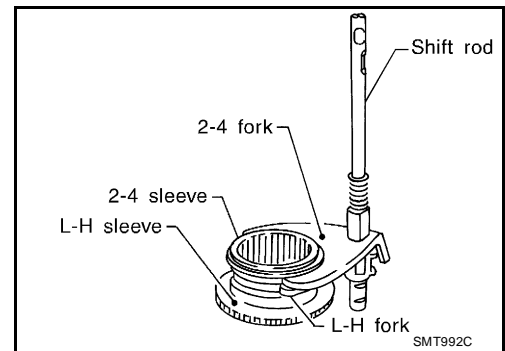

17. Drive out the retaining pin from the shift rod using suitable tool.

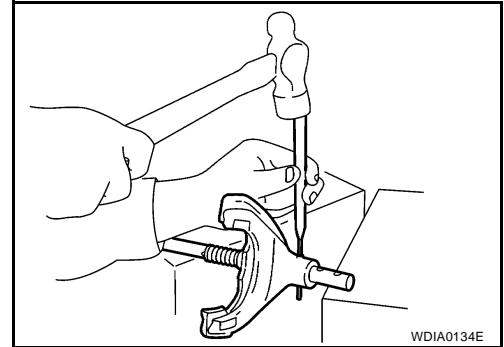

18. Remove the L-H fork, 2-4 fork, shift fork spring and fork guide from the shift rod.

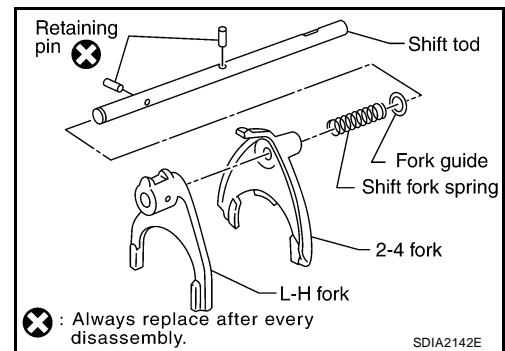

19. Remove the input oil seal from the front case using suitable tool.

**CAUTION:**  
Do not damage front case or sun gear.

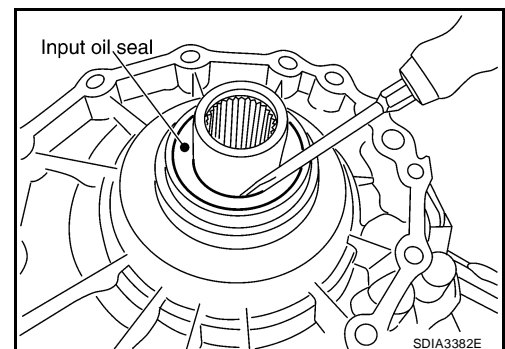

20. Remove the snap ring from the sun gear.

**CAUTION:**  
Do not damage front case or sun gear.

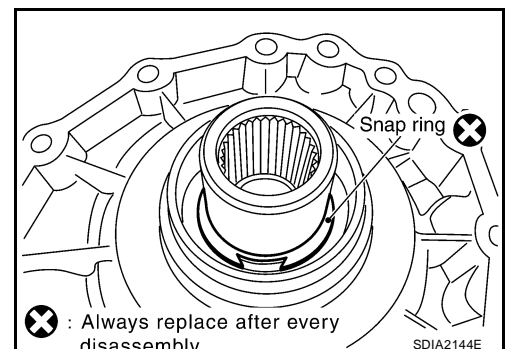

# TRANSFER ASSEMBLY

21. Remove the sun gear assembly and planetary carrier assembly from the front case using Tool.

**Tool number** : ST35300000 ( — )

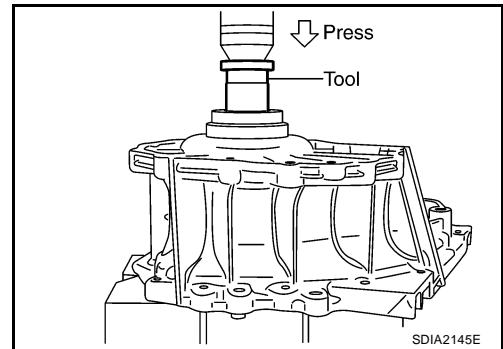

22. Remove the snap ring and internal gear using suitable tool.

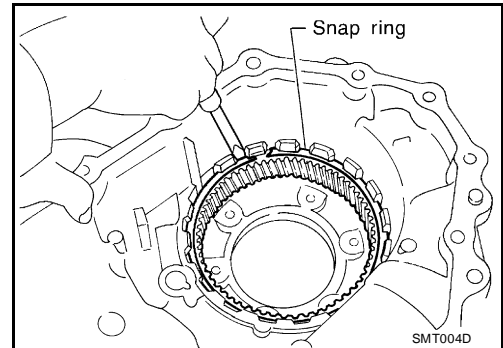

23. Remove the front oil seal using suitable tool.

**CAUTION:**  
Do not damage front case.

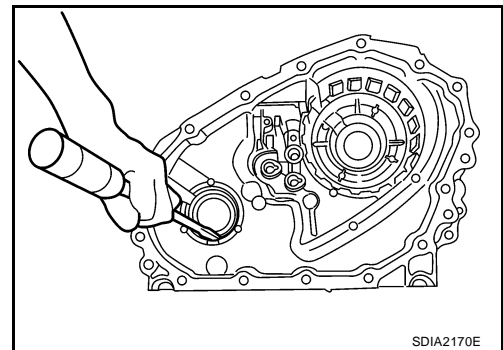

24. Remove the snap ring from the front case.

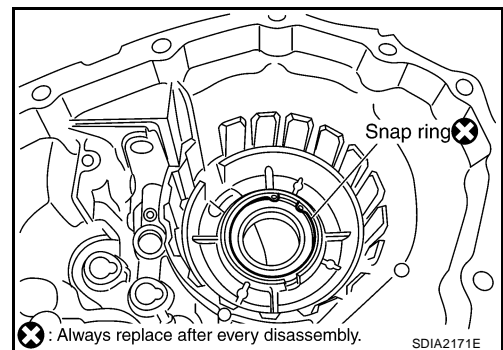

25. Remove the input front bearing from the front case using Tool.

**Tool number** : ST33200000 (J-26082)

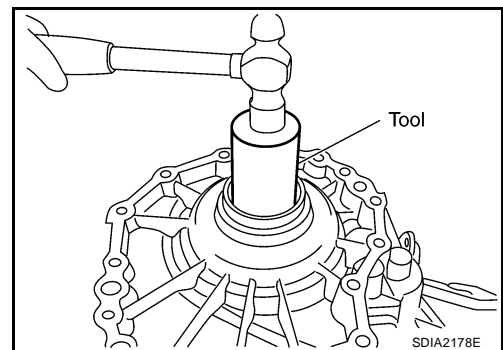

A  
B  
C  
TF  
E  
F  
G  
H  
I  
J  
K  
L  
M

# TRANSFER ASSEMBLY

26. Remove the snap ring from the planetary carrier assembly using suitable tool.

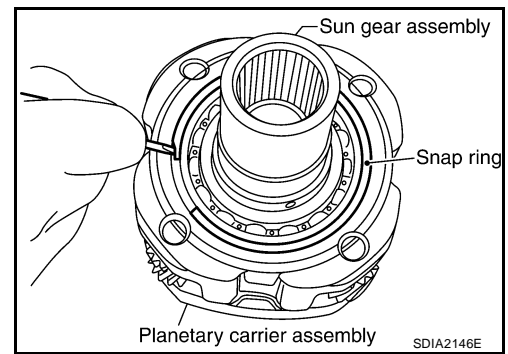

27. Remove the sun gear assembly from the planetary carrier assembly.

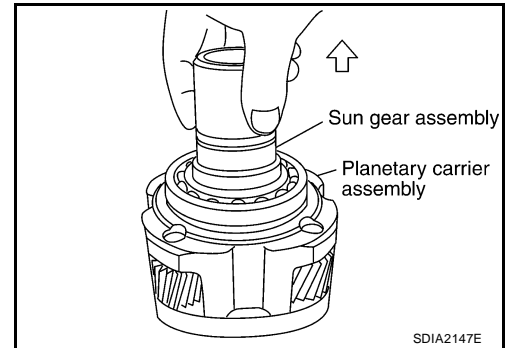

28. Remove the snap ring from the sun gear assembly using suitable tool.

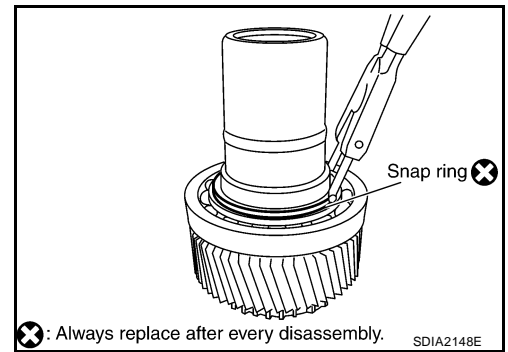

29. Remove the carrier bearing from the sun gear using Tools.

**Tool number**      **A: ST35300000 ( — )**

**B: ST30031000 ( — )**

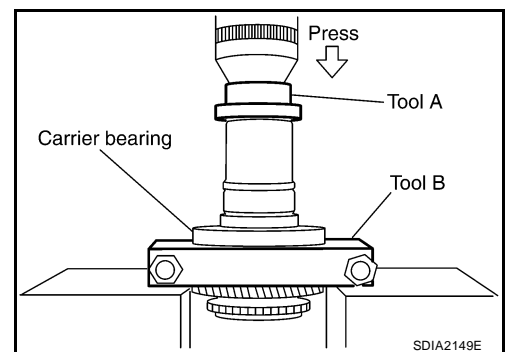

30. Remove the needle bearing from the sun gear using Tool.

**Tool number**      **: ST33710000 ( — )**

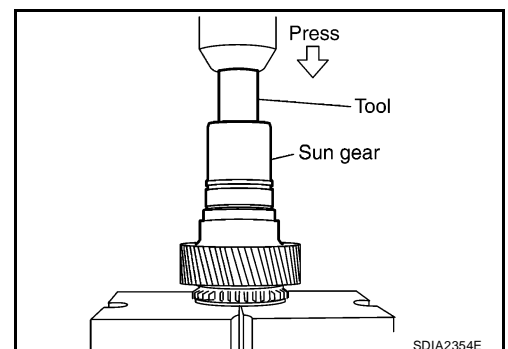



# TRANSFER ASSEMBLY

31. Remove the metal bushing from the sun gear using Tools.

- Tool number**      **A: ST33710000 ( — )**  
                              **B: ST35325000 ( — )**  
                              **C: KV381054S0 (J-34286)**

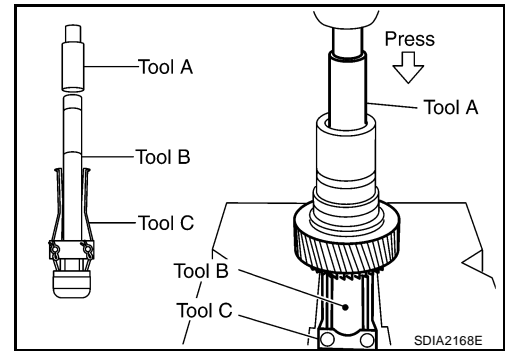

## Center Case

1. Remove the rear case assembly. Refer to [TF-147, "Rear Case"](#).
2. Remove the front case assembly. Refer to [TF-148, "Front Case"](#).
3. Hold the front drive shaft with one hand and tap to remove the front drive shaft with the drive chain.

**CAUTION:**  
**Do not tap drive chain.**

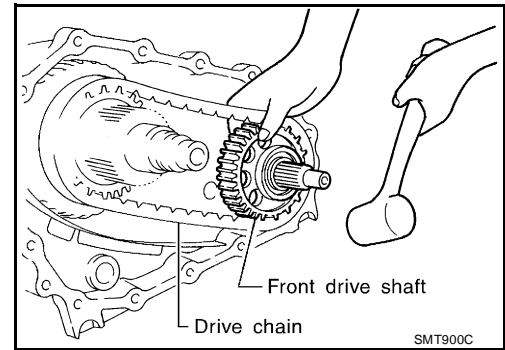

4. Remove the front drive shaft front bearing using Tools.

- Tool number**      **A: ST33052000 ( — )**  
                              **B: ST30031000 ( — )**

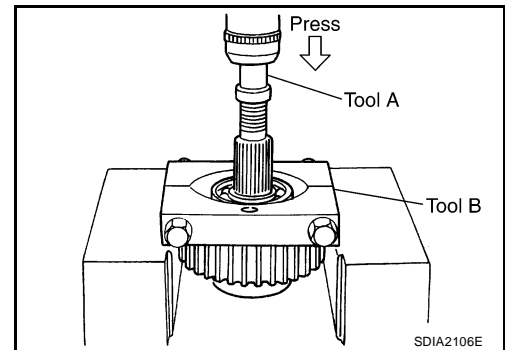

5. Remove the front drive shaft rear bearing using Tools.

- Tool number**      **A: ST33052000 ( — )**  
                              **B: ST30031000 ( — )**

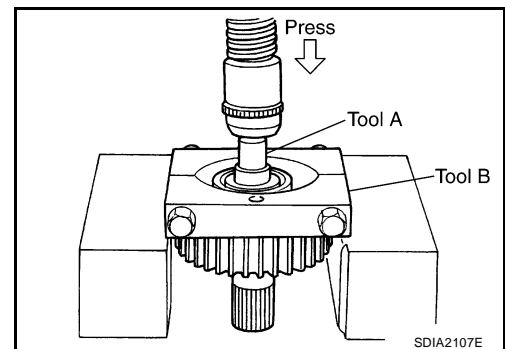

# TRANSFER ASSEMBLY

6. Remove the neutral-4LO and ATP switches.

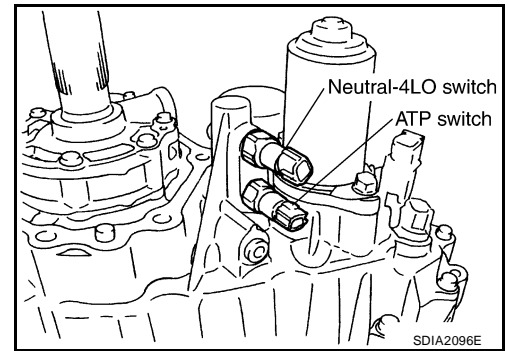

7. Remove the bolts and main oil pump cover.

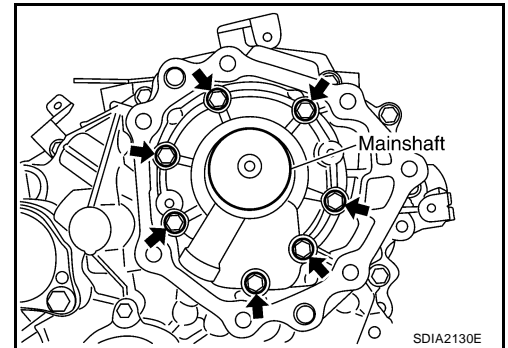

8. Remove the outer gear, inner gear and main oil pump housing from the center case.

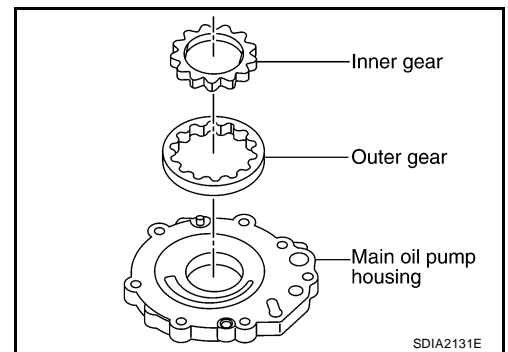

9. Remove the seal ring from the main oil pump cover.

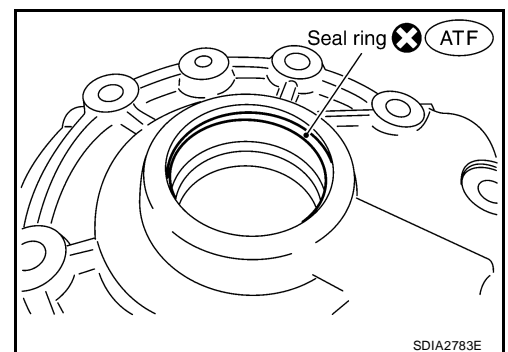

10. Remove the stem bleeder from the bleed hole.

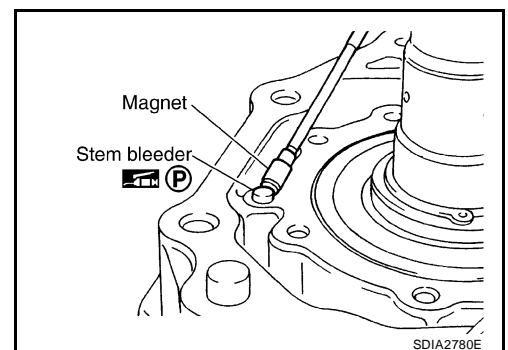

# TRANSFER ASSEMBLY

11. Remove the snap ring and washer holder from the mainshaft.

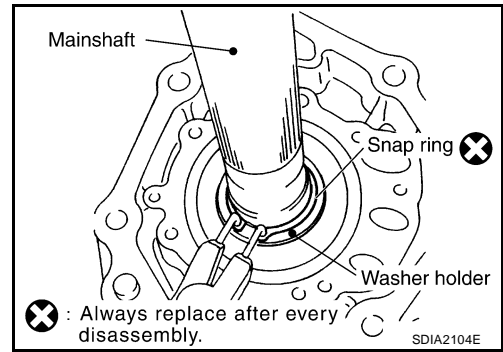

12. Remove the C-rings from the mainshaft using suitable tool.

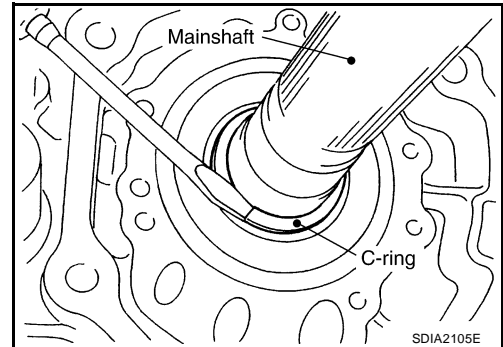

13. Set the center case on the press stand. Remove the mainshaft from the center case.

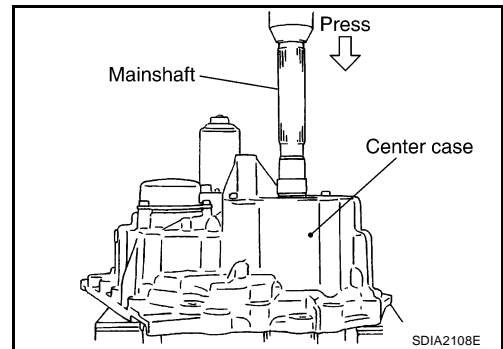

14. Remove the snap ring from the mainshaft using suitable tool.

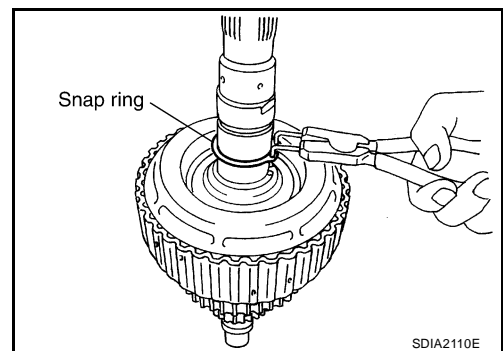

15. Remove the thrust needle bearing from the press flange.

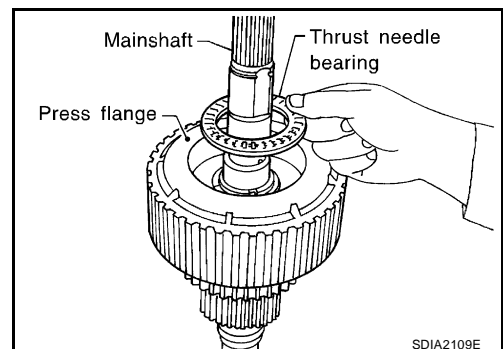

A  
B  
C  
TF  
E  
F  
G  
H  
I  
J  
K  
L  
M

# TRANSFER ASSEMBLY

16. Press the press flange until the snap ring is out of place using Tools.

**Tool number**      **A: ST22452000 (J-34335)**  
                             **B: ST30911000 ( — )**  
                             **C: KV31103300 ( — )**

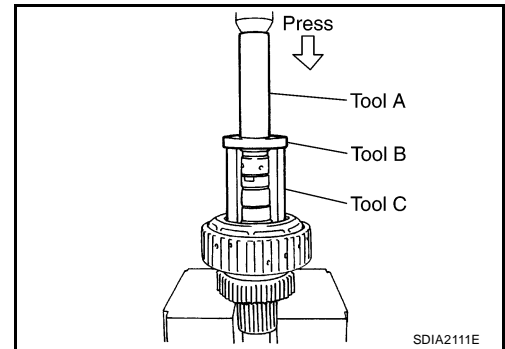

17. Remove the snap ring from the mainshaft using suitable tool.

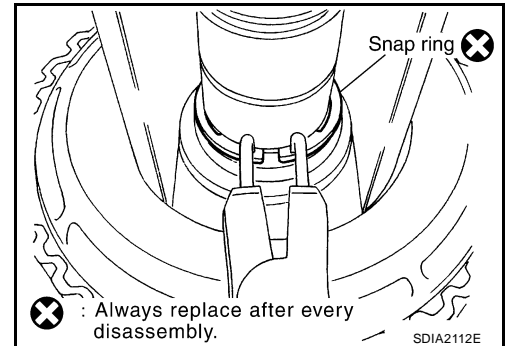

18. Remove the press flange from the mainshaft.

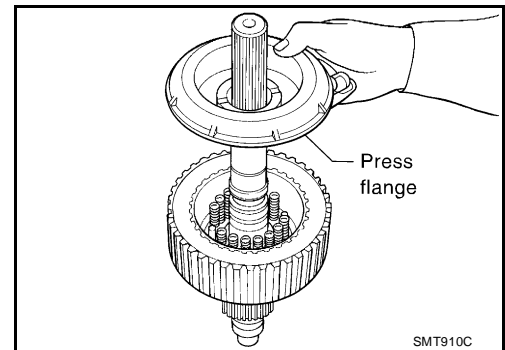

19. Remove the return spring assembly from the clutch hub.

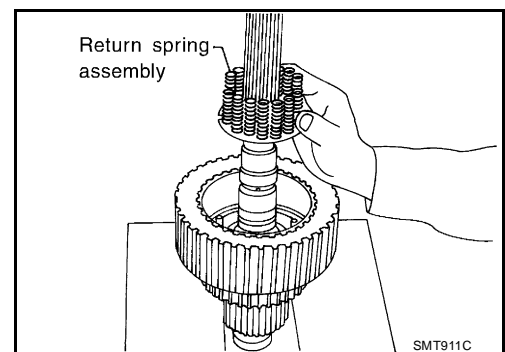

20. Remove each plate from the clutch drum.

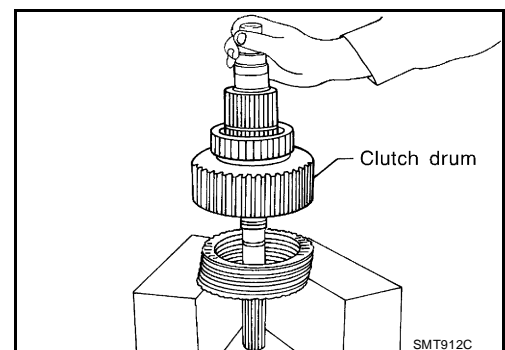

# TRANSFER ASSEMBLY

21. Remove the snap ring from the mainshaft.

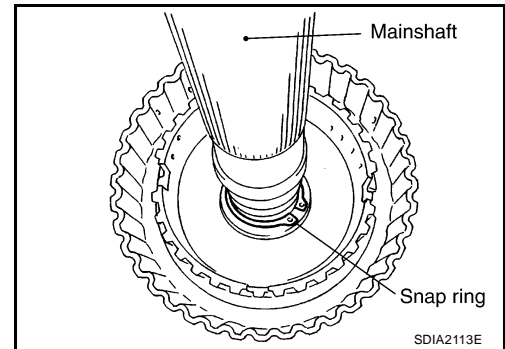

22. Remove the mainshaft from the clutch drum and clutch hub using suitable tool.

23. Remove the needle bearing and spacer from the mainshaft.

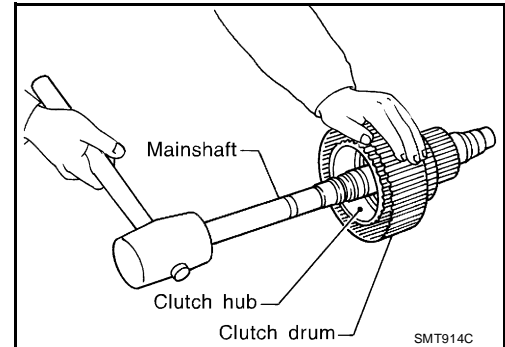

24. Remove the snap ring from the clutch hub using suitable tool.

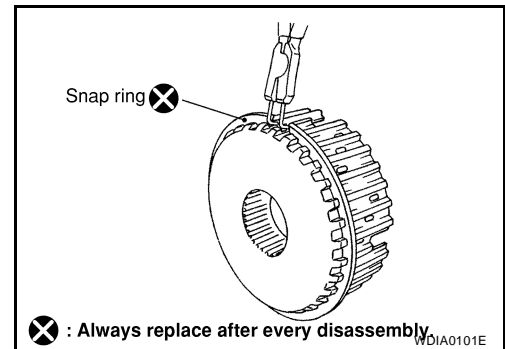

25. Remove the oil pressure check plug from the oil pressure check port.

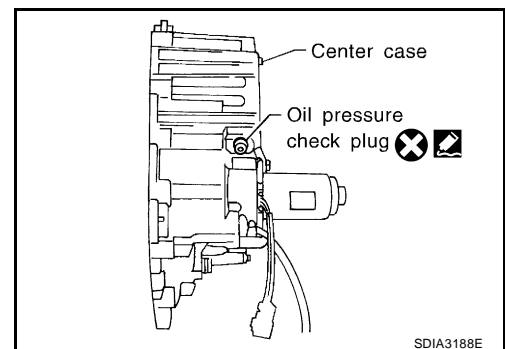

26. Apply air gradually from the oil pressure check port, and remove the clutch piston assembly from the center case.

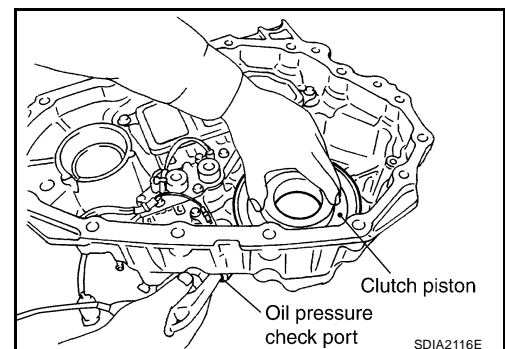

A  
B  
C  
TF  
E  
F  
G  
H  
I  
J  
K  
L  
M

## TRANSFER ASSEMBLY

27. Remove the thrust needle bearing race from the clutch piston by hooking a edge into 3 notches of the thrust needle bearing race using suitable tool.

**CAUTION:**

**Do not damage clutch piston or thrust needle bearing race.**

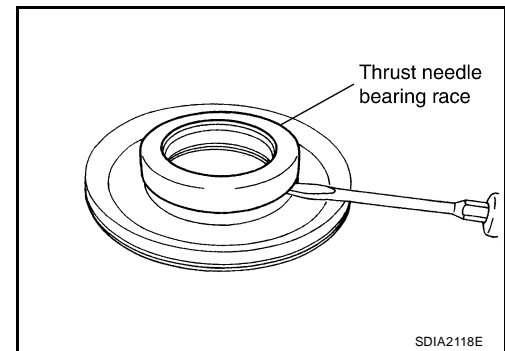

28. Remove the two D-rings from the clutch piston.

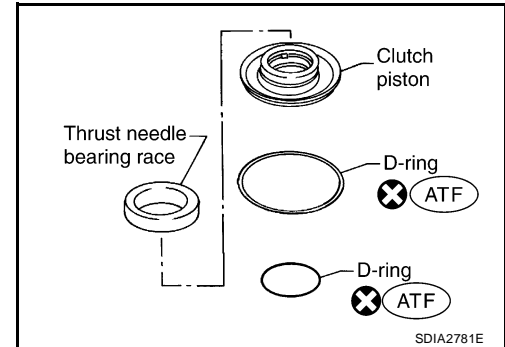

29. Remove the mainshaft rear bearing from the center case using Tool.

**Tool number : KV38100300 (J-25523)**

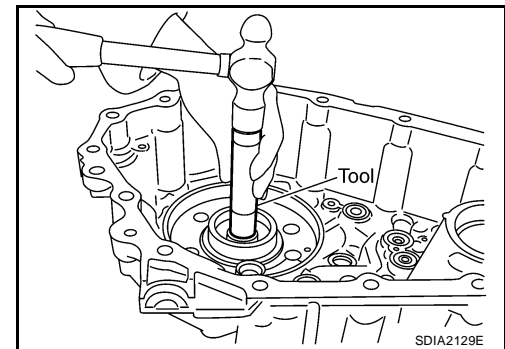

30. Remove the two bolts and oil strainer.

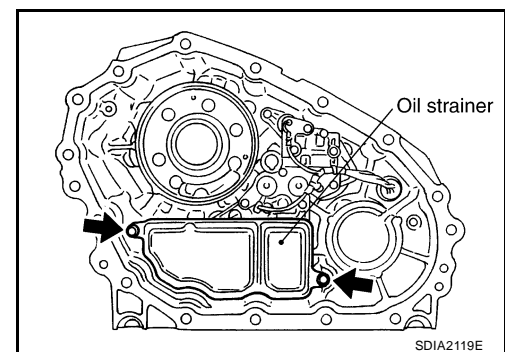

31. Remove the two O-rings from the oil strainer.

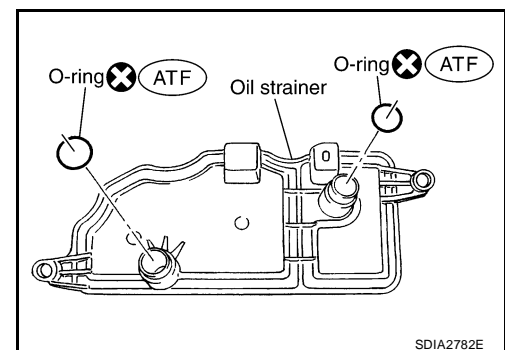

# TRANSFER ASSEMBLY

32. Remove the snap ring. Then push the connector assembly into the center case to remove the control valve assembly.

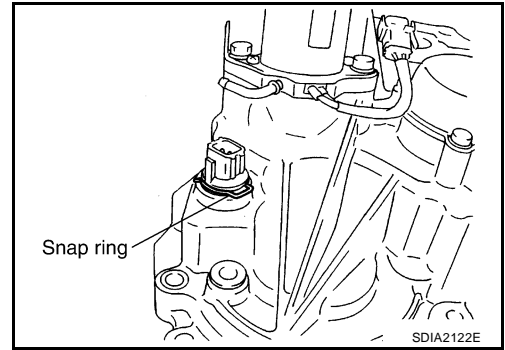

33. Remove the control valve assembly bolts.  
34. Remove the control valve assembly.

**CAUTION:**

- Do not reuse any part that has been dropped or damaged.
- Make sure valve is assembled in the proper direction.
- Do not use a magnet because residual magnetism stays during disassembly.

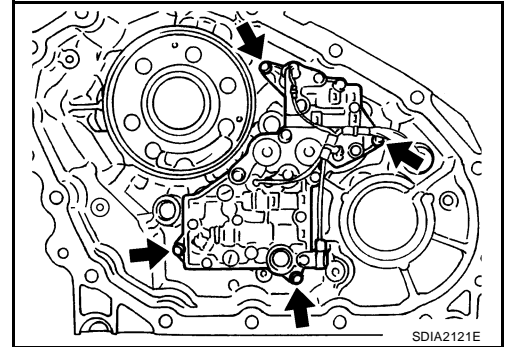

35. Remove the lip seals from the center case.

**CAUTION:**

There are two kinds of lip seals (lip seal of large inner diameter: 5 pieces, lip seal of small inner diameter: 2 pieces). Confirm the position before disassembly.

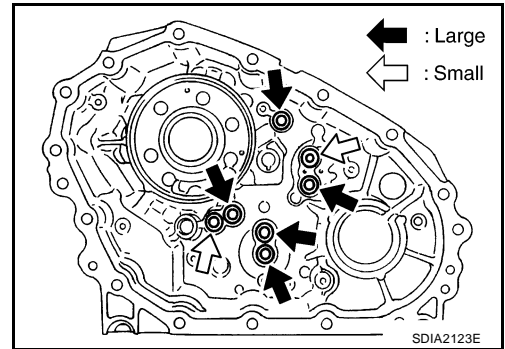

36. Disassemble the control valve assembly with the following procedure.

**CAUTION:**

- Do not reuse any part that has been dropped or damaged.
- Make sure valve is assembled in the proper direction.
- Do not use a magnet because residual magnetism stays during disassembly.

- a. Remove all the bolts except for the two shown.

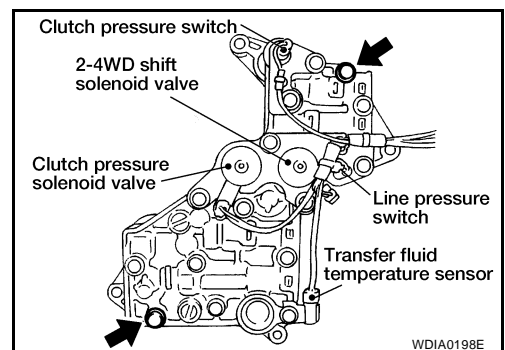

# TRANSFER ASSEMBLY

b. Remove the following from the control valve assembly:

- Clutch pressure solenoid valve
- 2-4WD shift solenoid valve
- Clutch pressure switch
- Line pressure switch
- Transfer fluid temperature sensor

c. Remove the O-rings from each solenoid valve, switch and terminal body.

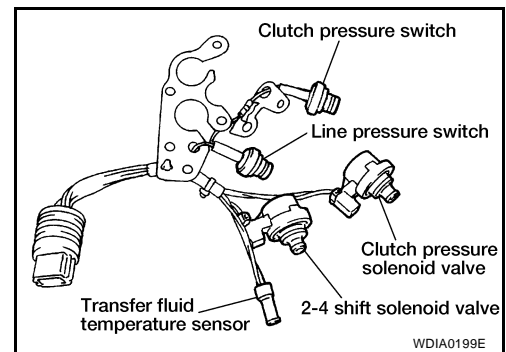

d. Place the control valve with the lower body facing up. Remove the two bolts, and then remove the lower body and separator plate from the upper body.

**CAUTION:**

**Do not drop relief balls. Detach lower body carefully.**

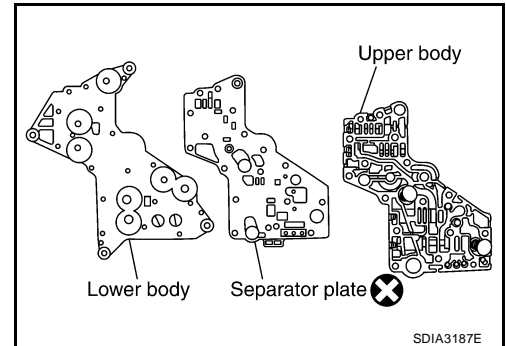

e. Make sure the reverse balls, relief balls, relief springs, accumulator pistons and valve springs are securely installed as shown, and remove them.

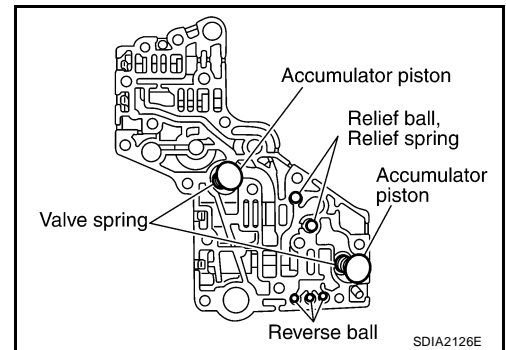

f. Remove the retainer plates.

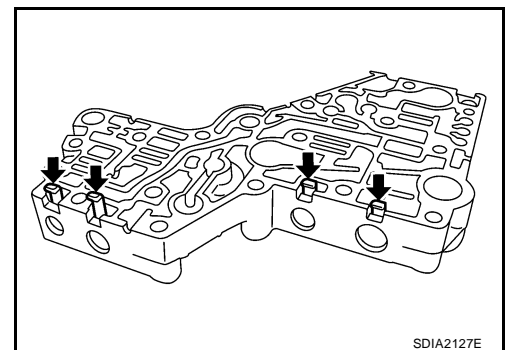

g. Remove each control valve, spring and plug.

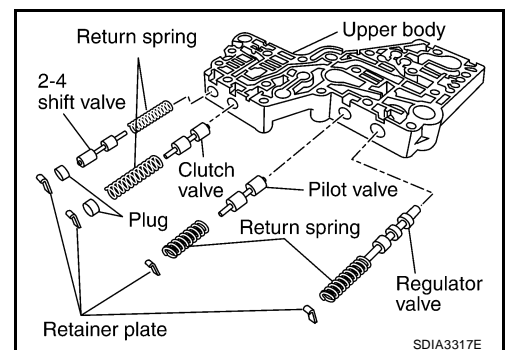



# TRANSFER ASSEMBLY

37. Remove the transfer motor bolts and motor from the center case. Then remove the O-ring from the transfer motor.

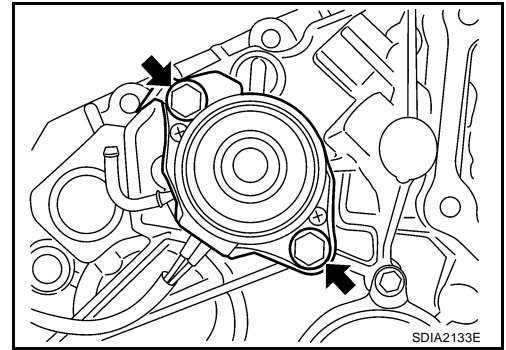

38. Remove the sub oil pump cover bolts.

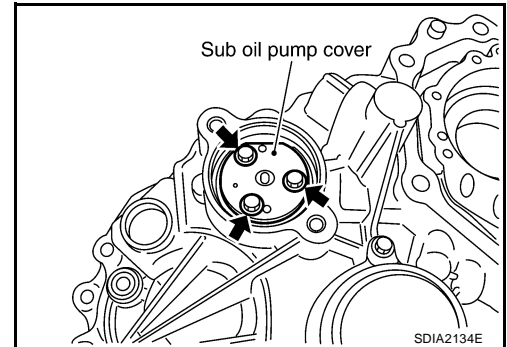

39. Thread two bolts (M4 x 0.8) into the holes of sub oil pump cover as shown, and pull out to remove the sub oil pump assembly.

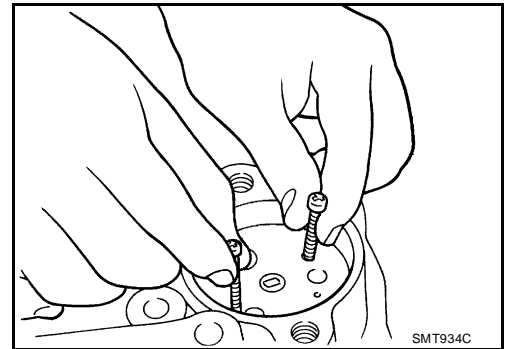

40. Remove the outer gear and inner gear from the sub oil pump housing.

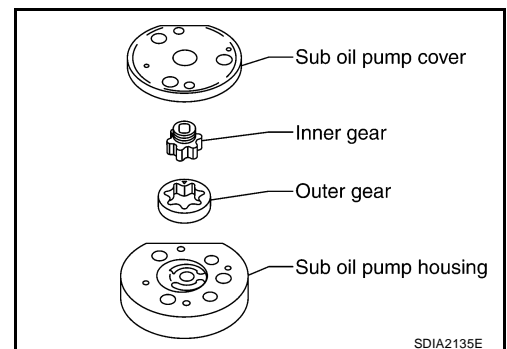

41. Remove the oil filter bolts and oil filter.

**CAUTION:**

- Do not damage center case and oil filter.
- Loosen bolts and detach oil filter evenly.

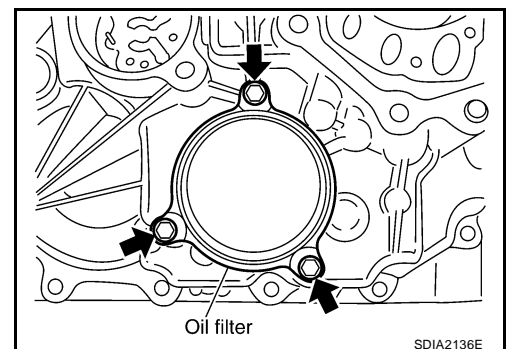

A  
B  
C  
TF  
E  
F  
G  
H  
I  
J  
K  
L  
M

# TRANSFER ASSEMBLY

42. Remove the O-rings (1) from the oil filter (2).

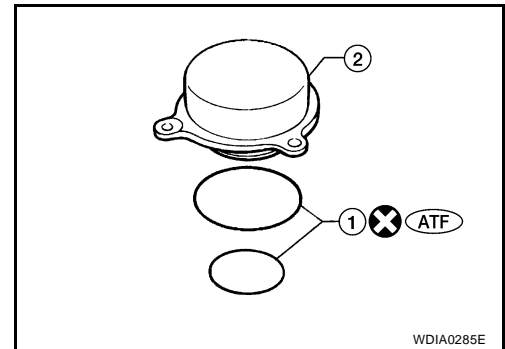

43. Remove the oil filter stud from the oil filter.

44. Remove the O-ring from the oil filter stud.

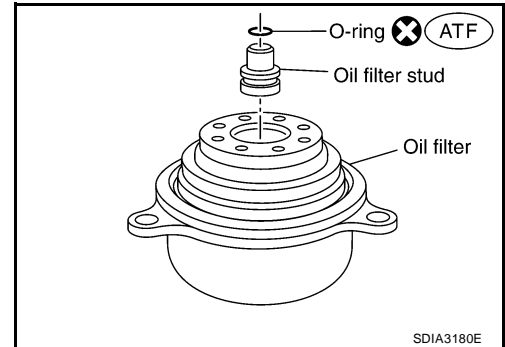

## INSPECTION AFTER DISASSEMBLY

### Shift Rod Components

- Check the working face of the shift rod and fork for wear, partial wear, bending and other abnormality. If any is found, replace with a new one.

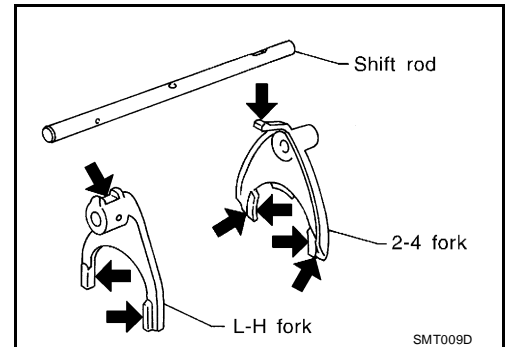

- Measure the clearance between the shift fork and sleeve. If it is out of specification, replace it with a new one.

**Specification : Less than 0.36 mm (0.0142 in)**

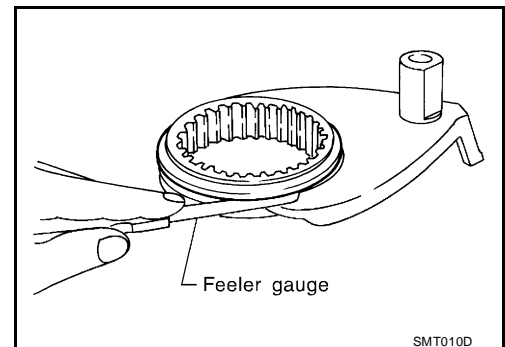

# TRANSFER ASSEMBLY

## Planetary Carrier

- Measure the end play of each pinion gear. If it is out of specification, replace the planetary carrier assembly with a new one.

**Pinion gear end play : 0.1 - 0.7 mm (0.004 - 0.028 in)**

- Check the working face of each gear and bearing for damage, burrs, partial wear, dents and other abnormality. If any is found, replace the planetary carrier assembly with a new one.

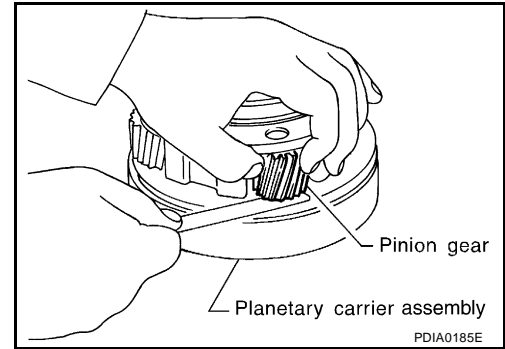

## Sun Gear

- Check if the oil passage of the sun gear assembly is clogged. For this, try to pass a 3.6 mm (0.142 in) dia. pin through the oil passage as shown.
- Check the sliding and contact surface of each gear and bearing for damage, burrs, partial wear, dents, and other abnormality. If any is found, replace the sun gear assembly with a new one.

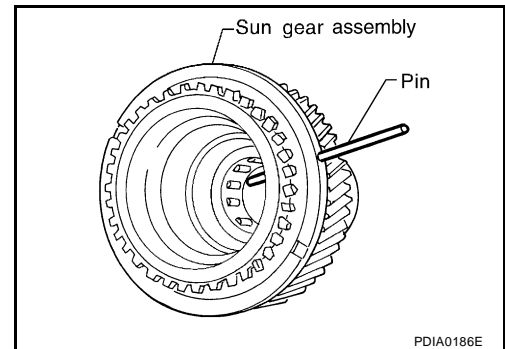

## Internal Gear

- Check the internal gear teeth for damage, partial wear, dents and other abnormality. If any is found, replace the internal gear with a new one.

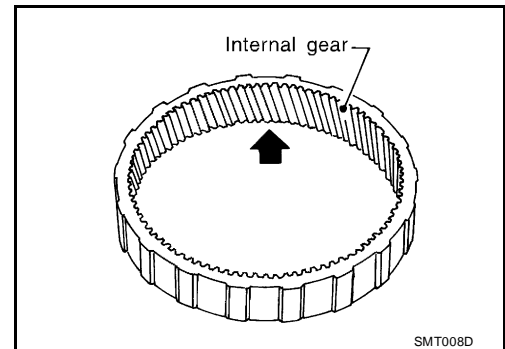

## Gears and Drive Chain

- Check the gear faces and shaft for wear, cracks, damage, and seizure.
- Check the surfaces which contact the sun gear, clutch drum, clutch hub, press flange, clutch piston and each bearing for damage, peel, partial wear, dents, bending, or other abnormal damage. If any is found, replace with a new one.

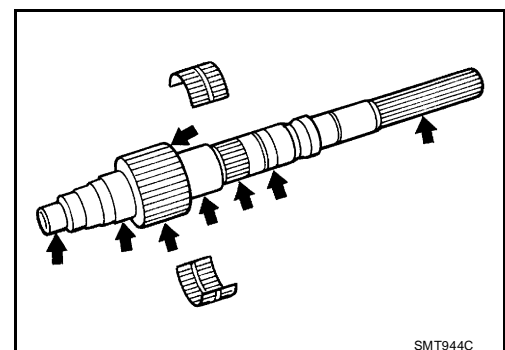

A  
B  
C  
TF

E  
F  
G  
H

I  
J  
K  
L

M

# TRANSFER ASSEMBLY

## Bearing

- Make sure the bearings roll freely and are free from noise, pitting and cracks.

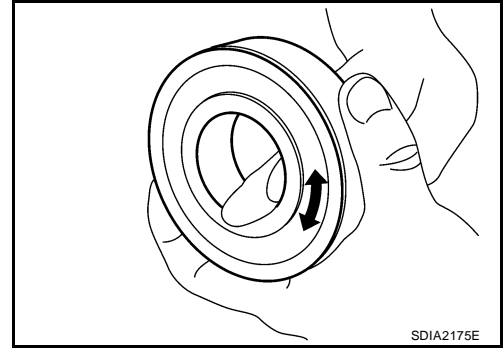

## Main Oil Pump

1. Check the inner and outer circumference, tooth face, and side-face of the inner and outer gears for damage or abnormal wear.
2. Measure the side clearance between the main oil pump housing edge and the inner and outer gears.
3. Make sure the side clearance is within specification. If the measurement is out of specification, replace the inner and outer gears with new ones as a set. Refer to [TF-164, "Main Oil Pump"](#).

**Specification : 0.015 - 0.035 mm (0.0006 - 0.0014 in)**

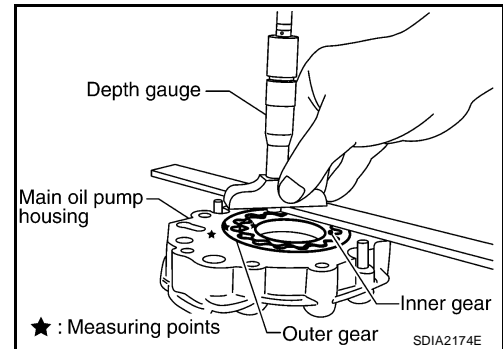

## Sub-oil Pump

1. Check the inner and outer circumference, tooth face, and side-face of the inner and outer gears for damage or abnormal wear.
2. Measure the side clearance between the sub oil pump housing edge and the inner and outer gears.
3. Make sure the side clearance is within specification. If the measurement is out of specification, replace the inner and outer gears with new ones as a set. Refer to [TF-164, "Sub-oil Pump"](#).

**Specification : 0.015 - 0.035 mm (0.0006 - 0.0014 in)**

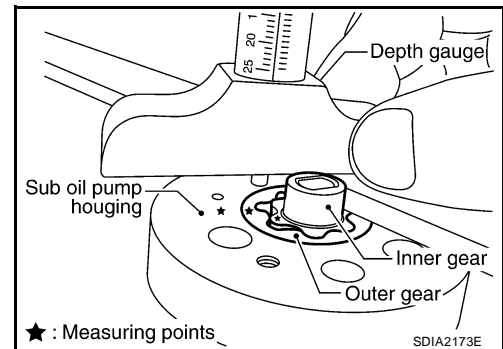

## Control Valve

- Check resistance between the terminals of the clutch pressure solenoid valve, 2-4WD shift solenoid valve, clutch pressure switch, line pressure switch and the transfer fluid temperature sensor. Refer to [TF-89, "COMPONENT INSPECTION"](#) (clutch pressure solenoid valve), [TF-93, "COMPONENT INSPECTION"](#) (2-4WD solenoid valve), [TF-106, "COMPONENT INSPECTION"](#) (clutch pressure switch), [TF-109, "COMPONENT INSPECTION"](#) (line pressure switch) and [TF-103, "COMPONENT INSPECTION"](#) (transfer fluid temperature sensor).

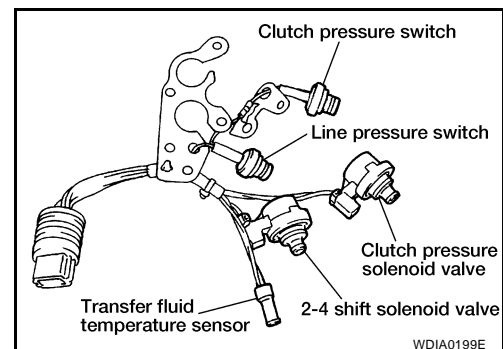

# TRANSFER ASSEMBLY

- Check the sliding faces of the control valves and plugs for abnormality. If any is found, replace the control valve assembly with a new one. Refer to [TF-164, "Control Valve"](#) .

**CAUTION:**

Replace control valve body together with clutch return spring as a set.

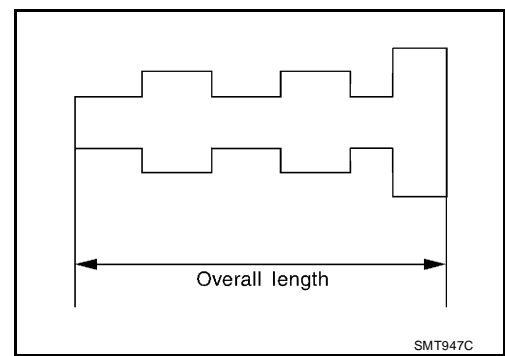

- Check each control valve spring for damage or distortion. Also check its free length, outer diameter and wire diameter. If any damage or fatigue is found, replace the control valve body with a new one. Refer to [TF-165, "Return Spring"](#) .

**CAUTION:**

Replace control valve body together with clutch return spring as a set.

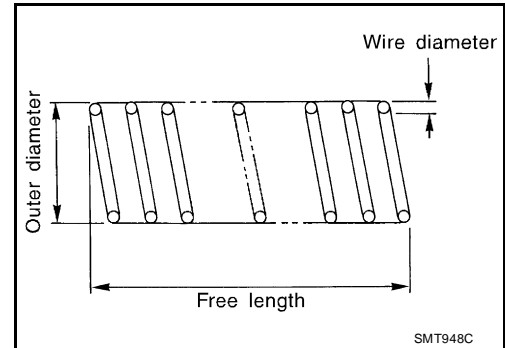

## Clutch

- Check the drive plate facings and driven plate for damage, cracks or other abnormality. If any abnormalities are found, replace with a new one.
- Check the thickness of the drive plate facings and driven plate. Refer to [TF-182, "CLUTCH"](#) .

**CAUTION:**

- Measure facing thickness at 3 points to take an average.
- Check all drive and driven plates.
- Check return spring for damage or deformation.
- Do not remove spring from plate.

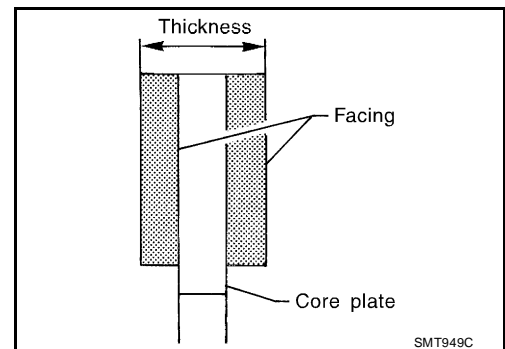

## Return Spring

- Check the stamped mark shown. Then, check that the free lengths, (include thickness of plate) are within specifications. If any abnormality is found, replace with a new return spring assembly of the same stamped number. Refer to [TF-165, "Return Spring"](#) .

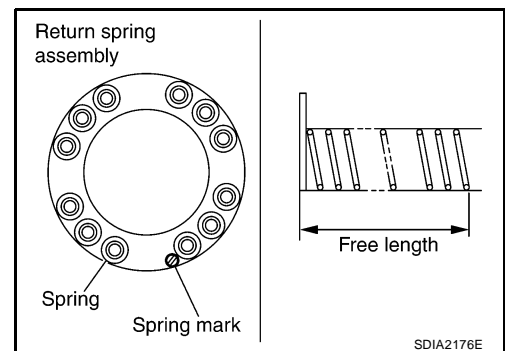

# TRANSFER ASSEMBLY

## ASSEMBLY

### Center Case

1. Apply ATF to the new O-ring, and install it on the oil filter stud.

**CAUTION:**

**Do not reuse O-ring.**

2. Install the oil filter stud to the oil filter.

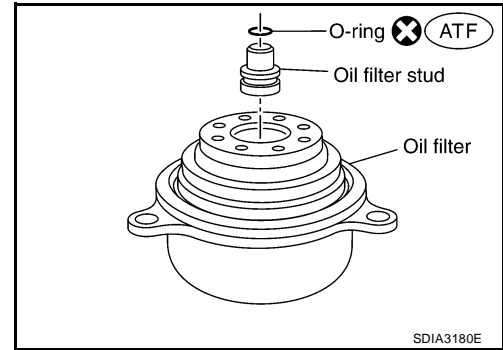

3. Apply ATF to the two new O-rings (1), and install them on the oil filter (2).

**CAUTION:**

**Do not reuse O-rings.**

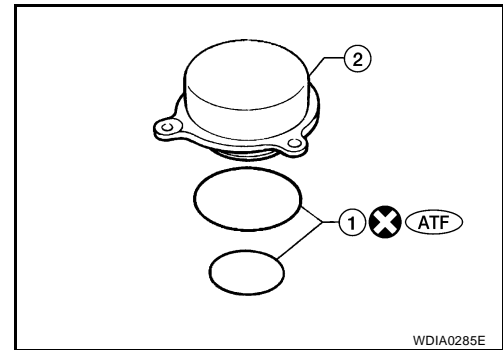

4. Install the oil filter to the center case. Tighten the bolts to the specified torque. Refer to [TF-145, "COMPONENTS"](#).

**CAUTION:**

- Do not damage oil filter.
- Attach oil filter and tighten bolts evenly.

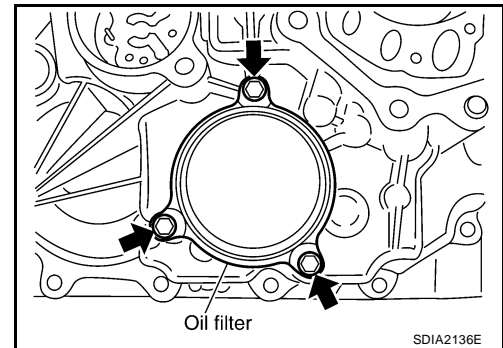

5. Install the outer gear and inner gear into the sub oil pump housing, and measure the side clearance. Refer to [TF-164, "Sub-oil Pump"](#).

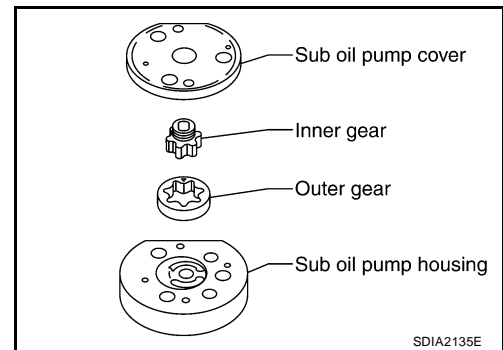

# TRANSFER ASSEMBLY

6. Align the dowel pin hole and bolt hole of the sub oil pump assembly with the center case. Install the sub oil pump cover. Then tighten to the specified torque. Refer to [TF-145, "COMPONENTS"](#) .

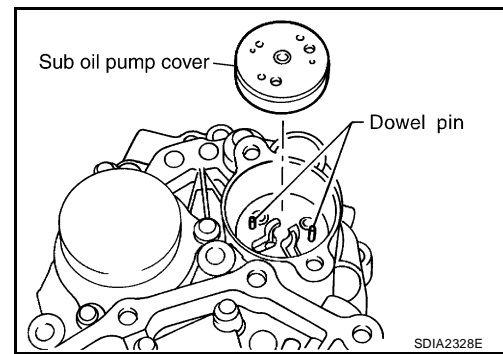

7. Apply ATF to the new O-ring and install it to the transfer motor.  
**CAUTION:**  
**Do not reuse O-ring.**
8. Fit the double-flat end of the transfer motor shaft into the slot of the sub-oil pump assembly. Then tighten to the specified torque. Refer to [TF-145, "COMPONENTS"](#) .

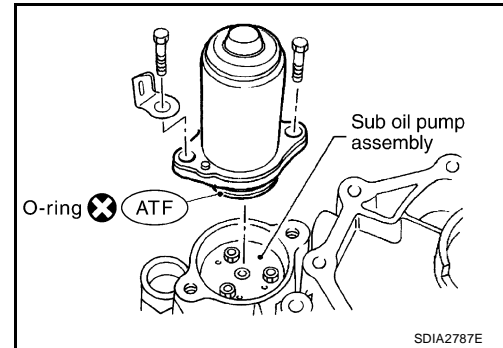

**CAUTION:**  
**Be sure to install connector bracket.**

9. Assemble the control valve assembly with the following procedure.

**CAUTION:**

- Do not reuse any part that has been dropped or damaged.
- Make sure valve is assembled in the proper direction.
- Do not use a magnet because residual magnetism stays during assembly.

- a. Clean the upper body, control valves and springs with cleaning agent, and dry with compressed air.
- b. Dip the control valves in ATF, and apply ATF to the valve-mounting area of the upper body.

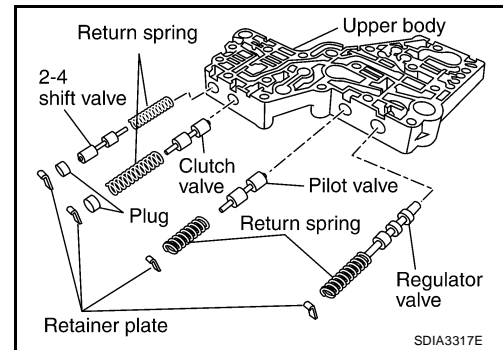

- c. Install each control valve, spring, and plug to the upper body, and install retainer plates to hold them in place.

**CAUTION:**

- To insert control valves into upper body, place upper body on a level surface in order to prevent flaw or damage.
- Make sure each control valve is smoothly inserted.

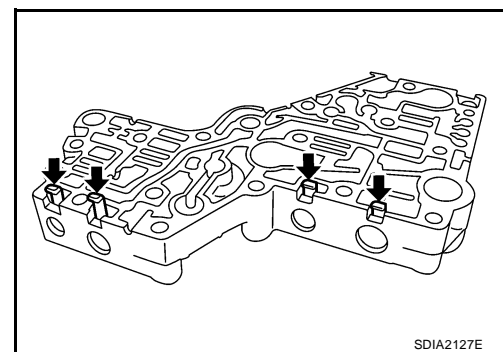

# TRANSFER ASSEMBLY

- d. Install the reverse balls, relief balls and relief springs, accumulator pistons and valve springs to the upper body.

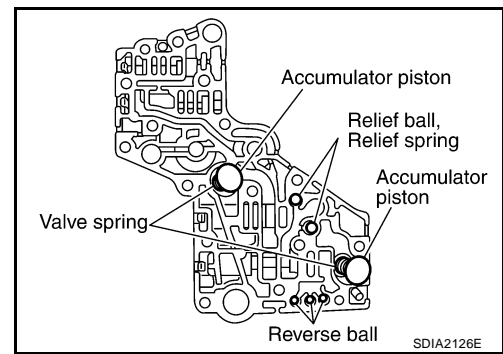

- e. Install the lower body and new separator plate to the upper body.

**CAUTION:**

**Do not reuse separator plate.**

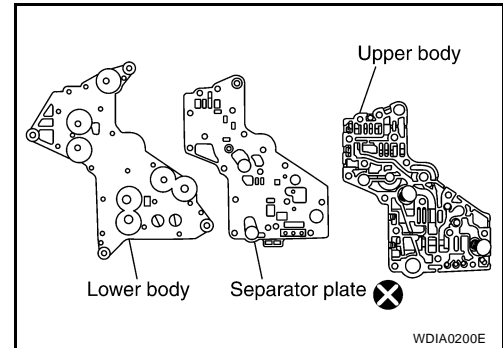

- f. With the lower body down, tighten the two bolts shown.  
g. Apply ATF to the new O-rings, and install them to each solenoid valve, switch and terminal body.

**CAUTION:**

**Do not reuse O-rings.**

- h. Install the following to the control valve assembly:

- Clutch pressure solenoid valve
- 2-4WD shift solenoid valve
- Clutch pressure switch
- Line pressure switch
- Transfer fluid temperature sensor

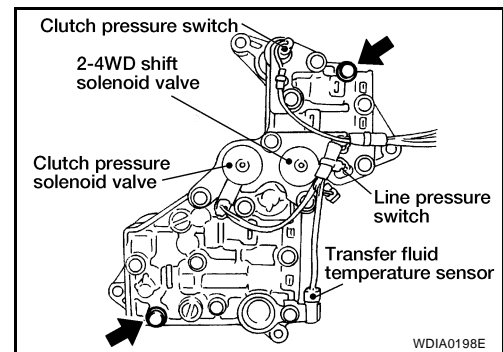

10. Apply ATF to the new lip seals, and install them to the center case.

**CAUTION:**

- **Do not reuse lip seals.**
- **There are 2 kinds of lip seals (lip seal of large inner diameter: 5 pieces, lip seal of small inner diameter: 2 pieces). Confirm their position for installation.**

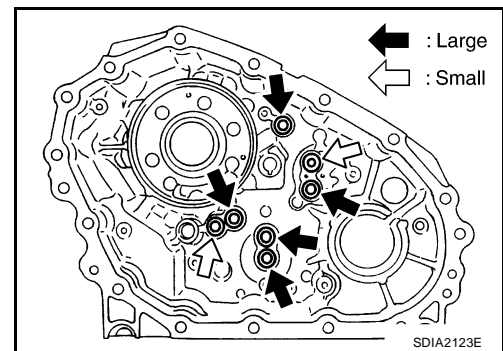



# TRANSFER ASSEMBLY

11. Install the control valve assembly to the center case, and tighten to the specified torque. Refer to [TF-145, "COMPONENTS"](#).

**CAUTION:**

- Do not reuse any part that has been dropped or damaged.
- Make sure valve is assembled in the proper direction.
- Do not use a magnet because residual magnetism stays during assembly.

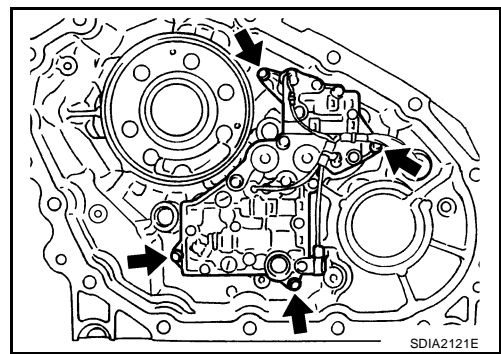

12. Install the connector assembly into the center case, and secure with a snap ring.

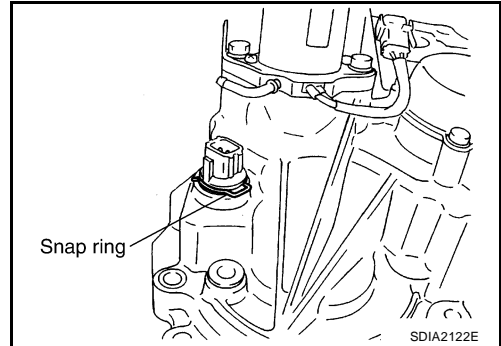

13. Apply ATF to the new O-rings, and install them on the oil strainer.

**CAUTION:**

**Do not reuse O-rings.**

14. Install the oil strainer to the control valve assembly.

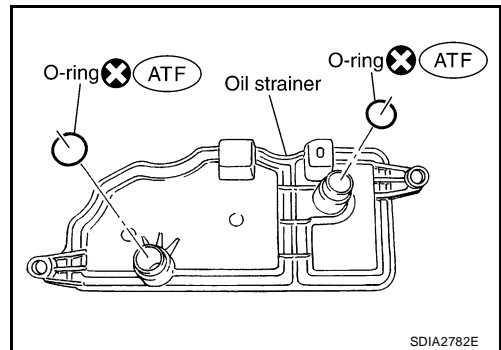

15. Tighten the bolts to the specified torque. Refer to [TF-145, "COMPONENTS"](#).

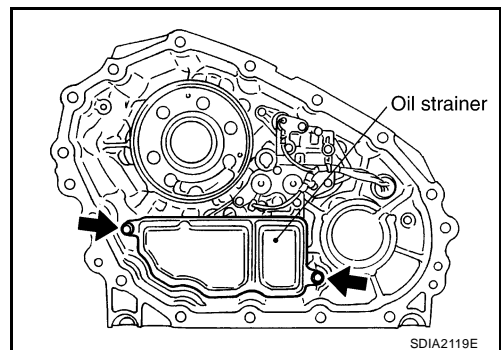

16. Apply ATF to the new D-rings, and install them to the clutch piston.

**CAUTION:**

**Do not reuse D-rings.**

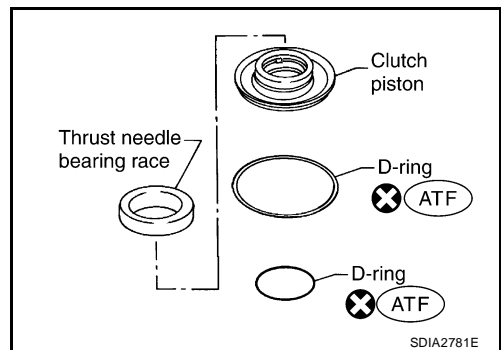

A  
B  
C  
TF  
E  
F  
G  
H  
I  
J  
K  
L  
M

## TRANSFER ASSEMBLY

17. Install the thrust needle bearing race to the clutch piston.

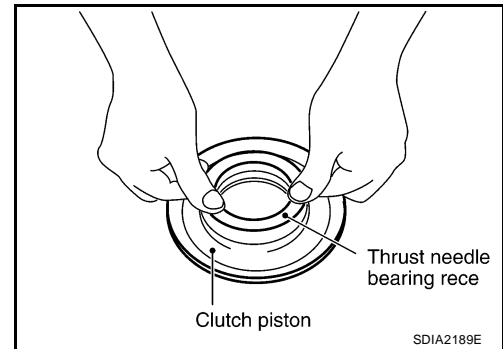

18. Install the clutch piston to the center case as shown.

**CAUTION:**

**Install so the fitting protrusion of clutch piston aligns with the dent of center case.**

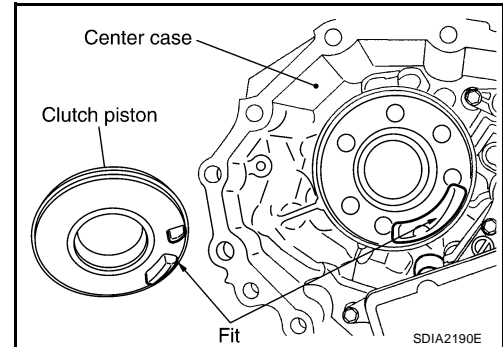

19. Remove all the sealant from the oil pressure check port and inside the center case.

**CAUTION:**

**Remove old sealant adhering to mating surfaces. Also remove any moisture, oil, or foreign material adhering to application and mating surfaces.**

20. Thread the new oil pressure check plug in 1 or 2 pitches and apply sealant to the oil pressure check plug threads. Tighten to the specified torque. Refer to [TF-145, "COMPONENTS"](#).

- **Use Genuine Silicone RTV or equivalent. Refer to [GI-45, "RECOMMENDED CHEMICAL PRODUCTS AND SEALANTS"](#).**

**CAUTION:**

**Do not reuse oil pressure check plug.**

21. Install the new snap ring to the clutch hub using suitable tool.

**CAUTION:**

**Do not reuse snap ring.**

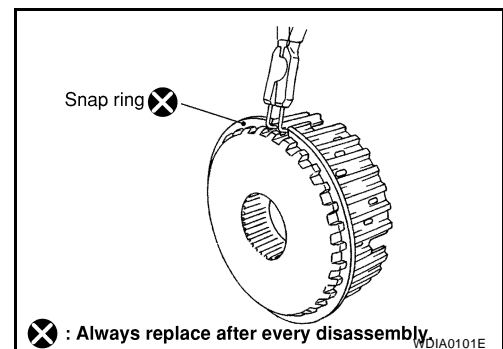
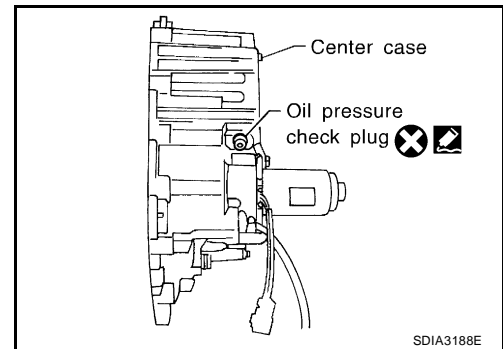

# TRANSFER ASSEMBLY

22. Apply petroleum jelly to the needle bearing, and install the needle bearing, spacer, clutch drum and clutch hub to the mainshaft.

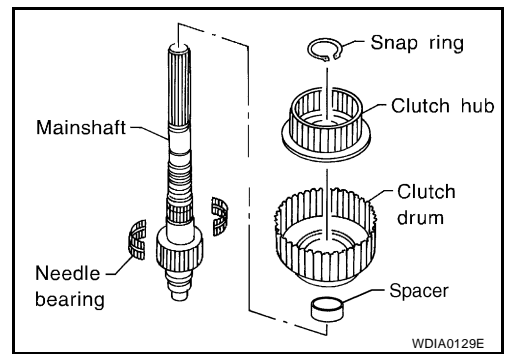

23. Install the new snap ring to the mainshaft.

**CAUTION:**  
Do not reuse snap ring.

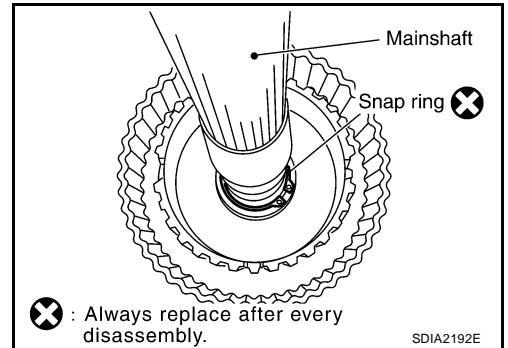

24. Apply ATF to each plate, then install them into the clutch drum as shown.

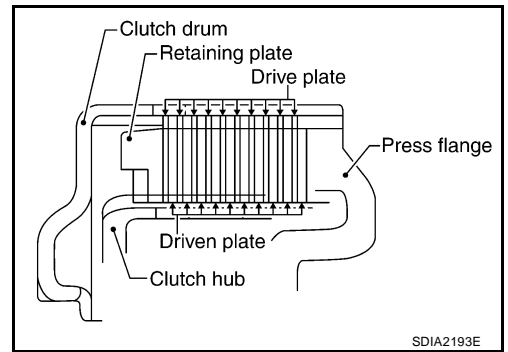

25. Install the return spring assembly into the clutch hub.

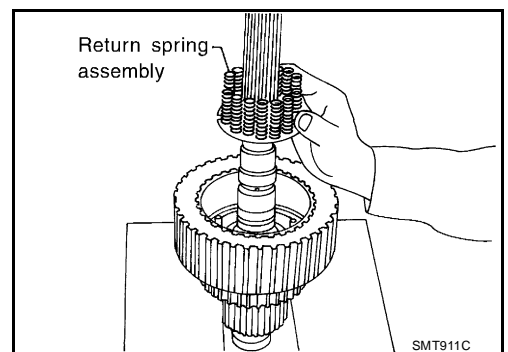

26. Install the press flange by aligning the notches to the clutch hub as shown.

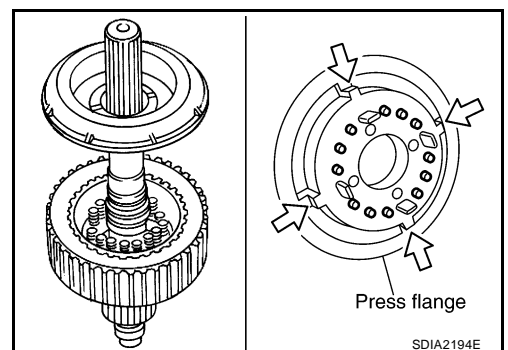

A  
B  
C  
TF  
E  
F  
G  
H  
I  
J  
K  
L  
M

# TRANSFER ASSEMBLY

27. Press the press flange to install the new snap ring into snap ring groove on mainshaft using Tools.

**Tool number**      **A: ST22452000 (J-34335)**  
                             **B: ST30911000 ( — )**  
                             **C: KV31103300 ( — )**

**CAUTION:**  
**Do not reuse snap ring.**

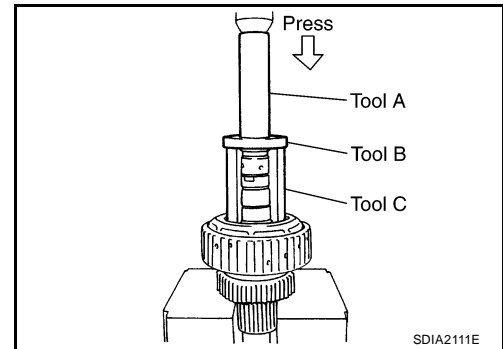

28. Install the new snap ring to the mainshaft using suitable tool.

**CAUTION:**  
**Do not reuse snap ring.**

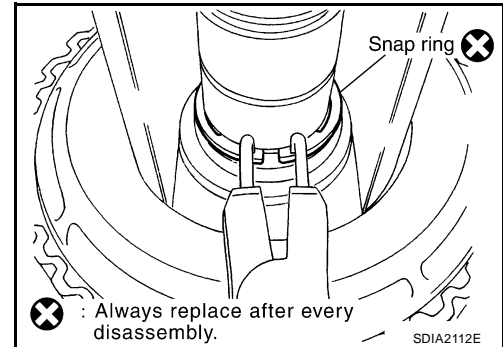

29. Apply ATF to the thrust needle bearing and install it on the press flange.

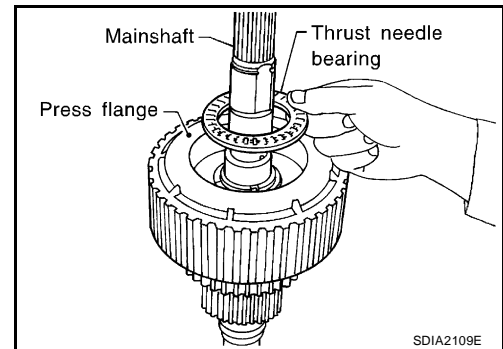

30. Install the new snap ring to the main shaft.

**CAUTION:**  
**Do not reuse snap ring.**

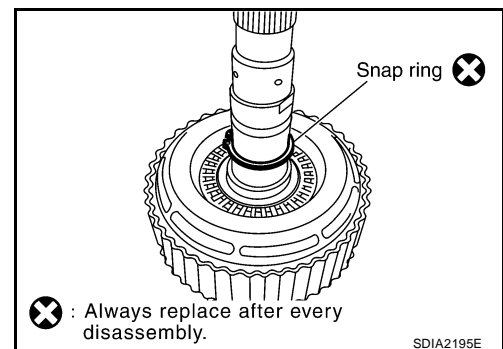

31. Install the mainshaft rear bearing to the center case using Tool.

**Tool number**      **: ST15310000 (J-25640-B)**

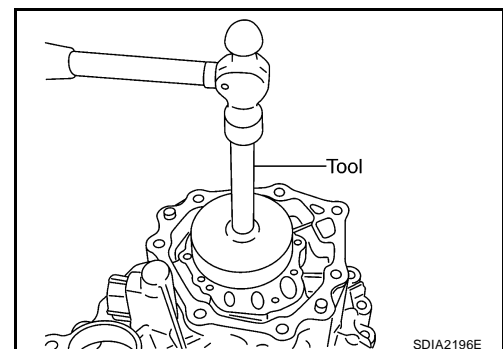

# TRANSFER ASSEMBLY

32. Press the mainshaft assembly into the center case using Tools.

**Tool number**      **A: ST30911000 ( — )**

**B: ST33052000 ( — )**

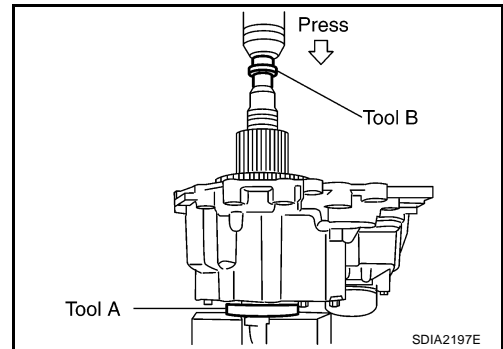

33. Install the C-rings to the mainshaft.

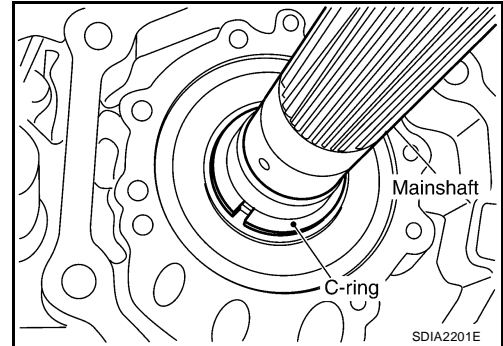

34. Set the washer holder on the mainshaft, and secure it with a new snap ring using suitable tool.

**CAUTION:**

**Do not reuse snap ring.**

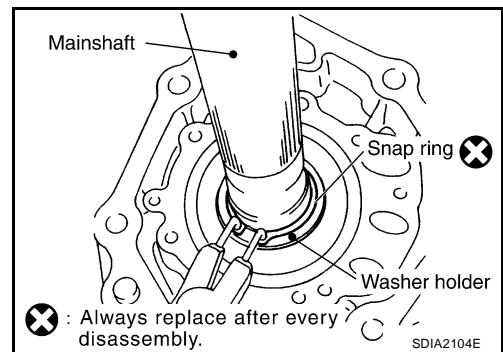

35. Apply petroleum jelly to the stem bleeder and install it to the center case.

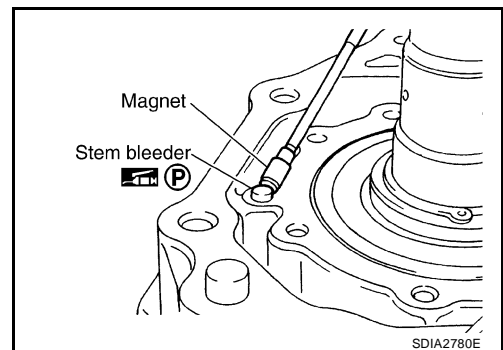

36. Apply ATF to the new seal ring and install it to the main oil pump cover.

**CAUTION:**

**Do not reuse seal ring.**

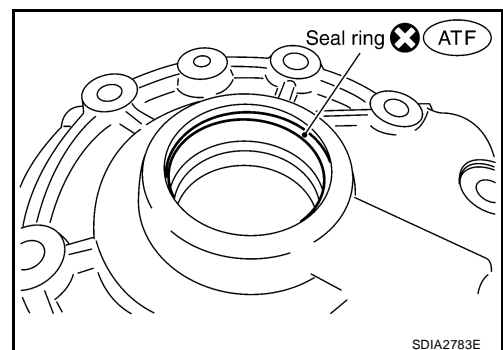

A  
B  
C  
TF  
E  
F  
G  
H  
I  
J  
K  
L  
M

## TRANSFER ASSEMBLY

37. Install the inner gear and outer gear in the main oil pump housing. Then measure the side clearance. Refer to [TF-164, "Main Oil Pump"](#) .

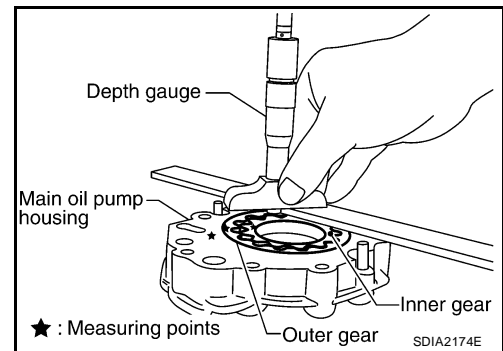

38. Install the main oil pump housing, outer gear and inner gear to the center case.

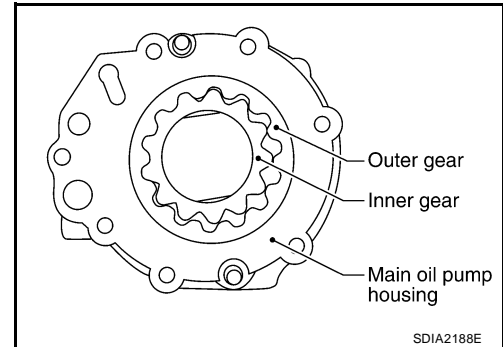

39. Install the main oil pump cover to the center case, and tighten to the specified torque. Refer to [TF-145, "COMPONENTS"](#) .

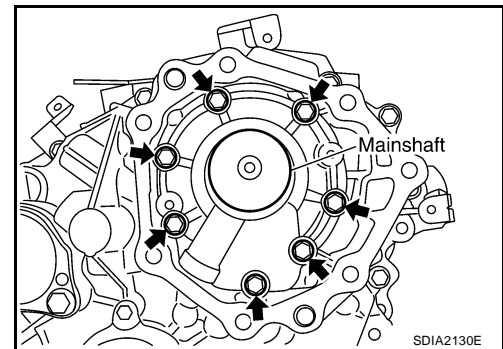

40. Remove all the sealant from the switch mating area and inside the center case.

**CAUTION:**

**Remove old sealant adhering to mating surfaces. Also remove any moisture, oil, or foreign material adhering to application and mating surfaces.**

41. Thread the ATP switch and neutral-4LO switch in one to two pitches and apply sealant to the threads of the switches. Tighten to the specified torque. Refer to [TF-145, "COMPONENTS"](#) .

● **Use Genuine Silicone RTV or equivalent. Refer to [GI-45, "Recommended Chemical Products and Sealants"](#) .**

**NOTE:**

- Neutral-4LO switch harness connector is gray.
- ATP switch harness connector is black.

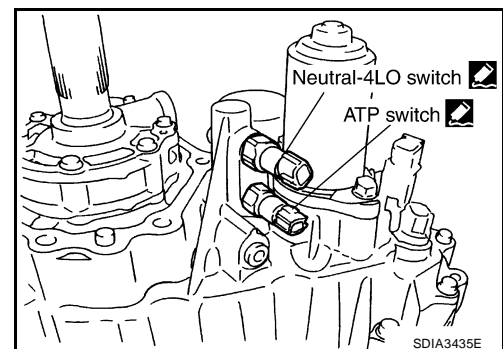

# TRANSFER ASSEMBLY

42. Install the front drive shaft rear bearing using Tools.

**Tool number**      **A: KV40100621 (J-25273)**  
                              **B: ST30032000 (J-26010-01)**

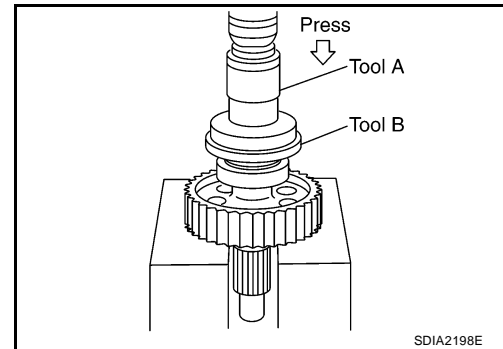

43. Install the front drive shaft to the front bearing using Tools.

**Tool number**      **A: KV40100621 (J-25273)**  
                              **B: ST30032000 (J-26010-01)**

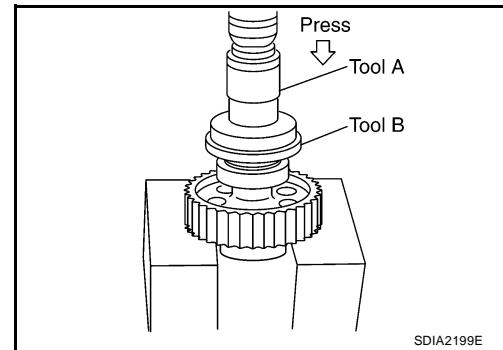

44. Install the drive chain to the front drive shaft and clutch drum.

**CAUTION:**  
**Install drive chain by aligning identification marks to the rear as shown.**

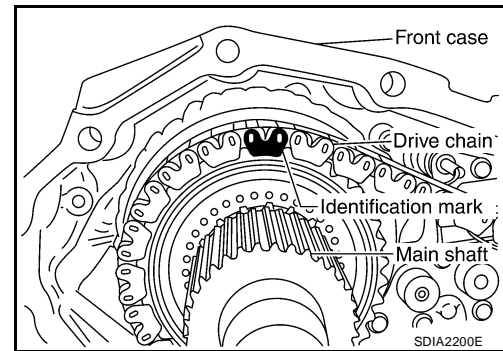

45. Tap the front drive shaft while keeping it upright and press-fit the front drive shaft rear bearing.

**CAUTION:**  
**Do not tap drive chain.**

46. Install the front case assembly. Refer to [TF-175, "Front Case"](#).

47. Install the rear case assembly. Refer to [TF-180, "Rear Case"](#).

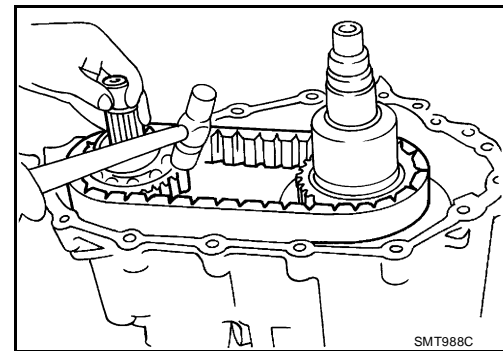

## Front Case

1. Install the carrier bearing to the sun gear using Tools.

**Tool number**      **A: ST30911000 ( — )**  
                              **B: KV31103300 ( — )**

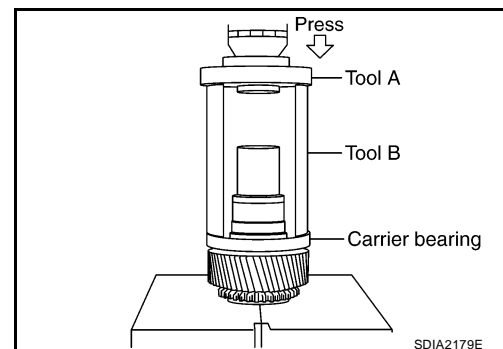

A  
B  
C  
TF  
E  
F  
G  
H  
I  
J  
K  
L  
M

# TRANSFER ASSEMBLY

2. Install the new snap ring to the sun gear assembly using suitable tool.

**CAUTION:**  
Do not reuse snap ring.

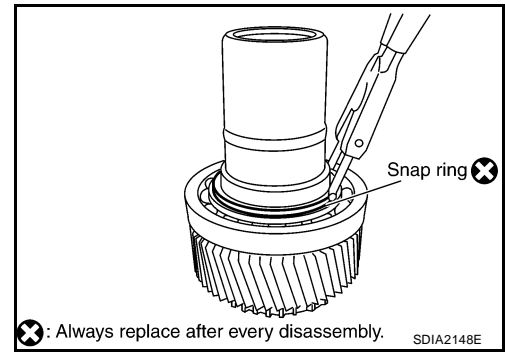

3. Apply ATF to the circumference of the new metal bushing and install it to the sun gear assembly using Tool.

**Tool number** : ST35300000 ( — )

**Dimension A** : 7.7 - 8.3 mm (0.303 - 0.327 in)

**CAUTION:**

- Do not reuse metal bushing.
- Apply ATF to metal bushing before installing.

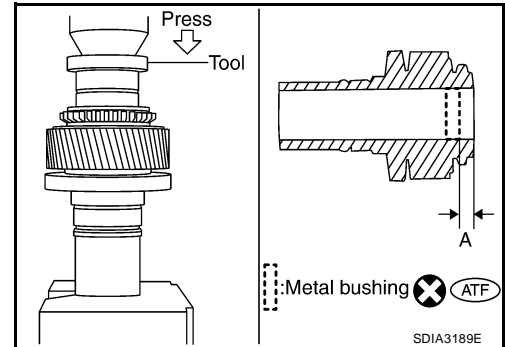

4. Apply ATF to the new needle bearing and install it to the sun gear assembly using Tool.

**Tool number** : ST33220000 ( — )

**Dimension B** : 62.5 - 63.1 mm (2.461 - 2.484 in)

**CAUTION:**

- Do not reuse needle bearing.
- Apply ATF to needle bearing before installing.

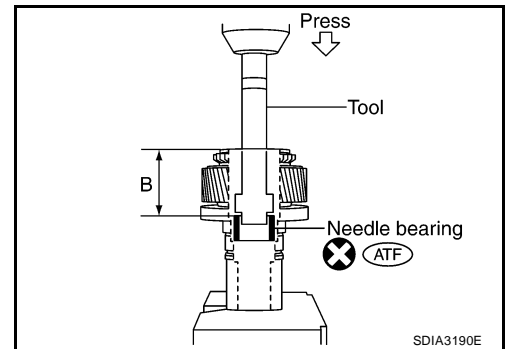

5. Install the sun gear assembly to the planetary carrier assembly.

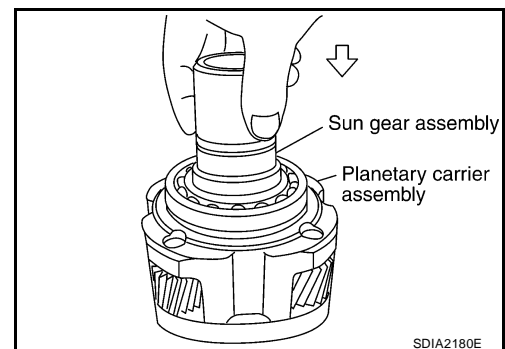

6. Install the new snap ring to the planetary carrier assembly.

**CAUTION:**  
Do not reuse snap ring.

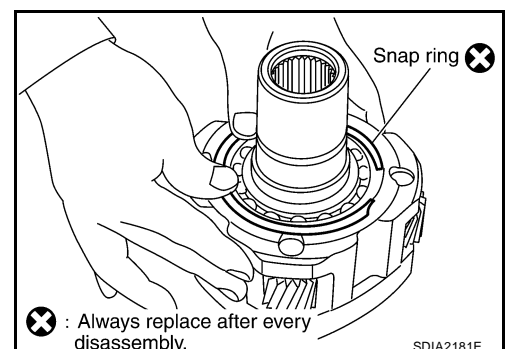



# TRANSFER ASSEMBLY

7. Set the input bearing into the front case and install using Tool.

**Tool number** : ST30720000 (J-25405)

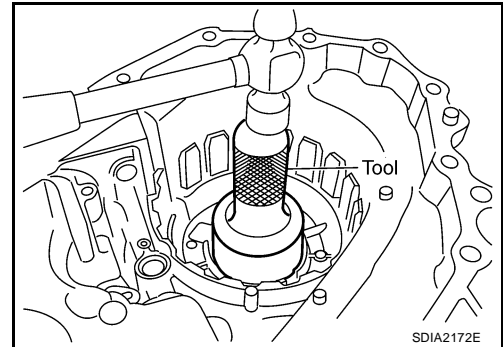

8. Install the new snap ring into the front case.

**CAUTION:**  
Do not reuse snap ring.

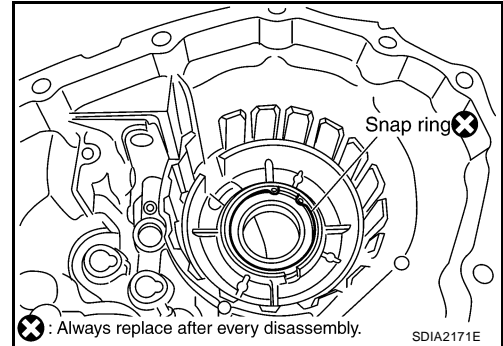

9. Install the internal gear with its groove facing the new snap ring into the front case. Then secure it with the new snap ring.

**CAUTION:**  
Do not reuse snap ring.

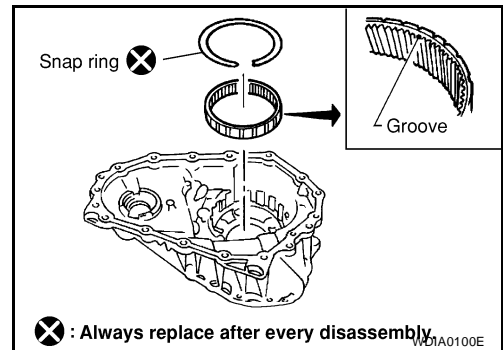

10. Install new front oil seal until it is seated flush with the end face of the front case using Tool.

**Tool number** : KV38100500 ( — )

**CAUTION:**

- Do not reuse oil seal.
- Apply petroleum jelly to front oil seal lip before installing.

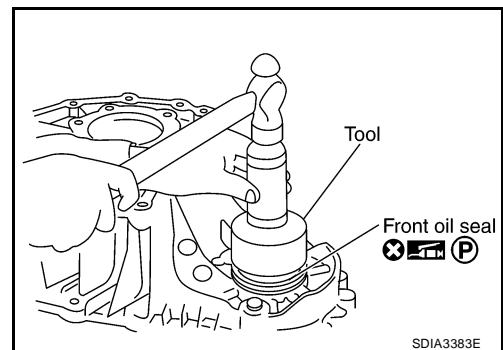

11. Install the planetary carrier assembly and sun gear assembly to the front case using Tool.

**Tool number** : ST33200000 (J-26082)

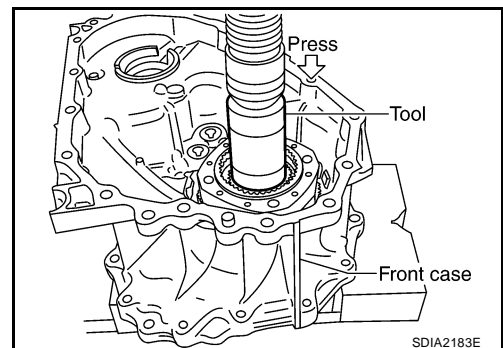

A  
B  
C  
TF  
E  
F  
G  
H  
I  
J  
K  
L  
M

## TRANSFER ASSEMBLY

12. Install the new snap ring to the sun gear assembly.

**CAUTION:**  
Do not reuse snap ring.

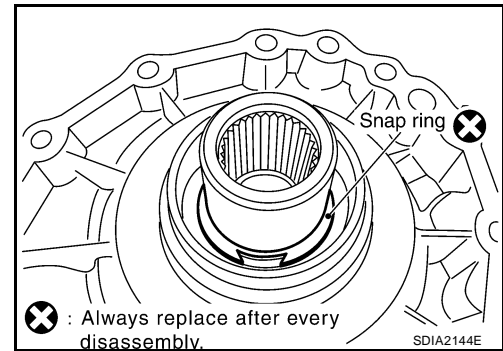

13. Apply petroleum jelly to the circumference of the new input oil seal, and install it to the front case using Tools.

**Tool number**            **A: ST30720000 (J-25405)**  
                                     **B: ST33200000 (J-26082)**

**Dimension "A"**        **: 4.0 - 4.6 mm (0.157 - 0.181 mm)**

**CAUTION:**  
● Do not reuse input oil seal.  
● Apply petroleum jelly to input oil seal.

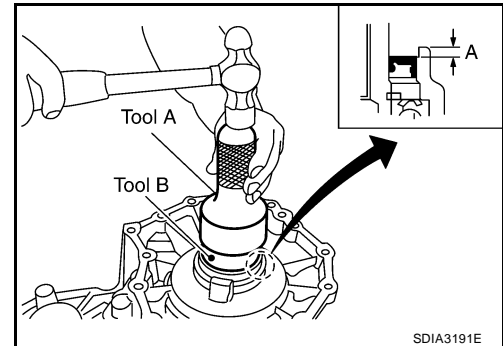

14. Install the fork guide, shift fork spring, 2-4 fork, and L-H fork to the shift rod, and secure them with new retaining pins.

**CAUTION:**  
Do not reuse retaining pins.

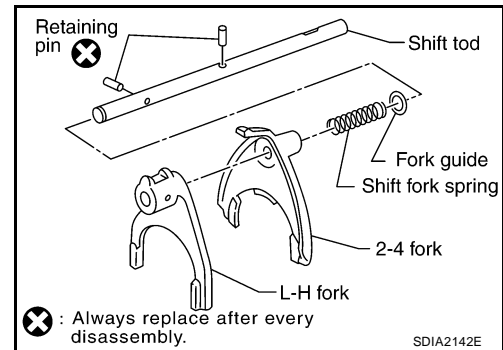

15. Install the 2-4 sleeve and L-H sleeve to each fork.  
16. Install the shift cross to the front case.

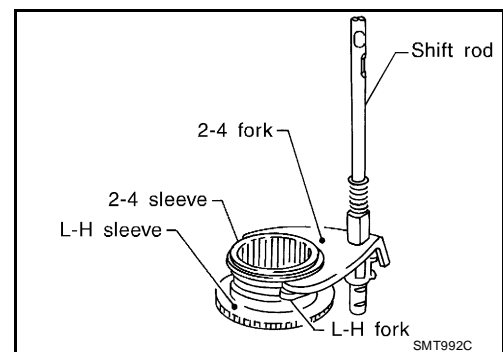

17. While aligning the L-H sleeve with the planetary carrier, install the shift rod assembly to the front case.

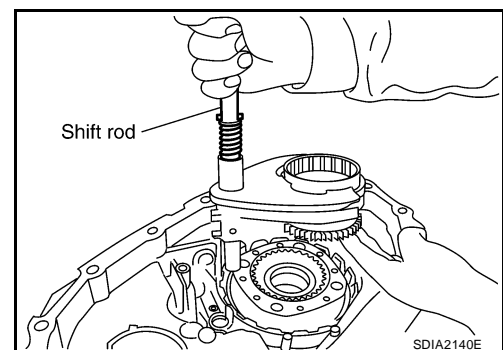

# TRANSFER ASSEMBLY

18. Apply liquid gasket to the entire center case mating surface of the front case assembly as shown.

- Use **Genuine Anaerobic Liquid Gasket** or equivalent. Refer to [GI-45, "Recommended Chemical Products and Sealants"](#).

**CAUTION:**

Remove all foreign materials such as water, oil and grease from center case and front case mating surfaces.

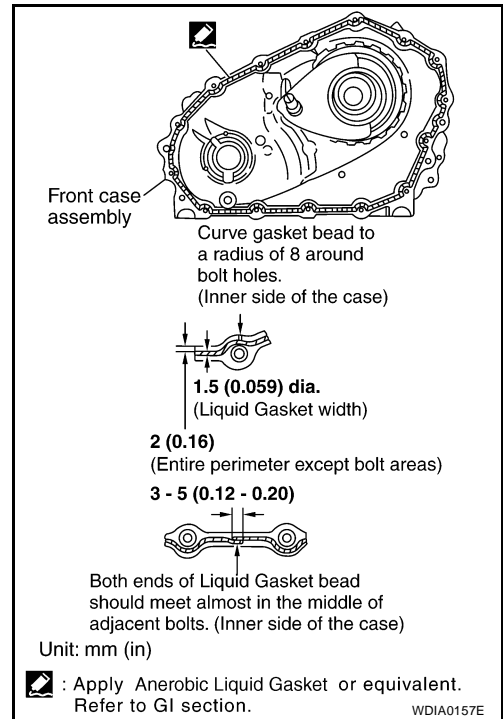

19. Install the center case assembly to the front case assembly.

**CAUTION:**

Do not damage mainshaft end.

20. Tap the center case lightly and press-fit the front drive shaft bearing into the front case.

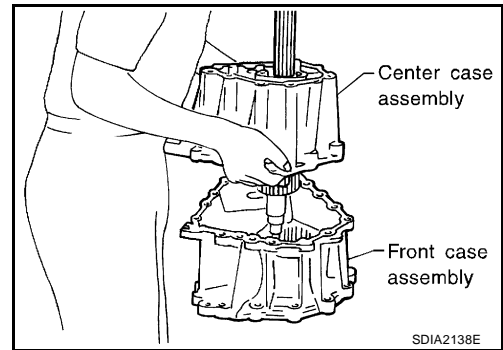

21. Tighten the front case bolts to the specified torque. Refer to [IF-145, "COMPONENTS"](#).

**CAUTION:**

Be sure to install harness bracket and air breather hose clamp.

22. Install the drain plug with a new gasket.

**CAUTION:**

Do not reuse gasket.

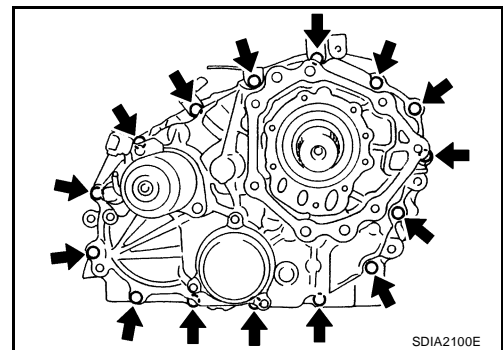

23. Align the matching mark on the front drive shaft with the mark on the companion flange, then install the companion flange.

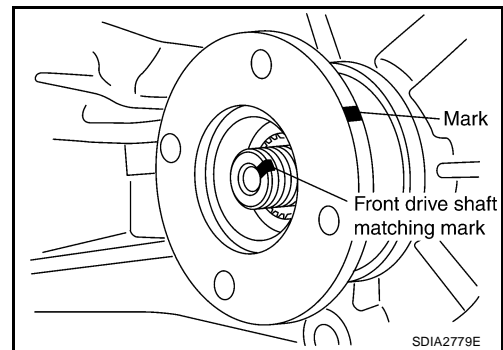

A  
B  
C  
TF  
E  
F  
G  
H  
I  
J  
K  
L  
M

# TRANSFER ASSEMBLY

24. Install the new companion flange self-lock nut. Tighten to the specified torque using Tool. Refer to [TF-145, "COMPONENTS"](#) .

**Tool number** : KV40104000 ( — )

**CAUTION:**

Do not reuse self-lock nut.

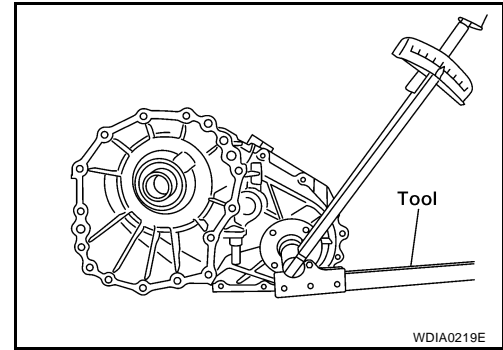

25. Remove all the sealant from the check plug, switch mating surface and front case.

**CAUTION:**

Remove old sealant adhering to mating surfaces. Also remove any moisture, oil, or foreign material adhering to application and mating surfaces.

26. Install the check ball and check spring to the front case. Apply silicone gasket, to the check plug and wait detection switch and install them to the front case. Tighten to the specified torque. Refer to [TF-145, "COMPONENTS"](#) .

- Use Genuine Silicone RTV or equivalent. Refer to [GI-45, "Recommended Chemical Products and Sealants"](#) .

**NOTE:**

Wait detection switch harness connector is black.

27. Install the new oil seal in the front case using Tool.

**Tool number** : ST22360002 (J-25679-01)

**CAUTION:**

- Do not reuse oil seal.
- Apply petroleum jelly to seal lip before installing.

28. Install the shift lever to the shift cross.  
29. Install the lock pin and lock pin nut. Tighten to the specified torque. Refer to [TF-145, "COMPONENTS"](#) .

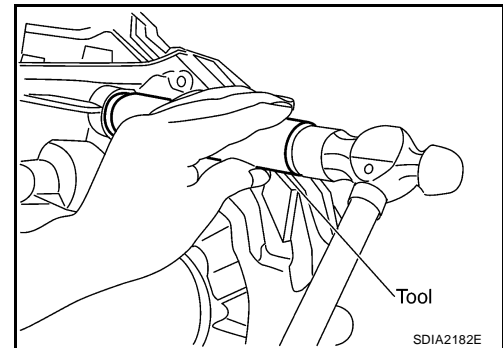
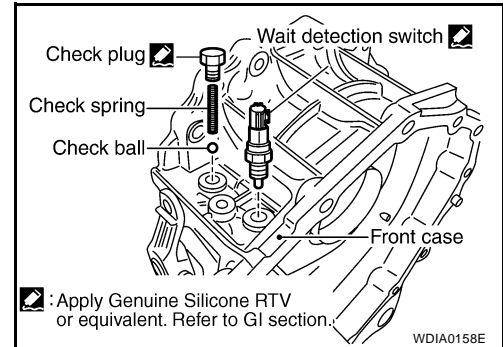

## Rear Case

1. Apply petroleum jelly to the circumference of the new rear oil seal. Install the new rear oil seal so that it is flush with the case tip face using Tool.

**Tool number** : ST30720000 (J-25405)

**CAUTION:**

- Do not reuse oil seal.
- Apply petroleum jelly to seal lip before installing.

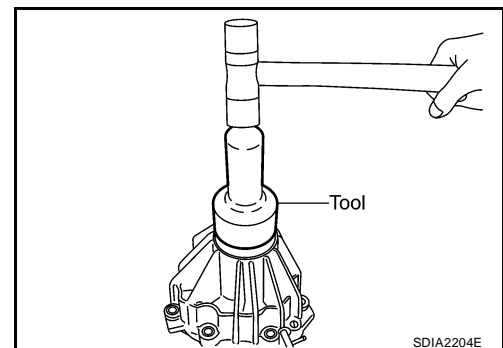

# TRANSFER ASSEMBLY

- Apply petroleum jelly to the circumference of the new dust cover. Position the new dust cover using the identification mark as shown.

**CAUTION:**

- Do not reuse dust cover.
- Position the identification mark at the position shown.

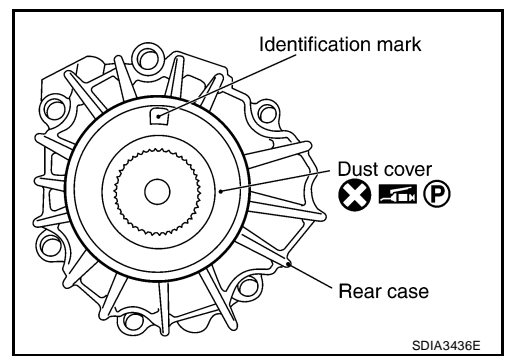

- Install the dust cover using Tool.

**Tool number** : KV40105310 ( — )

- Install the breather tube into the rear case.
- Remove all the sealant from the rear case to center case mating surfaces.

**CAUTION:**

Remove all foreign materials such as water, oil, and grease from center case and rear case mating surfaces.

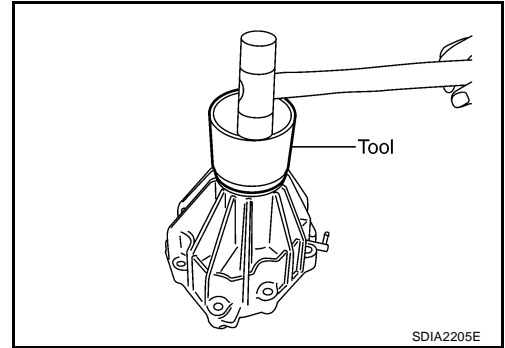

- Apply liquid gasket to the entire rear case mating surface of the center case.

- Use Genuine Anaerobic Liquid Gasket or equivalent. Refer to [GI-45, "Recommended Chemical Products and Sealants"](#).

**CAUTION:**

Do not to allow Liquid Gasket to enter stem bleeder hole.

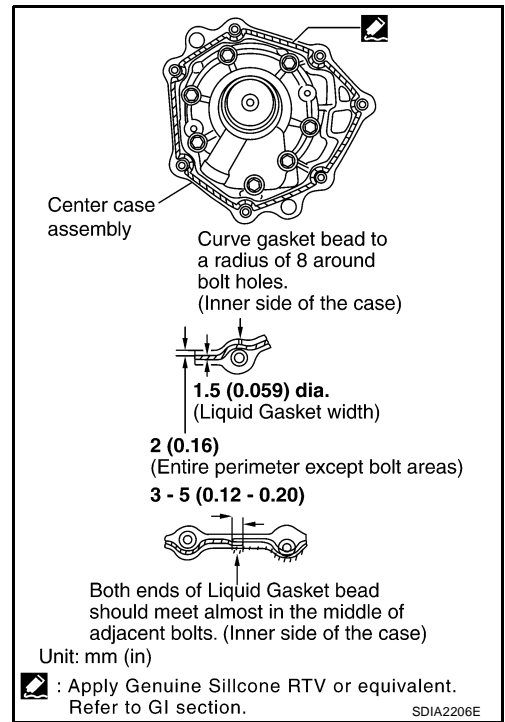

- Install the rear case to the center case. Tighten the bolts to the specified torque. Refer to [TF-145, "COMPONENTS"](#).

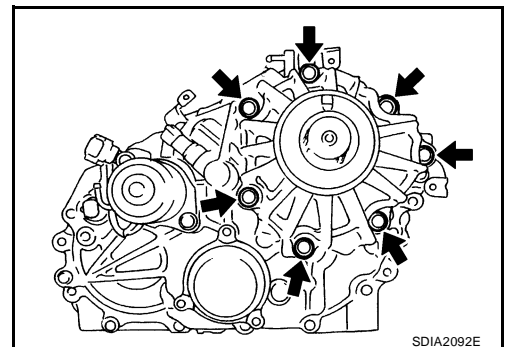

# SERVICE DATA AND SPECIFICATIONS (SDS)

## SERVICE DATA AND SPECIFICATIONS (SDS)

PFP:00030

### General Specifications

EDS001ZR

|   |                      |                    |
|---|----------------------|--------------------|
| Applied model                                   |                      | VK56DE             |
| Transfer model                                  |                      | ATX14B             |
| Fluid capacity (Approx.)      ℓ (US qt, Imp qt) |                      | 3.0 (3-1/8, 2-5/8) |
| Gear ratio                                      | High                 | 1.000              |
|   | Low                  | 2.596              |
| Number of teeth                                 | Sun gear             | 57                 |
|   | Internal gear        | 91                 |
|   | Front drive sprocket | 38                 |
|   | Front drive shaft    | 38                 |

### Inspection and Adjustment

EDS001ZS

#### CLEARANCE BETWEEN INNER GEAR AND OUTER GEAR

Unit: mm (in)

| Item          | Specification                   |
|---------------|---------------------------------|
| Main oil pump | 0.015 - 0.035 (0.0006 - 0.0014) |
| Sub-oil pump  | 0.015 - 0.035 (0.0006 - 0.0014) |

#### CLUTCH

Unit: mm (in)

| Item        | Limit value |
|-------------|-------------|
| Drive plate | 1.4 (0.055) |

#### PINION GEAR END PLAY

Unit: mm (in)

| Item                 | Standard                  |
|----------------------|---------------------------|
| Pinion gear end play | 0.1 - 0.7 (0.004 - 0.028) |

#### CLEARANCE BETWEEN SHIFT FORK AND SLEEVE

Unit: mm (in)

| Item                  | Standard                |
|-----------------------|-------------------------|
| Shift fork and sleeve | Less than 0.36 (0.0142) |

### SELECTIVE PARTS

#### Sub-oil Pump

Unit: mm (in)

| Gear thickness                | Part number* |             |
|-------------------------------|--------------|-------------|
|                               | Inner gear   | Outer gear  |
| 9.27 - 9.28 (0.3650 - 0.3654) | 31346 0W462  | 31347 0W462 |
| 9.28 - 9.29 (0.3654 - 0.3657) | 31346 0W461  | 31347 0W461 |
| 9.29 - 9.30 (0.3657 - 0.3661) | 31346 0W460  | 31347 0W460 |

\*: Always check with the Parts Department for the latest parts information.

# SERVICE DATA AND SPECIFICATIONS (SDS)

## Main Oil Pump

Unit: mm (in)

| Gear thickness                | Part number* |             |
|-------------------------------|--------------|-------------|
|                               | Inner gear   | Outer gear  |
| 8.27 - 8.28 (0.3256 - 0.3260) | 31346 7S112  | 31347 7S112 |
| 8.28 - 8.29 (0.3260 - 0.3264) | 31346 7S111  | 31347 7S111 |
| 8.29 - 8.30 (0.3264 - 0.3268) | 31346 7S110  | 31347 7S110 |

\*: Always check with the Parts Department for the latest parts information.

## Control Valve

Unit: mm (in)

| Mounting position (Part name) | Part number* | Outer dia.   | Overall length |
|-------------------------------|--------------|--------------|----------------|
| L1 (2-4 shift valve)          | 31772 21X00  | 8.0 (0.315)  | 38.5 (1.516)   |
| L2 (Clutch valve)             | 31772 80X11  | 10.0 (0.394) | 40.0 (1.575)   |
| L4 (Pilot valve)              | 31772 80X11  | 10.0 (0.394) | 40.0 (1.575)   |
| L5 (Regulator valve)          | 31741 0W410  | 12.0 (0.472) | 68.0 (2.677)   |

\*: Always check with the Parts Department for the latest parts information.

## Control Valve Spring

Unit: mm (in)

| Mounting position (Part name) | Part number* | Free length    | Outer dia.   | Overall length |
|-------------------------------|--------------|----------------|--------------|----------------|
| L1 (2-4 shift valve spring)   | 31742 2W500  | 31.85 (1.2539) | 7.0 (0.276)  | 0.6 (0.024)    |
| L2 (Clutch valve spring)      | 31742 2W505  | 40.6 (1.598)   | 8.9 (0.350)  | 0.7 (0.028)    |
| L4 (Pilot valve spring)       | 31742 0W410  | 28.1 (1.106)   | 9.0 (0.354)  | 1.2 (0.047)    |
| L5 (Regulator valve spring)   | 31742 2W515  | 39.7 (1.563)   | 11.0 (0.433) | 1.3 (0.051)    |

\*: Always check with the Parts Department for the latest parts information.

## Return Spring

Unit: mm (in)

| Stamped mark | Part number* | Free length  |
|--------------|--------------|--------------|
| 1            | 31521 7S111  | 42.7 (1.168) |
| 2            | 31521 7S112  | 43.1 (1.697) |
| 3            | 31521 7S113  | 43.6 (1.717) |
| 4            | 31521 7S114  | 44.0 (1.731) |

\*: Always check with the Parts Department for the latest parts information.

# SERVICE DATA AND SPECIFICATIONS (SDS)

---