

SECTION **SB**
SEAT BELT

A
B
C
D
E
F
G
SB
I
J
K
L
M
N
O
P

CONTENTS

PRECAUTION	2	Removal and Installation of Second Row Seat Belt	7
PRECAUTIONS	2	Removal and Installation of Third Row Seat Belt	9
Precaution for Supplemental Restraint System (SRS) "AIR BAG" and "SEAT BELT PRE-TENSIONER"	2	Seat Belt Inspection	11
Precaution for Seat Belt Service	2	LATCH (LOWER ANCHORS AND TETHER FOR CHILDREN) SYSTEM	14
ON-VEHICLE REPAIR	4	Removal and Installation	14
SEAT BELTS	4	TOP TETHER STRAP CHILD RESTRAINT	15
Removal and Installation of Front Seat Belt	4	Removal and Installation	15

PRECAUTIONS

< PRECAUTION >

PRECAUTION

PRECAUTIONS

Precaution for Supplemental Restraint System (SRS) "AIR BAG" and "SEAT BELT PRE-TENSIONER"

INFOID:000000003710737

The Supplemental Restraint System such as "AIR BAG" and "SEAT BELT PRE-TENSIONER", used along with a front seat belt, helps to reduce the risk or severity of injury to the driver and front passenger for certain types of collision. This system includes seat belt switch inputs and dual stage front air bag modules. The SRS system uses the seat belt switches to determine the front air bag deployment, and may only deploy one front air bag, depending on the severity of a collision and whether the front occupants are belted or unbelted. Information necessary to service the system safely is included in the SR and SB section of this Service Manual.

WARNING:

- To avoid rendering the SRS inoperative, which could increase the risk of personal injury or death in the event of a collision which would result in air bag inflation, all maintenance must be performed by an authorized NISSAN/INFINITI dealer.
- Improper maintenance, including incorrect removal and installation of the SRS, can lead to personal injury caused by unintentional activation of the system. For removal of Spiral Cable and Air Bag Module, see the SR section.
- Do not use electrical test equipment on any circuit related to the SRS unless instructed to in this Service Manual. SRS wiring harnesses can be identified by yellow and/or orange harnesses or harness connectors.

Precaution for Seat Belt Service

INFOID:000000003710738

CAUTION:

- Before removing the seat belt pre-tensioner assembly, turn the ignition switch OFF, disconnect both battery terminals and wait at least three minutes. For approximately three minutes after the battery terminals have been removed, it is still possible for the air bag and seat belt pretensioner to deploy. Therefore, do not attempt work on any SRS connectors or wires until at least three minutes have passed.
- After replacing or reinstalling seat belt pre-tensioner assembly, or reconnecting seat belt pre-tensioner assembly connector, make sure entire SRS operates properly. Refer to [SRC-13, "SRS Operation Check"](#).
- Do not disassemble buckle or seat belt assembly.
- Replace anchor bolts if they are deformed or worn out.
- Never oil tongue and buckle.
- If any component of seat belt assembly is questionable, do not repair. Replace the whole seat belt assembly.
- If webbing is cut, frayed, or damaged, replace seat belt assembly.
- When replacing seat belt assembly, use a genuine NISSAN seat belt assembly.

AFTER A COLLISION

WARNING:

- Inspect all seat belt assemblies including retractors and attaching hardware after any collision.
- NISSAN recommends that all seat belt assemblies in use during a collision be replaced unless the collision was minor and the belts show no damage and continue to operate properly. Failure to do so could result in serious personal injury in an accident. Seat belt assemblies not in use during a collision should also be replaced if either damage or improper operation is noted. Seat belt pre-tensioner should be replaced even if the seat belts are not in use during a frontal collision in which the air bags are deployed.

Replace any seat belt assembly (including anchor bolts) if:

- The seat belt was in use at the time of a collision (except for minor collisions and the belts, retractors and buckles show no damage and continue to operate properly).
- The seat belt was damaged in an accident. (i.e., torn webbing, bent retractor or guide, etc.)
- The seat belt attaching point was damaged in an accident. Inspect the seat belt attaching area for damage or distortion and repair as necessary before installing a new seat belt assembly.
- Anchor bolts are deformed or worn out.

PRECAUTIONS

< PRECAUTION >

- The seat belt pre-tensioner should be replaced even if the seat belts are not in use during the collision in which the air bags are deployed.

A

OCCUPANT CLASSIFICATION SYSTEM

- Replace occupant classification system control unit and passenger front seat cushion as an assembly. Refer to [SE-74. "Disassembly and Assembly"](#).

B

C

D

E

F

G

SB

I

J

K

L

M

N

O

P

SEAT BELTS

< ON-VEHICLE REPAIR >

ON-VEHICLE REPAIR

SEAT BELTS

Removal and Installation of Front Seat Belt

INFOID:000000003710739

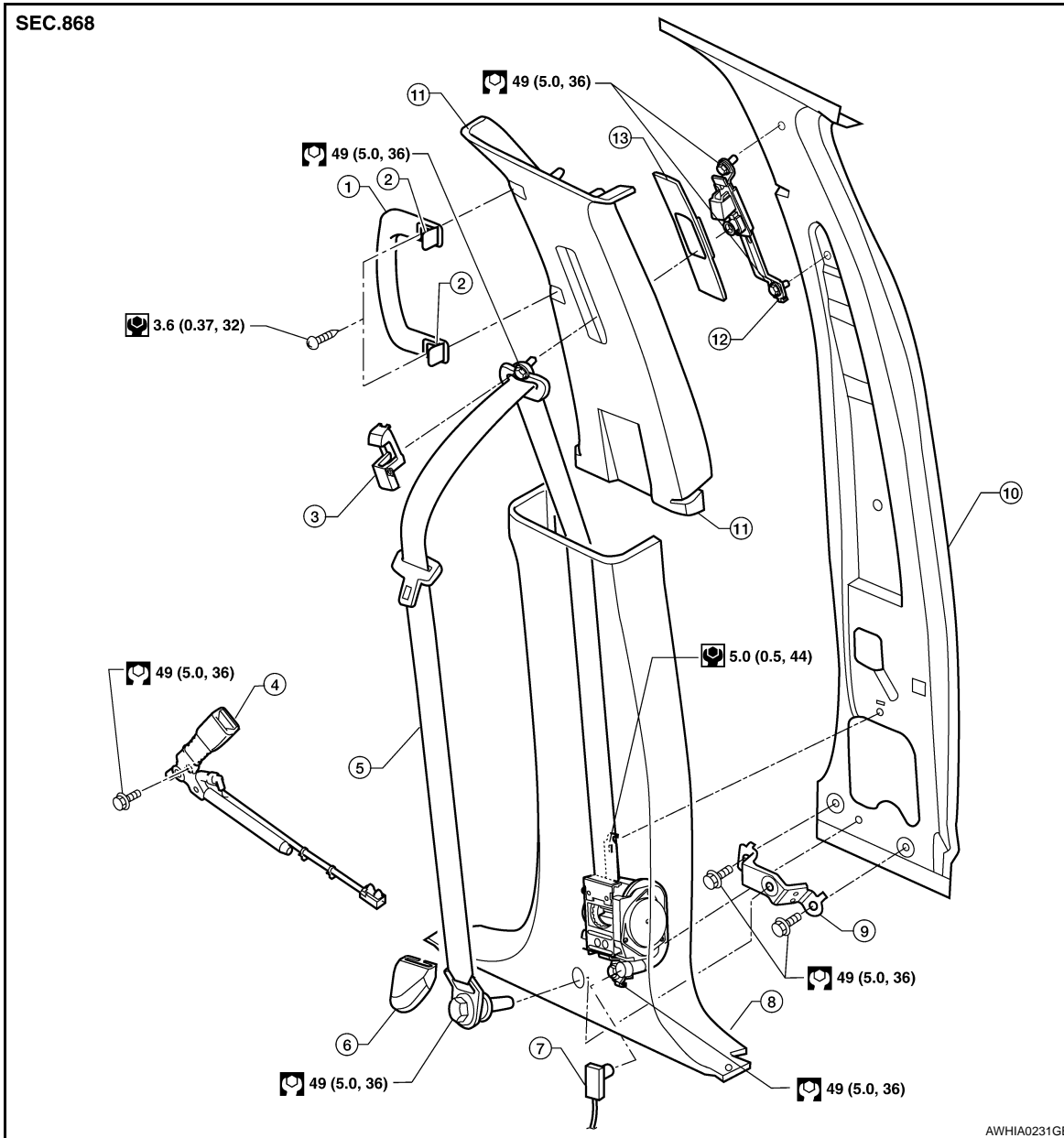

- | | | |
|--|---|-------------------------------|
| 1. Assist handle | 2. Assist handle screw cover | 3. D-ring anchor bolt cover |
| 4. Seat belt buckle | 5. Seat belt retractor and belt assembly LH | 6. Anchor cover |
| 7. Seat belt pre-tensioner connector | 8. Center pillar lower finisher | 9. Seat belt anchor bracket |
| 10. Center pillar | 11. Center pillar upper finisher | 12. Seat belt height adjuster |
| 13. Seat belt height adjuster finisher | | |

FRONT SEAT BELT RETRACTOR

Removal

CAUTION:

SEAT BELTS

< ON-VEHICLE REPAIR >

- Before servicing SRS, turn the ignition switch off, disconnect both battery cables and wait at least 3 minutes.

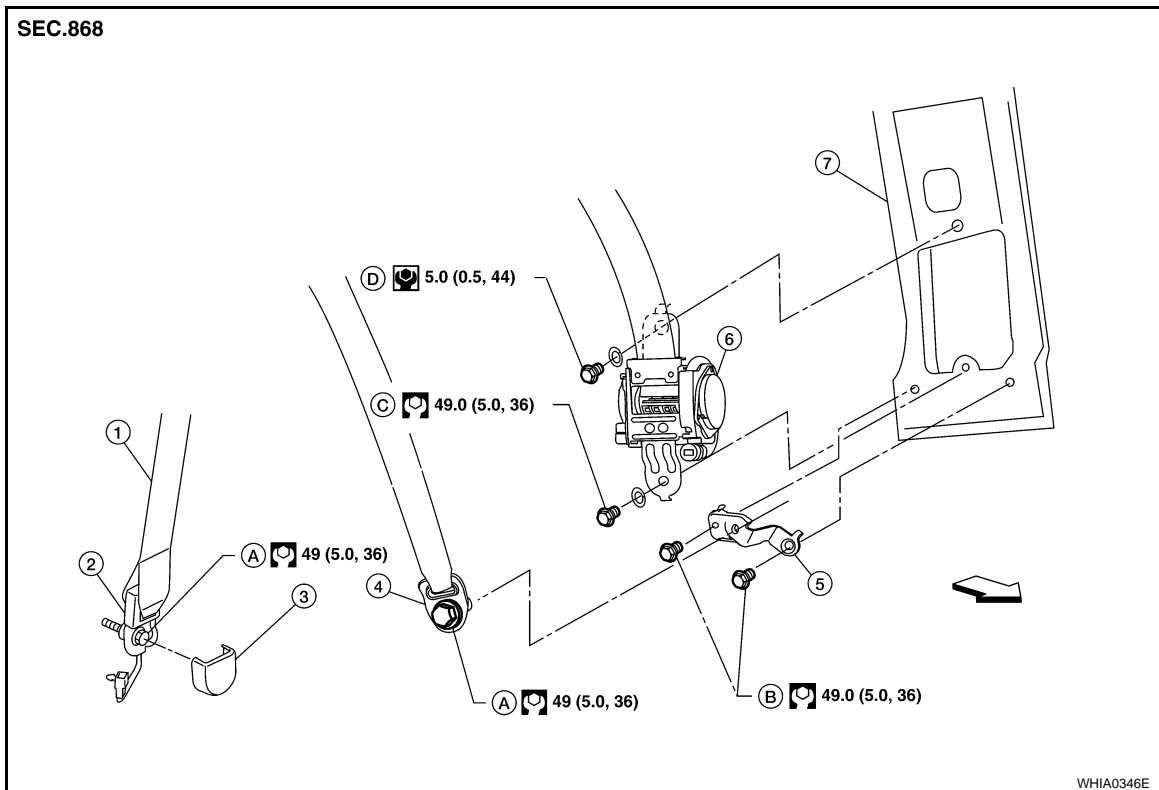

- | | | |
|---|---|---|
| 1. Seat belt retractor and belt assembly RH | 2. Seat belt lower anchor RH (seat belt tension sensor) | 3. Anchor cover RH (LH similar) |
| 4. Seat belt lower anchor LH | 5. Seat belt anchor bracket | 6. Seat belt retractor and belt assembly LH |
| 7. Center pillar | A. Lower anchor bolt | B. Anchor bracket bolt |
| C. Retractor anchor bolt | D. Retractor bolt upper | ← Vehicle front |

1. Disconnect both battery cables. then wait at least 3 minutes.
2. Remove the center pillar upper/lower finishers. Refer to [INT-13, "Removal and Installation"](#).
3. Remove the retractor anchor bolt, retractor bolt upper, then remove the retractor and belt assembly.
 - On RH side, disconnect the seat belt tension sensor.
4. Disconnect the seat belt pre-tensioner electrical connector.

CAUTION:

- For removing pre-tensioner connector, insert a thin screwdriver (1) wrapped in tape (3) into the notch. Lift the locking tab to unlock (2), then remove the connector.
- Install the pre-tensioner connector with the locking tab raised, then push the locking tab into the connector to lock (4).

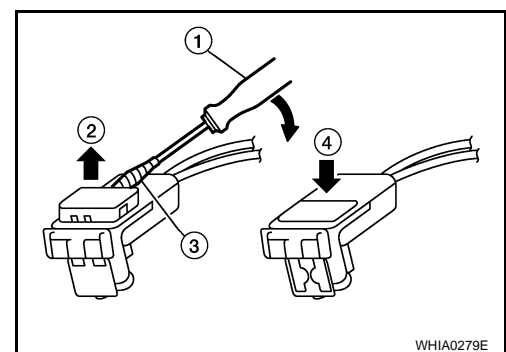

Installation

- Installation is in the reverse order of removal.
- Install the seat belt retractor and belt assembly bolt upper first.
 - Make sure that seat belt height adjuster is locked in the lowest position during installation.

FRONT SEAT BELT BUCKLE

SEAT BELTS

< ON-VEHICLE REPAIR >

Removal

1. Remove the front seat. Refer to [SE-51, "Removal and Installation"](#).
2. Remove the seat cushion. Refer to [SE-74, "Disassembly and Assembly"](#).
3. Disconnect the seat belt buckle pre-tensioner electrical connector.

CAUTION:

- For removing pre-tensioner connector, insert a thin screwdriver (1) wrapped in tape (3) into the notch. Lift the locking tab to unlock (2), then remove the connector.
- Install the pre-tensioner connector with the locking tab raised, then push the locking tab into the connector to lock (4).

4. Remove screw and seat cushion inner finisher.

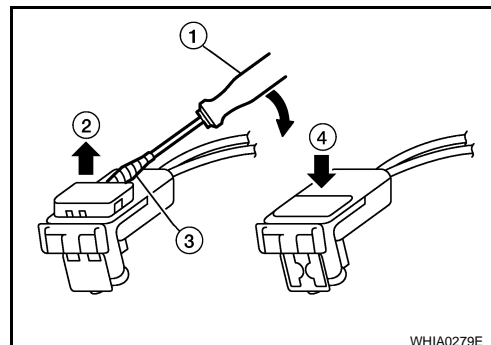

5. Remove the anchor bolt, then remove front seat belt buckle from the seat frame.

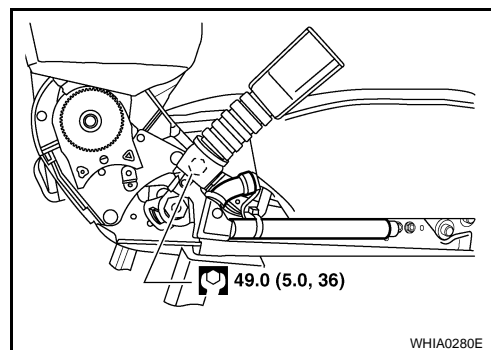

Installation

CAUTION:

- Front passenger seat is equipped with Occupant Classification System sensor and control module. Do not disassemble front passenger seat cushion assembly or remove trim, this will affect the Occupant Classification System calibration.
- On the passenger seat during installation, the wire harness clips must be installed in the holes they were originally in. Do not add additional clips.

Installation is in the reverse order of removal.

SEAT BELTS

< ON-VEHICLE REPAIR >

Removal and Installation of Second Row Seat Belt

INFOID:000000003710740

SEC. 869

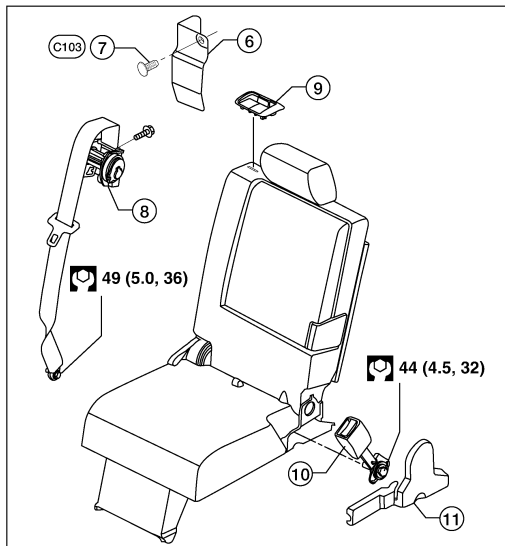
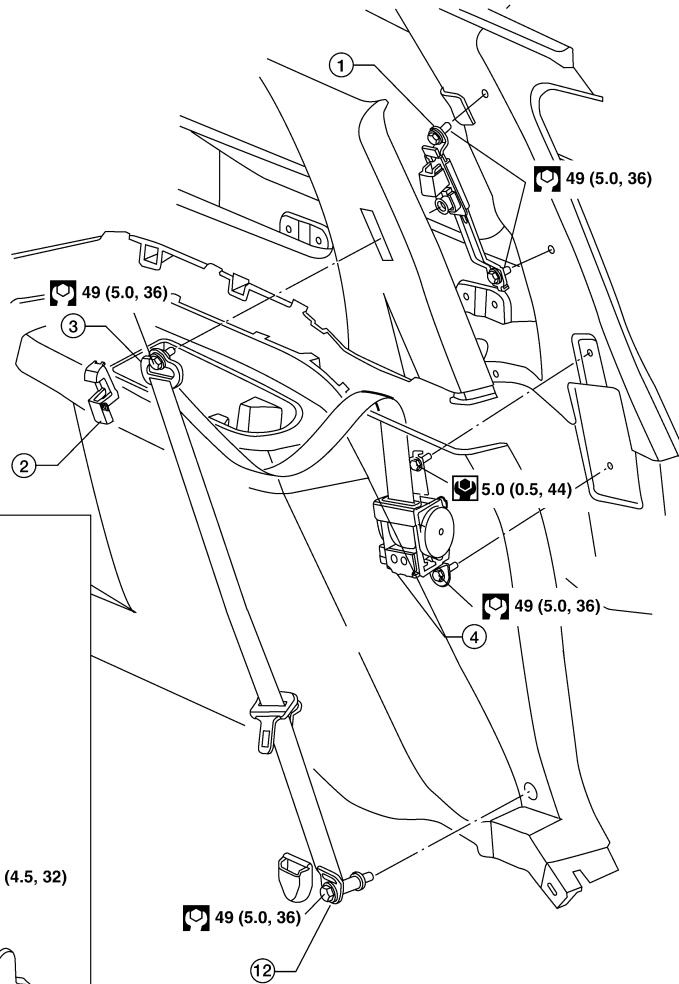
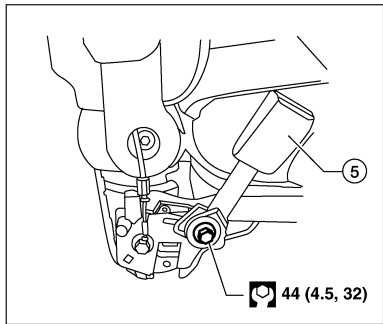

AWHIA0221GB

- | | | |
|---|---|------------------------------|
| 1. Seat belt height adjuster assembly | 2. D-ring anchor bolt cover | 3. D-ring anchor |
| 4. Seat belt retractor and belt assembly (outboard) | 5. Seat belt buckle (outboard) | 6. Seat belt retractor cover |
| 7. Push pin C103 | 8. Seat belt retractor and belt assembly (center) | 9. Seat belt bezel |
| 10. Seat belt buckle (center) | 11. Seat cushion finisher | 12. Seat belt lower anchor |

REMOVAL

1. Remove seat belt lower anchor cover and bolt.
2. Remove the D-ring anchor bolt cover and D-ring anchor bolt.
3. Remove the upper and lower luggage area trim. Refer to [INT-13, "Removal and Installation"](#).
4. Remove the seat belt guide bolt.
5. Remove seat belt retractor anchor bolt and the seat belt assembly.
6. Remove the seat belt height adjuster assembly.

A
B
C
D
E
F
G
SB
I
J
K
L
M
N
O
P

SEAT BELTS

< ON-VEHICLE REPAIR >

INSTALLATION

Installation is in the reverse order of removal.

- Make sure that seat belt height adjuster is locked in the lowest position during installation.

SECOND ROW SEAT BELT BUCKLE

Removal - Center Seat

1. Remove the rear center seat. Refer to [SE-56, "Second Row Center"](#).
2. Remove the screw and seat cushion inner finisher. Refer to [SE-77, "Exploded View"](#).
3. Remove the anchor bolt and buckle.

Installation - Center Seat

Installation is in the reverse order of removal.

Removal - Outboard Seat

1. Remove the rear bench seat. Refer to [SE-56, "Second Row Outboard"](#).
2. Remove the seat cushion finisher. Refer to [SE-77, "Exploded View"](#).
3. Remove the anchor bolt and buckle.

Installation - Outboard Seat

Installation is in the reverse order of removal.

SECOND ROW SEAT BELT RETRACTOR - BENCH SEAT

Removal

1. Remove seat belt anchor.
2. Remove seat belt bezel.
3. Remove seat back upholstery and foam. Refer to [SE-77, "Exploded View"](#).
4. Remove seat belt retractor cover.
5. Remove bolt and remove seat belt retractor and seat belt assembly.

Installation

Installation is in the reverse order of removal.

SEAT BELTS

< ON-VEHICLE REPAIR >

Third Row Center

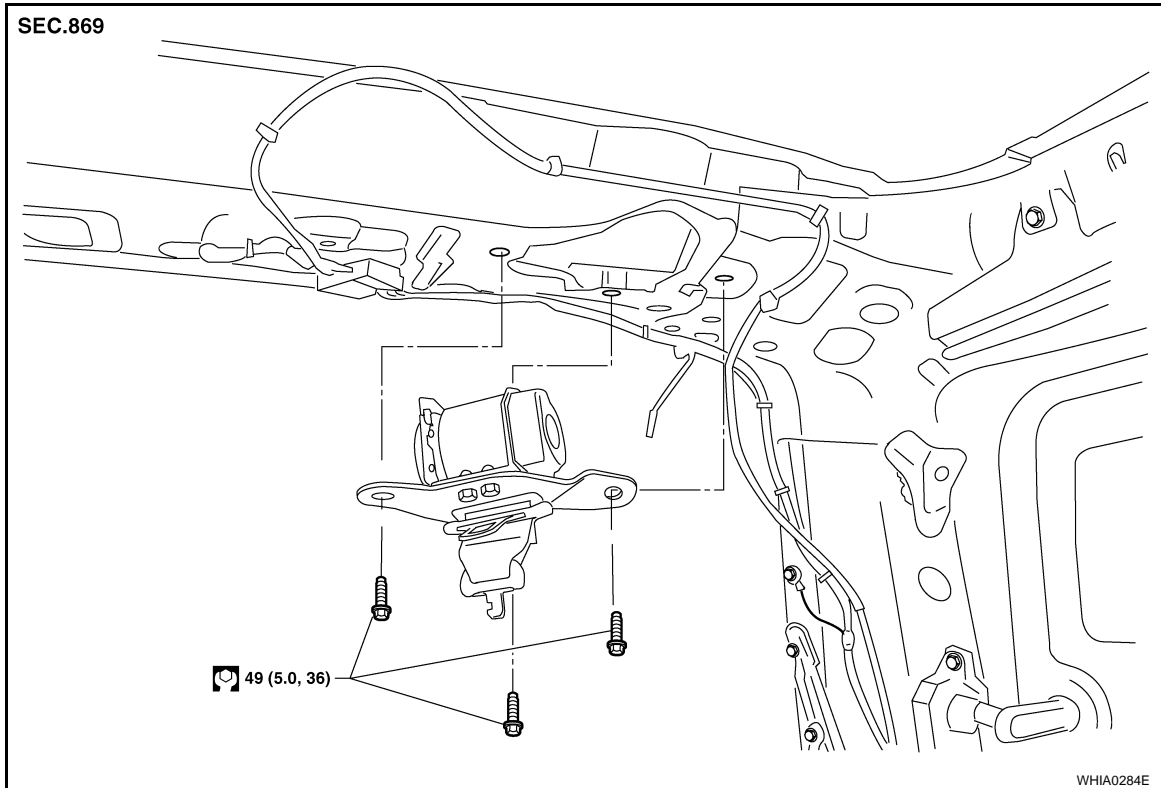

REMOVAL

1. Remove the rear roof finisher. Refer to [INT-16, "Removal and Installation"](#).
2. Lower the rear portion of the headliner.
3. Remove the seat belt retractor anchor bolts and retractor and belt assembly.

INSTALLATION

Installation is in the reverse order of removal.

THIRD ROW SEAT BELT BUCKLE

Removal

1. Place seatback RH/LH in the folded position.
2. Remove luggage floor board assembly and storage box. Refer to [INT-18, "Removal and Installation"](#).
3. Remove seat belt buckle bolt (2) from rear seat hinge (1).
 - ←: Vehicle front

Seat belt buckle bolt : 49 N·m (5.0 kg-m, 36 ft-lb)

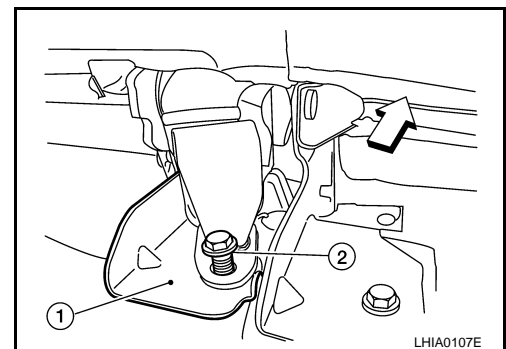

SEAT BELTS

< ON-VEHICLE REPAIR >

4. Remove push pin (2) and release elastic ban (3) from seat frame (1). Repeat for opposite seat.
 - ⇐: Vehicle front

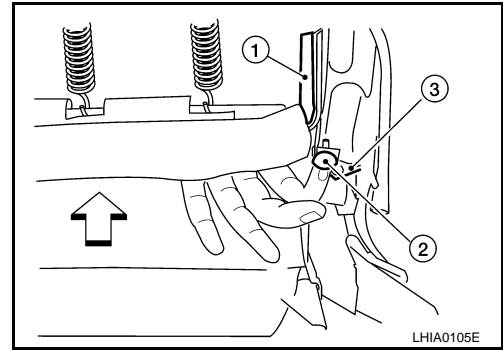

5. Partially lift seatback upright, then remove seat belt buckle (2) from between hinge cover (1) and seat cushion side facing (3). Repeat for LH seat.
 - ⇐: Vehicle front

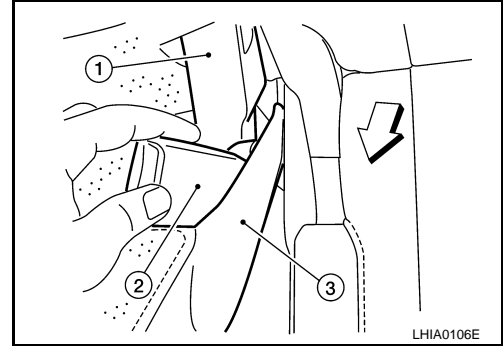

Installation

Installation is in the reverse order of removal.

- Raise and lock both seats in the full upright position to check for abnormal noises or binding.

Seat Belt Inspection

INFOID:000000003710742

AFTER A COLLISION

WARNING:

Inspect all seat belt assemblies including retractors and attaching hardware after any collision. NISSAN recommends that all seat belt assemblies in use during a collision be replaced unless the collision was minor and the belts show no damage and continue to operate properly. Failure to do so could result in serious personal injury in an accident. Seat belt assemblies not in use during a collision should also be replaced if either damage or improper operation is noted. Seat belt pre-tensioners should be replaced even if the seat belts are not in use during a frontal collision in which the air bags are deployed.

Replace any seat belt assembly (including anchor bolts) if:

- The seat belt was in use at the time of a collision (except for minor collisions and the belts, retractors and buckles show no damage and continue to operate properly).
- The seat belt was damaged in an accident. (i.e. torn webbing, bent retractor or guide).
- The seat belt attaching point was damaged in an accident. Inspect the seat belt attaching area for damage or distortion and repair as necessary before installing a new seat belt assembly.
- Anchor bolts are deformed or worn out.
- The seat belt pre-tensioner should be replaced even if the seat belts are not in use during the collision in which the air bags are deployed.

PRELIMINARY CHECKS

1. Check the seat belt warning lamp/chime for proper operation as follows:
 - a. Switch ignition ON. The seat belt warning lamp should illuminate. Also, the seat belt warning chime should sound for about seven seconds.
 - b. Fasten drivers seat belt. The seat belt warning lamp should go out and the chime (if sounding) should stop.
2. If the air bag warning lamp is blinking, conduct self-diagnosis using CONSULT-II, and air bag warning lamp. Refer to [SRC-13. "SRS Operation Check"](#).
3. Check that the seat belt retractor, seat belt anchor and buckle bolts are securely attached.

SEAT BELTS

< ON-VEHICLE REPAIR >

4. Check the shoulder seat belt guide and shoulder belt height adjuster for front seats. Ensure guide swivels freely and that belt lays flat and does not bind in guide. Ensure height adjuster operates properly and holds securely.
5. Check retractor operation:
 - a. Fully extend the seat belt webbing and check for twists, tears or other damage.
 - b. Allow the seat belt to retract. Ensure that belt returns smoothly and completely into the retractor. If the seat belt does not return smoothly, wipe the inside of the loops with a clean paper cloth, because dirt built up in the loops of the upper anchors can cause the seat belts to retract slowly.
 - c. Fasten the seat belt. Check the seat belt returns smoothly and completely to the retractor. If the belt does not return smoothly, the cause may be an accumulation of dust or dirt. Use the "SEAT BELT TAPE SET" and perform the following steps.

Inspect the front seat belt through-anchor:

1. Pull the seat belt out to a length of 500 mm (19.69 in) or more.
2. Use a clip or other device to hold the seat belt at the center pillar belt opening.
3. Pass a thin wire through the through-anchor belt opening. Hold both ends of the wire and pull taut while moving it up and down several times along the belt opening surface to remove dirt.
4. Any dirt that cannot be removed with the wire can be removed by cleaning the opening with a clean cloth.
5. Apply tape at the point where the belt contacts the through-anchor belt opening.
NOTE:
Apply the tape so that there is no looseness or wrinkling.
6. Remove the clip holding the seat belt and check that the belt returns smoothly.
7. Repeat steps above as necessary to check the other seat belts.

SEAT BELT RETRACTOR ON-VEHICLE CHECK

Emergency Locking Retractors (ELR) and Automatic Locking Retractors (ALR)

NOTE:

All seat belt retractors are of the Emergency Locking Retractors (ELR) type. In an emergency (sudden stop) the retractor will lock and prevent the belt from extending any further. All 3-point type seat belt retractors except the driver's seat belt also have an Automatic Locking Retractors (ALR) mode. The ALR mode (also called child restraint mode) is used when installing child seats. The ALR mode is activated when the seat belt is fully extended. When the belt is then retracted partially, the ALR mode automatically locks the seat belt in a specific position so the belt cannot be extended any further. To cancel the ALR mode, allow the seat belt to fully wind back into the retractor.

Check the seat belt retractors using the following test(s) to determine if a retractor assembly is operating properly.

ELR Function Stationary Check

Grasp the shoulder belt and pull forward quickly. The retractor should lock and prevent the belt from extending further.

ALR Function Stationary Check

1. Pull out entire length of seat belt from retractor until a click is heard.
2. Retract the belt partially. A clicking noise should be heard as the belt retracts indicating that the retractor is in the Automatic Locking Retractor (ALR) mode.
3. Grasp the seat belt and try to pull out the retractor. The belt must lock and not extend any further. If necessary replace the retractor assembly.
4. Allow the entire length of the belt to retract to cancel the automatic locking mode.

ELR Function Moving Check

WARNING:

Perform the following test in a safe, open area clear of other vehicles and obstructions (for example, a large, empty parking lot). Road surface must be paved and dry. DO NOT perform the following test on wet or gravel roads or on public streets and highways. This could result in an accident and serious personal injury. The driver and passenger must be prepared to brace themselves in the event the retractor does not lock.

1. Fasten drivers seat belt. Buckle a passenger into the seat for the belt that is to be tested.

SEAT BELTS

< ON-VEHICLE REPAIR >

2. Proceed to the designated safe area.
3. Drive the vehicle at approximately 16 km/h (10 MPH). Notify any passengers of a pending sudden stop. The driver and passenger must be prepared to brace themselves in the event the retractor does not lock. Apply brakes firmly and make a very hard stop.

During stop, seat belts should lock and not be extended. If the seat belt retractor assembly does not lock, perform the retractor off-vehicle check.

SEAT BELT RETRACTOR OFF-VEHICLE CHECK

1. Remove the seat belt retractor assembly.
2. Slowly pull out belt while tilting the retractor assembly forward from the mounted position without twisting the retractor assembly as shown in the illustration.

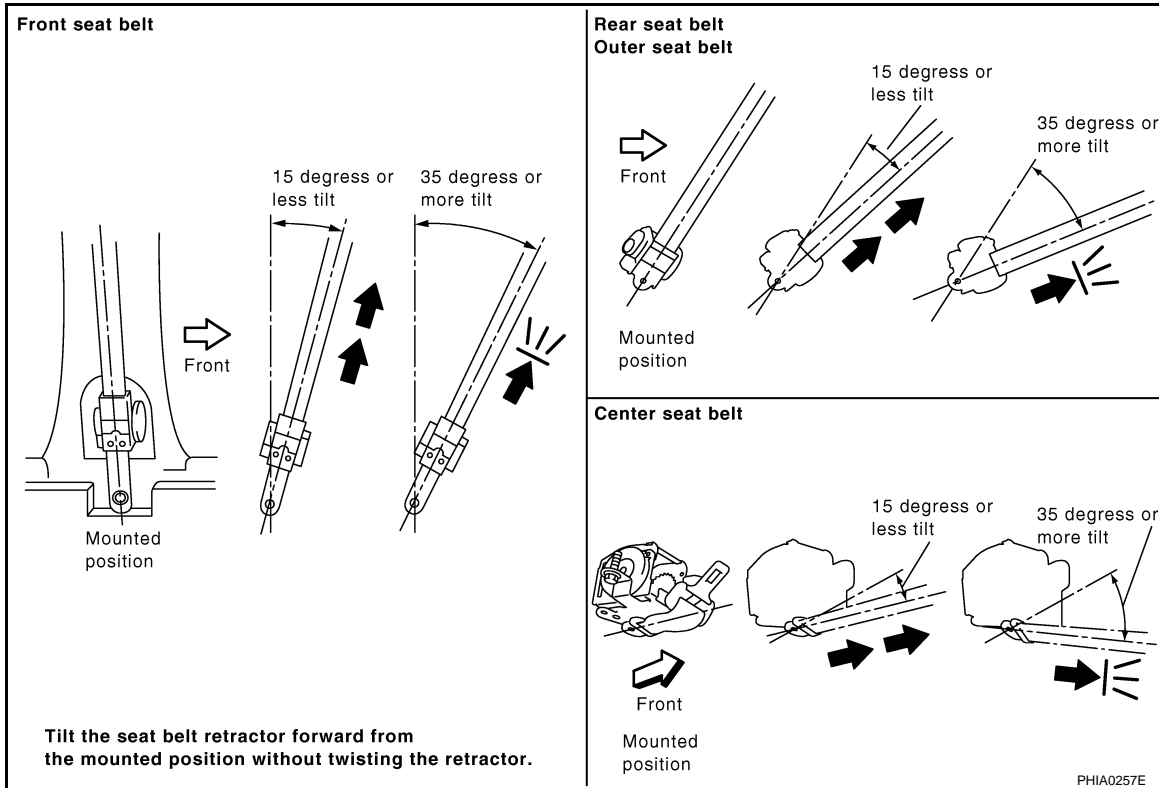

15 degrees or less tilt : Belt can be pulled out.

35 degrees or more tilt : Belt locks and cannot be pulled out.

If retractor does not operate within specifications, replace the retractor assembly.

LATCH (LOWER ANCHORS AND TETHER FOR CHILDREN) SYSTEM

< ON-VEHICLE REPAIR >

LATCH (LOWER ANCHORS AND TETHER FOR CHILDREN) SYSTEM

Removal and Installation

INFOID:000000003710743

NOTE:

The LATCH (Lower Anchors and Tether for Children) system is not serviceable.

TOP TETHER STRAP CHILD RESTRAINT

< ON-VEHICLE REPAIR >

TOP TETHER STRAP CHILD RESTRAINT

Removal and Installation

INFOID:000000003710744

REMOVAL

- ←: Vehicle front

1. Remove luggage room rear lower finisher. Refer to [INT-18, "Removal and Installation"](#).
2. Remove bolt and remove tether anchor from the luggage box bracket.

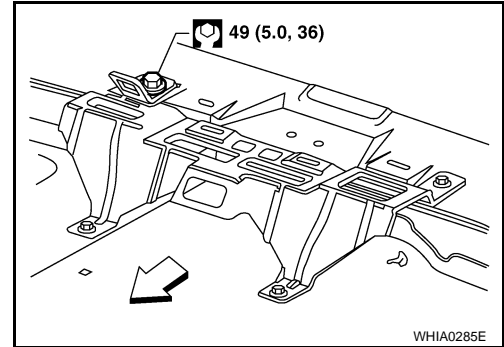

INSTALLATION

Installation is in the reverse order of removal.

A
B
C
D
E
F
G
I
J
K
L
M
N
O
P

SB