

BL

SECTION

BODY, LOCK & SECURITY SYSTEM

CONTENTS

PRECAUTIONS	4	RADIATOR CORE SUPPORT	17
Precautions for Supplemental Restraint System (SRS) "AIR BAG" and "SEAT BELT PRE-TENSIONER"	4	Removal and Installation	17
Precautions for work	4	REMOVAL	17
Wiring Diagrams and Trouble Diagnosis	4	INSTALLATION	18
PREPARATION	5	POWER DOOR LOCK SYSTEM	19
Special Service Tools	5	Component Parts and Harness Connector Location..	19
Commercial Service Tools	5	System Description	20
SQUEAK AND RATTLE TROUBLE DIAGNOSIS	6	OUTLINE	21
Work Flow	6	CAN Communication System Description	22
CUSTOMER INTERVIEW	6	TYPE 1/TYPE 3	22
DUPLICATE THE NOISE AND TEST DRIVE	7	TYPE 2	24
CHECK RELATED SERVICE BULLETINS	7	Schematic	26
LOCATE THE NOISE AND IDENTIFY THE ROOT CAUSE	7	Wiring Diagram -D/LOCK-	27
REPAIR THE CAUSE	7	FIG. 1	27
CONFIRM THE REPAIR	8	FIG. 2	28
Generic Squeak and Rattle Troubleshooting	8	FIG. 3	29
INSTRUMENT PANEL	8	FIG. 4	30
CENTER CONSOLE	8	Terminals and Reference Value for BCM	31
DOORS	8	Terminals and Reference Value for Combination Meter	31
TRUNK	9	Work Flow	31
SUNROOF/HEADLINING	9	Preliminary Check	32
SEATS	9	FUSE CHECK	32
UNDERHOOD	9	CONSULT-II Function	32
Diagnostic Worksheet	10	CONSULT-IIBASICOPERATIONPROCEDURE	33
HOOD	12	WORK SUPPORT	33
Fitting Adjustment	12	DATA MONITOR	34
LONGITUDINAL AND LATERAL CLEARANCE ADJUSTMENT	12	ACTIVE TEST	34
FRONT END HEIGHT ADJUSTMENT	12	Trouble Diagnoses Symptom Chart	34
SURFACE HEIGHT ADJUSTMENT	13	Check Door Switch / With Navigation System	35
Removal and Installation of Hood Assembly	14	Check Door Switch / Without Navigation System... ..	37
REMOVAL	14	Check Key Switch	38
INSTALLATION	14	Check Door Lock and Unlock Switch (With Interruption Function Detection for All Door Window) ...	38
Removal and Installation of Hood Lock Control	15	Check Door Lock and Unlock Switch (With Interruption Function Detection for Front Door Window)..	42
REMOVAL	15	Check Door Lock Actuator (Driver Side)	44
INSTALLATION	16	Check Door Lock Actuator (Passenger Side and Rear LH/RH)	45
Hood Lock Control Inspection	16		

Check Fuel Lid Opener Actuator	46	Inspection and Adjustment	83
Check Front Door Key Cylinder Switch (Lock)	47	EXTERIOR HANDLE ROD ADJUSTMENT	83
Check Front Door Key Cylinder Switch (Unlock) ...	48	Removal and Installation	83
REMOTE KEYLESS ENTRY SYSTEM	49	REMOVAL	83
Component Parts and Harness Connector Location..	49	INSTALLATION	84
System Description	50	Disassembly and Assembly	84
INPUTS	50	DISASSEMBLY	84
OPERATED PROCEDURE	51	ASSEMBLY	85
CAN Communication System Description	53	REAR DOOR LOCK	86
TYPE 1/TYPE 3	53	Component Structure	86
TYPE 2	55	INSPECTION AND ADJUSTMENT	86
Schematic	57	EXTERIOR HANDLE ROD ADJUSTMENT	86
Wiring Diagram — KEYLES—	58	Removal and Installation of Door Lock	87
FIG. 1	58	REMOVAL	87
FIG. 2	59	INSTALLATION	87
FIG. 3	60	Disassembly and Assembly	87
Terminals and Reference Value for BCM	61	DISASSEMBLY	87
Terminals and Reference Value for IPDM E/R	61	ASSEMBLY	88
Terminals and Reference Value for Combination		TRUNK LID	89
Meter	62	Fitting Adjustment	89
CONSULT-II Function	62	LONGITUDINAL AND LATERAL CLEARANCE	
CONSULT-II Inspection Procedure	62	ADJUSTMENT	89
“MULTI REMOTE ENT”	62	SURFACE HEIGHT ADJUSTMENT	89
CONSULT-II Application Items	63	Removal and Installation of Trunk Lid Assembly ...	90
“MULTI REMOTE CONTENT”	63	REMOVAL	90
Work Flow	65	INSTALLATION	90
Trouble Diagnosis Chart by Symptom	65	Removal and Installation of Trunk Lid Stay	90
Check Key Fob Battery and Function	67	REMOVAL	90
Check ACC Switch	68	INSTALLATION	90
Check Door Switch / With Navigation System	69	Removal and Installation of Trunk Lid Lock	91
Check Door Switch / Without Navigation System ...	71	REMOVAL	91
Check Key Switch	72	INSTALLATION	91
Check IPDM E/R Operation	73	Removal and Installation of Trunk Lid Striker	91
Check Trunk Lid Opener Function	73	REMOVAL	91
Check Hazard Function	73	INSTALLATION	91
Check Horn Function	73	Removal and Installation of Trunk lid Emergency	
Check Headlamp Function	74	Opener Cable	92
Check Map Lamp and Ignition Keyhole Illumination		REMOVAL	92
Function	74	INSTALLATION	92
ID Code Entry Procedure	75	Removal and Installation of Trunk Lid Weatherstrip..	93
KEY FOB ID SET UP WITH CONSULT-II	75	REMOVAL	93
KEY FOB ID SET UP WITHOUT CONSULT-II ...	77	INSTALLATION	93
Key Fob Battery Replacement	78	TRUNK LID OPENER	94
DOOR	79	Wiring Diagram - TLID- / Models with Up To Serial	
Fitting Adjustment	79	Number 099999	94
FRONT DOOR	79	Wiring Diagram - TLID - / Models with from Serial	
REAR DOOR	79	Number 300001	95
STRIKER ADJUSTMENT	79	Terminals and Reference Value for BCM	96
Removal and Installation of Front Door	80	VEHICLE SECURITY (THEFT WARNING) SYSTEM..	97
REMOVAL	80	Component Parts and Harness Connector Location..	97
INSTALLATION	80	System Description	98
Removal and Installation of Rear Door	80	DESCRIPTION	98
REMOVAL	81	POWER SUPPLY	99
INSTALLATION	81	INITIAL CONDITION TO ACTIVATE THE SYS-	
Door Weatherstrip	82	TEM	99
REMOVAL	82	VEHICLE SECURITY SYSTEM ALARM OPER-	
INSTALLATION	82	ATION	99
FRONT DOOR LOCK	83	VEHICLE SECURITY SYSTEM DEACTIVATION	100
Component Structure	83	PANIC ALARM OPERATION	100

CAN Communication System Description	101	SYMPTOM MATRIX CHART 2	134	
TYPE 1/TYPE 3	101	DIAGNOSTIC SYSTEM DIAGRAM	134	A
TYPE 2	103	Diagnostic Procedure 1	135	
Schematic	105	Diagnostic Procedure 2	136	B
Wiring Diagram -VEHSEC-	106	Diagnostic Procedure 3	137	
FIG. 1	106	Diagnostic Procedure 4	139	C
FIG. 2	107	Diagnostic Procedure 5	140	
FIG. 3	108	Diagnostic Procedure 6	141	
FIG. 4	109	How to Replace NATS Antenna Amp	142	
FIG. 5	110	INTEGRATED HOMELINK TRANSMITTER	143	
Terminals and Reference Value for BCM	111	Wiring Diagram —TRNSCV—	143	D
Terminals and Reference Value for IPDM E/R	111	Trouble Diagnoses	144	
CONSULT-II Function	111	DIAGNOSTIC PROCEDURE	144	
CONSULT-II INSPECTION PROCEDURE	111	BODY REPAIR	146	E
CONSULT-II APPLICATION ITEM	113	Body Exterior Paint Color	146	
Trouble Diagnosis	114	Body Component Parts	147	
WORK FLOW	114	UNDERBODY COMPONENT PARTS	147	
Preliminary Check	115	BODY COMPONENT PARTS	149	F
Symptom Chart	116	Corrosion Protection	151	
Diagnostic Procedure 1	117	DESCRIPTION	151	
1 – 1 CHECK DOOR SWITCH / WITH NAVIGATION SYSTEM	117	ANTI-CORROSIVE WAX	152	G
1 – 2 CHECK DOOR SWITCH / WITHOUT NAVIGATION SYSTEM	119	UNDERCOATING	153	
1 – 3 HOOD SWITCH CHECK	120	STONE GUARD COAT	154	
1 – 4 TRUNK ROOM LAMP SWITCH CHECK	121	Body Sealing	155	H
Diagnostic Procedure 2	122	DESCRIPTION	155	
SECURITY INDICATOR LAMP CHECK	122	Body Construction	158	
Diagnostic Procedure 3	123	BODY CONSTRUCTION	158	
FRONT DOOR KEY CYLINDER SWITCH CHECK	123	Body Alignment	159	BL
Diagnostic Procedure 4	123	BODY CENTER MARKS	159	
VEHICLE SECURITY HORN ALARM CHECK	123	PANEL PARTS MATCHING MARKS	160	J
Diagnostic Procedure 5	124	DESCRIPTION	161	
VEHICLE SECURITY HEADLAMP ALARM CHECK	124	ENGINE COMPARTMENT	162	
Diagnostic Procedure 6	124	UNDERBODY	164	
DOOR LOCK AND UNLOCK SWITCH CHECK	124	PASSENGER COMPARTMENT	166	K
IVIS (INFINITI VEHICLE IMMOBILIZER SYSTEM-NATS)	125	REAR BODY	168	
Component Parts and Harness Connector Location	125	Handling Precautions For Plastics	170	
System Description	126	HANDLING PRECAUTIONS FOR PLASTICS	170	
System Composition	127	LOCATION OF PLASTIC PARTS	171	L
ECM Re-communicating Function	127	Precautions In Repairing High Strength Steel	173	
Wiring Diagram — NATS —	128	HIGH STRENGTH STEEL (HSS) USED IN NISSAN VEHICLES	173	M
Terminals and Reference Value for BCM	129	Replacement Operations	176	
CONSULT-II	129	DESCRIPTION	176	
CONSULT-II INSPECTION PROCEDURE	129	HOODLEDGE	179	
CONSULT-II DIAGNOSTIC TEST MODE FUNCTION	130	FRONT SIDE MEMBER	180	
HOW TO READ SELF-DIAGNOSTIC RESULTS	131	FRONT SIDE MEMBER (PARTIAL REPLACEMENT)	181	
IVIS (NATS) SELF-DIAGNOSTIC RESULTS ITEM CHART	131	FRONT PILLAR	182	
Work Flow	132	CENTER PILLAR	183	
Trouble Diagnoses	133	OUTER SILL	184	
SYMPTOM MATRIX CHART 1	133	OUTER SILL (CONT'D)	185	
		REAR FENDER	186	
		REAR PANEL	187	
		REAR FLOOR REAR	188	
		REAR SIDE MEMBER EXTENSION	189	

PRECAUTIONS

PRECAUTIONS

PFP:00001

Precautions for Supplemental Restraint System (SRS) “AIR BAG” and “SEAT BELT PRE-TENSIONER”

AIS005EN

The Supplemental Restraint System such as “AIR BAG” and “SEAT BELT PRE-TENSIONER”, used along with a front seat belt, helps to reduce the risk or severity of injury to the driver and front passenger for certain types of collision. This system includes seat belt switch inputs and dual stage front air bag modules. The SRS system uses the seat belt switches to determine the front air bag deployment, and may only deploy one front air bag, depending on the severity of a collision and whether the front occupants are belted or unbelted. Information necessary to service the system safely is included in the SRS and SB section of this Service Manual.

WARNING:

- To avoid rendering the SRS inoperative, which could increase the risk of personal injury or death in the event of a collision which would result in air bag inflation, all maintenance must be performed by an authorized NISSAN/INFINITI dealer.
- Improper maintenance, including incorrect removal and installation of the SRS, can lead to personal injury caused by unintentional activation of the system. For removal of Spiral Cable and Air Bag Module, see the SRS section.
- Do not use electrical test equipment on any circuit related to the SRS unless instructed to in this Service Manual. SRS wiring harnesses can be identified by yellow and/or orange harnesses or harness connectors.

Precautions for work

AIS005EO

- After removing and installing the opening/closing parts, be sure to carry out fitting adjustments to check their operation.
- Check the lubrication level, damage, and wear of each part. If necessary, grease or replace it.

Wiring Diagrams and Trouble Diagnosis

AIS005EP

When you read wiring diagrams, refer to the following:

- [GI-14, "How to Read Wiring Diagrams"](#)
- [PG-3, "POWER SUPPLY ROUTING CIRCUIT"](#)

When you perform trouble diagnosis, refer to the following:

- [GI-10, "HOW TO FOLLOW TEST GROUPS IN TROUBLE DIAGNOSES"](#)
- [GI-26, "How to Perform Efficient Diagnosis for an Electrical Incident"](#)
Check for any Service bulletins before servicing the vehicle.

PREPARATION



PREPARATION

PFP:00002

Special Service Tools

AIS005EQ

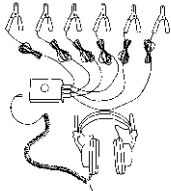
The actual shapes of Kent-Moore tools may differ from those of special service tools illustrated here.

Tool number (Kent-Moore No.) Tool name	Description
(J-39570) Chassis ear  SIIA0993E	Locating the noise
(J-43980) NISSAN Squeak and Rattle Kit  SIIA0994E	Repairing the cause of noise

Commercial Service Tools

AIS005ER

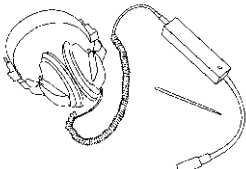
Tool name	Description
Engine ear  SIIA0995E	Locating the noise

A
B
C
D
E
F
G
H
BL
J
K
L
M

BL

SQUEAK AND RATTLE TROUBLE DIAGNOSIS

SQUEAK AND RATTLE TROUBLE DIAGNOSIS

PFP:00000

Work Flow

AIS005ES

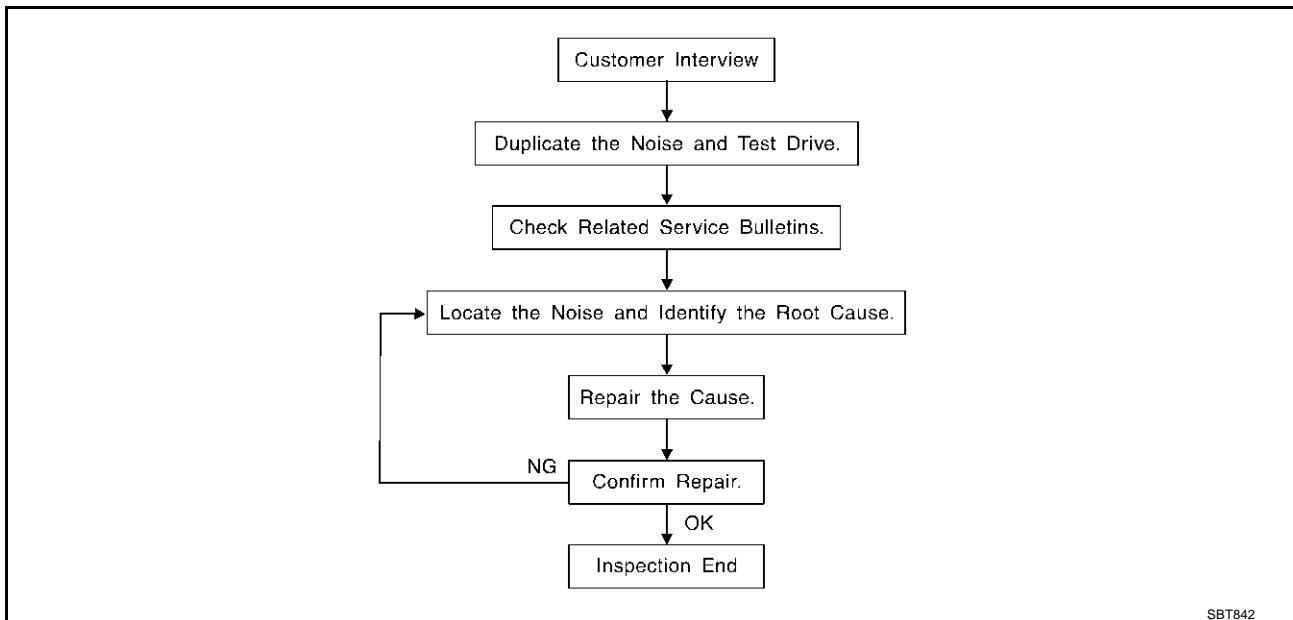

CUSTOMER INTERVIEW

Interview the customer if possible, to determine the conditions that exist when the noise occurs. Use the Diagnostic Worksheet during the interview to document the facts and conditions when the noise occurs and any customer's comments; refer to [BL-10, "Diagnostic Worksheet"](#). This information is necessary to duplicate the conditions that exist when the noise occurs.

- The customer may not be able to provide a detailed description or the location of the noise. Attempt to obtain all the facts and conditions that exist when the noise occurs (or does not occur).
- If there is more than one noise in the vehicle, be sure to diagnose and repair the noise that the customer is concerned about. This can be accomplished by test driving the vehicle with the customer.
- After identifying the type of noise, isolate the noise in terms of its characteristics. The noise characteristics are provided so the customer, service adviser and technician are all speaking the same language when defining the noise.
- Squeak —(Like tennis shoes on a clean floor)
Squeak characteristics include the light contact/fast movement/brought on by road conditions/hard surfaces=higher pitch noise/softer surfaces=lower pitch noises/edge to surface=chirping
- Creak—(Like walking on an old wooden floor)
Creak characteristics include firm contact/slow movement/twisting with a rotational movement/pitch dependent on materials/often brought on by activity.
- Rattle—(Like shaking a baby rattle)
Rattle characteristics include the fast repeated contact/vibration or similar movement/loose parts/missing clip or fastener/incorrect clearance.
- Knock —(Like a knock on a door)
Knock characteristics include hollow sounding/sometimes repeating/often brought on by driver action.
- Tick—(Like a clock second hand)
Tick characteristics include gentle contacting of light materials/loose components/can be caused by driver action or road conditions.
- Thump—(Heavy, muffled knock noise)
Thump characteristics include softer knock/dead sound often brought on by activity.
- Buzz—(Like a bumble bee)
Buzz characteristics include high frequency rattle/firm contact.
- Often the degree of acceptable noise level will vary depending upon the person. A noise that you may judge as acceptable may be very irritating to the customer.
- Weather conditions, especially humidity and temperature, may have a great effect on noise level.

SQUEAK AND RATTLE TROUBLE DIAGNOSIS

DUPLICATE THE NOISE AND TEST DRIVE

If possible, drive the vehicle with the customer until the noise is duplicated. Note any additional information on the Diagnostic Worksheet regarding the conditions or location of the noise. This information can be used to duplicate the same conditions when you confirm the repair.

If the noise can be duplicated easily during the test drive, to help identify the source of the noise, try to duplicate the noise with the vehicle stopped by doing one or all of the following:

- 1) Close a door.
 - 2) Tap or push/pull around the area where the noise appears to be coming from.
 - 3) Rev the engine.
 - 4) Use a floor jack to recreate vehicle "twist".
 - 5) At idle, apply engine load (electrical load, half-clutch on M/T model, drive position on A/T model).
 - 6) Raise the vehicle on a hoist and hit a tire with a rubber hammer.
- Drive the vehicle and attempt to duplicate the conditions the customer states exist when the noise occurs.
 - If it is difficult to duplicate the noise, drive the vehicle slowly on an undulating or rough road to stress the vehicle body.

CHECK RELATED SERVICE BULLETINS

After verifying the customer concern or symptom, check ASIST for Technical Service Bulletins (TSBs) related to that concern or symptom.

If a TSB relates to the symptom, follow the procedure to repair the noise.

LOCATE THE NOISE AND IDENTIFY THE ROOT CAUSE

1. Narrow down the noise to a general area. To help pinpoint the source of the noise, use a listening tool (Chassis Ear: J-39570, Engine Ear and mechanics stethoscope).
2. Narrow down the noise to a more specific area and identify the cause of the noise by:
 - removing the components in the area that you suspect the noise is coming from.
Do not use too much force when removing clips and fasteners, otherwise clips and fastener can be broken or lost during the repair, resulting in the creation of new noise.
 - tapping or pushing/pulling the component that you suspect is causing the noise.
Do not tap or push/pull the component with excessive force, otherwise the noise will be eliminated only temporarily.
 - feeling for a vibration with your hand by touching the component(s) that you suspect is (are) causing the noise.
 - placing a piece of paper between components that you suspect are causing the noise.
 - looking for loose components and contact marks.
Refer to [BL-8, "Generic Squeak and Rattle Troubleshooting"](#) .

REPAIR THE CAUSE

- If the cause is a loose component, tighten the component securely.
- If the cause is insufficient clearance between components:
 - separate components by repositioning or loosening and retightening the component, if possible.
 - insulate components with a suitable insulator such as urethane pads, foam blocks, felt cloth tape or urethane tape. A Nissan Squeak and Rattle Kit (J-43980) is available through your authorized Nissan Parts Department.

CAUTION:

Do not use excessive force as many components are constructed of plastic and may be damaged.

Always check with the Parts Department for the latest parts information.

The following materials are contained in the Nissan Squeak and Rattle Kit (J-43980). Each item can be ordered separately as needed.

URETHANE PADS [1.5 mm (0.059 in) thick]

Insulates connectors, harness, etc.

76268-9E005: 100 × 135 mm (3.94 × 5.31 in)/76884-71L01: 60 × 85 mm (2.36 × 3.35 in)/76884-71L02: 15 × 25 mm (0.59 × 0.98 in)

INSULATOR (Foam blocks)

Insulates components from contact. Can be used to fill space behind a panel.

73982-9E000: 45 mm (1.77 in) thick, 50 × 50 mm (1.97 × 1.97 in)/73982-50Y00: 10 mm (0.39 in) thick, 50 × 50 mm (1.97 × 1.97 in)

SQUEAK AND RATTLE TROUBLE DIAGNOSIS

INSULATOR (Light foam block)

80845-71L00: 30 mm (1.18 in) thick, 30 × 50 mm (1.18×1.97 in)

FELT CLOTHTAPE

Used to insulate where movement does not occur. Ideal for instrument panel applications.

68370-4B000: 15 × 25 mm (0.59 × 0.98 in) pad/68239-13E00: 5 mm (0.20 in) wide tape roll

The following materials, not found in the kit, can also be used to repair squeaks and rattles.

UHMW(TEFLON) TAPE

Insulates where slight movement is present. Ideal for instrument panel applications.

SILICONE GREASE

Used in place of UHMW tape that will be visible or not fit.

Note: Will only last a few months.

SILICONE SPRAY

Use when grease cannot be applied.

DUCT TAPE

Use to eliminate movement.

CONFIRM THE REPAIR

Confirm that the cause of a noise is repaired by test driving the vehicle. Operate the vehicle under the same conditions as when the noise originally occurred. Refer to the notes on the Diagnostic Worksheet.

Generic Squeak and Rattle Troubleshooting

AIS005ET

Refer to Table of Contents for specific component removal and installation information.

INSTRUMENT PANEL

Most incidents are caused by contact and movement between:

1. The cluster lid A and instrument panel
2. Acrylic lens and combination meter housing
3. Instrument panel to front pillar garnish
4. Instrument panel to windshield
5. Instrument panel mounting pins
6. Wiring harnesses behind the combination meter
7. A/C defroster duct and duct joint

These incidents can usually be located by tapping or moving the components to duplicate the noise or by pressing on the components while driving to stop the noise. Most of these incidents can be repaired by applying felt cloth tape or silicon spray (in hard to reach areas). Urethane pads can be used to insulate wiring harness.

CAUTION:

Do not use silicone spray to isolate a squeak or rattle. If you saturate the area with silicone, you will not be able to recheck the repair.

CENTER CONSOLE

Components to pay attention to include:

1. Shifter assembly cover to finisher
2. A/C control unit and cluster lid C
3. Wiring harnesses behind audio and A/C control unit

The instrument panel repair and isolation procedures also apply to the center console.

DOORS

Pay attention to the:

1. Finisher and inner panel making a slapping noise
2. Inside handle escutcheon to door finisher
3. Wiring harnesses tapping
4. Door striker out of alignment causing a popping noise on starts and stops

Tapping or moving the components or pressing on them while driving to duplicate the conditions can isolate many of these incidents. You can usually insulate the areas with felt cloth tape or insulator foam blocks from the Nissan Squeak and Rattle Kit (J-43980) to repair the noise.

SQUEAK AND RATTLE TROUBLE DIAGNOSIS

TRUNK

Trunk noises are often caused by a loose jack or loose items put into the trunk by the owner. In addition look for:

1. Trunk lid dumpers out of adjustment
2. Trunk lid striker out of adjustment
3. The trunk lid torsion bars knocking together
4. A loose license plate or bracket

Most of these incidents can be repaired by adjusting, securing or insulating the item(s) or component(s) causing the noise.

SUNROOF/HEADLINING

Noises in the sunroof/headlining area can often be traced to one of the following:

1. Sunroof lid, rail, linkage or seals making a rattle or light knocking noise
2. Sunvisor shaft shaking in the holder
3. Front or rear windshield touching headlining and squeaking

Again, pressing on the components to stop the noise while duplicating the conditions can isolate most of these incidents. Repairs usually consist of insulating with felt cloth tape.

SEATS

When isolating seat noise it's important to note the position the seat is in and the load placed on the seat when the noise is present. These conditions should be duplicated when verifying and isolating the cause of the noise.

Cause of seat noise include:

1. Headrest rods and holder
2. A squeak between the seat pad cushion and frame
3. The rear seatback lock and bracket

These noises can be isolated by moving or pressing on the suspected components while duplicating the conditions under which the noise occurs. Most of these incidents can be repaired by repositioning the component or applying urethane tape to the contact area.

UNDERHOOD

Some interior noise may be caused by components under the hood or on the engine wall. The noise is then transmitted into the passenger compartment.

Causes of transmitted underhood noise include:

1. Any component mounted to the engine wall
2. Components that pass through the engine wall
3. Engine wall mounts and connectors
4. Loose radiator mounting pins
5. Hood bumpers out of adjustment
6. Hood striker out of adjustment

These noises can be difficult to isolate since they cannot be reached from the interior of the vehicle. The best method is to secure, move or insulate one component at a time and test drive the vehicle. Also, engine RPM or load can be changed to isolate the noise. Repairs can usually be made by moving, adjusting, securing, or insulating the component causing the noise.

A

B

C

D

E

F

G

H

BL

J

K

L

M

SQUEAK AND RATTLE TROUBLE DIAGNOSIS

Diagnostic Worksheet

AIS005EU



SQUEAK & RATTLE DIAGNOSTIC WORKSHEET

Dear Infiniti Customer:

We are concerned about your satisfaction with your Infiniti vehicle. Repairing a squeak or rattle sometimes can be very difficult. To help us fix your Infiniti right the first time, please take a moment to note the area of the vehicle where the squeak or rattle occurs and under what conditions. You may be asked to take a test drive with a service advisor or technician to ensure we confirm the noise you are hearing.

I. WHERE DOES THE NOISE COME FROM? (circle the area of the vehicle)

The illustrations are for reference only, and may not reflect the actual configuration of your vehicle.

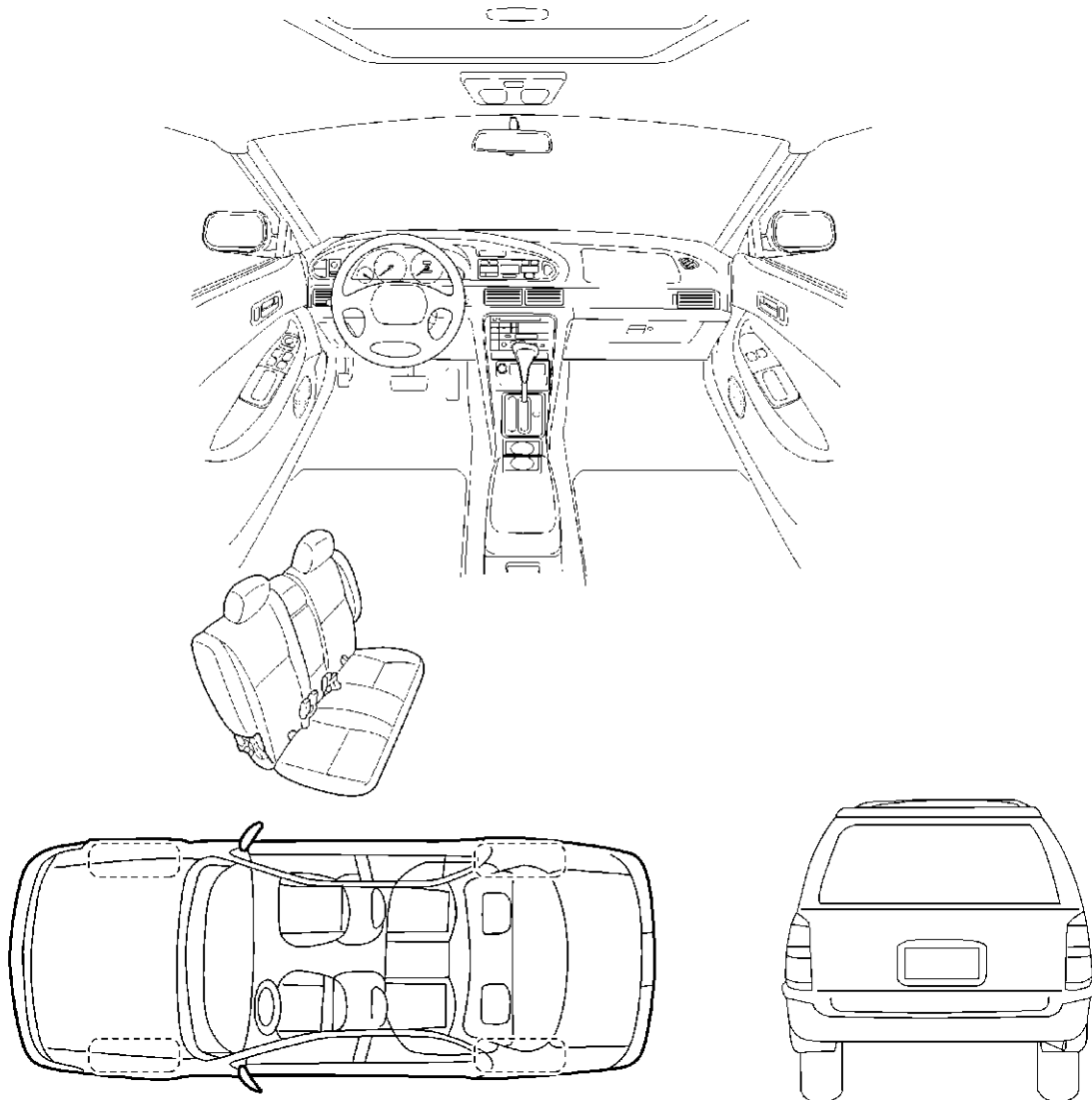

Continue to the back of the worksheet and briefly describe the location of the noise or rattle. In addition, please indicate the conditions which are present when the noise occurs.

SBT860

SQUEAK AND RATTLE TROUBLE DIAGNOSIS

SQUEAK & RATTLE DIAGNOSTIC WORKSHEET- page 2

Briefly describe the location where the noise occurs:

II. WHEN DOES IT OCCUR? (check the boxes that apply)

- | | |
|--|---|
| <input type="checkbox"/> anytime | <input type="checkbox"/> after sitting out in the sun |
| <input type="checkbox"/> 1 st time in the morning | <input type="checkbox"/> when it is raining or wet |
| <input type="checkbox"/> only when it is cold outside | <input type="checkbox"/> dry or dusty conditions |
| <input type="checkbox"/> only when it is hot outside | <input type="checkbox"/> other: _____ |

III. WHEN DRIVING:

- through driveways
- over rough roads
- over speed bumps
- only at about ____ mph
- on acceleration
- coming to a stop
- on turns : left, right or either (circle)
- with passengers or cargo
- other: _____
- after driving ____ miles or ____ minutes

IV. WHAT TYPE OF NOISE?

- squeak (like tennis shoes on a clean floor)
- creak (like walking on an old wooden floor)
- rattle (like shaking a baby rattle)
- knock (like a knock on a door)
- tick (like a clock second hand)
- thump (heavy, muffled knock noise)
- buzz (like a bumble bee)

TO BE COMPLETED BY DEALERSHIP PERSONNEL

Test Drive Notes:

	YES	NO	Initials of person performing
Vehicle test driven with customer	<input type="checkbox"/>	<input type="checkbox"/>	_____
- Noise verified on test drive	<input type="checkbox"/>	<input type="checkbox"/>	_____
- Noise source located and repaired	<input type="checkbox"/>	<input type="checkbox"/>	_____
- Follow up test drive performed to confirm repair	<input type="checkbox"/>	<input type="checkbox"/>	_____

VIN: _____ Customer Name: _____

W.O. #: _____ Date: _____

This form must be attached to Work Order

SBT844

HOOD

PFP:F5100

HOOD

Fitting Adjustment

AIS005EV

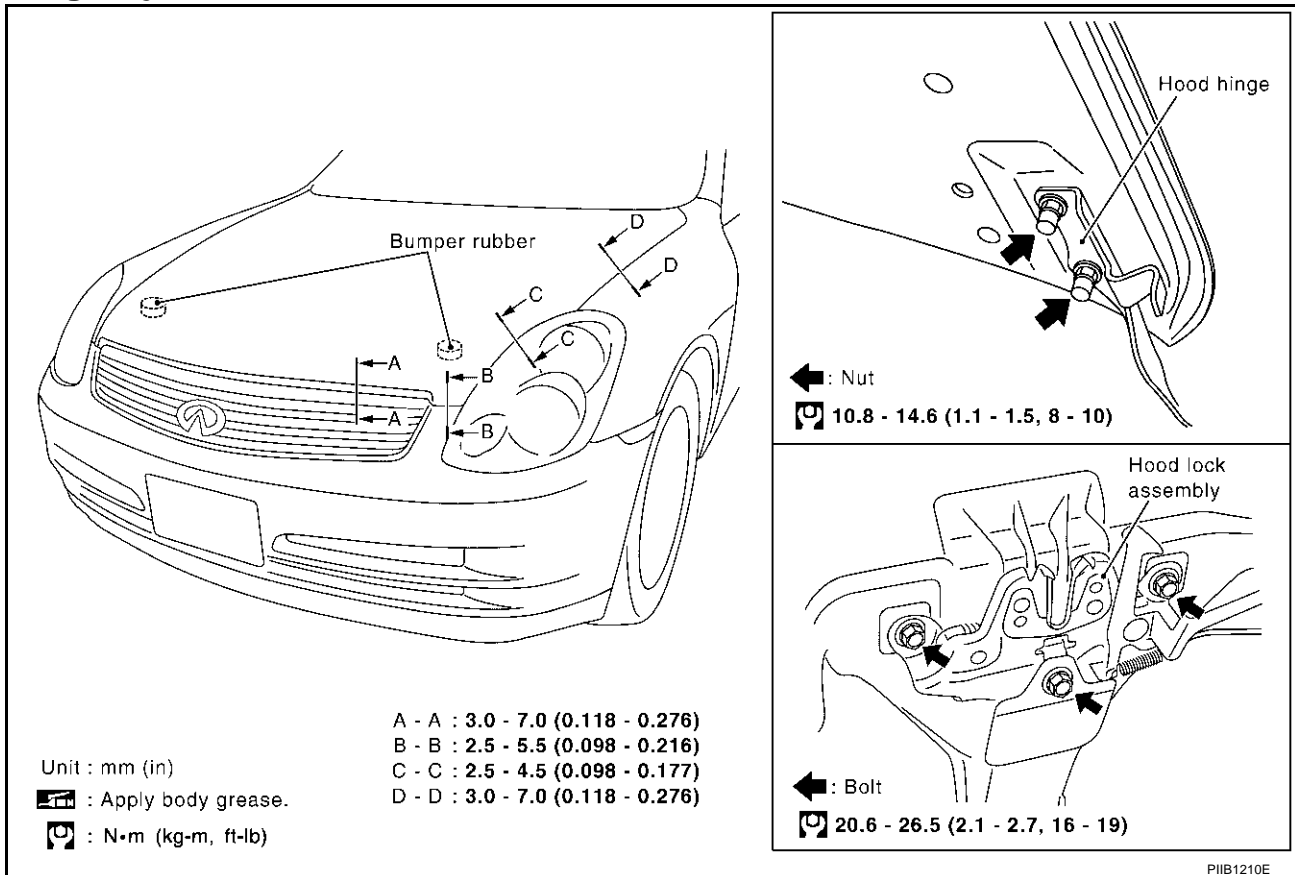

LONGITUDINAL AND LATERAL CLEARANCE ADJUSTMENT

1. Remove hood lock assembly, loosen the hood hinge nuts and close the hood.
2. Adjust the lateral and longitudinal clearance, and open the hood to tighten the hood hinge mounting bolts to the specified torque.
3. Install the hood lock temporarily, and align the hood striker and lock so that the centers of striker and lock become vertical viewed from the front, by moving the hood lock laterally.
4. Tighten hood lock mounting bolts to the specified torque.

FRONT END HEIGHT ADJUSTMENT

1. Remove the hood lock and adjust the height by rotating the bumper rubber until the hood becomes 1 to 1.5 mm (0.04 to 0.059 in) lower than the fender.
2. Temporarily tighten the hood lock, and position it by engaging it with the hood striker. Check the lock and striker for looseness, and tighten the hood lock mounting bolts to the specified torque.

CAUTION:

Adjust right/left clearance between hood and each part to the following specification.

Hood and front bumper (B-B)	: Less than 2.0 mm (0.08 in)
Hood and head lamp (C-C)	: Less than 2.0 mm (0.08 in)
Hood and fender (D-D)	: Less than 1.0 mm (0.04 in)

HOOD

SURFACE HEIGHT ADJUSTMENT

1. Remove hood lock, and adjust the surface height difference of hood, fender and headlamp according to the fitting standard dimension, by rotating RH and LH bumper rubbers.
2. Install hood lock temporarily, and move hood lock laterally until the centers of striker and lock become vertical when viewed from the front.
3. Make sure that the hood lock secondary latch is properly engaged with the secondary striker with hood's own weight.
4. Make sure that the hood lock primary latch is securely engaged with the hood striker with hood's own weight by dropping hood from approx. 200 mm (7.87in) height.

CAUTION:

Do not drop hood from a height of 300 mm (11.81 in) or more.

5. Move hood lockup and down until striker smoothly engages the lock when the hood is closed.
6. When pulling the hood opener lever gently, make sure that front end of the hood rises by approximately 20 mm (0.79 in) and that hood striker and hood lock primary latch is disengaged. Also make sure that hood opener returns to the original position.
7. After adjustment, tighten lock bolts to the specified torque.

CAUTION:

Adjust evenness between hood and each part to the following specification.

- | | |
|---------------------------------|--------------------------------------|
| Hood and head lamp (C-C) | : Less than 1.5 mm (0.059 in) |
| Hood and fender (D-D) | : Less than 1.0 mm (0.04 in) |

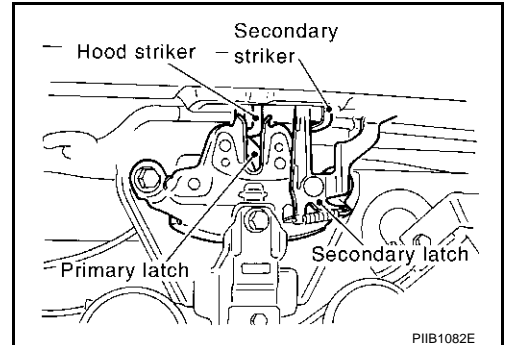

A
B
C
D
E
F
G
H
J
K
L
M

BL

HOOD

Removal and Installation of Hood Assembly

AIS005EW

SEC. 650

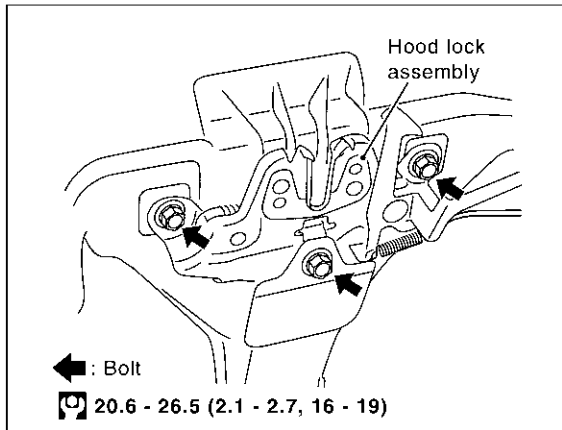
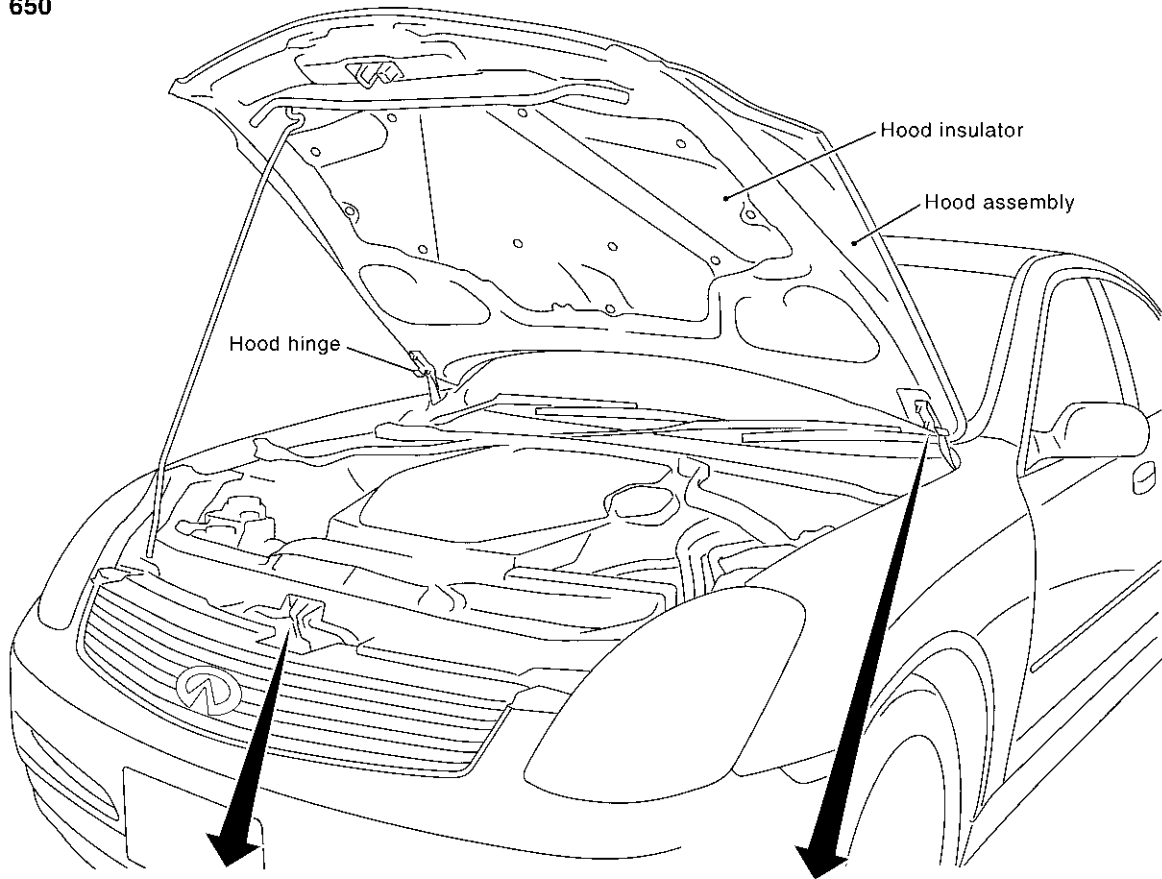

: N·m (kg-m, ft-lb)

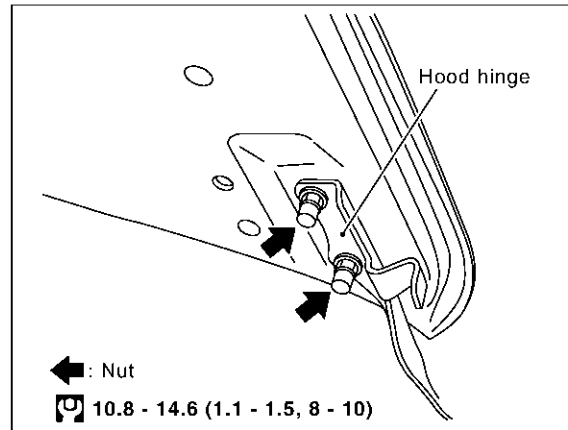

PIIA1087E

REMOVAL

Remove the hinge mounting nuts on the hood to remove the hood assembly.

CAUTION:

Operate with two workers, because of its heavy weight.

INSTALLATION

Install in the reverse order of removal.

CAUTION:

- Before installing hood hinge, apply anticorrosive agent onto the mounting surface of the vehicle body.
- After installing, perform hood fitting adjustment. Refer to [BL-12, "Fitting Adjustment"](#).

HOOD

Removal and Installation of Hood Lock Control

AIS005EX

A
B
C
D
E
F
G
H
BL
J
K
L
M

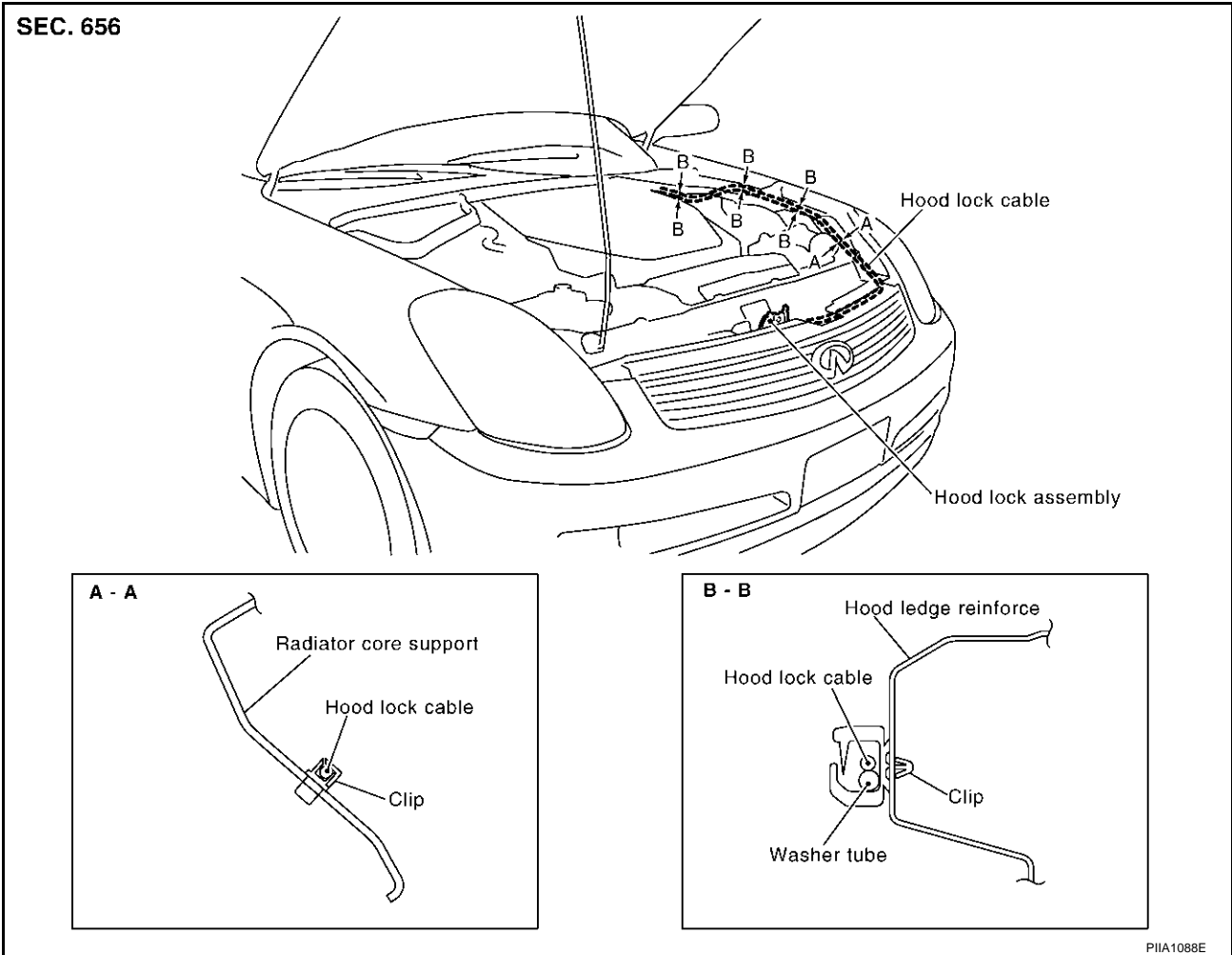

REMOVAL

1. Remove the front grill. Refer to [EI-20, "Removal and Installation"](#).
2. Remove the fender protector. Refer to [EI-22, "FENDER PROTECTOR"](#).
3. Remove the hood lock assembly. Refer to [BL-14, "Removal and Installation of Hood Assembly"](#).
4. Remove the instrument lower driver panel. Refer to [IP-10, "Component Parts Drawing"](#).
5. Disconnect the hood lock cable from the hood lock, and clip it from the radiator core upper support and hood ledge.
6. Remove the mounting screws, and remove the hood opener.
7. Remove the grommet on the instrument panel, and pull the hood lock cable toward the passenger compartment.

CAUTION:

While pulling, be careful not to damage (peeling) the outside of the hood lock cable.

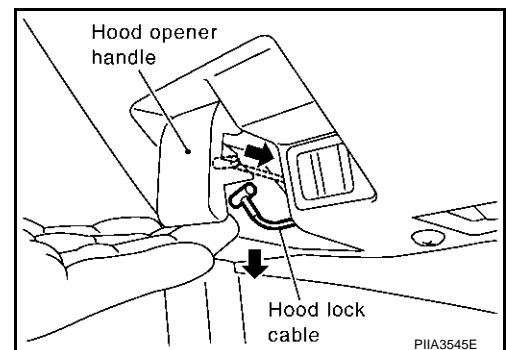

HOOD

INSTALLATION

1. Pull the hood lock cable through the panel hole to the engine compartment.
Be careful not to bend the cable too much, keeping the radius 100 mm (3.94 in) or more.
2. Check that the cable is not offset from the positioning grommet, and push the grommet into the panel hole securely.
3. Apply the sealant to the grommet (at * mark) properly.

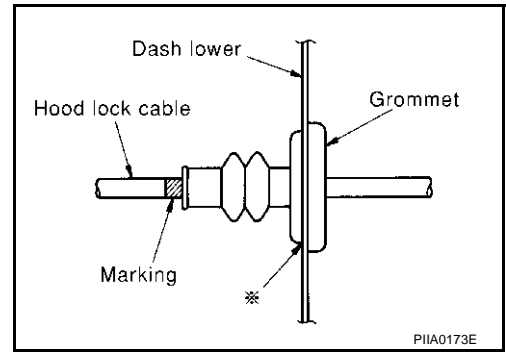

4. Install the cable securely to the lock.
5. After installing, check the hood lock adjustment and hood opener operation.

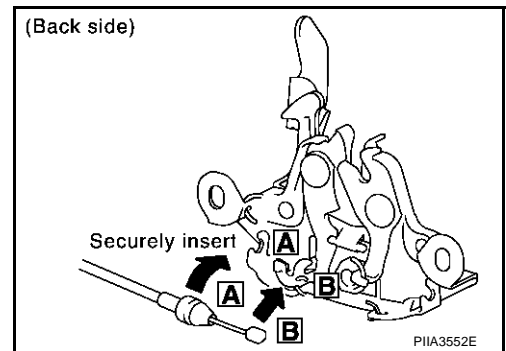

Hood Lock Control Inspection

CAUTION:

If the hood lock cable is bent or deformed, replace it.

1. Check that the hood lock secondary latch is properly engaged with the secondary striker with hood's own weight.
2. Check that the hood lock primary latch is securely engaged with the hood striker with hood's own weight by dropping it from approx. 200 mm (7.87 in) height.

CAUTION:

Do not drop hood from a height of 300 mm (11.81 in) or more.

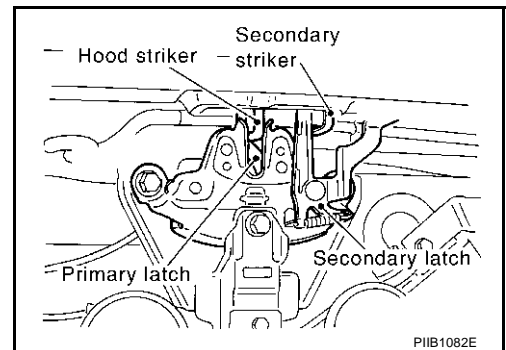

3. When pulling hood opener lever gently, make sure that front end of the hood rises by approximately 20 mm (0.79 in) and that hood striker and hood lock primary latch are disengaged. Also make sure that hood opener returns to the original position.
4. Confirm hood lock is properly lubricated. If necessary, apply grease at the point shown in the figure.

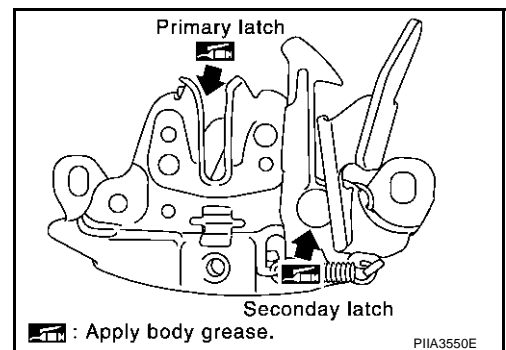

RADIATOR CORE SUPPORT

RADIATOR CORE SUPPORT

PFP:62500

Removal and Installation

AIS005EZ

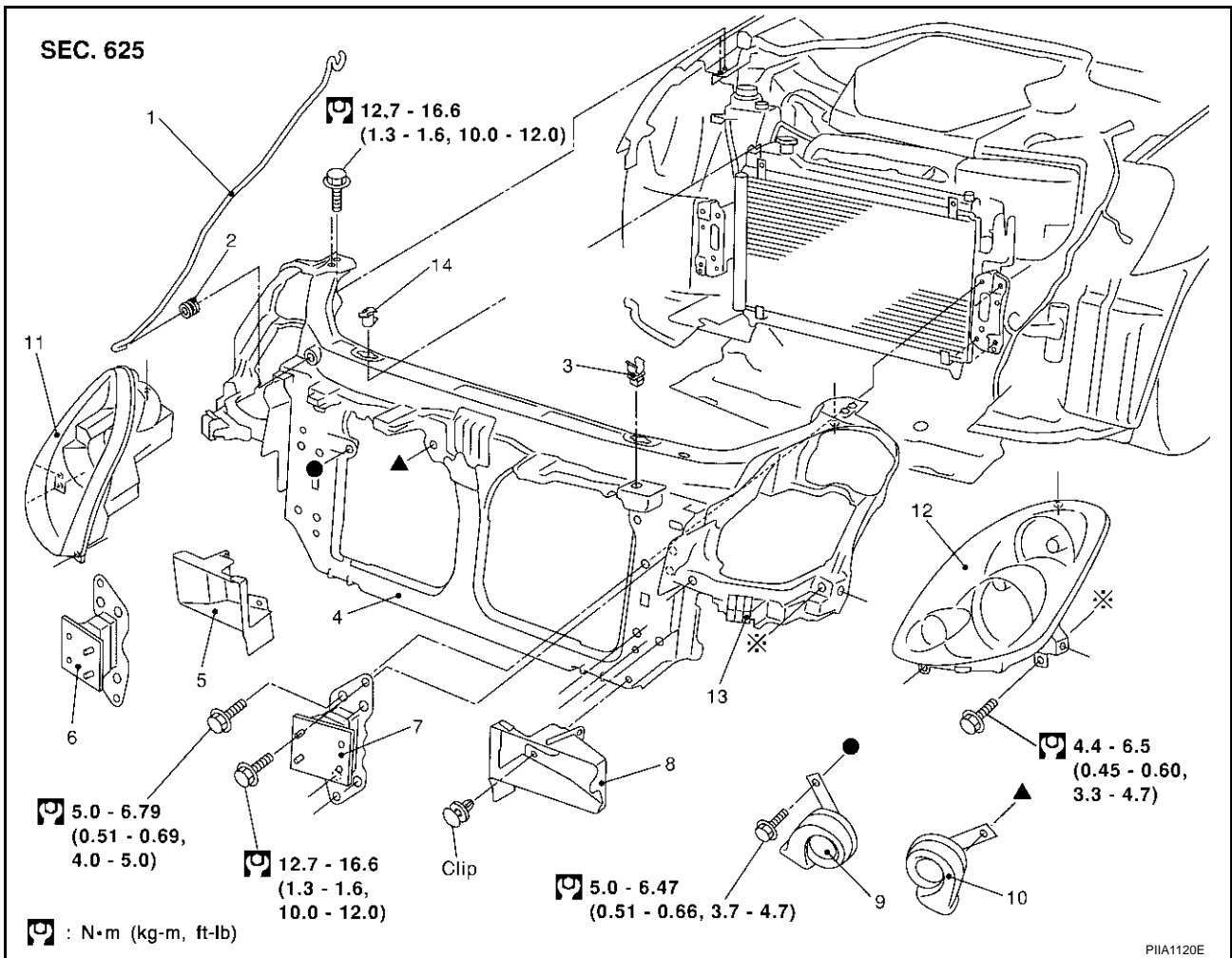

- | | | |
|-----------------------------------|----------------------------|------------------------|
| 1. Hood stay | 2. Grommet | 3. Hood rod clamp |
| 4. Radiator core support assembly | 5. Air intake duct (RH) | 6. Bumper bracket (RH) |
| 7. Bumper bracket (LH) | 8. Air intake duct (LH) | 9. Horn (Low) |
| 10. Horn (High) | 11. Headlamp (RH) | 12. Headlamp (LH) |
| 13. Front bumper clip | 14. Upper radiator bracket | |

REMOVAL

1. Remove hood assembly. Refer to [BL-14, "Removal and Installation of Hood Assembly"](#).
2. Remove front bumper, bumper reinforcement and bumper bracket. Refer to [EI-14, "FRONT BUMPER"](#).
3. Remove hood lock assembly, then remove hood lock cable.
4. Remove washer tank. Refer to [WW-33, "Removal and Installation for Washer Tank"](#).
5. Remove horn connectors.
6. Remove mounting harness clip on radiator core support assembly, the harness is separate.
7. Remove resonator mounting screws.
8. Remove air intake duct (LH/RH), and remove washer tank inlet clip.
9. Remove headlamp (LH/RH). Refer to [LT-30, "Removal and Installation"](#).
10. Remove upper radiator bracket.

RADIATOR CORE SUPPORT

11. Remove radiator core support assembly mounting bolts.

CAUTION:

Put a wooden block under the radiator assembly to prevent the radiator assembly from falling.

12. Remove radiator core support assembly.

13. After removing radiator core support assembly, the following parts are separate.

- Remove the hood stay, grommet and hood rod clamp
- Horn (High/Low)
- Air intake duct (LH/RH)
- Front bumper clip (LH/RH)

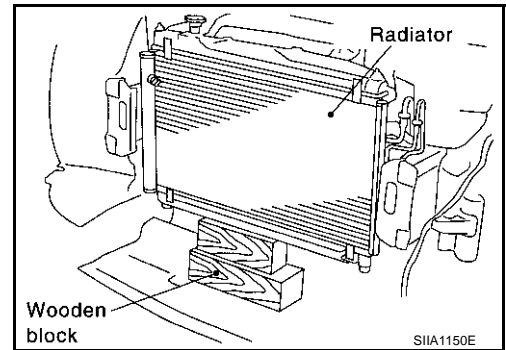

INSTALLATION

Install in the reverse order of removal.

POWER DOOR LOCK SYSTEM

POWER DOOR LOCK SYSTEM

PPF:24814

Component Parts and Harness Connector Location

AIS0000X

A
B
C
D
E
F
G
H
BL
J
K
L
M

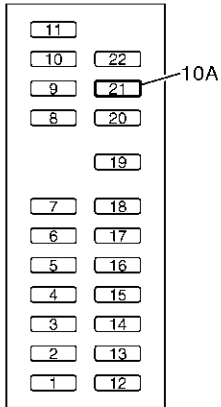

Fuse block (J/B) fuse layout

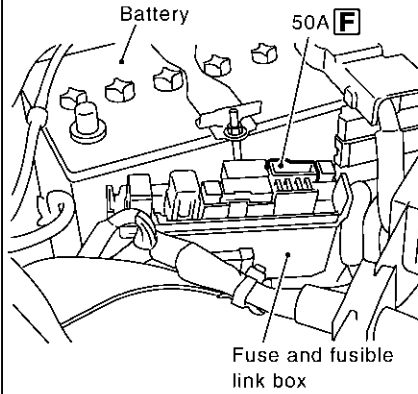

View with dash side LH removed

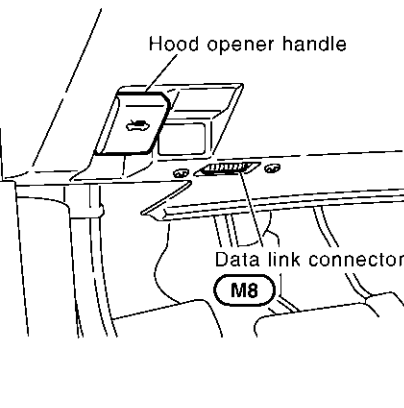
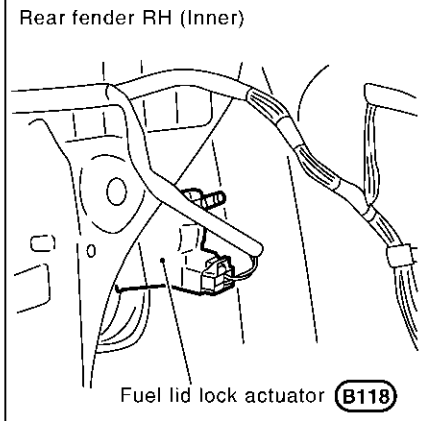
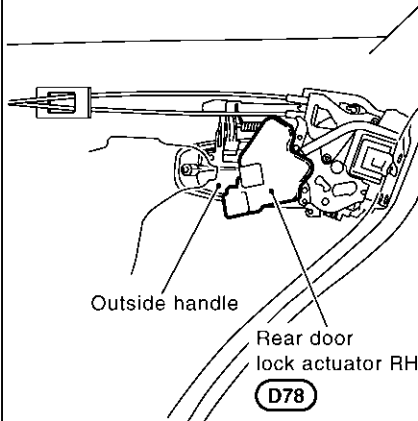
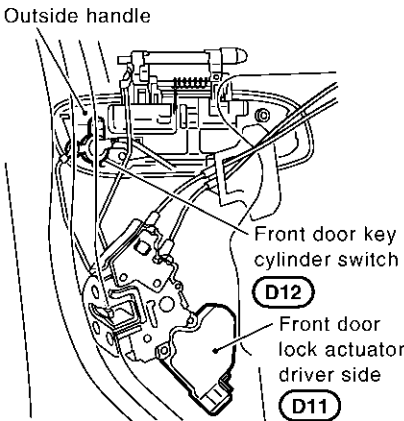
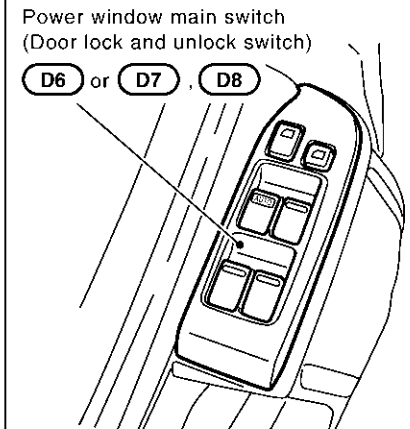
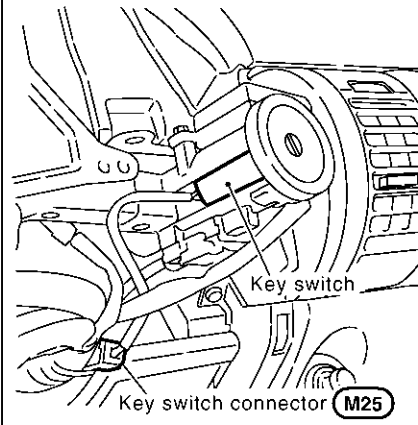
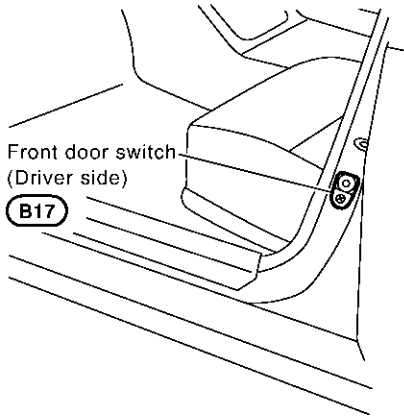
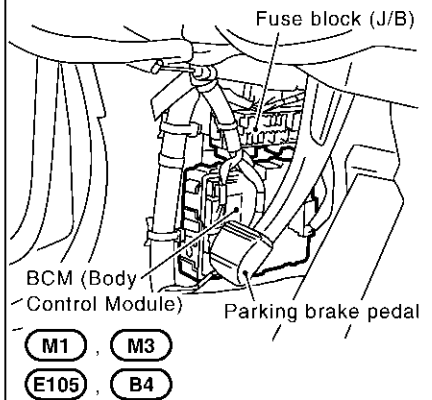

PIIA3828E

POWER DOOR LOCK SYSTEM

AIS0000Y

System Description

Power is supplied at all times

- to BCM terminal 7
- through 50A fusible link (letter **F** , located in the fuse and fusible link box).
- to key switch terminal 2
- through 10A fuse [No. 21, located in the fuse block (J/B)].

When key switch is ON (key is inserted in ignition key cylinder), power is supplied

- to BCM terminal 62
- through key switch terminal 1.

When the door is locked and unlocked with power window main switch (door lock and unlock switch), ground is supplied

- to CPU of power window main switch
- through power window main switch (door lock and unlock switch) terminal 15 (with interruption detection function for all door window), or
- through power window main switch (door lock and unlock switch) terminal 5 (except with interruption detection function for all door window)
- through grounds M30 and M66.

Then power window main switch (door lock and unlock switch) operation signal is supplied.

- to BCM terminal 74
- through power window main switch (door lock and unlock switch) terminal 9 (with interruption detection function for all door window), or
- through power window main switch (door lock and unlock switch) terminal 8 (except with interruption detection function for all door window).

When the door is locked with power window sub-switch (front passenger side) (door lock and unlock switch), ground is supplied

- to CPU of power window sub-switch
- through power window sub-switch (front passenger side) (door lock and unlock switch) terminal 7
- through grounds M30 and M66.

Then power window sub-switch (front passenger side) (door lock and unlock switch) operation signal is supplied

- to BCM terminal 74
- through power window sub-switch (front passenger side) (door lock and unlock switch) terminal 11.

When the door is locked with front door key cylinder switch driver side, ground is supplied

- to power window main switch (door lock and unlock switch) terminal 6
- through front door key cylinder switch (driver side) terminals 1 and 2
- through grounds M30 and M66.

Then front door key cylinder switch (driver side) operation signal (lock) is supplied

- to BCM terminal 74
- through power window main switch (door lock and unlock switch) terminal 9 (with interruption detection function for all door window), or
- through power window main switch (door lock and unlock switch) terminal 8 (except with interruption detection function for all door window).

When the door is unlocked with front door key cylinder switch driver side, ground is supplied

- to power window main switch (door lock and unlock switch) terminal 5 (with interruption detection function for all door window), or
- to power window main switch (door lock and unlock switch) terminal 19 (except with interruption detection function for all door window)
- through front door key cylinder switch (driver side) terminal 3 and 2
- through grounds M30 and M66.

Then front door key cylinder switch (driver side) operation signal (unlock) is supplied

- to BCM terminal 74

POWER DOOR LOCK SYSTEM

- through power window main switch (door lock and unlock switch) terminal 9 (with interruption detection function for all door window), or
- through power window main switch (door lock and unlock switch) terminal 8 (except with interruption detection function for all door window).

BCM is connected to power window main switch and power window sub-switch as serial link.

OUTLINE

Functions Available by Operating the Door Lock and Unlock Switches on Driver's Door and Passenger's Door

- Interlocked with the locking operation of door lock and unlock switch, door lock actuators of all doors and fuel lid lock actuator are locked.
- Interlocked with the unlocking operation of door lock and unlock switch, door lock actuators of all doors and fuel lid lock actuator are unlocked.

Functions Available by Operating the Key Cylinder Switch on Driver's

- Interlocked with the locking operation of door key cylinder, door lock actuators of all doors and fuel lid lock actuator are locked.
- When door key cylinder is unlocked, door lock actuator driver side is unlocked.
- When door key cylinder is unlocked for the second time within 5 seconds after the first operation, door lock actuators on all doors and fuel lid lock actuator are unlocked.

Unlock mode can be changed using "WORK SUPPORT" mode in "DOOR LOCK-UNLOCK SET".

Refer to [BL-33, "Work Support"](#).

Key Reminder Door System

When door lock and unlock switch is operated to lock doors with ignition key put in key cylinder and any door open, all door lock actuators are locked and then unlocked.

Key reminder door mode can be changed using "WORK SUPPORT" mode in "ANTI-LOCK OUT SET".

Refer to [BL-33, "Work Support"](#).

A

B

C

D

E

F

G

H

BL

J

K

L

M

POWER DOOR LOCK SYSTEM

CAN Communication System Description

AIS003XX

CAN (Controller Area Network) is a serial communication line for real time application. It is an on-vehicle multiplex communication line with high data communication speed and excellent error detection ability. Many electronic control units are equipped onto a vehicle, and each control unit shares information and links with other control units during operation (not independent). In CAN communication, control units are connected with 2 communication lines (CAN H line, CAN L line) allowing a high rate of information transmission with less wiring. Each control unit transmits/receives data but selectively reads required data only.

Body type	Sedan	
Axle	2WD	
Engine	VQ35DE	
Transmission	A/T	
	Up to serial 329287*	From serial 329288*
Brake control	VDC	
CAN communication unit		
ECM	×	×
TCM	×	
Data link connector	×	×
Combination meter	×	×
BCM	×	×
Steering angle sensor	×	×
VDC/TCS/ABS control unit	×	×
IPDM E/R	×	×
CAN communication type	BL-22, "TYPE 1/TYPE 3"	BL-24, "TYPE 2"

×: Applicable

*:For further information, refer to [GI-47, "IDENTIFICATION NUMBER"](#) in GI section.

TYPE 1/TYPE 3

System Diagram

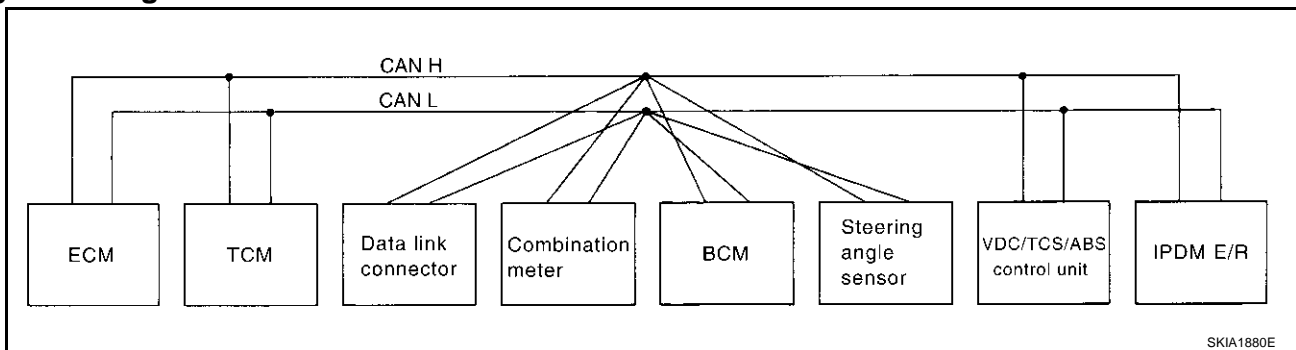

Input/Output Signal Chart

T: Transmit R: Receive

Signals	ECM	TCM	Combina- tion meter	BCM	Steering angle sensor	VDC/TCS/ ABS con- trol unit	IPDM E/R
Engine torque signal	T	R					
Engine speed signal	T	R	R			R	
Engine coolant temperature signal	T	R	R				
Accelerator pedal position signal	T	R				R	
Closed throttle position signal	T	R					
Wide open throttle position signal	T	R					
Battery voltage signal	T	R					

POWER DOOR LOCK SYSTEM

Signals	ECM	TCM	Combina- tion meter	BCM	Steering angle sensor	VDC/TCS/ ABS con- trol unit	IPDM E/R	
Stop lamp switch signal		R	T					A
Fuel consumption monitor signal	T		R					B
A/T self-diagnosis signal	R	T						
A/T CHECK indicator lamp signal		T	R					C
A/T position indicator signal		T	R			R		
ABS operation signal		R				T		
A/T shift schedule change demand signal		R				T		D
A/C switch signal	R			T				
A/C compressor request signal	T						R	E
A/C compressor feedback signal	T		R					
Blower fan motor switch signal	R			T				F
Cooling fan motor operation signal	T						R	
Position lights request signal			R	T			R	
Low beam request signal				T			R	G
Low beam status signal	R						T	
High beam request signal			R	T			R	
High beam status signal	R						T	H
Front fog lights request signal				T			R	
Vehicle speed signal			R			T		BL
	R	R	T	R				
Sleep request 1 signal			R	T				
Sleep request 2 signal				T			R	J
Wake up request 1 signal			R	T			R	
Wake up request 2 signal			R	T			R	K
Door switch signal (without naviga- tion system)			R	T			R	
Door switch signal (with navigation system)			T	R				L
Turn indicator signal			R	T				
Seat belt buckle switch signal			T	R				M
Oil pressure switch signal			R				T	
Buzzer output signal			R	T				
ASCD SET lamp signal	T		R					
ASCD CRUISE lamp signal	T		R					
ASCD OD cancel request signal	T	R						
ASCD operation signal	T	R						
Output shaft revolution signal	R	T						
Front wiper request signal				T			R	
Front wiper stop position signal				R			T	
Rear window defogger switch signal				T			R	
Rear window defogger control sig- nal	R						T	
Manual mode signal		R	T					

POWER DOOR LOCK SYSTEM

Signals	ECM	TCM	Combina- tion meter	BCM	Steering angle sensor	VDC/TCS/ ABS con- trol unit	IPDM E/R
Not manual mode signal		R	T				
Manual mode shift up signal		R	T				
Manual mode shift down signal		R	T				
Manual mode indicator signal		T	R				
Hood switch signal				R			T
Theft warning horn request signal				T			R
Horn chirp signal				T			R
Steering angle sensor signal					T	R	
Malfunction indicator lamp signal (Type 3 only: From serial 329288*)	T		R				
Fuel level sensor signal (Type 3 only: From serial 329288*)	R		T				
Turbine revolution signal (Type 3 only: From serial 329288*)	R	T					

*:For further information, refer to [GI-47, "IDENTIFICATION NUMBER"](#) in GI section.

TYPE 2

System Diagram

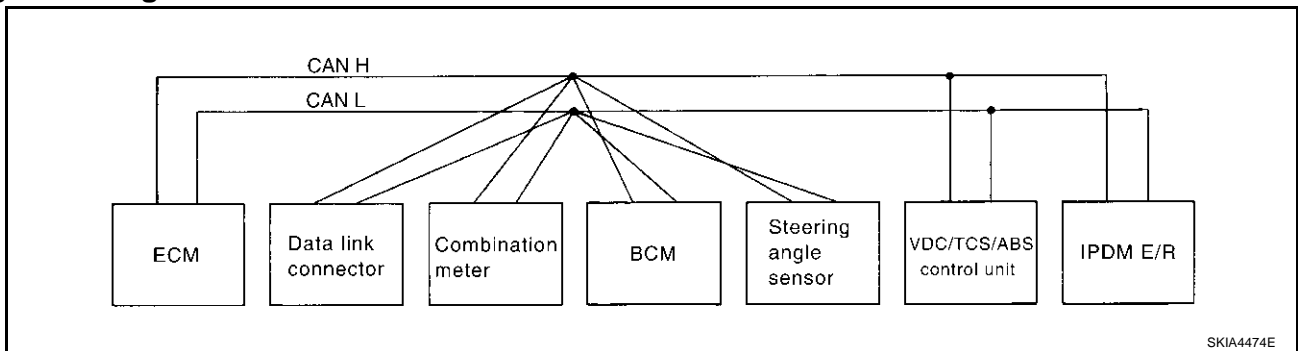

Input/Output Signal Chart

T: Transmit R: Receive

Signals	ECM	Combina- tion meter	BCM	Steering angle sen- sor	VDC/TCS/ ABS con- trol unit	IPDM E/R
Engine speed signal	T	R			R	
Engine coolant temperature signal	T	R				
Accelerator pedal position signal	T				R	
Fuel consumption monitor signal	T	R				
A/C switch signal	R		T			
A/C compressor request signal	T					R
A/C compressor feedback signal	T	R				
Blower fan motor switch signal	R		T			
Cooling fan motor operation signal	T					R
Position lights request signal		R	T			R
Low beam request signal			T			R
Low beam status signal	R		R			T
High beam request signal		R	T			R
High beam status signal	R		R			T

POWER DOOR LOCK SYSTEM

Signals	ECM	Combina- tion meter	BCM	Steering angle sen- sor	VDC/TCS/ ABS con- trol unit	IPDM E/R	
Front fog lights request signal			T			R	A
Vehicle speed signal		R			T		B
	R	T	R				
Sleep request 1 signal		R	T				C
Sleep request 2 signal			T			R	
Wake up request 1 signal		R	T				D
Wake up request 2 signal		R	T				
Door switch signal (without navigation system)		R	T			R	E
Door switch signal (with navigation system)		T	R				
Turn indicator signal		R	T				F
Seat belt buckle switch signal		T	R				
Oil pressure switch signal		R				T	G
Buzzer output signal		R	T				
Malfunction indicator lamp signal	T	R					H
ASCD SET lamp signal	T	R					
ASCD CRUISE lamp signal	T	R					I
Fuel level sensor signal	R	T					
Front wiper request signal			T			R	J
Front wiper stop position signal			R			T	
Rear window defogger switch signal			T			R	K
Rear window defogger control signal	R		R			T	
Hood switch signal			R			T	L
Theft warning horn request signal			T			R	
Horn chirp signal			T			R	M
Steering angle sensor signal				T	R		

A
B
C
D
E
F
G
H
I
J
K
L
M

BL

POWER DOOR LOCK SYSTEM

Schematic

AIS0000Z

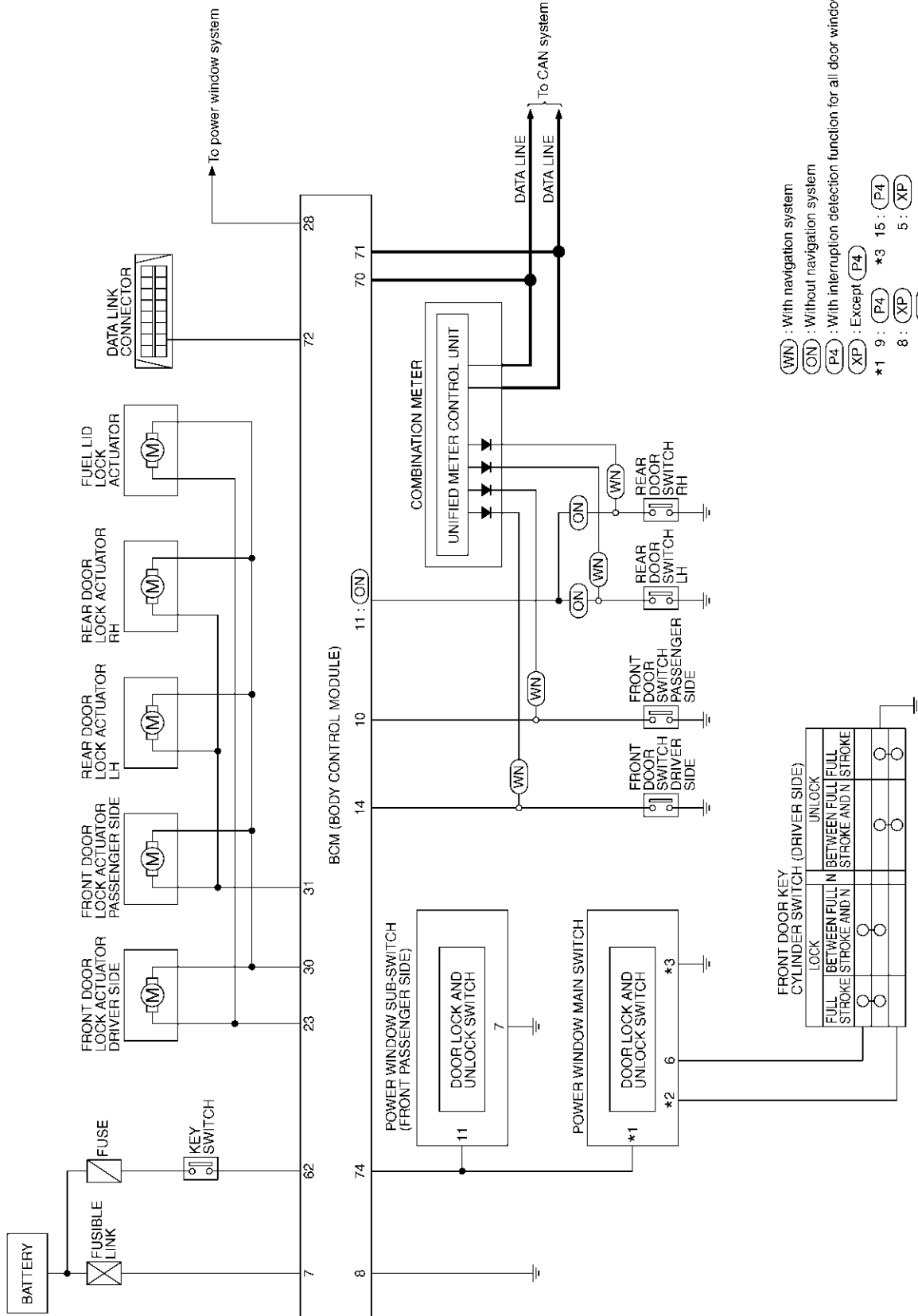

(WN) : With navigation system
 (ON) : Without navigation system
 (P4) : With interruption detection function for all door window
 (XP) : Except (P4)
 *1 9 : (P4) *3 15 : (P4)
 *2 5 : (P4) 8 : (XP) 5 : (XP)
 19 : (XP)

TIWT0207E

POWER DOOR LOCK SYSTEM

Wiring Diagram -D/LOCK-
FIG. 1

AIS00010

BL-D/LOCK-01

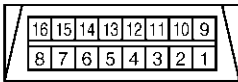
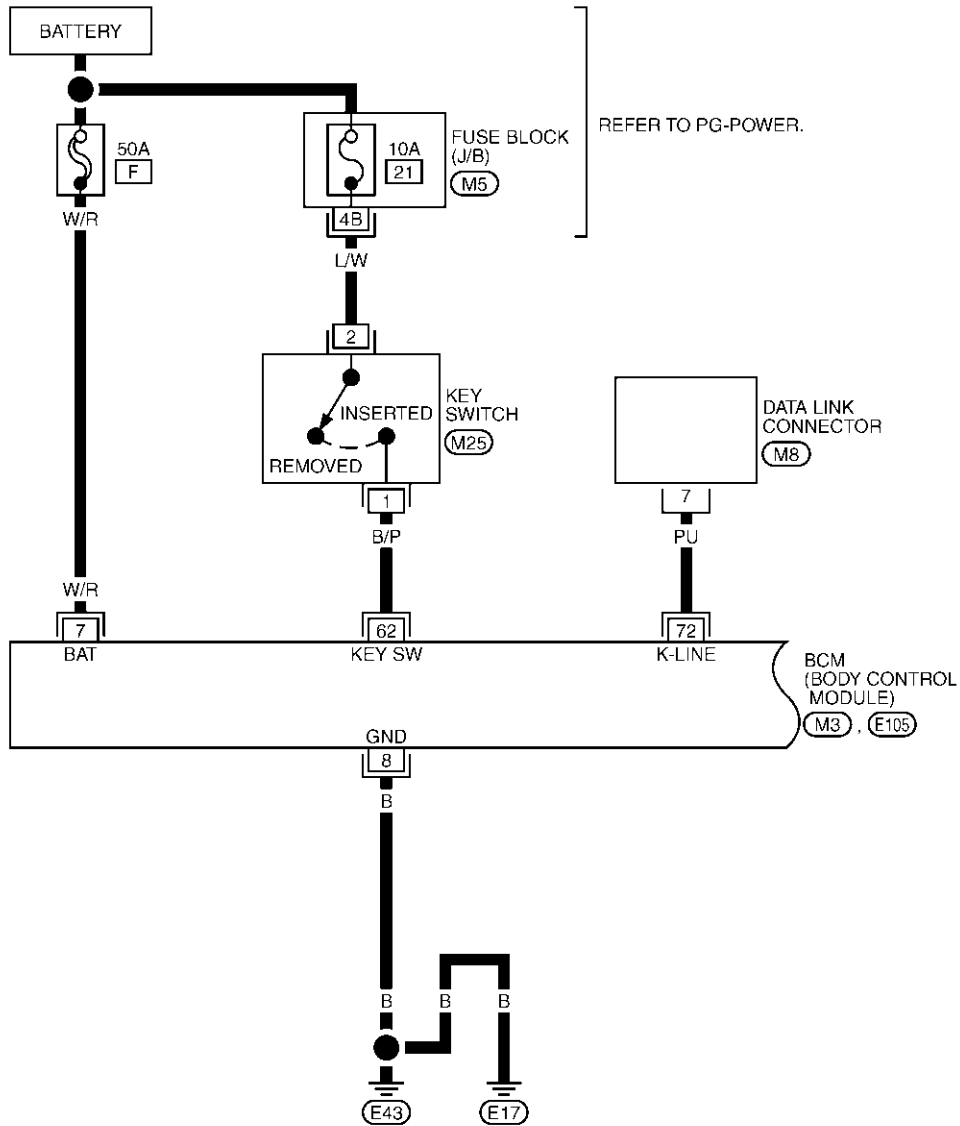

(M8)
W



(M25)
BR

REFER TO THE FOLLOWING.
(M5) - FUSE BLOCK-JUNCTION BOX (J/B)
(M3), (E105) - ELECTRICAL UNITS

TIWT0208E

POWER DOOR LOCK SYSTEM

FIG. 2

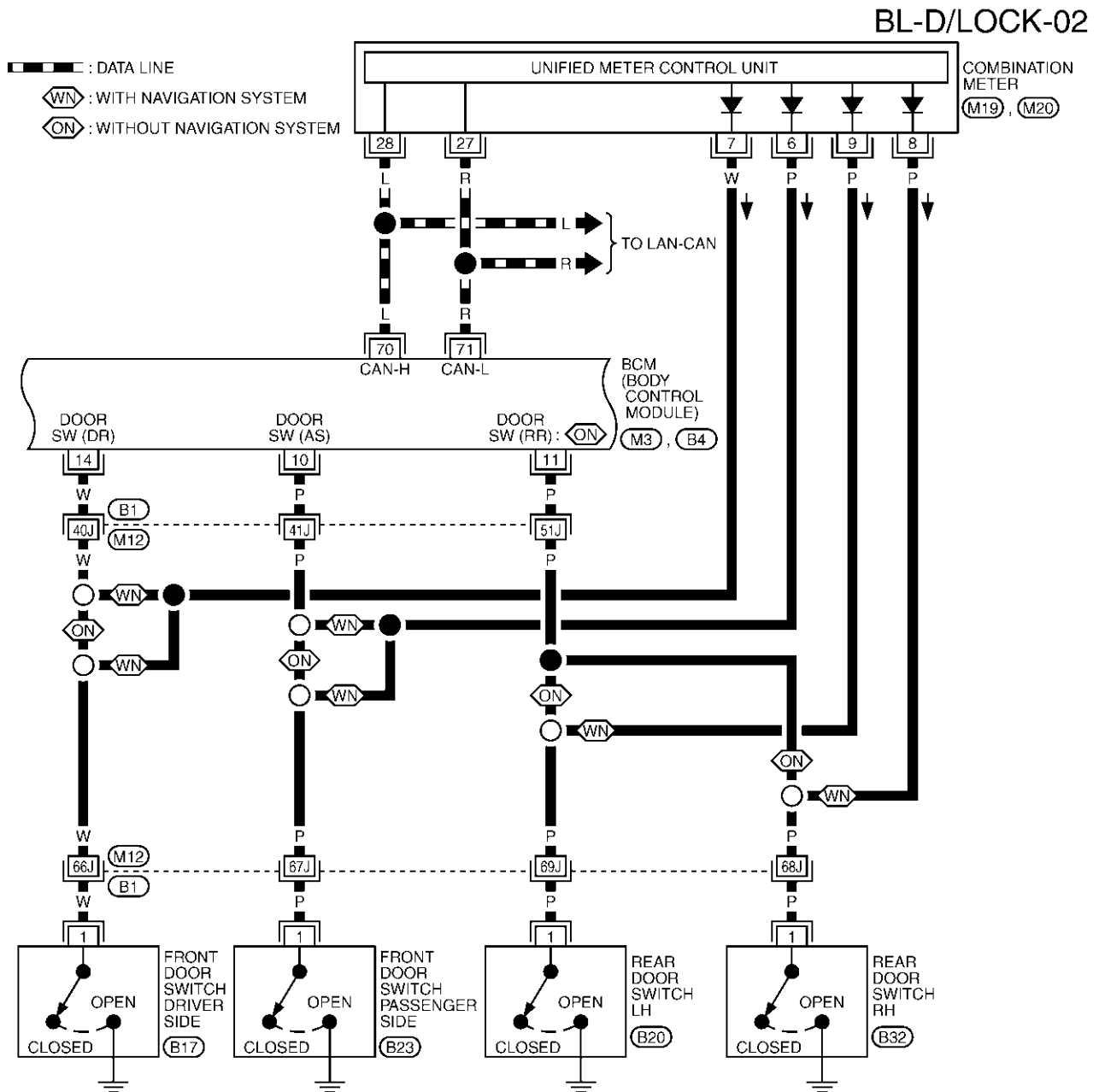

1	2	3	4	5	6	7	8	9	10	11	M19	25	26	27	28	29	30	31	32	33	34	35	M20				
12	13	14	15	16	17	18	19	20	21	22	23	24	BR	36	37	38	39	40	41	42	43	44	45	46	47	48	W

1	B17, B20, B23, B32
2	W
3	W

REFER TO THE FOLLOWING.

- (B1) -SUPER MULTIPLE JUNCTION (SMJ)
- (M3), (B4) -ELECTRICAL UNITS

POWER DOOR LOCK SYSTEM

FIG. 3

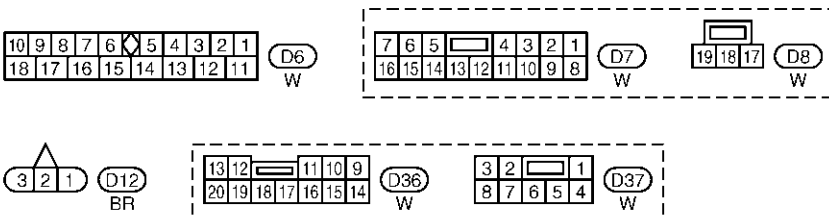
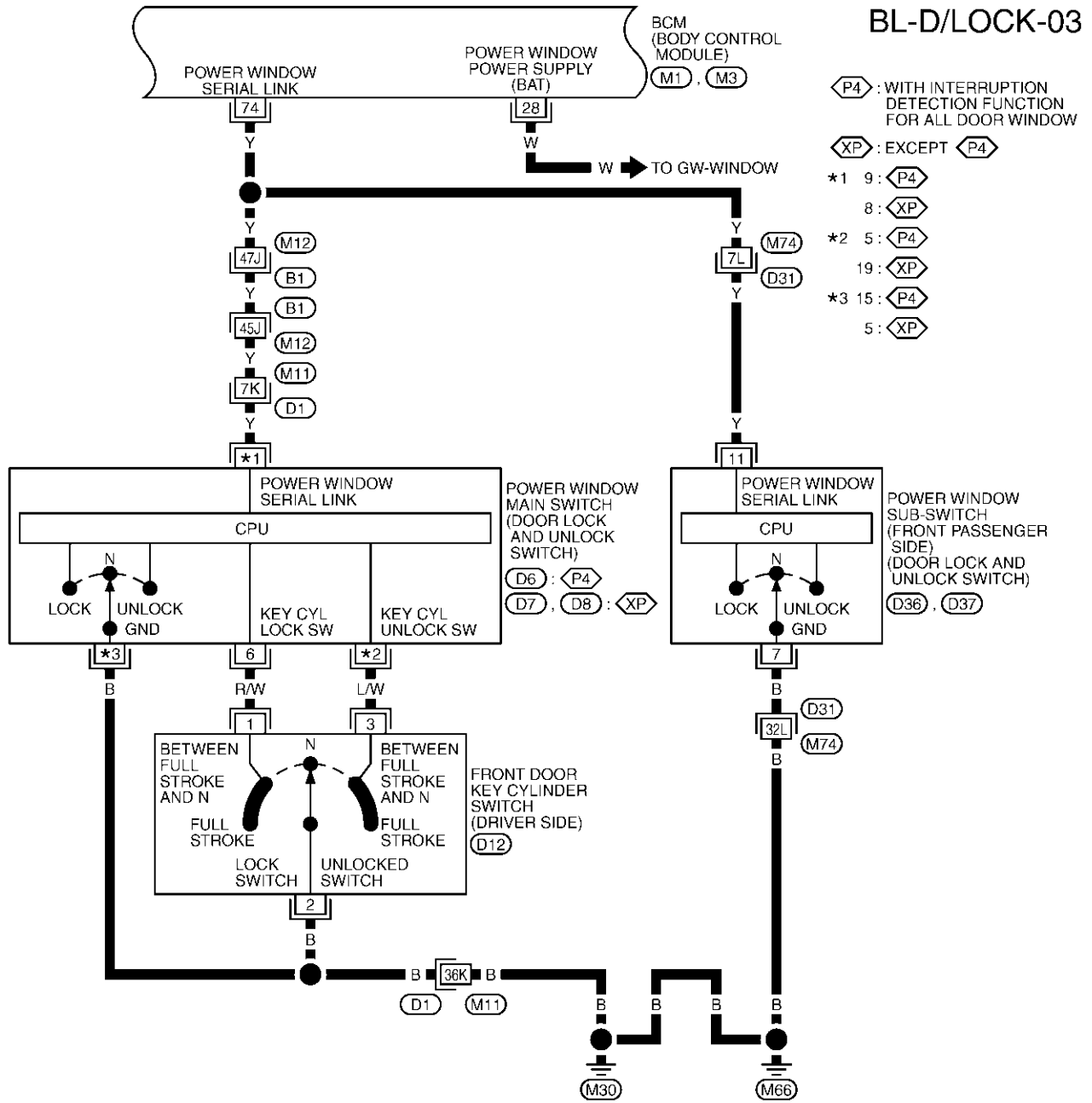

REFER TO THE FOLLOWING.
 (B1), (D1), (D31) -SUPER MULTIPLE JUNCTION (SMJ)
 (M1), (M3) -ELECTRICAL UNITS

POWER DOOR LOCK SYSTEM

FIG. 4

BL-D/LOCK-04

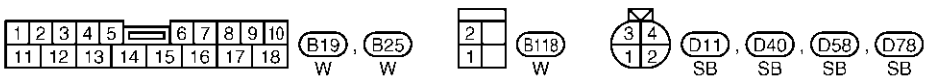
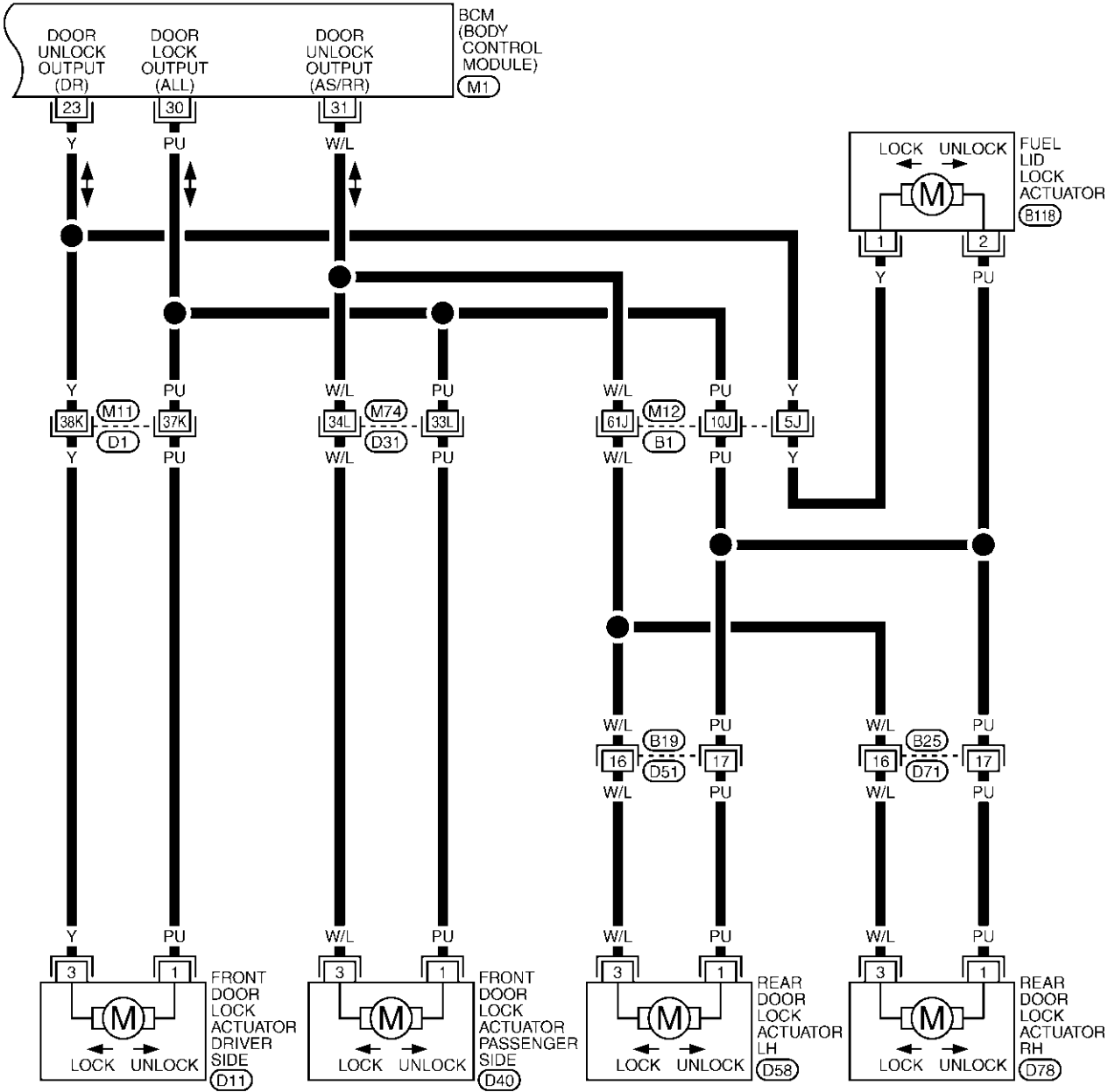

REFER TO THE FOLLOWING.
 (B1), (D1), (D31) -SUPER
 MULTIPLE JUNCTION (SMJ)
 (M1) -ELECTRICAL UNITS

TIWT0211E

POWER DOOR LOCK SYSTEM

Terminals and Reference Value for BCM

AIS00011

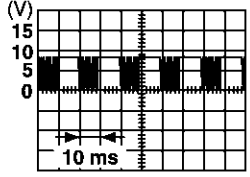
TERMI-NAL	WIRE COLOR	ITEM	CONDITION	VOLTAGE (V) Approx.
7	W/R	Power source (Fusible link)	—	Battery voltage
8	B	Ground	—	0
10	P	Passenger door switch	ON (door open) → OFF (door closed)	0 → Battery voltage
11*	P	Rear door switch	ON (door open) → OFF (door closed)	0 → Battery voltage
14	W	Driver door switch	ON (door open) → OFF (door closed)	0 → Battery voltage
23	Y	Driver door lock actuator (unlock)	Door lock / unlock switch (Free → Unlock)	0 → Battery voltage
28	W	Battery power supply	—	Battery voltage
30	PU	Door lock actuator	Door lock / unlock switch (Free → Lock)	0 → Battery voltage
31	W/L	Passenger and rear doors lock actuator	Door lock / unlock switch (Free → Unlock)	0 → Battery voltage
62	B/P	Key switch	ON (Key inserted) → OFF (Key removed from IGN key cylinder)	Battery voltage → 0
70	L	CAN-H	—	—
71	R	CAN-L	—	—
72	PU	Data link connector	—	—
74	Y	Power window switch (Serial link)	Ignition switch (OFF→ON)	

PIIA1297E

*: without navigation system

Terminals and Reference Value for Combination Meter

AIS002MF

TERMI-NAL	WIRE COLOR	ITEM	CONDITION	VOLTAGE (V) Approx.
6*	P	Front door switch passenger side	ON (door open) → OFF (door closed)	0 → Battery voltage
7*	W	Front door switch driver side	ON (door open) → OFF (door closed)	0 → Battery voltage
8*	P	Rear door switch LH	ON (door open) → OFF (door closed)	0 → Battery voltage
9*	P	Rear door switch RH	ON (door open) → OFF (door closed)	0 → Battery voltage
27	R	CAN-L	—	—
28	L	CAN-H	—	—

*: with navigation system

Work Flow

AIS00012

1. Check the symptom and customer's requests.
2. Understand the outline of system. Refer to [BL-20, "System Description"](#) .
3. Perform the preliminary check. Refer to [BL-32, "Preliminary Check"](#) .
4. According to the trouble diagnosis chart, repair or replace the cause of the malfunction. Refer to [BL-34, "Trouble Diagnoses Symptom Chart"](#) .
5. Does power door lock system operate normally?
YES: GO TO 6
NO: GO TO 4
6. INSPECTION END.

POWER DOOR LOCK SYSTEM

AIS00013

Preliminary Check FUSE CHECK

1. FUSE INSPECTION

Check 50A fusible link (letter F located in the fuse and fusible link box).

NOTE:

Refer to [BL-19, "Component Parts and Harness Connector Location"](#) .

OK or NG

OK >> GO TO 2

NG >> If fuse is blown, be sure to eliminate cause of problem before installing new fuse, refer to [PG-3, "POWER SUPPLY ROUTING CIRCUIT"](#) .

2. CHECK POWER SUPPLY CIRCUIT

1. Turn ignition switch OFF.
2. Disconnect BCM connector.
3. Check voltage between BCM connector E105 terminal 7 (W/R) and ground.

Battery voltage should exist.

OK or NG?

OK >> GO TO 3

NG >> Repair or replace BCM power supply circuit.

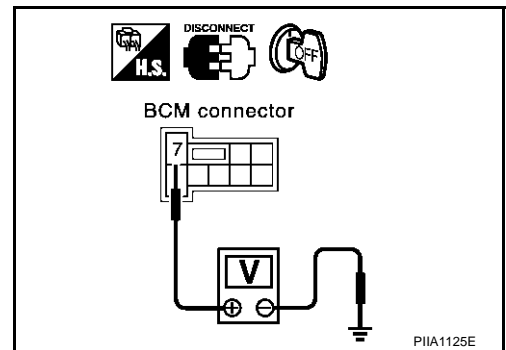

3. CHECK GROUND CIRCUIT

Check continuity between BCM harness connector E105 terminal 8 (B) and ground.

Continuity should exist.

OK or NG?

OK >> Power supply and ground circuit is OK.

NG >> Repair or replace BCM ground circuit.

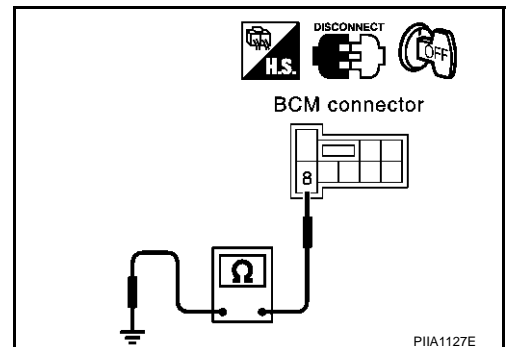

CONSULT-II Function

AIS00014

Power door lock system check with data monitor and active test can be executed by combining data reception and command transmission via communication line from BCM.

BCM diagnosis part	Inspection item, self-diagnosis mode	Content
Door lock	Data monitor	Displays BCM input data on real-time basis.
	Active test	Sends drive signals to door lock actuator to perform operation check.

POWER DOOR LOCK SYSTEM

CONSULT-II BASIC OPERATION PROCEDURE

1. With ignition switch "OFF".
2. Connect "CONSULT-II" and "CONSULT-II CONVERTER" to the data link connector.

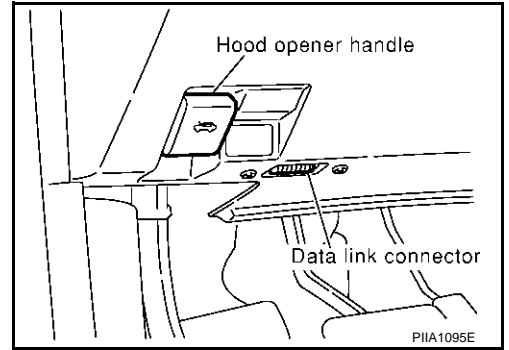

3. Turn ignition switch "ON".
4. Touch "START".

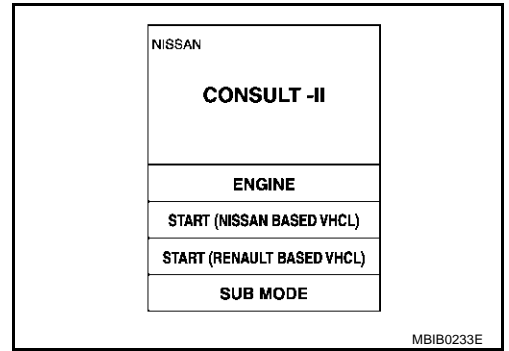

5. Touch "BCM" on "SELECT SYSTEM" screen.
If "BCM" is not indicated, go to [GI-38, "CONSULT-II Data Link Connector \(DLC\) Circuit"](#).

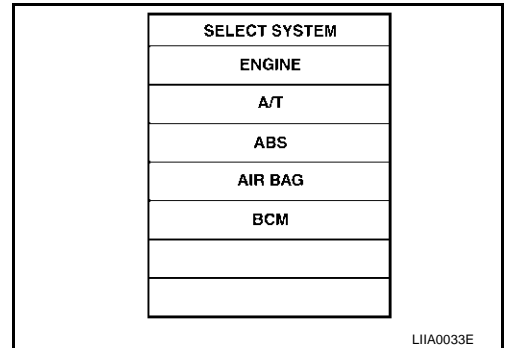

6. Select item to be diagnosed on "SELECT TEST ITEM" screen.

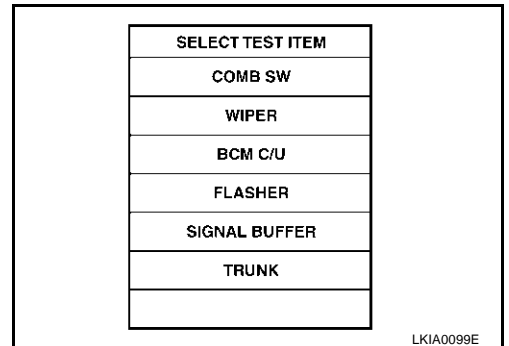

WORK SUPPORT

Work item	Description
DOOR LOCK-UNLOCK SET	Select unlock mode can be changed in this mode. Selects ON-OFF of select unlock mode.
ANTI-LOCK OUT SET	Key reminder door mods can be changed in this mode. Selects ON-OFF of key reminder door mode.

A
B
C
D
E
F
G
H
BL
J
K
L
M

POWER DOOR LOCK SYSTEM

DATA MONITOR

Monitor item "OPERATION"		Content
KEY ON SW	"ON/OFF"	Indicates [ON/OFF] condition of key switch.
LOCK SW DR/AS	"ON/OFF"	Indicates [ON/OFF] condition of lock signal from lock/unlock switch LH and RH.
UNLK SW DR/AS	"ON/OFF"	Indicates [ON/OFF] condition of unlock signal from lock/unlock switch LH and RH.
KEY CYL LK-SW	"ON/OFF"	Indicates [ON/OFF] condition of lock signal from key cylinder.
KEY CYL UN-SW	"ON/OFF"	Indicates [ON/OFF] condition of unlock signal from key cylinder.
LK BUTTON/SIG	"ON/OFF"	Indicates [ON/OFF] condition of lock signal from key fob.
UN BUTTON/SIG	"ON/OFF"	Indicates [ON/OFF] condition of unlock signal from key fob.
IGN ON SW	"ON/OFF"	Indicates [ON/OFF] condition of ignition switch.
DOOR SW-DR	"ON/OFF"	Indicates [ON/OFF] condition of front door switch LH.
DOOR SW-AS	"ON/OFF"	Indicates [ON/OFF] condition of front door switch RH.
DOOR SW-RR	"ON/OFF"	Indicates [ON/OFF] condition of door switch (Rear).

ACTIVE TEST

Test item	Content
ALL D/LK MTR	This test is able to check all door lock actuators lock operation. These actuators lock when "ON" on CONSULT-II screen is touched.
DR D/UN MTR	This test is able to check front door lock actuator LH unlock operation. These actuators lock when "ON" on CONSULT-II screen is touched.
NON DR D/UN	This test is able to check door lock actuators (except front door lock actuator LH) unlock operation. These actuators unlock when "ON" on CONSULT-II screen is touched.

Trouble Diagnoses Symptom Chart

AIS0029D

Always check the "Work Flow" before troubleshooting. Refer to [BL-31, "Work Flow"](#).

Symptom	Diagnoses service procedure	Refer to page
Key reminder door system does not operate properly.	1. Preliminary Check	BL-32
	2. Check key switch.	BL-38
	3. Check door switch.	BL-35 *1 BL-37 *2
	4. Replace BCM.	BCS-23
Power door lock does not operate with door lock and unlock switch on power window main switch or power window sub-switch.	1. Preliminary check	BL-32
	2. Check door lock and unlock switch.	BL-38 *3 BL-42 *4
	3. Replace BCM.	BCS-23
Specific door lock actuator does not operate.	1. Check door lock actuator.	BL-44 *5 BL-45 *6
	2. Replace BCM.	BCS-23
Power door lock does not operate with front door key cylinder operation. (Power door lock operate properly with door lock and unlock switch.)	1. Check front door key cylinder switch.	BL-47 BL-48
	2. Replace power window main switch.	—
Fuel lid opener actuator does not operate. (All door lock actuator operates properly.)	1. Check fuel lid opener actuator.	BL-46

*1 : With navigation system

*2 : Without navigation system

*3 : With interruption function detection for all door window

*4 : With interruption function detection for front door window

*5 : Front driver side

*6 : Passenger side and rear LH/RH

POWER DOOR LOCK SYSTEM

Check Door Switch / With Navigation System

AIS002NW

First perform the "SELF-DIAG RESULTS" in "BCM" with CONSULT-II, when perform the each trouble diagnosis. Refer to [BCS-16, "CAN Communication Inspection Using CONSULT-II \(Self-Diagnosis\)"](#).

1. CHECK DOOR SWITCH INPUT SIGNAL

With CONSULT-II

Check door switches ("DOOR SW-DR", "DOOR SW-AS" and "DOOR SW-RR") in "DATA MONITOR" mode with CONSULT-II.

Monitor item	Condition
DOOR SW-DR	CLOSE → OPEN : OFF → ON
DOOR SW-AS	
DOOR SW-RR	

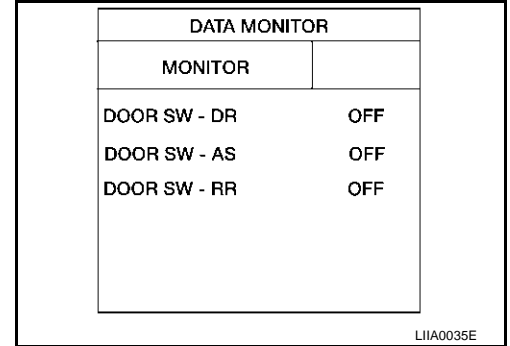

Without CONSULT-II

Check voltage between combination meter connector and ground.

Item	Connector	Terminals (Wire color)		Condition	Voltage (V) (Approx.)
		(+)	(-)		
Driver side	M19	7 (W)	Ground	CLOSE ↓ OPEN	Battery voltage ↓ 0
Passenger side		6 (P)			
Rear LH		9 (P)			
Rear RH		8 (P)			

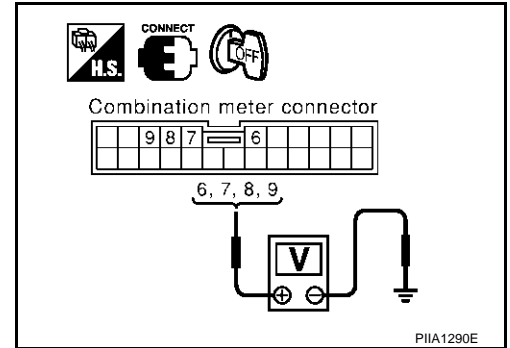

OK or NG

- OK >> Door switch circuit is OK.
- NG >> GO TO 2.

POWER DOOR LOCK SYSTEM

2. CHECK DOOR SWITCH

1. Turn ignition switch OFF.
2. Disconnect door switch and combination meter connector.
3. Check continuity between door switch connector B17, B23, B20, B32 terminals 1 and combination meter connector M19 terminals 7, 6, 9, 8.

Front door switch driver side

1 (W) – 7 (W) : Continuity should exist.

Front door switch passenger side

1 (P) – 6 (P) : Continuity should exist.

Rear door switch LH

1 (P) – 9 (P) : Continuity should exist.

Rear door switch RH

1 (P) – 8 (P) : Continuity should exist.

4. Check continuity between door switch connector B17, B23, B20, B32 terminals 1 and ground.

1 (W or P) – Ground : Continuity should not exist

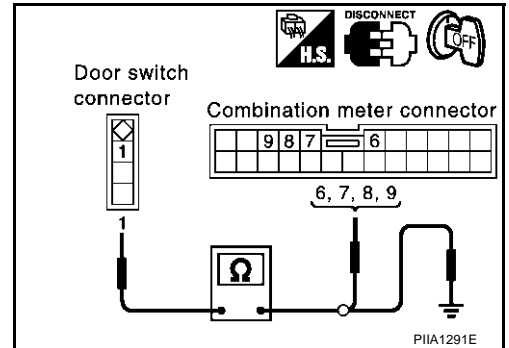

OK or NG

OK >> GO TO 3

NG >> Repair or replace harness.

3. CHECK DOOR SWITCH

Check continuity between each door switch terminal 1 and body ground part of door switch.

Terminal	Door switch	Continuity
1	Pushed	No
	Released	Yes

OK or NG

OK >> GO TO 4.

NG >> Replace door switch.

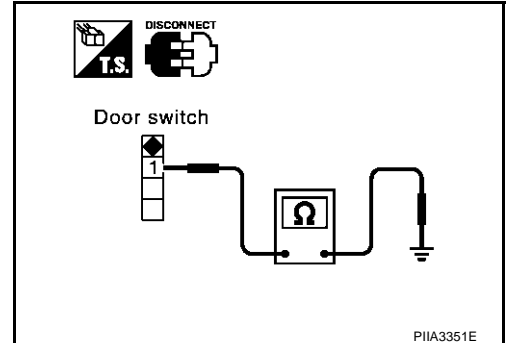

4. CHECK COMBINATION METER OUTPUT SIGNAL

1. Connect combination meter connector.
2. Check voltage between combination meter connector M19 terminals 6, 7, 8, 9 and ground.

6 (p) – Ground : Battery voltage

7 (w) – Ground : Battery voltage

8 (P) – Ground : Battery voltage

9 (P) – Ground : Battery voltage

OK or NG

OK >> Check harness connection.

NG >> Replace combination meter.

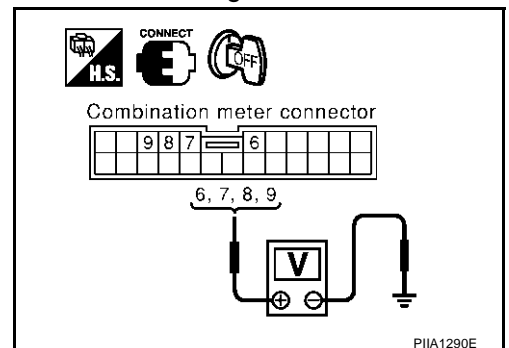

POWER DOOR LOCK SYSTEM

Check Door Switch / Without Navigation System

AIS002NX

1. CHECK DOOR SWITCH INPUT SIGNAL

With CONSULT-II

Check door switches ("DOOR SW-DR", "DOOR SW-AS" and "DOOR SW-RR") in "DATA MONITOR" mode with CONSULT-II.

Monitor item	Condition
DOOR SW-DR	CLOSE → OPEN : OFF → ON
DOOR SW-AS	
DOOR SW-RR	

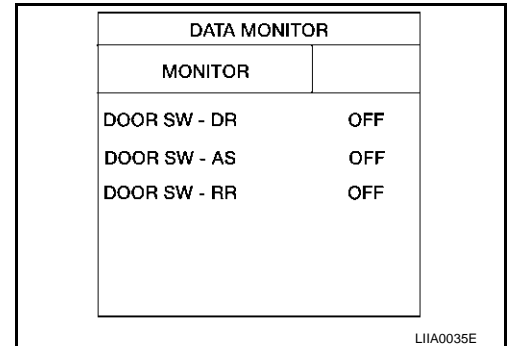

Without CONSULT-II

Check voltage between BCM connector and ground.

Item	Connector	Terminals (Wire color)		Condition	Voltage (V) (Approx.)
		(+)	(-)		
Driver side	B4	14(W)	Ground	CLOSE ↓ OPEN	Battery voltage ↓ 0
Passenger side		10 (P)			
Rear LH, RH		11 (P)			

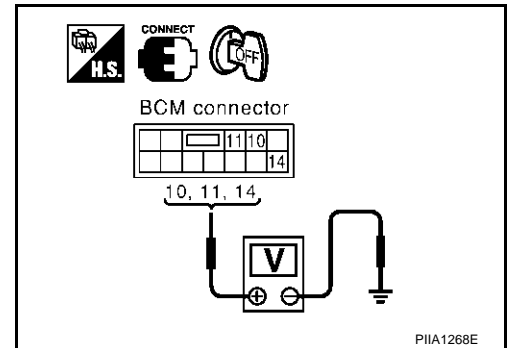

OK or NG

- OK >> Door switch circuit is OK.
- NG >> GO TO 2.

2. CHECK DOOR SWITCH CIRCUIT

1. Turn ignition switch OFF.
2. Disconnect door switch and BCM connector.
3. Check continuity between door switch connector B17, B23, B20, B32 terminals 1 and BCM connector B4 terminals 14, 10, 11.

Driver side door

1 (W) – 14 (W) : Continuity should exist.

Passenger side door

1 (P) – 10 (P) : Continuity should exist.

Rear door LH, RH

1 (P) – 11 (P) : Continuity should exist.

4. Check continuity between door switch connector B17, B23, B20, B32 terminal 1 and ground.

1 (W or P) – Ground : Continuity should not exist.

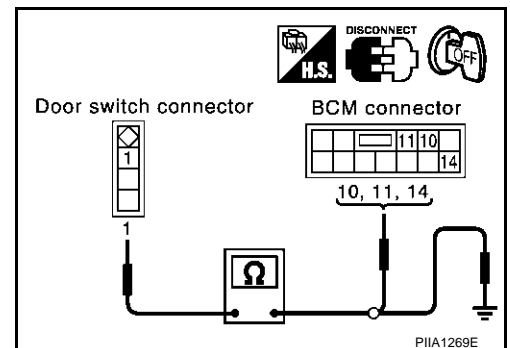

OK or NG

- OK >> GO TO 3.
- NG >> Repair or replace harness.

POWER DOOR LOCK SYSTEM

3. CHECK DOOR SWITCH

Check continuity between each door switch terminal 1 and ground part of door switch.

Terminal		Door switch	Continuity
1	Ground part of door switch	Pushed	No
		Released	Yes

OK or NG

- OK >> Check harness connection.
 NG >> Replace door switch.

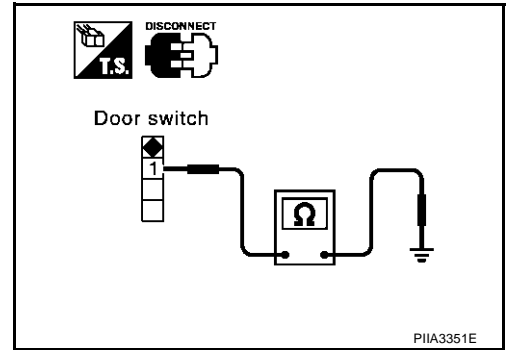

AIS0008Y

Check Key Switch

1. CHECK KEY SWITCH INPUT SIGNAL

Check voltage between BCM connector M3 terminal 62 (B/P) and ground.

Condition of key switch	Voltage (V) Approx.
Key is inserted in ignition key cylinder.	Battery voltage
Key is removed from ignition key cylinder.	0

OK or NG

- OK >> Key switch circuit is OK.
 NG >> GO TO 2.

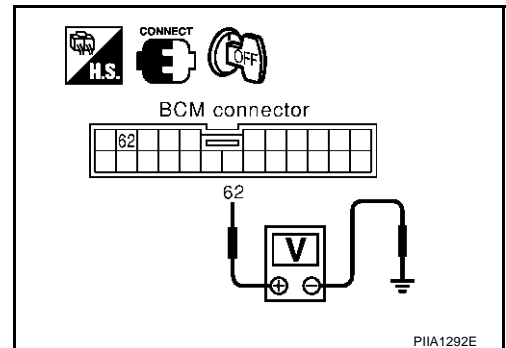

2. CHECK KEY SWITCH

1. Disconnect key switch connector.
2. Check continuity between key switch terminals 1 and 2.

Condition of key switch	Continuity
Key is inserted in ignition key cylinder.	Yes
Key is removed from ignition key cylinder.	No

OK or NG

- OK >> Check the following.
- 10A fuse [No. 21, located in fuse block (J/B)]
 - Harness for open or short between key switch and fuse
 - Harness for open or short between BCM and key switch

NG >> Replace key switch.

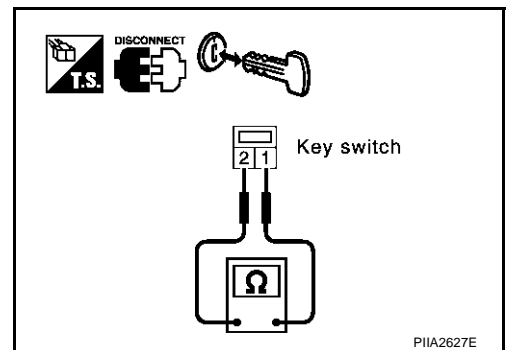

Check Door Lock and Unlock Switch (With Interruption Function Detection for All Door Window)

AIS00019

1. CHECK POWER WINDOW OPERATION

Does power window system operate normally?

OK or NG?

- OK >> GO TO 2
 NG >> Refer to [GW-49, "Trouble Diagnoses Symptom Chart / With Front and Rear Power Window Anti-Pinch System"](#) .

POWER DOOR LOCK SYSTEM

2. CHECK DOOR LOCK AND UNLOCK SWITCH INPUT SIGNAL

With CONSULT-II

Check door lock and unlock switch (“LOCK SW DR/AS”, “UNLK SW DR/AS”) in DATA MONITOR mode with CONSULT-II. Refer to [BL-34, "Data Monitor"](#).

- When door lock and unlock switch is turned to LOCK
LOCK SW DR/AS :ON
- When door lock and unlock switch is turned to UNLOCK
UNLK SW DR/AS :ON

DATA MONITOR	
MONITOR	
LOCK SW DR/AS	OFF
UNLK SW DR/AS	OFF

LIIA0172E

Without CONSULT-II

- Remove key from ignition key cylinder.
- Check the signal between BCM connector M3 terminal 74 (Y) and ground with oscilloscope when door lock and unlock switch is turned “LOCK” or “UNLOCK”.
- Make sure signals which are shown in the figure below can be detected during 10 second just after door lock and unlock switch is turned “LOCK” or “UNLOCK”.

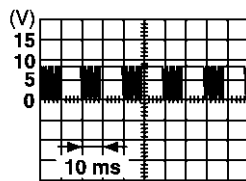
Connector	Terminal (wire color)		Signal
	(+)	(-)	
M3	74 (Y)	Ground	 <p style="text-align: right;">PIIA1297E</p>

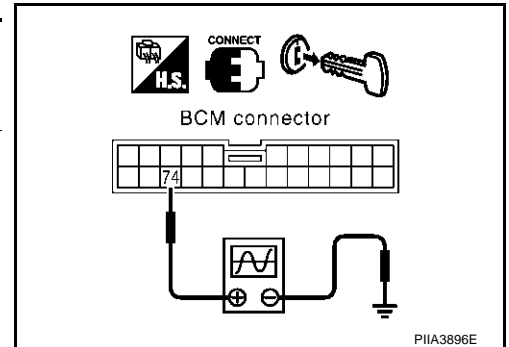

OK or NG

- OK >> Door lock and unlock switch is OK.
- NG >> GO TO 3.

POWER DOOR LOCK SYSTEM

3. CHECK POWER WINDOW SERIAL LINK CIRCUIT

1. Turn ignition switch OFF.
2. Disconnect BCM, power window main switch and power window sub-switch connectors.
3. Check continuity between BCM connector M3 terminal 74 (Y) and power window main switch (door lock and unlock switch) connector D6 terminal 9 (Y).

Continuity should exist.

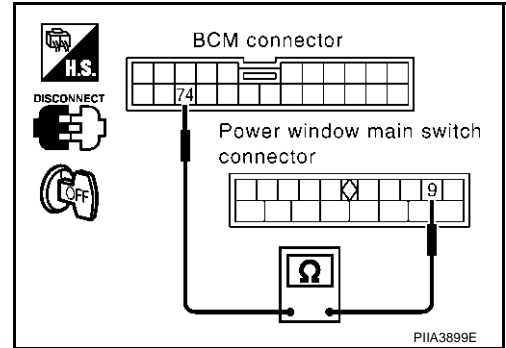

4. Check continuity between BCM connector M3 terminal 74 (Y) and power window sub-switch (door lock and unlock switch) connector D36 terminal 11 (Y).

Continuity should exist.

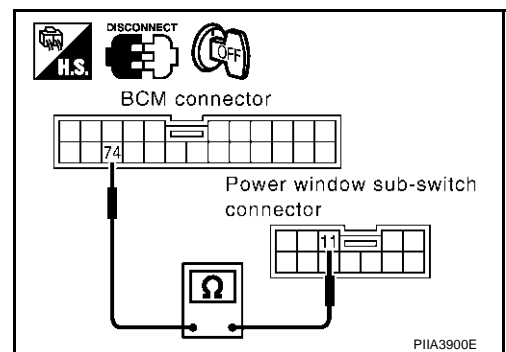

OK or NG

- OK >> GO TO 4.
- NG >> Repair or replace harness.

POWER DOOR LOCK SYSTEM

4. CHECK DOOR LOCK AND UNLOCK SWITCH GROUND HARNESS

- Check continuity between power window main switch (door lock and unlock switch) connector D6 terminal 15(B) and ground.

Continuity should exist.

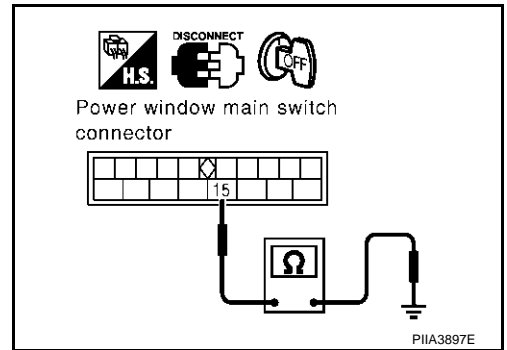

- Check continuity between power window sub-switch (front passenger side) (door lock and unlock switch) connector D37 terminal 7(B) and ground.

Continuity should exist.

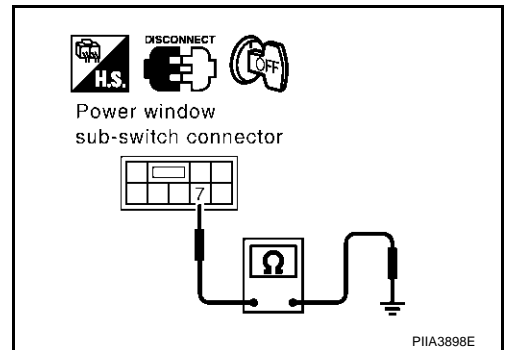

OK or NG

- OK >> Replace power window main switch or power window sub-switch (door lock and unlock switch).
- NG >> Repair or replace ground harness.

A
B
C
D
E
F
G
H

BL

J
K
L
M

POWER DOOR LOCK SYSTEM

Check Door Lock and Unlock Switch (With Interruption Function Detection for Front Door Window)

AIS0009R

1. CHECK POWER WINDOW OPERATION

Does power window system operate normally?

OK or NG

OK >> GO TO 2

NG >> Refer to [GW-48, "Trouble Diagnoses Symptom Chart / With Front Left and Right Power Window Anti-Pinch System"](#).

2. CHECK DOOR LOCK AND UNLOCK SWITCH INPUT SIGNAL

With CONSULT-II

Check door lock and unlock switch ("LOCK SW DR/AS", "UNLK SW DR/AS") in DATA MONITOR mode with CONSULT-II. Refer to [BL-34, "Data Monitor"](#).

- When door lock and unlock switch is turned to LOCK:

LOCK SW DR/AS :ON

- When door lock and unlock switch is turned to UNLOCK:

UNLK SW DR/AS :ON

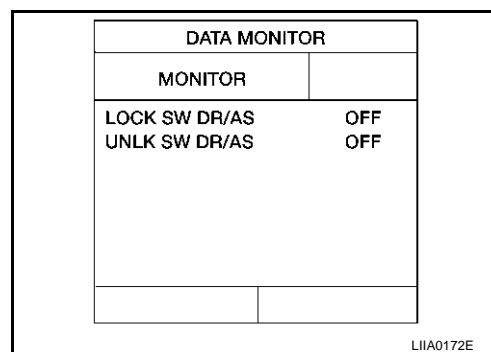

Without CONSULT-II

- Remove key from ignition key cylinder.
- Check the signal between BCM connector M3 terminal 74 (Y) and ground with oscilloscope when door lock and unlock switch is turned "LOCK" or "UNLOCK".
- Make sure signals which are shown in the figure below can be detected during 10 second just after door lock and unlock switch is turned "LOCK" or "UNLOCK".

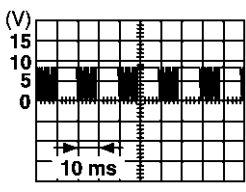
Connector	Terminal (wire color)		Voltage (V)
	(+)	(-)	
M3	74(Y)	Ground	 <p>PIIA1297E</p>

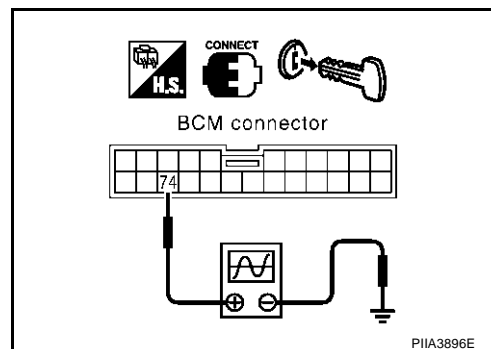

OK or NG

OK >> Door lock and unlock switch is OK.

NG >> GO TO 3.

POWER DOOR LOCK SYSTEM

3. CHECK POWER WINDOW SERIAL LINK CIRCUIT

1. Turn ignition switch OFF.
2. Disconnect BCM, power window main switch and power window sub-switch connectors.
3. Check continuity between BCM connector M3 terminal 74 (Y) and power window main switch (door lock and unlock switch) connector D7 terminal 8 (Y).

74 (Y) – 8 (Y) : Continuity should exist.

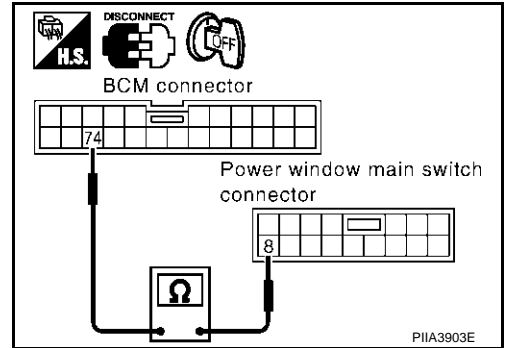

4. Check continuity between BCM connector M3 terminal 74 (Y) and power window sub-switch (door lock and unlock switch) connector D36 terminal 11 (Y).

74 (Y) – 11 (Y) : Continuity should exist.

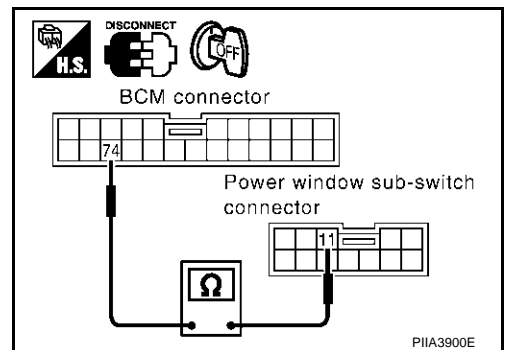

OK or NG

- OK >> GO TO 4.
- NG >> Repair or replace harness.

A
B
C
D
E
F
G
H
BL
J
K
L
M

POWER DOOR LOCK SYSTEM

4. CHECK DOOR LOCK AND UNLOCK SWITCH GROUND HARNESS

- Check continuity between power window main switch (door lock and unlock switch) connector D7 terminal 5 (B) and ground.

5 (B) – Ground : Continuity should exist.

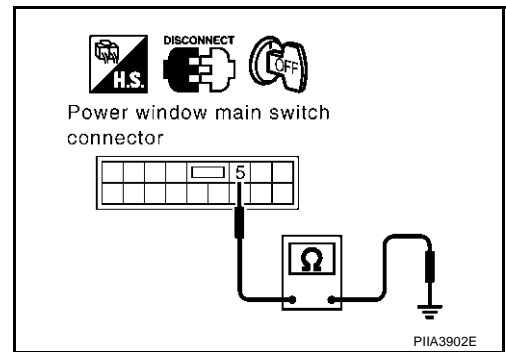

- Check continuity between power window sub-switch (front passenger side) (door lock and unlock switch) connector D37 terminal 7 (B) and ground.

7 (B) – Ground : Continuity should exist.

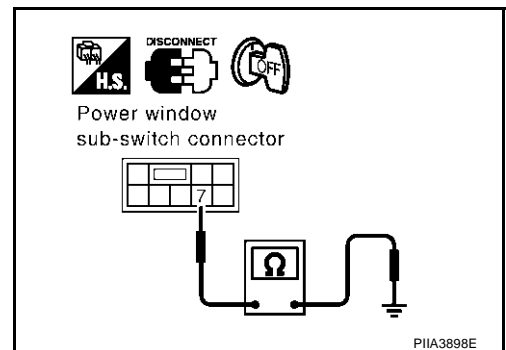

OK or NG

- OK >> Replace power window main switch or power window sub-switch.
- NG >> Repair or replace harness.

Check Door Lock Actuator (Driver Side)

AIS0001A

1. CHECK DOOR LOCK ACTUATOR HARNESS

- Turn ignition switch OFF.
- Disconnect BCM and front door lock actuator driver side connector.
- Check continuity between BCM connector M1 terminals 23 (Y), 30 (PU) and front door lock actuator driver side connector D11 terminals 1 (PU), 3 (Y).

23 (Y) – 3 (Y) : Continuity should exist.

30 (PU) – 1 (PU) : Continuity should exist.

- Check continuity between BCM connector M1 terminals 23 (Y), 30 (PU) and ground.

23 (Y) – Ground : Continuity should not exist.

30 (PU) – Ground : Continuity should not exist.

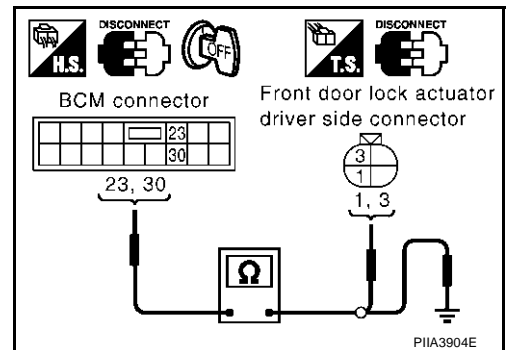

OK or NG

- OK >> GO TO 2.
- NG >> Repair or replace harness.

POWER DOOR LOCK SYSTEM

2. CHECK OUTPUT SIGNAL

1. Connect BCM and front door lock actuator driver side connector.
2. Check voltage between BCM connector M1 terminals 23 (Y), 30 (PU) and ground.

Con- nector	Terminal (wire color)		Condition	Voltage (V) Approx.
	(+)	(-)		
M1	23 (Y)	Ground	Driver door lock/unlock switch is turned to UNLOCK.	0 → Battery voltage
	30 (PU)	Ground	Driver door lock/unlock switch is turned to LOCK.	0 → Battery voltage

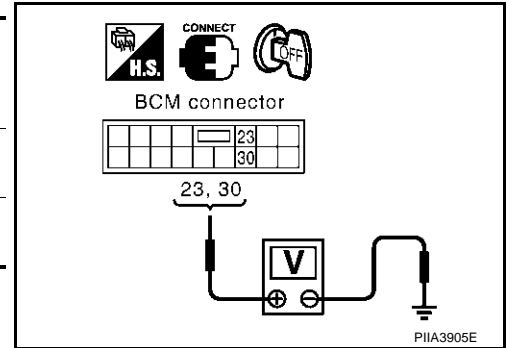

OK or NG

- OK >> GO TO 2.
 NG >> Replace BCM.

Check Door Lock Actuator (Passenger Side and Rear LH/RH)

AIS0001B

1. CHECK DOOR LOCK ACTUATOR HARNESS

1. Disconnect BCM and each door lock actuator connectors.
2. Check continuity between BCM connector M1 terminals 30 (PU), 31 (W/L) and front door lock actuator passenger side, rear door lock actuator LH/RH connector D40, D58, D78 terminals 1 (PU), 3 (W/L).

30 (PU) – 1 (PU) : Continuity should exist.

31 (W/L) – 3 (W/L) : Continuity should exist.

3. Check continuity between BCM connector M1 terminals 30 (PU), 31 (W/L) and ground.

30 (PU) – Ground : Continuity should not exist.

31 (W/L) – Ground : Continuity should not exist.

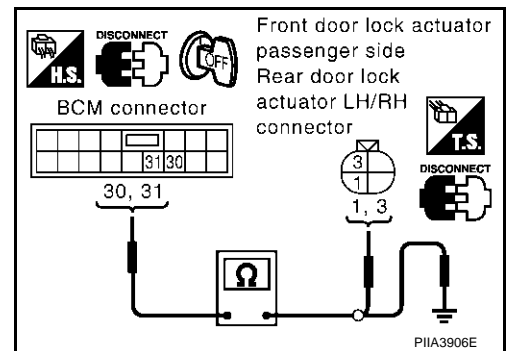

OK or NG

- OK >> GO TO 2.
 NG >> Repair or replace harness.

POWER DOOR LOCK SYSTEM

2. CHECK DOOR LOCK ACTUATOR SIGNAL

Check voltage between BCM connector M1 terminals 30 (PU), 31 (W/L) and ground.

Connector	Terminal (wire color)		Condition	Voltage (V) Approx.
	(+)	(-)		
M1	30 (PU)	Ground	Door lock/unlock switch is turned to LOCK.	0 → Battery voltage
	31 (W/L)	Ground	Door lock/unlock switch is turned to UNLOCK.	0 → Battery voltage

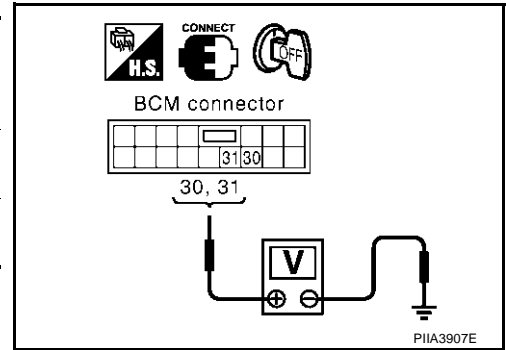

OK or NG

- OK >> Replace front door lock actuator passenger side or rear door lock actuator LH/RH.
- NG >> Replace BCM.

Check Fuel Lid Opener Actuator

AIS000B7

1. CHECK FUEL LID OPENER ACTUATOR HARNESS

1. Disconnect BCM and fuel lid lock actuator connector.
2. Check continuity between BCM connector M1 terminals 23 (Y), 30 (PU) and fuel lid lock actuator connector B118 terminals 1 (Y), 2 (PU).

23 (Y) – 1 (Y) : Continuity should exist.

30 (PU) – 2 (PU) : Continuity should exist.

3. Check continuity between BCM connector M1 terminals 23 (Y), 30 (PU) and ground.

23 (Y) – Ground : Continuity should not exist.

30 (PU) – Ground : Continuity should not exist.

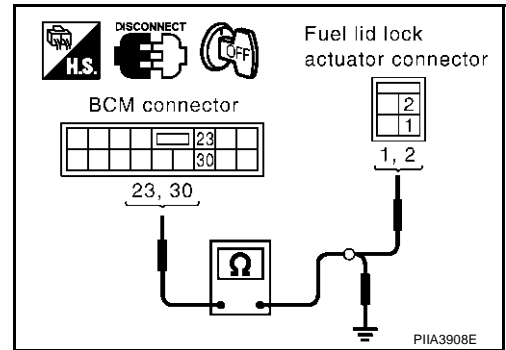

OK or NG

- OK >> Replace fuel lid actuator.
- NG >> Repair or replace harness.

POWER DOOR LOCK SYSTEM

AIS0001E

Check Front Door Key Cylinder Switch (Lock)

1. CHECK FRONT DOOR KEY CYLINDER SWITCH INPUT SIGNAL (LOCK SIGNAL)

① With CONSULT-II

Check front door key cylinder switch LH ("KEY CYL LK SW") in "DATA MONITOR" mode with CONSULT-II.

"KEY CYL LK-SW" should be "ON" when key inserted in door key cylinder was turned to lock.

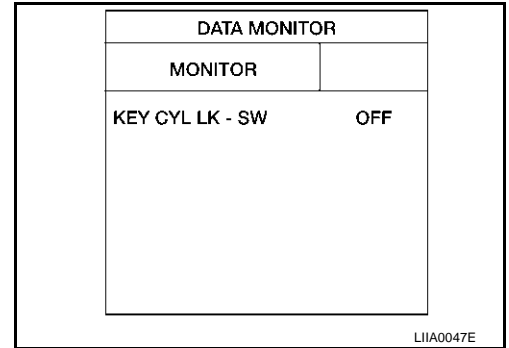

② Without CONSULT-II

Check voltage between power window main switch (door lock and unlock switch) connector D6 or D7 terminal 6 (R/W) and ground.

Connector	Terminal (wire color)	Front door key cylinder switch position	Voltage (V) Approx.
D6*1 or D7*2	6 (RW)	Neutral / Unlock	5
		Lock	0

*1 : with interruption detection function for all door window

*2 : except interruption detection function for all door window

OK or NG

- OK >> Front door key cylinder switch circuit driver side (lock) is OK.
 NG >> GO TO 2.

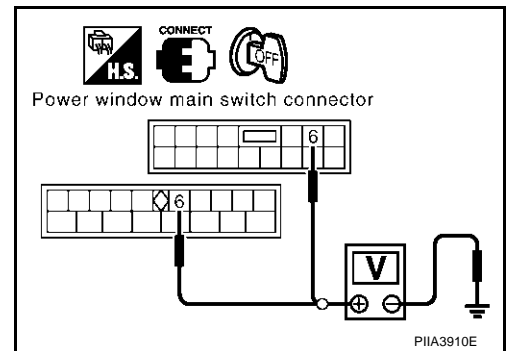

2. CHECK FRONT DOOR KEY CYLINDER SWITCH

1. Disconnect front door key cylinder switch driver side connector.
2. Check continuity between front door key cylinder switch driver side terminals 1 and 2.

Front door key cylinder switch position	Continuity
Neutral / Unlock	No
Lock	Yes

OK or NG

- OK >> Check the following.
- Front door key cylinder switch driver side ground circuit.
 - Harness for open or short between power window main switch (door lock and unlock switch) and front door key cylinder switch driver side.
- NG >> Replace front door key cylinder switch driver side.

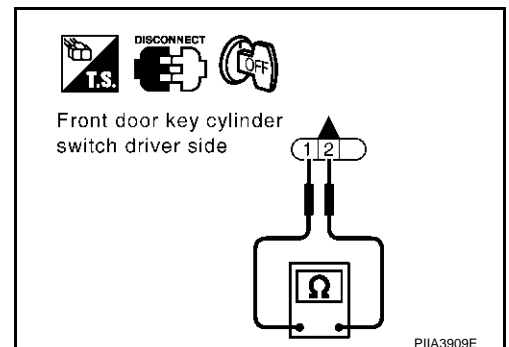

POWER DOOR LOCK SYSTEM

AIS0029E

Check Front Door Key Cylinder Switch (Unlock)

1. CHECK FRONT DOOR KEY CYLINDER SWITCH INPUT SIGNAL (UNLOCK SIGNAL)

④ With CONSULT-II

- Check front door key cylinder switch driver side ("KEY CYL UN-SW") in "DATA MONITOR" mode with CONSULT-II.

"KEY CYL UN-SW" should be "ON" when key inserted in door key cylinder was turned to unlock.

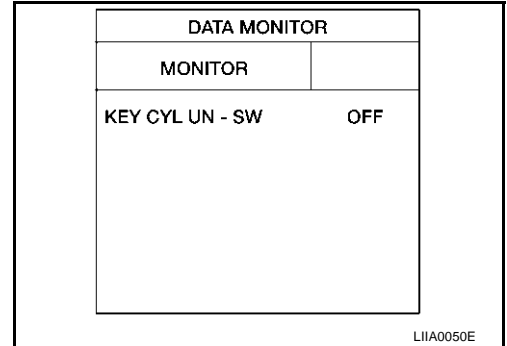

⊗ Without CONSULT-II

Check voltage between main power window switch (door lock and unlock switch) connector D6 or D8 terminals 5 (L/W) or 19 (L/W) and ground.

Connector	Terminal (wire color)	Front door key cylinder switch position	Voltage (V) Approx.
D6*1 or D7*2	5 (RW)*1 or 19 (L/W)*2	Neutral / Lock	5
		Unlock	0

*1 : with interruption detection function for all door window

*2 : except interruption detection function for all door window

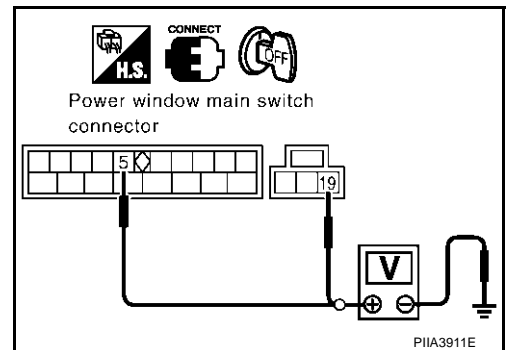

Front door key cylinder switch position	Voltage (V) Approx.
Neutral / Lock	5
Unlock	0

OK or NG

- OK >> Front door key cylinder switch circuit driver side (unlock) is OK.
- NG >> GO TO 2.

2. CHECK FRONT DOOR KEY CYLINDER SWITCH

- Disconnect front door key cylinder switch driver side connector.
- Check continuity between front door key cylinder switch driver side terminals 2 and 3.

Front door key cylinder switch position	Continuity
Neutral / Lock	No
Unlock	Yes

OK or NG

- OK >> Check the following.
 - Front door key cylinder switch driver side ground circuit
 - Harness for open or short between power window main switch (door lock and unlock switch) and front door key cylinder switch driver side
- NG >> Replace front door key cylinder switch driver side.

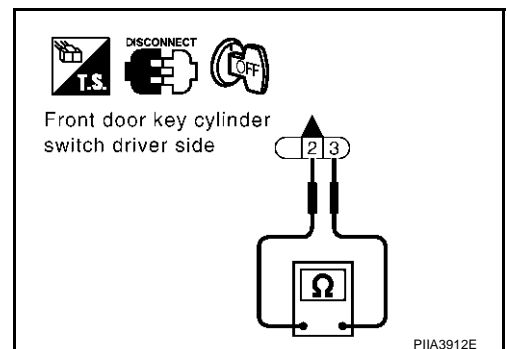

REMOTE KEYLESS ENTRY SYSTEM

PPF:28596

REMOTE KEYLESS ENTRY SYSTEM

Component Parts and Harness Connector Location

AIS0001F

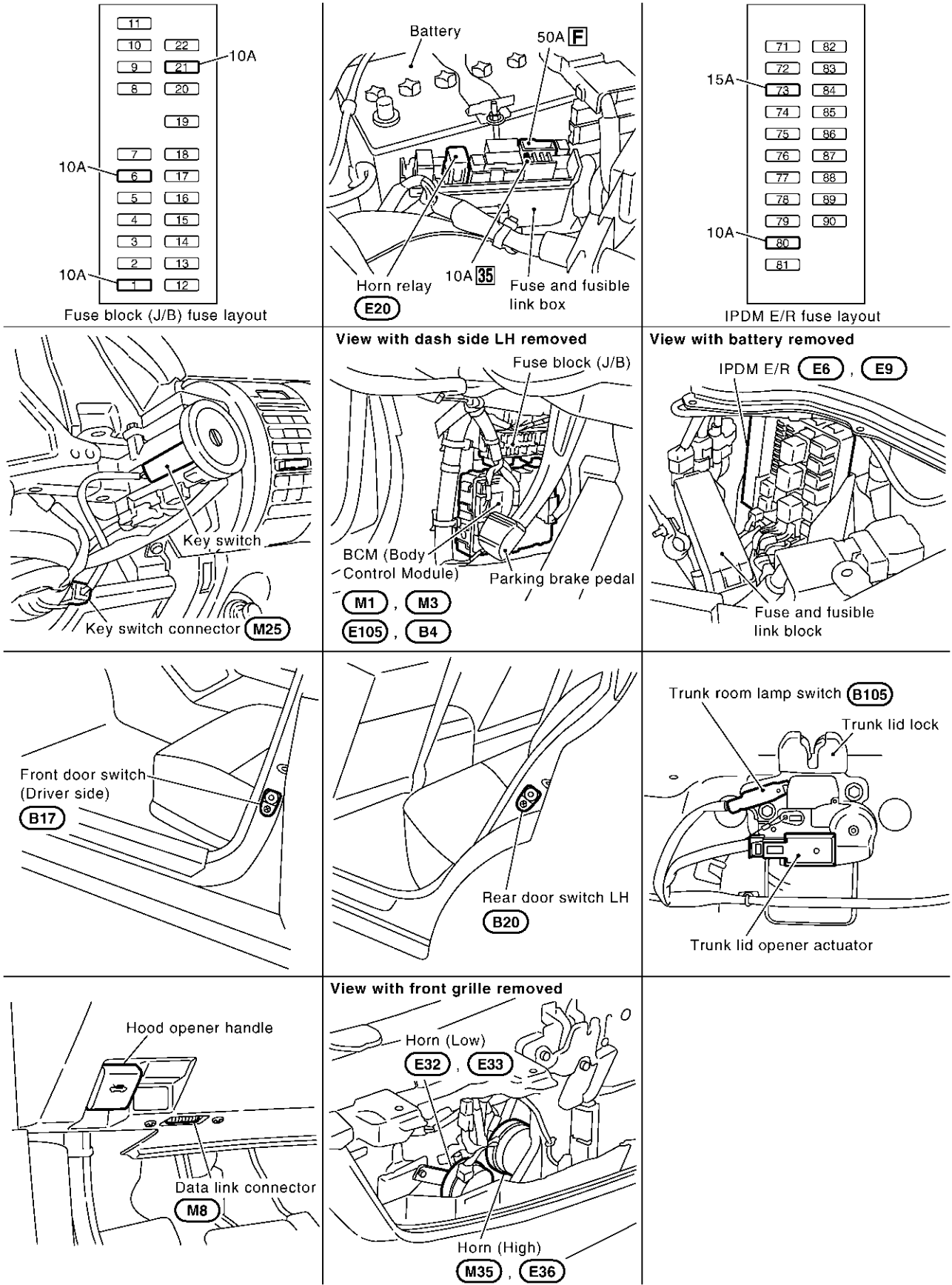

A
B
C
D
E
F
G
H
I
J
K
L
M

BL

REMOTE KEYLESS ENTRY SYSTEM

AIS0028F

System Description

INPUTS

Power is supplied at all times

When the key switch is ON (key is inserted in ignition key cylinder), power is supplied

- to BCM terminal 7
- through 50A fusible link (letter **F** , located in the fuse and fusible link box).
- to key switch terminal 2
- through 10A fuse (No.21,located in the fuse and fusible link box).

When the key switch is ON (key is inserted in ignition key cylinder), power is supplied

- to BCM terminal 62
- through key switch terminal 1.

When the ignition switch is ACC or ON, power is supplied

- to BCM terminal 36
- through 10A fuse [No.6,located in the fuse block (J/B)].

When the ignition switch is ON or START, power is supplied

- to BCM terminal 35
- through 10A fuse [No.1,located in the fuse block (J/B)].

When the front door switch driver side is ON (door is OPEN), ground is supplied

- to BCM terminal 14
- through front door switch driver side terminal 1
- through front door switch driver side case ground.

When the front door switch driver side is ON (door is OPEN), ground is supplied (with navigation system)

- to combination meter terminal 7
- through front door switch driver side terminal 1
- through driver door switch case ground.

Combination meter send door open signal to BCM with CAN communication system.

If CAN communication systems or combination meter is malfunction, operation is the same as without navigation system.

When the front door switch passenger is ON (door is OPEN), ground is supplied

- to BCM terminal 10
- through passenger side door switch terminal 1
- through passenger side door switch case ground.

When the front door switch passenger side is ON (door is OPEN), ground is supplied (with navigation system)

- to combination meter terminal 6
- through front door switch driver side terminal 1
- through front door switch passenger side case ground.

Combination meter send door open signal to BCM with CAN communication system.

If CAN communication systems or combination meter is malfunction, operation is the same as without navigation system.

When the rear door switches are ON (door is OPEN), ground is supplied (without navigation system)

- to BCM terminal 11
- through rear door switches terminal 1
- through rear door switches case grounds.

When the rear door switch LH is ON (door is OPEN), ground is supplied (with navigation system)

- to combination meter terminal 9
- through front door switch LH terminal 1
- through rear door switch LH case ground.

When the rear door switch RH is ON (door is OPEN), ground is supplied (with navigation system)

- to combination meter terminal 8
- through front door switch RH terminal 1

REMOTE KEYLESS ENTRY SYSTEM

- through rear door switch RH case ground.

Combination meter send door open signal to BCM with CAN communication system.

If CAN communication systems or combination meter is malfunction, operation is the same as without navigation system.

When the trunk room lamp switch is ON (Trunk is OPEN), ground is supplied

- to BCM terminal 18
- through trunk room lamp switch terminal 1 and 2
- through body grounds B5,B29.

Key fob signal is inputted to BCM (the antenna of the system is combined with BCM).

The remote keyless entry system controls operation of the

- power door lock
- hazard and horn reminder
- auto door lock
- map lamp and keyhole illumination
- panic alarm
- trunk opener
- keyless power window down (open)

OPERATED PROCEDURE

BCM can not receive signals from key fob when key switch is ON (except keyless power window down signal).

Power Door Lock Operation

BCM receives a LOCK signal from key fob. BCM locks all doors with input of LOCK signal from key fob.

When an UNLOCK signal is sent from key fob once, driver's door will be unlocked.

Then, if an UNLOCK signal is sent from key fob again within 5 seconds, all other door will be unlocked.

Hazard and Horn Reminder

When the doors are locked or unlocked by key fob, supply power to hazard warning lamp flashes as follows

- LOCK operation: C mode (flash twice) or S mode (flash twice)
- UNLOCK operation: C mode (flash once) or S mode (does not flash)

BCM outputs to IPDM E/R for horn reminder signal as DATA LINE (CAN H line and CAN L line).

The hazard and horn reminder has C mode (horn chirp mode) and S mode (non-horn chirp mode).

Operating function of hazard and horn reminder

	C mode		S mode	
	Lock	Unlock	Lock	Unlock
Remote controller operation	Lock	Unlock	Lock	Unlock
Hazard warning lamp flash	Twice	Once	Twice	—
Horn sound	Once	—	—	—

Hazard and horn reminder does not operate if any door switches are ON (any doors are OPEN).

How to change hazard and horn reminder mode

Ⓜ With CONSULT-II

Hazard and horn reminder can be changed using "WORK SUPPORT" mode in "MULTI ANSWER BACK SET".

Refer to [BL-64, "Work Support"](#).

ⓧ Without CONSULT-II

REMOTE KEYLESS ENTRY SYSTEM

When LOCK and UNLOCK signals are sent from the key fob for more than 2 seconds at the same time, the hazard and horn reminder mode is changed and hazard warning lamp flashes and horn sounds as follows:

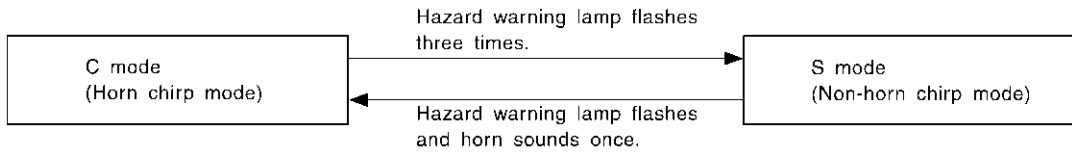

SEL153WA

Auto Door Lock Operation

Auto lock function signal is sent for operation when any of the following signals are not sent within 1 minute after the unlock signal is sent from the key fob:

- when door switch is turned ON for open.
- when the key switch is turned ON.
- when the lock signal is sent from the key fob.

Auto door lock mode can be changed using "WORK SUPPORT" mode in "AUTO LOCK SET". Refer to [BL-64, "Work Support"](#).

Map Lamp and Ignition Keyhole Illumination Operation

When the following conditions come:

- condition of interior lamp switch is DOOR position;
- door switch OFF (when all the doors are closed);

Remote keyless entry system turns on interior lamp (for 30 seconds) with input of UNLOCK signal from key fob. For detailed description, refer to [LT-166, "INTERIOR ROOM LAMP"](#).

Panic Alarm Operation

When key switch is OFF (when ignition key is not inserted in key cylinder), BCM turns on and off horn and headlamp intermittently with input of PANIC ALARM signal from key fob.

The alarm automatically turns off after 25 seconds or when BCM receives any signal from key fob.

Panic alarm operation mode can be changed using "WORK SUPPORT" mode in "PANIC ALARM SET".

Refer to [BL-64, "Work Support"](#).

For detailed description, refer to [BL-97, "VEHICLE SECURITY \(THEFT WARNING\) SYSTEM"](#).

Trunk Opener Operation

When a TRUNK OPEN signal is sent with key switch OFF (key removed from ignition key cylinder) from key fob, power is supplied through BCM terminal 19.

When power and ground are supplied, trunk opener actuator opens trunk.

Trunk opener operation mode can be changed using "WORK SUPPORT" mode in "TRUNK OPEN SET".

Refer to [BL-64, "Work Support"](#).

Keyless Power Window Down (Open) Operation

When key fob unlock switch is turned ON with ignition switch OFF, and key fob unlock switch is detected to be on continuously for 3 seconds, the driver's door and passenger's door power windows are simultaneously opened.

Power window is operated to open and the operation continues as long as the key fob unlock switch is pressed.

Keyless power window down operation mode can be changed using "WORK SUPPORT" mode in "PW DOWN SET". Refer to [BL-64, "Work Support"](#)

REMOTE KEYLESS ENTRY SYSTEM

CAN Communication System Description

AIS003Y0

CAN (Controller Area Network) is a serial communication line for real time application. It is an on-vehicle multiplex communication line with high data communication speed and excellent error detection ability. Many electronic control units are equipped onto a vehicle, and each control unit shares information and links with other control units during operation (not independent). In CAN communication, control units are connected with 2 communication lines (CAN H line, CAN L line) allowing a high rate of information transmission with less wiring. Each control unit transmits/receives data but selectively reads required data only.

Body type	Sedan	
Axle	2WD	
Engine	VQ35DE	
Transmission	A/T	
	Up to serial 329287*	From serial 329288*
Brake control	VDC	

CAN communication unit		
ECM	×	×
TCM	×	
Data link connector	×	×
Combination meter	×	×
BCM	×	×
Steering angle sensor	×	×
VDC/TCS/ABS control unit	×	×
IPDM E/R	×	×
CAN communication type	BL-53, "TYPE 1/TYPE 3"	BL-55, "TYPE 2"

×: Applicable

*:For further information, refer to [GI-47, "IDENTIFICATION NUMBER"](#) in GI section.

TYPE 1/TYPE 3

System Diagram

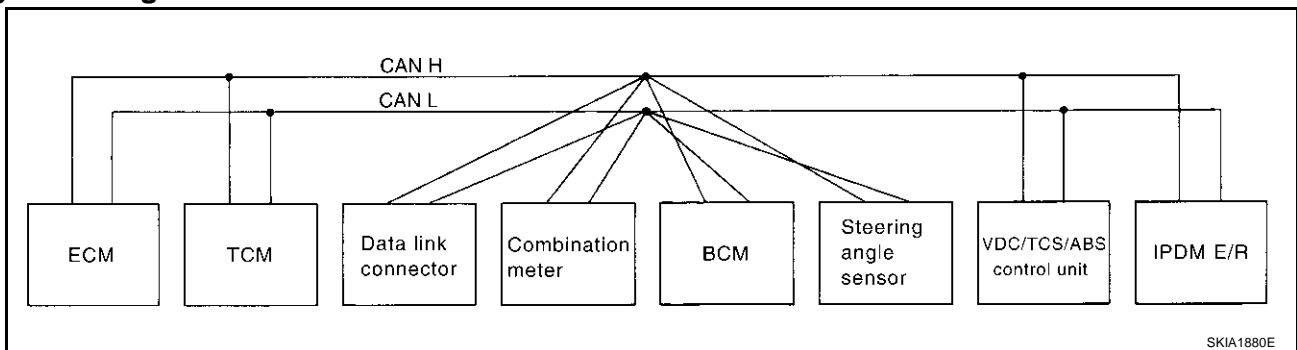

Input/Output Signal Chart

T: Transmit R: Receive

Signals	ECM	TCM	Combina- tion meter	BCM	Steering angle sensor	VDC/TCS/ ABS con- trol unit	IPDM E/R
Engine torque signal	T	R					
Engine speed signal	T	R	R			R	
Engine coolant temperature signal	T	R	R				
Accelerator pedal position signal	T	R				R	
Closed throttle position signal	T	R					
Wide open throttle position signal	T	R					
Battery voltage signal	T	R					

REMOTE KEYLESS ENTRY SYSTEM

Signals	ECM	TCM	Combina- tion meter	BCM	Steering angle sensor	VDC/TCS/ ABS con- trol unit	IPDM E/R
Stop lamp switch signal		R	T				
Fuel consumption monitor signal	T		R				
A/T self-diagnosis signal	R	T					
A/T CHECK indicator lamp signal		T	R				
A/T position indicator signal		T	R			R	
ABS operation signal		R				T	
A/T shift schedule change demand signal		R				T	
A/C switch signal	R			T			
A/C compressor request signal	T						R
A/C compressor feedback signal	T		R				
Blower fan motor switch signal	R			T			
Cooling fan motor operation signal	T						R
Position lights request signal			R	T			R
Low beam request signal				T			R
Low beam status signal	R						T
High beam request signal			R	T			R
High beam status signal	R						T
Front fog lights request signal				T			R
Vehicle speed signal			R			T	
	R	R	T	R			
Sleep request 1 signal			R	T			
Sleep request 2 signal				T			R
Wake up request 1 signal			R	T			R
Wake up request 2 signal			R	T			R
Door switch signal (without naviga- tion system)			R	T			R
Door switch signal (with navigation system)			T	R			
Turn indicator signal			R	T			
Seat belt buckle switch signal			T	R			
Oil pressure switch signal			R				T
Buzzer output signal			R	T			
ASCD SET lamp signal	T		R				
ASCD CRUISE lamp signal	T		R				
ASCD OD cancel request signal	T	R					
ASCD operation signal	T	R					
Output shaft revolution signal	R	T					
Front wiper request signal				T			R
Front wiper stop position signal				R			T
Rear window defogger switch signal				T			R
Rear window defogger control sig- nal	R						T
Manual mode signal		R	T				

REMOTE KEYLESS ENTRY SYSTEM

Signals	ECM	TCM	Combina- tion meter	BCM	Steering angle sensor	VDC/TCS/ ABS con- trol unit	IPDM E/R
Not manual mode signal		R	T				
Manual mode shift up signal		R	T				
Manual mode shift down signal		R	T				
Manual mode indicator signal		T	R				
Hood switch signal				R			T
Theft warning horn request signal				T			R
Horn chirp signal				T			R
Steering angle sensor signal					T	R	
Malfunction indicator lamp signal (Type 3 only: From serial 329288*)	T		R				
Fuel level sensor signal (Type 3 only: From serial 329288*)	R		T				
Turbine revolution signal (Type 3 only: From serial 329288*)	R	T					

*:For further information, refer to [GI-47, "IDENTIFICATION NUMBER"](#) in GI section.

TYPE 2

System Diagram

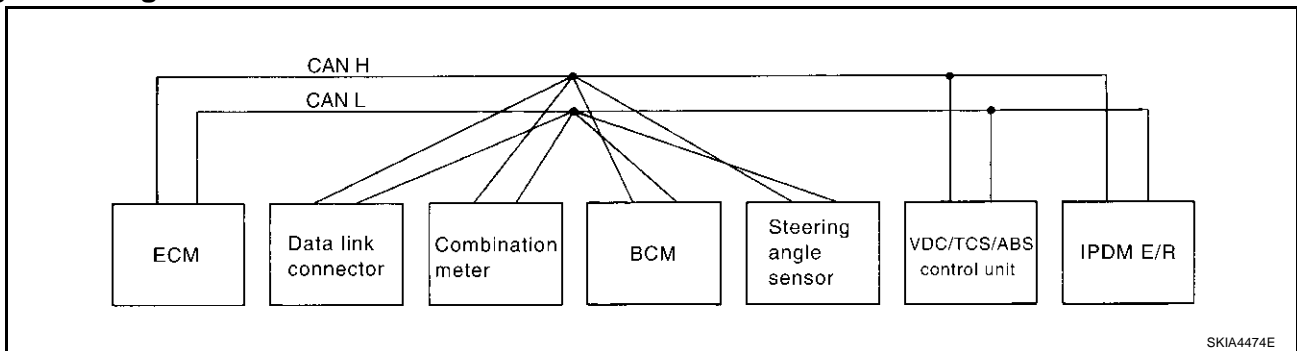

Input/Output Signal Chart

T: Transmit R: Receive

Signals	ECM	Combina- tion meter	BCM	Steering angle sen- sor	VDC/TCS/ ABS con- trol unit	IPDM E/R
Engine speed signal	T	R			R	
Engine coolant temperature signal	T	R				
Accelerator pedal position signal	T				R	
Fuel consumption monitor signal	T	R				
A/C switch signal	R		T			
A/C compressor request signal	T					R
A/C compressor feedback signal	T	R				
Blower fan motor switch signal	R		T			
Cooling fan motor operation signal	T					R
Position lights request signal		R	T			R
Low beam request signal			T			R
Low beam status signal	R		R			T
High beam request signal		R	T			R
High beam status signal	R		R			T

REMOTE KEYLESS ENTRY SYSTEM

Signals	ECM	Combina- tion meter	BCM	Steering angle sen- sor	VDC/TCS/ ABS con- trol unit	IPDM E/R
Front fog lights request signal			T			R
Vehicle speed signal		R			T	
	R	T	R			
Sleep request 1 signal		R	T			
Sleep request 2 signal			T			R
Wake up request 1 signal		R	T			
Wake up request 2 signal		R	T			
Door switch signal (without navigation system)		R	T			R
Door switch signal (with navigation system)		T	R			
Turn indicator signal		R	T			
Seat belt buckle switch signal		T	R			
Oil pressure switch signal		R				T
Buzzer output signal		R	T			
Malfunction indicator lamp signal	T	R				
ASCD SET lamp signal	T	R				
ASCD CRUISE lamp signal	T	R				
Fuel level sensor signal	R	T				
Front wiper request signal			T			R
Front wiper stop position signal			R			T
Rear window defogger switch signal			T			R
Rear window defogger control signal	R		R			T
Hood switch signal			R			T
Theft warning horn request signal			T			R
Horn chirp signal			T			R
Steering angle sensor signal				T	R	

REMOTE KEYLESS ENTRY SYSTEM

Schematic

AI500011

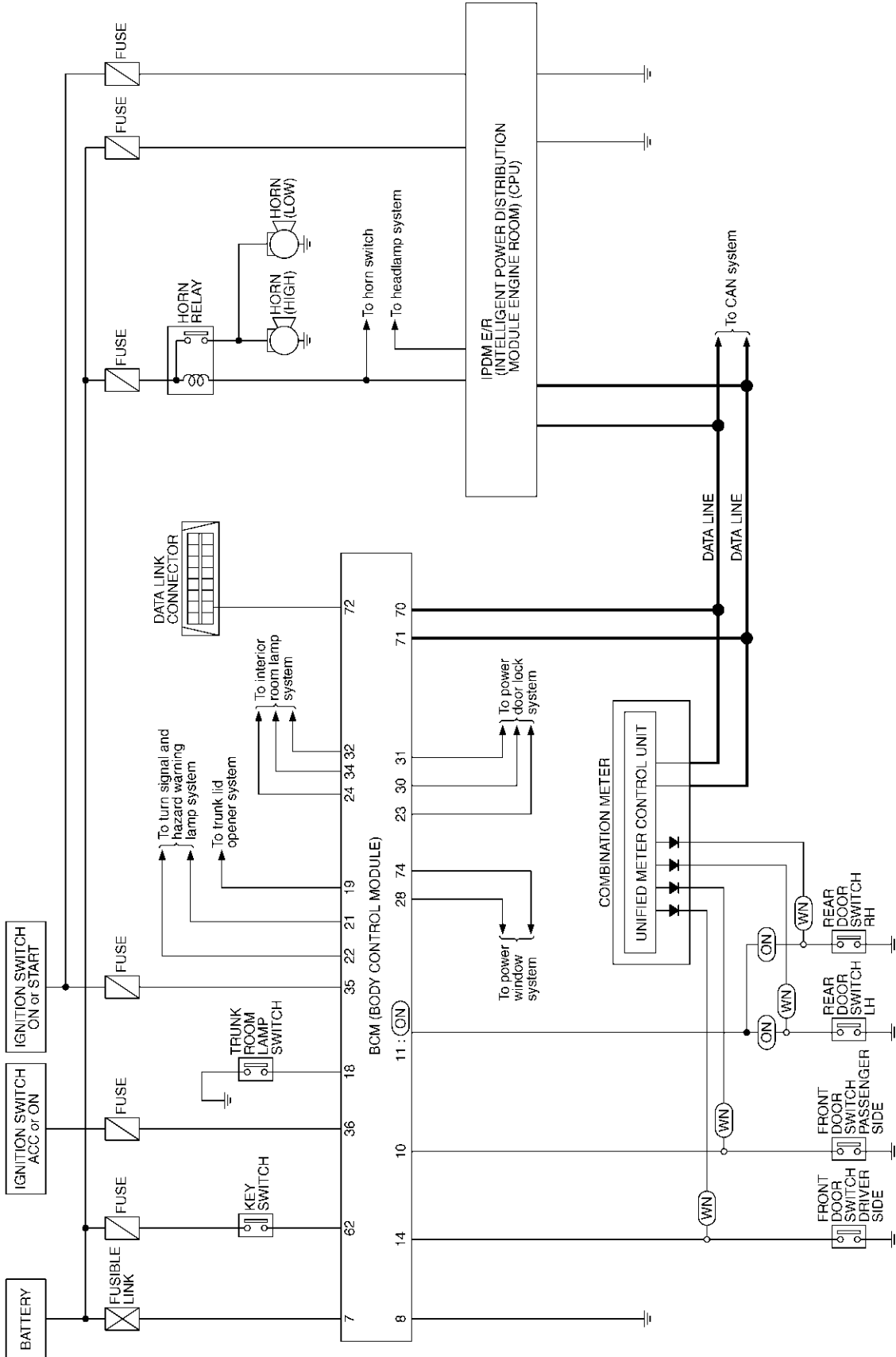

WN : With navigation system
ON : Without navigation system

A
B
C
D
E
F
G
H
I
J
K
L
M

BL

REMOTE KEYLESS ENTRY SYSTEM

AIS0001J

Wiring Diagram — KEYLES—
FIG. 1

BL-KEYLES-01

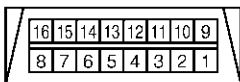
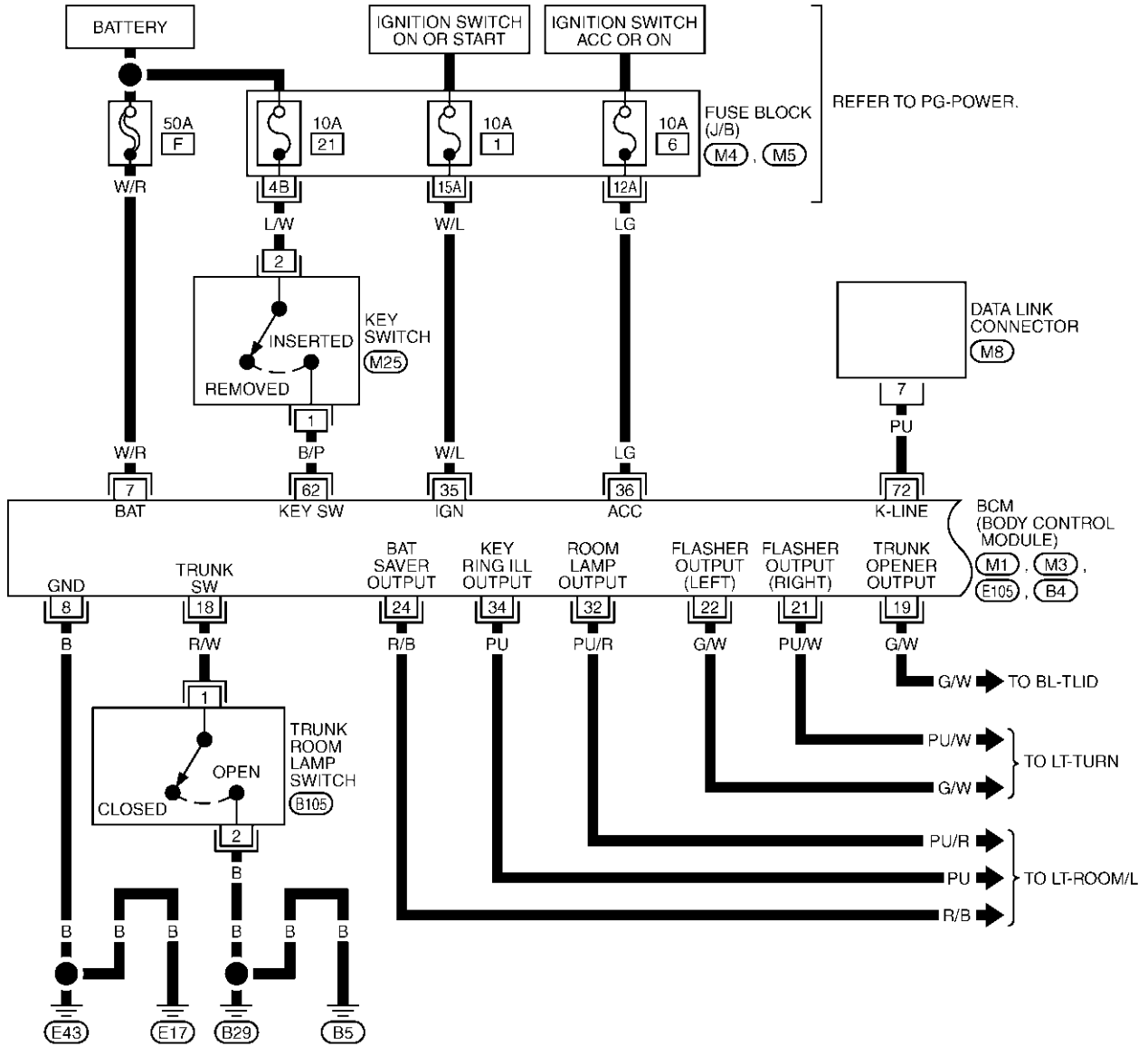

(M8)
W

(M25)
BR

(B105)
W

REFER TO THE FOLLOWING.
 (M4), (M5) - FUSE BLOCK-
 JUNCTION BOX (J/B)
 (M1), (M3), (E105), (B4)
 -ELECTRICAL UNITS

TIWT0364E

REMOTE KEYLESS ENTRY SYSTEM

FIG. 2

BL-KEYLES-02

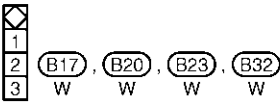
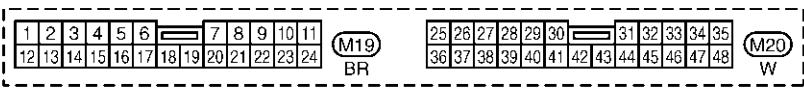
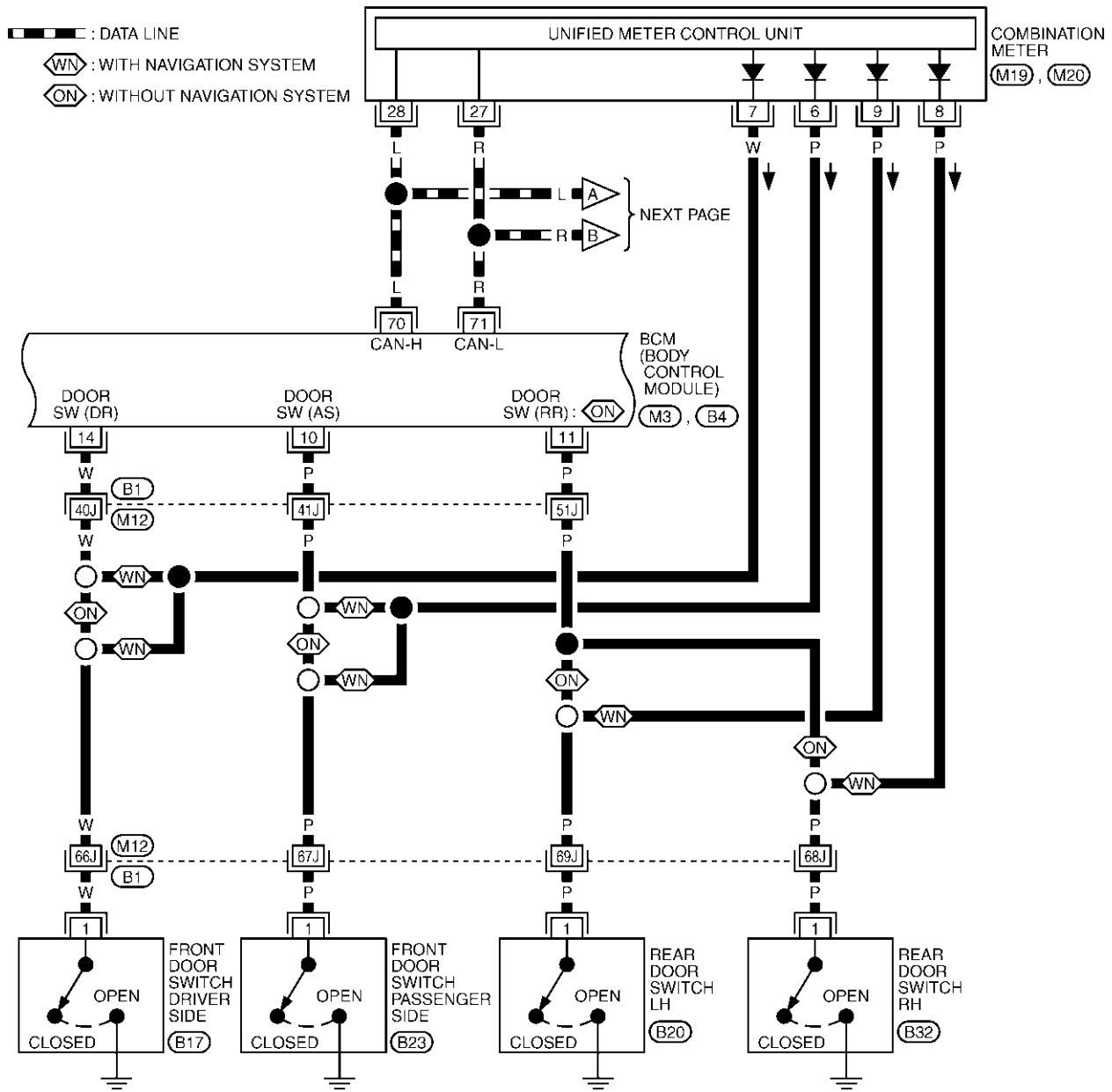

REFER TO THE FOLLOWING.

- (B1) -SUPER MULTIPLE JUNCTION (SMJ)
- (M3), (B4) -ELECTRICAL UNITS

A
B
C
D
E
F
G
H
J
K
L
M

BL

REMOTE KEYLESS ENTRY SYSTEM

FIG. 3

BL-KEYLES-03

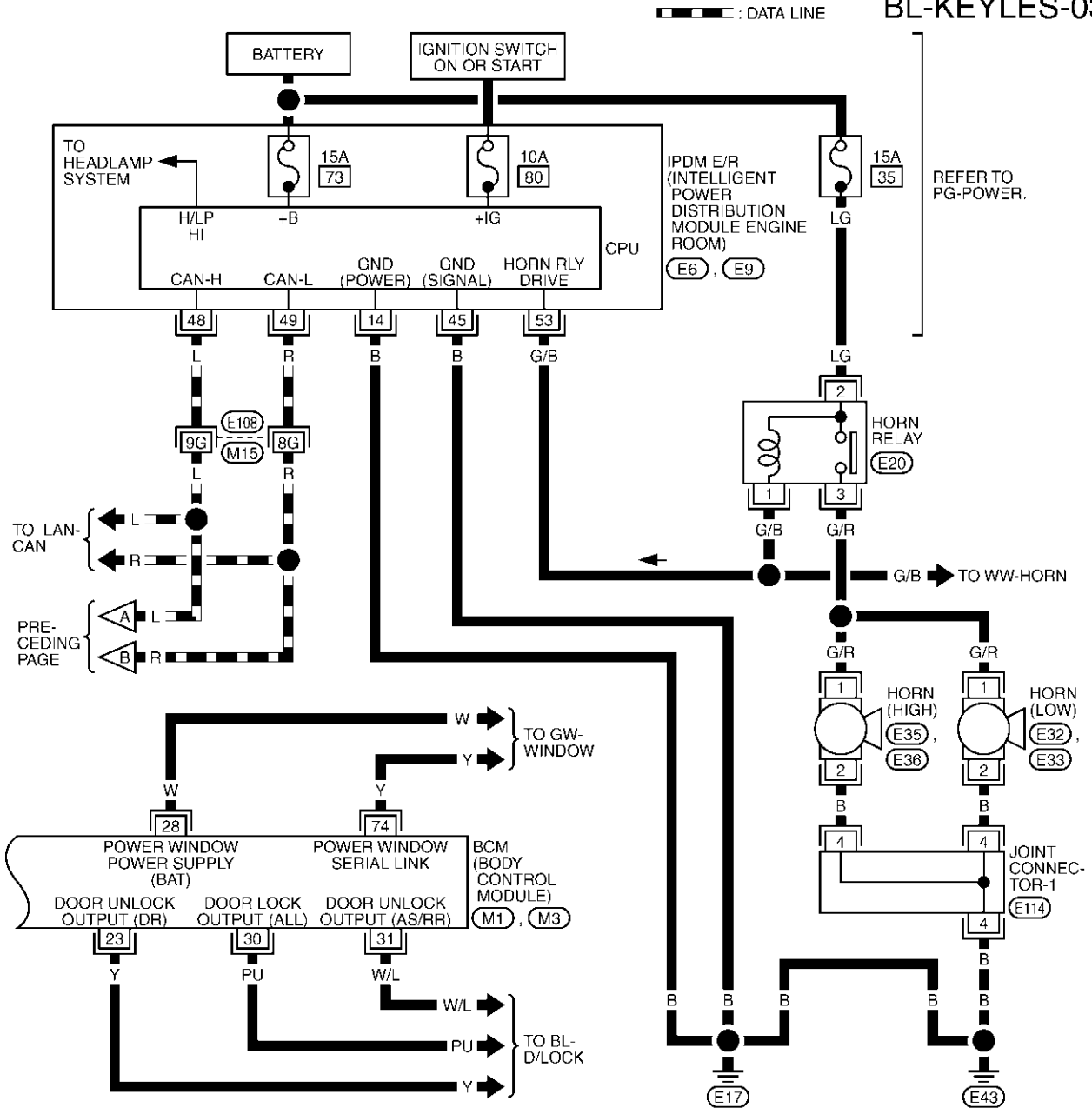

REFER TO THE FOLLOWING.
 (E108) -SUPER MULTIPLE JUNCTION (SMJ)
 (M1), (M3) -ELECTRICAL UNITS

TIWT0215E

REMOTE KEYLESS ENTRY SYSTEM

Terminals and Reference Value for BCM

AIS0001K

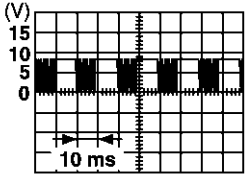
TERMINAL	WIRE COLOR	ITEM	CONDITION	VOLTAGE (V) Approx.
7	W/R	Power source (Fusible link)	—	Battery voltage
8	B	Ground	—	0
10	P	Passenger door switch	ON (door open) → OFF (door closed)	0 → Battery voltage
11*	P	Rear door switch	ON (door open) → OFF (door closed)	0 → Battery voltage
14	W	Drive door switch	ON (door open) → OFF (door closed)	0 → Battery voltage
18	R/W	Trunk room lamp switch	ON (trunk open) → OFF (trunk closed)	0 → Battery voltage
19	G/W	Trunk lid opener actuator	Closed (OFF) → Opened (ON)	0 → Battery voltage
21	PU/W	Right turn signal lamp	When door lock or unlock is operated using key fob (ON → OFF)	Battery voltage → 0
22	G/W	Left turn signal lamp	When door lock or unlock is operated using key fob (ON → OFF)	Battery voltage → 0
23	Y	Driver door lock actuator (Unlock)	Door lock / unlock switch (Free → Unlock)	0 → Battery voltage
28	W	Power window power supply	—	Battery voltage
30	PU	All door lock actuators (lock)	Door lock / unlock switch (Free → Lock)	0 → Battery voltage
31	W/L	Passenger and rear doors lock actuators (unlock)	Door lock / unlock switch (Free → Unlock)	0 → Battery voltage
35	W/L	Ignition switch (ON or START)	Ignition switch (ON or START position)	Battery voltage
36	LG	ACC power supply (ACC or ON)	Ignition switch (ACC or ON position)	Battery voltage
62	B/P	Key switch	ON (Key inserted in ignition key cylinder) → OFF (Key removed from IGN key cylinder)	Battery voltage → 0
70	L	CAN-H	—	—
71	R	CAN-L	—	—
72	PU	Data link connector	—	—
74	Y	Power window serial link	Ignition switch (OFF → ON)	

*: without navigation system

Terminals and Reference Value for IPDM E/R

AIS0028G

TERMINAL	WIRE COLOR	ITEM	CONDITION	VOLTAGE (V) Approx.
14	B	Ground	—	0
45	B	Ground	—	0
48	L	CAN – H	—	0
49	R	CAN – L	—	0
53	G/B	Horn relay	When door lock is operated using key fob* (ON → OFF)	Battery voltage → 0

REMOTE KEYLESS ENTRY SYSTEM

*: In the state that horn reminder operates.

Terminals and Reference Value for Combination Meter

AIS002MG

TERMI-NAL	WIRE COLOR	ITEM	CONDITION	VOLTAGE (V) Approx.
6*	P	Front door switch passenger side	ON (door open) → OFF (door closed)	0 → Battery voltage
7*	W	Front door switch driver side	ON (door open) → OFF (door closed)	0 → Battery voltage
8*	P	Rear door switch LH	ON (door open) → OFF (door closed)	0 → Battery voltage
9*	P	Rear door switch RH	ON (door open) → OFF (door closed)	0 → Battery voltage
27	R	CAN-L	—	—
28	L	CAN-H	—	—

*: with navigation system

CONSULT-II Function

AIS0001L

- The following functions are executed by combining data received and command transmitted via the communication line from the BCM.

BCM diagnosis position	Inspection items and diagnosis mode		Description
BCM C/U*	Self-diagnosis results		Carries out the self-diagnosis.
	Date monitor	Selection from menu	Displays the input data to BCM on real-time basis.
	CAN diagnostic support monitor		The results of transmit/receive diagnosis of CAN communication can be read.
MULTI REMOTE ENT	Data monitor		Displays the input remote keyless entry system data to BCM on real-time basis.
	Active test		Gives a drive to a load to check the operation.
	Work support		Changes the setting for each function.

*:Refer to [BCS-16, "CAN Communication Inspection Using CONSULT-II \(Self-Diagnosis\)"](#).

CONSULT-II Inspection Procedure "MULTI REMOTE ENT"

AIS0001M

- Turn ignition switch "OFF".
- Connect "CONSULT-II" and "CONSULT-II CONVERTER" to the data link connector.

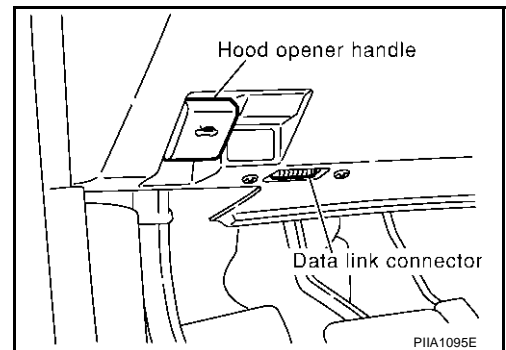

- Turn ignition switch "ON".
- Touch "START (NISSAN BASED VHCL)".

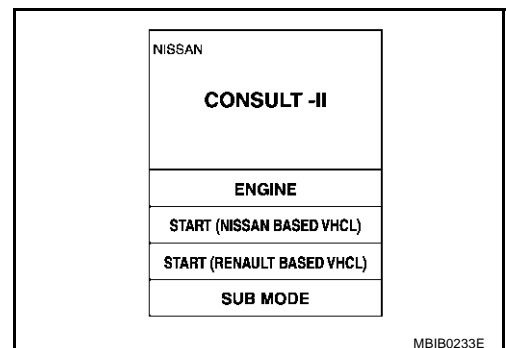

REMOTE KEYLESS ENTRY SYSTEM

5. Touch "BCM".
If "BCM" is not indicated, go to [GI-38, "CONSULT-II Data Link Connector \(DLC\) Circuit"](#).

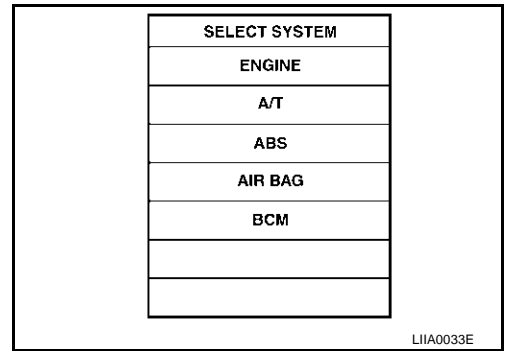

6. Touch "MULTI REMOTE ENT".

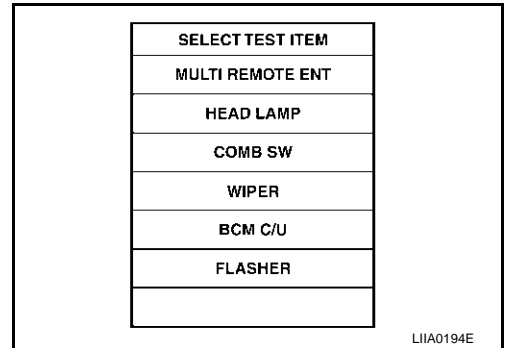

7. Select diagnosis mode.
"DATA MONITOR", "ACTIVE TEST" and "WORK SUPPORT" are available.

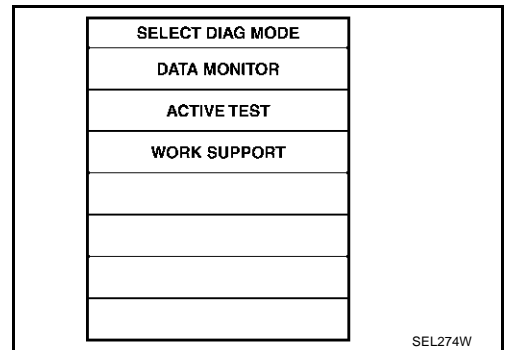

CONSULT-II Application Items "MULTI REMOTE CONTENT"

AIS0001N

Data Monitor

Monitored Item	Description
DOOR SW-AS	Indicates [ON/OFF] condition of door switch RH.
DOOR SW-DR	Indicates [ON/OFF] condition of front door switch LH.
KEY ON SW	Indicates [ON/OFF] condition of key switch.
ACC ON SW	Indicates [ON/OFF] condition of ignition switch in ACC position.
IGN ON SW	Indicates [ON/OFF] condition of ignition switch in ON position.
PANIC BTN	Indicates [ON/OFF] condition of panic signal from key fob.
UN BUTTON/SIG	Indicates [ON/OFF] condition of unlock signal from key fob.
LK BUTTON/SIG	Indicates [ON/OFF] condition of lock signal from key fob.
KEY CYL LKSW	Indicates [ON/OFF] condition of lock signal from door key cylinder switch.
KEY CYL UNSW	Indicates [ON/OFF] condition of unlock signal from door key cylinder switch.
UNLK SW DR/AS	Indicates [ON/OFF] condition of unlock signal from lock/unlock switch.
LOCK SW DR/AS	Indicates [ON/OFF] condition of lock signal from lock/unlock switch.
DOOR SW-RR	Indicates [ON/OFF] condition of rear door switch.
LK/UN BTN ON	Indicates [ON/OFF] condition of lock/unlock signal at the same time from key fob.

A
B
C
D
E
F
G
H
BL
J
K
L
M

REMOTE KEYLESS ENTRY SYSTEM

Monitored Item	Description
TRUNK BTN/SIG	Indicates [ON/OFF] condition of trunk open signal from key fob.
UN BUTTON ON	Indicates [ON/OFF] condition of unlock signal from key fob.

Active Test

Test Item	Description
INT LAMP	This test is able to check interior lamp operation. The interior lamp is turned on when "ON" on CONSULT-II screen is touched.
IGN ILLUM	This test is able to check ignition keyhole illumination operation. The ignition keyhole illumination is turned on when "ON" on CONSULT-II screen is touched.
FLASHER RIGHT	This test is able to check right hazard reminder operation. The right hazard lamp turns on when "ON" on CONSULT-II screen is touched.
FLASHER LEFT	This test is able to check left hazard reminder operation. The left hazard lamp turns on when "ON" on CONSULT-II screen is touched.
HORN	This test is able to check panic alarm and horn reminder operations. The horn activate for 0.5 seconds after "ON" on CONSULT-II screen is touched.
HEAD LAMP(HI)	This test is able to check headlamps panic alarm operation. The headlamp illuminates for 0.5 seconds after "ON" on CONSULT-II screen is touched.
TRUNK/BACK DOOR	This test is able to check trunk lid opener actuator operation. The trunk is unlocked when "ON" on CONSULT-II screen is touched.
POWER WINDOW DOWN	this test is able to check power window open operation. The front power windows activate for 10 seconds after "ON" or CONSULT-II screen is touched.

Work Support

Test Item	Description
REMO CONT ID CONFIR	It can be checked whether key fob ID code is registered or not in this mode.
REMO CONT ID REGIST	Key fob ID code can be registered.
REMO CONT ID ERASUR	Key fob ID code can be erased.
MULTI ANSWER BACK SET	Hazard and horn reminder mode can be changed in this mode. The reminder mode will be changed when "MODE SET" on CONSULT-II screen is touched.
AUTO LOCK SET	Auto locking function mode can be changed in this mode. The function mode will be changed when "MODE SET" on CONSULT-II screen is touched.
PANIC ALRM SET	Panic alarm operation mode can be changed in this mode. The operation mode will be changed when "MODE SET" on CONSULT-II screen is touched.
TRUNK OPEN SET	Trunk lid opener operation mode can be changed in this mode. The operation mode will be changed when "MODE SET" on CONSULT-II screen is touched.
PW DOWN SET	Keyless power window down (open) operation mode can be changed in this mode. The operation mode will be changed when "MODE SET" on CONSULT-II screen is touched.

REMOTE KEYLESS ENTRY SYSTEM

Hazard and horn reminder mode

	MODE 1 (C mode)		MODE 2 (S mode)		MODE 3		MODE 4		MODE 5		MODE 6	
	Lock	Unlock	Lock	Unlock	Lock	Unlock	Lock	Unlock	Lock	Unlock	Lock	Unlock
Key fob operation	Lock	Unlock	Lock	Unlock	Lock	Unlock	Lock	Unlock	Lock	Unlock	Lock	Unlock
Hazard warning lamp flash	Twice	Once	Twice	—	—	—	Twice	Once	Twice	—	—	Once
Horn sound	Once	—	—	—	—	—	—	—	Once	—	Once	—

Auto locking function mode

	MODE 1	MODE 2	MODE 3
Auto locking function	1 minutes	Nothing	5 minutes

Panic alarm operation mode

	MODE 1	MODE 2	MODE 3
Key fob operation	0.5 seconds	Nothing	1.5 seconds

Trunk open operation mode

	MODE 1	MODE 2	MODE 3
Key fob operation	0.5 seconds	Nothing	1.5 seconds

Power window down operation mode

	MODE 1	MODE 2	MODE 3
Key fob operation	3 seconds	Nothing	5 seconds

Work Flow

AIS00010

1. Check the trouble symptom and customer's requests.
2. Understand outline of system. Refer to [BL-50, "System Description"](#) .
3. Confirm that power door lock system operates normally.
Refer to [BL-49, "REMOTE KEYLESS ENTRY SYSTEM"](#) .
4. Refer to trouble diagnosis chart by symptom, repair or replace any malfunctioning parts.
Refer to [BL-65, "Trouble Diagnosis Chart by Symptom"](#) .
5. Inspection end.

Trouble Diagnosis Chart by Symptom

AIS00010

NOTE:

- Always check the "Work Flow" before troubleshooting. Refer to [BL-65, "Work Flow"](#) .
- Always check key fob battery before replacing key fob.

Symptom	Diagnoses/service procedure	Reference page
All function of remote keyless entry system do not operate.	1. Check key fob battery and function.	BL-67
	2. Replace key fob. Refer to ID Code Entry Procedure. NOTE: If the result of key fob function check with CONSULT-II is OK, key fob is not malfunctioning.	BL-75
	3. Replace BCM.	BCS-23

REMOTE KEYLESS ENTRY SYSTEM

Symptom	Diagnoses/service procedure	Reference page
The new ID of key fob cannot be entered.	1. Check key fob battery and function.	BL-67BL-67
	2. Check key switch.	BL-72
	3. Check door switch.	BL-69 *1 BL-71 *2
	4. Check ACC switch.	BL-68
	5. Replace key fob. Refer to ID Code Entry Procedure. NOTE: If the result of key fob function check with CONSULT-II is OK, key fob is not malfunctioning.	BL-75
	6. Replace BCM.	BCS-23
Door lock or unlock does not function with key fob. (Power door lock system is "OK".)	1. Check key fob battery and function.	BL-67
	2. Replace key fob. Refer to ID Code Entry Procedure. NOTE: If the result of key fob function check with CONSULT-II is OK, key fob is not malfunctioning.	BL-75
	3. Replace BCM.	BCS-23
Trunk lid does not open when trunk opener button is continuously pressed.	1. Check trunk lid opener function.	BL-73
	2. Check trunk open operation mode.* *: Trunk open operation can be changed. First check the trunk open operation setting.	BL-64
	3. Check key fob battery and function.	BL-67
	4. Check trunk lid opener actuator.	BL-94
	5. Check key switch.	BL-72
	6. Replace BCM.	BCS-23
Hazard and horn reminder does not activate properly when pressing lock or unlock button of key fob.	1. Check hazard and horn reminder.* *: Hazard and horn reminder can be activated or deactivated. First check the hazard and horn reminder setting.	BL-64
	2. Check door switch.	BL-69 *1 BL-71 *2
	3. Replace BCM.	BCS-23
Hazard reminder does not activate properly when pressing lock or unlock button of key fob. (Horn reminder is "OK".)	1. Check hazard reminder.* *: Hazard reminder can be activated or deactivated. First check the hazard reminder setting.	BL-64
	2. Check hazard function with hazard switch.	BL-73
	3. Replace BCM.	BCS-23
Horn reminder does not activate properly when pressing lock button of key fob. (Hazard reminder is "OK".)	1. Check horn reminder.* *: Horn reminder can be activated or deactivated. First check the horn chirp setting.	BL-64
	2. Check horn function.	BL-73
	3. Check IPDM E/R operation.	BL-73
	4. Replace BCM.	BCS-23

REMOTE KEYLESS ENTRY SYSTEM

Symptom	Diagnoses/service procedure	Reference page
Panic alarm (horn and headlamp) does not activate when panic alarm button is continuously pressed.	1. Check panic alarm mode.* *: Panic alarm can be activated or deactivated. First check the panic alarm setting.	BL-64
	2. Check key fob battery and function.	BL-67
	3. Check headlamp function.	BL-74
	4. Check horn function.	BL-73
	5. Check IPDM E/R operation.	BL-73
	6. Check key switch.	BL-72
	7. Replace key fob. Refer to ID Code Entry Procedure. NOTE: If the result of key fob function check with CONSULT-II is OK, key fob is not malfunctioning.	BL-75
	8. Replace BCM.	BCS-23
Auto door lock operation does not activate properly. (All other remote keyless entry system function is OK.)	1. Check auto door lock operation mode.* *: Auto door lock operation can be activated or deactivated. First check the auto door lock operation setting.	BL-64
	2. Replace BCM.	BCS-23
Keyless power window down (open) operation does not activate properly. (All other remote keyless entry system function is OK.)	1. Check power window down operation mode.* *: Power window down operation can be activated or deactivated. First check the power window down setting.	BL-64
	2. Check power window function.	GW-16
	3. Replace BCM.	BCS-23
Map lamp and ignition keyhole illumination operation does not activate properly.	1. Check map lamp and ignition keyhole illumination operation.	BL-74
	2. Check door switch.	BL-69 *1 BL-71 *2
	3. Replace BCM.	BCS-23

*1 : With navigation system

*2 : Without navigation system

Check Key Fob Battery and Function

AIS0001R

1. CHECK KEY FOB BATTERY

1. Remove key fob battery. Refer to [BL-78, "Key Fob Battery Replacement"](#).
2. Measure voltage between battery positive and negative terminals, (+) and (-).

Voltage : 2.5V – 3.0V

NOTE:

Key fob does not function if battery is not set correctly.

OK or NG

OK >> GO TO 2

NG >> Replace battery.

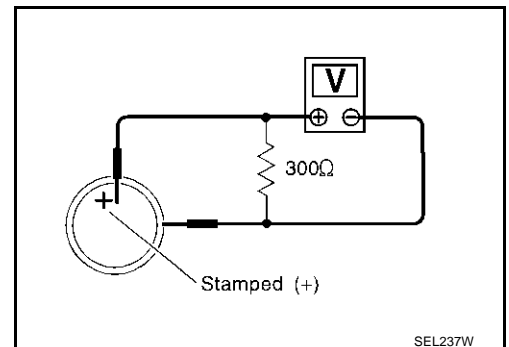

REMOTE KEYLESS ENTRY SYSTEM

2. CHECK KEY FOB FUNCTION

With CONSULT-II

Check key fob function in "DATA MONITOR" mode with CONSULT-II.

When pushing each button of key fob, the corresponding monitor item should be turned as follows.

Condition	Monitor item
Pushing LOCK	LK BUTTON/SIG : ON
Pushing UNLOCK	UN BUTTON/SIG : ON
Keep pushing UNLOCK	UN BUTTON ON : ON
	*: UN BUTTON ON turns to ON three seconds after UNLOCK button keeps pushing.
Pushing TRUNK	TRUNK BTN/SIG : ON
Pushing PANIC	PANIC BTN : ON
Pushing LOCK and UNLOCK at the same time	LK/UN BTN ON : ON

DATA MONITOR	
MONITOR	
LK BUTTON/SIG	OFF
UN BUTTON/SIG	OFF
UN BUTTON ON	OFF
TRUNK BTN/SIG	OFF
PANIC BTN	OFF
LK/UN BTN ON	OFF

PIIA4945E

OK or NG

OK >> Key fob is OK.

NG >> Replace key fob.

Check ACC Switch

AIS0028H

1. CHECK ACC SWITCH

With CONSULT-II

Check ACC switch ("ACC ON SW") in "DATA MONITOR" mode with CONSULT-II.

Monitor item	Condition
ACC SW	Ignition switch position is ACC or ON : ON
	Ignition switch position is OFF : OFF

DATA MONITOR	
MONITOR	
ACC ON SW	OFF

PIIA3367E

Without CONSULT-II

Check voltage between BCM connector and ground.

Item	Terminals (Wire color)			Condition	Voltage [V]
	(+)		(-)		
	Con- nector	Terminal (Wire color)			
BCM	M1	36 (LG)	Ground	ACC or ON OFF	Battery voltage 0

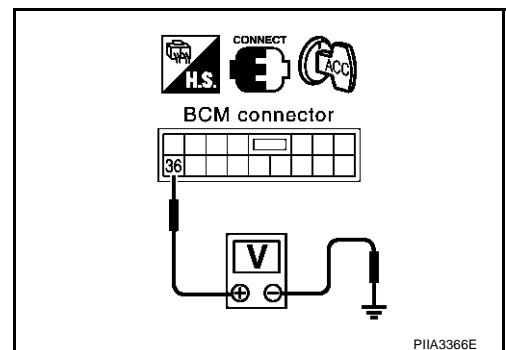

OK or NG

OK >> ACC switch is OK.

NG >> Check the following.

- 10A fuse [No. 6, located in fuse block (J/B)]
- Harness for open or short between BCM and fuse.

REMOTE KEYLESS ENTRY SYSTEM

Check Door Switch / With Navigation System

AIS00200

First perform the "SELF-DIAG RESULTS" in "BCM" with CONSULT-II, when perform the each trouble diagnosis. Refer to [BCS-16, "CAN Communication Inspection Using CONSULT-II \(Self-Diagnosis\)"](#).

1. CHECK DOOR SWITCH INPUT SIGNAL

With CONSULT-II

Check door switches ("DOOR SW-DR", "DOOR SW-AS" and "DOOR SW-RR") in "DATA MONITOR" mode with CONSULT-II.

Monitor item	Condition
DOOR SW-DR	CLOSE → OPEN : OFF → ON
DOOR SW-AS	
DOOR SW-RR	

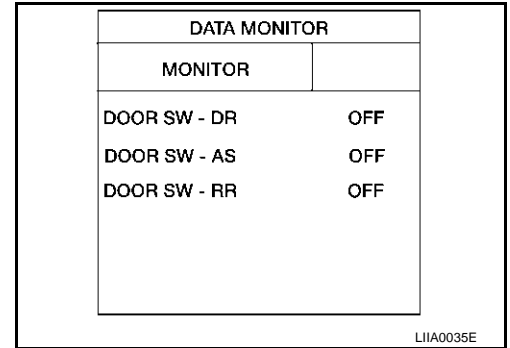

Without CONSULT-II

Check voltage between combination meter connector and ground.

Item	Connector	Terminals (Wire color)		Condition	Voltage (V) (Approx.)
		(+)	(-)		
Driver side	M19	7 (W)	Ground	CLOSE ↓ OPEN	Battery voltage ↓ 0
Passenger side		6 (P)			
Rear LH		9 (P)			
Rear RH		8 (P)			

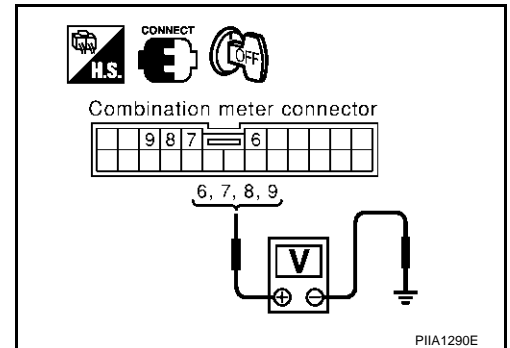

OK or NG

- OK >> Door switch circuit is OK.
- NG >> GO TO 2.

REMOTE KEYLESS ENTRY SYSTEM

2. CHECK DOOR SWITCH

1. Turn ignition switch OFF.
2. Disconnect door switch and combination meter connector.
3. Check continuity between door switch connector B17, B23, B20, B32 terminals 1 and combination meter connector M19 terminals 7, 6, 9, 8.

Front door switch driver side

1 (W) – 7 (W) : Continuity should exist.

Front door switch passenger side

1 (P) – 6 (P) : Continuity should exist.

Rear door switch LH

1 (P) – 9 (P) : Continuity should exist.

Rear door switch RH

1 (P) – 8 (P) : Continuity should exist.

4. Check continuity between door switch connector B17, B23, B20, B32 terminals 1 and ground.

1 (W or P) – Ground : Continuity should not exist

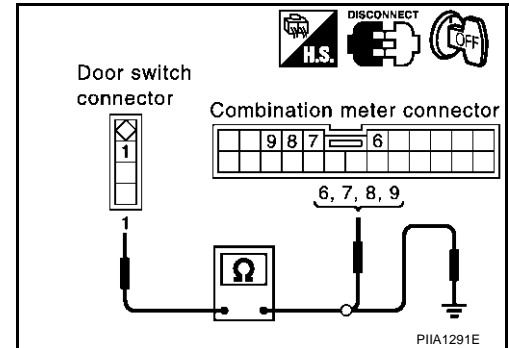

OK or NG

OK >> GO TO 3

NG >> Repair or replace harness.

3. CHECK DOOR SWITCH

Check continuity between each door switch terminal 1 and ground part of door switch.

Terminal	Door switch	Continuity
1	Pushed	No
	Released	Yes

OK or NG

OK >> GO TO 4.

NG >> Replace door switch.

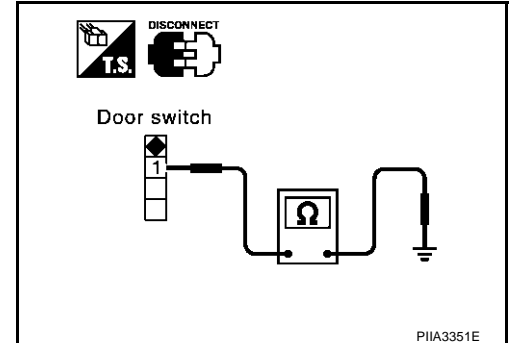

4. CHECK COMBINATION METER OUTPUT SIGNAL

1. Connect combination meter connector.
2. Check voltage between combination meter connector M19 terminals 6, 7, 8, 9 and ground.

6 (P) – Ground : Battery voltage

7 (W) – Ground : Battery voltage

8 (P) – Ground : Battery voltage

9 (P) – Ground : Battery voltage

OK or NG

OK >> Check harness connection.

NG >> Replace combination meter.

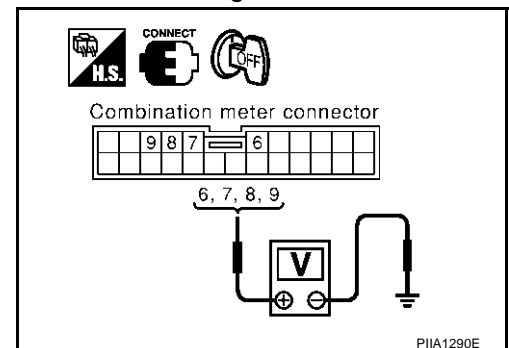

REMOTE KEYLESS ENTRY SYSTEM

Check Door Switch / Without Navigation System

AIS00201

1. CHECK DOOR SWITCH INPUT SIGNAL

With CONSULT-II

Check door switches ("DOOR SW-DR", "DOOR SW-AS" and "DOOR SW-RR") in "DATA MONITOR" mode with CONSULT-II.

Monitor item	Condition
DOOR SW-DR	CLOSE → OPEN : OFF → ON
DOOR SW-AS	
DOOR SW-RR	

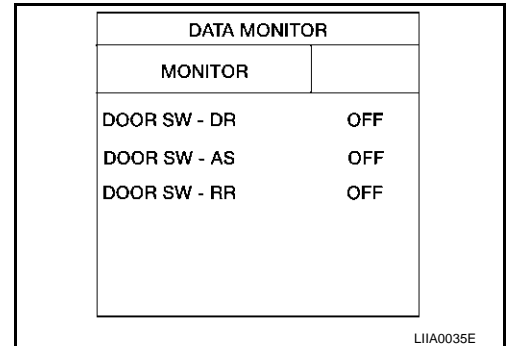

Without CONSULT-II

Check voltage between BCM connector and ground.

Item	Connector	Terminals (Wire color)		Condition	Voltage (V) (Approx.)
		(+)	(-)		
Driver side	B4	14(W)	Ground	CLOSE ↓ OPEN	Battery voltage ↓ 0
Passenger side		10 (P)			
Rear LH, RH		11 (P)			

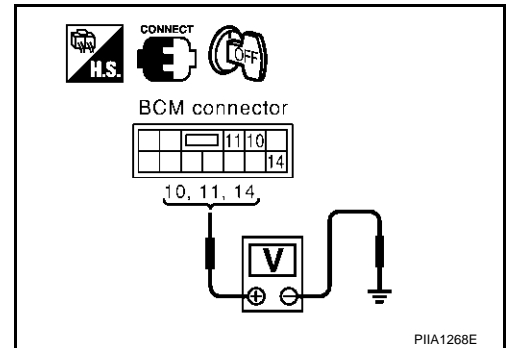

OK or NG

- OK >> Door switch circuit is OK.
- NG >> GO TO 2.

2. CHECK DOOR SWITCH CIRCUIT

1. Turn ignition switch OFF.
2. Disconnect door switch and BCM connector.
3. Check continuity between door switch connector B17, B23, B20, B32 terminals 1 and BCM connector B4 terminals 14, 10, 11.

Driver side door

1 (W) – 14 (W) : Continuity should exist.

Passenger side door

1 (P) – 10 (P) : Continuity should exist.

Rear door LH, RH

1 (P) – 11 (P) : Continuity should exist.

4. Check continuity between door switch connector B17, B23, B20, B32 terminal 1 and ground.

1 (W or P) – Ground : Continuity should not exist.

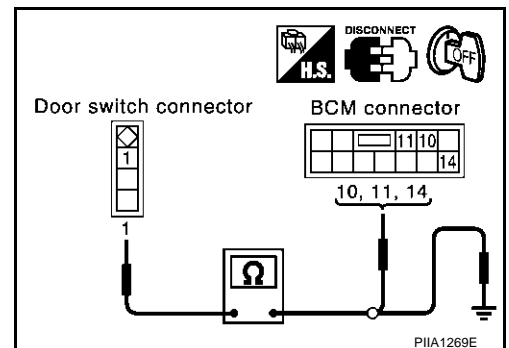

OK or NG

- OK >> GO TO 3.
- NG >> Repair or replace harness.

REMOTE KEYLESS ENTRY SYSTEM

3. CHECK DOOR SWITCH

Check continuity between each door switch terminal 1 and ground part of door switch.

Terminal	Door switch	Continuity
1	Pushed	No
	Released	Yes

OK or NG

- OK >> Check harness connection.
 NG >> Replace door switch.

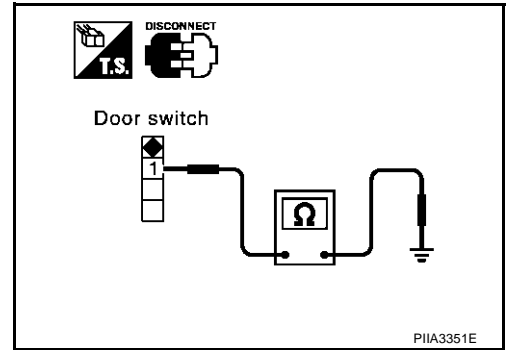

AIS0001T

Check Key Switch

1. CHECK KEY SWITCH INPUT SIGNAL

Check voltage between BCM connector M3 terminal 62 (B/P) and ground.

Condition of key switch	Voltage (V) Approx.
Key is inserted.	Battery voltage
Key is removed.	0

OK or NG

- OK >> Key switch is OK.
 NG >> GO TO 2

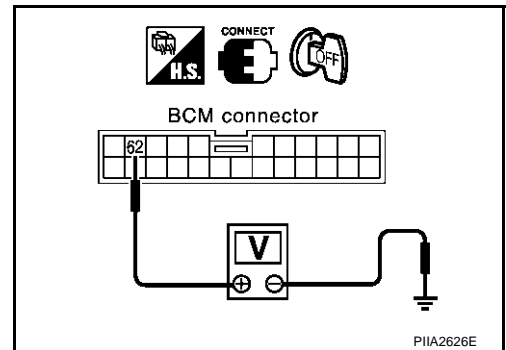

2. CHECK KEY SWITCH

Check continuity between key switch connector M25 terminals 1 and 2.

Condition of key switch	Continuity
Key is inserted.	Yes
Key is removed.	No

OK or NG?

- OK >> Check the following.
- 10A fuse [No. 21, located in fuse block (J/B)]
 - Harness for open or short between key switch and fuse
 - Harness for open or short between BCM and key switch
- NG >> Replace key switch.

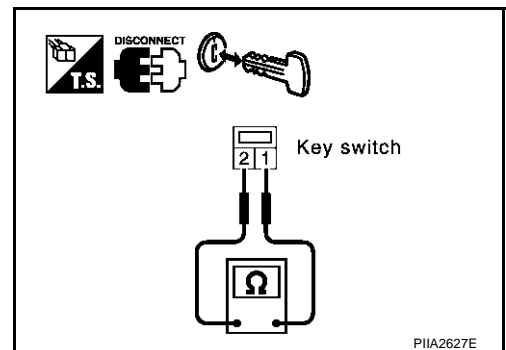

REMOTE KEYLESS ENTRY SYSTEM

AIS0028I

Check IPDM E/R Operation

1. CHECK IPDM E/R INPUT VOLTAGE

Check voltage between IPDM E/R connector E9 terminal 53 (G/B) and ground.

Connector	Terminal (Wire color)		Voltage (V) Approx.
	(+)	(-)	
E9	53 (G/B)	Ground	Battery voltage

OK or NG

- OK >> Replace IPDM E/R.
- NG >> GO TO 2

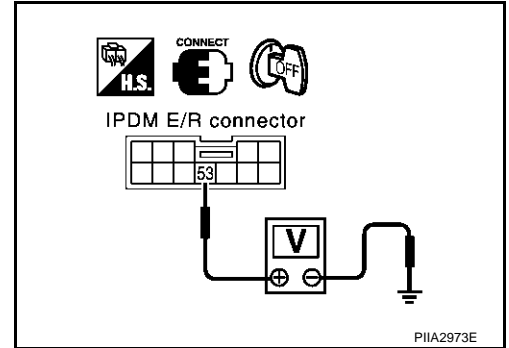

2. CHECK IPDM E/R HARNESS

1. Turn ignition switch OFF.
2. Disconnect IPDM E/R and horn relay connector.
3. Check continuity between IPDM E/R connector E9 terminal 53 (G/B) and horn relay connector E20 terminal 1 (G/B).

53 (G/B) – 1 (G/B) : Continuity should exist.

OK or NG?

- OK >> Check harness connection.
- NG >> Repair or replace harness.

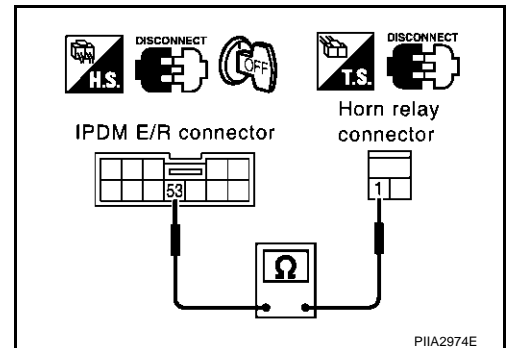

Check Trunk Lid Opener Function

1. CHECK TRUNK LID OPENER

Does trunk lid release with trunk lid opener switch?

NOTE:

First check trunk lid opener cancel switch position.

Yes or No

- Yes >> Trunk lid opener actuator circuit is OK.
- No >> Check trunk lid opener actuator and the circuit.

Check Hazard Function

AIS0001V

1. CHECK HAZARD WARNING LAMP

Does hazard warning lamp flash with hazard switch?

Yes or No

- Yes >> Hazard warning lamp circuit is OK.
- No >> Check hazard circuit. Refer to [LT-101, "TURN SIGNAL AND HAZARD WARNING LAMPS"](#).

Check Horn Function

AIS0028J

First perform the "SELF-DIAG RESULTS" in "BCM" with CONSULT-II, then perform the trouble diagnosis of malfunction system indicated "SELF-DIAG RESULTS" of "BCM". Refer to [BCS-16, "CAN Communication Inspection Using CONSULT-II \(Self-Diagnosis\)"](#).

REMOTE KEYLESS ENTRY SYSTEM

1. CHECK HORN FUNCTION

Does horn sound with horn switch?

Yes or NO

Yes >> Horn circuit is OK.

No >> Check horn circuit. Refer to [WW-39, "HORN"](#) .

Check Headlamp Function

AIS0028K

First perform the "SELF-DIAG RESULTS" in "BCM" with CONSULT-II, then perform the trouble diagnosis of malfunction system indicated "SELF-DIAG RESULTS" of "BCM". Refer to [BCS-16, "CAN Communication Inspection Using CONSULT-II \(Self-Diagnosis\)"](#) .

1. CHECK HEADLAMP OPERATION

Does headlamp come on when turning lighting switch "ON"?

YES or NO

Yes >> Headlamp operation circuit is OK.

No >> Check headlamp system. Refer to [LT-7, "HEADLAMP \(FOR USA\)"](#) , [LT-33, "HEADLAMP \(FOR CANADA\) - DAYTIME LIGHT SYSTEM -"](#) .

Check Map Lamp and Ignition Keyhole Illumination Function

AIS0001Y

1. CHECK MAP LAMP AND IGNITION KEYHOLE ILLUMINATION FUNCTION

When map lamp switch is in "DOOR" position, open the front door (LH or RH).

Map lamp and ignition keyhole illumination should illuminate.

OK or NG

OK >> Replace BCM.

NG >> Check ignition illumination circuit. Refer to [LT-166, "INTERIOR ROOM LAMP"](#) .

REMOTE KEYLESS ENTRY SYSTEM

AIS00020

ID Code Entry Procedure KEY FOB ID SET UP WITH CONSULT-II

NOTE:

- If a key fob is lost, the ID code of the lost key fob must be erased to prevent unauthorized use. A specific ID code can be erased with CONSULT-II. However, when the ID code of a lost key fob is not known, all controller ID codes should be erased. After all ID codes are erased, the ID codes of all remaining and/or new key fobs must be re-registered.
- When registering an additional key fob, the existing ID codes in memory may or may not be erased. If four ID codes are stored in memory, when an additional code is registered, only the oldest code is erased. If less than five ID codes are stored in memory, when an additional ID code is registered, the new ID code is added and no ID codes are erased.
- Entry of maximum five ID codes is allowed. When more than four ID codes are entered, the oldest ID code will be erased.
- Even if same ID code that is already in the memory is input, the same ID code can be entered. The code is counted as an additional code.

1. Turn ignition switch "OFF".
2. Connect "CONSULT-II" and "CONSULT-II CONVERTER" to the data link connector.

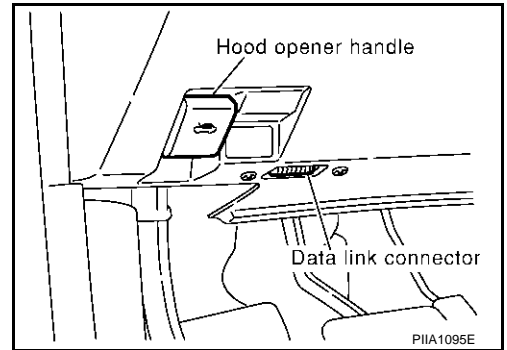

3. Turn ignition switch ON.
4. Touch "START (NISSAN BASED VHCL)".

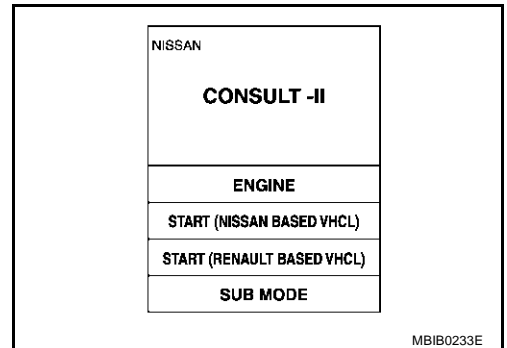

5. Touch "BCM".
If "BCM" is not indicated, go to [GI-38, "CONSULT-II Data Link Connector \(DLC\) Circuit"](#).

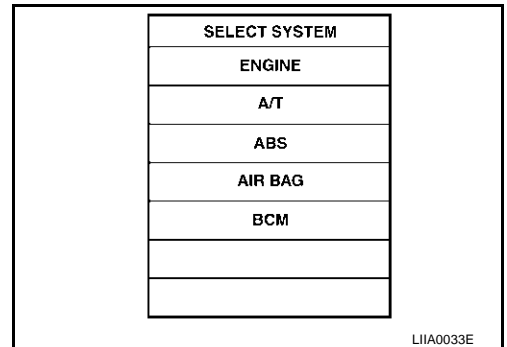

REMOTE KEYLESS ENTRY SYSTEM

6. Touch "MULTI REMOTE ENT".

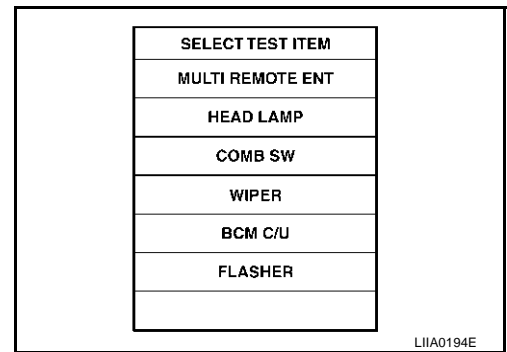

7. Touch "WORK SUPPORT".

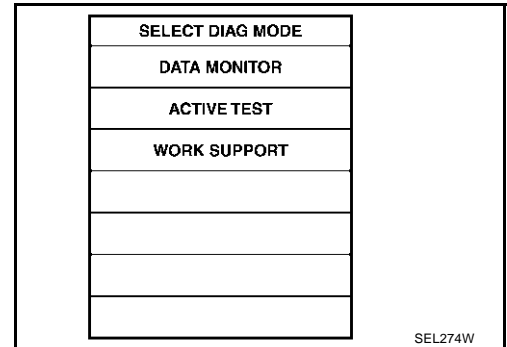

8. The items are shown on the figure can be set up.

- "REMO CONT ID CONFIR"
Use this mode to confirm if a key fob ID code is registered or not.
 - "REMO CONT ID REGIST"
Use this mode to register a key fob ID code.
- NOTE:**
Register the ID code when key fob or BCM is replaced, or when additional key fob is required.
- "REMO CONT ID ERASUR"
Use this mode to erase a key fob ID code.

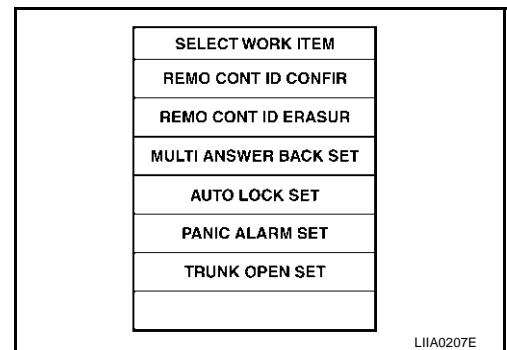

REMOTE KEYLESS ENTRY SYSTEM

KEY FOB ID SET UP WITHOUT CONSULT-II

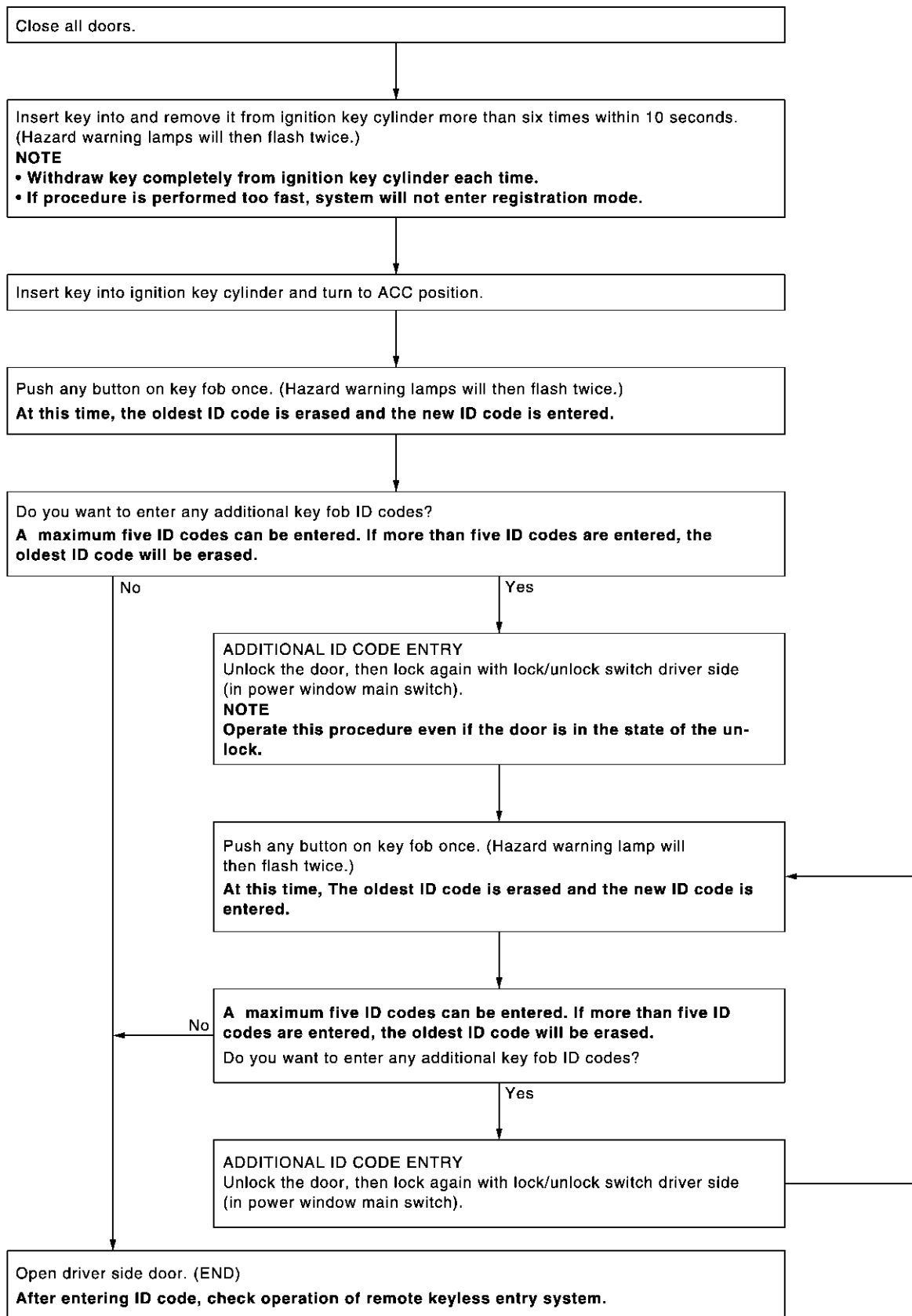

A

B

C

D

E

F

G

H

BL

J

K

L

M

PIIA2839E

REMOTE KEYLESS ENTRY SYSTEM

NOTE:

- If a key fob is lost, the ID code of the lost key fob must be erased to prevent unauthorized use. A specific ID code can be erased with CONSULT-II. However, when the ID code of a lost key fob is not known, all controller ID codes should be erased. After all ID codes are erased, the ID codes of all remaining and/or new key fobs must be re-registered.
To erase all ID codes in memory, register one ID code (key fob) five times. After all ID codes are erased, the ID codes of all remaining and/or new key fobs must be re-registered.
- When registering an additional key fob, the existing ID codes in memory may or may not be erased. If four ID codes are stored in memory, when an additional code is registered, only the oldest code is erased. If less than five ID codes are stored in memory, when an additional ID code is registered, the new ID code is added and no ID codes are erased.
- If you need to activate more than two additional new key fobs, repeat the procedure “Additional ID code entry” for each new key fob.
- Entry of maximum five ID codes is allowed. When more than four ID codes are entered, the oldest ID code will be erased.
- Even if same ID code that is already in the memory is input, the same ID code can be entered. The code is counted as an additional code.

Key Fob Battery Replacement

AIS00021

NOTE:

- Be careful not to touch the circuit board or battery terminal.
- The keyfob is water-resistant. However, if it does get wet, immediately wipe it dry.

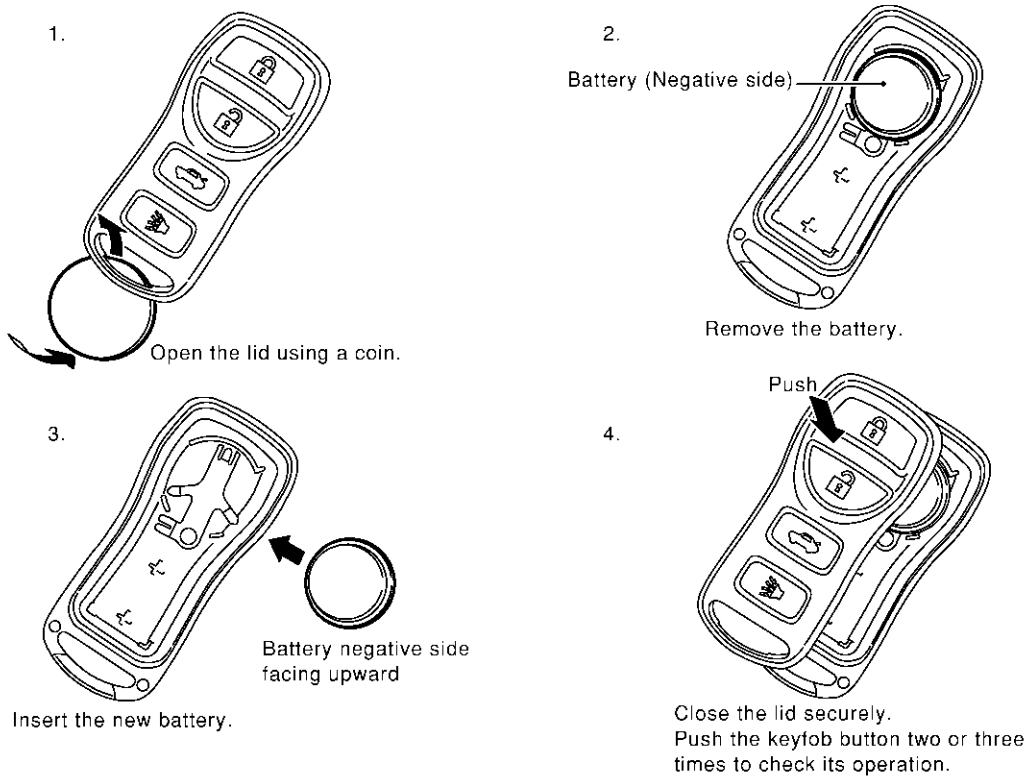

DOOR

DOOR

PPF:80100

Fitting Adjustment

AIS00022

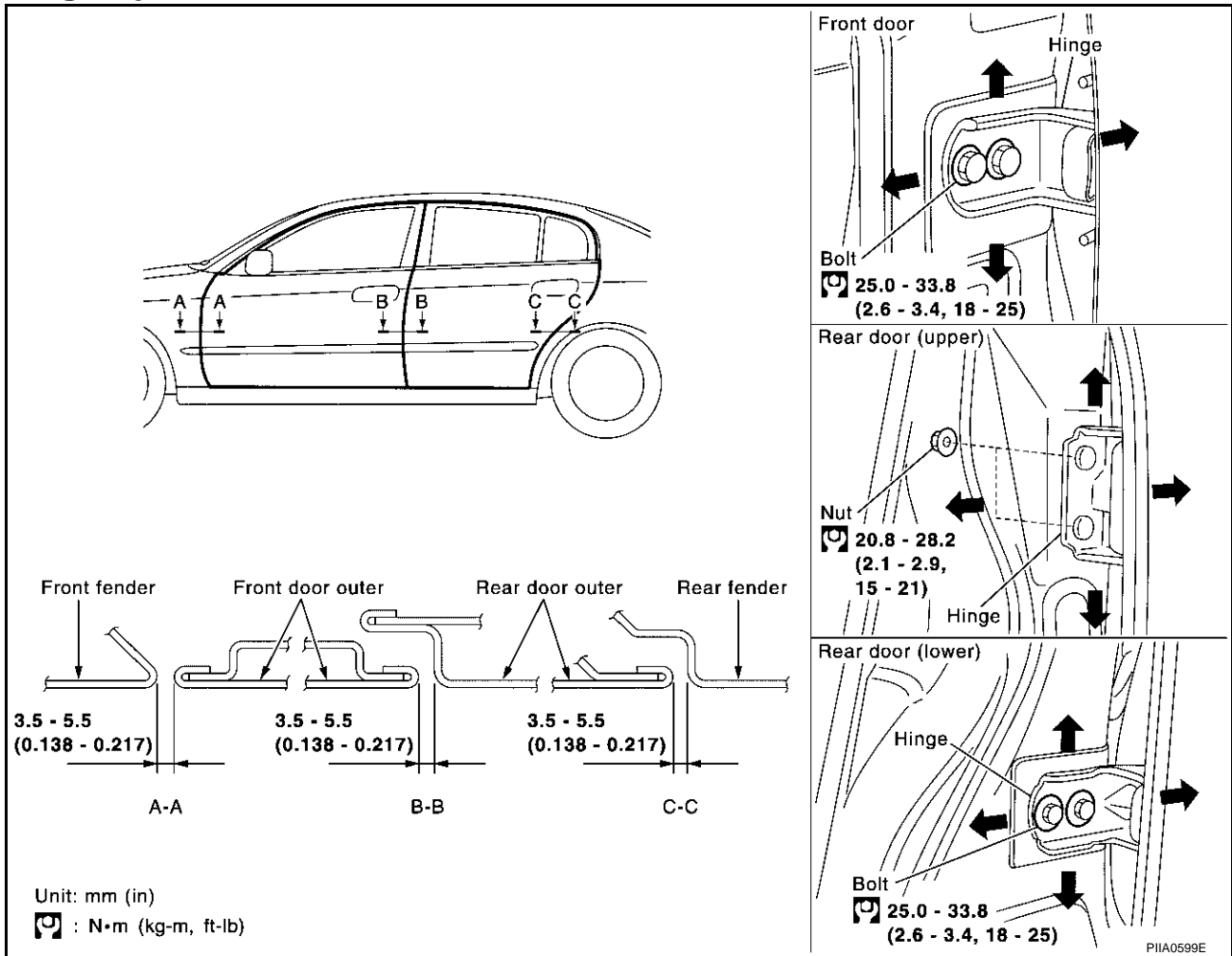

FRONT DOOR

Longitudinal Clearance and Surface Height Adjustment at Front End

Loosen the hinge mounting bolts. Raise the front door at rear end to adjust.

REAR DOOR

Longitudinal Clearance and Surface Height Adjustment at Front End

1. Remove the center pillar upper garnish and center pillar lower garnish. Refer to [EI-39. "Removal and Installation"](#).
2. Accessing from inside the vehicle, loosen the mounting nuts. Open the rear door, and raise the rear door at rear end to adjust.

STRIKER ADJUSTMENT

1. Adjust the striker so that it becomes parallel with the lock insertion direction.

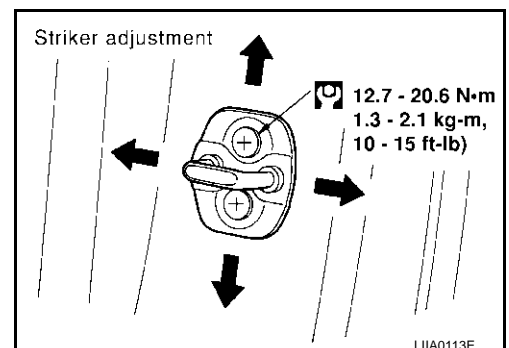

DOOR

Removal and Installation of Front Door

AIS00620

REMOVAL

CAUTION:

- When removing and installing the front door assembly, support the door with a jack and cloth to protect the door and body.
 - When removing and installing front door assembly, be sure to carry out the fitting adjustment. Refer to [BL-79, "Fitting Adjustment"](#).
 - After installing, apply touch-up paint (the body color) onto the head of the hinge mounting nuts.
 - Check the hinge rotating part for poor lubrication. If necessary, apply "body grease".
 - Operate with two workers, because of its heavy weight.
 - Check rear door open/close operation after installation.
1. Pull the lever and remove the door harness connector while removing tabs of door harness connector.

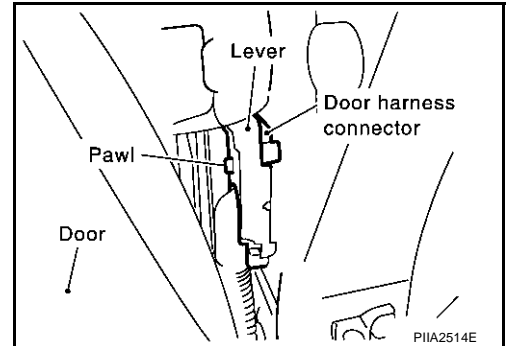

2. Remove the mounting bolts of the check link on the vehicle.

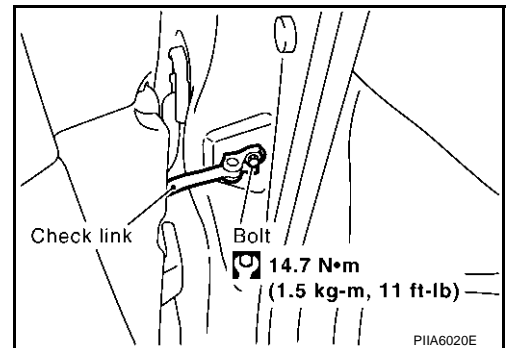

3. Remove the door-side hinge mounting nuts, then remove the door assembly.

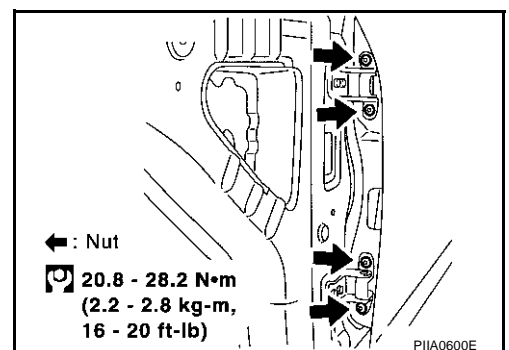

INSTALLATION

Install in the reverse order of removal.

Removal and Installation of Rear Door

AIS00621

CAUTION:

- When removing and installing the rear door assembly, support the door with a jack and cloth to protect the door and body.
- When removing and installing rear door assembly, be sure to carry out the fitting adjustment. Refer to [BL-79, "Fitting Adjustment"](#).
- Check the hinge rotating part for poor lubrication. If necessary, apply "body grease".

DOOR

- After installing, apply touch-up paint (the body color) onto the head of the hinge mounting nuts.
- Operate with two workers, because of its heavy weight.
- Check rear door open/close operation after installation.

REMOVAL

1. Grommet is pulled out, and the Rear door harness connector is detached.

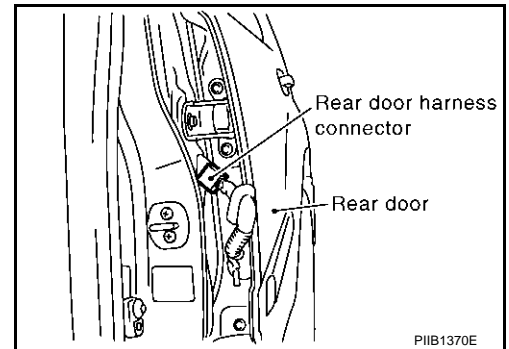

2. Remove the mounting bolts of the check link on the vehicle.

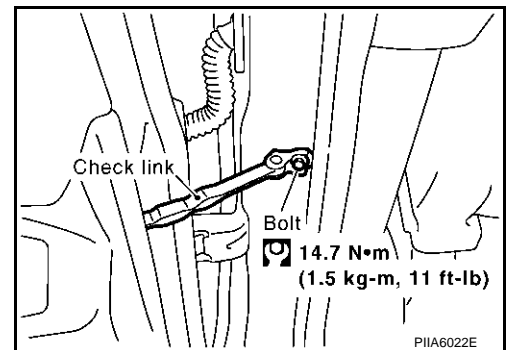

3. Remove the door-side hinge mounting nuts, and remove the door assembly.

 : 24.5 N·m (2.5 kg-m, 18 ft-lb)

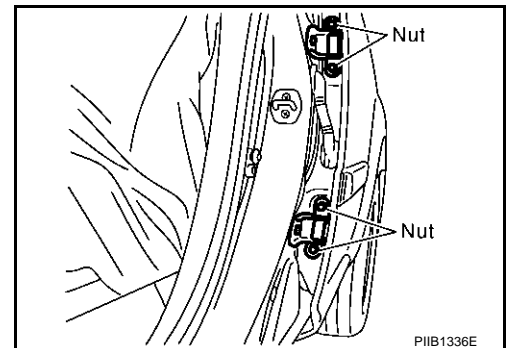

INSTALLATION

Install in the reverse order of removal.

A
B
C
D
E
F
G
H
BL
J
K
L
M

DOOR

Door Weatherstrip

AI500024

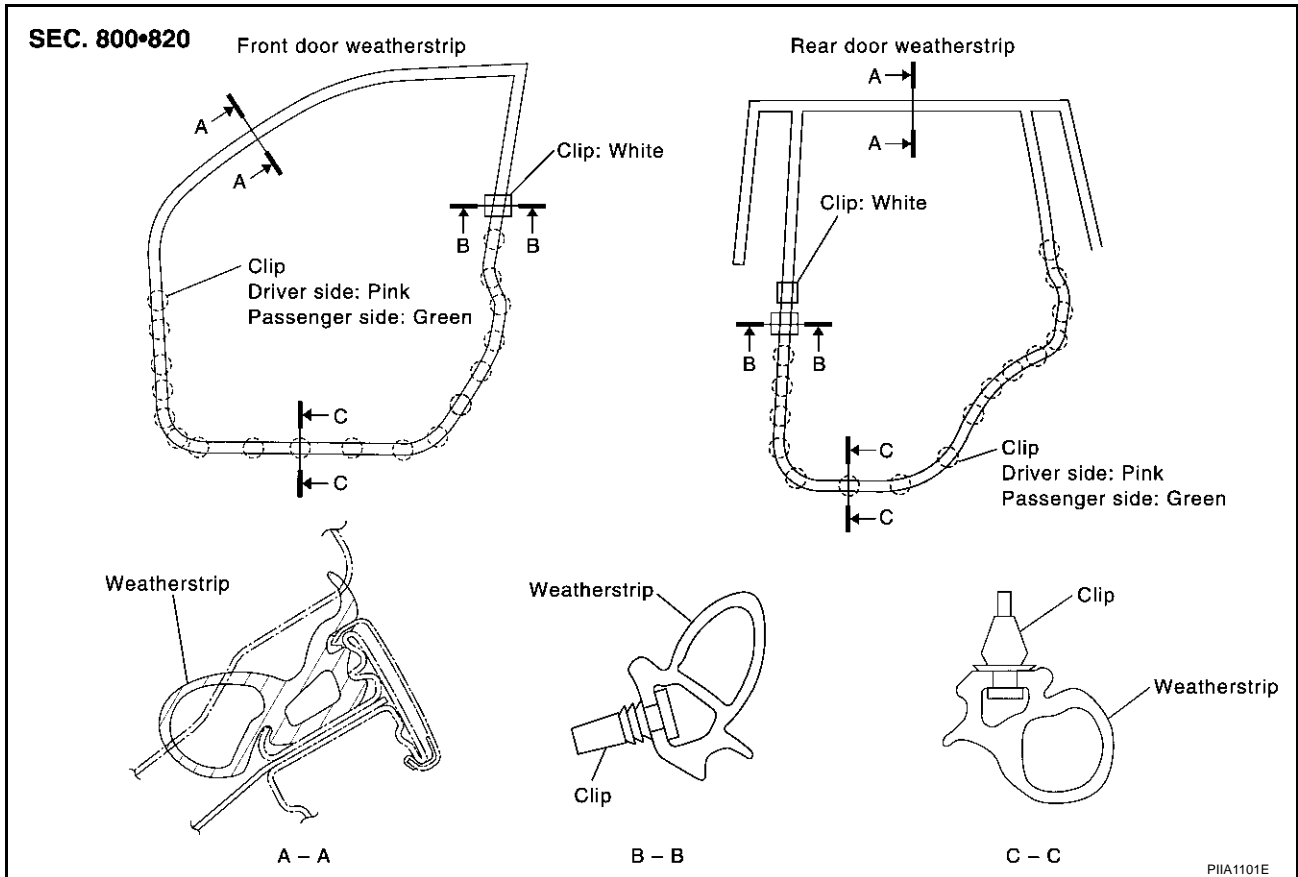

REMOVAL

1. Remove the mounting bolts of the check link on the vehicle. Refer to [BL-80, "Removal and Installation of Front Door"](#) or [BL-80, "Removal and Installation of Rear Door"](#).
2. Remove the weatherstrip clips and remove weatherstrip.

CAUTION:

After removal, do not pull strongly on the weatherstrip.

INSTALLATION

Install in the reverse order of removal.

FRONT DOOR LOCK

FRONT DOOR LOCK

PFP:80502

Component Structure

AIS005F0

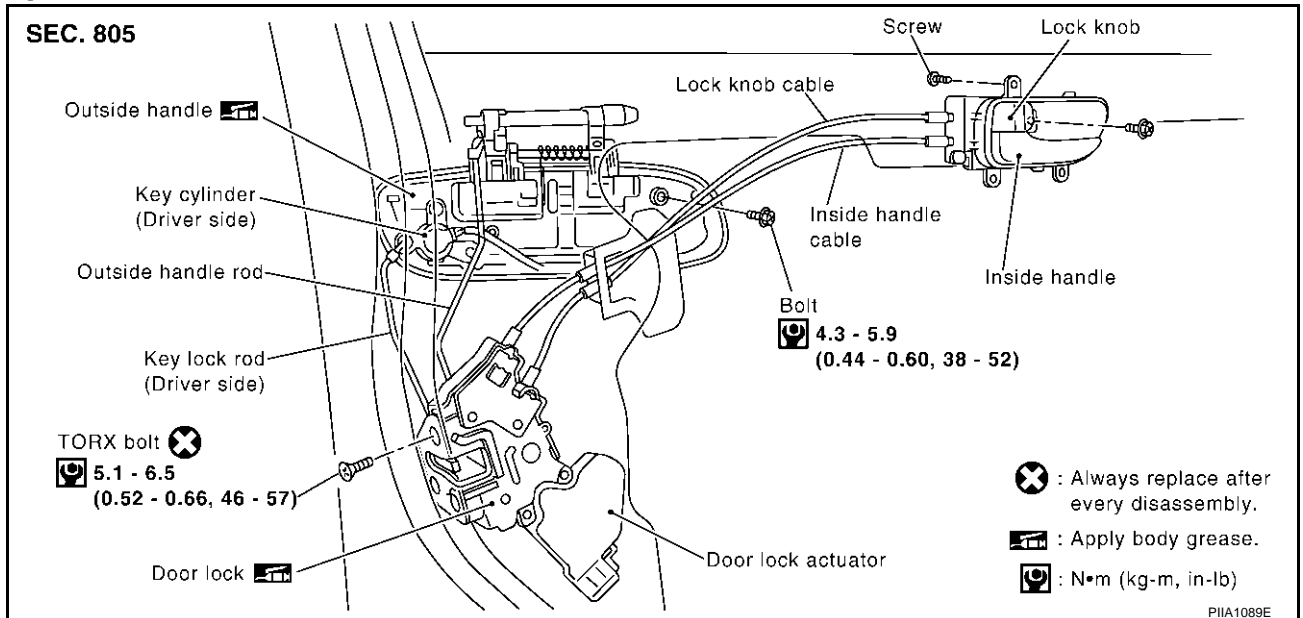

Inspection and Adjustment

AIS005F1

1. Remove the front door finisher. Refer to [EI-37, "Removal and Installation"](#).
2. Remove the front door speaker. Refer to [AV-34, "Removal and Installation of Door Speaker \(Base System\)"](#).
3. Remove the front door window and front door module assembly. Refer to [GW-91, "FRONT DOOR GLASS AND REGULATOR"](#).

EXTERIOR HANDLE ROD ADJUSTMENT

Rotate the bushing to adjust so that the clearance between the bushing and rod becomes as shown in the figure.

CAUTION:

Be careful not to make the clearance 0 mm (0 in) or the rod will be pressed continuously.

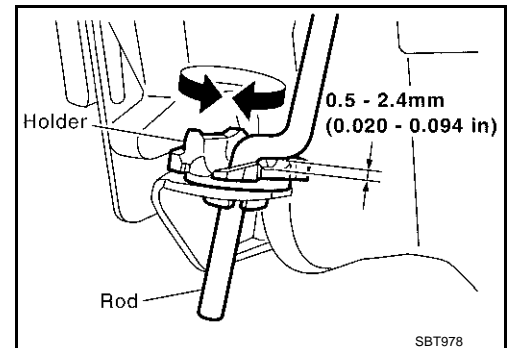

Removal and Installation

REMOVAL

AIS005F2

1. Remove the front door finisher. Refer to [EI-37, "Removal and Installation"](#).
2. Remove the front door speaker. Refer to [AV-34, "Removal and Installation of Door Speaker \(Base System\)"](#).
3. Remove the front door window and front door module assembly. Refer to [GW-91, "FRONT DOOR GLASS AND REGULATOR"](#).

FRONT DOOR LOCK

4. Disconnect the inside handle cable and lock knob cable from the back side of the front door finisher.

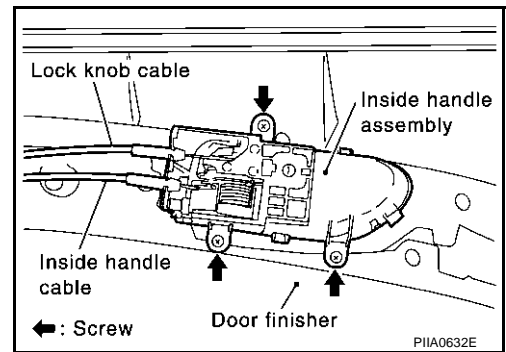

5. Reach to separate the key cylinder rod and outside handle rod connection (on the handle).
6. Remove the mounting bolts (TORX T30), remove the door lock assembly.
7. Disconnect the door lock actuator connector.

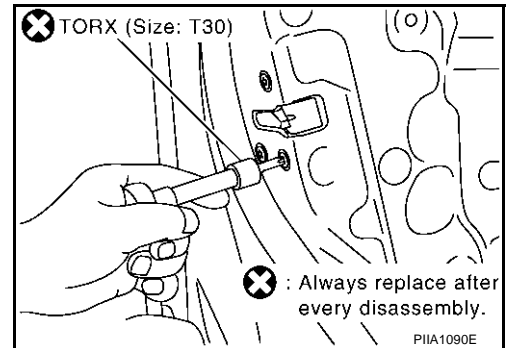

8. Remove the exterior handle mounting bolts, move the outside handle assembly backward, and then remove it from the panel in front of the outside handle escutcheon.

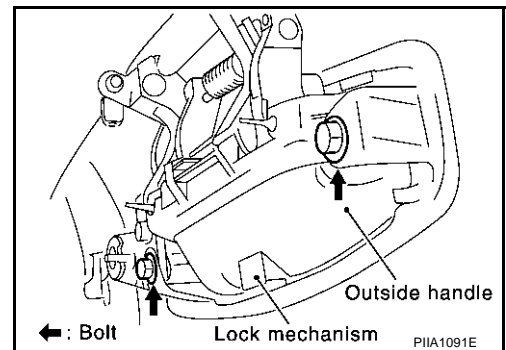

INSTALLATION

Install in the reverse order of removal.

CAUTION:

To install each rod, be sure to rotate the rod holder until a click is felt.

Disassembly and Assembly DISASSEMBLY

AIS005F3

CAUTION:

Be sure to remove or install the actuator with the door lock assembly removed.

1. Remove the mounting screws, and remove the actuator from the door lock assembly.
2. Pull the actuator straight downward to separate it from the door lock assembly.

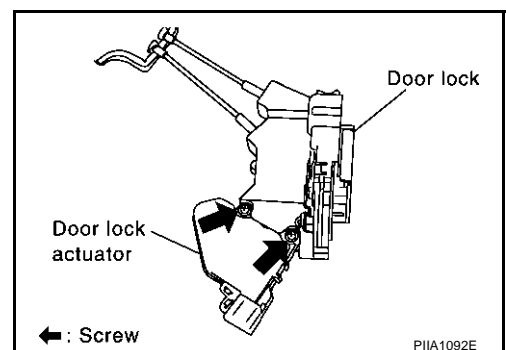

FRONT DOOR LOCK

ASSEMBLY

1. Align the actuator pivot with the cutout on the knob lever of the door lock assembly, then assemble the actuator. A
2. Move the knob lever and the actuator pivot toward the lock-on direction, and check that it engages securely. B

C

D

E

F

G

H

BL

J

K

L

M

REAR DOOR LOCK

REAR DOOR LOCK

PFP:82502

Component Structure

AIS005F4

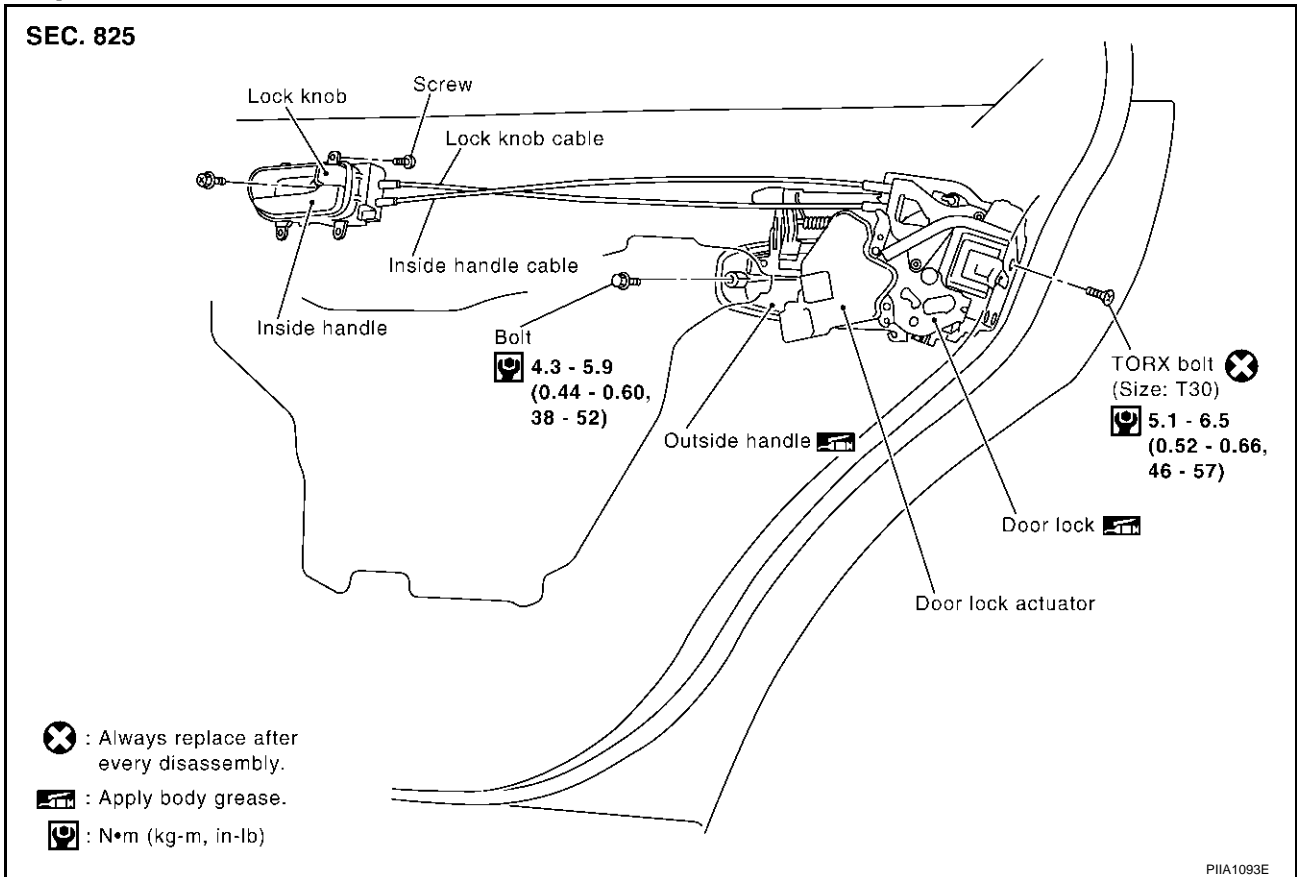

INSPECTION AND ADJUSTMENT

1. Remove the rear door finisher. Refer to [EI-37, "Removal and Installation"](#).

EXTERIOR HANDLE ROD ADJUSTMENT

Rotate the bushing to adjust so that the clearance between the bushing and rod becomes as shown in the figure.

CAUTION:

Be careful not to make the clearance 0 mm (0 in) or the rod will be pressed continuously.

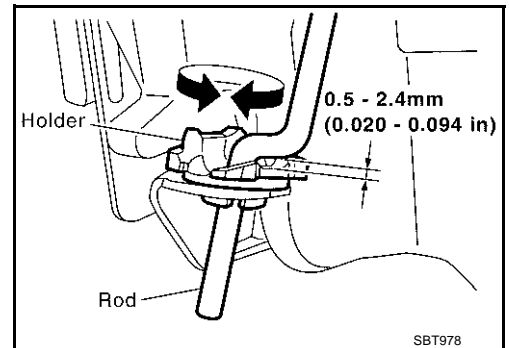

REAR DOOR LOCK

Removal and Installation of Door Lock

AIS005F5

REMOVAL

1. Remove the rear door finisher. Refer to [EI-37, "Removal and Installation"](#) .
2. After gaining access to the inside handle on the back side of the rear door finisher, disconnect the inside handle cable and lock knob cable.

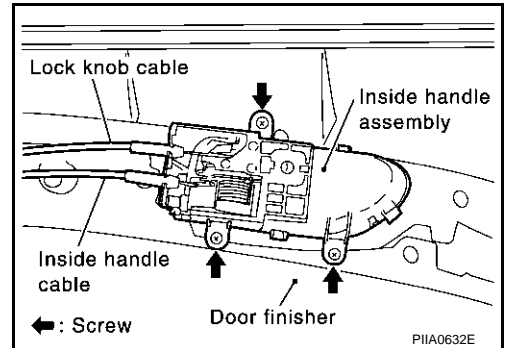

3. Remove the mounting bolt (TORX T30), remove the door lock assembly.
4. Disconnect the door lock actuator connector.

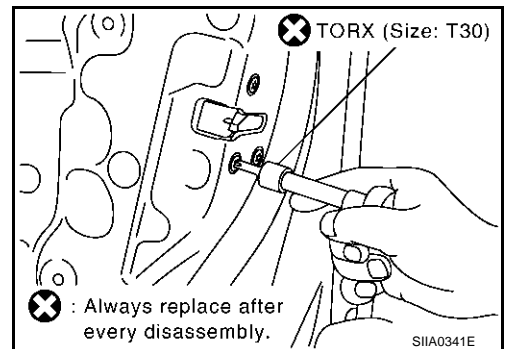

5. Remove the outside handle mounting bolts, and move the handle backward to disengage it from the panel in front of the outside handle escutcheon, then remove the handle.

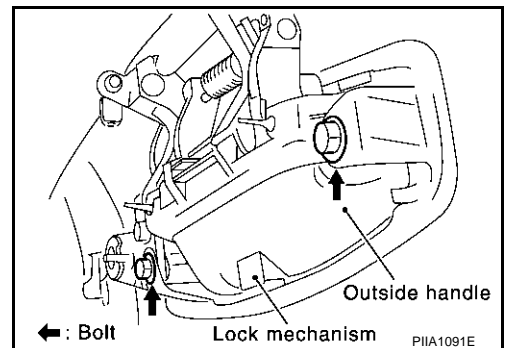

INSTALLATION

Install in the reverse order of removal.

CAUTION:

To install each rod, be sure to rotate the rod holder until a click is felt.

Disassembly and Assembly

DISASSEMBLY

AIS005F6

CAUTION:

Be sure to remove or install the actuator with the door lock assembly removed.

REAR DOOR LOCK

1. Remove the mounting screws, and remove the actuator from the door lock assembly.
2. Pull the actuator straight downward to separate it from the door lock assembly.

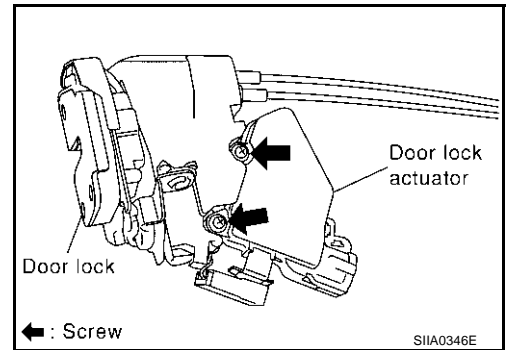

ASSEMBLY

1. Align the actuator pivot with the cutout on the knob lever of the door lock assembly, then assemble the actuator.
2. Move the knob lever and the actuator pivot toward the lock-on direction, and check that it engages securely.

TRUNK LID

PFP:H4300

TRUNK LID

Fitting Adjustment

AIS005WE

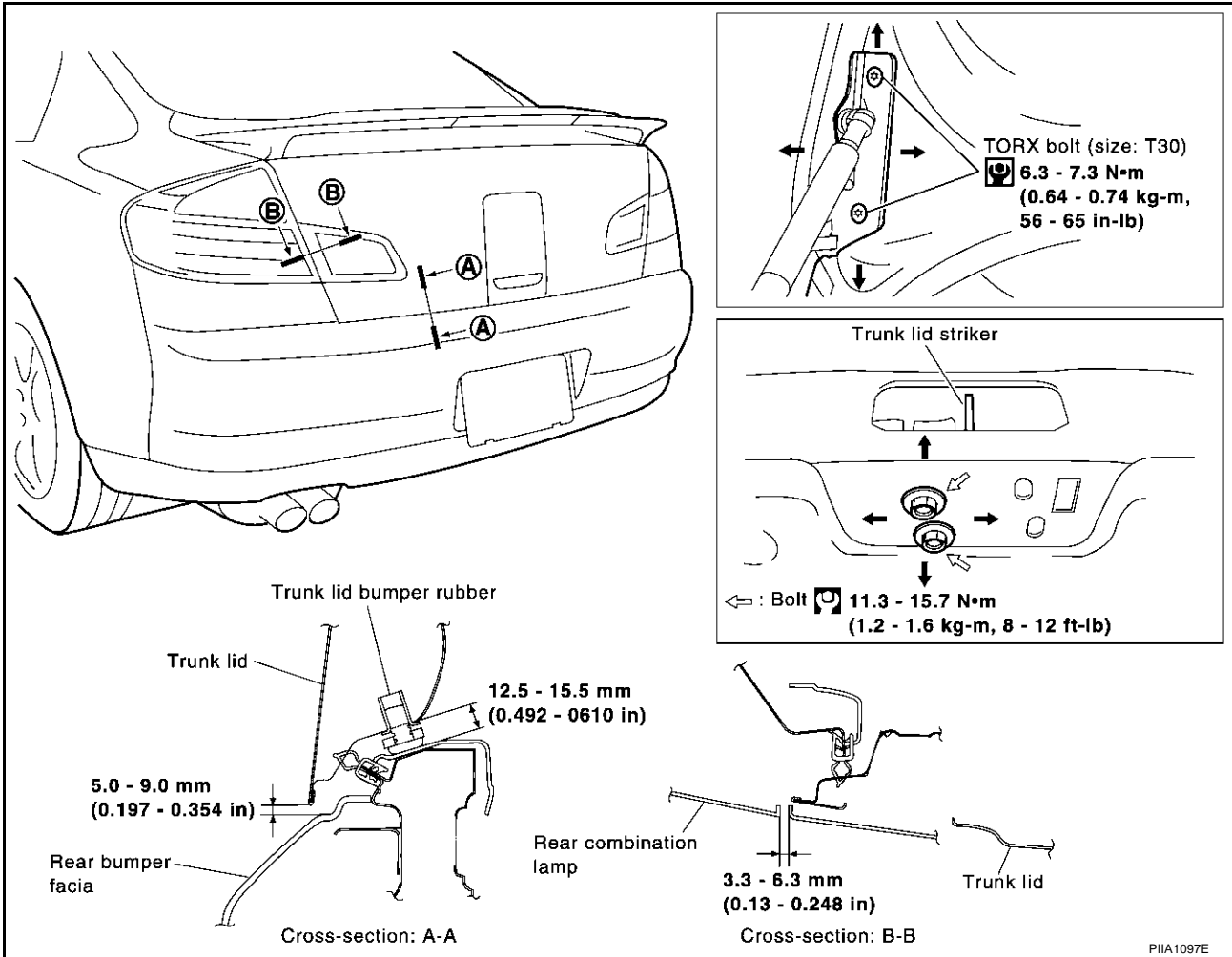

LONGITUDINAL AND LATERAL CLEARANCE ADJUSTMENT

1. With the striker released, loosen the trunk lid hinge mounting bolts to close the trunk lid.
2. Make the lateral clearance and the clearance to the rear window glass equal, and open the trunk lid to tighten the mounting bolts to the specified torque.

SURFACE HEIGHT ADJUSTMENT

1. Loosen the striker mounting bolts. Raise the striker to the top position, and temporarily tighten the upper mounting bolt at the position.
2. Loosen the bumper rubber collar, and the damper is drawn out.
3. Close the trunk lid lightly and adjust the surface height, then open the trunk lid to finally tighten the striker mounting bolts to the specified torque or bumper rubber collar is tighten by the hand.

A
B
C
D
E
F
G
H
BL
J
K

TRUNK LID

Removal and Installation of Trunk Lid Assembly

AIS005WF

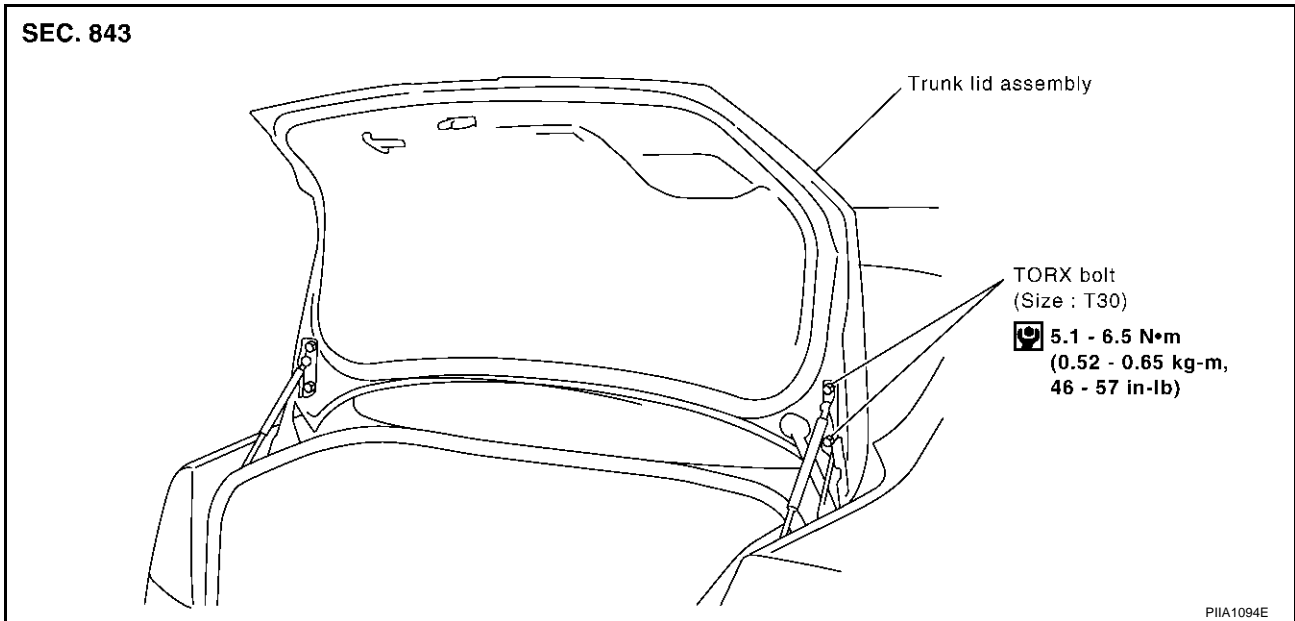

REMOVAL

1. Disconnect the connectors in the trunk lid, and remove the harness clamps to pull the harness out of the trunk lid.
2. Insert flat-bladed screwdriver into the gap and remove holder.
3. Remove trunk lid stay (gas stay).
4. Remove the mounting bolts, and remove the trunk lid assembly.

CAUTION:

After installing, apply touch-up paint (the body color) onto the head of the hinge mounting bolts.

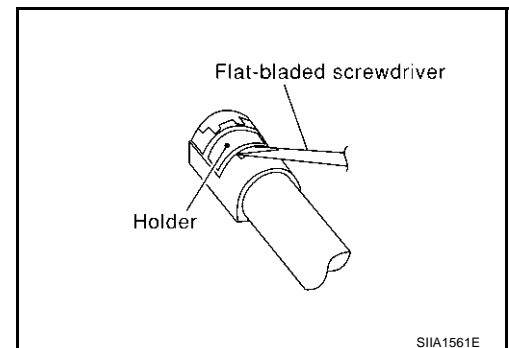

INSTALLATION

Install in the reverse order of removal.

Removal and Installation of Trunk Lid Stay

REMOVAL

1. Insert flat-bladed screwdriver into the gap and remove holder.
2. Remove trunk lid stay on the trunk lid.
3. Remove the stud balls, and trunk lid stay.

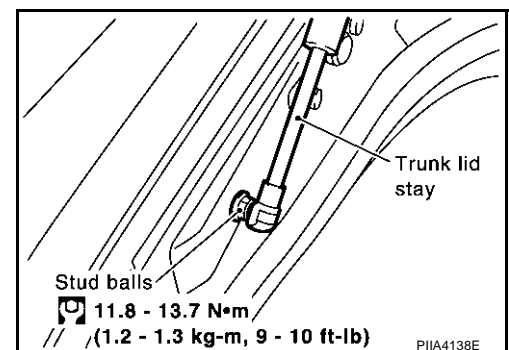

INSTALLATION

1. Install in the reverse order of removal.
2. After installing, check the operation.

TRUNK LID

Removal and Installation of Trunk Lid Lock

AIS005WH

REMOVAL

1. Remove the trunk lid finisher. Refer to [EI-47, "TRUNK ROOM TRIM & TRUNK LID FINISHER"](#) .
2. Disconnect the trunk lid emergency opener cable from the trunk lid lock.
3. After removing the harness connector, remove the mounting bolts, and remove the trunk lid lock.

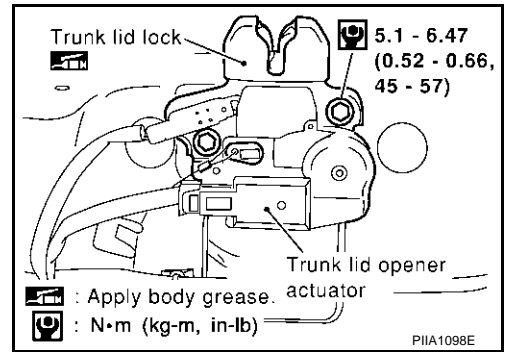

INSTALLATION

1. Install in the reverse order of removal.
2. After installing, close the trunk lid height. Perform the lock and surface height adjustment. Refer to [BL-89, "Fitting Adjustment"](#) .
3. After installing, check the operation.

Removal and Installation of Trunk Lid Striker

AIS005WI

REMOVAL

1. Remove the trunk rear plate and trunk rear finisher. Refer to [EI-47, "TRUNK ROOM TRIM & TRUNK LID FINISHER"](#) .
2. Remove the mounting bolts, and remove the striker from the trunk lock support.

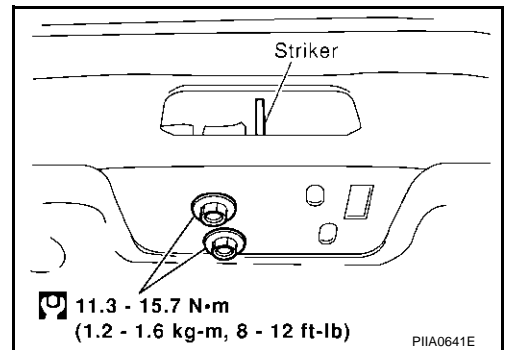

INSTALLATION

1. Install in the reverse order of removal.
2. After installing, close the trunk lid height. Perform the lock and surface height adjustment. Refer to [BL-89, "Fitting Adjustment"](#) .
3. After installing, check the operation.

TRUNK LID

Removal and Installation of Trunk lid Emergency Opener Cable

AIS0061M

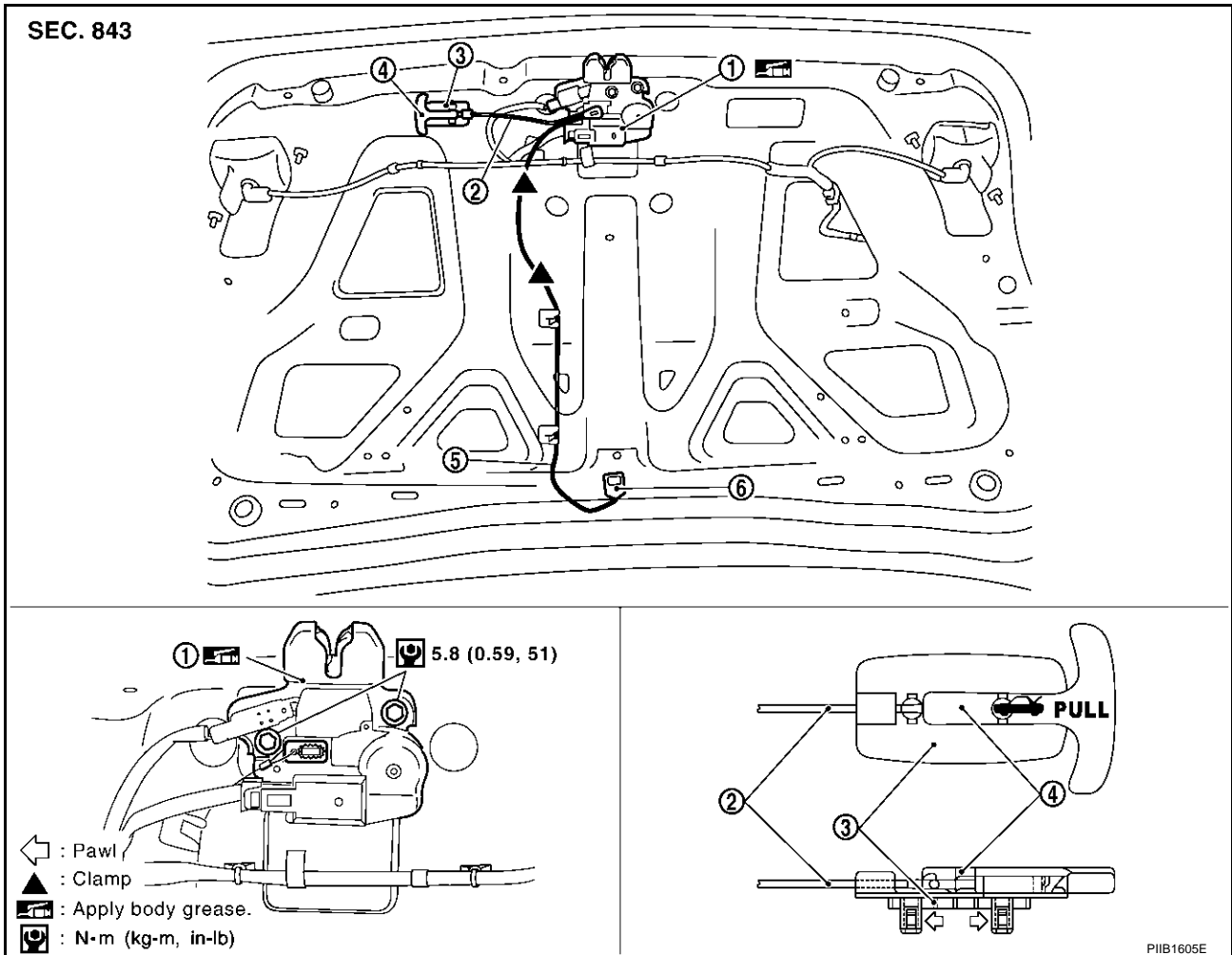

REMOVAL

1. Remove trunk lid finisher. Refer to [EI-47, "TRUNK ROOM TRIM & TRUNK LID FINISHER"](#) .
2. Disconnect each clamp of trunk lid emergency opener cable.
3. Disconnect the trunk lid emergency opener cable and from the trunk lid lock assembly.
4. Disconnect the trunk lid emergency opener cable (secondary) from the trunk lid emergency opener lever holder.
5. Remove trunk lid emergency opener cable.

INSTALLATION

1. Install in the reverse order of removal.
2. After installing, check the operation.

TRUNK LID

Removal and Installation of Trunk Lid Weatherstrip

AIS005WK

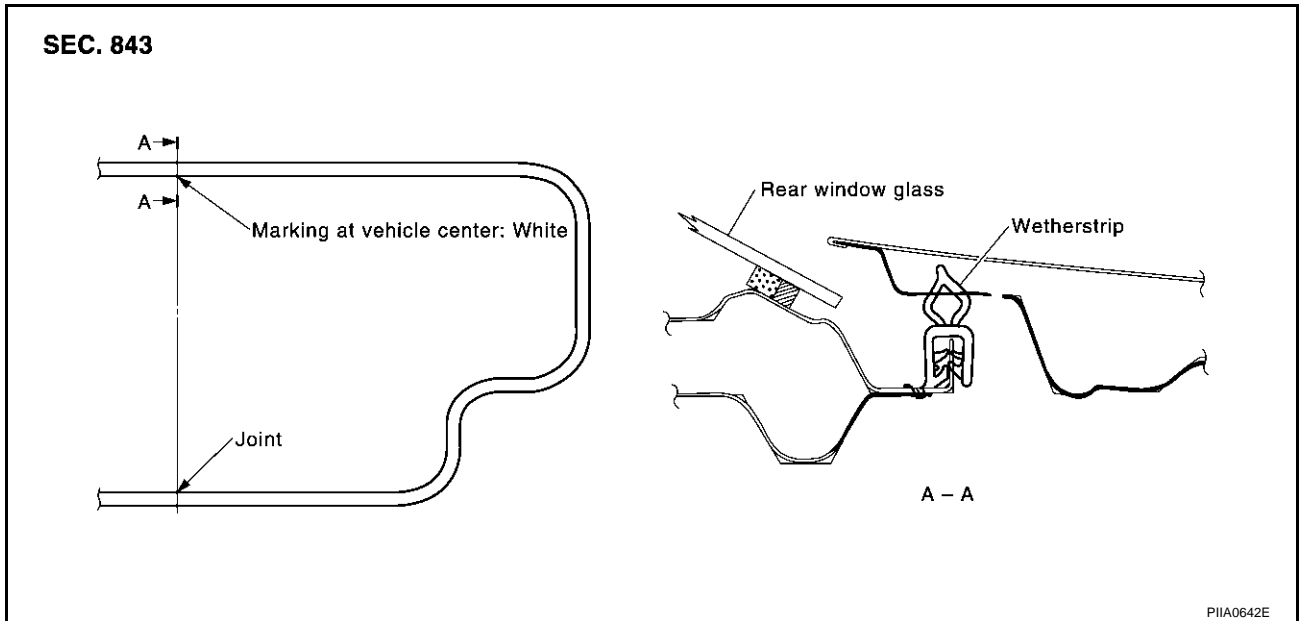

REMOVAL

1. Pull up and remove engagement with body from weatherstrip joint.

CAUTION:

After removal, do not pull strongly on the weatherstrip.

INSTALLATION

1. Working from the upper section, align weatherstrip mark with vehicle center position mark and install weatherstrip onto the vehicle.
2. For the lower section, align the weatherstrip seam with center of the striker.
3. After installation, pull the weatherstrip gently to ensure that there is no loose section.

NOTE:

Make sure the weatherstrip is fit tightly at each corner and trunk lid rear plate.

A
B
C
D
E
F
G
H
BL
J
K
L
M

TRUNK LID OPENER

PFP:84640

TRUNK LID OPENER

Wiring Diagram -TLID- / Models with Up To Serial Number 099999

AIS0002H

BL-TLID-01

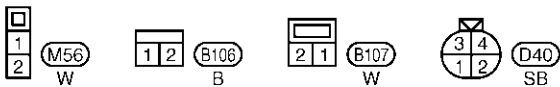
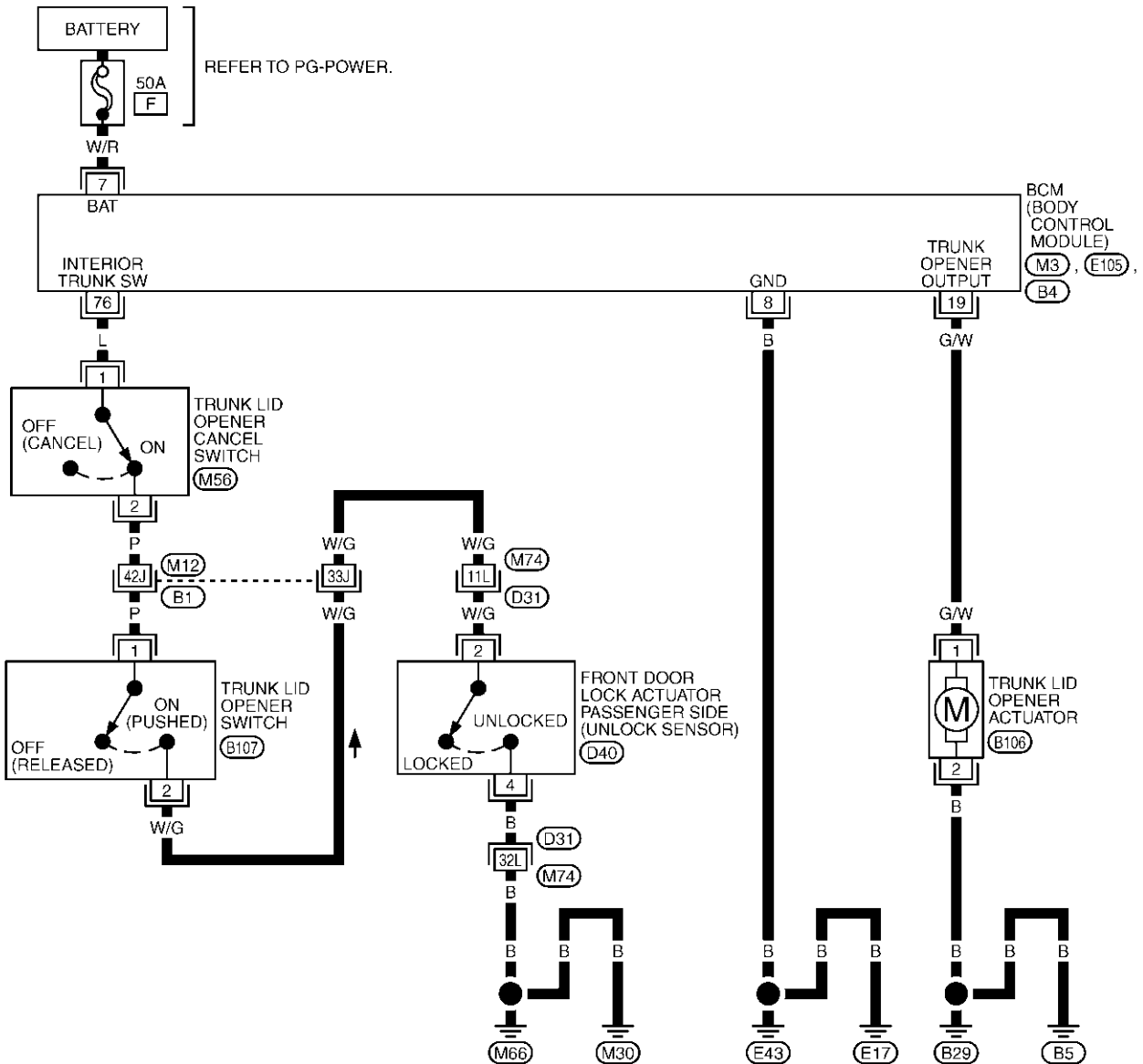

REFER TO THE FOLLOWING.

(B1), (D31) -SUPER MULTIPLE JUNCTION (SMJ)

(M3), (E105), (B4) -ELECTRICAL UNITS

TIWT0216E

TRUNK LID OPENER

Wiring Diagram - TLID - / Models with from Serial Number 300001

AIS002GG

BL-TLID-02

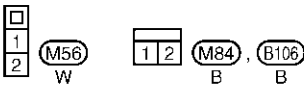
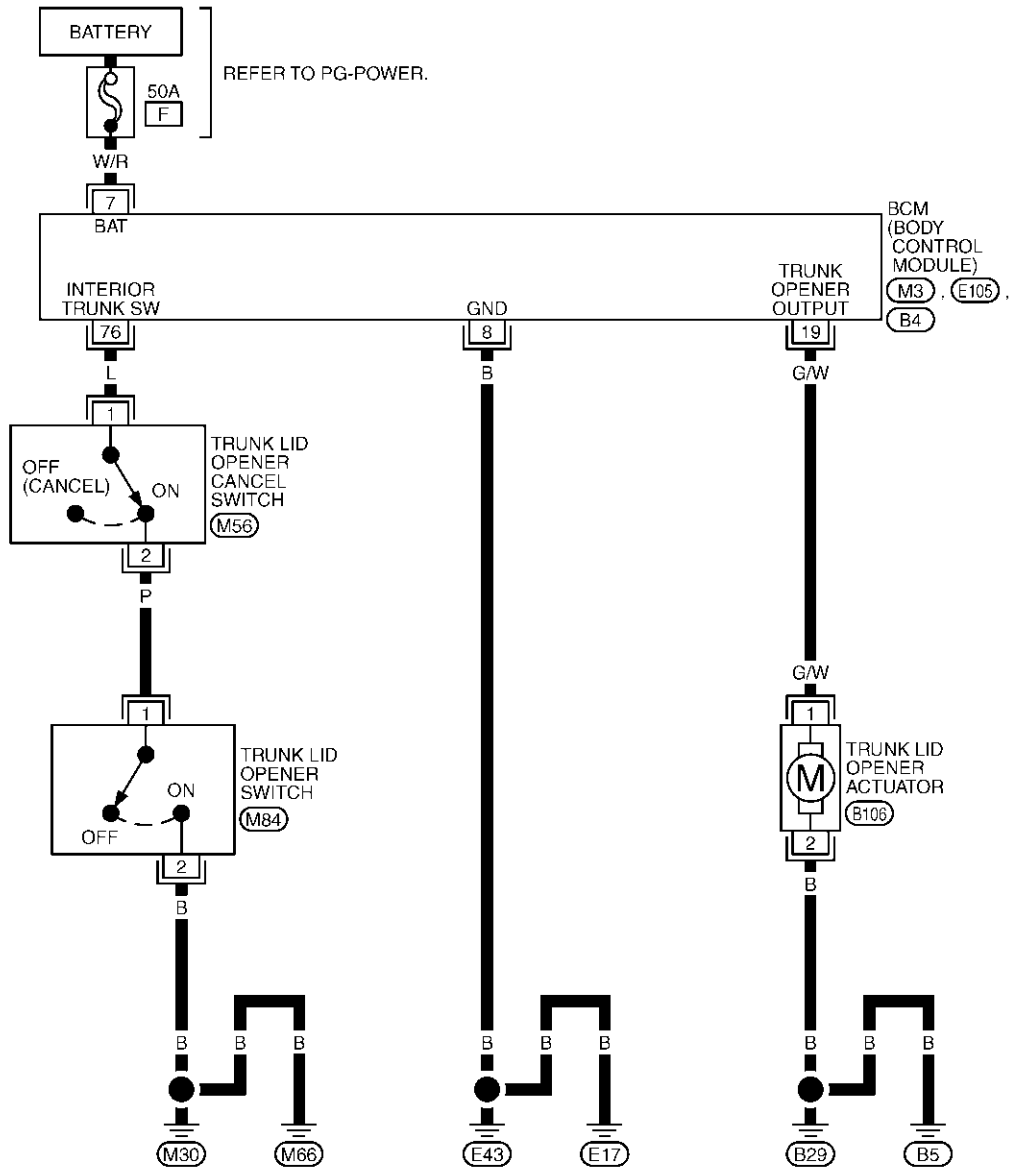

REFER TO THE FOLLOWING.

M3, E105, B4
-ELECTRICAL UNITS

TIWT0365E

TRUNK LID OPENER

Terminals and Reference Value for BCM

AI500021

TER-MINAL	WIRE COLOR	ITEM	CONDITION		VOLTAGE (V) (Approx.)		
7	W/R	Power source (Fusible link)	—		Battery voltage		
8	B	Ground	—		0		
19	G/W	Trunk lid opener output signal	Locked (OFF) → Unlocked (ON)		0 → Battery voltage		
76	L	Trunk lid opener switch	Front passenger door lock actuator is unlocked *	Trunk lid opener cancel switch is ON position	Trunk lid opener switch is ON	0	
					Trunk lid opener cancel switch is OFF position	Trunk lid opener switch is OFF	Battery voltage
							Battery voltage

*: Models with up to serial number 099999.

VEHICLE SECURITY (THEFT WARNING) SYSTEM

VEHICLE SECURITY (THEFT WARNING) SYSTEM

PPF:28491

Component Parts and Harness Connector Location

AIS0002J

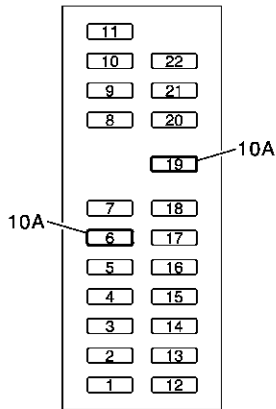

Fuse block (J/B) fuse layout

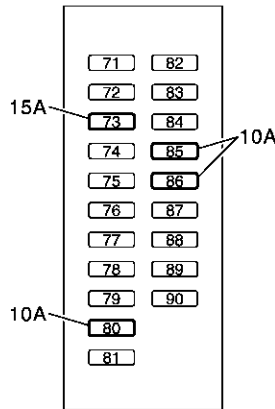

IPDM E/R fuse layout

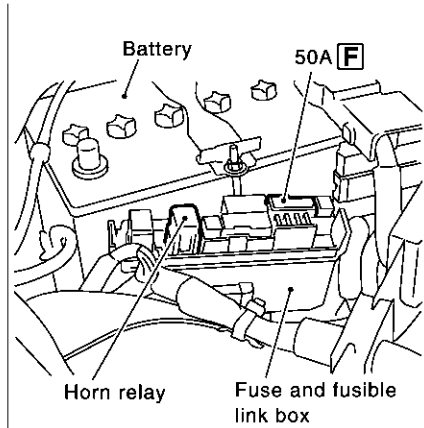

Battery
Horn relay
Fuse and fusible link box

View with dash side LH removed

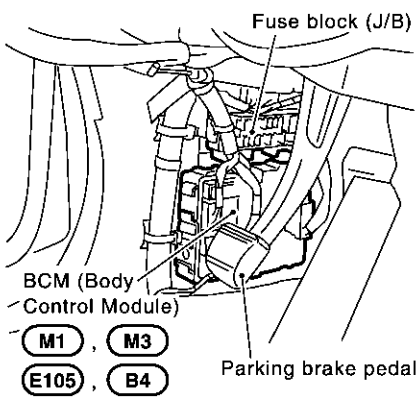

View with battery removed

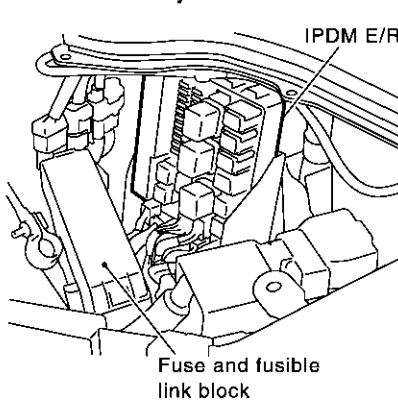

Power window main switch (Door lock and unlock switch)

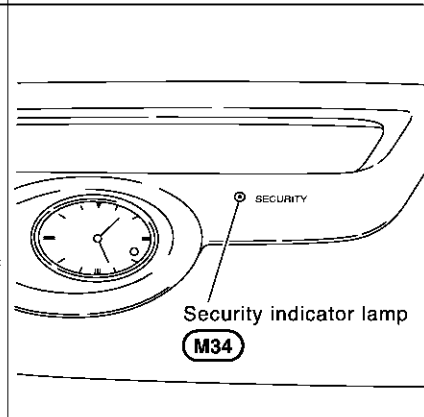
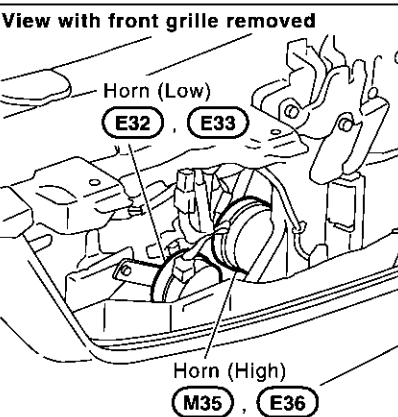
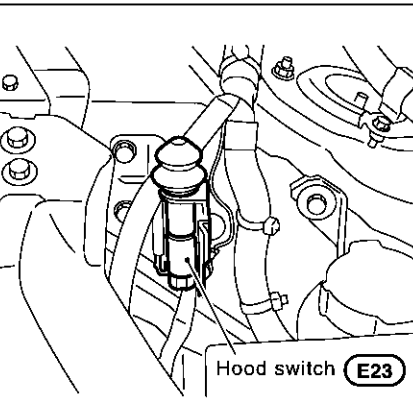
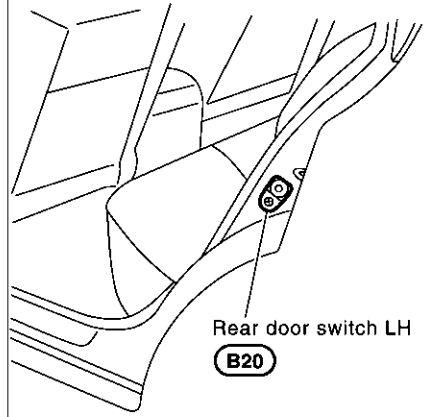
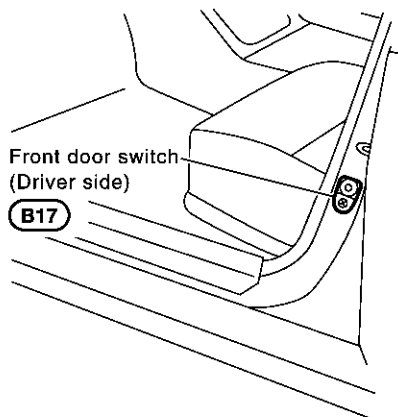
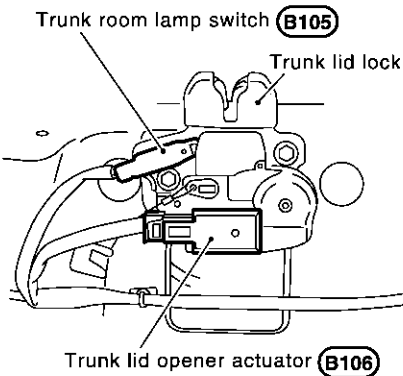
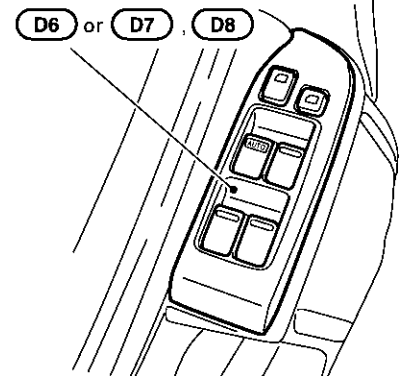

PIA1103E

VEHICLE SECURITY (THEFT WARNING) SYSTEM

AIS0002K

System Description

DESCRIPTION

Operation Flow

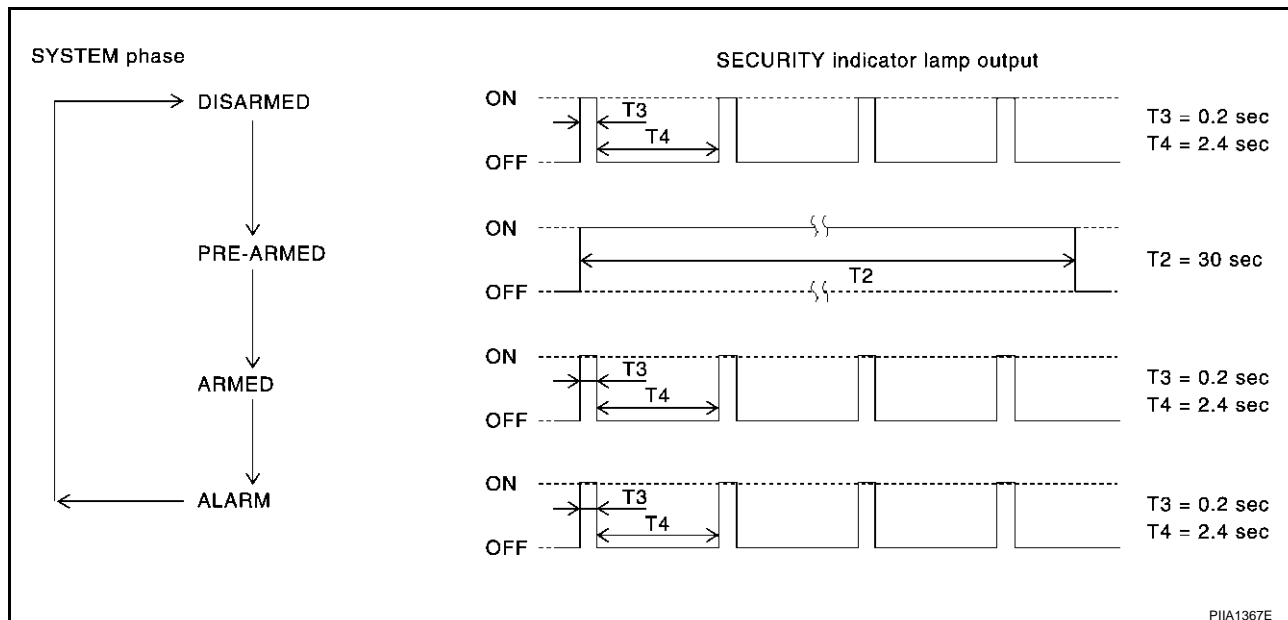

Setting the Vehicle Security System

Initial condition

- Ignition switch is in OFF position.

Disarmed phase

- When the vehicle is being driven or when doors or trunk lid is open, the vehicle security system is set in the disarmed phase on the assumption that the owner is inside or near the vehicle.
- When the vehicle security system is in the disarmed phase, the security indicator lamp blinks every 2.6 seconds.

Pre-armed phase and armed phase

When the following operation 1 or 2 is performed, the vehicle security system turns into the “prearmed” phase. (The security indicator lamp illuminates.)

1. BCM receives LOCK signal from front door key cylinder switch or key fob after hood, trunk lid and all doors are closed.
2. Hood, trunk lid and all doors are closed after front doors are locked by key or door lock and unlock switch. The security indicator lamp illuminates for 30 seconds. then, the system automatically shifts into the “armed” phase.

Canceling the Set Vehicle Security System

When one of the following operations is performed, the armed phase is canceled.

1. Unlock the doors with the key or the key fob.
2. Open the trunk lid with the key fob.
3. Turn ignition switch “ON” or “ACC” position.

Activating the Alarm Operation of the Vehicle Security System

Make sure the system is in the armed phase. (The security indicator lamp blinks every 2.6 seconds.)

When the following operation 1 or 2 is performed, the system sounds the horns and flashes the head lamps for about 50 seconds.

1. Engine hood, trunk lid or any door is opened during armed phase.
2. Disconnecting and connecting the battery connector before canceling armed phase.

Canceling the Alarm Operation of the Vehicle Security System

When one of the following operations is performed, the alarm operation is canceled.

1. Unlock the door with the key or the key fob.

VEHICLE SECURITY (THEFT WARNING) SYSTEM

2. Open the trunk lid with key fob.

POWER SUPPLY

Power is supplied at all times

- through 10A fuse [No.19, located in the fuse block (J/B)]
- to security indicator lamp terminal 1.

Power is supplied at all times

- through 50A fusible link (letter F , located in the fuse and fusible link box)
- to BCM terminal 7.

With the ignition switch in the ACC or ON position, power is supplied

- through 10A fuse [No. 6, located in the fuse block (J/B)]
- to BCM terminal 36.

INITIAL CONDITION TO ACTIVATE THE SYSTEM

The operation of the vehicle security system is controlled by the doors, hood and trunk lid.

To activate the vehicle security system, BCM must receive signals indicating the doors, hood and trunk lid are closed and the doors are locked by key fob.

When a door is open, BCM terminals 10, 11 or 14 receives a ground signal from each door switch. (Applied from without navigation system and with navigation system auxiliary circuit.)

When a door is open, combination meter terminal 6-9 receives a ground signal from each door switch.

The combination meter then sends a signal to the BCM through the CAN communication SYSTEM. (Applied from with navigation system formalities circuit.)

When front door LH is unlocked by power window main switch (door lock and unlock switch), BCM terminal 74 receives a signal from terminal 8 (except with interruption detection function for all door window) or 9 (with interruption detection function for all door window) of power window main switch.

When front door RH is unlocked by power window sub-switch (front passenger side) (door lock and unlock switch), BCM terminal 74 receives a signal from terminal 11 of power window sub-switch.

When the hood is open, IPDM E/R receives a ground signal

- to IPDM E/R terminal 51
- through hood switch terminal 2
- through body grounds E17 and E43.

The IPDM E/R then sends a signal to the BCM through the CAN communication SYSTEM.

When the trunk lid is open, BCM terminal 18 receives a ground signal

- from terminal 1 of the trunk lid switch
- through body grounds B5 and B29.

VEHICLE SECURITY SYSTEM ALARM OPERATION

The vehicle security system is triggered by

- opening a door
- opening the trunk lid
- opening the hood
- detection of battery disconnect and connect.

The vehicle security system will be triggered once the system is in armed phase,

When BCM receives a ground signal from door switch, trunk lid switch or hood switch.

Power is supplied at all times

- to horn relay terminal 2
- through 15A fuse (No. 35, located in fuse and fusible link box).

When the vehicle security system is triggered, ground is supplied intermittently from IPDM E/R terminals 14 and 45.

When both headlamp relay (with built-in IPDM E/R) and horn relay are energized and then power is supplied to headlamps LH and RH (high beam and low beam) and horns (HIGH and LOW).

The headlamps flash and the horn sounds intermittently.

The alarm automatically turns off after 50 seconds, but will reactivate if the vehicle is tampered with again.

A

B

C

D

E

F

G

H

BL

J

K

L

M

VEHICLE SECURITY (THEFT WARNING) SYSTEM

VEHICLE SECURITY SYSTEM DEACTIVATION

To deactivate the vehicle security system, a door or the trunk lid must be unlocked with the key or key fob.

When the key is used to unlock a door, BCM terminal 74 receives signal

- from terminal 8 (except with interruption detection function for all door window) or 9 (with interruption detection function for all door window) of power window main switch.

When the BCM receives either one of these signals or unlock signal from key fob, the vehicle security system is deactivated. (Disarmed phase)

PANIC ALARM OPERATION

Remote keyless entry system may or may not operate vehicle security system (horn and headlamps) as required.

When the remote keyless entry system is triggered, ground is supplied intermittently from IPDM E/R terminals 14 and 45.

When headlamp relay (with built-in IPDM E/R) and horn relay are energized and then power is supplied to headlamps LH and RH (high beam and low beam) and horns (HIGH and LOW).

The headlamp flashes and the horn sounds intermittently.

The alarm automatically turns off after 25 seconds or when BCM receives any signal from key fob.

VEHICLE SECURITY (THEFT WARNING) SYSTEM

CAN Communication System Description

AIS003Y1

CAN (Controller Area Network) is a serial communication line for real time application. It is an on-vehicle multiplex communication line with high data communication speed and excellent error detection ability. Many electronic control units are equipped onto a vehicle, and each control unit shares information and links with other control units during operation (not independent). In CAN communication, control units are connected with 2 communication lines (CAN H line, CAN L line) allowing a high rate of information transmission with less wiring. Each control unit transmits/receives data but selectively reads required data only.

Body type	Sedan	
Axle	2WD	
Engine	VQ35DE	
Transmission	A/T	
	Up to serial 329287*	From serial 329288*
Brake control	VDC	
CAN communication unit		
ECM	×	×
TCM	×	
Data link connector	×	×
Combination meter	×	×
BCM	×	×
Steering angle sensor	×	×
VDC/TCS/ABS control unit	×	×
IPDM E/R	×	×
CAN communication type	BL-101, "TYPE 1/TYPE 3"	BL-103, "TYPE 2"

×: Applicable

*:For further information, refer to [GI-47, "IDENTIFICATION NUMBER"](#) in GI section.

TYPE 1/TYPE 3

System Diagram

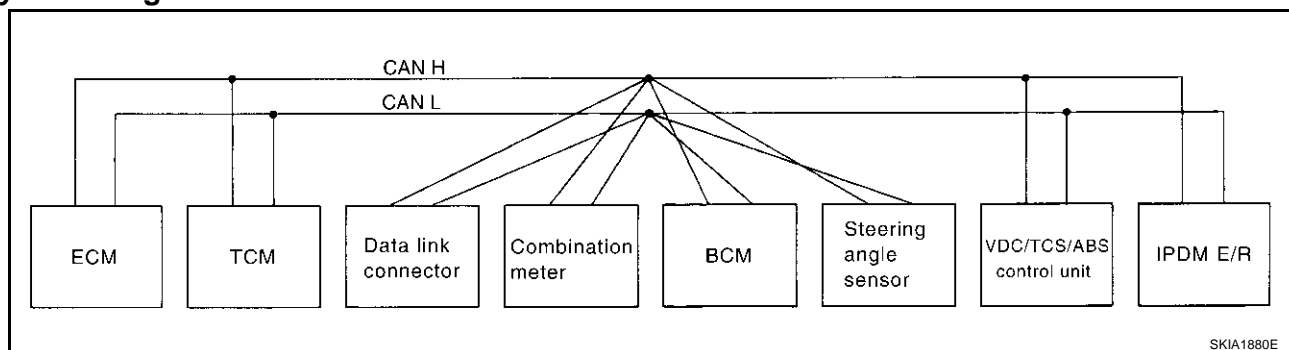

Input/Output Signal Chart

T: Transmit R: Receive

Signals	ECM	TCM	Combina- tion meter	BCM	Steering angle sensor	VDC/TCS/ ABS con- trol unit	IPDM E/R
Engine torque signal	T	R					
Engine speed signal	T	R	R			R	
Engine coolant temperature signal	T	R	R				
Accelerator pedal position signal	T	R				R	
Closed throttle position signal	T	R					
Wide open throttle position signal	T	R					
Battery voltage signal	T	R					

VEHICLE SECURITY (THEFT WARNING) SYSTEM

Signals	ECM	TCM	Combina- tion meter	BCM	Steering angle sensor	VDC/TCS/ ABS con- trol unit	IPDM E/R
Stop lamp switch signal		R	T				
Fuel consumption monitor signal	T		R				
A/T self-diagnosis signal	R	T					
A/T CHECK indicator lamp signal		T	R				
A/T position indicator signal		T	R			R	
ABS operation signal		R				T	
A/T shift schedule change demand signal		R				T	
A/C switch signal	R			T			
A/C compressor request signal	T						R
A/C compressor feedback signal	T		R				
Blower fan motor switch signal	R			T			
Cooling fan motor operation signal	T						R
Position lights request signal			R	T			R
Low beam request signal				T			R
Low beam status signal	R						T
High beam request signal			R	T			R
High beam status signal	R						T
Front fog lights request signal				T			R
Vehicle speed signal			R			T	
	R	R	T	R			
Sleep request 1 signal			R	T			
Sleep request 2 signal				T			R
Wake up request 1 signal			R	T			R
Wake up request 2 signal			R	T			R
Door switch signal (without naviga- tion system)			R	T			R
Door switch signal (with navigation system)			T	R			
Turn indicator signal			R	T			
Seat belt buckle switch signal			T	R			
Oil pressure switch signal			R				T
Buzzer output signal			R	T			
ASCD SET lamp signal	T		R				
ASCD CRUISE lamp signal	T		R				
ASCD OD cancel request signal	T	R					
ASCD operation signal	T	R					
Output shaft revolution signal	R	T					
Front wiper request signal				T			R
Front wiper stop position signal				R			T
Rear window defogger switch signal				T			R
Rear window defogger control sig- nal	R						T
Manual mode signal		R	T				

VEHICLE SECURITY (THEFT WARNING) SYSTEM

Signals	ECM	TCM	Combina- tion meter	BCM	Steering angle sensor	VDC/TCS/ ABS con- trol unit	IPDM E/R
Not manual mode signal		R	T				
Manual mode shift up signal		R	T				
Manual mode shift down signal		R	T				
Manual mode indicator signal		T	R				
Hood switch signal				R			T
Theft warning horn request signal				T			R
Horn chirp signal				T			R
Steering angle sensor signal					T	R	
Malfunction indicator lamp signal (Type 3 only: From serial 329288*)	T		R				
Fuel level sensor signal (Type 3 only: From serial 329288*)	R		T				
Turbine revolution signal (Type 3 only: From serial 329288*)	R	T					

*:For further information, refer to [GI-47, "IDENTIFICATION NUMBER"](#) in GI section.

TYPE 2

System Diagram

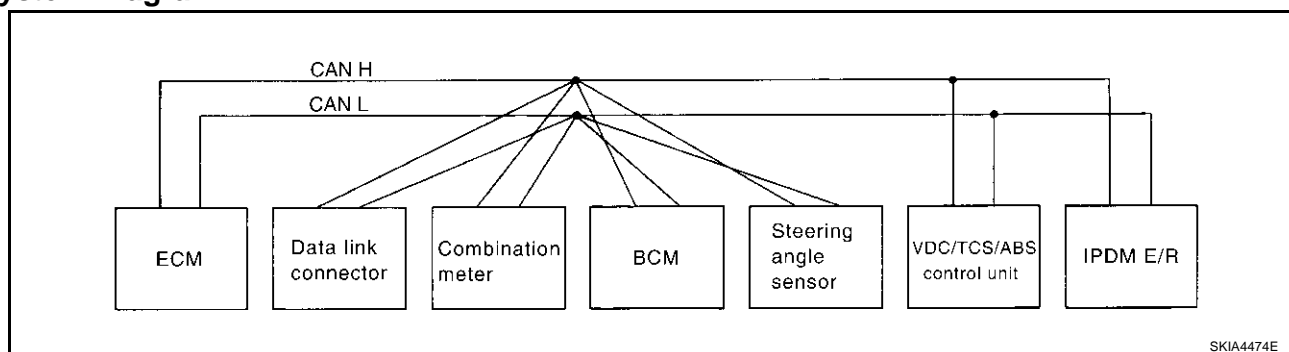

Input/Output Signal Chart

T: Transmit R: Receive

Signals	ECM	Combina- tion meter	BCM	Steering angle sen- sor	VDC/TCS/ ABS con- trol unit	IPDM E/R
Engine speed signal	T	R			R	
Engine coolant temperature signal	T	R				
Accelerator pedal position signal	T				R	
Fuel consumption monitor signal	T	R				
A/C switch signal	R		T			
A/C compressor request signal	T					R
A/C compressor feedback signal	T	R				
Blower fan motor switch signal	R		T			
Cooling fan motor operation signal	T					R
Position lights request signal		R	T			R
Low beam request signal			T			R
Low beam status signal	R		R			T
High beam request signal		R	T			R
High beam status signal	R		R			T

VEHICLE SECURITY (THEFT WARNING) SYSTEM

Signals	ECM	Combina- tion meter	BCM	Steering angle sen- sor	VDC/TCS/ ABS con- trol unit	IPDM E/R
Front fog lights request signal			T			R
Vehicle speed signal		R			T	
	R	T	R			
Sleep request 1 signal		R	T			
Sleep request 2 signal			T			R
Wake up request 1 signal		R	T			
Wake up request 2 signal		R	T			
Door switch signal (without navigation system)		R	T			R
Door switch signal (with navigation system)		T	R			
Turn indicator signal		R	T			
Seat belt buckle switch signal		T	R			
Oil pressure switch signal		R				T
Buzzer output signal		R	T			
Malfunction indicator lamp signal	T	R				
ASCD SET lamp signal	T	R				
ASCD CRUISE lamp signal	T	R				
Fuel level sensor signal	R	T				
Front wiper request signal			T			R
Front wiper stop position signal			R			T
Rear window defogger switch signal			T			R
Rear window defogger control signal	R		R			T
Hood switch signal			R			T
Theft warning horn request signal			T			R
Horn chirp signal			T			R
Steering angle sensor signal				T	R	

VEHICLE SECURITY (THEFT WARNING) SYSTEM

Schematic

AIS0002M

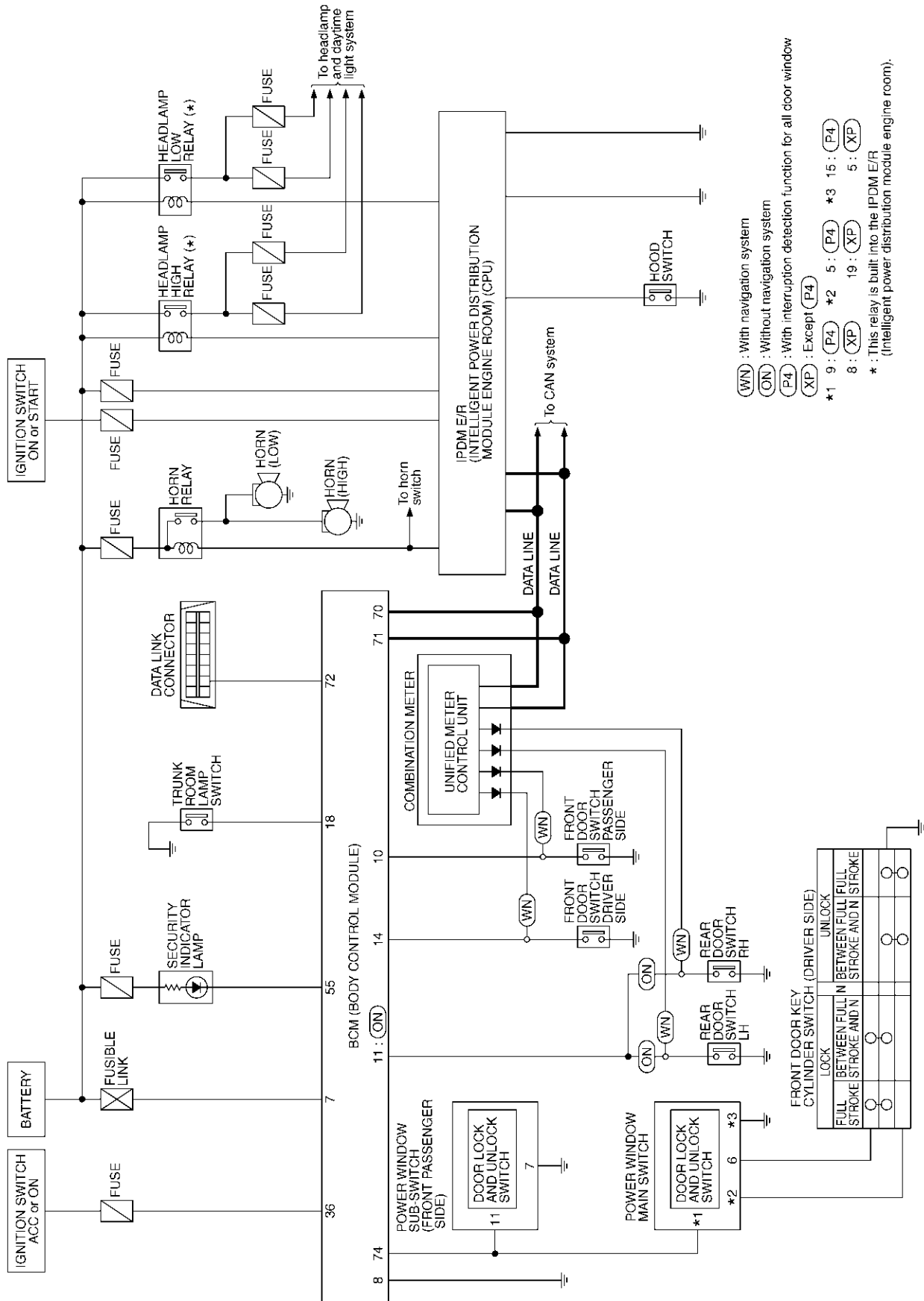

TIWT0366E

A
B
C
D
E
F
G
H
I
J
K
L
M

BL

VEHICLE SECURITY (THEFT WARNING) SYSTEM

AIS0002N

Wiring Diagram -VEHSEC-
FIG. 1

BL-VEHSEC-01

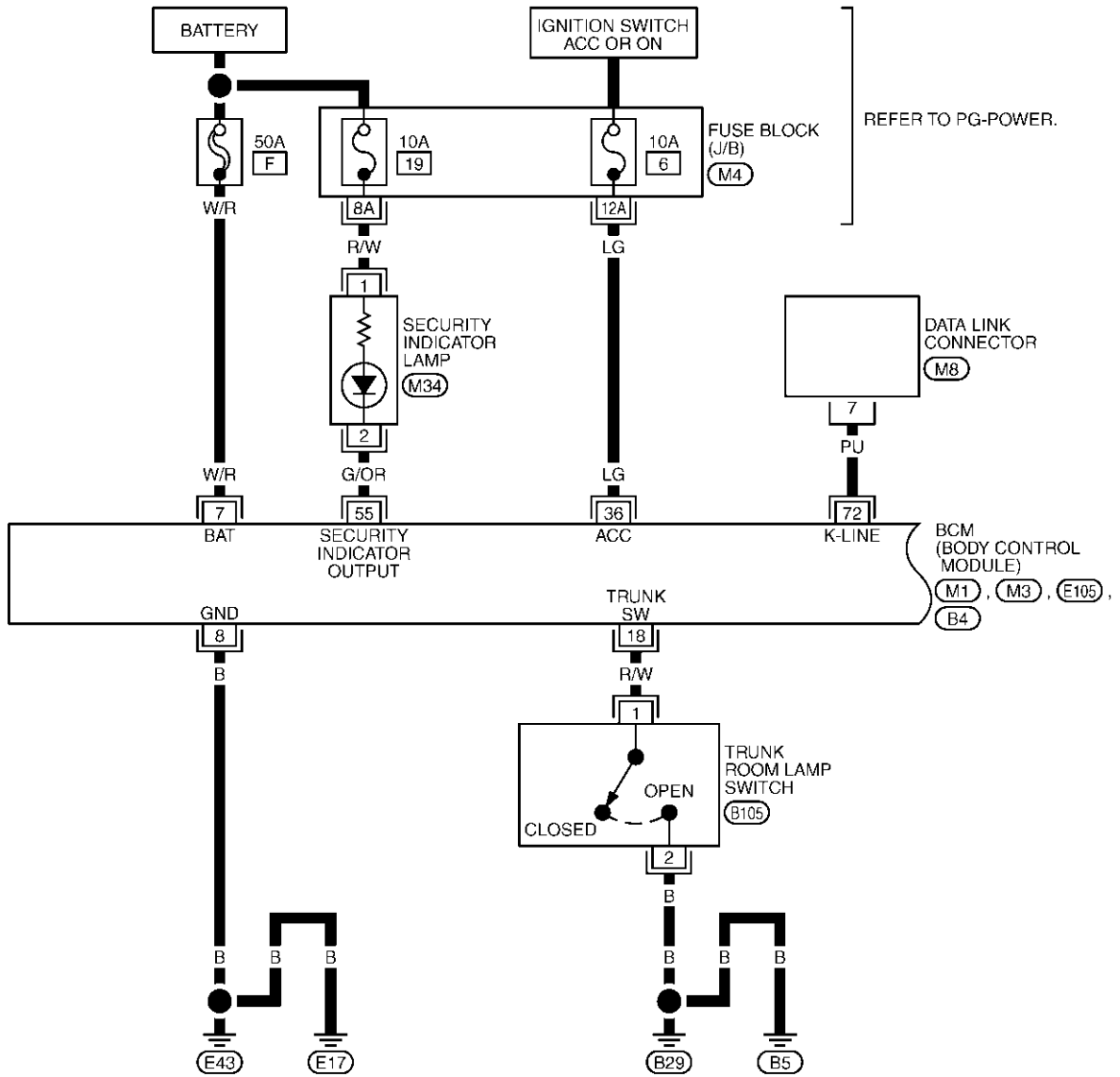

REFER TO PG-POWER.

BCM
(BODY CONTROL
MODULE)
(M1), (M3), (E105),
(B4)

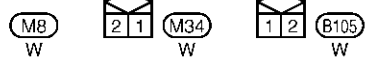
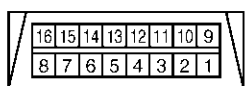

REFER TO THE FOLLOWING.
(M4) - FUSE BLOCK-JUNCTION BOX (J/B)
(M1), (M3), (E105), (B4) - ELECTRICAL UNITS

TIWT0218E

VEHICLE SECURITY (THEFT WARNING) SYSTEM

FIG. 2

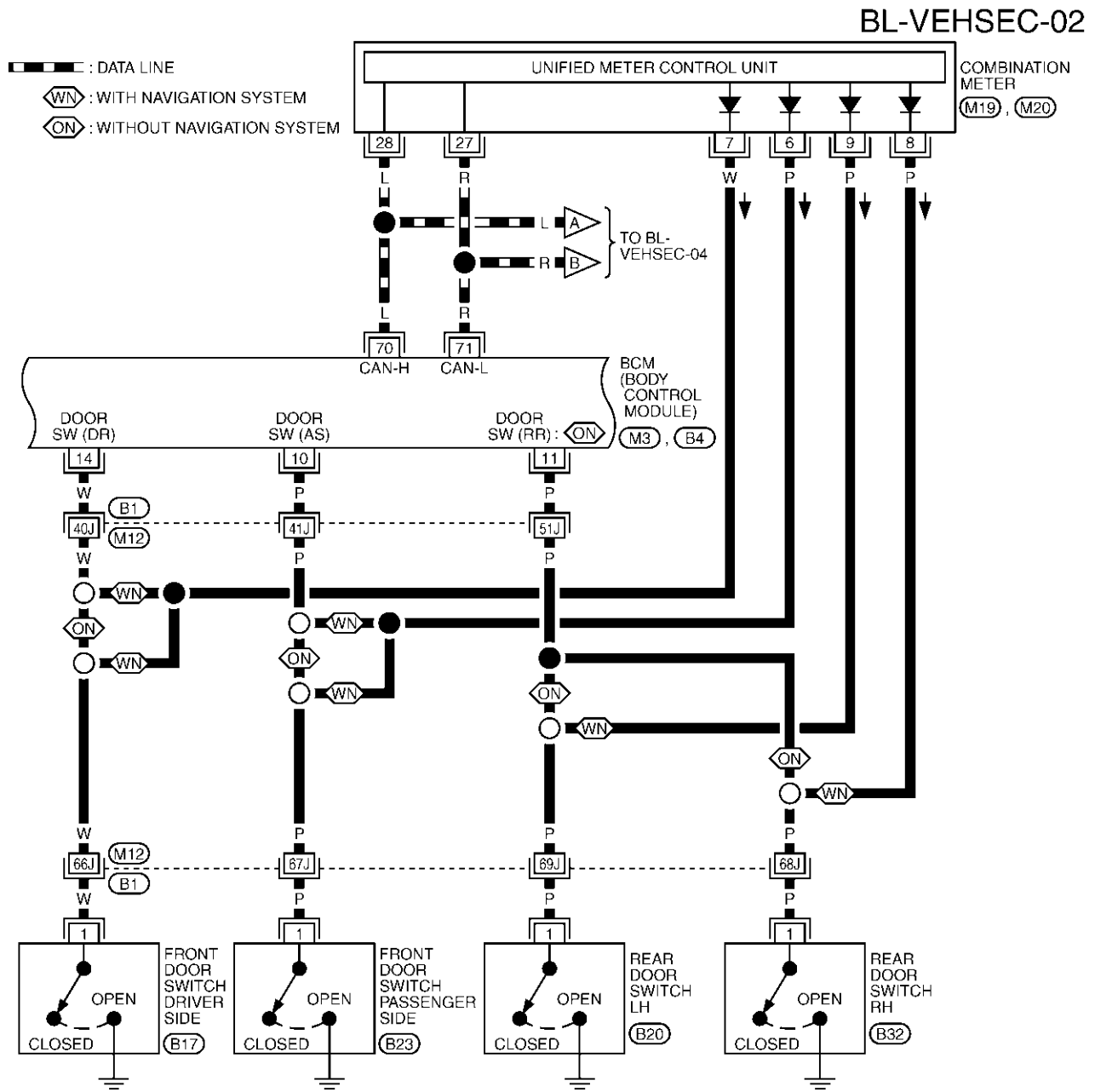

1	2	3	4	5	6	7	8	9	10	11	M19	25	26	27	28	29	30	31	32	33	34	35	M20				
12	13	14	15	16	17	18	19	20	21	22	23	24	BR	36	37	38	39	40	41	42	43	44	45	46	47	48	W

1	(B17), (B20), (B23), (B32)
2	W
3	W

REFER TO THE FOLLOWING.

(B1) -SUPER MULTIPLE JUNCTION (SMJ)

(M3), (B4) -ELECTRICAL UNITS

A
B
C
D
E
F
G
H
BL
J
K
L
M

VEHICLE SECURITY (THEFT WARNING) SYSTEM

FIG. 3

BL-VEHSEC-03

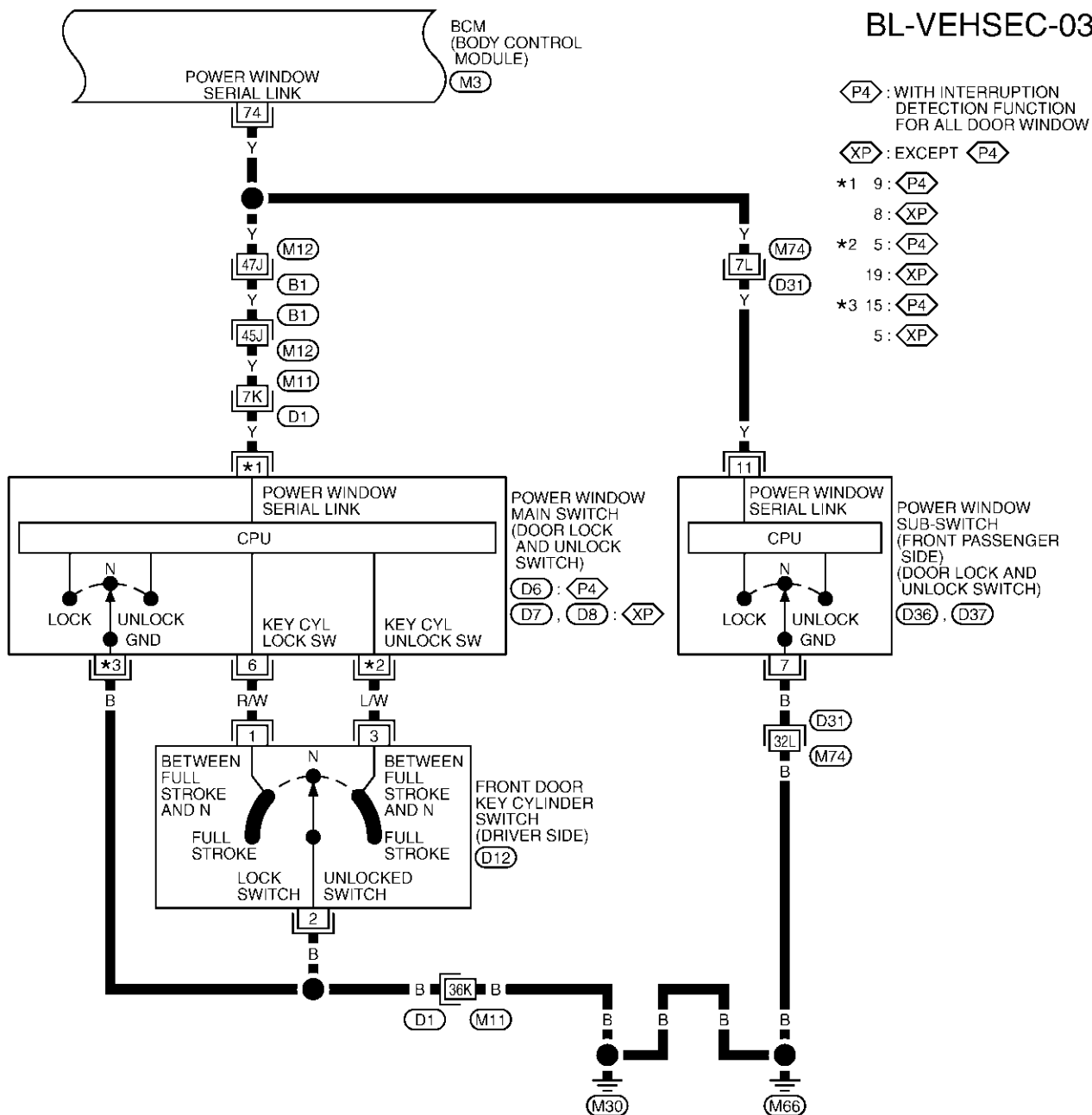

- ⬡ P4 : WITH INTERRUPTION DETECTION FUNCTION FOR ALL DOOR WINDOW
- ⬡ XP : EXCEPT ⬡ P4
- *1 9 : ⬡ P4
8 : ⬡ XP
- *2 5 : ⬡ P4
19 : ⬡ XP
- *3 15 : ⬡ P4
5 : ⬡ XP

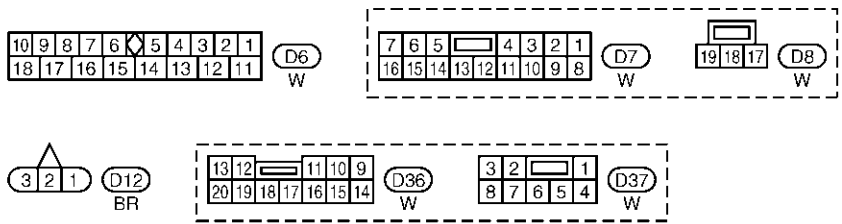

REFER TO THE FOLLOWING.
 ⬡ B1 , ⬡ D1 , ⬡ D31 -SUPER MULTIPLE JUNCTION (SMJ)
 ⬡ M3 -ELECTRICAL UNITS

VEHICLE SECURITY (THEFT WARNING) SYSTEM

FIG. 4

BL-VEHSEC-04

▬ : DATA LINE

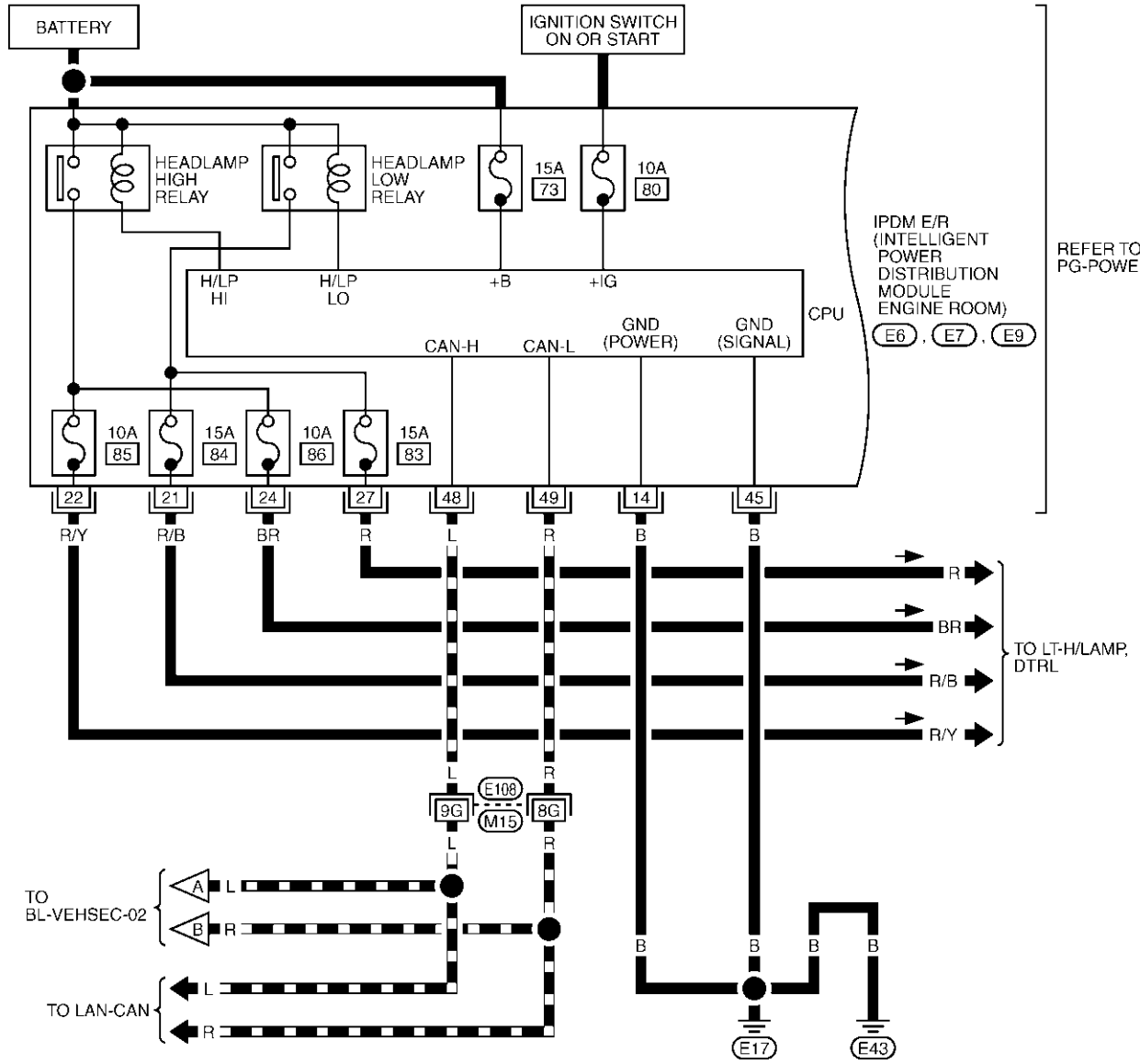

A
B
C
D
E
F
G
H
I
J
K
L
M

BL

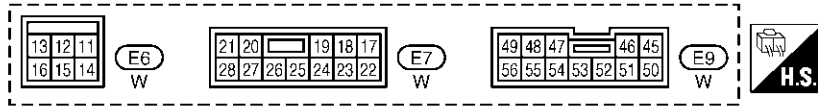

REFER TO THE FOLLOWING.

E108 -SUPER MULTIPLE JUNCTION (SMJ)

VEHICLE SECURITY (THEFT WARNING) SYSTEM

FIG. 5

BL-VEHSEC-05

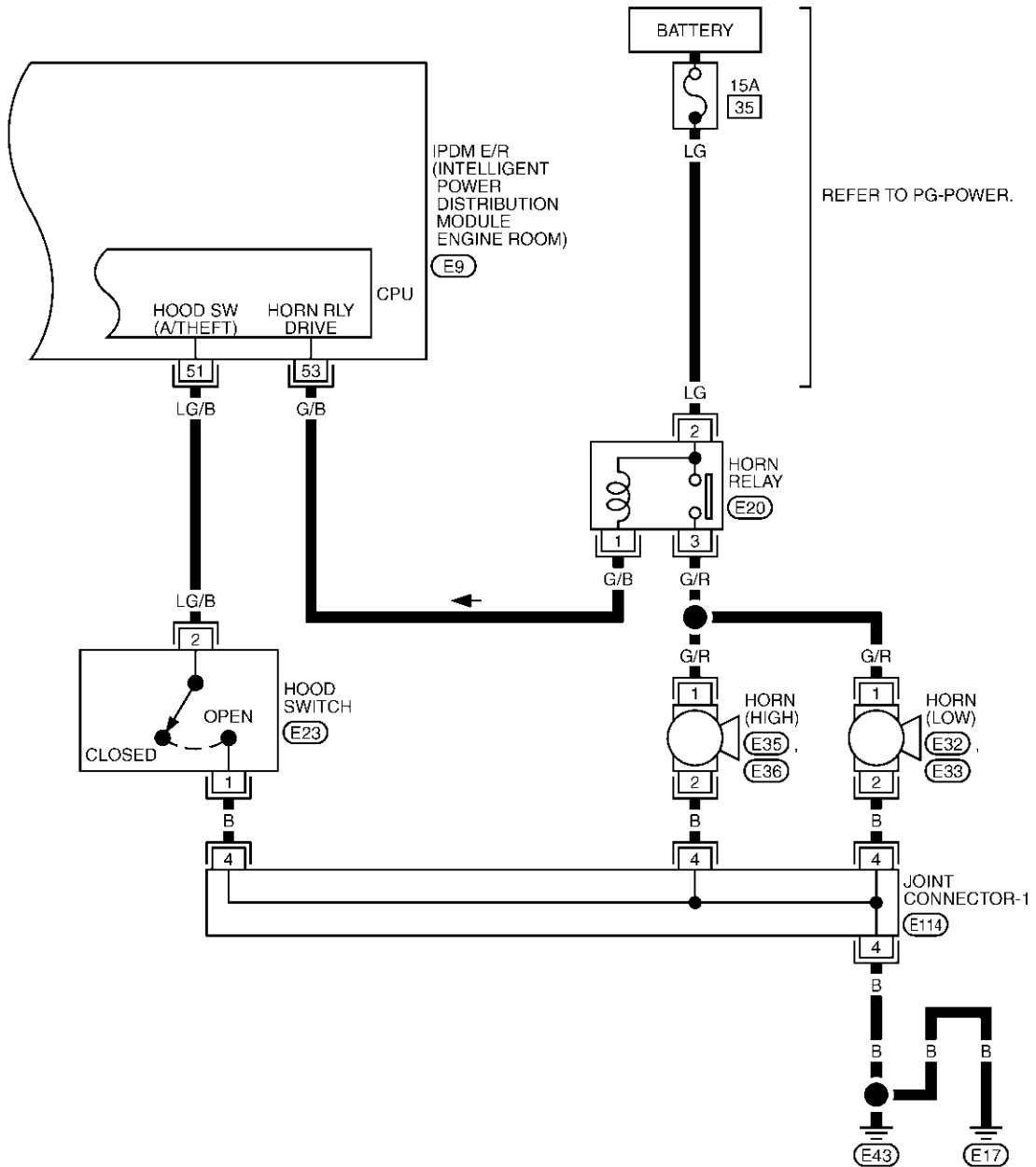

REFER TO PG-POWER.

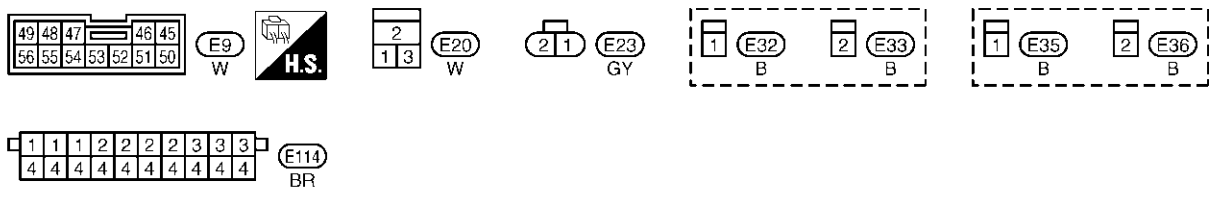

TIWT0222E

VEHICLE SECURITY (THEFT WARNING) SYSTEM

Terminals and Reference Value for BCM

AIS000A9

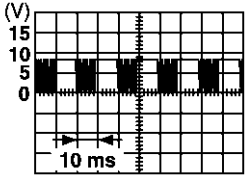
TERMINAL	WIRE COLOR	ITEM	CONDITION	VOLTAGE
7	W/R	Power source (Fusible link)	—	Battery voltage
8	B	Ground	—	0V
10	P	Passenger door switch	ON (Open) → OFF (Closed)	0V → Battery voltage
11	P	Rear door switch*	ON (Open) → OFF (Closed)	0V → Battery voltage
14	W	Driver door switch	ON (Open) → OFF (Closed)	0V → Battery voltage
18	R/W	Trunk room lamp switch	ON (Open) → OFF (Closed)	0V → Battery voltage
36	LG	ACC power supply (ACC or ON)	Ignition switch (ACC position)	Battery voltage
55	G/OR	Security indicator lamp	Goes off → Illuminates	Battery voltage → 0V
70	L	CAN - H		
71	R	CAN - L		
72	PU	Data link connector	—	—
74	Y	Power window switch (Serial link)	Ignition switch (OFF → ON)	 <p>PIIA1297E</p>

*: Without navigation system models.

Terminals and Reference Value for IPDM E/R

AIS000AA

TERMINAL	WIRE COLOR	ITEM	CONDITION	VOLTAGE
14	B	Ground	—	0V
45	B	Ground	—	0V
48	L	CAN - H		
49	R	CAN - L		
51	LG/B	Hood switch	ON (Open) → OFF (closed)	0V → Battery voltage
53	G/B	Horn relay	ON → OFF	0V → Battery voltage

CONSULT-II Function CONSULT-II INSPECTION PROCEDURE

AIS00020

1. Turn ignition switch "OFF".
2. Connect CONSULT-II and CONSULT-II CONVERTER to data link connector.

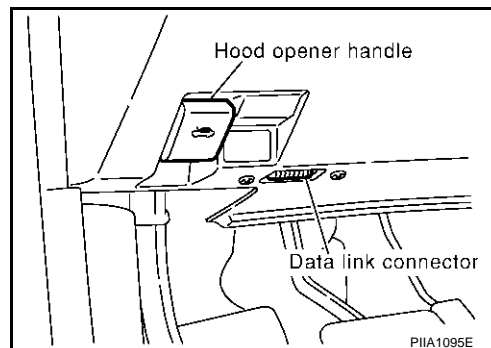

3. Turn ignition switch "ON".

VEHICLE SECURITY (THEFT WARNING) SYSTEM

4. Touch "START (NISSAN BASED VHCL)".

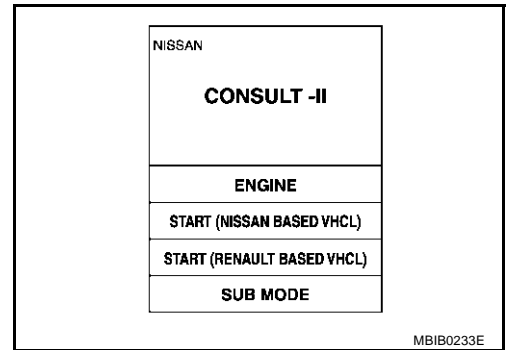

5. Touch "BCM" on the "SELECT SYSTEM" screen.
If "BCM" is not indicated, go to [GI-38. "CONSULT-II Data Link Connector \(DLC\) Circuit"](#) .

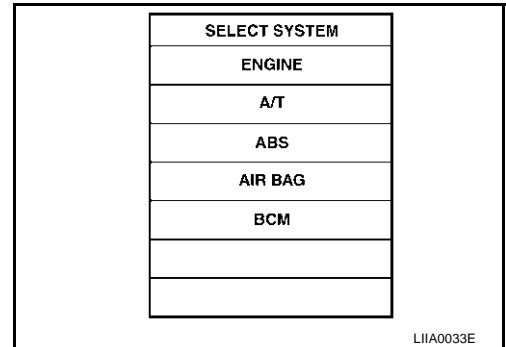

6. Touch "THEFT ALM" on the "SELECT TEST ITEM" screen.

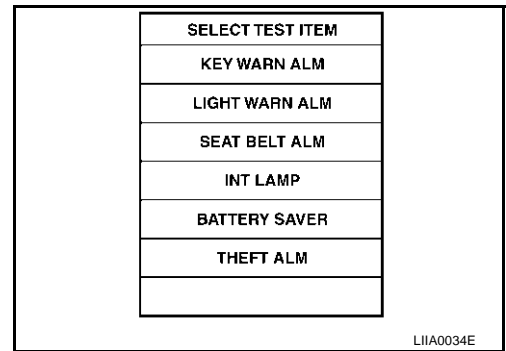

7. Select diagnosis mode.
"WORK SUPPORT, DATA MONITOR".

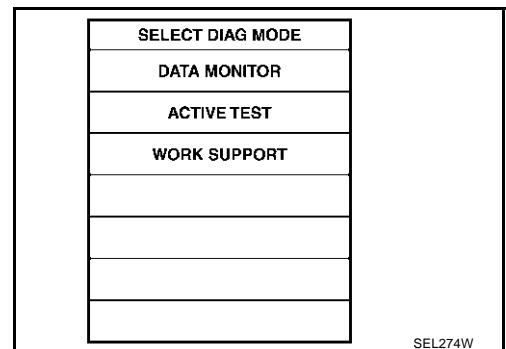

VEHICLE SECURITY (THEFT WARNING) SYSTEM

CONSULT-II APPLICATION ITEM

Data Monitor

Monitored Item	Description
IGN ON SW	Indicates [ON/OFF] condition of ignition switch.
ACC ON SW	Indicates [ON/OFF] condition of ignition switch in ACC position.
KEY CYL LK SW	Indicates [ON/OFF] condition of lock signal from key cylinder switch.
KEY CYL UN SW	Indicates [ON/OFF] condition of unlock signal from key cylinder switch.
DOOR SW-DR	Indicates [ON/OFF] condition of front door switch LH.
DOOR SW-AS	Indicates [ON/OFF] condition of front door switch RH.
DOOR SW-RR	Indicates [ON/OFF] condition of rear door switches.
TRUNK OPNR SW	Indicates [ON/OFF] condition of trunk open signal from trunk open switch.
TRUNK OPN MNTR	Indicates [ON/OFF] condition of trunk is opened/closed.
HOOD SW	Indicates [ON/OFF] condition of hood switch.
LOCK SW DR/AS	Indicates [ON/OFF] condition of lock signal from door lock/unlock switch LH and RH.
UNLK SW DR/AS	Indicates [ON/OFF] condition of unlock signal from door lock/unlock switch LH and RH.
LK BUTTON/SIG	Indicates [ON/OFF] condition of lock signal from key fob.
UN BUTTON/SIG	Indicates [ON/OFF] condition of unlock signal from key fob.
TRUNK BTN/SIG	Indicates [ON/OFF] condition of trunk open signal from key fob.

Active Test

Test Item	Description
THEFT IND	This test is able to check security indicator lamp operation. The lamp will be turned on when "ON" on CONSULT-II screen is touched.
HEADLAMP	This test is able to check vehicle security lamp operation. The headlamps will be activated for 0.5 seconds after "ON" on CONSULT-II screen is touched.
HORN	This test is able to check vehicle security horn operation. The horns will be activated for 0.5 seconds after "ON" on CONSULT-II screen is touched.

Work Support

Test Item	Description
SECURITY ALARM SET	This mode is able to confirm and change security alarm ON-OFF setting.
THEFT ALM TRG	The switch which triggered vehicle security alarm is recorded. This mode is able to confirm and erase the record of vehicle security alarm. The trigger data can be erased by touching "CLEAR" on CONSULT-II screen.

A
B
C
D
E
F
G
H
BL
J
K
L
M

VEHICLE SECURITY (THEFT WARNING) SYSTEM

Trouble Diagnosis WORK FLOW

AIS0002P

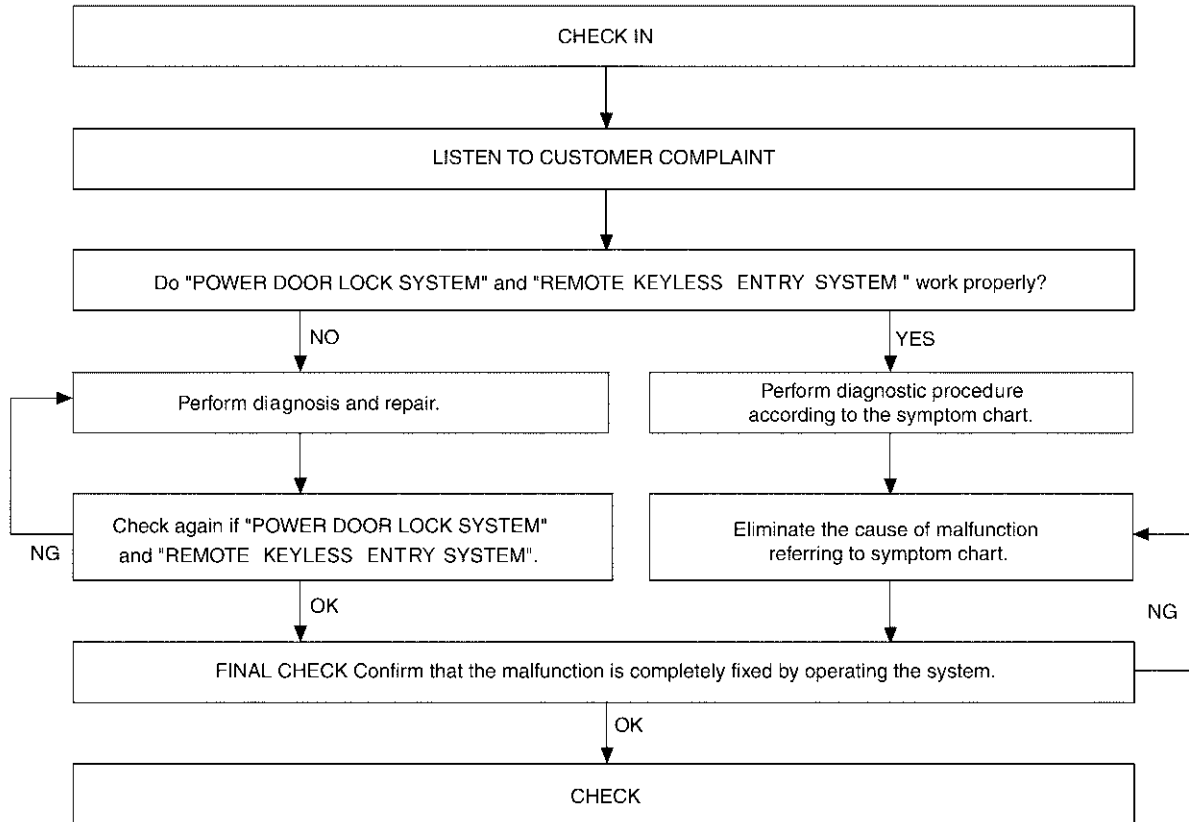

LIA0123E

- "POWER DOOR LOCK SYSTEM" Diagnosis; refer to [BL-31, "Work Flow"](#) .
- "REMOTE CONTROL SYSTEM" Diagnosis; refer to [BL-65, "Work Flow"](#) .

VEHICLE SECURITY (THEFT WARNING) SYSTEM

AIS0002Q

Preliminary Check

The system operation is canceled by turning ignition switch to "ACC" at any step between START and ARMED in the following flow chart.

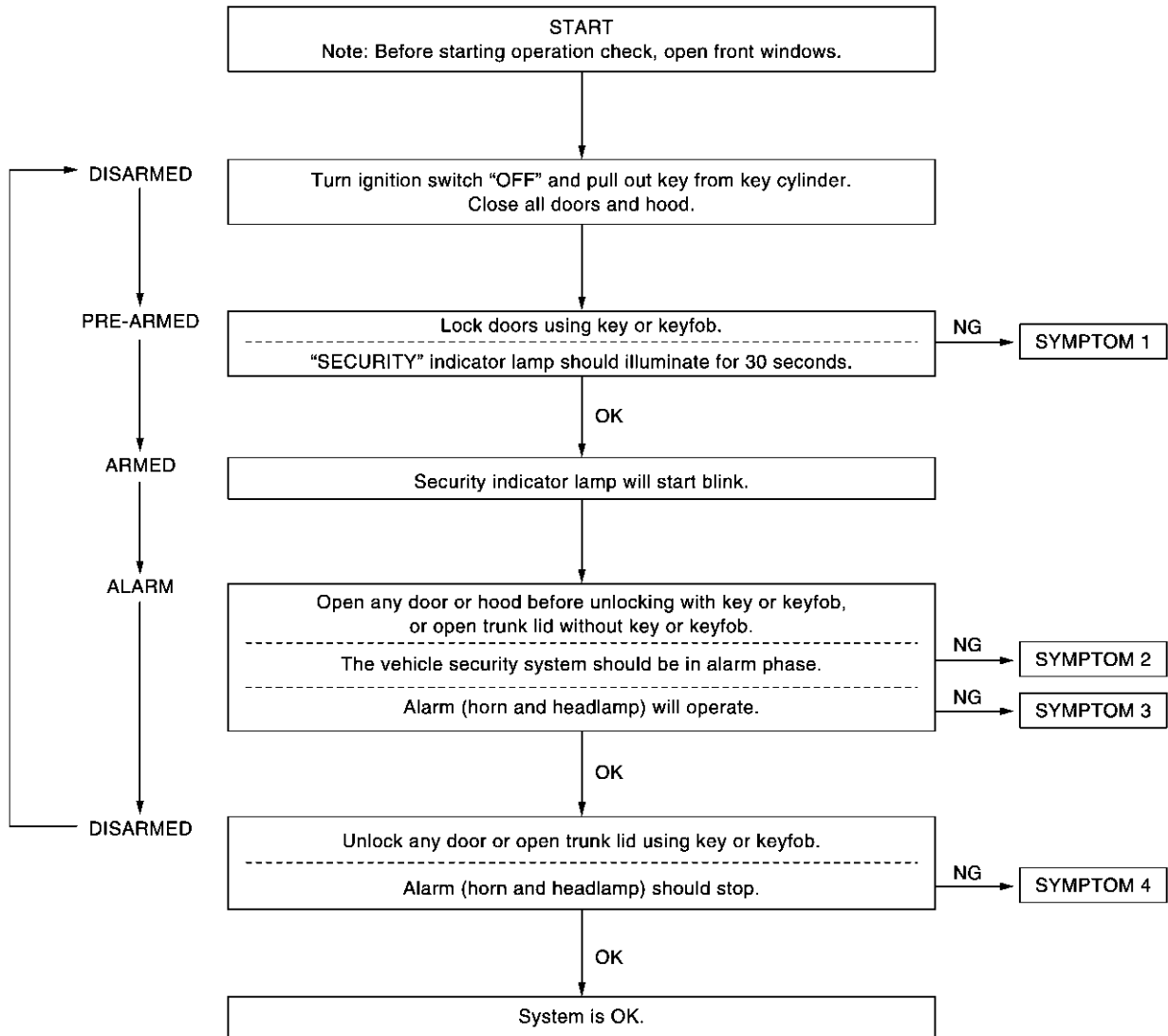

PIIA4894E

After performing preliminary check, go to symptom chart. Refer to [BL-116, "Symptom Chart"](#).

VEHICLE SECURITY (THEFT WARNING) SYSTEM

Symptom Chart

AIS0002R

PROCEDURE		Diagnostic procedure	Reference page	
SYMPTOM				
1	Vehicle security system cannot be set by	All items	Diagnostic Procedure 1 (Door, hood and trunk room lamp switch check)	BL-117
		Lock/unlock switch	Diagnostic Procedure 6 (Door lock/unlock switch check)	BL-124
		Door outside key	Diagnostic Procedure 3 (Door key cylinder switch check)	BL-123
		Key fob	Check remote keyless entry system function.	BL-65
	—	If the above systems are "OK", replace BCM.	BCS-23	
Security indicator does not turn "ON".		Diagnostic Procedure 2 (Security indicator lamp check)	BL-122	
		If the above systems are "OK", replace BCM.	BCS-23	
2	*1 Vehicle security system does not alarm when	Any door is opened.	Diagnostic Procedure 1 (Door, hood and trunk room lamp switch check)	BL-117
			If the above systems are "OK", replace BCM.	BCS-23
3	Vehicle security alarm does not activate.	Horn alarm	Diagnostic Procedure 4 (Vehicle security horn alarm check)	BL-123
			Check IPDM E/R function.	WW-39
			If the above systems are "OK", replace BCM.	BCS-23
	Head lamp alarm	Diagnostic Procedure 5 (Head lamp alarm check)	BL-124	
If the above systems are "OK", replace BCM.		BCS-23		
4	Vehicle security system cannot be canceled by	Door outside key	Diagnostic Procedure 3 (Door key cylinder switch check)	BL-123
			If the above systems are "OK", check power window main switch.	GW-45
	Key fob	Check remote keyless entry system function.	BL-65	
		If the above systems are "OK", replace BCM.	BCS-23	

*1: Make sure the system is in the armed phase.

VEHICLE SECURITY (THEFT WARNING) SYSTEM

Diagnostic Procedure 1

AIS0002S

1 - 1 CHECK DOOR SWITCH / WITH NAVIGATION SYSTEM

First perform the "SELF-DIAG RESULTS" in "BCM" with CONSULT-II, when perform the each trouble diagnosis. Refer to [BCS-16, "CAN Communication Inspection Using CONSULT-II \(Self-Diagnosis\)"](#).

1. CHECK DOOR SWITCH INPUT SIGNAL

Ⓜ With CONSULT-II

Check door switches ("DOOR SW-DR", "DOOR SW-AS" and "DOOR SW-RR") in "DATA MONITOR" mode with CONSULT-II.

Monitor item	Condition
DOOR SW-DR	CLOSE → OPEN : OFF → ON
DOOR SW-AS	
DOOR SW-RR	

DATA MONITOR	
MONITOR	
DOOR SW - DR	OFF
DOOR SW - AS	OFF
DOOR SW - RR	OFF

LIIA0035E

⊗ Without CONSULT-II

Check voltage between combination meter connector and ground.

Item	Connector	Terminals (Wire color)		Condition	Voltage (V) (Approx.)
		(+)	(-)		
Driver side	M19	7 (W)	Ground	CLOSE ↓ OPEN	Battery voltage ↓ 0
Passenger side		6 (P)			
Rear LH		9 (P)			
Rear RH		8 (P)			

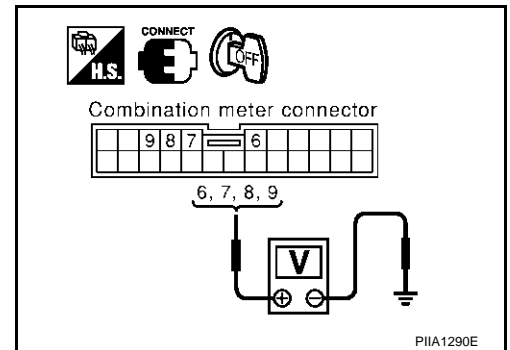

OK or NG

- OK >> Door switch circuit is OK.
- NG >> GO TO 2.

VEHICLE SECURITY (THEFT WARNING) SYSTEM

2. CHECK DOOR SWITCH

1. Turn ignition switch OFF.
2. Disconnect door switch and combination meter connector.
3. Check continuity between door switch connector B17, B23, B20, B32 terminals 1 and combination meter connector M19 terminals 7, 6, 9, 8.

Front door switch driver side

1 (W) – 7 (W) : Continuity should exist.

Front door switch passenger side

1 (P) – 6 (P) : Continuity should exist.

Rear door switch LH

1 (P) – 9 (P) : Continuity should exist.

Rear door switch RH

1 (P) – 8 (P) : Continuity should exist.

4. Check continuity between door switch connector B17, B23, B20, B32 terminals 1 and ground.

1 (W or P) – Ground : Continuity should not exist

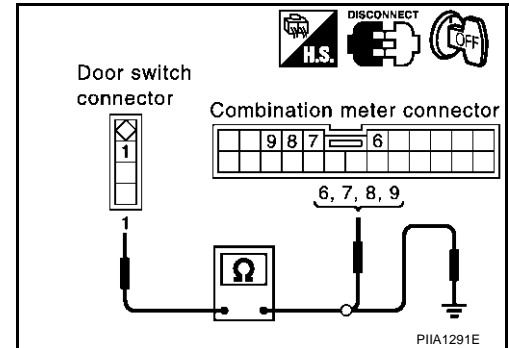

OK or NG

OK >> GO TO 3

NG >> Repair or replace harness.

3. CHECK DOOR SWITCH

Check continuity between each door switch terminal 1 and ground part of door switch.

Terminal	Door switch	Continuity
1	Pushed	No
	Released	Yes

OK or NG

OK >> GO TO 4.

NG >> Replace door switch.

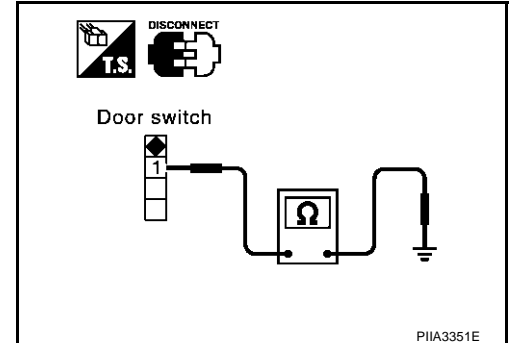

4. CHECK COMBINATION METER OUTPUT SIGNAL

1. Connect combination meter connector.
2. Check voltage between combination meter connector M19 terminals 6, 7, 8, 9 and ground.

6 (P) – Ground : Battery voltage

7 (W) – Ground : Battery voltage

8 (P) – Ground : Battery voltage

9 (P) – Ground : Battery voltage

OK or NG

OK >> Check harness connection.

NG >> Replace combination meter.

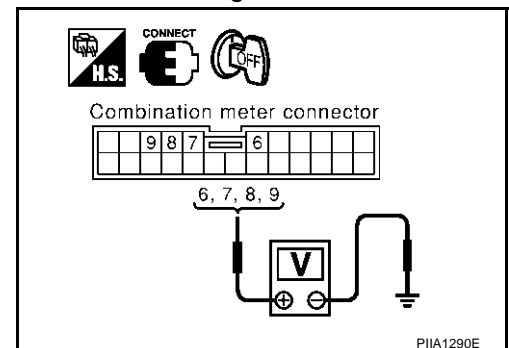

VEHICLE SECURITY (THEFT WARNING) SYSTEM

1 – 2 CHECK DOOR SWITCH / WITHOUT NAVIGATION SYSTEM

1. CHECK DOOR SWITCH INPUT SIGNAL

① With CONSULT-II

Check door switches (“DOOR SW-DR”, “DOOR SW-AS” and “DOOR SW-RR”) in “DATA MONITOR” mode with CONSULT-II.

Monitor item	Condition
DOOR SW-DR	CLOSE → OPEN : OFF → ON
DOOR SW-AS	
DOOR SW-RR	

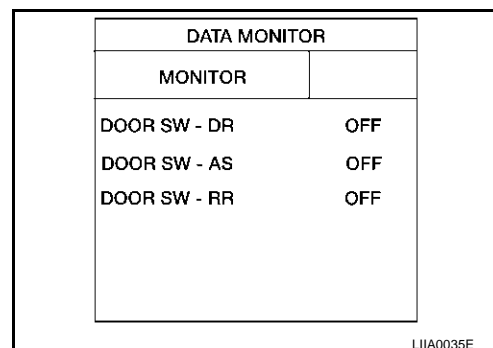

⊗ Without CONSULT-II

Check voltage between BCM connector and ground.

Item	Connector	Terminals (Wire color)		Condition	Voltage (V) (Approx.)
		(+)	(-)		
Driver side	B4	14(W)	Ground	CLOSE ↓ OPEN	Battery voltage ↓ 0
Passenger side		10 (P)			
Rear LH, RH		11 (P)			

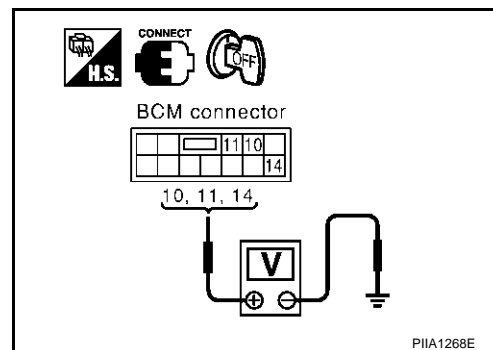

OK or NG

- OK >> Door switch circuit is OK.
- NG >> GO TO 2.

2. CHECK DOOR SWITCH CIRCUIT

1. Turn ignition switch OFF.
2. Disconnect door switch and BCM connector.
3. Check continuity between door switch connector B17, B23, B20, B32 terminals 1 and BCM connector B4 terminals 14, 10, 11.

Driver side door

1 (W) – 14 (W) : Continuity should exist.

Passenger side door

1 (P) – 10 (P) : Continuity should exist.

Rear door LH, RH

1 (P) – 11 (P) : Continuity should exist.

4. Check continuity between door switch connector B17, B23, B20, B32 terminal 1 and ground.

1 (W or P) – Ground : Continuity should not exist.

OK or NG

- OK >> GO TO 3.
- NG >> Repair or replace harness.

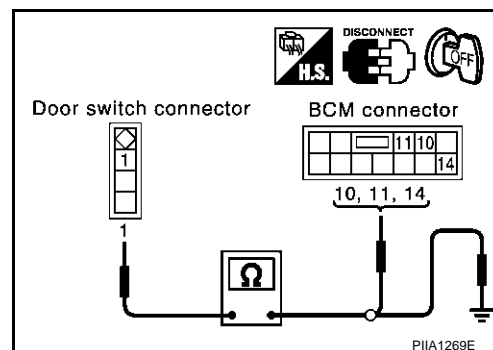

VEHICLE SECURITY (THEFT WARNING) SYSTEM

3. CHECK DOOR SWITCH

Check continuity between each door switch terminal 1 and ground part of door switch.

Terminal	Door switch	Continuity
1	Pushed	No
	Released	Yes

OK or NG

- OK >> Check harness connection.
- NG >> Replace door switch.

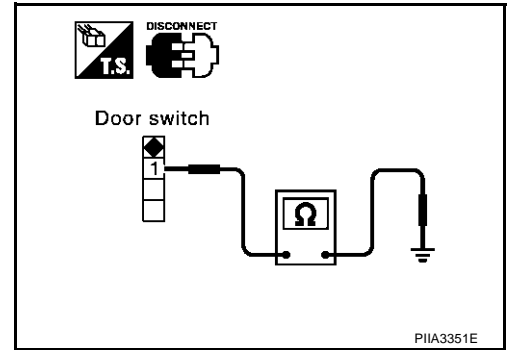

1 – 3 HOOD SWITCH CHECK

First perform the “SELF-DIAG RESULTS” in “BCM” with CONSULT-II, when perform the each trouble diagnosis. Refer to [BCS-16, "CAN Communication Inspection Using CONSULT-II \(Self-Diagnosis\)"](#).

1. CHECK HOOD SWITCH

Check hood switch and hood fitting condition.

OK or NG

- OK >> GO TO 2.
- NG >> Adjust installation of hood switch.

2. CHECK HOOD SWITCH INPUT SIGNAL

With CONSULT-II

Check “HOOD SW” in “DATA MONITOR” mode with CONSULT-II.

Monitor item	Condition
HOOD SW	Hood open : ON
	Hood closed : OFF

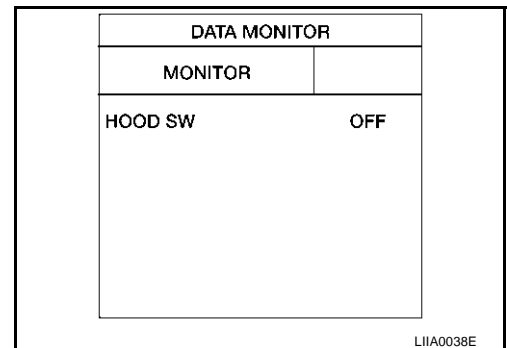

Without CONSULT-II

- Check voltage between IPDM E/R connector and ground.

Terminals (Wire color)		Condition	Voltage (V)	
(+)	(-)			
Con- nector	Terminal (Wire color)	Ground	Closed	Approx. 12
			Open	0

OK or NG

- OK >> Hood switch is OK.
- NG >> GO TO 3.

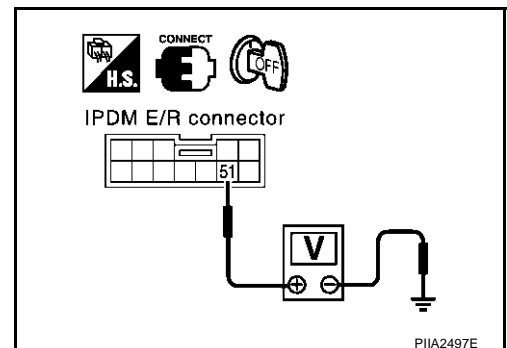

VEHICLE SECURITY (THEFT WARNING) SYSTEM

3. CHECK HOOD SWITCH

1. Disconnect hood switch connector.
2. Check continuity between hood switch connector E23 terminals 1 and 2.

Connector	Terminals	Condition	Continuity
E23	1 - 2	Pressed	No
		Released	Yes

OK or NG

OK >> Check the following.

- Hood switch ground circuit
- Harness for open or short between hood switch and IPDM E/R

NG >> Replace hood switch.

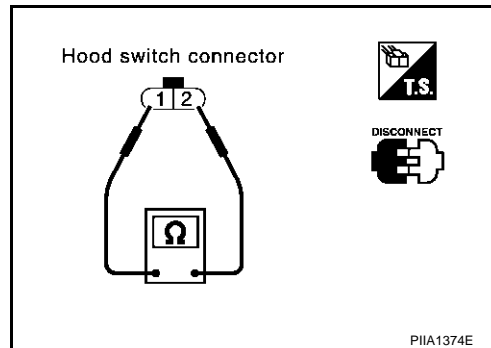

1 - 4 TRUNK ROOM LAMP SWITCH CHECK

1. CHECK TRUNK ROOM LAMP SWITCH INPUT SIGNAL

With CONSULT-II

- Check "TRUNK OPN MNTR" in "DATA MONITOR" mode with CONSULT-II.

Monitor item	Condition
TRUNK OPN MNTR	Trunk lid is open : ON
	Trunk lid is closed : OFF

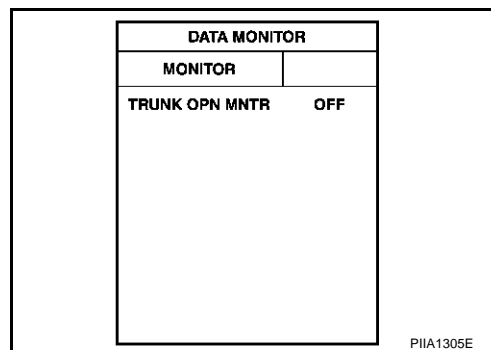

Without CONSULT-II

- Check voltage between BCM connector and ground.

Terminals (Wire color)		Condition	Voltage (V)
(+)	(-)		
E4	18 (R/W)	Closed	Approx. 12
		Open	0

OK or NG

OK >> Trunk room lamp switch is OK.

NG >> GO TO 2.

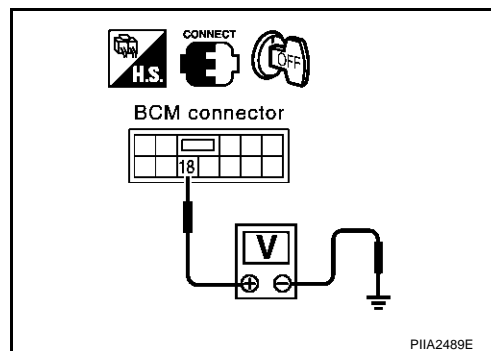

VEHICLE SECURITY (THEFT WARNING) SYSTEM

2. CHECK TRUNK ROOM LAMP SWITCH

1. Disconnect trunk room lamp switch connector.
2. Check continuity between trunk room lamp switch connector B105 terminals 1 and 2.

Connector	Terminals	Condition	Continuity
B105	1 - 2	Closed	No
		Open	Yes

OK or NG

OK >> Check the following.

- Trunk room lamp switch ground circuit
- Harness for open or short between trunk room lamp switch and BCM

NG >> Replace trunk room lamp switch.

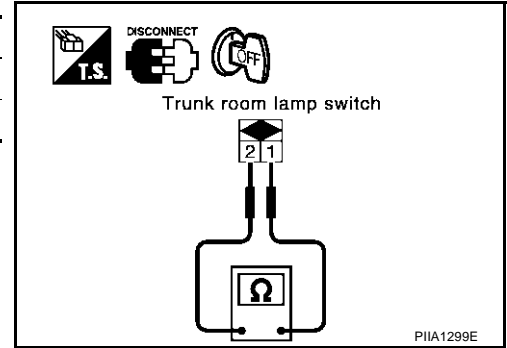

Diagnostic Procedure 2 SECURITY INDICATOR LAMP CHECK

AIS0002T

1. SECURITY INDICATOR LAMP ACTIVE TEST

With CONSULT-II

Check "THEFT IND" in "ACTIVE TEST" mode with CONSULT-II.

Perform operation shown on display indicator lamp should illuminate.

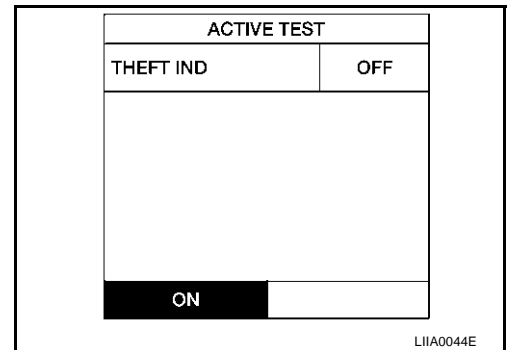

Without CONSULT-II

1. Disconnect BCM connector M3.
2. Check voltage between BCM connector M3 terminal 55 (G/OR) and ground.

Battery voltage should exist.

OK or NG

OK >> Security indicator lamp is OK.

NG >> GO TO 2.

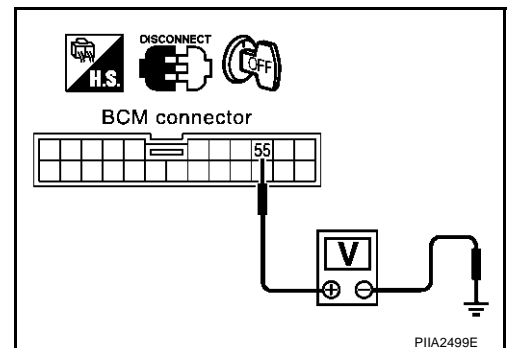

VEHICLE SECURITY (THEFT WARNING) SYSTEM

2. CHECK POWER SUPPLY CIRCUIT FOR SECURITY INDICATOR LAMP

1. Disconnect security indicator lamp connector.
2. Check voltage between security indicator lamp harness connector M34 terminal 1 (R/W) and ground.

Battery voltage should exist.

OK or NG

- OK >> Check the following.
- Harness for open or short between security indicator lamp and BCM.
 - Indicator lamp condition
- NG >> Check the following.
- 10A fuse [No. 19, located in fuse block (J/B)]
 - Harness for open or short between security indicator lamp and fuse

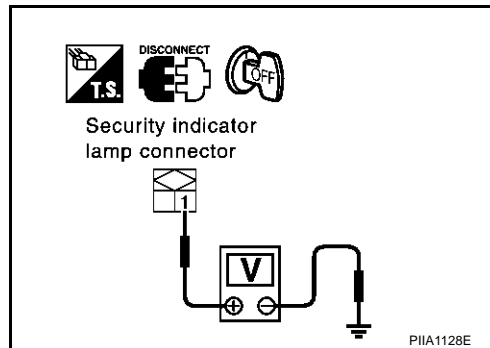

Diagnostic Procedure 3 FRONT DOOR KEY CYLINDER SWITCH CHECK

AIS0002U

1. CHECK FRONT DOOR KEY CYLINDER SWITCH DRIVER SIDE OPERATION

Do doors lock/unlock with using the key?

OK or NG

- OK >> Front door key cylinder switch operation is OK.
- NG >> Check door key cylinder switch circuit. Refer to [GW-88, "Power Window Lock Switch Circuit Check / With Front Left and Right Power Window Anti-Pinch System"](#) or [GW-89, "Power Window Lock Switch Circuit Check / With Front and Rear Power Window Anti-Pinch System"](#).

Diagnostic Procedure 4 VEHICLE SECURITY HORN ALARM CHECK

AIS0002W

First perform the "SELF-DIAG RESULTS" in "BCM" with CONSULT-II. When perform the each trouble diagnosis. Refer to [BCS-16, "CAN Communication Inspection Using CONSULT-II \(Self-Diagnosis\)"](#).

1. CHECK HORN OPERATION

Check if horn sounds with horn switch.

Does horn operate?

- Yes >> GO TO 2.
- No >> Check horn circuit. Refer to [WW-39, "HORN"](#).

2. CHECK IPDM E/R INPUT VOLTAGE

Check voltage between IPDM E/R connector E9 terminal 53 (G/B) and ground.

Connector	Terminal (Wire color)		Voltage (V) Approx.
	(+)	(-)	
E9	53 (G/B)	Ground	Battery voltage

OK or NG

- OK >> Replace IPDM E/R.
- NG >> GO TO 3.

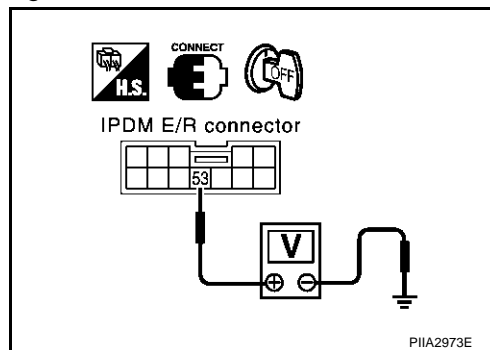

VEHICLE SECURITY (THEFT WARNING) SYSTEM

3. CHECK IPDM E/R HARNESS

1. Turn ignition switch OFF.
2. Disconnect IPDM E/R and horn relay connector.
3. Check continuity between IPDM E/R connector E9 terminal 53 (G/B) and horn relay connector E20 terminal 1 (G/B).

53 (G/B) – 1 (G/B) : Continuity should exist.

OK or NG?

- OK >> Check harness connection.
NG >> Repair or replace harness.

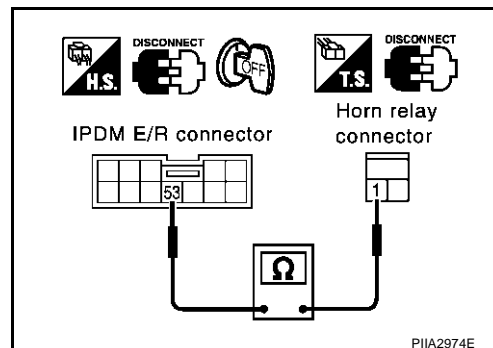

AIS0002X

Diagnostic Procedure 5 VEHICLE SECURITY HEADLAMP ALARM CHECK

1. CHECK HEAD LAMP OPERATION

Does headlamp come on with turning lighting switch "ON"?

YES or NO

- YES >> Headlamp alarm circuit is OK.
NO >> Check headlamp system. Refer to [LT-7, "HEADLAMP \(FOR USA\)"](#) , [LT-33, "HEADLAMP \(FOR CANADA\) - DAYTIME LIGHT SYSTEM -"](#) .

Diagnostic Procedure 6 DOOR LOCK AND UNLOCK SWITCH CHECK

AIS0002Y

1. CHECK DOOR LOCK AND UNLOCK SWITCH INPUT SIGNAL

Do doors lock/unlock with using power window main switch (door lock and unlock switch) or power window sub-switch (front passenger side) (door lock and unlock switch)?

YES or NO?

- YES >> Door lock and unlock switch is OK.
NO >> Refer to [BL-38, "Check Door Lock and Unlock Switch \(With Interruption Function Detection for All Door Window\)"](#) or [BL-42, "Check Door Lock and Unlock Switch \(With Interruption Function Detection for Front Door Window\)"](#) .

IVIS (INFINITI VEHICLE IMMOBILIZER SYSTEM-NATS)

IVIS (INFINITI VEHICLE IMMOBILIZER SYSTEM-NATS)

PFP:28591

Component Parts and Harness Connector Location

AIS0006D

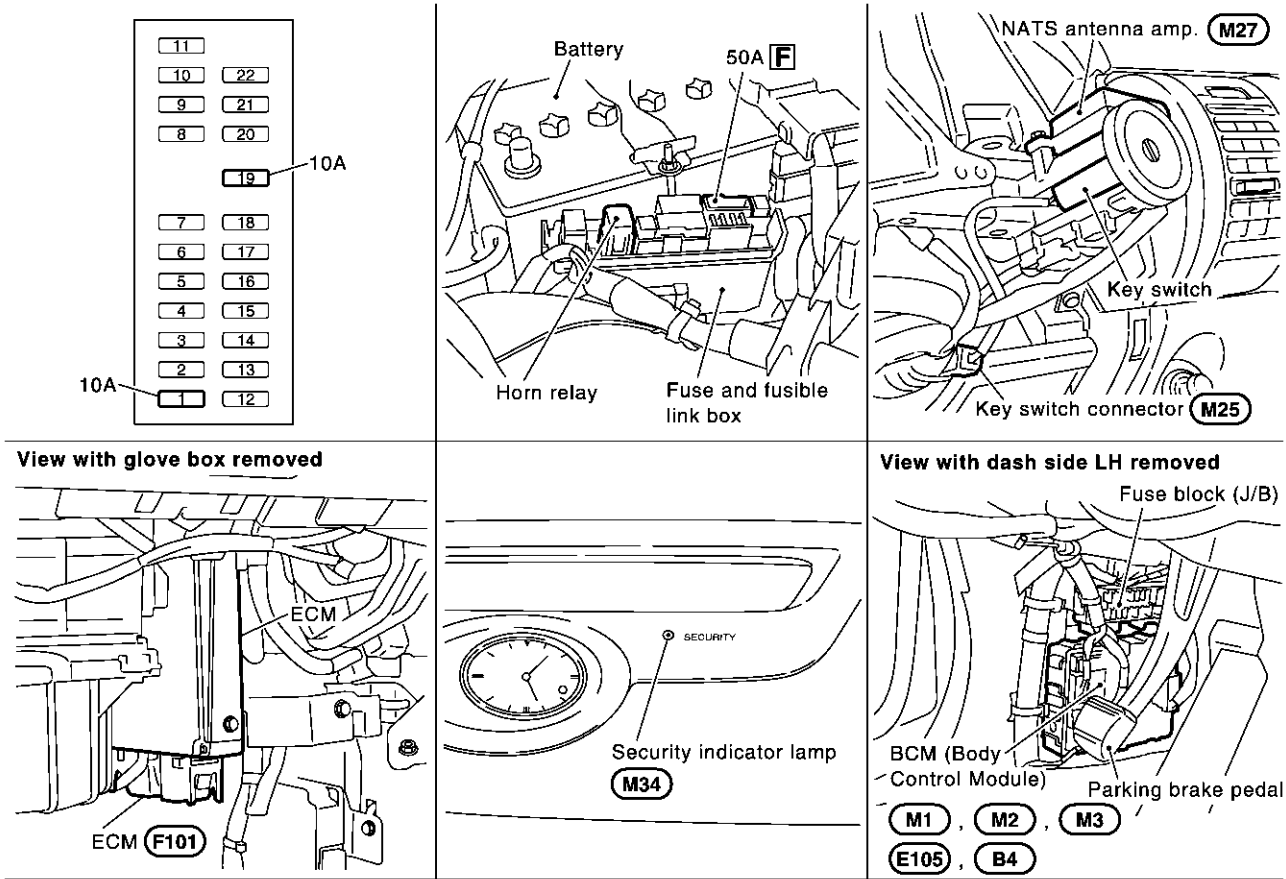

A
B
C
D
E
F
G
H
BL
J
K
L
M

IVIS (INFINITI VEHICLE IMMOBILIZER SYSTEM-NATS)

NOTE:

If customer reports a “No start” condition, request ALL KEYS to be brought to an INFINITI dealer in case of a IVIS [NATS (Nissan Anti-Theft System)] malfunction.

System Description

AIS0006E

IVIS (Infiniti Vehicle Immobilizer System-NATS) has the following immobilizer functions:

- Since only IVIS (NATS) ignition keys, whose ID nos. have been registered into the ECM and BCM (NATS control unit), allow the engine to run, operation of a stolen vehicle without a IVIS (NATS) registered key is prevented by IVIS (NATS).
That is to say, IVIS (NATS) will immobilize the engine if someone tries to start it without the registered key of IVIS (NATS).
- All of the originally supplied ignition key IDs (except for card plate key) have been IVIS (NATS) registered. If requested by the vehicle owner, a maximum of five key IDs can be registered into the IVIS (NATS) components.
- The security indicator blinks when the ignition switch is in “OFF” or “ACC” position. Therefore, IVIS (NATS) warns outsiders that the vehicle is equipped with the immobilizer system.
- When IVIS (NATS) detects trouble, the security indicator lamp lights up while ignition key is in the “ON” position.
- IVIS (NATS) trouble diagnoses, system initialization and additional registration of other IVIS (NATS) ignition key IDs must be carried out using CONSULT-II hardware and CONSULT-II IVIS (NATS) software.
When IVIS (NATS) initialization has been completed, the ID of the inserted ignition key is automatically IVIS (NATS) registered. Then, if necessary, additional registration of other IVIS (NATS) ignition key IDs can be carried out.
Regarding the procedures of IVIS (NATS) initialization and IVIS (NATS) ignition key ID registration, refer to CONSULT-II Operation Manual NATS-IVIS/NVIS.
- **When servicing a malfunction of the IVIS (NATS) (indicated by lighting up of Security Indicator Lamp) or registering another IVIS (NATS) ignition key ID no., it may be necessary to re-register original key identification. Therefore, be sure to receive ALL KEYS from vehicle owner.**

IVIS (INFINITI VEHICLE IMMOBILIZER SYSTEM-NATS)

System Composition

AIS0006F

The immobilizer function of the IVIS (NATS) consists of the following:

- NATS ignition key
- NATS antenna amp. located in the ignition key cylinder
- BCM (NATS control unit)
- Engine control module (ECM)
- Security indicator

NOTE:

The communication between ECM and BCM uses the CAN communication system.

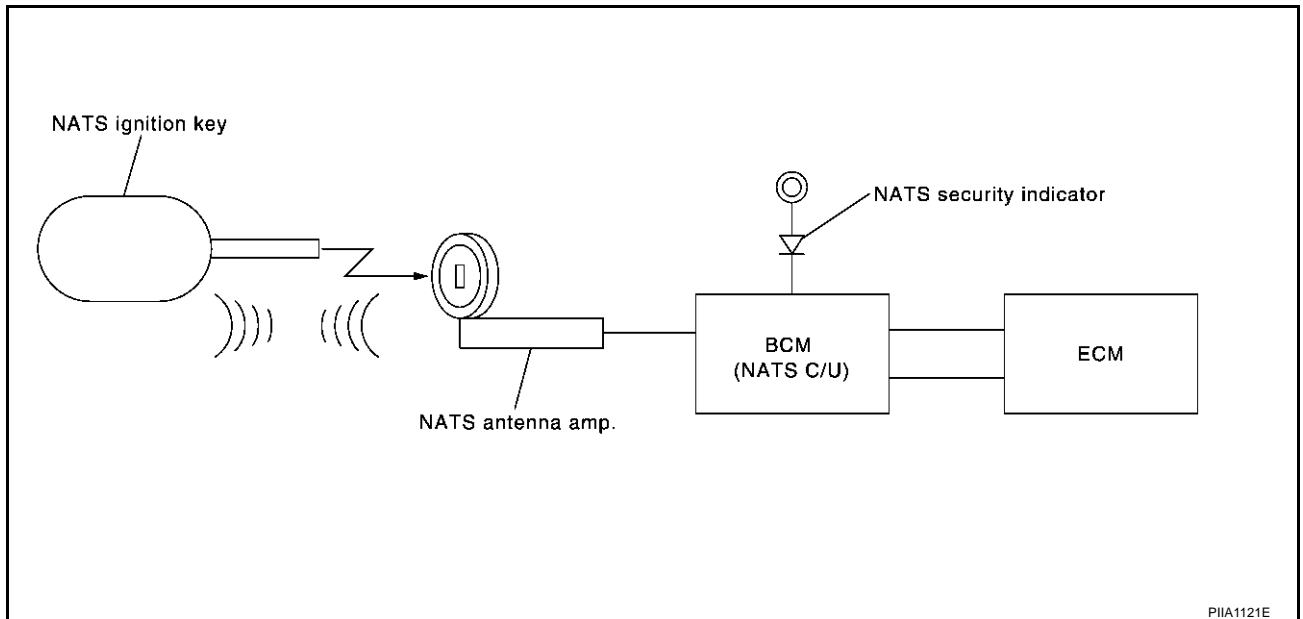

ECM Re-communicating Function

AIS000BJ

Performing following procedure can automatically perform re-communication of ECM and BCM, but only when the ECM has been replaced with a new one (*1).

*1: New one means a virgin ECM which has never been energized on-board.

(In this step, initialization procedure by CONSULT-II is not necessary)

NOTE:

- When registering new Key IDs or replacing the ECM other than brand new, refer to CONSULT-II Operation Manual NATS-IVIS/NVIS.
 - If multiple keys are attached to the key holder, separate them before work.
 - Distinguish keys with unregistered key ID from those with registered ID.
1. Install ECM.
 2. Using a registered key (*2), turn ignition switch to "ON".
*2: To perform this step, use the key (except for card plate key) that has been used before performing ECM replacement.
 3. Maintain ignition switch in "ON" position for at least 5 seconds.
 4. Turn ignition switch to "OFF".
 5. Start engine.
If engine can be started, procedure is completed.
If engine cannot be started, refer to CONSULT-II Operation Manual NATS-IVIS/NVIS and initialize control unit.

IVIS (INFINITI VEHICLE IMMOBILIZER SYSTEM-NATS)

AIS0006G

Wiring Diagram — NATS —

BL-NATS-01

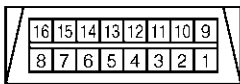
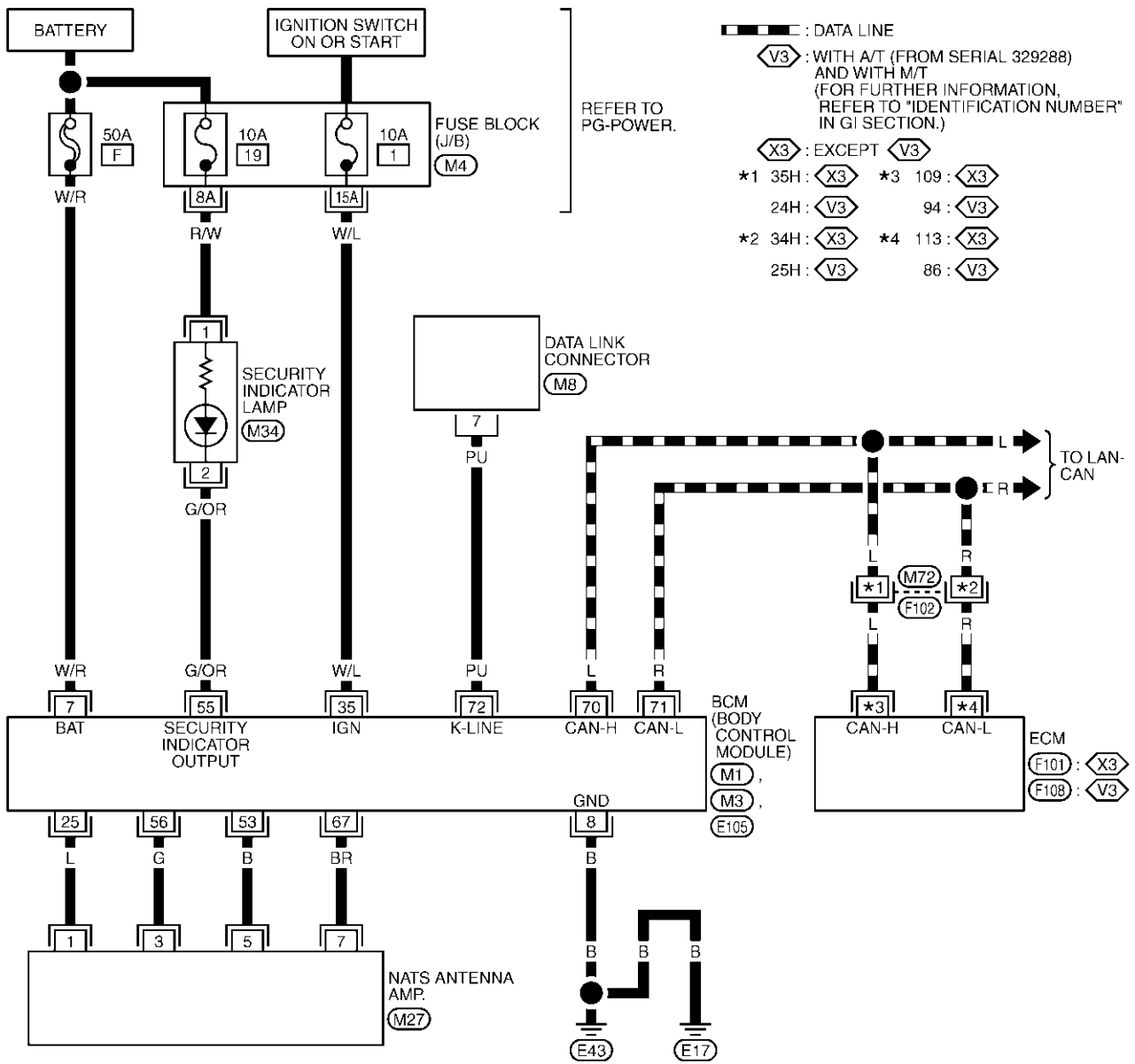

(M8) W

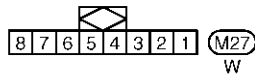

(M27) W

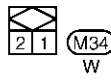

(M34) W

REFER TO THE FOLLOWING.

- (F102) -SUPER MULTIPLE JUNCTION (SMJ)
- (M4) -FUSE BLOCK-JUNCTION BOX (J/B)
- (M1), (M3), (E105), (F101), (F108) -ELECTRICAL UNITS

TIWT0477E

IVIS (INFINITI VEHICLE IMMOBILIZER SYSTEM-NATS)

Terminals and Reference Value for BCM

AIS000A8

TERMINAL	WIRE COLOR	ITEM	CONDITION	VOLTAGE
7	W/R	Power source (Fusible link)	—	Battery voltage
8	B	Ground	—	0V
25	L	NATS antenna amp.	Ignition switch: OFF → ON	0V → 5V (for 3 seconds)
35	W/L	Ignition switch (ON or START)	Ignition switch (ON or START position)	Battery voltage
53	B	NATS antenna amp.	—	0V
55	G/OR	Security indicator lamp.	Goes OFF → illuminates (Every 2.4 seconds)	Battery voltage → 0V
56	G	NATS antenna amp.	Ignition switch (OFF → ON)	Just after turning ignition switch "ON": Pointer of tester should move.
67	BR	NATS antenna amp.	Ignition switch (OFF → ON)	Just after turning ignition switch "ON": Pointer of tester should move.
70		CAN - H	—	—
71		CAN - L	—	—
72		Data link connector	—	—

CONSULT-II

CONSULT-II INSPECTION PROCEDURE

AIS0006H

1. Turn ignition switch OFF.
2. Insert IVIS (NATS) program card into CONSULT-II.
Program card : NATS (AEN02B)
3. Connect CONSULT-II and CONSULT-II CONVERTER to data link connector.
4. Turn ignition switch ON.
5. Touch "START".

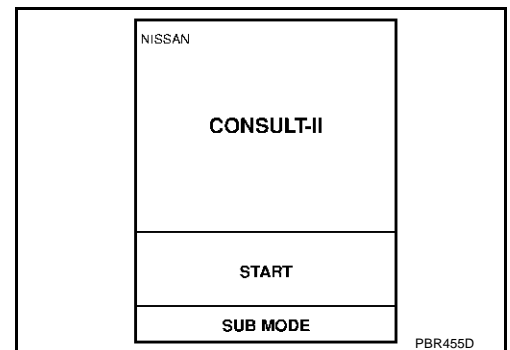
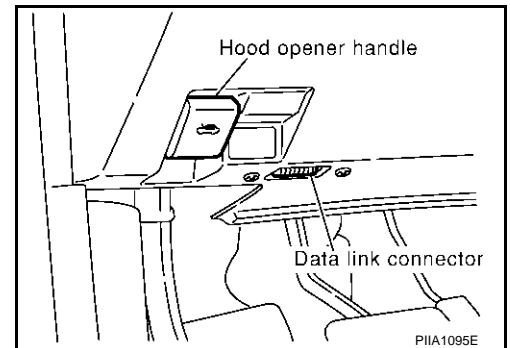

IVIS (INFINITI VEHICLE IMMOBILIZER SYSTEM-NATS)

6. Select "NATS V.5.0".

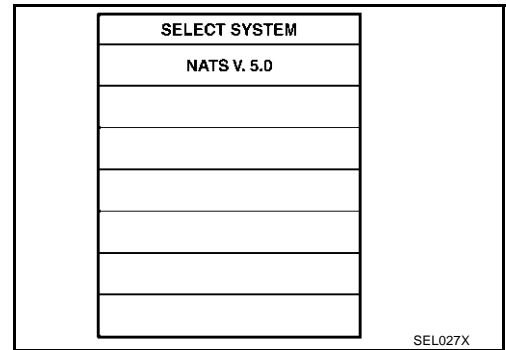

7. Perform each diagnostic test mode according to each service procedure.

For further information, see the CONSULT-II Operation Manual NATS-IVIS/NVIS.

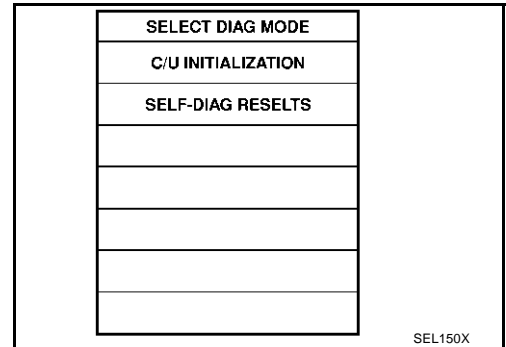

CONSULT-II DIAGNOSTIC TEST MODE FUNCTION

CONSULT-II DIAGNOSTIC TEST MODE	Description
C/U INITIALIZATION	When replacing any of the following components, C/U initialization and re-registration of all NATS ignition keys are necessary. [(NATS ignition key/ BCM (NATS control unit)/ ECM*)]
SELF-DIAG RESULTS	Detected items (screen terms) are as shown in the chart. Refer to BL-131, "IVIS (NATS) SELF-DIAGNOSTIC RESULTS ITEM CHART" .

*: When replace ECM, refer to [BL-127, "ECM Re-communicating Function"](#) .

NOTE:

- When any initialization is performed, all ID previously registered will be erased and all NATS ignition keys must be registered again.
- The engine cannot be started with an unregistered key. In this case, the system will show "DIFFERENCE OF KEY" or "LOCK MODE" as a self-diagnostic result on the CONSULT-II screen.
- In rare case, "CHAIN OF ECM-IMMU" might be stored as a self-diagnostic result during key registration procedure, even if the system is not malfunctioning.

IVIS (INFINITI VEHICLE IMMOBILIZER SYSTEM-NATS)

HOW TO READ SELF-DIAGNOSTIC RESULTS

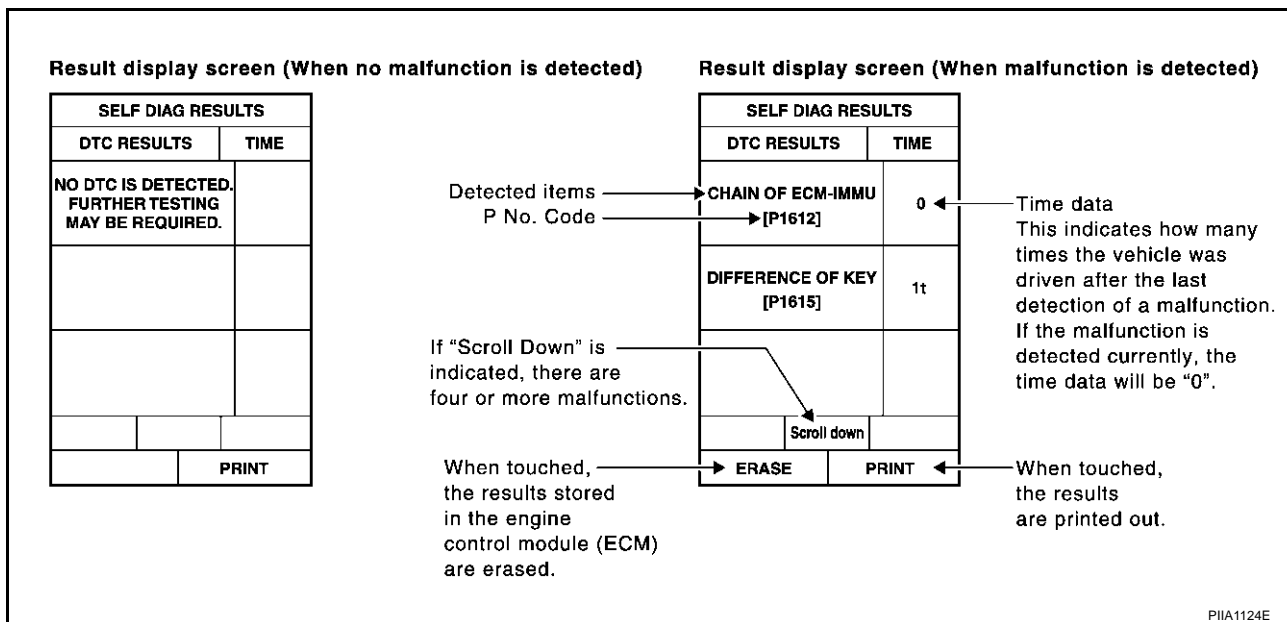

IVIS (NATS) SELF-DIAGNOSTIC RESULTS ITEM CHART

Detected items (IVIS (NATS) program card screen terms)	P No. Code (Self-diagnostic result of "ENGINE")	Malfunction is detected when....	Reference page
CHAIN OF ECM-IMMU [P1612]	NATS MAL-FUNCTION P1612	Communication impossible between ECM and BCM (NATS control unit) In rare case, "CHAIN OF ECM-IMMU" might be stored during key registration procedure, even if the system is not malfunctioning.	Refer to BL-135, "Diagnostic Procedure 1" .
DIFFERENCE OF KEY [P1615]	NATS MAL-FUNCTION P1615	BCM (NATS control unit) can receive the key ID signal but the result of ID verification between key ID and BCM (NATS control unit) is NG.	Refer to BL-136, "Diagnostic Procedure 2" .
CHAIN OF IMMU-KEY [P1614]	NATS MAL-FUNCTION P1614	BCM (NATS control unit) cannot receive the key ID signal.	Refer to BL-137, "Diagnostic Procedure 3" .
ID DISCORD, IMM-ECM [P1611]	NATS MAL-FUNCTION P1611	The result of ID verification between BCM (NATS control unit) and ECM is NG. System initialization is required.	Refer to BL-139, "Diagnostic Procedure 4" .
LOCK MODE [P1610]	NATS MAL-FUNCTION P1610	When the starting operation is carried out five or more times consecutively under the following conditions, IVIS (NATS) will shift the mode to one which prevents the engine from being started. <ul style="list-style-type: none"> ● Unregistered ignition key is used. ● BCM (NATS control unit) or ECM's malfunctioning. 	Refer to BL-141, "Diagnostic Procedure 6" .
DON'T ERASE BEFORE CHECKING ENG DIAG	—	All engine trouble codes except IVIS (NATS) trouble code has been detected in ECM.	Refer to BL-132, "Work Flow" .

IVIS (INFINITI VEHICLE IMMOBILIZER SYSTEM-NATS)

Work Flow

AIS0006I

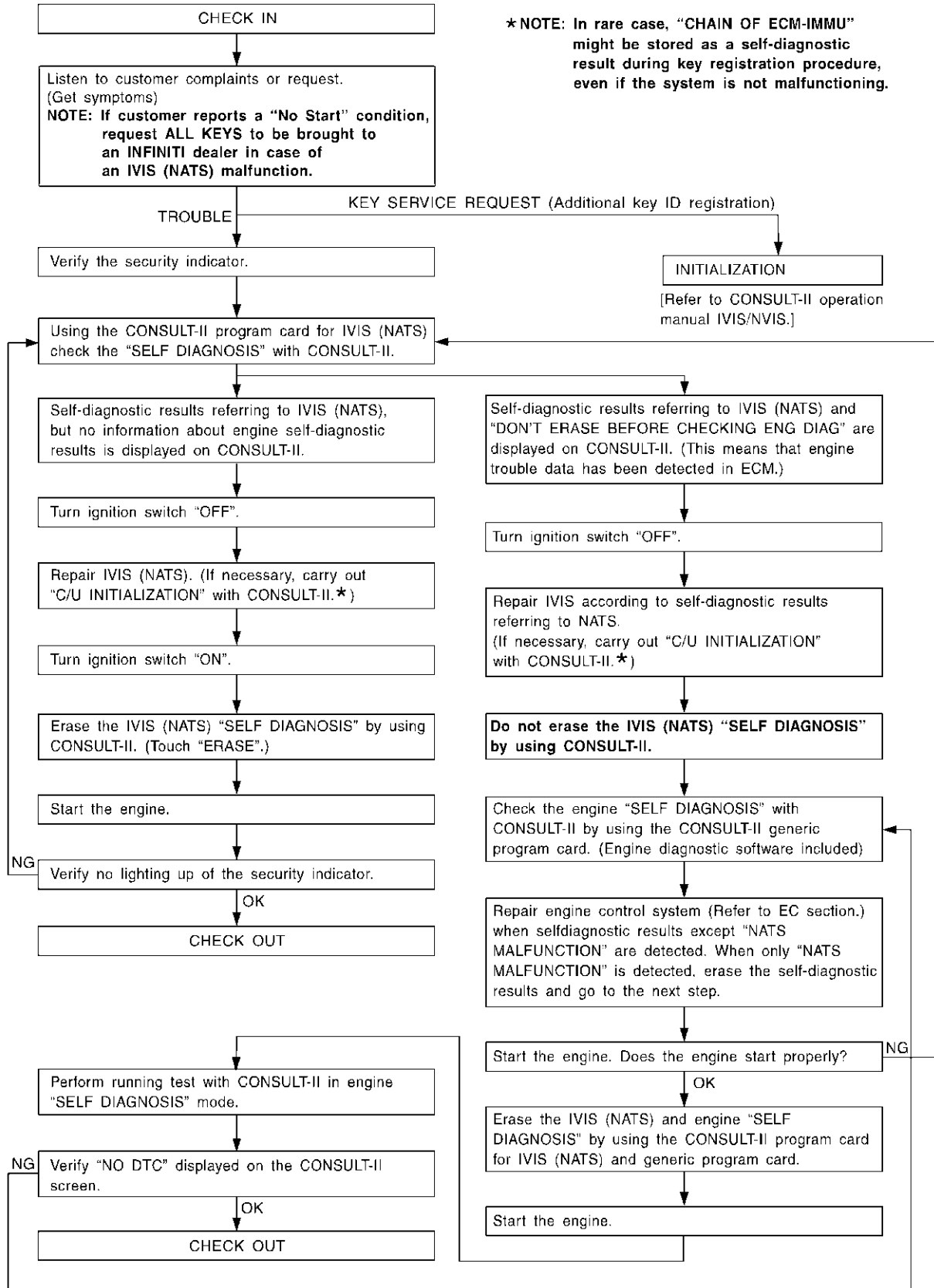

SEL024X

IVIS (INFINITI VEHICLE IMMOBILIZER SYSTEM-NATS)

AIS0006J

Trouble Diagnoses SYMPTOM MATRIX CHART 1

Self-diagnosis related item

SYMPTOM	Displayed "SELF-DIAG RESULTS" on CONSULT-II screen.	DIAGNOSTIC PROCEDURE (Reference page)	SYSTEM (Malfunctioning part or mode)	REFERENCE PART NO. OF ILLUSTRATION ON SYSTEM DIAGRAM
<ul style="list-style-type: none"> ● Security indicator lighting up* ● Engine cannot be started 	CHAIN OF ECM-IMMU [P1612]	PROCEDURE 1 (BL-135)	In rare case, "CHAIN OF ECM-IMMU" might be stored during key registration procedure, even if the system is not malfunctioning.	—
			Open circuit in battery voltage line of BCM (NATS control unit) circuit	C1
			Open circuit in ignition line of BCM (NATS control unit) circuit	C2
			Open circuit in ground line of BCM (NATS control unit) circuit	C3
			Open or short circuit between BCM (NATS control unit) and ECM	C4
			ECM	B
			BCM (NATS control unit)	A
			DIFFERENCE OF KEY [P1615]	PROCEDURE 2 (BL-136)
			BCM (NATS control unit)	A
	CHAIN OF IMMU-KEY [P1614]	PROCEDURE 3 (BL-137)	Malfunction of key ID chip	E5
			Communication line between ANT/ AMP and BCM (NATS control unit):	E1
			Open circuit or short circuit of battery voltage line or ground line	E2
			Open circuit in power source line of ANT/ AMP circuit	E3
			Open circuit in ground line of ANT/ AMP circuit	E4
			NATS antenna amp.	E6
BCM (NATS control unit)			A	
ID DISCORD, IMM-ECM [P1611]			PROCEDURE 4 (BL-139)	System initialization has not yet been completed.
		ECM	B	
LOCK MODE [P1610]	PROCEDURE 6 (BL-141)	LOCK MODE	D	
Security indicator lighting up*	DON'T ERASE BEFORE CHECKING ENG DIAG	WORK FLOW (BL-132)	Engine trouble data and IVIS (NATS) trouble data have been detected in ECM	—

*: When IVIS (NATS) detects trouble, the security indicator lights up while ignition key is in the "ON" position.

IVIS (INFINITI VEHICLE IMMOBILIZER SYSTEM-NATS)

SYMPTOM MATRIX CHART 2

Non self-diagnosis related item

SYMPTOM	DIAGNOSTIC PROCEDURE (Reference page)	SYSTEM (Malfunctioning part or mode)	REFERENCE PART NO. OF ILLUSTRATION ON SYSTEM DIAGRAM
Security indicator does not light up*.	PROCEDURE 5 (BL-140)	Security indicator.	—
		Open circuit between Fuse and BCM (NATS control unit)	—
		BCM (NATS control unit)	A

*: CONSULT-II Self-diagnostic results display screen "no malfunction is detected".

DIAGNOSTIC SYSTEM DIAGRAM

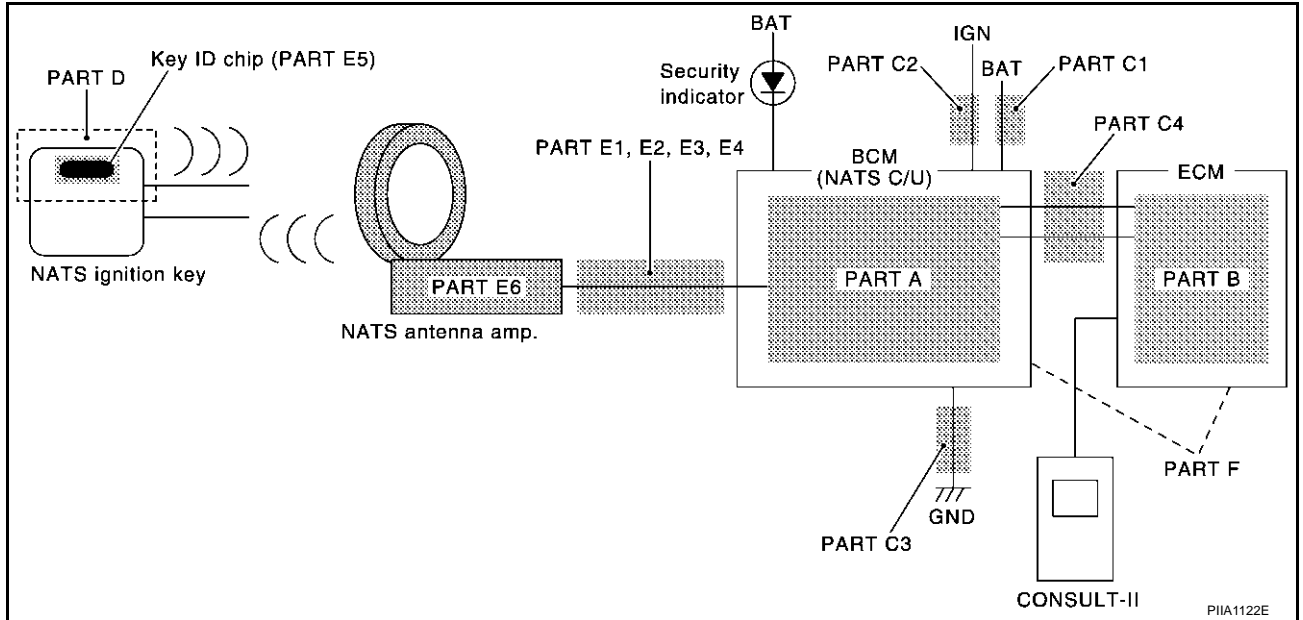

IVIS (INFINITI VEHICLE IMMOBILIZER SYSTEM-NATS)

AIS0006L

Diagnostic Procedure 1

Self-diagnostic results:

“CHAIN OF ECM-IMMU” displayed on CONSULT-II screen

First perform the “SELF-DIAG RESULTS” in “BCM” with CONSULT-II, when perform the each trouble diagnosis. Refer to [BCS-16, "CAN Communication Inspection Using CONSULT-II \(Self-Diagnosis\)"](#).

1. CONFIRM SELF-DIAGNOSTIC RESULTS

Confirm SELF-DIAGNOSTIC RESULTS “CHAIN OF ECM-IMMU” displayed on CONSULT-II screen.

NOTE:

In rare case, “CHAIN OF ECM-IMMU” might be stored during key registration procedure, even if the system is not malfunctioning.

Is CONSULT-II screen displayed as above?

Yes >> GO TO 2.

No >> GO TO [BL-133, "SYMPTOM MATRIX CHART 1"](#).

SELF DIAGNOSIS	
DTC RESULTS	TIME
CHAIN OF ECM-IMMU [P1612]	0

PIIA1260E

2. CHECK POWER SUPPLY CIRCUIT FOR BCM (NATS CONTROL UNIT)

1. Disconnect BCM (NATS control unit) connector.
2. Check voltage between BCM (NATS control unit) connector E105 terminal 7 (W/R) and ground with CONSULT-II or tester.

Battery voltage should exist.

OK or NG

OK >> GO TO 3.

NG >> Check the following

- 50A fusible link (letter **F**, located in fuse and fusible link box)
- Harness for open or short between fuse and BCM (NATS control unit) connector
Ref. Part No. C1

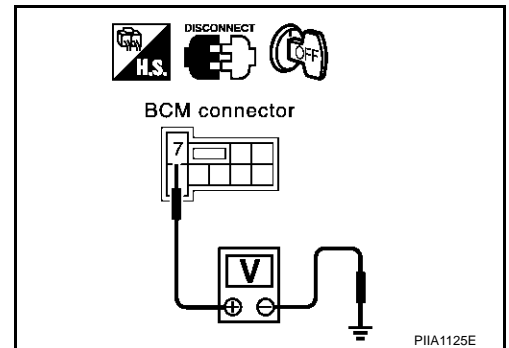

3. CHECK IGNITION SWITCH ON SIGNAL

1. Turn ignition switch ON.
2. Check voltage between BCM (NATS control unit) connector M1 terminal 35 (W/L) and ground with CONSULT-II or tester.

Battery voltage should exist.

OK or NG

OK >> GO TO 4.

NG >> Check the following.

- 10A fuse [No. 1, located in the fuse block (J/B)]
- Harness for open or short between fuse and BCM (NATS control unit) connector
Ref. part No. C2

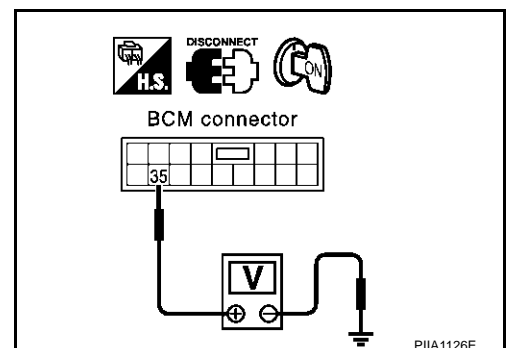

IVIS (INFINITI VEHICLE IMMOBILIZER SYSTEM-NATS)

4. CHECK GROUND CIRCUIT FOR BCM (NATS CONTROL UNIT)

1. Turn ignition switch OFF.
2. Check continuity between BCM (NATS control unit) connector E105 terminal 8 (B) and ground.

Continuity should exist.

OK or NG

- OK >> GO TO 5.
NG >> Repair harness. **Ref. part No. C3**

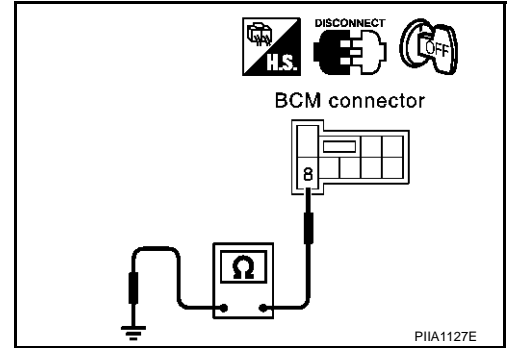

5. REPLACE BCM (NATS CONTROL UNIT)

1. Replace BCM (NATS control unit) **Ref. part No. A**
2. Perform initialization with CONSULT-II.
For initialization, refer to "CONSULT-II Operation Manual NATS-IVIS/NVIS."

Does the engine start?

- Yes >> BCM (NATS control unit) is malfunctioning.
No >> ● ECM is malfunctioning.
- Replace ECM. **Ref. part No. B**
 - Perform initialization or re-communicating function.
 - For initialization, refer to "CONSULT-II Operation Manual NATS-IVIS/NVIS."
 - For re-communication function, refer to [BL-127, "ECM Re-communicating Function"](#).

Diagnostic Procedure 2

AIS0006M

Self-diagnostic results:

"DIFFERENCE OF KEY" displayed on CONSULT-II screen

1. CONFIRM SELF-DIAGNOSTIC RESULTS

Confirm SELF-DIAGNOSTIC RESULTS "DIFFERENCE OF KEY" displayed on CONSULT-II screen.

Is CONSULT-II screen displayed as above?

- Yes >> GO TO 2.
No >> GO TO [BL-133, "SYMPTOM MATRIX CHART 1"](#).

SELF DIAG RESULTS	
DTC RESULTS	TIME
DIFFERENCE OF KEY [P1615]	0

PIA1261E

IVIS (INFINITI VEHICLE IMMOBILIZER SYSTEM-NATS)

2. PERFORM INITIALIZATION WITH CONSULT-II

Perform initialization with CONSULT-II. Re-register all NATS ignition key IDs.
For initialization and registration of NATS ignition key IDs, refer to "CONSULT-II Operation Manual NATS-IVIS/NVIS."

NOTE:

If the initialization is not completed or malfunctions, CONSULT-II shows message on the screen.

Can the system be initialized and can the engine be started with re-registered NATS ignition key?

- Yes >> ● Ignition key ID was unregistered. **Ref. part No. D**
- No >> ● BCM (NATS control unit) is malfunctioning.
● Replace BCM (NATS control unit). **Ref. part No. A**
● Perform initialization with CONSULT-II.
● For initialization, refer to "CONSULT-II Operation Manual NATS-IVIS/NVIS."

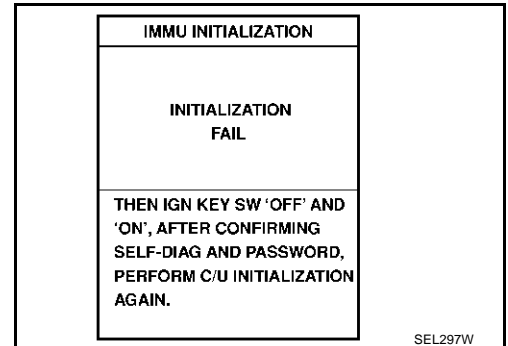

Diagnostic Procedure 3

Self-diagnostic results:

"CHAIN OF IMMU-KEY" displayed on CONSULT-II screen

1. CONFIRM SELF-DIAGNOSTIC RESULTS

Confirm SELF-DIAGNOSTIC RESULTS "CHAIN OF IMMU-KEY" displayed on CONSULT-II screen.

Is CONSULT-II screen displayed as above?

- Yes >> GO TO 2.
- No >> GO TO [BL-133, "SYMPTOM MATRIX CHART 1"](#).

SELF DIAGNOSIS	
DTC RESULTS	TIME
CHAIN OF IMMU-KEY [P1614]	0

PIIA1263E

2. CHECK NATS ANTENNA AMP. INSTALLATION

Check NATS antenna amp. installation. Refer to [BL-142, "How to Replace NATS Antenna Amp"](#).

OK or NG

- OK >> GO TO 3.
- NG >> Reinstall NATS antenna amp. correctly.

3. CHECK IVIS (NATS) IGNITION KEY ID CHIP

Start engine with another registered NATS ignition key.

Does the engine start?

- Yes >> ● Ignition key ID chip is malfunctioning.
● Replace the ignition key.
Ref. part No, E5
● Perform initialization with CONSULT-II.
For initialization, refer to "CONSULT-II Operation Manual NATS-IVIS/NVIS."
- No >> GO TO 4.

IVIS (INFINITI VEHICLE IMMOBILIZER SYSTEM-NATS)

4. CHECK POWER SUPPLY FOR NATS ANTENNA AMP.

1. Turn ignition switch "ON".
2. Check voltage between NATS antenna amp. connector M27 terminal 1 (L) and ground with CONSULT-II or tester.

Just after turning ignition switch "ON"

Voltage: Approx. 5V (For 3 seconds)

OK or NG

OK >> GO TO 5.

NG >> ● Check harness for open or short between NATS antenna amp. and BCM (NATS control unit).

NOTE:

If harness is OK, replace BCM (NATS control unit), perform initialization with CONSULT-II. For initialization, refer to "CONSULT-II Operation Manual NATS-IVIS/NVIS."

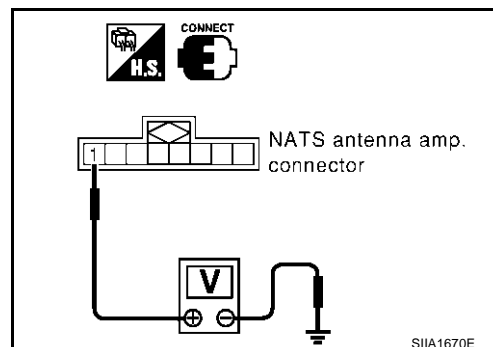

5. CHECK NATS ANTENNA AMP. SIGNAL LINE- 1

Check voltage between NATS antenna amp. connector M27 terminal 3 (G) and ground with analogue tester.

Before turning ignition switch "ON"

: Voltage: 0V

Just after turning ignition switch "ON"

: Pointer of tester should move.

OK or NG

OK >> GO TO 6.

NG >> ● Check harness for open or short between NATS antenna amp. and BCM (NATS control unit).

NOTE:

If harness is OK, replace BCM (NATS control unit), perform initialization with CONSULT-II. For initialization, refer to "CONSULT-II Operation Manual NATS-IVIS/NVIS."

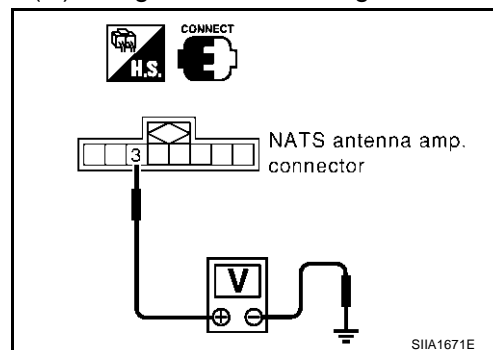

6. CHECK NATS ANTENNA AMP. SIGNAL LINE- 2

Check voltage between NATS antenna amp. connector M27 terminal 7 (BR) and ground with analogue tester.

Before turning ignition switch "ON"

: Voltage: 0V

Just after turning ignition switch "ON"

: Pointer of tester should move.

OK or NG

OK >> GO TO 7.

NG >> ● Check harness for open or short between NATS antenna amp. and BCM (NATS control unit).

NOTE:

If harness is OK, replace BCM (NATS control unit), perform initialization with CONSULT-II. For initialization, refer to "CONSULT-II Operation Manual NATS-IVIS/NVIS."

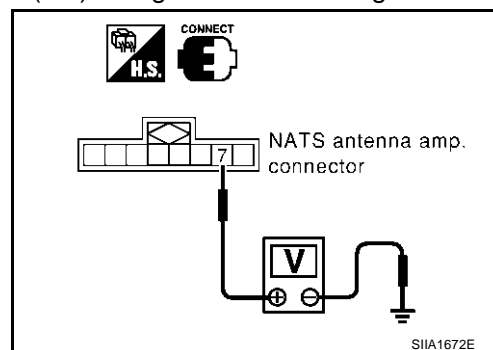

IVIS (INFINITI VEHICLE IMMOBILIZER SYSTEM-NATS)

7. CHECK NATS ANTENNA AMP. GROUND LINE CIRCUIT

1. Turn ignition switch "OFF"
2. Disconnect NATS antenna amp. connector.
3. Check continuity between NATS antenna amp. connector M27 terminal 5 (B) and ground.

Continuity should exist.

OK or NG

- OK >> ● NATS antenna amp. malfunctioning.
Ref. part No. E6
- NG >> ● Check harness for open or short between NATS antenna amp. and BCM (NATS control unit).

NOTE:

If harness is OK, replace BCM (NATS control unit), perform initialization with CONSULT-II. For initialization, refer to "CONSULT-II Operation Manual NATS-IVIS/NVIS.

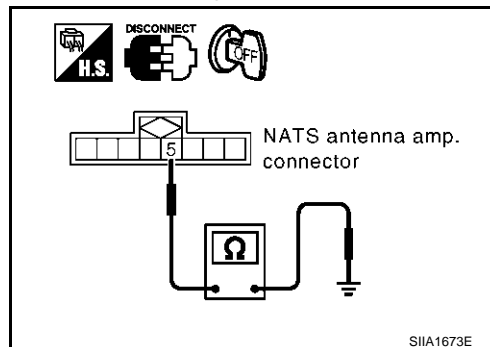

Diagnostic Procedure 4

Self-diagnostic results:

"ID DISCORD, IMM-ECM" displayed on CONSULT-II screen

1. CONFIRM SELF-DIAGNOSTIC RESULTS

Confirm SELF-DIAGNOSTIC RESULTS "ID DISCORD, IMM-ECM" displayed on CONSULT-II screen.

NOTE:

"ID DISCORD IMM-ECM":

Registered ID of BCM (NATS control unit) is in discord with that of ECM.

Is CONSULT-II screen displayed as above?

- Yes >> GO TO 2.
No >> GO TO [BL-133, "SYMPTOM MATRIX CHART 1"](#).

SELF DIAG RESULTS	
DTC RESULTS	TIME
ID DISCORD, IMM-ECM [P1611]	0

2. PERFORM INITIALIZATION WITH CONSULT-II

Perform initialization with CONSULT-II. Re-register all NATS ignition key IDs.

For initialization, refer to "CONSULT-II Operation Manual NATS-IVIS/NVIS.

NOTE:

If the initialization is not completed or malfunctions, CONSULT-II shows message on the screen.

Can the system be initialized?

- Yes >> ● Start engine. (END)
● (System initialization had not been completed. **Ref. part No. B**)
- No >> ● ECM is malfunctioning.
● Replace ECM. **Ref. part No. B**
● Perform initialization with CONSULT-II.
For initialization, refer to "CONSULT-II Operation Manual NATS-IVIS/NVIS.

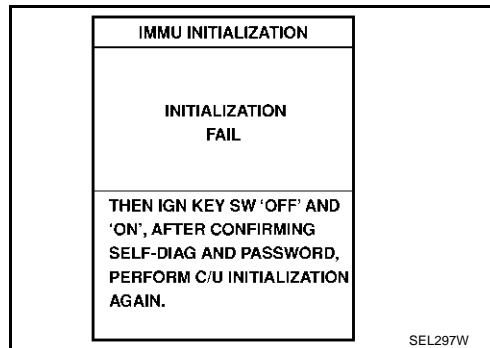

IVIS (INFINITI VEHICLE IMMOBILIZER SYSTEM-NATS)

AI/S0006P

Diagnostic Procedure 5

“SECURITY INDICATOR LAMP DOES NOT LIGHT UP”

1. CHECK FUSE

Check 10A fuse [No. 19, located in the fuse block (J/B)]

10A fuse OK

- OK >> GO TO 2.
- NG >> Replace fuse.

2. CHECK SECURITY INDICATOR LAMP

1. Install 10A fuse.
2. Start engine and turn ignition switch OFF.
3. Check the security indicator lamp lights up.

Security indicator lamp should be light up.

OK or NG

- OK >> Inspection END.
- NG >> GO TO 3.

3. CHECK SECURITY INDICATOR LAMP POWER SUPPLY CIRCUIT

1. Disconnect security indicator lamp connector.
2. Check voltage between security indicator lamp connector M34 terminal 1 (R/W) and ground.

Battery voltage should exist.

OK or NG

- OK >> GO TO 4.
- NG >> Check harness for open or short between fuse and security indicator lamp.

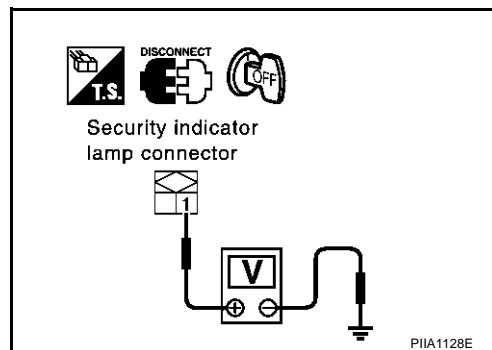

4. CHECK BCM (NATS CONTROL UNIT) FUNCTION

1. Connect security indicator lamp connector.
2. Disconnect BCM (NATS control unit) connector M3.
3. Check voltage between BCM (NATS control unit) connector M3 terminal 55 (G/OR) and ground.

Battery voltage should exist.

OK or NG

- OK >> BCM (NATS control unit) is malfunctioning.
 - Replace BCM (NATS control unit)
Ref. part No. A
 - Perform initialization with CONSULT-II.
 - For initialization, refer to “CONSULT-II Operation Manual NATS-IVIS/NVIS.
- NG >> Check the following.
 - Harness for open or short between security indicator lamp and BCM (NATS control unit).
 - Indicator lamp condition.

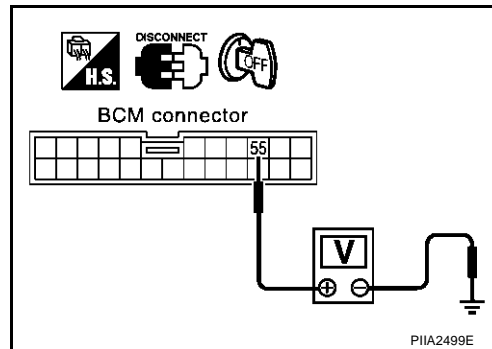

IVIS (INFINITI VEHICLE IMMOBILIZER SYSTEM-NATS)

AIS0006Q

Diagnostic Procedure 6

Self-diagnostic results:

“LOCK MODE” displayed on CONSULT-II screen

1. CONFIRM SELF-DIAGNOSTIC RESULTS

Confirm SELF-DIAGNOSTIC RESULTS “LOCK MODE” is displayed on CONSULT-II screen.

Is CONSULT-II screen displayed as above?

- Yes >> GO TO 2.
- No >> GO TO [BL-133, "SYMPTOM MATRIX CHART 1"](#).

SELF DIAG RESULTS	
DTC RESULTS	TIME
LOCK MODE [P1610]	0

PIIA1264E

2. ESCAPE FROM LOCK MODE

1. Turn ignition switch OFF.
2. Turn ignition switch ON with registered key. (Do not start engine.) Wait 5 seconds.
3. Return the key to OFF position. Wait 5 seconds.
4. Repeat steps 2 and 3 twice (total of three cycles).
5. Start the engine.

Does engine start?

- Yes >> System is OK (Now system is escaped from “LOCK MODE”).
- No >> GO TO 3.

3. PERFORM INITIALIZATION WITH CONSULT-II

Perform initialization with CONSULT-II.

For initialization, refer to “CONSULT-II Operation Manual NATS-IVIS/NVIS.

NOTE:

If the initialization is not completed or malfunctions, CONSULT-II shows the message on the screen.

Can the system be initialized?

- Yes >> System is OK.
- No >> GO TO 4

IMMU INITIALIZATION
INITIALIZATION FAIL
THEN IGN KEY SW 'OFF' AND 'ON', AFTER CONFIRMING SELF-DIAG AND PASSWORD, PERFORM C/U INITIALIZATION AGAIN.

SEL297W

A

B

C

D

E

F

G

H

BL

J

K

L

M

IVIS (INFINITI VEHICLE IMMOBILIZER SYSTEM-NATS)

4. PERFORM INITIALIZATION WITH CONSULT-II AGAIN

1. Replace BCM (NATS control unit).
2. Perform initialization with CONSULT-II.
For initialization, refer to "CONSULT-II Operation Manual NATS-IVIS/NVIS.

NOTE:

If the initialization is not completed or malfunctions, CONSULT-II shows the message on the screen.

Can the system be initialized?

- Yes >> System is OK. (BCM (NATS control unit) is malfunctioning. **Ref. part No. A**)
- No >> ● ECM is malfunctioning.
Replace ECM. **Ref. part No. B**
Perform initialization with CONSULT-II.
For initialization, refer to "CONSULT-II Operation Manual NATS-IVIS/NVIS.

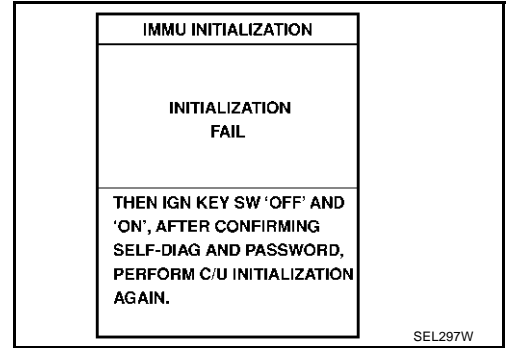

How to Replace NATS Antenna Amp

AIS0006T

NOTE:

- If NATS antenna amp. is not installed correctly, IVIS (NATS) system will not operate properly and SELF-DIAG RESULTS on CONSULT-II screen will show "LOCK MODE" or "CHAIN OF IMMU- KEY".
- Initialization is not necessary only when NATS antenna amp. is replaced with a new one.

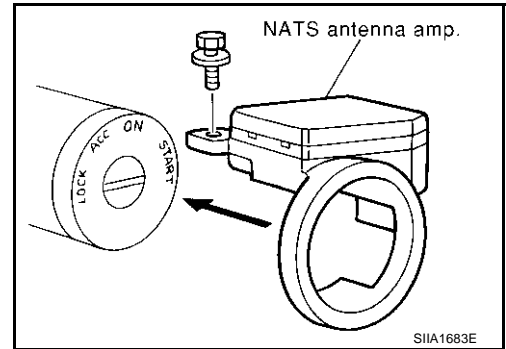

INTEGRATED HOMELINK TRANSMITTER

PPF:96401

INTEGRATED HOMELINK TRANSMITTER

Wiring Diagram —TRNSCV—

AIS00036

BL-TRNSCV-01

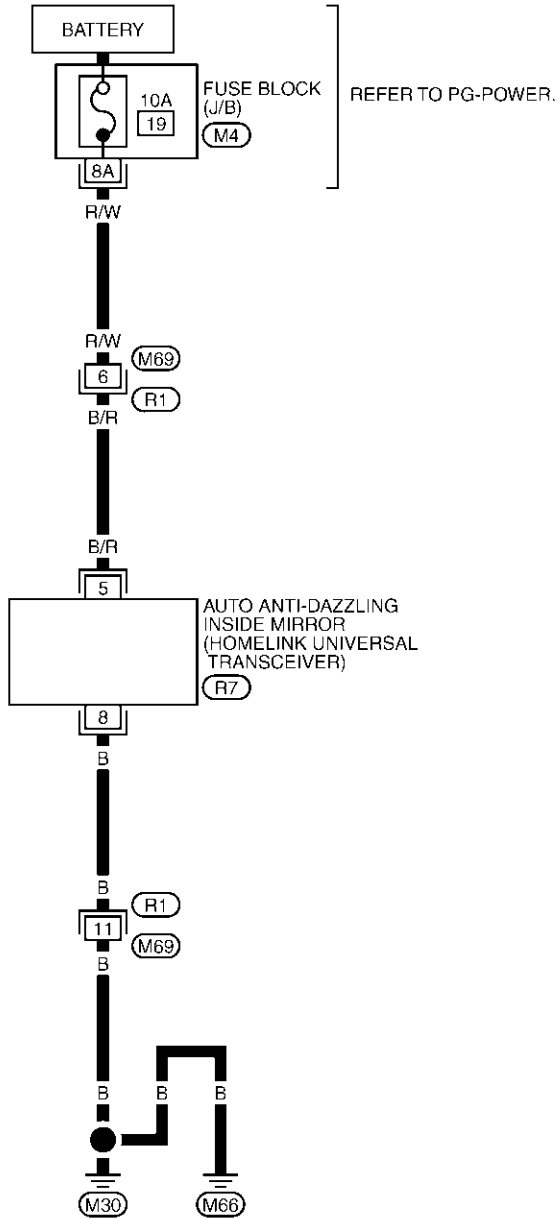

A
B
C
D
E
F
G
H
BL
J
K
L
M

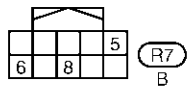
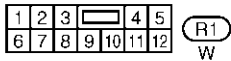

REFER TO THE FOLLOWING.
 (M4) - FUSE BLOCK-JUNCTION BOX (J/B)

TIWT0368E

INTEGRATED HOMELINK TRANSMITTER

AIS00037

Trouble Diagnoses DIAGNOSTIC PROCEDURE

SYMPTOM: Transmitter does not activate receiver.

Before conducting the procedure given below, make sure that system receiver (garage door opener, etc.) operates with original, hand-held transmitter. If NG, receiver or hand-held transmitter is malfunctioning, not vehicle related.

1. ILLUMINATE CHECK

- Turn ignition switch "OFF".
- Does red light (LED) of transmitter illuminate when any transmitter button is pressed?

YES or NO

YES >> GO TO 2.

NO >> GO TO 3.

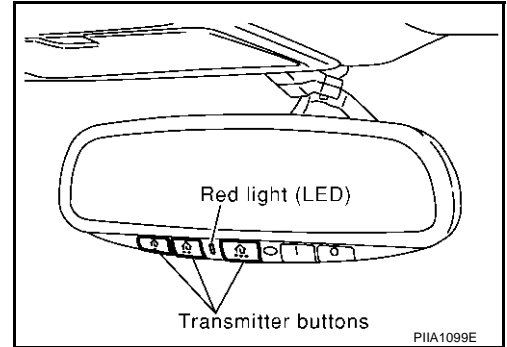

2. TRANSMITTER CHECK

Check transmitter with Tool*.

*:For details, refer to Technical Service Bulletin.

OK or NG

OK >> Receiver or hand-held transmitter malfunction, not vehicle related.

NG >> Replace transmitter with inside mirror assembly.

3. CHECK POWER SUPPLY

1. Disconnect transmitter connector.
2. Turn ignition switch "OFF".
3. Check voltage between transmitter harness connector R7 terminal 5 (B/R) and body ground.

Battery voltage should exist.

OK or NG

OK >> GO TO 4.

NG >> ● Check 10A fuse [No. 19 located in the fuse block (J/B)]

- Harness for open or short between fuse and transmitter

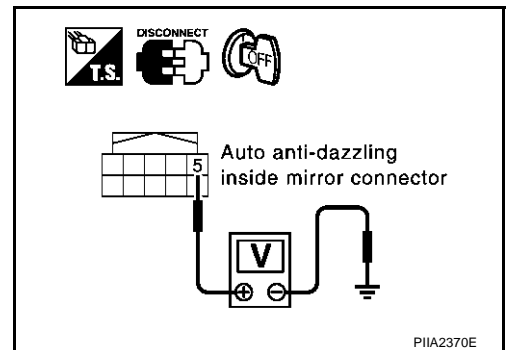

INTEGRATED HOMELINK TRANSMITTER

4. GROUND CIRCUIT CHECK

Check continuity between transmitter harness connector R7 terminal 8 (B) and body ground.

Continuity should exist.

OK or NG

- OK >> Replace transmitter with inside mirror assembly.
- NG >> Repair harness.

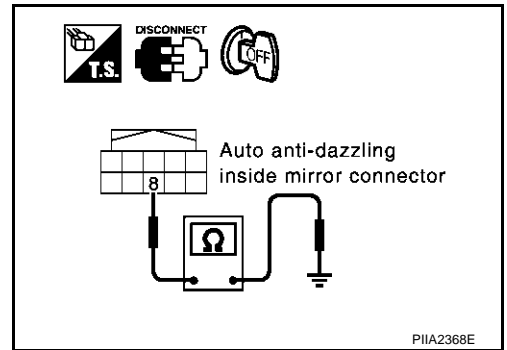

A
B
C
D
E
F
G
H
BL
J
K
L
M

BODY REPAIR

BODY REPAIR

PFP:60100

Body Exterior Paint Color

AIS00001

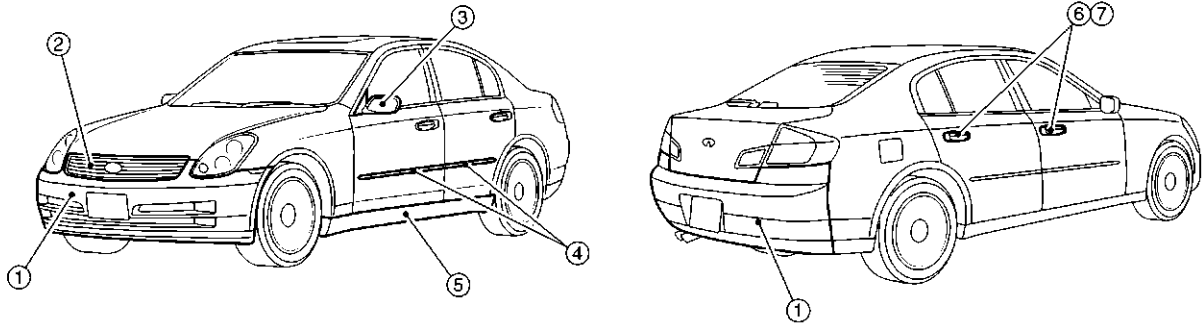

SIIA2352E

Component			Color code	BAY2	BBW5	BB16	BKH3	BKX6	BKY0	BQX1
			Description	Red	Dark Blue	Blue	Black	Silver	Silver	White
			Paint type	PM	P	M	2S	TM	M	3P
			Hard clear coat	X	X	X	X	-	-	-
1	Bumper fascia	Upper	Body color	BAY2	BBW5	BB16	BKH3	BKX6	BKY0	BQX1
		Lower	Material color	G64-1	G64-1	G64-1	G64-1	G64-1	G64-1	G64-1
2	Front grille		Chromium-plate + Smoke clear	Cr + HFM-09	Cr + HFM-09	Cr + HFM-09	Cr + HFM-09	Cr + HFM-09	Cr + HFM-09	Cr + HFM-09
3	Door outside mirror	Case	Body color	BAY2	BBW5	BB16	BKH3	BKX6	BKY0	BQX1
		Base	Material color	AG01	AG01	AG01	AG01	AG01	AG01	AG01
4	Side guard molding		Body color	BAY2	BBW5	BB16	BKH3	BKX6	BKY0	BQX1
5	Center mudguard		Material color	G64-1	G64-1	G64-1	G64-1	G64-1	G64-1	G64-1
6	Door outside handle escutcheon		Body color	BAY2	BBW5	BB16	BKH3	BKX6	BKY0	BQX1
7	Door outside handle		Chromium-plate	Cr	Cr	Cr	Cr	Cr	Cr	Cr



2S:Solid + Clear, M :Metallic, P: Pearl, 3P:3-Coat pearl, TM: Micro titanium metallic, PM: Pearl metallic

BODY REPAIR

Body Component Parts UNDERBODY COMPONENT PARTS

AIS00638

A
B
C
D
E
F
G
H
BL
J
K
L
M

-  : Indicates both sided anti-corrosive pre-coated steel portions
-  : Indicates high strength steel (HSS) portions
-  : Indicates both sided anti-corrosive steel and HSS portions
- * Indicates aluminum portion

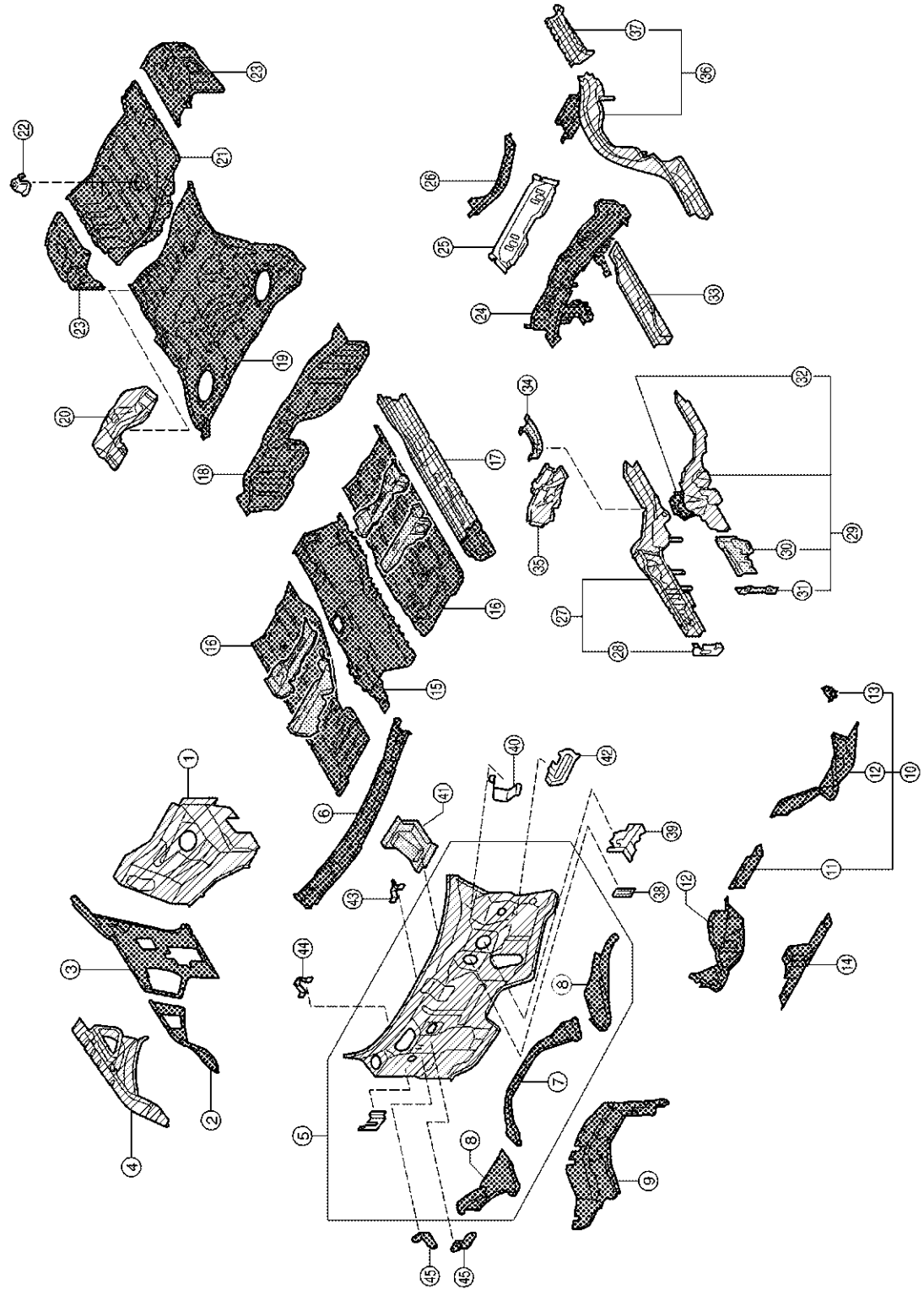



SIIA2354E

BODY REPAIR

1. Front strut housing (RH&LH)
2. Upper front hoodledge (RH&LH)
3. Upper rear hoodledge (RH&LH)
4. Hoodledge reinforcement (RH&LH)
5. Upper dash assembly
6. Upper dash crossmember assembly
7. Lower center dash crossmember reinforcement
8. Lower dash crossmember reinforcement
9. Cowl top
10. Lower dash crossmember assembly
11. Front crossmember center
12. Lower dash crossmember
13. Steering column mounting reinforcement
14. Lower dash
15. Front floor center
16. Front floor
17. Inner sill (RH&LH)
18. Rear seat crossmember assembly
19. Rear floor front
20. Rear floor seat belt anchor reinforcement
21. Rear floor rear
22. Spare tire clamp bracket
23. Rear floor side (RH&LH)
24. Rear seat crossmember
25. 2ND rear crossmember assembly
26. Rear crossmember center assembly
27. Front side member (RH&LH)
28. Front towing hook inner bracket (RH&LH)
29. Front side member closing plate assembly (RH&LH)
30. Front side member front closing plate (RH&LH)
31. Front towing hook outer bracket (RH&LH)
32. Front side member rear extension (RH&LH)
33. Front side member center closing plate (RH&LH)
34. Front side member rear reinforcement (RH&LH)
35. Front side member outrigger assembly (RH&LH)
36. Rear side member (RH&LH)
37. Rear side member extension (RH&LH)
38. Accel pedal bracket
39. Pedal bracket
40. Wiper mounting bracket
41. Parking brake mounting bracket
42. Parking brake bracket assembly
43. Instrument bracket
44. Upper instrument mounting bracket (RH&LH)
45. Harness clamp bracket

BODY REPAIR

BODY COMPONENT PARTS

-  : Indicates both sided anti-corrosive precoated steel portions
-  : Indicates high strength steel (HSS) portions
-  : Indicates both sided anti-corrosive steel and HSS portions
- * : Indicates aluminum portion

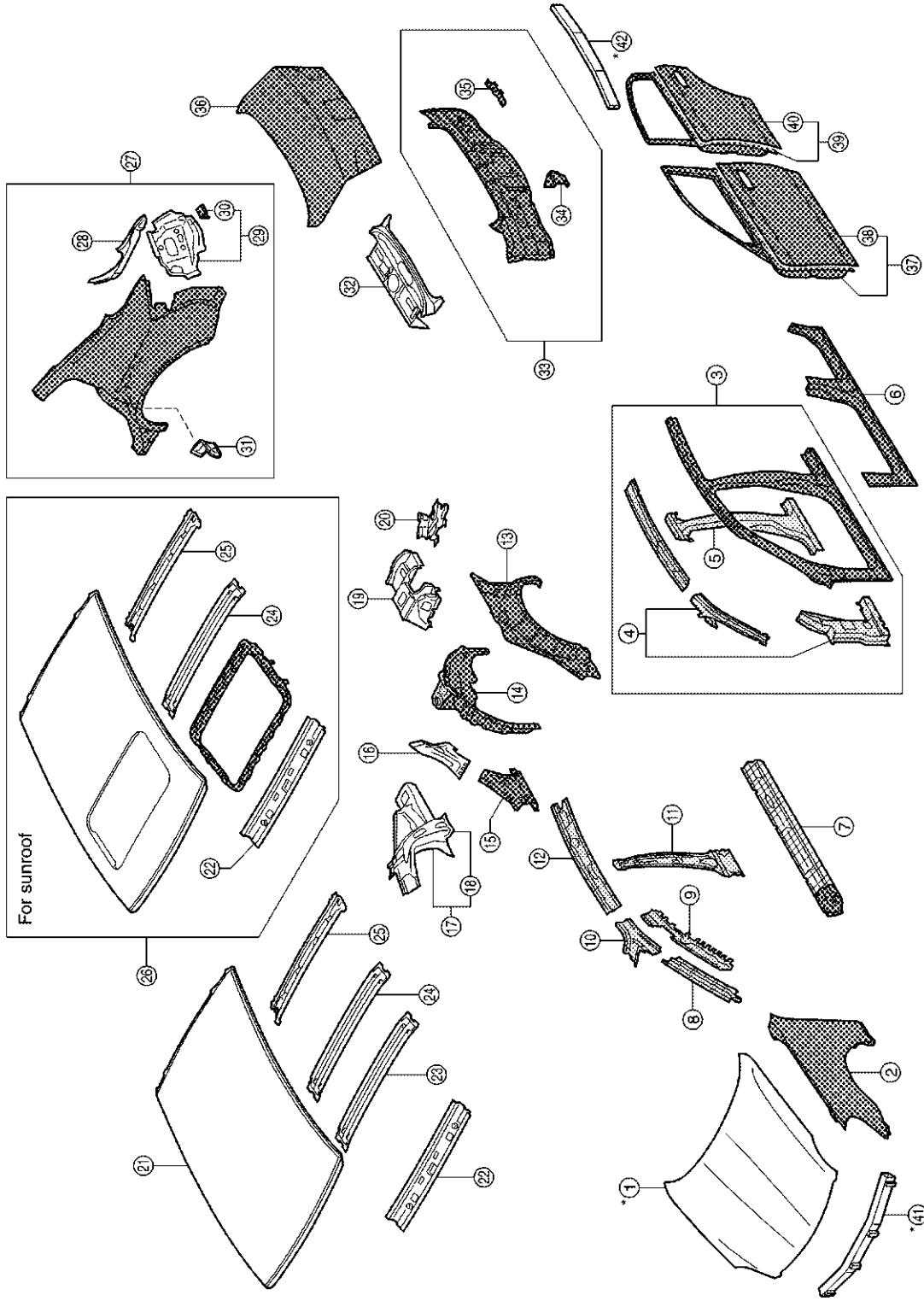

A
B
C
D
E
F
G
H
BL
J
K
L
M

BODY REPAIR

1. Hood
2. Front fender (RH&LH)
3. Side body assembly (RH&LH)
4. Outer front pillar reinforcement (RH&LH)
5. Center pillar reinforcement (RH&LH)
6. Outer sill (RH&LH)
7. Outer sill reinforcement (RH&LH)
8. Upper inner front pillar (RH&LH)
9. Inner front pillar reinforcement (RH&LH)
10. Front roof rail brace (RH&LH)
11. Inner center pillar (RH&LH)
12. Inner side roof rail (RH&LH)
13. Outer rear wheelhouse (RH&LH)
14. Inner rear wheelhouse (RH&LH)
15. Outer rear wheelhouse extension (RH&LH)
16. Seat back support (RH&LH)
17. Inner rear pillar assembly (RH&LH)
18. Inner rear pillar reinforcement (RH&LH)
19. Side parcel shelf (RH&LH)
20. Jack mounting bracket
21. Roof
22. Front roof rail
23. Front roof bow
24. Rear roof bow
25. Rear roof rail
26. Roof assembly
27. Rear fender assembly (RH&LH)
28. Rear fender extension (RH&LH)
29. Rear combination lamp base assembly (RH&LH)
30. Center rear bumper bracket (RH&LH)
31. Striker tapping retainer (RH&LH)
32. Parcel shelf
33. Upper rear panel assembly
34. Rear bumper side bracket
35. Rear bumper fascia bracket (RH&LH)
36. Trunk lid
37. Front door (RH&LH)
38. Outer front door panel (RH&LH)
39. Rear door (RH&LH)
40. Outer rear door panel (RH&LH)
41. Front bumper reinforcement
42. Rear bumper reinforcement

BODY REPAIR

Corrosion Protection DESCRIPTION

AIS00639

To provide improved corrosion prevention, the following anti-corrosive measures have been implemented in NISSAN production plants. When repairing or replacing body panels, it is necessary to use the same anti-corrosive measures.

Anti-Corrosive Precoated Steel (Galvannealed Steel)

To improve repairability and corrosion resistance, a new type of anti-corrosive precoated steel sheet has been adopted replacing conventional zinc-coated steel sheet.

Galvannealed steel is electroplated and heated to form Zinc-iron alloy, which provides excellent and long term corrosion resistance with cationic electrodeposition primer.

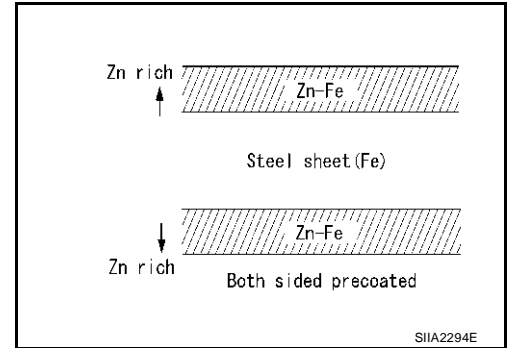

Nissan Genuine Service Parts are fabricated from galvannealed steel. Therefore, it is recommended that GENUINE NISSAN PARTS or equivalent be used for panel replacement to maintain the anti-corrosive performance built into the vehicle at the factory.

Phosphate Coating Treatment and Cationic Electrodeposition Primer

A phosphate coating treatment and a cationic electrodeposition primer, which provide excellent corrosion protection, are employed on all body components.

CAUTION:

Confine paint removal during welding operations to an absolute minimum.

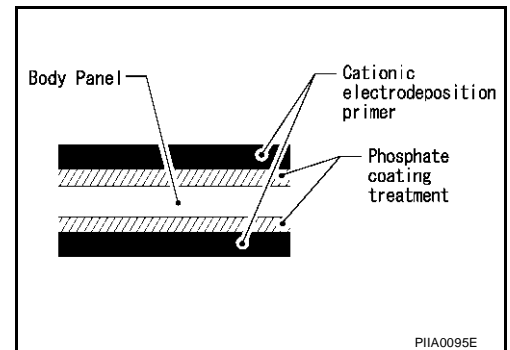



Nissan Genuine Service Parts are also treated in the same manner. Therefore, it is recommended that GENUINE NISSAN PARTS or equivalent be used for panel replacement to maintain anti-corrosive performance built into the vehicle at the factory.

BODY REPAIR

ANTI-CORROSIVE WAX

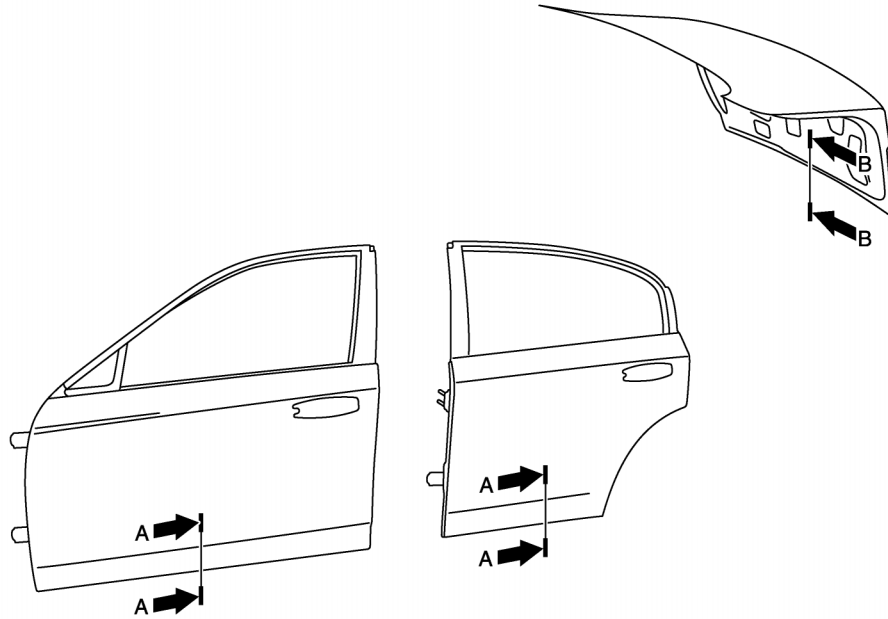
To improve corrosion resistance, anti-corrosive wax is applied inside the body sill and inside other closed sections. Accordingly, when replacing these parts, be sure to apply anti-corrosive wax to the appropriate areas of the new parts. Select an excellent anti-corrosive wax which will penetrate after application and has a long shelf life.



 : Indicates anti-corrosive wax coated portions.

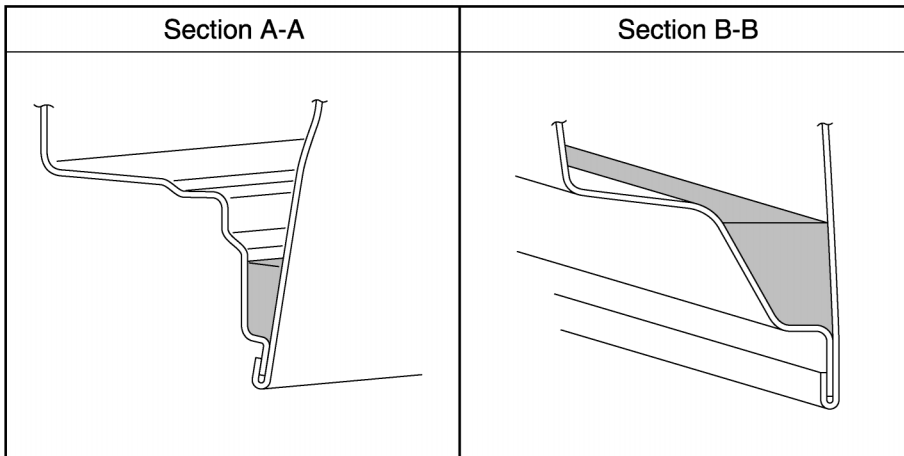

PIIA1202E

BODY REPAIR

UNDERCOATING

The underside of the floor and wheelhouse are undercoated to prevent rust, vibration, noise and stone chipping. Therefore, when such a panel is replaced or repaired, apply undercoating to that part. Use an undercoating which is rust preventive, soundproof, vibration-proof, shock-resistant, adhesive, and durable.

Precautions in Undercoating

1. Do not apply undercoating to any place unless specified (such as the areas above the muffler and three way catalyst which are subjected to heat).
2. Do not undercoat the exhaust pipe or other parts which become hot.
3. Do not undercoat rotating parts.
4. Apply bitumen wax after applying undercoating.

 : Indicates undercoated portions.

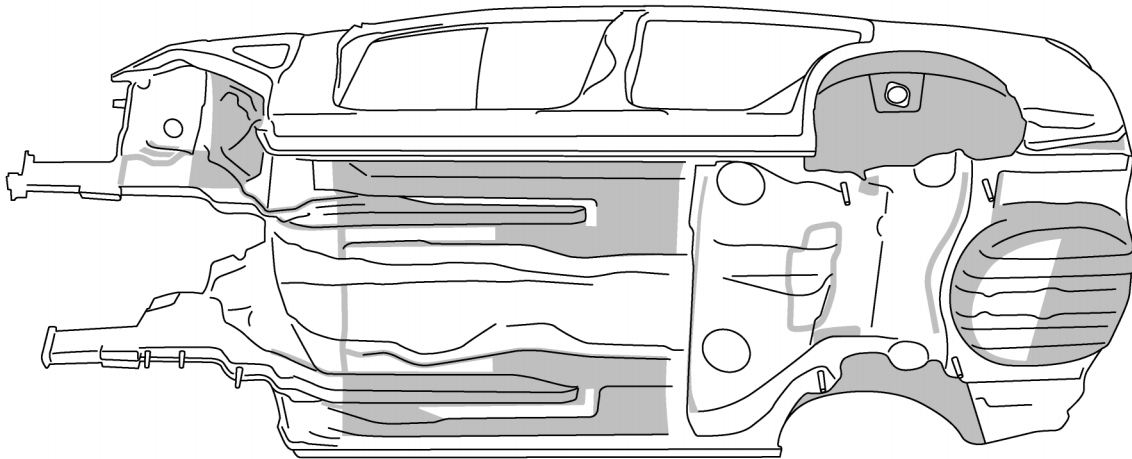

PIIA0735E

BODY REPAIR

STONE GUARD COAT

To prevent damage caused by stones, the lower outer body panel (fender, door, etc.) have an additional layer of Stone Guard Coating over the ED primer coating. When replacing or repairing these panels, apply Stone Guard coating to the same portions as before. Use a coating which is rust preventive, durable, shock-resistant and has a long shelf life.

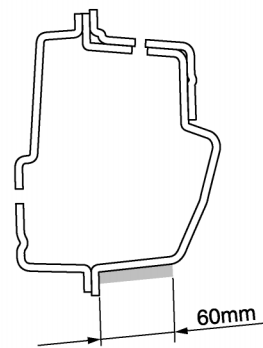
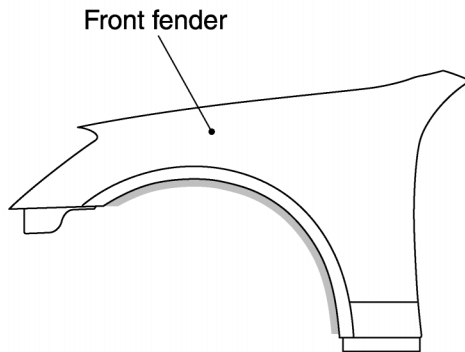
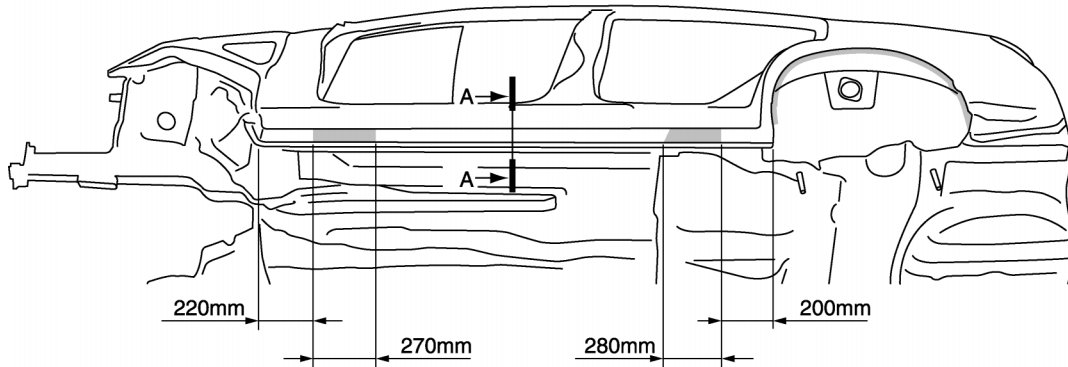

Section A-A

PIIA0736E

BODY REPAIR

Body Sealing DESCRIPTION

AIS0063A

The following figure shows the areas which are sealed at the factory. Sealant which has been applied to these areas should be smooth and free from cuts or gaps. Care should be taken not to apply an excess amount of sealant and not to allow other unaffected parts to come into contact with the sealant.

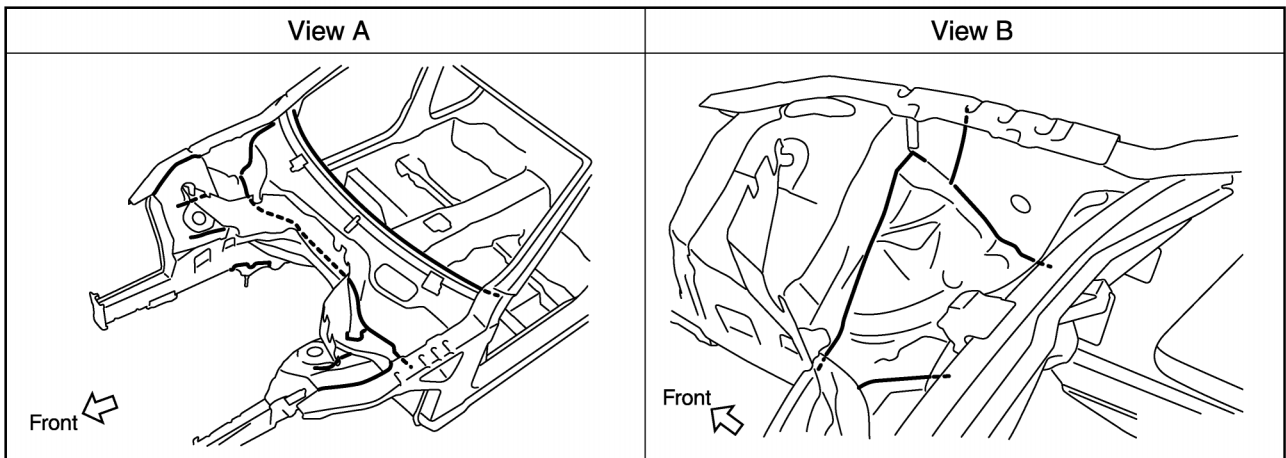
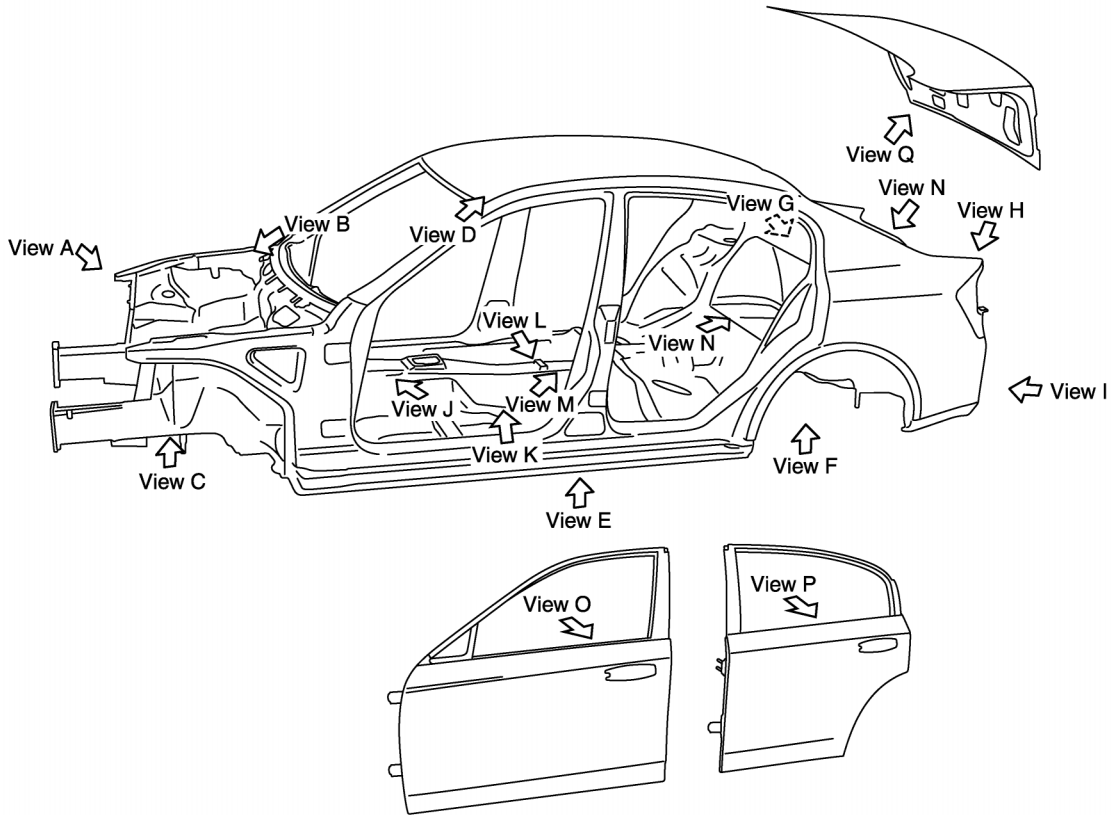

PIIA0732E

BODY REPAIR

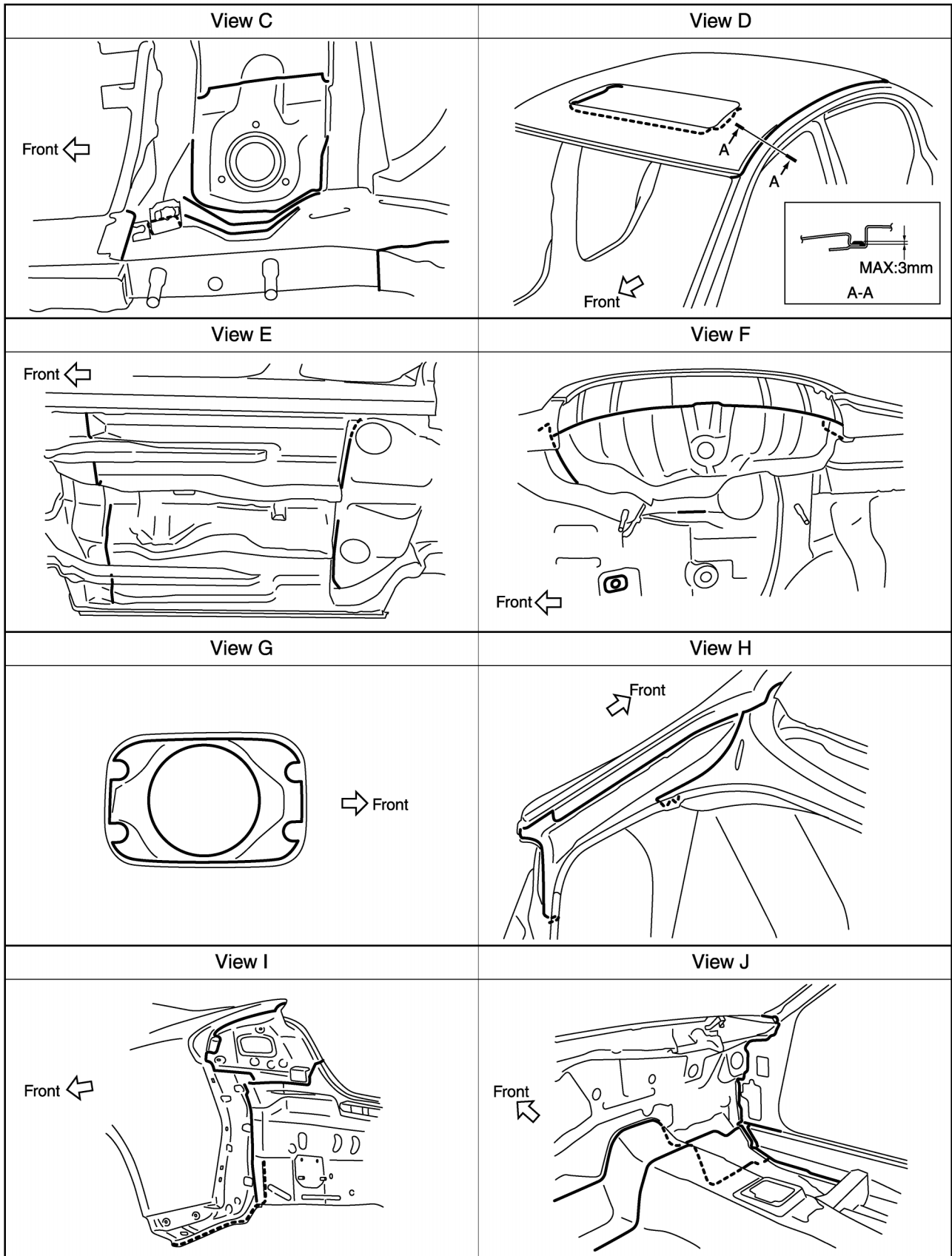

PIIA0733E

BODY REPAIR

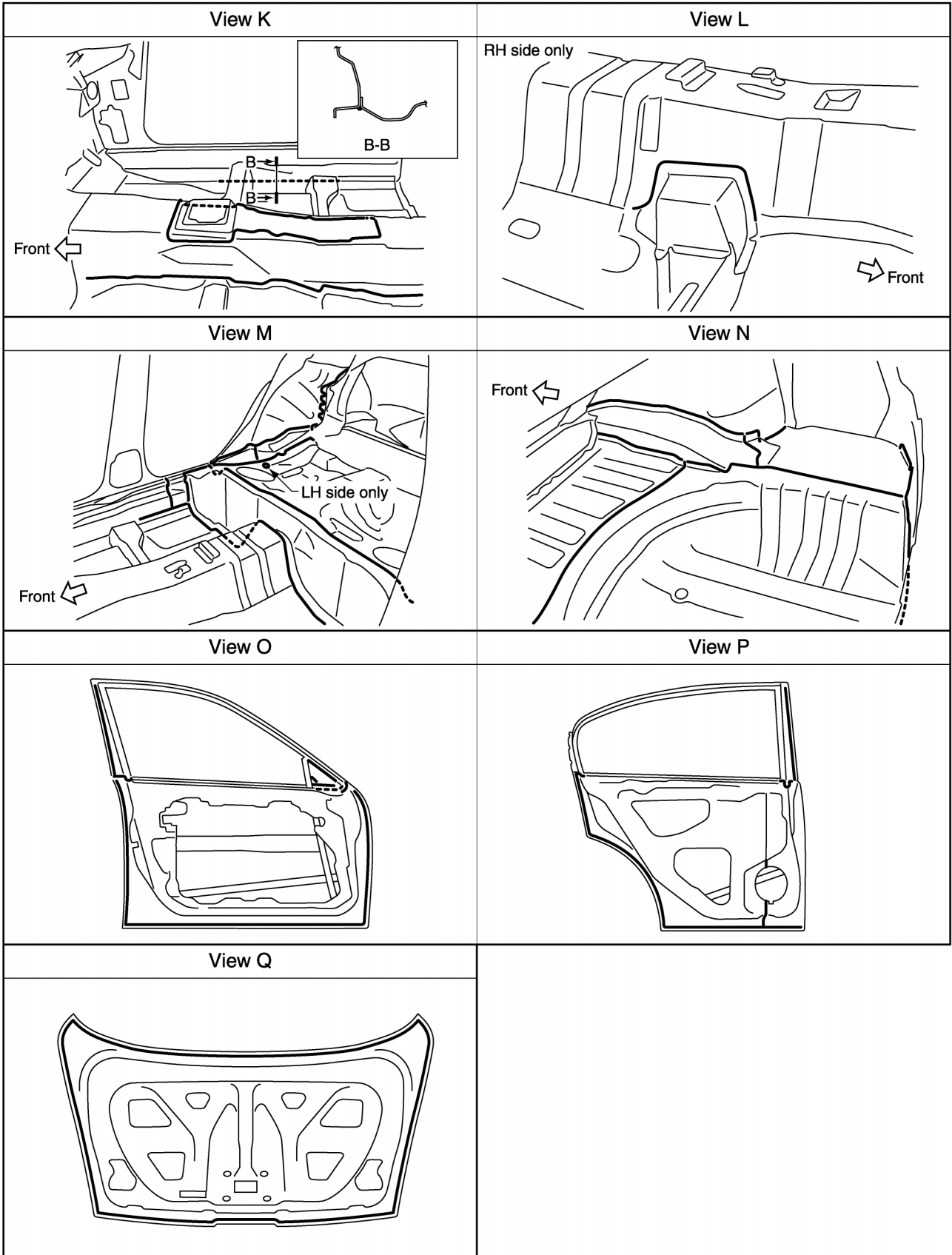

A
B
C
D
E
F
G
H
BL
J
K
L
M

PIIA0734E

BODY REPAIR

Body Construction BODY CONSTRUCTION

AIS0063B

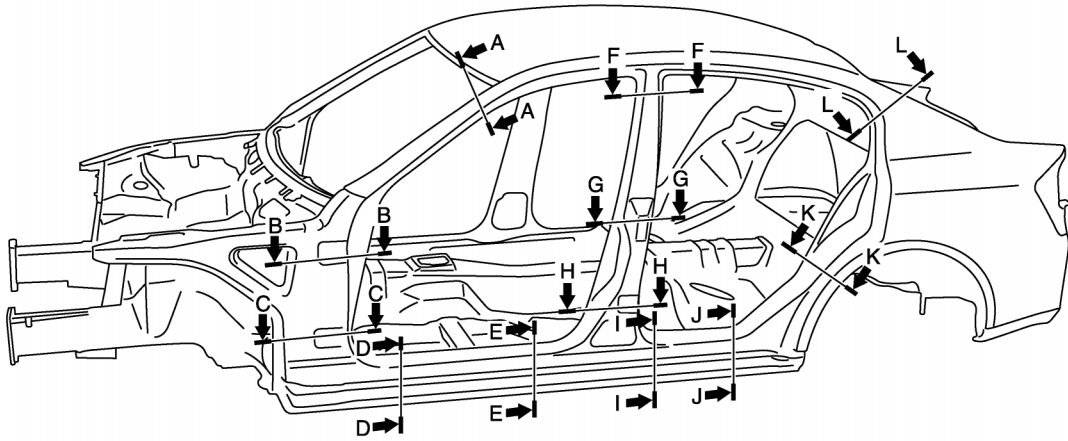

Section A-A	Section B-B	Section C-C	Section D-D
Section E-E	Section F-F	Section G-G	Section H-H
Section I-I	Section J-J	Section K-K	Section L-L

PIIA0744E

BODY REPAIR

Body Alignment BODY CENTER MARKS

AIS0063C

A mark has been placed on each part of the body to indicate the vehicle center. When repairing parts damaged by an accident which might affect the vehicle frame (members, pillars, etc.), more accurate and effective repair will be possible by using these marks together with body alignment specifications.

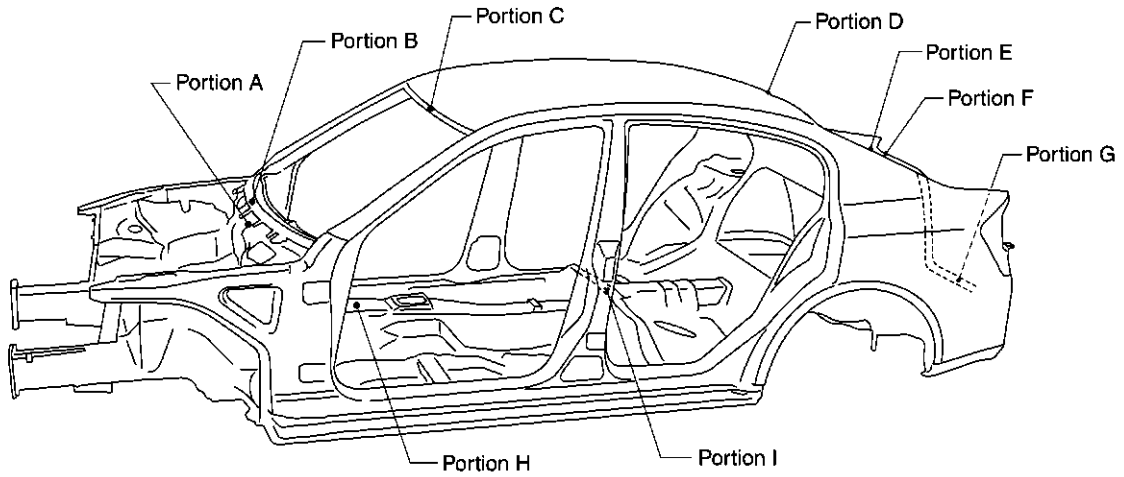

Portion A,B	Portion C,D	Portion E,F
<p>Embossment</p> <p>Embossment</p> <p>Front</p> <p>● Cowl top</p>	<p>Embossment</p> <p>Front</p> <p>● Front roof</p> <p>● Rear roof</p>	<p>Front</p> <p>Groove</p> <p>Embossment</p> <p>● Rear waist panel</p>
<p>Front</p> <p>Flange end</p> <p>● Rear panel</p>	<p>Front</p> <p>Hole 5dia.</p> <p>Embossment</p> <p>● Front floor</p> <p>● Rear floor</p>	

PIIA0730E

BODY REPAIR

PANEL PARTS MATCHING MARKS

A mark has been placed on each body panel to indicate the parts matching positions. When repairing parts damaged by an accident which might affect the vehicle structure (members, pillars, etc.), more accurate and effective repair will be possible by using these marks together with body alignment specifications.

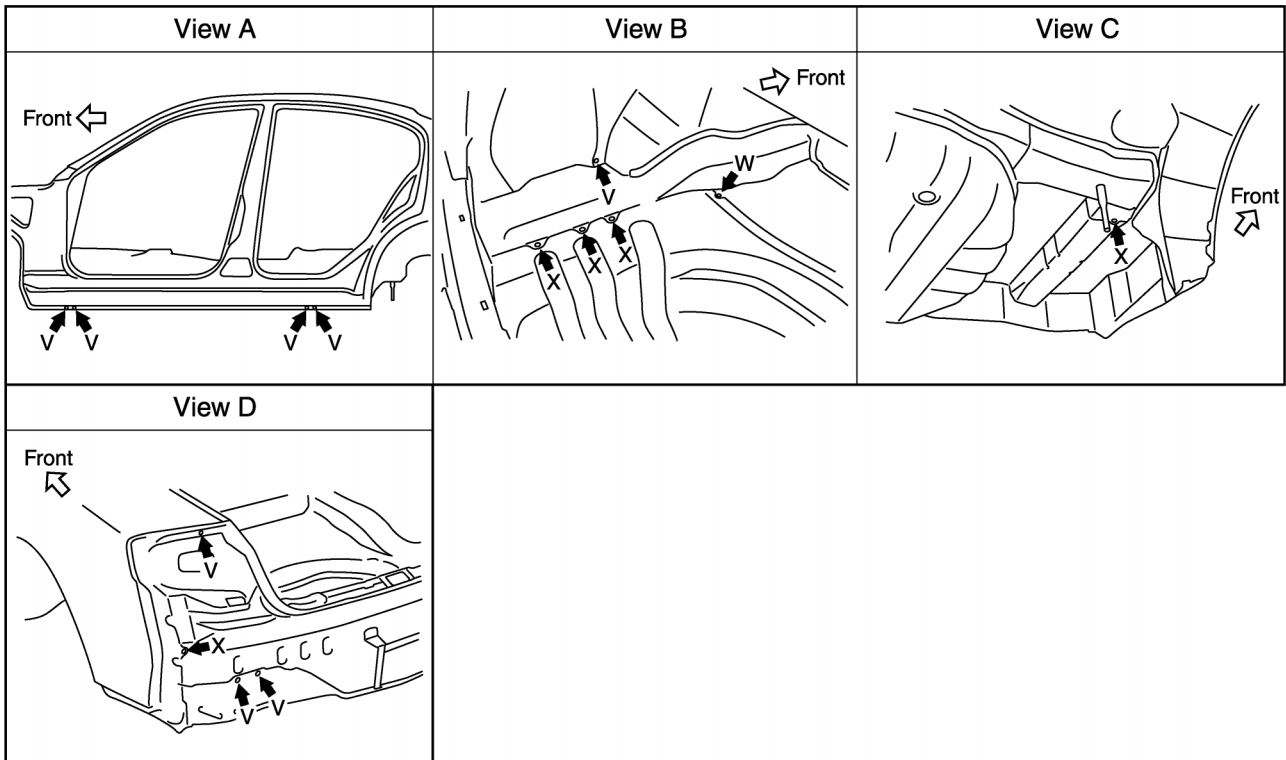
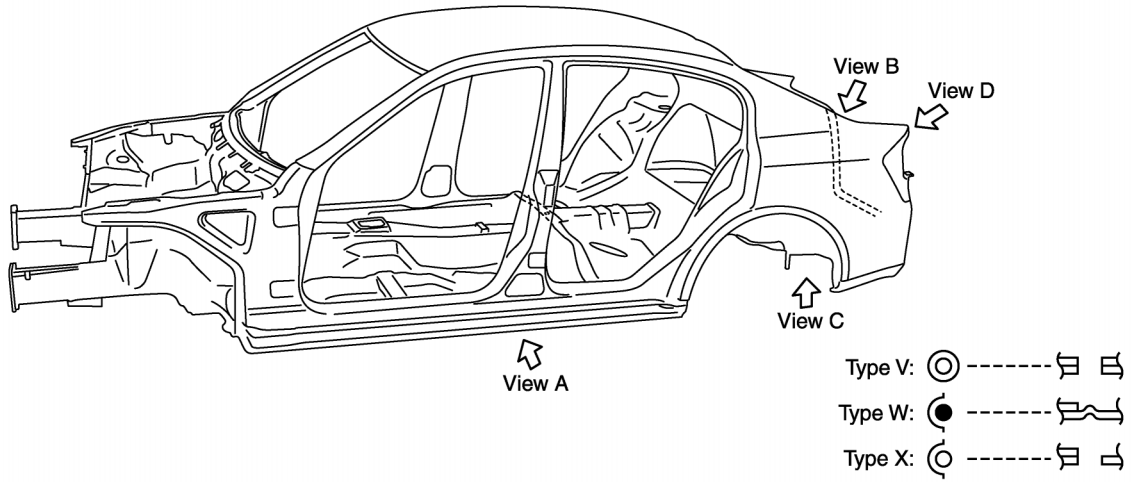

PIA0731E

BODY REPAIR

DESCRIPTION

- All dimensions indicated in the figures are actual.
- When using a tracking gauge, adjust both pointers to equal length. Then check the pointers and gauge itself to make sure there is no free play.
- When a measuring tape is used, check to be sure there is no elongation, twisting or bending.
- Measurements should be taken at the center of the mounting holes.
- An asterisk (*) following the value at the measuring point indicates that the measuring point on the other side is symmetrically the same value.
- The coordinates of the measurement points are the distances measured from the standard line of "X", "Y" and "Z".

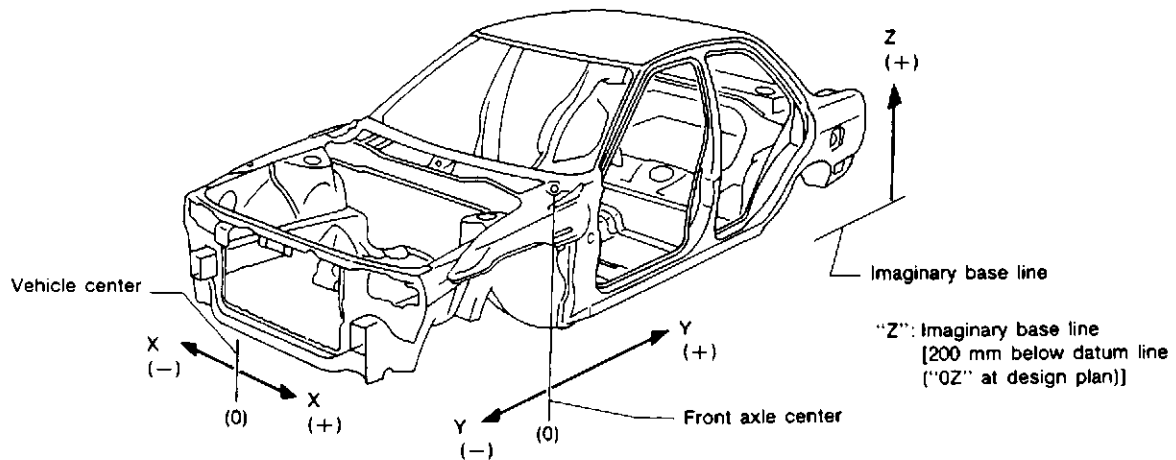

PIIA0104E

A
B
C
D
E
F
G
H
J
K
L
M

BL

BODY REPAIR

ENGINE COMPARTMENT

Measurement

Figures marked with a (*) indicate symmetrically identical dimensions on both right and left hand sides of the vehicle.

Unit : mm

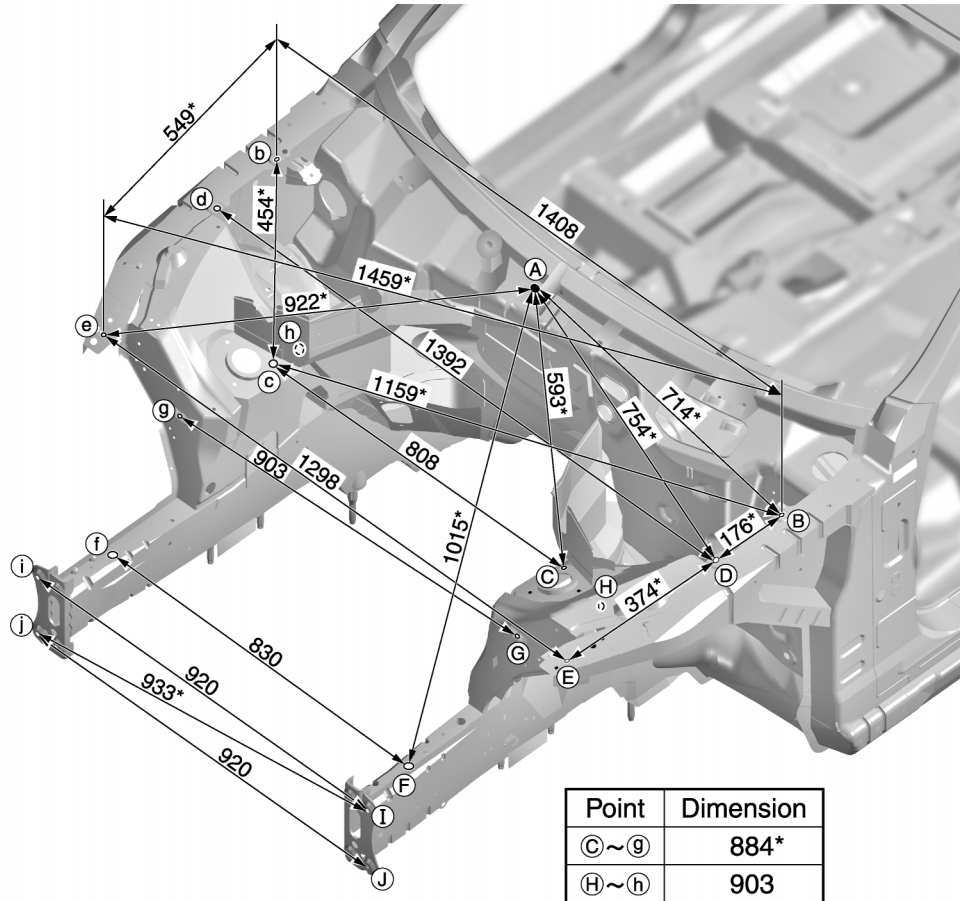

PIIA0739E

BODY REPAIR

Measurement Points

(A) : Upper dash positioning mark center of center positioning mark

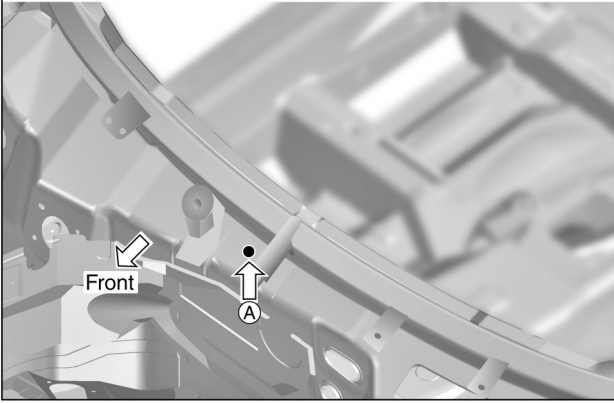

(B, b, D, d) : Front fender installing hole center (7dia.)
(C, c) : Front strut installing hole center (9dia.)
(E, e) : Radiator core support installing hole center (9dia.)

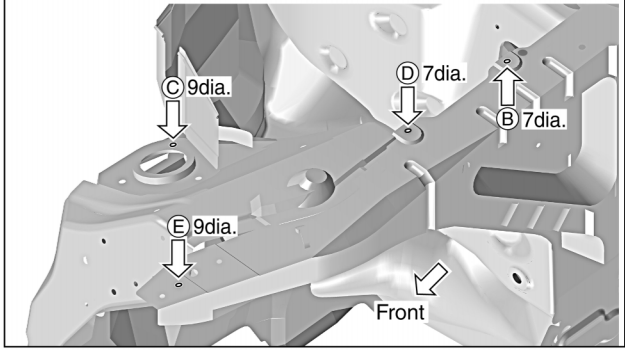

(F, f) : Front side member hole center (20dia.)
(G, g) : Nut holder hole center (16dia.)
(I, i, J, j) : Front bumper stay installing hole center (9dia.)

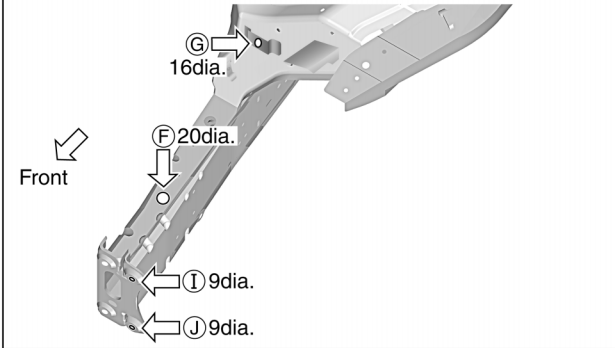

(H, h) : Nut holder hole center (16dia.)

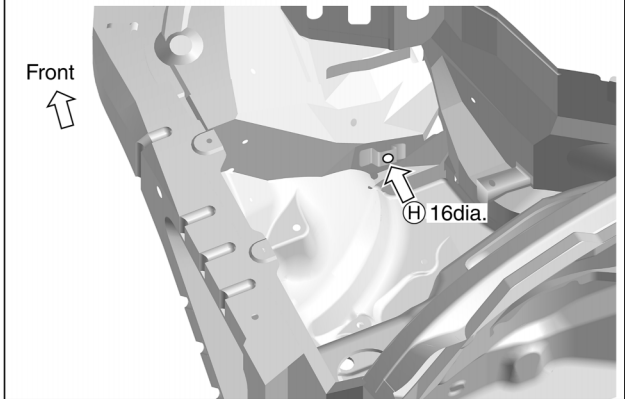

A

B

C

D

E

F

G

H

BL

J

K

L

M

PIIA0743E

BODY REPAIR

UNDERBODY Measurement

Figures marked with a (*) indicate symmetrically identical dimensions on both right and left hand sides of the vehicle.

★ : Bolt head
As viewed from underside.

All dimensions indicated in this figure are actual.

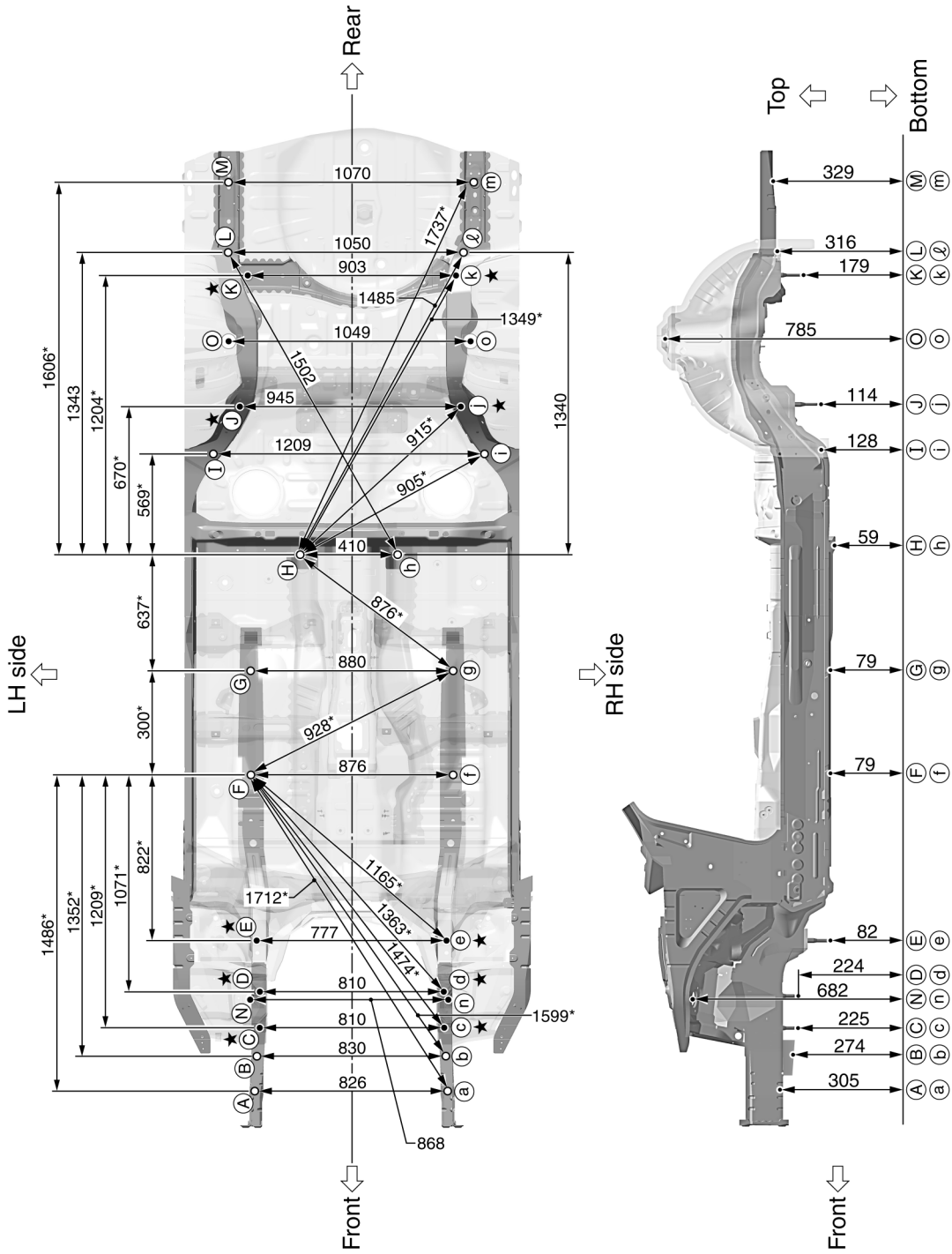

SIIA2367E

BODY REPAIR

Measurement Points

Unit : mm

As viewed from underside.

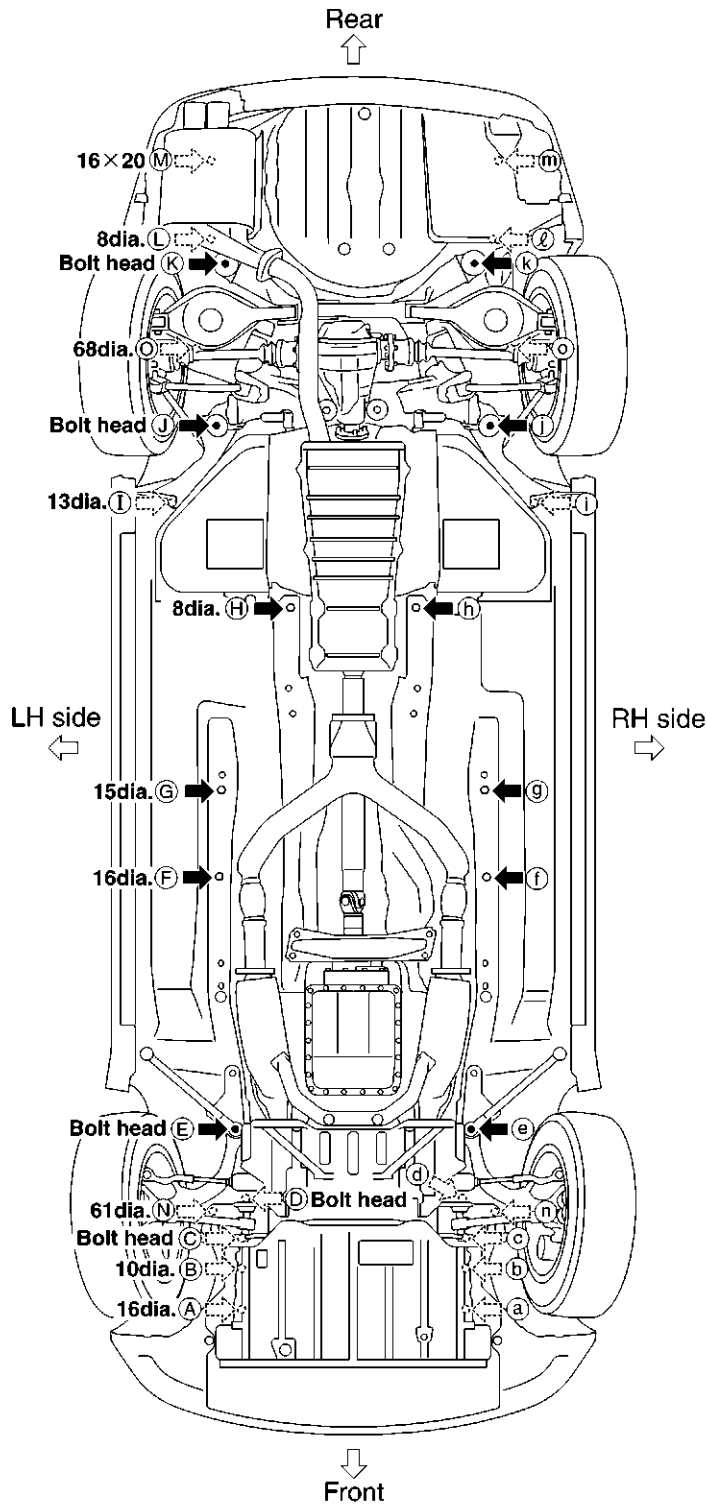

Coordinates:

(A), (a)	(I), (i)
X:413	X:605
Y:-368	Y:2391
Z:305	Z:128
(B), (b)	(J), (j)
X:415	X:473
Y:-238	Y:2604
Z:274	Z:114
(C), (c)	(K), (k)
X:405	X:452
Y:-100	Y:3164
Z:225	Z:179
(D), (d)	(L)
X:405	X:550
Y:39	Y:3265
Z:224	Z:316
(E), (e)	(l)
X:388	X:-500
Y:279	Y:3273
Z:82	Z:316
(F), (f)	(M), (m)
X:438	X:535
Y:1100	Y:3540
Z:79	Z:329
(G), (g)	
X:440	
Y:1400	
Z:79	
(H), (h)	
X:205	
Y:1992	
Z:59	

Front and rear strut tower centers

Coordinates:

(N), (n)
X:434
Y:29
Z:682

(O), (o)
X:524
Y:2882
Z:785

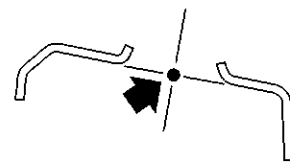

Front: (N), (n) 61dia.
Rear: (O), (o) 68dia.

SIIA2368E

BODY REPAIR

PASSENGER COMPARTMENT

Measurement

Unit : mm

Figures marked with a (*) indicate symmetrically identical dimensions on both right and left hand sides of the vehicle.

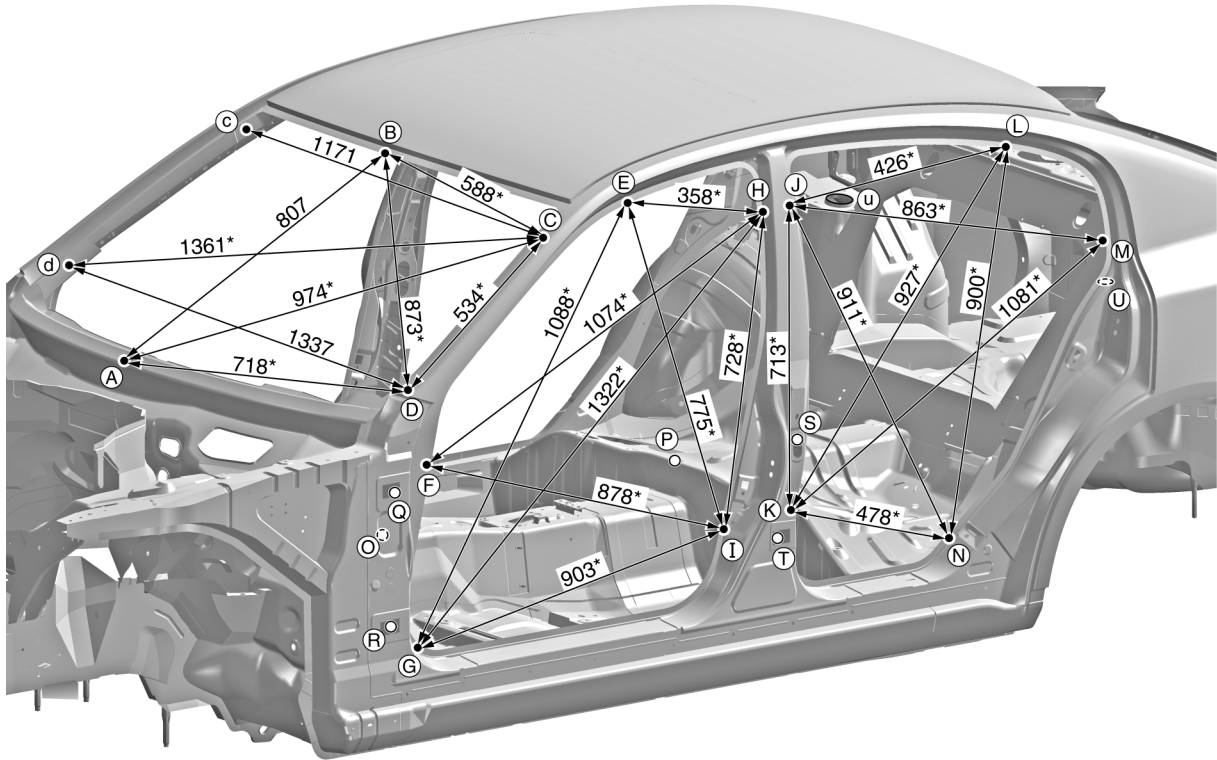

Point	Dimension	Point	Dimension	Point	Dimension
E~e	1,169	J~k	1,516*	Q~Q	755*
E~g	1,697*	J~l	1,269*	Q~H	1,319*
E~h	1,253*	J~m	1,549*	Q~I	1,007*
E~i	1,516*	J~n	1,619*	P~J	998*
F~f	1,452	K~k	1,452	P~K	771*
F~h	1,716*	K~l	1,593*	P~L	1,044*
F~i	1,696*	K~m	1,765*	P~M	1,136*
G~g	1,452	K~n	1,528*	P~N	758*
G~h	1,881*	L~l	1,157	P~U	1,063*
G~i	1,709*	L~n	1,578*	Q~S	1,150*
H~h	1,233	M~m	1,342	Q~T	1,125*
H~i	1,523*	N~n	1,452	R~S	1,219*
I~i	1,452	O~E	1,131*	R~T	1,108*
J~j	1,233	O~F	834*		

SIIA2369E

BODY REPAIR

Measurement Points

(A) : Upper dash crossmember positioning mark center of center positioning mark

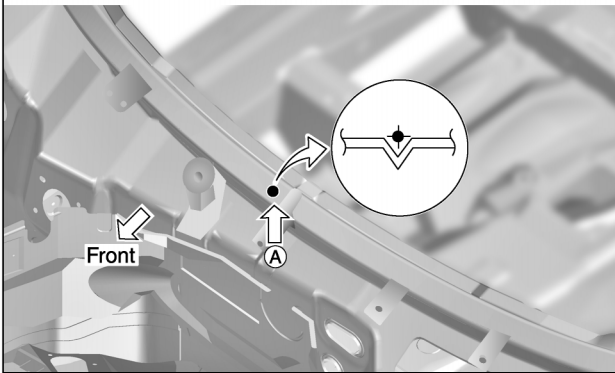

(B) : Front roof flange end of center positioning mark
(C), (C) : Front pillar flange end

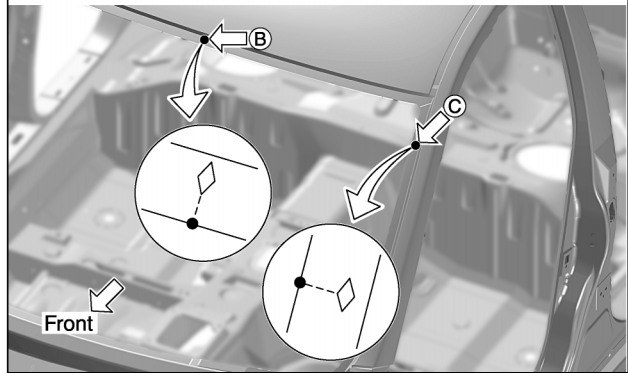

(D), (D) : Front pillar flange end

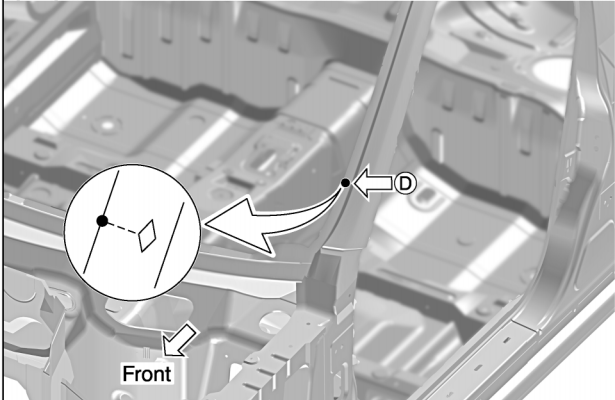

(E), (E), (G), (G) : Front pillar indent
(F), (f) : Front pillar flange end
(Q), (Q), (R), (R) : Door hinge installing nut center (12dia.)

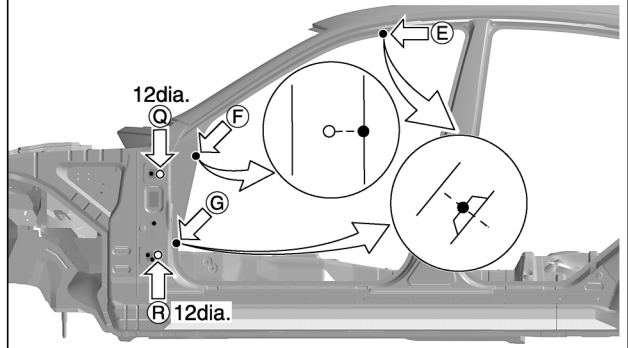

(H), (h), (I), (I), (J), (I), (K), (k) : Center pillar indent
(S), (S), (T), (t) : Door hinge installing nut center (S, S: 9dia., T, t: 12dia.)

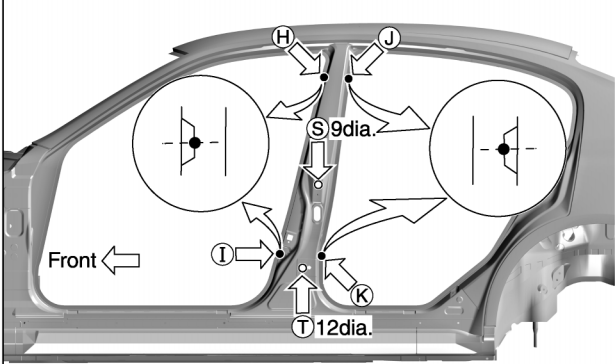

(L), (L), (N), (n) : Rear fender indent
(M), (m) : Rear fender flange end

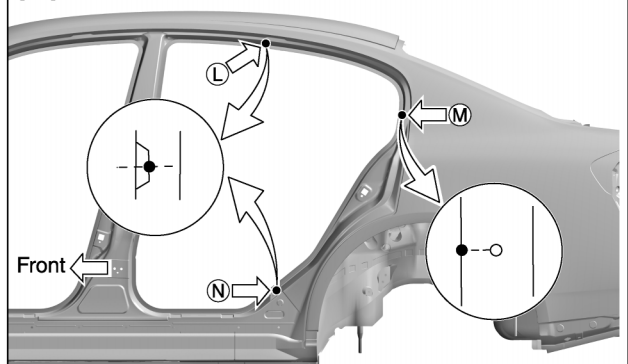

(O) : Center front floor positioning mark center of center positioning mark
(P) : Harness installing hole center of center positioning mark (5dia.)

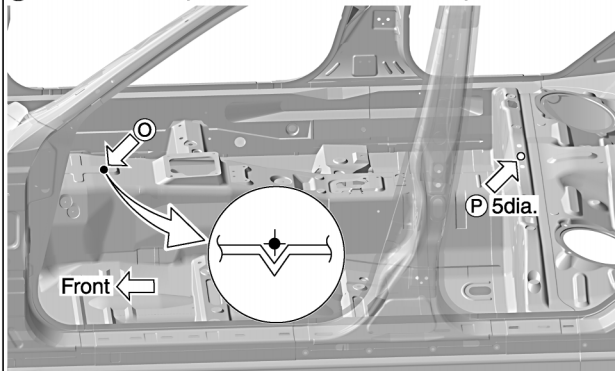

(U), (U) : Rear strut installing hole center (68dia.)

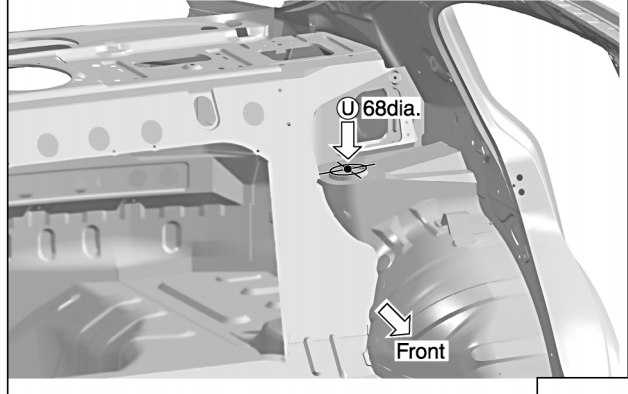

PIIA0742E

A
B
C
D
E
F
G
H
J
K
L
M

BL

BODY REPAIR

REAR BODY Measurement

Figures marked with a (*) indicate symmetrically identical dimensions on both right and left hand sides of the vehicle.

Unit : mm

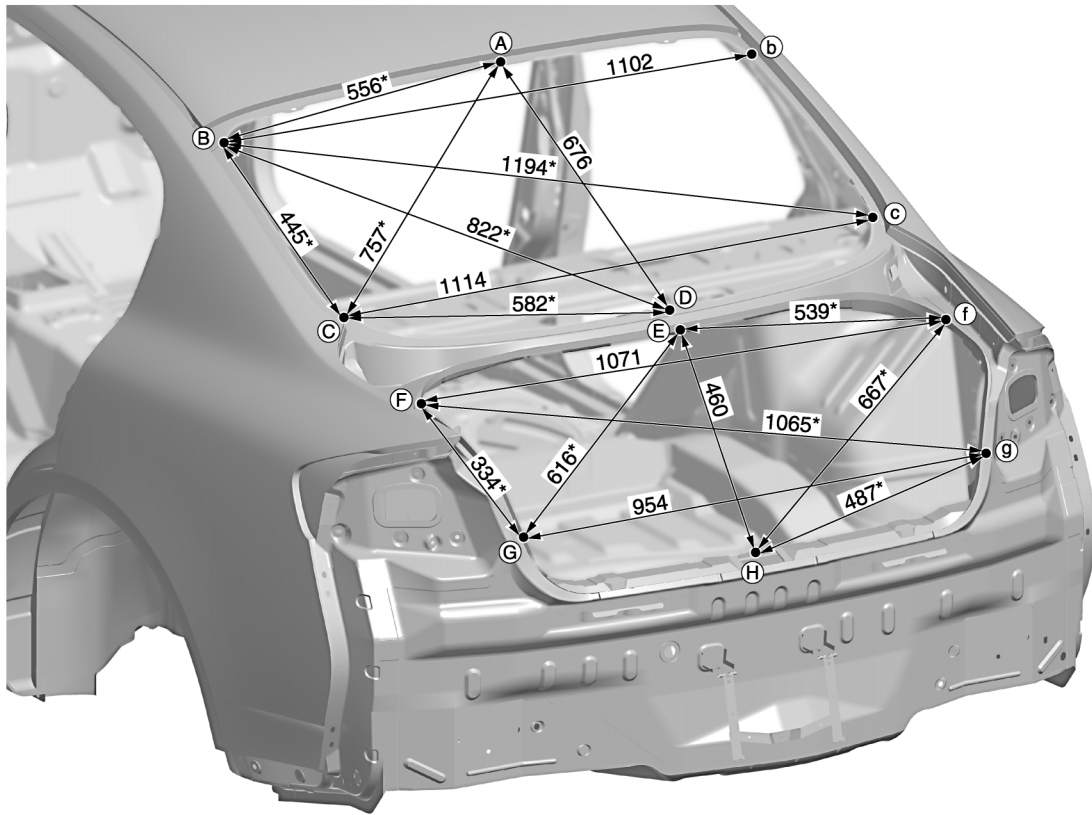

PIIA0737E

BODY REPAIR

Measurement Points

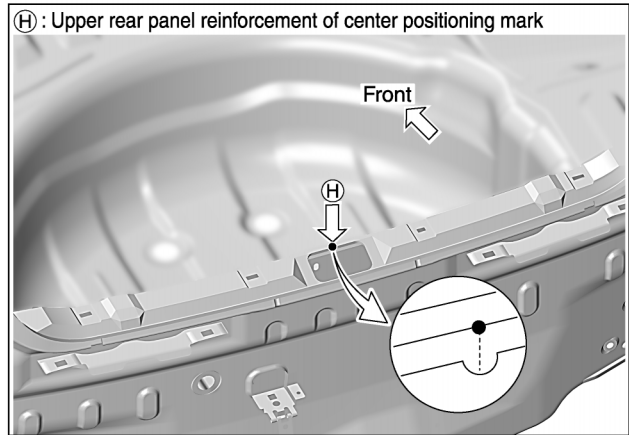
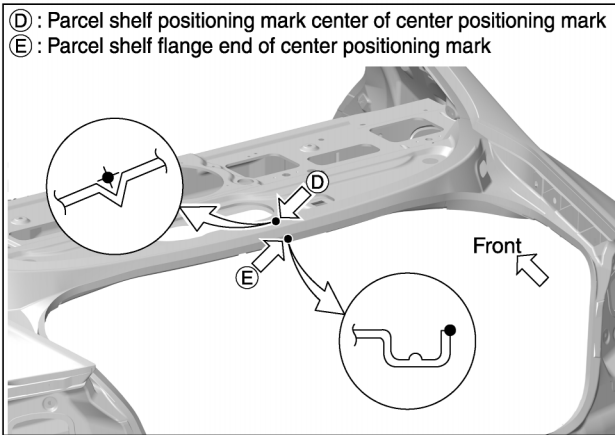
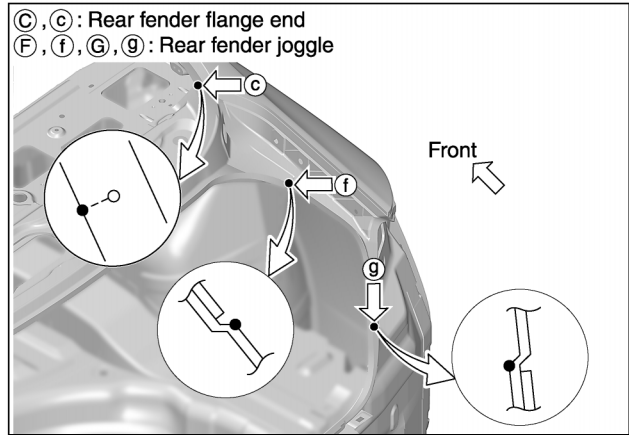
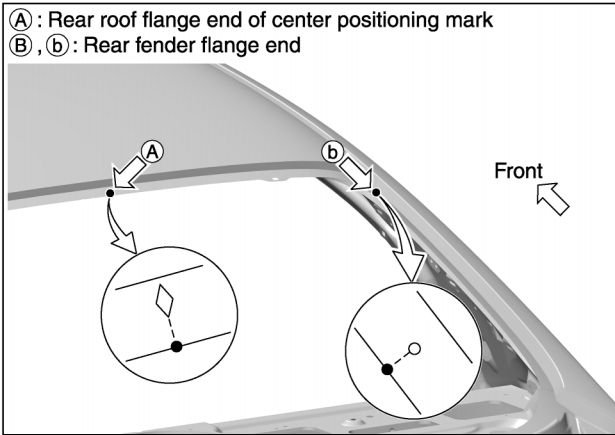

A
B
C
D
E
F
G
H
BL
J
K
L
M

BL

PIIA0741E

BODY REPAIR

Handling Precautions For Plastics HANDLING PRECAUTIONS FOR PLASTICS

AIS0063D

Abbreviation	Material name	Heat resisting temperature °C(°F)	Resistance to gasoline and solvents	Other cautions
PE	Polyethylene	60(140)	Gasoline and most solvents are harmless if applied for a very short time (wipe up quickly).	Flammable
PVC	Poly Vinyl Chloride	80(176)	Same as above.	Poison gas is emitted when burned.
EPM/EPDM	Ethylene Propylene (Diene) copolymer	80(176)	Same as above.	Flammable
PP	Polypropylene	90(194)	Same as above.	Flammable, avoid battery acid.
UP	Unsaturated Polyester	90(194)	Same as above.	Flammable
PS	Polystyrene	80(176)	Avoid solvents.	Flammable
ABS	Acrylonitrile Butadiene Styrene	80(176)	Avoid gasoline and solvents.	
PMMA	Poly Methyl Methacrylate	85(185)	Same as above.	
EVAC	Ethylene Vinyl Acetate	90(194)	Same as above.	
ASA	Acrylonitrile Styrene Acrylate	100(222)	Same as above.	Flammable
PPE	Poly Phenylene Ether	110(230)	Same as above.	
PC	Polycarbonate	120(248)	Same as above.	
PAR	Polyarylate	180(356)	Same as above.	
PUR	Polyurethane	90(194)	Same as above.	
POM	Poly Oxymethylene	120(248)	Same as above.	Avoid battery acid.
PBT+PC	Poly Butylene Terephthalate + Polycarbonate	120(248)	Same as above.	Flammable
PA	Polyamide	140(284)	Same as above.	Avoid immersing in water.
PBT	Poly Butylene Terephthalate	140(284)	Same as above.	
PET	Polyester	180(356)	Same as above.	
PEI	Polyetherimide	200(392)	Same as above.	

1. When repairing and painting a portion of the body adjacent to plastic parts, consider their characteristics (influence of heat and solvent) and remove them if necessary or take suitable measures to protect them.
2. Plastic parts should be repaired and painted using methods suiting the materials' characteristics.

BODY REPAIR

LOCATION OF PLASTIC PARTS

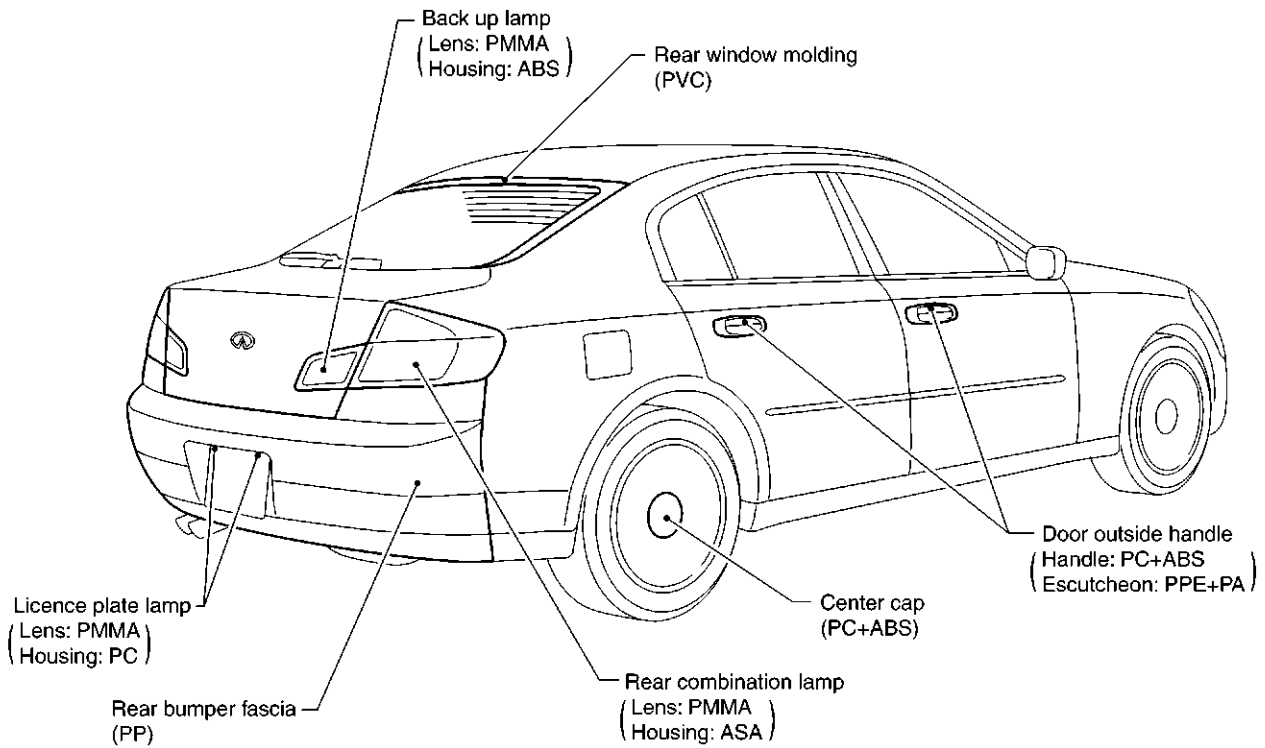
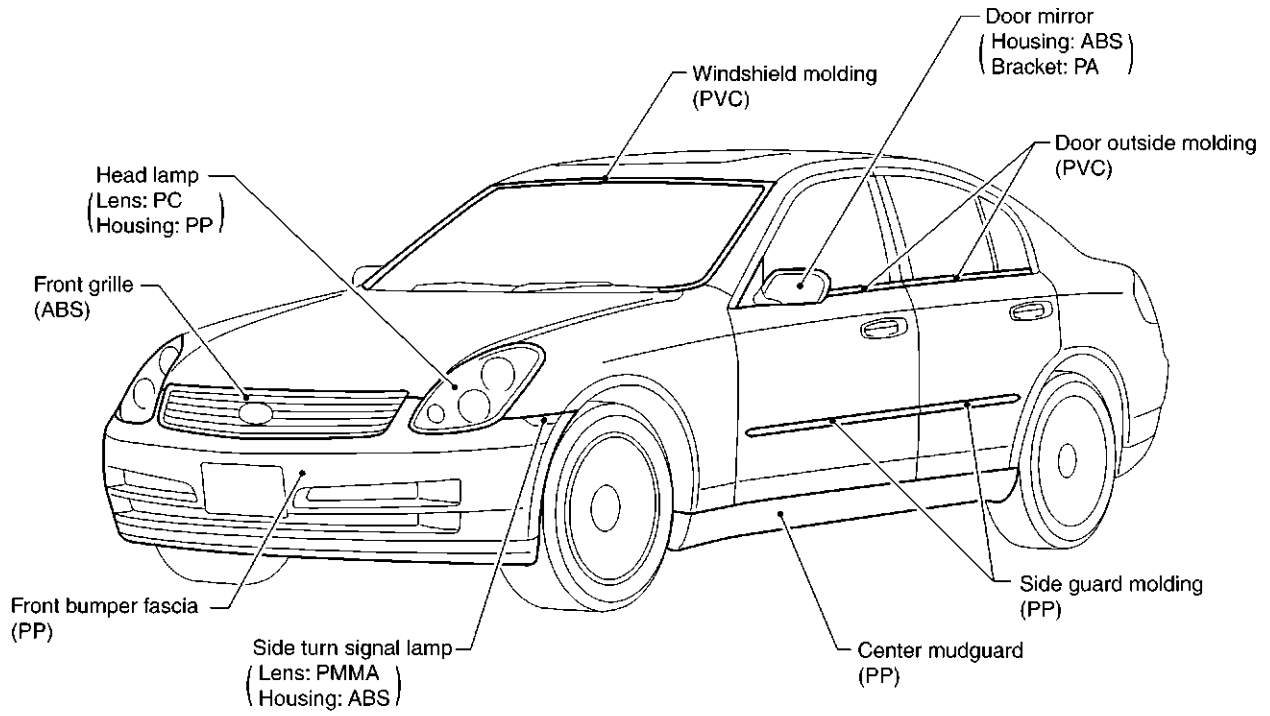

SIIA2353E

BODY REPAIR

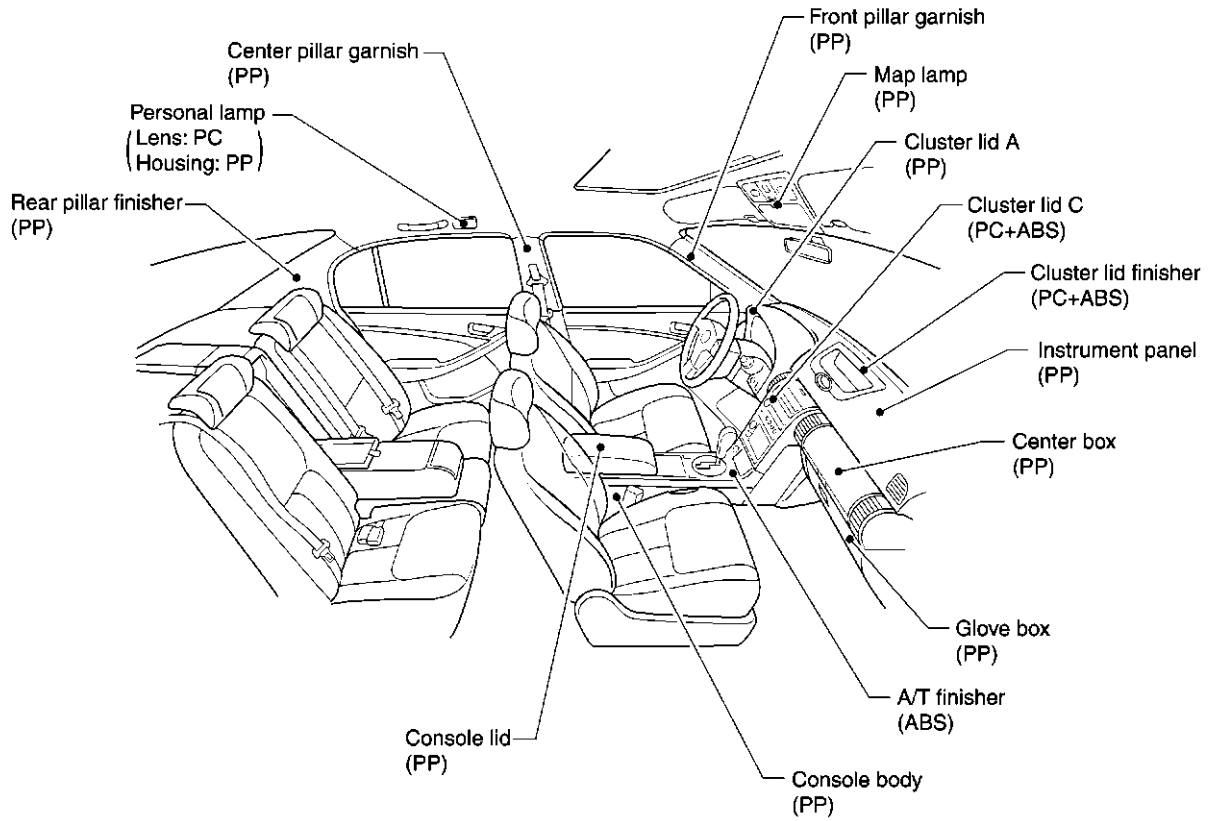

PIIA0841E

BODY REPAIR

Precautions In Repairing High Strength Steel

AIS0063E

High strength steel is used for body panels in order to reduce vehicle weight. Accordingly, precautions in repairing automotive bodies made of high strength steel are described below:

HIGH STRENGTH STEEL (HSS) USED IN NISSAN VEHICLES

Tensile strength	Nissan/Infiniti designation	Major applicable parts
373 N/mm ² (38kg/mm ² ,54klb/sq in)	SP130	<ul style="list-style-type: none">● Front side member assembly● Hoodledge assembly● Upper dash● Rear side member assembly● Other reinforcements

SP130 is the most commonly used HSS.

A
B
C
D
E
F
G
H
BL
J
K
L
M

BODY REPAIR

Read the following precautions when repairing HSS:

1. Additional points to consider

- The repair of reinforcements (such as side members) by heating is not recommended since it may weaken the component. When heating is unavoidable, do not heat HSS parts above 550°C (1,022°F). Verify heating temperature with a thermometer. (Crayon-type and other similar type thermometer are appropriate.)

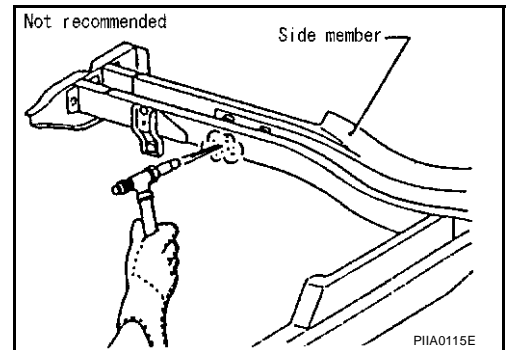

- When straightening body panels, use caution in pulling any HSS panel. Because HSS is very strong, pulling may cause deformation in adjacent portions of the body. In this case, increase the number of measuring points, and carefully pull the HSS panel.

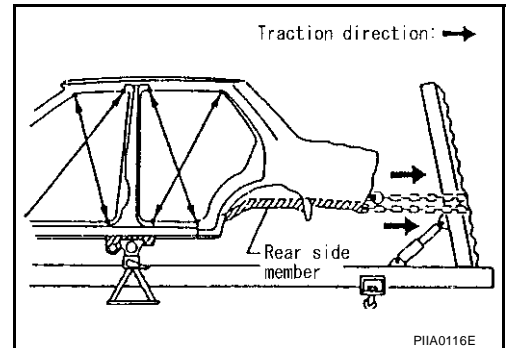

- When cutting HSS panels, avoid gas (torch) cutting if possible. Instead, use a saw to avoid weakening surrounding areas due to heat. If gas (torch) cutting is unavoidable, allow a minimum margin of 50 mm (1.97in).

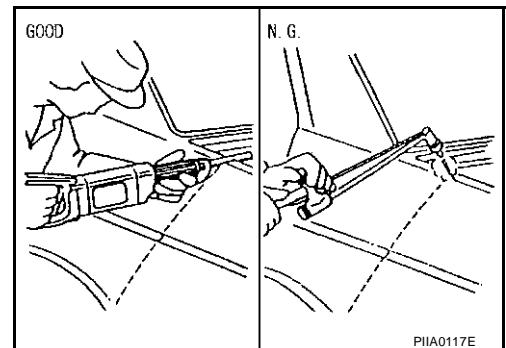

- When welding HSS panels, use spot welding whenever possible in order to minimize weakening surrounding areas due to heat. If spot welding is impossible, use M.I.G. welding. Do not use gas (torch) welding because it is inferior in welding strength.

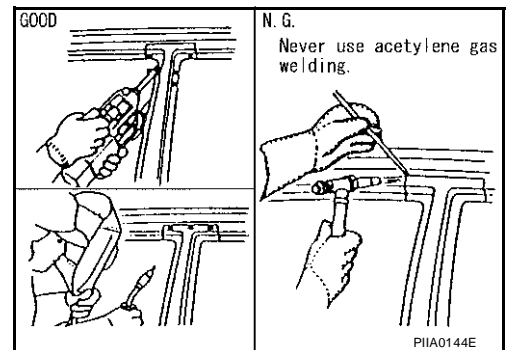

BODY REPAIR

- The spot weld on HSS panels is harder than that of an ordinary steel panel.
Therefore, when cutting spot welds on a HSS panel, use a low speed high torque drill (1,000 to 1,200 rpm) to increase drill bit durability and facilitate the operation.

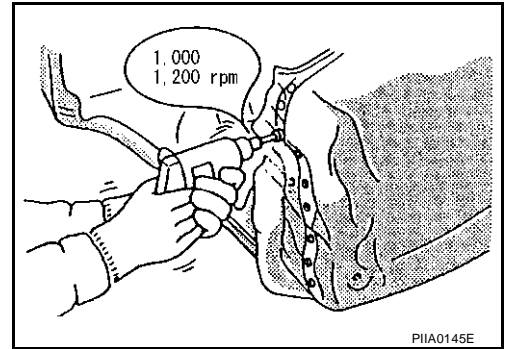

2. Precautions in spot welding HSS

This work should be performed under standard working conditions. Always note the following when spot welding HSS:

- The electrode tip diameter must be sized properly according to the metal thickness.

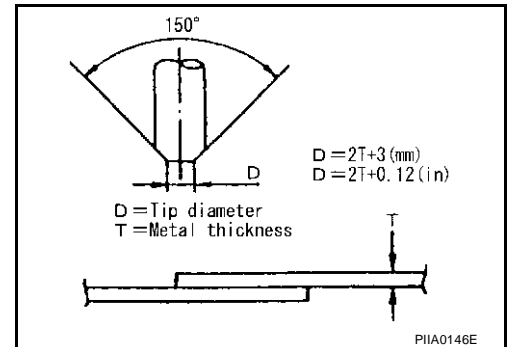

- The panel surfaces must fit flush to each other, leaving no gaps.

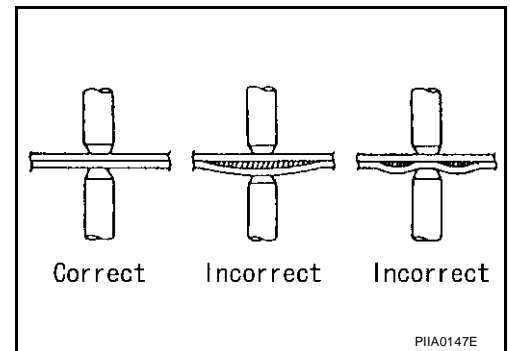

- Follow the specifications for the proper welding pitch.

Thickness (t)	Minimum pitch (l)
0.6 (0.024)	10 (0.39) or over
0.8 (0.031)	12 (0.47) or over
1.0 (0.039)	18 (0.71) or over
1.2 (0.047)	20 (0.79) or over
1.6 (0.063)	27 (1.06) or over
1.8 (0.071)	31 (1.22) or over

Unit:mm

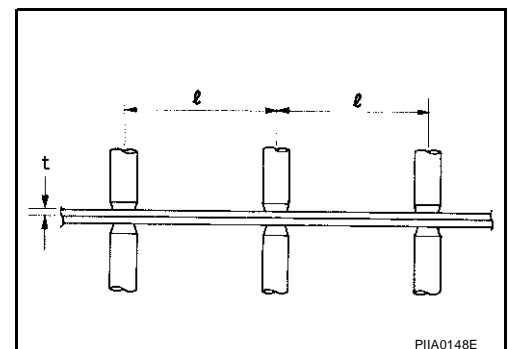

BODY REPAIR

Replacement Operations

AIS0063F

DESCRIPTION









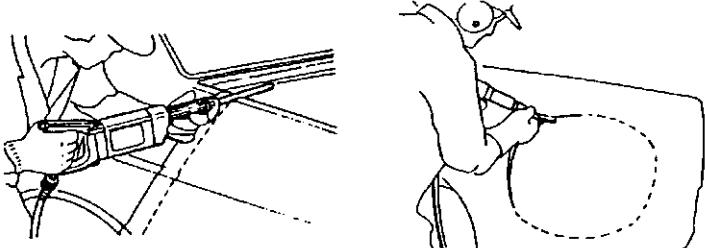

This section is prepared for technicians who have attained a high level of skill and experience in repairing collision-damaged vehicles and also use modern service tools and equipment. Persons unfamiliar with body repair techniques should not attempt to repair collision-damaged vehicles by using this section.

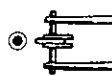
Technicians are also encouraged to read Body Repair Manual (Fundamentals) in order to ensure that the original functions and quality of the vehicle can be maintained. The Body Repair Manual (Fundamentals) contains additional information, including cautions and warning, that are not including in this manual. Technicians should refer to both manuals to ensure proper repairs.

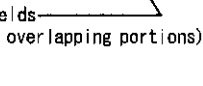
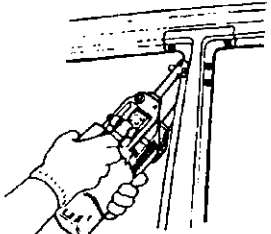
Please note that these information are prepared for worldwide usage, and as such, certain procedures might not apply in some regions or countries.

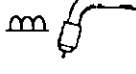
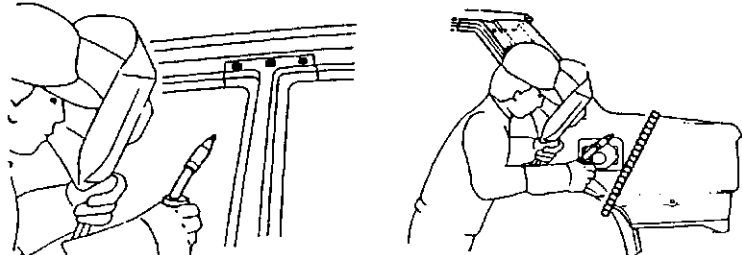
BODY REPAIR

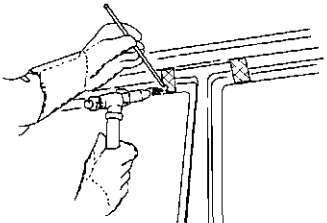
The symbols used in this section for cutting and welding / brazing operations are shown below.

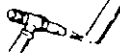
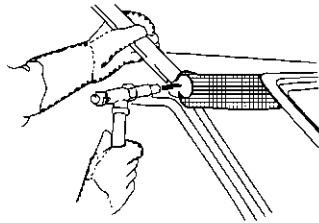
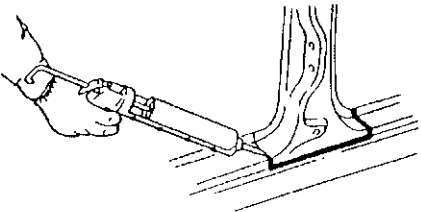
 <p>Saw cut or air chisel cut</p>	
<p>Spot weld</p> <p>● ● ● ● 2-spot welds</p>  <p>● ● ● ● ● ● 3-spot welds</p> 	<p>2-spot welds (2-panel overlapping portions)</p>  <p>3-spot welds (3-panel overlapping portions)</p>  
<p>■ ■ ■ ■ MIG plug weld</p>  <p>⌒ ⌒ ⌒ ⌒ MIG seam weld/ Point weld</p> 	
<p>⌘ ⌘ ⌘ ⌘ Brazing</p>  	
<p>⌘ ⌘ ⌘ ⌘ Soldering</p>  	
<p>— Sealing</p>	

A
B
C
D
E
F
G
H
BL
J
K
L
M

BODY REPAIR

- Front pillar butt joint can be determined anywhere within shaded area as shown in the figure. The best location for the butt joint is at position A due to the construction of the vehicle. Refer to the front pillar section.

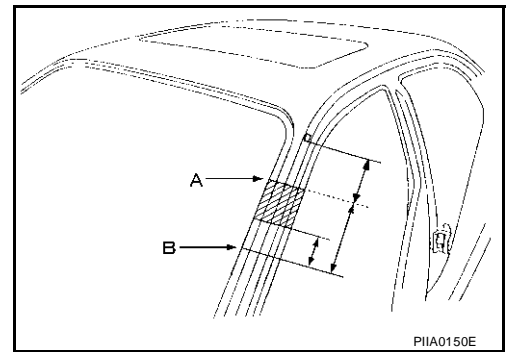

- Determine cutting position and record distance from the locating indent. Use this distance when cutting the service part. Cut outer front pillar over 60 mm above inner front pillar cut position.

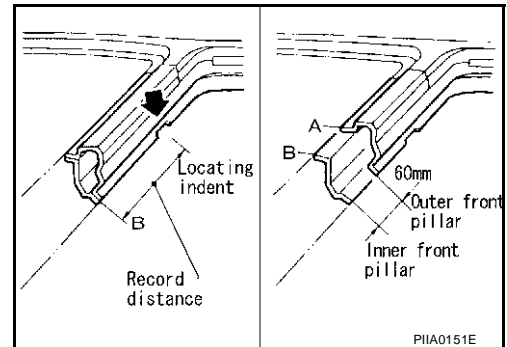

- Prepare a cutting jig to make outer pillar easier to cut. Also, this will permit service part to be accurately cut at joint position.

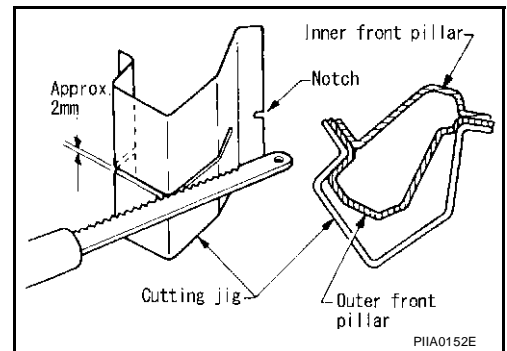

- An example of cutting operation using a cutting jig is as follows.

1. Mark cutting lines.
A: Cut position of outer pillar
B: Cut position of inner pillar
2. Align cutting line with notch on jig. Clamp jig to pillar.
3. Cut outer pillar along groove of jig. (At position A)
4. Remove jig and cut remaining portions.
5. Cut inner pillar at position B in same manner.

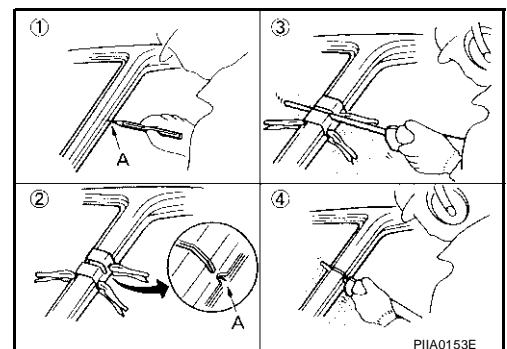

BODY REPAIR

HOODLEDGE

Service Joint

Remove front side member center closing plate for easier installation.

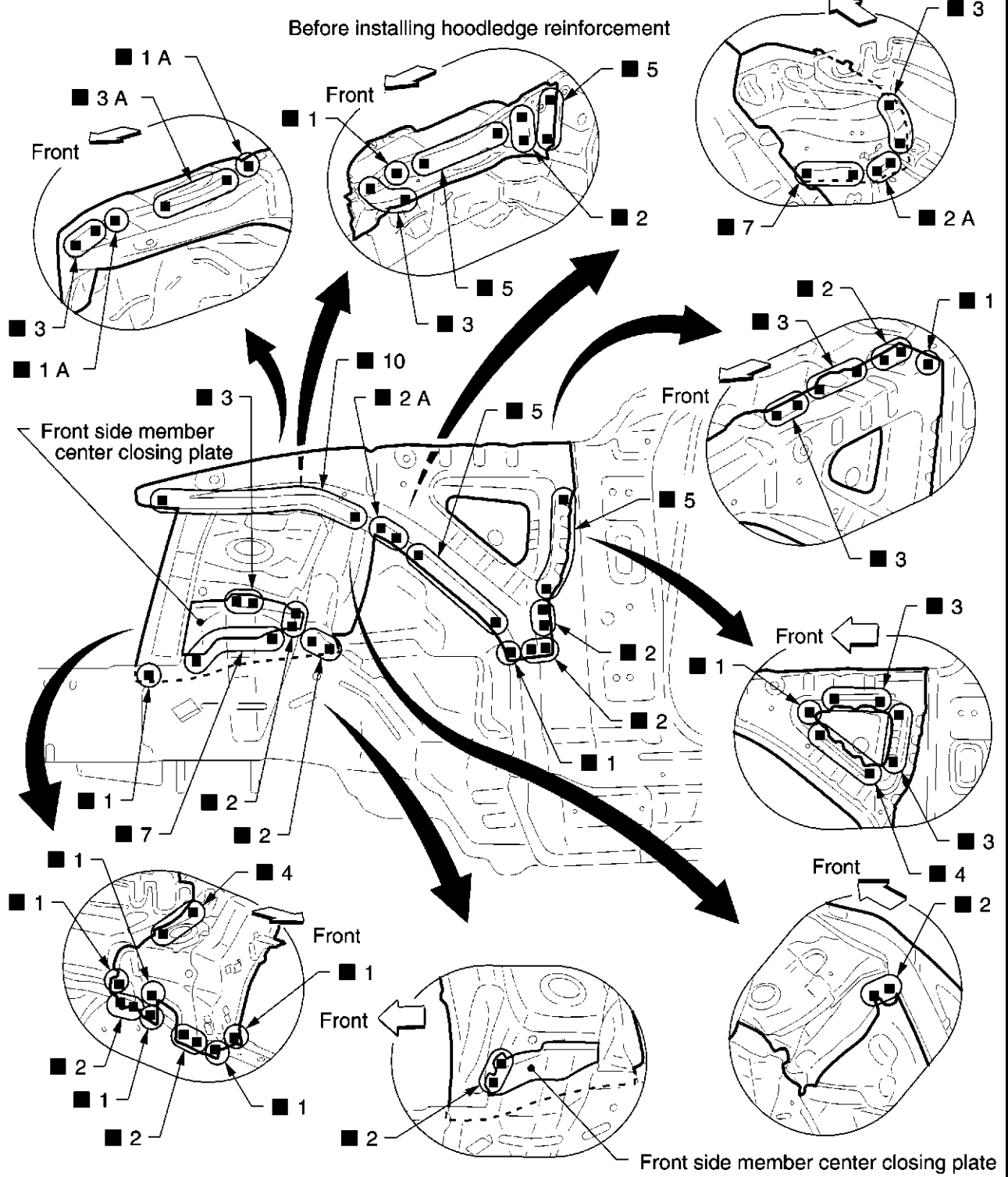

2-spot welds

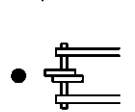

3-spot welds

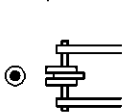

MIG plug weld

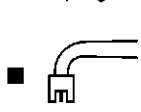

(For 3 panels plug weld method)



MIG seam weld/
Point weld

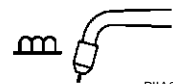

PIIA0953E

BODY REPAIR

FRONT SIDE MEMBER (PARTIAL REPLACEMENT)

Service Joint

(This figure shows right front side member)

Remove stabilizer bracket reinforcement for easier installation.

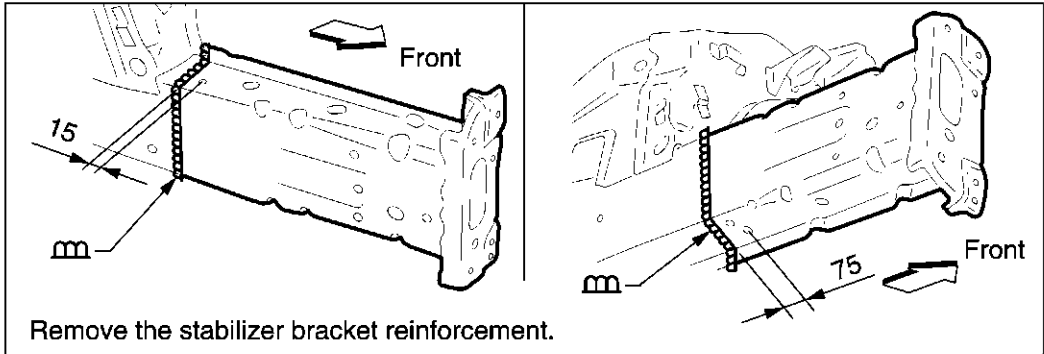
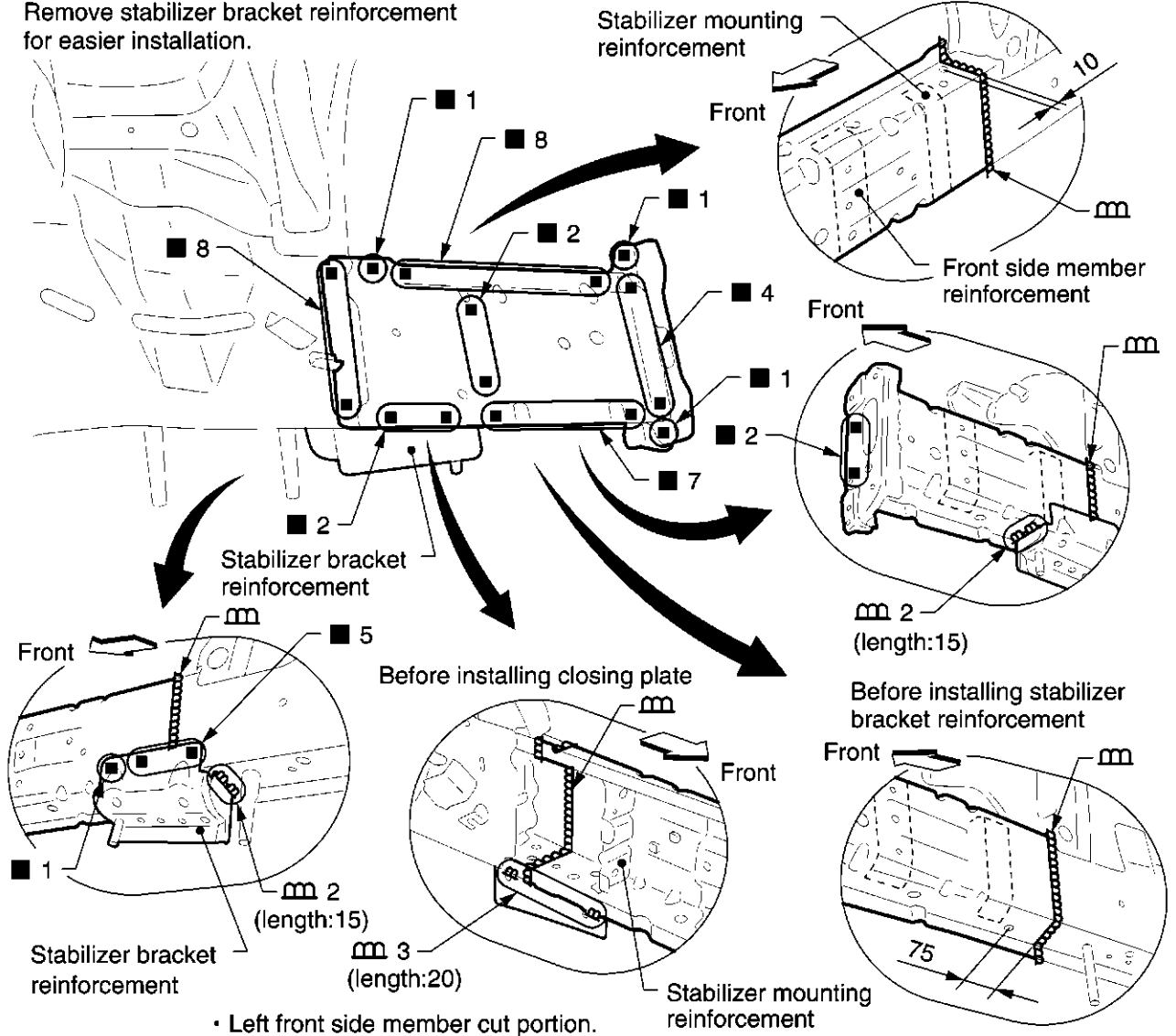

Unit:mm

2-spot welds

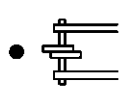

3-spot welds



M I G plug weld



(For 3 panels plug weld method)



M I G seam weld/
Point weld

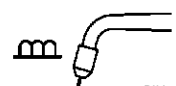

PIIA0955E

A
B
C
D
E
F
G
H
BL
J
K
L
M

BODY REPAIR

FRONT PILLAR

- Work after hoodledge reinforcement has been removed.

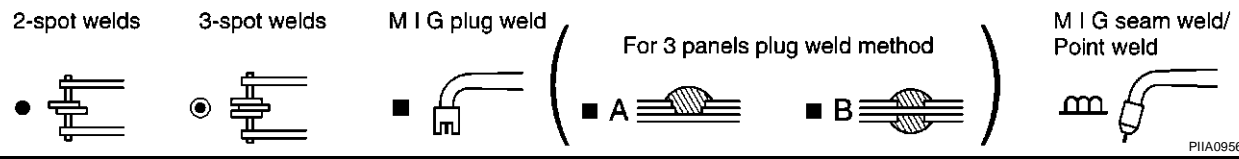
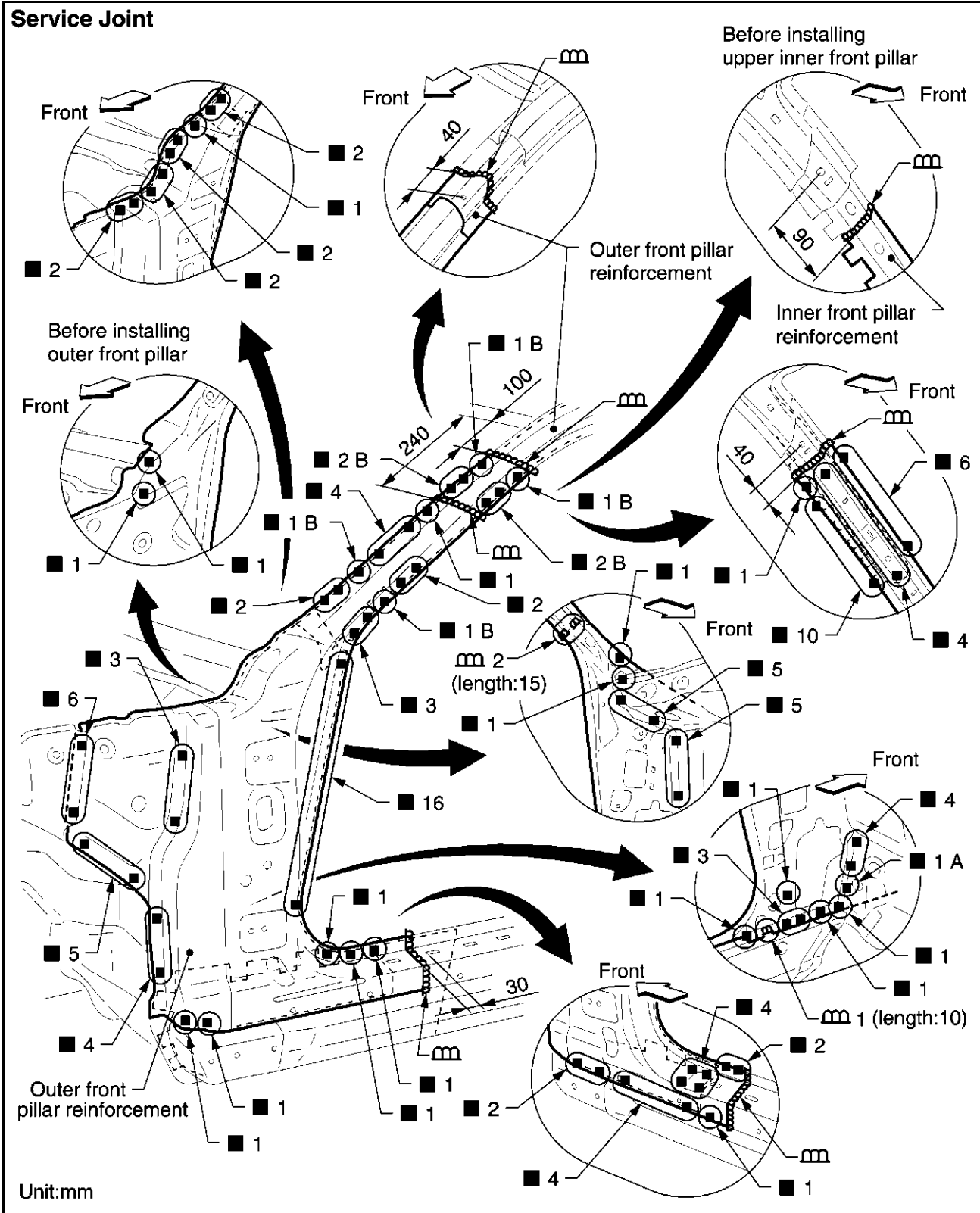

PIIA0956E

BODY REPAIR

OUTER SILL

Service Joint

Replacement part consists of outer sill, outer sill reinforcement and center pillar reinforcement.

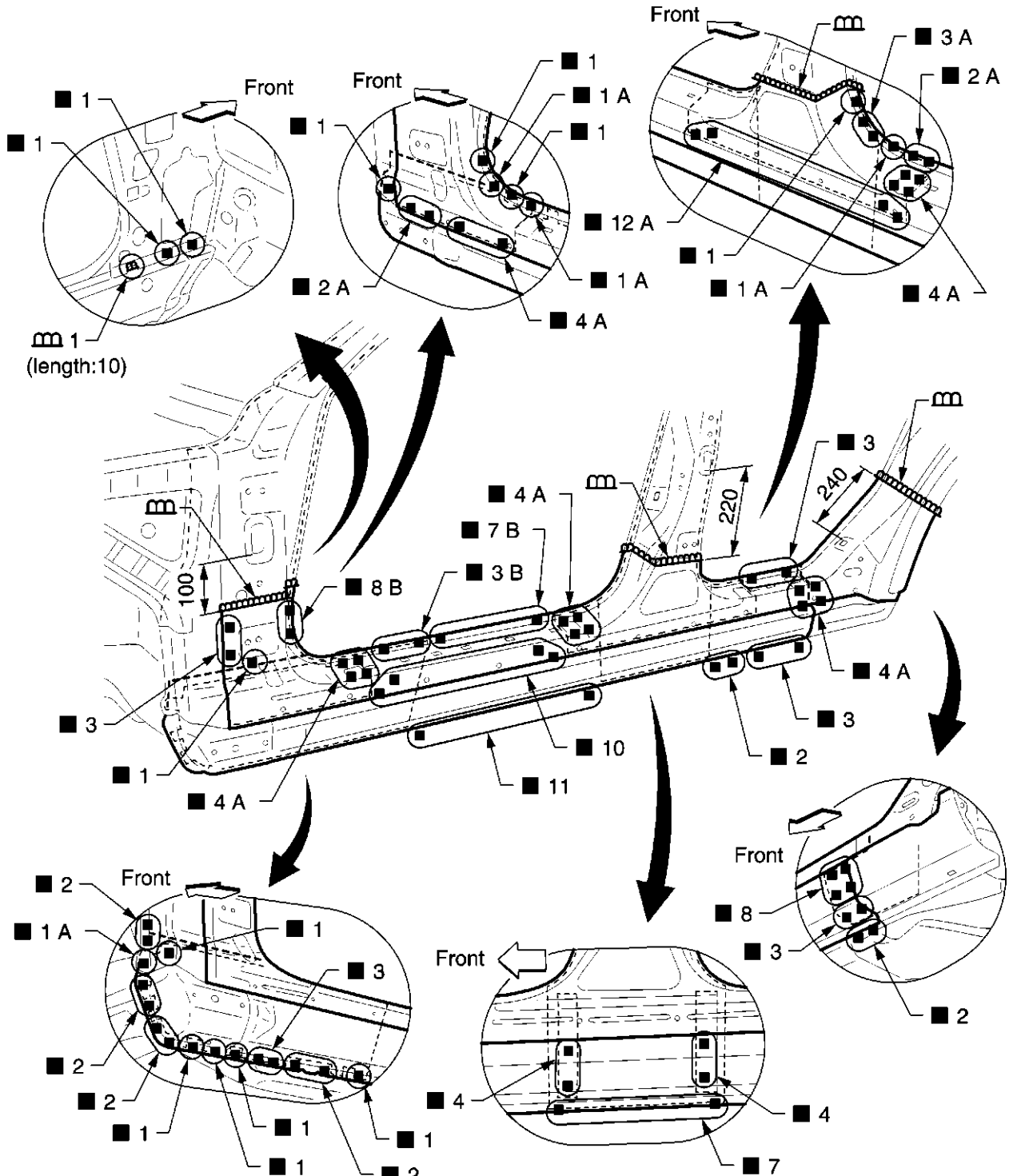

Unit:mm

2-spot welds	3-spot welds	MIG plug weld	For 3 panels plug weld method		MIG seam weld/ Point weld

PIIA0958E

BODY REPAIR

OUTER SILL (CONT'D)

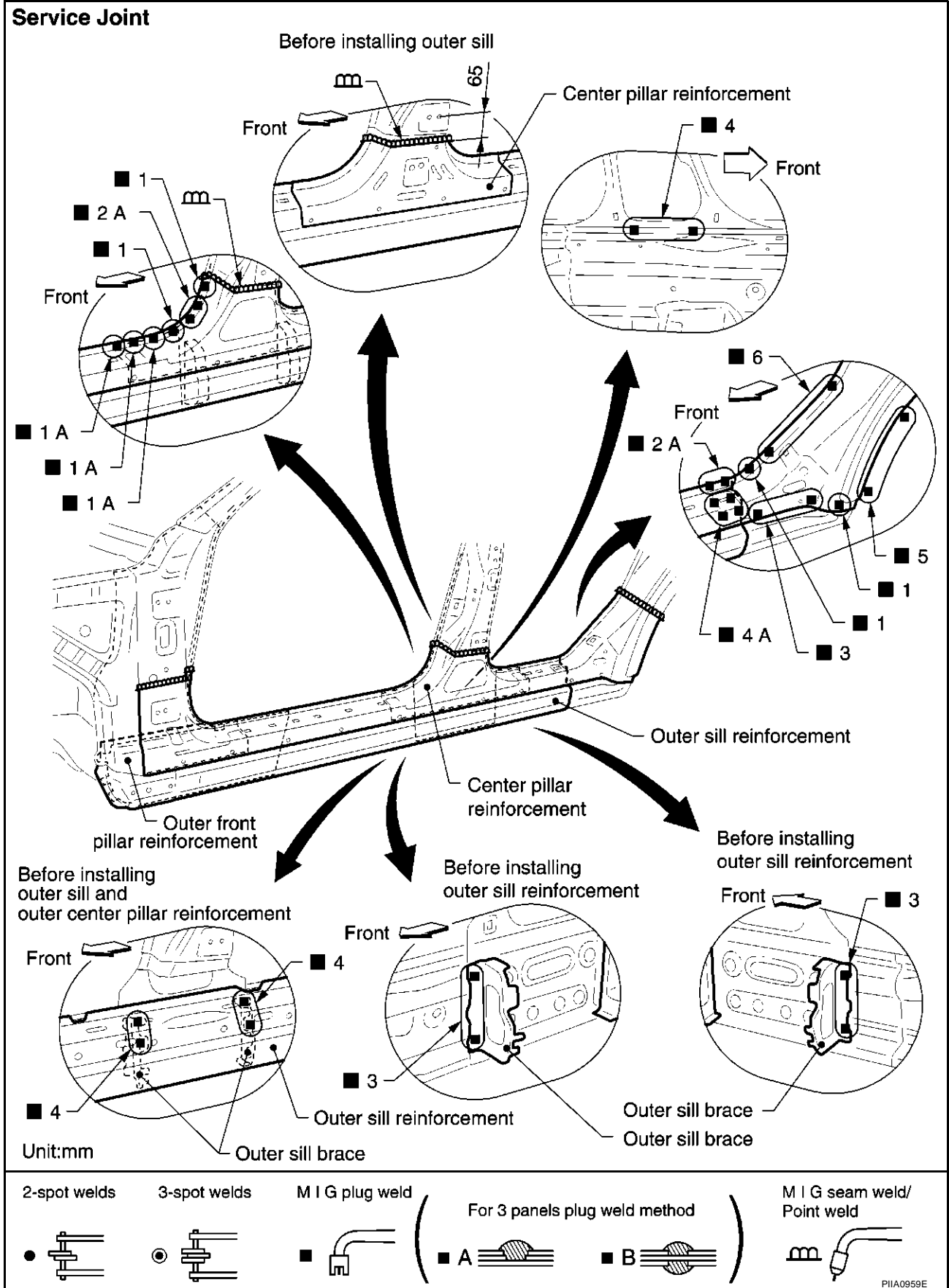

A
B
C
D
E
F
G
H
BL
J
K
L
M

BODY REPAIR

REAR FENDER

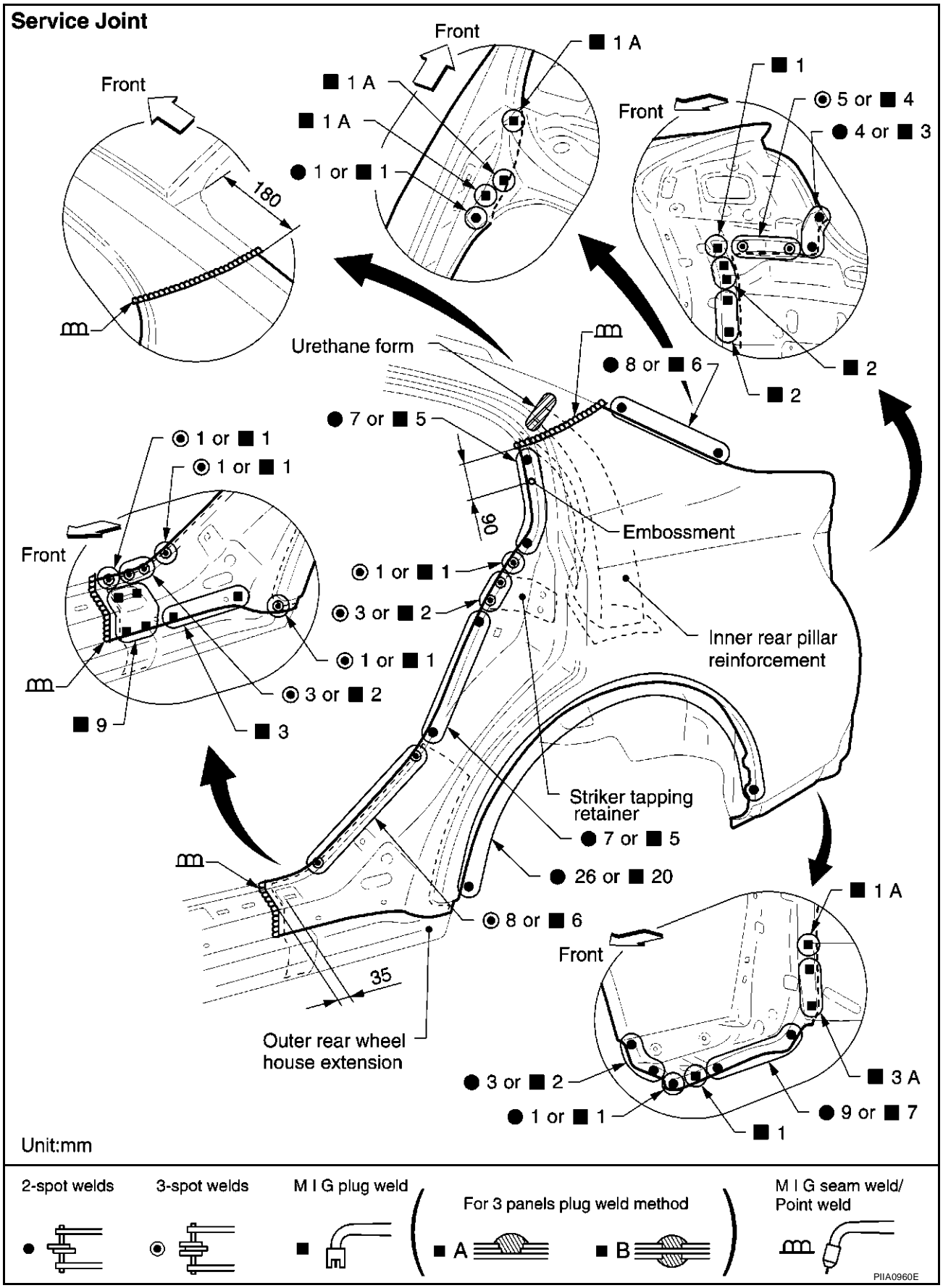

BODY REPAIR

REAR PANEL

Service Joint

★ indicates that there is an equivalent welding portion with the same dimensions on the opposite side.

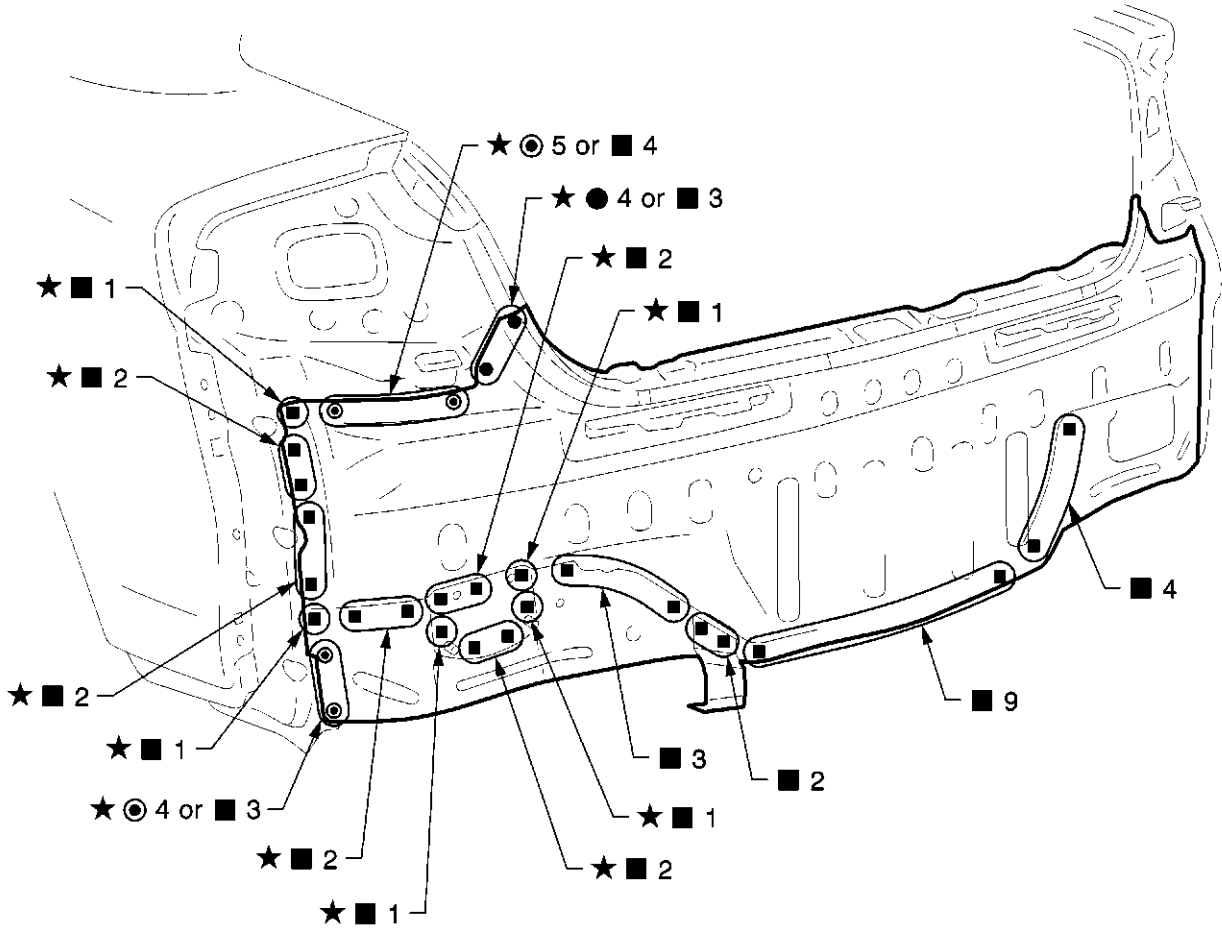

2-spot welds

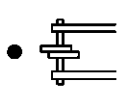

3-spot welds

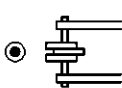

MIG plug weld



For 3 panels plug weld method

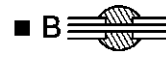

MIG seam weld/
Point weld



PIIA0961E

A
B
C
D
E
F
G
H
BL
J
K
L
M

BODY REPAIR

REAR FLOOR REAR

- Work after upper rear panel assembly has been removed.

Service Joint

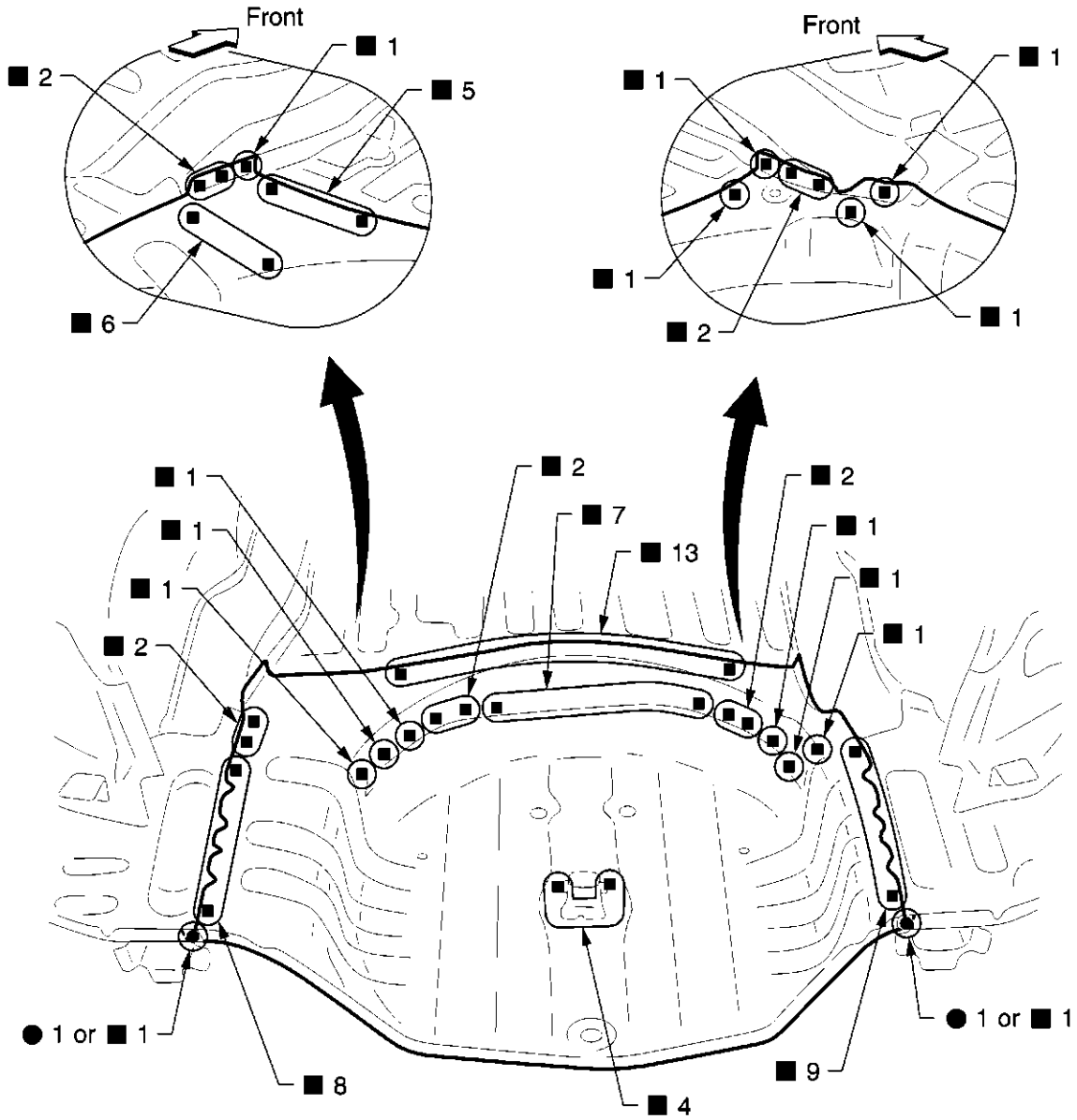

2-spot welds

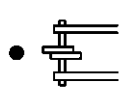

3-spot welds

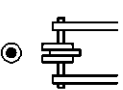

M I G plug weld

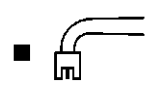

For 3 panels plug weld method



M I G seam weld/
Point weld

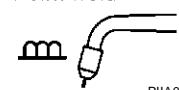

PIIA0962E

BODY REPAIR

REAR SIDE MEMBER EXTENSION

- Work after upper rear panel assembly has been removed.

Service Joint

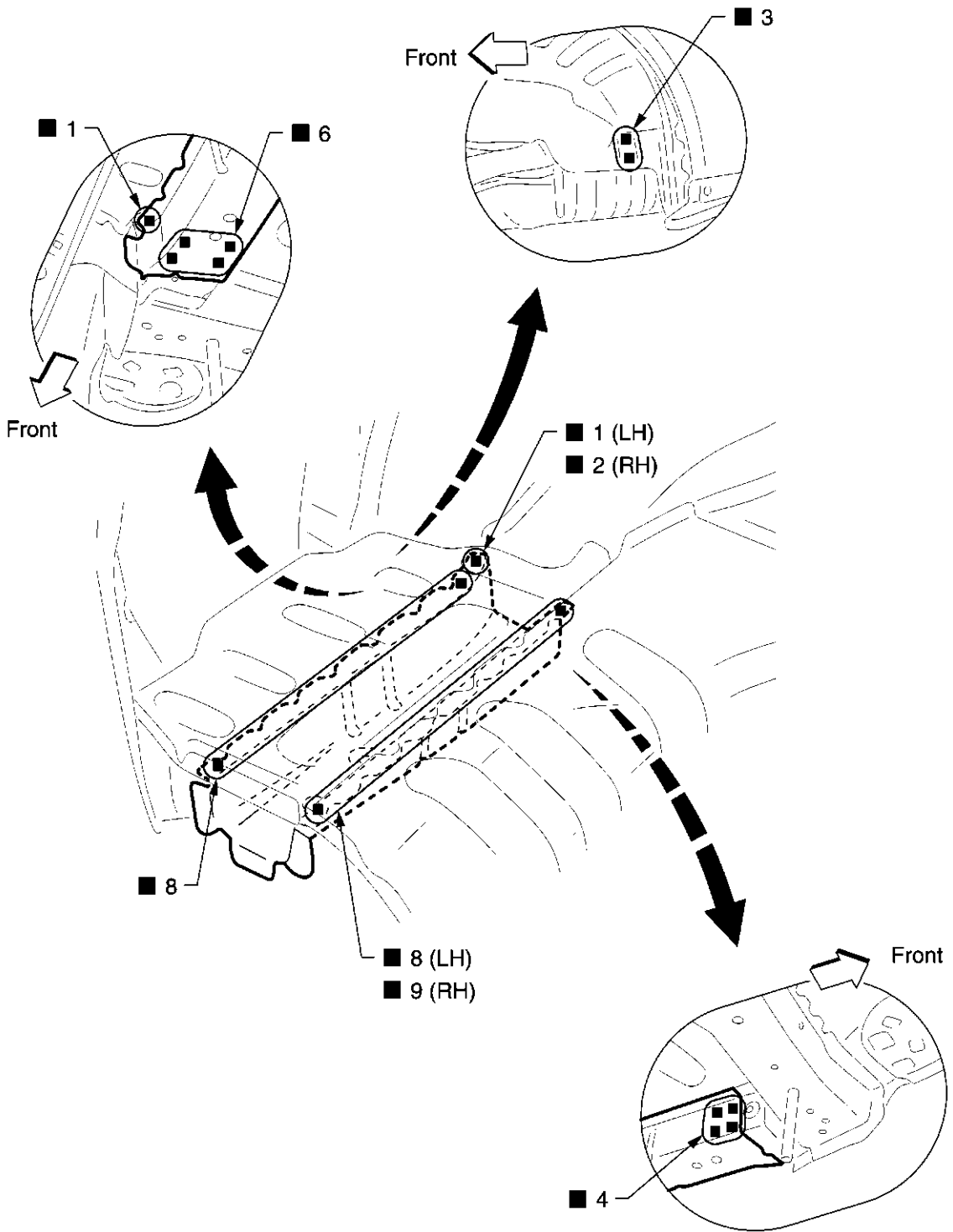

2-spot welds

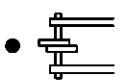

3-spot welds

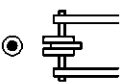

M I G plug weld

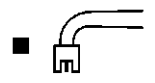

For 3 panels plug weld method



M I G seam weld/
Point weld

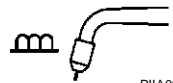

PIIA0963E

A
B
C
D
E
F
G
H
BL
J
K
L
M

BODY REPAIR
