

SECTION **PG**

POWER SUPPLY, GROUND & CIRCUIT ELEMENTS

CONTENTS

POWER SUPPLY ROUTING CIRCUIT	3	(FROM SERIAL 329288*)	35
Schematic	3	ENGINE CONTROL HARNESS/M/T MODELS...	36
Wiring Diagram - POWER -	4	BODY HARNESS	37
BATTERY POWER SUPPLY - IGNITION SW. IN ANY POSITION	4	HARNESS	40
ACCESSORY POWER SUPPLY - IGNITION SW. IN "ACC" OR "ON"	9	Harness Layout	40
IGNITION POWER SUPPLY - IGNITION SW. IN "ON" AND/OR "START"	10	HOW TO READ HARNESS LAYOUT	40
Fuse	15	OUTLINE	41
Fusible Link	15	MAIN HARNESS	42
Circuit Breaker	15	ENGINE ROOM HARNESS	45
IPDM E/R (INTELLIGENT POWER DISTRIBUTION MODULE ENGINE ROOM)	16	ENGINE CONTROL HARNESS	49
System Description	16	BODY HARNESS	51
SYSTEMS CONTROLLED BY IPDM E/R	16	BODY NO.2 HARNESS	54
CAN COMMUNICATION LINE CONTROL	16	ROOM LAMP HARNESS	55
IPDM E/R STATUS CONTROL	17	FRONT DOOR HARNESS	56
CAN Communication Unit	17	REAR DOOR HARNESS	57
TYPE 1/TYPE 3	17	Wiring Diagram Codes (Cell Codes)	58
TYPE 2	19	ELECTRICAL UNITS LOCATION	62
Function of Detecting Ignition Relay Malfunction ...	20	Electrical Units Location	62
Auto Active Test	21	ENGINE COMPARTMENT	62
DESCRIPTION	21	PASSENGER COMPARTMENT	63
OPERATION PROCEDURE	21	LUGGAGE COMPARTMENT	65
INSPECTION IN AUTO ACTIVE TEST MODE...	21	HARNESS CONNECTOR	66
Schematic	23	Description	66
IPDM E/R Terminal Arrangement	24	HARNESS CONNECTOR (TAB-LOCKING TYPE)	66
IPDM E/R Terminal Inspection	25	HARNESS CONNECTOR (SLIDE-LOCKING TYPE)	67
IPDM E/R Power/Ground Circuit Inspection	26	JOINT CONNECTOR (J/C)	68
Removal and Installation of IPDM E/R	27	Terminal Arrangement	68
GROUND	28	ELECTRICAL UNITS	69
Ground Distribution	28	Terminal Arrangement	69
MAIN HARNESS	28	SMJ (SUPER MULTIPLE JUNCTION)	71
ENGINE ROOM HARNESS	32	Terminal Arrangement	71
ENGINE CONTROL HARNESS/WITH A/T (UP TO SERIAL 329287*)	34	STANDARDIZED RELAY	73
ENGINE CONTROL HARNESS/WITH A/T		Description	73
		NORMAL OPEN, NORMAL CLOSED AND MIXED TYPE RELAYS	73
		TYPE OF STANDARDIZED RELAYS	73
		FUSE BLOCK - JUNCTION BOX (J/B)	75
		Terminal Arrangement	75

FUSE, FUSIBLE LINK AND RELAY BOX	76
Terminal Arrangement	76

POWER SUPPLY ROUTING CIRCUIT

POWER SUPPLY ROUTING CIRCUIT

Schematic

PFP:24110

AKS000CM

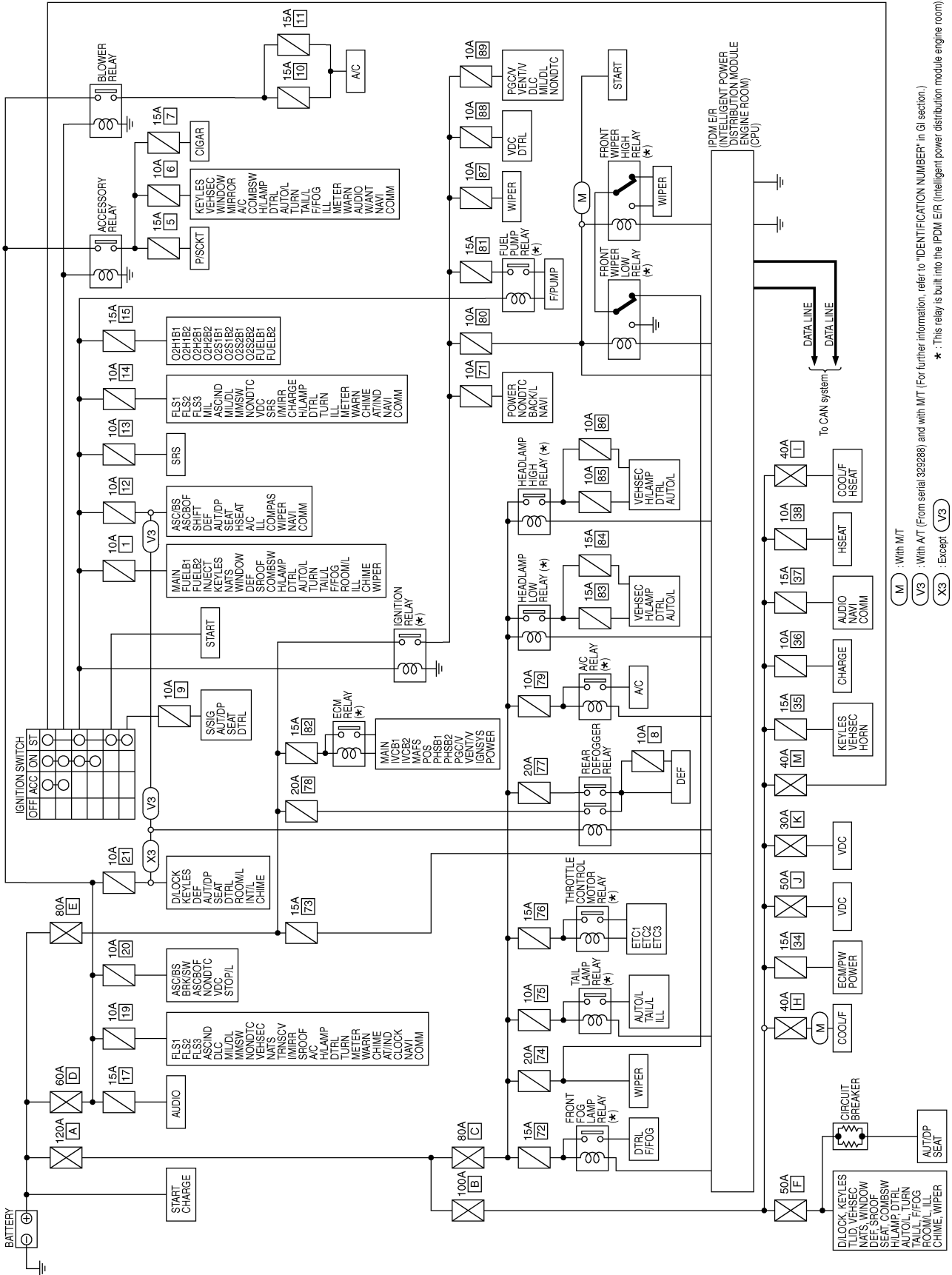

TKWT1040E

A
B
C
D
E
F
G
H
I
J
K
L
M

PG

POWER SUPPLY ROUTING CIRCUIT

AKS000CN

Wiring Diagram - POWER - BATTERY POWER SUPPLY - IGNITION SW. IN ANY POSITION

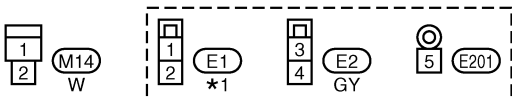
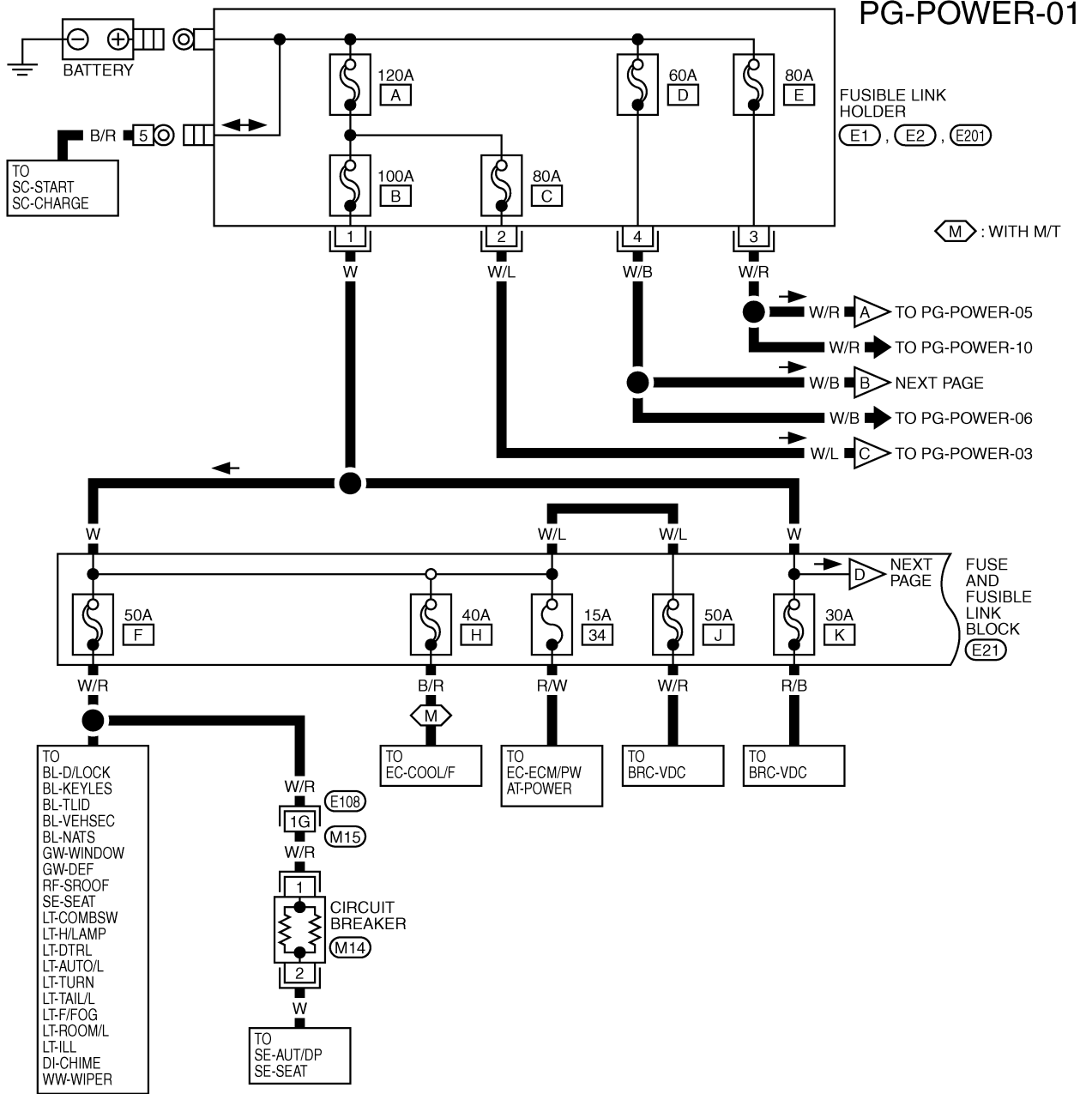

*1 : BR or B

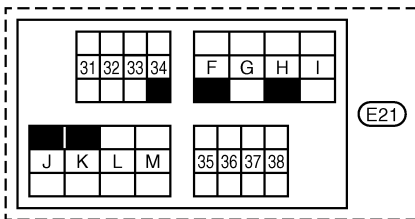

REFER TO THE FOLLOWING.

(E108) -SUPER MULTIPLE JUNCTION (SMJ)

TKWT0972E

POWER SUPPLY ROUTING CIRCUIT

PG-POWER-02

PRECEDING PAGE

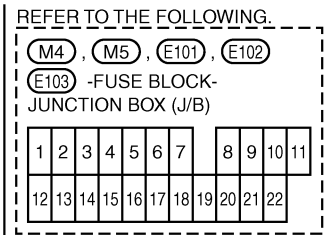
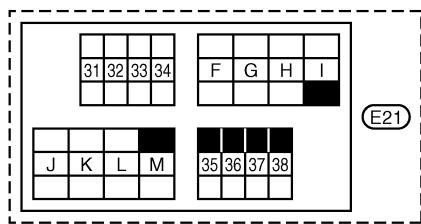
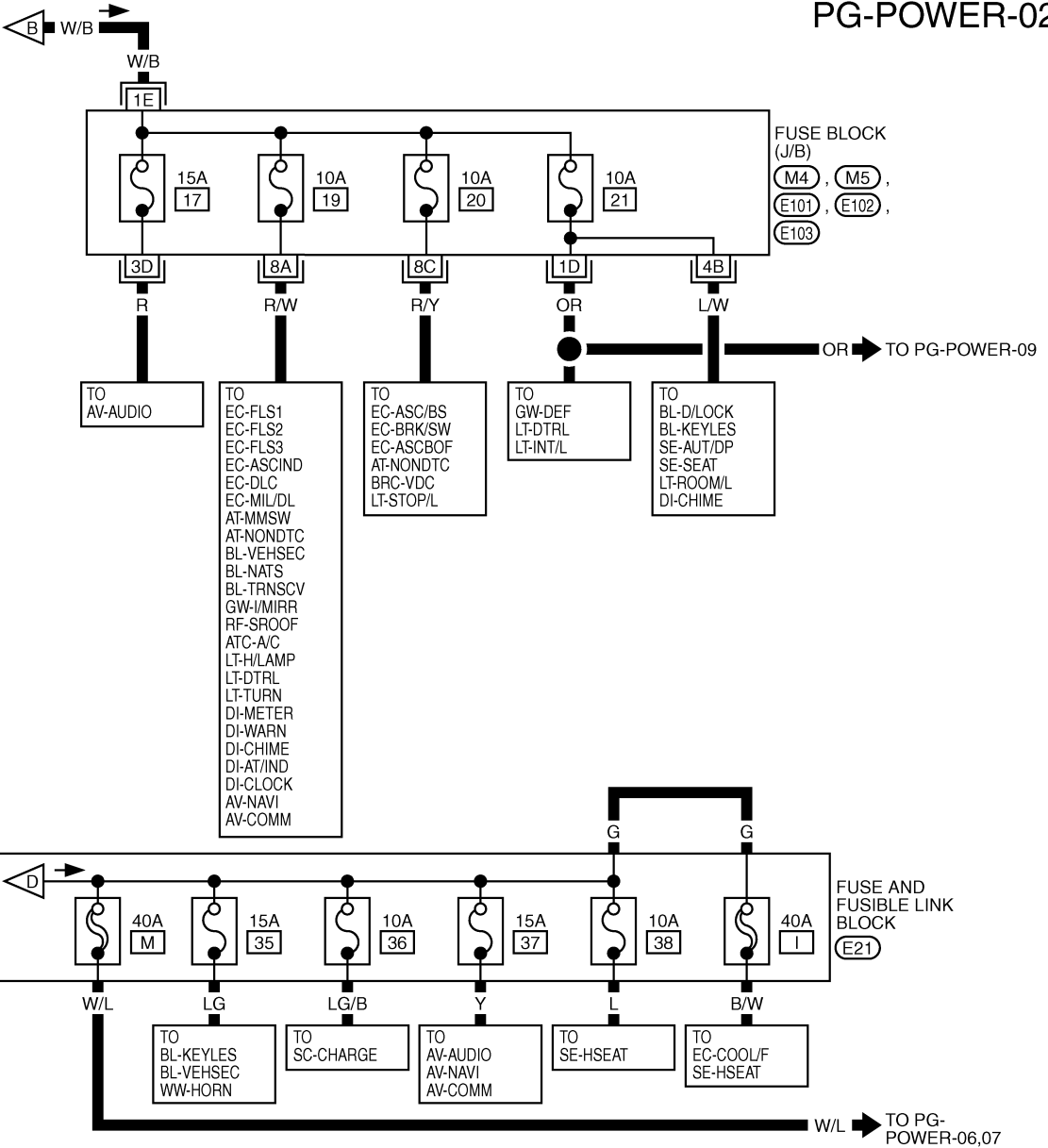

TKWT0973E

POWER SUPPLY ROUTING CIRCUIT

PG-POWER-03

U : FOR U.S.A.

C : FOR CANADA

*1 W/G : U

Y/G : C

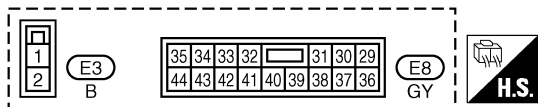
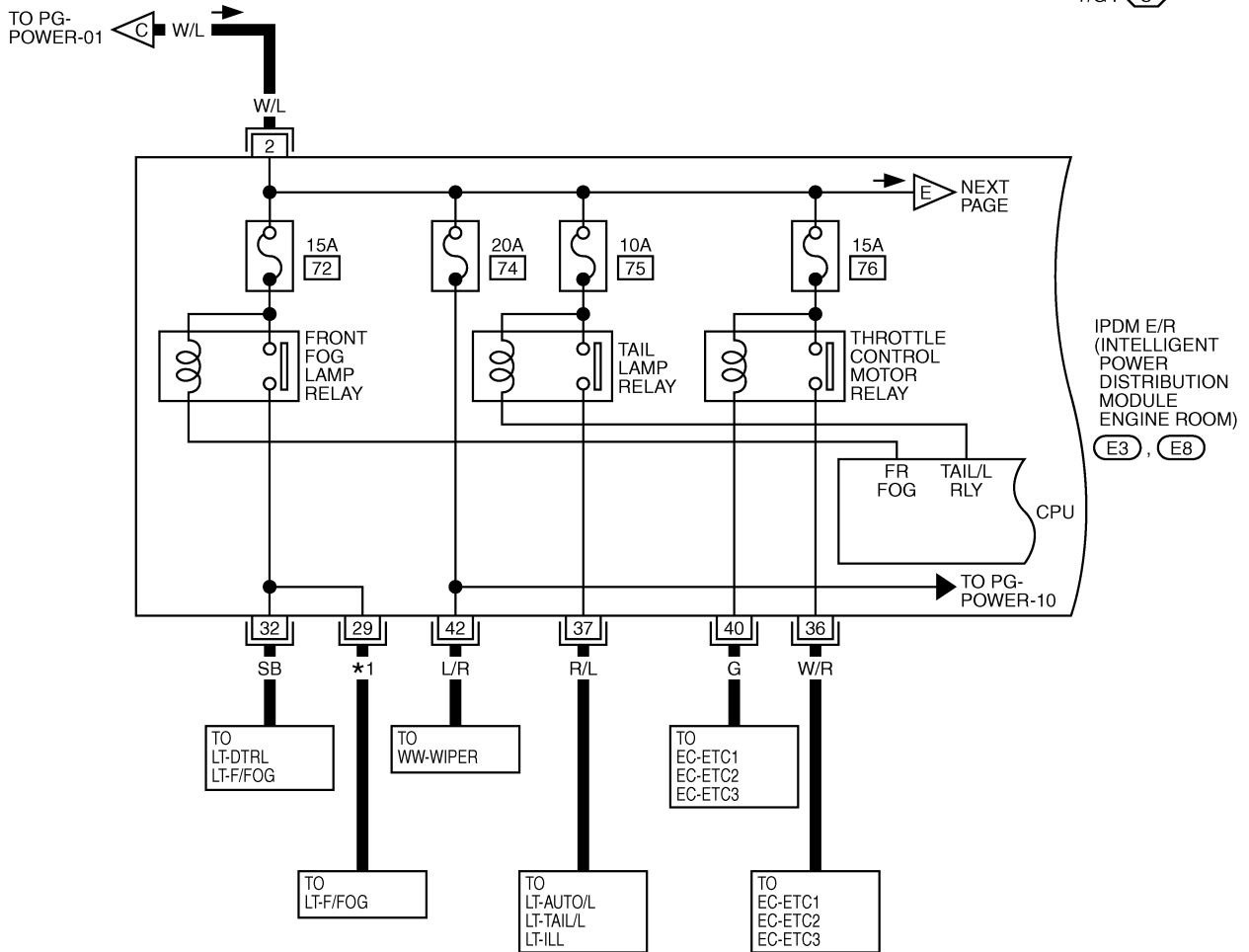

TKWT0369E

POWER SUPPLY ROUTING CIRCUIT

PG-POWER-04

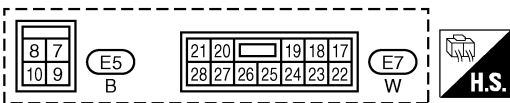
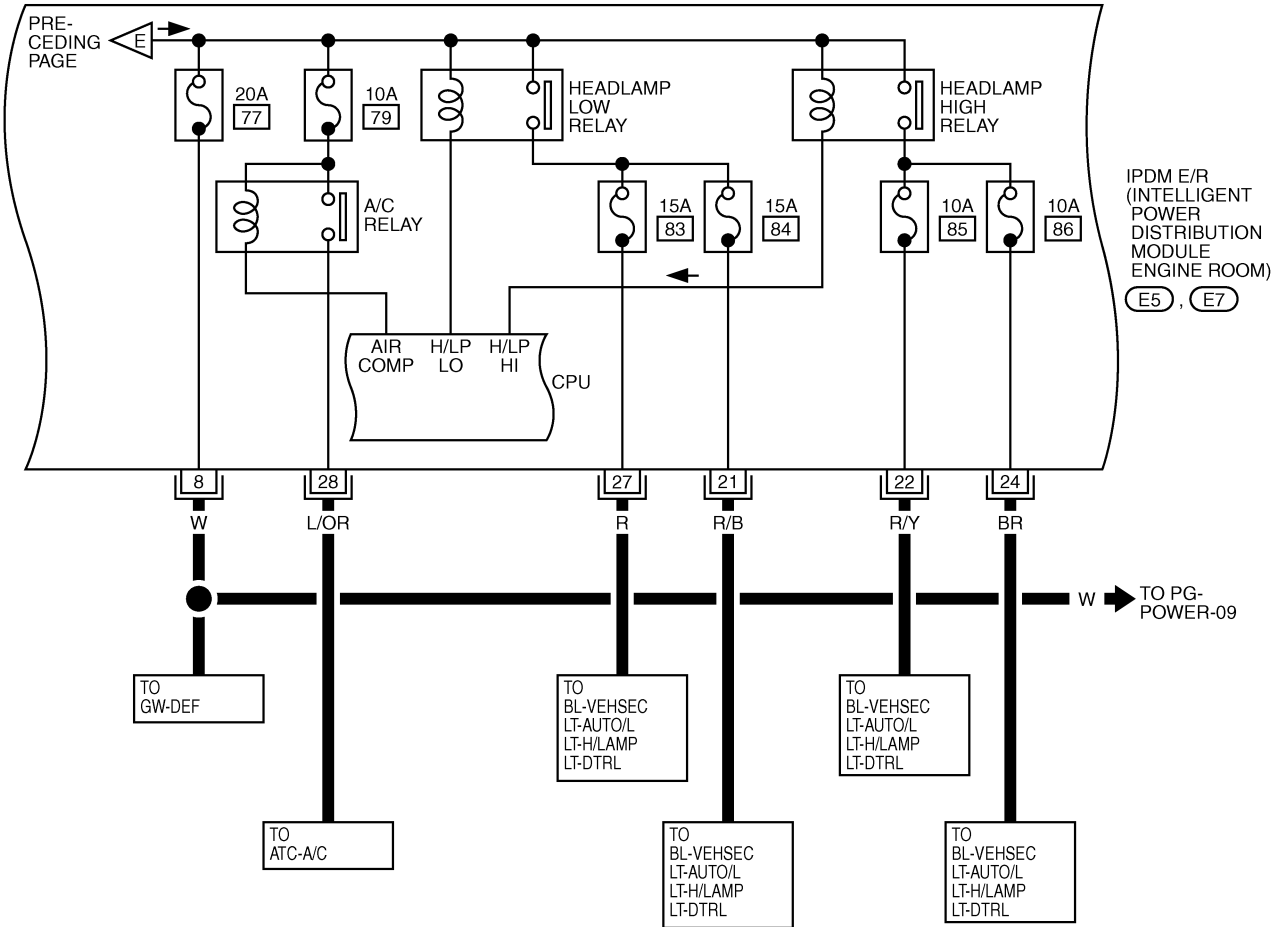

A
B
C
D
E
F
G
H
I
J
PG
L
M

POWER SUPPLY ROUTING CIRCUIT

PG-POWER-05

TO PG-POWER-01

▬ : DATA LINE

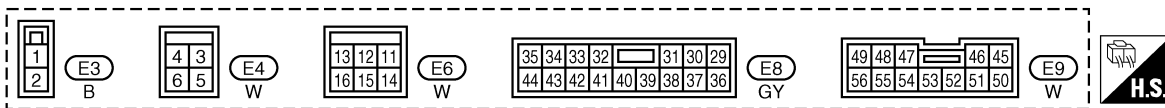
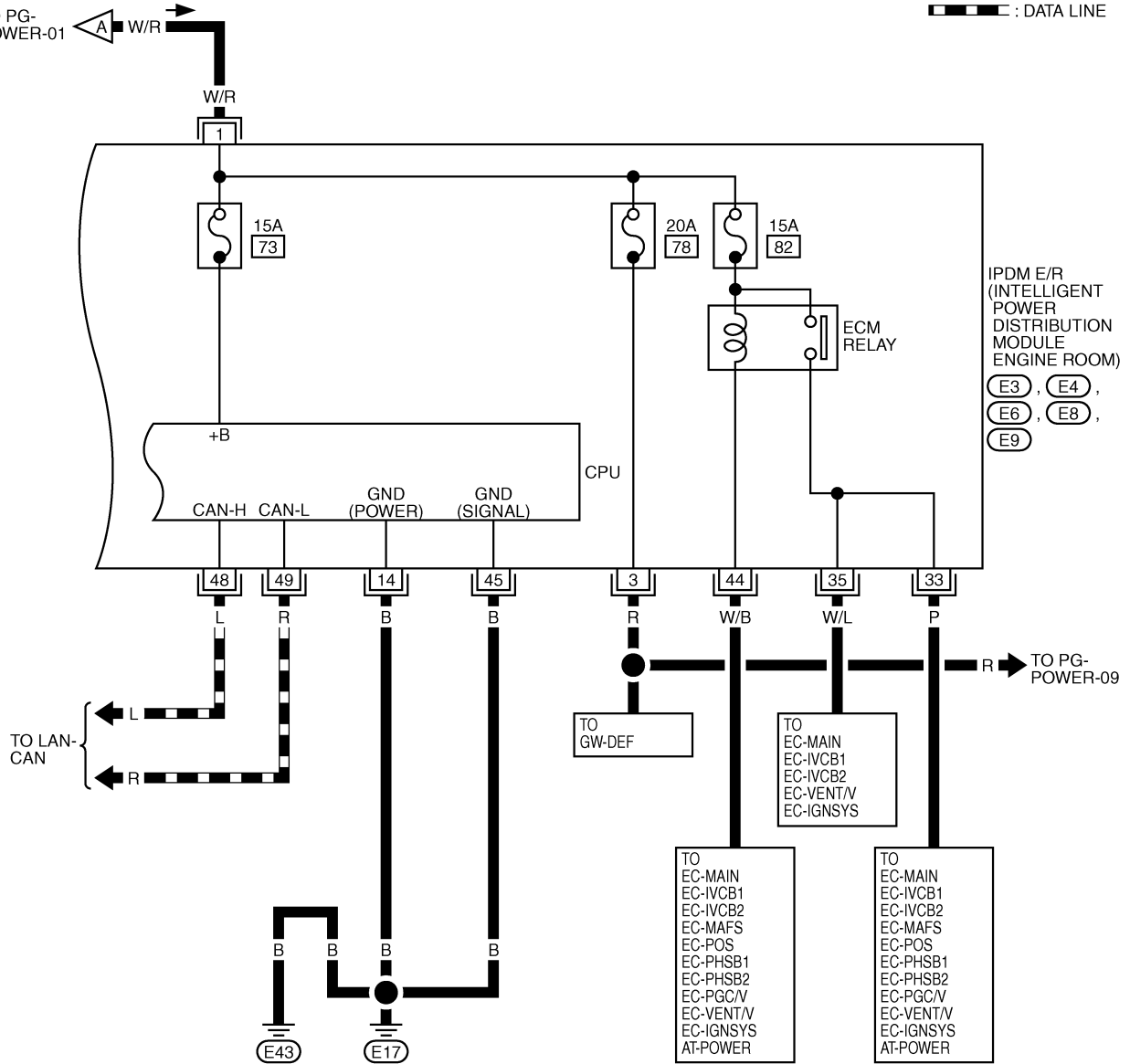

TKWT0974E

POWER SUPPLY ROUTING CIRCUIT

ACCESSORY POWER SUPPLY - IGNITION SW. IN "ACC" OR "ON"

PG-POWER-06

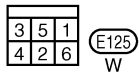
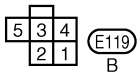
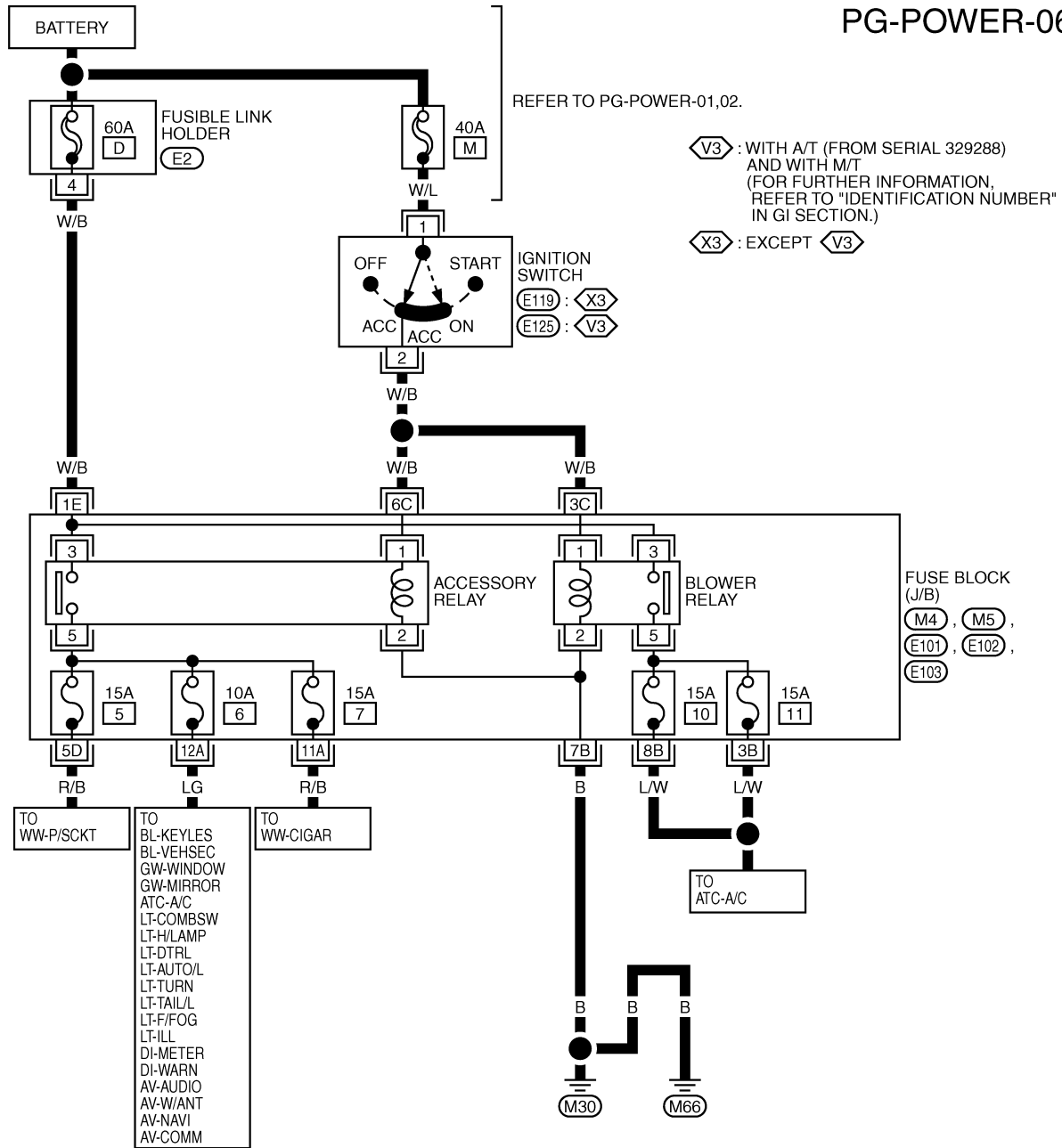

REFER TO THE FOLLOWING.

(M4), (M5), (E101), (E102)

(E103) - FUSE BLOCK-
JUNCTION BOX (J/B)

1	2	3	4	5	6	7	8	9	10	11
12	13	14	15	16	17	18	19	20	21	22

TKWT1041E

POWER SUPPLY ROUTING CIRCUIT

IGNITION POWER SUPPLY - IGNITION SW. IN "ON" AND/OR "START"

PG-POWER-07

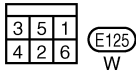
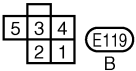
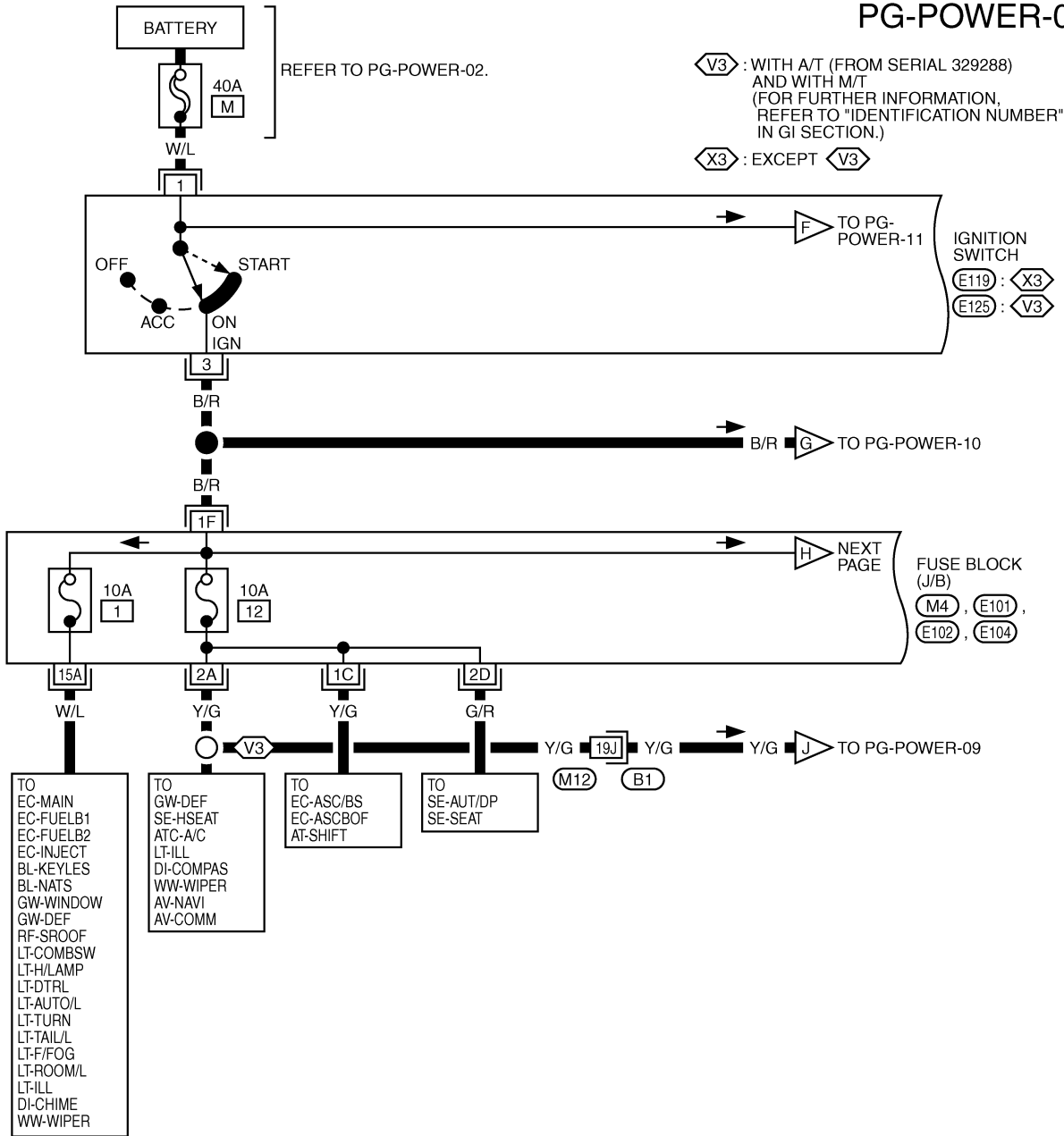

REFER TO THE FOLLOWING.

(B1) -SUPER MULTIPLE JUNCTION (SMJ)

(M4), (E101), (E102), (E104)
-FUZE BLOCK-JUNCTION BOX (J/B)

1	2	3	4	5	6	7	8	9	10	11
12	13	14	15	16	17	18	19	20	21	22

TKWT1042E

POWER SUPPLY ROUTING CIRCUIT

PG-POWER-08

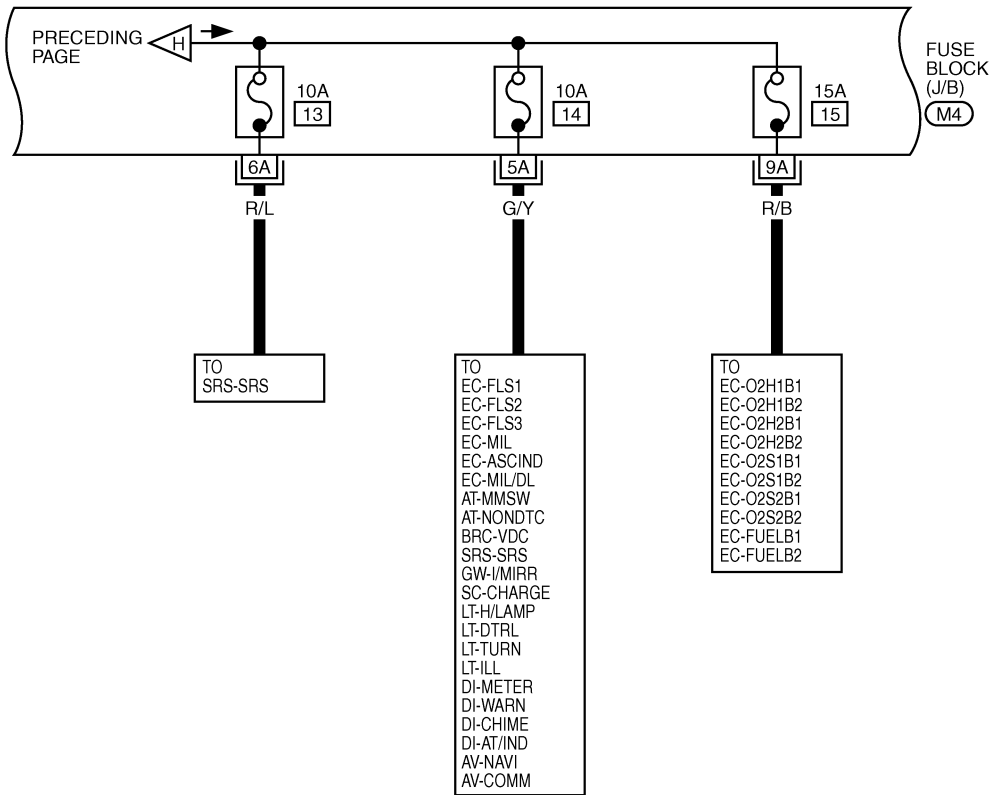

REFER TO THE FOLLOWING.

(M4) - FUSE BLOCK-
JUNCTION BOX (J/B)

1	2	3	4	5	6	7	8	9	10	11
12	13	14	15	16	17	18	19	20	21	22

TKWT0977E

POWER SUPPLY ROUTING CIRCUIT

PG-POWER-10

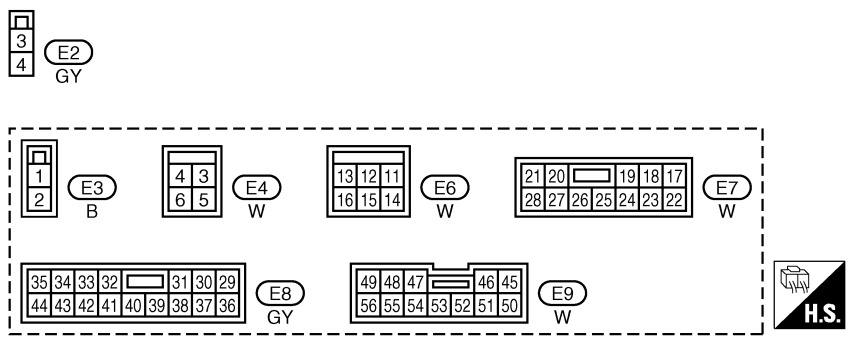
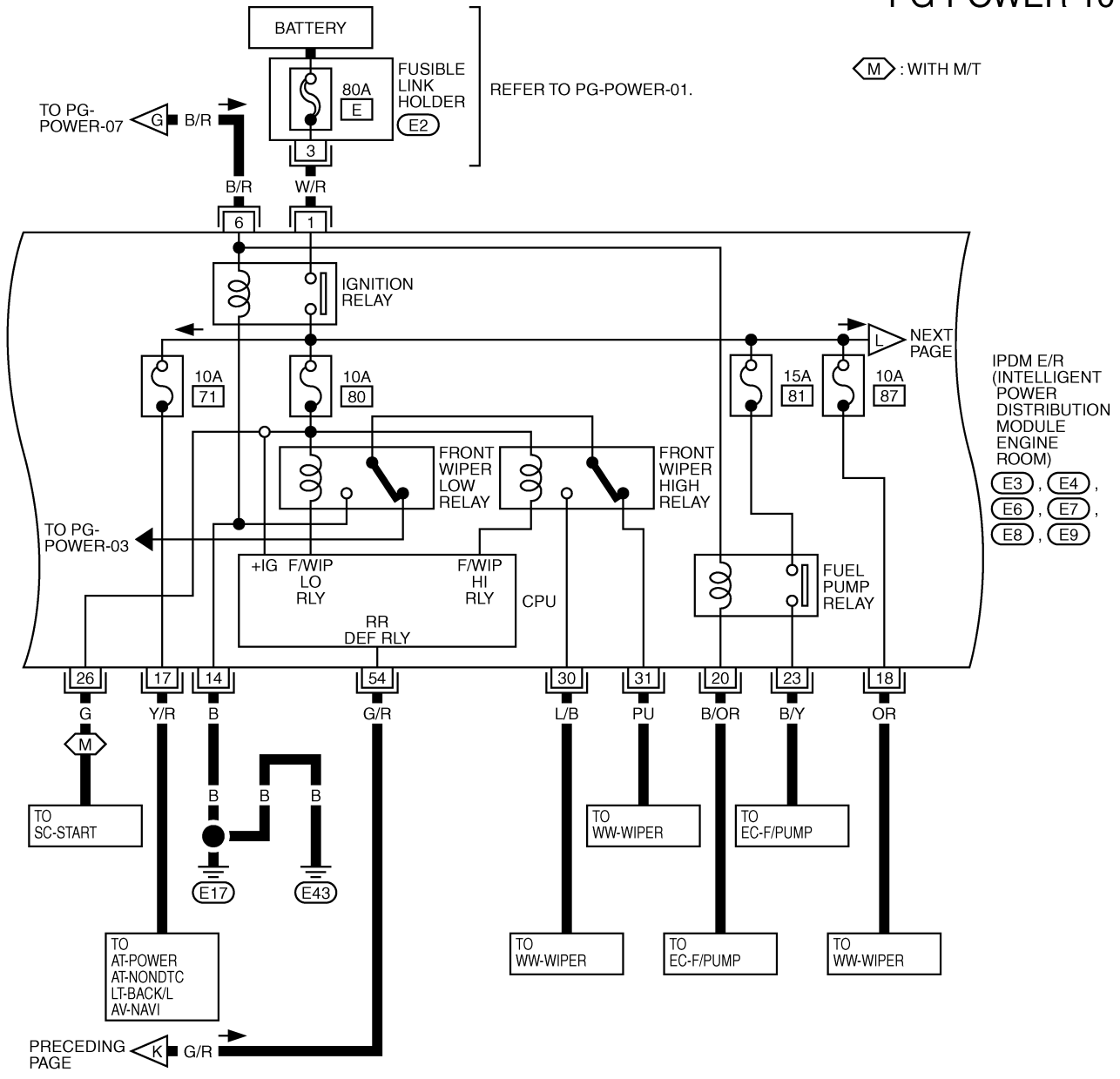

TKWT0979E

POWER SUPPLY ROUTING CIRCUIT

PG-POWER-11

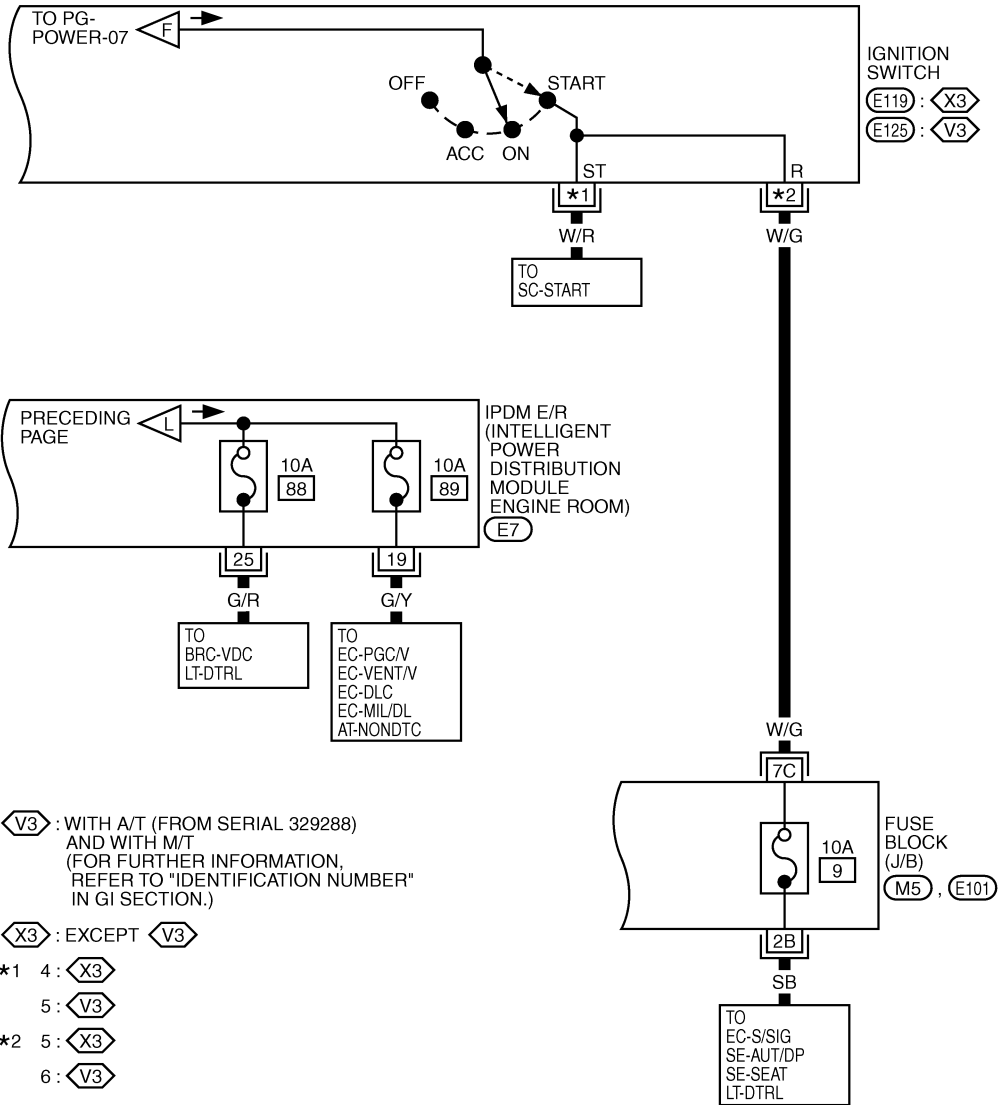

21	20	19	18	17		
28	27	26	25	24	23	22

E7
W



5	3	4
2	1	

E119
B

3	5	1
4	2	6

E125
W

REFER TO THE FOLLOWING.

M5, E101 - FUSE BLOCK-JUNCTION BOX (J/B)

1	2	3	4	5	6	7	8	9	10	11
12	13	14	15	16	17	18	19	20	21	22

TKWT1044E

POWER SUPPLY ROUTING CIRCUIT

Fuse

AKS00018

- If fuse is blown, be sure to eliminate cause of incident before installing new fuse.
- Use fuse of specified rating. Never use fuse of more than specified rating.
- Do not partially install fuse; always insert it into fuse holder properly.
- Remove fuse for "ELECTRICAL PARTS (BAT)" if vehicle is not used for a long period of time.

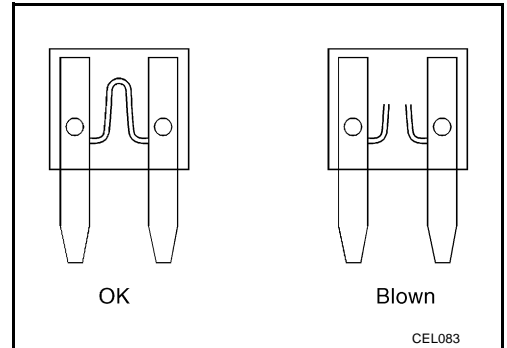

Fusible Link

AKS00019

A melted fusible link can be detected either by visual inspection or by feeling with finger tip. If its condition is questionable, use circuit tester or test lamp.

CAUTION:

- If fusible link should melt, it is possible that critical circuit (power supply or large current carrying circuit) is shorted. In such a case, carefully check and eliminate cause of incident.
- Never wrap outside of fusible link with vinyl tape. Important: Never let fusible link touch any other wiring harness, vinyl or rubber parts.

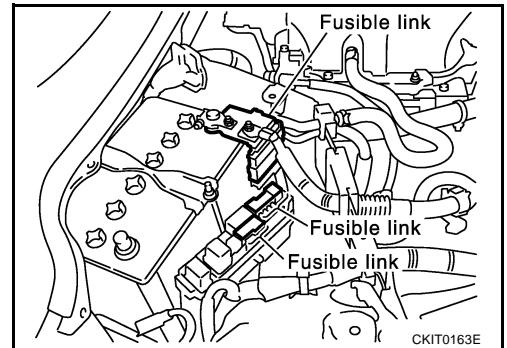

Circuit Breaker

AKS0001A

The PTC thermistor generates heat in response to current flow. The temperature (and resistance) of the thermistor element varies with current flow. Excessive current flow will cause the element's temperature to rise. When the temperature reaches a specified level, the electrical resistance will rise sharply to control the circuit current. Reduced current flow will cause the element to cool. Resistance falls accordingly and normal circuit current flow is allowed to resume.

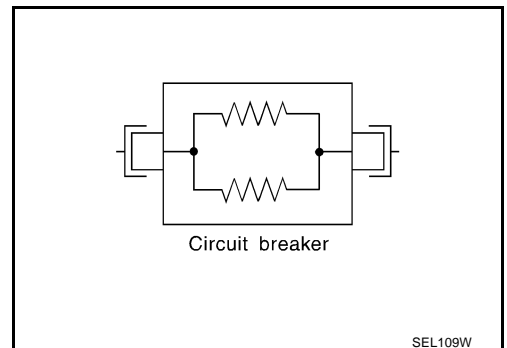

A
B
C
D
E
F
G
H
I
J
PG
L
M

IPDM E/R (INTELLIGENT POWER DISTRIBUTION MODULE ENGINE ROOM)

PFP:284B7

System Description

AKS00010

- IPDM E/R (Intelligent Power Distribution Module Engine Room) integrates the relay box and fuse block which were originally placed in engine compartment. It controls integrated relay via IPDM E/R control circuit.
- IPDM E/R-integrated control circuit performs ON-OFF operation of relay, CAN communication control, oil pressure switch signal reception, etc.
- It controls operation of each electrical part via BCM and CAN communication lines.

CAUTION:

None of the IPDM E/R-integrated relays can be removed.

SYSTEMS CONTROLLED BY IPDM E/R

1. Lamp control
Using CAN communication line, it receives signal from BCM and controls the following lamps:
 - Head lamps (Hi, Lo)
 - Parking lamps
 - Tail lamps
 - Front fog lamps
2. Wiper control
Using CAN communication line, it receives signals from BCM and controls the front wipers.
3. Rear window defogger relay control
Using CAN communication line, it receives signals from BCM and controls the rear window defogger relay.
4. A/C compressor control
Using CAN communication line, it receives signals from ECM and controls the A/C relay.
5. Cooling fan control
Using CAN communication line, it receives signals from ECM and controls cooling fan relay.
6. Horn control
Using CAN communication line, it receives signals from BCM and controls horn relay.

CAN COMMUNICATION LINE CONTROL

With CAN communication, by connecting each control unit using two communication lines (CAN L-line, CAN H-line), it is possible to transmit maximum amount of information with minimum wiring. Each control unit can transmit and receive data, and reads necessary information only.

1. Fail-safe control
 - When CAN communication with other control units is impossible, IPDM E/R performs fail-safe control. After CAN communication recovers normally, it also returns to normal control.
 - Operation of control parts by IPDM E/R during fail-safe mode is as follows:

Controlled parts	Fail-safe mode
Head lamps	Head lamp low relay ON
Front fog lamps	Front fog lamp relay OFF
Tail and parking lamps	Tail lamp relay OFF
Front wipers	Until ignition switch is turned OFF, status immediately before fail-safe control is performed is maintained.
Rear window defogger	Rear window defogger relay OFF
Cooling fan	Cooling fan ON
A/C compressor	A/C relay OFF

IPDM E/R (INTELLIGENT POWER DISTRIBUTION MODULE ENGINE ROOM)

IPDM E/R STATUS CONTROL

In order to save power, IPDM E/R switches status by itself based on each operating condition.

1. CAN communication status
 - CAN communication is normally performed with other control units.
 - Individual unit control by IPDM E/R is normally performed.
 - When sleep request signal is received from BCM, mode is switched to sleep waiting status.
2. Sleep waiting status
 - Process to stop CAN communication is activated.
 - All systems controlled by IPDM E/R are stopped. When 3 seconds have elapsed after CAN communication with other control units is stopped, mode switches to sleep status.
3. Sleep status
 - IPDM E/R operates in low current-consumption mode.
 - CAN communication is stopped.
 - When a change in CAN communication line is detected, mode switches to CAN communication status.
 - When a change hood switch signal is detected, mode switches to CAN communication status.

CAN Communication Unit

AKS0092W

Body type	Sedan	
Axle	2WD	
Engine	VQ35DE	
Transmission	A/T	
	UP to serial 329287*	From serial 329288*
		M/T
Brake control	VDC	
CAN communication unit		
ECM	×	×
TCM	×	
Data link connector	×	×
Combination meter	×	×
BCM	×	×
Steering angle sensor	×	×
VDC/TCS/ABS control unit	×	×
IPDM E/R	×	×
CAN communication type	PG-17, "TYPE 1/TYPER 3"	PG-19, "TYPE 2"

×: Applicable

*:For further information, refer to [GI-47, "IDENTIFICATION NUMBER"](#) .

TYPE 1/TYPER 3

System Diagram

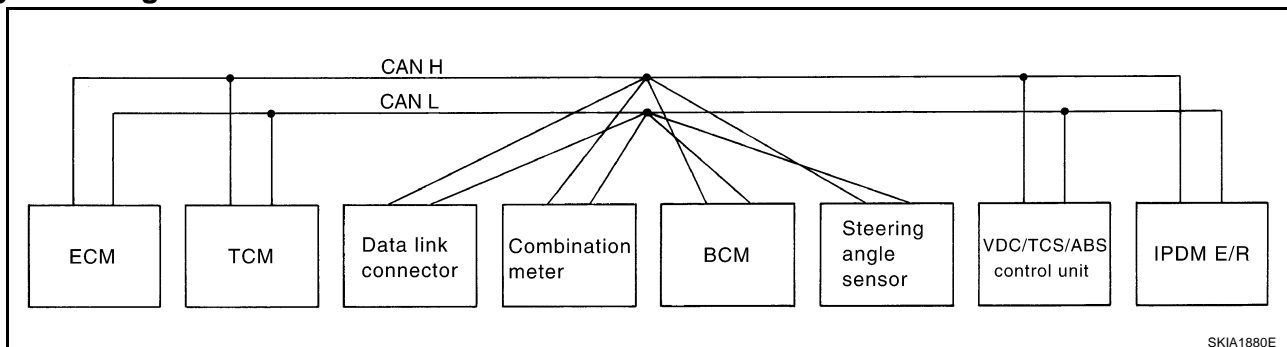

SKIA1880E

IPDM E/R (INTELLIGENT POWER DISTRIBUTION MODULE ENGINE ROOM)

Input/Output Signal Chart

T: Transmit R: Receive

Signals	ECM	TCM	Combina- tion meter	BCM	Steering angle sensor	VDC/TCS/ ABS con- trol unit	IPDM E/R
Engine torque signal	T	R					
Engine speed signal	T	R	R			R	
Engine coolant temperature signal	T	R	R				
Accelerator pedal position signal	T	R				R	
Closed throttle position signal	T	R					
Wide open throttle position signal	T	R					
Battery voltage signal	T	R					
Stop lamp switch signal		R	T				
Fuel consumption monitor signal	T		R				
A/T self-diagnosis signal	R	T					
A/T CHECK indicator lamp signal		T	R				
A/T position indicator signal		T	R			R	
ABS operation signal		R				T	
A/T shift schedule change demand signal		R				T	
A/C switch signal	R			T			
A/C compressor request signal	T						R
A/C compressor feedback signal	T		R				
Blower fan motor switch signal	R			T			
Cooling fan motor operation signal	T						R
Position lights request signal			R	T			R
Low beam request signal				T			R
Low beam status signal	R						T
High beam request signal			R	T			R
High beam status signal	R						T
Front fog lights request signal				T			R
Vehicle speed signal			R			T	
	R	R	T	R			
Sleep request 1 signal			R	T			
Sleep request 2 signal				T			R
Wake up request 1 signal			R	T			R
Wake up request 2 signal			R	T			R
Door switch signal (without naviga- tion system)			R	T			R
Door switch signal (with navigation system)			T	R			
Turn indicator signal			R	T			
Seat belt buckle switch signal			T	R			
Oil pressure switch signal			R				T
Buzzer output signal			R	T			
ASCD SET lamp signal	T		R				
ASCD CRUISE lamp signal	T		R				

IPDM E/R (INTELLIGENT POWER DISTRIBUTION MODULE ENGINE ROOM)

Signals	ECM	TCM	Combina- tion meter	BCM	Steering angle sensor	VDC/TCS/ ABS con- trol unit	IPDM E/R
ASCD OD cancel request signal	T	R					
ASCD operation signal	T	R					
Output shaft revolution signal	R	T					
Front wiper request signal				T			R
Front wiper stop position signal				R			T
Rear window defogger switch signal				T			R
Rear window defogger control signal	R						T
Manual mode signal		R	T				
Not manual mode signal		R	T				
Manual mode shift up signal		R	T				
Manual mode shift down signal		R	T				
Manual mode indicator signal		T	R				
Hood switch signal				R			T
Theft warning horn request signal				T			R
Horn chirp signal				T			R
Steering angle sensor signal					T	R	
Malfunction indicator lamp signal (Type 3 only : From serial 329288*)	T		R				
Fuel level sensor signal (Type 3 only : From serial 329288*)	R		T				
Turbine revolution signal (Type 3 only : From serial 329288*)	R	T					

* : For further information, refer to [GI-47, "IDENTIFICATION NUMBER"](#) .

TYPE 2

System Diagram

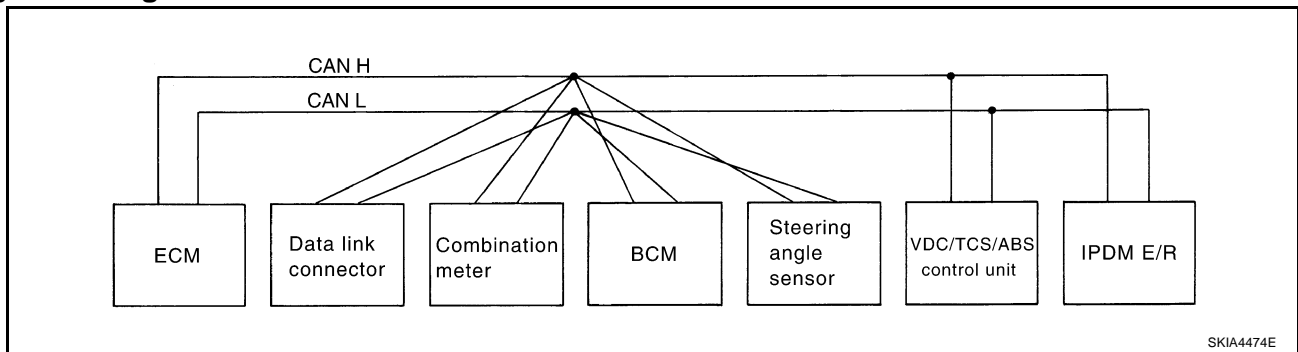

Input/Output Signal Chart

T: Transmit R: Receive

Signals	ECM	Combina- tion meter	BCM	Steering angle sen- sor	VDC/TCS/ ABS con- trol unit	IPDM E/R
Engine speed signal	T	R			R	
Engine coolant temperature signal	T	R				
Accelerator pedal position signal	T				R	
Fuel consumption monitor signal	T	R				
A/C switch signal	R		T			
A/C compressor request signal	T					R

IPDM E/R (INTELLIGENT POWER DISTRIBUTION MODULE ENGINE ROOM)

Signals	ECM	Combina- tion meter	BCM	Steering angle sen- sor	VDC/TCS/ ABS con- trol unit	IPDM E/R
A/C compressor feedback signal	T	R				
Blower fan motor switch signal	R		T			
Cooling fan motor operation signal	T					R
Position lights request signal		R	T			R
Low beam request signal			T			R
Low beam status signal	R		R			T
High beam request signal		R	T			R
High beam status signal	R		R			T
Front fog lights request signal			T			R
Vehicle speed signal		R			T	
	R	T	R			
Sleep request 1 signal		R	T			
Sleep request 2 signal			T			R
Wake up request 1 signal		R	T			
Wake up request 2 signal		R	T			
Door switch signal (without navigation system)		R	T			R
Door switch signal (with navigation system)		T	R			
Turn indicator signal		R	T			
Seat belt buckle switch signal		T	R			
Oil pressure switch signal		R				T
Buzzer output signal		R	T			
Malfunction indicator lamp signal	T	R				
ASCD SET lamp signal	T	R				
ASCD CRUISE lamp signal	T	R				
Fuel level sensor signal	R	T				
Front wiper request signal			T			R
Front wiper stop position signal			R			T
Rear window defogger switch signal			T			R
Rear window defogger control signal	R		R			T
Hood switch signal			R			T
Theft warning horn request signal			T			R
Horn chirp signal			T			R
Steering angle sensor signal				T	R	

Function of Detecting Ignition Relay Malfunction

AKS000I2

- When contact point of integrated ignition relay is stuck and cannot be turned OFF, IPDM E/R turns ON tail and parking lamps for 10 minutes to indicate IPDM E/R malfunction.

Auto Active Test DESCRIPTION

- In auto active test mode, operation inspection can be performed when IPDM E/R sends a drive signal to the following systems:
 - Rear window defogger
 - Front wipers
 - Tail and parking lamps
 - Front fog lamps
 - Headlamps (Hi, Lo)
 - A/C compressor (magnetic clutch)
 - Cooling fan

OPERATION PROCEDURE

1. Close hood and lift wiper arms away from windshield (to prevent glass damage by wiper operation).

NOTE:

When auto active test is performed with hood opened, sprinkle water on windshield beforehand.

2. Turn ignition switch OFF.
3. Turn ignition switch ON and, within 10 seconds, press front door switch LH 10 times. Then turn ignition switch OFF.

CAUTION:

Close front door RH.

4. Turn ignition switch ON.
5. When auto active test mode is actuated, horn chirps once, and oil pressure warning lamp starts blinking.
6. After a series of operations is repeated three times, auto active test is completed.

NOTE:

When auto active test mode has to be cancelled halfway, turn ignition switch OFF.

CAUTION:

Be sure to inspect [DI-37, "Oil Pressure Warning Lamp Stays Off \(Ignition Switch ON\)"](#) and [BL-35, "Check Door Switch / With Navigation System"](#) or [BL-37, "Check Door Switch / Without Navigation System"](#) when the auto active test cannot be performed.

INSPECTION IN AUTO ACTIVE TEST MODE

- When auto active test mode is actuated, the following eight steps are repeated three times.

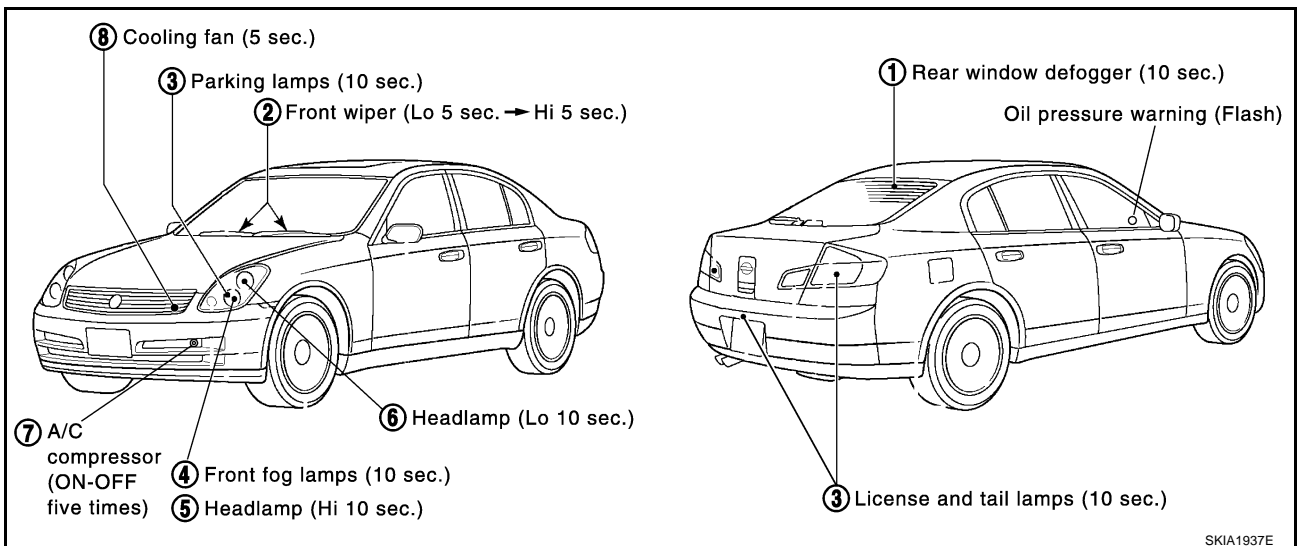

A
B
C
D
E
F
G
H
I
J
PG
L
M

IPDM E/R (INTELLIGENT POWER DISTRIBUTION MODULE ENGINE ROOM)

Concept of Auto Active Test

- IPDM E/R actuates auto active test mode when it receives door switch signal from BCM via CAN communication line. Therefore, when auto active test mode is activated successfully, CAN communication between IPDM E/R and BCM is normal.
- If any of systems controlled by IPDM E/R cannot be operated, possible cause can be easily diagnosed using auto active test.

Diagnosis chart in auto active test mode

Symptom	Inspection contents		Possible cause
Any of front wipers, tail and parking lamps, front fog lamps, and head lamps (Hi, Lo) do not operate.	Perform auto active test. Does system in question operate?	YES	● BCM signal input system
		NO	<ul style="list-style-type: none"> ● Lamp/wiper motor malfunction ● Lamp/wiper motor ground circuit malfunction ● Harness/connector malfunction between IPDM E/R and system in question ● IPDM E/R (integrated relay) malfunction
Rear window defogger does not operate.	Perform auto active test. Does rear window defogger operate?	YES	● BCM signal input circuit
		NO	<ul style="list-style-type: none"> ● Rear window defogger relay circuit ● Open circuit of rear window defogger ● IPDM E/R malfunction
A/C compressor does not operate.	Perform auto active test. Does magnetic clutch operate?	YES	<ul style="list-style-type: none"> ● BCM signal input circuit ● CAN communication signal between BCM and ECM. ● CAN communication signal between ECM and IPDM E/R ● BCM ● ECM
		NO	<ul style="list-style-type: none"> ● Magnetic clutch malfunction ● Harness/connector malfunction between IPDM E/R and magnetic clutch ● IPDM E/R (integrated relay) malfunction
Cooling fan does not operate.	Perform auto active test. Does cooling fan operate?	YES	<ul style="list-style-type: none"> ● ECM signal input circuit ● CAN communication signal between ECM and IPDM E/R ● ECM
		NO	<ul style="list-style-type: none"> ● Cooling fan motor malfunction ● Harness/connector malfunction between IPDM E/R and cooling fan motor ● IPDM E/R (integrated relay) malfunction
Oil pressure warning lamp does not operate.	Perform auto active test. Does oil pressure warning lamp blink?	YES	<ul style="list-style-type: none"> ● Harness/connector malfunction between IPDM E/R and oil pressure switch ● Oil pressure switch malfunction
		NO	<ul style="list-style-type: none"> ● CAN communication signal between IPDM E/R and combination meter ● Combination meter

IPDM E/R (INTELLIGENT POWER DISTRIBUTION MODULE ENGINE ROOM)

Schematic

AKS000CS

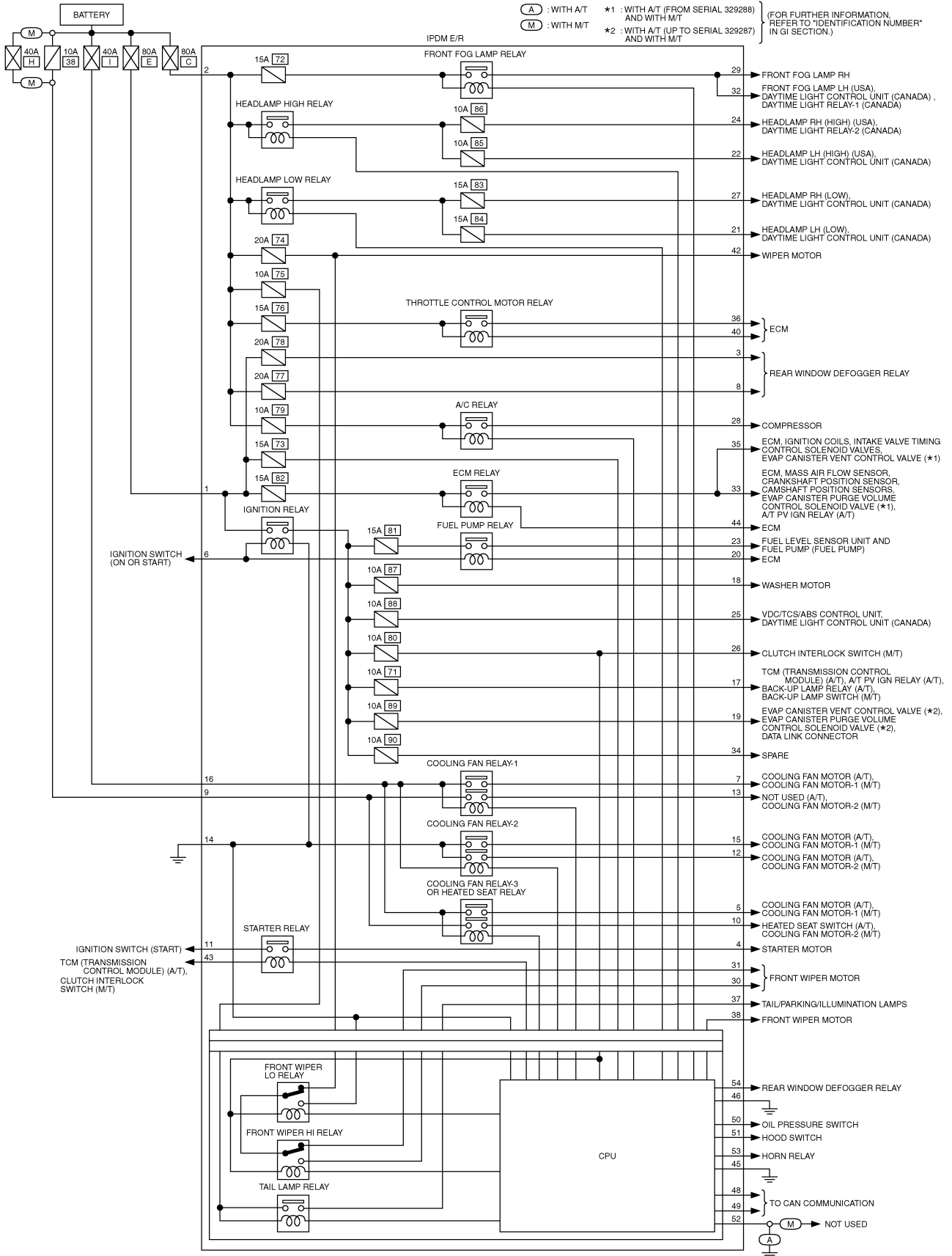

TKWT1045E

IPDM E/R (INTELLIGENT POWER DISTRIBUTION MODULE ENGINE ROOM)

IPDM E/R Terminal Arrangement

AKS00010

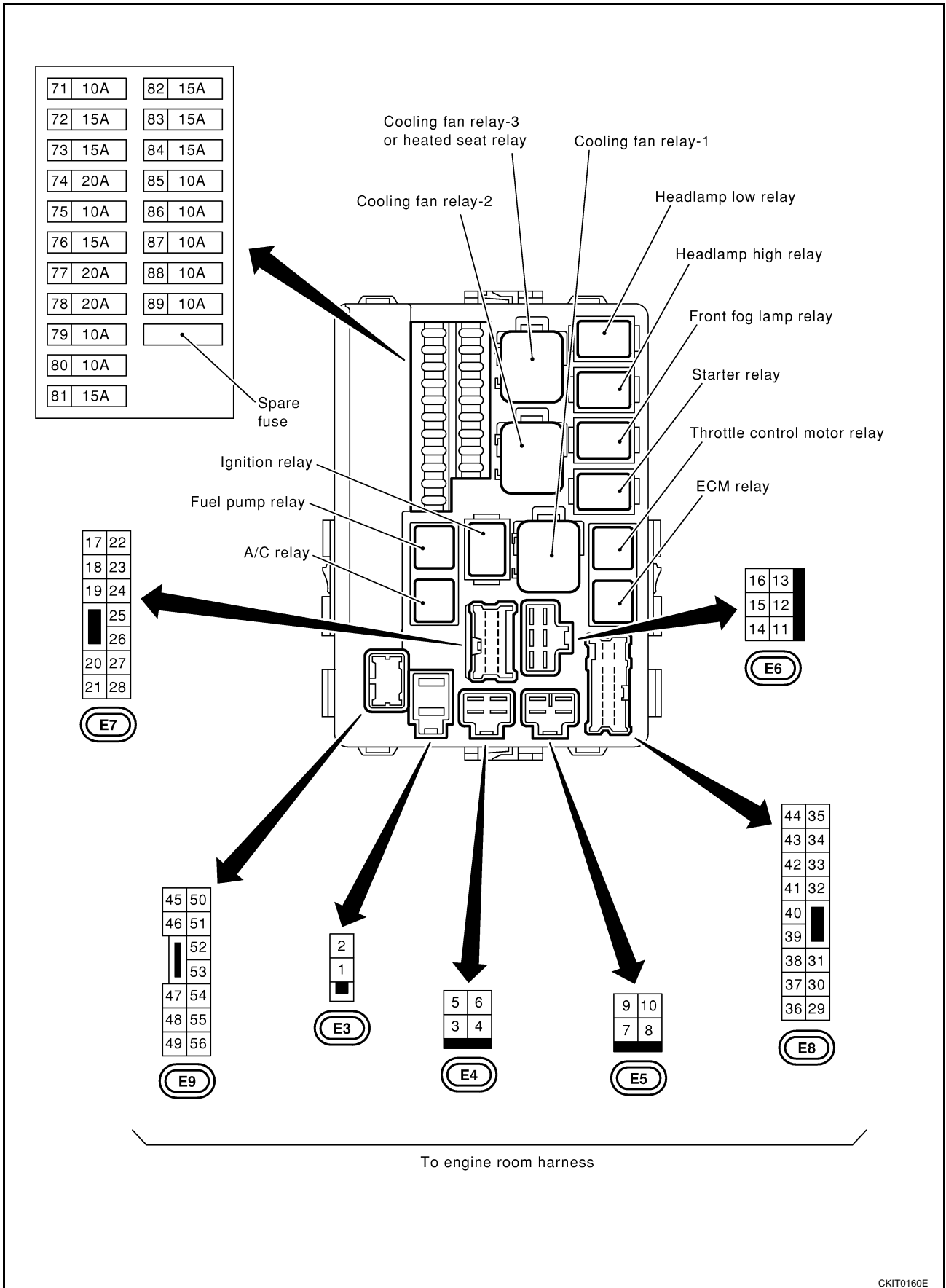

CKIT0160E

IPDM E/R (INTELLIGENT POWER DISTRIBUTION MODULE ENGINE ROOM)

IPDM E/R Terminal Inspection

AKS00014

1. Remove hood ledge cover. Refer to [SC-8, "Removal and Installation"](#).
2. Remove cowl top cover (left).
3. Pull up to remove IPDM E/R cover A.

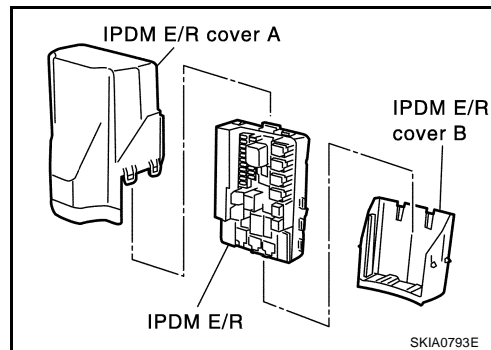

4. While pushing pawl on back side of IPDM E/R cover "B" toward vehicle front to unlock, lift up IPDM E/R.

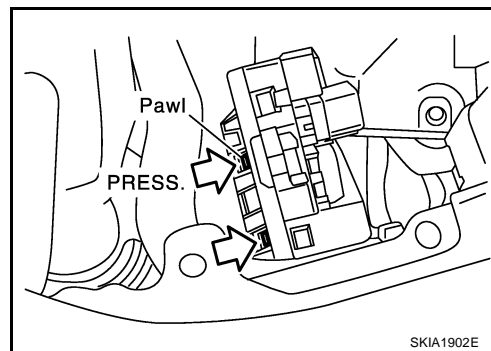

5. Be sure to incline IPDM E/R when placing it. Then perform inspection on each terminal.

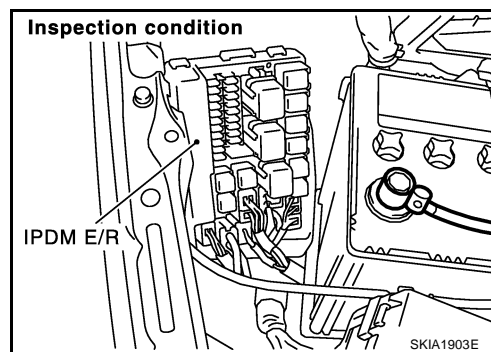

A
B
C
D
E
F
G
H
I
J
PG
L
M

IPDM E/R (INTELLIGENT POWER DISTRIBUTION MODULE ENGINE ROOM)

AKS00015

IPDM E/R Power/Ground Circuit Inspection

1. FUSE AND FUSIBLE LINK INSPECTION

- Check that the following fusible links or IPDM E/R fuses are not blown.

Terminal No.	Signal name	Fuse, fusible link No.
1, 2	Battery power	F/L-C, F/L-E, Fuse No. 73
-	Ignition power	Fuse No. 80

OK or NG?

- OK >> GO TO 2.
- NG >> Replace fuse or fusible link.

2. POWER CIRCUIT INSPECTION

- Disconnect IPDM E/R harness connector E3.
- Check voltage between IPDM E/R harness connector E3 terminals 1 (W/R), 2 (W/L) and ground.

Terminal No. (wire color)	Signal name	Ignition switch	Reference value
1 (W/R), 2 (W/L)	Battery power	OFF	Battery voltage

OK or NG?

- OK >> GO TO 3.
- NG >> Replace IPDM E/R power circuit harness.

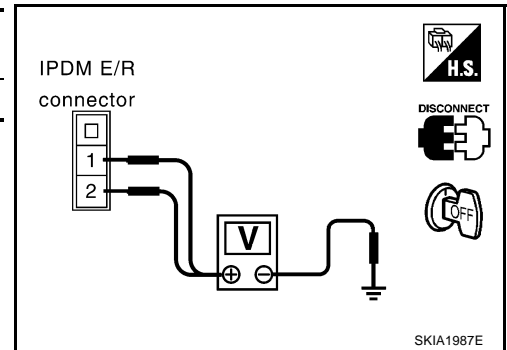

3. GROUND CIRCUIT INSPECTION

- Disconnect IPDM E/R harness connectors E6 and E7.
- Check continuity between IPDM E/R harness connectors E6 terminal 14 (B), E9 terminal 45 (B), 52 (B) and ground.

Terminal No. (wire color)	Signal name	Ignition switch	Continuity
14 (B), 45 (B), 52 (B)	Ground	OFF	YES

OK or NG?

- OK >> Normal
- NG >> Replace ground circuit harness of IPDM E/R.

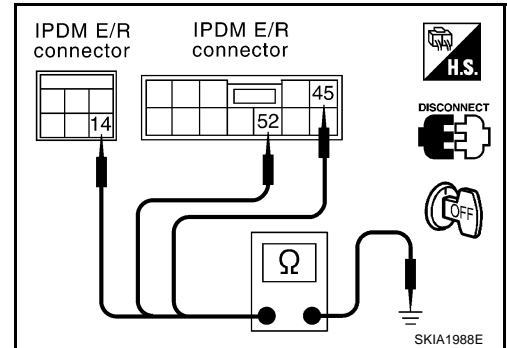

IPDM E/R (INTELLIGENT POWER DISTRIBUTION MODULE ENGINE ROOM)

Removal and Installation of IPDM E/R

AKS00016

1. Remove battery. Refer to [SC-8, "Removal and Installation"](#) in "Starting and Charging System (SC)" section.

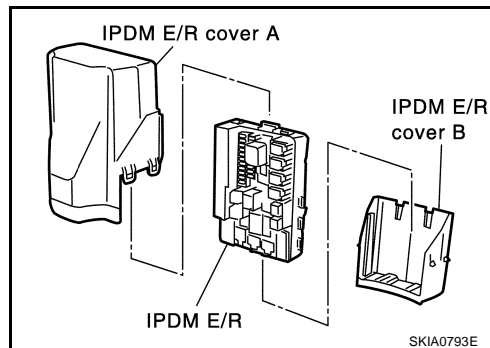

2. Remove IPDM E/R cover A. While pushing pawl on backside of IPDM E/R cover B toward vehicle front to unlock, lift up IPDM E/R.

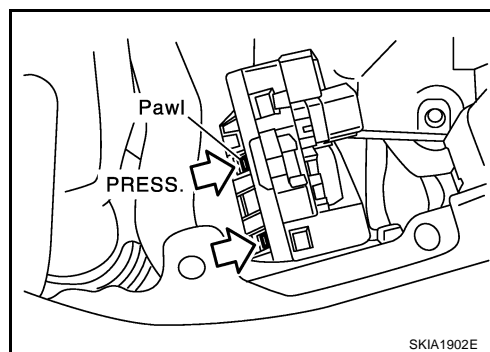

3. While pushing tabs on right and left side of IPDM E/R, remove IPDM E/R cover B from IPDM E/R.
4. Remove harness connector from IPDM E/R.

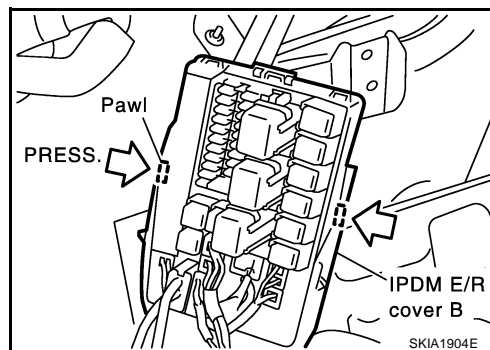

GROUND

PFP:00011

AKS0001B

GROUND

Ground Distribution MAIN HARNESS

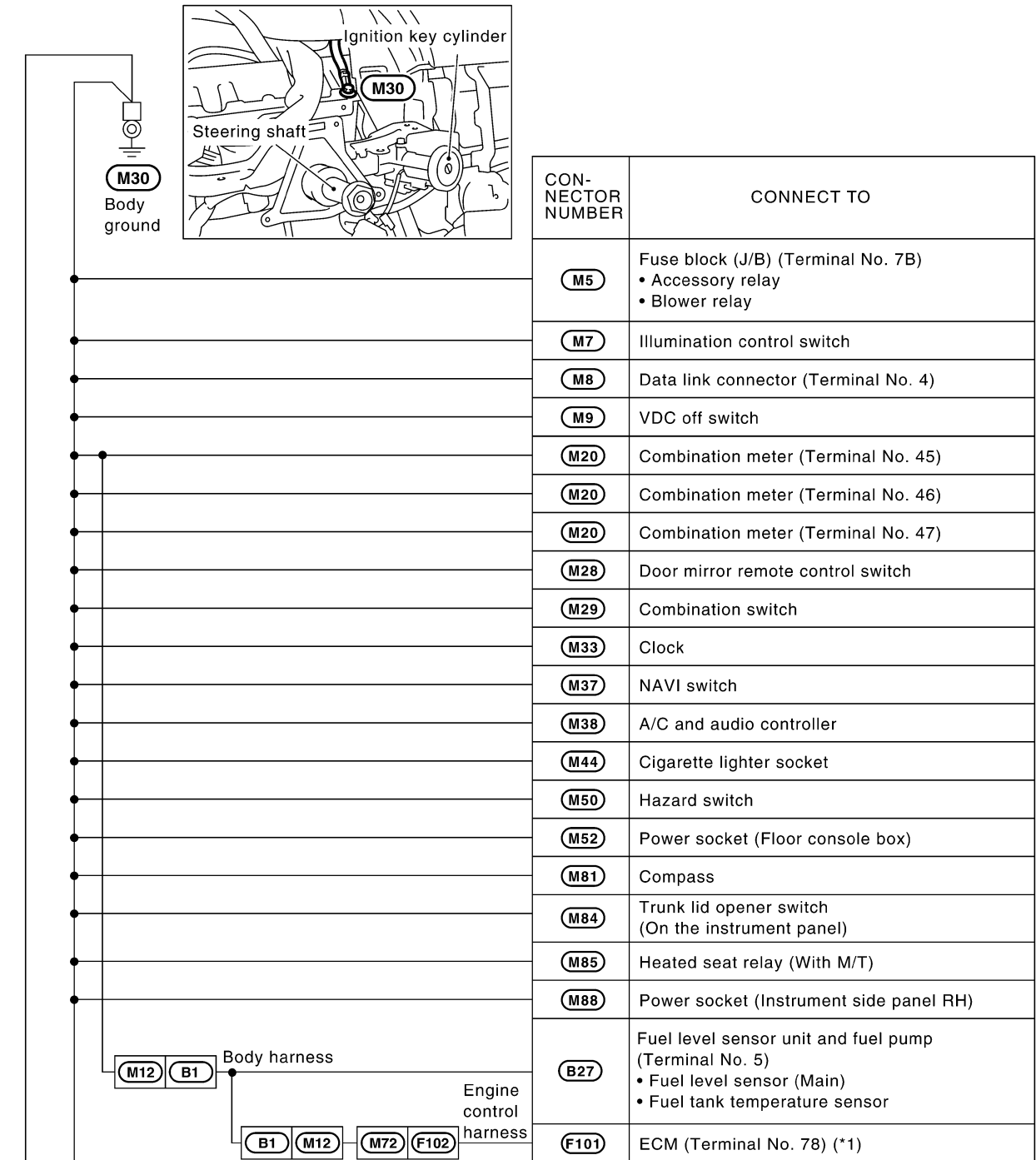

*1 ... With A/T (Up to serial 329287)
(For further information, refer to "IDENTIFICATION NUMBER" in GI section.)

A B
Next page

CKIT0335E

GROUND

Preceding page

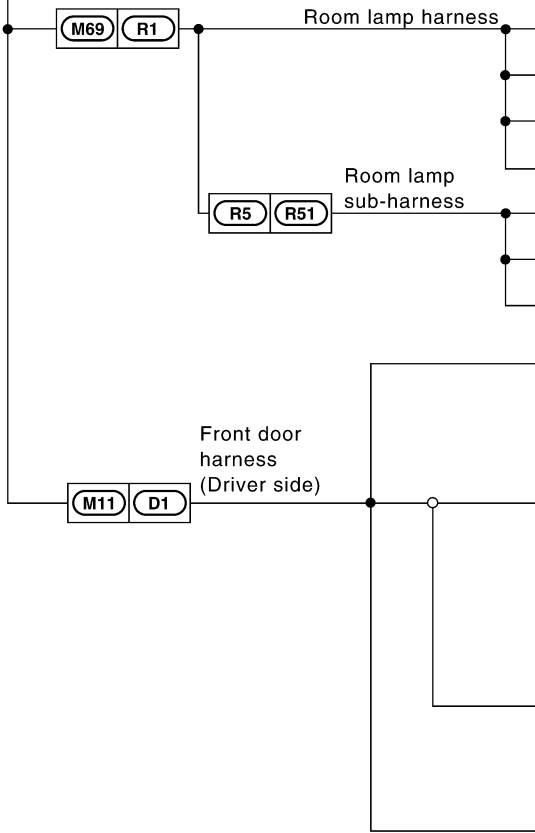

CON-NECTOR NUMBER	CONNECT TO
R4	Vanity mirror lamp (Passenger side)
R6	Sunroof motor assembly
R7	Auto anti-dazzling inside mirror
R9	Vanity mirror lamp (Driver side)
R52	Map lamp
R54	Personal lamp LH
R55	Personal lamp RH
D2	Door mirror (Driver side) (With door mirror defogger)
D6	Power window main switch (With interruption detection function for all door window) • CPU • Power window lock switch • Door lock and unlock switch • Illumination
D7	Power window main switch (With interruption detection function for front door window) • CPU • Power window lock switch • Door lock and unlock switch • Illumination
D12	Front door key cylinder switch (Driver side)



Next page

A
B
C
D
E
F
G
H
I
J
L
M

PG

CKIT0306E

GROUND

Preceding page

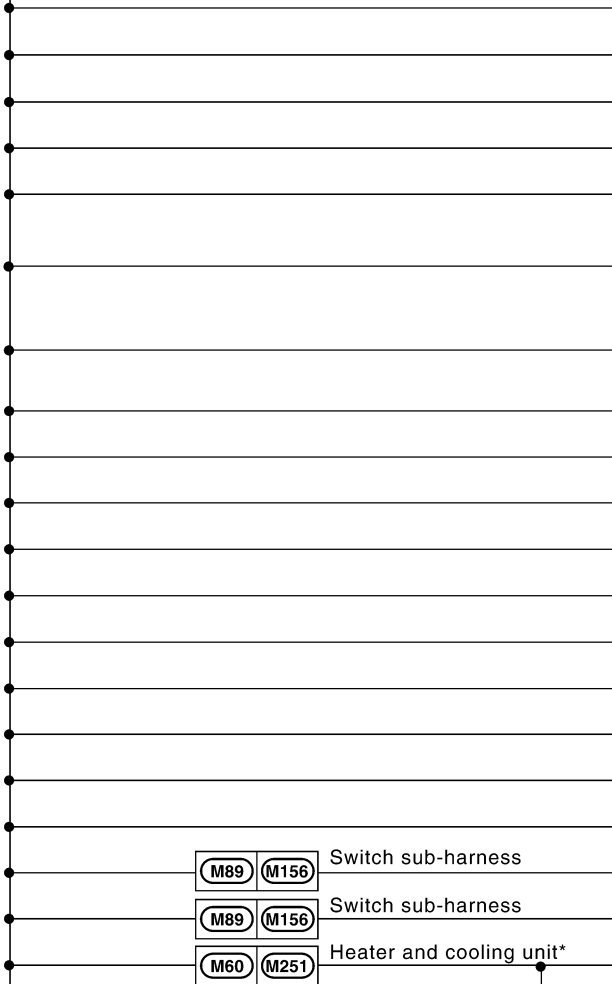
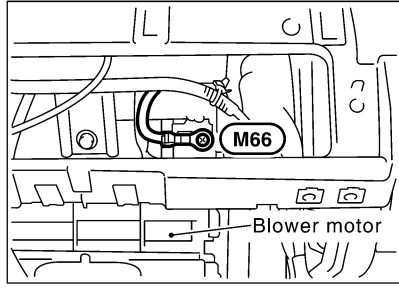
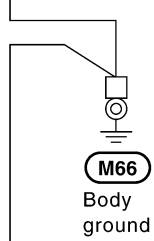

CON-NECTOR NUMBER	CONNECT TO
M8	Data link connector (Terminal No. 5) (*1)
M17	Air mix door motor (Driver side)
M32	Display and A/C auto amp. (Terminal No. 24)
M35	Display unit (Terminal No. 22)
M35	Display unit (Terminal No. 24)
M47	A/T device (Terminal No. 1) • Detention switch • Shift lock solenoid
M47	A/T device (Terminal No. 9) • Mode select switch
M49	Ashtray illumination
M53	Heated seat switch (Passenger side) (With A/T)
M54	Heated seat switch (Driver side) (With A/T)
M55	Air bag diagnosis sensor unit
M57	NAVI control unit (Terminal No. 1)
M57	NAVI control unit (Terminal No. 4)
M62	Blow motor
M64	Glove box lamp
M67	Intake door motor
M68	Upper glove box lamp
M154	Heated seat switch (Driver side) (With M/T)
M155	Heated seat switch (Passenger side) (With M/T)
M252	Mode door motor
M253	Air mix door motor (Passenger side)

*: This sub-harness is not shown in "HARNESSE LAYOUT".

*1 ... With A/T (From serial 329288) and with M/T
(For further information, refer to "IDENTIFICATION NUMBER" in GI section.)



Next page

CKIT0336E

GROUND

A
B
C
D
E
F
G
H
I
J
PG
L
M

Preceding page

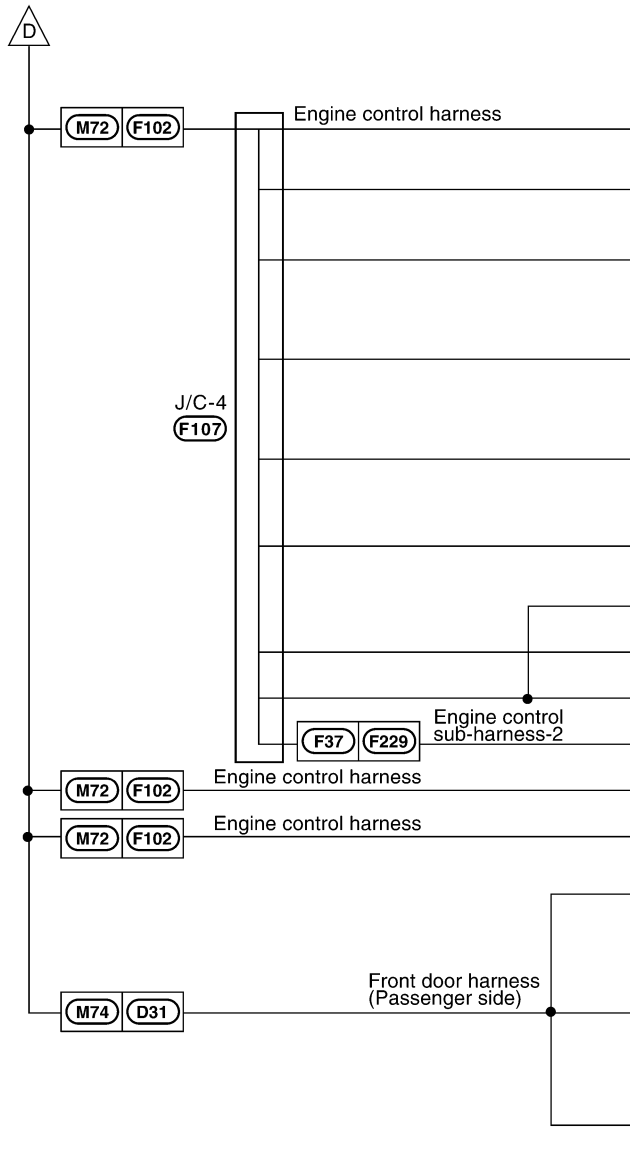

CON-NECTOR NUMBER	CONNECT TO
F4	Camshaft position sensor (PHASE) (BANK 1) (*1)
F10	Crankshaft position sensor (POS) (*1)
F31	Shield wire [Electric throttle control actuator (Throttle position sensor 1)] (For circuit from terminal No. 1) (*1)
F31	Shield wire [Electric throttle control actuator (Throttle position sensor 1, 2)] (For circuit from terminal No. 2,4,5) (*1)
F31	Shield wire [Electric throttle control actuator (Throttle control motor)] (For circuit from terminal No. 3,6) (*1)
F32	Camshaft position sensor (PHASE) (BANK 2) (*1)
F35	Park/Neutral position switch (*1)
F108	ECM (Terminal No. 1) (*1)
F108	ECM (Terminal No. 116) (*1)
F228	Shield wire (Knock sensor) (*1)
F105	A/T PV IGN relay
F108	ECM (Terminal No. 115) (With M/T)
D32	Door mirror (Passenger side) (With door mirror defogger)
D37	Power window sub-switch (Front passenger side) <ul style="list-style-type: none"> • CPU • Door lock and unlock switch • Illumination
D40	Front door lock actuator passenger side (Unlock sensor)

J/C: Joint connector

*1 . . . With A/T (From serial 329288) and with M/T
(For further information, refer to "IDENTIFICATION NUMBER" in GI section.)

CKIT0337E

GROUND

ENGINE ROOM HARNESS

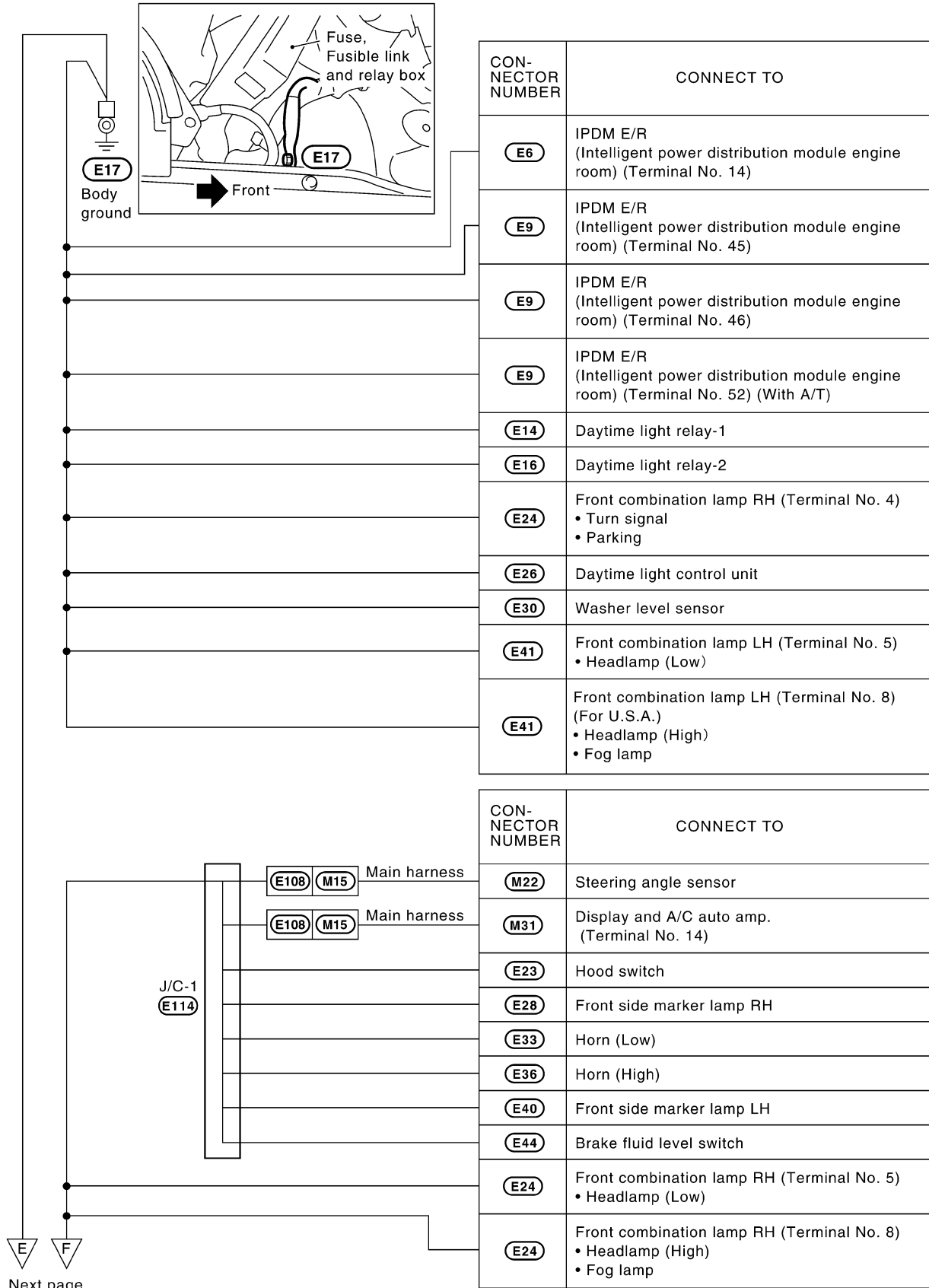

Next page

J/C: Joint connector

CKIT0338E

GROUND

Preceding page

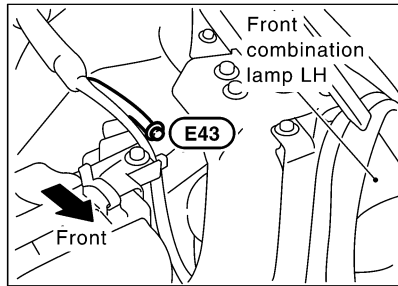
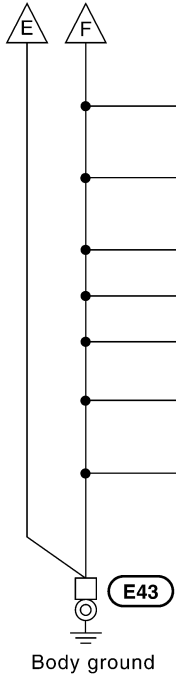

CON-NECTOR NUMBER	CONNECT TO
E39	Cooling fan motor-1 (With M/T)
E41	Front combination lamp LH (Terminal No. 4) • Turn signal • Parking
E52	Front wiper motor
E53	Cooling fan motor-2 (With M/T)
E105	BCM (Body control module)
E118	VDC/TCS/ABS control unit (Terminal No. 28)
E118	VDC/TCS/ABS control unit (Terminal No. 29)

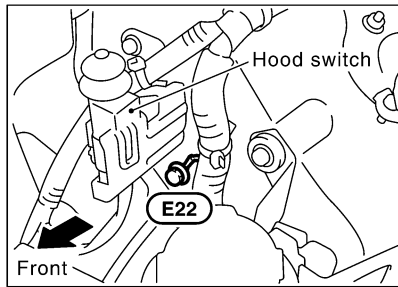
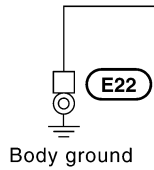

CON-NECTOR NUMBER	CONNECT TO
E37	Shield wire (Crash zone sensor)

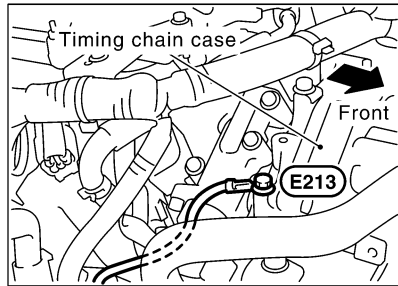
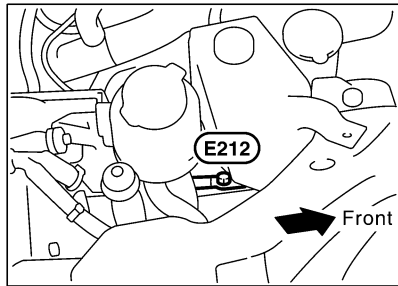
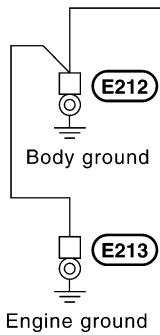

CON-NECTOR NUMBER	CONNECT TO
E211	Alternator (E)

A
B
C
D
E
F
G
H
I
J
PG
L
M

CKIT0310E

GROUND

ENGINE CONTROL HARNESS/WITH A/T (UP TO SERIAL 329287*)

*: For further information, refer to [GI-47, "IDENTIFICATION NUMBER"](#) .

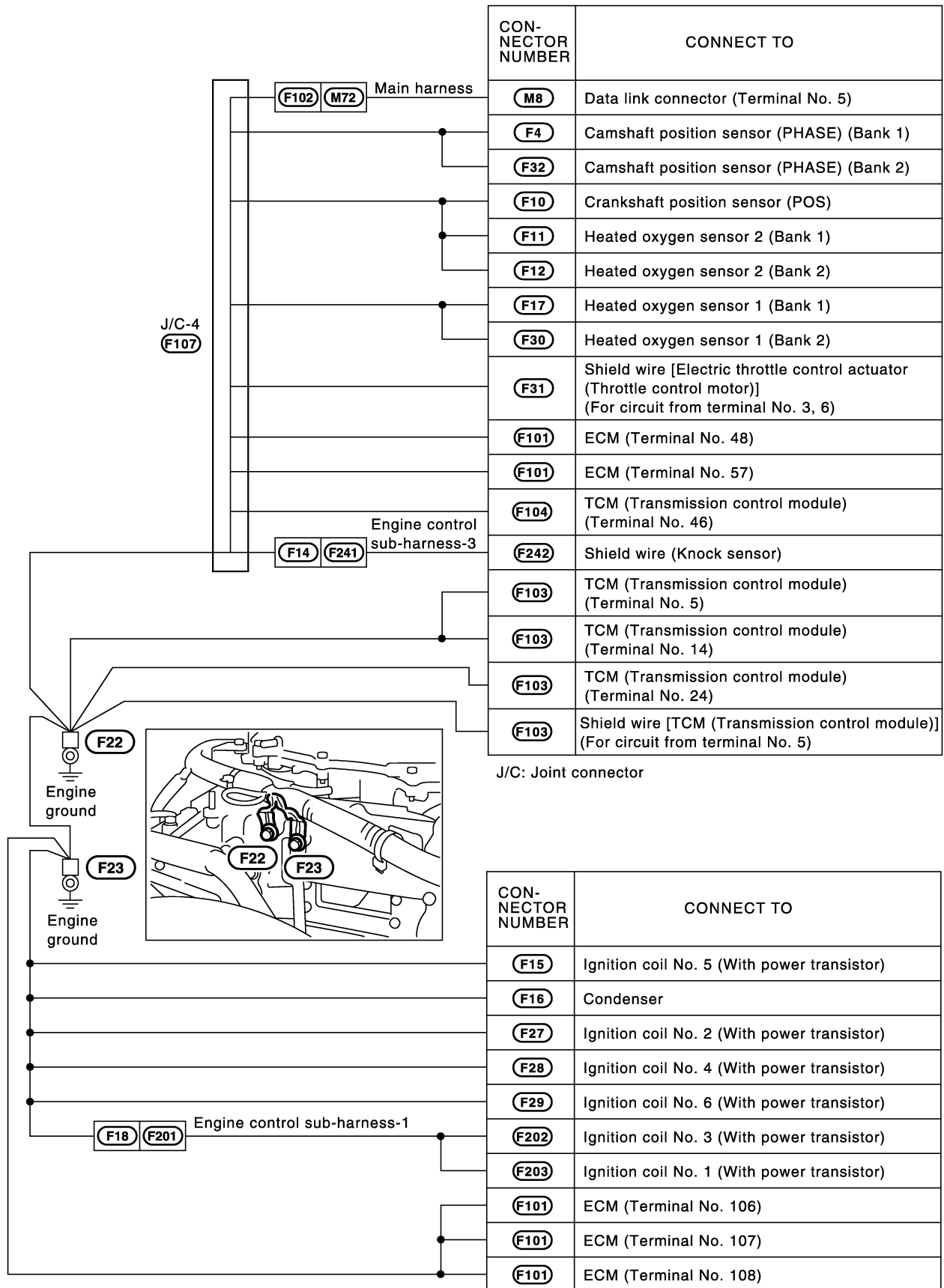

CKIT0120E

GROUND

ENGINE CONTROL HARNESS/WITH A/T (FROM SERIAL 329288*)

*: For further information, refer to [GI-47, "IDENTIFICATION NUMBER"](#) .

A
B
C
D
E
F
G
H
I
J
PG
L
M

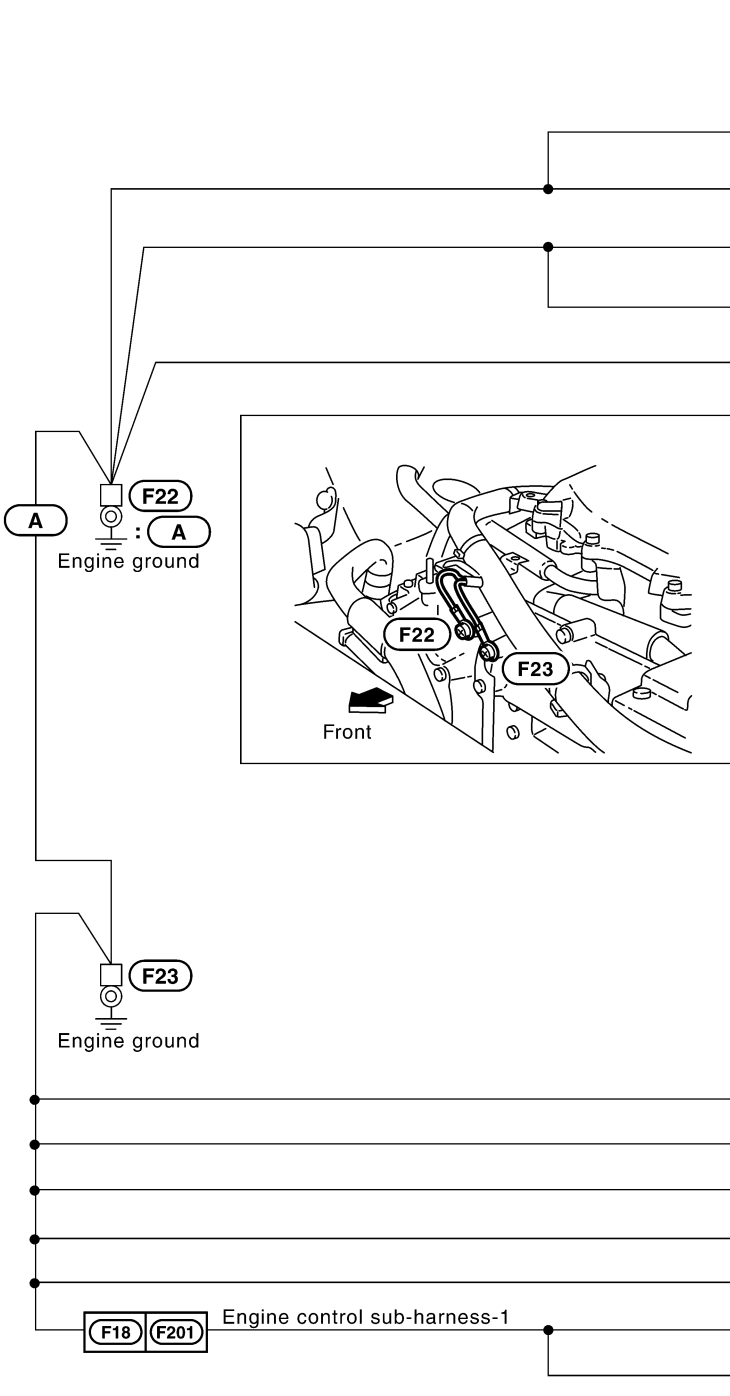

CON-NECTOR NUMBER	CONNECT TO
F103	TCM (Transmission control module) (Terminal No. 5)
F103	TCM (Transmission control module) (Terminal No. 14)
F103	TCM (Transmission control module) (Terminal No. 24)
F104	TCM (Transmission control module) (Terminal No. 46)
F103	Shield wire [TCM (Transmission control module)] (For circuit from terminal No. 5)

CON-NECTOR NUMBER	CONNECT TO
F15	Ignition coil No. 5 (With power transistor)
F27	Ignition coil No. 2 (With power transistor)
F28	Ignition coil No. 4 (With power transistor)
F29	Ignition coil No. 6 (With power transistor)
F38	Condenser
F202	Ignition coil No. 3 (With power transistor)
F203	Ignition coil No. 1 (With power transistor)

A : With A/T

GROUND

ENGINE CONTROL HARNESS/M/T MODELS

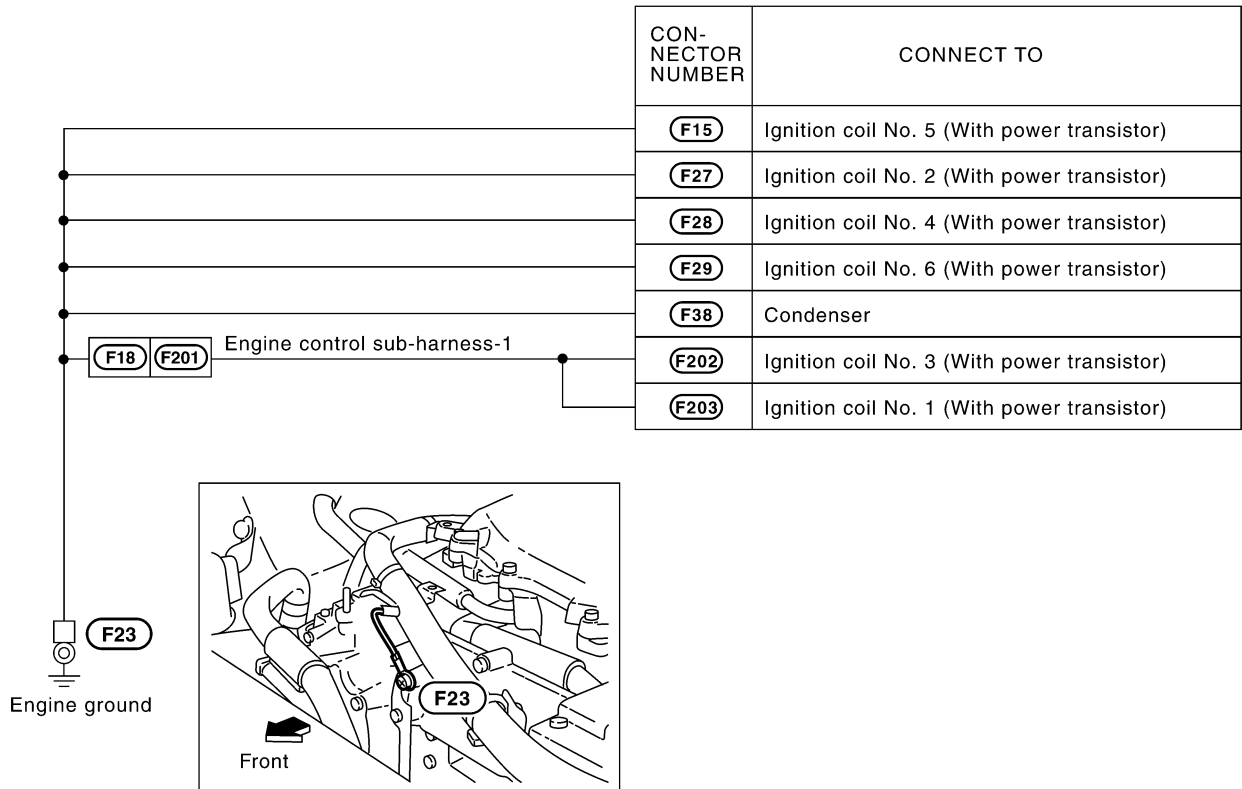

CKIT0311E

GROUND

BODY HARNESS

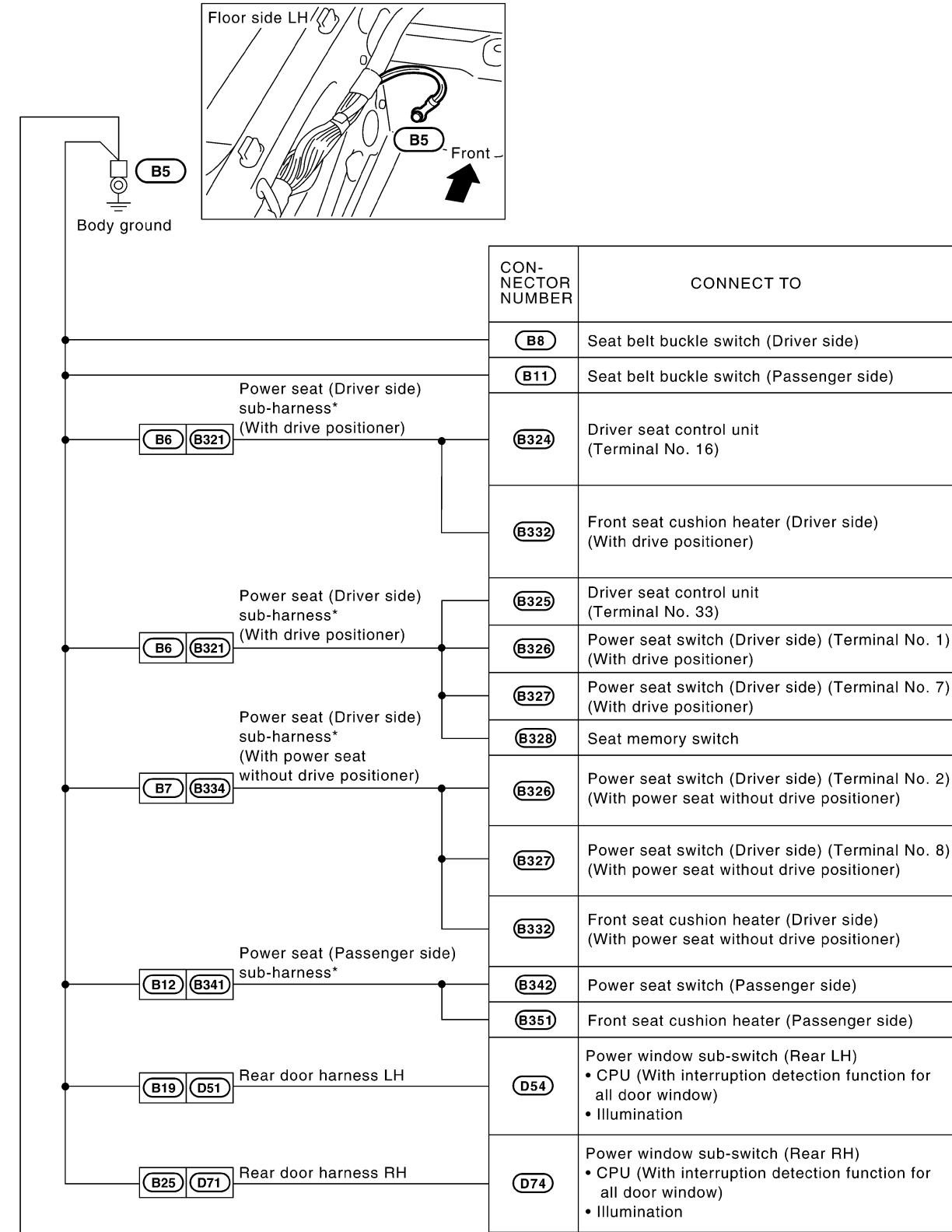

*: This sub-harness is not shown in "HARNESS LAYOUT".



Next page

A
B
C
D
E
F
G
H
I
J
PG
L
M

PG

CKIT0339E

GROUND

Preceding page

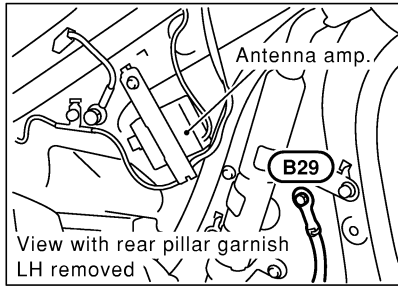
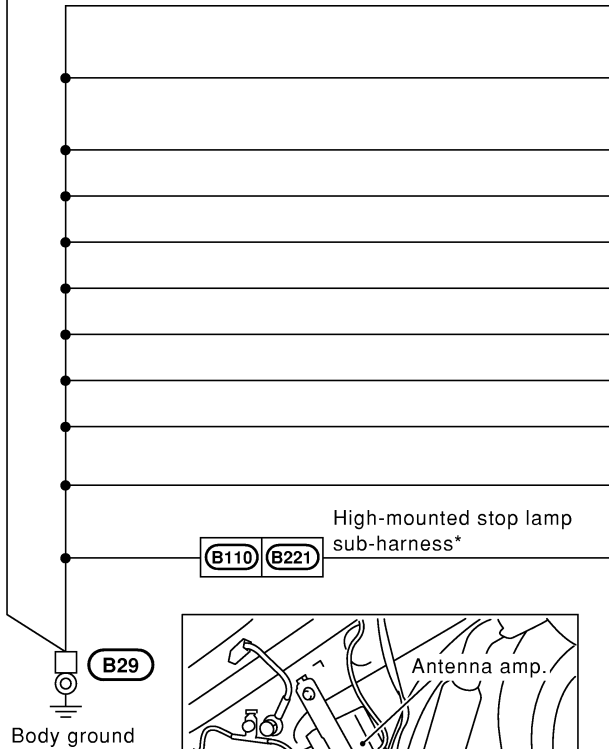

CON-NECTOR NUMBER	CONNECT TO
B26	Condenser
B27	Fuel level sensor unit and fuel pump (Terminal No. 3) • Fuel pump
B102	Back-up lamp LH
B104	License plate lamp
B105	Trunk room lamp switch
B106	Trunk lid opener actuator
B112	Back-up lamp RH
B114	BOSE speaker amp.
B115	Woofer
B116	High-mounted stop lamp (On the rear parcel shelf)
B222	High-mounted stop lamp (In the rear air spoiler)

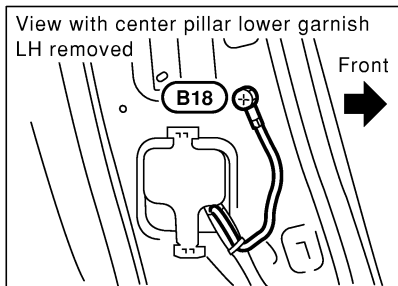
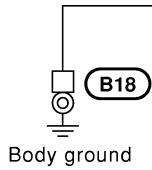

CON-NECTOR NUMBER	CONNECT TO
B15	Shield wire [LH side air bag (Satellite) sensor]

*: This sub-harness is not shown in "HARNES LAYOUT".

CKIT0122E

GROUND

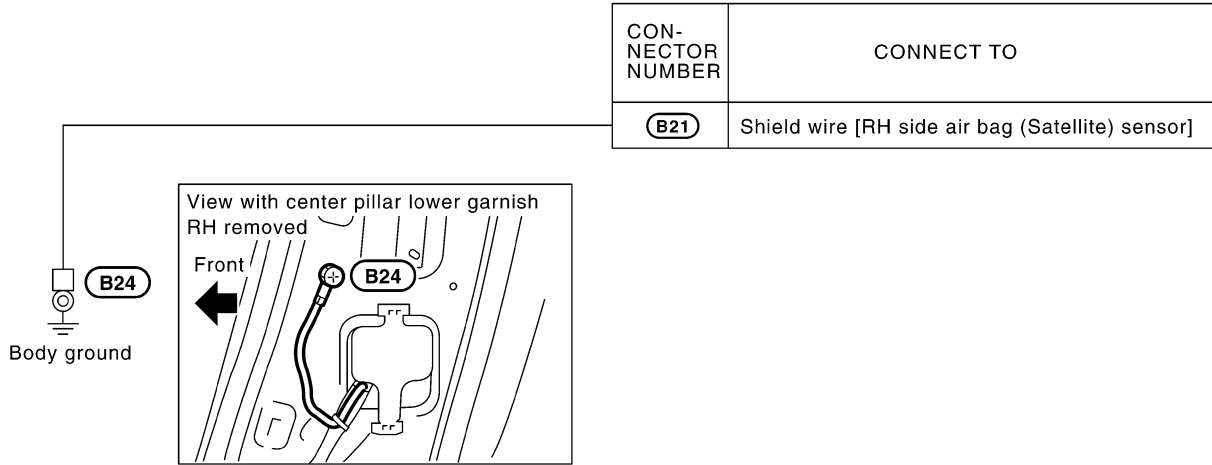

CON-NECTOR NUMBER	CONNECT TO
B21	Shield wire [RH side air bag (Satellite) sensor]

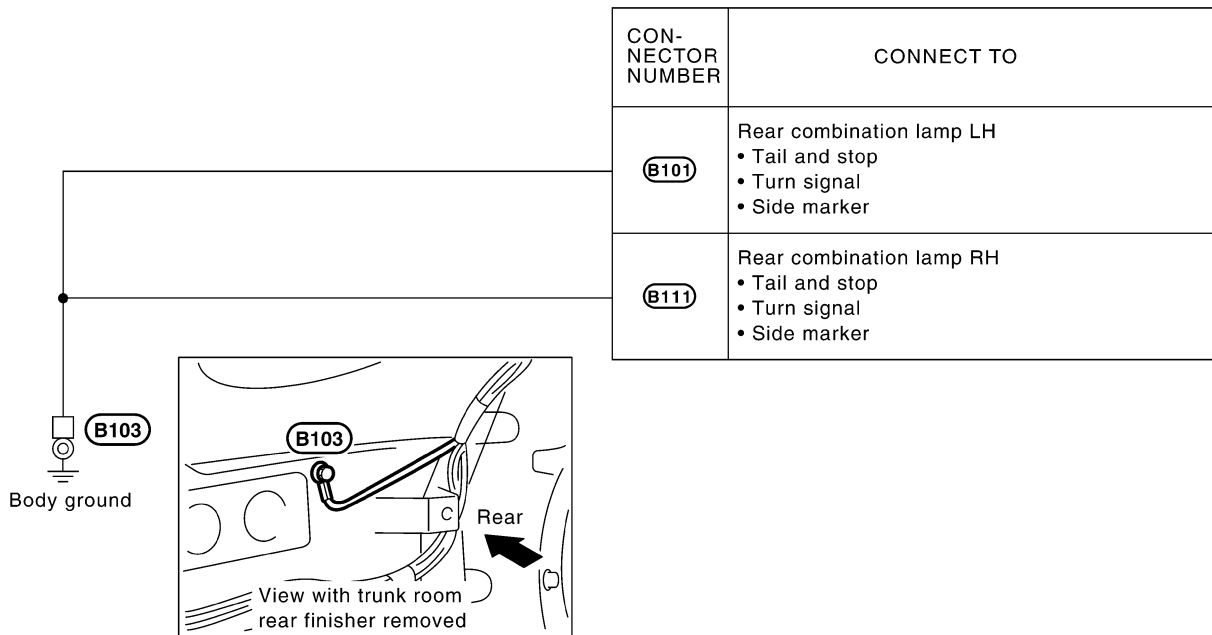

CON-NECTOR NUMBER	CONNECT TO
B101	Rear combination lamp LH • Tail and stop • Turn signal • Side marker
B111	Rear combination lamp RH • Tail and stop • Turn signal • Side marker

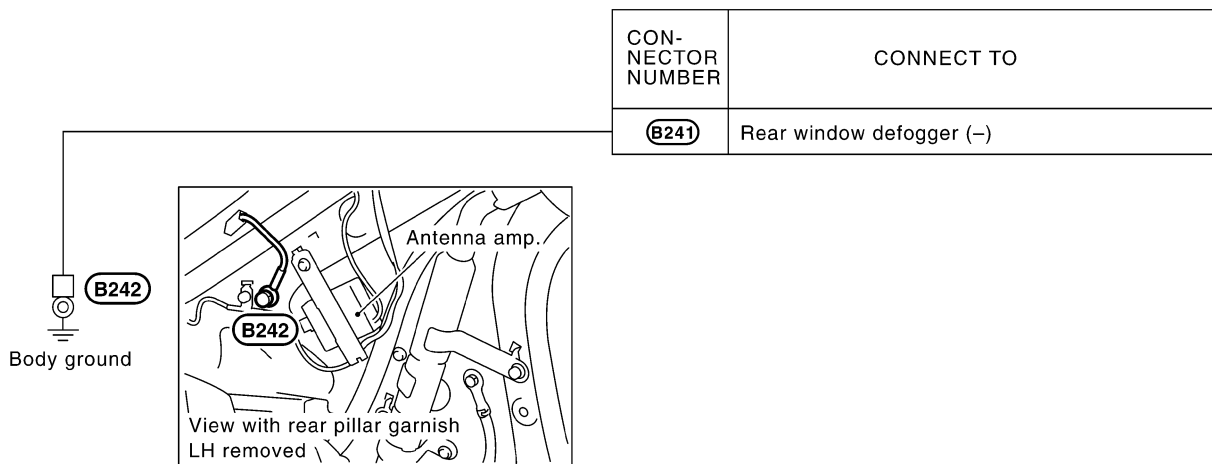

CON-NECTOR NUMBER	CONNECT TO
B241	Rear window defogger (-)

CKIT0340E

HARNESS

PF0:00011

HARNESS

Harness Layout

AKS0001C

HOW TO READ HARNESS LAYOUT

The following Harness Layouts use a map style grid to help locate connectors on the drawings:

- Main Harness
- Engine Room Harness (Engine Compartment)
- Engine Control Harness
- Body Harness (Passenger Compartment)

To use the grid reference

1. Find the desired connector number on the connector list.
2. Find the grid reference.
3. On the drawing, find the crossing of the grid reference letter column and number row.
4. Find the connector number in the crossing zone.
5. Follow the line (if used) to the connector.

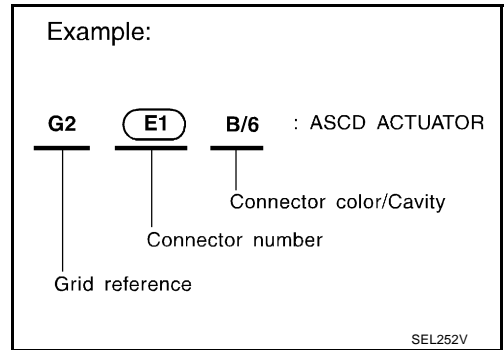

CONNECTOR SYMBOL

Main symbols of connector (in Harness Layout) are indicated in the below.

Connector type	Water proof type		Standard type	
	Male	Female	Male	Female
<ul style="list-style-type: none"> • Cavity: Less than 4 • Relay connector 				
<ul style="list-style-type: none"> • Cavity: From 5 to 8 				
<ul style="list-style-type: none"> • Cavity: More than 9 				
<ul style="list-style-type: none"> • Ground terminal etc. 	—			

CKIT0108E

HARNESS

OUTLINE

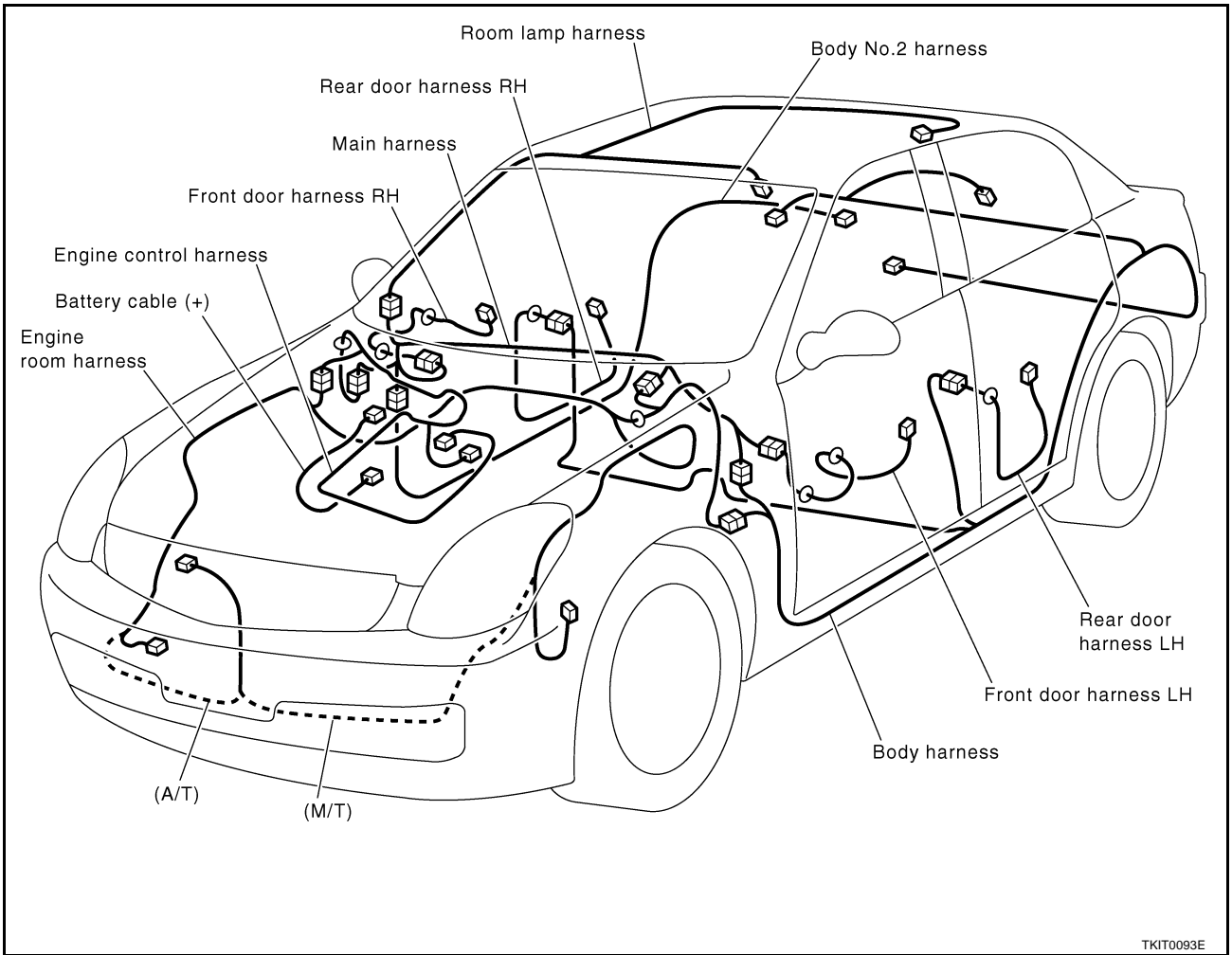

A
B
C
D
E
F
G
H
I
J
PG
L
M

HARNESS

MAIN HARNESS

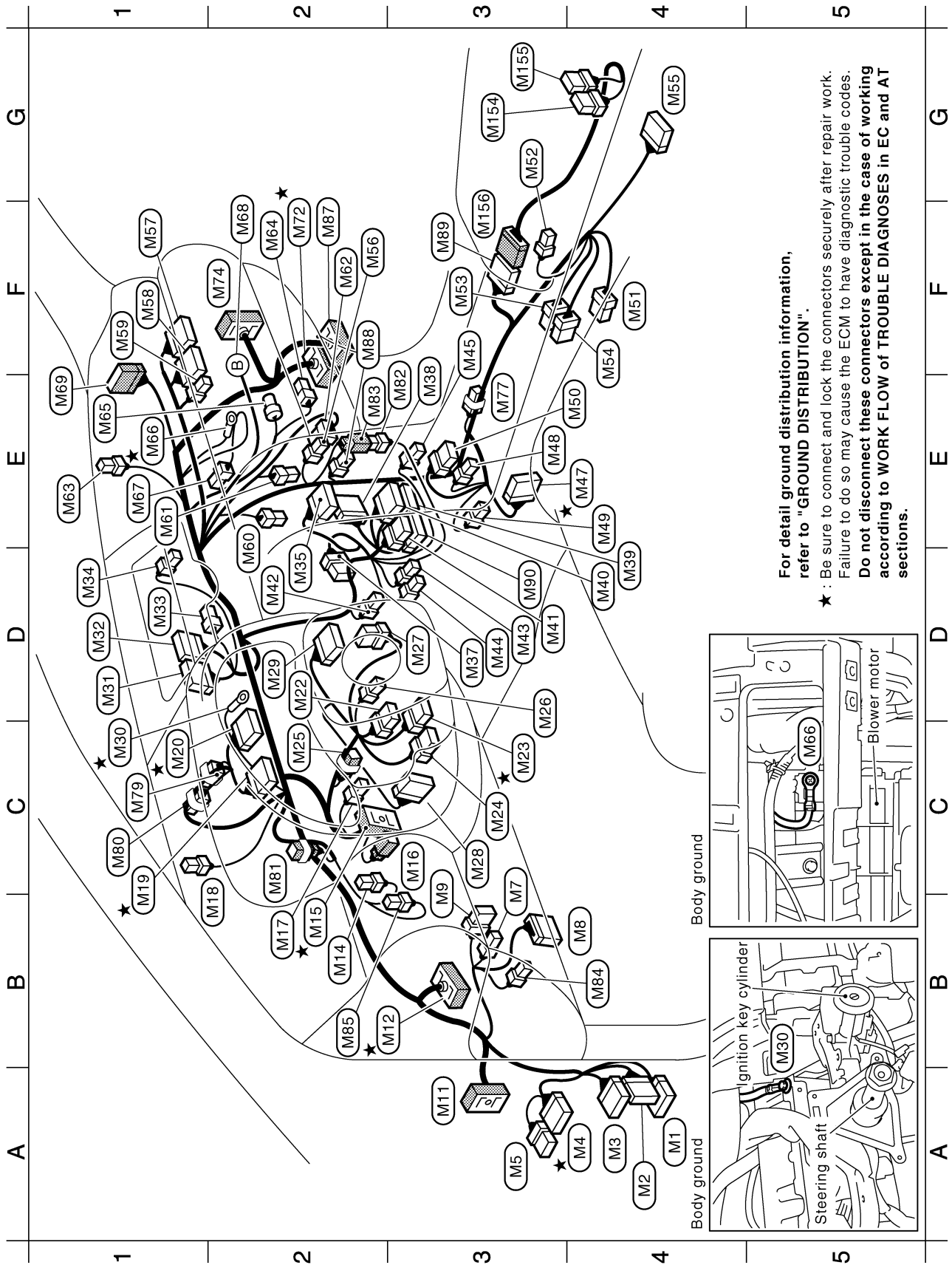

TKIT0094E

A4	(M1)	W/16	: BCM (Body control module)	: Audio unit	F2	★ (M72)	SMJ	: To (E102)
A4	(M2)	W/16	: BCM (Body control module)	: In-vehicle sensor	F2	(M74)	SMJ	: To (D31)
A4	(M3)	BR/24	: BCM (Body control module)	: Cigarette lighter illumination	E3	(M77)	W/2	: Diode (★1)
A4	★ (M4)	W/16	: Fuse block (J/B)	: Cigarette lighter socket	C1	(M79)	W/2	: Diode
A3	(M5)	W/8	: Fuse block (J/B)	: Antenna amp. (Via sub-harness)	C1	(M80)	W/2	: Diode (With navigation system)
B3	(M7)	W/3	: Illumination control switch	: A/T device (With A/T)	C2	(M81)	W/4	: Compass
B4	(M8)	W/16	: Data link connector	: A/T illumination (With A/T)	E3	(M82)	W/4	: To (M83)
B3	(M9)	GY/6	: VDC off switch	: Ashtray illumination	E2	(M83)	W/4	: (With navigation system)
A3	(M11)	SMJ	: To (D1)	: Hazard switch	E2	(M83)	W/4	: To (M82)
B3	★ (M12)	SMJ	: To (B1)	: Yaw rate / side G sensor	B4	(M84)	B/2	: (With navigation system)
B2	(M14)	W/2	: Circuit breaker (With M/T or automatic drive positioner)	: Power socket (Floor console box) (With A/T)	B4	(M84)	B/2	: Trunk lid opener switch
B2	★ (M15)	SMJ	: To (E108)	: Heated seat switch	B2	(M85)	L/4	: (On the instrument panel) (★1)
C3	(M16)	Y/4	: To (E109)	: (Passenger side)	F2	(M87)	SMJ	: Heated seat relay (With M/T)
B2	(M17)	W/3	: Air mix door motor (Driver side)	: (With A/T and heated seat)	F2	(M88)	B/2	: To (E40) (★1)
B2	(M18)	B/2	: Sunload sensor	: Heated seat switch	F2	(M88)	B/2	: Power socket
C1	★ (M19)	BR/24	: Combination meter	: (Driver side)	F3	(M89)	W/12	: (Instrument side panel RH) (★1)
C1	★ (M20)	W/24	: Combination meter	: (With A/T and heated seat)	D3	(M90)	W/12	: To (M156) (With M/T)
D2	(M22)	W/8	: Steering angle sensor	: Air bag diagnosis sensor unit	F3	(M89)	W/12	: Option connector for audio unit
C3	★ (M23)	GY/8	: Combination switch (Spiral cable)	: Trunk lid opener cancel switch	D3	(M90)	W/12	: (★1)
C3	(M24)	Y/6	: Combination switch (Spiral cable)	: NAVI control unit				
C2	(M25)	BR/2	: Key switch	: (With navigation system)				
D3	(M26)	W/2	: Ignition key hole illumination	: NAVI control unit	G3	(M154)	W/6	: Heated seat switch (Driver side)
D3	(M27)	W/8	: NATS antenna amp.	: (With navigation system)	G3	(M155)	BR/6	: Heated seat switch
C3	(M28)	W/10	: Door mirror remote control switch	: NAVI control unit	F3	(M156)	W/12	: (Passenger side)
D2	(M29)	W/16	: Combination switch	: (With navigation system)				
C1	★ (M30)	—	: Body ground	: Heater and cooling unit				
D1	(M31)	GY/20	: Display and A/C auto amp.	: (Via sub-harness)				
D1	(M32)	GY/16	: Display and A/C auto amp.	: Intake sensor				
D1	(M33)	W/4	: Clock	: Blower motor				
D1	(M34)	W/2	: Security indicator lamp	: Optical sensor				
D2	(M35)	W/24	: Display unit	: Glove box lamp				
			: (With navigation system)	: Front passenger air bag module				
D3	(M37)	W/8	: NAVI switch	: Body ground				
E3	(M38)	W/12	: (With navigation system)	: Intake door motor				
D4	(M39)	W/16	: A/C and audio controller	: Upper glove box lamp				
D4	(M40)	W/10	: Audio unit	: (Without navigation system)				

★ 1...If so equipped

★ : Be sure to connect and lock the connectors securely after repair work. Failure to do so may cause the ECM to have diagnostic trouble codes. **Do not disconnect these connectors except in the case of working according to WORK FLOW of TROUBLE DIAGNOSES in EC and AT sections.**

Switch sub-harness (With M/T)

G3	(M154)	W/6	: Heated seat switch (Driver side)
G3	(M155)	BR/6	: Heated seat switch (Passenger side)
F3	(M156)	W/12	: To (M89)

A B C D E F G H I J K L M N O P Q R S T U V W X Y Z

PG

HARNESS

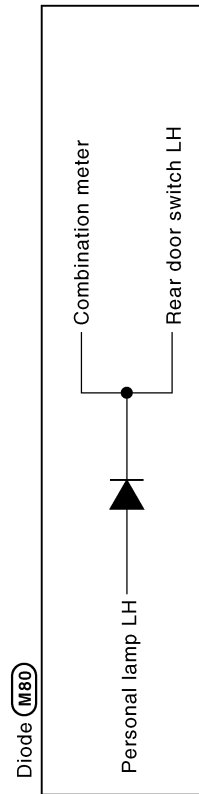
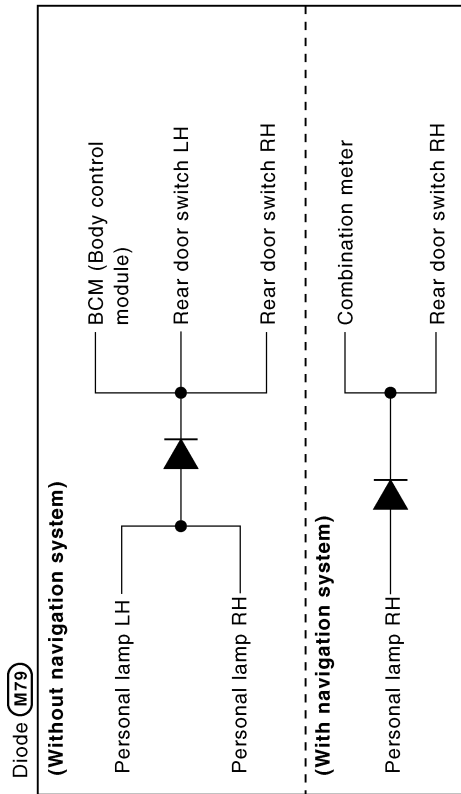
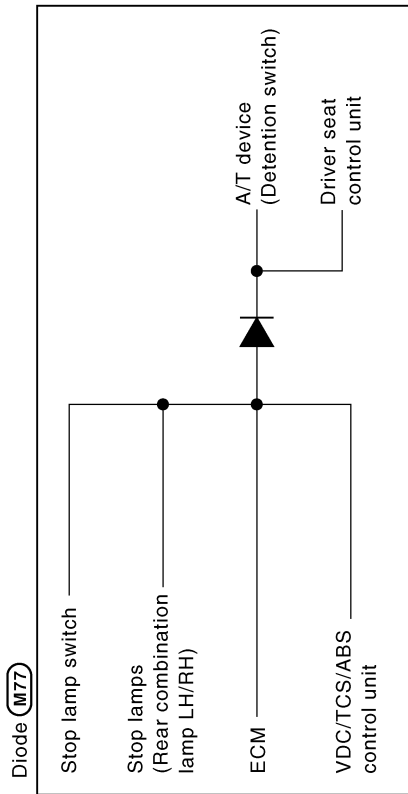

TKIT0027E

HARNESS

ENGINE ROOM HARNESS Engine Compartment

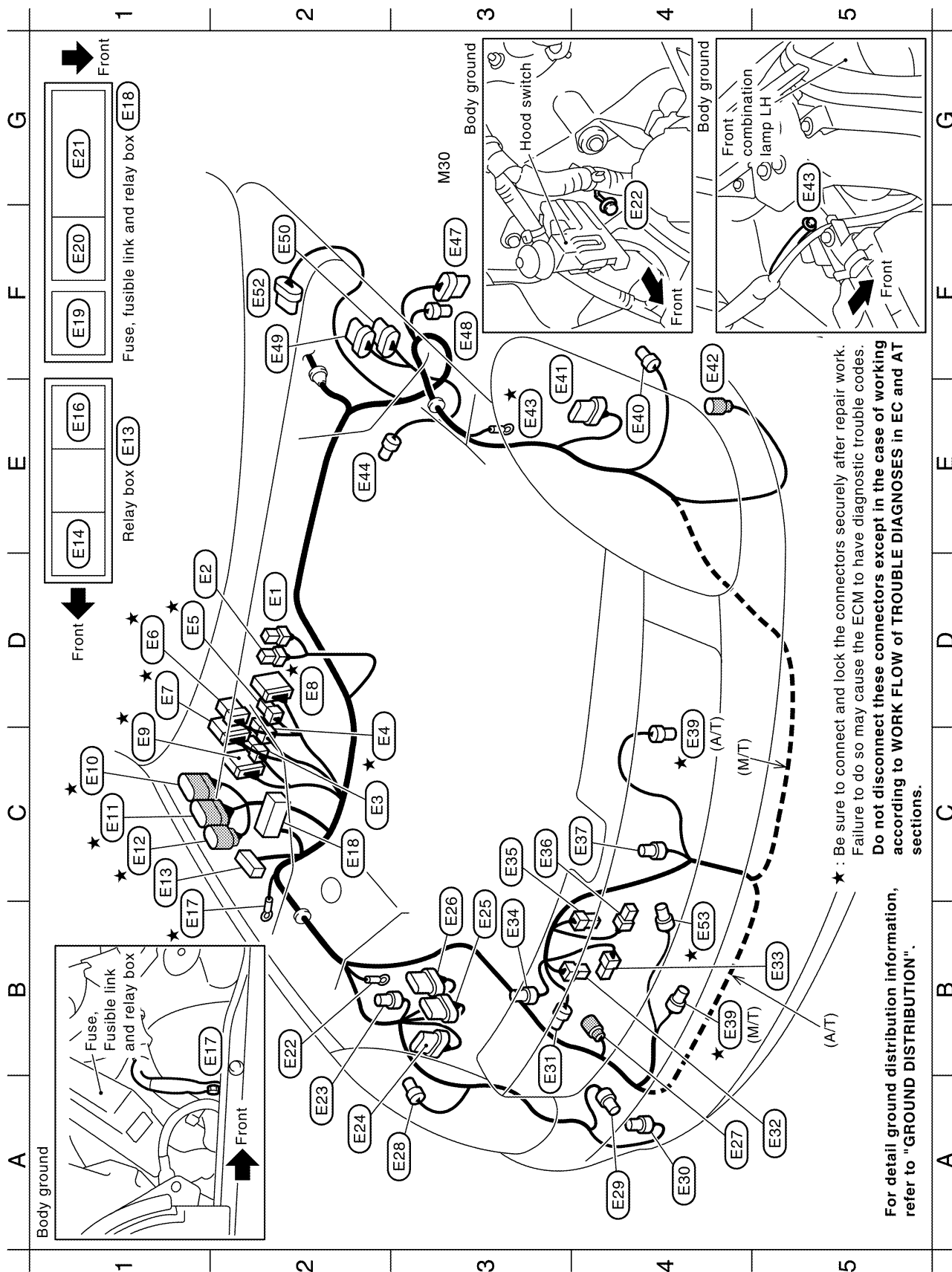

TKIT0073E

HARNESS

D2	(E1)	*1/2	:	Fusible link holder		F4	(E42)	*3/2	:	Front wheel sensor LH
D1	(E2)	GY/2	:	Fusible link holder		E3	★(E43)	—	:	Body ground
C2	(E3)	B/2	:	IPDM E/R (Intelligent power distribution module engine room)		E2	(E44)	GY/2	:	Brake fluid level switch
C2	★(E4)	W/4	:	IPDM E/R (Intelligent power distribution module engine room)		F3	(E47)	B/8	:	VDC relay box
D1	★(E5)	B/4	:	IPDM E/R (Intelligent power distribution module engine room)		F3	(E48)	B/2	:	VDC relay box
D1	★(E6)	W/6	:	IPDM E/R (Intelligent power distribution module engine room)		F2	(E49)	*4/8	:	VDC actuator
D1	★(E7)	W/12	:	IPDM E/R (Intelligent power distribution module engine room)		F2	(E50)	*5/8	:	VDC actuator
D2	★(E8)	GY/16	:	IPDM E/R (Intelligent power distribution module engine room)		F2	(E52)	GY/5	:	Front wiper motor
C1	★(E9)	W/12	:	IPDM E/R (Intelligent power distribution module engine room)		B4	★(E53)	GY/4	:	Cooling fan motor-2 (With M/T)
C1	(E10)	GY/9	:	To (F1)						
C1	★(E11)	GY/10	:	To (F2)						
C1	★(E12)	B/8	:	To (F3)						
C1	(E13)	—	:	Relay box (For Canada)						
E1	(E14)	L/4	:	Daytime light relay-1 (For Canada)						
E1	(E16)	L/4	:	Daytime light relay-2 (For Canada)						
B1	★(E17)	—	:	Body ground						
C2	(E18)	—	:	Fuse, fusible link and relay box						
F1	(E19)	L/4	:	Back-up lamp relay (With A/T)						
F1	(E20)	W/3	:	Horn relay						
G1	(E21)	—	:	Fuse and fusible link block						
B2	(E22)	—	:	Body ground						
A2	(E23)	GY/2	:	Hood switch						
A2	(E24)	B/8	:	Front combination lamp RH						
B3	(E25)	GY/6	:	Daytime light control unit (For Canada)						
B3	(E26)	GY/8	:	Daytime light control unit (For Canada)						
A4	(E27)	GY/2	:	Front wheel sensor RH						
A3	(E28)	*2/2	:	Front side marker lamp RH						
A4	(E29)	GY/2	:	Front washer motor						
A4	(E30)	BR/2	:	Washer level sensor						
B3	(E31)	B/3	:	Refrigerant pressure sensor						
A5	(E32)	B/1	:	Horn (Low)						
B5	(E33)	B/1	:	Horn (Low)						
B3	(E34)	B/2	:	Ambient sensor						
C3	(E35)	B/1	:	Horn (High)						
C3	(E36)	B/1	:	Horn (High)						
C4	(E37)	Y/2	:	Crash zone sensor						
B4,C4	★(E39)	GY/4	:	Cooling fan motor-1						
E4	(E40)	*2/2	:	Front side marker lamp LH						
E3	(E41)	B/8	:	Front combination lamp LH						

- ★1...BR or B
- ★2...BR or GY
- ★3...L or B
- ★4...SB or GY
- ★5...GY or B

★ : Be sure to connect and lock the connectors securely after repair work.
 Failure to do so may cause the ECM to have diagnostic trouble codes.
Do not disconnect these connectors except in the case of working according to WORK FLOW of TROUBLE DIAGNOSES in EC and AT sections.

TKIT0074E

Passenger Compartment

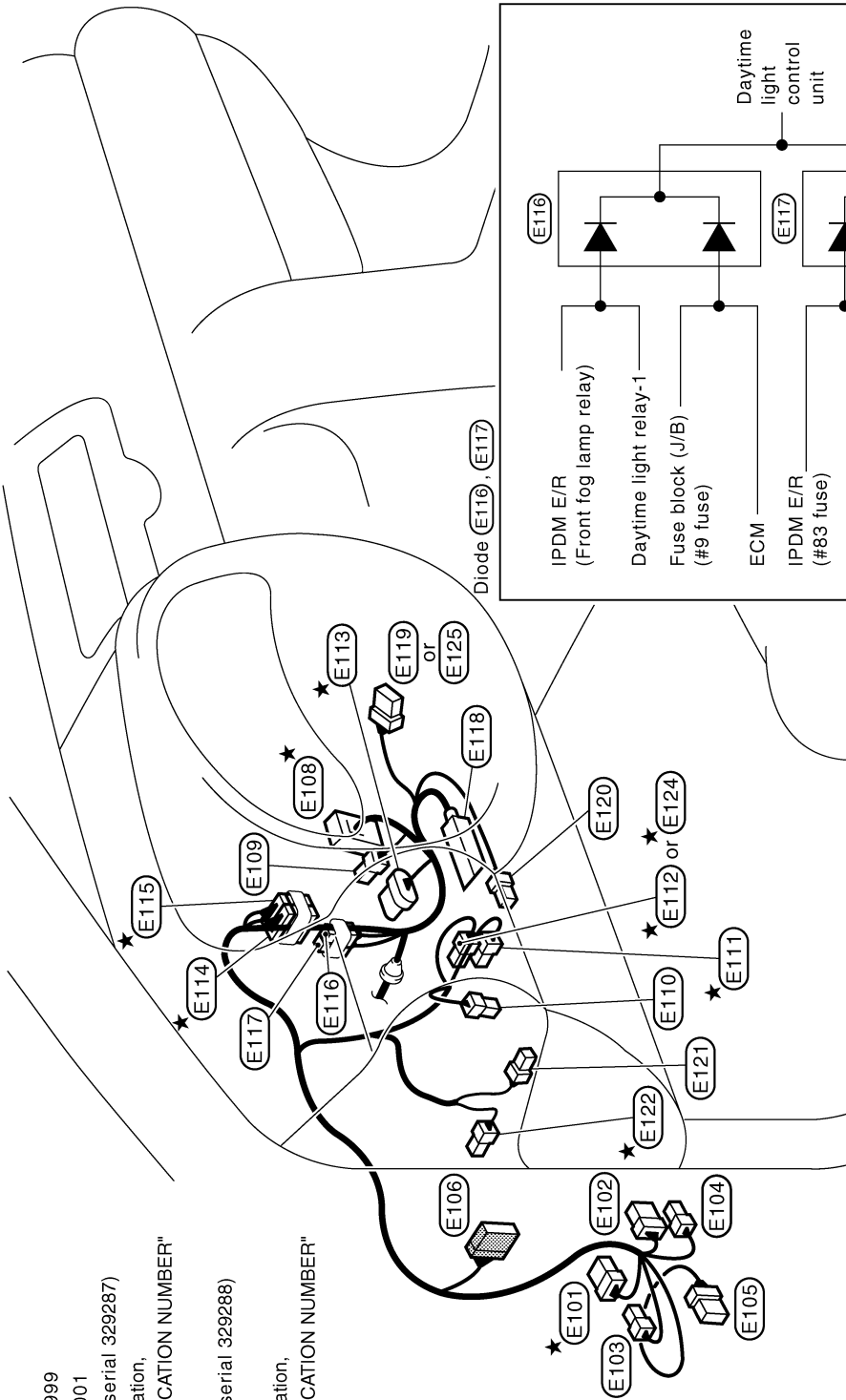

- *1...Up to serial 099999
- *2...From serial 300001
- *3...With A/T (Up to serial 329287)
(For further information, refer to "IDENTIFICATION NUMBER" in GI section.)
- *4...With A/T (From serial 329288) and with M/T
(For further information, refer to "IDENTIFICATION NUMBER" in GI section.)

- * (E101) W/8 : Fuse block (J/B)
- (E102) W/6 : Fuse block (J/B)
- (E103) B/1 : Fuse block (J/B)
- (E104) B/2 : Fuse block (J/B)
- (E105) W/8 : BCM (Body control module)
- (E106) W/18 : To (B2)
- * (E108) SMJ : To (M15)
- (E109) Y/4 : To (M16)
- (E110) W/1 : Parking brake switch (With M/T)
- * (E111) BR/2 : ASCD brake switch
- * (E112) B/2 : Stop lamp switch (*1)
- * (E113) GY/6 : Accelerator pedal position sensor

- * (E114) BR/20 : Joint connector-1
- * (E115) OR/20 : Joint connector-2
- (E116) -/3 : Diode (For Canada)
- (E117) -/3 : Diode (For Canada)
- (E118) SMJ : VDC/TCS/ABS control unit
- (E119) B/5 : Ignition switch (*3)
- (E120) W/2 : To (B35)
- (E121) L/2 : Clutch interlock switch (With M/T)
- * (E122) L/2 : ASCD clutch switch (With M/T)
- * (E124) W/4 : Stop lamp switch (*2)
- (E125) W/6 : Ignition switch (*4)

★ : Be sure to connect and lock the connectors securely after repair work. Failure to do so may cause the ECM to have diagnostic trouble codes. **Do not disconnect these connectors except in the case of working according to WORK FLOW of TROUBLE DIAGNOSES in EC and AT sections.**

TKIT0096E

A
B
C
D
E
F
G
H
I
J
K
L
M
PG

HARNESS

Battery Cable

- (E201)** : Fusible link holder
- (E202)** : Alternator (B)
- (E203)** : Starter motor
- (E211)** : Alternator (E)
- (E212)** : Body ground
- (E213)** : Engine ground

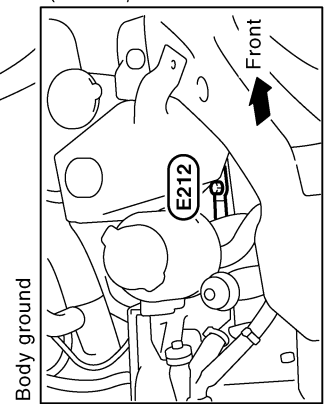
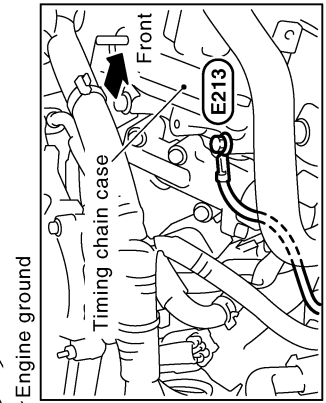
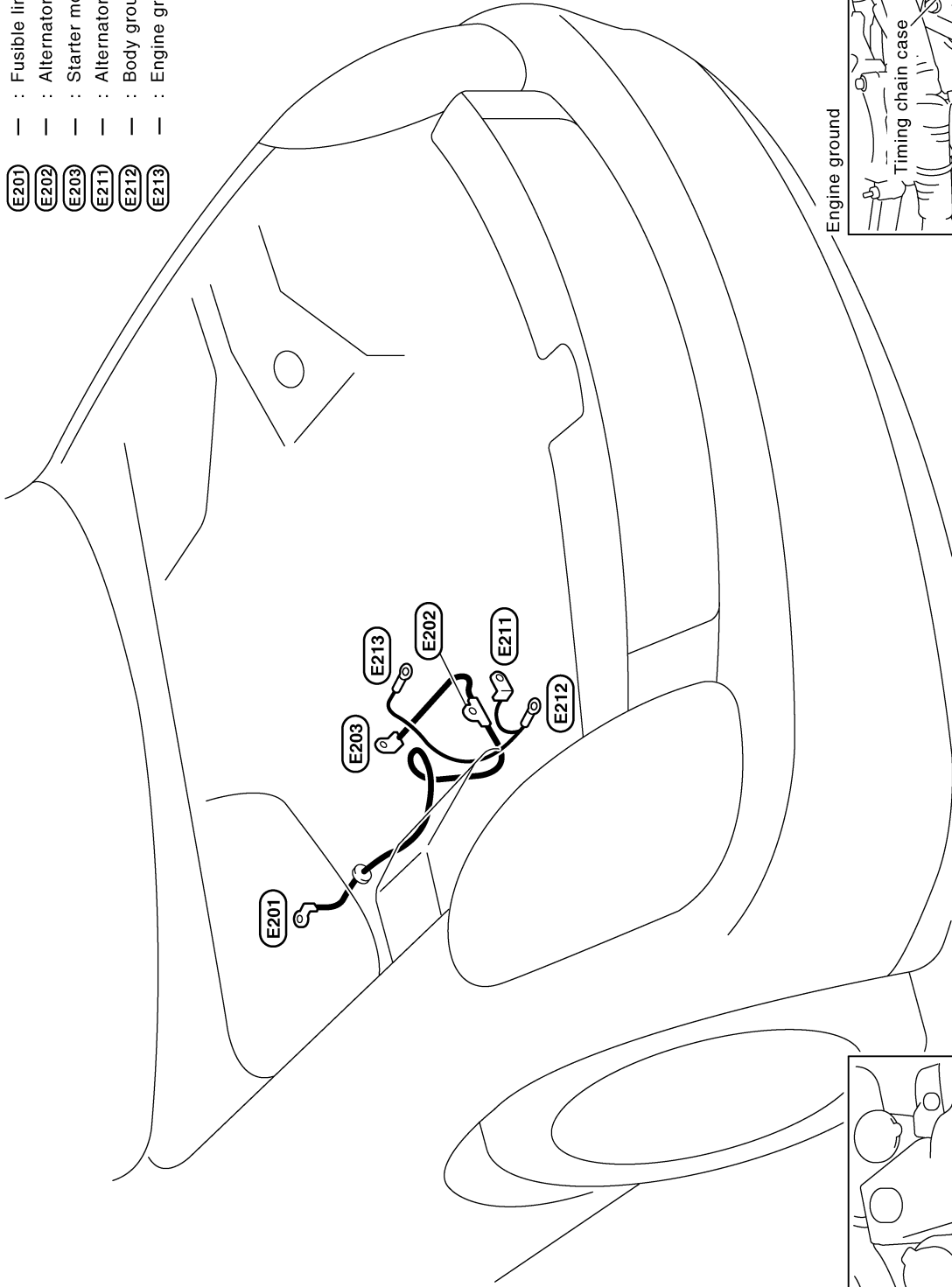

For detail ground distribution information, refer to "GROUND DISTRIBUTION".

TKIT0031E

HARNESS

ENGINE CONTROL HARNESS

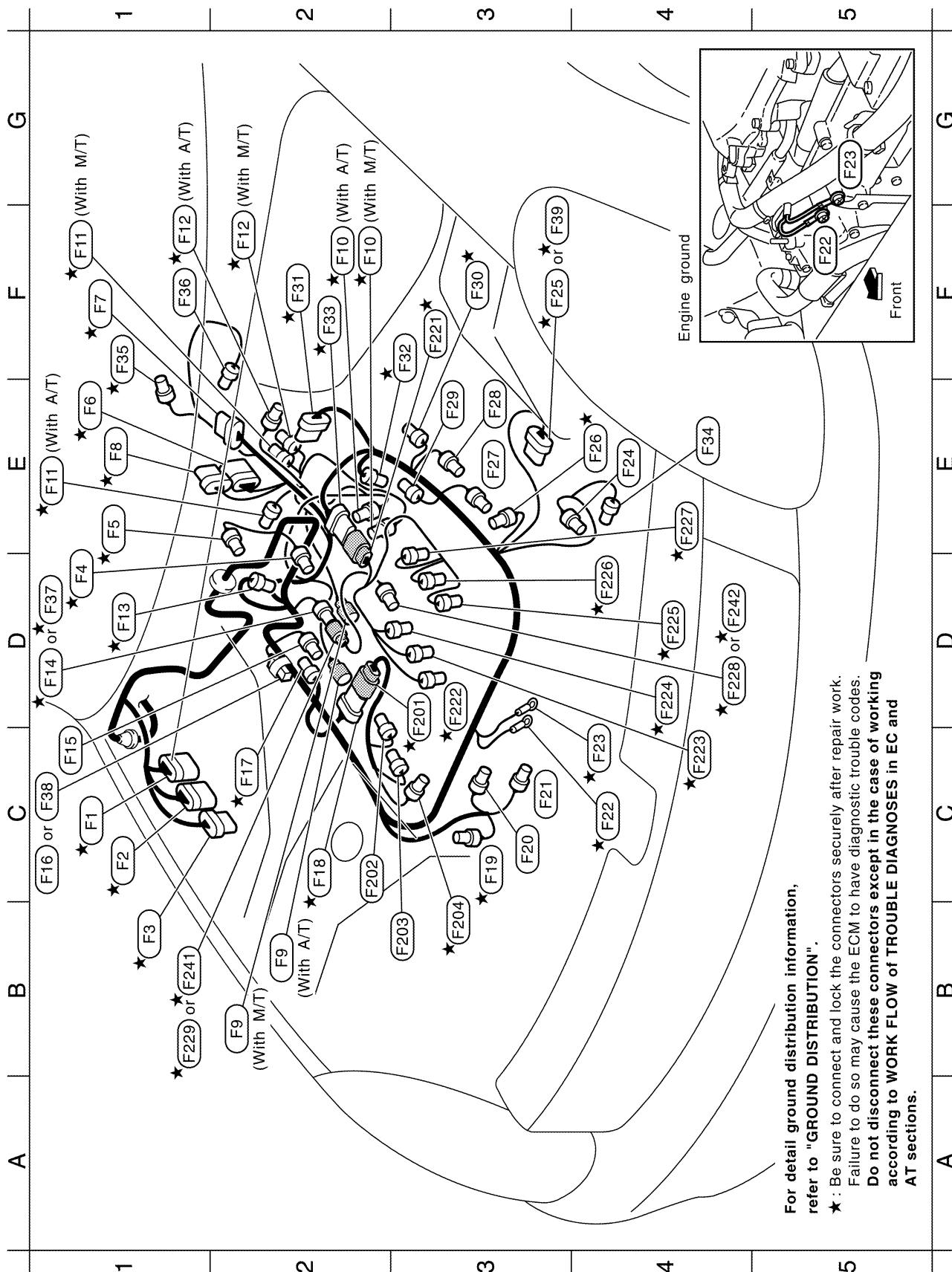

For detail ground distribution information, refer to "GROUND DISTRIBUTION".

★ : Be sure to connect and lock the connectors securely after repair work. Failure to do so may cause the ECM to have diagnostic trouble codes. Do not disconnect these connectors except in the case of working according to WORK FLOW of TROUBLE DIAGNOSES in EC and AT sections.

TKIT0076E

A
B
C
D
E
F
G
H
J
L
M
PG

Passenger compartment

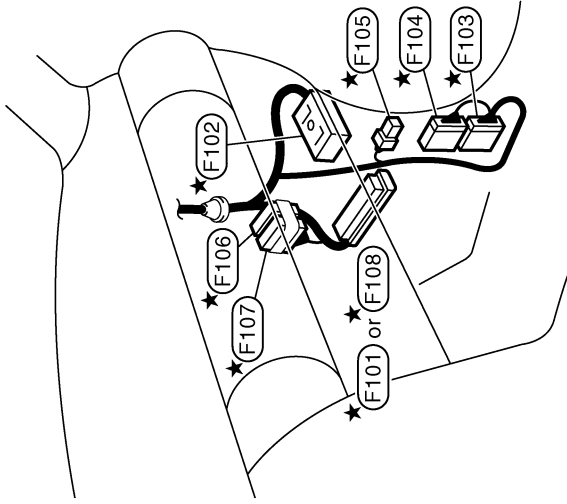

- F2 ★ (F33) *3/8 : To (E221)
- E4 (F34) B/2 : Compressor
- F1 ★ (F35) B/2 : Park/Neutral position switch (With M/T)
- F1 (F36) B/2 : Back-up lamp switch (With M/T)
- D1 ★ (F37) B/2 : To (E229) (*5)
- C1 (F38) W/2 : Condenser (*5)
- F3 ★ (F39) B/6 : Mass air flow sensor (*5)

Engine control sub-harness-1

- D3 ★ (F201) L/6 : To (F18)
- C2 (F202) GY/3 : Ignition coil No. 3 (With power transistor)
- B3 (F203) GY/3 : Ignition coil No. 1 (With power transistor)
- B3 ★ (F204) G/2 : Intake valve timing control solenoid valve (Bank 1)

Engine control sub-harness-2

- F3 ★ (F221) G/8 : To (F33)
- D3 ★ (F222) GY/2 : Injector No. 1
- C4 ★ (F223) GY/2 : Injector No. 3
- D4 ★ (F224) GY/2 : Injector No. 5
- D4 ★ (F225) GY/2 : Injector No. 2
- D4 ★ (F226) GY/2 : Injector No. 4
- E4 ★ (F227) GY/2 : Injector No. 6
- D4 ★ (F228) L/2 : Knock sensor (*5)
- B1 ★ (F229) SB/2 : To (F37) (*5)

Engine control sub-harness-3

- B1 ★ (F241) SB/2 : To (F14) (*4)
- D4 ★ (F242) GY/2 : Knock sensor (With *4)

- ★ 1...L or GY *5...With A/T (From serial 329288) and with M/T
- ★ 2...L or B (For further information,
- ★ 3...G or GY refer to "IDENTIFICATION NUMBER" in GI section.)
- ★ 4...With A/T (Up to serial 329287) (For further information,

refer to "IDENTIFICATION NUMBER" in GI section.)

★ : Be sure to connect and lock the connectors securely after repair work. Failure to do so may cause the ECM to have diagnostic trouble codes. Do not disconnect these connectors except in the case of working according to WORK FLOW of TROUBLE DIAGNOSES in EC and AT sections.

- C1 ★ (F1) GY/9 : To (E10)
- C1 ★ (F2) GY/10 : To (E11)
- B1 ★ (F3) B/8 : To (E12)
- D1 ★ (F4) G/3 : Camshaft position sensor (PHASE) (Bank 1)
- E1 ★ (F5) *1/2 : EVAP canister purge volume control solenoid valve
- E1 ★ (F6) *3/10 : A/T assembly (With A/T)
- F1 ★ (F7) *3/8 : A/T assembly (With A/T)
- E1 ★ (F8) B/8 : A/T assembly (With A/T)
- B2 (F9) GY/1 : Starter motor
- F2 ★ (F10) B/3 : Crankshaft position sensor (POS)
- E1,F1 ★ (F11) *2/4 : Heated oxygen sensor 2 (Bank 1)
- F1,F2 ★ (F12) *3/4 : Heated oxygen sensor 2 (Bank 2)
- D1 ★ (F13) GY/2 : Engine coolant temperature sensor
- D1 ★ (F14) SB/2 : To (E241) (*4)
- C1 (F15) GY/3 : Ignition coil No. 5 (With power transistor)
- C1 (F16) W/2 : Condenser (*4)
- C2 ★ (F17) *3/4 : Heated oxygen sensor 1 (Bank 1)
- C2 ★ (F18) *2/6 : To (F201)
- C3 ★ (F19) B/3 : Power steering pressure sensor
- C3 (F20) GY/2 : Alternator (S, L)
- C3 (F21) GY/1 : Oil pressure switch
- C4 ★ (F22) - : Engine ground (With A/T)
- C4 ★ (F23) - : Engine ground
- E4 (F24) B/1 : Compressor
- F3 (F25) GY/5 : Mass air flow sensor (*4)
- E4 ★ (F26) *3/2 : Intake valve timing control solenoid valve (Bank 2)
- E3 (F27) GY/3 : Ignition coil No. 2 (With power transistor)
- E3 (F28) GY/3 : Ignition coil No. 4 (With power transistor)
- E3 (F29) GY/3 : Ignition coil No. 6 (With power transistor)
- F3 ★ (F30) *3/4 : Heated oxygen sensor 1 (Bank 2)
- F2 ★ (F31) *3/6 : Electric throttle control actuator
- F3 ★ (F32) B/3 : Camshaft position sensor (PHASE) (Bank 2)

TKIT0097E

HARNESS

BODY HARNESS

Passenger Compartment

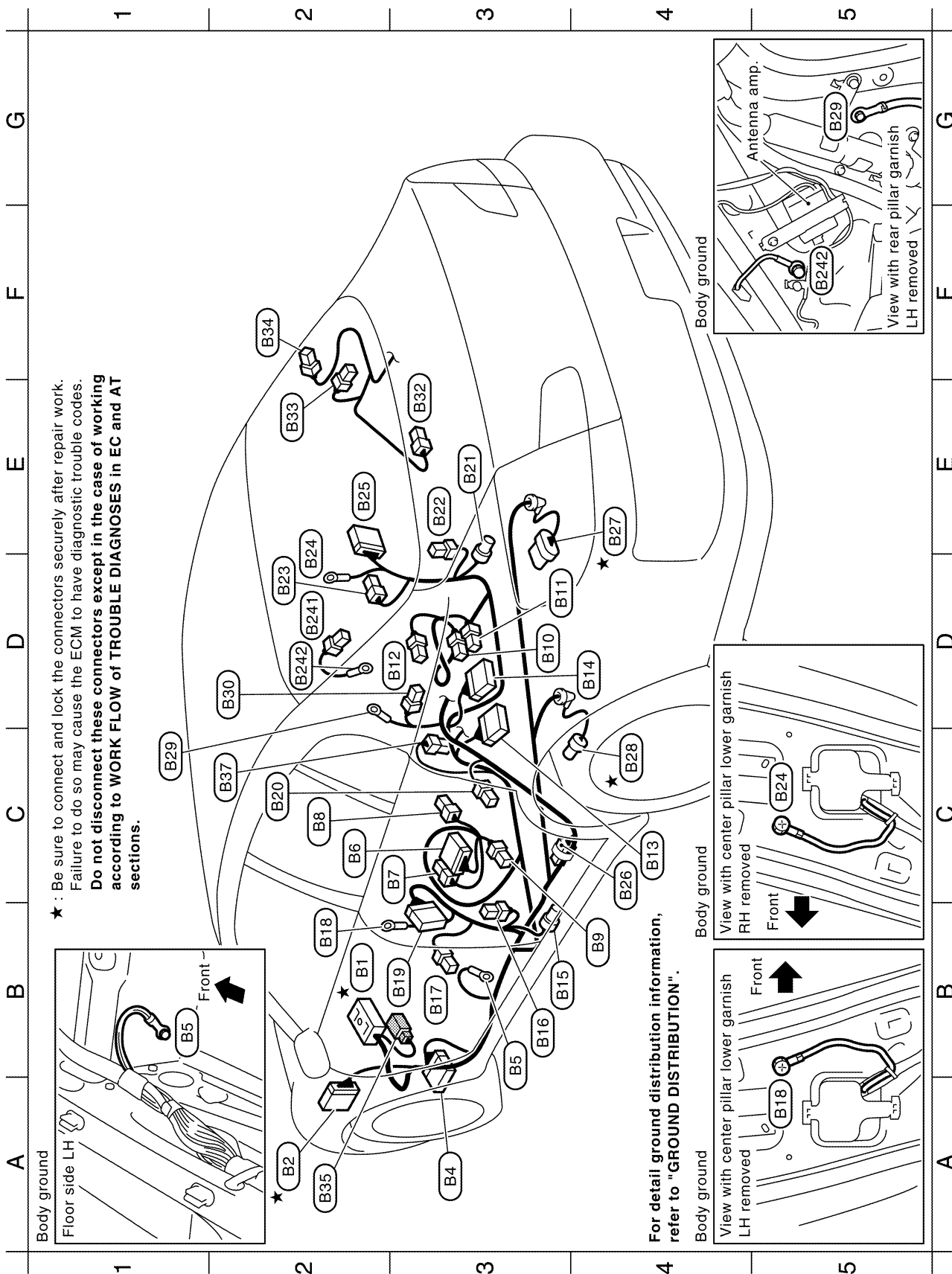

★ : Be sure to connect and lock the connectors securely after repair work. Failure to do so may cause the ECM to have diagnostic trouble codes. Do not disconnect these connectors except in the case of working according to WORK FLOW of TROUBLE DIAGNOSES in EC and AT sections.

For detail ground distribution information, refer to "GROUND DISTRIBUTION".

PG

TKIT0078E

HARNESSES

B2	★	(B1)	SMJ	:	To	(M12)
A2	★	(B2)	W/18	:	To	(E109)
A3		(B4)	W/12	:	BCM	(Body control module)
B3		(B5)	—	:	Body	ground
C2		(B6)	W/12	:	Front	power seat (Driver side) (With drive positioner)
C3		(B7)	W/4	:	Front	power seat (Driver side) (Without drive positioner)
C2		(B8)	W/3	:	Seat	belt buckle switch (Driver side)
B4		(B9)	Y/2	:	Front	LH side air bag module
D3		(B10)	Y/2	:	Front	RH side air bag module
D3		(B11)	W/3	:	Seat	belt buckle switch (Passenger side)
D3		(B12)	W/4	:	Front	power seat (Passenger side)
C4		(B13)	Y/12	:	Air	bag diagnosis sensor unit
D4		(B14)	Y/12	:	Air	bag diagnosis sensor unit
B3		(B15)	Y/2	:	LH	side air bag (Satellite) sensor
B3		(B16)	Y/2	:	Front	LH seat belt pre-tensioner
B3		(B17)	W/3	:	Front	door switch driver side
B2		(B18)	—	:	Body	ground
B3		(B19)	W/18	:	To	(D51)
C2		(B20)	W/3	:	Rear	door switch LH
E3		(B21)	Y/2	:	RH	side air bag (Satellite) sensor
E3		(B22)	Y/2	:	Front	RH seat belt pre-tensioner
D2		(B23)	W/3	:	Front	door switch passenger side
D2		(B24)	—	:	Body	ground
E2		(B25)	W/18	:	To	(D71)
C4		(B26)	W/2	:	Condenser	
E4	★	(B27)	GY/5	:	Fuel	level sensor unit and fuel pump
C4	★	(B28)	GY/2	:	Fuel	level sensor unit (Sub)
C1		(B29)	—	:	Body	ground
D2		(B30)	Y/2	:	LH	side curtain air bag module
E3		(B32)	W/3	:	Rear	door switch RH
E2		(B33)	Y/2	:	RH	side curtain air bag module
F2		(B34)	W/1	:	Condenser	
A2		(B35)	W/2	:	To	(E120)
C2		(B37)	B/1	:	Parking	brake switch (With M/T)

Body sub-harness

D2	(B241)	B/1	:	Rear	window defogger (-)
D2	(B242)	—	:	Body	ground

★ : Be sure to connect and lock the connectors securely after repair work.
 Failure to do so may cause the ECM to have diagnostic trouble codes.
Do not disconnect these connectors except in the case of working according to WORK FLOW of TROUBLE DIAGNOSES in EC and AT sections.

TKIT0079E

HARNESSES

Trunk Room

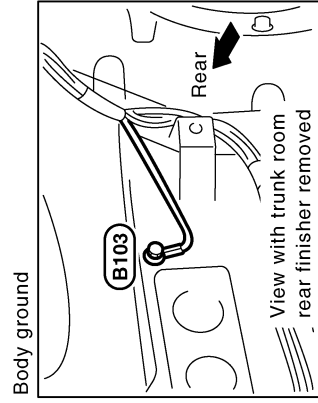
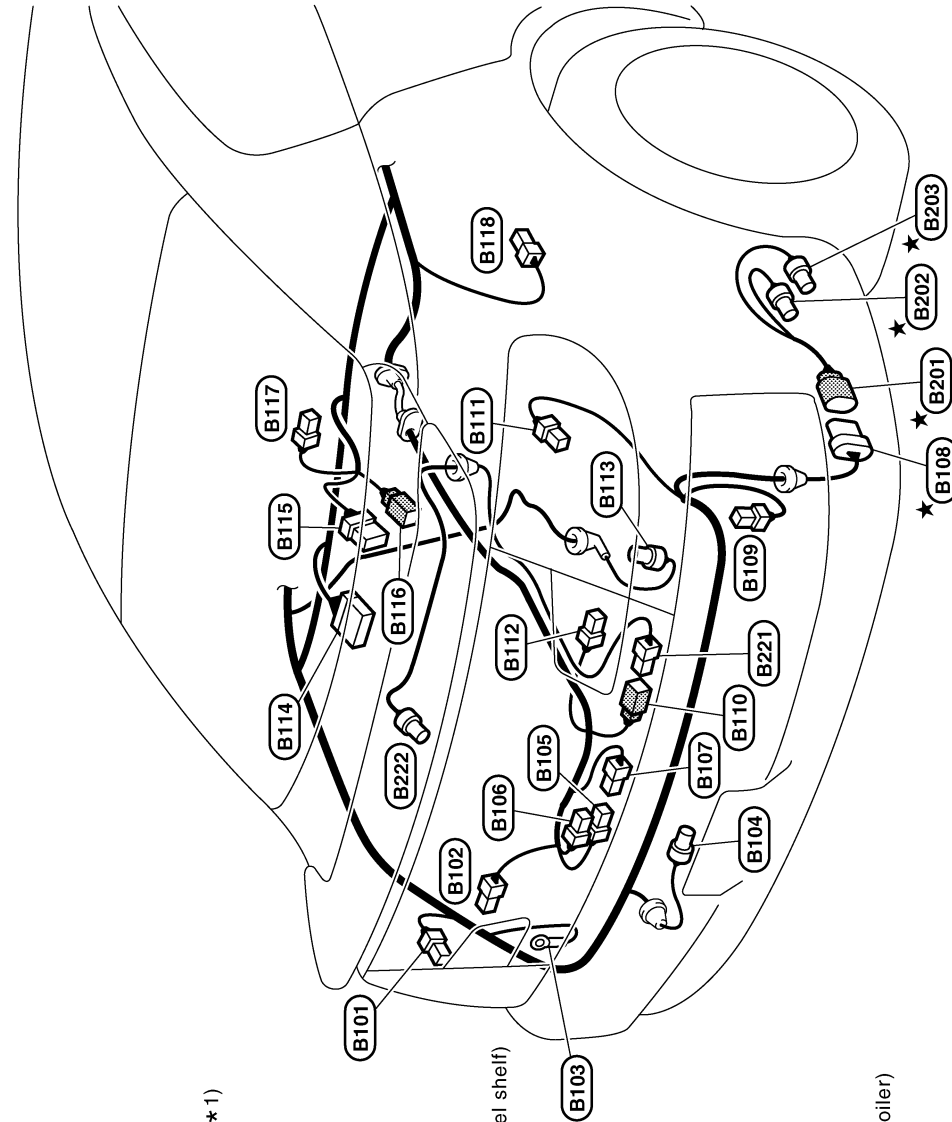

- (B101) W/4 : Rear combination lamp LH
- (B102) W/2 : Back-up lamp LH
- (B103) - : Body ground
- (B104) BR/2 : License plate lamp
- (B105) W/2 : Trunk room lamp switch
- (B106) B/2 : Trunk lid opener actuator
- (B107) W/2 : Trunk lid opener switch (On the trunk lid) (*1)
- ★ (B108) G/6 : To (B201)
- (B109) BR/6 : Rear window defogger relay
- (B110) GY/2 : To (B221) (With rear air spoiler)
- (B111) W/4 : Rear combination lamp RH
- (B112) W/2 : Back-up lamp RH
- (B113) SB/4 : Rear wheel sensor
- (B114) GY/26 : BOSE speaker amp. (With BOSE system)
- (B115) BR/6 : Woofer (With BOSE system)
- (B116) BR/2 : High-mounted stop lamp (On the rear parcel shelf)
- (B117) W/2 : Trunk room lamp
- (B118) W/4 : Fuel lid lock actuator

Body sub-harness-1

- ★ (B201) G/6 : To (B108)
- ★ (B202) GY/3 : EVAP control system pressure sensor
- ★ (B203) B/2 : EVAP canister vent control valve

Body sub-harness-2

- (B221) GY/2 : To (B110)
- (B222) GY/2 : High-mounted stop lamp (In the rear air spoiler)

*1...If so equipped

★ : Be sure to connect and lock the connectors securely after repair work.
 Failure to do so may cause the ECM to have diagnostic trouble codes.
Do not disconnect these connectors except in the case of working according to WORK FLOW of TROUBLE DIAGNOSES in EC and AT sections.

For detailed ground distribution information, refer to "GROUND DISTRIBUTION".

TKIT0033E

A
B
C
D
E
F
G
H
I
J
PG
L
M

HARNESS

BODY NO.2 HARNESS

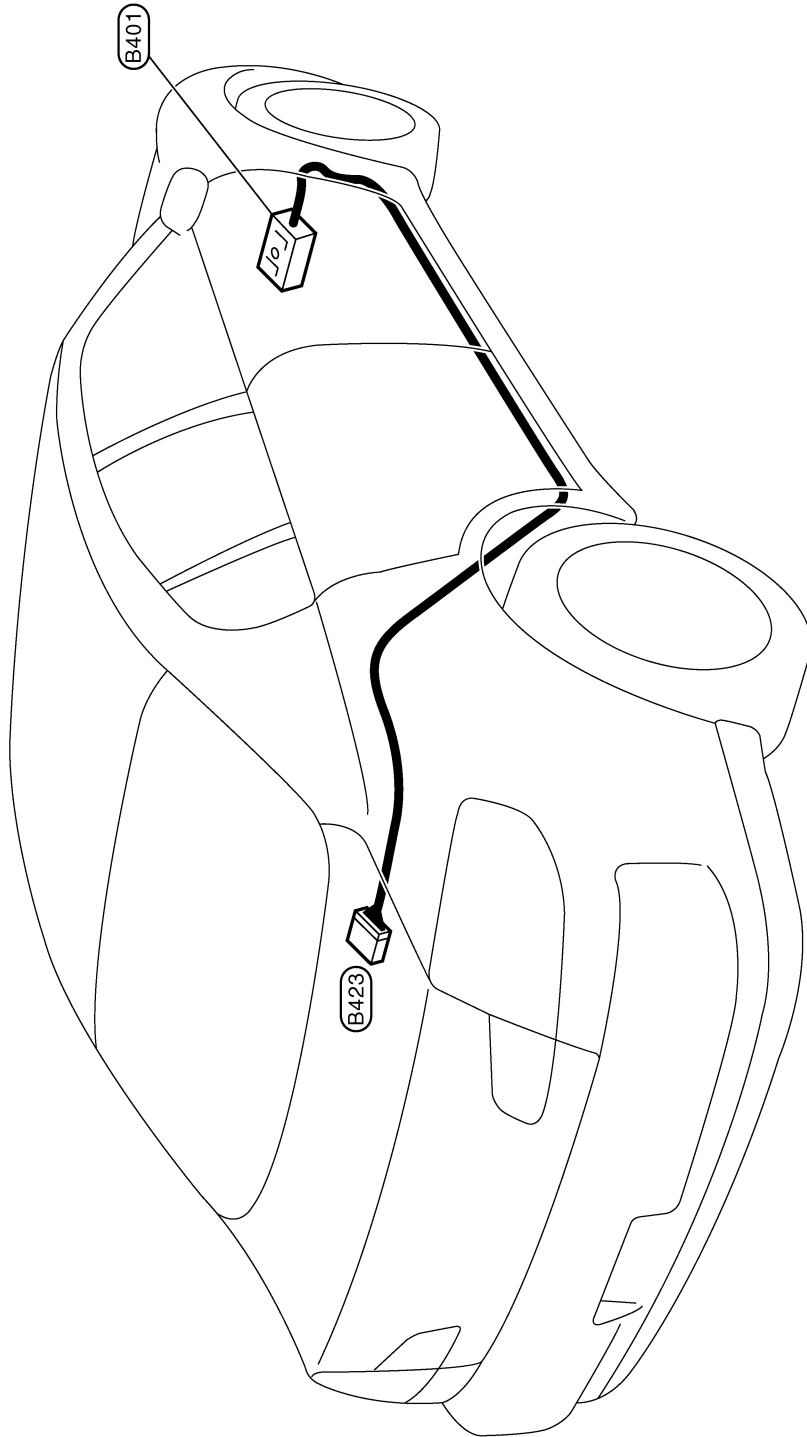

B401 SMJ : To **M87**
B423 W/16 : Option connector for satellite radio receiver

TKIT0098E

HARNESS

ROOM LAMP HARNESS

Room lamp sub-harness

- | | | | |
|-------|------|---|--|
| (R1) | W/12 | : | To (M69) |
| (R4) | -/2 | : | Vanity mirror lamp (Passenger side) |
| (R5) | W/8 | : | To (R51) |
| (R6) | B/12 | : | Sunroof motor assembly (With sunroof) |
| (R7) | B/10 | : | Auto anti-dazzling inside mirror (With drive positioner) |
| (R9) | -/2 | : | Vanity mirror lamp (Driver side) |
| (R51) | W/8 | : | To (R5) |
| (R52) | W/3 | : | Map lamp |
| (R53) | W/3 | : | Sunroof switch (With sunroof) |
| (R54) | W/3 | : | Personal lamp LH |
| (R55) | W/3 | : | Personal lamp RH |

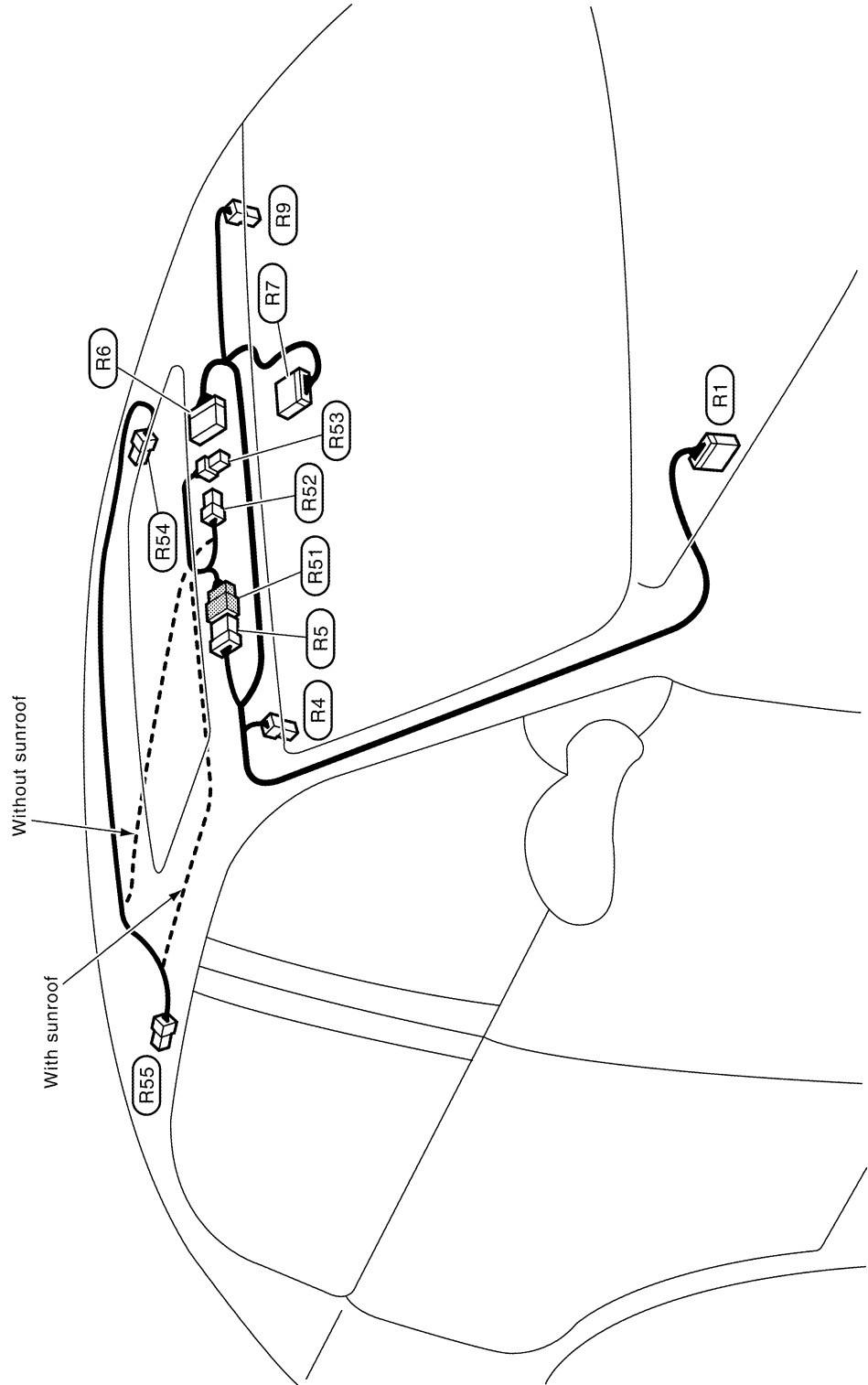

A
B
C
D
E
F
G
H
I
J
L
M

PG

TKIT0080E

HARNESS

FRONT DOOR HARNESS

LH Side

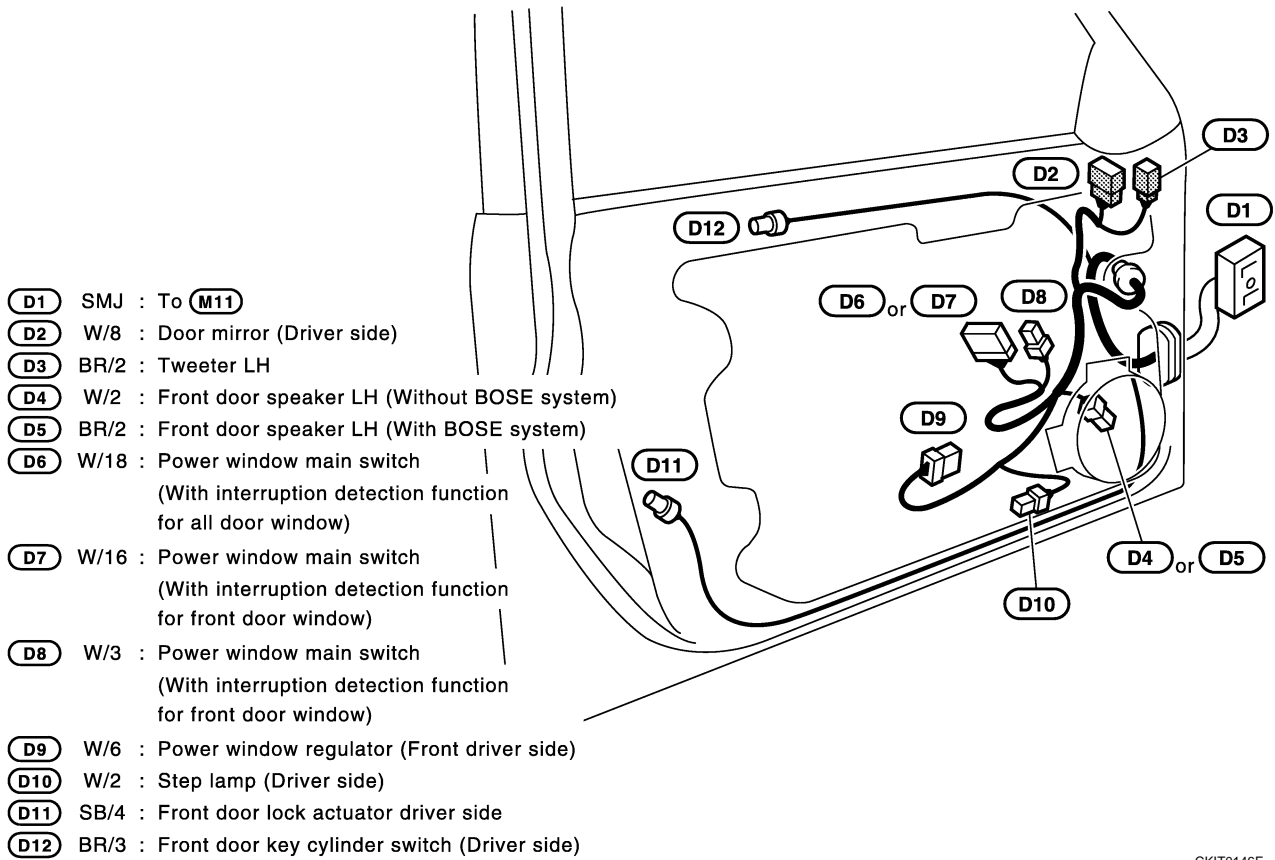

CKIT0146E

RH Side

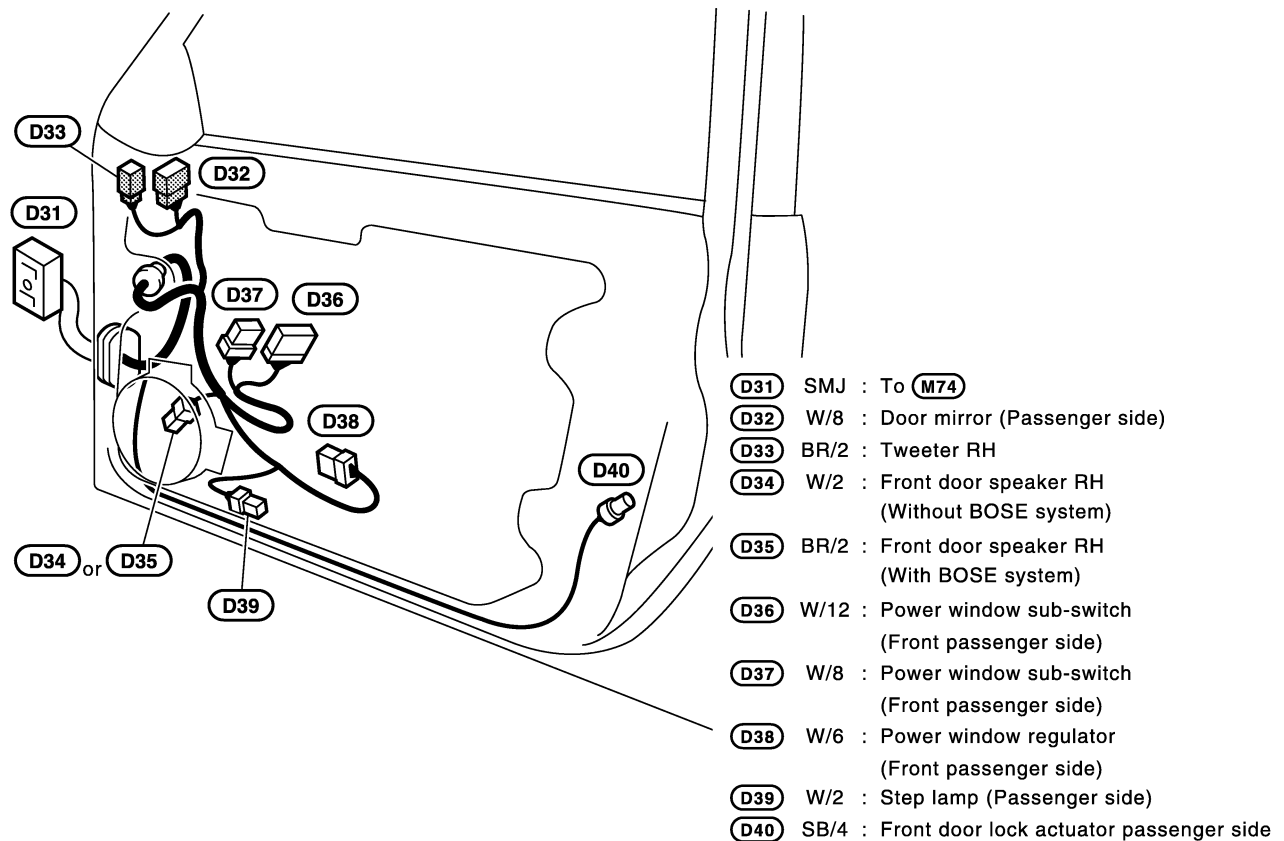

CKIT0147E

HARNESS

REAR DOOR HARNESS

LH Side

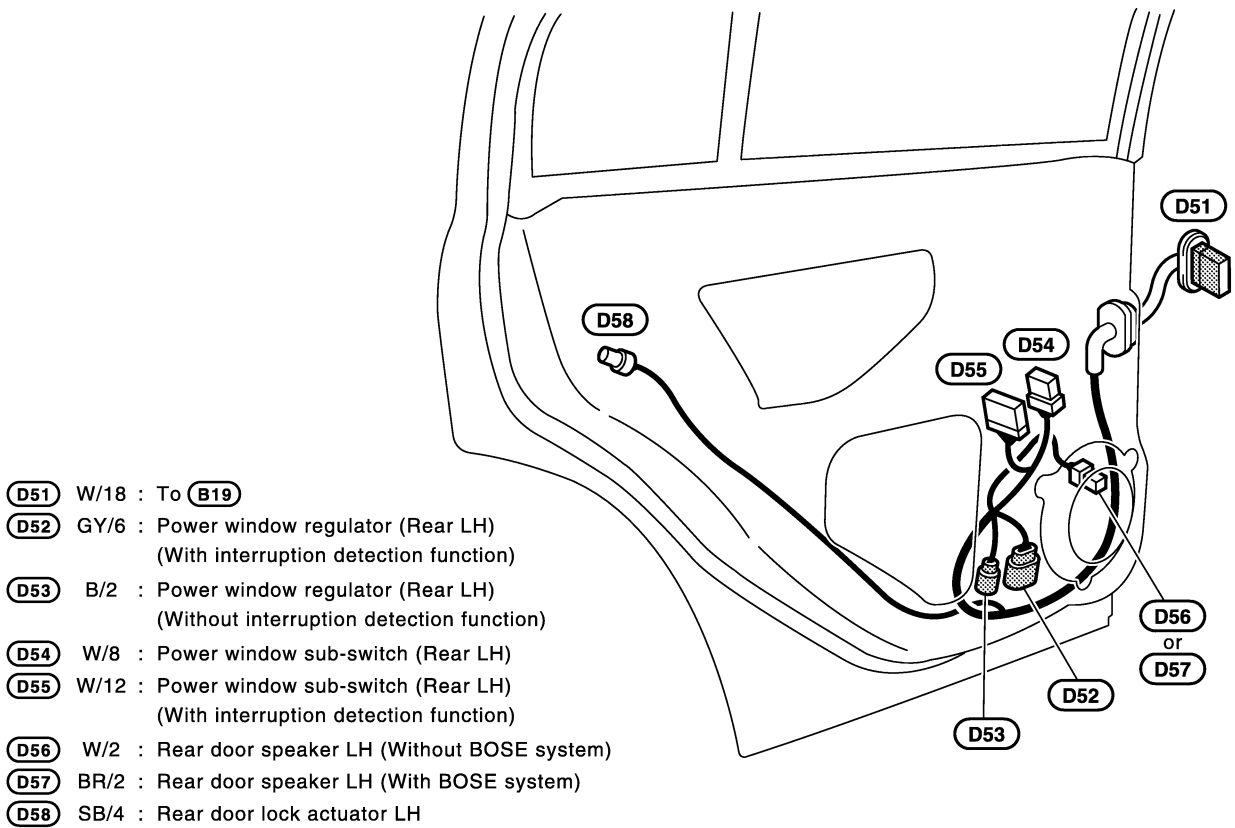

CKIT0148E

RH Side

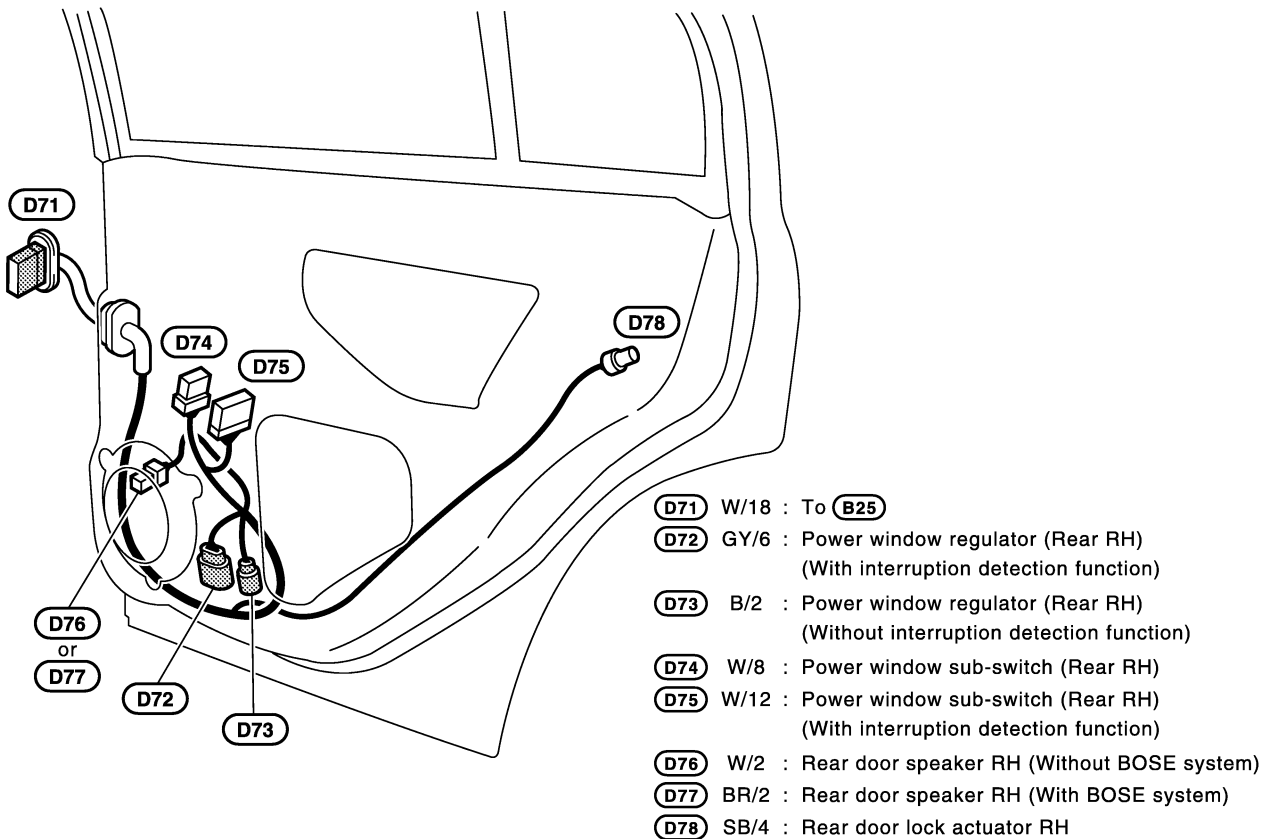

CKIT0149E

A
B
C
D
E
F
G
H
I
J
PG
L
M

HARNESS

Wiring Diagram Codes (Cell Codes)

AKS000ID

Use the chart below to find out what each wiring diagram code stands for.

Refer to the wiring diagram code in the alphabetical index to find the location (page number) of each wiring diagram.

Code	Section	Wiring Diagram Name
A/C	ATC	Air Conditioner
APPS1	EC	Accelerator Pedal Position Sensor
APPS2	EC	Accelerator Pedal Position Sensor
APPS3	EC	Accelerator Pedal Position Sensor
ASC/BS	EC	Automatic Speed Control Device (ASCD) Brake Switch
ASC/SW	EC	Automatic Speed Control Device (ASCD) Steering Switch
ASCBOF	EC	Automatic Speed Control Device (ASCD) Brake Switch
ASCIND	EC	Automatic Speed Control Device (ASCD) Indicator
AT/IND	DI	A/T Indicator Lamp
AUDIO	AV	Audio
AUT/DP	SE	Automatic Drive Positioner
AUTO/L	LT	Automatic Light System
BACK/L	LT	Back-Up Lamp
BRK/SW	EC	Brake Switch
CAN	AT	CAN Communication Line
CAN	EC	CAN Communication Line
CAN	LAN	CAN System
CHARGE	SC	Charging System
CHIME	DI	Warning Chime
CIGAR	WW	Cigarette Lighter
CLOCK	DI	Clock
COMBSW	LT	Combination Switch
COMM	AV	Audio Visual Communication Line
COMPAS	DI	Compass and Thermometer
COOL/F	EC	Cooling Fan Control
D/C	AT	Direct Clutch Solenoid Valve
D/CF	AT	Direct Clutch Solenoid Valve Function
D/LOCK	BL	Power Door Lock
DEF	GW	Rear Window Defogger
DLC	EC	Data Link Connector
DTRL	LT	Headlamp - With Daytime Light System
E/BRE	AT	A/T 1st Engine Braking
ECM/PW	EC	ECM Power Supply For Back-Up
ECTS	EC	Engine Coolant Temperature Sensor
ETC1	EC	Electric Throttle Control Function
ETC2	EC	Throttle Control Motor Relay
ETC3	EC	Throttle Control Motor
F/FOG	LT	Front Fog Lamp
F/PUMP	EC	Fuel Pump
FLS1	EC	Fuel Level Sensor Circuit (SLOSH)
FLS2	EC	Fuel Level Sensor Circuit

HARNESS

Code	Section	Wiring Diagram Name
FLS3	EC	Fuel Level Sensor Circuit (Ground Signal)
FPSW1	AT	ATF Pressure Switch 1
FPSW3	AT	ATF Pressure Switch 3
FPSW5	AT	ATF Pressure Switch 5
FPSW6	AT	ATF Pressure Switch 6
FR/B	AT	Front Brake Solenoid Valve
FR/BF	AT	Front Brake Solenoid Valve Function
FTS	AT	A/T Fluid Temperature Sensor Circuit
FTTS	EC	Fuel Tank Temperature Sensor
FUELB1	EC	Fuel Injection System Function (Bank 1)
FUELB2	EC	Fuel Injection System Function (Bank 2)
H/LAMP	LT	Headlamp
HLR/C	AT	High and Low Reverse Clutch Solenoid Valve
HLR/CF	AT	High and Low Reverse Clutch Solenoid Valve Function
HORN	WW	Horn
HSEAT	SE	Heated Seat
I/C	AT	Input Clutch Solenoid Valve
I/CF	AT	Input Clutch Solenoid Valve Function
I/LOCK	AT	A/T Interlock
I/MIRR	GW	Inside Mirror (Auto Anti-Dazzling Mirror)
IATS	EC	Intake Air Temperature Sensor
IGNSYS	EC	Ignition System
ILL	LT	Illumination
INJECT	EC	Injector
INT/L	LT	Trunk Room Lamp
IVCB1	EC	Intake Valve Timing Control Solenoid Valve Bank 1
IVCB2	EC	Intake Valve Timing Control Solenoid Valve Bank 2
KEYLES	BL	Remote Keyless Entry System
KS	EC	Knock Sensor
LC/B	AT	Low Coast Brake Solenoid Valve
LC/BF	AT	Low Coast Brake Solenoid Valve Function
LPSV	AT	Line Pressure Solenoid Valve
MAFS	EC	Mass Air Flow Sensor
MAIN	EC	Main Power Supply and Ground Circuit
METER	DI	Speedometer, Tachometer, Temp., and Fuel Gauges
MIL	EC	Malfunction Indicator Lamp
MIL/DL	EC	Mil & Data Link Connectors
MIRROR	GW	Power Door Mirror
MMSW	AT	Manual Mode Switch
NATS	BL	Nissan Anti-Theft System
NAVI	AV	Navigation System
NONDTC	AT	Non-Detective Items
O2H1B1	EC	Heated Oxygen Sensor 1 Heater Bank 1
O2H1B2	EC	Heated Oxygen Sensor 1 Heater Bank 2

A
B
C
D
E
F
G
H
I
J
PG
L
M

HARNESSES

Code	Section	Wiring Diagram Name
O2H2B1	EC	Heated Oxygen Sensor 2 Heater Bank 1
O2H2B2	EC	Heated Oxygen Sensor 2 Heater Bank 2
O2S1B1	EC	Heated Oxygen Sensor 1 Bank 1
O2S1B2	EC	Heated Oxygen Sensor 1 Bank 2
O2S2B1	EC	Heated Oxygen Sensor 2 Bank 1
O2S2B2	EC	Heated Oxygen Sensor 2 Bank 2
P/SCKT	WW	Power Socket
PGC/V	EC	EVAP Canister Purge Volume Control Solenoid Valve
PHSB1	EC	Camshaft Position Sensor (PHASE) (Bank 1)
PHSB2	EC	Camshaft Position Sensor (PHASE) (Bank 2)
PNP/SW	AT	Park / Neutral Position Switch
PNP/SW	EC	Park / Neutral Position Switch
POS	EC	Crankshaft Position Sensor (CKPS) (POS)
POWER	AT	Transmission Control Module Power Supply
POWER	PG	Power Supply Routing
PRE/SE	EC	EVAP Control System Pressure Sensor
PS/SEN	EC	Power Steering Pressure Sensor
ROOM/L	LT	Interior Room Lamp
RP/SEN	EC	Refrigerant Pressure Sensor
S/SIG	EC	Start Signal
SEAT	SE	Power Seat
SEN/PW	EC	Sensor Power Supply
SHIFT	AT	A/T Shift Lock System
SROOF	RF	Sunroof
SRS	SRS	Supplemental Restraint System
START	SC	Starting System
STOP/L	LT	Stop Lamp
STSIG	AT	Start Signal Circuit
TAIL/L	LT	Parking, License and Tail Lamps
TCCSIG	AT	A/T Tcc S/V Function (Lock-Up)
TCV	AT	Torque Converter Clutch Solenoid Valve
TLID	BL	Trunk Lid Opener
TPS1	EC	Throttle Position Sensor (Sensor 1)
TPS2	EC	Throttle Position Sensor (Sensor 2)
TPS3	EC	Throttle Position Sensor
TRNSCV	BL	Homelink Universal Transceiver
TRSA/T	AT	Turbine Revolution Sensor
TURN	LT	Turn Signal and Hazard Warning Lamp
VDC	BRC	Vehicle Dynamics Control System
VEHSEC	BL	Vehicle Security System
VENT/V	EC	EVAP Canister Vent Control Valve
VSSA/T	AT	Vehicle Speed Sensor A/T (Revolution Sensor)
W/ANT	AV	Audio Antenna
WARN	DI	Warning Lamps

HARNESS

Code	Section	Wiring Diagram Name
WINDOW	GW	Power Window
WIPER	WW	Front Wiper and Washer

A

B

C

D

E

F

G

H

I

J

PG

L

M

ELECTRICAL UNITS LOCATION

ELECTRICAL UNITS LOCATION

PFP:25230

Electrical Units Location ENGINE COMPARTMENT

AKS0001E

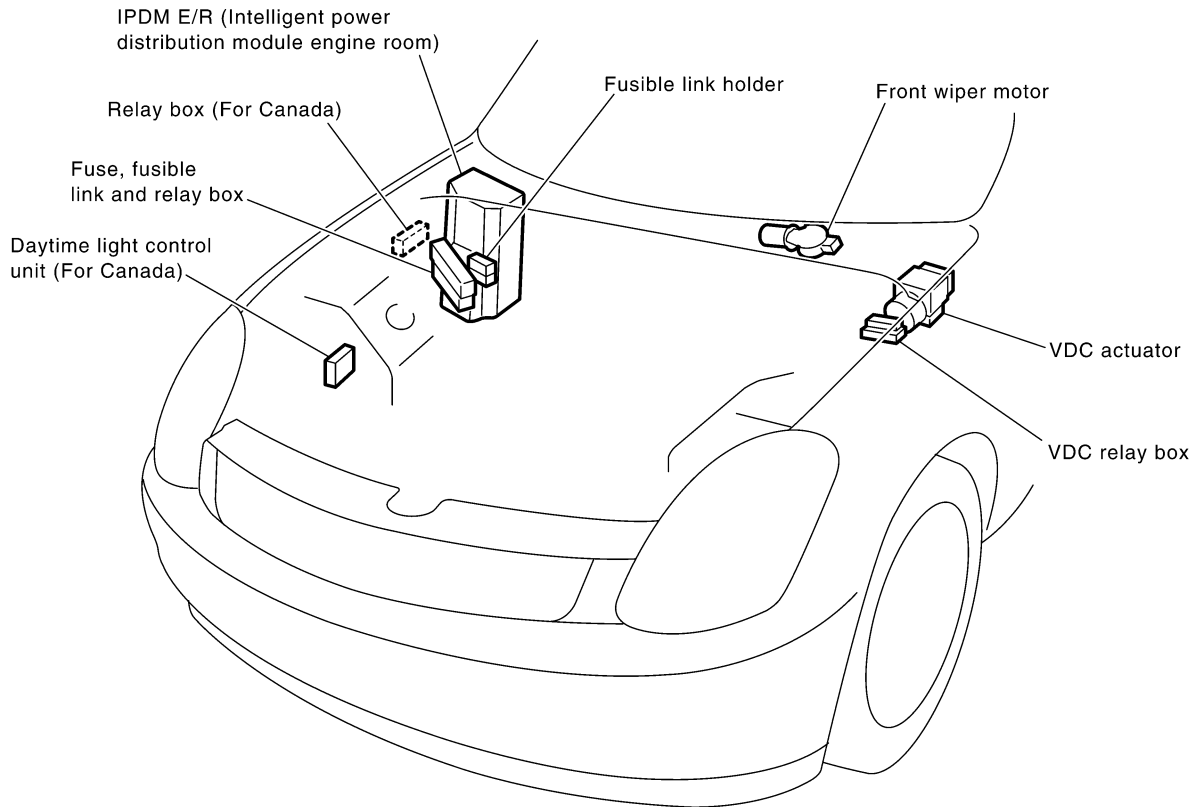

- Relay box **(E13)** (For Canada)
- Built-in daytime light relay-1 **(E14)** (For Canada)
- Built-in daytime light relay-2 **(E16)** (For Canada)

- IPDM E/R (Intelligent power distribution module engine room)
- (E3)**, **(E4)**, **(E5)**, **(E6)**,
- (E7)**, **(E8)**, **(E9)**

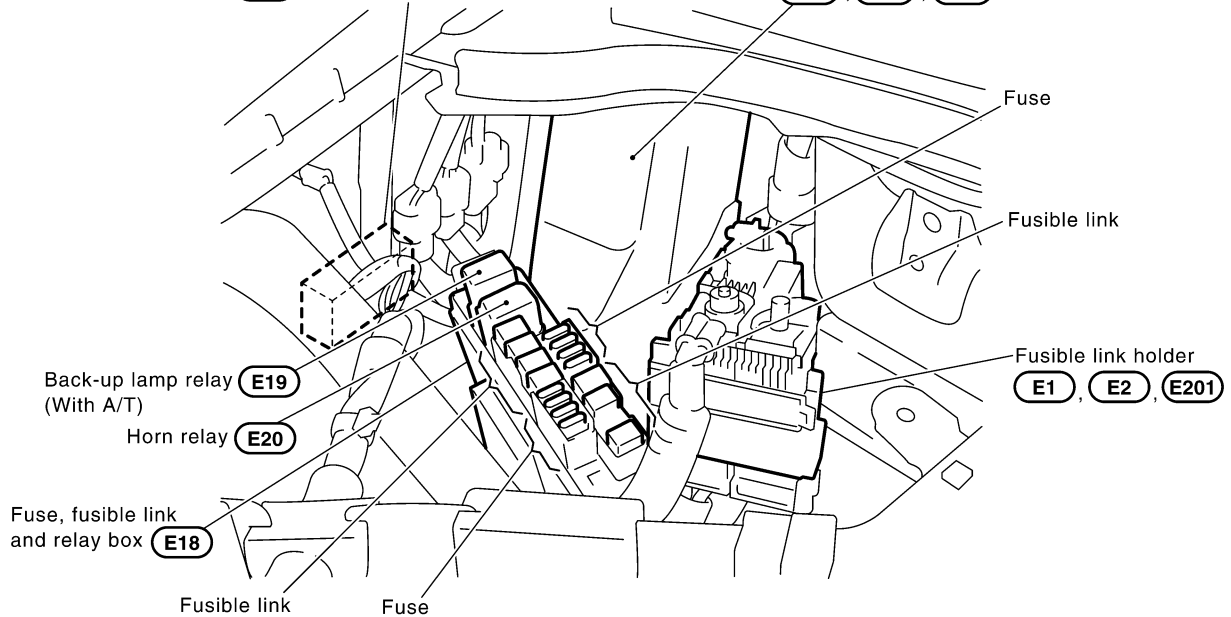

CKIT0315E

ELECTRICAL UNITS LOCATION

PASSENGER COMPARTMENT

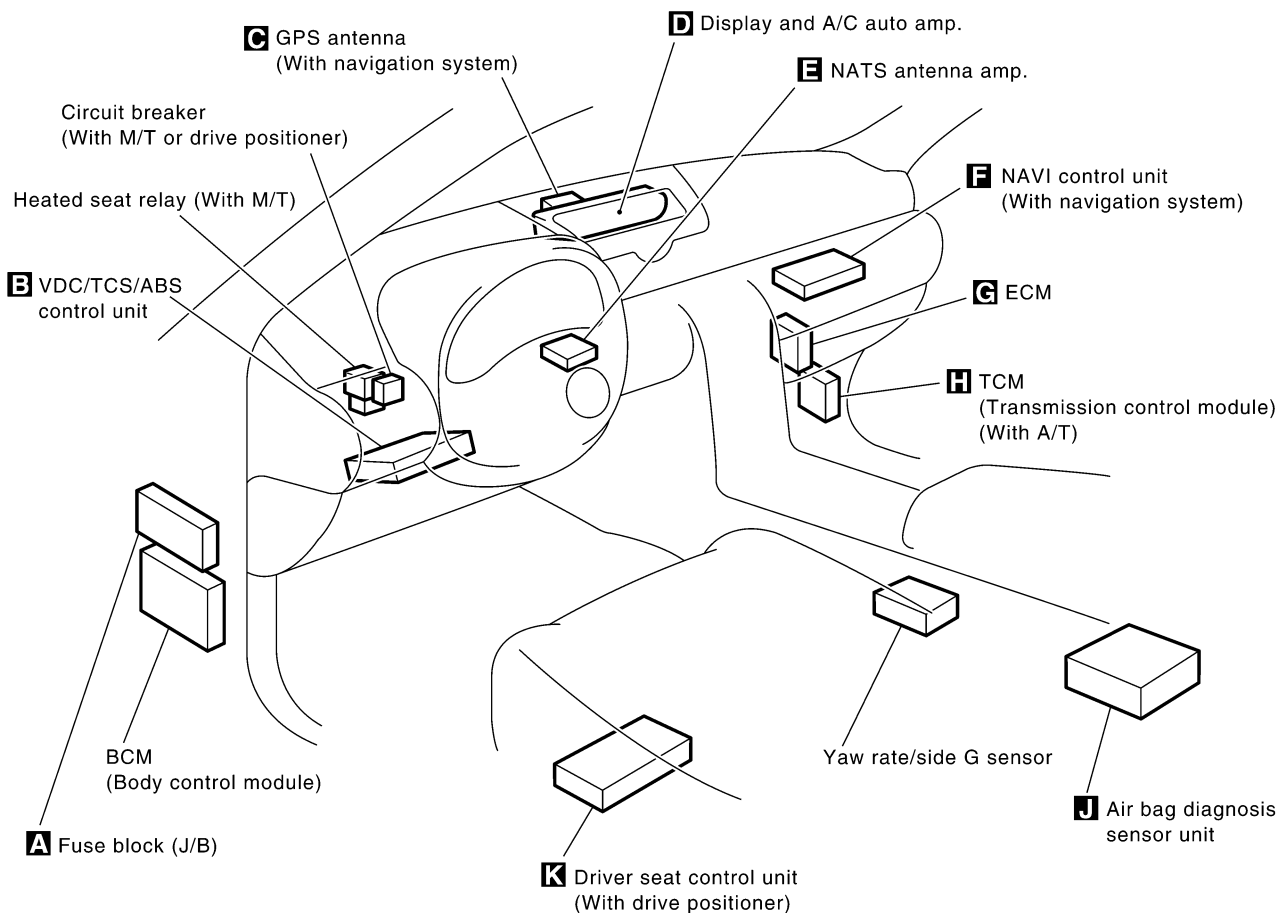

A Behind the dash side lower LH finisher

Fuse block (J/B) rear view

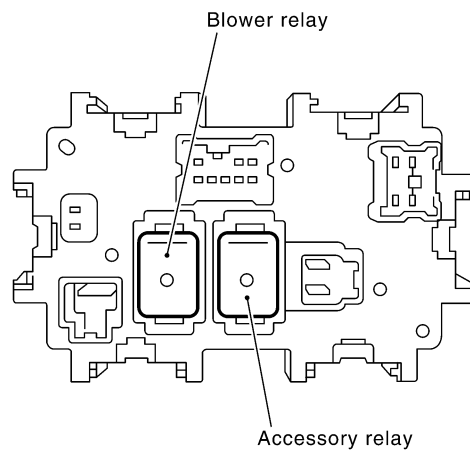
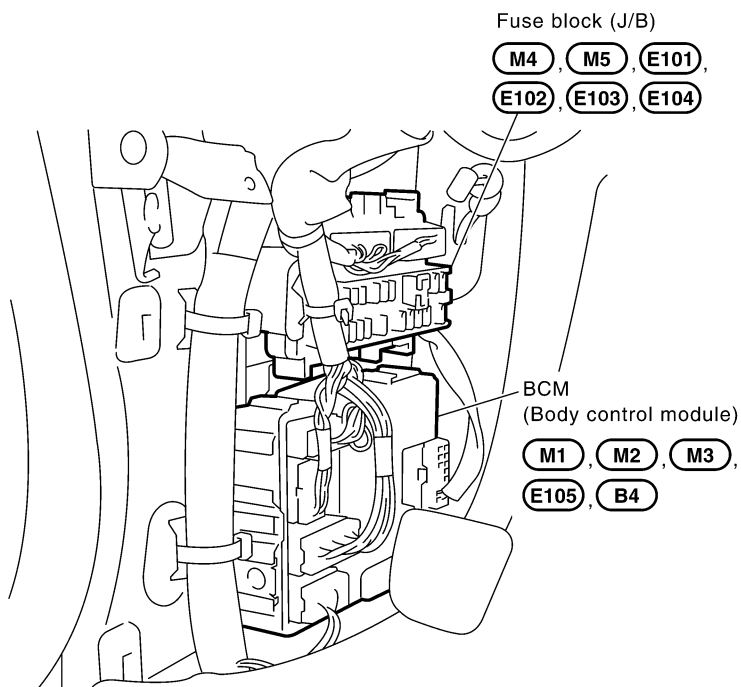

CKIT0316E

ELECTRICAL UNITS LOCATION

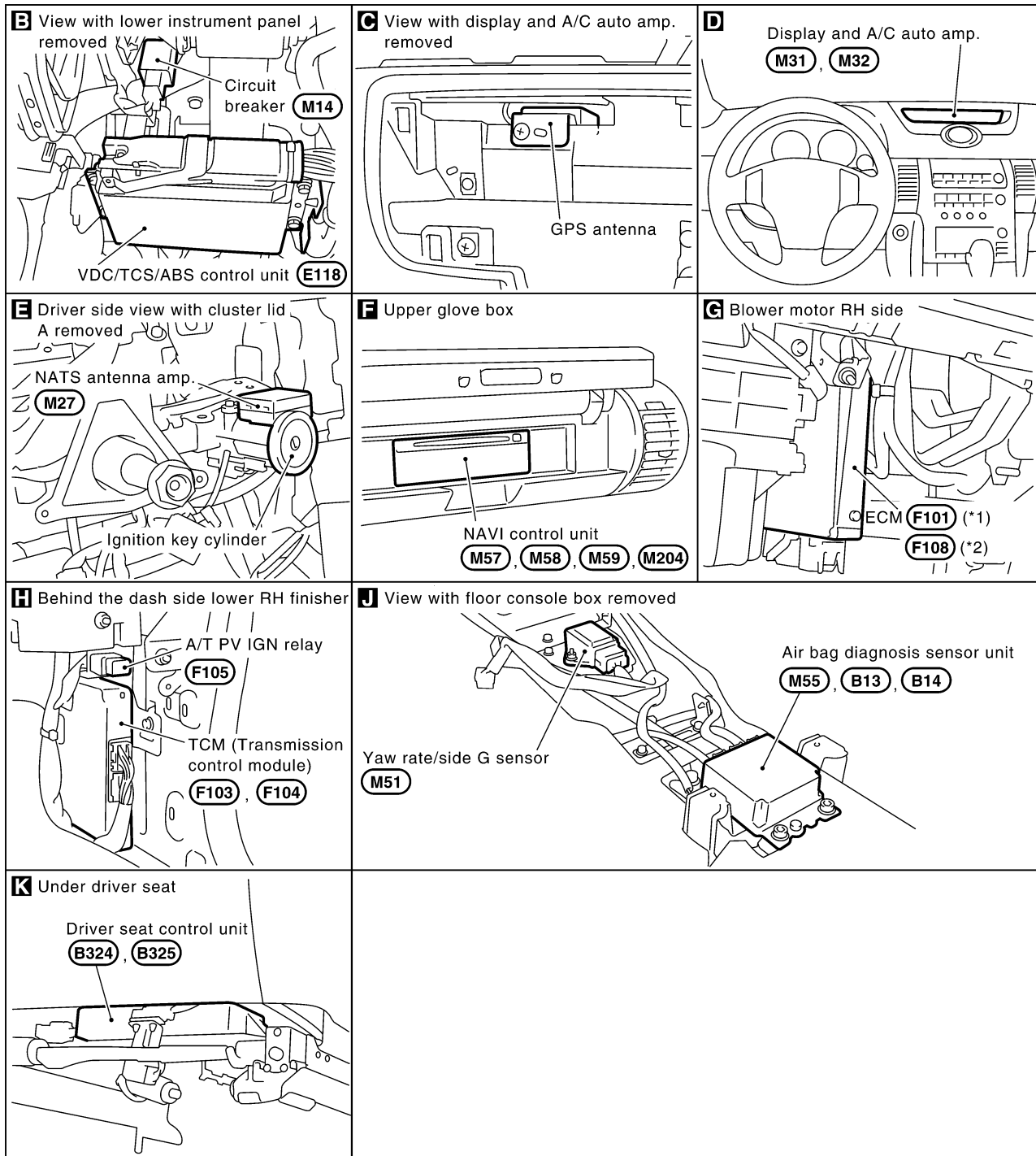

*1... With A/T (Up to serial 329287)

*2... With A/T (From serial 329288) and with M/T

(For further information, refer to "IDENTIFICATION NUMBER" in GI section.)

CKIT0341E

ELECTRICAL UNITS LOCATION

LUGGAGE COMPARTMENT

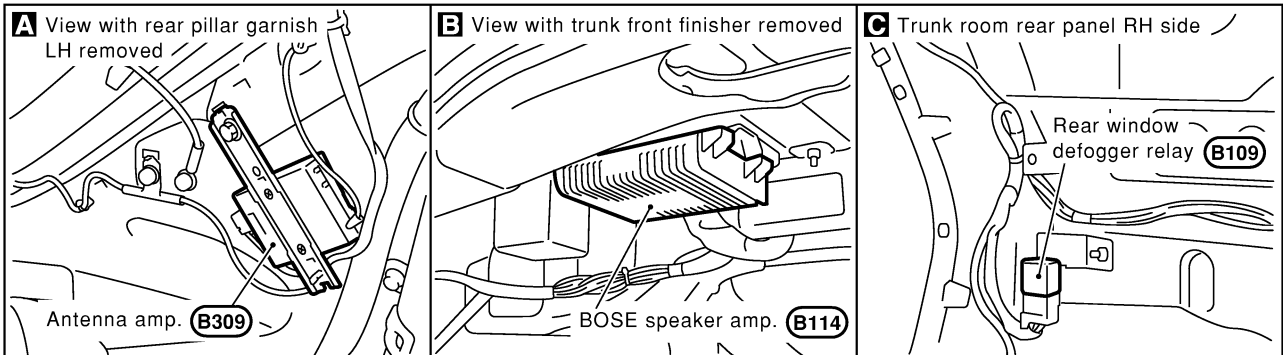
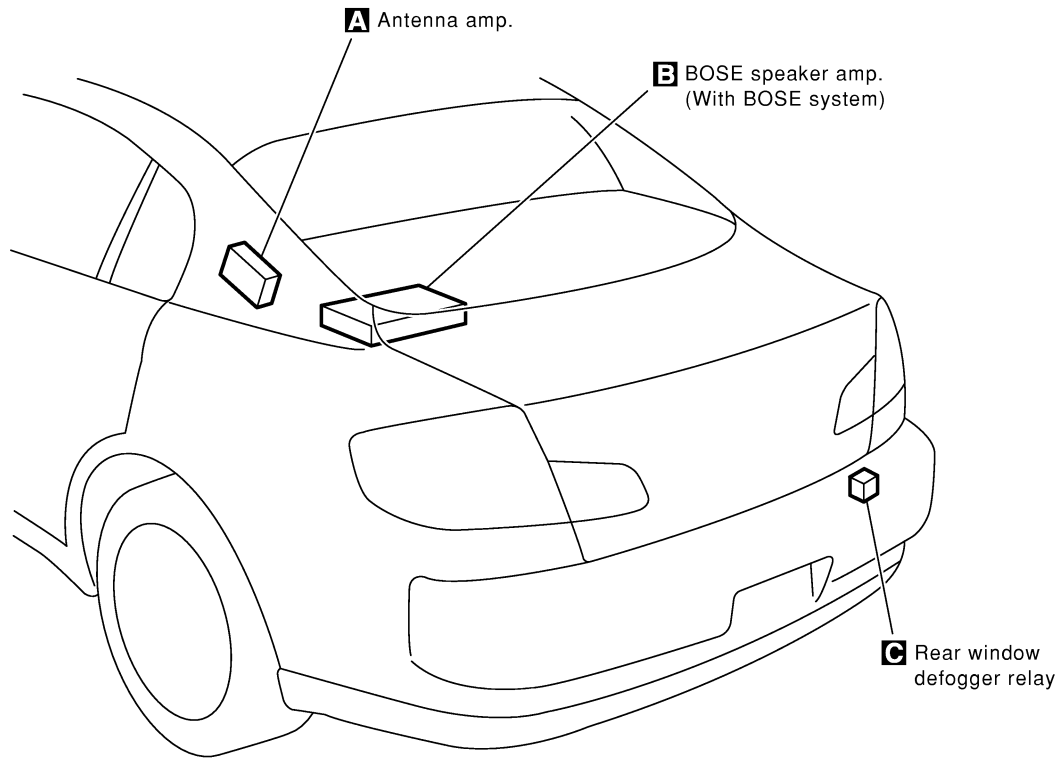

A
B
C
D
E
F
G
H
I
J
PG
L
M

CKIT0131E

HARNESS CONNECTOR

PFP:00011

HARNESS CONNECTOR

Description

HARNESS CONNECTOR (TAB-LOCKING TYPE)

AKS000IF

- The tab-locking type connectors help prevent accidental looseness or disconnection.
- The tab-locking type connectors are disconnected by pushing or lifting the locking tab(s). Refer to the illustration below.

Refer to the next page for description of the slide-locking type connector.

CAUTION:

Do not pull the harness or wires when disconnecting the connector.

[Example]

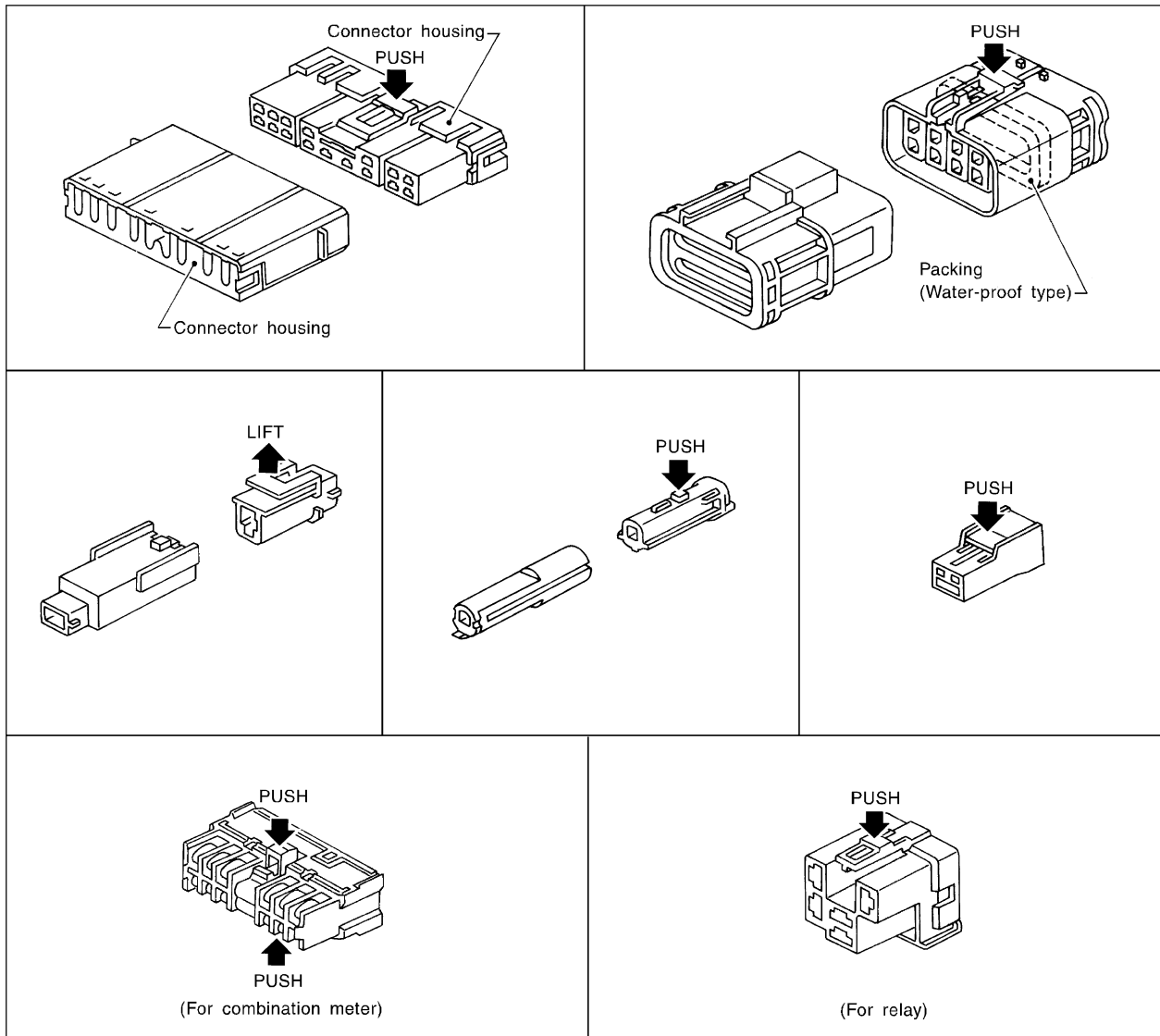

SEL769DA

HARNESS CONNECTOR

HARNESS CONNECTOR (SLIDE-LOCKING TYPE)

- A new style slide-locking type connector is used on certain systems and components, especially those related to OBD.
- The slide-locking type connectors help prevent incomplete locking and accidental looseness or disconnection.
- The slide-locking type connectors are disconnected by pushing or pulling the slider. Refer to the illustration below.

CAUTION:

- Do not pull the harness or wires when disconnecting the connector.
- Be careful not to damage the connector support bracket when disconnecting the connector.

[Example]

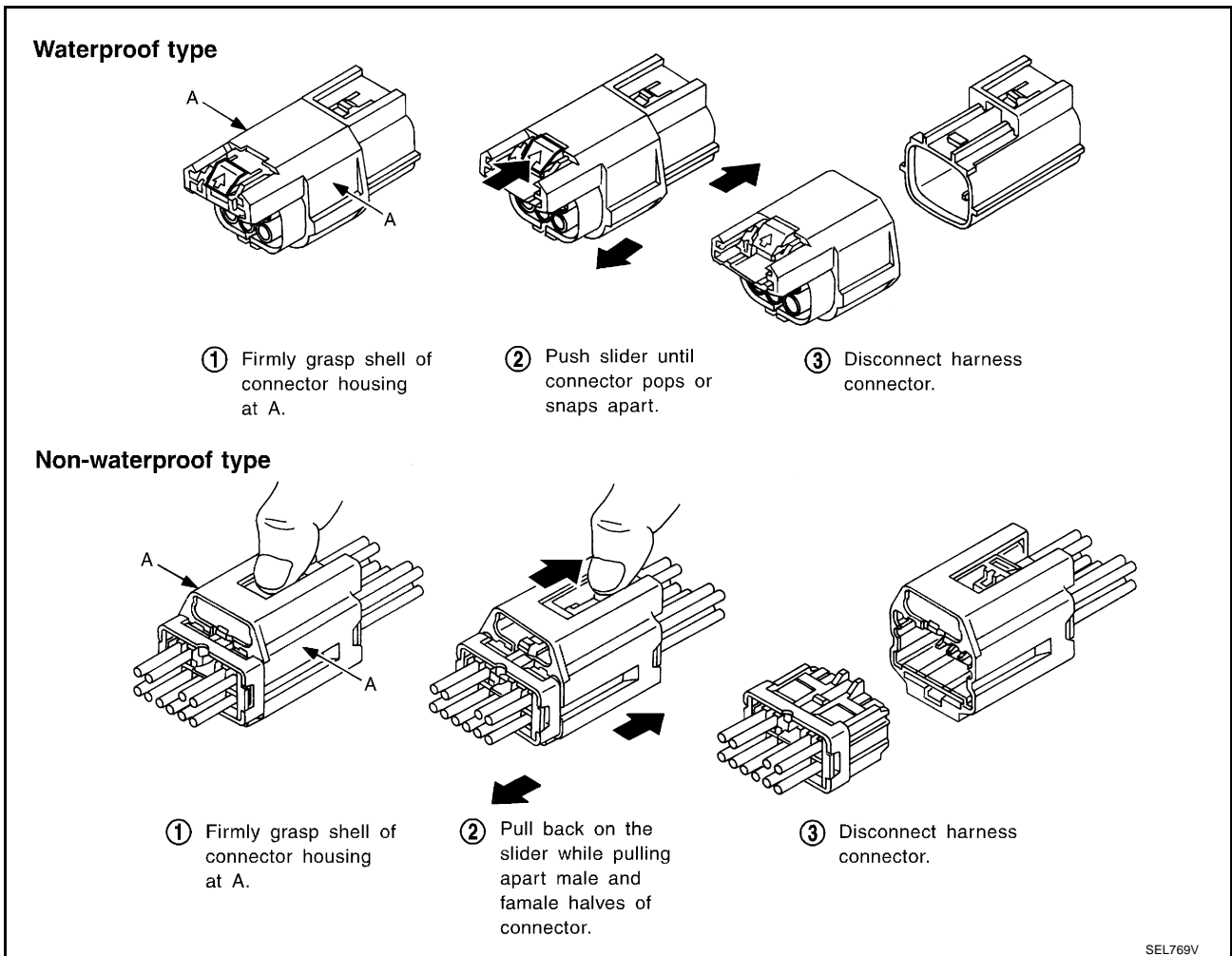

A
B
C
D
E
F
G
H
I
J
PG
L
M

JOINT CONNECTOR (J/C)

PFP:B4341

AKS000IG

JOINT CONNECTOR (J/C)

Terminal Arrangement

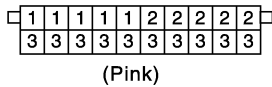
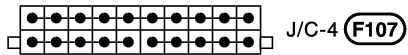
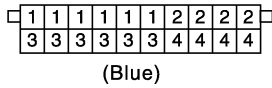
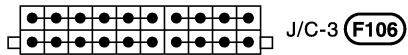
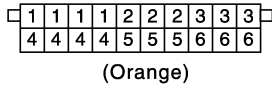
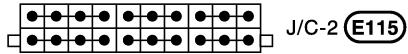
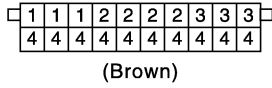
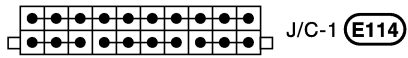

CKIT0154E

ELECTRICAL UNITS

BCM (BODY CONTROL MODULE)

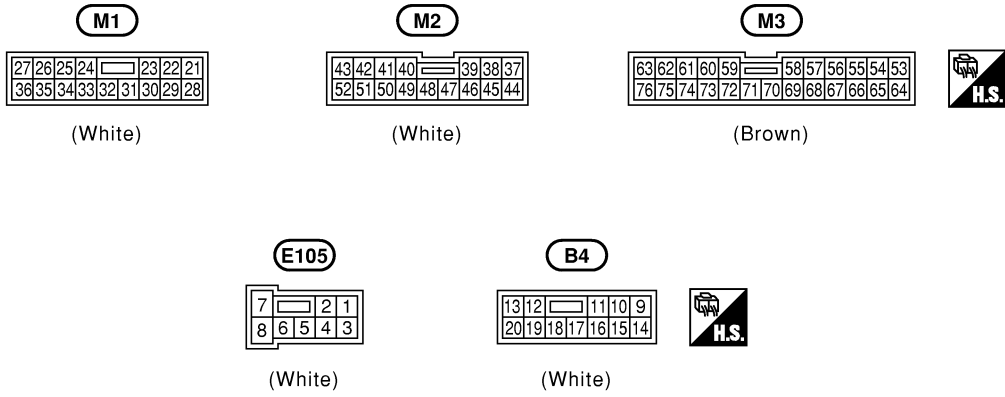

CKIT0156E

SMJ (SUPER MULTIPLE JUNCTION)

SMJ (SUPER MULTIPLE JUNCTION)

PFP:B4341

Terminal Arrangement

AKS000U

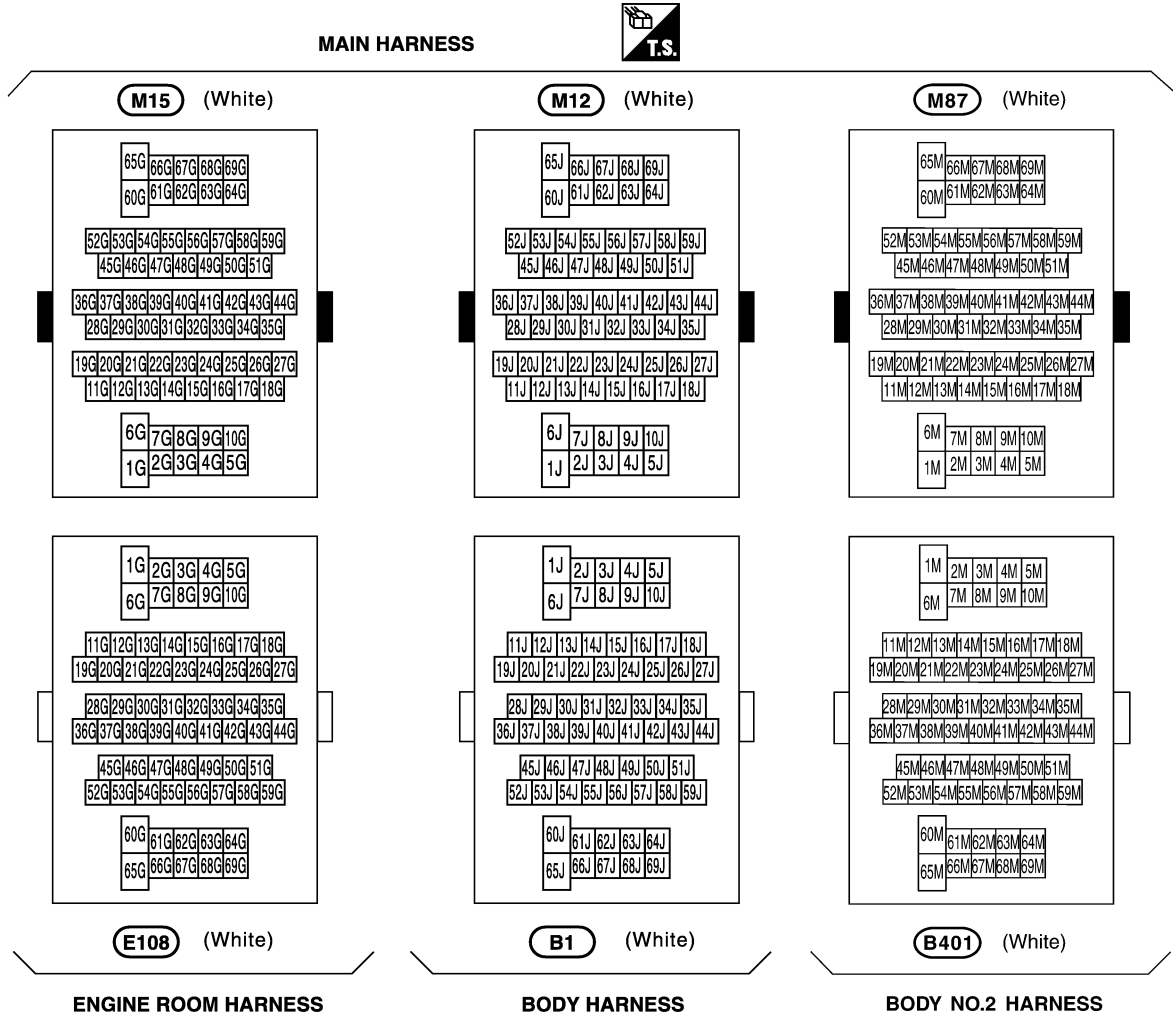

A

B

C

D

E

F

G

H

I

J

PG

L

M

CKIT0260E

SMJ (SUPER MULTIPLE JUNCTION)



MAIN HARNESS

M72 (White)

6H	7H	8H	9H	10H	21H	22H	23H	24H	25H	26H	27H	28H	29H	39H	40H	41H	42H	43H	44H	45H	46H		
1H	2H	3H	4H	5H	11H	12H	13H	14H	15H	16H	17H	18H	19H	20H	30H	31H	32H	33H	34H	35H	36H	37H	38H

1H	2H	3H	4H	5H	11H	12H	13H	14H	15H	16H	17H	18H	19H	20H	30H	31H	32H	33H	34H	35H	36H	37H	38H
6H	7H	8H	9H	10H	21H	22H	23H	24H	25H	26H	27H	28H	29H	39H	40H	41H	42H	43H	44H	45H	46H		

F102 (White)

ENGINE CONTROL HARNESS



MAIN HARNESS

M11 (White)

20K	21K	22K	23K	24K	25K	26K	27K	36K	37K	38K	39K		
11K	12K	13K	14K	15K	16K	17K	18K	19K	32K	33K	34K	35K	
1K	2K	3K	4K	5K	6K	7K	8K	9K	10K	28K	29K	30K	31K

M74 (White)

20L	21L	22L	23L	24L	25L	26L	27L	36L	37L	38L	39L		
11L	12L	13L	14L	15L	16L	17L	18L	19L	32L	33L	34L	35L	
1L	2L	3L	4L	5L	6L	7L	8L	9L	10L	28L	29L	30L	31L

1K	2K	3K	4K	5K	6K	7K	8K	9K	10K	28K	29K	30K	31K
11K	12K	13K	14K	15K	16K	17K	18K	19K	32K	33K	34K	35K	
20K	21K	22K	23K	24K	25K	26K	27K	36K	37K	38K	39K		

1L	2L	3L	4L	5L	6L	7L	8L	9L	10L	28L	29L	30L	31L
11L	12L	13L	14L	15L	16L	17L	18L	19L	32L	33L	34L	35L	
20L	21L	22L	23L	24L	25L	26L	27L	36L	37L	38L	39L		

D1 (White)

FRONT DOOR HARNESS (DRIVER SIDE)

D31 (White)

FRONT DOOR HARNESS (PASSENGER SIDE)

CKIT0158E

STANDARDIZED RELAY

PF0:00011

AKS000IK

STANDARDIZED RELAY

Description

NORMAL OPEN, NORMAL CLOSED AND MIXED TYPE RELAYS

Relays can mainly be divided into three types: normal open, normal closed and mixed type relays.

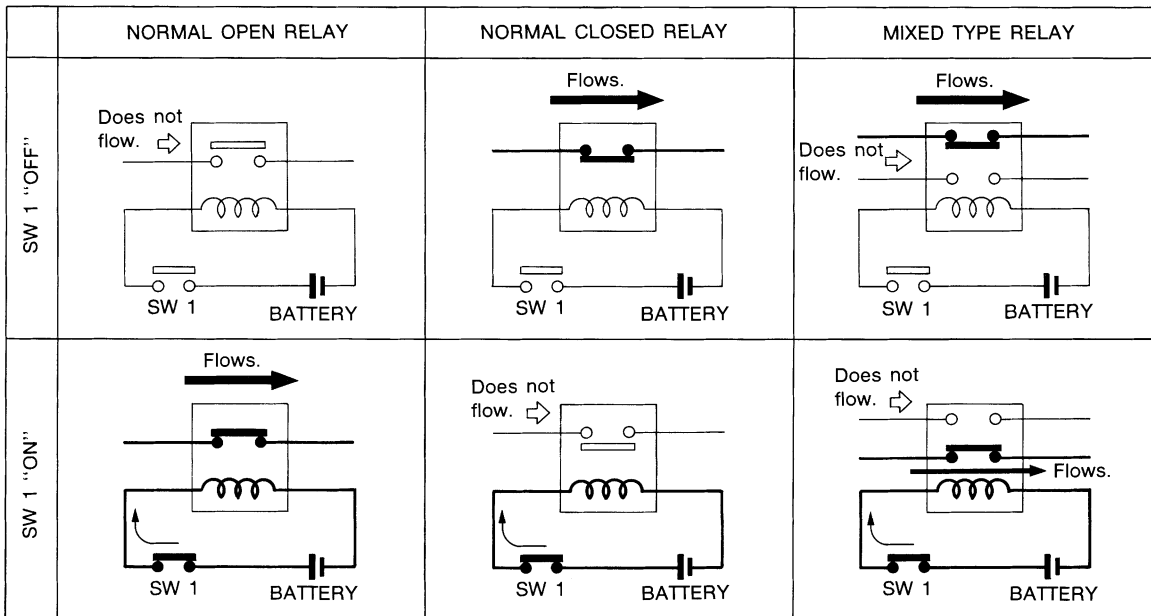

SEL881H

TYPE OF STANDARDIZED RELAYS

- 1M 1 Make 2M 2 Make
 1T 1 Transfer 1M·1B 1 Make 1 Break

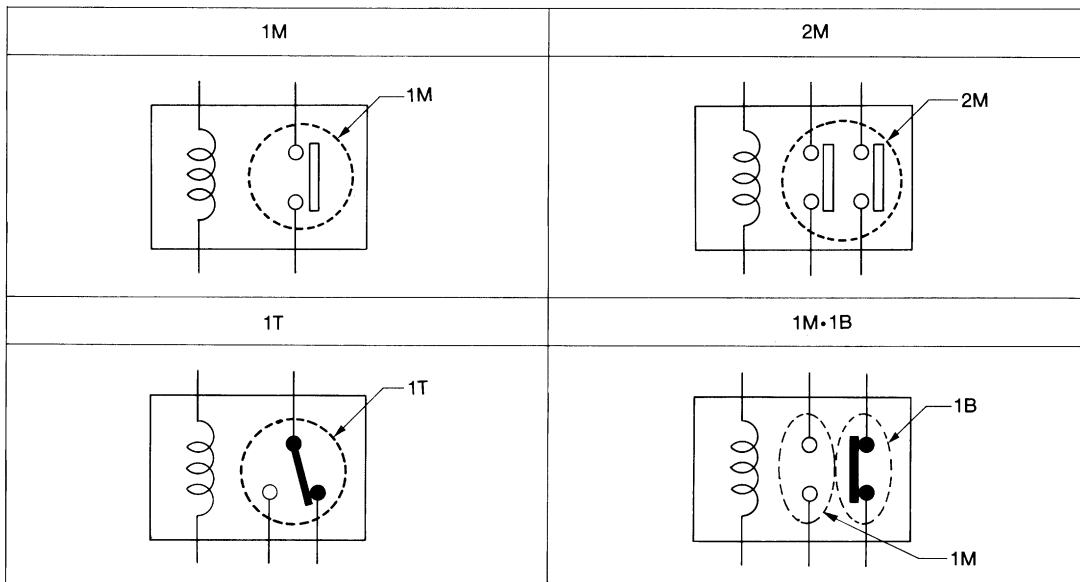

SEL882H

A
B
C
D
E
F
G
H
I
J
PG
L
M

STANDARDIZED RELAY

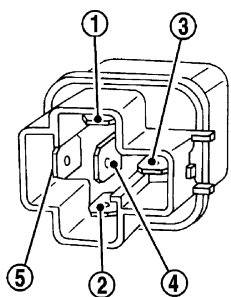
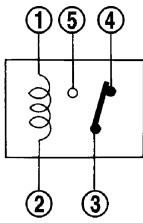
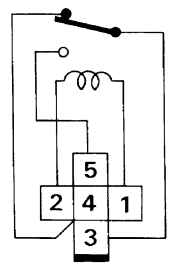
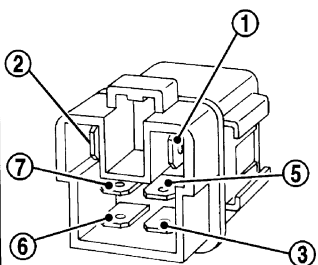
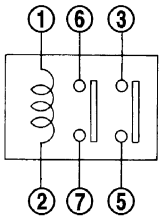
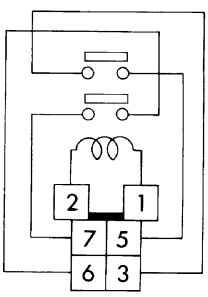
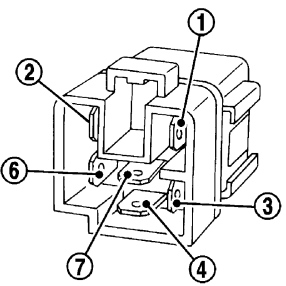
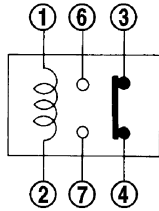
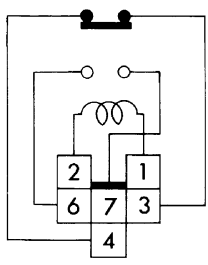
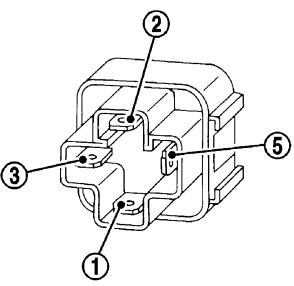
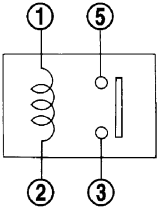
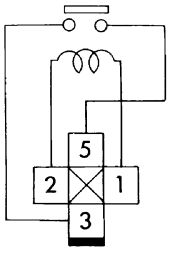
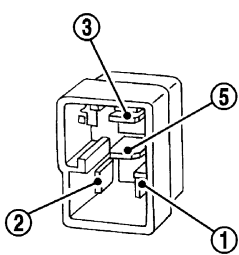
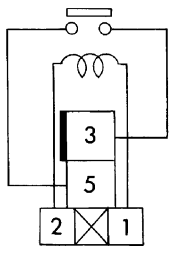
Type	Outer view	Circuit	Connector symbol and connection	Case color
1T				BLACK
2M				BROWN
1M•1B				GRAY
1M				BLUE
				

The arrangement of terminal numbers on the actual relays may differ from those shown above.

SEL188W

FUSE BLOCK - JUNCTION BOX (J/B)

FUSE BLOCK - JUNCTION BOX (J/B)

PPF:24350

Terminal Arrangement

AKS000D7

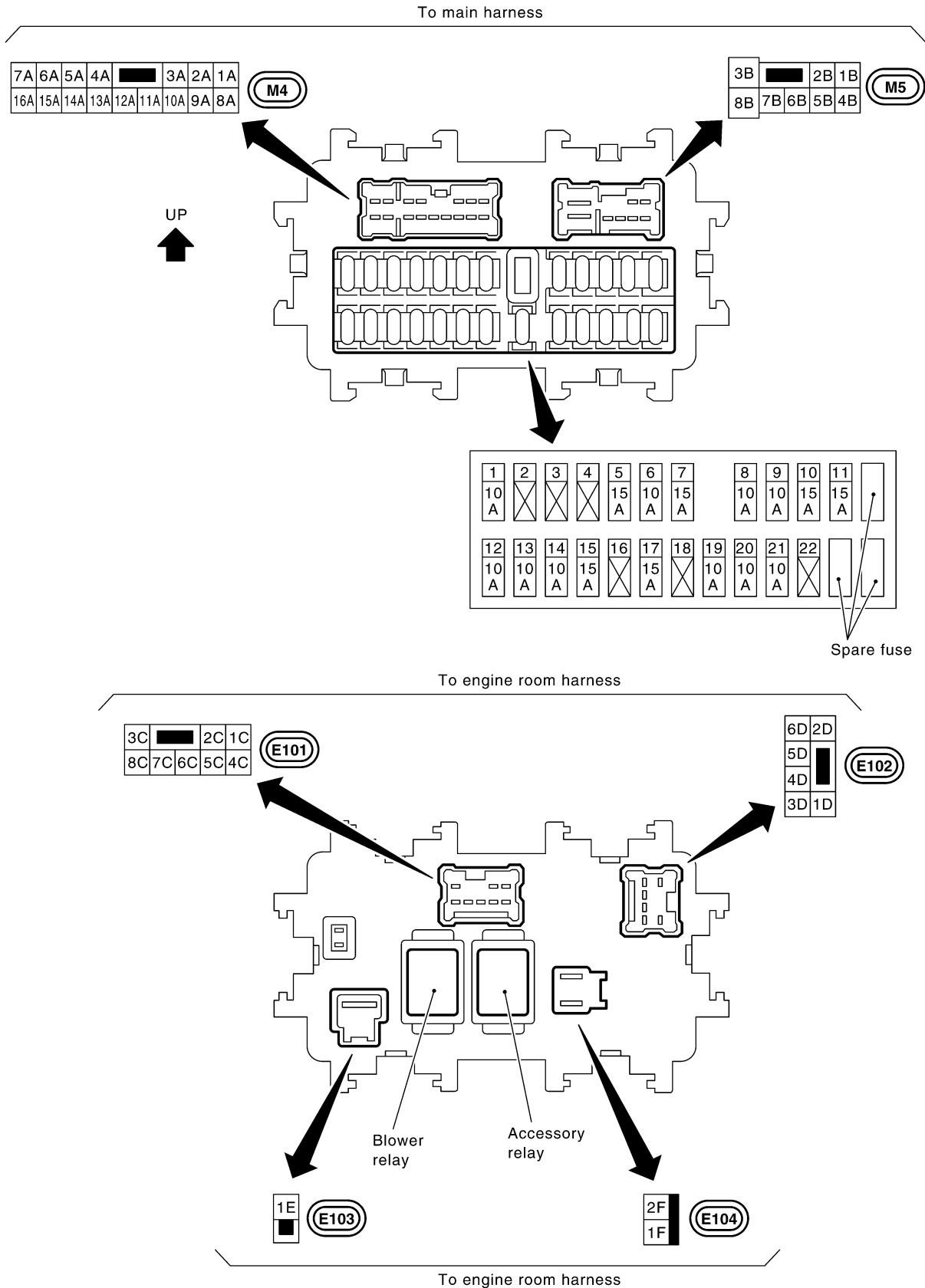

A
B
C
D
E
F
G
H
I
J
PG
L
M

FUSE, FUSIBLE LINK AND RELAY BOX

PFP:24382

FUSE, FUSIBLE LINK AND RELAY BOX

Terminal Arrangement

AKS000L

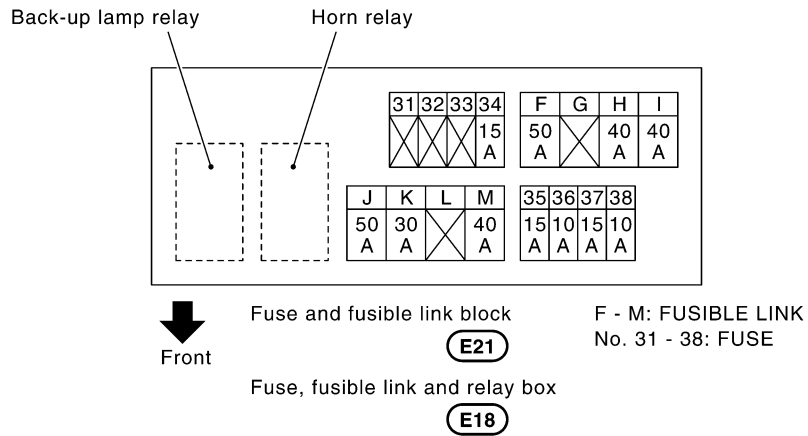
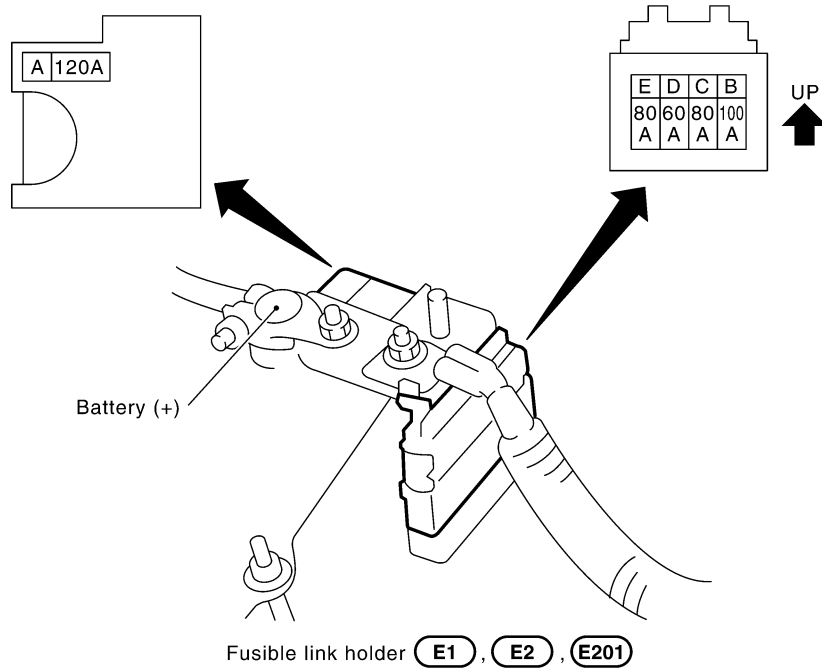

CKIT0302E