

A  
B  
C  
D  
E  
F  
G  
H  
I  
J  
K  
L  
M

# SECTION **BL**

## BODY, LOCK & SECURITY SYSTEM

### CONTENTS

<b>PRECAUTIONS</b> .....	<b>RADIATOR CORE SUPPORT</b> .....
Precautions for Supplemental Restraint System (SRS) "AIR BAG" and "SEAT BELT PRE-TENSIONER" .....	Removal and Installation .....
Precautions for Work .....	REMOVAL .....
Wiring Diagrams and Trouble Diagnosis .....	INSTALLATION .....
<b>PREPARATION</b> .....	<b>POWER DOOR LOCK SYSTEM</b> .....
Special Service Tools .....	Component Parts and Harness Connector Location..
Commercial Service Tools .....	System Description .....
<b>SQUEAK AND RATTLE TROUBLE DIAGNOSIS</b> .....	DOOR SWITCH OPERATION WITHOUT NAVIGATION SYSTEM .....
Work Flow .....	DOOR SWITCH OPERATION WITH NAVIGATION SYSTEM .....
CUSTOMER INTERVIEW .....	FUEL LID OPERATION .....
DUPLICATE THE NOISE AND TEST DRIVE .....	OUTLINE .....
CHECK RELATED SERVICE BULLETINS .....	CAN Communication System Description .....
LOCATE THE NOISE AND IDENTIFY THE ROOT CAUSE .....	CAN Communication Unit .....
REPAIR THE CAUSE .....	Schematic .....
CONFIRM THE REPAIR .....	Wiring Diagram -D/LOCK- .....
Generic Squeak and Rattle Troubleshooting .....	FIG. 1 .....
INSTRUMENT PANEL .....	FIG. 2 .....
CENTER CONSOLE .....	FIG. 3 .....
DOORS .....	FIG. 4 .....
TRUNK .....	Terminals and Reference Value of BCM .....
SUNROOF/HEADLINING .....	Terminals and Reference Value of Combination Meter (With Navigation System) .....
SEATS .....	Work Flow .....
UNDERHOOD .....	CONSULT-II Function .....
Diagnostic Worksheet .....	CONSULT-II INSPECTION PROCEDURE .....
<b>HOOD</b> .....	CONSULT-II APPLICATION ITEMS .....
Fitting Adjustment .....	Trouble Diagnosis Chart by Symptom .....
LONGITUDINAL AND LATERAL CLEARANCE ADJUSTMENT .....	Power Supply and Ground Circuit Check of BCM..
FRONT END HEIGHT ADJUSTMENT .....	Check Door Switch / With Navigation System .....
SURFACE HEIGHT ADJUSTMENT .....	Check Door Switch / Without Navigation System...
Removal and Installation of Hood Assembly .....	Check Key Switch .....
REMOVAL .....	Check Door Lock and Unlock Switch (With Anti-pinch System For All Door Window) .....
INSTALLATION .....	Check Door Lock and Unlock Switch (With Anti-pinch System for Front Door Window) .....
Removal and Installation of Hood Lock Control .....	Check Door Lock Actuator (Driver side) .....
REMOVAL .....	Check Door Lock Actuator (Passenger Side and Rear LH/RH) .....
INSTALLATION .....	
Hood Lock Control Inspection .....	

Check Fuel Lid Opener Actuator .....	47	INSTALLATION .....	85
Door Key Cylinder Switch Check .....	48	Disassembly and Assembly .....	85
<b>REMOTE KEYLESS ENTRY SYSTEM .....</b>	<b>51</b>	DISASSEMBLY .....	85
Component Parts and Harness Connector Location..	51	ASSEMBLY .....	86
System Description .....	52	<b>REAR DOOR LOCK .....</b>	<b>87</b>
INPUTS .....	52	Component Structure .....	87
OPERATED PROCEDURE .....	53	INSPECTION AND ADJUSTMENT .....	87
CAN Communication System Description .....	54	EXTERIOR HANDLE ROD ADJUSTMENT .....	87
CAN Communication Unit .....	54	Removal and Installation of Door Lock .....	88
Schematic .....	55	REMOVAL .....	88
Wiring Diagram —KEYLES— .....	56	INSTALLATION .....	88
FIG. 1 .....	56	Disassembly and Assembly .....	88
FIG. 2 .....	57	DISASSEMBLY .....	88
FIG. 3 .....	58	ASSEMBLY .....	89
FIG. 4 .....	59	<b>TRUNK LID .....</b>	<b>90</b>
Terminals and Reference Value for BCM .....	60	Fitting Adjustment .....	90
Terminals and Reference Value for IPDM E/R .....	61	LONGITUDINAL AND LATERAL CLEARANCE	
Terminals and Reference Value or Combination		ADJUSTMENT .....	90
Meter (With Navigation System) .....	61	SURFACE HEIGHT ADJUSTMENT .....	90
CONSULT-II Function .....	62	Removal and Installation of Trunk Lid Assembly ...	91
INSPECTION PROCEDURE .....	62	REMOVAL .....	91
CONSULT-II APPLICATION ITEMS .....	63	INSTALLATION .....	91
Work Flow .....	65	Removal and Installation of Trunk Lid Stay .....	91
Trouble Diagnosis Chart by Symptom .....	66	REMOVAL .....	91
Check Key Fob Battery and Function .....	68	INSTALLATION .....	92
Check ACC Switch .....	69	Removal and Installation of Trunk Lid Lock .....	92
Check Door Switch / With Navigation System .....	69	REMOVAL .....	92
Check Door Switch/Without Navigation System ....	71	INSTALLATION .....	92
Check Key Switch .....	73	Removal and Installation of Trunk Lid Striker .....	92
Check IPDM E/R Operation .....	74	REMOVAL .....	92
Check Hazard Function .....	75	INSTALLATION .....	92
Check Horn Function .....	75	Removal and Installation of Trunk lid Emergency	
Check Headlamp Function .....	75	Opener Cable .....	93
Check Map Lamp and Ignition Keyhole Illumination		REMOVAL .....	93
Function .....	75	INSTALLATION .....	93
ID Code Entry Procedure .....	76	Removal and Installation of Trunk Lid Weatherstrip..	94
KEY FOB ID SET UP WITH CONSULT-II .....	76	REMOVAL .....	94
KEY FOB ID SET UP WITHOUT CONSULT-II ...	78	INSTALLATION .....	94
Key Fob Battery Replacement .....	79	<b>TRUNK LID OPENER .....</b>	<b>95</b>
<b>DOOR .....</b>	<b>80</b>	Component Parts and Harness Connector Location..	95
Fitting Adjustment .....	80	System Description .....	95
FRONT DOOR .....	80	TRUNK LID OPENER OPERATION .....	96
REAR DOOR .....	80	Wiring Diagram —TLID— .....	97
STRIKER ADJUSTMENT .....	80	Terminals and Reference Value for BCM .....	98
Removal and Installation of Front Door .....	81	CONSULT-II Function .....	99
REMOVAL .....	81	BASIC OPERATION PROCEDURE .....	99
INSTALLATION .....	81	DATA MONITOR .....	100
Removal and Installation of Rear Door .....	81	ACTIVE TEST .....	100
REMOVAL .....	82	Trouble Diagnosis .....	101
INSTALLATION .....	82	TRUNK DOSE NOT OPEN WITH TRUNK LID	
Door Weatherstrip .....	83	OPENER SWITCH .....	101
REMOVAL .....	83	TRUNK DOSE NOT CLOSE .....	104
INSTALLATION .....	83	<b>VEHICLE SECURITY (THEFT WARNING) SYSTEM 106</b>	
<b>FRONT DOOR LOCK .....</b>	<b>84</b>	Component Parts and Harness Connector Location	106
Component Structure .....	84	System Description .....	107
Inspection and Adjustment .....	84	DESCRIPTION .....	107
EXTERIOR HANDLE ROD ADJUSTMENT .....	84	POWER SUPPLY AND GROUND CIRCUIT ....	108
Removal and Installation .....	84	INITIAL CONDITION TO ACTIVATE THE SYS-	
REMOVAL .....	84	TEM / WITH NAVIGATION SYSTEM .....	108

VEHICLE SECURITY SYSTEM ALARM OPERATION .....	109	Diagnostic Procedure 1 .....	145	
VEHICLE SECURITY SYSTEM DEACTIVATION .....	109	Diagnostic Procedure 2 .....	147	A
PANIC ALARM OPERATION .....	109	Diagnostic Procedure 3 .....	147	
CAN Communication System Description .....	110	Diagnostic Procedure 4 .....	149	B
CAN Communication Unit .....	110	Diagnostic Procedure 5 .....	150	
Schematic .....	111	Diagnostic Procedure 6 .....	152	
Wiring Diagram —VEHSEC— .....	112	How to Replace NATS Antenna Amp. ....	153	
Terminals and Reference Value of BCM .....	117	<b>INTEGRATED HOMELINK TRANSMITTER .....</b>	<b>154</b>	C
Terminals and Reference Value of IPDM E/R .....	118	Wiring Diagram —TRNSCV— .....	154	
Terminals and Reference Value of Combination Meter .....	118	Trouble Diagnoses .....	155	
CONSULT-II Inspection Procedure .....	119	DIAGNOSTIC PROCEDURE .....	155	D
CONSULT-II APPLICATION ITEM .....	120	<b>BODY REPAIR .....</b>	<b>157</b>	
Trouble Diagnosis .....	121	Body Exterior Paint Color .....	157	
WORK FLOW .....	121	Body Component Parts .....	158	E
Preliminary Check .....	122	UNDERBODY COMPONENT PARTS .....	158	
Trouble Diagnosis Symptom Chart .....	123	BODY COMPONENT PARTS .....	160	
Diagnostic Procedure 1 .....	124	Corrosion Protection .....	162	
1 – 1 DOOR SWITCH CHECK / WITH NAVIGATION SYSTEM .....	124	DESCRIPTION .....	162	F
1 – 2 DOOR SWITCH CHECK / WITHOUT NAVIGATION SYSTEM .....	126	ANTI-CORROSIVE WAX .....	163	
1 – 3 HOOD SWITCH CHECK .....	128	UNDERCOATING .....	164	
1 – 4 TRUNK ROOM LAMP SWITCH CHECK .....	130	STONE GUARD COAT .....	165	G
Diagnostic Procedure 2 .....	131	Body Sealing .....	166	
SECURITY INDICATOR LAMP CHECK .....	131	DESCRIPTION .....	166	
Diagnostic Procedure 3 .....	133	Body Construction .....	169	
FRONT DOOR KEY CYLINDER SWITCH CHECK .....	133	BODY CONSTRUCTION .....	169	H
Diagnostic Procedure 4 .....	133	Body Alignment .....	170	
VEHICLE SECURITY HORN ALARM CHECK .....	133	BODY CENTER MARKS .....	170	
Diagnostic Procedure 5 .....	134	PANEL PARTS MATCHING MARKS .....	171	BL
VEHICLE SECURITY HEADLAMP ALARM CHECK .....	134	DESCRIPTION .....	172	
Diagnostic Procedure 6 .....	134	ENGINE COMPARTMENT .....	173	
DOOR LOCK AND UNLOCK SWITCH CHECK .....	134	UNDERBODY (2WD MODELS) .....	175	J
<b>IVIS (INFINITI VEHICLE IMMOBILIZER SYSTEM-NATS) .....</b>	<b>135</b>	UNDERBODY (AWD MODELS) .....	177	
Component Parts and Harness Connector Location .....	135	PASSENGER COMPARTMENT .....	179	
System Description .....	136	REAR BODY .....	181	
System Composition .....	137	Handling Precautions For Plastics .....	183	K
ECM Re-communicating Function .....	137	HANDLING PRECAUTIONS FOR PLASTICS .....	183	
Wiring Diagram — NATS — .....	138	LOCATION OF PLASTIC PARTS .....	184	
Terminals and Reference Value for BCM .....	139	Precautions In Repairing High Strength Steel .....	186	L
CONSULT-II .....	139	HIGH STRENGTH STEEL (HSS) USED IN NISSAN VEHICLES .....	186	
CONSULT-II INSPECTION PROCEDURE .....	139	Replacement Operations .....	189	M
CONSULT-II DIAGNOSTIC TEST MODE FUNCTION .....	140	DESCRIPTION .....	189	
HOW TO READ SELF-DIAGNOSTIC RESULTS .....	141	HOODLEGE .....	192	
IVIS (NATS) SELF-DIAGNOSTIC RESULTS ITEM CHART .....	141	FRONT SIDE MEMBER (2WD MODELS) .....	193	
Work Flow .....	142	FRONT SIDE MEMBER (AWD MODELS) .....	194	
Trouble Diagnoses .....	143	FRONT SIDE MEMBER (PARTIAL REPLACEMENT) (2WD MODELS) .....	195	
SYMPTOM MATRIX CHART 1 .....	143	FRONT SIDE MEMBER (PARTIAL REPLACEMENT) (AWD MODELS) .....	196	
SYMPTOM MATRIX CHART 2 .....	144	FRONT PILLAR .....	197	
DIAGNOSTIC SYSTEM DIAGRAM .....	144	CENTER PILLAR .....	198	
		OUTER SILL .....	199	
		OUTER SILL (CONT'D) .....	200	
		REAR FENDER .....	201	
		REAR PANEL .....	202	
		REAR FLOOR REAR .....	203	
		REAR SIDE MEMBER EXTENSION .....	204	

# PRECAUTIONS

## PRECAUTIONS

PFP:00001

### Precautions for Supplemental Restraint System (SRS) “AIR BAG” and “SEAT BELT PRE-TENSIONER”

AIS000AS

The Supplemental Restraint System such as “AIR BAG” and “SEAT BELT PRE-TENSIONER”, used along with a front seat belt, helps to reduce the risk or severity of injury to the driver and front passenger for certain types of collision. This system includes seat belt switch inputs and dual stage front air bag modules. The SRS system uses the seat belt switches to determine the front air bag deployment, and may only deploy one front air bag, depending on the severity of a collision and whether the front occupants are belted or unbelted. Information necessary to service the system safely is included in the SRS and SB section of this Service Manual.

#### **WARNING:**

- To avoid rendering the SRS inoperative, which could increase the risk of personal injury or death in the event of a collision which would result in air bag inflation, all maintenance must be performed by an authorized NISSAN/INFINITI dealer.
- Improper maintenance, including incorrect removal and installation of the SRS, can lead to personal injury caused by unintentional activation of the system. For removal of Spiral Cable and Air Bag Module, see the SRS section.
- Do not use electrical test equipment on any circuit related to the SRS unless instructed to in this Service Manual. SRS wiring harnesses can be identified by yellow and/or orange harnesses or harness connectors.

### Precautions for Work

AIS0000M

- After removing and installing the opening/closing parts, be sure to carry out fitting adjustments to check their operation.
- Check the lubrication level, damage, and wear of each part. If necessary, grease or replace it.

### Wiring Diagrams and Trouble Diagnosis

AIS0000N

When you read wiring diagrams, refer to the following:

- [GI-14, "How to Read Wiring Diagrams"](#)
- [PG-3, "POWER SUPPLY ROUTING CIRCUIT"](#)

When you perform trouble diagnosis, refer to the following:

- [GI-10, "HOW TO FOLLOW TEST GROUPS IN TROUBLE DIAGNOSES"](#)
- [GI-26, "How to Perform Efficient Diagnosis for an Electrical Incident"](#)  
Check for any Service bulletins before servicing the vehicle.



# PREPARATION

## PREPARATION

PFP:00002

### Special Service Tools

AIS005AQ

The actual shapes of Kent-Moore tools may differ from those of special service tools illustrated here.

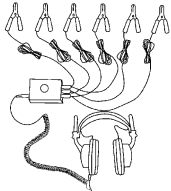
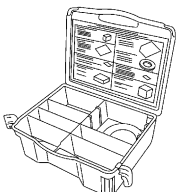
Tool number (Kent-Moore No.) Tool name	Description
(J-39570) Chassis ear   SIIA0993E	Locating the noise
(J-43980) NISSAN Squeak and Rattle Kit   SIIA0994E	Repairing the cause of noise

### Commercial Service Tools

AIS005AR

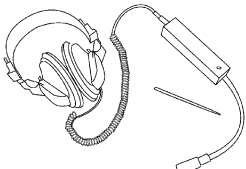
Tool name	Description
Engine ear   SIIA0995E	Locating the noise

A  
B  
C  
D  
E  
F  
G  
H  
BL  
J  
K  
L  
M

BL

# SQUEAK AND RATTLE TROUBLE DIAGNOSIS

## SQUEAK AND RATTLE TROUBLE DIAGNOSIS

PFP:00000

### Work Flow

AIS005AS

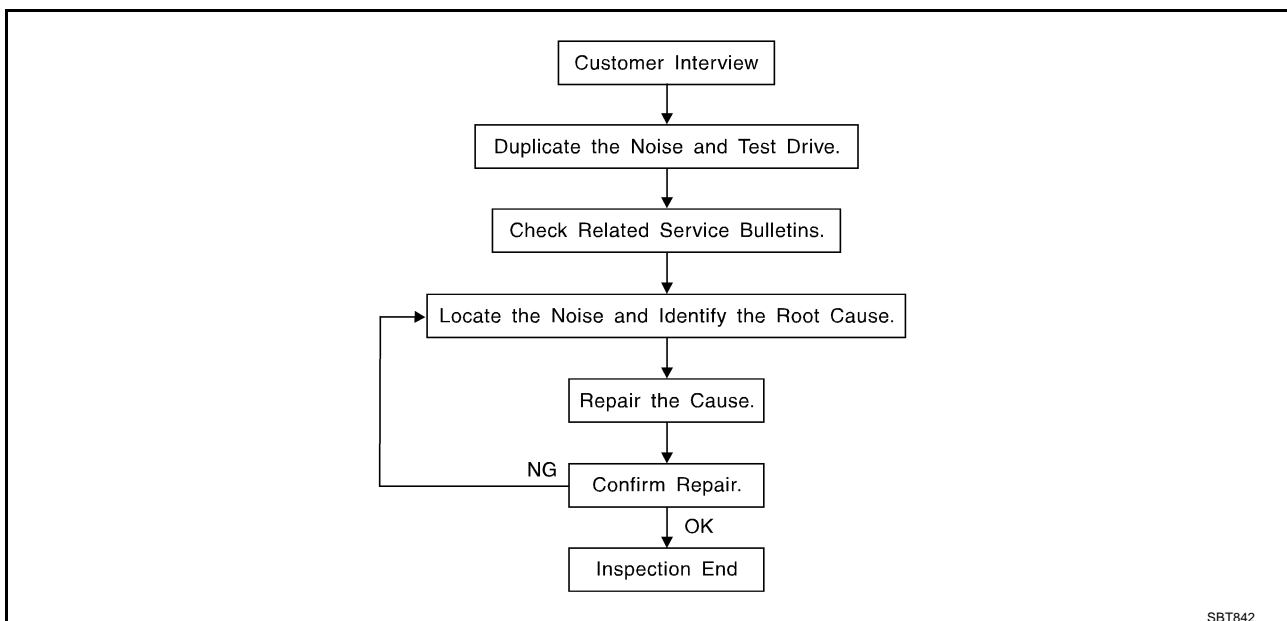

### CUSTOMER INTERVIEW

Interview the customer if possible, to determine the conditions that exist when the noise occurs. Use the Diagnostic Worksheet during the interview to document the facts and conditions when the noise occurs and any customer's comments; refer to [BL-10, "Diagnostic Worksheet"](#). This information is necessary to duplicate the conditions that exist when the noise occurs.

- The customer may not be able to provide a detailed description or the location of the noise. Attempt to obtain all the facts and conditions that exist when the noise occurs (or does not occur).
- If there is more than one noise in the vehicle, be sure to diagnose and repair the noise that the customer is concerned about. This can be accomplished by test driving the vehicle with the customer.
- After identifying the type of noise, isolate the noise in terms of its characteristics. The noise characteristics are provided so the customer, service adviser and technician are all speaking the same language when defining the noise.
- Squeak —(Like tennis shoes on a clean floor)  
Squeak characteristics include the light contact/fast movement/brought on by road conditions/hard surfaces=higher pitch noise/softer surfaces=lower pitch noises/edge to surface=chirping
- Creak—(Like walking on an old wooden floor)  
Creak characteristics include firm contact/slow movement/twisting with a rotational movement/pitch dependent on materials/often brought on by activity.
- Rattle—(Like shaking a baby rattle)  
Rattle characteristics include the fast repeated contact/vibration or similar movement/loose parts/missing clip or fastener/incorrect clearance.
- Knock —(Like a knock on a door)  
Knock characteristics include hollow sounding/sometimes repeating/often brought on by driver action.
- Tick—(Like a clock second hand)  
Tick characteristics include gentle contacting of light materials/loose components/can be caused by driver action or road conditions.
- Thump—(Heavy, muffled knock noise)  
Thump characteristics include softer knock/dead sound often brought on by activity.
- Buzz—(Like a bumble bee)  
Buzz characteristics include high frequency rattle/firm contact.
- Often the degree of acceptable noise level will vary depending upon the person. A noise that you may judge as acceptable may be very irritating to the customer.
- Weather conditions, especially humidity and temperature, may have a great effect on noise level.

# SQUEAK AND RATTLE TROUBLE DIAGNOSIS

## DUPLICATE THE NOISE AND TEST DRIVE

If possible, drive the vehicle with the customer until the noise is duplicated. Note any additional information on the Diagnostic Worksheet regarding the conditions or location of the noise. This information can be used to duplicate the same conditions when you confirm the repair.

If the noise can be duplicated easily during the test drive, to help identify the source of the noise, try to duplicate the noise with the vehicle stopped by doing one or all of the following:

- 1) Close a door.
  - 2) Tap or push/pull around the area where the noise appears to be coming from.
  - 3) Rev the engine.
  - 4) Use a floor jack to recreate vehicle "twist".
  - 5) At idle, apply engine load (electrical load, half-clutch on M/T model, drive position on A/T model).
  - 6) Raise the vehicle on a hoist and hit a tire with a rubber hammer.
- Drive the vehicle and attempt to duplicate the conditions the customer states exist when the noise occurs.
  - If it is difficult to duplicate the noise, drive the vehicle slowly on an undulating or rough road to stress the vehicle body.

## CHECK RELATED SERVICE BULLETINS

After verifying the customer concern or symptom, check ASIST for Technical Service Bulletins (TSBs) related to that concern or symptom.

If a TSB relates to the symptom, follow the procedure to repair the noise.

## LOCATE THE NOISE AND IDENTIFY THE ROOT CAUSE

1. Narrow down the noise to a general area. To help pinpoint the source of the noise, use a listening tool (Chassis Ear: J-39570, Engine Ear and mechanics stethoscope).
2. Narrow down the noise to a more specific area and identify the cause of the noise by:
  - removing the components in the area that you suspect the noise is coming from.  
Do not use too much force when removing clips and fasteners, otherwise clips and fastener can be broken or lost during the repair, resulting in the creation of new noise.
  - tapping or pushing/pulling the component that you suspect is causing the noise.  
Do not tap or push/pull the component with excessive force, otherwise the noise will be eliminated only temporarily.
  - feeling for a vibration with your hand by touching the component(s) that you suspect is (are) causing the noise.
  - placing a piece of paper between components that you suspect are causing the noise.
  - looking for loose components and contact marks.  
Refer to [BL-8, "Generic Squeak and Rattle Troubleshooting"](#) .

## REPAIR THE CAUSE

- If the cause is a loose component, tighten the component securely.
- If the cause is insufficient clearance between components:
  - separate components by repositioning or loosening and retightening the component, if possible.
  - insulate components with a suitable insulator such as urethane pads, foam blocks, felt cloth tape or urethane tape. A Nissan Squeak and Rattle Kit (J-43980) is available through your authorized Nissan Parts Department.

### CAUTION:

**Do not use excessive force as many components are constructed of plastic and may be damaged.**

**Always check with the Parts Department for the latest parts information.**

**The following materials are contained in the Nissan Squeak and Rattle Kit (J-43980). Each item can be ordered separately as needed.**

**URETHANE PADS [1.5 mm (0.059 in) thick]**

**Insulates connectors, harness, etc.**

**76268-9E005: 100 × 135 mm (3.94 × 5.31 in)/76884-71L01: 60 × 85 mm (2.36 × 3.35 in)/76884-71L02: 15 × 25 mm (0.59 × 0.98 in)**

**INSULATOR (Foam blocks)**

**Insulates components from contact.Can be used to fill space behind a panel.**

**73982-9E000: 45 mm (1.77 in) thick, 50 × 50 mm (1.97 × 1.97 in)/73982-50Y00: 10 mm (0.39 in) thick, 50 × 50 mm (1.97 × 1.97 in)**

# SQUEAK AND RATTLE TROUBLE DIAGNOSIS

---

## **INSULATOR (Light foam block)**

80845-71L00: 30 mm (1.18 in) thick, 30 × 50 mm (1.18×1.97 in)

## **FELT CLOTHTAPE**

Used to insulate where movement does not occur. Ideal for instrument panel applications.

68370-4B000: 15 × 25 mm (0.59 × 0.98 in) pad/68239-13E00: 5 mm (0.20 in) wide tape roll

The following materials, not found in the kit, can also be used to repair squeaks and rattles.

## **UHMW(TEFLON) TAPE**

Insulates where slight movement is present. Ideal for instrument panel applications.

## **SILICONE GREASE**

Used in place of UHMW tape that will be visible or not fit.

Note: Will only last a few months.

## **SILICONE SPRAY**

Use when grease cannot be applied.

## **DUCT TAPE**

Use to eliminate movement.

## **CONFIRM THE REPAIR**

Confirm that the cause of a noise is repaired by test driving the vehicle. Operate the vehicle under the same conditions as when the noise originally occurred. Refer to the notes on the Diagnostic Worksheet.

## **Generic Squeak and Rattle Troubleshooting**

AIS005AT

Refer to Table of Contents for specific component removal and installation information.

## **INSTRUMENT PANEL**

Most incidents are caused by contact and movement between:

1. The cluster lid A and instrument panel
2. Acrylic lens and combination meter housing
3. Instrument panel to front pillar garnish
4. Instrument panel to windshield
5. Instrument panel mounting pins
6. Wiring harnesses behind the combination meter
7. A/C defroster duct and duct joint

These incidents can usually be located by tapping or moving the components to duplicate the noise or by pressing on the components while driving to stop the noise. Most of these incidents can be repaired by applying felt cloth tape or silicon spray (in hard to reach areas). Urethane pads can be used to insulate wiring harness.

### **CAUTION:**

**Do not use silicone spray to isolate a squeak or rattle. If you saturate the area with silicone, you will not be able to recheck the repair.**

## **CENTER CONSOLE**

Components to pay attention to include:

1. Shifter assembly cover to finisher
2. A/C control unit and cluster lid C
3. Wiring harnesses behind audio and A/C control unit

The instrument panel repair and isolation procedures also apply to the center console.

## **DOORS**

Pay attention to the:

1. Finisher and inner panel making a slapping noise
2. Inside handle escutcheon to door finisher
3. Wiring harnesses tapping
4. Door striker out of alignment causing a popping noise on starts and stops

Tapping or moving the components or pressing on them while driving to duplicate the conditions can isolate many of these incidents. You can usually insulate the areas with felt cloth tape or insulator foam blocks from the Nissan Squeak and Rattle Kit (J-43980) to repair the noise.

# SQUEAK AND RATTLE TROUBLE DIAGNOSIS

## TRUNK

Trunk noises are often caused by a loose jack or loose items put into the trunk by the owner. In addition look for:

1. Trunk lid dumpers out of adjustment
2. Trunk lid striker out of adjustment
3. The trunk lid torsion bars knocking together
4. A loose license plate or bracket

Most of these incidents can be repaired by adjusting, securing or insulating the item(s) or component(s) causing the noise.

## SUNROOF/HEADLINING

Noises in the sunroof/headlining area can often be traced to one of the following:

1. Sunroof lid, rail, linkage or seals making a rattle or light knocking noise
2. Sunvisor shaft shaking in the holder
3. Front or rear windshield touching headlining and squeaking

Again, pressing on the components to stop the noise while duplicating the conditions can isolate most of these incidents. Repairs usually consist of insulating with felt cloth tape.

## SEATS

When isolating seat noise it's important to note the position the seat is in and the load placed on the seat when the noise is present. These conditions should be duplicated when verifying and isolating the cause of the noise.

Cause of seat noise include:

1. Headrest rods and holder
2. A squeak between the seat pad cushion and frame
3. The rear seatback lock and bracket

These noises can be isolated by moving or pressing on the suspected components while duplicating the conditions under which the noise occurs. Most of these incidents can be repaired by repositioning the component or applying urethane tape to the contact area.

## UNDERHOOD

Some interior noise may be caused by components under the hood or on the engine wall. The noise is then transmitted into the passenger compartment.

Causes of transmitted underhood noise include:

1. Any component mounted to the engine wall
2. Components that pass through the engine wall
3. Engine wall mounts and connectors
4. Loose radiator mounting pins
5. Hood bumpers out of adjustment
6. Hood striker out of adjustment

These noises can be difficult to isolate since they cannot be reached from the interior of the vehicle. The best method is to secure, move or insulate one component at a time and test drive the vehicle. Also, engine RPM or load can be changed to isolate the noise. Repairs can usually be made by moving, adjusting, securing, or insulating the component causing the noise.

A

B

C

D

E

F

G

H

BL

J

K

L

M

# SQUEAK AND RATTLE TROUBLE DIAGNOSIS

## Diagnostic Worksheet

AI5005AU



### SQUEAK & RATTLE DIAGNOSTIC WORKSHEET

Dear Infiniti Customer:

We are concerned about your satisfaction with your Infiniti vehicle. Repairing a squeak or rattle sometimes can be very difficult. To help us fix your Infiniti right the first time, please take a moment to note the area of the vehicle where the squeak or rattle occurs and under what conditions. You may be asked to take a test drive with a service advisor or technician to ensure we confirm the noise you are hearing.

#### I. WHERE DOES THE NOISE COME FROM? (circle the area of the vehicle)

The illustrations are for reference only, and may not reflect the actual configuration of your vehicle.

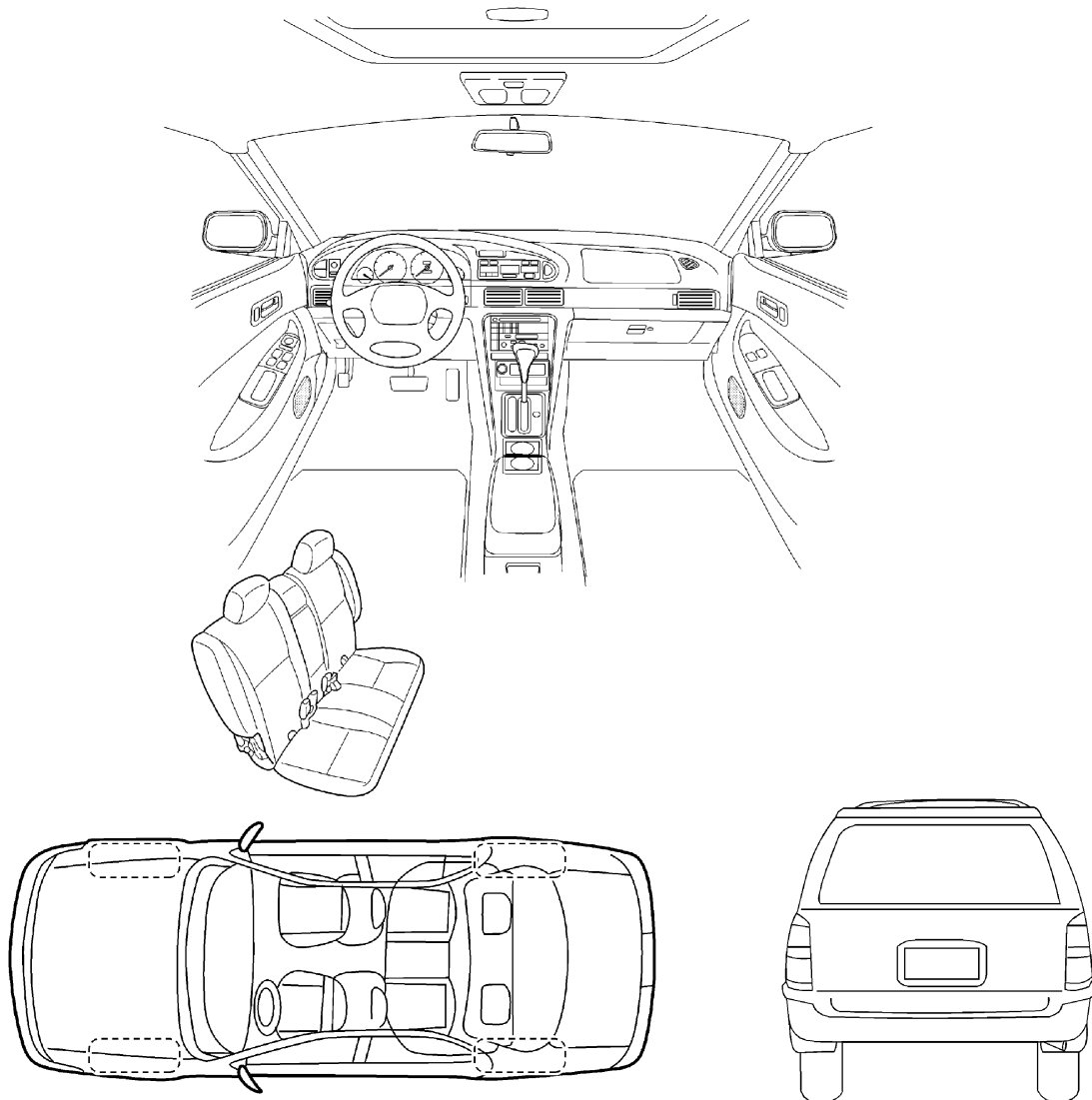

Continue to the back of the worksheet and briefly describe the location of the noise or rattle. In addition, please indicate the conditions which are present when the noise occurs.

SBT860

# SQUEAK AND RATTLE TROUBLE DIAGNOSIS

## SQUEAK & RATTLE DIAGNOSTIC WORKSHEET- page 2

Briefly describe the location where the noise occurs:

---

---

---

### II. WHEN DOES IT OCCUR? (check the boxes that apply)

- |  |   |
|--|---|
| <input type="checkbox"/> anytime                             | <input type="checkbox"/> after sitting out in the sun |
| <input type="checkbox"/> 1 <sup>st</sup> time in the morning | <input type="checkbox"/> when it is raining or wet    |
| <input type="checkbox"/> only when it is cold outside        | <input type="checkbox"/> dry or dusty conditions      |
| <input type="checkbox"/> only when it is hot outside         | <input type="checkbox"/> other: _____                 |

### III. WHEN DRIVING:

- through driveways
- over rough roads
- over speed bumps
- only at about \_\_\_\_ mph
- on acceleration
- coming to a stop
- on turns : left, right or either (circle)
- with passengers or cargo
- other: \_\_\_\_\_
- after driving \_\_\_\_ miles or \_\_\_\_ minutes

### IV. WHAT TYPE OF NOISE?

- squeak (like tennis shoes on a clean floor)
- creak (like walking on an old wooden floor)
- rattle (like shaking a baby rattle)
- knock (like a knock on a door)
- tick (like a clock second hand)
- thump (heavy, muffled knock noise)
- buzz (like a bumble bee)

### TO BE COMPLETED BY DEALERSHIP PERSONNEL

#### Test Drive Notes:

---

---

	YES	NO	Initials of person performing
Vehicle test driven with customer	<input type="checkbox"/>	<input type="checkbox"/>	_____
- Noise verified on test drive	<input type="checkbox"/>	<input type="checkbox"/>	_____
- Noise source located and repaired	<input type="checkbox"/>	<input type="checkbox"/>	_____
- Follow up test drive performed to confirm repair	<input type="checkbox"/>	<input type="checkbox"/>	_____

VIN: \_\_\_\_\_ Customer Name: \_\_\_\_\_

W.O. #: \_\_\_\_\_ Date: \_\_\_\_\_

**This form must be attached to Work Order**

SBT844

# HOOD

PFP:F5100

## HOOD

### Fitting Adjustment

AIS0000T

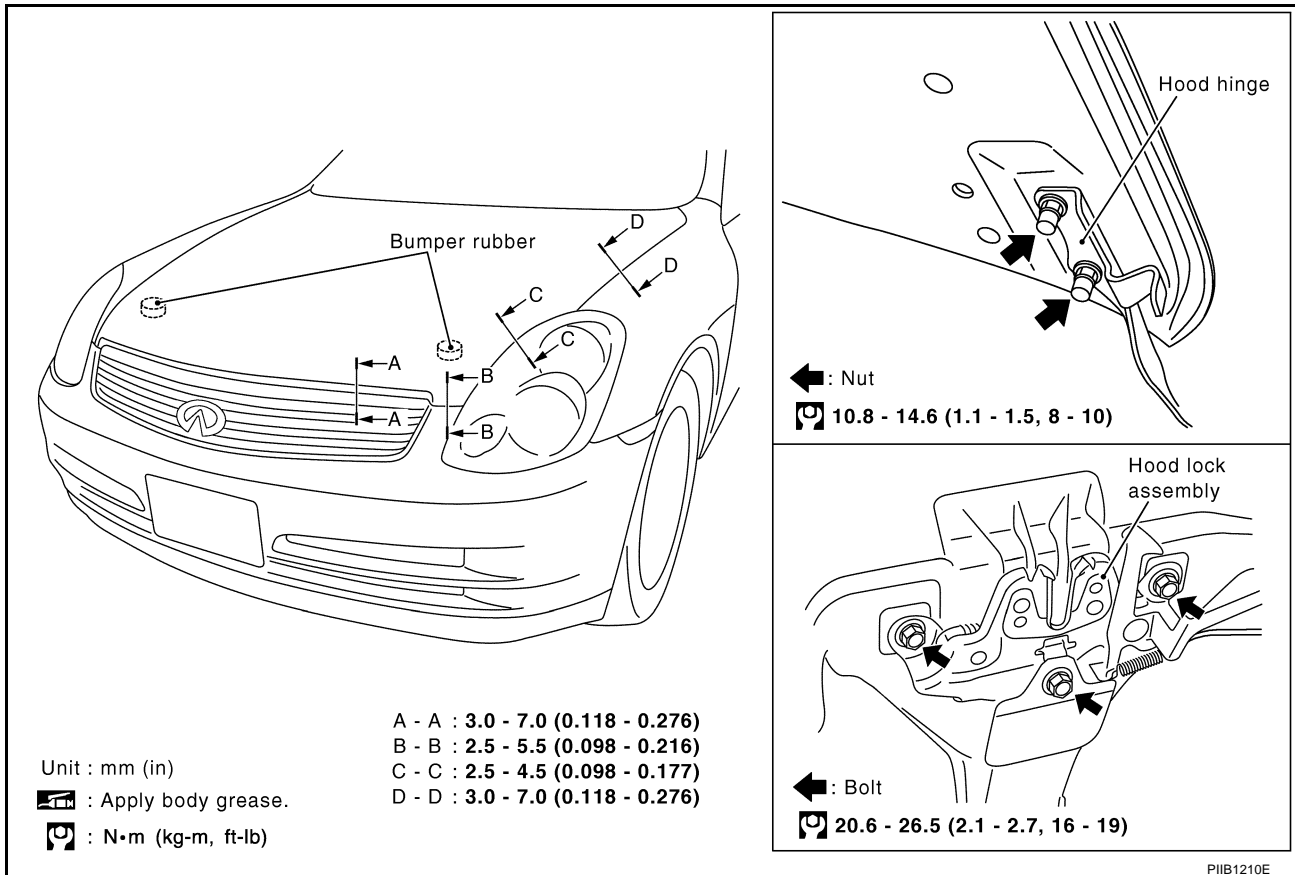

### LONGITUDINAL AND LATERAL CLEARANCE ADJUSTMENT

1. Remove hood lock assembly, loosen the hood hinge nuts and close the hood.
2. Adjust the lateral and longitudinal clearance, and open the hood to tighten the hood hinge mounting bolts to the specified torque.
3. Install the hood lock temporarily, and align the hood striker and lock so that the centers of striker and lock become vertical viewed from the front, by moving the hood lock laterally.
4. Tighten hood lock mounting bolts to the specified torque.

### FRONT END HEIGHT ADJUSTMENT

1. Remove the hood lock and adjust the height by rotating the bumper rubber until the hood becomes 1 to 1.5 mm (0.04 to 0.059 in) lower than the fender.
2. Temporarily tighten the hood lock, and position it by engaging it with the hood striker. Check the lock and striker for looseness, and tighten the hood lock mounting bolts to the specified torque.

### CAUTION:

Adjust right/left clearance between hood and each part to the following specification.

- Hood and front bumper (B-B) : Less than 2.0 mm (0.08 in)
- Hood and head lamp (C-C) : Less than 2.0 mm (0.08 in)
- Hood and fender (D-D) : Less than 1.0 mm (0.04 in)



# HOOD

## SURFACE HEIGHT ADJUSTMENT

1. Remove hood lock, and adjust the surface height difference of hood, fender and headlamp according to the fitting standard dimension, by rotating RH and LH bumper rubbers.
2. Install hood lock temporarily, and move hood lock laterally until the centers of striker and lock become vertical when viewed from the front.
3. Make sure that the hood lock secondary latch is properly engaged with the secondary striker with hood's own weight.
4. Make sure that the hood lock primary latch is securely engaged with the hood striker with hood's own weight by dropping hood from approx. 200 mm (7.87in) height.

### CAUTION:

**Do not drop hood from a height of 300 mm (11.81 in) or more.**

5. Move hood lockup and down until striker smoothly engages the lock when the hood is closed.
6. When pulling the hood opener lever gently, make sure that front end of the hood rises by approximately 20 mm (0.79 in) and that hood striker and hood lock primary latch is disengaged. Also make sure that hood opener returns to the original position.
7. After adjustment, tighten lock bolts to the specified torque.

### CAUTION:

**Adjust evenness between hood and each part to the following specification.**

- |                          |                               |
|--------------------------|-------------------------------|
| Hood and head lamp (C-C) | : Less than 1.5 mm (0.059 in) |
| Hood and fender (D-D)    | : Less than 1.0 mm (0.04 in)  |

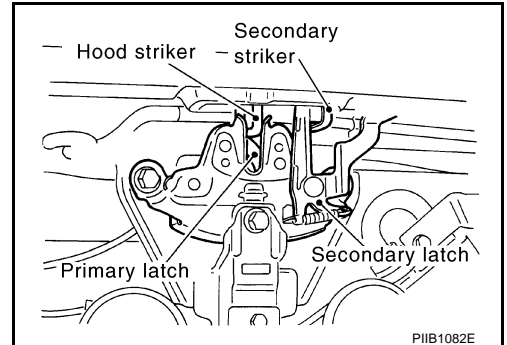

A  
B  
C  
D  
E  
F  
G  
H  
J  
K  
L  
M

BL

# HOOD

## Removal and Installation of Hood Assembly

AI50000U

SEC. 650

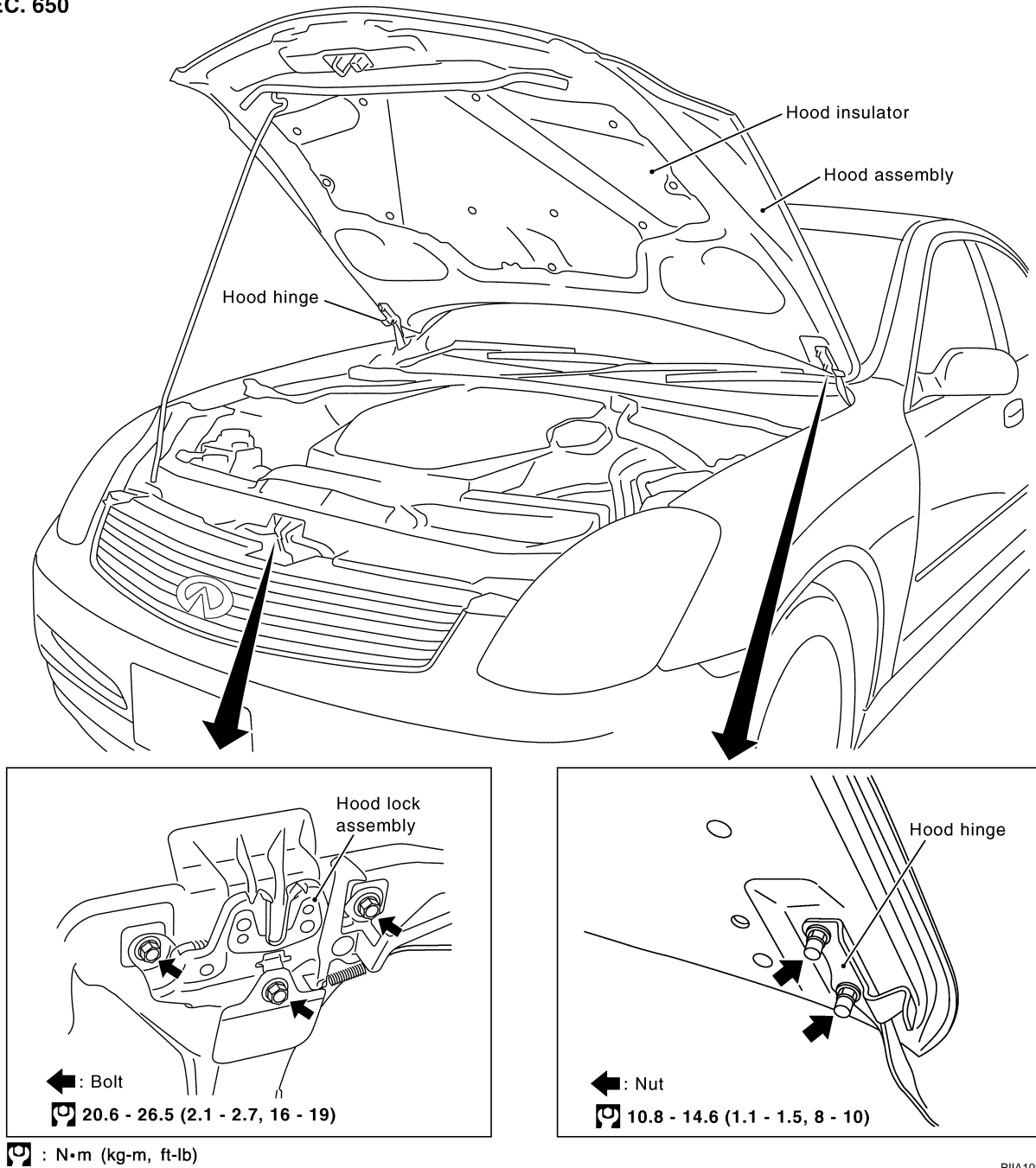

### REMOVAL

Remove the hinge mounting nuts on the hood to remove the hood assembly.

#### CAUTION:

Operate with two workers, because of its heavy weight.

### INSTALLATION

Install in the reverse order of removal.

#### CAUTION:

- Before installing hood hinge, apply anticorrosive agent onto the mounting surface of the vehicle body.
- After installing, perform hood fitting adjustment. Refer to [BL-12, "Fitting Adjustment"](#).

# HOOD

## Removal and Installation of Hood Lock Control

AIS0000V

A  
B  
C  
D  
E  
F  
G  
H  
BL  
J  
K  
L  
M

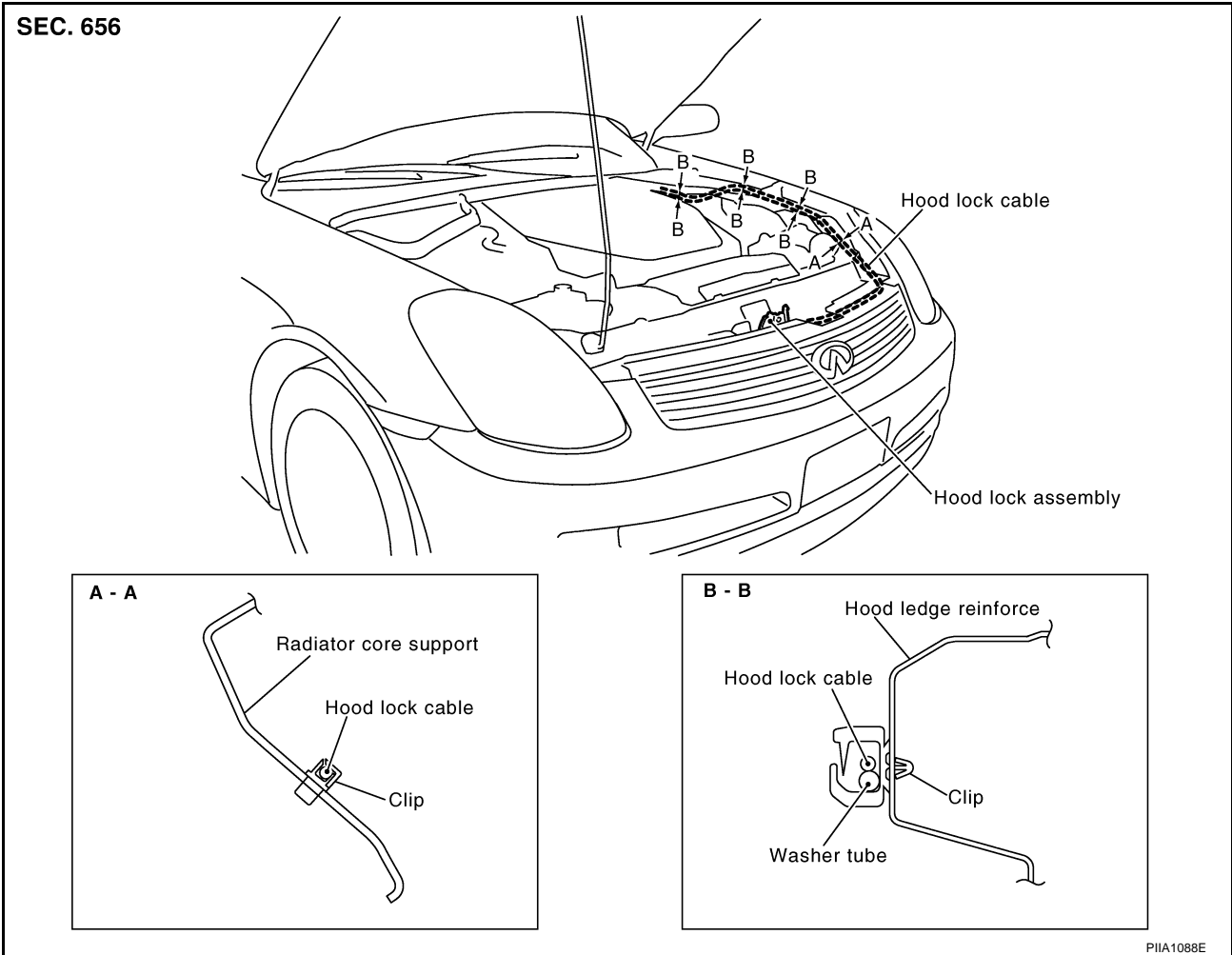

### REMOVAL

1. Remove the front grill. Refer to [EI-20, "Removal and Installation"](#).
2. Remove the fender protector. Refer to [EI-22, "Removal and Installation"](#).
3. Remove the hood lock assembly. Refer to [BL-14, "Removal and Installation of Hood Assembly"](#).
4. Remove the instrument lower driver panel. Refer to [IP-10, "Component Parts Drawing"](#).
5. Disconnect the hood lock cable from the hood lock, and clip it from the radiator core upper support and hood ledge.
6. Remove the mounting screws, and remove the hood opener.
7. Remove the grommet on the instrument panel, and pull the hood lock cable toward the passenger compartment.

### CAUTION:

While pulling, be careful not to damage (peeling) the outside of the hood lock cable.

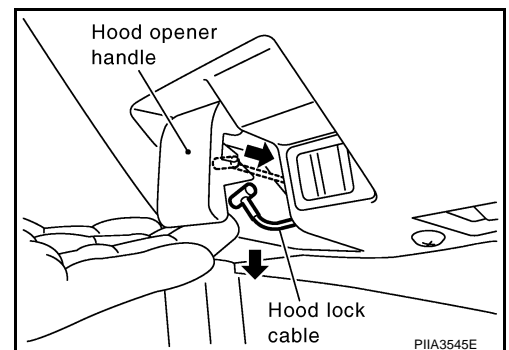

# HOOD

## INSTALLATION

1. Pull the hood lock cable through the panel hole to the engine compartment.  
Be careful not to bend the cable too much, keeping the radius 100 mm (3.94 in) or more.
2. Check that the cable is not offset from the positioning grommet, and push the grommet into the panel hole securely.
3. Apply the sealant to the grommet (at \* mark) properly.

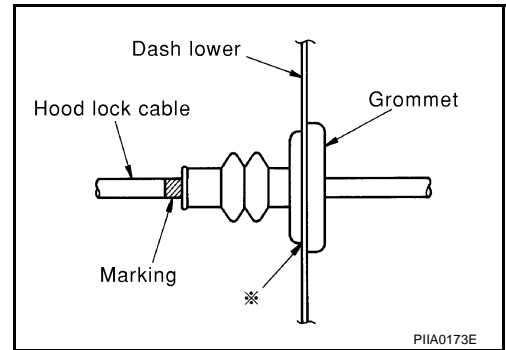

4. Install the cable securely to the lock.
5. After installing, check the hood lock adjustment and hood opener operation.

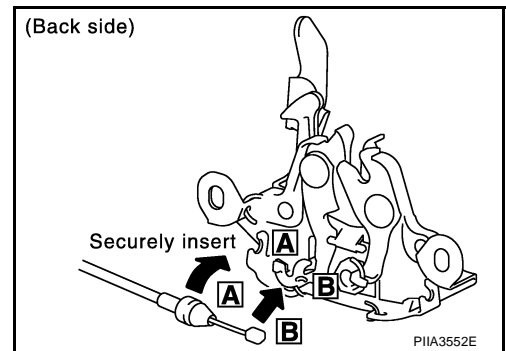

## Hood Lock Control Inspection

### CAUTION:

If the hood lock cable is bent or deformed, replace it.

1. Check that the hood lock secondary latch is properly engaged with the secondary striker with hood's own weight.
2. Check that the hood lock primary latch is securely engaged with the hood striker with hood's own weight by dropping it from approx. 200 mm (7.87 in) height.

### CAUTION:

Do not drop hood from a height of 300 mm (11.81 in) or more.

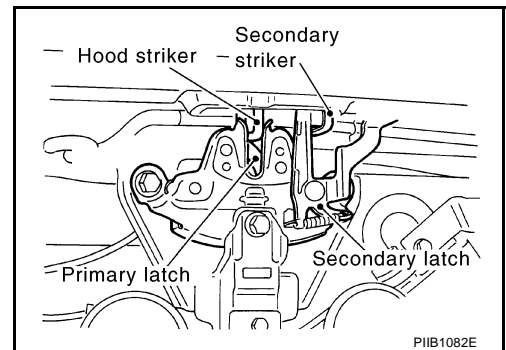

3. When pulling hood opener lever gently, make sure that front end of the hood rises by approximately 20 mm (0.79 in) and that hood striker and hood lock primary latch are disengaged. Also make sure that hood opener returns to the original position.
4. Confirm hood lock is properly lubricated. If necessary, apply grease at the point shown in the figure.

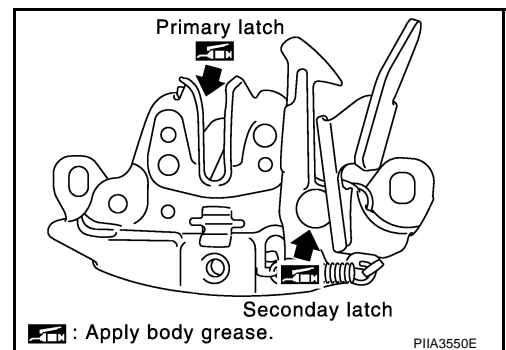

# RADIATOR CORE SUPPORT

## RADIATOR CORE SUPPORT

PF6:62500

### Removal and Installation

AIS0007V

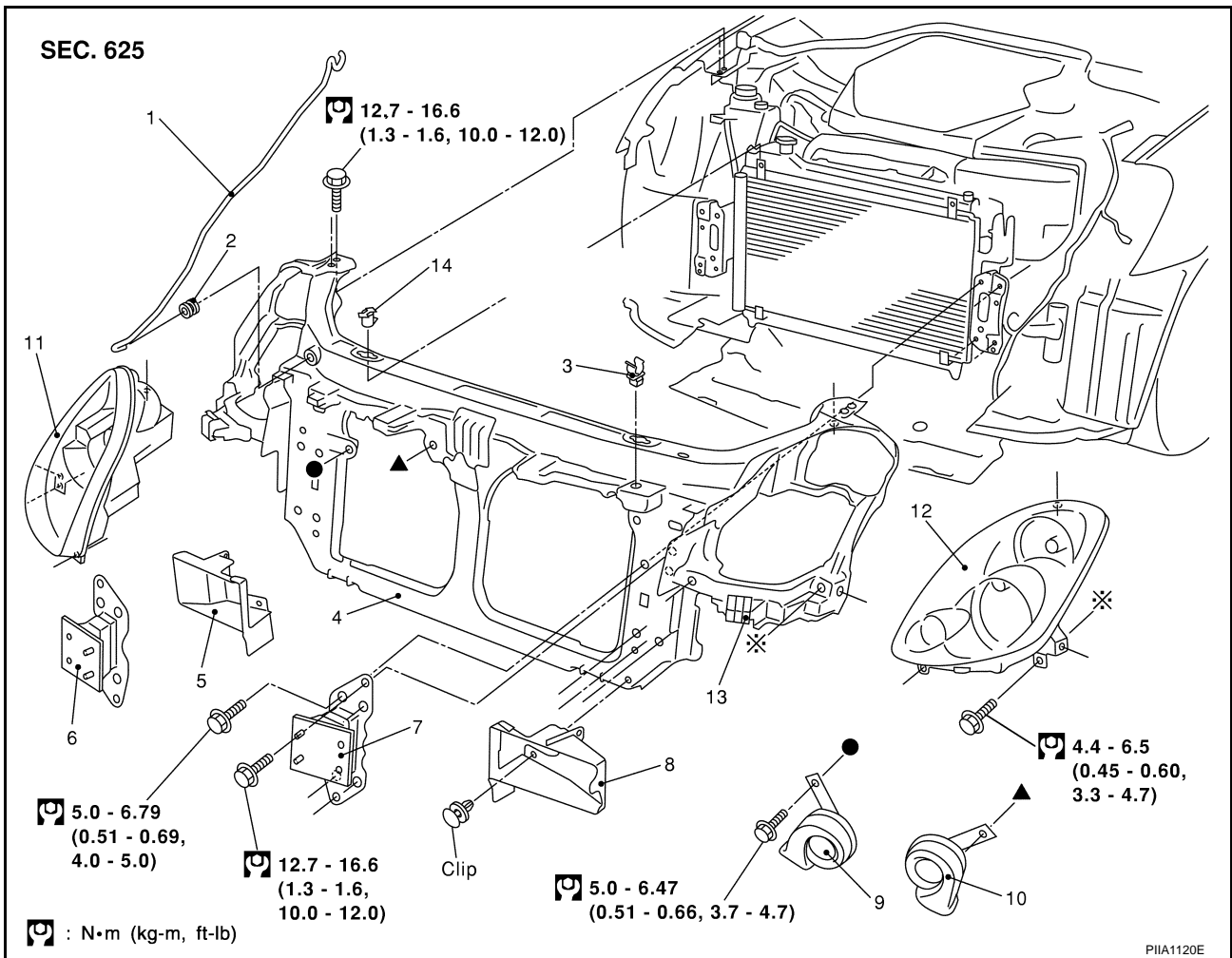

- |                                   |                            |                        |
|-----------------------------------|----------------------------|------------------------|
| 1. Hood stay                      | 2. Grommet                 | 3. Hood rod clamp      |
| 4. Radiator core support assembly | 5. Air intake duct (RH)    | 6. Bumper bracket (RH) |
| 7. Bumper bracket (LH)            | 8. Air intake duct (LH)    | 9. Horn (Low)          |
| 10. Horn (High)                   | 11. Headlamp (RH)          | 12. Headlamp (LH)      |
| 13. Front bumper clip             | 14. Upper radiator bracket |                        |

### REMOVAL

- Remove hood assembly. Refer to [BL-14, "Removal and Installation of Hood Assembly"](#).
- Remove front bumper, bumper reinforcement and bumper bracket. Refer to [EI-14, "Removal and Installation"](#).
- Remove hood lock assembly, then remove hood lock cable.
- Remove washer tank. Refer to [WW-39, "Removal and Installation of Washer Tank"](#).
- Remove horn connectors.
- Remove mounting harness clip on radiator core support assembly, the harness is separate.
- Remove resonator mounting screws. Refer to [EM-17, "AIR CLEANER AND AIR DUCT"](#).
- Remove air intake duct (LH/RH), and remove washer tank inlet clip.
- Remove headlamp (LH/RH). Refer to [LT-35, "Removal and Installation"](#).
- Remove upper radiator bracket.

## RADIATOR CORE SUPPORT

11. Remove radiator core support assembly mounting bolts. Remove bolts with power tool.

**CAUTION:**

**Put a wooden block under the radiator assembly to prevent the radiator assembly from falling.**

12. Remove radiator core support assembly.
13. After removing radiator core support assembly, the following parts are separate.
  - Remove the hood stay, grommet and hood rod clamp
  - Horn (High/Low)
  - Air intake duct (LH/RH)
  - Front bumper clip (LH/RH)

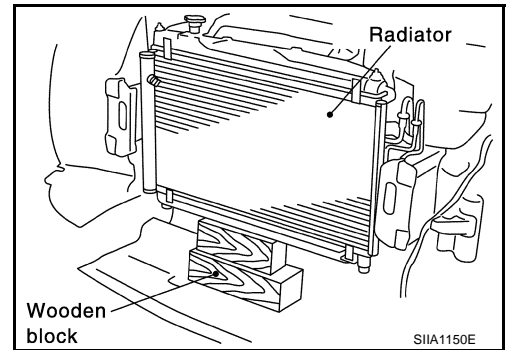

### INSTALLATION

Install in the reverse order of removal.

# POWER DOOR LOCK SYSTEM

## POWER DOOR LOCK SYSTEM

PFP:24814

### Component Parts and Harness Connector Location

AIS0049F

A  
B  
C  
D  
E  
F  
G  
H  
BL  
J  
K  
L  
M

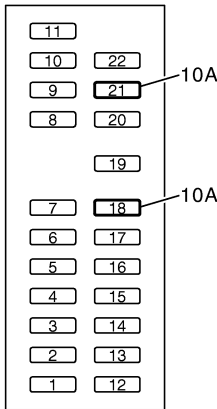

Fuse block (J/B) fuse layout

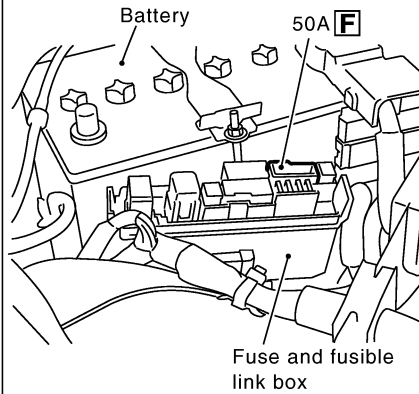

View with dash side LH removed

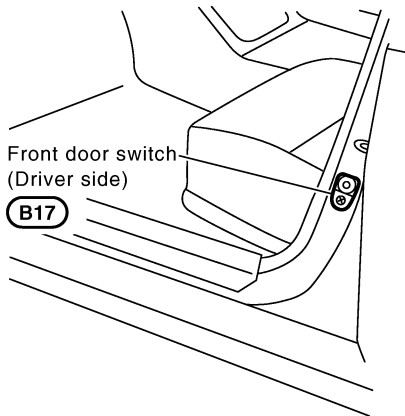
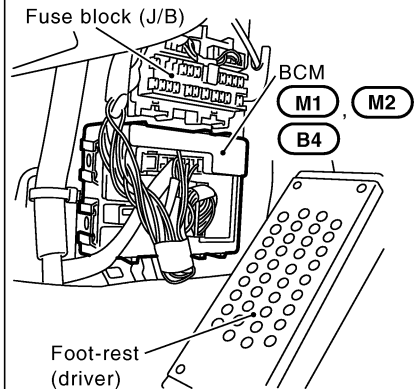

Front door switch (Driver side)

B17

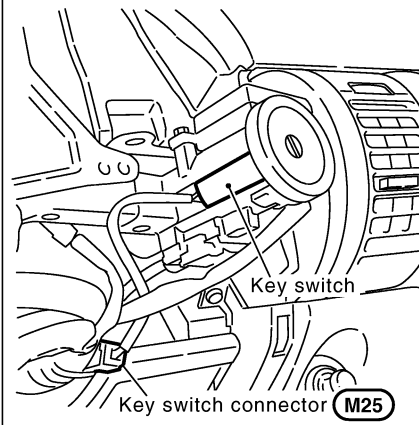

Key switch

Key switch connector M25

Door lock and unlock switch

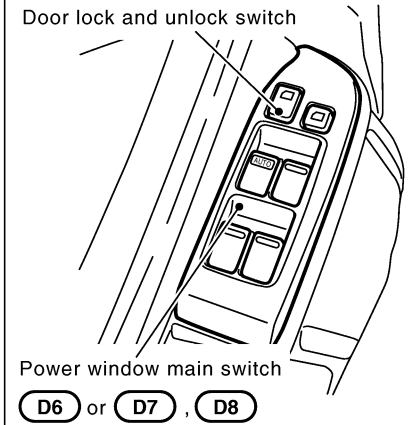

Power window main switch

D6 or D7, D8

Outside handle

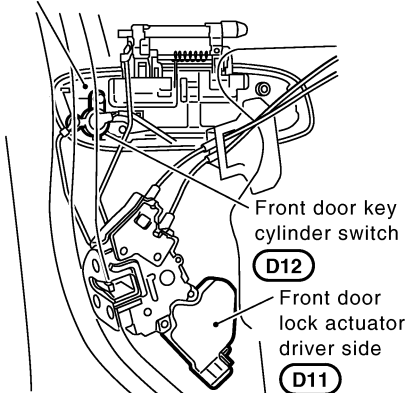

Front door key cylinder switch

D12

Front door lock actuator driver side

D11

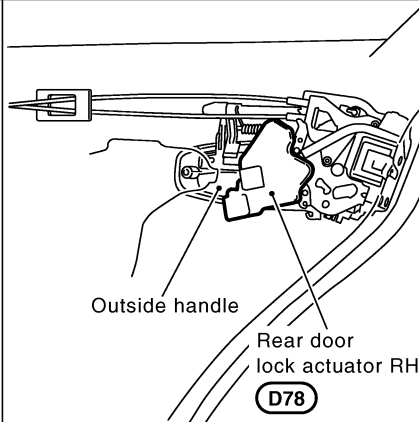

Outside handle

Rear door lock actuator RH

D78

Rear fender RH (Inner)

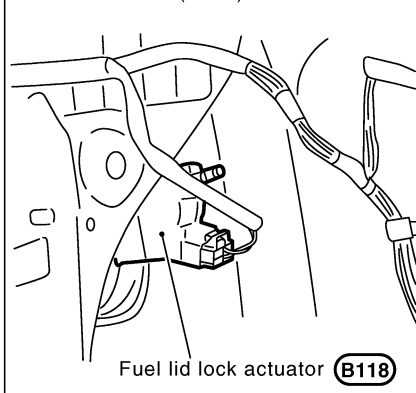

Fuel lid lock actuator B118

PIIA9652E

# POWER DOOR LOCK SYSTEM

AIS0049H

## System Description

Power is supplied at all times

- through 50A fusible link (letter **F** , located in the fuse and fusible link box).
- to BCM terminal 55,
- through 10A fuse [No. 18, located in the fuse block (J/B)]
- to BCM terminal 42,
- through 10A fuse [No. 21, located in the fuse block (J/B)]
- to key switch terminal 2.

When key switch is ON (key is inserted in ignition key cylinder), power is supplied

- through key switch terminal 1
- to BCM terminal 37.

Ground is supplied

- to BCM terminal 52
- through body grounds M30 and M66.

When the door is locked or unlocked with power window main switch (door lock and unlock switch), ground is supplied

- to CPU of power window main switch
- through power window main switch (door lock and unlock switch) terminal 15 (with anti-pinch system for all door window), or
- through power window main switch (door lock and unlock switch) terminal 5 (except with anti-pinch system for all door window)
- through grounds M30 and M66.

Then power window main switch (door lock and unlock switch) operation signal is sent.

- to BCM terminal 22
- from power window main switch (door lock and unlock switch) terminal 9 (with anti-pinch system for all door window), or
- from power window main switch (door lock and unlock switch) terminal 8 (except with anti-pinch system for all door window).

When the door is locked or unlocked with power window sub-switch (front passenger side) (door lock and unlock switch), ground is supplied

- to CPU of power window sub-switch
- through power window sub-switch (front passenger side) (door lock and unlock switch) terminal 7
- through grounds M30 and M66.

Then power window sub-switch (front passenger side) (door lock and unlock switch) operation signal is sent

- to BCM terminal 22
- from power window sub-switch (front passenger side) (door lock and unlock switch) terminal 11.

When the door is locked with front door key cylinder switch (driver side), ground is supplied

- to CPU of power window main switch
- through power window main switch (door lock and unlock switch) terminal 6
- through front door key cylinder switch (driver side) terminals 1 and 2
- through grounds M30 and M66.

Then front door key cylinder switch (driver side) operation signal (lock) is sent

- to BCM terminal 22
- from power window main switch (door lock and unlock switch) terminal 9 (with anti-pinch system for all door window), or
- from power window main switch (door lock and unlock switch) terminal 8 (except with anti-pinch system for all door window).

When the door is unlocked with front door key cylinder switch (driver side), ground is supplied

- to CPU of power window main switch



# POWER DOOR LOCK SYSTEM

- through power window main switch (door lock and unlock switch) terminal 5 (with anti-pinch system for all door window), or
- through power window main switch (door lock and unlock switch) terminal 19 (except with anti-pinch system for all door window)
- through front door key cylinder switch (driver side) terminals 3 and 2
- through grounds M30 and M66.

Then front door key cylinder switch (driver side) operation signal (unlock) is sent

- to BCM terminal 22
- from power window main switch (door lock and unlock switch) terminal 9 (with anti-pinch system for all door window), or
- from power window main switch (door lock and unlock switch) terminal 8 (except with anti-pinch system for all door window).

BCM is connected to power window main switch and power window sub-switch as serial link.

## DOOR SWITCH OPERATION WITHOUT NAVIGATION SYSTEM

When the front door switch driver side is ON (door is OPEN), ground is supplied

- to BCM terminal 62
- through front door switch driver side terminal 1 and
- through front door switch driver side case ground.

When the front door switch passenger side is ON (door is OPEN), ground is supplied

- to BCM terminal 12
- through front door switch passenger side terminal 1 and
- through front door switch passenger side case ground.

When the rear door switch LH is ON (door is OPEN), ground is supplied

- to BCM terminal 63
- through rear door switch LH terminal 1 and
- through rear door switch LH case ground.

When the rear door switch RH is ON (door is OPEN), ground is supplied

- to BCM terminal 13
- through front door switch RH terminal 1 and
- through rear door switch RH case ground.

## DOOR SWITCH OPERATION WITH NAVIGATION SYSTEM

When front door switch driver side is ON (door is OPEN), ground is supplied

- to combination meter terminal 7
- through front door switch driver side terminal 1 and
- through front door switch driver side case ground.

When front door switch passenger side is ON (door is OPEN), ground is supplied

- to combination meter terminal 6
- through front door switch passenger side terminal 1 and
- through front door switch passenger side case ground.

When rear door switch LH is ON (door is OPEN), ground is supplied

- to combination meter terminal 9
- through rear door switch LH terminal 1 and
- through rear door switch LH case ground.

When rear door switch RH is ON (door is OPEN), ground is supplied

- to combination meter terminal 8
- through rear door switch RH terminal 1 and
- through rear door switch RH case ground.

A

B

C

D

E

F

G

H

BL

J

K

L

M

# POWER DOOR LOCK SYSTEM

---

## FUEL LID OPERATION

When door is unlocked with power window main switch (door lock and unlock switch), fuel lid lock actuator is unlocked. Ground is supplied

- to BCM terminal 44
- through fuel lid lock actuator terminals 1 and 2
- through BCM terminal 50.

In this condition, fuel lid can be opened if it is pushed.

## OUTLINE

### Functions Available by Operating the Door Lock and Unlock Switches on Driver's Door and Passenger's Door

- Interlocked with the locking operation of door lock and unlock switch, door lock actuators of all doors and fuel lid lock actuator are locked.
- Interlocked with the unlocking operation of door lock and unlock switch, door lock actuators of all doors and fuel lid lock actuator are unlocked.

### Functions Available by Operating the Key Cylinder Switch on Driver's

- Interlocked with the locking operation of door key cylinder, door lock actuators of all doors and fuel lid lock actuator are locked.

### Select Unlock Operation

- When door key cylinder is unlocked, door lock actuator driver side and fuel lid lock actuator are unlocked.
- When door key cylinder is unlocked for the second time within 5 seconds after the first operation, door lock actuators on all doors are unlocked.  
Select unlock operation mode can be changed using "DOOR LOCK-UNLOCK SET" mode in "WORK SUPPORT". Refer to [BL-31, "Work Support"](#) .

### Key Reminder Door System

When door lock and unlock switch is operated to lock doors with ignition key put in key cylinder and any door open, all door lock actuators are locked and then unlocked.

Key reminder door mode can be changed using "WORK SUPPORT" mode in "ANTI-LOCK OUT SET".

Refer to [BL-31, "Work Support"](#) .

## CAN Communication System Description

AIS0049I

CAN (Controller Area Network) is a serial communication line for real time application. It is an on-vehicle multiplex communication line with high data communication speed and excellent error detection ability. Many electronic control units are equipped onto a vehicle, and each control unit shares information and links with other control units during operation (not independent). In CAN communication, control units are connected with 2 communication lines (CAN H line, CAN L line) allowing a high rate of information transmission with less wiring. Each control unit transmits/receives data but selectively reads required data only.

## CAN Communication Unit

AIS004CP

Refer to [LAN-5, "CAN COMMUNICATION"](#) .

# POWER DOOR LOCK SYSTEM

## Schematic

AI50049J

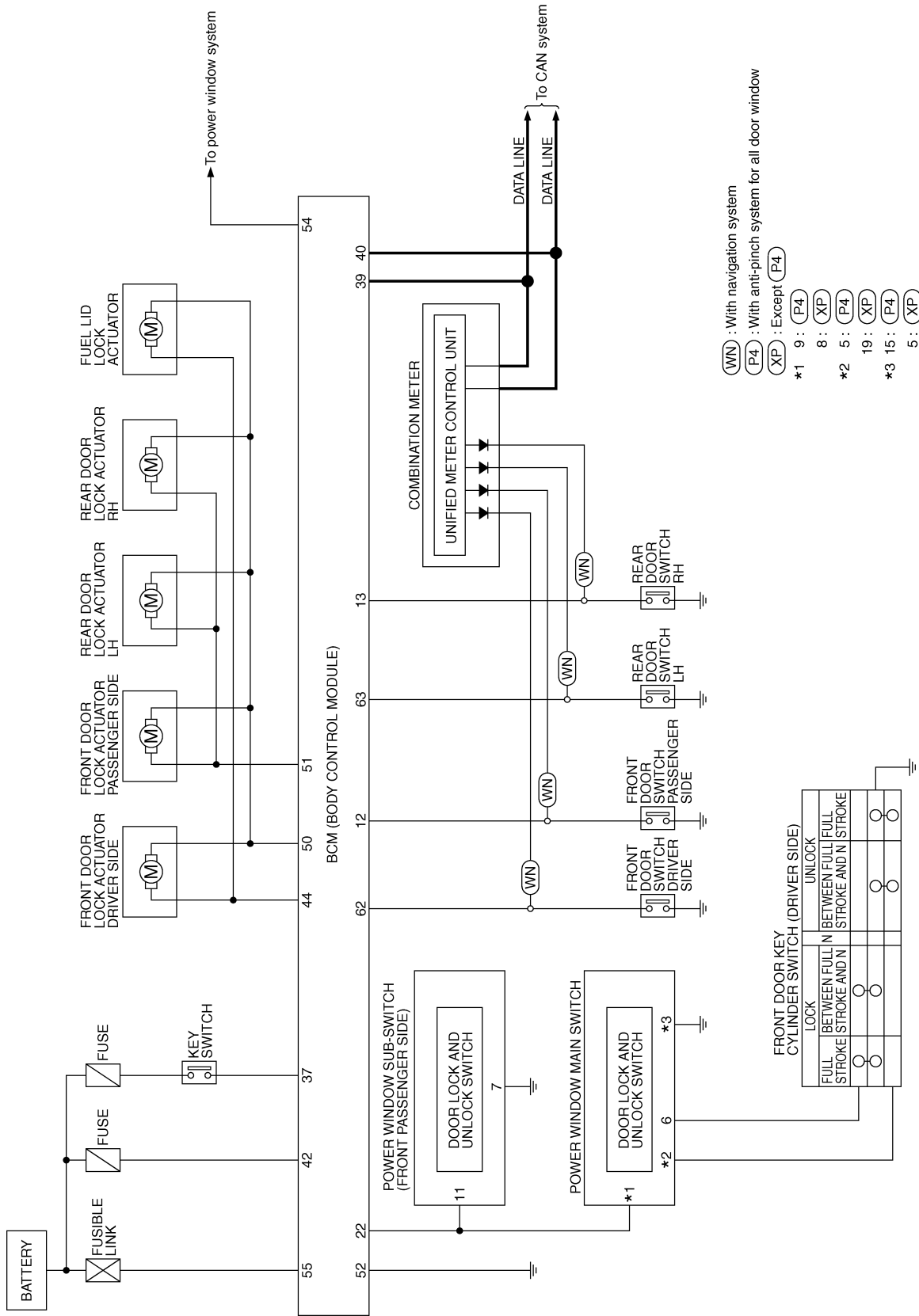

A  
B  
C  
D  
E  
F  
G  
H  
I  
J  
K  
L  
M

BL

TIWT0689E

# POWER DOOR LOCK SYSTEM

Wiring Diagram -D/LOCK-  
FIG. 1

AIS0049K

BL-D/LOCK-01

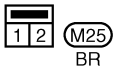
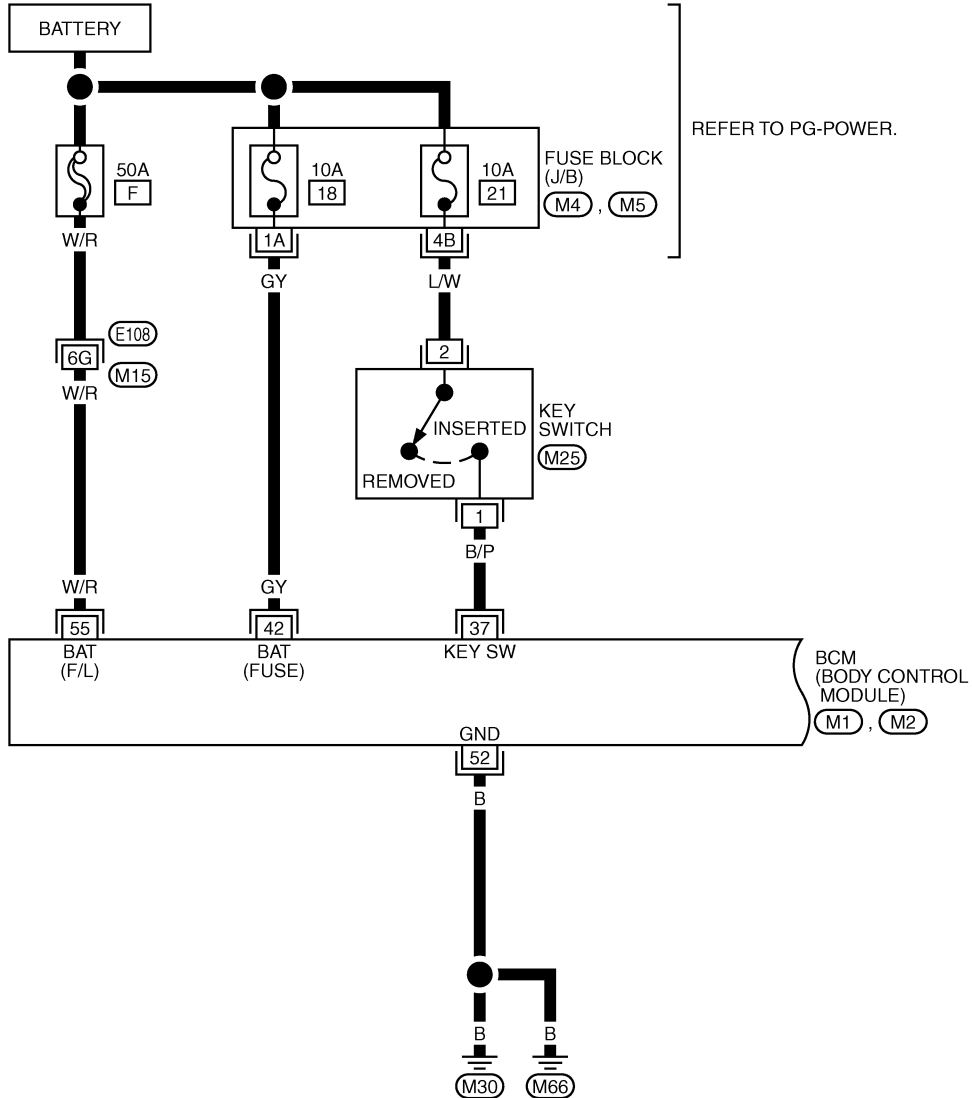

REFER TO THE FOLLOWING.



- (E108) -SUPER MULTIPLE JUNCTION (SMJ)
- (M4), (M5) -FUSE BLOCK-JUNCTION BOX (J/B)
- (M1), (M2) -ELECTRICAL UNITS

TIWT0690E

# POWER DOOR LOCK SYSTEM



FIG. 2

BL-D/LOCK-02

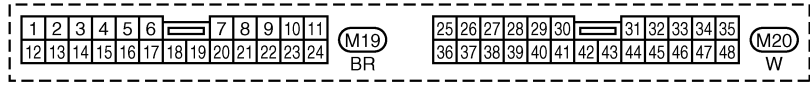
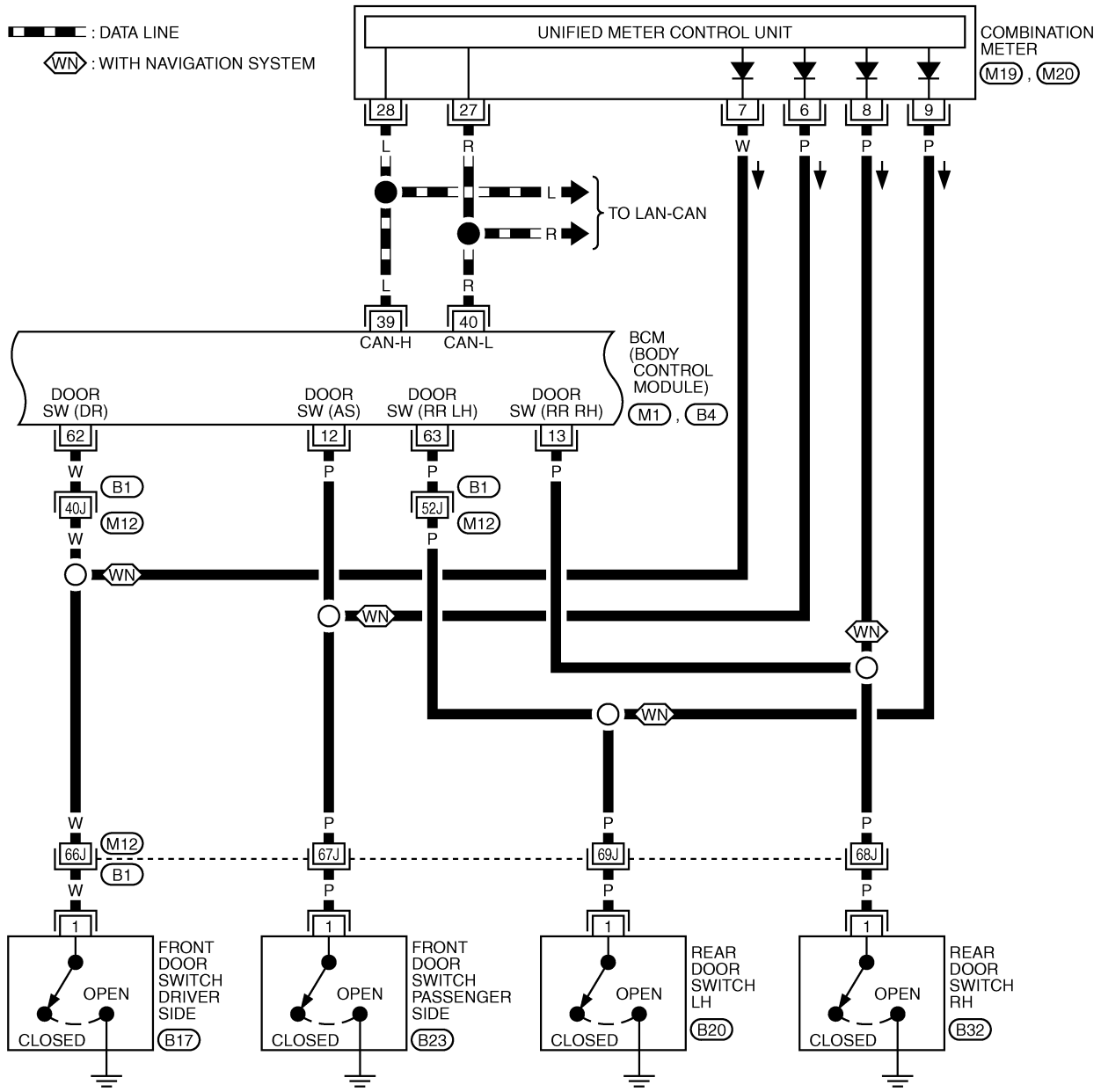
 : DATA LINE  
 : WITH NAVIGATION SYSTEM



REFER TO THE FOLLOWING.

-  -SUPER MULTIPLE JUNCTION (SMJ)
-  -ELECTRICAL UNITS

A  
B  
C  
D  
E  
F  
G  
H  
BL  
J  
K  
L  
M

# POWER DOOR LOCK SYSTEM

FIG. 3

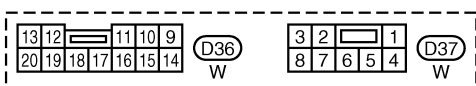
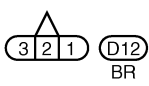
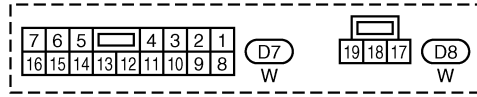
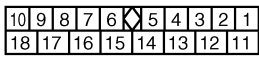
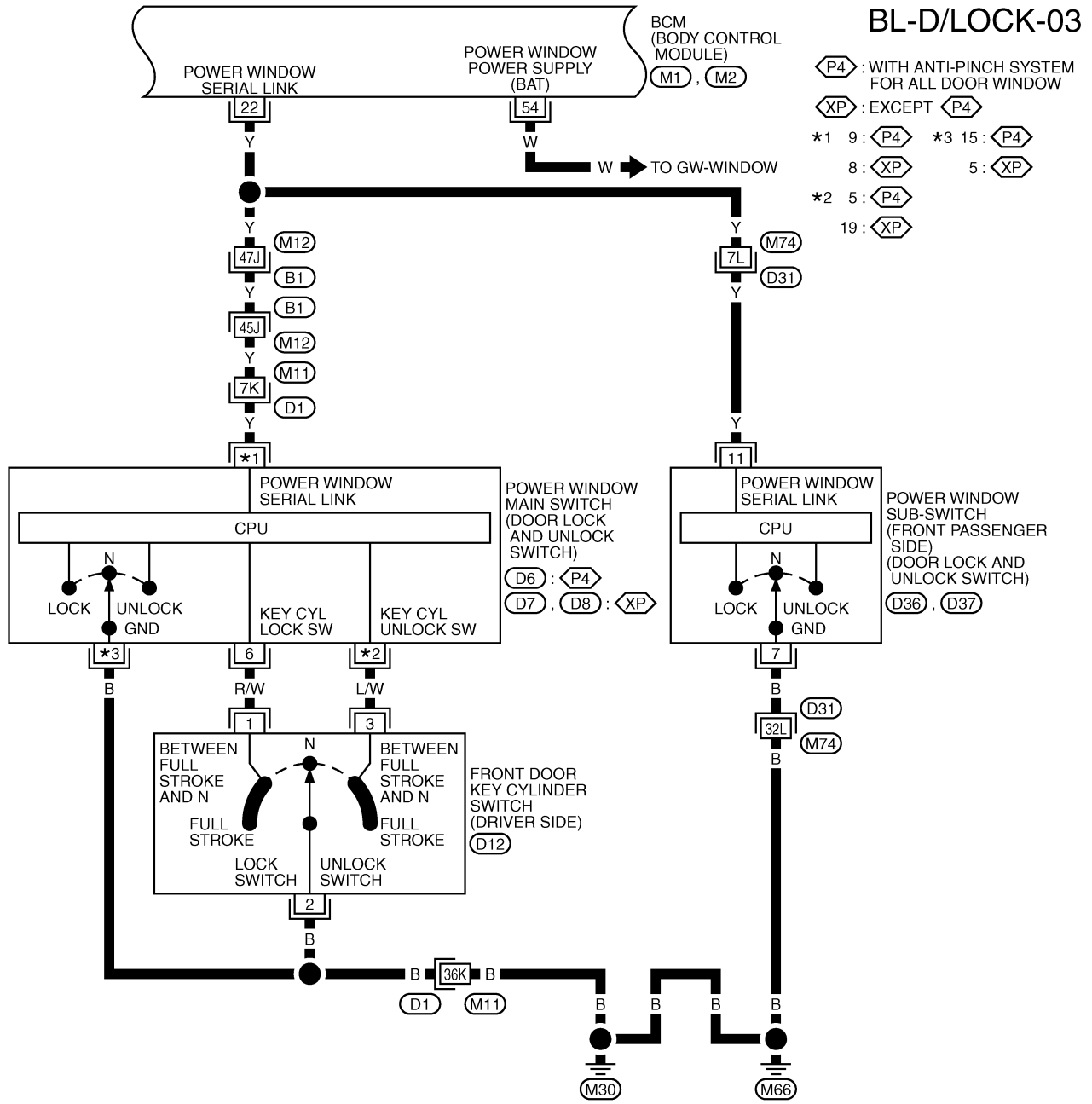

REFER TO THE FOLLOWING.  
 B1, D1, D31 -SUPER MULTIPLE JUNCTION (SMJ)  
 M1, M2 -ELECTRICAL UNITS

# POWER DOOR LOCK SYSTEM

FIG. 4

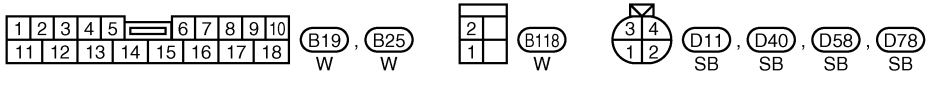
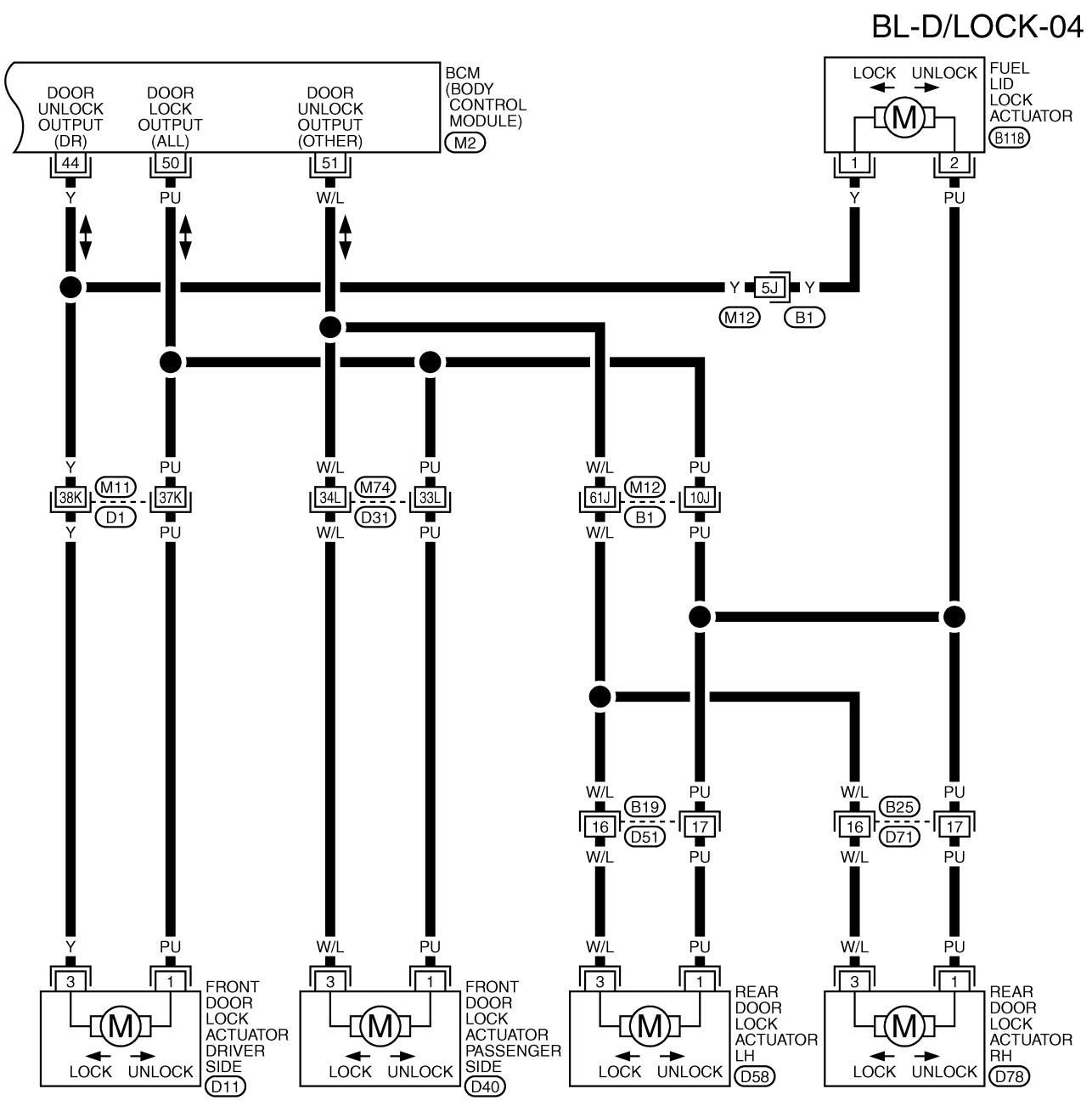

REFER TO THE FOLLOWING.

(B1), (D1), (D31) -SUPER MULTIPLE JUNCTION (SMJ)

(M2) -ELECTRICAL UNITS

# POWER DOOR LOCK SYSTEM

## Terminals and Reference Value of BCM

AIS0049N

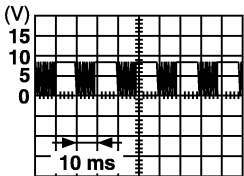
Terminal	Wire color	Item	Condition	Voltage [V] (Approx.)
12*	P	Front door switch passenger side	ON (door open) → OFF (door closed)	0 → Battery voltage
13*	P	Rear door switch RH	ON (door open) → OFF (door closed)	0 → Battery voltage
22	Y	Power window switch (Serial link)	Ignition switch (OFF→ON)	 <p style="text-align: right;">PIIA1297E</p>
37	B/P	Key switch	ON (Key inserted) → OFF (Key removed from IGN key cylinder)	Battery voltage → 0
39	L	CAN H	—	—
40	R	CAN L	—	—
42	G/Y	Battery power supply	—	Battery voltage
44	Y	Driver door lock actuator (unlock) signal	Door lock / unlock switch (Free → Unlock)	0 → Battery voltage → 0
50	PU	Door lock actuator (lock) signal	Door lock / unlock switch (Free → Lock)	0 → Battery voltage → 0
51	W/L	Passenger and rear doors lock actuator (unlock) signal	Door lock / unlock switch (Free → Unlock)	0 → Battery voltage → 0
52	B	Ground	—	0
55	W/R	Power source (Fusible link)	—	Battery voltage
62*	W	Front door switch driver side	ON (door open) → OFF (door closed)	0 → Battery voltage
63*	P	Rear door switch LH	ON (Door open) → OFF (Door closed)	0 → Battery voltage

\*: Without navigation system

## Terminals and Reference Value of Combination Meter (With Navigation System)

AIS0049O

Terminal	Wire color	Item	Condition	Voltage [V] (Approx.)
6	P	Front door switch passenger side	ON (door open) → OFF (door closed)	0 → Battery voltage
7	W	Front door switch driver side	ON (door open) → OFF (door closed)	0 → Battery voltage
8	P	Rear door switch RH	ON (door open) → OFF (door closed)	0 → Battery voltage
9	P	Rear door switch LH	ON (door open) → OFF (door closed)	0 → Battery voltage
27	R	CAN-L	—	—
28	L	CAN-H	—	—



# POWER DOOR LOCK SYSTEM

## Work Flow

AIS0049P

1. Check the symptom and customer's requests.
2. Understand the outline of system. Refer to [BL-20, "System Description"](#) .
3. According to the trouble diagnosis chart by symptom, repair or replace the cause of the malfunction. Refer to [BL-33, "Trouble Diagnosis Chart by Symptom"](#) .
4. Does power door lock system operate normally?  
YES: GO TO 5.  
NO: GO TO 3.
5. INSPECTION END

A

B

C

D

E

F

G

H

BL

J

K

L

M

# POWER DOOR LOCK SYSTEM

AIS0049R

## CONSULT-II Function

Power door lock system check with data monitor, active test and work support can be performed by combining data reception and command transmission via communication line from BCM.

BCM diagnosis part	Inspection item, self-diagnosis mode	Content
Door lock	DATA MONITOR	Displays BCM input data on real-time basis.
	ACTIVE TEST	Sends drive signals to door lock actuator to perform operation check.
	WORK SUPPORT	Change the setting for each function.

## CONSULT-II INSPECTION PROCEDURE

### CAUTION:

If CONSULT-II is used with no connection of CONSULT-II CONVERTER, malfunction might be detected in self-diagnosis depending on control unit which carry out CAN communication.

1. With ignition switch "OFF".
2. Connect "CONSULT-II" and "CONSULT-II CONVERTER" to the data link connector.

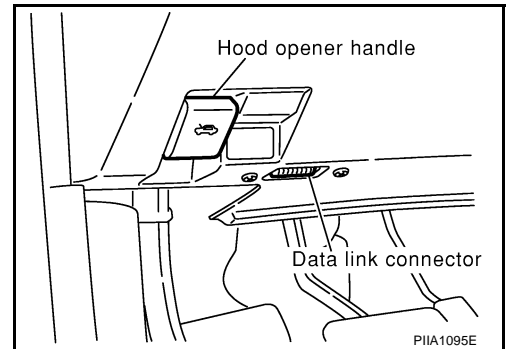

3. Turn ignition switch "ON".
4. Touch "START".

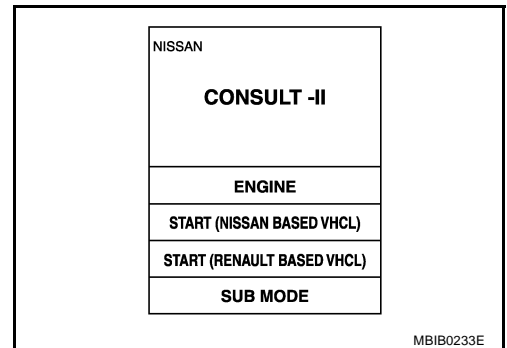

5. Touch "BCM" on "SELECT SYSTEM" screen.  
If "BCM" is not indicated, go to [GI-38, "CONSULT-II Data Link Connector \(DLC\) Circuit"](#).

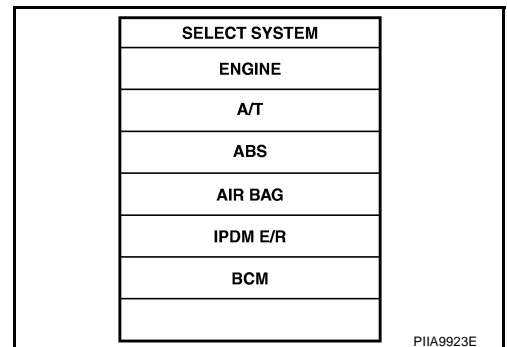

# POWER DOOR LOCK SYSTEM

6. Touch "DOOR LOCK" on "SELECT TEST ITEM" screen.

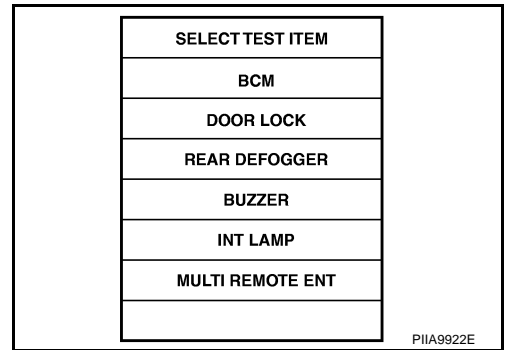

7. Select diagnosis mode. "DATA MONITOR", "ACTIVE TEST" and "WORK SUPPORT" are available.

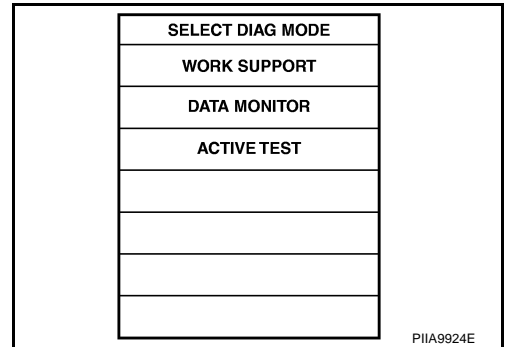

## CONSULT-II APPLICATION ITEMS

### Work Support

Work item	Description
DOOR LOCK-UNLOCK SET	Select unlock mode can be changed in this mode. Selects ON-OFF of select unlock mode.
ANTI-LOCK OUT SET	Key reminder door mode can be changed in this mode. Selects ON-OFF of key reminder door mode.

### Data Monitor

Monitor item	Content
IGN ON SW	Indicates [ON/OFF] condition of ignition switch in ON position.
KEY ON SW	Indicates [ON/OFF] condition of key switch.
CDL LOCK SW	Indicates [ON/OFF] condition of lock signal from door lock and unlock switch.
CDL UNLOCK SW	Indicates [ON/OFF] condition of unlock signal from door lock and unlock switch.
DOOR SW-DR	Indicates [ON/OFF] condition of front door switch driver side.
DOOR SW-AS	Indicates [ON/OFF] condition of front door switch passenger side.
DOOR SW-RR	Indicates [ON/OFF] condition of rear door switch RH.
DOOR SW-RL	Indicates [ON/OFF] condition of rear door switch LH.
BACK DOOR SW	This is displayed even if it is not equipped.
KEY CYL LK-SW	Indicates [ON/OFF] condition of lock signal from key cylinder.
KEY CYL UN-SW	Indicates [ON/OFF] condition of unlock signal from key cylinder.
KEYLESS LOCK	Indicates [ON/OFF] condition of lock signal from key fob.
KEYLESS UNLOCK	Indicates [ON/OFF] condition of unlock signal from key fob.

# POWER DOOR LOCK SYSTEM

## Active Test

Test item in "DOOR LOCK"	Content
ALL LOCK	This test is able to check all door lock actuators lock operation. These actuators lock when "ALL LOCK" on CONSULT-II screen is touched.
ALL UNLOCK	This test is able to check all door lock actuators unlock operation. These actuators unlock when "ALL UNLOCK" on CONSULT-II screen is touched.
DR UNLOCK	This test is able to check door lock actuator (driver side) lock/unlock operation. This actuator unlock when "DR UNLOCK" on CONSULT-II screen is touched.
OTHER UNLOCK	This test is able to check all door lock actuators (except driver side) unlock operation. These actuators unlock when "OTHER UNLOCK" on CONSULT-II screen is touched.

# POWER DOOR LOCK SYSTEM

## Trouble Diagnosis Chart by Symptom

AIS0049S

Always check the "Work Flow" before troubleshooting. Refer to [BL-29, "Work Flow"](#) .

Symptom	Diagnoses service procedure	Reference page
Key reminder door system does not operate properly.	1. Check key reminder door mode.* *: Key reminder door mode can be changed. First check key reminder door mode.	<a href="#">BL-31</a>
	2. Power supply and ground circuit check of BCM.	<a href="#">BL-34</a>
	3. Check key switch.	<a href="#">BL-38</a>
	4. Check door switch.	<a href="#">BL-35</a> *1 <a href="#">BL-36</a> *2
	5. Replace BCM.	<a href="#">BCS-15</a>
Power door lock does not operate with door lock and unlock switch.	1. Power supply and ground circuit check of BCM.	<a href="#">BL-34</a>
	2. Check door lock and unlock switch.	<a href="#">BL-40</a>
	3. Replace BCM.	<a href="#">BCS-15</a>
Power door lock does not operate with door key cylinder operation. (Power door lock operate properly with door lock and unlock switch.)	1. Check front door key cylinder switch.	<a href="#">BL-48</a>
	2. Replace power window main switch.	-
Specific door lock actuator does not operate.	1. Check door lock actuator.	<a href="#">BL-46</a> <a href="#">BL-46</a>
	2. Replace BCM.	<a href="#">BCS-15</a>
Select unlock does not operate. (All other power door lock system is "OK".)	1. Check select unlock mode.* *: Select unlock mode can be changed. First check select unlock mode.	<a href="#">BL-31</a>
	2. Replace BCM.	<a href="#">BCS-15</a>
Fuel lid opener actuator does not operate. (All door lock actuators operates properly.)	1. Check fuel lid opener actuator.	<a href="#">BL-47</a>

\*1: With navigation system

\*2: Without navigation system

A  
B  
C  
D  
E  
F  
G  
H  
BL  
J  
K  
L  
M

# POWER DOOR LOCK SYSTEM

AIS0049Q

## Power Supply and Ground Circuit Check of BCM

### 1. CHECK FUSE

Check the following fuse and fusible link.

- 50A fusible link (letter **F** , located in the fuse and fusible link box)
- 10A fuse [No.18, located in the fuse block (J/B)]

#### NOTE:

Refer to [BL-19, "Component Parts and Harness Connector Location"](#) .

OK or NG

OK >> GO TO 2.

NG >> If fuse is blown, be sure to eliminate cause of malfunction before installing new fuse, refer to [PG-3, "POWER SUPPLY ROUTING CIRCUIT"](#) .

### 2. CHECK POWER SUPPLY CIRCUIT

1. Turn ignition switch OFF.
2. Disconnect BCM connectors.
3. Check voltage between BCM and ground.

Connector	Terminals (Wire color)		Ignition switch position		
	(+)	(-)	OFF	ACC	ON
M2	42 (GY)	Ground	Battery voltage	Battery voltage	Battery voltage
	55 (W/R)				

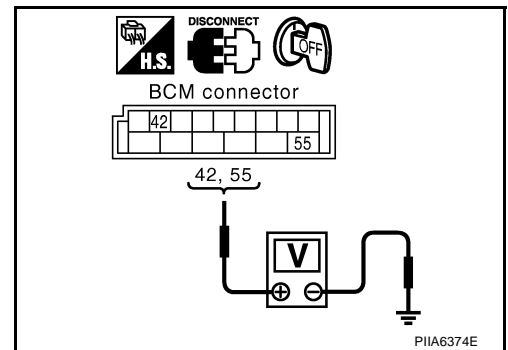

OK or NG

OK >> GO TO 3.

NG >> Repair or replace BCM power supply circuit.

### 3. CHECK GROUND CIRCUIT

Check continuity between BCM harness connector M2 terminal 52 and ground.

**52 (B) - Ground : Continuity should exist.**

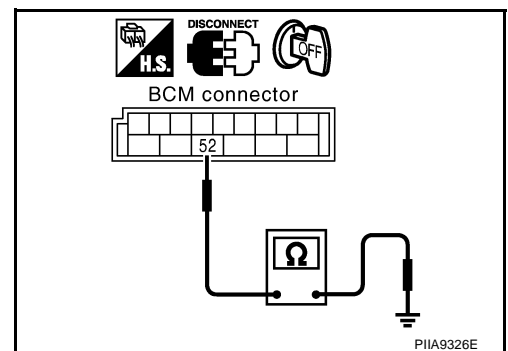

OK or NG

OK >> Power supply and ground circuit are OK.

NG >> Repair or replace BCM ground circuit.

# POWER DOOR LOCK SYSTEM

AIS004CQ

## Check Door Switch / With Navigation System

First perform the "SELF-DIAG RESULTS" in "BCM" with CONSULT-II, when perform the each trouble diagnosis. Refer to [BCS-14, "CAN Communication Inspection Using CONSULT-II \(Self-Diagnosis\)"](#).

### 1. CHECK DOOR SWITCH INPUT SIGNAL

Check voltage between combination meter connector and ground.

Item	Connector	Terminals (Wire color)		Door condition	Voltage [V] (Approx.)
		(+)	(-)		
Driver side	M19	7 (W)	Ground	CLOSE ↓ OPEN	Battery voltage ↓ 0
Passenger side		6 (P)			
Rear LH		9 (P)			
Rear RH		8 (P)			

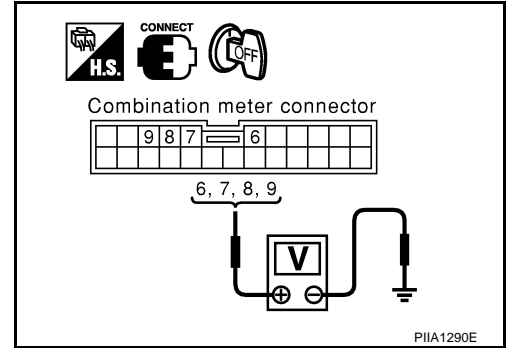

OK or NG

- OK >> Door switch circuit is OK.
- NG >> GO TO 2.

### 2. CHECK DOOR SWITCH CIRCUIT

1. Turn ignition switch OFF.
2. Disconnect door switch and combination meter connector.
3. Check continuity between door switch connector B17, B23, B20, B32 terminals 1 and combination meter connector M19 terminals 7, 6, 9, 8.

**Front door switch driver side**

**1 (W) – 7 (W) : Continuity should exist.**

**Front door switch passenger side**

**1 (P) – 6 (P) : Continuity should exist.**

**Rear door switch LH**

**1 (P) – 9 (P) : Continuity should exist.**

**Rear door switch RH**

**1 (P) – 8 (P) : Continuity should exist.**

4. Check continuity between door switch connector B17, B23, B20, B32 terminals 1 and ground.

**1 (W or P) – Ground : Continuity should not exist**

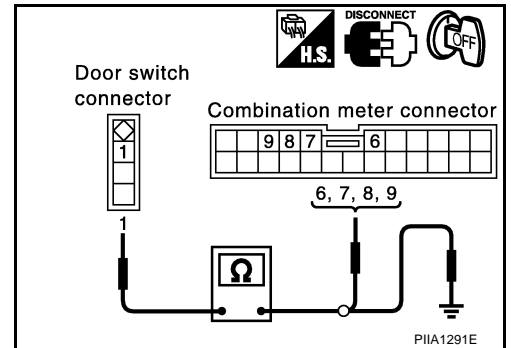

OK or NG

- OK >> GO TO 3.
- NG >> Repair or replace harness.

### 3. CHECK DOOR SWITCH

Check continuity between each door switch terminal 1 and body ground part of door switch.

Terminal	Condition of door switch	Continuity
1	Pushed	No
	Released	Yes

OK or NG

- OK >> GO TO 4.
- NG >> Replace door switch.

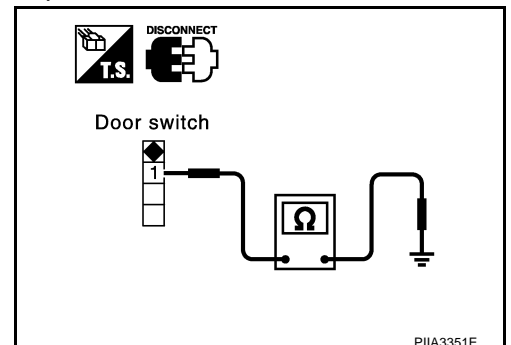

# POWER DOOR LOCK SYSTEM

## 4. CHECK COMBINATION METER OUTPUT SIGNAL

1. Connect combination meter connector.
2. Check voltage between combination meter connector M19 terminals 6, 7, 8, 9 and ground.

**6 (P) - Ground : Battery voltage**  
**7 (W) - Ground : Battery voltage**  
**8 (P) - Ground : Battery voltage**  
**9 (P) - Ground : Battery voltage**

OK or NG

- OK >> Check harness connection.  
 NG >> Replace combination meter.

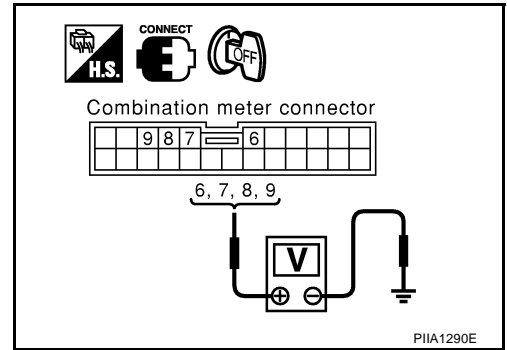

## Check Door Switch / Without Navigation System

AIS0049T

### 1. CHECK DOOR SWITCH INPUT SIGNAL

#### With CONSULT-II

Check door switches ("DOOR SW-DR", "DOOR SW-AS", "DOOR SW-RL" and "DOOR SW-RR") in "DATA MONITOR" mode with CONSULT-II.

Monitor item	Condition
DOOR SW-DR	CLOSE → OPEN: OFF → ON
DOOR SW-AS	
DOOR SW-RL	
DOOR SW-RR	

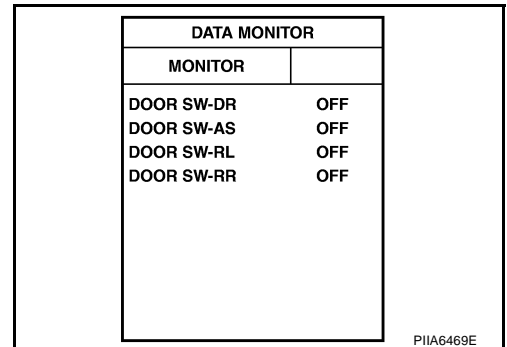

#### Without CONSULT-II

Check voltage between BCM connector and ground.

Item	Connector	Terminals (Wire color)		Door condition	Voltage (V) (Approx.)
		(+)	(-)		
Driver side	B4	62 (W)	Ground	CLOSE ↓ OPEN	Battery voltage ↓ 0
Rear LH		63 (P)			
Passenger side	M1	12 (P)			
Rear RH		13 (P)			

OK or NG

- OK >> Door switch circuit is OK.  
 NG >> GO TO 2.

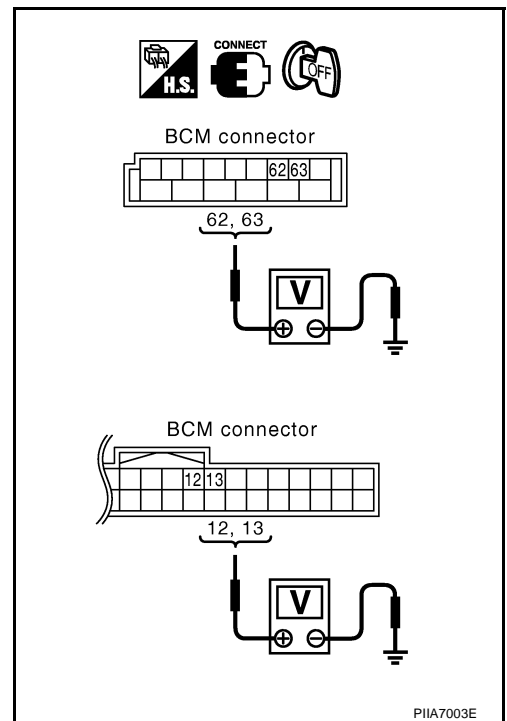



# POWER DOOR LOCK SYSTEM

## 2. CHECK DOOR SWITCH

1. Turn ignition switch OFF.
2. Disconnect door switch connector.
3. Check continuity between door switch terminal 1 and ground part of door switch.

Terminal	Condition of door switch	Continuity
1	Pushed	No
	Released	Yes

OK or NG

OK >> GO TO 3.

NG >> Replace door switch.

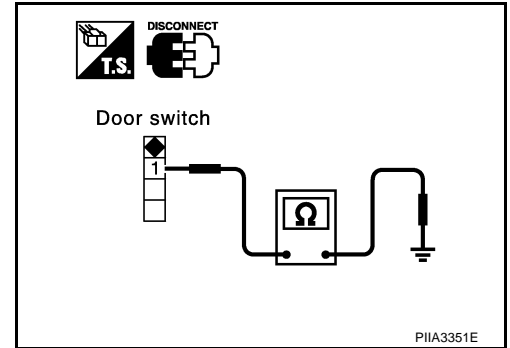

## 3. CHECK DOOR SWITCH CIRCUIT

1. Disconnect BCM connector.
2. Check continuity between door switch connector B26, B36, B46, B206 terminals 1 and BCM connector M3, B14 terminals 62, 12, 63, 13.

**Driver side door**

**1 (W) – 62 (W) : Continuity should exist.**

**Passenger side door**

**1 (P) – 12 (P) : Continuity should exist.**

**Rear door LH**

**1 (P) – 63 (P) : Continuity should exist.**

**Rear door RH**

**1 (P) – 13 (P) : Continuity should exist.**

3. Check continuity between door switch connector B26, B36, B46, B206 terminal 1 and ground.

**1 (W or P) – Ground : Continuity should not exist.**

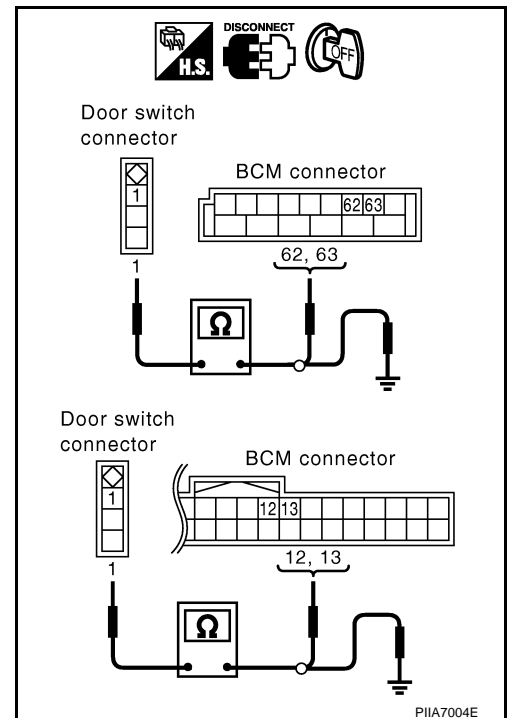

OK or NG

OK >> Check door switch case ground condition.

NG >> Repair or replace harness.

# POWER DOOR LOCK SYSTEM

AIS0049U

## Check Key Switch

### 1. CHECK KEY SWITCH INPUT SIGNAL

#### With CONSULT-II

Check ignition key switch "KEY ON SW" in "DATA MONITOR" mode with CONSULT-II.

- When key is inserted in ignition key cylinder  
**KEY ON SW : ON**
- When key is removed from ignition key cylinder  
**KEY ON SW : OFF**

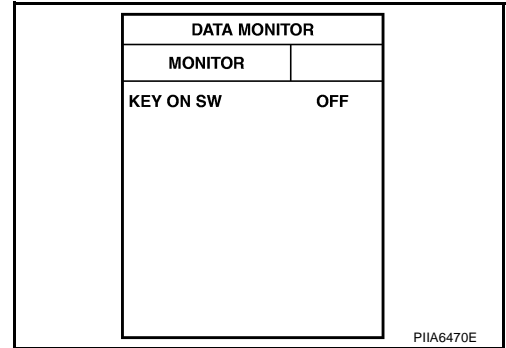

#### Without CONSULT-II

Check voltage between BCM connector and ground.

Connector	Terminals (wire color)		Condition of key switch	Voltage [V] Approx.
	(+)	(-)		
M1	37 (B/P)	Ground	Key is inserted	Battery voltage
			Key is removed	0

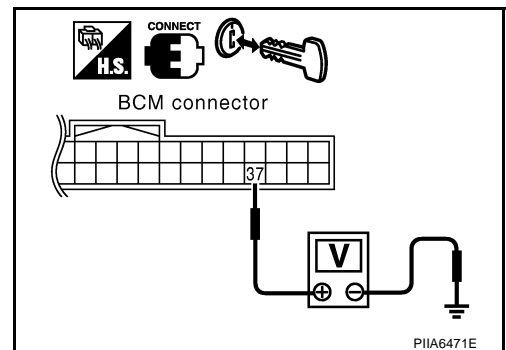

#### OK or NG

- OK >> Key switch circuit is OK.
- NG >> GO TO 2.

### 2. CHECK KEY SWITCH

- Disconnect key switch connector.
- Check continuity between key switch terminal 1 and 2.

Terminals		Condition of key switch	Continuity
1	2		
		Key is inserted	Yes
		Key is removed	No

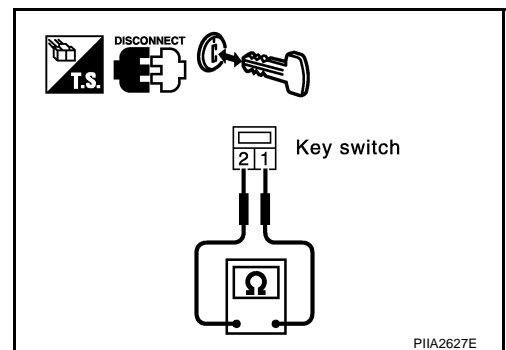

#### OK or NG

- OK >> GO TO 3.
- NG >> Replace key switch.

# POWER DOOR LOCK SYSTEM

## 3. CHECK KEY SWITCH CIRCUIT

1. Disconnect key switch connector.
2. Check continuity between BCM harness connector M90 terminal 37 and key switch harness connector M25 terminal 4.

**37 (B/R) - 1 (B/R) : Continuity should exist.**

3. Check continuity between BCM harness connector M90 terminal 37 and ground.

**37 (B/R) - Ground : Continuity should not exist.**

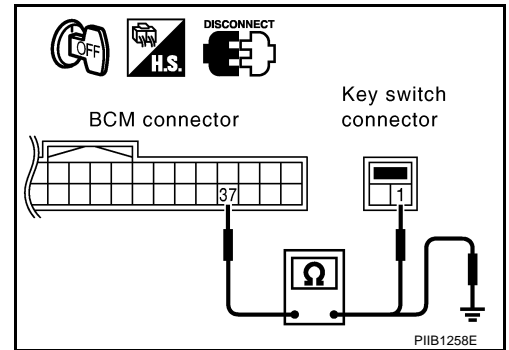

### OK or NG

OK >> Check the following.

- 10A fuse [No. 21, located in the fuse block (J/B)]
- Harness for open or short between key switch and fuse

NG >> Replace harness or connector.

A  
B  
C  
D  
E  
F  
G  
H  
BL  
J  
K  
L  
M

# POWER DOOR LOCK SYSTEM

## Check Door Lock and Unlock Switch (With Anti-pinch System For All Door Window)

AIS0049V

### 1. CHECK POWER WINDOW OPERATION

Does power window system operate normally?

OK or NG

OK >> GO TO 2.

NG >> Refer to [GW-17, "POWER WINDOW SYSTEM"](#).

### 2. CHECK DOOR LOCK AND UNLOCK SWITCH INPUT SIGNAL

#### With CONSULT-II

Check door lock and unlock switch ("CDL LOCK SW" and "CDL UNLOCK SW") in DATA MONITOR mode with CONSULT-II.

- When door lock and unlock switch is turned to LOCK:

**CDL LOCK SW : ON**

- When door lock and unlock switch is turned to UNLOCK:

**CDL UNLOCK SW : ON**

DATA MONITOR	
MONITOR	
CDL LOCK SW	OFF
CDL UNLOCK SW	OFF

PIIA6538E

#### Without CONSULT-II

- Remove key from ignition key cylinder, and close the doors of driver side and passenger side.
- Check the signal between BCM connector M1 terminal 22 and ground with oscilloscope when door lock and unlock switch is turned "LOCK" or "UNLOCK".
- Make sure signals which are shown in the figure below can be detected during 10 second just after door lock and unlock switch (driver side or passenger side) is turned "LOCK" or "UNLOCK".

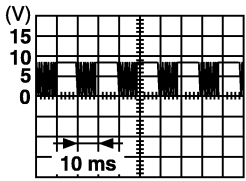
Connector	Terminal (Wire color)		Voltage [V] (Reference value)
	(+)	(-)	
M1	22(Y)	Ground	 <p>PIIA1297E</p>

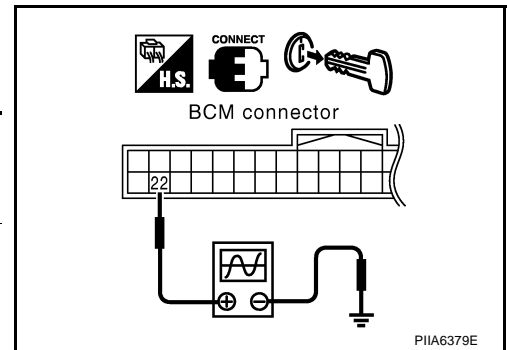

OK or NG

OK >> Door lock and unlock switch circuit is OK.

NG >> GO TO 3.

# POWER DOOR LOCK SYSTEM

## 3. CHECK POWER WINDOW SERIAL LINK CIRCUIT

1. Turn ignition switch OFF.
2. Disconnect BCM, power window main switch and front power window switch connectors.
3. Check continuity between BCM connector M1 terminal 22 and power window main switch (door lock and unlock switch) connector D6 terminal 9.

**22 (Y) – 9 (Y) : Continuity should exist.**

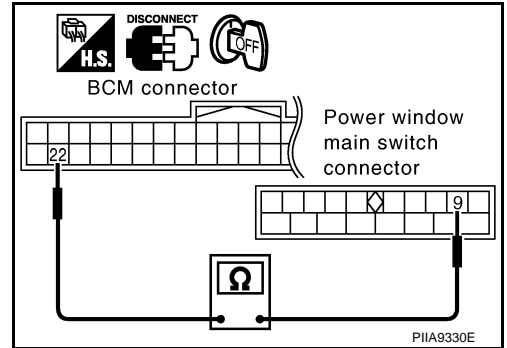

4. Check continuity between BCM connector M1 terminal 22 and front power window sub-switch (front passenger side) (door lock and unlock switch) connector D36 terminal 11.

**22 (Y) – 11 (Y) : Continuity should exist.**

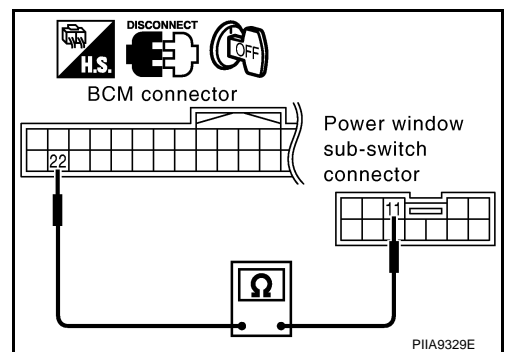

### OK or NG

- OK >> GO TO 4.  
NG >> Repair or replace harness.

A  
B  
C  
D  
E  
F  
G  
H  
BL  
J  
K  
L  
M

# POWER DOOR LOCK SYSTEM

## 4. CHECK DOOR LOCK AND UNLOCK SWITCH GROUND CIRCUIT

- Check continuity between power window main switch (door lock and unlock switch) connector D7 terminal 15 and ground.

**15 (B) – Ground : Continuity should exist.**

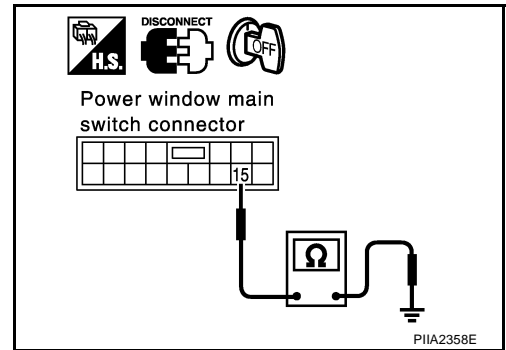

- Check continuity between power window sub-switch (front passenger side) (door lock and unlock switch) connector D37 terminal 7 and ground.

**7 (B) – Ground : Continuity should exist.**

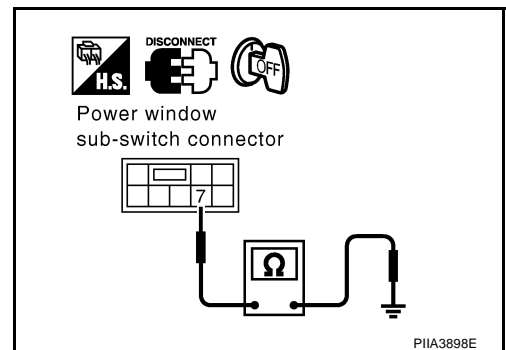

### OK or NG

- OK >> Replace power window main switch or power window sub-switch.
- NG >> Repair or replace harness.

# POWER DOOR LOCK SYSTEM

## Check Door Lock and Unlock Switch (With Anti-pinch System for Front Door Window)

AIS004CY

### 1. CHECK POWER WINDOW OPERATION

Does power window system operate normally?

OK or NG?

OK >> GO TO 2.

NG >> Refer to [GW-17, "POWER WINDOW SYSTEM"](#).

### 2. CHECK DOOR LOCK AND UNLOCK SWITCH INPUT SIGNAL

#### Ⓜ With CONSULT-II

Check door lock and unlock switch ("CDL LOCK SW", "CDL UNLOCK SW") in DATA MONITOR mode with CONSULT-II.

- When door lock and unlock switch is turned to LOCK

**CDL LOCK SW :ON**

- When door lock and unlock switch is turned to UNLOCK

**CDL UNLOCK SW :ON**

DATA MONITOR	
MONITOR	
CDL LOCK SW	OFF
CDL UNLOCK SW	OFF

PIIA6538E

#### ⊗ Without CONSULT-II

- Remove key from ignition key cylinder,
- Check the signal between BCM connector M1 terminal 22 and ground with oscilloscope when door lock and unlock switch is turned "LOCK" or "UNLOCK".
- Make sure signals which are shown in the figure below can be detected during 10 second just after door lock and unlock switch is turned "LOCK" or "UNLOCK".

Connector	Terminal (wire color)		Voltage [V] (Reference value)
	(+)	(-)	
M1	22 (Y)	Ground	<p>PIIA1297E</p>

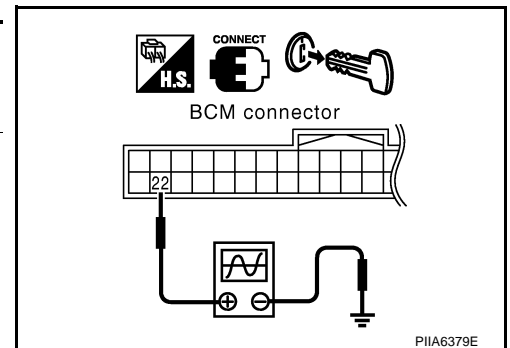

OK or NG

OK >> Door lock and unlock switch is OK.

NG >> GO TO 3.

# POWER DOOR LOCK SYSTEM

## 3. CHECK POWER WINDOW SERIAL LINK CIRCUIT

1. Turn ignition switch OFF.
2. Disconnect BCM, power window main switch and power window sub-switch connectors.
3. Check continuity between BCM connector M1 terminal 22 and power window main switch (door lock and unlock switch) connector D7 terminal 8.

**22 (Y) - 8 (Y) : Continuity should exist.**

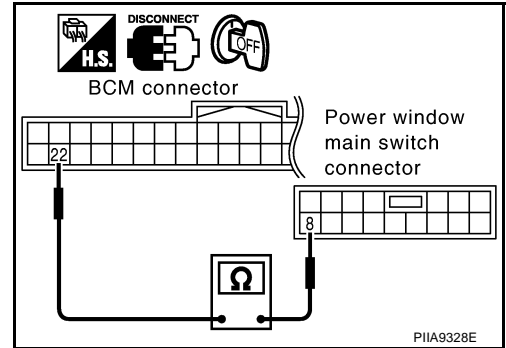

4. Check continuity between BCM connector M1 terminal 22 and power window sub-switch (door lock and unlock switch) connector D36 terminal 11.

**22 (Y) - 11 (Y) : Continuity should exist.**

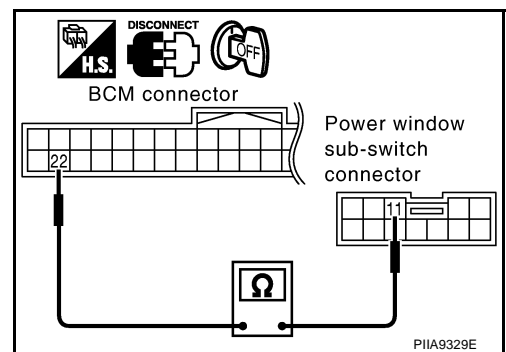

### OK or NG

- OK >> GO TO 4.
- NG >> Repair or replace harness.



# POWER DOOR LOCK SYSTEM

## 4. CHECK DOOR LOCK AND UNLOCK SWITCH GROUND CIRCUIT

1. Check continuity between power window main switch (door lock and unlock switch) connector D7 terminal 5 and ground.

**5 (B) - Ground : Continuity should exist.**

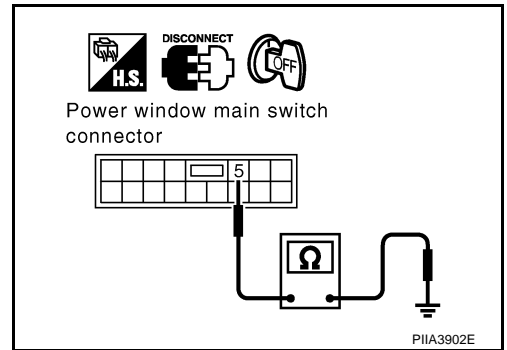

2. Check continuity between power window sub-switch (front passenger side) (door lock and unlock switch) connector D37 terminal 7 and ground.

**7 (B) - Ground : Continuity should exist.**

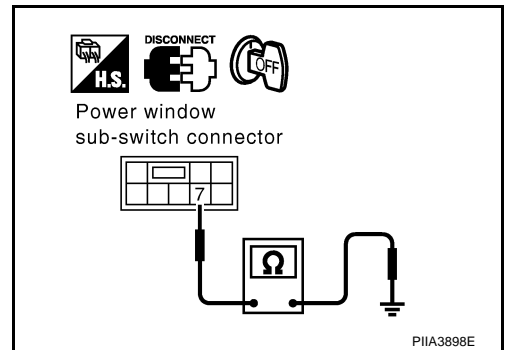

### OK or NG

- OK >> Replace power window main switch or power window sub-switch.
- NG >> Repair or replace ground harness.

A  
B  
C  
D  
E  
F  
G  
H

BL

J  
K  
L  
M

# POWER DOOR LOCK SYSTEM

## Check Door Lock Actuator (Driver side)

AIS0049W

### 1. CHECK OUTPUT SIGNAL

Check voltage between BCM connector and ground.

Con- nector	Terminal (Wire color)		Condition of driver door lock and unlock switch	Voltage [V] (Approx.)
	(+)	(-)		
M2	44 (Y)	Ground	Unlocked.	0 → Battery voltage → 0
	50 (PU)		Locked.	0 → Battery voltage → 0

OK or NG

- OK >> GO TO 2.  
NG >> Replace BCM.

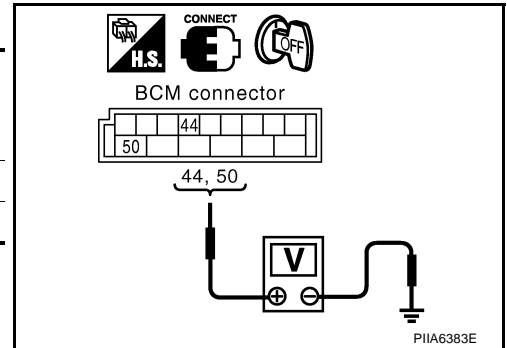

### 2. CHECK DOOR LOCK ACTUATOR CIRCUIT

1. Turn ignition switch OFF.
2. Disconnect BCM and front door lock actuator driver side connector.
3. Check continuity between BCM connector M4 terminals 44, 50 and front door lock actuator driver side connector D11 terminals 1, 3.

**44 (Y) – 3 (Y) : Continuity should exist.**

**50 (PU) – 1 (PU) : Continuity should exist.**

4. Check continuity between BCM connector M4 terminals 44, 50 and ground.

**44 (Y) – Ground : Continuity should not exist.**

**50 (PU) – Ground : Continuity should not exist.**

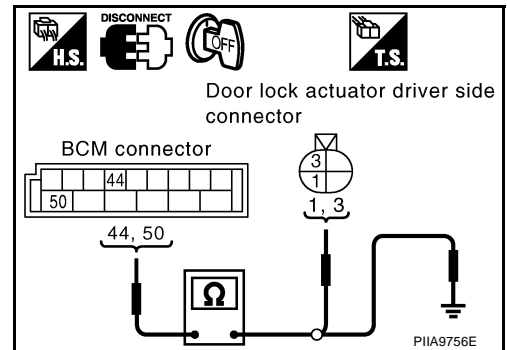

OK or NG

- OK >> Replace front door lock actuator.  
NG >> Repair or replace harness.

## Check Door Lock Actuator (Passenger Side and Rear LH/RH)

AIS0049X

### 1. CHECK DOOR LOCK ACTUATOR SIGNAL

Check voltage between BCM connector and ground.

Conne- ctor	Terminal (Wire color)		Condition of door lock and unlock switch	Voltage [V] (Approx.)
	(+)	(-)		
M4	50 (PU)	Ground	Locked.	0 → Battery voltage → 0
	51 (W/L)		Unlocked.	0 → Battery voltage → 0

OK or NG

- OK >> GO TO 2.  
NG >> Replace BCM.

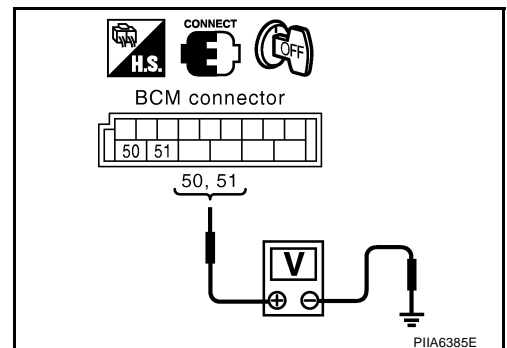

# POWER DOOR LOCK SYSTEM

## 2. CHECK DOOR LOCK ACTUATOR CIRCUIT

1. Disconnect BCM and each door lock actuator connectors.
2. Check continuity between BCM connector M2 terminals 50, 51 and front door lock actuator passenger side, rear door lock actuator LH/RH connectors D40, D58, D78 terminals 1, 3.

**50 (PU) – 1 (PU) : Continuity should exist.**

**51 (W/L) – 3 (W/L) : Continuity should exist.**

3. Check continuity between BCM connector M4 terminals 50, 51 and ground.

**50 (PU) – Ground : Continuity should not exist.**

**51 (W/L) – Ground : Continuity should not exist.**

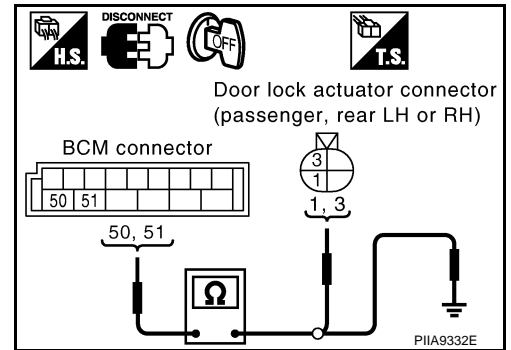

### OK or NG

OK >> Replace door lock actuator.

NG >> Repair or replace harness.

## Check Fuel Lid Opener Actuator

### 1. CHECK FUEL LID OPENER ACTUATOR CIRCUIT

1. Turn ignition switch OFF.
2. Disconnect BCM and fuel lid lock actuator connector.
3. Check continuity between BCM connector M2 terminals 44, 50 and fuel lid lock actuator connector B118 terminals 1, 2.

**44 (Y) – 1 (Y) : Continuity should exist.**

**50 (PU) – 2 (PU) : Continuity should exist.**

4. Check continuity between BCM connector M2 terminals 44, 50 and ground.

**44 (Y) – Ground : Continuity should not exist.**

**50 (PU) – Ground : Continuity should not exist.**

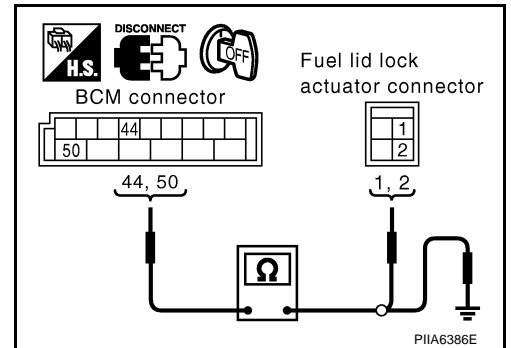

### OK or NG

OK >> Replace fuel lid actuator.

NG >> Repair or replace harness.

# POWER DOOR LOCK SYSTEM

AIS004A0

## Door Key Cylinder Switch Check

### 1. CHECK DOOR KEY CYLINDER SWITCH INPUT SIGNAL

#### With CONSULT-II

- Check door key cylinder switch ("KEY CYL LK SW") in "DATA MONITOR" mode with CONSULT-II.

**"KEY CYL LK-SW" should be "ON" when key inserted in door key cylinder is turned to lock.**

- Check door key cylinder switch ("KEY CYL UN-SW") in "DATA MONITOR" mode with CONSULT-II.

**"KEY CYL UN-SW" should be "ON" when key inserted in door key cylinder is turned to unlock.**

DATA MONITOR	
MONITOR	
KEY CYL LK-SW	OFF
KEY CYL UN-SW	OFF

PIIB1425E

#### Without CONSULT-II

Check voltage between power window main switch (door lock and unlock switch) connector and ground.

#### With anti-pinch system for all door window models

Connector	Terminal (Wire color)		Key position	Voltage [V] (Approx.)
	(+)	(-)		
D6	6 (R/W)	Ground	Neutral/Unlock	5
			Lock	0
	5 (L/W)		Neutral/Lock	5
			Unlock	0

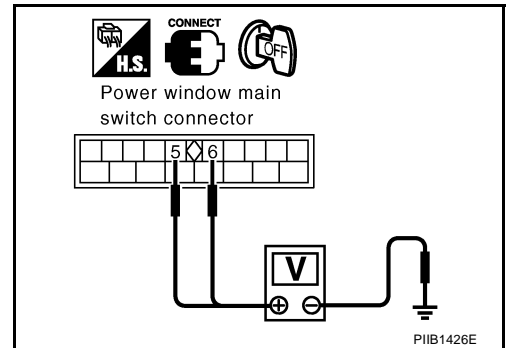

#### With anti-pinch system with for front door window models

Connector	Terminal (Wire color)		Key position	Voltage [V] (Approx.)
	(+)	(-)		
D7	6 (R/W)	Ground	Neutral/Unlock	5
			Lock	0
D8	19 (L/W)		Neutral/Lock	5
			Unlock	0

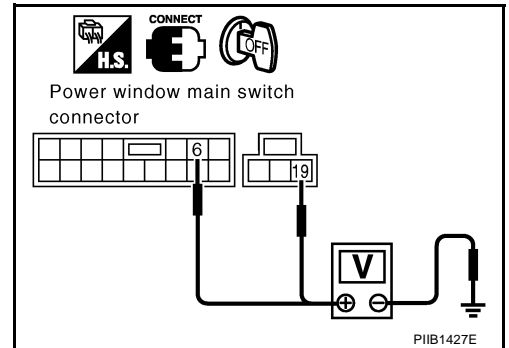

#### OK or NG

- OK >> Further inspection is necessary. Refer to symptom chart.
- NG >> ● GO TO 2. (With anti-pinch system for all door window)  
 ● GO TO 3. (With anti-pinch system for front door window)

# POWER DOOR LOCK SYSTEM

## 2. CHECK DOOR KEY CYLINDER SWITCH CIRCUIT/WITH ANTI-PINCH SYSTEM FOR ALL DOOR WINDOW

1. Turn ignition switch OFF.
2. Disconnect power window main switch (door lock and unlock switch) and door key cylinder switch connector.
3. Check continuity between power window main switch (door lock and unlock switch) connector D7 terminals 5, 6 and door key cylinder switch connector D6 terminals 1, 3.

**6 (R/W) – 1 (R/W) :Continuity should exist.**

**5 (L/W) – 3 (L/W) :Continuity should exist.**

### OK or NG

OK >> GO TO 4.

NG >> Repair or replace harness between power window main switch and door key cylinder switch.

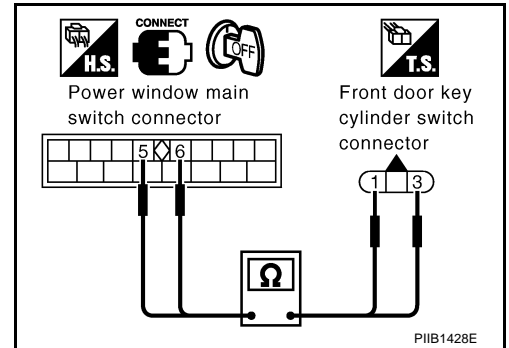

## 3. CHECK DOOR KEY CYLINDER SWITCH CIRCUIT/WITH ANTI-PINCH SYSTEM FOR FRONT DOOR WINDOW

1. Turn ignition switch OFF.
2. Disconnect power window main switch (door lock and unlock switch) and door key cylinder switch connector.
3. Check continuity between power window main switch (door lock and unlock switch) connector D7 terminals 6, 19 and door key cylinder switch connector D12 terminals 1, 3.

**6 (R/W) – 1 (R/W) :Continuity should exist.**

**19 (L/W) – 3 (L/W) :Continuity should exist.**

### OK or NG

OK >> GO TO 4.

NG >> Repair or replace harness between power window main switch and door key cylinder switch.

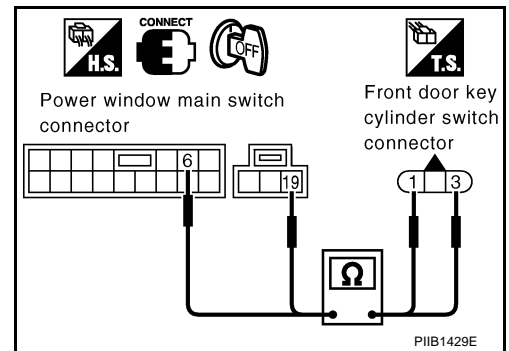

## 4. CHECK DOOR KEY CYLINDER SWITCH GROUND CHECK

Check continuity between door key cylinder switch connector D12 terminal 2 and ground.

**2 (B) – Ground :Continuity should exist.**

### OK or NG

OK >> GO TO 4.

NG >> Repair or replace harness.

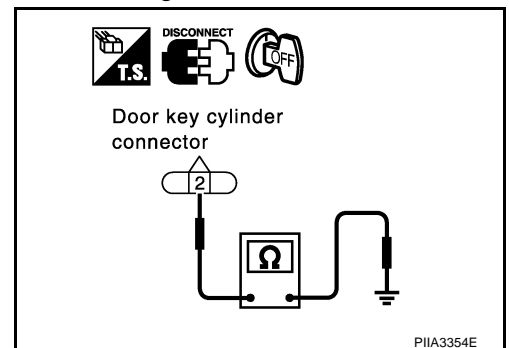

# POWER DOOR LOCK SYSTEM

## 5. CHECK DOOR KEY CYLINDER SWITCH

Check continuity between door key cylinder switch terminals 1, 3 and 2.

Terminals		Key position	Continuity
1	2	Neutral/Lock	No
		Unlock	Yes
Neutral/Unlock		No	
Lock		Yes	

OK or NG

OK >> Further inspection is necessary. Refer to symptom chart.

NG >> Replace door key cylinder switch.

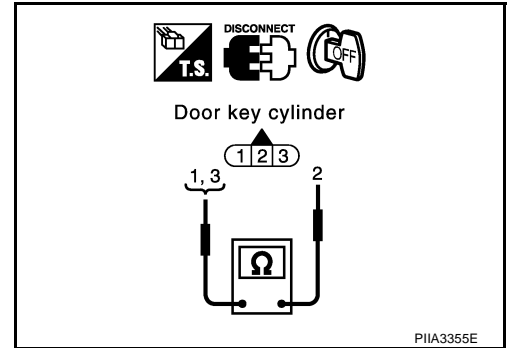

# REMOTE KEYLESS ENTRY SYSTEM

PPF:28596

AIS004A2

## REMOTE KEYLESS ENTRY SYSTEM

### Component Parts and Harness Connector Location

A  
B  
C  
D  
E  
F  
G  
H  
BL  
J  
K  
L  
M

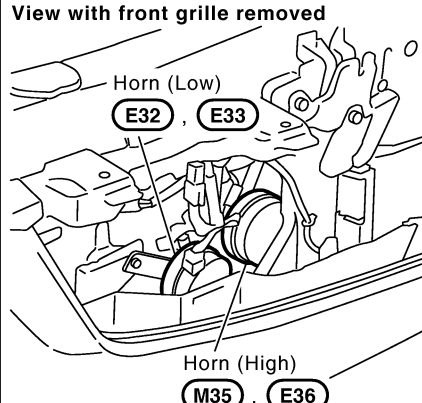
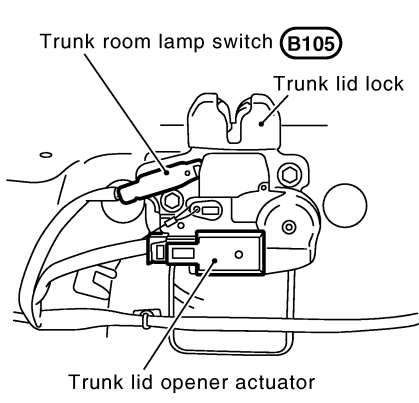
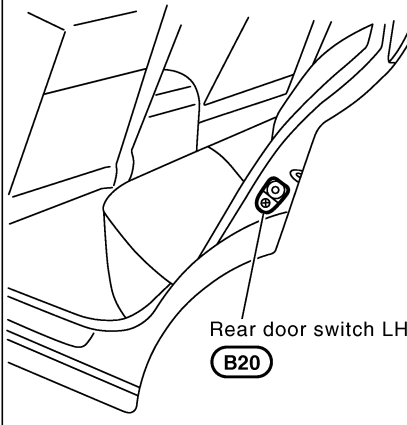
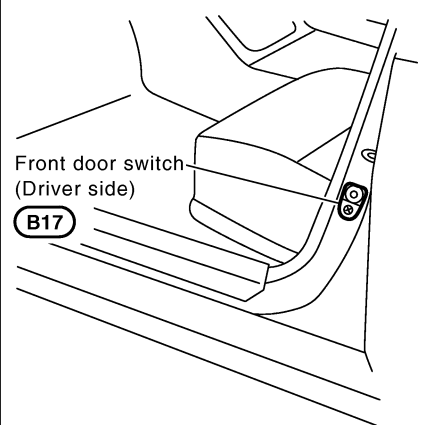
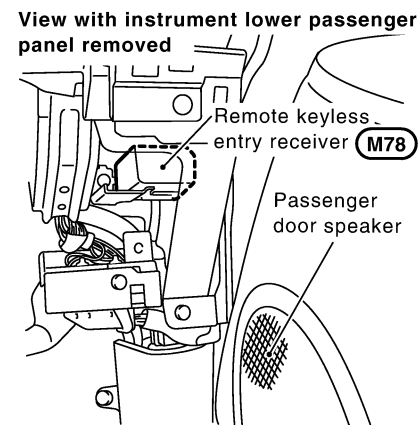
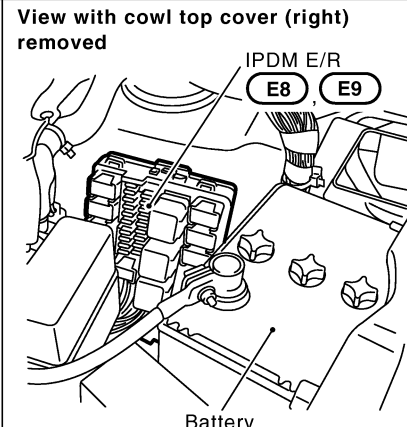
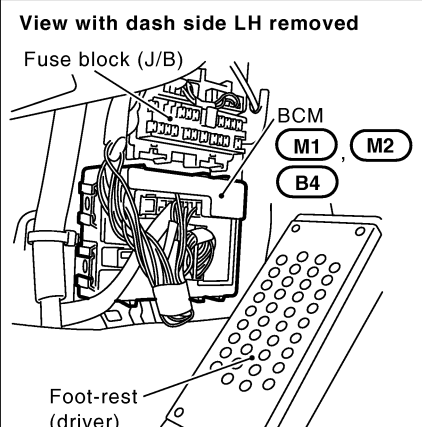
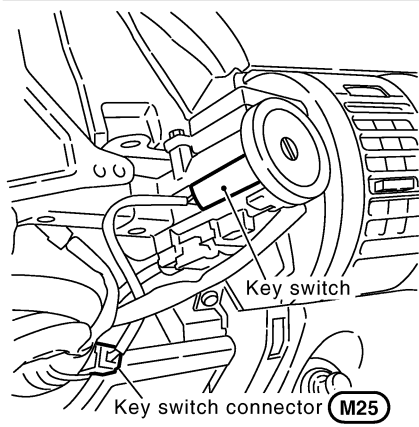
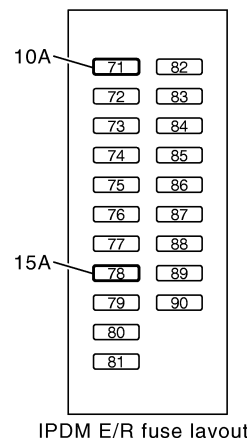
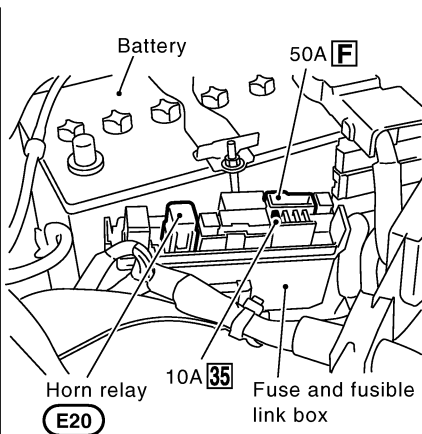
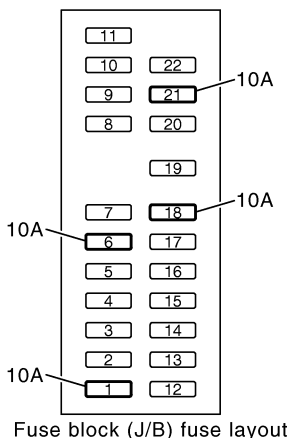

PIIA9653E

# REMOTE KEYLESS ENTRY SYSTEM

AIS004A3

## System Description

### INPUTS

Power is supplied at all times

- through 50A fusible link (letter **F** , located in the fuse and fusible link box)
- to BCM terminal 55,
- through 15A fuse (No. 22, located in the fuse and fusible link box)
- to BCM terminal 42,
- through BCM terminal 19
- to remote keyless entry receiver terminal 4.

When the key switch is ON (key is inserted in ignition key cylinder), power is supplied

- through 15A fuse (No. 22, located in the fuse and fusible link box)
- through key switch terminal 1 and 2
- to BCM terminal 37.

When the ignition switch is ACC or ON, power is supplied

- through 10A fuse [No. 6, located in the fuse block (J/B)]
- to BCM terminal 11.

When the ignition switch is ON or START, power is supplied

- through 10A fuse [No. 12, located in the fuse block (J/B)]
- to BCM terminal 38.

Ground is supplied

- to remote keyless entry receiver terminal 1
- through BCM terminal 18,
- to BCM terminal 52
- through body grounds M30 and M66.

When the front door switch (driver side) is ON (door is OPEN), ground is supplied

- to BCM terminal 62
- through front door switch (driver side) terminal 1 and
- through front door switch (driver side) case ground.

When the front door switch (passenger side) is ON (door is OPEN), ground is supplied

- to BCM terminal 12
- through front door switch (passenger side) terminal 1 and
- through front door switch (passenger side) case ground.

When the rear door switch LH is ON (door is OPEN), ground is supplied

- to BCM terminal 63
- through rear door switch LH terminal 1 and
- through rear door switch LH case ground.

When the rear door switch RH is ON (door is OPEN), ground is supplied

- to BCM meter terminal 13
- through rear door switch RH terminal 1 and
- through rear door switch RH case ground.

Key fob signal is inputted to remote keyless entry receiver (the antenna of the system is built in remote keyless entry receiver).

Remote keyless entry receiver sends key fob signal

- to BCM terminal 20
- from remote keyless entry receiver terminal 2.

The remote keyless entry system controls operation of the

- power door lock
- hazard and horn reminder
- auto door lock



# REMOTE KEYLESS ENTRY SYSTEM

- panic alarm
- keyless power window down (open)
- room lamp and key ring illumination

## OPERATED PROCEDURE

### Power Door Lock Operation

BCM receives a LOCK signal from remote keyless entry receiver. BCM locks all doors with input of LOCK signal from remote keyless entry receiver.

When an UNLOCK signal is sent from remote keyless entry receiver once, driver's door will be unlocked. Then, if an UNLOCK signal is sent from remote keyless entry receiver again within 5 seconds, all other door will be unlocked.

#### NOTE:

Remote keyless entry receiver is received key fob signal from key fob.

Power door lock operation mode can be changed using "DOOR LOCK-UNLOCK SET" mode in "WORK SUPPORT" of "POWER DOOR LOCK SYSTEM".

Refer to [BL-63, "Work Support"](#) .

### Hazard and Horn Reminder

When the doors are locked or unlocked by key fob, supply power to hazard warning lamp flashes as follows

- LOCK operation: C mode (flash twice) or S mode (flash twice)
- UNLOCK operation: C mode (flash once) or S mode (does not flash)

BCM outputs to IPDM E/R for horn reminder signal as DATA LINE (CAN H line and CAN L line).

The hazard and horn reminder has C mode (horn chirp mode) and S mode (non-horn chirp mode).

### Operating function of hazard and horn reminder

Remote controller operation	C mode		S mode	
	Lock	Unlock	Lock	Unlock
Hazard warning lamp flash	Twice	Once	Twice	—
Horn sound	Once	—	—	—

Hazard and horn reminder does not operate if any door switch is ON (any door is OPEN).

### How to change hazard and horn reminder mode

#### ④ With CONSULT-II

Hazard and horn reminder can be changed using "MULTI ANSWER BACK SET" mode in "WORK SUPPORT". Refer to [BL-63, "Work Support"](#) .

#### ⊗ Without CONSULT-II

When LOCK and UNLOCK signals are sent from the key fob for more than 2 seconds at the same time, the hazard and horn reminder mode is changed and hazard warning lamp flashes and horn sounds as follows:

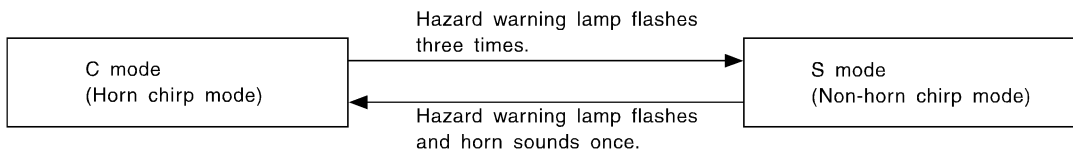

SEL153WA

# REMOTE KEYLESS ENTRY SYSTEM

---

## Auto Door Lock Operation

Auto lock function signal is sent for operation when any of the following signals are not sent within 1 minute after the unlock signal is sent from the key fob:

- when door switch is turned ON for open.
- when the key switch is turned ON.
- when the lock signal is sent from the key fob.

Auto door lock mode can be changed using "AUTO LOCK SET" mode in "WORK SUPPORT".

Refer to [BL-63, "Work Support"](#) .

## Panic Alarm Operation

When key switch is OFF (when ignition key is not inserted in key cylinder), BCM turns on and off horn and headlamp intermittently with input of PANIC ALARM signal from key fob.

The alarm automatically turns off after 25 seconds or when BCM receives any signal from key fob.

Panic alarm operation mode can be changed using "PANIC ALARM SET" mode in "WORK SUPPORT".

Refer to [BL-63, "Work Support"](#) .

For detailed description, refer to [BL-106, "VEHICLE SECURITY \(THEFT WARNING\) SYSTEM"](#) .

## Keyless Power Window Down (open) Operation

When key fob unlock switch is turned ON with ignition switch OFF, and key fob unlock switch is detected to be on continuously for 3 seconds, the driver's door and passenger's door power windows are simultaneously opened.

Power window is operated to open and the operation continues as long as the key fob unlock switch is pressed.

Keyless power window down operation mode can be changed using "PW DOWN SET" mode in "WORK SUPPORT". Refer to [BL-63, "Work Support"](#) .

## Room Lamp and Ignition Key ring Illumination Operation

When the following conditions come:

- condition of interior lamp switch is DOOR position;
- door switch OFF (when all the doors are closed);

Remote keyless entry system turns on interior lamp (for 30 seconds) with input of UNLOCK signal from key fob. For detailed description, refer to [LT-164, "INTERIOR ROOM LAMP"](#) .

## CAN Communication System Description

AIS004A4

CAN (Controller Area Network) is a serial communication line for real time application. It is an on-vehicle multiplex communication line with high data communication speed and excellent error detection ability. Many electronic control units are equipped onto a vehicle, and each control unit shares information and links with other control units during operation (not independent). In CAN communication, control units are connected with 2 communication lines (CAN H line, CAN L line) allowing a high rate of information transmission with less wiring. Each control unit transmits/receives data but selectively reads required data only.

## CAN Communication Unit

AIS004CS

Refer to [LAN-5, "CAN COMMUNICATION"](#) .

# REMOTE KEYLESS ENTRY SYSTEM

## Schematic

AIS004A5

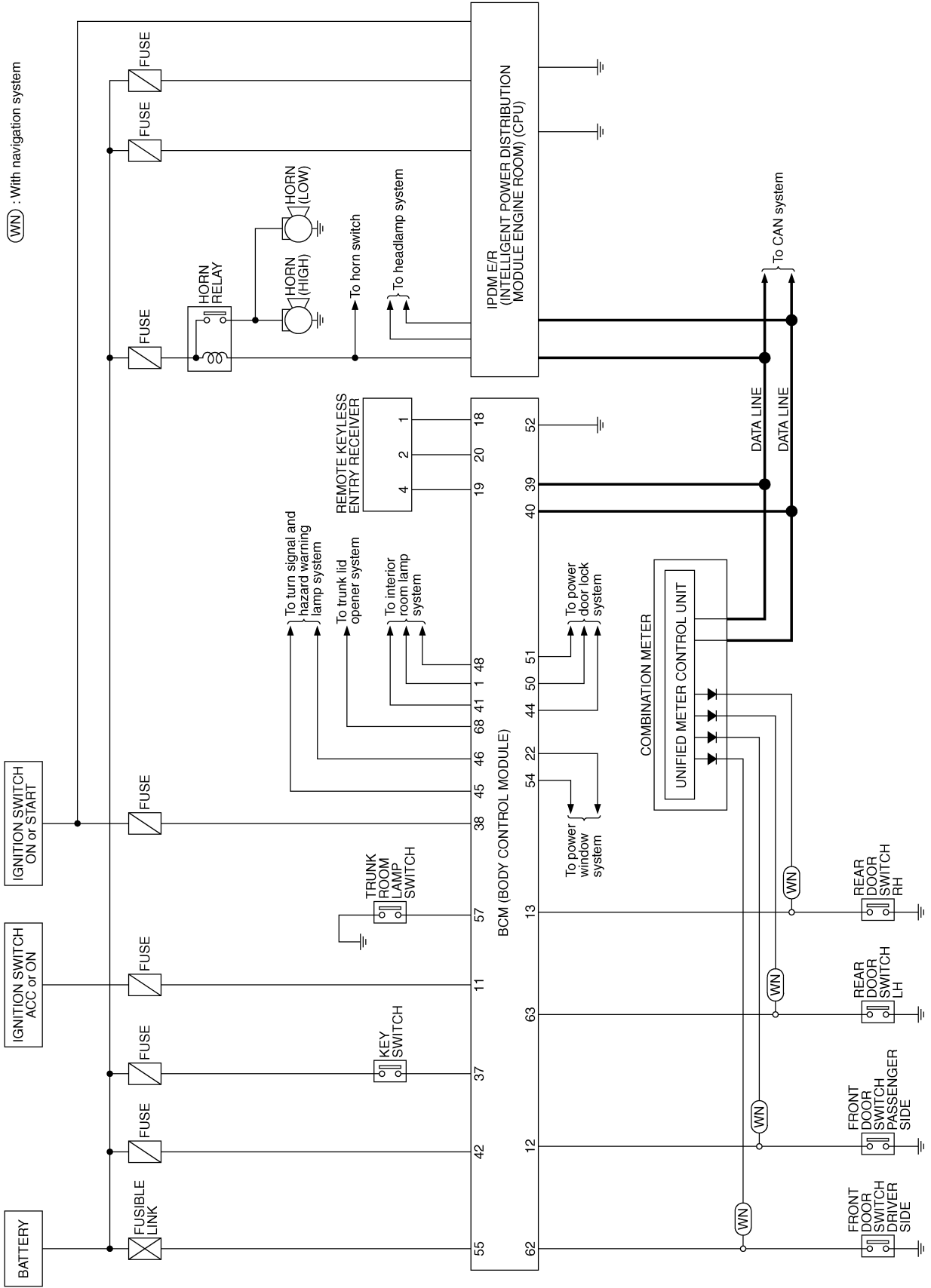

A  
B  
C  
D  
E  
F  
G  
H  
I  
J  
K  
L  
M

BL

# REMOTE KEYLESS ENTRY SYSTEM

AIS004A6

**Wiring Diagram —KEYLES—**  
**FIG. 1**

BL-KEYLES-01

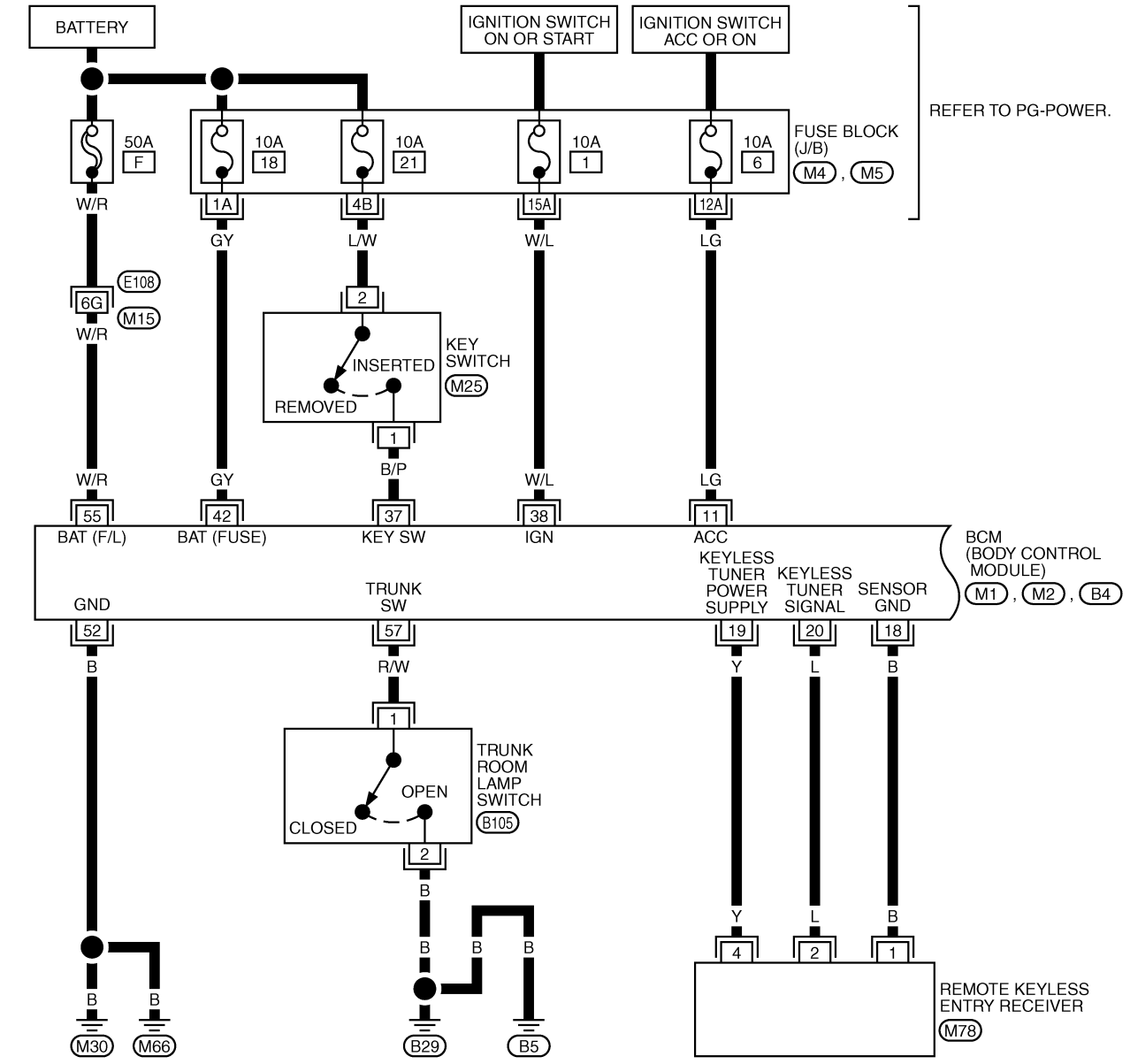

REFER TO PG-POWER.

BCM  
(BODY CONTROL  
MODULE)  
(M1, M2, B4)

REMOTE KEYLESS  
ENTRY RECEIVER  
(M78)

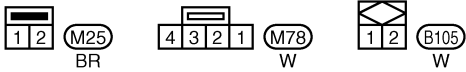

REFER TO THE FOLLOWING.

- (E108) -SUPER MULTIPLE JUNCTION (SMJ)
- (M4), (M5) -FUSE BLOCK-JUNCTION BOX (J/B)
- (M1), (M2), (B4) -ELECTRICAL UNITS

TIWT0695E

# REMOTE KEYLESS ENTRY SYSTEM

FIG. 2

BL-KEYLES-02

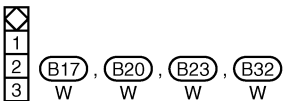
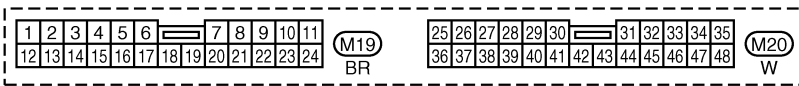
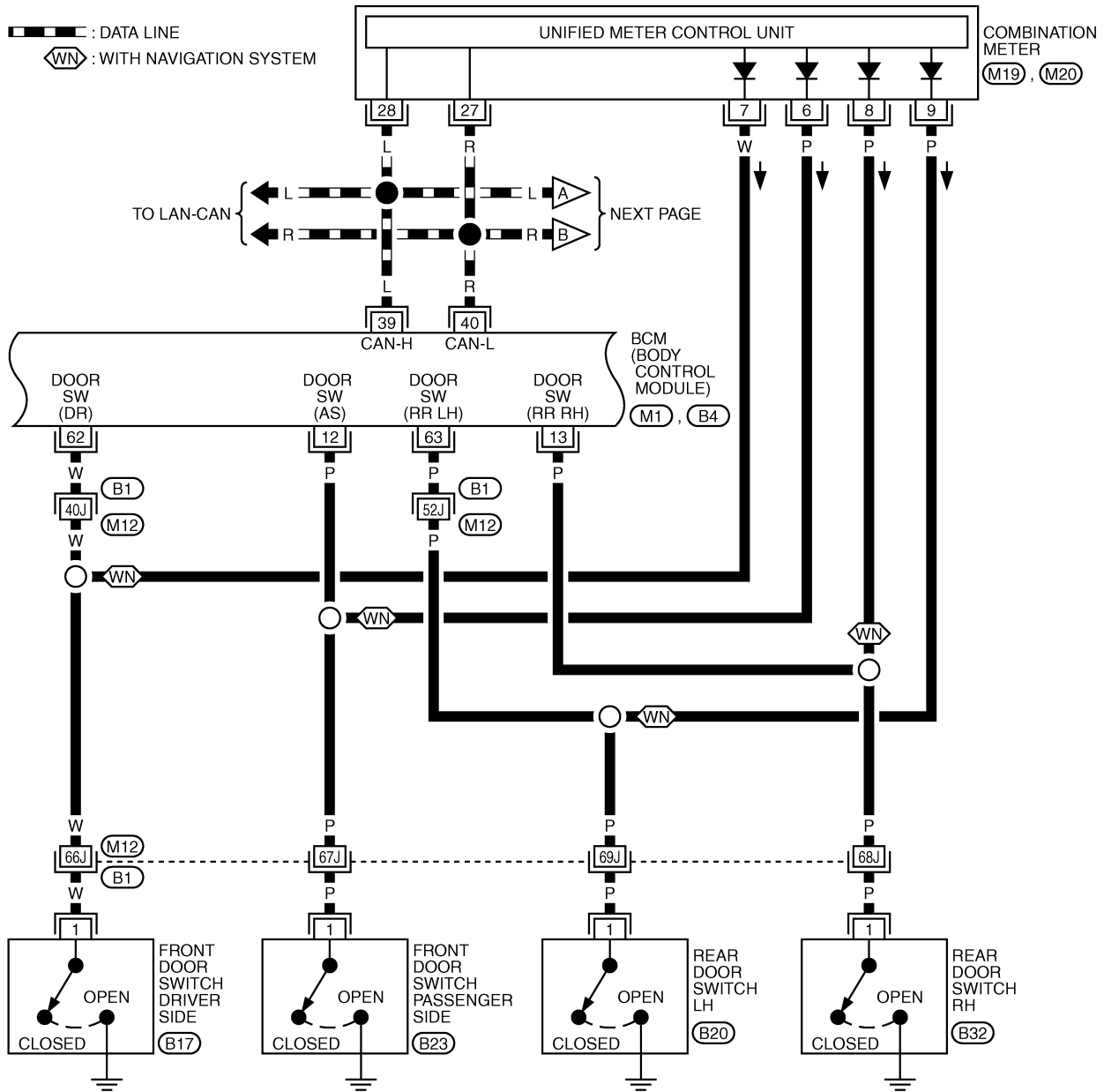

REFER TO THE FOLLOWING.

- (B1) -SUPER MULTIPLE JUNCTION (SMJ)
- (M1), (B4) -ELECTRICAL UNITS

# REMOTE KEYLESS ENTRY SYSTEM

FIG. 3

BL-KEYLES-03

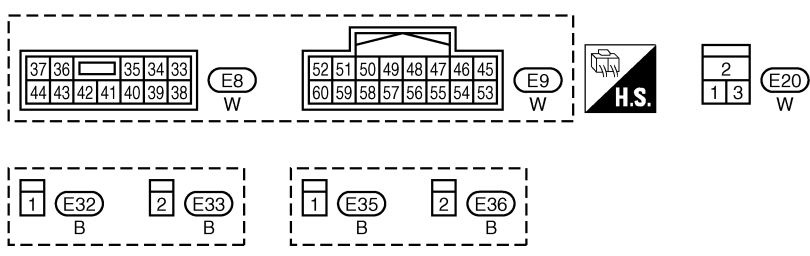
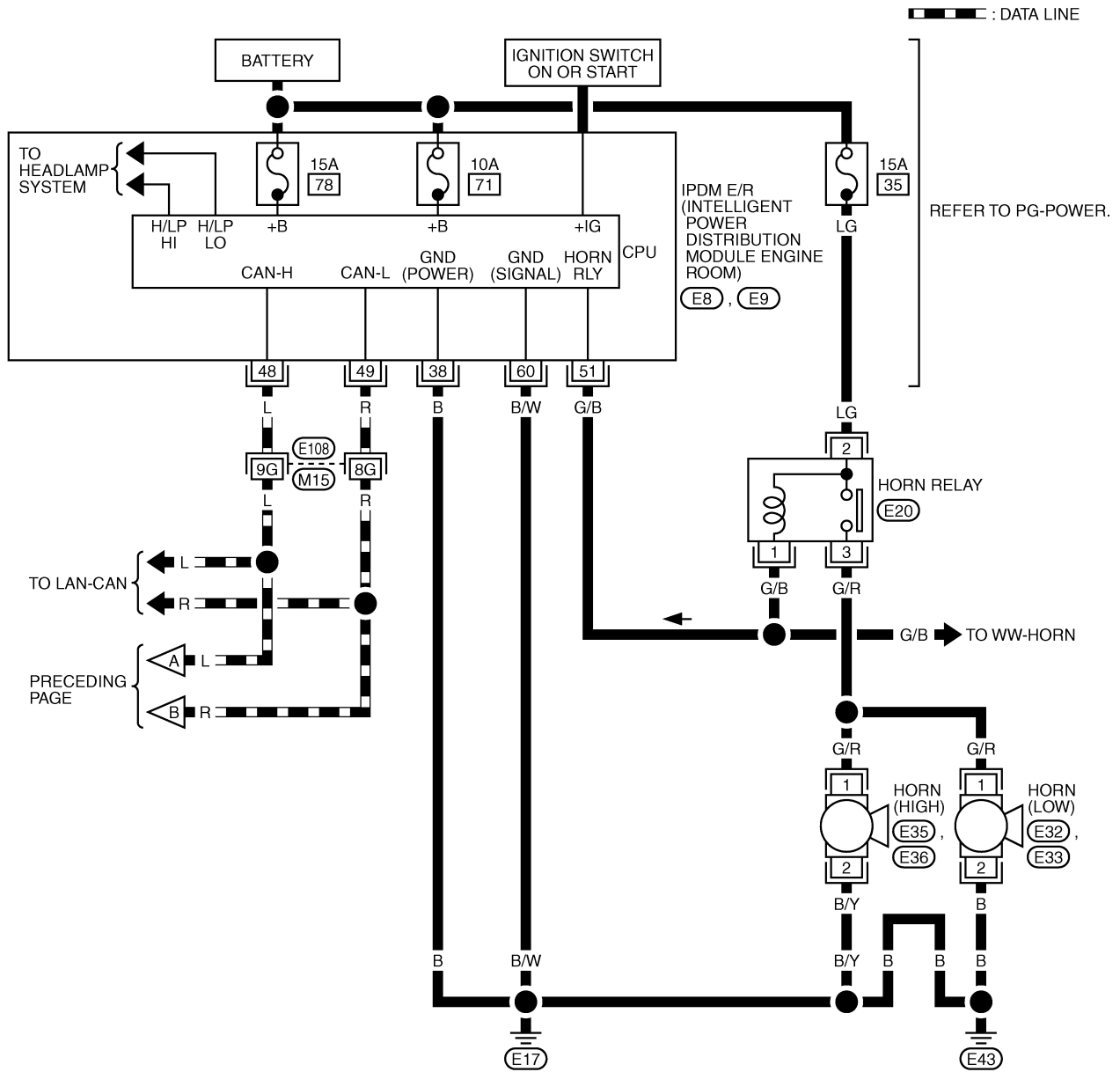

REFER TO THE FOLLOWING.  
(E108) -SUPER MULTIPLE  
JUNCTION (SMJ)

TIWT0697E

# REMOTE KEYLESS ENTRY SYSTEM

FIG. 4

BL-KEYLES-04

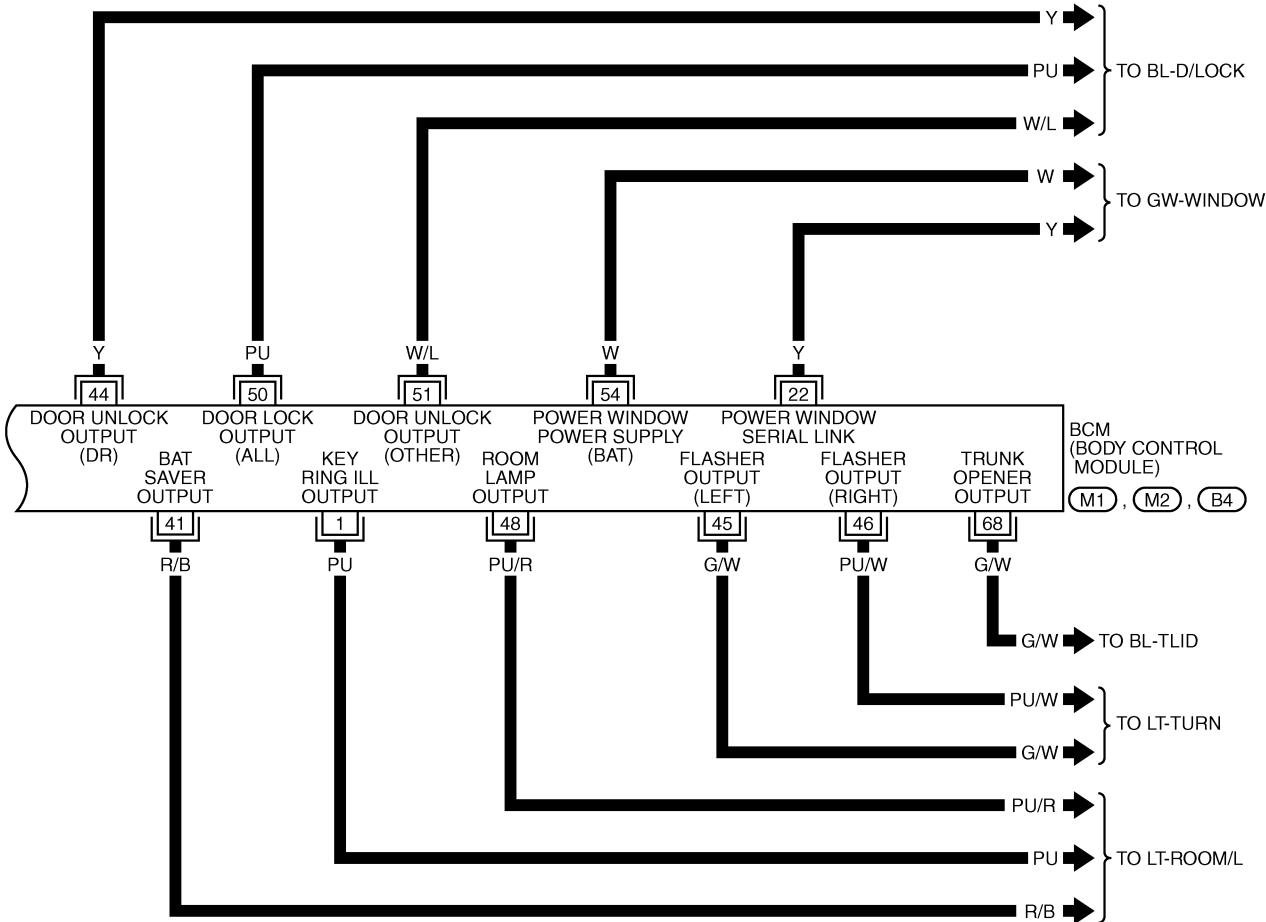

REFER TO THE FOLLOWING.  
 (M1), (M2), (B4)  
 -ELECTRICAL UNITS

TIWT0698E

# REMOTE KEYLESS ENTRY SYSTEM

## Terminals and Reference Value for BCM

AIS004A7

Terminal	Wire color	Item	Condition	Voltage [V] (Approx.)	
1	PU	Key ring illumination output signal	Key ring illumination is lighting.	Battery voltage	
			Key ring illumination is being turned off.	0	
11	LG	Ignition switch (ACC)	Ignition switch is in ACC or ON position	Battery voltage	
12	P	Front door switch (Passenger side)	ON (door open) → OFF (door closed)	0 → Battery voltage	
13	P	Rear door switch RH	ON (door open) → OFF (door closed)	0 → Battery voltage	
18	B	Sensor ground	—	0	
19	Y	Remote keyless entry receiver power supply	Ignition switch is removed from key cylinder	Waiting state	<p style="text-align: right;">OCC3881D</p>
				Any operation using key fob	<p style="text-align: right;">OCC3882D</p>
20	L	Remote keyless entry receiver signal	Ignition switch is removed from key cylinder	Waiting state	<p style="text-align: right;">OCC3879D</p>
				Any operation using key fob	<p style="text-align: right;">OCC3880D</p>
37	B/P	Key switch	ON (Key is inserted in IGN key cylinder) → OFF (Key is removed from IGN key cylinder)	Battery voltage → 0	
38	W/L	Ignition switch (START)	Ignition switch is in ON or START position	Battery voltage	
39	L	CAN H	—	—	
40	R	CAN L	—	—	
41	R/B	Battery saver output signal	30 minutes after ignition switch is turned to OFF	0	
			Ignition switch is in ON position	Battery voltage	
42	GY	Power source (Fuse)	—	Battery voltage	
44	Y	Driver door lock actuator (Unlock)	Door lock / unlock switch (Free → Unlock)	0 → Battery voltage	
45	G/W	Left turn signal lamp	When door lock or unlock is operated using key fob.*1 (ON → OFF)	Battery voltage → 0	



# REMOTE KEYLESS ENTRY SYSTEM

Terminal	Wire color	Item	Condition	Voltage [V] (Approx.)
46	PU/W	Right turn signal lamp	When door lock or unlock is operated using key fob.* <sup>1</sup> (ON → OFF)	Battery voltage → 0
48	PU/R	Room lamp output signal	Room lamp is lighting.* <sup>2</sup>	0
			Room lamp is being turned off.* <sup>2</sup>	Battery voltage
52	B	Ground	—	0
50	PU	Door lock actuator (Lock)	Door lock / unlock switch (Free → Lock)	0 → Battery voltage → 0
51	W/L	Passenger and rear doors lock actuator (Unlock)	Door lock / unlock switch (Free → Unlock)	0 → Battery voltage → 0
54	W	Battery power supply (power window)	—	Battery voltage
55	W/R	Power source (Fusible link)	—	Battery voltage
57	R/W	Trunk room lamp switch	close → open	Battery voltage → 0
62	W	Front door switch (Driver side)	OFF (Door close) → ON (Door open)	Battery voltage → 0
63	P	Rear door switch LH	OFF (Door close) → ON (Door open)	Battery voltage → 0

\*<sup>1</sup> : In the state that hazard reminder operates.

\*<sup>2</sup> : In the state that room lamp switch is in "DOOR" position.

## Terminals and Reference Value for IPDM E/R

AIS004A8

Terminal	Wire color	Item	Condition	Voltage [V] (Approx.)
38	B	Ground	—	0
48	L	CAN H	—	—
49	R	CAN L	—	—
51	G/B	Horn relay	When door lock is operated using key fob* (OFF → ON)	Battery voltage → 0
60	B/W	Ground	—	0

\* : In the state that horn reminder operates.

## Terminals and Reference Value or Combination Meter (With Navigation System)

AIS004KA

Terminal	Wire color	Item	Condition	Voltage [V] (Approx.)
6	P	Front door switch passenger side	ON (Door open) → OFF (Door closed)	0 → Battery voltage
7	W	Front door switch driver side	ON (Door open) → OFF (Door closed)	0 → Battery voltage
8	P	Rear door switch RH	ON (Door open) → OFF (Door closed)	0 → Battery voltage
9	P	Rear door switch LH	ON (Door open) → OFF (Door closed)	0 → Battery voltage
27	R	CAN-L	—	—
28	L	CAN-H	—	—

# REMOTE KEYLESS ENTRY SYSTEM

AIS004A9

## CONSULT-II Function

The following functions are performed by combining data received and command transmitted via the communication line from the BCM.

BCM diagnosis position	Inspection items and diagnosis mode		Description
BCM C/U*	Self-diagnosis results		Carries out the self-diagnosis.
	DATA MONITOR	CAN diagnosis support monitor	Displays CAN communication system diagnosis, disabled transmission status, and communication status of each unit communicated with BCM.
		Selection from menu	Displays the input data to BCM on real-time basis.
MULTI REMOTE ENT	DATA MONITOR		Displays the input remote keyless entry system data to BCM on real-time basis.
	ACTIVE TEST		Gives a drive to a load to check the operation.
	WORK SUPPORT		Changes the setting for each function.

\*:Refer to [BCS-14, "CAN Communication Inspection Using CONSULT-II \(Self-Diagnosis\)"](#).

## INSPECTION PROCEDURE

### CAUTION:

If CONSULT-II is used with no connection of CONSULT-II CONVERTER, malfunctions might be detected in self-diagnosis depending on control unit which carry out CAN communication.

1. Turn ignition switch "OFF".
2. Connect "CONSULT-II" and "CONSULT-II CONVERTER" to the data link connector.

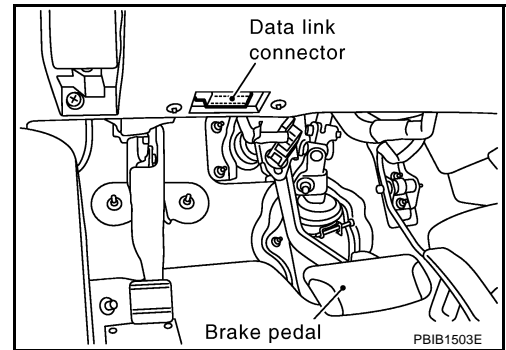

3. Turn ignition switch "ON".
4. Touch "START (NISSAN BASED VHCL)".

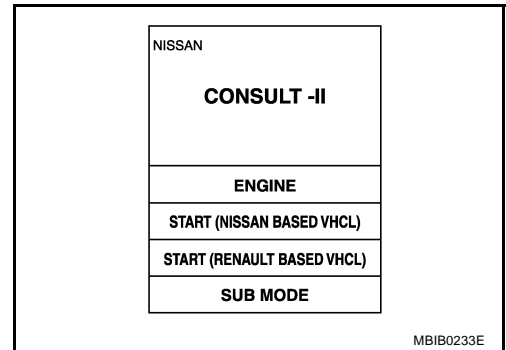

5. Touch "BCM".  
If "BCM" is not indicated, go to [GI-38, "CONSULT-II Data Link Connector \(DLC\) Circuit"](#).

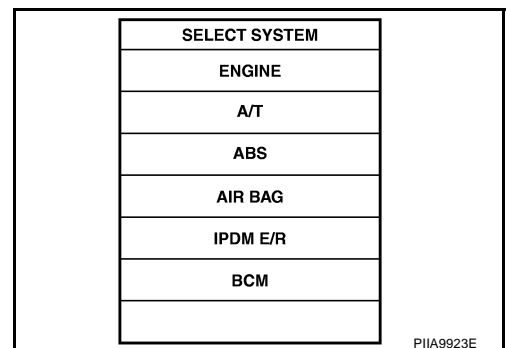

# REMOTE KEYLESS ENTRY SYSTEM

6. Touch "MULTI REMOTE ENT".

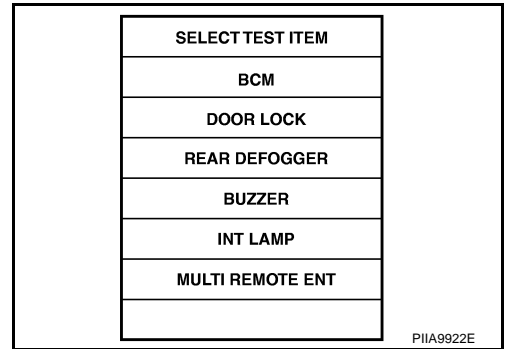

7. Select diagnosis mode. "DATA MONITOR", "ACTIVE TEST" and "WORK SUPPORT" are available.

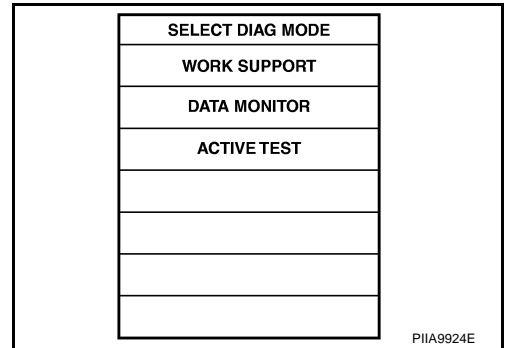

## CONSULT-II APPLICATION ITEMS

### Work Support

Test Item	Description
HORN CHIRP SET*	Horn reminder mode can be changed in this mode. The horn reminder mode will be changed when "CHANGE SETT" on CONSULT-II screen is touched.
HAZARD LAMP SET*	Hazard reminder mode can be changed in this mode. The hazard reminder mode will be changed when "CHANGE SETT" on CONSULT-II screen is touched.
MULTI ANSWER BACK SET	Hazard and horn reminder mode can be changed in this mode. The hazard and horn reminder mode will be changed when "CHANGE SETT" on CONSULT-II screen is touched.
AUTO LOCK SET	Auto locking function mode can be changed in this mode. The function mode will be changed when "CHANGE SETT" on CONSULT-II screen is touched.
PANIC ALARM SET	Panic alarm operation mode can be changed in this mode. The operation mode will be changed when "CHANGE SETT" on CONSULT-II screen is touched.
TRUNK OPEN SET	Trunk lid opener operation mode can be changed in this mode. The operation mode will be changed when "MODE SET" on CONSULT-II screen is touched.
PW DOWN SET	Keyless power window down (open) operation mode can be changed in this mode. The operation mode will be changed when "CHANGE SETT" on CONSULT-II screen is touched.

\*: Perform this mode always in the state of C mode. Refer to [BL-53, "Hazard and Horn Reminder"](#) .

### HORN CHIRP SET\*

Horn chirp function	ON	OFF

\*: Perform this mode always in the state of C mode. Refer to [BL-53, "Hazard and Horn Reminder"](#) .

### HAZARD LAMP BACK SET\*

	MODE1	MODE2	MODE3	MODE4
Hazard lamp operation mode	Nothing	Unlock only	Lock only	Lock and Unlock

\*: Perform this mode always in the state of C mode. Refer to [BL-53, "Hazard and Horn Reminder"](#) .

# REMOTE KEYLESS ENTRY SYSTEM

## MULTI ANSWER BACK SET

	MODE 1 (C mode)		MODE 2 (S mode)	
	Lock	Unlock	Lock	Unlock
Key fob operation	Lock	Unlock	Lock	Unlock
Hazard warning lamp flash	Twice	Once	Twice	—
Horn sound	Once	—	—	—

## AUTO LOCK SET

	MODE 1	MODE 2	MODE 3
Auto locking function	1 minutes	Nothing	5 minutes

## PANIC ALARM SET

	MODE 1	MODE 2	MODE 3
Key fob operation	0.5 seconds	Nothing	1.5 seconds

## Trunk open operation mode

	MODE 1	MODE 2	MODE 3
Key fob operation	0.5 seconds	Nothing	1.5 seconds

## PW DOWN SET

	MODE 1	MODE 2	MODE 3
Key fob operation	3 seconds	Nothing	5 seconds

# REMOTE KEYLESS ENTRY SYSTEM

## Data Monitor

Monitored Item	Description
IGN ON SW	Indicates [ON/OFF] condition of ignition switch in ON position.
KEY ON SW	Indicates [ON/OFF] condition of key switch.
ACC ON SW	Indicates [ON/OFF] condition of ignition switch in ACC position.
KEYLESS LOCK	Indicates [ON/OFF] condition of lock signal from key fob.
KEYLWSS UNLOCK	Indicates [ON/OFF] condition of unlock signal from key fob.
KEYLESS PANIC	Indicates [ON/OFF] condition of panic signal from key fob.
KEYLESS TRUNK	Indicates [ON/OFF] condition of panic signal from key fob.
DOOR SW-DR	Indicates [ON/OFF] condition of front door switch driver side.
DOOR SW-AS	Indicates [ON/OFF] condition of front door switch passenger side.
DOOR SW-RR	Indicates [ON/OFF] condition of rear door switch RH.
DOOR SW-RL	Indicates [ON/OFF] condition of rear door switch LH.
BACK DOOR SW	This is displayed even when it is not equipped.
TRUNK OPN MNTR	Indicates [ON/OFF] condition of trunk room lamp switch.
CDL LOCK SW	Indicates [ON/OFF] condition of lock signal from door lock and unlock switch.
CDL UNLOCK SW	Indicates [ON/OFF] condition of unlock signal from door lock and unlock switch.
RKE LCK-UNLOCK	Indicates [ON/OFF] condition of simultaneous signal of lock and unlock from key fob.
RKE KEEP UNLK	Indicates [ON/OFF] condition of unlock continuousness signal from key fob.
KEY CYL LK-SW	Indicates [ON/OFF] condition of lock signal from door key cylinder switch.
KEY CYL UN-SW	Indicates [ON/OFF] condition of unlock signal from door key cylinder switch.

## Active Test

Test Item	Description
FLASHER	This test is able to check right hazard reminder operation. The right hazard lamp turns on when "ON" on CONSULT-II screen is touched.
POWER WINDOW DOWN	This test is able to check power window open operation. The front power windows activate for 10 seconds after "ON" on CONSULT-II screen is touched.
HORN	This test is able to check panic alarm and horn reminder operations. The horn activate for 0.5 seconds after "ON" on CONSULT-II screen is touched.
DOOR LOCK	This test is able to check door lock actuator operation. <ul style="list-style-type: none"> <li>● The all door lock actuator are locked when "ALL LOCK" on CONSULT-II screen is touched.</li> <li>● The all door lock actuator are unlocked when "ALL UNLOCK" on CONSULT-II screen is touched.</li> <li>● The door lock actuator (driver side) is unlocked when "DR UNLOCK" on CONSULT-II screen is touched.</li> <li>● The all door lock actuator (except driver side) are unlocked when "OTHER UNLOCK" on CONSULT-II screen is touched.</li> </ul>
TRUNK/BACK DOOR	This is displayed even when it is not equipped.

## Work Flow

AIS004AA

1. Check the symptom and customer's requests.
2. Understand outline of system. Refer to [BL-52, "System Description"](#) .
3. Confirm that power door lock system operates normally.  
Refer to [BL-19, "POWER DOOR LOCK SYSTEM"](#) .
4. Repair or replace any malfunctioning parts.  
Refer to [BL-66, "Trouble Diagnosis Chart by Symptom"](#) .
5. INSPECTION END

# REMOTE KEYLESS ENTRY SYSTEM

AIS004AB

## Trouble Diagnosis Chart by Symptom

### NOTE:

- Always check the “Work Flow” before troubleshooting. Refer to [BL-65, "Work Flow"](#) .
- Always check key fob battery before replacing key fob.

Symptom	Diagnoses/service procedure	Reference page
All function of remote keyless entry system do not operate.	1. Check key fob battery and function.	<a href="#">BL-68</a>
	2. Replace key fob. Refer to ID Code Entry Procedure. <b>NOTE:</b> If the result of key fob function check with CONSULT-II is OK, key fob is not malfunctioning.	<a href="#">BL-76</a>
	3. Replace BCM.	<a href="#">BCS-15</a>
The new ID of key fob cannot be registered.	1. Check key fob battery and function.	<a href="#">BL-68</a>
	2. Check key switch.	<a href="#">BL-73</a>
	3. Check door switch.	<a href="#">BL-71</a>
	4. Check ACC switch.	<a href="#">BL-69</a>
	5. Replace key fob. Refer to ID Code Entry Procedure. <b>NOTE:</b> If the result of key fob function check with CONSULT-II is OK, key fob is not malfunctioning.	<a href="#">BL-76</a>
	6. Replace BCM.	<a href="#">BCS-15</a>
Door lock or unlock does not function with key fob. (Power door lock system is “OK”.)	1. Check key fob battery and function.	<a href="#">BL-68</a>
	2. Replace key fob. Refer to ID Code Entry Procedure. <b>NOTE:</b> If the result of key fob function check with CONSULT-II is OK, key fob is not malfunctioning.	<a href="#">BL-76</a>
	3. Replace BCM.	<a href="#">BCS-15</a>
Hazard and horn reminder does not activate properly when pressing lock or unlock button of key fob.	1. Check hazard and horn reminder mode.* *: Hazard and horn reminder mode can be changed. First check the hazard and horn reminder setting.	<a href="#">BL-63</a>
	2. Check door switch.	<a href="#">BL-71</a>
	3. Replace BCM.	<a href="#">BCS-15</a>
Hazard reminder does not activate properly when pressing lock or unlock button of key fob. (Horn reminder is “OK”.)	1. Check hazard reminder mode.* *: Hazard reminder mode can be changed. First check the hazard reminder setting.	<a href="#">BL-63</a>
	2. Check hazard function with hazard switch.	<a href="#">BL-75</a>
	3. Replace BCM.	<a href="#">BCS-15</a>
Horn reminder does not activate properly when pressing lock button of key fob. (Hazard reminder is “OK”.)	1. Check horn reminder mode.* *: Horn reminder can be changed. First check the horn chirp setting.	<a href="#">BL-63</a>
	2. Check horn function.	<a href="#">BL-75</a>
	3. Check IPDM E/R operation.	<a href="#">BL-74</a>
	4. Replace BCM.	<a href="#">BCS-15</a>

# REMOTE KEYLESS ENTRY SYSTEM

Symptom	Diagnoses/service procedure	Reference page
Panic alarm (horn and headlamp) does not activate when panic alarm button is continuously pressed.	1. Check panic alarm mode.* *: Panic alarm mode can be changed. First check the panic alarm setting.	<a href="#">BL-63</a>
	2. Check key fob battery and function.	<a href="#">BL-68</a>
	3. Check headlamp function.	<a href="#">BL-75</a>
	4. Check horn function.	<a href="#">BL-75</a>
	5. Check IPDM E/R operation.	<a href="#">BL-74</a>
	6. Check key switch.	<a href="#">BL-73</a>
	7. Replace key fob. Refer to ID Code Entry Procedure. <b>NOTE:</b> If the result of key fob function check with CONSULT-II is OK, key fob is not malfunctioning.	<a href="#">BL-76</a>
	8. Replace BCM.	<a href="#">BCS-15</a>
Auto door lock operation does not activate properly. (All other remote keyless entry system function is OK.)	1. Check auto door lock operation mode.* *: Auto door lock operation mode can be changed. First check the auto door lock operation setting.	<a href="#">BL-63</a>
	2. Replace BCM.	<a href="#">BCS-15</a>
Keyless power window down (open) operation does not activate properly. (All other remote keyless entry system function is OK.)	1. Check power window down operation mode.* *: Power window down operation mode can be changed. First check the power window down setting.	<a href="#">BL-63</a>
	2. Check power window function.	<a href="#">GW-17</a>
	3. Replace BCM.	<a href="#">BCS-15</a>
Map lamp and ignition keyhole illumination operation does not activate properly.	1. Check map lamp and ignition keyhole illumination operation.	<a href="#">BL-75</a>
	2. Check door switch.	<a href="#">BL-71</a>
	3. Replace BCM.	<a href="#">BCS-15</a>

A  
B  
C  
D  
E  
F  
G  
H  
BL  
J  
K  
L  
M

# REMOTE KEYLESS ENTRY SYSTEM

AIS004AC

## Check Key Fob Battery and Function

### 1. CHECK KEY FOB BATTERY

1. Remove key fob battery. Refer to [BL-79, "Key Fob Battery Replacement"](#).
2. Measure voltage between battery positive and negative terminals, (+) and (-).

**Voltage** : 2.5 – 3.0V

**NOTE:**

Key fob does not function if battery is not set correctly.

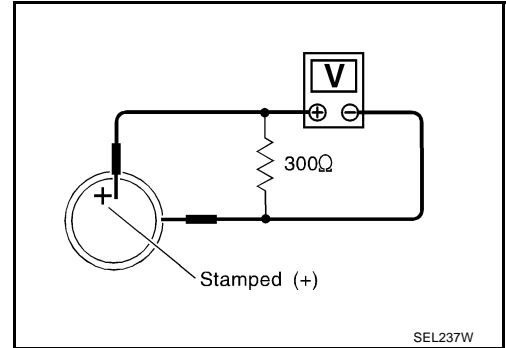

OK or NG

- OK >> GO TO 2.
- NG >> Replace battery.

### 2. CHECK KEY FOB FUNCTION

**With CONSULT-II**

Check key fob function in "DATA MONITOR" mode with CONSULT-II. When pushing each button of key fob, the corresponding monitor item should be turned as follows.

Condition	Monitor item
Pushing LOCK	KEYLESS LOCK : ON
Pushing UNLOCK	KEYLESS UNLOCK : ON
Keep pushing UNLOCK	RKE KEEP UNLK : ON
	*: UN BUTTON ON turns to ON three seconds after UNLOCK button keeps pushing.
Pushing PANIC	KEYLESS PANIC : ON
Pushing LOCK and UNLOCK at the same time	RKE LCK-UNLOCK : ON

DATA MONITOR	
MONITOR	
KEYLESS LOCK	OFF
KEYLESS UNLOCK	OFF
RKE KEEP UNLK	OFF
RKE LCK-UNLOCK	OFF
KEYLESS PANIC	OFF

OK or NG

- OK >> Keyfob is OK.
- NG >> Replace key fob.



# REMOTE KEYLESS ENTRY SYSTEM

AIS004AD

## Check ACC Switch

### 1. CHECK ACC SWITCH

#### With CONSULT-II

Check ACC switch ("ACC ON SW") in "DATA MONITOR" mode with CONSULT-II.

Monitor item	Condition
ACC SW	Ignition switch position is ACC or ON : ON
	Ignition switch position is OFF : OFF

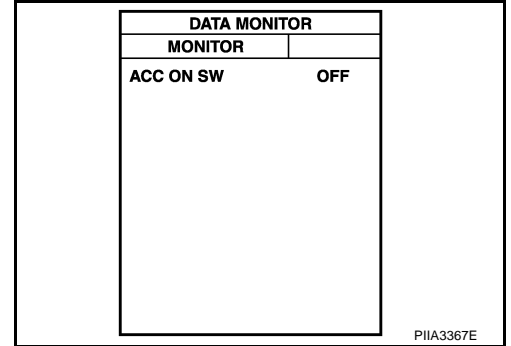

#### Without CONSULT-II

Check voltage between BCM connector and ground.

Connector	Terminal (Wire color)		Ignition switch position	Voltage [V] (Approx.)
	(+)	(-)		
M1	11 (LG/R)	Ground	ACC	Battery voltage
			OFF	0

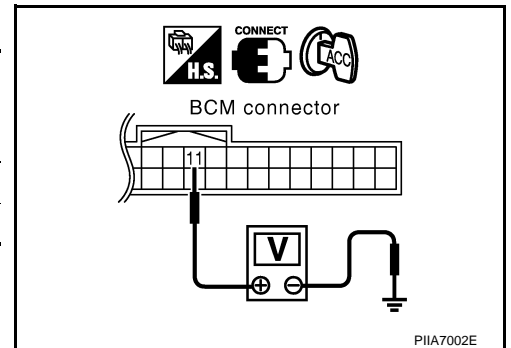

#### OK or NG

OK >> ACC switch is OK.

NG >> Check the following.

- 10A fuse [No. 6, located in the fuse block (J/B)]
- Harness for open or short between BCM and fuse

## Check Door Switch / With Navigation System

AIS005A2

First perform the "SELF-DIAG RESULTS" in "BCM" with CONSULT-II, when perform the each trouble diagnosis. Refer to [BCS-14, "CAN Communication Inspection Using CONSULT-II \(Self-Diagnosis\)"](#).

### 1. CHECK DOOR SWITCH INPUT SIGNAL

Check voltage between combination meter connector and ground.

Item	Connector	Terminals (Wire color)		Condition	Voltage [V] (Approx.)
		(+)	(-)		
Driver side	M19	7 (W)	Ground	CLOSE ↓ OPEN	Battery voltage ↓ 0
Passenger side		6 (P)			
Rear LH		9 (P)			
Rear RH		8 (P)			

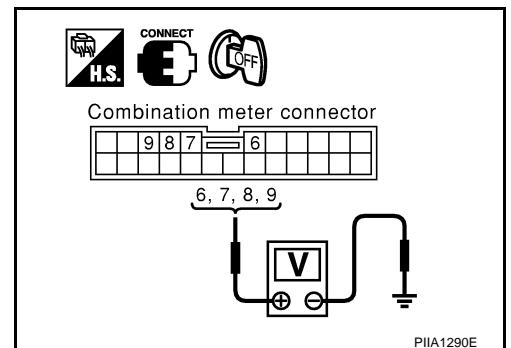

#### OK or NG

OK >> Door switch circuit is OK.

NG >> GO TO 2.

# REMOTE KEYLESS ENTRY SYSTEM

## 2. CHECK DOOR SWITCH

1. Turn ignition switch OFF.
2. Disconnect door switch and combination meter connector.
3. Check continuity between door switch connector B17, B23, B20, B32 terminals 1 and combination meter connector M19 terminals 7, 6, 9, 8.

### Front door switch driver side

**1 (W) – 7 (W) : Continuity should exist.**

### Front door switch passenger side

**1 (P) – 6 (P) : Continuity should exist.**

### Rear door switch LH

**1 (P) – 9 (P) : Continuity should exist.**

### Rear door switch RH

**1 (P) – 8 (P) : Continuity should exist.**

4. Check continuity between door switch connector B17, B23, B20, B32 terminals 1 and ground.

**1 (W or P) – Ground : Continuity should not exist**

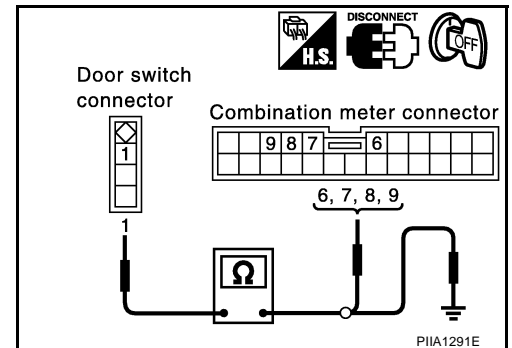

### OK or NG

OK >> GO TO 3.

NG >> Repair or replace harness.

## 3. CHECK DOOR SWITCH

Check continuity between each door switch terminal 1 and body ground part of door switch.

Terminal	Door switch	Continuity
1	Pushed	No
	Released	Yes

### OK or NG

OK >> GO TO 4.

NG >> Replace door switch.

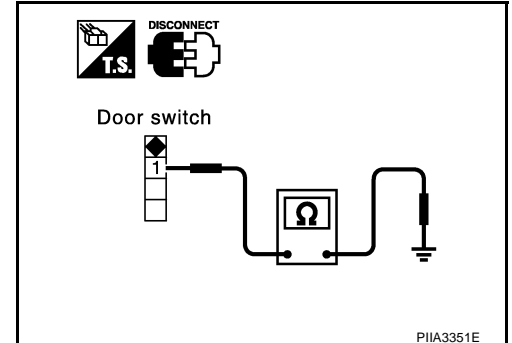

## 4. CHECK COMBINATION METER OUTPUT SIGNAL

1. Connect combination meter connector.
2. Check voltage between combination meter connector M19 terminals 6, 7, 8, 9 and ground.

**6 (P) - Ground : Battery voltage**

**7 (W) - Ground : Battery voltage**

**8 (P) - Ground : Battery voltage**

**9 (P) - Ground : Battery voltage**

### OK or NG

OK >> Check harness connection.

NG >> Replace combination meter.

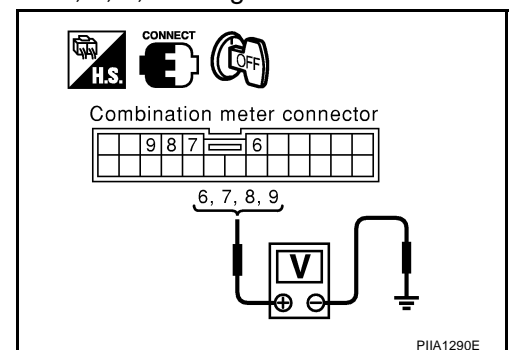

# REMOTE KEYLESS ENTRY SYSTEM

AIS005A3

## Check Door Switch/Without Navigation System

### 1. CHECK DOOR SWITCH INPUT SIGNAL

#### With CONSULT-II

Check door switches ("DOOR SW-DR", "DOOR SW-AS", "DOOR SW-RL" and "DOOR SW-RR") in "DATA MONITOR" mode with CONSULT-II.

Monitor item	Condition
DOOR SW-DR	CLOSE → OPEN: OFF → ON
DOOR SW-AS	
DOOR SW-RL	
DOOR SW-RR	

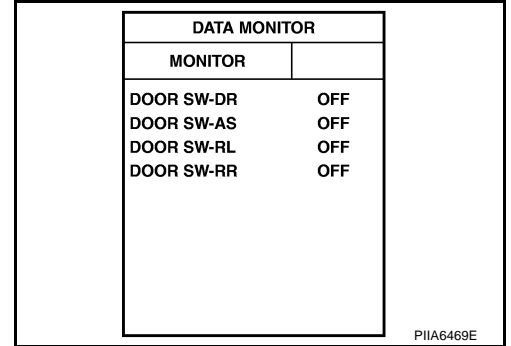

#### Without CONSULT-II

Check voltage between BCM connector and ground.

Item	Connector	Terminals (Wire color)		Door condition	Voltage [V] (Approx.)
		(+)	(-)		
Driver side	B4	62 (W)	Ground	CLOSE ↓ OPEN	Battery voltage ↓ 0
Rear LH		63 (P)			
Passenger side	M1	12 (P)			
Rear RH		13 (P)			

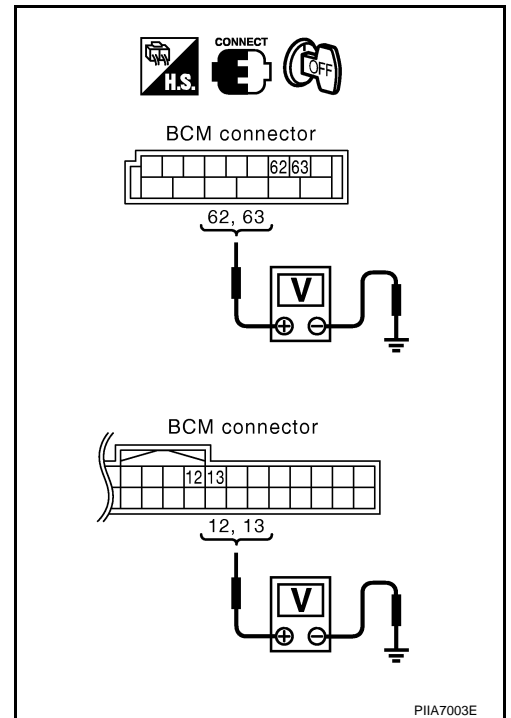

#### OK or NG

- OK >> Door switch circuit is OK.
- NG >> GO TO 2.

### 2. CHECK DOOR SWITCH

Check continuity between door switch terminal 1 and ground part of door switch.

Terminal	Door switch condition	Continuity
1	Pushed	No
	Released	Yes

#### OK or NG

- OK >> GO TO 3.
- NG >> Replace door switch.

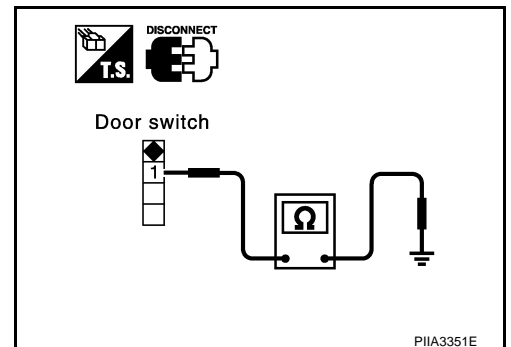

# REMOTE KEYLESS ENTRY SYSTEM

## 3. CHECK DOOR SWITCH CIRCUIT

1. Turn ignition switch OFF.
2. Disconnect door switch and BCM connector.
3. Check continuity between door switch connector B17, B23, B20, B32 terminals 1 and BCM connector M1, B4 terminals 62, 12, 63, 13.

### Driver side door

1 (W) – 62 (W) : Continuity should exist.

### Passenger side door

1 (P) – 12 (P) : Continuity should exist.

### Rear door LH

1 (P) – 63 (P) : Continuity should exist.

### Rear door RH

1 (P) – 13 (P) : Continuity should exist.

4. Check continuity between door switch connector B26, B36, B46, B206 terminal 1 and ground.

1 (W or P) – Ground : Continuity should not exist.

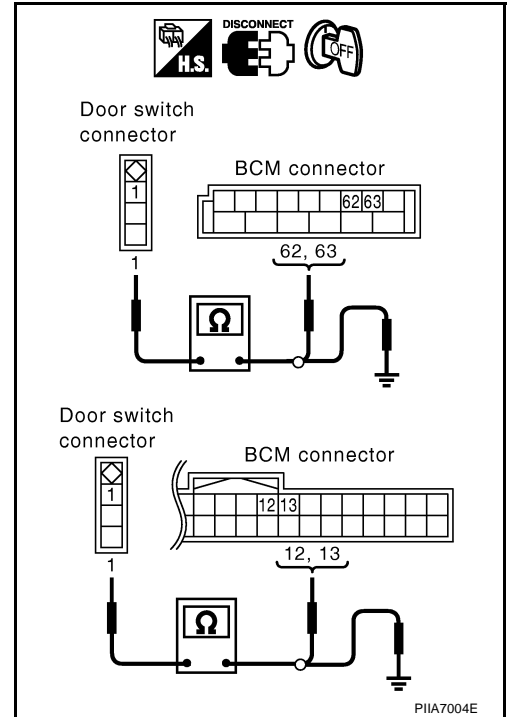

### OK or NG

- OK >> GO TO 4.  
NG >> Repair or replace harness.

## 4. CHECK BCM OUTPUT SIGNAL

1. Connect BCM connector.
2. Check voltage between BCM connector M1, B4 terminal 62, 12, 63, 13 and ground.

62 (W) – Ground : Battery voltage

12 (P) – Ground : Battery voltage

63 (P) – Ground : Battery voltage

13 (P) – Ground : Battery voltage

### OK or NG

- OK >> Check harness condition.  
NG >> Replace BCM.

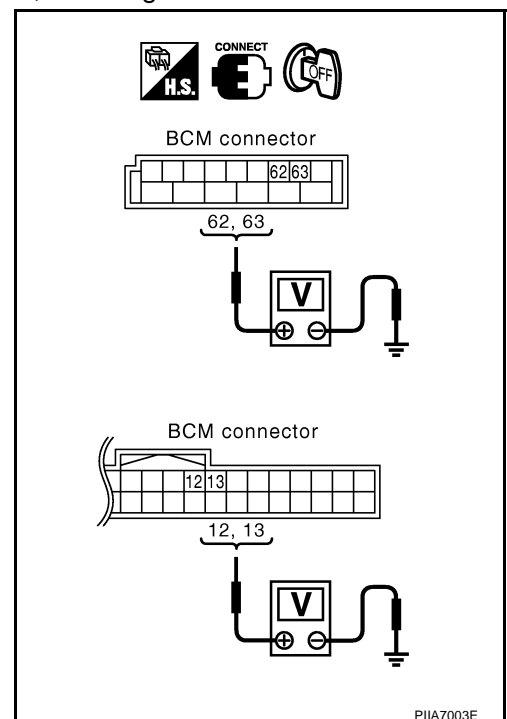

# REMOTE KEYLESS ENTRY SYSTEM

AIS005A4

## Check Key Switch

### 1. CHECK KEY SWITCH INPUT SIGNAL

#### With CONSULT-II

Check ignition key switch "KEY ON SW" in "DATA MONITOR" mode with CONSULT-II.

- When key is inserted in ignition key cylinder

**KEY ON SW : ON**

- When key is removed from ignition key cylinder

**KEY ON SW : OFF**

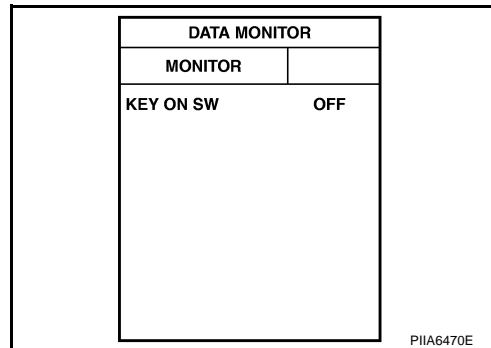

#### Without CONSULT-II

Check voltage between BCM connector M1 terminal 37 (B/P) and ground.

Terminal (Wire color)		Condition of key switch	Voltage [V] (Approx.)
(+)	(-)		
37 (B/P)	Ground	Key is inserted in ignition key cylinder.	Battery voltage
		Key is removed from ignition key cylinder.	0

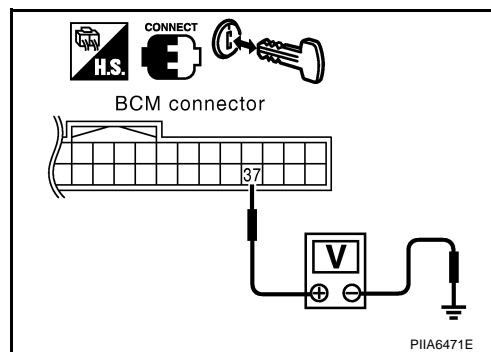

#### OK or NG

- OK >> Key switch circuit is OK.
- NG >> GO TO 2.

### 2. CHECK KEY SWITCH (WITHOUT INTELLIGENT KEY)

- Turn ignition switch OFF.
- Disconnect key switch connector.
- Check continuity between key switch terminals 1 and 2.

Key switch condition	Continuity
Key switch is "ON". (Key is inserted in IGN key cylinder.)	Yes
Key switch is "OFF". (Key is removed from IGN key cylinder.)	No

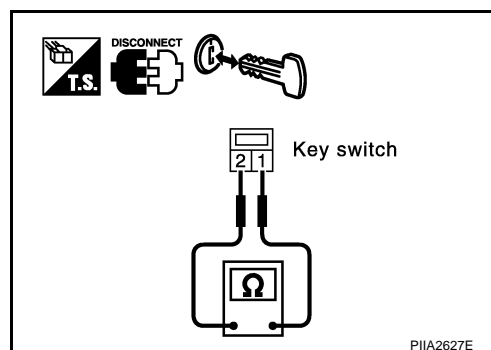

#### OK or NG

- OK >> Check the following.
  - 15A fuse [No. 22, located in fuse block (J/B)]
  - Harness for open or short between key switch and fuse
  - Harness for open or short between BCM and key switch
- NG >> Replace key switch.

# REMOTE KEYLESS ENTRY SYSTEM

AIS005A5

## Check IPDM E/R Operation

### 1. CHECK IPDM E/R INPUT VOLTAGE

Check voltage between IPDM E/R connector E9 terminal 51 and ground.

**51 (G/B) – Ground : Battery voltage**

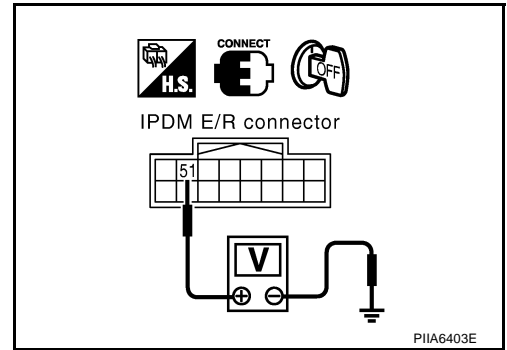

OK or NG

- OK >> Replace IPDM E/R.
- NG >> GO TO 2.

### 2. CHECK IPDM E/R HARNESS

1. Turn ignition switch OFF.
2. Disconnect IPDM E/R and horn relay connector.
3. Check continuity between IPDM E/R connector E9 terminal 51 and horn relay connector E20 terminal 1.

**51 (G/B) – 1 (G/B) : Continuity should exist.**

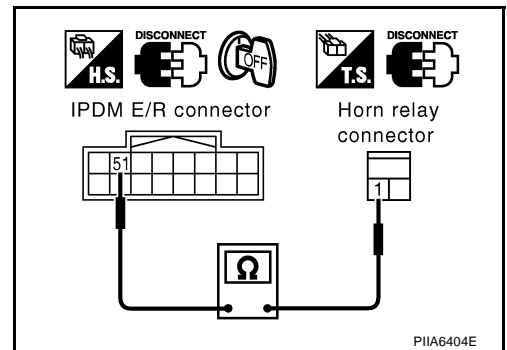

OK or NG

- OK >> Check the condition of the harness and the connector.
- NG >> Repair or replace harness.

# REMOTE KEYLESS ENTRY SYSTEM

## Check Hazard Function

AIS005A6

### 1. CHECK HAZARD WARNING LAMP

Does hazard warning lamp flash with hazard switch?

YES or NO

YES >> Hazard warning lamp circuit is OK.

NO >> Check hazard circuit. Refer to [LT-107, "TURN SIGNAL AND HAZARD WARNING LAMPS"](#) .

## Check Horn Function

AIS005A7

First perform the "SELF-DIAG RESULTS" in "BCM" with CONSULT-II, then perform the trouble diagnosis of malfunction system indicated "SELF-DIAG RESULTS" of "BCM". Refer to [BCS-14, "CAN Communication Inspection Using CONSULT-II \(Self-Diagnosis\)"](#) .

### 1. CHECK HORN FUNCTION

Does horn sound with horn switch?

YES or NO

YES >> Horn circuit is OK.

NO >> Check horn circuit. Refer to [WW-45, "HORN"](#) .

## Check Headlamp Function

AIS005A8

First perform the "SELF-DIAG RESULTS" in "BCM" with CONSULT-II, then perform the trouble diagnosis of malfunction system indicated "SELF-DIAG RESULTS" of "BCM". Refer to [BCS-14, "CAN Communication Inspection Using CONSULT-II \(Self-Diagnosis\)"](#) .

### 1. CHECK HEADLAMP OPERATION

Does headlamp come on when turning lighting switch "ON"?

YES or NO

YES >> Headlamp operation circuit is OK.

NO >> Check headlamp system. Refer to [LT-7, "HEADLAMP \(FOR USA\)"](#) or [LT-38, "HEADLAMP \(FOR CANADA\) - DAYTIME LIGHT SYSTEM -"](#) .

## Check Map Lamp and Ignition Keyhole Illumination Function

AIS005A9

### 1. CHECK MAP LAMP AND IGNITION KEYHOLE ILLUMINATION FUNCTION

When map lamp switch is in "DOOR" position, open the front door (LH or RH).

**Map lamp and ignition keyhole illumination should illuminate.**

OK or NG

OK >> Replace BCM.

NG >> Check ignition illumination circuit. Refer to [LT-164, "INTERIOR ROOM LAMP"](#) .

# REMOTE KEYLESS ENTRY SYSTEM

AIS005AA

## ID Code Entry Procedure KEY FOB ID SET UP WITH CONSULT-II

### NOTE:

- If a key fob is lost, the ID code of the lost key fob must be erased to prevent unauthorized use. A specific ID code can be erased with CONSULT-II. However, when the ID code of a lost key fob is not known, all controller ID codes should be erased. After all ID codes are erased, the ID codes of all remaining and/or new key fobs must be re-registered.
- When registering an additional key fob, the existing ID codes in memory may or may not be erased. If four ID codes are stored in memory, when an additional code is registered, only the oldest code is erased. If less than five ID codes are stored in memory, when an additional ID code is registered, the new ID code is added and no ID codes are erased.
- Entry of maximum five ID codes is allowed. When more than four ID codes are entered, the oldest ID code will be erased.
- Even if same ID code that is already in the memory is input, the same ID code can be entered. The code is counted as an additional code.

### CAUTION:

If CONSULT-II is used with no connection of CONSULT-II CONVERTER, malfunctions might be detected in self-diagnosis depending on control unit which carry out CAN communication.

1. Turn ignition switch "OFF".
2. Connect "CONSULT-II" and "CONSULT-II CONVERTER" to the data link connector.

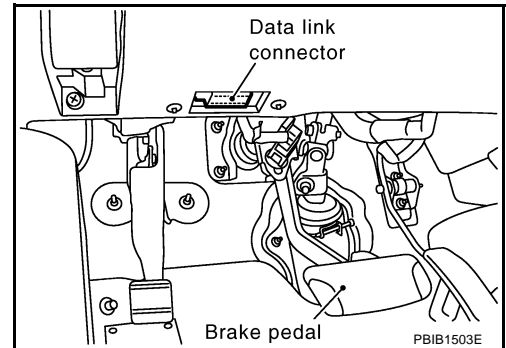

3. Turn ignition switch ON.
4. Touch "START (NISSAN BASED VHCL)".

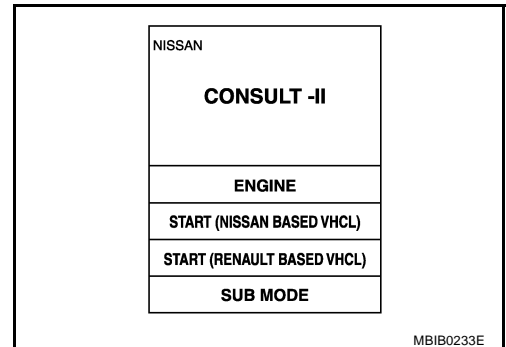

5. Touch "BCM".  
If "BCM" is not indicated, go to [GI-38, "CONSULT-II Data Link Connector \(DLC\) Circuit"](#).

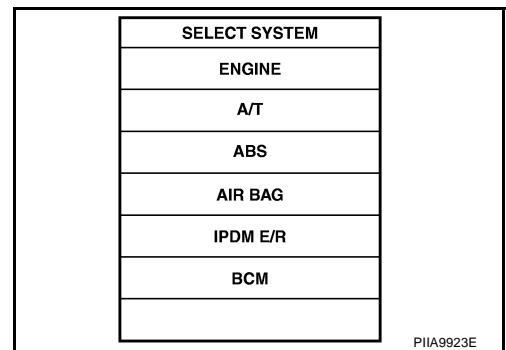



# REMOTE KEYLESS ENTRY SYSTEM

6. Touch "MULTI REMOTE ENT".

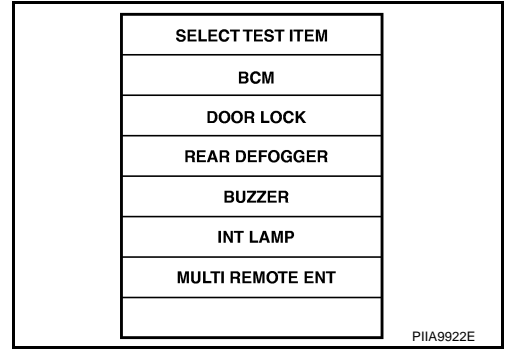

A  
B  
C

7. Touch "WORK SUPPORT".

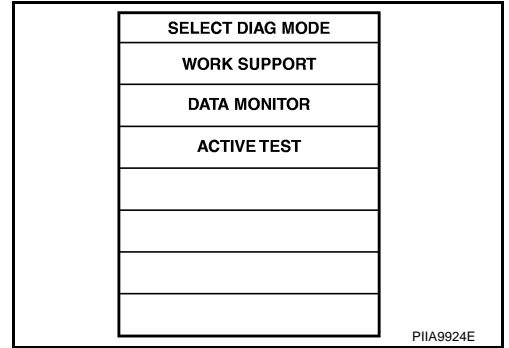

D  
E  
F  
G

8. The items are shown on the figure can be set up.

- "REMO CONT ID REGIST"  
Use this mode to register a key fob ID code.

**NOTE:**

**Register the ID code when key fob or BCM is replaced, or when additional key fob is required.**

- "REMO CONT ID ERASUR"  
Use this mode to erase a key fob ID code.
- "REMO CONT ID CONFIR"  
Use this mode to confirm if a key fob ID code is registered or not.

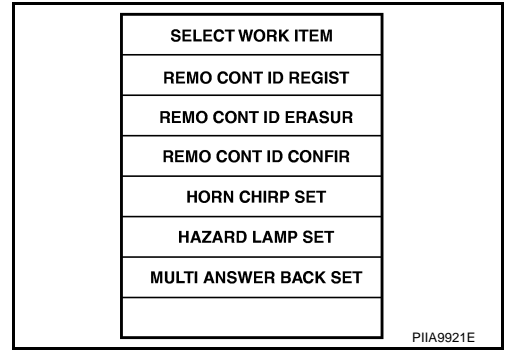

H  
BL  
J  
K  
L  
M

# REMOTE KEYLESS ENTRY SYSTEM

## KEY FOB ID SET UP WITHOUT CONSULT-II

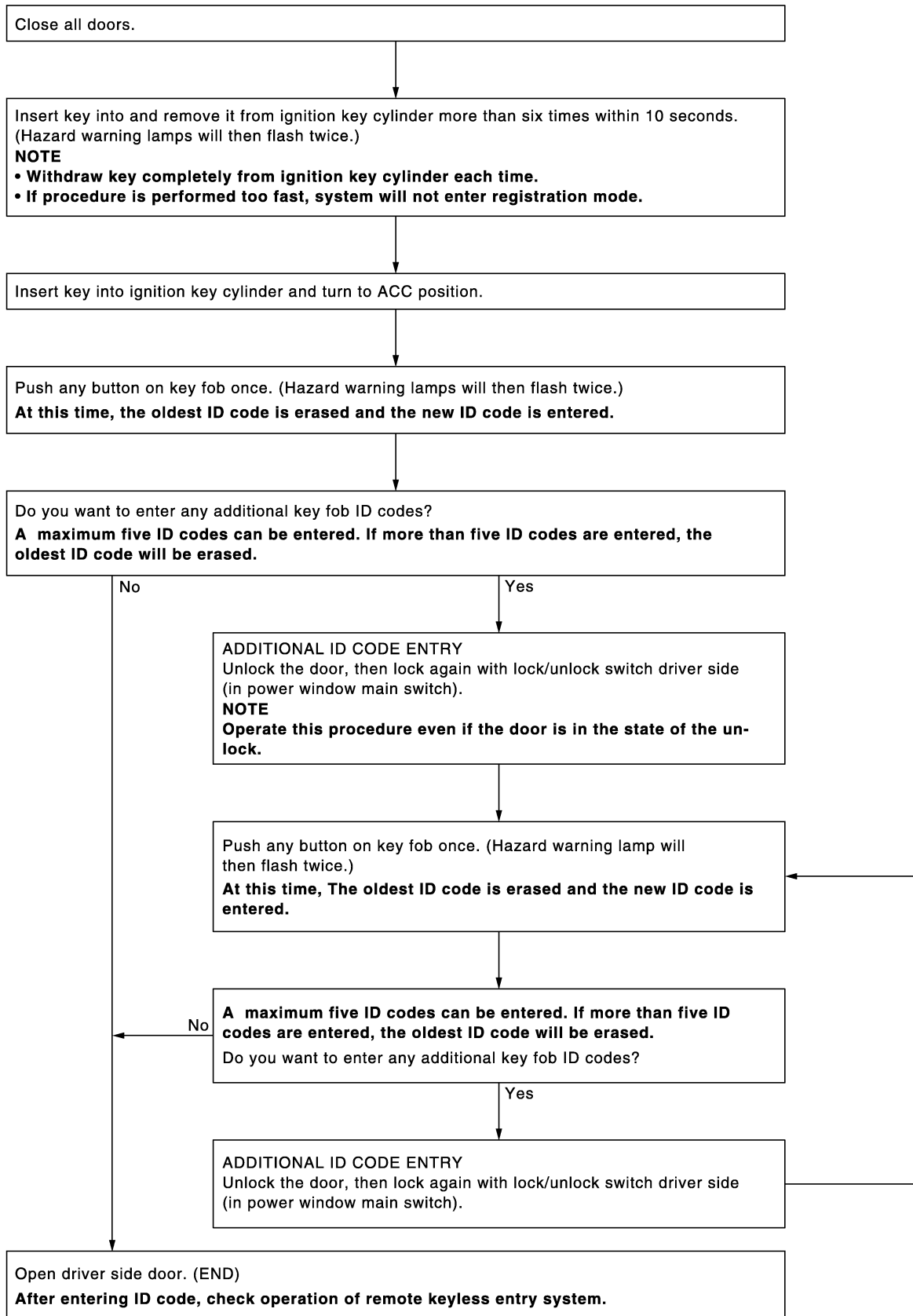

PIIA2839E

# REMOTE KEYLESS ENTRY SYSTEM

## NOTE:

- If a key fob is lost, the ID code of the lost key fob must be erased to prevent unauthorized use. A specific ID code can be erased with CONSULT-II. However, when the ID code of a lost key fob is not known, all controller ID codes should be erased. After all ID codes are erased, the ID codes of all remaining and/or new key fobs must be re-registered.  
To erase all ID codes in memory, register one ID code (key fob) five times. After all ID codes are erased, the ID codes of all remaining and/or new key fobs must be re-registered.
- When registering an additional key fob, the existing ID codes in memory may or may not be erased. If five ID codes are stored in memory, when an additional code is registered, only the oldest code is erased. If less than five ID codes are stored in memory, when an additional ID code is registered, the new ID code is added and no ID codes are erased.
- If you need to activate more than two additional new key fobs, repeat the procedure “Additional ID code entry” for each new key fob.
- Entry of maximum five ID codes is allowed. When more than five ID codes are entered, the oldest ID code will be erased.
- Even if same ID code that is already in the memory is input, the same ID code can be entered. The code is counted as an additional code.

## Key Fob Battery Replacement

AIS005AB

### SEC. 998

#### NOTE:

- Be careful not to touch the circuit board or battery terminal.
- The keyfob is water-resistant. However, if it does get wet, immediately wipe it dry.

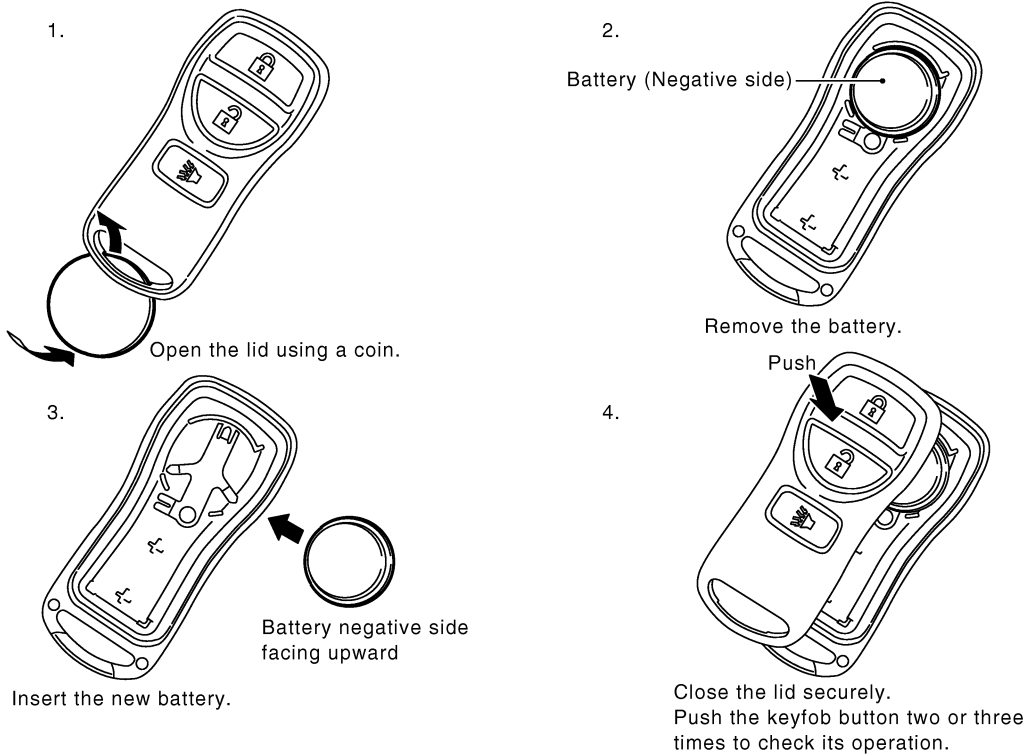

# DOOR

PFP:80100

AIS00022

## DOOR

### Fitting Adjustment

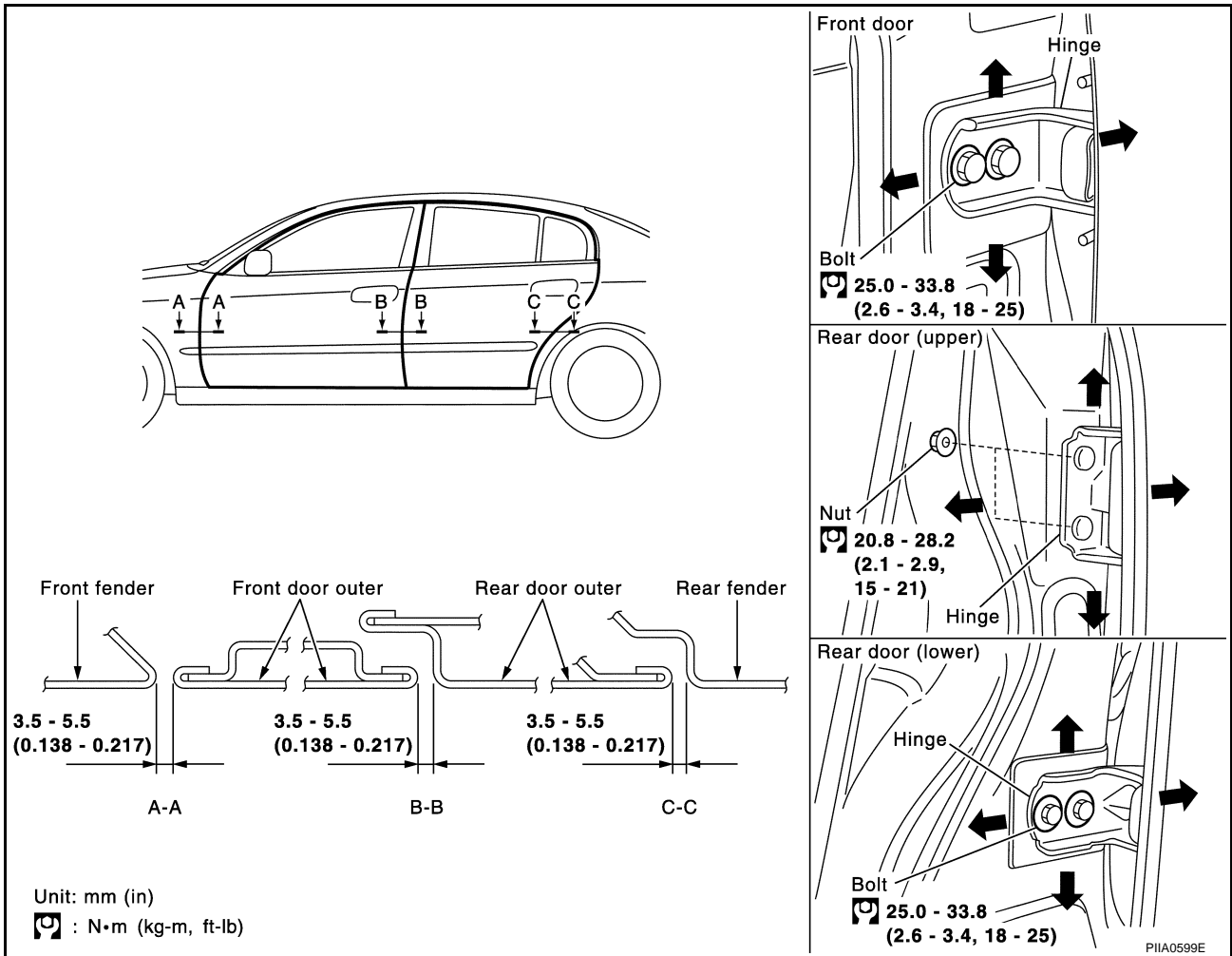

### FRONT DOOR

#### Longitudinal Clearance and Surface Height Adjustment At Front End

Loosen the hinge mounting bolts. Raise the front door at rear end to adjust.

### REAR DOOR

#### Longitudinal Clearance and Surface Height Adjustment At Front End

1. Remove the center pillar upper garnish and center pillar lower garnish. Refer to [EI-39. "Removal and Installation"](#).
2. Accessing from inside the vehicle, loosen the mounting nuts. Open the rear door, and raise the rear door at rear end to adjust.

### STRIKER ADJUSTMENT

1. Adjust the striker so that it becomes parallel with the lock insertion direction.

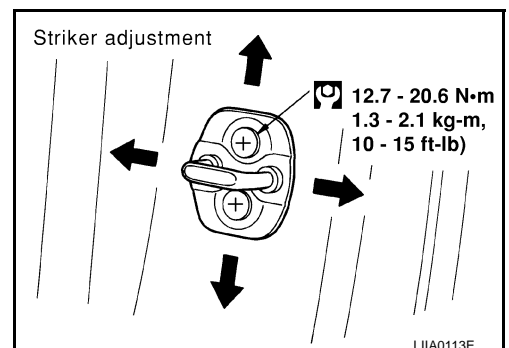

# DOOR

## Removal and Installation of Front Door

AIS0062E

### REMOVAL

#### CAUTION:

- When removing and installing the front door assembly, support the door with a jack and cloth to protect the door and body.
  - When removing and installing front door assembly, be sure to carry out the fitting adjustment. Refer to [BL-80, "Fitting Adjustment"](#).
  - After installing, apply touch-up paint (the body color) onto the head of the hinge mounting nuts.
  - Check the hinge rotating part for poor lubrication. If necessary, apply "body grease".
  - Operate with two workers, because of its heavy weight.
  - Check rear door open/close operation after installation.
1. Pull the lever and remove the door harness connector while removing tabs of door harness connector.

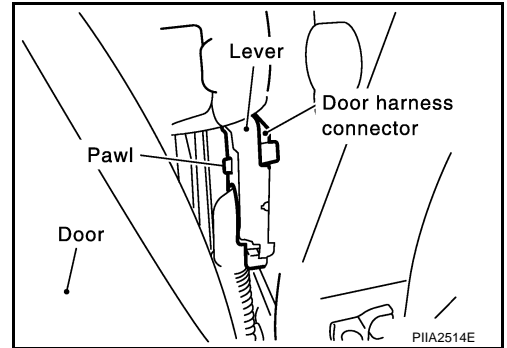

2. Remove the mounting bolts of the check link on the vehicle.

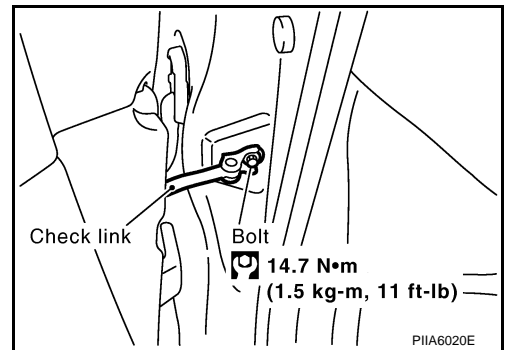

3. Remove the door-side hinge mounting nuts, then remove the door assembly.

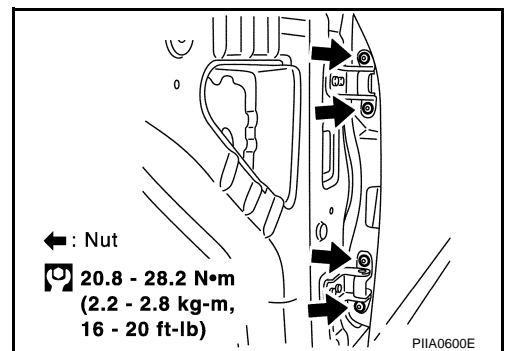

### INSTALLATION

Install in the reverse order of removal.

## Removal and Installation of Rear Door

AIS0062F

#### CAUTION:

- When removing and installing the rear door assembly, support the door with a jack and cloth to protect the door and body.
- When removing and installing rear door assembly, be sure to carry out the fitting adjustment. Refer to [BL-80, "Fitting Adjustment"](#).
- Check the hinge rotating part for poor lubrication. If necessary, apply "body grease".

A  
B  
C  
D  
E  
F  
G  
H  
BL  
J  
K  
L  
M

# DOOR

- After installing, apply touch-up paint (the body color) onto the head of the hinge mounting nuts.
- Operate with two workers, because of its heavy weight.
- Check rear door open/close operation after installation.

## REMOVAL

1. Grommet is pulled out, and the Rear door harness connector is detached.

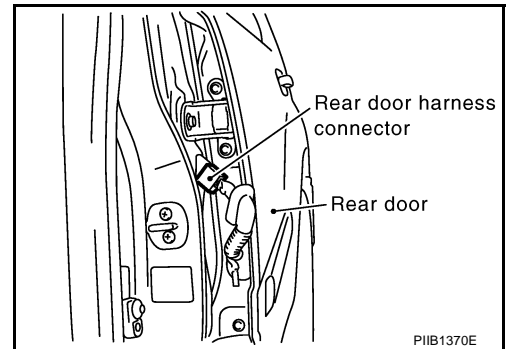

2. Remove the mounting bolts of the check link on the vehicle.

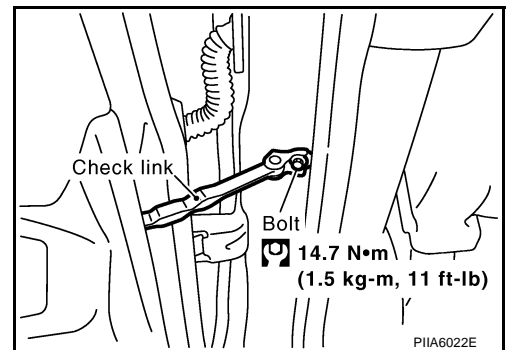

3. Remove the door-side hinge mounting nuts, and remove the door assembly.

 : **24.5 N•m (2.5 kg-m, 18 ft-lb)**

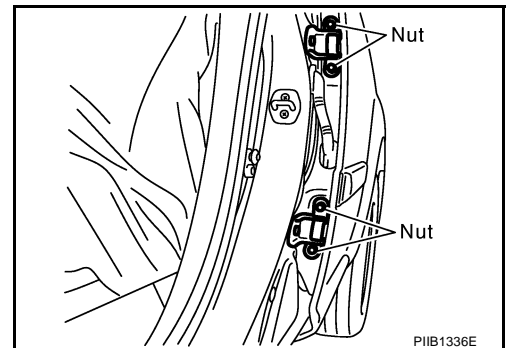

## INSTALLATION

Install in the reverse order of removal.

# DOOR

## Door Weatherstrip

AIS0062G

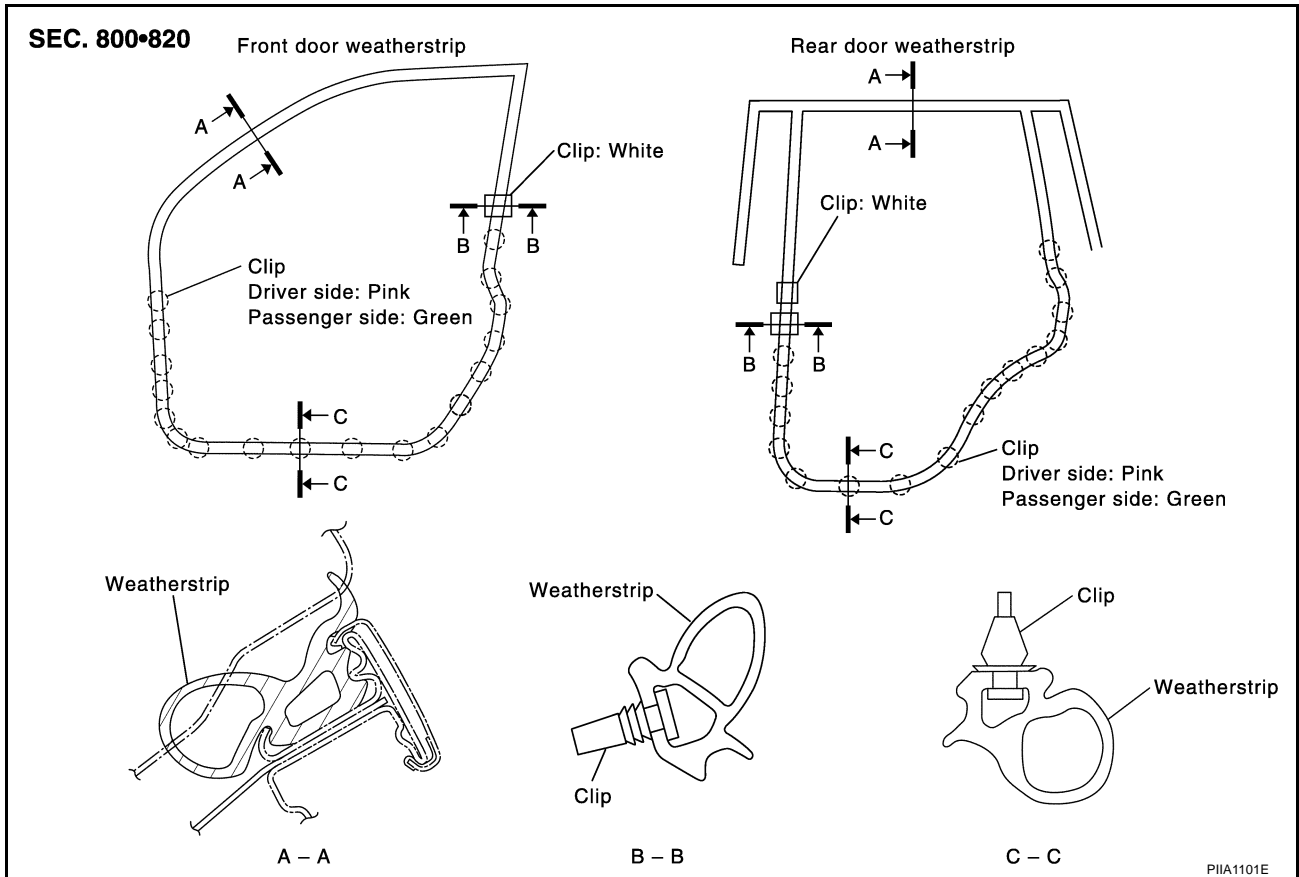

A  
B  
C  
D  
E  
F  
G  
H

BL

### REMOVAL

1. Remove the mounting bolts of the check link on the vehicle. Refer to [BL-81, "Removal and Installation of Front Door"](#) or [BL-81, "Removal and Installation of Rear Door"](#).
2. Remove the weatherstrip clips and remove weatherstrip.

#### CAUTION:

After removal, do not pull strongly on the weatherstrip.

### INSTALLATION

Install in the reverse order of removal.

J  
K  
L  
M

# FRONT DOOR LOCK

## FRONT DOOR LOCK

PFP:80502

### Component Structure

AIS00025

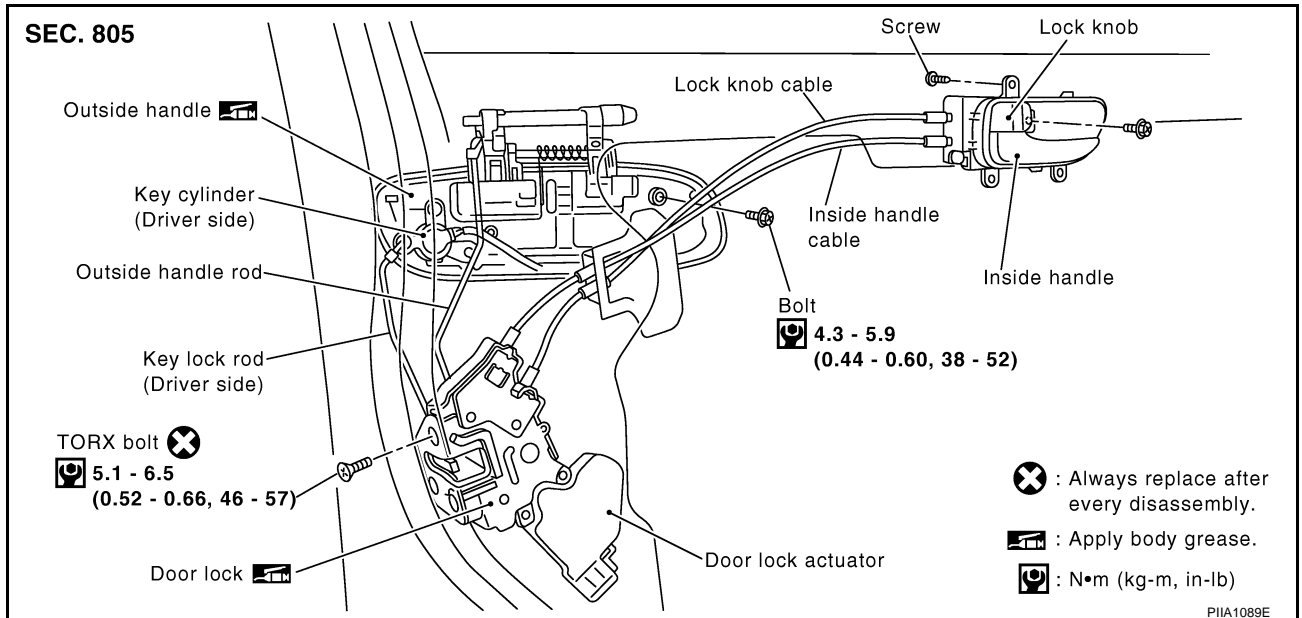

### Inspection and Adjustment

AIS00026

1. Remove the front door finisher. Refer to [EI-37, "Removal and Installation"](#) .
2. Remove the front door speaker. Refer to [AV-36, "Removal and Installation of Door Speaker"](#) .
3. Remove the front door window and front door module assembly. Refer to [GW-88, "Removal and Installation"](#) .

### EXTERIOR HANDLE ROD ADJUSTMENT

Rotate the bushing to adjust so that the clearance between the bushing and rod becomes as shown in the figure.

#### CAUTION:

Be careful not to make the clearance 0 mm (0 in) or the rod will be pressed continuously.

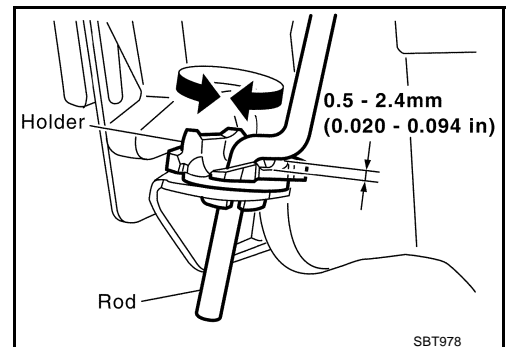

### Removal and Installation

#### REMOVAL

AIS00027

1. Remove the front door finisher. Refer to [EI-37, "Removal and Installation"](#) .
2. Remove the front door speaker. Refer to [AV-36, "Removal and Installation of Door Speaker"](#) .
3. Remove the front door window and front door module assembly. Refer to [GW-88, "Removal and Installation"](#) .



# FRONT DOOR LOCK

4. Disconnect the inside handle cable and lock knob cable from the back side of the front door finisher.

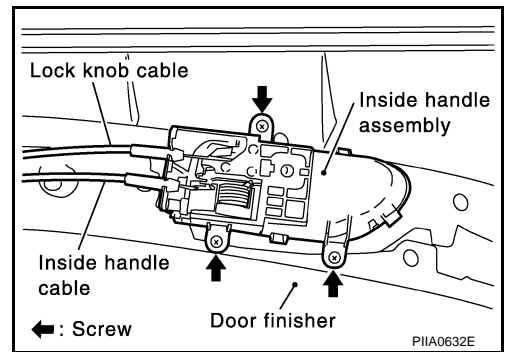

5. Reach to separate the key cylinder rod and outside handle rod connection (on the handle).
6. Remove the mounting bolts (TORX T30), remove the door lock assembly.
7. Disconnect the door lock actuator connector.

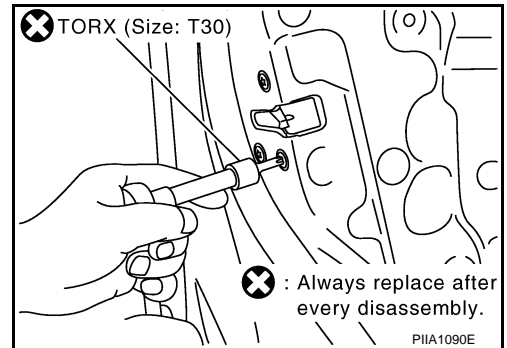

8. Remove the exterior handle mounting bolts, move the outside handle assembly backward, and then remove it from the panel in front of the outside handle escutcheon.

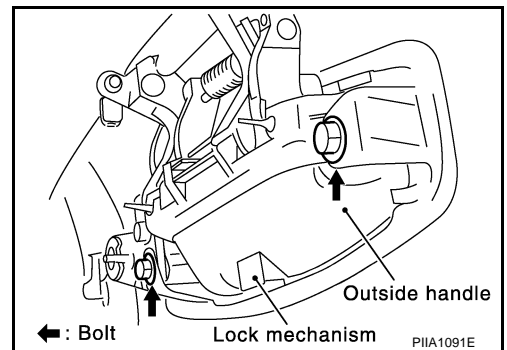

## INSTALLATION

Install in the reverse order of removal.

### CAUTION:

To install each rod, be sure to rotate the rod holder until a click is felt.

## Disassembly and Assembly DISASSEMBLY

### CAUTION:

Be sure to remove or install the actuator with the door lock assembly removed.

1. Remove the mounting screws, and remove the actuator from the door lock assembly.
2. Pull the actuator straight downward to separate it from the door lock assembly.

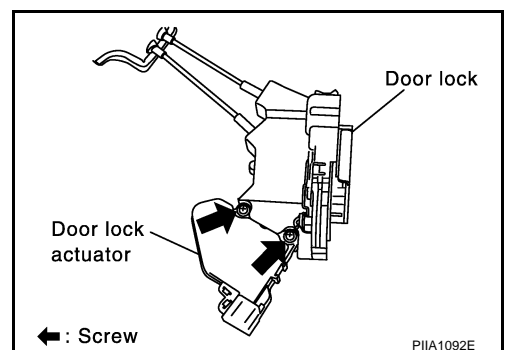

# FRONT DOOR LOCK

---

## ASSEMBLY

1. Align the actuator pivot with the cutout on the knob lever of the door lock assembly, then assemble the actuator.
2. Move the knob lever and the actuator pivot toward the lock-on direction, and check that it engages securely.

# REAR DOOR LOCK

## REAR DOOR LOCK

PFP:82502

### Component Structure

AIS0002A

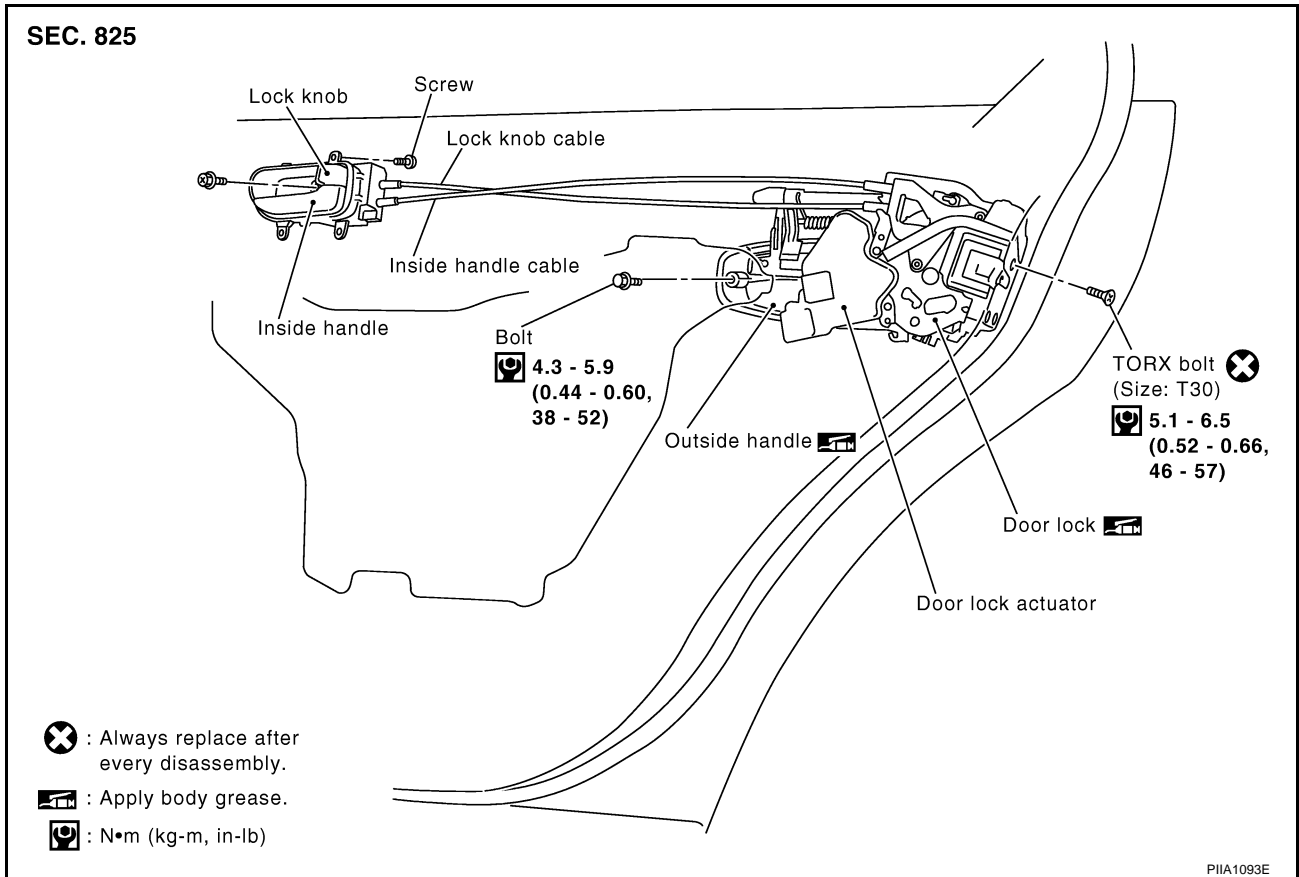

### INSPECTION AND ADJUSTMENT

1. Remove the rear door finisher. Refer to [EI-37, "Removal and Installation"](#).

### EXTERIOR HANDLE ROD ADJUSTMENT

Rotate the bushing to adjust so that the clearance between the bushing and rod becomes as shown in the figure.

#### CAUTION:

Be careful not to make the clearance 0 mm (0 in) or the rod will be pressed continuously.

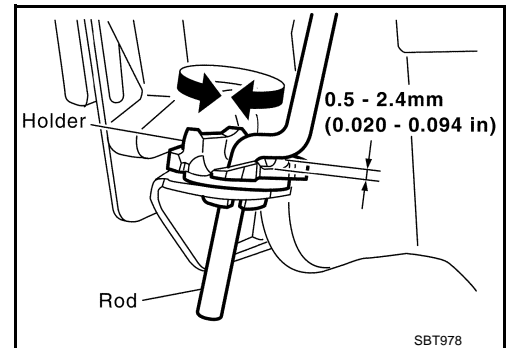

# REAR DOOR LOCK

## Removal and Installation of Door Lock

AI/S0002B

### REMOVAL

1. Remove the rear door finisher. Refer to [EI-37, "Removal and Installation"](#) .
2. After gaining access to the inside handle on the back side of the rear door finisher, disconnect the inside handle cable and lock knob cable.

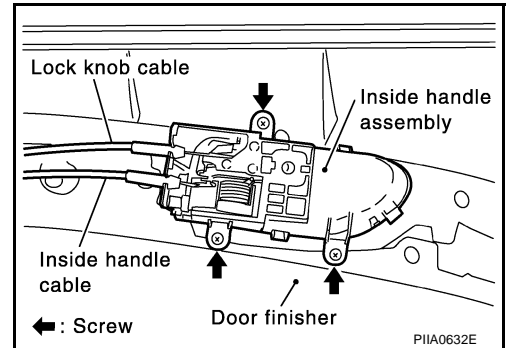

3. Remove the mounting bolts (TORX T30), remove the door lock assembly.
4. Disconnect the door lock actuator connector.

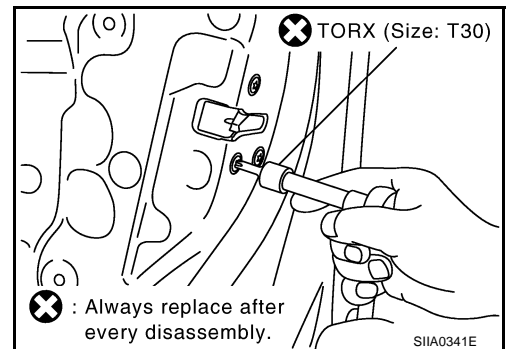

5. Remove the outside handle mounting bolts, and move the handle backward to disengage it from the panel in front of the outside handle escutcheon, then remove the handle.

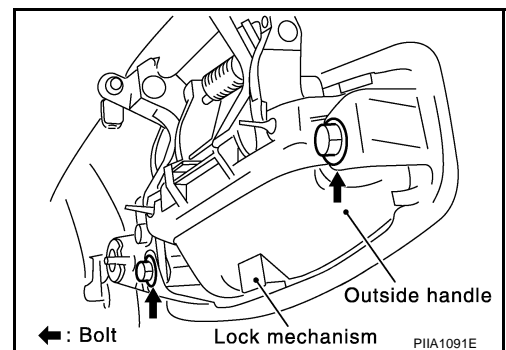

### INSTALLATION

Install in the reverse order of removal.

#### **CAUTION:**

To install each rod, be sure to rotate the rod holder until a click is felt.

### Disassembly and Assembly

#### DISASSEMBLY

AI/S0002C

#### **CAUTION:**

Be sure to remove or install the actuator with the door lock assembly removed.

## REAR DOOR LOCK

1. Remove the mounting screws, and remove the actuator from the door lock assembly.
2. Pull the actuator straight downward to separate it from the door lock assembly.

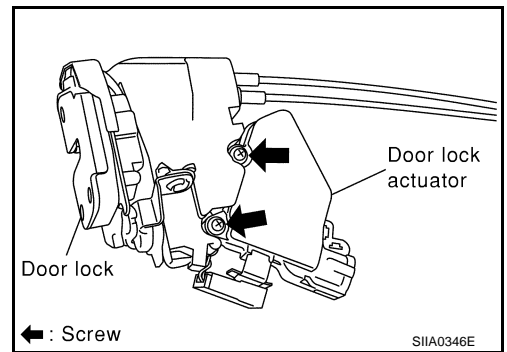

### ASSEMBLY

1. Align the actuator pivot with the cutout on the knob lever of the door lock assembly, then assemble the actuator.
2. Move the knob lever and the actuator pivot toward the lock-on direction, and check that it engages securely.

A

B

C

D

E

F

G

H

BL

J

K

L

M

# TRUNK LID

PFP:H4300

AIS005WL

## TRUNK LID

### Fitting Adjustment

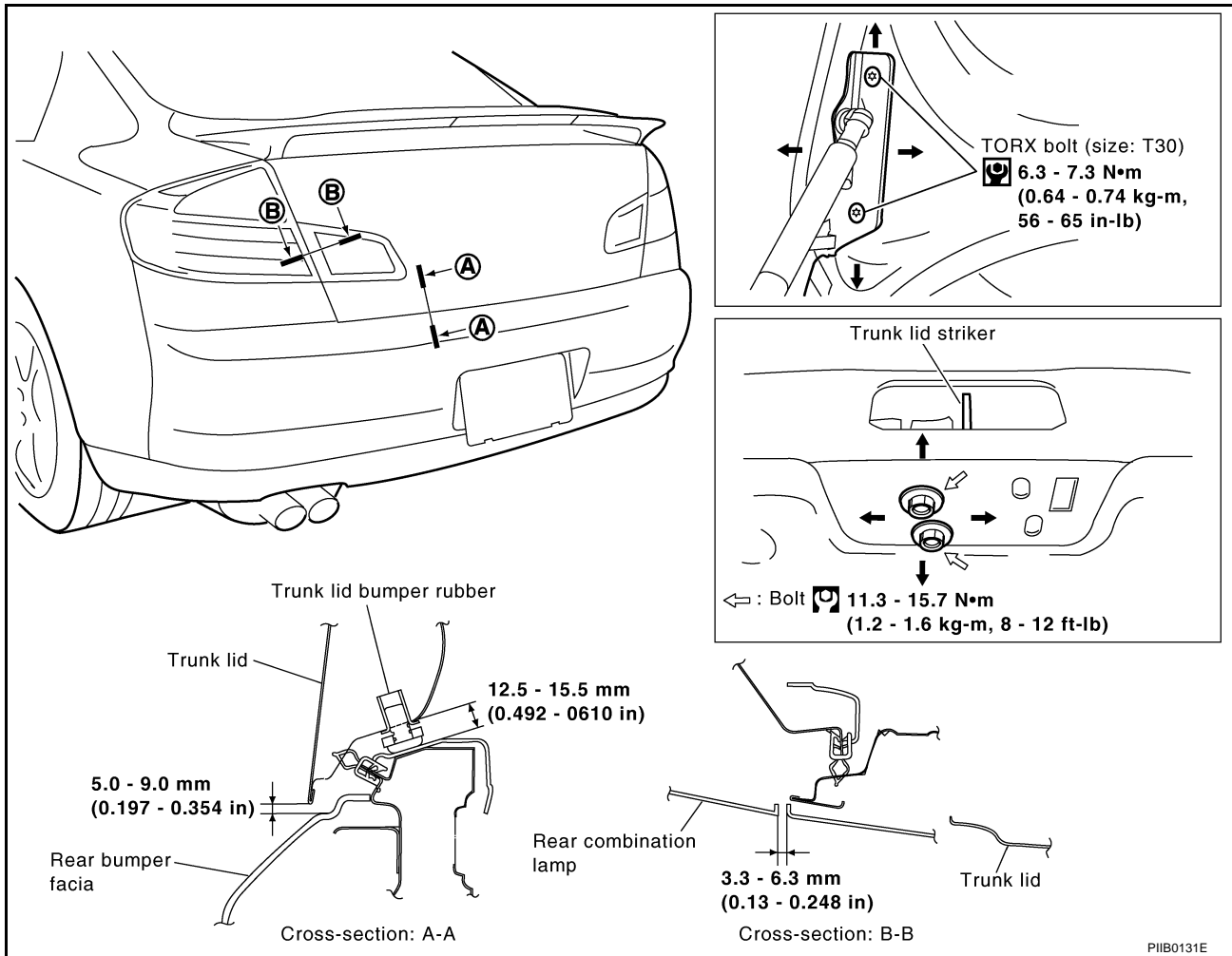

### LONGITUDINAL AND LATERAL CLEARANCE ADJUSTMENT

1. With the striker released, loosen the trunk lid hinge mounting bolts to close the trunk lid.
2. Make the lateral clearance and the clearance to the rear window glass equal, and open the trunk lid to tighten the mounting bolts to the specified torque.

### SURFACE HEIGHT ADJUSTMENT

1. Loosen the striker mounting bolts. Raise the striker to the top position, and temporarily tighten the upper mounting bolt at the position.
2. Loosen the bumper rubber collar, and the damper is drawn out.
3. Close the trunk lid lightly and adjust the surface height, then open the trunk lid to finally tighten the striker mounting bolts to the specified torque or bumper rubber collar is tighten by the hand.

# TRUNK LID

## Removal and Installation of Trunk Lid Assembly

AIS005WM

A  
B  
C  
D  
E  
F  
G  
H

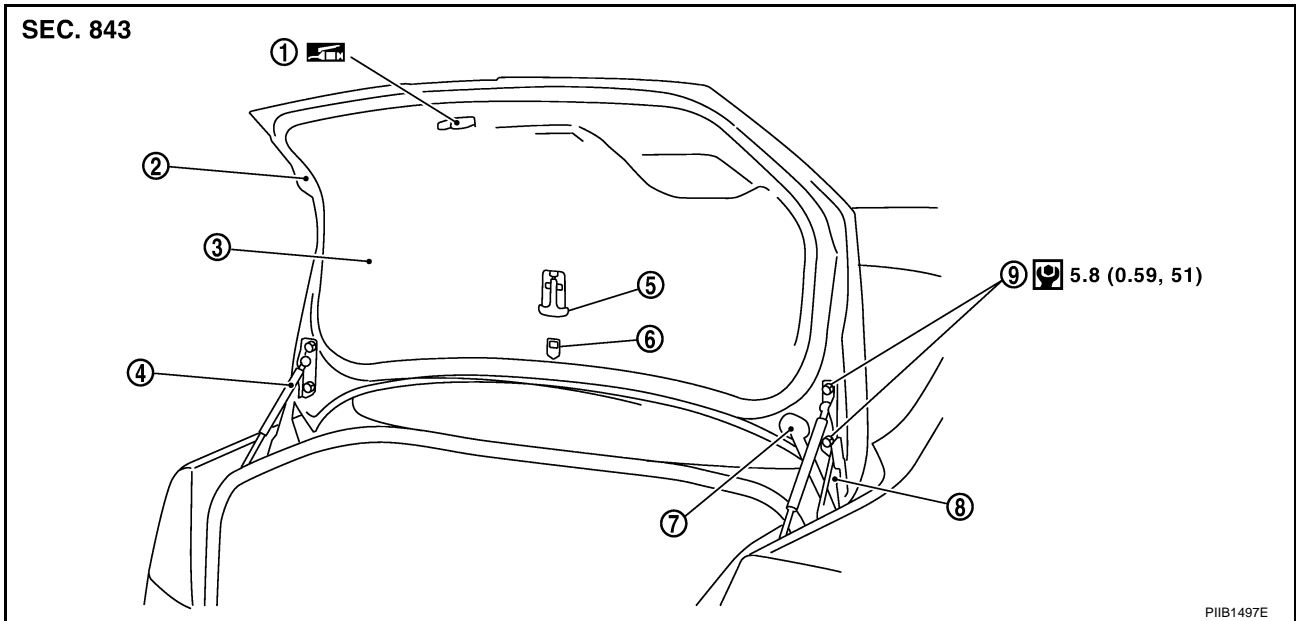

- |                            |   |                                    |
|----------------------------|---|------------------------------------|
| 1. Trunk lid lock assembly | 2. Trunk lid assembly                           | 3. Trunk lid finisher              |
| 4. Trunk lid stay          | 5. Trunk lid opener emergency lever (secondary) | 6. Trunk lid opener emergency hook |
| 7. Trunk lid harness       | 8. Trunk lid hinge                              | 9. TORX bolt                       |

### REMOVAL

1. Disconnect the connectors in the trunk lid, and remove the harness clamps to pull the harness out of the trunk lid.
2. Insert flat-bladed screwdriver into the gap and remove holder.
3. Remove trunk lid stay (gas stay).
4. Remove the mounting bolts, and remove the trunk lid assembly.

#### CAUTION:

- After installing, apply touch-up paint (the body color) onto the head of the hinge mounting bolts.
- After installing, check operation.
- After installing, perform fitting adjustment. Refer to [BL-90, "Fitting Adjustment"](#).

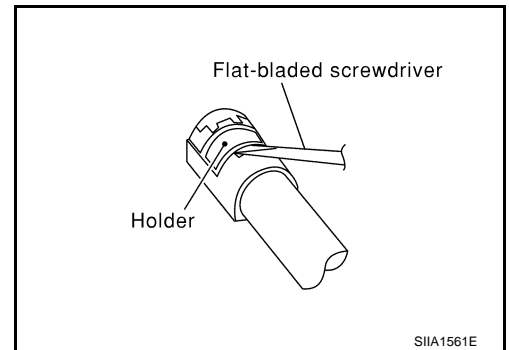

BL  
J  
K  
L  
M

### INSTALLATION

Install in the reverse order of removal.

## Removal and Installation of Trunk Lid Stay

AIS005WN

### REMOVAL

1. Insert flat-bladed screwdriver into the gap and remove holder.
2. Remove trunk lid stay on the trunk lid.
3. Remove the stud balls, and trunk lid stay.

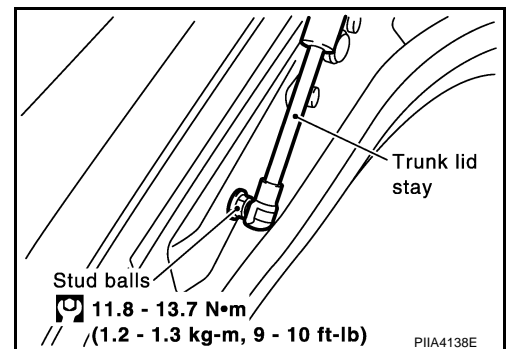

# TRUNK LID

## INSTALLATION

1. Install in the reverse order of removal.
2. After installing, check the operation.

## Removal and Installation of Trunk Lid Lock

### REMOVAL

1. Remove the trunk lid finisher. Refer to [EI-47, "TRUNK ROOM TRIM & TRUNK LID FINISHER"](#).
2. Disconnect the trunk lid emergency opener cable from the trunk lid lock.
3. After removing the harness connector, remove the mounting bolts, and remove the trunk lid lock.

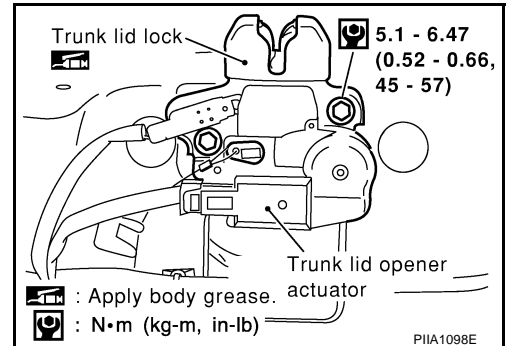

## INSTALLATION

1. Install in the reverse order of removal.
2. After installing, close the trunk lid height. Perform the lock and surface height adjustment. Refer to [BL-90, "Fitting Adjustment"](#).
3. After installing, check the operation.

## Removal and Installation of Trunk Lid Striker

### REMOVAL

1. Remove the trunk rear plate and trunk rear finisher. Refer to [EI-47, "TRUNK ROOM TRIM & TRUNK LID FINISHER"](#).
2. Remove the mounting bolts, and remove the striker from the trunk lock support.

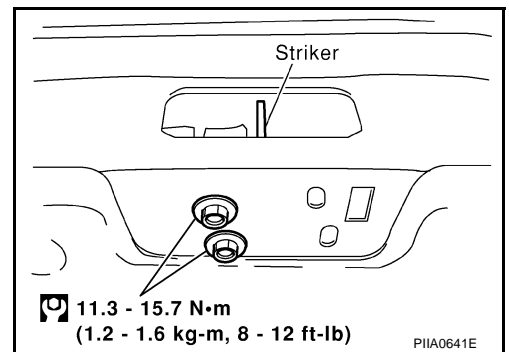

## INSTALLATION

1. Install in the reverse order of removal.
2. After installing, close the trunk lid height. Perform the lock and surface height adjustment. Refer to [BL-90, "Fitting Adjustment"](#).
3. After installing, check the operation.



# TRUNK LID

## Removal and Installation of Trunk lid Emergency Opener Cable

AIS005WQ

A  
B  
C  
D  
E  
F  
G  
H  
BL  
J  
K  
L  
M

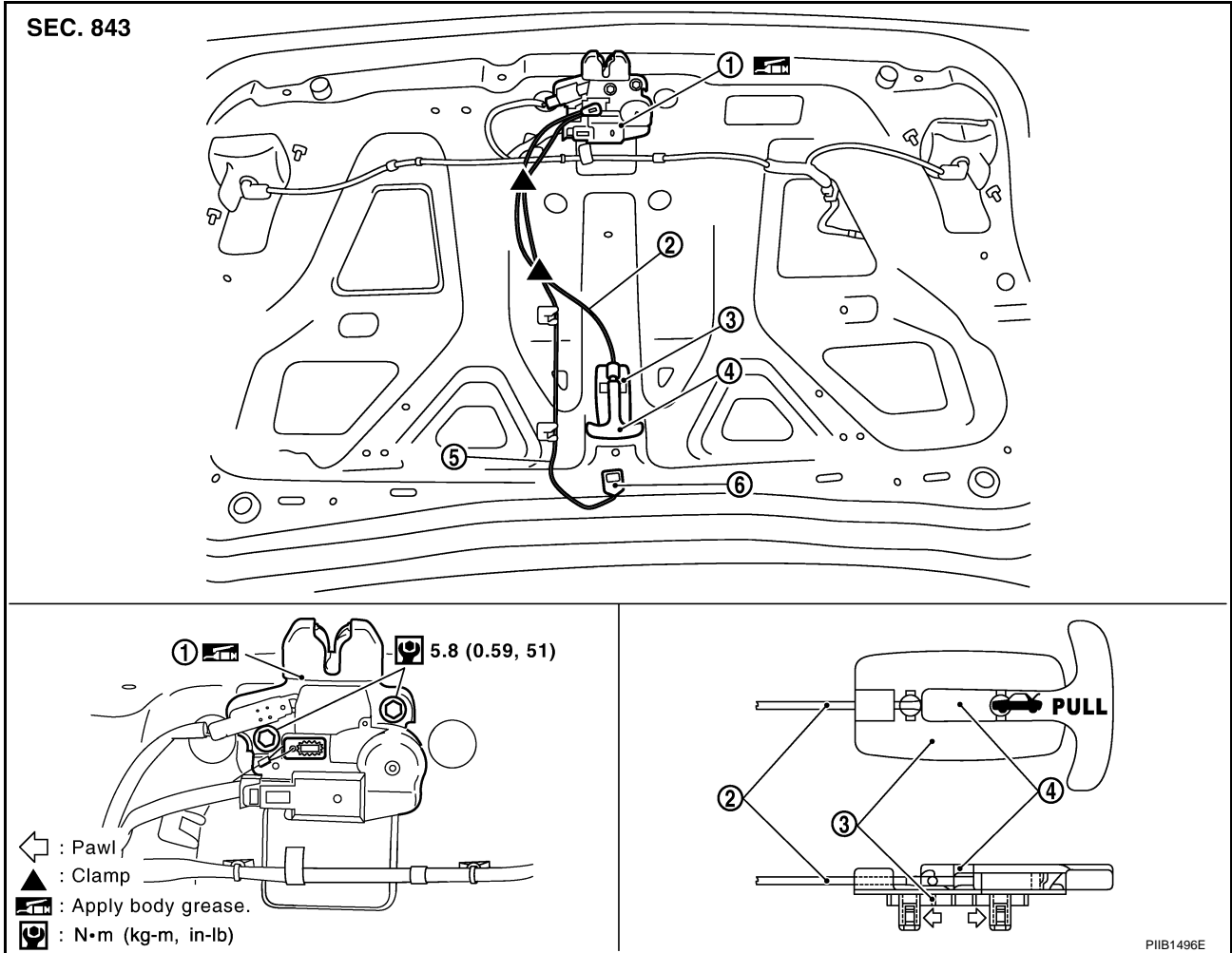

- |   |   |  |
|---|---|--|
| 1. Trunk lid lock assembly                      | 2. Trunk lid emergency opener cable (secondary) | 3. Trunk lid emergency opener lever holder |
| 4. Trunk lid emergency opener lever (secondary) | 5. Trunk lid emergency opener cable             | 6. Trunk lid emergency opener hook         |

### REMOVAL

1. Remove trunk lid finisher. Refer to [EI-47, "TRUNK ROOM TRIM & TRUNK LID FINISHER"](#).
2. Disconnect each clamp of trunk lid emergency opener cable.
3. Disconnect the trunk lid emergency opener cable and from the trunk lid lock assembly.
4. Disconnect the trunk lid emergency opener cable (secondary) from the trunk lid emergency opener lever holder.
5. Remove trunk lid emergency opener cable.

### INSTALLATION

1. Install in the reverse order of removal.

#### CAUTION:

After installing, check the operation.

# TRUNK LID

## Removal and Installation of Trunk Lid Weatherstrip

AIS005WR

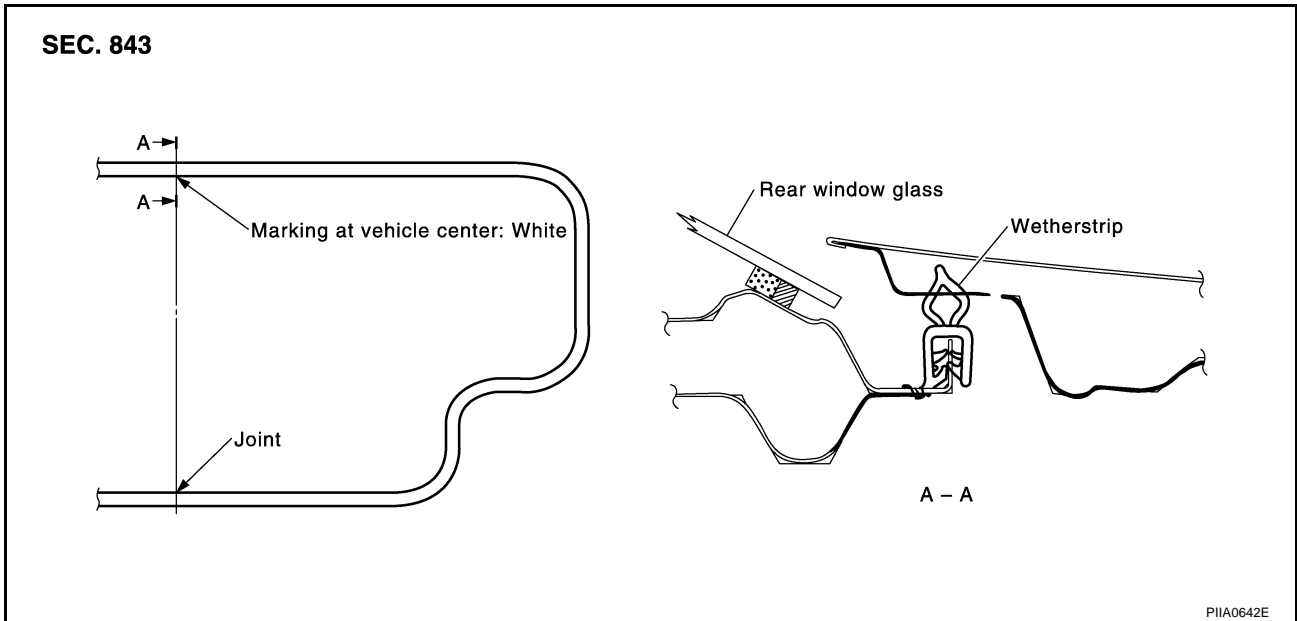

### REMOVAL

1. Pull up and remove engagement with body from weatherstrip joint.

### CAUTION:

After removal, do not pull strongly on the weatherstrip.

### INSTALLATION

1. Working from the upper section, align weatherstrip mark with vehicle center position mark and install weatherstrip onto the vehicle.
2. For the lower section, align the weatherstrip seam with center of the striker.
3. After installation, pull the weatherstrip gently to ensure that there is no loose section.

### NOTE:

Make sure the weatherstrip is fit tightly at each corner and back door rear plate.

# TRUNK LID OPENER

## TRUNK LID OPENER

PFP:84640

### Component Parts and Harness Connector Location

AIS004CT

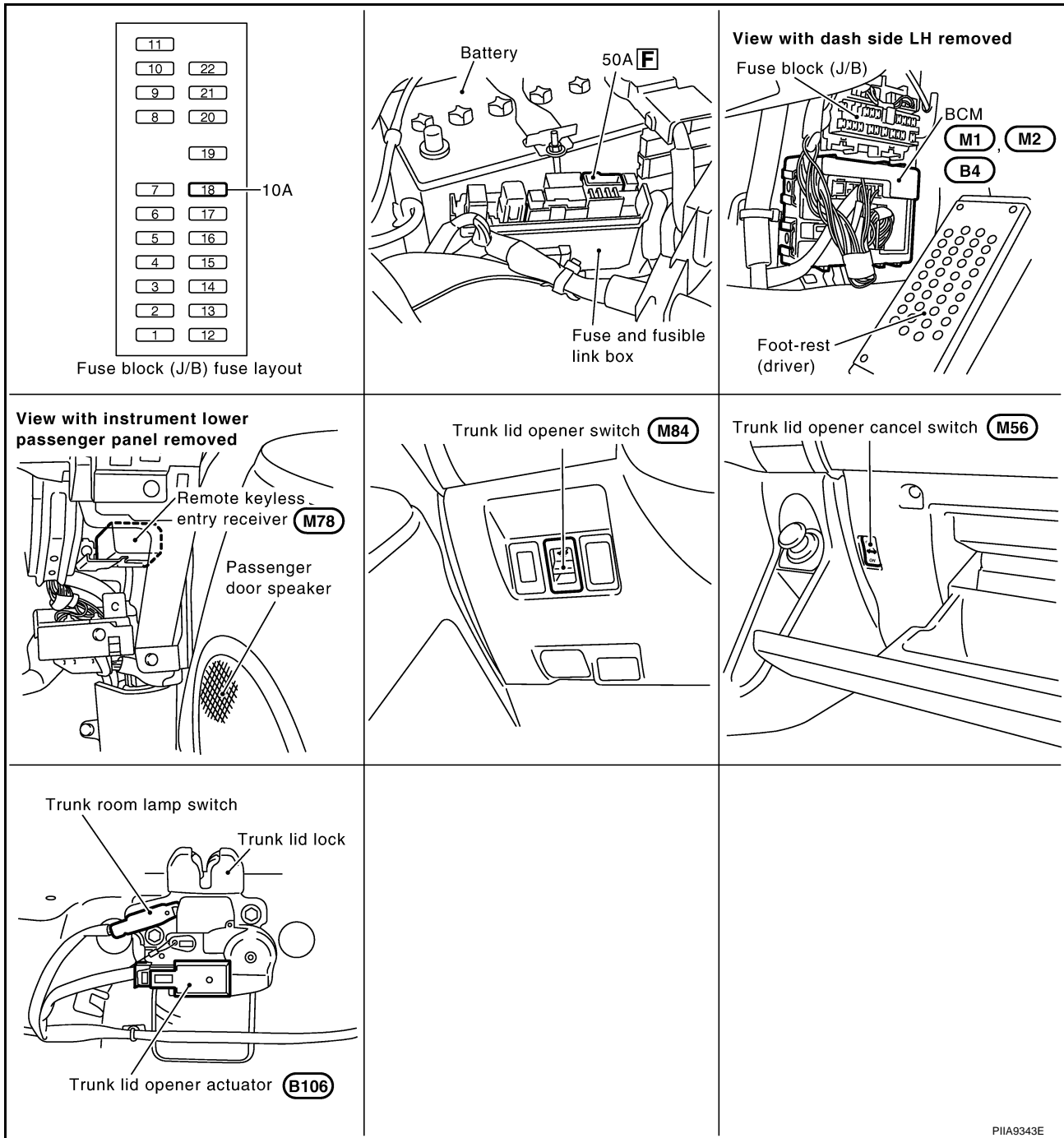

A  
B  
C  
D  
E  
F  
G  
H  
BL  
J  
K  
L  
M

### System Description

AIS004CU

Power is supplied at all times

- through 50A fusible link (letter **F**, located in the fuse and fusible link box)
- to BCM terminal 55,
- through 10A fuse [No.18, located in the fuse block (J/B)]
- to BCM terminal 42.

Ground is supplied

- to BCM terminal 52
- through body grounds M30 and M66.

When trunk lid opener cancel switch is ON and trunk lid opener switch is ON (pushed), ground is supplied

# TRUNK LID OPENER

---

- to BCM terminal 30
- through trunk lid opener cancel switch terminals 1 and 2
- through trunk lid opener switch terminals 1 and 2 and
- through body grounds M30 and M66.

And power is supplied

- through BCM terminal 68
- to trunk lid opener actuator terminal 1.

Ground is supplied

- to trunk lid opener actuator terminal 2
- through body grounds B5 and B29.

Then BCM unlocks trunk lid opener actuator.

## TRUNK LID OPENER OPERATION

When trunk lid opener switch or trunk button of key fob is ON, BCM is unlocked trunk opener actuator. BCM can unlock trunk lid opener actuator when

- vehicle speed is less than 5 km/h (3MPH)
- vehicle security system is disarmed or pre-armed phase

BCM does not unlock trunk lid opener actuator when



- trunk lid opener cancel switch is OFF (CANCEL)
- vehicle speed is more than 5 km/h (3MPH)
- vehicle security system is armed or alarm phase
- key is inserted in ignition key cylinder



# TRUNK LID OPENER

## Terminals and Reference Value for BCM

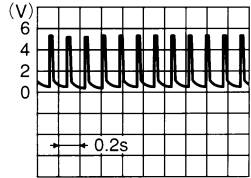
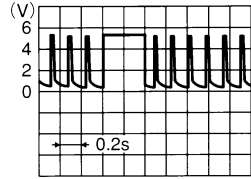
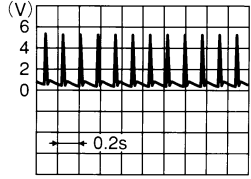
AI500021

TERMI- NAL	WIRE COLOR	ITEM	CONDITION		VOLTAGE (V) (Approx.)
18	B	Sensor ground	—		0
19	Y	Remote keyless entry receiver power supply	Ignition switch is removed from key cylinder	Waiting state	 <p>OCC3881D</p>
				Any operation using key fob	 <p>OCC3882D</p>
20	L	Remote keyless entry receiver signal	Ignition switch is removed from key cylinder	Waiting state	 <p>OCC3879D</p>
				Any operation using key fob	 <p>OCC3880D</p>
30	L	Trunk lid opener switch	Trunk lid opener cancel switch is ON position	Trunk lid opener switch is ON	0
				Trunk lid opener switch is OFF	Battery voltage
				Trunk lid opener cancel switch is OFF position	Battery voltage
39	L	CAN-H	—		—
40	R	CAN-L	—		—
42	GY	Power source (Fuse)	—		Battery voltage
52	B	Ground	—		0
55	W/R	Power source (Fusible link)	—		Battery voltage
68	G/W	Trunk lid opener output signal	Locked (OFF) → Unlocked (ON)		0 → Battery voltage

# TRUNK LID OPENER

AIS004CV

## CONSULT-II Function BASIC OPERATION PROCEDURE

### CAUTION:

If CONSULT-II is used with no connection of CONSULT-II CONVERTER, malfunctions might be detected in self-diagnosis depending on control unit which carry out CAN communication.

1. Turn ignition switch "OFF".
2. Connect "CONSULT-II" and CONSULT-II CONVERTER to data link connector.

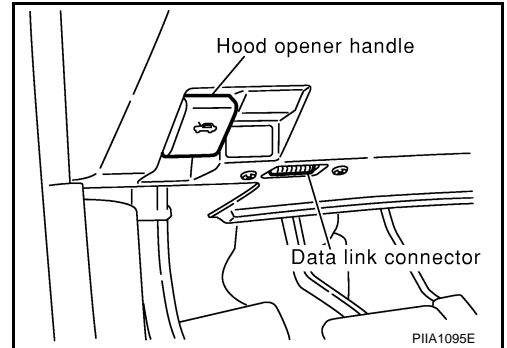

3. Turn ignition switch "ON".
4. Touch "START(NISSAN BASED VHCL)".

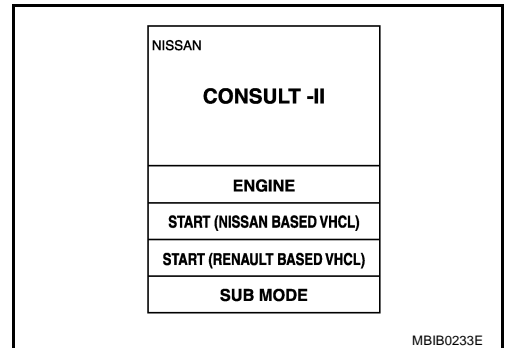

5. Touch "BCM".  
If "BCM" is not indicated, go to [GI-38, "CONSULT-II Data Link Connector \(DLC\) Circuit"](#).

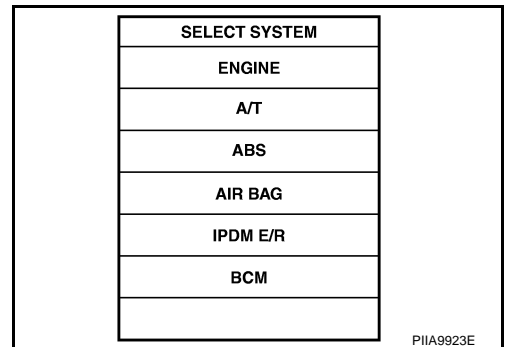

6. Touch "TRUNK".

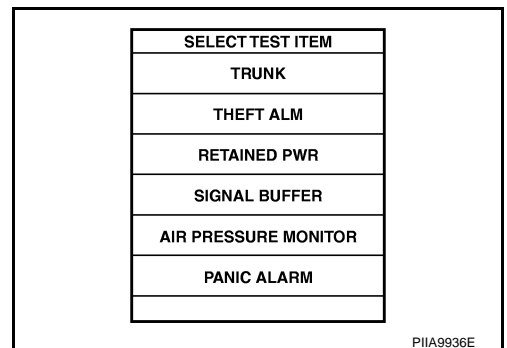

A  
B  
C  
D  
E  
F  
G  
H  
BL  
J  
K  
L  
M

# TRUNK LID OPENER

7. Select diagnosis mode.  
“DATA MONITOR” and “ACTIVE TEST” are available

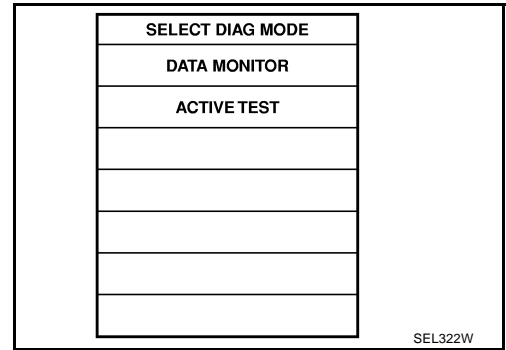

## DATA MONITOR

Monitored Item	Description
IGN ON SW	Indicates [ON/OFF] condition of ignition switch in ON position.
KEYLESS TRUNK	Indicates [ON/OFF] condition of trunk open signal from key fob.
TRUNK OPNR SW	Indicates [ON/OFF] condition of trunk lid opener switch.
VEHICLE SPEED	This item displays vehicle speed.

## ACTIVE TEST

Test item	Content
TRUNK/BACK DOOR	This test is able to check trunk lid opener actuator unlock operation. This actuator unlocks when “ON” on CONSULT-II screen is touched.



# TRUNK LID OPENER

## Trouble Diagnosis

AIS004CW

### TRUNK DOSE NOT OPEN WITH TRUNK LID OPENER SWITCH

#### 1. CHECK TRUNK LID OPENER CANCEL SWITCH

Check trunk lid opener cancel switch position.

**Does trunk lid opener cancel switch turn OFF (CANCEL)?**

Yes or No

- Yes >> Turn on trunk lid opener cancel switch.
- No >> GO TO 2.

#### 2. CHECK TRUNK LID OPEN INPUT SIGNAL

 **With CONSULT-II**

Check trunk lid opener switch ("TRNK OPNR SW") in "DATA MONITOR" mode with CONSULT-II.

- When trunk lid opener switch is turned to "LOCK".

**TRNK OPNR SW : ON**

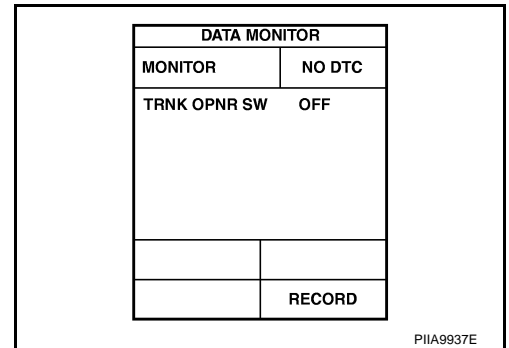

 **Without CONSULT-II**

1. Remove key from ignition key cylinder.
2. Turn on trunk lid opener cancel switch.
3. Check voltage between BCM and ground.

Connector	Terminal (Wire color)		Condition	Voltage [V] (Approx.)
	(+)	(-)		
M1	30 (P)	Ground	Trunk lid opener switch ON	0
			Trunk lid opener switch OFF	5

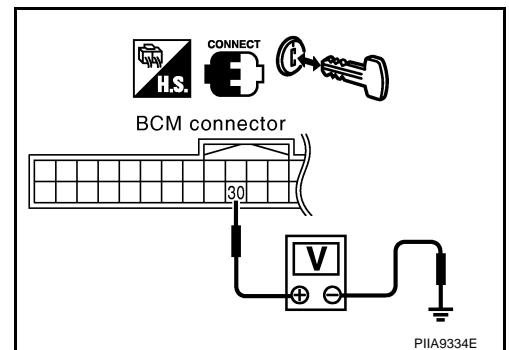

OK or NG

- OK >> GO TO 3.
- NG >> GO TO 6.

#### 3. CHECK TRUNK LID OPEN OUTPUT SIGNAL

Check voltage between BCM connector and ground.

Connector	Terminal (Wire color)		Condition	Voltage [V] (Approx.)
	(+)	(-)		
B4	68 (G/W)	Ground	Trunk lid opener switch ON	Battery voltage
			Trunk lid opener switch OFF	0

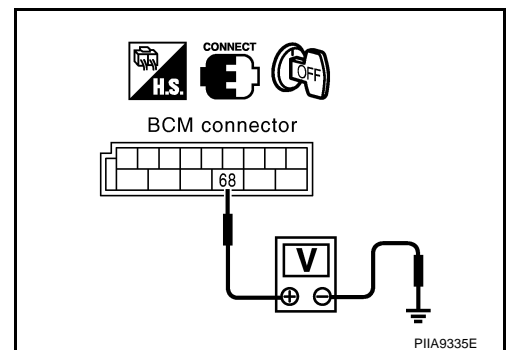

OK or NG

- OK >> GO TO 4.
- NG >> Replace BCM. Refer to [BCS-15, "Removal and Installation of BCM"](#) .

# TRUNK LID OPENER

## 4. CHECK TRUNK LID OPENER ACTUATOR CIRCUIT

1. Disconnect BCM connector and trunk lid opener actuator connector.
2. Check the following.
  - Continuity between BCM harness connector B4 terminal 68 and trunk lid opener actuator harness connector B106 terminal 1.

**68 (G/W) - 1 (G/W) : Continuity should exist.**

- Continuity between BCM harness connector B4 terminal 68 and ground.

**68 (G/W) - ground : Continuity should not exist.**

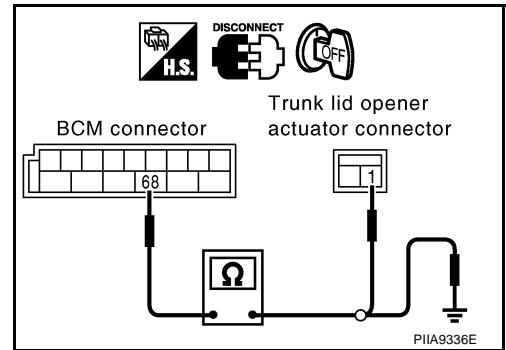

OK or NG

OK >> GO TO 5.

NG >> Repair harness or connector.

## 5. CHECK TRUNK LID OPENER ACTUATOR GROUND CIRCUIT

Check continuity between trunk lid opener actuator harness connector B106 terminal 2 and ground.

**2 (B) - ground : Continuity should exist.**

OK or NG

OK >> Replace trunk lid opener actuator.

NG >> Repair harness or connector.

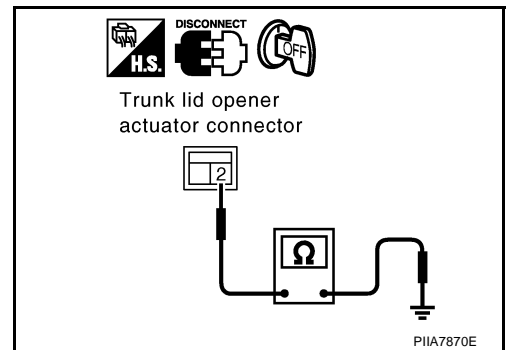

## 6. CHECK TRUNK LID OPENER CANCEL SWITCH

1. Turn ignition switch OFF.
2. Disconnect trunk lid opener cancel switch.
3. Check continuity between trunk lid opener cancel switch harness connector M56 terminals 1 and 2.

Terminals		Trunk lid opener cancel switch condition	Continuity
1	2	ON	Yes
		OFF	No

OK or NG

OK >> GO TO 7.

NG >> Replace trunk lid opener cancel switch.

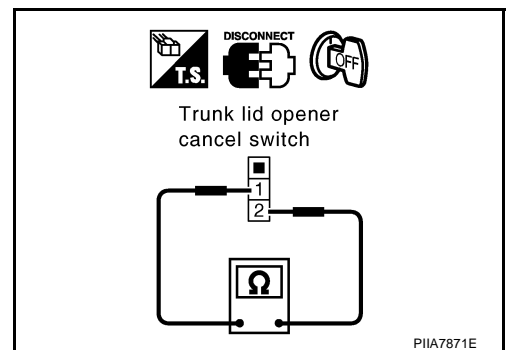

# TRUNK LID OPENER

## 7. CHECK TRUNK LID OPENER SWITCH

1. Disconnect trunk lid opener switch
2. Check continuity between trunk lid opener switch harness connector B106 terminals 1 and 2.

Terminals		Trunk lid opener switch condition	Continuity
1	2	ON (Pushed)	Yes
		OFF (Released)	No

OK or NG

OK >> GO TO 8.

NG >> Replace trunk lid opener switch.

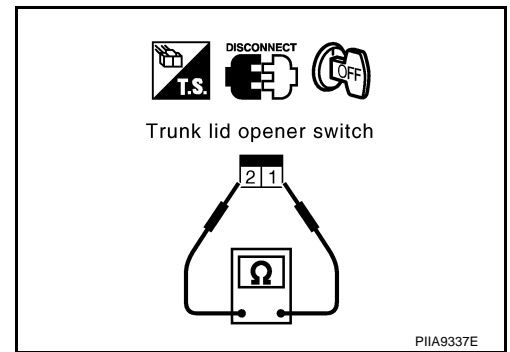

## 8. CHECK TRUNK LID OPENER CANCEL SWITCH CIRCUIT

1. Disconnect BCM connector.
2. Check continuity between BCM harness connector M1 terminal 30 and trunk lid opener cancel switch harness connector M56 terminal 1.

**30 (L) - 1 (L) : Continuity should exist.**

OK or NG

OK >> GO TO 9.

NG >> Repair harness or connector.

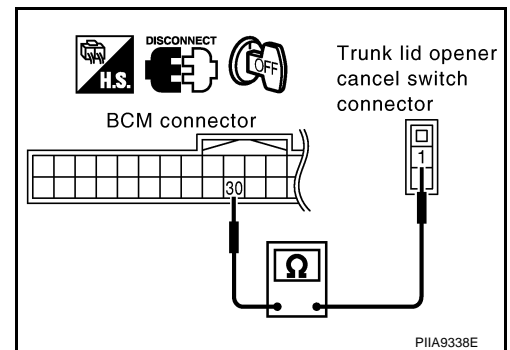

## 9. CHECK TRUNK LID OPENER SWITCH CIRCUIT

1. Check continuity between trunk lid opener cancel switch harness connector M56 terminal 2 and trunk lid opener switch harness connector M84 terminal 1.

**2 (P) - 1 (P) : Continuity should exist.**

OK or NG

OK >> Replace BCM. Refer to [BCS-15, "Removal and Installation of BCM"](#).

NG >> Repair harness or connector.

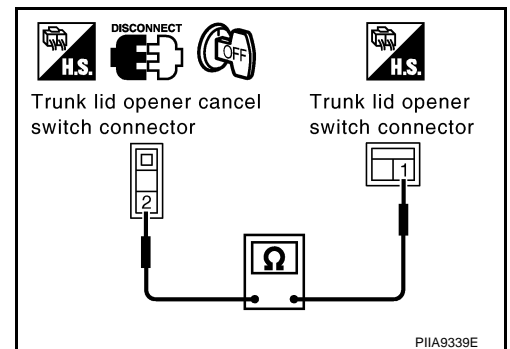

# TRUNK LID OPENER

## TRUNK DOSE NOT CLOSE

### 1. CHECK TRUNK LID OPEN INPUT SIGNAL

#### With CONSULT-II

Check trunk lid opener switch ("TRNK OPNR SW") in "DATA MONITOR" mode with CONSULT-II.

- When trunk lid opener switch is turned to "LOCK".

**TRNK OPNR SW : ON**

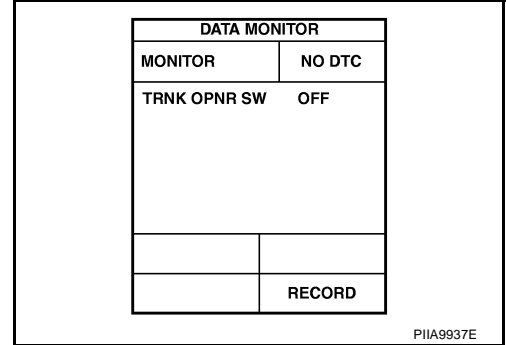

PIIA9937E

#### Without CONSULT-II

- Remove key from ignition key cylinder.
- Turn on trunk lid opener cancel switch.
- Check voltage between BCM and ground.

Connector	Terminal (Wire color)		Condition	Voltage [V] (Approx.)
	(+)	(-)		
M1	30 (L)	Ground	Trunk lid opener switch ON	0
			Trunk lid opener switch OFF	5

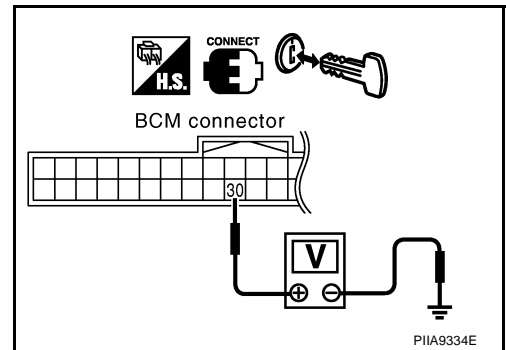

PIIA9334E

#### OK or NG

- OK >> GO TO 2.  
 NG >> Replace BCM.

### 2. CHECK TRUNK LID OPENER CANCEL SWITCH

- Turn ignition switch OFF.
- Disconnect trunk lid opener cancel switch.
- Check continuity between trunk lid opener cancel switch harness connector M56 terminals 1 and 2.

Terminals		Trunk lid opener cancel switch condition	Continuity
1	2		
1	2	ON	Yes
		OFF	No

#### OK or NG

- OK >> GO TO 3.  
 NG >> Replace trunk lid opener cancel switch.

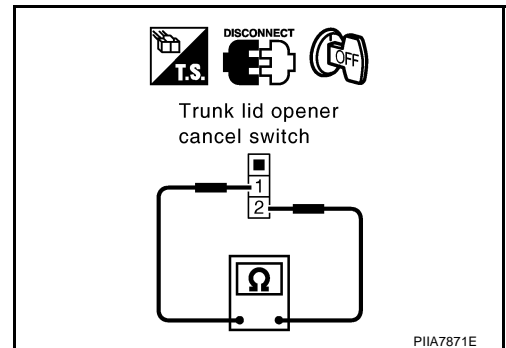

PIIA7871E

# TRUNK LID OPENER

## 3. CHECK TRUNK LID OPENER SWITCH

1. Disconnect trunk lid opener switch
2. Check continuity between trunk lid opener switch harness connector M84 terminals 1 and 2.

Terminals		Trunk lid opener switch condition	Continuity
1	2	ON (Pushed)	Yes
		OFF (Released)	No

OK or NG

- OK >> GO TO 4.  
 NG >> Replace trunk lid opener switch.

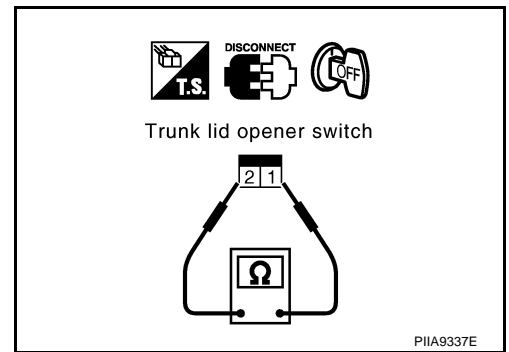

## 4. CHECK TRUNK LID OPENER CANCEL SWITCH CIRCUIT

1. Disconnect BCM connector.
2. Check continuity between BCM harness connector M1 terminal 30 and ground.

**30 (L) - ground : Continuity should not exist.**

OK or NG

- OK >> GO TO 5.  
 NG >> Repair harness or connector.

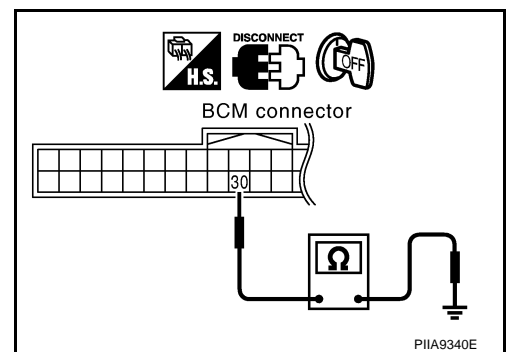

## 5. CHECK TRUNK LID OPENER SWITCH CIRCUIT

Check continuity between trunk lid opener cancel switch harness connector M56 terminal 2 and ground.

**2 (P) - ground : Continuity should not exist.**

OK or NG

- OK >> GO TO 6.  
 NG >> Repair harness or connector.

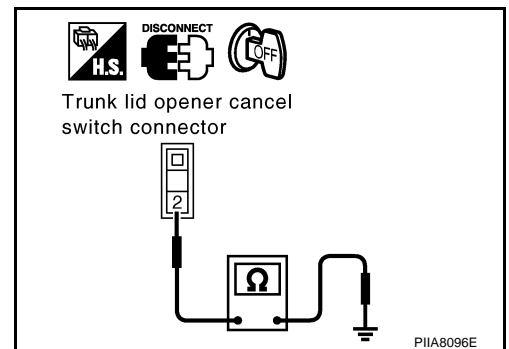

## 6. CHECK TRUNK LID OPENER CIRCUIT

1. Check continuity between trunk lid opener switch harness connector M84 terminal 2 and ground.

**2 (B) - ground : Continuity should not exist.**

OK or NG

- OK >> Replace BCM.  
 NG >> Repair harness or connector.

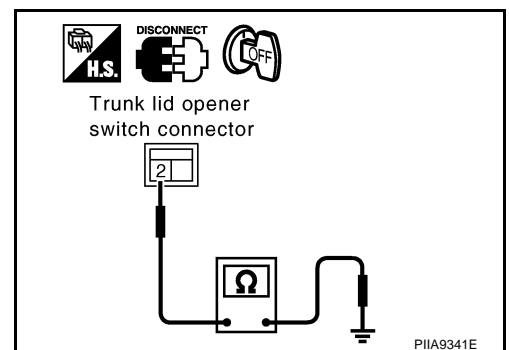

# VEHICLE SECURITY (THEFT WARNING) SYSTEM

PF28491

AIS004AN

## VEHICLE SECURITY (THEFT WARNING) SYSTEM

### Component Parts and Harness Connector Location

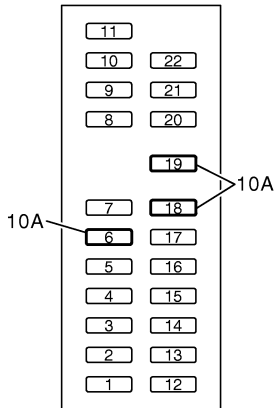

Fuse block (J/B) fuse layout

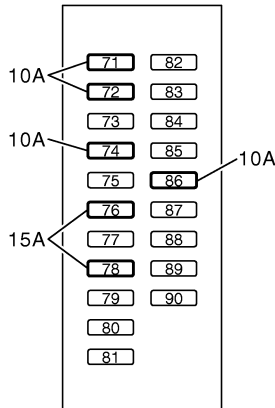

IPDM E/R fuse layout

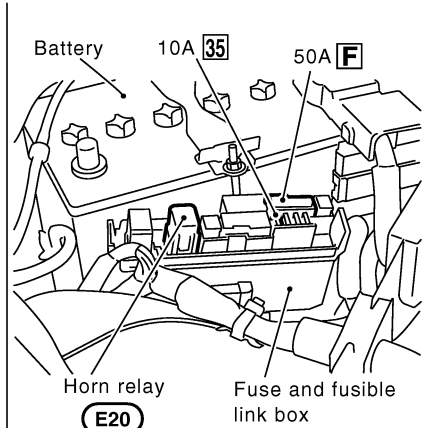

**E20**

Fuse and fusible link box

**View with dash side LH removed**

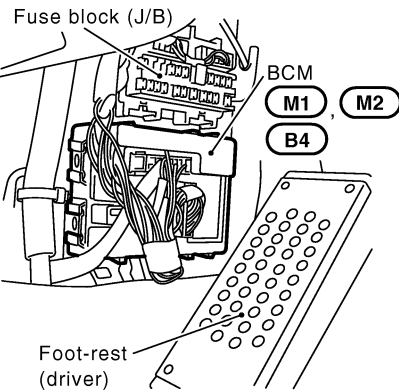

**View with cowl top cover (right) removed**

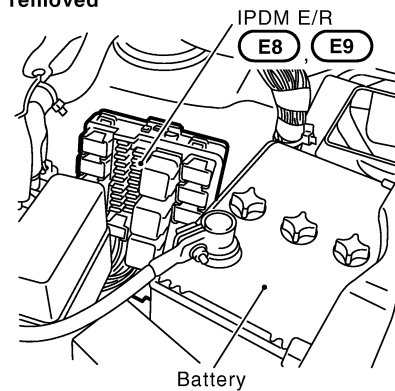

**Door lock and unlock switch**

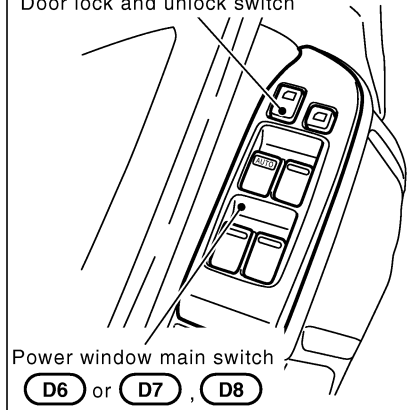

Power window main switch  
**D6** or **D7**, **D8**

**Trunk room lamp switch B105**

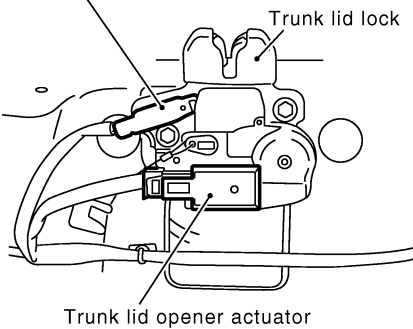

Trunk lid opener actuator

**Front door switch (Driver side) B17**

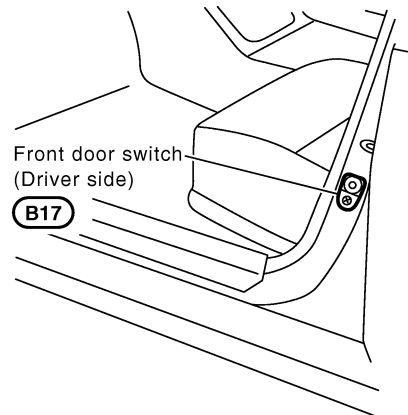

**Rear door switch LH B20**

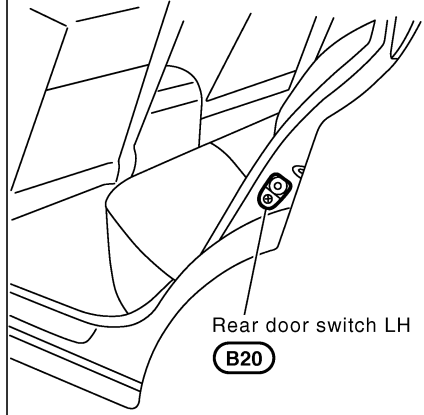

**View with front grille removed**

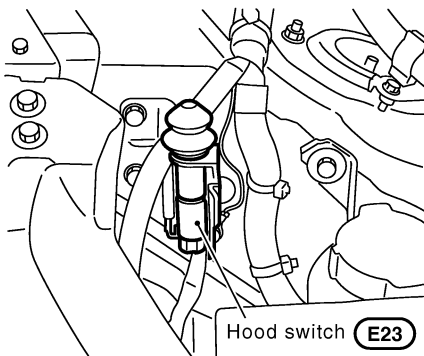

Hood switch **E23**

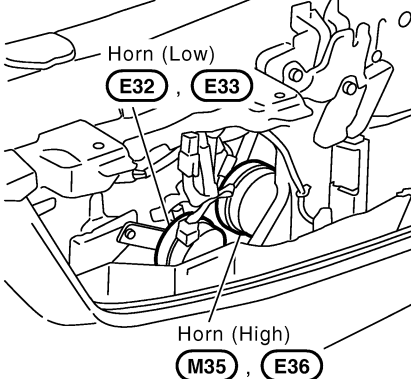

Horn (Low) **E32**, **E33**

Horn (High) **M35**, **E36**

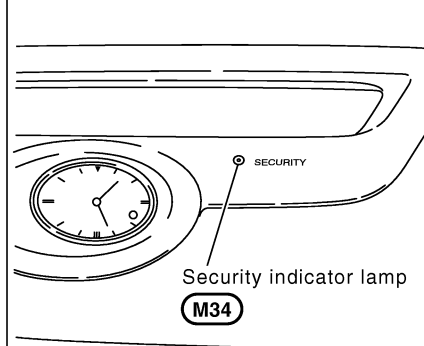

Security indicator lamp **M34**

PIIA9654E

# VEHICLE SECURITY (THEFT WARNING) SYSTEM

AIS004AO

## System Description

### DESCRIPTION

### Operation Flow

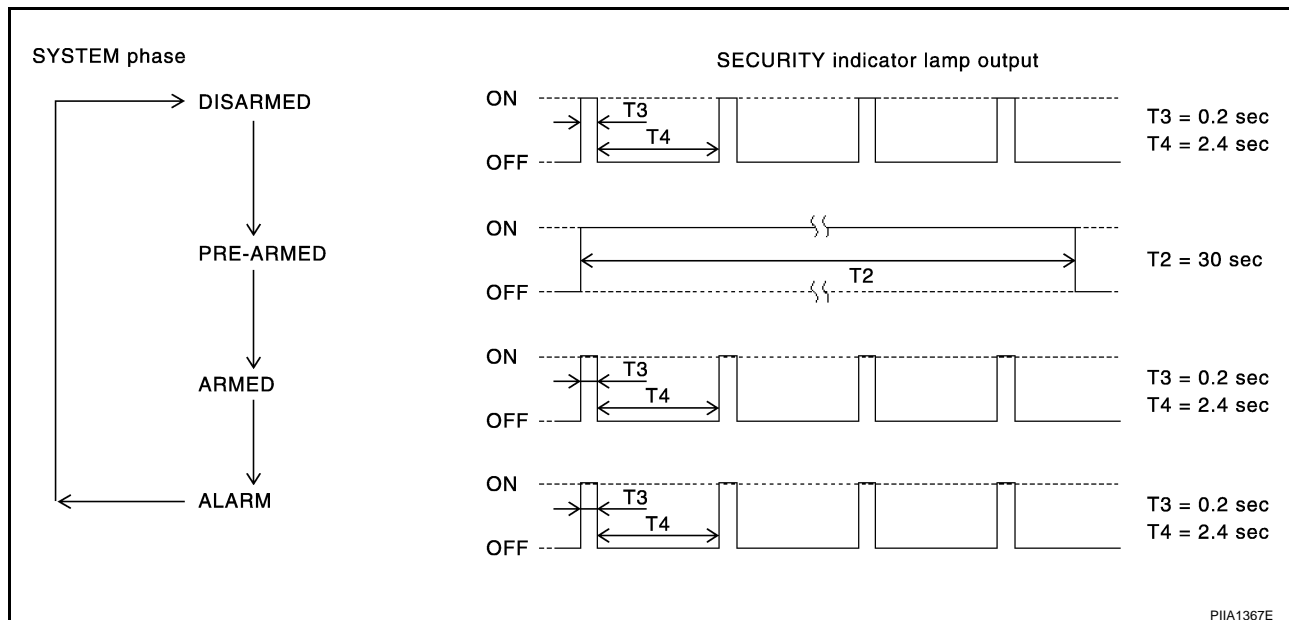

## Setting the Vehicle Security System

### Initial condition

- Ignition switch is in OFF position.

### Disarmed phase

- When hood, doors or trunk is open, the vehicle security system is set in the disarmed phase on the assumption that the owner is inside or near the vehicle.
- When the vehicle security system is in the disarmed phase, the security indicator lamp blinks every 2.4 seconds.

### Pre-armed phase and armed phase

When the following operation 1 or 2 is performed, the vehicle security system turns into the “pre-armed” phase. (The security indicator lamp illuminates.)

1. BCM receives LOCK signal from front door key cylinder switch or key fob, after hood, trunk and all doors are closed.
2. Hood, trunk and all doors are closed after front doors are locked by key or door lock and unlock switch. The security indicator lamp illuminates for 30 seconds. Then, the system automatically shifts into the “armed” phase.

# VEHICLE SECURITY (THEFT WARNING) SYSTEM

---

## Canceling the Set Vehicle Security System

When one of the following operations is performed, the armed phase is canceled.

1. Unlock the doors with the key or key fob.
2. Turn ignition switch "ON" or "ACC" position.

## Canceling the Alarm Operation of the Vehicle Security System

When unlock the door with the key or key fob the alarm operation is canceled.

## Activating the Alarm Operation of the Vehicle Security System

Make sure the system is in the armed phase. (The security indicator lamp blinks every 2.4 seconds.)

When the following operation 1 or 2 is performed, the system sounds the horns and flashes the headlamps for about 50 seconds.

1. Hood, trunk or any door is opened during armed phase.
2. Disconnecting and connecting the battery connector before canceling armed phase.

## POWER SUPPLY AND GROUND CIRCUIT

Power is supplied at all times

- through 50A fusible link (letter **F** , located in the fuse and fusible link box)
- to BCM terminal 55,
- through 10A fuse [No. 18, located in the fuse block (J/B)]
- to BCM terminal 42,
- through 15A fuse [No. 35, located in the fuse block (J/B)]
- to horn relay terminal 2,
- through 10A fuse [No. 71, located in the IPDM E/R]
- to IPDM E/R internal CPU,
- through 15A fuse [No. 78, located in the IPDM E/R]
- to IPDM E/R internal CPU,
- through 10A fuse [No. 19, located in the fuse block (J/B)]
- to security indicator lamp terminal 1.

With the ignition switch in the ACC or ON position, power is supplied

- through 10A fuse [No. 6, located in the fuse block (J/B)]
- to BCM terminal 11.

Ground is supplied

- to BCM terminal 52
- through body grounds M30 and M66.

## INITIAL CONDITION TO ACTIVATE THE SYSTEM / WITH NAVIGATION SYSTEM

The operation of the vehicle security system is controlled by the doors, hood and trunk

To activate the vehicle security system, BCM must receive signals indicating the doors, hood and trunk are closed and the doors are locked by key fob.

When a door is open, combination meter terminal 6 (passenger side door), 7 (driver side door), 8 (rear RH door) or 9 (rear LH door) receives a ground signal from each door switch. Then combination meter send door open signal to BCM via CAN communication line (with navigation system).

When a door is open, terminal 12 (passenger side door), 13 (rear RH door), 62 (driver side door), 63 (rear LH door) receives a ground signal from each door switch (without navigation switch).

When front door LH is unlocked by power window main switch (door lock and unlock switch), BCM terminal 22 receives a lock signal from terminal 8 (with anti-pinch system for all door window) or 9 (except for anti-pinch system for all door window) of power window main switch with power window serial link.

When front door RH is unlocked by power window sub-switch (passenger side) (door lock and unlock switch), BCM terminal 22 receives a signal from terminal 11 of power window sub-switch (passenger side) with power window serial link.

When front door key cylinder switch is in LOCK position, ground is supplied

- to power window main switch terminal 6
- through front door key cylinder switch terminals 1 and 2
- through body grounds M30 and M66.



# VEHICLE SECURITY (THEFT WARNING) SYSTEM

When the hood is open, IPDM E/R receives a ground signal

- to IPDM E/R terminal 56
- through hood switch terminal 2
- through hood switch terminal 1
- through body grounds E17, and E43.

The IPDM E/R then sends a signal to BCM via CAN communication line.

When the trunk is open, ground is supplied

- to BCM terminal 57
- through trunk room lamp switch terminal 1
- through trunk room lamp switch terminal 2
- through body grounds B5 and B29.

## VEHICLE SECURITY SYSTEM ALARM OPERATION

The vehicle security system is triggered by

- opening a door
- opening the trunk
- opening the hood
- detection of battery disconnect and connect.

The vehicle security system will be triggered once the system is in armed phase, when BCM receives a ground signal at terminals 12 (passenger side door), 13 (rear RH door), 59 (trunk), 62 (driver side door), 63 (rear LH door), (without navigation system), or receives a signal from the IPDM E/R (hood switch).

When the vehicle security system is triggered,

ground is supplied intermittently to both headlamp relay and horn relay.

When headlamp relay (with built-in IPDM E/R) and horn relay are energized, then power is supplied to headlamps (LH and RH) and horns (HIGH and LOW).

The headlamps flash and the horn sounds intermittently.

The alarm automatically turns off after 50 seconds, but will reactivate if the vehicle is tampered with again.

## VEHICLE SECURITY SYSTEM DEACTIVATION

To deactivate the vehicle security system, a door or the trunk must be unlocked with the key, key fob.

When the key is used to unlock a door, BCM terminal 22 receives signal

- from the power window main switch (door lock and unlock switch) terminal 8 (except for anti-pinch system for all door window) or 9 (with anti-pinch system for all door window).

When the BCM receives either one of these signals or unlock signal from key cylinder switch or key fob, the vehicle security system is deactivated. (Disarmed phase)

## PANIC ALARM OPERATION

Remote keyless entry system may or may not operate vehicle security system (horn and headlamps) as required.

When the remote keyless entry system is triggered, ground is supplied intermittently to both headlamp relay and horn relay.

When headlamp relay (with built-in IPDM E/R) and horn relay are energized, then power is supplied to headlamps (LH and RH) and horns (HIGH and LOW).

The headlamp flashes and the horn sounds intermittently.

The alarm automatically turns off after 25 seconds or when BCM receives any signal from key fob.

A  
B  
C  
D  
E  
F  
G  
H  
BL  
J  
K  
L  
M

# VEHICLE SECURITY (THEFT WARNING) SYSTEM

---

## CAN Communication System Description

AIS004AP

CAN (Controller Area Network) is a serial communication line for real time application. It is an on-vehicle multiplex communication line with high data communication speed and excellent error detection ability. Many electronic control units are equipped onto a vehicle, and each control unit shares information and links with other control units during operation (not independent). In CAN communication, control units are connected with 2 communication lines (CAN H line, CAN L line) allowing a high rate of information transmission with less wiring. Each control unit transmits/receives data but selectively reads required data only.

## CAN Communication Unit

AIS004AQ

Refer to [LAN-5, "CAN COMMUNICATION"](#) .

# VEHICLE SECURITY (THEFT WARNING) SYSTEM

## Schematic

AIS004AR

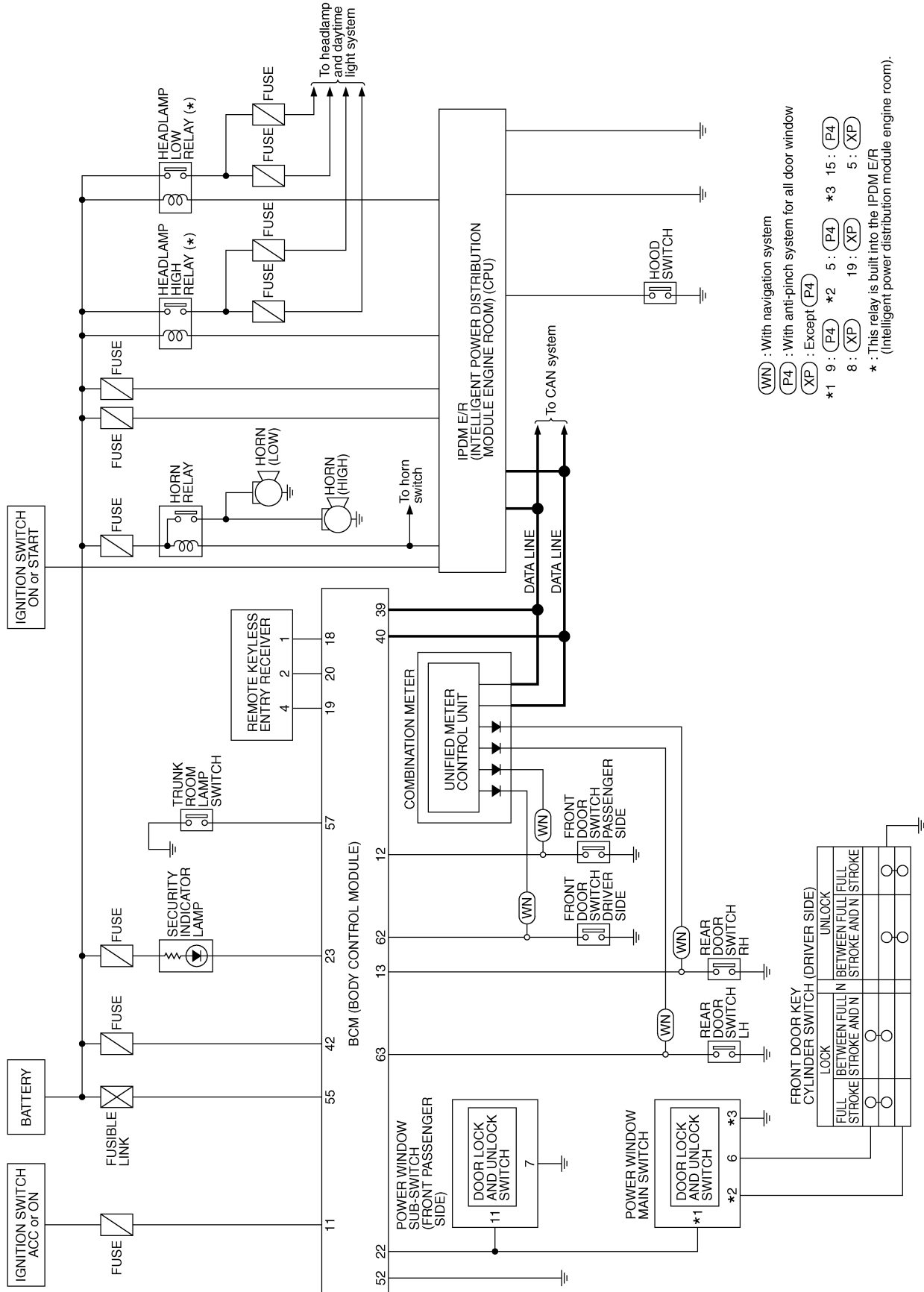

- (WN) : With navigation system
- (P4) : With anti-pinch system for all door window
- (XP) : Except (P4)
- \*1 9 : (P4) \*2 5 : (P4) \*3 15 : (P4)
- 8 : (XP) 19 : (XP) 5 : (XP)
- \* : This relay is built into the IPDM E/R (Intelligent power distribution module engine room).

TIWT0700E

A  
B  
C  
D  
E  
F  
G  
H  
I  
J  
K  
L  
M

BL

# VEHICLE SECURITY (THEFT WARNING) SYSTEM

AIS004AS

## Wiring Diagram —VEHSEC—

BL-VEHSEC-01

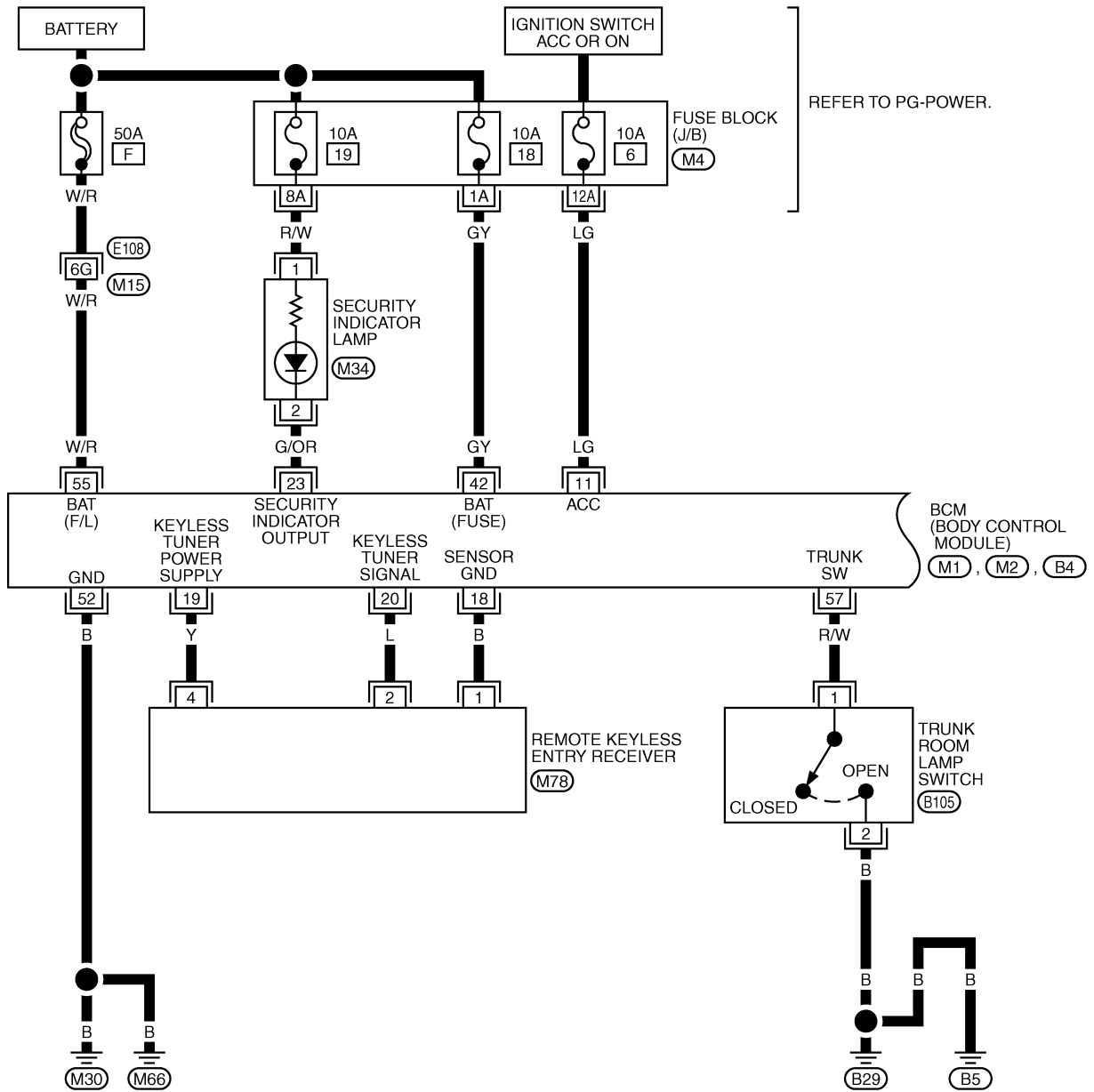

REFER TO PG-POWER.

BCM  
(BODY CONTROL  
MODULE)  
M1, M2, B4

REMOTE KEYLESS  
ENTRY RECEIVER  
M78

TRUNK  
ROOM  
LAMP  
SWITCH  
B105

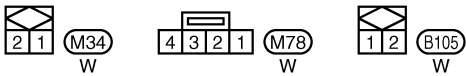

REFER TO THE FOLLOWING.

- E108 -SUPER MULTIPLE JUNCTION (SMJ)
- M4 -FUSE BLOCK-JUNCTION BOX (J/B)
- M1, M2, B4 -ELECTRICAL UNITS

TIWT0701E

# VEHICLE SECURITY (THEFT WARNING) SYSTEM

BL-VEHSEC-02

▬ : DATA LINE

◻WN : WITH NAVIGATION SYSTEM

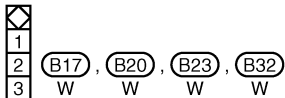
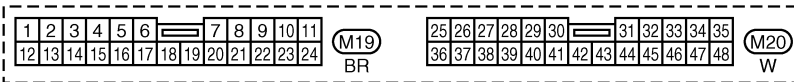
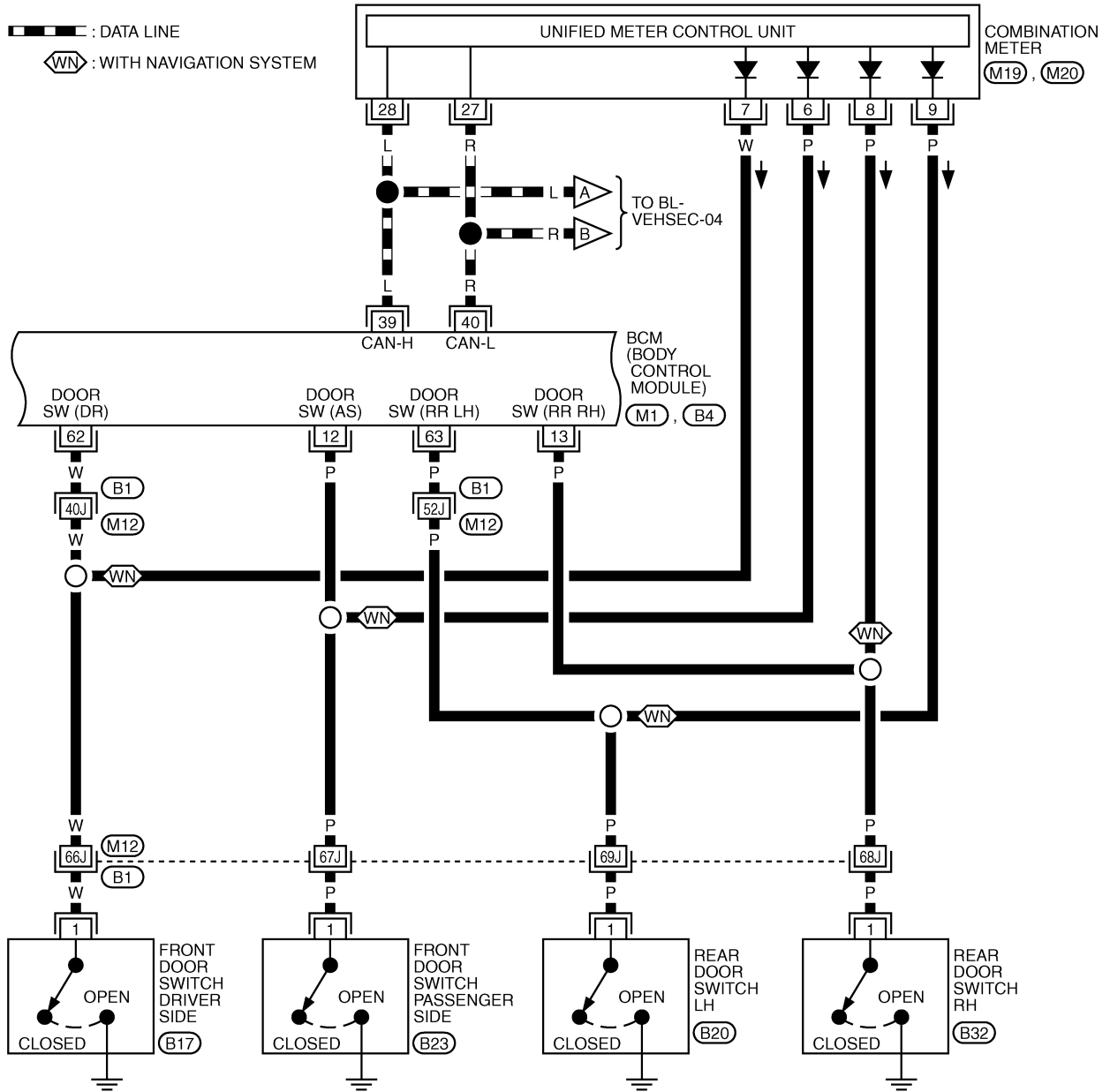

REFER TO THE FOLLOWING.

(B1) -SUPER MULTIPLE JUNCTION (SMJ)  
(M1), (B4) -ELECTRICAL UNITS

TIWT0702E



# VEHICLE SECURITY (THEFT WARNING) SYSTEM

BL-VEHSEC-04

▬ : DATA LINE

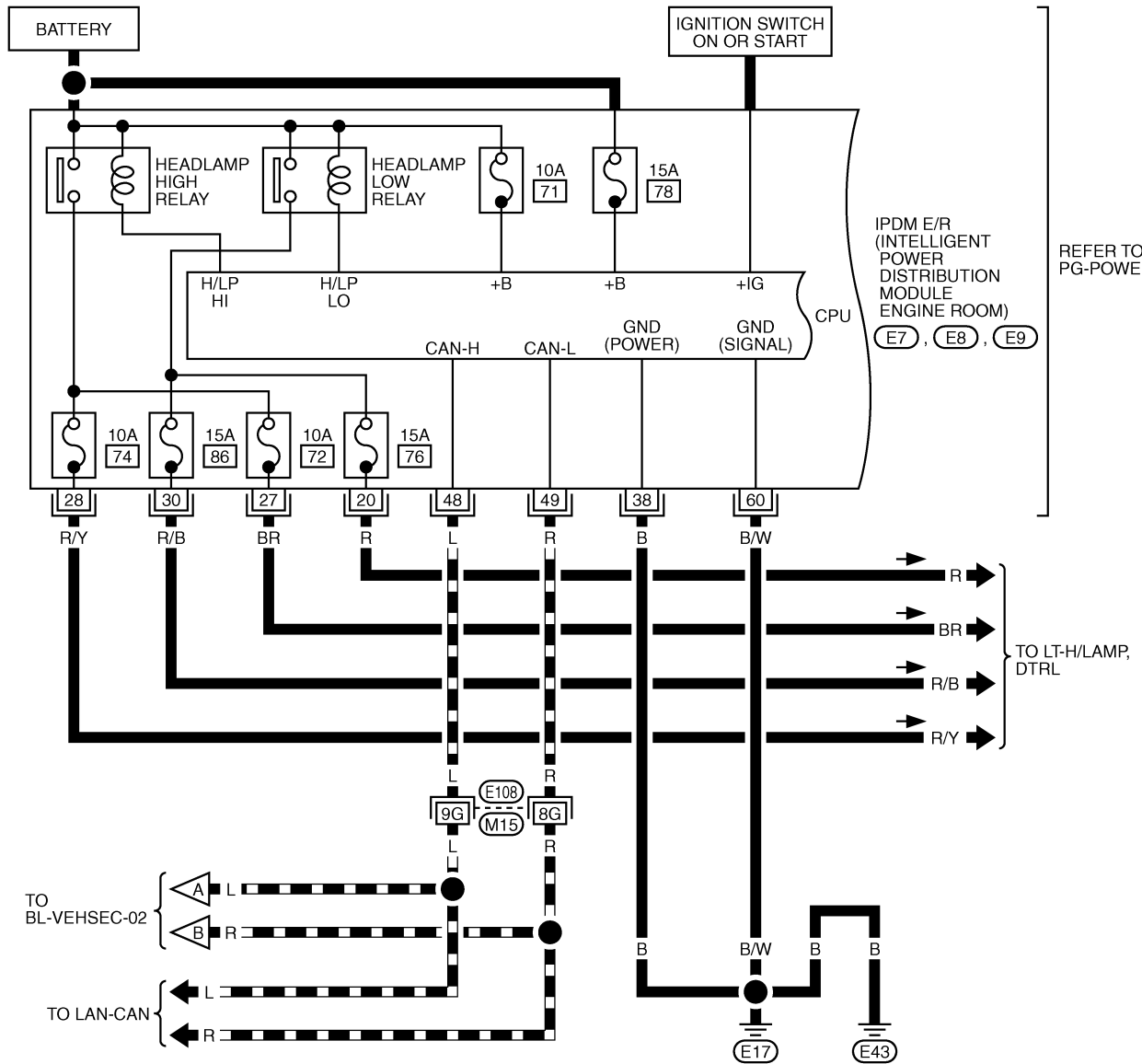

A  
B  
C  
D  
E  
F  
G  
H  
J  
K  
L  
M

BL

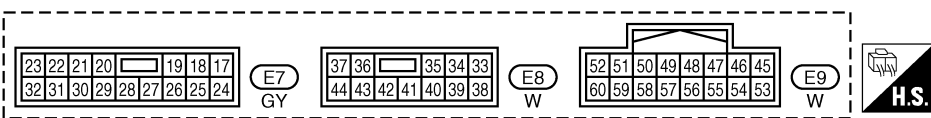

REFER TO THE FOLLOWING.  
E108 -SUPER MULTIPLE JUNCTION (SMJ)



# VEHICLE SECURITY (THEFT WARNING) SYSTEM

BL-VEHSEC-05

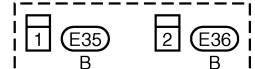
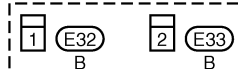
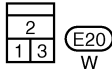
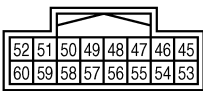
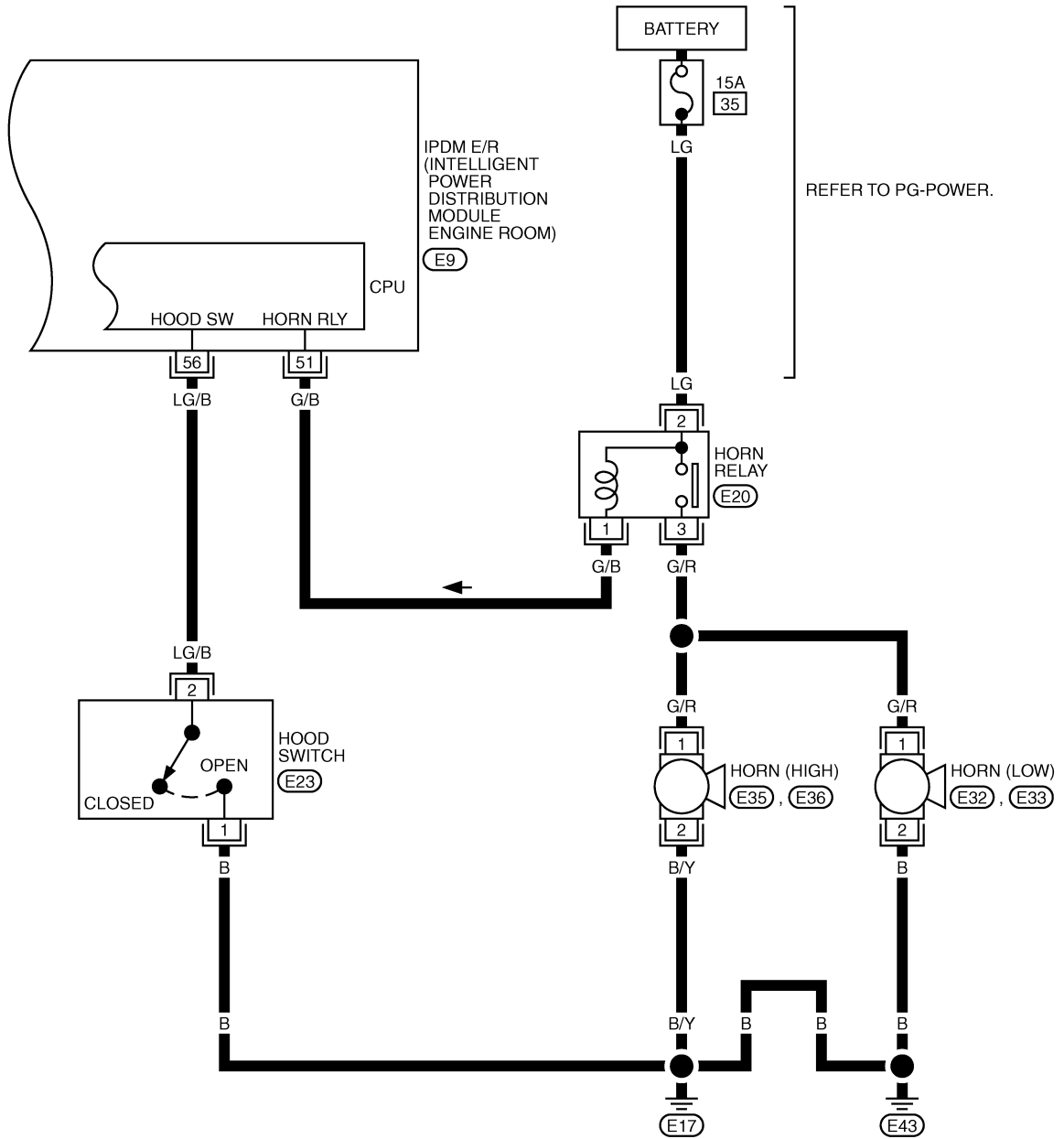

TIWT0705E



# VEHICLE SECURITY (THEFT WARNING) SYSTEM

## Terminals and Reference Value of BCM

AIS004AT

Terminal	Wire color	Item	Condition	Voltage [V] (Approx.)	
11	LG	Power supply (ACC)	Ignition switch (ACC or ON position)	Battery voltage	
12	P	Front door switch passenger side signal	ON (Open) → OFF (Closed)	0 → Battery voltage	
13	P	Rear door (RH) switch signal	ON (Open) → OFF (Closed)	0 → Battery voltage	
18	B	sensor ground	—	0	
19	Y	Remote keyless entry receiver power supply	Ignition switch is removed from key cylinder	Waiting state	
				Any operation using keyfob	
20	L	Remote keyless entry receiver signal	Ignition switch is removed from key cylinder	Waiting state	
				Any operation using keyfob	
23	G/OR	Security indicator lamp	Goes off → Illuminates	Battery voltage → 0	
22	Y	Power window serial link	Ignition switch ON or power window timer operating		
39	L	CAN-H	—	—	
40	R	CAN-L	—	—	
42	GY	Battery power supply (fuse)	—	Battery voltage	
52	B	Ground	—	0	
55	W/R	Battery power supply (fusible link)	—	Battery voltage	
57	R/W	Trunk room lamp switch signal	ON (Open) → OFF (Closed)	0 → Battery voltage	

A  
B  
C  
D  
E  
F  
G  
H  
I  
J  
K  
L  
M

BL

# VEHICLE SECURITY (THEFT WARNING) SYSTEM

Terminal	Wire color	Item	Condition	Voltage [V] (Approx.)
62	W	Front door switch driver side signal	ON (Open) → OFF (Closed)	0 → Battery voltage
63	P	Rear door (LH) switch signal	ON (Open) → OFF (Closed)	0 → Battery voltage

## Terminals and Reference Value of IPDM E/R

AIS004AU

Terminal	Wire color	Item	Condition	Voltage [V] (Approx.)
38	B	Ground (power)	—	0
48	L	CAN-H	—	—
49	R	CAN-L	—	—
51	G/B	Horn relay control signal	Panic alarm is operating	0
			Other than above	Battery voltage
56	LG/B	Hood switch signal	ON (Open) → OFF (closed)	0 → Battery voltage
60	B/W	Ground (signal)	—	0

## Terminals and Reference Value of Combination Meter

AIS004CX

Terminal	Wire color	Item	Condition	Voltage [V] (Approx.)
6	P	Front door switch passenger side	ON (door open) → OFF (door closed)	0 → Battery voltage
7	W	Front door switch driver side	ON (door open) → OFF (door closed)	0 → Battery voltage
8	P	Rear door switch RH	ON (door open) → OFF (door closed)	0 → Battery voltage
9	P	Rear door switch LH	ON (door open) → OFF (door closed)	0 → Battery voltage
27	R	CAN-L	—	—
28	L	CAN-H	—	—

# VEHICLE SECURITY (THEFT WARNING) SYSTEM

## CONSULT-II Inspection Procedure

AIS004AV

### CAUTION:

CONSULT-II is used with no connection of CONSULT-II CONVERTER, malfunction might be detected in self-diagnosis depending on control units with carry out CAN communication.

1. Turn ignition switch OFF.
2. Connect CONSULT-II and CONSULT-II CONVERTER to data link connector.

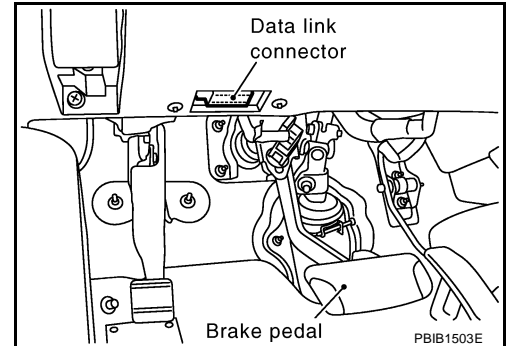

3. Turn ignition switch ON.
4. Touch "START" (NISSAN BASED VHCL).

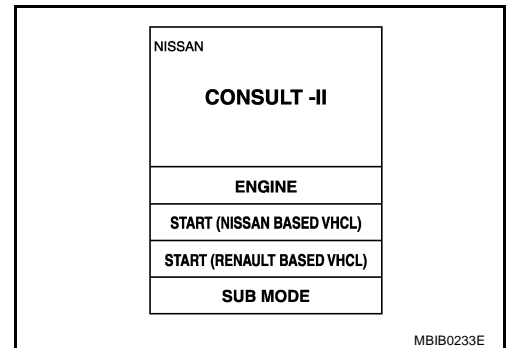

5. Touch "BCM".  
If "BCM" is not indicated, go to [GI-38, "CONSULT-II Data Link Connector \(DLC\) Circuit"](#).

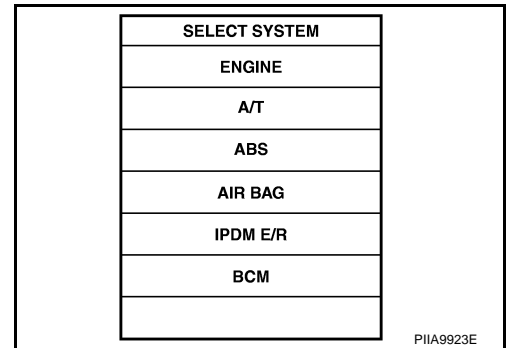

6. Touch "THEFT ALM".

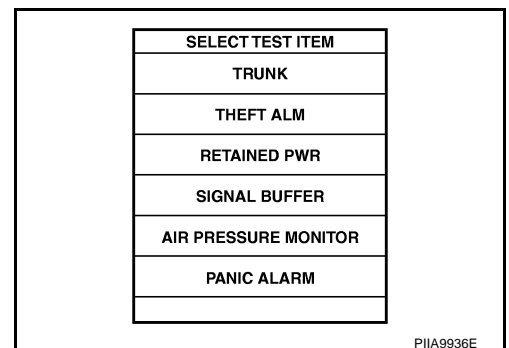

A  
B  
C  
D  
E  
F  
G  
H  
BL  
J  
K  
L  
M

# VEHICLE SECURITY (THEFT WARNING) SYSTEM

7. Select diagnosis mode.  
 “WORK SUPPORT”, “DATA MONITOR” and “ACTIVE TEST”

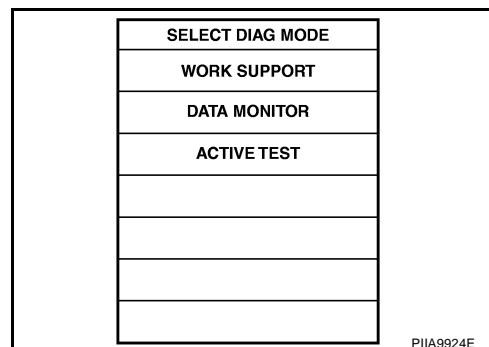

## CONSULT-II APPLICATION ITEM

### Work Support

Test Item	Description
SECURITY ALARM SET	This mode is able to confirm and change security alarm ON-OFF setting.
THEFT ALM TRG	The switch which triggered vehicle security alarm is recorded. This mode is able to confirm and erase the record of vehicle security alarm. The trigger data can be erased by touching “CLEAR” on CONSULT-II screen.

### Data Monitor

Monitored Item	Description
IGN ON SW	Indicates [ON/OFF] condition of ignition switch.
ACC ON SW	Indicates [ON/OFF] condition of ignition switch in ACC position.
KEY ON SW	Indicates [ON/OFF] condition of key switch.
KEYLESS LOCK	Indicates [ON/OFF] condition of lock signal from key fob.
KEYLESS UNLOCK	Indicates [ON/OFF] condition of unlock signal from key fob.
KEYLESS TRUNK	Indicates [ON/OFF] condition of trunk opener signal from key fob.
TRUNK OPNR SW	This is displayed even when it is not equipped.
TRUNK CYL SW	This is displayed even when it is not equipped.
TRUNK OPN MNTR	Indicates [ON/OFF] condition of trunk room lamp switch.
HOOD SW	Indicates [ON/OFF] condition of hood switch.
DOOR SW-DR	Indicates [ON/OFF] condition of front door switch LH.
DOOR SW-AS	Indicates [ON/OFF] condition of front door switch RH.
DOOR SW-RR	Indicates [ON/OFF] condition of rear door switch RH.
DOOR SW-RL	Indicates [ON/OFF] condition of rear door switch LH.
BACK DOOR SW	This is displayed even when it is not equipped.
KEY CYL LK-SW	Indicates [ON/OFF] condition of lock signal from front door key cylinder switch.
KEY CYL UN-SW	Indicates [ON/OFF] condition of unlock signal from front door key cylinder switch.
CDL LOCK SW	Indicates [ON/OFF] condition of lock signal from door lock/unlock switch LH and RH.
CDL UNLOCK SW	Indicates [ON/OFF] condition of unlock signal from door lock/unlock switch LH and RH.

### Active Test

Test Item	Description
THEFT IND	This test is able to check security indicator lamp operation. The lamp will be turned on when “ON” on CONSULT-II screen is touched.
VEHICLE SECURITY HORN	This test is able to check vehicle security horn operation. The horns will be activated for 0.5 seconds after “ON” on CONSULT-II screen is touched.
HEADLAMP(HI)	This test is able to check vehicle security lamp operation. The headlamps will be activated for 0.5 seconds after “ON” on CONSULT-II screen is touched.

# VEHICLE SECURITY (THEFT WARNING) SYSTEM

## Trouble Diagnosis WORK FLOW

AIS004AW

A  
B  
C  
D  
E  
F  
G  
H  
BL  
J  
K  
L  
M

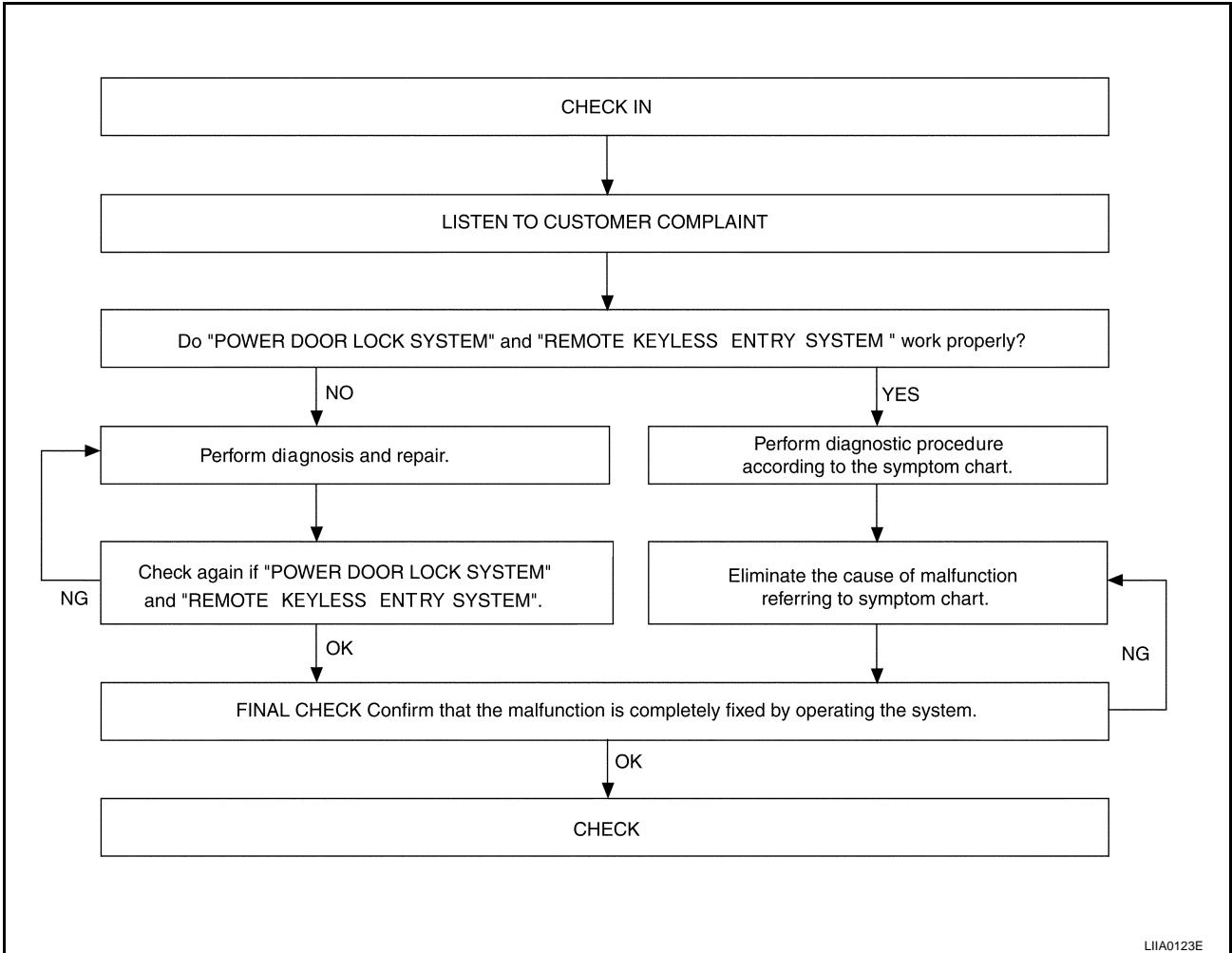

LIA0123E

- "POWER DOOR LOCK SYSTEM" Diagnosis; refer to [BL-29, "Work Flow"](#) .
- "REMOTE CONTROL SYSTEM" Diagnosis; refer to [BL-65, "Work Flow"](#) .

# VEHICLE SECURITY (THEFT WARNING) SYSTEM

AIS004AX

## Preliminary Check

The system operation is canceled by turning ignition switch to "ACC" at any step between START and ARMED in the following flow chart.

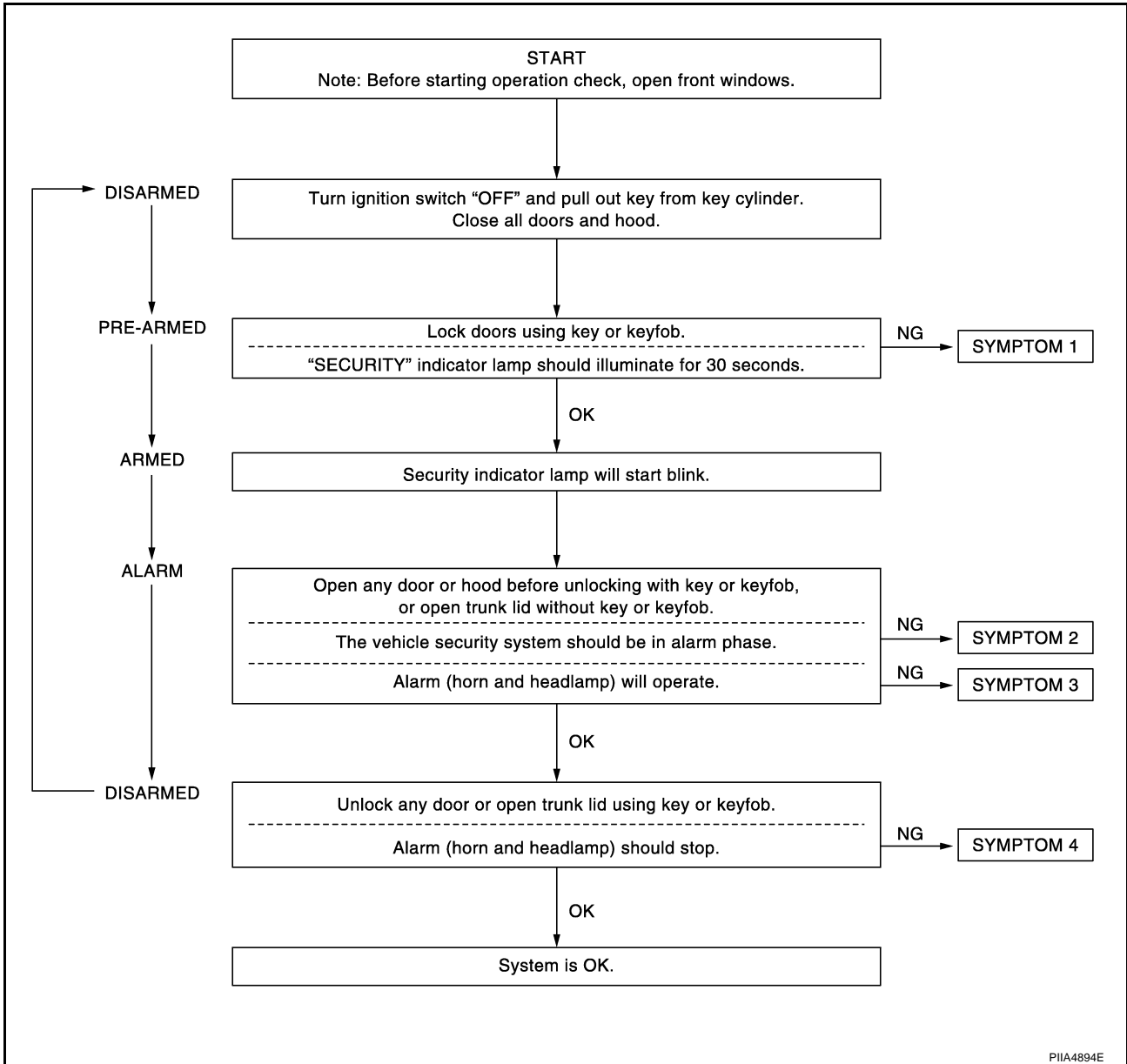

PIIA4894E

After performing preliminary check, go to symptom chart. Refer to [BL-123, "Trouble Diagnosis Symptom Chart"](#).

# VEHICLE SECURITY (THEFT WARNING) SYSTEM

## Trouble Diagnosis Symptom Chart

AIS004AY

Procedure		Diagnostic procedure	Refer to page
Symptom			
1	Vehicle security system cannot be set by ....	Door switch	Diagnostic Procedure 1 (Check door, hood and trunk switch) / With navigation system <a href="#">BL-124</a>
			Diagnostic Procedure 1 (Check door, hood and trunk switch) / Without navigation system <a href="#">BL-126</a>
		Lock / unlock switch	Diagnostic Procedure 6 (Check door lock / unlock switch) <a href="#">BL-134</a>
		Door outside key	Diagnostic Procedure 3 (Check door key cylinder switch) <a href="#">BL-133</a>
		Key fob	Check remote keyless entry. <a href="#">BL-66</a>
	—	If the above systems are "OK", replace BCM. <a href="#">BCS-15</a>	
	Security indicator does not turn "ON".		Diagnostic Procedure 2 (Check security indicator lamp) <a href="#">BL-131</a>
		If the above systems are "OK", replace BCM. <a href="#">BCS-15</a>	
2	*1 Vehicle security system does not alarm when ....	Any door is opened.	Diagnostic Procedure 1 (Check door, hood and trunk switch) / With navigation system <a href="#">BL-124</a>
			Diagnostic Procedure 1 (Check door, hood and trunk switch) / Without navigation system <a href="#">BL-126</a>
			If the above systems are "OK", replace BCM. <a href="#">BCS-15</a>
3	Vehicle security alarm does not activate.	Horn alarm	Diagnostic Procedure 4 (Check vehicle security horn alarm) <a href="#">BL-133</a>
			Check horn function. <a href="#">BL-75</a>
			If the above systems are "OK", replace BCM. <a href="#">BCS-15</a>
	Head lamp alarm	Diagnostic Procedure 5 (Check head lamp alarm) <a href="#">BL-134</a>	
		If the above systems are "OK", replace BCM. <a href="#">BCS-15</a>	
4	Vehicle security system cannot be canceled by ....	Door outside key	Diagnostic Procedure 3 (Check door key cylinder switch) <a href="#">BL-133</a>
			If the above systems are "OK", check power window main switch. <a href="#">EI-37</a>
	Key fob	Check remote keyless entry function. <a href="#">BL-52</a>	
		If the above systems are "OK", replace BCM. <a href="#">BCS-15</a>	

\*1: Make sure the system is in the armed phase.

# VEHICLE SECURITY (THEFT WARNING) SYSTEM

AIS004AZ

## Diagnostic Procedure 1

### 1 – 1 DOOR SWITCH CHECK / WITH NAVIGATION SYSTEM

First perform the "SELF-DIAG RESULTS" in "BCM" with CONSULT-II, when perform the each trouble diagnosis. Refer to [BCS-14, "CAN Communication Inspection Using CONSULT-II \(Self-Diagnosis\)"](#).

#### 1. CHECK DOOR SWITCH INPUT SIGNAL

Check voltage between combination meter connector and ground.

Item	Connector	Terminals (Wire color)		Condition	Voltage [V] (Approx.)
		(+)	(-)		
Driver side	M19	7 (W)	Ground	CLOSE ↓ OPEN	Battery voltage ↓ 0
Passenger side		6 (P)			
Rear LH		9 (P)			
Rear RH		8 (P)			

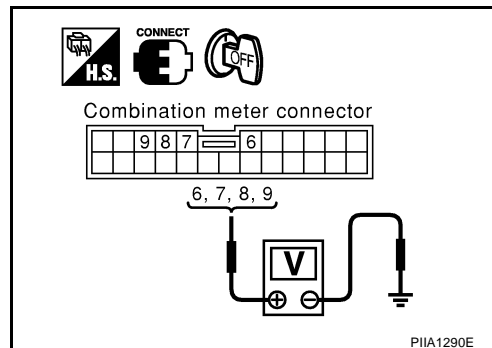

OK or NG

- OK >> Door switch circuit is OK, go to [BL-128, "1 – 3 HOOD SWITCH CHECK"](#).
- NG >> GO TO 2.

#### 2. CHECK DOOR SWITCH CIRCUIT

- Turn ignition switch OFF.
- Disconnect door switch and combination meter connector.
- Check continuity between door switch connector B17, B23, B20, B32 terminals 1 and combination meter connector M19 terminals 7, 6, 9, 8.

##### Front door switch driver side

1 (W) – 7 (W) : Continuity should exist.

##### Front door switch passenger side

1 (P) – 6 (P) : Continuity should exist.

##### Rear door switch LH

1 (P) – 9 (P) : Continuity should exist.

##### Rear door switch RH

1 (P) – 8 (P) : Continuity should exist.

- Check continuity between door switch connector B17, B23, B20, B32 terminals 1 and ground.

1 (W or P) – Ground : Continuity should not exist

OK or NG

- OK >> GO TO 3.
- NG >> Repair or replace harness.

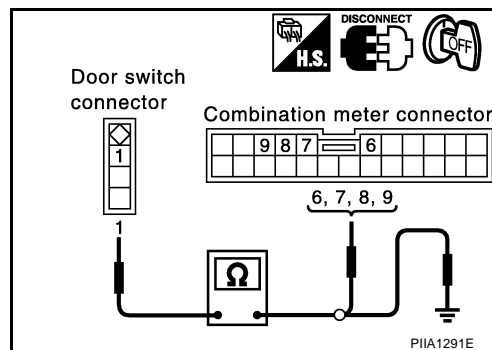



# VEHICLE SECURITY (THEFT WARNING) SYSTEM

## 3. CHECK DOOR SWITCH

Check continuity between each door switch terminal 1 and body ground part of door switch.

Terminal		Condition of door switch	Continuity
1	Body ground part of door switch	Pushed	No
		Released	Yes

OK or NG

OK >> GO TO 4.

NG >> Replace door switch.

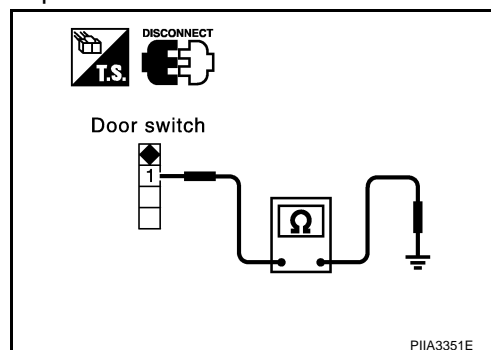

## 4. CHECK COMBINATION METER OUTPUT SIGNAL

1. Connect combination meter connector.
2. Check voltage between combination meter connector M19 terminals 6, 7, 8, 9 and ground.

**6 (P) - Ground : Battery voltage**

**7 (W) - Ground : Battery voltage**

**8 (P) - Ground : Battery voltage**

**9 (P) - Ground : Battery voltage**

OK or NG

OK >> Check the condition of the harness and the connector.

NG >> Replace combination meter.

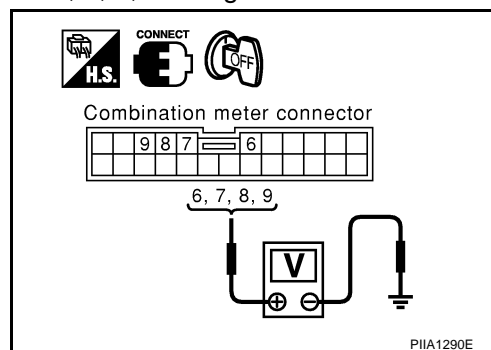

# VEHICLE SECURITY (THEFT WARNING) SYSTEM

## 1 – 2 DOOR SWITCH CHECK / WITHOUT NAVIGATION SYSTEM

### 1. CHECK DOOR SWITCH INPUT SIGNAL

#### Ⓜ With CONSULT-II

Check ("DOOR SW-DR", "DOOR SW-AS", "DOOR SW-RR" and "DOOR SW-RL") in "DATA MONITOR" mode with CONSULT-II.

Monitor item	Condition
DOOR SW-DR	CLOSE → OPEN: OFF → ON
DOOR SW-AS	
DOOR SW-RR	
DOOR SW-RL	

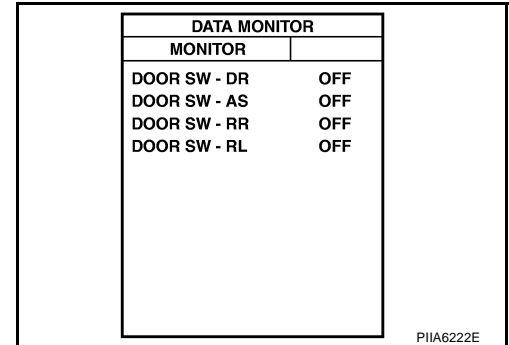

#### ⊗ Without CONSULT-II

Check voltage between BCM connector and ground.

Item	Connector	Terminals (Wire color)		Condition	Voltage [V] (Approx.)
		(+)	(-)		
Driver side	B4	62 (W)	Ground	CLOSE ↓ OPEN	Battery voltage ↓ 0
Passenger side		12 (P)			
Rear LH	M1	63 (P)			
Rear RH		13 (P)			

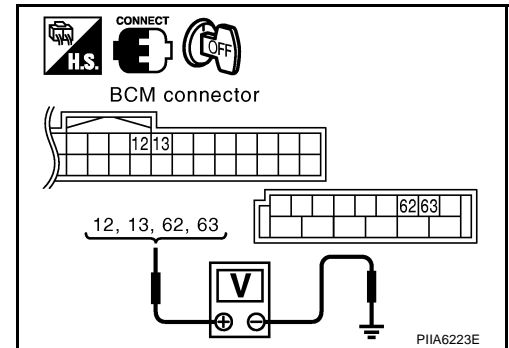

#### OK or NG

OK >> Door switch circuit is OK, and go to [BL-128, "1 – 3 HOOD SWITCH CHECK"](#).

NG >> GO TO 2.

### 2. CHECK DOOR SWITCH

Check continuity between each door switches terminals 1 and ground part of door switch.

Terminal	Condition of door switch	Continuity
1	Pushed	No
	Released	Yes

#### OK or NG

OK >> GO TO 3.

NG >> Replace malfunctioning door switch.

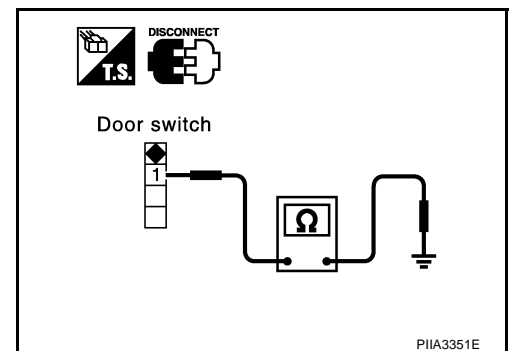

# VEHICLE SECURITY (THEFT WARNING) SYSTEM

## 3. CHECK DOOR SWITCH CIRCUIT

1. Turn ignition switch OFF.
2. Disconnect BCM and door switches connector.
3. Check continuity between BCM connector B4 terminal 62, 63 and door switch connector B17, B20 terminal 1 and ground.

### Front door switch driver side

- 62 (W) – 1 (W) : Continuity should exist.**  
**62 (W) – Ground : Continuity should not exist.**  
**Rear door switch LH**  
**63 (P) – 1 (P) : Continuity should exist.**  
**63 (P) – Ground : Continuity should not exist.**

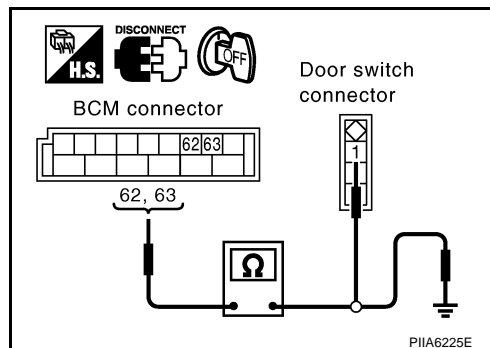

4. Check continuity between BCM connector M1 terminals 12, 13 and door switch connector B23, B32 terminal 1 and ground.

### Front door switch passenger side

- 12 (P) – 1 (P) : Continuity should exist.**  
**12 (P) – Ground : Continuity should not exist.**  
**Rear door switch RH**  
**13 (P) – 1 (P) : Continuity should exist.**  
**13 (P) – Ground : Continuity should not exist.**

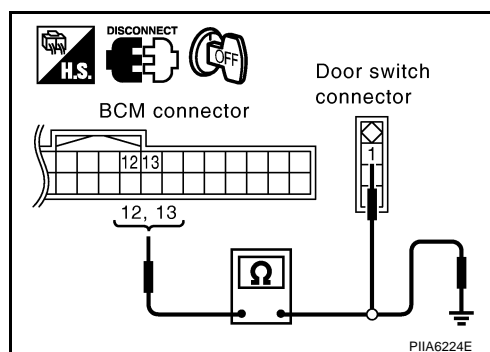

### OK or NG

- OK >> GO TO 4.  
NG >> Repair or replace harness.

## 4. CHECK BCM OUTPUT SIGNAL

1. Connect BCM connector.
2. Check voltage between BCM connector M1, B4 terminals 12, 13, 62, 63 and ground.

- 12 (P) – Ground : Battery voltage**  
**13 (P) – Ground : Battery voltage**  
**62 (W) – Ground : Battery voltage**  
**63 (P) – Ground : Battery voltage**

### OK or NG

- OK >> Check condition of harness and connector.  
NG >> Replace BCM.

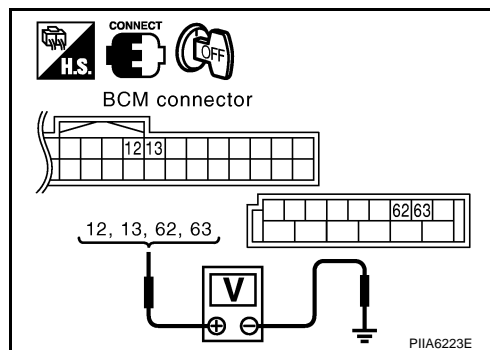

# VEHICLE SECURITY (THEFT WARNING) SYSTEM

## 1 – 3 HOOD SWITCH CHECK

### 1. CHECK HOOD SWITCH

Check hood switch and hood fitting condition.

OK or NG

OK >> GO TO 2.

NG >> Adjust installation of hood switch.

### 2. CHECK HOOD SWITCH INPUT SIGNAL

#### With CONSULT-II

Check ("HOOD SW") in "DATA MONITOR" mode with CONSULT-II.

- When hood is opened:

**HOOD SW : ON**

- When hood is closed:

**HOOD SW : OFF**

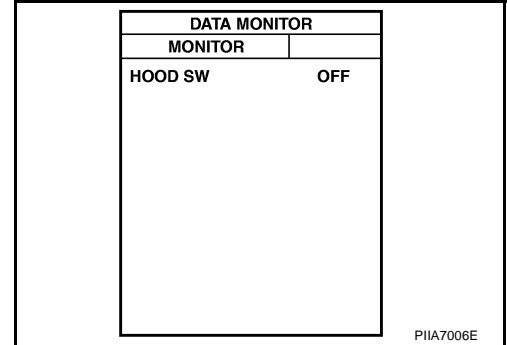

#### Without CONSULT-II

Check voltage between IPDM E/R connector and ground.

Connector	Terminals (Wire color)		Condition of hood	Voltage [V] (Approx.)
	(+)	(-)		
E9	56 (LG/B)	Ground	OPEN	0
			CLOSE	Battery voltage

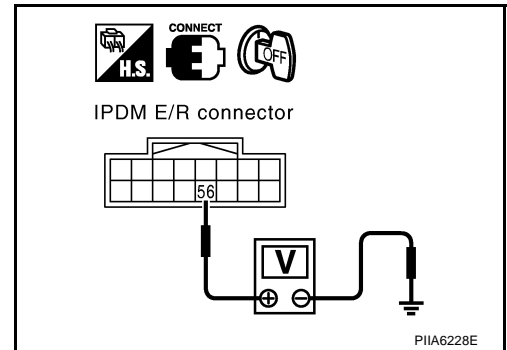

OK or NG

OK >> Hood switch is OK, and go to [BL-130, "1 – 4 TRUNK ROOM LAMP SWITCH CHECK"](#).

NG >> GO TO 3.

### 3. CHECK HOOD SWITCH

- Turn ignition switch OFF.
- Disconnect hood switch connector.
- Check continuity between hood switch terminals 1 and 2.

Terminals		Condition of hood switch	Continuity
1	2		
1	2	Pressed	No
		Released	Yes

OK or NG

OK >> GO TO 4.

NG >> Replace hood switch.

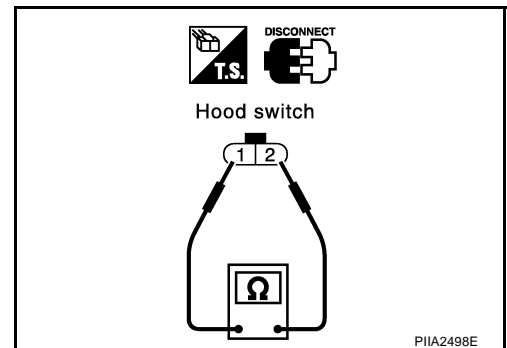

# VEHICLE SECURITY (THEFT WARNING) SYSTEM

## 4. CHECK HOOD SWITCH CIRCUIT

1. Disconnect IPDM E/R connector.
2. Check continuity between hood switch connector E23 terminal 2 and IPDM E/R connector E9 terminal 56.

**2 (LG/B) - 56 (LG/B) : Continuity should exist.**

3. Check continuity between hood switch connector E23 terminal 2 and ground.

**2 (LG/B) - Ground : Continuity should not exist.**

OK or NG

OK >> GO TO 5.

NG >> Repair or replace hood switch harness.

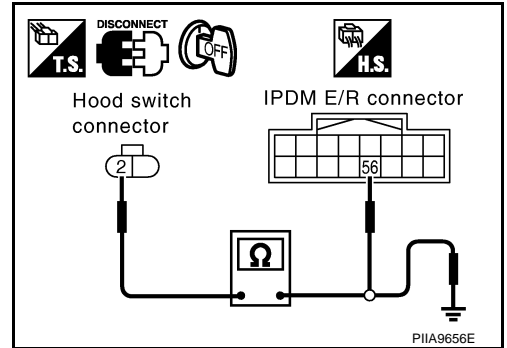

## 5. CHECK HOOD SWITCH GROUND CIRCUIT

Check continuity between hood switch connector E23 terminal 1 and ground.

**1 (B) - Ground : Continuity should exist.**

OK or NG

OK >> Check condition of harness and connector.

NG >> Repair or replace hood switch harness.

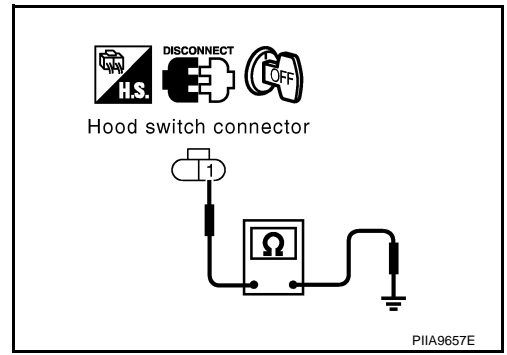

# VEHICLE SECURITY (THEFT WARNING) SYSTEM

## 1 – 4 TRUNK ROOM LAMP SWITCH CHECK

### 1. CHECK TRUNK ROOM LAMP SWITCH INPUT SIGNAL

#### Ⓟ With CONSULT-II

Check trunk lid opener switch ("TRUNK OPN MNTR") in "DATA MONITOR" mode in "BCM".

- When trunk is opened:

**TRNK OPN MONTR : ON**

- When trunk is closed:

**TRNK OPN MONTR : OFF**

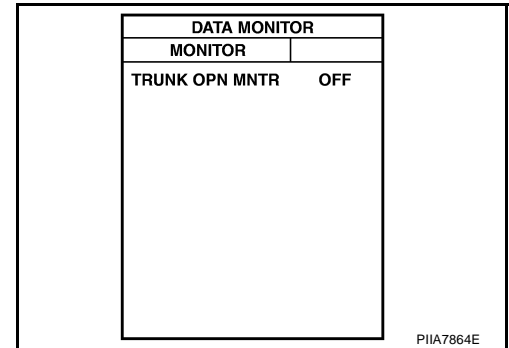

#### ⓧ Without CONSULT-II

Check voltage between BCM connector and ground.

Item	Con- nector	Terminals (Wire color)		Condition of trunk	Voltage [V] (Approx.)
		(+)	(-)		
Trunk room lamp	B4	57 (R/W)	Ground	OPEN	0
				CLOSE	Battery voltage*

\*: When interior lamp battery saver is in OFF position: Approx. 5V.

OK or NG

- OK >> Trunk room lamp switch is OK.  
 NG >> GO TO 2.

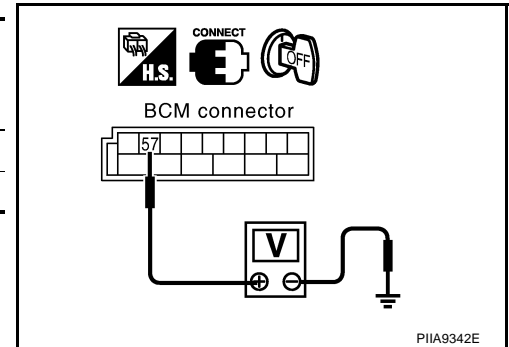

### 2. CHECK TRUNK ROOM LAMP SWITCH CIRCUIT

- Turn ignition switch OFF.
- Disconnect trunk room lamp switch and BCM connector.
- Check continuity between trunk room lamp switch connector B105 terminal 1 and BCM connector B4 terminal 57.

**1 (R/W) - 57 (R/W) : Continuity should exist.**

- Check continuity between trunk room lamp switch connector B105 terminal 1 and ground.

**1 (R/W) - Ground : Continuity should not exist.**

OK or NG

- OK >> GO TO 3.  
 NG >> Replace trunk room lamp switch harness.

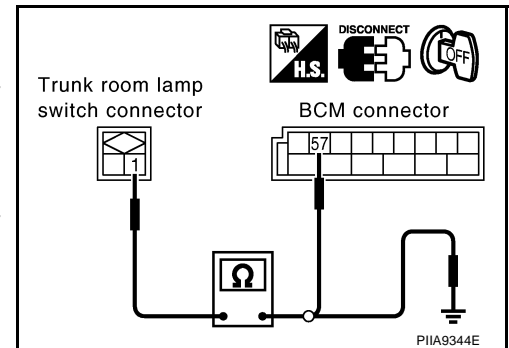

# VEHICLE SECURITY (THEFT WARNING) SYSTEM

## 3. CHECK TRUNK ROOM LAMP SWITCH GROUND CIRCUIT

1. Turn ignition switch OFF.
2. Check continuity between trunk room lamp switch connector B105 terminal 2 and ground.

**2 (B) - Ground : Continuity should exist.**

OK or NG

- OK >> Check trunk room lamp switch.  
 NG >> Repair or replace trunk room lamp switch harness.

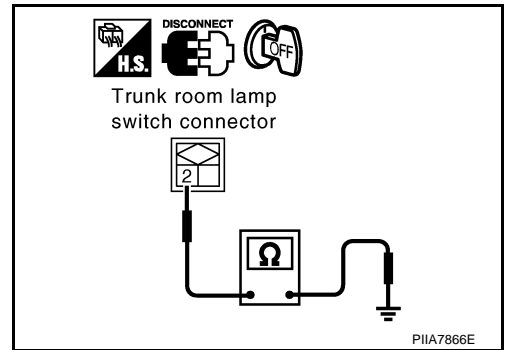

## Diagnostic Procedure 2 SECURITY INDICATOR LAMP CHECK

### 1. SECURITY INDICATOR LAMP ACTIVE TEST

**With CONSULT-II**

Check ("THEFT IND") in "ACTIVE TEST" mode with CONSULT-II.

**Perform operation shown on display indicator lamp should illuminate.**

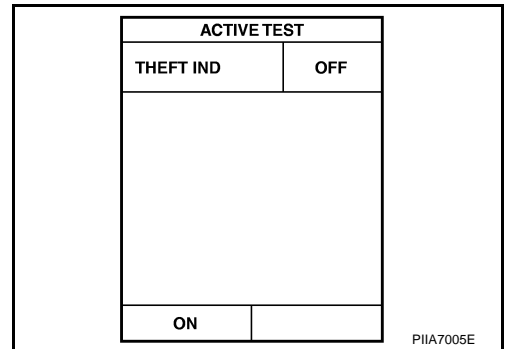

**Without CONSULT-II**

Check voltage between BCM connector and ground.

Connector	Terminals (Wire color)		Condition	Voltage [V] (Approx.)
	(+)	(-)		
M1	23 (G/OR)	Ground	Illuminates	0
			Goes off	Battery voltage

OK or NG

- OK >> Security indicator lamp is OK.  
 NG >> GO TO 2.

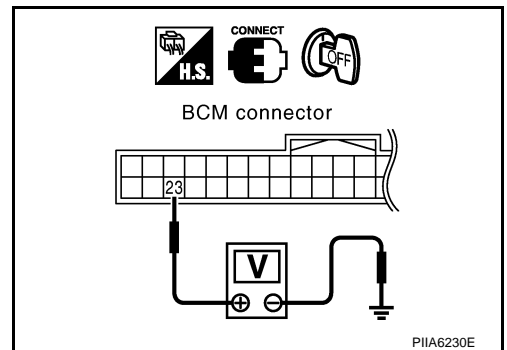

# VEHICLE SECURITY (THEFT WARNING) SYSTEM

## 2. CHECK HARNESS CONTINUITY

1. Turn ignition switch OFF.
2. Disconnect security indicator lamp connector.
3. Check voltage between security indicator lamp connector M34 terminal 1 and ground.

**1 (R/W) – Ground : Battery voltage**

### OK or NG

OK >> Check the following.

- Harness for open or short between BCM and security indicator lamp
- Security indicator lamp condition

NG >> Check the following.

- 10A fuse [No.19, located in fuse block (J/B)]
- Harness for open or short between security indicator lamp and fuse

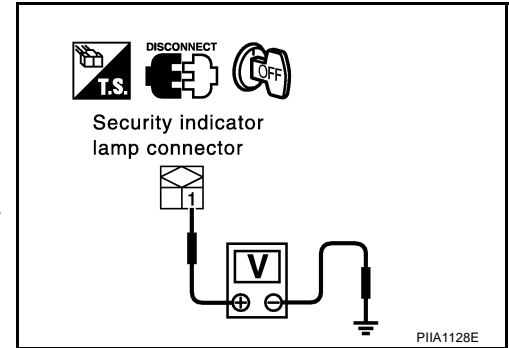



# VEHICLE SECURITY (THEFT WARNING) SYSTEM

## Diagnostic Procedure 3 FRONT DOOR KEY CYLINDER SWITCH CHECK

AIS004B1

### 1. CHECK KEY CYLINDER SWITCH OPERATION

Check if door key cylinder switch using key.

Do doors lock / unlock when using the key?

YES >> Front door key cylinder switch operation is OK.

NO >> Check door key cylinder switch circuit. Refer to [BL-48, "Door Key Cylinder Switch Check"](#) .

## Diagnostic Procedure 4 VEHICLE SECURITY HORN ALARM CHECK

AIS004B2

First perform the "SELF-DIAG RESULTS" of "BCM" with CONSULT-II, then perform the trouble diagnosis of malfunction system indicated in "SELF-DIAG RESULTS" of "BCM". Refer to [BCS-14, "CAN Communication Inspection Using CONSULT-II \(Self-Diagnosis\)"](#).

### 1. CHECK HORN OPERATION

Check if horn sounds with horn switch.

Does horn operate?

Yes >> GO TO 2.

No >> Check horn circuit. Refer to [WW-45, "HORN"](#) .

### 2. CHECK IPDM E/R INPUT SIGNAL

Check voltage between IPDM E/R connector E9 terminal 51 and ground.

**51 (G/B) – Ground : Battery voltage**

OK or NG

OK >> Replace IPDM E/R.

NG >> GO TO 3.

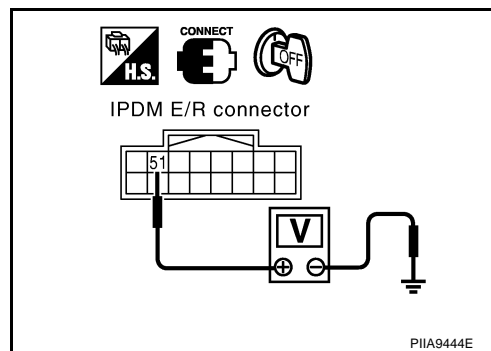

### 3. CHECK HORN RELAY CIRCUIT

1. Turn ignition switch OFF.
2. Disconnect IPDM E/R and horn relay connector.
3. Check continuity between IPDM E/R connector E9 terminal 51 and horn relay connector E20 terminal 1.

**51 (G/B) – 1 (G/B) : Continuity should exist.**

OK or NG

OK >> Check harness connection.

NG >> Repair or replace harness.

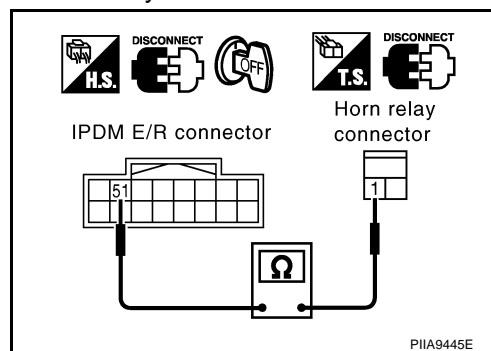

# VEHICLE SECURITY (THEFT WARNING) SYSTEM

---

## Diagnostic Procedure 5

AIS004B3

### VEHICLE SECURITY HEADLAMP ALARM CHECK

#### 1. CHECK HEADLAMP OPERATION

---

Check if headlamp operate by lighting switch.

Does headlamp come on when turning switch "ON"?

YES >> Headlamp alarm circuit is OK.

NO >> Check headlamp system. Refer to [LT-7, "HEADLAMP \(FOR USA\)"](#) or [LT-38, "HEADLAMP \(FOR CANADA\) - DAYTIME LIGHT SYSTEM -"](#) .

## Diagnostic Procedure 6

AIS004B4

### DOOR LOCK AND UNLOCK SWITCH CHECK

#### 1. CHECK DOOR LOCK AND UNLOCK SWITCH INPUT SIGNAL

---

Check if power door lock operated by door lock and unlock switch.

Do doors lock / unlock when using each door lock and unlock switches?

YES >> Door lock and unlock switch is OK.

NO >> Check door lock and unlock switch. Refer to [BL-40, "Check Door Lock and Unlock Switch \(With Anti-pinch System For All Door Window\)"](#) .

# IVIS (INFINITI VEHICLE IMMOBILIZER SYSTEM-NATS)

## IVIS (INFINITI VEHICLE IMMOBILIZER SYSTEM-NATS)

PFP:28591

### Component Parts and Harness Connector Location

AIS004BP

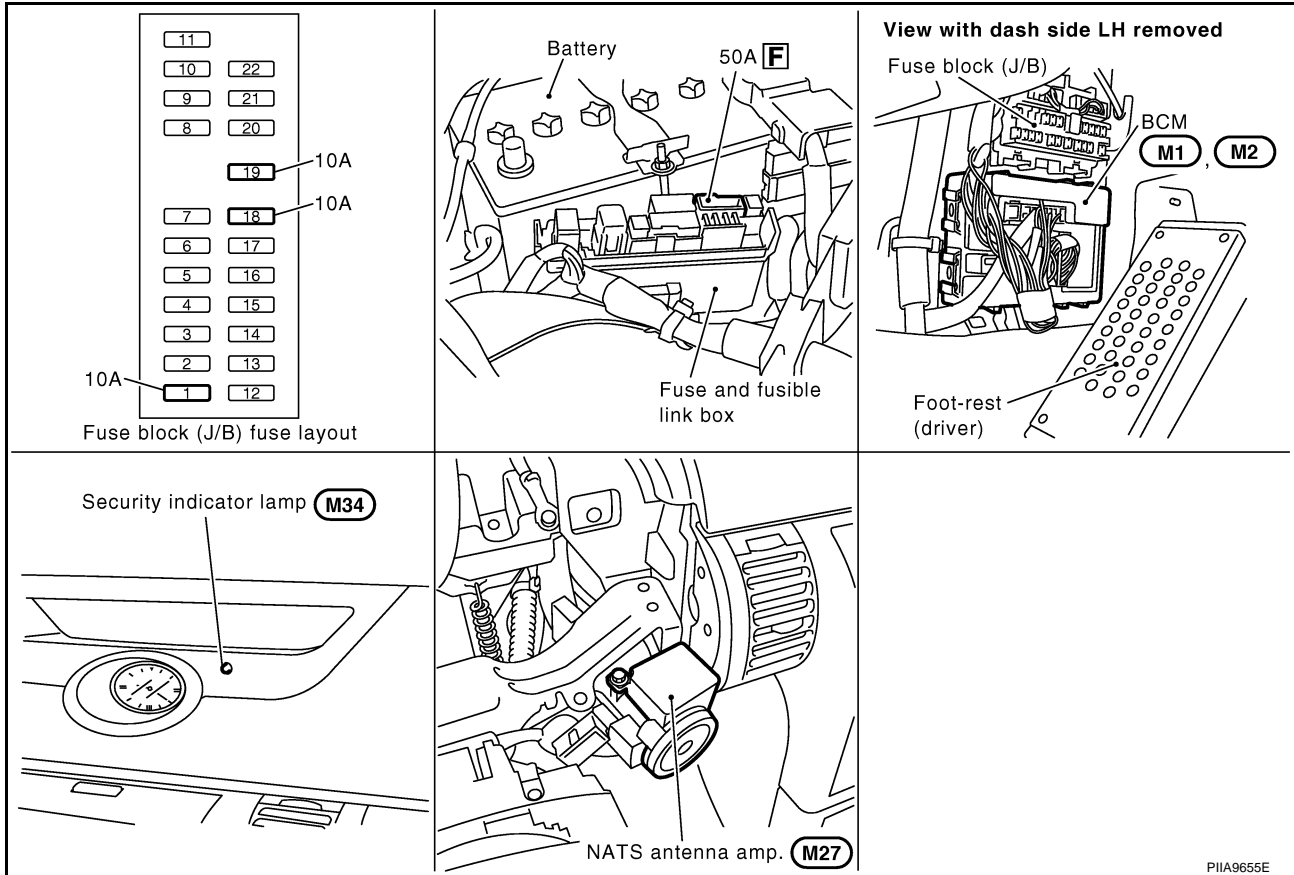

**NOTE:**

If customer reports a "No start" condition, request ALL KEYS to be brought to an INFINITI dealer in case of a IVIS (NATS) malfunction.

A  
B  
C  
D  
E  
F  
G  
H  
BL  
J  
K  
L  
M

# IVIS (INFINITI VEHICLE IMMOBILIZER SYSTEM-NATS)

## System Description

AIS004BQ

IVIS (INFINITI VEHICLE IMMOBILIZER SYSTEM-NATS) has the following immobilizer functions:

- Since only IVIS (NATS) ignition keys, whose ID Nos. have been registered into the ECM and BCM (NATS control unit), allow the engine to run, a vehicle operation without a key registered in IVIS (NATS) is prevented by IVIS (NATS).  
That is to say, IVIS (NATS) will immobilize the engine if someone tries to start it without the registered key of IVIS (NATS).
- All of the originally supplied ignition key IDs (except for card plate key) have been registered in IVIS (NATS).  
If requested by the vehicle owner, a maximum of five key IDs can be registered into the IVIS (NATS) components.
- The security indicator blinks when the ignition switch is in “OFF” or “ACC” position. Therefore, IVIS (NATS) warns outsiders that the vehicle is equipped with the immobilizer system.
- When IVIS (NATS) detects trouble, the security indicator lamp lights up while ignition key is in the “ON” position.
- IVIS (NATS) trouble diagnoses, system initialization and additional registration of other IVIS (NATS) ignition key IDs must be carried out using CONSULT-II hardware and CONSULT-II IVIS (NATS) software.  
When IVIS (NATS) initialization has been completed, the ID of the inserted ignition key is automatically registered in IVIS (NATS). Then, if necessary, additional registration of other IVIS (NATS) ignition key IDs can be carried out.  
Regarding the procedures of IVIS (NATS) initialization and IVIS (NATS) ignition key ID registration, refer to CONSULT-II Operation Manual NATS-IVIS/NVIS.
- **When servicing a malfunction of the IVIS (NATS) (indicated by lighting up of Security Indicator Lamp) or registering another IVIS (NATS) ignition key ID No., it may be necessary to re-register original key identification. Therefore, be sure to receive ALL KEYS from vehicle owner.**

# IVIS (INFINITI VEHICLE IMMOBILIZER SYSTEM-NATS)

AIS004BR

## System Composition

The immobilizer function of the IVIS (NATS) consists of the following:

- NATS ignition key
- NATS antenna amp. located in the ignition key cylinder
- BCM (NATS control unit)
- Engine control module (ECM)
- Security indicator

### NOTE:

The communication between ECM and BCM uses the CAN communication system.

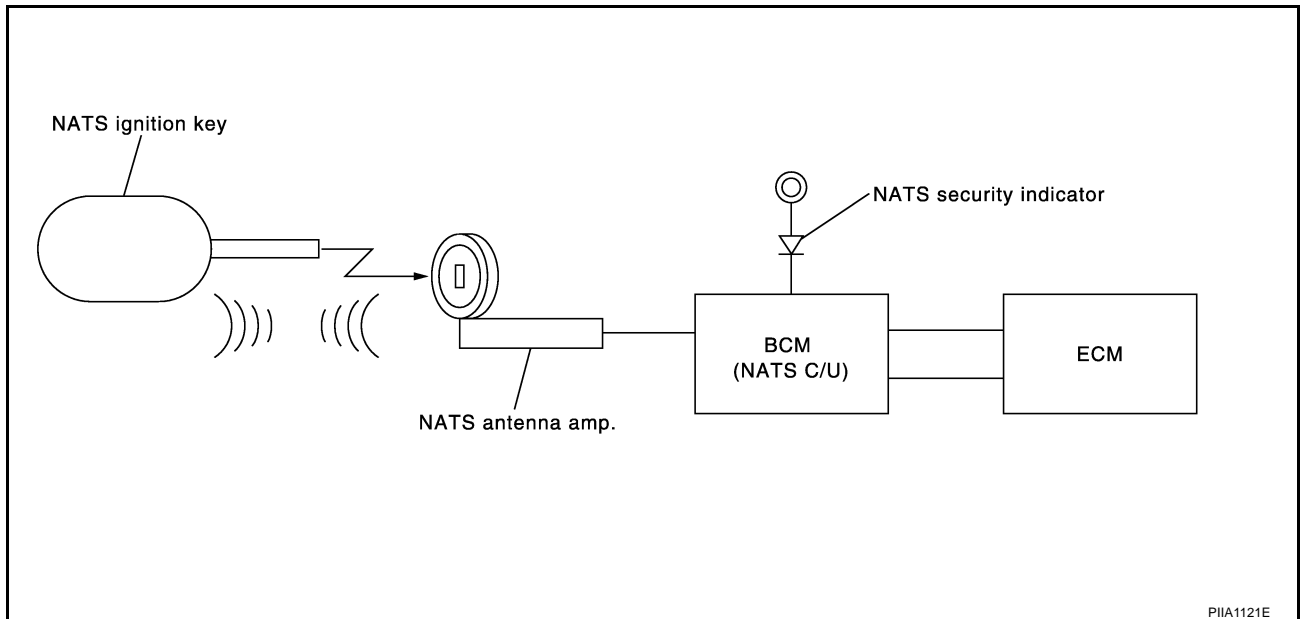

## ECM Re-communicating Function

AIS004BS

Performing following procedure can automatically perform re-communication of ECM and BCM, but only when the ECM has been replaced with a new one (\*1).

\*1: New one means a virgin ECM which has never been energized on-board.

(In this step, initialization procedure by CONSULT-II is not necessary)

### NOTE:

- When registering new Key IDs or replacing the ECM other than brand new, refer to CONSULT-II Operation Manual NATS-IVIS/NVIS.
  - If multiple keys are attached to the key holder, separate them before work.
  - Distinguish keys with unregistered key ID from those with registered ID.
1. Install ECM.
  2. Using a registered key (\*2), turn ignition switch to "ON".  
\*2: To perform this step, use the key (except for card plate key) that has been used before performing ECM replacement.
  3. Maintain ignition switch in "ON" position for at least 5 seconds.
  4. Turn ignition switch to "OFF".
  5. Start engine.  
If engine can be started, procedure is completed.  
If engine cannot be started, refer to CONSULT-II Operation Manual NATS-IVIS/NVIS and initialize control unit.

# IVIS (INFINITI VEHICLE IMMOBILIZER SYSTEM-NATS)

AIS004BT

## Wiring Diagram — NATS —

BL-NATS-01

▬▬▬▬ : DATA LINE

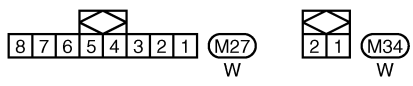
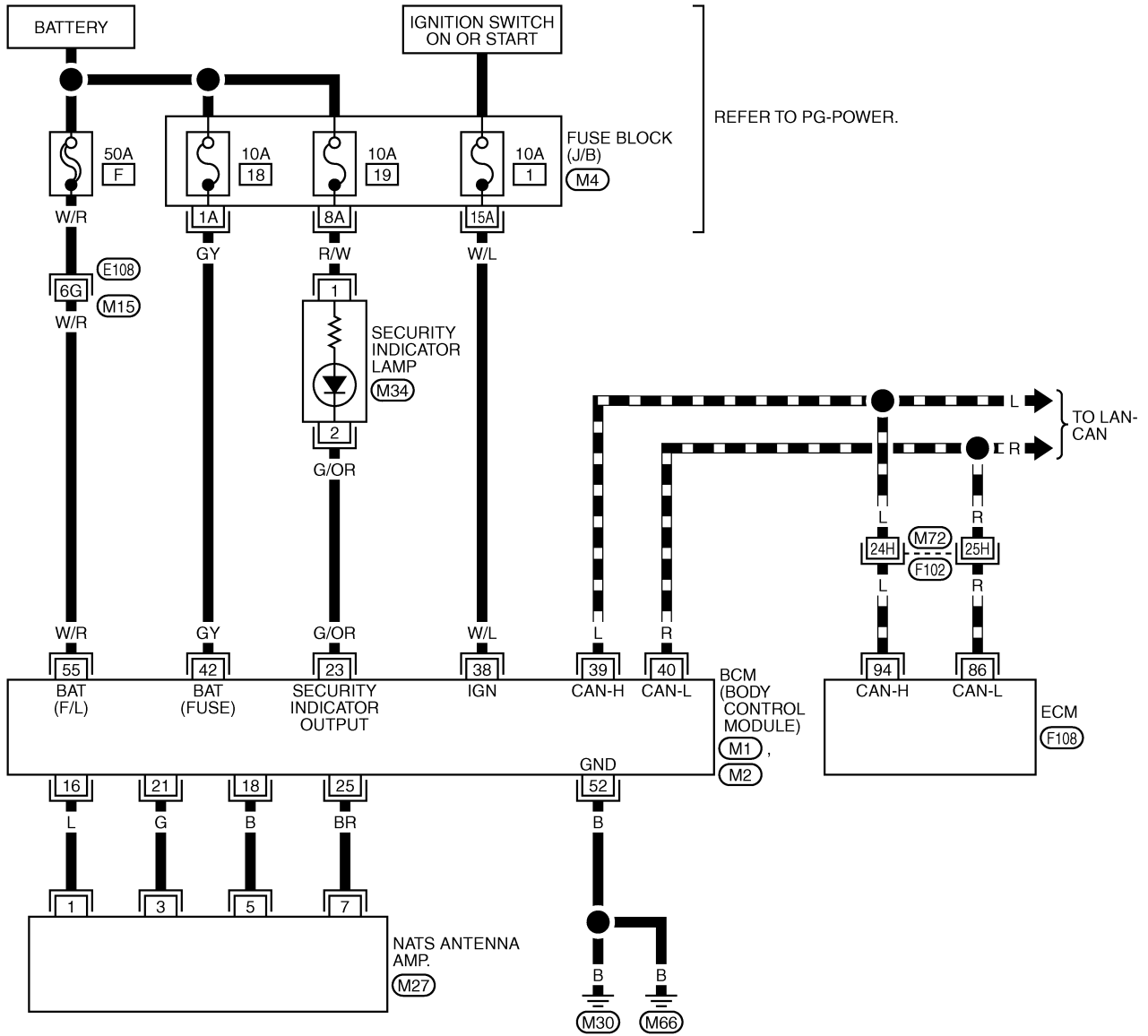

REFER TO THE FOLLOWING.  
 (E108), (F102) -SUPER MULTIPLE JUNCTION (SMJ)  
 (M4) -FUSE BLOCK-JUNCTION BOX (J/B)  
 (M1), (M2), (F108) -ELECTRICAL UNITS

TIWT0706E

# IVIS (INFINITI VEHICLE IMMOBILIZER SYSTEM-NATS)

## Terminals and Reference Value for BCM

AIS004BU

Terminal	Wire color	Item	Condition	Voltage [V] (Approx.)
16	L	NATS antenna amp.	Ignition switch: OFF → ON	0 → 5 (for 3 seconds)
18	B	NATS antenna amp.	—	0
21	G	NATS antenna amp.	Ignition switch (OFF → ON)	Just after turning ignition switch "ON": Pointer of tester should move.
23	G/OR	Security indicator lamp	Goes OFF → illuminates (Every 2.4 seconds)	Battery voltage → 0
25	BR	NATS antenna amp.	Ignition switch (OFF → ON)	Just after turning ignition switch "ON": Pointer of tester should move.
38	W/L	Ignition switch (ON or START)	Ignition switch (ON or START position)	Battery voltage
39	L	CAN-H	—	—
40	R	CAN-L	—	—
42	GY	Power source (Fuse)	—	Battery voltage
52	B	Ground	—	0
55	W/R	Power source (Fusible link)	—	Battery voltage

## CONSULT-II

### CONSULT-II INSPECTION PROCEDURE

AIS004BV

1. Turn ignition switch OFF.
2. Insert IVIS (NATS) program card into CONSULT-II.  
**Program card : NATS (AEN02C)**
3. Connect CONSULT-II and CONSULT-II CONVERTER to data link connector.
4. Turn ignition switch ON.
5. Touch "START".

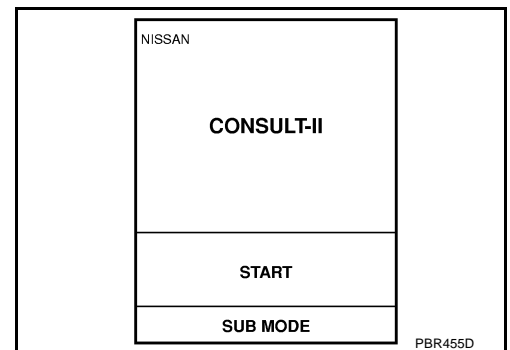
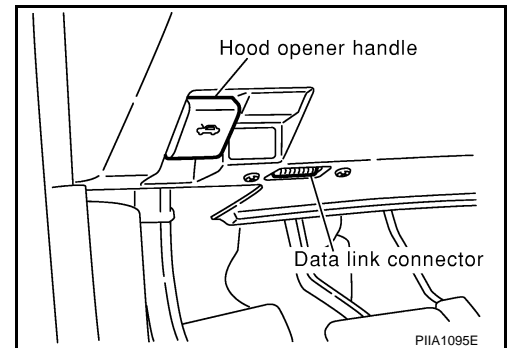

# IVIS (INFINITI VEHICLE IMMOBILIZER SYSTEM-NATS)

6. Touch "OTHER".

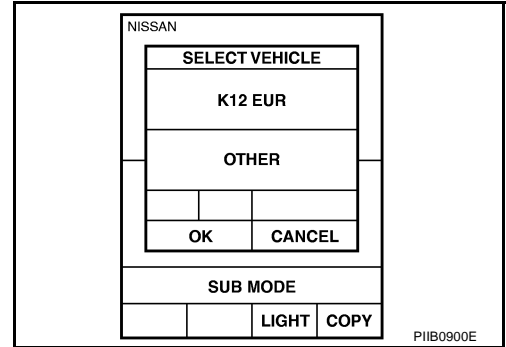

7. Select "NATS V.5.0".  
If "NATS V5.0" is not indicated, go to [GI-38, "CONSULT-II Data Link Connector \(DLC\) Circuit"](#) .

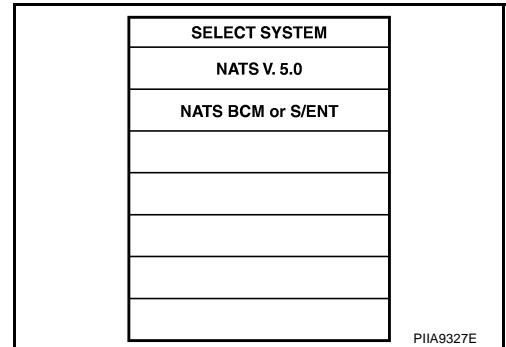

8. Perform each diagnostic test mode according to each service procedure.  
**For further information, see the CONSULT-II Operation Manual NATS-IVIS/NVIS.**

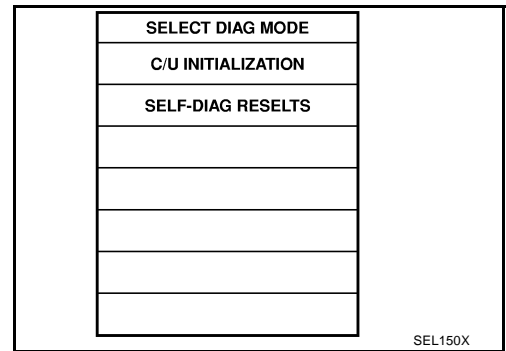

## CONSULT-II DIAGNOSTIC TEST MODE FUNCTION

CONSULT-II DIAGNOSTIC TEST MODE	Description
C/U INITIALIZATION	When replacing any of the following components, C/U initialization and re-registration of all NATS ignition keys are necessary. [(NATS ignition key/ BCM (NATS control unit)/ ECM*]
SELF-DIAG RESULTS	Detected items (screen terms) are as shown in the chart. Refer to <a href="#">BL-141, "IVIS (NATS) SELF-DIAGNOSTIC RESULTS ITEM CHART"</a> .

\*: When replace ECM, refer to [BL-137, "ECM Re-communicating Function"](#) .

### NOTE:

- When any initialization is performed, all ID previously registered will be erased and all NATS ignition keys must be registered again.
- The engine cannot be started with an unregistered key. In this case, the system will show "DIFFERENCE OF KEY" or "LOCK MODE" as a self-diagnostic result on the CONSULT-II screen.
- In rare case, "CHAIN OF ECM-IMMU" might be stored as a self-diagnostic result during key registration procedure, even if the system is not malfunctioning.





# IVIS (INFINITI VEHICLE IMMOBILIZER SYSTEM-NATS)

## Work Flow

AI5004BW

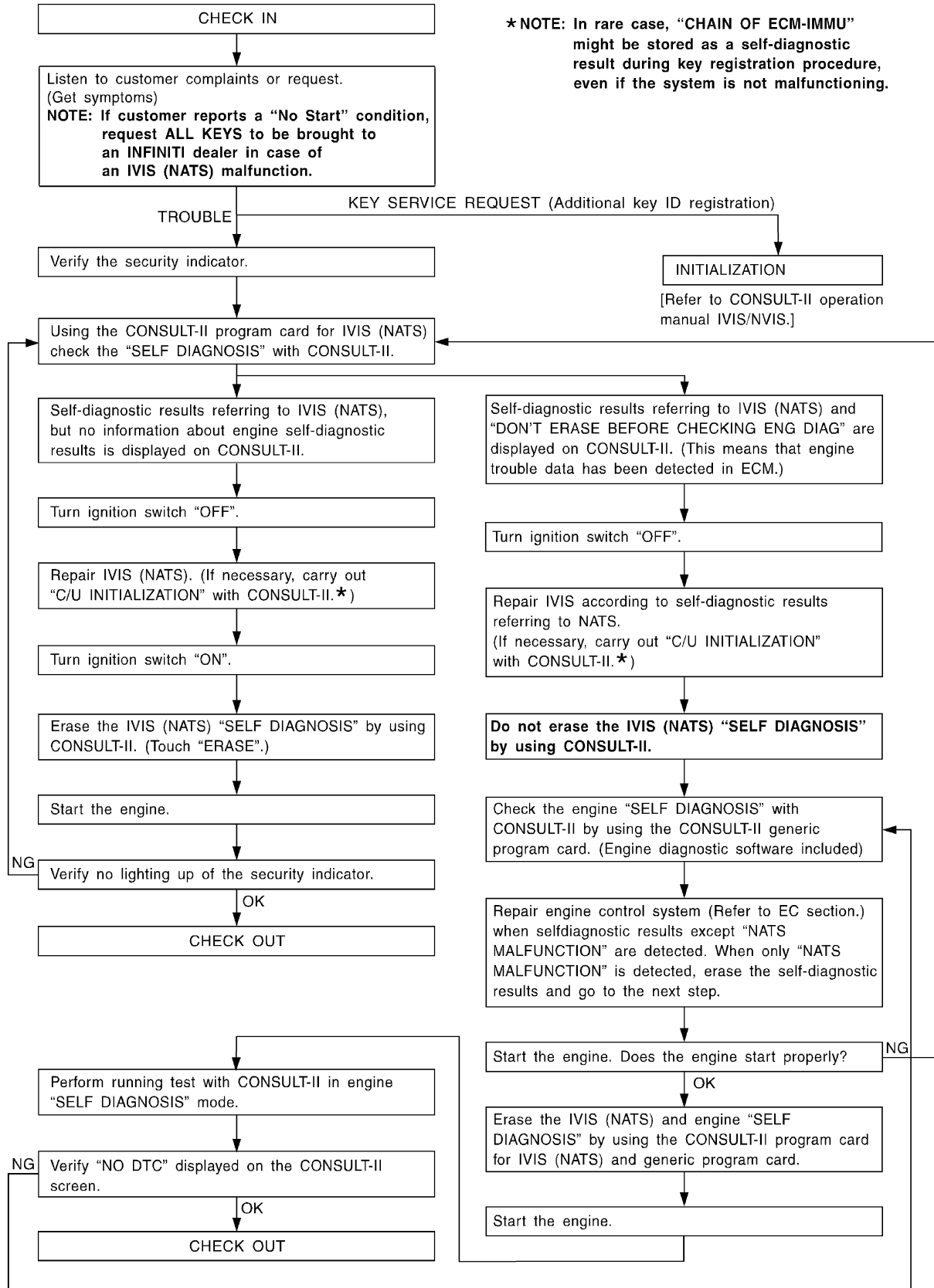

SEL024X

# IVIS (INFINITI VEHICLE IMMOBILIZER SYSTEM-NATS)

AISO04BX

## Trouble Diagnoses SYMPTOM MATRIX CHART 1

### Self-diagnosis related item

SYMPTOM	Displayed "SELF-DIAG RESULTS" on CONSULT-II screen.	DIAGNOSTIC PROCEDURE (Reference page)	SYSTEM (Malfunctioning part or mode)	REFERENCE PART NO. OF FIGURE ON DIAGNOSTIC SYSTEM DIAGRAM
<ul style="list-style-type: none"> <li>● Security indicator lighting up*</li> <li>● Engine cannot be started</li> </ul>	CHAIN OF ECM-IMMU [P1612]	PROCEDURE 1 (BL-145)	In rare case, "CHAIN OF ECM-IMMU" might be stored during key registration procedure, even if the system is not malfunctioning.	—
			Open circuit in battery voltage line of BCM (NATS control unit) circuit	C1
			Open circuit in ignition line of BCM (NATS control unit) circuit	C2
			Open circuit in ground line of BCM (NATS control unit) circuit	C3
			Open or short circuit between BCM (NATS control unit) and ECM communication line	C4
			ECM	B
			BCM (NATS control unit)	A
	DIFFERENCE OF KEY [P1615]	PROCEDURE 2 (BL-147)	Unregistered key	D
			BCM (NATS control unit)	A
	CHAIN OF IMMU-KEY [P1614]	PROCEDURE 3 (BL-147)	Malfunction of key ID chip	E5
			Communication line between ANT/ AMP and BCM (NATS control unit): Open circuit or short circuit of battery voltage line or ground line	E1
				E2
			Open circuit in power source line of ANT/ AMP circuit	E3
			Open circuit in ground line of ANT/ AMP circuit	E4
			NATS antenna amp.	E6
			BCM (NATS control unit)	A
	ID DISCORD, IMM-ECM [P1611]	PROCEDURE 4 (BL-149)	System initialization has not yet been completed.	F
			ECM	B

# IVIS (INFINITI VEHICLE IMMOBILIZER SYSTEM-NATS)

SYMPTOM	Displayed "SELF-DIAG RESULTS" on CONSULT-II screen.	DIAGNOSTIC PROCEDURE (Reference page)	SYSTEM (Malfunctioning part or mode)	REFERENCE PART NO. OF FIGURE ON DIAGNOSTIC SYSTEM DIAGRAM
<ul style="list-style-type: none"> <li>Security indicator lighting up*</li> <li>Engine cannot be started</li> </ul>	LOCK MODE [P1610]	PROCEDURE 6 (BL-152)	LOCK MODE	When the starting operation is carried out five or more times consecutively under the following conditions, IVIS (NATS) will shift the mode to one which prevents the engine from being started. <ul style="list-style-type: none"> <li>Unregistered ignition key is used.</li> <li>BCM (NATS control unit) or ECM's malfunctioning.</li> </ul>
Security indicator lighting up*	DON'T ERASE BEFORE CHECKING ENG DIAG	WORK FLOW (BL-142)	Engine trouble data and IVIS (NATS) trouble data have been detected in ECM	—

\*: When IVIS (NATS) detects trouble, the security indicator lights up while ignition key is in the "ON" position.

## SYMPTOM MATRIX CHART 2

### Non self-diagnosis related item

SYMPTOM	DIAGNOSTIC PROCEDURE (Reference page)	SYSTEM (Malfunctioning part or mode)	REFERENCE PART NO. OF FIGURE ON DIAGNOSTIC SYSTEM DIAGRAM
Security indicator does not light up*.	PROCEDURE 5 (BL-150)	Security indicator.	—
		Open circuit between Fuse and BCM (NATS control unit)	—
		BCM (NATS control unit)	A

\*: CONSULT-II self-diagnostic results display screen "no malfunction is detected".

## DIAGNOSTIC SYSTEM DIAGRAM

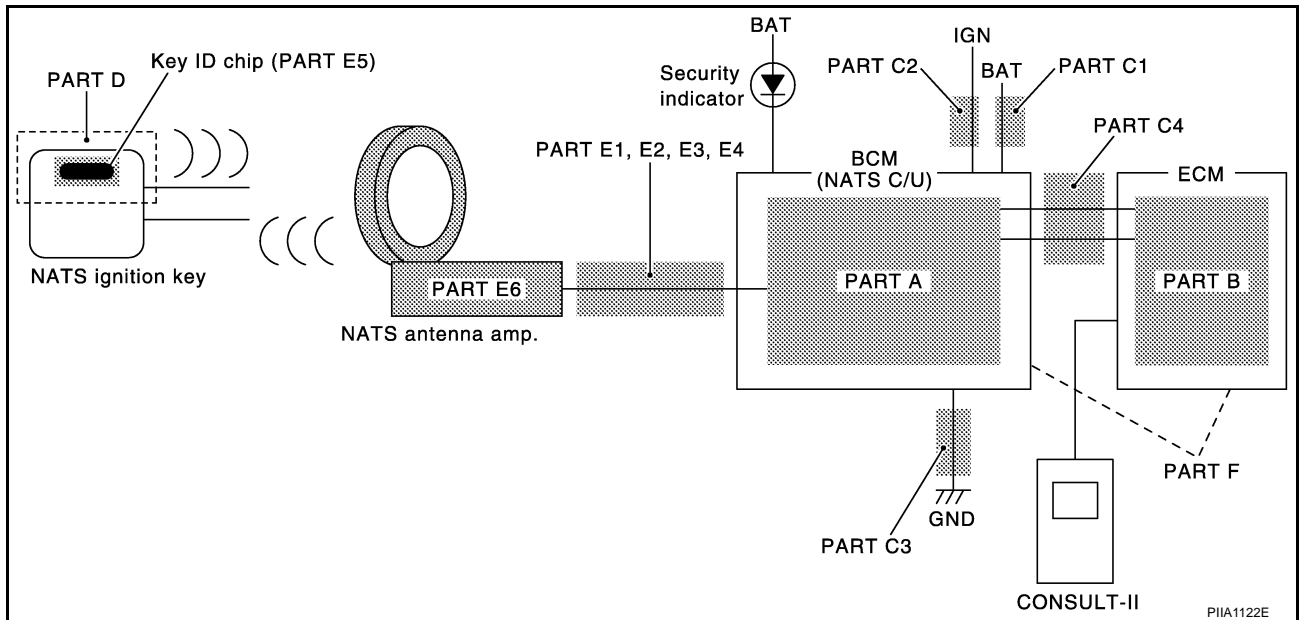

# IVIS (INFINITI VEHICLE IMMOBILIZER SYSTEM-NATS)

AI5004BY

## Diagnostic Procedure 1

### Self-diagnostic results:

“CHAIN OF ECM-IMMU” displayed on CONSULT-II screen

First perform the “SELF-DIAG RESULTS” in “BCM” with CONSULT-II, then perform the trouble diagnosis of malfunction system indicated “SELF-DIAG RESULTS” of “BCM”. Refer to [BCS-14, "CAN Communication Inspection Using CONSULT-II \(Self-Diagnosis\)"](#) .

### 1. CONFIRM SELF-DIAGNOSTIC RESULTS

Confirm SELF-DIAGNOSTIC RESULTS “CHAIN OF ECM-IMMU” displayed on CONSULT-II screen.

#### NOTE:

In rare case, “CHAIN OF ECM-IMMU” might be stored during key registration procedure, even if the system is not malfunctioning.

Is CONSULT-II screen displayed as shown in figure?

Yes >> GO TO 2.

No >> GO TO [BL-143, "SYMPTOM MATRIX CHART 1"](#) .

SELF DIAGNOSIS	
DTC RESULTS	TIME
CHAIN OF ECM-IMMU [P1612]	0

PIIA1260E

### 2. CHECK POWER SUPPLY CIRCUIT FOR BCM (NATS CONTROL UNIT)

1. Disconnect BCM (NATS control unit) connector.
2. Check voltage between BCM (NATS control unit) and ground with CONSULT-II or tester.

Connector	Terminals (Wire color)		Voltage [V] (Approx.)
	(+)	(-)	
M2	42 (GY)	Ground	Battery voltage
	55 (W/R)		

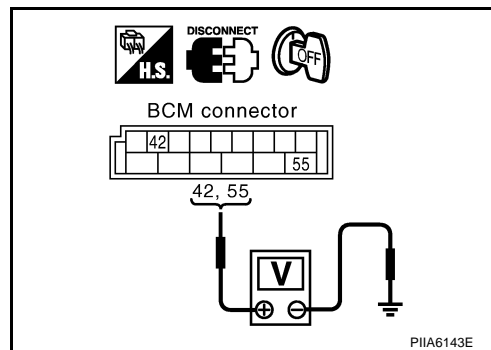

#### OK or NG

OK >> GO TO 3.

NG >> Check the following.

- 50A fusible link (letter F , located in the fuse and fusible link box)
- 10A fuse [No.18, located in the fuse block (J/B)]
- Harness for open or short between fusible link and BCM (NATS control unit)
- Harness for open or short between fuse and BCM (NATS control unit)

Ref. Part No. C1

### 3. CHECK IGNITION SWITCH ON SIGNAL

1. Turn ignition switch ON.
2. Check voltage between BCM (NATS control unit) connector M1 terminal 38 and ground with CONSULT-II or tester.

**38 (W/L) - Ground : Battery voltage**

#### OK or NG

OK >> GO TO 4.

NG >> Check the following.

- 10A fuse [No. 1, located in the fuse block (J/B)]
- Harness for open or short between fuse and BCM (NATS control unit)

Ref. part No. C2

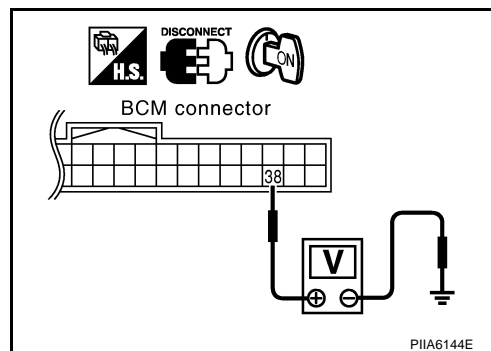

# IVIS (INFINITI VEHICLE IMMOBILIZER SYSTEM-NATS)

## 4. CHECK GROUND CIRCUIT FOR BCM (NATS CONTROL UNIT)

1. Turn ignition switch OFF.
2. Check continuity between BCM (NATS control unit) connector M2 terminal 52 and ground.

**52 (B) – Ground : Continuity should exist.**

OK or NG

OK >> GO TO 5.

NG >> Repair harness. **Ref. part No. C3**

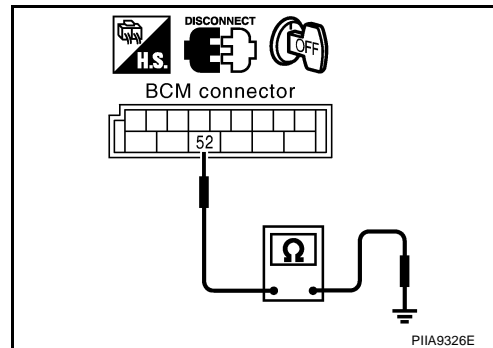

## 5. REPLACE BCM (NATS CONTROL UNIT)

1. Replace BCM (NATS control unit) **Ref. part No. A**
2. Perform initialization with CONSULT-II.  
For initialization, refer to “CONSULT-II Operation Manual NATS-IVIS/NVIS”.

Does the engine start?

Yes >> BCM (NATS control unit) is malfunctioning.

- Replace BCM (NATS control unit). **Ref. part No. A**
- Perform initialization with CONSULT-II
- For initialization, refer to “CONSULT-II Operation Manual NATS-IVIS/NVIS”

No >> ECM is malfunctioning.

- Replace ECM. **Ref. part No. B**
- Perform initialization or re-communicating function
- For initialization, refer to “CONSULT-II Operation Manual NATS-IVIS/NVIS”
- For re-communicating function, refer to [BL-137, "ECM Re-communicating Function"](#)

# IVIS (INFINITI VEHICLE IMMOBILIZER SYSTEM-NATS)

AIS004BZ

## Diagnostic Procedure 2

Self-diagnostic results:  
"DIFFERENCE OF KEY" displayed on CONSULT-II screen

### 1. CONFIRM SELF-DIAGNOSTIC RESULTS

Confirm SELF-DIAGNOSTIC RESULTS "DIFFERENCE OF KEY" displayed on CONSULT-II screen.

Is CONSULT-II screen displayed as shown in figure?

- Yes >> GO TO 2.  
No >> GO TO [BL-143, "SYMPTOM MATRIX CHART 1"](#).

SELF DIAG RESULTS	
DTC RESULTS	TIME
DIFFERENCE OF KEY [P1615]	0

PIIA1261E

### 2. PERFORM INITIALIZATION WITH CONSULT-II

Perform initialization with CONSULT-II. Re-register all NATS ignition key IDs.  
For initialization and registration of NATS ignition key IDs, refer to "CONSULT-II Operation Manual NATS-IVIS/NVIS".

#### NOTE:

If the initialization is not completed or malfunctions, CONSULT-II shows message on the screen.

Can the system be initialized and can the engine be started with re-registered NATS ignition key?

- Yes >> Ignition key ID was unregistered. **Ref. part No. D**  
No >> BCM (NATS control unit) is malfunctioning.
- Replace BCM (NATS control unit). **Ref. part No. A**
  - Perform initialization with CONSULT-II
  - For initialization, refer to "CONSULT-II Operation Manual NATS-IVIS/NVIS"

IMMU INITIALIZATION
INITIALIZATION FAIL
THEN IGN KEY SW 'OFF' AND 'ON', AFTER CONFIRMING SELF-DIAG AND PASSWORD, PERFORM C/U INITIALIZATION AGAIN.

SEL297W

## Diagnostic Procedure 3

AIS004C0

Self-diagnostic results:  
"CHAIN OF IMMU-KEY" displayed on CONSULT-II screen

### 1. CONFIRM SELF-DIAGNOSTIC RESULTS

Confirm SELF-DIAGNOSTIC RESULTS "CHAIN OF IMMU-KEY" displayed on CONSULT-II screen.

Is CONSULT-II screen displayed as shown in figure?

- Yes >> GO TO 2.  
No >> GO TO [BL-143, "SYMPTOM MATRIX CHART 1"](#).

SELF DIAGNOSIS	
DTC RESULTS	TIME
CHAIN OF IMMU-KEY [P1614]	0

PIIA1263E

### 2. CHECK NATS ANTENNA AMP. INSTALLATION

Check NATS antenna amp. installation. Refer to [BL-153, "How to Replace NATS Antenna Amp."](#)

OK or NG

- OK >> GO TO 3.  
NG >> Reinstall NATS antenna amp. correctly.

# IVIS (INFINITI VEHICLE IMMOBILIZER SYSTEM-NATS)

## 3. CHECK IVIS (NATS) IGNITION KEY ID CHIP

Start engine with another registered NATS ignition key.

Does the engine start?

Yes >> Ignition key ID chip is malfunctioning.

- Replace the ignition key  
**Ref. part No, E5**
- Perform initialization with CONSULT-II  
For initialization, refer to "CONSULT-II Operation Manual NATS-IVIS/NVIS"

No >> GO TO 4.

## 4. CHECK POWER SUPPLY FOR NATS ANTENNA AMP.

1. Turn ignition switch "ON".
2. Check voltage between NATS antenna amp. connector M27 terminal 1 and ground with CONSULT-II or tester.

**Just after turning ignition switch "ON"**

**Voltage: Approx. 5V (For 3 seconds)**

OK or NG

OK >> GO TO 5.

NG >> ● Check harness for open or short between NATS antenna amp. and BCM (NATS control unit).

**NOTE:**

If harness is OK, replace BCM (NATS control unit), perform initialization with CONSULT-II. For initialization, refer to "CONSULT-II Operation Manual NATS-IVIS/NVIS".

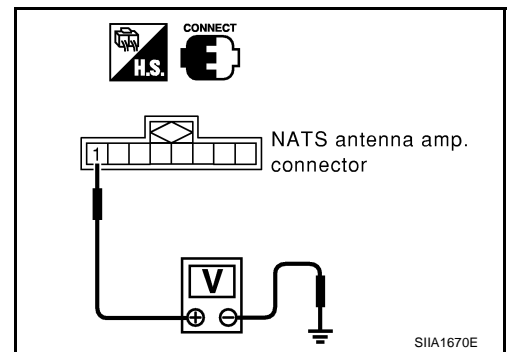

## 5. CHECK NATS ANTENNA AMP. SIGNAL LINE- 1

Check voltage between NATS antenna amp. connector M27 terminal 3 and ground with analogue tester.

**Before turning ignition switch "ON"**

**Voltage: Approx. 0V**

**Just after turning ignition switch "ON"**

**: Pointer of tester should move.**

OK or NG

OK >> GO TO 6.

NG >> ● Check harness for open or short between NATS antenna amp. and BCM (NATS control unit).

**NOTE:**

If harness is OK, replace BCM (NATS control unit), perform initialization with CONSULT-II. For initialization, refer to "CONSULT-II Operation Manual NATS-IVIS/NVIS".

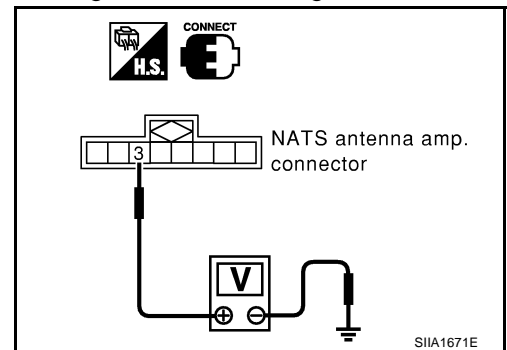



# IVIS (INFINITI VEHICLE IMMOBILIZER SYSTEM-NATS)

## 6. CHECK NATS ANTENNA AMP. SIGNAL LINE- 2

Check voltage between NATS antenna amp. connector M27 terminal 7 and ground with analogue tester.

**Before turning ignition switch "ON"**

**Voltage: Approx. 0V**

**Just after turning ignition switch "ON"**

**: Pointer of tester should move.**

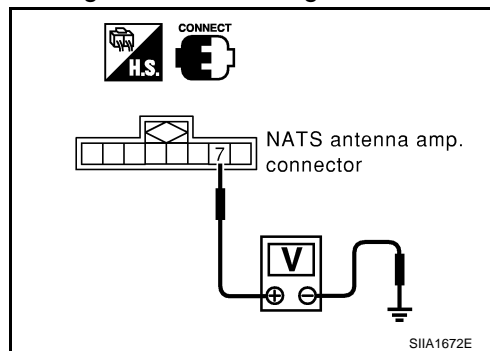

OK or NG

OK >> GO TO 7.

NG >> ● Check harness for open or short between NATS antenna amp. and BCM (NATS control unit).

**NOTE:**

If harness is OK, replace BCM (NATS control unit), perform initialization with CONSULT-II. For initialization, refer to "CONSULT-II Operation Manual NATS-IVIS/NVIS".

## 7. CHECK NATS ANTENNA AMP. GROUND LINE CIRCUIT

1. Turn ignition switch "OFF".

2. Check continuity between NATS antenna amp. connector M27 terminal 5 and ground.

**5 (B) – Ground : Continuity should exist.**

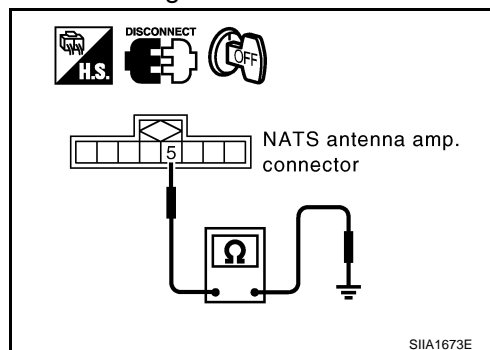

OK or NG

OK >> NATS antenna amp. is malfunctioning. **Ref. part No. E6**

NG >> ● Check harness for open or short between NATS antenna amp. and BCM (NATS control unit).

**NOTE:**

If harness is OK, replace BCM (NATS control unit), perform initialization with CONSULT-II. For initialization, refer to "CONSULT-II Operation Manual NATS-IVIS/NVIS".

## Diagnostic Procedure 4

AIS004C1

**Self-diagnostic results:**

**"ID DISCORD, IMM-ECM" displayed on CONSULT-II screen**

### 1. CONFIRM SELF-DIAGNOSTIC RESULTS

Confirm SELF-DIAGNOSTIC RESULTS "ID DISCORD, IMM-ECM" displayed on CONSULT-II screen.

**NOTE:**

"ID DISCORD IMM-ECM":

Registered ID of BCM (NATS control unit) is in discord with that of ECM.

Is CONSULT-II screen displayed as shown in figure?

Yes >> GO TO 2.

No >> GO TO [BL-145, "Diagnostic Procedure 1"](#) .

SELF DIAG RESULTS	
DTC RESULTS	TIME
ID DISCORD, IMM-ECM [P1611]	0

PIIA1262E

# IVIS (INFINITI VEHICLE IMMOBILIZER SYSTEM-NATS)

## 2. PERFORM INITIALIZATION WITH CONSULT-II

Perform initialization with CONSULT-II. Re-register all NATS ignition key IDs.  
For initialization, refer to "CONSULT-II Operation Manual NATS-IVIS/NVIS".

### NOTE:

If the initialization is not completed or malfunctions, CONSULT-II shows message on the screen.

Can the system be initialized?

Yes >> ● Start engine. (END)

- (System initialization had not been completed. **Ref. part No. F**)

No >> ECM is malfunctioning.

- Replace ECM. **Ref. part No. B**
- Perform initialization with CONSULT-II  
For initialization, refer to "CONSULT-II Operation Manual NATS-IVIS/NVIS"

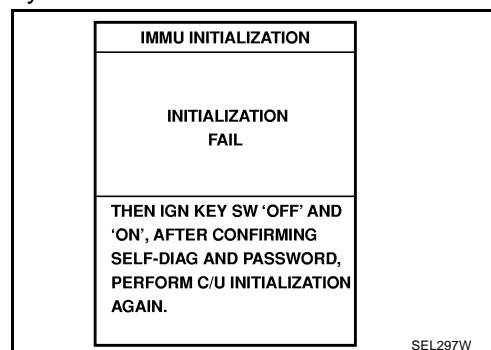

## Diagnostic Procedure 5

AIS004C2

"SECURITY INDICATOR LAMP DOES NOT LIGHT UP"

### 1. CHECK FUSE

Check 10A fuse [No.19, located in the fuse block (J/B)]

OK or NG

OK >> GO TO 2.

NG >> Replace fuse.

### 2. CHECK SECURITY INDICATOR LAMP

1. Install 10A fuse.
2. Start engine and turn ignition switch OFF.
3. Check the security indicator lamp lights up.

**Security indicator lamp should light up.**

OK or NG

OK >> INSPECTION END.

NG >> GO TO 3.

### 3. CHECK SECURITY INDICATOR LAMP POWER SUPPLY CIRCUIT

1. Disconnect security indicator lamp connector.
2. Check voltage between security indicator lamp connector M34 terminal 1 and ground.

**1 (R/W) - Ground : Battery voltage**

OK or NG

OK >> GO TO 4.

NG >> Check harness for open or short between fuse and security indicator lamp.

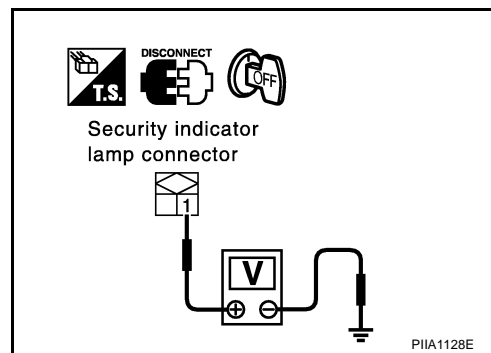

# IVIS (INFINITI VEHICLE IMMOBILIZER SYSTEM-NATS)

## 4. CHECK BCM (NATS CONTROL UNIT) FUNCTION

1. Connect security indicator lamp connector.
2. Disconnect BCM (NATS control unit) connector.
3. Check voltage between BCM (NATS control unit) connector M1 terminal 23 and ground.

**23 (OR) - Ground : Battery voltage**

### OK or NG

OK >> BCM (NATS control unit) is malfunctioning.

- Replace BCM (NATS control unit).  
**Ref. part No. A**
- Perform initialization with CONSULT-II
- For initialization, refer to "CONSULT-II Operation Manual NATS-IVIS/NVIS"

NG >> Check the following.

- Harness for open or short between security indicator lamp and BCM (NATS control unit)
- Indicator lamp condition

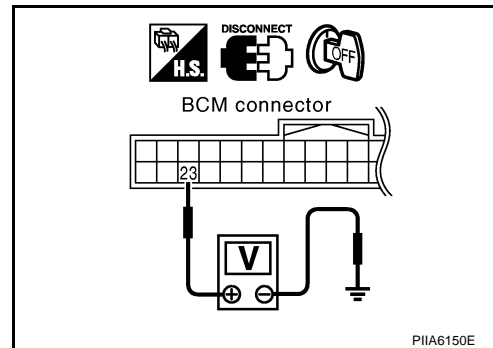

A  
B  
C  
D  
E  
F  
G  
H  
J  
K  
L  
M

BL

# IVIS (INFINITI VEHICLE IMMOBILIZER SYSTEM-NATS)

AI5004C3

## Diagnostic Procedure 6

### Self-diagnostic results:

“LOCK MODE” displayed on CONSULT-II screen

### 1. CONFIRM SELF-DIAGNOSTIC RESULTS

Confirm SELF-DIAGNOSTIC RESULTS “LOCK MODE” is displayed on CONSULT-II screen.

Is CONSULT-II screen displayed as shown in figure?

- Yes >> GO TO 2.  
No >> GO TO [BL-145, "Diagnostic Procedure 1"](#) .

SELF DIAG RESULTS	
DTC RESULTS	TIME
LOCK MODE [P1610]	0

PIIA1264E

### 2. ESCAPE FROM LOCK MODE

1. Turn ignition switch OFF.
2. Turn ignition switch ON with registered key. (Do not start engine.) Wait 5 seconds.
3. Return the key to OFF position. Wait 5 seconds.
4. Repeat steps 2 and 3 twice (total of three cycles).
5. Start the engine.

Does engine start?

- Yes >> System is OK (Now system is escaped from “LOCK MODE”).  
No >> GO TO 3.

### 3. PERFORM INITIALIZATION WITH CONSULT-II

Perform initialization with CONSULT-II.

For initialization, refer to “CONSULT-II Operation Manual NATS-IVIS/NVIS”.

#### NOTE:

If the initialization is not completed or malfunctions, CONSULT-II shows the message on the screen.

Can the system be initialized?

- Yes >> System is OK.  
No >> GO TO 4.

IMMU INITIALIZATION
INITIALIZATION FAIL
THEN IGN KEY SW 'OFF' AND 'ON', AFTER CONFIRMING SELF-DIAG AND PASSWORD, PERFORM C/U INITIALIZATION AGAIN.

SEL297W

# IVIS (INFINITI VEHICLE IMMOBILIZER SYSTEM-NATS)

## 4. PERFORM INITIALIZATION WITH CONSULT-II AGAIN

1. Replace BCM (NATS control unit).
2. Perform initialization with CONSULT-II.  
For initialization, refer to "CONSULT-II Operation Manual NATS-IVIS/NVIS".

### NOTE:

If the initialization is not completed or malfunctions, CONSULT-II shows the message on the screen.

Can the system be initialized?

- Yes >> System is OK. (BCM (NATS control unit) is malfunctioning. **Ref. part No. A**)
- No >> ECM is malfunctioning.
- Replace ECM. **Ref. part No. B**
  - Perform initialization with CONSULT-II
  - For initialization, refer to "CONSULT-II Operation Manual NATS-IVIS/NVIS"

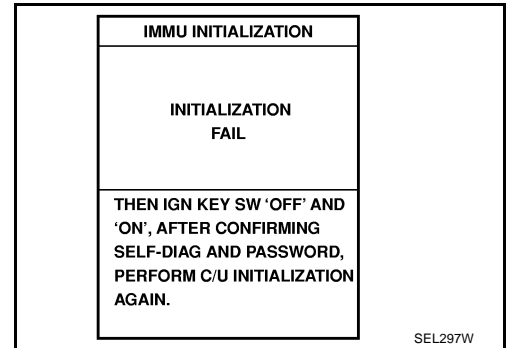

## How to Replace NATS Antenna Amp.

AIS004C4

### NOTE:

- If NATS antenna amp. is not installed correctly, IVIS (NATS) system will not operate properly and SELF-DIAG RESULTS on CONSULT-II screen will show "LOCK MODE" or "CHAIN OF IMMU-KEY".
- Initialization is not necessary only when NATS antenna amp. is replaced with a new one.

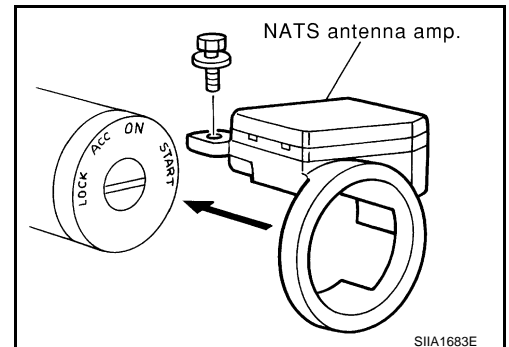

# INTEGRATED HOMELINK TRANSMITTER

PF9:96401

## INTEGRATED HOMELINK TRANSMITTER

### Wiring Diagram —TRNSCV—

AIS00036

## BL-TRNSCV-01

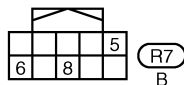
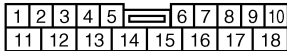
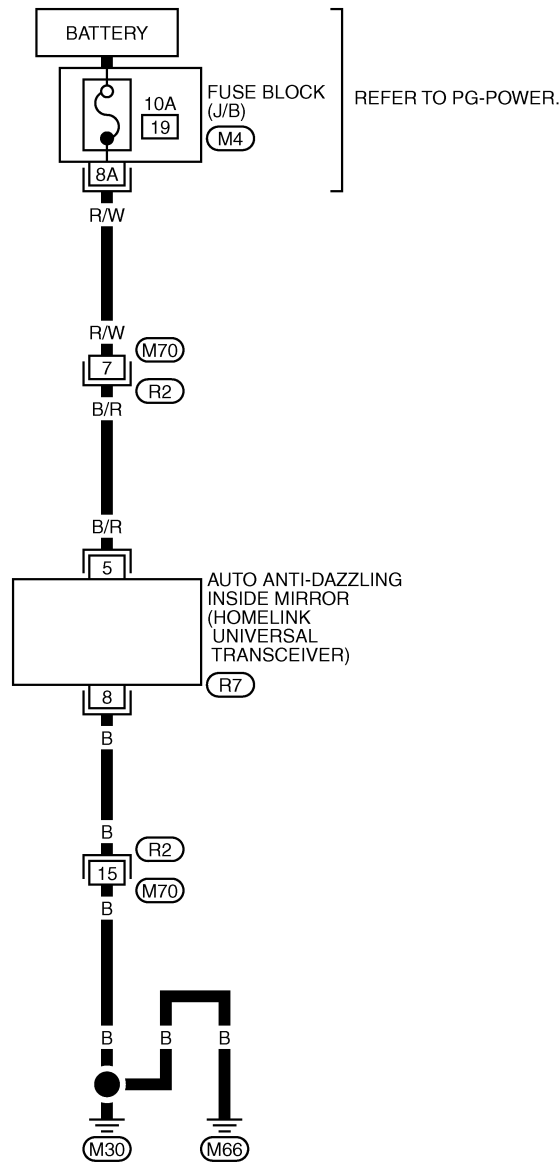

REFER TO THE FOLLOWING.

M4 - FUSE BLOCK-JUNCTION BOX (J/B)

TIWT0707E

# INTEGRATED HOMELINK TRANSMITTER

AI500037

## Trouble Diagnoses DIAGNOSTIC PROCEDURE

### SYMPTOM: Transmitter does not activate receiver.

Before conducting the procedure given below, make sure that system receiver (garage door opener, etc.) operates with original, hand-held transmitter. If NG, receiver or hand-held transmitter is malfunctioning, not vehicle related.

### 1. ILLUMINATE CHECK

1. Turn ignition switch "OFF".
2. Does red light (LED) of transmitter illuminate when any transmitter button is pressed?

#### YES or NO

- YES >> GO TO 2.  
NO >> GO TO 3.

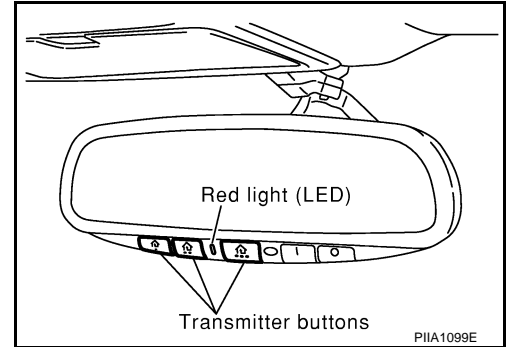

### 2. TRANSMITTER CHECK

Check transmitter with Tool\*.

\*:For details, refer to Technical Service Bulletin.

#### OK or NG

- OK >> Receiver or hand-held transmitter malfunction, not vehicle related.  
NG >> Replace transmitter with inside mirror assembly.

### 3. CHECK POWER SUPPLY

1. Disconnect transmitter connector.
2. Turn ignition switch "OFF".
3. Check voltage between transmitter harness connector R7 terminal 5 and ground.

**5 (B/R) – Ground : Battery voltage**

#### OK or NG

- OK >> GO TO 4.  
NG >> Check the following.
- 10A fuse [No. 19 located in the fuse block (J/B)]
  - Harness for open or short between fuse and transmitter

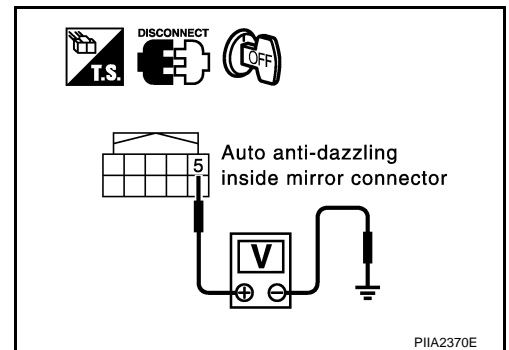

# INTEGRATED HOMELINK TRANSMITTER

## 4. GROUND CIRCUIT CHECK

Check continuity between transmitter harness connector R7 terminal 8 and ground.

**8 (B) – Ground : Continuity should exist.**

OK or NG

- OK >> Replace transmitter with inside mirror assembly.
- NG >> Repair harness.

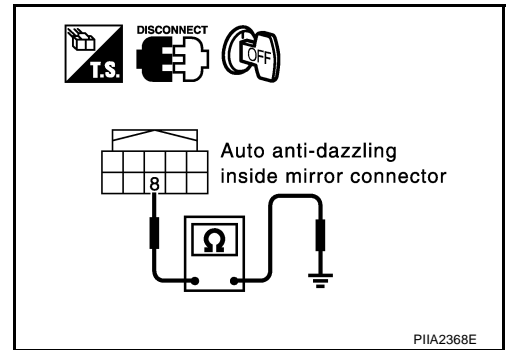



# BODY REPAIR

## BODY REPAIR

PFP:60100

### Body Exterior Paint Color

AIS00001

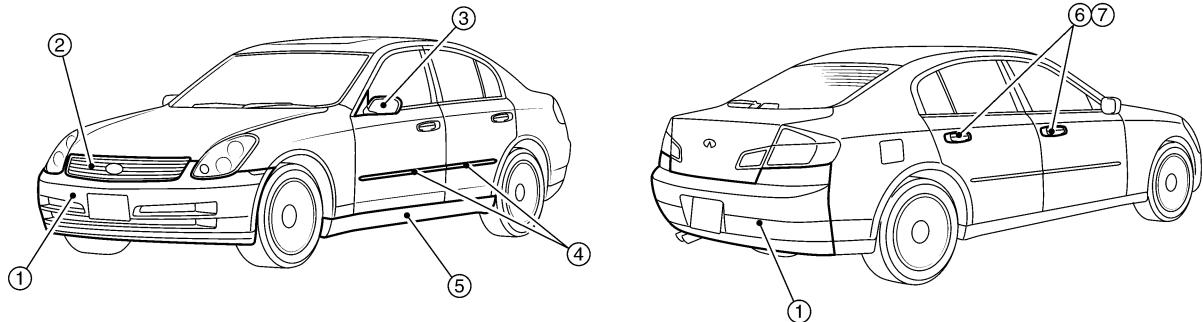

SIIA2352E

Component			Color code	BAY2	BB16	BBW5	BKH3	BKX6	BKY0	BQX1	BWV2
			Description	Red	Blue	Dark Blue	Black	Silver	Silver	White	Silver
			Paint type	PM	2P	P	2S	TM	M	3P	M
			Hard clear coat	-	-	-	-	X	X	X	X
1	Bumper fascia	Upper	Body color	BAY2	BB16	BBW5	BKH3	BKX6	BKY0	BQX1	BWV2
		Lower	Material color	G64-1	G64-1	G64-1	G64-1	G64-1	G64-1	G64-1	G64-1
2	Front grille		Chromium-plate + Smoke clear	Cr + HFM-09	Cr + HFM-09	Cr + HFM-09	Cr + HFM-09	Cr + HFM-09	Cr + HFM-09	Cr + HFM-09	Cr + HFM-09
3	Door outside mirror	Case	Body color	BAY2	BB16	BBW5	BKH3	BKX6	BKY0	BQX1	BWV2
		Base	Material color	AG01	AG01	AG01	AG01	AG01	AG01	AG01	AG01
4	Side guard molding		Body color	BAY2	BB16	BBW5	BKH3	BKX6	BKY0	BQX1	BWV2
5	Center mudguard		Material color	G64-1	G64-1	G64-1	G64-1	G64-1	G64-1	G64-1	G64-1
6	Door outside handle escutcheon		Body color	BAY2	BB16	BBW5	BKH3	BKX6	BKY0	BQX1	BWV2
7	Door outside handle		Chromium-plate	Cr	Cr	Cr	Cr	Cr	Cr	Cr	Cr

2S:Solid + Clear, M :Metallic, P: Pearl, 2P:2-Coat pearl, 3P:3-Coat pearl, TM: Micro titanium metallic, PM: Pearl metallic

# BODY REPAIR

## Body Component Parts UNDERBODY COMPONENT PARTS

AIS00002

\* Indicates aluminum portion

▨ : Indicates both sided anti-corrosive pre-coated steel portions

▧ : Indicates high strength steel (HSS) portions

▩ : Indicates both sided anti-corrosive steel and HSS portions

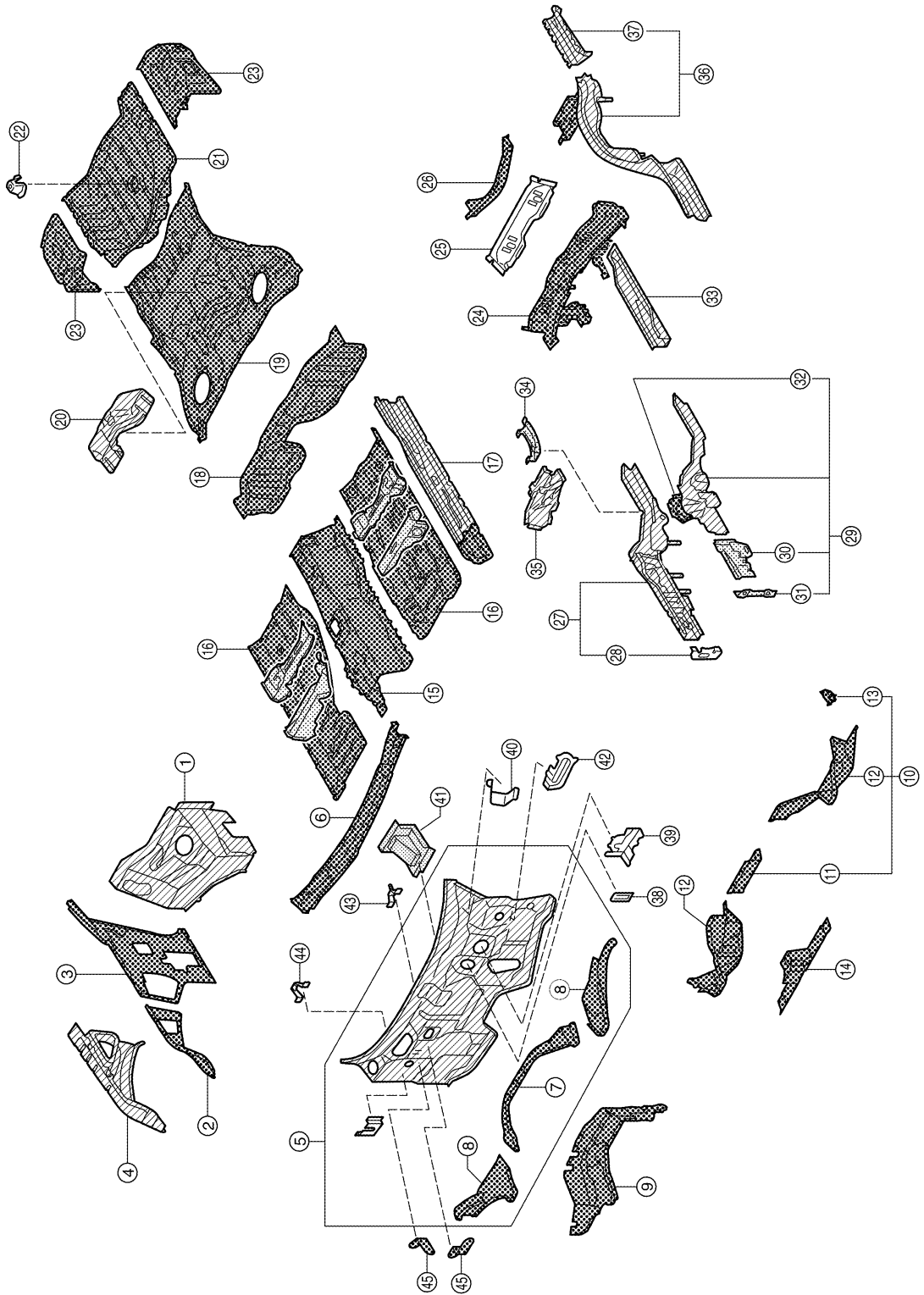



SIIA2354E

# BODY REPAIR

1.	Front strut housing (RH&LH)	A
2.	Upper front hoodledge (RH&LH)	
3.	Upper rear hoodledge (RH&LH)	
4.	Hoodledge reinforcement (RH&LH)	B
5.	Upper dash assembly	
6.	Upper dash crossmember assembly	
7.	Lower center dash crossmember reinforcement	C
8.	Lower dash crossmember reinforcement	
9.	Cowl top	
10.	Lower dash crossmember assembly	D
11.	Front crossmember center	
12.	Lower dash crossmember	
13.	Steering column mounting reinforcement	E
14.	Lower dash	
15.	Front floor center	
16.	Front floor	F
17.	Inner sill (RH&LH)	
18.	Rear seat crossmember assembly	
19.	Rear floor front	G
20.	Rear floor seat belt anchor reinforcement	
21.	Rear floor rear	
22.	Spare tire clamp bracket	H
23.	Rear floor side (RH&LH)	
24.	Rear seat crossmember	
25.	2ND rear crossmember assembly	BL
26.	Rear crossmember center assembly	
27.	Front side member (RH&LH)	
28.	Front towing hook inner bracket (RH&LH)	J
29.	Front side member closing plate assembly (RH&LH)	
30.	Front side member front closing plate (RH&LH)	
31.	Front towing hook outer bracket (RH&LH)	K
32.	Front side member rear extension (RH&LH)	
33.	Front side member center closing plate (RH&LH)	
34.	Front side member rear reinforcement (RH&LH)	L
35.	Front side member outrigger assembly (RH&LH)	
36.	Rear side member (RH&LH)	
37.	Rear side member extension (RH&LH)	M
38.	Accel pedal bracket	
39.	Pedal bracket	
40.	Wiper mounting bracket	
41.	Parking brake mounting bracket	
42.	Parking brake bracket assembly	
43.	Instrument bracket	
44.	Upper instrument mounting bracket (RH&LH)	
45.	Harness clamp bracket	

# BODY REPAIR

## BODY COMPONENT PARTS

-  : Indicates both sided anti-corrosive pre-coated steel portions
-  : Indicates high strength steel (HSS) portions
-  : Indicates both sided anti-corrosive steel and HSS portions
- \* : Indicates aluminum portion

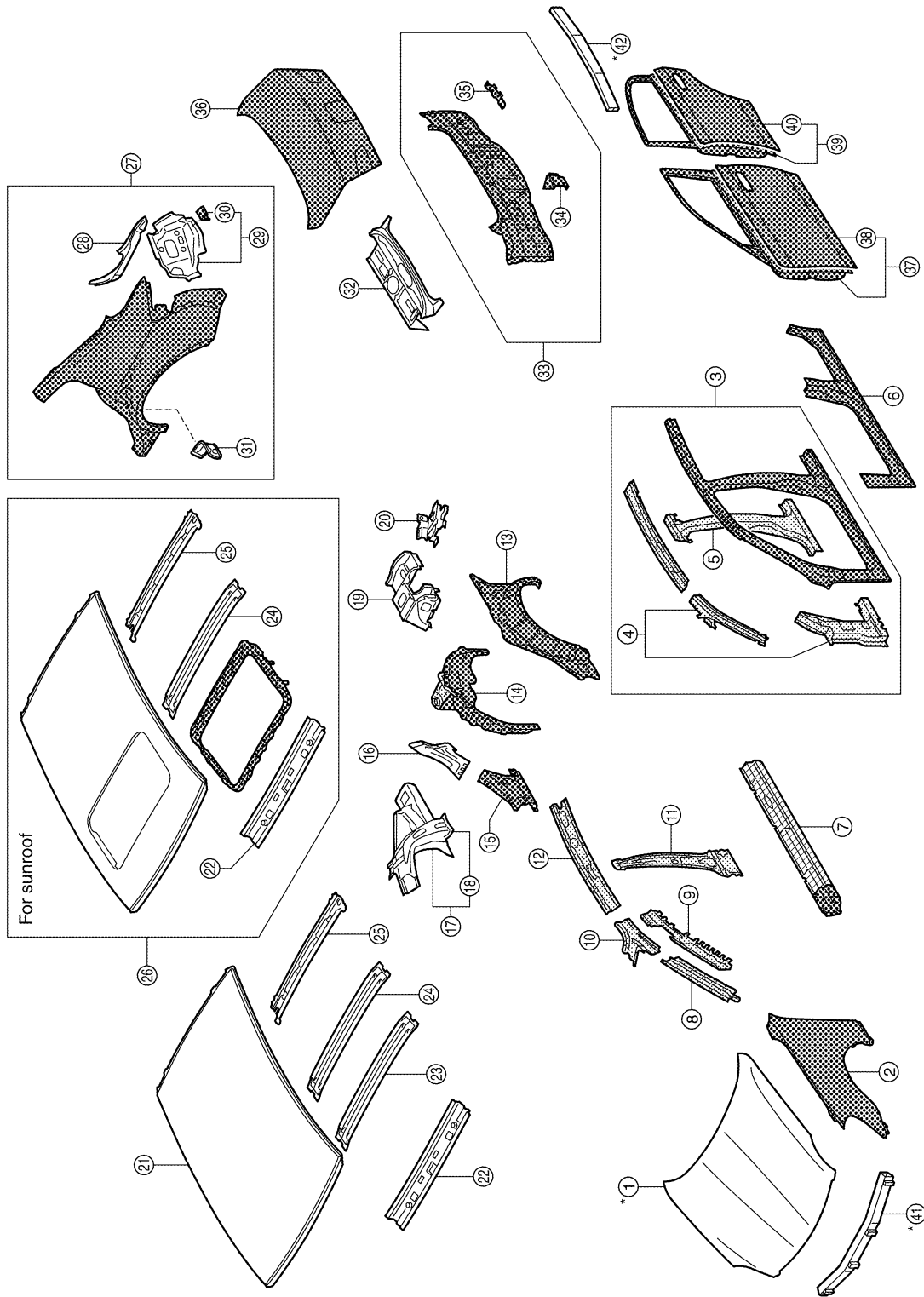

SIIA2355E

# BODY REPAIR

1.	Hood	A
2.	Front fender (RH&LH)	
3.	Side body assembly (RH&LH)	
4.	Outer front pillar reinforcement (RH&LH)	
5.	Center pillar reinforcement (RH&LH)	B
6.	Outer sill (RH&LH)	
7.	Outer sill reinforcement (RH&LH)	
8.	Upper inner front pillar (RH&LH)	C
9.	Inner front pillar reinforcement (RH&LH)	
10.	Front roof rail brace (RH&LH)	
11.	Inner center pillar (RH&LH)	D
12.	Inner side roof rail (RH&LH)	
13.	Outer rear wheelhouse (RH&LH)	
14.	Inner rear wheelhouse (RH&LH)	E
15.	Outer rear wheelhouse extension (RH&LH)	
16.	Seat back support (RH&LH)	
17.	Inner rear pillar assembly (RH&LH)	F
18.	Inner rear pillar reinforcement (RH&LH)	
19.	Side parcel shelf (RH&LH)	
20.	Jack mounting bracket	G
21.	Roof	
22.	Front roof rail	
23.	Front roof bow	H
24.	Rear roof bow	
25.	Rear roof rail	
26.	Roof assembly	BL
27.	Rear fender assembly (RH&LH)	
28.	Rear fender extension (RH&LH)	
29.	Rear combination lamp base assembly (RH&LH)	J
30.	Center rear bumper bracket (RH&LH)	
31.	Striker tapping retainer (RH&LH)	
32.	Parcel shelf	K
33.	Upper rear panel assembly	
34.	Rear bumper side bracket	
35.	Rear bumper fascia bracket (RH&LH)	L
36.	Trunk lid	
37.	Front door (RH&LH)	
38.	Outer front door panel (RH&LH)	
39.	Rear door (RH&LH)	
40.	Outer rear door panel (RH&LH)	
41.	Front bumper reinforcement	
42.	Rear bumper reinforcement	M

# BODY REPAIR

AIS00003

## Corrosion Protection

### DESCRIPTION

To provide improved corrosion prevention, the following anti-corrosive measures have been implemented in NISSAN production plants. When repairing or replacing body panels, it is necessary to use the same anti-corrosive measures.

### Anti-corrosive precoated steel (Galvannealed steel)

To improve repairability and corrosion resistance, a new type of anti-corrosive precoated steel sheet has been adopted replacing conventional zinc-coated steel sheet.

Galvannealed steel is electroplated and heated to form Zinc-iron alloy, which provides excellent and long term corrosion resistance with cationic electrodeposition primer.

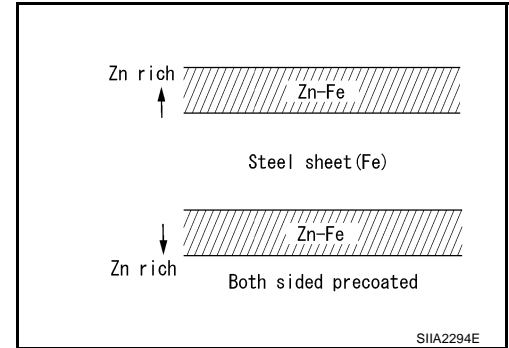

Nissan Genuine Service Parts are fabricated from galvannealed steel. Therefore, it is recommended that GENUINE NISSAN PARTS or equivalent be used for panel replacement to maintain the anti-corrosive performance built into the vehicle at the factory.

### Phosphate coating treatment and cationic electrodeposition primer

A phosphate coating treatment and a cationic electrodeposition primer, which provide excellent corrosion protection, are employed on all body components.

#### CAUTION:

Confine paint removal during welding operations to an absolute minimum.

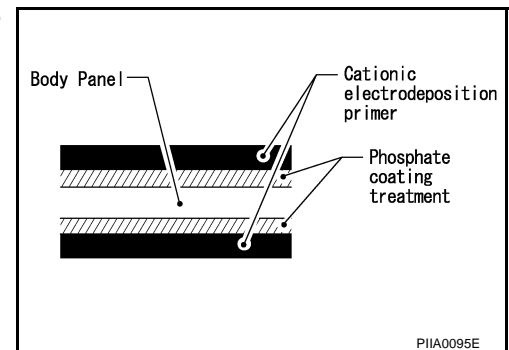

Nissan Genuine Service Parts are also treated in the same manner. Therefore, it is recommended that GENUINE NISSAN PARTS or equivalent be used for panel replacement to maintain anti-corrosive performance built into the vehicle at the factory.

# BODY REPAIR

## ANTI-CORROSIVE WAX

To improve corrosion resistance, anti-corrosive wax is applied inside the body sill and inside other closed sections. Accordingly, when replacing these parts, be sure to apply anti-corrosive wax to the appropriate areas of the new parts. Select an excellent anti-corrosive wax which will penetrate after application and has a long shelf life.

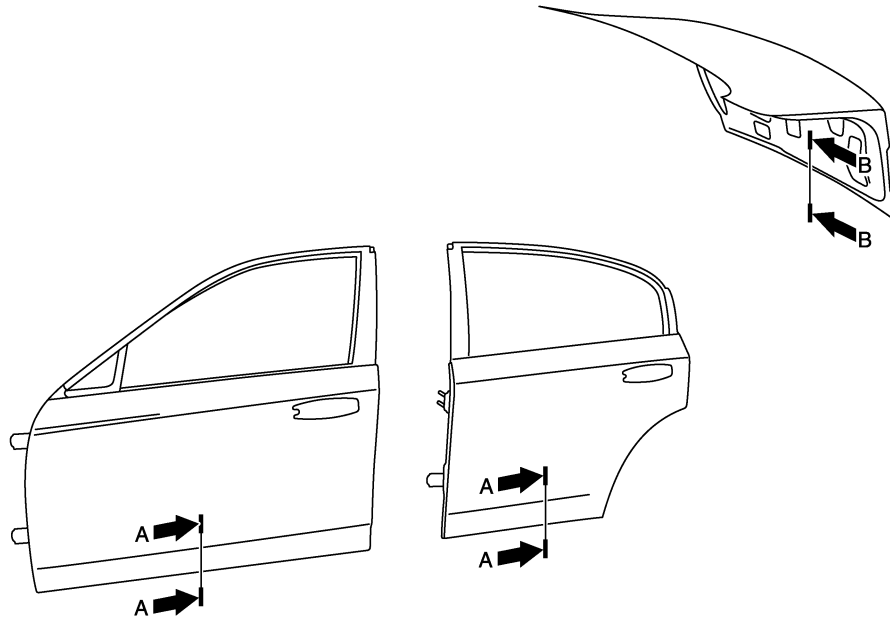

A  
B  
C  
D  
E  
F  
G  
H  
BL  
J  
K  
L  
M

 : Indicates anti-corrosive wax coated portions.

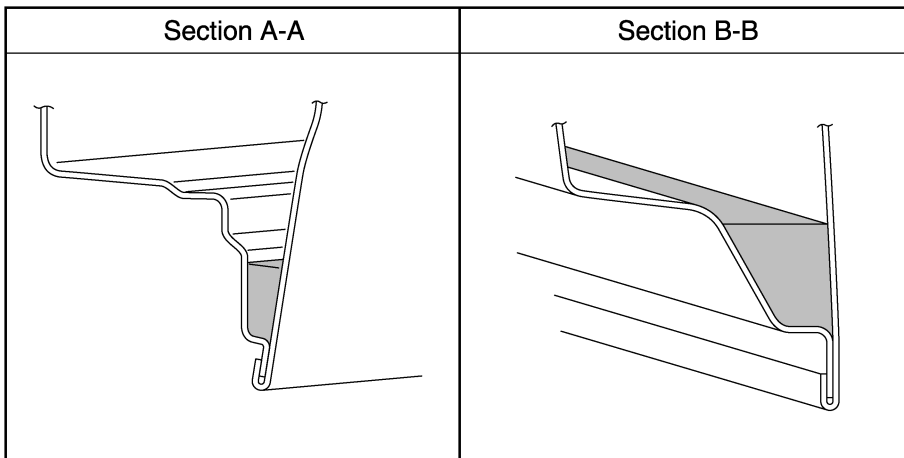

PIIA1202E

# BODY REPAIR

## UNDERCOATING

The underside of the floor and wheelhouse are undercoated to prevent rust, vibration, noise and stone chipping. Therefore, when such a panel is replaced or repaired, apply undercoating to that part. Use an undercoating which is rust preventive, soundproof, vibration-proof, shock-resistant, adhesive, and durable.

### Precautions in Undercoating

1. Do not apply undercoating to any place unless specified (such as the areas above the muffler and three way catalyst which are subjected to heat).
2. Do not undercoat the exhaust pipe or other parts which become hot.
3. Do not undercoat rotating parts.
4. Apply bitumen wax after applying undercoating.

 : Indicates undercoated portions.

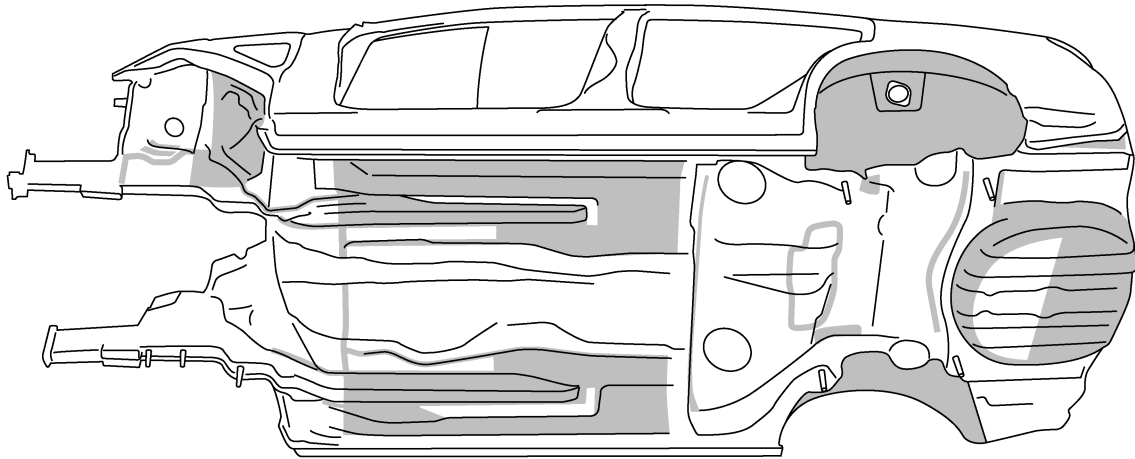

PIIA0735E



# BODY REPAIR

## STONE GUARD COAT

To prevent damage caused by stones, the lower outer body panel (fender, door, etc.) have an additional layer of Stone Guard Coating over the ED primer coating. When replacing or repairing these panels, apply Stone Guard coating to the same portions as before. Use a coating which is rust preventive, durable, shock-resistant and has a long shelf life.

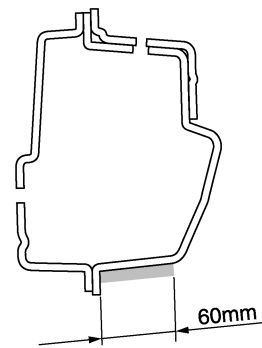
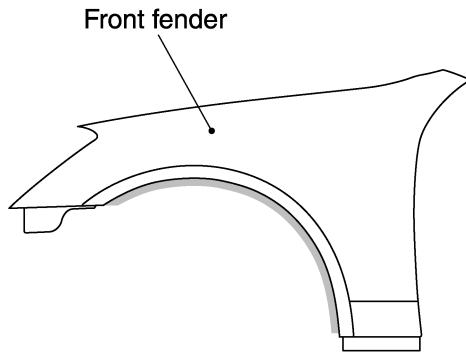
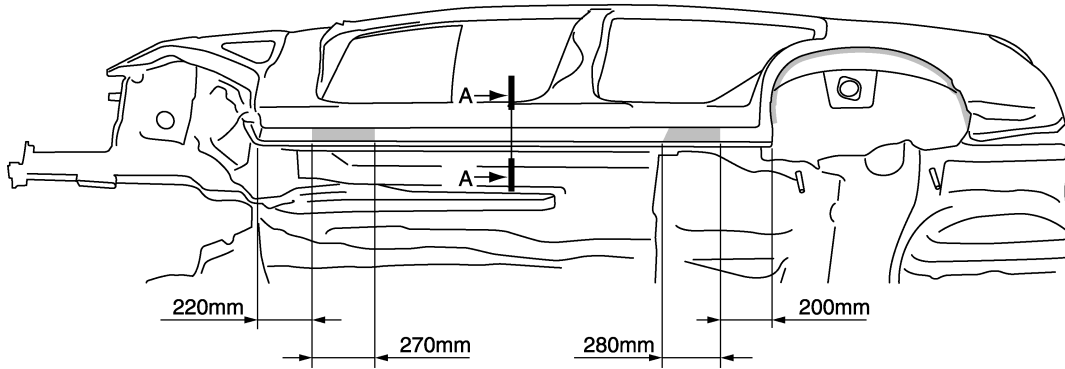

Section A-A

PIIA0736E

A  
B  
C  
D  
E  
F  
G  
H  
BL  
J  
K  
L  
M

# BODY REPAIR

AI500004

## Body Sealing DESCRIPTION

The following figure shows the areas which are sealed at the factory. Sealant which has been applied to these areas should be smooth and free from cuts or gaps. Care should be taken not to apply an excess amount of sealant and not to allow other unaffected parts to come into contact with the sealant.

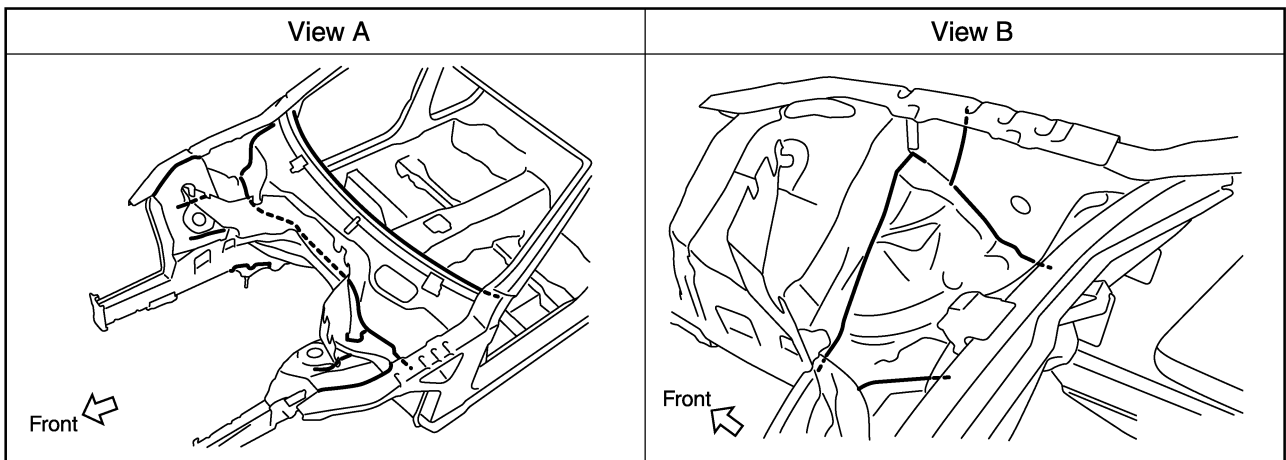
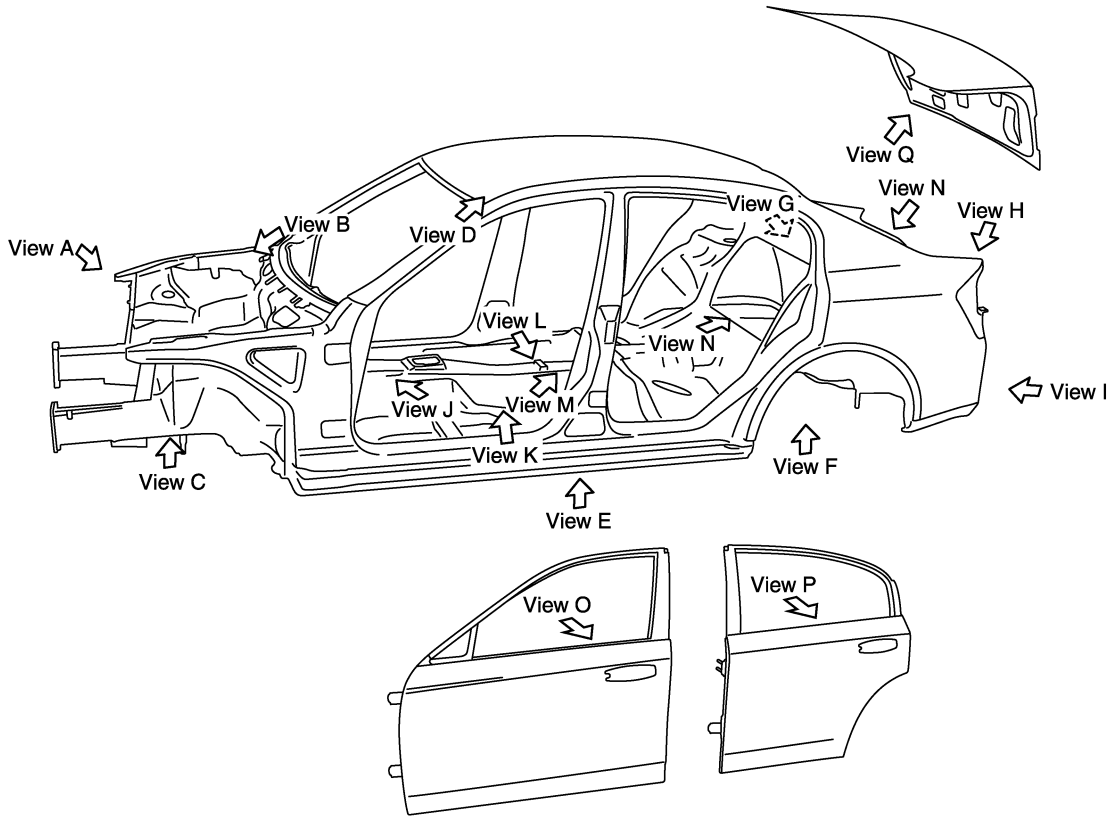

PIIA0732E

# BODY REPAIR

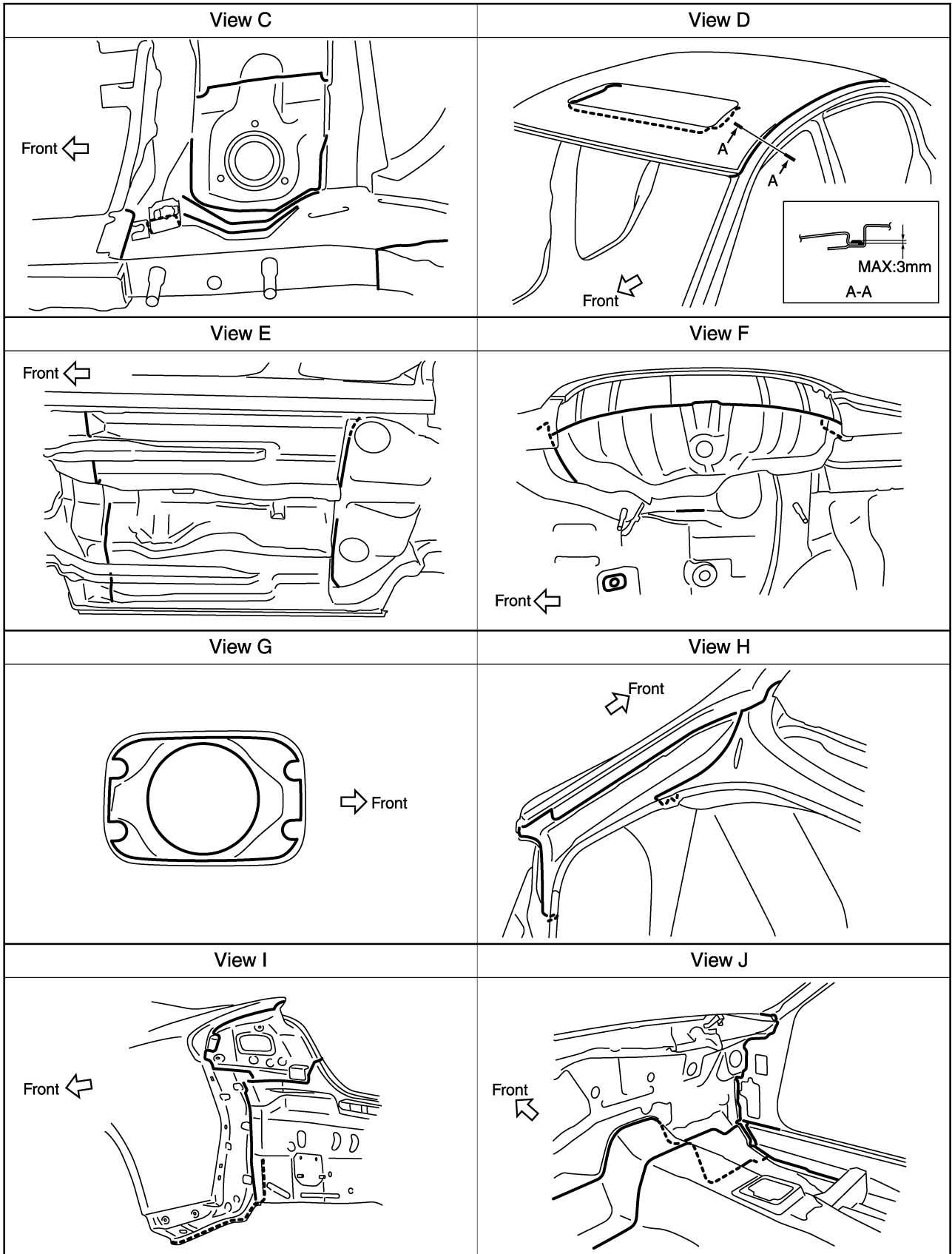

A  
B  
C  
D  
E  
F  
G  
H  
BL  
J  
K  
L  
M

PIIA0733E

# BODY REPAIR

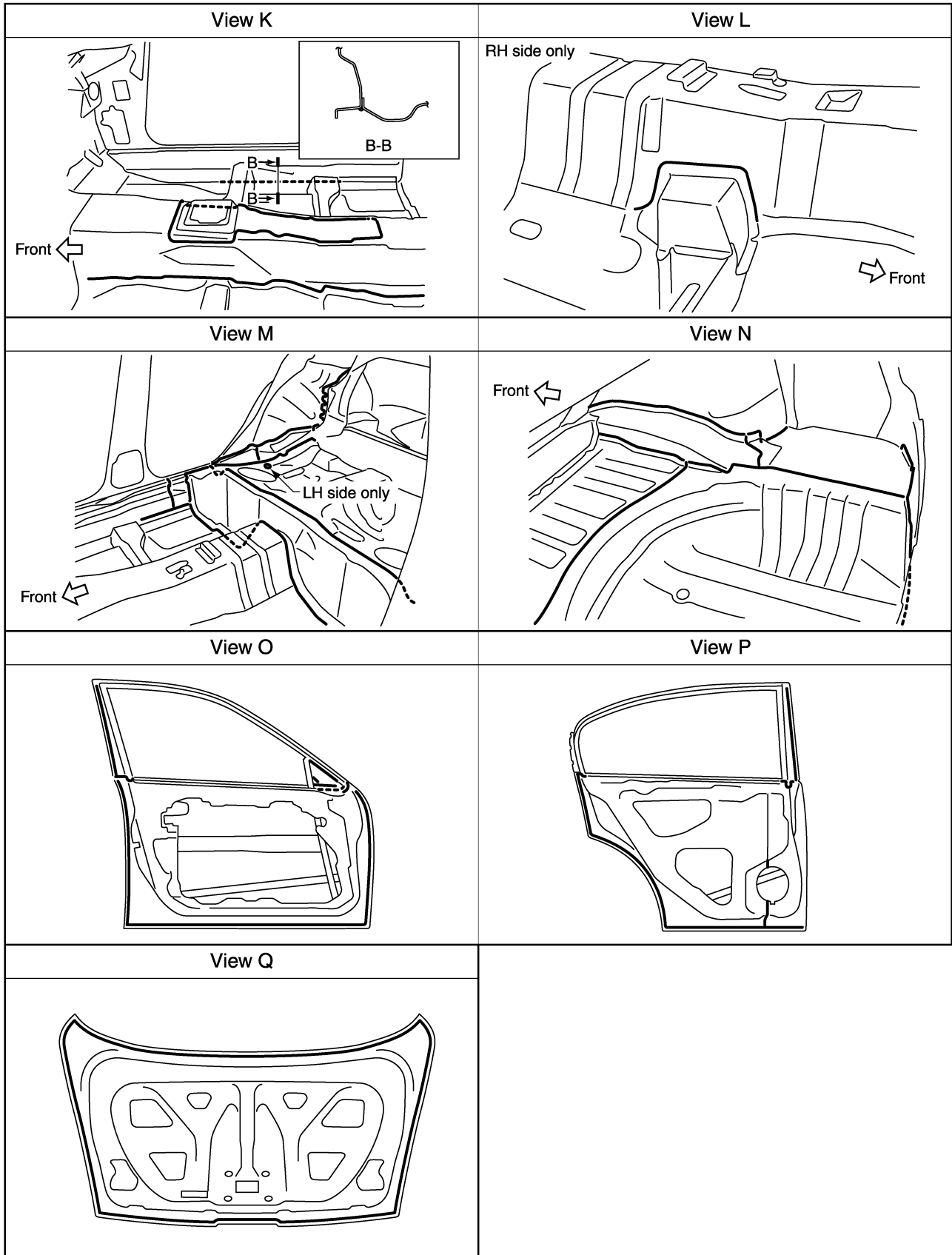

PIIA0734E

# BODY REPAIR

## Body Construction BODY CONSTRUCTION

AI500005

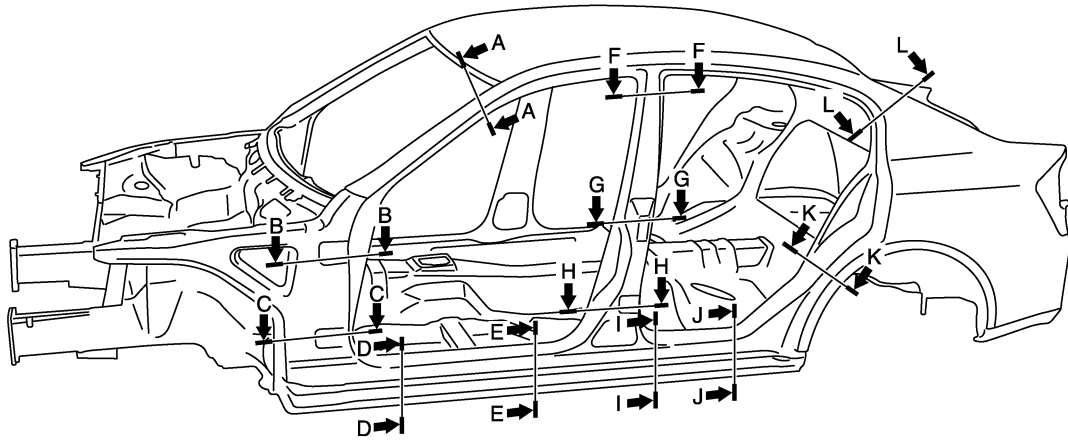

Section A-A	Section B-B	Section C-C	Section D-D
Section E-E	Section F-F	Section G-G	Section H-H
Section I-I	Section J-J	Section K-K	Section L-L

A  
B  
C  
D  
E  
F  
G  
H  
J  
K  
L  
M

BL

PIIA0744E

# BODY REPAIR

AI500006

## Body Alignment BODY CENTER MARKS

A mark has been placed on each part of the body to indicate the vehicle center. When repairing parts damaged by an accident which might affect the vehicle frame (members, pillars, etc.), more accurate and effective repair will be possible by using these marks together with body alignment specifications.

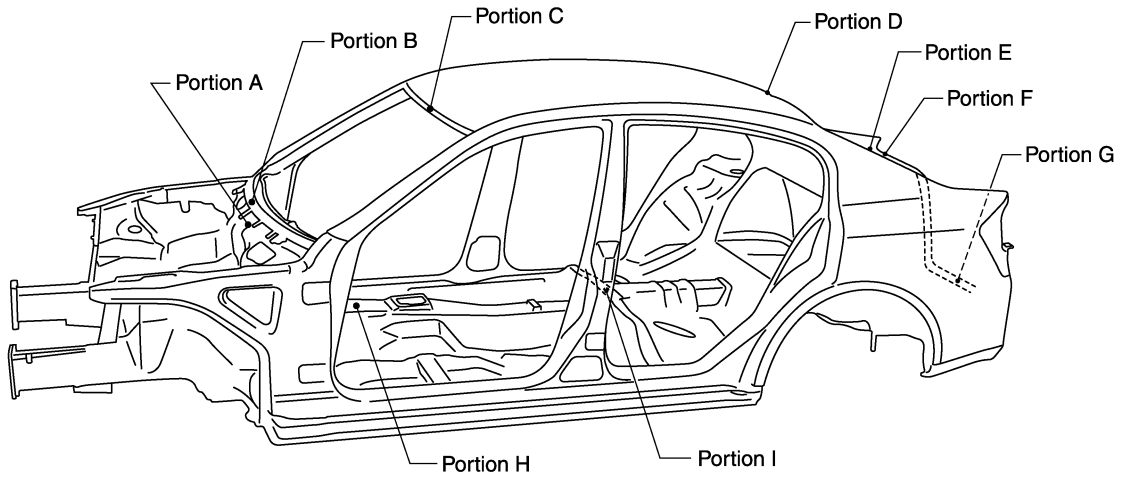

Portion A,B	Portion C,D	Portion E,F
<p>● Cowl top</p>	<p>● Front roof ● Rear roof</p>	<p>● Rear waist panel</p>
Portion G	Portion H,I	
<p>● Rear panel</p>	<p>● Front floor ● Rear floor</p>	



PIIA0730E

# BODY REPAIR

## PANEL PARTS MATCHING MARKS

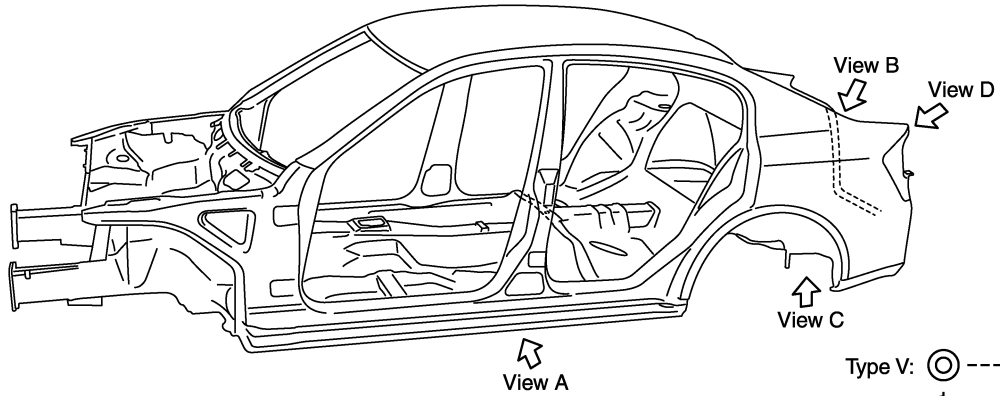
A mark has been placed on each body panel to indicate the parts matching positions. When repairing parts damaged by an accident which might affect the vehicle structure (members, pillars, etc.), more accurate and effective repair will be possible by using these marks together with body alignment specifications.

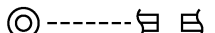
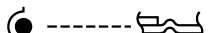

- Type V: 
- Type W: 
- Type X: 

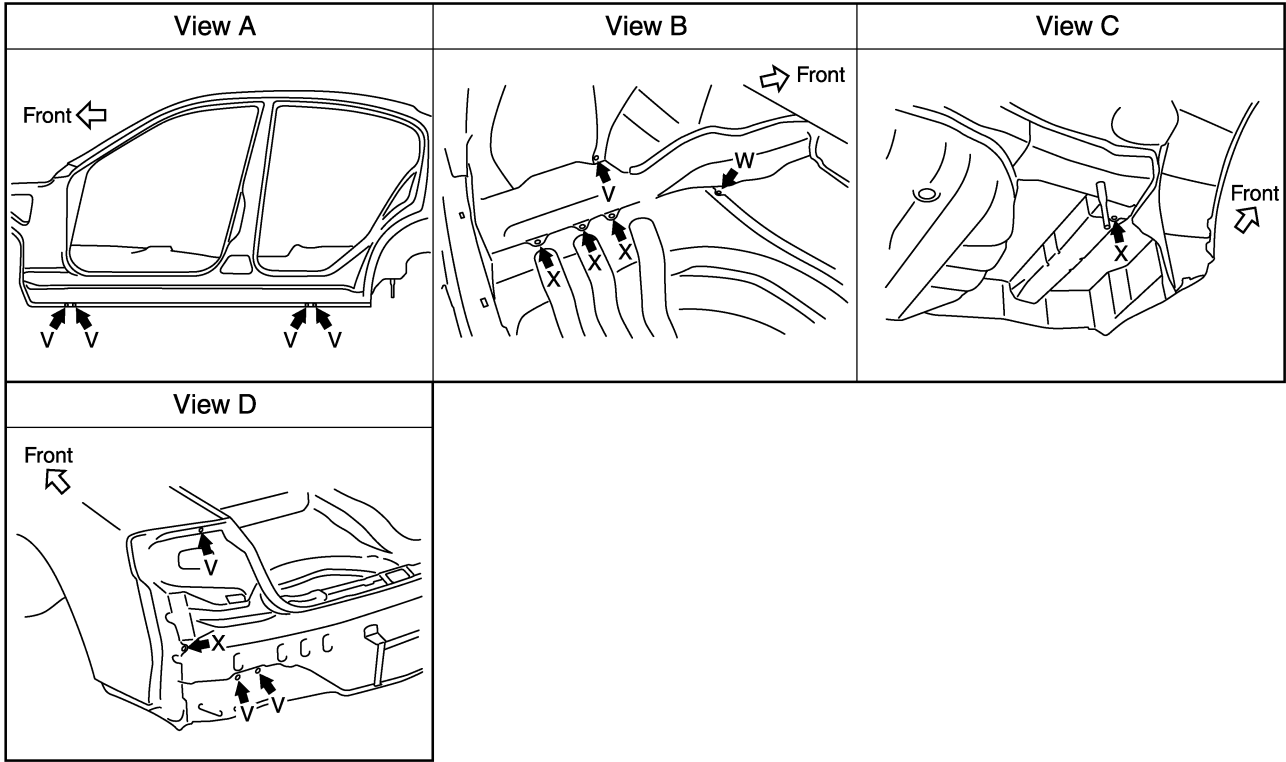

A  
B  
C  
D  
E  
F  
G  
H  
BL  
J  
K  
L  
M

PIIA0731E

# BODY REPAIR

## DESCRIPTION

- All dimensions indicated in the figures are actual.
- When using a tracking gauge, adjust both pointers to equal length. Then check the pointers and gauge itself to make sure there is no free play.
- When a measuring tape is used, check to be sure there is no elongation, twisting or bending.
- Measurements should be taken at the center of the mounting holes.
- An asterisk (\*) following the value at the measuring point indicates that the measuring point on the other side is symmetrically the same value.
- The coordinates of the measurement points are the distances measured from the standard line of "X", "Y" and "Z".

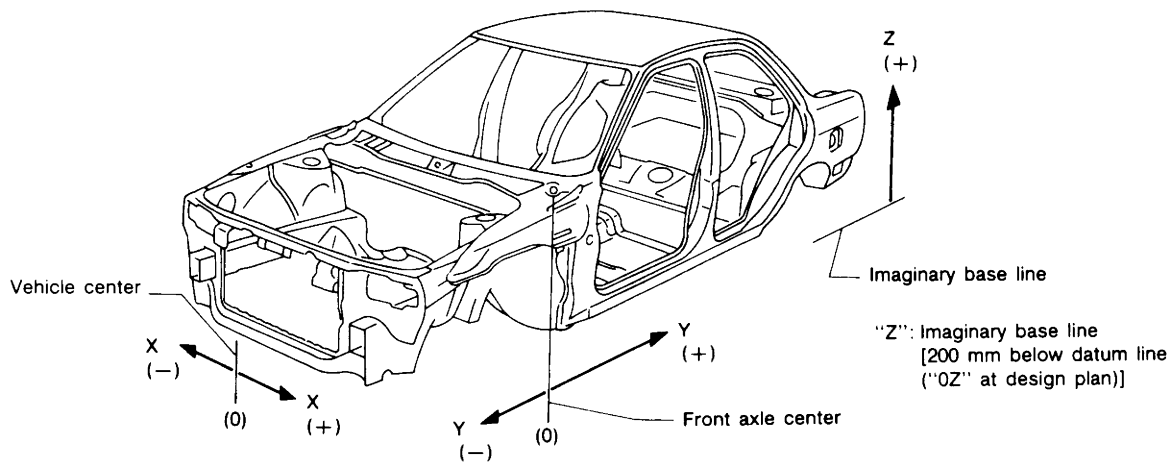

PIIA0104E



# BODY REPAIR

## ENGINE COMPARTMENT

### Measurement

Figures marked with a (\*) indicate symmetrically identical dimensions on both right and left hand sides of the vehicle.

Unit : mm

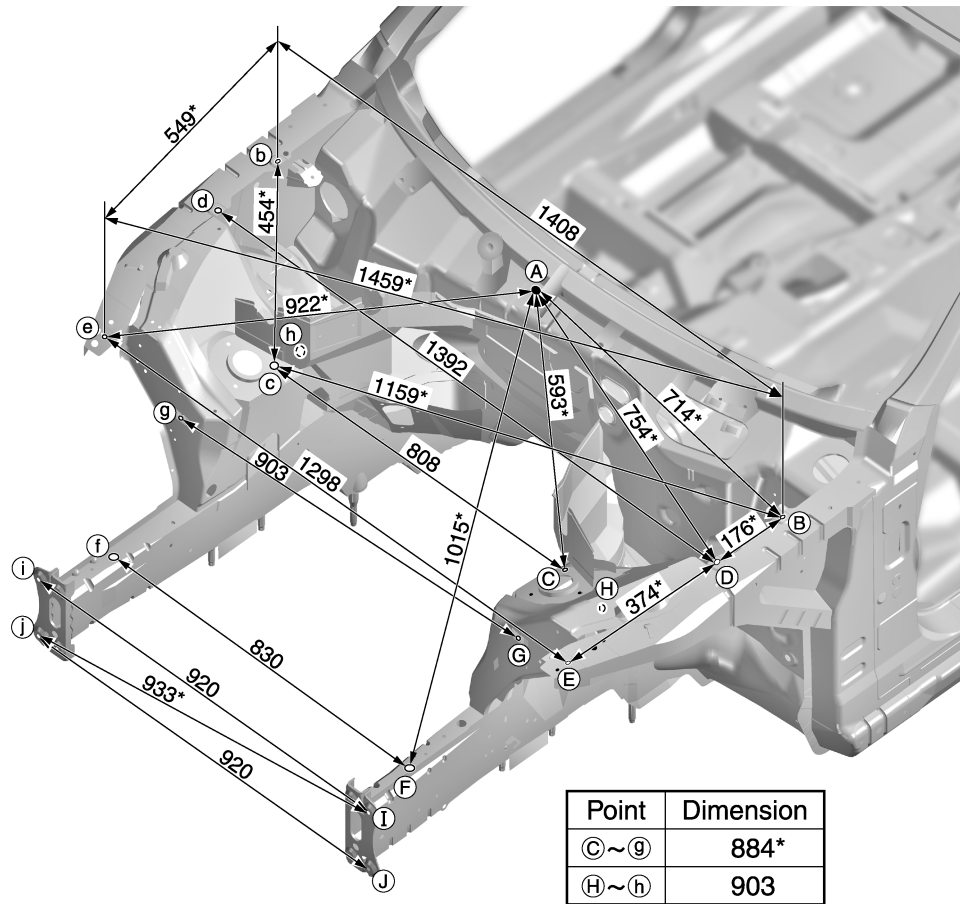

PIIA0739E

A  
B  
C  
D  
E  
F  
G  
H  
BL  
J  
K  
L  
M

# BODY REPAIR

## Measurement Points

(A) : Upper dash positioning mark center of center positioning mark

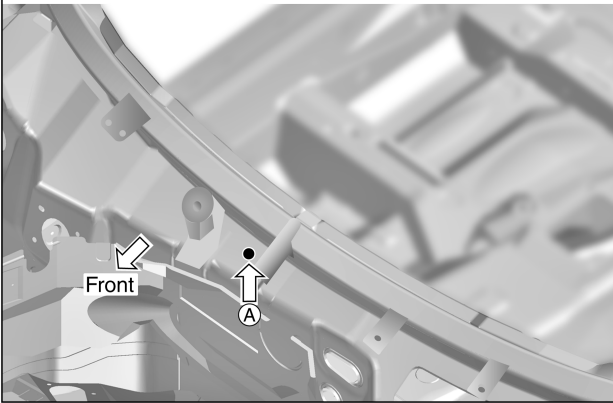

(B),(b),(D),(d) : Front fender installing hole center (7dia.)

(C),(c) : Front strut installing hole center (9dia.)

(E),(e) : Radiator core support installing hole center (9dia.)

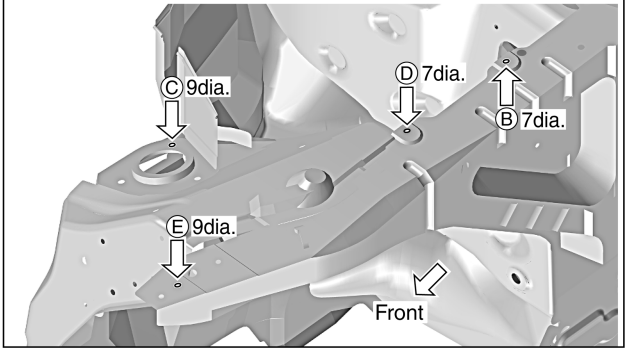

(F),(f) : Front side member hole center (20dia.)

(G),(g) : Nut holder hole center (16dia.)

(I),(i),(J),(j) : Front bumper stay installing hole center (9dia.)

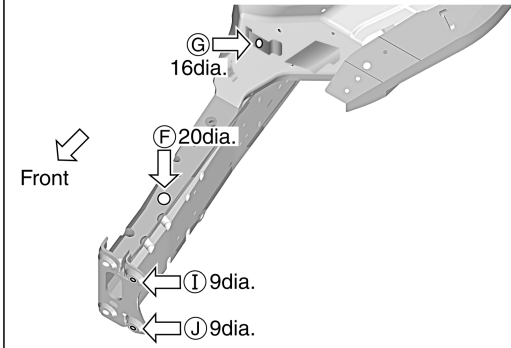

(H),(h) : Nut holder hole center (16dia.)

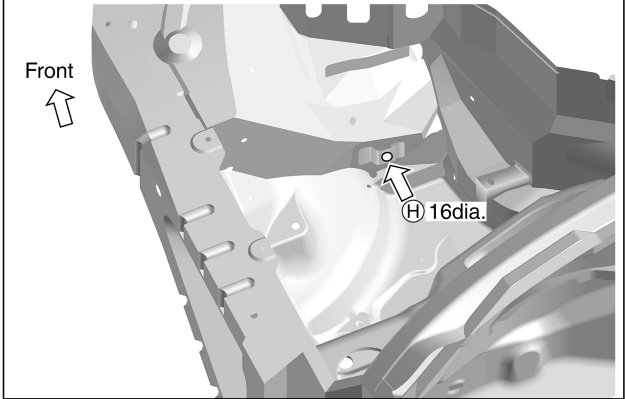

PIIA0743E



# BODY REPAIR

## Measurement Points

Unit : mm

As viewed from underside.

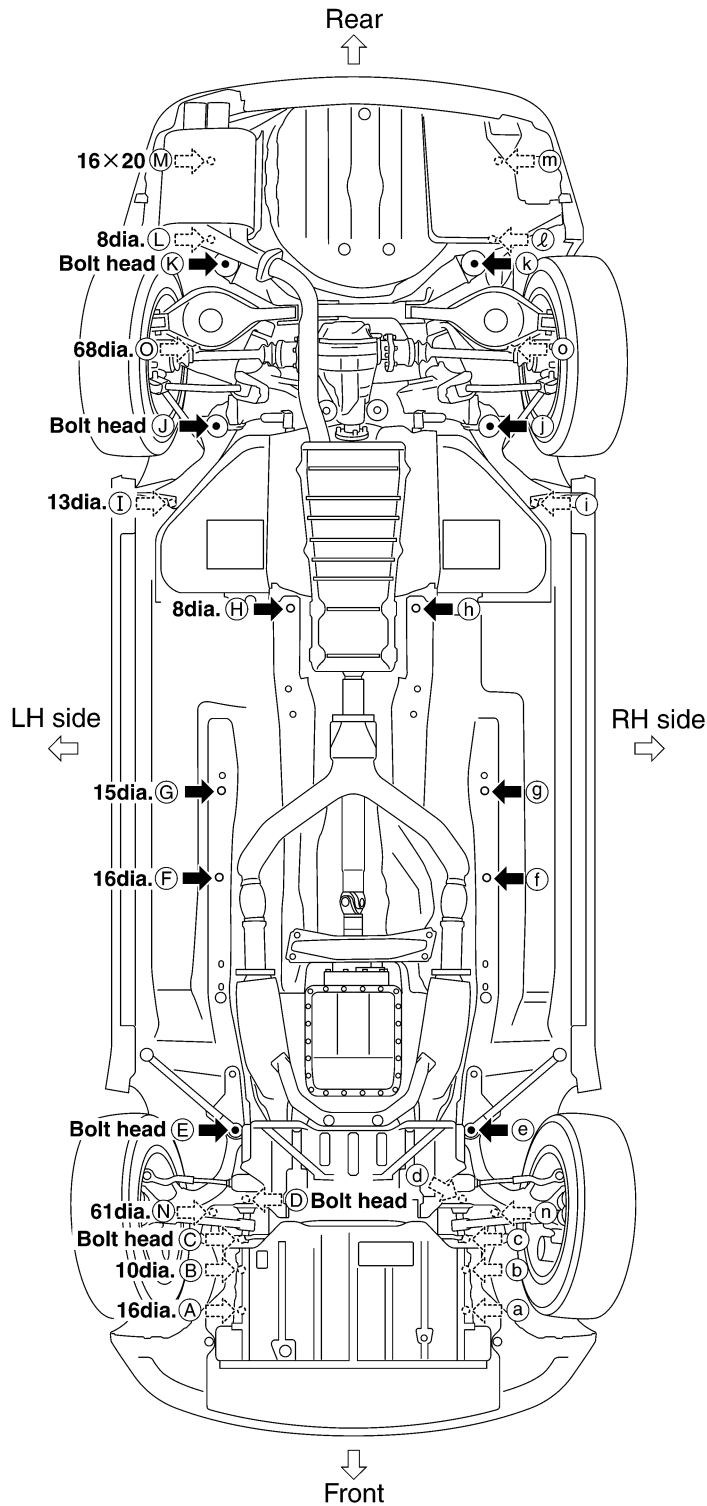

Coordinates:

(A), (a)	(I), (i)
X:413	X:605
Y:-368	Y:2391
Z:305	Z:128
(B), (b)	(J), (j)
X:415	X:473
Y:-238	Y:2604
Z:274	Z:114
(C), (c)	(K), (k)
X:405	X:452
Y:-100	Y:3164
Z:225	Z:179
(D), (d)	(L)
X:405	X:550
Y:39	Y:3265
Z:224	Z:316
(E), (e)	(l)
X:388	X:-500
Y:279	Y:3273
Z:82	Z:316
(F), (f)	(M), (m)
X:438	X:535
Y:1100	Y:3540
Z:79	Z:329
(G), (g)	
X:440	
Y:1400	
Z:79	
(H), (h)	
X:205	
Y:1992	
Z:59	

Front and rear strut tower centers

Coordinates:

(N), (n)
X:434
Y:29
Z:682

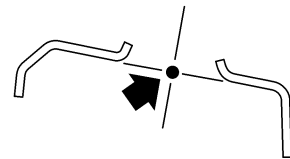

(O), (o)
X:524
Y:2882
Z:785

Front: (N), (n) 61dia.  
Rear: (O), (o) 68dia.

SIIA2368E

# BODY REPAIR

## UNDERBODY (AWD MODELS)

### Measurement

Unit : mm

Figures marked with a (\*) indicate symmetrically identical dimensions on both right and left hand sides of the vehicle.

As viewed from underside.

★ : Bolt head

All dimensions indicated in this figure are actual.

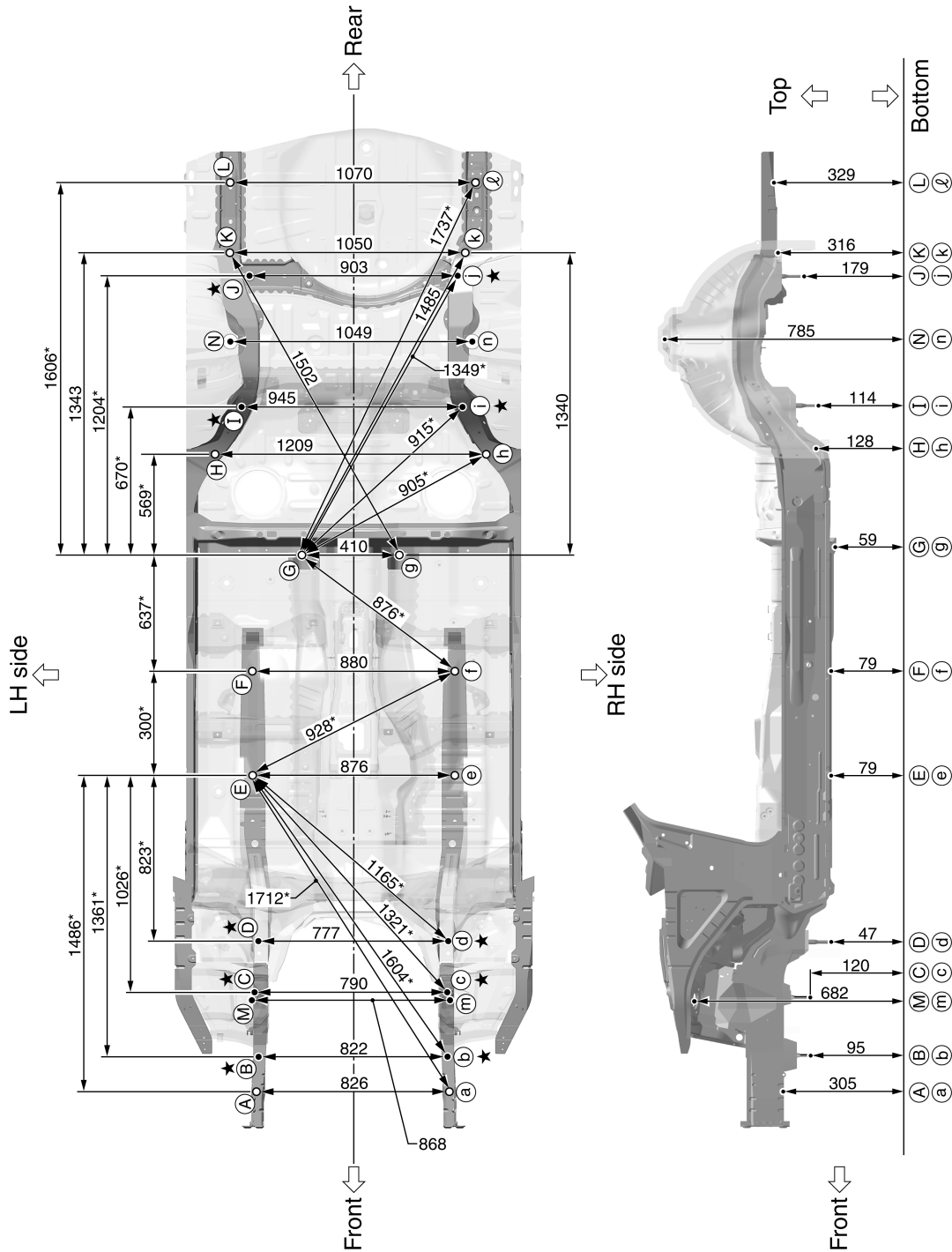

A  
B  
C  
D  
E  
F  
G  
H  
BL  
J  
K  
L  
M

# BODY REPAIR

## Measurement Points

Unit : mm

As viewed from underside.

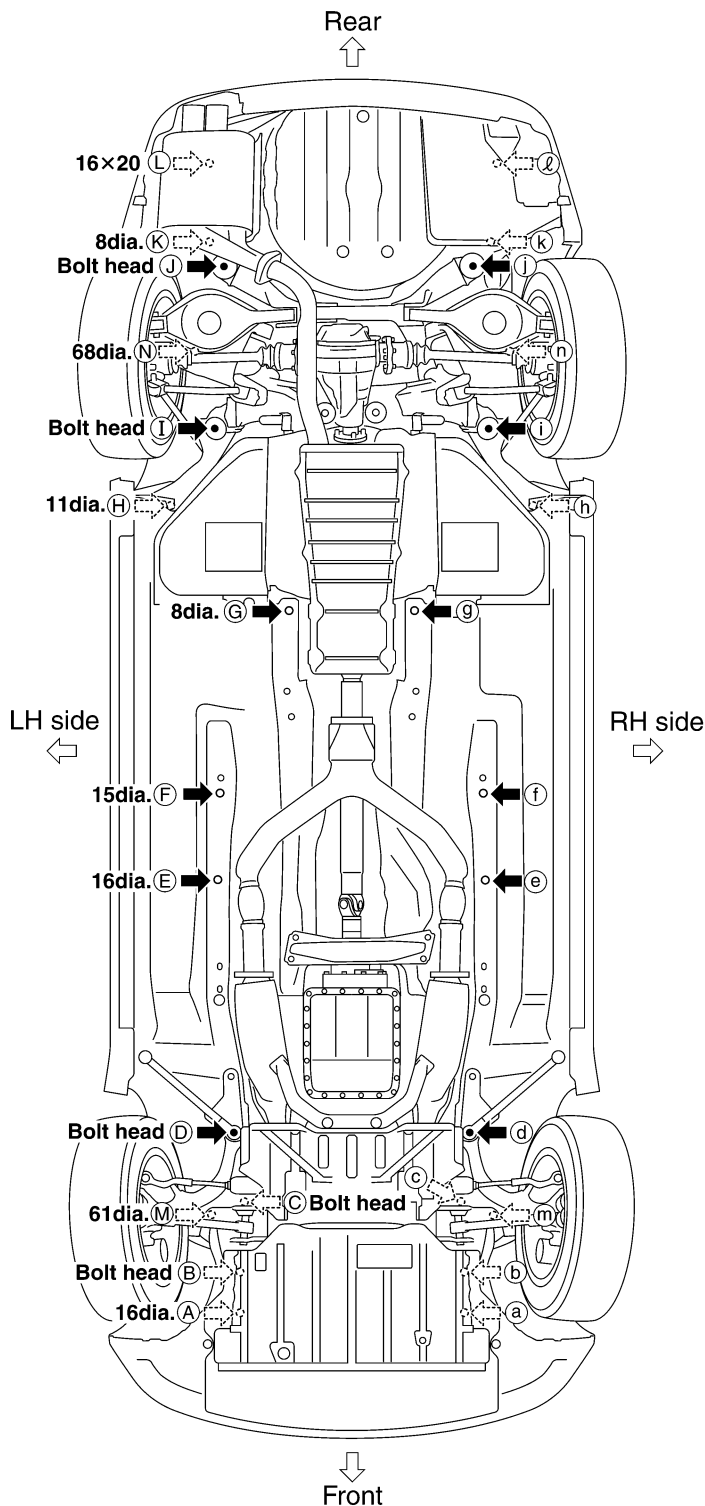

Coordinates:

(A), (a)	(I), (i)
X:413	X:473
Y:-368	Y:2604
Z:305	Z:114
(B), (b)	(J), (j)
X:411	X:452
Y:-261	Y:3164
Z:95	Z:179
(C), (c)	(K)
X:395	X:550
Y:76	Y:3265
Z:120	Z:316
(D), (d)	(k)
X:388	X:-500
Y:279	Y:3273
Z:47	Z:316
(E), (e)	(L), (l)
X:438	X:535
Y:1100	Y:3540
Z:79	Z:329
(F), (f)	
X:440	
Y:1400	
Z:79	
(G), (g)	
X:205	
Y:1992	
Z:59	
(H), (h)	
X:605	
Y:2391	
Z:128	

Front and rear strut tower centers

Coordinates:

(M), (m)
X:434
Y:29
Z:682

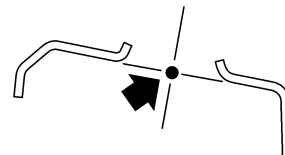

(N), (n)
X:524
Y:2882
Z:785

Front: (M), (m) 61dia.  
Rear: (N), (n) 68dia.

SIIA2396E

# BODY REPAIR

## PASSENGER COMPARTMENT

### Measurement

Unit : mm

Figures marked with a (\*) indicate symmetrically identical dimensions on both right and left hand sides of the vehicle.

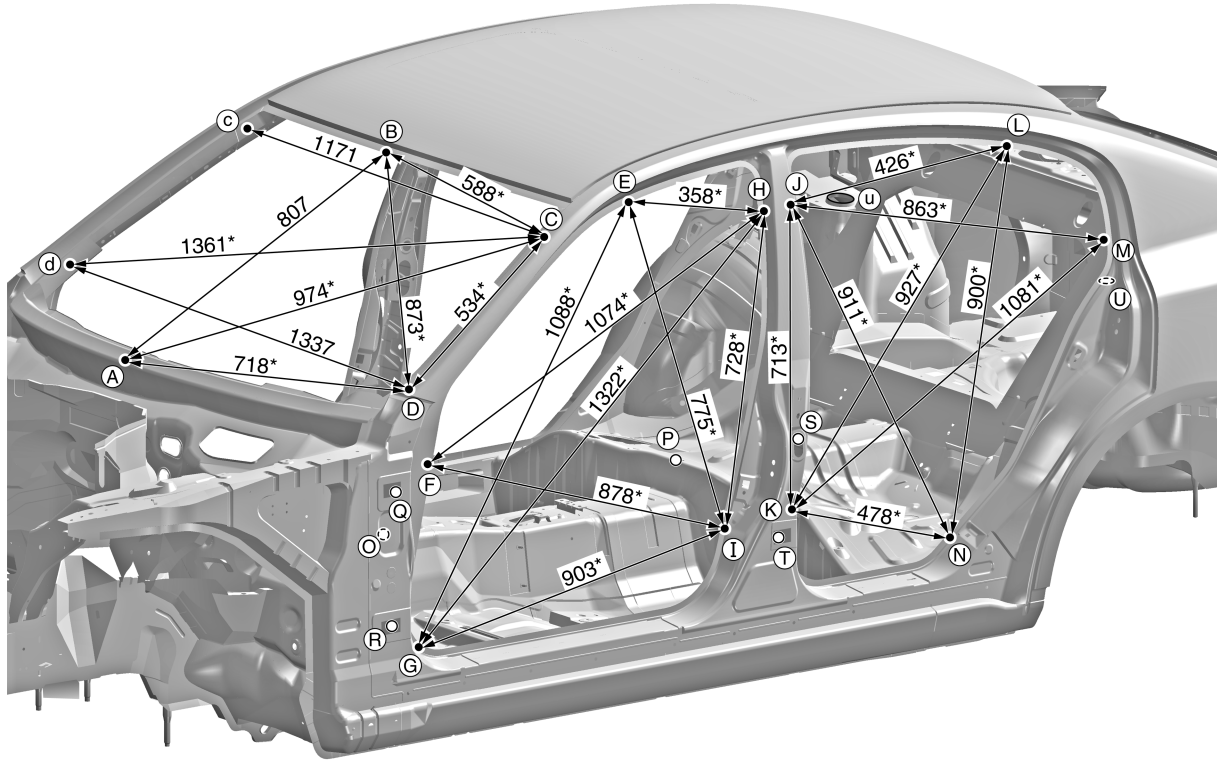

Point	Dimension	Point	Dimension	Point	Dimension
E~e	1,169	J~k	1,516*	Q~Q	755*
E~g	1,697*	J~l	1,269*	Q~H	1,319*
E~h	1,253*	J~m	1,549*	Q~I	1,007*
E~i	1,516*	J~n	1,619*	P~J	998*
F~f	1,452	K~k	1,452	P~K	771*
F~h	1,716*	K~l	1,593*	P~L	1,044*
F~i	1,696*	K~m	1,765*	P~M	1,136*
G~g	1,452	K~n	1,528*	P~N	758*
G~h	1,881*	L~l	1,157	P~U	1,063*
G~i	1,709*	L~n	1,578*	Q~S	1,150*
H~h	1,233	M~m	1,342	Q~T	1,125*
H~i	1,523*	N~n	1,452	R~S	1,219*
I~i	1,452	O~E	1,131*	R~T	1,108*
J~j	1,233	O~F	834*		

SIIA2369E

# BODY REPAIR

## Measurement Points

(A) : Upper dash crossmember positioning mark center of center positioning mark

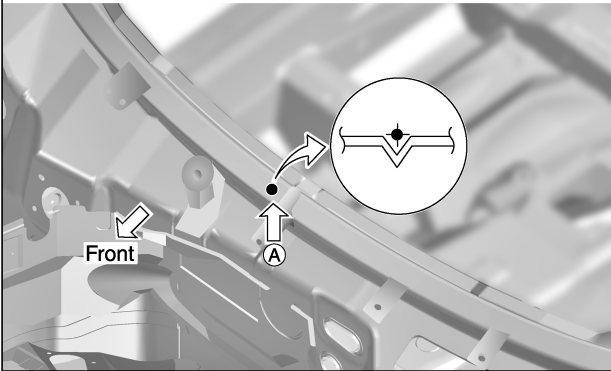

(B) : Front roof flange end of center positioning mark  
(C), (C) : Front pillar flange end

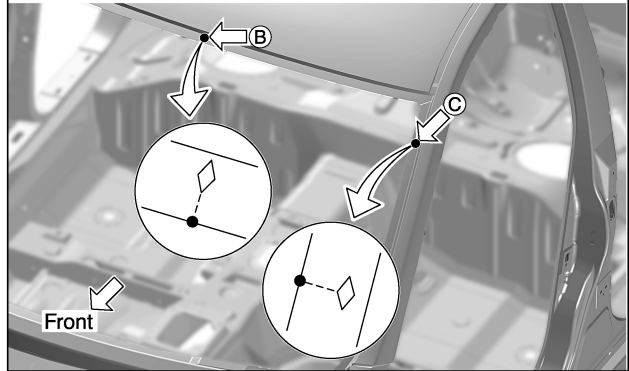

(D), (D) : Front pillar flange end

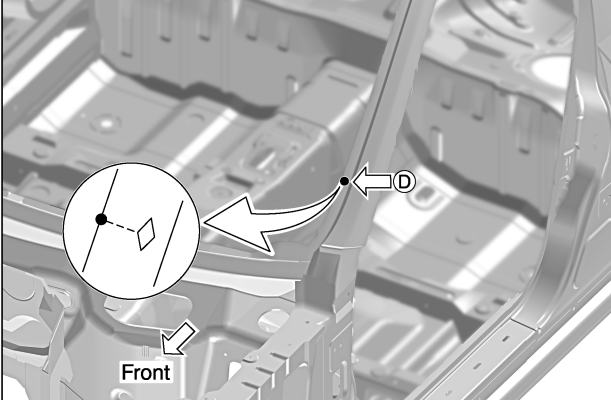

(E, e, G, g) : Front pillar indent  
(F, f) : Front pillar flange end  
(Q, q, R, r) : Door hinge installing nut center(12dia.)

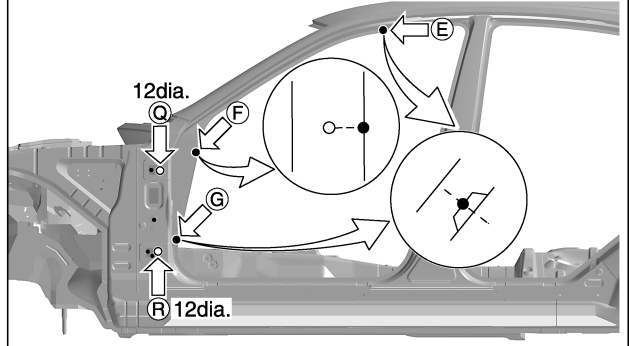

(H, h, I, i, J, j, K, k) : Center pillar indent  
(S, s, T, t) : Door hinge installing nut center (S, s: 9dia., T, t: 12dia.)

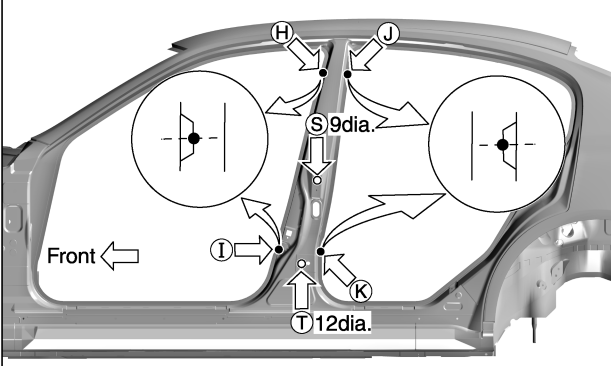

(L, l, N, n) : Rear fender indent  
(M, m) : Rear fender flange end

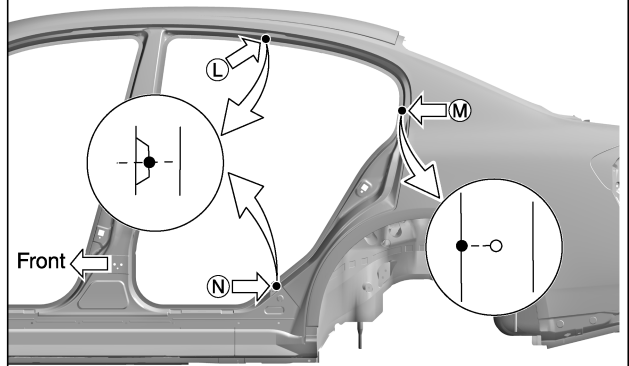

(O) : Center front floor positioning mark center of center positioning mark  
(P) : Harness installing hole center of center positioning mark (5dia.)

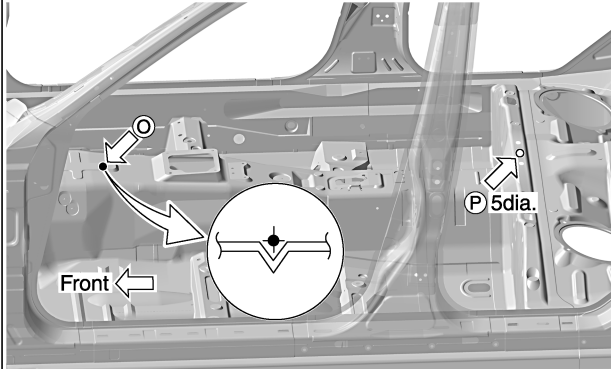

(U, u) : Rear strut installing hole center (68dia.)

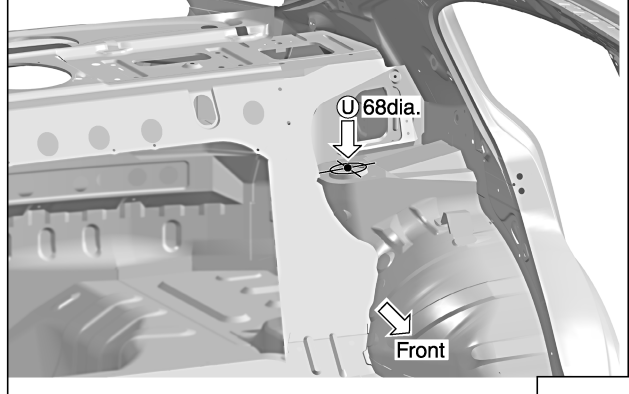

PIA0742E



# BODY REPAIR

## REAR BODY Measurement

Figures marked with a (\*) indicate symmetrically identical dimensions on both right and left hand sides of the vehicle.

Unit : mm

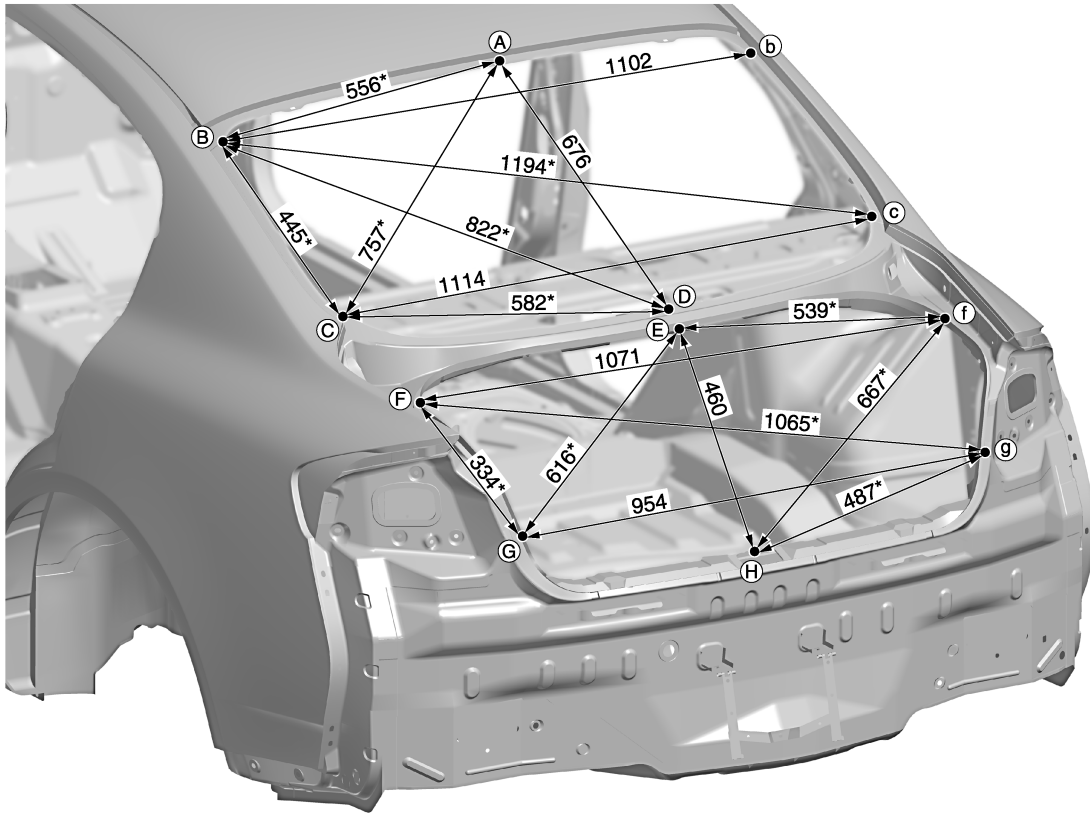

A  
B  
C  
D  
E  
F  
G  
H  
BL  
J  
K  
L  
M

PIIA0737E

# BODY REPAIR

## Measurement Points

- (A) : Rear roof flange end of center positioning mark  
(B) , (b) : Rear fender flange end

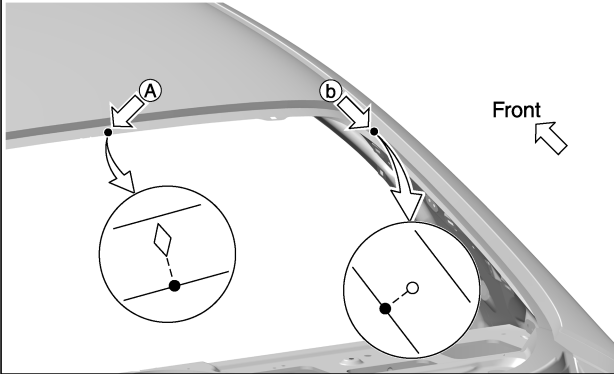

- (C) , (c) : Rear fender flange end  
(F) , (f) , (G) , (g) : Rear fender joggle

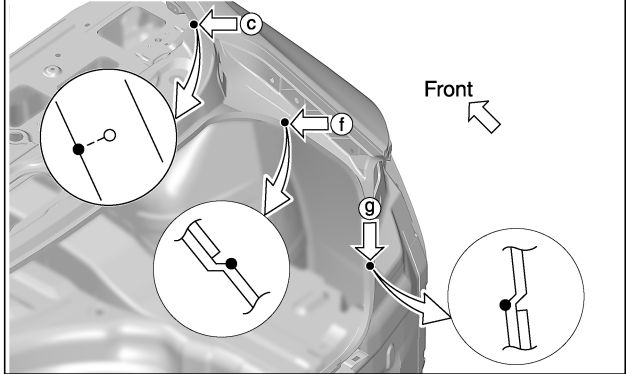

- (D) : Parcel shelf positioning mark center of center positioning mark  
(E) : Parcel shelf flange end of center positioning mark

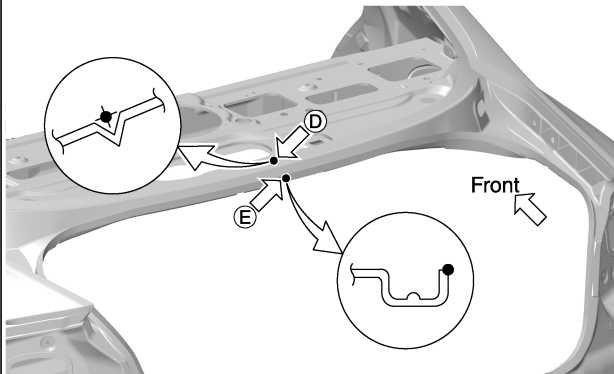

- (H) : Upper rear panel reinforcement of center positioning mark

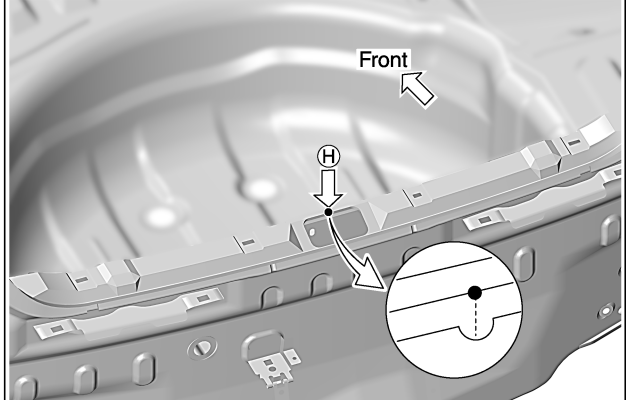

PIIA0741E

# BODY REPAIR

## Handling Precautions For Plastics HANDLING PRECAUTIONS FOR PLASTICS

AIS00007

Abbreviation	Material name	Heat resisting temperature °C(°F)	Resistance to gasoline and solvents	Other cautions
PE	Polyethylene	60(140)	Gasoline and most solvents are harmless if applied for a very short time (wipe up quickly).	Flammable
PVC	Poly Vinyl Chloride	80(176)	Same as above.	Poison gas is emitted when burned.
EPM/EPDM	Ethylene Propylene (Diene) copolymer	80(176)	Same as above.	Flammable
PP	Polypropylene	90(194)	Same as above.	Flammable, avoid battery acid.
UP	Unsaturated Polyester	90(194)	Same as above.	Flammable
PS	Polystyrene	80(176)	Avoid solvents.	Flammable
ABS	Acrylonitrile Butadiene Styrene	80(176)	Avoid gasoline and solvents.	
PMMA	Poly Methyl Methacrylate	85(185)	Same as above.	
EVAC	Ethylene Vinyl Acetate	90(194)	Same as above.	
ASA	Acrylonitrile Styrene Acrylate	100(222)	Same as above.	Flammable
PPE	Poly Phenylene Ether	110(230)	Same as above.	
PC	Polycarbonate	120(248)	Same as above.	
PAR	Polyarylate	180(356)	Same as above.	
PUR	Polyurethane	90(194)	Same as above.	
POM	Poly Oxymethylene	120(248)	Same as above.	Avoid battery acid.
PBT+PC	Poly Butylene Terephthalate + Polycarbonate	120(248)	Same as above.	Flammable
PA	Polyamide	140(284)	Same as above.	Avoid immersing in water.
PBT	Poly Butylene Terephthalate	140(284)	Same as above.	
PET	Polyester	180(356)	Same as above.	
PEI	Polyetherimide	200(392)	Same as above.	

1. When repairing and painting a portion of the body adjacent to plastic parts, consider their characteristics (influence of heat and solvent) and remove them if necessary or take suitable measures to protect them.
2. Plastic parts should be repaired and painted using methods suiting the materials' characteristics.

# BODY REPAIR

## LOCATION OF PLASTIC PARTS

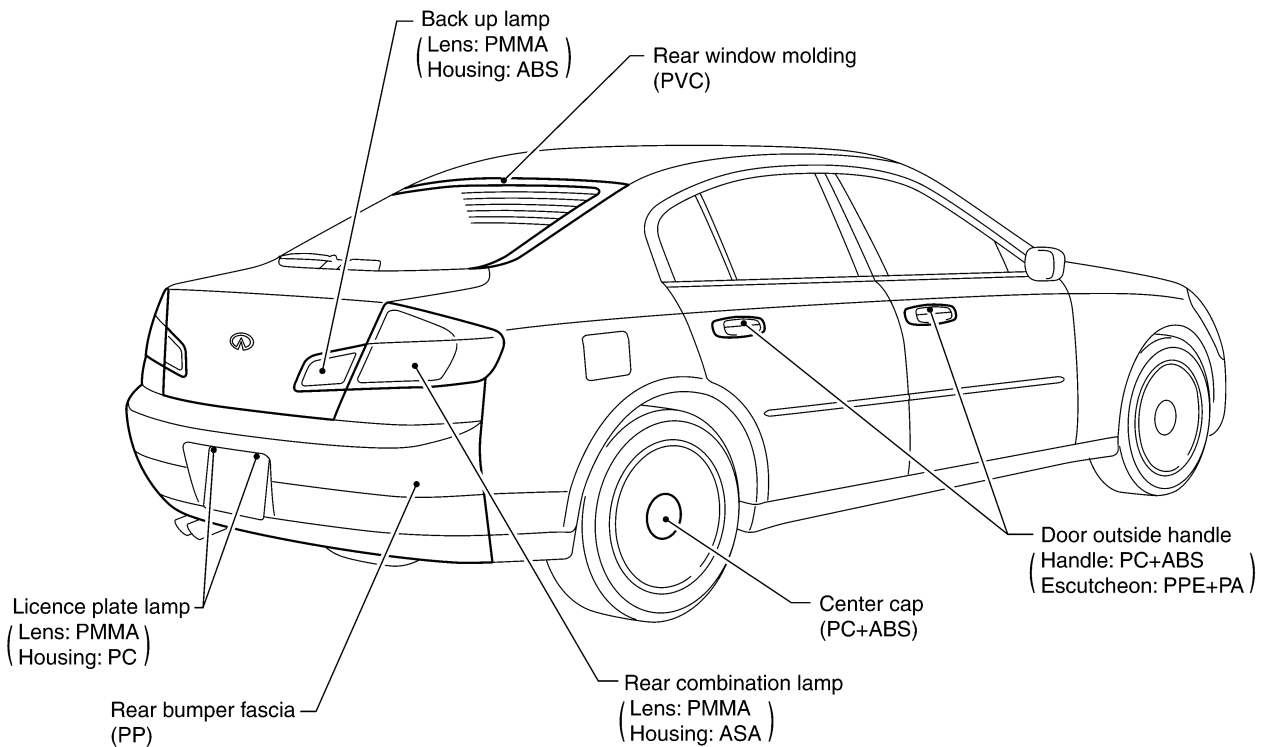
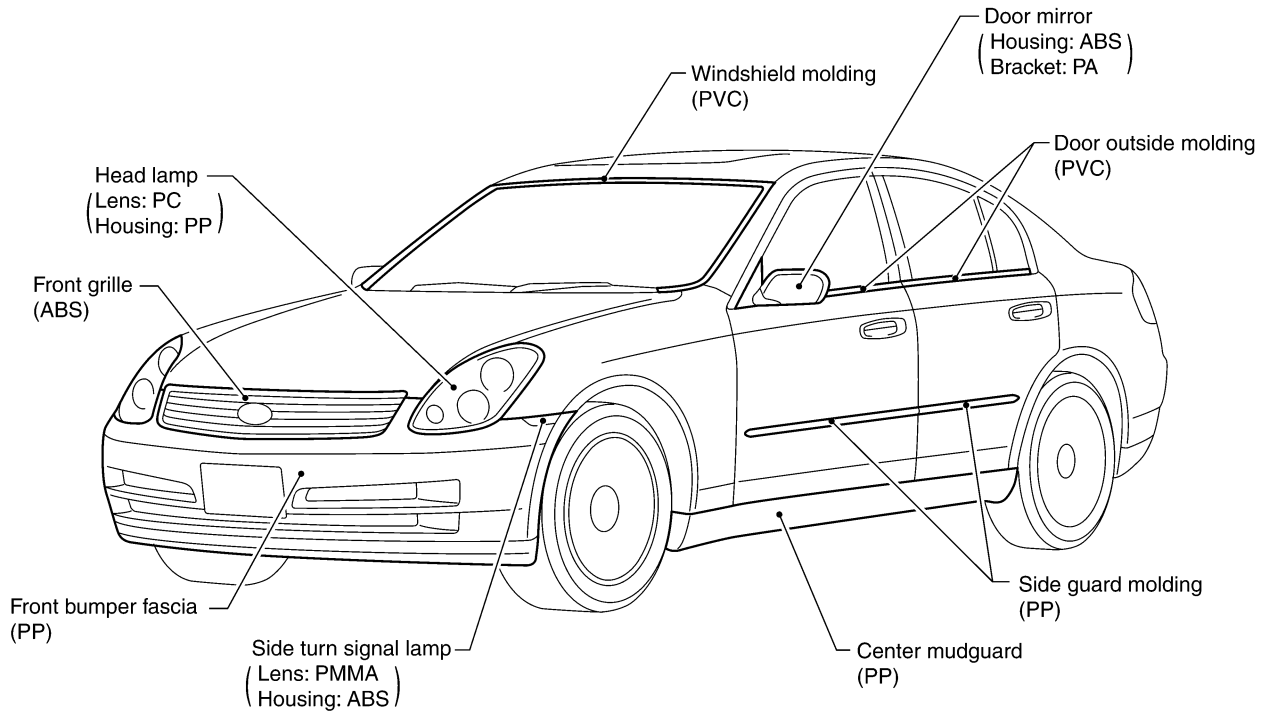

SIA2353E

# BODY REPAIR

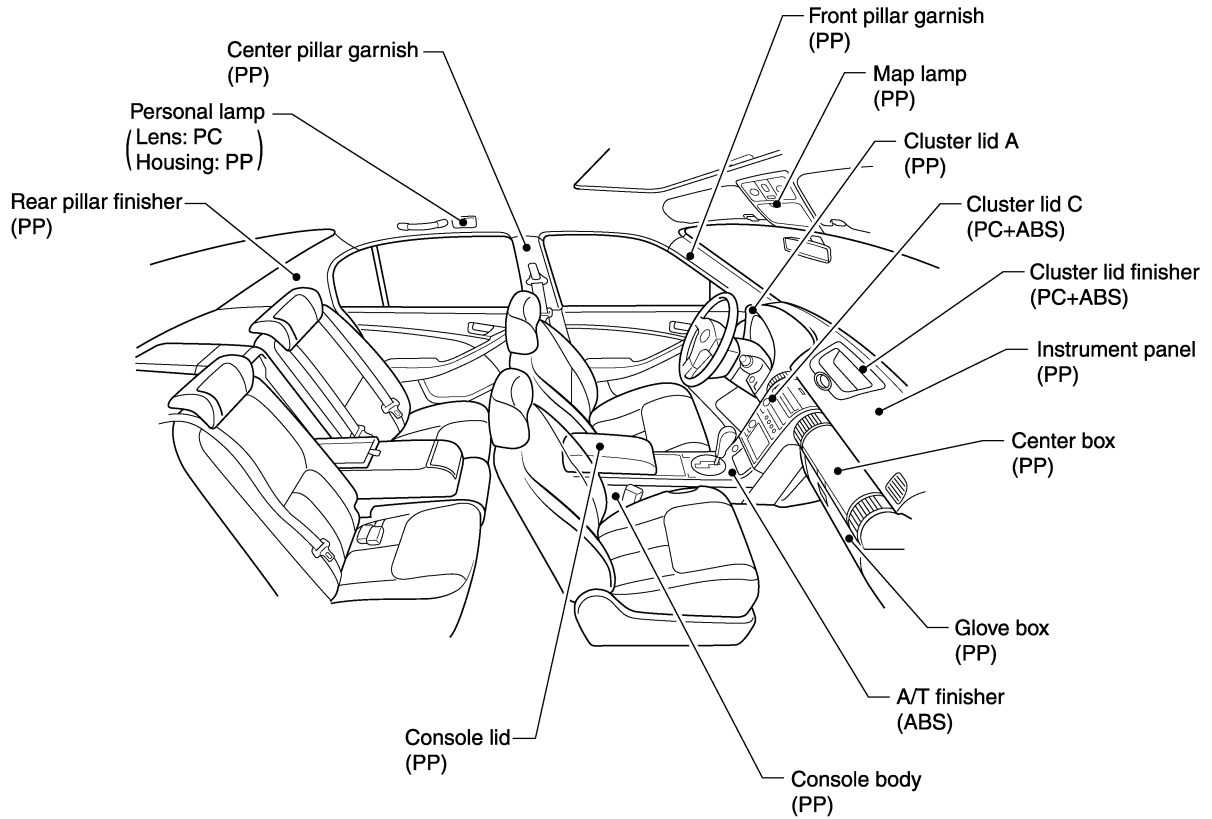

A  
B  
C  
D  
E  
F  
G  
H  
J  
K  
L  
M

**BL**

PIIA0841E

# BODY REPAIR

## Precautions In Repairing High Strength Steel

AIS00008

High strength steel is used for body panels in order to reduce vehicle weight. Accordingly, precautions in repairing automotive bodies made of high strength steel are described below:

### HIGH STRENGTH STEEL (HSS) USED IN NISSAN VEHICLES

Tensile strength	Nissan/Infiniti designation	Major applicable parts
373 N/mm <sup>2</sup> (38kg/mm <sup>2</sup> ,54klb/sq in)	SP130	<ul style="list-style-type: none"><li>● Front side member assembly</li><li>● Hoodledge assembly</li><li>● Upper dash</li><li>● Rear side member assembly</li><li>● Other reinforcements</li></ul>

SP130 is the most commonly used HSS.

# BODY REPAIR

## Read the following precautions when repairing HSS:

### 1. Additional points to consider

- The repair of reinforcements (such as side members) by heating is not recommended since it may weaken the component. When heating is unavoidable, do not heat HSS parts above 550°C (1,022°F). Verify heating temperature with a thermometer. (Crayon-type and other similar type thermometer are appropriate.)

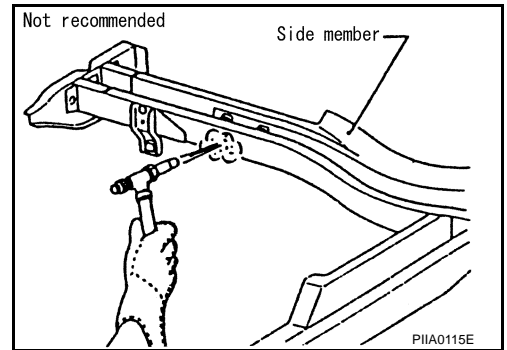

- When straightening body panels, use caution in pulling any HSS panel. Because HSS is very strong, pulling may cause deformation in adjacent portions of the body. In this case, increase the number of measuring points, and carefully pull the HSS panel.

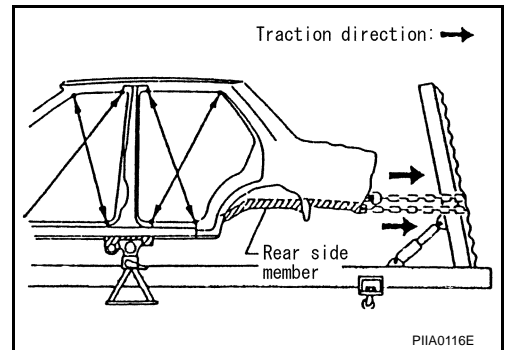

- When cutting HSS panels, avoid gas (torch) cutting if possible. Instead, use a saw to avoid weakening surrounding areas due to heat. If gas (torch) cutting is unavoidable, allow a minimum margin of 50 mm (1.97in).

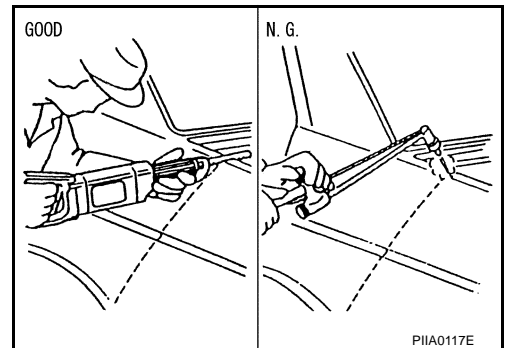

- When welding HSS panels, use spot welding whenever possible in order to minimize weakening surrounding areas due to heat. If spot welding is impossible, use M.I.G. welding. Do not use gas (torch) welding because it is inferior in welding strength.

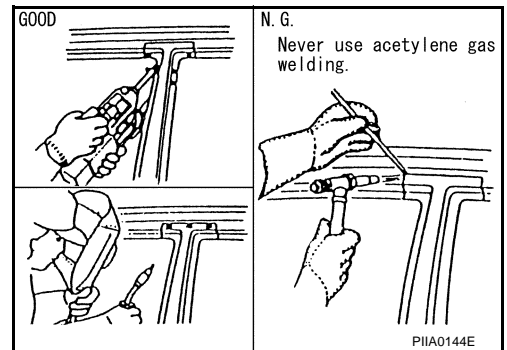

A  
B  
C  
D  
E  
F  
G  
H  
BL  
J  
K  
L  
M

# BODY REPAIR

- The spot weld on HSS panels is harder than that of an ordinary steel panel. Therefore, when cutting spot welds on a HSS panel, use a low speed high torque drill (1,000 to 1,200 rpm) to increase drill bit durability and facilitate the operation.

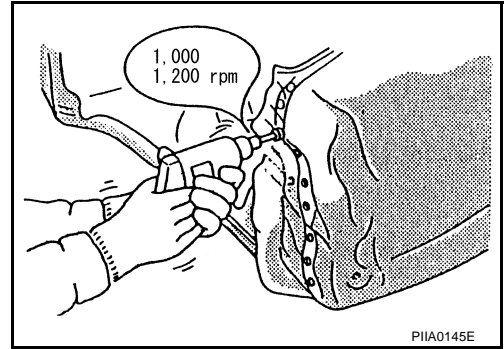

## 2. Precautions in spot welding HSS

This work should be performed under standard working conditions. Always note the following when spot welding HSS:

- The electrode tip diameter must be sized properly according to the metal thickness.

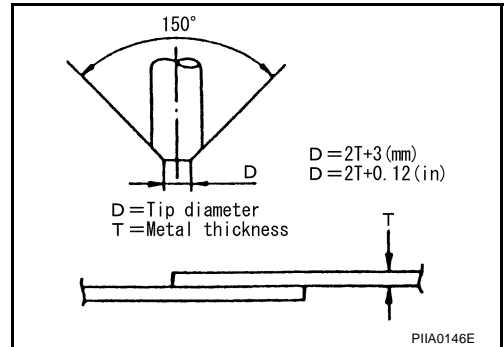

- The panel surfaces must fit flush to each other, leaving no gaps.

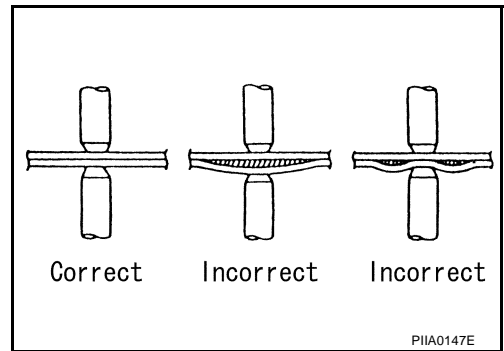

- Follow the specifications for the proper welding pitch.

Thickness (t)	Minimum pitch (l)
0.6 (0.024)	10 (0.39) or over
0.8 (0.031)	12 (0.47) or over
1.0 (0.039)	18 (0.71) or over
1.2 (0.047)	20 (0.79) or over
1.6 (0.063)	27 (1.06) or over
1.8 (0.071)	31 (1.22) or over

Unit:mm

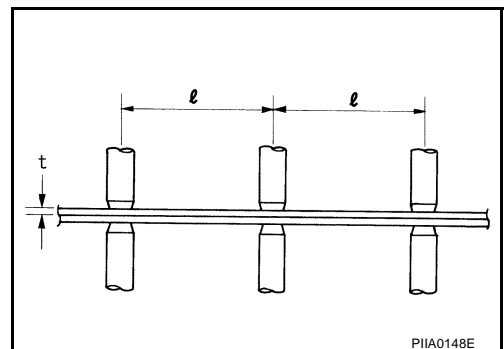



# BODY REPAIR

## Replacement Operations

AIS00009

### DESCRIPTION

This section is prepared for technicians who have attained a high level of skill and experience in repairing collision-damaged vehicles and also use modern service tools and equipment. Persons unfamiliar with body repair techniques should not attempt to repair collision-damaged vehicles by using this section.

Technicians are also encouraged to read Body Repair Manual (Fundamentals) in order to ensure that the original functions and quality of the vehicle can be maintained. The Body Repair Manual (Fundamentals) contains additional information, including cautions and warning, that are not including in this manual. Technicians should refer to both manuals to ensure proper repairs.

Please note that these information are prepared for worldwide usage, and as such, certain procedures might not apply in some regions or countries.

A

B

C

D

E

F

G

H

**BL**

J









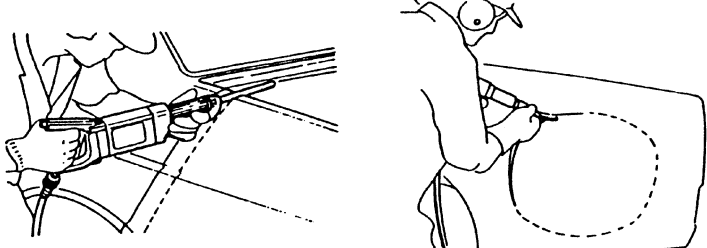
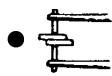
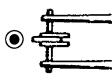

K

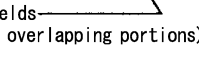
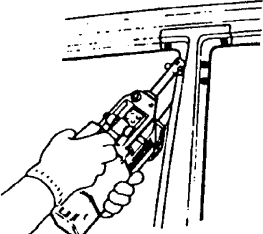
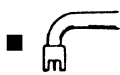
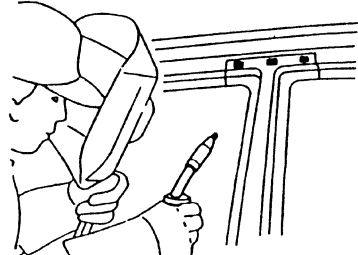
L

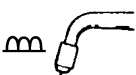
M

# BODY REPAIR

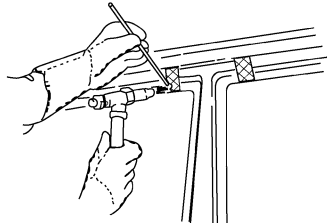
The symbols used in this section for cutting and welding / brazing operations are shown below.

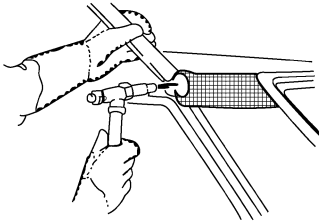
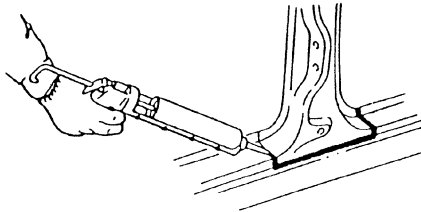
 <p>Saw cut or air chisel cut</p>		
<p>Spot weld</p> <p>●●●●● 2-spot welds</p>  <p>●●●●● 3-spot welds</p> 	<p>2-spot welds (2-panel overlapping portions)</p>  <p>3-spot welds (3-panel overlapping portions)</p> 	
<p>■ ■ ■ ■</p> <p>MIG plug weld</p> 		
 <p>MIG seam weld/ Point weld</p> 		
 <p>Brazing</p> 		
 <p>Soldering</p> 		
<p>Sealing</p>		

PIIA0149E

# BODY REPAIR

- Front pillar butt joint can be determined anywhere within shaded area as shown in the figure. The best location for the butt joint is at position A due to the construction of the vehicle. Refer to the front pillar section.

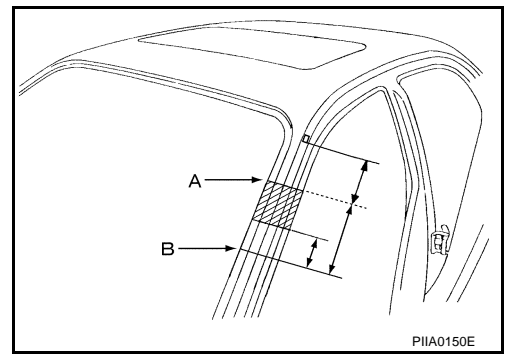

- Determine cutting position and record distance from the locating indent. Use this distance when cutting the service part. Cut outer front pillar over 60 mm above inner front pillar cut position.

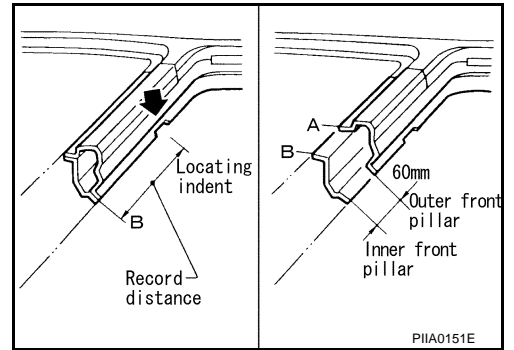

- Prepare a cutting jig to make outer pillar easier to cut. Also, this will permit service part to be accurately cut at joint position.

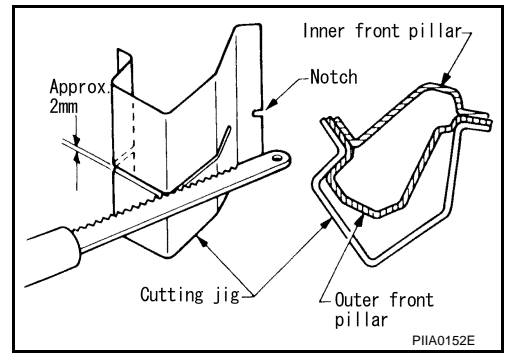

- An example of cutting operation using a cutting jig is as follows.

1. Mark cutting lines.  
A: Cut position of outer pillar  
B: Cut position of inner pillar
2. Align cutting line with notch on jig. Clamp jig to pillar.
3. Cut outer pillar along groove of jig. (At position A)
4. Remove jig and cut remaining portions.
5. Cut inner pillar at position B in same manner.

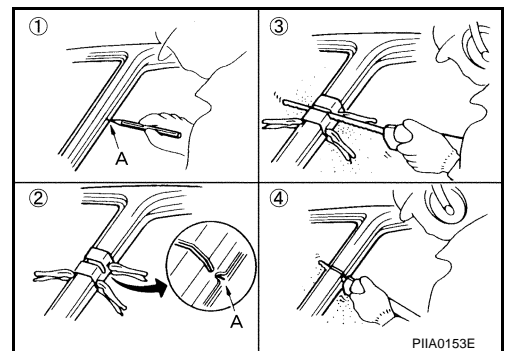

A  
B  
C  
D  
E  
F  
G  
H  
BL  
J  
K  
L  
M

# BODY REPAIR

## HOODLEDGE

### Service Joint

Remove front side member center closing plate for easier installation.

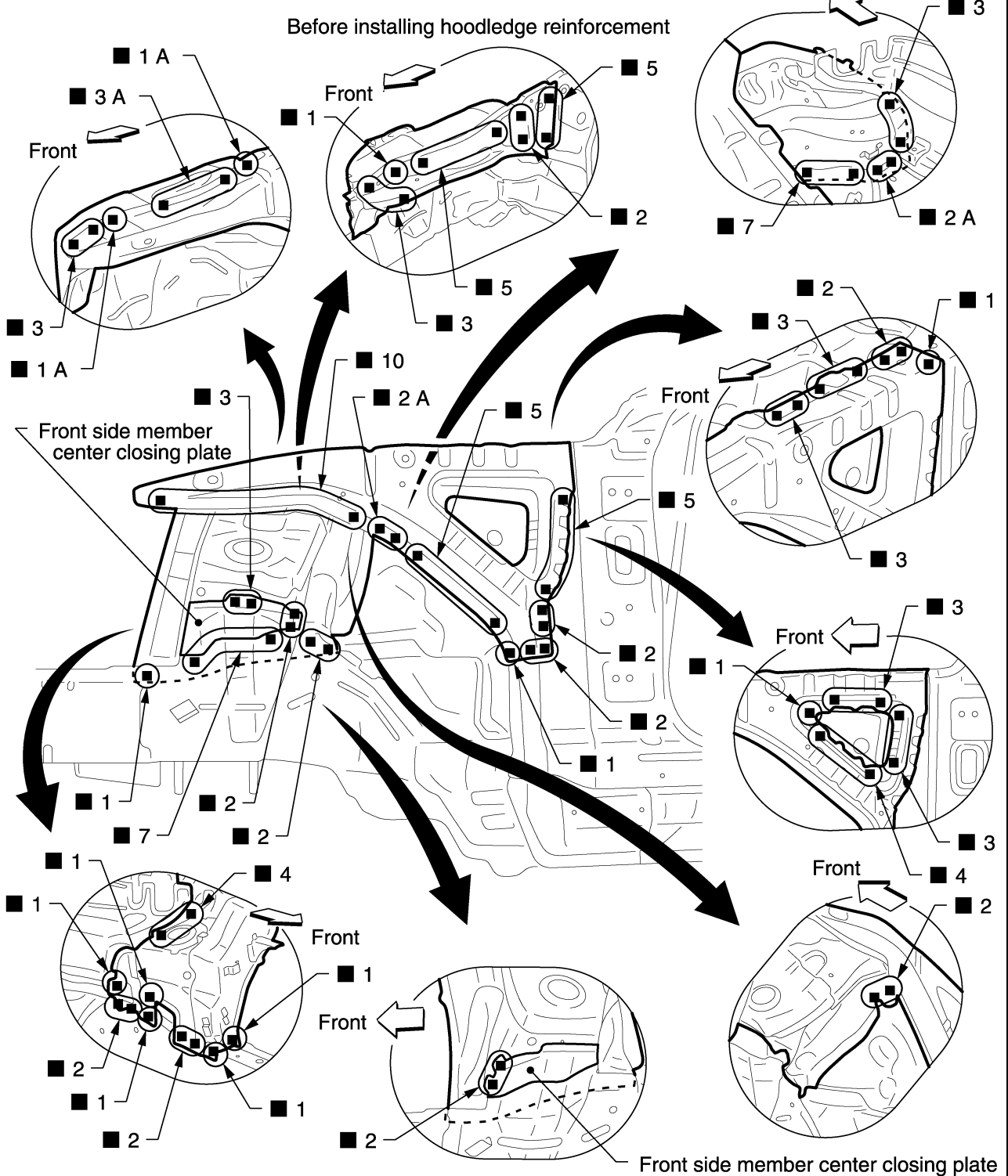

2-spot welds

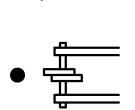

3-spot welds

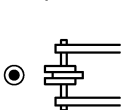

MIG plug weld

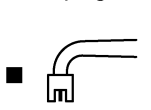

For 3 panels plug weld method



MIG seam weld/  
Point weld



PIIA0953E







# BODY REPAIR

## FRONT SIDE MEMBER (PARTIAL REPLACEMENT) (AWD MODELS)

### Service Joint

(This figure shows right front side member)

Remove front suspension mounting member bracket for easier installation.

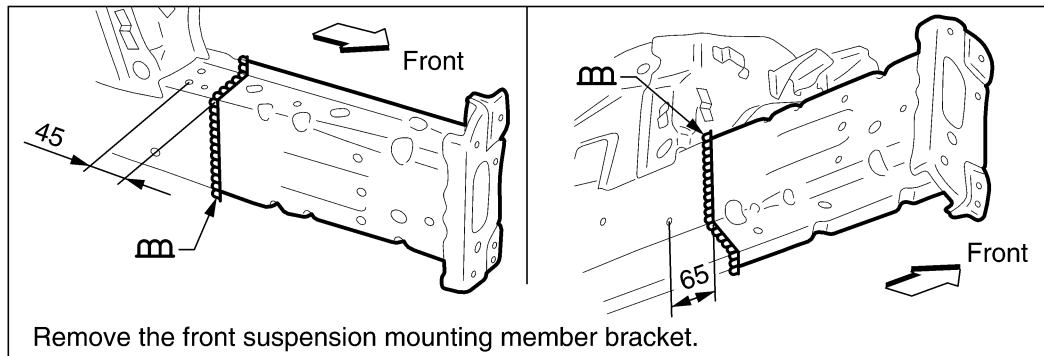
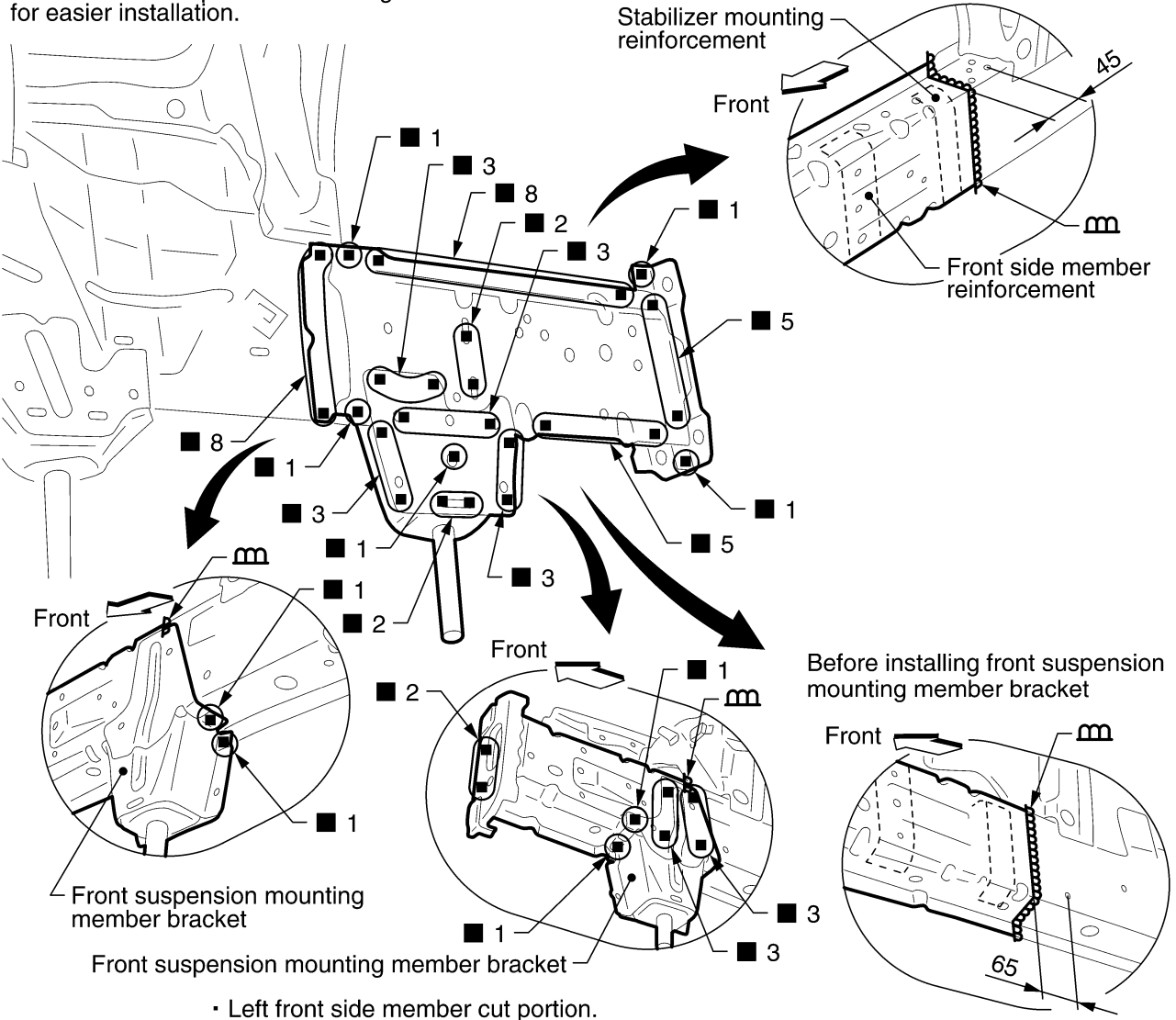

2-spot welds



3-spot welds



MIG plug weld



For 3 panels plug weld method



MIG seam weld/  
Point weld



SIIA2398E





# BODY REPAIR

## CENTER PILLAR

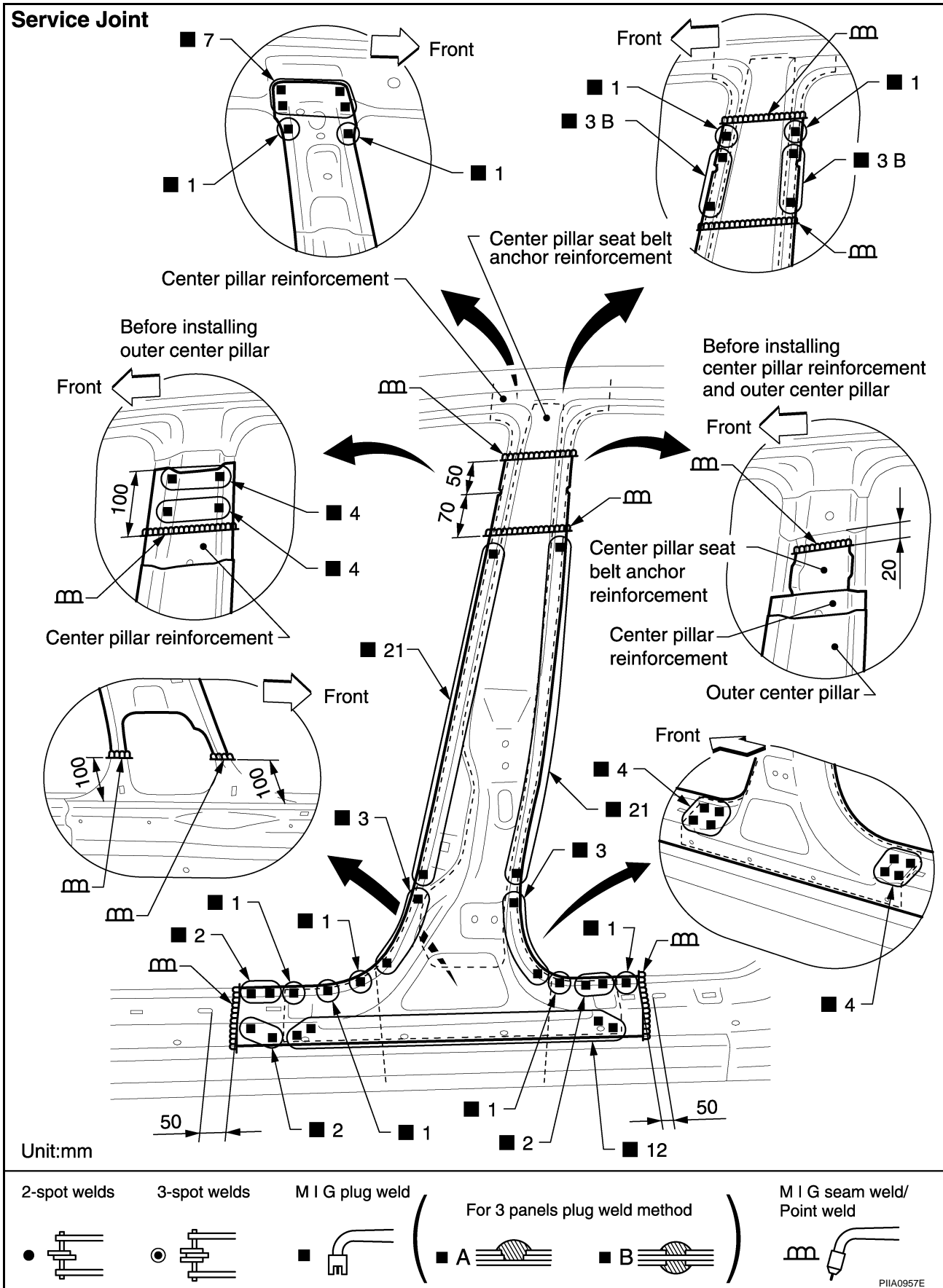

# BODY REPAIR

## OUTER SILL

### Service Joint

Replacement part consists of outer sill, outer sill reinforcement and center pillar reinforcement.

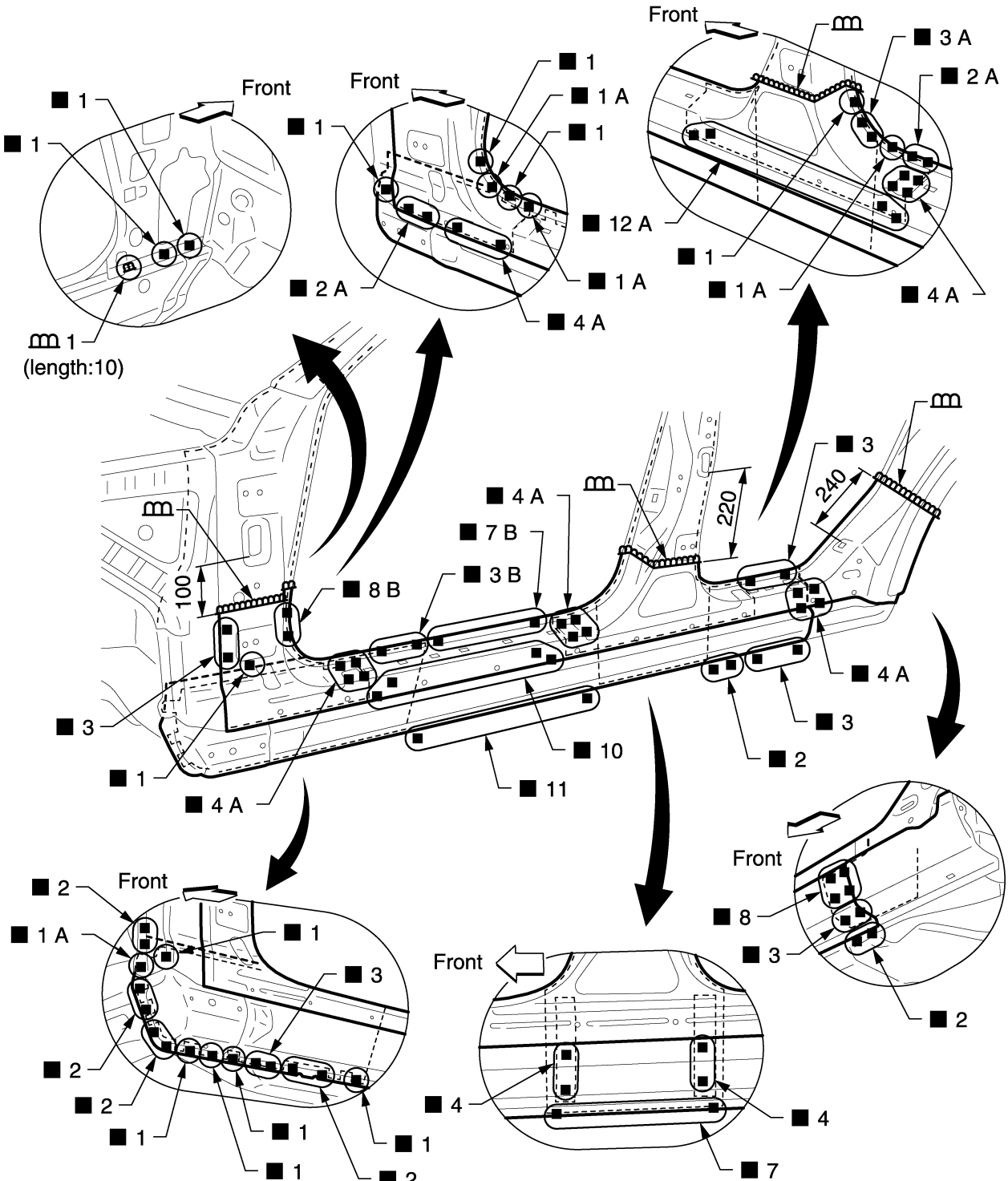

Unit:mm

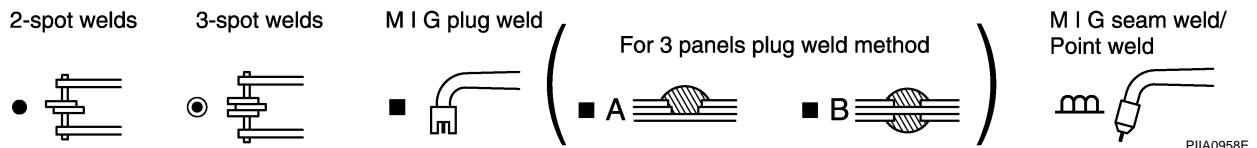

PIIA0958E

A  
B  
C  
D  
E  
F  
G  
H  
BL  
J  
K  
L  
M

# BODY REPAIR

## OUTER SILL (CONT'D)

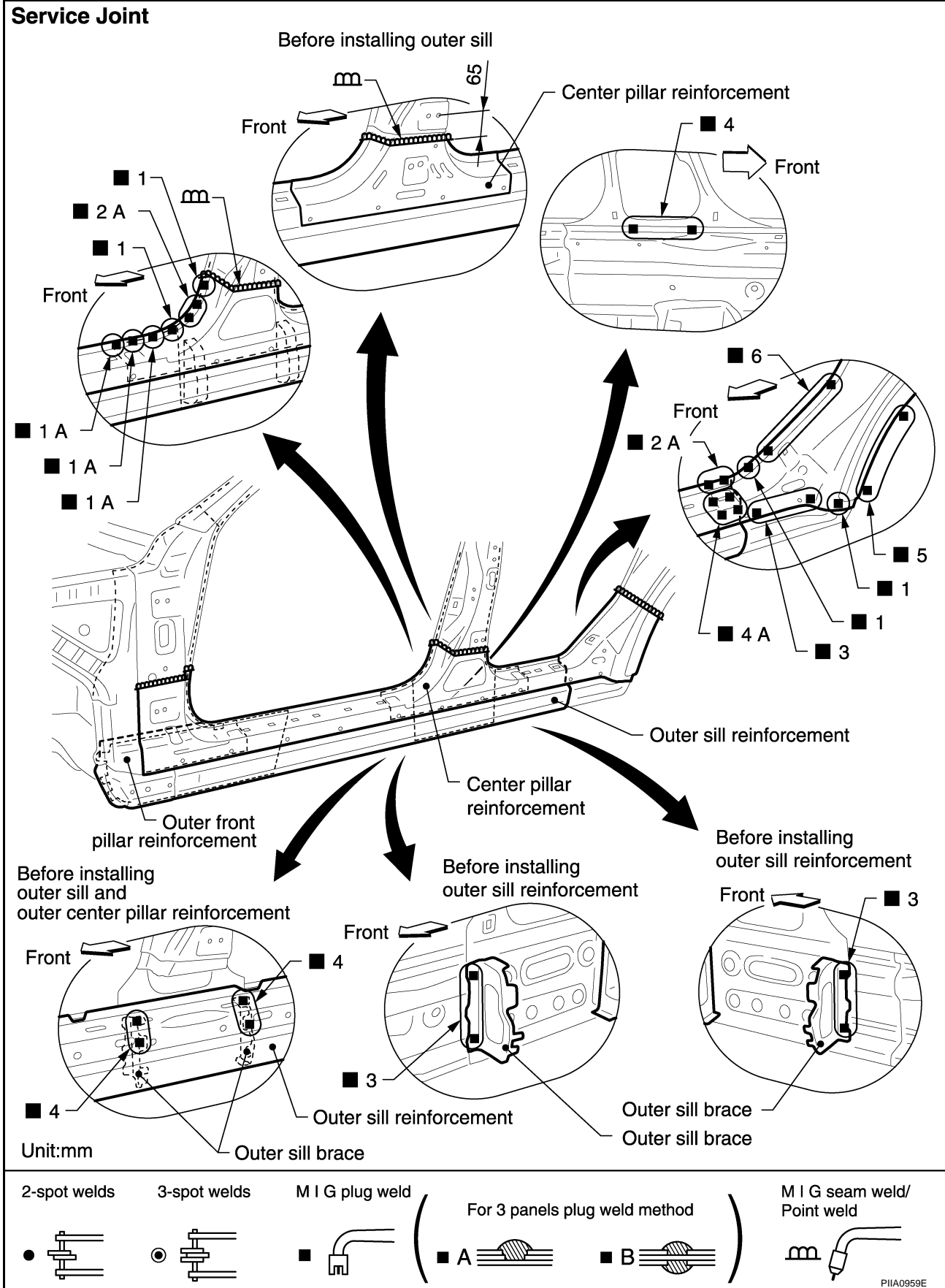

# BODY REPAIR

## REAR FENDER

### Service Joint

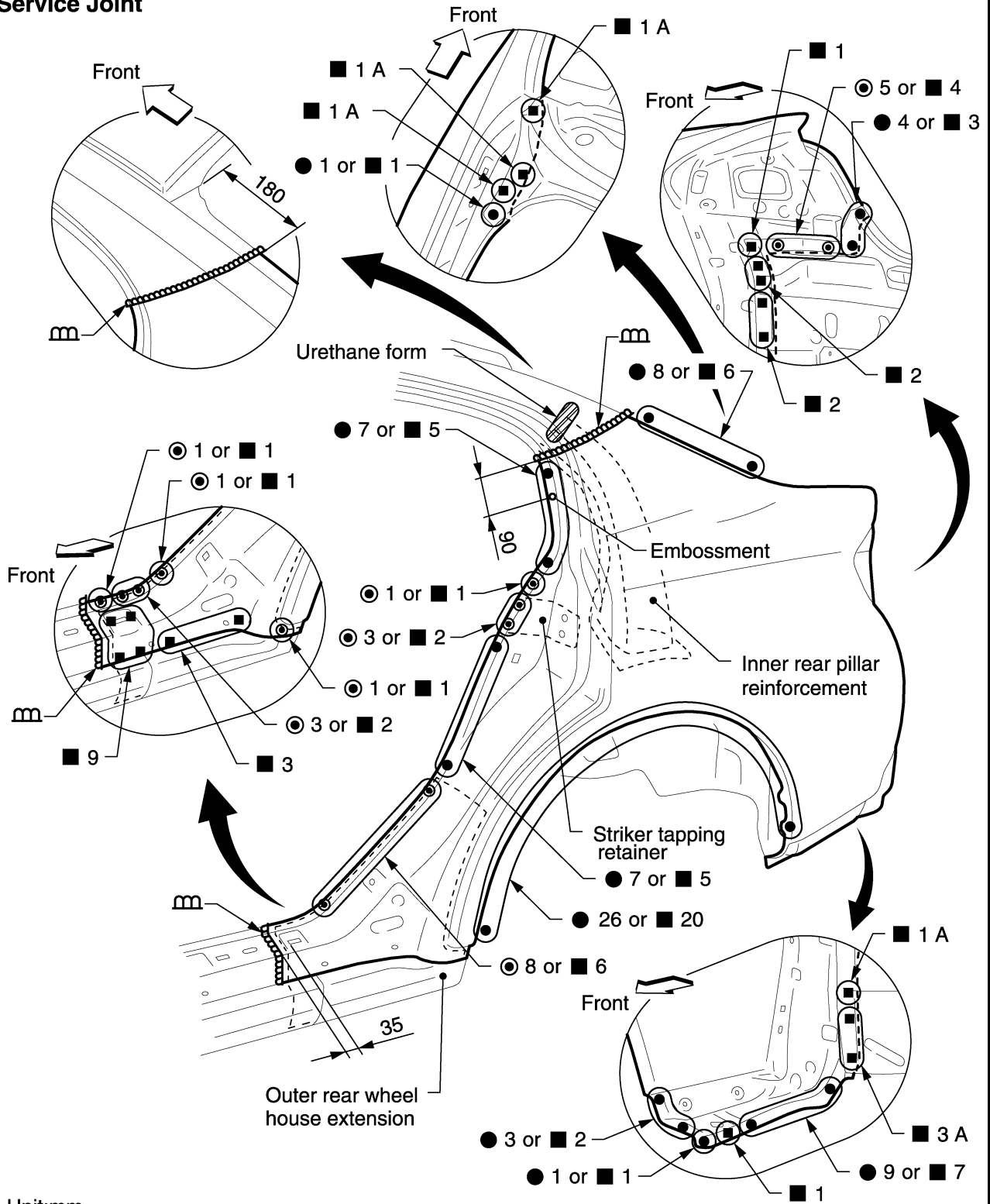

Unit:mm

2-spot welds

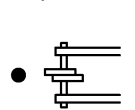

3-spot welds

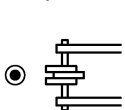

M I G plug weld

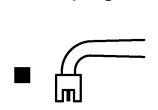

For 3 panels plug weld method



M I G seam weld/  
Point weld



PIIA0960E

A  
B  
C  
D  
E  
F  
G  
H  
BL  
J  
K  
L  
M

# BODY REPAIR

## REAR PANEL

### Service Joint

★ indicates that there is an equivalent welding portion with the same dimensions on the opposite side.

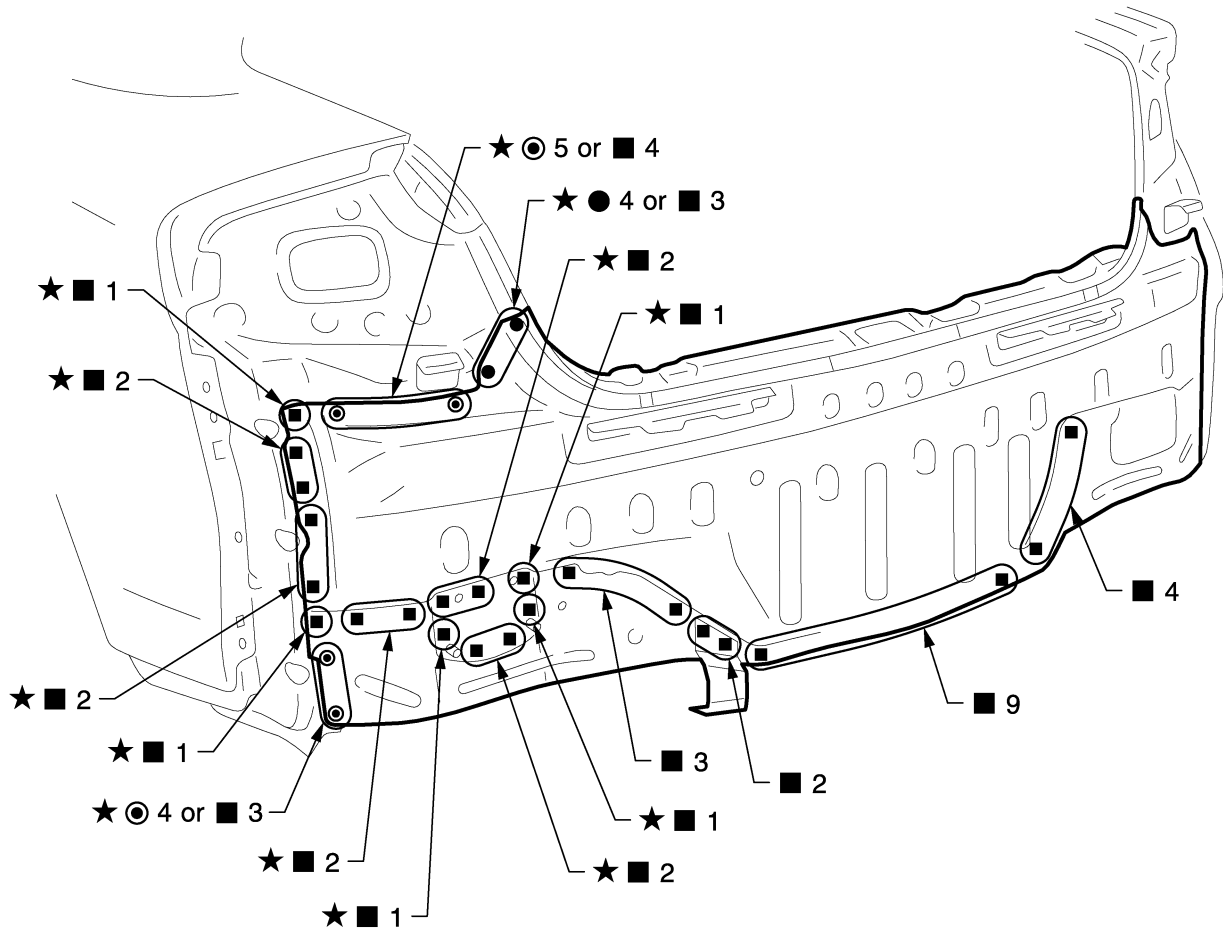

2-spot welds

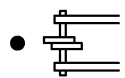

3-spot welds

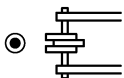

M I G plug weld

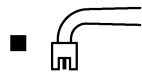

( For 3 panels plug weld method )



M I G seam weld/  
Point weld



PIIA0961E

# BODY REPAIR

## REAR FLOOR REAR

- Work after upper rear panel assembly has been removed.

A  
B  
C  
D  
E  
F  
G  
H  
BL  
J  
K  
L  
M

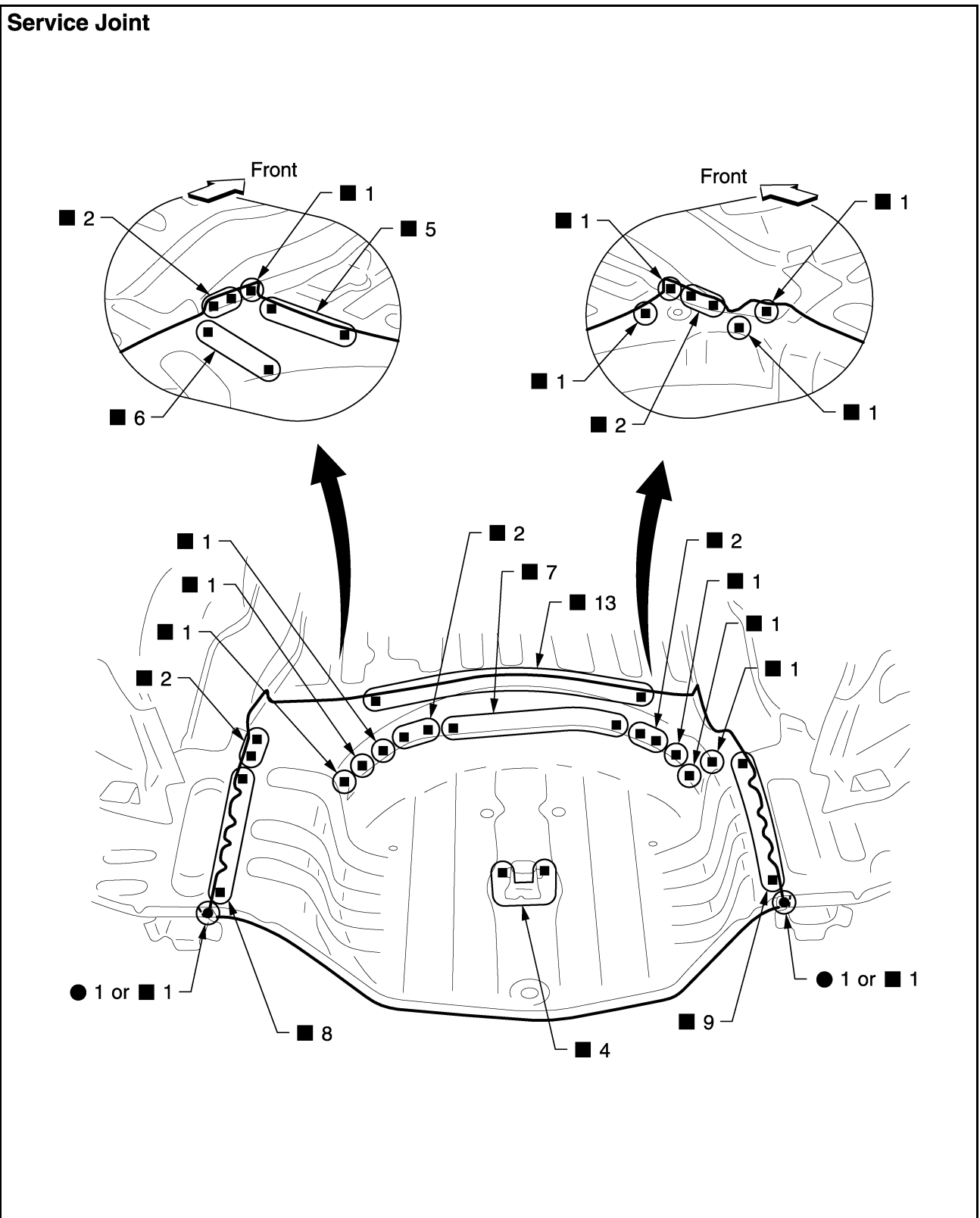

2-spot welds	3-spot welds	M I G plug weld	For 3 panels plug weld method		M I G seam weld/ Point weld
●	⊙	■	■ A	■ B	

PIIA0962E

# BODY REPAIR

## REAR SIDE MEMBER EXTENSION

- Work after upper rear panel assembly has been removed.

### Service Joint

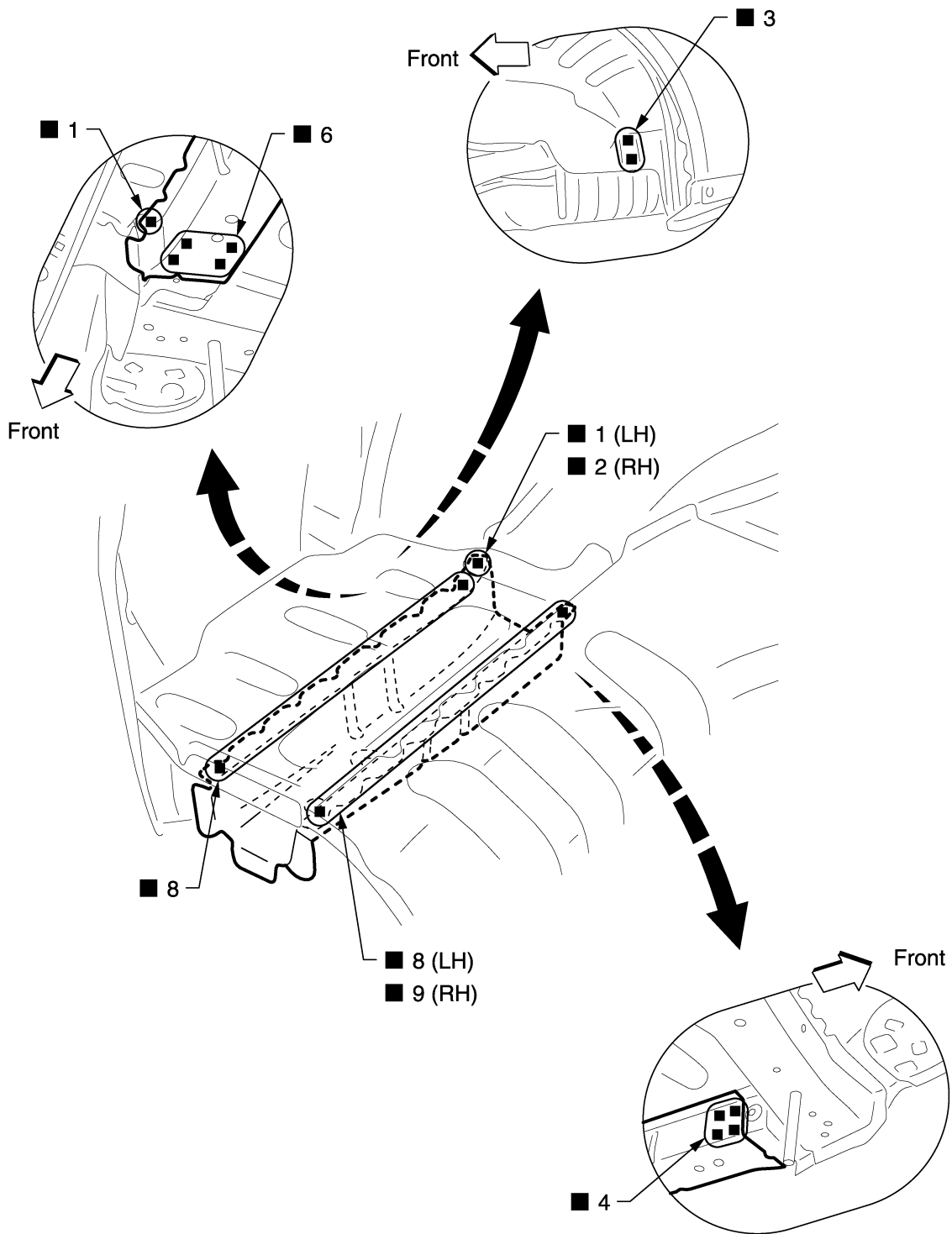

2-spot welds

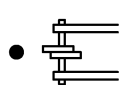

3-spot welds

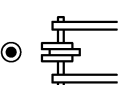

M I G plug weld

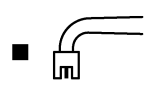

For 3 panels plug weld method



M I G seam weld/  
Point weld



PIIA0963E