

# SECTION **AT**

## AUTOMATIC TRANSMISSION

A  
B  
AT

### CONTENTS

D  
E  
F  
G  
H  
I  
J  
K  
L  
M

<b>INDEX FOR DTC</b> .....	<b>5</b>	Accurate Repair .....	44
Alphabetical Index .....	5	A/T Electrical Parts Location .....	49
DTC No. Index .....	6	Circuit Diagram .....	50
<b>PRECAUTIONS</b> .....	<b>7</b>	Inspections before Trouble Diagnosis .....	51
Precautions for Supplemental Restraint System (SRS) "AIR BAG" and "SEAT BELT PRE-TENSIONER" .....	7	Check before Engine Is Started .....	56
Precautions for On Board Diagnostic (OBD) System of A/T and Engine .....	7	Check at Idle .....	56
Precautions .....	8	Cruise Test - Part 1 .....	60
Service Notice or Precautions .....	9	Cruise Test - Part 2 .....	63
<b>PREPARATION</b> .....	<b>10</b>	Cruise Test - Part 3 .....	64
Special Service Tools .....	10	Vehicle Speed at Which Gear Shifting Occurs .....	65
Commercial Service Tools .....	11	Vehicle Speed at Which Lock-Up Occurs/Releases..	65
<b>A/T FLUID</b> .....	<b>12</b>	Symptom Chart .....	66
Changing A/T Fluid .....	12	TCM Input/Output Signal Reference Values .....	91
Checking A/T Fluid .....	12	CONSULT-II Function (A/T) .....	92
A/T Fluid Cooler Cleaning .....	14	Diagnostic Procedure without CONSULT-II .....	105
<b>A/T CONTROL SYSTEM</b> .....	<b>17</b>	<b>DTC U1000 CAN COMMUNICATION LINE</b> .....	<b>110</b>
Cross-Sectional View (2WD Models) .....	17	Description .....	110
Cross-Sectional View (AWD Models) .....	18	On Board Diagnosis Logic .....	110
Shift Mechanism .....	19	Possible Cause .....	110
TCM Function .....	30	DTC Confirmation Procedure .....	110
CAN Communication .....	31	Wiring Diagram — AT — CAN .....	111
Input/Output Signal of TCM .....	31	Diagnostic Procedure .....	112
Line Pressure Control .....	32	<b>DTC P0615 START SIGNAL CIRCUIT</b> .....	<b>113</b>
Shift Control .....	33	Description .....	113
Lock-Up Control .....	35	CONSULT-II Reference Value .....	113
Engine Brake Control .....	36	On Board Diagnosis Logic .....	113
Control Valve .....	37	Possible Cause .....	113
<b>ON BOARD DIAGNOSTIC (OBD) SYSTEM</b> .....	<b>38</b>	DTC Confirmation Procedure .....	113
Introduction .....	38	Wiring Diagram — AT — STSIG .....	114
OBD-II Function for A/T System .....	38	Diagnostic Procedure .....	115
One or Two Trip Detection Logic of OBD-II .....	38	<b>DTC P0700 TCM</b> .....	<b>117</b>
OBD-II Diagnostic Trouble Code (DTC) .....	38	Description .....	117
Malfunction Indicator Lamp (MIL) .....	41	On Board Diagnosis Logic .....	117
<b>TROUBLE DIAGNOSIS</b> .....	<b>42</b>	Possible Cause .....	117
DTC Inspection Priority Chart .....	42	DTC Confirmation Procedure .....	117
Fail-safe .....	42	Diagnostic Procedure .....	117
How to Perform Trouble Diagnosis for Quick and		<b>DTC P0705 PARK/NEUTRAL POSITION SWITCH</b> .....	<b>118</b>
		Description .....	118
		CONSULT-II Reference Value .....	118
		On Board Diagnosis Logic .....	118

Possible Cause .....	118	On Board Diagnosis Logic .....	137
DTC Confirmation Procedure .....	118	Possible Cause .....	137
Wiring Diagram — AT — PNP/SW .....	119	DTC Confirmation Procedure .....	137
Diagnostic Procedure .....	120	Diagnostic Procedure .....	138
<b>DTC P0720 VEHICLE SPEED SENSOR A/T (REVOLUTION SENSOR) .....</b>	<b>122</b>	<b>DTC P1710 A/T FLUID TEMPERATURE SENSOR CIRCUIT .....</b>	<b>140</b>
Description .....	122	Description .....	140
CONSULT-II Reference Value .....	122	CONSULT-II Reference Value .....	140
On Board Diagnosis Logic .....	122	On Board Diagnosis Logic .....	140
Possible Cause .....	122	Possible Cause .....	140
DTC Confirmation Procedure .....	122	DTC Confirmation Procedure .....	140
Wiring Diagram — AT — VSSA/T .....	124	Wiring Diagram — AT — FTS .....	141
Diagnostic Procedure .....	125	Diagnostic Procedure .....	142
<b>DTC P0725 ENGINE SPEED SIGNAL .....</b>	<b>127</b>	Component Inspection .....	144
Description .....	127	<b>DTC P1716 TURBINE REVOLUTION SENSOR ...</b>	<b>145</b>
CONSULT-II Reference Value .....	127	Description .....	145
On Board Diagnosis Logic .....	127	CONSULT-II Reference Value .....	145
Possible Cause .....	127	On Board Diagnosis Logic .....	145
DTC Confirmation Procedure .....	127	Possible Cause .....	145
Diagnostic Procedure .....	128	DTC Confirmation Procedure .....	145
<b>DTC P0740 TORQUE CONVERTER CLUTCH SOLENOID VALVE .....</b>	<b>129</b>	Diagnostic Procedure .....	146
Description .....	129	<b>DTC P1721 VEHICLE SPEED SENSOR MTR .....</b>	<b>147</b>
CONSULT-II Reference Value .....	129	Description .....	147
On Board Diagnosis Logic .....	129	CONSULT-II Reference Value .....	147
Possible Cause .....	129	On Board Diagnosis Logic .....	147
DTC Confirmation Procedure .....	129	Possible Cause .....	147
Diagnostic Procedure .....	130	DTC Confirmation Procedure .....	147
<b>DTC P0744 A/T TCC S/V FUNCTION (LOCK-UP) .....</b>	<b>131</b>	Diagnostic Procedure .....	148
Description .....	131	<b>DTC P1730 A/T INTERLOCK .....</b>	<b>149</b>
CONSULT-II Reference Value .....	131	Description .....	149
On Board Diagnosis Logic .....	131	On Board Diagnosis Logic .....	149
Possible Cause .....	131	Possible Cause .....	149
DTC Confirmation Procedure .....	131	DTC Confirmation Procedure .....	149
Diagnostic Procedure .....	132	Judgement of A/T Interlock .....	150
<b>DTC P0745 LINE PRESSURE SOLENOID VALVE .....</b>	<b>133</b>	Diagnostic Procedure .....	150
Description .....	133	<b>DTC P1731 A/T 1ST ENGINE BRAKING .....</b>	<b>152</b>
CONSULT-II Reference Value .....	133	Description .....	152
On Board Diagnosis Logic .....	133	CONSULT-II Reference Value .....	152
Possible Cause .....	133	On Board Diagnosis Logic .....	152
DTC Confirmation Procedure .....	133	Possible Cause .....	152
Diagnostic Procedure .....	134	DTC Confirmation Procedure .....	152
<b>DTC P1702 TRANSMISSION CONTROL MODULE (RAM) .....</b>	<b>135</b>	Diagnostic Procedure .....	153
Description .....	135	<b>DTC P1752 INPUT CLUTCH SOLENOID VALVE .....</b>	<b>154</b>
On Board Diagnosis Logic .....	135	Description .....	154
Possible Cause .....	135	CONSULT-II Reference Value .....	154
DTC Confirmation Procedure .....	135	On Board Diagnosis Logic .....	154
Diagnostic Procedure .....	135	Possible Cause .....	154
<b>DTC P1703 TRANSMISSION CONTROL MODULE (ROM) .....</b>	<b>136</b>	DTC Confirmation Procedure .....	154
Description .....	136	Diagnostic Procedure .....	155
On Board Diagnosis Logic .....	136	<b>DTC P1754 INPUT CLUTCH SOLENOID VALVE FUNCTION .....</b>	<b>156</b>
Possible Cause .....	136	Description .....	156
DTC Confirmation Procedure .....	136	CONSULT-II Reference Value .....	156
Diagnostic Procedure .....	136	On Board Diagnosis Logic .....	156
<b>DTC P1705 THROTTLE POSITION SENSOR .....</b>	<b>137</b>	Possible Cause .....	156
Description .....	137	DTC Confirmation Procedure .....	156
CONSULT-II Reference Value .....	137	Diagnostic Procedure .....	157
		<b>DTC P1757 FRONT BRAKE SOLENOID VALVE .....</b>	<b>158</b>
		Description .....	158

CONSULT-II Reference Value .....	158	DTC Confirmation Procedure .....	172
On Board Diagnosis Logic .....	158	Diagnostic Procedure .....	173
Possible Cause .....	158	<b>DTC P1815 MANUAL MODE SWITCH .....</b>	<b>174</b>
DTC Confirmation Procedure .....	158	Description .....	174
Diagnostic Procedure .....	159	CONSULT-II Reference Value .....	174
<b>DTC P1759 FRONT BRAKE SOLENOID VALVE</b>		On Board Diagnosis Logic .....	174
<b>FUNCTION .....</b>	<b>160</b>	Possible Cause .....	174
Description .....	160	DTC Confirmation Procedure .....	174
CONSULT-II Reference Value .....	160	Wiring Diagram — AT — MMSW .....	175
On Board Diagnosis Logic .....	160	Diagnostic Procedure .....	176
Possible Cause .....	160	Component Inspection .....	177
DTC Confirmation Procedure .....	160	<b>DTC P1841 ATF PRESSURE SWITCH 1 .....</b>	<b>178</b>
Diagnostic Procedure .....	161	Description .....	178
<b>DTC P1762 DIRECT CLUTCH SOLENOID VALVE</b>	<b>162</b>	CONSULT-II Reference Value .....	178
Description .....	162	On Board Diagnosis Logic .....	178
CONSULT-II Reference Value .....	162	Possible Cause .....	178
On Board Diagnosis Logic .....	162	DTC Confirmation Procedure .....	178
Possible Cause .....	162	Diagnostic Procedure .....	179
DTC Confirmation Procedure .....	162	<b>DTC P1843 ATF PRESSURE SWITCH 3 .....</b>	<b>180</b>
Diagnostic Procedure .....	163	Description .....	180
<b>DTC P1764 DIRECT CLUTCH SOLENOID VALVE</b>		CONSULT-II Reference Value .....	180
<b>FUNCTION .....</b>	<b>164</b>	On Board Diagnosis Logic .....	180
Description .....	164	Possible Cause .....	180
CONSULT-II Reference Value .....	164	DTC Confirmation Procedure .....	180
On Board Diagnosis Logic .....	164	Diagnostic Procedure .....	181
Possible Cause .....	164	<b>DTC P1845 ATF PRESSURE SWITCH 5 .....</b>	<b>182</b>
DTC Confirmation Procedure .....	164	Description .....	182
Diagnostic Procedure .....	165	CONSULT-II Reference Value .....	182
<b>DTC P1767 HIGH AND LOW REVERSE CLUTCH</b>		On Board Diagnosis Logic .....	182
<b>SOLENOID VALVE .....</b>	<b>166</b>	Possible Cause .....	182
Description .....	166	DTC Confirmation Procedure .....	182
CONSULT-II Reference Value .....	166	Diagnostic Procedure .....	183
On Board Diagnosis Logic .....	166	<b>DTC P1846 ATF PRESSURE SWITCH 6 .....</b>	<b>184</b>
Possible Cause .....	166	Description .....	184
DTC Confirmation Procedure .....	166	CONSULT-II Reference Value .....	184
Diagnostic Procedure .....	167	On Board Diagnosis Logic .....	184
<b>DTC P1769 HIGH AND LOW REVERSE CLUTCH</b>		Possible Cause .....	184
<b>SOLENOID VALVE FUNCTION .....</b>	<b>168</b>	DTC Confirmation Procedure .....	184
Description .....	168	Diagnostic Procedure .....	185
CONSULT-II Reference Value .....	168	<b>MAIN POWER SUPPLY AND GROUND CIRCUIT. 186</b>	
On Board Diagnosis Logic .....	168	Wiring Diagram — AT — MAIN .....	186
Possible Cause .....	168	Diagnostic Procedure .....	187
DTC Confirmation Procedure .....	168	<b>CLOSED THROTTLE POSITION AND WIDE OPEN</b>	
Diagnostic Procedure .....	169	<b>THROTTLE POSITION CIRCUIT .....</b>	<b>190</b>
<b>DTC P1772 LOW COAST BRAKE SOLENOID</b>		CONSULT-II Reference Value .....	190
<b>VALVE .....</b>	<b>170</b>	Diagnostic Procedure .....	190
Description .....	170	<b>BRAKE SIGNAL CIRCUIT .....</b>	<b>191</b>
CONSULT-II Reference Value .....	170	CONSULT-II Reference Value .....	191
On Board Diagnosis Logic .....	170	Diagnostic Procedure .....	191
Possible Cause .....	170	<b>A/T INDICATOR CIRCUIT .....</b>	<b>192</b>
DTC Confirmation Procedure .....	170	Description .....	192
Diagnostic Procedure .....	171	CONSULT-II Reference Value .....	192
<b>DTC P1774 LOW COAST BRAKE SOLENOID</b>		Diagnostic Procedure .....	192
<b>VALVE FUNCTION .....</b>	<b>172</b>	<b>TROUBLE DIAGNOSIS FOR SYMPTOMS .....</b>	<b>193</b>
Description .....	172	Wiring Diagram — AT — NONDTC .....	193
CONSULT-II Reference Value .....	172	A/T CHECK Indicator Lamp Does Not Come On .	195
On Board Diagnosis Logic .....	172	Engine Cannot Be Started in "P" or "N" Position .	196
Possible Cause .....	172	In "P" Position, Vehicle Moves When Pushed ....	196
		In "N" Position, Vehicle Moves .....	197

A  
B  
AT  
D  
E  
F  
G  
H  
I  
J  
K  
L  
M

Large Shock (“N” to “D” Position) .....	198	Rear Oil Seal .....	268
Vehicle Does Not Creep Backward in “R” Position .....	201	Revolution Sensor (2WD Models Only) .....	269
Vehicle Does Not Creep Forward in “D” Position .....	204	<b>AIR BREATHER HOSE .....</b>	<b>274</b>
Vehicle Cannot Be Started from D1 .....	206	Removal and Installation .....	274
A/T Does Not Shift: D1 → D2 .....	209	<b>TRANSMISSION ASSEMBLY .....</b>	<b>275</b>
A/T Does Not Shift: D2 → D3 .....	211	Removal and Installation .....	275
A/T Does Not Shift: D3 → D4 .....	213	<b>OVERHAUL .....</b>	<b>280</b>
A/T Does Not Shift: D4 → D5 .....	216	Components .....	280
A/T Does Not Perform Lock-Up .....	218	Oil Channel .....	288
A/T Does Not Hold Lock-Up Condition .....	220	Locations of Adjusting Shims, Needle Bearings, Thrust Washers and Snap Rings .....	290
Lock-Up Is Not Released .....	222	<b>DISASSEMBLY .....</b>	<b>292</b>
Engine Speed Does Not Return to Idle .....	222	Disassembly .....	292
Cannot Be Changed to Manual Mode .....	224	<b>REPAIR FOR COMPONENT PARTS .....</b>	<b>310</b>
A/T Does Not Shift: 5th Gear → 4th Gear .....	224	Oil Pump .....	310
A/T Does Not Shift: 4th Gear → 3rd Gear .....	226	Front Sun Gear, 3rd One-Way Clutch .....	313
A/T Does Not Shift: 3rd Gear → 2nd Gear .....	228	Front Carrier, Input Clutch, Rear Internal Gear .....	315
A/T Does Not Shift: 2nd Gear → 1st Gear .....	230	Mid Sun Gear, Rear Sun Gear, High and Low Reverse Clutch Hub .....	320
Vehicle Does Not Decelerate by Engine Brake .....	232	High and Low Reverse Clutch .....	325
<b>SHIFT CONTROL SYSTEM .....</b>	<b>234</b>	Direct Clutch .....	327
Control Device Removal and Installation .....	234	<b>ASSEMBLY .....</b>	<b>329</b>
Control Rod Removal and Installation .....	237	Assembly (1) .....	329
Adjustment of A/T Position .....	238	Adjustment .....	342
Checking of A/T Position .....	239	Assembly (2) .....	345
<b>A/T SHIFT LOCK SYSTEM .....</b>	<b>240</b>	<b>SERVICE DATA AND SPECIFICATIONS (SDS) .....</b>	<b>352</b>
Description .....	240	General Specifications .....	352
Shift Lock System Electrical Parts Location .....	240	Vehicle Speed at Which Gear Shifting Occurs .....	352
Wiring Diagram — AT — SHIFT .....	241	Vehicle Speed at Which Lock-Up Occurs/Releases .....	353
A/T Device Inspection Table .....	242	Stall Speed .....	353
Diagnostic Procedure .....	242	Line Pressure .....	353
<b>KEY INTERLOCK CABLE .....</b>	<b>245</b>	A/T Fluid Temperature Sensor .....	353
Components .....	245	Turbine Revolution Sensor .....	353
Removal and Installation .....	246	Vehicle Speed Sensor A/T (Revolution Sensor) .....	353
<b>ON-VEHICLE SERVICE .....</b>	<b>248</b>	Reverse Brake .....	354
Control Valve with TCM and A/T Fluid Temperature Sensor 2 .....	248	Total End Play .....	354
Parking Components (2WD Models Only) .....	260		

# INDEX FOR DTC

## INDEX FOR DTC

PF0:00024

### Alphabetical Index

ACS005W7

#### NOTE:

If DTC “U1000 CAN COMM CIRCUIT” is displayed with other DTCs, first perform the trouble diagnosis for “DTC U1000 CAN COMMUNICATION LINE”. Refer to [AT-110](#).

Items (CONSULT-II screen terms)	DTC		Reference page
	OBD-II	Except OBD-II	
	CONSULT-II or GST (*1)	CONSULT-II only “A/T”	
A/T 1ST E/BRAKING	—	P1731	<a href="#">AT-152</a>
ATF PRES SW 1/CIRC	—	P1841	<a href="#">AT-178</a>
ATF PRES SW 3/CIRC	—	P1843	<a href="#">AT-180</a>
ATF PRES SW 5/CIRC	—	P1845	<a href="#">AT-182</a>
ATF PRES SW 6/CIRC	—	P1846	<a href="#">AT-184</a>
A/T INTERLOCK	P1730	P1730	<a href="#">AT-149</a>
A/T TCC S/V FNCTN	P0744	P0744	<a href="#">AT-131</a>
ATF TEMP SEN/CIRC	P0710	P1710	<a href="#">AT-140</a>
CAN COMM CIRCUIT	U1000	U1000	<a href="#">AT-110</a>
D/C SOLENOID/CIRC	P1762	P1762	<a href="#">AT-162</a>
D/C SOLENOID FNCTN	P1764	P1764	<a href="#">AT-164</a>
ENGINE SPEED SIG	P0725	P0725	<a href="#">AT-127</a>
FR/B SOLENOID/CIRC	P1757	P1757	<a href="#">AT-158</a>
FR/B SOLENOID FNCT	P1759	P1759	<a href="#">AT-160</a>
HLR/C SOL/CIRC	P1767	P1767	<a href="#">AT-166</a>
HLR/C SOL FNCTN	P1769	P1769	<a href="#">AT-168</a>
I/C SOLENOID/CIRC	P1752	P1752	<a href="#">AT-154</a>
I/C SOLENOID FNCTN	P1754	P1754	<a href="#">AT-156</a>
L/PRESS SOL/CIRC	P0745	P0745	<a href="#">AT-133</a>
LC/B SOLENOID/CIRC	P1772	P1772	<a href="#">AT-170</a>
LC/B SOLENOID FNCT	P1774	P1774	<a href="#">AT-172</a>
MANU MODE SW/CIRC	—	P1815	<a href="#">AT-174</a>
PNP SW/CIRC	P0705	P0705	<a href="#">AT-118</a>
STARTER RELAY/CIRC	—	P0615	<a href="#">AT-113</a>
TCC SOLENOID/CIRC	P0740	P0740	<a href="#">AT-129</a>
TCM	P0700	P0700	<a href="#">AT-117</a>
TCM-RAM	—	P1702	<a href="#">AT-135</a>
TCM-ROM	—	P1703	<a href="#">AT-136</a>
TP SEN/CIRC A/T	P1705	P1705	<a href="#">AT-137</a>
TURBINE REV S/CIRC	P1716	P1716	<a href="#">AT-145</a>
VEH SPD SE/CIR-MTR	—	P1721	<a href="#">AT-147</a>
VEH SPD SEN/CIR AT	P0720	P0720	<a href="#">AT-122</a>

\*1: These numbers are prescribed by SAE J2012.

# INDEX FOR DTC

ACS005W8

## DTC No. Index

### NOTE:

If DTC “U1000 CAN COMM CIRCUIT” is displayed with other DTCs, first perform the trouble diagnosis for “DTC U1000 CAN COMMUNICATION LINE”. Refer to [AT-110](#).

DTC		Items (CONSULT-II screen terms)	Reference page
OBD-II CONSULT-II or GST (*1)	Except OBD-II CONSULT-II only “A/T”		
—	P0615	STARTER RELAY/CIRC	<a href="#">AT-113</a>
P0700	P0700	TCM	<a href="#">AT-117</a>
P0705	P0705	PNP SW/CIRC	<a href="#">AT-118</a>
P0710	P1710	ATF TEMP SEN/CIRC	<a href="#">AT-140</a>
P0720	P0720	VEH SPD SEN/CIR AT	<a href="#">AT-122</a>
P0725	P0725	ENGINE SPEED SIG	<a href="#">AT-127</a>
P0740	P0740	TCC SOLENOID/CIRC	<a href="#">AT-129</a>
P0744	P0744	A/T TCC S/V FNCTN	<a href="#">AT-131</a>
P0745	P0745	L/PRESS SOL/CIRC	<a href="#">AT-133</a>
—	P1702	TCM-RAM	<a href="#">AT-135</a>
—	P1703	TCM-ROM	<a href="#">AT-136</a>
P1705	P1705	TP SEN/CIRC A/T	<a href="#">AT-137</a>
P1716	P1716	TURBINE REV S/CIRC	<a href="#">AT-145</a>
—	P1721	VEH SPD SE/CIR-MTR	<a href="#">AT-147</a>
P1730	P1730	A/T INTERLOCK	<a href="#">AT-149</a>
—	P1731	A/T 1ST E/BRAKING	<a href="#">AT-152</a>
P1752	P1752	I/C SOLENOID/CIRC	<a href="#">AT-154</a>
P1754	P1754	I/C SOLENOID FNCTN	<a href="#">AT-156</a>
P1757	P1757	FR/B SOLENOID/CIRC	<a href="#">AT-158</a>
P1759	P1759	FR/B SOLENOID FNCT	<a href="#">AT-160</a>
P1762	P1762	D/C SOLENOID/CIRC	<a href="#">AT-162</a>
P1764	P1764	D/C SOLENOID FNCTN	<a href="#">AT-164</a>
P1767	P1767	HLR/C SOL/CIRC	<a href="#">AT-166</a>
P1769	P1769	HLR/C SOL FNCTN	<a href="#">AT-168</a>
P1772	P1772	LC/B SOLENOID/CIRC	<a href="#">AT-170</a>
P1774	P1774	LC/B SOLENOID FNCT	<a href="#">AT-172</a>
—	P1815	MANU MODE SW/CIRC	<a href="#">AT-174</a>
—	P1841	ATF PRES SW 1/CIRC	<a href="#">AT-178</a>
—	P1843	ATF PRES SW 3/CIRC	<a href="#">AT-180</a>
—	P1845	ATF PRES SW 5/CIRC	<a href="#">AT-182</a>
—	P1846	ATF PRES SW 6/CIRC	<a href="#">AT-184</a>
U1000	U1000	CAN COMM CIRCUIT	<a href="#">AT-110</a>

\*1: These numbers are prescribed by SAE J2012.

# PRECAUTIONS

## PRECAUTIONS

PPF:00001

### Precautions for Supplemental Restraint System (SRS) “AIR BAG” and “SEAT BELT PRE-TENSIONER”

ACS005W9

The Supplemental Restraint System such as “AIR BAG” and “SEAT BELT PRE-TENSIONER”, used along with a front seat belt, helps to reduce the risk or severity of injury to the driver and front passenger for certain types of collision. This system includes seat belt switch inputs and dual stage front air bag modules. The SRS system uses the seat belt switches to determine the front air bag deployment, and may only deploy one front air bag, depending on the severity of a collision and whether the front occupants are belted or unbelted. Information necessary to service the system safely is included in the SRS and SB section of this Service Manual.

#### **WARNING:**

- To avoid rendering the SRS inoperative, which could increase the risk of personal injury or death in the event of a collision which would result in air bag inflation, all maintenance must be performed by an authorized NISSAN/INFINITI dealer.
- Improper maintenance, including incorrect removal and installation of the SRS, can lead to personal injury caused by unintentional activation of the system. For removal of Spiral Cable and Air Bag Module, see the SRS section.
- Do not use electrical test equipment on any circuit related to the SRS unless instructed to in this Service Manual. SRS wiring harnesses can be identified by yellow and/or orange harnesses or harness connectors.

### Precautions for On Board Diagnostic (OBD) System of A/T and Engine

ACS005WA

The ECM has an on board diagnostic system. It will light up the malfunction indicator lamp (MIL) to warn the driver of a malfunction causing emission deterioration.

#### **CAUTION:**

- Be sure to turn the ignition switch OFF and disconnect the battery cable from the negative terminal before any repair or inspection work. The open/short circuit of related switches, sensors, solenoid valves, etc. will cause the MIL to light up.
- Be sure to connect and lock the connectors securely after work. A loose (unlocked) connector will cause the MIL to light up due to an open circuit. (Be sure the connector is free from water, grease, dirt, bent terminals, etc.)
- Be sure to route and secure the harnesses properly after work. Interference of the harness with a bracket, etc. may cause the MIL to light up due to a short circuit.
- Be sure to connect rubber tubes properly after work. A misconnected or disconnected rubber tube may cause the MIL to light up due to a malfunction of the EGR system or fuel injection system, etc.
- Be sure to erase the unnecessary malfunction information (repairs completed) from the TCM and ECM before returning the vehicle to the customer.

# PRECAUTIONS

## Precautions

ACS005WB

- Before connecting or disconnecting A/T assembly harness connector, turn ignition switch OFF and disconnect negative battery cable. Because battery voltage is applied to TCM even if ignition switch is turned OFF.

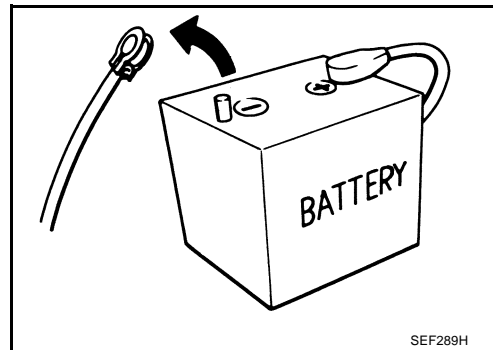

- After performing each TROUBLE DIAGNOSIS, perform "DTC Confirmation Procedure".  
If the repair is completed the DTC should not be displayed in the "DTC Confirmation Procedure".

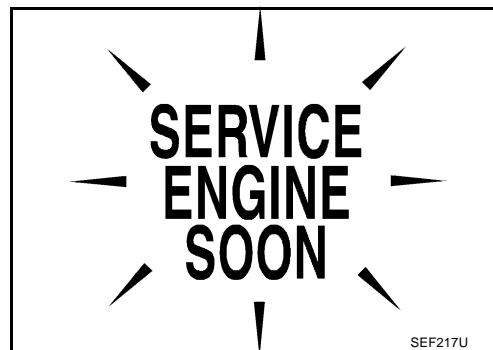

- Always use the specified brand of ATF. Refer to [MA-11, "Fluids and Lubricants"](#) .
- Use lint-free paper not cloth rags during work.
- After replacing the ATF, dispose of the waste oil using the methods prescribed by law, ordinance, etc.
- Before proceeding with disassembly, thoroughly clean the outside of the transmission. It is important to prevent the internal parts from becoming contaminated by dirt or other foreign matter.
- Disassembly should be done in a clean work area.
- Use lint-free paper for wiping parts clean. Common shop rags can leave fibers that could interfere with the operation of the transmission.
- Place disassembled parts in order for easier and proper assembly.
- All parts should be carefully cleaned with a general purpose, non-flammable solvent before inspection or reassembly.
- Gaskets, seals and O-rings should be replaced any time the transmission is disassembled.
- It is very important to perform functional tests whenever they are indicated.
- The valve body contains precision parts and requires extreme care when parts are removed and serviced. Place disassembled valve body parts in order for easier and proper assembly. Care will also prevent springs and small parts from becoming scattered or lost.
- Properly installed valves, sleeves, plugs, etc. will slide along bores in valve body under their own weight.
- Before assembly, apply a coat of recommended ATF to all parts. Apply petroleum jelly to protect O-rings and seals, or hold bearings and washers in place during assembly. Do not use grease.
- Extreme care should be taken to avoid damage to O-rings, seals and gaskets when assembling.
- Clean or replace A/T fluid cooler if excessive foreign material is found in oil pan or clogging strainer. Refer to [AT-9, "A/T FLUID COOLER SERVICE"](#) .
- After overhaul, refill the transmission with new ATF.
- When the drain plug is removed, only some of the fluid is drained. Old A/T fluid will remain in torque converter and A/T fluid cooling system.  
Always follow the procedures under "Changing A/T Fluid" in the AT section when changing A/T fluid. Refer to [AT-12, "Changing A/T Fluid"](#) , [AT-12, "Checking A/T Fluid"](#) .



# PRECAUTIONS

ACS005WC

## Service Notice or Precautions A/T FLUID COOLER SERVICE

If A/T fluid contains frictional material (clutches, bands, etc.), or if an A/T is repaired, overhauled, or replaced, inspect and clean the A/T fluid cooler mounted in the radiator or replace the radiator. Flush cooler lines using cleaning solvent and compressed air after repair. For A/T fluid cooler cleaning procedure, refer to [AT-14, "A/T Fluid Cooler Cleaning"](#) . For radiator replacement, refer to [CO-13, "RADIATOR"](#) , [CO-17, "RADIATOR \(ALUMINUM TYPE\)"](#) .

## OBD-II SELF-DIAGNOSIS

- A/T self-diagnosis is performed by the TCM in combination with the ECM. The results can be read through the blinking pattern of the A/T CHECK indicator lamp or the malfunction indicator lamp (MIL). Refer to the table on [AT-95, "SELF-DIAGNOSTIC RESULT MODE"](#) for the indicator used to display each self-diagnostic result.
- The self-diagnostic results indicated by the MIL are automatically stored in both the ECM and TCM memories.  
**Always perform the procedure on [AT-39, "HOW TO ERASE DTC"](#) to complete the repair and avoid unnecessary blinking of the MIL.**

For details of OBD-II, refer to [EC-47, "ON BOARD DIAGNOSTIC \(OBD\) SYSTEM"](#) .

- **Certain systems and components, especially those related to OBD, may use the new style slide-locking type harness connector. For description and how to disconnect, refer to [PG-69, "HARNESS CONNECTOR"](#) .**

A  
B  
AT  
D  
E  
F  
G  
H  
I  
J  
K  
L  
M

# PREPARATION

## PREPARATION

PFP:00002

### Special Service Tools

ACS005WE

The actual shapes of Kent-Moore tools may differ from those of special service tools illustrated here.

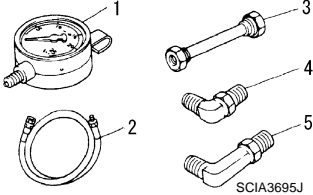
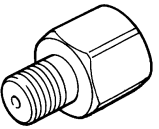
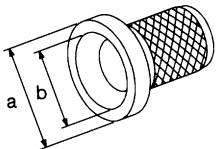
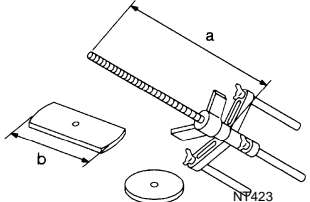
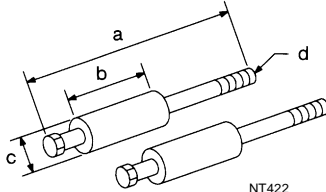
Tool number (Kent-Moore No.) Tool name	Description
ST2505S001 (J-34301-C) Oil pressure gauge set 1. ST25051001 ( — ) Oil pressure gauge 2. ST25052000 ( — ) Hose 3. ST25053000 ( — ) Joint pipe 4. ST25054000 ( — ) Adapter 5. ST25055000 ( — ) Adapter	Measuring line pressure 
KV31103600 (J-45674) Joint pipe adapter (With ST25054000)	Measuring line pressure  <p style="text-align: center;">ZZA1227D</p>
ST33400001 (J-26082) Drift a: 60 mm (2.36 in) dia. b: 47 mm (1.85 in) dia.	<ul style="list-style-type: none"> <li>● Installing rear oil seal (2WD models)</li> <li>● Installing oil pump housing oil seal</li> </ul>  <p style="text-align: center;">NT086</p>
KV31102400 (J-34285 and J-34285-87) Clutch spring compressor a: 320 mm (12.60 in) b: 174 mm (6.85 in)	Installing reverse brake return spring retainer  <p style="text-align: center;">NT423</p>
ST25850000 (J-25721-A) Sliding hammer a: 179 mm (7.05 in) b: 70 mm (2.76 in) c: 40 mm (1.57 in) d: M12X1.75P	Remove oil pump assembly  <p style="text-align: center;">NT422</p>

# PREPARATION

## Commercial Service Tools

ACS005WF

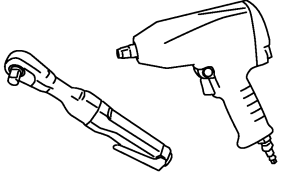
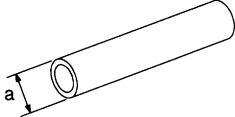
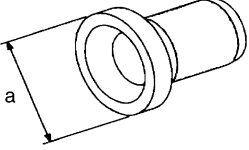
Tool name	Description
<p>Power tool</p>  <p>PBI0190E</p>	<p>Loosening bolts and nuts</p>
<p>Drift a: 22 mm (0.87 in) dia.</p>  <p>NT083</p>	<p>Installing manual shaft oil seals</p>
<p>Drift a: 64 mm (2.52 in) dia.</p>  <p>SCIA5338E</p>	<p>Installing rear oil seal (AWD models)</p>

A  
B  
**AT**  
D  
E  
F  
G  
H  
I  
J  
K  
L  
M

## A/T FLUID

PFP:KLE40

### Changing A/T Fluid

ACS005WG

1. Warm up ATF.
2. Stop engine.
3. Loosen the level gauge bolt.
4. Drain ATF from drain plug and refill with new ATF. Always refill same volume with drained ATF.
  - To replace the ATF, pour in new ATF at the A/T fluid charging pipe with the engine idling and at the same time drain the old ATF from the radiator cooler hose return side.
  - When the color of the ATF coming out is about the same as the color of the new ATF, the replacement is complete. The amount of new ATF to use should be 30 to 50% increase of the stipulated amount.

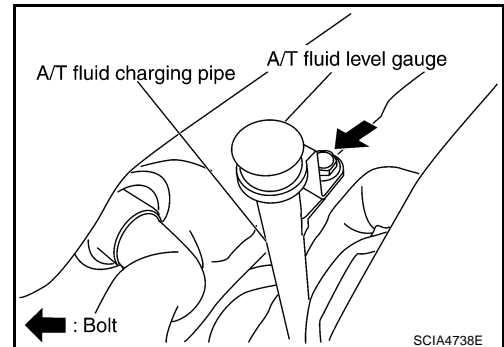

**ATF: Genuine NISSAN Matic J ATF**

**Fluid capacity: 10.3 ℓ (10-7/8 US qt, 9-1/8 Imp qt)**

#### CAUTION:

- Use only Genuine NISSAN Matic J ATF. Do not mix with other ATF.
- Using ATF other than Genuine NISSAN Matic J ATF will cause deterioration in driveability and automatic transmission durability, and may damage the automatic transmission, which is not covered by the warranty.
- When filling ATF, take care not to scatter heat generating parts such as exhaust.
- Do not reuse drain plug gasket.

**Drain plug:**

 : 34 N·m (3.5 kg·m, 25 ft·lb)

5. Run engine at idle speed for 5 minutes.
6. Check A/T fluid level and condition. Refer to [AT-12. "Checking A/T Fluid"](#) . If ATF is still dirty, repeat step 2. through 5.
7. Install the removed A/T fluid level gauge in the A/T fluid charging pipe.
8. Tighten the level gauge bolt.

**Level gauge bolt:**

 : 5.1 N·m (0.52 kg·m, 45 in·lb)

### Checking A/T Fluid

ACS005WH

1. Warm up engine.
2. Check for A/T fluid leakage.
3. Loosen the level gauge bolt.
4. Before driving, A/T fluid level can be checked at A/T fluid temperatures of 30 to 50°C (86 to 122°F) using "COLD" range on A/T fluid level gauge as follows.
  - a. Park vehicle on level surface and set parking brake.
  - b. Start engine and move selector lever through each gear position. Leave selector lever in "P" position.
  - c. Check A/T fluid level with engine idling.
  - d. Remove A/T fluid level gauge and wipe clean with lint-free paper.

#### CAUTION:

**When wiping away the A/T fluid level gauge, always use lint-free paper, not a cloth one.**

- e. Reinsert A/T fluid level gauge into A/T fluid charging pipe as far as it will go.

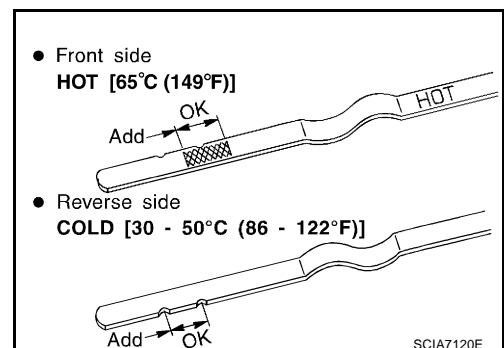

# A/T FLUID

## CAUTION:

To check A/T fluid level, insert the A/T fluid level gauge until the cap contacts the end of the A/T fluid charging pipe, with the A/T fluid level gauge reversed from the normal attachment conditions.

- f. Remove A/T fluid level gauge and note reading. If reading is at low side of range, add ATF to the A/T fluid charging pipe.

## CAUTION:

Do not overfill.

5. Drive vehicle for approximately 5 minutes in urban areas.
6. Make the A/T fluid temperature approximately 65°C (149°F).

## NOTE:

A/T fluid level will be greatly affected by temperature as shown in figure. Therefore, be certain to perform operation while checking data with CONSULT-II.

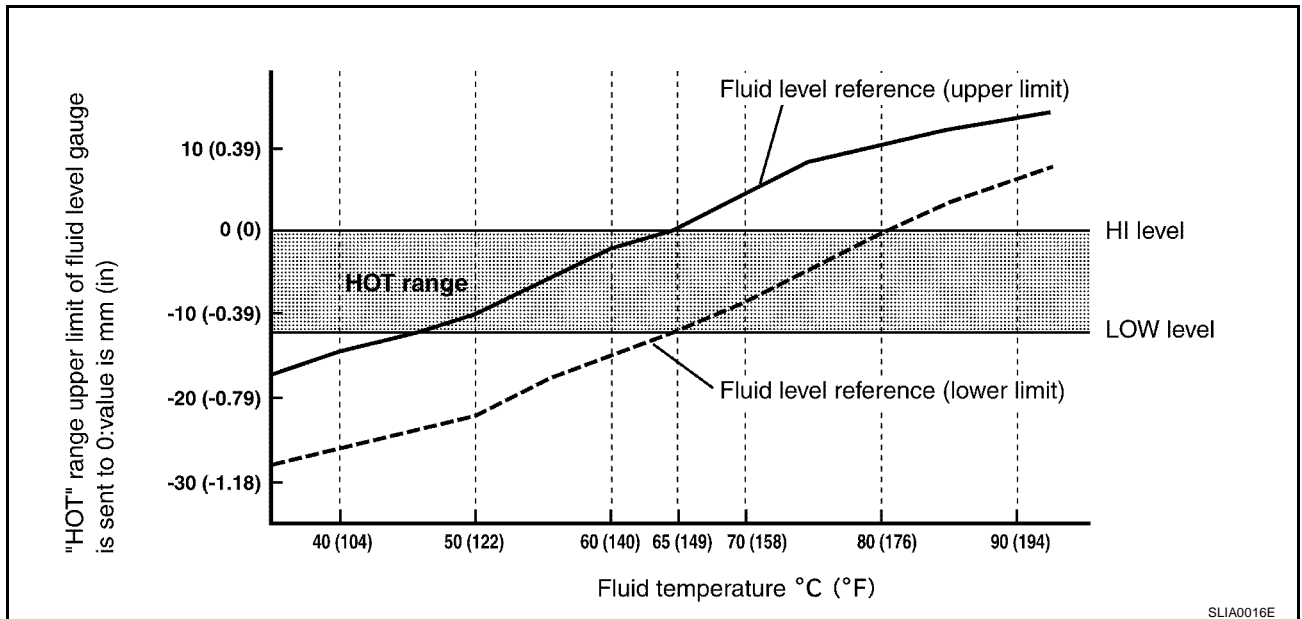

- a. Connect CONSULT-II to data link connector. Refer to [AT-94, "CONSULT-II SETTING PROCEDURE"](#).
- b. Select "MAIN SIGNALS" in "DATA MONITOR" mode for "A/T" with CONSULT-II.
- c. Read out the value of "ATF TEMP 1".
7. Recheck A/T fluid level at A/T fluid temperatures of approximately 65°C (149°F) using "HOT" range on A/T fluid level gauge.

## CAUTION:

- When wiping away the A/T fluid level gauge, always use lint-free paper, not a cloth one.
- To check A/T fluid level, insert the A/T fluid level gauge until the cap contacts the end of the A/T fluid charging pipe, with the A/T fluid level gauge reversed from the normal attachment conditions as shown.

8. Check ATF condition.

- If ATF is very dark or smells burned, check operation of A/T. Flush cooling system after repair of A/T.
- If ATF contains frictional material (clutches, bands, etc.), replace radiator and flush cooler line using cleaning solvent and compressed air after repair of A/T. Refer to [CO-13, "RADIATOR"](#) and [AT-14, "A/T Fluid Cooler Cleaning"](#).

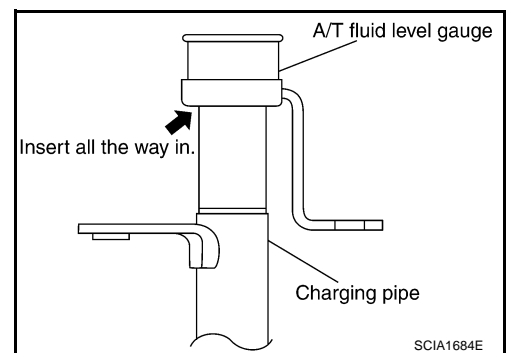

# A/T FLUID

9. Install the removed A/T fluid level gauge in the A/T fluid charging pipe.
10. Tighten the level gauge bolt.

### Level gauge bolt:

 : 5.1 N·m (0.52 kg-m, 45 in-lb)

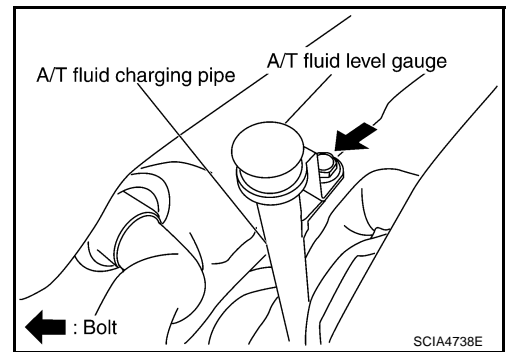

## A/T Fluid Cooler Cleaning

ACS005W

Whenever an automatic transmission is replaced, the A/T fluid cooler mounted in the radiator must be inspected and cleaned.

Metal debris and friction material, if present, can become trapped in the A/T fluid cooler. This debris can contaminate the newly serviced A/T or, in severe cases, can block or restrict the flow of A/T fluid. In either case, malfunction of the newly serviced A/T may result.

Debris, if present, may build up as A/T fluid enters the cooler inlet. It will be necessary to back flush the cooler through the cooler outlet in order to flush out any built up debris.

### A/T FLUID COOLER CLEANING PROCEDURE

1. Position an oil pan under the automatic transmission's inlet and outlet cooler hoses.
2. Identify the inlet and outlet fluid cooler hoses.
3. Disconnect the fluid cooler inlet and outlet rubber hoses from the steel cooler tubes or bypass valve.

#### NOTE:

Replace the cooler hoses if rubber material from the hose remains on the tube fitting.

4. Allow any A/T fluid that remains in the cooler hoses to drain into the oil pan.

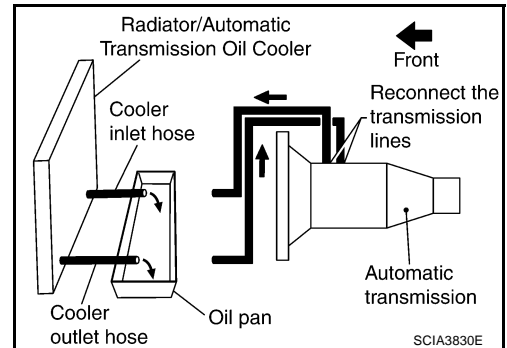

5. Insert the extension adapter hose of a can of Transmission Cooler Cleaner (Nissan P/N 999MP-AM006) into the cooler outlet hose.

#### CAUTION:

- Wear safety glasses and rubber gloves when spraying the Transmission Cooler Cleaner.
- Spray cooler cleaner only with adequate ventilation.
- Avoid contact with eyes and skin.
- Do not breath vapors or spray mist.

6. Hold the hose and can as high as possible and spray Transmission Cooler Cleaner in a continuous stream into the cooler outlet hose until fluid flows out of the cooler inlet hose for 5 seconds.

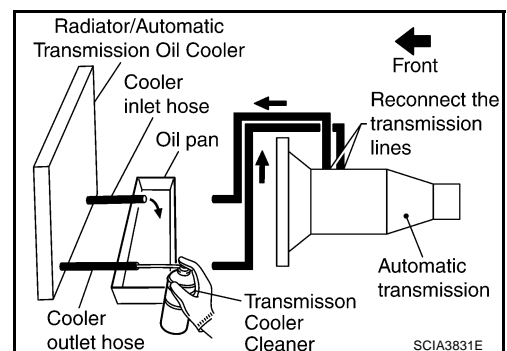

## A/T FLUID

7. Insert the tip of an air gun into the end of the cooler outlet hose.
8. Wrap a shop rag around the air gun tip and of the cooler outlet hose.
9. Blow compressed air regulated to 5 to 9 kg/cm<sup>2</sup> (70 to 130 psi) through the cooler outlet hose for 10 seconds to force out any remaining fluid.
10. Repeat steps 5 through 9 three additional times.
11. Position an oil pan under the banjo bolts that connect the fluid cooler steel lines to the transmission.
12. Remove the banjo bolts.
13. Flush each steel line from the cooler side back toward the transmission by spraying Transmission Cooler Cleaner in a continuous stream for 5 seconds.
14. Blow compressed air regulated to 5 to 9 kg/cm<sup>2</sup> (70 to 130 psi) through each steel line from the cooler side back toward the transmission for 10 seconds to force out any remaining fluid.
15. Ensure all debris is removed from the steel cooler lines.
16. Ensure all debris is removed from the banjo bolts and fittings.
17. Perform [AT-15, "A/T FLUID COOLER DIAGNOSIS PROCEDURE"](#).

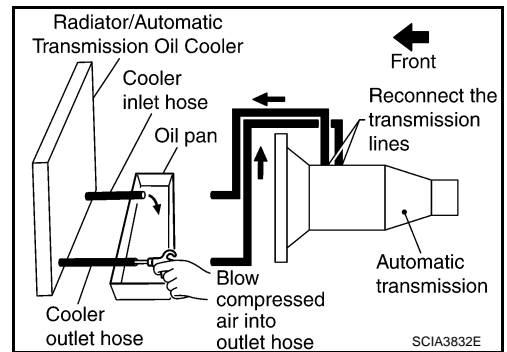

### A/T FLUID COOLER DIAGNOSIS PROCEDURE

#### NOTE:

Insufficient cleaning of the cooler inlet hose exterior may lead to inaccurate debris identification.

1. Position an oil pan under the automatic transmission's inlet and outlet cooler hoses.
2. Clean the exterior and tip of the cooler inlet hose.
3. Insert the extension adapter hose of a can of Transmission Cooler Cleaner (Nissan P/N 999MP-AM006) into the cooler outlet hose.

#### CAUTION:

- Wear safety glasses and rubber gloves when spraying the Transmission Cooler Cleaner.
  - Spray cooler cleaner only with adequate ventilation.
  - Avoid contact with eyes and skin.
  - Do not breath vapors or spray mist.
4. Hold the hose and can as high as possible and spray Transmission Cooler Cleaner in a continuous stream into the cooler outlet hose until fluid flows out of the cooler inlet hose for 5 seconds.
  5. Tie a common white, basket-type coffee filter to the end of the cooler inlet hose.

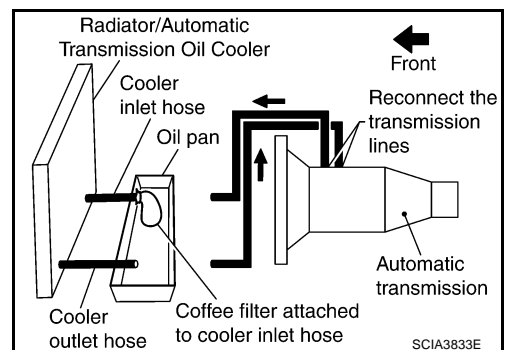
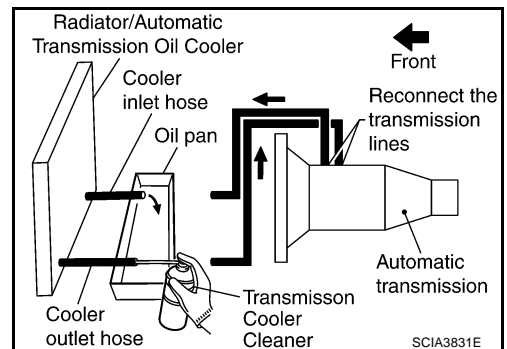

## A/T FLUID

6. Insert the tip of an air gun into the end of the cooler outlet hose.
7. Wrap a shop rag around the air gun tip and end of cooler outlet hose.
8. Blow compressed air regulated to 5 to 9 kg/cm<sup>2</sup> (70 to 130 psi) through the cooler outlet hose to force any remaining A/T fluid into the coffee filter.
9. Remove the coffee filter from the end of the cooler inlet hose.
10. Perform [AT-16, "A/T FLUID COOLER INSPECTION PROCEDURE"](#).

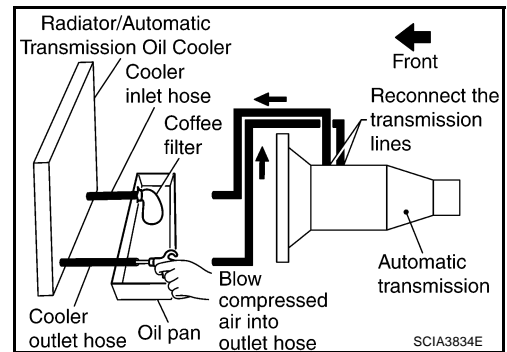

### A/T FLUID COOLER INSPECTION PROCEDURE

1. Inspect the coffee filter for debris.
  - a. If small metal debris less than 1 mm (0.040 in) in size or metal powder is found in the coffee filter, this is normal. If normal debris is found, the A/T fluid cooler/radiator can be re-used and the procedure is ended.
  - b. If one or more pieces of debris are found that are over 1 mm (0.040 in) size and/or peeled clutch facing material is found in the coffee filter, the fluid cooler is not serviceable. The A/T fluid cooler/radiator must be replaced and the inspection procedure is ended. Refer to [CO-13, "RADIATOR"](#), [CO-17, "RADIATOR \(ALUMINUM TYPE\)"](#).

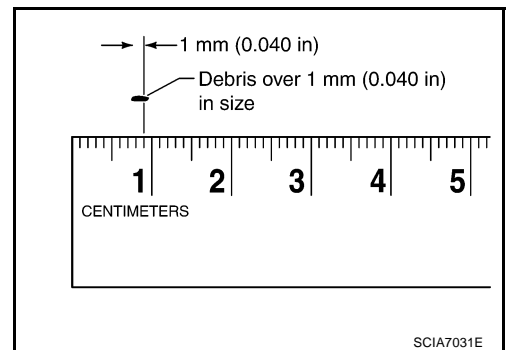
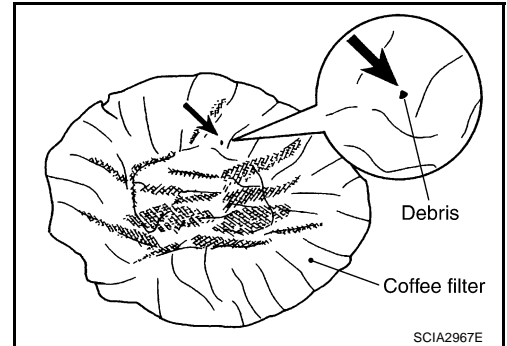

### A/T FLUID COOLER FINAL INSPECTION

After performing all procedures, ensure that all remaining oil is cleaned from all components.



# A/T CONTROL SYSTEM

## A/T CONTROL SYSTEM

PFP:31036

### Cross-Sectional View (2WD Models)

ACS005WJ

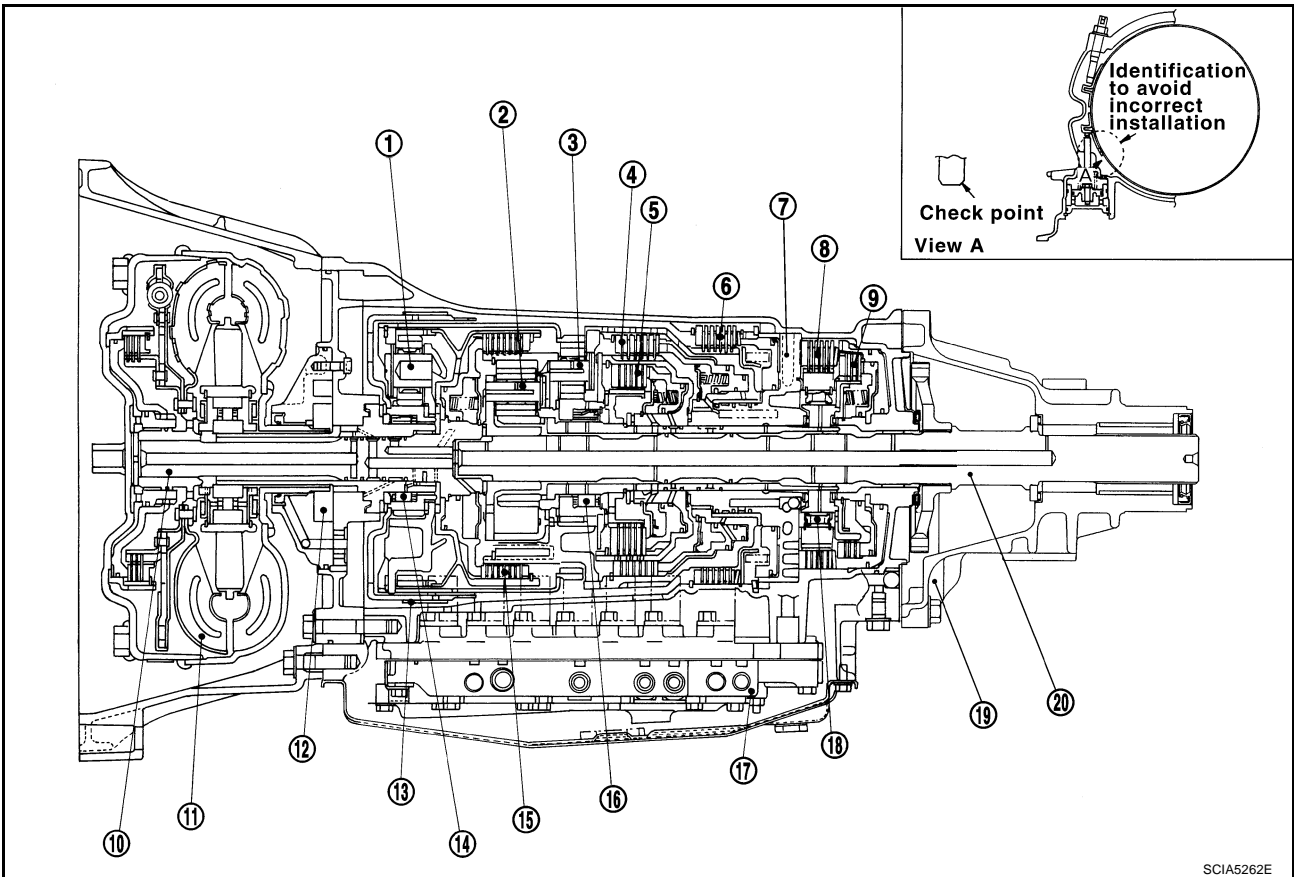

- |                         |                                |                            |
|-------------------------|--------------------------------|----------------------------|
| 1. Front planetary gear | 2. Mid planetary gear          | 3. Rear planetary gear     |
| 4. Direct clutch        | 5. High and low reverse clutch | 6. Reverse brake           |
| 7. Drum support         | 8. Forward brake               | 9. Low coast brake         |
| 10. Input shaft         | 11. Torque converter           | 12. Oil pump               |
| 13. Front brake         | 14. 3rd one-way clutch         | 15. Input clutch           |
| 16. 1st one-way clutch  | 17. Control valve with TCM     | 18. Forward one-way clutch |
| 19. Rear extension      | 20. Output shaft               |                            |

SCIA5262E

# A/T CONTROL SYSTEM

## Cross-Sectional View (AWD Models)

ACS005WK

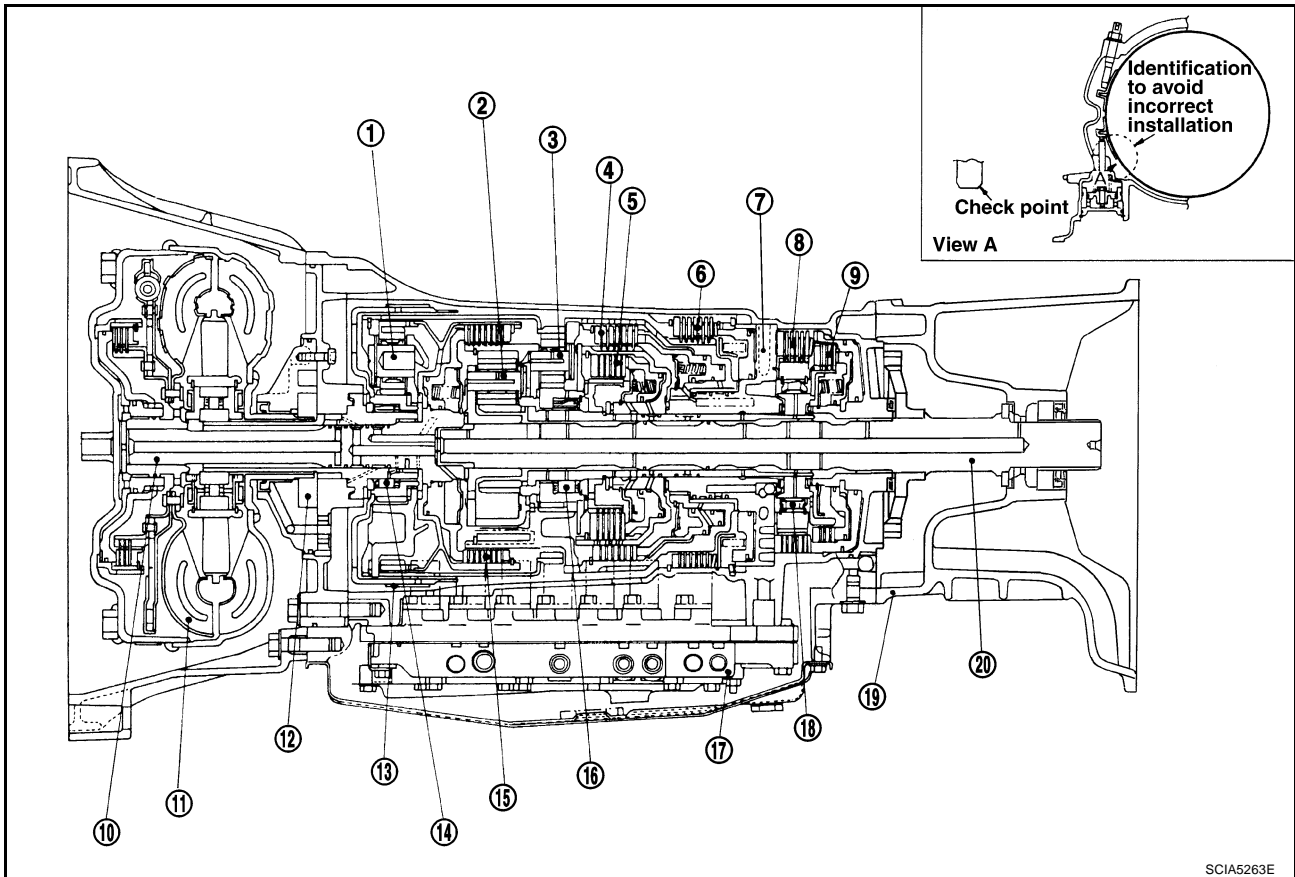

SCIA5263E

- |                         |                                |                            |
|-------------------------|--------------------------------|----------------------------|
| 1. Front planetary gear | 2. Mid planetary gear          | 3. Rear planetary gear     |
| 4. Direct clutch        | 5. High and low reverse clutch | 6. Reverse brake           |
| 7. Drum support         | 8. Forward brake               | 9. Low coast brake         |
| 10. Input shaft         | 11. Torque converter           | 12. Oil pump               |
| 13. Front brake         | 14. 3rd one-way clutch         | 15. Input clutch           |
| 16. 1st one-way clutch  | 17. Control valve with TCM     | 18. Forward one-way clutch |
| 19. Adapter case        | 20. Output shaft               |                            |

# A/T CONTROL SYSTEM

ACS005WL

## Shift Mechanism

The automatic transmission uses compact triple planetary gear systems to improve power-transmission efficiency, simplify construction and reduce weight. It also employs an optimum shift control and super wide gear ratios. They improve starting performance and acceleration during medium and high-speed operation.

## CONSTRUCTION

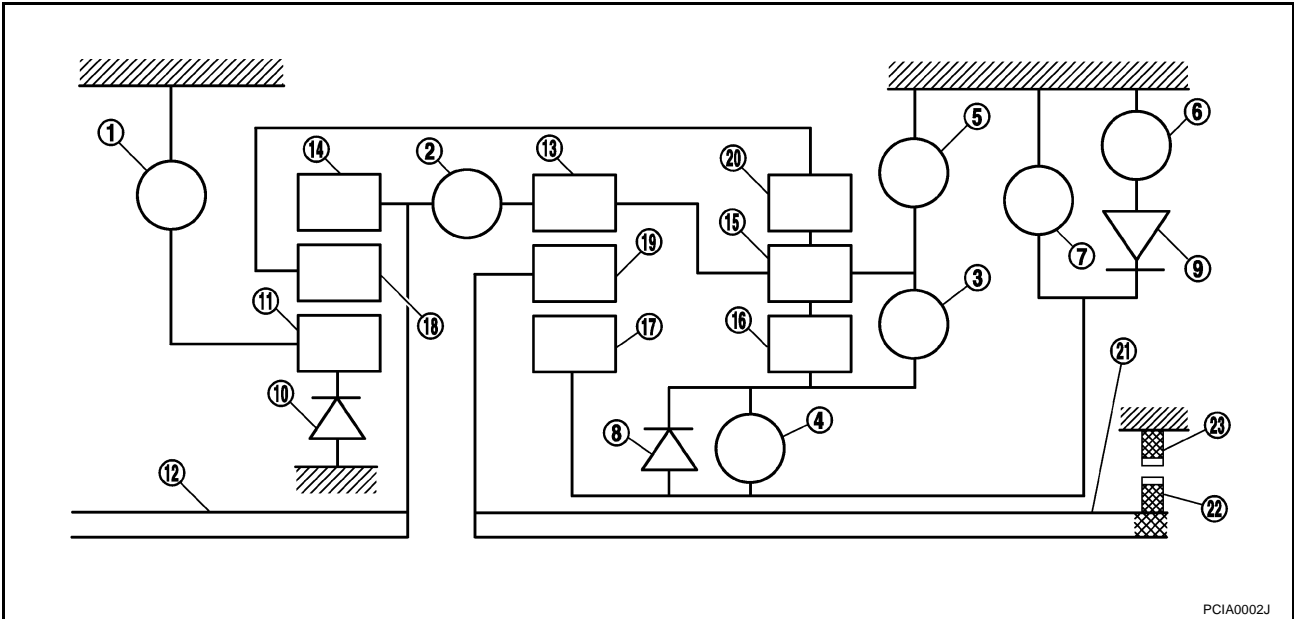

- |                                |                         |                           |
|--------------------------------|-------------------------|---------------------------|
| 1. Front brake                 | 2. Input clutch         | 3. Direct clutch          |
| 4. High and low reverse clutch | 5. Reverse brake        | 6. Forward brake          |
| 7. Low coast brake             | 8. 1st one-way clutch   | 9. Forward one-way clutch |
| 10. 3rd one-way clutch         | 11. Front sun gear      | 12. Input shaft           |
| 13. Mid internal gear          | 14. Front internal gear | 15. Rear carrier          |
| 16. Rear sun gear              | 17. Mid sun gear        | 18. Front carrier         |
| 19. Mid carrier                | 20. Rear internal gear  | 21. Output shaft          |
| 22. Parking gear               | 23. Parking pawl        |                           |

## FUNCTION OF CLUTCH AND BRAKE

Name of the Part	Abbreviation	Function
Front brake (1)	FR/B	Fastens the front sun gear (11).
Input clutch (2)	I/C	Connects the input shaft (12), the front internal gear (14) and the mid internal gear (13).
Direct clutch (3)	D/C	Connects the rear carrier (15) and the rear sun gear (16).
High and low reverse clutch (4)	HLR/C	Connects the mid sun gear (17) and the rear sun gear (16).
Reverse brake (5)	R/B	Fastens the rear carrier (15).
Forward brake (6)	Fwd/B	Fastens the mid sun gear (17).
Low coast brake (7)	LC/B	Fastens the mid sun gear (17).
1st one-way clutch (8)	1st OWC	Allows the rear sun gear (16) to turn freely forward relative to the mid sun gear (17) but fastens it for reverse rotation.
Forward one-way clutch (9)	Fwd OWC	Allows the mid sun gear (17) to turn freely in the forward direction but fastens it for reverse rotation.
3rd one-way clutch (10)	3rd OWC	Allows the front sun gear (11) to turn freely in the forward direction but fastens it for reverse rotation.

# A/T CONTROL SYSTEM

## CLUTCH AND BAND CHART

Shift position	I/C	HLR/C	D/C	R/B	FR/B	LC/B	Fwd/B	1st OWC	Fwd OWC	3rd OWC	Remarks
P		△			△						PARK POSITION
R		○		○	○			◎		◎	REVERSE POSITION
N		△			△						NEUTRAL POSITION
D	1st	△ *			△	△ **	○	◎	◎	◎	Automatic shift 1↔2↔3↔4↔5
	2nd		○		△		○		◎	◎	
	3rd		○	○		○	△	◇		◎	
	4th	○	○	○			△	◇			
	5th	○	○			○	△	◇		◇	
M5	5th	○	○				△	◇		◇	Locks* (held stationary) in 5th gear
M4	4th	○	○	○			△	◇			Locks* (held stationary) in 4th gear
M3	3rd		○	○		○	△	◇		◎	Locks* (held stationary) in 3rd gear
M2	2nd			○		○	○		◎	◎	Locks* (held stationary) in 2nd gear
M1	1st		○			○	○	◎	◎	◎	Locks* (held stationary) in 1st gear

○ – Operates

◎ – Operates during “progressive” acceleration.

◇ – Operates and affects power transmission while coasting.

△ – Line pressure is applied but does not affect power transmission.

△ \* – Operates under conditions shown in illustration ①.

△ \*\* – Operates under conditions shown in illustration ②. Delay control is applied during D(4,3,2,1) → N shift.

\* : Down shift automatically according to the vehicle speed.

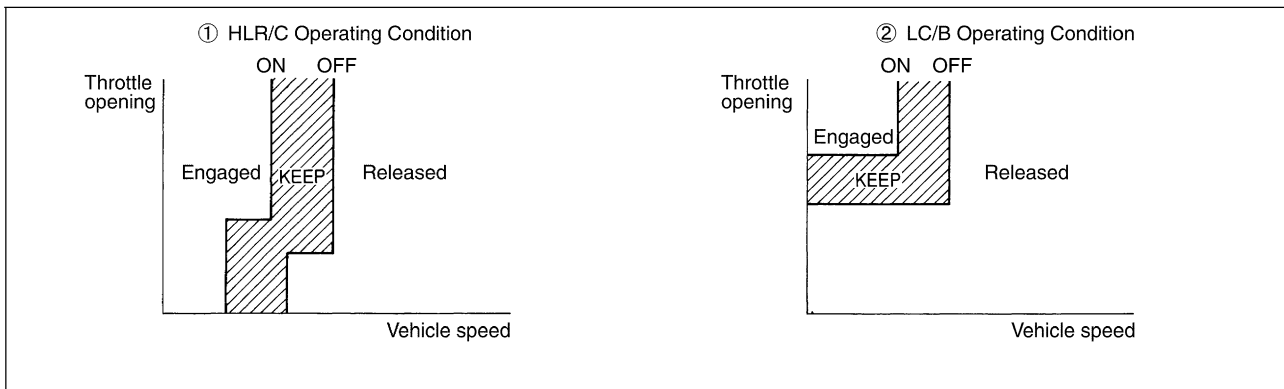

SCIA6962E

# A/T CONTROL SYSTEM

## POWER TRANSMISSION

### “N” Position

Since both the forward brake and the reverse brake are released, torque from the input shaft drive is not transmitted to the output shaft.

### “P” Position

- The same as for the “N” position, both the forward brake and the reverse brake are released, so torque from the input shaft drive is not transmitted to the output shaft.
- The parking pawl linked with the selector lever meshes with the parking gear and fastens the output shaft mechanically.

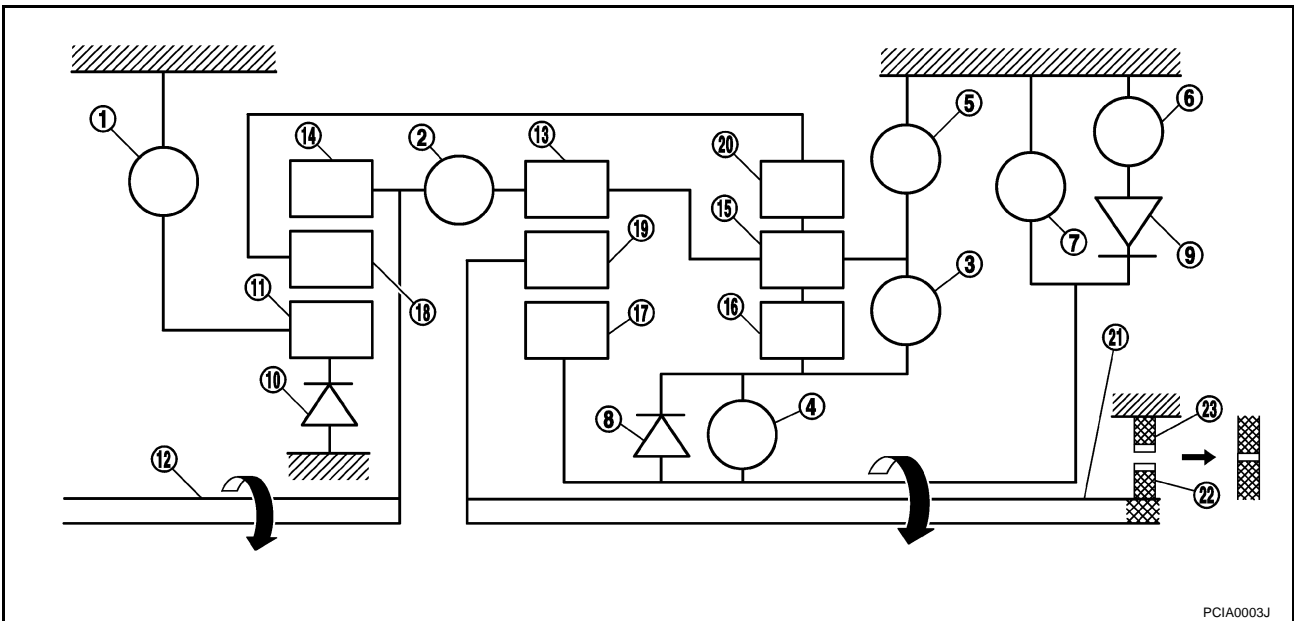

- |                                |                         |                           |
|--------------------------------|-------------------------|---------------------------|
| 1. Front brake                 | 2. Input clutch         | 3. Direct clutch          |
| 4. High and low reverse clutch | 5. Reverse brake        | 6. Forward brake          |
| 7. Low coast brake             | 8. 1st one-way clutch   | 9. Forward one-way clutch |
| 10. 3rd one-way clutch         | 11. Front sun gear      | 12. Input shaft           |
| 13. Mid internal gear          | 14. Front internal gear | 15. Rear carrier          |
| 16. Rear sun gear              | 17. Mid sun gear        | 18. Front carrier         |
| 19. Mid carrier                | 20. Rear internal gear  | 21. Output shaft          |
| 22. Parking gear               | 23. Parking pawl        |                           |

# A/T CONTROL SYSTEM

## “D1 ” Position

- The forward brake and the forward one-way clutch regulate reverse rotation of the mid sun gear.
- The 1st one-way clutch regulates reverse rotation of the rear sun gear.
- The 3rd one-way clutch regulates reverse rotation of the front sun gear.
- During deceleration, the mid sun gear turns forward, so the forward one-way clutch idles and the engine brake is not activated.

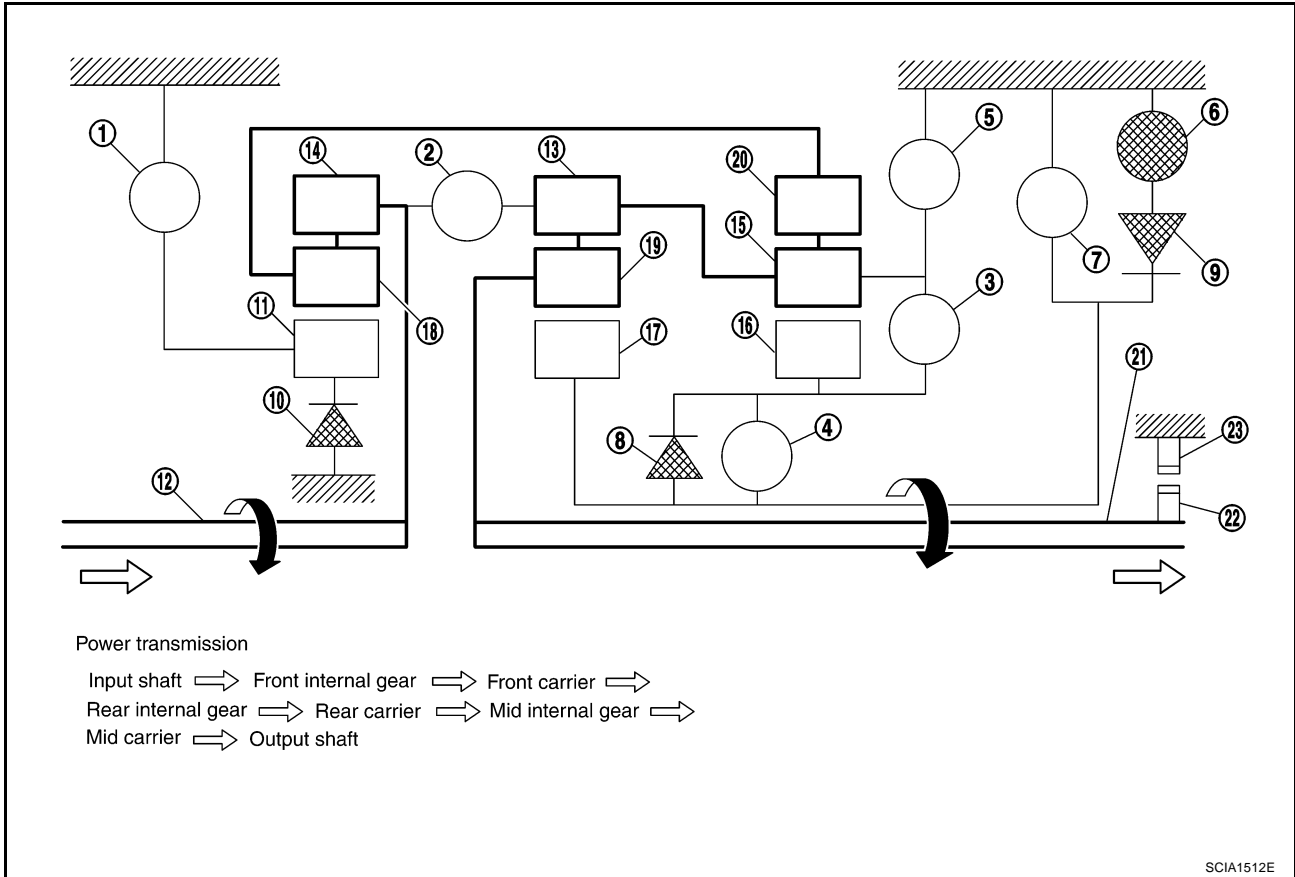

- |                                |                         |                           |
|--------------------------------|-------------------------|---------------------------|
| 1. Front brake                 | 2. Input clutch         | 3. Direct clutch          |
| 4. High and low reverse clutch | 5. Reverse brake        | 6. Forward brake          |
| 7. Low coast brake             | 8. 1st one-way clutch   | 9. Forward one-way clutch |
| 10. 3rd one-way clutch         | 11. Front sun gear      | 12. Input shaft           |
| 13. Mid internal gear          | 14. Front internal gear | 15. Rear carrier          |
| 16. Rear sun gear              | 17. Mid sun gear        | 18. Front carrier         |
| 19. Mid carrier                | 20. Rear internal gear  | 21. Output shaft          |
| 22. Parking gear               | 23. Parking pawl        |                           |

# A/T CONTROL SYSTEM

## “M1” Position

- The front brake fastens the front sun gear.
- The forward brake and the forward one-way clutch regulate reverse rotation of the mid sun gear.
- High and low reverse clutch connects the rear sun gear and the mid sun gear.
- The low coast brake fastens the mid sun gear.
- During deceleration, the low coast brake regulates forward rotation of the mid sun gear and the engine brake functions.

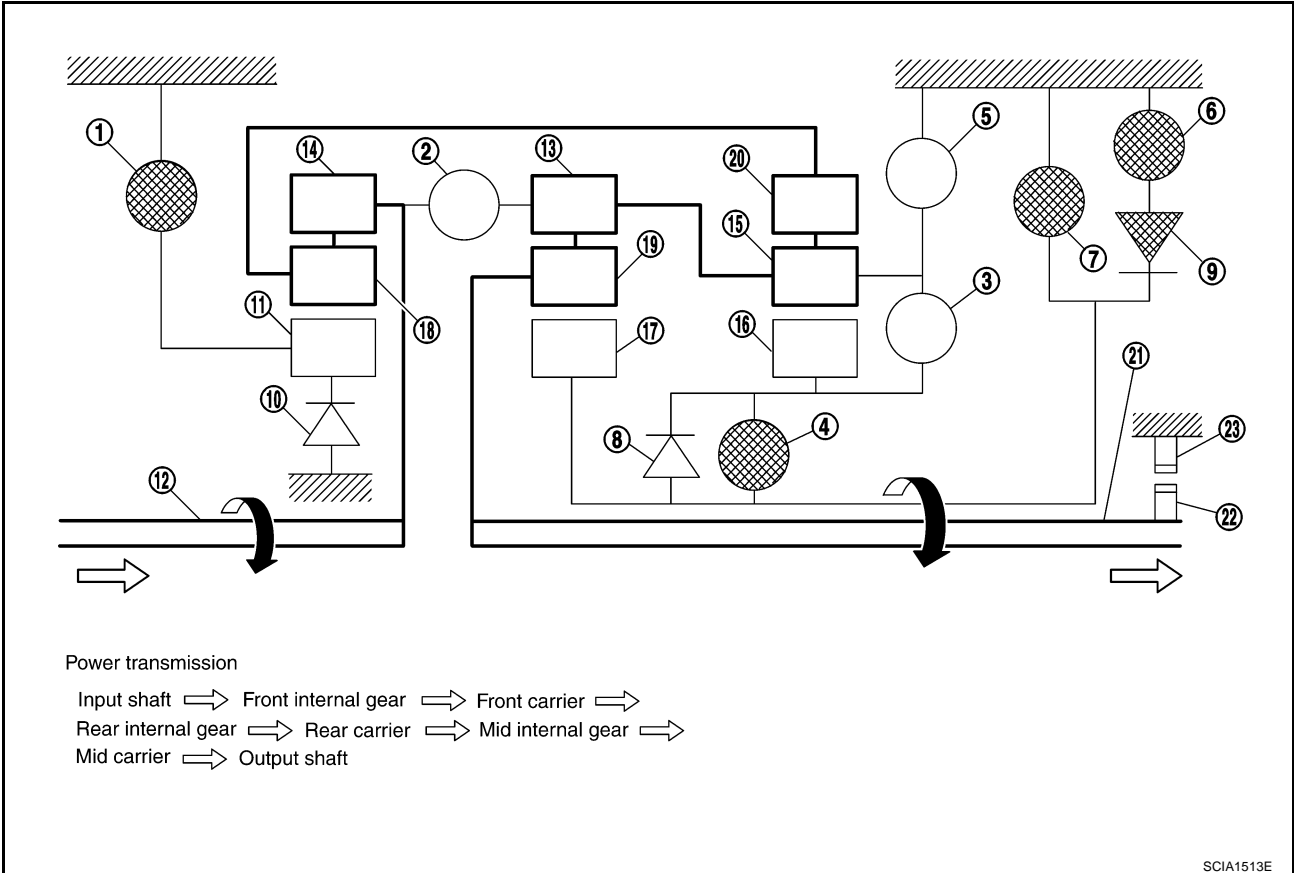

- |                                |                         |                           |
|--------------------------------|-------------------------|---------------------------|
| 1. Front brake                 | 2. Input clutch         | 3. Direct clutch          |
| 4. High and low reverse clutch | 5. Reverse brake        | 6. Forward brake          |
| 7. Low coast brake             | 8. 1st one-way clutch   | 9. Forward one-way clutch |
| 10. 3rd one-way clutch         | 11. Front sun gear      | 12. Input shaft           |
| 13. Mid internal gear          | 14. Front internal gear | 15. Rear carrier          |
| 16. Rear sun gear              | 17. Mid sun gear        | 18. Front carrier         |
| 19. Mid carrier                | 20. Rear internal gear  | 21. Output shaft          |
| 22. Parking gear               | 23. Parking pawl        |                           |

# A/T CONTROL SYSTEM

## “D2 ” Position

- The forward brake and the forward one-way clutch regulate reverse rotation of the mid sun gear.
- The 3rd one-way clutch regulates reverse rotation of the front sun gear.
- The direct clutch is coupled, and the rear carrier and rear sun gear are connected.
- During deceleration, the mid sun gear turns forward, so the forward one-way clutch idles and engine brake is not activated.

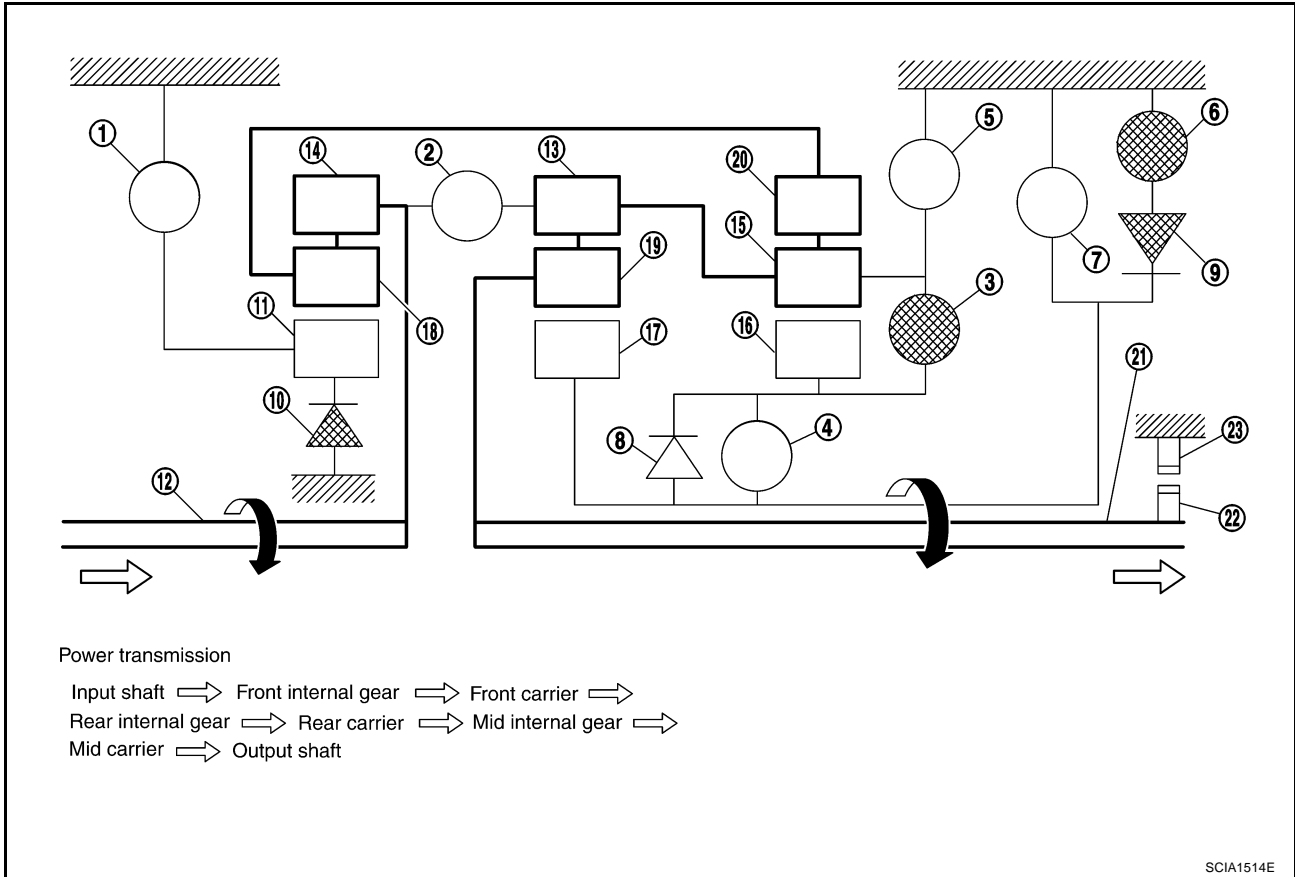

- |                                |                         |                           |
|--------------------------------|-------------------------|---------------------------|
| 1. Front brake                 | 2. Input clutch         | 3. Direct clutch          |
| 4. High and low reverse clutch | 5. Reverse brake        | 6. Forward brake          |
| 7. Low coast brake             | 8. 1st one-way clutch   | 9. Forward one-way clutch |
| 10. 3rd one-way clutch         | 11. Front sun gear      | 12. Input shaft           |
| 13. Mid internal gear          | 14. Front internal gear | 15. Rear carrier          |
| 16. Rear sun gear              | 17. Mid sun gear        | 18. Front carrier         |
| 19. Mid carrier                | 20. Rear internal gear  | 21. Output shaft          |
| 22. Parking gear               | 23. Parking pawl        |                           |



# A/T CONTROL SYSTEM

## “M2” Position

- The front brake fastens the front sun gear.
- The forward brake and the forward one-way clutch regulate reverse rotation of the mid sun gear.
- The direct clutch is coupled, and the rear carrier and rear sun gear are connected.
- The low coast brake fastens the mid sun gear.
- During deceleration, the low coast brake regulates forward rotation of the mid sun gear and the engine brake functions.

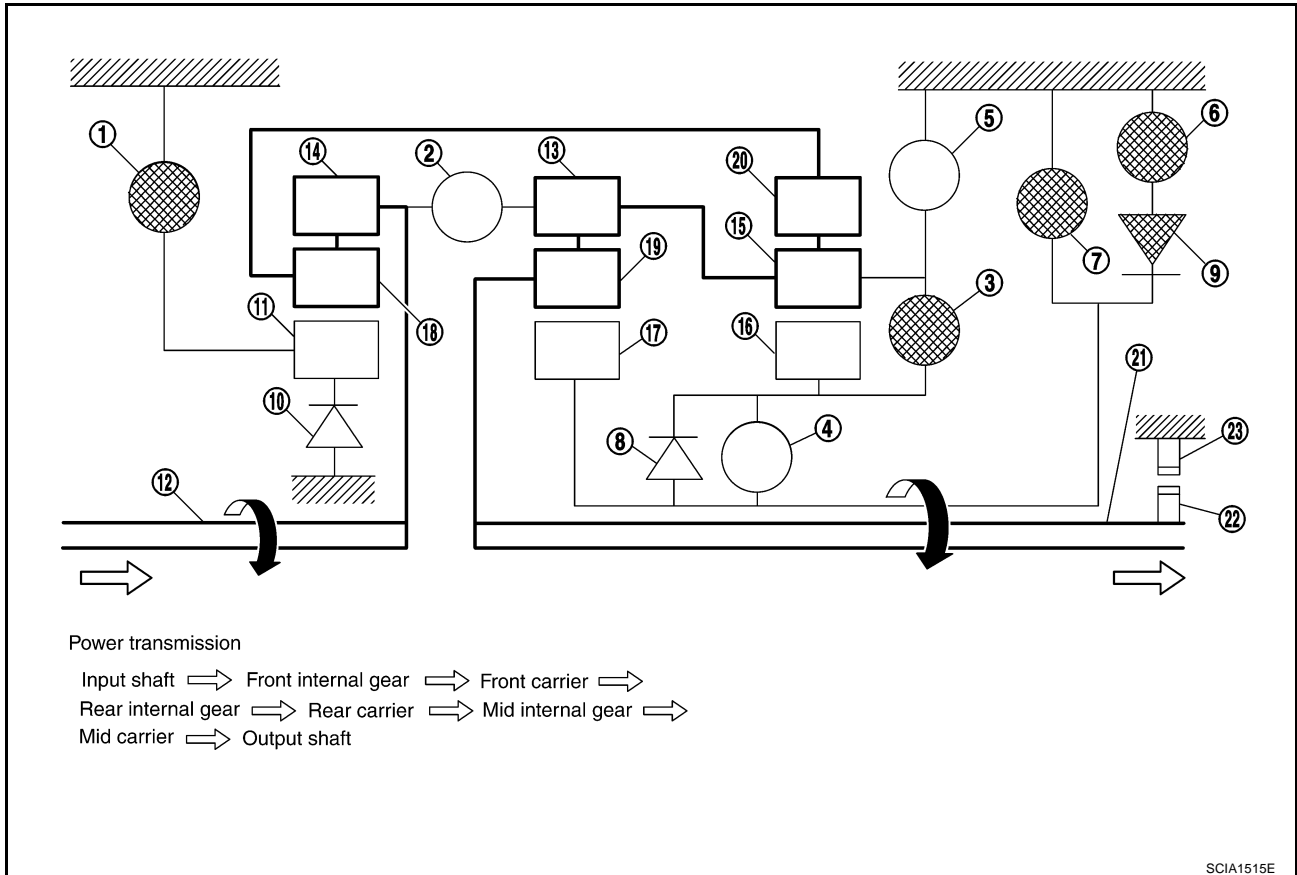

- |                                |                         |                           |
|--------------------------------|-------------------------|---------------------------|
| 1. Front brake                 | 2. Input clutch         | 3. Direct clutch          |
| 4. High and low reverse clutch | 5. Reverse brake        | 6. Forward brake          |
| 7. Low coast brake             | 8. 1st one-way clutch   | 9. Forward one-way clutch |
| 10. 3rd one-way clutch         | 11. Front sun gear      | 12. Input shaft           |
| 13. Mid internal gear          | 14. Front internal gear | 15. Rear carrier          |
| 16. Rear sun gear              | 17. Mid sun gear        | 18. Front carrier         |
| 19. Mid carrier                | 20. Rear internal gear  | 21. Output shaft          |
| 22. Parking gear               | 23. Parking pawl        |                           |

A  
B  
AT  
D  
E  
F  
G  
H  
I  
J  
K  
L  
M

# A/T CONTROL SYSTEM

## “D3 ” and “M3” Positions

- The front brake fastens the front sun gear.
- The direct clutch is coupled, and the rear carrier and rear sun gear are connected.
- The high and low reverse clutch is coupled, and the mid sun gear and rear sun gear are connected.

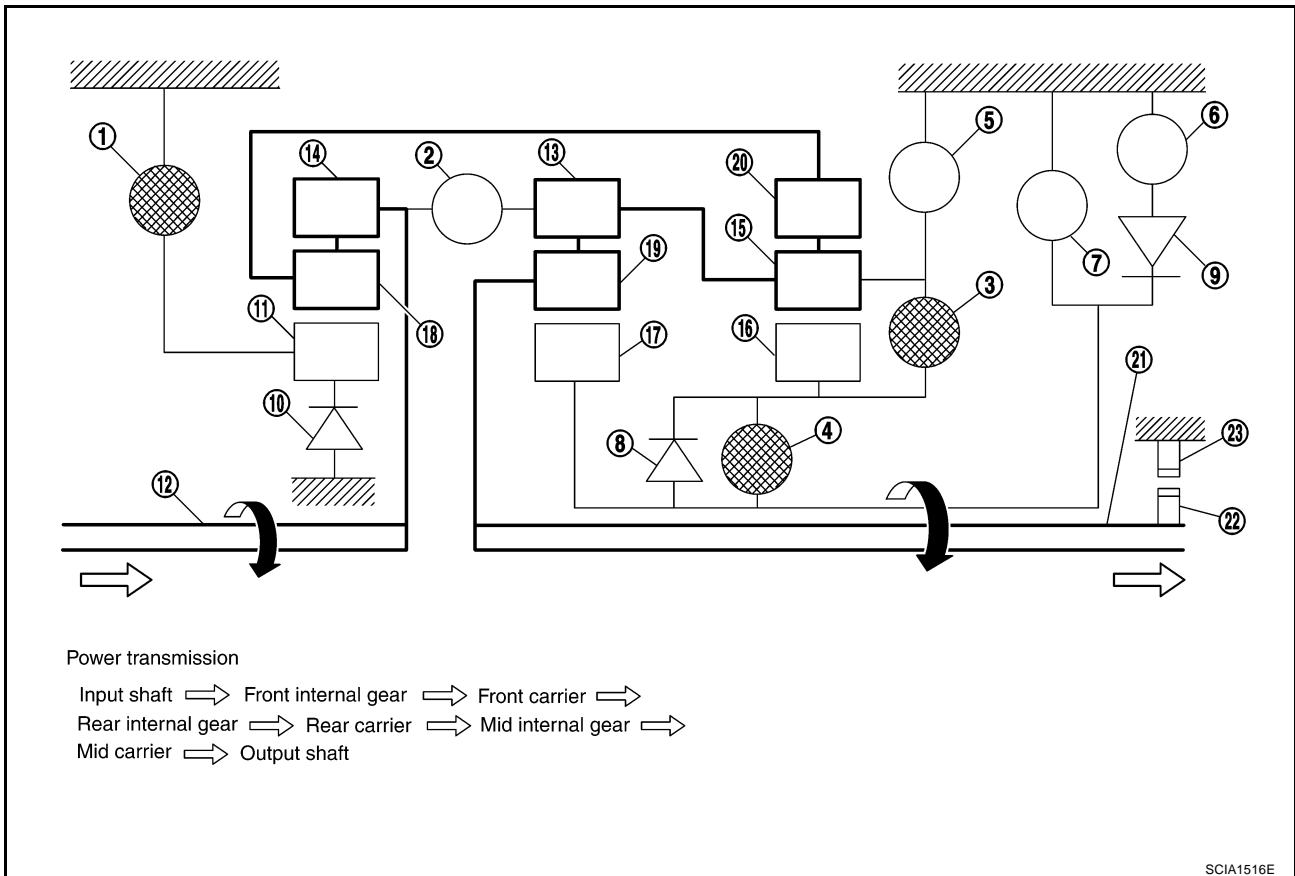

- |                                |                         |                           |
|--------------------------------|-------------------------|---------------------------|
| 1. Front brake                 | 2. Input clutch         | 3. Direct clutch          |
| 4. High and low reverse clutch | 5. Reverse brake        | 6. Forward brake          |
| 7. Low coast brake             | 8. 1st one-way clutch   | 9. Forward one-way clutch |
| 10. 3rd one-way clutch         | 11. Front sun gear      | 12. Input shaft           |
| 13. Mid internal gear          | 14. Front internal gear | 15. Rear carrier          |
| 16. Rear sun gear              | 17. Mid sun gear        | 18. Front carrier         |
| 19. Mid carrier                | 20. Rear internal gear  | 21. Output shaft          |
| 22. Parking gear               | 23. Parking pawl        |                           |

# A/T CONTROL SYSTEM

## “D4 ” and “M4” Positions

- The direct clutch is coupled, and the rear carrier and rear sun gear are connected.
- The high and low reverse clutch is coupled, and the mid sun gear and rear sun gear are connected.
- The input clutch is coupled, and the front internal gear and mid internal gear are connected.
- The drive power is conveyed to the front internal gear, mid internal gear, and rear carrier and the three planetary gears rotate forward as one unit.

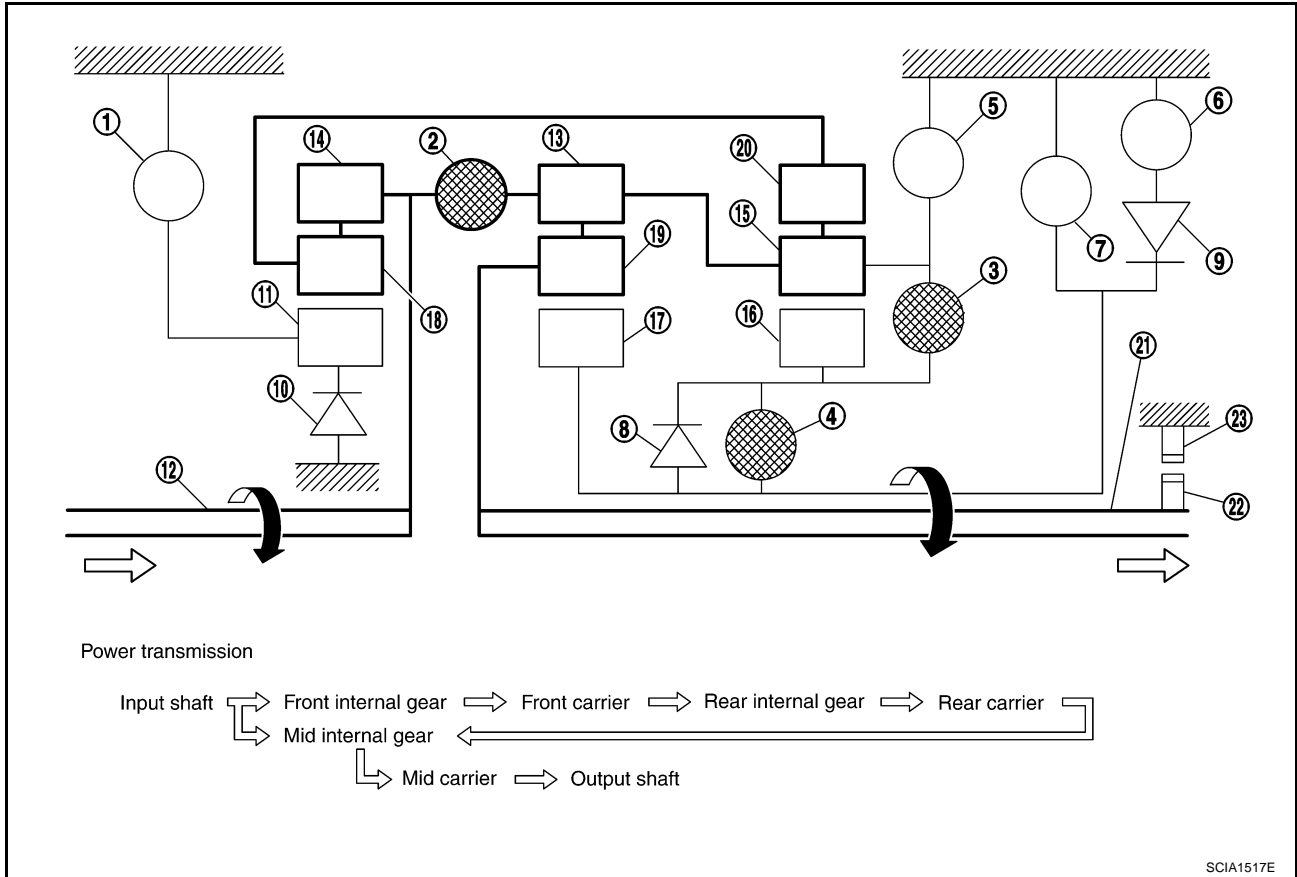

- |                                |                         |                           |
|--------------------------------|-------------------------|---------------------------|
| 1. Front brake                 | 2. Input clutch         | 3. Direct clutch          |
| 4. High and low reverse clutch | 5. Reverse brake        | 6. Forward brake          |
| 7. Low coast brake             | 8. 1st one-way clutch   | 9. Forward one-way clutch |
| 10. 3rd one-way clutch         | 11. Front sun gear      | 12. Input shaft           |
| 13. Mid internal gear          | 14. Front internal gear | 15. Rear carrier          |
| 16. Rear sun gear              | 17. Mid sun gear        | 18. Front carrier         |
| 19. Mid carrier                | 20. Rear internal gear  | 21. Output shaft          |
| 22. Parking gear               | 23. Parking pawl        |                           |

# A/T CONTROL SYSTEM

## “D5” and “M5” Positions

- The front brake fastens the front sun gear.
- The input clutch is coupled, and the front internal gear and mid internal gear are connected.
- The high and low reverse clutch is coupled, and the mid sun gear and rear sun gear are connected.

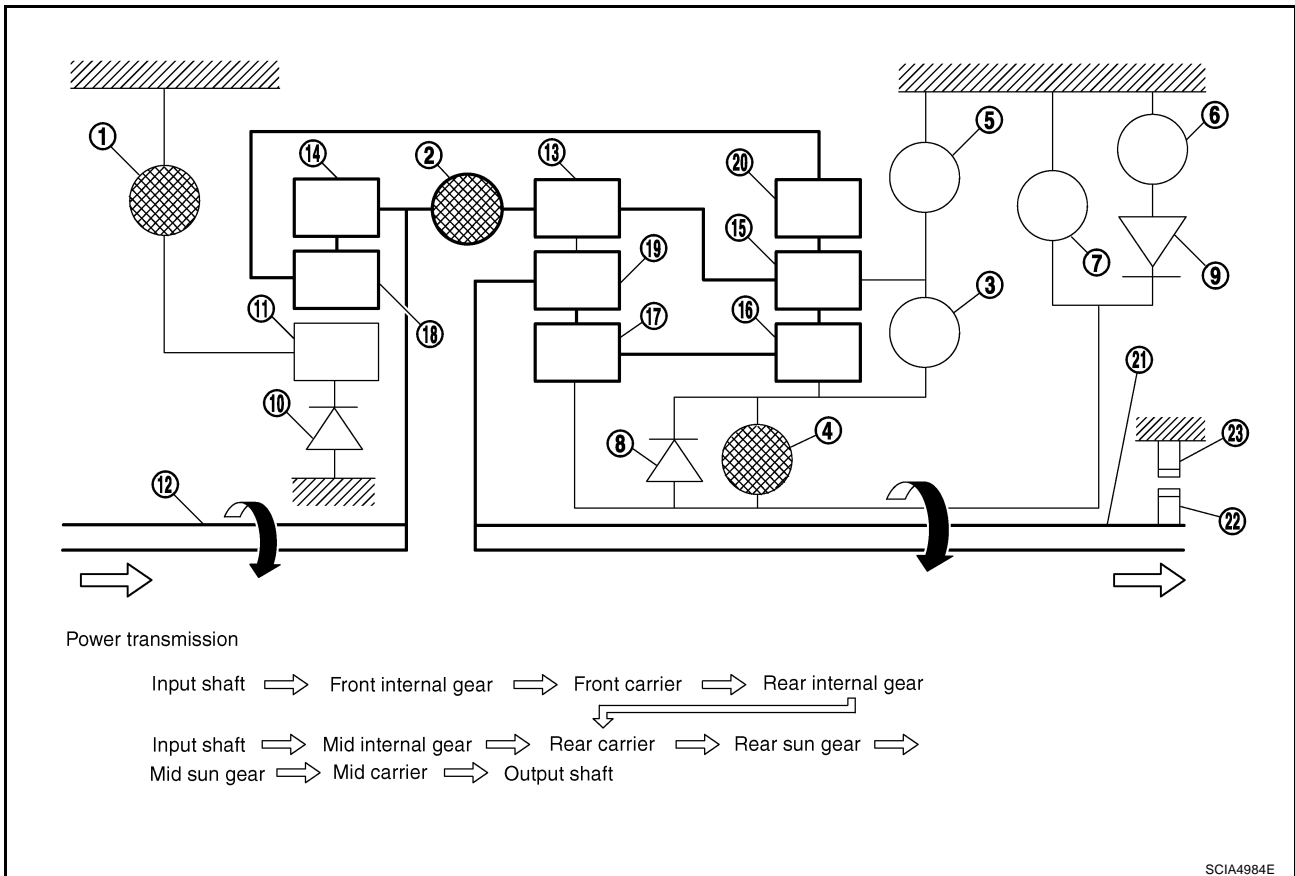

- |                                |                         |                           |
|--------------------------------|-------------------------|---------------------------|
| 1. Front brake                 | 2. Input clutch         | 3. Direct clutch          |
| 4. High and low reverse clutch | 5. Reverse brake        | 6. Forward brake          |
| 7. Low coast brake             | 8. 1st one-way clutch   | 9. Forward one-way clutch |
| 10. 3rd one-way clutch         | 11. Front sun gear      | 12. Input shaft           |
| 13. Mid internal gear          | 14. Front internal gear | 15. Rear carrier          |
| 16. Rear sun gear              | 17. Mid sun gear        | 18. Front carrier         |
| 19. Mid carrier                | 20. Rear internal gear  | 21. Output shaft          |
| 22. Parking gear               | 23. Parking pawl        |                           |



# A/T CONTROL SYSTEM

ACS005WM

## TCM Function

The function of the TCM is to:

- Receive input signals sent from various switches and sensors.
- Determine required line pressure, shifting point, lock-up operation, and engine brake operation.
- Send required output signals to the respective solenoids.

## CONTROL SYSTEM OUTLINE

The automatic transmission senses vehicle operating conditions through various sensors or signals. It always controls the optimum shift position and reduces shifting and lock-up shocks.

SENSORS (or SIGNALS)		TCM		ACTUATORS
PNP switch Accelerator pedal position signal Closed throttle position signal Wide open throttle position signal Engine speed signal A/T fluid temperature sensor Revolution sensor Vehicle speed signal Manual mode switch signal Stop lamp switch signal Turbine revolution sensor ATF pressure switch	⇒	Shift control Line pressure control Lock-up control Engine brake control Timing control Fail-safe control Self-diagnosis CONSULT-II communication line Duet-EA control CAN system	⇒	Input clutch solenoid valve Direct clutch solenoid valve Front brake solenoid valve High and low reverse clutch solenoid valve Low coast brake solenoid valve Torque converter clutch solenoid valve Line pressure solenoid valve A/T CHECK indicator lamp Back-up lamp relay Starter relay

## CONTROL SYSTEM DIAGRAM

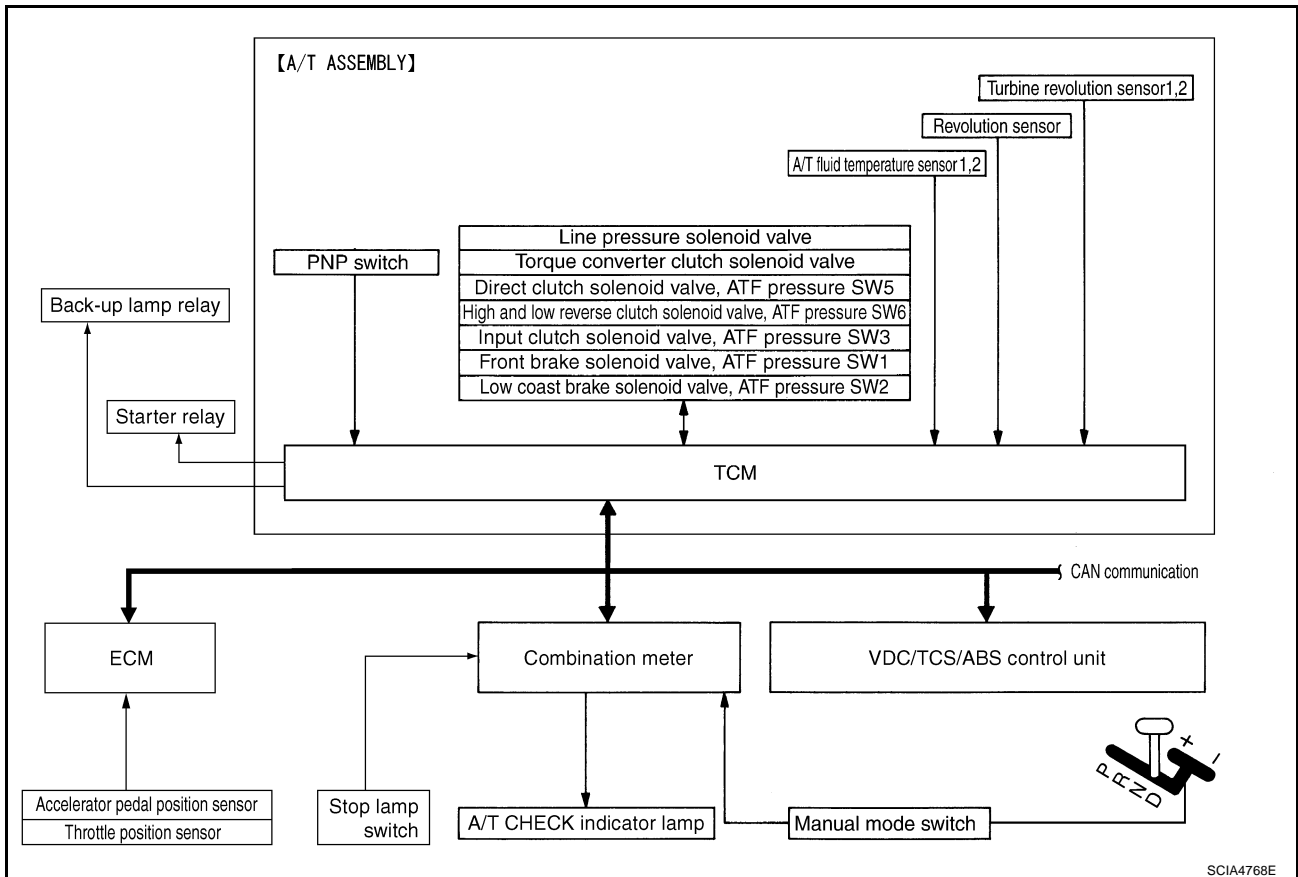

SCIA4768E

# A/T CONTROL SYSTEM

## CAN Communication SYSTEM DESCRIPTION

ACS005WN

CAN (Controller Area Network) is a serial communication line for real time application. It is an on-vehicle multiplex communication line with high data communication speed and excellent error detection ability. Many electronic control units are equipped onto a vehicle, and each control unit shares information and links with other control units during operation (not independent). In CAN communication, control units are connected with 2 communication lines (CAN H line, CAN L line) allowing a high rate of information transmission with less wiring. Each control unit transmits/receives data but selectively reads required data only. For details, refer to [LAN-21, "CAN Communication Unit"](#).

## Input/Output Signal of TCM

ACS005WO

Control item		Line pressure control	Vehicle speed control	Shift control	Lock-up control	Engine brake control	Fail-safe function (*3)	Self-diagnostics function
Input	Accelerator pedal position signal (*5)	X	X	X	X	X	X	X
	Vehicle speed sensor A/T (revolution sensor)	X	X	X	X	X	X	X
	Vehicle speed sensor MTR(*1) (*5)						X	
	Closed throttle position signal(*5)		X (*2)	X	X		X	X (*4)
	Wide open throttle position signal(*5)						X	X (*4)
	Turbine revolution sensor 1		X		X	X	X	X
	Turbine revolution sensor 2 (for 4th speed only)		X		X	X	X	X
	Engine speed signals(*5)	X	X	X	X	X	X	X
	Stop lamp switch signal(*5)		X	X	X			X (*4)
	A/T fluid temperature sensors 1, 2	X	X	X	X		X	X
	ASCD	Operation signal(*5)		X	X	X		
Overdrive cancel signal(*5)			X					
Output	Direct clutch solenoid (ATF pressure switch 5)		X	X			X	X
	Input clutch solenoid (ATF pressure switch 3)		X	X			X	X
	High and low reverse clutch solenoid (ATF pressure switch 6)		X	X			X	X
	Front brake solenoid (ATF pressure switch 1)		X	X			X	X
	Low coast brake solenoid (ATF pressure switch 2)		X	X		X	X	X
	Line pressure solenoid	X	X	X	X	X	X	X
	TCC solenoid				X		X	X
	Self-diagnostics table(*6)							X
Starter relay						X	X	

\*1: Spare for vehicle speed sensor-A/T (revolution sensor)

\*2: Spare for accelerator pedal position signal

\*3: If these input and output signals are different, the TCM triggers the fail-safe function.

\*4: Used as a condition for starting self-diagnostics; if self-diagnostics are not started, it is judged that there is some kind of error.

\*5: Input by CAN communications

\*6: Output by CAN communications

# A/T CONTROL SYSTEM

ACS005WP

## Line Pressure Control

- When an input torque signal equivalent to the engine drive force is sent from the ECM to the TCM, the TCM controls the line pressure solenoid.
- This line pressure solenoid controls the pressure regulator valve as the signal pressure and adjusts the pressure of the operating oil discharged from the oil pump to the line pressure most appropriate to the driving state.

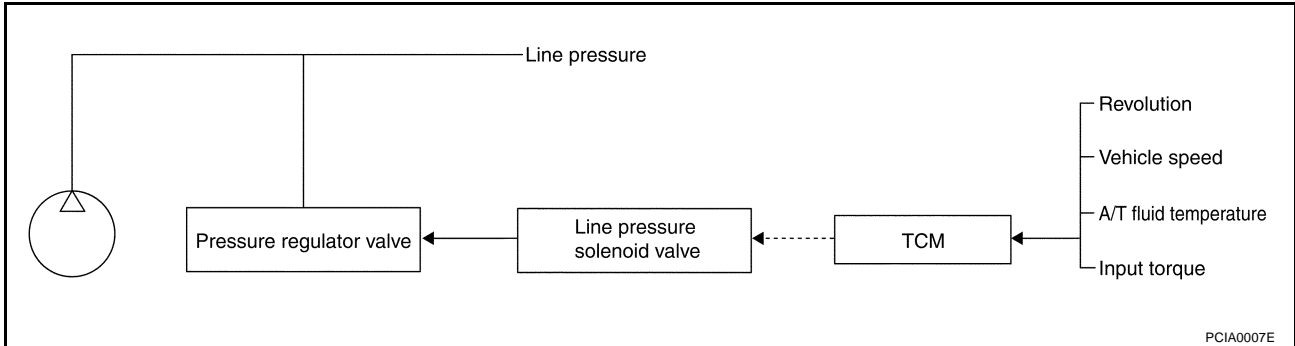

## LINE PRESSURE CONTROL IS BASED ON THE TCM LINE PRESSURE CHARACTERISTIC PATTERN

- The TCM has stored in memory a number of patterns for the optimum line pressure characteristic for the driving state.
- In order to obtain the most appropriate line pressure characteristic to meet the current driving state, the TCM controls the line pressure solenoid current value and thus controls the line pressure.

### Normal Control

Each clutch is adjusted to the necessary pressure to match the engine drive force.

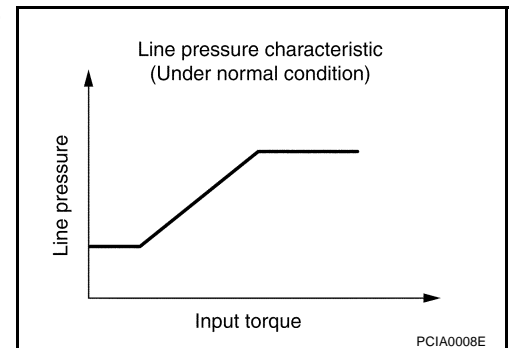

### Back-up Control (Engine Brake)

When the select operation is performed during driving and the transmission is shifted down, the line pressure is set according to the vehicle speed.

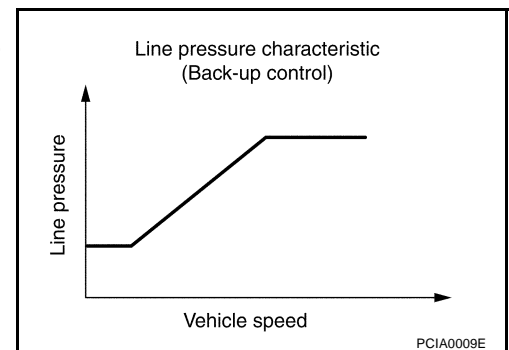



# A/T CONTROL SYSTEM

## During Shift Change

The necessary and adequate line pressure for shift change is set. For this reason, line pressure pattern setting corresponds to input torque and gearshift selection. Also, line pressure characteristic is set according to engine speed, during engine brake operation.

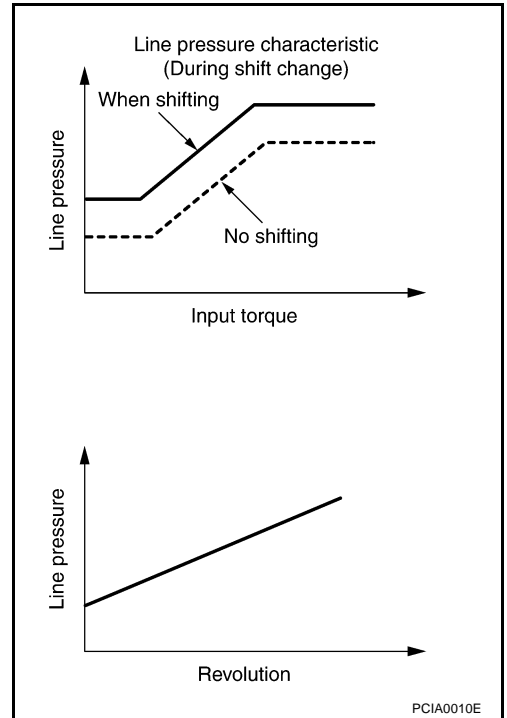

## At Low Fluid Temperature

When the A/T fluid temperature drops below the prescribed temperature, in order to speed up the action of each friction element, the line pressure is set higher than the normal line pressure characteristic.

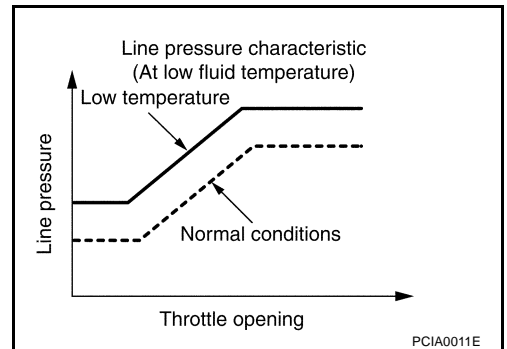

## Shift Control

The clutch pressure control solenoid is controlled by the signals from the switches and sensors. Thus, the clutch pressure is adjusted to be appropriate to the engine load state and vehicle driving state. It becomes possible to finely control the clutch hydraulic pressure with high precision and a smoother shift change characteristic is attained.

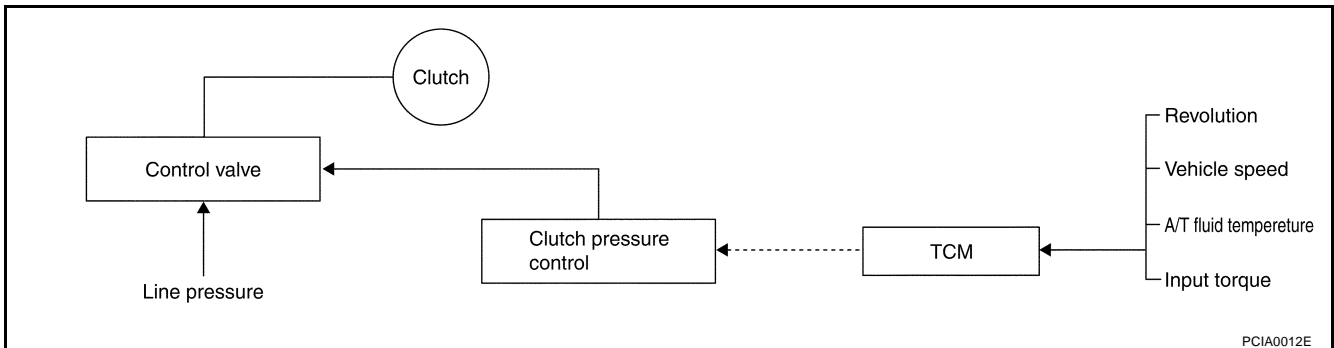

## NORMAL SHIFT CONTROL

The clutch is controlled with the optimum timing and oil pressure by the engine speed, engine torque information, etc.

# A/T CONTROL SYSTEM

## Shift Change System Diagram

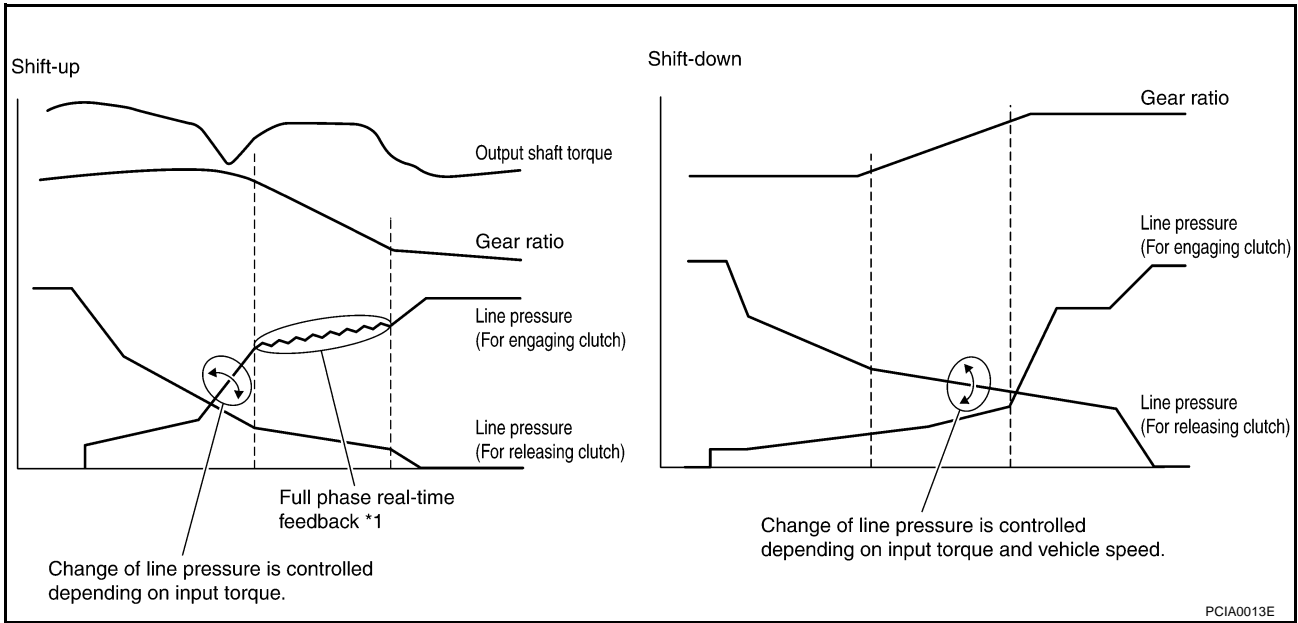

- \*1: Full phase real-time feedback control monitors movement of gear ratio at gear change, and controls oil pressure at real-time to achieve the best gear ratio.

## BLIPPING CONTROL

This system makes transmission clutch engage readily by controlling (synchronizing) engine revolution according to the (calculation of) engine revolution after shifting down.

- "BLIPPING CONTROL" functions.
  - When downshifting by accelerator pedal depression at "D" position.
  - When downshifting under the manual mode.
- TCM selects "BLIPPING CONTROL" or "NORMAL SHIFT CONTROL" according to the gear position, the select lever position, the engine torque and the speed when accelerating by pedal depression.
- Revolution control demand signal is transmitted from TCM to ECM under "BLIPPING CONTROL".
- TCM synchronizes engine revolution according to the revolution control demand signal.

## Shift Change System Diagram

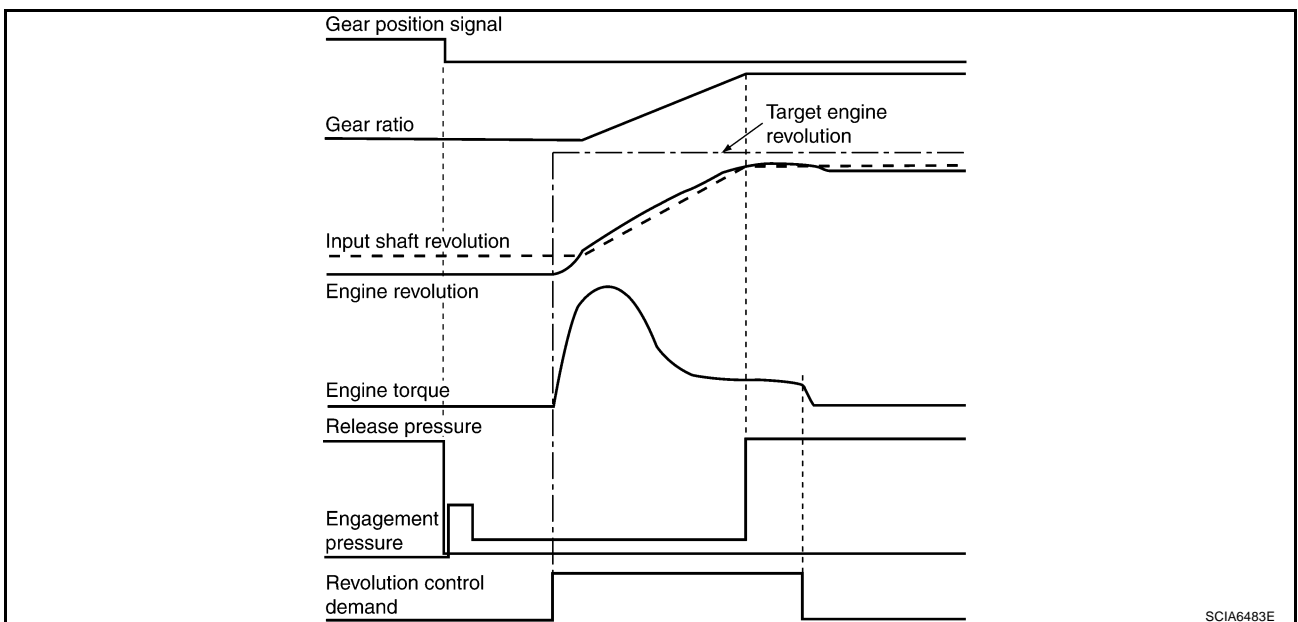

# A/T CONTROL SYSTEM

## Lock-Up Control

ACS005WR

The torque converter clutch piston in the torque converter is engaged to eliminate torque converter slip to increase power transmission efficiency.

The torque converter clutch control valve operation is controlled by the torque converter clutch solenoid valve, which is controlled by a signal from TCM, and the torque converter clutch control valve engages or releases the torque converter clutch piston.

### Lock-up Operation Condition Table

Selector lever	"D" position		"M" position			
	5	4	5	4	3	2
Gear position	5	4	5	4	3	2
Lock-up	×	—	×	×	×	×
Slip lock-up	×	×	—	—	—	—

## TORQUE CONVERTER CLUTCH CONTROL VALVE CONTROL

### Lock-up Control System Diagram

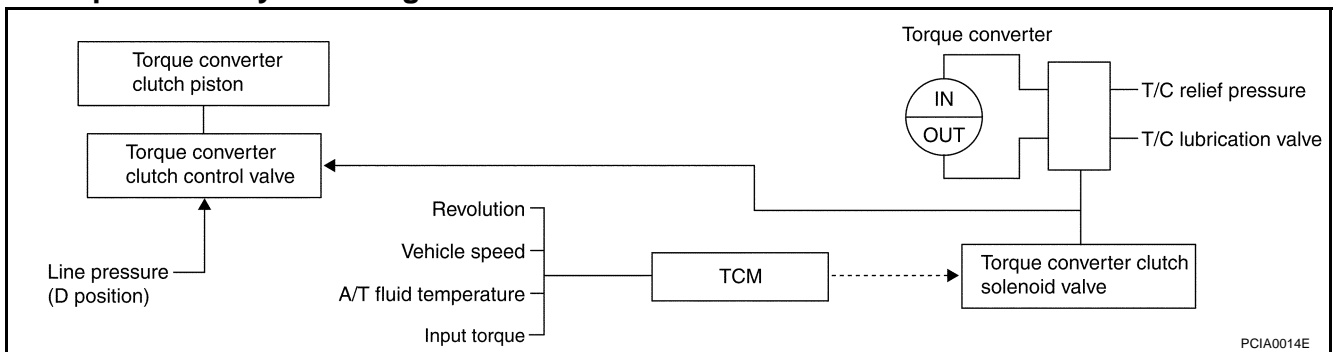

### Lock-up Released

- In the lock-up released state, the torque converter clutch control valve is set into the unlocked state by the torque converter clutch solenoid and the lock-up apply pressure is drained. In this way, the torque converter clutch piston is not coupled.

### Lock-up Applied

- In the lock-up applied state, the torque converter clutch control valve is set into the locked state by the torque converter clutch solenoid and lock-up apply pressure is generated. In this way, the torque converter clutch piston is pressed and coupled.

## SMOOTH LOCK-UP CONTROL

When shifting from the lock-up released state to the lock-up applied state, the current output to the torque converter clutch solenoid is controlled with the TCM. In this way, when shifting to the lock-up applied state, the torque converter clutch is temporarily set to the half-clutched state to reduce the shock.

### Half-clutched State

- The current output from the TCM to the torque converter clutch solenoid is varied to gradually increase the torque converter clutch solenoid pressure. In this way, the lock-up apply pressure gradually rises and while the torque converter clutch piston is put into half-clutched status, the torque converter clutch piston operating pressure is increased and the coupling is completed smoothly.

### Slip Lock-up Control

- In the slip region, the torque converter clutch solenoid current is controlled with the TCM to put it into the half-clutched state. This absorbs the engine torque fluctuation and lock-up operates from low speed. This raises the fuel efficiency for 4th and 5th gears at both low speed and when the accelerator has a low degree of opening.

## Engine Brake Control

- The forward one-way clutch transmits the drive force from the engine to the rear wheels. But the reverse drive from the rear wheels is not transmitted to the engine because the one-way clutch is idling. Therefore, the low coast brake solenoid is operated to prevent the forward one-way clutch from idling and the engine brake is operated in the same manner as conventionally.

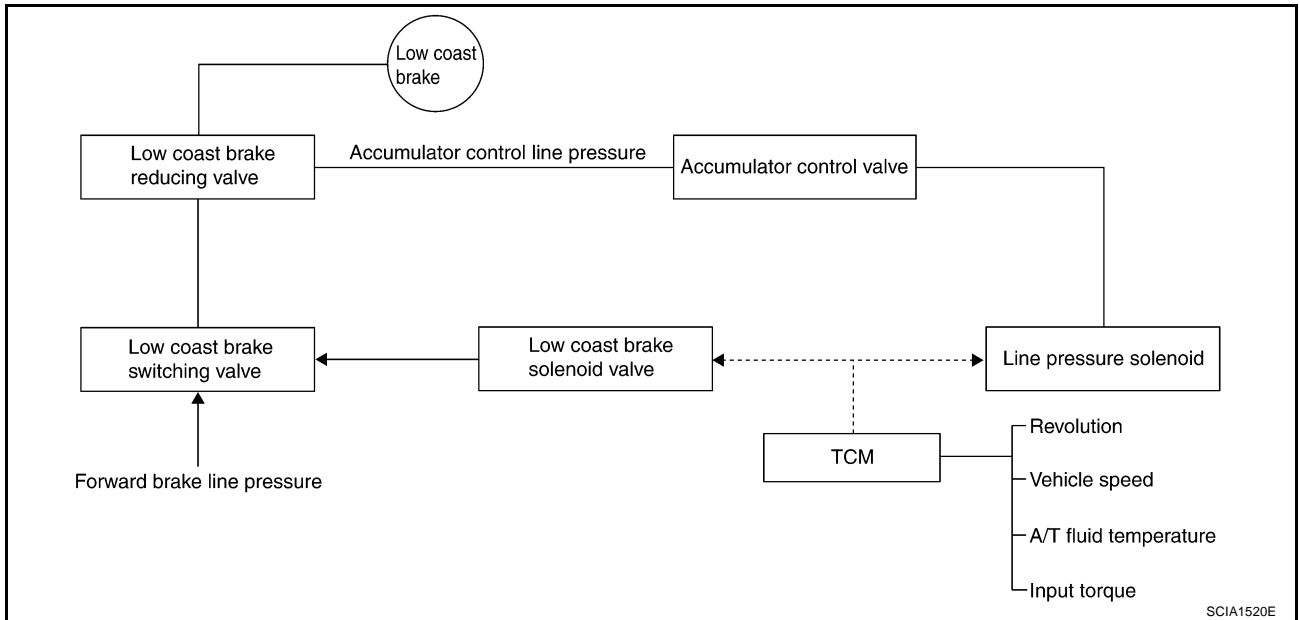

SCIA1520E

- The operation of the low coast brake solenoid switches the low coast brake switching valve and controls the coupling and releasing of the low coast brake. The low coast brake reducing valve controls the low coast brake coupling force.

# A/T CONTROL SYSTEM

## Control Valve FUNCTION OF CONTROL VALVE

ACS005WT

Name	Function
Torque converter regulator valve	In order to prevent the pressure supplied to the torque converter from being excessive, the line pressure is adjusted to the optimum pressure (torque converter operating pressure).
Pressure regulator valve Pressure regulator plug Pressure regulator sleeve	Adjusts the oil discharged from the oil pump to the optimum pressure (line pressure) for the driving state.
Front brake control valve	When the front brake is coupled, adjusts the line pressure to the optimum pressure (front brake pressure) and supplies it to the front brake. (In 1st, 2nd, 3rd, and 5th gears, adjusts the clutch pressure.)
Accumulator control valve	Adjusts the pressure (accumulator control pressure) acting on the accumulator piston and low coast reducing valve to the pressure appropriate to the driving state.
Pilot valve A	Adjusts the line pressure and produces the constant pressure (pilot pressure) required for line pressure control, shift change control, and lock-up control.
Pilot valve B	Adjusts the line pressure and produces the constant pressure (pilot pressure) required for shift change control.
Low coast brake switching valve	During engine braking, supplies the line pressure to the low coast brake reducing valve.
Low coast brake reducing valve	When the low coast brake is coupled, adjusts the line pressure to the optimum pressure (low coast brake pressure) and supplies it to the low coast brake.
N-R accumulator	Produces the stabilizing pressure for when N-R is selected.
Direct clutch piston switching valve	Operates in 4th gear and switches the direct clutch coupling capacity.
High and low reverse clutch control valve	When the high and low reverse clutch is coupled, adjusts the line pressure to the optimum pressure (high and low reverse clutch pressure) and supplies it to the high and low reverse clutch. (In 1st, 3rd, 4th and 5th gears, adjusts the clutch pressure.)
Input clutch control valve	When the input clutch is coupled, adjusts the line pressure to the optimum pressure (input clutch pressure) and supplies it to the input clutch. (In 4th and 5th gears, adjusts the clutch pressure.)
Direct clutch control valve	When the direct clutch is coupled, adjusts the line pressure to the optimum pressure (direct clutch pressure) and supplies it to the direct clutch. (In 2nd, 3rd, and 4th gears, adjusts the clutch pressure.)
TCC control valve TCC control plug TCC control sleeve	Switches the lock-up to operating or released. Also, by performing the lock-up operation transiently, lock-up smoothly.
Torque converter lubrication valve	Operates during lock-up to switch the torque converter, cooling, and lubrication system oil passage.
Cool bypass valve	Allows excess oil to bypass cooler circuit without being fed into it.
Line pressure relief valve	Discharges excess oil from line pressure circuit.
N-D accumulator	Produces the stabilizing pressure for when N-D is selected.
Manual valve	Sends line pressure to each circuit according to the select position. The circuits to which the line pressure is not sent drain.

## FUNCTION OF ATF PRESSURE SWITCH

Name	Function
ATF pressure switch 1 (FR/B)	Detects any malfunction in the front brake hydraulic pressure. When it detects any malfunction, it puts the system into fail-safe mode.
ATF pressure switch 2 (LC/B)	Detects any malfunction in the low coast brake hydraulic pressure. When it detects any malfunction, it puts the system into fail-safe mode.
ATF pressure switch 3 (I/C)	Detects any malfunction in the input clutch hydraulic pressure. When it detects any malfunction, it puts the system into fail-safe mode.
ATF pressure switch 5 (D/C)	Detects any malfunction in the direct clutch hydraulic pressure. When it detects any malfunction, it puts the system into fail-safe mode.
ATF pressure switch 6 (HLR/C)	Detects any malfunction in the high and low reverse clutch hydraulic pressure. When it detects any malfunction, it puts the system into fail-safe mode.

# ON BOARD DIAGNOSTIC (OBD) SYSTEM

## ON BOARD DIAGNOSTIC (OBD) SYSTEM

PDF:00028

### Introduction

ACS005WU

The A/T system has two self-diagnostic systems.

The first is the emission-related on board diagnostic system (OBD-II) performed by the TCM in combination with the ECM. The malfunction is indicated by the MIL (malfunction indicator lamp) and is stored as a DTC in the ECM memory but not the TCM memory.

The second is the TCM original self-diagnosis indicated by the A/T CHECK indicator lamp. The malfunction is stored in the TCM memory. The detected items are overlapped with OBD-II self-diagnostic items. For detail, refer to [AT-95. "SELF-DIAGNOSTIC RESULT MODE"](#).

### OBD-II Function for A/T System

ACS005WV

The ECM provides emission-related on board diagnostic (OBD-II) functions for the A/T system. One function is to receive a signal from the TCM used with OBD-related parts of the A/T system. The signal is sent to the ECM when a malfunction occurs in the corresponding OBD-related part. The other function is to indicate a diagnostic result by means of the MIL (malfunction indicator lamp) on the instrument panel. Sensors, switches and solenoid valves are used as sensing elements.

The MIL automatically illuminates in One or Two Trip Detection Logic when a malfunction is sensed in relation to A/T system parts.

### One or Two Trip Detection Logic of OBD-II ONE TRIP DETECTION LOGIC

ACS005WW

If a malfunction is sensed during the first test drive, the MIL will illuminate and the malfunction will be stored in the ECM memory as a DTC. The TCM is not provided with such a memory function.

### TWO TRIP DETECTION LOGIC

When a malfunction is sensed during the first test drive, it is stored in the ECM memory as a 1st trip DTC (diagnostic trouble code) or 1st trip freeze frame data. At this point, the MIL will not illuminate. — 1st trip



If the same malfunction as that experienced during the first test drive is sensed during the second test drive, the MIL will illuminate. — 2nd trip

The “trip” in the “One or Two Trip Detection Logic” means a driving mode in which self-diagnosis is performed during vehicle operation.

### OBD-II Diagnostic Trouble Code (DTC) HOW TO READ DTC AND 1ST TRIP DTC

ACS005WX

DTC and 1st trip DTC can be read by the following methods.

( with **CONSULT-II** or ( **GST**) CONSULT-II or GST (Generic Scan Tool) Examples: P0705, P0720 etc. These DTC are prescribed by SAE J2012.

(CONSULT-II also displays the malfunctioning component or system.)

- **1st trip DTC No. is the same as DTC No.**
- **Output of the diagnostic trouble code indicates that the indicated circuit has a malfunction. However, in case of the Mode II and GST, they do not indicate whether the malfunction is still occurring or occurred in the past and returned to normal. CONSULT-II can identify them as shown below, therefore, CONSULT-II (if available) is recommended.**

A sample of CONSULT-II display for DTC and 1st trip DTC is shown on the next page. DTC or 1st trip DTC of a malfunction is displayed in SELF-DIAGNOSTIC RESULTS mode for “ENGINE” with CONSULT-II. Time data indicates how many times the vehicle was driven after the last detection of a DTC.

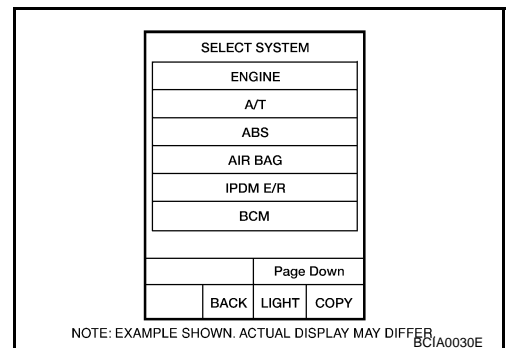

# ON BOARD DIAGNOSTIC (OBD) SYSTEM

If the DTC is being detected currently, the time data will be "0".

SELF-DIAG RESULTS	
DTC RESULTS	TIME
PNP SW/CIRC [P0705]	0

SAT015K

If a 1st trip DTC is stored in the ECM, the time data will be "1t".

SELF-DIAG RESULTS	
DTC RESULTS	TIME
PNP SW/CIRC [P0705]	1 t

SAT016K

## Freeze Frame Data and 1st Trip Freeze Frame Data

The ECM has a memory function, which stores the driving condition such as fuel system status, calculated load value, engine coolant temperature, short term fuel trim, long term fuel trim, engine speed and vehicle speed at the moment the ECM detects a malfunction.

Data which are stored in the ECM memory, along with the 1st trip DTC, are called 1st trip freeze frame data, and the data, stored together with the DTC data, are called freeze frame data and displayed on CONSULT-II or GST. The 1st trip freeze frame data can only be displayed on the CONSULT-II screen, not on the GST. For detail, refer to [EC-137, "CONSULT-II Function \(ENGINE\)"](#).

Only one set of freeze frame data (either 1st trip freeze frame data or freeze frame data) can be stored in the ECM. 1st trip freeze frame data is stored in the ECM memory along with the 1st trip DTC. There is no priority for 1st trip freeze frame data and it is updated each time a different 1st trip DTC is detected. However, once freeze frame data (2nd trip detection/MIL on) is stored in the ECM memory, 1st trip freeze frame data is no longer stored. Remember, only one set of freeze frame data can be stored in the ECM. The ECM has the following priorities to update the data.

Priority	Items	
1	Freeze frame data	Misfire — DTC: P0300 - P0306 Fuel Injection System Function — DTC: P0171, P0172, P0174, P0175
2		Except the above items (Includes A/T related items)
3	1st trip freeze frame data	

Both 1st trip freeze frame data and freeze frame data (along with the DTC) are cleared when the ECM memory is erased.

## HOW TO ERASE DTC

The diagnostic trouble code can be erased by CONSULT-II, GST or ECM DIAGNOSTIC TEST MODE as described following.

- If the battery cable is disconnected, the diagnostic trouble code will be lost within 24 hours.
- When you erase the DTC, using CONSULT-II or GST is easier and quicker than switching the mode selector on the ECM.

The following emission-related diagnostic information is cleared from the ECM memory when erasing DTC related to OBD-II. For details, refer to [EC-48, "Emission-Related Diagnostic Information"](#).

- Diagnostic trouble codes (DTC)
- 1st trip diagnostic trouble codes (1st trip DTC)
- Freeze frame data

# ON BOARD DIAGNOSTIC (OBD) SYSTEM

- 1st trip freeze frame data
- System readiness test (SRT) codes
- Test values

## HOW TO ERASE DTC (WITH CONSULT-II)

- If a DTC is displayed for both ECM and TCM, it is necessary to be erased for both ECM and TCM.
1. If the ignition switch stays "ON" after repair work, be sure to turn ignition switch "OFF" once. Wait at least 10 seconds and then turn it "ON" (engine stopped) again.
  2. Turn CONSULT-II "ON" and touch "A/T".
  3. Touch "SELF-DIAG RESULTS".
  4. Touch "ERASE". (The DTC in the TCM will be erased.) Then touch "BACK" twice.
  5. Touch "ENGINE".
  6. Touch "SELF-DIAG RESULTS".
  7. Touch "ERASE". (The DTC in the ECM will be erased.)

### How to erase DTC (With CONSULT-II)

1. If the ignition switch stays "ON" after repair work, be sure to turn ignition switch "OFF" once. Wait at least 10 seconds and then turn it "ON" (engine stopped) again.

SELECT SYSTEM
A/T
ENGINE

2. Turn CONSULT-II "ON", and touch "A/T".

SELECT DIAG MODE
SELF-DIAG RESULTS
DATA MONITOR
CAN DIAG SUPPORT MNTR
FUNCTION TEST
DTC WORK SUPPORT
ECU PART NUMBER

3. Touch "SELF-DIAG RESULTS".

SELF-DIAG RESULTS
DTC RESULTS
TCC SOLENOID/CIRC [P0740]

4. Touch "ERASE". (The DTC in the TCM will be erased.)

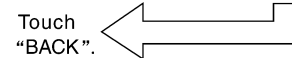
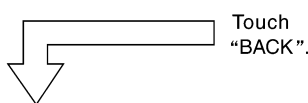

SELECT SYSTEM
A/T
ENGINE

5. Touch "ENGINE".

SELECT DIAG MODE
WORK SUPPORT
SELF-DIAG RESULTS
DATA MONITOR
DATA MONITOR(SPEC)
CAN DIAG SUPPORT MNTR
ACTIVE TEST

6. Touch "SELF-DIAG RESULTS".

SELF-DIAG RESULTS	
DTC RESULTS	TIME
TCC SOLENOID/CIRC [P0740]	0

7. Touch "ERASE". (The DTC in the TCM will be erased.)

SCIA5671E



# ON BOARD DIAGNOSTIC (OBD) SYSTEM

## HOW TO ERASE DTC (WITH GST)

1. If the ignition switch stays "ON" after repair work, be sure to turn ignition switch "OFF" once. Wait at least 10 seconds and then turn it "ON" (engine stopped) again.
2. Perform [AT-105, "TCM SELF-DIAGNOSTIC PROCEDURE \(NO TOOLS\)"](#) . (The engine warm-up step can be skipped when performing the diagnosis only to erase the DTC.)
3. Select Mode 4 with Generic Scan Tool (GST). For details, refer to [EC-150, "Generic Scan Tool \(GST\) Function"](#) .

## HOW TO ERASE DTC (NO TOOLS)

The A/T CHECK indicator lamp is located on the instrument panel.

1. If the ignition switch stays "ON" after repair work, be sure to turn ignition switch "OFF" once. Wait at least 10 seconds and then turn it "ON" (engine stopped) again.
2. Perform [AT-105, "TCM SELF-DIAGNOSTIC PROCEDURE \(NO TOOLS\)"](#) . (The engine warm-up step can be skipped when performing the diagnosis only to erase the DTC.)
3. Perform "OBD-II SELF-DIAGNOSTIC PROCEDURE (No tools)". Refer to [EC-61, "How to Erase DTC"](#) .

## Malfunction Indicator Lamp (MIL) DESCRIPTION

ACS005WY

The MIL is located on the combination meters.

1. The MIL will light up when the ignition switch is turned "ON" without the engine running. This is a bulb check.
  - If the MIL does not light up, refer to [DI-28, "WARNING LAMPS"](#) , or see [EC-720, "MIL AND DATA LINK CONNECTOR"](#) .
2. When the engine is started, the MIL should go off.
  - If the MIL remains on, the on board diagnostic system has detected an engine system malfunction.

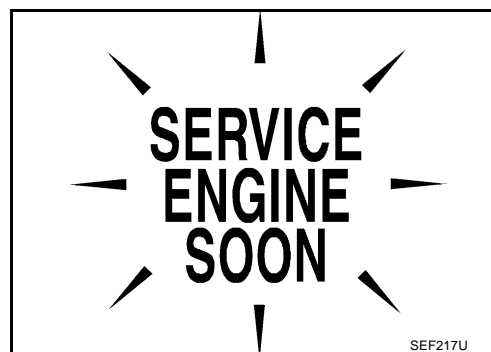

# TROUBLE DIAGNOSIS

## TROUBLE DIAGNOSIS

PFP:00004

### DTC Inspection Priority Chart

ACS005WZ

If some DTCs are displayed at the same time, perform inspections one by one based on the following priority chart.

#### NOTE:

If DTC "U1000 CAN COMM CIRCUIT" is displayed with other DTCs, first perform the trouble diagnosis for "DTC U1000 CAN COMMUNICATION LINE". Refer to [AT-110](#).

Priority	Detected items (DTC)
1	U1000 CAN communication line
2	Except above

### Fail-safe

ACS005X0

The TCM has an electrical fail-safe mode. This mode makes it possible to operate even if there is an error in a main electronic control input/output signal circuit.

In fail-safe mode, even if the selector lever is "D" or "M" mode, the transmission is fixed in 2nd, 4th or 5th (depending on the breakdown position), so the customer should feel "slipping" or "poor acceleration". When fail-safe mode is triggered, when the ignition switch is switched "ON", the A/T CHECK indicator lamp flashes for about 8 seconds. Refer to [AT-105, "TCM SELF-DIAGNOSTIC PROCEDURE \(NO TOOLS\)"](#).

Even when the electronic circuits are normal, under special conditions (for example, when slamming on the brake with the wheels spinning drastically and stopping the tire rotation), the transmission can go into fail-safe mode. If this happens, switch "OFF" the ignition switch for 10 seconds, then switch it "ON" again to return to the normal shift pattern. Also, the A/T CHECK indicator lamp flashes for about 8 seconds once, then is cleared. Therefore, the customer's vehicle has returned to normal, so handle according to the [AT-45, "WORK FLOW"](#).

### FAIL-SAFE FUNCTION

If any malfunction occurs in a sensor or solenoid, this function controls the A/T to mark driving possible.

#### Vehicle Speed Sensor A/T (Revolution Sensor)

- Signals are input from two systems - from vehicle speed sensor A/T (revolution sensor) installed on the transmission and from combination meter so normal driving is possible even if there is a malfunction in one of the systems. And if vehicle speed sensor A/T (revolution sensor) has unusual cases, 5th gear and manual mode are prohibited.

#### Accelerator Pedal Position Sensor

- If there is a malfunction in one of the systems, the accelerator opening angle is controlled by ECM according to a pre-determined accelerator angle to make driving possible. And if there are malfunctions in tow systems, the engine speed is fixed by ECM to a pre-determined engine speed to make driving possible.

#### Throttle Position Sensor

- If there is a malfunction in one of the systems, the accelerator opening angle is controlled by ECM according to a pre-determined accelerator angle to make driving possible. And if there are malfunctions in tow systems, the accelerator opening angle is controlled by the idle signal sent from the ECM which is based on input indicating either idle condition or off-idle condition (pre-determined accelerator opening) in order to make driving possible.

#### PNP Switch

- In the unlikely event that a malfunction signal enters the TCM, the position indicator is switched "OFF", the starter relay is switched "OFF" (starter starting is disabled), the back-up lamp relay switched "OFF" (back-up lamp is OFF) and the position is fixed to the "D" range to make driving possible.

#### Starter Relay

- The starter relay is switched "OFF". (Starter starting is disabled.)

# TROUBLE DIAGNOSIS

## A/T Interlock

- If there is an A/T interlock judgment malfunction, the transmission is fixed in 2nd gear to make driving possible.

### NOTE:

**When the vehicle is driven fixed in 2nd gear, a turbine revolution sensor malfunction is displayed, but this is not a turbine revolution sensor malfunction.**

- When the coupling pattern below is detected, the fail-safe action corresponding to the pattern is performed.

### A/T INTERLOCK COUPLING PATTERN TABLE

●: NG X: OK

Gear position		ATF pressure switch output					Fail-safe function	Clutch pressure output pattern after fail-safe function					
		SW3 (I/C)	SW6 (HLR/C)	SW5 (D/C)	SW1 (FR/B)	SW2 (LC/B)		I/C	HLR/C	D/C	FR/B	LC/B	L/U
A/T interlock coupling pattern	3rd	–	X	X	–	●	Held in 2nd gear	OFF	OFF	ON	OFF	OFF	OFF
	4th	–	X	X	–	●	Held in 2nd gear	OFF	OFF	ON	OFF	OFF	OFF
	5th	X	X	–	X	●	Held in 2nd gear	OFF	OFF	ON	OFF	OFF	OFF

## A/T 1st Engine Braking

- When there is an A/T first gear engine brake judgment malfunction, the low coast brake solenoid is switched “OFF” to avoid the engine brake operation.

## Line Pressure Solenoid

- The solenoid is switched “OFF” and the line pressure is set to the maximum hydraulic pressure to make driving possible.

## Torque Converter Clutch Solenoid

- The solenoid is switched “OFF” to release the lock-up.

## Low Coast Brake Solenoid

- When a malfunction (electrical or functional) occurs, in order to make driving possible, if the solenoid is “ON”, the transmission is held in 2nd gear; if the solenoid is “OFF”, the transmission is held in 4th gear. (engine brake is not applied in 1st and 2nd gear.)

## Input Clutch Solenoid

- If a malfunction (electrical or functional) occurs with the solenoid either “ON” or “OFF”, the transmission is held in 4th gear to make driving possible.

## Direct Clutch Solenoid

- If a malfunction (electrical or functional) occurs with the solenoid either “ON” or “OFF”, the transmission is held in 4th gear to make driving possible.

## Front Brake Solenoid

- If a malfunction (electrical or functional) occurs with the solenoid “ON”, in order to make driving possible, the A/T is held in 5th gear; if the solenoid is OFF, 4th gear.

## High and Low Reverse Clutch Solenoid

- If a malfunction (electrical or functional) occurs with the solenoid either “ON” or “OFF”, the transmission is held in 4th gear to make driving possible.

## Turbine Revolution Sensor 1 or 2

- The control is the same as if there were no turbine revolution sensors, 5th gear and manual mode are prohibited.

# TROUBLE DIAGNOSIS

## How to Perform Trouble Diagnosis for Quick and Accurate Repair INTRODUCTION

ACS005X1

The TCM receives a signal from the vehicle speed sensor, accelerator pedal position sensor (throttle position sensor) or PNP switch and provides shift control or lock-up control via A/T solenoid valves.

The TCM also communicates with the ECM by means of a signal sent from sensing elements used with the OBD-related parts of the A/T system for malfunction-diagnostic purposes. The TCM is capable of diagnosing malfunctioning parts while the ECM can store malfunctions in its memory.

Input and output signals must always be correct and stable in the operation of the A/T system. The A/T system must be in good operating condition and be free of valve seizure, solenoid valve malfunction, etc.

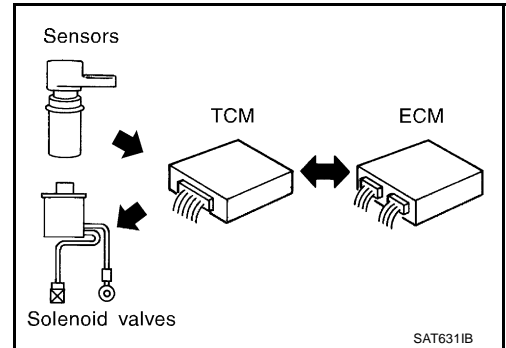

It is much more difficult to diagnose a error that occurs intermittently rather than continuously. Most intermittent errors are caused by poor electric connections or improper wiring. In this case, careful checking of suspected circuits may help prevent the replacement of good parts.

A visual check only may not find the cause of the errors. A road test with CONSULT-II (or GST) or a circuit tester connected should be performed. Follow the [AT-45, "WORK FLOW"](#) .

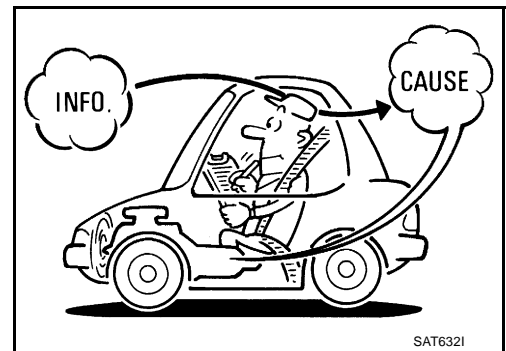

Before undertaking actual checks, take a few minutes to talk with a customer who approaches with a driveability complaint. The customer can supply good information about such errors, especially intermittent ones. Find out what symptoms are present and under what conditions they occur. A "Diagnostic Worksheet" as shown on the example (Refer to [AT-46](#) ) should be used.

Start your diagnosis by looking for "conventional" errors first. This will help troubleshoot driveability errors on an electronically controlled engine vehicle.

Also check related Service bulletins.

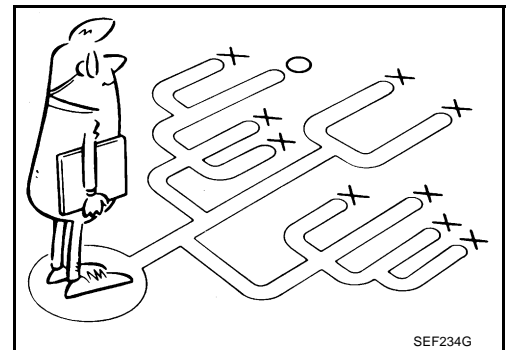

# TROUBLE DIAGNOSIS

## WORK FLOW

A good understanding of the malfunction conditions can make troubleshooting faster and more accurate. In general, each customer feels differently about a malfunction. It is important to fully understand the symptoms or conditions for a customer complaint.

Make good use of the two sheets provided, [AT-46, "Information from Customer"](#) and [AT-46, "Diagnostic Worksheet Chart"](#), to perform the best troubleshooting possible.

## Work Flow Chart

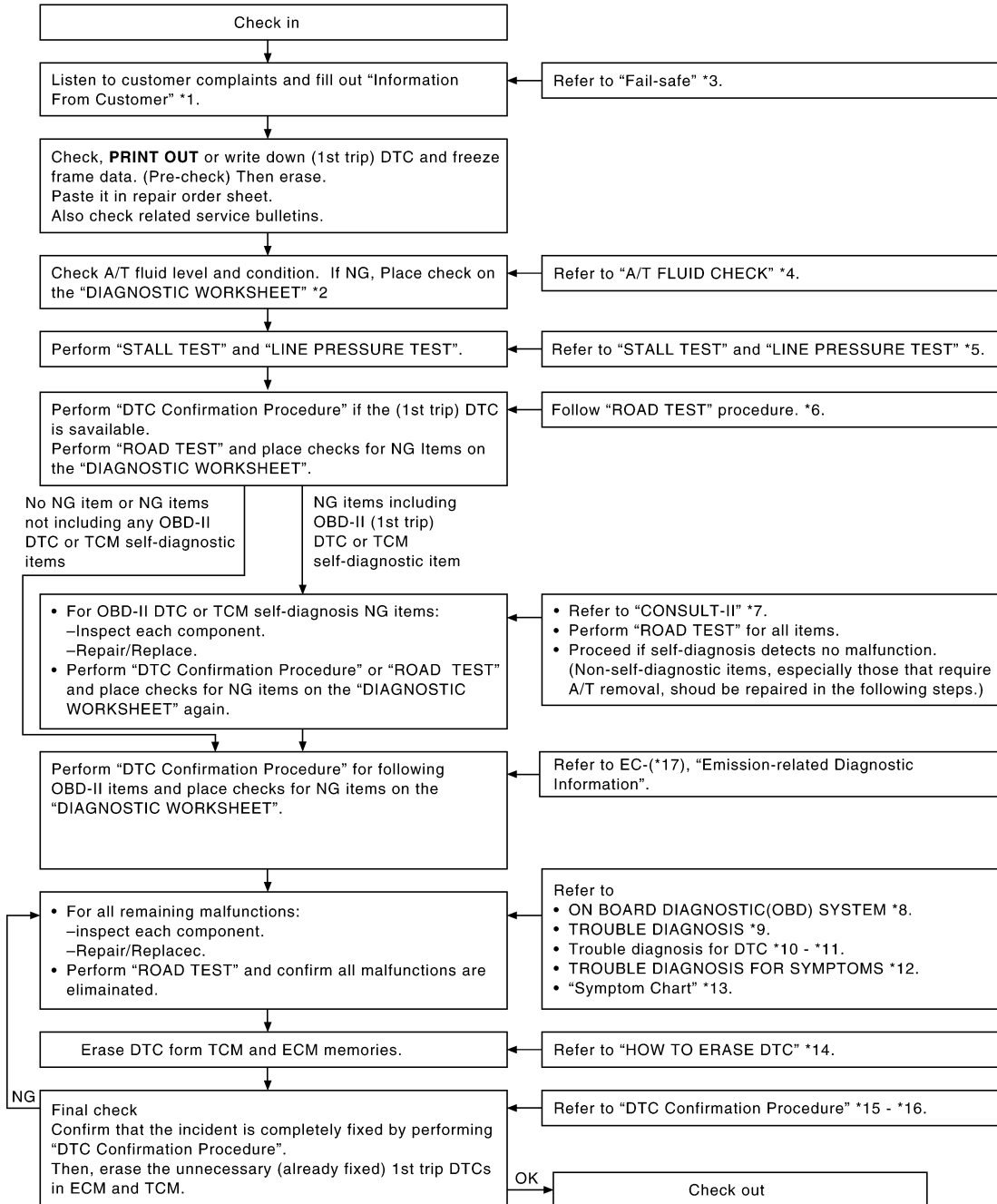

- \*1. [AT-46](#)
- \*4. [AT-51](#)
- \*7. [AT-92](#)
- \*10. [AT-110](#)
- \*13. [AT-66](#)
- \*16. [AT-184](#)

- \*2. [AT-46](#)
- \*5. [AT-51, AT-53](#)
- \*8. [AT-38](#)
- \*11. [AT-184](#)
- \*14. [AT-39](#)
- \*17. [EC-48](#)

- \*3. [AT-42](#)
- \*6. [AT-55](#)
- \*9. [AT-42](#)
- \*12. [AT-193](#)
- \*15. [AT-110](#)

SCIA6878E



# TROUBLE DIAGNOSIS

	<input type="checkbox"/> Perform all road tests and enter checks in required inspection items.	<a href="#">AT-55</a>	A
4	Check Before Engine Is Started <span style="float: right;"><a href="#">AT-56</a></span>	<input type="checkbox"/> <a href="#">AT-195, "A/T CHECK Indicator Lamp Does Not Come On"</a> . <input type="checkbox"/> Perform self-diagnostics. Enter checks for detected items. <a href="#">AT-95</a> , <a href="#">AT-105</a>	B
	4-1.	<input type="checkbox"/> <a href="#">AT-110, "DTC U1000 CAN COMMUNICATION LINE"</a> . <input type="checkbox"/> <a href="#">AT-113, "DTC P0615 START SIGNAL CIRCUIT"</a> . <input type="checkbox"/> <a href="#">AT-117, "DTC P0700 TCM"</a> . <input type="checkbox"/> <a href="#">AT-118, "DTC P0705 PARK/NEUTRAL POSITION SWITCH"</a> . <input type="checkbox"/> <a href="#">AT-122, "DTC P0720 VEHICLE SPEED SENSOR A/T (REVOLUTION SENSOR)"</a> . <input type="checkbox"/> <a href="#">AT-127, "DTC P0725 ENGINE SPEED SIGNAL"</a> . <input type="checkbox"/> <a href="#">AT-129, "DTC P0740 TORQUE CONVERTER CLUTCH SOLENOID VALVE"</a> . <input type="checkbox"/> <a href="#">AT-131, "DTC P0744 A/T TCC S/V FUNCTION (LOCK-UP)"</a> . <input type="checkbox"/> <a href="#">AT-133, "DTC P0745 LINE PRESSURE SOLENOID VALVE"</a> . <input type="checkbox"/> <a href="#">AT-135, "DTC P1702 TRANSMISSION CONTROL MODULE (RAM)"</a> . <input type="checkbox"/> <a href="#">AT-136, "DTC P1703 TRANSMISSION CONTROL MODULE (ROM)"</a> . <input type="checkbox"/> <a href="#">AT-137, "DTC P1705 THROTTLE POSITION SENSOR"</a> . <input type="checkbox"/> <a href="#">AT-140, "DTC P1710 A/T FLUID TEMPERATURE SENSOR CIRCUIT"</a> . <input type="checkbox"/> <a href="#">AT-145, "DTC P1716 TURBINE REVOLUTION SENSOR"</a> . <input type="checkbox"/> <a href="#">AT-147, "DTC P1721 VEHICLE SPEED SENSOR MTR"</a> . <input type="checkbox"/> <a href="#">AT-149, "DTC P1730 A/T INTERLOCK"</a> . <input type="checkbox"/> <a href="#">AT-152, "DTC P1731 A/T 1ST ENGINE BRAKING"</a> . <input type="checkbox"/> <a href="#">AT-154, "DTC P1752 INPUT CLUTCH SOLENOID VALVE"</a> . <input type="checkbox"/> <a href="#">AT-156, "DTC P1754 INPUT CLUTCH SOLENOID VALVE FUNCTION"</a> . <input type="checkbox"/> <a href="#">AT-158, "DTC P1757 FRONT BRAKE SOLENOID VALVE"</a> . <input type="checkbox"/> <a href="#">AT-160, "DTC P1759 FRONT BRAKE SOLENOID VALVE FUNCTION"</a> . <input type="checkbox"/> <a href="#">AT-162, "DTC P1762 DIRECT CLUTCH SOLENOID VALVE"</a> . <input type="checkbox"/> <a href="#">AT-164, "DTC P1764 DIRECT CLUTCH SOLENOID VALVE FUNCTION"</a> . <input type="checkbox"/> <a href="#">AT-166, "DTC P1767 HIGH AND LOW REVERSE CLUTCH SOLENOID VALVE"</a> . <input type="checkbox"/> <a href="#">AT-168, "DTC P1769 HIGH AND LOW REVERSE CLUTCH SOLENOID VALVE FUNCTION"</a> . <input type="checkbox"/> <a href="#">AT-170, "DTC P1772 LOW COAST BRAKE SOLENOID VALVE"</a> . <input type="checkbox"/> <a href="#">AT-172, "DTC P1774 LOW COAST BRAKE SOLENOID VALVE FUNCTION"</a> . <input type="checkbox"/> <a href="#">AT-174, "DTC P1815 MANUAL MODE SWITCH"</a> . <input type="checkbox"/> <a href="#">AT-178, "DTC P1841 ATF PRESSURE SWITCH 1"</a> . <input type="checkbox"/> <a href="#">AT-180, "DTC P1843 ATF PRESSURE SWITCH 3"</a> . <input type="checkbox"/> <a href="#">AT-182, "DTC P1845 ATF PRESSURE SWITCH 5"</a> . <input type="checkbox"/> <a href="#">AT-184, "DTC P1846 ATF PRESSURE SWITCH 6"</a> .	C D E F G H I J
4	4-2.	Check at Idle <span style="float: right;"><a href="#">AT-56</a></span> <input type="checkbox"/> <a href="#">AT-196, "Engine Cannot Be Started in "P" or "N" Position"</a> . <input type="checkbox"/> <a href="#">AT-196, "In "P" Position, Vehicle Moves When Pushed"</a> . <input type="checkbox"/> <a href="#">AT-197, "In "N" Position, Vehicle Moves"</a> . <input type="checkbox"/> <a href="#">AT-198, "Large Shock ("N" to "D" Position)"</a> . <input type="checkbox"/> <a href="#">AT-201, "Vehicle Does Not Creep Backward in "R" Position"</a> . <input type="checkbox"/> <a href="#">AT-204, "Vehicle Does Not Creep Forward in "D" Position"</a> .	K L
4	4-3.	Cruise Test <span style="float: right;"><a href="#">AT-60</a></span> Part 1 <input type="checkbox"/> <a href="#">AT-206, "Vehicle Cannot Be Started from D1"</a> . <input type="checkbox"/> <a href="#">AT-209, "A/T Does Not Shift: D1 → D2"</a> . <input type="checkbox"/> <a href="#">AT-211, "A/T Does Not Shift: D2 → D3"</a> . <input type="checkbox"/> <a href="#">AT-213, "A/T Does Not Shift: D3 → D4"</a> . <input type="checkbox"/> <a href="#">AT-216, "A/T Does Not Shift: D4 → D5"</a> . <input type="checkbox"/> <a href="#">AT-218, "A/T Does Not Perform Lock-Up"</a> . <input type="checkbox"/> <a href="#">AT-220, "A/T Does Not Hold Lock-Up Condition"</a> . <input type="checkbox"/> <a href="#">AT-222, "Lock-Up Is Not Released"</a> . <input type="checkbox"/> <a href="#">AT-222, "Engine Speed Does Not Return to Idle"</a> .	M

# TROUBLE DIAGNOSIS

4	4-3	<p>Part 2</p> <ul style="list-style-type: none"> <li><input type="checkbox"/> <a href="#">AT-206, "Vehicle Cannot Be Started from D1"</a> .</li> <li><input type="checkbox"/> <a href="#">AT-209, "A/T Does Not Shift: D1 → D2"</a> .</li> <li><input type="checkbox"/> <a href="#">AT-211, "A/T Does Not Shift: D2 → D3"</a> .</li> <li><input type="checkbox"/> <a href="#">AT-213, "A/T Does Not Shift: D3 → D4"</a> .</li> </ul>	<a href="#">AT-63</a>
		<p>Part 3</p> <ul style="list-style-type: none"> <li><input type="checkbox"/> <a href="#">AT-224, "Cannot Be Changed to Manual Mode"</a> .</li> <li><input type="checkbox"/> <a href="#">AT-224, "A/T Does Not Shift: 5th Gear → 4th Gear"</a> .</li> <li><input type="checkbox"/> <a href="#">AT-226, "A/T Does Not Shift: 4th Gear → 3rd Gear"</a> .</li> <li><input type="checkbox"/> <a href="#">AT-228, "A/T Does Not Shift: 3rd Gear → 2nd Gear"</a> .</li> <li><input type="checkbox"/> <a href="#">AT-230, "A/T Does Not Shift: 2nd Gear → 1st Gear"</a> .</li> <li><input type="checkbox"/> <a href="#">AT-232, "Vehicle Does Not Decelerate by Engine Brake"</a> .</li> <li><input type="checkbox"/> Perform self-diagnostics. Enter checks for detected items. <a href="#">AT-95</a> , <a href="#">AT-105</a></li> </ul>	<a href="#">AT-64</a>
		<ul style="list-style-type: none"> <li><input type="checkbox"/> <a href="#">AT-110, "DTC U1000 CAN COMMUNICATION LINE"</a> .</li> <li><input type="checkbox"/> <a href="#">AT-113, "DTC P0615 START SIGNAL CIRCUIT"</a> .</li> <li><input type="checkbox"/> <a href="#">AT-117, "DTC P0700 TCM"</a> .</li> <li><input type="checkbox"/> <a href="#">AT-118, "DTC P0705 PARK/NEUTRAL POSITION SWITCH"</a> .</li> <li><input type="checkbox"/> <a href="#">AT-122, "DTC P0720 VEHICLE SPEED SENSOR A/T (REVOLUTION SENSOR)"</a> .</li> <li><input type="checkbox"/> <a href="#">AT-127, "DTC P0725 ENGINE SPEED SIGNAL"</a> .</li> <li><input type="checkbox"/> <a href="#">AT-129, "DTC P0740 TORQUE CONVERTER CLUTCH SOLENOID VALVE"</a> .</li> <li><input type="checkbox"/> <a href="#">AT-131, "DTC P0744 A/T TCC S/V FUNCTION (LOCK-UP)"</a> .</li> <li><input type="checkbox"/> <a href="#">AT-133, "DTC P0745 LINE PRESSURE SOLENOID VALVE"</a> .</li> <li><input type="checkbox"/> <a href="#">AT-135, "DTC P1702 TRANSMISSION CONTROL MODULE (RAM)"</a> .</li> <li><input type="checkbox"/> <a href="#">AT-136, "DTC P1703 TRANSMISSION CONTROL MODULE (ROM)"</a> .</li> <li><input type="checkbox"/> <a href="#">AT-137, "DTC P1705 THROTTLE POSITION SENSOR"</a> .</li> <li><input type="checkbox"/> <a href="#">AT-140, "DTC P1710 A/T FLUID TEMPERATURE SENSOR CIRCUIT"</a> .</li> <li><input type="checkbox"/> <a href="#">AT-145, "DTC P1716 TURBINE REVOLUTION SENSOR"</a> .</li> <li><input type="checkbox"/> <a href="#">AT-147, "DTC P1721 VEHICLE SPEED SENSOR MTR"</a> .</li> <li><input type="checkbox"/> <a href="#">AT-149, "DTC P1730 A/T INTERLOCK"</a> .</li> <li><input type="checkbox"/> <a href="#">AT-152, "DTC P1731 A/T 1ST ENGINE BRAKING"</a> .</li> <li><input type="checkbox"/> <a href="#">AT-154, "DTC P1752 INPUT CLUTCH SOLENOID VALVE"</a> .</li> <li><input type="checkbox"/> <a href="#">AT-156, "DTC P1754 INPUT CLUTCH SOLENOID VALVE FUNCTION"</a> .</li> <li><input type="checkbox"/> <a href="#">AT-158, "DTC P1757 FRONT BRAKE SOLENOID VALVE"</a> .</li> <li><input type="checkbox"/> <a href="#">AT-160, "DTC P1759 FRONT BRAKE SOLENOID VALVE FUNCTION"</a> .</li> <li><input type="checkbox"/> <a href="#">AT-162, "DTC P1762 DIRECT CLUTCH SOLENOID VALVE"</a> .</li> <li><input type="checkbox"/> <a href="#">AT-164, "DTC P1764 DIRECT CLUTCH SOLENOID VALVE FUNCTION"</a> .</li> <li><input type="checkbox"/> <a href="#">AT-166, "DTC P1767 HIGH AND LOW REVERSE CLUTCH SOLENOID VALVE"</a> .</li> <li><input type="checkbox"/> <a href="#">AT-168, "DTC P1769 HIGH AND LOW REVERSE CLUTCH SOLENOID VALVE FUNCTION"</a> .</li> <li><input type="checkbox"/> <a href="#">AT-170, "DTC P1772 LOW COAST BRAKE SOLENOID VALVE"</a> .</li> <li><input type="checkbox"/> <a href="#">AT-172, "DTC P1774 LOW COAST BRAKE SOLENOID VALVE FUNCTION"</a> .</li> <li><input type="checkbox"/> <a href="#">AT-174, "DTC P1815 MANUAL MODE SWITCH"</a> .</li> <li><input type="checkbox"/> <a href="#">AT-178, "DTC P1841 ATF PRESSURE SWITCH 1"</a> .</li> <li><input type="checkbox"/> <a href="#">AT-180, "DTC P1843 ATF PRESSURE SWITCH 3"</a> .</li> <li><input type="checkbox"/> <a href="#">AT-182, "DTC P1845 ATF PRESSURE SWITCH 5"</a> .</li> <li><input type="checkbox"/> <a href="#">AT-184, "DTC P1846 ATF PRESSURE SWITCH 6"</a> .</li> </ul>	
		<p>5 <input type="checkbox"/> Inspect each system for items found to be NG in the self-diagnostics and repair or replace the malfunctioning parts.</p>	
<p>6 <input type="checkbox"/> Perform all road tests and enter the checks again for the required items.</p>	<a href="#">AT-55</a>		
<p>7 <input type="checkbox"/> For any remaining NG items, perform the "diagnostics procedure" and repair or replace the malfunctioning parts. See the chart for diagnostics by symptoms. (This chart also contains other symptoms and inspection procedures.)</p>	<a href="#">AT-66</a>		
<p>8 <input type="checkbox"/> Erase the results of the self-diagnostics from the TCM.</p>	<a href="#">AT-39</a> , <a href="#">AT-109</a>		



# TROUBLE DIAGNOSIS

## A/T Electrical Parts Location

ACS005X2

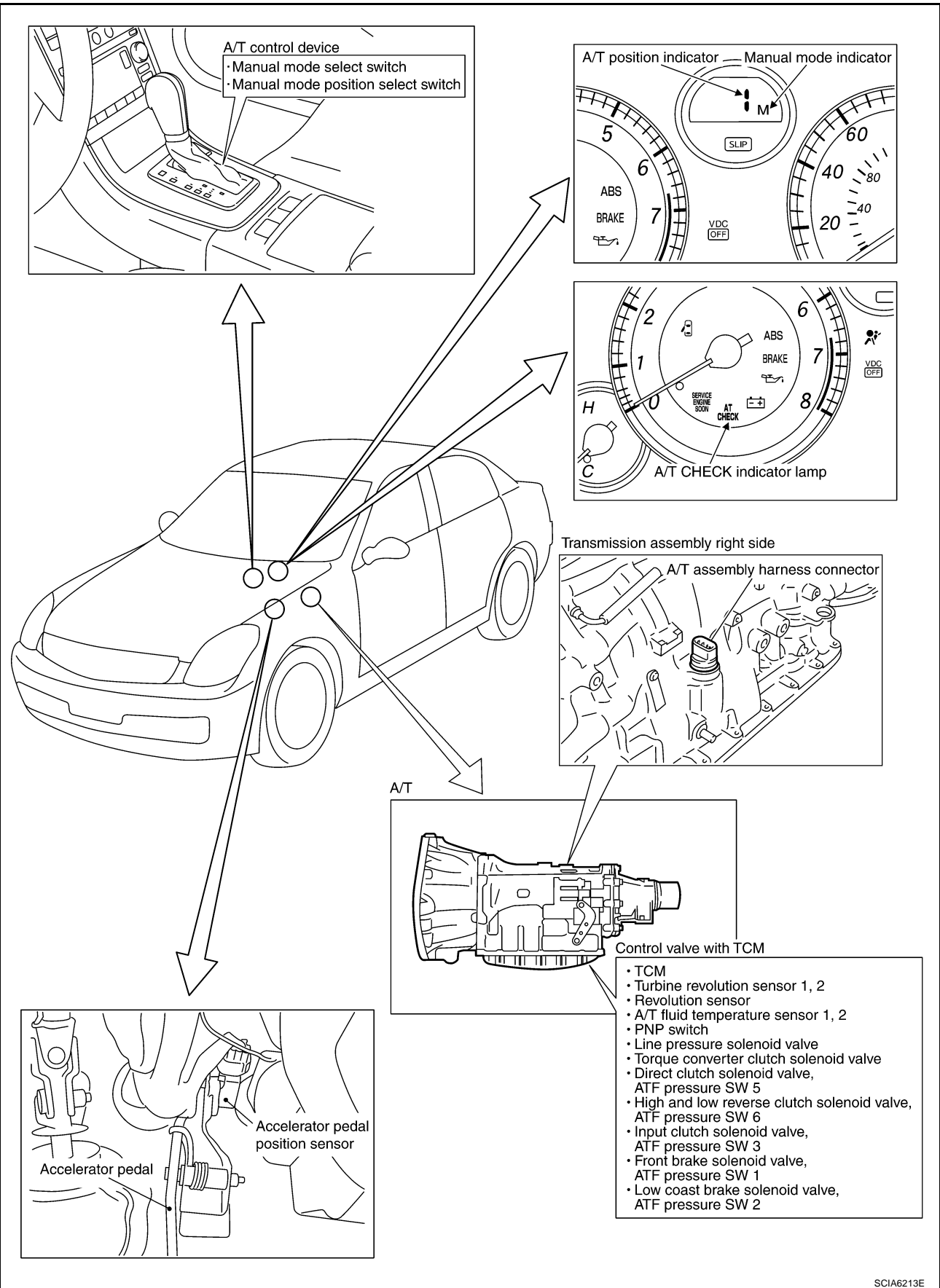

A  
B  
AT  
D  
E  
F  
G  
H  
I  
J  
K  
L  
M

SCIA6213E

# TROUBLE DIAGNOSIS

## Circuit Diagram

ACS005X3

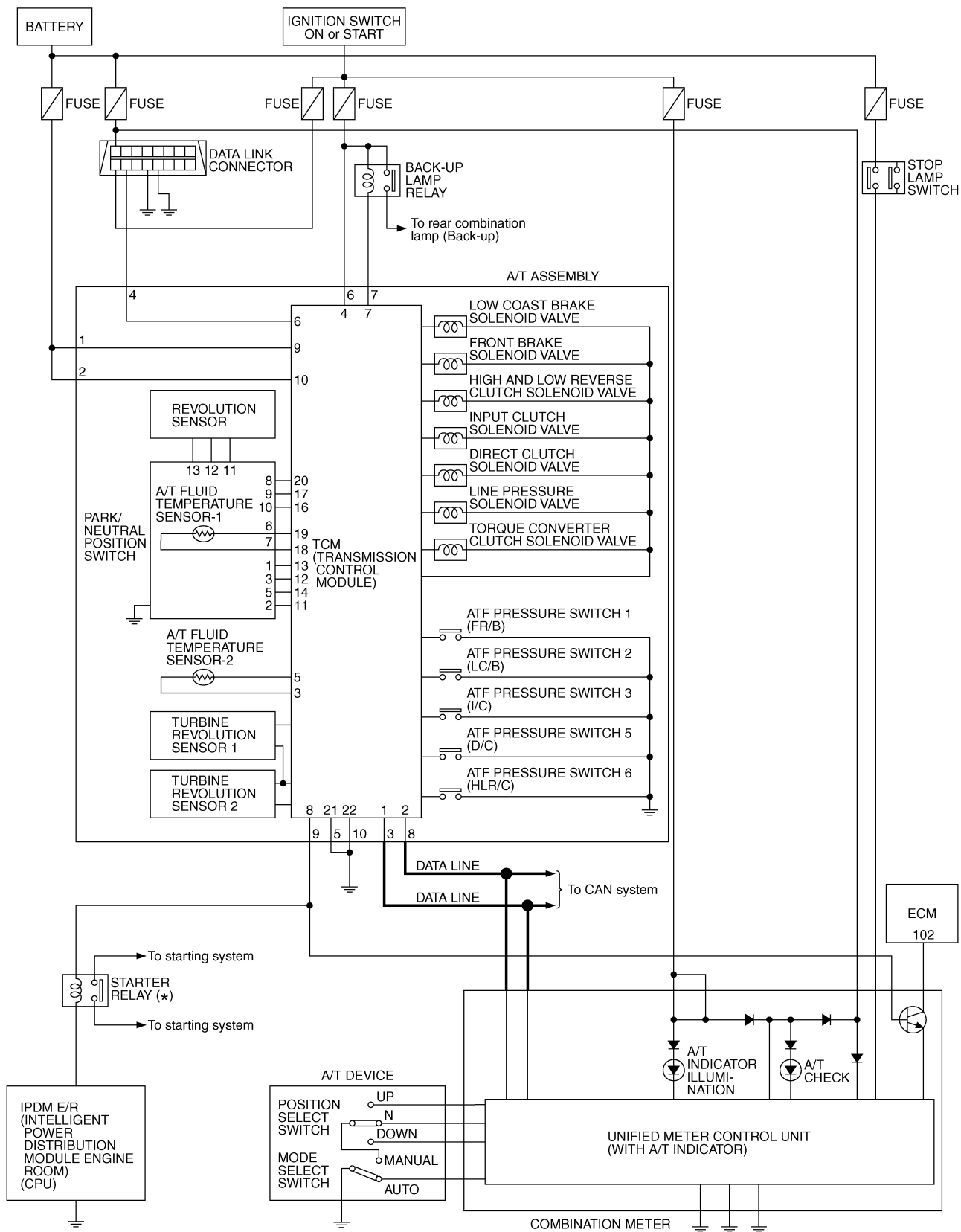

\* : This relay is built into the IPDM E/R (Intelligent power distribution module engine room).

TCWM0390E

# TROUBLE DIAGNOSIS

ACS005X5

A  
B  
AT  
D  
E  
F  
G  
H  
I  
J  
K  
L  
M

## Inspections before Trouble Diagnosis

### A/T FLUID CHECK

#### A/T Fluid Leakage and A/T Fluid Level Check

- Inspect for A/T fluid leakage and check the A/T fluid level. Refer to [AT-12. "Checking A/T Fluid"](#).

#### A/T Fluid Condition Check

Inspect the A/T fluid condition.

Fluid condition	Conceivable Cause	Required Operation
Varnished (viscous varnish state)	Clutch, brake scorched	Replace the ATF and check the A/T main unit and the vehicle for malfunctions (wire harnesses, cooler pipes, etc.)
Milky white or cloudy	Water in the fluid	Replace the ATF and check for places where water is getting in.
Large amount of metal powder mixed in	Unusual wear of sliding parts within A/T	Replace the ATF and check for improper operation of the A/T.

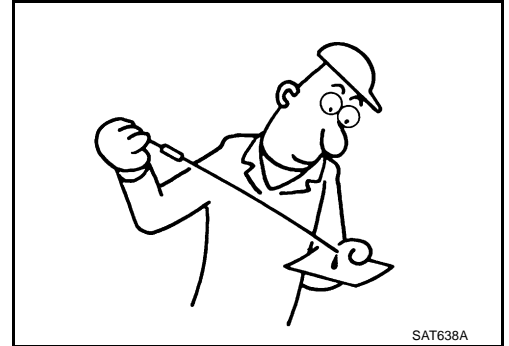

## STALL TEST

### Stall Test Procedure

- Inspect the amount of engine oil. Replenish the engine oil if necessary.
- Drive for about 10 minutes to warm up the vehicle so that the A/T fluid temperature is 50 to 80°C (122 to 176°F). Inspect the amount of ATF. Replenish if necessary.

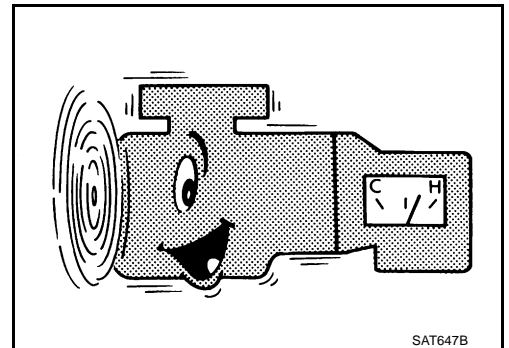

- Securely engage the parking brake so that the tires do not turn.

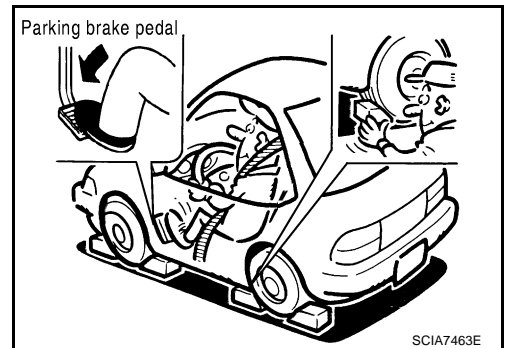

- Engine start, apply foot brake, and place selector lever in "D" position.

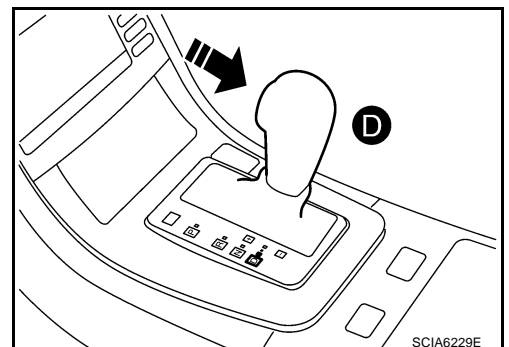

# TROUBLE DIAGNOSIS

5. While holding down the foot brake, gradually press down the accelerator pedal.
6. Quickly read off the stall speed, then quickly remove your foot from the accelerator pedal.

**CAUTION:**

**Do not hold down the accelerator pedal for more than 5 seconds during this test.**

**Stall speed: 2,300 - 2,600 rpm**

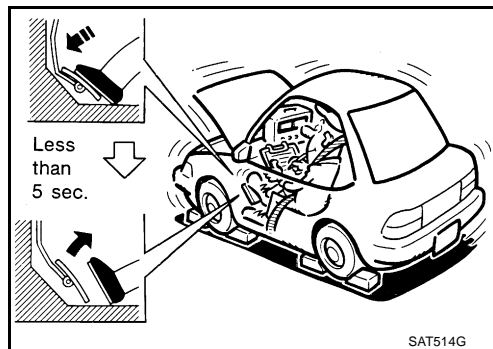

7. Move the selector lever to the "N" position.
8. Cool down the ATF.
9. Repeat steps 5 through 8 with selector lever in "R" position.

**CAUTION:**

**Run the engine at idle for at least 1 minute.**

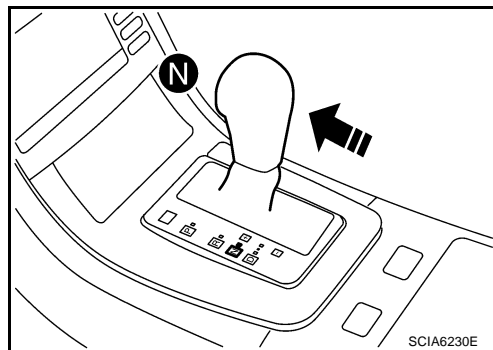

## Judgement of Stall Test

	Selector lever position		Possible location of malfunction
	"D", "M"	"R"	
Stall speed	H	O	<ul style="list-style-type: none"> <li>● Forward brake</li> <li>● Forward one-way clutch</li> <li>● 1st one-way clutch</li> <li>● 3rd one-way clutch</li> </ul>
	O	H	<ul style="list-style-type: none"> <li>● Reverse brake</li> </ul>
	L	L	<ul style="list-style-type: none"> <li>● Engine and torque converter one-way clutch</li> </ul>
	H	H	<ul style="list-style-type: none"> <li>● Line pressure low</li> </ul>

O: Stall speed within standard value position

H: Stall speed higher than standard value

L: Stall speed lower than standard value

# TROUBLE DIAGNOSIS

## Stall test standard value position

Does not shift-up "D", "M" position 1 → 2	Slipping in 2nd, 3rd, 4th gears	Direct clutch slippage
Does not shift-up "D", "M" position 2 → 3	Slipping in 3rd, 4th, 5th gears	High and low reverse clutch slippage
Does not shift-up "D", "M" position 3 → 4	Slipping in 4th, 5th gears	Input clutch slippage
Does not shift-up "D", "M" position 4 → 5	Slipping in 5th gear	Front brake slippage

## LINE PRESSURE TEST

### Line Pressure Test Port

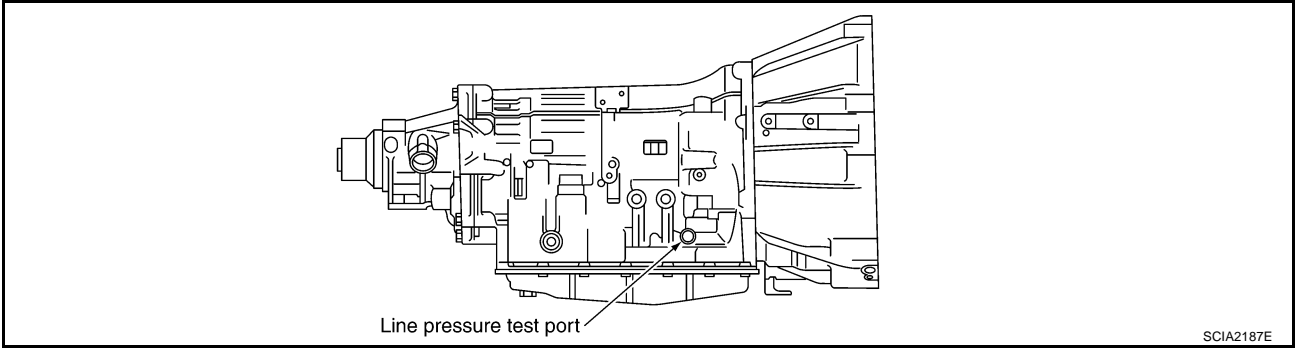

### Line Pressure Test Procedure

1. Inspect the amount of engine oil and replenish if necessary.
2. Drive the car for about 10 minutes to warm it up so that the ATF reaches in range of 50 to 80°C (122 to 176°F), then inspect the amount of ATF and replenish if necessary.

#### NOTE:

The A/T fluid temperature rises in range of 50 to 80°C (122 to 176°F) during 10 minutes of driving.

3. Remove the front propeller shaft from vehicle (with AWD models). Refer to [PR-14, "Removal and Installation"](#).
4. After warming up remove the oil pressure detection plug and install the oil pressure gauge.

#### CAUTION:

When using the oil pressure gauge, be sure to use the O-ring attached to the oil pressure detection plug.

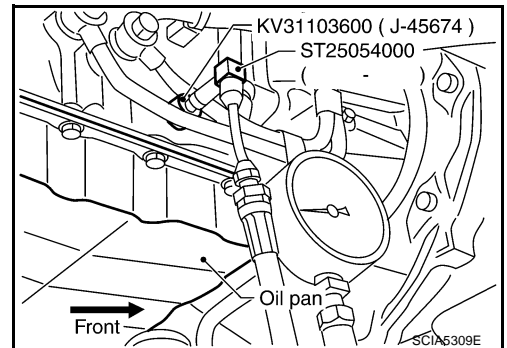

5. Securely engage the parking brake so that the tires do not turn.

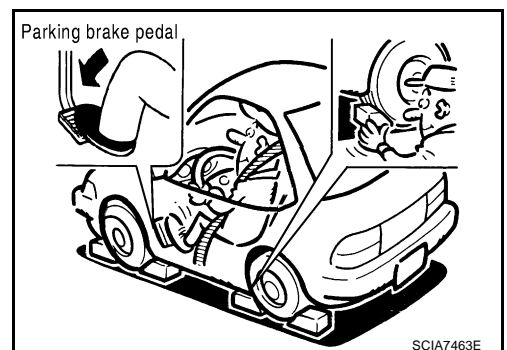

## TROUBLE DIAGNOSIS

6. Start the engine, then measure the line pressure at both idle and the stall speed.

**CAUTION:**

- Keep the brake pedal pressed all the way down during measurement.
- When measuring the line pressure at the stall speed, refer to [AT-51, "STALL TEST"](#) .

7. After the measurements are complete, install the oil pressure detection plug and tighten to the specified torque below.

 : 7.3 N·m (0.74 kg·m, 65 in·lb)

**CAUTION:**

- Do not reuse O-ring.
- Apply ATF to O-ring.

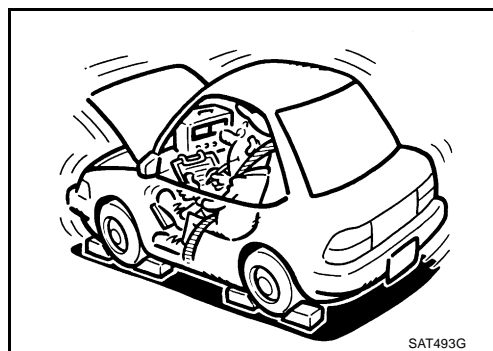

### Line Pressure

Engine speed	Line pressure [kPa (kg/cm <sup>2</sup> , psi)]	
	"R" position	"D" and "M" positions
At idle speed	425 - 465 (4.3 - 4.7, 62 - 67)	379 - 428 (3.9 - 4.4, 55 - 62)
At stall speed	1,605 - 1,950 (16.4 - 19.9, 233 - 283)	1,310 - 1,500 (13.4 - 15.3, 190 - 218)

### Judgement of Line Pressure Test

Judgement		Possible cause
Idle speed	Low for all positions ("P", "R", "N", "D", "M")	Possible causes include malfunctions in the pressure supply system and low oil pump output. For example <ul style="list-style-type: none"> <li>● Oil pump wear</li> <li>● Pressure regulator valve or plug sticking or spring fatigue</li> <li>● Oil strainer ⇒ oil pump ⇒ pressure regulator valve passage oil leak</li> <li>● Engine idle speed too low</li> </ul>
	Only low for a specific position	Possible causes include an oil pressure leak in a passage or device related to the position after the pressure is distributed by the manual valve.
	High	Possible causes include a sensor malfunction or malfunction in the line pressure adjustment function. For example <ul style="list-style-type: none"> <li>● Accelerator pedal position signal malfunction</li> <li>● A/T fluid temperature sensor malfunction</li> <li>● Line pressure solenoid malfunction (sticking in "OFF" state, filter clog, cut line)</li> <li>● Pressure regulator valve or plug sticking</li> </ul>

# TROUBLE DIAGNOSIS

Judgement		Possible cause
Stall speed	Oil pressure does not rise higher than the oil pressure for idle.	<p>Possible causes include a sensor malfunction or malfunction in the pressure adjustment function.</p> <p>For example</p> <ul style="list-style-type: none"> <li>● Accelerator pedal position signal malfunction</li> <li>● TCM breakdown</li> <li>● Line pressure solenoid malfunction (shorting, sticking in "ON" state)</li> <li>● Pressure regulator valve or plug sticking</li> <li>● Pilot valve sticking or pilot filter clogged</li> </ul>
	The pressure rises, but does not enter the standard position.	<p>Possible causes include malfunctions in the pressure supply system and malfunction in the pressure adjustment function.</p> <p>For example</p> <ul style="list-style-type: none"> <li>● Accelerator pedal position signal malfunction</li> <li>● Line pressure solenoid malfunction (sticking, filter clog)</li> <li>● Pressure regulator valve or plug sticking</li> <li>● Pilot valve sticking or pilot filter clogged</li> </ul>
	Only low for a specific position	Possible causes include an oil pressure leak in a passage or device related to the position after the pressure is distributed by the manual valve.

## ROAD TEST

### Description

- The road test inspects overall performance of the A/T and analyzes possible malfunction causes.
- The road test is performed in the following three stages.
  1. Check before engine is started. Refer to [AT-56](#) .
  2. Check at idle. Refer to [AT-56](#) .
  3. Cruise test
    - Inspect all the items from Part 1 to Part 3. Refer to [AT-60](#) , [AT-63](#) , [AT-64](#) .
- Before beginning the road test, check the test procedure and inspection items.
- Test all inspection items until the symptom is uncovered. Diagnose NG items when all road tests are complete.

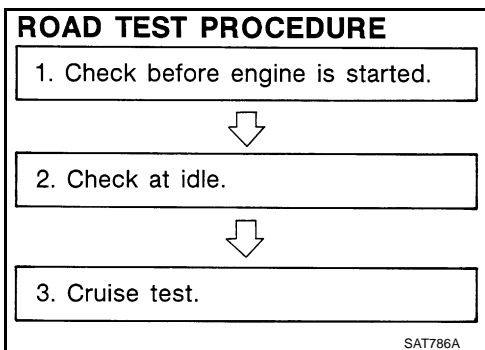

# TROUBLE DIAGNOSIS

## Check before Engine Is Started

ACS00989

### 1. CHECK A/T CHECK INDICATOR LAMP

1. Park vehicle on level surface.
2. Move selector lever to "P" position.
3. Turn ignition switch OFF and wait at least 10 seconds.
4. Turn ignition switch ON. (Do not start engine.)

Does A/T CHECK indicator lamp light up for about 2 seconds?

YES >> GO TO 2.

NO >> Stop the road test and go to [AT-195, "A/T CHECK Indicator Lamp Does Not Come On"](#).

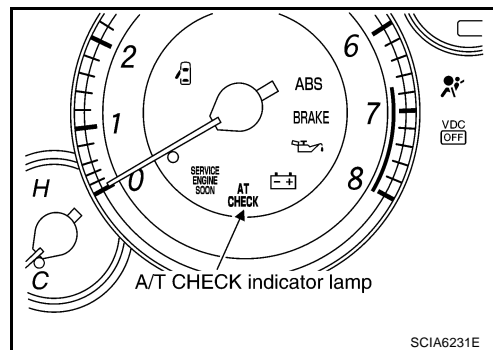

### 2. CHECK A/T CHECK INDICATOR LAMP

Does A/T CHECK indicator lamp flash for about 8 seconds?

YES >> For TCM fail-safe mode, carry out self-diagnostics and record all NG items on [AT-46, "DIAGNOSTIC WORKSHEET"](#). Refer to [AT-95, "SELF-DIAGNOSTIC RESULT MODE"](#), [AT-105, "Diagnostic Procedure without CONSULT-II"](#).

NO >> 1. Turn ignition switch OFF.

2. Carry out the self-diagnostics and record all NG items on [AT-46, "DIAGNOSTIC WORKSHEET"](#). Refer to [AT-95, "SELF-DIAGNOSTIC RESULT MODE"](#), [AT-105, "Diagnostic Procedure without CONSULT-II"](#).

3. Go to [AT-56, "Check at Idle"](#).

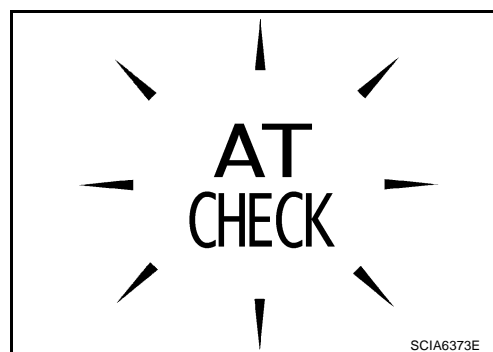

## Check at Idle

ACS0098A

### 1. CHECK STARTING THE ENGINE

1. Park vehicle on level surface.
2. Move selector lever to "P" or "N" position.
3. Turn ignition switch OFF.
4. Turn ignition switch START.

Does the engine start?

YES >> GO TO 2.

NO >> Stop the road test and go to [AT-196, "Engine Cannot Be Started in "P" or "N" Position"](#).

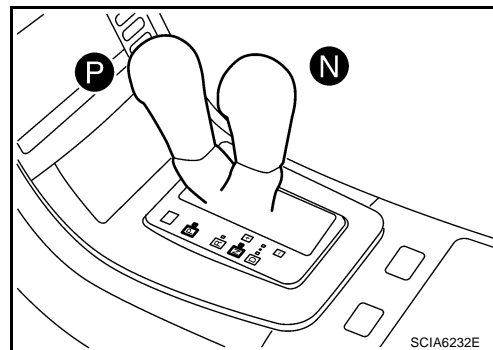

### 2. CHECK STARTING THE ENGINE

1. Turn ignition switch ON. (Do not start engine.)
2. Move selector lever in "D", "M" or "R" position.
3. Turn ignition switch START.

Does the engine start in either position?

YES >> Stop the road test and go to [AT-196, "Engine Cannot Be Started in "P" or "N" Position"](#).

NO >> GO TO 3.

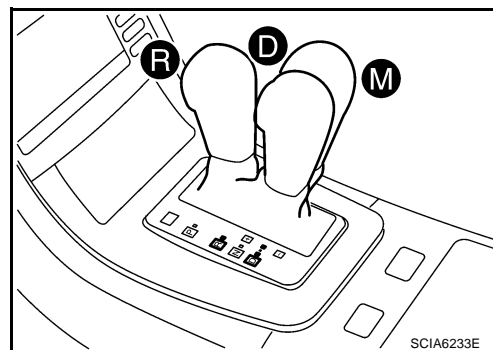



# TROUBLE DIAGNOSIS

## 3. CHECK "P" POSITION FUNCTIONS

1. Move selector lever to "P" position.
2. Turn ignition switch OFF.
3. Release the parking brake.

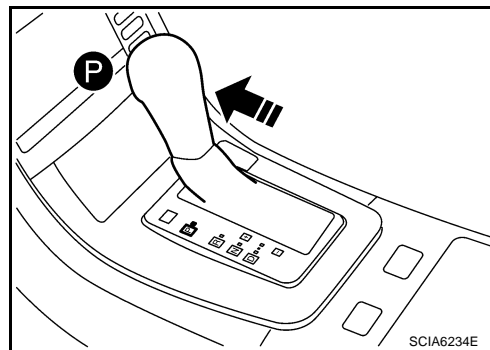

4. Push the vehicle forward or backward.
5. Engage the parking brake.

When you push the vehicle with releasing the parking brake, does it move?

- YES >> Enter a check mark at "In "P" Position Vehicle Moves When Pushed" on [AT-46. "DIAGNOSTIC WORKSHEET"](#) , then continue the road test.
- NO >> GO TO 4.



## 4. CHECK "N" POSITION FUNCTIONS

1. Start the engine.
2. Move selector lever to "N" position.
3. Release the parking brake.

Does vehicle move forward or backward?

- YES >> Enter a check mark at "In "N" Position Vehicle Moves" on [AT-46. "DIAGNOSTIC WORKSHEET"](#) , then continue the road test.
- NO >> GO TO 5.

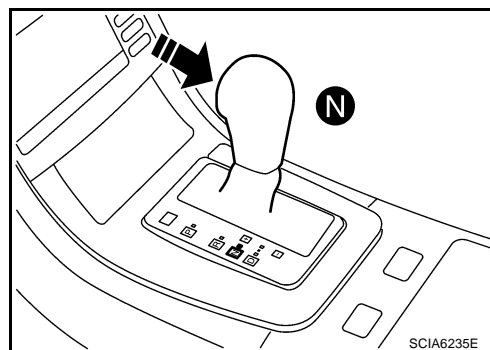

A  
B  
AT  
D  
E  
F  
G  
H  
I  
J  
K  
L  
M

# TROUBLE DIAGNOSIS

## 5. CHECK SHIFT SHOCK

1. Engage the brake.

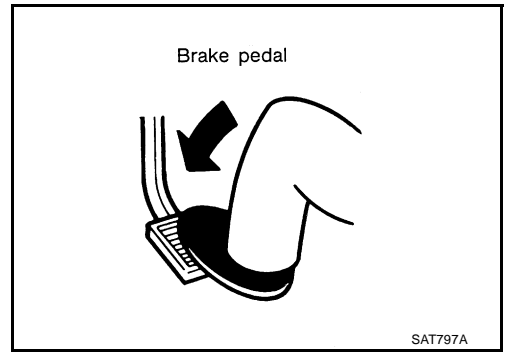

2. Move selector lever to "D" position.

When the transmission is shifted from "N" to "D", is there an excessive shock?

- YES >> Enter a check mark at "Large Shock ("N" to "D" Position)" on [AT-46, "DIAGNOSTIC WORKSHEET"](#), then continue the road test.
- NO >> GO TO 6.

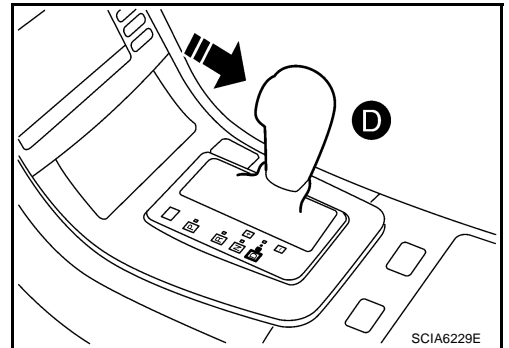

# TROUBLE DIAGNOSIS

## 6. CHECK "R" POSITION FUNCTIONS

1. Engage the brake.

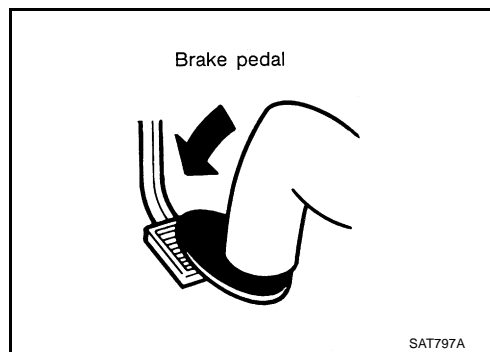

2. Move selector lever to "R" position.

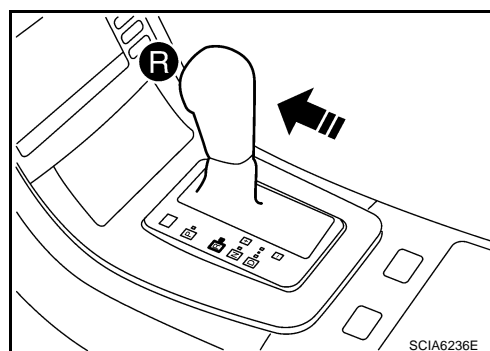

3. Release the brake for 4 to 5 seconds.

Does the vehicle creep backward?

YES >> GO TO 7.

NO >> Enter a check mark at "Vehicle Does Not Creep Backward in "R" Position" on [AT-46, "DIAGNOSTIC WORK-SHEET"](#) , then continue the road test.

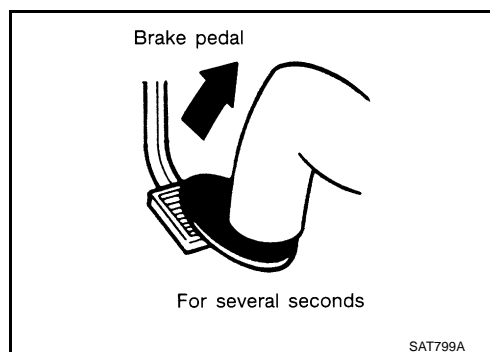

## 7. CHECK "D" POSITION FUNCTIONS

Inspect whether the vehicle creep forward when the transmission is put into the "D" position.

Does the vehicle creep forward in the "D" positions?

YES >> Go to [AT-60, "Cruise Test - Part 1"](#) , [AT-63, "Cruise Test - Part 2"](#) and [AT-64, "Cruise Test - Part 3"](#) .

NO >> Enter a check mark at "Vehicle Does Not Creep Forward in "D" Position" on [AT-46, "DIAGNOSTIC WORK-SHEET"](#) , then continue the road test. Go to [AT-60, "Cruise Test - Part 1"](#) , [AT-63, "Cruise Test - Part 2"](#) and [AT-64, "Cruise Test - Part 3"](#) .

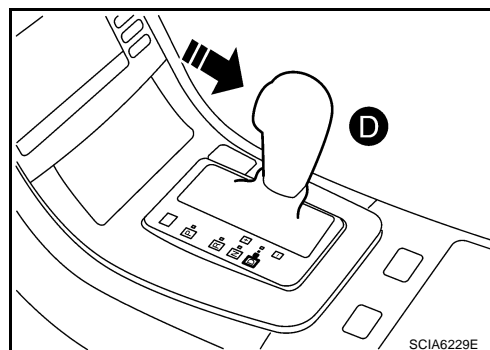

# TROUBLE DIAGNOSIS

ACS0098B

## Cruise Test - Part 1

### 1. CHECK STARTING OUT FROM D1

1. Drive the vehicle for about 10 minutes to warm up the engine oil and ATF.  
Appropriate temperature for the ATF: 50 to 80°C (122 to 176°F)
2. Park the vehicle on a level surface.
3. Move selector lever to "P" position.
4. Start the engine.

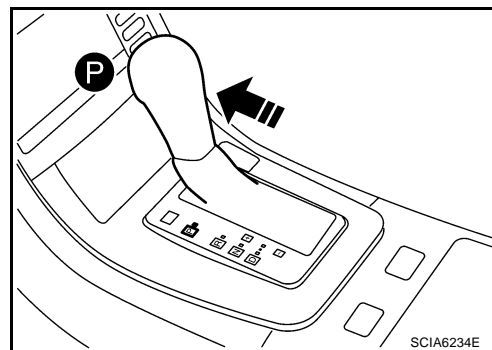

5. Move selector lever to "D" position.

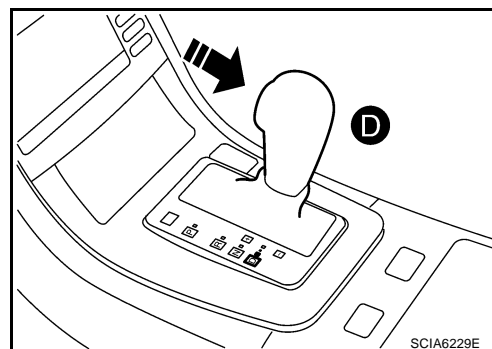

6. Press the accelerator pedal about half way down to accelerate the vehicle.

#### With CONSULT-II

Read the gear positions. Refer to [AT-99, "DATA MONITOR MODE"](#). Starts from D1?

YES >> GO TO 2.

NO >> Enter a check mark at "Vehicle Cannot Be Started From D1" on [AT-46, "DIAGNOSTIC WORKSHEET"](#), then continue the road test.

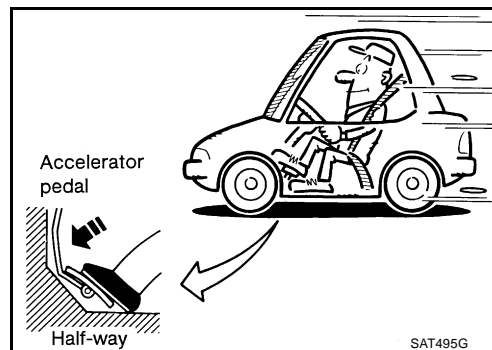

### 2. CHECK SHIFT-UP D1 → D2

Press down the accelerator pedal about half way and inspect if the vehicle shifts up (D1 → D2) at the appropriate speed.

- Refer to [AT-65, "Vehicle Speed at Which Gear Shifting Occurs"](#).

#### With CONSULT-II

Read the gear position, throttle degree of opening, and vehicle speed. Refer to [AT-99, "DATA MONITOR MODE"](#).

Does the A/T shift-up D1 → D2 at the correct speed?

YES >> GO TO 3.

NO >> Enter a check mark at "A/T Does Not Shift: D1 → D2" on [AT-46, "DIAGNOSTIC WORKSHEET"](#), then continue the road test.

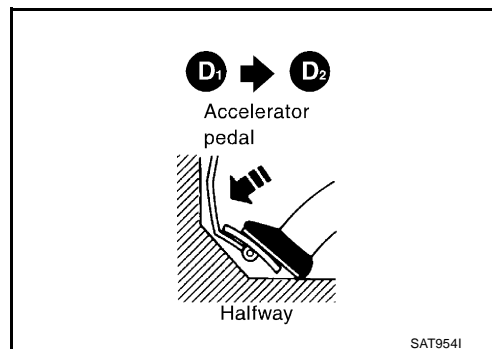

# TROUBLE DIAGNOSIS

## 3. CHECK SHIFT-UP D2 → D3

Press down the accelerator pedal about half way and inspect if the vehicle shifts up (D2 → D3) at the appropriate speed.

- Refer to [AT-65, "Vehicle Speed at Which Gear Shifting Occurs"](#) .

### ④ With CONSULT-II

Read the gear position, throttle degree of opening, and vehicle speed. Refer to [AT-99, "DATA MONITOR MODE"](#) .

Does the A/T shift-up D2 → D3 at the correct speed?

YES >> GO TO 4.

NO >> Enter a check mark at "A/T Does Not Shift: D2 → D3" on [AT-46, "DIAGNOSTIC WORKSHEET"](#) , then continue the road test.

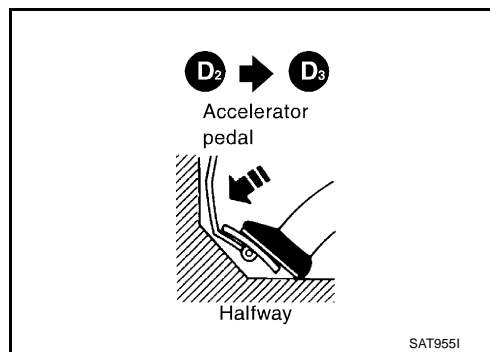

## 4. CHECK SHIFT-UP D3 → D4

Press down the accelerator pedal about half way and inspect if the vehicle shifts up (D3 → D4) at the appropriate speed.

- Refer to [AT-65, "Vehicle Speed at Which Gear Shifting Occurs"](#) .

### ④ With CONSULT-II

Read the gear position, throttle degree of opening, and vehicle speed. Refer to [AT-99, "DATA MONITOR MODE"](#) .

Does the A/T shift-up D3 → D4 at the correct speed?

YES >> GO TO 5.

NO >> Enter a check mark at "A/T Does Not Shift: D3 → D4" on [AT-46, "DIAGNOSTIC WORKSHEET"](#) , then continue the road test.

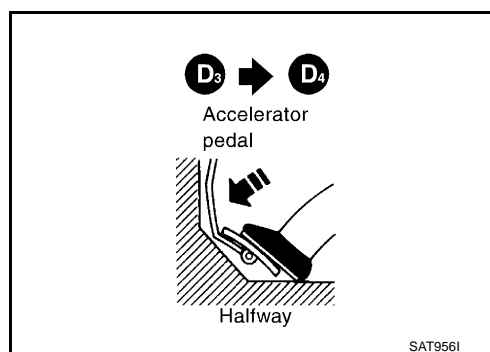

## 5. CHECK SHIFT-UP D4 → D5

Press down the accelerator pedal about half way and inspect if the vehicle shifts up (D4 → D5) at the appropriate speed.

- Refer to [AT-65, "Vehicle Speed at Which Gear Shifting Occurs"](#) .

### ④ With CONSULT-II

Read the gear position, throttle degree of opening, and vehicle speed. Refer to [AT-99, "DATA MONITOR MODE"](#) .

Does the A/T shift-up D4 → D5 at the correct speed?

YES >> GO TO 6.

NO >> Enter a check mark at "A/T Does Not Shift: D4 → D5" on [AT-46, "DIAGNOSTIC WORKSHEET"](#) , then continue the road test.

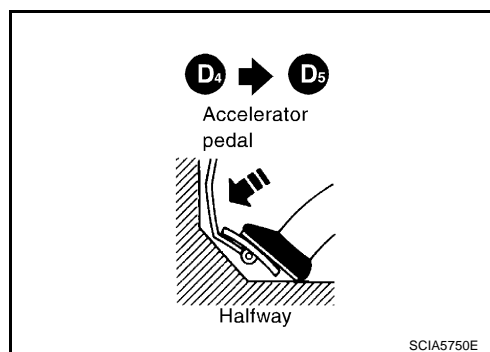

## 6. CHECK LOCK-UP

When releasing accelerator pedal (closed throttle position signal: OFF) from D5, check lock-up from D5 to L/U.

- Refer to [AT-65, "Vehicle Speed at Which Gear Shifting Occurs"](#) .

### ④ With CONSULT-II

Select "TCC SOLENOID" with the "MAIN SIGNAL" mode for "A/T". Refer to [AT-92, "CONSULT-II REFERENCE VALUE"](#) .

Does it lock-up?

YES >> GO TO 7.

NO >> Enter a check mark at "A/T Does Not Perform Lock-up" on [AT-46, "DIAGNOSTIC WORKSHEET"](#) , then continue the road test.

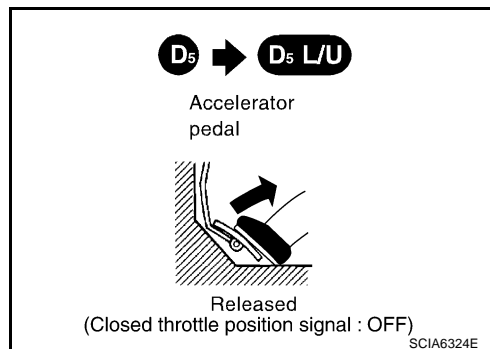

# TROUBLE DIAGNOSIS

## 7. CHECK LOCK-UP HOLD

Check hold lock-up.

④ **With CONSULT-II**

Select "TCC SOLENOID" with the "MAIN SIGNAL" mode for "A/T". Refer to [AT-92, "CONSULT-II REFERENCE VALUE"](#).

Does it maintain lock-up status?

YES >> GO TO 8.

NO >> Enter a check mark at "A/T Does Not Hold Lock-up Condition" on [AT-46, "DIAGNOSTIC WORKSHEET"](#), then continue the road test.

## 8. CHECK LOCK-UP RELEASE

Check lock-up cancellation by depressing brake pedal lightly to decelerate.

④ **With CONSULT-II**

Select "TCC SOLENOID" with the "MAIN SIGNAL" mode for "A/T". Refer to [AT-92, "CONSULT-II REFERENCE VALUE"](#).

Does lock-up cancel?

YES >> GO TO 9.

NO >> Enter a check mark at "Lock-up Is Not Released" on [AT-46, "DIAGNOSTIC WORKSHEET"](#), then continue the road test.

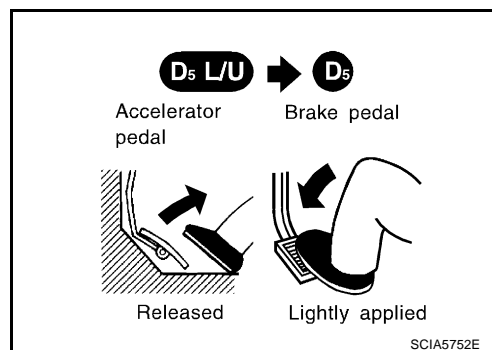

## 9. CHECK SHIFT-DOWN D5 → D4

Decelerate by pressing lightly on the brake pedal.

④ **With CONSULT-II**

Read the gear position and engine speed. Refer to [AT-99, "DATA MONITOR MODE"](#).

When the A/T shift-down D5 → D4, does the engine speed drop smoothly back to idle?

YES >> 1. Stop the vehicle.

2. Go to [AT-63, "Cruise Test - Part 2"](#).

NO >> Enter a check mark at "Engine Speed Does Not Return to Idle" on [AT-46, "DIAGNOSTIC WORKSHEET"](#), then continue the road test. Go to [AT-63, "Cruise Test - Part 2"](#).

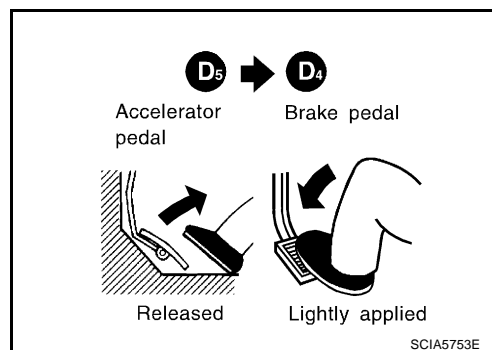

# TROUBLE DIAGNOSIS

## Cruise Test - Part 2

ACS0098C

### 1. CHECK STARTING FROM D1

1. Move selector lever the "D" position.

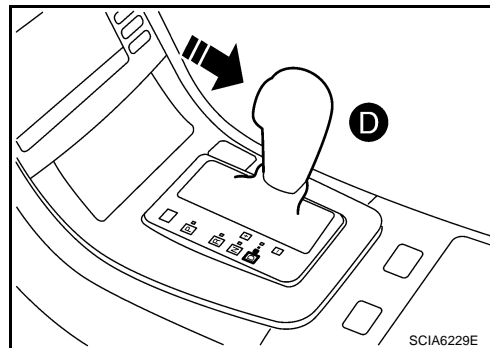

2. Accelerate at half throttle.

**With CONSULT-II**

Read the gear position. Refer to [AT-99, "DATA MONITOR MODE"](#).

Does it start from D1?

YES >> GO TO 2.

NO >> Enter a check mark at "Vehicle Cannot Be Started From D1" on [AT-46, "DIAGNOSTIC WORKSHEET"](#), then continue the road test.

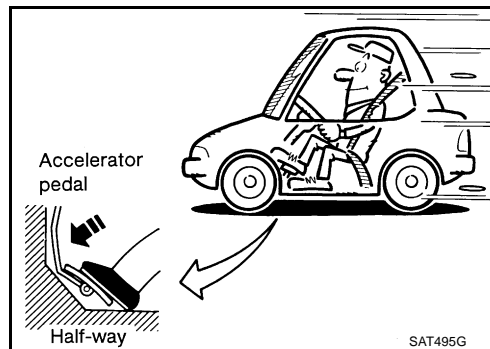

### 2. CHECK SHIFT-UP D1 → D2

Press the accelerator pedal down all the way and inspect whether or not the transmission shifts up (D1 → D2) at the correct speed.

- Refer to [AT-65, "Vehicle Speed at Which Gear Shifting Occurs"](#).

**With CONSULT-II**

Read the gear position, throttle position and vehicle speed. Refer to [AT-99, "DATA MONITOR MODE"](#).

Does the A/T shift-up D1 → D2 at the correct speed?

YES >> GO TO 3.

NO >> Enter a check mark at "A/T Does Not Shift: D1 → D2" on [AT-46, "DIAGNOSTIC WORKSHEET"](#), then continue the road test.

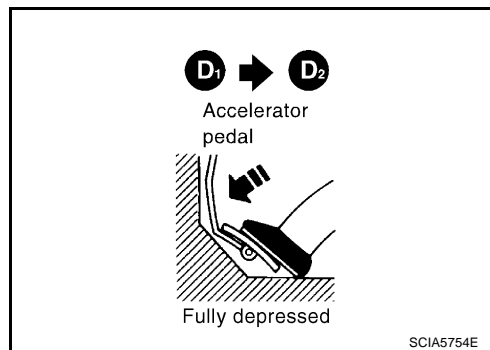

### 3. CHECK SHIFT-UP D2 → D3

Press the accelerator pedal down all the way and inspect whether or not the transmission shifts up (D2 → D3) at the correct speed.

- Refer to [AT-65, "Vehicle Speed at Which Gear Shifting Occurs"](#).

**With CONSULT-II**

Read the gear position, throttle position and vehicle speed. Refer to [AT-99, "DATA MONITOR MODE"](#).

Does the A/T shift-up D2 → D3 at the correct speed?

YES >> GO TO 4.

NO >> Enter a check mark at "A/T Does Not Shift: D2 → D3" on [AT-46, "DIAGNOSTIC WORKSHEET"](#), then continue the road test.

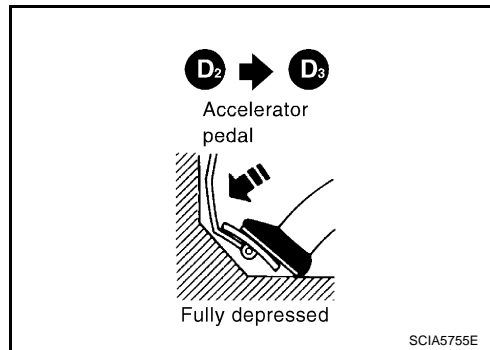

# TROUBLE DIAGNOSIS

## 4. CHECK SHIFT-UP D3 → D4 AND ENGINE BRAKE

When the transmission changes speed D3 → D4, return the accelerator pedal.

④ **With CONSULT-II**

Read the gear position. Refer to [AT-99, "DATA MONITOR MODE"](#).

Does the A/T shift-up D3 → D4 and apply the engine brake?

YES >> 1. Stop the vehicle.

Go to [AT-64, "Cruise Test - Part 3"](#).

NO >> Enter a check mark at "A/T Does Not Shift: D3 → D4" on [AT-46, "DIAGNOSTIC WORKSHEET"](#), then continue the road test. Go to [AT-64, "Cruise Test - Part 3"](#).

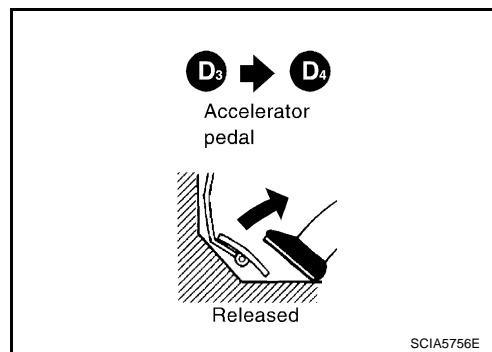

## Cruise Test - Part 3

### 1. CHECK MANUAL MODE FUNCTION

Move to manual mode from "D" position.

Does it switch to manual mode?

YES >> GO TO 2.

NO >> Continue road test and add chicanery to "Cannot Be Changed to Manual Mode" on the [AT-46, "DIAGNOSTIC WORKSHEET"](#).

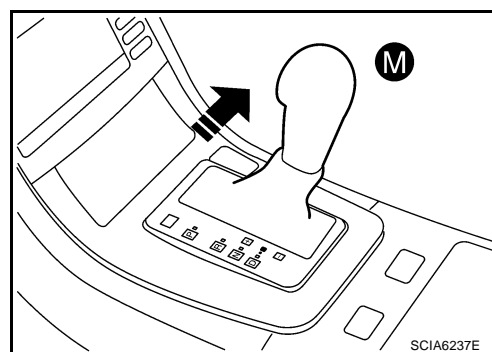

### 2. CHECK SHIFT-DOWN

During manual mode driving, is downshift from M5 → M4 → M3 → M2 → M1 performed?

④ **With CONSULT-II**

Read the gear position. Refer to [AT-99, "DATA MONITOR MODE"](#).

Is downshifting correctly performed?

YES >> GO TO 2.

NO >> Enter a check mark at "A/T Does Not Shift" at the corresponding position (5th → 4th, 4th → 3rd, 3rd → 2nd, 2nd → 1st) on [AT-46, "DIAGNOSTIC WORKSHEET"](#), then continue the road test.

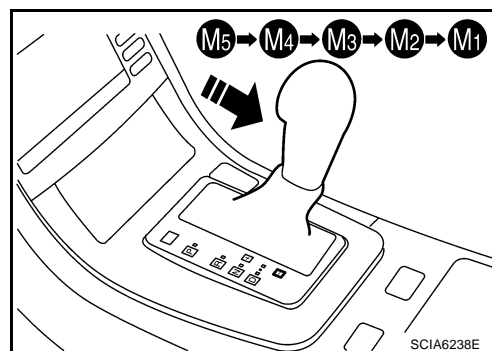

### 3. CHECK ENGINE BRAKE

Check engine brake.

Does engine braking effectively reduce speed in M1 position?

YES >> 1. Stop the vehicle.

2. Perform the self-diagnostics. Refer to [AT-95, "SELF-DIAGNOSTIC RESULT MODE"](#), [AT-105, "Diagnostic Procedure without CONSULT-II"](#).

NO >> Enter a check mark at "Vehicle Does Not Decelerate by Engine Brake" on the [AT-46, "DIAGNOSTIC WORKSHEET"](#), then continue trouble diagnosis.

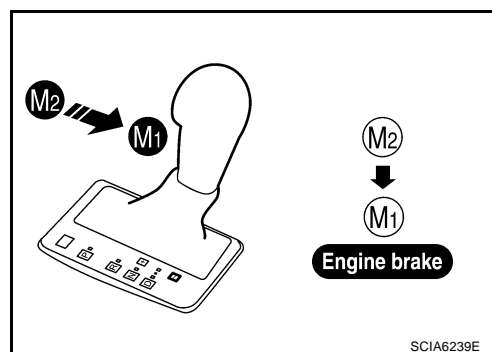



# TROUBLE DIAGNOSIS

## Vehicle Speed at Which Gear Shifting Occurs

ACS0098E

### 2WD MODELS

Throttle position	Vehicle speed km/h (MPH)							
	D1 →D2	D2 →D3	D3 →D4	D4 →D5	D5 →D4	D4 →D3	D3 →D2	D2 →D1
Full throttle	56 - 64 (35 - 40)	90 - 98 (56 - 61)	141 - 149 (88 - 93)	202 - 210 (126 - 130)	198 - 206 (123 - 128)	123 - 131 (76 - 81)	74 - 82 (46 - 51)	32 - 40 (20 - 25)
Half throttle	44 - 52 (27 - 32)	71 - 79 (44 - 49)	108 - 116 (67 - 72)	136 - 144 (85 - 89)	89 - 97 (55 - 60)	64 - 72 (40 - 45)	29 - 37 (18 - 23)	9 - 17 (6 - 11)

- At half throttle, the accelerator opening is 4/8 of the full opening.

### AWD MODELS

Throttle position	Vehicle speed km/h (MPH)							
	D1 →D2	D2 →D3	D3 →D4	D4 →D5	D5 →D4	D4 →D3	D3 →D2	D2 →D1
Full throttle	54 - 62 (34 - 39)	86 - 94 (53 - 58)	135 - 143 (84 - 89)	194 - 202 (121 - 126)	190 - 198 (118 - 123)	117 - 125 (73 - 78)	70 - 78 (43 - 48)	30 - 38 (19 - 24)
Half throttle	42 - 50 (26 - 31)	68 - 76 (42 - 47)	104 - 112 (65 - 70)	130 - 138 (81 - 86)	85 - 93 (53 - 58)	62 - 70 (39 - 43)	28 - 36 (17 - 22)	9 - 17 (6 - 11)

- At half throttle, the accelerator opening is 4/8 of the full opening.

## Vehicle Speed at Which Lock-Up Occurs/Releases

ACS0098F

### 2WD MODELS

Throttle position	Vehicle speed km/h (MPH)	
	Lock-up "ON"	Lock-up "OFF"
Closed throttle	56 - 64 (35 - 40)	53 - 61 (33 - 38)
Half throttle	168 - 176 (104 - 110)	131 - 139 (81 - 86)

- At closed throttle, the accelerator opening is less than 1/8 condition. (Closed throttle position signal: OFF)
- At half throttle, the accelerator opening is 4/8 of the full opening.

### AWD MODELS

Throttle position	Vehicle speed km/h (MPH)	
	Lock-up "ON"	Lock-up "OFF"
Closed throttle	54 - 62 (34 - 39)	51 - 59 (32 - 37)
Half throttle	161 - 169 (100 - 105)	126 - 134 (78 - 83)

- At closed throttle, the accelerator opening is less than 1/8 condition. (Closed throttle position signal: OFF)
- At half throttle, the accelerator opening is 4/8 of the full opening.

# TROUBLE DIAGNOSIS

## Symptom Chart

ACS009BH

- The diagnostics item numbers show the sequence for inspection. Inspect in order from Item 1.
- Overhaul and inspection inside the A/T only if A/T fluid condition is NG. Refer to [AT-51, "A/T Fluid Condition Check"](#) .

No.	Items	Symptom	Condition	Diagnostic Item	Reference page
1	Shift Shock	Large shock. ("N" → "D" position) Refer to <a href="#">AT-198, "Large Shock ("N" to "D" Position)"</a> .	ON vehicle	1. Engine idle speed	<a href="#">EC-77</a>
				2. Engine speed signal	<a href="#">AT-127</a>
				3. Accelerator pedal position sensor	<a href="#">AT-137</a>
				4. Control linkage adjustment	<a href="#">AT-238</a>
				5. A/T fluid temperature sensor	<a href="#">AT-140</a>
				6. ATF pressure switch 1 and front brake solenoid valve	<a href="#">AT-178, AT-158</a>
				7. CAN communication line	<a href="#">AT-110</a>
				8. A/T fluid level and state	<a href="#">AT-51</a>
				9. Line pressure test	<a href="#">AT-53</a>
				10. Control valve with TCM	<a href="#">AT-248</a>
			OFF vehicle	11. Forward brake (Parts behind drum support is impossible to perform inspection by disassembly. Refer to <a href="#">AT-17, "Cross-Sectional View (2WD Models)"</a> or <a href="#">AT-18, "Cross-Sectional View (AWD Models)"</a> )	<a href="#">AT-275</a>
2		Shock is too large when changing D1 → D2 or M1 → M2 .	ON vehicle	1. Accelerator pedal position sensor	<a href="#">AT-137</a>
				2. Control linkage adjustment	<a href="#">AT-238</a>
				3. ATF pressure switch 5 and direct clutch solenoid valve	<a href="#">AT-182, AT-162</a>
				4. CAN communication line	<a href="#">AT-110</a>
				5. Engine speed signal	<a href="#">AT-127</a>
				6. Turbine revolution sensor	<a href="#">AT-145</a>
				7. Vehicle speed sensor-A/T and vehicle speed sensor-MTR	<a href="#">AT-122, AT-147</a>
				8. A/T fluid level and state	<a href="#">AT-51</a>
				9. Control valve with TCM	<a href="#">AT-248</a>
			OFF vehicle	10. Direct clutch	<a href="#">AT-327</a>

## TROUBLE DIAGNOSIS

No.	Items	Symptom	Condition	Diagnostic Item	Reference page
3		Shock is too large when changing D2 → D3 or M2 → M3 .	ON vehicle	1. Accelerator pedal position sensor	<a href="#">AT-137</a>
				2. Control linkage adjustment	<a href="#">AT-238</a>
				3. ATF pressure switch 6, high and low reverse clutch solenoid valve	<a href="#">AT-184</a> , <a href="#">AT-166</a>
				4. CAN communication line	<a href="#">AT-110</a>
				5. Engine speed signal	<a href="#">AT-127</a>
				6. Turbine revolution sensor	<a href="#">AT-145</a>
				7. Vehicle speed sensor-A/T and vehicle speed sensor-MTR	<a href="#">AT-122</a> , <a href="#">AT-147</a>
				8. A/T fluid level and state	<a href="#">AT-51</a>
				9. Control valve with TCM	<a href="#">AT-248</a>
			OFF vehicle	10. High and low reverse clutch	<a href="#">AT-325</a>
4	Shift Shock	Shock is too large when changing D3 → D4 or M3 → M4 .	ON vehicle	1. Accelerator pedal position sensor	<a href="#">AT-137</a>
				2. Control linkage adjustment	<a href="#">AT-238</a>
				3. ATF pressure switch 3 and input clutch solenoid valve	<a href="#">AT-180</a> , <a href="#">AT-154</a>
				4. CAN communication line	<a href="#">AT-110</a>
				5. Engine speed signal	<a href="#">AT-127</a>
				6. Turbine revolution sensor	<a href="#">AT-145</a>
				7. Vehicle speed sensor-A/T and vehicle speed sensor-MTR	<a href="#">AT-122</a> , <a href="#">AT-147</a>
				8. A/T fluid level and state	<a href="#">AT-51</a>
				9. Control valve with TCM	<a href="#">AT-248</a>
			OFF vehicle	10. Input clutch	<a href="#">AT-315</a>
5		Shock is too large when changing D4 → D5 or M4 → M5 .	ON vehicle	1. Accelerator pedal position sensor	<a href="#">AT-137</a>
				2. Control linkage adjustment	<a href="#">AT-238</a>
				3. ATF pressure switch 1 and front brake solenoid valve	<a href="#">AT-178</a> , <a href="#">AT-158</a>
				4. CAN communication line	<a href="#">AT-110</a>
				5. Engine speed signal	<a href="#">AT-127</a>
				6. Turbine revolution sensor	<a href="#">AT-145</a>
				7. Vehicle speed sensor-A/T and vehicle speed sensor-MTR	<a href="#">AT-122</a> , <a href="#">AT-147</a>
				8. A/T fluid level and state	<a href="#">AT-51</a>
				9. Control valve with TCM	<a href="#">AT-248</a>
			OFF vehicle	10. Front brake (brake band)	<a href="#">AT-280</a>
				11. Input clutch	<a href="#">AT-315</a>

A  
B  
AT  
D  
E  
F  
G  
H  
I  
J  
K  
L  
M

## TROUBLE DIAGNOSIS

No.	Items	Symptom	Condition	Diagnostic Item	Reference page
6		Shock is too large for downshift when accelerator pedal is pressed.	ON vehicle	1. Accelerator pedal position sensor	<a href="#">AT-137</a>
				2. Control linkage adjustment	<a href="#">AT-238</a>
				3. CAN communication line	<a href="#">AT-110</a>
				4. Engine speed signal	<a href="#">AT-127</a>
				5. Turbine revolution sensor	<a href="#">AT-145</a>
				6. Vehicle speed sensor-A/T and vehicle speed sensor-MTR	<a href="#">AT-122,</a> <a href="#">AT-147</a>
				7. A/T fluid level and state	<a href="#">AT-51</a>
				8. Control valve with TCM	<a href="#">AT-248</a>
			OFF vehicle	9. Front brake (brake band)	<a href="#">AT-280</a>
				10. Input clutch	<a href="#">AT-315</a>
				11. High and low reverse clutch	<a href="#">AT-325</a>
				12. Direct clutch	<a href="#">AT-327</a>
7	Shift Shock	Shock is too large for upshift when accelerator pedal is released.	ON vehicle	1. Accelerator pedal position sensor	<a href="#">AT-137</a>
				2. Control linkage adjustment	<a href="#">AT-238</a>
				3. Engine speed signal	<a href="#">AT-127</a>
				4. CAN communication line	<a href="#">AT-110</a>
				5. Turbine revolution sensor	<a href="#">AT-145</a>
				6. Vehicle speed sensor-A/T and vehicle speed sensor-MTR	<a href="#">AT-122,</a> <a href="#">AT-147</a>
				7. A/T fluid level and state	<a href="#">AT-51</a>
				8. Control valve with TCM	<a href="#">AT-248</a>
			OFF vehicle	9. Front brake (brake band)	<a href="#">AT-280</a>
				10. Input clutch	<a href="#">AT-315</a>
				11. High and low reverse clutch	<a href="#">AT-325</a>
				12. Direct clutch	<a href="#">AT-327</a>
8		Shock is too large for lock-up.	ON vehicle	1. Accelerator pedal position sensor	<a href="#">AT-137</a>
				2. Control linkage adjustment	<a href="#">AT-238</a>
				3. Engine speed signal	<a href="#">AT-127</a>
				4. CAN communication line	<a href="#">AT-110</a>
				5. Turbine revolution sensor	<a href="#">AT-145</a>
				6. Vehicle speed sensor-A/T and vehicle speed sensor-MTR	<a href="#">AT-122,</a> <a href="#">AT-147</a>
				7. Torque converter clutch solenoid valve	<a href="#">AT-129</a>
				8. A/T fluid level and state	<a href="#">AT-51</a>
				9. Control valve with TCM	<a href="#">AT-248</a>
			OFF vehicle	10. Torque converter	<a href="#">AT-292</a>

## TROUBLE DIAGNOSIS

No.	Items	Symptom	Condition	Diagnostic Item	Reference page
9	Shift Shock	Shock is too large during engine brake.	ON vehicle	1. Accelerator pedal position sensor	<a href="#">AT-137</a>
				2. Control linkage adjustment	<a href="#">AT-238</a>
				3. CAN communication line	<a href="#">AT-110</a>
				4. A/T fluid level and state	<a href="#">AT-51</a>
				5. Control valve with TCM	<a href="#">AT-248</a>
			OFF vehicle	6. Front brake (brake band)	<a href="#">AT-280</a>
				7. Input clutch	<a href="#">AT-315</a>
				8. High and low reverse clutch	<a href="#">AT-325</a>
				9. Direct clutch	<a href="#">AT-327</a>
10	No Up Shift	Gear does not change from D1 → D2 or from M1 → M2 . Refer to <a href="#">AT-209, "A/T Does Not Shift: D1 → D2"</a> .	ON vehicle	1. A/T fluid level and state	<a href="#">AT-51</a>
				2. Vehicle speed sensor-A/T and vehicle speed sensor-MTR	<a href="#">AT-122, AT-147</a>
				3. ATF pressure switch 5 and direct clutch solenoid valve	<a href="#">AT-182, AT-162</a>
				4. Line pressure test	<a href="#">AT-53</a>
				5. CAN communication line	<a href="#">AT-110</a>
				6. Control valve with TCM	<a href="#">AT-248</a>
			OFF vehicle	7. Direct clutch	<a href="#">AT-327</a>
11	No Up Shift	Gear does not change from D2 → D3 or from M2 → M3 . Refer to <a href="#">AT-211, "A/T Does Not Shift: D2 → D3"</a> .	ON vehicle	1. A/T fluid level and state	<a href="#">AT-51</a>
				2. Vehicle speed sensor-A/T and vehicle speed sensor-MTR	<a href="#">AT-122, AT-147</a>
				3. ATF pressure switch 6, high and low reverse clutch solenoid valve	<a href="#">AT-184, AT-166</a>
				4. Line pressure test	<a href="#">AT-53</a>
				5. CAN communication line	<a href="#">AT-110</a>
				6. Control valve with TCM	<a href="#">AT-248</a>
			OFF vehicle	7. High and low reverse clutch	<a href="#">AT-325</a>
12	No Up Shift	Gear does not change from D3 → D4 or from M3 → M4 . Refer to <a href="#">AT-213, "A/T Does Not Shift: D3 → D4"</a> .	ON vehicle	1. A/T fluid level and state	<a href="#">AT-51</a>
				2. Vehicle speed sensor-A/T and vehicle speed sensor-MTR	<a href="#">AT-122, AT-147</a>
				3. ATF pressure switch 3 and input clutch solenoid valve	<a href="#">AT-180, AT-154</a>
				4. ATF pressure switch 1 and front brake solenoid valve	<a href="#">AT-178, AT-158</a>
				5. Line pressure test	<a href="#">AT-53</a>
				6. CAN communication line	<a href="#">AT-110</a>
				7. Control valve with TCM	<a href="#">AT-248</a>
			OFF vehicle	8. Input clutch	<a href="#">AT-315</a>

## TROUBLE DIAGNOSIS

No.	Items	Symptom	Condition	Diagnostic Item	Reference page
13	No Up Shift	Gear does not change from D4 → D5 or from M4 → M5 . Refer to <a href="#">AT-216</a> , "A/T Does Not Shift: D4 → D5" .	ON vehicle	1. A/T fluid level and state	<a href="#">AT-51</a>
				2. Vehicle speed sensor-A/T and vehicle speed sensor-MTR	<a href="#">AT-122</a> , <a href="#">AT-147</a>
				3. ATF pressure switch 1 and front brake solenoid valve	<a href="#">AT-178</a> , <a href="#">AT-158</a>
				4. ATF pressure switch 5 and direct clutch solenoid valve	<a href="#">AT-182</a> , <a href="#">AT-162</a>
				5. Turbine revolution sensor	<a href="#">AT-145</a>
				6. Line pressure test	<a href="#">AT-53</a>
				7. CAN communication line	<a href="#">AT-110</a>
				8. Control valve with TCM	<a href="#">AT-248</a>
			OFF vehicle	9. Front brake (brake band)	<a href="#">AT-292</a>
				10. Input clutch	<a href="#">AT-315</a>
14	No Down Shift	In "D" or "M" position, does not downshift to 4th gear.	ON vehicle	1. A/T fluid level and state	<a href="#">AT-51</a>
				2. Vehicle speed sensor-A/T and vehicle speed sensor-MTR	<a href="#">AT-122</a> , <a href="#">AT-147</a>
				3. ATF pressure switch 1 and front brake solenoid valve	<a href="#">AT-178</a> , <a href="#">AT-158</a>
				4. ATF pressure switch 5 and direct clutch solenoid valve	<a href="#">AT-182</a> , <a href="#">AT-162</a>
				5. CAN communication line	<a href="#">AT-110</a>
				6. Line pressure test	<a href="#">AT-53</a>
				7. Control valve with TCM	<a href="#">AT-248</a>
			OFF vehicle	8. Front brake (brake band)	<a href="#">AT-292</a>
				9. Input clutch	<a href="#">AT-315</a>
15	No Down Shift	In "D" or "M" position, does not downshift to 3rd gear.	ON vehicle	1. A/T fluid level and state	<a href="#">AT-51</a>
				2. Vehicle speed sensor-A/T and vehicle speed sensor-MTR	<a href="#">AT-122</a> , <a href="#">AT-147</a>
				3. ATF pressure switch 3 and input clutch solenoid valve	<a href="#">AT-180</a> , <a href="#">AT-154</a>
				4. ATF pressure switch 1 and front brake solenoid valve	<a href="#">AT-178</a> , <a href="#">AT-158</a>
				5. CAN communication line	<a href="#">AT-110</a>
				6. Line pressure test	<a href="#">AT-53</a>
				7. Control valve with TCM	<a href="#">AT-248</a>
			OFF vehicle	8. Input clutch	<a href="#">AT-315</a>

## TROUBLE DIAGNOSIS

No.	Items	Symptom	Condition	Diagnostic Item	Reference page
16	No Down Shift	In "D" or "M" position, does not downshift to 2nd gear.	ON vehicle	1. A/T fluid level and state	<a href="#">AT-51</a>
				2. Vehicle speed sensor-A/T and vehicle speed sensor-MTR	<a href="#">AT-122,</a> <a href="#">AT-147</a>
				3. ATF pressure switch 6, high and low reverse clutch solenoid valve	<a href="#">AT-184,</a> <a href="#">AT-166</a>
				4. CAN communication line	<a href="#">AT-110</a>
				5. Line pressure test	<a href="#">AT-53</a>
				6. Control valve with TCM	<a href="#">AT-248</a>
			OFF vehicle	7. High and low reverse clutch	<a href="#">AT-325</a>
17	No Down Shift	In "D" or "M" position, does not downshift to 1st gear.	ON vehicle	1. A/T fluid level and state	<a href="#">AT-51</a>
				2. Vehicle speed sensor-A/T and vehicle speed sensor-MTR	<a href="#">AT-122,</a> <a href="#">AT-147</a>
				3. ATF pressure switch 5 and direct clutch solenoid valve	<a href="#">AT-182,</a> <a href="#">AT-162</a>
				4. CAN communication line	<a href="#">AT-110</a>
				5. Line pressure test	<a href="#">AT-53</a>
				6. Control valve with TCM	<a href="#">AT-248</a>
			OFF vehicle	7. Direct clutch	<a href="#">AT-327</a>
18	Slips/Will Not Engage	When "D" or "M" position, remains in 1st gear.	ON vehicle	1. A/T fluid level and state	<a href="#">AT-51</a>
				2. Vehicle speed sensor-A/T and vehicle speed sensor-MTR	<a href="#">AT-122,</a> <a href="#">AT-147</a>
				3. Direct clutch solenoid valve	<a href="#">AT-162</a>
				4. Line pressure test	<a href="#">AT-53</a>
				5. CAN communication line	<a href="#">AT-110</a>
				6. Control valve with TCM	<a href="#">AT-248</a>
			OFF vehicle	7. 3rd one-way clutch	<a href="#">AT-313</a>
				8. 1st one-way clutch	<a href="#">AT-320</a>
				9. Gear system	<a href="#">AT-280</a>
				10. Reverse brake	<a href="#">AT-292</a>
				11. Forward one-way clutch (Parts behind drum support is impossible to perform inspection by disassembly. Refer to <a href="#">AT-17, "Cross-Sectional View (2WD Models)"</a> or <a href="#">AT-18, "Cross-Sectional View (AWD Models)"</a> )	<a href="#">AT-275</a>
				12. Forward brake (Parts behind drum support is impossible to perform inspection by disassembly. Refer to <a href="#">AT-17, "Cross-Sectional View (2WD Models)"</a> or <a href="#">AT-18, "Cross-Sectional View (AWD Models)"</a> )	<a href="#">AT-275</a>

A  
B  
AT  
D  
E  
F  
G  
H  
I  
J  
K  
L  
M

## TROUBLE DIAGNOSIS

No.	Items	Symptom	Condition	Diagnostic Item	Reference page
19		When "D" or "M" position, remains in 2nd gear.	ON vehicle	1. A/T fluid level and state	<a href="#">AT-51</a>
				2. Vehicle speed sensor-A/T and vehicle speed sensor-MTR	<a href="#">AT-122, AT-147</a>
				3. Low coast brake solenoid valve	<a href="#">AT-170</a>
				4. Line pressure test	<a href="#">AT-53</a>
				5. CAN communication line	<a href="#">AT-110</a>
			OFF vehicle	6. Control valve with TCM	<a href="#">AT-248</a>
				7. 3rd one-way clutch	<a href="#">AT-313</a>
				8. Gear system	<a href="#">AT-280</a>
				9. Direct clutch	<a href="#">AT-327</a>
				10. Forward brake (Parts behind drum support is impossible to perform inspection by disassembly. Refer to <a href="#">AT-17, "Cross-Sectional View (2WD Models)"</a> or <a href="#">AT-18, "Cross-Sectional View (AWD Models)"</a> )	<a href="#">AT-275</a>
20	Slips/Will Not Engage	When "D" or "M" position, remains in 3rd gear.	ON vehicle	1. A/T fluid level and state	<a href="#">AT-51</a>
				2. Vehicle speed sensor-A/T and vehicle speed sensor-MTR	<a href="#">AT-122, AT-147</a>
				3. Line pressure test	<a href="#">AT-53</a>
				4. CAN communication line	<a href="#">AT-110</a>
				5. Control valve with TCM	<a href="#">AT-248</a>
			OFF vehicle	6. 3rd one-way clutch	<a href="#">AT-313</a>
				7. Gear system	<a href="#">AT-280</a>
				8. High and low reverse clutch	<a href="#">AT-325</a>
				9. Forward one-way clutch (Parts behind drum support is impossible to perform inspection by disassembly. Refer to <a href="#">AT-17, "Cross-Sectional View (2WD Models)"</a> or <a href="#">AT-18, "Cross-Sectional View (AWD Models)"</a> )	<a href="#">AT-275</a>
				10. Forward brake (Parts behind drum support is impossible to perform inspection by disassembly. Refer to <a href="#">AT-17, "Cross-Sectional View (2WD Models)"</a> or <a href="#">AT-18, "Cross-Sectional View (AWD Models)"</a> )	<a href="#">AT-275</a>



## TROUBLE DIAGNOSIS

No.	Items	Symptom	Condition	Diagnostic Item	Reference page
21	Slips/Will Not Engage	When "D" or "M" position, remains in 4th gear.	ON vehicle	1. A/T fluid level and state	<a href="#">AT-51</a>
				2. Vehicle speed sensor-A/T and vehicle speed sensor-MTR	<a href="#">AT-122, AT-147</a>
				3. ATF pressure switch 3 and input clutch solenoid valve	<a href="#">AT-180, AT-154</a>
				4. ATF pressure switch 5 and direct clutch solenoid valve	<a href="#">AT-182, AT-162</a>
				5. ATF pressure switch 6, high and low reverse clutch solenoid valve	<a href="#">AT-184, AT-166</a>
				6. Low coast brake solenoid valve	<a href="#">AT-170</a>
				7. Front brake solenoid valve	<a href="#">AT-158</a>
				8. Line pressure test	<a href="#">AT-53</a>
				9. CAN communication line	<a href="#">AT-110</a>
				10. Control valve with TCM	<a href="#">AT-248</a>
			OFF vehicle	11. Input clutch	<a href="#">AT-315</a>
				12. Gear system	<a href="#">AT-280</a>
				13. High and low reverse clutch	<a href="#">AT-325</a>
				14. Direct clutch	<a href="#">AT-327</a>
22		When "D" or "M" position, remains in 5th gear.	ON vehicle	1. A/T fluid level and state	<a href="#">AT-51</a>
				2. Vehicle speed sensor-A/T and vehicle speed sensor-MTR	<a href="#">AT-122, AT-147</a>
				3. ATF pressure switch 1 and front brake solenoid valve	<a href="#">AT-178, AT-158</a>
				4. Line pressure test	<a href="#">AT-53</a>
				5. CAN communication line	<a href="#">AT-110</a>
				6. Control valve with TCM	<a href="#">AT-248</a>
			OFF vehicle	7. Front brake (brake band)	<a href="#">AT-292</a>
				8. Input clutch	<a href="#">AT-315</a>
				9. Gear system	<a href="#">AT-280</a>
				10. High and low reverse clutch	<a href="#">AT-325</a>

A  
B  
AT  
D  
E  
F  
G  
H  
I  
J  
K  
L  
M

## TROUBLE DIAGNOSIS

No.	Items	Symptom	Condition	Diagnostic Item	Reference page			
23	Slips/Will Not Engage	Vehicle cannot be started from D1 . Refer to <a href="#">AT-206</a> , " <a href="#">Vehicle Cannot Be Started from D1</a> ".	ON vehicle	1. A/T fluid level and state	<a href="#">AT-51</a>			
				2. Accelerator pedal position sensor	<a href="#">AT-137</a>			
				3. Line pressure test	<a href="#">AT-53</a>			
				4. CAN communication line	<a href="#">AT-110</a>			
				5. Control valve with TCM	<a href="#">AT-248</a>			
			OFF vehicle	6. Torque converter	<a href="#">AT-292</a>			
				7. Oil pump assembly	<a href="#">AT-310</a>			
				8. 3rd one-way clutch	<a href="#">AT-313</a>			
				9. 1st one-way clutch	<a href="#">AT-320</a>			
				10. Gear system	<a href="#">AT-280</a>			
				11. Reverse brake	<a href="#">AT-292</a>			
				12. Forward one-way clutch (Parts behind drum support is impossible to perform inspection by disassembly. Refer to <a href="#">AT-17</a> , " <a href="#">Cross-Sectional View (2WD Models)</a> " or <a href="#">AT-18</a> , " <a href="#">Cross-Sectional View (AWD Models)</a> " )	<a href="#">AT-275</a>			
				13. Forward brake (Parts behind drum support is impossible to perform inspection by disassembly. Refer to <a href="#">AT-17</a> , " <a href="#">Cross-Sectional View (2WD Models)</a> " or <a href="#">AT-18</a> , " <a href="#">Cross-Sectional View (AWD Models)</a> " )	<a href="#">AT-275</a>			
24	Slips/Will Not Engage	Does not lock-up. Refer to <a href="#">AT-218</a> , " <a href="#">A/T Does Not Perform Lock-Up</a> ".	ON vehicle	1. A/T fluid level and state	<a href="#">AT-51</a>			
				2. Line pressure test	<a href="#">AT-53</a>			
				3. Engine speed signal	<a href="#">AT-127</a>			
				4. Turbine revolution sensor	<a href="#">AT-145</a>			
				5. Torque converter clutch solenoid valve	<a href="#">AT-129</a>			
				6. CAN communication line	<a href="#">AT-110</a>			
				7. Control valve with TCM	<a href="#">AT-248</a>			
			OFF vehicle	8. Torque converter	<a href="#">AT-292</a>			
				9. Oil pump assembly	<a href="#">AT-310</a>			
			25	Slips/Will Not Engage	Does not hold lock-up condition. Refer to <a href="#">AT-220</a> , " <a href="#">A/T Does Not Hold Lock-Up Condition</a> ".	ON vehicle	1. A/T fluid level and state	<a href="#">AT-51</a>
							2. Line pressure test	<a href="#">AT-53</a>
							3. Engine speed signal	<a href="#">AT-127</a>
							4. Turbine revolution sensor	<a href="#">AT-145</a>
5. Torque converter clutch solenoid valve	<a href="#">AT-129</a>							
6. CAN communication line	<a href="#">AT-110</a>							
7. Control valve with TCM	<a href="#">AT-248</a>							
OFF vehicle	8. Torque converter	<a href="#">AT-292</a>						
	9. Oil pump assembly	<a href="#">AT-310</a>						

## TROUBLE DIAGNOSIS

No.	Items	Symptom	Condition	Diagnostic Item	Reference page
26		Lock-up is not released. Refer to <a href="#">AT-222</a> , " <a href="#">Lock-Up Is Not Released</a> ".	ON vehicle	1. A/T fluid level and state	<a href="#">AT-51</a>
				2. Line pressure test	<a href="#">AT-53</a>
				3. Engine speed signal	<a href="#">AT-127</a>
				4. Turbine revolution sensor	<a href="#">AT-145</a>
				5. Torque converter clutch solenoid valve	<a href="#">AT-129</a>
				6. CAN communication line	<a href="#">AT-110</a>
				7. Control valve with TCM	<a href="#">AT-248</a>
			OFF vehicle	8. Torque converter	<a href="#">AT-292</a>
				9. Oil pump assembly	<a href="#">AT-310</a>
27	Slips/Will Not Engage	No shock at all or the clutch slips when vehicle changes speed D1 → D2 or M1 → M2 .	ON vehicle	1. A/T fluid level and state	<a href="#">AT-51</a>
				2. Vehicle speed sensor-A/T and vehicle speed sensor-MTR	<a href="#">AT-122</a> , <a href="#">AT-147</a>
				3. ATF pressure switch 5 and direct clutch solenoid valve	<a href="#">AT-182</a> , <a href="#">AT-162</a>
				4. CAN communication line	<a href="#">AT-110</a>
				5. Line pressure test	<a href="#">AT-53</a>
				6. Control valve with TCM	<a href="#">AT-248</a>
			OFF vehicle	7. Torque converter	<a href="#">AT-292</a>
				8. Oil pump assembly	<a href="#">AT-310</a>
				9. 3rd one-way clutch	<a href="#">AT-313</a>
				10. Gear system	<a href="#">AT-280</a>
				11. Direct clutch	<a href="#">AT-327</a>
				12. Forward brake (Parts behind drum support is impossible to perform inspection by disassembly. Refer to <a href="#">AT-17</a> , " <a href="#">Cross-Sectional View (2WD Models)</a> " or <a href="#">AT-18</a> , " <a href="#">Cross-Sectional View (AWD Models)</a> " )	<a href="#">AT-275</a>

## TROUBLE DIAGNOSIS

No.	Items	Symptom	Condition	Diagnostic Item	Reference page
28	Slips/Will Not Engage	No shock at all or the clutch slips when vehicle changes speed D2 → D3 or M2 → M3 .	ON vehicle	1. A/T fluid level and state	<a href="#">AT-51</a>
				2. Vehicle speed sensor-A/T and vehicle speed sensor-MTR	<a href="#">AT-122, AT-147</a>
				3. ATF pressure switch 6, high and low reverse clutch solenoid valve	<a href="#">AT-184, AT-166</a>
				4. CAN communication line	<a href="#">AT-110</a>
				5. Line pressure test	<a href="#">AT-53</a>
				6. Control valve with TCM	<a href="#">AT-248</a>
			OFF vehicle	7. Torque converter	<a href="#">AT-292</a>
				8. Oil pump assembly	<a href="#">AT-310</a>
				9. 3rd one-way clutch	<a href="#">AT-313</a>
				10. Gear system	<a href="#">AT-280</a>
				11. High and low reverse clutch	<a href="#">AT-325</a>
				12. Forward one-way clutch (Parts behind drum support is impossible to perform inspection by disassembly. Refer to <a href="#">AT-17, "Cross-Sectional View (2WD Models)"</a> or <a href="#">AT-18, "Cross-Sectional View (AWD Models)"</a> )	<a href="#">AT-275</a>
				13. Forward brake (Parts behind drum support is impossible to perform inspection by disassembly. Refer to <a href="#">AT-17, "Cross-Sectional View (2WD Models)"</a> or <a href="#">AT-18, "Cross-Sectional View (AWD Models)"</a> )	<a href="#">AT-275</a>
29		No shock at all or the clutch slips when vehicle changes speed D3 → D4 or M3 → M4 .	ON vehicle	1. A/T fluid level and state	<a href="#">AT-51</a>
				2. Vehicle speed sensor-A/T and vehicle speed sensor-MTR	<a href="#">AT-122, AT-147</a>
				3. ATF pressure switch 3 and input clutch solenoid valve	<a href="#">AT-180, AT-154</a>
				4. ATF pressure switch 1 and front brake solenoid valve	<a href="#">AT-178, AT-158</a>
				5. CAN communication line	<a href="#">AT-110</a>
				6. Line pressure test	<a href="#">AT-53</a>
				7. Control valve with TCM	<a href="#">AT-248</a>
			OFF vehicle	8. Torque converter	<a href="#">AT-292</a>
				9. Oil pump assembly	<a href="#">AT-310</a>
				10. Input clutch	<a href="#">AT-315</a>
				11. Gear system	<a href="#">AT-280</a>
				12. High and low reverse clutch	<a href="#">AT-325</a>
				13. Direct clutch	<a href="#">AT-327</a>

## TROUBLE DIAGNOSIS

No.	Items	Symptom	Condition	Diagnostic Item	Reference page
30	Slips/Will Not Engage	No shock at all or the clutch slips when vehicle changes speed D4 → D5 or M4 → M5 .	ON vehicle	1. A/T fluid level and state	<a href="#">AT-51</a>
				2. Vehicle speed sensor-A/T and vehicle speed sensor-MTR	<a href="#">AT-122,</a> <a href="#">AT-147</a>
				3. ATF pressure switch 1 and front brake solenoid valve	<a href="#">AT-178,</a> <a href="#">AT-158</a>
				4. ATF pressure switch 5 and direct clutch solenoid valve	<a href="#">AT-182,</a> <a href="#">AT-162</a>
				5. CAN communication line	<a href="#">AT-110</a>
				6. Line pressure test	<a href="#">AT-53</a>
				7. Control valve with TCM	<a href="#">AT-248</a>
			OFF vehicle	8. Torque converter	<a href="#">AT-292</a>
				9. Oil pump assembly	<a href="#">AT-310</a>
				10. Front brake (brake band)	<a href="#">AT-292</a>
				11. Input clutch	<a href="#">AT-315</a>
				12. Gear system	<a href="#">AT-280</a>
				13. High and low reverse clutch	<a href="#">AT-325</a>
31	Slips/Will Not Engage	When you press the accelerator pedal and shift speed D5 → D4 or M5 → M4 the engine idles or the transmission slips.	ON vehicle	1. A/T fluid level and state	<a href="#">AT-51</a>
				2. Vehicle speed sensor-A/T and vehicle speed sensor-MTR	<a href="#">AT-122,</a> <a href="#">AT-147</a>
				3. ATF pressure switch 1 and front brake solenoid valve	<a href="#">AT-178,</a> <a href="#">AT-158</a>
				4. ATF pressure switch 5 and direct clutch solenoid valve	<a href="#">AT-182,</a> <a href="#">AT-162</a>
				5. CAN communication line	<a href="#">AT-110</a>
				6. Line pressure test	<a href="#">AT-53</a>
				7. Control valve with TCM	<a href="#">AT-248</a>
			OFF vehicle	8. Torque converter	<a href="#">AT-292</a>
				9. Oil pump assembly	<a href="#">AT-310</a>
				10. Input clutch	<a href="#">AT-315</a>
				11. Gear system	<a href="#">AT-280</a>
				12. High and low reverse clutch	<a href="#">AT-325</a>
				13. Direct clutch	<a href="#">AT-327</a>

A  
B  
AT  
D  
E  
F  
G  
H  
I  
J  
K  
L  
M

## TROUBLE DIAGNOSIS

No.	Items	Symptom	Condition	Diagnostic Item	Reference page
32	Slips/Will Not Engage	When you press the accelerator pedal and shift speed D4 → D3 or M4 → M3 the engine idles or the transmission slips.	ON vehicle	1. A/T fluid level and state	<a href="#">AT-51</a>
				2. Vehicle speed sensor-A/T and vehicle speed sensor-MTR	<a href="#">AT-122, AT-147</a>
				3. ATF pressure switch 3 and input clutch solenoid valve	<a href="#">AT-180, AT-154</a>
				4. ATF pressure switch 1 and front brake solenoid valve	<a href="#">AT-178, AT-158</a>
				5. CAN communication line	<a href="#">AT-110</a>
				6. Line pressure test	<a href="#">AT-53</a>
				7. Control valve with TCM	<a href="#">AT-248</a>
			OFF vehicle	8. Torque converter	<a href="#">AT-292</a>
				9. Oil pump assembly	<a href="#">AT-310</a>
				10. 3rd one-way clutch	<a href="#">AT-313</a>
				11. Gear system	<a href="#">AT-280</a>
				12. High and low reverse clutch	<a href="#">AT-325</a>
				13. Forward one-way clutch (Parts behind drum support is impossible to perform inspection by disassembly. Refer to <a href="#">AT-17, "Cross-Sectional View (2WD Models)"</a> or <a href="#">AT-18, "Cross-Sectional View (AWD Models)"</a> )	<a href="#">AT-275</a>
				14. Forward brake (Parts behind drum support is impossible to perform inspection by disassembly. Refer to <a href="#">AT-17, "Cross-Sectional View (2WD Models)"</a> or <a href="#">AT-18, "Cross-Sectional View (AWD Models)"</a> )	<a href="#">AT-275</a>
33		When you press the accelerator pedal and shift speed D3 → D2 or M3 → M2 the engine idles or the transmission slips.	ON vehicle	1. A/T fluid level and state	<a href="#">AT-51</a>
				2. Vehicle speed sensor-A/T and vehicle speed sensor-MTR	<a href="#">AT-122, AT-147</a>
				3. ATF pressure switch 6, high and low reverse clutch solenoid valve	<a href="#">AT-184, AT-166</a>
				4. ATF pressure switch 5 and direct clutch solenoid valve	<a href="#">AT-182, AT-162</a>
				5. CAN communication line	<a href="#">AT-110</a>
				6. Line pressure test	<a href="#">AT-53</a>
				7. Control valve with TCM	<a href="#">AT-248</a>
			OFF vehicle	8. Torque converter	<a href="#">AT-292</a>
				9. Oil pump assembly	<a href="#">AT-310</a>
				10. 3rd one-way clutch	<a href="#">AT-313</a>
				11. Gear system	<a href="#">AT-280</a>
				12. Direct clutch	<a href="#">AT-327</a>
				13. Forward brake (Parts behind drum support is impossible to perform inspection by disassembly. Refer to <a href="#">AT-17, "Cross-Sectional View (2WD Models)"</a> or <a href="#">AT-18, "Cross-Sectional View (AWD Models)"</a> )	<a href="#">AT-275</a>

## TROUBLE DIAGNOSIS

No.	Items	Symptom	Condition	Diagnostic Item	Reference page
34	Slips/Will Not Engage	When you press the accelerator pedal and shift speed D2 → D1 or M2 → M1 the engine idles or the transmission slips.	ON vehicle	1. A/T fluid level and state	<a href="#">AT-51</a>
				2. Vehicle speed sensor-A/T and vehicle speed sensor-MTR	<a href="#">AT-122</a> , <a href="#">AT-147</a>
				3. ATF pressure switch 5 and direct clutch solenoid valve	<a href="#">AT-182</a> , <a href="#">AT-162</a>
				4. CAN communication line	<a href="#">AT-110</a>
				5. Line pressure test	<a href="#">AT-53</a>
				6. Control valve with TCM	<a href="#">AT-248</a>
			OFF vehicle	7. Torque converter	<a href="#">AT-292</a>
				8. Oil pump assembly	<a href="#">AT-310</a>
				9. 3rd one-way clutch	<a href="#">AT-313</a>
				10. 1st one-way clutch	<a href="#">AT-320</a>
				11. Gear system	<a href="#">AT-280</a>
				12. Reverse brake	<a href="#">AT-292</a>
				13. Forward one-way clutch (Parts behind drum support is impossible to perform inspection by disassembly. Refer to <a href="#">AT-17</a> , " <a href="#">Cross-Sectional View (2WD Models)</a> " or <a href="#">AT-18</a> , " <a href="#">Cross-Sectional View (AWD Models)</a> " )	<a href="#">AT-275</a>
				14. Forward brake (Parts behind drum support is impossible to perform inspection by disassembly. Refer to <a href="#">AT-17</a> , " <a href="#">Cross-Sectional View (2WD Models)</a> " or <a href="#">AT-18</a> , " <a href="#">Cross-Sectional View (AWD Models)</a> " )	<a href="#">AT-275</a>
35	With selector lever in "D" position, acceleration is extremely poor.		ON vehicle	1. A/T fluid level and state	<a href="#">AT-51</a>
				2. Line pressure test	<a href="#">AT-53</a>
				3. Accelerator pedal position sensor	<a href="#">AT-137</a>
				4. CAN communication line	<a href="#">AT-110</a>
				5. PNP switch	<a href="#">AT-118</a>
				6. Control linkage adjustment	<a href="#">AT-238</a>
				7. Control valve with TCM	<a href="#">AT-248</a>
			OFF vehicle	8. Torque converter	<a href="#">AT-292</a>
				9. Oil pump assembly	<a href="#">AT-310</a>
				10. 1st one-way clutch	<a href="#">AT-320</a>
				11. Gear system	<a href="#">AT-280</a>
				12. Reverse brake	<a href="#">AT-292</a>
				13. Forward one-way clutch (Parts behind drum support is impossible to perform inspection by disassembly. Refer to <a href="#">AT-17</a> , " <a href="#">Cross-Sectional View (2WD Models)</a> " or <a href="#">AT-18</a> , " <a href="#">Cross-Sectional View (AWD Models)</a> " )	<a href="#">AT-275</a>
				14. Forward brake (Parts behind drum support is impossible to perform inspection by disassembly. Refer to <a href="#">AT-17</a> , " <a href="#">Cross-Sectional View (2WD Models)</a> " or <a href="#">AT-18</a> , " <a href="#">Cross-Sectional View (AWD Models)</a> " )	<a href="#">AT-275</a>

## TROUBLE DIAGNOSIS

No.	Items	Symptom	Condition	Diagnostic Item	Reference page
36		With selector lever in "R" position, acceleration is extremely poor.	ON vehicle	1. A/T fluid level and state	<a href="#">AT-51</a>
				2. Line pressure test	<a href="#">AT-53</a>
				3. Accelerator pedal position sensor	<a href="#">AT-137</a>
				4. ATF pressure switch 6, high and low reverse clutch solenoid valve	<a href="#">AT-184</a> , <a href="#">AT-166</a>
				5. CAN communication line	<a href="#">AT-110</a>
				6. PNP switch	<a href="#">AT-118</a>
				7. Control linkage adjustment	<a href="#">AT-238</a>
				8. Control valve with TCM	<a href="#">AT-248</a>
			OFF vehicle	9. Gear system	<a href="#">AT-280</a>
				10. Output shaft	<a href="#">AT-292</a>
				11. Reverse brake	<a href="#">AT-292</a>
37	Slips/Will Not Engage	While starting off by accelerating in 1st, engine races or slippage occurs.	ON vehicle	1. A/T fluid level and state	<a href="#">AT-51</a>
				2. Line pressure test	<a href="#">AT-53</a>
				3. Accelerator pedal position sensor	<a href="#">AT-137</a>
				4. CAN communication line	<a href="#">AT-110</a>
				5. Control valve with TCM	<a href="#">AT-248</a>
			OFF vehicle	6. Torque converter	<a href="#">AT-292</a>
				7. Oil pump assembly	<a href="#">AT-310</a>
				8. 3rd one-way clutch	<a href="#">AT-313</a>
				9. 1st one-way clutch	<a href="#">AT-320</a>
				10. Gear system	<a href="#">AT-280</a>
				11. Reverse brake	<a href="#">AT-292</a>
				12. Forward one-way clutch (Parts behind drum support is impossible to perform inspection by disassembly. Refer to <a href="#">AT-17</a> , " <a href="#">Cross-Sectional View (2WD Models)</a> " or <a href="#">AT-18</a> , " <a href="#">Cross-Sectional View (AWD Models)</a> " )	<a href="#">AT-275</a>
				13. Forward brake (Parts behind drum support is impossible to perform inspection by disassembly. Refer to <a href="#">AT-17</a> , " <a href="#">Cross-Sectional View (2WD Models)</a> " or <a href="#">AT-18</a> , " <a href="#">Cross-Sectional View (AWD Models)</a> " )	<a href="#">AT-275</a>



## TROUBLE DIAGNOSIS

No.	Items	Symptom	Condition	Diagnostic Item	Reference page
38		While accelerating in 2nd, engine races or slippage occurs.	ON vehicle	1. A/T fluid level and state	<a href="#">AT-51</a>
				2. Line pressure test	<a href="#">AT-53</a>
				3. Accelerator pedal position sensor	<a href="#">AT-137</a>
				4. CAN communication line	<a href="#">AT-110</a>
				5. ATF pressure switch 5 and direct clutch solenoid valve	<a href="#">AT-182,</a> <a href="#">AT-162</a>
				6. Control valve with TCM	<a href="#">AT-248</a>
			OFF vehicle	7. Torque converter	<a href="#">AT-292</a>
				8. Oil pump assembly	<a href="#">AT-310</a>
				9. 3rd one-way clutch	<a href="#">AT-313</a>
				10. Gear system	<a href="#">AT-280</a>
				11. Direct clutch	<a href="#">AT-327</a>
				12. Forward brake (Parts behind drum support is impossible to perform inspection by disassembly. Refer to <a href="#">AT-17,</a> " <a href="#">Cross-Sectional View (2WD Models)</a> " or <a href="#">AT-18,</a> " <a href="#">Cross-Sectional View (AWD Models)</a> " )	<a href="#">AT-275</a>
39	Slips/Will Not Engage	While accelerating in 3rd, engine races or slippage occurs.	ON vehicle	1. A/T fluid level and state	<a href="#">AT-51</a>
				2. Line pressure test	<a href="#">AT-53</a>
				3. Accelerator pedal position sensor	<a href="#">AT-137</a>
				4. CAN communication line	<a href="#">AT-110</a>
				5. ATF pressure switch 6, high and low reverse clutch solenoid valve	<a href="#">AT-184,</a> <a href="#">AT-166</a>
				6. Control valve with TCM	<a href="#">AT-248</a>
			OFF vehicle	7. Torque converter	<a href="#">AT-292</a>
				8. Oil pump assembly	<a href="#">AT-310</a>
				9. 3rd one-way clutch	<a href="#">AT-313</a>
				10. Gear system	<a href="#">AT-280</a>
				11. High and low reverse clutch	<a href="#">AT-325</a>
				12. Forward one-way clutch (Parts behind drum support is impossible to perform inspection by disassembly. Refer to <a href="#">AT-17,</a> " <a href="#">Cross-Sectional View (2WD Models)</a> " or <a href="#">AT-18,</a> " <a href="#">Cross-Sectional View (AWD Models)</a> " )	<a href="#">AT-275</a>
				13. Forward brake (Parts behind drum support is impossible to perform inspection by disassembly. Refer to <a href="#">AT-17,</a> " <a href="#">Cross-Sectional View (2WD Models)</a> " or <a href="#">AT-18,</a> " <a href="#">Cross-Sectional View (AWD Models)</a> " )	<a href="#">AT-275</a>

## TROUBLE DIAGNOSIS

No.	Items	Symptom	Condition	Diagnostic Item	Reference page
40		While accelerating in 4th, engine races or slippage occurs.	ON vehicle	1. A/T fluid level and state	<a href="#">AT-51</a>
				2. Line pressure test	<a href="#">AT-53</a>
				3. Accelerator pedal position sensor	<a href="#">AT-137</a>
				4. CAN communication line	<a href="#">AT-110</a>
				5. ATF pressure switch 3 and input clutch solenoid valve	<a href="#">AT-180,</a> <a href="#">AT-154</a>
				6. Control valve with TCM	<a href="#">AT-248</a>
			OFF vehicle	7. Torque converter	<a href="#">AT-292</a>
				8. Oil pump assembly	<a href="#">AT-310</a>
				9. Input clutch	<a href="#">AT-315</a>
				10. Gear system	<a href="#">AT-280</a>
				11. High and low reverse clutch	<a href="#">AT-325</a>
				12. Direct clutch	<a href="#">AT-327</a>
41	Slips/Will Not Engage	While accelerating in 5th, engine races or slippage occurs.	ON vehicle	1. A/T fluid level and state	<a href="#">AT-51</a>
				2. Line pressure test	<a href="#">AT-53</a>
				3. Accelerator pedal position sensor	<a href="#">AT-137</a>
				4. CAN communication line	<a href="#">AT-110</a>
				5. ATF pressure switch 1 and front brake solenoid valve	<a href="#">AT-178,</a> <a href="#">AT-158</a>
				6. Control valve with TCM	<a href="#">AT-248</a>
			OFF vehicle	7. Torque converter	<a href="#">AT-292</a>
				8. Oil pump assembly	<a href="#">AT-310</a>
				9. Front brake (brake band)	<a href="#">AT-292</a>
				10. Input clutch	<a href="#">AT-315</a>
				11. Gear system	<a href="#">AT-280</a>
				12. High and low reverse clutch	<a href="#">AT-325</a>
42		Slips at lock-up.	ON vehicle	1. A/T fluid level and state	<a href="#">AT-51</a>
				2. Line pressure test	<a href="#">AT-53</a>
				3. Engine speed signal	<a href="#">AT-127</a>
				4. Turbine revolution sensor	<a href="#">AT-145</a>
				5. Torque converter clutch solenoid valve	<a href="#">AT-129</a>
				6. CAN communication line	<a href="#">AT-110</a>
				7. Control valve with TCM	<a href="#">AT-248</a>
			OFF vehicle	8. Torque converter	<a href="#">AT-292</a>
				9. Oil pump assembly	<a href="#">AT-310</a>

## TROUBLE DIAGNOSIS

No.	Items	Symptom	Condition	Diagnostic Item	Reference page
43	Slips/Will Not Engage	No creep at all. Refer to <a href="#">AT-201</a> . "Vehicle Does Not Creep Backward in "R" Position", <a href="#">AT-204</a> . "Vehicle Does Not Creep Forward in "D" Position"	ON vehicle	1. A/T fluid level and state	<a href="#">AT-51</a>
				2. Line pressure test	<a href="#">AT-53</a>
				3. Accelerator pedal position sensor	<a href="#">AT-137</a>
				4. ATF pressure switch 5 and direct clutch solenoid valve	<a href="#">AT-182</a> , <a href="#">AT-162</a>
				5. PNP switch	<a href="#">AT-118</a>
				6. CAN communication line	<a href="#">AT-110</a>
				7. Control linkage adjustment	<a href="#">AT-238</a>
				8. Control valve with TCM	<a href="#">AT-248</a>
			OFF vehicle	9. Torque converter	<a href="#">AT-292</a>
				10. Oil pump assembly	<a href="#">AT-310</a>
				11. 1st one-way clutch	<a href="#">AT-320</a>
				12. Gear system	<a href="#">AT-280</a>
				13. Reverse brake	<a href="#">AT-292</a>
				14. Direct clutch	<a href="#">AT-327</a>
				15. Forward one-way clutch (Parts behind drum support is impossible to perform inspection by disassembly. Refer to <a href="#">AT-17</a> , " <a href="#">Cross-Sectional View (2WD Models)</a> " or <a href="#">AT-18</a> , " <a href="#">Cross-Sectional View (AWD Models)</a> " )	<a href="#">AT-275</a>
				16. Forward brake (Parts behind drum support is impossible to perform inspection by disassembly. Refer to <a href="#">AT-17</a> , " <a href="#">Cross-Sectional View (2WD Models)</a> " or <a href="#">AT-18</a> , " <a href="#">Cross-Sectional View (AWD Models)</a> " )	<a href="#">AT-275</a>
44	Vehicle cannot run in all positions.		ON vehicle	1. A/T fluid level and state	<a href="#">AT-51</a>
				2. Line pressure test	<a href="#">AT-53</a>
				3. PNP switch	<a href="#">AT-118</a>
				4. Control linkage adjustment	<a href="#">AT-238</a>
				5. Control valve with TCM	<a href="#">AT-248</a>
			OFF vehicle	6. Oil pump assembly	<a href="#">AT-310</a>
				7. Gear system	<a href="#">AT-280</a>
				8. Output shaft	<a href="#">AT-292</a>

A  
B  
AT  
D  
E  
F  
G  
H  
I  
J  
K  
L  
M

## TROUBLE DIAGNOSIS

No.	Items	Symptom	Condition	Diagnostic Item	Reference page
45	Slips/Will Not Engage	With selector lever in "D" position, driving is not possible.	ON vehicle	1. A/T fluid level and state	<a href="#">AT-51</a>
				2. Line pressure test	<a href="#">AT-53</a>
				3. PNP switch	<a href="#">AT-118</a>
				4. Control linkage adjustment	<a href="#">AT-238</a>
				5. Control valve with TCM	<a href="#">AT-248</a>
			OFF vehicle	6. Torque converter	<a href="#">AT-292</a>
				7. Oil pump assembly	<a href="#">AT-310</a>
				8. 1st one-way clutch	<a href="#">AT-320</a>
				9. Gear system	<a href="#">AT-280</a>
				10. Reverse brake	<a href="#">AT-292</a>
				11. Forward one-way clutch (Parts behind drum support is impossible to perform inspection by disassembly. Refer to <a href="#">AT-17. "Cross-Sectional View (2WD Models)"</a> or <a href="#">AT-18. "Cross-Sectional View (AWD Models)"</a> )	<a href="#">AT-275</a>
				12. Forward brake (Parts behind drum support is impossible to perform inspection by disassembly. Refer to <a href="#">AT-17. "Cross-Sectional View (2WD Models)"</a> or <a href="#">AT-18. "Cross-Sectional View (AWD Models)"</a> )	<a href="#">AT-275</a>
46		With selector lever in "R" position, driving is not possible.	ON vehicle	1. A/T fluid level and state	<a href="#">AT-51</a>
				2. Line pressure test	<a href="#">AT-53</a>
				3. PNP switch	<a href="#">AT-118</a>
				4. Control linkage adjustment	<a href="#">AT-238</a>
				5. Control valve with TCM	<a href="#">AT-248</a>
			OFF vehicle	6. Gear system	<a href="#">AT-280</a>
				7. Output shaft	<a href="#">AT-292</a>
				8. Reverse brake	<a href="#">AT-292</a>
47	Does Not Change	Does not change M5 → M4. Refer to <a href="#">AT-224. "A/T Does Not Shift: 5th Gear → 4th Gear"</a> .	ON vehicle	1. PNP switch	<a href="#">AT-118</a>
				2. A/T fluid level and state	<a href="#">AT-51</a>
				3. Control linkage adjustment	<a href="#">AT-238</a>
				4. Manual mode switch	<a href="#">AT-174</a>
				5. ATF pressure switch 1	<a href="#">AT-178</a>
				6. CAN communication line	<a href="#">AT-110</a>
				7. Control valve with TCM	<a href="#">AT-248</a>
			OFF vehicle	8. Front brake (brake band)	<a href="#">AT-292</a>

## TROUBLE DIAGNOSIS

No.	Items	Symptom	Condition	Diagnostic Item	Reference page	
48	Does Not Change	Does not change M4 → M3. Refer to <a href="#">AT-226, "A/T Does Not Shift: 4th Gear → 3rd Gear"</a> .	ON vehicle	1. PNP switch	<a href="#">AT-118</a>	
				2. A/T fluid level and state	<a href="#">AT-51</a>	
				3. Control linkage adjustment	<a href="#">AT-238</a>	
				4. Manual mode switch	<a href="#">AT-174</a>	
				5. ATF pressure switch 1 and ATF pressure switch 3	<a href="#">AT-178, AT-180</a>	
				6. CAN communication line	<a href="#">AT-110</a>	
				7. Control valve with TCM	<a href="#">AT-248</a>	
OFF vehicle		8. Front brake (brake band)	<a href="#">AT-292</a>			
		9. Input clutch	<a href="#">AT-315</a>			
49		Does Not Change	Does not change M3 → M2. Refer to <a href="#">AT-228, "A/T Does Not Shift: 3rd Gear → 2nd Gear"</a> .	ON vehicle	1. PNP switch	<a href="#">AT-118</a>
					2. A/T fluid level and state	<a href="#">AT-51</a>
					3. Control linkage adjustment	<a href="#">AT-238</a>
					4. Manual mode switch	<a href="#">AT-174</a>
					5. ATF pressure switch 6	<a href="#">AT-184</a>
	6. CAN communication line				<a href="#">AT-110</a>	
	7. Control valve with TCM				<a href="#">AT-248</a>	
	OFF vehicle			8. Front brake (brake band)	<a href="#">AT-292</a>	
				9. Input clutch	<a href="#">AT-315</a>	
				10. High and low reverse clutch	<a href="#">AT-325</a>	
50	Does Not Change	Does not change M2 → M1. Refer to <a href="#">AT-230, "A/T Does Not Shift: 2nd Gear → 1st Gear"</a> .	ON vehicle	1. PNP switch	<a href="#">AT-118</a>	
				2. A/T fluid level and state	<a href="#">AT-51</a>	
				3. Control linkage adjustment	<a href="#">AT-238</a>	
				4. Manual mode switch	<a href="#">AT-174</a>	
				5. ATF pressure switch 5	<a href="#">AT-182</a>	
				6. CAN communication line	<a href="#">AT-110</a>	
				7. Control valve with TCM	<a href="#">AT-248</a>	
			OFF vehicle	8. Input clutch	<a href="#">AT-315</a>	
				9. High and low reverse clutch	<a href="#">AT-325</a>	
				10. Direct clutch	<a href="#">AT-327</a>	
51	Cannot be changed to manual mode. Refer to <a href="#">AT-224, "Cannot Be Changed to Manual Mode"</a> .	ON vehicle	1. Manual mode switch	<a href="#">AT-174</a>		
			2. Turbine revolution sensor	<a href="#">AT-145</a>		
			3. CAN communication line	<a href="#">AT-110</a>		
52	Others	Shift point is high in "D" position.	ON vehicle	1. Vehicle speed sensor-A/T and vehicle speed sensor-MTR	<a href="#">AT-122, AT-147</a>	
				2. Accelerator pedal position sensor	<a href="#">AT-137</a>	
				3. CAN communication line	<a href="#">AT-110</a>	
				4. A/T fluid temperature sensor	<a href="#">AT-140</a>	
				5. Control valve with TCM	<a href="#">AT-248</a>	

## TROUBLE DIAGNOSIS

No.	Items	Symptom	Condition	Diagnostic Item	Reference page
53		Shift point is low in "D" position.	ON vehicle	1. Vehicle speed sensor-A/T and vehicle speed sensor-MTR	<a href="#">AT-122</a> , <a href="#">AT-147</a>
				2. Accelerator pedal position sensor	<a href="#">AT-137</a>
				3. CAN communication line	<a href="#">AT-110</a>
				4. Control valve with TCM	<a href="#">AT-248</a>
54		Judder occurs during lock-up.	ON vehicle	1. A/T fluid level and state	<a href="#">AT-51</a>
				2. Engine speed signal	<a href="#">AT-127</a>
				3. Turbine revolution sensor	<a href="#">AT-145</a>
				4. Vehicle speed sensor-A/T and vehicle speed sensor-MTR	<a href="#">AT-122</a> , <a href="#">AT-147</a>
			OFF vehicle	5. Accelerator pedal position sensor	<a href="#">AT-137</a>
				6. CAN communication line	<a href="#">AT-110</a>
				7. Torque converter clutch solenoid valve	<a href="#">AT-129</a>
				8. Control valve with TCM	<a href="#">AT-248</a>
9. Torque converter	<a href="#">AT-292</a>				
55	Others	Strange noise in "R" position.	ON vehicle	1. A/T fluid level and state	<a href="#">AT-51</a>
				2. Engine speed signal	<a href="#">AT-127</a>
				3. CAN communication line	<a href="#">AT-110</a>
				4. Control valve with TCM	<a href="#">AT-248</a>
			OFF vehicle	5. Torque converter	<a href="#">AT-292</a>
				6. Oil pump assembly	<a href="#">AT-310</a>
				7. Gear system	<a href="#">AT-280</a>
				8. High and low reverse clutch	<a href="#">AT-325</a>
				9. Reverse brake	<a href="#">AT-292</a>
56		Strange noise in "N" position.	ON vehicle	1. A/T fluid level and state	<a href="#">AT-51</a>
				2. Engine speed signal	<a href="#">AT-127</a>
				3. CAN communication line	<a href="#">AT-110</a>
				4. Control valve with TCM	<a href="#">AT-248</a>
			OFF vehicle	5. Torque converter	<a href="#">AT-292</a>
				6. Oil pump assembly	<a href="#">AT-310</a>
				7. Gear system	<a href="#">AT-280</a>

## TROUBLE DIAGNOSIS

No.	Items	Symptom	Condition	Diagnostic Item	Reference page
57		Strange noise in "D" position.	ON vehicle	1. A/T fluid level and state	<a href="#">AT-51</a>
				2. Engine speed signal	<a href="#">AT-127</a>
				3. CAN communication line	<a href="#">AT-110</a>
				4. Control valve with TCM	<a href="#">AT-248</a>
			OFF vehicle	5. Torque converter	<a href="#">AT-292</a>
				6. Oil pump assembly	<a href="#">AT-310</a>
				7. Gear system	<a href="#">AT-280</a>
				8. Forward brake (Parts behind drum support is impossible to perform inspection by disassembly. Refer to <a href="#">AT-17</a> , " <a href="#">Cross-Sectional View (2WD Models)</a> " or <a href="#">AT-18</a> , " <a href="#">Cross-Sectional View (AWD Models)</a> " )	<a href="#">AT-275</a>
58	Others	Vehicle does not decelerate by engine brake. Refer to <a href="#">AT-232</a> , " <a href="#">Vehicle Does Not Decelerate by Engine Brake</a> ".	ON vehicle	1. PNP switch	<a href="#">AT-118</a>
				2. A/T fluid level and state	<a href="#">AT-51</a>
				3. Control linkage adjustment	<a href="#">AT-238</a>
				4. Manual mode switch	<a href="#">AT-174</a>
				5. ATF pressure switch 5	<a href="#">AT-182</a>
				6. CAN communication line	<a href="#">AT-110</a>
				7. Control valve with TCM	<a href="#">AT-248</a>
			OFF vehicle	8. Input clutch	<a href="#">AT-315</a>
				9. High and low reverse clutch	<a href="#">AT-325</a>
				10. Direct clutch	<a href="#">AT-327</a>
59		Engine brake does not work M5 → M4.	ON vehicle	1. PNP switch	<a href="#">AT-118</a>
				2. A/T fluid level and state	<a href="#">AT-51</a>
				3. Control linkage adjustment	<a href="#">AT-238</a>
				4. Manual mode switch	<a href="#">AT-174</a>
				5. ATF pressure switch 1	<a href="#">AT-178</a>
				6. CAN communication line	<a href="#">AT-110</a>
				7. Control valve with TCM	<a href="#">AT-248</a>
			OFF vehicle	8. Front brake (brake band)	<a href="#">AT-292</a>
60		Engine brake does not work M4 → M3.	ON vehicle	1. PNP switch	<a href="#">AT-118</a>
				2. A/T fluid level and state	<a href="#">AT-51</a>
				3. Control linkage adjustment	<a href="#">AT-238</a>
				4. Manual mode switch	<a href="#">AT-174</a>
				5. ATF pressure switch 1 and ATF pressure switch 3	<a href="#">AT-178</a> , <a href="#">AT-180</a>
				6. CAN communication line	<a href="#">AT-110</a>
				7. Control valve with TCM	<a href="#">AT-248</a>
			OFF vehicle	8. Front brake (brake band)	<a href="#">AT-292</a>
				9. Input clutch	<a href="#">AT-315</a>

## TROUBLE DIAGNOSIS

No.	Items	Symptom	Condition	Diagnostic Item	Reference page
61		Engine brake does not work M3 → M2.	ON vehicle	1. PNP switch	<a href="#">AT-118</a>
				2. A/T fluid level and state	<a href="#">AT-51</a>
				3. Control linkage adjustment	<a href="#">AT-238</a>
				4. Manual mode switch	<a href="#">AT-174</a>
				5. ATF pressure switch 6	<a href="#">AT-184</a>
				6. CAN communication line	<a href="#">AT-110</a>
				7. Control valve with TCM	<a href="#">AT-248</a>
			OFF vehicle	8. Front brake (brake band)	<a href="#">AT-292</a>
				9. Input clutch	<a href="#">AT-315</a>
				10. High and low reverse clutch	<a href="#">AT-325</a>
62	Others	Engine brake does not work M2 → M1.	ON vehicle	1. PNP switch	<a href="#">AT-118</a>
				2. A/T fluid level and state	<a href="#">AT-51</a>
				3. Control linkage adjustment	<a href="#">AT-238</a>
				4. Manual mode switch	<a href="#">AT-174</a>
				5. ATF pressure switch 5	<a href="#">AT-182</a>
				6. CAN communication line	<a href="#">AT-110</a>
				7. Control valve with TCM	<a href="#">AT-248</a>
			OFF vehicle	8. Input clutch	<a href="#">AT-315</a>
				9. High and low reverse clutch	<a href="#">AT-325</a>
				10. Direct clutch	<a href="#">AT-327</a>
63		Maximum speed low.	ON vehicle	1. A/T fluid level and state	<a href="#">AT-51</a>
				2. Line pressure test	<a href="#">AT-53</a>
				3. Accelerator pedal position sensor	<a href="#">AT-137</a>
				4. CAN communication line	<a href="#">AT-110</a>
				5. Direct clutch solenoid valve	<a href="#">AT-162</a>
				6. Control valve with TCM	<a href="#">AT-248</a>
			OFF vehicle	7. Torque converter	<a href="#">AT-292</a>
				8. Oil pump assembly	<a href="#">AT-310</a>
				9. Input clutch	<a href="#">AT-315</a>
				10. Gear system	<a href="#">AT-280</a>
				11. High and low reverse clutch	<a href="#">AT-325</a>
				12. Direct clutch	<a href="#">AT-327</a>
				13. Forward one-way clutch (Parts behind drum support is impossible to perform inspection by disassembly. Refer to <a href="#">AT-17, "Cross-Sectional View (2WD Models)"</a> or <a href="#">AT-18, "Cross-Sectional View (AWD Models)"</a> )	<a href="#">AT-275</a>
				14. Forward brake (Parts behind drum support is impossible to perform inspection by disassembly. Refer to <a href="#">AT-17, "Cross-Sectional View (2WD Models)"</a> or <a href="#">AT-18, "Cross-Sectional View (AWD Models)"</a> )	<a href="#">AT-275</a>



## TROUBLE DIAGNOSIS

No.	Items	Symptom	Condition	Diagnostic Item	Reference page
64	Others	Extremely large creep.	ON vehicle	1. Engine idle speed	<a href="#">EC-77</a>
				2. CAN communication line	<a href="#">AT-110</a>
				3. ATF pressure switch 5	<a href="#">AT-182</a>
OFF vehicle		4. Torque converter	<a href="#">AT-292</a>		
65		With selector lever in "P" position, vehicle does not enter parking condition or, with selector lever in another position, parking condition is not cancelled. Refer to <a href="#">AT-196, "In "P" Position, Vehicle Moves When Pushed"</a> .	ON vehicle	1. PNP switch	<a href="#">AT-118</a>
				2. Control linkage adjustment	<a href="#">AT-238</a>
	OFF vehicle			3. Parking pawl components	<a href="#">AT-260</a> (2WD models) or <a href="#">AT-292</a> (AWD models)
66	Vehicle runs with transmission in "P" position.	ON vehicle	1. PNP switch	<a href="#">AT-118</a>	
			2. A/T fluid level and state	<a href="#">AT-51</a>	
			3. Control linkage adjustment	<a href="#">AT-238</a>	
			4. Control valve with TCM	<a href="#">AT-248</a>	
		OFF vehicle	5. Parking pawl components	<a href="#">AT-260</a> (2WD models) or <a href="#">AT-292, "Disassembly"</a> (AWD models)	
			6. Gear system	<a href="#">AT-280</a>	
67	Vehicle runs with transmission in "N" position. Refer to <a href="#">AT-197, "In "N" Position, Vehicle Moves"</a> .	ON vehicle	1. PNP switch	<a href="#">AT-118</a>	
			2. A/T fluid level and state	<a href="#">AT-51</a>	
			3. Control linkage adjustment	<a href="#">AT-238</a>	
			4. Control valve with TCM	<a href="#">AT-248</a>	
		OFF vehicle	5. Input clutch	<a href="#">AT-315</a>	
			6. Gear system	<a href="#">AT-280</a>	
			7. Direct clutch	<a href="#">AT-327</a>	
			8. Reverse brake	<a href="#">AT-292</a>	
			9. Forward one-way clutch (Parts behind drum support is impossible to perform inspection by disassembly. Refer to <a href="#">AT-17, "Cross-Sectional View (2WD Models)"</a> or <a href="#">AT-18, "Cross-Sectional View (AWD Models)"</a> )	<a href="#">AT-275</a>	
			10. Low coast brake (Parts behind drum support is impossible to perform inspection by disassembly. Refer to <a href="#">AT-17, "Cross-Sectional View (2WD Models)"</a> or <a href="#">AT-18, "Cross-Sectional View (AWD Models)"</a> )	<a href="#">AT-275</a>	

## TROUBLE DIAGNOSIS

No.	Items	Symptom	Condition	Diagnostic Item	Reference page
68		Engine does not start in "N" or "P" position. Refer to <a href="#">AT-196</a> . " <a href="#">Engine Cannot Be Started in "P" or "N" Position</a> ".	ON vehicle	1. Ignition switch and starter	<a href="#">PG-3, SC-9</a>
				2. Control linkage adjustment	<a href="#">AT-238</a>
				3. PNP switch	<a href="#">AT-118</a>
69		Engine starts in positions other than "N" or "P".	ON vehicle	1. Ignition switch and starter	<a href="#">PG-3, SC-9</a>
				2. Control linkage adjustment	<a href="#">AT-238</a>
				3. PNP switch	<a href="#">AT-118</a>
70		Engine stall.	ON vehicle	1. A/T fluid level and state	<a href="#">AT-51</a>
				2. Engine speed signal	<a href="#">AT-127</a>
				3. Turbine revolution sensor	<a href="#">AT-145</a>
				4. Torque converter clutch solenoid valve	<a href="#">AT-129</a>
				5. CAN communication line	<a href="#">AT-110</a>
				6. Control valve with TCM	<a href="#">AT-248</a>
			OFF vehicle	7. Torque converter	<a href="#">AT-292</a>
71	Others	Engine stalls when selector lever shifted "N" → "D", "R".	ON vehicle	1. A/T fluid level and state	<a href="#">AT-51</a>
				2. Engine speed signal	<a href="#">AT-127</a>
				3. Turbine revolution sensor	<a href="#">AT-145</a>
				4. Torque converter clutch solenoid valve	<a href="#">AT-129</a>
				5. CAN communication line	<a href="#">AT-110</a>
				6. Control valve with TCM	<a href="#">AT-248</a>
			OFF vehicle	7. Torque converter	<a href="#">AT-292</a>
72		Engine speed does not return to idle. Refer to <a href="#">AT-222</a> . " <a href="#">Engine Speed Does Not Return to Idle</a> ".	ON vehicle	1. A/T fluid level and state	<a href="#">AT-51</a>
				2. ATF pressure switch 5 and direct clutch solenoid valve	<a href="#">AT-182</a> , <a href="#">AT-162</a>
				3. ATF pressure switch 1 and front brake solenoid valve	<a href="#">AT-178</a> , <a href="#">AT-158</a>
				4. Accelerator pedal position sensor	<a href="#">AT-137</a>
				5. Vehicle speed sensor-A/T and vehicle speed sensor-MTR	<a href="#">AT-122</a> , <a href="#">AT-147</a>
				6. CAN communication line	<a href="#">AT-110</a>
				7. Control valve with TCM	<a href="#">AT-248</a>
			OFF vehicle	8. Front brake (brake band)	<a href="#">AT-292</a>
				9. Direct clutch	<a href="#">AT-327</a>

# TROUBLE DIAGNOSIS

## TCM Input/Output Signal Reference Values A/T ASSEMBLY HARNESS CONNECTOR TERMINAL LAYOUT

ACS0098I

A  
B  
AT

D

E

F

G

H

I

J

K



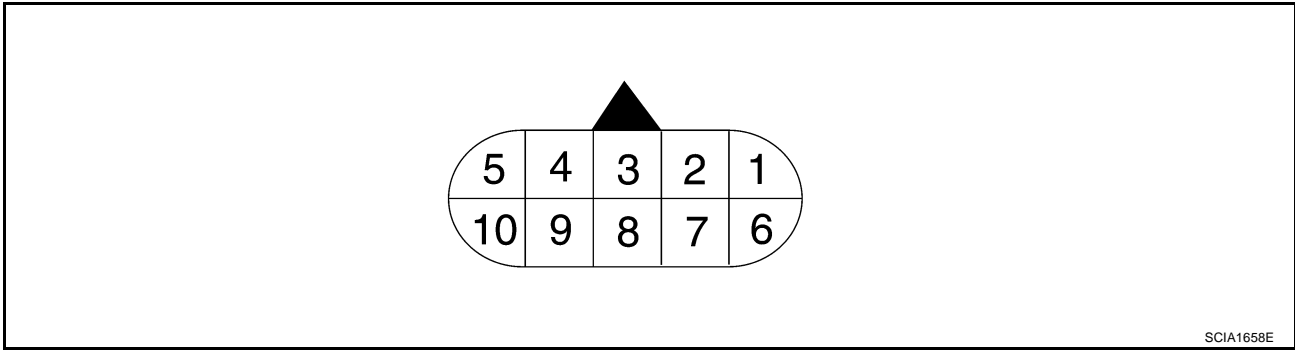

L

M



### TCM INSPECTION TABLE

Data are reference value and are measured between each terminal and ground.

Terminal	Wire color	Item	Condition	Data (Approx.)	
1	R/W	Power supply (Memory back-up)	Always	Battery voltage	
2	R/W	Power supply (Memory back-up)	Always	Battery voltage	
3	L	CAN-H	-	-	
4	PU	K-line (CONSULT-II signal)	The terminal is connected to the data link connector for CONSULT-II.		
5	B	Ground	Always	0V	
6	Y/R	Power supply		-	Battery voltage
				-	0V
7	R/L	Back-up lamp relay		Selector lever in "R" position.	0V
				Selector lever in other positions.	Battery voltage
8	R	CAN-L	-	-	
9	GY/R	Starter relay		Selector lever in "N", "P" positions.	Battery voltage
				Selector lever in other positions.	0V
10	B	Ground	Always	0V	

# TROUBLE DIAGNOSIS

## CONSULT-II Function (A/T)

ACS0098J

CONSULT-II can display each diagnostic item using the diagnostic test modes shown following.

### FUNCTION

Diagnostic test mode	Function	Reference page
Self-diagnostic results	Self-diagnostic results can be read and erased quickly.	<a href="#">AT-95</a>
Data monitor	Input/Output data in the TCM can be read.	<a href="#">AT-99</a>
CAN diagnostic support monitor	The results of transmit/receive diagnosis of CAN communication can be read.	<a href="#">AT-102</a>
Function test	Performed by CONSULT-II instead of a technician to determine whether each system is "OK" or "NG".	—
DTC work support	Select the operating condition to confirm Diagnostic Trouble Codes.	<a href="#">AT-103</a>
ECU part number	TCM part number can be read.	—

### CONSULT-II REFERENCE VALUE

#### NOTICE:

- The CONSULT-II electrically displays shift timing and lock-up timing (that is, operation timing of each solenoid).  
Check for time difference between actual shift timing and the CONSULT-II display. If the difference is noticeable, mechanical parts (except solenoids, sensors, etc.) may be malfunctioning. Check mechanical parts using applicable diagnostic procedures.
- Shift schedule (which implies gear position) displayed on CONSULT-II and that indicated in Service Manual may differ slightly. This occurs because of the following reasons:
  - Actual shift schedule has more or less tolerance or allowance,
  - Shift schedule indicated in Service Manual refers to the point where shifts start, and
  - Gear position displayed on CONSULT-II indicates the point where shifts are completed.
- Display of solenoid valves on CONSULT-II changes at the start of shifting, while gear position is displayed upon completion of shifting (which is computed by TCM).

Item name	Condition	Display value (Approx.)
ATF TEMP SE 1	0°C (32° F) - 20°C (68°F) - 80°C (176°F)	3.3 - 2.7 - 0.9 V
ATF TEMP SE 2		3.3 - 2.5 - 0.7 V
TCC SOLENOID	When perform slip lock-up	0.2 - 0.4 A
	When perform lock-up	0.4 - 0.6 A
SLCT LVR POSI	Selector lever in "N", "P" positions.	N/P
	Selector lever in "R" position.	R
	Selector lever in "D" position.	D
VHCL/S SE-A/T	During driving	Approximately matches the speedometer reading.
ENGINE SPEED	Engine running	Closely matches the tachometer reading.
LINE PRES SOL	During driving	0.2 - 0.6A
TURBINE REV	During driving (lock-up ON)	Approximately matches the engine speed.
VHCL/S SE-MTR	During driving	Approximately matches the speedometer reading.
ATF PRES SW 1	Front brake engaged. Refer to <a href="#">AT-20</a> .	ON
	Front brake disengaged. Refer to <a href="#">AT-20</a> .	OFF
ATF PRES SW 2	Low coast brake engaged. Refer to <a href="#">AT-20</a> .	ON
	Low coast brake disengaged. Refer to <a href="#">AT-20</a> .	OFF
ATF PRES SW 3	Input clutch engaged. Refer to <a href="#">AT-20</a> .	ON
	Input clutch disengaged. Refer to <a href="#">AT-20</a> .	OFF

## TROUBLE DIAGNOSIS

Item name	Condition	Display value (Approx.)	
ATF PRES SW 5	Direct clutch engaged. Refer to <a href="#">AT-20</a> .	ON	A
	Direct clutch disengaged. Refer to <a href="#">AT-20</a> .	OFF	
ATF PRES SW 6	High and low reverse clutch engaged. Refer to <a href="#">AT-20</a> .	ON	B
	High and low reverse clutch disengaged. Refer to <a href="#">AT-20</a> .	OFF	
I/C SOLENOID	Input clutch disengaged. Refer to <a href="#">AT-20</a> .	0.6 - 0.8 A	AT
	Input clutch engaged. Refer to <a href="#">AT-20</a> .	0 - 0.05 A	
FR/B SOLENOID	Front brake engaged. Refer to <a href="#">AT-20</a> .	0.6 - 0.8 A	D
	Front brake disengaged. Refer to <a href="#">AT-20</a> .	0 - 0.05 A	
D/C SOLENOID	Direct clutch disengaged. Refer to <a href="#">AT-20</a> .	0.6 - 0.8 A	E
	Direct clutch engaged. Refer to <a href="#">AT-20</a> .	0 - 0.05 A	
HLR/C SOL	High and low reverse clutch disengaged. Refer to <a href="#">AT-20</a> .	0.6 - 0.8 A	F
	High and low reverse clutch engaged. Refer to <a href="#">AT-20</a> .	0 - 0.05 A	
ON OFF SOL	Low coast brake engaged. Refer to <a href="#">AT-20</a> .	ON	G
	Low coast brake disengaged. Refer to <a href="#">AT-20</a> .	OFF	
MANU MODE SW	Manual shift gate position (neutral)	ON	H
	Other than the above	OFF	
NON M-MODE SW	Manual shift gate position	OFF	I
	Other than the above	ON	
UP SW LEVER	Selector lever: + side	ON	J
	Other than the above	OFF	
DOWN SW LEVER	Selector lever: - side	ON	K
	Other than the above	OFF	
STARTER RELAY	Selector lever in "N", "P" positions.	ON	L
	Selector lever in other position.	OFF	
ACCELE POSI	Released accelerator pedal.	0.0/8	M
	Fully depressed accelerator pedal.	8/8	
CLSD THL POS	Released accelerator pedal.	ON	
	Fully depressed accelerator pedal.	OFF	
W/O THL POS	Fully depressed accelerator pedal.	ON	
	Released accelerator pedal.	OFF	
BRAKE SW	Depressed brake pedal.	ON	
	Released brake pedal.	OFF	

# TROUBLE DIAGNOSIS

## CONSULT-II SETTING PROCEDURE

### CAUTION:

If CONSULT-II is used with no connection of CONSULT-II CONVERTER, malfunctions might be detected in self-diagnosis depending on control unit which perform CAN communication.

- For details, refer to the separate "CONSULT-II Operations Manual".

- Turn ignition switch OFF.
- Connect CONSULT-II and CONSULT-II CONVERTER to data link connector, which is located in instrument lower driver panel on driver side.
- Turn ignition switch ON. (Do not start engine.)

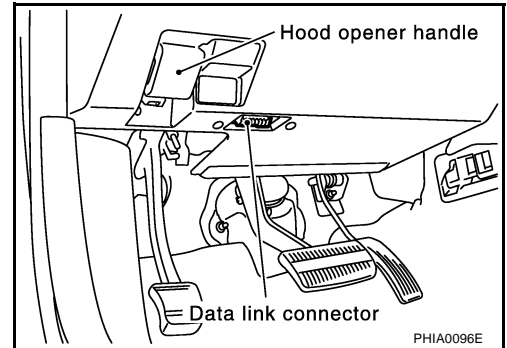

- Touch "START (NISSAN BASED VHCL)".

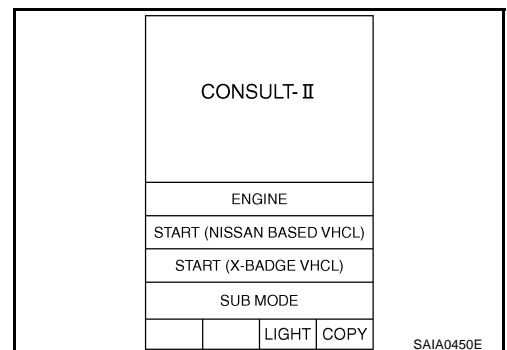

- Touch "A/T".  
If "A/T" is not indicated, go to [GI-39, "CONSULT-II Data Link Connector \(DLC\) Circuit"](#).

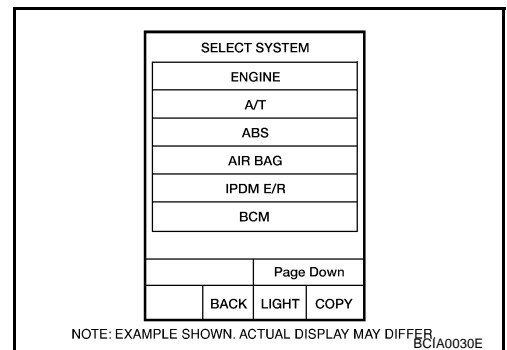

- Perform each diagnostic test mode according to each service procedure.

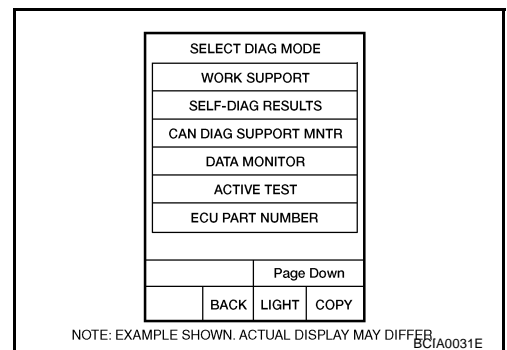

# TROUBLE DIAGNOSIS

## SELF-DIAGNOSTIC RESULT MODE

After performing self-diagnosis, place check marks for results on the [AT-46, "DIAGNOSTIC WORKSHEET"](#) . Reference pages are provided following the items.

### Operation Procedure

1. Perform [AT-94, "CONSULT-II SETTING PROCEDURE"](#) .
2. Touch "SELF-DIAG RESULTS".  
Display shows malfunction experienced since the last erasing operation.

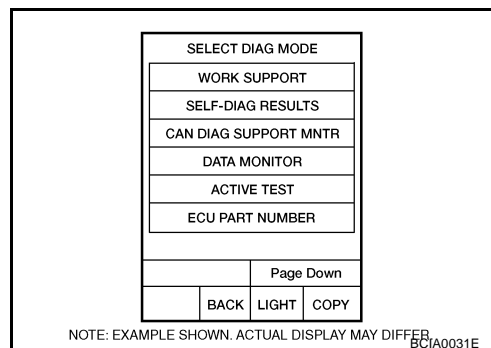

### Display Items List

X: Applicable, —: Not applicable

Items (CONSULT-II screen terms)	Malfunction is detected when...	TCM self-diagnosis	OBD-II (DTC)	Reference page
		"A/T" with CONSULT-II	MIL indicator lamp*1, "ENGINE" with CONSULT-II or GST	
CAN COMM CIRCUIT	<ul style="list-style-type: none"> <li>When a malfunction is detected in CAN communications</li> </ul>	U1000	U1000	<a href="#">AT-110</a>
STARTER RELAY/CIRC	<ul style="list-style-type: none"> <li>If this signal is ON other than in "P" or "N" position, this is judged to be a malfunction. (And if it is OFF in "P" or "N" position, this too is judged to be a malfunction.)</li> </ul>	P0615	—	<a href="#">AT-113</a>
TCM	<ul style="list-style-type: none"> <li>TCM is malfunctioning.</li> </ul>	P0700	P0700	<a href="#">AT-117</a>
PNP SW/CIRC	<ul style="list-style-type: none"> <li>PNP switch 1-4 signals input with impossible pattern</li> <li>PNP switch 3 monitor terminal cut line</li> <li>P position is detected from "N" position without any other positions being detected in between.</li> </ul>	P0705	P0705	<a href="#">AT-118</a>
VEH SPD SEN/CIR AT	<ul style="list-style-type: none"> <li>Signal from vehicle speed sensor A/T (Revolution sensor) not input due to cut line or the like</li> <li>Unexpected signal input during running</li> <li>After ignition switch is turned ON, unexpected signal input from vehicle speed sensor MTR before the vehicle starts moving</li> </ul>	P0720	P0720	<a href="#">AT-122</a>
ENGINE SPEED SIG	<ul style="list-style-type: none"> <li>TCM does not receive the CAN communication signal from the ECM.</li> </ul>	P0725	P0725	<a href="#">AT-127</a>
TCC SOLENOID/CIRC	<ul style="list-style-type: none"> <li>Normal voltage not applied to solenoid due to cut line, short, or the like</li> </ul>	P0740	P0740	<a href="#">AT-129</a>
A/T TCC S/V FNCTN	<ul style="list-style-type: none"> <li>A/T cannot perform lock-up even if electrical circuit is good.</li> <li>TCM detects as irregular by comparing difference value with slip rotation.</li> </ul>	P0744	P0744*2	<a href="#">AT-131</a>
L/PRESS SOL/CIRC	<ul style="list-style-type: none"> <li>Normal voltage not applied to solenoid due to cut line, short, or the like</li> <li>TCM detects as irregular by comparing target value with monitor value.</li> </ul>	P0745	P0745	<a href="#">AT-133</a>

## TROUBLE DIAGNOSIS

Items (CONSULT-II screen terms)	Malfunction is detected when...	TCM self-diagnosis	OBD-II (DTC)	Reference page
		"A/T" with CONSULT-II	MIL indicator lamp*1, "ENGINE" with CONSULT-II or GST	
TCM-RAM	<ul style="list-style-type: none"> <li>● TCM memory (RAM) is malfunctioning.</li> </ul>	P1702	—	<a href="#">AT-135</a>
TCM-ROM	<ul style="list-style-type: none"> <li>● TCM memory (ROM) is malfunctioning.</li> </ul>	P1703	—	<a href="#">AT-136</a>
TP SEN/CIRC A/T	<ul style="list-style-type: none"> <li>● TCM does not receive the proper accelerator pedal position signals (input by CAN communication) from ECM.</li> </ul>	P1705	P1705	<a href="#">AT-137</a>
ATF TEMP SEN/CIRC	<ul style="list-style-type: none"> <li>● During running, the A/T fluid temperature sensor signal voltage is excessively high or low</li> </ul>	P1710	P0710	<a href="#">AT-140</a>
TURBINE REV S/CIRC	<ul style="list-style-type: none"> <li>● TCM does not receive the proper voltage signal from the sensor.</li> <li>● TCM detects an irregularity only at position of 4th gear for turbine revolution sensor 2.</li> </ul>	P1716	P1716	<a href="#">AT-145</a>
VEH SPD SE/CIR-MTR	<ul style="list-style-type: none"> <li>● Signal (CAN communication) from vehicle speed sensor MTR not input due to cut line or the like</li> <li>● Unexpected signal input during running</li> </ul>	P1721	—	<a href="#">AT-147</a>
A/T INTERLOCK	<ul style="list-style-type: none"> <li>● Except during shift change, the gear position and ATF pressure switch states are monitored and comparative judgement made.</li> </ul>	P1730	P1730	<a href="#">AT-149</a>
A/T 1ST E/BRAKING	<ul style="list-style-type: none"> <li>● Each ATF pressure switch and solenoid current is monitored and if a pattern is detected having engine braking 1st gear other than in the M1 position, a malfunction is detected.</li> </ul>	P1731	—	<a href="#">AT-152</a>
I/C SOLENOID/CIRC	<ul style="list-style-type: none"> <li>● Normal voltage not applied to solenoid due to functional malfunction, cut line, short, or the like</li> <li>● TCM detects as irregular by comparing target value with monitor value.</li> </ul>	P1752	P1752	<a href="#">AT-154</a>
I/C SOLENOID FNCTN	<ul style="list-style-type: none"> <li>● TCM detects that actual gear ratio is irregular, and relation between gear position and condition of ATF pressure switch 3 is irregular during depressing accelerator pedal. (Other than during shift change)</li> <li>● TCM detects that relation between gear position and condition of ATF pressure switch 3 is irregular during releasing accelerator pedal. (Other than during shift change)</li> </ul>	P1754	P1754*2	<a href="#">AT-156</a>
FR/B SOLENOID/CIRC	<ul style="list-style-type: none"> <li>● Normal voltage not applied to solenoid due to functional malfunction, cut line, short, or the like</li> <li>● TCM detects as irregular by comparing target value with monitor value.</li> </ul>	P1757	P1757	<a href="#">AT-158</a>
FR/B SOLENOID FNCT	<ul style="list-style-type: none"> <li>● TCM detects that actual gear ratio is irregular, and relation between gear position and condition of ATF pressure switch 1 is irregular during depressing accelerator pedal. (Other than during shift change)</li> <li>● TCM detects that relation between gear position and condition of ATF pressure switch 1 is irregular during releasing accelerator pedal. (Other than during shift change)</li> </ul>	P1759	P1759*2	<a href="#">AT-160</a>
D/C SOLENOID/CIRC	<ul style="list-style-type: none"> <li>● Normal voltage not applied to solenoid due to cut line, short, or the like</li> <li>● TCM detects as irregular by comparing target value with monitor value.</li> </ul>	P1762	P1762	<a href="#">AT-162</a>



# TROUBLE DIAGNOSIS

Items (CONSULT-II screen terms)	Malfunction is detected when...	TCM self-diagnosis	OBD-II (DTC)	Reference page
		"A/T" with CONSULT-II	MIL indicator lamp*1, "ENGINE" with CONSULT-II or GST	
D/C SOLENOID FNCTN	<ul style="list-style-type: none"> <li>TCM detects that actual gear ratio is irregular, and relation between gear position and condition of ATF pressure switch 5 is irregular during depressing accelerator pedal. (Other than during shift change)</li> <li>TCM detects that relation between gear position and condition of ATF pressure switch 5 is irregular during releasing accelerator pedal. (Other than during shift change)</li> </ul>	P1764	P1764*2	<a href="#">AT-164</a>
HLR/C SOL/CIRC	<ul style="list-style-type: none"> <li>Normal voltage not applied to solenoid due to functional malfunction, cut line, short, or the like</li> <li>TCM detects as irregular by comparing target value with monitor value.</li> </ul>	P1767	P1767	<a href="#">AT-166</a>
HLR/C SOL FNCTN	<ul style="list-style-type: none"> <li>TCM detects that actual gear ratio is irregular, and relation between gear position and condition of ATF pressure switch 6 is irregular during depressing accelerator pedal. (Other than during shift change)</li> <li>TCM detects that relation between gear position and condition of ATF pressure switch 6 is irregular during releasing accelerator pedal. (Other than during shift change)</li> </ul>	P1769	P1769*2	<a href="#">AT-168</a>
LC/B SOLENOID/CIRC	<ul style="list-style-type: none"> <li>Normal voltage not applied to solenoid due to functional malfunction, cut line, short, or the like</li> </ul>	P1772	P1772	<a href="#">AT-170</a>
LC/B SOLENOID FNCT	<ul style="list-style-type: none"> <li>TCM detects an improper voltage drop when it tries to operate the solenoid valve.</li> <li>Condition of ATF pressure switch 2 is different from monitor value, and relation between gear position and actual gear ratio is irregular.</li> </ul>	P1774	P1774*2	<a href="#">AT-172</a>
MANU MODE SW/CIRC	<ul style="list-style-type: none"> <li>When an impossible pattern of switch signals is detected, a malfunction is detected.</li> </ul>	P1815	—	<a href="#">AT-174</a>
ATF PRES SW 1/CIRC	<ul style="list-style-type: none"> <li>TCM detects that actual gear ratio is normal, and relation between gear position and condition of ATF pressure switch 1 is irregular during depressing accelerator pedal. (Other than during shift change)</li> </ul>	P1841	—	<a href="#">AT-178</a>
ATF PRES SW 3/CIRC	<ul style="list-style-type: none"> <li>TCM detects that actual gear ratio is normal, and relation between gear position and condition of ATF pressure switch 3 is irregular during depressing accelerator pedal. (Other than during shift change)</li> </ul>	P1843	—	<a href="#">AT-180</a>
ATF PRES SW 5/CIRC	<ul style="list-style-type: none"> <li>TCM detects that actual gear ratio is normal, and relation between gear position and condition of ATF pressure switch 5 is irregular during depressing accelerator pedal. (Other than during shift change)</li> </ul>	P1845	—	<a href="#">AT-182</a>
ATF PRES SW 6/CIRC	<ul style="list-style-type: none"> <li>TCM detects that actual gear ratio is normal, and relation between gear position and condition of ATF pressure switch 6 is irregular during depressing accelerator pedal. (Other than during shift change)</li> </ul>	P1846	—	<a href="#">AT-184</a>
NO DTC IS DETECTED FURTHER TESTING MAY BE REQUIRED	<ul style="list-style-type: none"> <li>No NG item has been detected.</li> </ul>	X	X	—

\*1: Refer to [AT-41, "Malfunction Indicator Lamp \(MIL\)"](#).

\*2: These malfunctions cannot be displayed MIL if another malfunction is assigned to MIL.

# TROUBLE DIAGNOSIS

## How to Erase Self-diagnostic Results

1. Perform [AT-94, "CONSULT-II SETTING PROCEDURE"](#).
2. Touch "SELF-DIAG RESULTS".

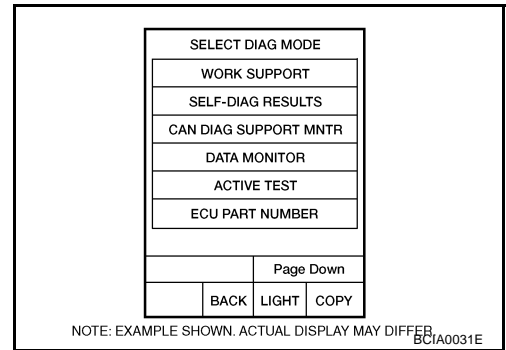

3. Touch "ERASE". (The self-diagnostic results will be erased.)

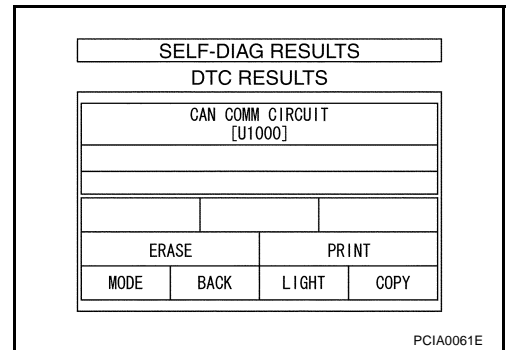

# TROUBLE DIAGNOSIS

## DATA MONITOR MODE

### Operation Procedure

1. Perform [AT-94, "CONSULT-II SETTING PROCEDURE"](#).
2. Touch "DATA MONITOR".

#### NOTE:

When malfunction is detected, CONSULT-II performs "REAL-TIME DIAGNOSIS". Also, any malfunction detected while in this mode will be displayed at real time.

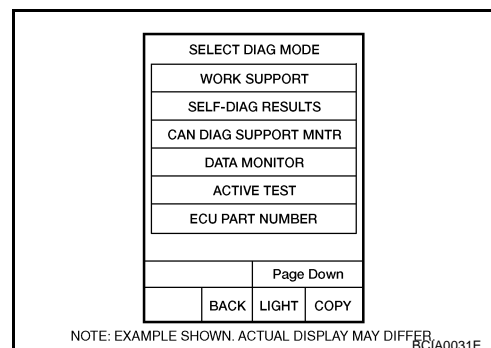

### Display Items List

X: Standard, —: Not applicable, ▼: Option

Monitored item (Unit)	Monitor Item Selection			Remarks
	ECU INPUT SIGNALS	MAIN SIGNALS	SELECTION FROM MENU	
VHCL/S SE-A/T (km/h)	X	X	▼	Revolution sensor
VHCL/S SE-MTR (km/h)	X	—	▼	
ACCELE POSI (0.0/8)	X	—	▼	Accelerator pedal position signal
THROTTLE POSI (0.0/8)	X	X	▼	Degree of opening for accelerator recognized by the TCM For fail-safe operation, the specific value used for control is displayed.
CLSD THL POS (ON/OFF)	X	—	▼	Signal input with CAN communications
W/O THL POS (ON/OFF)	X	—	▼	
BRAKE SW (ON/OFF)	X	—	▼	Stop lamp switch
GEAR	—	X	▼	Gear position recognized by the TCM updated after gear-shifting
ENGINE SPEED (rpm)	X	X	▼	
TURBINE REV (rpm)	X	X	▼	
OUTPUT REV (rpm)	X	X	▼	
GEAR RATIO	—	X	▼	
TC SLIP SPEED (rpm)	—	X	▼	Difference between engine speed and torque converter input shaft speed
F SUN GR REV (rpm)	—	—	▼	
F CARR GR REV (rpm)	—	—	▼	
ATF TEMP SE 1 (V)	X	—	▼	
ATF TEMP SE 2 (V)	X	—	▼	
ATF TEMP 1 (°C)	—	X	▼	
ATF TEMP 2 (°C)	—	X	▼	
BATTERY VOLT (V)	X	—	▼	
ATF PRES SW 1 (ON/OFF)	X	X	▼	(for FR/B solenoid)

# TROUBLE DIAGNOSIS

Monitored item (Unit)	Monitor Item Selection			Remarks
	ECU INPUT SIGNALS	MAIN SIGNALS	SELECTION FROM MENU	
ATF PRES SW 2 (ON/OFF)	X	X	▼	(for LC/B solenoid)
ATF PRES SW 3 (ON/OFF)	X	X	▼	(for I/C solenoid)
ATF PRES SW 5 (ON/OFF)	X	X	▼	(for D/C solenoid)
ATF PRES SW 6 (ON/OFF)	X	X	▼	(for HLR/C solenoid)
PNP SW 1 (ON/OFF)	X	—	▼	
PNP SW 2 (ON/OFF)	X	—	▼	
PNP SW 3 (ON/OFF)	X	—	▼	
PNP SW 4 (ON/OFF)	X	—	▼	
1 POSITION SW (ON/OFF)	X	—	▼	Not mounted but displayed.
SLCT LVR POSI	—	X	▼	Selector lever position is recognized by the TCM. For fail-safe operation, the specific value used for control is displayed.
OD CONT SW (ON/OFF)	X	—	▼	
POWERSHIFT SW (ON/OFF)	X	—	▼	Not mounted but displayed.
HOLD SW (ON/OFF)	X	—	▼	
MANU MODE SW (ON/OFF)	X	—	▼	
NON M-MODE SW (ON/OFF)	X	—	▼	
UP SW LEVER (ON/OFF)	X	—	▼	
DOWN SW LEVER (ON/OFF)	X	—	▼	
SFT UP ST SW (ON/OFF)	—	—	▼	Not mounted but displayed.
SFT DWN ST SW (ON/OFF)	—	—	▼	
ASCD-OD CUT (ON/OFF)	—	—	▼	
ASCD-CRUISE (ON/OFF)	—	—	▼	
ABS SIGNAL (ON/OFF)	—	—	▼	
ACC OD CUT (ON/OFF)	—	—	▼	Not mounted but displayed.
ACC SIGNAL (ON/OFF)	—	—	▼	
TCS GR/P KEEP (ON/OFF)	—	—	▼	
TCS SIGNAL 2 (ON/OFF)	—	—	▼	
TCS SIGNAL 1 (ON/OFF)	—	—	▼	
TCC SOLENOID (A)	—	X	▼	
LINE PRES SOL (A)	—	X	▼	
I/C SOLENOID (A)	—	X	▼	
FR/B SOLENOID (A)	—	X	▼	
D/C SOLENOID (A)	—	X	▼	
HLR/C SOL (A)	—	X	▼	

# TROUBLE DIAGNOSIS

Monitored item (Unit)	Monitor Item Selection			Remarks	
	ECU INPUT SIGNALS	MAIN SIGNALS	SELECTION FROM MENU		
ON OFF SOL (ON/OFF)	—	—	▼	LC/B solenoid	A
TCC SOL MON (A)	—	—	▼		B
L/P SOL MON (A)	—	—	▼		AT
I/C SOL MON (A)	—	—	▼		D
FR/B SOL MON (A)	—	—	▼		E
D/C SOL MON (A)	—	—	▼		F
HLR/C SOL MON (A)	—	—	▼		G
ON OFF SOL MON (ON/OFF)	—	—	▼	LC/B solenoid	H
P POSI IND (ON/OFF)	—	—	▼		I
R POSI IND (ON/OFF)	—	—	▼		J
N POSI IND (ON/OFF)	—	—	▼		K
D POSI IND (ON/OFF)	—	—	▼		L
4TH POSI IND (ON/OFF)	—	—	▼		M
3RD POSI IND (ON/OFF)	—	—	▼		
2ND POSI IND (ON/OFF)	—	—	▼		
1ST POSI IND (ON/OFF)	—	—	▼		
MANU MODE IND (ON/OFF)	—	—	▼		
POWER M LAMP (ON/OFF)	—	—	▼		
F-SAFE IND/L (ON/OFF)	—	—	▼		
ATF WARN LAMP (ON/OFF)	—	—	▼	Not mounted but displayed.	
BACK-UP LAMP (ON/OFF)	—	—	▼		
STARTER RELAY (ON/OFF)	—	—	▼		
PNP SW3 MON (ON/OFF)	—	—	▼		
C/V CLB ID1	—	—	▼		
C/V CLB ID2	—	—	▼		
C/V CLB ID3	—	—	▼		
UNIT CLB ID1	—	—	▼		
UNIT CLB ID2	—	—	▼		
UNIT CLB ID3	—	—	▼		
TRGT GR RATIO	—	—	▼		
TRGT PRES TCC (kPa)	—	—	▼		
TRGT PRES L/P (kPa)	—	—	▼		
TRGT PRES I/C (kPa)	—	—	▼		
TRGT PRE FR/B (kPa)	—	—	▼		
TRGT PRES D/C (kPa)	—	—	▼		

# TROUBLE DIAGNOSIS

Monitored item (Unit)	Monitor Item Selection			Remarks
	ECU INPUT SIGNALS	MAIN SIGNALS	SELECTION FROM MENU	
TRG PRE HLR/C (kPa)	—	—	▼	
SHIFT PATTERN	—	—	▼	
DRV CST JUDGE	—	—	▼	
START RLY MON	—	—	▼	
NEXT GR POSI	—	—	▼	
SHIFT MODE	—	—	▼	
MANU GR POSI	—	—	▼	
VEHICLE SPEED (km/h)	—	X	▼	Vehicle speed recognized by the TCM.
Voltage (V)	—	—	▼	Displays the value measured by the voltage probe.
Frequency (Hz)	—	—	▼	The value measured by the pulse probe is displayed.
DUTY-HI (high) (%)	—	—	▼	
DUTY-LOW (low) (%)	—	—	▼	
PLS WIDTH-HI (ms)	—	—	▼	
PLS WIDTH-LOW (ms)	—	—	▼	

## CAN DIAGNOSTIC SUPPORT MONITOR MODE

### Operation Procedure

1. Perform [AT-94, "CONSULT-II SETTING PROCEDURE"](#).
2. Touch "CAN DAIG SUPPORT MNTR". Refer to [LAN-3, "Precautions When Using CONSULT-II"](#).

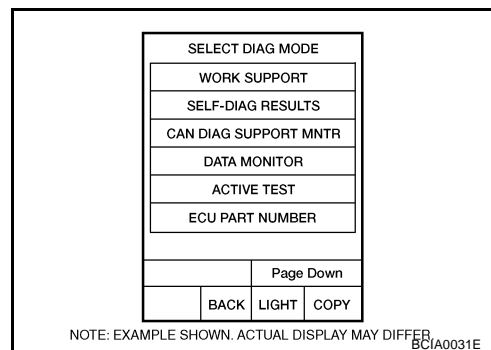

# TROUBLE DIAGNOSIS

## DTC WORK SUPPORT MODE

### Operation Procedure

1. Perform [AT-94, "CONSULT-II SETTING PROCEDURE"](#).
2. Touch "DTC WORK SUPPORT".

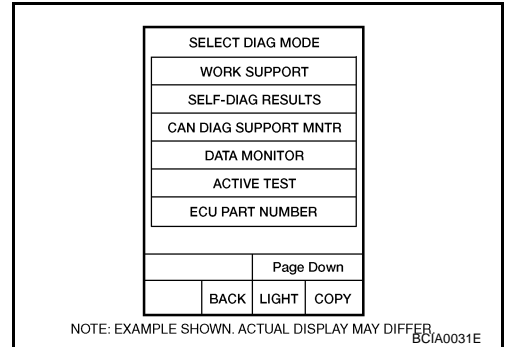

3. Touch select item menu.

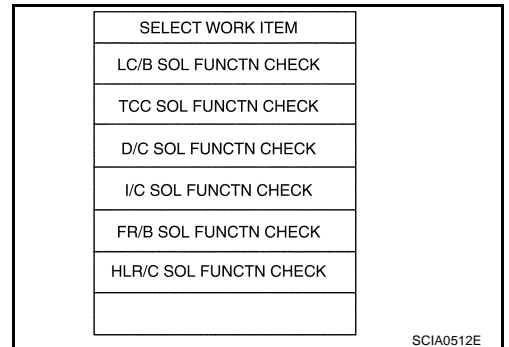

4. Touch "START".

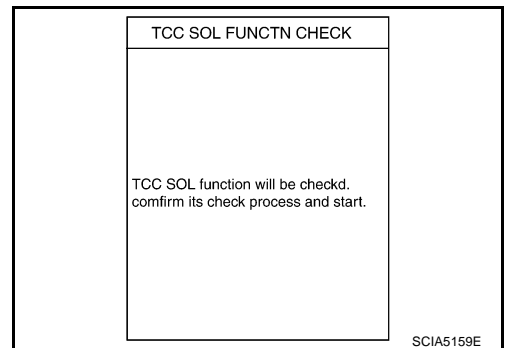

5. Perform driving test according to "DTC Confirmation Procedure" in "TROUBLE DIAGNOSIS FOR DTC".

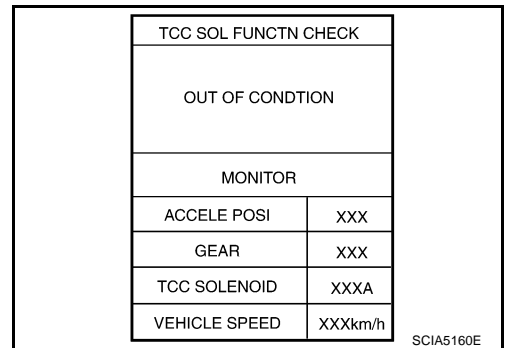

A  
B  
AT  
D  
E  
F  
G  
H  
I  
J  
K  
L  
M

# TROUBLE DIAGNOSIS

- When testing conditions are satisfied, CONSULT-II screen changes from “OUT OF CONDITION” to “TESTING”.

TCC SOL FUNCTN CHECK	
TESTING	
MONITOR	
ACCELE POSI	XXX
GEAR	XXX
TCC SOLENOID	XXXA
VEHICLE SPEED	XXXkm/h

SCIA5161E

6. Stop vehicle.

TCC SOL FUNCTN CHECK
STOP VEHICLE

SCIA5164E

- If “NG” appears on the screen, malfunction may exist. Go to “Diagnostic Procedure”.

TCC SOL FUNCTN CHECK
NG

SCIA5162E

7. Perform test drive to check gear shift feeling in accordance with instructions displayed.
8. Touch “YES” or “NO”.
9. CONSULT-II procedure is ended.

TCC SOL FUNCTN CHECK
OK

SCIA5163E



# TROUBLE DIAGNOSIS

- If “NG” appears on the screen, a malfunction may exist. Go to “Diagnostic Procedure”.

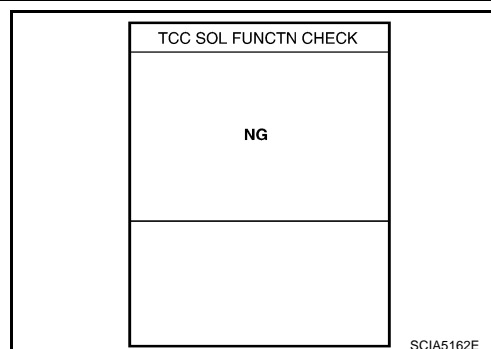

A  
B  
AT

## Display Items List

DTC work support item	Description	Check item
I/C SOL FUNCTN CHECK*	—	—
FR/B SOL FUNCTN CHECK*	—	—
D/C SOL FUNCTN CHECK*	—	—
HLR/C SOL FUNCTN CHECK*	—	—
LC/B SOL FUNCTN CHECK*	—	—
TCC SOL FUNCTN CHECK	<p>Following items for “TCC solenoid function (lock-up)” can be confirmed.</p> <ul style="list-style-type: none"> <li>● Self-diagnosis status (whether the diagnosis is being performed or not)</li> <li>● Self-diagnostic results (OK or NG)</li> </ul>	<ul style="list-style-type: none"> <li>● TCC solenoid valve</li> <li>● Hydraulic control circuit</li> </ul>

D  
E  
F  
G  
H

\*: Do not use, but displayed.

## Diagnostic Procedure without CONSULT-II

ACS0098M

### OBD-II SELF-DIAGNOSTIC PROCEDURE (WITH GST)

Refer to [EC-150, "Generic Scan Tool \(GST\) Function"](#) .

### OBD-II SELF-DIAGNOSTIC PROCEDURE (NO TOOLS)

Refer to [EC-63, "Malfunction Indicator Lamp \(MIL\)"](#) .

### TCM SELF-DIAGNOSTIC PROCEDURE (NO TOOLS)

I  
J  
K  
L  
M

## Description

In the unlikely event of a malfunction in the electrical system, when the ignition switch is switched “ON”, the A/T CHECK indicator lamp lights up for 2 seconds, then flashes for 8 seconds. If there is no malfunction, when the ignition switch is turned “ON”, the indicator lamp lights up for 2 seconds. As a method for locating the suspect circuit, when the self-diagnostics start signal is input, the memory for the malfunction location is output and the A/T CHECK indicator lamp flashes to display the corresponding DTC.

## Operation Procedure

### 1. CHECK A/T CHECK INDICATOR LAMP

1. Start the engine with selector lever in “P” position. Warm engine to normal operating temperature.
2. Turn ignition switch ON and OFF at least twice, then leave it in the OFF position.
3. Wait 10 seconds.
4. Turn ignition switch ON. (Do not start engine.)

Does A/T CHECK indicator lamp come on for about 2 seconds?

YES >> GO TO 2.

NO >> GO TO [AT-195, "A/T CHECK Indicator Lamp Does Not Come On"](#) .

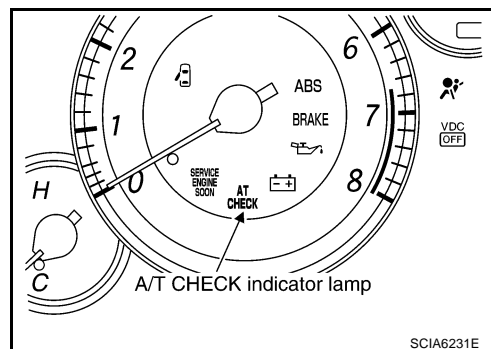

SCIA6231E

# TROUBLE DIAGNOSIS

## 2. JUDGEMENT PROCEDURE STEP 1

1. Turn ignition switch OFF.
2. Keep pressing shift lock release button.

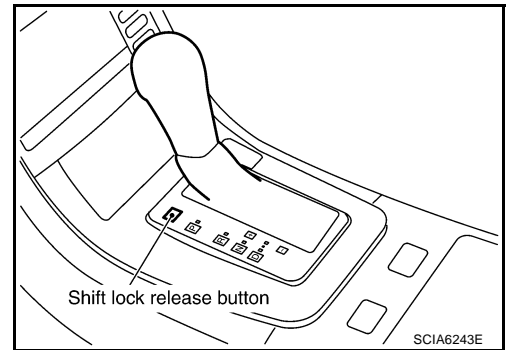

3. Move selector lever from "P" to "D" position.
4. Release accelerator pedal. (Set the closed throttle position signal ON.)

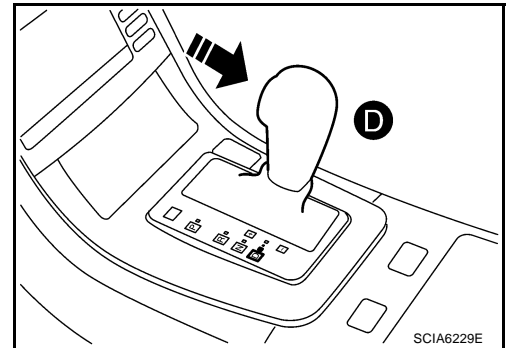

5. Depress brake pedal. (Stop lamp switch signal ON.)
6. Turn ignition switch ON.
7. Wait 3 seconds.

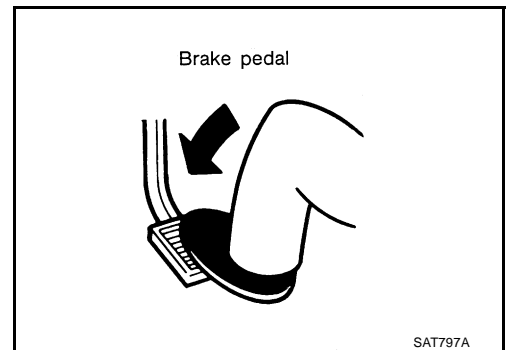

>> GO TO 3.

# TROUBLE DIAGNOSIS

## 3. JUDGEMENT PROCEDURE STEP 2

1. Move the selector lever to the manual shift gate side. (Manual mode signal ON.)

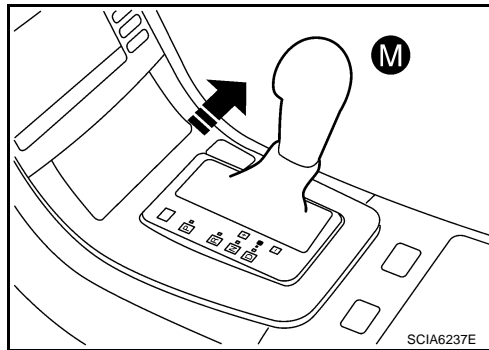

2. Release brake pedal. (Stop lamp switch signal OFF.)

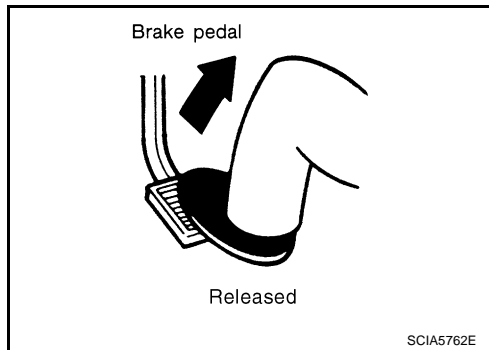

>> GO TO 4.

A  
B  
AT  
D  
E  
F  
G  
H  
I  
J  
K  
L  
M

# TROUBLE DIAGNOSIS

## 4. JUDGEMENT PROCEDURE STEP 3

1. Move the selector lever to "D" position. (Manual mode signal OFF.)

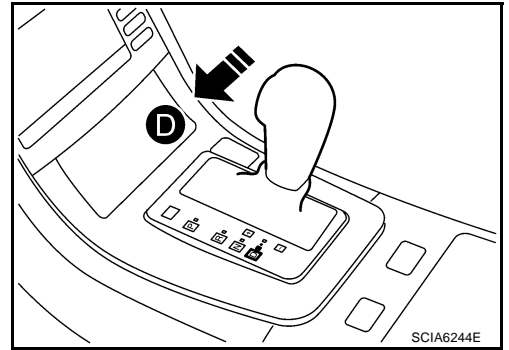

2. Depress brake pedal. (Stop lamp switch signal ON.)
3. Release brake pedal. (Stop lamp switch signal OFF.)

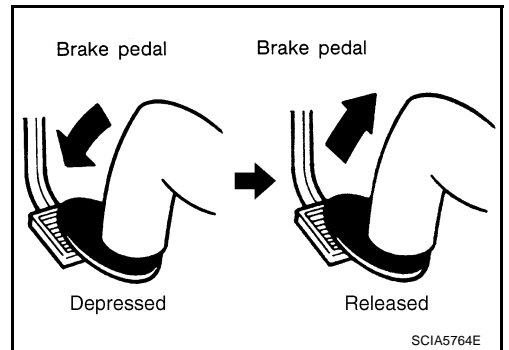

4. Depress accelerator pedal fully and release it.

>> GO TO 5.

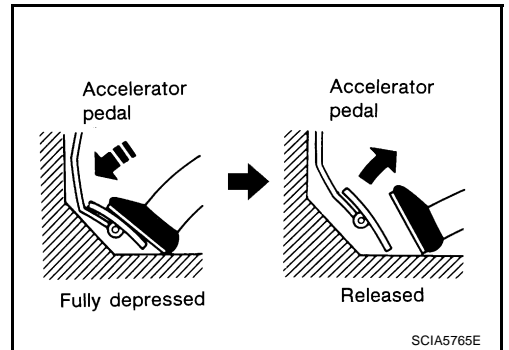

## 5. CHECK SELF-DIAGNOSIS CODE

Check A/T CHECK indicator lamp.

Refer to [AT-109, "Judgement Self-diagnosis Code"](#).

If the system does not go into self-diagnostics. Refer to [AT-118, "DTC P0705 PARK/NEUTRAL POSITION SWITCH"](#), [AT-174, "DTC P1815 MANUAL MODE SWITCH"](#), [AT-190, "CLOSED THROTTLE POSITION AND WIDE OPEN THROTTLE POSITION CIRCUIT"](#), [AT-191, "BRAKE SIGNAL CIRCUIT"](#).

>> DIAGNOSIS END

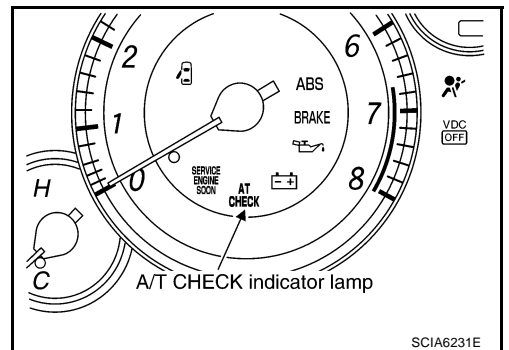

# TROUBLE DIAGNOSIS

## Judgement Self-diagnosis Code

If there is a malfunction, the lamp lights up for the time corresponding to the suspect circuit.

No.	Malfunctioning item	No.	Malfunctioning item
1.	Revolution sensor <a href="#">AT-122</a>	10.	A/T fluid temperature sensor <a href="#">AT-140</a>
2.	Direct clutch solenoid valve <a href="#">AT-162</a> , <a href="#">AT-164</a>	11.	Turbine revolution sensor <a href="#">AT-145</a>
3.	Torque converter clutch solenoid valve <a href="#">AT-129</a> , <a href="#">AT-131</a>	12.	A/T interlock <a href="#">AT-149</a>
4.	Line pressure solenoid valve <a href="#">AT-133</a>	13.	A/T 1st engine braking <a href="#">AT-152</a>
5.	Input clutch solenoid valve <a href="#">AT-154</a> , <a href="#">AT-156</a>	14.	Start signal <a href="#">AT-113</a>
6.	Front brake solenoid valve <a href="#">AT-158</a> , <a href="#">AT-160</a>	15.	Accelerator pedal position sensor <a href="#">AT-137</a>
7.	Low coast brake solenoid valve <a href="#">AT-170</a> , <a href="#">AT-172</a>	16.	Engine speed signal <a href="#">AT-127</a>
8.	High and low reverse clutch solenoid valve <a href="#">AT-166</a> , <a href="#">AT-168</a>	17.	CAN communication line <a href="#">AT-110</a>
9.	PNP switch <a href="#">AT-118</a>		

All circuits that can be confirmed by self-diagnosis are OK.

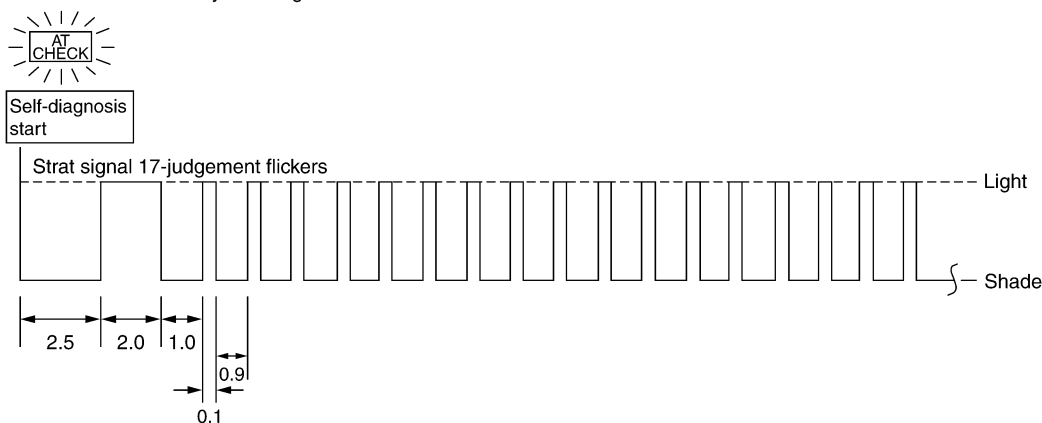

Example: No.4 Line pressure solenoid valve

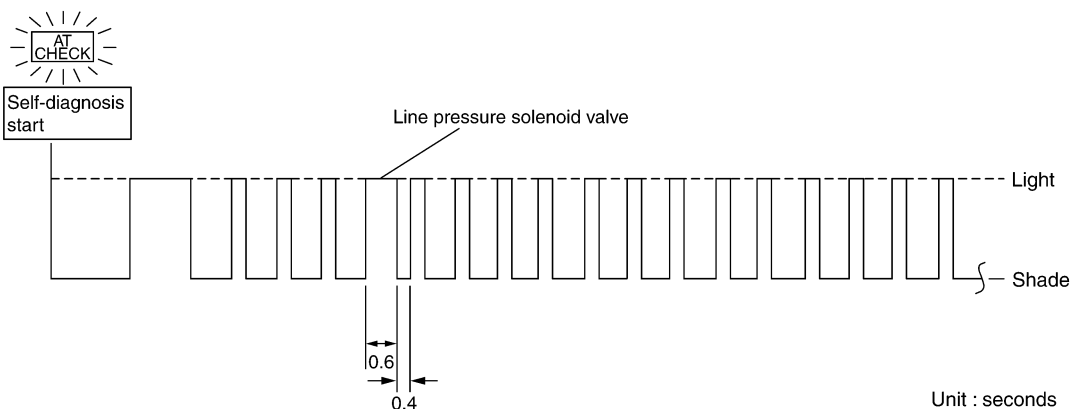

Unit : seconds

SCIA5767E

## Erase Self-diagnosis

- In order to make it easier to find the cause of hard-to-duplicate malfunctions, malfunction information is stored into the control unit as necessary during use by the user. This memory is not erased no matter how many times the ignition switch is turned ON and OFF.
- However, this information is erased by turning ignition switch OFF after performing self-diagnostics or by erasing the memory using the CONSULT-II.

# DTC U1000 CAN COMMUNICATION LINE

## DTC U1000 CAN COMMUNICATION LINE

PFP:23710

### Description

ACS005XI

CAN (Controller Area Network) is a serial communication line for real time application. It is an on-vehicle multiplex communication line with high data communication speed and excellent malfunction detection ability. Many electronic control units are equipped onto a vehicle, and each control unit shares information and links with other control units during operation (not independent). In CAN communication, control units are connected with 2 communication lines (CAN H line, CAN L line) allowing a high rate of information transmission with less wiring. Each control unit transmits/receives data but selectively reads required data only.

### On Board Diagnosis Logic

ACS005XJ

- This is an OBD-II self-diagnostic item.
- Diagnostic trouble code "U1000 CAN COMM CIRCUIT" with CONSULT-II or 17th judgement flicker without CONSULT-II is detected when TCM cannot communicate to other control units.

### Possible Cause

ACS005XK

Harness or connector  
(CAN communication line is open or shorted.)

### DTC Confirmation Procedure

ACS005XL

#### NOTE:

If "DTC Confirmation Procedure" has been previously performed, always turn ignition switch OFF and wait at least 10 seconds before performing the next test.

After the repair, perform the following procedure to confirm the malfunction is eliminated.

#### ④ WITH CONSULT-II

1. Turn ignition switch ON.
2. Select "DATA MONITOR" mode for "A/T" with CONSULT-II.
3. Start engine and wait for at least 6 seconds.
4. If DTC is detected, go to [AT-112, "Diagnostic Procedure"](#).

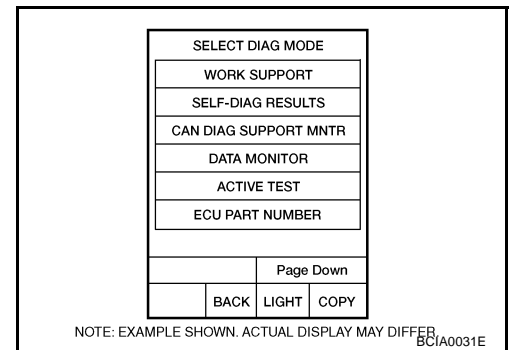

#### ④ WITH GST

Follow the procedure "WITH CONSULT-II".

# DTC U1000 CAN COMMUNICATION LINE

## Wiring Diagram — AT — CAN

ACS00869

### AT-CAN-01

: DETECTABLE LINE FOR DTC  
 : NON-DETECTABLE LINE FOR DTC  
 : DATA LINE

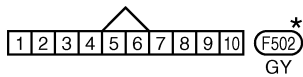
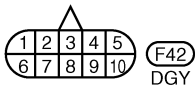
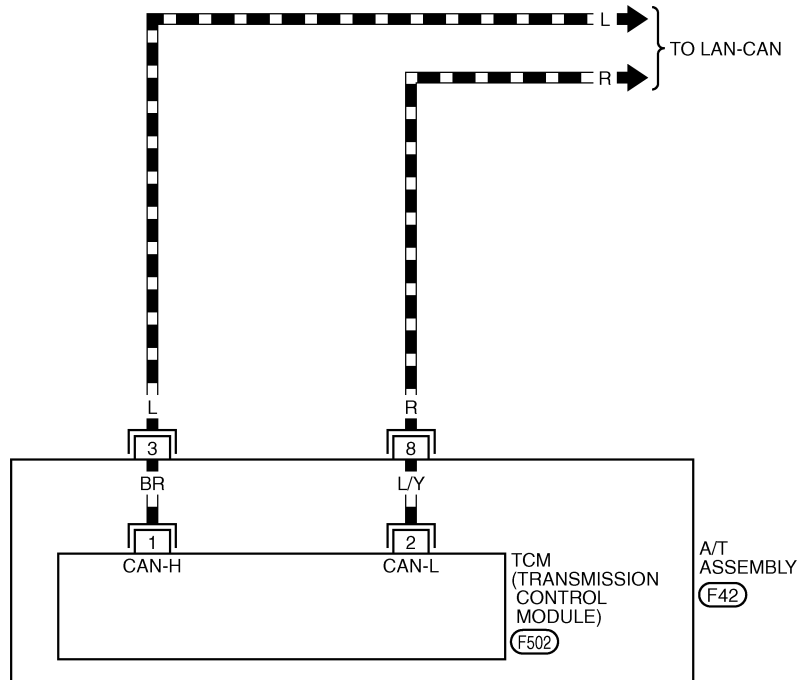

\*: THIS CONNECTOR IS NOT SHOWN IN "HARNESS LAYOUT", PG SECTION.

TCWM0391E

# DTC U1000 CAN COMMUNICATION LINE

TCM terminals and data are reference value. Measured between each terminal and ground.

Terminal	Wire color	Item	Condition	Data (Approx.)
3	L	CAN-H	-	-
8	R	CAN-L	-	-

## Diagnostic Procedure

ACS005XM

### 1. CHECK CAN COMMUNICATION CIRCUIT

#### ④ With CONSULT-II

- Turn ignition switch ON and start engine.
- Select "SELF-DIAG RESULTS" mode for "A/T" with CONSULT-II.

Is any malfunction of the "U1000 CAN COMM CIRCUIT" indicated?

YES >> Print out CONSULT-II screen, GO TO LAN section.  
Refer to [LAN-3, "Precautions When Using CONSULT-II"](#)

NO >> **INSPECTION END**

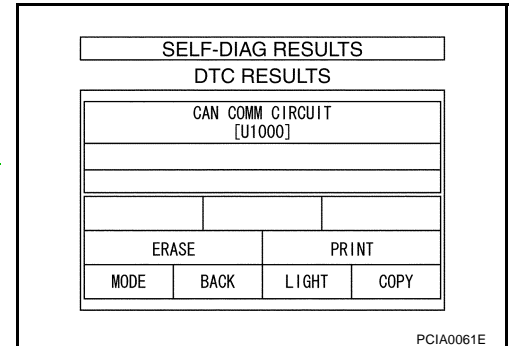



# DTC P0615 START SIGNAL CIRCUIT

## DTC P0615 START SIGNAL CIRCUIT

PDF:25230

### Description

ACS005XN

Prohibits cranking other than at "P" or "N" position.

### CONSULT-II Reference Value

ACS005XO

Item name	Condition	Display value
STARTER RELAY	Selector lever in "N" or "P" position.	ON
	Selector lever in other position.	OFF

### On Board Diagnosis Logic

ACS005XP

- This is not an OBD-II self-diagnostic item.
- Diagnostic trouble code "P0615 STARTER RELAY/CIRC" with CONSULT-II or 14th judgement flicker without CONSULT-II is detected when starter relay is switched ON other than at "P" or "N" position. (Or when switched OFF at "P" or "N" position).

### Possible Cause

ACS005XQ

- Harness or connectors.  
(starter relay and TCM circuit is open or shorted.)
- Starter relay circuit

### DTC Confirmation Procedure

ACS005XR

#### CAUTION:

Always drive vehicle at a safe speed.

#### NOTE:

If "DTC Confirmation Procedure" has been previously performed, always turn ignition switch OFF and wait at least 10 seconds before performing the next test.

After the repair, perform the following procedure to confirm the malfunction is eliminated.

#### WITH CONSULT-II

1. Turn ignition switch ON.
2. Select "SELECTION FROM MENU" in "DATA MONITOR" mode for "A/T" with CONSULT-II and check monitor "STARTER RELAY" ON/OFF.
3. Start engine.
4. Drive vehicle for at least 2 consecutive seconds.
5. If DTC is detected, go to [AT-115, "Diagnostic Procedure"](#).

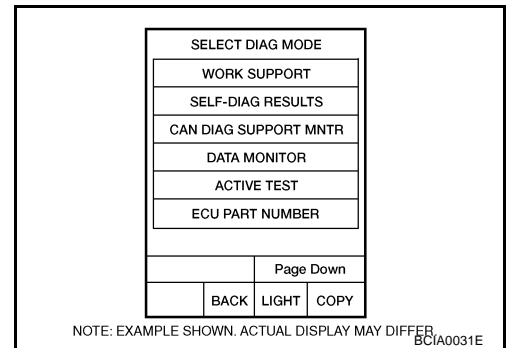

# DTC P0615 START SIGNAL CIRCUIT

## Wiring Diagram — AT — STSIG

ACS0086A

### AT-STSIG-01

: DETECTABLE LINE FOR DTC  
 : NON-DETECTABLE LINE FOR DTC

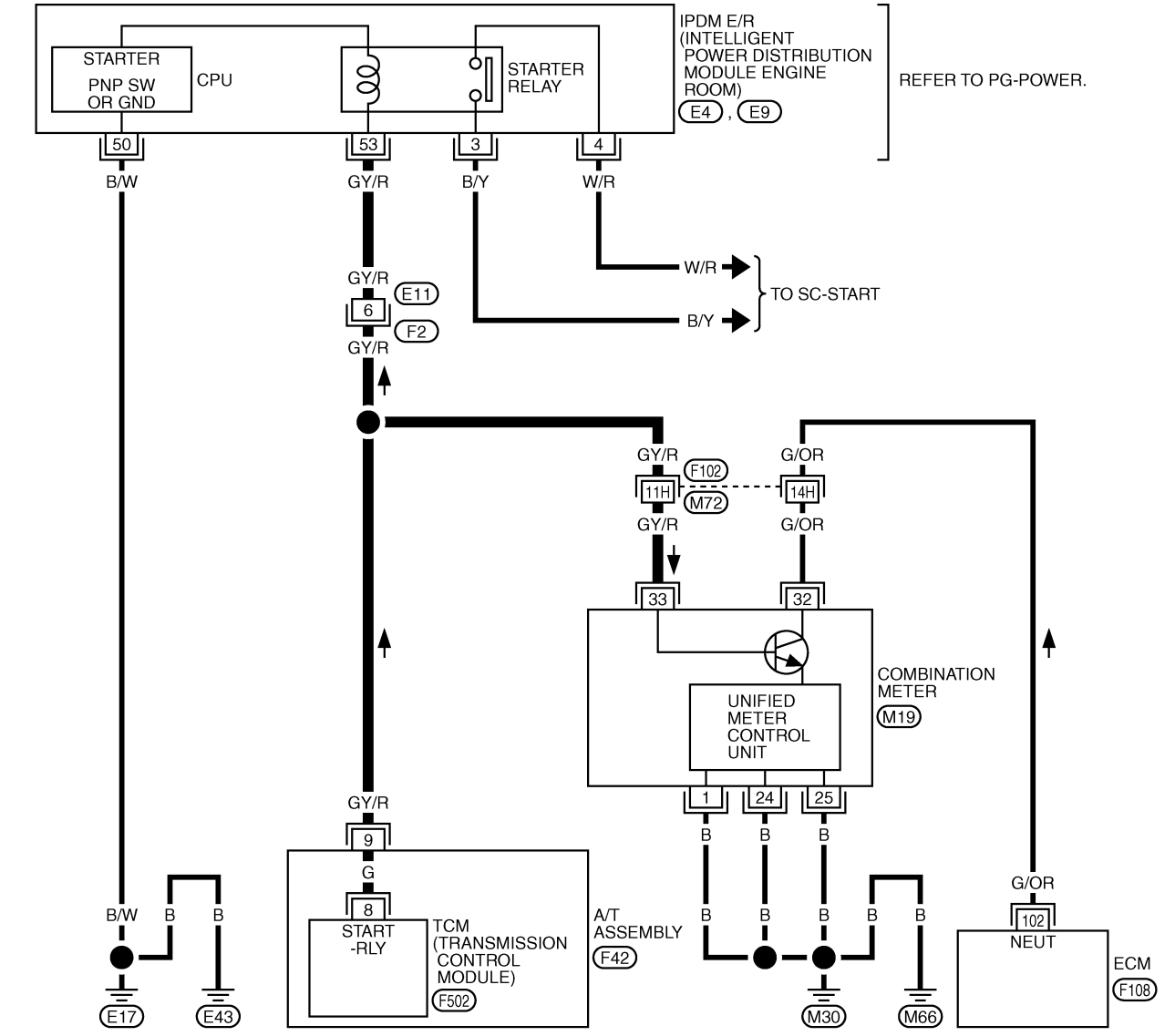

REFER TO PG-POWER.

TO SC-START

COMBINATION METER (M19)

A/T ASSEMBLY (F42)

TCM (TRANSMISSION CONTROL MODULE) (F502)

REFER TO THE FOLLOWING.  
 (F102) -SUPER MULTIPLE JUNCTION (SMJ)  
 (F108) -ELECTRICAL UNITS

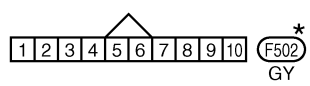
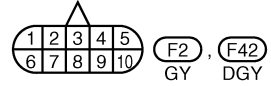
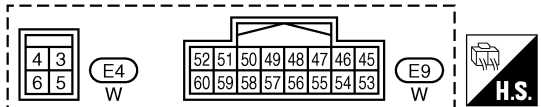
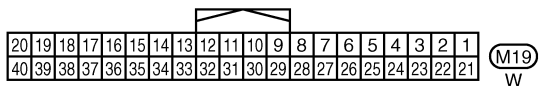

\*: THIS CONNECTOR IS NOT SHOWN IN "HARNESS LAYOUT", PG SECTION.

TCWM0392E

# DTC P0615 START SIGNAL CIRCUIT

TCM terminals and data are reference value. Measured between each terminal and ground.

Terminal	Wire color	Item	Condition	Data (Approx.)
9	GY/R	Starter relay	 Selector lever in "N" or "P" position.	Battery voltage
			Selector lever in other positions.	0V

## Diagnostic Procedure

ACS008FO

### 1. CHECK STARTER RELAY

#### With CONSULT-II

- Turn ignition switch ON. (Do not start engine.)
- Select "SELECTION FROM MENU" in "DATA MONITOR" mode for "A/T" with CONSULT-II and check monitor "STARTER RELAY" ON/OFF.

Item name	Condition	Display value
STARTER RELAY	Selector lever in "N" or "P" position.	ON
	Selector lever in other positions.	OFF

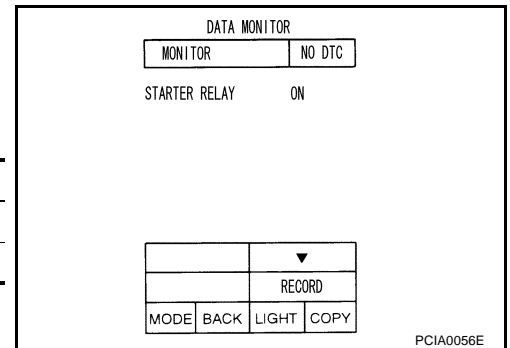

#### Without CONSULT-II

- Turn ignition switch ON. (Do not start engine.)
- Check voltage between the IPDM E/R connector and ground.

Item	Connector	Terminal (Wiring color)	Shift position	Voltage (Approx.)
Starter relay	E9	53 (GY/R)	Ground	"N" or "P" : Battery voltage
				"R" or "D" : 0V

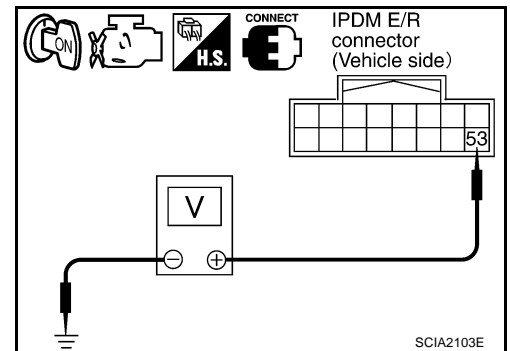

#### OK or NG

- OK >> GO TO 5.  
 NG >> GO TO 2.

### 2. CHECK HARNESS BETWEEN A/T ASSEMBLY HARNESS CONNECTOR AND IPDM E/R CONNECTOR

- Turn ignition switch OFF.
- Disconnect A/T assembly harness connector and IPDM E/R connector.
- Check continuity between A/T assembly harness connector and IPDM E/R connector.

Item	Connector	Terminal (Wire color)	Continuity
A/T assembly harness connector	F42	9 (GY/R)	Yes
IPDM E/R connector	E9	53 (GY/R)	

- If OK, check harness for short to ground and short to power.
- Reinstall any part removed.

#### OK or NG

- OK >> GO TO 3.  
 NG >> Repair open circuit or short to ground or short to power in harness or connectors.

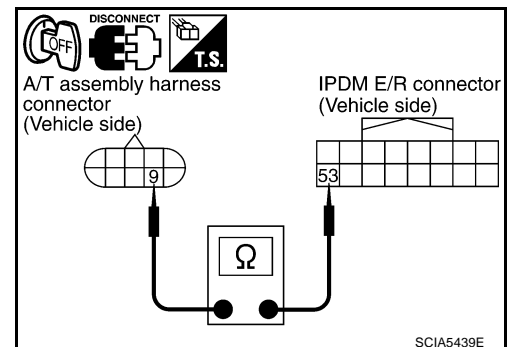

# DTC P0615 START SIGNAL CIRCUIT

## 3. CHECK TERMINAL CORD ASSEMBLY

1. Remove control valve with TCM. Refer to [AT-248, "Control Valve with TCM and A/T Fluid Temperature Sensor 2"](#) .
2. Disconnect A/T assembly harness connector and TCM connector.
3. Check continuity between A/T assembly harness connector terminal and TCM connector terminal.

Item	Connector	Terminal (Wire color)	Continuity
A/T assembly harness connector	F42	9 (G)	Yes
TCM connector	F502	8 (G)	

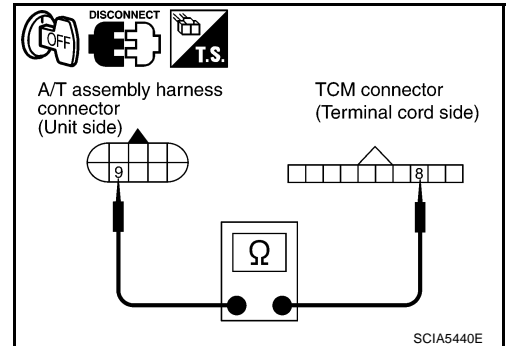

4. If OK, check harness for short to ground and short to power.
5. Reinstall any part removed.

### OK or NG

- OK >> GO TO 4.  
NG >> Replace open circuit or short to ground and short to power in harness or connectors.

## 4. DETECT MALFUNCTIONING ITEM

Check the following.

- Starter relay, Refer to [SC-9, "STARTING SYSTEM"](#) .
- IPDM E/R, Refer to [PG-16, "IPDM E/R \(INTELLIGENT POWER DISTRIBUTION MODULE ENGINE ROOM\)"](#) .

### OK or NG

- OK >> Replace control valve with TCM. Refer to [AT-248, "Control Valve with TCM and A/T Fluid Temperature Sensor 2"](#) .  
NG >> Repair or replace damaged parts.

## 5. CHECK DTC

Perform "DTC Confirmation Procedure".

- Refer to [AT-113, "DTC Confirmation Procedure"](#) .

### OK or NG

- OK >> **INSPECTION END**  
NG >> GO TO 2.

# DTC P0700 TCM

## DTC P0700 TCM

PPF:31036

### Description

ACS006DG

The TCM consists of a microcomputer and connectors for signal input and output and for power supply. The TCM controls the A/T.

### On Board Diagnosis Logic

ACS006DH

- This is an OBD-II self-diagnostic item.
- Diagnostic trouble code "P0700 TCM" with CONSULT-II is detected when TCM is malfunctioning.

### Possible Cause

ACS006DI

TCM.

### DTC Confirmation Procedure

ACS006DJ

#### NOTE:

If "DTC Confirmation Procedure" has been previously performed, always turn ignition switch OFF and wait at least 10 seconds before performing the next test.

After the repair, perform the following procedure to confirm the malfunction is eliminated.

#### WITH CONSULT-II

1. Turn ignition switch ON. (Do not start engine.)
2. Select "ECU INPUT SIGNALS" or "MAIN SIGNALS" in "DATA MONITOR" mode for "A/T" with CONSULT-II.
3. Touch "START".
4. Start engine.
5. Run engine for at least 2 consecutive seconds at idle speed.
6. If DTC is detected, go to [AT-117, "Diagnostic Procedure"](#).

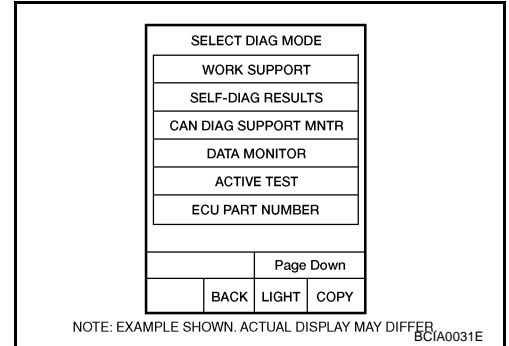

#### WITH GST

Follow the procedure "WITH CONSULT-II".

### Diagnostic Procedure

ACS006DK

#### 1. CHECK DTC

##### With CONSULT-II

1. Turn ignition switch ON. (Do not start engine.)
2. Select "SELF DIAG RESULTS" mode for "A/T" with CONSULT-II.
3. Touch "ERASE".
4. Turn ignition switch OFF and wait at least 10 seconds.
5. Perform DTC confirmation procedure, [AT-117, "DTC Confirmation Procedure"](#).

Is the "P0700 TCM" displayed again?

- YES >> Replace the control valve with TCM. Refer to [AT-248, "Control Valve with TCM and A/T Fluid Temperature Sensor 2"](#).
- NO >> **INSPECTION END**

# DTC P0705 PARK/NEUTRAL POSITION SWITCH

## DTC P0705 PARK/NEUTRAL POSITION SWITCH

PF3:32006

### Description

ACS005XT

- The park/neutral position (PNP) switch includes a transmission position switch.
- The transmission range switch detects the selector lever position and sends a signal to the TCM.

### CONSULT-II Reference Value

ACS005XU

Item name	Condition	Display value
SLCTLVR POSI	Selector lever in "N" or "P" position.	N·P
	Selector lever in "R" position.	R
	Selector lever in "D" position.	D

### On Board Diagnosis Logic

ACS005XV

- This is an OBD-II self-diagnostic item.
- Diagnostic trouble code "P0705 PNP SW/CIRC" with CONSULT-II or 9th judgement flicker without CONSULT-II is detected under the following conditions.
  - When TCM does not receive the correct voltage signal from the PNP switch 1, 2, 3 and 4 based on the gear position.
  - When no other position but "P" position is detected from "N" positions.

### Possible Cause

ACS005XW

- Harness or connectors.  
[Park/neutral position (PNP) switch 1, 2, 3, 4 and TCM circuit is open or shorted.]
- Park/neutral position (PNP) switch 1, 2, 3, 4.

### DTC Confirmation Procedure

ACS005XX

#### CAUTION:

Always drive vehicle at a safe speed.

#### NOTE:

If "DTC Confirmation Procedure" has been previously performed, always turn ignition switch OFF and wait at least 10 seconds before performing the next test.

After the repair, perform the following procedure to confirm the malfunction is eliminated.

#### Ⓟ WITH CONSULT-II

1. Turn ignition switch ON.
2. Select "ECU INPUT SIGNALS" or "MAIN SIGNALS" in "DATA MONITOR" mode for "A/T" with CONSULT-II.
3. Touch "START".
4. Start engine.
5. Drive vehicle and maintain the following conditions for at least 2 consecutive seconds.  
**ACCELE POSI: More than 1.0/8**
6. If DTC is detected, go to [AT-120, "Diagnostic Procedure"](#).

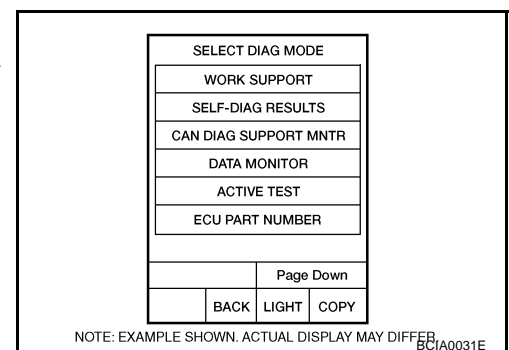

#### Ⓟ WITH GST

Follow the procedure "WITH CONSULT-II".

# DTC P0705 PARK/NEUTRAL POSITION SWITCH

## Wiring Diagram — AT — PNP/SW

ACS0086B

### AT-PNP/SW-01

**—** : DETECTABLE LINE FOR DTC  
**—** : NON-DETECTABLE LINE FOR DTC

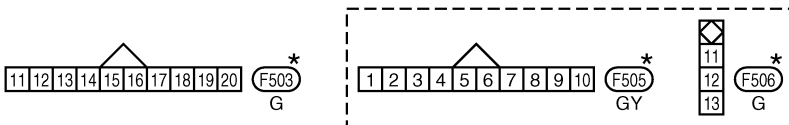
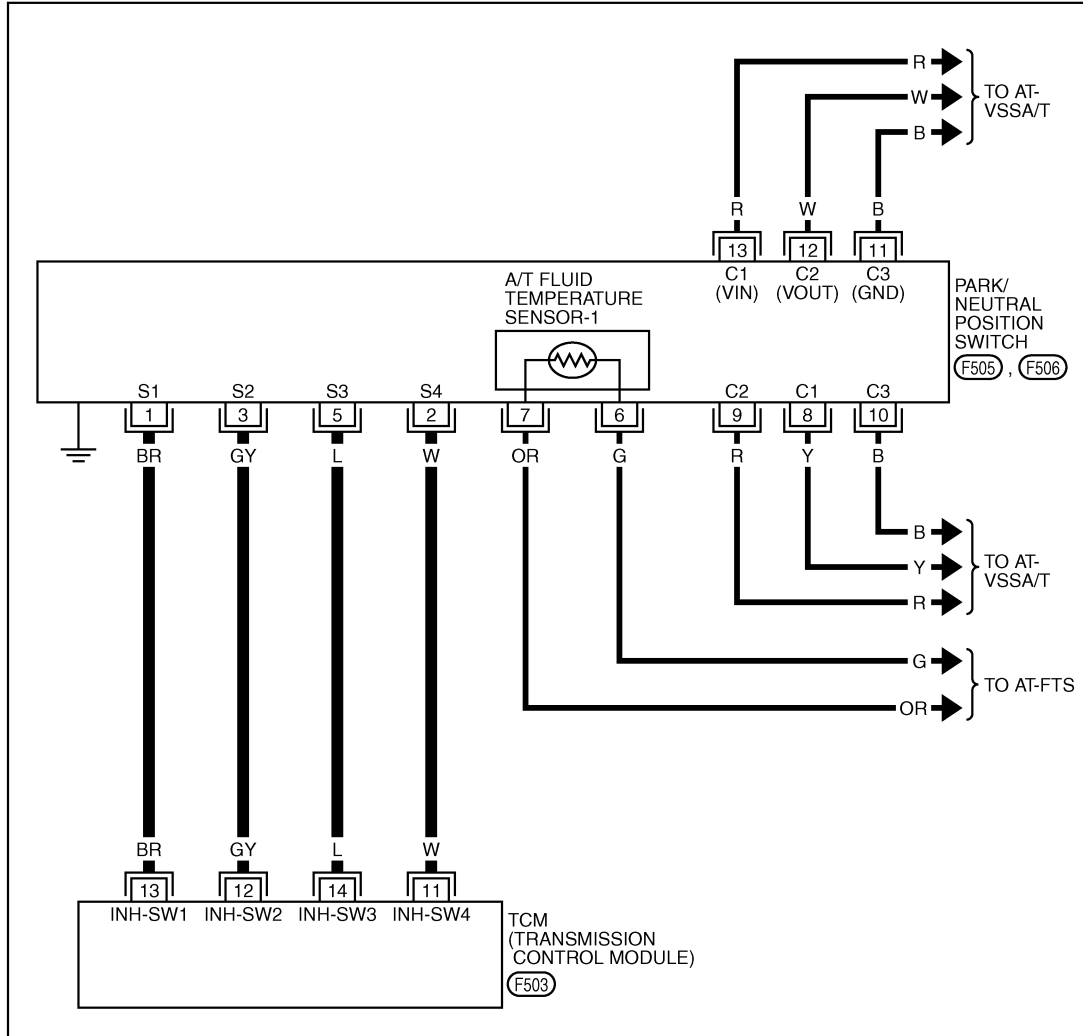

\*: THIS CONNECTOR IS NOT SHOWN IN "HARNES LAYOUT", PG SECTION.

A/T ASSEMBLY

A  
B  
AT  
D  
E  
F  
G  
H  
I  
J  
K  
L  
M

# DTC P0705 PARK/NEUTRAL POSITION SWITCH

ACS008FR

## Diagnostic Procedure

### 1. CHECK PNP SW CIRCUIT

#### With CONSULT-II

1. Turn ignition switch ON. (Do not start engine.)
2. Select "SELECTION FROM MENU" in "DATA MONITOR" mode for "A/T" with CONSULT-II.
3. Check if correct selector lever position ("N/P", "R" or "D") is displayed as selector lever is moved into each position.

Item name	Condition	Display value
SLCT LVR POSI	Selector lever in "N" or "P" position.	N/P
	Selector lever in "R" position.	R
	Selector lever in "D" position.	D

DATA MONITOR			
MONITOR		NO DTC	
ATF PRES SW 2	xxx		
ATF PRES SW 3	xxx		
ATF PRES SW 5	xxx		
ATF PRES SW 6	xxx		
SLCT LVR POSI	xxx		
RECORD			
MODE	BACK	LIGHT	COPY

SCIA5296E

#### OK or NG

- OK >> GO TO 5.  
NG >> GO TO 2.

### 2. CHECK TCM POWER SUPPLY AND GROUND CIRCUIT

Check TCM power supply and ground circuit. Refer to [AT-186, "MAIN POWER SUPPLY AND GROUND CIRCUIT"](#).

#### OK or NG

- OK >> GO TO 3.  
NG >> Repair or replace damaged parts.

### 3. DETECT MALFUNCTIONING ITEM

Check the following.

- A/T assembly harness connector pin terminals for damage or loose connection with harness connector.

#### OK or NG

- OK >> GO TO 4.  
NG >> Repair or replace damaged parts.



# DTC P0705 PARK/NEUTRAL POSITION SWITCH

## 4. CHECK SUB-HARNESS

1. Remove control valve with TCM. Refer to [AT-248, "Control Valve with TCM and A/T Fluid Temperature Sensor 2"](#) .
2. Disconnect park/neutral position switch connector and TCM connector.
3. Check continuity between park/neutral position switch connector terminals and TCM connector terminals.

Item	Connector	Terminal (Wire color)	Continuity
Park/neutral position switch connector	F505	1 (BR)	Yes
TCM connector	F503	13 (BR)	
Park/neutral position switch connector	F505	2 (W)	Yes
TCM connector	F503	11 (W)	
Park/neutral position switch connector	F505	3 (GY)	Yes
TCM connector	F503	12 (GY)	
Park/neutral position switch connector	F505	5 (L)	Yes
TCM connector	F503	14 (L)	

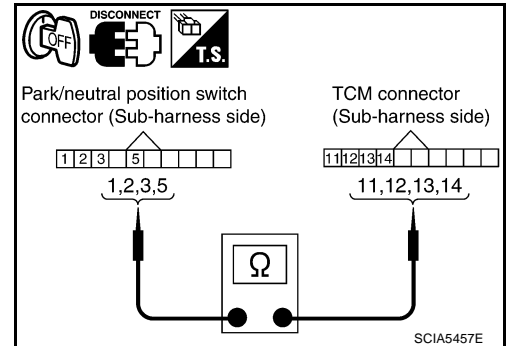

4. If OK, check harness for short to ground and short to power.

5. Reinstall any part removed.

OK or NG

OK >> Replace control valve with TCM. Refer to [AT-248, "Control Valve with TCM and A/T Fluid Temperature Sensor 2"](#) .

NG >> Replace open circuit or short to ground and short to power in harness or connectors.

## 5. CHECK DTC

Perform "DTC Confirmation Procedure".

- Refer to [AT-118, "DTC Confirmation Procedure"](#) .

OK or NG

OK >> **INSPECTION END**

NG >> GO TO 2.

# DTC P0720 VEHICLE SPEED SENSOR A/T (REVOLUTION SENSOR)

## DTC P0720 VEHICLE SPEED SENSOR A/T (REVOLUTION SENSOR)

PFP:32702

### Description

ACS005XZ

The revolution sensor detects the revolution of the idler gear parking pawl lock gear and emits a pulse signal. The pulse signal is sent to the TCM which converts it into vehicle speed.

### CONSULT-II Reference Value

ACS005Y0

Item name	Condition	Display value
VHCL/S SE-A/T	During driving	Approximately matches the speedometer reading.

### On Board Diagnosis Logic

ACS005Y1

- This is an OBD-II self-diagnostic item.
- Diagnostic trouble code "P0720 VEH SPD SEN/CIR AT" with CONSULT-II or 1st judgement flicker without CONSULT-II is detected under the following conditions.
  - When TCM does not receive the proper voltage signal from the sensor.
  - After ignition switch is turned ON, irregular signal input from vehicle speed sensor MTR before the vehicle starts moving.

### Possible Cause

ACS005Y2

- Harness or connectors.  
(Sensor circuit is open or shorted.)
- Revolution sensor.
- Vehicle speed sensor MTR.

### DTC Confirmation Procedure

ACS005Y3

#### CAUTION:

- Always drive vehicle at a safe speed.
- Be careful not to rev engine into the red zone on the tachometer.

#### NOTE:

If "DTC Confirmation Procedure" has been previously performed, always turn ignition switch OFF and wait at least 10 seconds before performing the next test.

After the repair, perform the following procedure to confirm the malfunction is eliminated.

#### WITH CONSULT-II

1. Turn ignition switch ON. (Do not start engine.)
2. Select "SELECTION FROM MENU" in "DATA MONITOR" mode for "A/T" with CONSULT-II.
3. Touch "START".
4. Drive vehicle and check for an increase of "VHCL/S SE-A/T" value in response to "VHCL/S SE-MTR" value.  
If the check result is NG, go to [AT-125, "Diagnostic Procedure"](#).  
If the check result is OK, go to following step.
5. Select "DATA MONITOR" mode for "A/T" with CONSULT-II.
6. Start engine and maintain the following conditions for at least 5 consecutive seconds.

**VHCL/S SE-A/T: 30 km/h (19 MPH) or more**

**ACCELE POSI: More than 1.0/8**

**SLCT LVR POSI: "D" position**

**Driving location: Driving the vehicle uphill (increased engine load) will help maintain the driving conditions required for this test.**

If the check result is NG, go to [AT-125, "Diagnostic Procedure"](#).

If the check result is OK, go to following step.

7. Maintain the following conditions for at least 5 consecutive seconds.

**ENGINE SPEED: 3,500 rpm or more**

**ACCELE POSI: More than 1.0/8**

**SLCTLVR POSI: "D" position**

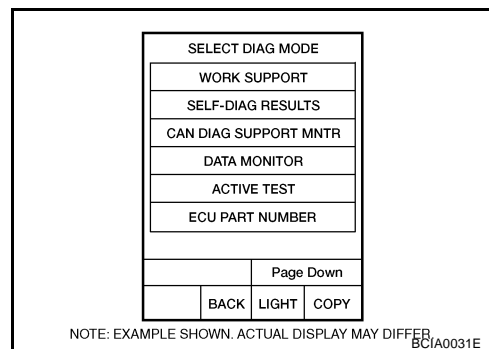

## DTC P0720 VEHICLE SPEED SENSOR A/T (REVOLUTION SENSOR)

**Driving location: Driving the vehicle uphill (increased engine load) will help maintain the driving conditions required for this test.**

8. If DTC is detected, go to [AT-125, "Diagnostic Procedure"](#).

 **WITH GST**

Follow the procedure "WITH CONSULT-II".

A

B

AT

D

E

F

G

H

I

J

K

L

M

# DTC P0720 VEHICLE SPEED SENSOR A/T (REVOLUTION SENSOR)

## Wiring Diagram — AT — VSSA/T

ACS0086C

### AT-VSSA/T-01

: DETECTABLE LINE FOR DTC  
 : NON-DETECTABLE LINE FOR DTC

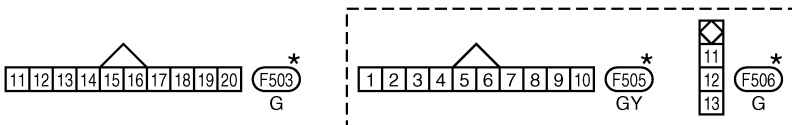
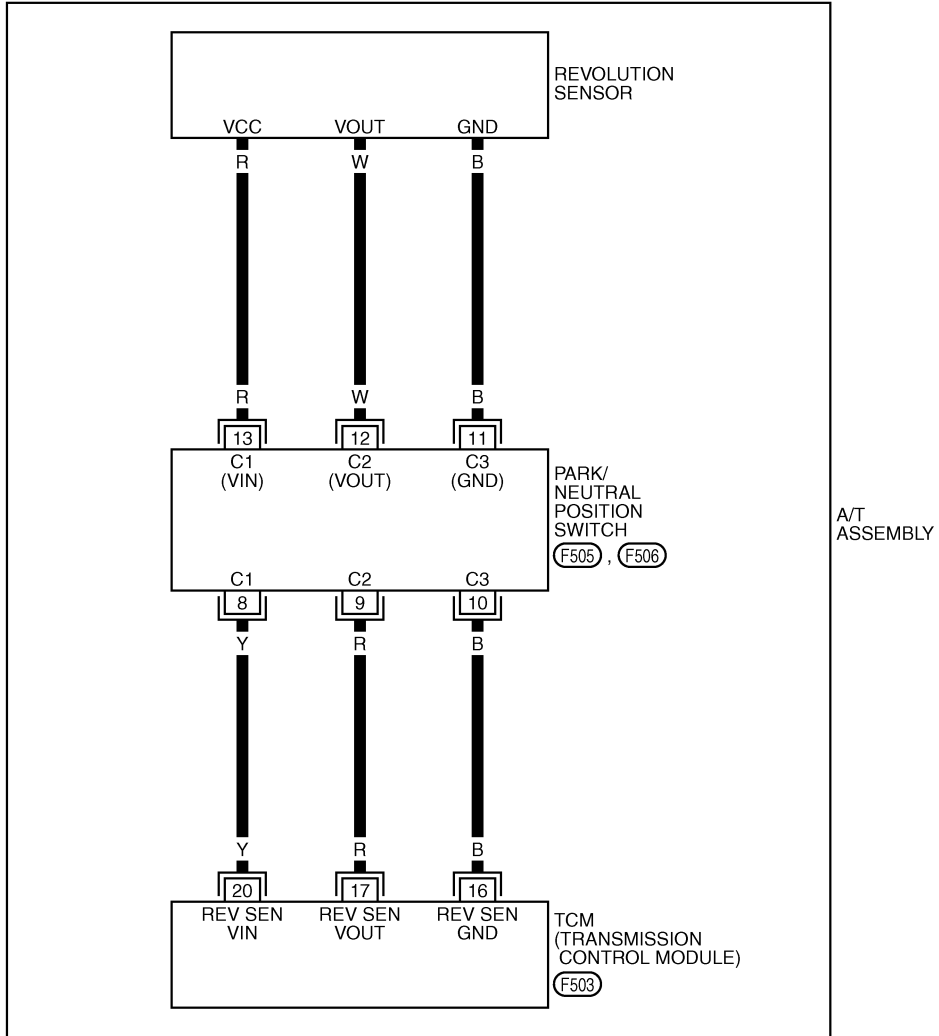

\*: THIS CONNECTOR IS NOT SHOWN IN "HARNESS LAYOUT", PG SECTION.

TCWM0249E

# DTC P0720 VEHICLE SPEED SENSOR A/T (REVOLUTION SENSOR)

## Diagnostic Procedure

ACS008FS

### 1. CHECK INPUT SIGNAL

#### With CONSULT-II

1. Turn ignition switch ON. (Do not start engine.)
2. Select "ECU INPUT SIGNALS" in "DATA MONITOR" mode for "A/T" with CONSULT-II.
3. Start the engine.
4. Read out the value of "VHCL/S SE·A/T" while driving. Check the value changes according to driving speed.

Item name	Condition	Display value (km/h)
VHCL/S SE·A/T	During driving	Approximately matches the speedometer reading.

DATA MONITOR			
MONITOR	NO DTC		
VHCL/S SE·A/T	0km/h		
VHCL/S SE·MTR	0km/h		
ACCELE POSI	0.0/8		
THROTTLE POS	0.0/8		
CLSD THL POS	ON		
W/O THL POS	OFF		
	▽		
RECORD			
MODE	BACK	LIGHT	COPY

SCIA2148E

#### OK or NG

- OK >> GO TO 6.
- NG >> GO TO 2.

### 2. CHECK TCM POWER SUPPLY AND GROUND CIRCUIT

Check TCM power supply and ground circuit. Refer to [AT-186. "MAIN POWER SUPPLY AND GROUND CIRCUIT"](#).

#### OK or NG

- OK >> GO TO 3.
- NG >> Repair or replace damaged parts.

### 3. DETECT MALFUNCTIONING ITEM

Check the following.

- A/T assembly harness connector pin terminals for damage or loose connection with harness connector.

#### OK or NG

- OK >> GO TO 4.
- NG >> Repair or replace damaged parts.

# DTC P0720 VEHICLE SPEED SENSOR A/T (REVOLUTION SENSOR)

## 4. CHECK SUB-HARNESS

1. Remove control valve with TCM. Refer to [AT-248, "Control Valve with TCM and A/T Fluid Temperature Sensor 2"](#) .
2. Disconnect park/neutral position switch connector and TCM connector.
3. Check continuity between park/neutral position switch connector terminals and TCM connector terminals.

Item	Connector	Terminal (Wire color)	Continuity
Park/neutral position switch connector	F505	8 (Y)	Yes
TCM connector	F503	20 (Y)	
Park/neutral position switch connector	F505	9 (R)	Yes
TCM connector	F503	17 (R)	
Park/neutral position switch connector	F505	10 (B)	Yes
TCM connector	F503	16 (B)	

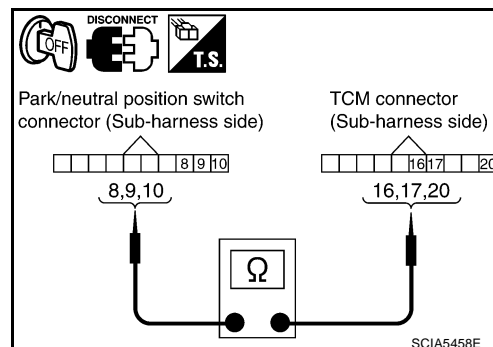

4. If OK, check harness for short to ground and short to power.
5. Reinstall any part removed.

### OK or NG

OK >> GO TO 5.

NG >> Replace open circuit or short to ground and short to power in harness or connectors.

## 5. REPLACE THE REVOLUTION SENSOR AND CHECK DTC

1. Replace the revolution sensor. Refer to [AT-269, "Revolution Sensor \(2WD Models Only\)"](#) or [AT-292, "DISASSEMBLY"](#) , [AT-329, "ASSEMBLY"](#) (AWD models).
2. Perform "DTC Confirmation Procedure". Refer to [AT-122, "DTC Confirmation Procedure"](#) .

### OK or NG

OK >> **INSPECTION END**

NG >> Replace the control valve with TCM. Refer to [AT-248, "Control Valve with TCM and A/T Fluid Temperature Sensor 2"](#) .

## 6. CHECK DTC

Perform "DTC Confirmation Procedure".

- Refer to [AT-122, "DTC Confirmation Procedure"](#) .

### OK or NG

OK >> **INSPECTION END**

NG >> GO TO 2.

# DTC P0725 ENGINE SPEED SIGNAL

## DTC P0725 ENGINE SPEED SIGNAL

PPF:24825

### Description

ACS005Y5

The engine speed signal is sent from the ECM to the TCM.

### CONSULT-II Reference Value

ACS005Y6

Item name	Condition	Display value
ENGINE SPEED	Engine running	Closely matches the tachometer reading.

### On Board Diagnosis Logic

ACS005Y7

- This is an OBD-II self-diagnostic item.
- Diagnostic trouble code “P0725 ENGINE SPEED SIG” with CONSULT-II or 16th judgement flicker without CONSULT-II is detected when TCM does not receive the ignition signal from ECM during engine cranking or running.

### Possible Cause

ACS005Y8

Harness or connectors.  
(ECM to TCM circuit is open or shorted.)

### DTC Confirmation Procedure

ACS005Y9

#### CAUTION:

Always drive vehicle at a safe speed.

#### NOTE:

If “DTC Confirmation Procedure” has been previously performed, always turn ignition switch OFF and wait at least 10 seconds before performing the next test.

After the repair, perform the following procedure to confirm the malfunction is eliminated.

#### WITH CONSULT-II

1. Turn ignition switch ON. (Do not start engine.)
2. Select “SELECTION FROM MENU” in “DATA MONITOR” mode for “A/T” with CONSULT-II and check monitor “VHCL/S SE-A/T”, “ACCELE POSI” and “SLCT LVR POSI”.
3. Touch “START”.
4. Start engine and maintain the following conditions for at least 10 consecutive seconds.  
**VHCL/S SE-A/T: 10 km/h (6 MPH) or more**  
**ACCELE POSI: More than 1.0/8**  
**SLCTLVR POSI: “D” position**
5. If DTC is detected, go to [AT-128, "Diagnostic Procedure"](#).

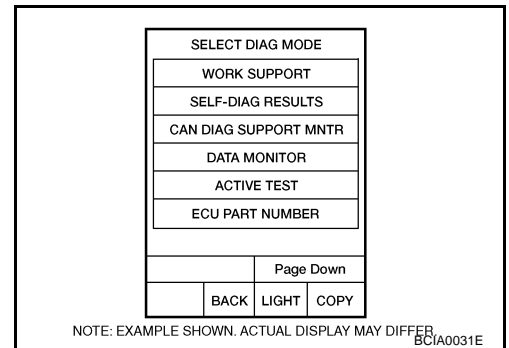

#### WITH GST

Follow the procedure “WITH CONSULT-II”.

# DTC P0725 ENGINE SPEED SIGNAL

ACS008FT

## Diagnostic Procedure

### 1. CHECK CAN COMMUNICATION LINE

Perform self-diagnosis. Refer to [AT-95, "SELF-DIAGNOSTIC RESULT MODE"](#) , [AT-105, "Diagnostic Procedure without CONSULT-II"](#) .

Is a malfunction in the CAN communication indicated in the results?

- YES >> Check CAN communication line. Refer to [AT-110, "DTC U1000 CAN COMMUNICATION LINE"](#) .
- NO >> GO TO 2.

### 2. CHECK DTC WITH TCM

#### With CONSULT-II

1. Start engine.
2. Select "ECU INPUT SIGNALS" in "DATA MONITOR" mode for "A/T" with CONSULT-II.
3. While monitoring engine speed, check for engine speed change corresponding to wide-open throttle position signal.

Item name	Condition	Display value
ENGINE SPEED	Engine running	Closely matches the tachometer reading.

DATA MONITOR			
MONITOR	NO. DTC		
W/O THL POS	OFF		
BRAKE SW	OFF		
ENGINE SPEED	0 rpm		
TURBINE REV	0 rpm		
OUTPUT REV	0 rpm		
▼			
RECORD			
MODE	BACK	LIGHT	COPY

PCIA0041E

OK or NG

- OK >> GO TO 3.
- NG >> Check the ignition signal circuit. Refer to [EC-664, "IGNITION SIGNAL"](#) .

### 3. CHECK DTC

Perform "DTC Confirmation Procedure".

- Refer to [AT-127, "DTC Confirmation Procedure"](#) .

OK or NG

- OK >> **INSPECTION END**
- NG >> GO TO 4.

### 4. CHECK TCM POWER SUPPLY AND GROUND CIRCUIT

Check TCM power supply and ground circuit. Refer to [AT-186, "MAIN POWER SUPPLY AND GROUND CIRCUIT"](#) .

OK or NG

- OK >> GO TO 5.
- NG >> Repair or replace damaged parts.

### 5. DETECT MALFUNCTIONING ITEM

Check the following.

- A/T assembly harness connector pin terminals for damage or loose connection with harness connector.

OK or NG

- OK >> Replace control valve with TCM. Refer to [AT-248, "Control Valve with TCM and A/T Fluid Temperature Sensor 2"](#) .
- NG >> Repair or replace damaged parts.



# DTC P0740 TORQUE CONVERTER CLUTCH SOLENOID VALVE

## DTC P0740 TORQUE CONVERTER CLUTCH SOLENOID VALVE

PFP:31940

### Description

ACS005YB

- The torque converter clutch solenoid valve is activated, with the gear in D4 , D5 , M2, M3, M4 and M5 by the TCM in response to signals sent from the vehicle speed sensor and accelerator pedal position sensor (throttle position sensor). Torque converter clutch piston operation will then be controlled.
- Lock-up operation, however, is prohibited when A/T fluid temperature is too low.
- When the accelerator pedal is depressed (less than 1/8) in lock-up condition, the engine speed should not change abruptly. If there is a big jump in engine speed, there is no lock-up.

### CONSULT-II Reference Value

ACS005YC

Item name	Condition	Display value (Approx.)
TCC SOLENOID	When performing slip lock-up	0.2 - 0.4A
	When performing lock-up	0.4 - 0.6A

### On Board Diagnosis Logic

ACS005YD

- This is an OBD-II self-diagnostic item.
- Diagnostic trouble code "P0740 TCC SOLENOID/CIRC" with CONSULT-II or 3rd judgement flicker without CONSULT-II is detected under the following conditions.
  - When TCM detects an improper voltage drop when it tries to operate the solenoid valve.
  - When TCM detects as irregular by comparing target value with monitor value.

### Possible Cause

ACS005YE

- Torque converter clutch solenoid valve.
- Harness or connectors.  
(Solenoid circuit is open or shorted.)

### DTC Confirmation Procedure

ACS005YF

#### CAUTION:

Always drive vehicle at a safe speed.

#### NOTE:

If "DTC Confirmation Procedure" has been previously performed, always turn ignition switch OFF and wait at least 10 seconds before performing the next test.

After the repair, perform the following procedure to confirm the malfunction is eliminated.

#### WITH CONSULT-II

1. Turn ignition switch ON. (Do not start engine.)
2. Select "SELECTION FROM MENU" in "DATA MONITOR" mode for "A/T" with CONSULT-II and check monitor "VHCL/S SE-A/T", "ACCELE POSI" and "SLCT LVR POSI".
3. Touch "START".
4. Start engine and maintain the following conditions for at least 5 consecutive seconds.  
**VHCL/S SE-A/T: 80 km/h (50 MPH) or more**  
**ACCELE POSI: 0.5/8 - 1.0/8**  
**SLCT LVR POSI: "D" position**  
**Driving location: Driving the vehicle uphill (increased engine load) will help maintain the driving conditions required for this test.**
5. If DTC is detected go to [AT-130, "Diagnostic Procedure"](#).

#### WITH GST

Follow the procedure "WITH CONSULT-II".

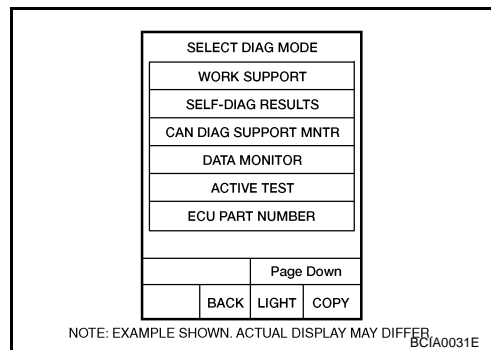

# DTC P0740 TORQUE CONVERTER CLUTCH SOLENOID VALVE

ACS008FU

## Diagnostic Procedure

### 1. CHECK INPUT SIGNAL

#### With CONSULT-II

1. Turn ignition switch ON. (Do not start engine.)
2. Select "MAIN SIGNALS" in "DATA MONITOR" mode for "A/T" with CONSULT-II.
3. Start engine.
4. Read out the value of "TCC SOLENOID" while driving.

Item name	Condition	Display value (Approx.)
TCC SOLENOID	When performing slip lock-up	0.2 - 0.4 A
	When performing lock-up	0.4 - 0.6 A

DATA MONITOR	
MONITOR	NO DTC
TCC SOLENOID	XXXX
LINE PRES SOL	XXXX
I/C SOLENOID	XXXX
FR/B SOLENOID	XXXX
D/C SOLENOID	XXXX
HLR/C SOL	XXXX
	▽
	RECORD
MODE	BACK
LIGHT	COPY

SCIA4793E

#### OK or NG

- OK >> GO TO 4.  
NG >> GO TO 2.

### 2. CHECK TCM POWER SUPPLY AND GROUND CIRCUIT

Check TCM power supply and ground circuit. Refer to [AT-186, "MAIN POWER SUPPLY AND GROUND CIRCUIT"](#).

#### OK or NG

- OK >> GO TO 3.  
NG >> Repair or replace damaged parts.

### 3. DETECT MALFUNCTIONING ITEM

Check the following.

- A/T assembly harness connector pin terminals for damage or loose connection with harness connector.

#### OK or NG

- OK >> Replace control valve with TCM. Refer to [AT-248, "Control Valve with TCM and A/T Fluid Temperature Sensor 2"](#).  
NG >> Repair or replace damaged parts.

### 4. CHECK DTC

Perform "DTC Confirmation Procedure".

- Refer to [AT-129, "DTC Confirmation Procedure"](#).

#### OK or NG

- OK >> **INSPECTION END**  
NG >> GO TO 2.

# DTC P0744 A/T TCC S/V FUNCTION (LOCK-UP)

## DTC P0744 A/T TCC S/V FUNCTION (LOCK-UP)

PFP:31940

### Description

ACS005YH

This malfunction is detected when the A/T does not shift into 5th gear position or the torque converter clutch does not lock-up as instructed by the TCM. This is not only caused by electrical malfunction (circuits open or shorted) but also by mechanical malfunction such as control valve sticking, improper solenoid valve operation, etc.

### CONSULT-II Reference Value

ACS005YI

Item name	Condition	Display value (Approx.)
TCC SOLENOID	When performing slip lock-up	0.2 - 0.4A
	When performing lock-up	0.4 - 0.6A

### On Board Diagnosis Logic

ACS005YJ

- This is an OBD-II self-diagnostic item.
- Diagnostic trouble code "P0744 A/T TCC S/V FNCTN" with CONSULT-II or 3rd judgement flicker without CONSULT-II is detected under the following conditions.
  - When A/T cannot perform lock-up even if electrical circuit is good.
  - When TCM detects as irregular by comparing difference value with slip rotation.

### Possible Cause

ACS005YK

- Harness or connectors.  
(Solenoid circuit is open or shorted.)
- Torque converter clutch solenoid valve.
- Hydraulic control circuit.

### DTC Confirmation Procedure

ACS005YL

#### CAUTION:

Always drive vehicle at a safe speed.

#### NOTE:

If "DTC Confirmation Procedure" has been previously performed, always turn ignition switch OFF and wait at least 10 seconds before performing the next test.

After the repair, perform the following procedure to confirm the malfunction is eliminated.

#### WITH CONSULT-II

1. Start engine and Select "TCC SOL FUNCTN CHECK" of "DTC WORK SUPPORT" mode for "A/T" with CONSULT-II and touch "START".
2. Accelerate vehicle to more than 80 km/h (50 MPH) and maintain the following condition continuously until "TESTING" has turned to "COMPLETE". (It will take approximately 30 seconds after "TESTING" shows.)

**ACCELE POSI: More than 1.0/8 (at all times during step 4)**

**TCC SOLENOID: 0.4 - 0.6 A**

**SLCT LVR POSI: "D" position**

**[Reference speed: Constant speed of more than 80 km/h (50 MPH)]**

- Make sure "GEAR" shows "5".
  - For shift schedule, refer to [AT-65, "Vehicle Speed at Which Lock-Up Occurs/Releases"](#).
  - If "TESTING" does not appear on CONSULT-II for a long time, select "SELF-DIAG RESULTS". In case a DTC other than P0744 is shown, refer to applicable "TROUBLE DIAGNOSIS FOR DTC".
3. Make sure that "OK" is displayed. (If "NG" is displayed, refer to [AT-132, "Diagnostic Procedure"](#).) Refer to shift schedule, [AT-65, "Vehicle Speed at Which Lock-Up Occurs/Releases"](#).

#### WITH GST

Follow the procedure "WITH CONSULT-II".

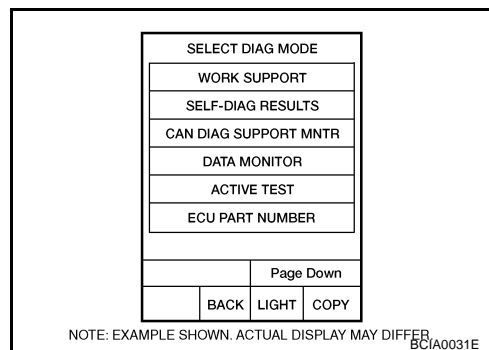

# DTC P0744 A/T TCC S/V FUNCTION (LOCK-UP)

ACS008FV

## Diagnostic Procedure

### 1. CHECK INPUT SIGNAL

#### With CONSULT-II

1. Turn ignition switch ON. (Do not start engine.)
2. Select "MAIN SIGNALS" in "DATA MONITOR" mode for "A/T" with CONSULT-II.
3. Start the engine.
4. Read out the value of "TCC SOLENOID" while driving.

Item name	Condition	Display value (Approx.)
TCC SOLENOID	When performing slip lock-up	0.2 - 0.4 A
	When performing lock-up	0.4 - 0.6 A

DATA MONITOR	
MONITOR	NO DTC
TCC SOLENOID	XXXX
LINE PRES SOL	XXXX
I/C SOLENOID	XXXX
FR/B SOLENOID	XXXX
D/C SOLENOID	XXXX
HLR/C SOL	XXXX
	▽
	RECORD
MODE	BACK
LIGHT	COPY

SCIA4793E

#### OK or NG

- OK >> GO TO 4.  
NG >> GO TO 2.

### 2. CHECK TCM POWER SUPPLY AND GROUND CIRCUIT

Check TCM power supply and ground circuit. Refer to [AT-186, "MAIN POWER SUPPLY AND GROUND CIRCUIT"](#).

#### OK or NG

- OK >> GO TO 3.  
NG >> Repair or replace damaged parts.

### 3. DETECT MALFUNCTIONING ITEM

Check the following.

- A/T assembly harness connector pin terminals for damage or loose connection with harness connector.

#### OK or NG

- OK >> Replace control valve with TCM. Refer to [AT-248, "Control Valve with TCM and A/T Fluid Temperature Sensor 2"](#).  
NG >> Repair or replace damaged parts.

### 4. CHECK DTC

Perform "DTC Confirmation Procedure".

- Refer to [AT-131, "DTC Confirmation Procedure"](#).

#### OK or NG

- OK >> **INSPECTION END**  
NG >> GO TO 2.

# DTC P0745 LINE PRESSURE SOLENOID VALVE

## DTC P0745 LINE PRESSURE SOLENOID VALVE

PFP:31940

### Description

ACS005YN

The line pressure solenoid valve regulates the oil pump discharge pressure to suit the driving condition in response to a signal sent from the TCM.

### CONSULT-II Reference Value

ACS005YO

Item name	Condition	Display value (Approx.)
LINE PRES SOL	During driving	0.2 - 0.6A

### On Board Diagnosis Logic

ACS005YP

- This is an OBD-II self-diagnostic item.
- Diagnostic trouble code "P0745 L/PRESS SOL/CIRC" with CONSULT-II or 4th judgement flicker without CONSULT-II is detected under the following conditions.
  - When TCM detects an improper voltage drop when it tries to operate the solenoid valve.
  - When TCM detects as irregular by comparing target value with monitor value.

### Possible Cause

ACS005YQ

- Harness or connectors.  
(Solenoid circuit is open or shorted.)
- Line pressure solenoid valve.

### DTC Confirmation Procedure

ACS005YR

#### NOTE:

If "DTC Confirmation Procedure" has been previously performed, always turn ignition switch OFF and wait at least 10 seconds before performing the next test.

After the repair, perform the following procedure to confirm the malfunction is eliminated.

#### Ⓟ WITH CONSULT-II

1. Turn ignition switch ON. (Do not start engine.)
2. Select "MAIN SIGNALS" in "DATA MONITOR" mode for "A/T" with CONSULT-II.
3. Touch "START".
4. Engine start and wait for at least 5 seconds.
5. If DTC is detected, go to [AT-134. "Diagnostic Procedure"](#).

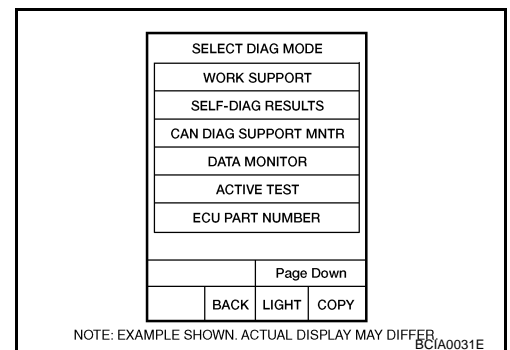

#### Ⓢ WITH GST

Follow the procedure "WITH CONSULT-II".

# DTC P0745 LINE PRESSURE SOLENOID VALVE

ACS008FW

## Diagnostic Procedure

### 1. CHECK INPUT SIGNAL

#### With CONSULT-II

1. Turn ignition switch ON. (Do not start engine.)
2. Select "MAIN SIGNALS" in "DATA MONITOR" mode for "A/T" with CONSULT-II.
3. Start the engine.
4. Read out the value of "LINE PRES SOL" while driving.

Item name	Condition	Display value (Approx.)
LINE PRES SOL	During driving	0.2 - 0.6 A

#### OK or NG

- OK >> GO TO 4.  
NG >> GO TO 2.

DATA MONITOR	
MONITOR	NO DTC
TCC SOLENOID	XXXX
LINE PRES SOL	XXXX
I/C SOLENOID	XXXX
FR/B SOLENOID	XXXX
D/C SOLENOID	XXXX
HLR/C SOL	XXXX
	▽
	RECORD
MODE	BACK
LIGHT	COPY

SCIA4793E

### 2. CHECK TCM POWER SUPPLY AND GROUND CIRCUIT

Check TCM power supply and ground circuit. Refer to [AT-186, "MAIN POWER SUPPLY AND GROUND CIRCUIT"](#).

#### OK or NG

- OK >> GO TO 3.  
NG >> Repair or replace damaged parts.

### 3. DETECT MALFUNCTIONING ITEM

Check the following.

- A/T assembly harness connector pin terminals for damage or loose connection with harness connector.

#### OK or NG

- OK >> Replace control valve with TCM. Refer to [AT-248, "Control Valve with TCM and A/T Fluid Temperature Sensor 2"](#).
- NG >> Repair or replace damaged parts.

### 4. CHECK DTC

Perform "DTC Confirmation Procedure".

- Refer to [AT-133, "DTC Confirmation Procedure"](#).

#### OK or NG

- OK >> **INSPECTION END**  
NG >> GO TO 2.

# DTC P1702 TRANSMISSION CONTROL MODULE (RAM)

## DTC P1702 TRANSMISSION CONTROL MODULE (RAM)

PFP:31036

### Description

ACS005YY

The TCM consists of a microcomputer and connectors for signal input and output and for power supply. The TCM controls the A/T.

### On Board Diagnosis Logic

ACS005YZ

- This is not an OBD-II self-diagnostic item.
- Diagnostic trouble code "P1702 TCM·RAM" with CONSULT-II is detected when TCM memory RAM is malfunctioning.

### Possible Cause

ACS005Z0

TCM.

### DTC Confirmation Procedure

ACS005Z1

#### NOTE:

If "DTC Confirmation Procedure" has been previously performed, always turn ignition switch OFF and wait at least 10 seconds before performing the next test.

After the repair, perform the following procedure to confirm the malfunction is eliminated.

#### WITH CONSULT-II

1. Turn ignition switch ON. (Do not start engine.)
2. Select "ECU INPUT SIGNALS" or "MAIN SIGNALS" in "DATA MONITOR" mode for "A/T" with CONSULT-II.
3. Touch "START".
4. Start engine.
5. Run engine for at least 2 consecutive seconds at idle speed.
6. If DTC is detected, go to [AT-135, "Diagnostic Procedure"](#).

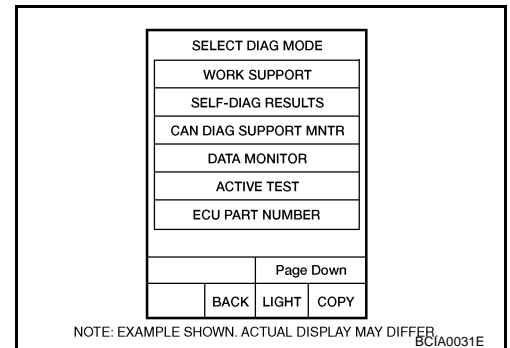

## Diagnostic Procedure

ACS008FX

### 1. CHECK DTC

#### With CONSULT-II

1. Turn ignition switch ON. (Do not start engine.)
2. Select "SELF-DIAG RESULTS" mode for "A/T" with CONSULT-II.
3. Touch "ERASE".
4. Turn ignition switch OFF and wait at least 10 seconds.
5. Perform "DTC confirmation procedure". Refer to [AT-135, "DTC Confirmation Procedure"](#).

Is the "P1702 TCM·RAM" displayed again?

YES >> Replace control valve with TCM. Refer to [AT-248, "Control Valve with TCM and A/T Fluid Temperature Sensor 2"](#).

NO >> **INSPECTION END**

# DTC P1703 TRANSMISSION CONTROL MODULE (ROM)

## DTC P1703 TRANSMISSION CONTROL MODULE (ROM)

PFP:31036

### Description

ACS005Z3

The TCM consists of a microcomputer and connectors for signal input and output and for power supply. The TCM controls the A/T.

### On Board Diagnosis Logic

ACS005Z4

- This is not an OBD-II self-diagnostic item.
- Diagnostic trouble code "P1703 TCM-ROM" with CONSULT-II is detected when TCM memory ROM is malfunctioning.

### Possible Cause

ACS005Z5

TCM.

### DTC Confirmation Procedure

ACS005Z6

#### NOTE:

If "DTC Confirmation Procedure" has been previously performed, always turn ignition switch OFF and wait at least 10 seconds before performing the next test.

After the repair, perform the following procedure to confirm the malfunction is eliminated.

#### ④ WITH CONSULT-II

1. Turn ignition switch ON. (Do not start engine.)
2. Select "ECU INPUT SIGNALS" or "MAIN SIGNALS" in "DATA MONITOR" mode for "A/T" with CONSULT-II.
3. Touch "START".
4. Start engine.
5. Run engine for at least 2 consecutive seconds at idle speed.
6. If DTC is detected, go to [AT-136, "Diagnostic Procedure"](#).

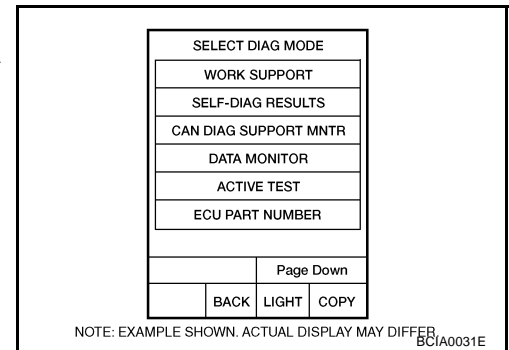

## Diagnostic Procedure

ACS008FY

### 1. CHECK DTC

#### ④ With CONSULT-II

1. Turn ignition switch ON. (Do not start engine.)
2. Select "SELF-DIAG RESULTS" mode for "A/T" with CONSULT-II.
3. Touch "ERASE".
4. Turn ignition switch OFF and wait at least 10 seconds.
5. Perform "DTC confirmation procedure". Refer to [AT-136, "DTC Confirmation Procedure"](#).

Is the "P1703 TCM-ROM" displayed again?

YES >> Replace control valve with TCM. Refer to [AT-248, "Control Valve with TCM and A/T Fluid Temperature Sensor 2"](#).

NO >> **INSPECTION END**



# DTC P1705 THROTTLE POSITION SENSOR

## DTC P1705 THROTTLE POSITION SENSOR

PFP:22620

### Description

ACS005ZD

Electric throttle control actuator consists of throttle control motor, accelerator pedal position sensor, throttle position sensor, etc. The actuator sends a signal to the ECM, and ECM sends signals to TCM with CAN communication.

### CONSULT-II Reference Value

ACS006CF

Item name	Condition	Display value (Approx.)
ACCELE POSI	Released accelerator pedal.	0.0/8
	Fully depressed accelerator pedal.	8/8

### On Board Diagnosis Logic

ACS005ZE

- This is an OBD-II self-diagnostic item.
- Diagnostic trouble code “P1705 TP SEN/CIRC A/T” with CONSULT-II or 15th judgement flicker without CONSULT-II is detected when TCM does not receive the proper accelerator pedal position signals (input by CAN communication) from ECM.

### Possible Cause

ACS005ZF

Harness or connectors.  
(Sensor circuit is open or shorted.)

### DTC Confirmation Procedure

ACS005ZG

#### NOTE:

If “DTC Confirmation Procedure” has been previously performed, always turn ignition switch OFF and wait at least 10 seconds before performing the next test.

After the repair, perform the following procedure to confirm the malfunction is eliminated.

#### WITH CONSULT-II

1. Turn ignition switch ON. (Do not start engine.)
2. Select “ECU INPUT SIGNALS” in “DATA MONITOR” mode for “A/T” with CONSULT-II.
3. Touch “START”.
4. Start engine and let it idle for 1 second.
5. If DTC is detected, go to [AT-138, "Diagnostic Procedure"](#).

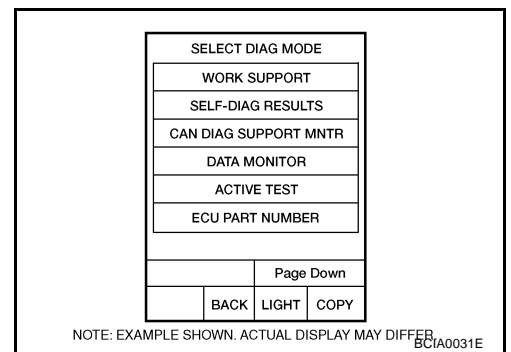

#### WITH GST

Follow the procedure “WITH CONSULT-II”.

# DTC P1705 THROTTLE POSITION SENSOR

ACS008FZ

## Diagnostic Procedure

### 1. CHECK CAN COMMUNICATION LINE

Perform self-diagnosis. Refer to [AT-95, "SELF-DIAGNOSTIC RESULT MODE"](#) , [AT-105, "Diagnostic Procedure without CONSULT-II"](#) .

Is a malfunction in the CAN communication indicated in the results?

- YES >> Check CAN communication line. Refer to [AT-110, "DTC U1000 CAN COMMUNICATION LINE"](#) .
- NO >> GO TO 2.

### 2. CHECK DTC WITH TCM

#### With CONSULT-II

1. Turn ignition switch ON. (Do not start engine.)
2. Select "ECU INPUT SIGNALS" in "DATA MONITOR" mode for "A/T" with CONSULT-II.
3. Depress accelerator pedal and read out the value of "ACCELE POSI".

Item name	Condition	Display value (Approx.)
ACCELE POSI	Released accelerator pedal.	0.0/8
	Fully depressed accelerator pedal.	8/8

DATA MONITOR			
MONITOR	NO DTC		
ACCELE POSI	0.0/8		
THROTTLE POSI	0.0/8		
CLSD THL POS	ON		
W/OTHL POS	OFF		
BRAKE SW	OFF		
▽			
RECORD			
MODE	BACK	LIGHT	COPY

PCIA0070E

4. Select "SELF-DIAG RESULTS" mode for "A/T" with CONSULT-II. Refer to [AT-95, "SELF-DIAGNOSTIC RESULT MODE"](#)

OK or NG

- OK >> GO TO 4.
- NG >> GO TO 3.

### 3. CHECK DTC WITH ECM

#### With CONSULT-II

1. Turn ignition switch ON. (Do not start engine.)
2. Select "SELF-DIAG RESULTS" mode for "ENGINE" with CONSULT-II. Refer to [EC-137, "CONSULT-II Function \(ENGINE\)"](#) .

OK or NG

- OK >> GO TO 4.
- NG >> Check the DTC detected item. Refer to [EC-137, "CONSULT-II Function \(ENGINE\)"](#) .
  - If CAN communication line is detected, go to [AT-110, "DTC U1000 CAN COMMUNICATION LINE"](#) .

SELECT SYSTEM			
ENGINE			
A/T			
ABS			
AIR BAG			
IPDM E/R			
BCM			
			Page Down
BACK	LIGHT	COPY	

NOTE: EXAMPLE SHOWN. ACTUAL DISPLAY MAY DIFFER. BCIA0030E

### 4. CHECK DTC

Perform "DTC Confirmation Procedure".

- Refer to [AT-137, "DTC Confirmation Procedure"](#) .

OK or NG

- OK >> **INSPECTION END**
- NG >> GO TO 5.

# DTC P1705 THROTTLE POSITION SENSOR

---

## 5. CHECK TCM POWER SUPPLY AND GROUND CIRCUIT

---

Check TCM power supply and ground circuit. Refer to [AT-186, "MAIN POWER SUPPLY AND GROUND CIRCUIT"](#) .

OK or NG

- OK >> GO TO 6.
- NG >> Repair or replace damaged parts.

---

## 6. DETECT MALFUNCTIONING ITEM

---

Check the following.

- A/T assembly harness connector pin terminals for damage or loose connection with harness connector.

OK or NG

- OK >> Replace control valve with TCM. Refer to [AT-248, "Control Valve with TCM and A/T Fluid Temperature Sensor 2"](#) .
- NG >> Repair or replace damaged parts.

A  
B  
AT  
D  
E  
F  
G  
H  
I  
J  
K  
L  
M

# DTC P1710 A/T FLUID TEMPERATURE SENSOR CIRCUIT

## DTC P1710 A/T FLUID TEMPERATURE SENSOR CIRCUIT

PFP:31940

### Description

ACS005ZJ

The A/T fluid temperature sensor detects the A/T fluid temperature and sends a signal to the TCM.

### CONSULT-II Reference Value

ACS005ZJ

Item name	Condition °C (°F)	Display value (Approx.)
ATF TEMP SE 1	0 (32) - 20 (68) - 80 (176)	3.3 - 2.7 - 0.9 V
ATF TEMP SE 2		3.3 - 2.5 - 0.7 V

### On Board Diagnosis Logic

ACS005ZK

- This is an OBD-II self-diagnostic item.
- Diagnostic trouble code "P1710 (A/T), P0710 (ENGINE) ATF TEMP SEN/CIRC" with CONSULT-II or 10th judgement flicker without CONSULT-II is detected when TCM receives an excessively low or high voltage from the sensor.

### Possible Cause

ACS005ZL

- Harness or connectors.  
(Sensor circuit is open or shorted.)
- A/T fluid temperature sensors 1 and/or 2.

### DTC Confirmation Procedure

ACS005ZM

#### CAUTION:

Always drive vehicle at a safe speed.

#### NOTE:

If "DTC Confirmation Procedure" has been previously performed, always turn ignition switch OFF and wait at least 10 seconds before performing the next test.

After the repair, perform the following procedure to confirm the malfunction is eliminated.

#### WITH CONSULT-II

1. Turn ignition switch ON. (Do not start engine.)
2. Select "SELECTION FROM MENU" in "DATA MONITOR" mode for "A/T" with CONSULT-II and check monitor "VHCL/S SE-A/T", "ACCELE POSI" and "SLCT LVR POSI".
3. Touch "START".
4. Start engine and maintain the following conditions for at least 10 minutes (Total). (It is not necessary to maintain continuously.)  
**VHCL/S SE-A/T: 10 km/h (6 MPH) or more**  
**ACCELE POSI: More than 1.0/8**  
**SLCT LVR POSI: "D" position**
5. If DTC is detected, go to [AT-142, "Diagnostic Procedure"](#).

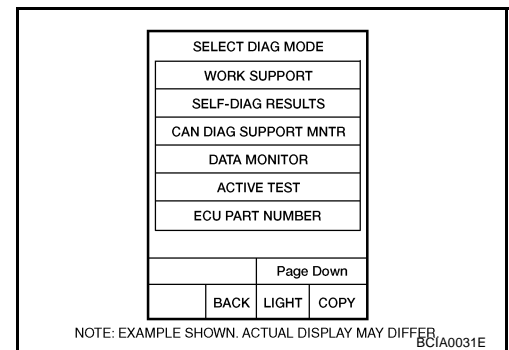

#### WITH GST

Follow the procedure "WITH CONSULT-II".

# DTC P1710 A/T FLUID TEMPERATURE SENSOR CIRCUIT

ACS0086D

## Wiring Diagram — AT — FTS

### AT-FTS-01

: DETECTABLE LINE FOR DTC  
 : NON-DETECTABLE LINE FOR DTC

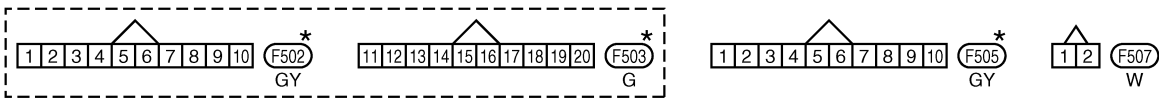
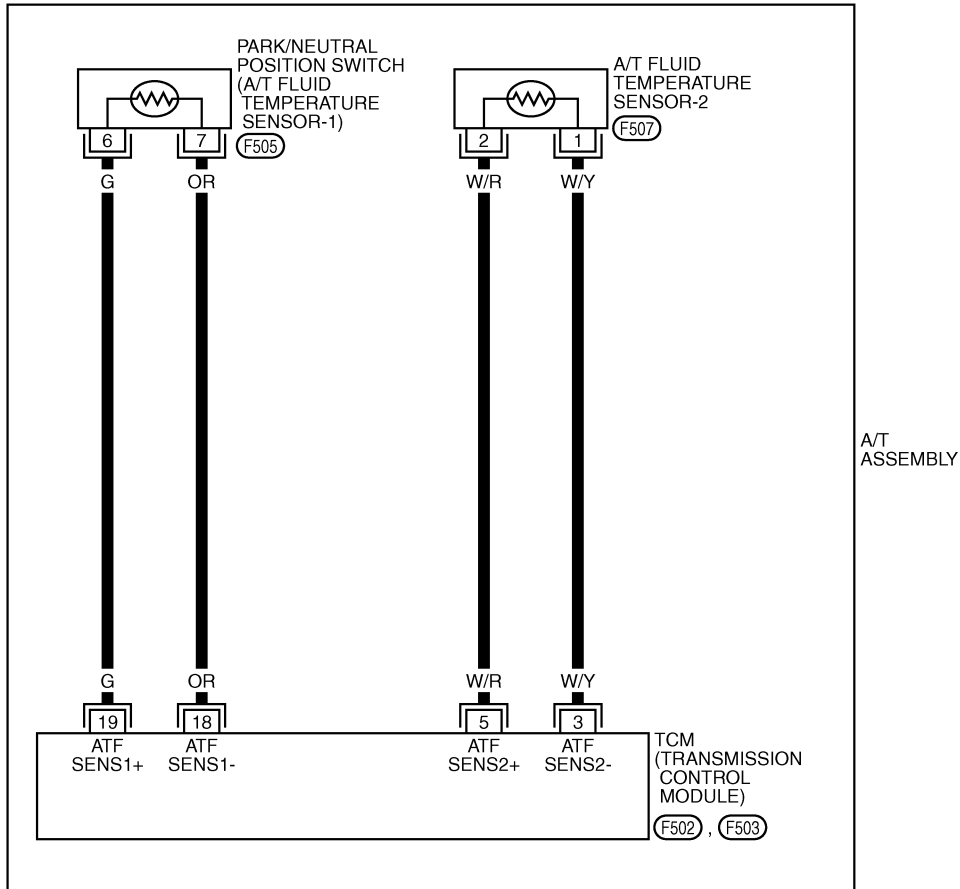

\*: THIS CONNECTOR IS NOT SHOWN IN "HARNESS LAYOUT", PG SECTION.

TCWM0251E

# DTC P1710 A/T FLUID TEMPERATURE SENSOR CIRCUIT

ACS008G0

## Diagnostic Procedure

### 1. CHECK A/T FLUID TEMPERATURE SENSOR 1 SIGNAL

#### With CONSULT-II

- Start engine.
- Select "ECU INPUT SIGNALS" in "DATA MONITOR" mode for "A/T" with CONSULT-II.
- Read out the value of "ATF TEMP SE 1".

Item name	Condition °C (°F)	Display value (Approx.)
ATF TEMP SE 1	0 (32) - 20 (68) - 80 (176)	3.3 - 2.7 - 0.9 V

#### OK or NG

- OK >> GO TO 2.  
NG >> GO TO 3.

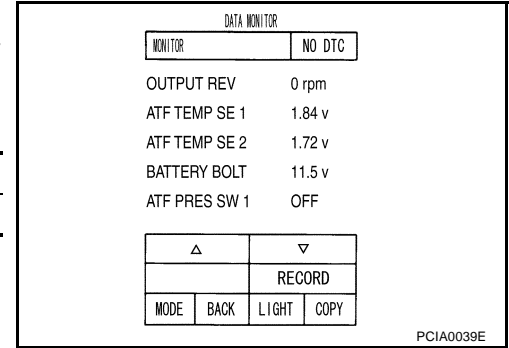

### 2. CHECK A/T FLUID TEMPERATURE SENSOR 2 SIGNAL

#### With CONSULT-II

- Start engine.
- Select "ECU INPUT SIGNALS" in "DATA MONITOR" mode for "A/T" with CONSULT-II.
- Read out the value of "ATF TEMP SE 2".

Item name	Condition °C (°F)	Display value (Approx.)
ATF TEMP SE 2	0 (32) - 20 (68) - 80 (176)	3.3 - 2.5 - 0.7 V

#### OK or NG

- OK >> GO TO 8.  
NG >> GO TO 5.

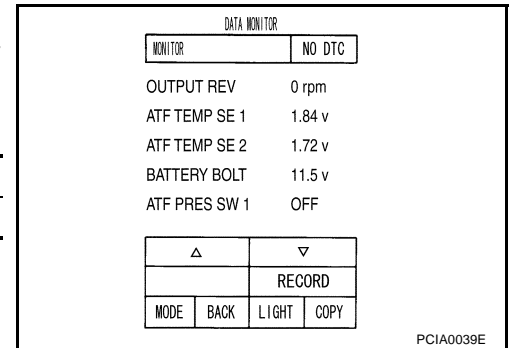

### 3. CHECK A/T FLUID TEMPERATURE SENSOR 1

Check A/T fluid temperature sensor 1. Refer to [AT-144, "A/T FLUID TEMPERATURE SENSOR 1"](#).

#### OK or NG

- OK >> GO TO 4.  
NG >> Replace control valve with TCM. Refer to [AT-248, "Control Valve with TCM and A/T Fluid Temperature Sensor 2"](#).

### 4. CHECK SUB-HARNESS

- Disconnect park/neutral position switch connector and TCM connector.
- Check continuity between park/neutral position switch connector terminals and TCM connector terminals.

Item	Connector	Terminal (Wire color)	Continuity
Park/neutral position switch connector	F505	6 (G)	Yes
TCM connector	F503	19 (G)	
Park/neutral position switch connector	F505	7 (OR)	Yes
TCM connector	F503	18 (OR)	

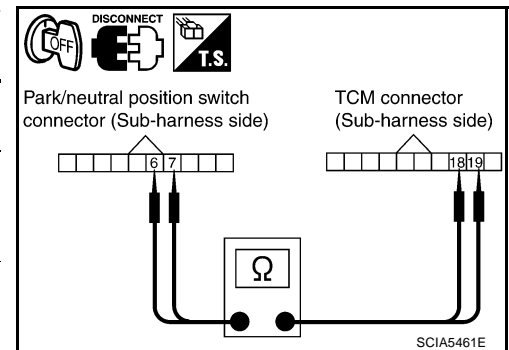

- If OK, check harness for short to ground and short to power.

#### OK or NG

- OK >> GO TO 7.  
NG >> Replace open circuit or short to ground and short to power in harness or connectors.

# DTC P1710 A/T FLUID TEMPERATURE SENSOR CIRCUIT

## 5. CHECK A/T FLUID TEMPERATURE SENSOR 2

Check A/T fluid temperature sensor 2. Refer to [AT-144, "A/T FLUID TEMPERATURE SENSOR 2"](#) .

OK or NG

OK >> GO TO 6.

NG >> Replace A/T fluid temperature sensor 2. Refer to [AT-256, "A/T FLUID TEMPERATURE SENSOR 2 REMOVAL AND INSTALLATION"](#) .

## 6. CHECK TERMINAL CORD ASSEMBLY

1. Disconnect A/T fluid temperature sensor 2 connector and TCM connector.
2. Check continuity between A/T fluid temperature sensor 2 connector terminals and TCM connector terminals.

Item	Connector	Terminal (Wire color)	Continuity
A/T fluid temperature sensor 2 connector	F507	1 (W/Y)	Yes
TCM connector	F502	3 (W/Y)	
A/T fluid temperature sensor 2 connector	F507	2 (W/R)	Yes
TCM connector	F502	5 (W/R)	

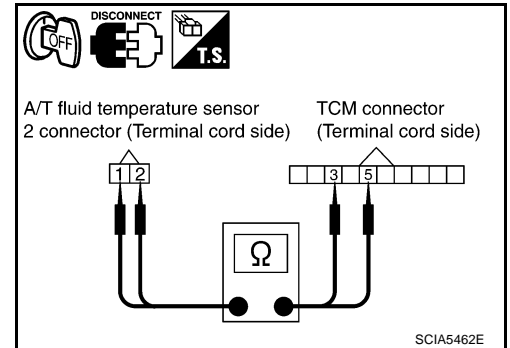

3. If OK, check harness for short to ground and short to power.

OK or NG

OK >> GO TO 7.

NG >> Replace open circuit or short to ground and short to power in harness or connectors.

## 7. CHECK TCM POWER SUPPLY AND GROUND CIRCUIT

1. Check TCM power supply and ground circuit. Refer to [AT-186, "MAIN POWER SUPPLY AND GROUND CIRCUIT"](#) .
2. Reinstall any part removed.

OK or NG

OK >> Replace control valve with TCM. Refer to [AT-248, "Control Valve with TCM and A/T Fluid Temperature Sensor 2"](#) .

NG >> Repair or replace damaged parts.

## 8. CHECK DTC

Perform "DTC Confirmation Procedure".

- Refer to [AT-110, "DTC Confirmation Procedure"](#) .

OK or NG

OK >> **INSPECTION END**

NG >> GO TO 1.

# DTC P1710 A/T FLUID TEMPERATURE SENSOR CIRCUIT

ACS008G1

## Component Inspection

### A/T FLUID TEMPERATURE SENSOR 1

1. Remove control valve with TCM. Refer to [AT-248, "Control Valve with TCM and A/T Fluid Temperature Sensor 2"](#) .
2. Check resistance between terminals.

Name	Connector	Terminal	Temperature °C (°F)	Resistance (Approx.) (kΩ)
A/T fluid temperature sensor 1	F505	6 - 7	0 (32)	15
			20 (68)	6.5
			80 (176)	0.9

3. If NG, replace control valve with TCM. Refer to [AT-248, "Control Valve with TCM and A/T Fluid Temperature Sensor 2"](#) .

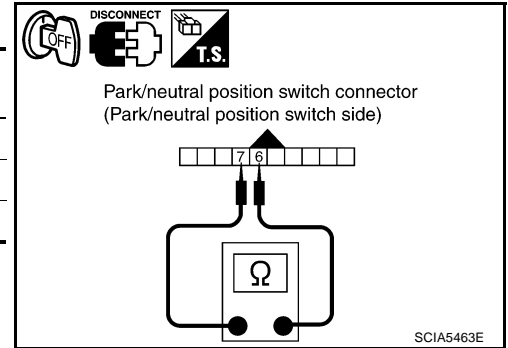

### A/T FLUID TEMPERATURE SENSOR 2

1. Remove A/T fluid temperature sensor 2. Refer to [AT-256, "A/T FLUID TEMPERATURE SENSOR 2 REMOVAL AND INSTALLATION"](#) .
2. Check resistance between terminals.

Name	Connector	Terminal	Temperature °C (°F)	Resistance (Approx.) (kΩ)
A/T fluid temperature sensor 2	F507	1 - 2	0 (32)	10
			20 (68)	4
			80 (176)	0.5

3. If NG, replace A/T fluid temperature sensor 2. Refer to [AT-256, "A/T FLUID TEMPERATURE SENSOR 2 REMOVAL AND INSTALLATION"](#) .

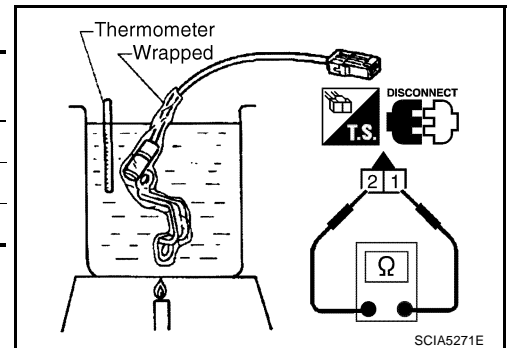



# DTC P1716 TURBINE REVOLUTION SENSOR

## DTC P1716 TURBINE REVOLUTION SENSOR

PFP:31935

### Description

ACS005Z0

The turbine revolution sensor detects input shaft rpm (revolutions per minute). It is located on the input side of the automatic transmission. Monitors revolution of sensor 1 and sensor 2 for non-standard conditions.

### CONSULT-II Reference Value

ACS005ZP

Item name	Condition	Display value
TURBINE REV	During driving (lock-up ON)	Approximately matches the engine speed.

### On Board Diagnosis Logic

ACS005ZQ

- This is an OBD-II self-diagnostic item.
- Diagnostic trouble code “P1716 TURBINE REV S/CIRC” with CONSULT-II or 11th judgement flicker without CONSULT-II is detected under the following conditions.
  - When TCM does not receive the proper voltage signal from the sensor.
  - When TCM detects an irregularity only at position of 4th gear for turbine revolution sensor 2.

### Possible Cause

ACS005ZR

- Harness or connectors.  
(Sensor circuit is open or shorted.)
- Turbine revolution sensor 1 and/or 2.

### DTC Confirmation Procedure

ACS005ZS

#### CAUTION:

- Always drive vehicle at a safe speed.
- Be careful not to rev engine into the red zone on the tachometer.

#### NOTE:

If “DTC Confirmation Procedure” has been previously performed, always turn ignition switch OFF and wait at least 10 seconds before performing the next test.

After the repair, perform the following procedure to confirm the malfunction is eliminated.

#### WITH CONSULT-II

1. Turn ignition switch ON. (Do not start engine.)
2. Select “SELECTION FROM MENU” in “DATA MONITOR” mode for “A/T” with CONSULT-II and check monitor “VHCL/S SE-A/T”, “ENGINE SPEED”, “ACCELE POSI”, “SLCT LVR POSI” and “GEAR”.
3. Touch “START”.
4. Start engine and maintain the following conditions for at least 5 consecutive seconds.
  - VHCL/S SE-A/T: 40 km/h (25 MPH) or more**
  - ENGINE SPEED: 1,500 rpm or more**
  - ACCELE POSI: More than 0.5/8**
  - SLCT LVR POSI: “D” position**
  - GEAR (Turbine revolution sensor 1): “4” or “5” position**
  - GEAR (Turbine revolution sensor 2): All positions**
  - Driving location: Driving the vehicle uphill (increased engine load) will help maintain the driving conditions required for this test.**
5. If DTC is detected, go to [AT-146, "Diagnostic Procedure"](#).

#### WITH GST

Follow the procedure “WITH CONSULT-II”.

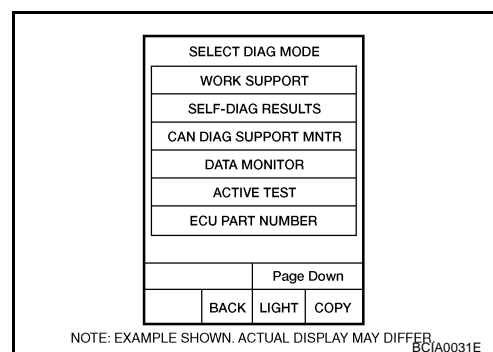

# DTC P1716 TURBINE REVOLUTION SENSOR

ACS008G2

## Diagnostic Procedure

### 1. CHECK INPUT SIGNAL

#### With CONSULT-II

1. Start engine.
2. Select "ECU INPUT SIGNALS" in "DATA MONITOR" mode for "A/T" with CONSULT-II.
3. Vehicle start and read out the value of "TURBINE REV".

Item name	Condition	Display value
TURBINE REV	During driving (lock-up ON)	Approximately matches the engine speed.

#### OK or NG

- OK >> GO TO 4.  
NG >> GO TO 2.

DATA MONITOR			
MONITOR	NO. DTC		
W/O THL POS	OFF		
BRAKE SW	OFF		
ENGINE SPEED	0 rpm		
TURBINE REV	0 rpm		
OUTPUT REV	0 rpm		
▼			
RECORD			
MODE	BACK	LIGHT	COPY

PCIA0041E

### 2. CHECK TCM POWER SUPPLY AND GROUND CIRCUIT

Check TCM power supply and ground circuit. Refer to [AT-186, "MAIN POWER SUPPLY AND GROUND CIRCUIT"](#).

#### OK or NG

- OK >> GO TO 3.  
NG >> Repair or replace damaged parts.

### 3. DETECT MALFUNCTIONING ITEM

Check the following.

- A/T assembly harness connector pin terminals for damage or loose connection with harness connector.

#### OK or NG

- OK >> Replace control valve with TCM. Refer to [AT-248, "Control Valve with TCM and A/T Fluid Temperature Sensor 2"](#).
- NG >> Repair or replace damaged parts.

### 4. CHECK DTC

Perform "DTC Confirmation Procedure".

- Refer to [AT-145, "DTC Confirmation Procedure"](#).

#### OK or NG

- OK >> **INSPECTION END**  
NG >> GO TO 2.

# DTC P1721 VEHICLE SPEED SENSOR MTR

## DTC P1721 VEHICLE SPEED SENSOR MTR

PFP:24814

### Description

ACS005ZU

The vehicle speed sensor-MTR signal is transmitted from combination meter to TCM by CAN communication line. The signal functions as an auxiliary device to the revolution sensor when it is malfunctioning. The TCM will then use the vehicle speed sensor-MTR signal.

### CONSULT-II Reference Value

ACS005ZV

Item name	Condition	Display value
VHCL/S SE-MTR	During driving	Approximately matches the speedometer reading.

### On Board Diagnosis Logic

ACS005ZW

- This is not an OBD-II self-diagnostic item.
- Diagnostic trouble code "P1721 VHE SPD SE/CIR-MTR" with CONSULT-II is detected when TCM does not receive the proper vehicle speed sensor MTR signal (input by CAN communication) from combination meter.

### Possible Cause

ACS005ZX

Harness or connectors.  
(Sensor circuit is open or shorted.)

### DTC Confirmation Procedure

ACS005ZY

#### CAUTION:

Always drive vehicle at a safe speed.

#### NOTE:

If "DTC Confirmation Procedure" has been previously performed, always turn ignition switch OFF and wait at least 10 seconds before performing the next test.

After the repair, perform the following procedure to confirm the malfunction is eliminated.

#### Ⓟ WITH CONSULT-II

1. Turn ignition switch ON. (Do not start engine.)
2. Select "ECU INPUT SIGNALS" in "DATA MONITOR" mode for "A/T" with CONSULT-II.
3. Touch "START".
4. Start engine and maintain the following conditions for at least 5 consecutive seconds.  
**ACCELE POSI: 1.0/8 or less**  
**VHCL/S SE-MTR: 30 km/h (17 MPH) or more**
5. If DTC is detected, go to [AT-148, "Diagnostic Procedure"](#).

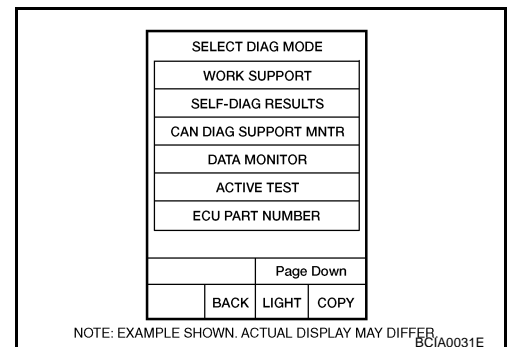

# DTC P1721 VEHICLE SPEED SENSOR MTR

ACS008G3

## Diagnostic Procedure

### 1. CHECK CAN COMMUNICATION LINE

Perform self-diagnosis. Refer to [AT-95, "SELF-DIAGNOSTIC RESULT MODE"](#) , [AT-105, "Diagnostic Procedure without CONSULT-II"](#) .

Is malfunction in the CAN communication indicated in the result?

- YES >> Check CAN communication line. Refer to [AT-110, "DTC U1000 CAN COMMUNICATION LINE"](#) .
- NO >> GO TO 2.

### 2. CHECK INPUT SIGNAL

#### With CONSULT-II

1. Start engine.
2. Select "ECU INPUT SIGNALS" in "DATA MONITOR" mode for "A/T" with CONSULT-II.
3. Drive vehicle and read out the value of "VHCL/S SE·MTR".

Item name	Condition	Display value
VHCL/S SE·MTR	During driving	Approximately matches the speedometer reading.

OK or NG

- OK >> GO TO 4.
- NG >> GO TO 3.

DATA MONITOR	
MONITOR	NO DTC
VHCL/S SE·A/T	0km/h
VHCL/S SE·MTR	0km/h
ACCELE POSI	0.0/8
THROTTLE POS	0.0/8
CLSD THL POS	ON
W/O THL POS	OFF
	▽
	RECORD
MODE	BACK
LIGHT	COPY

SCIA2148E

### 3. CHECK COMBINATION METERS

Check combination meters. Refer to [DI-12, "Trouble Diagnosis"](#) .

OK or NG

- OK >> GO TO 4.
- NG >> Repair or replace damaged parts.

### 4. CHECK DTC

Perform "DTC Confirmation Procedure".

- Refer to [AT-147, "DTC Confirmation Procedure"](#) .

OK or NG

- OK >> **INSPECTION END**
- NG >> GO TO 5.

### 5. CHECK TCM POWER SUPPLY AND GROUND CIRCUIT

Check TCM power supply and ground circuit. Refer to [AT-186, "MAIN POWER SUPPLY AND GROUND CIRCUIT"](#) .

OK or NG

- OK >> GO TO 6.
- NG >> Repair or replace damaged parts.

### 6. DETECT MALFUNCTIONING ITEM

Check the following.

- A/T assembly harness connector pin terminals for damage or loose connection with harness connector.

OK or NG

- OK >> Replace control valve with TCM. Refer to [AT-248, "Control Valve with TCM and A/T Fluid Temperature Sensor 2"](#) .
- NG >> Repair or replace damaged parts.

# DTC P1730 A/T INTERLOCK

## DTC P1730 A/T INTERLOCK

PFP:00000

### Description

ACS00600

- Fail-safe function to detect interlock conditions.

### On Board Diagnosis Logic

ACS00601

- This is an OBD-II self-diagnostic item.
- Diagnostic trouble code "P1730 A/T INTERLOCK" with CONSULT-II or 12th judgement flicker without CONSULT-II is detected when TCM does not receive the proper voltage signal from the sensor and switch.
- TCM monitors and compares gear position and conditions of each ATF pressure switch when gear is steady.

### Possible Cause

ACS00602

- Harness or connectors.  
(Solenoid and switch circuit is open or shorted.)
- Low coast brake solenoid valve.
- ATF pressure switch 2.

### DTC Confirmation Procedure

ACS00603

#### CAUTION:

Always drive vehicle at a safe speed.

#### NOTE:

If "DTC Confirmation Procedure" has been previously performed, always turn ignition switch OFF and wait at least 10 seconds before performing the next test.

After the repair, perform the following procedure to confirm the malfunction is eliminated.

#### WITH CONSULT-II

1. Turn ignition switch ON. (Do not start engine.)
2. Select "MAIN SIGNALS" in "DATA MONITOR" mode for "A/T" with CONSULT-II.
3. Touch "START".
4. Start engine.
5. Drive vehicle and maintain the following conditions for at least 2 consecutive seconds.  
**SLCT LVR POSI: "D" position**
6. If DTC is detected, go to [AT-150, "Diagnostic Procedure"](#).

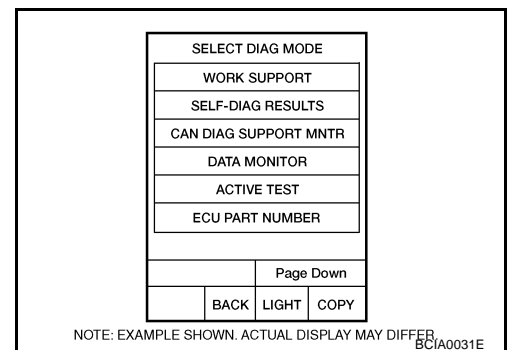

#### WITH GST

Follow the procedure "WITH CONSULT-II".

# DTC P1730 A/T INTERLOCK

ACS00604

## Judgement of A/T Interlock

When A/T Interlock is judged to be malfunctioning, the vehicle should be fixed in 2nd gear, and should be set in a condition in which it can travel.

When one of the following fastening patterns is detected, the fail-safe function in correspondence with the individual pattern should be performed.

### NOTE:

**When the vehicle is driven fixed in 2nd gear, a turbine revolution sensor malfunction is displayed, but this is not a turbine revolution sensor malfunction.**

## A/T INTERLOCK COUPLING PATTERN TABLE

●: NG, X: OK

Gear position		ATF pressure switch output					Fail-safe function	Clutch pressure output pattern after fail-safe function					
		SW3 (I/C)	SW6 (HLR/C)	SW5 (D/C)	SW1 (FR/B)	SW2 (LC/B)		I/C	HLR/C	D/C	FR/B	LC/B	L/U
A/T interlock coupling pattern	3rd	-	X	X	-	●	Held in 2nd gear	OFF	OFF	ON	OFF	OFF	OFF
	4th	-	X	X	-	●	Held in 2nd gear	OFF	OFF	ON	OFF	OFF	OFF
	5th	X	X	-	X	●	Held in 2nd gear	OFF	OFF	ON	OFF	OFF	OFF

## Diagnostic Procedure

ACS008G4

### 1. CHECK SELF-DIAGNOSTIC RESULTS

#### ④ With CONSULT-II

1. Drive vehicle.
2. Stop vehicle and turn ignition switch OFF.
3. Turn ignition switch ON. (Do not start engine.)
4. Select "SELF-DIAG RESULTS" mode for "A/T" with CONSULT-II.

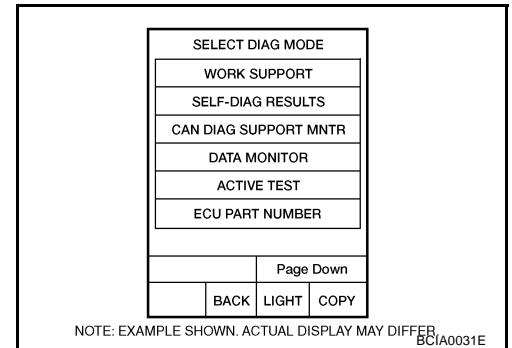

#### ⊗ Without CONSULT-II

1. Drive vehicle.
2. Stop vehicle and turn ignition switch OFF.
3. Turn ignition switch ON. (Do not start engine.)
4. Perform self-diagnosis. Refer to [AT-105, "TCM SELF-DIAGNOSTIC PROCEDURE \(NO TOOLS\)"](#).

#### OK or NG

- OK >> GO TO 2.  
 NG >> Check low coast brake solenoid valve circuit and function. Refer to [AT-170, "DTC P1772 LOW COAST BRAKE SOLENOID VALVE"](#), [AT-172, "DTC P1774 LOW COAST BRAKE SOLENOID VALVE FUNCTION"](#).

# DTC P1730 A/T INTERLOCK

---

## 2. CHECK DTC

---

Perform "DTC Confirmation Procedure".

- Refer to [AT-149, "DTC Confirmation Procedure"](#).

OK or NG

- OK >> **INSPECTION END**  
NG >> GO TO 3.

## 3. CHECK TCM POWER SUPPLY AND GROUND CIRCUIT

---

Check TCM power supply and ground circuit. Refer to [AT-186, "MAIN POWER SUPPLY AND GROUND CIRCUIT"](#).

OK or NG

- OK >> GO TO 4.  
NG >> Repair or replace damaged parts.

## 4. DETECT MALFUNCTIONING ITEM

---

Check the following.

- A/T assembly harness connector pin terminals for damage or loose connection with harness connector.

OK or NG

- OK >> Replace control valve with TCM. Refer to [AT-248, "Control Valve with TCM and A/T Fluid Temperature Sensor 2"](#).  
NG >> Repair or replace damaged parts.

A  
B  
AT  
D  
E  
F  
G  
H  
I  
J  
K  
L  
M

# DTC P1731 A/T 1ST ENGINE BRAKING

## DTC P1731 A/T 1ST ENGINE BRAKING

PFP:00000

### Description

ACS00606

Fail-safe function to prevent sudden decrease in speed by engine brake other than at M1 position.

### CONSULT-II Reference Value

ACS00607

Item name	Condition	Display value
ON OFF SOL	Low coast brake engaged. Refer to <a href="#">AT-20</a> .	ON
	Low coast brake disengaged. Refer to <a href="#">AT-20</a> .	OFF
ATF PRES SW 2	Low coast brake engaged. Refer to <a href="#">AT-20</a> .	ON
	Low coast brake disengaged. Refer to <a href="#">AT-20</a> .	OFF

### On Board Diagnosis Logic

ACS00608

- This is not an OBD-II self-diagnostic item.
- Diagnostic trouble code “P1731 A/T 1ST E/BRAKING” with CONSULT-II or 13th judgement flicker without CONSULT-II is detected under the following conditions.
  - When TCM does not receive the proper voltage signal from the sensor.
  - When TCM monitors each ATF pressure switch and solenoid monitor value, and detects as irregular when engine brake of 1st gear acts other than at M1 position.

### Possible Cause

ACS00609

- Harness or connectors.  
(Sensor circuit is open or shorted.)
- Low coast brake solenoid valve.
- ATF pressure switch 2.

### DTC Confirmation Procedure

ACS0060A

#### CAUTION:

- Always drive vehicle at a safe speed.
- Be careful not to rev engine into the red zone on the tachometer.

#### NOTE:

If “DTC Confirmation Procedure” has been previously preformed, always turn ignition switch OFF and wait at least 10 seconds before performing the next test.

After the repair, perform the following procedure to confirm the malfunction is eliminated.

#### WITH CONSULT-II

1. Turn ignition switch ON. (Do not start engine.)
2. Select “SELECTION FROM MENU” in “DATA MONITOR” mode for “A/T” with CONSULT-II and check monitor “ENGINE SPEED” , “MANU MODE SW” and “GEAR”.
3. Touch “START”.
4. Start engine.
5. Drive vehicle and maintain the following conditions for at least 2 consecutive seconds.  
**ENGINE SPEED: 1,200 rpm**  
**MANU MODE SW: ON**  
**GEAR: “1” position**
6. If DTC is detected, go to [AT-153, "Diagnostic Procedure"](#) .

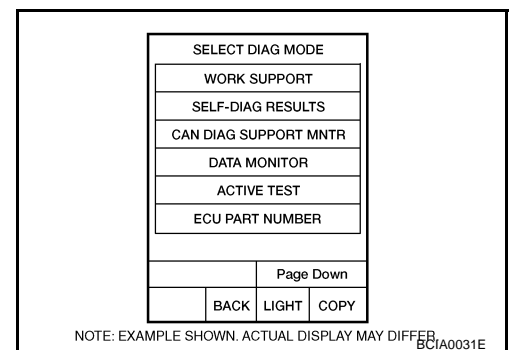



# DTC P1731 A/T 1ST ENGINE BRAKING

ACS008G5

## Diagnostic Procedure

### 1. CHECK INPUT SIGNALS

#### With CONSULT-II

1. Start the engine.
2. Select "SELECTION FROM MENU" in "DATA MONITOR" mode for "A/T" with CONSULT-II.
3. Drive vehicle in the "M" position (1st gear), and confirm the ON/OFF actuation of "ATF PRES SW 2" and "ON OFF SOL".

Item name	Condition	Display value
ON OFF SOL	Low coast brake engaged. Refer to <a href="#">AT-20</a> .	ON
	Low coast brake disengaged. Refer to <a href="#">AT-20</a> .	OFF
ATF PRES SW 2	Low coast brake engaged. Refer to <a href="#">AT-20</a> .	ON
	Low coast brake disengaged. Refer to <a href="#">AT-20</a> .	OFF

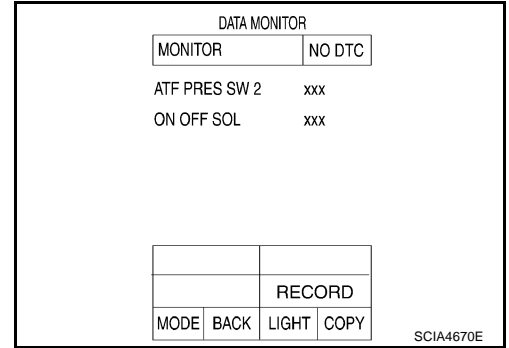

#### OK or NG

- OK >> GO TO 4.  
NG >> GO TO 2.

### 2. CHECK TCM POWER SUPPLY AND GROUND CIRCUIT

Check TCM power supply and ground circuit. Refer to [AT-186, "MAIN POWER SUPPLY AND GROUND CIRCUIT"](#) .

#### OK or NG

- OK >> GO TO 3.  
NG >> Repair or replace damaged parts.

### 3. DETECT MALFUNCTIONING ITEM

Check the following.

- A/T assembly harness connector pin terminals for damage or loose connection with harness connector.

#### OK or NG

- OK >> Replace control valve with TCM. Refer to [AT-248, "Control Valve with TCM and A/T Fluid Temperature Sensor 2"](#) .  
NG >> Repair or replace damaged parts.

### 4. CHECK DTC

Perform "DTC Confirmation Procedure".

- Refer to [AT-152, "DTC Confirmation Procedure"](#) .

#### OK or NG

- OK >> **INSPECTION END**  
NG >> GO TO 2.

# DTC P1752 INPUT CLUTCH SOLENOID VALVE

## DTC P1752 INPUT CLUTCH SOLENOID VALVE

PFP:31940

### Description

ACS0060C

Input clutch solenoid valve is controlled by the TCM in response to signals sent from the PNP switch, vehicle speed sensor and accelerator pedal position sensor (throttle position sensor). Gears will then be shifted to the optimum position.

### CONSULT-II Reference Value

ACS0060D

Item name	Condition	Display value (Approx)
I/C SOLENOID	Input clutch disengaged. Refer to <a href="#">AT-20</a> .	0.6 - 0.8A
	Input clutch engaged. Refer to <a href="#">AT-20</a> .	0 - 0.05A

### On Board Diagnosis Logic

ACS0060E

- This is an OBD-II self-diagnostic item.
- Diagnostic trouble code "P1752 I/C SOLENOID/CIRC" with CONSULT-II or 5th judgement without CONSULT-II is detected under the following conditions.
  - When TCM detects an improper voltage drop when it tries to operate the solenoid valve.
  - When TCM detects as irregular by comparing target value with monitor value.

### Possible Cause

ACS0060F

- Harness or connectors.  
(Solenoid circuit is open or shorted.)
- Input clutch solenoid valve.

### DTC Confirmation Procedure

ACS0060G

#### CAUTION:

Always drive vehicle at a safe speed.

#### NOTE:

If "DTC Confirmation Procedure" has been previously performed, always turn ignition switch OFF and wait at least 10 seconds before performing the next test.

After the repair, perform the following procedure to confirm the malfunction is eliminated.

#### WITH CONSULT-II

1. Turn ignition switch ON. (Do not start engine.)
2. Select "SELECTION FROM MENU" in "DATA MONITOR" mode for "A/T" with CONSULT-II and check monitor "ACCELE POSI", "SLCT LVR POSI" and "GEAR".
3. Touch "START".
4. Start engine.
5. Drive vehicle and maintain the following conditions for at least 5 consecutive seconds.

**ACCELE POSI: 1.5/8 - 2.0/8**

**SLCT LVR POSI: "D" position**

**GEAR: "3" ⇒ "4" (I/C ON/OFF)**

**Driving location: Driving the vehicle uphill (increased engine load) will help maintain the driving conditions required for this test.**

6. If DTC is detected go to [AT-155, "Diagnostic Procedure"](#) .

#### WITH GST

Follow the procedure "WITH CONSULT-II".

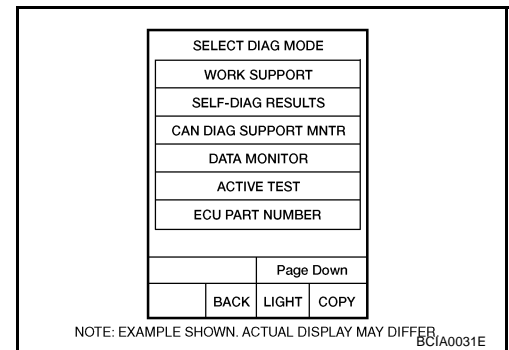

# DTC P1752 INPUT CLUTCH SOLENOID VALVE

ACS008G6

## Diagnostic Procedure

### 1. CHECK INPUT SIGNAL

#### With CONSULT-II

1. Turn ignition switch ON. (Do not start engine.)
2. Select "MAIN SIGNALS" in "DATA MONITOR" mode for "A/T" with CONSULT-II.
3. Start the engine.
4. Read out the value of "I/C SOLENOID" while driving.

Item name	Condition	Display value (Approx.)
I/C SOLENOID	Input clutch disengaged. Refer to <a href="#">AT-20</a> .	0.6 - 0.8 A
	Input clutch engaged. Refer to <a href="#">AT-20</a> .	0 - 0.05 A

DATA MONITOR	
MONITOR	NO DTC
TCC SOLENOID	XXXX
LINE PRES SOL	XXXX
I/C SOLENOID	XXXX
FR/B SOLENOID	XXXX
D/C SOLENOID	XXXX
HLR/C SOL	XXXX
	▽
	RECORD
MODE	BACK
LIGHT	COPY

SCIA4793E

#### OK or NG

- OK >> GO TO 4.  
NG >> GO TO 2.

### 2. CHECK TCM POWER SUPPLY AND GROUND CIRCUIT

Check TCM power supply and ground circuit. Refer to [AT-186, "MAIN POWER SUPPLY AND GROUND CIRCUIT"](#) .

#### OK or NG

- OK >> GO TO 3.  
NG >> Repair or replace damaged parts.

### 3. DETECT MALFUNCTIONING ITEM

Check the following.

- A/T assembly harness connector pin terminals for damage or loose connection with harness connector.

#### OK or NG

- OK >> Replace control valve with TCM. Refer to [AT-248, "Control Valve with TCM and A/T Fluid Temperature Sensor 2"](#) .  
NG >> Repair or replace damaged parts.

### 4. CHECK DTC

Perform "DTC Confirmation Procedure".

- Refer to [AT-154, "DTC Confirmation Procedure"](#) .

#### OK or NG

- OK >> **INSPECTION END**  
NG >> GO TO 2.

# DTC P1754 INPUT CLUTCH SOLENOID VALVE FUNCTION

## DTC P1754 INPUT CLUTCH SOLENOID VALVE FUNCTION

PF3:31940

### Description

ACS0060I

- Input clutch solenoid valve is controlled by the TCM in response to signals sent from the PNP switch, vehicle speed sensor and accelerator pedal position sensor (throttle position sensor). Gears will then be shifted to the optimum position.
- This is not only caused by electrical malfunction (circuits open or shorted) but also by mechanical malfunction such as control valve sticking, improper solenoid valve operation.

### CONSULT-II Reference Value

ACS0060J

Item name	Condition	Display value (Approx)
I/C SOLENOID	Input clutch disengaged. Refer to <a href="#">AT-20</a> .	0.6 - 0.8A
	Input clutch engaged. Refer to <a href="#">AT-20</a> .	0 - 0.05A
ATF PRES SW 3	Input clutch engaged. Refer to <a href="#">AT-20</a> .	ON
	Input clutch disengaged. Refer to <a href="#">AT-20</a> .	OFF

### On Board Diagnosis Logic

ACS0060K

- This is an OBD-II self-diagnostic item.
- Diagnostic trouble code “P1754 I/C SOLENOID FNCTN” with CONSULT-II or 5th judgement flicker without CONSULT-II is detected under the following conditions.
  - When TCM detects that actual gear ratio is irregular, and relation between gear position and condition of pressure switch 3 is irregular during depressing accelerator pedal. (Other than during shift change)
  - When TCM detects that relation between gear position and condition of ATF pressure switch 3 is irregular during releasing accelerator pedal. (Other than during shift change)

### Possible Cause

ACS0060L

- Harness or connectors.  
(Solenoid and switch circuits are open or shorted.)
- Input clutch solenoid valve.
- ATF pressure switch 3.

### DTC Confirmation Procedure

ACS0060M

#### CAUTION:

Always drive vehicle at a safe speed.

#### NOTE:

If “DTC Confirmation Procedure” has been previously performed, always turn ignition switch OFF and wait at least 10 seconds before performing the next test.

After the repair, perform the following procedure to confirm the malfunction is eliminated.

#### WITH CONSULT-II

1. Start engine.
2. Accelerate vehicle to maintain the following conditions.  
**ACCELE POSI: 1.5/8 - 2.0/8**  
**SLCTLVR POSI: “D” position**  
**GEAR: “3” ⇒ “4” (I/C ON/OFF)**  
**Driving location: Driving the vehicle uphill (increased engine load) will help maintain the driving conditions required for this test.**
3. Perform step “2” again.
4. Turn ignition switch “OFF”, then perform step “1” to “3” again.
5. Check “SELF-DIAG RESULTS” mode for “A/T” with CONSULT-II. If DTC (P1754) is detected, go to [AT-157, "Diagnostic Procedure"](#) .  
If DTC (P1752) is detected, go to [AT-155, "Diagnostic Procedure"](#) .  
If DTC (P1843) is detected, go to [AT-181, "Diagnostic Procedure"](#) .

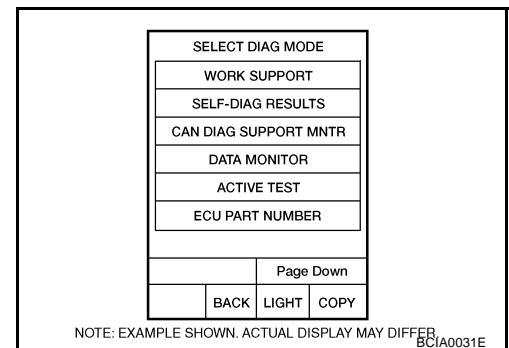

# DTC P1754 INPUT CLUTCH SOLENOID VALVE FUNCTION

## WITH GST

Follow the procedure "WITH CONSULT-II".

## Diagnostic Procedure

ACS008G7

### 1. CHECK INPUT SIGNALS

#### With CONSULT-II

1. Start engine.
2. Select "SELECTION FROM MENU" in "DATA MONITOR" mode for "A/T" with CONSULT-II.
3. Drive vehicle in "D" position (3rd ⇒ 4th gear), and confirm the ON/OFF actuation of "ATF PRES SW 3" and electrical current value of "I/C SOLENOID".

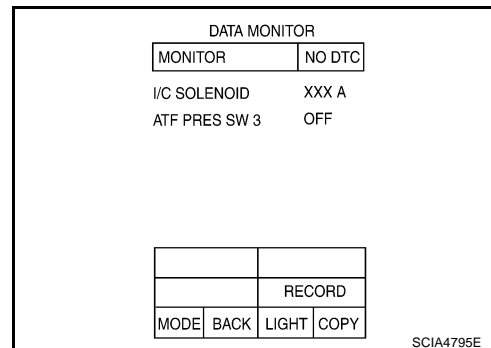

Item name	Condition	Display value (Approx.)
I/C SOLENOID	Input clutch disengaged. Refer to <a href="#">AT-20</a> .	0.6 - 0.8 A
	Input clutch engaged. Refer to <a href="#">AT-20</a> .	0 - 0.05 A
ATF PRES SW 3	Input clutch engaged. Refer to <a href="#">AT-20</a> .	ON
	Input clutch disengaged. Refer to <a href="#">AT-20</a> .	OFF

#### OK or NG

- OK >> GO TO 4.  
NG >> GO TO 2.

### 2. CHECK TCM POWER SUPPLY AND GROUND CIRCUIT

Check TCM power supply and ground circuit. Refer to [AT-186, "MAIN POWER SUPPLY AND GROUND CIRCUIT"](#) .

#### OK or NG

- OK >> GO TO 3.  
NG >> Repair or replace damaged parts.

### 3. DETECT MALFUNCTIONING ITEM

Check the following.

- A/T assembly harness connector pin terminals for damage or loose connection with harness connector.

#### OK or NG

- OK >> Replace control valve with TCM. Refer to [AT-248, "Control Valve with TCM and A/T Fluid Temperature Sensor 2"](#) .  
NG >> Repair or replace damaged parts.

### 4. CHECK DTC

Perform "DTC Confirmation Procedure".

- Refer to [AT-156, "DTC Confirmation Procedure"](#) .

#### OK or NG

- OK >> **INSPECTION END**  
NG >> GO TO 2.

# DTC P1757 FRONT BRAKE SOLENOID VALVE

## DTC P1757 FRONT BRAKE SOLENOID VALVE

PDF:31940

### Description

ACS00600

Front brake solenoid valve is controlled by the TCM in response to signals sent from the PNP switch, vehicle speed sensor and accelerator pedal position sensor (throttle position sensor). Gears will then be shifted to the optimum position.

### CONSULT-II Reference Value

ACS0060P

Item name	Condition	Display value (Approx.)
FR/B SOLENOID	Front brake engaged. Refer to <a href="#">AT-20</a> .	0.6 - 0.8 A
	Front brake disengaged. Refer to <a href="#">AT-20</a> .	0 - 0.05 A

### On Board Diagnosis Logic

ACS0060Q

- This is an OBD-II self-diagnostic item.
- Diagnostic trouble code "P1757 FR/B SOLENOID/CIRC" with CONSULT-II or 6th judgement flicker without CONSULT-II is detected under the following conditions.
  - When TCM detects an improper voltage drop when it tries to operate the solenoid valve.
  - When TCM detects as irregular by comparing target value with monitor value.

### Possible Cause

ACS0060R

- Harness or connectors.  
(Solenoid circuit is open or shorted.)
- Front brake solenoid valve.

### DTC Confirmation Procedure

ACS0060S

#### CAUTION:

Always drive vehicle at a safe speed.

#### NOTE:

If "DTC Confirmation Procedure" has been previously performed, always turn ignition switch OFF and wait at least 10 seconds before performing the next test.

After the repair, perform the following procedure to confirm the malfunction is eliminated.

#### WITH CONSULT-II

1. Turn ignition switch ON. (Do not start engine.)
2. Select "SELECTION FROM MENU" in "DATA MONITOR" mode for "A/T" with CONSULT-II and check monitor "ACCELE POSI", "SLCT LVR POSI" and "GEAR".
3. Touch "START".
4. Start engine.
5. Drive vehicle and maintain the following conditions for at least 5 consecutive seconds.

**ACCELE POSI: 1.5/8 - 2.0/8**

**SLCT LVR POSI: "D" position**

**GEAR: "3" ⇒ "4" (FR/B ON/OFF)**

**Driving location: Driving the vehicle uphill (increased engine load) will help maintain the driving conditions required for this test.**

6. If DTC is detected go to [AT-159, "Diagnostic Procedure"](#) .

#### WITH GST

Follow the procedure "WITH CONSULT-II".

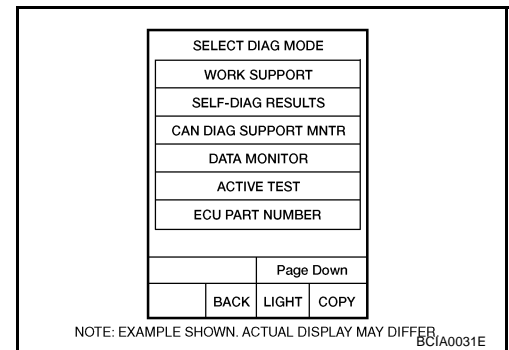

# DTC P1757 FRONT BRAKE SOLENOID VALVE

ACS008G8

## Diagnostic Procedure

### 1. CHECK INPUT SIGNAL

#### With CONSULT-II

1. Turn ignition switch ON. (Do not start engine.)
2. Select "MAIN SIGNALS" in "DATA MONITOR" mode for "A/T" with CONSULT-II.
3. Start engine.
4. Read out the value of "FR/B SOLENOID" while driving.

DATA MONITOR	
MONITOR	NO DTC
TCC SOLENOID	XXXX
LINE PRES SOL	XXXX
I/C SOLENOID	XXXX
FR/B SOLENOID	XXXX
D/C SOLENOID	XXXX
HLR/C SOL	XXXX
	▽
	RECORD
MODE	BACK
LIGHT	COPY

SCIA4793E

Item name	Condition	Display value (Approx.)
FR/B SOLENOID	Front brake engaged. Refer to <a href="#">AT-20</a> .	0.6 - 0.8 A
	Front brake disengaged. Refer to <a href="#">AT-20</a> .	0 - 0.05 A

#### OK or NG

- OK >> GO TO 4.  
NG >> GO TO 2.

### 2. CHECK TCM POWER SUPPLY AND GROUND CIRCUIT

Check TCM power supply and ground circuit. Refer to [AT-186, "MAIN POWER SUPPLY AND GROUND CIRCUIT"](#) .

#### OK or NG

- OK >> GO TO 3.  
NG >> Repair or replace damaged parts.

### 3. DETECT MALFUNCTIONING ITEM

Check the following.

- A/T assembly harness connector pin terminals for damage or loose connection with harness connector.

#### OK or NG

- OK >> Replace control valve with TCM. Refer to [AT-248, "Control Valve with TCM and A/T Fluid Temperature Sensor 2"](#) .  
NG >> Repair or replace damaged parts.

### 4. CHECK DTC

Perform "DTC Confirmation Procedure".

- Refer to [AT-158, "DTC Confirmation Procedure"](#) .

#### OK or NG

- OK >> **INSPECTION END**  
NG >> GO TO 2.

# DTC P1759 FRONT BRAKE SOLENOID VALVE FUNCTION

## DTC P1759 FRONT BRAKE SOLENOID VALVE FUNCTION

PFP:31940

### Description

ACS0060U

- Front brake solenoid valve is controlled by the TCM in response to signals sent from the PNP switch, vehicle speed sensor and accelerator pedal position sensor (throttle position sensor). Gears will then be shifted to the optimum position.
- This is not only caused by electrical malfunction (circuits open or shorted) but also by mechanical malfunction such as control valve sticking, improper solenoid valve operation.

### CONSULT-II Reference Value

ACS0060V

Item name	Condition	Display value (Approx)
FR/B SOLENOID	Front brake engaged. Refer to <a href="#">AT-20</a> .	0.6 - 0.8A
	Front brake disengaged. Refer to <a href="#">AT-20</a> .	0 - 0.05A
ATF PRES SW 1	Front brake engaged. Refer to <a href="#">AT-20</a> .	ON
	Front brake disengaged. Refer to <a href="#">AT-20</a> .	OFF

### On Board Diagnosis Logic

ACS0060W

- This is an OBD-II self-diagnostic item.
- Diagnostic trouble code "P1759 FR/B SOLENOID FNCT" with CONSULT-II or 6th judgement flicker without CONSULT-II is detected under the following conditions.
  - When TCM detects that actual gear ratio is irregular, and relation between gear position and condition of ATF pressure switch 1 is irregular during depressing accelerator pedal. (Other than during shift change)
  - When TCM detects that relation between gear position and condition of ATF pressure switch 1 is irregular during releasing accelerator pedal. (Other than during shift change)

### Possible Cause

ACS0060X

- Harness or connectors.  
(Solenoid and switch circuits are open or shorted.)
- Front brake solenoid valve.
- ATF pressure switch 1.

### DTC Confirmation Procedure

ACS0060Y

#### CAUTION:

Always drive vehicle at a safe speed.

#### NOTE:

If "DTC Confirmation Procedure" has been previously performed, always turn ignition switch OFF and wait at least 10 seconds before performing the next test.

After the repair, perform the following procedure to confirm the malfunction is eliminated.

#### WITH CONSULT-II

1. Start engine.
2. Accelerate vehicle to maintain the following conditions.  
**ACCELE POSI: 1.5/8 - 2.0/8**  
**SLCTLVR POSI: "D" position**  
**GEAR: "3" ⇒ "4" (FR/B ON/OFF)**  
**Driving location: Driving the vehicle uphill (increased engine load) will help maintain the driving conditions required for this test.**
3. Perform step "2" again.
4. Turn ignition switch "OFF", then perform step "1" to "3" again.
5. Check "SELF-DIAG RESULTS" mode for "A/T" with CONSULT-II. If DTC (P1759) is detected, go to [AT-161, "Diagnostic Procedure"](#) .  
If DTC (P1757) is detected, go to [AT-159, "Diagnostic Procedure"](#) .  
If DTC (P1841) is detected, go to [AT-179, "Diagnostic Procedure"](#) .

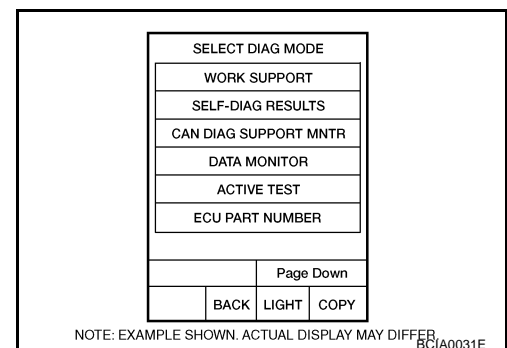



# DTC P1759 FRONT BRAKE SOLENOID VALVE FUNCTION

## WITH GST

Follow the procedure "WITH CONSULT-II".

## Diagnostic Procedure

ACS008G9

### 1. CHECK INPUT SIGNALS

#### With CONSULT-II

1. Start engine.
2. Select "SELECTION FROM MENU" in "DATA MONITOR" mode for "A/T" with CONSULT-II.
3. Drive vehicle in the "D" position (3rd ⇒ 4th gear), and confirm the ON/OFF actuation of the "ATF PRES SW 1" and electrical current value of "FR/B SOLENOID".

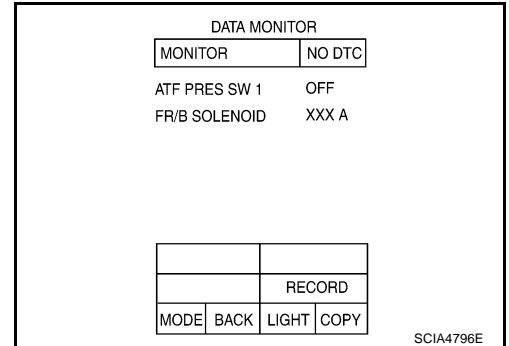

Item name	Condition	Display value (Approx.)
FR/B SOLENOID	Front brake engaged. Refer to <a href="#">AT-20</a> .	0.6 - 0.8 A
	Front brake disengaged. Refer to <a href="#">AT-20</a> .	0 - 0.05 A
ATF PRES SW 1	Front brake engaged. Refer to <a href="#">AT-20</a> .	ON
	Front brake disengaged. Refer to <a href="#">AT-20</a> .	OFF

#### OK or NG

- OK >> GO TO 4.  
NG >> GO TO 2.

### 2. CHECK TCM POWER SUPPLY AND GROUND CIRCUIT

Check TCM power supply and ground circuit. Refer to [AT-186, "MAIN POWER SUPPLY AND GROUND CIRCUIT"](#) .

#### OK or NG

- OK >> GO TO 3.  
NG >> Repair or replace damaged parts.

### 3. DETECT MALFUNCTIONING ITEM

Check the following.

- A/T assembly harness connector pin terminals for damage or loose connection with harness connector.

#### OK or NG

- OK >> Replace control valve with TCM. Refer to [AT-248, "Control Valve with TCM and A/T Fluid Temperature Sensor 2"](#) .  
NG >> Repair or replace damaged parts.

### 4. CHECK DTC

Perform "DTC Confirmation Procedure".

- Refer to [AT-160, "DTC Confirmation Procedure"](#) .

#### OK or NG

- OK >> **INSPECTION END**  
NG >> GO TO 2.

# DTC P1762 DIRECT CLUTCH SOLENOID VALVE

## DTC P1762 DIRECT CLUTCH SOLENOID VALVE

PFP:31940

### Description

ACS00610

Direct clutch solenoid valve is controlled by the TCM in response to signals sent from the PNP switch, vehicle speed sensor and accelerator pedal position sensor (throttle position sensor). Gears will then be shifted to the optimum position.

### CONSULT-II Reference Value

ACS00611

Item name	Condition	Display value (Approx)
D/C SOLENOID	Direct clutch disengaged. Refer to <a href="#">AT-20</a> .	0.6 - 0.8A
	Direct clutch engaged. Refer to <a href="#">AT-20</a> .	0 - 0.05A

### On Board Diagnosis Logic

ACS00612

- This is an OBD-II self-diagnostic item.
- Diagnostic trouble code “P1762 D/C SOLENOID/CIRC” with CONSULT-II or 2nd judgement flicker without CONSULT-II is detected under the following conditions.
  - When TCM detects an improper voltage drop when it tries to operate the solenoid valve.
  - When TCM detects as irregular by comparing target value with monitor value.

### Possible Cause

ACS00613

- Harness or connectors.  
(Solenoid circuit is open or shorted.)
- Direct clutch solenoid valve.

### DTC Confirmation Procedure

ACS00614

#### CAUTION:

Always drive vehicle at a safe speed.

#### NOTE:

If “DTC Confirmation Procedure” has been previously performed, always turn ignition switch OFF and wait at least 10 seconds before performing the next test.

After the repair, perform the following procedure to confirm the malfunction is eliminated.

#### WITH CONSULT-II

1. Turn ignition switch ON. (Do not start engine.)
2. Select “SELECTION FROM MENU” in “DATA MONITOR” mode for “A/T” with CONSULT-II and check monitor “ACCELE POSI” , “SLCT LVR POSI” and “GEAR”.
3. Touch “START”.
4. Start engine.
5. Drive vehicle and maintain the following conditions for at least 5 consecutive seconds.

**ACCELE POSI: 1.5/8 - 2.0/8**

**SLCT LVR POSI: “D” position**

**GEAR: “1” ⇒ “2” (D/C ON/OFF)**

**Driving location: Driving the vehicle uphill (increased engine load) will help maintain the driving conditions required for this test.**

6. If DTC is detected, go to [AT-163](#), “Diagnostic Procedure” .

#### WITH GST

Follow the procedure “WITH CONSULT-II”.

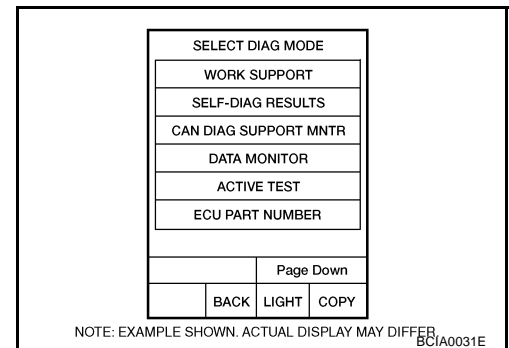

# DTC P1762 DIRECT CLUTCH SOLENOID VALVE

ACS008GA

## Diagnostic Procedure

### 1. CHECK INPUT SIGNAL

#### With CONSULT-II

1. Turn ignition switch ON. (Do not start engine.)
2. Select "MAIN SIGNALS" in "DATA MONITOR" mode for "A/T" with CONSULT-II.
3. Start the engine.
4. Read out the value of "D/C SOLENOID" while driving.

DATA MONITOR	
MONITOR	NO DTC
TCC SOLENOID	XXXX
LINE PRES SOL	XXXX
I/C SOLENOID	XXXX
FR/B SOLENOID	XXXX
D/C SOLENOID	XXXX
HLR/C SOL	XXXX
	▽
	RECORD
MODE	BACK
LIGHT	COPY

SCIA4793E

Item name	Condition	Display value (Approx.)
D/C SOLENOID	Direct clutch disengaged. Refer to <a href="#">AT-20</a> .	0.6 - 0.8 A
	Direct clutch engaged. Refer to <a href="#">AT-20</a> .	0 - 0.05 A

#### OK or NG

- OK >> GO TO 4.  
NG >> GO TO 2.

### 2. CHECK TCM POWER SUPPLY AND GROUND CIRCUIT

Check TCM power supply and ground circuit. Refer to [AT-186, "MAIN POWER SUPPLY AND GROUND CIRCUIT"](#) .

#### OK or NG

- OK >> GO TO 3.  
NG >> Repair or replace damaged parts.

### 3. DETECT MALFUNCTIONING ITEM

Check the following.

- A/T assembly harness connector pin terminals for damage or loose connection with harness connector.

#### OK or NG

- OK >> Replace control valve with TCM. Refer to [AT-248, "Control Valve with TCM and A/T Fluid Temperature Sensor 2"](#) .  
NG >> Repair or replace damaged parts.

### 4. CHECK DTC

Perform "DTC Confirmation Procedure".

- Refer to [AT-162, "DTC Confirmation Procedure"](#) .

#### OK or NG

- OK >> **INSPECTION END**  
NG >> GO TO 2.

# DTC P1764 DIRECT CLUTCH SOLENOID VALVE FUNCTION

## DTC P1764 DIRECT CLUTCH SOLENOID VALVE FUNCTION

PF3:31940

### Description

ACS00616

- Direct clutch solenoid valve is controlled by the TCM in response to signals sent from the PNP switch, vehicle speed sensor and accelerator pedal position sensor (throttle position sensor). Gears will then be shifted to the optimum position.
- This is not only caused by electrical malfunction (circuits open or shorted) but also by mechanical malfunction such as control valve sticking, improper solenoid valve operation.

### CONSULT-II Reference Value

ACS00617

Item name	Condition	Display value (Approx)
D/C SOLENOID	Direct clutch disengaged. Refer to <a href="#">AT-20</a> .	0.6 - 0.8A
	Direct clutch engaged. Refer to <a href="#">AT-20</a> .	0 - 0.05A
ATF PRES SW 5	Direct clutch engaged. Refer to <a href="#">AT-20</a> .	ON
	Direct clutch disengaged. Refer to <a href="#">AT-20</a> .	OFF

### On Board Diagnosis Logic

ACS00618

- This is an OBD-II self-diagnostic item.
- Diagnostic trouble code "P1764 D/C SOLENOID FNCTN" with CONSULT-II or 2nd judgement flicker without CONSULT-II is detected under the following conditions.
  - When TCM detects that actual gear ratio is irregular, and relation between gear position and condition of ATF pressure switch 5 is irregular during depressing accelerator pedal. (Other than during shift change)
  - When TCM detects that relation between gear position and condition of ATF pressure switch 5 is irregular during releasing accelerator pedal. (Other than during shift change)

### Possible Cause

ACS00619

- Harness or connectors.  
(Solenoid and switch circuits are open or shorted.)
- Direct clutch solenoid valve.
- ATF pressure switch 5.

### DTC Confirmation Procedure

ACS0061A

#### CAUTION:

Always drive vehicle at a safe speed.

#### NOTE:

If "DTC Confirmation Procedure" has been previously performed, always turn ignition switch OFF and wait at least 10 seconds before performing the next test.

After the repair, perform the following procedure to confirm the malfunction is eliminated.

#### WITH CONSULT-II

1. Start engine.
2. Accelerate vehicle to maintain the following conditions.  
**THROTTLE POSI: 1.5/8 - 2.0/8**  
**SLCTLVR POSI: "D" position**  
**GEAR: "1" ⇒ "2" (D/C ON/OFF)**  
**Driving location: Driving the vehicle uphill (increased engine load) will help maintain the driving conditions required for this test.**
3. Perform step "2" again.
4. Turn ignition switch OFF, then perform step "1" to "3" again.
5. Check "SELF-DIAG RESULTS" mode for "A/T" with CONSULT-II. If DTC (P1764) is detected, go to [AT-165, "Diagnostic Procedure"](#) .  
If DTC (P1762) is detected, go to [AT-163, "Diagnostic Procedure"](#) .  
If DTC (P1845) is detected, go to [AT-183, "Diagnostic Procedure"](#) .

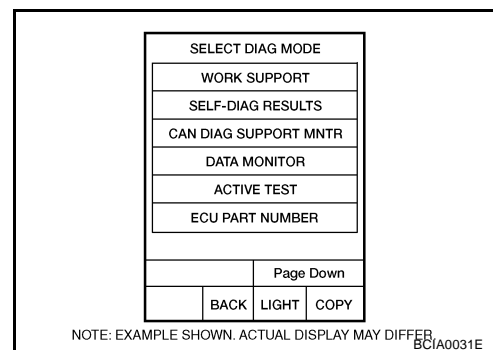

# DTC P1764 DIRECT CLUTCH SOLENOID VALVE FUNCTION

## WITH GST

Follow the procedure "WITH CONSULT-II".

## Diagnostic Procedure

ACS008GB

### 1. CHECK INPUT SIGNALS

#### With CONSULT-II

1. Start engine.
2. Select "SELECTION FROM MENU" in "DATA MONITOR" mode for "A/T" with CONSULT-II.
3. Drive vehicle in the "D" position (1st ⇒ 2nd gear), and confirm the display actuation of the "ATF PRES SW 5" and electrical current value of "D/C SOLENOID".

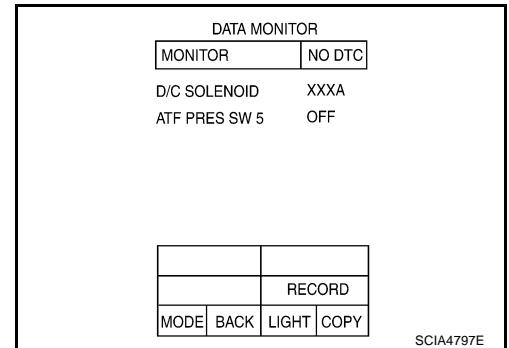

Item name	Condition	Display value (Approx.)
D/C SOLENOID	Direct clutch disengaged. Refer to <a href="#">AT-20</a> .	0.6 - 0.8 A
	Direct clutch engaged. Refer to <a href="#">AT-20</a> .	0 - 0.05 A
ATF PRES SW 5	Direct clutch engaged. Refer to <a href="#">AT-20</a> .	ON
	Direct clutch disengaged. Refer to <a href="#">AT-20</a> .	OFF

#### OK or NG

- OK >> GO TO 4.  
NG >> GO TO 2.

### 2. CHECK TCM POWER SUPPLY AND GROUND CIRCUIT

Check TCM power supply and ground circuit. Refer to [AT-186, "MAIN POWER SUPPLY AND GROUND CIRCUIT"](#) .

#### OK or NG

- OK >> GO TO 3.  
NG >> Repair or replace damaged parts.

### 3. DETECT MALFUNCTIONING ITEM

Check the following.

- A/T assembly harness connector pin terminals for damage or loose connection with harness connector.

#### OK or NG

- OK >> Replace control valve with TCM. Refer to [AT-248, "Control Valve with TCM and A/T Fluid Temperature Sensor 2"](#) .  
NG >> Repair or replace damaged parts.

### 4. CHECK DTC

Perform "DTC Confirmation Procedure".

- Refer to [AT-164, "DTC Confirmation Procedure"](#) .

#### OK or NG

- OK >> **INSPECTION END**  
NG >> GO TO 2.

# DTC P1767 HIGH AND LOW REVERSE CLUTCH SOLENOID VALVE

## DTC P1767 HIGH AND LOW REVERSE CLUTCH SOLENOID VALVE

PFP:31940

### Description

ACS0061C

High and low reverse clutch solenoid valve is controlled by the TCM in response to signals sent from the PNP switch, vehicle speed sensor and accelerator pedal position sensor (throttle position sensor). Gears will then be shifted to the optimum position.

### CONSULT-II Reference Value

ACS0061D

Item name	Condition	Display value (Approx)
HLR/C SOL	High and low reverse clutch disengaged. Refer to <a href="#">AT-20</a> .	0.6 - 0.8A
	High and low reverse clutch engaged. Refer to <a href="#">AT-20</a> .	0 - 0.05A

### On Board Diagnosis Logic

ACS0061E

- This is an OBD-II self-diagnostic item.
- Diagnostic trouble code “P1767 HLR/C SOL/CIRC” with CONSULT-II or 8th judgement flicker without CONSULT-II is detected under the following conditions.
  - When TCM detects an improper voltage drop when it tries to operate the solenoid valve.
  - When TCM detects as irregular by comparing target value with monitor value.

### Possible Cause

ACS0061F

- Harness or connectors.  
(Solenoid circuit is open or shorted.)
- High and low reverse clutch solenoid valve.

### DTC Confirmation Procedure

ACS0061G

#### CAUTION:

Always drive vehicle at a safe speed.

#### NOTE:

If “DTC Confirmation Procedure” has been previously performed, always turn ignition switch OFF and wait at least 10 seconds before performing the next test.

After the repair, perform the following procedure to confirm the malfunction is eliminated.

#### WITH CONSULT-II

1. Turn ignition switch ON. (Do not start engine.)
2. Select “SELECTION FROM MENU” in “DATA MONITOR” mode for “A/T” with CONSULT-II and check monitor “ACCELE POSI” , “SLCT LVR POSI” and “GEAR”.
3. Touch “START”.
4. Start engine.
5. Drive vehicle and maintain the following conditions for at least 5 consecutive seconds.

**ACCELE POSI: 1.5/8 - 2.0/8**

**SLCT LVR POSI: “D” position**

**GEAR: “2” ⇒ “3” (HLR/C ON/OFF)**

**Driving location: Driving the vehicle uphill (increased engine load) will help maintain the driving conditions required for this test.**

6. If DTC is detected, go to [AT-167](#), “Diagnostic Procedure” .

#### WITH GST

Follow the procedure “WITH CONSULT-II”.

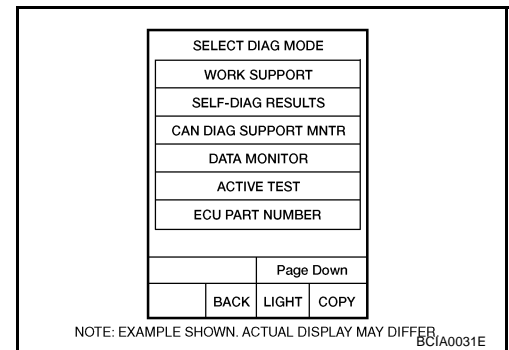

# DTC P1767 HIGH AND LOW REVERSE CLUTCH SOLENOID VALVE

ACS008GC

## Diagnostic Procedure

### 1. CHECK INPUT SIGNAL

#### With CONSULT-II

1. Turn ignition switch ON. (Do not start engine.)
2. Select "MAIN SIGNALS" in "DATA MONITOR" mode for "A/T" with CONSULT-II.
3. Start the engine.
4. Read out the value of "HLR/C SOL" while driving.

Item name	Condition	Display value (Approx.)
HLR/C SOL	High and low reverse clutch disengaged. Refer to <a href="#">AT-20</a> .	0.6 - 0.8 A
	High and low reverse clutch engaged. Refer to <a href="#">AT-20</a> .	0 - 0.05 A

DATA MONITOR	
MONITOR	NO DTC
TCC SOLENOID	XXXX
LINE PRES SOL	XXXX
I/C SOLENOID	XXXX
FR/B SOLENOID	XXXX
D/C SOLENOID	XXXX
HLR/C SOL	XXXX
	▽
	RECORD
MODE	BACK
LIGHT	COPY

SCIA4793E

#### OK or NG

- OK >> GO TO 4.
- NG >> GO TO 2.

### 2. CHECK TCM POWER SUPPLY AND GROUND CIRCUIT

Check TCM power supply and ground circuit. Refer to [AT-186, "MAIN POWER SUPPLY AND GROUND CIRCUIT"](#).

#### OK or NG

- OK >> GO TO 3.
- NG >> Repair or replace damaged parts.

### 3. DETECT MALFUNCTIONING ITEM

Check the following.

- A/T assembly harness connector pin terminals for damage or loose connection with harness connector.

#### OK or NG

- OK >> Replace control valve with TCM. Refer to [AT-248, "Control Valve with TCM and A/T Fluid Temperature Sensor 2"](#).
- NG >> Repair or replace damaged parts.

### 4. CHECK TCM

Perform "DTC Confirmation Procedure".

- Refer to [AT-166, "DTC Confirmation Procedure"](#).

#### OK or NG

- OK >> **INSPECTION END**
- NG >> GO TO 2.

# DTC P1769 HIGH AND LOW REVERSE CLUTCH SOLENOID VALVE FUNCTION

## DTC P1769 HIGH AND LOW REVERSE CLUTCH SOLENOID VALVE FUNCTION

PDF:31940

### Description

ACS0061I

- High and low reverse clutch solenoid valve is controlled by the TCM in response to signals sent from the PNP switch, vehicle speed sensor and accelerator pedal position sensor (throttle position sensor). Gears will then be shifted to the optimum position.
- This is not only caused by electrical malfunction (circuits open or shorted) but also by mechanical malfunction such as control valve sticking, improper solenoid valve operation.

### CONSULT-II Reference Value

ACS0061J

Item name	Condition	Display value (Approx)
HLR/C SOL	High and low reverse clutch disengaged. Refer to <a href="#">AT-20</a> .	0.6 - 0.8A
	High and low reverse clutch engaged. Refer to <a href="#">AT-20</a> .	0 - 0.05A
ATF PRES SW 6	High and low reverse clutch engaged. Refer to <a href="#">AT-20</a> .	ON
	High and low reverse clutch disengaged. Refer to <a href="#">AT-20</a> .	OFF

### On Board Diagnosis Logic

ACS0061K

- This is an OBD-II self-diagnostic item.
- Diagnostic trouble code "P1769 HLR/C SOL FNCTN" with CONSULT-II or 8th judgement flicker without CONSULT-II is detected under the following conditions.
  - When TCM detects that actual gear ratio is irregular, and relation between gear position and condition of ATF pressure switch 6 is irregular during depressing accelerator pedal. (Other than during shift change)
  - When TCM detects that relation between gear position and condition of ATF pressure switch 6 is irregular during releasing accelerator pedal. (Other than during shift change)

### Possible Cause

ACS0061L

- Harness or connectors.  
(Solenoid and switch circuits are open or shorted.)
- High and low reverse clutch solenoid valve.
- ATF pressure switch 6.

### DTC Confirmation Procedure

ACS0061M

#### CAUTION:

Always drive vehicle at a safe speed.

#### NOTE:

If "DTC Confirmation Procedure" has been previously performed, always turn ignition switch OFF and wait at least 10 seconds before performing the next test.

After the repair, perform the following procedure to confirm the malfunction is eliminated.

#### ④ WITH CONSULT-II

1. Start engine.
2. Accelerate vehicle to maintain the following conditions.  
**THROTTLE POSI: 1.5/8 - 2.0/8**  
**SLCTLVR POSI: "D" position**  
**GEAR: "2" ⇒ "3" (HLR/C ON/OFF)**  
**Driving location: Driving the vehicle uphill (increased engine load) will help maintain the driving conditions required for this test.**
3. Perform step "2" again.
4. Turn ignition switch "OFF", then perform step "1" to "3" again.
5. Check "SELF-DIAG RESULTS" mode for "A/T" with CONSULT-II. If DTC (P1769) is detected, go to [AT-169, "Diagnostic Procedure"](#) .  
If DTC (P1767) is detected, go to [AT-167, "Diagnostic Procedure"](#) .  
If DTC (P1846) is detected, go to [AT-185, "Diagnostic Procedure"](#) .

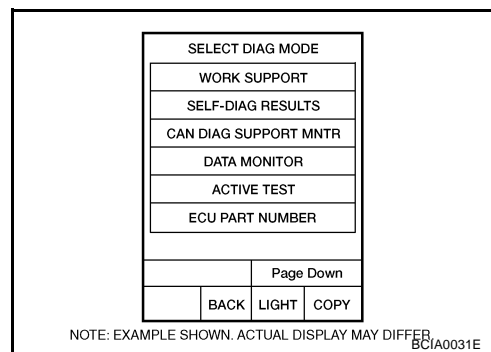



# DTC P1769 HIGH AND LOW REVERSE CLUTCH SOLENOID VALVE FUNCTION

## WITH GST

Follow the procedure "WITH CONSULT-II".

## Diagnostic Procedure

ACS008GD

### 1. CHECK INPUT SIGNALS

#### With CONSULT-II

1. Start the engine.
2. Select "SELECTION FROM MENU" in "DATA MONITOR" mode for "A/T" with CONSULT-II.
3. Drive vehicle in the "D" position (2nd ⇒ 3rd gear), and confirm the ON/OFF actuation of the "ATF PRES SW 6" and electrical current value of "HLR/C SOL".

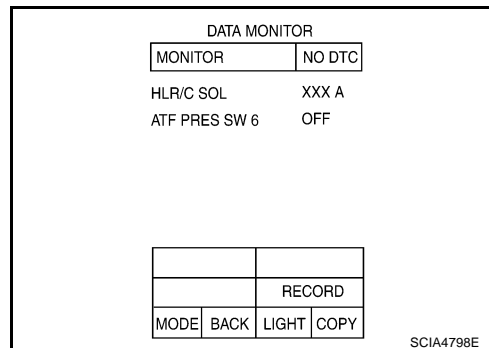

Item name	Condition	Display value (Approx.)
HLR/C SOL	High and low reverse clutch disengaged. Refer to <a href="#">AT-20</a> .	0.6 - 0.8 A
	High and low reverse clutch engaged. Refer to <a href="#">AT-20</a> .	0 - 0.05 A
ATF PRES SW 6	High and low reverse clutch engaged. Refer to <a href="#">AT-20</a> .	ON
	High and low reverse clutch disengaged. Refer to <a href="#">AT-20</a> .	OFF

#### OK or NG

- OK >> GO TO 4.  
NG >> GO TO 2.

### 2. CHECK TCM POWER SUPPLY AND GROUND CIRCUIT

Check TCM power supply and ground circuit. Refer to [AT-186, "MAIN POWER SUPPLY AND GROUND CIRCUIT"](#) .

#### OK or NG

- OK >> GO TO 3.  
NG >> Repair or replace damaged parts.

### 3. DETECT MALFUNCTIONING ITEM

Check the following.

- A/T assembly harness connector pin terminals for damage or loose connection with harness connector.

#### OK or NG

- OK >> Replace control valve with TCM. Refer to [AT-248, "Control Valve with TCM and A/T Fluid Temperature Sensor 2"](#) .  
NG >> Repair or replace damaged parts.

### 4. CHECK DTC

Perform "DTC Confirmation Procedure".

- Refer to [AT-168, "DTC Confirmation Procedure"](#) .

#### OK or NG

- OK >> **INSPECTION END**  
NG >> GO TO 2.

# DTC P1772 LOW COAST BRAKE SOLENOID VALVE

## DTC P1772 LOW COAST BRAKE SOLENOID VALVE

PFP:31940

### Description

ACS00610

Low coast brake solenoid valve is turned "ON" or "OFF" by the TCM in response to signals sent from the PNP switch, vehicle speed sensor and accelerator pedal position sensor (throttle position sensor). Gears will then be shifted to the optimum position.

### CONSULT-II Reference Value

ACS0061P

Item name	Condition	Display value
ON OFF SOL	Low coast brake engaged. Refer to <a href="#">AT-20</a> .	ON
	Low coast brake disengaged. Refer to <a href="#">AT-20</a> .	OFF

### On Board Diagnosis Logic

ACS0061Q

- This is an OBD-II self-diagnostic item.
- Diagnostic trouble code "P1772 LC/B SOLENOID/CIRC" with CONSULT-II or 7th judgement flicker without CONSULT-II is detected when TCM detects an improper voltage drop when it tries to operate the solenoid valve.

### Possible Cause

ACS0061R

- Harness or connectors.  
(Solenoid circuit is open or shorted.)
- Low coast brake solenoid valve.

### DTC Confirmation Procedure

ACS0061S

#### CAUTION:

Always drive vehicle at a safe speed.

#### NOTE:

If "DTC Confirmation Procedure" has been previously performed, always turn ignition switch OFF and wait at least 10 seconds before performing the next test.

After the repair, perform the following procedure to confirm the malfunction is eliminated.

#### ④ WITH CONSULT-II

1. Turn ignition switch ON. (Do not start engine.)
2. Select "SELECTION FROM MENU" in "DATA MONITOR" mode for "A/T" with CONSULT-II and check monitor "MANU MODE SW" and "GEAR".
3. Touch "START".
4. Start engine.
5. Drive vehicle and maintain the following conditions for at least 5 consecutive seconds.  
**MANU MODE SW: ON**  
**GEAR: "1" or "2" (LC/B ON/OFF)**
6. If DTC is detected, go to [AT-171, "Diagnostic Procedure"](#) .

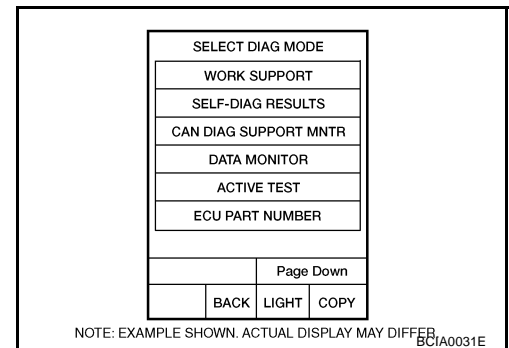

#### ④ WITH GST

Follow the procedure "WITH CONSULT-II".

# DTC P1772 LOW COAST BRAKE SOLENOID VALVE

## Diagnostic Procedure

ACS008GE

### 1. CHECK INPUT SIGNAL

#### With CONSULT-II

1. Turn ignition switch ON. (Do not start engine.)
2. Select "SELECTION FROM MENU" in "DATA MONITOR" mode for "A/T" with CONSULT-II.
3. Start the engine.
4. Read out the value of "ON OFF SOL" while driving.

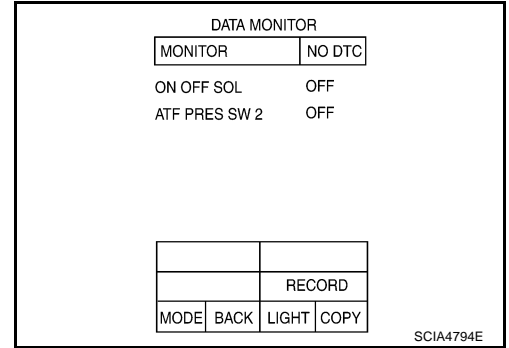

Item name	Condition	Display value
ON OFF SOL	Low coast brake engaged. Refer to <a href="#">AT-20</a> .	ON
	Low coast brake disengaged. Refer to <a href="#">AT-20</a> .	OFF

#### OK or NG

- OK >> GO TO 4.  
NG >> GO TO 2.

### 2. CHECK TCM POWER SUPPLY AND GROUND CIRCUIT

Check TCM power supply and ground circuit. Refer to [AT-186, "MAIN POWER SUPPLY AND GROUND CIRCUIT"](#) .

#### OK or NG

- OK >> GO TO 3.  
NG >> Repair or replace damaged parts.

### 3. DETECT MALFUNCTIONING ITEM

Check the following.

- A/T assembly harness connector pin terminals for damage or loose connection with harness connector.

#### OK or NG

- OK >> Replace control valve with TCM. Refer to [AT-248, "Control Valve with TCM and A/T Fluid Temperature Sensor 2"](#) .  
NG >> Repair or replace damaged parts.

### 4. CHECK DTC

Perform "DTC Confirmation Procedure".

- Refer to [AT-170, "DTC Confirmation Procedure"](#) .

#### OK or NG

- OK >> **INSPECTION END**  
NG >> GO TO 2.

# DTC P1774 LOW COAST BRAKE SOLENOID VALVE FUNCTION

## DTC P1774 LOW COAST BRAKE SOLENOID VALVE FUNCTION

PF3:31940

### Description

ACS0061U

- Low coast brake solenoid valve is turned “ON” or “OFF” by the TCM in response to signals sent from the PNP switch, vehicle speed sensor and accelerator pedal position sensor (throttle position sensor). Gears will then be shifted to the optimum position.
- This is not only caused by electrical malfunction (circuits open or shorted) but also by mechanical malfunction such as control valve sticking, improper solenoid valve operation.

### CONSULT-II Reference Value

ACS0061V

Item name	Condition	Display value
ON OFF SOL	Low coast brake engaged. Refer to <a href="#">AT-20</a> .	ON
	Low coast brake disengaged. Refer to <a href="#">AT-20</a> .	OFF
ATF PRES SW 2	Low coast brake engaged. Refer to <a href="#">AT-20</a> .	ON
	Low coast brake disengaged. Refer to <a href="#">AT-20</a> .	OFF

### On Board Diagnosis Logic

ACS0061W

- This is an OBD-II self-diagnostic item.
- Diagnostic trouble code “P1774 LC/B SOLENOID FNCT” with CONSULT-II or 7th judgement flicker without CONSULT-II is detected under the following conditions.
  - When TCM detects that actual gear ratio is irregular, and relation between gear position and condition of ATF pressure switch 2 is irregular during depressing accelerator pedal. (Other than during shift change)
  - When TCM detects that relation between gear position and condition of ATF pressure switch 2 is irregular during releasing accelerator pedal. (Other than during shift change)

### Possible Cause

ACS0061X

- Harness or connectors.  
(Solenoid and switch circuits are open or shorted.)
- Low coast brake solenoid valve.
- ATF pressure switch 2.

### DTC Confirmation Procedure

ACS0061Y

#### CAUTION:

Always drive vehicle at a safe speed.

#### NOTE:

If “DTC Confirmation Procedure” has been previously performed, always turn ignition switch OFF and wait at least 10 seconds before performing the next test.

After the repair, perform the following procedure to confirm the malfunction is eliminated.

#### WITH CONSULT-II

1. Start engine.
2. Accelerate vehicle to maintain the following conditions.  
**MANU MODE SW: ON**  
**GEAR: “1” or “2” (LC/B ON/OFF)**
3. Perform step “2” again.
4. Turn ignition switch OFF, then perform step “1” to “3” again.
5. Check “SELF-DIAG RESULTS” mode for “A/T” with CONSULT-II. If DTC (P1774) is detected, go to [AT-173, "Diagnostic Procedure"](#) .  
If DTC (P1772) is detected, go to [AT-171, "Diagnostic Procedure"](#) .

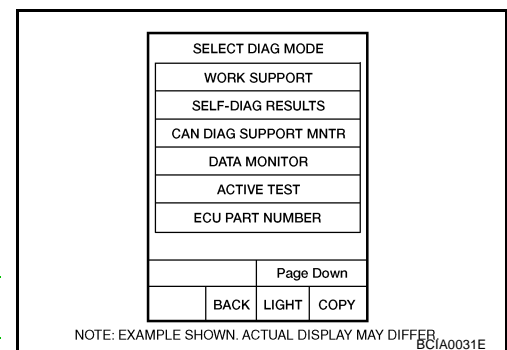

#### WITH GST

Follow the procedure “WITH CONSULT-II”.

# DTC P1774 LOW COAST BRAKE SOLENOID VALVE FUNCTION

ACS008GF

## Diagnostic Procedure

### 1. CHECK INPUT SIGNALS

#### With CONSULT-II

1. Start the engine.
2. Select "SELECTION FROM MENU" in "DATA MONITOR" mode for "A/T" with CONSULT-II.
3. Drive vehicle in the manual mode ("1st" or "2nd" gear), and confirm the ON/OFF actuation of the "ATF PRES SW 2" and "ON OFF SOL".

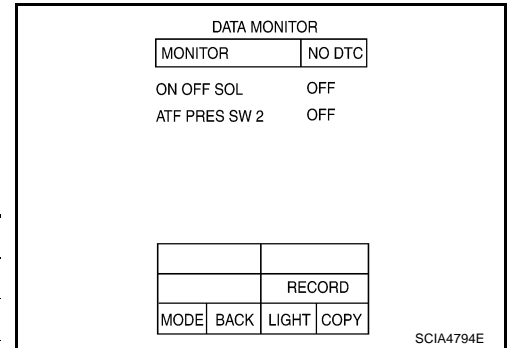

Item name	Condition	Display value
ON OFF SOL	Low coast brake engaged. Refer to <a href="#">AT-20</a> .	ON
	Low coast brake disengaged. Refer to <a href="#">AT-20</a> .	OFF
ATF PRES SW 2	Low coast brake engaged. Refer to <a href="#">AT-20</a> .	ON
	Low coast brake disengaged. Refer to <a href="#">AT-20</a> .	OFF

#### OK or NG

- OK >> GO TO 4.
- NG >> GO TO 2.

### 2. CHECK TCM POWER SUPPLY AND GROUND CIRCUIT

Check TCM power supply and ground circuit. Refer to [AT-186, "MAIN POWER SUPPLY AND GROUND CIRCUIT"](#) .

#### OK or NG

- OK >> GO TO 3.
- NG >> Repair or replace damaged parts.

### 3. DETECT MALFUNCTIONING ITEM

Check the following.

- A/T assembly harness connector pin terminals for damage or loose connection with harness connector.

#### OK or NG

- OK >> Replace control valve with TCM. Refer to [AT-248, "Control Valve with TCM and A/T Fluid Temperature Sensor 2"](#) .
- NG >> Repair or replace damaged parts.

### 4. CHECK DTC

Perform "DTC Confirmation Procedure".

- Refer to [AT-172, "DTC Confirmation Procedure"](#) .

#### OK or NG

- OK >> **INSPECTION END**
- NG >> GO TO 2.

# DTC P1815 MANUAL MODE SWITCH

## DTC P1815 MANUAL MODE SWITCH

PFP:34901

### Description

ACS00620

Manual mode switch is installed in A/T control device. It sends manual mode switch, shift-up and shift-down switch signals to TCM.

TCM sends the switch signals to combination meter. By CAN communication line. Then manual mode switch position is indicated on the A/T position indicator. For inspection, refer to [AT-192. "A/T INDICATOR CIRCUIT"](#) .

### CONSULT-II Reference Value

ACS00621

Item name	Condition	Display value
MANU MODE SW	Manual shift gate position (neutral)	ON
	Other than the above	OFF
NON M-MODE SW	Manual shift gate position	OFF
	Other than the above	ON
UP SW LEVER	Selector lever: + side	ON
	Other than the above	OFF
DOWN SW LEVER	Selector lever: - side	ON
	Other than the above	OFF

### On Board Diagnosis Logic

ACS00622

- This is not an OBD-II self-diagnostic item.
- Diagnostic trouble code "P1815 MANU MODE SW/CIRC" with CONSULT-II is detected when TCM monitors Manual mode, Non manual mode, Up or Down switch signal, and detects as irregular when impossible input pattern occurs 1 second or more.

### Possible Cause

ACS00623

- Harness or connectors.  
(These switches circuit is open or shorted.)
- Manual mode select switch. (Into control device)
- Manual mode position select switch. (Into control device)

### DTC Confirmation Procedure

ACS00624

#### CAUTION:

Always drive vehicle at a safe speed.

#### NOTE:

If "DTC Confirmation Procedure" has been previously performed, always turn ignition switch OFF and wait at least 10 seconds before performing the next test.

After the repair, perform the following procedure to confirm the malfunction is eliminated.

#### WITH CONSULT-II

1. Turn ignition switch ON. (Do not start engine.)
2. Select "ECU INPUT SIGNALS" in "DATA MONITOR" mode for "A/T" with CONSULT-II.
3. Start engine.
4. Drive vehicle and maintain the following conditions for at least 2 consecutive seconds.  
**MANU MODE SW: ON**
5. If DTC is detected, go to [AT-176. "Diagnostic Procedure"](#) .

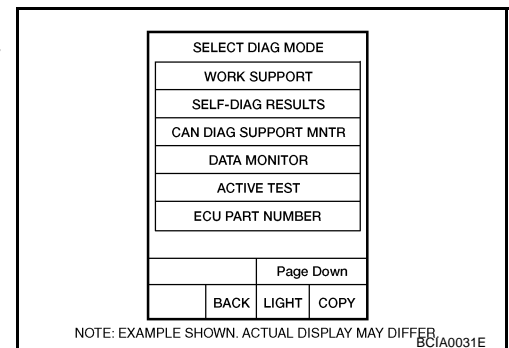

# DTC P1815 MANUAL MODE SWITCH

## Wiring Diagram — AT — MMSW

ACS0086F

AT-MMSW-01

A  
B  
AT  
D  
E  
F  
G  
H  
I  
J  
K  
L  
M

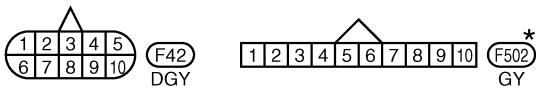
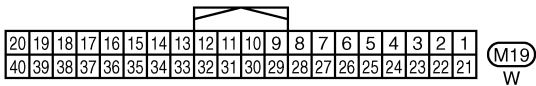
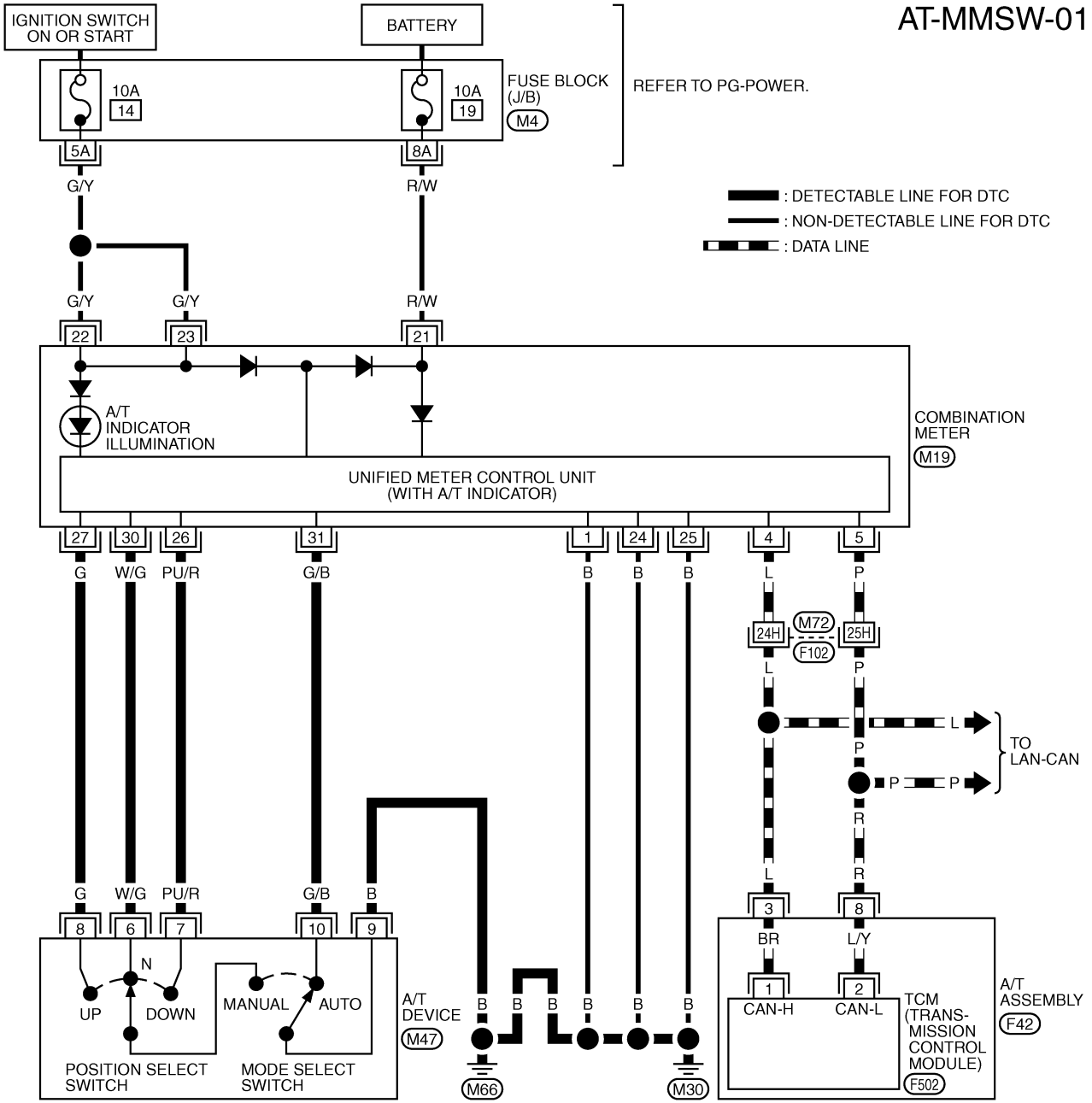

REFER TO THE FOLLOWING.

- (F102) -SUPER MULTIPLE JUNCTION (SMJ)
- (M4) -FUSE BLOCK-JUNCTION BOX (J/B)

\*: THIS CONNECTOR IS NOT SHOWN IN "HARNESS LAYOUT", PG SECTION.

TCWM0393E

# DTC P1815 MANUAL MODE SWITCH

TCM terminals and data are reference value. Measured between each terminal and ground.

Terminal	Wire color	Item	Condition	Data (Approx.)
3	L	CAN-H	-	-
8	R	CAN-L	-	-

## Diagnostic Procedure

ACS008GG

### 1. CHECK CAN COMMUNICATION LINE

Perform self-diagnosis. Refer to [AT-95, "SELF-DIAGNOSTIC RESULT MODE"](#) .

Is a malfunction in the CAN communication indicated in the results?

- YES >> Check CAN communication line. Refer to [AT-110, "DTC U1000 CAN COMMUNICATION LINE"](#) .  
 NO >> GO TO 2.

### 2. CHECK MANUAL MODE SWITCH CIRCUIT

#### With CONSULT-II

- Turn ignition switch ON. (Do not start engine.)
- Select "ECU INPUT SIGNALS" in "DATA MONITOR" mode for "A/T" with CONSULT-II.
- Read out ON/OFF switching action of "MANU MODE SW", "NON M-MODE SW", "UP SW LEVER", "DOWN SW LEVER".

DATA MONITOR			
MONITOR	NO DTC		
MANU MODE SW	OFF		
NON M-MODE SW	ON		
UP SW LEVER	OFF		
DOWN SW LEVER	OFF		
△			
RECORD			
MODE	BACK	LIGHT	COPY

SCIA4988E

Item name	Condition	Display Value
MANU MODE SW	Manual shift gate position (neutral)	ON
	Other than the above	OFF
NON M-MODE SW	Manual shift gate position	OFF
	Other than the above	ON
UP SW LEVER	Selector lever: +side	ON
	Other than the above	OFF
DOWN SW LEVER	Selector lever: -side	ON
	Other than the above	OFF

#### Without CONSULT-II

Drive vehicle in the manual mode, and confirm that the actual gear position and the meter's indication of the position mutually coincide when the selector lever is shifted to the "+" (up)" or "-" (down)" side (1st ↔ 5th gear).

OK or NG

- OK >> GO TO 4.  
 NG >> GO TO 3.

### 3. DETECT MALFUNCTIONING ITEM

Check the following.

- Manual mode switch. Refer to [AT-177, "Component Inspection"](#) .
- Pin terminals for damage or loose connection with harness connector.
- Open circuit or short to ground or short to power in harness or connector for A/T control device (manual mode switch).
- Combination meter. Refer to [DI-4, "COMBINATION METERS"](#) .

OK or NG

- OK >> GO TO 4.  
 NG >> Repair or replace damaged parts.



# DTC P1815 MANUAL MODE SWITCH

## 4. CHECK DTC

Perform "DTC Confirmation Procedure".

- Refer to [AT-174, "DTC Confirmation Procedure"](#).

OK or NG

- OK >> **INSPECTION END**
- NG >> GO TO 5.

## 5. CHECK TCM POWER SUPPLY AND GROUND CIRCUIT

Check TCM power supply and ground circuit. Refer to [AT-186, "MAIN POWER SUPPLY AND GROUND CIRCUIT"](#).

OK or NG

- OK >> GO TO 6.
- NG >> Repair or replace damaged parts.

## 6. DETECT MALFUNCTIONING ITEM

Check the following.

- A/T assembly harness connector pin terminals for damage or loose connection with harness connector.

OK or NG

- OK >> Replace control valve with TCM. Refer to [AT-248, "Control Valve with TCM and A/T Fluid Temperature Sensor 2"](#).
- NG >> Repair or replace damaged parts.

## Component Inspection MANUAL MODE SWITCH

ACS00626

Check continuity between terminals.

Item	Position	Connector	Terminal	Continuity
Manual mode select switch	Auto	M47	9 - 10	Yes
	Manual		6 - 9	
Manual mode position select switch	UP		8 - 9	
	DOWN		7 - 9	

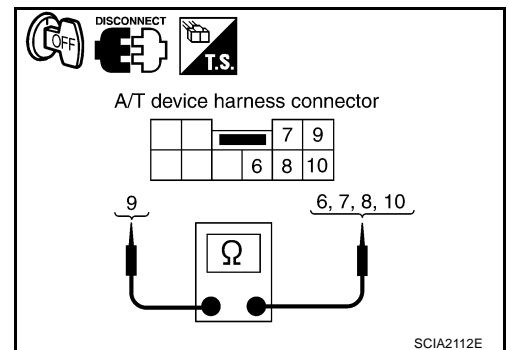

SCIA2112E

# DTC P1841 ATF PRESSURE SWITCH 1

## DTC P1841 ATF PRESSURE SWITCH 1

PFP:25240

### Description

ACS00628

Fail-safe function to detect front brake solenoid valve condition.

### CONSULT-II Reference Value

ACS00629

Item name	Condition	Display value
ATF PRES SW 1	Front brake engaged. Refer to <a href="#">AT-20</a> .	ON
	Front brake disengaged. Refer to <a href="#">AT-20</a> .	OFF

### On Board Diagnosis Logic

ACS0062A

- This is not an OBD-II self-diagnostic item.
- Diagnostic trouble code “P1841 ATF PRES SW 1/CIRC” with CONSULT-II is detected when TCM detects that actual gear ratio is normal, and relation between gear position and condition of ATF pressure switch 1 is irregular during depressing accelerator pedal. (Other than during shift change)

### Possible Cause

ACS0062B

- ATF pressure switch 1.
- Harness or connectors.  
(Switch circuit is open or shorted.)

### DTC Confirmation Procedure

ACS0062C

#### CAUTION:

Always drive vehicle at a safe speed.

#### NOTE:

If “DTC Confirmation Procedure” has been previously performed, always turn ignition switch OFF and wait at least 10 seconds before performing the next test.

After the repair, perform the following procedure to confirm the malfunction is eliminated.

#### WITH CONSULT-II

1. Start engine.
2. Accelerate vehicle to maintain the following conditions.  
**ACCELE POSI: 1.5/8 - 2.0/8**  
**SLCT LVR POSI: “D” position**  
**GEAR: “3” ⇒ “4” (FR/B ON/OFF)**  
**Driving location: Driving the vehicle uphill (increased engine load) will help maintain the driving conditions required for this test.**
3. Perform step “2” again.
4. Turn ignition switch OFF, then perform step “1” to “3” again.
5. Check “SELF-DIAG RESULTS” mode for “A/T” with CONSULT-II.

If DTC (P1841) is detected, go to [AT-179, "Diagnostic Procedure"](#) .

If DTC (P1757) is detected, go to [AT-159, "Diagnostic Procedure"](#) .

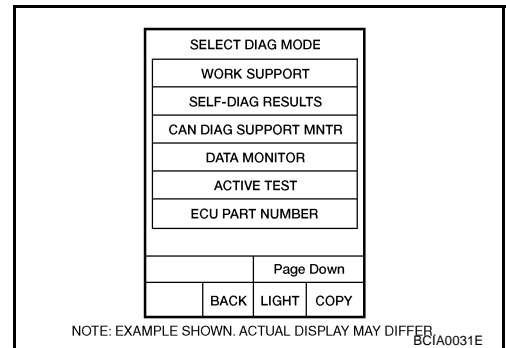

# DTC P1841 ATF PRESSURE SWITCH 1

ACS008GH

## Diagnostic Procedure

### 1. CHECK INPUT SIGNAL

#### With CONSULT-II

1. Start engine.
2. Select "ECU INPUT SIGNALS" or "MAIN SIGNALS" in "DATA MONITOR" mode for "A/T" with CONSULT-II.
3. Drive vehicle in the "D" position (3rd ⇒ 4th gear), and confirm the ON/OFF actuation of the "ATF PRES SW 1".

Item name	Condition	Display value
ATF PRES SW 1	Front brake engaged. Refer to <a href="#">AT-20</a> .	ON
	Front brake disengaged. Refer to <a href="#">AT-20</a> .	OFF

#### OK or NG

- OK >> GO TO 4.  
NG >> GO TO 2.

DATA MONITOR	
MONITOR	NO DTC
ATF PRES SW 1	OFF
ATF PRES SW 2	OFF
ATF PRES SW 3	OFF
ATF PRES SW 5	OFF
ATF PRES SW 6	OFF

Δ	▽		
RECORD			
MODE	BACK	LIGHT	COPY

PCIA0067E

### 2. CHECK TCM POWER SUPPLY AND GROUND CIRCUIT

Check TCM power supply and ground circuit. Refer to [AT-186, "MAIN POWER SUPPLY AND GROUND CIRCUIT"](#) .

#### OK or NG

- OK >> GO TO 3.  
NG >> Repair or replace damaged parts.

### 3. DETECT MALFUNCTIONING ITEM

Check the following.

- A/T assembly harness connector pin terminals for damage or loose connection with harness connector.

#### OK or NG

- OK >> Replace control valve with TCM. Refer to [AT-248, "Control Valve with TCM and A/T Fluid Temperature Sensor 2"](#) .  
NG >> Repair or replace damaged parts.

### 4. CHECK DTC

Perform "DTC Confirmation Procedure".

- Refer to [AT-178, "DTC Confirmation Procedure"](#) .

#### OK or NG

- OK >> **INSPECTION END**  
NG >> GO TO 2.

# DTC P1843 ATF PRESSURE SWITCH 3

## DTC P1843 ATF PRESSURE SWITCH 3

PFP:25240

### Description

ACS0062E

Fail-safe function to detect input clutch solenoid valve condition.

### CONSULT-II Reference Value

ACS0062F

Item name	Condition	Display value
ATF PRES SW 3	Input clutch engaged. Refer to <a href="#">AT-20</a> .	ON
	Input clutch disengaged. Refer to <a href="#">AT-20</a> .	OFF

### On Board Diagnosis Logic

ACS0062G

- This is not an OBD-II self-diagnostic item.
- Diagnostic trouble code “P1843 ATF PRES SW 3/CIRC” with CONSULT-II is detected when TCM detects that actual gear ratio is normal, and relation between gear position and condition of ATF pressure switch 3 is irregular during depressing accelerator pedal. (Other than during shift change)

### Possible Cause

ACS0062H

- ATF pressure switch 3.
- Harness or connectors.  
(Switch circuit is open or shorted.)

### DTC Confirmation Procedure

ACS0062I

#### CAUTION:

Always drive vehicle at a safe speed.

#### NOTE:

If “DTC Confirmation Procedure” has been previously performed, always turn ignition switch OFF and wait at least 10 seconds before performing the next test.

After the repair, perform the following procedure to confirm the malfunction is eliminated.

#### WITH CONSULT-II

1. Start engine.
2. Accelerate vehicle to maintain the following conditions.  
**ACCELE POSI: 1.5/8 - 2.0/8**  
**SLCT LVR POSI: “D” position**  
**GEAR: “3” ⇒ “4” (I/C ON/OFF)**  
**Driving location: Driving the vehicle uphill (increased engine load) will help maintain the driving conditions required for this test.**
3. Perform step “2” again.
4. Turn ignition switch OFF, then perform step “1” to “3” again.
5. Check “SELF-DIAG RESULTS” mode for “A/T” with CONSULT-II.

If DTC (P1843) is detected, go to [AT-181, "Diagnostic Procedure"](#) .

If DTC (P1752) is detected, go to [AT-155, "Diagnostic Procedure"](#) .

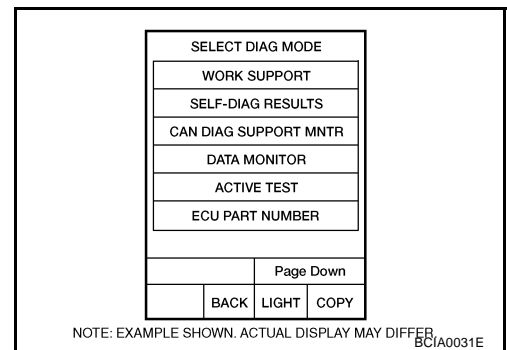

# DTC P1843 ATF PRESSURE SWITCH 3

## Diagnostic Procedure

ACS008G1

### 1. CHECK INPUT SIGNAL

#### With CONSULT-II

1. Start engine.
2. Select "ECU INPUT SIGNALS" or "MAIN SIGNALS" in "DATA MONITOR" mode for "A/T" with CONSULT-II.
3. Drive vehicle in the "D" position (3rd ⇒ 4th gear), and confirm the ON/OFF actuation of the "ATF PRES SW 3".

DATA MONITOR	
MONITOR	NO DTC
ATF PRES SW 1	OFF
ATF PRES SW 2	OFF
ATF PRES SW 3	OFF
ATF PRES SW 5	OFF
ATF PRES SW 6	OFF

△	▽		
RECORD			
MODE	BACK	LIGHT	COPY

PCIA0067E

Item name	Condition	Display value
ATF PRES SW 3	Input clutch engaged. Refer to <a href="#">AT-20</a> .	ON
	Input clutch disengaged. Refer to <a href="#">AT-20</a> .	OFF

#### OK or NG

- OK >> GO TO 4.  
NG >> GO TO 2.

### 2. CHECK TCM POWER SUPPLY AND GROUND CIRCUIT

Check TCM power supply and ground circuit. Refer to [AT-186, "MAIN POWER SUPPLY AND GROUND CIRCUIT"](#) .

#### OK or NG

- OK >> GO TO 3.  
NG >> Repair or replace damaged parts.

### 3. DETECT MALFUNCTIONING ITEM

Check the following.

- A/T assembly harness connector pin terminals for damage or loose connection with harness connector.

#### OK or NG

- OK >> Replace control valve with TCM. Refer to [AT-248, "Control Valve with TCM and A/T Fluid Temperature Sensor 2"](#) .  
NG >> Repair or replace damaged parts.

### 4. CHECK DTC

Perform "DTC Confirmation Procedure".

- Refer to [AT-180, "DTC Confirmation Procedure"](#) .

#### OK or NG

- OK >> **INSPECTION END**  
NG >> GO TO 2.

# DTC P1845 ATF PRESSURE SWITCH 5

## DTC P1845 ATF PRESSURE SWITCH 5

PFP:25240

### Description

ACS0062K

Fail-safe function to detect direct clutch solenoid valve condition.

### CONSULT-II Reference Value

ACS0062L

Item name	Condition	Display value
ATF PRES SW 5	Direct clutch engaged. Refer to <a href="#">AT-20</a> .	ON
	Direct clutch disengaged. Refer to <a href="#">AT-20</a> .	OFF

### On Board Diagnosis Logic

ACS0062M

- This is not an OBD-II self-diagnostic item.
- Diagnostic trouble code “P1845 ATF PRES SW 5/CIRC” with CONSULT-II is detected when TCM detects that actual gear ratio is normal, and relation between gear position and condition of ATF pressure switch 5 is irregular during depressing accelerator pedal. (Other than during shift change)

### Possible Cause

ACS0062N

- ATF pressure switch 5.
- Harness or connectors.  
(Switch circuit is open or shorted.)

### DTC Confirmation Procedure

ACS0062O

#### CAUTION:

Always drive vehicle at a safe speed.

#### NOTE:

If “DTC Confirmation Procedure” has been previously performed, always turn ignition switch OFF and wait at least 10 seconds before performing the next test.

After the repair, perform the following procedure to confirm the malfunction is eliminated.

#### WITH CONSULT-II

1. Start engine.
2. Accelerate vehicle to maintain the following conditions.  
**ACCELE POSI: 1.5/8 - 2.0/8**  
**SLCT LVR POSI: “D” position**  
**GEAR: “1” ⇒ “2” (D/C ON/OFF)**  
**Driving location: Driving the vehicle uphill (increased engine load) will help maintain the driving conditions required for this test.**
3. Perform step “2” again.
4. Turn ignition switch OFF, then perform step “1” to “3” again.
5. Check “SELF-DIAG RESULTS” mode for “A/T” with CONSULT-II.

If DTC (P1845) is detected, go to [AT-183, "Diagnostic Procedure"](#) .

If DTC (P1762) is detected, go to [AT-163, "Diagnostic Procedure"](#) .

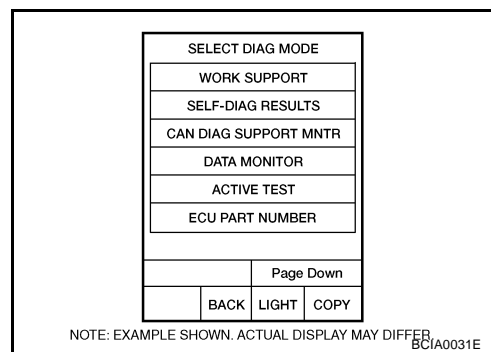

# DTC P1845 ATF PRESSURE SWITCH 5

## Diagnostic Procedure

ACS008GJ

### 1. CHECK INPUT SIGNAL

#### With CONSULT-II

1. Start engine.
2. Select "ECU INPUT SIGNALS" or "MAIN SIGNALS" in "DATA MONITOR" mode for "A/T" with CONSULT-II.
3. Drive vehicle in the "D" position (1st ⇒ 2nd gear), and confirm the ON/OFF actuation of the "ATF PRES SW 5".

Item name	Condition	Display value
ATF PRES SW 5	Direct clutch engaged. Refer to <a href="#">AT-20</a> .	ON
	Direct clutch disengaged. Refer to <a href="#">AT-20</a> .	OFF

DATA MONITOR	
MONITOR	NO DTC
ATF PRES SW 1	OFF
ATF PRES SW 2	OFF
ATF PRES SW 3	OFF
ATF PRES SW 5	OFF
ATF PRES SW 6	OFF

Δ	▽		
RECORD			
MODE	BACK	LIGHT	COPY

PCIA0067E

#### OK or NG

- OK >> GO TO 4.  
NG >> GO TO 2.

### 2. CHECK TCM POWER SUPPLY AND GROUND CIRCUIT

Check TCM power supply and ground circuit. Refer to [AT-186, "MAIN POWER SUPPLY AND GROUND CIRCUIT"](#) .

#### OK or NG

- OK >> GO TO 3.  
NG >> Repair or replace damaged parts.

### 3. DETECT MALFUNCTIONING ITEM

Check the following.

- A/T assembly harness connector pin terminals for damage or loose connection with harness connector.

#### OK or NG

- OK >> Replace control valve with TCM. Refer to [AT-248, "Control Valve with TCM and A/T Fluid Temperature Sensor 2"](#) .  
NG >> Repair or replace damaged parts.

### 4. CHECK DTC

Perform "DTC Confirmation Procedure".

- Refer to [AT-182, "DTC Confirmation Procedure"](#) .

#### OK or NG

- OK >> **INSPECTION END**  
NG >> GO TO 2.

# DTC P1846 ATF PRESSURE SWITCH 6

## DTC P1846 ATF PRESSURE SWITCH 6

PFP:25240

### Description

ACS0062Q

Fail-safe function to detect high and low reverse clutch solenoid valve condition.

### CONSULT-II Reference Value

ACS0062R

Item name	Condition	Display value
ATF PRES SW 6	High and low reverse clutch engaged. Refer to <a href="#">AT-20</a> .	ON
	High and low reverse clutch disengaged. Refer to <a href="#">AT-20</a> .	OFF

### On Board Diagnosis Logic

ACS0062S

- This is not an OBD-II self-diagnostic item.
- Diagnostic trouble code “P1846 ATF PRES SW 6/CIRC” with CONSULT-II is detected when TCM detects that actual gear ratio is normal, and relation between gear position and condition of ATF pressure switch 6 is irregular during depressing accelerator pedal. (Other than during shift change)

### Possible Cause

ACS0062T

- ATF pressure switch 6.
- Harness or connectors.  
(Switch circuit is open or shorted.)

### DTC Confirmation Procedure

ACS0062U

#### CAUTION:

Always drive vehicle at a safe speed.

#### NOTE:

If “DTC Confirmation Procedure” has been previously performed, always turn ignition switch OFF and wait at least 10 seconds before performing the next test.

After the repair, perform the following procedure to confirm the malfunction is eliminated.

#### WITH CONSULT-II

1. Start engine.
2. Accelerate vehicle to maintain the following conditions.  
**ACCELE POSI: 1.5/8 - 2.0/8**  
**SLCT LVR POSI: “D” position**  
**GEAR: “2” ⇒ “3” (HLR/C ON/OFF)**  
**Driving location: Driving the vehicle uphill (increased engine load) will help maintain the driving conditions required for this test.**
3. Perform step “2” again.
4. Turn ignition switch OFF, then perform step “1” to “3” again.
5. Check “SELF-DIAG RESULTS” mode for “A/T” with CONSULT-II.

If DTC (P1846) is detected, go to [AT-185, "Diagnostic Procedure"](#) .

If DTC (P1767) is detected, go to [AT-167, "Diagnostic Procedure"](#) .

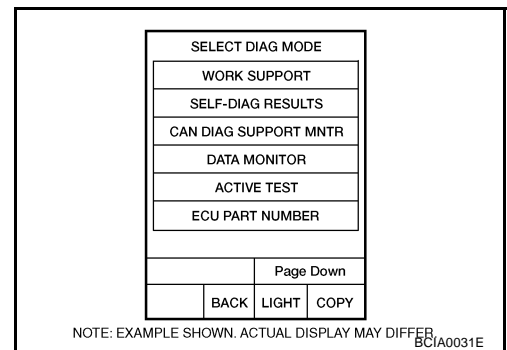



# DTC P1846 ATF PRESSURE SWITCH 6

ACS008GK

## Diagnostic Procedure

### 1. CHECK INPUT SIGNAL

#### With CONSULT-II

1. Start the engine.
2. Select "ECU INPUT SIGNALS" or "MAIN SIGNALS" in "DATA MONITOR" mode for "A/T" with CONSULT-II.
3. Drive vehicle in the "D" position (2nd ⇒ 3rd gear), and confirm the ON/OFF actuation of the "ATF PRES SW 6".

DATA MONITOR	
MONITOR	NO DTC
ATF PRES SW 1	OFF
ATF PRES SW 2	OFF
ATF PRES SW 3	OFF
ATF PRES SW 5	OFF
ATF PRES SW 6	OFF

△	▽		
RECORD			
MODE	BACK	LIGHT	COPY

PCIA0067E

Item name	Condition	Display value
ATF PRES SW 6	High and low reverse clutch engaged. Refer to <a href="#">AT-20</a> .	ON
	High and low reverse clutch disengaged. Refer to <a href="#">AT-20</a> .	OFF

#### OK or NG

- OK >> GO TO 4.  
NG >> GO TO 2.

### 2. CHECK TCM POWER SUPPLY AND GROUND CIRCUIT

Check TCM power supply and ground circuit. Refer to [AT-186, "MAIN POWER SUPPLY AND GROUND CIRCUIT"](#) .

#### OK or NG

- OK >> GO TO 3.  
NG >> Repair or replace damaged parts.

### 3. DETECT MALFUNCTIONING ITEM

Check the following.

- A/T assembly harness connector pin terminals for damage or loose connection with harness connector.

#### OK or NG

- OK >> Replace control valve with TCM. Refer to [AT-248, "Control Valve with TCM and A/T Fluid Temperature Sensor 2"](#) .  
NG >> Repair or replace damaged parts.

### 4. CHECK DTC

Perform "DTC Confirmation Procedure".

- Refer to [AT-184, "DTC Confirmation Procedure"](#) .

#### OK or NG

- OK >> **INSPECTION END**  
NG >> GO TO 2.

# MAIN POWER SUPPLY AND GROUND CIRCUIT

## MAIN POWER SUPPLY AND GROUND CIRCUIT

PFP:00100

### Wiring Diagram — AT — MAIN

ACS0086K

#### AT-MAIN-01

: DETECTABLE LINE FOR DTC  
 : NON-DETECTABLE LINE FOR DTC

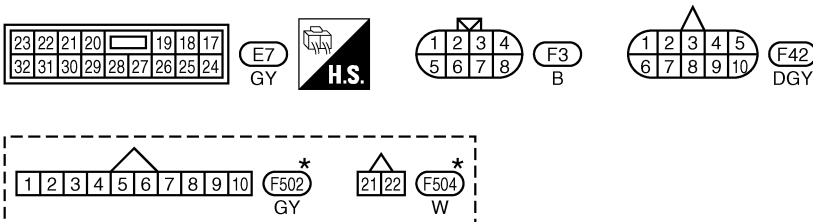
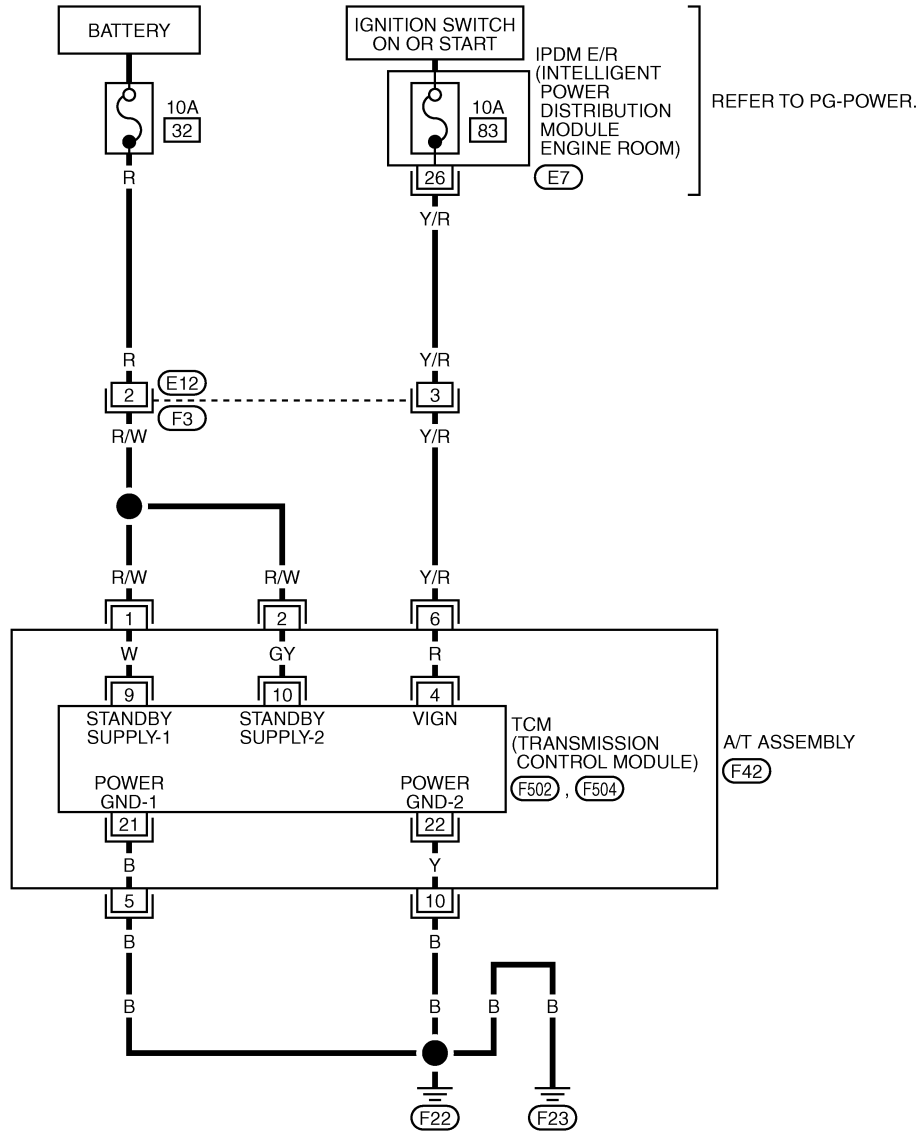



\*: THIS CONNECTOR IS NOT SHOWN IN "HARNES LAYOUT", PG SECTION.

TCWM0394E

# MAIN POWER SUPPLY AND GROUND CIRCUIT

TCM terminals and data are reference value. Measured between each terminal and ground.

Terminal	Wire color	Item	Condition	Data (Approx.)
1	R/W	Power supply (Memory back-up)	Always	Battery voltage
2	R/W	Power supply (Memory back-up)	Always	Battery voltage
5	B	Ground	Always	0V
6	Y/R	Power supply		Battery voltage
				0V
10	B	Ground	Always	0V

## Diagnostic Procedure

ACS008GL

### 1. CHECK TCM POWER SOURCE STEP 1

1. Turn ignition switch OFF.
2. Disconnect A/T assembly harness connector.
3. Check voltage between A/T assembly harness connector and ground.

Item	Connector	Terminal (Wire color)	Voltage
TCM	F42	1 (R/W) - Ground	Battery voltage
		2 (R/W) - Ground	Battery voltage
		6 (Y/R) - Ground	0V

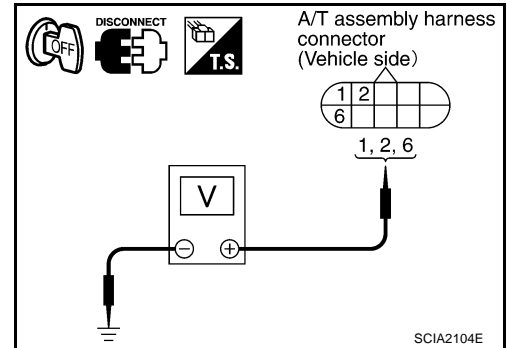

#### OK or NG

- OK >> GO TO 2.  
 NG >> GO TO 3.

### 2. CHECK TCM POWER SOURCE STEP 2

1. Disconnect A/T assembly harness connector.
2. Turn ignition switch ON. (Do not start engine.)
3. Check voltage between A/T assembly harness connector and ground.

Item	Connector	Terminal (Wire color)	Voltage
TCM	F42	1 (R/W) - Ground	Battery voltage
		2 (R/W) - Ground	Battery voltage
		6 (Y/R) - Ground	Battery voltage

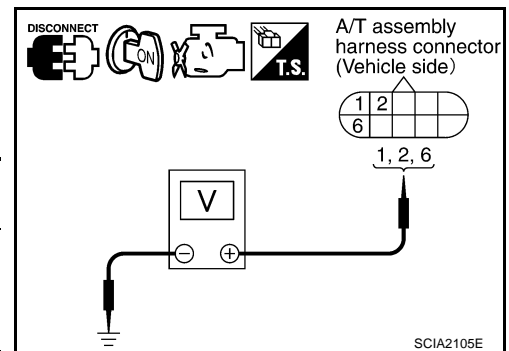

#### OK or NG

- OK >> GO TO 4.  
 NG >> GO TO 3.

# MAIN POWER SUPPLY AND GROUND CIRCUIT

## 3. DETECT MALFUNCTIONING ITEM

Check the following.

- Harness for short or open between battery and A/T assembly harness connector terminals 1, 2
- Harness for short or open between ignition switch and A/T assembly harness connector terminal 6
- 10A fuse (No.32, located in the fuse and fusible link block) and 10A fuse (No.83, located in the IPDM E/R)
- Ignition switch, Refer to [PG-3, "POWER SUPPLY ROUTING CIRCUIT"](#) .

OK or NG

OK >> GO TO 4.

NG >> Repair or replace damaged parts.

## 4. CHECK TCM GROUND CIRCUIT

1. Turn ignition switch OFF.
2. Disconnect A/T assembly harness connector.
3. Check continuity between A/T assembly harness connector terminals and ground.

**Continuity should exist.**

If OK, check harness for short to ground and short to power.

OK or NG

OK >> GO TO 5.

NG >> Repair open circuit or short to ground or short to power in harness or connectors.

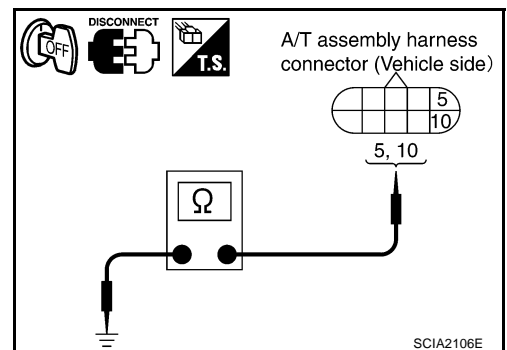

## 5. DETECT MALFUNCTIONING ITEM

Check the following.

- The A/T assembly harness connector terminals for damage or loose connection with harness connector.

OK or NG

OK >> GO TO 6.

NG >> Repair or replace damaged parts.

## 6. PERFORM SELF-DIAGNOSIS

Perform self-diagnosis. Refer to [AT-95, "SELF-DIAGNOSTIC RESULT MODE"](#) .

OK or NG

OK >> **INSPECTION END**

NG-1 >> Self-diagnosis does not activate: GO TO 7.

NG-2 >> DTC is displayed: Check the malfunctioning system. Refer to [AT-95, "SELF-DIAGNOSTIC RESULT MODE"](#) .

# MAIN POWER SUPPLY AND GROUND CIRCUIT

## 7. CHECK TERMINAL CORD ASSEMBLY

1. Remove control valve with TCM. Refer to [AT-248, "Control Valve with TCM and A/T Fluid Temperature Sensor 2"](#) .
2. Disconnect A/T assembly harness connector and TCM connector.
3. Check continuity between A/T assembly harness connector terminals and TCM connector terminals.

Item	Connector	Terminal (Wire color)	Continuity
A/T assembly harness connector	F42	1 (W)	Yes
TCM connector	F502	9 (W)	
A/T assembly harness connector	F42	2 (GY)	Yes
TCM connector	F502	10 (GY)	
A/T assembly harness connector	F42	6 (R)	Yes
TCM connector	F502	4 (R)	

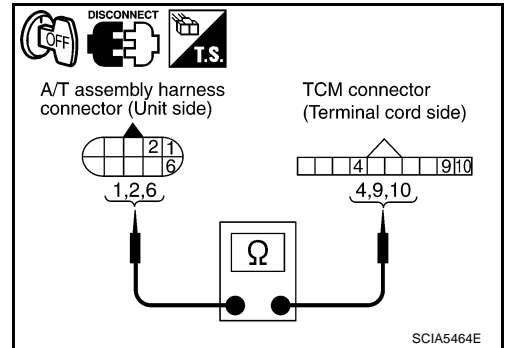

4. Check continuity between A/T assembly harness connector terminals and TCM connector terminals.

Item	Connector	Terminal (Wire color)	Continuity
A/T assembly harness connector	F42	5 (B)	Yes
TCM connector	F504	21 (B)	
A/T assembly harness connector	F42	10 (Y)	Yes
TCM connector	F504	22 (Y)	

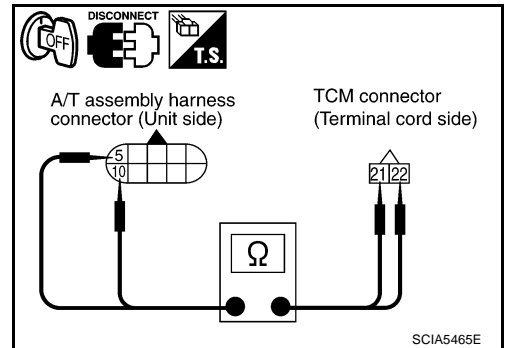

5. If OK, check harness for short to ground and short to power.

OK or NG

- OK >> Replace control valve with TCM. Refer to [AT-248, "Control Valve with TCM and A/T Fluid Temperature Sensor 2"](#) .
- NG >> Replace open circuit or short to ground and short to power in harness or connectors.

# CLOSED THROTTLE POSITION AND WIDE OPEN THROTTLE POSITION CIRCUIT

## CLOSED THROTTLE POSITION AND WIDE OPEN THROTTLE POSITION CIRCUIT

PFP:18002

### CONSULT-II Reference Value

ACS006C1

Item name	Condition	Display value
CLSD THL POS	Released accelerator pedal.	ON
	Fully depressed accelerator pedal.	OFF
W/O THL POS	Fully depressed accelerator pedal.	ON
	Released accelerator pedal.	OFF

### Diagnostic Procedure

ACS008GM

#### 1. CHECK CAN COMMUNICATION LINE

Perform self-diagnosis. Refer to [AT-95, "SELF-DIAGNOSTIC RESULT MODE"](#) , [AT-105, "Diagnostic Procedure without CONSULT-II"](#) .

Is a malfunction in the CAN communication indicated in the results?

- YES >> Check CAN communication line. Refer to [AT-110, "DTC U1000 CAN COMMUNICATION LINE"](#) .  
 NO >> GO TO 2.

#### 2. CHECK THROTTLE POSITION SIGNAL CIRCUIT

##### With CONSULT-II

- Turn ignition switch ON. (Do not start engine.)
- Select "ECU INPUT SIGNALS" in "DATA MONITOR" mode for "A/T" with CONSULT-II.
- Depress accelerator pedal and read out the value of "CLSD THL POS" and "W/O THL POS".

Accelerator Pedal Operation	Monitor Item	
	CLSD THL POS	W/O THL POS
Released	ON	OFF
Fully depressed	OFF	ON

DATA MONITOR			
MONITOR		NO DTC	
ACCELE POSI	0.0/8		
THROTTLE POSI	0.0/8		
CLSD THL POS	ON		
W/O THL POS	OFF		
BRAKE SW	OFF		
		▽	
RECORD			
MODE	BACK	LIGHT	COPY

PCIA0070E

##### OK or NG

- OK >> **INSPECTION END**  
 NG >> Check the following. If NG, repair or replace damaged parts.
- Perform self-diagnosis for "ENGINE" with CONSULT-II. Refer to [EC-137, "CONSULT-II Function \(ENGINE\)"](#) .
  - Open circuit or short to ground or short to power in harness or connectors.
  - Pin terminals for damage or loose connection with harness connector.

# BRAKE SIGNAL CIRCUIT

## BRAKE SIGNAL CIRCUIT

PFP:25320

### CONSULT-II Reference Value

ACS006CJ

Item name	Condition	Display value
BRAKE SW	Depressed brake pedal.	ON
	Released brake pedal.	OFF

### Diagnostic Procedure

ACS0062X

#### 1. CHECK CAN COMMUNICATION LINE

Perform the self-diagnosis. Refer to [AT-95, "SELF-DIAGNOSTIC RESULT MODE"](#) , [AT-105, "Diagnostic Procedure without CONSULT-II"](#) .

Is a malfunction in the CAN communication indicated in the results?

- YES >> Check CAN communication line. Refer to [AT-110, "DTC U1000 CAN COMMUNICATION LINE"](#) .  
 NO >> GO TO 2.

#### 2. CHECK STOP LAMP SWITCH CIRCUIT

##### With CONSULT-II

- Turn ignition switch ON. (Do not start engine.)
- Select "ECU INPUT SIGNALS" in "DATA MONITOR" mode for "A/T" with CONSULT-II.
- Read out ON/OFF switching action of the "BRAKE SW".

Item name	Condition	Display value
BRAKE SW	Depressed brake pedal.	ON
	Released brake pedal.	OFF

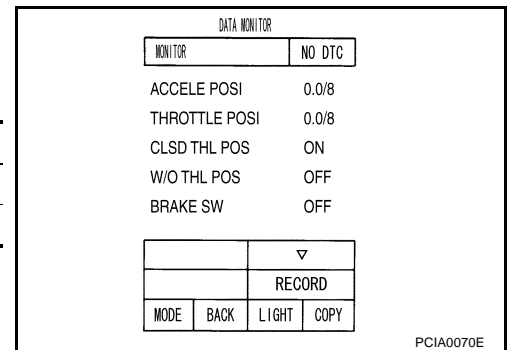

OK or NG

- OK >> **INSPECTION END**  
 NG >> GO TO 3.

#### 3. CHECK STOP LAMP SWITCH

Check continuity between stop lamp switch harness connector E124 terminals 1 and 2. Refer to [AT-193, "Wiring Diagram — AT — NON-DTC"](#) .

Condition	Continuity
When brake pedal is depressed	Yes
When brake pedal is released	No

Check stop lamp switch after adjusting brake pedal — refer to [BR-6, "BRAKE PEDAL"](#) .

OK or NG

- OK >> Check the following. If NG, repair or replace damaged parts.
- Harness for short or open between battery and stop lamp switch.
  - Harness for short or open between stop lamp switch and combination meter.
  - 10A fuse (No.20, located in fuse block).
- NG >> Repair or replace the stop lamp switch.

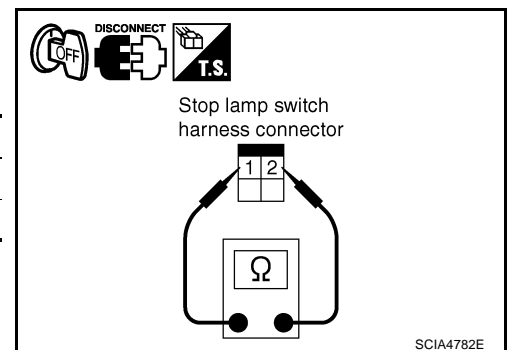

# A/T INDICATOR CIRCUIT

## A/T INDICATOR CIRCUIT

PFP:24810

### Description

ACS008TG

TCM sends the switch signals to combination meters. By CAN communication line. Then manual mode switch position is indicated on the A/T indicator.

### CONSULT-II Reference Value

ACS008TH

Item name	Condition	Display value
GEAR	During driving	1, 2, 3, 4, 5

### Diagnostic Procedure

ACS008TI

#### 1. CHECK INPUT SIGNALS

##### Ⓟ With CONSULT-II

- Start engine.
- Select "MAIN SIGNALS" in "DATA MONITOR" mode for "A/T" with CONSULT-II and read out the value of "GEAR".
- Drive vehicle in the manual mode, and confirm that the actual gear position and the meter's indication of the position mutually coincide when the selector lever is shifted to the "+ (up)" or "- (down)" side (1st ⇔ 5th gear).

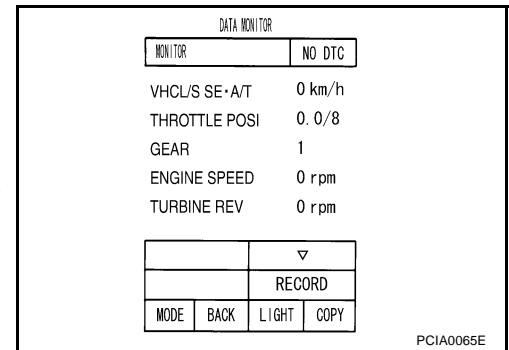

##### OK or NG

- OK >> **INSPECTION END**  
 NG >> Check the following.

### A/T INDICATOR SYMPTOM CHART

Items	Possible location of malfunction
The actual gear position does not change, or shifting into the manual mode is not possible (no gear shifting in the manual mode possible). The A/T indicator is not indicated.	Manual mode switch Refer to <a href="#">AT-174, "DTC P1815 MANUAL MODE SWITCH"</a> . A/T main system (Fail-safe function actuated) ● Refer to <a href="#">AT-95, "SELF-DIAGNOSTIC RESULT MODE"</a> .
The actual gear position changes, but the A/T indicator is not indicated.	Perform the self-diagnosis function. ● Refer to <a href="#">AT-95, "SELF-DIAGNOSTIC RESULT MODE"</a> .
The actual gear position and the indication on the A/T indicator do not coincide.	Perform the self-diagnosis function. ● Refer to <a href="#">AT-95, "SELF-DIAGNOSTIC RESULT MODE"</a> .
Only a specific position or positions is/are not indicated on the A/T indicator.	Check the combination meters. Refer to <a href="#">DI-4, "COMBINATION METERS"</a> .



# TROUBLE DIAGNOSIS FOR SYMPTOMS

## TROUBLE DIAGNOSIS FOR SYMPTOMS

PFP:00007

### Wiring Diagram — AT — NONDTC

ACS00899

#### AT-NONDTC-01

REFER TO PG-POWER.

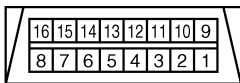
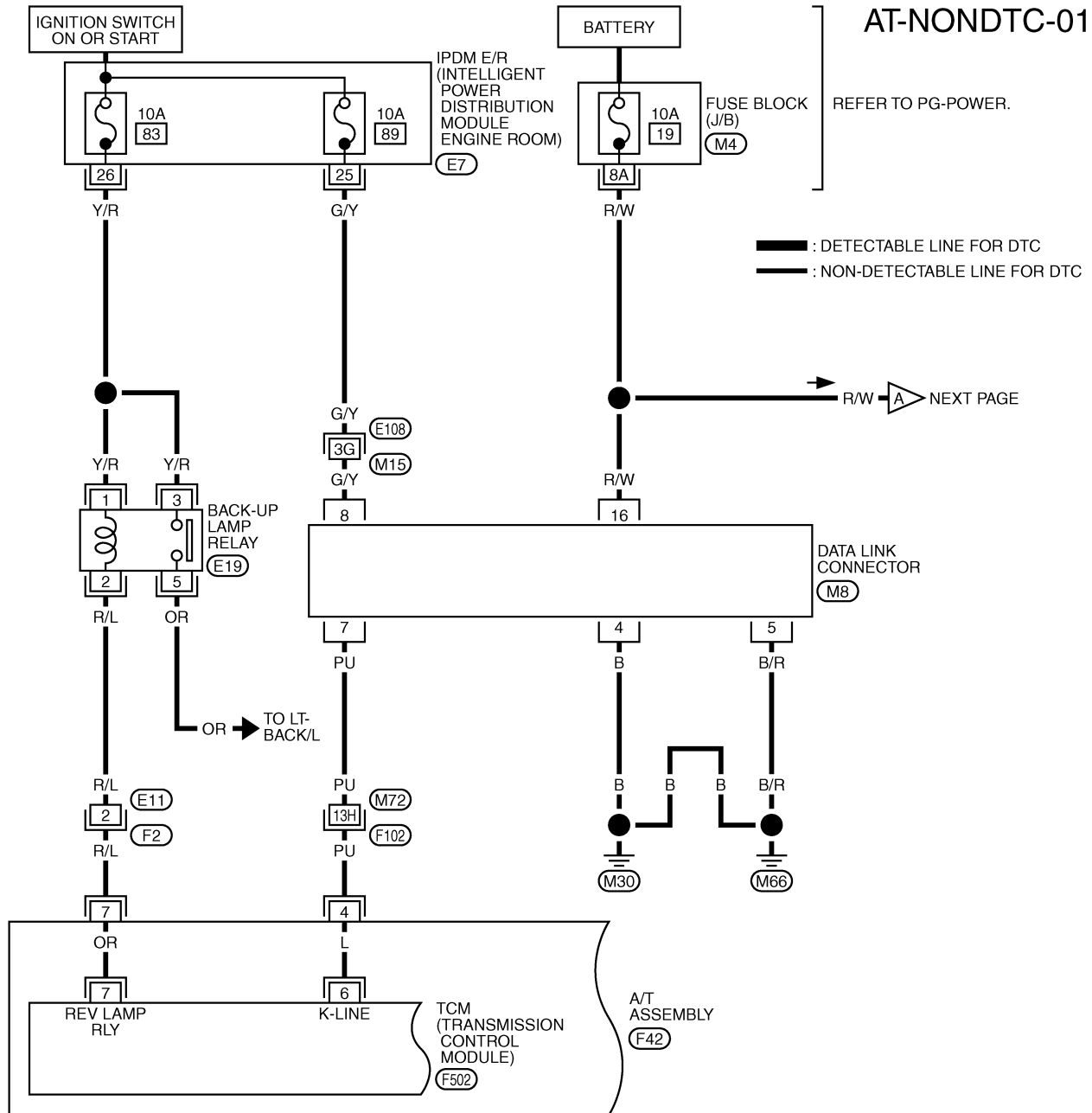

(M8) W

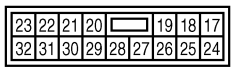

(E7) GY



H.S.

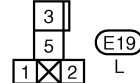

(E19) L

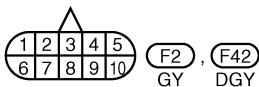

(F2) GY, (F42) DGY

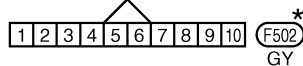

(F502) GY \*

REFER TO THE FOLLOWING.

(E108), (F102) -SUPER MULTIPLE JUNCTION (SMJ)

(M4) -FUSE BLOCK-JUNCTION BOX (J/B)

\*: THIS CONNECTOR IS NOT SHOWN IN "HARNESS LAYOUT", PG SECTION.

# TROUBLE DIAGNOSIS FOR SYMPTOMS

## AT-NONDTC-02

REFER TO PG-POWER.

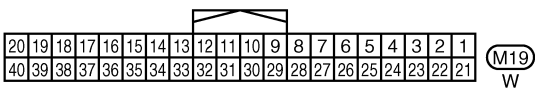
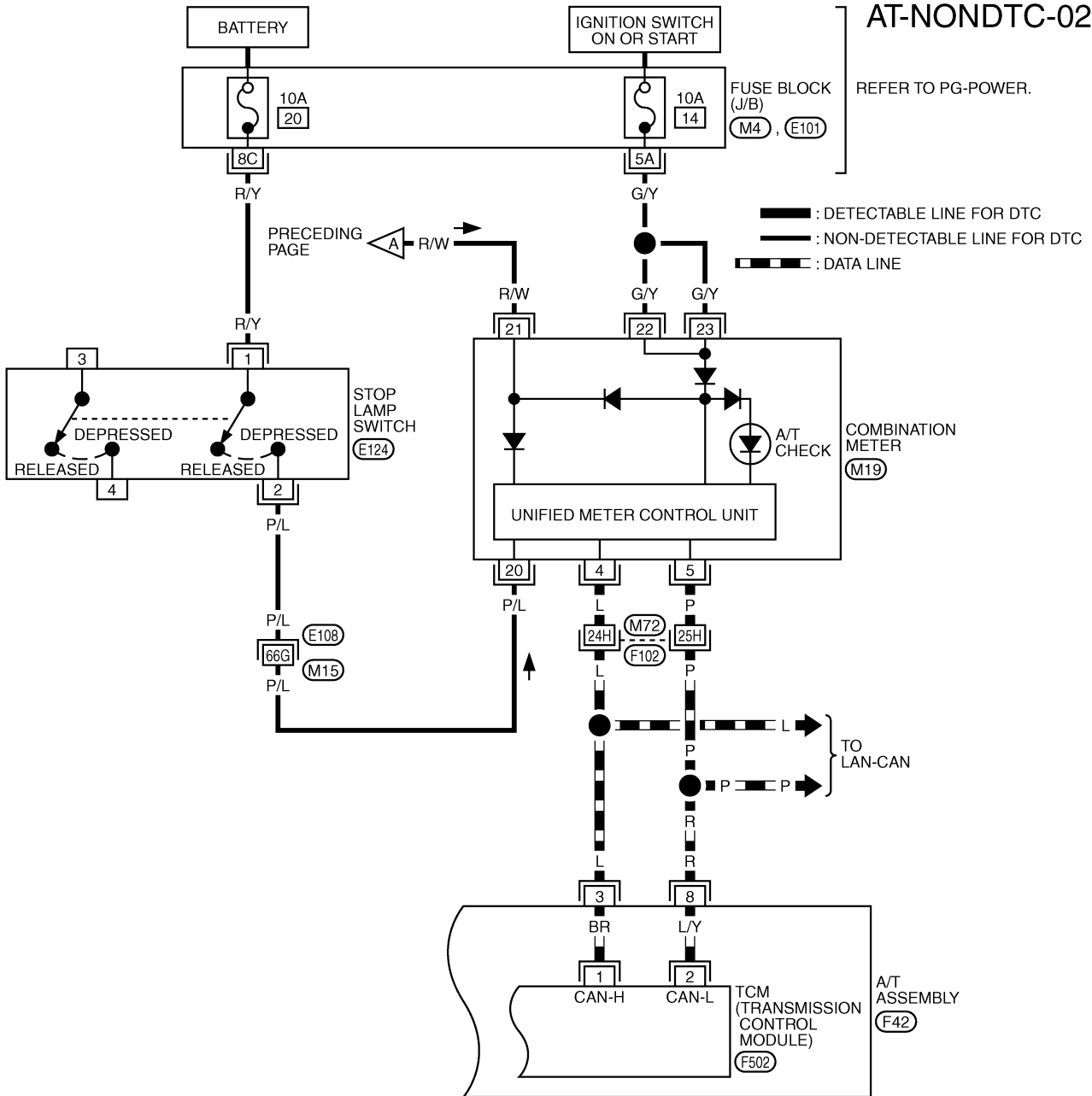

\*: THIS CONNECTOR IS NOT SHOWN IN "HARNESS LAYOUT", PG SECTION.

REFER TO THE FOLLOWING.

(E108), (F102) -SUPER MULTIPLE JUNCTION (SMJ)

(M4), (E101) -FUSE BLOCK-JUNCTION BOX (J/B)

TCWM0396E

# TROUBLE DIAGNOSIS FOR SYMPTOMS

TCM terminals and data are reference value. Measured between each terminal and ground.

Terminal	Wire color	Item	Condition	Data (Approx.)
3	L	CAN-H	-	-
4	PU	K-line (CONSULT-II signal)	The terminal is connected to the data link connector for CONSULT-II.	-
7	R/L	Back-up lamp relay	 Selector lever in "R" position.	0V
			Selector lever in other positions.	Battery voltage
8	R	CAN-L	-	-

## A/T CHECK Indicator Lamp Does Not Come On SYMPTOM:

ACS008H4

A/T CHECK indicator lamp does not come on for about 2 seconds when turning ignition switch to ON.

### DIAGNOSTIC PROCEDURE

#### 1. CHECK CAN COMMUNICATION LINE

Perform self-diagnosis. Refer to [AT-95, "SELF-DIAGNOSTIC RESULT MODE"](#) , [AT-105, "Diagnostic Procedure without CONSULT-II"](#) .

Is a malfunction in the CAN communication indicated in the results?

- YES >> Check CAN communication line. Refer to [AT-110, "DTC U1000 CAN COMMUNICATION LINE"](#) .
- NO >> GO TO 2.

#### 2. CHECK A/T CHECK INDICATOR LAMP CIRCUIT

Check combination meter. Refer to [DI-4, "COMBINATION METERS"](#) .

OK or NG

- OK >> GO TO 3.
- NG >> Repair or replace damaged parts.

#### 3. CHECK TCM POWER SUPPLY AND GROUND CIRCUIT

Check TCM power supply and ground circuit. Refer to [AT-186, "MAIN POWER SUPPLY AND GROUND CIRCUIT"](#) .

OK or NG

- OK >> **INSPECTION END**
- NG >> Repair or replace damaged parts.

# TROUBLE DIAGNOSIS FOR SYMPTOMS

## Engine Cannot Be Started in “P” or “N” Position

ACS008H5

### SYMPTOM:

- Engine cannot be started with selector lever in “P” or “N” position.
- Engine can be started with selector lever in “D” or “R” position.

### DIAGNOSTIC PROCEDURE

#### 1. CHECK PNP SWITCH CIRCUIT

Perform self-diagnosis. Refer to [AT-95, "SELF-DIAGNOSTIC RESULT MODE"](#) , [AT-105, "Diagnostic Procedure without CONSULT-II"](#) .

Do the self-diagnostic results indicate PNP switch?

YES >> Check the malfunctioning system. Refer to [AT-118, "DTC P0705 PARK/NEUTRAL POSITION SWITCH"](#) .

NO >> GO TO 2.

#### 2. CHECK CONTROL LINKAGE

Check the control linkage.

- Refer to [AT-239, "Checking of A/T Position"](#) .

OK or NG

OK >> GO TO 3.

NG >> Adjust control linkage. Refer to [AT-238, "Adjustment of A/T Position"](#) .

#### 3. CHECK STARTING SYSTEM

Check starting system. Refer to [SC-9, "STARTING SYSTEM"](#) .

OK or NG

OK >> **INSPECTION END**

NG >> Repair or replace damaged parts.

## In “P” Position, Vehicle Moves When Pushed

ACS008H6

### SYMPTOM:

Even though the selector lever is set in the “P” position, the parking mechanism is not actuated, allowing the vehicle to be moved when it is pushed.

### DIAGNOSTIC PROCEDURE

#### 1. CHECK PNP SWITCH CIRCUIT

Perform self-diagnosis. Refer to [AT-95, "SELF-DIAGNOSTIC RESULT MODE"](#) , [AT-105, "Diagnostic Procedure without CONSULT-II"](#) .

Do the self-diagnostic results indicate PNP switch?

YES >> Check the malfunctioning system. Refer to [AT-118, "DTC P0705 PARK/NEUTRAL POSITION SWITCH"](#) .

NO >> GO TO 2.

#### 2. CHECK CONTROL LINKAGE

Check the control linkage.

- Refer to [AT-239, "Checking of A/T Position"](#) .

OK or NG

OK >> GO TO 3.

NG >> Adjust control linkage. Refer to [AT-238, "Adjustment of A/T Position"](#) .

# TROUBLE DIAGNOSIS FOR SYMPTOMS

## 3. CHECK PARKING COMPONENTS

Check parking components. Refer to [AT-260, "Parking Components \(2WD Models Only\)"](#) or [AT-292, "Disassembly"](#) (AWD models).

OK or NG

- OK >> GO TO 4.
- NG >> Repair or replace damaged parts.

## 4. CHECK A/T FLUID CONDITION

1. Remove oil pan. Refer to [AT-248, "Control Valve with TCM and A/T Fluid Temperature Sensor 2"](#).
2. Check A/T fluid condition. Refer to [AT-51, "A/T Fluid Condition Check"](#).

OK or NG

- OK >> **INSPECTION END**
- NG >> Check the malfunction items. If any items are damaged, repair or replace damaged parts. Refer to [AT-66, "Symptom Chart"](#) (Symptom No.65)

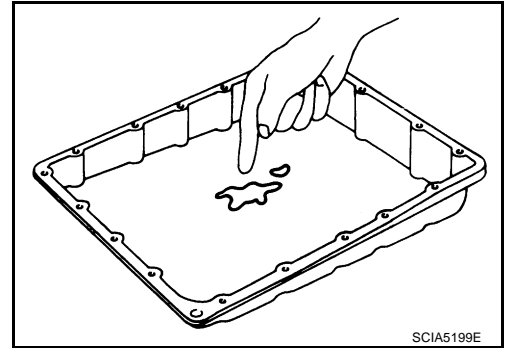

ACS008H7

### In "N" Position, Vehicle Moves SYMPTOM:

Vehicle moves forward or backward when selecting "N" position.

### DIAGNOSTIC PROCEDURE

#### 1. CHECK PNP SWITCH CIRCUIT

Perform self-diagnosis. Refer to [AT-95, "SELF-DIAGNOSTIC RESULT MODE"](#), [AT-105, "Diagnostic Procedure without CONSULT-II"](#).

Do the self-diagnostic results indicate PNP switch?

- YES >> Check the malfunctioning system. Refer to [AT-118, "DTC P0705 PARK/NEUTRAL POSITION SWITCH"](#).
- NO >> GO TO 2.

#### 2. CHECK CONTROL LINKAGE

Check the control linkage.

- Refer to [AT-239, "Checking of A/T Position"](#).

OK or NG

- OK >> GO TO 3.
- NG >> Adjust control linkage. Refer to [AT-238, "Adjustment of A/T Position"](#).

#### 3. CHECK A/T FLUID LEVEL

Check A/T fluid level. Refer to [AT-12, "Checking A/T Fluid"](#).

OK or NG

- OK >> GO TO 4.
- NG >> Refill ATF.

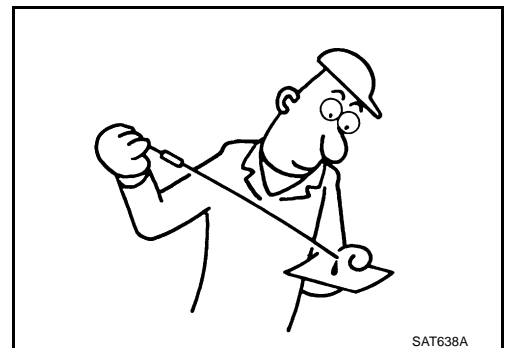

# TROUBLE DIAGNOSIS FOR SYMPTOMS

## 4. CHECK A/T FLUID CONDITION

1. Remove oil pan. Refer to [AT-248, "Control Valve with TCM and A/T Fluid Temperature Sensor 2"](#) .
2. Check A/T fluid condition. Refer to [AT-51, "A/T Fluid Condition Check"](#) .

OK or NG

- OK >> GO TO 5.  
NG >> Check the malfunction items. If any items are damaged, repair or replace damaged parts. Refer to [AT-66, "Symptom Chart"](#) (Symptom No.67).

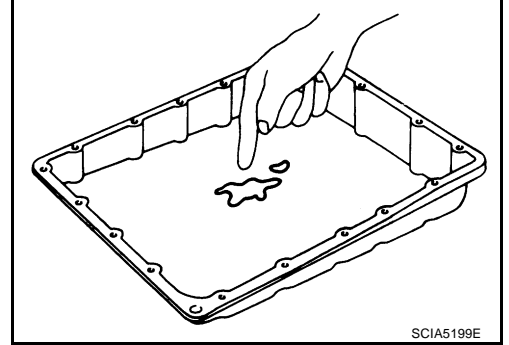

## 5. CHECK SYMPTOM

Check again. Refer to [AT-56, "Check at Idle"](#) .

OK or NG

- OK >> **INSPECTION END**  
NG >> GO TO 6.

## 6. CHECK TCM

1. Check TCM input/output signals. Refer to [AT-91, "TCM Input/Output Signal Reference Values"](#) .
2. If NG, recheck A/T assembly harness connector terminals for damage or loose connection with harness connector.

OK or NG

- OK >> **INSPECTION END**  
NG >> Repair or replace damaged parts.

## Large Shock ("N" to "D" Position) SYMPTOM:

ACS008H8

A noticeable shock occurs when the selector lever is shifted from the "N" to "D" position.

### DIAGNOSTIC PROCEDURE

#### 1. CHECK SELF-DIAGNOSTIC RESULTS

Perform self-diagnosis. Refer to [AT-95, "SELF-DIAGNOSTIC RESULT MODE"](#) , [AT-105, "Diagnostic Procedure without CONSULT-II"](#) .

Is any malfunction detected by self-diagnostic results?

- YES >> Check the malfunctioning system. Refer to [AT-95, "SELF-DIAGNOSTIC RESULT MODE"](#) , [AT-109, "Judgement Self-diagnosis Code"](#) .  
NO >> GO TO 2.

#### 2. CHECK ENGINE IDLE SPEED

Check the engine idle speed. Refer to [EC-77, "Idle Speed and Ignition Timing Check"](#) .

OK or NG

- OK >> GO TO 3.  
NG >> Adjust engine idle speed. Refer to [EC-77, "Idle Speed and Ignition Timing Check"](#) .

# TROUBLE DIAGNOSIS FOR SYMPTOMS

## 3. CHECK CONTROL LINKAGE

Check the control linkage.

- Refer to [AT-239, "Checking of A/T Position"](#) .

OK or NG

OK >> GO TO 4.

NG >> Adjust control linkage. Refer to [AT-238, "Adjustment of A/T Position"](#) .

## 4. CHECK A/T FLUID LEVEL

Check the A/T fluid level. Refer to [AT-12, "Checking A/T Fluid"](#) .

OK or NG

OK >> GO TO 5.

NG >> Refill ATF.

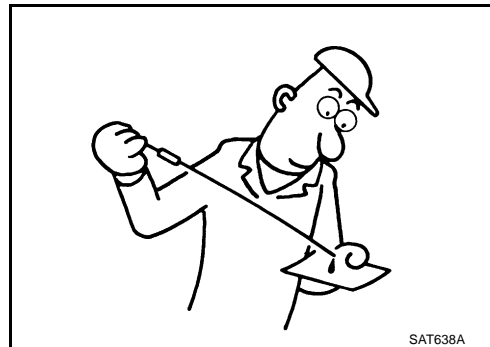

## 5. CHECK LINE PRESSURE

Check line pressure at idle with selector lever in "D" position. Refer to [AT-53, "LINE PRESSURE TEST"](#) .

OK or NG

OK >> GO TO 8.

NG - 1 >> Line pressure high: GO TO 6.

NG - 2 >> Line pressure low: GO TO 7.

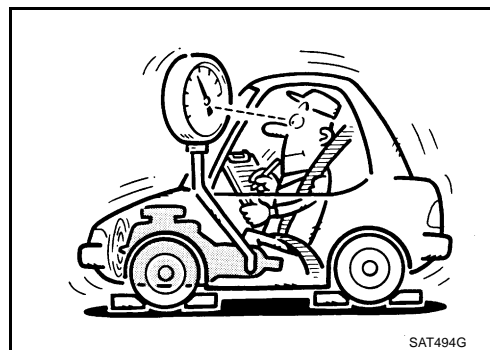

## 6. DETECT MALFUNCTIONING ITEM

1. Check control valve with TCM. Refer to [AT-248, "Control Valve with TCM and A/T Fluid Temperature Sensor 2"](#) .
2. Disassemble A/T. Refer to [AT-292, "DISASSEMBLY"](#) .
3. Check the following.
  - Oil pump assembly. Refer to [AT-310, "Oil Pump"](#) .

OK or NG

OK >> GO TO 8.

NG >> Repair or replace damaged parts.

# TROUBLE DIAGNOSIS FOR SYMPTOMS

## 7. DETECT MALFUNCTIONING ITEM

1. Check control valve with TCM. Refer to [AT-248, "Control Valve with TCM and A/T Fluid Temperature Sensor 2"](#) .
2. Disassemble A/T. Refer to [AT-292, "DISASSEMBLY"](#) .
3. Check the following.
  - Oil pump assembly. Refer to [AT-310, "Oil Pump"](#) .
  - Power train system. Refer to [AT-292, "DISASSEMBLY"](#) .
  - Transmission case. Refer to [AT-292, "DISASSEMBLY"](#) .

### OK or NG

- OK >> GO TO 8.  
NG >> Repair or replace damaged parts.

## 8. CHECK A/T FLUID CONDITION

1. Remove oil pan. Refer to [AT-248, "Control Valve with TCM and A/T Fluid Temperature Sensor 2"](#) .
2. Check A/T fluid condition. Refer to [AT-51, "A/T Fluid Condition Check"](#) .

### OK or NG

- OK >> GO TO 10.  
NG >> GO TO 9.

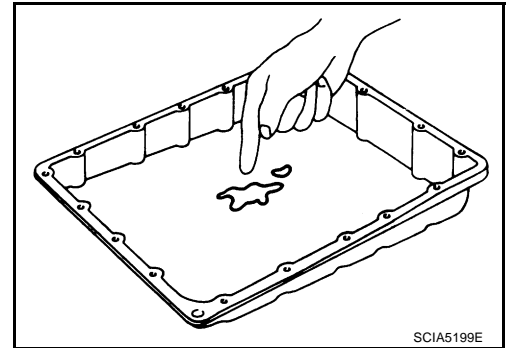

## 9. DETECT MALFUNCTIONING ITEM

- Check the malfunction items. If any items are damaged, repair or replace damaged parts. Refer to [AT-66, "Symptom Chart"](#) (Symptom No.1).

### OK or NG

- OK >> GO TO 10.  
NG >> Repair or replace damaged parts.

## 10. CHECK SYMPTOM

Check again. Refer to [AT-56, "Check at Idle"](#) .

### OK or NG

- OK >> **INSPECTION END**  
NG >> GO TO 11.

## 11. CHECK TCM

1. Check TCM input/output signals. Refer to [AT-91, "TCM Input/Output Signal Reference Values"](#) .
2. If NG, recheck A/T assembly harness connector terminals for damage or loose connection with harness connector.

### OK or NG

- OK >> **INSPECTION END**  
NG >> Repair or replace damaged parts.



# TROUBLE DIAGNOSIS FOR SYMPTOMS

ACS008H9

## Vehicle Does Not Creep Backward in "R" Position

### SYMPTOM:

The vehicle does not creep in the "R" position. Or an extreme lack of acceleration is observed.

### DIAGNOSTIC PROCEDURE

#### 1. CHECK SELF-DIAGNOSTIC RESULTS

Perform self-diagnosis. Refer to [AT-95, "SELF-DIAGNOSTIC RESULT MODE"](#) , [AT-105, "Diagnostic Procedure without CONSULT-II"](#) .

Is any malfunction detected by self-diagnostic results?

- YES >> Check the malfunctioning system. Refer to [AT-95, "SELF-DIAGNOSTIC RESULT MODE"](#) , [AT-109, "Judgement Self-diagnosis Code"](#) .
- NO >> GO TO 2.

#### 2. CHECK CONTROL LINKAGE

Check the control linkage.

- Refer to [AT-239, "Checking of A/T Position"](#) .

OK or NG

- OK >> GO TO 3.
- NG >> Adjust control linkage. Refer to [AT-238, "Adjustment of A/T Position"](#) .

#### 3. CHECK A/T FLUID LEVEL

Check A/T fluid level. Refer to [AT-12, "Checking A/T Fluid"](#) .

OK or NG

- OK >> GO TO 4.
- NG >> Refill ATF.

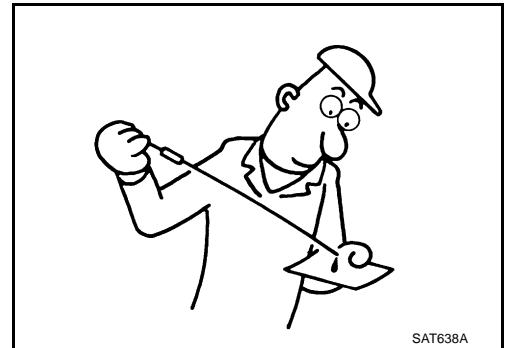

#### 4. CHECK STALL TEST

Check stall revolution with selector lever in "M" and "R" positions. Refer to [AT-51, "STALL TEST"](#) .

OK or NG

- OK >> GO TO 6.
- OK in "M" position, NG in "R" position>>GO TO 5.
- NG in both "M" and "R" positions>>GO TO 8.

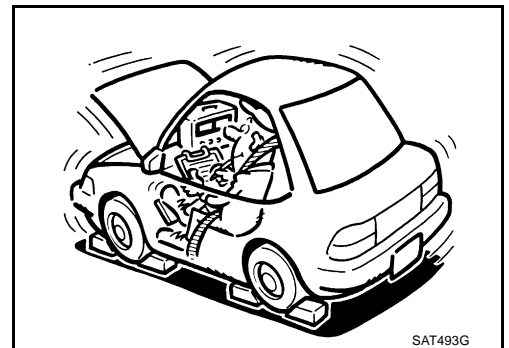

# TROUBLE DIAGNOSIS FOR SYMPTOMS

## 5. DETECT MALFUNCTIONING ITEM

1. Disassemble A/T. Refer to [AT-292, "DISASSEMBLY"](#) .
2. Check the following.
  - Reverse brake. Refer to [AT-292, "DISASSEMBLY"](#) .

### OK or NG

- OK >> GO TO 9.  
NG >> Repair or replace damaged parts.

## 6. CHECK LINE PRESSURE

Check the line pressure with the engine idling. Refer to [AT-53, "LINE PRESSURE TEST"](#) .

### OK or NG

- OK >> GO TO 9.  
NG - 1 >> Line pressure high. GO TO 7.  
NG - 2 >> Line pressure low. GO TO 8.

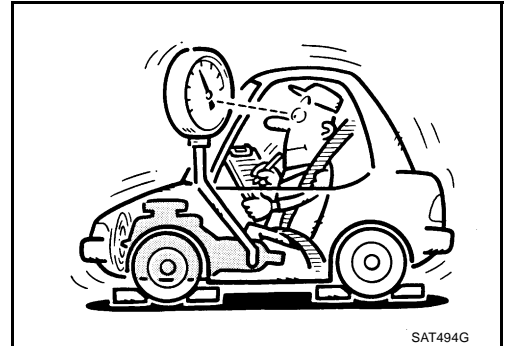

## 7. DETECT MALFUNCTIONING ITEM

1. Check control valve with TCM. Refer to [AT-248, "Control Valve with TCM and A/T Fluid Temperature Sensor 2"](#) .
2. Disassemble A/T. Refer to [AT-292, "DISASSEMBLY"](#) .
3. Check the following.
  - Oil pump assembly. Refer to [AT-310, "Oil Pump"](#) .

### OK or NG

- OK >> GO TO 9.  
NG >> Repair or replace damaged parts.

## 8. DETECT MALFUNCTIONING ITEM

1. Check control valve with TCM. Refer to [AT-248, "Control Valve with TCM and A/T Fluid Temperature Sensor 2"](#) .
2. Disassemble A/T. Refer to [AT-292, "DISASSEMBLY"](#) .
3. Check the following.
  - Oil pump assembly. Refer to [AT-310, "Oil Pump"](#) .
  - Power train system. Refer to [AT-292, "DISASSEMBLY"](#) .
  - Transmission case. Refer to [AT-292, "DISASSEMBLY"](#) .

### OK or NG

- OK >> GO TO 9.  
NG >> Repair or replace damaged parts.

# TROUBLE DIAGNOSIS FOR SYMPTOMS

## 9. CHECK A/T FLUID CONDITION

1. Remove oil pan. Refer to [AT-248, "Control Valve with TCM and A/T Fluid Temperature Sensor 2"](#) .
2. Check A/T fluid condition. Refer to [AT-51, "A/T Fluid Condition Check"](#) .

OK or NG

OK >> GO TO 10.

NG >> GO TO 13.

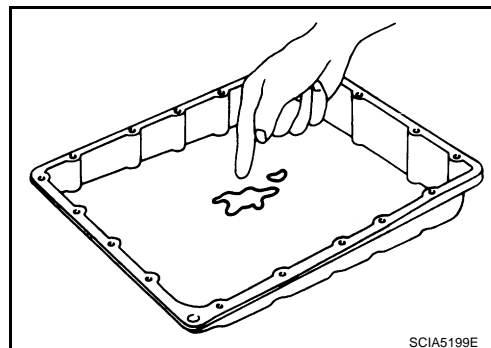

## 10. DETECT MALFUNCTIONING ITEM

- Check the malfunction items. If any items are damaged, repair or replace damaged parts. Refer to [AT-66, "Symptom Chart"](#) (Symptom No.43).

OK or NG

OK >> GO TO 11.

NG >> Repair or replace damaged parts.

## 11. CHECK SYMPTOM

Check again. Refer to [AT-56, "Check at Idle"](#) .

OK or NG

OK >> **INSPECTION END**

NG >> GO TO 12.

## 12. CHECK TCM

1. Check TCM input/output signals. Refer to [AT-91, "TCM Input/Output Signal Reference Values"](#) .
2. If NG, recheck A/T assembly harness connector terminals for damage or loose connection with harness connector.

OK or NG

OK >> **INSPECTION END**

NG >> Repair or replace damaged parts.

## 13. DETECT MALFUNCTIONING ITEM

- Check the malfunction items. If any items are damaged, repair or replace damaged parts. Refer to [AT-66, "Symptom Chart"](#) (Symptom No.43).

OK or NG

OK >> GO TO 11.

NG >> Repair or replace damaged parts.

# TROUBLE DIAGNOSIS FOR SYMPTOMS

ACS008HA

## Vehicle Does Not Creep Forward in "D" Position

### SYMPTOM:

Vehicle does not creep forward when selecting "D" position.

### DIAGNOSTIC PROCEDURE

#### 1. CHECK SELF-DIAGNOSTIC RESULTS

Perform self-diagnosis. Refer to [AT-95, "SELF-DIAGNOSTIC RESULT MODE"](#) , [AT-105, "Diagnostic Procedure without CONSULT-II"](#) .

Is any malfunction detected by self-diagnostic results?

- YES >> Check the malfunctioning system. Refer to [AT-95, "SELF-DIAGNOSTIC RESULT MODE"](#) , [AT-109, "Judgement Self-diagnosis Code"](#) .
- NO >> GO TO 2.

#### 2. CHECK CONTROL LINKAGE

Check the control linkage.

- Refer to [AT-239, "Checking of A/T Position"](#) .

OK or NG

- OK >> GO TO 3.
- NG >> Adjust control linkage. Refer to [AT-238, "Adjustment of A/T Position"](#) .

#### 3. CHECK A/T FLUID LEVEL

Check A/T fluid level. Refer to [AT-12, "Checking A/T Fluid"](#) .

OK or NG

- OK >> GO TO 4.
- NG >> Refill ATF.

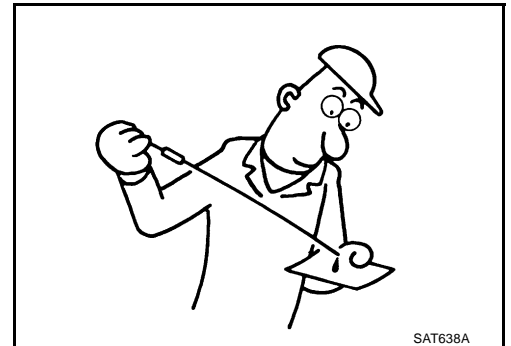

#### 4. CHECK STALL TEST

Check stall revolution with selector lever in "D" position. Refer to [AT-51, "STALL TEST"](#) .

OK or NG

- OK >> GO TO 5.
- NG >> GO TO 7.

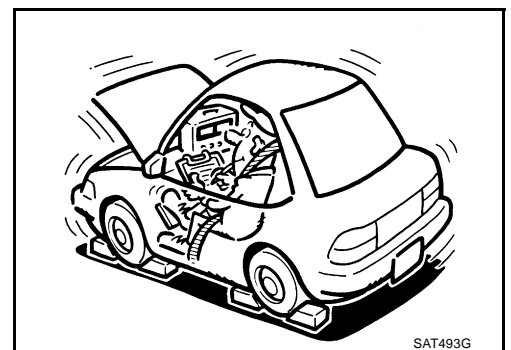

# TROUBLE DIAGNOSIS FOR SYMPTOMS

## 5. CHECK LINE PRESSURE

Check line pressure at idle with selector lever in "D" position. Refer to [AT-53, "LINE PRESSURE TEST"](#) .

OK or NG

- OK >> GO TO 8.
- NG - 1 >> Line pressure high. GO TO 6.
- NG - 2 >> Line pressure low. GO TO 7.

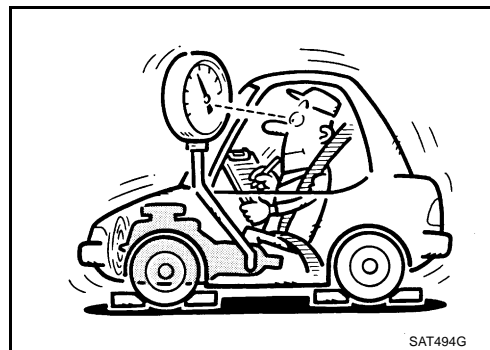

## 6. DETECT MALFUNCTIONING ITEM

1. Check control valve with TCM. Refer to [AT-248, "Control Valve with TCM and A/T Fluid Temperature Sensor 2"](#) .
2. Disassemble A/T. Refer to [AT-292, "DISASSEMBLY"](#) .
3. Check the following.
  - Oil pump assembly. Refer to [AT-310, "Oil Pump"](#) .

OK or NG

- OK >> GO TO 8.
- NG >> Repair or replace damaged parts.

## 7. DETECT MALFUNCTIONING ITEM

1. Check control valve with TCM. Refer to [AT-248, "Control Valve with TCM and A/T Fluid Temperature Sensor 2"](#) .
2. Disassemble A/T. Refer to [AT-292, "DISASSEMBLY"](#) .
3. Check the following.
  - Oil pump assembly. Refer to [AT-310, "Oil Pump"](#) .
  - Power train system. Refer to [AT-292, "DISASSEMBLY"](#) .
  - Transmission case. Refer to [AT-292, "DISASSEMBLY"](#) .

OK or NG

- OK >> GO TO 8.
- NG >> Repair or replace damaged parts.

## 8. CHECK A/T FLUID CONDITION

1. Remove oil pan. Refer to [AT-248, "Control Valve with TCM and A/T Fluid Temperature Sensor 2"](#) .
2. Check A/T fluid condition. Refer to [AT-51, "A/T Fluid Condition Check"](#) .

OK or NG

- OK >> GO TO 9.
- NG >> GO TO 12.

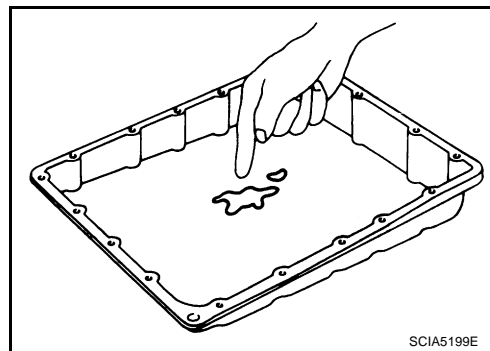

# TROUBLE DIAGNOSIS FOR SYMPTOMS

---

## 9. DETECT MALFUNCTIONING ITEM

---

- Check the malfunction items. If any items are damaged, repair or replace damaged parts. Refer to [AT-66, "Symptom Chart"](#) (Symptom No.43).

OK or NG

- OK >> GO TO 10.  
NG >> Repair or replace damaged parts.

---

## 10. CHECK SYMPTOM

---

Check again. Refer to [AT-56, "Check at Idle"](#) .

OK or NG

- OK >> **INSPECTION END**  
NG >> GO TO 11.

---

## 11. CHECK TCM

---

1. Check TCM input/output signals. Refer to [AT-91, "TCM Input/Output Signal Reference Values"](#) .
2. If NG, recheck A/T assembly harness connector terminals for damage or loose connection with harness connector.

OK or NG

- OK >> **INSPECTION END**  
NG >> Repair or replace damaged parts.

---

## 12. DETECT MALFUNCTIONING ITEM

---

- Check the malfunction items. If any items are damaged, repair or replace damaged parts. Refer to [AT-66, "Symptom Chart"](#) (Symptom No.43).

OK or NG

- OK >> GO TO 10.  
NG >> Repair or replace damaged parts.

### Vehicle Cannot Be Started from D1 SYMPTOM:

ACS008HB

Vehicle cannot be started from D1 on "Cruise Test - Part 1" and "Cruise Test - Part 2".

### DIAGNOSTIC PROCEDURE

---

#### 1. CHECK SYMPTOM

---

Check if vehicle creeps in "R" position.

OK or NG

- OK >> GO TO 2.  
NG >> Refer to [AT-201, "Vehicle Does Not Creep Backward in "R" Position"](#) .

---

#### 2. CHECK SELF-DIAGNOSTIC RESULTS

---

Perform self-diagnosis. Refer to [AT-95, "SELF-DIAGNOSTIC RESULT MODE"](#) , [AT-105, "Diagnostic Procedure without CONSULT-II"](#) .

Is any malfunction detected by self-diagnostic results?

- YES >> Check the malfunctioning system. Refer to [AT-95, "SELF-DIAGNOSTIC RESULT MODE"](#) , [AT-109, "Judgement Self-diagnosis Code"](#) .  
NO >> GO TO 3.

# TROUBLE DIAGNOSIS FOR SYMPTOMS

## 3. CHECK ACCELERATOR PEDAL POSITION (APP) SENSOR

Check accelerator pedal position (APP) sensor. Refer to [AT-137, "DTC P1705 THROTTLE POSITION SENSOR"](#)

OK or NG

OK >> GO TO 4.

NG >> Repair or replace accelerator pedal position (APP) sensor.

## 4. CHECK A/T FLUID LEVEL

Check A/T fluid level. Refer to [AT-12, "Checking A/T Fluid"](#) .

OK or NG

OK >> GO TO 5.

NG >> Refill ATF.

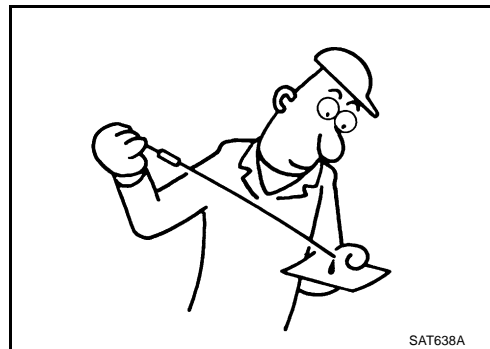

## 5. CHECK LINE PRESSURE

Check line pressure at the engine stall point. Refer to [AT-53, "LINE PRESSURE TEST"](#) .

OK or NG

OK >> GO TO 8.

NG - 1 >> Line pressure high. GO TO 6.

NG - 2 >> Line pressure low. GO TO 7.

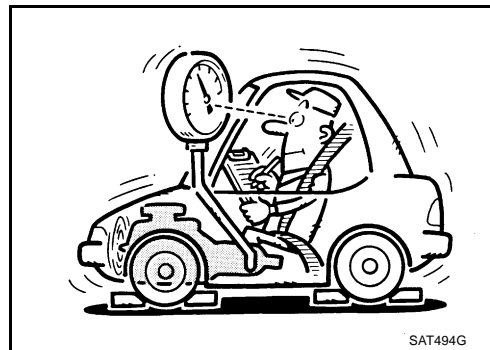

## 6. DETECT MALFUNCTIONING ITEM

1. Check control valve with TCM. Refer to [AT-248, "Control Valve with TCM and A/T Fluid Temperature Sensor 2"](#) .

2. Disassemble A/T. Refer to [AT-292, "DISASSEMBLY"](#) .

3. Check the following.

- Oil pump assembly. Refer to [AT-310, "Oil Pump"](#) .

OK or NG

OK >> GO TO 8.

NG >> Repair or replace damaged parts.

# TROUBLE DIAGNOSIS FOR SYMPTOMS

## 7. DETECT MALFUNCTIONING ITEM

1. Check control valve with TCM. Refer to [AT-248, "Control Valve with TCM and A/T Fluid Temperature Sensor 2"](#) .
2. Disassemble A/T. Refer to [AT-292, "DISASSEMBLY"](#) .
3. Check the following.
  - Oil pump assembly. Refer to [AT-310, "Oil Pump"](#) .
  - Power train system. Refer to [AT-292, "DISASSEMBLY"](#) .
  - Transmission case. Refer to [AT-292, "DISASSEMBLY"](#) .

### OK or NG

- OK >> GO TO 8.  
NG >> Repair or replace damaged parts.

## 8. CHECK A/T FLUID CONDITION

1. Remove oil pan. Refer to [AT-248, "Control Valve with TCM and A/T Fluid Temperature Sensor 2"](#) .
2. Check A/T fluid condition. Refer to [AT-51, "A/T Fluid Condition Check"](#) .

### OK or NG

- OK >> GO TO 9.  
NG >> GO TO 12.

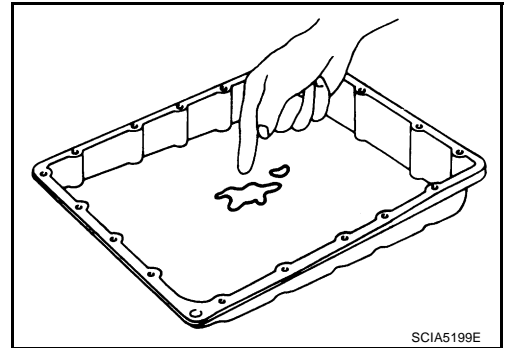

SCIA5199E

## 9. DETECT MALFUNCTIONING ITEM

- Check the malfunction items. If any items are damaged, repair or replace damaged parts. Refer to [AT-66, "Symptom Chart"](#) (Symptom No.23).

### OK or NG

- OK >> GO TO 10.  
NG >> Repair or replace damaged parts.

## 10. CHECK SYMPTOM

Check again. Refer to [AT-60, "Cruise Test - Part 1"](#) , [AT-63, "Cruise Test - Part 2"](#) .

### OK or NG

- OK >> **INSPECTION END**  
NG >> GO TO 11.

## 11. CHECK TCM

1. Check TCM input/output signals. Refer to [AT-91, "TCM Input/Output Signal Reference Values"](#) .
2. If NG, recheck A/T assembly harness connector terminals for damage or loose connection with harness connector.

### OK or NG

- OK >> **INSPECTION END**  
NG >> Repair or replace damaged parts.



# TROUBLE DIAGNOSIS FOR SYMPTOMS

## 12. DETECT MALFUNCTIONING ITEM

- Check the malfunction items. If any items are damaged, repair or replace damaged parts. Refer to [AT-66, "Symptom Chart"](#) (Symptom No.23).

OK or NG

- OK >> GO TO 10.
- NG >> Repair or replace damaged parts.

### A/T Does Not Shift: D1 → D2

ACS008HC

**SYMPTOM:**

The vehicle does not shift-up from the D1 to D2 gear at the specified speed.

### DIAGNOSTIC PROCEDURE

#### 1. CHECK SYMPTOM

Check if vehicle creeps forward in "D" position and vehicle can be started from D1.

OK or NG

- OK >> GO TO 2.
- NG >> Refer to [AT-204, "Vehicle Does Not Creep Forward in "D" Position"](#) , [AT-206, "Vehicle Cannot Be Started from D1"](#) .

#### 2. CHECK SELF-DIAGNOSTIC RESULTS

Perform self-diagnosis. Refer to [AT-95, "SELF-DIAGNOSTIC RESULT MODE"](#) , [AT-105, "Diagnostic Procedure without CONSULT-II"](#) .

Is any malfunction detected by self-diagnostic results?

- YES >> Check the malfunctioning system. Refer to [AT-95, "SELF-DIAGNOSTIC RESULT MODE"](#) , [AT-109, "Judgement Self-diagnosis Code"](#) .
- NO >> GO TO 3.

#### 3. CHECK A/T FLUID LEVEL

Check A/T fluid level. Refer to [AT-12, "Checking A/T Fluid"](#) .

OK or NG

- OK >> GO TO 4.
- NG >> Refill ATF.

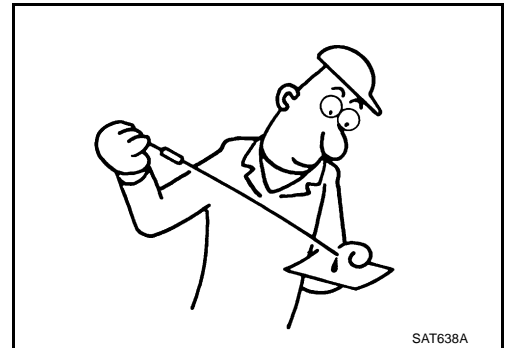

SAT638A

#### 4. CHECK LINE PRESSURE

Check line pressure at the engine stall point. Refer to [AT-53, "LINE PRESSURE TEST"](#) .

OK or NG

- OK >> GO TO 7.
- NG - 1 >> Line pressure high. GO TO 5.
- NG - 2 >> Line pressure low. GO TO 6.

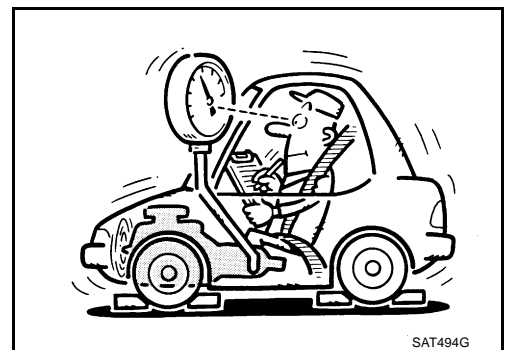

SAT494G

# TROUBLE DIAGNOSIS FOR SYMPTOMS

## 5. DETECT MALFUNCTIONING ITEM

1. Check control valve with TCM. Refer to [AT-248, "Control Valve with TCM and A/T Fluid Temperature Sensor 2"](#) .
2. Disassemble A/T. Refer to [AT-292, "DISASSEMBLY"](#) .
3. Check the following.
  - Oil pump assembly. Refer to [AT-310, "Oil Pump"](#) .

OK or NG

- OK >> GO TO 7.
- NG >> Repair or replace damaged parts.

## 6. DETECT MALFUNCTIONING ITEM

1. Check control valve with TCM. Refer to [AT-248, "Control Valve with TCM and A/T Fluid Temperature Sensor 2"](#) .
2. Disassemble A/T. Refer to [AT-292, "DISASSEMBLY"](#) .
3. Check the following.
  - Oil pump assembly. Refer to [AT-310, "Oil Pump"](#) .
  - Power train system. Refer to [AT-292, "DISASSEMBLY"](#) .
  - Transmission case. Refer to [AT-292, "DISASSEMBLY"](#) .

OK or NG

- OK >> GO TO 7.
- NG >> Repair or replace damaged parts.

## 7. CHECK A/T FLUID CONDITION

1. Remove oil pan. Refer to [AT-248, "Control Valve with TCM and A/T Fluid Temperature Sensor 2"](#) .
2. Check A/T fluid condition. Refer to [AT-51, "A/T Fluid Condition Check"](#) .

OK or NG

- OK >> GO TO 8.
- NG >> GO TO 11.

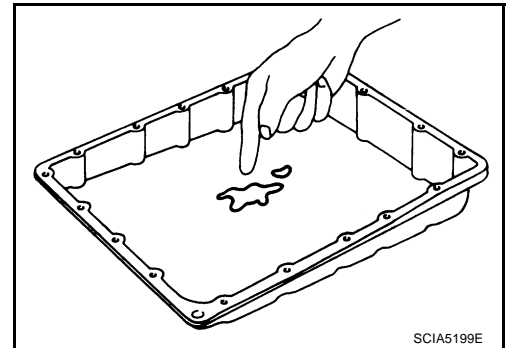

## 8. DETECT MALFUNCTIONING ITEM

- Check the malfunction items. If any items are damaged, repair or replace damaged parts. Refer to [AT-66, "Symptom Chart"](#) (Symptom No.10).

OK or NG

- OK >> GO TO 9.
- NG >> Repair or replace damaged parts.

## 9. CHECK SYMPTOM

Check again. Refer to [AT-60, "Cruise Test - Part 1"](#) , [AT-63, "Cruise Test - Part 2"](#) .

OK or NG

- OK >> **INSPECTION END**
- NG >> GO TO 10.

# TROUBLE DIAGNOSIS FOR SYMPTOMS

## 10. CHECK TCM

1. Check TCM input/output signals. Refer to [AT-91, "TCM Input/Output Signal Reference Values"](#) .
2. If NG, recheck A/T assembly harness connector terminals for damage or loose connection with harness connector.

OK or NG

- OK >> **INSPECTION END**  
NG >> Repair or replace damaged parts.

## 11. DETECT MALFUNCTIONING ITEM

- Check the malfunction items. If any items are damaged, repair or replace damaged parts. Refer to [AT-66, "Symptom Chart"](#) (Symptom No.10).

OK or NG

- OK >> GO TO 9.  
NG >> Repair or replace damaged parts.

### A/T Does Not Shift: D2 → D3

ACS008HD

#### SYMPTOM:

The vehicle does not shift-up from D2 to D3 gear at the specified speed.

#### DIAGNOSTIC PROCEDURE

### 1. CHECK SYMPTOM

Check if vehicle creeps forward in "D" position and vehicle can be started from D1.

OK or NG

- OK >> GO TO 2.  
NG >> Refer to [AT-204, "Vehicle Does Not Creep Forward in "D" Position"](#) , [AT-206, "Vehicle Cannot Be Started from D1"](#) .

### 2. CHECK SELF-DIAGNOSTIC RESULTS

Perform self-diagnosis. Refer to [AT-95, "SELF-DIAGNOSTIC RESULT MODE"](#) , [AT-105, "Diagnostic Procedure without CONSULT-II"](#) .

Is any malfunction detected by self-diagnostic results?

- YES >> Check the malfunctioning system. Refer to [AT-95, "SELF-DIAGNOSTIC RESULT MODE"](#) , [AT-109, "Judgement Self-diagnosis Code"](#) .  
NO >> GO TO 3.

### 3. CHECK A/T FLUID LEVEL

Check A/T fluid level. Refer to [AT-12, "Checking A/T Fluid"](#) .

OK or NG

- OK >> GO TO 4.  
NG >> Refill ATF.

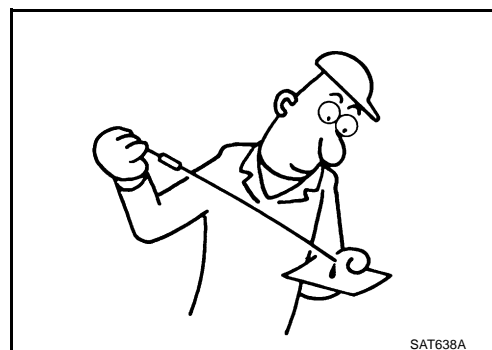

# TROUBLE DIAGNOSIS FOR SYMPTOMS

## 4. CHECK LINE PRESSURE

Check line pressure at the engine stall point. Refer to [AT-53, "LINE PRESSURE TEST"](#) .

OK or NG

- OK >> GO TO 7.
- NG - 1 >> Line pressure high. GO TO 5.
- NG - 2 >> Line pressure low. GO TO 6.

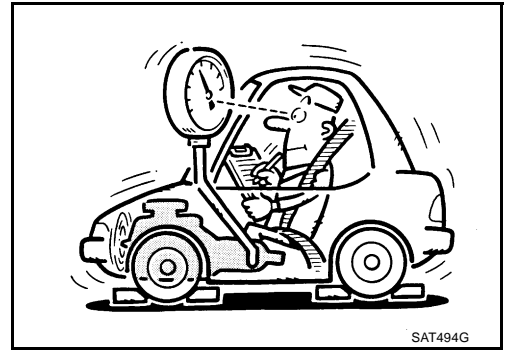

## 5. DETECT MALFUNCTIONING ITEM

1. Check control valve with TCM. Refer to [AT-248, "Control Valve with TCM and A/T Fluid Temperature Sensor 2"](#) .
2. Disassemble A/T. Refer to [AT-292, "DISASSEMBLY"](#) .
3. Check the following.
  - Oil pump assembly. Refer to [AT-310, "Oil Pump"](#) .

OK or NG

- OK >> GO TO 7.
- NG >> Repair or replace damaged parts.

## 6. DETECT MALFUNCTIONING ITEM

1. Check control valve with TCM. Refer to [AT-248, "Control Valve with TCM and A/T Fluid Temperature Sensor 2"](#) .
2. Disassemble A/T. Refer to [AT-292, "DISASSEMBLY"](#) .
3. Check the following.
  - Oil pump assembly. Refer to [AT-310, "Oil Pump"](#) .
  - Power train system. Refer to [AT-292, "DISASSEMBLY"](#) .
  - Transmission case. Refer to [AT-292, "DISASSEMBLY"](#) .

OK or NG

- OK >> GO TO 7.
- NG >> Repair or replace damaged parts.

## 7. CHECK A/T FLUID CONDITION

1. Remove oil pan. Refer to [AT-248, "Control Valve with TCM and A/T Fluid Temperature Sensor 2"](#) .
2. Check A/T fluid condition. Refer to [AT-51, "A/T Fluid Condition Check"](#) .

OK or NG

- OK >> GO TO 8.
- NG >> GO TO 11.

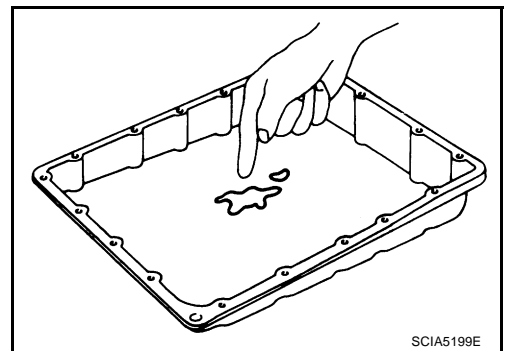

# TROUBLE DIAGNOSIS FOR SYMPTOMS

## 8. DETECT MALFUNCTIONING ITEM

- Check the malfunction items. If any items are damaged, repair or replace damaged parts. Refer to [AT-66, "Symptom Chart"](#) (Symptom No.11).

### OK or NG

- OK >> GO TO 9.  
NG >> Repair or replace damaged parts.

## 9. CHECK SYMPTOM

Check again. Refer to [AT-60, "Cruise Test - Part 1"](#) , [AT-63, "Cruise Test - Part 2"](#) .

### OK or NG

- OK >> **INSPECTION END**  
NG >> GO TO 10.

## 10. CHECK TCM

1. Check TCM input/output signals. Refer to [AT-91, "TCM Input/Output Signal Reference Values"](#) .
2. If NG, recheck A/T assembly harness connector terminals for damage or loose connection with harness connector.

### OK or NG

- OK >> **INSPECTION END**  
NG >> Repair or replace damaged parts.

## 11. DETECT MALFUNCTIONING ITEM

- Check the malfunction items. If any items are damaged, repair or replace damaged parts. Refer to [AT-66, "Symptom Chart"](#) (Symptom No.11).

### OK or NG

- OK >> GO TO 9.  
NG >> Repair or replace damaged parts.

## A/T Does Not Shift: D3 → D4

ACS008HE

### SYMPTOM:

The vehicle does not shift-up from the D3 to D4 gear at the specified speed.

### DIAGNOSTIC PROCEDURE

#### 1. CHECK SYMPTOM

Check if vehicle creeps forward in "D" position and vehicle can be started from D1.

### OK or NG

- OK >> GO TO 2.  
NG >> Refer to [AT-204, "Vehicle Does Not Creep Forward in "D" Position"](#) , [AT-206, "Vehicle Cannot Be Started from D1"](#) .

#### 2. CHECK SELF-DIAGNOSTIC RESULTS

Perform self-diagnosis. Refer to [AT-95, "SELF-DIAGNOSTIC RESULT MODE"](#) , [AT-105, "Diagnostic Procedure without CONSULT-II"](#) .

Is any malfunction detected by self-diagnostic results?

- YES >> Check the malfunctioning system. Refer to [AT-95, "SELF-DIAGNOSTIC RESULT MODE"](#) , [AT-109, "Judgement Self-diagnosis Code"](#) .  
NO >> GO TO 3.

# TROUBLE DIAGNOSIS FOR SYMPTOMS

## 3. CHECK A/T FLUID LEVEL

Check A/T fluid level. Refer to [AT-12, "Checking A/T Fluid"](#) .

OK or NG

- OK >> GO TO 4.
- NG >> Refill ATF.

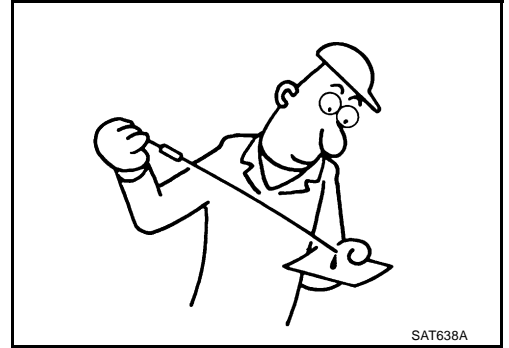

## 4. CHECK LINE PRESSURE

Check line pressure at the engine stall point. Refer to [AT-53, "LINE PRESSURE TEST"](#) .

OK or NG

- OK >> GO TO 7.
- NG - 1 >> Line pressure high. GO TO 5.
- NG - 2 >> Line pressure low. GO TO 6.

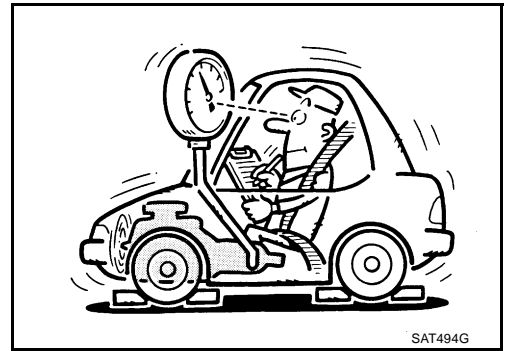

## 5. DETECT MALFUNCTIONING ITEM

1. Check control valve with TCM. Refer to [AT-248, "Control Valve with TCM and A/T Fluid Temperature Sensor 2"](#) .
2. Disassemble A/T. Refer to [AT-292, "DISASSEMBLY"](#) .
3. Check the following.
  - Oil pump assembly. Refer to [AT-310, "Oil Pump"](#) .

OK or NG

- OK >> GO TO 7.
- NG >> Repair or replace damaged parts.

## 6. DETECT MALFUNCTIONING ITEM

1. Check control valve with TCM. Refer to [AT-248, "Control Valve with TCM and A/T Fluid Temperature Sensor 2"](#) .
2. Disassemble A/T. Refer to [AT-292, "DISASSEMBLY"](#) .
3. Check the following.
  - Oil pump assembly. Refer to [AT-310, "Oil Pump"](#) .
  - Power train system. Refer to [AT-292, "DISASSEMBLY"](#) .
  - Transmission case. Refer to [AT-292, "DISASSEMBLY"](#) .

OK or NG

- OK >> GO TO 7.
- NG >> Repair or replace damaged parts.

# TROUBLE DIAGNOSIS FOR SYMPTOMS

## 7. CHECK A/T FLUID CONDITION

1. Remove oil pan. Refer to [AT-248, "Control Valve with TCM and A/T Fluid Temperature Sensor 2"](#) .
2. Check A/T fluid condition. Refer to [AT-51, "A/T Fluid Condition Check"](#) .

OK or NG

- OK >> GO TO 8.
- NG >> GO TO 11.

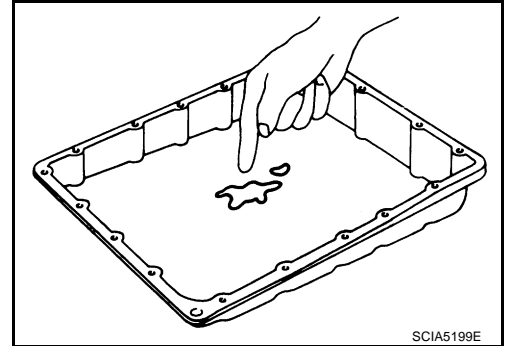

## 8. DETECT MALFUNCTIONING ITEM

- Check the malfunction items. If any items are damaged, repair or replace damaged parts. Refer to [AT-66, "Symptom Chart"](#) (Symptom No.12).

OK or NG

- OK >> GO TO 9.
- NG >> Repair or replace damaged parts.

## 9. CHECK SYMPTOM

Check again. Refer to [AT-60, "Cruise Test - Part 1"](#) , [AT-63, "Cruise Test - Part 2"](#) .

OK or NG

- OK >> **INSPECTION END**
- NG >> GO TO 10.

## 10. CHECK TCM

1. Check TCM input/output signals. Refer to [AT-91, "TCM Input/Output Signal Reference Values"](#) .
2. If NG, recheck A/T assembly harness connector terminals for damage or loose connection with harness connector.

OK or NG

- OK >> **INSPECTION END**
- NG >> Repair or replace damaged parts.

## 11. DETECT MALFUNCTIONING ITEM

- Check the malfunction items. If any items are damaged, repair or replace damaged parts. Refer to [AT-66, "Symptom Chart"](#) (Symptom No.12).

OK or NG

- OK >> GO TO 9.
- NG >> Repair or replace damaged parts.

A  
B  
AT  
D  
E  
F  
G  
H  
I  
J  
K  
L  
M

# TROUBLE DIAGNOSIS FOR SYMPTOMS

ACS008HF

## A/T Does Not Shift: D4 → D5

### SYMPTOM:

- The vehicle does not shift-up from the D4 to D5 gear at the specified speed.
- The vehicle does not shift-up from the D4 to D5 gear unless A/T is warmed up.

### DIAGNOSTIC PROCEDURE

#### 1. CHECK SYMPTOM

Check if vehicle creeps forward in "D" position and vehicle can be started from D1.

##### OK or NG

OK >> GO TO 2.

NG >> Refer to [AT-204, "Vehicle Does Not Creep Forward in "D" Position"](#) , [AT-206, "Vehicle Cannot Be Started from D1"](#) .

#### 2. CHECK SELF-DIAGNOSTIC RESULTS

Perform self-diagnosis. Refer to [AT-95, "SELF-DIAGNOSTIC RESULT MODE"](#) , [AT-105, "Diagnostic Procedure without CONSULT-II"](#) .

Is any malfunction detected by self-diagnostic results?

YES >> Check the malfunctioning system. Refer to [AT-95, "SELF-DIAGNOSTIC RESULT MODE"](#) , [AT-109, "Judgement Self-diagnosis Code"](#) .

NO >> GO TO 3.

#### 3. CHECK A/T FLUID LEVEL

Check A/T fluid level. Refer to [AT-12, "Checking A/T Fluid"](#) .

##### OK or NG

OK >> GO TO 4.

NG >> Refill ATF.

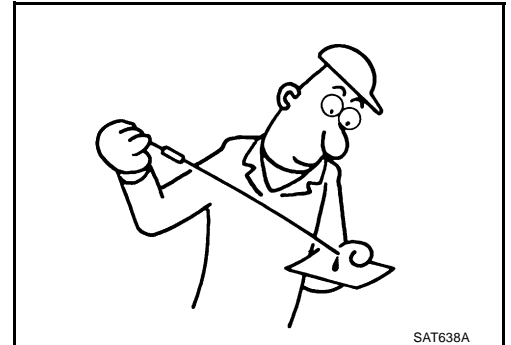

#### 4. CHECK LINE PRESSURE

Check line pressure at the engine stall point. Refer to [AT-53, "LINE PRESSURE TEST"](#) .

##### OK or NG

OK >> GO TO 7.

NG - 1 >> Line pressure high. GO TO 5.

NG - 2 >> Line pressure low. GO TO 6.

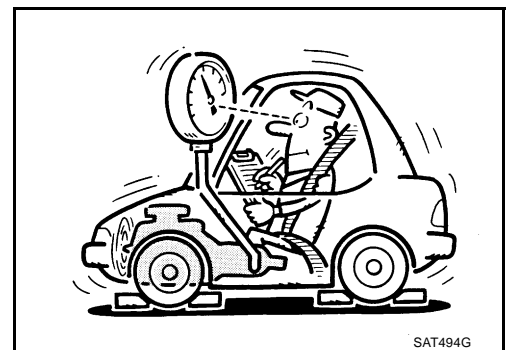



# TROUBLE DIAGNOSIS FOR SYMPTOMS

## 5. DETECT MALFUNCTIONING ITEM

1. Check control valve with TCM. Refer to [AT-248, "Control Valve with TCM and A/T Fluid Temperature Sensor 2"](#) .
2. Disassemble A/T. Refer to [AT-292, "DISASSEMBLY"](#) .
3. Check the following.
  - Oil pump assembly. Refer to [AT-310, "Oil Pump"](#) .

OK or NG

- OK >> GO TO 7.
- NG >> Repair or replace damaged parts.

## 6. DETECT MALFUNCTIONING ITEM

1. Check control valve with TCM. Refer to [AT-248, "Control Valve with TCM and A/T Fluid Temperature Sensor 2"](#) .
2. Disassemble A/T. Refer to [AT-292, "DISASSEMBLY"](#) .
3. Check the following.
  - Oil pump assembly. Refer to [AT-310, "Oil Pump"](#) .
  - Power train system. Refer to [AT-292, "DISASSEMBLY"](#) .
  - Transmission case. Refer to [AT-292, "DISASSEMBLY"](#) .

OK or NG

- OK >> GO TO 7.
- NG >> Repair or replace damaged parts.

## 7. CHECK A/T FLUID CONDITION

1. Remove oil pan. Refer to [AT-248, "Control Valve with TCM and A/T Fluid Temperature Sensor 2"](#) .
2. Check A/T fluid condition. Refer to [AT-51, "A/T Fluid Condition Check"](#) .

OK or NG

- OK >> GO TO 8.
- NG >> GO TO 11.

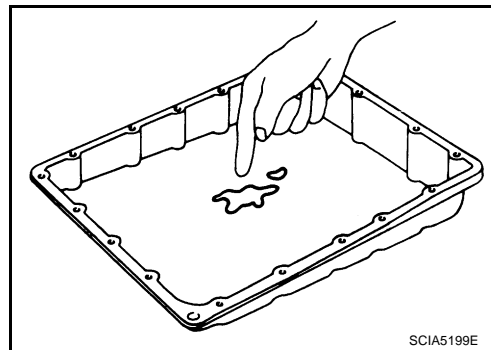

## 8. DETECT MALFUNCTIONING ITEM

- Check the malfunction items. If any items are damaged, repair or replace damaged parts. Refer to [AT-66, "Symptom Chart"](#) (Symptom No.13).

OK or NG

- OK >> GO TO 9.
- NG >> Repair or replace damaged parts.

## 9. CHECK SYMPTOM

Check again. Refer to [AT-60, "Cruise Test - Part 1"](#) .

OK or NG

- OK >> **INSPECTION END**
- NG >> GO TO 10.

# TROUBLE DIAGNOSIS FOR SYMPTOMS

## 10. CHECK TCM

1. Check TCM input/output signals. Refer to [AT-91, "TCM Input/Output Signal Reference Values"](#) .
2. If NG, recheck A/T assembly harness connector terminals for damage or loose connection with harness connector.

OK or NG

- OK >> **INSPECTION END**  
NG >> Repair or replace damaged parts.

## 11. DETECT MALFUNCTIONING ITEM

- Check the malfunction items. If any items are damaged, repair or replace damaged parts. Refer to [AT-66, "Symptom Chart"](#) (Symptom No.13).

OK or NG

- OK >> GO TO 9.  
NG >> Repair or replace damaged parts.

### A/T Does Not Perform Lock-Up SYMPTOM:

ACS008HG

A/T does not perform lock-up at the specified speed.

### DIAGNOSTIC PROCEDURE

#### 1. CHECK SELF-DIAGNOSTIC RESULTS

Perform self-diagnosis. Refer to [AT-95, "SELF-DIAGNOSTIC RESULT MODE"](#) , [AT-105, "Diagnostic Procedure without CONSULT-II"](#) .

Is any malfunction detected by self-diagnostic results?

- YES >> Check the malfunctioning system. Refer to [AT-95, "SELF-DIAGNOSTIC RESULT MODE"](#) , [AT-109, "Judgement Self-diagnosis Code"](#) .  
NO >> GO TO 2.

#### 2. CHECK A/T FLUID LEVEL

Check A/T fluid level. Refer to [AT-12, "Checking A/T Fluid"](#) .

OK or NG

- OK >> GO TO 3.  
NG >> Refill ATF.

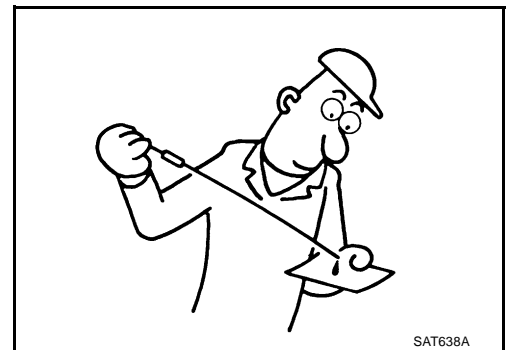

#### 3. CHECK LINE PRESSURE

Check line pressure at the engine stall point. Refer to [AT-53, "LINE PRESSURE TEST"](#) .

OK or NG

- OK >> GO TO 6.  
NG - 1 >> Line pressure high. GO TO 4.  
NG - 2 >> Line pressure low. GO TO 5.

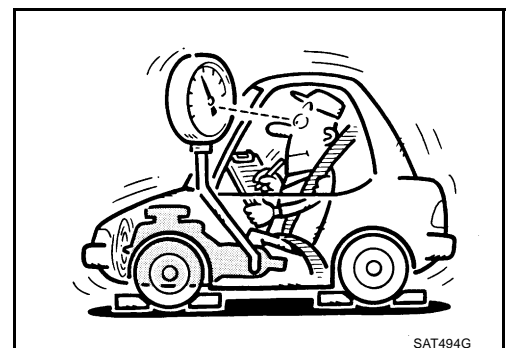

# TROUBLE DIAGNOSIS FOR SYMPTOMS

## 4. DETECT MALFUNCTIONING ITEM

1. Check control valve with TCM. Refer to [AT-248, "Control Valve with TCM and A/T Fluid Temperature Sensor 2"](#) .
2. Disassemble A/T. Refer to [AT-292, "DISASSEMBLY"](#) .
3. Check the following.
  - Oil pump assembly. Refer to [AT-310, "Oil Pump"](#) .

OK or NG

- OK >> GO TO 6.
- NG >> Repair or replace damaged parts.

## 5. DETECT MALFUNCTIONING ITEM

1. Check control valve with TCM. Refer to [AT-248, "Control Valve with TCM and A/T Fluid Temperature Sensor 2"](#) .
2. Disassemble A/T. Refer to [AT-292, "DISASSEMBLY"](#) .
3. Check the following.
  - Oil pump assembly. Refer to [AT-310, "Oil Pump"](#) .
  - Power train system. Refer to [AT-292, "DISASSEMBLY"](#) .
  - Transmission case. Refer to [AT-292, "DISASSEMBLY"](#) .

OK or NG

- OK >> GO TO 6.
- NG >> Repair or replace damaged parts.

## 6. CHECK A/T FLUID CONDITION

1. Remove oil pan. Refer to [AT-248, "Control Valve with TCM and A/T Fluid Temperature Sensor 2"](#) .
2. Check A/T fluid condition. Refer to [AT-51, "A/T Fluid Condition Check"](#) .

OK or NG

- OK >> GO TO 7.
- NG >> GO TO 10.

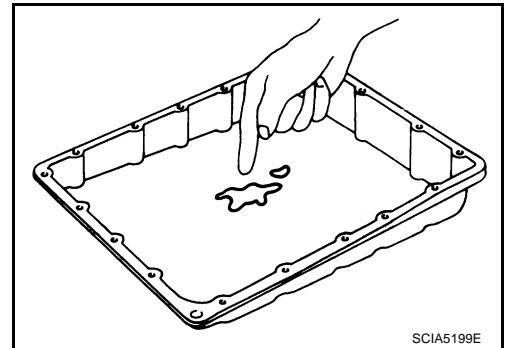

## 7. DETECT MALFUNCTIONING ITEM

- Check the malfunction items. If any items are damaged, repair or replace damaged parts. Refer to [AT-66, "Symptom Chart"](#) (Symptom No.24).

OK or NG

- OK >> GO TO 8.
- NG >> Repair or replace damaged parts.

## 8. CHECK SYMPTOM

Check again. Refer to [AT-60, "Cruise Test - Part 1"](#) .

OK or NG

- OK >> **INSPECTION END**
- NG >> GO TO 9.

# TROUBLE DIAGNOSIS FOR SYMPTOMS

## 9. CHECK TCM

1. Check TCM input/output signals. Refer to [AT-91, "TCM Input/Output Signal Reference Values"](#) .
2. If NG, recheck A/T assembly harness connector terminals for damage or loose connection with harness connector.

OK or NG

- OK >> **INSPECTION END**  
NG >> Repair or replace damaged parts.

## 10. DETECT MALFUNCTIONING ITEM

- Check the malfunction items. If any items are damaged, repair or replace damaged parts. Refer to [AT-66, "Symptom Chart"](#) (Symptom No.24).

OK or NG

- OK >> GO TO 8.  
NG >> Repair or replace damaged parts.

### A/T Does Not Hold Lock-Up Condition

ACS008HH

#### SYMPTOM:

The lock-up condition cannot be maintained for more than 30 seconds.

#### DIAGNOSTIC PROCEDURE

### 1. CHECK SELF-DIAGNOSTIC RESULTS

Perform self-diagnosis. Refer to [AT-95, "SELF-DIAGNOSTIC RESULT MODE"](#) , [AT-105, "Diagnostic Procedure without CONSULT-II"](#) .

Is any malfunction detected by self-diagnostic results?

- YES >> Check the malfunctioning system. Refer to [AT-95, "SELF-DIAGNOSTIC RESULT MODE"](#) , [AT-109, "Judgement Self-diagnosis Code"](#) .  
NO >> GO TO 2.

### 2. CHECK A/T FLUID LEVEL

Check A/T fluid level. Refer to [AT-12, "Checking A/T Fluid"](#) .

OK or NG

- OK >> GO TO 3.  
NG >> Refill ATF.

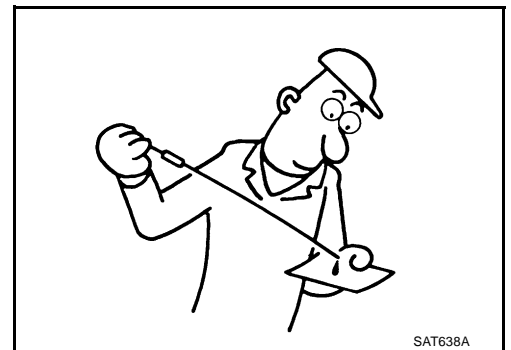

# TROUBLE DIAGNOSIS FOR SYMPTOMS

## 3. CHECK A/T FLUID CONDITION

1. Remove oil pan. Refer to [AT-248, "Control Valve with TCM and A/T Fluid Temperature Sensor 2"](#) .
2. Check A/T fluid condition. Refer to [AT-51, "A/T Fluid Condition Check"](#) .

OK or NG

- OK >> GO TO 4.
- NG >> GO TO 7.

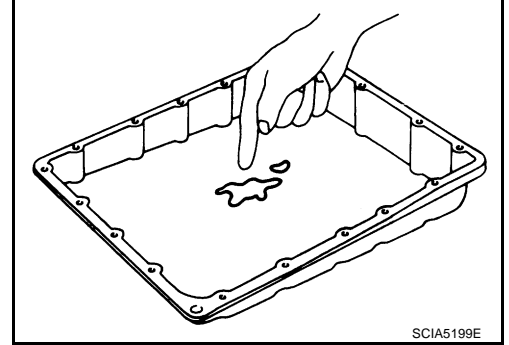

## 4. DETECT MALFUNCTIONING ITEM

- Check the malfunction items. If any items are damaged, repair or replace damaged parts. Refer to [AT-66, "Symptom Chart"](#) (Symptom No.25).

OK or NG

- OK >> GO TO 5.
- NG >> Repair or replace damaged parts.

## 5. CHECK SYMPTOM

Check again. Refer to [AT-60, "Cruise Test - Part 1"](#) .

OK or NG

- OK >> **INSPECTION END**
- NG >> GO TO 6.

## 6. CHECK TCM

1. Check TCM input/output signals. Refer to [AT-91, "TCM Input/Output Signal Reference Values"](#) .
2. If NG, recheck A/T assembly harness connector terminals for damage or loose connection with harness connector.

OK or NG

- OK >> **INSPECTION END**
- NG >> Repair or replace damaged parts.

## 7. DETECT MALFUNCTIONING ITEM

- Check the malfunction items. If any items are damaged, repair or replace damaged parts. Refer to [AT-66, "Symptom Chart"](#) (Symptom No.25).

OK or NG

- OK >> GO TO 5.
- NG >> Repair or replace damaged parts.

# TROUBLE DIAGNOSIS FOR SYMPTOMS

## Lock-Up Is Not Released

ACS008HI

### SYMPTOM:

The lock-up condition cannot be cancelled even after releasing the accelerator pedal.

### DIAGNOSTIC PROCEDURE

#### 1. CHECK SELF-DIAGNOSTIC RESULTS

Perform self-diagnosis. Refer to [AT-95, "SELF-DIAGNOSTIC RESULT MODE"](#) , [AT-105, "Diagnostic Procedure without CONSULT-II"](#) .

Is any malfunction detected by self-diagnostic results?

- YES >> Check the malfunctioning system. Refer to [AT-95, "SELF-DIAGNOSTIC RESULT MODE"](#) , [AT-109, "Judgement Self-diagnosis Code"](#) .
- NO >> GO TO 2.

#### 2. CHECK SYMPTOM

Check again. Refer to [AT-60, "Cruise Test - Part 1"](#) .

OK or NG

- OK >> **INSPECTION END**
- NG >> GO TO 3.

#### 3. CHECK TCM

1. Check TCM input/output signals. Refer to [AT-91, "TCM Input/Output Signal Reference Values"](#) .
2. If NG, recheck A/T assembly harness connector terminals for damage or loose connection with harness connector.

OK or NG

- OK >> **INSPECTION END**
- NG >> Repair or replace damaged parts.

## Engine Speed Does Not Return to Idle

ACS008HJ

### SYMPTOM:

When a shift-down is performed, the engine speed does not smoothly return to the idling speed.

### DIAGNOSTIC PROCEDURE

#### 1. CHECK A/T FLUID LEVEL

Check A/T fluid level. Refer to [AT-12, "Checking A/T Fluid"](#) .

OK or NG

- OK >> GO TO 2.
- NG >> Refill ATF.

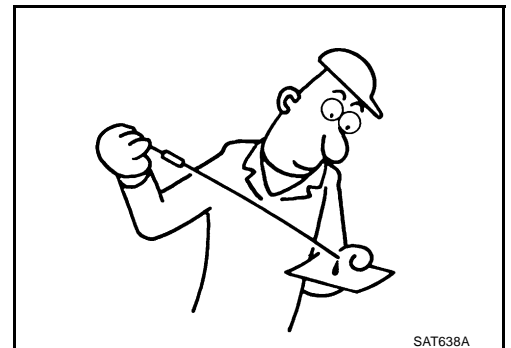

#### 2. CHECK SELF-DIAGNOSTIC RESULTS

Perform self-diagnosis. Refer to [AT-95, "SELF-DIAGNOSTIC RESULT MODE"](#) , [AT-105, "Diagnostic Procedure without CONSULT-II"](#) .

Is any malfunction detected by self-diagnostic results?

- YES >> Check the malfunctioning system. Refer to [AT-95, "SELF-DIAGNOSTIC RESULT MODE"](#) , [AT-109, "Judgement Self-diagnosis Code"](#) .
- NO >> GO TO 3.

# TROUBLE DIAGNOSIS FOR SYMPTOMS

## 3. CHECK A/T FLUID CONDITION

1. Remove oil pan. Refer to [AT-248, "Control Valve with TCM and A/T Fluid Temperature Sensor 2"](#) .
2. Check A/T fluid condition. Refer to [AT-51, "A/T Fluid Condition Check"](#) .

OK or NG

- OK >> GO TO 4.
- NG >> GO TO 7.

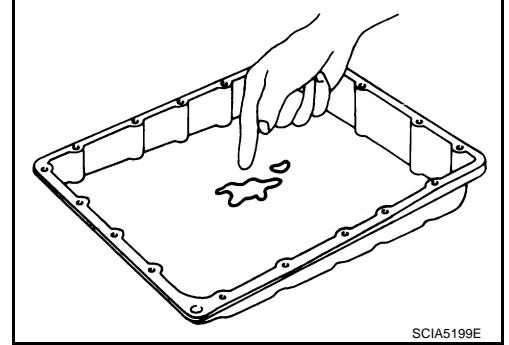

## 4. DETECT MALFUNCTIONING ITEM

- Check the malfunction items. If any items are damaged, repair or replace damaged parts. Refer to [AT-66, "Symptom Chart"](#) (Symptom No.72).

OK or NG

- OK >> GO TO 5.
- NG >> Repair or replace damaged parts.

## 5. CHECK SYMPTOM

Check again. Refer to [AT-60, "Cruise Test - Part 1"](#) .

OK or NG

- OK >> **INSPECTION END**
- NG >> GO TO 6.

## 6. CHECK TCM

1. Check TCM input/output signals. Refer to [AT-91, "TCM Input/Output Signal Reference Values"](#) .
2. If NG, recheck A/T assembly harness connector terminals for damage or loose connection with harness connector.

OK or NG

- OK >> **INSPECTION END**
- NG >> Repair or replace damaged parts.

## 7. DETECT MALFUNCTIONING ITEM

- Check the malfunction items. If any items are damaged, repair or replace damaged parts. Refer to [AT-66, "Symptom Chart"](#) (Symptom No.72).

OK or NG

- OK >> GO TO 5.
- NG >> Repair or replace damaged parts.

A  
B  
AT  
D  
E  
F  
G  
H  
I  
J  
K  
L  
M

# TROUBLE DIAGNOSIS FOR SYMPTOMS

## Cannot Be Changed to Manual Mode

ACS008HK

### SYMPTOM:

Does not change to manual mode when manual shift gate is used.

### DIAGNOSTIC PROCEDURE

#### 1. CHECK MANUAL MODE SWITCH

Check the manual mode switch. Refer to [AT-174, "DTC P1815 MANUAL MODE SWITCH"](#) .

#### OK or NG

- OK >> GO TO 2.
- NG >> Repair or replace damaged parts.

#### 2. CHECK SELF-DIAGNOSTIC RESULTS

Perform self-diagnosis. Refer to [AT-95, "SELF-DIAGNOSTIC RESULT MODE"](#) , [AT-105, "Diagnostic Procedure without CONSULT-II"](#) .

Is any malfunction detected by self-diagnostic results?

- YES >> Check the malfunctioning system. Refer to [AT-95, "SELF-DIAGNOSTIC RESULT MODE"](#) , [AT-109, "Judgement Self-diagnosis Code"](#) .
- NO >> **INSPECTION END**

## A/T Does Not Shift: 5th Gear → 4th Gear

ACS008HL

### SYMPTOM:

When shifted from M5 to M4 position in manual mode, does not downshift from 5th to 4th gear.

### DIAGNOSTIC PROCEDURE

#### 1. CHECK SELF-DIAGNOSTIC RESULTS

Perform self-diagnosis. Refer to [AT-95, "SELF-DIAGNOSTIC RESULT MODE"](#) , [AT-105, "Diagnostic Procedure without CONSULT-II"](#) .

Is any malfunction detected by self-diagnostic results?

- YES >> Check the malfunctioning system. Refer to [AT-95, "SELF-DIAGNOSTIC RESULT MODE"](#) , [AT-109, "Judgement Self-diagnosis Code"](#) .
- NO >> GO TO 2.

#### 2. CHECK A/T FLUID LEVEL

Check A/T fluid level. Refer to [AT-12, "Checking A/T Fluid"](#) .

#### OK or NG

- OK >> GO TO 3.
- NG >> Refill ATF.



SAT638A

#### 3. CHECK CONTROL LINKAGE

Check the control linkage.

- Refer to [AT-239, "Checking of A/T Position"](#) .

#### OK or NG

- OK >> GO TO 4.
- NG >> Adjust control linkage. Refer to [AT-238, "Adjustment of A/T Position"](#) .



# TROUBLE DIAGNOSIS FOR SYMPTOMS

## 4. CHECK MANUAL MODE SWITCH

Check the manual mode switch. Refer to [AT-174, "DTC P1815 MANUAL MODE SWITCH"](#) .

OK or NG

- OK >> GO TO 5.
- NG >> Repair or replace damaged parts.

## 5. CHECK A/T FLUID CONDITION

1. Remove oil pan. Refer to [AT-248, "Control Valve with TCM and A/T Fluid Temperature Sensor 2"](#) .
2. Check A/T fluid condition. Refer to [AT-51, "A/T Fluid Condition Check"](#) .

OK or NG

- OK >> GO TO 6.
- NG >> GO TO 9.

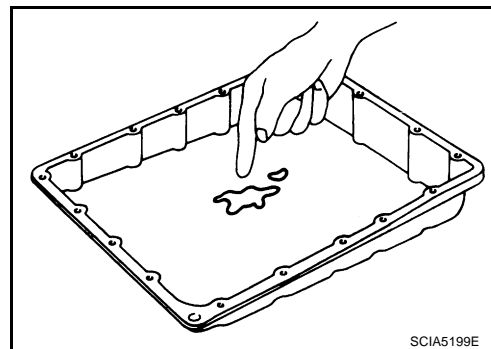

## 6. DETECT MALFUNCTIONING ITEM

- Check the malfunction items. If any items are damaged, repair or replace damaged parts. Refer to [AT-66, "Symptom Chart"](#) (Symptom No.47).

OK or NG

- OK >> GO TO 7.
- NG >> Repair or replace damaged parts.

## 7. CHECK SYMPTOM

Check again. Refer to [AT-64, "Cruise Test - Part 3"](#) .

OK or NG

- OK >> **INSPECTION END**
- NG >> GO TO 8.

## 8. CHECK TCM

1. Check TCM input/output signals. Refer to [AT-91, "TCM Input/Output Signal Reference Values"](#) .
2. If NG, recheck A/T assembly harness connector terminals for damage or loose connection with harness connector.

OK or NG

- OK >> **INSPECTION END**
- NG >> Repair or replace damaged parts.

## 9. DETECT MALFUNCTIONING ITEM

- Check the malfunction items. If any items are damaged, repair or replace damaged parts. Refer to [AT-66, "Symptom Chart"](#) (Symptom No.47).

OK or NG

- OK >> GO TO 7.
- NG >> Repair or replace damaged parts.

# TROUBLE DIAGNOSIS FOR SYMPTOMS

ACS008HM

## A/T Does Not Shift: 4th Gear → 3rd Gear

### SYMPTOM:

When shifted from M4 to M3 position in manual mode, does not downshift from 4th to 3rd gear.

### DIAGNOSTIC PROCEDURE

#### 1. CHECK SELF-DIAGNOSTIC RESULTS

Perform self-diagnosis. Refer to [AT-95, "SELF-DIAGNOSTIC RESULT MODE"](#) , [AT-105, "Diagnostic Procedure without CONSULT-II"](#) .

Is any malfunction detected by self-diagnostic results?

- YES >> Check the malfunctioning system. Refer to [AT-95, "SELF-DIAGNOSTIC RESULT MODE"](#) , [AT-109, "Judgement Self-diagnosis Code"](#) .
- NO >> GO TO 2.

#### 2. CHECK A/T FLUID LEVEL

Check A/T fluid level. Refer to [AT-12, "Checking A/T Fluid"](#) .

OK or NG

- OK >> GO TO 3.
- NG >> Refill ATF.

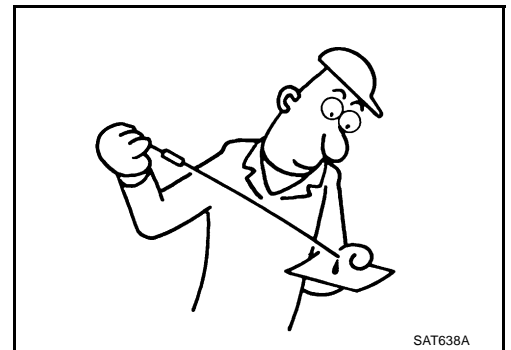

#### 3. CHECK CONTROL LINKAGE

Check the control linkage.

- Refer to [AT-239, "Checking of A/T Position"](#) .

OK or NG

- OK >> GO TO 4.
- NG >> Adjust control linkage. Refer to [AT-238, "Adjustment of A/T Position"](#) .

#### 4. CHECK MANUAL MODE SWITCH

Check the manual mode switch. Refer to [AT-174, "DTC P1815 MANUAL MODE SWITCH"](#) .

OK or NG

- OK >> GO TO 5.
- NG >> Repair or replace damaged parts.

#### 5. CHECK A/T FLUID CONDITION

- Remove oil pan. Refer to [AT-248, "Control Valve with TCM and A/T Fluid Temperature Sensor 2"](#) .
- Check A/T fluid condition. Refer to [AT-51, "A/T Fluid Condition Check"](#) .

OK or NG

- OK >> GO TO 6.
- NG >> GO TO 9.

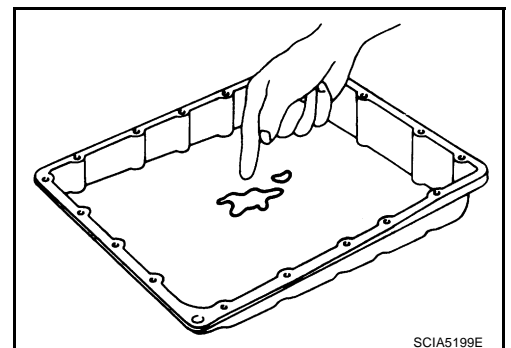

# TROUBLE DIAGNOSIS FOR SYMPTOMS

---

## 6. DETECT MALFUNCTIONING ITEM

---

- Check the malfunction items. If any items are damaged, repair or replace damaged parts. Refer to [AT-66, "Symptom Chart"](#) (Symptom No.48).

### OK or NG

- OK >> GO TO 7.  
NG >> Repair or replace damaged parts.

---

## 7. CHECK SYMPTOM

---

Check again. Refer to [AT-64, "Cruise Test - Part 3"](#) .

### OK or NG

- OK >> **INSPECTION END**  
NG >> GO TO 8.

---

## 8. CHECK TCM

---

1. Check TCM input/output signals. Refer to [AT-91, "TCM Input/Output Signal Reference Values"](#) .
2. If NG, recheck A/T assembly harness connector terminals for damage or loose connection with harness connector.

### OK or NG

- OK >> **INSPECTION END**  
NG >> Repair or replace damaged parts.

---

## 9. DETECT MALFUNCTIONING ITEM

---

- Check the malfunction items. If any items are damaged, repair or replace damaged parts. Refer to [AT-66, "Symptom Chart"](#) (Symptom No.48).

### OK or NG

- OK >> GO TO 7.  
NG >> Repair or replace damaged parts.

A  
B  
AT  
D  
E  
F  
G  
H  
I  
J  
K  
L  
M

# TROUBLE DIAGNOSIS FOR SYMPTOMS

ACS008HN

## A/T Does Not Shift: 3rd Gear → 2nd Gear

### SYMPTOM:

When shifted from M3 to M2 position in manual mode, does not downshift from 3rd to 2nd gear.

### DIAGNOSTIC PROCEDURE

#### 1. CHECK SELF-DIAGNOSTIC RESULTS

Perform self-diagnosis. Refer to [AT-95, "SELF-DIAGNOSTIC RESULT MODE"](#) , [AT-105, "Diagnostic Procedure without CONSULT-II"](#) .

Is any malfunction detected by self-diagnostic results?

- YES >> Check the malfunctioning system. Refer to [AT-95, "SELF-DIAGNOSTIC RESULT MODE"](#) , [AT-109, "Judgement Self-diagnosis Code"](#) .
- NO >> GO TO 2.

#### 2. CHECK A/T FLUID LEVEL

Check A/T fluid level. Refer to [AT-12, "Checking A/T Fluid"](#) .

OK or NG

- OK >> GO TO 3.
- NG >> Refill ATF.

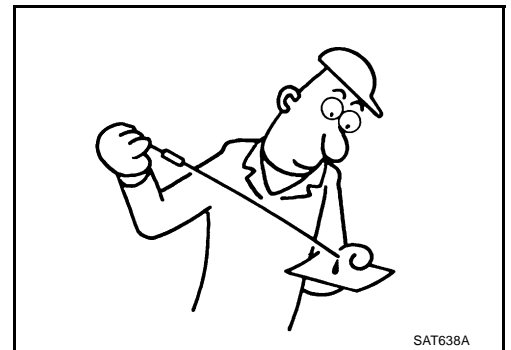

#### 3. CHECK CONTROL LINKAGE

Check the control linkage.

- Refer to [AT-239, "Checking of A/T Position"](#) .

OK or NG

- OK >> GO TO 4.
- NG >> Adjust control linkage. Refer to [AT-238, "Adjustment of A/T Position"](#) .

#### 4. CHECK MANUAL MODE SWITCH

Check the manual mode switch. Refer to [AT-174, "DTC P1815 MANUAL MODE SWITCH"](#) .

OK or NG

- OK >> GO TO 5.
- NG >> Repair or replace damaged parts.

#### 5. CHECK A/T FLUID CONDITION

- Remove oil pan. Refer to [AT-248, "Control Valve with TCM and A/T Fluid Temperature Sensor 2"](#) .
- Check A/T fluid condition. Refer to [AT-51, "A/T Fluid Condition Check"](#) .

OK or NG

- OK >> GO TO 6.
- NG >> GO TO 9.

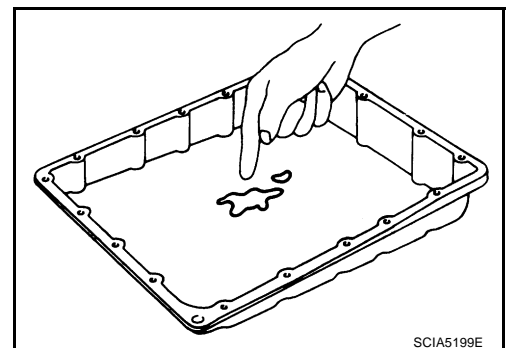

# TROUBLE DIAGNOSIS FOR SYMPTOMS

---

## 6. DETECT MALFUNCTIONING ITEM

---

- Check the malfunction items. If any items are damaged, repair or replace damaged parts. Refer to [AT-66, "Symptom Chart"](#) (Symptom No.49).

### OK or NG

- OK >> GO TO 7.  
NG >> Repair or replace damaged parts.

---

## 7. CHECK SYMPTOM

---

Check again. Refer to [AT-64, "Cruise Test - Part 3"](#) .

### OK or NG

- OK >> **INSPECTION END**  
NG >> GO TO 8.

---

## 8. CHECK TCM

---

1. Check TCM input/output signals. Refer to [AT-91, "TCM Input/Output Signal Reference Values"](#) .
2. If NG, recheck A/T assembly harness connector terminals for damage or loose connection with harness connector.

### OK or NG

- OK >> **INSPECTION END**  
NG >> Repair or replace damaged parts.

---

## 9. DETECT MALFUNCTIONING ITEM

---

- Check the malfunction items. If any items are damaged, repair or replace damaged parts. Refer to [AT-66, "Symptom Chart"](#) (Symptom No.49).

### OK or NG

- OK >> GO TO 7.  
NG >> Repair or replace damaged parts.

A  
B  
AT  
D  
E  
F  
G  
H  
I  
J  
K  
L  
M

# TROUBLE DIAGNOSIS FOR SYMPTOMS

ACS008HO

## A/T Does Not Shift: 2nd Gear → 1st Gear

### SYMPTOM:

When shifted from M2 to M1 position in manual mode, does not downshift from 2nd to 1st gear.

### DIAGNOSTIC PROCEDURE

#### 1. CHECK SELF-DIAGNOSTIC RESULTS

Perform self-diagnosis. Refer to [AT-95, "SELF-DIAGNOSTIC RESULT MODE"](#) , [AT-105, "Diagnostic Procedure without CONSULT-II"](#) .

Is any malfunction detected by self-diagnostic results?

- YES >> Check the malfunctioning system. Refer to [AT-95, "SELF-DIAGNOSTIC RESULT MODE"](#) , [AT-109, "Judgement Self-diagnosis Code"](#) .
- NO >> GO TO 2.

#### 2. CHECK A/T FLUID LEVEL

Check A/T fluid level. Refer to [AT-12, "Checking A/T Fluid"](#) .

OK or NG

- OK >> GO TO 3.
- NG >> Refill ATF.

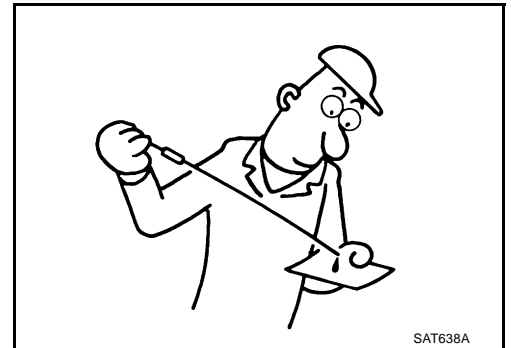

#### 3. CHECK CONTROL LINKAGE

Check the control linkage.

- Refer to [AT-239, "Checking of A/T Position"](#) .

OK or NG

- OK >> GO TO 4.
- NG >> Adjust control linkage. Refer to [AT-238, "Adjustment of A/T Position"](#) .

#### 4. CHECK MANUAL MODE SWITCH

Check the manual mode switch. Refer to [AT-174, "DTC P1815 MANUAL MODE SWITCH"](#) .

OK or NG

- OK >> GO TO 5.
- NG >> Repair or replace damaged parts.

#### 5. CHECK A/T FLUID CONDITION

- Remove oil pan. Refer to [AT-248, "Control Valve with TCM and A/T Fluid Temperature Sensor 2"](#) .
- Check A/T fluid condition. Refer to [AT-51, "A/T Fluid Condition Check"](#) .

OK or NG

- OK >> GO TO 6.
- NG >> GO TO 9.

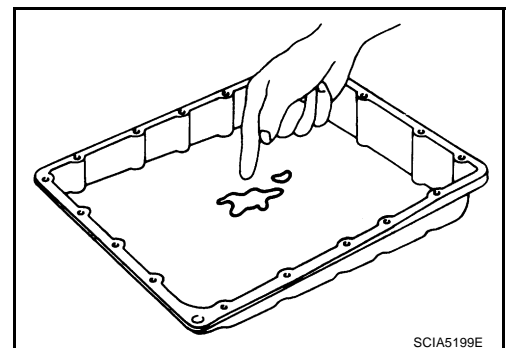

# TROUBLE DIAGNOSIS FOR SYMPTOMS

---

## 6. DETECT MALFUNCTIONING ITEM

---

- Check the malfunction items. If any items are damaged, repair or replace damaged parts. Refer to [AT-66, "Symptom Chart"](#) (Symptom No.50).

### OK or NG

- OK >> GO TO 7.  
NG >> Repair or replace damaged parts.

---

## 7. CHECK SYMPTOM

---

Check again. Refer to [AT-64, "Cruise Test - Part 3"](#) .

### OK or NG

- OK >> **INSPECTION END**  
NG >> GO TO 8.

---

## 8. CHECK TCM

---

1. Check TCM input/output signals. Refer to [AT-91, "TCM Input/Output Signal Reference Values"](#) .
2. If NG, recheck A/T assembly harness connector terminals for damage or loose connection with harness connector.

### OK or NG

- OK >> **INSPECTION END**  
NG >> Repair or replace damaged parts.

---

## 9. DETECT MALFUNCTIONING ITEM

---

- Check the malfunction items. If any items are damaged, repair or replace damaged parts. Refer to [AT-66, "Symptom Chart"](#) (Symptom No.50).

### OK or NG

- OK >> GO TO 7.  
NG >> Repair or replace damaged parts.

A  
B  
AT  
D  
E  
F  
G  
H  
I  
J  
K  
L  
M

# TROUBLE DIAGNOSIS FOR SYMPTOMS

ACS008HP

## Vehicle Does Not Decelerate by Engine Brake

### SYMPTOM:

No engine brake is applied when the gear is shifted from the 2nd to 1st gear.

### DIAGNOSTIC PROCEDURE

#### 1. CHECK SELF-DIAGNOSTIC RESULTS

Perform self-diagnosis. Refer to [AT-95, "SELF-DIAGNOSTIC RESULT MODE"](#) , [AT-105, "Diagnostic Procedure without CONSULT-II"](#) .

Is any malfunction detected by self-diagnostic results?

- YES >> Check the malfunctioning system. Refer to [AT-95, "SELF-DIAGNOSTIC RESULT MODE"](#) , [AT-109, "Judgement Self-diagnosis Code"](#) .
- NO >> GO TO 2.

#### 2. CHECK A/T FLUID LEVEL

Check A/T fluid level. Refer to [AT-12, "Checking A/T Fluid"](#) .

OK or NG

- OK >> GO TO 3.
- NG >> Refill ATF.

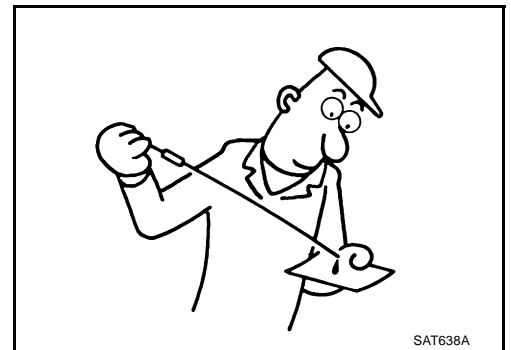

#### 3. CHECK CONTROL LINKAGE

Check the control linkage.

- Refer to [AT-239, "Checking of A/T Position"](#) .

OK or NG

- OK >> GO TO 4.
- NG >> Adjust control linkage. Refer to [AT-238, "Adjustment of A/T Position"](#) .

#### 4. CHECK MANUAL MODE SWITCH

Check the manual mode switch. Refer to [AT-174, "DTC P1815 MANUAL MODE SWITCH"](#) .

OK or NG

- OK >> GO TO 5.
- NG >> Repair or replace damaged parts.

#### 5. CHECK A/T FLUID CONDITION

- Remove oil pan. Refer to [AT-248, "Control Valve with TCM and A/T Fluid Temperature Sensor 2"](#) .
- Check A/T fluid condition. Refer to [AT-51, "A/T Fluid Condition Check"](#) .

OK or NG

- OK >> GO TO 6.
- NG >> GO TO 9.

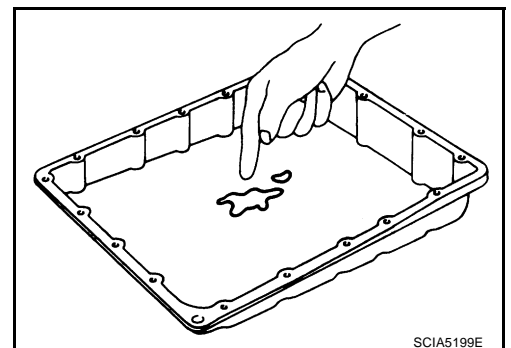



# TROUBLE DIAGNOSIS FOR SYMPTOMS

---

## 6. DETECT MALFUNCTIONING ITEM

---

- Check the malfunction items. If any items are damaged, repair or replace damaged parts. Refer to [AT-66, "Symptom Chart"](#) (Symptom No.58).

### OK or NG

- OK >> GO TO 7.  
NG >> Repair or replace damaged parts.

---

## 7. CHECK SYMPTOM

---

Check again. Refer to [AT-64, "Cruise Test - Part 3"](#) .

### OK or NG

- OK >> **INSPECTION END**  
NG >> GO TO 8.

---

## 8. CHECK TCM

---

1. Check TCM input/output signals. Refer to [AT-91, "TCM Input/Output Signal Reference Values"](#) .
2. If NG, recheck A/T assembly harness connector terminals for damage or loose connection with harness connector.

### OK or NG

- OK >> **INSPECTION END**  
NG >> Repair or replace damaged parts.

---

## 9. DETECT MALFUNCTIONING ITEM

---

- Check the malfunction items. If any items are damaged, repair or replace damaged parts. Refer to [AT-66, "Symptom Chart"](#) (Symptom No.58).

### OK or NG

- OK >> GO TO 7.  
NG >> Repair or replace damaged parts.

A  
B  
AT  
D  
E  
F  
G  
H  
I  
J  
K  
L  
M

# SHIFT CONTROL SYSTEM

PFP:34901

## SHIFT CONTROL SYSTEM

### Control Device Removal and Installation CONTROL DEVICE COMPONENTS (2WD MODELS)

ACS0063K

SEC.349

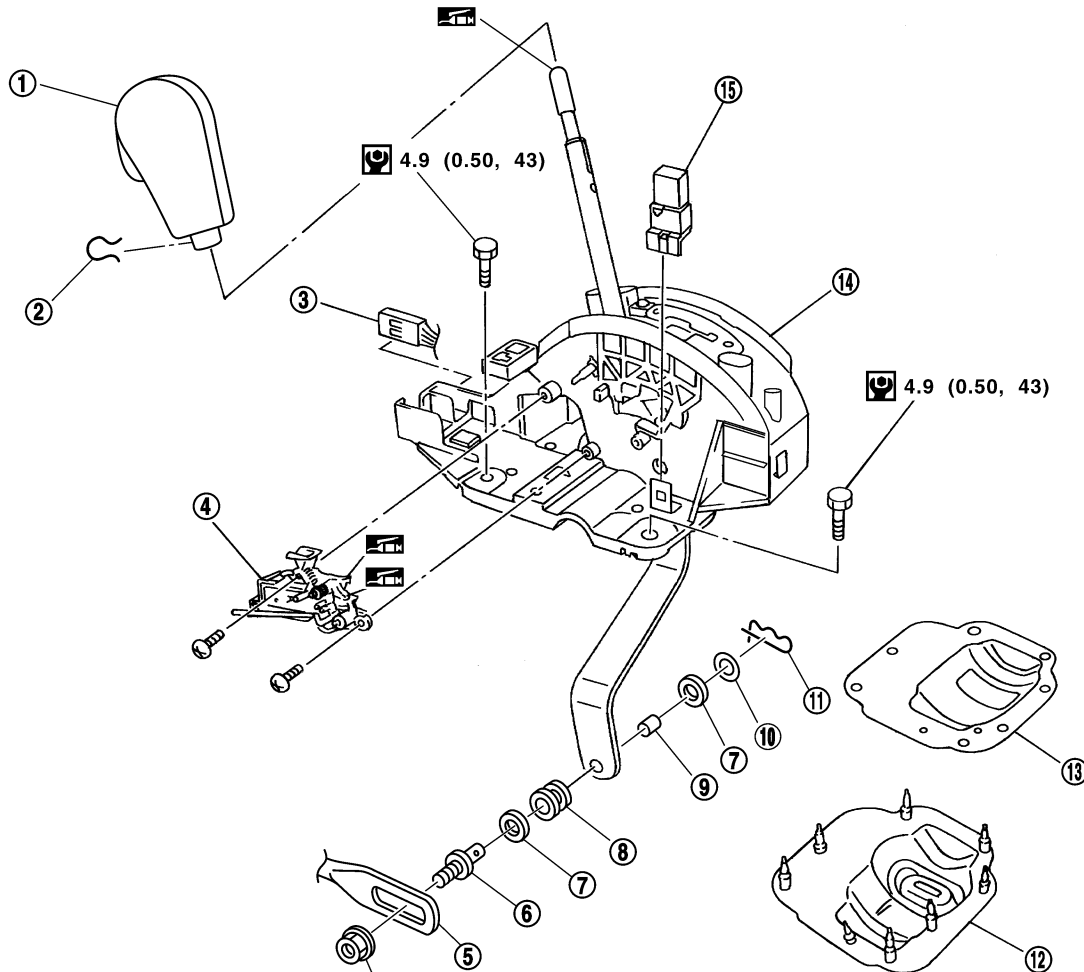

: Apply multi purpose grease.

: N·m (kg-m, in-lb)

: N·m (kg-m, ft-lb)

26 (2.7, 19)

SCIA6245E

- |  |                             |                                 |
|--|-----------------------------|---------------------------------|
| 1. Selector lever knob                                   | 2. Lock pin                 | 3. A/T device harness connector |
| 4. Shift lock solenoid and park position switch assembly | 5. Control rod              | 6. Pivot pin                    |
| 7. Plain washer  | 8. Bushing                  | 9. Collar                       |
| 10. Conical washer                                       | 11. Snap pin                | 12. Dust cover                  |
| 13. Dust cover plate                                     | 14. Control device assembly | 15. Shift lock relay            |

# SHIFT CONTROL SYSTEM

## CONTROL DEVICE COMPONENTS (AWD MODELS)

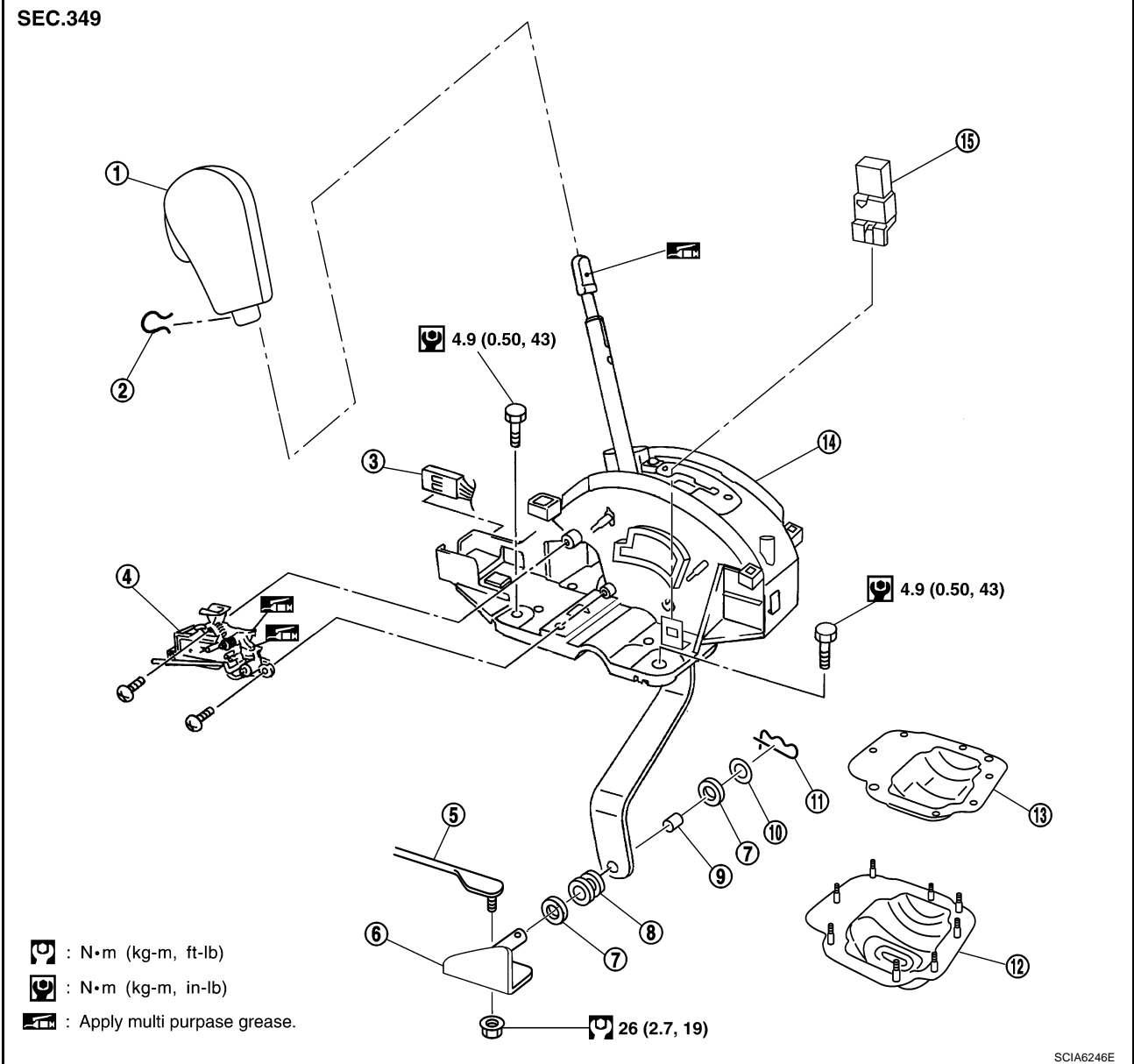

- |  |                             |                                 |
|--|-----------------------------|---------------------------------|
| 1. Selector lever knob                                   | 2. Lock pin                 | 3. A/T device harness connector |
| 4. Shift lock solenoid and park position switch assembly | 5. Control rod              | 6. Bracket                      |
| 7. Plain washer  | 8. Bushing                  | 9. Collar                       |
| 10. Conical washer                                       | 11. Snap pin                | 12. Dust cover                  |
| 13. Dust cover plate                                     | 14. Control device assembly | 15. Shift lock relay            |

A  
B  
AT  
D  
E  
F  
G  
H  
I  
J  
K  
L  
M

# SHIFT CONTROL SYSTEM

## REMOVAL

1. Disconnect lower lever of control device and control rod.
2. Remove knob cover below selector lever downward.
3. Pull lock pin out of selector lever knob.
4. Remove selector lever knob.
5. Remove console finisher. Refer to [IP-11, "Removal and Installation"](#).
6. Remove center console. Refer to [IP-21, "CENTER CONSOLE \(A/T MODELS\)"](#).
7. Remove rear ventilator duct 2. Refer to [ATC-139, "Removal of Rear Ventilator Ducts"](#).
8. Remove key interlock cable from control device. Refer to [AT-246, "Removal and Installation"](#).
9. Disconnect A/T device harness connector.
10. Remove control device assembly.

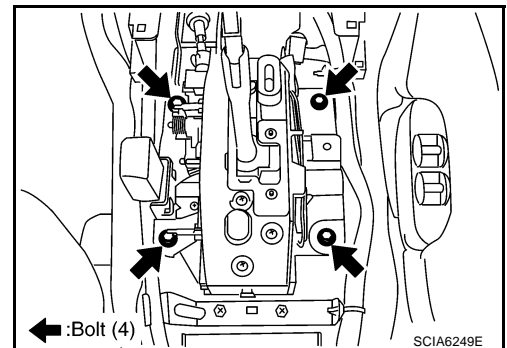
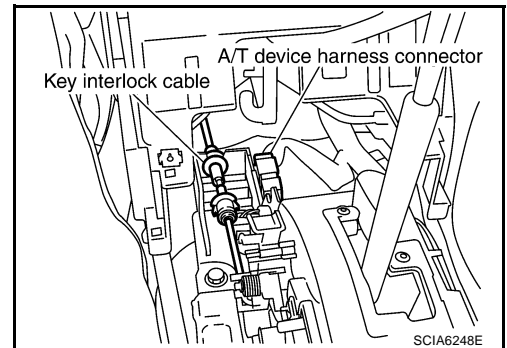
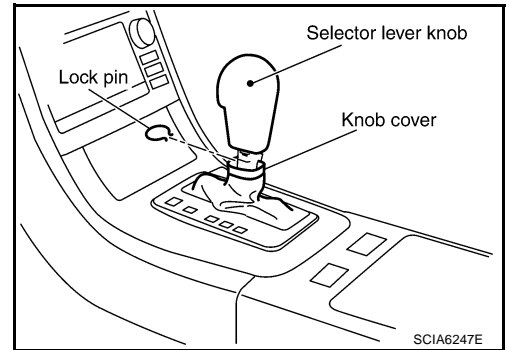

## INSTALLATION

Note the following, and install in the reverse order of removal.

- After installation is completed, adjust and check A/T position. Refer to [AT-238, "Adjustment of A/T Position"](#) and [AT-239, "Checking of A/T Position"](#).

# SHIFT CONTROL SYSTEM

ACS0098L

## Control Rod Removal and Installation CONTROL ROD COMPONENTS (2WD MODELS)

A  
B  
AT  
D  
E  
F  
G  
H  
I  
J  
K  
L  
M

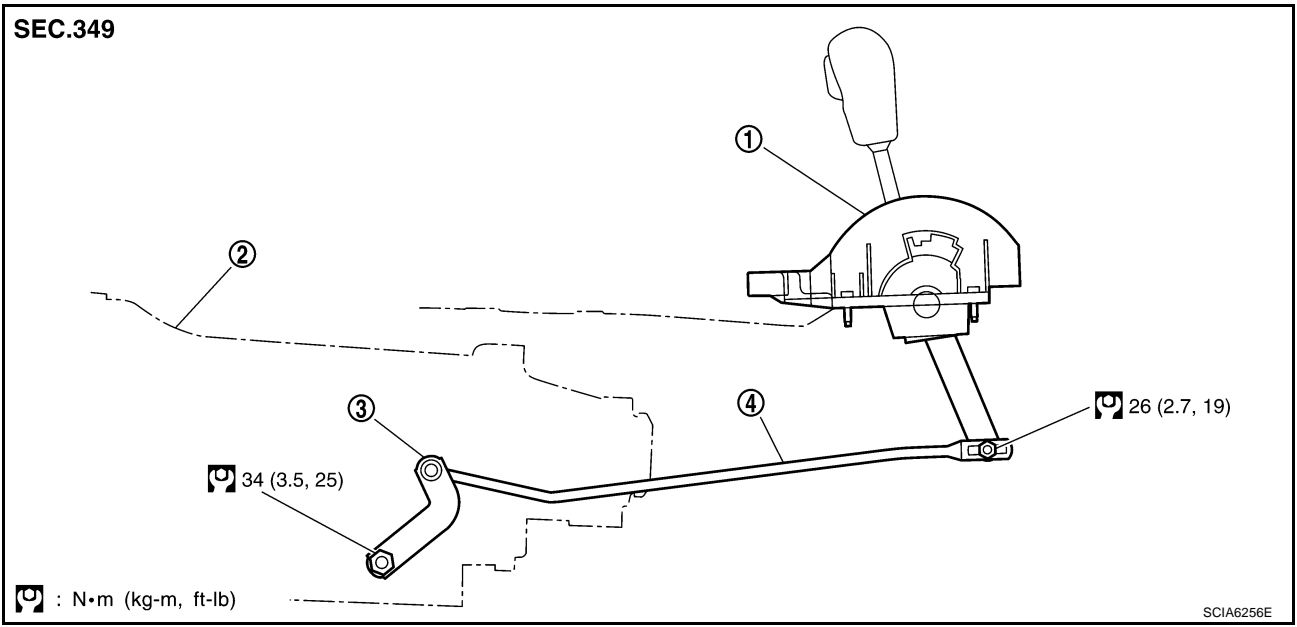

- 1. Control device assembly
- 2. Transmission
- 3. Manual lever
- 4. Control rod

## CONTROL ROD COMPONENTS (AWD MODELS)

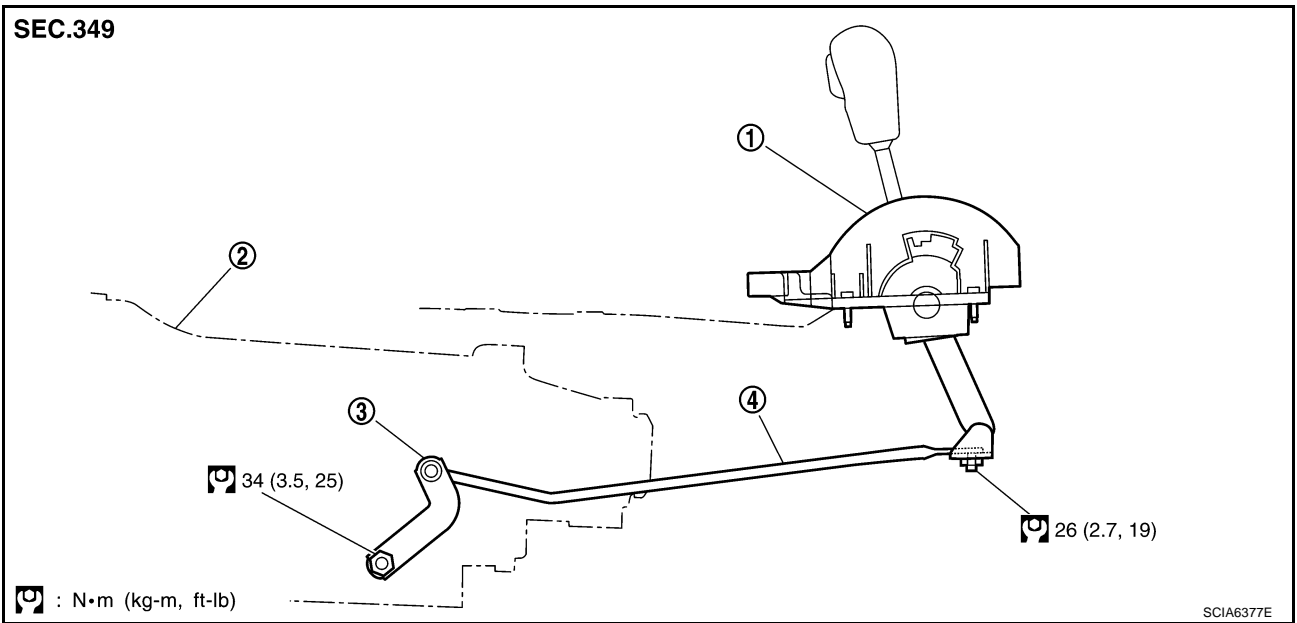

- 1. Control device assembly
- 2. Transmission
- 3. Manual lever
- 4. Control rod

# SHIFT CONTROL SYSTEM

## REMOVAL

1. Disconnect lower lever of control device and control rod.
2. Remove manual lever from transmission.
3. Remove control rod from vehicle.

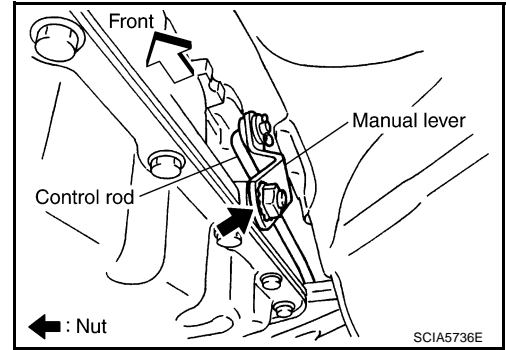

## INSTALLATION

Note the following, and install in the reverse order of removal.

- After installation is completed, adjust and check A/T position. Refer to [AT-238, "Adjustment of A/T Position"](#) and [AT-239, "Checking of A/T Position"](#).

## Adjustment of A/T Position 2WD MODELS

ACS0063L

1. Loosen nut of pivot pin.
2. Place PNP switch and selector lever in "P" position.
3. While pressing lower lever toward rear of vehicle (in "P" position direction), tighten nut to specified torque. Refer to [AT-237, "CONTROL ROD COMPONENTS \(2WD MODELS\)"](#).

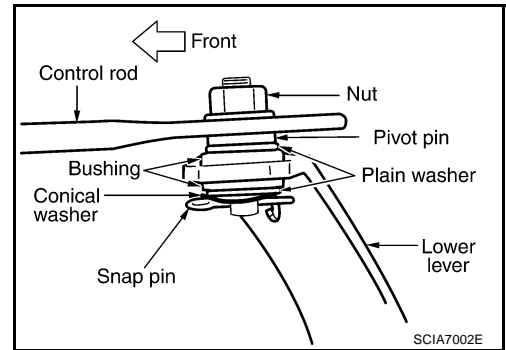

## AWD MODELS

1. Loosen nut of control rod.
2. Place PNP switch and selector lever in "P" position.
3. While pressing lower lever toward rear of vehicle (in P position direction), tighten nut to specified torque. Refer to [AT-237, "CONTROL ROD COMPONENTS \(AWD MODELS\)"](#).

### CAUTION:

Do not push the bracket.

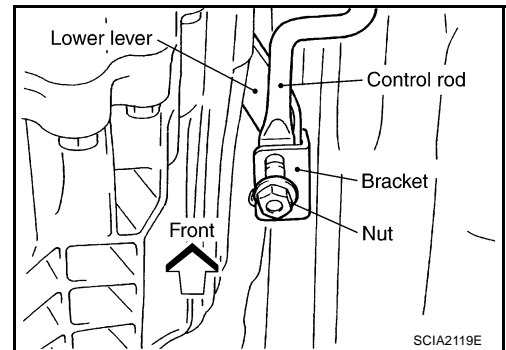

# SHIFT CONTROL SYSTEM

## Checking of A/T Position

ACS0063M

1. Place selector lever in "P" position, and turn ignition switch ON (engine stop).
2. Make sure selector lever can be shifted to other than "P" position when brake pedal is depressed. Also make sure selector lever can be shifted from "P" position only when brake pedal is depressed.
3. Move the selector lever and check for excessive effort, sticking, noise or rattle.
4. Confirm the selector lever stops at each position with the feel of engagement when it is moved through all the positions. Check whether or not the actual position the selector lever is in matches the position shown by the shift position indicator and the transmission body.
5. The method of operating the lever to individual positions correctly should be as shown in the figure.
6. When selector button is pressed in "P", "R", or "N" position without applying forward/backward force to selector lever, check button operation for sticking.
7. Confirm the back-up lamps illuminate only when lever is placed in the "R" position. Confirm the back-up lamps does not illuminate when selector lever is pushed against "R" position in the "P" or "N" position.
8. Confirm the engine can only be started with the selector lever in the "P" and "N" positions.
9. Make sure transmission is locked completely in "P" position.
10. When selector lever is set to manual shift gate, make sure manual mode is displayed on combination meter.  
Shift selector lever to "+" and "-" sides, and make sure set shift position changes.

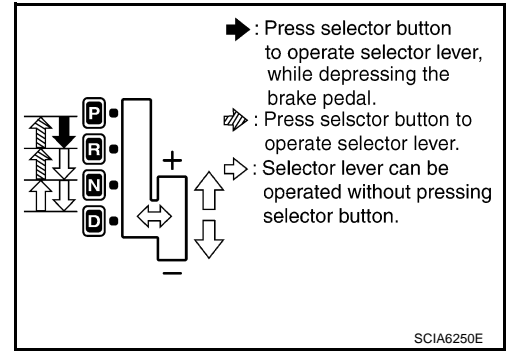

A

B

AT

D

E

F

G

H

I

J

K

L

M

# A/T SHIFT LOCK SYSTEM

## A/T SHIFT LOCK SYSTEM

PFP:34950

### Description

ACS00645

- The mechanical key interlock mechanism also operates as a shift lock:  
With the ignition switch turned to ON, the selector lever cannot be shifted from "P" (parking) to any other position unless the brake pedal is depressed.  
With the key removed, the selector lever cannot be shifted from "P" to any other position.  
The key cannot be removed unless the selector lever is placed in "P".
- The shift lock and key interlock mechanisms are controlled by the ON-OFF operation of the shift lock solenoid and by the operation of the rotator and slider located inside the key cylinder.

### Shift Lock System Electrical Parts Location

ACS00646

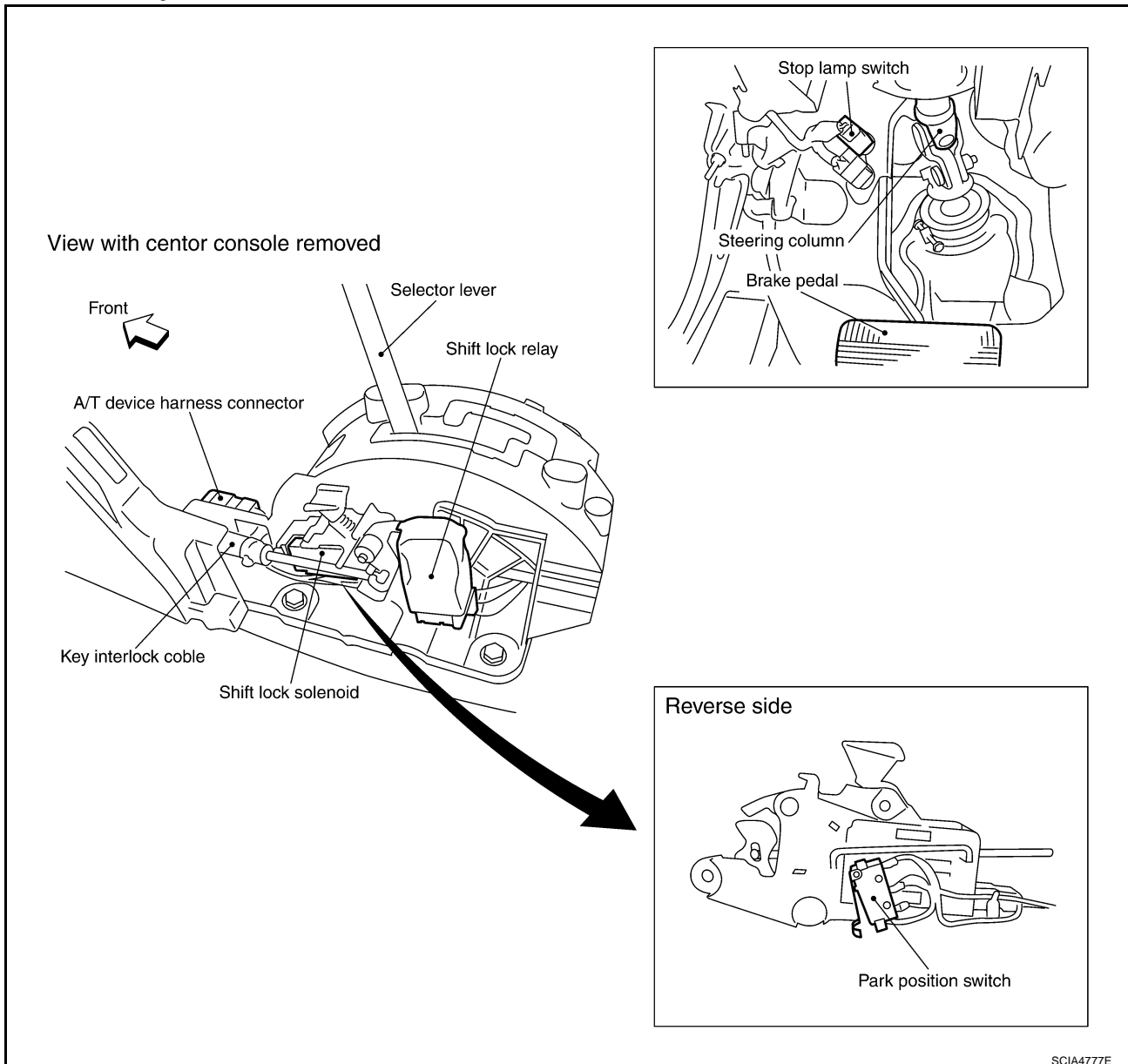



# A/T SHIFT LOCK SYSTEM

## Wiring Diagram — AT — SHIFT

ACS00647

### AT-SHIFT-01

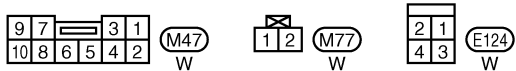
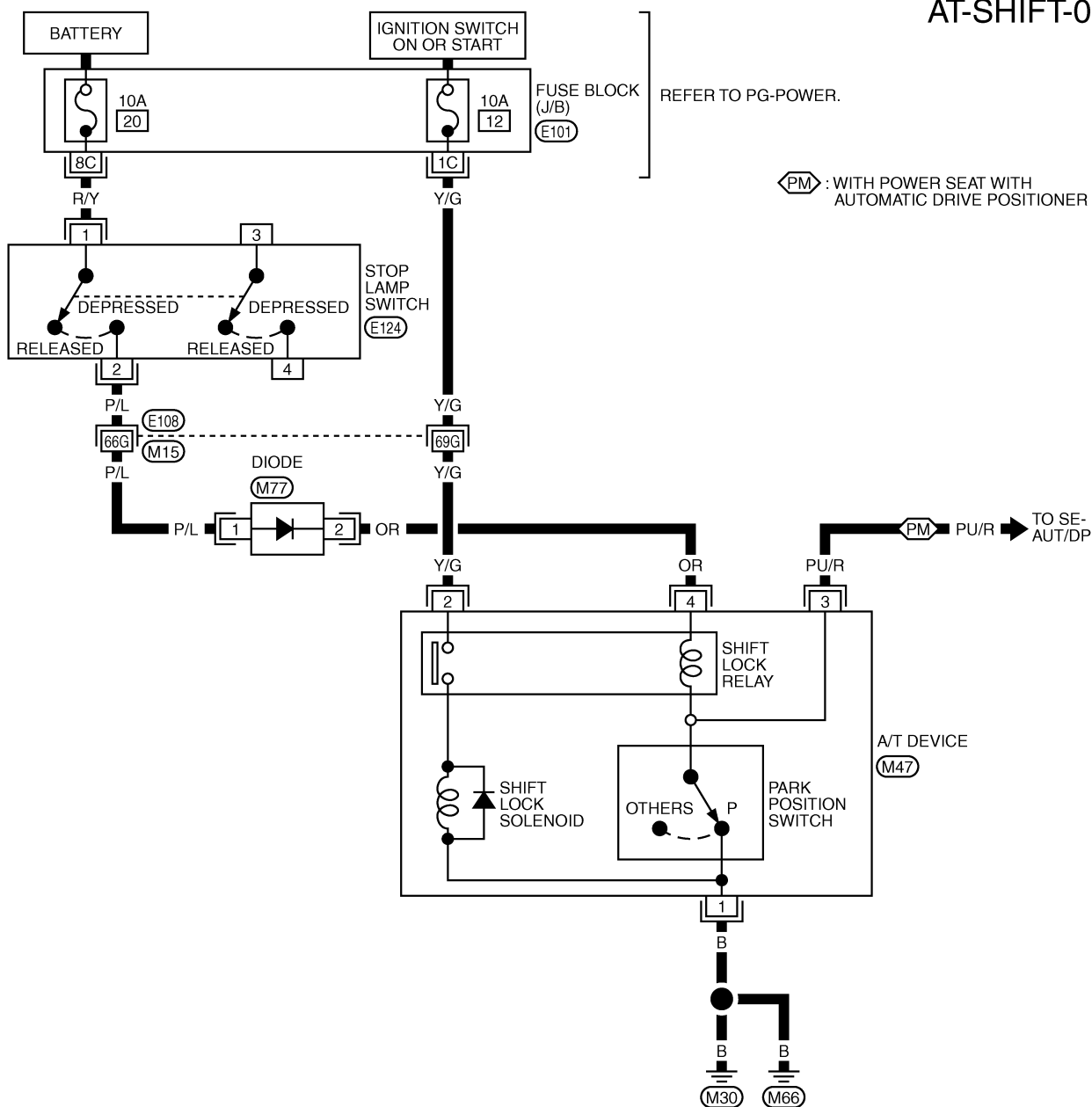

REFER TO THE FOLLOWING.  
 (E108) -SUPER MULTIPLE JUNCTION (SMJ)  
 (E101) -FUSE BLOCK-JUNCTION BOX (J/B)

TCWM0441E

# A/T SHIFT LOCK SYSTEM

## A/T Device Inspection Table

ACS006CK

Data are reference value and are measured between each terminal and ground.

Terminal (Wire color)	Item	Condition	Judgement standard
1 (B)	Ground	Always	Approx. 0V
2 (Y/G)	Shift lock relay (switch side) and shift lock solenoid	Ignition switch: ON	Battery voltage
		Ignition switch: OFF	Approx. 0V
4 (OR)	Shift lock relay (coil side) and park position switch	When brake pedal is depressed	Battery voltage
		When brake pedal is released	Approx. 0V

## Diagnostic Procedure

ACS00648

### SYMPTOM 1:

- Selector lever cannot be moved from "P" position with key in ON position and brake pedal applied.
- Selector lever can be moved from "P" position with key in ON position and brake pedal released.
- Selector lever can be moved from "P" position when key is removed from key cylinder.

### SYMPTOM 2:

- Ignition key cannot be removed when selector lever is set to "P" position.
- Ignition key can be removed when selector lever is set to any position except "P".

## 1. CHECK KEY INTERLOCK CABLE

Check key interlock cable for damage.

OK or NG

OK >> GO TO 2.

NG >> Repair key interlock cable. Refer to [AT-245, "KEY INTERLOCK CABLE"](#).

## 2. CHECK SELECTOR LEVER POSITION

Check selector lever position for damage. Refer to [AT-239, "Checking of A/T Position"](#).

OK or NG

OK >> GO TO 3.

NG >> Adjustment A/T position. Refer to [AT-238, "Adjustment of A/T Position"](#).

## 3. CHECK POWER SOURCE

1. Turn ignition switch ON. (Do not start engine.)
2. Check voltage between A/T device harness connector terminal 2 and ground.

**Voltage: Battery voltage**

OK or NG

OK >> GO TO 5.

NG >> GO TO 4.

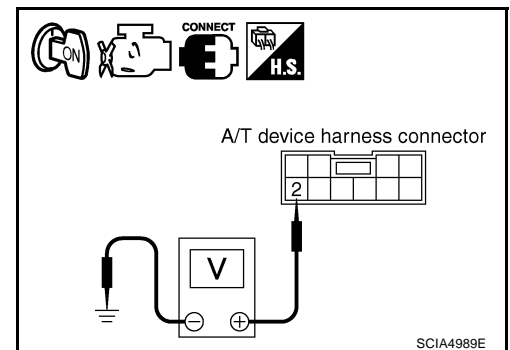

# A/T SHIFT LOCK SYSTEM

## 4. DETECT MALFUNCTIONING ITEM

Check the following.

1. Harness for short or open between ignition switch and A/T device harness connector terminal 2
2. 10A fuse [No.12, located in the fuse block (J/B)]
3. Ignition switch. Refer to [PG-3, "POWER SUPPLY ROUTING CIRCUIT"](#) .

OK or NG

- OK >> GO TO 5.
- NG >> Repair or replace damaged parts.

## 5. CHECK INPUT SIGNAL A/T DEVICE

1. Turn ignition switch OFF.
2. Disconnect A/T device harness connector.
- Check voltage between A/T device harness connector terminal 4 and ground.

**Voltage:**

**Depressed brake pedal**

**: Battery voltage**

**Released brake pedal**

**: Approx. 0V**

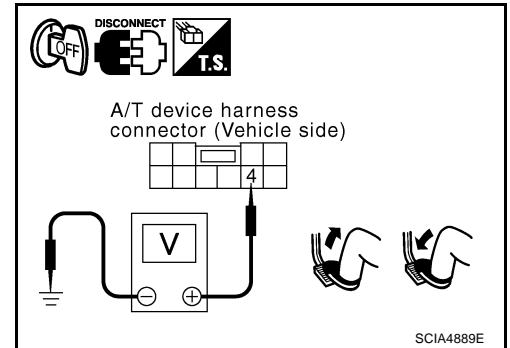

OK or NG

- OK >> GO TO 7.
- NG >> GO TO 6.

## 6. DETECT MALFUNCTIONING ITEM

Check the following.

1. Harness for short or open between battery and stop lamp switch harness connector terminal 1.
2. Harness for short or open between stop lamp switch harness connector terminal 2 and A/T device harness connector terminal 4.
3. 10A fuse [No.20, located in the fuse block (J/B)]
4. Stop lamp switch
  - Check continuity between stop lamp switch harness connector terminals 1 and 2.

Condition	Continuity
When brake pedal is depressed	Yes
When brake pedal is released	No

**Check stop lamp switch after adjusting brake pedal — refer to [BR-6, "BRAKE PEDAL"](#) .**

OK or NG

- OK >> GO TO 7.
- NG >> Repair or replace damaged parts.

# A/T SHIFT LOCK SYSTEM

## 7. CHECK GROUND CIRCUIT

1. Turn ignition switch OFF.
2. Disconnect A/T device harness connector.
3. Check continuity between A/T device harness connector terminal 1 and ground.

**Continuity should exist.**

If OK, check harness for short to ground and short to power.

OK or NG

OK >> GO TO 8.

NG >> Repair open circuit or short to ground or short to power in harness or connectors.

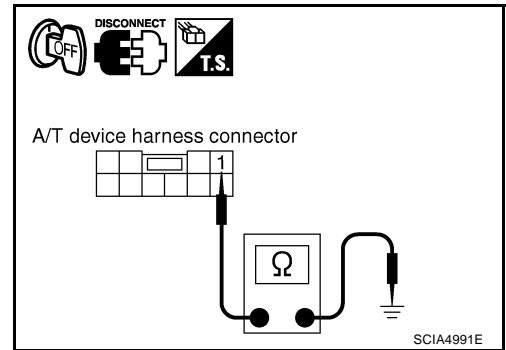

## 8. CHECK PARK POSITION SWITCH AND SHIFT LOCK RELAY CIRCUIT (COIL SIDE)

Check continuity between A/T device harness connector terminals 1 and 4.

Condition	Continuity
When selector lever is set in "P" position and selector lever button is released	Yes
Except above	No

OK or NG

OK >> GO TO 9.

NG >> ● Replace park position switch or shift lock relay.

- Repair open circuit or short to ground or short to power in harness or connectors.

## 9. CHECK SHIFT SOLENOID AND SHIFT LOCK RELAY CIRCUIT (SWITCH SIDE)

1. Connect A/T device harness connector.
2. Turn ignition switch ON. (Do not start engine.)
3. Check shift lock solenoid and shift lock relay operation.

Condition	Brake pedal	Operation
When ignition switch is turned to ON position and selector lever is set in "P" position.	Depressed	Yes
	Released	No

OK or NG

OK >> GO TO 10.

NG >> ● Replace shift lock solenoid or shift lock relay.

- Repair open circuit or short to ground or short to power in harness or connectors.

## 10. CHECK A/T DEVICE INSPECTION

1. Perform A/T device input/output signal inspection test. Refer to [AT-242, "A/T Device Inspection Table"](#).
2. If NG, recheck harness connector connection.

OK or NG

OK >> **INSPECTION END**

NG >> Repair or replace damaged parts.

# KEY INTERLOCK CABLE

## KEY INTERLOCK CABLE

PFP:34908

### Components

ACS00649

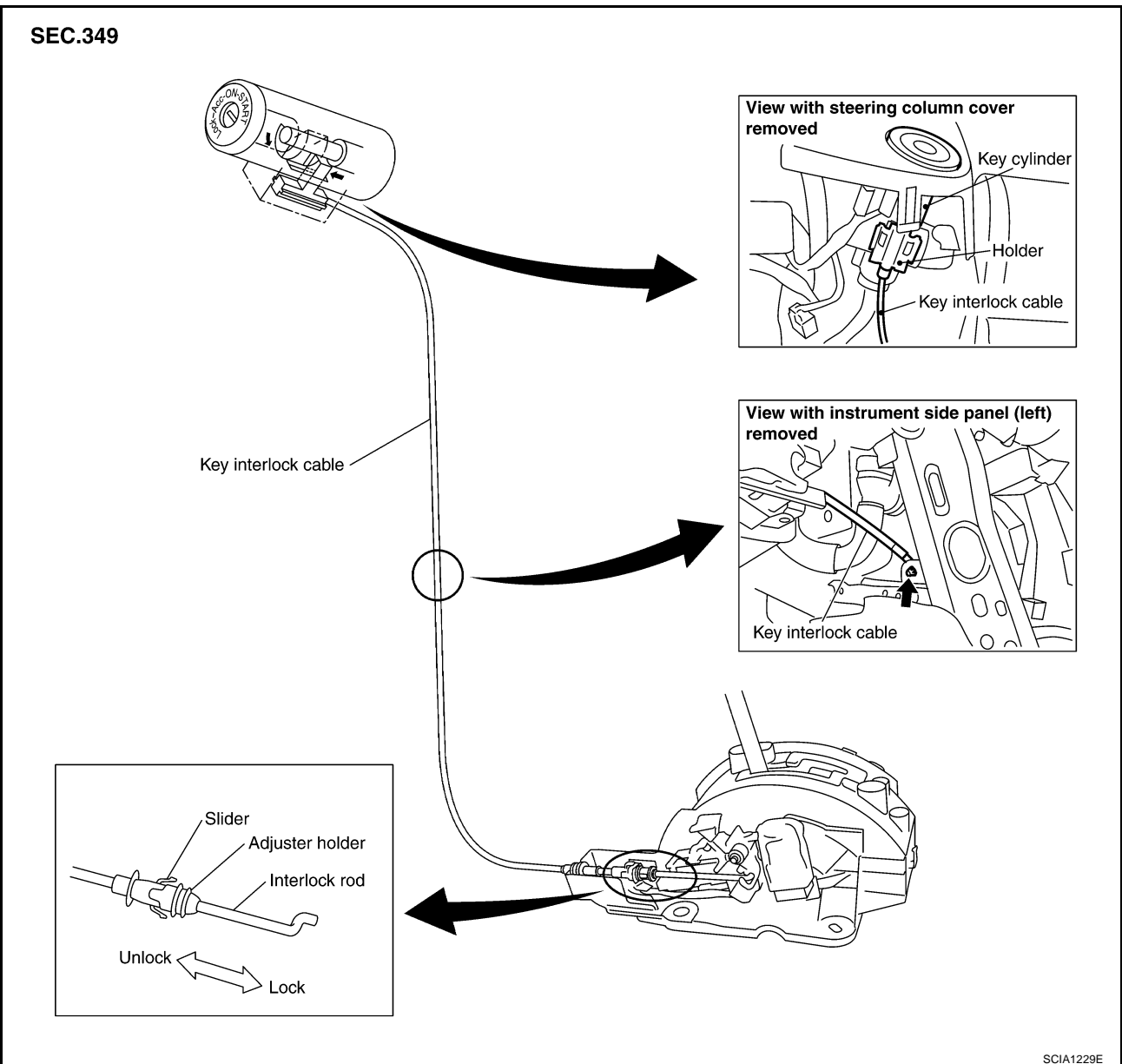

#### CAUTION:

- Install key interlock cable in such a way that it will not be damaged by sharp bends, twists or interference with adjacent parts.
- After installing key interlock cable to control device, make sure that casing cap and bracket are firmly secured in their positions. If casing cap be removed with an external load of less than 39 N (4.0 kg, 8.8 lb), replace key interlock cable with new one.

A  
B  
AT  
D  
E  
F  
G  
H  
I  
J  
K  
L  
M

# KEY INTERLOCK CABLE

ACS006G/

## Removal and Installation

### REMOVAL

1. Unlock slider by squeezing lock tabs on slider from adjuster holder.
2. Remove casing cap from bracket of control device assembly and remove interlock rod from cable.

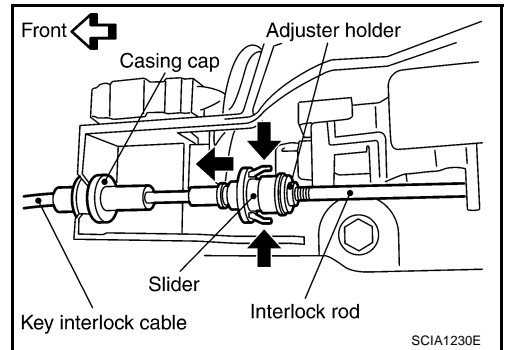

3. Remove holder from key cylinder and remove key interlock cable.

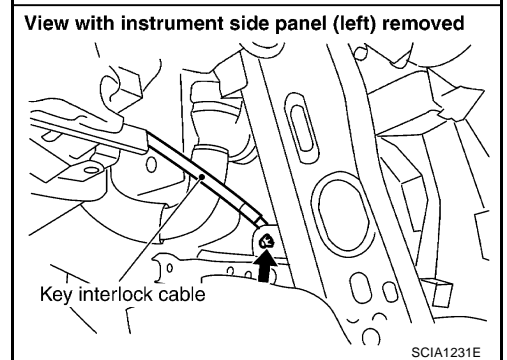
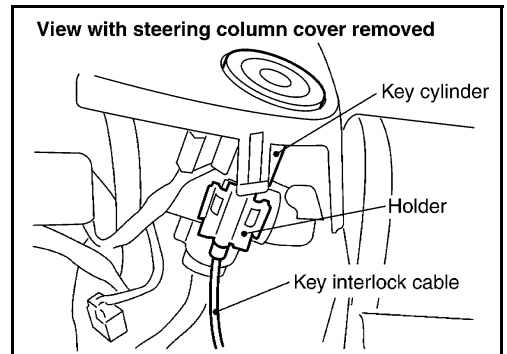

# KEY INTERLOCK CABLE

## INSTALLATION

1. Set key interlock cable to key cylinder and install holder.
2. Clamp cable and fix to control cable with band.
3. Turn ignition key to lock position.
4. Set selector lever to "P" position.

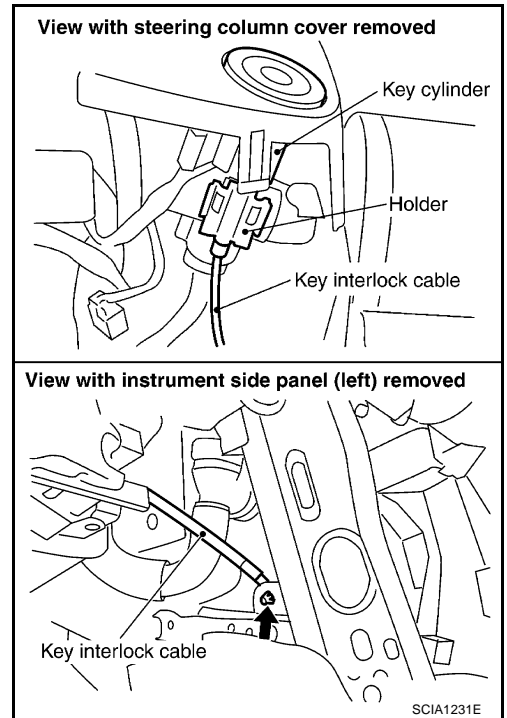

5. Insert interlock rod into adjuster holder.
6. Install casing cap to bracket.
7. Move slider in order to fix adjuster holder to interlock rod.

### **CAUTION:**

**Do not touch any adjacent parts of key interlock cable when slider is being held.**

**Insert slider into key interlock rod straightly.**

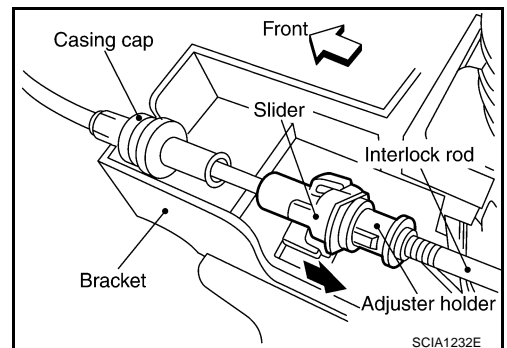

A  
B  
AT  
D  
E  
F  
G  
H  
I  
J  
K  
L  
M

## ON-VEHICLE SERVICE

PFP:00000

### Control Valve with TCM and A/T Fluid Temperature Sensor 2 COMPONENTS

ACS008H0

SEC.313 · 314 · 315 · 316 · 317 · 319

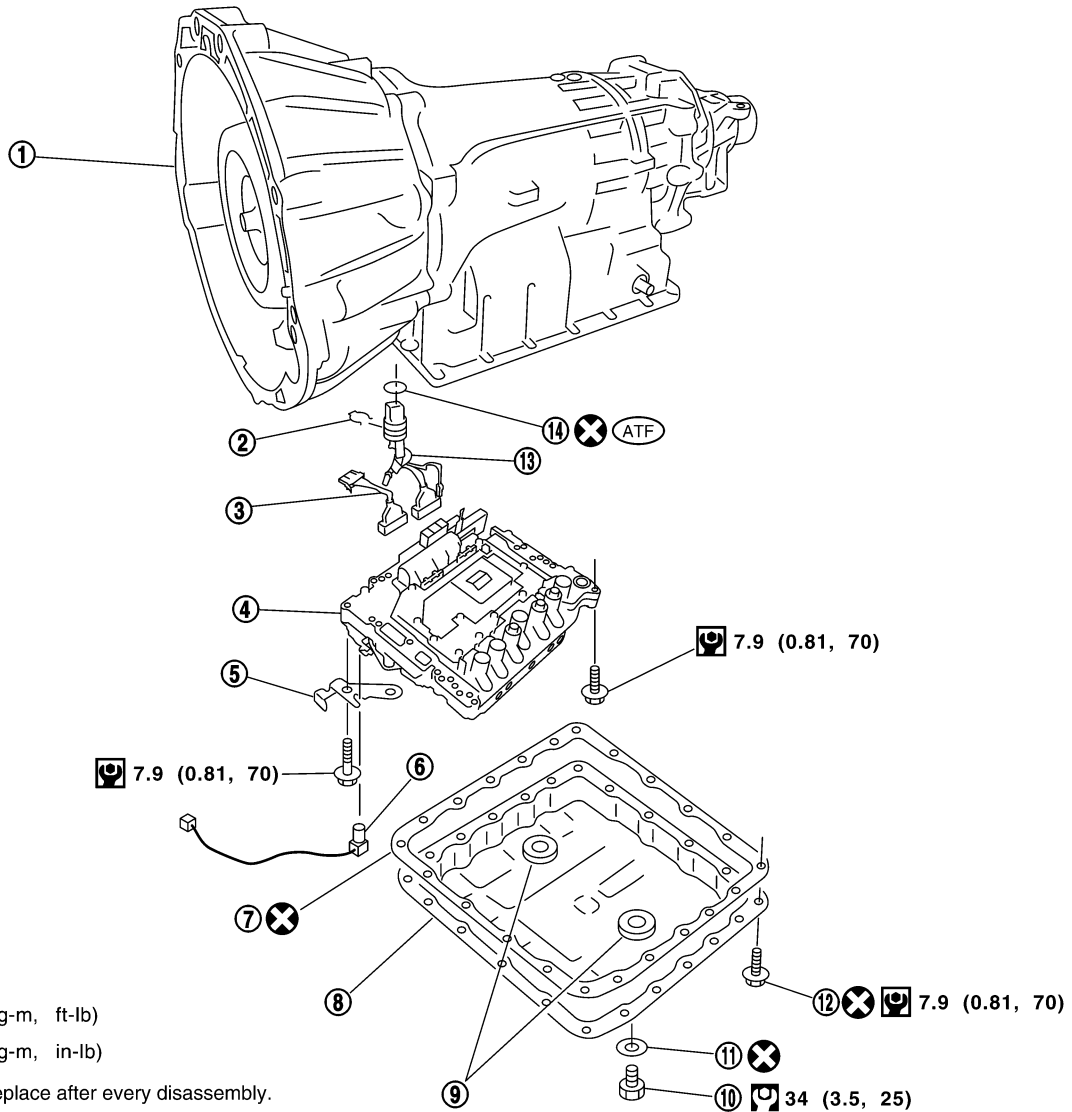

SCIA5445E

- |                            |                       |                                   |
|----------------------------|-----------------------|-----------------------------------|
| 1. Transmission            | 2. Snap ring          | 3. Sub-harness                    |
| 4. Control valve with TCM  | 5. Bracket            | 6. A/T fluid temperature sensor 2 |
| 7. Oil pan gasket          | 8. Oil pan            | 9. Magnet                         |
| 10. Drain plug             | 11. Drain plug gasket | 12. Oil pan mounting bolt         |
| 13. Terminal cord assembly | 14. O-ring            |                                   |

## CONTROL VALVE WITH TCM REMOVAL AND INSTALLATION

### Removal

1. Disconnect the battery cable from the negative terminal.
2. Disconnect heated oxygen sensor 2 harness connector.
3. Drain ATF through drain plug.
4. Disconnect A/T assembly harness connector.



# ON-VEHICLE SERVICE

5. Remove snap ring from A/T assembly harness connector.

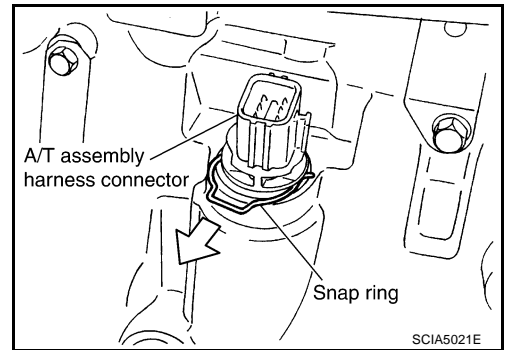

6. Push A/T assembly harness connector.

**CAUTION:**  
Be careful not to damage connector.

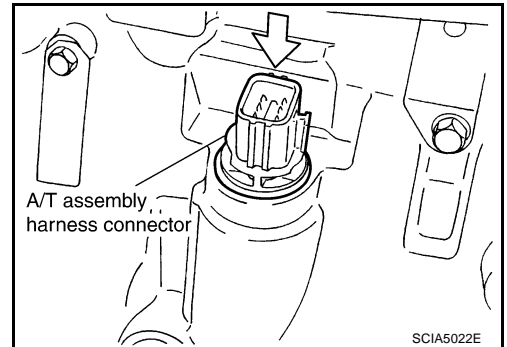

7. Remove oil pan and oil pan gasket.

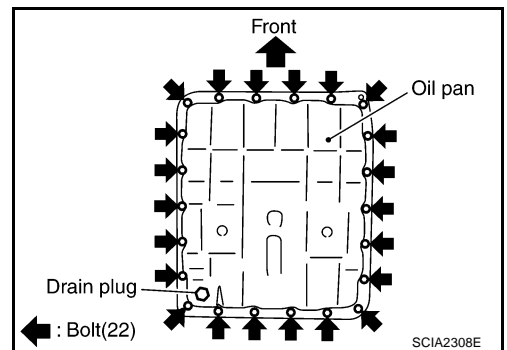

8. Check foreign materials in oil pan to help determine causes of malfunction. If the A/T fluid is very dark, smells burned, or contains foreign particles, the frictional material (clutches, band) may need replacement. A tacky film that will not wipe clean indicates varnish build up. Varnish can cause valves, servo, and clutches to stick and can inhibit pump pressure.

● If frictional material is detected, perform A/T fluid cooler cleaning. Refer to [AT-14, "A/T Fluid Cooler Cleaning"](#).

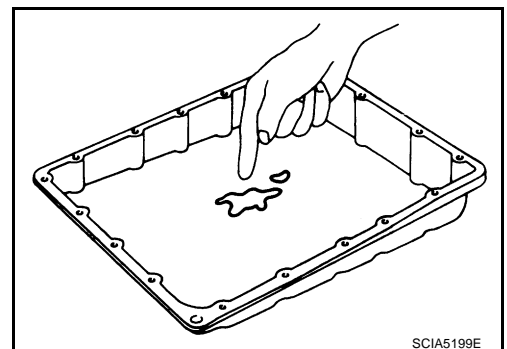

9. Remove magnets from oil pan.

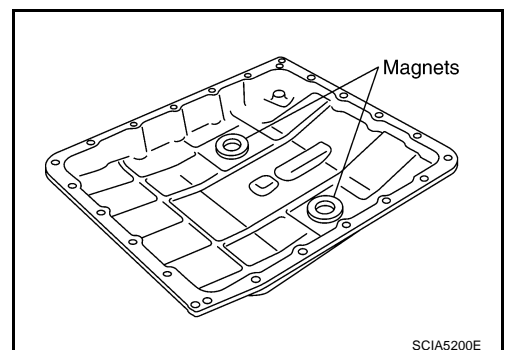

A  
B  
AT  
D  
E  
F  
G  
H  
I  
J  
K  
L  
M

# ON-VEHICLE SERVICE

10. Disconnect A/T fluid temperature sensor 2 connector.

**CAUTION:**  
Be careful not to damage connector.

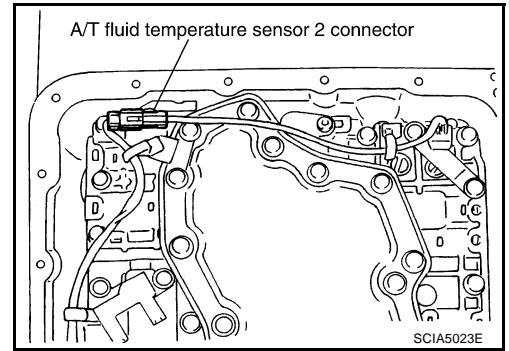

11. Straighten terminal clips to free terminal cord assembly and A/T fluid temperature sensor 2 harness.

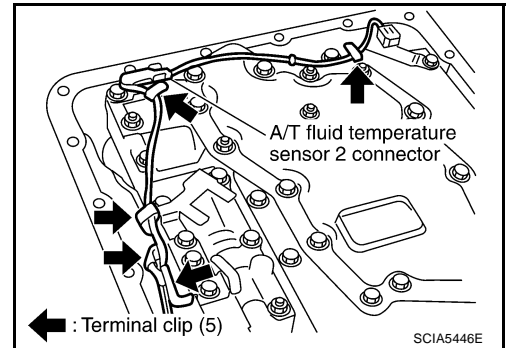

12. Disconnect revolution sensor connector.

**CAUTION:**  
Be careful not to damage connector.

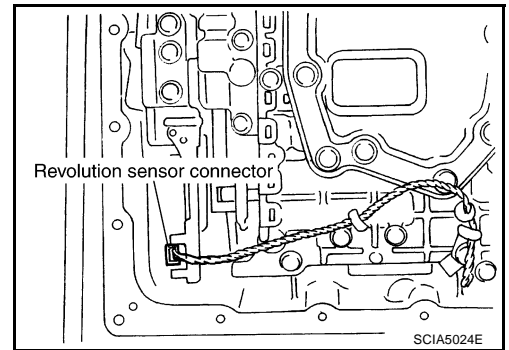

13. Straighten terminal clips to free revolution sensor harness.

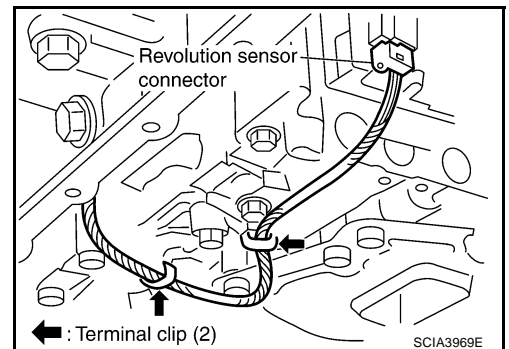

14. Remove bolts A, B and C from control valve with TCM.

Bolt symbol	Length mm (in)	Number of bolts
A	42 (1.65)	5
B	55 (2.17)	6
C	40 (1.57)	1

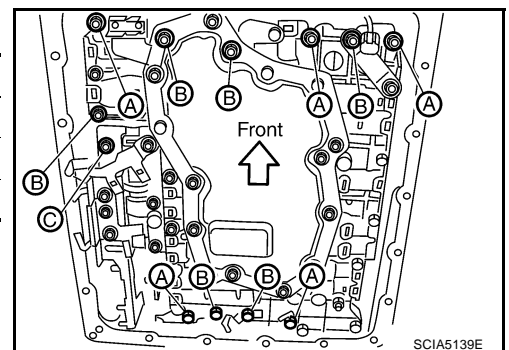

# ON-VEHICLE SERVICE

15. Remove control valve with TCM from transmission case.

**CAUTION:**

When removing, be careful with the manual valve notch and manual plate height. Remove it vertically.

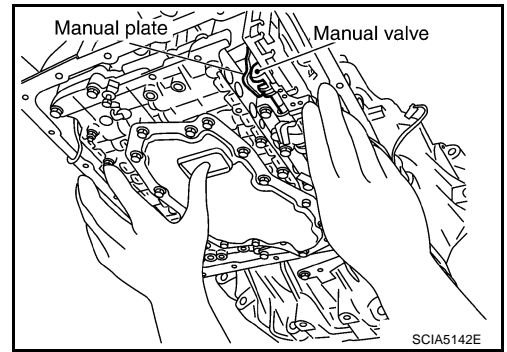

16. Remove A/T fluid temperature sensor 2 with bracket from control valve with TCM.

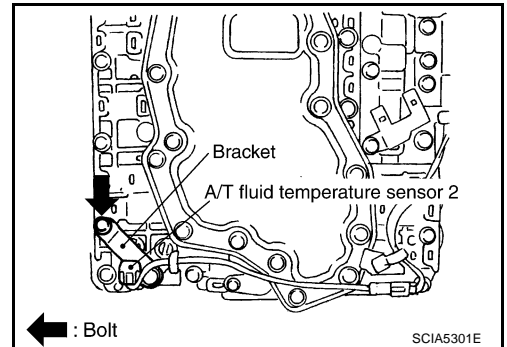

17. Remove bracket from A/T fluid temperature sensor 2.

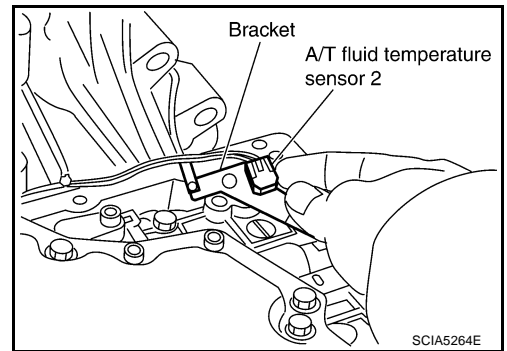

18. Remove O-ring from A/T assembly harness connector.

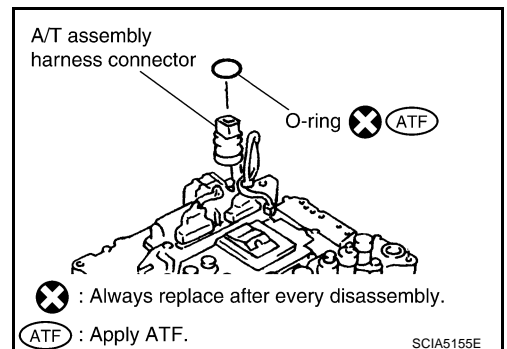

19. Disconnect TCM connectors.

**CAUTION:**

Be careful not to damage connectors.

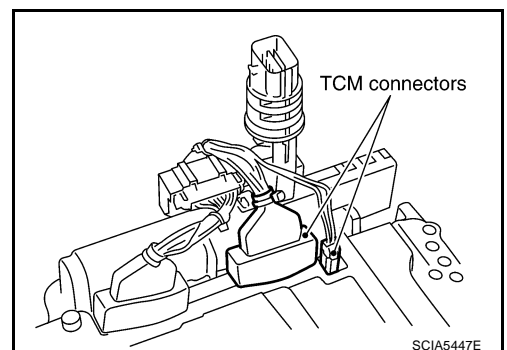

A  
B  
AT  
D  
E  
F  
G  
H  
I  
J  
K  
L  
M

## ON-VEHICLE SERVICE

20. Remove A/T assembly harness connector from control valve with TCM using a flat-bladed screwdriver.

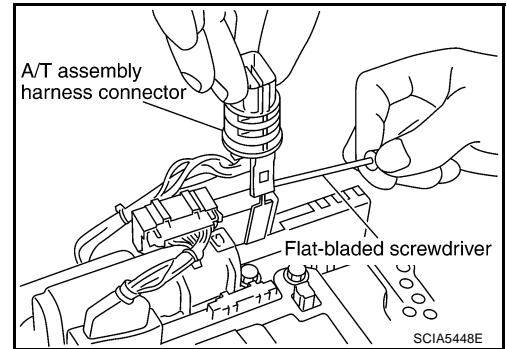

21. Disconnect TCM connector and park/neutral position switch connector.

**CAUTION:**

**Be careful not to damage connectors.**

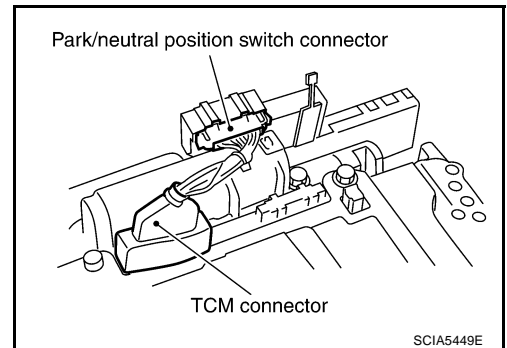

### Installation

**CAUTION:**

After completing installation, check A/T fluid leakage and A/T fluid level. Refer to [AT-12, "Changing A/T Fluid"](#) , [AT-12, "Checking A/T Fluid"](#) .

1. Connect TCM connector and park/neutral position switch connector.

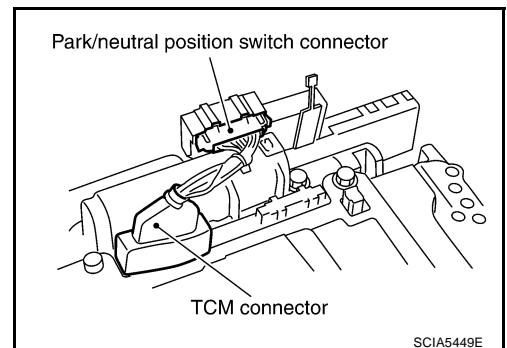

2. Install A/T assembly harness connector from control valve with TCM.

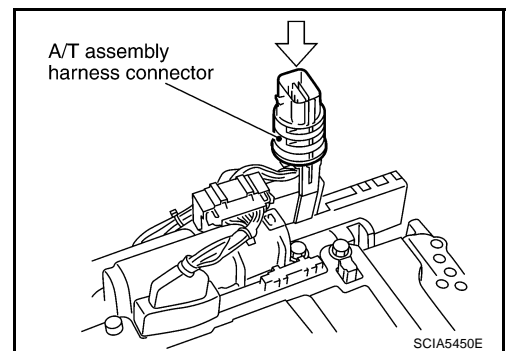

# ON-VEHICLE SERVICE

3. Connect TCM connectors.

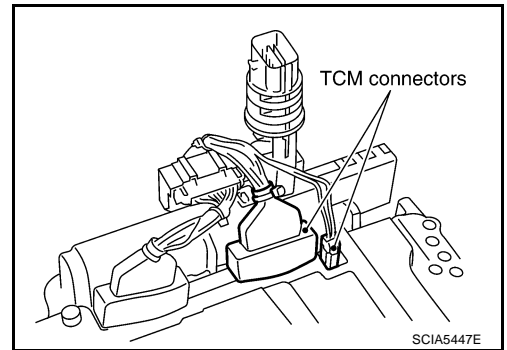

4. Install O-ring in A/T assembly harness connector.

**CAUTION:**

- Do not reuse O-ring.
- Apply ATF to O-ring.

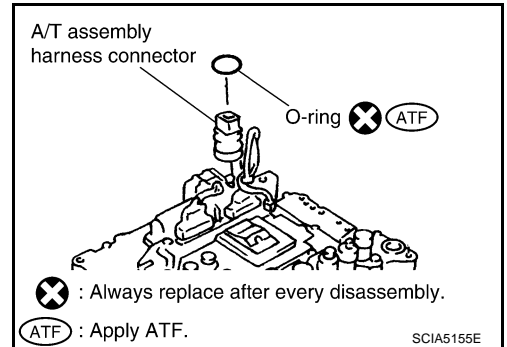

5. Install A/T fluid temperature sensor 2 to bracket.

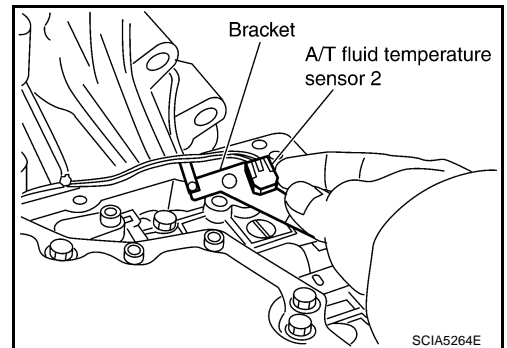

6. Install A/T fluid temperature sensor 2 (with bracket) in control valve with TCM.

**CAUTION:**

Adjust bolt hole of bracket to bolt hole of control valve with TCM.

 : 7.9 N·m (0.81 kg-m, 70 in-lb)

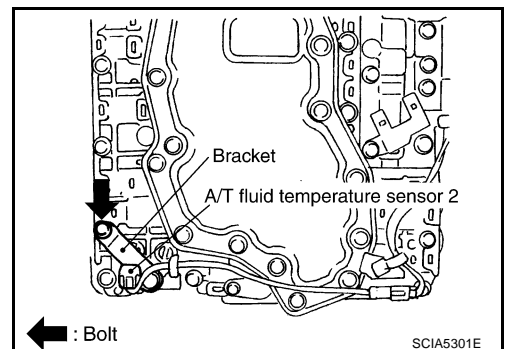

7. Install control valve with TCM in transmission case.

**CAUTION:**

- Make sure that turbine revolution sensor securely installs turbine revolution sensor hole.
- Hang down revolution sensor harness toward outside so as not to disturb installation of control valve with TCM.
- Adjust A/T assembly harness connector of control valve with TCM to terminal hole of transmission case.

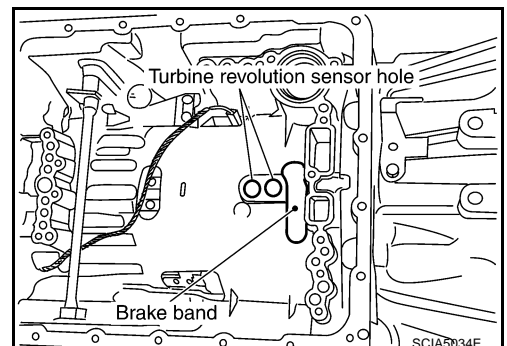

A  
B  
AT  
D  
E  
F  
G  
H  
I  
J  
K  
L  
M

# ON-VEHICLE SERVICE

- Assemble it so that manual valve cutout is engaged with manual plate projection.

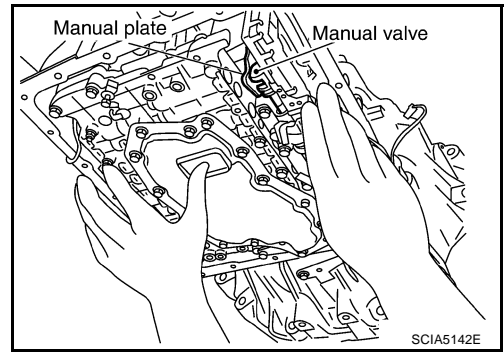

8. Install bolts A, B and C in control valve with TCM.

Bolt symbol	Length mm (in)	Number of bolts
A	42 (1.65)	5
B	55 (2.17)	6
C	40 (1.57)	1

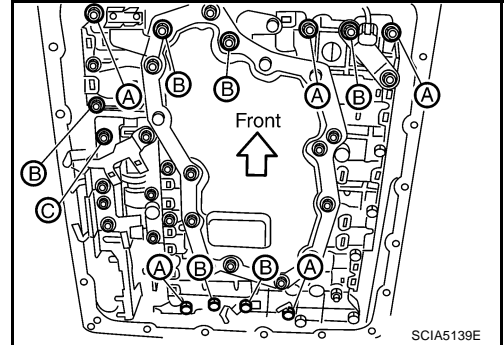

9. Tighten bolt 1, 2 and 3 temporarily to prevent dislocation. After that tighten them in order (1 → 2 → 3), and then tighten other bolts.

 : 7.9 N-m (0.81 kg-m, 70 in-lb)

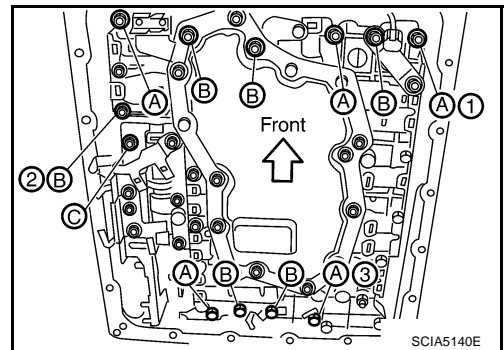

10. Connect A/T fluid temperature sensor 2 connector.

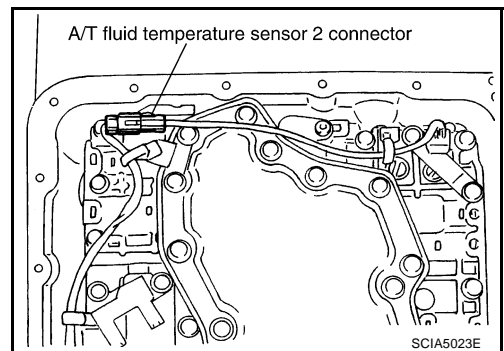

11. Securely fasten terminal cord assembly and A/T fluid temperature sensor 2 harness with terminal clips.

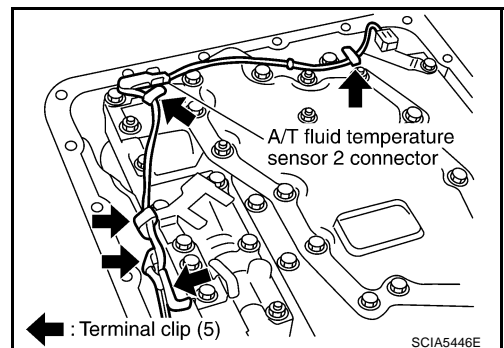

# ON-VEHICLE SERVICE

12. Connect revolution sensor connector.

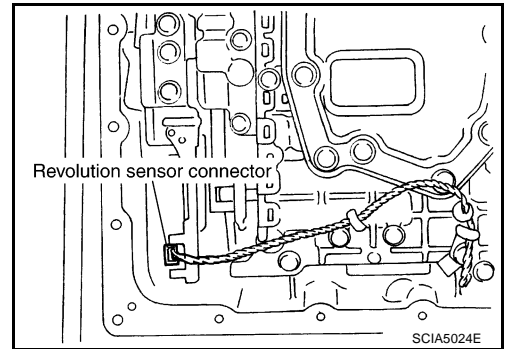

13. Securely fasten revolution sensor harness with terminal clips.

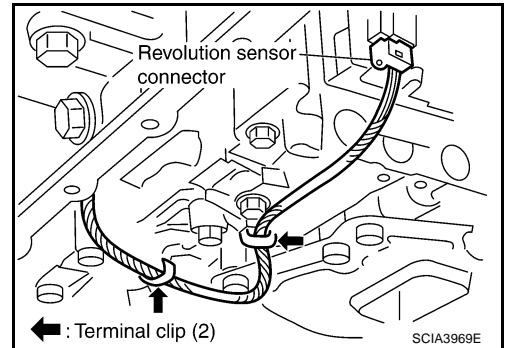

14. Install magnets in oil pan.

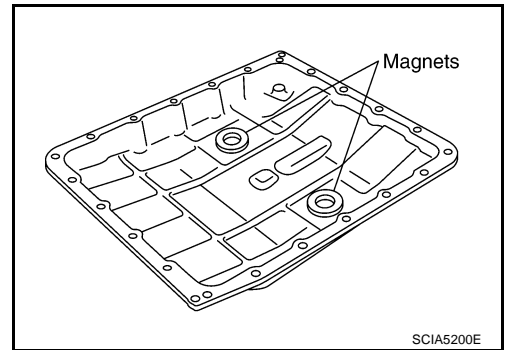

15. Install oil pan to transmission case.

a. Install oil pan gasket to oil pan.

**CAUTION:**

- Do not reuse oil pan gasket.
- Install it in the direction to align hole positions.
- Complete remove all moisture, oil and old gasket, etc. from oil pan gasket mounting surface.

b. Install oil pan (with oil pan gasket) to transmission case.

**CAUTION:**

- Install it so that drain plug comes to the position as shown in the figure.
- Be careful not to pinch harnesses.
- Complete remove all moisture, oil and old gasket, etc. from oil pan mounting surface.

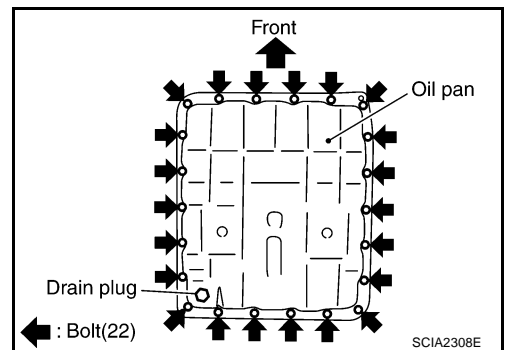

A  
B  
AT  
D  
E  
F  
G  
H  
I  
J  
K  
L  
M

## ON-VEHICLE SERVICE

- c. Tighten oil pan mounting bolts to the specified torque in numerical order shown in the figure after temporarily tightening them.

**CAUTION:**

**Do not reuse oil pan mounting bolts.**

 : 7.9 N·m (0.81 kg·m, 70 in·lb)

16. Install drain plug to oil pan.

**CAUTION:**

**Do not reuse drain plug gasket.**

 : 34 N·m (3.5 kg·m, 25 ft·lb)

17. Pull up A/T assembly harness connector.

**CAUTION:**

**Be careful not to damage connector.**

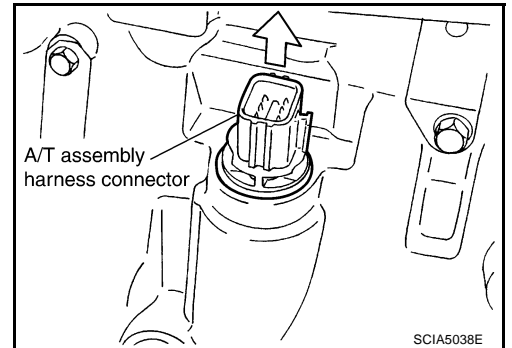
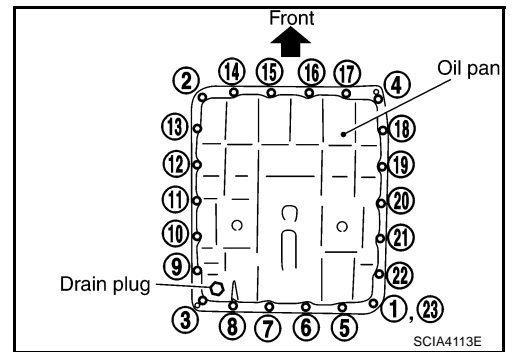

18. Install snap ring to A/T assembly harness connector.  
 19. Connect A/T assembly harness connector.  
 20. Connect heated oxygen sensor 2 harness connector.  
 21. Pour ATF into transmission assembly. Refer to [AT-12, "Changing A/T Fluid"](#) .  
 22. Connect the battery cable to the negative terminal.

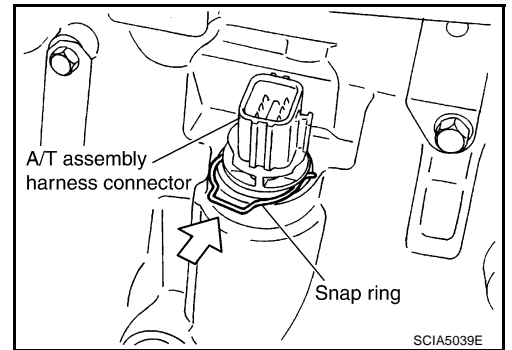

### A/T FLUID TEMPERATURE SENSOR 2 REMOVAL AND INSTALLATION

#### Removal

1. Disconnect the battery cable from the negative terminal.
2. Disconnect heated oxygen sensor 2 harness connector.
3. Drain ATF through drain plug.
4. Remove oil pan and oil pan gasket.

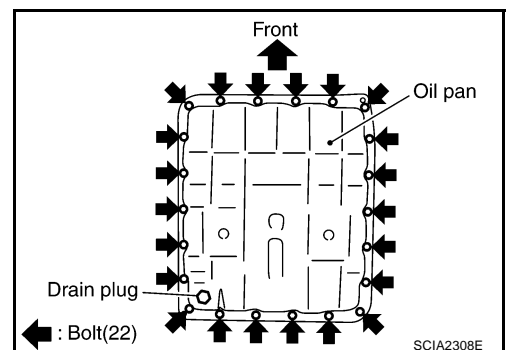



# ON-VEHICLE SERVICE

5. Check foreign materials in oil pan to help determine causes of malfunction. If the A/T fluid is very dark, smells burned, or contains foreign particles, the frictional material (clutches, band) may need replacement. A tacky film that will not wipe clean indicates varnish build up. Varnish can cause valves, servo, and clutches to stick and can inhibit pump pressure.

- If frictional material is detected, perform A/T fluid cooler cleaning. Refer to [AT-14, "A/T Fluid Cooler Cleaning"](#).

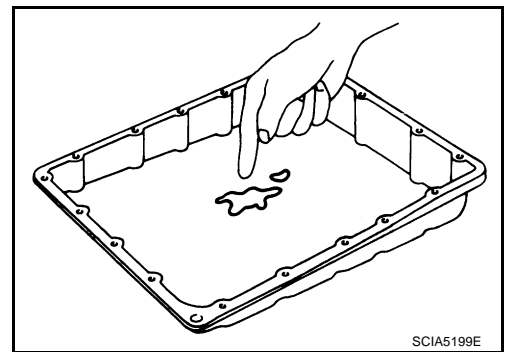

6. Disconnect A/T fluid temperature sensor 2 connector.

**CAUTION:**  
Be careful not to damage connector.

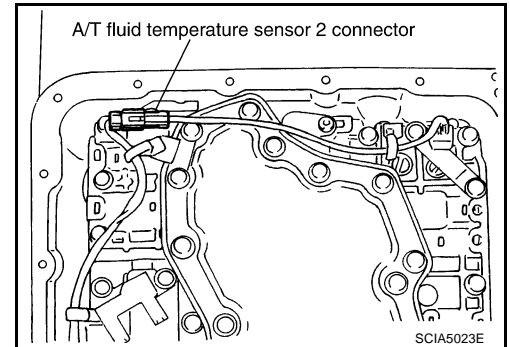

7. Straighten terminal clip to free A/T fluid temperature sensor 2 harness.

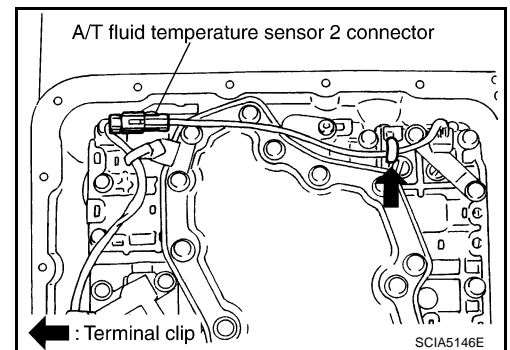

8. Remove A/T fluid temperature sensor 2 with bracket from control valve with TCM.

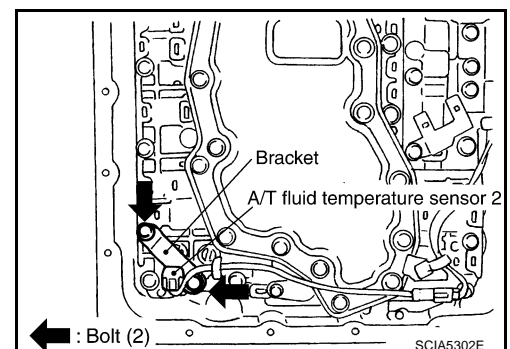

9. Remove bracket from A/T fluid temperature sensor 2.

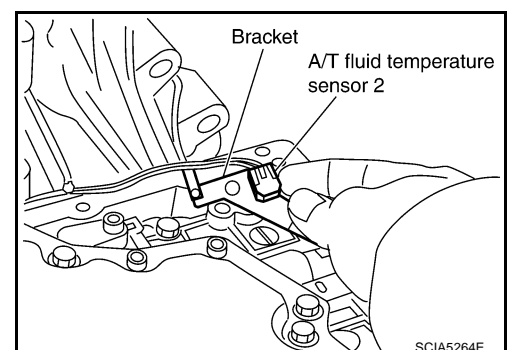

A  
B  
AT  
D  
E  
F  
G  
H  
I  
J  
K  
L  
M

# ON-VEHICLE SERVICE

## Installation

### CAUTION:

After completing installation, check A/T fluid leakage and A/T fluid level. Refer to [AT-12, "Changing A/T Fluid"](#) , [AT-12, "Checking A/T Fluid"](#) .

1. Install A/T fluid temperature sensor 2 to bracket.

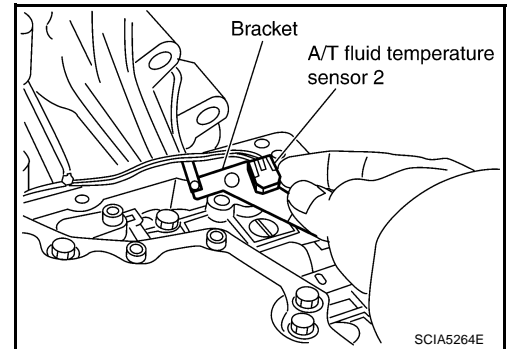

2. Install A/T fluid temperature sensor 2 (with bracket) in control valve with TCM.

 : 7.9 N-m (0.81 kg-m, 70 in-lb)

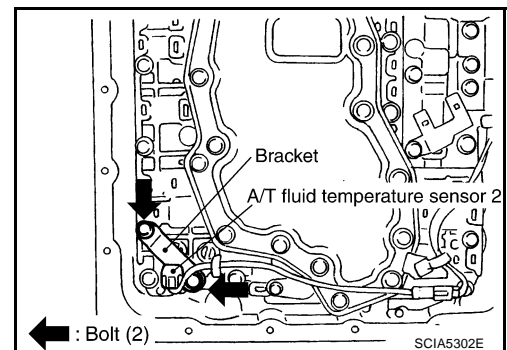

3. Connect A/T fluid temperature sensor 2 connector.

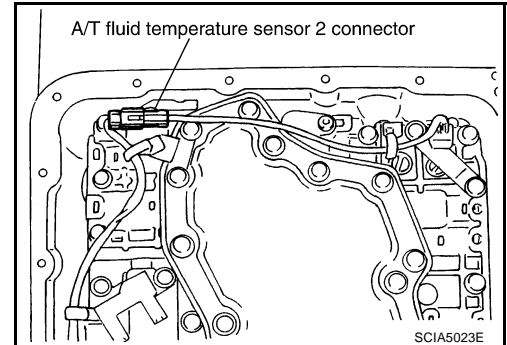

4. Securely fasten A/T fluid temperature sensor 2 harness with terminal clip.

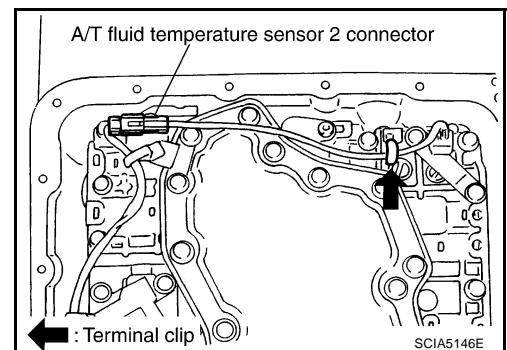

5. Install oil pan to transmission case.

- a. Install oil pan gasket to oil pan.

### CAUTION:

- Do not reuse oil pan gasket.
- Install it in the direction to align hole positions.
- Complete remove all moisture, oil and old gasket, etc. from oil pan gasket mounting surface.

## ON-VEHICLE SERVICE

- b. Install oil pan (with oil pan gasket) to transmission case.

**CAUTION:**

- Install it so that drain plug comes to the position as shown in the figure.
- Be careful not to pinch harnesses.
- Complete remove all moisture, oil and old gasket, etc. from oil pan mounting surface.

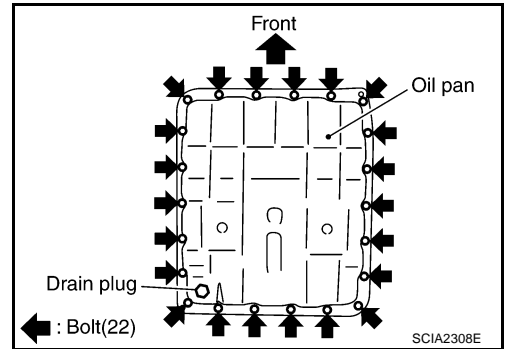

- c. Tighten oil pan mounting bolts to the specified torque in numerical order shown in the figure after temporarily tightening them.

**CAUTION:**

**Do not reuse oil pan mounting bolts.**

 : 7.9 N·m (0.81 kg-m, 70 in-lb)

6. Install drain plug to oil pan.

**CAUTION:**

**Do not reuse drain plug gasket.**

 : 34 N·m (3.5 kg-m, 25 ft-lb)

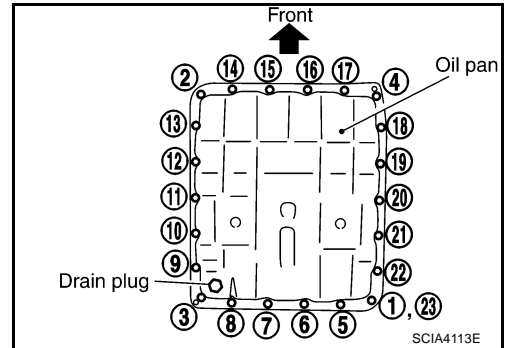

7. Connect heated oxygen sensor 2 harness connector.  
8. Pour ATF into transmission assembly. Refer to [AT-12, "Changing A/T Fluid"](#) .  
9. Connect the battery cable to the negative terminal.

A  
B  
AT  
D  
E  
F  
G  
H  
I  
J  
K  
L  
M

# ON-VEHICLE SERVICE

AC5008H1

## Parking Components (2WD Models Only) COMPONENTS

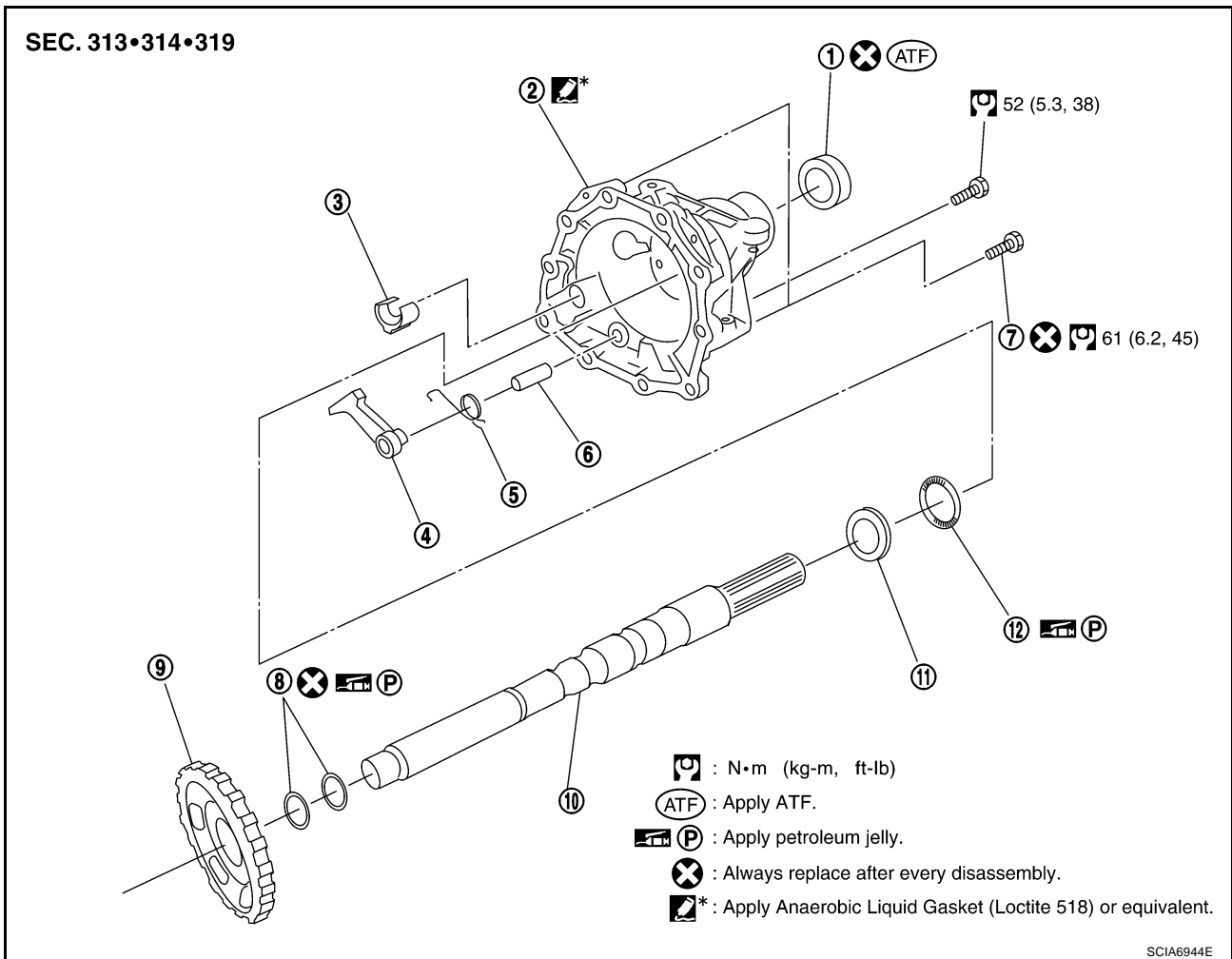

- |                      |                   |                             |
|----------------------|-------------------|-----------------------------|
| 1. Rear oil seal     | 2. Rear extension | 3. Parking actuator support |
| 4. Parking pawl      | 5. Return spring  | 6. Pawl shaft               |
| 7. Self-sealing bolt | 8. Seal ring      | 9. Parking gear             |
| 10. Output shaft     | 11. Bearing race  | 12. Needle bearing          |

### REMOVAL

1. Drain ATF through drain plug.
2. Remove exhaust front tube and center muffler with power tool. Refer to [EX-4, "Removal and Installation"](#) .
3. Remove rear propeller shaft. Refer to [PR-5, "Removal and Installation"](#) .
4. Remove control rod. Refer to [AT-237, "Control Rod Removal and Installation"](#) .
5. Support transmission assembly with a transmission jack.

### CAUTION:

**When setting transmission jack, be careful not to allow it to collide against the drain plug.**

# ON-VEHICLE SERVICE

6. Remove rear engine mounting member with power tool. Refer to [AT-275, "Removal and Installation"](#).

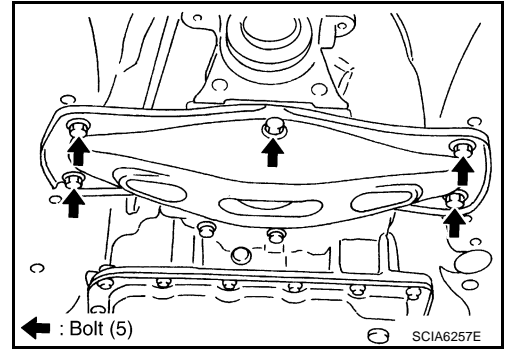

7. Remove engine mounting insulator (rear). Refer to [AT-275, "Removal and Installation"](#).

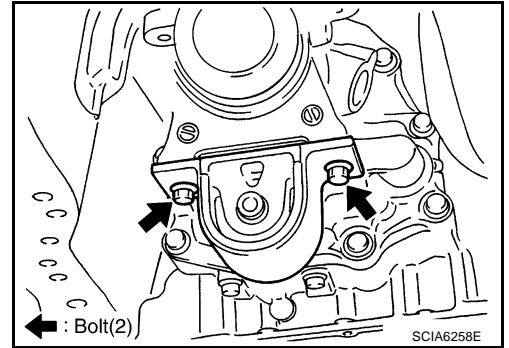

8. Remove tightening bolts for rear extension assembly and transmission case.

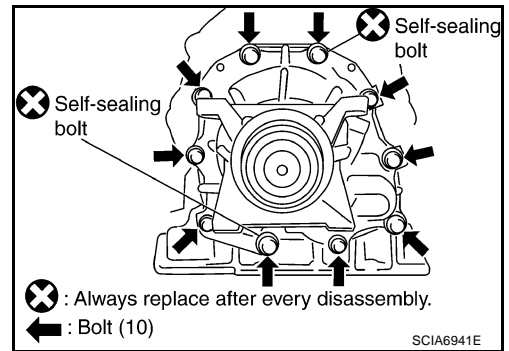

9. Tap rear extension assembly with a soft hammer.

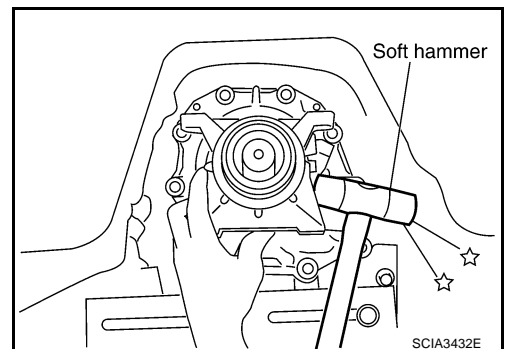

10. Remove rear extension assembly from transmission case. (With needle bearing.)

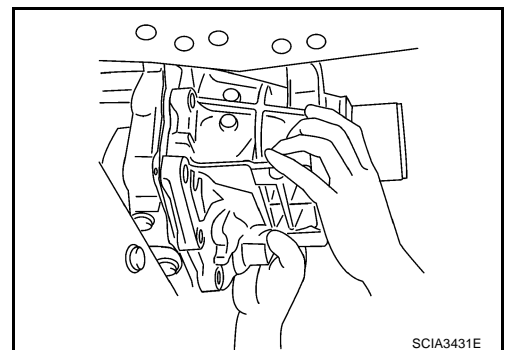

A  
B  
AT  
D  
E  
F  
G  
H  
I  
J  
K  
L  
M

# ON-VEHICLE SERVICE

11. Remove bearing race from output shaft.

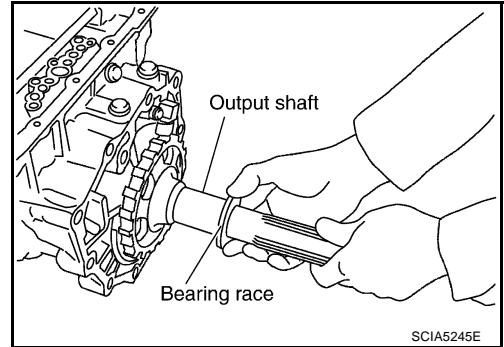

12. Remove output shaft from transmission case by rotating left/right.

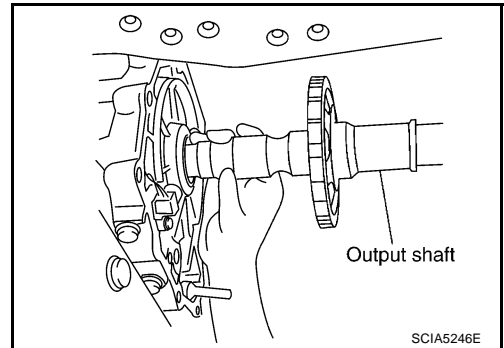

13. Remove parking gear from output shaft.

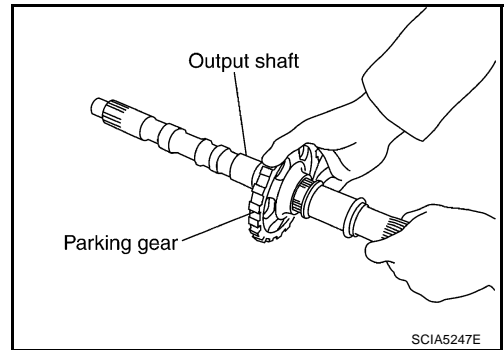

14. Remove seal rings from output shaft.

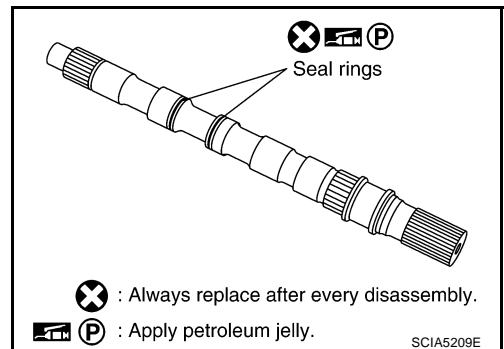

15. Remove needle bearing from rear extension.

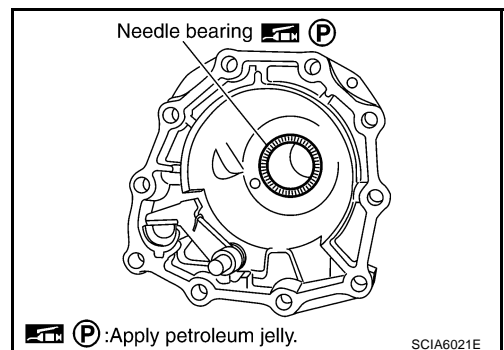

# ON-VEHICLE SERVICE

16. Remove parking actuator support from rear extension.

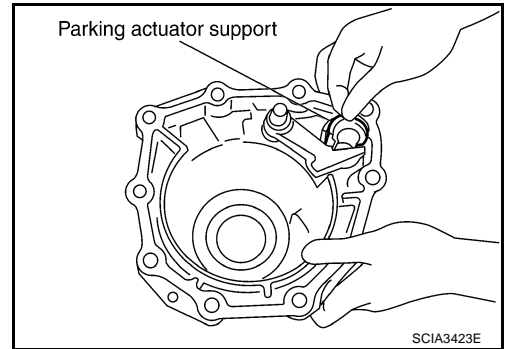

17. Remove parking pawl (with return spring) and pawl shaft from rear extension.

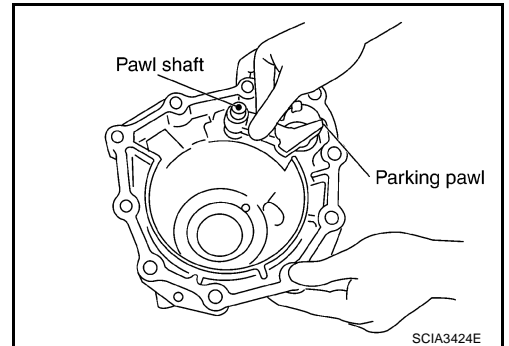

18. Remove return spring from parking pawl.

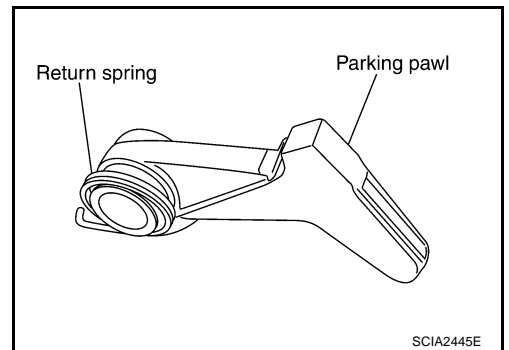

19. Remove rear oil seal from rear extension.  
**CAUTION:**  
**Be careful not to scratch rear extension.**

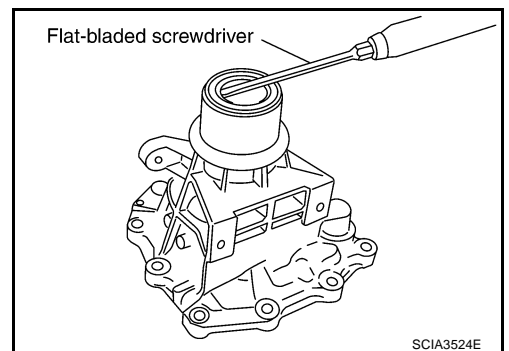

A  
B  
AT  
D  
E  
F  
G  
H  
I  
J  
K  
L  
M

# ON-VEHICLE SERVICE

## INSPECTION

- If the contact surface on parking actuator support, parking pawl, etc. has excessive wear, abrasion, bend, or any other damage, replace the components.

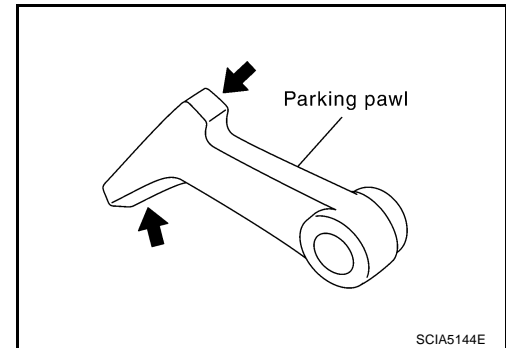
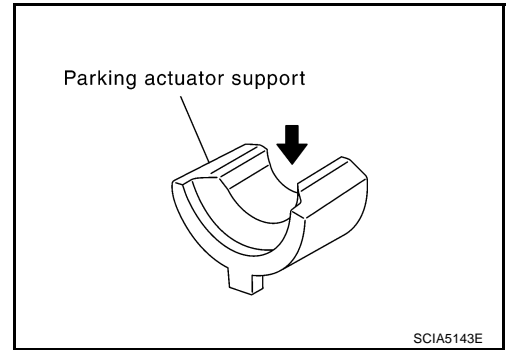

## INSTALLATION

### CAUTION:

After completing installation, check A/T fluid leakage and A/T fluid level. Refer to [AT-12, "Changing A/T Fluid"](#) , [AT-12, "Checking A/T Fluid"](#) .

1. As shown in the right figure, use a drift to drive rear oil seal into the rear extension until it is flush.

### CAUTION:

- Apply ATF to rear oil seal.
- Do not reuse rear oil seal.

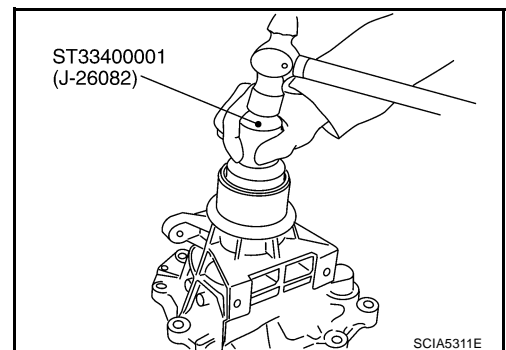

2. Install return spring to parking pawl.

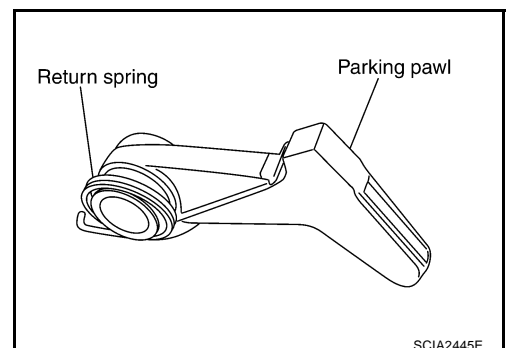



# ON-VEHICLE SERVICE

3. Install parking pawl (with return spring) and pawl shaft to rear extension.

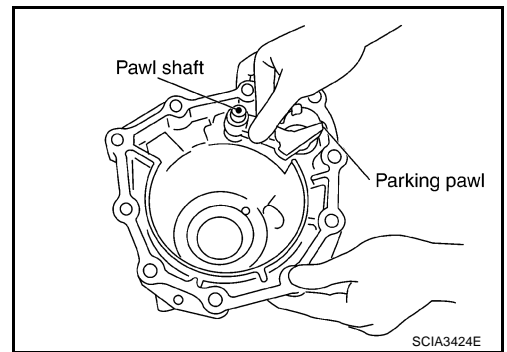

4. Install parking actuator support to rear extension.

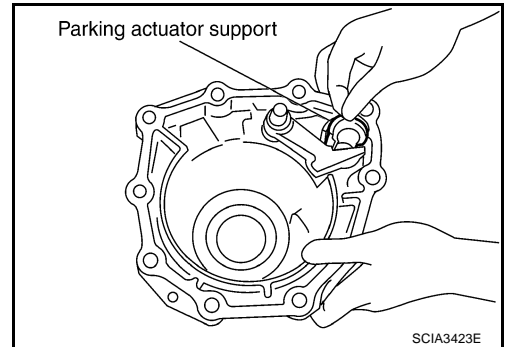

5. Install needle bearing to rear extension.  
**CAUTION:**  
 Apply petroleum jelly to needle bearing.

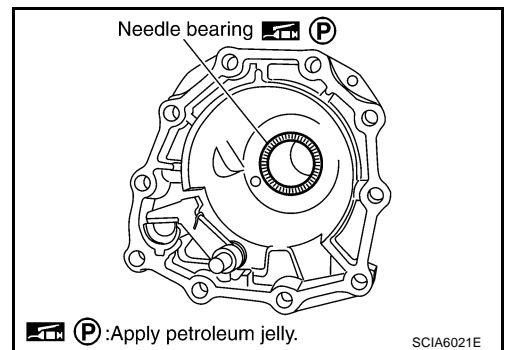

6. Install seal rings to output shaft.  
**CAUTION:**  
 • Do not reuse seal rings.  
 • Apply petroleum jelly to seal rings.

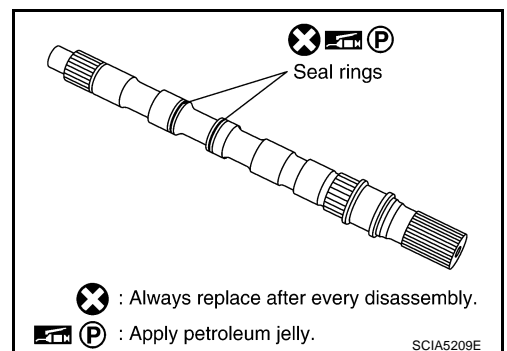

7. Install parking gear to output shaft.

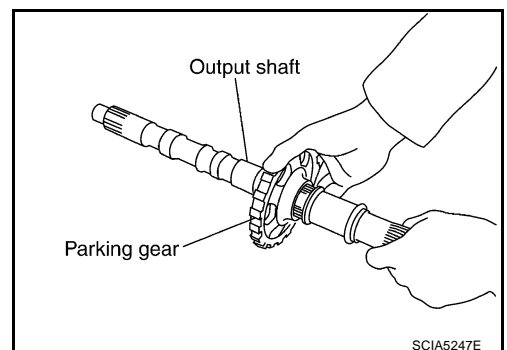

A  
B  
AT  
D  
E  
F  
G  
H  
I  
J  
K  
L  
M

# ON-VEHICLE SERVICE

8. Install output shaft in transmission case.

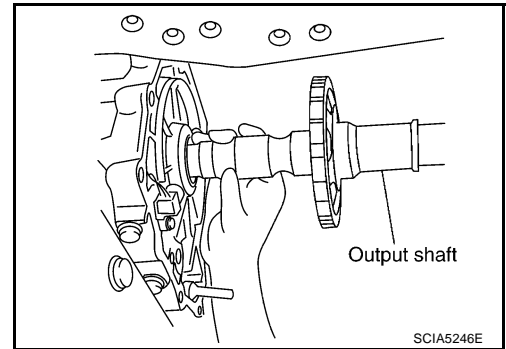

9. Install bearing race to output shaft.

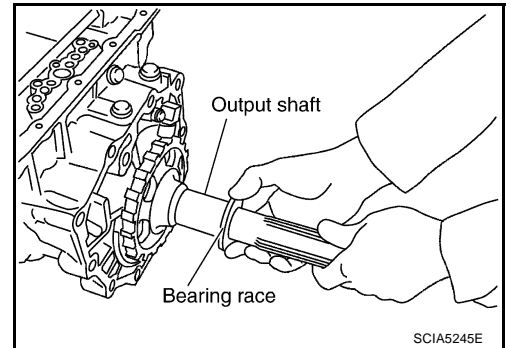

10. Apply recommended sealant (Genuine Anaerobic Liquid Gasket or equivalent. Refer to [GI-47, "Recommended Chemical Products and Sealants"](#) .) to rear extension assembly as shown in the figure.

**CAUTION:**

**Complete remove all moisture, oil and old sealant, etc. from the transmission case and rear extension assembly mounting surfaces.**

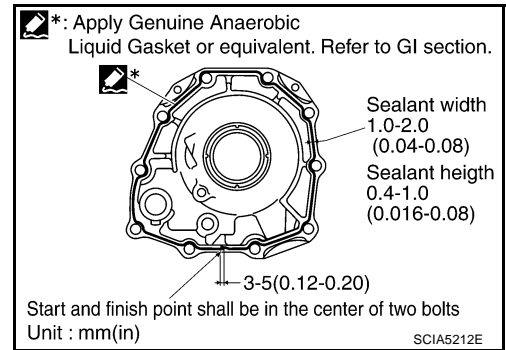

11. Install rear extension assembly to transmission case. (With needle bearing.)

**CAUTION:**

**Insert the tip of parking rod between the parking pawl and the parking actuator support when assembling the rear extension assembly.**

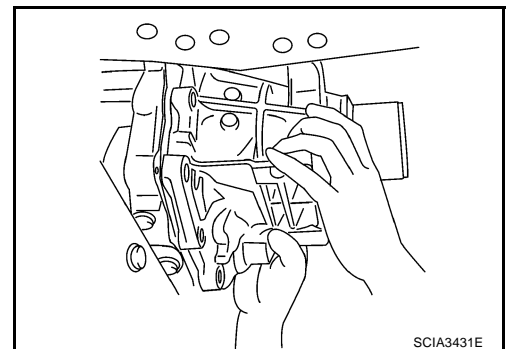

12. Tighten rear extension assembly mounting bolts to specified torque.

**CAUTION:**

**Do not reuse self-sealing bolt.**

**Rear extension assembly mounting bolt:**

: 52 N·m (5.3 Kg·m, 38 ft·lb)

**Self-sealing bolt:**

: 61 N·m (6.2 Kg·m, 45 ft·lb)

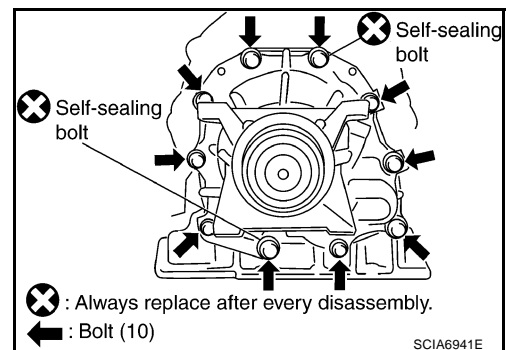

## ON-VEHICLE SERVICE

13. Install engine mounting insulator (rear). Refer to [AT-275, "Removal and Installation"](#) .

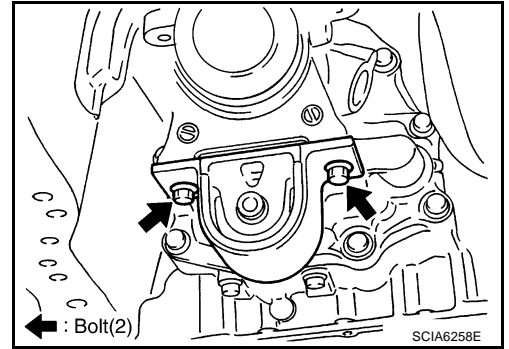

14. Install rear engine mounting member. Refer to [AT-275, "Removal and Installation"](#) .
15. Install rear propeller shaft. Refer to [PR-5, "Removal and Installation"](#) .
16. Install control rod. Refer to [AT-237, "Control Rod Removal and Installation"](#) .
17. Install exhaust front tube and center muffler. Refer to [EX-4, "Removal and Installation"](#) .
18. Install drain plug in oil pan.

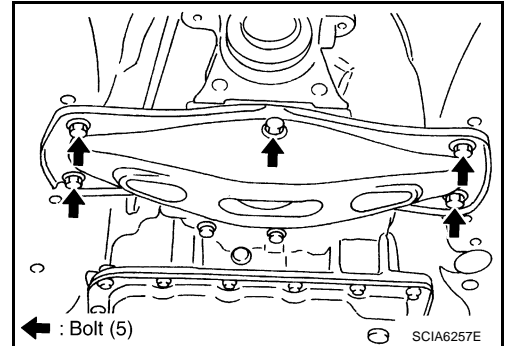

**CAUTION:**  
Do not reuse drain plug gasket.

 : 34 N·m (3.5 kg-m, 25 ft-lb)

19. Pour ATF into transmission assembly. Refer to [AT-12, "Changing A/T Fluid"](#) .

A  
B  
AT  
D  
E  
F  
G  
H  
I  
J  
K  
L  
M

# ON-VEHICLE SERVICE

ACS008H2

## Rear Oil Seal REMOVAL

1. Remove exhaust front tube and center muffler with power tool. Refer to [EX-4, "Removal and Installation"](#) .
2. Remove rear propeller shaft. Refer to [PR-5, "Removal and Installation"](#) .
3. Remove transfer assembly from transmission assembly (AWD models). Refer to [TF-49, "Removal and Installation"](#) .
4. Remove rear oil seal using a flat-bladed screwdriver.

### CAUTION:

Be careful not to scratch rear extension assembly (2WD models) or adapter case assembly (AWD models).

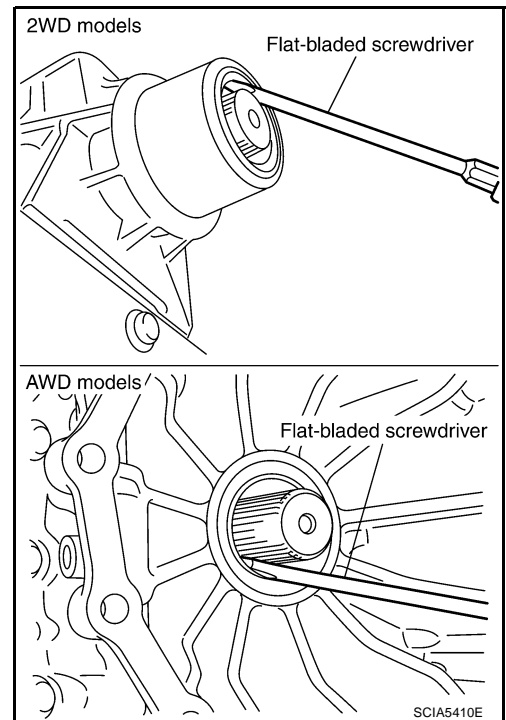

## INSTALLATION

### CAUTION:

After completing installation, check A/T fluid leakage and A/T fluid level. Refer to [AT-12, "Changing A/T Fluid"](#) , [AT-12, "Checking A/T Fluid"](#) .

1. As shown in the figure, use the drift to drive rear oil seal into rear extension assembly (2WD models) or adapter case assembly (AWD models) until it is flush.

### CAUTION:

- Apply ATF to rear oil seal.
- Do not reuse rear oil seal.

2. Install transfer assembly to transmission assembly (AWD models). Refer to [TF-49, "Removal and Installation"](#) .
3. Install rear propeller shaft. Refer to [PR-5, "Removal and Installation"](#) .
4. Install exhaust front tube and center muffler. Refer to [EX-4, "Removal and Installation"](#) .

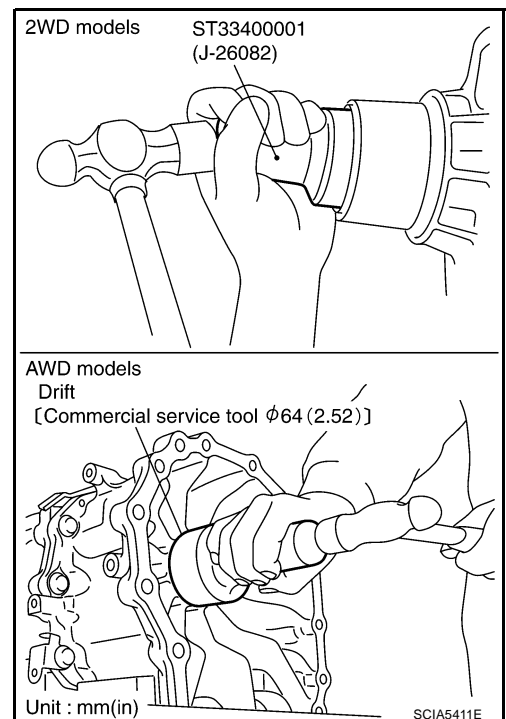

# ON-VEHICLE SERVICE

## Revolution Sensor (2WD Models Only) COMPONENTS

ACS008H3

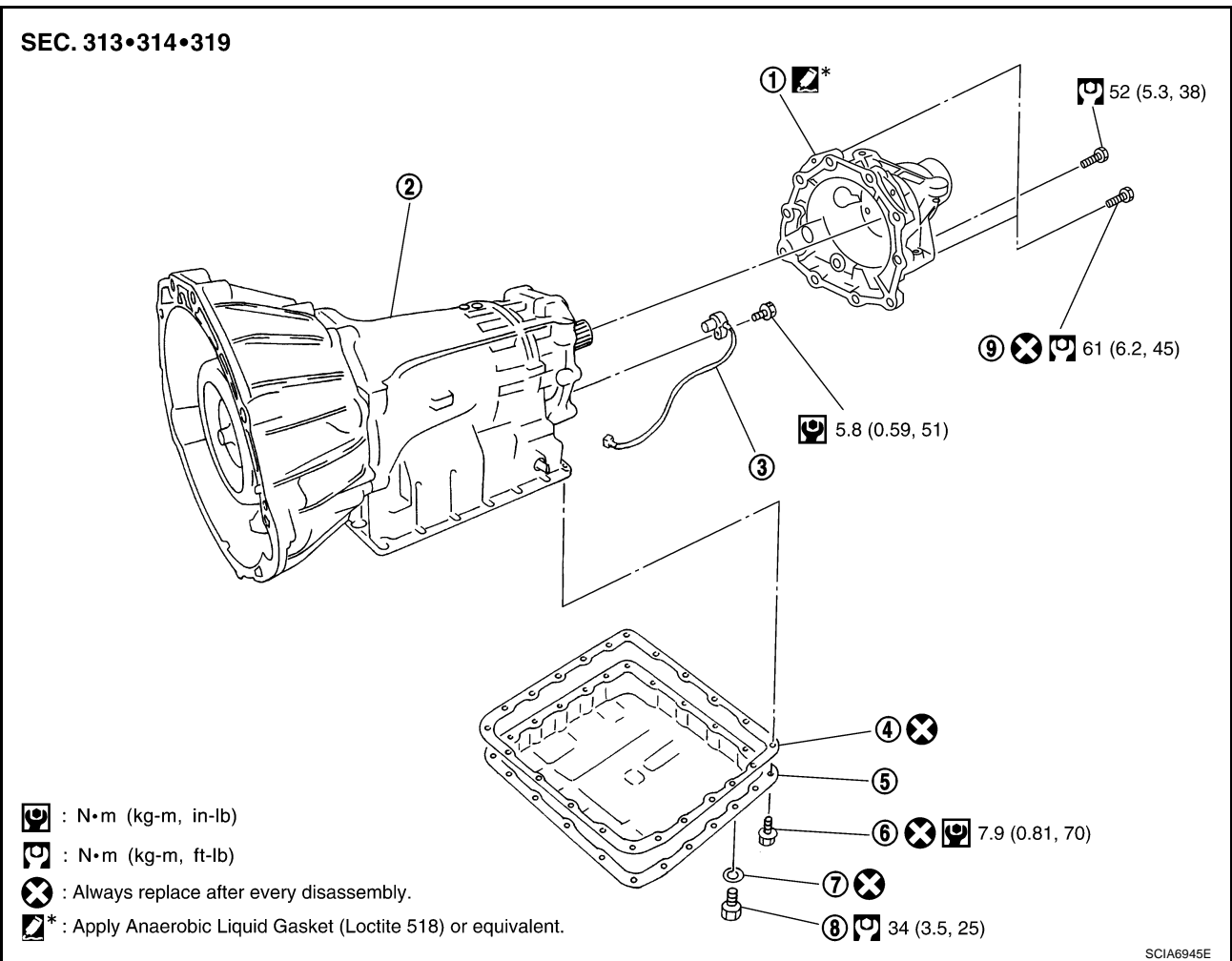

- |                      |                 |                          |
|----------------------|-----------------|--------------------------|
| 1. Rear extension    | 2. Transmission | 3. Revolution sensor     |
| 4. Oil pan gasket    | 5. Oil pan      | 6. Oil pan mounting bolt |
| 7. Drain plug gasket | 8. Drain plug   | 9. Self-sealing bolt     |

### REMOVAL

1. Disconnect the battery cable from the negative terminal.
2. Drain ATF through drain plug.
3. Remove exhaust front tube and center muffler with power tool. Refer to [EX-4, "Removal and Installation"](#).
4. Remove rear propeller shaft. Refer to [PR-5, "Removal and Installation"](#).
5. Remove control rod. Refer to [AT-237, "Control Rod Removal and Installation"](#).
6. Remove oil pan and oil pan gasket.

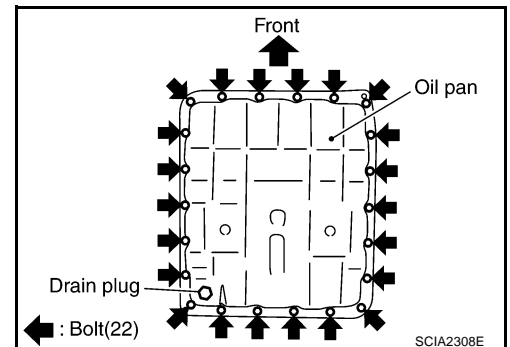

## ON-VEHICLE SERVICE

7. Check foreign materials in oil pan to help determine causes of malfunction. If the A/T fluid is very dark, smells burned, or contains foreign particles, the frictional material (clutches, band) may need replacement. A tacky film that will not wipe clean indicates varnish build up. Varnish can cause valves, servo, and clutches to stick and can inhibit pump pressure.

- If frictional material is detected, perform A/T fluid cooler cleaning. Refer to [AT-14, "A/T Fluid Cooler Cleaning"](#).

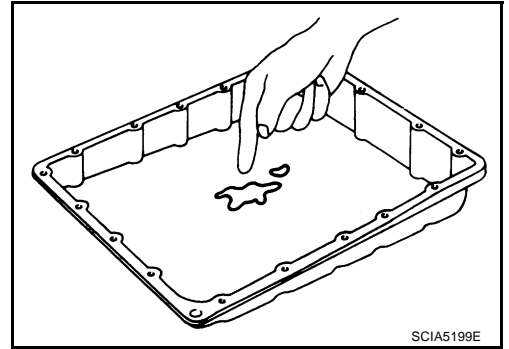

8. Support transmission assembly with a transmission jack.

**CAUTION:**

**When setting transmission jack, place wooden blocks to prevent from damaging control valve with TCM and transmission case.**

9. Remove rear engine mounting member with power tool. Refer to [AT-275, "Removal and Installation"](#).

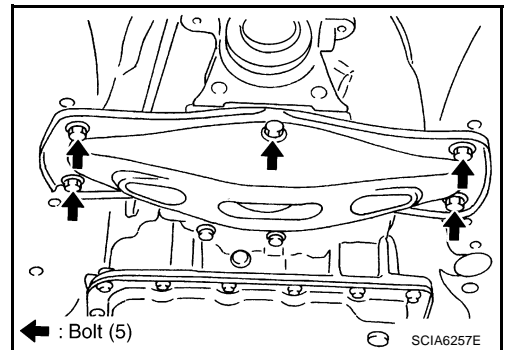

10. Remove tightening bolts for rear extension assembly and transmission case.

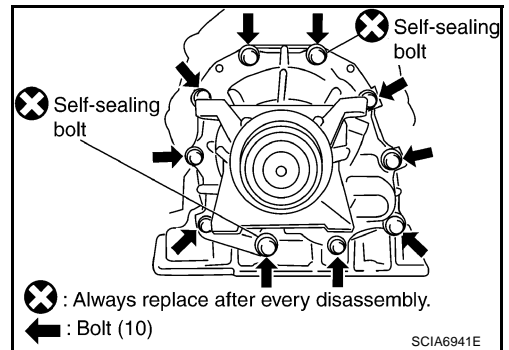

11. Tap rear extension assembly with a soft hammer.

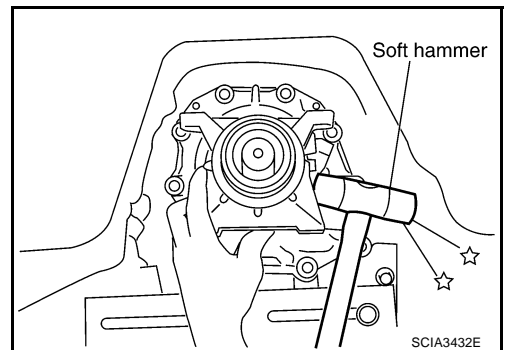

# ON-VEHICLE SERVICE

12. Remove rear extension assembly from transmission case. (With needle bearing.)

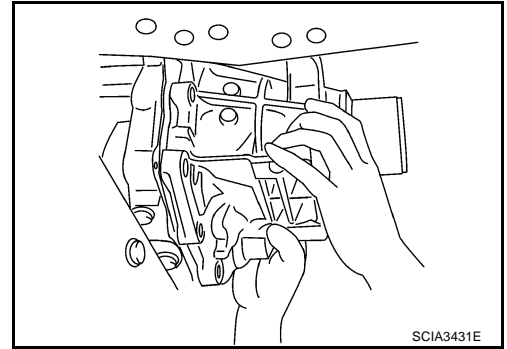

13. Disconnect revolution sensor connector.

**CAUTION:**

**Be careful not to damage connector.**

14. Straighten terminal clips to free revolution sensor harness.

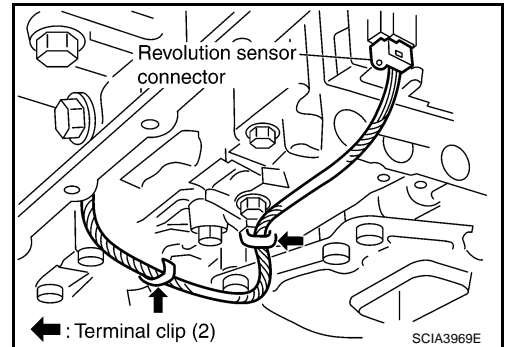

15. Remove revolution sensor from transmission case.

**CAUTION:**

- Do not subject it to impact by dropping or hitting it.
- Do not disassemble.
- Do not allow metal filings, etc., to get on the sensor's front edge magnetic area.
- Do not place in an area affected by magnetism.

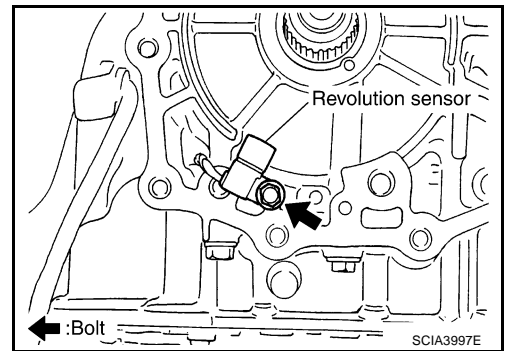

## INSTALLATION

**CAUTION:**

After completing installation, check A/T fluid leakage and A/T fluid level. Refer to [AT-12. "Changing A/T Fluid"](#) , [AT-12. "Checking A/T Fluid"](#) .

1. Install revolution sensor in transmission case.

**CAUTION:**

- Do not subject it to impact by dropping or hitting it.
- Do not disassemble.
- Do not allow metal filings, etc., to get on the sensor's front edge magnetic area.
- Do not place in an area affected by magnetism.

 : 5.8 N-m (0.59 kg-m, 51 in-lb)

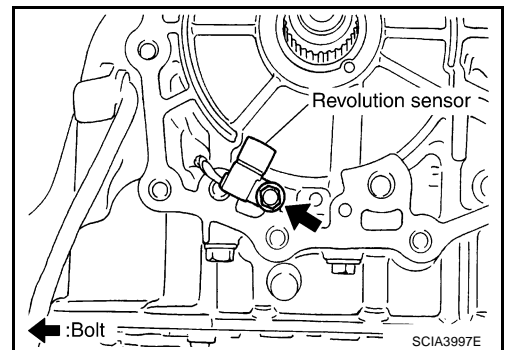

A  
B  
AT  
D  
E  
F  
G  
H  
I  
J  
K  
L  
M

## ON-VEHICLE SERVICE

2. Connect revolution sensor connector.
3. Securely fasten revolution sensor harness with clips.

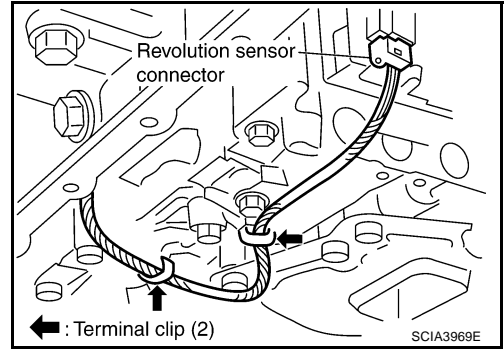

4. Apply recommended sealant (Genuine Anaerobic Liquid Gasket or equivalent. Refer to [GI-47, "Recommended Chemical Products and Sealants"](#) .) to rear extension assembly as shown in figure.

**CAUTION:**

**Complete remove all moisture, oil and old sealant, etc. from transmission case and rear extension assembly mounting surfaces.**

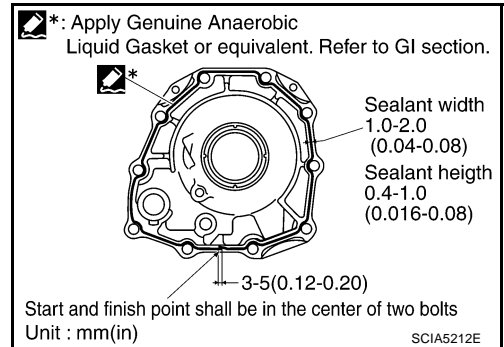

5. Install rear extension assembly to transmission case. (With needle bearing.)

**CAUTION:**

**Insert the tip of parking rod between the parking pawl and the parking actuator support when assembling the rear extension assembly.**

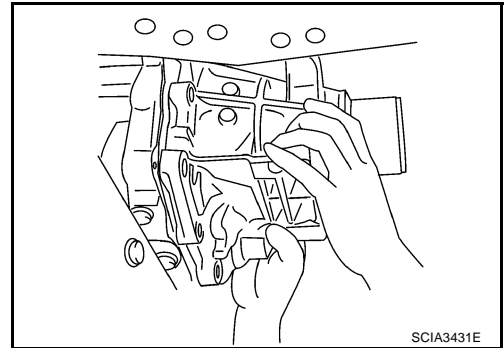

6. Tighten rear extension assembly mounting bolts to specified torque.

**CAUTION:**

**Do not reuse self-sealing bolt.**

**Rear extension assembly mounting bolt:**

: 52 N·m (5.3 Kg·m, 38 ft·lb)

**Self-sealing bolt:**

: 61 N·m (6.2 Kg·m, 45 ft·lb)

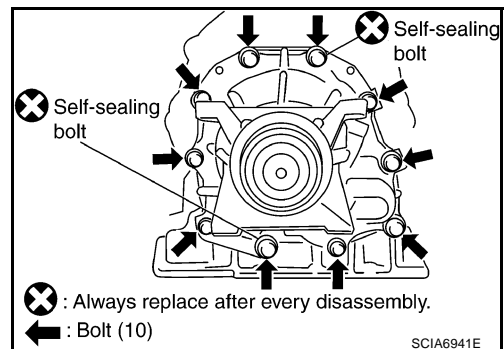

7. Install rear engine mounting member. Refer to [AT-275, "Removal and Installation"](#) .
8. Install oil pan to transmission case.
- a. Install oil pan gasket to oil pan.

**CAUTION:**

- Do not reuse oil pan gasket.
- Install it in the direction to align hole positions.
- Complete remove all moisture, oil and old gasket, etc. from oil pan gasket mounting surface.

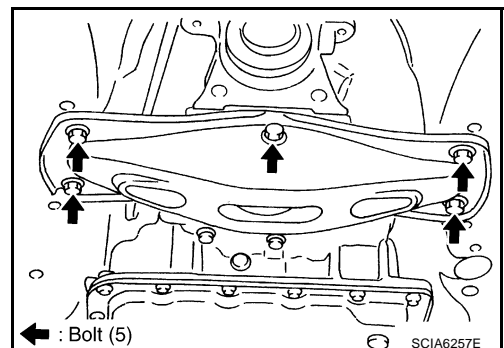



# ON-VEHICLE SERVICE

b. Install oil pan (with oil pan gasket) to transmission case.

**CAUTION:**

- Install it so that drain plug comes to the position as shown in the figure.
- Be careful not to pinch harnesses.
- Complete remove all moisture, oil and old gasket, etc. from oil pan mounting surface.

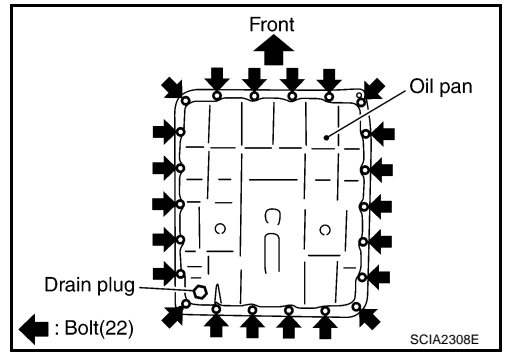

c. Tighten oil pan mounting bolts to the specified torque in numerical order shown in the figure after temporarily tightening them.

**CAUTION:**

**Do not reuse oil pan mounting bolts.**

 : 7.9 N·m (0.81 kg-m, 70 in-lb)

9. Install drain plug to oil pan.

**CAUTION:**

**Do not reuse drain plug gasket.**

 : 34 N·m (3.5 kg-m, 25 ft-lb)

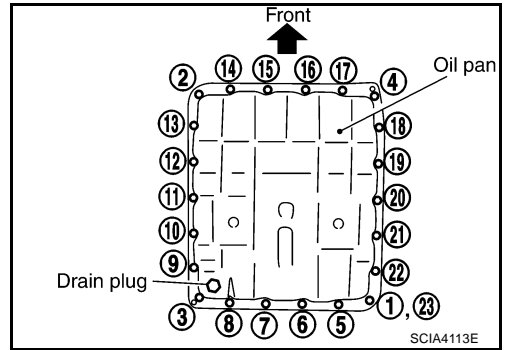

10. Install control rod. Refer to [AT-237, "Control Rod Removal and Installation"](#) .
11. Install rear propeller shaft. Refer to [PR-5, "Removal and Installation"](#) .
12. Install exhaust front tube and center muffler. Refer to [EX-4, "Removal and Installation"](#) .
13. Pour ATF into transmission assembly. Refer to [AT-12, "Changing A/T Fluid"](#) .
14. Connect the battery cable to the negative terminal.

A  
B  
AT  
D  
E  
F  
G  
H  
I  
J  
K  
L  
M

# AIR BREATHER HOSE

PFP:31098

## AIR BREATHER HOSE Removal and Installation

ACS0063U

Refer to the figure below for air breather hose removal and installation procedure.

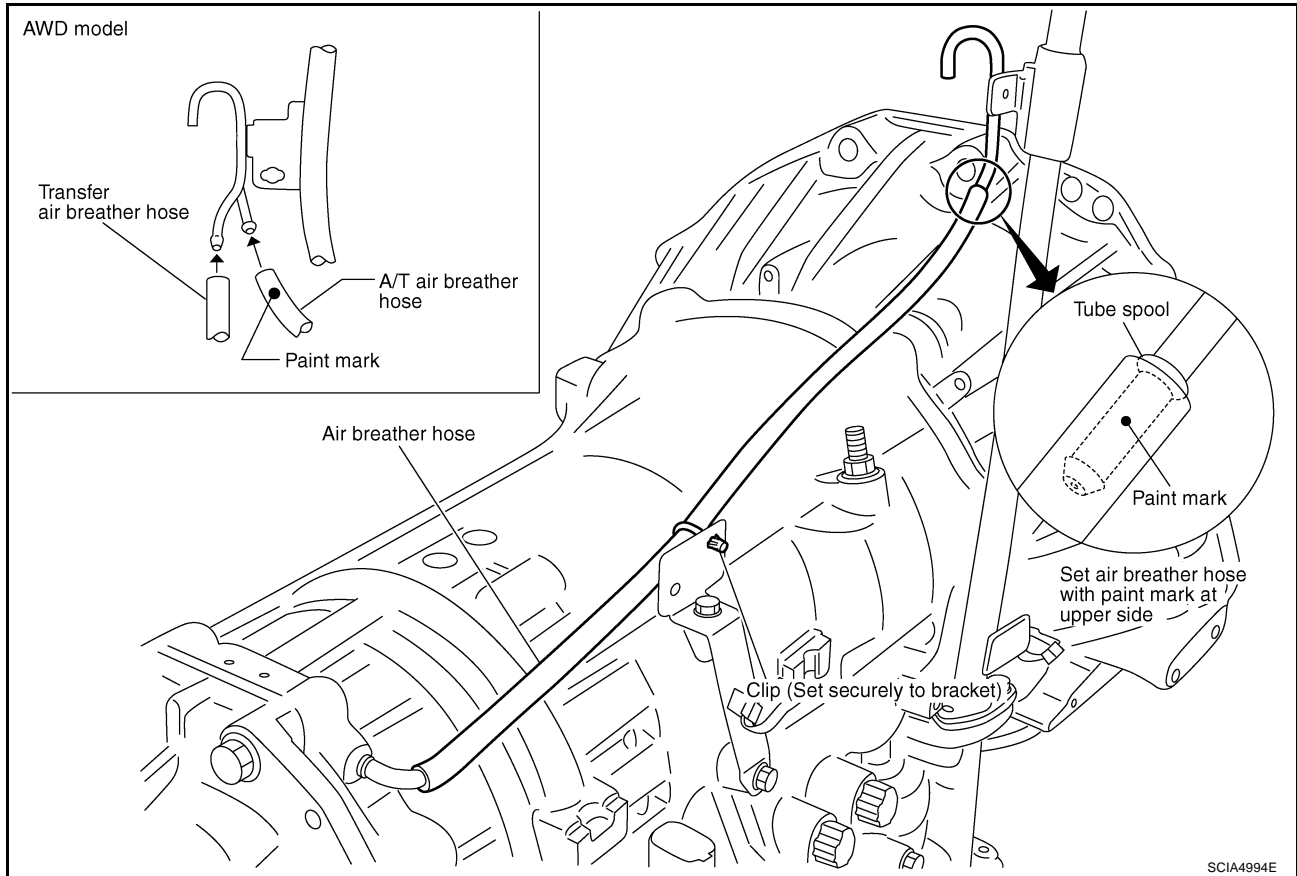

### CAUTION:

- When installing an air breather hose, be careful not to be crushed or blocked by folding or bending the hose.
- When inserting a hose to the transmission tube, be sure to insert it fully until its end reaches the tube bend R portion.
- When inserting a hose to the air breather tube, be sure to insert it fully until its end reaches the tube spool portion.



# TRANSMISSION ASSEMBLY

## COMPONENTS (AWD MODELS)

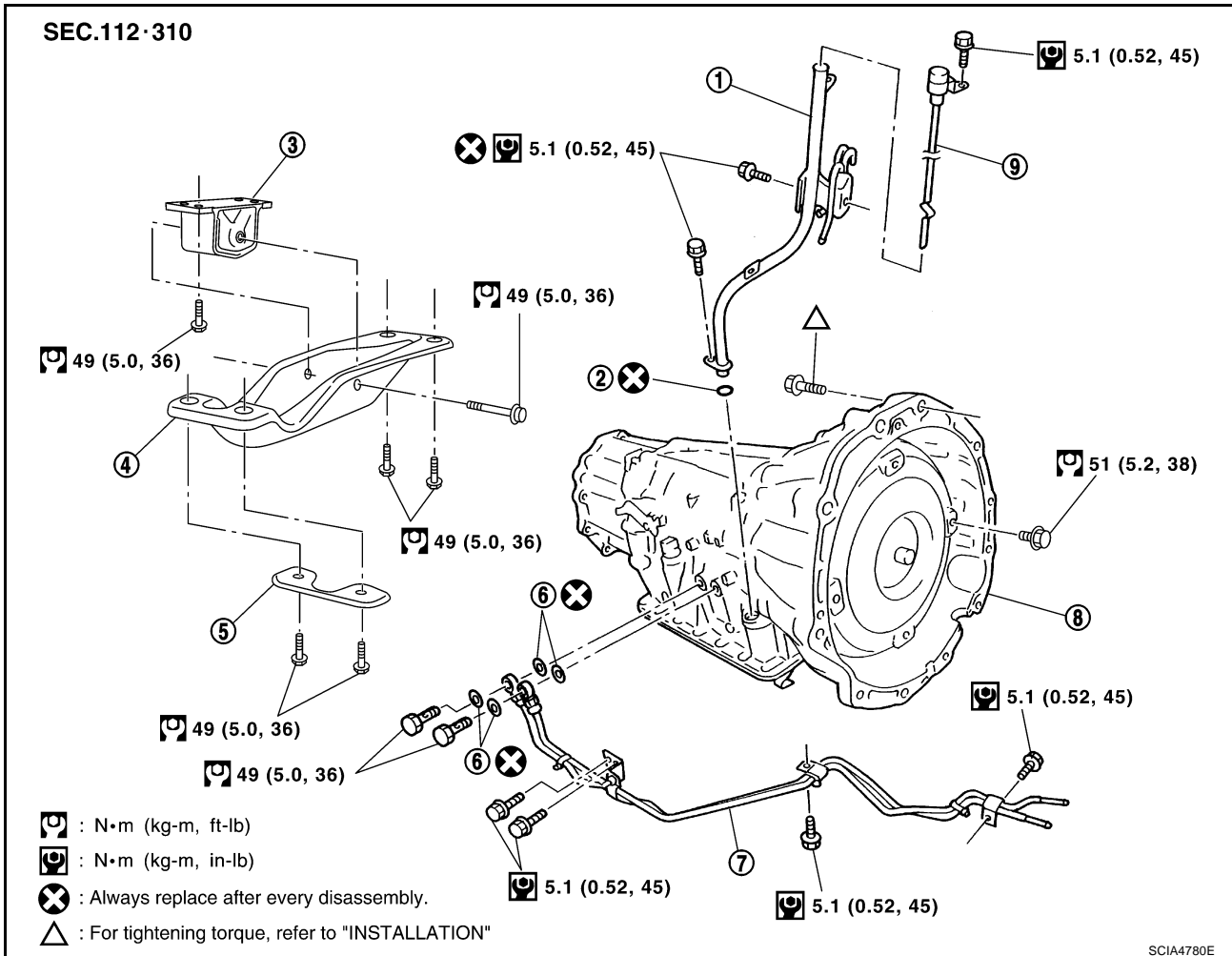

- |                                |                          |                                     |
|--------------------------------|--------------------------|-------------------------------------|
| 1. A/T fluid charging pipe     | 2. O-ring                | 3. Engine mounting insulator (rear) |
| 4. Rear engine mounting member | 5. Heat insulator        | 6. Copper washer                    |
| 7. Fluid cooler tube           | 8. Transmission assembly | 9. A/T fluid level gauge            |

## REMOVAL

### CAUTION:

- When removing the A/T assembly from engine, first remove the crankshaft position sensor (POS) from the A/T assembly.
  - Be careful not to damage sensor edge.
1. Disconnect the battery cable from the negative terminal.
  2. Remove engine cover.
  3. Remove A/T fluid level gauge.
  4. Remove engine under cover with power tool.
  5. Remove exhaust front tube and center muffler with power tool. Refer to [EX-4, "Removal and Installation"](#).
  6. Remove three way catalyst. Refer to [EM-27, "Removal and Installation"](#).
  7. Remove rear propeller shaft. Refer to [PR-5, "Removal and Installation"](#) (2WD models) or [PR-17, "Removal and Installation"](#) (AWD models).
  8. Remove front propeller shaft. (AWD models) Refer to [PR-14, "Removal and Installation"](#).
  9. Remove control rod. Refer to [AT-237, "Control Rod Removal and Installation"](#).

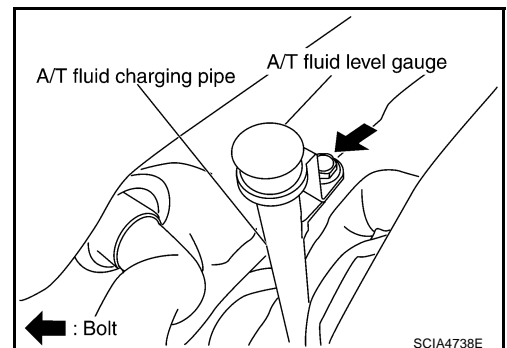

# TRANSMISSION ASSEMBLY

10. Remove crankshaft position sensor (POS) from transmission assembly.

**CAUTION:**

- Do not subject it to impact by dropping or hitting it.
- Do not disassemble.
- Do not allow metal filings, etc., to get on the sensor's front edge magnetic area.
- Do not place in an area affected by magnetism.

11. Remove starter motor. Refer to [SC-18, "Removal and Installation"](#) .

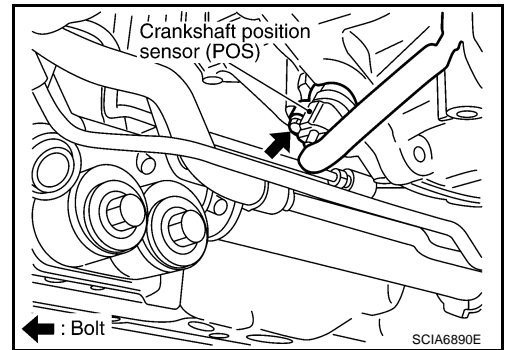

12. Remove rear cover plate. (2WD models) Refer to [EM-31, "Removal and Installation \(2WD Model\)"](#) .

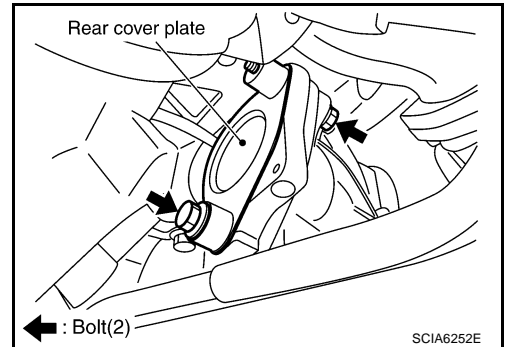

13. Remove rear plate cover from converter housing part. Refer to [EM-31, "Removal and Installation \(2WD Model\)"](#) , [EM-37, "Removal and Installation \(AWD Model\)"](#) .

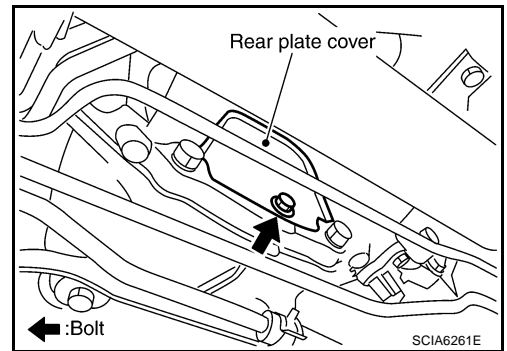

14. Turn crankshaft, and remove the four tightening bolts for drive plate and torque converter.

**CAUTION:**

**When turning crankshaft, turn it clockwise as viewed from the front of the engine.**

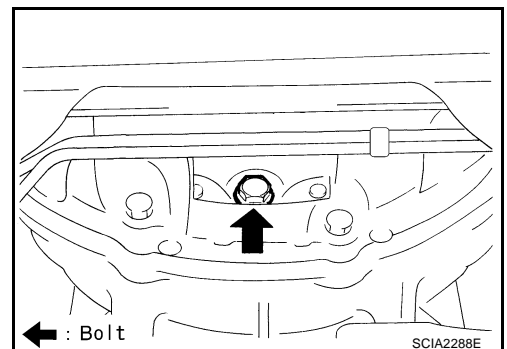

15. Remove dynamic damper. (AWD models) Refer to [EM-145, "Removal and Installation \(AWD Model\)"](#) .

16. Support transmission assembly with a transmission jack.

**CAUTION:**

**When setting the transmission jack, be careful not to allow it to collide against the drain plug.**

17. Remove rear engine mounting member with power tool.

18. Remove engine mounting insulator (rear).

19. Remove air breather hose. Refer to [AT-274, "Removal and Installation"](#) .

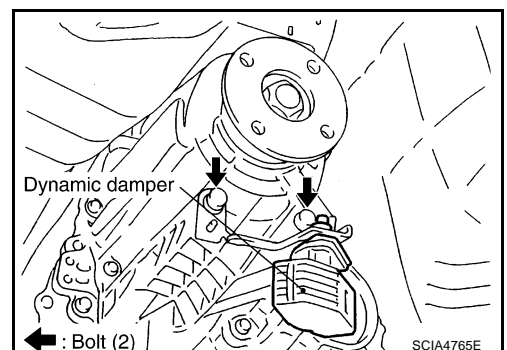

A  
B  
AT  
D  
E  
F  
G  
H  
I  
J  
K  
L  
M

# TRANSMISSION ASSEMBLY

20. Disconnect A/T assembly harness connector.
21. Remove A/T fluid charging pipe from A/T assembly.
22. Remove O-ring from A/T fluid charging pipe.
23. Remove fluid cooler tube.
24. Plug up openings such as the A/T fluid charging pipe hole, etc.
25. Remove bolts fixing transmission assembly to engine with power tool.
26. Remove transmission assembly from vehicle. (2WD models)
  - **Secure torque converter to prevent it from dropping.**
  - **Secure transmission assembly to a transmission jack.**

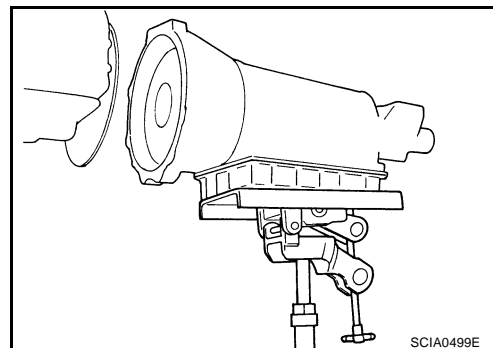

27. Remove transmission assembly with transfer assembly from vehicle. (AWD models)
  - **Secure torque converter to prevent it from dropping.**
  - **Secure transmission assembly to a transmission jack.**
28. Remove transfer assembly from transmission assembly with power tool. (AWD models) Refer to [TF-49, "Removal and Installation"](#) .

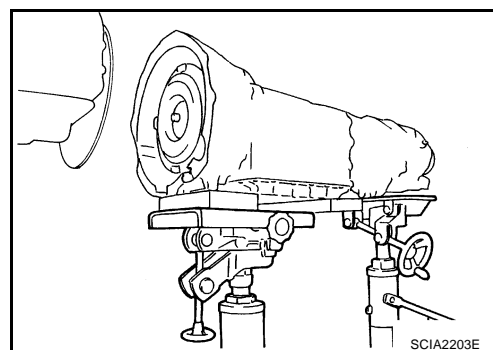

## INSPECTION

### Installation and Inspection of Torque Converter

- After inserting a torque converter to a transmission, be sure to check distance "A" to ensure it is within the reference value limit.

**Distance "A": 25.0 mm (0.98 in) or more**

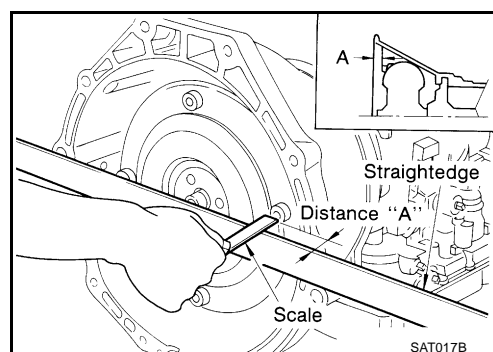

# TRANSMISSION ASSEMBLY

## INSTALLATION

Install the removed parts in the reverse order of the removal, while paying attention to the following work.

- When installing transmission assembly to the engine, attach the fixing bolts in accordance with the following standard.

### For 2WD models

Bolt No.	1	2	3	4
Number of bolts	1	5	2	2
Bolt length "ℓ"mm (in)	55 (2.17)	65 (2.56)	50 (2.20)	35 (1.38)
Tightening torque N-m (kg-m, ft-lb)	75 (7.7, 55)		55 (5.6, 41)	47 (4.8, 35)

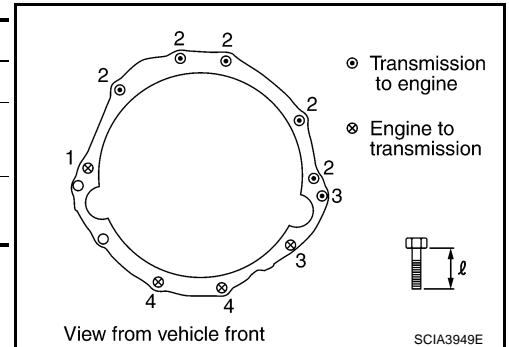

### For AWD models

Bolt No.	1	2	3	4
Number of bolts	1	5	2	1
Bolt length "ℓ"mm (in)	55 (2.17)	65 (2.56)	35 (1.38)	40 (1.57)
Tightening torque N-m (kg-m, ft-lb)	75 (7.7, 55)		47 (4.8, 35)	34 (3.5, 25)

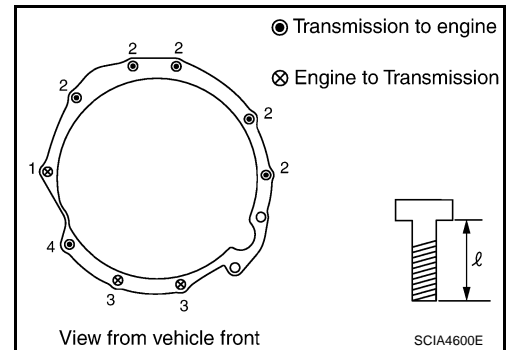

- Align the positions of tightening bolts for drive plate with those of the torque converter, and temporarily tighten the bolts. Then, tighten the bolts with the specified torque.

 : 51 N-m (5.2 kg-m, 38 ft-lb)

### CAUTION:

- When turning crankshaft, turn it clockwise as viewed from the front of the engine.
- When tightening the tightening bolts for the torque converter after fixing the crankshaft pulley bolts, be sure to confirm the tightening torque of the crankshaft pulley mounting bolts. Refer to [EM-98, "INSTALLATION"](#).
- After converter is installed to drive plate, rotate crankshaft several turns and check to be sure that transmission rotates freely without binding.
- Install crankshaft position sensor (POS). Refer to [EM-31, "Removal and Installation \(2WD Model\)"](#), [EM-37, "Removal and Installation \(AWD Model\)"](#).
- After completing installation, check A/T fluid leakage, A/T fluid level, and the A/T positions of A/T. Refer to [AT-12, "Changing A/T Fluid"](#), [AT-238, "Adjustment of A/T Position"](#), [AT-239, "Checking of A/T Position"](#).

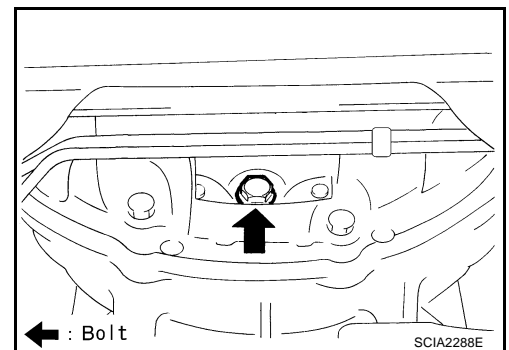

# OVERHAUL

PFP:00000

ACS008GN

## OVERHAUL Components

SEC.311•313•314•315

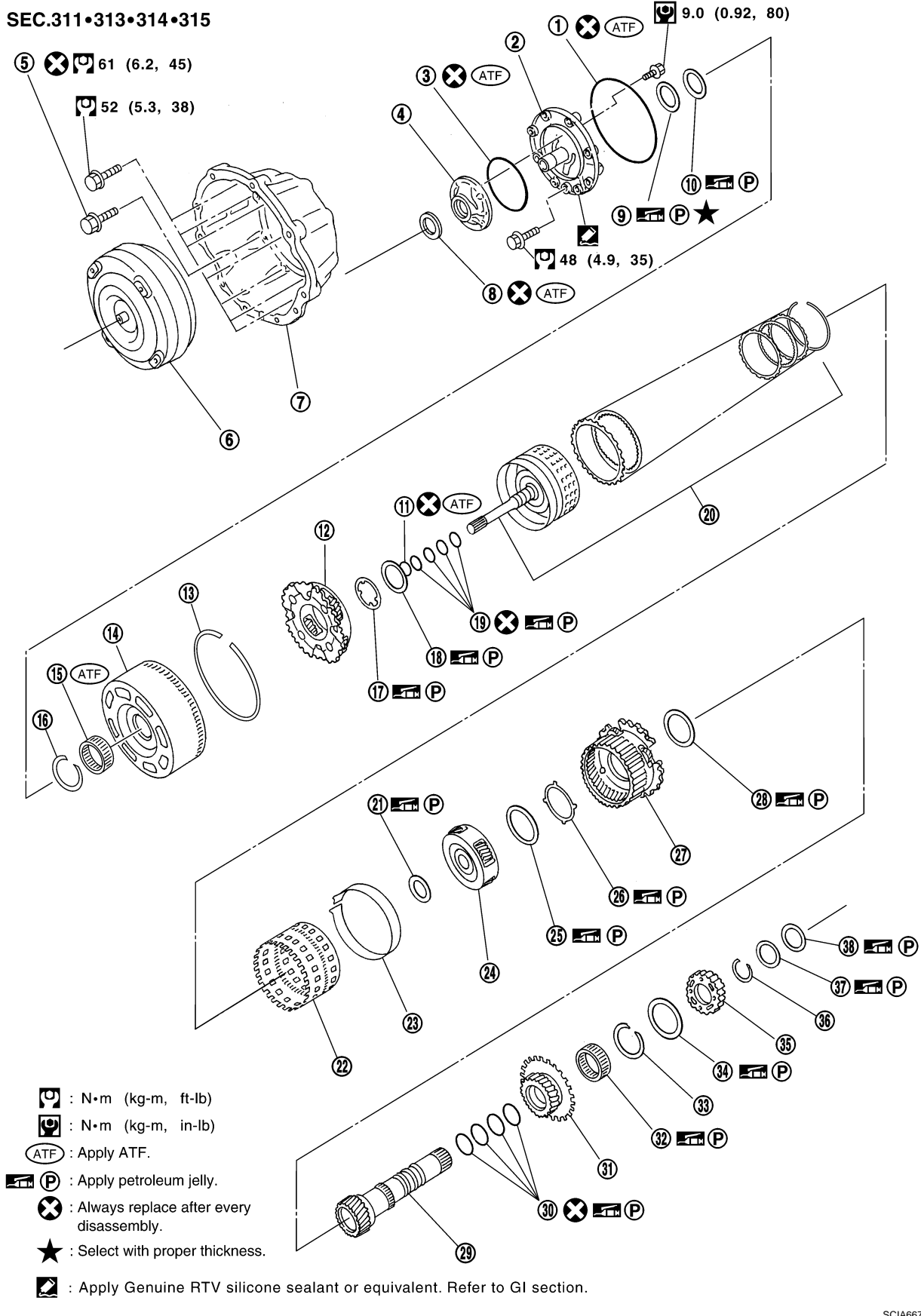

SCIA6677E



# OVERHAUL

- 
- |                        |                                     |                            |
|------------------------|-------------------------------------|----------------------------|
| 1. O-ring              | 2. Oil pump cover                   | 3. O-ring                  |
| 4. Oil pump housing    | 5. Self-sealing bolt                | 6. Torque converter        |
| 7. Converter housing   | 8. Oil pump housing oil seal        | 9. Bearing race            |
| 10. Needle bearing     | 11. O-ring                          | 12. Front carrier assembly |
| 13. Snap ring          | 14. Front sun gear                  | 15. 3rd one-way clutch     |
| 16. Snap ring          | 17. Bearing race                    | 18. Needle bearing         |
| 19. Seal ring          | 20. Input clutch assembly           | 21. Needle bearing         |
| 22. Rear internal gear | 23. Brake band                      | 24. Mid carrier assembly   |
| 25. Needle bearing     | 26. Bearing race                    | 27. Rear carrier assembly  |
| 28. Needle bearing     | 29. Mid sun gear                    | 30. Seal ring              |
| 31. Rear sun gear      | 32. 1st one-way clutch              | 33. Snap ring              |
| 34. Needle bearing     | 35. High and low reverse clutch hub | 36. Snap ring              |
| 37. Bearing race       | 38. Needle bearing                  |                            |

A

B

AT

D

E

F

G

H

I

J

K

L

M

# OVERHAUL

SEC.315•316

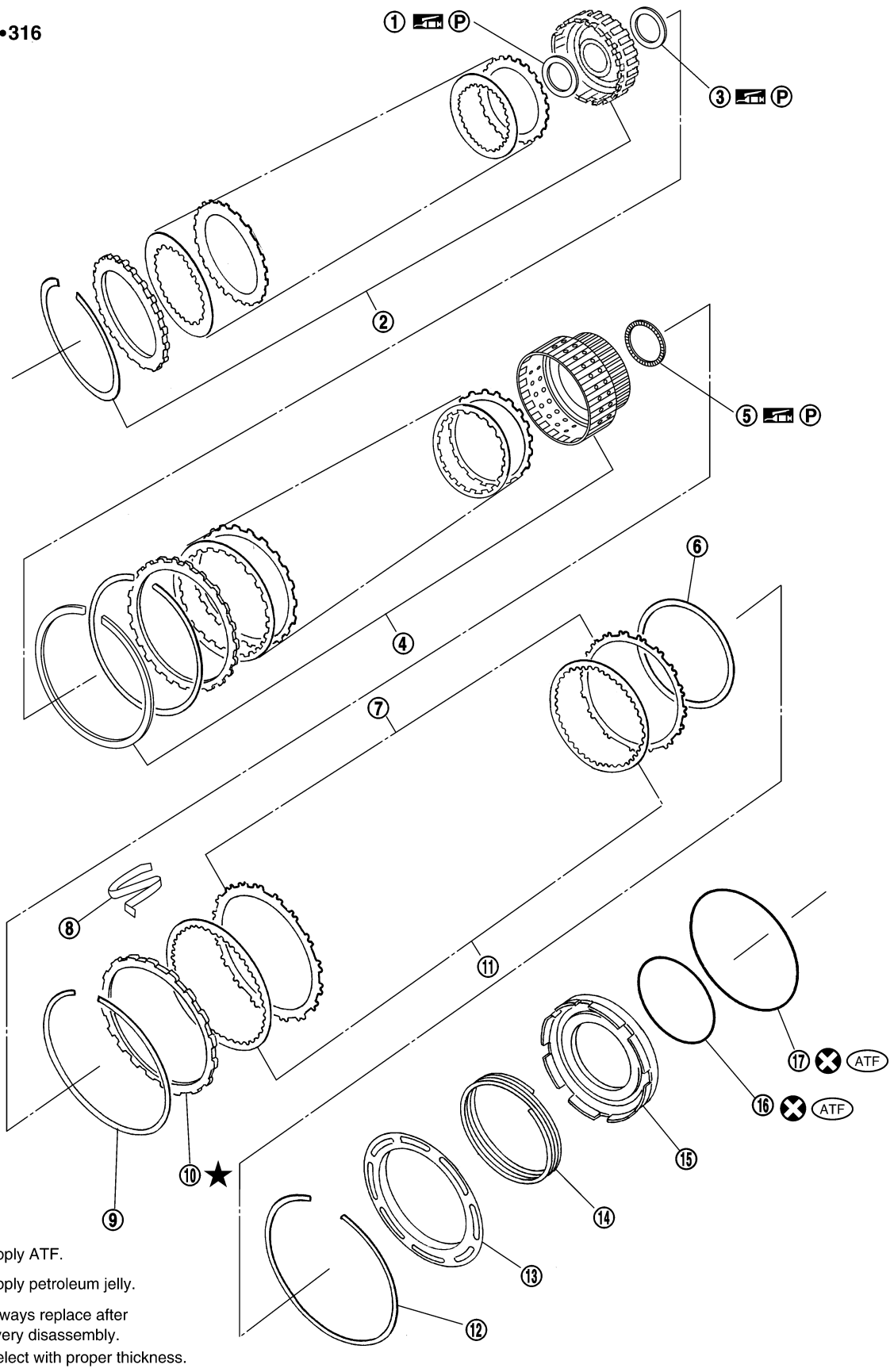

SCIA6678E

- |                           |   |                             |
|---------------------------|---|-----------------------------|
| 1. Bearing race           | 2. High and low reverse clutch assembly | 3. Needle bearing           |
| 4. Direct clutch assembly | 5. Needle bearing                       | 6. Reverse brake dish plate |

# OVERHAUL

- 
- |                                   |                               |                          |
|-----------------------------------|-------------------------------|--------------------------|
| 7. Reverse brake driven plate     | 8. N-spring                   | 9. Snap ring             |
| 10. Reverse brake retaining plate | 11. Reverse brake drive plate | 12. Snap ring            |
| 13. Spring retainer               | 14. Return spring             | 15. Reverse brake piston |
| 16. D-ring                        | 17. D-ring                    |                          |

A

B

**AT**

D

E

F

G

H

I

J

K

L

M

# OVERHAUL

## 2WD models

SEC. 313•314•315•316•317•319

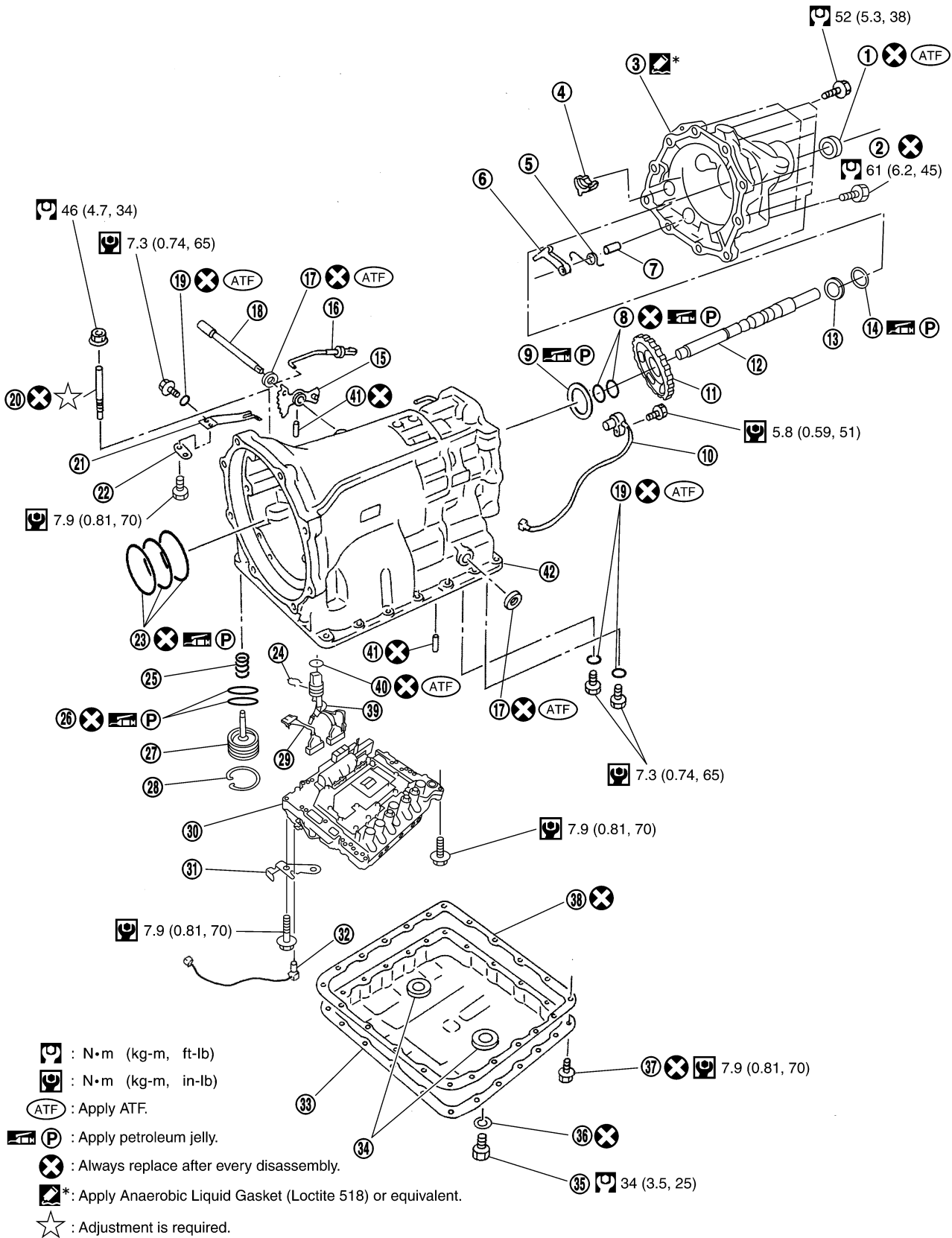

SCIA6942E

- 1. Rear oil seal
- 4. Parking actuator support

- 2. Self-sealing bolt
- 5. Return spring

- 3. Rear extension
- 6. Parking pawl

# OVERHAUL

- 
- |                           |                                    |                            |
|---------------------------|------------------------------------|----------------------------|
| 7. Pawl shaft             | 8. Seal ring                       | 9. Needle bearing          |
| 10. Revolution sensor     | 11. Parking gear                   | 12. Output shaft           |
| 13. Bearing race          | 14. Needle bearing                 | 15. Manual plate           |
| 16. Parking rod           | 17. Manual shaft oil seal          | 18. Manual shaft           |
| 19. O-ring                | 20. Band servo anchor end pin      | 21. Detent spring          |
| 22. Spacer                | 23. Seal ring                      | 24. Snap ring              |
| 25. Return spring         | 26. O-ring                         | 27. Servo assembly         |
| 28. Snap ring             | 29. Sub-harness                    | 30. Control valve with TCM |
| 31. Bracket               | 32. A/T fluid temperature sensor 2 | 33. Oil pan                |
| 34. Magnet                | 35. Drain plug                     | 36. Drain plug gasket      |
| 37. Oil pan mounting bolt | 38. Oil pan gasket                 | 39. Terminal cord assembly |
| 40. O-ring                | 41. Retaining pin                  | 42. Transmission case      |

A

B

AT

D

E

F

G

H

I

J

K

L

M

# OVERHAUL

## AWD models

SEC.313 • 314 • 315 • 316 • 317 • 319

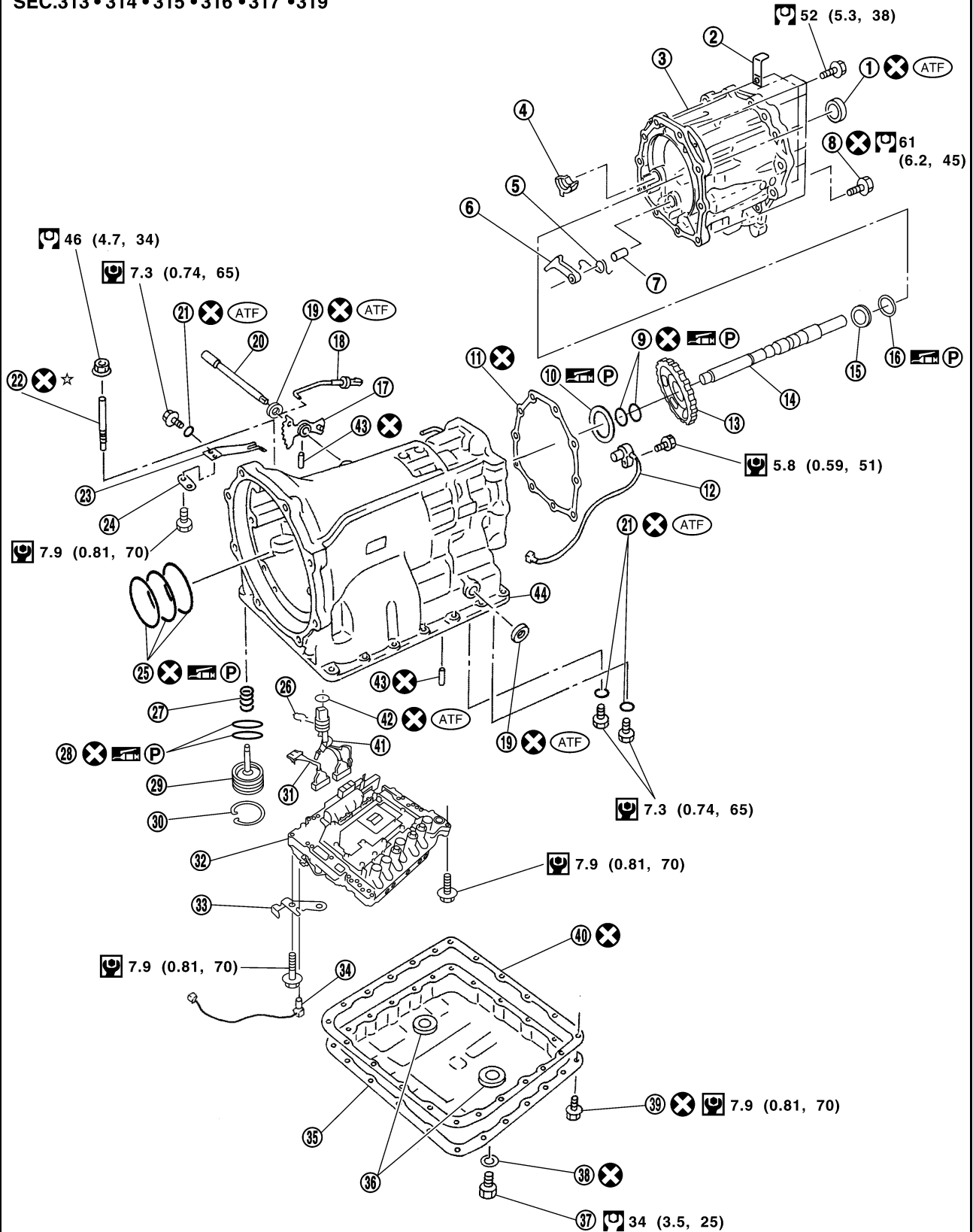

SCIA7208E

- 1. Rear oil seal
- 4. Parking actuator support

- 2. Bracket
- 5. Return spring

- 3. Adapter case
- 6. Parking pawl

# OVERHAUL

- 
- |                                    |                            |                           |    |
|------------------------------------|----------------------------|---------------------------|----|
| 7. Pawl shaft                      | 8. Self-sealing bolt       | 9. Seal ring              | A  |
| 10. Needle bearing                 | 11. Gasket                 | 12. Revolution sensor     |    |
| 13. Parking gear                   | 14. Output shaft           | 15. Bearing race          |    |
| 16. Needle bearing                 | 17. Manual plate           | 18. Parking rod           | B  |
| 19. Manual shaft oil seal          | 20. Manual shaft           | 21. O-ring                |    |
| 22. Band servo anchor end pin      | 23. Detent spring          | 24. Spacer                |    |
| 25. Seal ring                      | 26. Snap ring              | 27. Return spring         | AT |
| 28. O-ring                         | 29. Servo assembly         | 30. Snap ring             |    |
| 31. Sub-harness                    | 32. Control valve with TCM | 33. Bracket               |    |
| 34. A/T fluid temperature sensor 2 | 35. Oil pan                | 36. Magnet                | D  |
| 37. Drain plug                     | 38. Drain plug gasket      | 39. Oil pan mounting bolt |    |
| 40. Oil pan gasket                 | 41. Terminal cord assembly | 42. O-ring                |    |
| 43. Retaining pin                  | 44. Transmission case      |                           | E  |

Refer to GI section to mark sure icons (symbol marks) in the figure. Refer to [GI-10. "Components"](#) .

F

G

H

I

J

K

L

M

# OVERHAUL

## Oil Channel

ACS008G0

### 2WD models

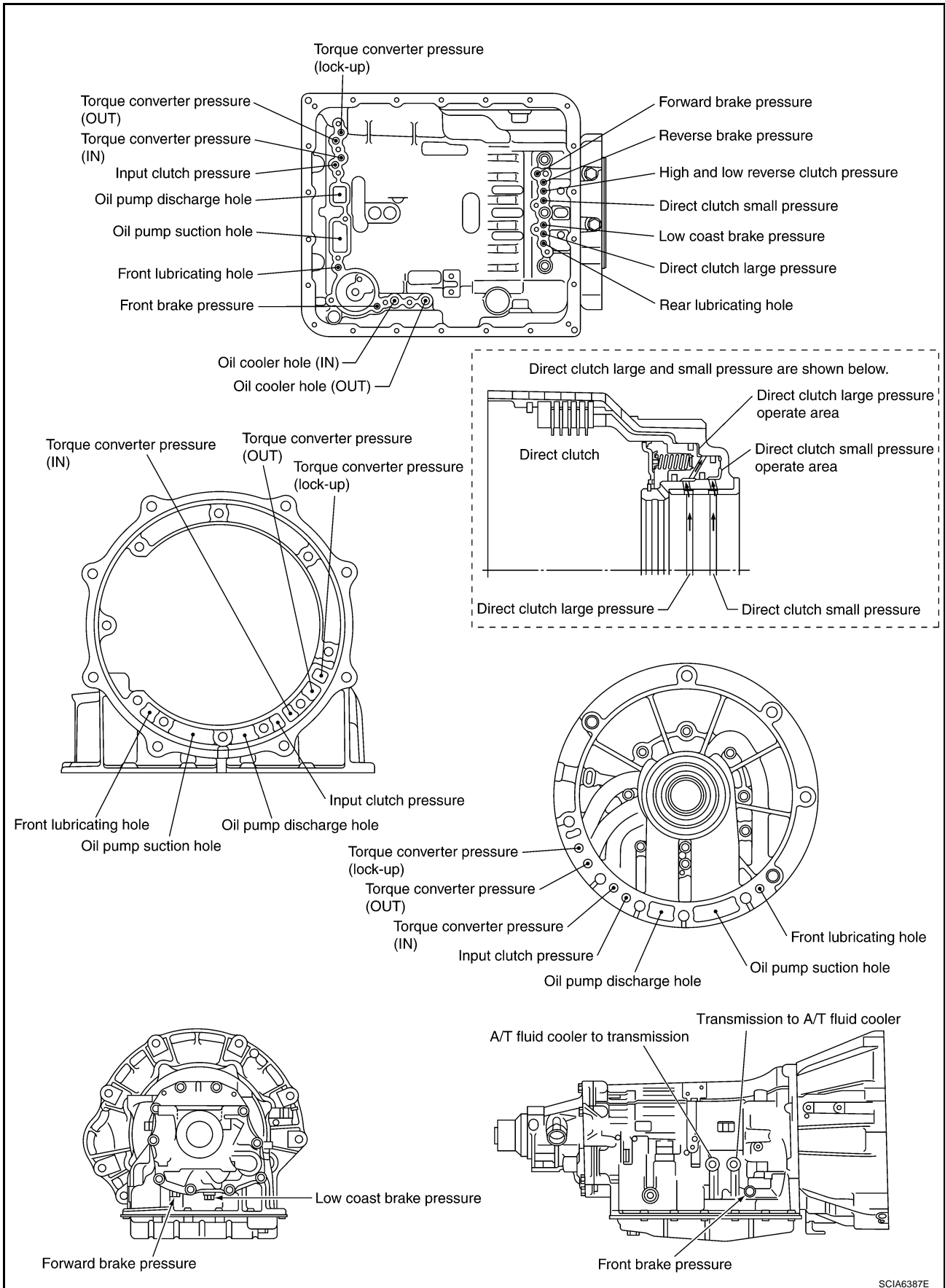

SCIA6387E



# OVERHAUL

## AWD models

A  
B  
AT  
D  
E  
F  
G  
H  
I  
J  
K  
L  
M

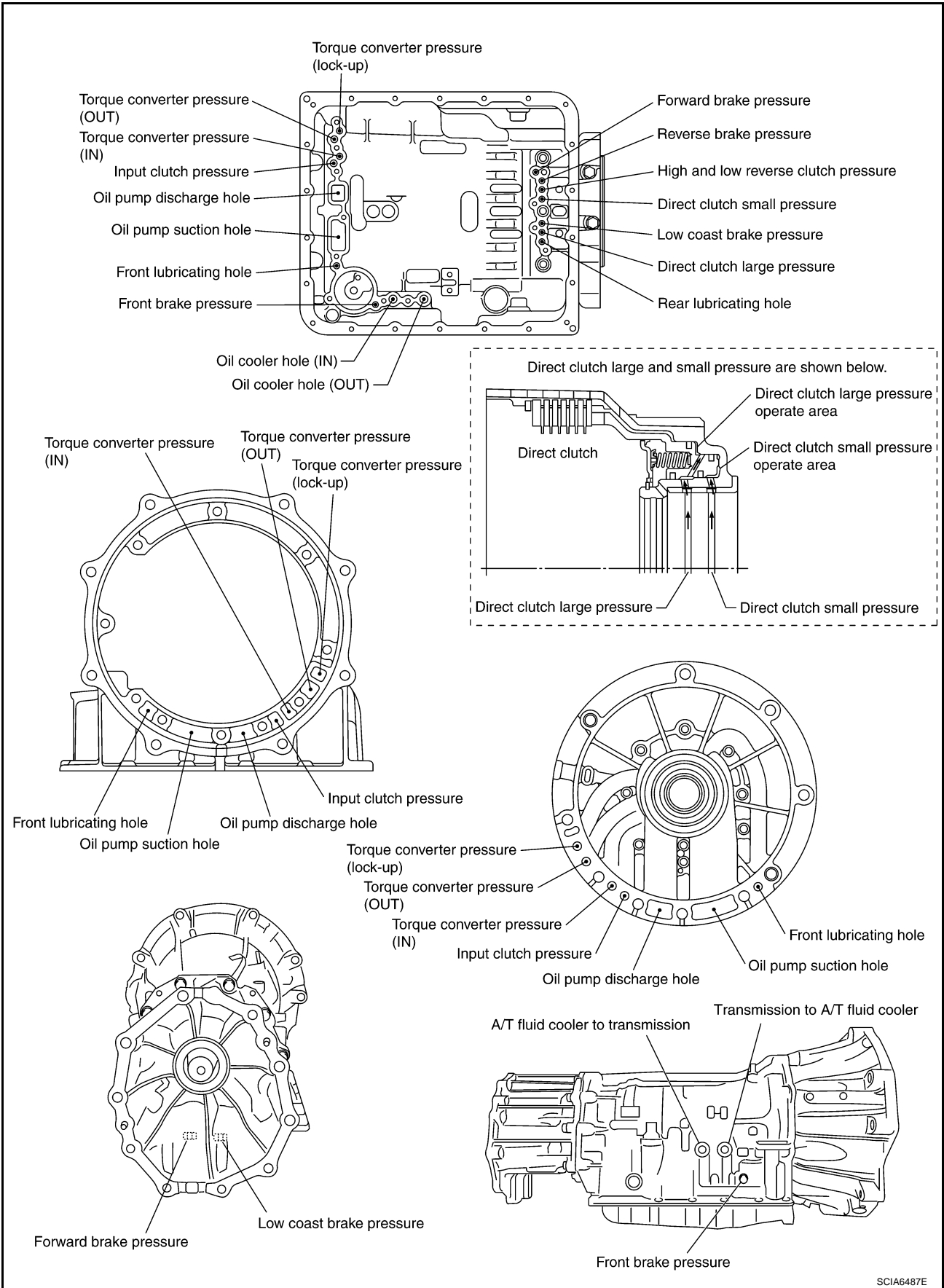

SCIA6487E

# OVERHAUL

## Locations of Adjusting Shims, Needle Bearings, Thrust Washers and Snap Rings

ACS008GP

### 2WD models

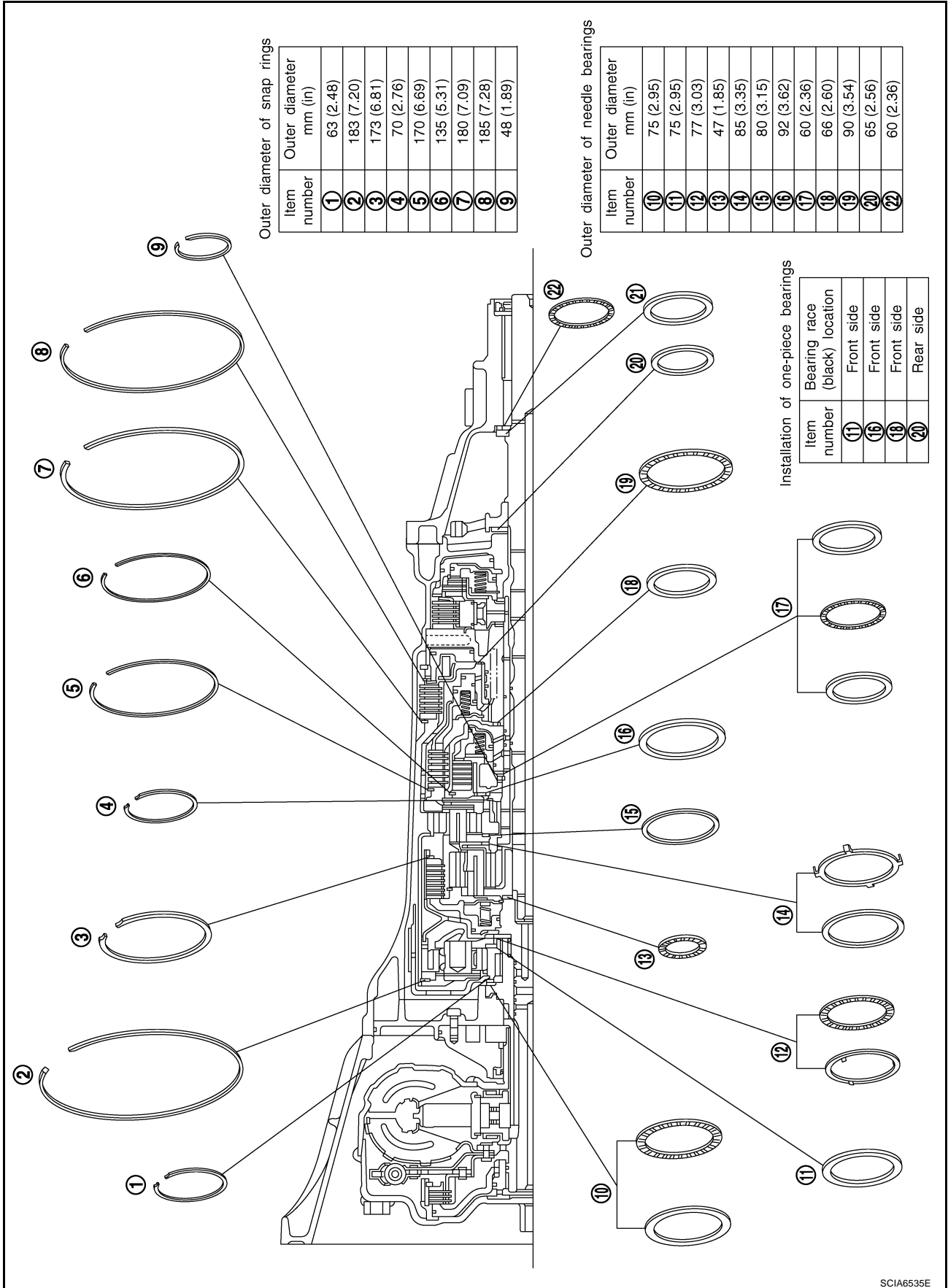

SCIA6535E

# OVERHAUL

## AWD models

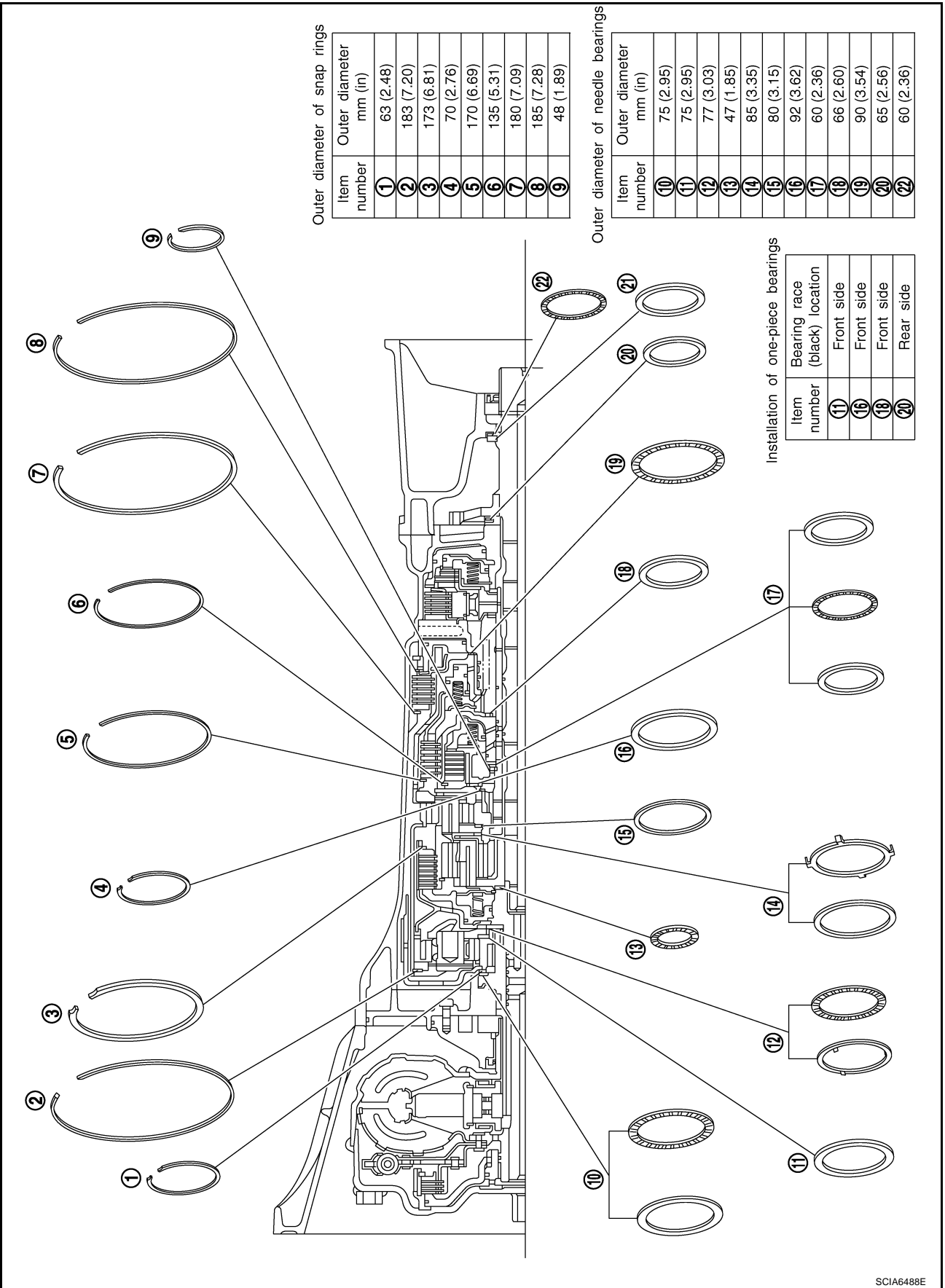

Outer diameter of snap rings

Item number	Outer diameter mm (in)
1	63 (2.48)
2	183 (7.20)
3	173 (6.81)
4	70 (2.76)
5	170 (6.69)
6	135 (5.31)
7	180 (7.09)
8	185 (7.28)
9	48 (1.89)

Outer diameter of needle bearings

Item number	Outer diameter mm (in)
10	75 (2.95)
11	75 (2.95)
12	77 (3.03)
13	47 (1.85)
14	85 (3.35)
15	80 (3.15)
16	92 (3.62)
17	60 (2.36)
18	66 (2.60)
19	90 (3.54)
20	65 (2.56)
22	60 (2.36)

Installation of one-piece bearings

Item number	Bearing race (black) location
11	Front side
16	Front side
18	Front side
20	Rear side

A  
B  
**AT**  
D  
E  
F  
G  
H  
I  
J  
K  
L  
M

SCIA6488E

## DISASSEMBLY

PFP:31020

### Disassembly

ACS008G0

**CAUTION:**

Do not disassemble parts behind Drum Support. Refer to [AT-17, "Cross-Sectional View \(2WD Models\)"](#) or [AT-18, "Cross-Sectional View \(AWD Models\)"](#) .

1. Drain ATF through drain plug.
2. Remove torque converter by holding it firmly and turning while pulling straight out.

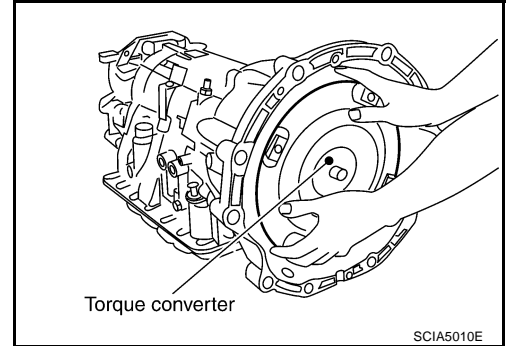

3. Check torque converter one-way clutch using a check tool as shown at figure.
  - a. Insert a check tool into the groove of bearing support built into one-way clutch outer race.
  - b. When fixing bearing support with a check tool, rotate one-way clutch spline using screwdriver.
  - c. Make sure that inner race rotates clockwise only. If not, replace torque converter assembly.

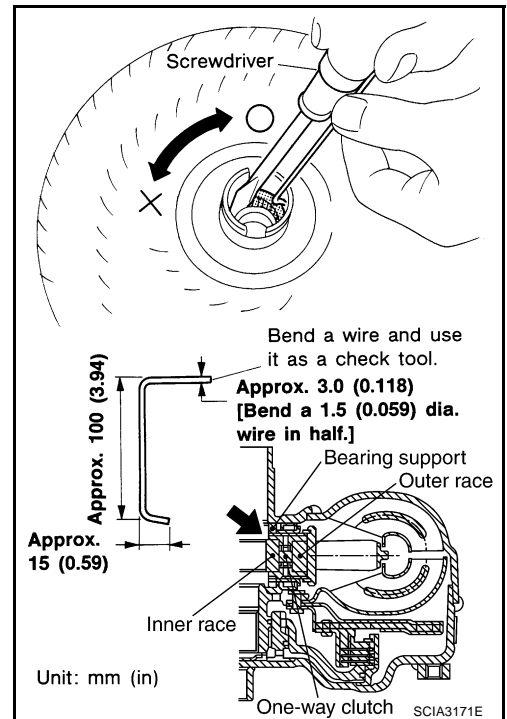

4. Remove converter housing from transmission case.

**CAUTION:**

**Be careful not to scratch converter housing.**

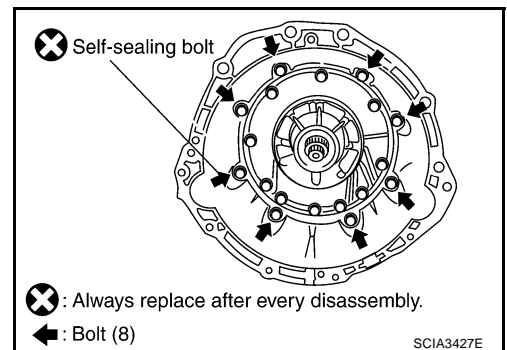

# DISASSEMBLY

5. Remove O-ring from input clutch assembly.

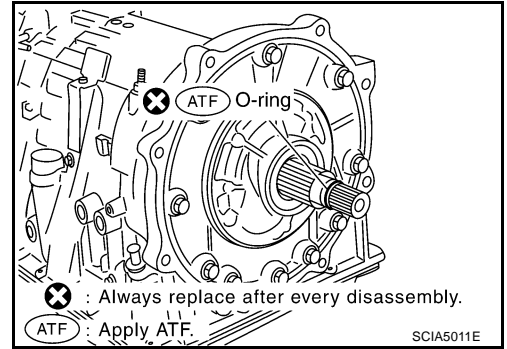

6. Remove tightening bolts for oil pump assembly and transmission case.

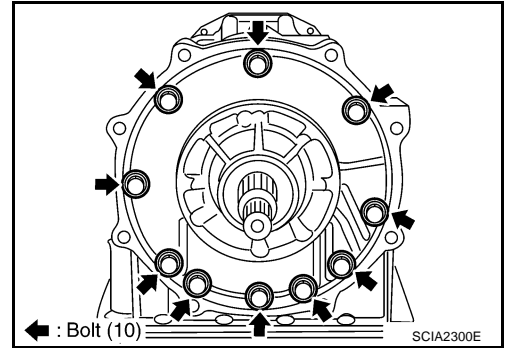

7. Attach the sliding hammers to oil pump assembly and extract it evenly from transmission case.

**CAUTION:**

- Fully tighten sliding hammer screws.
- Make sure that bearing race is installed to the oil pump assembly edge surface.

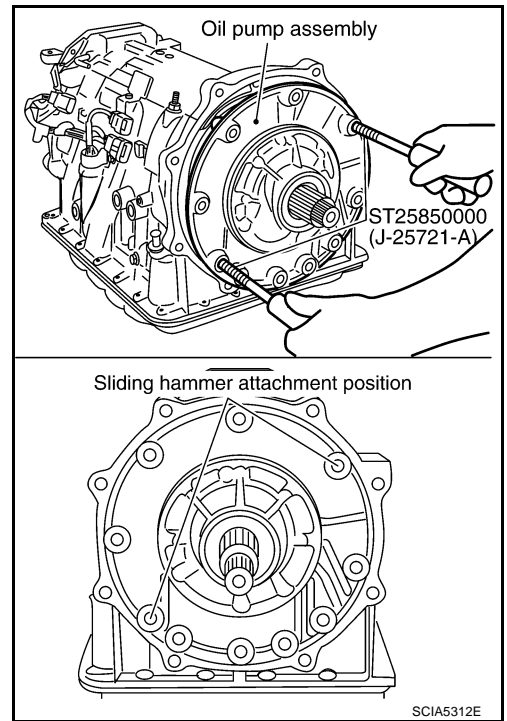

8. Remove O-ring from oil pump assembly.

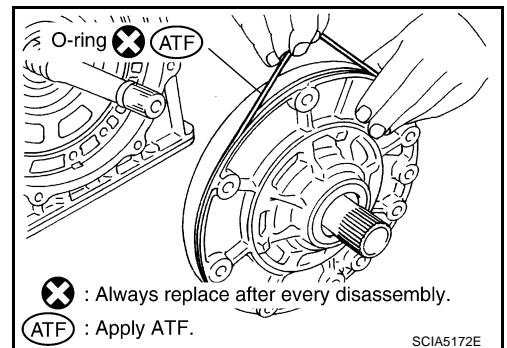

A  
B  
AT  
D  
E  
F  
G  
H  
I  
J  
K  
L  
M

# DISASSEMBLY

9. Remove bearing race from oil pump assembly.

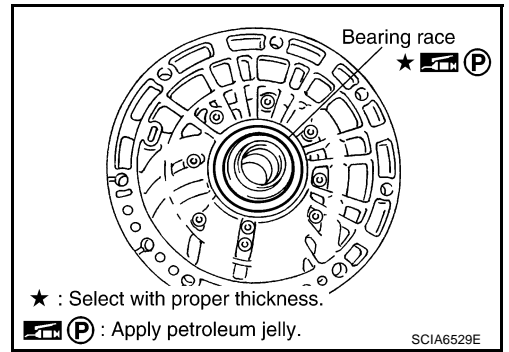

10. Remove needle bearing from front sun gear.

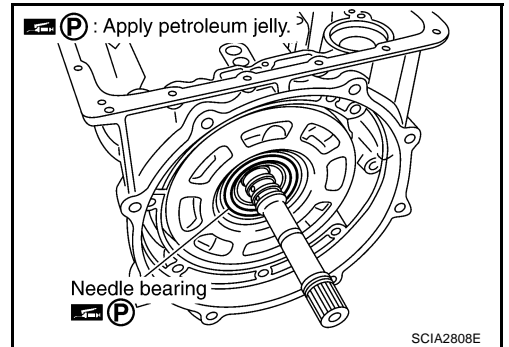

11. Remove front sun gear assembly from front carrier assembly.

**NOTE:**  
Remove front sun gear by rotating left/right.

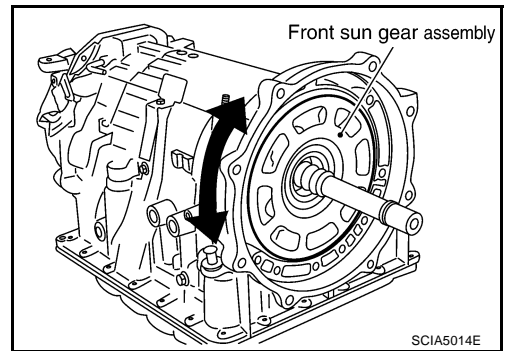

12. Remove seal rings from input clutch assembly.

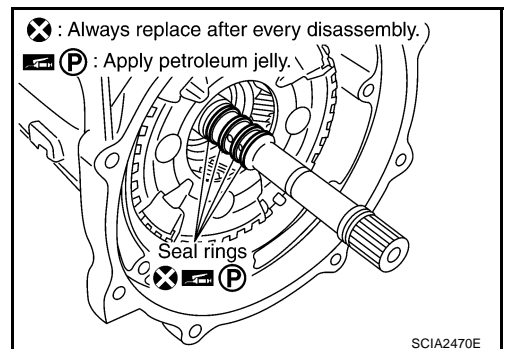

13. Remove front carrier assembly from rear carrier assembly. (With input clutch assembly and rear internal gear.)

**CAUTION:**  
Be careful to remove it with needle bearing.

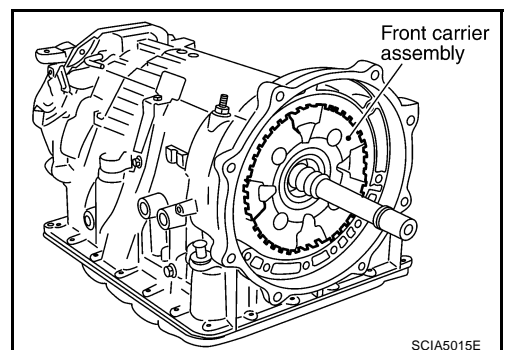

# DISASSEMBLY

14. Loosen lock nut and remove band servo anchor end pin from transmission case.

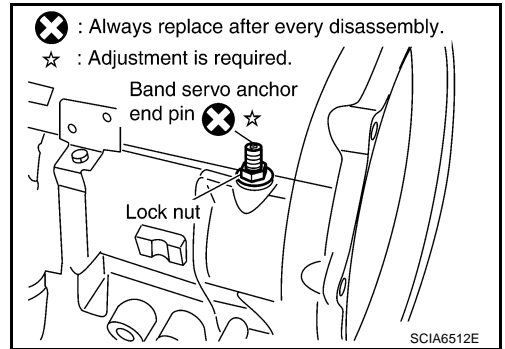

15. Remove brake band from transmission case.

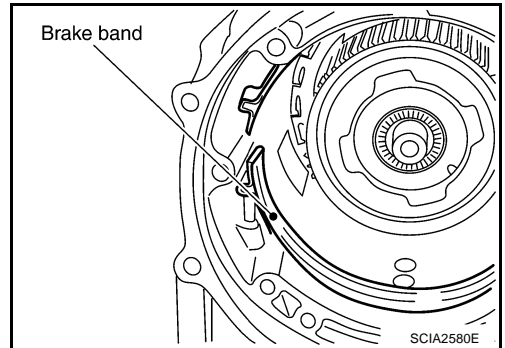

- To prevent brake linings from cracking or peeling, do not stretch the flexible band unnecessarily. When removing the brake band, always secure it with a clip as shown in the figure at right. Leave the clip in position after removing the brake band.
- Check brake band facing for damage, cracks, wear or burns.

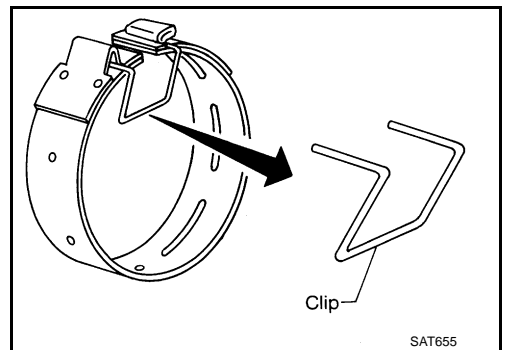

16. Remove mid carrier assembly and rear carrier assembly as a unit.

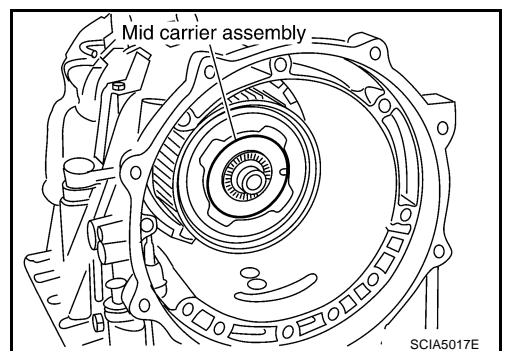

17. Remove mid carrier assembly from rear carrier assembly.

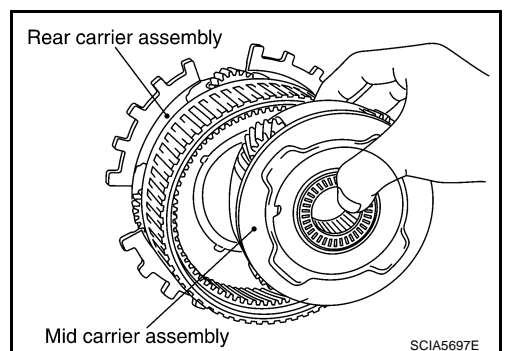

A  
B  
AT  
D  
E  
F  
G  
H  
I  
J  
K  
L  
M

## DISASSEMBLY

18. Remove needle bearing (front side) from mid carrier assembly.

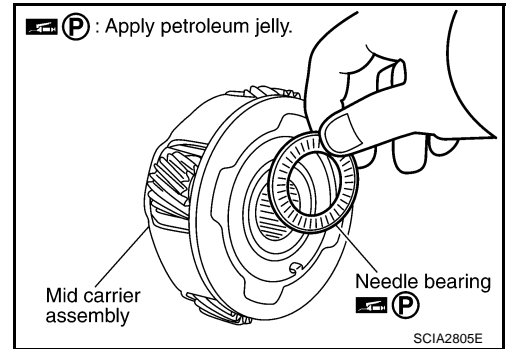

19. Remove needle bearing (rear side) from mid carrier assembly.

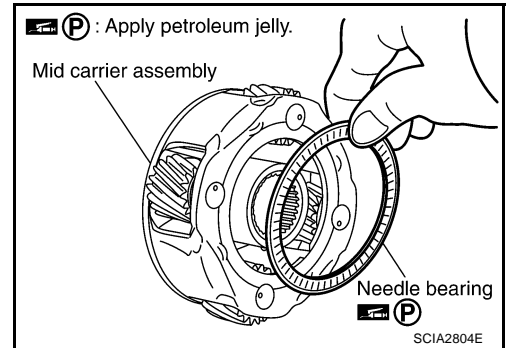

20. Remove bearing race from rear carrier assembly.

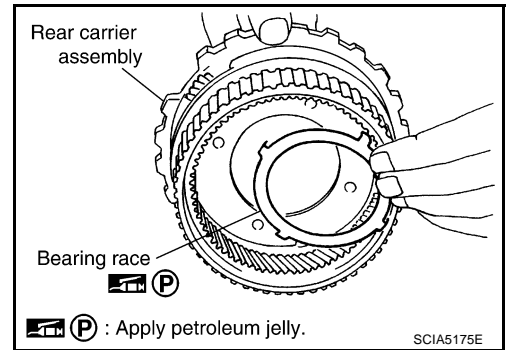

21. Remove needle bearing from rear carrier assembly.

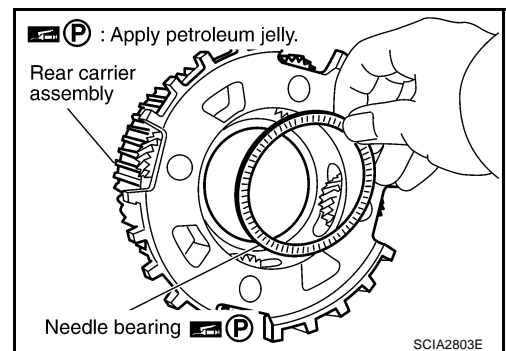

22. Remove mid sun gear assembly, rear sun gear assembly and high and low reverse clutch hub as a unit.

**CAUTION:**

**Be careful to remove them with bearing race and needle bearing.**

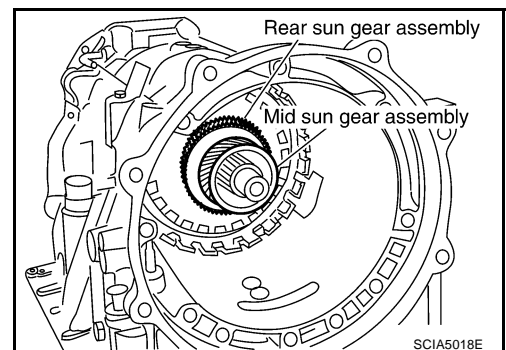



# DISASSEMBLY

23. Remove high and low reverse clutch assembly from direct clutch assembly.

**CAUTION:**

Make sure that needle bearing is installed to the high and low reverse clutch assembly edge surface.

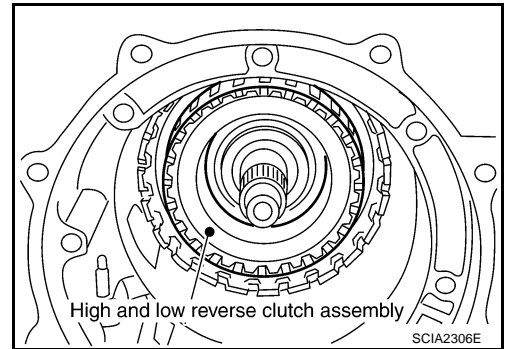

24. Remove direct clutch assembly from reverse brake.

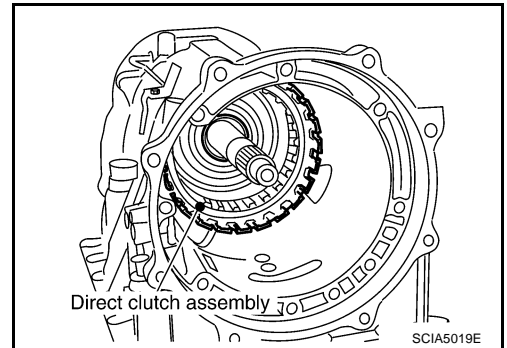

25. Remove needle bearing from drum support.

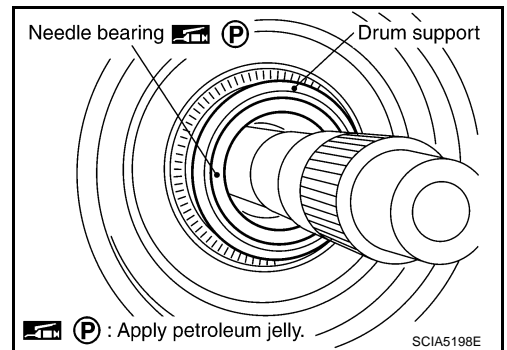

26. Remove snap ring from A/T assembly harness connector.

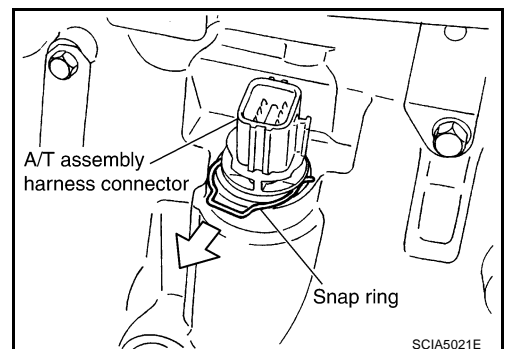

27. Push A/T assembly harness connector.

**CAUTION:**

Be careful not to damage connector.

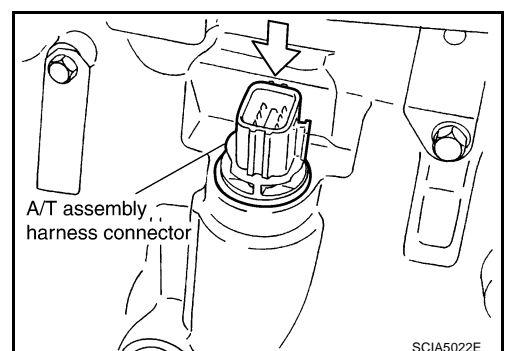

A  
B  
AT  
D  
E  
F  
G  
H  
I  
J  
K  
L  
M

## DISASSEMBLY

28. Remove oil pan and oil pan gasket.

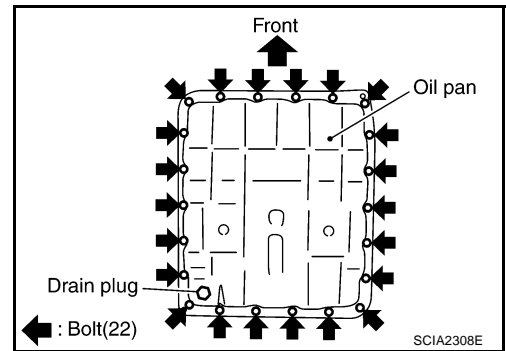

29. Check foreign materials in oil pan to help determine causes of malfunction. If the A/T fluid is very dark, smells burned, or contains foreign particles, the frictional material (clutches, band) may need replacement. A tacky film that will not wipe clean indicates varnish build up. Varnish can cause valves, servo, and clutches to stick and can inhibit pump pressure.

- If frictional material is detected, perform A/T fluid cooler cleaning. Refer to [AT-14, "A/T Fluid Cooler Cleaning"](#).

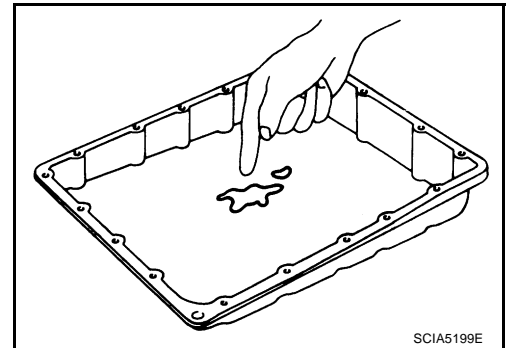

30. Remove magnets from oil pan.

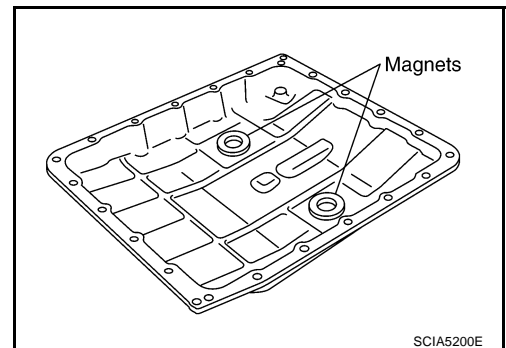

31. Disconnect A/T fluid temperature sensor 2 connector.

- CAUTION:**  
Be careful not to damage connector.

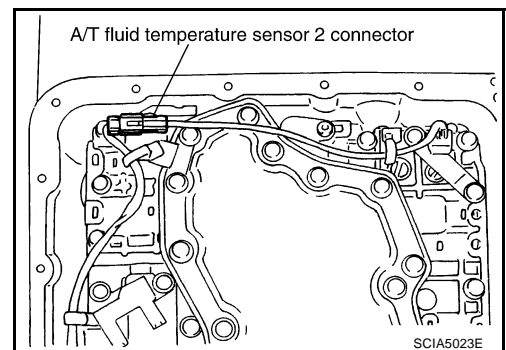

# DISASSEMBLY

32. Straighten terminal clips to free terminal cord assembly and A/T fluid temperature sensor 2 harness.

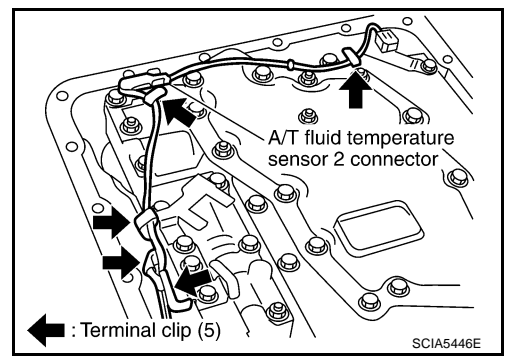

33. Disconnect revolution sensor connector.

**CAUTION:**  
Be careful not to damage connector.

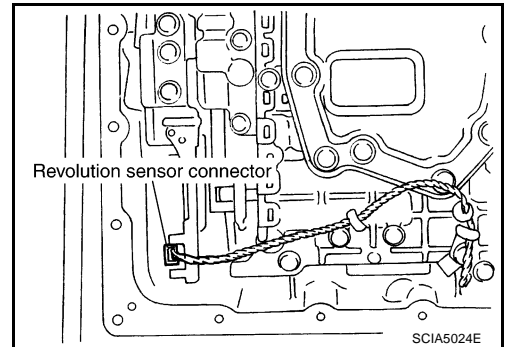

34. Straighten terminal clips to free revolution sensor harness.

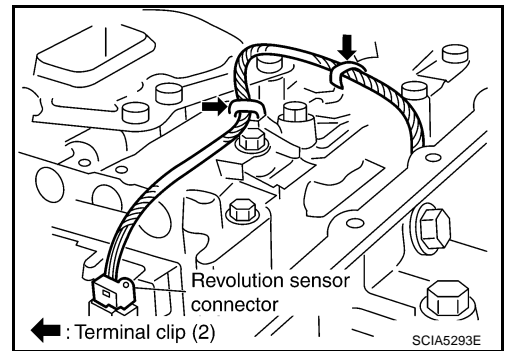

35. Remove bolts A, B and C from control valve with TCM.

Bolt symbol	Length mm (in)	Number of bolts
A	42 (1.65)	5
B	55 (2.17)	6
C	40 (1.57)	1

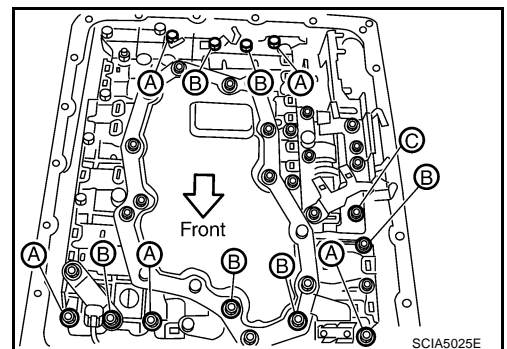

36. Remove control valve with TCM from transmission case.

**CAUTION:**  
When removing, be careful with the manual valve notch and manual plate height. Remove it vertically.

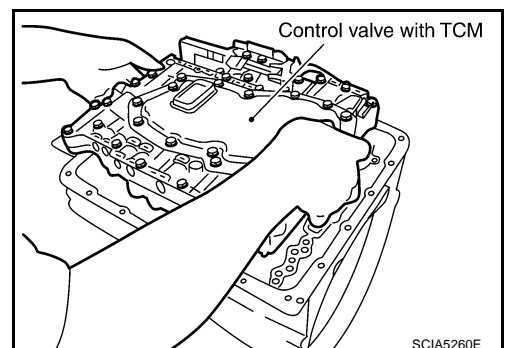

A  
B  
AT  
D  
E  
F  
G  
H  
I  
J  
K  
L  
M

# DISASSEMBLY

37. Remove A/T fluid temperature sensor 2 with bracket from control valve with TCM.

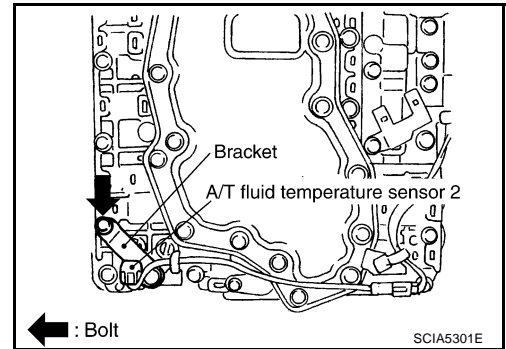

38. Remove bracket from A/T fluid temperature sensor 2.

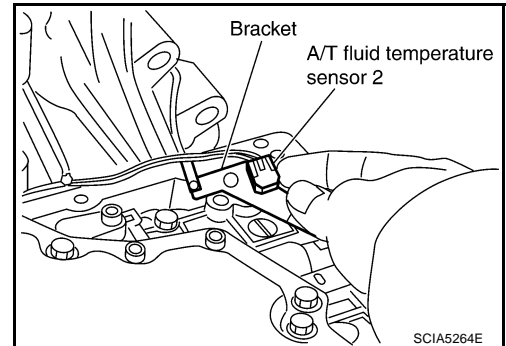

39. Remove O-ring from A/T assembly harness connector.

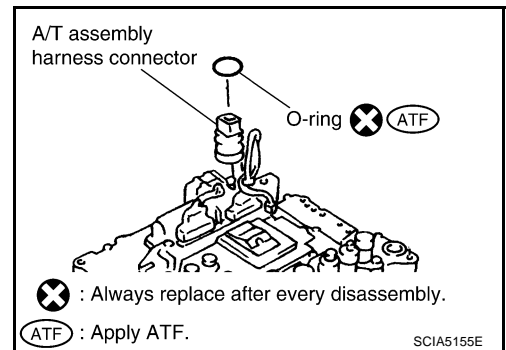

40. Disconnect TCM connectors.

**CAUTION:**  
**Be careful not to damage connectors.**

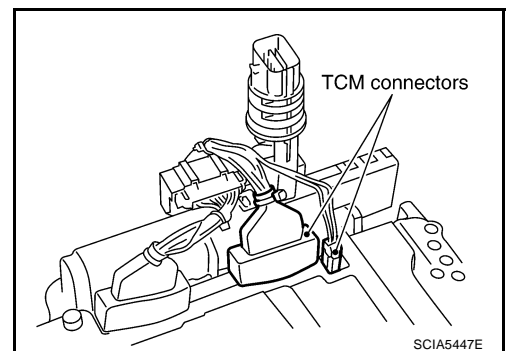

41. Remove A/T assembly harness connector from control valve with TCM using a flat-bladed screwdriver.

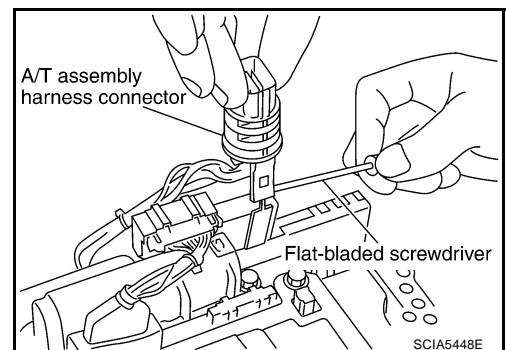

# DISASSEMBLY

42. Disconnect TCM connector and park/neutral position switch connector.

**CAUTION:**  
Be careful not to damage connectors.

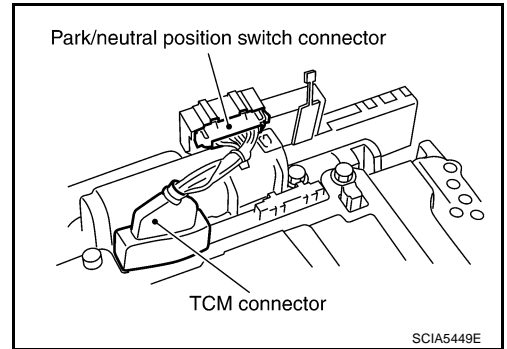

43. Remove rear extension assembly (2WD models) or adapter case assembly (AWD models) according to the following procedures.

a. **2WD models**

- i. Remove tightening bolts for rear extension assembly and transmission case.

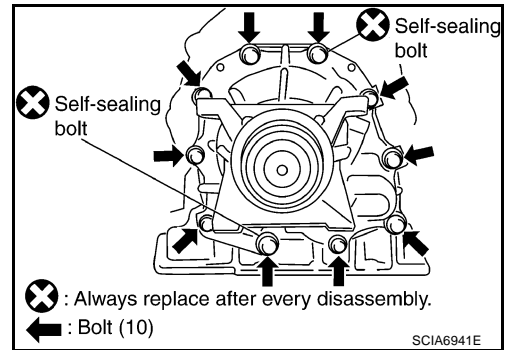

- ii. Tap rear extension assembly with a soft hammer.

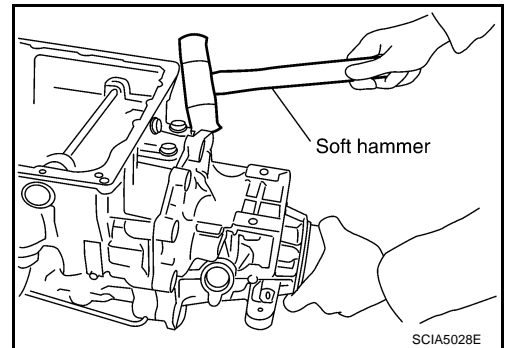

- iii. Remove rear extension assembly from transmission case. (With needle bearing.)

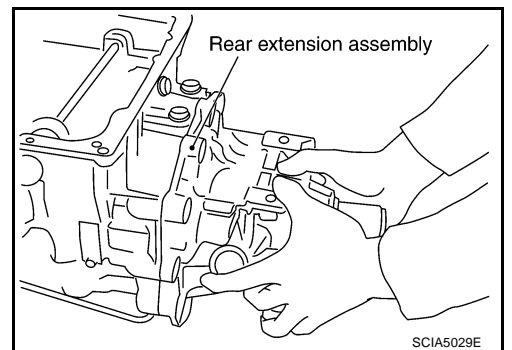

A  
B  
AT  
D  
E  
F  
G  
H  
I  
J  
K  
L  
M

# DISASSEMBLY

## b. AWD models

i. Remove tightening bolts (1) for adapter case assembly and transmission case. [With bracket (2).]

←: Bolt (10)

● Self-sealing bolts (3)

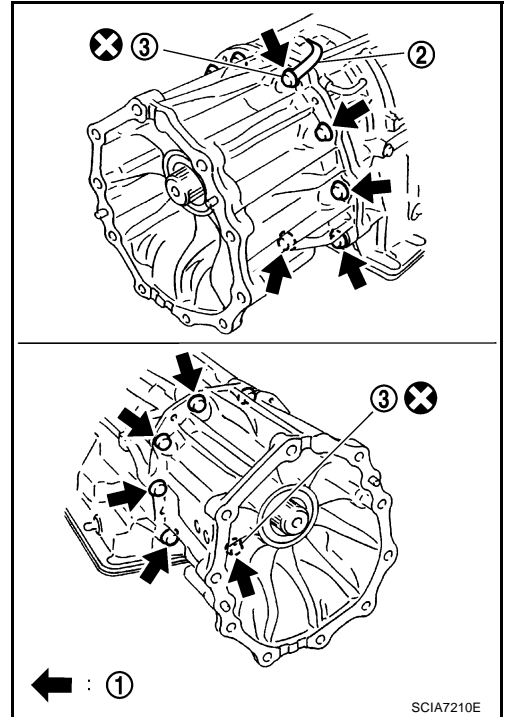

ii. Tap adapter case assembly with a soft hammer.

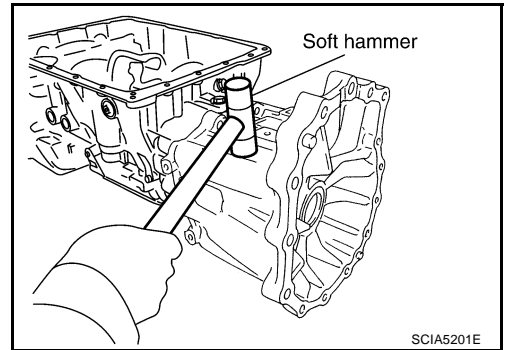

iii. Remove adapter case assembly from transmission case. (With needle bearing)

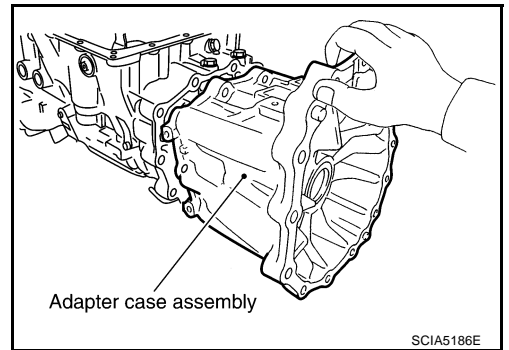

iv. Remove gasket from transmission case.

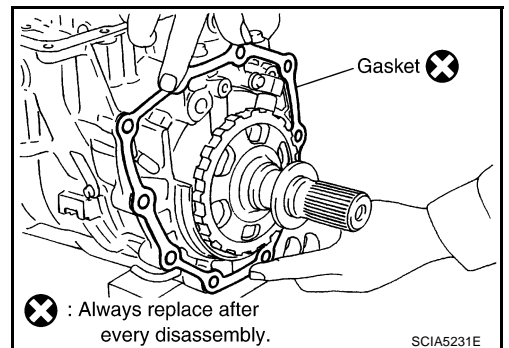

# DISASSEMBLY

44. Remove bearing race from output shaft.

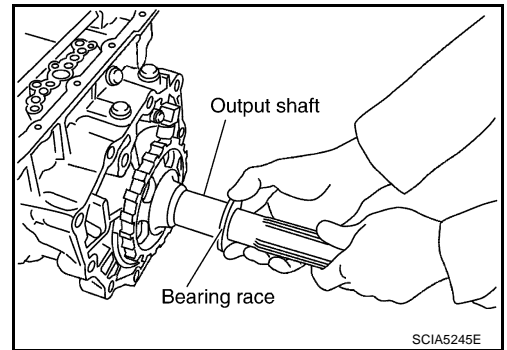

45. Remove output shaft from transmission case by rotating left/right.

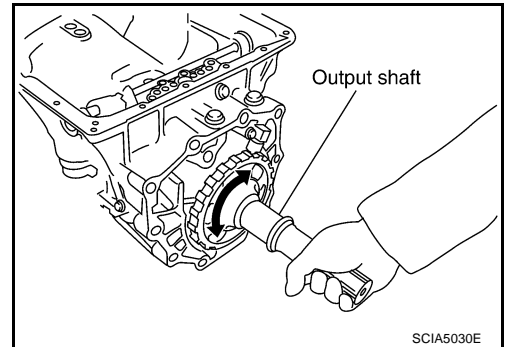

46. Remove parking gear from output shaft.

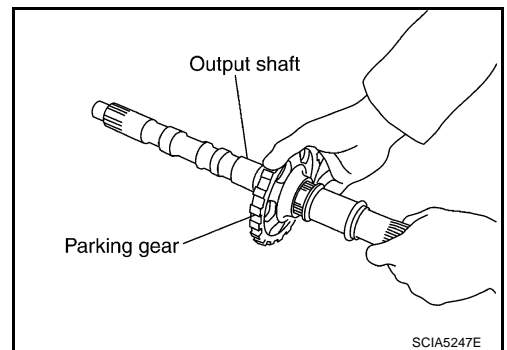

47. Remove seal rings from output shaft.

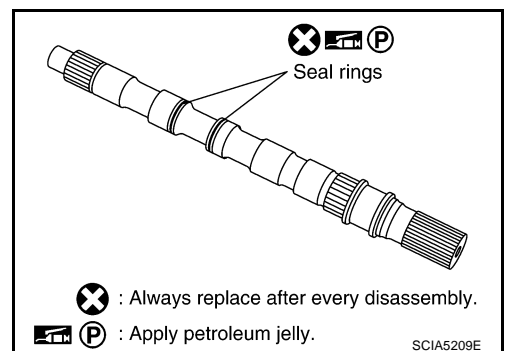

48. Remove needle bearing from transmission case.

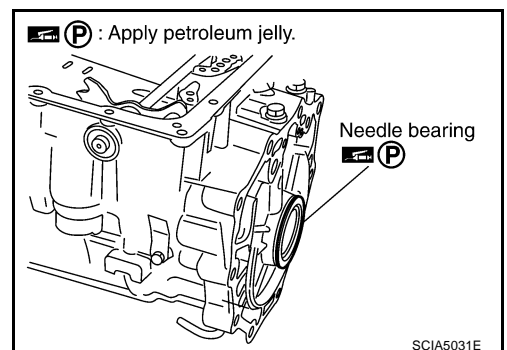

A  
B  
AT  
D  
E  
F  
G  
H  
I  
J  
K  
L  
M

## DISASSEMBLY

49. Remove revolution sensor from transmission case.

**CAUTION:**

- Do not subject it to impact by dropping or hitting it.
- Do not disassemble.
- Do not allow metal filings, etc., to get on the sensor's front edge magnetic area.
- Do not place in an area affected by magnetism.

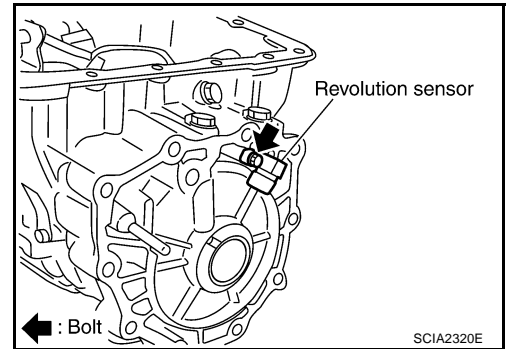

50. Remove reverse brake snap ring (fixing plate) using 2 flat-bladed screwdrivers.

**NOTE:**

Press out snap ring from the transmission case oil pan side gap using a flat-bladed screwdriver, and remove it using a another screwdriver.

51. Remove reverse brake retaining plate from transmission case.

- Check facing for burns, cracks or damage. If necessary, replace the plate.

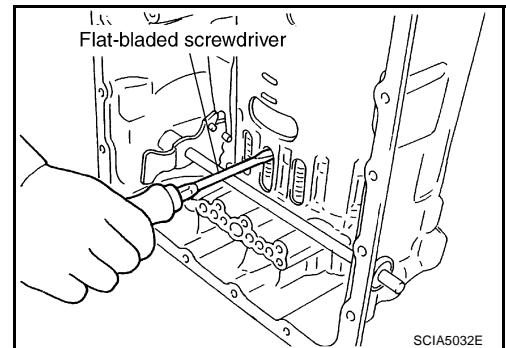

52. Remove N-spring from transmission case.

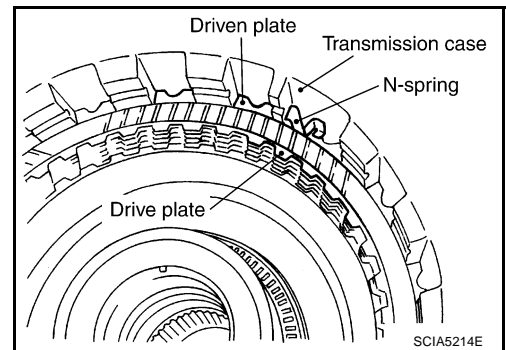

53. Remove reverse brake drive plates, driven plates and dish plate from transmission case.

- Check facing for burns, cracks or damage. If necessary, replace the plate.

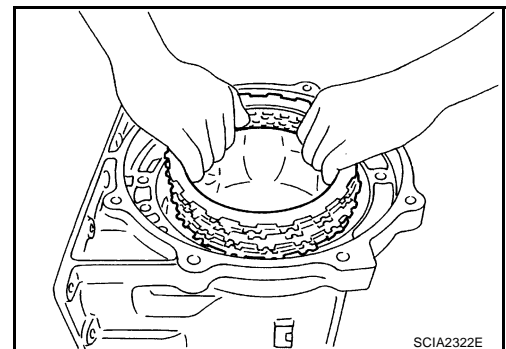

54. Remove snap ring (fixing spring retainer) using a flat-bladed screwdriver.

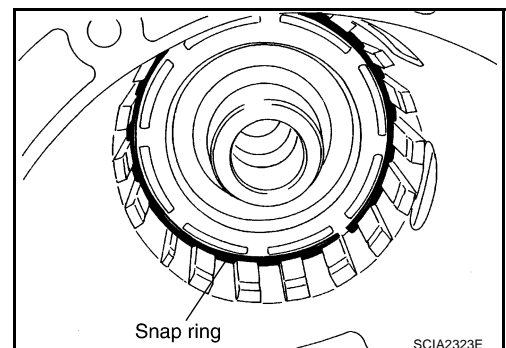



# DISASSEMBLY

55. Remove spring retainer and return spring from transmission case.

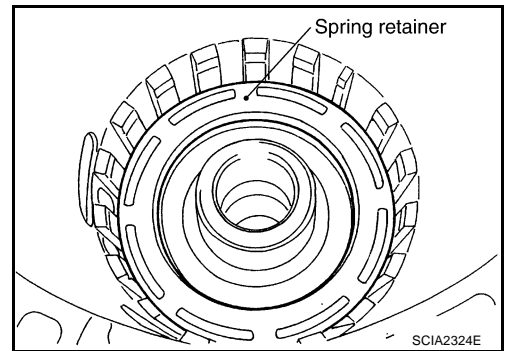

56. Remove seal rings from drum support.

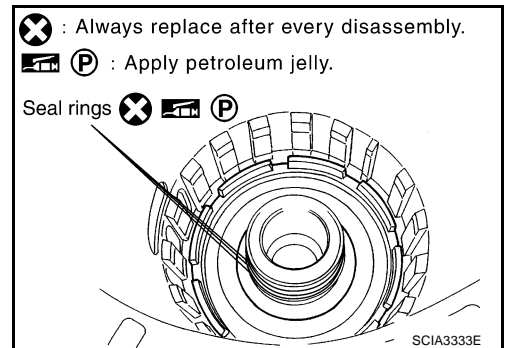

57. Remove needle bearing from drum support edge surface.

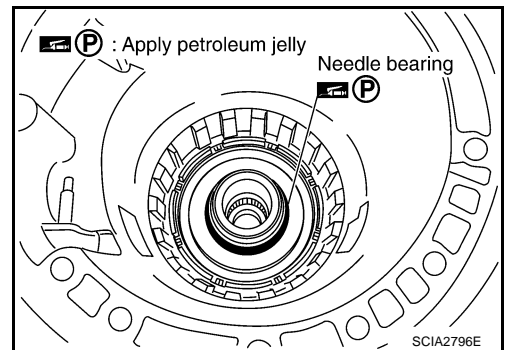

58. Remove reverse brake piston from transmission case with compressed air. Refer to [AT-288, "Oil Channel"](#).

**CAUTION:**

Care should be taken not to abruptly blow air. It makes pistons incline, as the result, it becomes hard to disassemble the pistons.

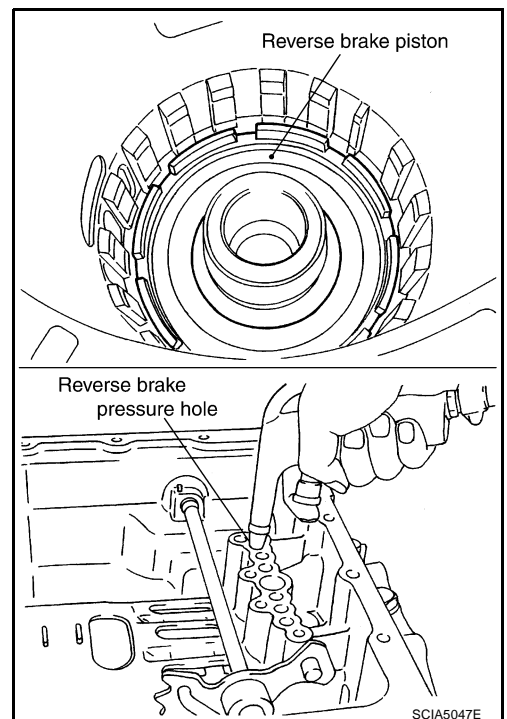

A  
B  
AT  
D  
E  
F  
G  
H  
I  
J  
K  
L  
M

# DISASSEMBLY

59. Remove D-rings from reverse brake piston.

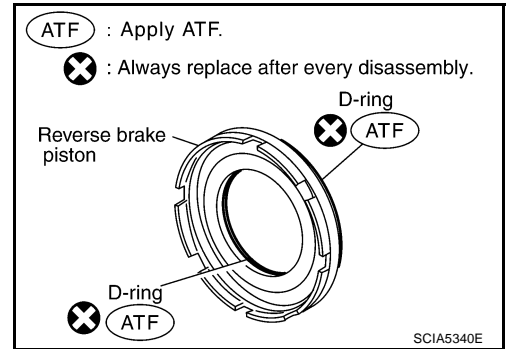

60. Use a pin punch [4 mm (0.16 in) dia. commercial service tool] to knock out retaining pin.

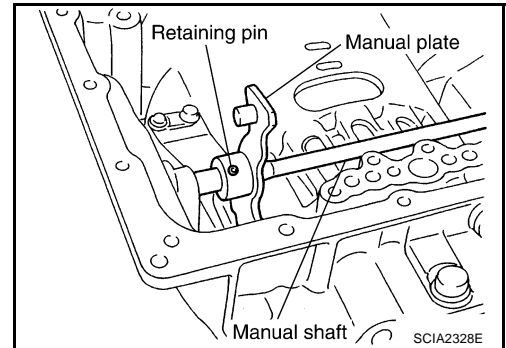

61. Remove manual shaft retaining pin with a pair of nippers.

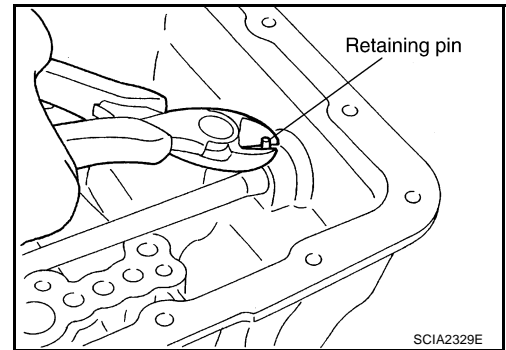

62. Remove manual plate (with parking rod) from manual shaft.

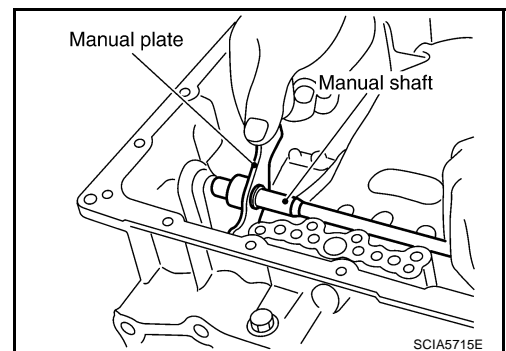

63. Remove parking rod from manual plate.

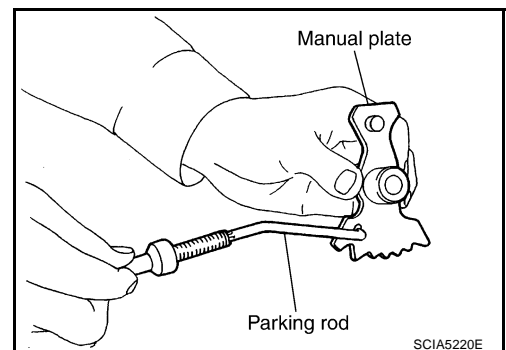

# DISASSEMBLY

64. Remove manual shaft from transmission case.

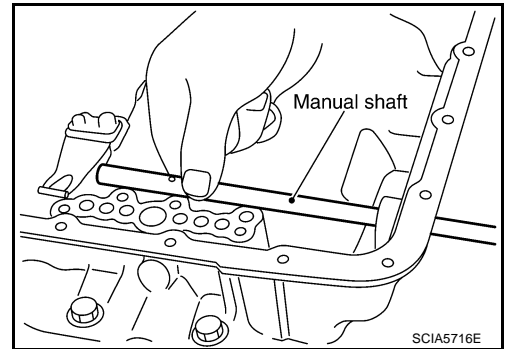

65. Remove manual shaft oil seals using a flat-bladed screwdriver.

**CAUTION:**

**Be careful not to scratch transmission case.**

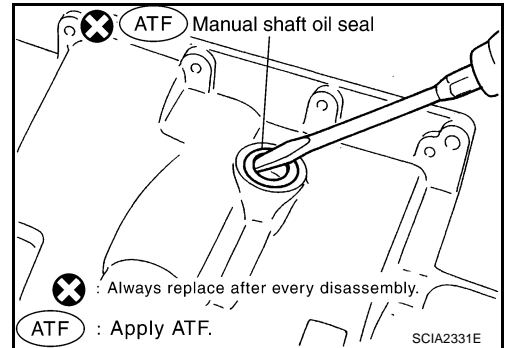

66. Remove detent spring and spacer from transmission case.

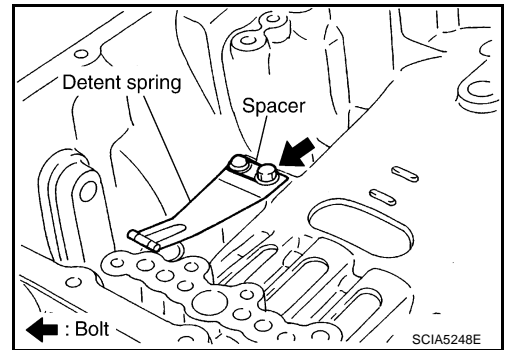

67. Using a pair of snap ring pliers, remove snap ring from transmission case.

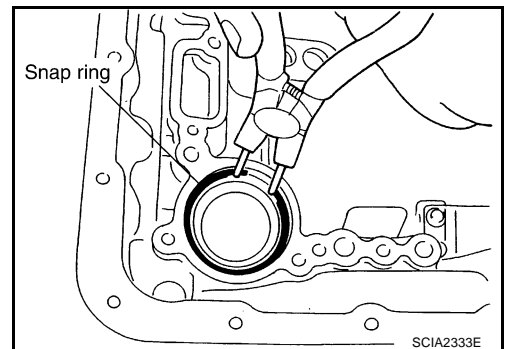

68. Remove servo assembly (with return spring) from transmission case.

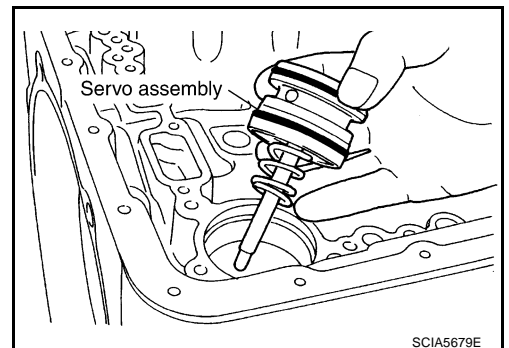

A  
B  
AT  
D  
E  
F  
G  
H  
I  
J  
K  
L  
M

# DISASSEMBLY

69. Remove return spring from servo assembly.

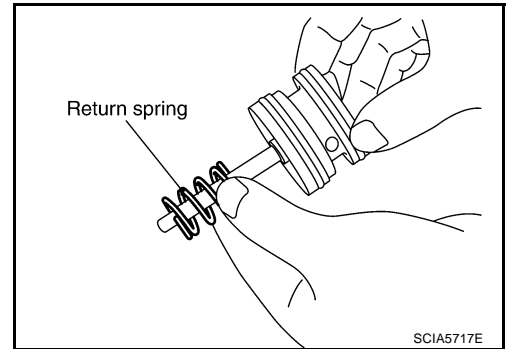

70. Remove O-rings from servo assembly.

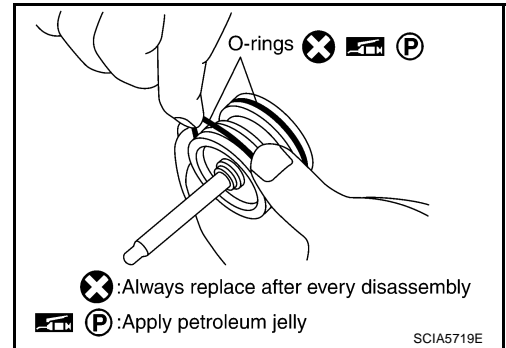

71. Remove needle bearing from rear extension (2WD models) or adapter case (AWD models).

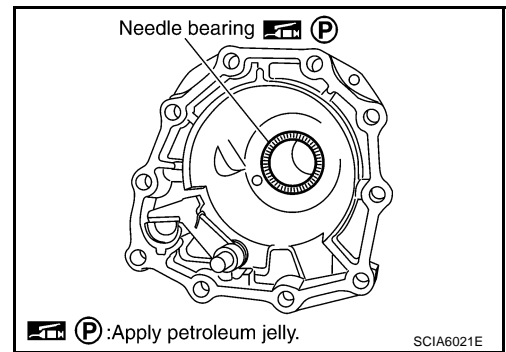

72. Remove parking actuator support from rear extension (2WD models) or adapter case (AWD models).

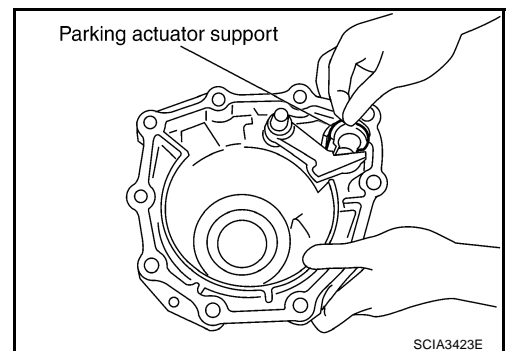

73. Remove parking pawl (with return spring) and pawl shaft from rear extension (2WD models) or adapter case (AWD models).

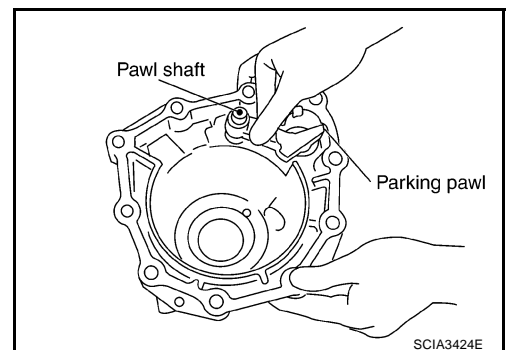

# DISASSEMBLY

74. Remove return spring from parking pawl.

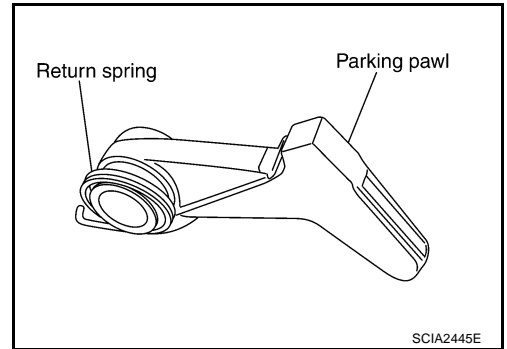

75. Remove rear oil seal from rear extension (2WD models) or adapter case (AWD models).

**CAUTION:**

**Be careful not to scratch rear extension (2WD models) or adapter case (AWD models).**

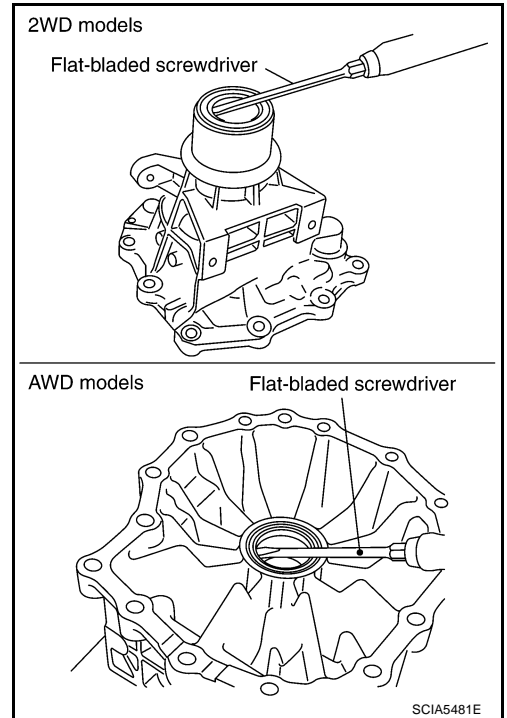

A  
B  
AT  
D  
E  
F  
G  
H  
I  
J  
K  
L  
M

# REPAIR FOR COMPONENT PARTS

PFP:00000

ACS008GR

## REPAIR FOR COMPONENT PARTS

### Oil Pump COMPONENTS

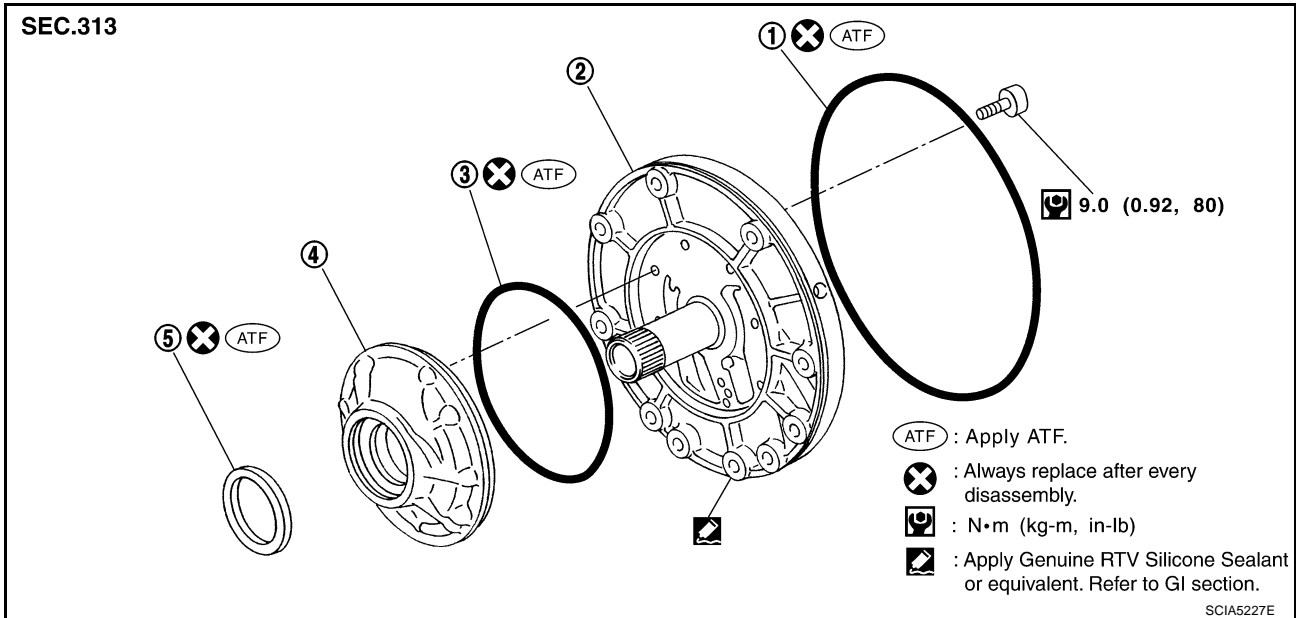

### DISASSEMBLY

1. Remove oil pump housing from oil pump cover.

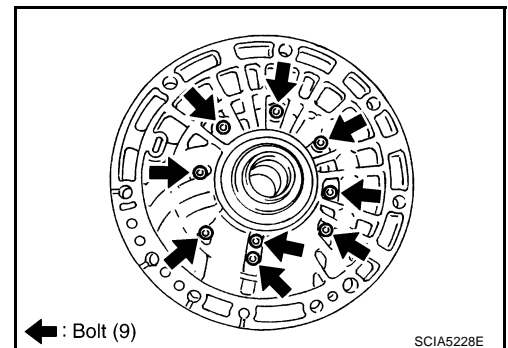

2. Remove oil pump housing oil seal using a flat-bladed screwdriver.

**CAUTION:**

**Be careful not to scratch oil pump housing.**

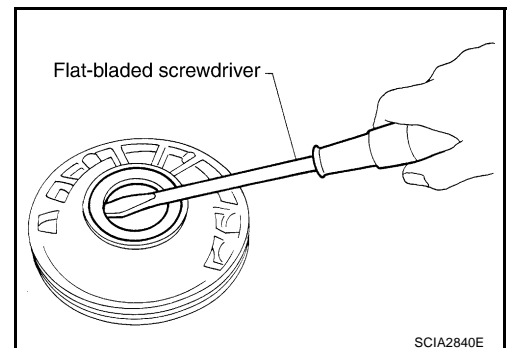

# REPAIR FOR COMPONENT PARTS

3. Remove O-ring from oil pump housing.

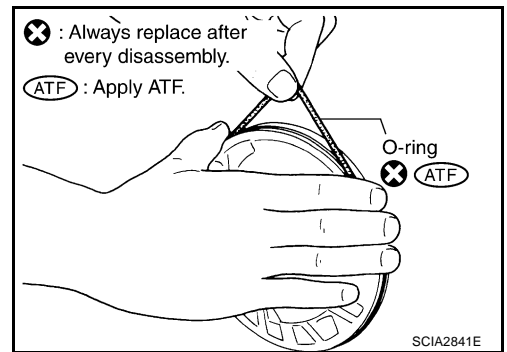

4. Remove O-ring from oil pump cover.

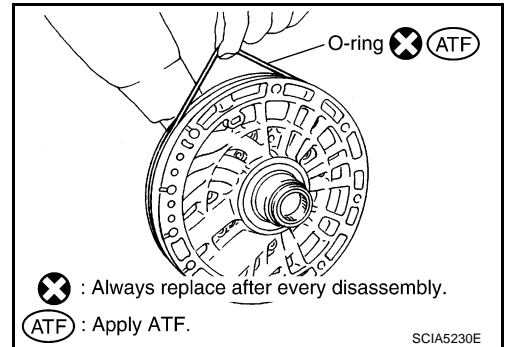

## ASSEMBLY

1. Install O-ring to oil pump cover.

### CAUTION:

- Do not reuse O-ring.
- Apply ATF to O-ring.

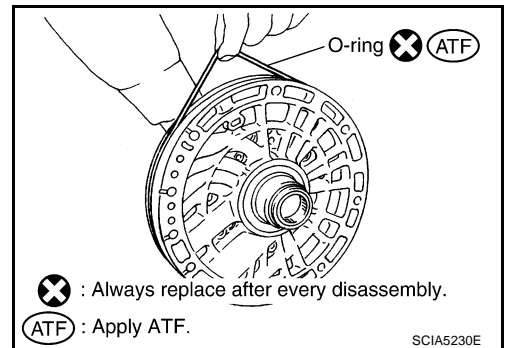

2. Install O-ring to oil pump housing.

### CAUTION:

- Do not reuse O-ring.
- Apply ATF to O-ring.

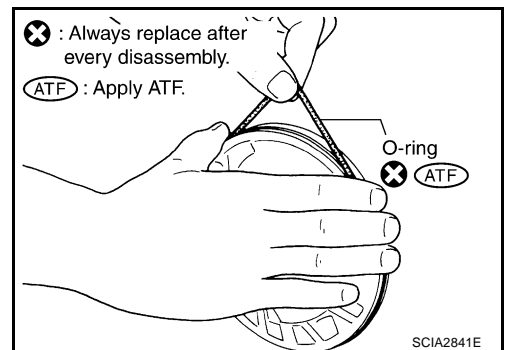

A  
B  
AT  
D  
E  
F  
G  
H  
I  
J  
K  
L  
M

## REPAIR FOR COMPONENT PARTS

3. Using the drift, install oil pump housing oil seal to the oil pump housing until it is flush.

**CAUTION:**

- Do not reuse oil pump housing oil seal.
- Apply ATF to oil pump housing oil seal.

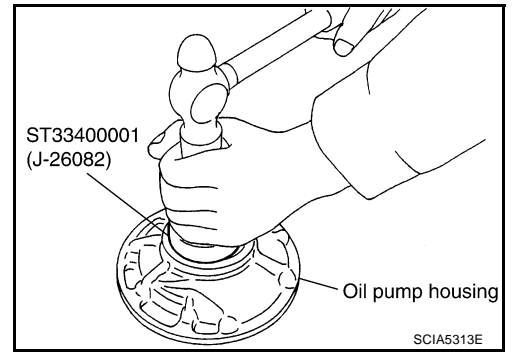

4. Install oil pump housing to oil pump cover.
5. Tighten bolts to the specified torque in numerical order shown in the figure after temporarily tightening them.

 : 9.0 N-m (0.92 kg-m, 80 in-lb.)

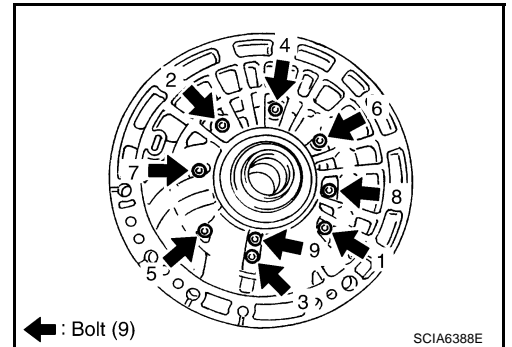



# REPAIR FOR COMPONENT PARTS

## Front Sun Gear, 3rd One-Way Clutch COMPONENTS

ACS008GS

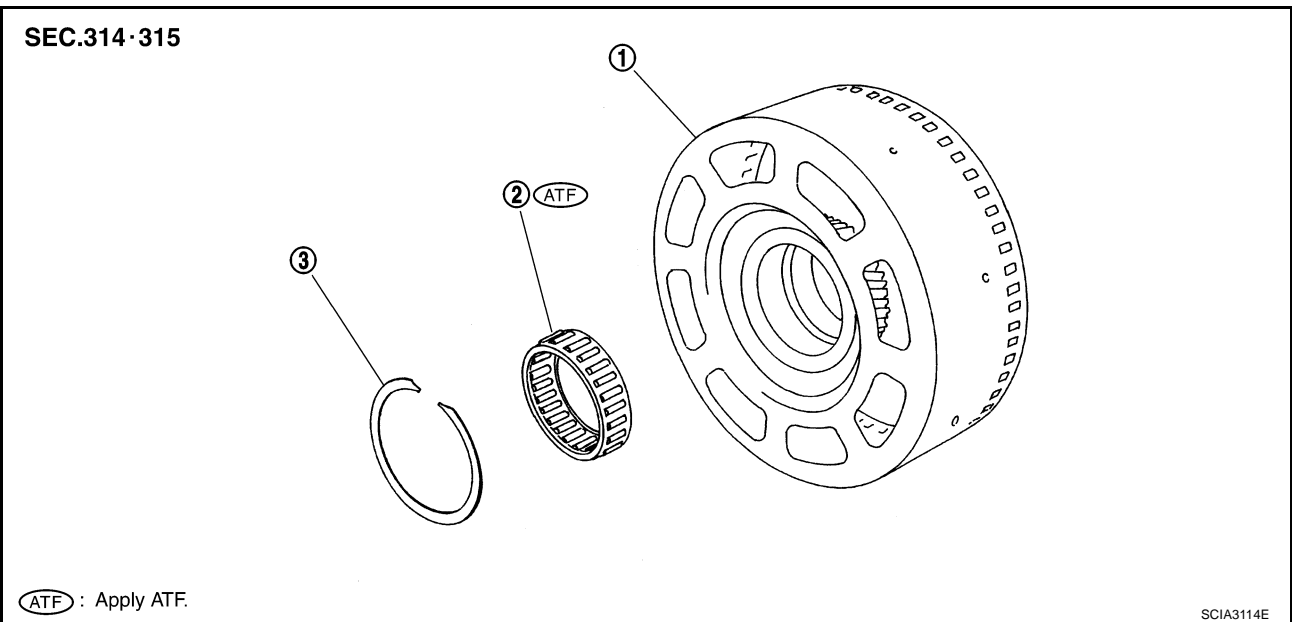

1. Front sun gear

2. 3rd one-way clutch

3. Snap ring

### DISASSEMBLY

1. Using a flat-bladed screwdriver, remove snap ring from front sun gear.

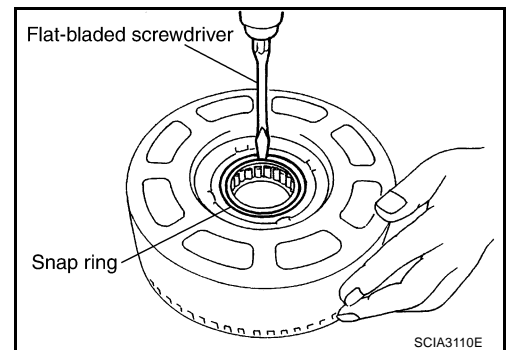

2. Remove 3rd one-way clutch from front sun gear.

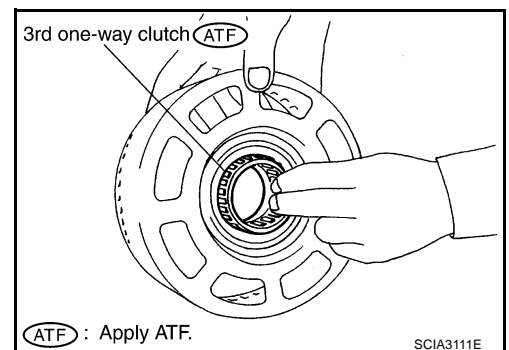

### INSPECTION

#### 3rd One-way Clutch

- Check frictional surface for wear or damage.

#### **CAUTION:**

If necessary, replace the 3rd one-way clutch.

A  
B  
AT  
D  
E  
F  
G  
H  
I  
J  
K  
L  
M

# REPAIR FOR COMPONENT PARTS

## Front Sun Gear Snap Ring

- Check for deformation, fatigue or damage.

**CAUTION:**

If necessary, replace the snap ring.

## Front Sun Gear

- Check for deformation, fatigue or damage.

**CAUTION:**

If necessary, replace the front sun gear.

## ASSEMBLY

1. Install 3rd one-way clutch in front sun gear.

**CAUTION:**

Apply ATF to 3rd one-way clutch.

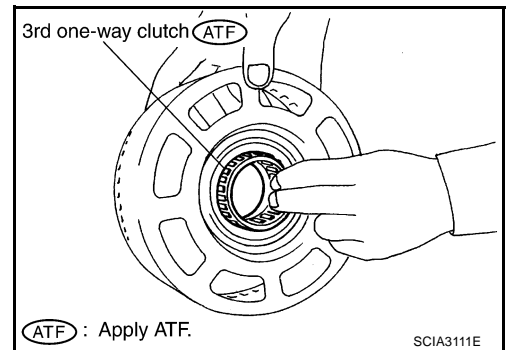

2. Using a flat-bladed screwdriver, install snap ring in front sun gear.

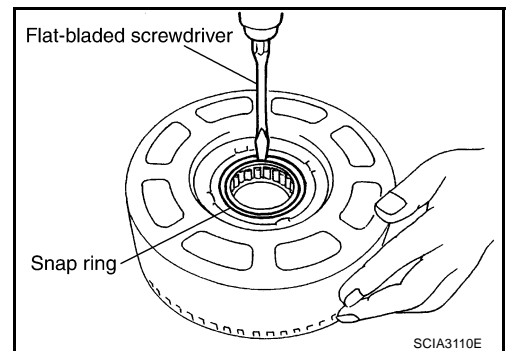

3. Check operation of 3rd one-way clutch.
  - a. Hold oil pump assembly and turn front sun gear.
  - b. Check 3rd one-way clutch for correct locking and unlocking directions.

**CAUTION:**

If not as shown in the figure, check installation direction of 3rd one-way clutch.

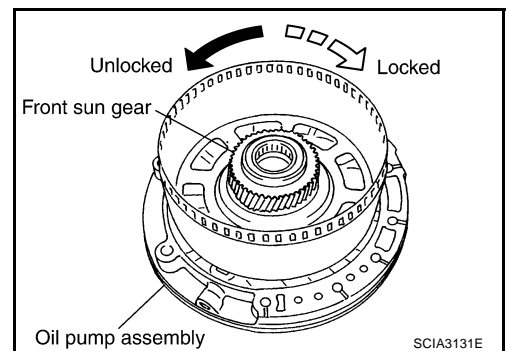

# REPAIR FOR COMPONENT PARTS

ACS008GT

## Front Carrier, Input Clutch, Rear Internal Gear COMPONENTS

A  
B  
AT  
D  
E  
F  
G  
H  
I  
J  
K  
L  
M

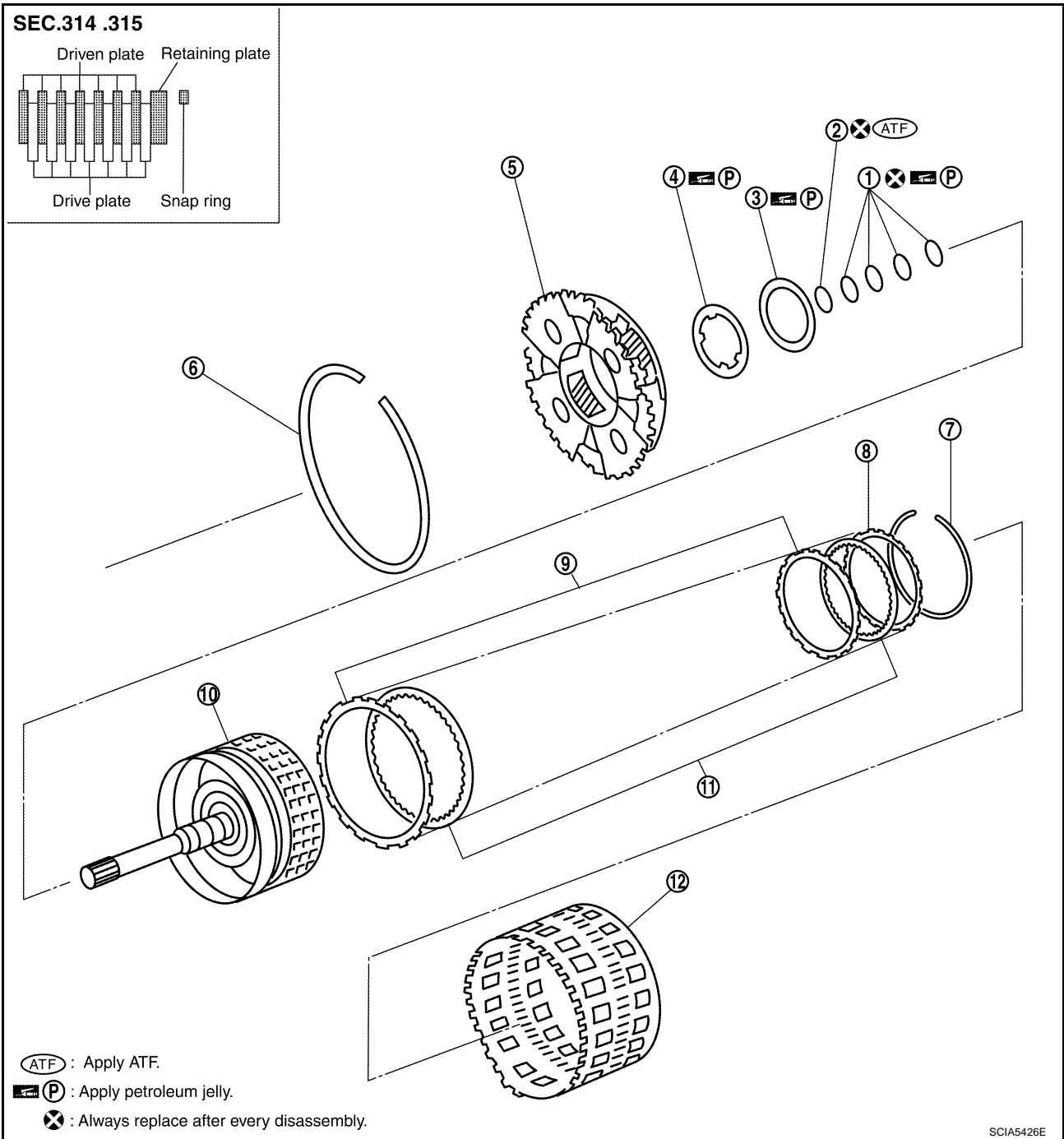

SCIA5426E

- |                       |                           |                        |
|-----------------------|---------------------------|------------------------|
| 1. Seal ring          | 2. O-ring                 | 3. Needle bearing      |
| 4. Bearing race       | 5. Front carrier assembly | 6. Snap ring           |
| 7. Snap ring          | 8. Retaining plate        | 9. Driven plate        |
| 10. Input clutch drum | 11. Drive plate           | 12. Rear internal gear |

# REPAIR FOR COMPONENT PARTS

## DISASSEMBLY

1. Compress snap ring using 2 flat-bladed screwdrivers.
2. Remove front carrier assembly and input clutch assembly from rear internal gear.
3. Remove front carrier assembly from input clutch assembly.

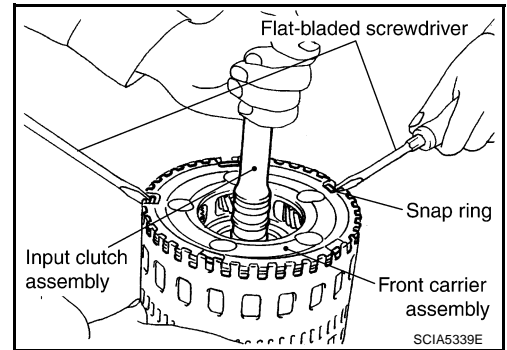

- a. Remove bearing race from front carrier assembly.

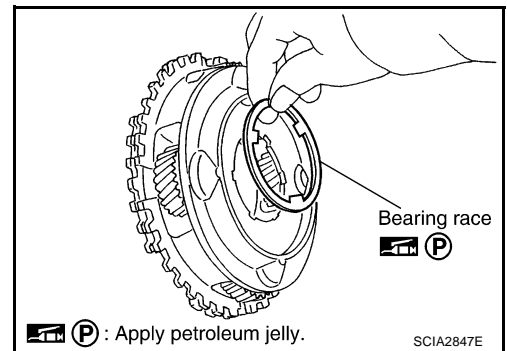

- b. Remove snap ring from front carrier assembly.

**CAUTION:**  
Do not expand snap ring excessively.

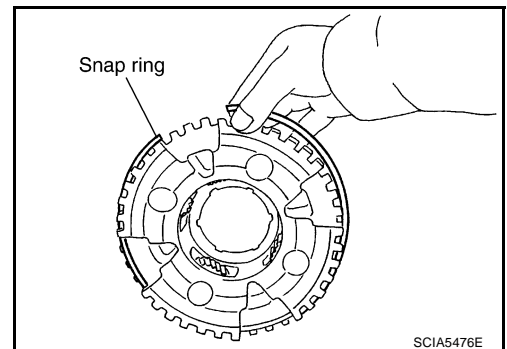

4. Disassemble input clutch assembly.

  - a. Remove O-ring and seal rings from input clutch assembly.

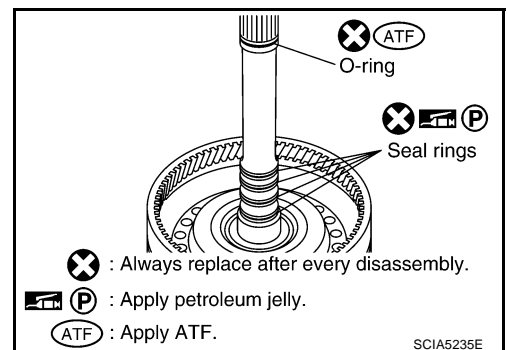

## REPAIR FOR COMPONENT PARTS

- b. Remove needle bearing from input clutch assembly.

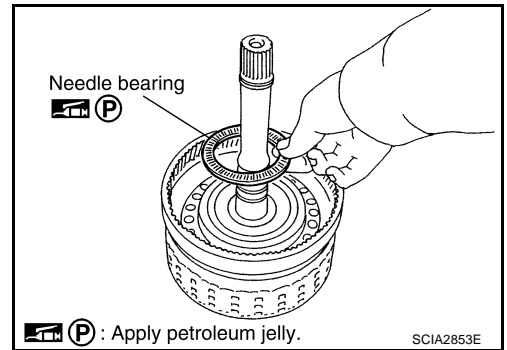

- c. Using a flat-bladed screwdriver, remove snap ring from input clutch drum.
- d. Remove drive plates, driven plates and retaining plate from input clutch drum.

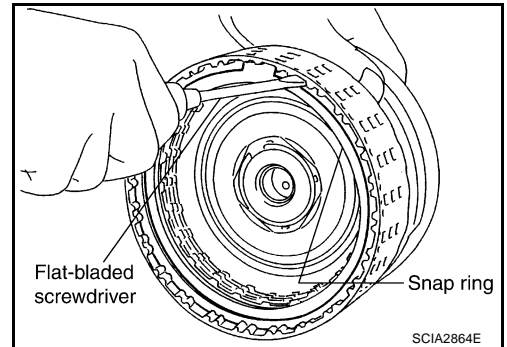

### INSPECTION

#### Front Carrier Snap Ring

- Check for deformation, fatigue or damage.

**CAUTION:**

If necessary, replace the snap ring.

#### Input Clutch Snap Ring

- Check for deformation, fatigue or damage.

**CAUTION:**

If necessary, replace the input clutch assembly.

#### Input Clutch Drum

- Check for deformation, fatigue or damage or burns.

**CAUTION:**

If necessary, replace the input clutch assembly.

#### Input Clutch Drive Plates

- Check facing for burns, cracks or damage.

**CAUTION:**

If necessary, replace the input clutch assembly.

#### Input Clutch Retaining Plate and Driven Plates

- Check facing for burns, cracks or damage.

**CAUTION:**

If necessary, replace the input clutch assembly.

#### Front Carrier

- Check for deformation, fatigue or damage.

**CAUTION:**

If necessary, replace the front carrier assembly.

#### Rear Internal Gear

- Check for deformation, fatigue or damage.

**CAUTION:**

If necessary, replace the rear internal gear.

## REPAIR FOR COMPONENT PARTS

### ASSEMBLY

1. Install input clutch.
  - a. Install drive plates, driven plates and retaining plate in input clutch drum.

**CAUTION:**

**Take care with order of plates.**

- b. Using a flat-bladed screwdriver, install snap ring in input clutch drum.

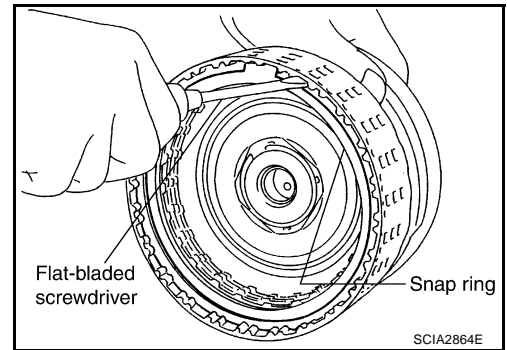

- c. Install needle bearing in input clutch assembly.

**CAUTION:**

**Apply petroleum jelly to needle bearing.**

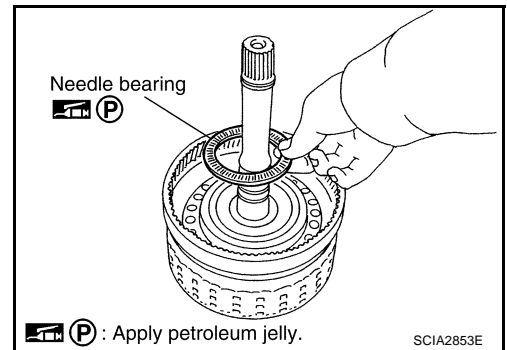

- d. Install O-ring and seal rings in input clutch assembly.

**CAUTION:**

- Do not reuse O-ring and seal rings.
- Apply ATF to O-ring.
- Apply petroleum jelly to seal rings.

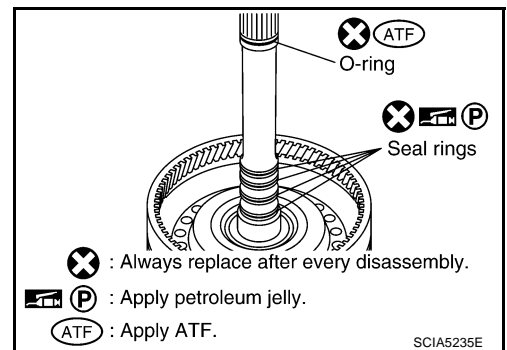

2. Install front carrier assembly.

- a. Install snap ring to front carrier assembly.

**CAUTION:**

**Do not expand snap ring excessively.**

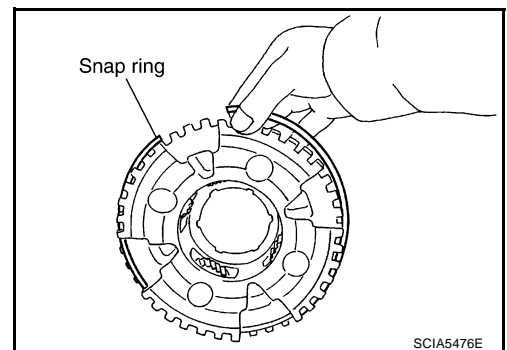

## REPAIR FOR COMPONENT PARTS

- b. Install bearing race in front carrier assembly.

**CAUTION:**

**Apply petroleum jelly to bearing race.**

- c. Install front carrier assembly to input clutch assembly.

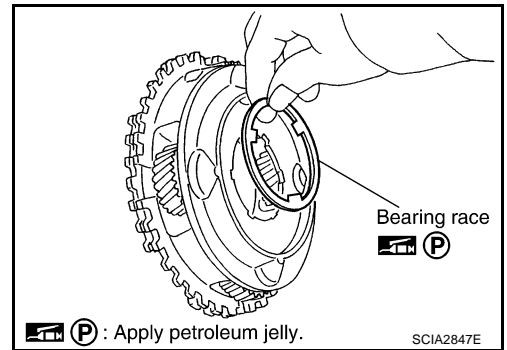

3. Compress snap ring using 2 flat-bladed screwdrivers.  
4. Install front carrier assembly and input clutch assembly to rear internal gear.

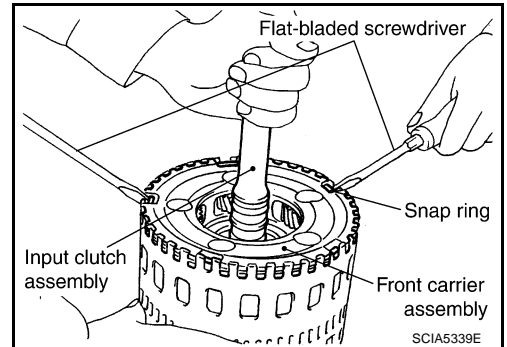

A  
B  
AT  
D  
E  
F  
G  
H  
I  
J  
K  
L  
M

# REPAIR FOR COMPONENT PARTS

## Mid Sun Gear, Rear Sun Gear, High and Low Reverse Clutch Hub COMPONENTS

ACS008GU

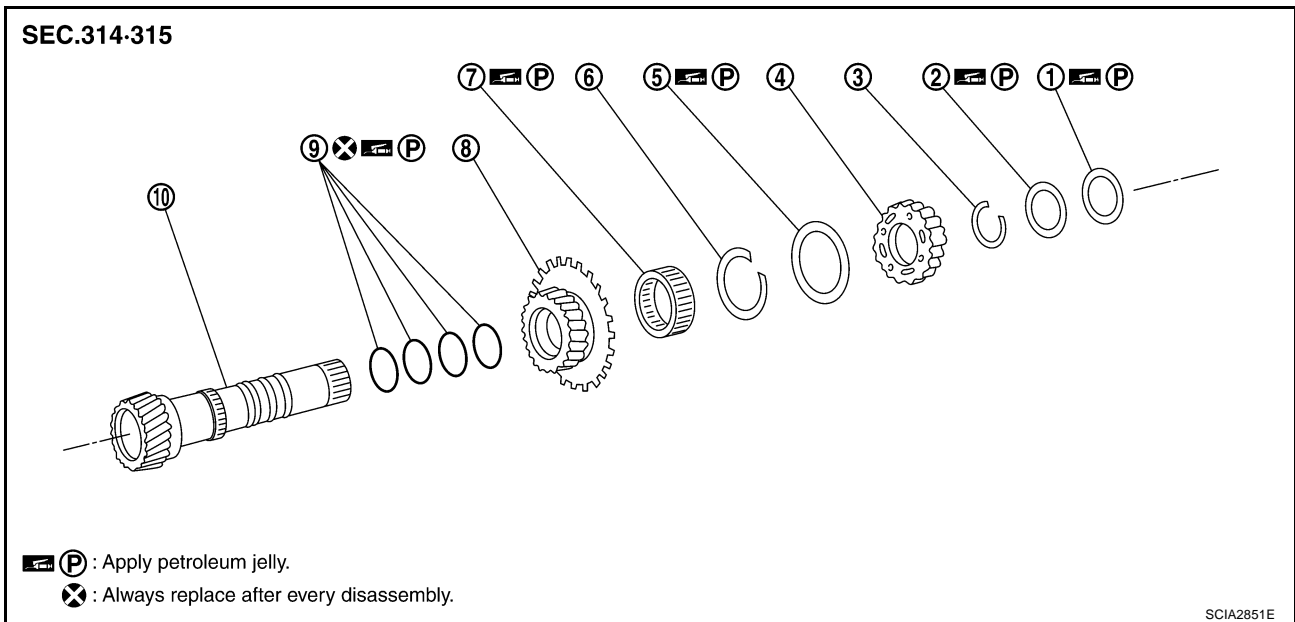

- |                                    |                   |              |
|------------------------------------|-------------------|--------------|
| 1. Needle bearing                  | 2. Bearing race   | 3. Snap ring |
| 4. High and low reverse clutch hub | 5. Needle bearing | 6. Snap ring |
| 7. 1st one-way clutch              | 8. Rear sun gear  | 9. Seal ring |
| 10. Mid sun gear                   |                   |              |

### DISASSEMBLY

1. Remove needle bearing and bearing race from high and low reverse clutch hub.

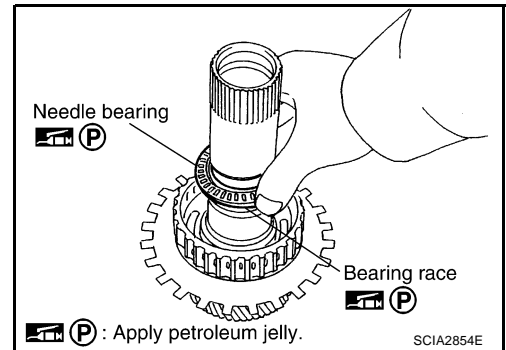

2. Using a pair of snap ring pliers, remove snap ring from mid sun gear assembly.

### CAUTION:

**Do not expand snap ring excessively.**

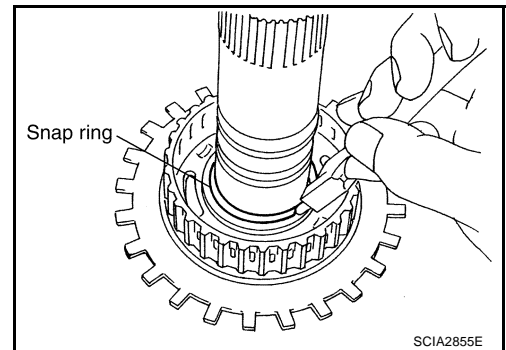



# REPAIR FOR COMPONENT PARTS

3. Remove high and low reverse clutch hub from mid sun gear assembly.

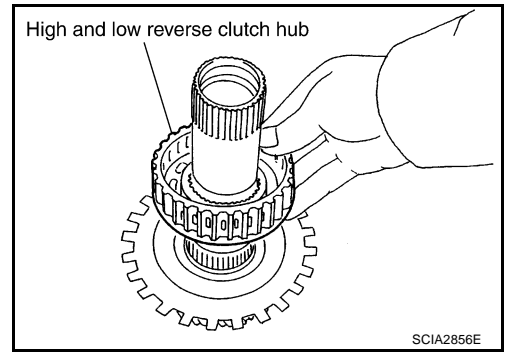

- a. Remove needle bearing from high and low reverse clutch hub.

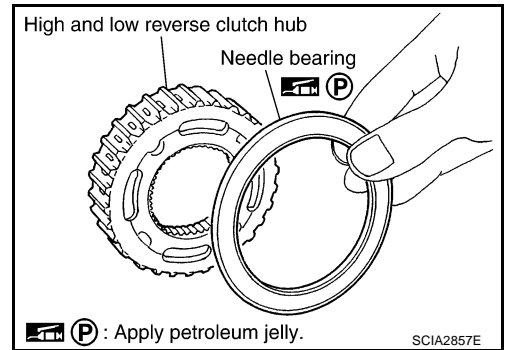

4. Remove rear sun gear assembly from mid sun gear assembly.

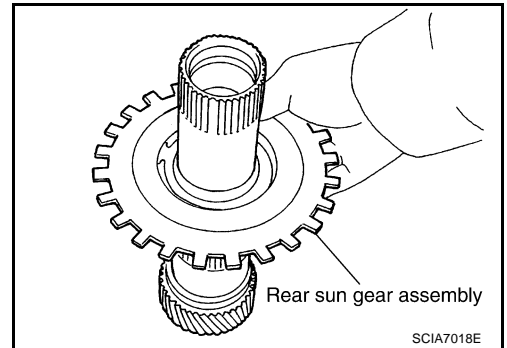

- a. Using a flat-bladed screwdriver, remove snap ring from rear sun gear.

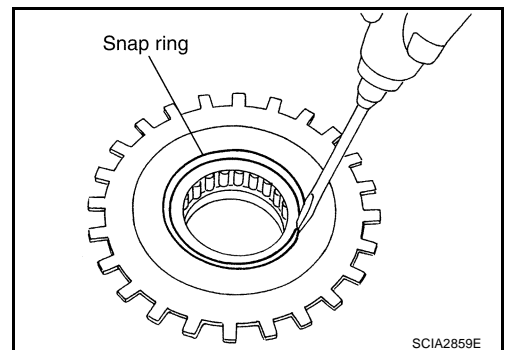

A  
B  
AT  
D  
E  
F  
G  
H  
I  
J  
K  
L  
M

## REPAIR FOR COMPONENT PARTS

- b. Remove 1st one-way clutch from rear sun gear.

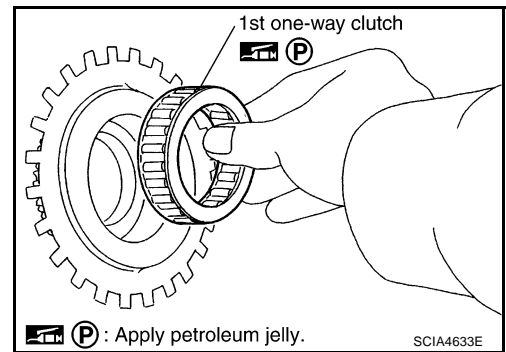

5. Remove seal rings from mid sun gear.

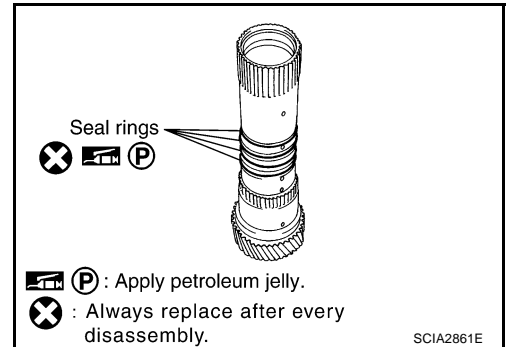

### INSPECTION

#### High and Low Reverse Clutch Hub Snap Ring, Rear Sun Gear Snap Ring

- Check for deformation, fatigue or damage.

**CAUTION:**

If necessary, replace the snap ring.

#### 1st One-way Clutch

- Check frictional surface for wear or damage.

**CAUTION:**

If necessary, replace the 1st one-way clutch.

#### Mid Sun Gear

- Check for deformation, fatigue or damage.

**CAUTION:**

If necessary, replace the mid sun gear.

#### Rear Sun Gear

- Check for deformation, fatigue or damage.

**CAUTION:**

If necessary, replace the rear sun gear.

#### High and Low Reverse Clutch Hub

- Check for deformation, fatigue or damage.

**CAUTION:**

If necessary, replace the high and low reverse clutch hub.

# REPAIR FOR COMPONENT PARTS

## ASSEMBLY

1. Install seal rings to mid sun gear.

**CAUTION:**

- Do not reuse seal rings.
- Apply petroleum jelly to seal rings.

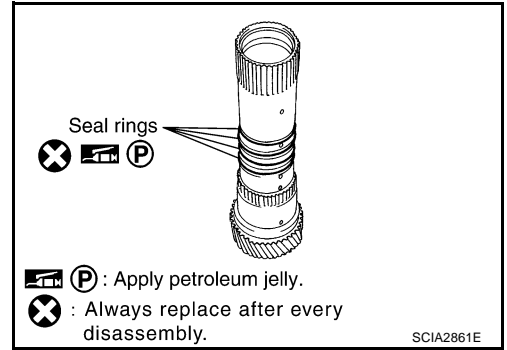

2. Install 1st one-way clutch to rear sun gear.

**CAUTION:**

- Apply petroleum jelly to 1st one-way clutch.

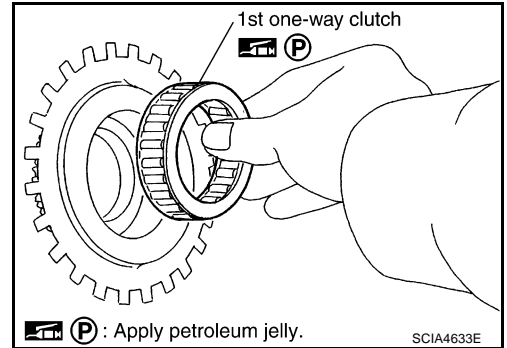

3. Using a flat-bladed screwdriver, install snap ring to rear sun gear.

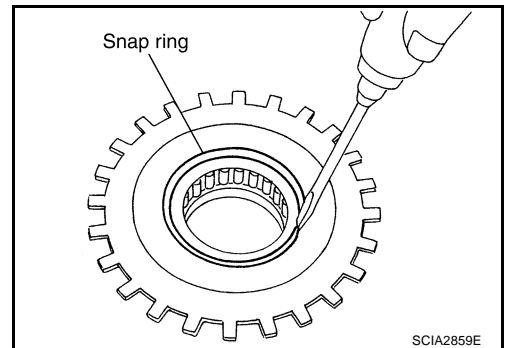

4. Install rear sun gear assembly to mid sun gear assembly.

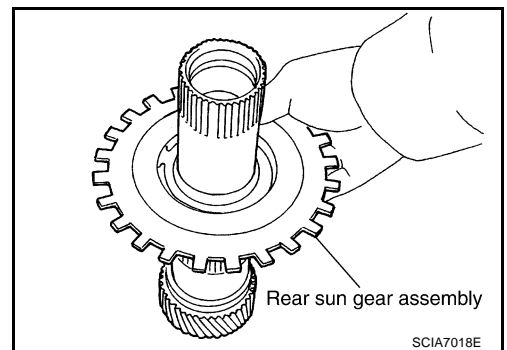

A  
B  
AT  
D  
E  
F  
G  
H  
I  
J  
K  
L  
M

## REPAIR FOR COMPONENT PARTS

5. Install needle bearing to high and low reverse clutch hub.

**CAUTION:**  
Apply petroleum jelly to needle bearing.

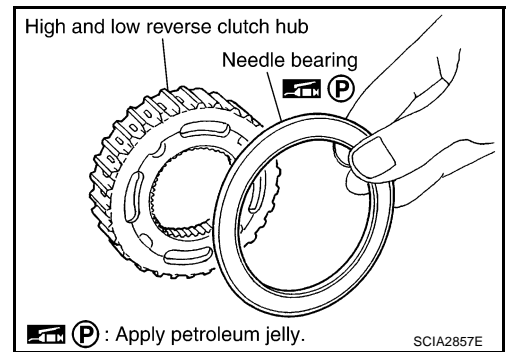

6. Install high and low reverse clutch hub to mid sun gear assembly.

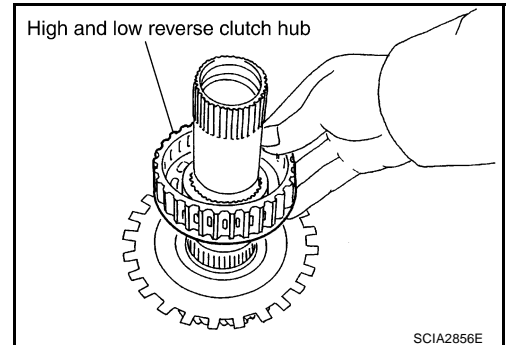

7. Using a pair of snap ring pliers, install snap ring to mid sun gear assembly.

**CAUTION:**  
Do not expand snap ring excessively.

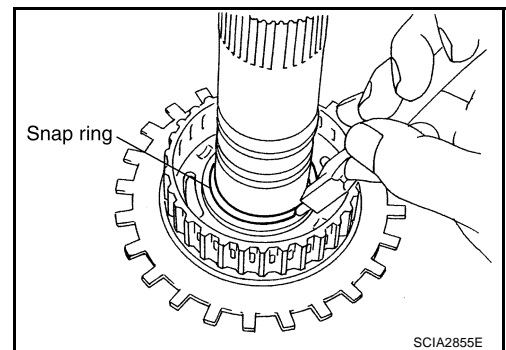

8. Check operation of 1st one-way clutch.

- a. Hold mid sun gear and turn rear sun gear.  
b. Check 1st one-way clutch for correct locking and unlocking directions.

**CAUTION:**  
If not as shown in the figure, check installation direction of 1st one-way clutch.

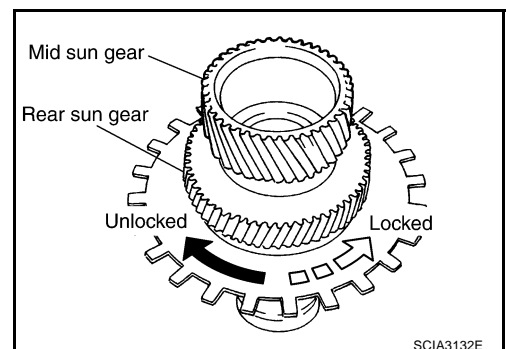

9. Install needle bearing and bearing race to high and low reverse clutch hub.

**CAUTION:**  
Apply petroleum jelly to needle bearing and bearing race.

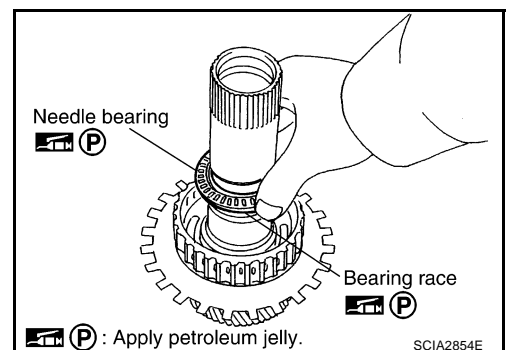

# REPAIR FOR COMPONENT PARTS

ACS008GV

## High and Low Reverse Clutch COMPONENTS

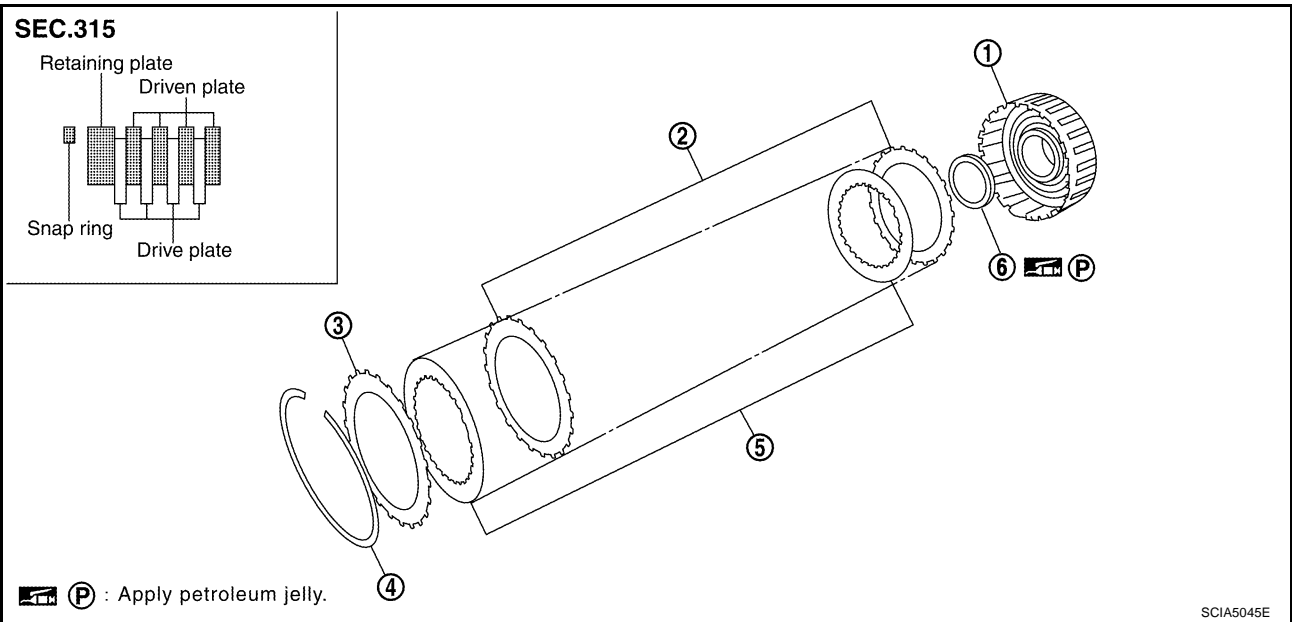

- |                                     |                 |                    |
|-------------------------------------|-----------------|--------------------|
| 1. High and low reverse clutch drum | 2. Driven plate | 3. Retaining plate |
| 4. Snap ring                        | 5. Drive plate  | 6. Bearing race    |

### DISASSEMBLY

1. Remove bearing race from high and low reverse clutch drum.

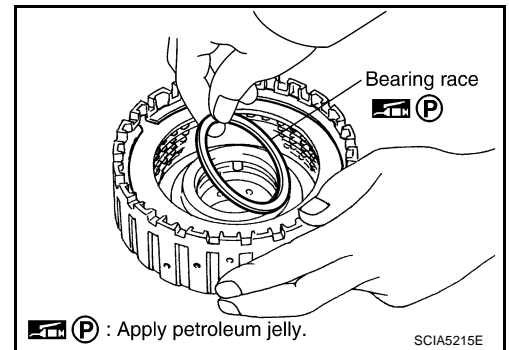

2. Using a flat-bladed screwdriver, remove snap ring from high and low reverse clutch drum.
3. Remove drive plates, driven plates and retaining plate from high and low reverse clutch drum.

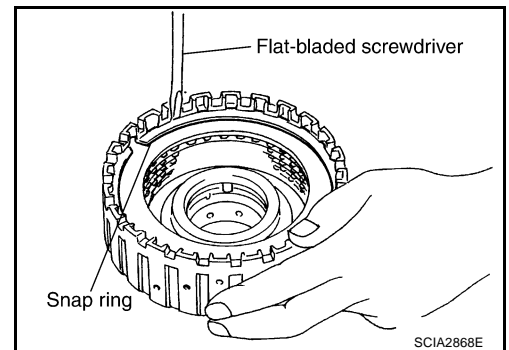

A  
B  
AT  
D  
E  
F  
G  
H  
I  
J  
K  
L  
M

# REPAIR FOR COMPONENT PARTS

## INSPECTION

- Check the following, and replace high and low reverse clutch assembly if necessary.

### High and Low Reverse Clutch Snap Ring

- Check for deformation, fatigue or damage.

### High and Low Reverse Clutch Drive Plates

- Check facing for burns, cracks or damage.

### High and Low Reverse Clutch Retaining Plate and Driven Plates

- Check facing for burns, cracks or damage.

## ASSEMBLY

1. Install drive plates, driven plates and retaining plate in high and low reverse clutch drum.

### CAUTION:

Take care with order of plates.

2. Using a flat-bladed screwdriver, install snap ring in high and low reverse clutch drum.

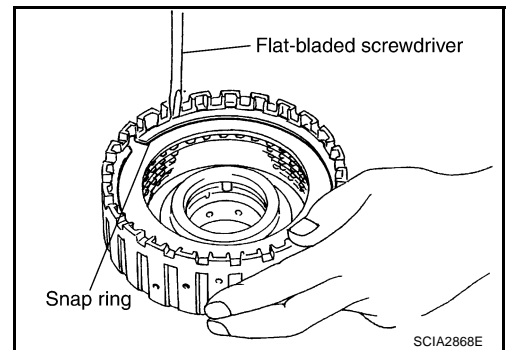

3. Install bearing race to high and low reverse clutch drum.

### CAUTION:

Apply petroleum jelly to bearing race.

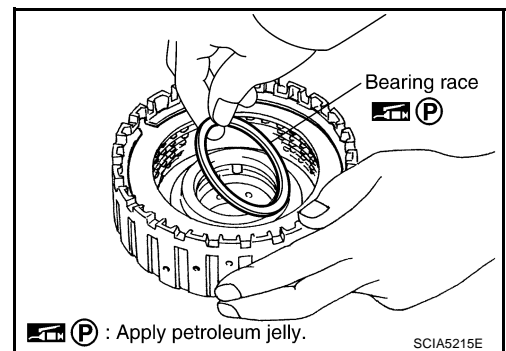

# REPAIR FOR COMPONENT PARTS

ACS008GW

## Direct Clutch COMPONENTS

A

B

AT

D

E

F

G

H

I

J

K

L

M

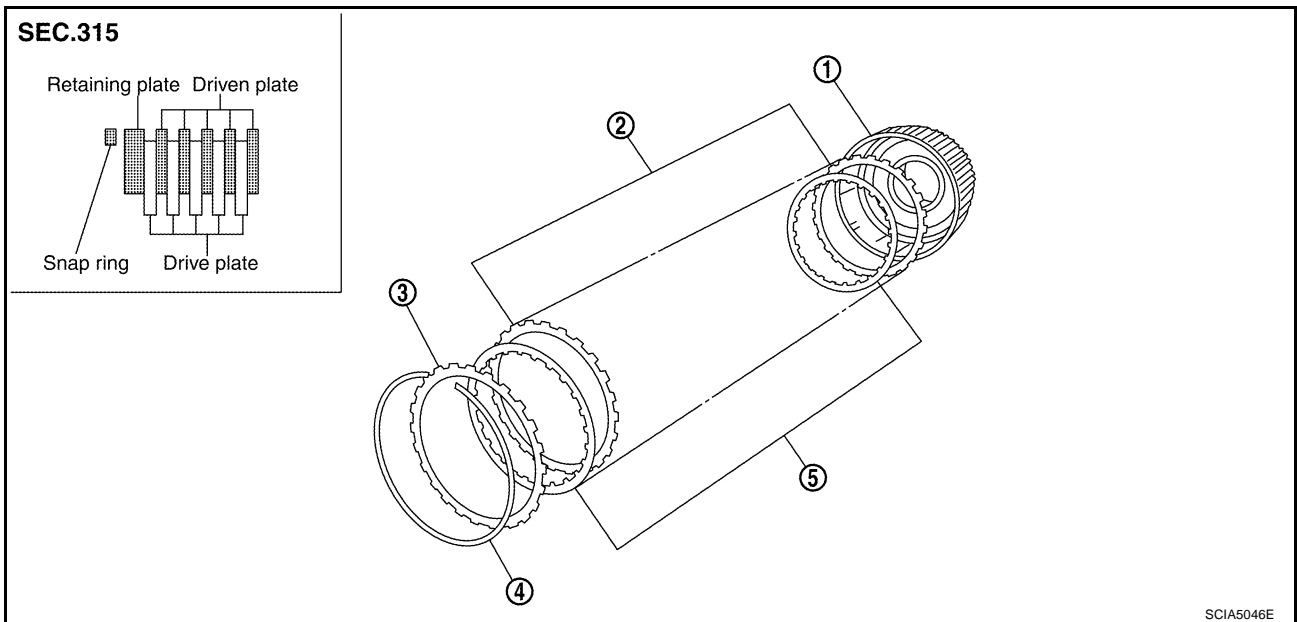

1. Direct clutch drum

2. Driven plate

3. Retaining plate

4. Snap ring

5. Drive plate

## DISASSEMBLY

1. Using a flat-bladed screwdriver, remove snap ring from direct clutch drum.
2. Remove drive plates, driven plates and retaining plate from direct clutch drum.

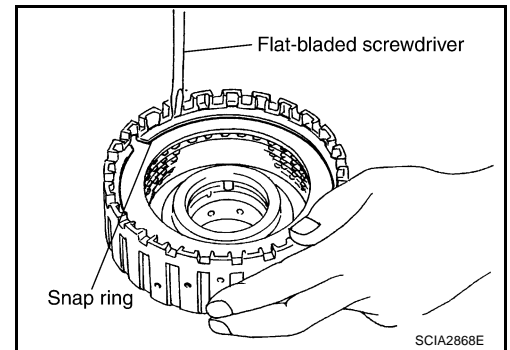

## INSPECTION

- Check the following, and replace direct clutch assembly if necessary.

### Direct Clutch Snap Ring

- Check for deformation, fatigue or damage.

### Direct Clutch Drive Plates

- Check facing for burns, cracks or damage.

### Direct Clutch Retaining Plate and Driven Plates

- Check facing for burns, cracks or damage.

## REPAIR FOR COMPONENT PARTS

### ASSEMBLY

1. Install drive plates, driven plates and retaining plate in direct clutch drum.

**CAUTION:**

**Take care with order of plates.**

2. Using a flat-bladed screwdriver, install snap ring in direct clutch drum.

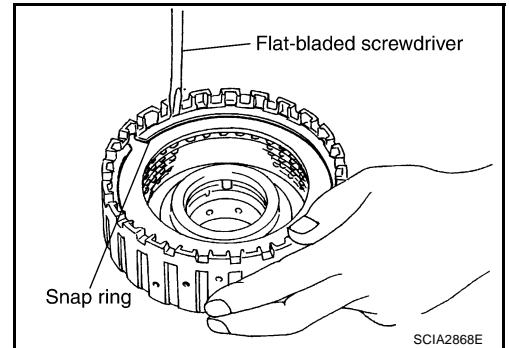



# ASSEMBLY

## ASSEMBLY

PF0:00000

### Assembly (1)

ACS008GX

1. As shown in the right figure, use a drift [commercial service tool: 22 mm (0.87 in) dia.] to drive manual shaft oil seals into the transmission case until it is flush.

**CAUTION:**

- Apply ATF to manual shaft oil seals.
- Do not reuse manual shaft oil seals.

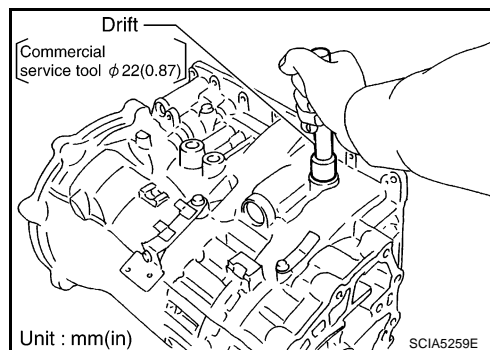

2. Install detent spring and spacer in transmission case.

 : 7.9 N·m (0.81 kg·m, 70 in·lb)

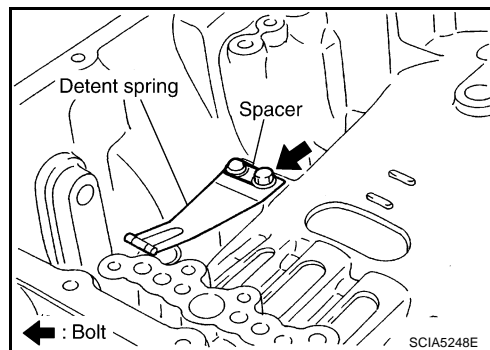

3. Install manual shaft to transmission case.

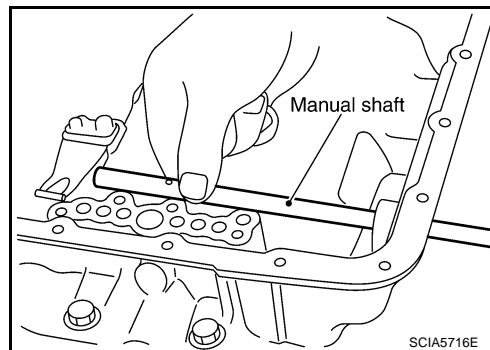

4. Install parking rod to manual plate.

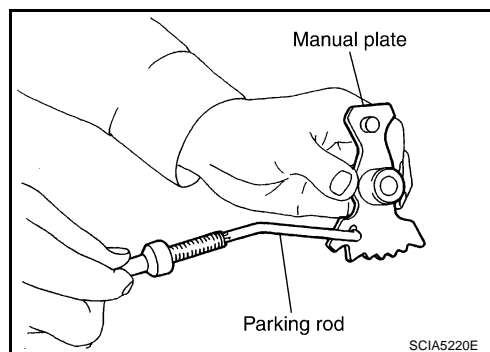

A  
B  
AT  
D  
E  
F  
G  
H  
I  
J  
K  
L  
M

# ASSEMBLY

5. Install manual plate (with parking rod) to manual shaft.

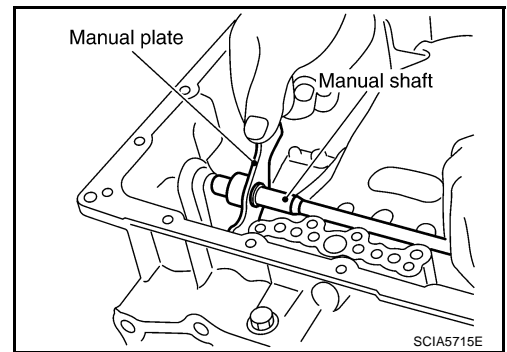

6. Install retaining pin into the manual plate and manual shaft.  
a. Fit pinhole of the manual plate to pinhole of the manual shaft with a pin punch.  
b. Use a hammer to tap the retaining pin into the manual plate.

**CAUTION:**

- Drive retaining pin to  $2\pm 0.5$  mm ( $0.08\pm 0.020$  in) over the manual plate.
- Do not reuse retaining pin.

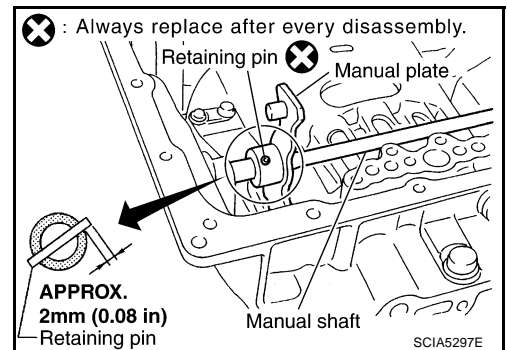

7. Install retaining pin into the transmission case and manual shaft.  
a. Fit pinhole of the transmission case to pinhole of the manual shaft with a pin punch.  
b. Use a hammer to tap the retaining pin into the transmission case.

**CAUTION:**

- Drive retaining pin to  $5\pm 1$  mm ( $0.20\pm 0.04$  in) over the transmission case.
- Do not reuse retaining pin.

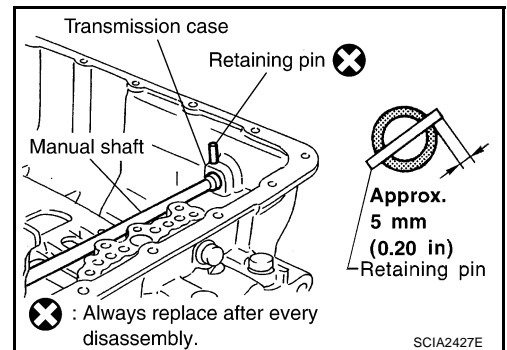

8. Install O-rings to servo assembly.

**CAUTION:**

- Do not reuse O-rings.
- Apply petroleum jelly to O-rings.

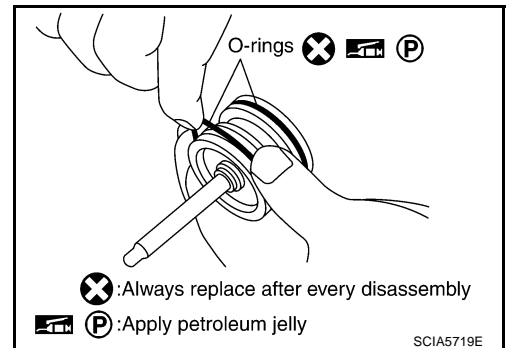

# ASSEMBLY

9. Install return spring to servo assembly.

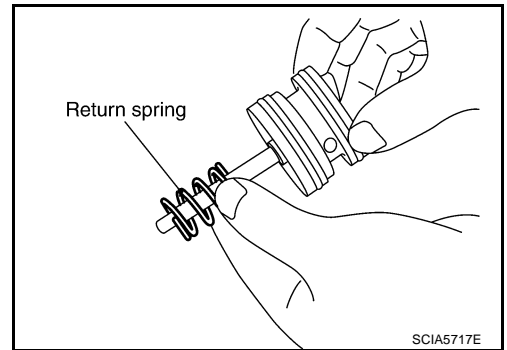

10. Install servo assembly in transmission case.

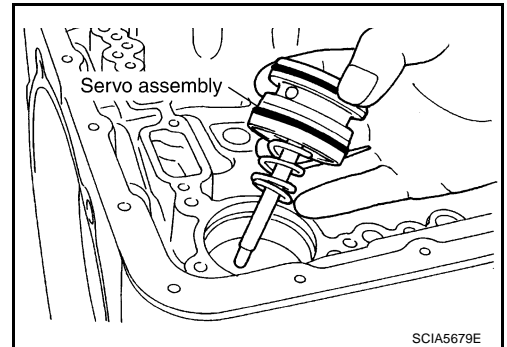

11. Using a pair of snap ring pliers, install snap ring to transmission case.

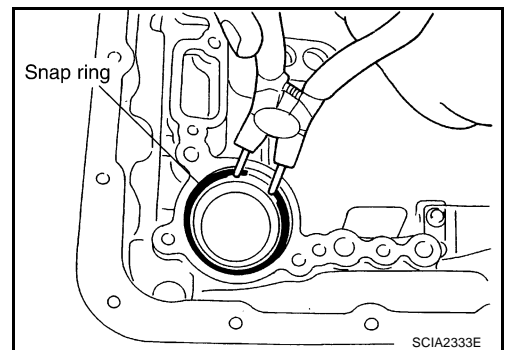

12. Install D-rings in reverse brake piston.

**CAUTION:**

- Do not reuse D-rings.
- Apply ATF to D-rings.

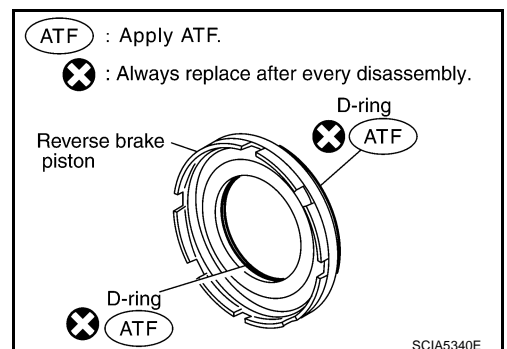

13. Install reverse brake piston in transmission case.

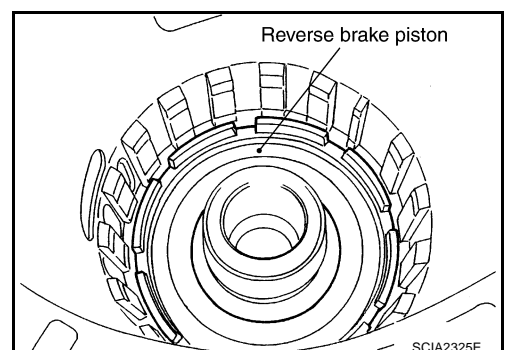

A  
B  
AT  
D  
E  
F  
G  
H  
I  
J  
K  
L  
M

# ASSEMBLY

14. Install needle bearing to drum support edge surface.

**CAUTION:**

**Apply petroleum jelly to needle bearing.**

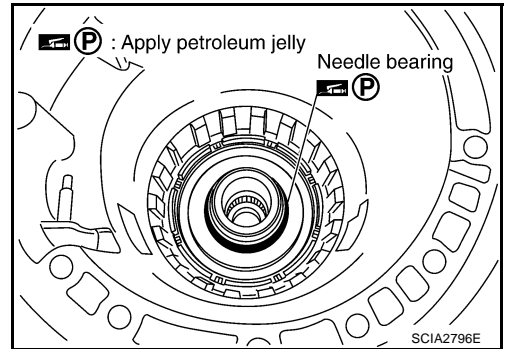

15. Install seal rings to drum support.

**CAUTION:**

- Do not reuse seal rings.
- Apply petroleum jelly to seal rings.

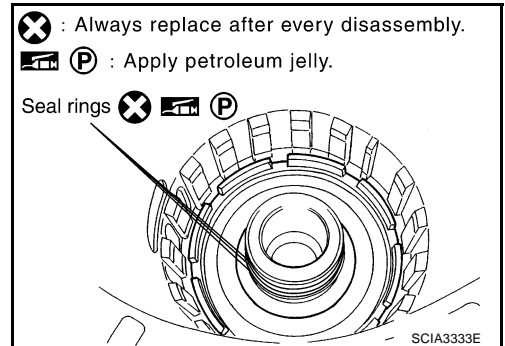

16. Install spring retainer and return spring in transmission case.

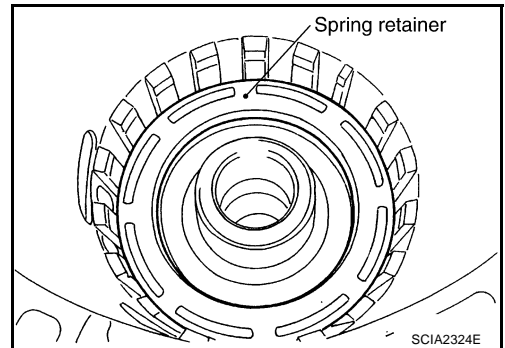

17. Set the SST on spring retainer and install snap ring (fixing spring retainer) in transmission case while compressing return spring.

**CAUTION:**

**Securely assemble them using a flat-bladed screwdriver so that snap ring tension is slightly weak.**

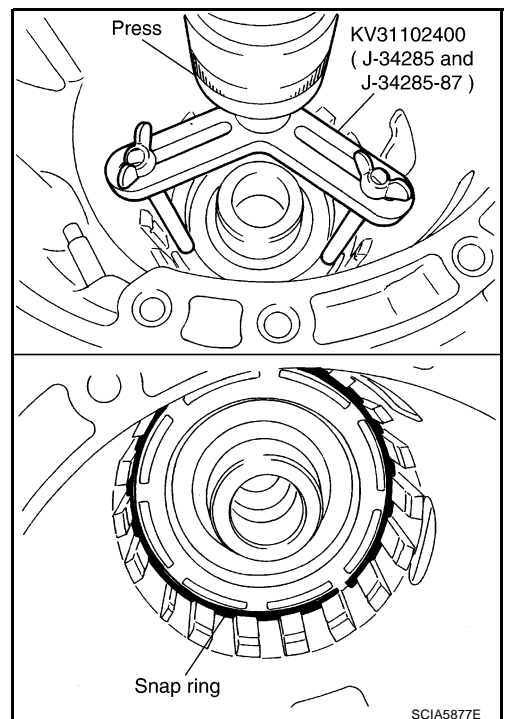

# ASSEMBLY

18. Install reverse brake drive plates, driven plates and dish plate in transmission case.

**CAUTION:**

Take care with order of plates.

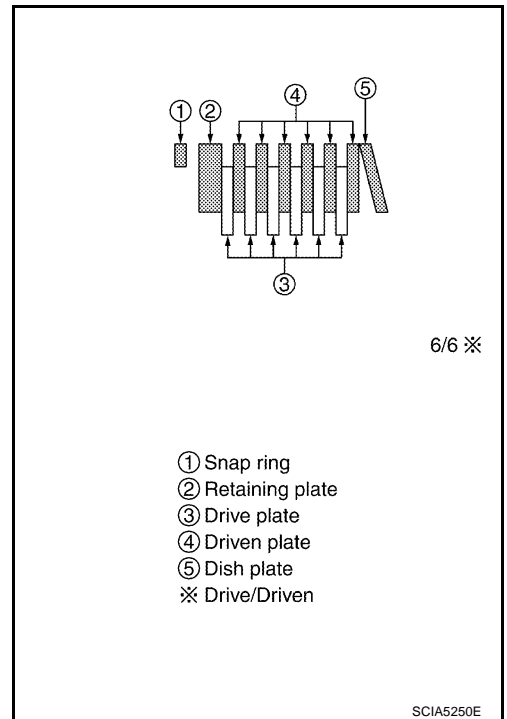

19. Assemble N-spring.

20. Install reverse brake retaining plate in transmission case.

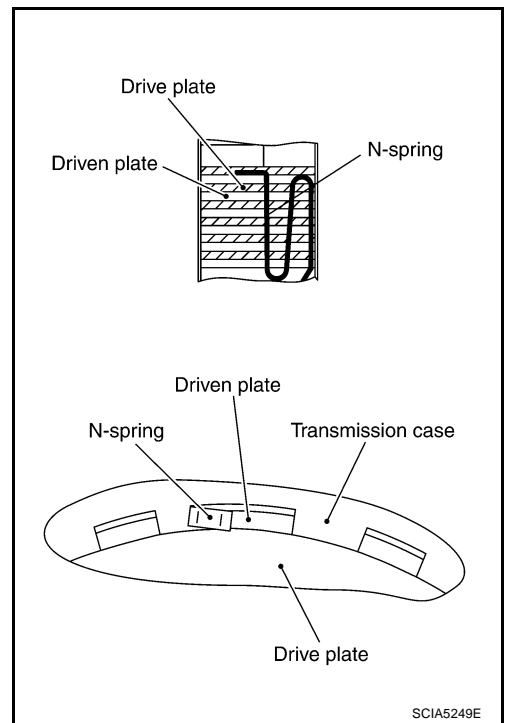

21. Install snap ring in transmission case.

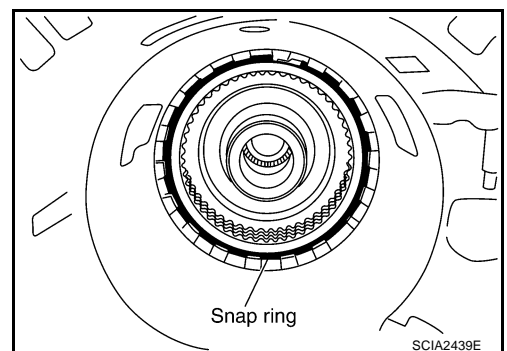

A  
B  
AT  
D  
E  
F  
G  
H  
I  
J  
K  
L  
M

# ASSEMBLY

22. Measure clearance between retaining plate and snap ring. If not within specified clearance, select proper retaining plate.

**Specified clearance "A":**

**Standard: 0.7 - 1.1mm (0.028 - 0.043 in)**

**Retaining plate:**

**Refer to [AT-354, "Reverse Brake"](#) .**

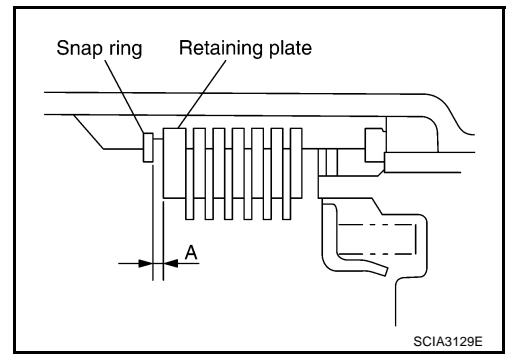

23. Install needle bearing to transmission case.

**CAUTION:**

- Apply petroleum jelly to needle bearing.

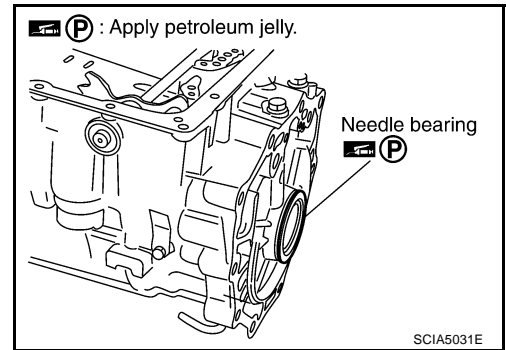

24. Install revolution sensor to transmission case.

**CAUTION:**

- Do not subject it to impact by dropping or hitting it.
- Do not disassemble.
- Do not allow metal filings, etc., to get on the sensor's front edge magnetic area.
- Do not place in an area affected by magnetism.

 : 5.8 N·m (0.59 kg-m, 51 in-lb)

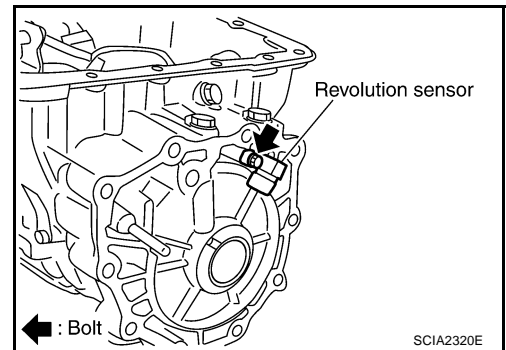

25. As shown in the right figure, use the drift to drive rear oil seal into the rear extension (2WD models) or adapter case (AWD models) until it is flush.

**CAUTION:**

- Do not reuse rear oil seal.
- Apply ATF to rear oil seal.

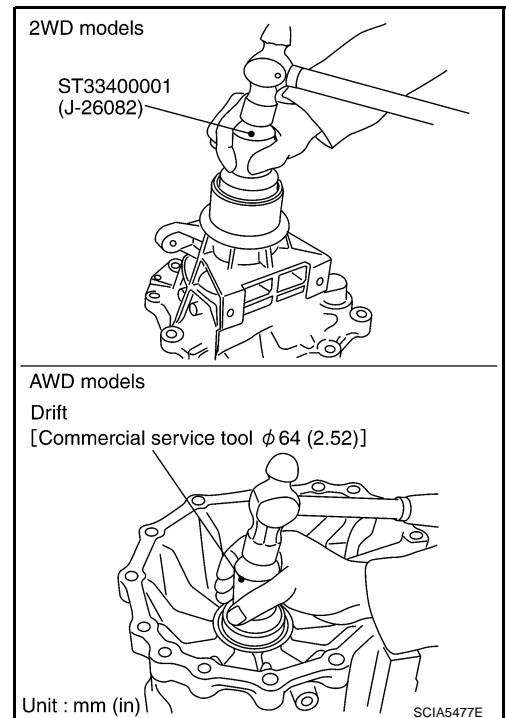

# ASSEMBLY

26. Install return spring to parking pawl.

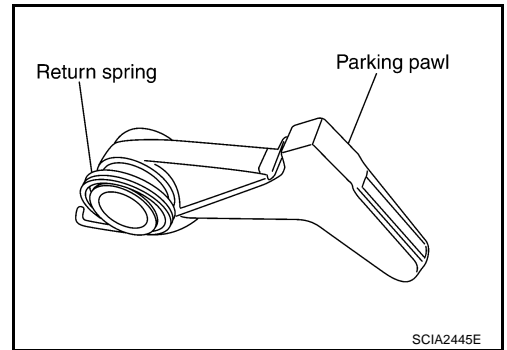

27. Install parking pawl (with return spring) and pawl shaft to rear extension (2WD models) or adapter case (AWD models).

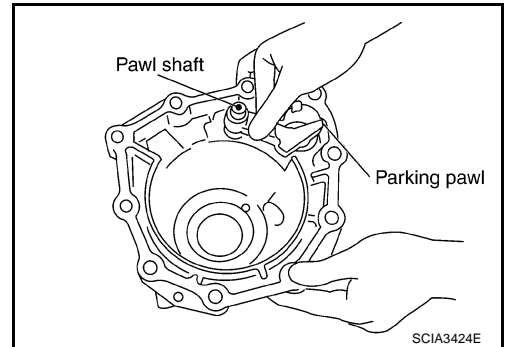

28. Install parking actuator support to rear extension (2WD models) or adapter case (AWD models).

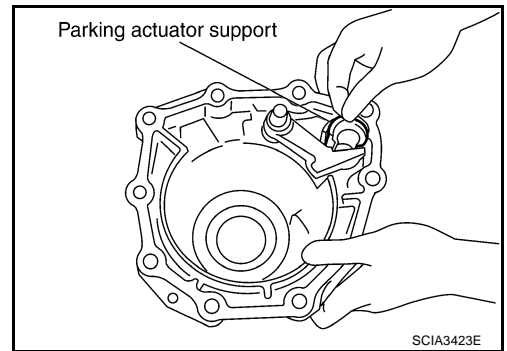

29. Install needle bearing to rear extension (2WD models) or adapter case (AWD models).

**CAUTION:**  
Apply petroleum jelly to needle bearing.

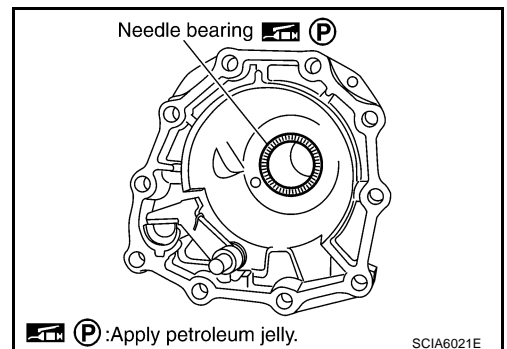

**P** : Apply petroleum jelly.

30. Install seal rings to output shaft.

**CAUTION:**

- Do not reuse seal rings.
- Apply petroleum jelly to seal rings.

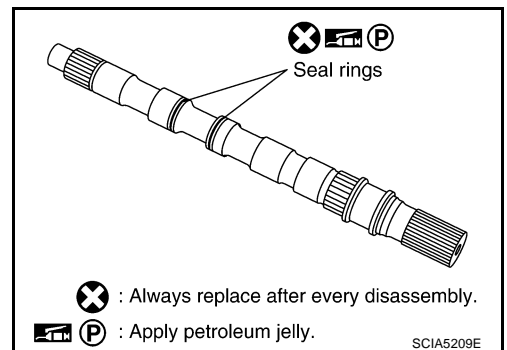

: Always replace after every disassembly.

**P** : Apply petroleum jelly.

A  
B  
AT  
D  
E  
F  
G  
H  
I  
J  
K  
L  
M

# ASSEMBLY

31. Install parking gear to output shaft.

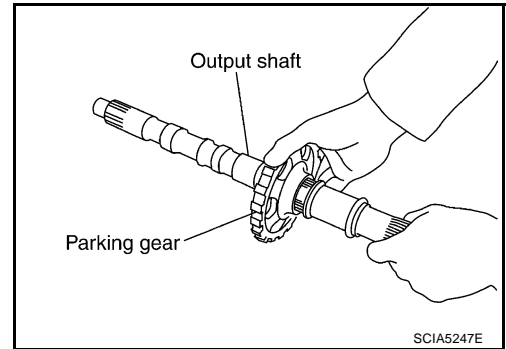

32. Install output shaft in transmission case.

**CAUTION:**

Be careful not to mistake front for rear because both sides looks similar. (Thinner end is front side.)

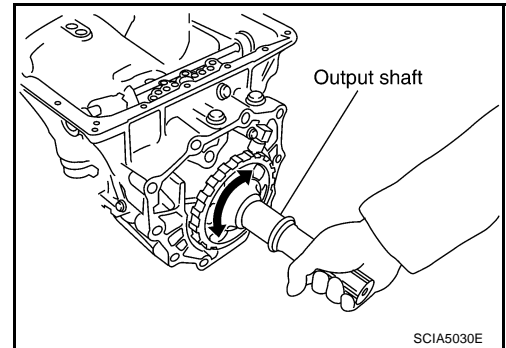

33. Install bearing race to output shaft.

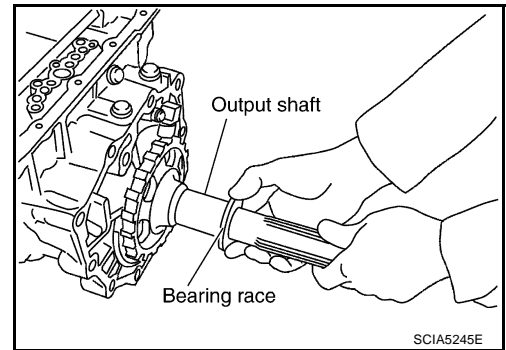

34. Install rear extension assembly (2WD models) or adapter case assembly (AWD models) according to the following procedures.

a. **2WD models**

i. Apply recommended sealant (Genuine Anaerobic Liquid Gasket or equivalent. Refer to [GI-47, "Recommended Chemical Products and Sealants"](#) .) to rear extension assembly as shown in the figure.

**CAUTION:**

Completely remove all moisture, oil and old sealant, etc. from the transmission case and rear extension assembly mounting surfaces.

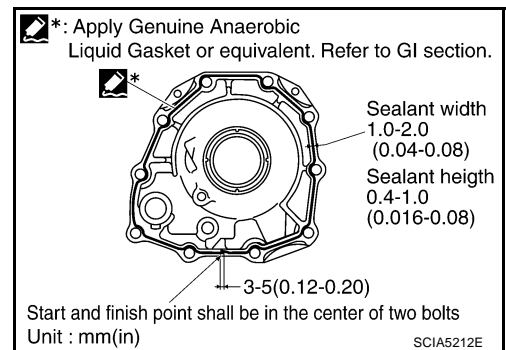



# ASSEMBLY

- ii. Install rear extension assembly to transmission case.

**CAUTION:**

Insert the tip of parking rod between the parking pawl and the parking actuator support when assembling the rear extension assembly.

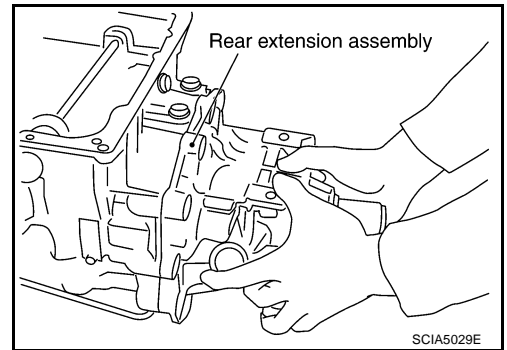

- iii. Tighten rear extension assembly mounting bolts to specified torque.

**CAUTION:**

Do not reuse self-sealing bolt.

**Rear extension assembly mounting bolt:**

 : 52 N·m (5.3 kg-m, 38 ft-lb)

**Self-sealing bolt:**

 : 61 N·m (6.2 kg-m, 45 ft-lb)

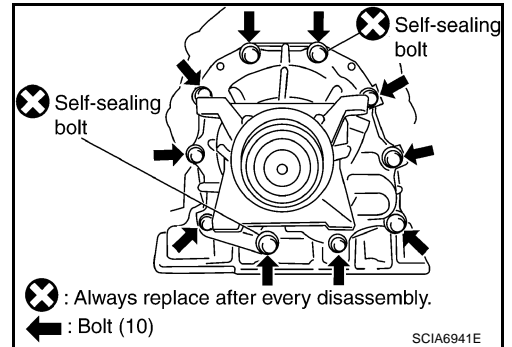

- b. AWD models

- i. Install gasket onto transmission case.

**CAUTION:**

- Completely remove all moisture, oil and old gasket, etc. from the transmission case and adapter case assembly mounting surfaces.
- Do not reuse gasket.

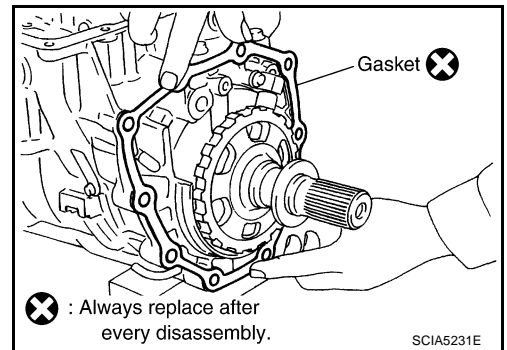

- ii. Install adapter case assembly to transmission case.

**CAUTION:**

Insert the tip of parking rod between the parking pawl and the parking actuator support when assembling the adapter case assembly.

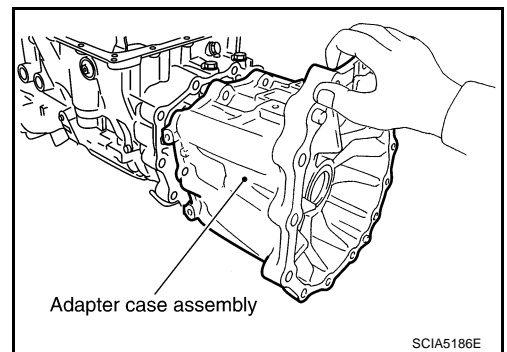

A  
B  
AT  
D  
E  
F  
G  
H  
I  
J  
K  
L  
M

# ASSEMBLY

- iii. Tighten adapter case assembly bolts (1) to the specified torque.  
[With bracket (2).]  
←: Bolt (10)

**CAUTION:**

**Do not reuse self-sealing bolts (3).**

Refer to GI section to mark sure icons (symbol marks) in the figure. Refer to [GI-10, "Components"](#) .

**Adapter case assembly mounting bolt:**

 : 52 N·m (5.3 kg-m, 38 ft-lb)

**Self-sealing bolt:**

 : 61 N·m (6.2 kg-m, 45 ft-lb)

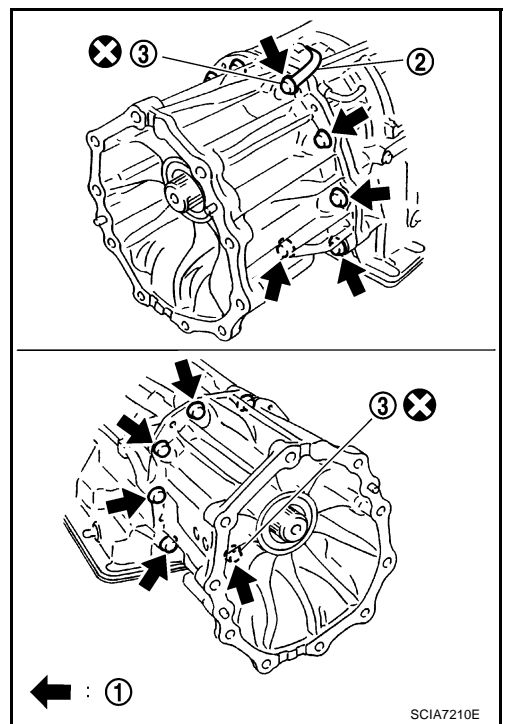

35. Install needle bearing in drum support.

**CAUTION:**

**Apply petroleum jelly to needle bearing.**

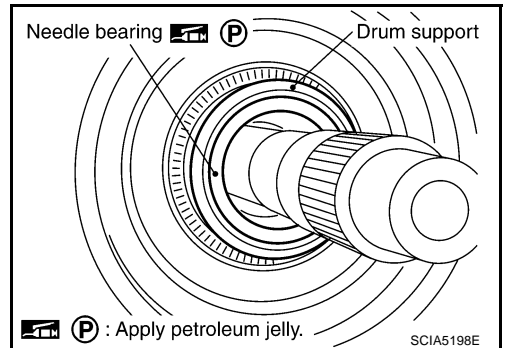

36. Install direct clutch assembly in reverse brake.

**CAUTION:**

**Make sure that drum support edge surface and direct clutch inner boss edge surface come to almost same place.**

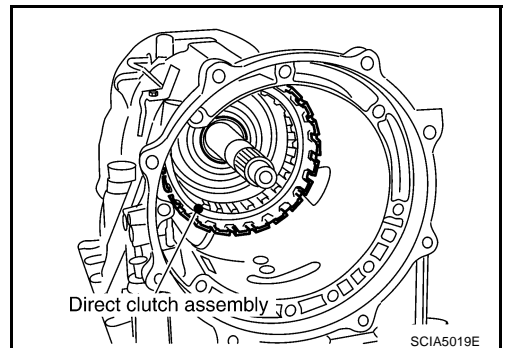

37. Install high and low reverse clutch assembly in direct clutch.

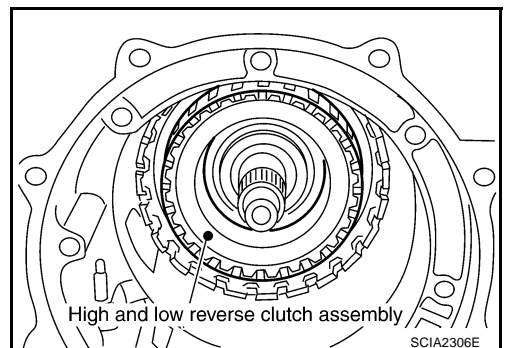

# ASSEMBLY

38. Using a flat-bladed screwdriver, align the drive plate.

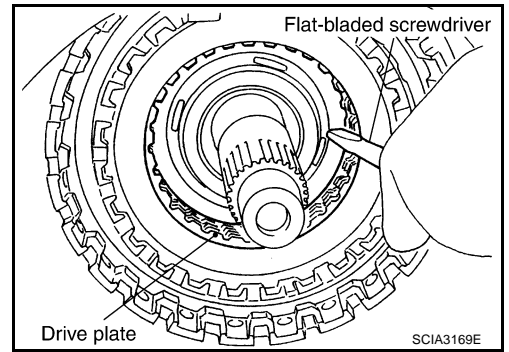

39. Install high and low reverse clutch hub, mid sun gear assembly and rear sun gear assembly as a unit.

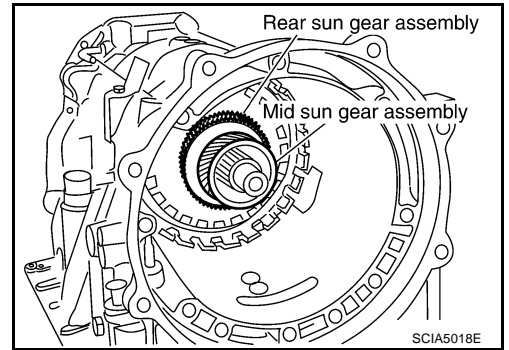

## CAUTION:

Make sure that portion "A" of high and low reverse clutch drum protrudes approximately 2 mm (0.08 in) beyond portion "B" of rear sun gear.

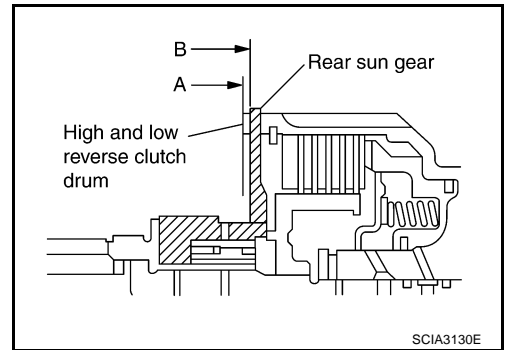

40. Install needle bearing in rear carrier assembly.

## CAUTION:

Apply petroleum jelly to needle bearing.

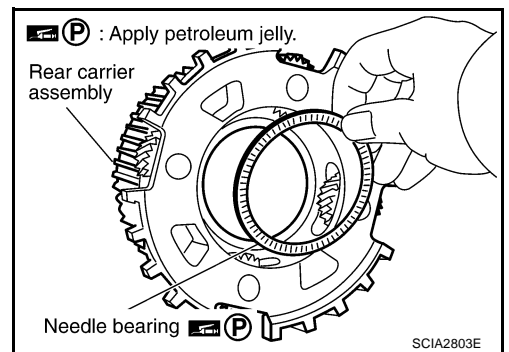

A  
B  
AT  
D  
E  
F  
G  
H  
I  
J  
K  
L  
M

# ASSEMBLY

41. Install bearing race in rear carrier assembly.

**CAUTION:**

**Apply petroleum jelly to bearing race.**

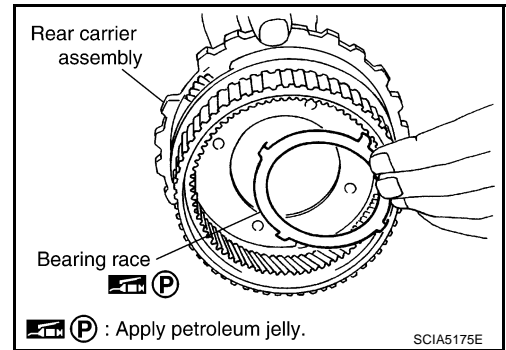

42. Install rear carrier assembly in direct clutch drum.

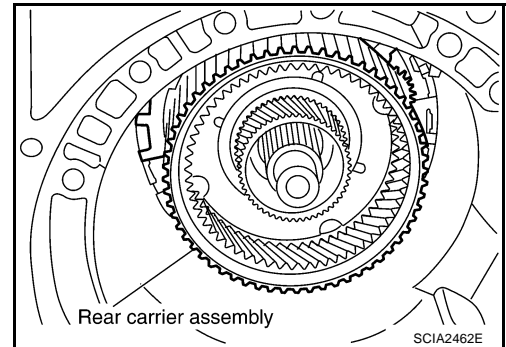

43. Install needle bearing (rear side) to mid carrier assembly.

**CAUTION:**

**Apply petroleum jelly to needle bearing.**

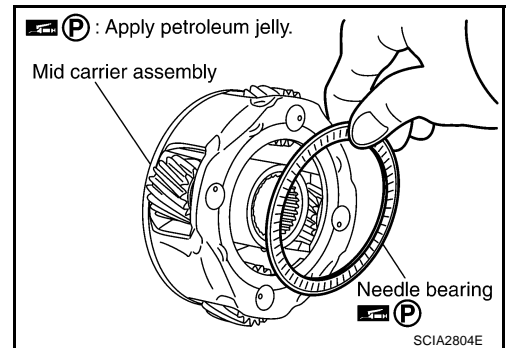

44. Install needle bearing (front side) to mid carrier assembly.

**CAUTION:**

**Apply petroleum jelly to needle bearing.**

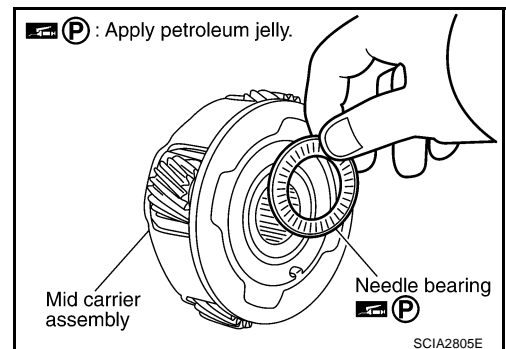

45. Install mid carrier assembly in rear carrier assembly.

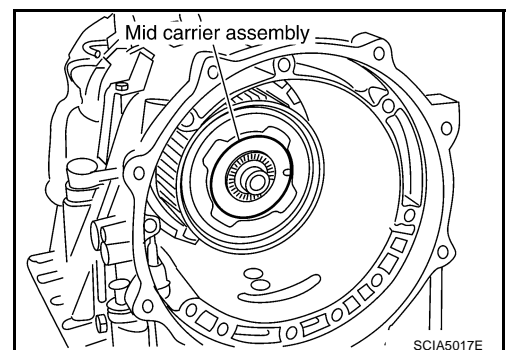

# ASSEMBLY

46. Install front carrier assembly, input clutch assembly and rear internal gear as a unit.

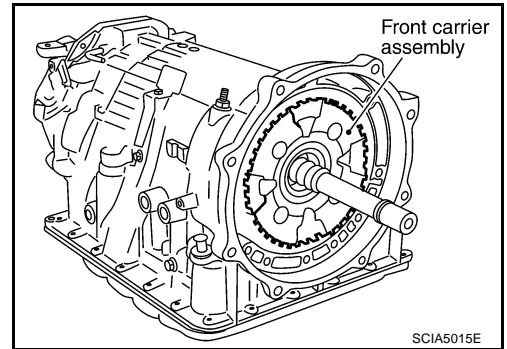

47. Install seal rings in input clutch assembly.

**CAUTION:**

- Do not reuse seal rings.
- Apply petroleum jelly to seal rings.

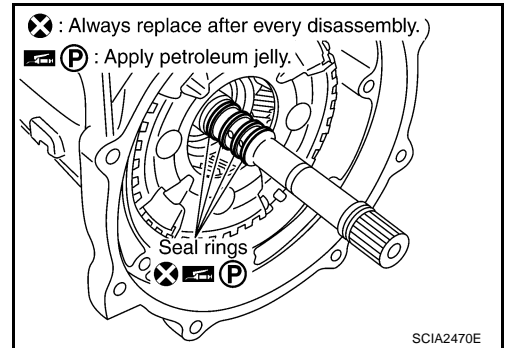

48. Install band servo anchor end pin and lock nut in transmission case.

**CAUTION:**

- Do not reuse band servo anchor end pin.

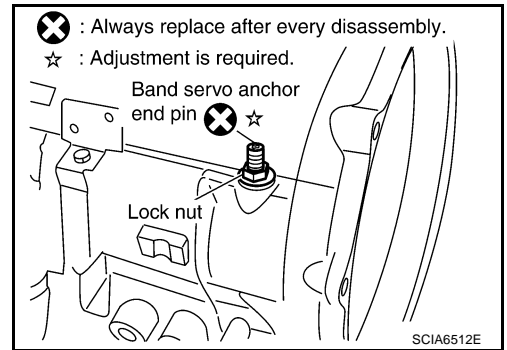

49. Install brake band in transmission case.

**CAUTION:**

- Assemble it so that identification to avoid incorrect installation faces servo side.

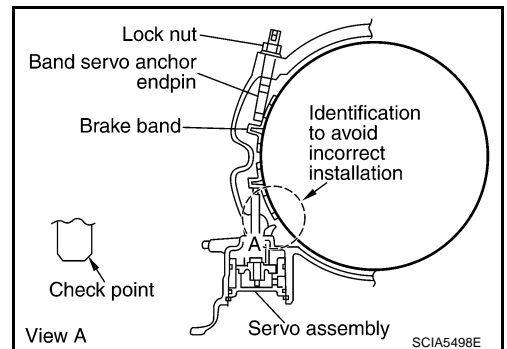

50. Install front sun gear to front carrier assembly.

**CAUTION:**

- Apply ATF to front sun gear bearing and 3rd one-way clutch end bearing.

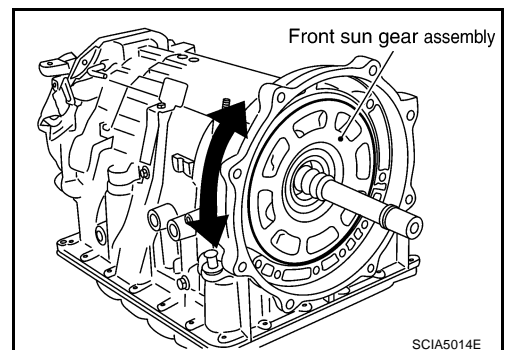

A  
B  
AT  
D  
E  
F  
G  
H  
I  
J  
K  
L  
M

# ASSEMBLY

51. Install needle bearing to front sun gear.

**CAUTION:**  
Apply petroleum jelly to needle bearing.

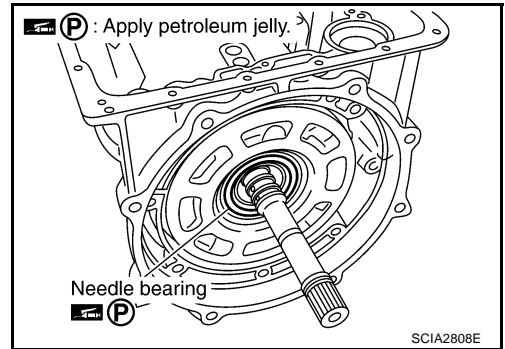

52. Adjust brake band tilting using a clips so that brake band contacts front sun gear drum evenly.

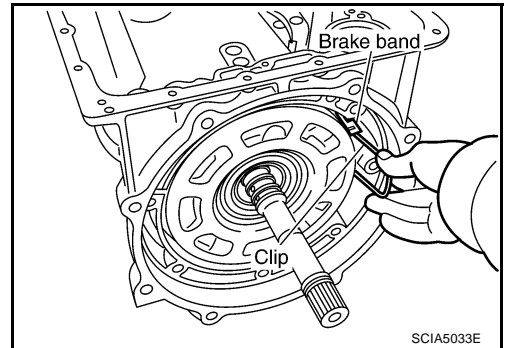

53. Adjust brake band.

- Loosen lock nut.
- Tighten band servo anchor end pin to specified torque.

 : 5.0 N·m (0.51 kg-m, 44 in-lb)

- Back of band servo anchor end pin three turns.
- Holding band servo anchor end pin, tighten lock nut to specified torque.

 : 46 N·m (4.7 kg-m, 34 ft-lb)

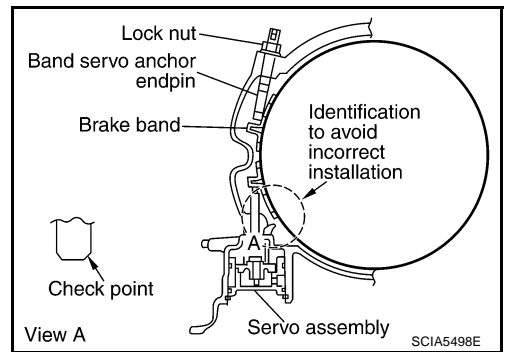

## Adjustment TOTAL END PLAY

- Measure clearance between front sun gear and bearing race for oil pump cover.
- Select proper thickness of bearing race so that end play is within specifications.

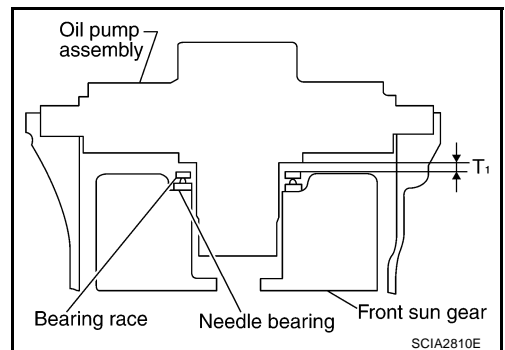

# ASSEMBLY

1. Measure dimensions "K" and "L" and then calculate dimension "J".

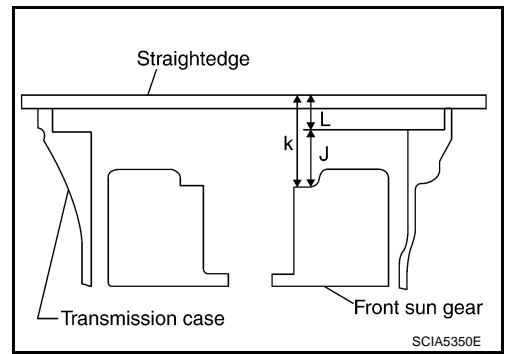

- a. Measure dimension "K".

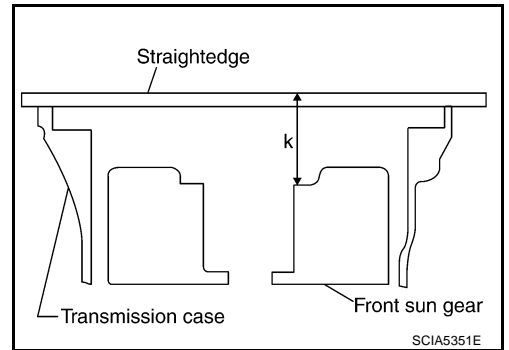

- b. Measure dimension "L".
- c. Calculate dimension "J".

**"J": Distance between oil pump fitting surface of transmission case and needle bearing mating surface of front sun gear.**

$$J = K - L$$

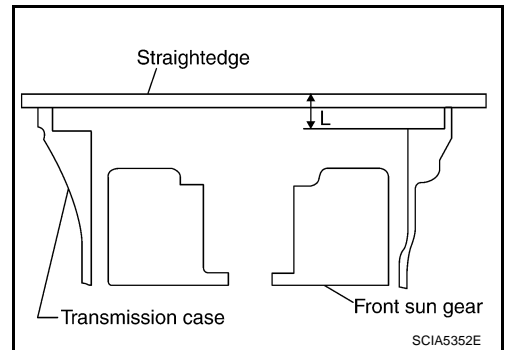

2. Measure dimensions "M1" and "M2" and then calculate dimension "M".

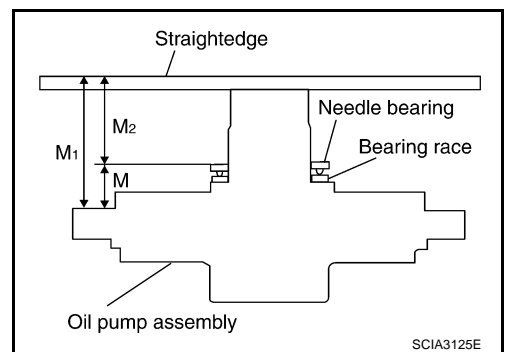

- a. Place bearing race and needle bearing on oil pump assembly.

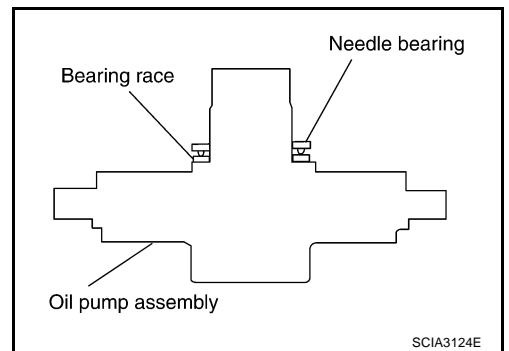

A  
B  
AT  
D  
E  
F  
G  
H  
I  
J  
K  
L  
M

# ASSEMBLY

b. Measure dimension "M1".

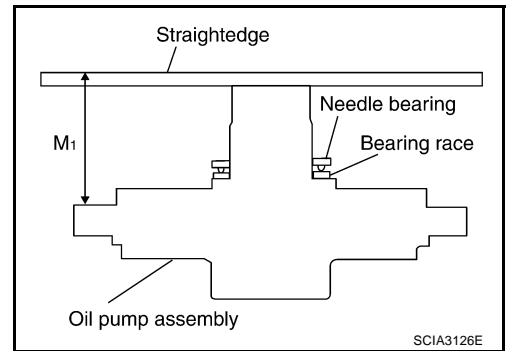

c. Measure dimension "M2".

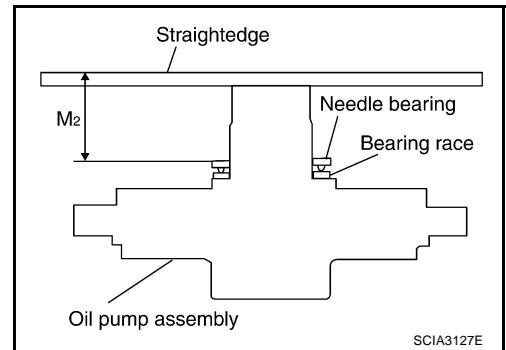

d. Calculate dimension "M".

**"M": Distance between transmission case fitting surface of oil pump and needle bearing on oil pump.**

$$M = M_1 - M_2$$

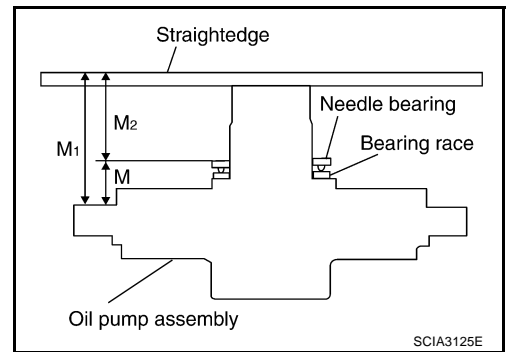

3. Adjust total end play "T1".

$$T_1 = J - M$$

**Total end play "T1":**

**0.25 - 0.55 mm (0.0098 - 0.0217 in)**

- Select proper thickness of bearing race so that total end play is within specifications.

**Bearing races:**

**Refer to [AT-354, "BEARING RACE FOR ADJUSTING TOTAL END PLAY"](#).**

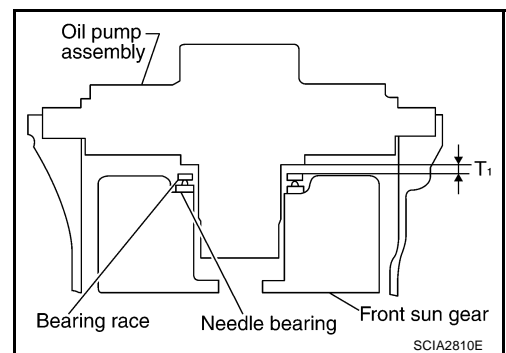



# ASSEMBLY

## Assembly (2)

ACS008GZ

1. Install O-ring to oil pump assembly.

**CAUTION:**

- Do not reuse O-ring.
- Apply ATF to O-ring.

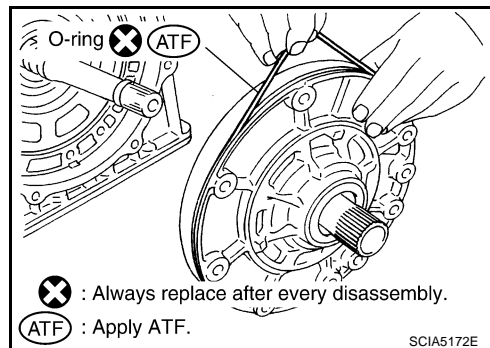

2. Install bearing race to oil pump assembly.

**CAUTION:**

Apply petroleum jelly to bearing race.

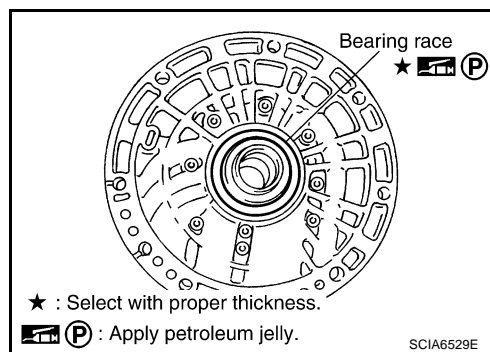

3. Install oil pump assembly in transmission case.

**CAUTION:**

Apply ATF to oil pump bearing.

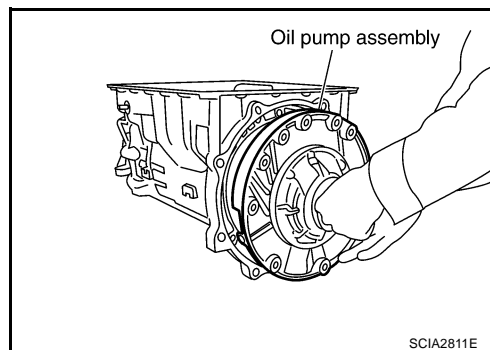

4. Apply recommended sealant (Genuine RTV Silicone Sealant or equivalent. Refer to [GI-47, "Recommended Chemical Products and Sealants"](#) .) to oil pump assembly as shown in the figure.

**CAUTION:**

Completely remove all moisture, oil and old sealant, etc. From the oil pump mounting bolts and oil pump mounting bolt mounting surfaces.

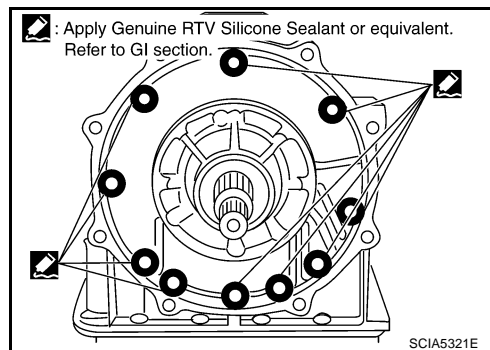

A  
B  
AT  
D  
E  
F  
G  
H  
I  
J  
K  
L  
M

# ASSEMBLY

5. Tighten oil pump mounting bolts to specified torque.

**CAUTION:**

Apply ATF to oil pump bushing.

 : 48 N·m (4.9 kg-m, 35 ft-lb)

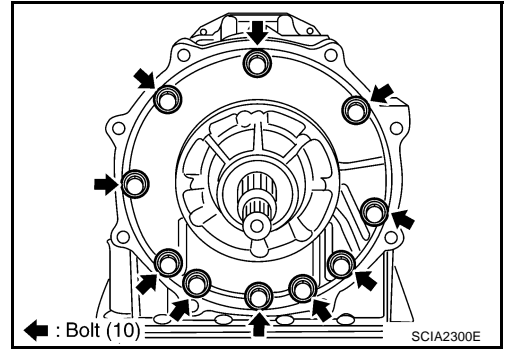

6. Install O-ring to input clutch assembly.

**CAUTION:**

- Do not reuse O-ring.
- Apply ATF to O-ring.

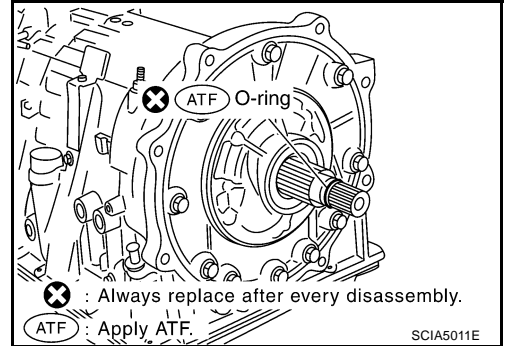

7. Install converter housing to transmission case.

**CAUTION:**

Do not reuse self-sealing bolt.

Converter housing mounting bolt:

 : 52 N·m (5.3 kg-m, 38 ft-lb)

Self-sealing bolt:

 : 61 N·m (6.2 kg-m, 45 ft-lb)

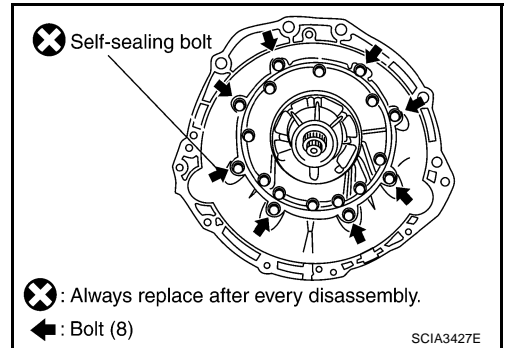

8. Make sure that brake band does not close turbine revolution sensor hole.

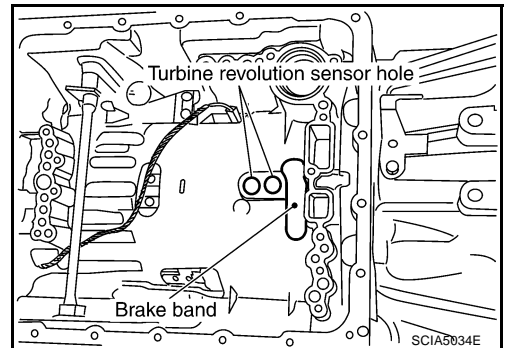

9. Install control valve with TCM.

- a. Connect TCM connector and park/neutral position switch connector.

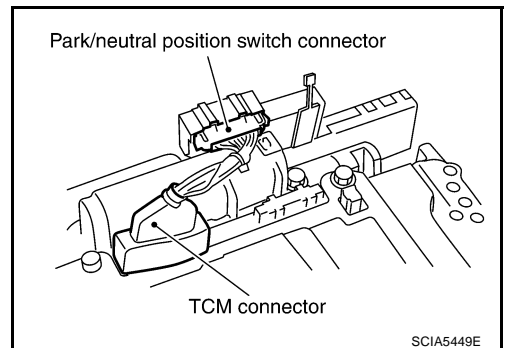

# ASSEMBLY

- b. Install A/T assembly harness connector from control valve with TCM.

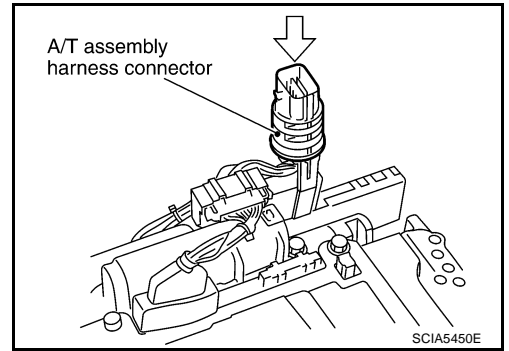

- c. Connect TCM connectors.

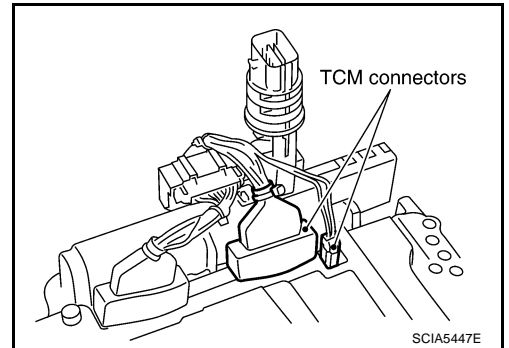

- d. Install O-ring to A/T assembly harness connector.

**CAUTION:**

- Do not reuse O-ring.
- Apply ATF to O-ring.

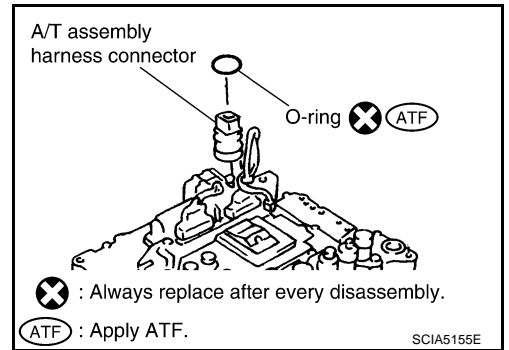

- e. Install A/T fluid temperature sensor 2 to bracket.

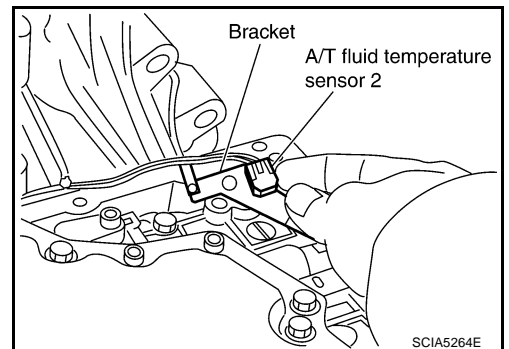

- f. Install A/T fluid temperature sensor 2 (with bracket) in control valve with TCM.

**CAUTION:**

Adjust bolt hole of bracket to bolt hole of control valve.

 : 7.9 N·m (0.81 kg-m, 70 in-lb)

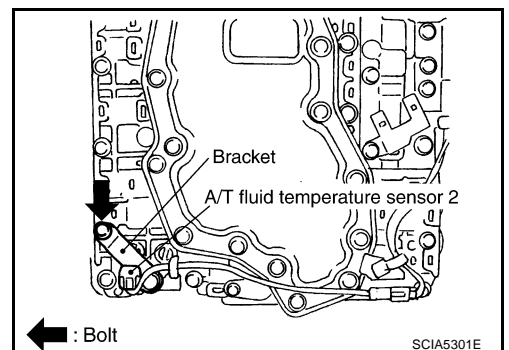

A  
B  
AT  
D  
E  
F  
G  
H  
I  
J  
K  
L  
M

# ASSEMBLY

g. Install control valve with TCM in transmission case.

**CAUTION:**

- Make sure that turbine revolution sensor securely installs turbine revolution sensor hole.
- Hang down revolution sensor harness toward outside so as not to disturb installation of control valve with TCM.
- Adjust A/T assembly harness connector of control valve with TCM to terminal hole of transmission case.

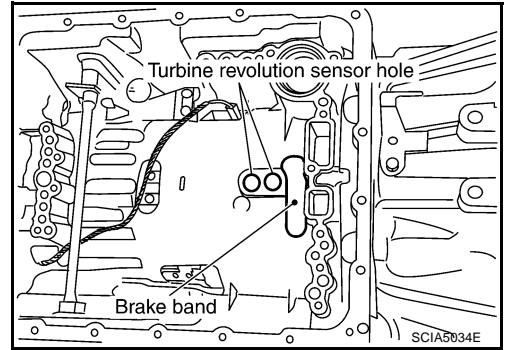

- Assemble it so that manual valve cutout is engaged with manual plate projection.

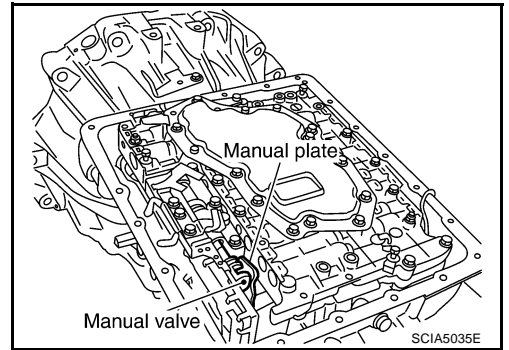

h. Install bolts A, B and C to control valve with TCM.

Bolt symbol	Length mm (in)	Number of bolts
A	42 (1.65)	5
B	55 (2.17)	6
C	40 (1.57)	1

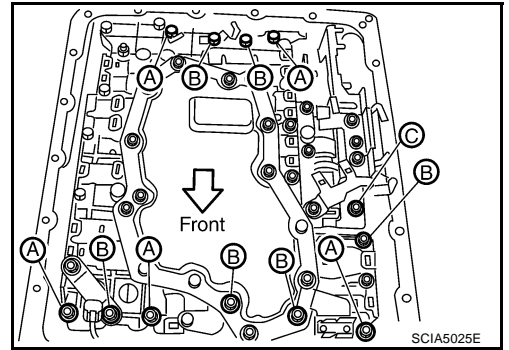

i. Tighten bolt 1, 2 and 3 temporarily to prevent dislocation. After that tighten them in order (1 → 2 → 3), and then tighten other bolts.

 : 7.9 N-m (0.81 kg-m, 70 in-lb)

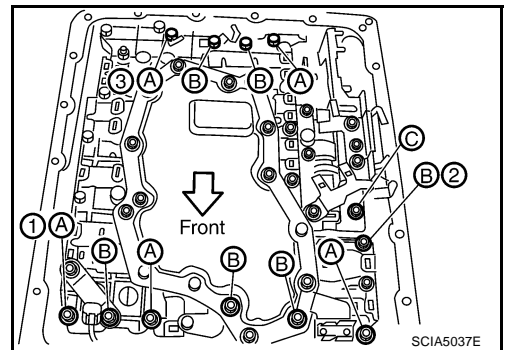

# ASSEMBLY

10. Connect A/T fluid temperature sensor 2 connector.

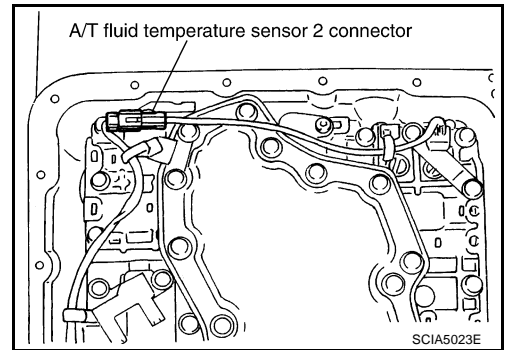

11. Securely fasten terminal cord assembly and A/T fluid temperature sensor 2 harness with terminal clips.

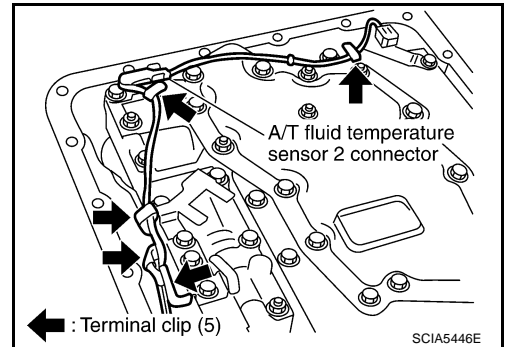

12. Connect revolution sensor connector.

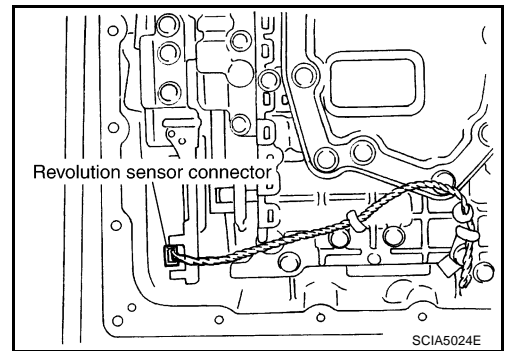

13. Securely fasten revolution sensor harness with terminal clips.

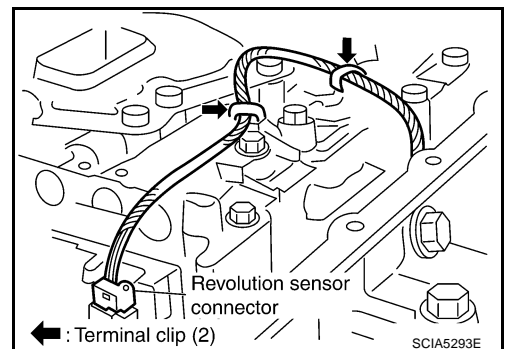

14. Pull down A/T assembly harness connector.

**CAUTION:**  
Be careful not to damage connector.

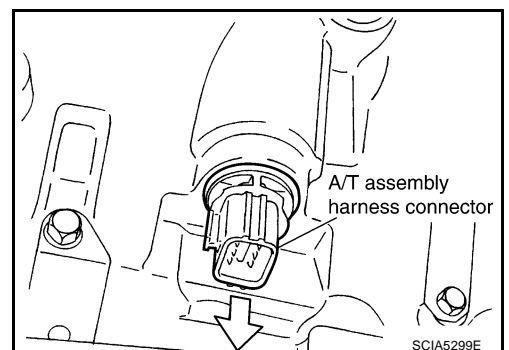

A  
B  
AT  
D  
E  
F  
G  
H  
I  
J  
K  
L  
M

# ASSEMBLY

15. Install snap ring to A/T assembly harness connector.

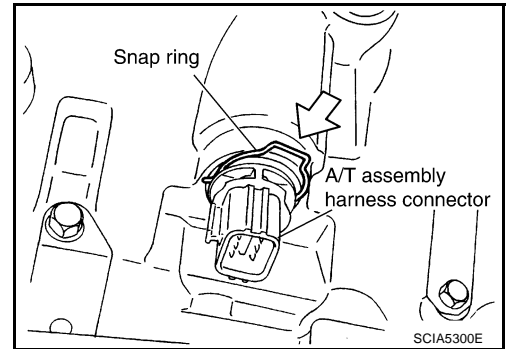

16. Install magnets in oil pan.

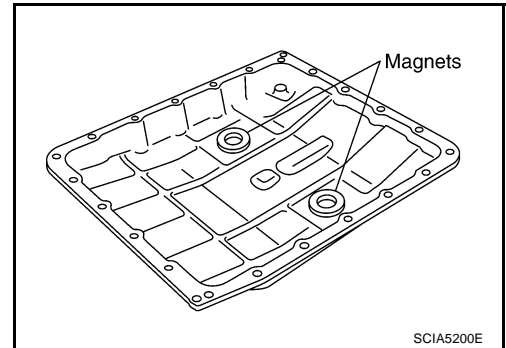

17. Install oil pan to transmission case.

a. Install oil pan gasket to transmission case.

**CAUTION:**

- Do not reuse oil pan gasket.
- Install it in the direction to align hole positions.
- Completely remove all moisture, oil and old gasket, etc. from oil pan gasket mounting surface.

b. Install oil pan to transmission case.

**CAUTION:**

- Install it so that drain plug comes to the position as shown in the figure.
- Be careful not to pinch harnesses.
- Completely remove all moisture, oil and old gasket, etc. from oil pan gasket mounting surface.

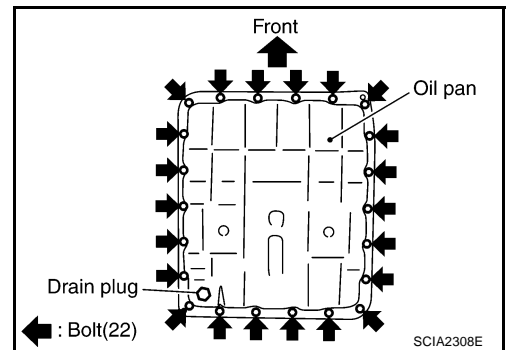

c. Tighten oil pan mounting bolts to the specified torque in numerical order shown in the figure after temporarily tightening them.

**CAUTION:**

**Do not reuse oil pan mounting bolts.**

 : 7.9 N·m (0.81 kg-m, 70 in-lb)

18. Install drain plug to oil pan.

**CAUTION:**

**Do not reuse drain plug gasket.**

 : 34 N·m (3.5 kg-m, 25 ft-lb)

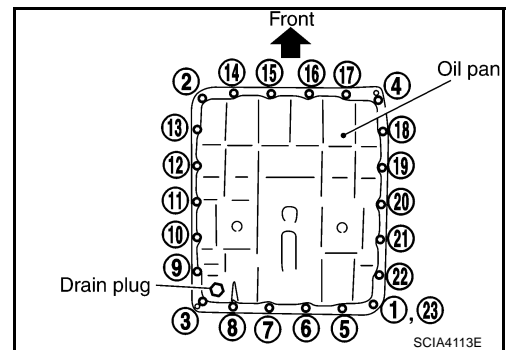

# ASSEMBLY

19. Install torque converter.

a. Pour ATF into torque converter.

- Approximately 2 liter (2-1/8 US qt, 1-3/4 Imp qt) of ATF is required for a new torque converter.
- When reusing old torque converter, add the same amount of ATF as was drained.

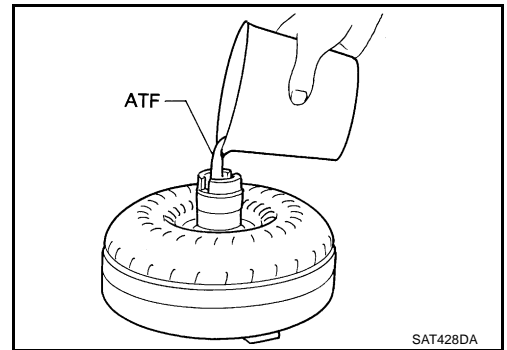

b. Install torque converter while aligning notches of torque converter with notches of oil pump.

**CAUTION:**

**Install torque converter while rotating it.**

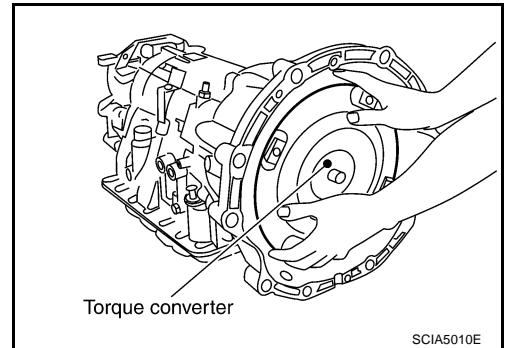

c. Measure distance "A" to make sure that torque converter is in proper position.

**Distance "A": 25.0 mm (0.98 in) or more**

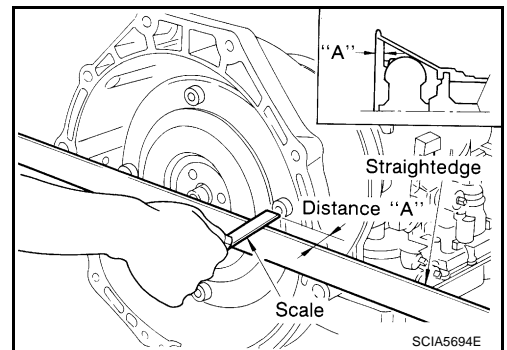

A  
B  
AT  
D  
E  
F  
G  
H  
I  
J  
K  
L  
M

# SERVICE DATA AND SPECIFICATIONS (SDS)

## SERVICE DATA AND SPECIFICATIONS (SDS)

PFP:00030

### General Specifications

ACS0063X

Applied model		VQ35DE engine	
		2WD	AWD
Automatic transmission model		RE5R05A	
Transmission model code number		92X18, 90X1C	92X19, 90X1D
Stall torque ratio		2.0: 1	
Transmission gear ratio	1st	3.540	
	2nd	2.264	
	3rd	1.471	
	4th	1.000	
	5th	0.834	
	Reverse	2.370	
Recommended fluid		Genuine NISSAN Matic J ATF*1	
Fluid capacity		10.3 liter (10-7/8 US qt, 9-1/8 Imp qt)	

**CAUTION:**

- Use only Genuine NISSAN Matic J ATF. Do not mix with other fluid.
- Using A/T fluid other than Genuine NISSAN Matic J ATF will deteriorate in driveability and automatic transmission durability, and may damage the automatic transmission, which is not covered by the warranty.

\*1: Refer to [MA-11, "Fluids and Lubricants"](#) .

### Vehicle Speed at Which Gear Shifting Occurs 2WD MODELS

ACS0063Y

Throttle position	Vehicle speed km/h (MPH)							
	D1 →D2	D2 →D3	D3 →D4	D4 →D5	D5 →D4	D4 →D3	D3 →D2	D2 →D1
Full throttle	56 - 64 (35 - 40)	90 - 98 (56 - 61)	141 - 149 (88 - 93)	202 - 210 (126 - 130)	198 - 206 (123 - 128)	123 - 131 (76 - 81)	74 - 82 (46 - 51)	32 - 40 (20 - 25)
Half throttle	44 - 52 (27 - 32)	71 - 79 (44 - 49)	108 - 116 (67 - 72)	136 - 144 (85 - 89)	89 - 97 (55 - 60)	64 - 72 (40 - 45)	29 - 37 (18 - 23)	9 - 17 (6 - 11)

- At half throttle, the accelerator opening is 4/8 of the full opening.

### AWD MODELS

Throttle position	Vehicle speed km/h (MPH)							
	D1 →D2	D2 →D3	D3 →D4	D4 →D5	D5 →D4	D4 →D3	D3 →D2	D2 →D1
Full throttle	54 - 62 (34 - 39)	86 - 94 (53 - 58)	135 - 143 (84 - 89)	194 - 202 (121 - 126)	190 - 198 (118 - 123)	117 - 125 (73 - 78)	70 - 78 (43 - 48)	30 - 38 (19 - 24)
Half throttle	42 - 50 (26 - 31)	68 - 76 (42 - 47)	104 - 112 (65 - 70)	130 - 138 (81 - 86)	85 - 93 (53 - 58)	62 - 70 (39 - 43)	28 - 36 (17 - 22)	9 - 17 (6 - 11)

- At half throttle, the accelerator opening is 4/8 of the full opening.



## SERVICE DATA AND SPECIFICATIONS (SDS)

### Vehicle Speed at Which Lock-Up Occurs/Releases

ACS0063Z

#### 2WD MODELS

Throttle position	Vehicle speed km/h (MPH)	
	Lock-up "ON"	Lock-up "OFF"
Closed throttle	56 - 64 (35 - 40)	53 - 61 (33 - 38)
Half throttle	168 - 176 (104 - 110)	131 - 139 (81 - 86)

- At closed throttle, the accelerator opening is less than 1/8 condition. (Closed throttle position signal: OFF)
- At half throttle, the accelerator opening is 4/8 of the full opening.

#### AWD MODELS

Throttle position	Vehicle speed km/h (MPH)	
	Lock-up "ON"	Lock-up "OFF"
Closed throttle	54 - 62 (34 - 39)	51 - 59 (32 - 37)
Half throttle	161 - 169 (100 - 105)	126 - 134 (78 - 83)

- At closed throttle, the accelerator opening is less than 1/8 condition. (Closed throttle position signal: OFF)
- At half throttle, the accelerator opening is 4/8 of the full opening.

### Stall Speed

ACS00641

Stall speed	2,300 - 2,600 rpm
-------------	-------------------

### Line Pressure

ACS00642

Engine speed	Line pressure [kPa (kg/cm <sup>2</sup> , psi)]	
	"R" position	"D", "M" positions
At idle speed	425 - 465 (4.3 - 4.7, 62 - 67)	379 - 428 (3.9 - 4.4, 55 - 62)
At stall speed	1,605 - 1,950 (16.4 - 19.9, 233 - 283)	1,310 - 1,500 (13.4 - 15.3, 190 - 218)

### A/T Fluid Temperature Sensor

ACS0087M

Name	Condition	CONSULT-II "DATA MONITOR" (Approx.) (V)	Resistance (Approx.) (kΩ)
ATF TEMP SE 1	0°C (32°F)	3.3	15
	20°C (68°F)	2.7	6.5
	80°C (176°F)	0.9	0.9
ATF TEMP SE 2	0°C (32°F)	3.3	10
	20°C (68°F)	2.5	4
	80°C (176°F)	0.7	0.5

### Turbine Revolution Sensor

ACS0087N

Name	Condition	Data (Approx.)
Turbine revolution sensor 1	When running at 50 km/h (31 MPH) in 4th gear with the closed throttle position switch "OFF".	1.3 (kHz)
Turbine revolution sensor 2	When running at 20 km/h (12 MPH) in 1st gear with the closed throttle position switch "OFF".	

### Vehicle Speed Sensor A/T (Revolution Sensor)

ACS0087O

Name	Condition	Data (Approx.)
Revolution sensor	When running at 20 km/h (12 MPH).	185 (Hz)

# SERVICE DATA AND SPECIFICATIONS (SDS)

## Reverse Brake

ACS0087P

	Thickness mm (in)	Part number*
Thickness of retaining plates	4.2 (0.165)	31667 90X14
	4.4 (0.173)	31667 90X15
	4.6 (0.181)	31667 90X16
	4.8 (0.189)	31667 90X17
	5.0 (0.197)	31667 90X18
	5.2 (0.205)	31667 90X19

\*: Always check with the Parts Department for the latest parts information.

## Total End Play

ACS0087Q

Total end play mm (in)	0.25 - 0.55 (0.0098 - 0.0217)
------------------------	-------------------------------

## BEARING RACE FOR ADJUSTING TOTAL END PLAY

Thickness mm (in)	Part number*
1.2 (0.047)	31435 90X02
1.4 (0.055)	31435 90X03
1.6 (0.063)	31435 90X04
1.8 (0.071)	31435 90X05
2.0 (0.079)	31435 90X06

\*: Always check with the Parts Department for the latest parts information.