

SECTION **FSU**
FRONT SUSPENSION

A
B
C
D

FSU

CONTENTS

2WD		COMPRESSION ROD	15	F
PRECAUTIONS	3	Removal and Installation	15	
Caution	3	REMOVAL	15	
PREPARATION	4	INSPECTION AFTER REMOVAL	15	G
Special Service Tools (SST)	4	AXIAL END PLAY INSPECTION	16	
Commercial Service Tools	4	INSTALLATION	16	
NOISE, VIBRATION AND HARSHNESS (NVH)		STABILIZER BAR	17	H
TROUBLESHOOTING	5	Removal and Installation	17	
NVH Troubleshooting Chart	5	REMOVAL	17	
FRONT SUSPENSION ASSEMBLY	6	INSPECTION AFTER REMOVAL	17	I
On-Vehicle Inspection and Service	6	INSTALLATION	17	
INSPECTION OF TRANSVERSE LINK BALL		FRONT SUSPENSION MEMBER	18	J
JOINT END PLAY	6	Removal and Installation	18	
SHOCK ABSORBER INSPECTION	6	REMOVAL	18	
Wheel Alignment Inspection	7	INSPECTION AFTER REMOVAL	18	
DESCRIPTION	7	INSTALLATION	18	
PRELIMINARY INSPECTION	7	SERVICE DATA	19	K
INSPECTION OF CAMBER, CASTER AND		Wheel Alignment (Unladen)	19	
KINGPIN INCLINATION ANGLES.	7	Ball Joint	19	
Components	9	Wheelarch Height (Unladen*)	19	L
COIL SPRING AND SHOCK ABSORBER	10			
Removal and Installation	10	AWD		
REMOVAL	10	PRECAUTIONS	20	M
INSTALLATION	10	Caution	20	
Disassembly and Assembly	10	PREPARATION	21	
DISASSEMBLY	10	Special Service Tools (SST)	21	
INSPECTION AFTER DISASSEMBLY	10	Commercial Service Tools	21	
ASSEMBLY	11	NOISE, VIBRATION AND HARSHNESS (NVH)		
TRANSVERSE LINK	12	TROUBLESHOOTING	22	
Removal and Installation	12	NVH Troubleshooting Chart	22	
REMOVAL	12	FRONT SUSPENSION ASSEMBLY	23	
INSPECTION AFTER REMOVAL	12	On-Vehicle Inspection and Service	23	
INSTALLATION	12	INSPECTION OF TRANSVERSE LINK BALL		
UPPER LINK	13	JOINT END PLAY	23	
Removal and Installation	13	SHOCK ABSORBER INSPECTION	23	
REMOVAL	13	Wheel Alignment Inspection	24	
INSPECTION AFTER REMOVAL	13	DESCRIPTION	24	
INSTALLATION	14	PRELIMINARY INSPECTION	24	
		INSPECTION OF CAMBER, CASTER AND		

KINGPIN INCLINATION ANGLES.	24	COMPRESSION ROD	32
Components	26	Removal and Installation	32
COIL SPRING AND SHOCK ABSORBER	27	REMOVAL	32
Removal and Installation	27	INSPECTION AFTER REMOVAL	32
REMOVAL	27	INSTALLATION	33
INSTALLATION	27	STABILIZER BAR	34
Disassembly and Assembly	27	Removal and Installation	34
DISASSEMBLY	27	REMOVAL	34
INSPECTION AFTER DISASSEMBLY	27	INSPECTION AFTER REMOVAL	34
ASSEMBLY	28	INSTALLATION	34
TRANSVERSE LINK	29	FRONT SUSPENSION MEMBER	35
Removal and Installation	29	Removal and Installation	35
REMOVAL	29	REMOVAL	35
INSPECTION AFTER REMOVAL	29	INSPECTION AFTER REMOVAL	35
INSTALLATION	29	INSTALLATION	35
UPPER LINK	30	SERVICE DATA	36
Removal and Installation	30	Wheel Alignment (Unladen)	36
REMOVAL	30	Ball Joint	36
INSPECTION AFTER REMOVAL	30	Wheelarch Height (Unladen*)	36
INSTALLATION	31		

PRECAUTIONS

[2WD]

PRECAUTIONS

PFP:00001

Caution

AES000S7

- When installing rubber bushings, final tightening must be carried out under unladen conditions with tires on ground. Oil will shorten the life of rubber bushings. Be sure to wipe off any spilled oil.
- Unladen conditions mean that fuel, engine coolant and lubricant are full. Spare tire, jack, hand tools and mats are in designated positions.
- After servicing suspension parts, be sure to check wheel alignment.
- Caulking nuts are not reusable. Always use new ones when installing. Since new caulking nuts are pre-oiled, tighten as they are.

A
B
C
D

FSU

F
G
H
I
J
K
L
M

PREPARATION

[2WD]

PF0:00002

AES000S8

PREPARATION

Special Service Tools (SST)

The actual shapes of Kent-Moore tools may differ from those of special service tools illustrated here.

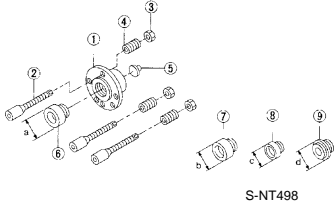
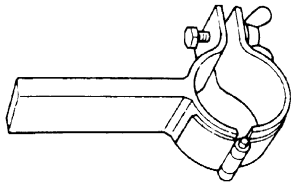
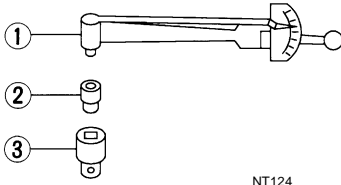
Tool number (Kent-Moore No.) Tool name	Description
KV991040S0 (—) CCK gauge 1. Plate 2. Guide bolts 3. Nuts 4. Springs 5. Center plate 6. KV9910 4030 Adapter A a: 72 mm (2.83 in) dia. 7. KV9910 4030 Adapter B b: 65 mm (2.56 in) dia. 8. KV9910 4040 Adapter C c: 57 mm (2.24 in) dia. 9. KV9910 4050 Adapter D d: 53.4 mm (2.102 in) dia.	 <p style="text-align: center;">S-NT498</p> Measuring wheel alignment
ST35652000 (—) Strut attachment	 <p style="text-align: center;">ZZA0807D</p> Strut disassembly/re-assembly
ST3127S000 (See J25742-1) Preload Gauge 1. GG91030000 Torque wrench (J25765) 2. HT62940000 (—) Socket adapter (1/2") 3. HT62900000 (—) Socket adapter (3/8")	 <p style="text-align: center;">NT124</p> Measuring sliding torque of ball joint

Commercial Service Tools

AES000S9

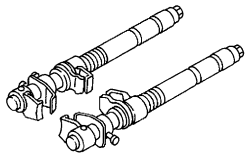
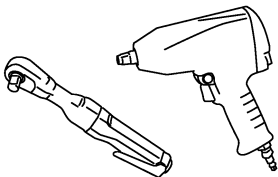
Tool name	Description
Spring compressor	 <p style="text-align: center;">S-NT717</p> Removing coil spring
Power tool	 <p style="text-align: center;">PBIC0190E</p> <ul style="list-style-type: none"> ● Removing wheel nuts ● Removing undercover ● Removing stabilizer assembly

NOISE, VIBRATION AND HARSHNESS (NVH) TROUBLESHOOTING

[2WD]

NOISE, VIBRATION AND HARSHNESS (NVH) TROUBLESHOOTING

PPF:00003

NVH Troubleshooting Chart

AES000SA

Use chart below to help you find the cause of the symptom. If necessary, repair or replace these parts.

Symptom		Possible cause and SUSPECTED PARTS	Reference page															
			FSU-9	FSU-10	—	—	—	FSU-9	FSU-7	FSU-17	NVH in PR section	NVH in RFD section.	NVH in FAX and FSU section.	NVH in WT section.	NVH in WT section.	NVH in BR section.	NVH in PS section.	
Symptom	FRONT SUSPENSION	Noise	x	x	x	x	x	x	x			x	x	x	x	x	x	
		Shake	x	x	x	x		x				x	x	x	x	x	x	
		Vibration	x	x	x	x	x					x		x				x
		Shimmy	x	x	x	x			x				x	x	x	x	x	x
		Judder	x	x	x								x	x	x	x	x	x
		Poor quality ride or handling	x	x	x	x	x		x	x			x	x	x			

x: Applicable

A
B
C
D
E
FSU
F
G
H
I
J
K
L
M

FRONT SUSPENSION ASSEMBLY

PFP:54010

On-Vehicle Inspection and Service

AES000SC

Make sure the mounting conditions (looseness, back lash) of each component and component statuses (wear, damage) are normal.

INSPECTION OF TRANSVERSE LINK BALL JOINT END PLAY

1. Set front wheels in a straight-ahead position. Do not depress brake pedal.
2. Check ball joint axial end play of each link.

CAUTION:

Be careful not to damage ball joint boot.

Upper Link Ball Joint

Measure axial end play by installing and moving up/down with an iron pry bar or something similar between upper link and steering knuckle.

Standard value

Axial end play : 0 mm (0 in)

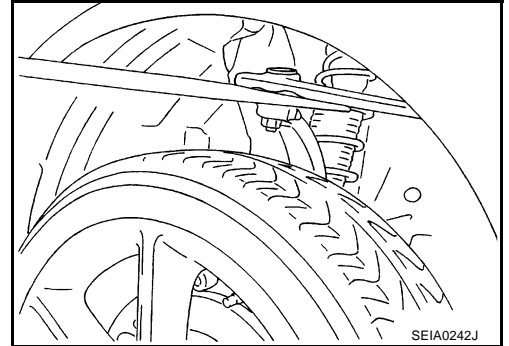

Steering Knuckle Lower Ball Joint

Measure axial end play by installing and moving up/down with an iron pry bar or something similar between steering knuckle and wheel.

Standard value

Axial end play : 0 mm (0 in)

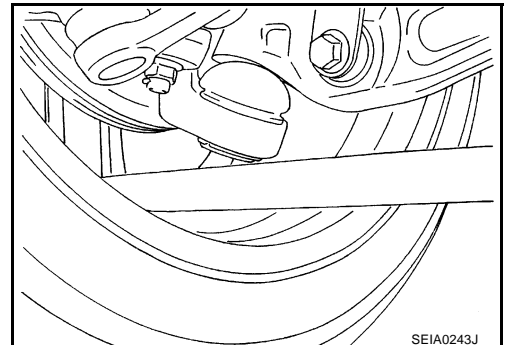

Compression Rod Ball Joint

Measure axial end play by installing and moving up/down with an iron pry bar or something similar between compression rod and transverse link.

Standard value

Axial end play : 0 mm (0 in)

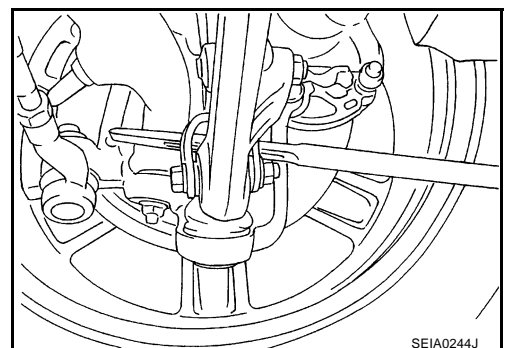

SHOCK ABSORBER INSPECTION

Check shock absorber for oil leakage, damage and replace if necessary. Refer to [FSU-10, "COIL SPRING AND SHOCK ABSORBER"](#).

Wheel Alignment Inspection DESCRIPTION

Measure wheel alignment under unladen conditions.

NOTE:

Unladen conditions mean that fuel, engine coolant, and lubricant are full. Spare tire, jack, hand tools and mats are designated positions.

PRELIMINARY INSPECTION

1. Check tires for improper air pressure and wear.
2. Check road wheels for runout.
3. Check wheel bearing axial end play.
4. Check ball joint axial end play of compression rod, upper link, and steering knuckle.
5. Check shock absorber operation.
6. Check each mounting part of axle and suspension for looseness and deformation.
7. Check each link, rod and member for cracks, deformation and other damage.
8. Check vehicle posture.

INSPECTION OF CAMBER, CASTER AND KINGPIN INCLINATION ANGLES.

- Camber, caster, kingpin inclination angles cannot be adjusted.
- Before inspection, mount front wheels onto turning radius gauge. Mount rear wheels onto a stand that has same height so vehicle will remain horizontal.

Using a CCK Gauge

Install CCK gauge attachment (SST: KV991040S0) as following procedure in wheel, then measure wheel alignment.

1. Remove wheel nuts (2), and install a guide bolt to hub bolt.
2. Screw adapter into plate body until it contacts body tightly.
3. Screw center plate into plate.
4. Insert plate on guide bolt. Put spring in, and then evenly screw both guide bolt nut. When fastening guide bolt nut, do not completely compress spring.

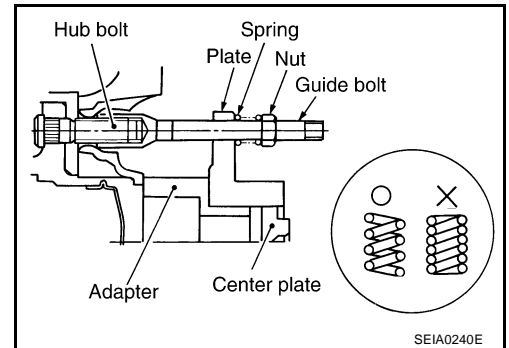

5. Place the dent of alignment gauge onto the projection of center plate and tightly contact them to measure.

Standard value

Camber, caster, king inclination angles:

Refer to [FSU-19, "SERVICE DATA"](#) .

CAUTION:

- If camber, caster, or kingpin inclination angle is outside the standard, check front suspension parts for wear and damage, and replace suspect parts if necessary.
- King pin inclination angles is reference value, no inspection is required. (Due to the type of suspension, the kingpin inclination angle cannot be measured correctly using a normal alignment tester.)

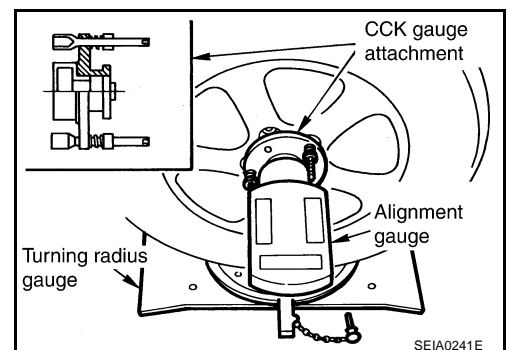

FRONT SUSPENSION ASSEMBLY

[2WD]

Toe-In Inspection

Measure toe-in using the following procedure.

WARNING:

- Always perform the following procedure on a flat surface.
- Make sure that no person is in front of vehicle before pushing it.

1. Bounce front of vehicle up and down to stabilize the posture.
2. Push vehicle straight ahead about 5 m (16 ft).
3. Put a mark on base line of the tread (rear side) of both tires at the same height as hub center. These are measuring points.

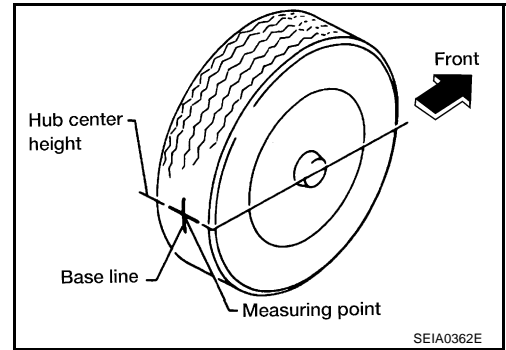

4. Measure distance "A" (rear side).
5. Push vehicle slowly ahead to rotate wheels 180 degrees (1/2 turn).
If wheels have rotated more than 180 degrees (1/2 turn), try the above procedure again from the beginning. Never push vehicle backward.
6. Measure distance "B" (front side).

Standard value

Total toe-in : Refer to [FSU-19, "SERVICE DATA"](#)

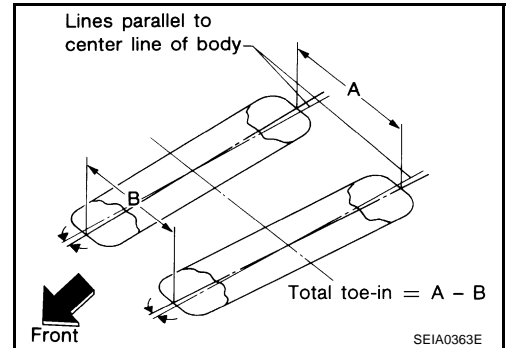

FRONT SUSPENSION ASSEMBLY

[2WD]

AES000SB

Components

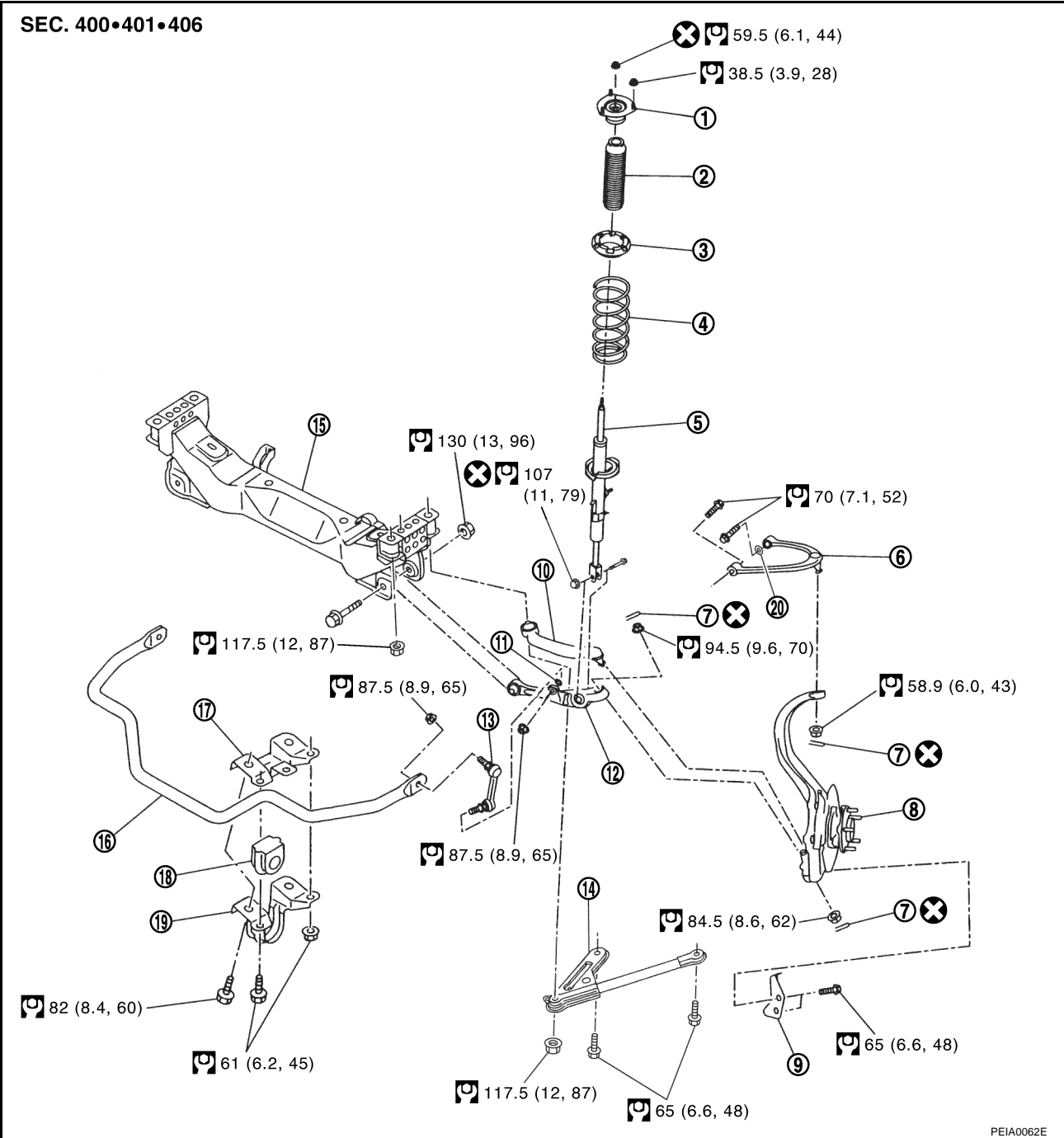

A
B
C
D
FSU
F
G
H
I
J
K
L
M

FSU

PEIA0062E

- | | | |
|-------------------------------|------------------------------|-----------------------------|
| 1. Mounting insulator | 2. Bound bumper | 3. Spring rubber seat |
| 4. Coil spring | 5. Shock absorber | 6. Upper link |
| 7. Cotter pin | 8. Front axle | 9. Steering stopper bracket |
| 10. Compression rod | 11. Washer | 12. Transverse link |
| 13. Stabilizer connecting rod | 14. Compression rod stay | 15. Front suspension member |
| 16. Stabilizer bar | 17. Stabilizer clamp bracket | 18. Stabilizer bushing |
| 19. Stabilizer clamp | 20. Stopper rubber | |

Refer to [GI-10. "Components"](#), for the symbols in figure

COIL SPRING AND SHOCK ABSORBER

PF5:54302

Removal and Installation

REMOVAL

AES000SE

1. Remove tire with power tool.
2. Remove undercover with power tool.
3. Remove harness of wheel sensor from shock absorber. Refer to [BRC-66, "WHEEL SENSOR"](#) .
4. Remove mounting nuts of brake hose from shock absorber.
5. Remove mounting bolt and nut between shock absorber and transverse link with power tool.
6. Remove mounting nuts on mounting insulator with power tool, then remove shock absorber from vehicle.

INSTALLATION

- Refer to [FSU-9, "Components"](#) for tightening torque. Install in the reverse order of removal.

NOTE:

Refer to component parts location and do not reuse non-reusable parts.

- Perform final tightening of shock absorber lower side (rubber bushing) under unladen condition with tires on ground. Check wheel alignment. Refer to [FSU-7, "Wheel Alignment Inspection"](#) .

Disassembly and Assembly

AES000SF

DISASSEMBLY

NOTE:

Make sure piston rod on shock absorber is not damaged when removing components from shock absorber.

1. Install strut attachment (SST) to shock absorber and fix it in a vise.

CAUTION:

When installing strut attachment (SST) to shock absorber, wrap a shop cloth around shock absorber to protect it from damage.

2. Using a spring compressor (commercial service tool), compress coil spring between spring upper seat and spring lower seat (on shock absorber) until coil spring is free.

CAUTION:

Be sure spring compressor (commercial service tool) is securely attached to coil spring. Compress coil spring.

3. Check that coil spring between spring upper seat and spring lower seat is free and then secure piston rod tip so that piston rod does not turn, and remove piston rod lock nut.
4. Remove mounting insulator, bound bumper, spring upper seat. Then remove coil spring from shock absorber.
5. Gradually release spring compressor (commercial service tool), and remove coil spring.

CAUTION:

Loosen while making sure coil spring attachment position does not move.

6. Remove strut attachment (SST) from shock absorber.

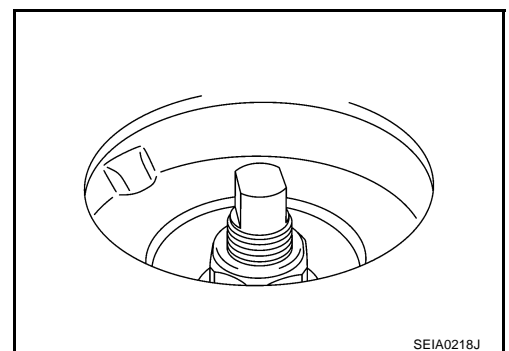
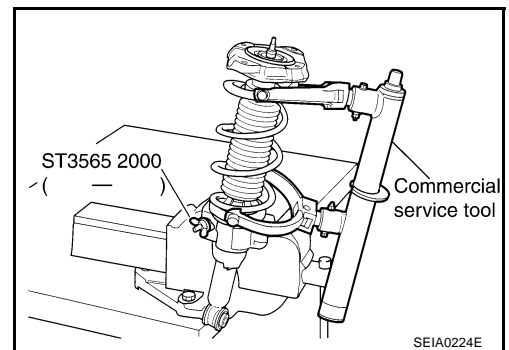

INSPECTION AFTER DISASSEMBLY

Shock Absorber Inspection

- Check shock absorber for deformation, cracks, damage, and replace if necessary.
- Check piston rod for damage, uneven wear, distortion, and replace if necessary.
- Check welded and sealed areas for oil leakage, and replace if necessary.

Mounting Insulator and Rubber Parts Inspection

Check mounting insulator for cracks and rubber parts for wear. Replace them if necessary.

Coil Spring Inspection

Check coil spring for cracks, wear, damage, and replace if necessary.

ASSEMBLY

NOTE:

Make sure piston rod on shock absorber is not damaged when attaching components to shock absorber.

1. Install strut attachment (SST) to shock absorber and fix it in a vise.

CAUTION:

When installing strut attachment (SST) to shock absorber, wrap a shop cloth around shock absorber to protect it from damage.

2. Compress coil spring using a spring compressor (commercial service tool), and install it onto shock absorber.

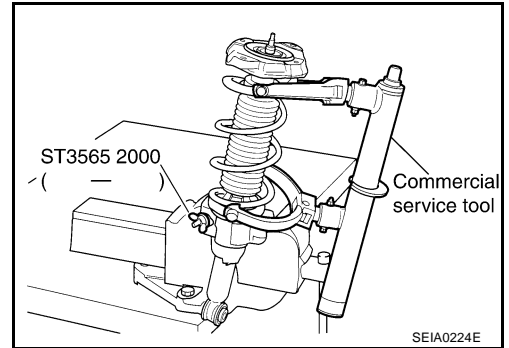

CAUTION:

- Install coil spring as shown in the figure with large diameter side [100 mm (3.94 in)] up and small diameter side [90 mm (3.54 in)] down. (Identification paint is the 4th winding point from lower side.

- Be sure spring compressor (commercial service tool) is securely attached to coil spring. Compress coil spring.

3. Apply soapy water to bound bumper and insert into mounting insulator.

CAUTION:

Do not use machine oil.

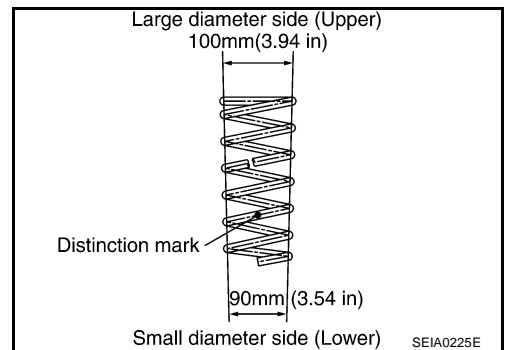

4. Attach spring upper seat and mounting insulator as shown in the figure.

CAUTION:

- Make sure coil spring is securely seated in spring mounting groove of spring upper seat.

- The bottom part of spring should be at the position of A point of spring seat.

5. Secure piston rod tip so that piston rod does not turn, and tighten the specified torque on piston rod lock nut.
6. Gradually release spring compressor (commercial service tool), and remove coil spring.

CAUTION:

Loosen spring compressor (commercial service tool) while making sure coil spring attachment position does not move.

7. Remove strut attachment (SST) from shock absorber.

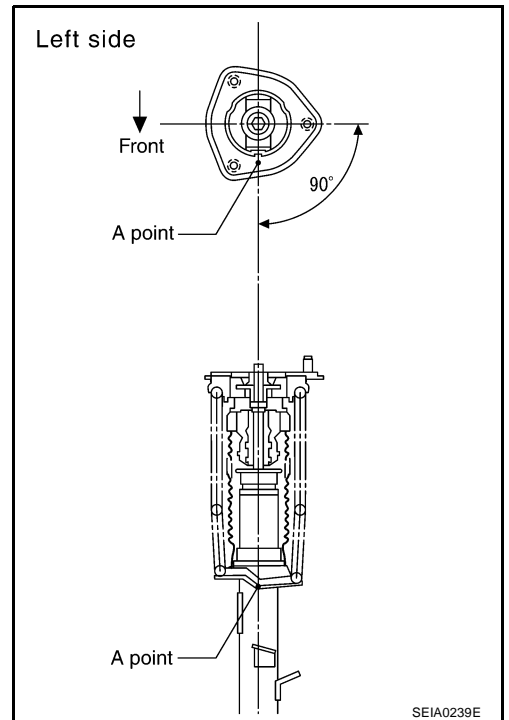

A
B
C
D

FSU

F
G
H
I
J
K
L
M

TRANSVERSE LINK

Removal and Installation

REMOVAL

1. Remove tire with power tool.
2. Remove undercover with power tool.
3. Remove mounting nut and washer on lower portion of stabilizer connecting rod with power tool.
4. Remove mounting nut between transverse link and shock absorber on lower position.
5. Remove mounting nut between transverse link and front suspension member with power tool.
6. Remove transverse link from steering knuckle. Refer to [FAX-4, "FRONT WHEEL HUB AND KNUCKLE"](#) .
7. Remove transverse link from vehicle.

INSPECTION AFTER REMOVAL

Visual Inspection

Check transverse link and bushing for deformation, cracks, or damage. If any non-standard condition is found, replace it

INSTALLATION

- Refer to [FSU-9, "Components"](#) for tightening torque. Install in the reverse order of removal.

NOTE:

Refer to component parts location and do not reuse non-reusable parts.

- Perform final tightening of front suspension member installation position and shock absorber lower side (rubber bushing) under unladen condition with tires on ground. Check wheel alignment. Refer to [FSU-7, "Wheel Alignment Inspection"](#) .

UPPER LINK

Removal and Installation

REMOVAL

1. Remove tire with power tool.
2. Remove undercover with power tool.
3. Remove shock absorber. Refer to [FSU-10, "COIL SPRING AND SHOCK ABSORBER"](#) .
4. Remove cotter pin of upper link ball joint, then loosen mounting nut.
5. Use a ball joint remover (suitable tool) to remove upper link from steering knuckle. Be careful not to damage ball joint boot.

CAUTION:

Tighten temporarily mounting nut to prevent damage to threads and to prevent ball joint remover (suitable tool) from coming off.

6. Remove bolts holding upper link to body with power tool.
7. Remove upper link from vehicle.

INSPECTION AFTER REMOVAL

Visual Inspection

- Check upper link and bushing for deformation, cracks, or damage. If any non-standard condition is found, replace it.
- Check boot of ball joint for cracks, or other damage, and also for grease leakage. If any non-standard condition is found, replace it.

Ball Joint Inspection

Manually move ball stud to confirm it moves smoothly with no binding.

Swing Torque Inspection

NOTE:

Before measurement, move ball joint at least ten times by hand to check for smooth movement.

- Hook spring scale at ball stud. Confirm spring scale measurement value is within specifications when ball stud begins moving.

Standard value

Swing torque:

Less than 2.0 N·m (0.20 kg·m, 18 in-lb)

Measured value of spring scale:

Less than 34.8 N (3.5 kg, 7.8 lb)

- If it is outside the specified range, replace upper link assembly.

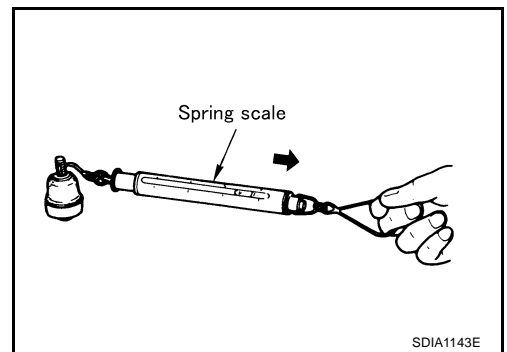

Rotating Torque Inspection

- Attach mounting nut to ball stud. Check that rotating torque is within specifications with a preload gauge (SST).

Standard value

Rotating torque:

Less than 2.0 N·m (0.20 kg·m, 18 in-lb)

- If it is outside the specified range, replace upper link assembly.

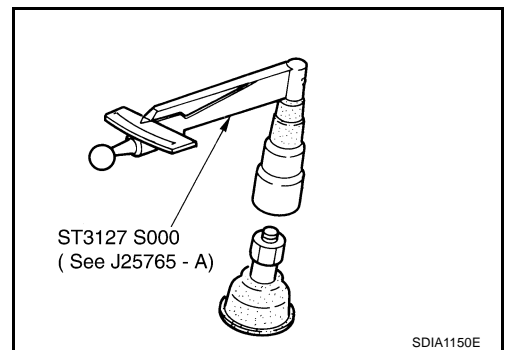

Axial End Play Inspection

- Move tip of ball joint in axial direction to check for looseness.

Standard value

Axial end play : 0 mm (0 in)

- If it is outside the specified range, replace upper link assembly.

INSTALLATION

- Refer to [FSU-9, "Components"](#) for tightening torque. Install in the reverse order of removal.

NOTE:

Refer to component parts location and do not reuse non-reusable parts.

- Perform final tightening of front suspension member installation position (rubber bushing) under unladen condition with tires on ground. Check wheel alignment. Refer to [FSU-19, "SERVICE DATA"](#) .

COMPRESSION ROD

Removal and Installation

REMOVAL

1. Remove tire with power tool.
2. Remove undercover with power tool.
3. Remove cotter pin of compression rod ball joint, and loosen nut.
4. Use a ball joint remover (suitable tool) to remove compression rod from steering knuckle. Be careful not to damage ball joint boot.

CAUTION:

Tighten temporarily mounting nut to prevent damage to threads and to prevent ball joint remover (SST) from coming off.

5. Remove compression rod and compression rod stay from vehicle.

INSPECTION AFTER REMOVAL

Visual Inspection

- Check compression rod and bushing for deformation, cracks, or damage. If any non-standard condition is found, replace it.
- Check boot of ball joint for cracks, or other damage, and also for grease leakage. If any non-standard condition is found, replace it.

Ball Joint Inspection

- Manually move ball stud to confirm it moves smoothly with no binding.

Swing Torque Inspection

NOTE:

Before measurement, move ball joint at least ten times by hand to check for smooth movement.

- Hook spring scale at ball stud. Confirm spring scale measurement value is within the specifications when ball stud begins moving.

Standard value

Swing torque:

0.147 - 2.45 N·m (0.02 - 0.24 kg·m, 2 - 21 in·lb)

Measured value of spring scale:

2.37 - 39.5 N (0.24 - 4.03 kg, 0.53 - 8.88 lb)

- If it is outside the specified range, replace compression rod assembly.

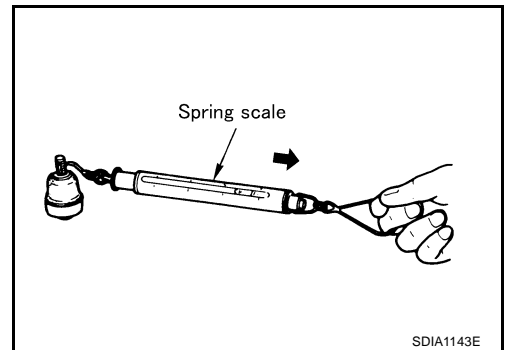

Rotating Torque Inspection

- Attach mounting nut to ball stud. Check that rotating torque is within the specifications with a preload gauge (SST).

Standard value

Rotating torque:

0.147 - 2.45 N·m (0.02 - 0.24 kg·m, 2 - 21 in·lb)

- If it is outside the specified range, replace compression rod assembly.

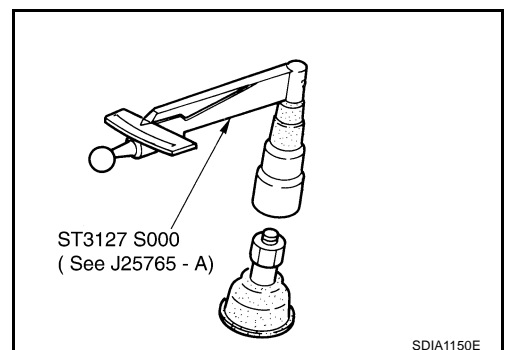

AXIAL END PLAY INSPECTION

- Move tip of ball joint in axial direction to check for looseness.

Standard value

Axial end play : 0 mm (0 in)

- If it is outside the specified range, replace compression rod assembly.

INSTALLATION

- Refer to [FSU-9, "Components"](#) for tightening torque. Install in the reverse order of removal.

NOTE:

Refer to component parts location and do not reuse non-reusable parts.

- Perform final tightening of installation position between front suspension member and front cross bar (rubber bushing) under unladen condition with tires on ground. Check wheel alignment. Refer to [FSU-19, "SERVICE DATA"](#).

STABILIZER BAR

[2WD]

STABILIZER BAR

PPF:54611

Removal and Installation

AES00070

REMOVAL

1. Remove tire with power tool.
2. Remove undercover with power tool.
3. Remove mounting nut on upper portion of stabilizer connecting rod with power tool.
4. Remove fixing bolts and nuts, then remove stabilizer clamp, stabilizer bushing, and stabilizer clamp bracket.
5. Remove stabilizer bar from vehicle.

INSPECTION AFTER REMOVAL

Check stabilizer bar, stabilizer connecting rod, stabilizer bushing, stabilizer clamp and stabilizer clamp bracket for deformation, cracks and damage, and replace if necessary.

INSTALLATION

- Refer to [FSU-9, "Components"](#) for tightening torque. Install in the reverse order of removal.
- Tighten each bolt and nut as shown in the figure for tightening stabilizer bracket and stabilizer clamp. Tightening order is as follows. 1 (fully tighten) → 2 (temporarily tighten) → 3 (temporarily tighten) → 2 (fully tighten) → 3 (fully tighten) → 4, 5 (temporarily tighten) → 4, 5 (fully tighten).

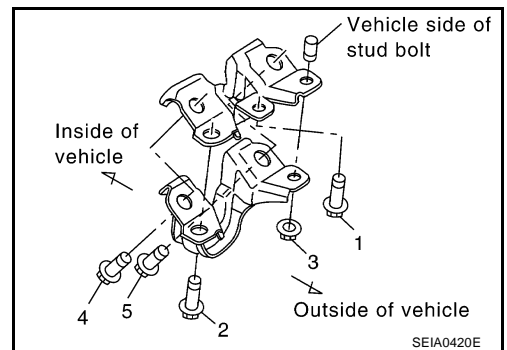

- Stabilizer bar uses pillow ball type connecting rod. Position ball joint with case on pillow ball head parallel to stabilizer bar.

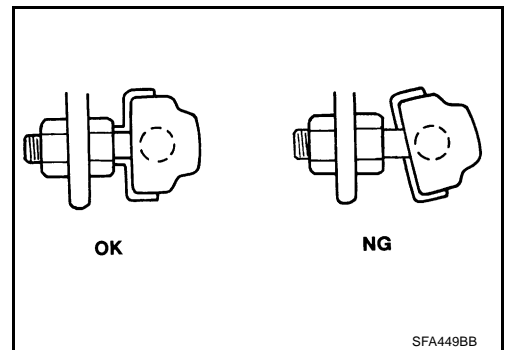

FRONT SUSPENSION MEMBER

PFP:54401

Removal and Installation

REMOVAL

AES000TP

1. Remove tire with power tool.
2. Remove undercover with power tool.
3. Remove steering hydraulic piping bracket from front suspension member. Refer to [PS-36, "HYDRAULIC LINE"](#).
4. Remove steering gear and front suspension member attachment bolts and hang steering gear on vehicle. Refer to [PS-20, "POWER STEERING GEAR AND LINKAGE"](#).
5. Remove fixing bolts and nut, then remove compression rod stay from vehicle.
6. Remove transverse link from front suspension member with power tool. Refer to [FSU-12, "TRANSVERSE LINK"](#).
7. Set jack under engine.
CAUTION:
When setting jack to engine, use a wooden block or an equivalent for the setting.
8. Remove fixing nuts between engine mounting insulator and front suspension member. Refer to [EM-139, "ENGINE ASSEMBLY"](#).
9. Remove fixing nuts between front suspension member and body with power tool.
10. Remove front suspension member from vehicle.

INSPECTION AFTER REMOVAL

Check front suspension member for deformation, cracks, or any other damage. Replace if necessary.

INSTALLATION

- Refer to [FSU-9, "Components"](#) for tightening torque. Install in the reverse order of removal.
- Perform final tightening of installation position between front suspension member and transverse link (rubber bushing) under unladen condition with tires on level ground. Check wheel alignment. Refer to [FSU-19, "SERVICE DATA"](#).

SERVICE DATA

[2WD]

SERVICE DATA

PFP:00030

Wheel Alignment (Unladen)

AES0007Q

Camber Degree minute (Decimal degree)	Minimum	- 0° 50' (- 0.83°)
	Nominal	- 0° 05' (- 0.08°)
	Maximum	0° 40' (0.67°)
	Left and right difference	45' (0.75°)
Caster Degree minute (Decimal degree)	Minimum	7° 00' (7.00°)
	Nominal	7° 45' (7.75°)
	Maximum	8° 30' (8.50°)
	Left and right difference	45' (0.75°)
Kingpin inclination Degree minute (Decimal degree)	Minimum	3° 45' (3.75°)
	Nominal	4° 30' (4.50°)
	Maximum	5° 15' (5.25°)
Total toe-in	Distance (A - B)	
	Minimum	0 mm (0 in)
	Nominal	1 mm (0.04 in)
	Maximum	2 mm (0.08 in)

Ball Joint

AES0007R

Swing torque	Less than 2.0 N-m (0.20 kg-m, 18 in-lb) (Upper link) 0.147 - 2.45 N-m (0.02 - 0.24 kg-m, 2 - 21 in-lb) (Compression rod)
Measurement on spring balance (cotter pinhole position)	Less than 34.8 N (3.5 kg, 7.8 lb) (Upper link) 2.37 - 39.5 N (0.24 - 4.03 kg, 0.53 - 8.88 lb) (Compression rod)
Rotating torque	Less than 2.0 N-m (0.20 kg-m, 18 in-lb) (Upper link) 0.147 - 2.45 N-m (0.02 - 0.24 kg-m, 2 - 21 in-lb) (Compression rod)
Axial end play	0 mm (0 in)

Wheelarch Height (Unladen*)

AES0007S

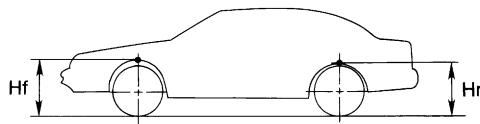

SFA818A

Tire	215/55R17	235/45R18
Front (Hf)	711 mm (27.99 in)	714 mm (28.11 in)
Rear (Hr)	704 mm (27.72 in)	705 mm (27.76 in)

*: Fuel, radiator coolant and engine oil full. Spare tire, jack, hand tools and mats in designated positions.

PRECAUTIONS

[AWD]

PRECAUTIONS

PFP:00001

Caution

AES000VR

- When installing rubber bushings, final tightening must be carried out under unladen conditions with tires on ground. Oil will shorten the life of rubber bushings. Be sure to wipe off any spilled oil.
- Unladen conditions mean that fuel, engine coolant and lubricant are full. Spare tire, jack, hand tools and mats are in designated positions.
- After servicing suspension parts, be sure to check wheel alignment.
- Caulking nuts are not reusable. Always use new ones when installing. Since new caulking nuts are pre-oiled, tighten as they are.

PREPARATION

[AWD]

PREPARATION

PFP:00002

Special Service Tools (SST)

AES000UY

The actual shapes of Kent-Moore tools may differ from those of special service tools illustrated here.

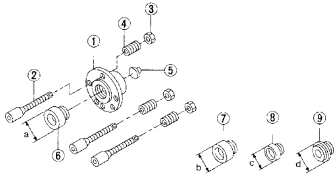
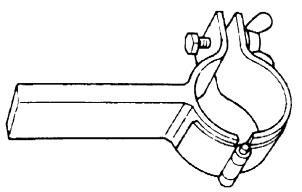
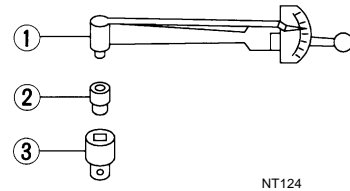
Tool number (Kent-Moore No.) Tool name	Description	
KV991040S0 (—) CCK gauge 1. Plate 2. Guide bolts 3. Nuts 4. Springs 5. Center plate 6. KV9910 4030 Adapter A a: 72 mm (2.83 in) dia. 7. KV9910 4030 Adapter B b: 65 mm (2.56 in) dia. 8. KV9910 4040 Adapter C c: 57 mm (2.24 in) dia. 9. KV9910 4050 Adapter D d: 53.4 mm (2.102 in) dia.	 <p style="text-align: center; font-size: small;">S-NT498</p>	Measuring wheel alignment
ST35652000 (—) Strut attachment	 <p style="text-align: center; font-size: small;">ZZA0807D</p>	Strut disassembly/re-assembly
ST3127S000 (See J25742-1) Preload Gauge 1. GG91030000 Torque wrench (J25765) 2. HT62940000 (—) Socket adapter (1/2") 3. HT62900000 (—) Socket adapter (3/8")	 <p style="text-align: center; font-size: small;">NT124</p>	Measuring rotating torque of ball joint

Commercial Service Tools

AES000UZ

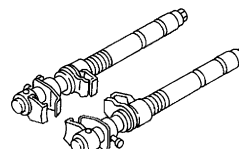
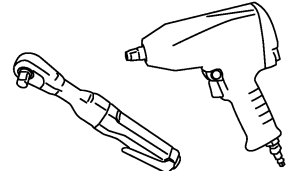
Tool name	Description	
Spring compressor	 <p style="text-align: center; font-size: small;">S-NT717</p>	Removing coil spring
Power tool	 <p style="text-align: center; font-size: small;">PBIC0190E</p>	<ul style="list-style-type: none"> ● Removing wheel nuts ● Removing undercover ● Removing stabilizer assembly

NOISE, VIBRATION AND HARSHNESS (NVH) TROUBLESHOOTING

[AWD]

NOISE, VIBRATION AND HARSHNESS (NVH) TROUBLESHOOTING

PPF:00003

NVH Troubleshooting Chart

AES000V0

Use chart below to help you find the cause of the symptom. If necessary, repair or replace these parts.

Symptom		Possible cause and SUSPECTED PARTS	Reference page																
			FSU-26	FSU-27	—	—	—	FSU-26	FSU-24	FSU-34	NVH in PR section	NVH in RFD section.	NVH in FAX and FSU section.	NVH in WT section.	NVH in WT section.	NVH in FAX section.	NVH in BR section.	NVH in PS section.	
Symptom	FRONT SUSPENSION	Noise	x	x	x	x	x	x	x	x	x	x	x	x	x	x	x	x	
		Shake	x	x	x	x		x			x		x	x	x	x	x	x	
		Vibration	x	x	x	x	x					x		x		x		x	
		Shimmy	x	x	x	x				x				x	x	x		x	x
		Judder	x	x	x									x	x	x		x	x
		Poor quality ride or handling	x	x	x	x	x			x	x				x	x	x		
			Improper installation, looseness	Shock absorber deformation, damage or deflection	Bushing or mounting deterioration	Parts interference	Spring fatigue	Suspension looseness	Incorrect wheel alignment	Stabilizer bar fatigue	PROPELLER SHAFT	DIFFERENTIAL	FRONT AXLE AND FRONT SUSPENSION	TIRES	ROAD WHEEL	DRIVE SHAFT	BRAKES	STEERING	

x: Applicable

FRONT SUSPENSION ASSEMBLY

PFP:54010

On-Vehicle Inspection and Service

AES000VS

Make sure the mounting conditions (looseness, back lash) of each component and component statuses (wear, damage) are normal.

INSPECTION OF TRANSVERSE LINK BALL JOINT END PLAY

1. Set front wheels in a straight-ahead position. Do not depress brake pedal.
2. Check ball joint axial end play of each link.

CAUTION:

Be careful not to damage ball joint boot.

Upper Link Ball Joint

Measure axial end play by installing and moving up/down with an iron pry bar or something similar between upper link and steering knuckle.

Standard value

Axial end play : 0 mm (0 in)

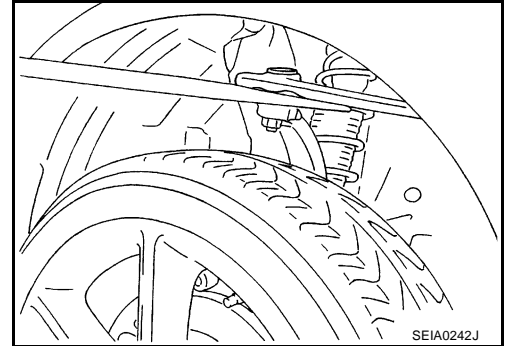

Steering Knuckle Lower Ball Joint

Measure axial end play by installing and moving up/down with an iron pry bar or something similar between steering knuckle and wheel.

Standard value

Axial end play : 0 mm (0 in)

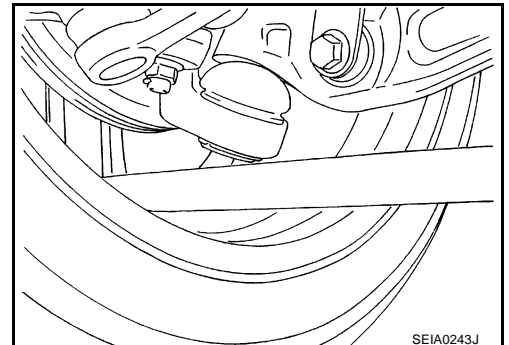

Compression Rod Ball Joint

Measure axial end play by installing and moving up/down with an iron pry bar or something similar between compression rod and transverse link.

Standard value

Axial end play : 0 mm (0 in)

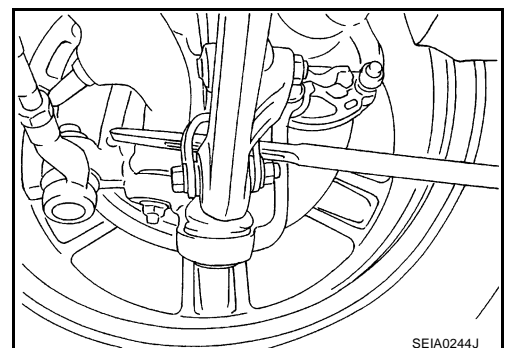

SHOCK ABSORBER INSPECTION

Check shock absorber for oil leakage, damage and replace if necessary. Refer to [FSU-27, "COIL SPRING AND SHOCK ABSORBER"](#).

A
B
C
D
FSU
F
G
H
I
J
K
L
M

Wheel Alignment Inspection

DESCRIPTION

Measure wheel alignment under unladen conditions.

NOTE:

Unladen conditions mean that fuel, engine coolant, and lubricant are full. Spare tire, jack, hand tools and mats are designated positions.

PRELIMINARY INSPECTION

1. Check tires for improper air pressure and wear.
2. Check road wheels for runout.
3. Check wheel bearing axial end play.
4. Check ball joint axial end play of compression rod, upper link, and steering knuckle.
5. Check shock absorber operation.
6. Check each mounting part of axle and suspension for looseness and deformation.
7. Check each link, rod and member for cracks, deformation and other damage.
8. Check vehicle posture.

INSPECTION OF CAMBER, CASTER AND KINGPIN INCLINATION ANGLES.

- Camber, caster, kingpin inclination angles cannot be adjusted.
- Before inspection, mount front wheels onto turning radius gauge. Mount rear wheels onto a stand that has same height so vehicle will remain horizontal.

Using a CCK Gauge

Install CCK gauge attachment (SST: KV991040S0) as following procedure in wheel, then measure wheel alignment.

1. Remove wheel nuts (2), and install a guide bolt to hub bolt.
2. Screw adapter into plate body until it contacts body tightly.
3. Screw center plate into plate.
4. Insert plate on guide bolt. Put spring in, and then evenly screw both guide bolt nut. When fastening guide bolt nut, do not completely compress spring.

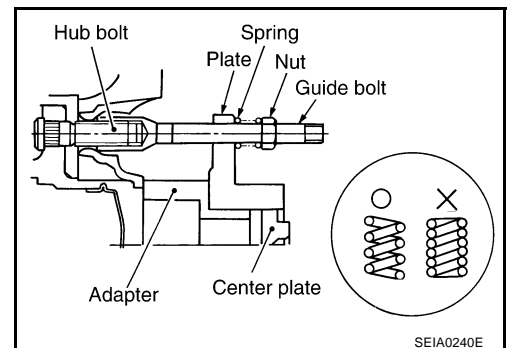

5. Place the dent of alignment gauge onto the projection of center plate and tightly contact them to measure.

Standard value

Camber, caster, king inclination angles:

Refer to [FSU-36. "SERVICE DATA"](#) .

CAUTION:

- If camber, caster, or kingpin inclination angle is outside the standard, check front suspension parts for wear and damage, and replace suspect parts if necessary.
- King pin inclination angles is reference value, no inspection is required. (Due to the type of suspension, the kingpin inclination angle cannot be measured correctly using a normal alignment tester.)

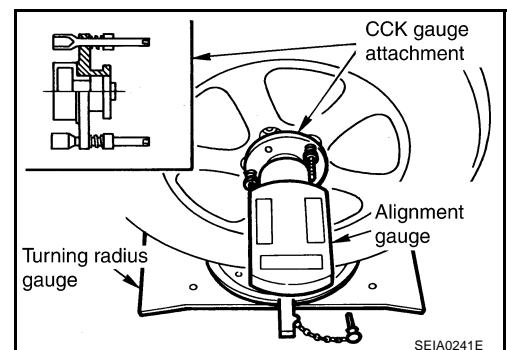

FRONT SUSPENSION ASSEMBLY

[AWD]

Toe-In Inspection

Measure toe-in using the following procedure.

WARNING:

- Always perform the following procedure on a flat surface.
- Make sure that no person is in front of vehicle before pushing it.

1. Bounce front of vehicle up and down to stabilize the posture.
2. Push vehicle straight ahead about 5 m (16 ft).
3. Put a mark on base line of the tread (rear side) of both tires at the same height as hub center. These are measuring points.

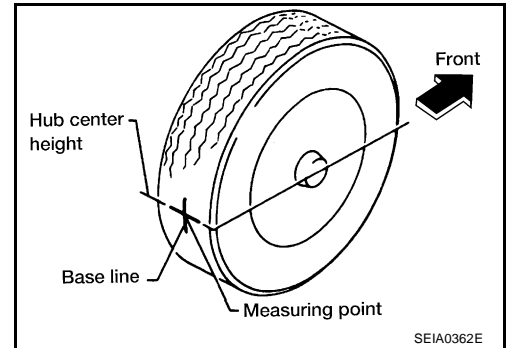

4. Measure distance "A" (rear side).
5. Push vehicle slowly ahead to rotate wheels 180 degrees (1/2 turn).
If wheels have rotated more than 180 degrees (1/2 turn), try the above procedure again from the beginning. Never push vehicle backward.
6. Measure distance "B" (front side).

Standard value

Total toe-in : Refer to [FSU-36, "SERVICE DATA"](#)

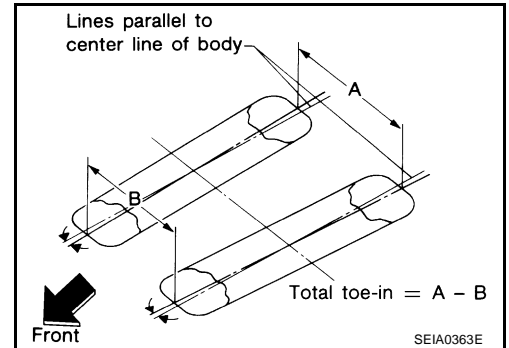

A
B
C
D

FSU

F
G
H

I
J
K
L
M

FRONT SUSPENSION ASSEMBLY

[AWD]

Components

AES000VU

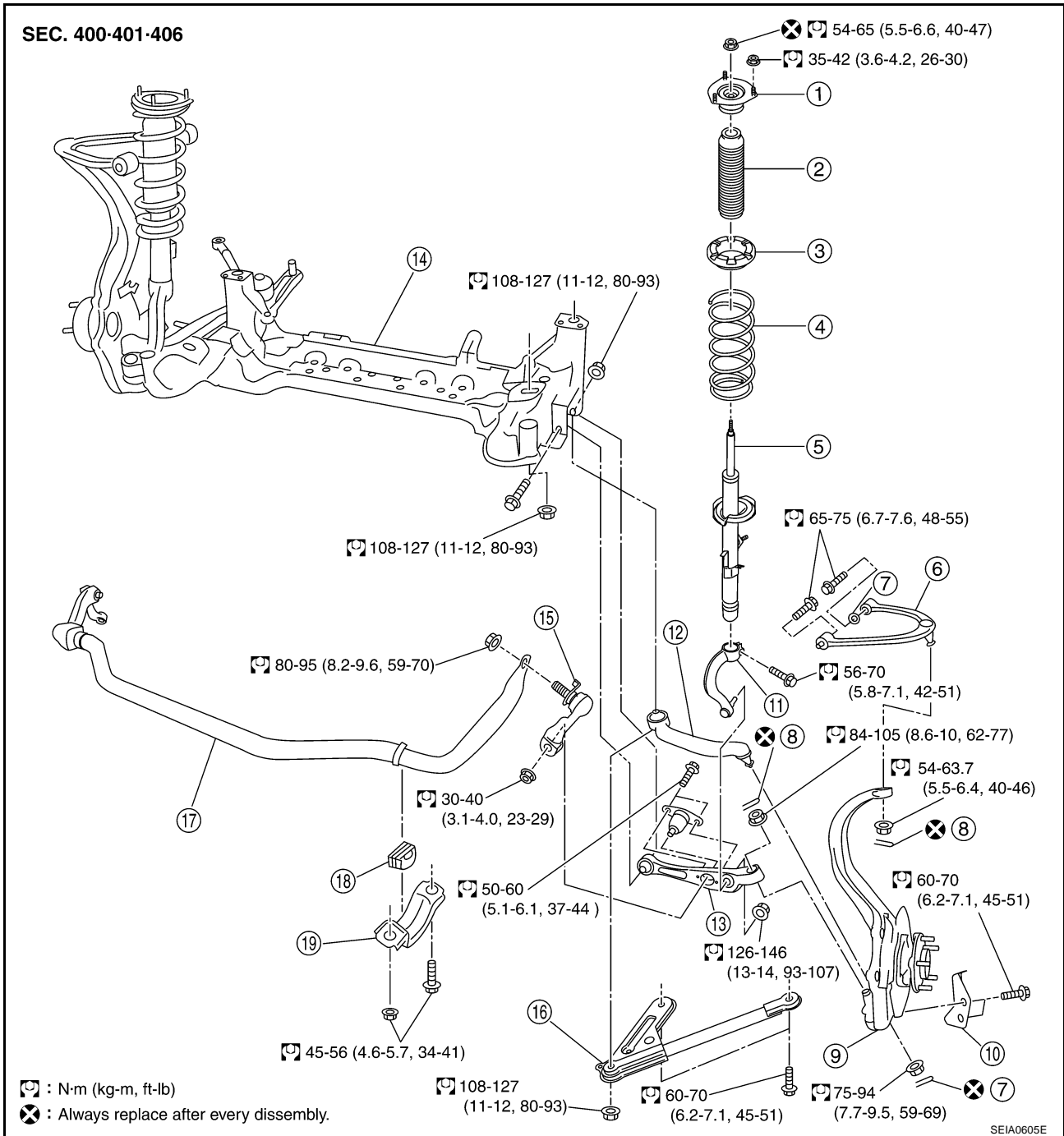

- | | | |
|------------------------------|-----------------------------|-------------------------------|
| 1. Mounting insulator | 2. Bound bumper | 3. Spring upper seat |
| 4. Coil spring | 5. Shock absorber | 6. Upper link |
| 7. Washer | 8. Cotter pin | 9. Front axle |
| 10. Steering stopper bracket | 11. Shock absorber arm | 12. Compression rod |
| 13. Transverse link | 14. Front suspension member | 15. Stabilizer connecting rod |
| 16. Compression rod stay | 17. Stabilizer bar | 18. Stabilizer bushing |
| 19. Stabilizer clamp | | |

COIL SPRING AND SHOCK ABSORBER

PFP:54302

Removal and Installation

AES000V4

REMOVAL

1. Remove tire with power tool.
2. Remove undercover with power tool.
3. Remove harness of wheel sensor from shock absorber. Refer to [BRC-66, "WHEEL SENSOR"](#) .
4. Remove mounting nuts of brake hose from shock absorber. Refer to [BR-11, "BRAKE PIPING AND HOSE"](#) .
5. Remove mounting nut of shock absorber arm lower side, then separate shock absorber arm and transverse link with power tool.
6. Remove mounting nuts on mounting insulator with power tool, then remove shock absorber from vehicle.

INSTALLATION

- Refer to [FSU-26, "Components"](#) for tightening torque. Install in the reverse order of removal.

NOTE:

Refer to component parts location and do not reuse non-reusable parts.

- Perform final tightening of shock absorber lower side (rubber bushing) under unladen condition with tires on ground. Check wheel alignment. Refer to [FSU-24, "Wheel Alignment Inspection"](#) .

Disassembly and Assembly

AES000V5

DISASSEMBLY

NOTE:

Make sure piston rod shock absorber is not damaged when removing components from shock absorber.

1. Install strut attachment (SST) to shock absorber and fix it in a vise.

CAUTION:

When installing strut attachment (SST) to shock absorber, wrap a shop cloth around shock absorber to protect it from damage.

2. Using a spring compressor (commercial service tool), compress coil spring between spring upper seat and spring lower seat (on shock absorber) until coil spring is free.

CAUTION:

Be sure spring compressor (commercial service tool) is securely attached to coil spring. Compress coil spring.

3. Check that coil spring between spring upper seat and spring lower seat is free and then secure piston rod does not turn, and remove piston rod lock nut.
4. Remove mounting insulator, bound bumper, spring upper seat. Then remove coil spring from shock absorber.
5. Gradually release spring compressor (commercial service tool), and remove coil spring.

CAUTION:

Loosen while making sure coil spring attachment position does not move.

6. Remove strut attachment (SST) from shock absorber.

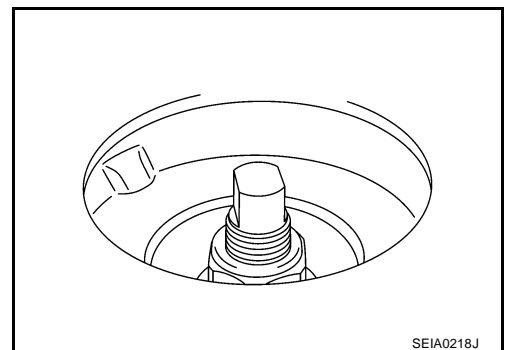
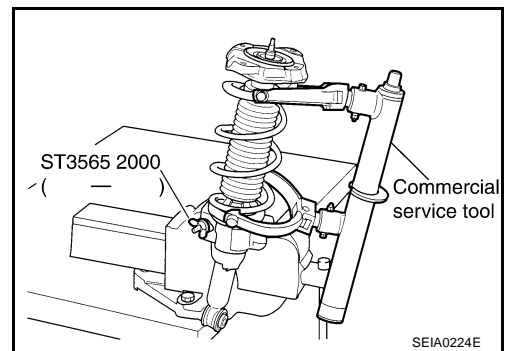

INSPECTION AFTER DISASSEMBLY

Shock Absorber Inspection

- Check shock absorber for deformation, cracks, damage, and replace if necessary.
- Check piston rod for damage, uneven wear, distortion, and replace if necessary.
- Check welded and sealed areas for oil leakage, and replace if necessary.

Mounting Insulator and Rubber Parts Inspection

Check mounting insulator for cracks and rubber parts for wear. Replace them if necessary.

Coil Spring Inspection

Check coil spring for cracks, wear, damage, and replace if necessary.

ASSEMBLY

NOTE:

Make sure piston rod on shock absorber is not damaged when attaching components to shock absorber.

1. Install strut attachment (SST) to shock absorber and fix it in a vise.

CAUTION:

When installing strut attachment (SST) to shock absorber, wrap a shop cloth around shock absorber to protect it from damage.

2. Compress coil spring using a spring compressor (commercial service tool), and install it onto shock absorber.

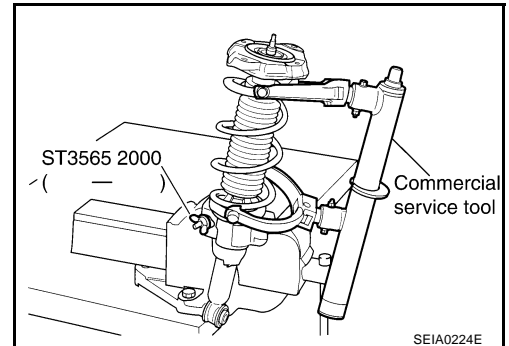

CAUTION:

- Install coil spring as shown in the figure with large diameter side [100 mm (3.94 in)] up and small diameter side [90 mm (3.54 in)] down.

- Be sure spring compressor (commercial service tool) is securely attached to coil spring. Compress coil spring.

3. Apply soapy water to bound bumper and insert into mounting insulator.

CAUTION:

Do not use machine oil.

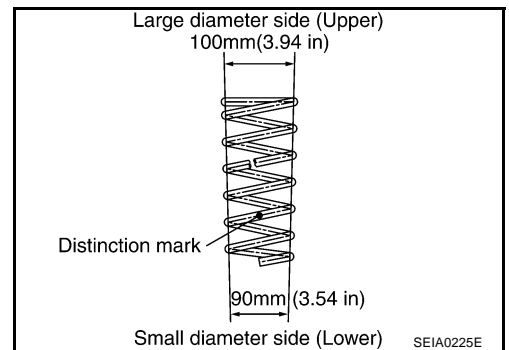

4. Attach spring upper seat and mounting insulator as shown in the figure.

CAUTION:

- Make sure coil spring is securely seated in spring mounting groove of spring upper seat.

- The bottom part of spring should be at the position of A point of spring seat.

5. Secure piston rod tip so that piston rod does not turn, and tighten the specified torque on piston rod lock nut.

6. Gradually release spring compressor (commercial service tool), and remove coil spring.

CAUTION:

Loosen spring compressor (commercial service tool) while making sure coil spring attachment position does not move.

7. Remove strut attachment (SST) from shock absorber.

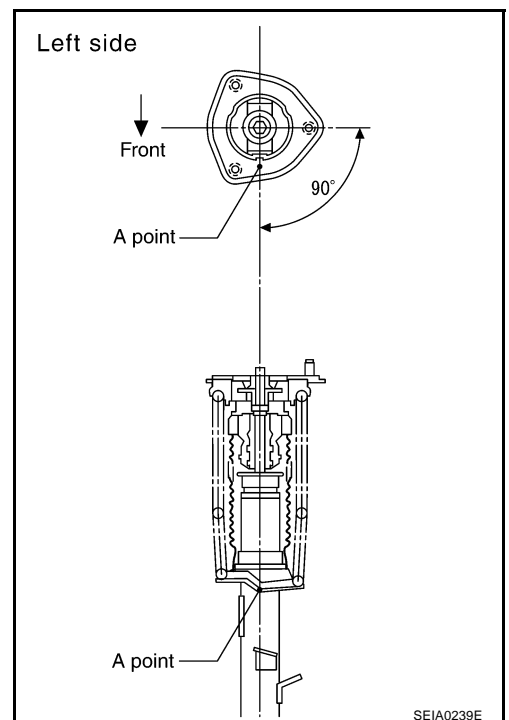

TRANSVERSE LINK

PFP:54500

Removal and Installation

AES000V6

REMOVAL

1. Remove tire with power tool.
2. Remove under cover with power tool.
3. Remove mounting nut on lower portion of stabilizer connecting rod with power tool.
4. Remove mounting nut between transverse link and shock absorber lower arm.
5. Remove mounting nut between transverse link and front suspension member with power tool.
6. Remove transverse link from steering knuckle. Refer to [FAX-12, "Removal and Installation"](#).
7. Remove transverse link from vehicle.

INSPECTION AFTER REMOVAL

Visual Inspection

Check transverse link and bushing for deformation, cracks, or damage. If any non-standard condition is found, replace it.

INSTALLATION

- Refer to [FSU-26, "Components"](#) for tightening torque. Install in the reverse order of removal.

NOTE:

Refer to component parts location and do not reuse non-reusable parts.

- Perform final tightening of front suspension member installation position and shock absorber lower side (rubber bushing) under unladen condition with tires on ground. Check wheel alignment. Refer to [FSU-24, "Wheel Alignment Inspection"](#).

A
B
C
D

FSU

F
G
H
I
J
K
L
M

UPPER LINK

Removal and Installation

REMOVAL

1. Remove tire with power tool.
2. Remove undercover with power tool.
3. Remove shock absorber. Refer to [FSU-27, "COIL SPRING AND SHOCK ABSORBER"](#).
4. Remove cotter pin of upper link ball joint, then loosen mounting nut.
5. Use a ball joint remover (suitable tool) to remove upper link from steering knuckle. Be careful not to damage ball joint boot.

CAUTION:

Tighten temporarily mounting nut to prevent damage to threads and to prevent ball joint remover (suitable tool) from coming off.

6. Remove bolts holding upper link to body with power tool.
7. Remove upper link from vehicle.

INSPECTION AFTER REMOVAL

Visual Inspection

- Check upper link and bushing for deformation, cracks, or damage. If any non-standard condition is found, replace it.
- Check boot of ball joint for cracks, or other damage, and also for grease leakage. If any non-standard condition is found, replace it.

Ball Joint Inspection

Manually move ball stud to confirm it moves smoothly with no binding.

Swing Torque Inspection

NOTE:

Before measurement, move ball joint at least ten times by hand to check for smooth movement.

- Hook spring scale at ball stud. Confirm spring scale measurement value is within specifications when ball stud begins moving.

Standard value

Swing torque:

Less than 2.0 N-m (0.20 kg-m, 18 in-lb)

- If it is outside the specified range, replace upper link assembly.

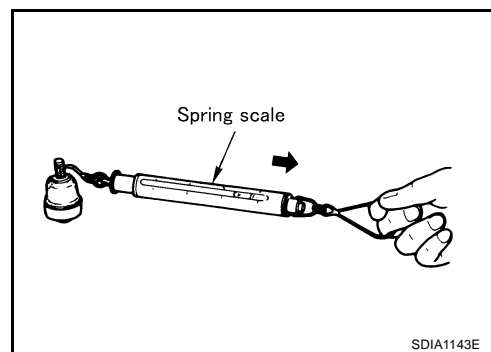

Rotating Torque Inspection

- Attach mounting nut to ball stud. Check that rotating torque is within specification with a preload gauge (SST).

Standard value

Rotating torque:

Less than 2.0 N-m (0.20 kg-m, 18 in-lb)

- If it is outside the specified range, replace upper link assembly.

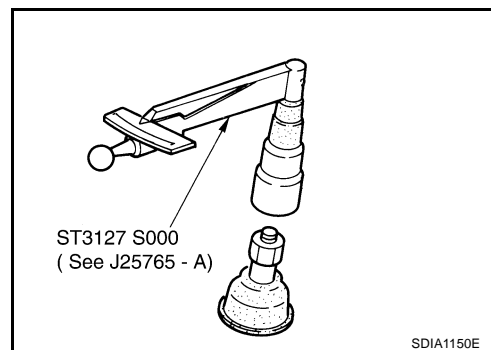

Axial End Play Inspection

- Move tip of ball joint in axial direction to check for looseness.

Standard value

Axial end play : 0 mm (0 in)

- If it is outside the specified range, replace upper link assembly.

INSTALLATION

- Refer to [FSU-26, "Components"](#) for tightening torque. Install in the reverse order of removal.

NOTE:

Refer to component parts location and do not reuse non-reusable parts.

- Perform final tightening of front suspension member installation position (rubber bushing) under unladen condition with tires on ground. Check wheel alignment. Refer to [FSU-24, "Wheel Alignment Inspection"](#).

A

B

C

D

FSU

F

G

H

I

J

K

L

M

COMPRESSION ROD

Removal and Installation

REMOVAL

1. Remove tires with power tool.
2. Remove undercover with power tool.
3. Remove cotter pin of compression rod ball joint, and loosen nut.
4. Use a ball joint remover (suitable tool) to remove compression rod from steering knuckle. Be careful not to damage ball joint boot.

CAUTION:

Tighten temporarily mounting nut to prevent damage to threads and to prevent ball joint remover (SST) from coming off.

5. Remove compression rod and compression rod stay from vehicle.

INSPECTION AFTER REMOVAL

Visual Inspection

- Check compression rod and bushing for deformation, cracks, or damage. If any non-standard condition is found, replace it.
- Check boot of ball joint for cracks, or other damage, and also for grease leakage. If any non-standard condition is found, replace it.

Ball Joint Inspection

- Manually move ball stud to confirm it moves smoothly with no binding.

Swing Torque Inspection

NOTE:

Before measurement, move ball joint at least ten times by hand to check for smooth movement.

- Hook spring scale at ball stud. Confirm spring scale measurement value is within the specifications when ball stud begins moving.

Standard value

Swing torque:

0.147 - 2.45 N·m (0.02 - 0.24 kg·m, 2 - 21 in·lb)

Measured value of spring scale:

2.37 - 39.5 N (0.24 - 4.03 kg, 0.53 - 8.88 lb)

- If it is outside the specified range, replace compression rod assembly.

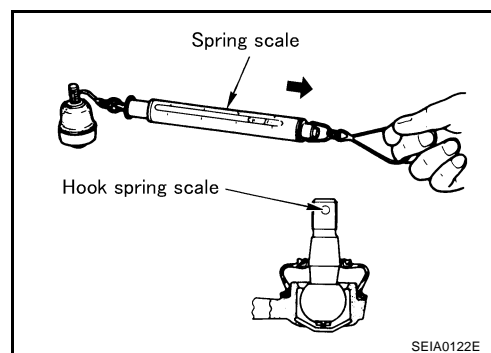

Rotating Torque Inspection

- Attach mounting nut to ball stud. Check that rotating torque is within the specifications with a preload gauge (SST).

Standard value

Rotating torque:

0.147 - 2.45 N·m (0.02 - 0.24 kg·m, 2 - 21 in·lb)

- If it is outside the specified range, replace compression rod assembly.

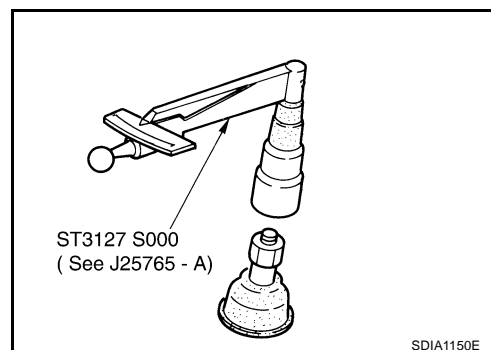

Axial End Play Inspection

- Move tip of ball joint in axial direction to check for looseness.

Standard value

Axial end play : 0 mm (0 in)

- If it is outside the specified range, replace compression rod assembly.

INSTALLATION

- Refer to [FSU-26, "Components"](#) for tightening torque. Install in the reverse order of removal.

NOTE:

Refer to component parts location and do not reuse non-reusable parts.

- Perform final tightening of Installation position between front suspension member and compression rod stay (rubber bushing) under unladen condition with tires on ground. Check wheel alignment. Refer to [FSU-36, "SERVICE DATA"](#).

A

B

C

D

FSU

F

G

H

I

J

K

L

M

STABILIZER BAR

PFP:54611

Removal and Installation

REMOVAL

1. Remove tire with power tool.
2. Remove undercover with power tool.
3. Remove mounting nut on upper portion of stabilizer connecting rod with power tool.
4. Remove fixing bolt and nut, then remove stabilizer clamp, stabilizer bushing.
5. Remove stabilizer bar from vehicle.

AES000V7

INSPECTION AFTER REMOVAL

Check stabilizer bar, stabilizer connecting rod, stabilizer bushing and clamp for deformation, cracks and damage, and replace if necessary.

INSTALLATION

- Refer to [FSU-26, "Components"](#) for tightening torque. Install in the reverse order of removal.
- Stabilizer bar uses pillow ball type connecting rod. Position ball joint with case on pillow ball head parallel to stabilizer bar.

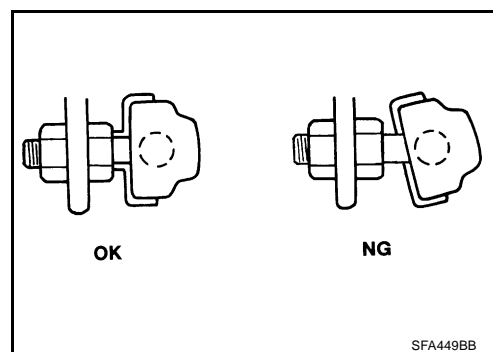

FRONT SUSPENSION MEMBER**Removal and Installation****REMOVAL**

1. Remove tire with power tool.
2. Remove undercover with power tool.
3. Remove stabilizer bar. Refer to [FSU-34, "STABILIZER BAR"](#) .
4. Remove steering hydraulic piping bracket from front suspension member. Refer to [PS-36, "HYDRAULIC LINE"](#) .
5. Remove steering gear and front suspension member attachment bolts and hang steering gear on vehicle. Refer to [PS-20, "POWER STEERING GEAR AND LINKAGE"](#) .
6. Remove fixing bolts and nut, then remove compression rod stay from vehicle.
7. Remove transverse link from front suspension member with power tool. Refer to [FSU-29, "TRANSVERSE LINK"](#) .
8. Set jack under engine.

CAUTION:

When setting jack to engine, use a wooden block or an equivalent for the setting.0

9. Remove fixing nuts between engine mounting insulator and front suspension member. Refer to [EM-139, "ENGINE ASSEMBLY"](#) .
10. Remove fixing nuts between front suspension member and body with power tool.
11. Remove front suspension member from vehicle.

INSPECTION AFTER REMOVAL

Check front suspension member for deformation, cracks, or any other damage. Replace if necessary.

INSTALLATION

- Refer to [FSU-26, "Components"](#) for tightening torque in the reverse order of removal.
- Perform final tightening of installation position between front suspension member and transverse link, compression rod (rubber bushing) under unladen condition with tires on level ground. Check wheel alignment. Refer to [FSU-36, "SERVICE DATA"](#) .

SERVICE DATA

[AWD]

SERVICE DATA

PFP:00030

Wheel Alignment (Unladen)

AES000VB

Camber Degree minute (Decimal degree)	Minimum	- 1°00' (- 1.00°)	
	Nominal	- 0°15' (- 0.25°)	
	Maximum	0°30' (0.50°)	
	Left and right difference	45' (0.75°)	
Caster Degree minute (Decimal degree)	Minimum	5°55' (5.92°)	
	Nominal	6°40' (6.67°)	
	Maximum	7°25' (7.42°)	
	Left and right difference	45' (0.75°)	
Kingpin offset Degree minute (Decimal degree)	Minimum	5°15' (5.25°)	
	Nominal	6°00' (6.00°)	
	Maximum	6°45' (6.75°)	
Total toe-in	Distance (A - B)	Minimum	0 mm (0 in)
		Nominal	1 mm (0.04 in)
		Maximum	2 mm (0.08 in)

Ball Joint

AES000VC

Swing torque	Less than 2.0 N·m (0.20 kg-m, 18 in-lb) (Upper link) 0.147 - 2.45 N·m (0.02 - 0.24 kg-m, 2 - 21 in-lb) (Compression rod)
Measurement on spring scale (cotter pinhole position)	Less than 34.8 N (3.5 kg, 7.8 lb) (Upper link) 2.37 - 39.5 N (0.24 - 4.03 kg, 0.53 - 8.88 lb) (Compression rod)
Rotating torque	Less than 2.0 N·m (0.20 kg-m, 18 in-lb) (Upper link) 0.147 - 2.45 N·m (0.02 - 0.24 kg-m, 2 - 21 in-lb) (Compression rod)
Axial end play	0 mm (0 in)

Wheelarch Height (Unladen*)

AES000VD

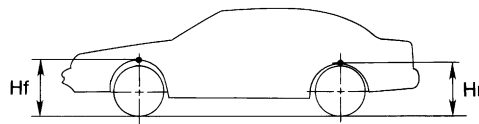

SFA818A

Applied model	215/55R17
Front (Hf)	709 mm (27.91 in)
Rear (Hr)	694 mm (27.32 in)

*: Fuel, radiator engine coolant and engine oil full. Spare tire, jack, hand tools and mats in designated positions.