

LT
SECTION
LIGHTING SYSTEM

A
 B
 C
 D
 E
 F
 G
 H
 I
 J
 LT
 L
 M

CONTENTS

<p>PRECAUTIONS 5</p> <p> Precautions for Supplemental Restraint System (SRS) "AIR BAG" and "SEAT BELT PRE-TENSIONER" 5</p> <p> General Precautions for Service Operations 5</p> <p>HEADLAMP (FOR USA) 6</p> <p> Component Parts and Harness Connector Location... 6</p> <p> System Description 6</p> <p> OUTLINE 6</p> <p> HEADLAMP OPERATION 7</p> <p> COMBINATION SWITCH READING FUNCTION... 8</p> <p> EXTERIOR LAMP BATTERY SAVER CONTROL... 8</p> <p> AUTO LIGHT OPERATION (IF EQUIPPED) 8</p> <p> VEHICLE SECURITY SYSTEM 8</p> <p> XENON HEADLAMP 8</p> <p> CAN Communication System Description 8</p> <p> CAN Communication Unit 8</p> <p> Schematic 9</p> <p> Wiring Diagram — H/LAMP — 10</p> <p> Terminals and Reference Values for BCM 14</p> <p> Terminals and Reference Values for IPDM E/R 14</p> <p> How to Proceed with Trouble Diagnosis 15</p> <p> Preliminary Check 15</p> <p> CHECK POWER SUPPLY AND GROUND CIRCUIT 15</p> <p> CONSULT-II Functions (BCM) 17</p> <p> CONSULT-II BASIC OPERATION 17</p> <p> WORK SUPPORT 18</p> <p> DATA MONITOR 18</p> <p> ACTIVE TEST 19</p> <p> CONSULT-II Functions (IPDM E/R) 20</p> <p> CONSULT-II BASIC OPERATION 20</p> <p> DATA MONITOR 21</p> <p> ACTIVE TEST 21</p> <p> Headlamp High Beam Does Not Illuminate (Both Sides) 22</p> <p> Headlamp High Beam Does Not Illuminate (One Side) 24</p> <p> High Beam Indicator Lamp Does Not Illuminate ... 25</p> <p> Headlamp Low Beam Does Not Illuminate (Both</p>	<p> Sides) 25</p> <p> Headlamp Low Beam Does Not Illuminate (One Side) 28</p> <p> Headlamps Does Not Turn OFF 29</p> <p> General Information for Xenon Headlamp Trouble Diagnosis 31</p> <p> Caution: 31</p> <p> Xenon Headlamp Trouble Diagnosis 31</p> <p> Aiming Adjustment 32</p> <p> PREPARATION BEFORE ADJUSTING 32</p> <p> LOW BEAM AND HIGH BEAM 32</p> <p> ADJUSTMENT USING AN ADJUSTMENT SCREEN (LIGHT/DARK BORDERLINE) 33</p> <p> Bulb Replacement 33</p> <p> HEADLAMP (UPPER) LOW BEAM 33</p> <p> HEADLAMP (LOWER) HIGH BEAM/FOG LAMP.. 34</p> <p> FRONT TURN SIGNAL/PARKING LAMP 34</p> <p> Removal and Installation 34</p> <p> REMOVAL 34</p> <p> INSTALLATION 34</p> <p> Disassembly 35</p> <p> Assembly 36</p> <p> Servicing to Replace Headlamps When Damaged.. 36</p> <p> REMOVAL AND INSTALLATION 36</p> <p>HEADLAMP (FOR CANADA) - DAYTIME LIGHT SYSTEM - 37</p> <p> Component Parts and Harness Connector Location.. 37</p> <p> System Description 37</p> <p> OUTLINE 37</p> <p> HEADLAMP OPERATION 38</p> <p> DAYTIME LIGHT OPERATION 40</p> <p> OPERATION 40</p> <p> COMBINATION SWITCH READING FUNCTION.. 40</p> <p> EXTERIOR LAMP BATTERY SAVER CONTROL.. 40</p> <p> AUTO LIGHT OPERATION (IF EQUIPPED) 40</p> <p> VEHICLE SECURITY SYSTEM 41</p> <p> XENON HEADLAMP 41</p> <p> CAN Communication System Description 41</p> <p> CAN Communication Unit 41</p> <p> Schematic 42</p>
---	---

Wiring Diagram — DTRL —	43	CAN Communication Unit	77
Terminals and Reference Values for Daytime Light Control Unit	49	Major Components and Functions	77
Terminals and Reference Values for BCM	50	Schematic	78
Terminals and Reference Values for IPDM E/R	50	Wiring Diagram — AUTO/L —	79
How to Proceed with Trouble Diagnosis	51	Terminals and Reference Values for BCM	82
Preliminary Check	51	Terminals and Reference Values for IPDM E/R	83
CHECK POWER SUPPLY AND GROUND CIRCUIT	51	How to Proceed With Trouble Diagnosis	83
CONSULT-II Functions (BCM)	53	Preliminary Check	84
CONSULT-II BASIC OPERATION	53	SETTING CHANGE FUNCTIONS	84
WORK SUPPORT	54	CHECK POWER SUPPLY AND GROUND CIRCUIT	84
DATA MONITOR	54	CONSULT-II Functions (BCM)	85
ACTIVE TEST	55	CONSULT-II BASIC OPERATION	85
CONSULT-II Functions (IPDM E/R)	56	WORK SUPPORT	86
CONSULT-II BASIC OPERATION	56	DATA MONITOR	86
DATA MONITOR	57	ACTIVE TEST	87
ACTIVE TEST	57	CONSULT-II Functions (IPDM E/R)	88
Daytime Light Control Does Not Operate Properly	58	CONSULT-II BASIC OPERATION	88
Headlamp High Beam Does Not Illuminate (Both Sides)	60	DATA MONITOR	89
RH High Beam Does Not Illuminate But RH Low Beam Illuminates	62	ACTIVE TEST	89
LH High Beam Does Not Illuminate But LH Low Beam Illuminates	64	Symptom Chart	90
Headlamp Low Beam Does Not Illuminate (Both Sides)	66	Lighting Switch Inspection	90
RH Low Beam Does Not Illuminate But RH High Beam Illuminates	68	Optical Sensor System Inspection	91
LH Low Beam Does Not Illuminate But LH High Beam Illuminates	69	Removal and Installation for Optical Sensor	93
General Information for Xenon Headlamp Trouble Diagnosis	70	REMOVAL	93
Caution:	70	INSTALLATION	93
Xenon Headlamp Trouble Diagnosis	70	FRONT FOG LAMP	94
Aiming Adjustment	71	Component Parts and Harness Connector Location	94
PREPARATION BEFORE ADJUSTING	71	System Description	94
LOW BEAM AND HIGH BEAM	71	OUTLINE	94
ADJUSTMENT USING AN ADJUSTMENT SCREEN (LIGHT/DARK BORDERLINE)	72	FOG LAMP OPERATION (FOR USA)	95
Bulb Replacement	72	FOG LAMP OPERATION (FOR CANADA)	95
HEADLAMP (UPPER) LOW BEAM	72	COMBINATION SWITCH READING FUNCTION	96
HEADLAMP (LOWER) HIGH BEAM/FOG LAMP	73	EXTERIOR LAMP BATTERY SAVER CONTROL	96
FRONT TURN SIGNAL/PARKING LAMP	73	CAN Communication System Description	96
Removal and Installation	73	CAN Communication Unit	96
REMOVAL	73	Wiring Diagram — F/FOG —	97
INSTALLATION	73	FOR USA	97
Disassembly	74	FOR CANADA	99
Assembly	75	Terminals and Reference Values for BCM	101
Servicing to Replace Headlamps When Damaged	75	Terminals and Reference Values for IPDM E/R	101
REMOVAL AND INSTALLATION	75	How to Proceed with Trouble Diagnosis	102
AUTO LIGHT SYSTEM	76	Preliminary Check	102
Component Parts and Harness Connector Location	76	CHECK POWER SUPPLY AND GROUND CIRCUIT	102
System Description	76	CONSULT-II Functions (BCM)	103
OUTLINE	76	CONSULT-II Functions (IPDM E/R)	103
COMBINATION SWITCH READING FUNCTION	77	Front Fog lamps Does Not Illuminate (Both Sides) (FOR USA)	104
EXTERIOR LAMP BATTERY SAVER CONTROL	77	Front Fog Lamp Does Not Illuminate (One Side) (FOR USA)	106
DELAY TIMER FUNCTION	77	Front Fog lamps Does Not Illuminate (Both Sides) (FOR CANADA)	107
CAN Communication System Description	77	LH Front Fog Lamp Does Not Illuminate (FOR CANADA)	108
		RH Front Fog Lamp Does Not Illuminate (FOR CANADA)	111
		Bulb Replacement	111
		TURN SIGNAL AND HAZARD WARNING LAMPS	112

Component Parts and Harness Connector Location	112	INSTALLATION	137	
System Description	112	Removal and Installation of Rear Combination Lamp (Stop Lamp)	137	A
TURN SIGNAL OPERATION	112	STEP LAMP	138	
HAZARD LAMP OPERATION	113	Bulb Replacement	138	B
REMOTE KEYLESS ENTRY SYSTEM OPERATION	114	Removal and Installation	138	
COMBINATION SWITCH READING FUNCTION	114	REMOVAL	138	
CAN Communication System Description	114	INSTALLATION	138	C
CAN Communication Unit	114	BACK-UP LAMP	139	
Schematic	115	Wiring Diagram — BACK/L —	139	
Wiring Diagram — TURN —	116	A/T MODELS	139	D
Terminals and Reference Values for BCM	119	M/T MODELS	140	
How to Proceed with Trouble Diagnosis	120	PARKING, LICENSE PLATE AND TAIL LAMPS	141	
Preliminary Check	120	Component Parts and Harness Connector Location	141	
CHECK POWER SUPPLY AND GROUND CIRCUIT	120	System Description	141	E
CONSULT-II Functions (BCM)	122	OPERATION BY LIGHTING SWITCH	142	
CONSULT-II BASIC OPERATION	122	COMBINATION SWITCH READING FUNCTION	142	F
DATA MONITOR	123	EXTERIOR LAMP BATTERY SAVER CONTROL	142	
ACTIVE TEST	123	CAN Communication System Description	143	
Turn Signal Lamp Does Not Operate	123	CAN Communication Unit	143	G
Hazard Warning Lamp Does Not Operate But Turn Signal Lamp Operate	125	Schematic	144	
Turn Signal Indicator Lamp Does Not Operate	126	Wiring Diagram — TAIL/L —	145	H
Bulb Replacement (Front Turn Signal Lamp)	127	Terminals and Reference Values for BCM	148	
Bulb Replacement (Rear Turn Signal Lamp)	127	Terminals and Reference Values for IPDM E/R	148	
Removal and Installation of Front Turn Signal Lamp	127	How to Proceed With Trouble Diagnosis	149	I
Removal and Installation of Rear Turn Signal Lamp	127	Preliminary Check	149	
LIGHTING AND TURN SIGNAL SWITCH	128	CHECK POWER SUPPLY AND GROUND CIRCUIT	149	J
Removal and Installation	128	CONSULT-II Functions (BCM)	150	
REMOVAL	128	CONSULT-II Functions (IPDM E/R)	150	
INSTALLATION	128	Parking, License Plate and Tail Lamps Do Not Illuminate	150	
HAZARD SWITCH	129	Parking, License Plate, Side marker and Tail Lamps Do Not Turn OFF (After Approx. 10 Minutes)	155	
Removal and Installation (M/T)	129	Bulb Replacement	156	LT
REMOVAL	129	FRONT SIDE MARKER LAMP	156	
INSTALLATION	129	LICENSE PLATE LAMP	156	
Removal and Installation (A/T)	129	FRONT TURN SIGNAL (PARKING) LAMP	156	L
REMOVAL	129	TAIL LAMP	156	
INSTALLATION	129	Removal and Installation	156	
COMBINATION SWITCH	130	FRONT SIDE MARKER LAMP	156	
Wiring Diagram — COMBSW —	130	LICENSE PLATE LAMP	157	M
Combination Switch Reading Function	131	FRONT TURN SIGNAL (PARKING) LAMP	157	
CONSULT-II Function (BCM)	131	TAIL LAMP	157	
CONSULT-II BASIC OPERATION	131	REAR COMBINATION LAMP	158	
DATA MONITOR	132	Bulb Replacement	158	
Combination Switch Inspection	133	REAR FENDER SIDE (REAR TURN SIGNAL LAMP BULB)	158	
Removal and Installation	135	TRUNK LID SIDE (BACK-UP LAMP)	158	
STOP LAMP	136	Removal and Installation	158	
Wiring Diagram — STOP/L —	136	REMOVAL	158	
Bulb Replacement of High-Mounted Stop Lamp	137	INSTALLATION	159	
WITH REAR SPOILER	137	VANITY MIRROR LAMP	160	
WITHOUT REAR SPOILER	137	Bulb Replacement	160	
Bulb Replacement of Rear Combination Lamp (Stop Lamp)	137	MAP LAMP	161	
Removal and Installation of High-Mounted Stop Lamp	137	Bulb Replacement	161	
REMOVAL (WITH REAR SPOILER)	137	Removal and Installation	161	
INSTALLATION	137	REMOVAL	161	
REMOVAL (WITHOUT REAR SPOILER)	137	INSTALLATION	161	

TRUNK ROOM LAMP	162	Terminals and Reference Values for BCM	182
Bulb Replacement, Removal and Installation	162	How to Proceed With Trouble Diagnosis	183
REMOVAL	162	Preliminary Check	183
INSTALLATION	162	CHECK POWER SUPPLY AND GROUND CIR- CUIT	183
PERSONAL LAMP	163	CONSULT-II Functions (BCM)	184
Bulb Replacement	163	CONSULT-II BASIC OPERATION	184
Removal and Installation	163	WORK SUPPORT	185
REMOVAL	163	DATA MONITOR	185
INSTALLATION	163	ACTIVE TEST	186
IGNITION KEY HOLE ILLUMINATION	164	Map Lamp Control Does Not Operate	187
Removal and Installation	164	Ignition Key Hole Illumination Control Does Not Operate	188
REMOVAL (WITHOUT INTELLIGENT KEY SYS- TEM)	164	All Step Lamps Does Not Operate	190
REMOVAL (WITH INTELLIGENT KEY SYSTEM)	164	All Interior Room Lamps Does Not Operate	191
INSTALLATION	164	Bulb Replacement	191
GLOVE BOX LAMP	165	MAP LAMP	191
Bulb Replacement, Removal and Installation	165	STEP LMP	191
REMOVAL	165	Removal and Installation	191
INSTALLATION	165	MAP LAMP	191
ASHTRAY ILLUMINATION	166	STEP LAMP	191
Bulb Replacement, Removal and Installation	166	ILLUMINATION	192
REMOVAL	166	System Description	192
INSTALLATION	166	ILLUMINATION OPERATION BY LIGHTING SWITCH	192
CIGARETTE LIGHTER ILLUMINATION	167	EXTERIOR LAMP BATTERY SAVER CONTROL	193
Bulb Replacement, Removal and Installation	167	CAN Communication System Description	194
REMOVAL	167	CAN Communication Unit	194
INSTALLATION	167	Schematic	195
INTERIOR ROOM LAMP	168	Wiring Diagram — ILL —	196
Component Parts and Harness Connector Location	168	Removal and Installation	205
System Description	169	GLOVE BOX LAMP	205
POWER SUPPLY AND GROUND	169	BULB SPECIFICATIONS	206
SWITCH OPERATION	170	Headlamp	206
ROOM LAMP TIMER OPERATION	171	Exterior Lamp	206
INTERIOR LAMP BATTERY SAVER CONTROL	172	Interior Lamp/Illumination	206
Schematic	173		
Wiring Diagram — ROOM/L —	175		

PRECAUTIONS

PRECAUTIONS

PPF:00011

Precautions for Supplemental Restraint System (SRS) “AIR BAG” and “SEAT BELT PRE-TENSIONER”

AKS00AW4

The Supplemental Restraint System such as “AIR BAG” and “SEAT BELT PRE-TENSIONER”, used along with a front seat belt, helps to reduce the risk or severity of injury to the driver and front passenger for certain types of collision. This system includes seat belt switch inputs and dual stage front air bag modules. The SRS system uses the seat belt switches to determine the front air bag deployment, and may only deploy one front air bag, depending on the severity of a collision and whether the front occupants are belted or unbelted. Information necessary to service the system safely is included in the SRS and SB section of this Service Manual.

WARNING:

- To avoid rendering the SRS inoperative, which could increase the risk of personal injury or death in the event of a collision which would result in air bag inflation, all maintenance must be performed by an authorized NISSAN/INFINITI dealer.
- Improper maintenance, including incorrect removal and installation of the SRS, can lead to personal injury caused by unintentional activation of the system. For removal of Spiral Cable and Air Bag Module, see the SRS section.
- Do not use electrical test equipment on any circuit related to the SRS unless instructed to in this Service Manual. SRS wiring harnesses can be identified by yellow and/or orange harnesses or harness connectors.

General Precautions for Service Operations

AKS00AW6

- Never work with wet hands.
- Xenon headlamp includes high voltage generating part. Be sure to disconnect battery negative cable (negative terminal) or power fuse before removing, installing, or touching the xenon headlamp (including lamp bulb).
- Turn the lighting switch OFF before disconnecting and connecting the connector.
- When turning the xenon headlamp on and while it is illuminated, never touch the harness, bulb, and socket of the headlamp.
- When checking the headlamp on/off operation, check it on vehicle and with the power connected to the vehicle-side connector.
- Do not touch the headlamp bulb glass surface with bare hands or allow oil or grease to get on it. Do not touch the headlamp bulb just after the headlamp is turned off, because it is very hot.
- Install the xenon headlamp bulb socket correctly. If it is installed improperly, high-voltage leak or corona discharge may occur that can melt the bulb, connector, and housing. Do not illuminate the xenon headlamp bulb out of the headlamp housing. Doing so can cause fire and harm your eyes.
- When the bulb has burned out, wrap it in a thick vinyl bag and discard. Do not break the bulb.
- Leaving the bulb removed from the headlamp housing for a long period of time can deteriorate the performance of the lens and reflector (dirt, clouding). Always prepare a new bulb and have it on hand when replacing the bulb.
- When adjusting the headlamp aiming, turn the aiming adjustment screw only in the tightening direction. (If it is necessary to loosen the screw, first fully loosen the screw, and then turn it in the tightening direction.)
- Do not use organic solvent (paint thinner or gasoline) to clean lamps and to remove old sealant.

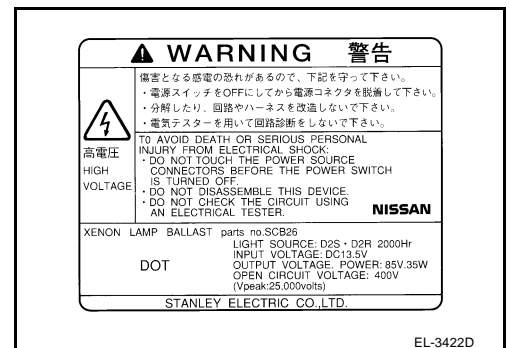
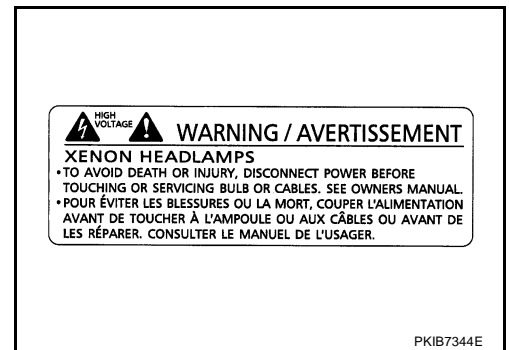

HEADLAMP (FOR USA)

- to combination meter terminal 21.

With the ignition switch in the ON or START position, power is supplied

- through 10A fuse [No. 1, located in fuse block (J/B)]
- to BCM terminal 38,
- through 10A fuse [No. 14, located in fuse block (J/B)]
- to combination meter terminal 22 and 23.

With the ignition switch in the ACC or ON position, power is supplied

- through 10A fuse [No. 6, located in fuse block (J/B)]
- to BCM terminal 11.

Ground is supplied

- to BCM terminal 52
- through grounds M30 and M66,
- to IPDM E/R terminals 38 and 60
- through grounds E17 and E43,
- to combination meter terminals 1, 24 and 25
- through grounds M30 and M66.

HEADLAMP OPERATION

Low Beam Operation

With the lighting switch in 2ND position, the BCM receives input signal requesting headlamps to illuminate. This input signal is communicated to IPDM E/R across CAN communication lines. The CPU located in the IPDM E/R controls headlamp low relay coil, which when energized, directs power

- through 15A fuse (No. 76, located in IPDM E/R)
- through IPDM E/R terminal 20
- to front combination lamp RH terminal 3,
- through 15A fuse (No. 86, located in IPDM E/R)
- through IPDM E/R terminal 30
- to front combination lamp LH terminal 3.

Ground is supplied

- to front combination lamp RH terminal 4
- through grounds E17 and E43,
- to front combination lamp LH terminal 4
- through grounds E17 and E43.

With power and ground supplied, low beam headlamps illuminate.

High Beam Operation/Flash-to-Pass Operation

With the lighting switch in 2ND position and placed in HIGH BEAM or PASSING position, the BCM receives input signal requesting the headlamp high beams to illuminate. This input signal is communicated to IPDM E/R across the CAN communication lines. The CPU located in the IPDM E/R controls headlamp high relay coil and low relay coil, which when energized, directs power

- through 15A fuse (No. 76, located in IPDM E/R)
- through IPDM E/R terminal 20
- to front combination lamp RH terminal 3,
- through 15A fuse (No. 86, located in IPDM E/R)
- through IPDM E/R terminal 30
- to front combination lamp LH terminal 3,
- through 10A fuse (No. 72, located in IPDM E/R)
- through IPDM E/R terminal 27
- to front combination lamp RH terminal 2,
- through 10A fuse (No. 74, located in IPDM E/R)
- through IPDM E/R terminal 28

HEADLAMP (FOR USA)

- to front combination lamp LH terminal 2.

Ground is supplied

- to front combination lamp RH terminals 4 and 8
- through grounds E17 and E43,
- to front combination lamp LH terminals 4 and 8
- through grounds E17 and E43.

With power and ground supplied, the high beam and low beam headlamps illuminate.

High beam indicator illuminates when combination meter receives input signal requesting high beam indicator to illuminate. This is communicated to BCM across the CAN communication lines.

COMBINATION SWITCH READING FUNCTION

Refer to [BCS-3, "COMBINATION SWITCH READING FUNCTION"](#) .

EXTERIOR LAMP BATTERY SAVER CONTROL

When the combination switch (lighting switch) is in the 2ND position (or if auto light system is activated), and the ignition switch is turned from ON or ACC to OFF, the battery saver control function is activated.

Under this condition, the headlamps remain illuminated for 5 minutes, then the headlamps are turned off.

Exterior lamp battery saver control mode can be changed by the function setting of CONSULT-II.

AUTO LIGHT OPERATION (IF EQUIPPED)

Refer to [LT-76, "System Description"](#) in "AUTO LIGHT SYSTEM".

VEHICLE SECURITY SYSTEM

The vehicle security system will flash the high beams if the system is triggered. Refer to [BL-199, "VEHICLE SECURITY \(THEFT WARNING\) SYSTEM"](#) .

XENON HEADLAMP

Xenon type lamps are used for to the low beam headlamps. Xenon bulbs do not use a filament. Instead, they produce light when a high voltage current is passed between two tungsten electrodes through a mixture of xenon (an inert gas) and certain other metal halides. In addition to strong lighting power, electronic control of the power supply gives the headlamps stable quality and tone color.

Followings are some advantages of the xenon type headlamp.

- The light produced by the headlamps is white color similar to sunlight that is easy to the eyes.
- Light output is nearly double that of halogen headlamps, affording increased area of illumination.
- Counter-reflected luminance increases and the contrast enhances on the wet road in the rain. That makes visibility go up more than the increase of the light volume.
- Power consumption is approximately 25 percent less than halogen headlamps, reducing battery load.

CAN Communication System Description

AKS009IG

CAN (Controller Area Network) is a serial communication line for real time application. It is an on-vehicle multiplex communication line with high data communication speed and excellent error detection ability. Many electronic control units are equipped onto vehicle, and each control unit shares information and links with other control units during operation (not independent). In CAN communication, control units are connected with 2 communication lines (CAN H line, CAN L line) allowing a high rate of information transmission with less wiring. Each control unit transmits/receives data but selectively reads required data only.

CAN Communication Unit

AKS009IH

Refer to [LAN-21, "CAN Communication Unit"](#) .

HEADLAMP (FOR USA)

Schematic

AKS009II

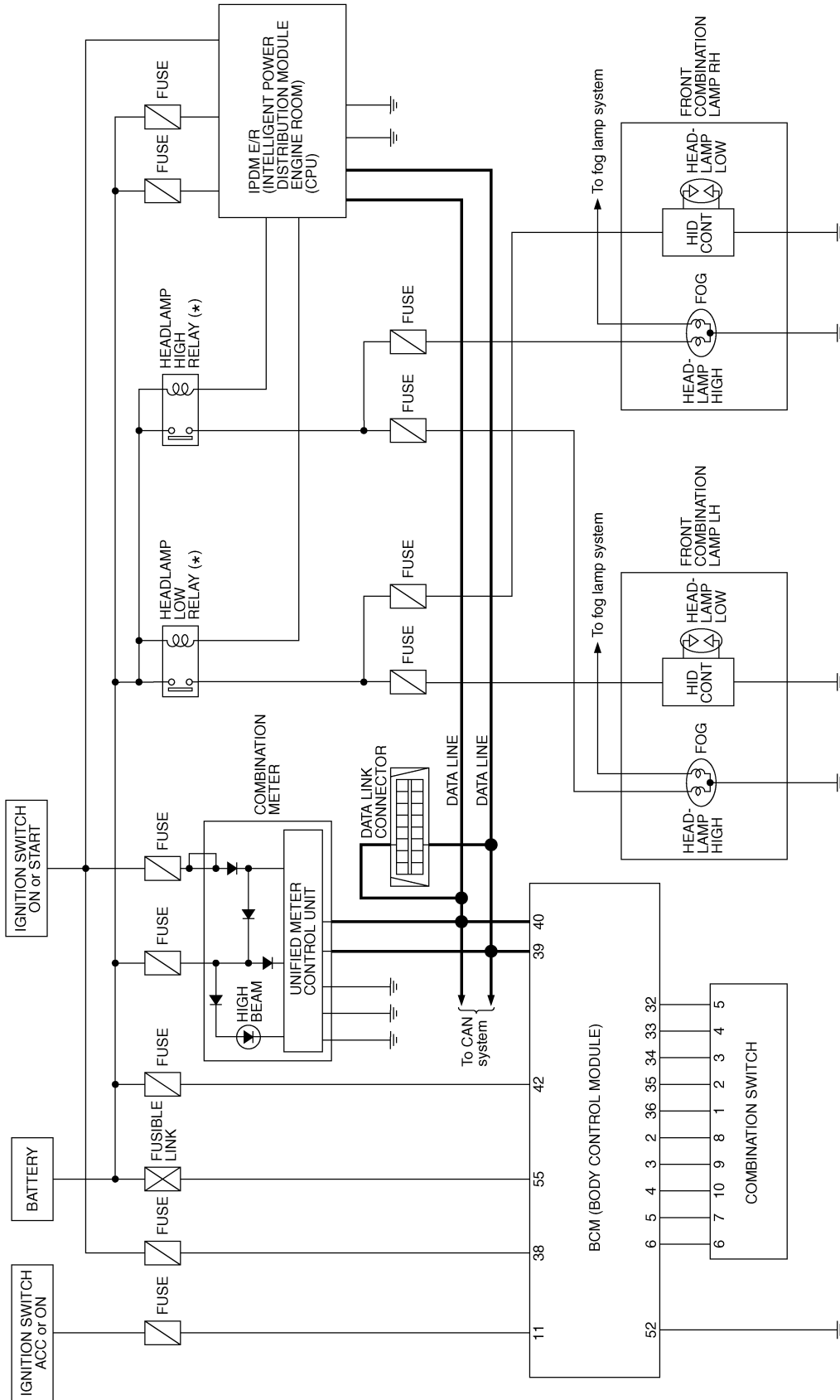

* : This relay is built into the IPDM E/R (Intelligent power distribution module engine room).

A
B
C
D
E
F
G
H
I
J
LT
L
M

HEADLAMP (FOR USA)

AKS009JJ

Wiring Diagram — H/LAMP —

LT-H/LAMP-01

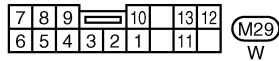
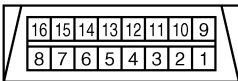
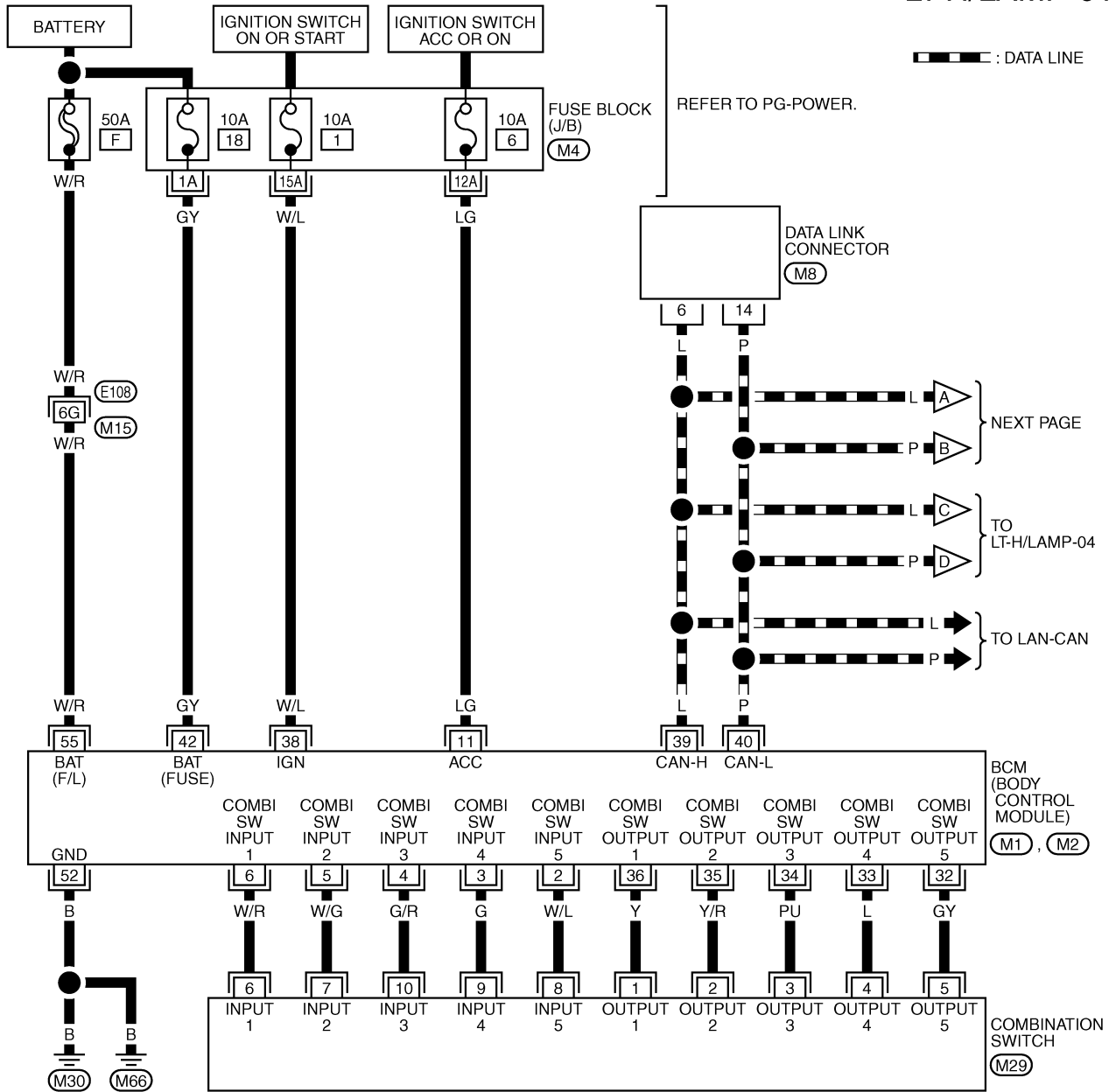

REFER TO THE FOLLOWING.

(E108) -SUPER MULTIPLE JUNCTION (SMJ)

(M4) -FUSE BLOCK-JUNCTION BOX (J/B)

(M1), (M2) -ELECTRICAL UNITS

TKWM2242E

HEADLAMP (FOR USA)

LT-H/LAMP-02

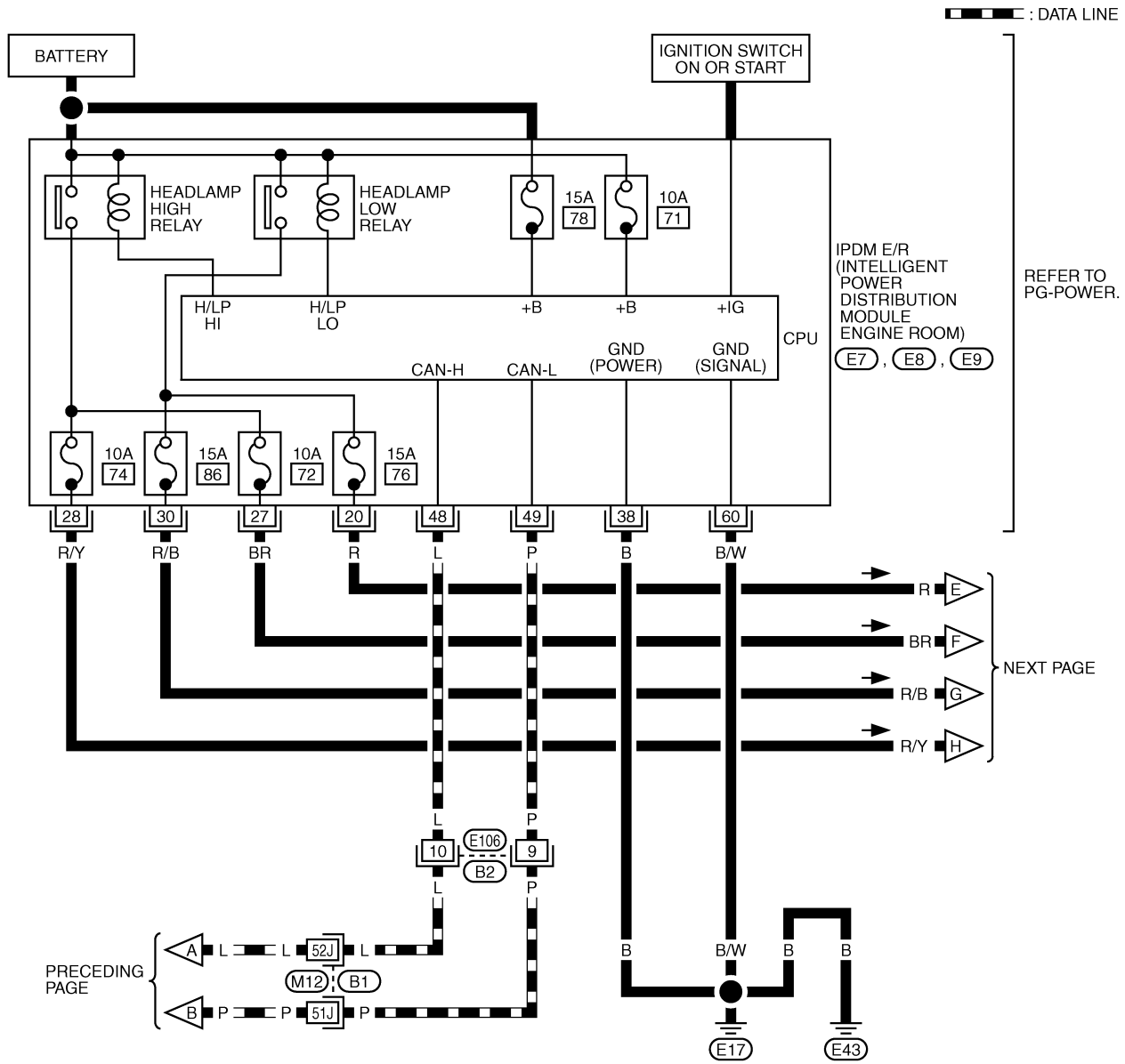

A
B
C
D
E
F
G
H
I
J
K
L
M

LT

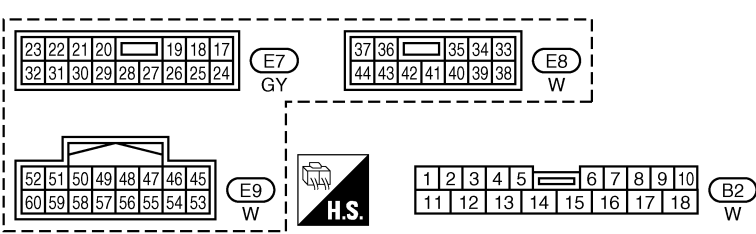

HEADLAMP (FOR USA)

LT-H/LAMP-03

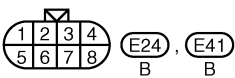
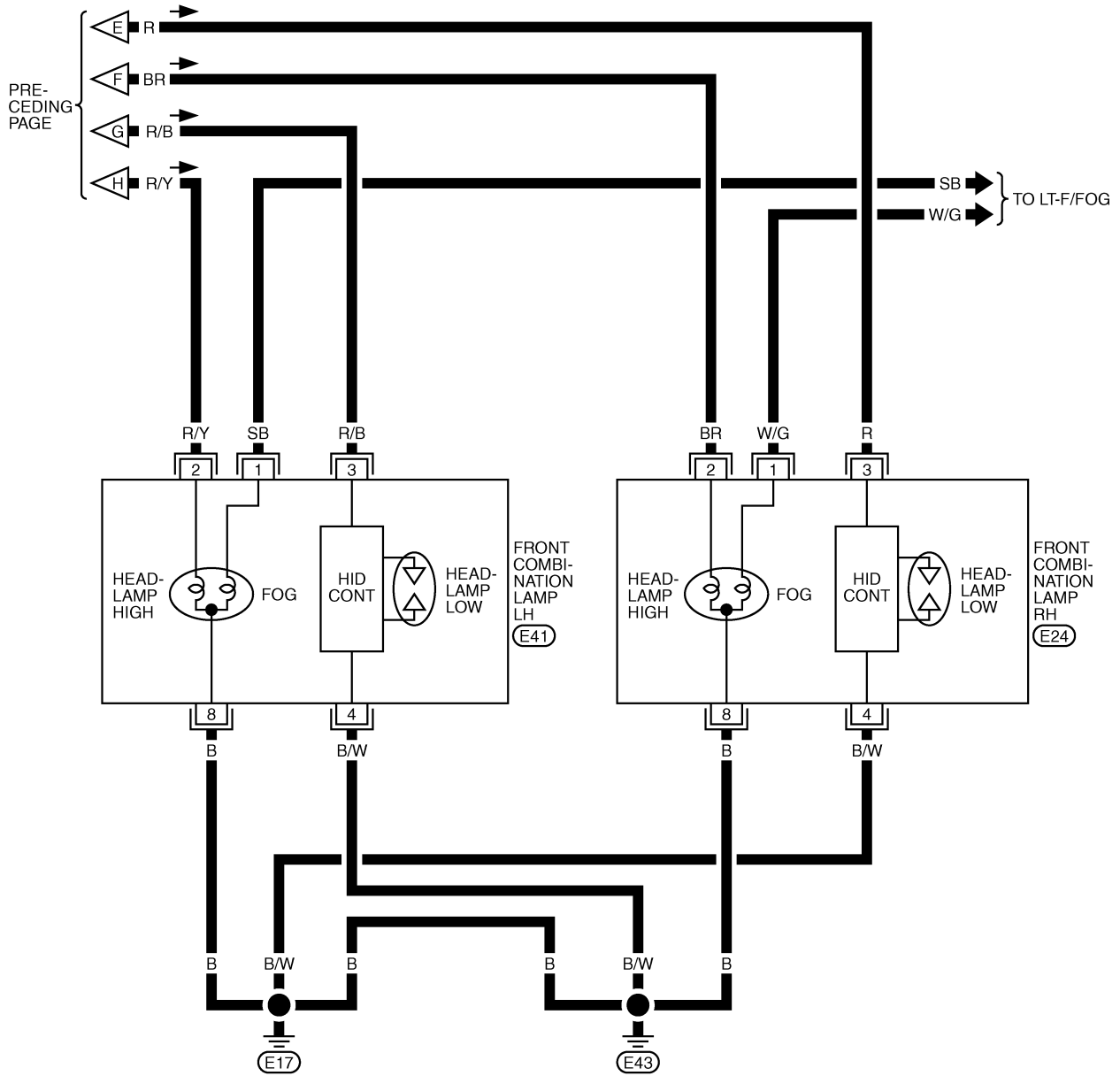

TKWM2244E

HEADLAMP (FOR USA)

LT-H/LAMP-04

▬ : DATA LINE

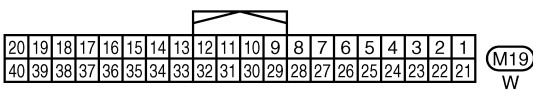
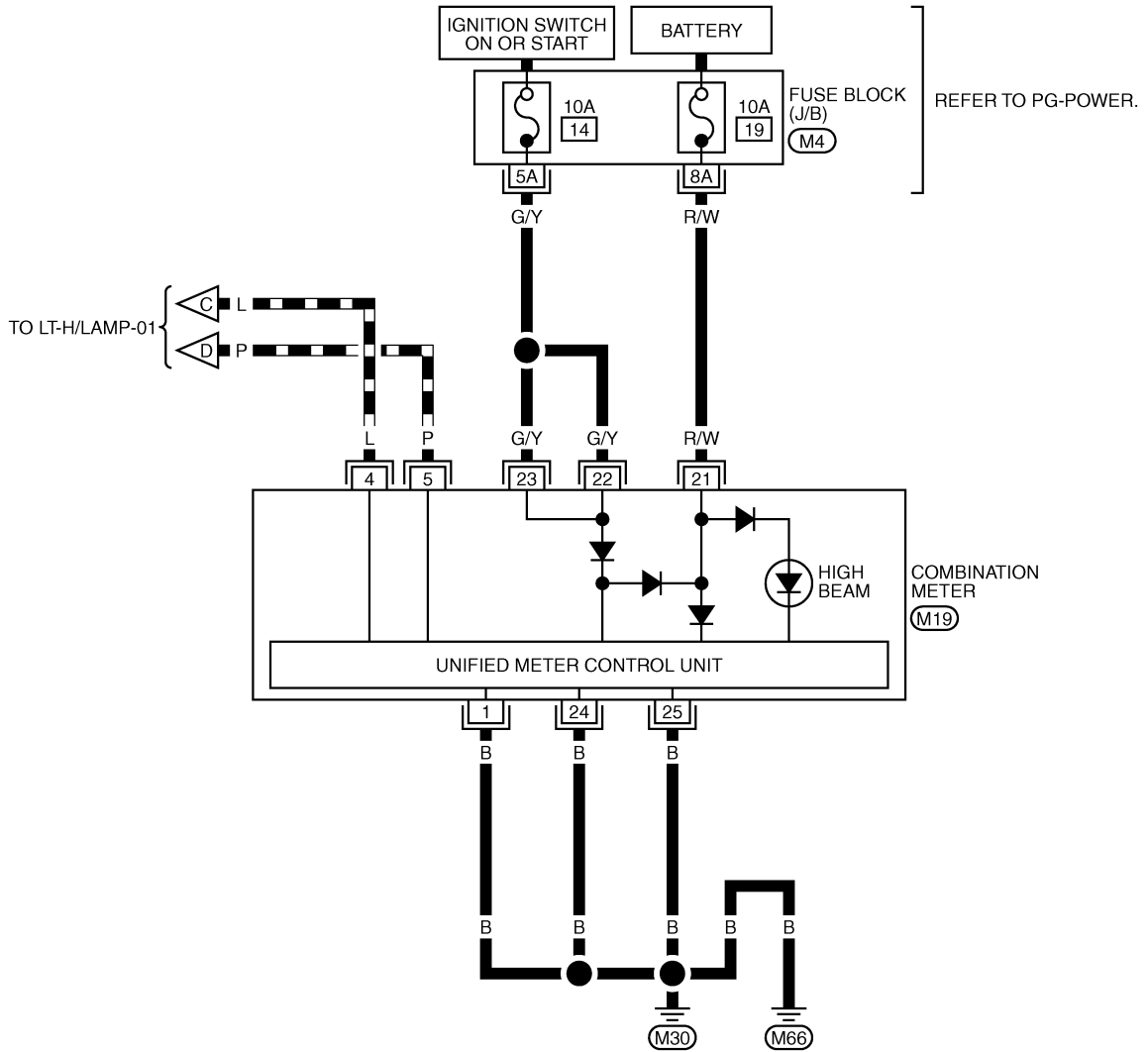

REFER TO THE FOLLOWING.

(M4) - FUSE BLOCK-JUNCTION BOX (J/B)

TKWM2245E

HEADLAMP (FOR USA)

Terminals and Reference Values for BCM

AKS009IK

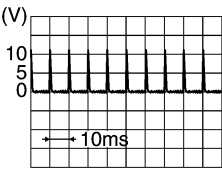
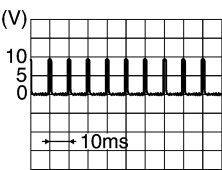
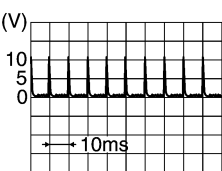
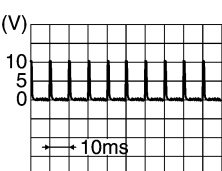
Terminal No.	Wire color	Signal name	Measuring condition		Reference value
			Ignition switch	Operation or condition	
2	W/L	Combination switch input 5	ON	Lighting, turn, wiper OFF Wiper intermittent dial position 4	 <p style="text-align: right;">PKIB3468E</p>
3	G	Combination switch input 4	ON	Lighting, turn, wiper OFF Wiper intermittent dial position 4	 <p style="text-align: right;">PKIB3469E</p>
4	G/R	Combination switch input 3			
5	W/G	Combination switch input 2			
6	W/R	Combination switch input 1			
11	LG	Ignition switch (ACC)	ACC	—	Battery voltage
32	GY	Combination switch output 5	ON	Lighting, turn, wiper OFF Wiper intermittent dial position 4	 <p style="text-align: right;">PKIB3470E</p>
33	L	Combination switch output 4	ON	Lighting, turn, wiper OFF Wiper intermittent dial position 4	 <p style="text-align: right;">PKIB3471E</p>
34	PU	Combination switch output 3			
35	Y/R	Combination switch output 2			
36	Y	Combination switch output 1			
38	W/L	Ignition switch (ON)	ON	—	Battery voltage
39	L	CAN – H	—	—	—
40	P	CAN – L	—	—	—
42	GY	Battery power supply	OFF	—	Battery voltage
52	B	Ground	ON	—	Approx. 0V
55	W/R	Battery power supply	OFF	—	Battery voltage

Terminals and Reference Values for IPDM E/R

AKS009IL

Terminal No.	Wire color	Signal name	Measuring condition		Reference value
			Ignition switch	Operation or condition	
20	R	Headlamp low (RH)	ON	Lighting switch 2ND position OFF	Approx. 0V
				ON	Battery voltage
27	BR	Headlamp high (RH)	ON	Lighting switch HIGH BEAM or PASSING position OFF	Approx. 0V
				ON	Battery voltage
28	R/Y	Headlamp high (LH)	ON	Lighting switch HIGH BEAM or PASSING position OFF	Approx. 0V
				ON	Battery voltage

HEADLAMP (FOR USA)

Terminal No.	Wire color	Signal name	Measuring condition		Reference value	
			Ignition switch	Operation or condition		
30	R/B	Headlamp low (LH)	ON	Lighting switch 2ND position	OFF	Approx. 0V
					ON	Battery voltage
38	B	Ground	ON	—	Approx. 0V	
48	L	CAN – H	—	—	—	
49	P	CAN – L	—	—	—	
60	B/W	Ground	ON	—	Approx. 0V	

How to Proceed with Trouble Diagnosis

AKS009IM

1. Confirm the symptom or customer complaint.
2. Understand operation description and function description. Refer to [LT-6, "System Description"](#).
3. Perform the preliminary check. Refer to [LT-15, "Preliminary Check"](#).
4. Check symptom and repair or replace the malfunctioning parts.
5. Does headlamp operate normally? If YES, GO TO 6. If NO, GO TO 4.
6. INSPECTION END

Preliminary Check

AKS009IN

CHECK POWER SUPPLY AND GROUND CIRCUIT

1. CHECK FUSES

Check for blown fuses.

Unit	Power source	Fuse and fusible link No.
BCM	Battery	F
		18
	Ignition switch ON or START position	1
	Ignition switch ACC or ON position	6
IPDM E/R	Battery	72
		74
		76
		86

Refer to [LT-10, "Wiring Diagram — H/LAMP —"](#).

OK or NG

OK >> GO TO 2.

NG >> If fuse or fusible link is blown, be sure to eliminate cause of malfunction before installing new fuse or fusible link. Refer to [PG-3, "POWER SUPPLY ROUTING CIRCUIT"](#).

HEADLAMP (FOR USA)

2. CHECK POWER SUPPLY CIRCUIT

1. Turn ignition switch OFF.
2. Disconnect BCM connector.
3. Check voltage between BCM harness connector and ground.

Terminal (+)		Terminal (-)	Ignition switch position		
Connector	Terminal (Wire color)		OFF	ACC	ON
M1	11 (LG)	Ground	Approx. 0V	Battery voltage	Battery voltage
	38 (W/L)		Approx. 0V	Approx. 0V	Battery voltage
M2	42 (GY)		Battery voltage	Battery voltage	Battery voltage
	55 (W/R)		Battery voltage	Battery voltage	Battery voltage

OK or NG

OK >> GO TO 3.

NG >> Check harness for open or short between BCM and fuse.

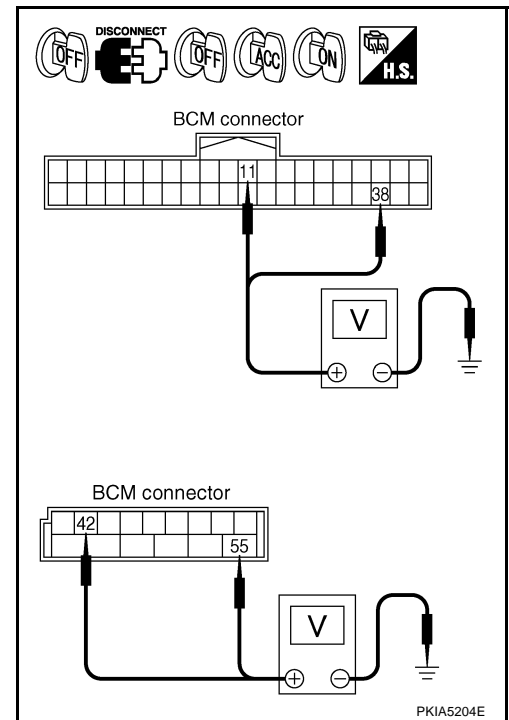

3. CHECK GROUND CIRCUIT

Check continuity between BCM harness connector and ground.

Terminal		Ground	Continuity
Connector	Terminal (Wire color)		Yes
M2	52 (B)		Yes

OK or NG

OK >> INSPECTION END

NG >> Check harness ground circuit.

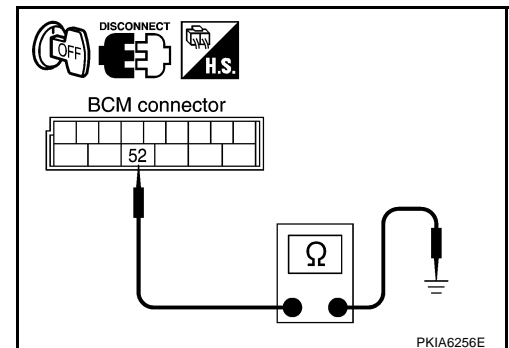

HEADLAMP (FOR USA)

CONSULT-II Functions (BCM)

AKS00910

CONSULT-II can display each diagnostic item using the diagnostic test modes shown following.

BCM diagnosis part	Diagnosis mode	Description
HEADLAMP	WORK SUPPORT	Changes the setting for each function.
	DATA MONITOR	Displays BCM input data in real time.
	ACTIVE TEST	Operation of electrical loads can be checked by sending drive signal to them.
BCM	SELF-DIAG RESULTS	BCM performs self-diagnosis of CAN communication.
	CAN DIAG SUPPORT MNTR	The result of transmit/receive diagnosis of CAN communication can be read.

CONSULT-II BASIC OPERATION

CAUTION:

If CONSULT-II is used with no connection of CONSULT-II CONVERTER, malfunctions might be detected in self-diagnosis depending on control unit which carry out CAN communication.

1. With ignition switch OFF, connect CONSULT-II and CONSULT-II CONVERTER to data link connector, and then turn ignition switch ON.

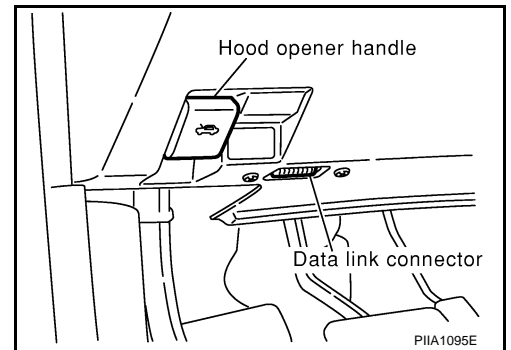

2. Touch "START (NISSAN BASED VHCL)".

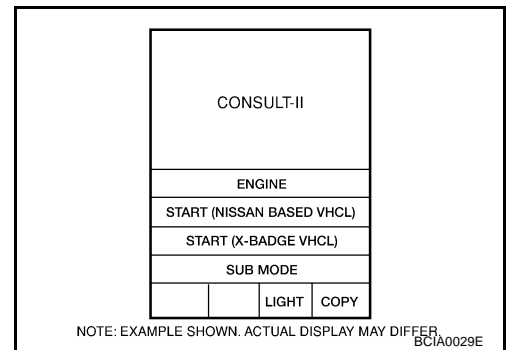

3. Touch "BCM" on "SELECT SYSTEM" screen. If "BCM" is not indicated, refer to [GI-39, "CONSULT-II Data Link Connector \(DLC\) Circuit"](#).

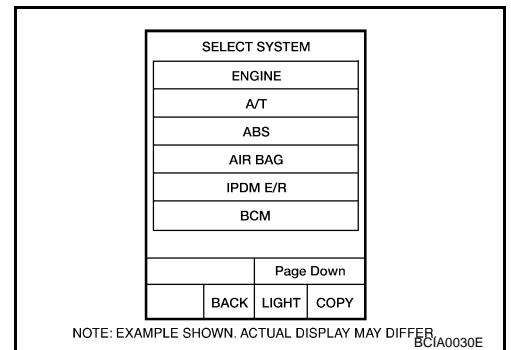

HEADLAMP (FOR USA)

4. Touch "HEAD LAMP" on "SELECT DIAG MODE" screen.

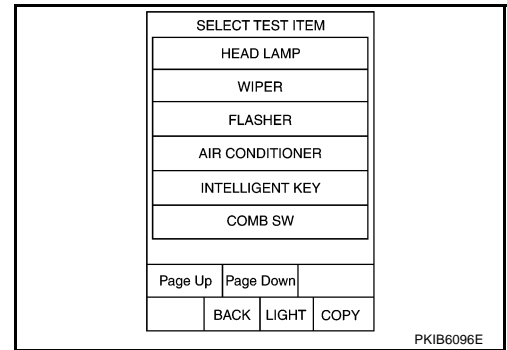

WORK SUPPORT

Operation Procedure

1. Touch "HEAD LAMP" on "SELECT TEST ITEM" screen.
2. Touch "WORK SUPPORT" on "SELECT DIAG MODE" screen.
3. Touch "BATTERY SAVER SET" on "SELECT WORK ITEM" screen.
4. Touch "START".
5. Touch "CHANGE SET".
6. The setting will be changed and "CUSTOMIZING COMPLETED" will be displayed.
7. Touch "END".

Display Item List

Item	Description	CONSULT-II	Factory setting
BATTERY SAVER SET	Exterior lamp battery saver control mode can be changed in this mode. Selects exterior lamp battery saver control mode between two ON/OFF.	ON	×
		OFF	—

DATA MONITOR

Operation Procedure

1. Touch "HEAD LAMP" on "SELECT TEST ITEM" screen.
2. Touch "DATA MONITOR" on "SELECT DIAG MODE" screen.
3. Touch either "ALL SIGNALS" or "SELECTION FROM MENU" on "SELECT MONITOR ITEM" screen.

ALL SIGNALS	Monitors all the signals.
SELECTION FROM MENU	Selects items and monitor them.

4. When "SELECTION FROM MENU" is selected, touch individual items to be monitored. When "ALL SIGNALS" is selected, all the items will be monitored.
5. Touch "START".
6. Touch "RECORD" while monitoring, then the status of the monitored item can be recorded. To stop recording, touch "STOP".

Display Item List

Monitor item	Contents
IGN ON SW "ON/OFF"	Displays status (ignition switch IGN position: ON/other: OFF) of ignition switch judged from the ignition switch signal.
ACC ON SW "ON/OFF"	Displays status (ignition switch ACC or IGN position: ON/other: OFF) of ignition switch judged from the ignition switch signal.
HI BEAM SW "ON/OFF"	Displays status (lighting switch high beam position: ON/other: OFF) of high beam switch judged from the lighting switch signal.
HEAD LAMP SW 1 "ON/OFF"	Displays status (lighting switch 2ND position: ON/other: OFF) of headlamp 1 switch judged from the lighting switch signal.
HEAD LAMP SW 2 "ON/OFF"	Displays status (lighting switch 2ND position: ON/other: OFF) of headlamp 2 switch judged from the lighting switch signal.

HEADLAMP (FOR USA)

Monitor item		Contents
LIGHT SW 1 ST	"ON/OFF"	Displays status (lighting switch 1ST or 2ND position: ON/other: OFF) of lighting switch 1ST position switch judged from the lighting switch signal.
AUTO LIGHT SW	"ON/OFF"	Displays status (lighting switch AUTO position: ON/other: OFF) of auto light switch position judged from the lighting switch signal.
PASSING SW	"ON/OFF"	Displays status (lighting switch passing position: ON/other: OFF) of passing switch judged from the lighting switch signal.
FR FOG SW	"ON/OFF"	Displays status (lighting switch front fog lamp ON position: ON/others: OFF) of front fog lamp switch judged from the lighting switch signal.
DOOR SW - DR	"ON/OFF"	Displays status (door is open: ON/door is closed: OFF) of driver side door switch judged from the driver side door switch signal.
DOOR SW - AS	"ON/OFF"	Displays status (door is open: ON/door is closed: OFF) of passenger side door switch judged from the passenger side door switch signal.
DOOR SW - RR	"ON/OFF"	Displays status (door is open: ON/door is closed: OFF) of rear door switch (RH) judged from the rear door switch (RH) signal.
DOOR SW - RL	"ON/OFF"	Displays status (door is open: ON/door is closed: OFF) of rear door switch (LH) judged from the rear door switch (LH) signal.
BACK DOOR SW ^{NOTE 1}	"OFF"	—
TURN SIGNAL R	"ON/OFF"	Displays status (turn signal switch right position: ON/other: OFF) of turn RH switch judged from the turn signal switch signal.
TURN SIGNAL L	"ON/OFF"	Displays status (turn signal switch left position: ON/other: OFF) of turn LH switch judged from the turn signal switch signal.
CARGO LAMP SW ^{NOTE 1}	"OFF"	—
OPTICAL SENSOR ^{NOTE 2}	"0 - 5V"	Displays status "outside brightness (close to 5V when light/close to 0V when dark)" of optical sensor judged from the optical sensor signal.

NOTE:

1. This item is displayed, but cannot be monitored.
2. Vehicles without auto light system display this item, but cannot be monitored.

ACTIVE TEST

Operation Procedure

1. Touch "HEAD LAMP" on "SELECT TEST ITEM" screen.
2. Touch "ACTIVE TEST" on "SELECT DIAG MODE" screen.
3. Touch item to be tested and check operation of the selected item.
4. During the operation check, touching "BACK" deactivates the operation.

Display Item List

Test item	Description
TAIL LAMP	Allows tail lamp relay to operate by switching ON-OFF.
HEAD LAMP	Allows headlamp high relay and headlamp low relay to operate by switching ON-OFF.
FR FOG LAMP	Allows front fog lamp relay to operate by switching ON-OFF.
CORNERING LAMP ^{NOTE}	—

NOTE:

This item is displayed, but cannot be tested.

HEADLAMP (FOR USA)

AKS009IP

CONSULT-II Functions (IPDM E/R)

CONSULT-II can display each diagnostic item using the diagnostic test modes shown following.

Diagnosis Mode	Description
SELF-DIAGNOSTIC RESULTS	Refer to PG-19. "SELF-DIAG RESULTS" .
DATA MONITOR	The input/output data of IPDM E/R is displayed in real time.
CAN DIAG SUPPORT MNTR	The result of transmit/receive diagnosis of CAN communication can be read.
ACTIVE TEST	IPDM E/R sends a drive signal to electronic components to check their operation.

CONSULT-II BASIC OPERATION

CAUTION:

If CONSULT-II is used with no connection of CONSULT-II CONVERTER, malfunctions might be detected in self-diagnosis depending on control unit which carry out CAN communication.

1. With ignition switch OFF, connect CONSULT-II and CONSULT-II CONVERTER to data link connector, and then turn ignition switch ON.

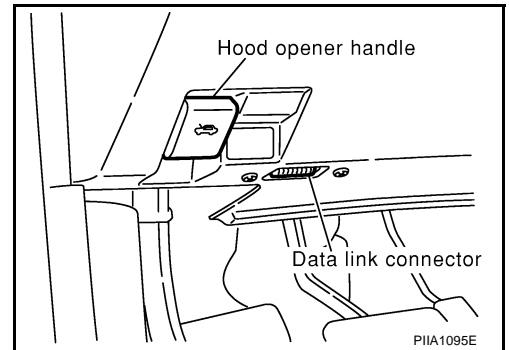

2. Touch "START (NISSAN BASED VHCL)".

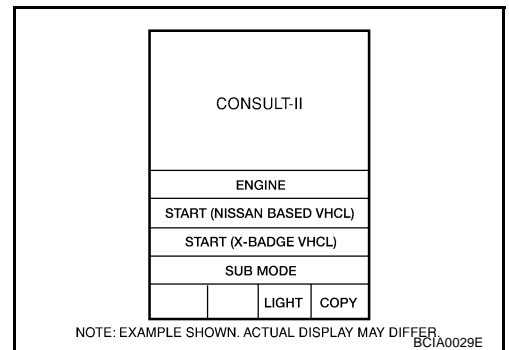

3. Touch "IPDM E/R" on "SELECT SYSTEM" screen. If "IPDM E/R" is not indicated, refer to [GI-39. "CONSULT-II Data Link Connector \(DLC\) Circuit"](#) .

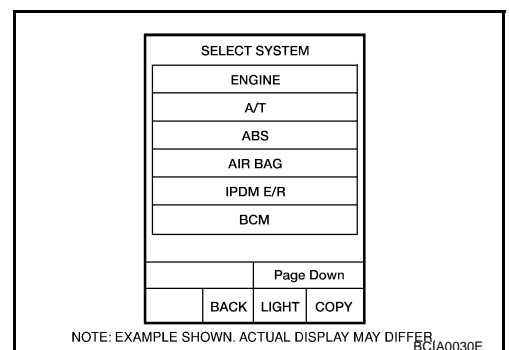

HEADLAMP (FOR USA)

- Select desired part to be diagnosed on "SELECT DIAG MODE" screen.

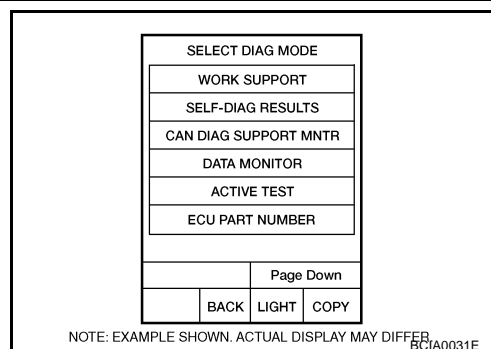

A
B
C
D

DATA MONITOR

Operation Procedure

- Touch "DATA MONITOR" on "SELECT DIAG MODE" screen.
- Touch "ALL SIGNALS", "MAIN SIGNALS" or "SELECTION FROM MENU" on "SELECT MONITOR ITEM" screen.

ALL SIGNALS	Monitors all items.
MAIN SIGNALS	Monitor the predetermined item.
SELECTION FROM MENU	Selects items and monitors them.

F
G

- When "SELECTION FROM MENU" is selected, touch individual items to be monitored. In "ALL SIGNALS", all items are monitored. In "MAIN SIGNALS", predetermined items are monitored.
- Touch "START".
- Touch "RECORD" while monitoring to record the status of the item being monitored. To stop recording, touch "STOP".

H
I

All Signals, Main Signals, Selection From Menu

Item name	CONSULT-II screen display	Display or unit	Monitor item selection			Description
			ALL SIGNALS	MAIN SIGNALS	SELECTION FROM MENU	
Position lights request	TAIL&CLR REQ	ON/OFF	×	×	×	Signal status input from BCM
Headlamp low beam request	HL LO REQ	ON/OFF	×	×	×	Signal status input from BCM
Headlamp high beam request	HL HI REQ	ON/OFF	×	×	×	Signal status input from BCM
Front fog lights request	FR FOG REQ	ON/OFF	×	×	×	Signal status input from BCM

LT

L
M

NOTE:

Perform monitoring of IPDM E/R data with ignition switch ON. When ignition switch is at ACC, display may not be correct.

ACTIVE TEST

Operation Procedure

- Touch "ACTIVE TEST" on "SELECT DIAG MODE" screen.
- Touch item to be tested, and check operation.
- Touch "START".
- Touch "STOP" while testing to stop the operation.

Test item	CONSULT-II screen display	Description
Headlamp relay (HI, LO) output	LAMPS	Allows headlamp relay (HI, LO) to operate by switching operation (OFF, HI ON, LO ON) at your option.
Front fog lamp relay output		Allows front fog lamp relay to operate by switching operation ON-OFF at your option.
Tail lamp relay output	TAIL LAMP	Allows tail lamp relay to operate by switching operation ON-OFF at your option.

HEADLAMP (FOR USA)

Headlamp High Beam Does Not Illuminate (Both Sides)

AKS009/Q

1. CHECK COMBINATION SWITCH INPUT SIGNAL

④ With CONSULT-II

Select "BCM" on CONSULT-II. With "HEAD LAMP" data monitor, make sure "HI BEAM SW" turns ON-OFF linked with operation of lighting switch.

**When lighting switch is : HI BEAM SW ON
HIGH BEAM position**

⊗ Without CONSULT-II

Refer to [LT-133, "Combination Switch Inspection"](#).

OK or NG

OK >> GO TO 2.

NG >> Check combination switch (lighting switch). Refer to [LT-133, "Combination Switch Inspection"](#).

DATA MONITOR			
MONITOR			
HI BEAM SW	ON		
		RECORD	
MODE	BACK	LIGHT	COPY

PKIA7585E

2. HEADLAMP ACTIVE TEST

④ With CONSULT-II

1. Select "IPDM E/R" on CONSULT-I, and select "ACTIVE TEST" on "SELECT DIAG MODE" screen.
2. Select "LAMPS" on "SELECT TEST ITEM" screen.
3. Touch "HI" screen.
4. Make sure headlamp high beam operates.

**Headlamp high beam should operate.
(Headlamp high beam repeats ON-OFF every 1 second).**

⊗ Without CONSULT-II

1. Start auto active test. Refer to [PG-22, "Auto Active Test"](#).
2. Make sure headlamp high beam operates.

Headlamp high beam should operate.

OK or NG

OK >> GO TO 3.

NG >> GO TO 4.

ACTIVE TEST			
LAMPS	OFF		
		HI	
LO	FOG		
		RECORD	
MODE	BACK	LIGHT	COPY

SKIA5774E

3. CHECK IPDM E/R

1. Select "IPDM E/R" on CONSULT-II, and select "DATA MONITOR" on "SELECT DIAG MODE" screen.
2. Make sure "HL LO REQ" and "HL HI REQ" turns ON when lighting switch is in HIGH BEAM position.

**When lighting switch is : HL LO REQ ON
HIGH BEAM position : HL HI REQ ON**

OK or NG

OK >> Replace IPDM E/R.

NG >> Replace BCM. Refer to [BCS-16, "Removal and Installation of BCM"](#).

DATA MONITOR			
MONITOR			
HL LO REQ	ON		
HL HI REQ	ON		
		RECORD	
MODE	BACK	LIGHT	COPY

PKIA7638E

HEADLAMP (FOR USA)

4. CHECK HEADLAMP INPUT SIGNAL

With CONSULT-II

1. Turn ignition switch OFF.
2. Disconnect front combination lamp RH and LH connector.
3. Select "IPDM E/R" on CONSULT-II, and select "ACTIVE TEST" on "SELECT DIAG MODE" screen.
4. Select "LAMPS" on "SELECT TEST ITEM" screen.
5. Touch "HI" screen.
6. When headlamp high relay is operating, check voltage between front combination lamp harness connector and ground (Headlamp high beam repeats ON-OFF every 1 second).

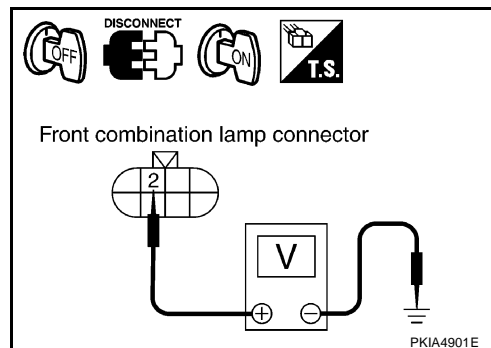

Terminal (+)			Terminal (-)	Voltage
Connector		Terminal (Wire color)		
RH	E24	2 (BR)	Ground	Battery voltage
LH	E41	2 (R/Y)		

Without CONSULT-II

1. Turn ignition switch OFF.
2. Disconnect front combination lamp RH and LH connector.
3. Start auto active test. Refer to [PG-22, "Auto Active Test"](#).
4. When headlamp high relay is operating, check voltage between front combination lamp harness connector and ground.

Terminal (+)			Terminal (-)	Voltage
Connector		Terminal (Wire color)		
RH	E24	2 (BR)	Ground	Battery voltage
LH	E41	2 (R/Y)		

OK or NG

- OK >> GO TO 6.
 NG >> GO TO 5.

5. CHECK HEADLAMP CIRCUIT

1. Turn ignition switch OFF.
2. Disconnect IPDM E/R connector.
3. Check continuity between IPDM E/R harness connector E7 terminal 27 (BR) and front combination lamp RH harness connector E24 terminal 2 (BR).

27 (BR) – 2 (BR) : Continuity should exist.

4. Check continuity between IPDM E/R harness connector E7 terminal 28 (R/Y) and front combination lamp LH harness connector E41 terminal 2 (R/Y).

28 (R/Y) – 2 (R/Y) : Continuity should exist.

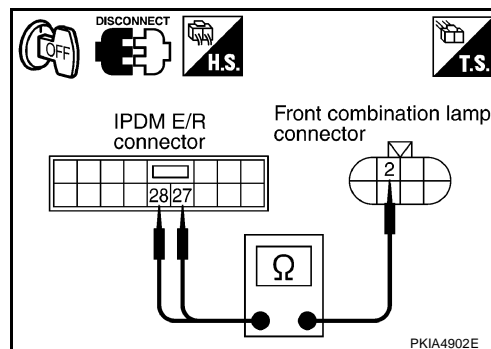

OK or NG

- OK >> Replace IPDM E/R.
 NG >> Repair harness or connector.

HEADLAMP (FOR USA)

6. CHECK HEADLAMP GROUND

1. Check continuity between front combination lamp RH harness connector E24 terminal 8 (B) and ground.

8 (B) – Ground : Continuity should exist.

2. Check continuity between front combination lamp LH harness connector E41 terminal 8 (B) and ground.

8 (B) – Ground : Continuity should exist.

OK or NG

- OK >> Check headlamp bulb.
 NG >> Repair harness or connector.

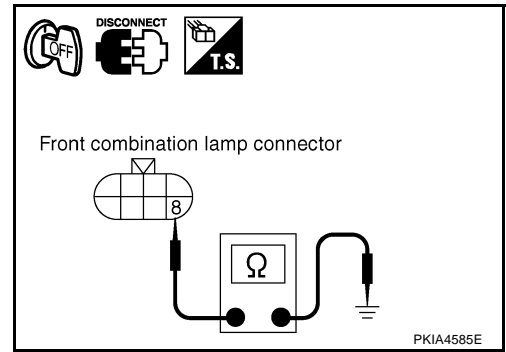

Headlamp High Beam Does Not Illuminate (One Side)

AKS009/R

1. CHECK BULB

Check bulbs of lamps which does not illuminate.

OK or NG

- OK >> GO TO 2.
 NG >> Replace headlamp bulb.

2. CHECK HEADLAMP INPUT SIGNAL

1. Turn ignition switch OFF.
2. Disconnect front combination lamp RH or LH connector.
3. Turn ignition switch ON.
4. Lighting switch is turned HIGH BEAM position.
5. Check voltage between front combination lamp harness connector and ground.

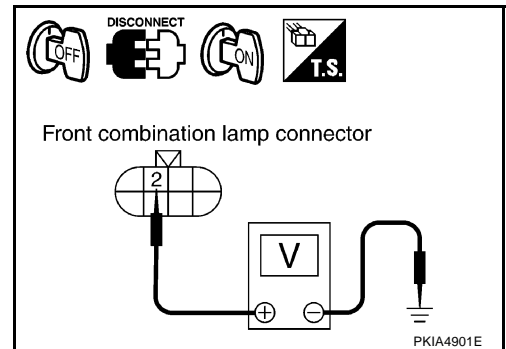

Terminal			(-)	Voltage
(+) Connector		Terminal (Wire color)		
RH	E24	2 (BR)	Ground	Battery voltage
LH	E41	2 (R/Y)		

OK or NG

- OK >> GO TO 4.
 NG >> GO TO 3.

HEADLAMP (FOR USA)

3. CHECK HEADLAMP CIRCUIT

1. Turn ignition switch OFF.
2. Disconnect IPDM E/R connector.
3. Check continuity between IPDM E/R harness connector E7 terminal 27 (BR) and front combination lamp RH harness connector E24 terminal 2 (BR).

27 (BR) – 2 (BR) : Continuity should exist.

4. Check continuity between IPDM E/R harness connector E7 terminal 28 (R/Y) and front combination lamp LH harness connector E41 terminal 2 (R/Y).

28 (R/Y) – 2 (R/Y) : Continuity should exist.

OK or NG

- OK >> Replace IPDM E/R.
- NG >> Repair harness or connector.

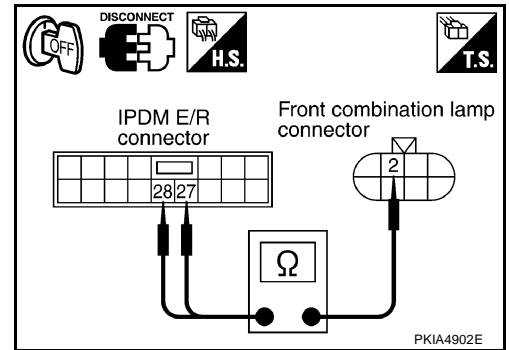

4. CHECK HEADLAMP GROUND

1. Check continuity between front combination lamp RH harness connector E24 terminal 8 (B) and ground.

8 (B) – Ground : Continuity should exist.

2. Check continuity between front combination lamp LH harness connector E41 terminal 8 (B) and ground.

8 (B) – Ground : Continuity should exist.

OK or NG

- OK >> Check headlamp harness and connector.
- NG >> Repair harness or connector.

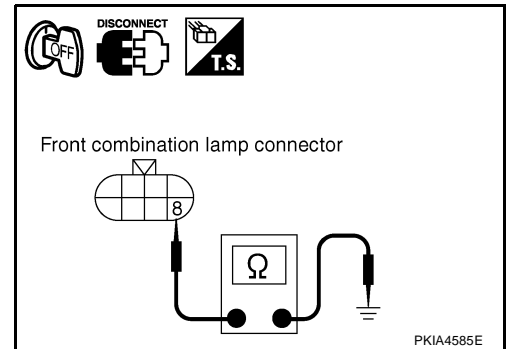

High Beam Indicator Lamp Does Not Illuminate

AKS009J

1. CHECK BULB

Check bulb of high beam indicator lamp which does not illuminate.

OK or NG

- OK >> Replace combination meter.
- NG >> Replace indicator bulb.

Headlamp Low Beam Does Not Illuminate (Both Sides)

AKS009I

1. CHECK COMBINATION SWITCH INPUT SIGNAL

Ⓜ With CONSULT-II

Select "BCM" on CONSULT-II. With "HEAD LAMP" data monitor, make sure "HEAD LAMP SW 1" and "HEAD LAMP SW 2" turns ON-OFF linked with operation of lighting switch.

**When lighting switch is 2ND position : HEAD LAMP SW 1 ON
: HEAD LAMP SW 2 ON**

Ⓧ Without CONSULT-II

Refer to [LT-133, "Combination Switch Inspection"](#).

OK or NG

- OK >> GO TO 2.
- NG >> Check combination switch (lighting switch). Refer to [LT-133, "Combination Switch Inspection"](#).

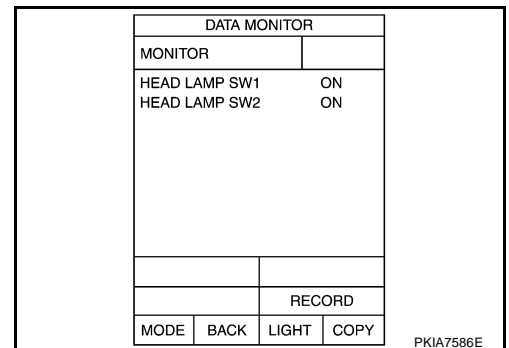

HEADLAMP (FOR USA)

2. HEADLAMP ACTIVE TEST

④ With CONSULT-II

1. Select "IPDM E/R" on CONSULT-II, and select "ACTIVE TEST" on "SELECT DIAG MODE" screen.
2. Select "LAMPS" on "SELECT TEST ITEM" screen.
3. Touch "LO" screen.
4. Make sure headlamp low beam operates.

Headlamp low beam should operate.

⊗ With out CONSULT-II

1. Start auto active test. Refer to [PG-22, "Auto Active Test"](#) .
2. Make sure headlamp low beam operates.

Headlamp low beam should operate.

ACTIVE TEST			
LAMPS		OFF	
		HI	
LO		FOG	
MODE	BACK	LIGHT	COPY

SKIA5774E

OK or NG

- OK >> GO TO 3.
NG >> GO TO 4.

3. CHECK IPDM E/R

1. Select "IPDM E/R" on CONSULT-II, and select "DATA MONITOR" on "SELECT DIAG MODE" screen.
2. Make sure "HL LO REQ" turns ON when lighting switch is in 2ND position.

When lighting switch is 2ND position : HL LO REQ ON

OK or NG

- OK >> Replace IPDM E/R.
NG >> Replace BCM. Refer to [BCS-16, "Removal and Installation of BCM"](#) .

DATA MONITOR			
MONITOR			
HL LO REQ		ON	
		RECORD	
MODE	BACK	LIGHT	COPY

PKIA7644E

HEADLAMP (FOR USA)

4. CHECK HEADLAMP INPUT SIGNAL

With CONSULT-II

1. Turn ignition switch OFF.
2. Disconnect front combination lamp RH and LH connector.
3. Select "IPDM E/R" on CONSULT-II, and select "ACTIVE TEST" on "SELECT DIAG MODE" screen.
4. Select "LAMPS" on "SELECT TEST ITEM" screen.
5. Touch "LO" screen.
6. When headlamp low relay is operating, check voltage between front combination lamp harness connector and ground.

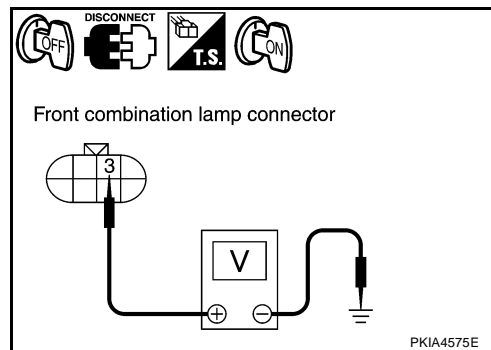

Terminal (+)			(-)	Voltage
Connector	Terminal (Wire color)			
RH	E24	3 (R)	Ground	Battery voltage
LH	E41	3 (R/B)		

Without CONSULT-II

1. Turn ignition switch OFF.
2. Disconnect front combination lamp RH and LH connector.
3. Start auto active test. Refer to [PG-22, "Auto Active Test"](#).
4. When headlamp low relay is operating, check voltage between front combination lamp harness connector and ground.

Terminal (+)			(-)	Voltage
Connector	Terminal (Wire color)			
RH	E24	3 (R)	Ground	Battery voltage
LH	E41	3 (R/B)		

OK or NG

- OK >> GO TO 6.
 NG >> GO TO 5.

5. CHECK HEADLAMP CIRCUIT

1. Turn ignition switch OFF.
2. Disconnect IPDM E/R connector.
3. Check continuity between IPDM E/R harness connector E7 terminal 20 (R) and front combination lamp RH harness connector E24 terminal 3 (R).

20 (R) – 3 (R) : Continuity should exist.

4. Check continuity between IPDM E/R harness connector E7 terminal 30 (R/B) and front combination lamp LH harness connector E41 terminal 3 (R/B).

30 (R/B) – 3 (R/B) : Continuity should exist.

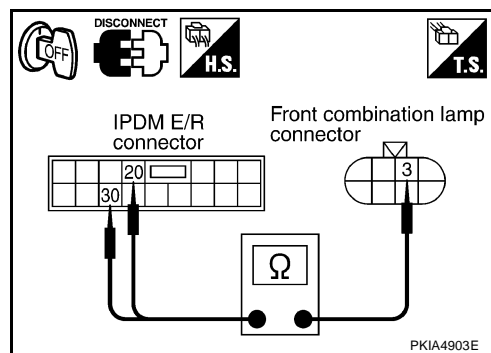

OK or NG

- OK >> Replace IPDM E/R.
 NG >> Repair harness or connector.

HEADLAMP (FOR USA)

6. CHECK HEADLAMP GROUND

1. Turn ignition switch OFF.
2. Check continuity between front combination lamp RH harness connector E24 terminal 4 (B/W) and ground.
4 (B/W) – Ground : Continuity should exist.
3. Check continuity between front combination lamp LH harness connector E41 terminal 4 (B/W) and ground.
4 (B/W) – Ground : Continuity should exist.

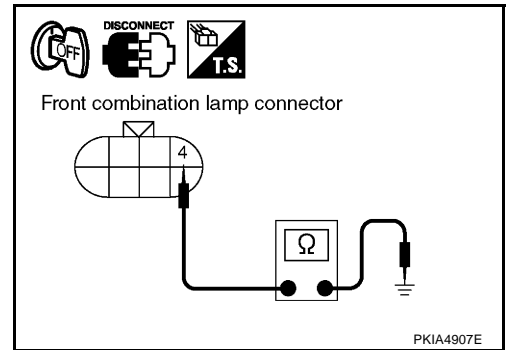

OK or NG

- OK >> Check headlamp harness and connectors, ballasts (HID control unit), and xenon bulbs. Refer to [LT-31, "Xenon Headlamp Trouble Diagnosis"](#) .
- NG >> Repair harness or connector.

Headlamp Low Beam Does Not Illuminate (One Side)

AKS009IU

1. CHECK BULB

Check ballast (HID control unit) and xenon bulb of lamp which does not illuminate. Refer to [LT-31, "Xenon Headlamp Trouble Diagnosis"](#) .

OK or NG

- OK >> GO TO 2.
- NG >> Replace malfunctioning part.

2. CHECK HEADLAMP INPUT SIGNAL

1. Turn ignition switch OFF.
2. Disconnect front combination lamp RH or LH connector.
3. Turn ignition switch ON.
4. Lighting switch is turned 2ND position.
5. Check voltage between front combination lamp harness connector and ground.

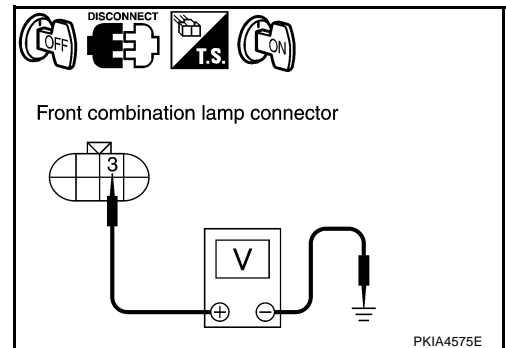

Terminal (+)			Terminal (-)	Voltage
Connector	Terminal (Wire color)			
RH	E24	3 (R)	Ground	Battery voltage
LH	E41	3 (R/B)		

OK or NG

- OK >> GO TO 4.
- NG >> GO TO 3.

HEADLAMP (FOR USA)

3. CHECK HEADLAMP CIRCUIT

1. Turn ignition switch OFF.
2. Disconnect IPDM E/R connector.
3. Check continuity between IPDM E/R harness connector E7 terminal 20 (R) and front combination lamp RH harness connector E24 terminal 3 (R).

20 (R) – 3 (R) : Continuity should exist.

4. Check continuity between IPDM E/R harness connector E7 terminal 30 (R/B) and front combination lamp LH harness connector E41 terminal 3 (R/B).

30 (R/B) – 3 (R/B) : Continuity should exist.

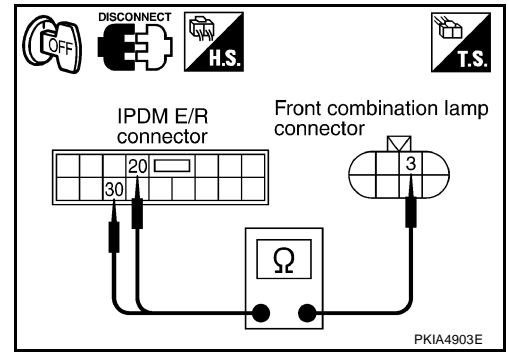

OK or NG

- OK >> Replace IPDM E/R.
- NG >> Repair harness or connector.

4. CHECK HEADLAMP GROUND

1. Check continuity between front combination lamp RH harness connector E24 terminal 4 (B/W) and ground.

4 (B/W) – Ground : Continuity should exist.

2. Check continuity between front combination lamp LH harness connector E41 terminal 4 (B/W) and ground.

4 (B/W) – Ground : Continuity should exist.

OK or NG

- OK >> Check headlamp harness and connectors.
- NG >> Repair harness or connector.

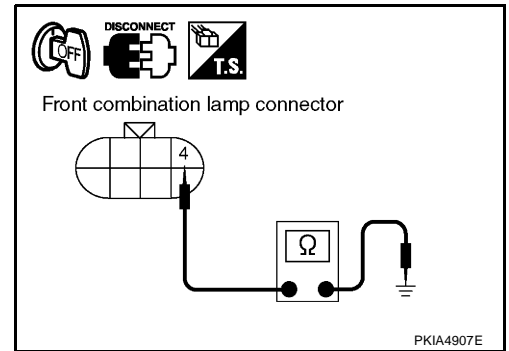

Headlamps Does Not Turn OFF

1. CHECK HEADLAMP TURN OFF

Make sure that lighting switch is OFF. And make sure is headlamp turns off when ignition switch is turned OFF.

OK or NG

- OK >> GO TO 3.
- NG >> GO TO 2.

2. CHECK COMBINATION SWITCH INPUT SIGNAL

Select "BCM" on CONSULT-II. With "HEAD LAMP" data monitor, make sure "HEAD LAMP SW 1" and "HEAD LAMP SW 2" turns ON-OFF linked with operation of lighting switch.

When lighting switch is OFF : HEAD LAMP SW 1 OFF position : HEAD LAMP SW 2 OFF

OK or NG

- OK >> Replace IPDM E/R.
- NG >> Check combination switch (lighting switch). Refer to [LT-133. "Combination Switch Inspection"](#).

DATA MONITOR			
MONITOR			
HEAD LAMP SW1	OFF		
HEAD LAMP SW2	OFF		
		Page Down	
		RECORD	
MODE	BACK	LIGHT	COPY

PKIA7588E

HEADLAMP (FOR USA)

3. CHECKING CAN COMMUNICATIONS BETWEEN BCM AND IPDM E/R

Select "BCM" on CONSULT-II, and perform self-diagnosis for "BCM".

Display of self-diagnosis results

NO DTC>> Replace IPDM E/R.

CAN COMM CIRCUIT>> Refer to [BCS-15, "CAN Communication Inspection Using CONSULT-II \(Self-Diagnosis\)"](#) .

SELF-DIAG RESULTS			
DTC RESULTS		TIME	
CAN COMM CIRCUIT [U1000]			
ERASE		PRINT	
MODE	BACK	LIGHT	COPY

PKIA7627E

HEADLAMP (FOR USA)

General Information for Xenon Headlamp Trouble Diagnosis

AKS00CMT

In most cases, malfunction of xenon headlamp - "does not illuminate", "flickers" or "dark" - is caused by a malfunctioning xenon bulb. A malfunctioning HID control unit or lamp housing, however, may be a cause. Be sure to perform trouble diagnosis following the steps described below.

Caution:

AKS00CMU

- Installation or removal of connector must be done with lighting switch OFF.
- Disconnect the battery cable from the negative terminal or remove power fuse.
- When the lamp is illuminated (when lighting switch is ON), never touch harness, HID control unit, inside of lamp, or lamp metal parts.
- To check illumination, temporarily install lamp in vehicle. Be sure to connect power at vehicle side connector.
- If error can be traced directly to electrical system, first check for items such as blown fuses and fusible links, broken wires or loose connectors, dislocated terminals, and improper connections.
- Never work with wet hands.
- Using a tester for HID control unit circuit trouble diagnosis is prohibited.
- Disassembling HID control unit or harnesses (bulb socket harness, ECM harness) is prohibited.
- Immediately after illumination, light intensity and color will fluctuate, but there is nothing wrong.
- When bulb has come to end of its life, brightness will drop significantly, it will flash repeatedly, or light color will turn reddish.

Xenon Headlamp Trouble Diagnosis

AKS00CMV

1. CHECK 1: XENON HEADLAMP LIGHTING

Install normal xenon bulb to corresponding xenon bulb headlamp, and check if lamp lights up.

OK or NG

- OK >> Replace xenon bulb.
- NG >> GO TO 2.

2. CHECK 2: XENON HEADLAMP LIGHTING

Install normal HID control unit to corresponding xenon headlamp, and check if lamp lights up.

OK or NG

- OK >> Replace HID control unit.
- NG >> GO TO 3.

3. CHECK 3: XENON HEADLAMP LIGHTING

Install normal xenon lamp housing assembly to corresponding xenon headlamp, and check if lamp lights up.

OK or NG

- OK >> Replace xenon headlamp housing assembly. [Malfunction in starter (boosting circuit) in xenon headlamp housing]
- NG >> INSPECTION END

HEADLAMP (FOR USA)

Aiming Adjustment

AKS00517

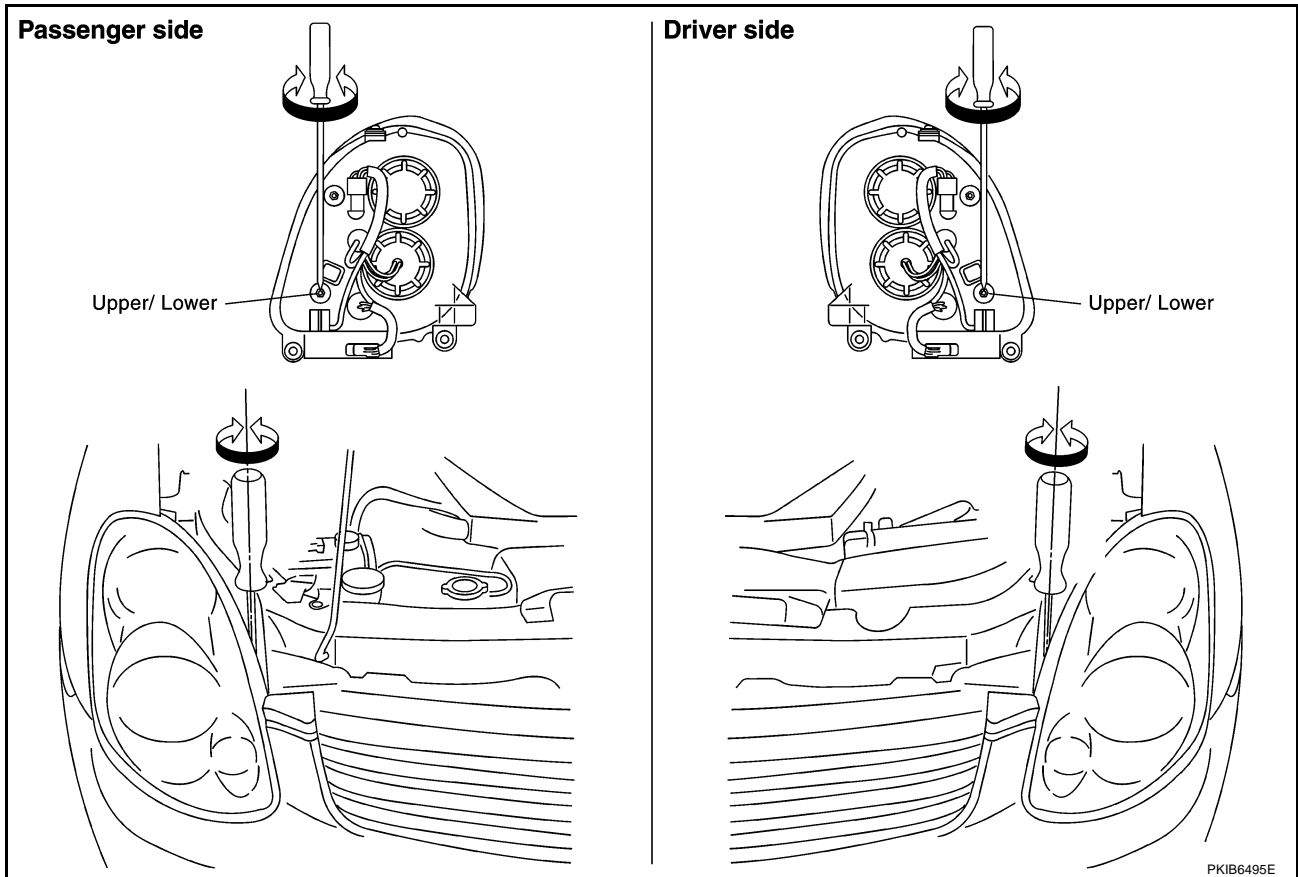

PREPARATION BEFORE ADJUSTING

For Details, Refer to the Regulations in Your Own Country.

Before performing aiming adjustment, check the following.

1. Keep all tires inflated to correct pressures.
2. Place vehicle on flat surface.
3. Set that there is no-load in vehicle other than the driver (or equivalent weight placed in driver's position). Coolant, engine oil filled up to correct level and full fuel tank.

LOW BEAM AND HIGH BEAM

1. Turn headlamp low beam ON.
2. Use adjusting screws to perform aiming adjustment.

HEADLAMP (FOR USA)

ADJUSTMENT USING AN ADJUSTMENT SCREEN (LIGHT/DARK BORDERLINE)

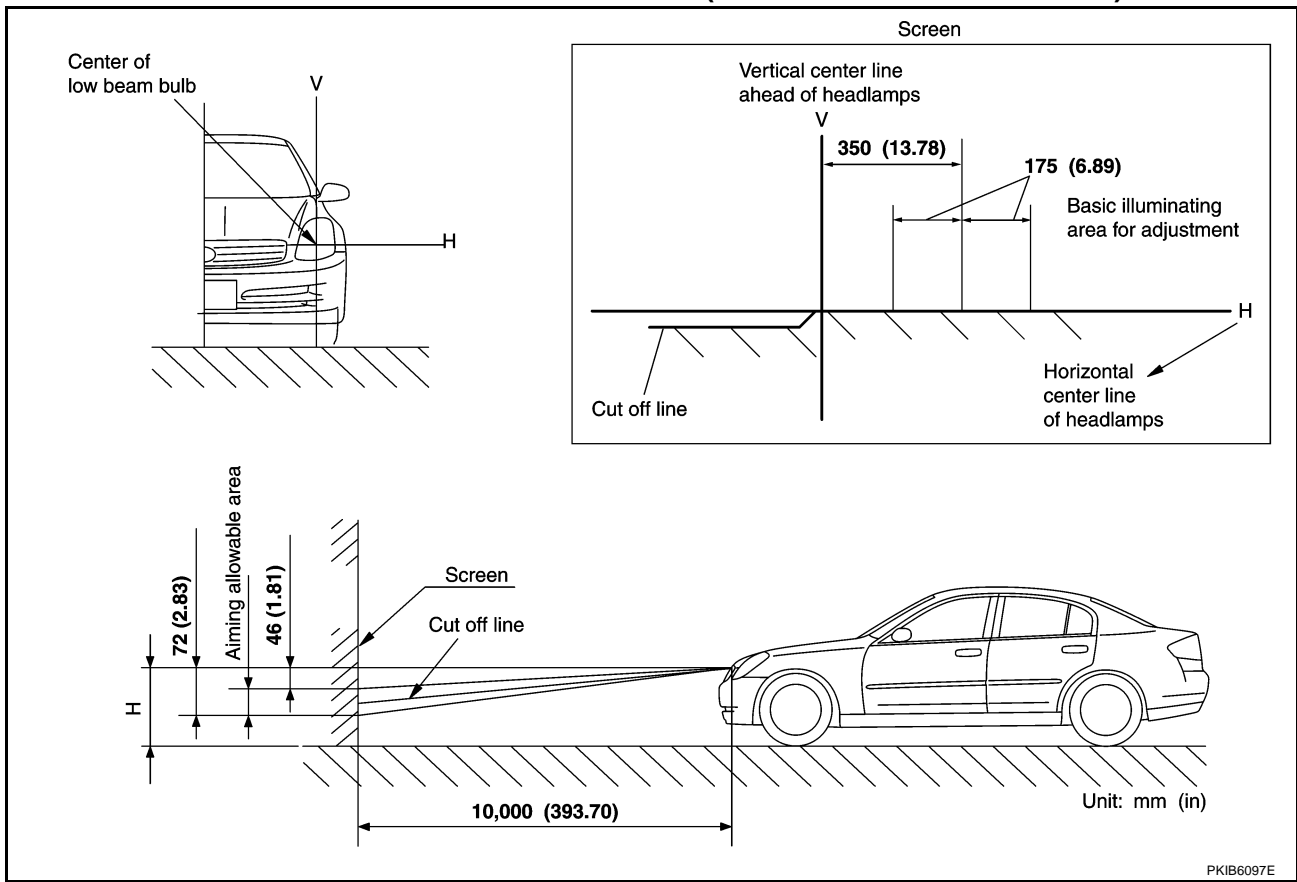

If vehicle front body has been repaired and/or headlamp assembly has been replaced, check aiming. Use aiming chart shown in the figure.

- Basic illumination area for adjustment should be within the range shown on the aiming chart. Adjust headlamp accordingly.

Bulb Replacement HEADLAMP (UPPER) LOW BEAM

1. Turn lighting switch OFF.
2. Disconnect the battery cable from the negative terminal or remove power fuse.
3. Remove headlamp. Refer to [LT-34, "Removal and Installation"](#).
4. Turn plastic cap counterclockwise and unlock it.
5. Turn bulb socket counterclockwise and unlock it.
6. Unlock retaining spring and remove bulb from headlamp.
7. Installation is the reverse order of removal.

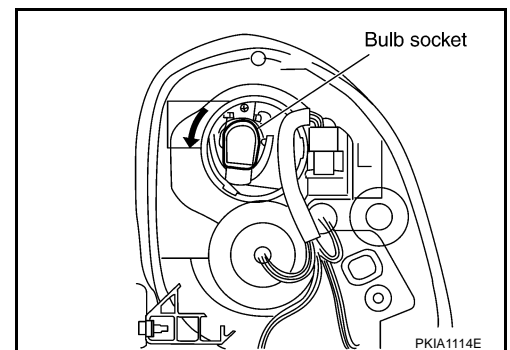

HEADLAMP (FOR USA)

HEADLAMP (LOWER) HIGH BEAM/FOG LAMP

1. Turn lighting switch OFF.
2. Disconnect the battery cable from the negative terminal or remove power fuse.
3. Remove fender protector (front). Refer to [EI-22, "FENDER PROTECTOR"](#) in "EI" section.
4. Turn plastic cap counterclockwise and unlock it.
5. Disconnect bulb socket.
6. Unlock retaining spring and remove bulb from headlamp.
7. Installation is the reverse order of removal.

FRONT TURN SIGNAL/PARKING LAMP

1. Turn lighting switch OFF.
2. Remove fender protector (front). Refer to [EI-22, "FENDER PROTECTOR"](#) in "EI" section.
3. Turn bulb socket counterclockwise and unlock it.
4. Remove bulb from its socket.
5. Installation is the reverse order of removal.

Headlamp (upper) low beam : 12V - 35W (D2R)

Headlamp (lower) high beam/Fog lamp : 12V - 60/55W (HB2)

Front turn signal/Parking lamp : 12V - 21/5W

CAUTION:

After installing bulb, be sure to install plastic cap and bulb socket securely to insure watertightness.

Removal and Installation

REMOVAL

1. Disconnect the battery cable from the negative terminal or remove power fuse.
2. Remove front grille. Refer to [EI-20, "FRONT GRILLE"](#) in "EI" section.
3. Remove front undercover and fender protector. Refer to [EI-22, "FENDER PROTECTOR"](#) in "EI" section.
4. Remove mounting clip on top of front bumper and screws on side of front bumper. Refer to [EI-14, "FRONT BUMPER"](#) in "EI" section.
5. Pull side of front bumper toward the vehicle front and disengage it from clips on the body.
6. Remove headlamp mounting bolts.
7. Pull headlamp toward the vehicle front, disconnect connector, and remove headlamp.

CAUTION:

When removing headlamps, put a shop cloth or something similar between headlamps and bumper to protect bumper.

INSTALLATION

Installation is the reverse order of removal.

Headlamp mounting bolt  : 5.9 N·m (0.60 kg·m, 52 in·lb)

AKS00519

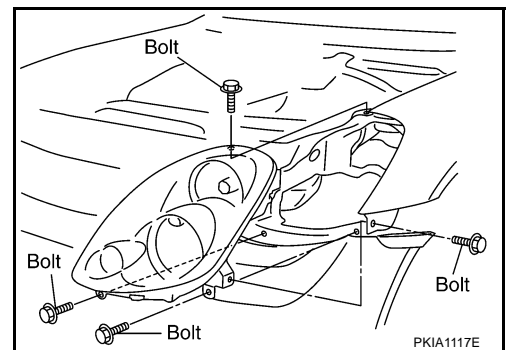
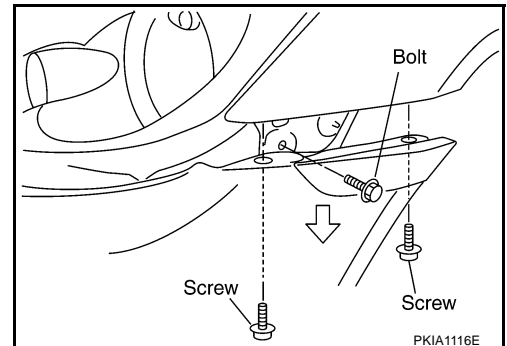

HEADLAMP (FOR USA)

Disassembly

AKS0051A

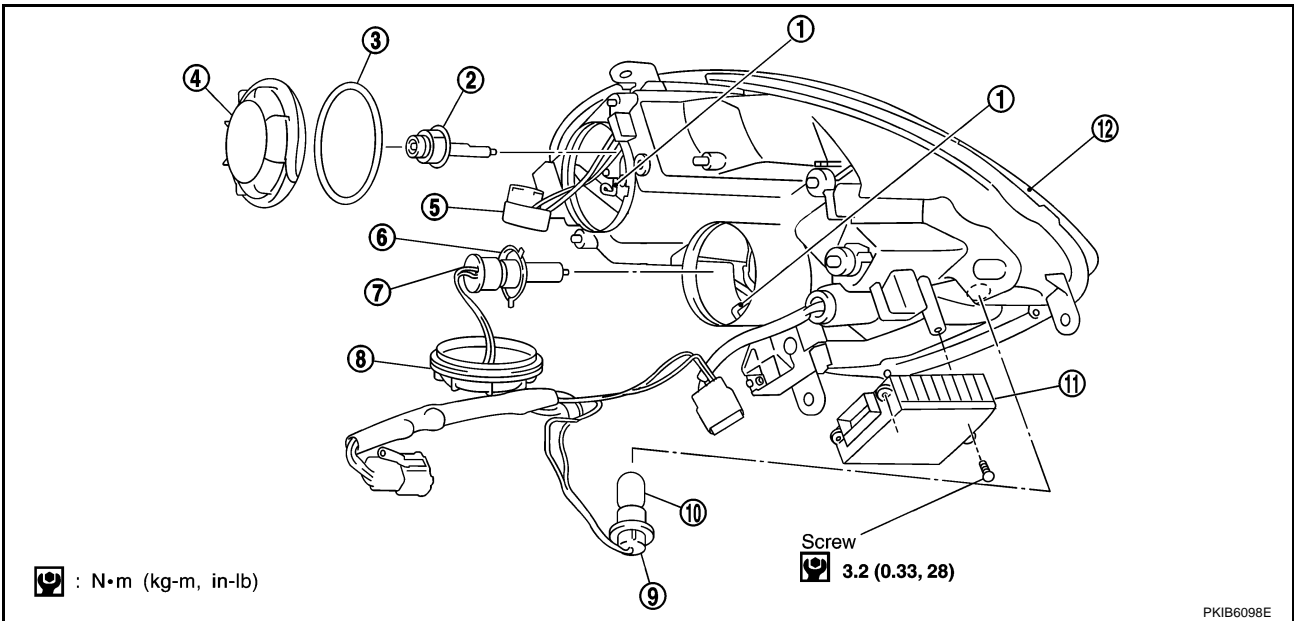

- | | | |
|---|----------------------------|---|
| 1. Retaining spring | 2. Xenon bulb (low) | 3. Seal rubber |
| 4. Plastic cap (low) | 5. Xenon bulb socket (low) | 6. Halogen bulb (high/fog) |
| 7. Halogen bulb (high/fog) socket | 8. Plastic cap (high/fog) | 9. Front turn signal/Parking lamp bulb socket |
| 10. Front turn signal/Parking lamp bulb | 11. HID control unit | 12. Headlamp housing assembly |

1. Turn plastic cap (low) counterclockwise and unlock it.
2. Turn xenon bulb (low) socket counterclockwise, and unlock it.
3. Unlock retaining spring, and remove xenon bulb (low).
4. Disconnect HID control unit connector, and remove HID control unit screws. (Xenon)
5. Turn plastic cap (high/fog) counterclockwise, and unlock it.
6. Disconnect the terminal connected to the halogen bulb (high/fog).
7. Unlock retaining spring, and remove halogen bulb (high/fog).
8. Turn front turn signal lamp/parking bulb socket counterclockwise and unlock it.
9. Remove front turn signal/parking lamp bulb from its socket.

A
B
C
D
E
F
G
H
I
J
LT
L
M

HEADLAMP (FOR USA)

Assembly

AKS0051B

Assembly is the reverse order of disassembly.

HID control unit  : 3.2 N·m (0.33 kg·m, 28 in·lb)

CAUTION:

- When HID control unit is removed, reinstall it securely and avoid any looseness.
- After installing bulb, be sure to install plastic cap and bulb socket securely to insure watertightness.

Servicing to Replace Headlamps When Damaged

AKS0051C

If only installation part as shown in the figure is damaged, and headlamp housing itself is not damaged, repair can be completed easily by installing correction brackets.

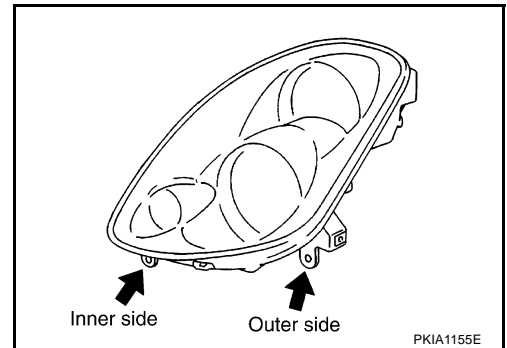

REMOVAL AND INSTALLATION

1. Remove headlamps. Refer to [LT-34, "Removal and Installation"](#).
2. Cut damaged section of installation part, then shape with sandpaper.
3. Attach each correction bracket to headlamp housing boss with 2 screws.

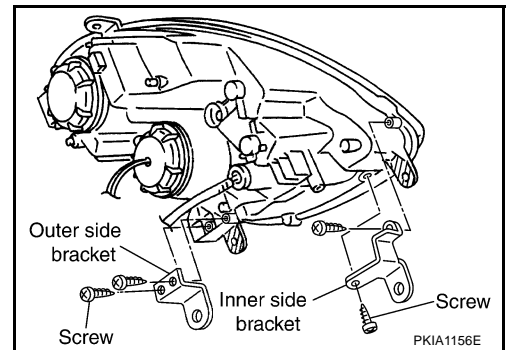

HEADLAMP (FOR CANADA) - DAYTIME LIGHT SYSTEM -

HEADLAMP (FOR CANADA) - DAYTIME LIGHT SYSTEM -

PPF:26010

Component Parts and Harness Connector Location

AKS004Q2

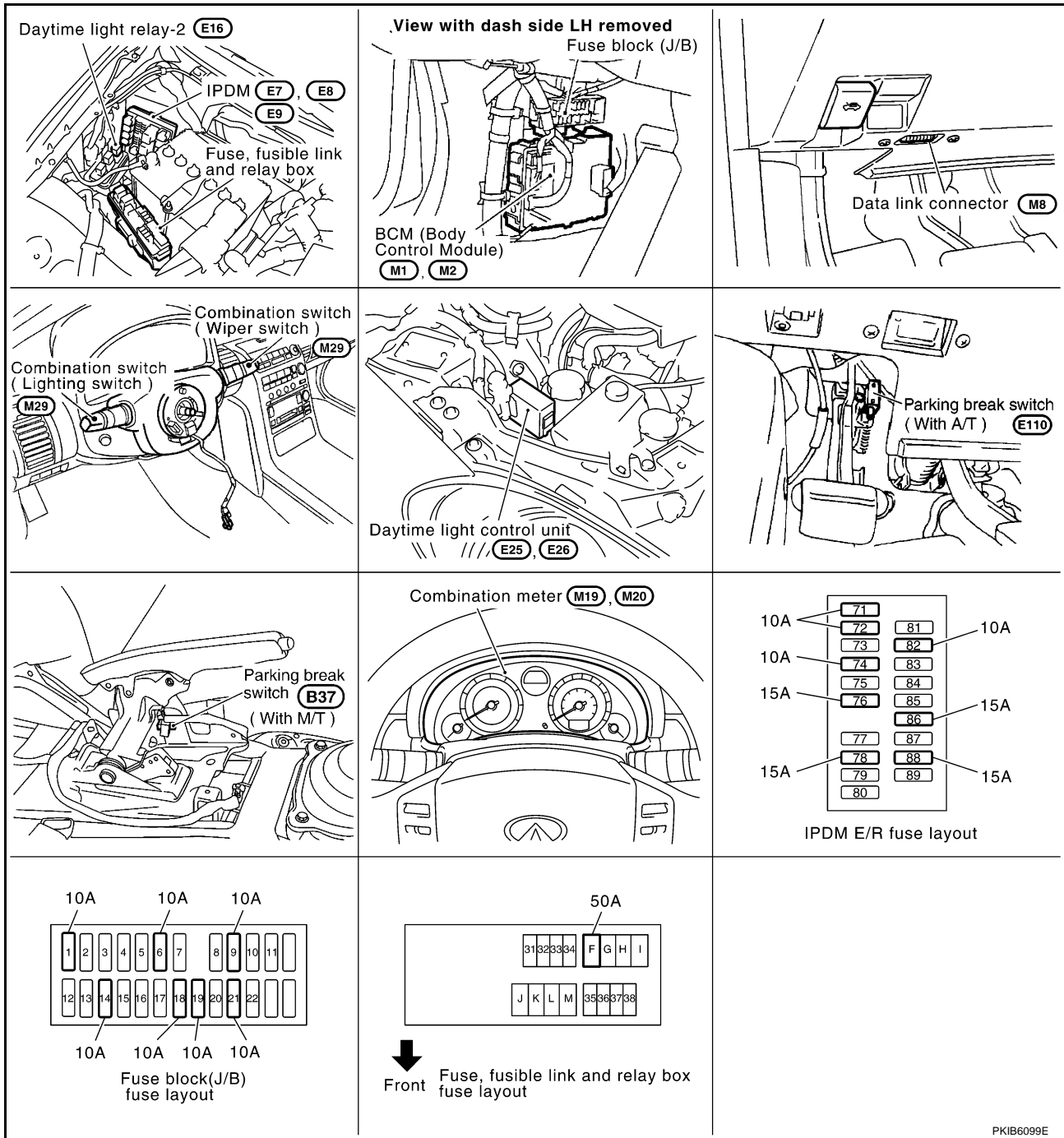

PKIB6099E

System Description

AKS0091Y

The headlamp system for Canada vehicles is equipped with a daytime light control unit that activates high beam headlamps at approximately half illumination whenever engine is running. If parking brake is applied before engine is started daytime lights will not be illuminated. The daytime lights will illuminate once parking brake is released. Thereafter, daytime lights will continue to operate when parking brake is applied. And battery saver system is controlled by BCM (body control module).

OUTLINE

Power is supplied at all times

- to headlamp high relay, located in IPDM E/R (intelligent power distribution module engine room) and
- to headlamp low relay, located in IPDM E/R, from battery direct,

A
B
C
D
E
F
G
H
I
J
LT
L
M

HEADLAMP (FOR CANADA) - DAYTIME LIGHT SYSTEM -

- through 15A fuse (No. 78, located in IPDM E/R)
- to CPU located in IPDM E/R,
- through 10A fuse (No. 71, located in IPDM E/R)
- to CPU located in IPDM E/R,
- through 15A fuse (No. 88, located in IPDM E/R)
- to front fog lamp relay, located in IPDM E/R,
- through 10A fuse [No. 19, located in fuse block (J/B)]
- to combination meter terminal 21,
- through 10A fuse [No. 21, located in fuse block (J/B)]
- to daytime light control unit terminals 2 and 3,
- through 50A fusible link (letter F, located in fuse, fusible link and relay box)
- to BCM terminal 55,
- through 10A fuse [No. 18, located in fuse block (J/B)]
- to BCM terminal 42.

With the ignition switch in the ON or START position, power is supplied

- to CPU located in IPDM E/R, from battery direct,
- through 10A fuse (No. 82, located in IPDM E/R)
- to daytime light control unit terminal 12,
- through 10A fuse [No. 1, located in fuse block (J/B)]
- to BCM terminal 38,
- through 10A fuse [No. 14, located in fuse block (J/B)]
- to combination meter terminals 22 and 23.

With the ignition switch in the ACC or ON position, power is supplied

- through 10A fuse [No. 6, located in fuse block (J/B)]
- to BCM terminal 11.

With the ignition switch in the START position, power is supplied

- through 10A fuse [No. 9, located in fuse block (J/B)]
- to daytime light control unit terminal 1.

Ground is supplied

- to daytime light control unit terminal 9
- through grounds E17 and E43,
- to BCM terminal 52
- through grounds M30 and M66,
- to IPDM E/R terminals 38 and 60
- through grounds E17 and E43,
- to combination meter terminals 1, 24 and 25
- through grounds M30 and M66.

HEADLAMP OPERATION

Low Beam Operation

With the lighting switch in 2ND position, the BCM receives input signal requesting the headlamps to illuminate. This input signal is communicated to IPDM E/R across the CAN communication lines. The CPU located in the IPDM E/R controls the headlamp low relay coil, which when energized, directs power

- through 15A fuse (No. 76, located in IPDM E/R)
- through IPDM E/R terminal 20
- to front combination lamp RH terminal 3,
- through 15A fuse (No. 86, located in IPDM E/R)
- through IPDM E/R terminal 30
- to front combination lamp LH terminal 3.

Ground is supplied

HEADLAMP (FOR CANADA) - DAYTIME LIGHT SYSTEM -

- to front combination lamp RH terminal 4
- through grounds E17 and E43,
- to front combination lamp LH terminal 4
- through grounds E17 and E43.

With power and ground supplied, low beam headlamps illuminate.

High Beam Operation (When Daytime Light Does Not Operate)/Flash-to-Pass Operation

With the lighting switch in 2ND position and placed in HIGH BEAM or PASSING position, the BCM receives input signal requesting headlamp high beams to illuminate. High beam request signal is communicated to the IPDM E/R across the CAN communication lines. The CPU located in the IPDM E/R controls headlamp high relay coil and daytime light relay-2 turned ON, which when energized, directs power

- through 10A fuse (No. 74, located in IPDM E/R)
- through IPDM E/R terminal 28
- to daytime light control unit terminal 5
- through daytime light control unit terminal 6
- to front combination lamp LH terminal 2,
- through 10A fuse (No. 72, located in IPDM E/R)
- through IPDM E/R terminal 27
- to daytime light relay-2 terminal 2 and 5, and
- to daytime light control unit terminal 1,
- through daytime light relay-2 terminal 3
- to front combination lamp RH terminal 2,
- through 15A fuse (No. 76, located in IPDM E/R)
- through IPDM E/R terminal 20
- to front combination lamp RH terminal 3, and
- to daytime light control unit terminal 1,
- through 15A fuse (No. 86, located in IPDM E/R)
- through IPDM E/R terminal 30
- to front combination lamp LH terminal 3, and
- to daytime light control unit terminal 4.

Ground is supplied

- to daytime light relay-2 terminal 1
- through grounds E17 and E43,
- to front combination lamp RH terminal 8
- through grounds E17 and E43,
- to front combination lamp RH terminal 4
- through grounds E17 and E43,
- to front combination lamp LH terminal 4
- through grounds E17 and E43,
- to front combination lamp LH terminal 8
- through daytime light control unit terminal 7
- through daytime light control unit terminal 9
- through grounds E17 and E43.

With the power and ground supplied, the headlamp high beam and low headlamp illuminate.

High beam indicator illuminates when combination meter receives input signal requesting high beam indicator to illuminate. This is communicated to BCM across the CAN communication lines.

A

B

C

D

E

F

G

H

I

J

LT

L

M

HEADLAMP (FOR CANADA) - DAYTIME LIGHT SYSTEM -

DAYTIME LIGHT OPERATION

With engine running, lighting switch in OFF or 1ST position and parking brake released, power is supplied

- through daytime light control unit terminal 6
- to front combination lamp LH terminal 2
- through front combination lamp LH terminal 8
- to daytime light control unit terminal 7
- through daytime light control unit terminal 8
- to front combination lamp RH terminal 2.

Ground is supplied

- to front combination lamp RH terminal 8
- through grounds E17 and E43.

Because high beam headlamps are now wired in series, they operate at half illumination.

If lighting switch is in HIGH position, daytime light operation is canceled. On this occasion, power is supplied

- through IPDM E/R terminal 27
- to daytime light control unit terminal 1.

Daytime light control unit is canceled power supplying from front combination lamp RH terminal 8 to terminal 2 (series power supplying is canceled). And then high beam is ON.

OPERATION

After starting engine with lighting switch in the OFF or 1ST position, headlamp high beam automatically turns on. Lighting switch operations other than above are same as conventional light systems.

Engine		With engine stopped												With engine running											
Lighting switch		OFF				1ST				2ND				OFF				1ST				2ND			
		Hi	Lo	P	F	Hi	Lo	P	F	Hi	Lo	P	F	Hi	Lo	P	F	Hi	Lo	P	F	Hi	Lo	P	F
Head-lamp	High beam	-	-	x	-	-	-	x	-	x	-	x	-	●*	●*	x	-	●*	●*	x	-	x	-	x	-
	Low beam	-	-	x	-	-	-	x	-	x	x	x	x	-	-	x	-	-	-	x	-	x	x	x	x
Tail lamp		-	-	-	-	x	x	x	x	x	x	x	x	-	-	-	-	x	x	x	x	x	x	x	x
License plate and instrument illumination lamp		-	-	-	-	x	x	x	x	x	x	x	x	-	-	-	-	x	x	x	x	x	x	x	x

- Hi: "HIGH BEAM" position
- Lo: "LOW BEAM" position
- P: "FLASH TO PASS" position
- F: "FOG LAMP" SW is ON
- x: Lamp "ON"
- -: Lamp "OFF"
- ●: Lamp dims. (Added functions)
- *: When starting the engine with the parking brake released, the daytime light will come ON.
When starting the engine with the parking brake pulled, the daytime light will not come ON.

COMBINATION SWITCH READING FUNCTION

Refer to [BCS-3, "COMBINATION SWITCH READING FUNCTION"](#) .

EXTERIOR LAMP BATTERY SAVER CONTROL

When the combination switch (lighting switch) is in the 2ND position (or if auto light system is activated), and the ignition switch is turned from ON or ACC to OFF, the battery saver control function is activated.

Under this condition, the headlamps remain illuminated for 5 minutes, then the headlamps are turned off.

Exterior lamp battery saver control mode can be changed by the function setting of CONSULT-II.

AUTO LIGHT OPERATION (IF EQUIPPED)

For auto light operation, refer to [LT-76, "System Description"](#) in "AUTO LIGHT SYSTEM".

HEADLAMP (FOR CANADA) - DAYTIME LIGHT SYSTEM -

VEHICLE SECURITY SYSTEM

The vehicle security system will flash the high beams if the system is triggered. Refer to [BL-199, "VEHICLE SECURITY \(THEFT WARNING\) SYSTEM"](#) .

XENON HEADLAMP

Xenon type lamps are used for to the low beam headlamps. Xenon bulbs do not use a filament. Instead, they produce light when a high voltage current is passed between two tungsten electrodes through a mixture of xenon (an inert gas) and certain other metal halides. In addition to strong lighting power, electronic control of the power supply gives the headlamps stable quality and tone color.

Followings are some advantages of the xenon type headlamp.

- The light produced by the headlamps is white color similar to sunlight that is easy to the eyes.
- Light output is nearly double that of halogen headlamps, affording increased area of illumination.
- Counter-reflected luminance increases and the contrast enhances on the wet road in the rain. That makes visibility go up more than the increase of the light volume.
- Power consumption is approximately 25 percent less than halogen headlamps, reducing battery load.

CAN Communication System Description

AKS004Q4

CAN (Controller Area Network) is a serial communication line for real time application. It is an on-vehicle multiplex communication line with high data communication speed and excellent error detection ability. Many electronic control units are equipped onto vehicle, and each control unit shares information and links with other control units during operation (not independent). In CAN communication, control units are connected with 2 communication lines (CAN H line, CAN L line) allowing a high rate of information transmission with less wiring. Each control unit transmits/receives data but selectively reads required data only.

CAN Communication Unit

AKS0093K

Refer to [LAN-21, "CAN Communication Unit"](#) .

HEADLAMP (FOR CANADA) - DAYTIME LIGHT SYSTEM -

Schematic

AKS004Q6

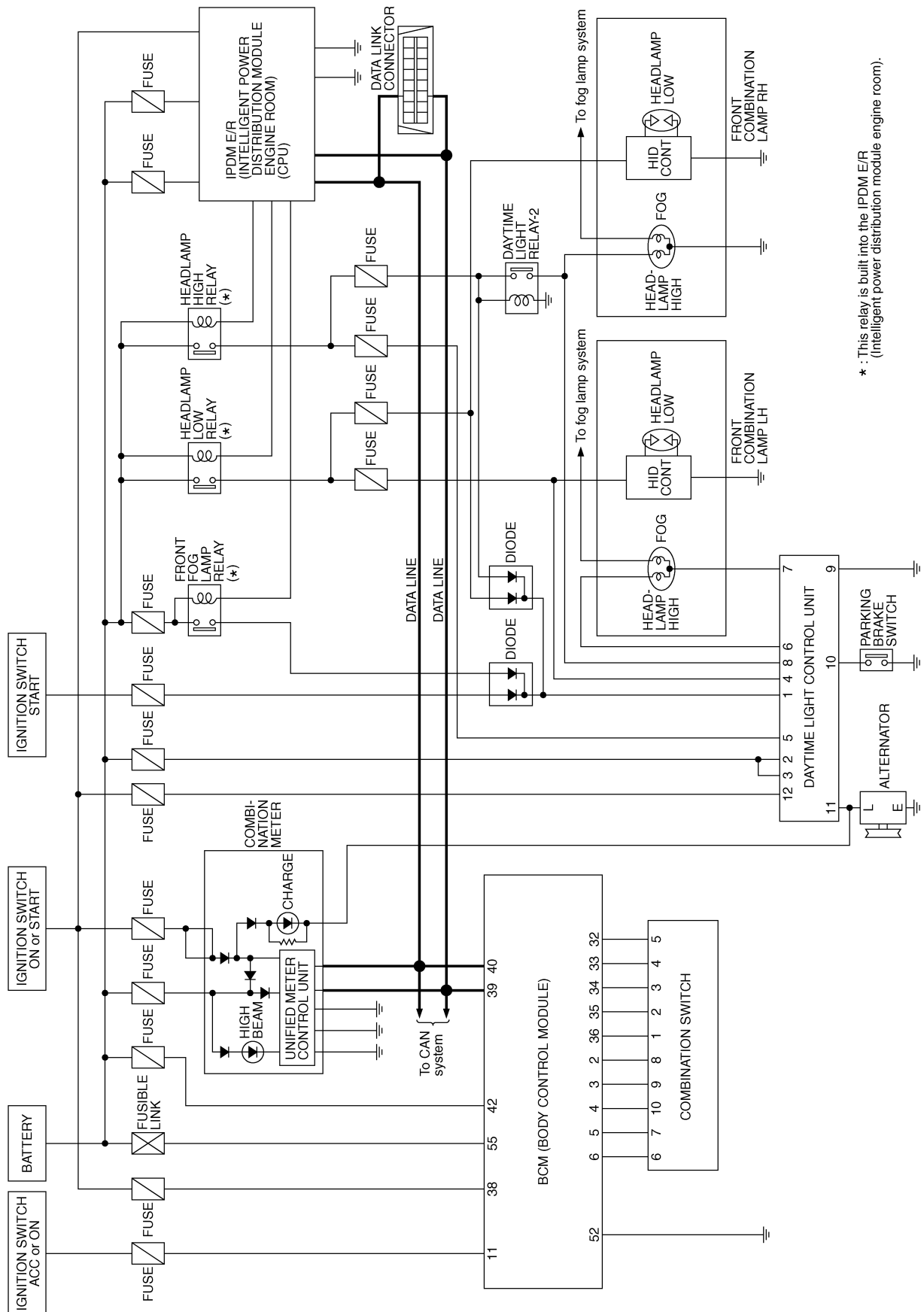

* : This relay is built into the IPDM E/R (intelligent power distribution module engine room).

TKWM2246E

HEADLAMP (FOR CANADA) - DAYTIME LIGHT SYSTEM -

Wiring Diagram — DTRL —

AKS0091T

LT-DTRL-01

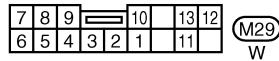
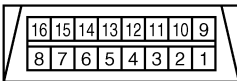
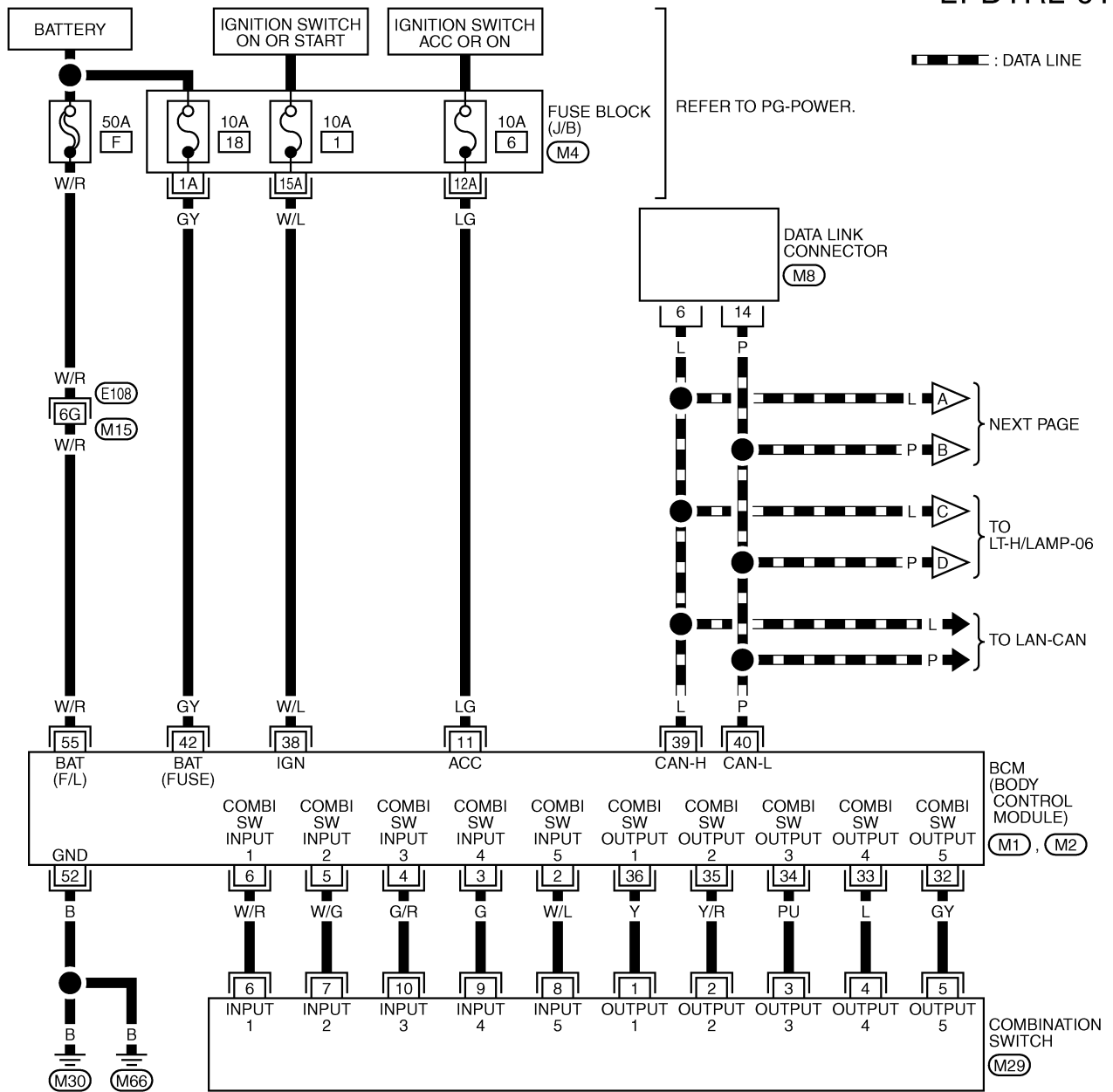

REFER TO THE FOLLOWING.

- (E108) -SUPER MULTIPLE JUNCTION (SMJ)
- (M4) -FUSE BLOCK-JUNCTION BOX (J/B)
- (M1), (M2) -ELECTRICAL UNITS

TKWM2247E

HEADLAMP (FOR CANADA) - DAYTIME LIGHT SYSTEM -

LT-DTRL-02

▬ : DATA LINE

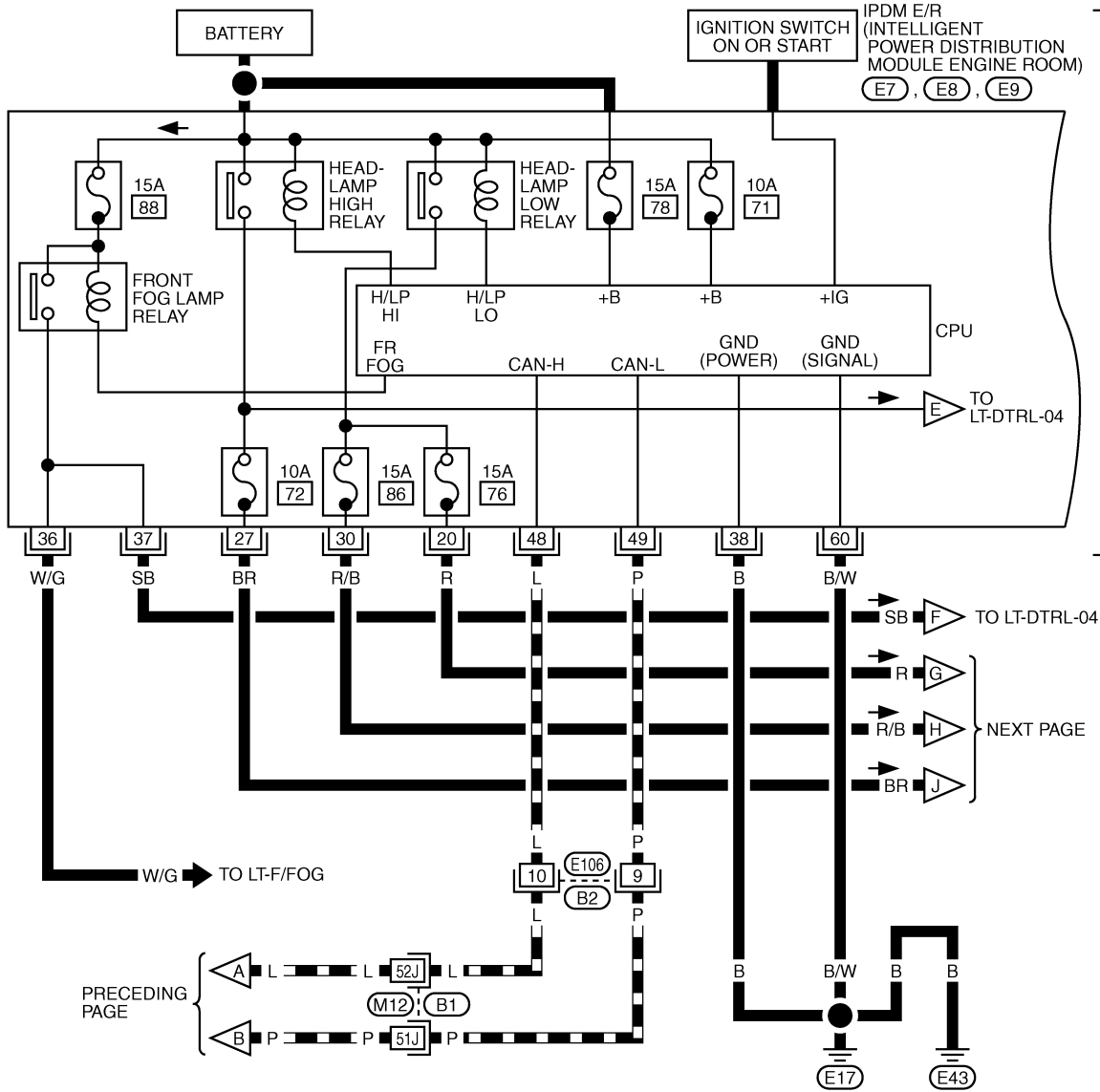

REFER TO PG-POWER.

TO LT-DTRL-04
NEXT PAGE
NEXT PAGE

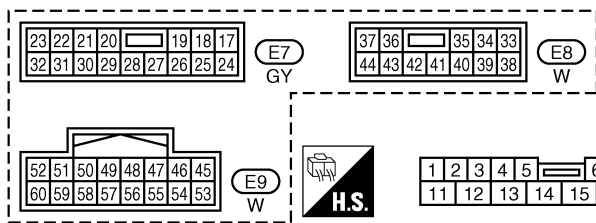

REFER TO THE FOLLOWING.

(B1) -SUPER MULTIPLE JUNCTION (SMJ)

TKWM2248E

HEADLAMP (FOR CANADA) - DAYTIME LIGHT SYSTEM -

LT-DTRL-03

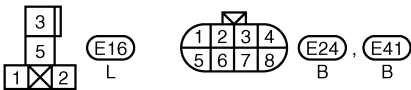
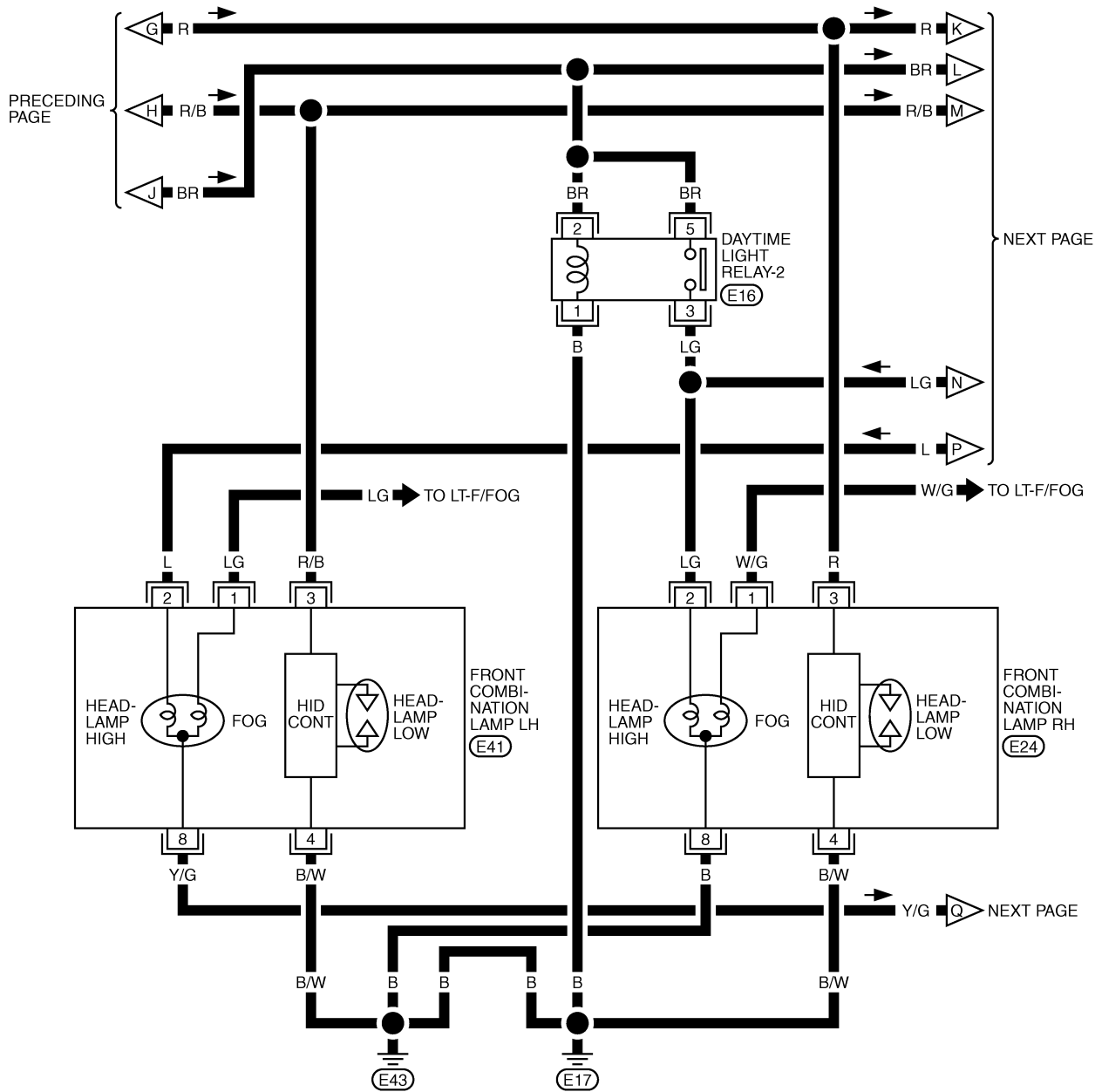

TKWM2249E

HEADLAMP (FOR CANADA) - DAYTIME LIGHT SYSTEM -

LT-DTRL-04

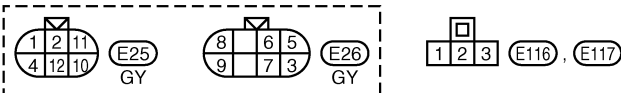
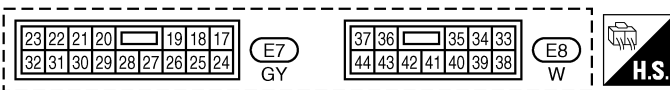
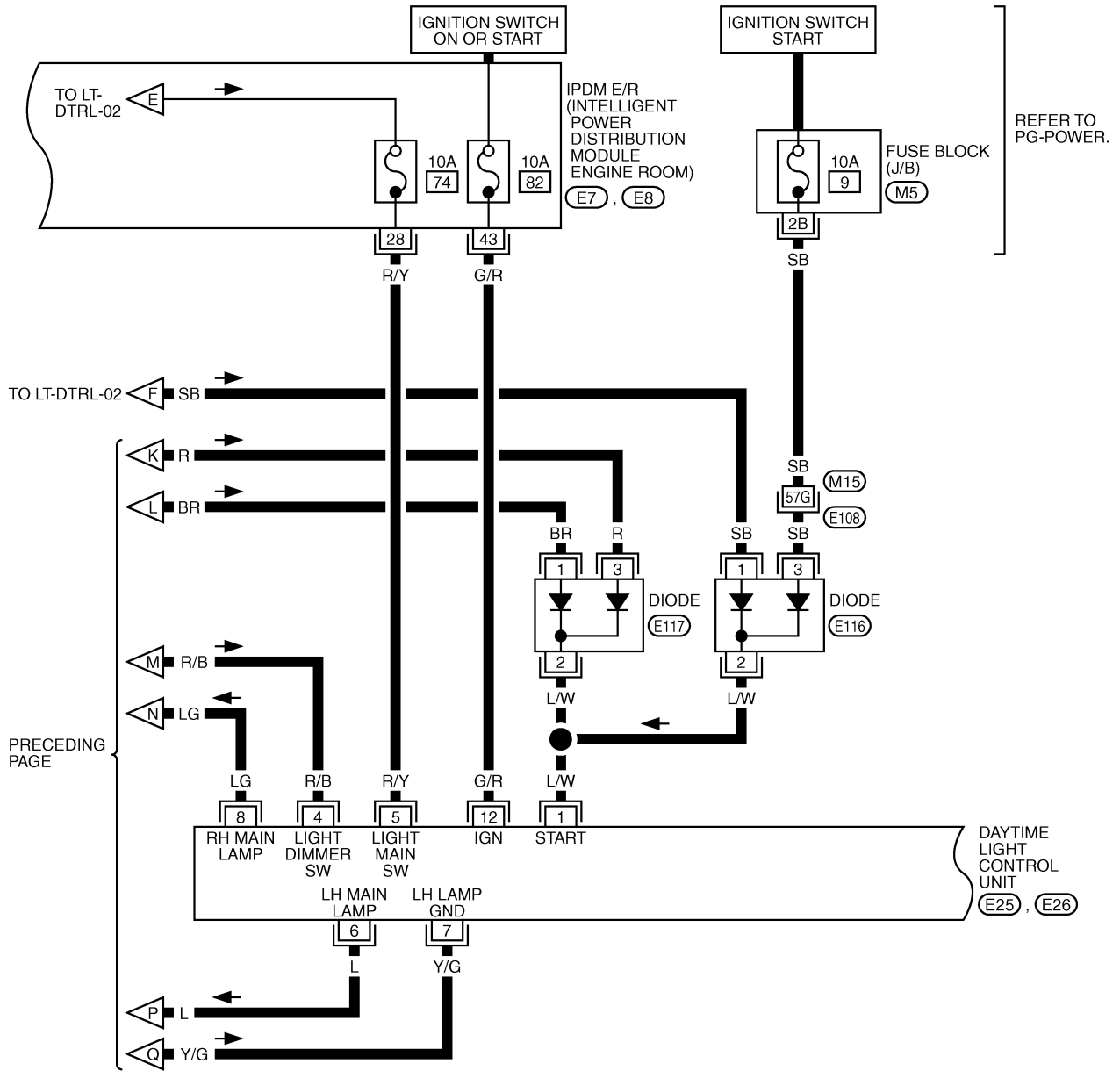

REFER TO THE FOLLOWING.

- (E108) -SUPER MULTIPLE JUNCTION (SMJ)
- (M5) -FUSE BLOCK-JUNCTION BOX (J/B)

TKWM2250E

HEADLAMP (FOR CANADA) - DAYTIME LIGHT SYSTEM -

LT-DTRL-05

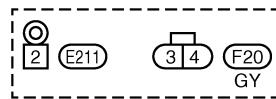
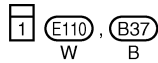
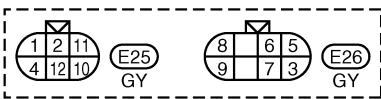
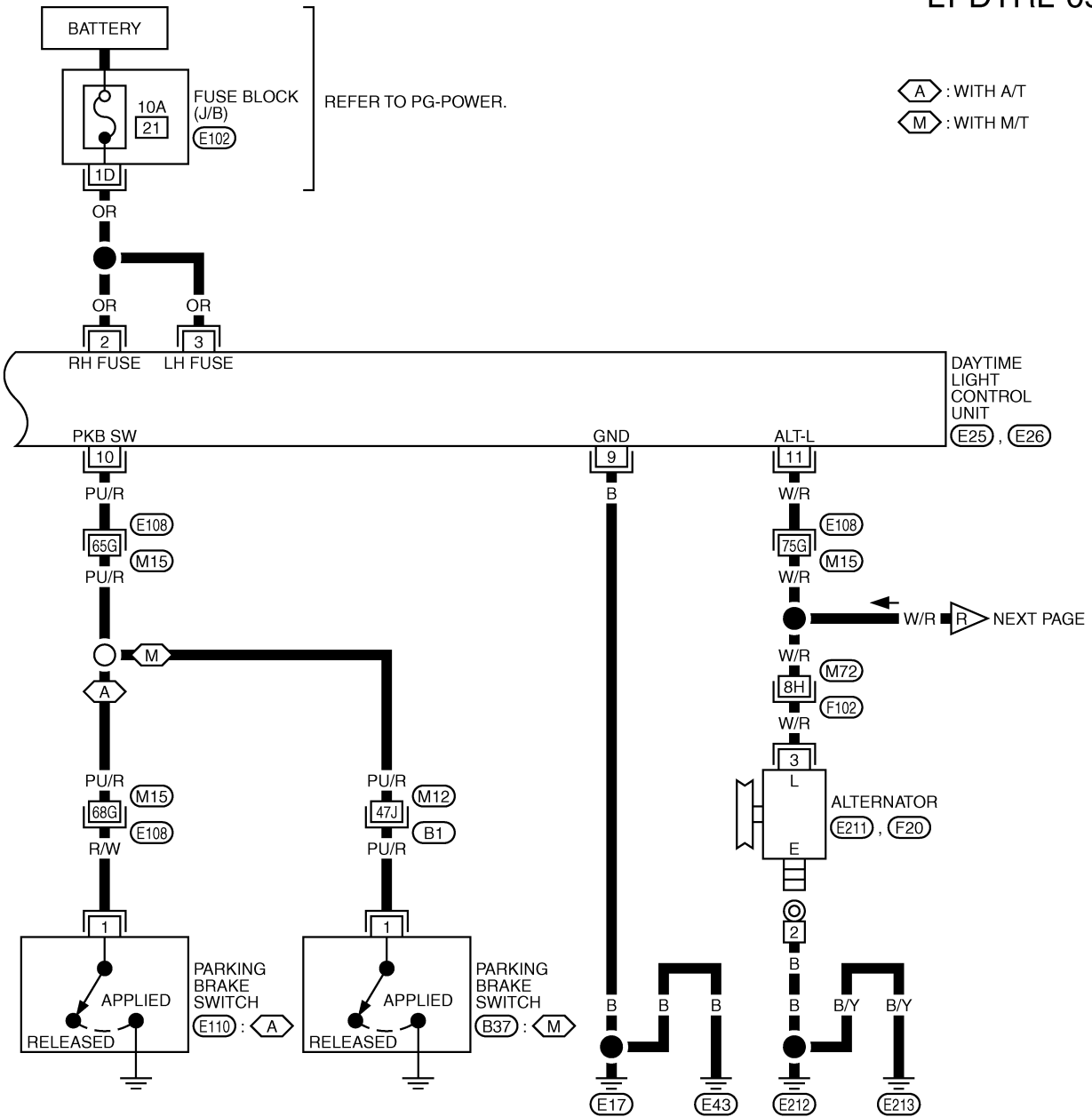

REFER TO THE FOLLOWING.

(E108), (F102), (B1) -SUPER MULTIPLE JUNCTION (SMJ)

(E102) -FUSE BLOCK-JUNCTION BOX (J/B)

TKWM2251E

HEADLAMP (FOR CANADA) - DAYTIME LIGHT SYSTEM -

LT-DTRL-06

▬ : DATA LINE

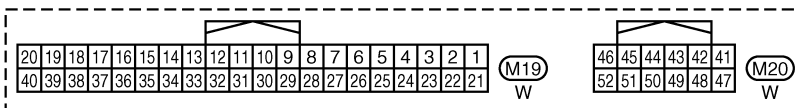
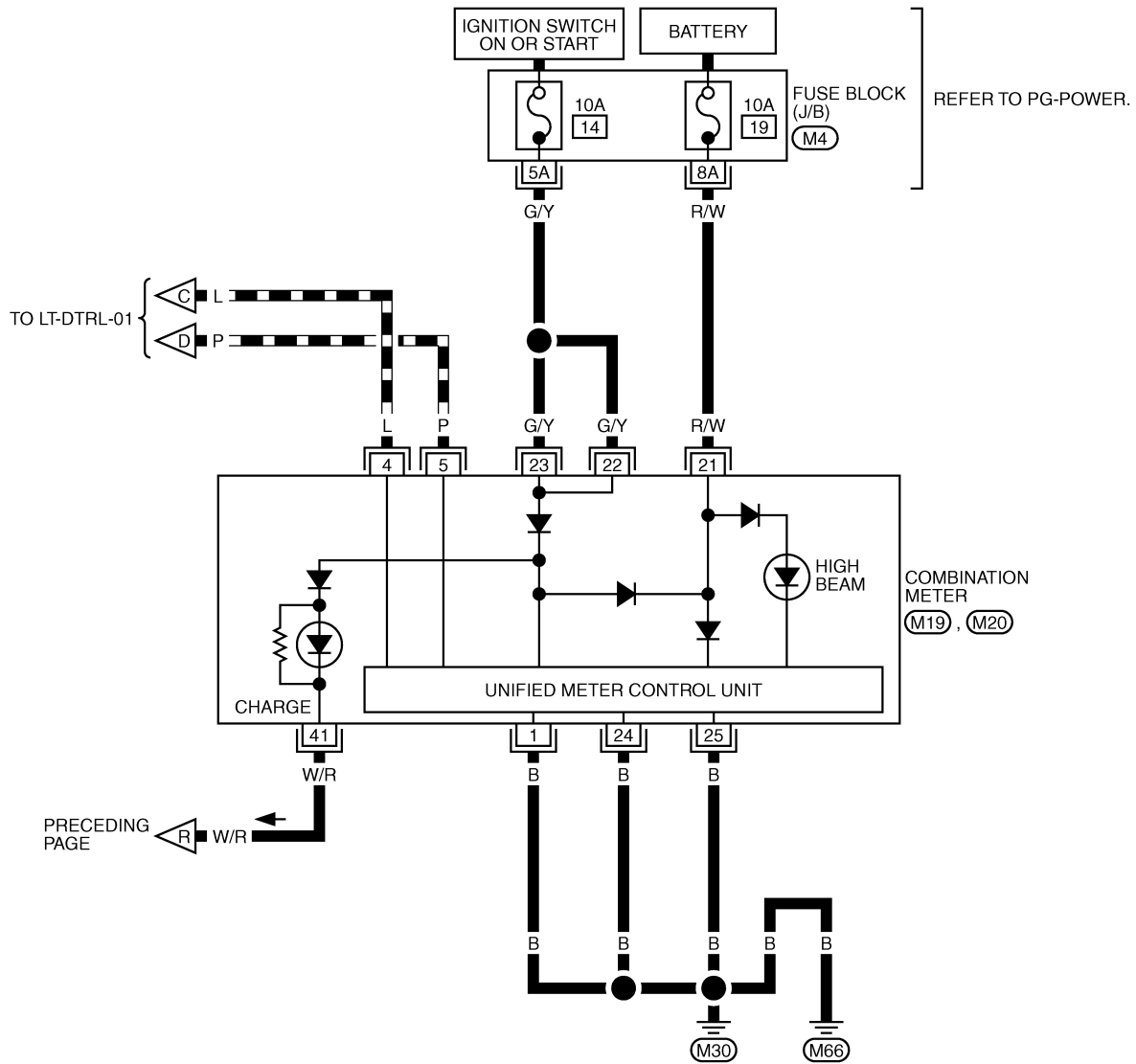

REFER TO THE FOLLOWING.

(M4) - FUSE BLOCK-JUNCTION BOX (J/B)

TKWM2252E

HEADLAMP (FOR CANADA) - DAYTIME LIGHT SYSTEM -

Terminals and Reference Values for Daytime Light Control Unit

AKS00AAV

Terminal No.	Wire color	Item	Condition	Reference value
1	L/W	Start signal	When turning ignition switch to START	Battery voltage
			When turning ignition switch to ON from START	Approx. 0V
			When turning ignition switch to OFF	Approx. 0V
2	OR	RH light fuse	—	Battery voltage
3	OR	LH light fuse	—	Battery voltage
4	R/B	Lighting switch (Low beam)	When lighting switch is turned 2ND position.	Battery voltage
5	R/Y	Lighting switch (High beam)	When lighting switch is turned 2ND position with HIGH BEAM or PASSING position	Battery voltage
6	L	LH High beam	When lighting switch is turned to 2ND position with HIGH BEAM or PASSING position	Battery voltage
			When releasing parking brake with engine running and turning lighting switch to OFF (daytime light operation) CAUTION: Block wheels and ensure selector lever is in N or P position.	Battery voltage
7	Y/G	LH High beam (Ground)	When lighting switch is turned to 2ND position with HIGH BEAM or PASSING position	Approx. 0V
			When releasing parking brake with engine running and turning lighting switch to OFF (daytime light operation) CAUTION: Block wheels and ensure selector lever is in N or P position.	Approx. 6V
8	LG	RH High beam	When lighting switch is turned to 2ND position with HIGH BEAM or PASSING position	Battery voltage
			When releasing parking brake with engine running and turning lighting switch to OFF (daytime light operation) CAUTION: Block wheels and ensure selector lever is in N or P position.	Approx. 6V
9	B	Ground	—	—
10	PU/R	Parking brake switch	When parking brake is released	Battery voltage
			When parking brake is applied	Approx. 0V
11	W/R	Alternator	When turning ignition switch to ON	Approx. 0V
			When engine is running	Battery voltage
			When turning ignition switch to OFF	Approx. 0V
12	G/R	Ignition switch (ON)	When turning ignition switch to ON	Battery voltage

A
B
C
D
E
F
G
H
I
J
L
M

LT

HEADLAMP (FOR CANADA) - DAYTIME LIGHT SYSTEM -

Terminals and Reference Values for BCM

AKS009IZ

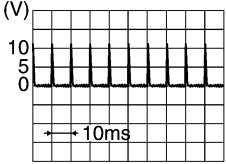
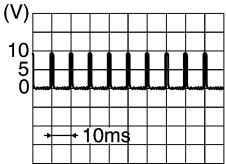
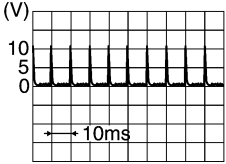
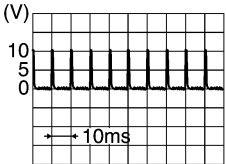
Terminal No.	Wire color	Signal name	Measuring condition		Reference value
			Ignition switch	Operation or condition	
2	W/L	Combination switch input 5	ON	Lighting, turn, wiper OFF Wiper intermittent dial position 4	 <p style="text-align: right;">PKIB3468E</p>
3	G	Combination switch input 4	ON	Lighting, turn, wiper OFF Wiper intermittent dial position 4	 <p style="text-align: right;">PKIB3469E</p>
4	G/R	Combination switch input 3			
5	W/G	Combination switch input 2			
6	W/R	Combination switch input 1			
11	LG	Ignition switch (ACC)	ACC	—	Battery voltage
32	GY	Combination switch output 5	ON	Lighting, turn, wiper OFF Wiper intermittent dial position 4	 <p style="text-align: right;">PKIB3470E</p>
33	L	Combination switch output 4	ON	Lighting, turn, wiper OFF Wiper intermittent dial position 4	 <p style="text-align: right;">PKIB3471E</p>
34	PU	Combination switch output 3			
35	Y/R	Combination switch output 2			
36	Y	Combination switch output 1			
38	W/L	Ignition switch (ON)	ON	—	Battery voltage
39	L	CAN – H	—	—	—
40	P	CAN – L	—	—	—
42	GY	Battery power supply	OFF	—	Battery voltage
52	B	Ground	ON	—	Approx. 0V
55	W/R	Battery power supply	OFF	—	Battery voltage

Terminals and Reference Values for IPDM E/R

AKS00AAW

Terminal No.	Wire color	Signal name	Measuring condition		Reference value	
			Ignition switch	Operation or condition		
20	R	Headlamp low (RH)	ON	Lighting switch 2ND position	OFF	Approx. 0V
					ON	Battery voltage
27	BR	Headlamp high (RH)	ON	Lighting switch HIGH BEAM or PASSING position	OFF	Approx. 0V
					ON	Battery voltage
28	R/Y	Headlamp high (LH)	ON	Lighting switch HIGH BEAM or PASSING position	OFF	Approx. 0V
					ON	Battery voltage

HEADLAMP (FOR CANADA) - DAYTIME LIGHT SYSTEM -

Terminal No.	Wire color	Signal name	Measuring condition			Reference value
			Ignition switch	Operation or condition		
30	R/B	Headlamp low (LH)	ON	Lighting switch 2ND position	OFF	Approx. 0V
					ON	Battery voltage
36	W/G	Front fog lamp (RH)	ON	Lighting switch must be in 2ND position or AUTO position (LOW beam is ON) and the front fog lamp switch must be ON	OFF	Approx. 0V
					ON	Battery voltage
37	SB	Front fog lamp (LH)	ON	Lighting switch must be in 2ND position or AUTO position (LOW beam is ON) and the front fog lamp switch must be ON	OFF	Approx. 0V
					ON	Battery voltage
38	B	Ground	ON	—		Approx. 0V
43	G/R	Ignition switch (ON)	ON	—		Battery voltage
48	L	CAN – H	—	—		—
49	P	CAN – L	—	—		—
60	B/W	Ground	ON	—		Approx. 0V

How to Proceed with Trouble Diagnosis

AKS009J0

1. Confirm the symptom or customer complaint.
2. Understand operation description and function description. Refer to [LT-37, "System Description"](#) .
3. Perform the preliminary check. Refer to [LT-51, "Preliminary Check"](#) .
4. Check symptom and repair or replace the malfunctioning parts.
5. Does the headlamp operate normally? If YES, GO TO 6. If NO, GO TO 4.
6. INSPECTION END

Preliminary Check

AKS009J1

CHECK POWER SUPPLY AND GROUND CIRCUIT

1. CHECK FUSES

Check for blown fuses.

Unit	Power source	Fuse and fusible link No.
BCM	Battery	F
		18
	Ignition switch ON or START position	1
	Ignition switch ACC or ON position	6
IPDM E/R	Battery	72
		74
		76
		86
		Ignition switch ON or START position
	DAYTIME LIGHT CONTROL UNIT	Battery
Ignition switch START position		9

Refer to [LT-43, "Wiring Diagram — DTRL —"](#) .

OK or NG

OK >> GO TO 2.

NG >> If fuse or fusible link is blown, be sure to eliminate cause of malfunction before installing new fuse or fusible link. Refer to [PG-3, "POWER SUPPLY ROUTING CIRCUIT"](#) .

HEADLAMP (FOR CANADA) - DAYTIME LIGHT SYSTEM -

2. CHECK POWER SUPPLY CIRCUIT

1. Turn ignition switch OFF.
2. Disconnect BCM connector.
3. Check voltage between BCM harness connector and ground.

Terminal (+)		Terminal (-)	Ignition switch position		
Connector	Terminal (Wire color)		OFF	ACC	ON
M1	11 (LG)	Ground	Approx. 0V	Battery voltage	Battery voltage
	38 (W/L)		Approx. 0V	Approx. 0V	Battery voltage
M2	42 (GY)		Battery voltage	Battery voltage	Battery voltage
	55 (W/R)		Battery voltage	Battery voltage	Battery voltage

OK or NG

OK >> GO TO 3.

NG >> Check harness for open or short between BCM and fuse.

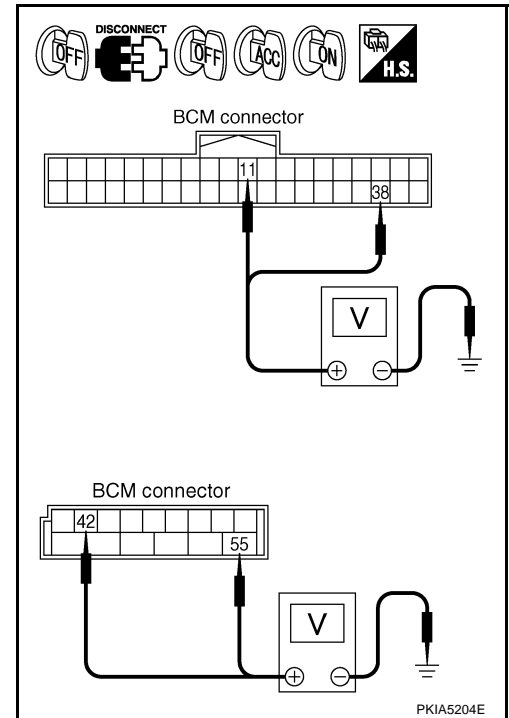

3. CHECK GROUND CIRCUIT

Check continuity between BCM harness connector and ground.

Terminal		Ground	Continuity
Connector	Terminal (Wire color)		Yes
M2	52 (B)		

OK or NG

OK >> INSPECTION END

NG >> Check harness ground circuit.

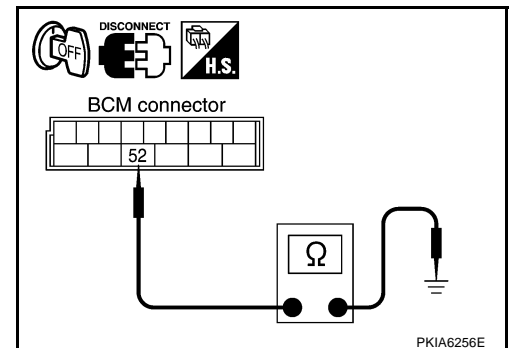

HEADLAMP (FOR CANADA) - DAYTIME LIGHT SYSTEM -

CONSULT-II Functions (BCM)

AKS00CN7

CONSULT-II can display each diagnostic item using the diagnostic test modes shown following.

BCM diagnosis part	Diagnosis mode	Description
HEADLAMP	WORK SUPPORT	Changes the setting for each function.
	DATA MONITOR	Displays BCM input data in real time.
	ACTIVE TEST	Operation of electrical loads can be checked by sending drive signal to them.
BCM	SELF-DIAG RESULTS	BCM performs self-diagnosis of CAN communication.
	CAN DIAG SUPPORT MNTR	The result of transmit/receive diagnosis of CAN communication can be read.

CONSULT-II BASIC OPERATION

CAUTION:

If CONSULT-II is used with no connection of CONSULT-II CONVERTER, malfunctions might be detected in self-diagnosis depending on control unit which carry out CAN communication.

1. With ignition switch OFF, connect CONSULT-II and CONSULT-II CONVERTER to data link connector, and then turn ignition switch ON.

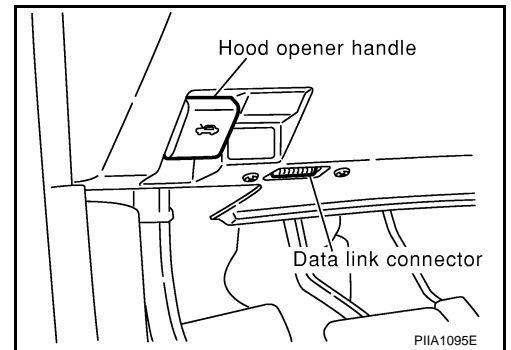

2. Touch "START (NISSAN BASED VHCL)".

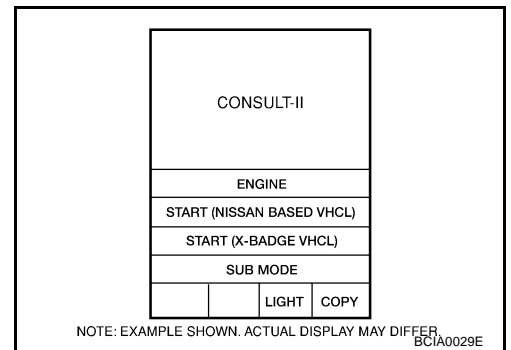

3. Touch "BCM" on "SELECT SYSTEM" screen. If "BCM" is not indicated, refer to [GI-39, "CONSULT-II Data Link Connector \(DLC\) Circuit"](#).

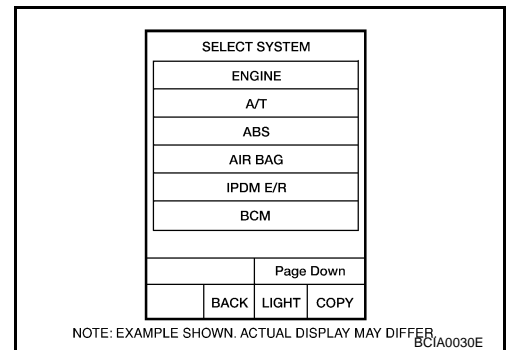

HEADLAMP (FOR CANADA) - DAYTIME LIGHT SYSTEM -

4. Touch "HEAD LAMP" on "SELECT DIAG MODE" screen.

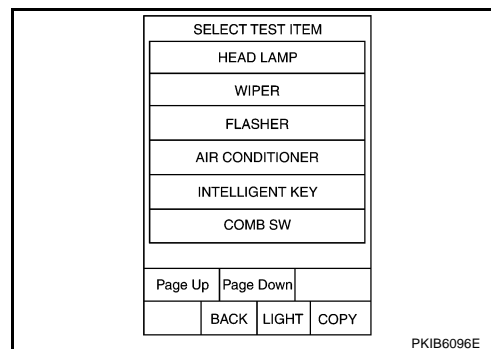

WORK SUPPORT

Operation Procedure

1. Touch "HEAD LAMP" on "SELECT TEST ITEM" screen.
2. Touch "WORK SUPPORT" on "SELECT DIAG MODE" screen.
3. Touch "BATTERY SAVER SET" on "SELECT WORK ITEM" screen.
4. Touch "START".
5. Touch "CHANGE SET".
6. The setting will be changed and "CUSTOMIZING COMPLETED" will be displayed.
7. Touch "END".

Display Item List

Item	Description	CONSULT-II	Factory setting
BATTERY SAVER SET	Exterior lamp battery saver control mode can be changed in this mode. Selects exterior lamp battery saver control mode between two ON/OFF.	ON	×
		OFF	—

DATA MONITOR

Operation Procedure

1. Touch "HEAD LAMP" on "SELECT TEST ITEM" screen.
2. Touch "DATA MONITOR" on "SELECT DIAG MODE" screen.
3. Touch either "ALL SIGNALS" or "SELECTION FROM MENU" on "SELECT MONITOR ITEM" screen.

ALL SIGNALS	Monitors all the signals.
SELECTION FROM MENU	Selects items and monitor them.

4. When "SELECTION FROM MENU" is selected, touch individual items to be monitored. When "ALL SIGNALS" is selected, all the items will be monitored.
5. Touch "START".
6. Touch "RECORD" while monitoring, then the status of the monitored item can be recorded. To stop recording, touch "STOP".

Display Item List

Monitor item	Contents
IGN ON SW "ON/OFF"	Displays status (ignition switch IGN position: ON/other: OFF) of ignition switch judged from the ignition switch signal.
ACC ON SW "ON/OFF"	Displays status (ignition switch ACC or IGN position: ON/other: OFF) of ignition switch judged from the ignition switch signal.
HI BEAM SW "ON/OFF"	Displays status (lighting switch high beam position: ON/other: OFF) of high beam switch judged from the lighting switch signal.
HEAD LAMP SW 1 "ON/OFF"	Displays status (lighting switch 2ND position: ON/other: OFF) of headlamp 1 switch judged from the lighting switch signal.
HEAD LAMP SW 2 "ON/OFF"	Displays status (lighting switch 2ND position: ON/other: OFF) of headlamp 2 switch judged from the lighting switch signal.

HEADLAMP (FOR CANADA) - DAYTIME LIGHT SYSTEM -

Monitor item	Contents
LIGHT SW 1 ST	"ON/OFF" Displays status (lighting switch 1ST or 2ND position: ON/other: OFF) of lighting switch 1ST position switch judged from the lighting switch signal.
AUTO LIGHT SW	"ON/OFF" Displays status (lighting switch AUTO position: ON/other: OFF) of auto light switch position judged from the lighting switch signal.
PASSING SW	"ON/OFF" Displays status (lighting switch passing position: ON/other: OFF) of passing switch judged from the lighting switch signal.
FR FOG SW	"ON/OFF" Displays status (lighting switch front fog lamp ON position: ON/others: OFF) of front fog lamp switch judged from the lighting switch signal.
DOOR SW - DR	"ON/OFF" Displays status (door is open: ON/door is closed: OFF) of driver side door switch judged from the driver side door switch signal.
DOOR SW - AS	"ON/OFF" Displays status (door is open: ON/door is closed: OFF) of passenger side door switch judged from the passenger side door switch signal.
DOOR SW - RR	"ON/OFF" Displays status (door is open: ON/door is closed: OFF) of rear door switch (RH) judged from the rear door switch (RH) signal.
DOOR SW - RL	"ON/OFF" Displays status (door is open: ON/door is closed: OFF) of rear door switch (LH) judged from the rear door switch (LH) signal.
BACK DOOR SW ^{NOTE 1}	—
TURN SIGNAL R	"ON/OFF" Displays status (turn signal switch right position: ON/other: OFF) of turn RH switch judged from the turn signal switch signal.
TURN SIGNAL L	"ON/OFF" Displays status (turn signal switch left position: ON/other: OFF) of turn LH switch judged from the turn signal switch signal.
CARGO LAMP SW ^{NOTE 1}	—
OPTICAL SENSOR ^{NOTE 2}	"0 - 5V" Displays status "outside brightness (close to 5V when light/close to 0V when dark)" of optical sensor judged from the optical sensor signal.

NOTE:

1. This item is displayed, but cannot be monitored.
2. Vehicles without auto light system display this item, but cannot be monitored.

ACTIVE TEST

Operation Procedure

1. Touch "HEAD LAMP" on "SELECT TEST ITEM" screen.
2. Touch "ACTIVE TEST" on "SELECT DIAG MODE" screen.
3. Touch item to be tested and check operation of the selected item.
4. During the operation check, touching "BACK" deactivates the operation.

Display Item List

Test item	Description
TAIL LAMP	Allows tail lamp relay to operate by switching ON-OFF.
HEAD LAMP	Allows headlamp high relay and headlamp low relay to operate by switching ON-OFF.
FR FOG LAMP	Allows front fog lamp relay to operate by switching ON-OFF.
CORNERING LAMP ^{NOTE}	—

NOTE:

This item is displayed, but cannot be tested.

HEADLAMP (FOR CANADA) - DAYTIME LIGHT SYSTEM -

CONSULT-II Functions (IPDM E/R)

AKS00CN8

CONSULT-II can display each diagnostic item using the diagnostic test mode shown following.

Check Item, Diagnosis Mode	Description
SELF-DIAGNOSTIC RESULTS	Refer to PG-19. "SELF-DIAG RESULTS" .
DATA MONITOR	The input/output data of IPDM E/R is displayed in real time.
CAN DIAG SUPPORT MNTR	The result of transmit/receive diagnosis of CAN communication can be read.
ACTIVE TEST	IPDM E/R sends a drive signal to electronic components to check their operation.

CONSULT-II BASIC OPERATION

CAUTION:

If CONSULT-II is used with no connection of CONSULT-II CONVERTER, malfunctions might be detected in self-diagnosis depending on control unit which carry out CAN communication.

1. With ignition switch OFF, connect CONSULT-II and CONSULT-II CONVERTER to data link connector, and then turn ignition switch ON.

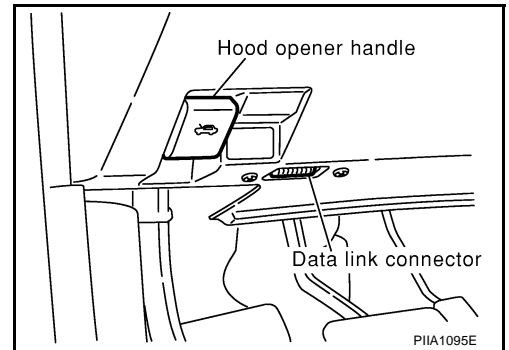

2. Touch "START (NISSAN BASED VHCL)".

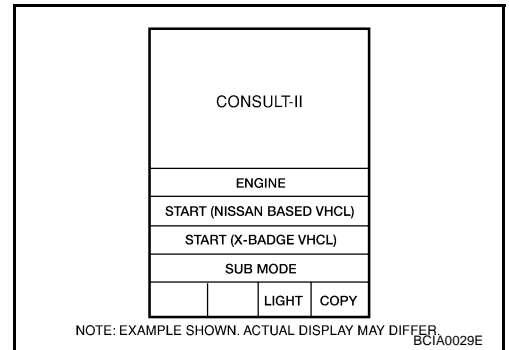

3. Touch "IPDM E/R" on "SELECT SYSTEM" screen. If "IPDM E/R" is not indicated, refer to [GI-39. "CONSULT-II Data Link Connector \(DLC\) Circuit"](#) .

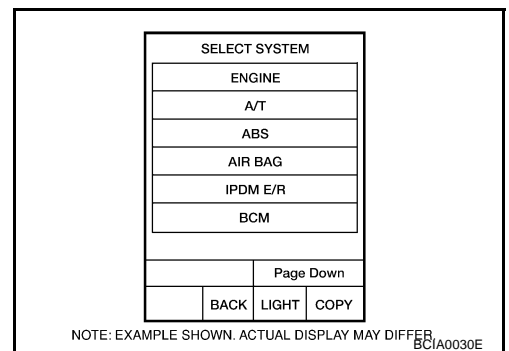

HEADLAMP (FOR CANADA) - DAYTIME LIGHT SYSTEM -

- Select desired part to be diagnosed on "SELECT DIAG MODE" screen.

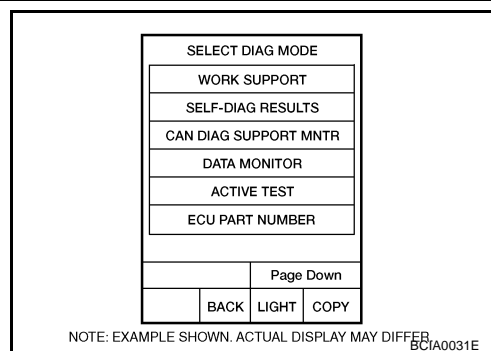

A
B
C
D

DATA MONITOR

Operation Procedure

- Touch "DATA MONITOR" on "SELECT DIAG MODE" screen.
- Touch "ALL SIGNALS", "MAIN SIGNALS" or "SELECTION FROM MENU" on "SELECT MONITOR ITEM" screen.

ALL SIGNALS	Monitors all items.
MAIN SIGNALS	Monitor the predetermined item.
SELECTION FROM MENU	Selects items and monitors them.

F
G

- When "SELECTION FROM MENU" is selected, touch individual items to be monitored. In "ALL SIGNALS", all items are monitored. In "MAIN SIGNALS", predetermined items are monitored.
- Touch "START".
- Touch "RECORD" while monitoring to record the status of the item being monitored. To stop recording, touch "STOP".

H
I

All Signals, Main Signals, Selection From Menu

Item name	CONSULT-II screen display	Display or unit	Monitor item selection			Description
			ALL SIGNALS	MAIN SIGNALS	SELECTION FROM MENU	
Position lights request	TAIL&CLR REQ	ON/OFF	×	×	×	Signal status input from BCM
Headlamp low beam request	HL LO REQ	ON/OFF	×	×	×	Signal status input from BCM
Headlamp high beam request	HL HI REQ	ON/OFF	×	×	×	Signal status input from BCM
Front fog lights request	FR FOG REQ	ON/OFF	×	×	×	Signal status input from BCM

LT

L
M

NOTE:

Perform monitoring of IPDM E/R data with ignition switch ON. When ignition switch is at ACC, display may not be correct.

ACTIVE TEST

Operation Procedure

- Touch "ACTIVE TEST" on "SELECT DIAG MODE" screen.
- Touch item to be tested, and check operation.
- Touch "START".
- Touch "STOP" while testing to stop the operation.

Test item	CONSULT-II screen display	Description
Headlamp relay (HI, LO) output	LAMPS	Allows headlamp relay (HI, LO) to operate by switching operation (OFF, HI ON, LO ON) at your option.
Front fog lamp relay output		Allows front fog lamp relay to operate by switching operation ON-OFF at your option
Tail lamp relay output	TAIL LAMP	Allows tail lamp relay to operate by switching operation ON-OFF at your option

HEADLAMP (FOR CANADA) - DAYTIME LIGHT SYSTEM -

AKS004QE

Daytime Light Control Does Not Operate Properly

1. CHECK DAYTIME LIGHT CONTROL UNIT

1. Turn ignition switch OFF.
2. Disconnect daytime light control unit connector.
3. Check voltage between daytime light control unit harness connector and ground.

Terminal (+)		Terminal (-)	Voltage
Connector	Terminal (Wire color)		
E25	2 (OR)	Ground	Battery voltage
E26	3 (OR)		

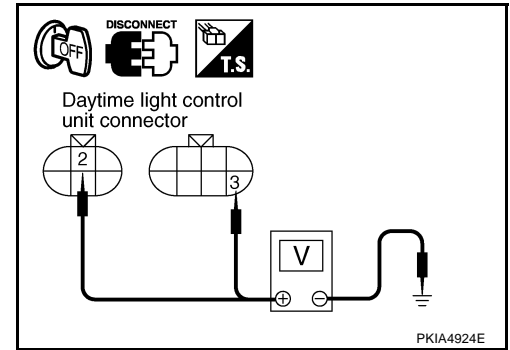

OK or NG

- OK >> GO TO 2.
 NG >> Repair or replace daytime light control unit power supply circuit harness.

2. CHECK GROUND FOR DAYTIME LIGHT CONTROL UNIT

Check continuity between daytime light control unit harness connector E26 terminal 9 (B) and ground.

9 (B) – Ground : Continuity should exist.

OK or NG

- OK >> GO TO 3.
 NG >> Repair harness or connector.

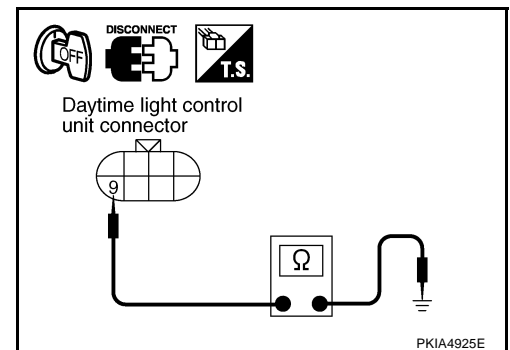

3. CHECK PARKING BRAKE SWITCH CIRCUIT

1. Disconnect parking brake switch connector.
2. Check continuity between daytime light control unit harness connector E25 terminal 10 (PU/R) and parking brake switch harness connector B37*1 or E110*2 terminal 1 (PU/R*1, R/W*2).

10 (PU/R) – 1 (PU/R*1, R/W*2) : Continuity should exist.

*1: M/T, *2: A/T

OK or NG

- OK >> GO TO 4.
 NG >> Repair harness or connector.

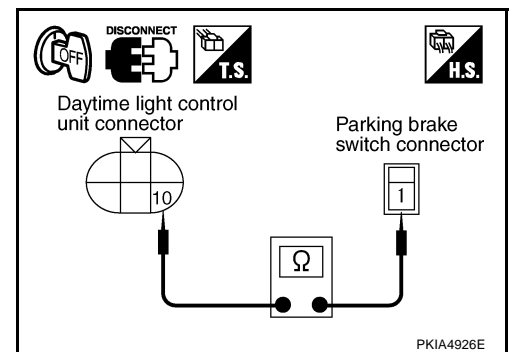

HEADLAMP (FOR CANADA) - DAYTIME LIGHT SYSTEM -

4. CHECK PARKING BRAKE SWITCH

1. Connect daytime light control unit connector and parking brake switch connector.
2. Turn ignition switch ON.
3. When parking brake is released, check voltage between parking brake switch harness connector B37*1 or E110*2 terminal 1 (PU/R*1, R/W*2) and ground.

1 (PU/R*1, R/W*2) – Ground : Battery voltage.

*1: M/T, *2: A/T

OK or NG

OK >> GO TO 5.

NG >> Replace parking brake switch.

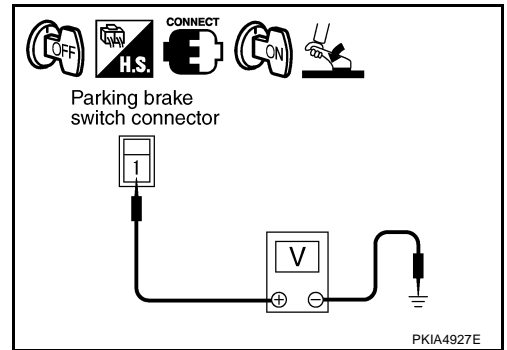

5. CHECK ALTERNATOR CIRCUIT

1. Turn ignition switch OFF.
2. Disconnect daytime light control unit connector.
3. Start engine running.
4. Check voltage between daytime light control unit harness connector E25 terminal 11 (W/R) and ground.

11 (W/R) – Ground : Battery voltage.

OK or NG

OK >> GO TO 6.

NG >> Repair harness or connector.

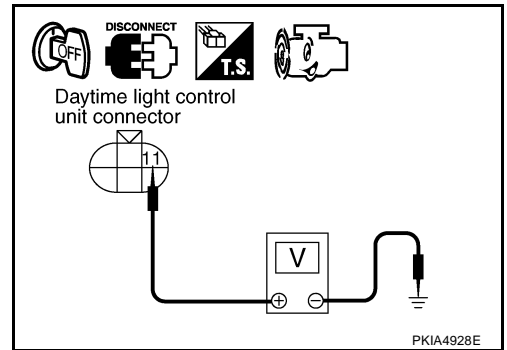

6. CHECK POWER CIRCUIT BETWEEN DAYTIME LIGHT CONTROL UNIT AND HEADLAMP LH

1. Turn ignition switch OFF.
2. Disconnect daytime light control unit connector and front combination lamp LH connector.
3. Check continuity between daytime light control unit harness connector E26 terminal 6 (L) and front combination lamp LH harness connector E41 terminal 2 (L).

6 (L) – 2 (L) : Continuity should exist.

OK or NG

OK >> GO TO 7.

NG >> Repair harness or connector.

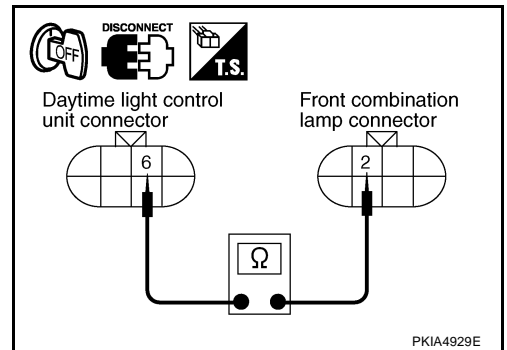

7. CHECK GROUND CIRCUIT BETWEEN DAYTIME LIGHT CONTROL UNIT AND HEADLAMP LH

Check continuity between daytime light control unit harness connector E26 terminal 7 (Y/G) and front combination lamp LH harness connector E41 terminal 8 (Y/G).

7 (Y/G) – 8 (Y/G) : Continuity should exist.

OK or NG

OK >> GO TO 8.

NG >> Repair harness or connector.

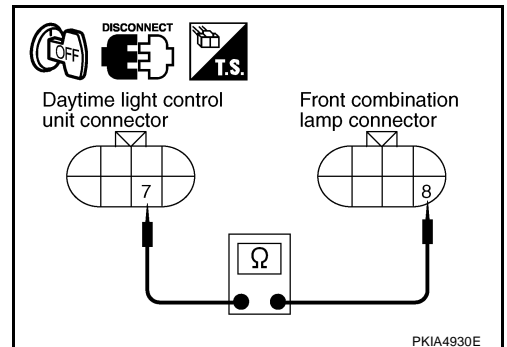

HEADLAMP (FOR CANADA) - DAYTIME LIGHT SYSTEM -

8. CHECK POWER CIRCUIT BETWEEN DAYTIME LIGHT CONTROL UNIT AND HEADLAMP RH

1. Disconnect front combination lamp RH connector.
2. Check continuity between daytime light control unit harness connector E26 terminal 8 (LG) and front combination lamp RH harness connector E24 terminal 2 (LG).

8 (LG) – 2 (LG) : Continuity should exist.

OK or NG

- OK >> GO TO 9.
 NG >> Repair harness or connector.

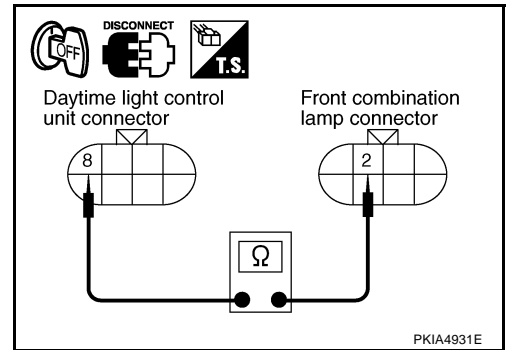

9. CHECK DAYTIME LIGHT CONTROL UNIT

1. Connect daytime light control unit connector.
2. Parking brake is released and engine is run.
3. Check voltage between front combination lamp LH harness connector E41 terminal 2 (L) and ground, when releasing parking brake with engine running and turning lighting switch to OFF.

2 (L) – Ground : Battery voltage.

OK or NG

- OK >> ● Check connector for connection, bend and loose fit and repair.
 ● Check headlamp bulb.
- NG >> Replace daytime light control unit.

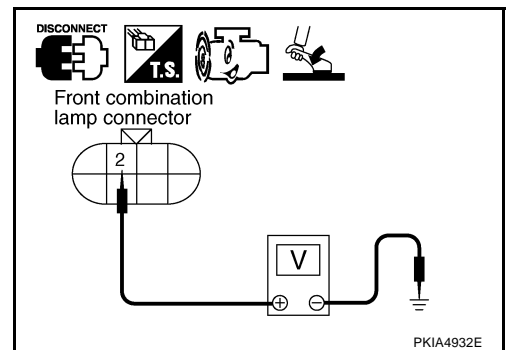

Headlamp High Beam Does Not Illuminate (Both Sides)

AKS004QF

1. CHECK COMBINATION SWITCH INPUT SIGNAL

Ⓜ With CONSULT-II

Select "BCM" on CONSULT-II. With "HEAD LAMP" data monitor, make sure "HI BEAM SW" turns ON-OFF linked with operation of lighting switch.

**When lighting switch is : HI BEAM SW ON
 HIGH BEAM position**

ⓧ Without CONSULT-II

Refer to [LT-133, "Combination Switch Inspection"](#).

OK or NG

- OK >> GO TO 2.
 NG >> Check combination switch (lighting switch). Refer to [LT-133, "Combination Switch Inspection"](#).

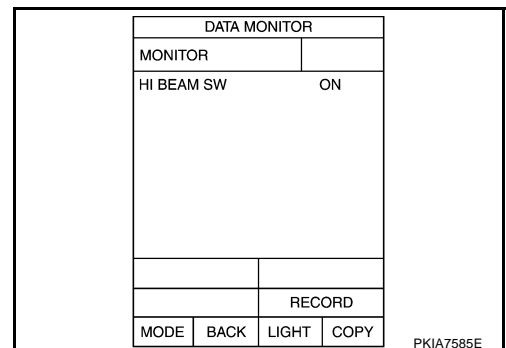

HEADLAMP (FOR CANADA) - DAYTIME LIGHT SYSTEM -

2. HEADLAMP ACTIVE TEST

Ⓜ With CONSULT-II

1. Select "IPDM E/R" on CONSULT-II, and select "ACTIVE TEST" on "SELECT DIAG MODE" screen.
2. Select "LAMPS" on "SELECT TEST ITEM" screen.
3. Touch "HI" screen.
4. Make sure headlamp high beam operates.

**Headlamp high beam should operate.
(Headlamp high beam repeats ON-OFF every 1 second).**

ⓧ Without CONSULT-II

1. Start auto active test. Refer to [PG-22, "Auto Active Test"](#).
2. Make sure headlamp high beam operates.

Headlamp high beam should operate.

OK or NG

- OK >> GO TO 3.
NG >> GO TO 4.

3. CHECK IPDM E/R

1. Select "IPDM E/R" on CONSULT-II, and select "DATA MONITOR" on "SELECT DIAG MODE" screen.
2. Make sure "HL LO REQ" and "HL HI REQ" turns ON when lighting switch is in HIGH BEAM position.

**When lighting switch is : HL LO REQ ON
HIGH BEAM position : HL HI REQ ON**

OK or NG

- OK >> Replace IPDM E/R.
NG >> Replace BCM. Refer to [BCS-16, "Removal and Installation of BCM"](#).

ACTIVE TEST			
LAMPS		HI	
OFF			
LO		FOG	
MODE	BACK	LIGHT	COPY

PKIA7741E

DATA MONITOR			
MONITOR			
HL LO REQ		ON	
HL HI REQ		ON	
RECORD			
MODE	BACK	LIGHT	COPY

PKIA7638E

A
B
C
D
E
F
G
H
I
J
LT
L
M

HEADLAMP (FOR CANADA) - DAYTIME LIGHT SYSTEM -

4. CHECK HEADLAMP INPUT SIGNAL

④ With CONSULT-II

1. Select "IPDM E/R" on CONSULT-II, and select "ACTIVE TEST" on "SELECT DIAG MODE" screen.
2. Select "LAMPS" on "SELECT TEST ITEM" screen.
3. Touch "HI" screen.
4. When headlamp high relay is operating, check voltage between front combination lamp harness connector and ground (Headlamp high beam repeats ON-OFF every 1 second).

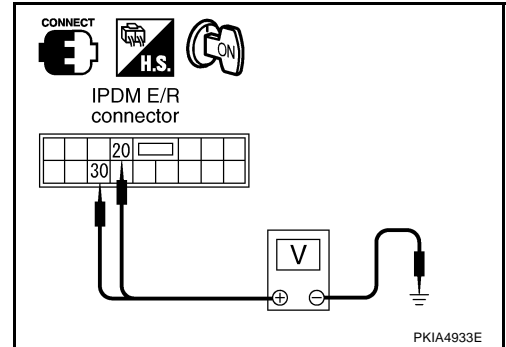

Terminal (+)		Terminal (-)	Voltage
Connector	Terminal (Wire color)		
E7	20 (R)	Ground	Battery voltage
	30 (R/B)		

⊗ Without CONSULT-II

1. Start auto active test. Refer to [PG-22, "Auto Active Test"](#) .
2. When headlamp high relay is operating, check voltage between front combination lamp harness connector and ground.

Terminal (+)		Terminal (-)	Voltage
Connector	Terminal (Wire color)		
E7	20 (R)	Ground	Battery voltage
	30 (R/B)		

OK or NG

- OK >> Check connector for connection, bend and loose fit and repair.
 NG >> Replace IPDM E/R.

RH High Beam Does Not Illuminate But RH Low Beam Illuminates

AKS004QG

1. CHECK BULB

Check bulb of lamp which does not illuminate.

OK or NG

- OK >> GO TO 2.
 NG >> Replace bulb of lamp.

HEADLAMP (FOR CANADA) - DAYTIME LIGHT SYSTEM -

2. CHECK CIRCUIT BETWEEN IPDM E/R AND DAYTIME LIGHT RELAY-2

1. Turn ignition switch OFF.
2. Disconnect IPDM E/R connector.
3. Remove daytime light relay-2.
4. Check continuity between IPDM E/R harness connector E7 terminal 27 (BR) and daytime light relay-2 harness connector E16 terminal 2 (BR).

27 (BR) – 2 (BR) : Continuity should exist.

5. Check continuity between IPDM E/R harness connector E7 terminal 27 (BR) and daytime light relay-2 harness connector E16 terminal 5 (BR).

27 (BR) – 5 (BR) : Continuity should exist.

OK or NG

- OK >> GO TO 3.
NG >> Repair harness or connector.

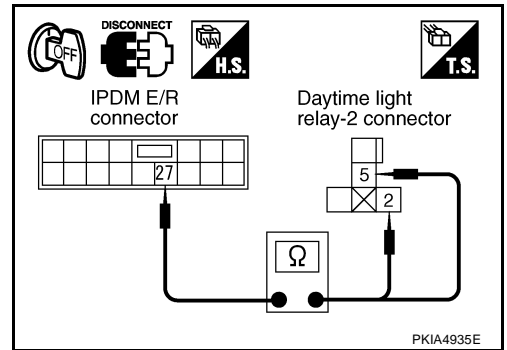

3. CHECK DAYTIME LIGHT RELAY-2 GROUND

Check continuity between daytime light relay-2 harness connector E16 terminal 1 (B) and ground.

1 (B) – Ground : Continuity should exist.

OK or NG

- OK >> GO TO 4.
NG >> Repair harness or connector.

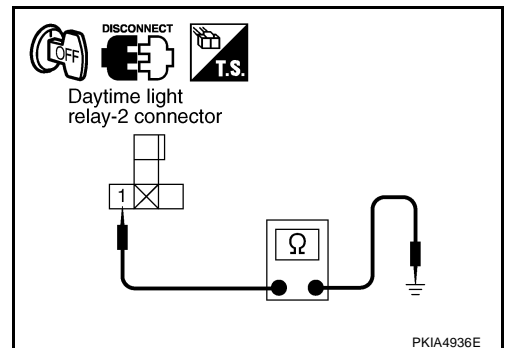

4. CHECK CIRCUIT BETWEEN DAYTIME LIGHT RELAY-2 AND HEADLAMP RH

1. Disconnect front combination lamp RH connector.
2. Check continuity between daytime light relay-2 harness connector E16 terminal 3 (LG) and front combination lamp RH harness connector E24 terminal 2 (LG).

3 (LG) – 2 (LG) : Continuity should exist.

OK or NG

- OK >> GO TO 5.
NG >> Repair harness or connector.

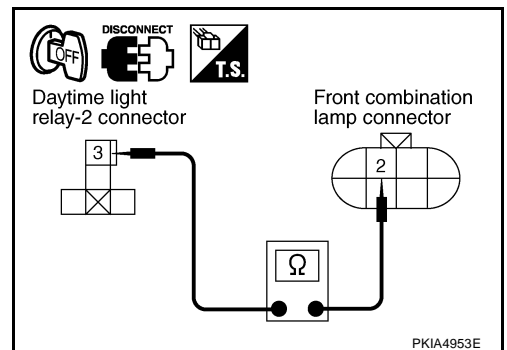

HEADLAMP (FOR CANADA) - DAYTIME LIGHT SYSTEM -

5. CHECK HEADLAMP RH GROUND CIRCUIT

Check continuity between front combination lamp RH harness connector E24 terminal 8 (B) and ground.

8 (B) – Ground : Continuity should exist.

OK or NG

OK >> GO TO 6.

NG >> Repair harness or connector.

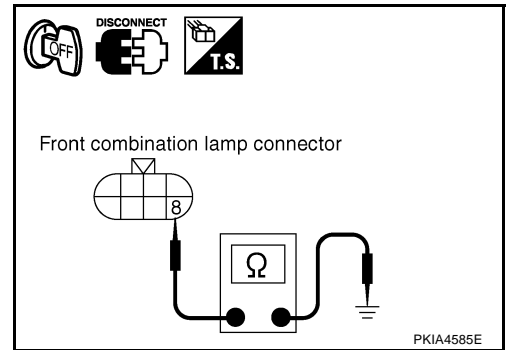

6. CHECK IPDM E/R

1. Connect IPDM E/R connector.
2. Turn ignition switch ON.
3. Lighting switch is turned HIGH position.
4. Check voltage between daytime light relay-2 harness connector E16 terminal 2 (BR) and ground.

2 (BR) – Ground : Battery voltage.

5. Check voltage between daytime light relay-2 harness connector E16 terminal 5 (BR) and ground.

5 (BR) – Ground : Battery voltage.

OK or NG

OK >> Replace daytime light relay-2.

NG >> Replace IPDM E/R.

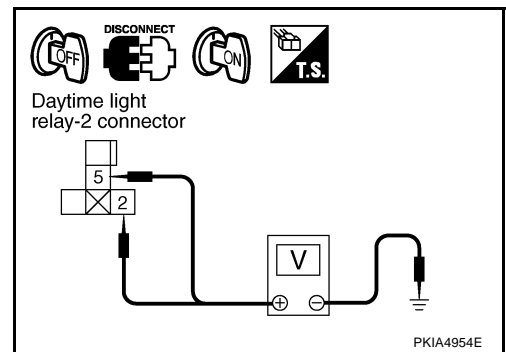

LH High Beam Does Not Illuminate But LH Low Beam Illuminates

AKS004QH

1. CHECK CIRCUIT BETWEEN IPDM E/R AND DAYTIME LIGHT CONTROL UNIT

1. Turn ignition switch OFF.
2. Disconnect IPDM E/R connector and daytime light control unit connector.
3. Check continuity between IPDM E/R harness connector E7 terminal 28 (R/Y) and daytime light control unit harness connector E26 terminal 5 (R/Y).

28 (R/Y) – 5 (R/Y) : Continuity should exist.

OK or NG

OK >> GO TO 2.

NG >> Repair harness or connector.

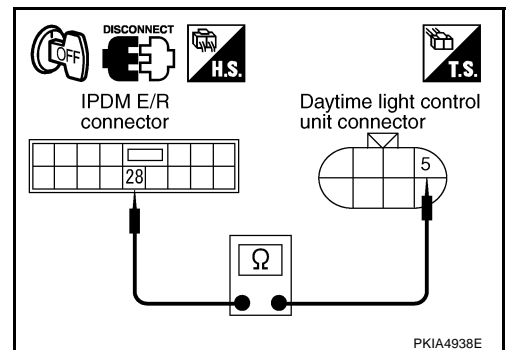

HEADLAMP (FOR CANADA) - DAYTIME LIGHT SYSTEM -

2. CHECK IPDM E/R

1. Connect IPDM E/R connector.
2. Turn ignition switch ON.
3. Lighting switch is turned HIGH position.
4. Check voltage between daytime light control unit harness connector E26 terminal 5 (R/Y) and ground.

5 (R/Y) – Ground : Battery voltage.

OK or NG

- OK >> GO TO 3.
NG >> Replace IPDM E/R.

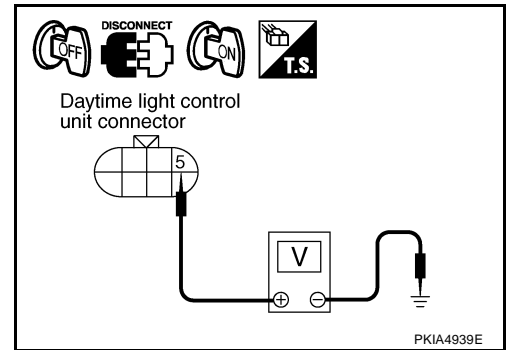

3. CHECK POWER CIRCUIT BETWEEN DAYTIME LIGHT CONTROL UNIT AND HEADLAMP LH

1. Turn ignition switch OFF.
2. Disconnect front combination lamp LH connector.
3. Check continuity between daytime light control unit harness connector E26 terminal 6 (L) and front combination lamp LH harness connector E41 terminal 2 (L).

6 (L) – 2 (L) : Continuity should exist.

OK or NG

- OK >> GO TO 4.
NG >> Repair harness or connector.

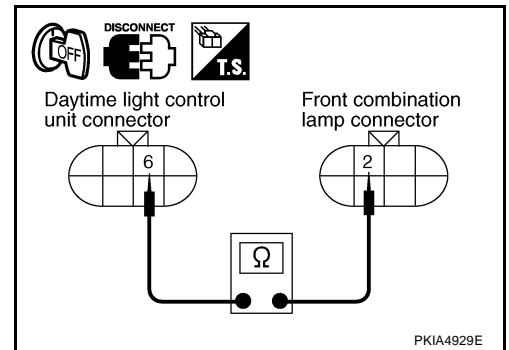

4. CHECK CIRCUIT BETWEEN DAYTIME LIGHT CONTROL UNIT AND HEADLAMP LH

Check continuity between daytime light control unit harness connector E26 terminal 7 (Y/G) and front combination lamp LH harness connector E41 terminal 8 (Y/G).

7 (Y/G) – 8 (Y/G) : Continuity should exist.

OK or NG

- OK >> GO TO 5.
NG >> Repair harness or connector.

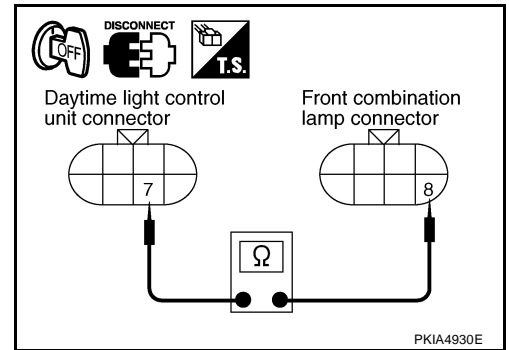

5. CHECK DAYTIME LIGHT CONTROL UNIT AND GROUND

Check continuity between daytime light control unit harness connector E26 terminal 9 (B) and ground.

9 (B) – Ground : Continuity should exist.

OK or NG

- OK >> GO TO 6.
NG >> Repair harness or connector.

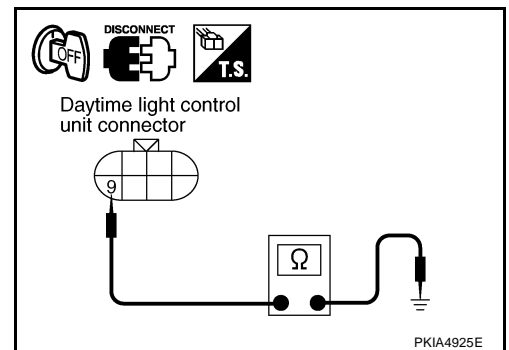

HEADLAMP (FOR CANADA) - DAYTIME LIGHT SYSTEM -

6. CHECK DAYTIME LIGHT CONTROL UNIT

1. Connect daytime light control unit connector.
2. Turn ignition switch ON.
3. Lighting switch is turned HIGH BEAM position.
4. Check voltage between front combination lamp LH harness connector E41 terminal 2 (L) and ground.

2 (L) – Ground : Battery voltage.

OK or NG

OK >> ● Check connector for connection, bend and loose fit and repair.

● Check headlamp bulb.

NG >> Replace daytime light control unit.

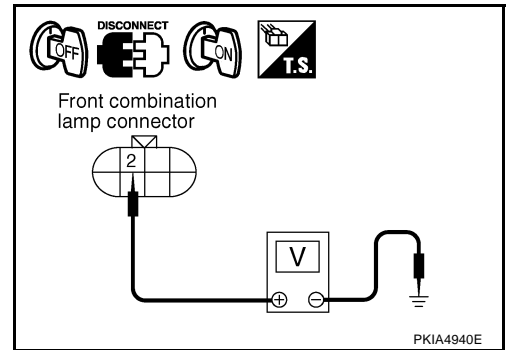

Headlamp Low Beam Does Not Illuminate (Both Sides)

AKS00AB1

1. CHECK COMBINATION SWITCH INPUT SIGNAL

With CONSULT-II

Select "BCM" on CONSULT-II. With "HEAD LAMP" data monitor, make sure "HEAD LAMP SW 1" and "HEAD LAMP SW 2" turns ON-OFF linked with operation of lighting switch.

**When lighting switch is 2ND position : HEAD LAMP SW 1 ON
: HEAD LAMP SW 2 ON**

Without CONSULT-II

Refer to [LT-133, "Combination Switch Inspection"](#) .

OK or NG

OK >> GO TO 2.

NG >> Check combination switch lighting switch. Refer to [LT-133, "Combination Switch Inspection"](#) .

DATA MONITOR			
MONITOR			
HEAD LAMP SW1	ON		
HEAD LAMP SW2	ON		
RECORD			
MODE	BACK	LIGHT	COPY

PKIA7586E

2. HEADLAMP ACTIVE TEST

With CONSULT-II

1. Select "IPDM E/R" on CONSULT-II, and select "ACTIVE TEST" on "SELECT DIAG MODE" screen.
2. Select "LAMPS" on "SELECT TEST ITEM" screen.
3. Touch "LO" screen.
4. Make sure headlamp low beam operates.

Headlamp low beam should operate.

Without CONSULT-II

1. Start auto active test. Refer to [PG-22, "Auto Active Test"](#) .

2. Make sure headlamp low beam operates.

Headlamp low beam should operate.

OK or NG

OK >> GO TO 3.

NG >> GO TO 4.

ACTIVE TEST			
LAMPS		LO	
OFF			
HI			
FOG			
MODE	BACK	LIGHT	COPY

PKIA7742E

HEADLAMP (FOR CANADA) - DAYTIME LIGHT SYSTEM -

3. CHECK IPDM E/R

1. Select "IPDM E/R" on CONSULT-II, and select "DATA MONITOR" on "SELECT DIAG MODE" screen.
2. Make sure "HL LO REQ" turns ON when lighting switch is in 2ND position.

When lighting switch is 2ND position : HL LO REQ ON

OK or NG

- OK >> Replace IPDM E/R.
- NG >> Replace BCM. Refer to [BCS-16, "Removal and Installation of BCM"](#).

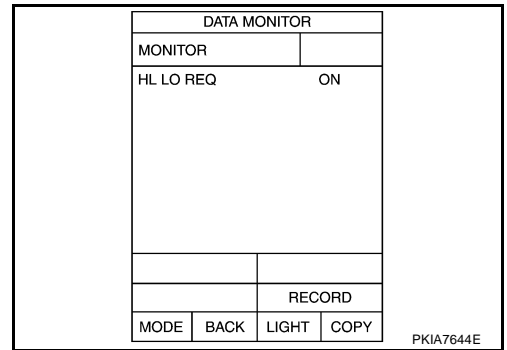

4. CHECK HEADLAMP INPUT SIGNAL

With CONSULT-II

1. Turn ignition switch OFF.
2. Disconnect front combination lamp RH and LH connector.
3. Select "IPDM E/R" on CONSULT-II, and select "ACTIVE TEST" on "SELECT DIAG MODE" screen.
4. Select "LAMPS" on "SELECT TEST ITEM" screen.
5. Touch "LO" screen.
6. When headlamp low relay is operating, check voltage between front combination lamp harness connector and ground.

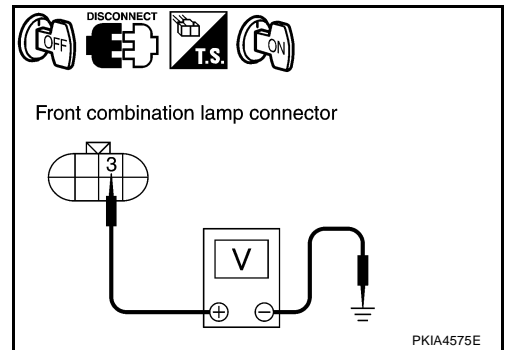

Terminal (+)			Terminal (-)	Voltage
Connector		Terminal (Wire color)		
RH	E24	3 (R)	Ground	Battery voltage
LH	E41	3 (R/B)		

Without CONSULT-II

1. Turn ignition switch OFF.
2. Disconnect front combination lamp RH and LH connector.
3. Start auto active test. Refer to [PG-22, "Auto Active Test"](#).
4. When headlamp low relay is operating, check voltage between front combination lamp harness connector and ground.

Terminal (+)			Terminal (-)	Voltage
Connector		Terminal (Wire color)		
RH	E24	3 (R)	Ground	Battery voltage
LH	E41	3 (R/B)		

OK or NG

- OK >> GO TO 6.
- NG >> GO TO 5.

HEADLAMP (FOR CANADA) - DAYTIME LIGHT SYSTEM -

5. CHECK HEADLAMP CIRCUIT

1. Turn ignition switch OFF.
2. Disconnect IPDM E/R connector.
3. Check continuity between IPDM E/R harness connector E7 terminal 20 (R) and front combination lamp RH harness connector E24 terminal 3 (R).

20 (R) – 3 (R) : Continuity should exist.

4. Check continuity between IPDM E/R harness connector E7 terminal 30 (R/B) and front combination lamp LH harness connector E41 terminal 3 (R/B).

30 (R/B) – 3 (R/B) : Continuity should exist.

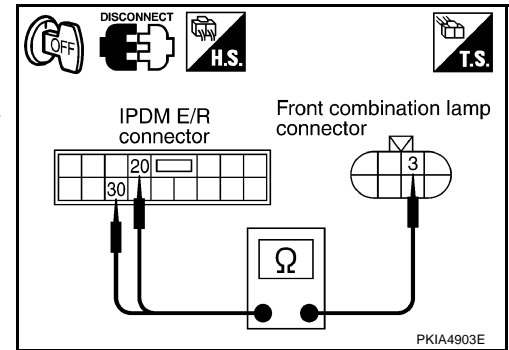

OK or NG

- OK >> Replace IPDM E/R.
NG >> Repair harness or connector.

6. CHECK HEADLAMP GROUND

1. Turn ignition switch OFF.
2. Check continuity between front combination lamp RH harness connector E24 terminal 4 (B/W) and ground.

4 (B/W) – Ground : Continuity should exist.

3. Check continuity between front combination lamp LH harness connector E41 terminal 4 (B/W) and ground.

4 (B/W) – Ground : Continuity should exist.

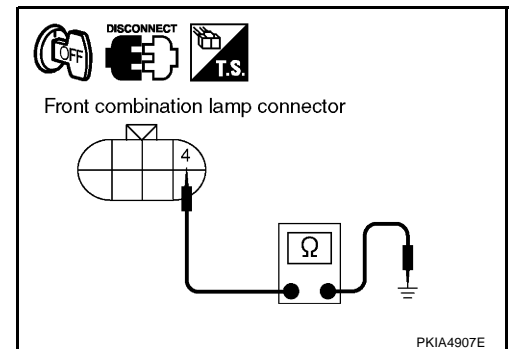

OK or NG

- OK >> Check headlamp harness and connectors, ballasts (HID control unit), and xenon bulbs. Refer to [LT-70, "Xenon Headlamp Trouble Diagnosis"](#) .
NG >> Repair harness or connector.

RH Low Beam Does Not Illuminate But RH High Beam Illuminates

AKS004QJ

1. CHECK BULB

Check ballast (HID control unit) and xenon bulb of lamp which does not illuminate. Refer to [LT-70, "Xenon Headlamp Trouble Diagnosis"](#) .

OK or NG

- OK >> GO TO 2.
NG >> Replace malfunctioning part.

2. CHECK CIRCUIT BETWEEN IPDM E/R AND HEADLAMP RH

1. Turn ignition switch OFF.
2. Disconnect IPDM E/R connector and front combination lamp RH connector.
3. Check continuity between IPDM E/R harness connector E7 terminal 20 (R) and front combination lamp RH harness connector E24 terminal 3 (R).

20 (R) – 3 (R) : Continuity should exist.

OK or NG

- OK >> GO TO 3.
NG >> Repair harness or connector.

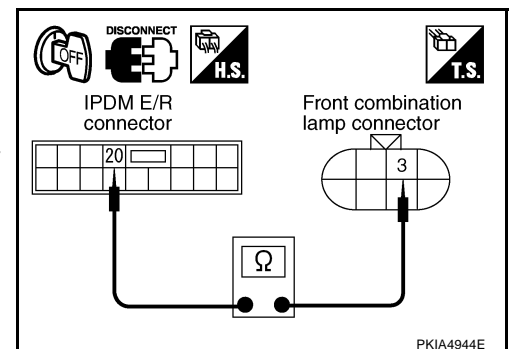

HEADLAMP (FOR CANADA) - DAYTIME LIGHT SYSTEM -

3. CHECK HEADLAMP RH GROUND CIRCUIT

Check continuity between front combination lamp RH harness connector E24 terminal 4 (B/W) and ground.

4 (B/W) – Ground : Continuity should exist.

OK or NG

- OK >> Replace IPDM E/R.
- NG >> Repair harness or connector.

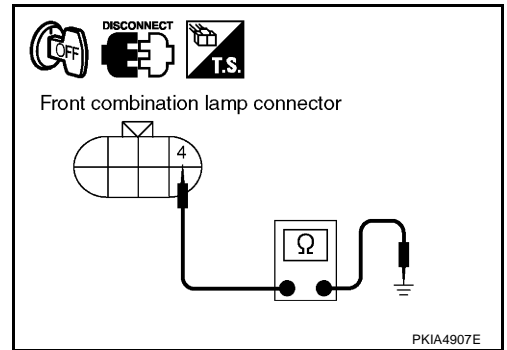

LH Low Beam Does Not Illuminate But LH High Beam Illuminates

AKS004QK

1. CHECK BULB

Check ballast (HID control unit) and xenon bulb of lamp which does not illuminate. Refer to [LT-70, "Xenon Headlamp Trouble Diagnosis"](#).

OK or NG

- OK >> GO TO 2.
- NG >> Replace malfunctioning part.

2. CHECK CIRCUIT BETWEEN IPDM E/R AND HEADLAMP LH

1. Turn ignition switch OFF.
2. Disconnect IPDM E/R connector and front combination lamp LH connector.
3. Check continuity between IPDM E/R harness connector E7 terminal 30 (R/B) and front combination lamp LH harness connector E41 terminal 3 (R/B).

30 (R/B) – 3 (R/B) : Continuity should exist.

OK or NG

- OK >> GO TO 3.
- NG >> Repair harness or connector.

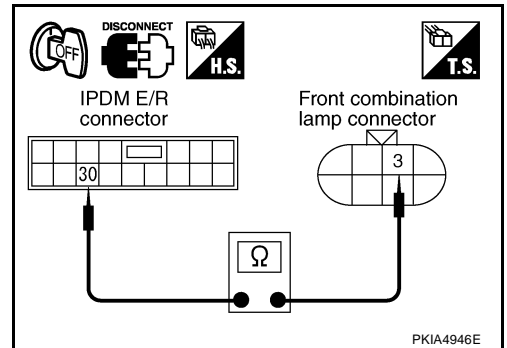

3. CHECK HEADLAMP AND GROUND

Check continuity between front combination lamp LH harness connector E41 terminal 4 (B/W) and ground.

4 (B/W) – Ground : Continuity should exist.

OK or NG

- OK >> Replace IPDM E/R.
- NG >> Repair harness or connector.

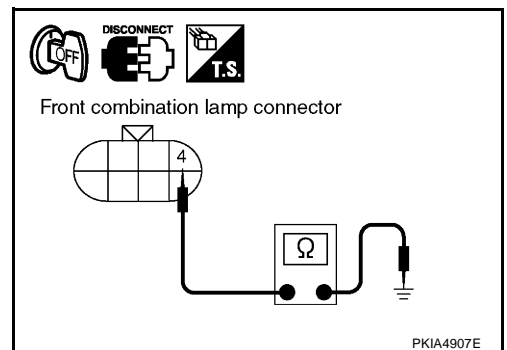

HEADLAMP (FOR CANADA) - DAYTIME LIGHT SYSTEM -

General Information for Xenon Headlamp Trouble Diagnosis

AKS00CMY

In most cases, malfunction of xenon headlamp - "does not illuminate", "flickers" or "dark" - is caused by a malfunctioning xenon bulb. A malfunctioning HID control unit or lamp housing, however, may be a cause. Be sure to perform trouble diagnosis following the steps described below.

Caution:

AKS00CMZ

- Installation or removal of connector must be done with lighting switch OFF.
- Disconnect the battery cable from the negative terminal or remove power fuse.
- When the lamp is illuminated (when lighting switch is ON), never touch harness, HID control unit, inside of lamp, or lamp metal parts.
- To check illumination, temporarily install lamp in vehicle. Be sure to connect power at vehicle side connector.
- If error can be traced directly to electrical system, first check for items such as blown fuses and fusible links, broken wires or loose connectors, dislocated terminals, and improper connections.
- Never work with wet hands.
- Using a tester for HID control unit circuit trouble diagnosis is prohibited.
- Disassembling HID control unit or harnesses (bulb socket harness, ECM harness) is prohibited.
- Immediately after illumination, light intensity and color will fluctuate, but there is nothing wrong.
- When bulb has come to end of its life, brightness will drop significantly, it will flash repeatedly, or light color will turn reddish.

Xenon Headlamp Trouble Diagnosis

AKS00CND

1. CHECK 1: XENON HEADLAMP LIGHTING

Install normal xenon bulb to corresponding xenon bulb headlamp, and check if lamp lights up.

OK or NG

- OK >> Replace xenon bulb.
- NG >> GO TO 2.

2. CHECK 2: XENON HEADLAMP LIGHTING

Install normal HID control unit to corresponding xenon headlamp, and check if lamp lights up.

OK or NG

- OK >> Replace HID control unit.
- NG >> GO TO 3.

3. CHECK 3: XENON HEADLAMP LIGHTING

Install normal xenon lamp housing assembly to corresponding xenon headlamp, and check if lamp lights up.

OK or NG

- OK >> Replace xenon headlamp housing assembly. [Malfunction in starter (boosting circuit) in xenon headlamp housing]
- NG >> INSPECTION END

HEADLAMP (FOR CANADA) - DAYTIME LIGHT SYSTEM -

Aiming Adjustment

AKS00CN1

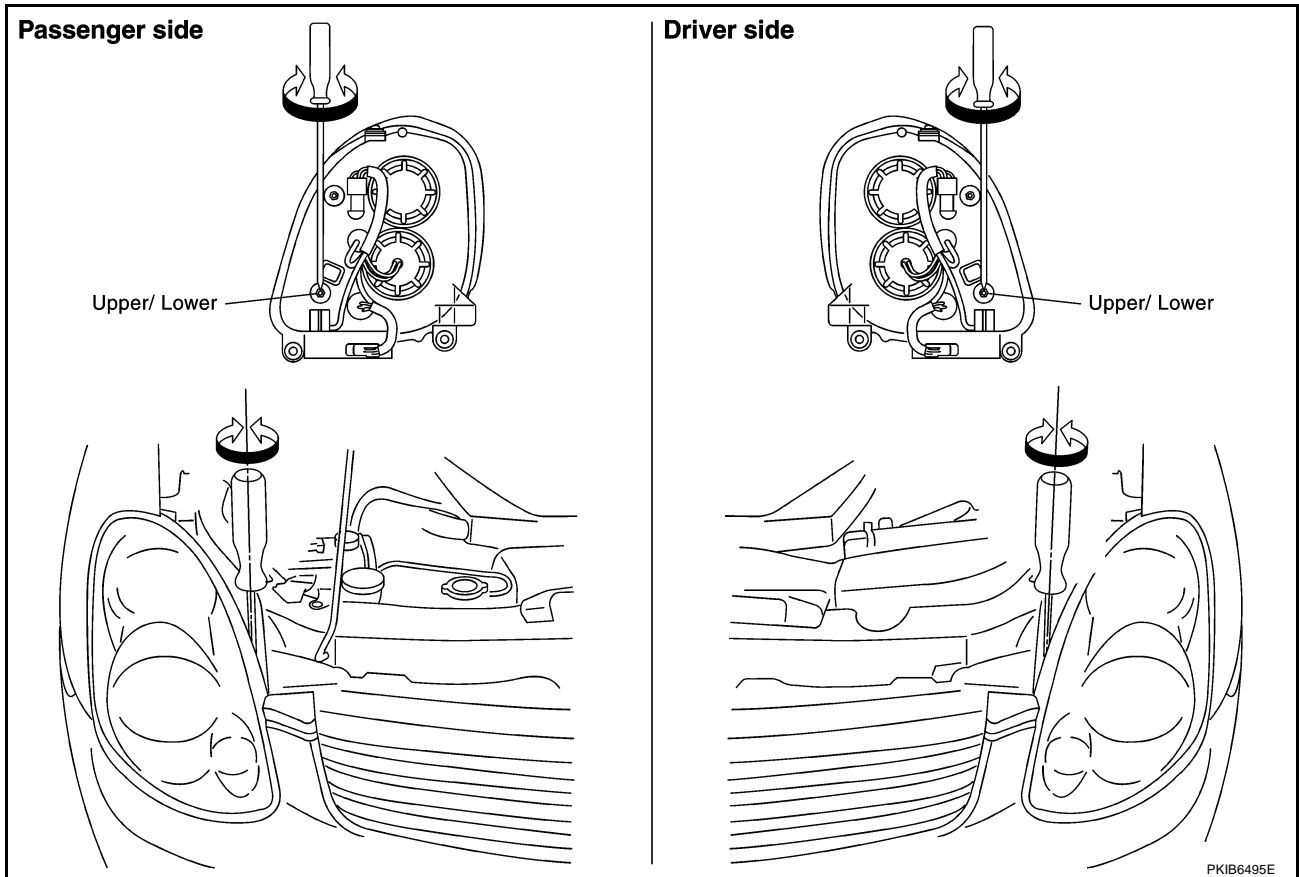

PREPARATION BEFORE ADJUSTING

For Details, Refer to the Regulations in Your Own Country.

Before performing aiming adjustment, check the following.

1. Keep all tires inflated to correct pressures.
2. Place vehicle on flat surface.
3. Set that there is no-load in vehicle other than the driver (or equivalent weight placed in driver's position). Coolant, engine oil filled up to correct level and full fuel tank.

LOW BEAM AND HIGH BEAM

1. Turn headlamp low beam ON.
2. Use adjusting screws to perform aiming adjustment.

A
B
C
D
E
F
G
H
I
J
LT
L
M

HEADLAMP (FOR CANADA) - DAYTIME LIGHT SYSTEM -

ADJUSTMENT USING AN ADJUSTMENT SCREEN (LIGHT/DARK BORDERLINE)

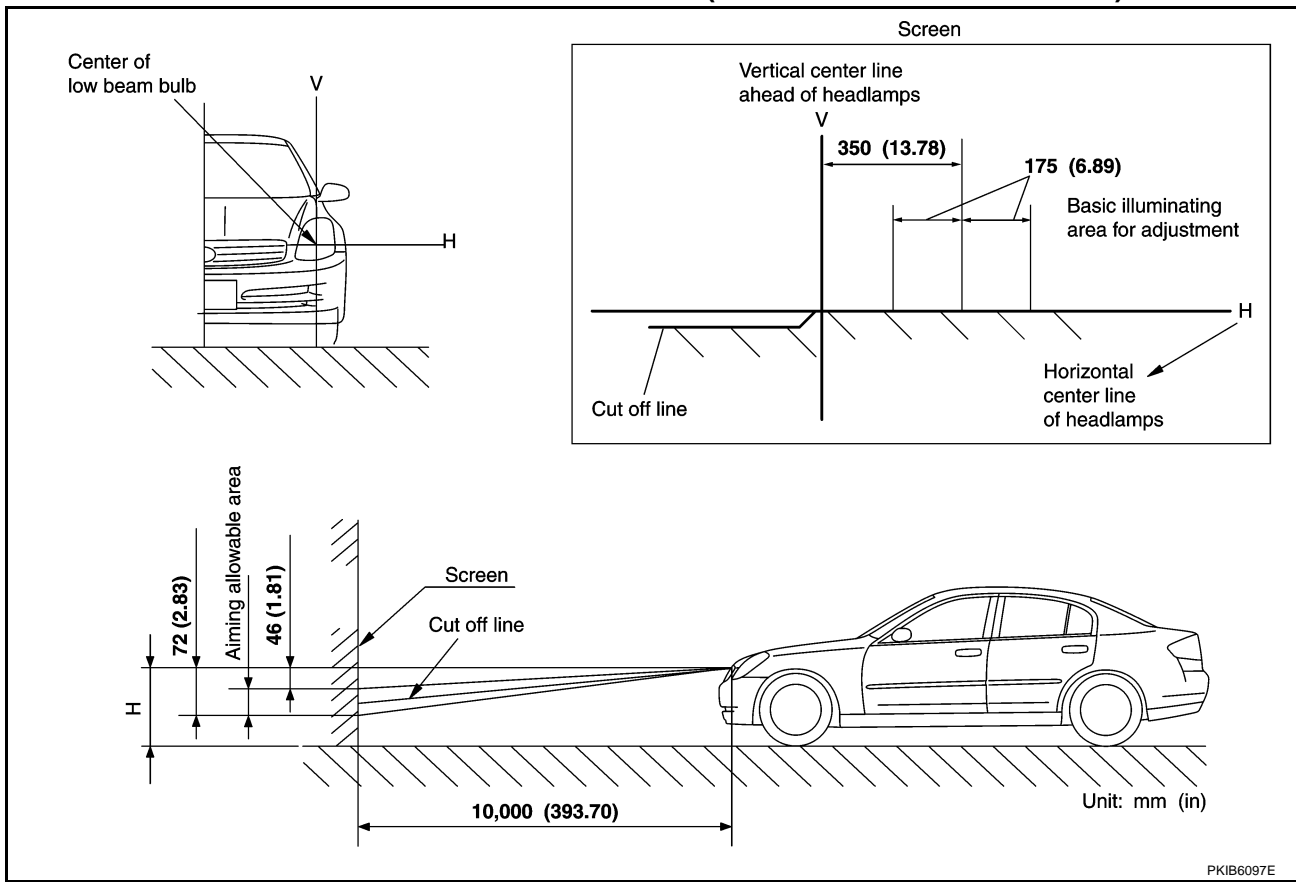

If vehicle front body has been repaired and/or headlamp assembly has been replaced, check aiming. Use aiming chart shown in the figure.

- Basic illumination area for adjustment should be within the range shown on the aiming chart. Adjust headlamp accordingly.

Bulb Replacement HEADLAMP (UPPER) LOW BEAM

1. Turn lighting switch OFF.
2. Disconnect the battery cable from the negative terminal or remove power fuse.
3. Remove headlamp. Refer to [LT-73, "Removal and Installation"](#).
4. Turn plastic cap counterclockwise and unlock it.
5. Turn bulb socket counterclockwise and unlock it.
6. Unlock retaining spring and remove bulb from headlamp.
7. Installation is the reverse order of removal.

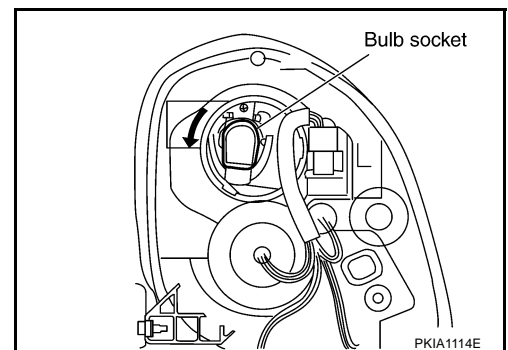

HEADLAMP (FOR CANADA) - DAYTIME LIGHT SYSTEM -

HEADLAMP (LOWER) HIGH BEAM/FOG LAMP

1. Turn lighting switch OFF.
2. Disconnect the battery cable from the negative terminal or remove power fuse.
3. Remove fender protector (front). Refer to [EI-22, "FENDER PROTECTOR"](#) in "EI" section.
4. Turn plastic cap counterclockwise and unlock it.
5. Disconnect bulb socket.
6. Unlock retaining spring and remove bulb from headlamp.
7. Installation is the reverse order of removal.

FRONT TURN SIGNAL/PARKING LAMP

1. Turn lighting switch OFF.
2. Remove fender protector (front). Refer to [EI-22, "FENDER PROTECTOR"](#) in "EI" section.
3. Turn bulb socket counterclockwise and unlock it.
4. Remove bulb from its socket.
5. Installation is the reverse order of removal.

Headlamp (upper) low beam : 12V - 35W (D2R)

Headlamp (lower) high beam/Fog lamp : 12V - 60/55W (HB2)

Front turn signal/Parking lamp : 12V - 21/5W

CAUTION:

After installing bulb, be sure to install plastic cap and bulb socket securely to insure watertightness.

Removal and Installation

REMOVAL

1. Disconnect the battery cable from the negative terminal or remove power fuse.
2. Remove front grille. Refer to [EI-20, "FRONT GRILLE"](#) in "EI" section.
3. Remove front undercover and fender protector. Refer to [EI-22, "FENDER PROTECTOR"](#) in "EI" section.
4. Remove mounting clip on top of front bumper and screws on side of front bumper. Refer to [EI-14, "FRONT BUMPER"](#) in "EI" section.
5. Pull side of front bumper toward the vehicle front and disengage it from clips on the body.
6. Remove headlamp mounting bolts.
7. Pull headlamp toward the vehicle front, disconnect connector, and remove headlamp.

CAUTION:

When removing headlamps, put a shop cloth or something similar between headlamps and bumper to protect bumper.

INSTALLATION

Installation is the reverse order of removal.

Headlamp mounting bolt  : 5.9 N·m (0.60 kg·m, 52 in·lb)

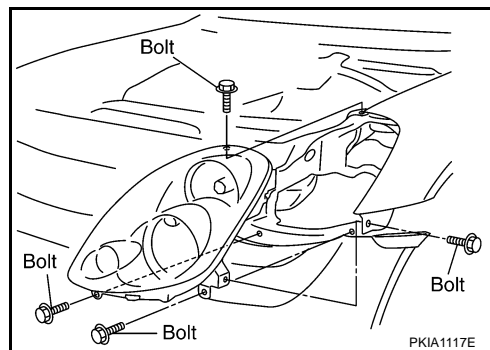
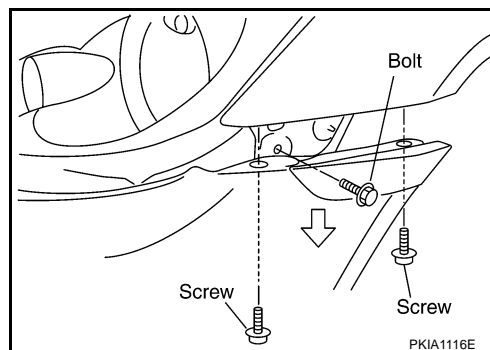

HEADLAMP (FOR CANADA) - DAYTIME LIGHT SYSTEM -

Disassembly

AKS00C04

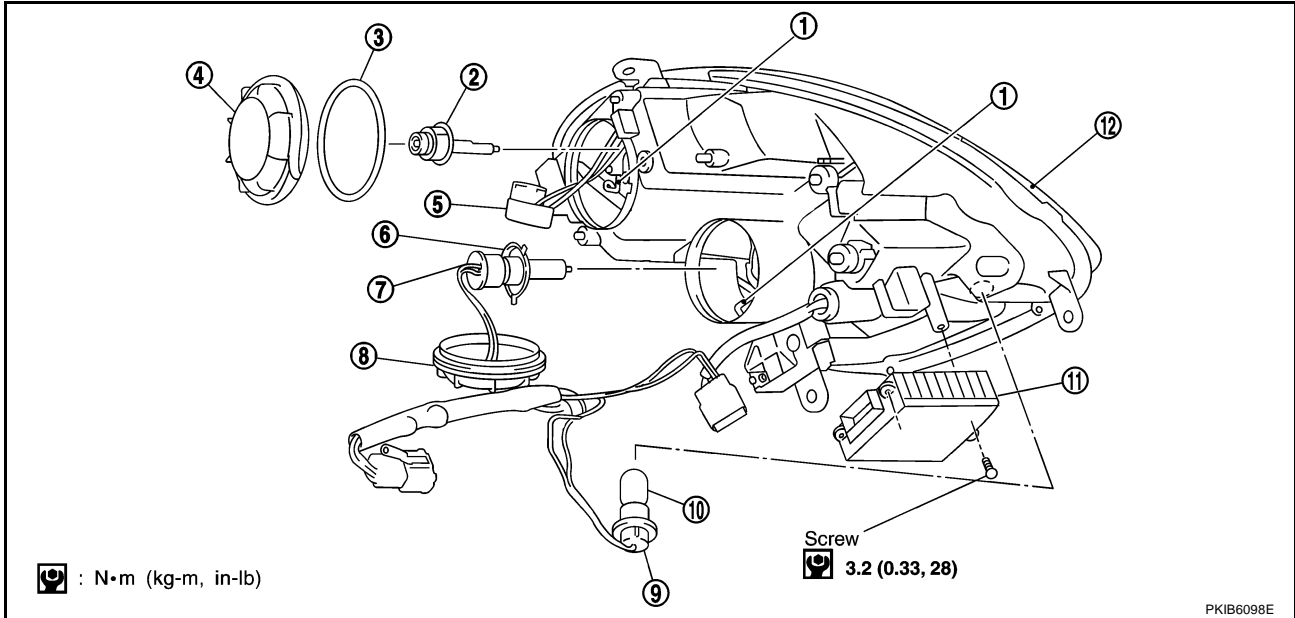

- | | | |
|---|----------------------------|---|
| 1. Retaining spring | 2. Xenon bulb (low) | 3. Seal rubber |
| 4. Plastic cap (low) | 5. Xenon bulb socket (low) | 6. Halogen bulb (high/fog) |
| 7. Halogen bulb (high/fog) socket | 8. Plastic cap (high/fog) | 9. Front turn signal/Parking lamp bulb socket |
| 10. Front turn signal/Parking lamp bulb | 11. HID control unit | 12. Headlamp housing assembly |

1. Turn plastic cap (low) counterclockwise and unlock it.
2. Turn xenon bulb (low) socket counterclockwise, and unlock it.
3. Unlock retaining spring, and remove xenon bulb (low).
4. Disconnect HID control unit connector, and remove HID control unit screws. (Xenon)
5. Turn plastic cap (high/fog) counterclockwise, and unlock it.
6. Disconnect the terminal connected to the halogen bulb (high/fog).
7. Unlock retaining spring, and remove halogen bulb (high/fog).
8. Turn front turn signal lamp/parking bulb socket counterclockwise and unlock it.
9. Remove front turn signal/parking lamp bulb from its socket.

HEADLAMP (FOR CANADA) - DAYTIME LIGHT SYSTEM -

Assembly

AKS00CN5

Assembly is the reverse order of disassembly.

HID control unit  : 3.2 N·m (0.33 kg-m, 28 in-lb)

CAUTION:

- When HID control unit is removed, reinstall it securely and avoid any looseness.
- After installing bulb, be sure to install plastic cap and bulb socket securely to insure watertightness.

Servicing to Replace Headlamps When Damaged

AKS00CN6

If only installation part as shown in the figure is damaged, and headlamp housing itself is not damaged, repair can be completed easily by installing correction brackets.

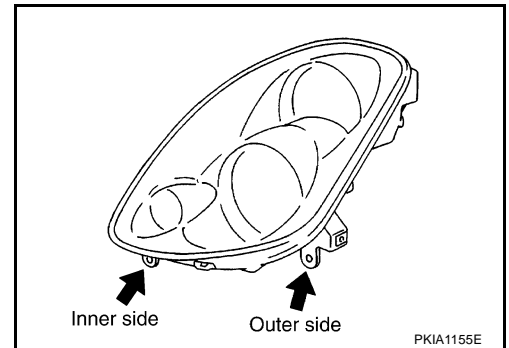

REMOVAL AND INSTALLATION

1. Remove headlamps. Refer to [LT-73, "Removal and Installation"](#).
2. Cut damaged section of installation part, then shape with sandpaper.
3. Attach each correction bracket to headlamp housing boss with 2 screws.

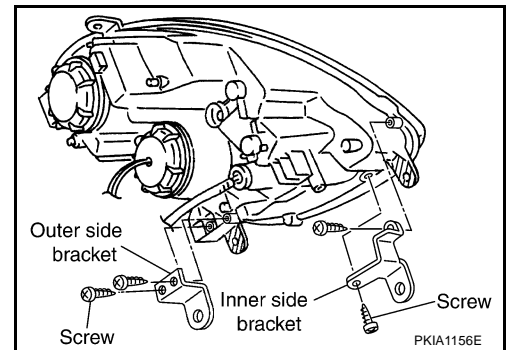

A
B
C
D
E
F
G
H
I
J
LT
L
M

AUTO LIGHT SYSTEM

AUTO LIGHT SYSTEM

PFP:28491

Component Parts and Harness Connector Location

AKS009LA

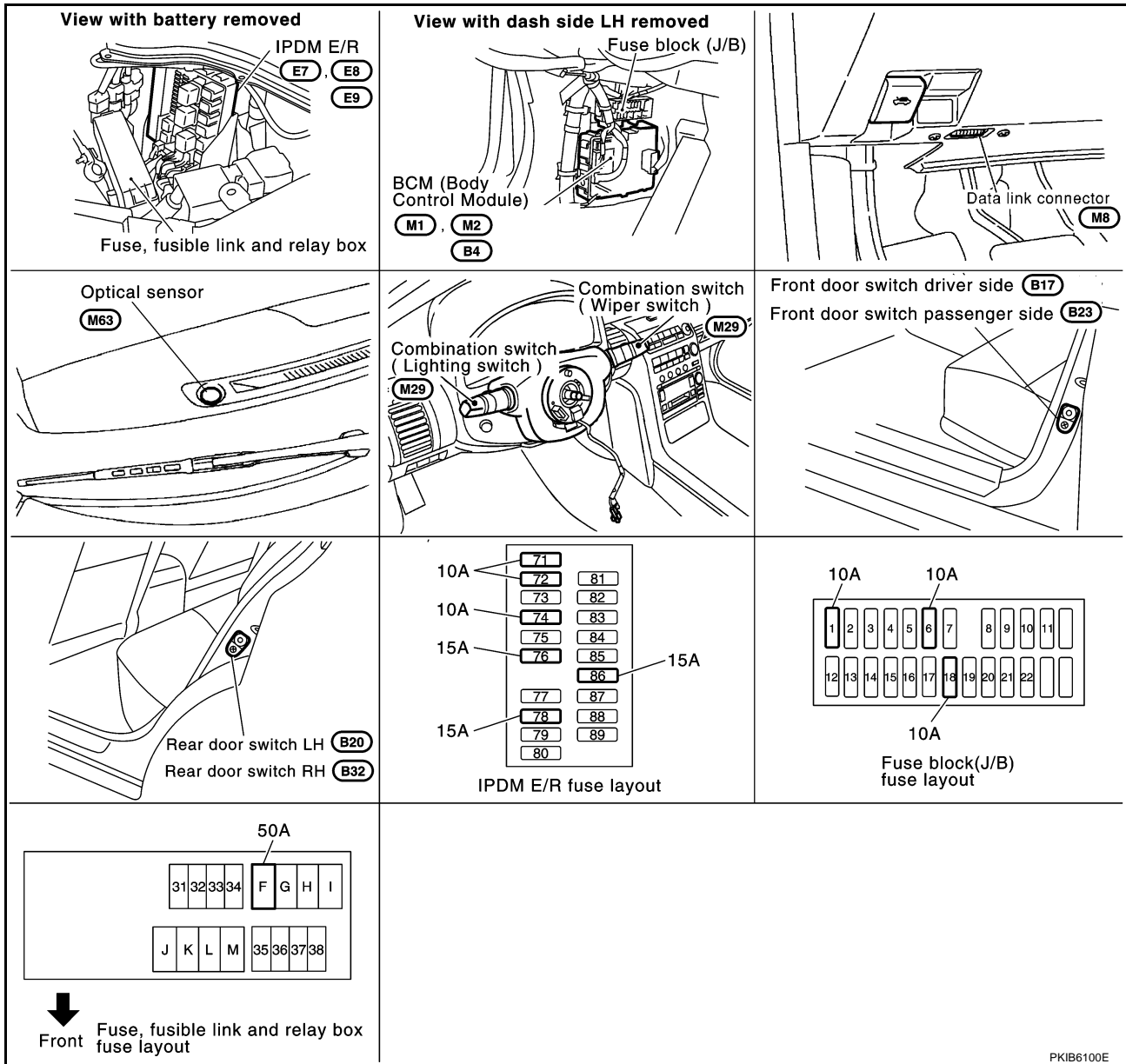

System Description

AKS009LB

Automatically turns ON/OFF the parking lamps and the headlamps in accordance with ambient light. Timing for when lamps turn ON/OFF can be selected using four modes.

OUTLINE

The auto light control system has an optical sensor inside it that detects outside brightness. When the lighting switch is in AUTO position, it automatically turns ON/OFF the parking lamps and the headlamps in accordance with ambient light. Sensitivity can be adjusted in four steps. For the details of the setting, Refer to [LT-84, "SETTING CHANGE FUNCTIONS"](#).

Optical sensor, power is supplied

- from BCM (body control module) terminal 17
- to optical sensor terminal 1.

Optical sensor, ground is supplied

- to optical sensor terminal 3
- through BCM terminal 18.

When ignition switch is turn to ON position, and

AUTO LIGHT SYSTEM

When outside brightness is darker than prescribed level, input is supplied

- from optical sensor terminal 2
- to BCM terminal 14.

The headlamps will then illuminate. For a description of headlamp operation, Refer to [LT-76, "System Description"](#).

COMBINATION SWITCH READING FUNCTION

Refer to [BCS-3, "COMBINATION SWITCH READING FUNCTION"](#).

EXTERIOR LAMP BATTERY SAVER CONTROL

When the combination switch (lighting switch) is in the 2ND position (or if auto light system is activated), and the ignition switch is turned from ON or ACC to OFF, the battery saver control function is activated.

Under this condition, the headlamps remain illuminated for 5 minutes, then the headlamps are turned off. Exterior lamp battery saver control mode can be changed by the function setting of CONSULT-II.

DELAY TIMER FUNCTION

Delay timer function carries out a function that BCM activates the timer and controls lights out of headlamps by door switch signal and lightning switch signal when turning the Ignition switch OFF while it is ON and headlamps are ON by the auto light function.

Timer types are a 5 minute timer and a 45 second timer

- When opening any door (door switch is ON), the 5 minute timer starts and then headlamps go out five minutes later
- When all the doors are closed (from door switch ON to OFF), the 45 second timer starts and then headlamps go out 45 seconds later. If any door is opened (door switch ON) while the 45 second timer is in operation, the 5 minute timer starts again
- The timer stops when turning on the ignition switch or turning off the auto light switch under the above conditions.

Delay timer control mode can be changed by the function setting of CONSULT-II.

CAN Communication System Description

AKS009LC

CAN (Controller Area Network) is a serial communication line for real time application. It is an on-vehicle multiplex communication line with high data communication speed and excellent error detection ability. Many electronic control units are equipped onto vehicle, and each control unit shares information and links with other control units during operation (not independent). In CAN communication, control units are connected with 2 communication lines (CAN H line, CAN L line) allowing the high rate of information transmission with less wiring. Each control unit transmits/receives data but selectively reads required data only.

CAN Communication Unit

AKS009LD

Refer to [LAN-21, "CAN Communication Unit"](#).

Major Components and Functions

AKS009LE

Components	Functions
BCM	● Turns on/off circuits of tail light and headlamp according to signals from light sensor, lighting switch (AUTO), driver door switch, passenger door switch, rear door switch, and ignition switch (ON, OFF).
Optical sensor	● Converts outside brightness (lux) to voltage, and sends it to BCM. (Detects brightness of 50 to 1,300 lux)

AUTO LIGHT SYSTEM

Schematic

AKS009LF

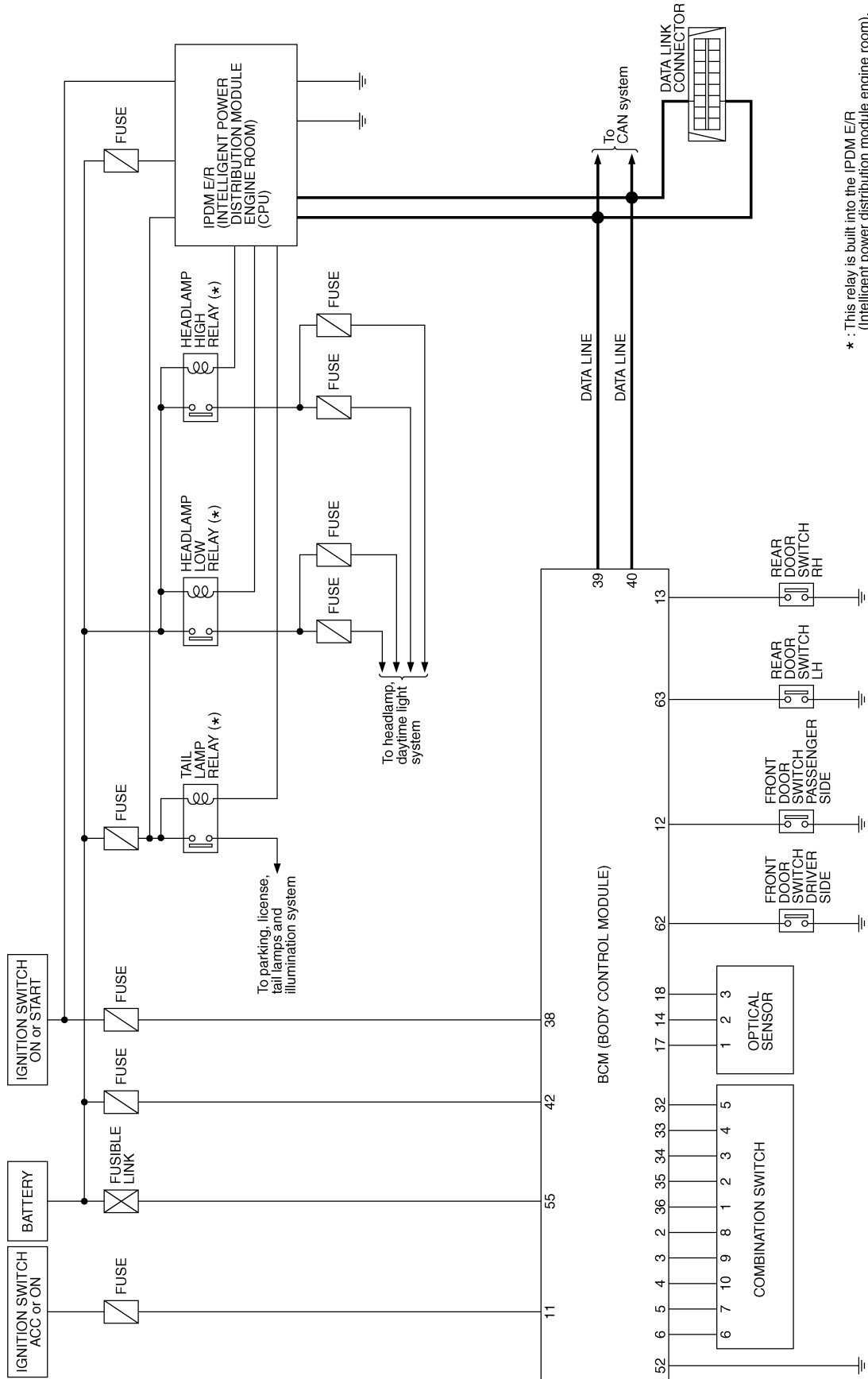

* : This relay is built into the IPDM E/R (Intelligent power distribution module engine room).

TKWM2253E

AUTO LIGHT SYSTEM

Wiring Diagram — AUTO/L —

AKS009LG

LT-AUTO/L-01

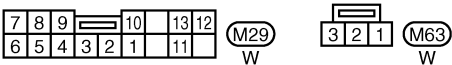
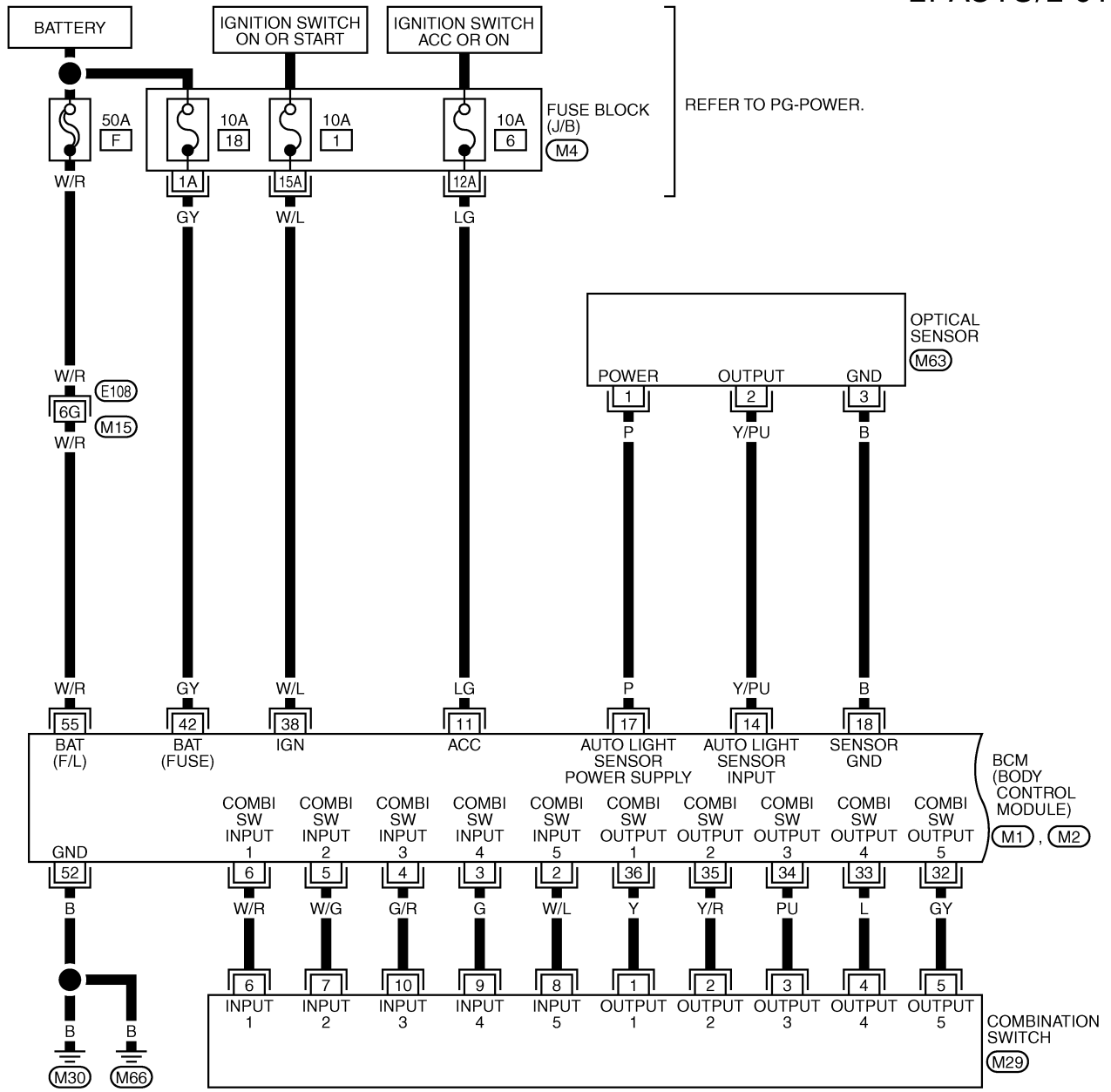

REFER TO THE FOLLOWING.

- (E108) -SUPER MULTIPLE JUNCTION (SMJ)
- (M4) -FUSE BLOCK-JUNCTION BOX (J/B)
- (M1), (M2) -ELECTRICAL UNITS

TKWT1416E

AUTO LIGHT SYSTEM

LT-AUTO/L-03

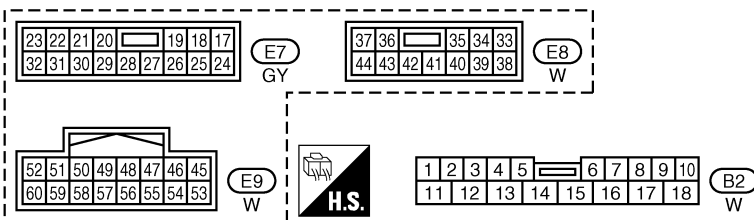
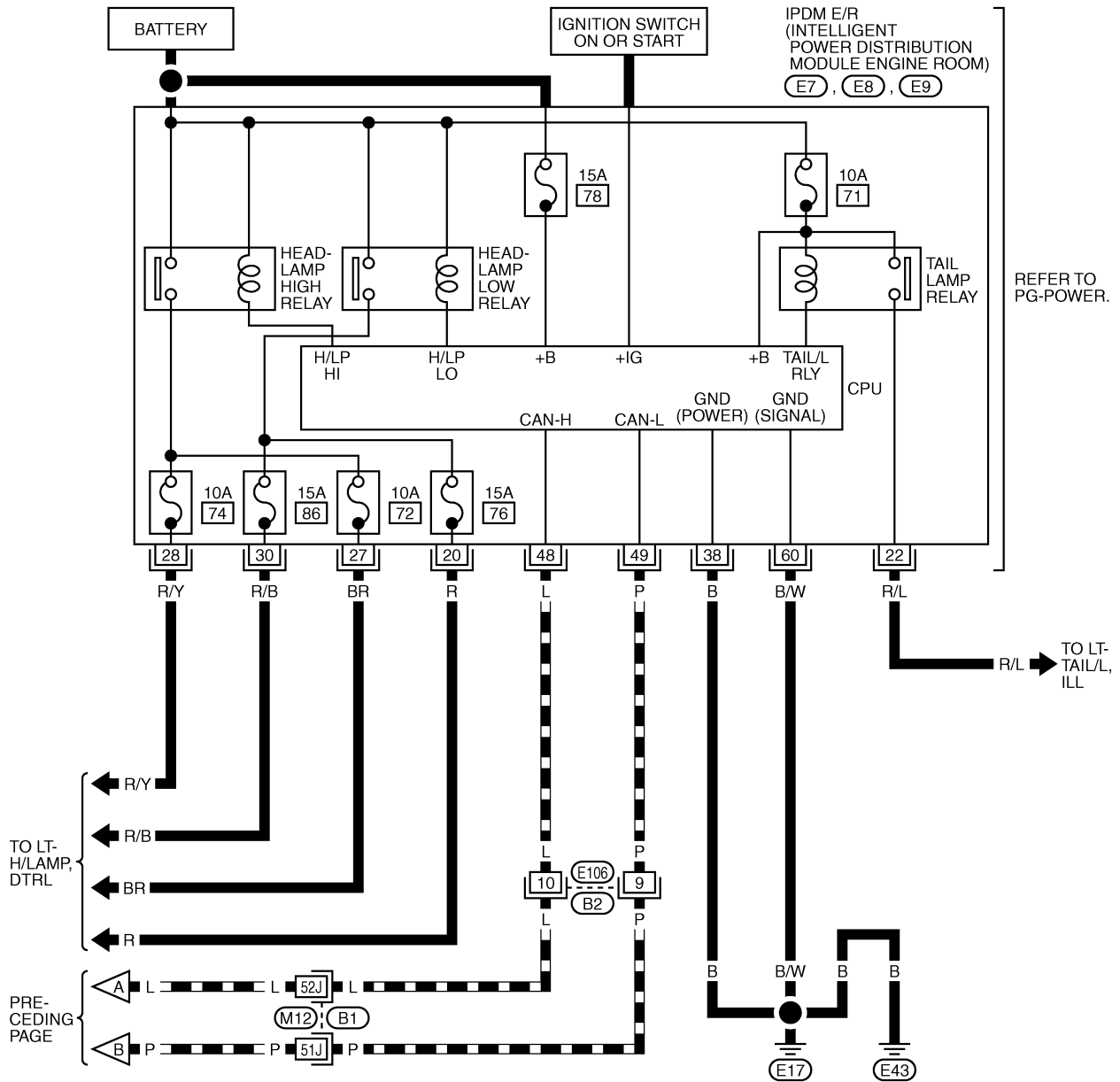

AUTO LIGHT SYSTEM

Terminals and Reference Values for BCM

AKS009LH

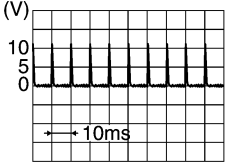
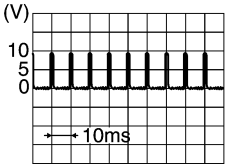
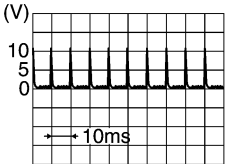
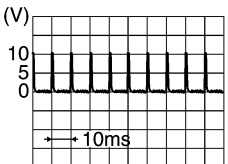
Terminal No.	Wire color	Signal name	Measuring condition		Reference value	
			Ignition switch	Operation or condition		
2	W/L	Combination switch input 5	ON	Lighting, turn, wiper OFF Wiper intermittent dial position 4	 <p style="text-align: right;">PKIB3468E</p>	
3	G	Combination switch input 4	ON	Lighting, turn, wiper OFF Wiper intermittent dial position 4	 <p style="text-align: right;">PKIB3469E</p>	
4	G/R	Combination switch input 3				
5	W/G	Combination switch input 2				
6	W/R	Combination switch input 1				
11	LG	Ignition switch (ACC)	ACC	—	Battery voltage	
12	P	Front door switch passenger side signal	OFF	Front door switch passenger side	ON (open)	Approx. 0V
					OFF (closed)	Battery voltage
13	P	Rear door switch RH signal	OFF	Rear door switch RH	ON (open)	Approx. 0V
					OFF (closed)	Battery voltage
14	Y/PU	Optical sensor signal	ON	When optical sensor is illuminated		3.1 V or more ^{Note}
				When optical sensor is not illuminated		0.6 V or less
17	P	Optical sensor power supply	ON	—	Approx. 5V	
18	B	Sensor ground	ON	—	Approx. 0V	
32	GY	Combination switch output 5	ON	Lighting, turn, wiper OFF Wiper intermittent dial position 4	 <p style="text-align: right;">PKIB3470E</p>	
33	L	Combination switch output 4	ON	Lighting, turn, wiper OFF Wiper intermittent dial position 4	 <p style="text-align: right;">PKIB3471E</p>	
34	PU	Combination switch output 3				
35	Y/R	Combination switch output 2				
36	Y	Combination switch output 1				
38	W/L	Ignition switch (ON)	ON	—	Battery voltage	
39	L	CAN - H	—	—	—	
40	P	CAN - L	—	—	—	
42	GY	Battery power supply	OFF	—	Battery voltage	
52	B	Ground	ON	—	Approx. 0V	
55	W/R	Battery power supply	OFF	—	Battery voltage	

AUTO LIGHT SYSTEM

Terminal No.	Wire color	Signal name	Measuring condition		Reference value
			Ignition switch	Operation or condition	
62	W	Front door switch driver side signal	OFF	Front door switch driver side	ON (open) Approx. 0V
					OFF (closed) Battery voltage
63	P	Rear door switch LH signal	OFF	Rear door switch LH	ON (open) Approx. 0V
					OFF (closed) Battery voltage

NOTE:

Optical sensor must be securely subjected to work lamp light. If the optical sensor is insufficiently illuminated, the measured value may not satisfy standard.

Terminals and Reference Values for IPDM E/R

AKS009LI

Terminal No.	Wire color	Signal name	Measuring condition		Reference value
			Ignition switch	Operation or condition	
20	R	Headlamp low (RH)	ON	Lighting switch 2ND position	OFF Approx. 0V
					ON Battery voltage
22	R/L	Parking, license, and tail lamp	ON	Lighting switch 1ST position	OFF Approx. 0V
					ON Battery voltage
27	BR	Headlamp high (RH)	ON	Lighting switch HIGH BEAM or PASSING position	OFF Approx. 0V
					ON Battery voltage
28	R/Y	Headlamp high (LH)	ON	Lighting switch HIGH BEAM or PASSING position	OFF Approx. 0V
					ON Battery voltage
30	R/B	Headlamp low (LH)	ON	Lighting switch 2ND position	OFF Approx. 0V
					ON Battery voltage
38	B	Ground	ON	—	Approx. 0V
48	L	CAN – H	—	—	—
49	P	CAN – L	—	—	—
60	B/W	Ground	ON	—	Approx. 0V

How to Proceed With Trouble Diagnosis

AKS009LJ

1. Confirm the symptom or customer complaint.
2. Understand operation description and function description. Refer to [LT-76, "System Description"](#) .
3. Perform the preliminary check. Refer to [LT-84, "Preliminary Check"](#) .
4. Check symptom and repair or replace the malfunctioning parts. Refer to [LT-90, "Symptom Chart"](#) .
5. Does the auto light system operate normally? If YES, GO TO 6. If NO, GO TO 4.
6. INSPECTION END.

AUTO LIGHT SYSTEM

AKS009LK

Preliminary Check SETTING CHANGE FUNCTIONS

- Sensitivity of auto light system can be adjusted using CONSULT-II. Refer to [LT-86, "WORK SUPPORT"](#) .

CHECK POWER SUPPLY AND GROUND CIRCUIT

1. CHECK FUSES

Check for blown fuses.

Unit	Power source	Fuse and fusible link No.
BCM	Battery	F
		18
	Ignition switch ON or START position	1
	Ignition switch ACC or ON position	6
IPDM E/R	Battery	71
		72
		74
		76
		76
		86

Refer to [LT-79, "Wiring Diagram — AUTO/L —"](#) .

OK or NG

OK >> GO TO 2.

NG >> If fuse or fusible link is blown, be sure to eliminate cause of malfunction before installing new fuse or fusible link. Refer to [PG-3, "POWER SUPPLY ROUTING CIRCUIT"](#) .

2. CHECK POWER SUPPLY CIRCUIT

1. Turn ignition switch OFF.
2. Disconnect BCM connector.
3. Check voltage between BCM harness connector and ground.

Terminal (+)		Terminal (-)	Ignition switch position		
Connector	Terminal (Wire color)		OFF	ACC	ON
M1	11 (LG)	Ground	Approx. 0V	Battery voltage	Battery voltage
	38 (W/L)		Approx. 0V	Approx. 0V	Battery voltage
M4	42 (GY)		Battery voltage	Battery voltage	Battery voltage
	55 (W/R)		Battery voltage	Battery voltage	Battery voltage

OK or NG

OK >> GO TO 3.

NG >> Check harness for open or short between BCM and fuse.

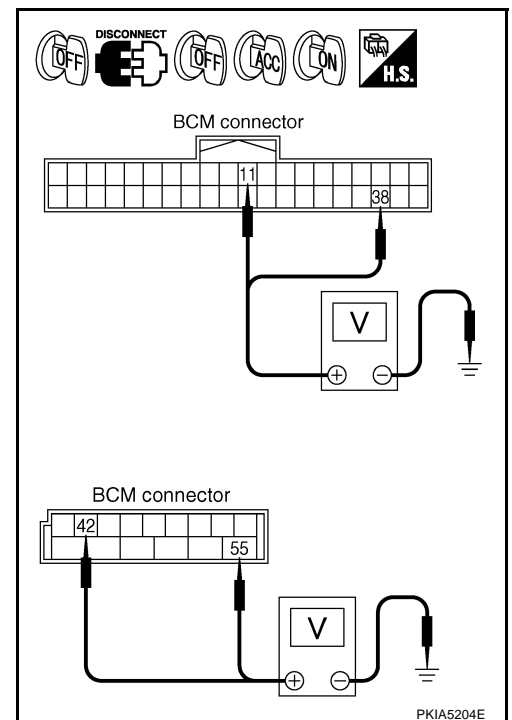

AUTO LIGHT SYSTEM

3. CHECK GROUND CIRCUIT

Check continuity between BCM harness connector and ground.

Terminal		Ground	Continuity
Connector	Terminal (Wire color)		
M2	52 (B)		Yes

OK or NG

- OK >> INSPECTION END
- NG >> Check harness ground circuit.

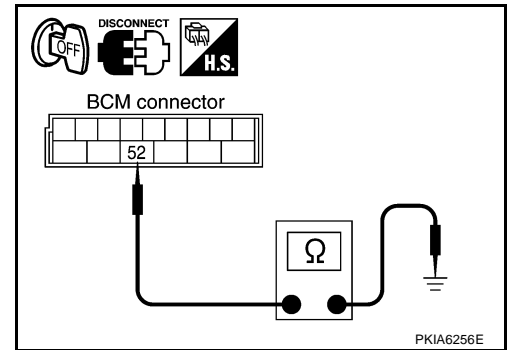

CONSULT-II Functions (BCM)

CONSULT-II can display each diagnostic item using the diagnostic test modes shown following.

BCM diagnosis part	Diagnosis mode	Description
HEADLAMP	WORK SUPPORT	Changes the setting for each function.
	DATA MONITOR	Displays BCM input data in real time.
	ACTIVE TEST	Operation of electrical loads can be checked by sending drive signal to them.
BCM	SELF-DIAG RESULTS	BCM performs self-diagnosis of CAN communication.
	CAN DIAG SUPPORT MNTR	The result of transmit/receive diagnosis of CAN communication can be read.

CONSULT-II BASIC OPERATION

CAUTION:

If CONSULT-II is used with no connection of CONSULT-II CONVERTER, malfunctions might be detected in self-diagnosis depending on control unit which carry out CAN communication.

- With ignition switch OFF, connect CONSULT-II and CONSULT-II CONVERTER to data link connector, and then turn ignition switch ON.

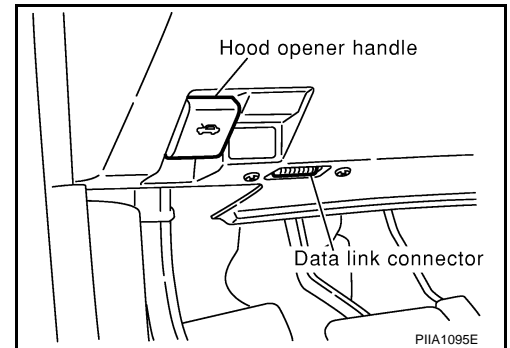

- Touch "START (NISSAN BASED VHCL)".

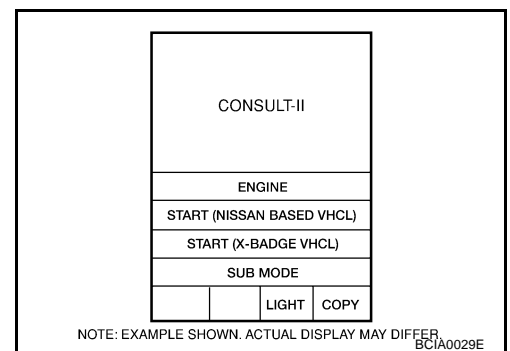

AUTO LIGHT SYSTEM

3. Touch "BCM" on "SELECT SYSTEM" screen.
If "BCM" is not indicated, refer to [GI-39, "CONSULT-II Data Link Connector \(DLC\) Circuit"](#).

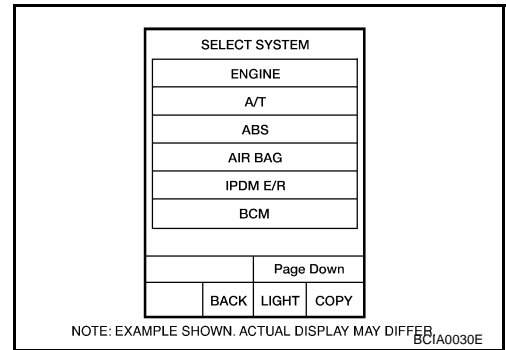

4. Touch "HEAD LAMP" on "SELECT DIAG MODE" screen.

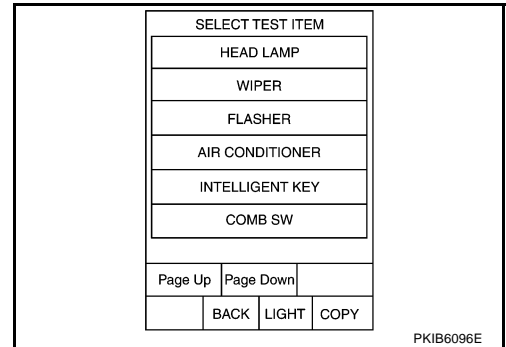

WORK SUPPORT

Operation Procedure

1. Touch "HEAD LAMP" on "SELECT TEST ITEM" screen.
2. Touch "WORK SUPPORT" on "SELECT DIAG MODE" screen.
3. Touch "CUSTOM A/LIGHT SETTING" or "ILL DELAY SET" on "SELECT WORK ITEM" screen.
4. Touch "START".
5. Touch "NORMAL" or "MODE 2 - 4" of setting to be changed (CUSTOM A/LIGHT SETTING), Touch "MODE1 - 8" of setting to be changed (ILL DELAY SET).
6. Touch "SETTING CHANGE".
7. The setting will be changed and "CUSTOMIZING COMPLETED" will be displayed.
8. Touch "END".

Work Support Setting Item

- Sensitivity of auto light can be selected and set from four modes.

Work item	Description
CUSTOM A/LIGHT SETTING	Auto light sensitivity can be changed in this mode. Sensitivity can be adjusted in four modes. <ul style="list-style-type: none"> ● MODE 1 (Normal)/ MODE 2 (sensitive)/MODE 3 (Desensitized)/MODE4 (Insensitive)
ILL DELAY SET	Auto light delay off timer period can be changed in this mode. Selects auto light delay off timer period among eight modes. <ul style="list-style-type: none"> ● MODE 1 (45 sec.)/MODE 2 (OFF)/MODE 3 (30 sec.)/MODE 4 (60 sec.)/MODE 5 (90 sec.)/MODE 6 (120 sec.)/MODE 7 (150 sec.)/MODE 8 (180 sec.)

DATA MONITOR

Operation Procedure

1. Touch "HEAD LAMP" on "SELECT TEST ITEM" screen.
2. Touch "DATA MONITOR" on "SELECT DIAG MODE" screen.
3. Touch either "ALL SIGNALS" or "SELECTION FROM MENU" on "SELECT MONITOR ITEM" screen.

ALL SIGNALS	Monitors all the signals.
SELECTION FROM MENU	Selects items and monitor them.

AUTO LIGHT SYSTEM

4. When "SELECTION FROM MENU" is selected, touch individual items to be monitored. When "ALL SIGNALS" is selected, all the items will be monitored.
5. Touch "START".
6. Touch "RECORD" while monitoring, then the status of the monitored item can be recorded. To stop recording, touch "STOP".

Display Item List

Monitor item	Contents
IGN ON SW "ON/OFF"	Displays status (ignition switch IGN position: ON/other: OFF) of ignition switch judged from the ignition switch signal.
ACC ON SW "ON/OFF"	Displays status (ignition switch ACC or IGN position: ON/other: OFF) of ignition switch judged from the ignition switch signal.
HI BEAM SW "ON/OFF"	Displays status (lighting switch high beam position: ON/other: OFF) of high beam switch judged from the lighting switch signal.
HEAD LAMP SW 1 "ON/OFF"	Displays status (lighting switch 2ND position: ON/other: OFF) of headlamp 1 switch judged from the lighting switch signal.
HEAD LAMP SW 2 "ON/OFF"	Displays status (lighting switch 2ND position: ON/other: OFF) of headlamp 2 switch judged from the lighting switch signal.
LIGHT SW 1 ST "ON/OFF"	Displays status (lighting switch 1ST or 2ND position: ON/other: OFF) of lighting switch 1ST position switch judged from the lighting switch signal.
AUTO LIGHT SW "ON/OFF"	Displays status (lighting switch AUTO position: ON/other: OFF) of auto light switch position judged from the lighting switch signal.
PASSING SW "ON/OFF"	Displays status (lighting switch passing position: ON/other: OFF) of passing switch judged from the lighting switch signal.
FR FOG SW "ON/OFF"	Displays status (lighting switch front fog lamp ON position: ON/others: OFF) of front fog lamp switch judged from the lighting switch signal.
DOOR SW - DR "ON/OFF"	Displays status (door is open: ON/door is closed: OFF) of driver side door switch judged from the driver side door switch signal.
DOOR SW - AS "ON/OFF"	Displays status (door is open: ON/door is closed: OFF) of passenger side door switch judged from the passenger side door switch signal.
DOOR SW - RR "ON/OFF"	Displays status (door is open: ON/door is closed: OFF) of rear door switch (RH) judged from the rear door switch (RH) signal.
DOOR SW - RL "ON/OFF"	Displays status (door is open: ON/door is closed: OFF) of rear door switch (LH) judged from the rear door switch (LH) signal.
BACK DOOR SW ^{NOTE 1} "OFF"	—
TURN SIGNAL R "ON/OFF"	Displays status (turn signal switch right position: ON/other: OFF) of turn RH switch judged from the turn signal switch signal.
TURN SIGNAL L "ON/OFF"	Displays status (turn signal switch left position: ON/other: OFF) of turn LH switch judged from the turn signal switch signal.
CARGO LAMP SW ^{NOTE 1} "OFF"	—
OPTICAL SENSOR ^{NOTE 2} "0 - 5V"	Displays status "outside brightness (close to 5V when light/close to 0V when dark)" of optical sensor judged from the optical sensor signal.

NOTE:

1. This item is displayed, but cannot be monitored.
2. Vehicles without auto light system display this item, but cannot be monitored.

ACTIVE TEST

Operation Procedure

1. Touch "HEAD LAMP" on "SELECT TEST ITEM" screen.
2. Touch "ACTIVE TEST" on "SELECT DIAG MODE" screen.
3. Touch item to be tested and check operation of the selected item.
4. During the operation check, touching "BACK" deactivates the operation.

AUTO LIGHT SYSTEM

Display Item List

Test item	Description
TAIL LAMP	Allows tail lamp relay to operate by switching ON-OFF.
HEAD LAMP	Allows headlamp high relay and head lamp low relay to operate by switching ON-OFF.
FR FOG LAMP	Allows front fog lamp relay to operate by switching ON-OFF.
CORNERING LAMP ^{NOTE}	—

NOTE:

This item is displayed, but cannot be tested.

CONSULT-II Functions (IPDM E/R)

AKS00CNA

CONSULT-II can display each diagnostic item using the diagnostic test modes shown following.

Check Item, Diagnosis Mode	Description
SELF-DIAGNOSTIC RESULTS	Refer to PG-19. "SELF-DIAG RESULTS" .
DATA MONITOR	The input/output data of IPDM E/R is displayed in real time.
CAN DIAG SUPPORT MNTR	The result of transmit/receive diagnosis of CAN communication can be read.
ACTIVE TEST	IPDM E/R sends a drive signal to electronic components to check their operation.

CONSULT-II BASIC OPERATION

CAUTION:

If CONSULT-II is used with no connection of CONSULT-II CONVERTER, malfunctions might be detected in self-diagnosis depending on control unit which carry out CAN communication.

1. With ignition switch OFF, connect CONSULT-II and CONSULT-II CONVERTER to data link connector, and then turn ignition switch ON.

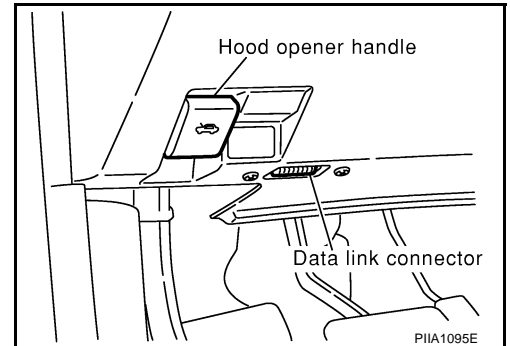

2. Touch "START (NISSAN BASED VHCL)".

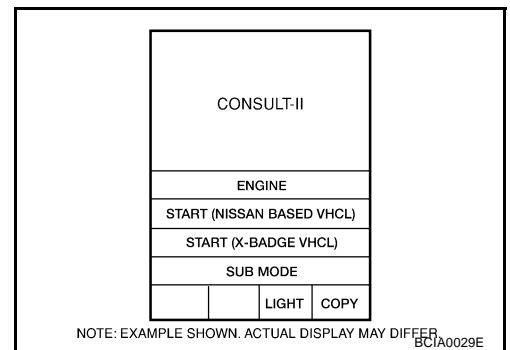

AUTO LIGHT SYSTEM

3. Touch "IPDM E/R" on "SELECT SYSTEM" screen.
If "IPDM E/R" is not indicated, refer to [GI-39, "CONSULT-II Data Link Connector \(DLC\) Circuit"](#).

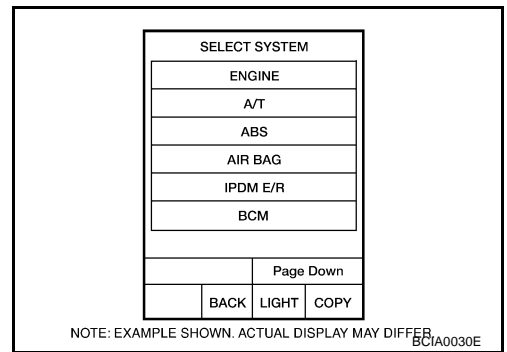

4. Select desired part to be diagnosed on "SELECT DIAG MODE" screen.

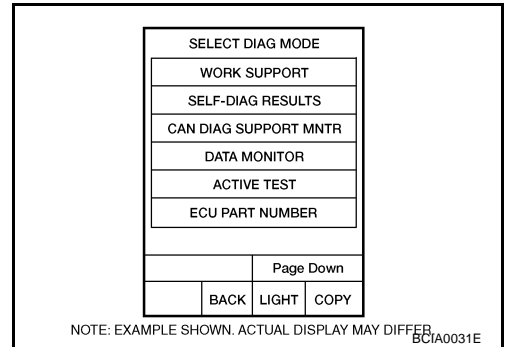

DATA MONITOR

Operation Procedure

1. Touch "DATA MONITOR" on "SELECT DIAG MODE" screen.
2. Touch "ALL SIGNALS", "MAIN SIGNALS" or "SELECTION FROM MENU" on "SELECT MONITOR ITEM" screen.

ALL SIGNALS	Monitors all items.
MAIN SIGNALS	Monitor the predetermined item.
SELECTION FROM MENU	Selects items and monitors them.

3. When "SELECTION FROM MENU" is selected, touch individual items to be monitored. In "ALL SIGNALS", all items are monitored. In "MAIN SIGNALS", predetermined items are monitored.
4. Touch "START".
5. Touch "RECORD" while monitoring to record the status of the item being monitored. To stop recording, touch "STOP".

All Signals, Main Signals, Selection From Menu

Item name	CONSULT-II screen display	Display or unit	Monitor item selection			Description
			ALL SIGNALS	MAIN SIGNALS	SELECTION FROM MENU	
Position lights request	TAIL&CLR REQ	ON/OFF	×	×	×	Signal status input from BCM
Headlamp low beam request	HL LO REQ	ON/OFF	×	×	×	Signal status input from BCM
Headlamp high beam request	HL HI REQ	ON/OFF	×	×	×	Signal status input from BCM
Front fog lights request	FR FOG REQ	ON/OFF	×	×	×	Signal status input from BCM

NOTE:

Perform monitoring of IPDM E/R data with ignition switch ON. When ignition switch is at ACC, display may not be correct.

ACTIVE TEST

Operation Procedure

1. Touch "ACTIVE TEST" on "SELECT DIAG MODE" screen.
2. Touch item to be tested, and check operation.
3. Touch "START".

AUTO LIGHT SYSTEM

4. Touch "STOP" while testing to stop the operation.

Test item	CONSULT-II screen display	Description
Headlamp relay (HI, LO) output	LAMPS	Allows headlamp relay (HI, LO) to operate by switching operation (OFF, HI ON, LO ON) at your option.
Front fog lamp relay output		Allows front fog lamp relay to operate by switching operation ON-OFF at your option
Tail lamp relay output	TAIL LAMP	Allows tail lamp relay to operate by switching operation ON-OFF at your option

Symptom Chart

AKS009LN

Phenomenon	Malfunction system and reference
<ul style="list-style-type: none"> ● Parking lamps and headlamps will not illuminate when outside of vehicle becomes dark. (Lighting switch 1ST position and 2ND position operate normally.) ● Parking lamps and headlamp will not go out when outside of vehicle becomes light. (Lighting switch 1ST position and 2ND position operate normally.) ● Headlamps go out when outside of vehicle becomes light, but parking lamps stay on. 	<ul style="list-style-type: none"> ● Refer to LT-86, "WORK SUPPORT" . ● Refer to LT-90, "Lighting Switch Inspection" . ● Refer to LT-91, "Optical Sensor System Inspection" . <p>If above systems are normal, replace BCM.</p>
Parking lamps illuminate when outside of vehicle becomes dark, but headlamps stay off. (Lighting switch 1ST position and 2ND position operate normally.)	<ul style="list-style-type: none"> ● Refer to LT-86, "WORK SUPPORT" . ● Refer to LT-91, "Optical Sensor System Inspection" . <p>If above systems are normal, replace BCM.</p>
Auto light adjustment system will not operate. (Lighting switch AUTO, 1ST position and 2ND position operate normally.)	<ul style="list-style-type: none"> ● Refer to LT-91, "Optical Sensor System Inspection" . <p>If above system is normal, replace BCM.</p>
Auto light adjustment system of combination meter will not operate.	<ul style="list-style-type: none"> ● CAN communication line inspection between BCM and combination meter. Refer to BCS-15, "CAN Communication Inspection Using CONSULT-II (Self-Diagnosis)" .
Shut off delay feature will not operate.	<ul style="list-style-type: none"> ● CAN communication line inspection between BCM and combination meter. Refer to BCS-15, "CAN Communication Inspection Using CONSULT-II (Self-Diagnosis)" . ● Refer to BL-41, "Check Door Switch" . <p>If above system is normal, replace BCM.</p>

Lighting Switch Inspection

AKS009LO

1. CHECK LIGHTING SWITCH INPUT SIGNAL

☑ With CONSULT-II

Select "BCM" on CONSULT-II. With "HEAD LAMP" data monitor, make sure "AUTO LIGHT SW" turns ON-OFF linked with operation of lighting switch.

When lighting switch is AUTO : AUTO LIGHT SW ON position

☒ Without CONSULT-II

Refer to [LT-133, "Combination Switch Inspection"](#) .

OK or NG

OK >> INSPECTION END

NG >> Check combination switch (lighting switch). Refer to [LT-133, "Combination Switch Inspection"](#) .

DATA MONITOR			
MONITOR			
AUTO LIGHT SW		ON	
		RECORD	
MODE	BACK	LIGHT	COPY

PKIA7595E

AUTO LIGHT SYSTEM

Optical Sensor System Inspection

AKS009LP

1. CHECK OPTICAL SENSOR INPUT SIGNAL

① With CONSULT-II

Select "BCM" on CONSULT-II. With "HEAD LAMP" data monitor, make sure "OPTICAL SENSOR", check difference in voltage when the optical sensor is illuminated and not illuminated.

Illuminated

OPTICAL SENSOR : 3.1V or more

Not illuminated

OPTICAL SENSOR : 0.6V or less

CAUTION:

Optical sensor must be securely subjected to work lamp light. If optical sensor is insufficiently illuminated, the measured value may not satisfy the standard.

② Without CONSULT-II

1. Turn ignition switch ON.
2. Check voltage between BCM harness connector M1 terminal 14 (Y/PU) and ground.

Illuminated

OPTICAL SENSOR : 3.1V or more

Not illuminated

OPTICAL SENSOR : 0.6V or less

CAUTION:

Optical sensor must be securely subjected to work lamp light. If optical sensor is insufficiently illuminated, the measured value may not satisfy the standard.

OK or NG

OK >> INSPECTION END

NG >> GO TO 2.

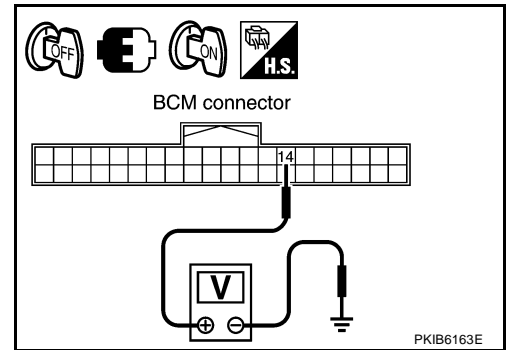
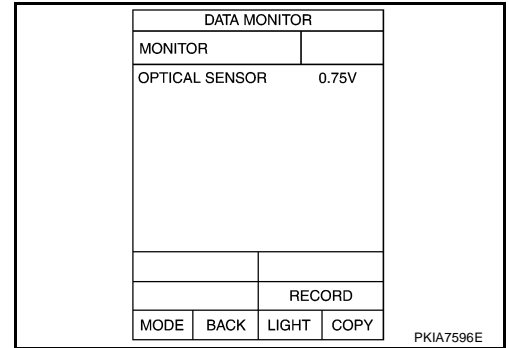

2. CHECK OPTICAL SENSOR POWER SUPPLY CIRCUIT

1. Turn ignition switch OFF.
2. Disconnect BCM connector and optical sensor connector.
3. Check continuity (open circuit) between BCM harness connector M1 terminal 17 (P) and optical sensor harness connector M63 terminal 1 (P).

17 (P) – 1 (P) : Continuity should exist.

4. Check continuity (short circuit) between BCM harness connector M3 terminal 17 (P) and ground.

17 (P) – Ground : Continuity should not exist.

OK or NG

OK >> GO TO 3.

NG >> Repair harness or connector.

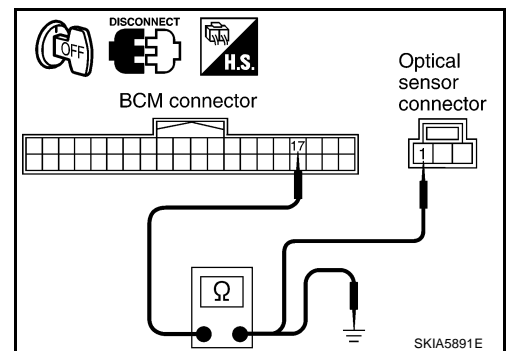

AUTO LIGHT SYSTEM

3. CHECK OPTICAL SENSOR SIGNAL CIRCUIT

1. Check continuity (open circuit) between BCM harness connector M1 terminal 14 (Y/PU) and optical sensor harness connector M63 terminal 2 (Y/PU).

14 (Y/PU) – 2 (Y/PU) : Continuity should exist.

2. Check continuity (short circuit) between BCM harness connector M1 terminal 14 (Y/PU) and ground.

14 (Y/PU) – Ground : Continuity should not exist.

OK or NG

OK >> GO TO 4.

NG >> Repair harness or connector.

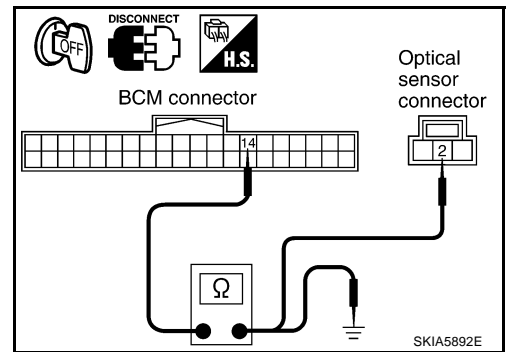

4. CHECK OPTICAL SENSOR GROUND CIRCUIT

1. Check continuity (open circuit) between BCM harness connector M1 terminal 18 (B) and optical sensor harness connector M63 terminal 3 (B).

18 (B) – 3 (B) : Continuity should exist.

2. Check continuity (short circuit) between BCM harness connector M1 terminal 18 (B) and ground.

18 (B) – Ground : Continuity should not exist.

OK or NG

OK >> GO TO 5.

NG >> Repair harness or connector.

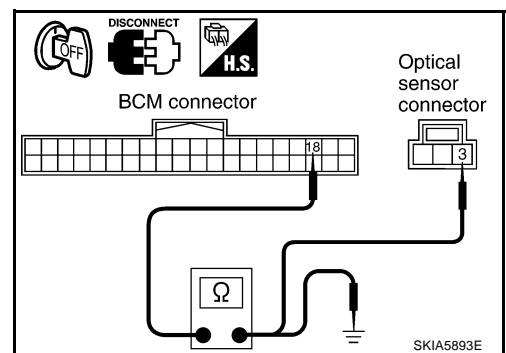

5. CHECK OPTICAL SENSOR VOLTAGE

1. Connect BCM connector.
2. Turn ignition switch ON.
3. Check voltage between BCM harness connector M1 terminal 17 (P) and ground.

17 (P) – Ground : Approx. 5V

OK or NG

OK >> Replace optical sensor.

NG >> Replace BCM. Refer to [BCS-16, "Removal and Installation of BCM"](#).

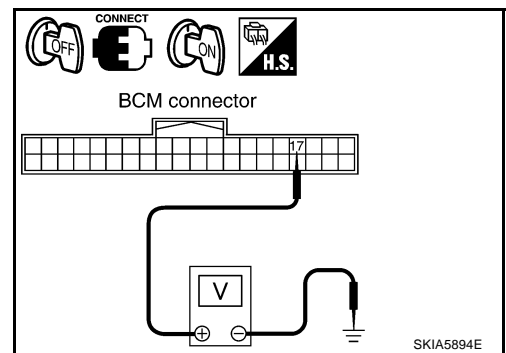

AUTO LIGHT SYSTEM

Removal and Installation for Optical Sensor

AKS009LQ

REMOVAL

1. Insert a screwdriver or similar tool and remove front defroster grill (LH). Refer to [IP-15. "\(Aa\) Defroster Grille \(RH/LH\)"](#) in "IP" section.
2. Disconnect optical sensor connector.
3. Remove optical sensor.

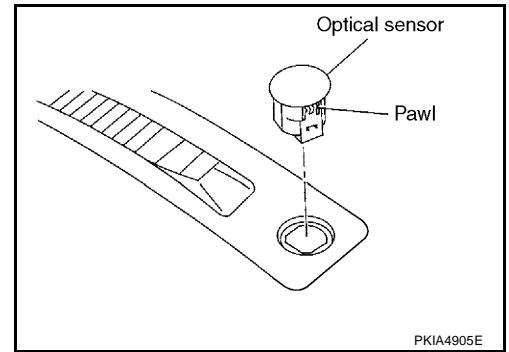

INSTALLATION

Installation is the reverse order of removal.

A
B
C
D
E
F
G
H
I
J
LT
L
M

FRONT FOG LAMP

PFP:26150

FRONT FOG LAMP

Component Parts and Harness Connector Location

AKS009KJ

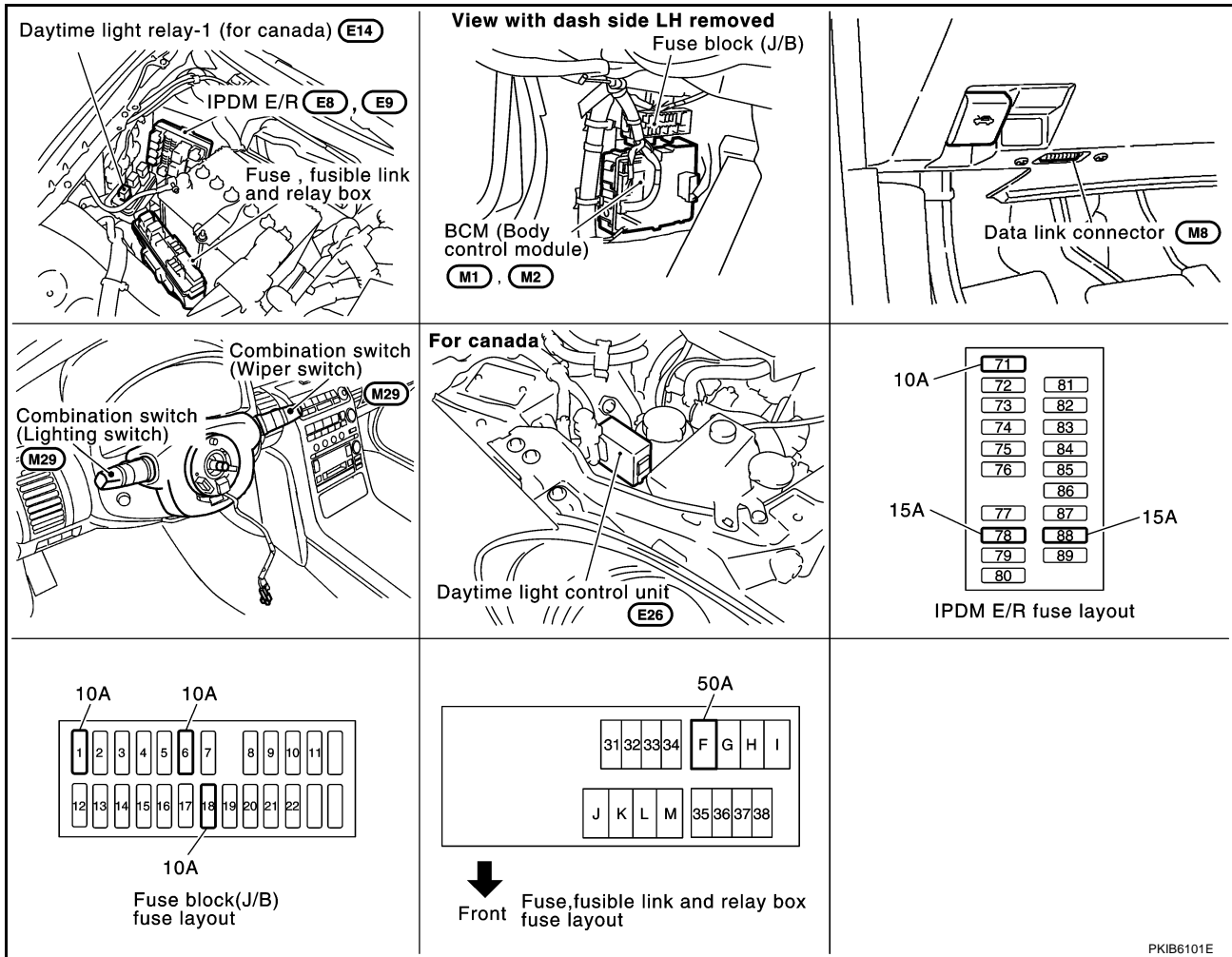

System Description

AKS009KK

The control of the fog lamps is dependent upon the position of the combination switch (lighting switch). The lighting switch must be in the 2ND position or AUTO position (headlamp is ON) for front fog lamp operation. When the lighting switch is placed in fog lamp position the BCM (body control module) receives input signal requesting the fog lamps to illuminate. When the headlamps are illuminated, this input signal is communicated to the IPDM E/R (intelligent power distribution module engine room) across the CAN communication lines. The CPU (central processing unit) located in the IPDM E/R controls the front fog lamp relay coil. When activated, this relay directs power to the front fog lamps.

OUTLINE

Power is supplied at all times

- through 15A fuse (No. 88, located in IPDM E/R)
- to front fog lamp relay, located in IPDM E/R,
- through 15A fuse (No. 78, located in IPDM E/R)
- to CPU located in IPDM E/R,
- through 10A fuse (No. 71, located in IPDM E/R)
- to CPU located in IPDM E/R,
- through 50A fusible link (letter F, located in fuse, fusible link and relay box)
- to BCM terminal 55,
- through 10A fuse [No. 18, located in fuse block (J/B)]
- to BCM terminal 42.

FRONT FOG LAMP

With the ignition switch in the ON or START position, power is supplied

- to CPU located in IPDM E/R, from battery direct,
- through 10A fuse [No. 1, located in fuse block (J/B)]
- to BCM terminal 38.

With the ignition switch in the ACC or ON position, power is supplied

- through 10A fuse [No. 6, located in fuse block (J/B)]
- to BCM terminal 11.

Ground is supplied

- to BCM terminal 52
- through grounds M30 and M66,
- to IPDM E/R terminals 38 and 60
- through grounds E17 and E43.

FOG LAMP OPERATION (FOR USA)

The fog lamp switch is built in combination switch. The lighting switch must be in 2ND position or AUTO position (headlamp is ON) and fog lamp switch must be ON for fog lamp operation.

With the fog lamp switch in the ON position, the CPU located in the IPDM E/R grounds coil side of the fog lamp relay. Fog lamp relay then directs power

- through IPDM E/R terminal 37
- to front fog lamp LH terminal 1,
- through IPDM E/R terminal 36
- to front fog lamp RH terminal 1.

Ground is supplied

- to front fog lamp LH terminal 8
- through grounds E17 and E43,
- to front fog lamp RH terminal 8
- through grounds E17 and E43.

With power and grounds supplied, front fog lamps illuminate.

FOG LAMP OPERATION (FOR CANADA)

The fog lamp switch is built in combination switch. The lighting switch must be in 2ND position or AUTO position (headlamp is ON) and fog lamp switch must be ON for fog lamp operation.

With the fog lamp switch in the ON position, the CPU located in the IPDM E/R grounds coil side of the fog lamp relay. Fog lamp relay then directs power

- through IPDM E/R terminal 37
- to daytime light relay-1 terminals 2 and 5
- through daytime light relay-1 terminal 3
- to front combination lamp LH terminal 1,
- through IPDM E/R terminal 36
- to front combination lamp RH terminal 1.

Ground is supplied

- to daytime light relay-1 terminal 1
- through grounds E17 and E43,
- to front combination lamp LH terminal 8
- through daytime light control unit terminal 7
- through daytime light control unit terminal 9
- through grounds E17 and E43,
- to front combination lamp RH terminal 8
- through grounds E17 and E43.

With power and grounds supplied, front fog lamps illuminate.

A

B

C

D

E

F

G

H

I

J

LT

L

M

FRONT FOG LAMP

COMBINATION SWITCH READING FUNCTION

Refer to [BCS-3, "COMBINATION SWITCH READING FUNCTION"](#) .

EXTERIOR LAMP BATTERY SAVER CONTROL

When combination switch (lighting switch) is in the 2ND position (or if auto light system is activated), fog lamp switch is ON, and ignition switch is turned from ON or ACC to OFF, the battery saver control feature is activated.

Under this condition, fog lamps (and headlamps) remain illuminated for 5 minutes, then fog lamps (and headlamps) are turned off.

Exterior lamp battery saver control mode can be changed by the function setting of CONSULT-II.

CAN Communication System Description

AKS009KL

CAN (Controller Area Network) is a serial communication line for real time application. It is an on-vehicle multiplex communication line with high data communication speed and excellent error detection ability. Many electronic control units are equipped onto vehicle, and each control unit shares information and links with other control units during operation (not independent). In CAN communication, control units are connected with 2 communication lines (CAN H line, CAN L line) allowing a high rate of information transmission with less wiring. Each control unit transmits/receives data but selectively reads required data only.

CAN Communication Unit

AKS009KM

Refer to [LAN-21, "CAN Communication Unit"](#) .

FRONT FOG LAMP

Wiring Diagram — F/FOG — FOR USA

AKS009KN

LT-F/FOG-01

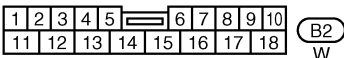
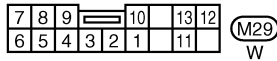
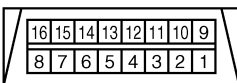
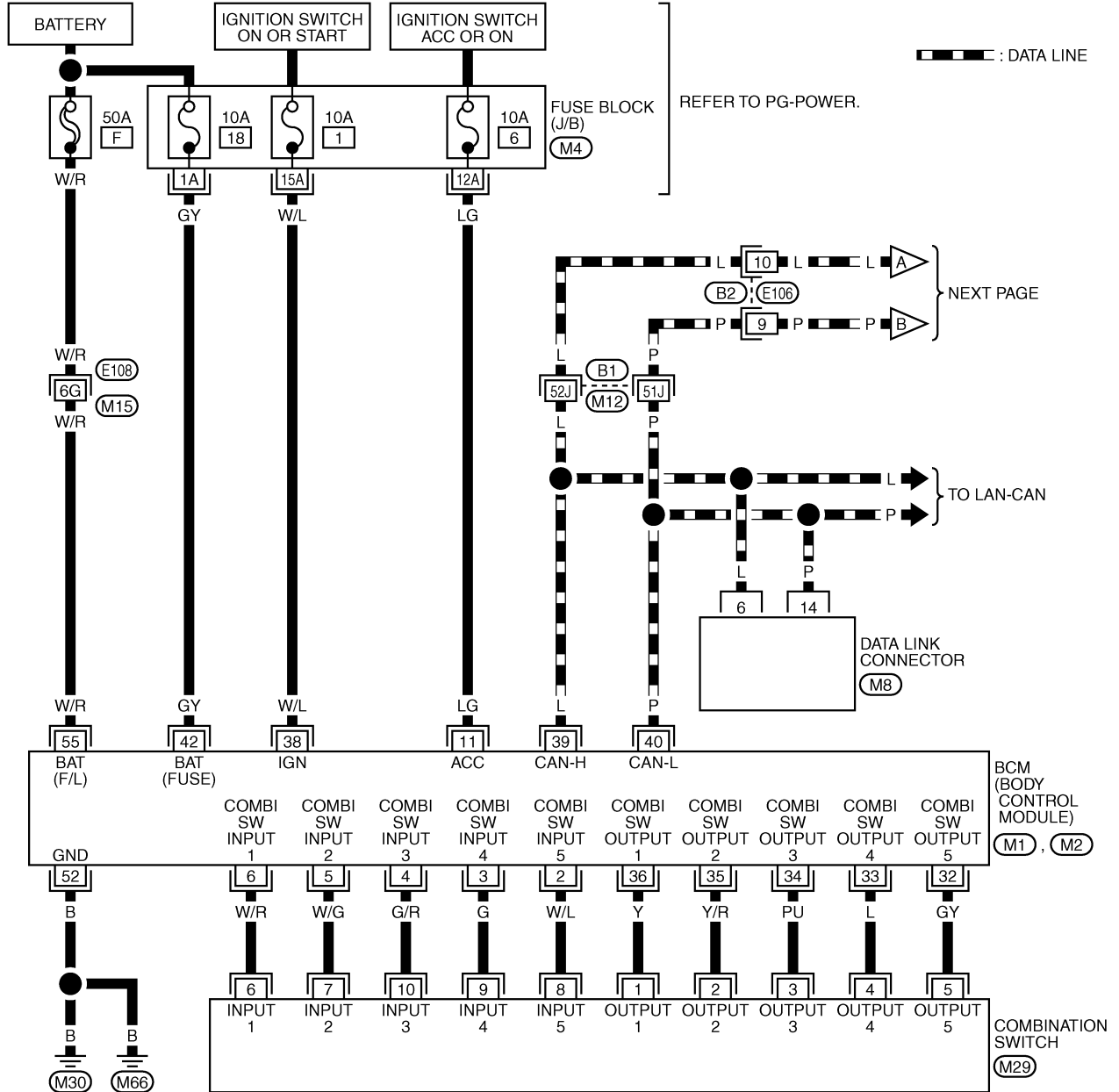

REFER TO THE FOLLOWING.
E108 , B1 : SUPER MULTIPLE JUNCTION (SMJ)
M4 : FUSE BLOCK-JUNCTION BOX (J/B)
M1 , M2 : ELECTRICAL UNITS

TKWM2256E

FRONT FOG LAMP

LT-F/FOG-02

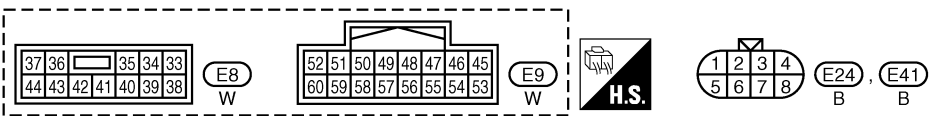
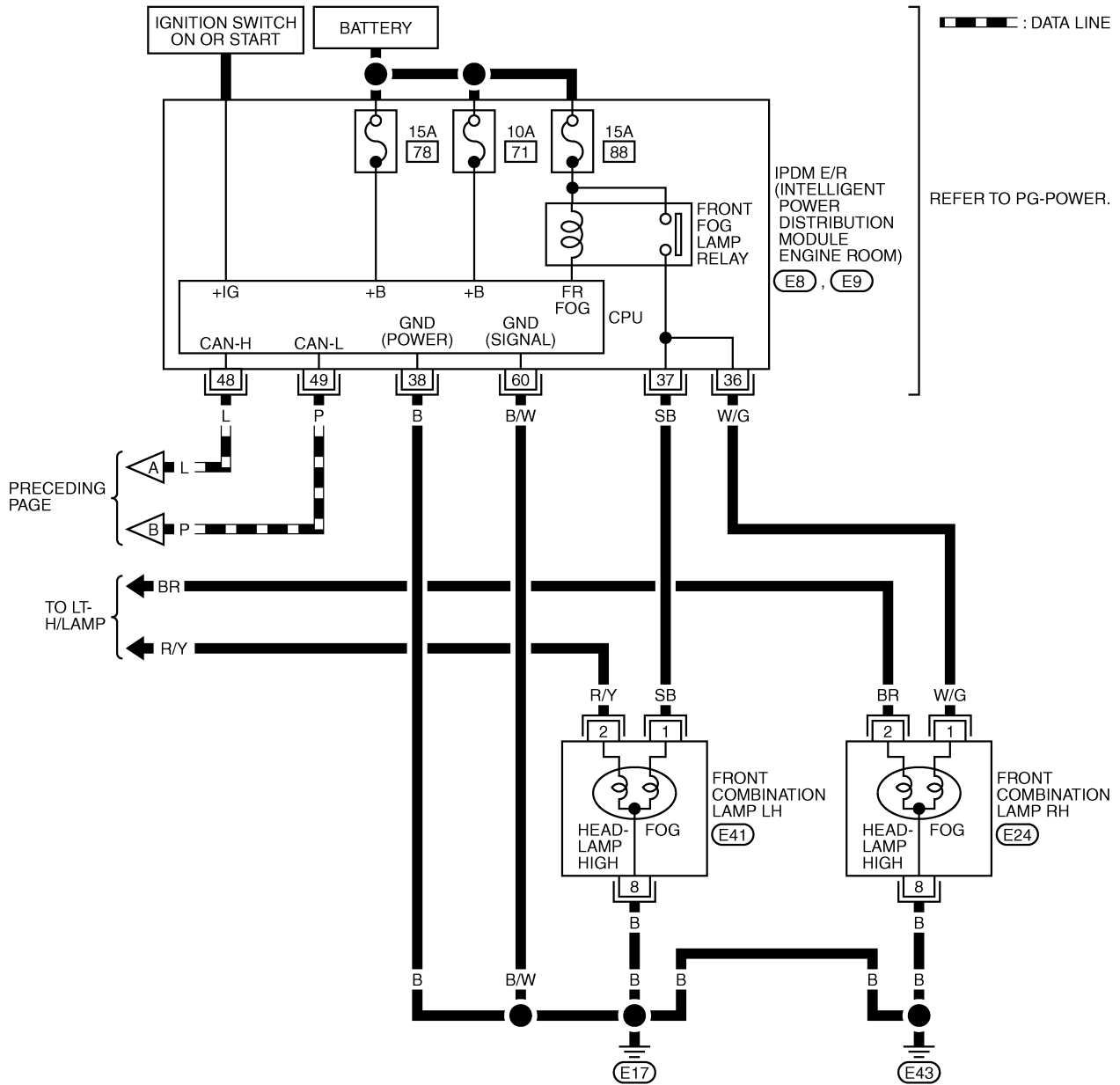

TKWM2257E

FRONT FOG LAMP

FOR CANADA

LT-F/FOG-03

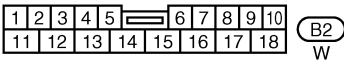
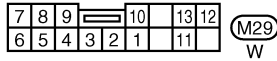
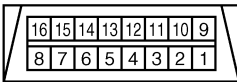
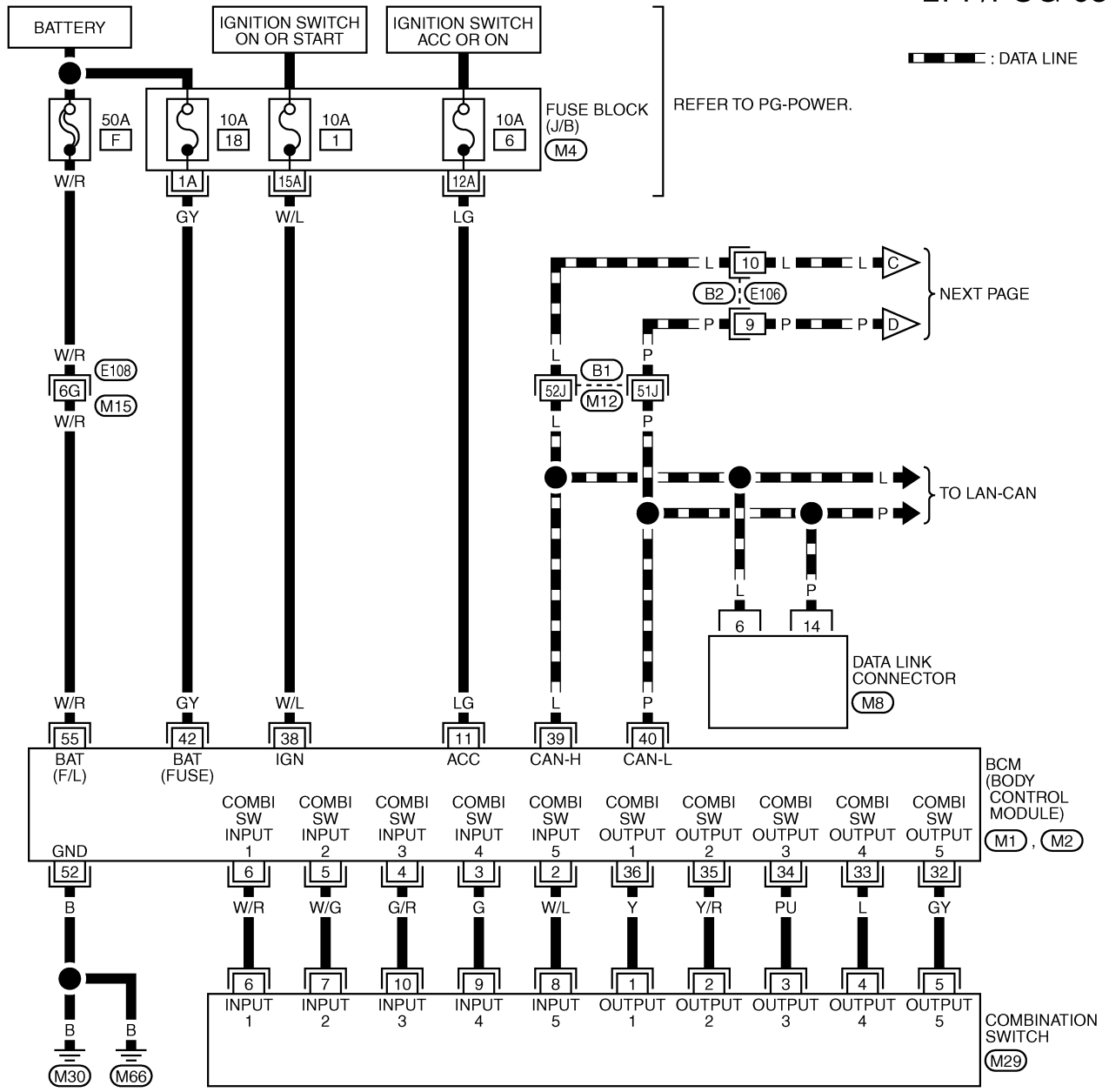

REFER TO THE FOLLOWING.

(E108), (B1) -SUPER MULTIPLE JUNCTION (SMJ)

(M4) -FUSE BLOCK-JUNCTION BOX (J/B)

(M1), (M2) -ELECTRICAL UNITS

TKWM2258E

FRONT FOG LAMP

Terminals and Reference Values for BCM

AKS009KO

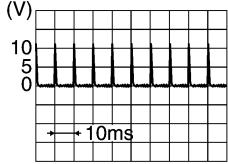
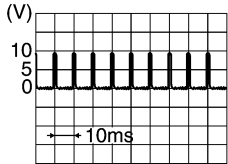
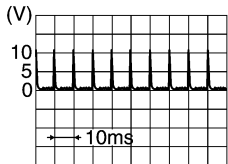
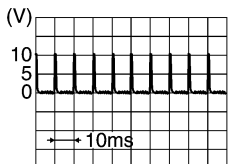
Terminal No.	Wire color	Signal name	Measuring condition		Reference value
			Ignition switch	Operation or condition	
2	W/L	Combination switch input 5	ON	Lighting, turn, wiper OFF Wiper intermittent dial position 4	 <p style="text-align: right; font-size: small;">PKIB3468E</p>
3	G	Combination switch input 4	ON	Lighting, turn, wiper OFF Wiper intermittent dial position 4	 <p style="text-align: right; font-size: small;">PKIB3469E</p>
4	G/R	Combination switch input 3			
5	W/G	Combination switch input 2			
6	W/R	Combination switch input 1			
11	LG	Ignition switch (ACC)	ACC	—	Battery voltage
32	GY	Combination switch output 5	ON	Lighting, turn, wiper OFF Wiper intermittent dial position 4	 <p style="text-align: right; font-size: small;">PKIB3470E</p>
33	L	Combination switch output 4	ON	Lighting, turn, wiper OFF Wiper intermittent dial position 4	 <p style="text-align: right; font-size: small;">PKIB3471E</p>
34	PU	Combination switch output 3			
35	Y/R	Combination switch output 2			
36	Y	Combination switch output 1			
38	W/L	Ignition switch (ON)	ON	—	Battery voltage
39	L	CAN – H	—	—	—
40	P	CAN – L	—	—	—
42	GY	Battery power supply	OFF	—	Battery voltage
52	B	Ground	ON	—	Approx. 0V
55	W/R	Battery power supply	OFF	—	Battery voltage

Terminals and Reference Values for IPDM E/R

AKS009KP

Terminal No.	Wire color	Signal name	Measuring condition		Reference value	
			Ignition switch	Operation or condition		
36	W/G	Front fog lamp (RH)	ON	Lighting switch must be in the 2ND position or AUTO position (headlamp is ON) and the front fog lamp switch must be ON	OFF	Approx. 0V
					ON	Battery voltage
37	SB	Front fog lamp (LH)		Lighting switch must be in the 2ND position or AUTO position (headlamp is ON) and the front fog lamp switch must be ON	OFF	Approx. 0V
					ON	Battery voltage
38	B	Ground	ON	—	Approx. 0V	
48	L	CAN – H	—	—	—	

FRONT FOG LAMP

Terminal No.	Wire color	Signal name	Measuring condition		Reference value
			Ignition switch	Operation or condition	
49	P	CAN – L	—	—	—
60	B/W	Ground	ON	—	Approx. 0V

How to Proceed with Trouble Diagnosis

AKS009KQ

1. Confirm the symptom or customer complaint.
2. Understand operation description and function description. Refer to [LT-94, "System Description"](#) .
3. Perform the Preliminary Check. Refer to [LT-102, "Preliminary Check"](#) .
4. Check symptom and repair or replace the malfunctioning parts.
5. Does the front fog lamp operate normally? If YES, GO TO 6. If NO, GO TO 4.
6. INSPECTION END

Preliminary Check

AKS009KR

CHECK POWER SUPPLY AND GROUND CIRCUIT

1. CHECK FUSES

Check for blown fuses.

Unit	Power source	Fuse and fusible link No.
BCM	Battery	F
		18
	Ignition switch ON or START position	1
	Ignition switch ACC or ON position	6
IPDM E/R	Battery	88

Refer to [LT-97, "Wiring Diagram — F/FOG —"](#) .

OK or NG

OK >> GO TO 2.

NG >> If fuse or fusible link is blown, be sure to eliminate cause of malfunction before installing new fuse or fusible link. Refer to [PG-3, "POWER SUPPLY ROUTING CIRCUIT"](#) .

FRONT FOG LAMP

2. CHECK POWER SUPPLY CIRCUIT

1. Turn ignition switch OFF.
2. Disconnect BCM connector.
3. Check voltage between BCM harness connector and ground.

Terminal (+)		Terminal (-)	Ignition switch position		
Connector	Terminal (Wire color)		OFF	ACC	ON
M1	11 (LG)	Ground	Approx. 0V	Battery voltage	Battery voltage
	38 (W/L)		Approx. 0V	Approx. 0V	Battery voltage
M2	42 (GY)		Battery voltage	Battery voltage	Battery voltage
	55 (W/R)		Battery voltage	Battery voltage	Battery voltage

OK or NG

OK >> GO TO 3.

NG >> Check harness for open or short between BCM and fuse.

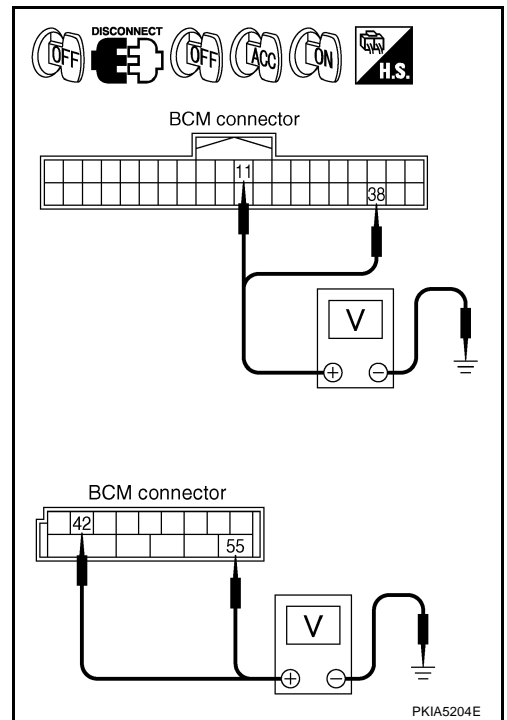

3. CHECK GROUND CIRCUIT

Check continuity between BCM harness connector and ground.

Terminal		Ground	Continuity
Connector	Terminal (Wire color)		Yes
M2	52 (B)		Yes

OK or NG

OK >> INSPECTION END

NG >> Check harness ground circuit.

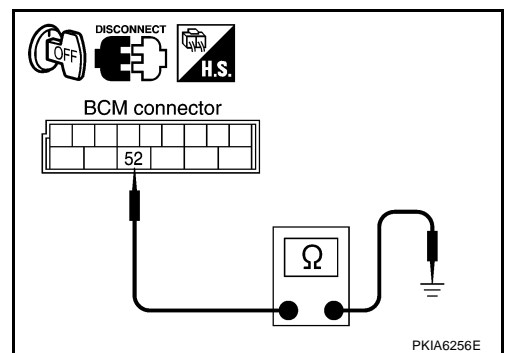

CONSULT-II Functions (BCM)

Refer to [LT-17, "CONSULT-II Functions \(BCM\)"](#) in HEADLAMP (FOR USA).

Refer to [LT-53, "CONSULT-II Functions \(BCM\)"](#) in HEADLAMP (FOR CANADA).

CONSULT-II Functions (IPDM E/R)

Refer to [LT-20, "CONSULT-II Functions \(IPDM E/R\)"](#) in HEADLAMP (FOR USA).

Refer to [LT-56, "CONSULT-II Functions \(IPDM E/R\)"](#) in HEADLAMP (FOR CANADA).

FRONT FOG LAMP

Front Fog lamps Does Not Illuminate (Both Sides) (FOR USA)

AKS009KT

1. CHECK COMBINATION SWITCH INPUT SIGNAL

④ With CONSULT-II

Select "BCM" on CONSULT-II. With "HEAD LAMP" data monitor, make sure "FR FOG SW" turns ON-OFF linked with operation of lighting switch.

When lighting switch is FOG : FR FOG SW ON position

⊗ Without CONSULT-II

Refer to [LT-133, "Combination Switch Inspection"](#) .

OK or NG

OK >> GO TO 2.

NG >> Check combination switch (lighting switch). Refer to [LT-133, "Combination Switch Inspection"](#) .

DATA MONITOR			
MONITOR			
FR FOG SW	ON		
		RECORD	
MODE	BACK	LIGHT	COPY

PKIA7598E

2. FOG LAMP ACTIVE TEST

④ With CONSULT-II

1. Select "IPDM E/R" on CONSULT-II, and select "ACTIVE TEST" on "SELECT DIAG MODE" screen.
2. Select "LAMPS" on "SELECT TEST ITEM" screen.
3. Touch "FOG" screen.
4. Make sure fog lamp operates.

Fog lamp should operate.

⊗ Without CONSULT-II

1. Start auto active test. Refer to [PG-22, "Auto Active Test"](#) .
2. Make sure fog lamp operates.

Fog lamp should operate.

ACTIVE TEST			
LAMPS		FOG	
		HI	
OFF			
LO			
MODE	BACK	LIGHT	COPY

PKIA7748E

OK or NG

OK >> GO TO 3.

NG >> GO TO 4.

3. CHECK IPDM E/R

1. Select "IPDM E/R" on CONSULT-II, and select "DATA MONITOR" on "SELECT DIAG MODE" screen.
2. Make sure "FR FOG REQ" turns ON when lighting switch is in FOG position.

When lighting switch is FOG : FR FOG REQ ON position

OK or NG

OK >> Replace IPDM E/R.

NG >> Replace BCM. Refer to [BCS-16, "Removal and Installation of BCM"](#) .

DATA MONITOR			
MONITOR			
FR FOG REQ	ON		
		Page Down	
		RECORD	
MODE	BACK	LIGHT	COPY

SKIA5898E

FRONT FOG LAMP

4. CHECK FOG LAMP INPUT SIGNAL

☑ With CONSULT-II

1. Turn ignition switch OFF.
2. Disconnect front combination lamp RH and LH connector.
3. Select "IPDM E/R" on CONSULT-II, and select "ACTIVE TEST" on "SELECT DIAG MODE" screen.
4. Select "TAIL LAMP" on "SELECT TEST ITEM" screen.
5. Touch "FOG" screen.
6. When front fog lamp relay is operating, check voltage between front combination lamp harness connector and ground.

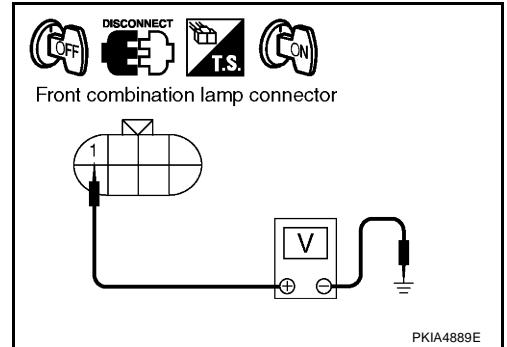

Terminal (+)			Terminal (-)	Voltage
Connector		Terminal (Wire color)		
RH	E24	1 (W/G)	Ground	Battery voltage
LH	E41	1 (SB)		

☒ Without CONSULT-II

1. Turn ignition switch OFF.
2. Disconnect front combination lamp RH and LH connector.
3. Start auto active test. Refer to [PG-22, "Auto Active Test"](#).
4. When front fog lamp relay is operating, check voltage between front combination lamp harness connector and ground.

Terminal (+)			Terminal (-)	Voltage
Connector		Terminal (Wire color)		
RH	E24	1 (W/G)	Ground	Battery voltage
LH	E41	1 (SB)		

OK or NG

- OK >> GO TO 6.
 NG >> GO TO 5.

5. CHECK FOG LAMP CIRCUIT

1. Turn ignition switch OFF.
2. Disconnect IPDM E/R connector.
3. Check continuity between IPDM E/R harness connector E8 terminal 36 (W/G) and front combination lamp RH harness connector E24 terminal 1 (W/G).

36 (W/G) – 1 (W/G) : Continuity should exist.

4. Check continuity between IPDM E/R harness connector E8 terminal 37 (SB) and front combination lamp LH harness connector E41 terminal 1 (SB).

37 (SB) – 1 (SB) : Continuity should exist.

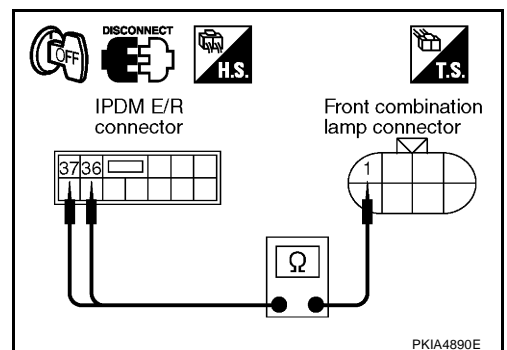

OK or NG

- OK >> Replace IPDM E/R.
 NG >> Repair harness or connector.

FRONT FOG LAMP

6. CHECK FOG LAMP GROUND

1. Check continuity between front combination lamp RH harness connector E24 terminal 8 (B) and ground.

8 (B) – Ground : Continuity should exist.

2. Check continuity between front combination lamp LH harness connector E41 terminal 8 (B) and ground.

8 (B) – Ground : Continuity should exist.

OK or NG

- OK >> Check front fog lamp bulbs.
NG >> Repair harness or connector.

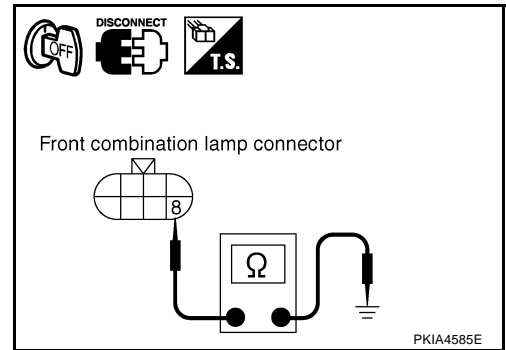

Front Fog Lamp Does Not Illuminate (One Side) (FOR USA)

AKS009KU

1. CHECK BULB

Check bulb of lamp with does not illuminate which does not illuminate.

OK or NG

- OK >> GO TO 2.
NG >> Replace front fog lamp bulb.

2. CHECK FOG LAMP CIRCUIT

1. Turn ignition switch OFF.
2. Disconnect IPDM E/R connector and front combination lamp RH or LH connector.
3. Check continuity between IPDM E/R harness connector E8 terminal 36 (W/G) and front combination lamp RH harness connector E24 terminal 1 (W/G).

36 (W/G) – 1 (W/G) : Continuity should exist.

4. Check continuity between IPDM E/R harness connector E8 terminal 37 (SB) and front combination lamp LH harness connector E41 terminal 1 (SB).

37 (SB) – 1 (SB) : Continuity should exist.

OK or NG

- OK >> GO TO 3.
NG >> Repair harness or connector.

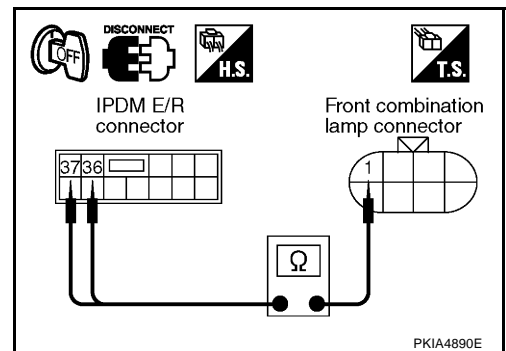

3. CHECK FOG LAMP GROUND

1. Check continuity between front combination lamp RH harness connector E24 terminal 8 (B) and ground.

8 (B) – Ground : Continuity should exist.

2. Check continuity between front combination lamp LH harness connector E41 terminal 8 (B) and ground.

8 (B) – Ground : Continuity should exist.

OK or NG

- OK >> Replace IPDM E/R.
NG >> Repair harness or connector.

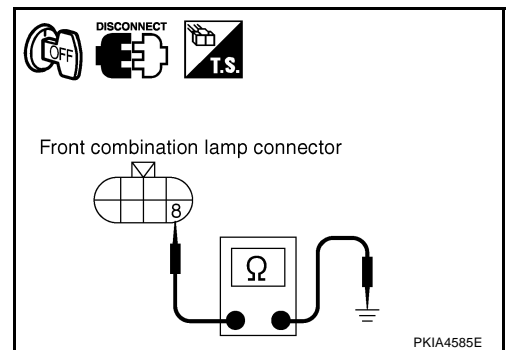

FRONT FOG LAMP

Front Fog lamps Does Not Illuminate (Both Sides) (FOR CANADA)

AKS009KV

1. CHECK COMBINATION SWITCH INPUT SIGNAL

④ With CONSULT-II

Select "BCM" on CONSULT-II. With "HEAD LAMP" data monitor, make sure "FR FOG SW" turns ON-OFF linked with operation of lighting switch.

When lighting switch is FOG : FR FOG SW ON position

⊗ Without CONSULT-II

Refer to [LT-133, "Combination Switch Inspection"](#) .

OK or NG

OK >> GO TO 2.

NG >> Check combination switch (lighting switch). Refer to [LT-133, "Combination Switch Inspection"](#) .

DATA MONITOR			
MONITOR			
FR FOG SW	ON		
		RECORD	
MODE	BACK	LIGHT	COPY

PKIA7598E

2. FOG LAMP ACTIVE TEST

④ With CONSULT-II

1. Select "IPDM E/R" on CONSULT-II, and select "ACTIVE TEST" on "SELECT DIAG MODE" screen.
2. Select "LAMPS" on "SELECT TEST ITEM" screen.
3. Touch "FOG" screen.
4. Make sure fog lamp operates.

Fog lamp should operate.

⊗ Without CONSULT-II

1. Start auto active test. Refer to [PG-22, "Auto Active Test"](#) .
2. Make sure fog lamp operates.

Fog lamp should operate.

OK or NG

OK >> GO TO 3.

NG >> GO TO 4.

ACTIVE TEST			
LAMPS	OFF		
		HI	
LO	FOG		
MODE	BACK	LIGHT	COPY

SKIA5774E

3. CHECK IPDM E/R

1. Select "IPDM E/R" on CONSULT-II, and select "DATA MONITOR" on "SELECT DIAG MODE" screen.
2. Make sure "FR FOG REQ" turns ON when lighting switch is in FOG position.

When lighting switch is FOG : FR FOG REQ ON position

OK or NG

OK >> Replace IPDM E/R.

NG >> Replace BCM. Refer to [BCS-16, "Removal and Installation of BCM"](#) .

DATA MONITOR			
MONITOR			
FR FOG REQ	ON		
		Page Down	
		RECORD	
MODE	BACK	LIGHT	COPY

SKIA5898E

FRONT FOG LAMP

4. CHECK IPDM E/R

④ With CONSULT-II

1. Select "IPDM E/R" on CONSULT-II, and select "ACTIVE TEST" on "SELECT DIAG MODE" screen.
2. Select "TAIL LAMP" on "SELECT TEST ITEM" screen.
3. Touch "FOG" screen.
4. When front fog lamp relay is operating, check voltage between IPDM E/R harness connector and ground.

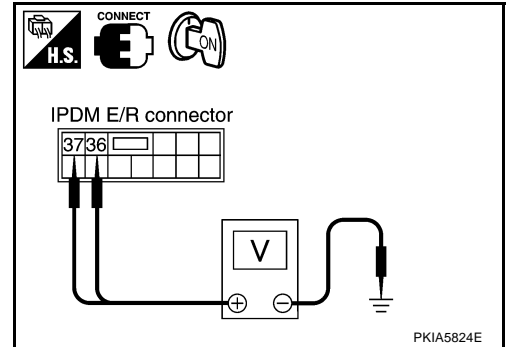

Terminal			Voltage	
(+)		(-)		
Connector	Terminal (Wire color)			
RH	E8	36 (W/G)	Ground	Battery voltage
LH		37 (SB)		

⊗ Without CONSULT-II

1. Start auto active test. Refer to [PG-22, "Auto Active Test"](#).
2. When front fog lamp relay is operating, check voltage between IPDM E/R harness connector and ground.

Terminal			Voltage	
(+)		(-)		
Connector	Terminal (Wire color)			
RH	E8	36 (W/G)	Ground	Battery voltage
LH		37 (SB)		

OK or NG

- OK >> Check front fog lamp bulbs.
 NG >> Replace IPDM E/R.

LH Front Fog Lamp Does Not Illuminate (FOR CANADA)

AKS009KW

1. CHECK BULB

Check bulb of lamp which does not illuminate .

OK or NG

- OK >> GO TO 2.
 NG >> Replace front fog lamp bulb.

FRONT FOG LAMP

2. CHECK CIRCUIT BETWEEN IPDM E/R AND DAYTIME LIGHT RELAY-1

1. Turn ignition switch OFF.
2. Disconnect IPDM E/R connector.
3. Remove daytime light relay-1.
4. Check continuity between IPDM E/R harness connector and daytime light relay-1 harness connector.

Terminal				Continuity
IPDM E/R		Daytime light relay-1		
Connector	Terminal (Wire color)	Connector	Terminal (Wire color)	
E8	37 (SB)	E14	2 (SB)	Yes
			5 (SB)	

OK or NG

- OK >> GO TO 3.
 NG >> Repair harness or connector.

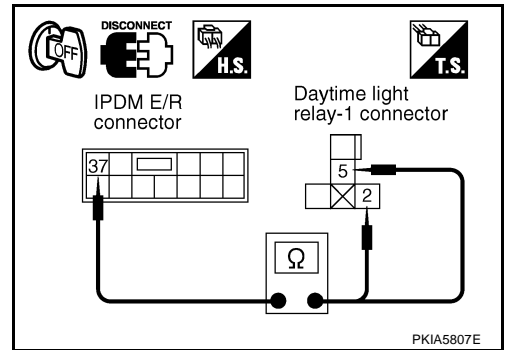

3. CHECK DAYTIME LIGHT RELAY-1 AND GROUND

Check continuity between daytime light relay-1 harness connector E14 terminal 1 (B) and ground.

1 (B) – Ground : Continuity should exist.

OK or NG

- OK >> GO TO 4.
 NG >> Repair harness or connector.

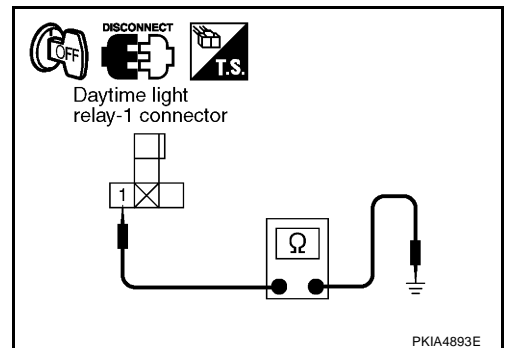

4. CHECK CIRCUIT DAYTIME LIGHT RELAY-1 AND HEADLAMP

1. Disconnect front combination lamp LH connector.
2. Check continuity between daytime light relay-1 harness connector E14 terminal 3 (LG) and front combination lamp LH harness connector E41 terminal 1 (LG).

3 (LG) – 1 (LG) : Continuity should exist.

OK or NG

- OK >> GO TO 5.
 NG >> Repair harness or connector.

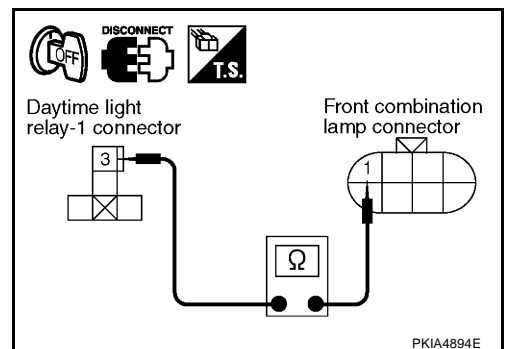

FRONT FOG LAMP

5. CHECK IPDM E/R

1. Connect IPDM E/R connector.
2. Turn ignition switch ON.
3. Lighting switch is turned FOG ON position.
4. Check voltage between daytime light relay-1 harness connector E14 terminal 2 (SB), 5 (SB) and ground.

2 (SB), 5 (SB) – Ground : Battery voltage.

OK or NG

- OK >> GO TO 6.
NG >> Replace IPDM E/R.

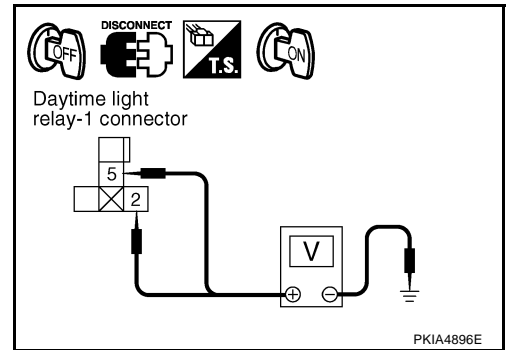

6. CHECK DAYTIME LIGHT RELAY-1

1. Turn ignition switch OFF.
2. Install daytime light relay-1.
3. Turn ignition switch ON.
4. Lighting switch is turned FOG ON position.
5. Check voltage between front combination lamp LH harness connector E41 terminal 1 (LG) and ground.

1 (LG) – Ground : Battery voltage.

OK or NG

- OK >> GO TO 7.
NG >> Replace daytime light relay-1.

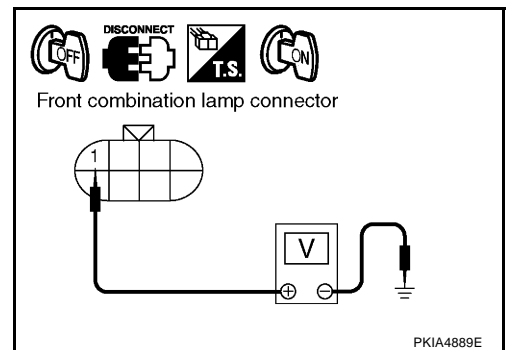

7. CHECK CIRCUIT BETWEEN HEADLAMP AND DAYTIME LIGHT CONTROL UNIT

1. Turn ignition switch OFF.
2. Disconnect daytime light control unit connector.
3. Check continuity between front combination lamp LH harness connector E41 terminal 8 (Y/G) and daytime light control unit harness connector E26 terminal 7 (Y/G).

8 (Y/G) – 7 (Y/G) : Continuity should exist.

OK or NG

- OK >> GO TO 8.
NG >> Repair harness or connector.

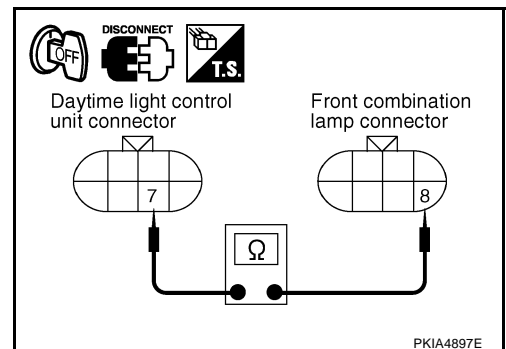

8. CHECK CIRCUIT BETWEEN HEADLAMP AND DAYTIME LIGHT CONTROL UNIT

Check continuity between daytime light control unit harness connector E26 terminal 9 (B) and ground.

9 (B) – Ground : Continuity should exist.

OK or NG

- OK >> Replace daytime light control unit.
NG >> Repair harness or connector.

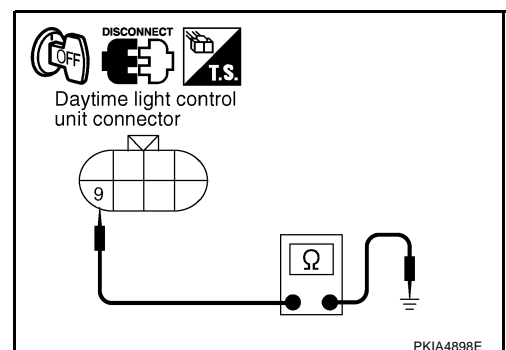

FRONT FOG LAMP

RH Front Fog Lamp Does Not Illuminate (FOR CANADA)

AKS00AB2

1. CHECK BULB

Check bulb of lamp which does not illuminate.

OK or NG

OK >> GO TO 2.

NG >> Replace front fog lamp bulb.

2. CHECK CIRCUIT BETWEEN IPDM E/R AND FRONT FOG LAMP

1. Turn ignition switch OFF.
2. Disconnect IPDM E/R connector and front combination lamp RH connector.
3. Check continuity between harness IPDM E/R harness connector E8 terminal 36 (W/G) and front combination lamp RH harness connector E24 terminal 1 (W/G).

36 (W/G) – 1 (W/G) : Continuity should exist.

OK or NG

OK >> GO TO 3.

NG >> Repair harness or connector.

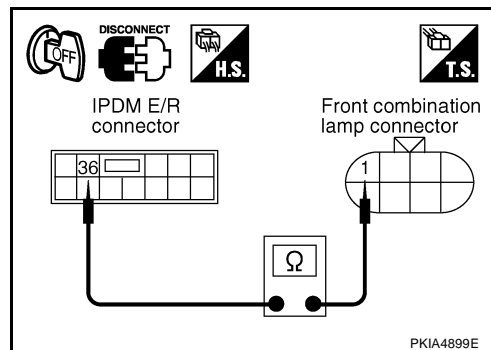

3. CHECK FRONT FOG LAMP GROUND

Check continuity between front combination lamp RH harness connector E24 terminal 8 (B) and ground.

8 (B) – Ground : Continuity should exist.

OK or NG

OK >> Replace IPDM E/R.

NG >> Repair harness or connector.

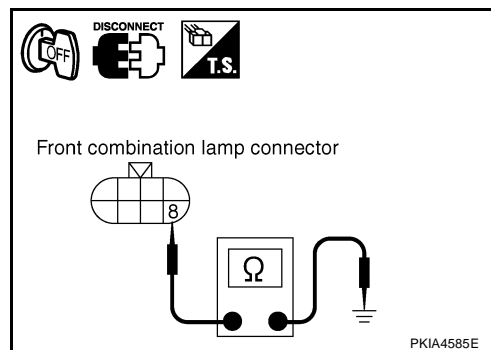

Bulb Replacement

AKS009KX

Refer to [LT-33, "Bulb Replacement"](#) in "HEADLAMP".

TURN SIGNAL AND HAZARD WARNING LAMPS

TURN SIGNAL AND HAZARD WARNING LAMPS

PFP:26120

Component Parts and Harness Connector Location

AKS009MF

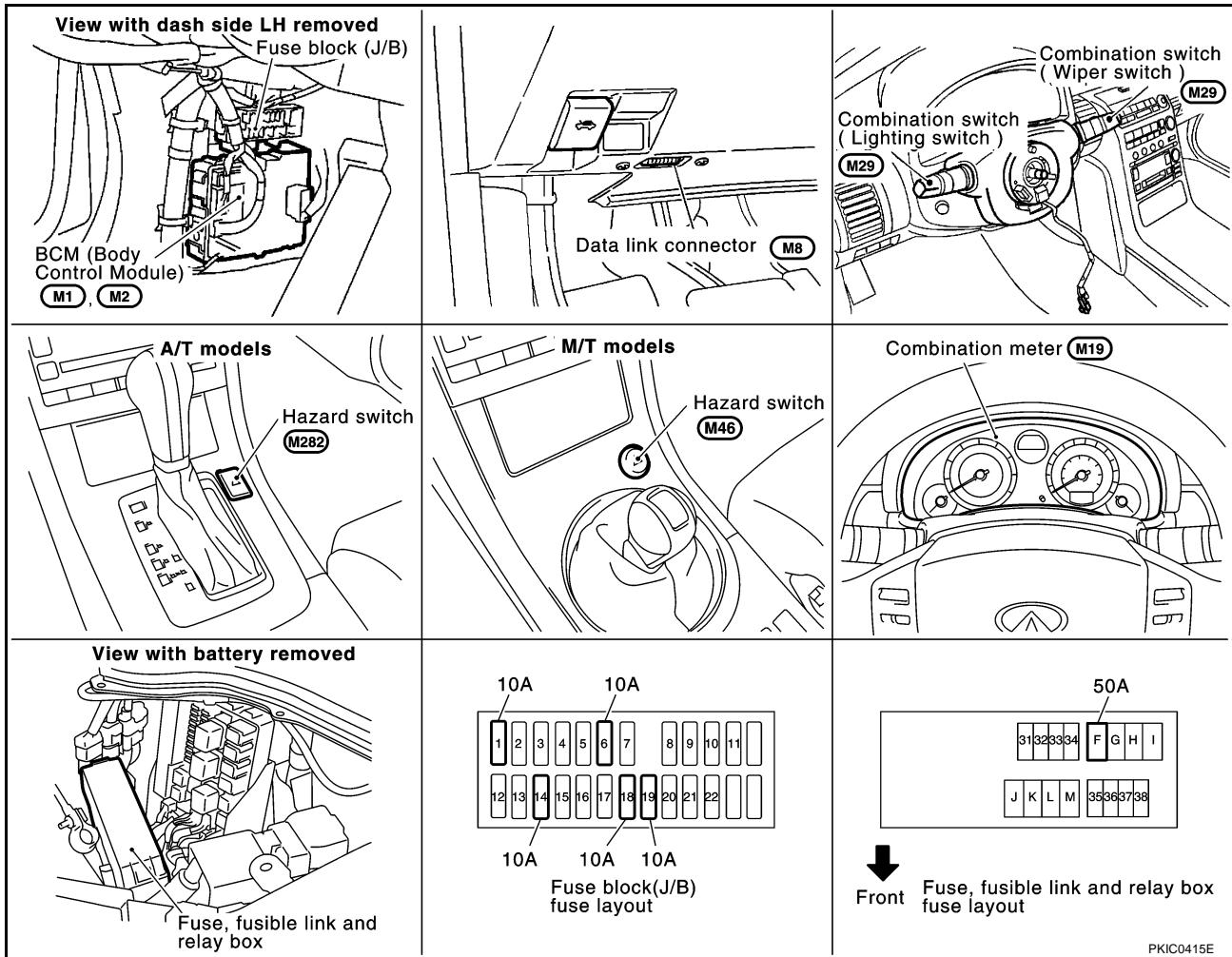

PKIC0415E

System Description TURN SIGNAL OPERATION

AKS005KK

With the ignition switch in the ON or START position, power is supplied

- through 10A fuse [No. 1, located in fuse block (J/B)]
- to BCM (body control module) terminal 38,
- through 10A fuse [No. 14, located in fuse block (J/B)]
- to combination meter terminals 22 and 23.

Ground is supplied

- to BCM terminal 52
- through grounds M30 and M66,
- to combination meter terminals 1, 24 and 25
- through grounds M30 and M66.

LH Turn Signal Lamp

When turn signal switch is moved to left position, BCM receives input signal requesting left turn signals to flash. BCM then supplies power

- through BCM terminal 45
- to front combination lamp LH terminal 6, and
- to rear combination lamp LH terminal 3.

Ground is supplied

- to front combination lamp LH terminal 4

TURN SIGNAL AND HAZARD WARNING LAMPS

- through grounds E17 and E43,
- to rear combination lamp LH terminal 4
- through ground B103.

The BCM also supplies input to combination meter terminals 4 and 5 across CAN communication lines. This input is processed by unified meter control unit in combination meter, which in turn supplies ground to the left turn signal indicator lamp.

With power and input supplied, BCM controls flashing of LH turn signal lamps.

RH Turn Signal Lamp

When turn signal switch is moved to right position, BCM receives input signal requesting right turn signals to flash. BCM then supplies power

- through BCM terminal 46
- to front combination lamp RH terminal 6, and
- to rear combination lamp RH terminal 3.

Ground is supplied

- to front combination lamp RH terminal 4
- through grounds E17 and E43,
- to rear combination lamp RH terminal 4
- through ground B103.

The BCM also supplies input to combination meter terminals 4 and 5 across CAN communication lines. This input is processed by unified meter control unit in combination meter, which in turn supplies ground to the right turn signal indicator lamp.

With power and input supplied, BCM controls flashing of RH turn signal lamps.

HAZARD LAMP OPERATION

Power is supplied at all times

- through 50A fusible link (letter F, located in fuse, fusible link and relay box)
- to BCM terminal 55,
- through 10A fuse [No. 18, located in fuse block (J/B)]
- to BCM terminal 42,
- through 10A fuse [No. 19, located in fuse block (J/B)]
- to combination meter terminal 21.

Ground is supplied

- to hazard switch terminal 1
- through grounds M30 and M66,
- to BCM terminal 52
- through grounds M30 and M66,
- to combination meter terminals 1, 24 and 25
- through grounds M30 and M66.

When hazard switch is depressed, ground is supplied

- to BCM terminal 29
- through hazard switch terminal 2.

BCM then supplies power

- through BCM terminal 45
- to front combination lamp LH terminal 6, and
- to rear combination lamp LH terminal 3,
- through BCM terminal 46
- to front combination lamp RH terminal 6, and
- to rear combination lamp RH terminal 3.

Ground is supplied

- to front combination lamp LH terminal 4, and
- to front combination lamp RH terminal 4

TURN SIGNAL AND HAZARD WARNING LAMPS

- through grounds E17 and E43,
- to rear combination lamp LH terminal 4, and
- to rear combination lamp RH terminal 4
- through ground B103.

The BCM also supplies input to combination meter terminals 4 and 5 across CAN communication lines. This input is processed by unified meter control unit in combination meter, which in turn supplies ground to the left and right turn signal indicator lamps.

With power and input supplied, BCM controls flashing of hazard warning lamps.

REMOTE KEYLESS ENTRY SYSTEM OPERATION

Power is supplied at all times

- through 50A fusible link (letter F, located in fuse, fusible link and relay box)
- to BCM terminal 55,
- through 10A fuse [No. 19, located in fuse block (J/B)]
- to combination meter terminal 21.

Ground is supplied

- to BCM terminal 52
- through grounds M30 and M66,
- to combination meter terminals 1, 24 and 25
- through grounds M30 and M66.

When the remote keyless entry system is triggered by input from key fob, BCM supplies power

- through BCM terminal 45
- to front combination lamp LH terminal 6, and
- to rear combination lamp LH terminal 3,
- through BCM terminal 46
- to front combination lamp RH terminal 6, and
- to rear combination lamp RH terminal 3.

Ground is supplied

- to front combination lamp LH terminal 4, and
- to front combination lamp RH terminal 4
- through grounds E17 and E43,
- to rear combination lamp LH terminal 4, and
- to rear combination lamp RH terminal 4
- through ground B103.

The BCM also supplies input to combination meter terminals 4 and 5 across CAN communication lines. This input is processed by unified meter control unit in combination meter, which in turn supplies ground to the left and right turn signal indicator lamps.

With power and ground supplied, BCM controls flashing of hazard warning lamps when key fob is used to activate remote keyless entry system.

COMBINATION SWITCH READING FUNCTION

Refer to [BCS-3, "COMBINATION SWITCH READING FUNCTION"](#) .

CAN Communication System Description

AKS009MG

CAN (Controller Area Network) is a serial communication line for real time application. It is an on-vehicle multiplex communication line with high data communication speed and excellent error detection ability. Many electronic control units are equipped onto vehicle, and each control unit shares information and links with other control units during operation (not independent). In CAN communication, control units are connected with 2 communication lines (CAN H line, CAN L line) allowing a high rate of information transmission with less wiring. Each control unit transmits/receives data but selectively reads required data only.

CAN Communication Unit

AKS009MH

Refer to [LAN-21, "CAN Communication Unit"](#) .

TURN SIGNAL AND HAZARD WARNING LAMPS

Schematic

AKS009MI

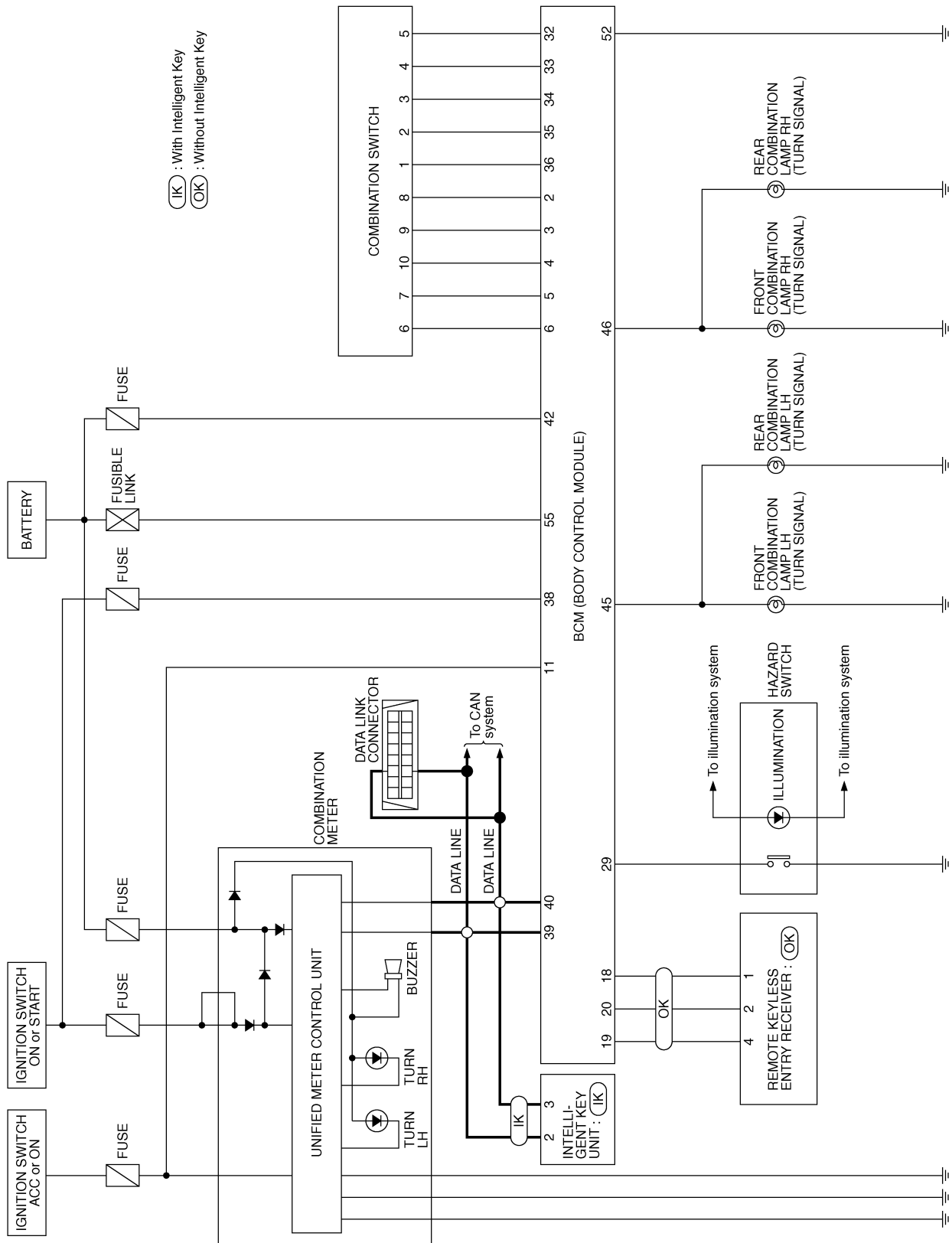

TKWM2260E

A
B
C
D
E
F
G
H
I
J
LT
L
M

TURN SIGNAL AND HAZARD WARNING LAMPS

AKS009MJ

Wiring Diagram — TURN —

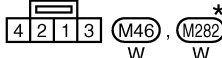
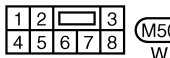
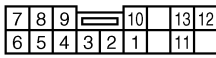
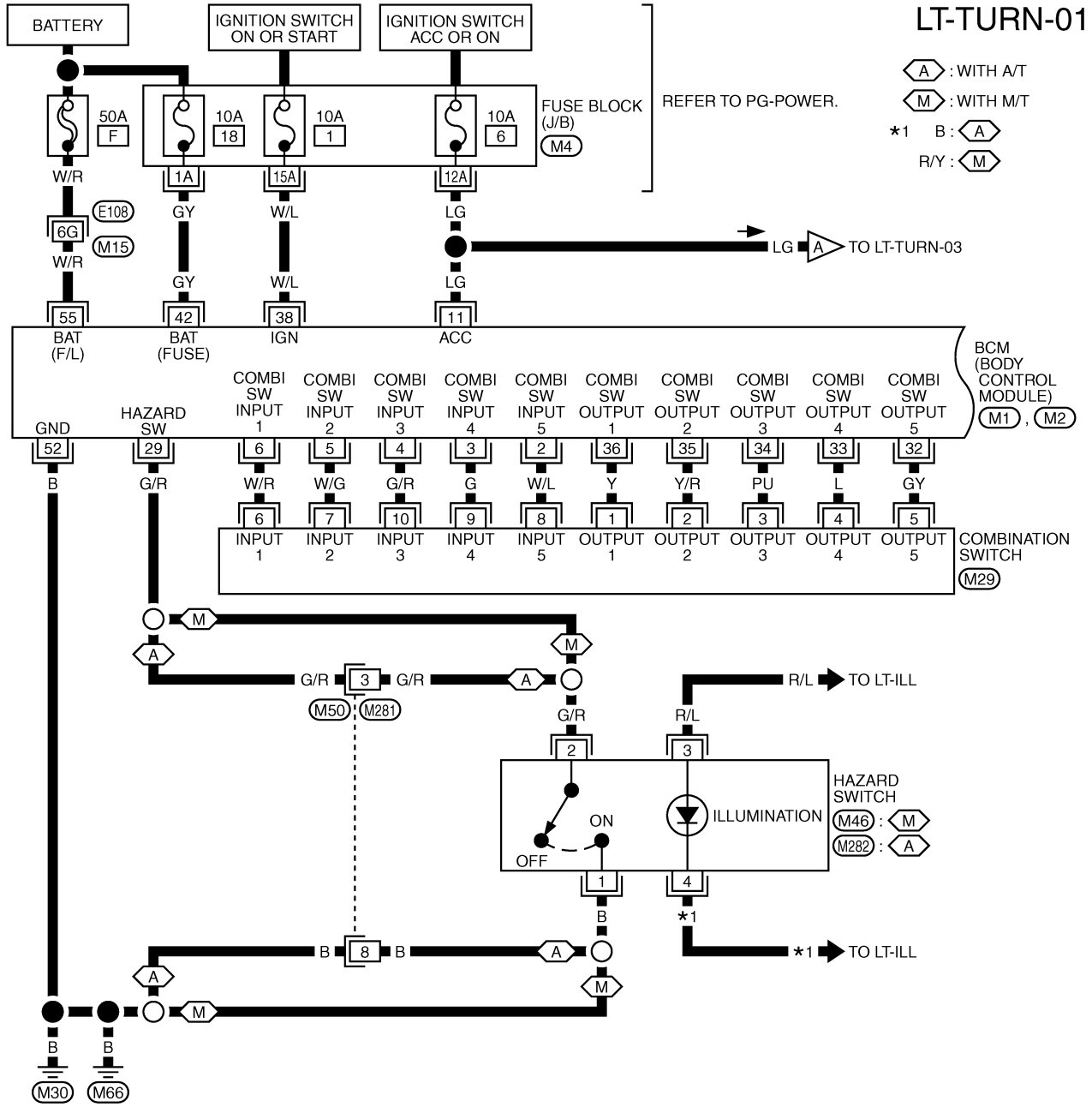

REFER TO THE FOLLOWING.

(E108) -SUPER MULTIPLE JUNCTION (SMJ)

(M4) -FUSE BLOCK-JUNCTION BOX (J/B)

(M1), (M2) -ELECTRICAL UNITS

*: THIS CONNECTOR IS NOT SHOWN IN "HARNESS LAYOUT", PG SECTION.

TKWM2933E

TURN SIGNAL AND HAZARD WARNING LAMPS

LT-TURN-02

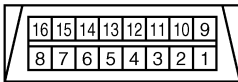
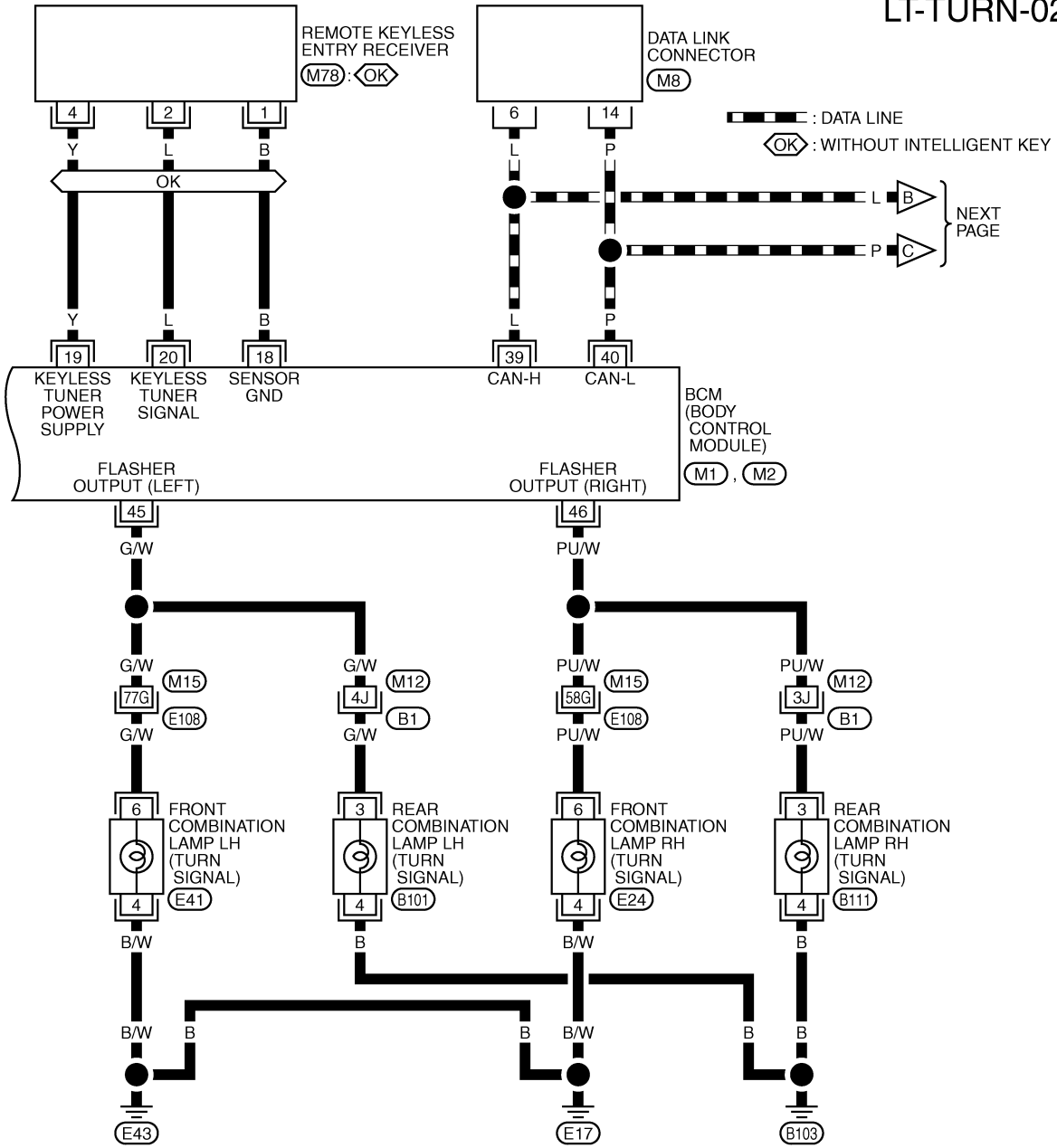

(M8) W

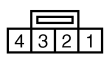

(M78) W

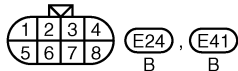

(E24), (E41) B, B

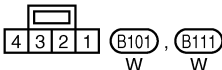

(B101), (B111) W, W

REFER TO THE FOLLOWING.
 (E108), (B1) -SUPER MULTIPLE JUNCTION (SMJ)
 (M1), (M2) -ELECTRICAL UNITS

A
B
C
D
E
F
G
H
I
J
LT
L
M

TURN SIGNAL AND HAZARD WARNING LAMPS

LT-TURN-03

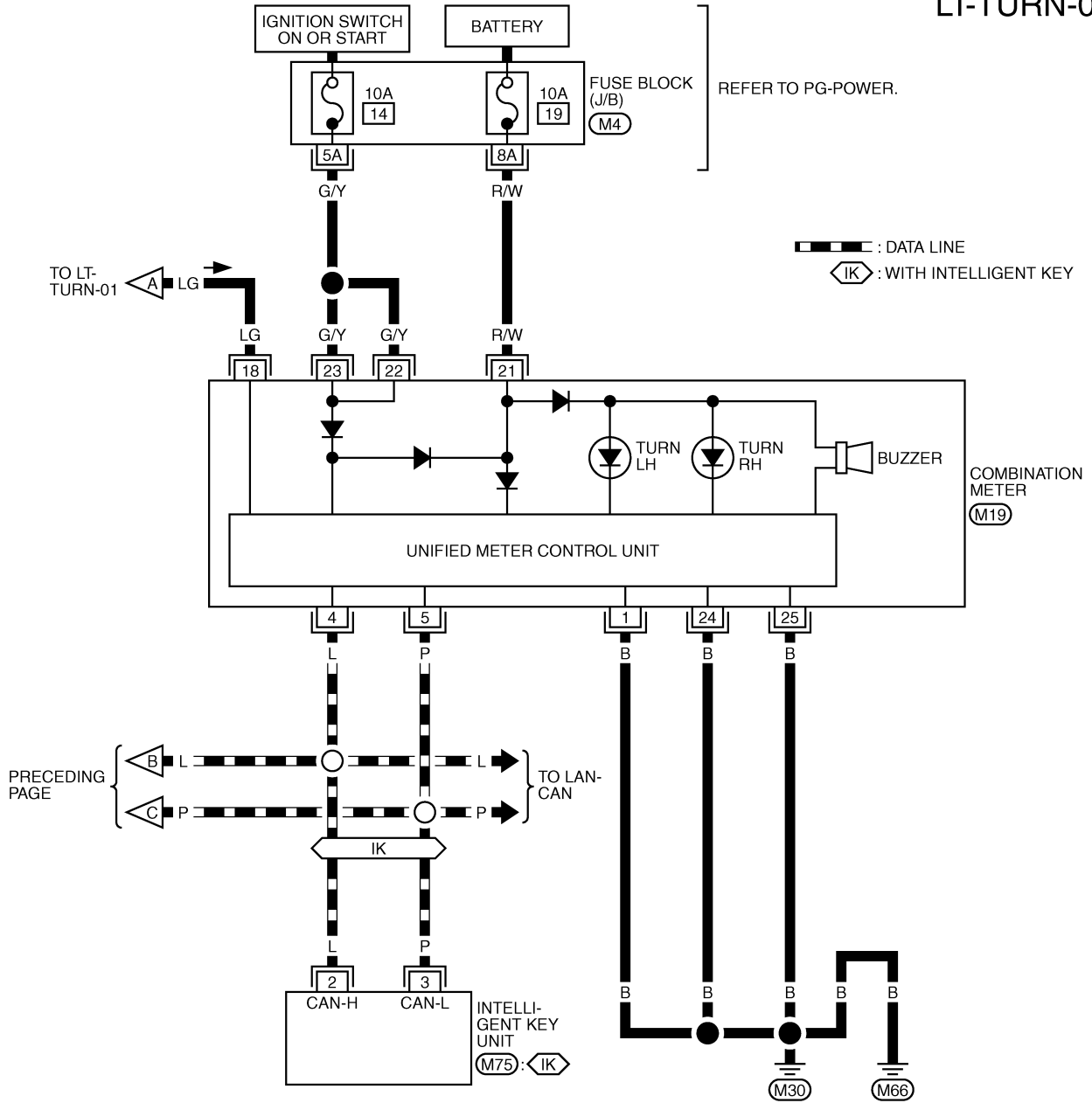

20	19	18	17	16	15	14	13	12	11	10	9	8	7	6	5	4	3	2	1
40	39	38	37	36	35	34	33	32	31	30	29	28	27	26	25	24	23	22	21

(M19)
W

REFER TO THE FOLLOWING.
 (M4) - FUSE BLOCK-JUNCTION BOX (J/B)
 (M75) - ELECTRICAL UNITS

TKWM2263E

TURN SIGNAL AND HAZARD WARNING LAMPS

Terminals and Reference Values for BCM

AKS009MK

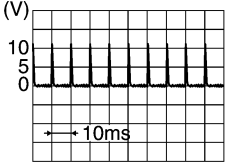
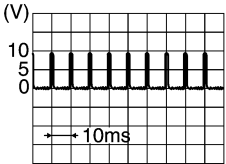
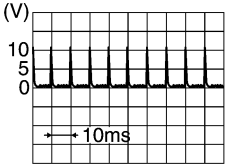
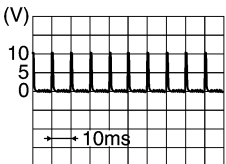
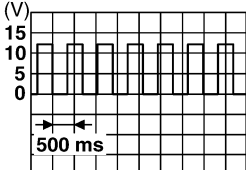
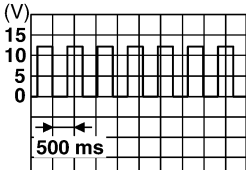
Terminal No.	Wire color	Signal name	Measuring condition		Reference value	
			Ignition switch	Operation or condition		
2	W/L	Combination switch input 5	ON	Lighting, turn, wiper OFF Wiper intermittent dial position 4	 <p style="text-align: right;">PKIB3468E</p>	
3	G	Combination switch input 4	ON	Lighting, turn, wiper OFF Wiper intermittent dial position 4	 <p style="text-align: right;">PKIB3469E</p>	
4	G/R	Combination switch input 3				
5	W/G	Combination switch input 2				
6	W/R	Combination switch input 1				
11	LG	Ignition switch (ACC)	ACC	—	Battery voltage	
29	G/R	Hazard switch signal	OFF	Hazard switch	ON	Approx. 0V
					OFF	Battery voltage
32	GY	Combination switch output 5	ON	Lighting, turn, wiper OFF Wiper intermittent dial position 4	 <p style="text-align: right;">PKIB3470E</p>	
33	L	Combination switch output 4	ON	Lighting, turn, wiper OFF Wiper intermittent dial position 4	 <p style="text-align: right;">PKIB3471E</p>	
34	PU	Combination switch output 3				
35	Y/R	Combination switch output 2				
36	Y	Combination switch output 1				
38	W/L	Ignition switch (ON)	ON	—	Battery voltage	
39	L	CAN – H	—	—	—	
40	P	CAN – L	—	—	—	
42	GY	Battery power supply	OFF	—	Battery voltage	
45	G/W	Turn signal (left)	ON	Combination switch	Turn left ON	 <p style="text-align: right;">SKIA3009J</p>
46	PU/W	Turn signal (right)	ON	Combination switch	Turn right ON	 <p style="text-align: right;">SKIA3009J</p>

A
B
C
D
E
F
G
H
I
J
LT
L
M

TURN SIGNAL AND HAZARD WARNING LAMPS

Terminal No.	Wire color	Signal name	Measuring condition		Reference value
			Ignition switch	Operation or condition	
52	B	Ground	ON	—	Approx. 0V
55	W/R	Battery power supply	OFF	—	Battery voltage

How to Proceed with Trouble Diagnosis

AKS009ML

1. Confirm the symptom or customer complaint.
2. Understand operation description and function description. Refer to [LT-112, "System Description"](#) .
3. Perform the preliminary check. Refer to [LT-120, "Preliminary Check"](#) .
4. Check symptom and repair or replace the malfunctioning parts.
5. Do turn signal and hazard warning lamps operate normally? If YES, GO TO 6. If NO, GO TO 4.
6. INSPECTION END

Preliminary Check

AKS009MM

CHECK POWER SUPPLY AND GROUND CIRCUIT

1. CHECK FUSES

Check for blown fuses.

Unit	Power source	Fuse and fusible link No.
BCM	Battery	F
		18
	Ignition switch ON or START position	1
	Ignition switch ACC or ON position	6
Combination meter	Battery	19
	Ignition switch ON or START position	14

Refer to [LT-116, "Wiring Diagram — TURN —"](#) .

OK or NG

OK >> GO TO 2.

NG >> If fuse or fusible link is blown, be sure to eliminate cause of malfunction before installing new fuse or fusible link. Refer to [PG-3, "POWER SUPPLY ROUTING CIRCUIT"](#) .

TURN SIGNAL AND HAZARD WARNING LAMPS

2. CHECK POWER SUPPLY CIRCUIT

1. Turn ignition switch OFF.
2. Disconnect BCM connector.
3. Check voltage between BCM harness connector and ground.

Terminal (+)		Terminal (-)	Ignition switch position		
Connector	Terminal (Wire color)		OFF	ACC	ON
M1	11 (LG)	Ground	Approx. 0V	Battery voltage	Battery voltage
	38 (W/L)		Approx. 0V	Approx. 0V	Battery voltage
M2	42 (GY)		Battery voltage	Battery voltage	Battery voltage
	55 (W/R)		Battery voltage	Battery voltage	Battery voltage

OK or NG

OK >> GO TO 3.

NG >> Check harness for open or short between BCM and fuse.

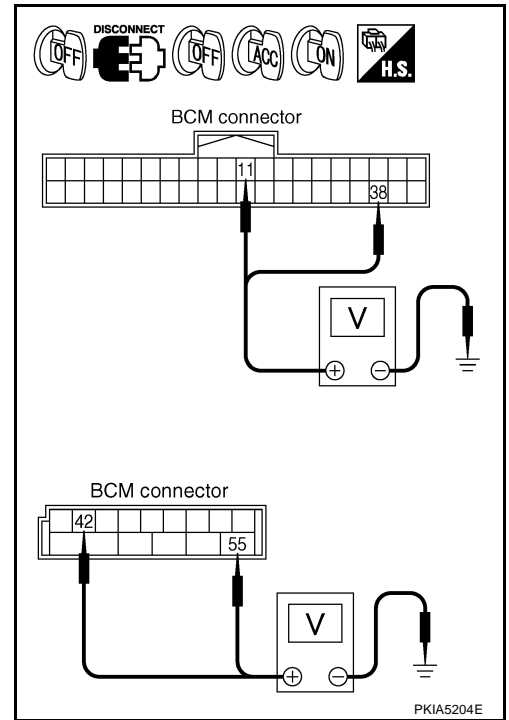

3. CHECK GROUND CIRCUIT

Check continuity between BCM harness connector and ground.

Terminal		Ground	Continuity
Connector	Terminal (Wire color)		Yes
M2	52 (B)		

OK or NG

OK >> INSPECTION END

NG >> Check harness ground circuit.

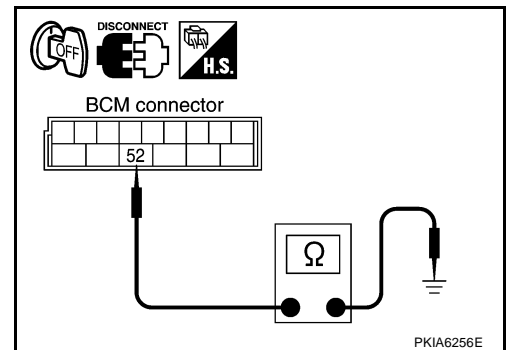

A
B
C
D
E
F
G
H
I
J
LT
L
M

TURN SIGNAL AND HAZARD WARNING LAMPS

AKS009MN

CONSULT-II Functions (BCM)

CONSULT-II can display each diagnostic item using the diagnostic test mode shown following.

BCM diagnosis part	Diagnosis mode	Description
FLASHER	DATA MONITOR	Displays BCM input data in real time.
	ACTIVE TEST	Operation of electrical loads can be checked by sending driving signal to them.

CONSULT-II BASIC OPERATION

CAUTION:

If CONSULT-II is used with no connection of CONSULT-II CONVERTER, malfunctions might be detected in self-diagnosis depending on control unit which carry out CAN communication.

1. With ignition switch OFF, connect CONSULT-II and CONSULT-II CONVERTER to data link connector, and then turn ignition switch ON.

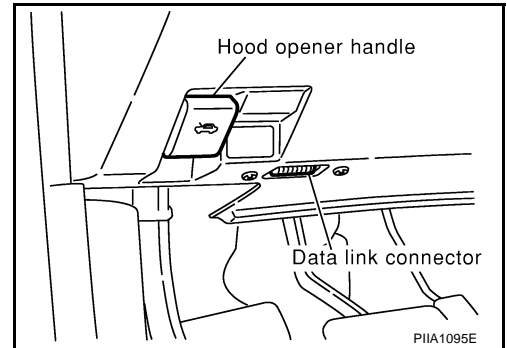

2. Touch "START (NISSAN BASED VHCL)".

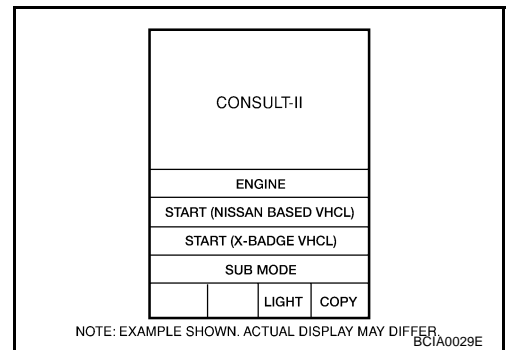

3. Touch "BCM" on "SELECT SYSTEM" screen.
If "BCM" is not indicated, refer to [GI-39, "CONSULT-II Data Link Connector \(DLC\) Circuit"](#).

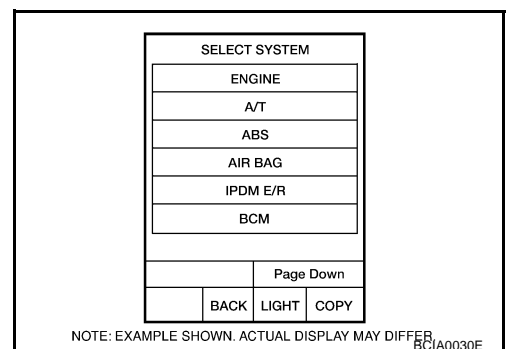

4. Touch "FLASHER" on "SELECT TEST ITEM" screen.

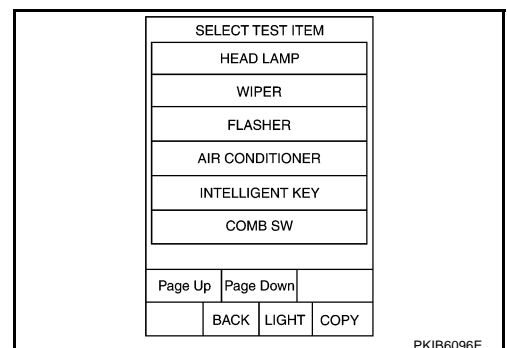

TURN SIGNAL AND HAZARD WARNING LAMPS

DATA MONITOR

Operation Procedure

1. Touch "FLASHER" on "SELECT TEST ITEM" screen.
2. Touch "DATA MONITOR" on "SELECT DIAG MODE" screen.
3. Touch either "ALL SIGNALS" or "SELECTION FROM MENU" on "SELECT MONITOR ITEM" screen.

ALL SIGNALS	Monitors all the signals.
SELECTION FROM MENU	Selects items and monitor them.

4. When "SELECTION FROM MENU" is selected, touch items to be monitored. When "ALL SIGNALS" is selected, all items will be monitored.
5. Touch "START".
6. Touch "RECORD" while monitoring, then the status of monitored item can be recorded. To stop recording, touch "STOP".

Display Item List

Monitor item	Contents
IGN ON SW "ON/OFF"	Displays status (ignition switch IGN position: ON/other: OFF) of ignition switch judged from the ignition switch signal.
HAZARD SW "ON/OFF"	Displays status (hazard switch ON position: ON/other: OFF) of hazard switch judged from the hazard switch signal.
TURN SIGNAL R "ON/OFF"	Displays status (turn signal switch right position: ON/other: OFF) of turn RH switch judged from the turn signal switch signal.
TURN SIGNAL L "ON/OFF"	Displays status (turn signal switch left position: ON/other: OFF) of turn LH switch judged from the turn signal switch signal.
BRAKE SW "ON/OFF"	Displays status (brake lamp switch ON position: ON/other: OFF) of brake lamp switch judged from the brake lamp switch signal.

ACTIVE TEST

Operation Procedure

1. Touch "FLASHER" on "SELECT TEST ITEM" screen.
2. Touch "ACTIVE TEST" on "SELECT DIAG MODE" screen.
3. Touch item to be tested and check operation of the selected item.
4. During the operation check, touching "BACK" deactivates the operation.

Display Item List

Test item	Description
FLASHER	Turn signal lamp (right or left) can be operated by any ON-OFF operations.

Turn Signal Lamp Does Not Operate

AKS009MO

1. CHECK BULB

Check bulb standard of each turn signal lamp is correct.

OK or NG

- OK >> GO TO 2.
NG >> Replace turn signal lamp bulb.

TURN SIGNAL AND HAZARD WARNING LAMPS

2. CHECK COMBINATION SWITCH INPUT SIGNAL

☑ With CONSULT-II

Select "BCM" on CONSULT-II. With "FLASHER" data monitor, make sure "TURN SIGNAL R" and "TURN SIGNAL L" turns ON-OFF linked with operation of turn signal switch.

When turn signal switch is : TURN SIGNAL R ON RH position

When turn signal switch is : TURN SIGNAL L ON LH position

☒ Without CONSULT-II

Refer to [LT-133, "Combination Switch Inspection"](#) .

OK or NG

OK >> GO TO 3.

NG >> Check combination switch (lighting switch). Refer to [LT-133, "Combination Switch Inspection"](#) .

DATA MONITOR			
MONITOR			
TURN SIGNAL R	ON		
TURN SIGNAL L	ON		
		RECORD	
MODE	BACK	LIGHT	COPY

PKIA7600E

3. ACTIVE TEST

☑ With CONSULT-II

- Select "BCM" on CONSULT-II. Select "FLASHER" active test. Refer to [LT-123, "ACTIVE TEST"](#) .
- Touch "RH" or "LH" screen.
- Make sure turn signal lamp RH and LH operates.

Turn signal lamp should operate

☒ Without CONSULT-II

GO TO 4.

OK or NG

OK >> Replace BCM. Refer to [BCS-16, "Removal and Installation of BCM"](#) .

NG >> GO TO 4.

ACTIVE TEST			
FLASHER		RH	
RH	LH	OFF	
MODE	BACK	LIGHT	COPY

PKIA7749E

4. CHECK SHORT CIRCUIT

- Turn ignition switch OFF.
- Disconnect BCM connector and all turn signal lamp connectors.
- Check continuity (short circuit) between BCM harness connector and ground.

Terminal			Continuity
BCM		Ground	
Connector	Terminal (Wire color)		
RH	M2	46 (PU/W)	No
LH		45 (G/W)	

OK or NG

OK >> Replace BCM if turn signal lamps does not work after setting the connector again. Refer to [BCS-16, "Removal and Installation of BCM"](#) .

NG >> Repair harness or connector.

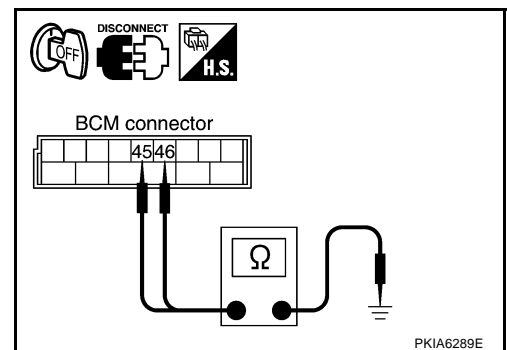

TURN SIGNAL AND HAZARD WARNING LAMPS

Hazard Warning Lamp Does Not Operate But Turn Signal Lamp Operate

AKS009MQ

1. CHECK BULB

Make sure bulb standard of each turn signal lamp is correct.

OK or NG

- OK >> GO TO 2.
- NG >> Replace bulb.

2. CHECK HAZARD SWITCH INPUT SIGNAL

☑ With CONSULT-II

Select "BCM" on CONSULT-II. With "FLASHER" data monitor, make sure "HAZARD SW" turns ON-OFF linked with operation of hazard switch.

When hazard switch is ON : HAZARD SW ON position

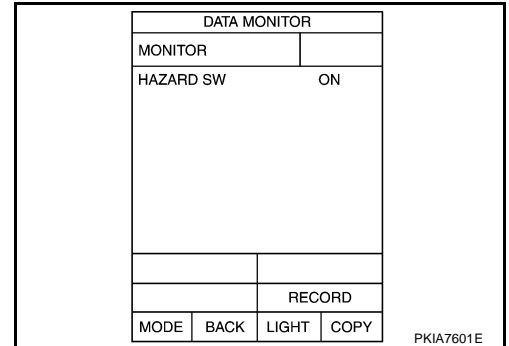

☒ Without CONSULT-II

Check voltage between BCM harness connector M1 terminal 29 (G/R) and ground.

Terminal (+)		(-)	Condition	Voltage
Connector	Terminal (Wire color)			
M1	29 (G/R)	Ground	Hazard switch is ON	Approx. 0V
			Hazard switch is OFF	Battery voltage

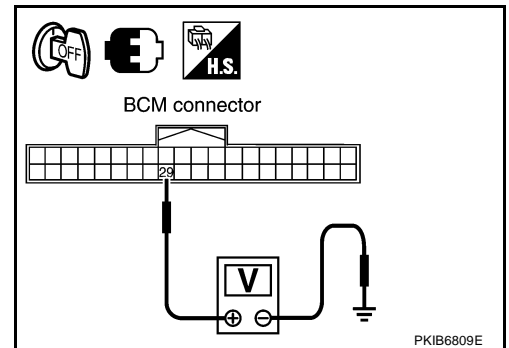

OK or NG

- OK >> Replace BCM. Refer to [BCS-16, "Removal and Installation of BCM"](#).
- NG >> GO TO 3.

3. CHECK HAZARD SWITCH CIRCUIT

1. Turn ignition switch OFF.
2. Disconnect BCM connector and hazard switch connector.
3. Check continuity BCM harness connector M1 terminal 29 (G/R) and hazard switch harness connector M282^{*1}, M46^{*2} terminal 2 (G/R).

29 (G/R) – 2 (G/R) : Continuity should exist.

*1: with A/T, *2: with M/T

OK or NG

- OK >> GO TO 4.
- NG >> Repair harness or connector.

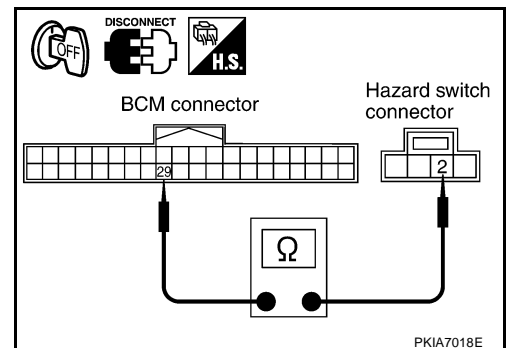

TURN SIGNAL AND HAZARD WARNING LAMPS

4. CHECK GROUND

Check continuity hazard switch harness connector M282*1 , M46*2 terminal 1 (B) and ground.

1 (B) – Ground : Continuity should exist.

*1: with A/T, *2: with M/T

OK or NG

OK >> GO TO 5.

NG >> Repair harness or connector.

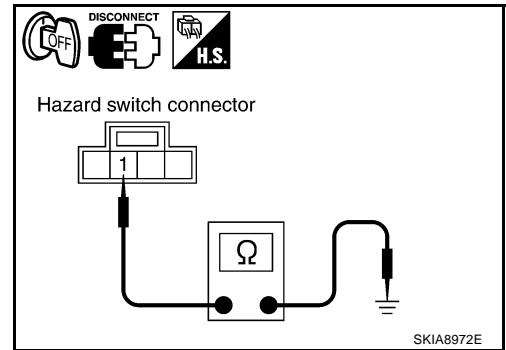

5. CHECK HAZARD SWITCH

1. Disconnect hazard switch connector.
2. Check continuity hazard switch.

Terminal		Condition	Continuity
Hazard switch			
1	2	Hazard switch is ON	Yes
		Hazard switch is OFF	No

OK or NG

OK >> Replace BCM if turn signal lamps does not work after setting the connector again. Refer to [BCS-16. "Removal and Installation of BCM"](#) .

NG >> Replace hazard switch.

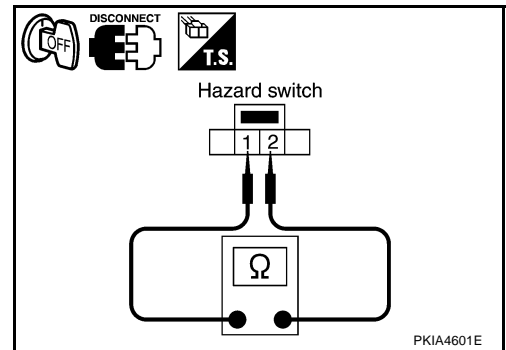

Turn Signal Indicator Lamp Does Not Operate

1. CHECK BULB

Check bulb of turn signal indicator lamp in combination meter.

OK or NG

OK >> Replace combination meter.

NG >> Replace indicator bulb.

AKS005KV

TURN SIGNAL AND HAZARD WARNING LAMPS

Bulb Replacement (Front Turn Signal Lamp)

AKS009MW

A

Refer to [LT-33, "Bulb Replacement"](#) in "HEADLAMP (FOR USA)".

Bulb Replacement (Rear Turn Signal Lamp)

AKS009MX

B

Refer to [LT-158, "Bulb Replacement"](#) in "REAR COMBINATION LAMP".

Removal and Installation of Front Turn Signal Lamp

AKS009MY

C

Refer to [LT-34, "Removal and Installation"](#) in "HEADLAMP (FOR USA)".

Removal and Installation of Rear Turn Signal Lamp

AKS009MZ

D

Refer to [LT-158, "Removal and Installation"](#) in "REAR COMBINATION LAMP".

E

F

G

H

I

J

LT

L

M

LIGHTING AND TURN SIGNAL SWITCH

LIGHTING AND TURN SIGNAL SWITCH

PFP:25540

Removal and Installation

AKS000M4

REMOVAL

1. Remove steering column cover. Refer to [IP-10, "INSTRUMENT PANEL ASSEMBLY"](#) in "IP" section.
2. Remove mounting bolts of cluster lid A and combination meter. Refer to [IP-10, "INSTRUMENT PANEL ASSEMBLY"](#) in "IP" section.
3. While pressing pawls in direction as shown in the figure, pull lighting and turn signal switch toward driver door and disconnect from the base.
4. Disconnect lighting and turn signal switch connector.

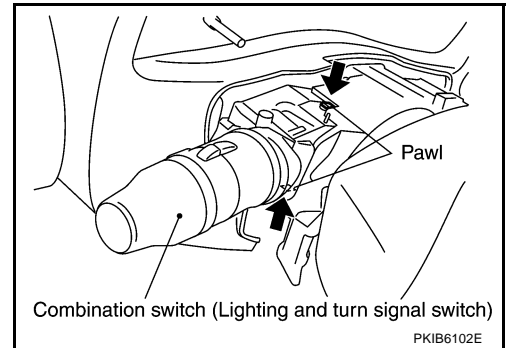

INSTALLATION

Installation is the reverse order of removal.

HAZARD SWITCH

HAZARD SWITCH

PPF:25290

Removal and Installation (M/T)

AKS0081D

REMOVAL

1. Remove console boot (M/T). Refer to [IP-10, "INSTRUMENT PANEL ASSEMBLY"](#) in "IP" section.
2. Disconnect hazard switch connector.
3. Remove screws.
4. Remove hazard switch.

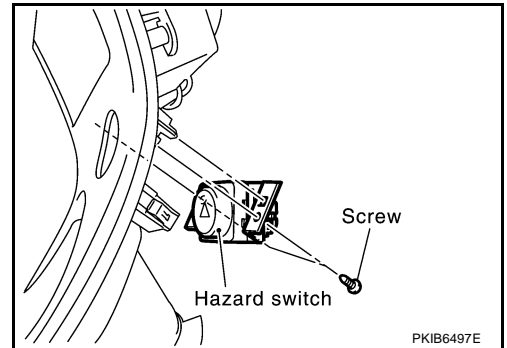

INSTALLATION

Installation is the reverse order of removal.

Removal and Installation (A/T)

AKS0081E

REMOVAL

1. Remove console finisher (A/T). Refer to [IP-10, "INSTRUMENT PANEL ASSEMBLY"](#) in "IP" section.
2. Disconnect hazard switch connector.
3. Remove screws.
4. Remove hazard switch.

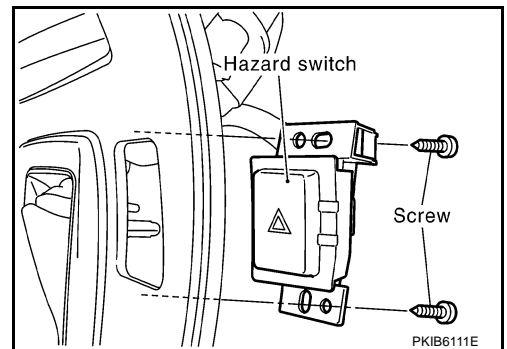

INSTALLATION

Installation is the reverse order of removal.

A

B

C

D

E

F

G

H

I

J

LT

L

M

COMBINATION SWITCH

PF:25567

AKS009M3

COMBINATION SWITCH

Wiring Diagram — COMBSW —

LT-COMBSW-01

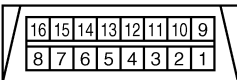
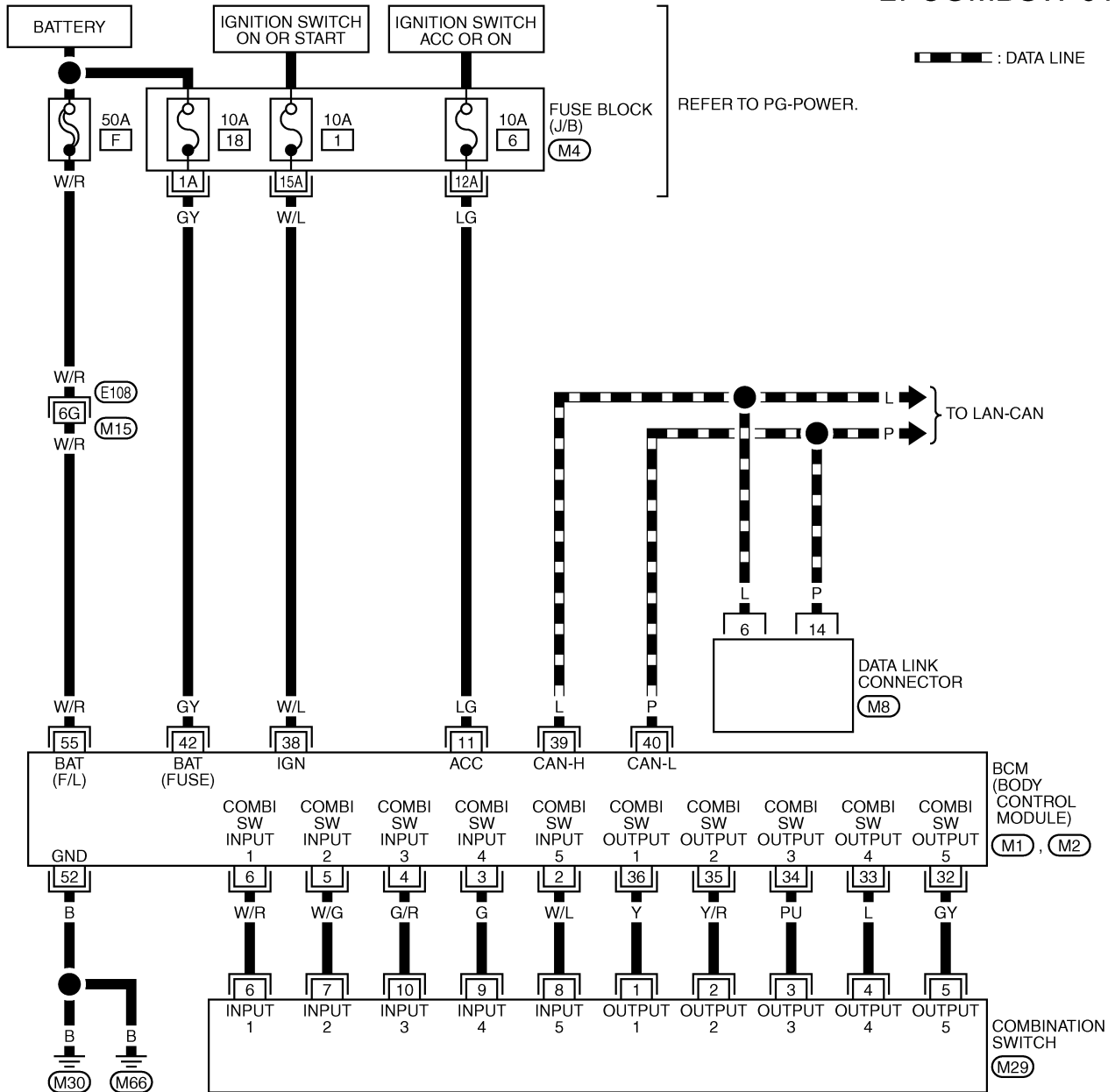

(M8)
W

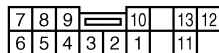

(M29)
W

REFER TO THE FOLLOWING.

- (E108) -SUPER MULTIPLE JUNCTION (SMJ)
- (M4) -FUSE BLOCK-JUNCTION BOX (J/B)
- (M1), (M2) -ELECTRICAL UNITS

TKWM2264E

COMBINATION SWITCH

Combination Switch Reading Function

AKS009M4

For details, refer to [BCS-3, "COMBINATION SWITCH READING FUNCTION"](#) in "BCS" section.

CONSULT-II Function (BCM)

AKS009M5

CONSULT-II can display each diagnostic item using the diagnostic test modes shown following.

BCM diagnosis part	Diagnosis mode	Description
COMB SW	DATA MONITOR	Displays BCM input data in real time.

CONSULT-II BASIC OPERATION

CAUTION:

If CONSULT-II is used with no connection of CONSULT-II CONVERTER, malfunctions might be detected in self-diagnosis depending on control unit which carry out CAN communication.

1. With ignition switch OFF, connect CONSULT-II and CONSULT-II CONVERTER to data link connector, and then turn ignition switch ON.

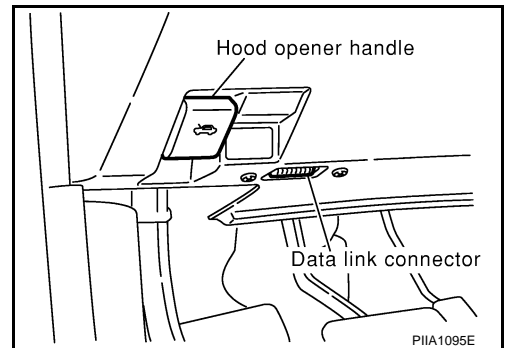

2. Touch "START (NISSAN BASED VHCL)".

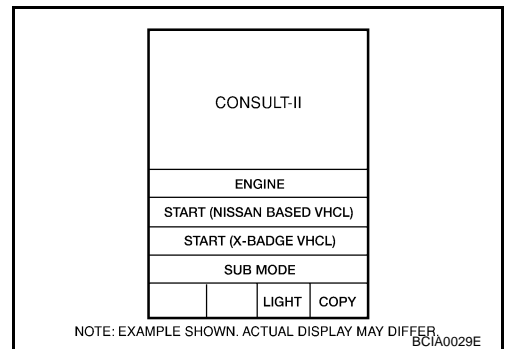

3. Touch "BCM" on "SELECT SYSTEM" screen. If "BCM" is not indicated, refer to [GI-39, "CONSULT-II Data Link Connector \(DLC\) Circuit"](#).

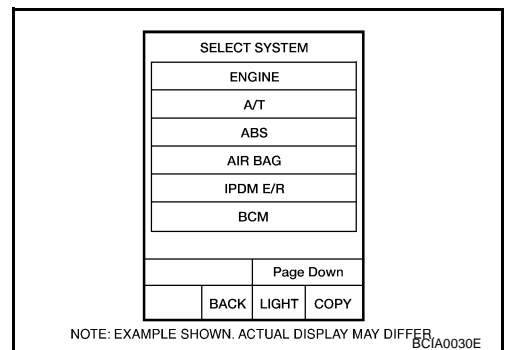

COMBINATION SWITCH

4. Touch "COMB SW".

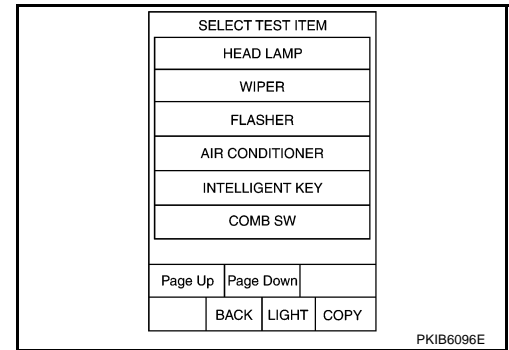

DATA MONITOR

Operation Procedure

1. Touch "COMB SW" on "SELECT TEST ITEM" screen.
2. Touch "DATA MONITOR" on "SELECT DIAG MODE" screen.
3. Touch either "ALL SIGNALS" or "SELECTION FROM MENU" on "SELECT MONITOR ITEM" screen.

ALL SIGNALS	Monitors all the signals.
SELECTION FROM MENU	Selects item and monitor them.

4. When "SELECTION FROM MENU" is selected, touch items to be monitored. When "ALL SIGNALS" is selected, all signals will be monitored.
5. Touch "START".
6. Touch "RECORD" while monitoring, then the status of monitored item can be recorded. To stop recording, touch "STOP".

Display Item List

Monitor item name	Contents
TURN SIGNAL R "ON/OFF"	Displays status (turn signal switch right position: ON/other: OFF) of turn RH switch judged from the turn signal switch signal.
TURN SIGNAL L "ON/OFF"	Displays status (turn signal switch left position: ON/other: OFF) of turn LH switch judged from the turn signal switch signal.
HI BEAM SW "ON/OFF"	Displays status (lighting switch high beam position: ON/other: OFF) of high beam switch judged from the lighting switch signal.
HEAD LAMP SW 1 "ON/OFF"	Displays status (lighting switch 2ND position: ON/other: OFF) of headlamp 1 switch judged from the lighting switch signal.
HEAD LAMP SW 2 "ON/OFF"	Displays status (lighting switch 2ND position: ON/other: OFF) of headlamp 2 switch judged from the lighting switch signal.
LIGHT SW 1ST "ON/OFF"	Displays status (lighting switch 1ST or 2ND position: ON/other: OFF) of lighting switch 1ST position switch judged from the lighting switch signal.
PASSING SW "ON/OFF"	Displays status (lighting switch passing position: ON/other: OFF) of passing switch judged from the lighting switch signal.
AUTO LIGHT SW "ON/OFF"	Displays status (lighting switch AUTO position: ON/other: OFF) of auto light switch position judged from the lighting switch signal.
FR FOG SW "ON/OFF"	Displays status (lighting switch front fog lamp ON position: ON/others: OFF) of front fog lamp switch judged from the lighting switch signal.
FR WIPER HI "ON/OFF"	Displays status (front wiper switch high position: ON/other: OFF) of front wiper high switch judged from the wiper switch signal.
FR WIPER LOW "ON/OFF"	Displays status (front wiper switch low position: ON/other: OFF) of front wiper low switch judged from the wiper switch signal.
FR WIPER INT "ON/OFF"	Displays status (front wiper switch intermittent position: ON/other: OFF) of front wiper intermittent switch judged from the wiper switch signal.
FR WASHER SW "ON/OFF"	Displays status (front washer switch ON position: ON/other: OFF) of front washer switch judged from the wiper switch signal.

COMBINATION SWITCH

Monitor item name		Contents
INT VOLUME	"1 - 7"	Displays status (wiper intermittent dial position setting 1-7) of intermittent volume switch judged from the wiper switch signal.
RR WIPER ON ^{NOTE}	"OFF"	—
RR WIPER INT ^{NOTE}	"OFF"	—
RR WASHER SW ^{NOTE}	"OFF"	—

NOTE:

This item is displayed, but cannot be monitored.

Combination Switch Inspection

AKS009M6

1. SYSTEM CHECK

Referring to table below, check which system malfunctioning switch belongs to.

System 1	System 2	System 3	System 4	System 5
—	FR WASHER	FR WIPER LO	TURN LH	TURN RH
FR WIPER HI	—	FR WIPER INT	PASSING	HEAD LAMP1
INT VOLUME 1	RR WASHER	—	HEAD LAMP2	HI BEAM
RR WIPER INT	INT VOLUME 3	AUTO LIGHT	—	LIGHT SW 1ST
INT VOLUME 2	RR WIPER ON	—	FR FOG	—

>> Check the system to which malfunctioning switch belongs, and GO TO 2.

2. SYSTEM CHECK

Ⓟ With CONSULT-II

CAUTION:

If CONSULT-II is used with no connection of CONSULT-II CONVERTER, malfunctions might be detected in self-diagnosis depending on control unit which carry out CAN communication.

1. Connect CONSULT-II, and select "COMB SW" on "SELECT TEST ITEM" screen.
2. Select "DATA MONITOR".
3. Select "START", and confirm that other switches in malfunctioning system operate normally.

Example: When the auto light switch is malfunctioning, confirm that "FRONT WIPER LOW" and "FRONT WIPER INT" in system 3, to which the auto light switch belongs, turn ON-OFF normally.

DATA MONITOR	
MONITOR	
TURN SIGNAL R	OFF
TURN SIGNAL L	OFF
HIBEAM SW	OFF
HEAD LAMP SW1	OFF
HEAD LAMP SW2	OFF
LIGHT SW 1ST	OFF
PASSING SW	OFF
AUTO LIGHT SW	OFF
FR FOG SW	OFF
	Page Down
	RECORD
MODE	BACK
LIGHT	COPY

PKIA7602E

ⓧ Without CONSULT-II

Operating combination switch, and confirm that other switches in malfunctioning system operate normally.

Example: When the auto light switch is malfunctioning, confirm that FRONT WIPER LOW and FRONT WIPER INT in system 3, to which auto light switch belongs, operate normally.

Check results

Other switches in malfunctioning system operate normally.>>Replace lighting switch or wiper switch.

Other switches in malfunctioning system do not operate normally.>>GO TO 3.

COMBINATION SWITCH

3. HARNESS INSPECTION

1. Turn ignition switch OFF.
2. Disconnect BCM connector and combination switch connector.
3. Check for continuity between BCM harness connector of the suspect system and the corresponding combination switch harness connector.

Suspect system	Terminal				Continuity	
	BCM		Combination switch			
	Connector	Terminal (Wire color)	Connector	Terminal (Wire color)		
1	M1	Input 1	6 (W/R)	M29	6 (W/R)	Yes
		Output 1	36 (Y)		1 (Y)	
2		Input 2	5 (W/G)		7 (W/G)	
		Output 2	35 (Y/R)		2 (Y/R)	
3		Input 3	4 (G/R)		10 (G/R)	
		Output 3	34 (PU)		3 (PU)	
4		Input 4	3 (G)		9 (G)	
		Output 4	33 (L)		4 (L)	
5		Input 5	2 (W/L)		8 (W/L)	
		Output 5	32 (GY)		5 (GY)	

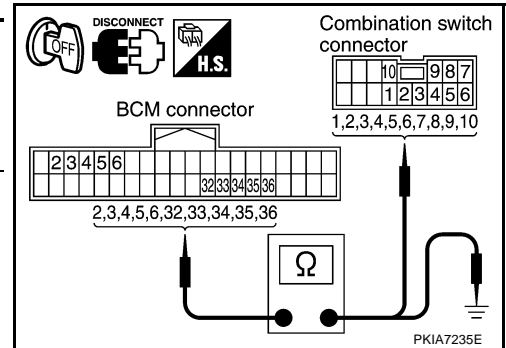

4. Check for continuity between BCM harness connector in suspect malfunctioning system and ground.

Suspect system	Terminal				Continuity
	BCM		Ground		
	Connector	Terminal (Wire color)			
1	M1	Input 1	6 (W/R)	Ground	No
		Output 1	36 (Y)		
2		Input 2	5 (W/G)		
		Output 2	35 (Y/R)		
3		Input 3	4 (G/R)		
		Output 3	34 (PU)		
4		Input 4	3 (G)		
		Output 4	33 (L)		
5		Input 5	2 (W/L)		
		Output 5	32 (GY)		

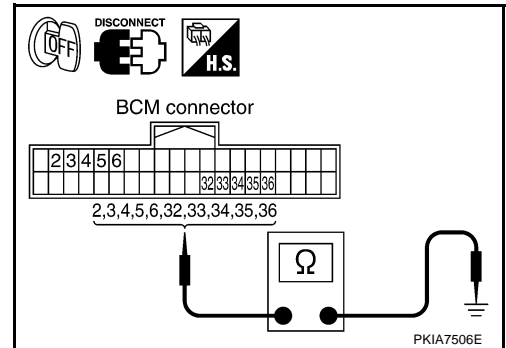

OK or NG

OK >> GO TO 4.

NG >> Check harness between BCM and combination switch for open or short circuit.

COMBINATION SWITCH

4. BCM OUTPUT TERMINAL INSPECTION

1. Turn lighting switch and wiper switch into OFF position.
2. Set wiper dial position 4.
3. Connect BCM connector and combination switch connector.
4. Check BCM output terminal voltage waveform of suspect malfunctioning system.

Suspect system	Terminal		
	Combination switch (+)		(-)
	Connector	Terminal (Wire color)	
1	M29	1 (Y)	Ground
2		2 (Y/R)	
3		3 (PU)	
4		4 (L)	
5		5 (GY)	

OK or NG

OK >> Open circuit in combination switch, GO TO 5.

NG >> Replace BCM. Refer to [BCS-16, "Removal and Installation of BCM"](#).

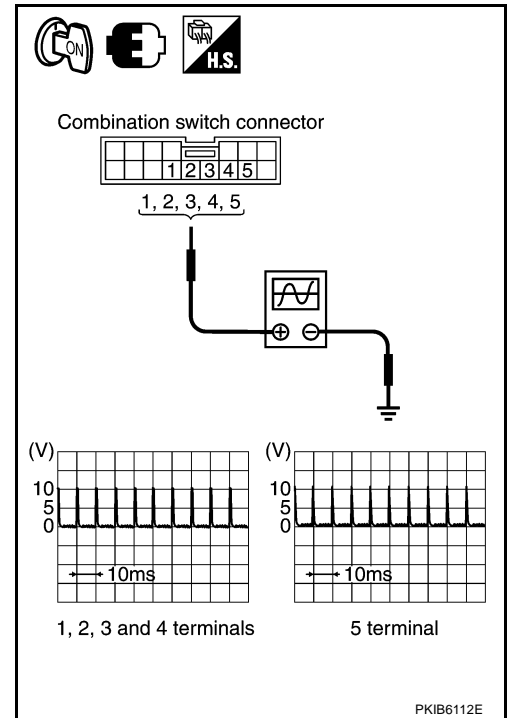

5. COMBINATION SWITCH INSPECTION

Referring to table below, perform combination switch inspection.

Procedure												
1	2		3		4		5		6		7	
Replace lighting switch	Confirm check results	OK	INSPECTION END		Confirm check results	OK	INSPECTION END		Confirm check results	OK	INSPECTION END	
		NG	Replace wiper switch			NG	Replace switch base			NG	Confirm symptom again	

>> INSPECTION END

Removal and Installation

For details, refer to [LT-128, "LIGHTING AND TURN SIGNAL SWITCH"](#).

STOP LAMP

PFP:26550

AKS009MA

STOP LAMP

Wiring Diagram — STOP/L —

LT-STOP/L-01

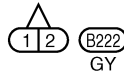
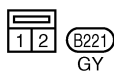
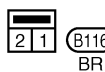
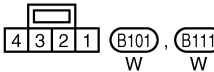
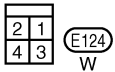
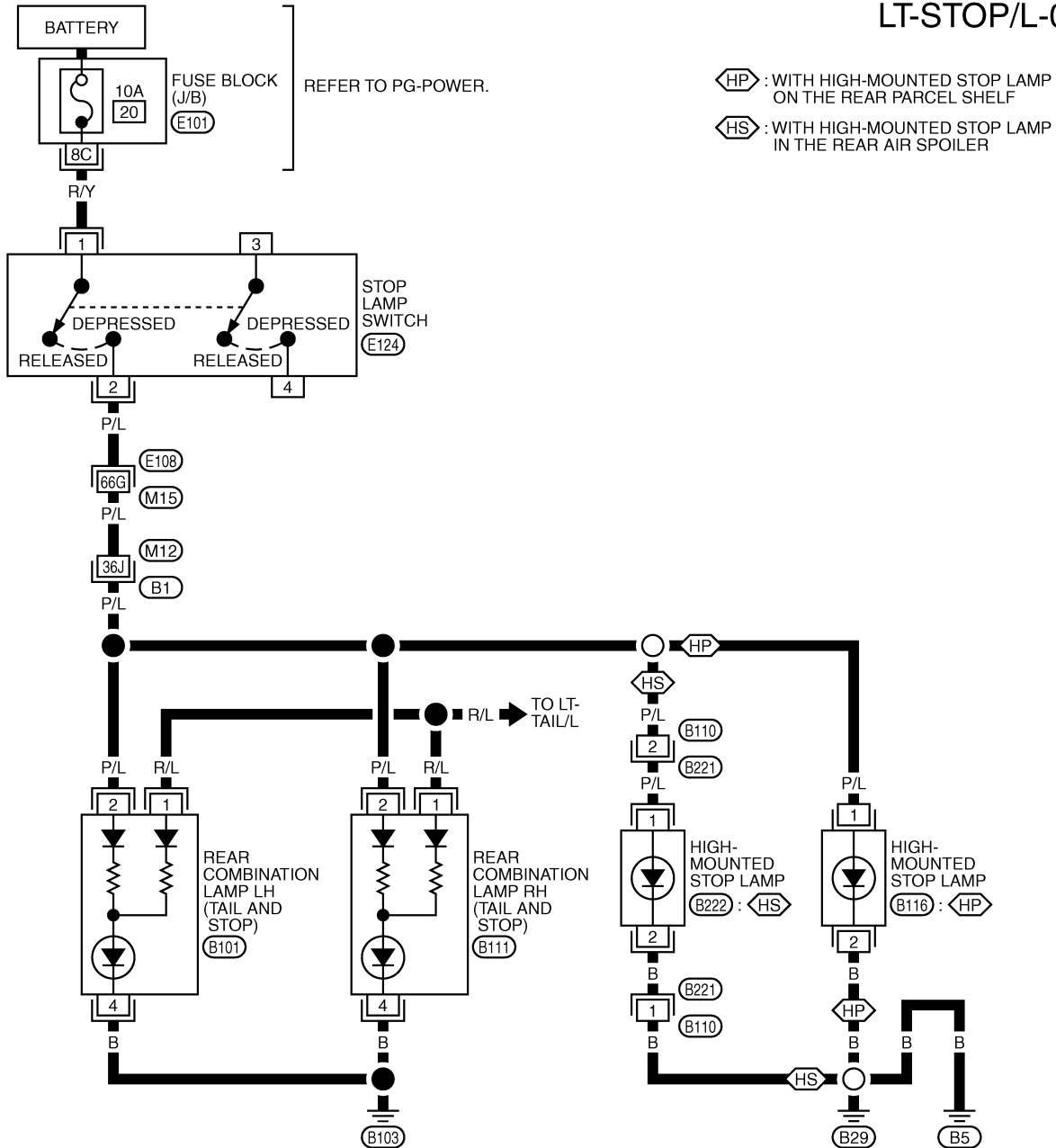

REFER TO THE FOLLOWING.

E108, B1 -SUPER MULTIPLE JUNCTION (SMJ)

E101 -FUSE BLOCK-JUNCTION BOX (J/B)

TKWM2265E

STOP LAMP

Bulb Replacement of High-Mounted Stop Lamp WITH REAR SPOILER

AKS009MB

1. Remove high-mounted stop lamp. Refer to [LT-137, "Removal and Installation of High-Mounted Stop Lamp"](#).
2. Replace together with high-mounted stop lamp.

High-mounted stop lamp : LED

3. Installation is the reverse order of removal.

WITHOUT REAR SPOILER

1. Remove high-mounted stop lamp. Refer to [LT-137, "Removal and Installation of High-Mounted Stop Lamp"](#).
2. Replace together with high-mounted stop lamp.

High-mounted stop lamp : LED

3. Installation is the reverse order of removal.

Bulb Replacement of Rear Combination Lamp (Stop Lamp)

AKS009MC

Refer to [LT-158, "Bulb Replacement"](#) in "REAR COMBINATION LAMP".

Removal and Installation of High-Mounted Stop Lamp REMOVAL (WITH REAR SPOILER)

AKS009MD

1. Remove rear spoiler. Refer to [EI-35, "REAR SPOILER"](#) in "EI" section.
2. Remove screws and remove high-mounted stop lamp from rear spoiler.
3. Disconnect high-mounted stop lamp connector.

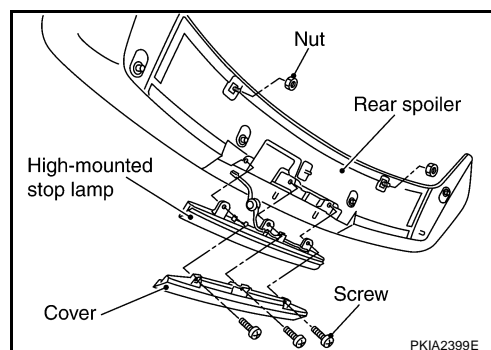

INSTALLATION

Installation is the reverse order of removal.

REMOVAL (WITHOUT REAR SPOILER)

1. Remove rear parcel shelf finisher. Refer to [EI-41, "REAR PARCEL SHELF FINISHER"](#) in "EI" section.
2. Remove screws and remove high-mounted stop lamp from rear parcel shelf finisher.
3. Disconnect high-mounted stop lamp connector.

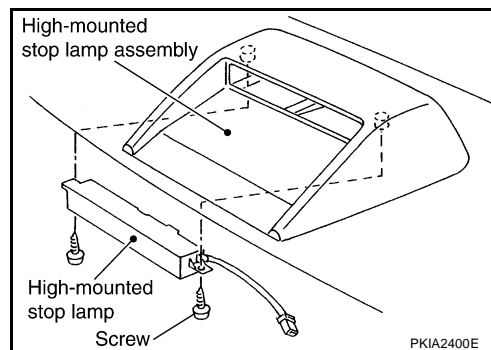

INSTALLATION

Installation is the reverse order of removal.

Removal and Installation of Rear Combination Lamp (Stop Lamp)

AKS009ME

Refer to [LT-158, "Removal and Installation"](#) in "REAR COMBINATION LAMP".

STEP LAMP

STEP LAMP

PFP:26420

Bulb Replacement

AKS000M5

Wiring diagram. Refer to [LT-175, "Wiring Diagram — ROOM/L —"](#) .

1. Remove step lamp. Refer to [LT-138, "Removal and Installation"](#) .
2. Remove bulb.

Step lamp : 12V - 5W

3. Installation is the reverse order of removal.

Removal and Installation

AKS000M6

REMOVAL

1. Remove clips which are lower part of front door finisher and lift finisher up.
2. Disconnect step lamp connector.
3. Press pawl on reverse side and remove the step lamp.

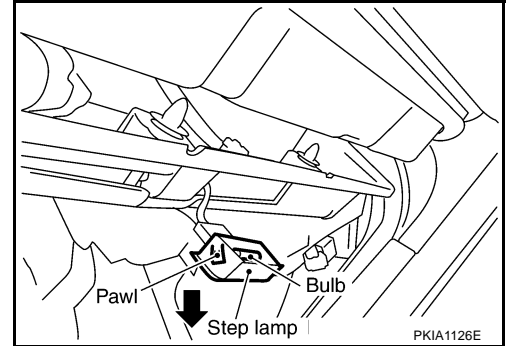

INSTALLATION

Installation is the reverse order of removal.

BACK-UP LAMP

PPF:26550

BACK-UP LAMP

Wiring Diagram — BACK/L — A/T MODELS

AKS0007X

LT-BACK/L-01

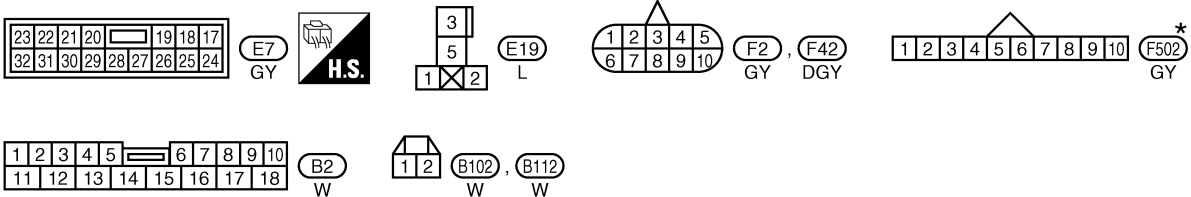
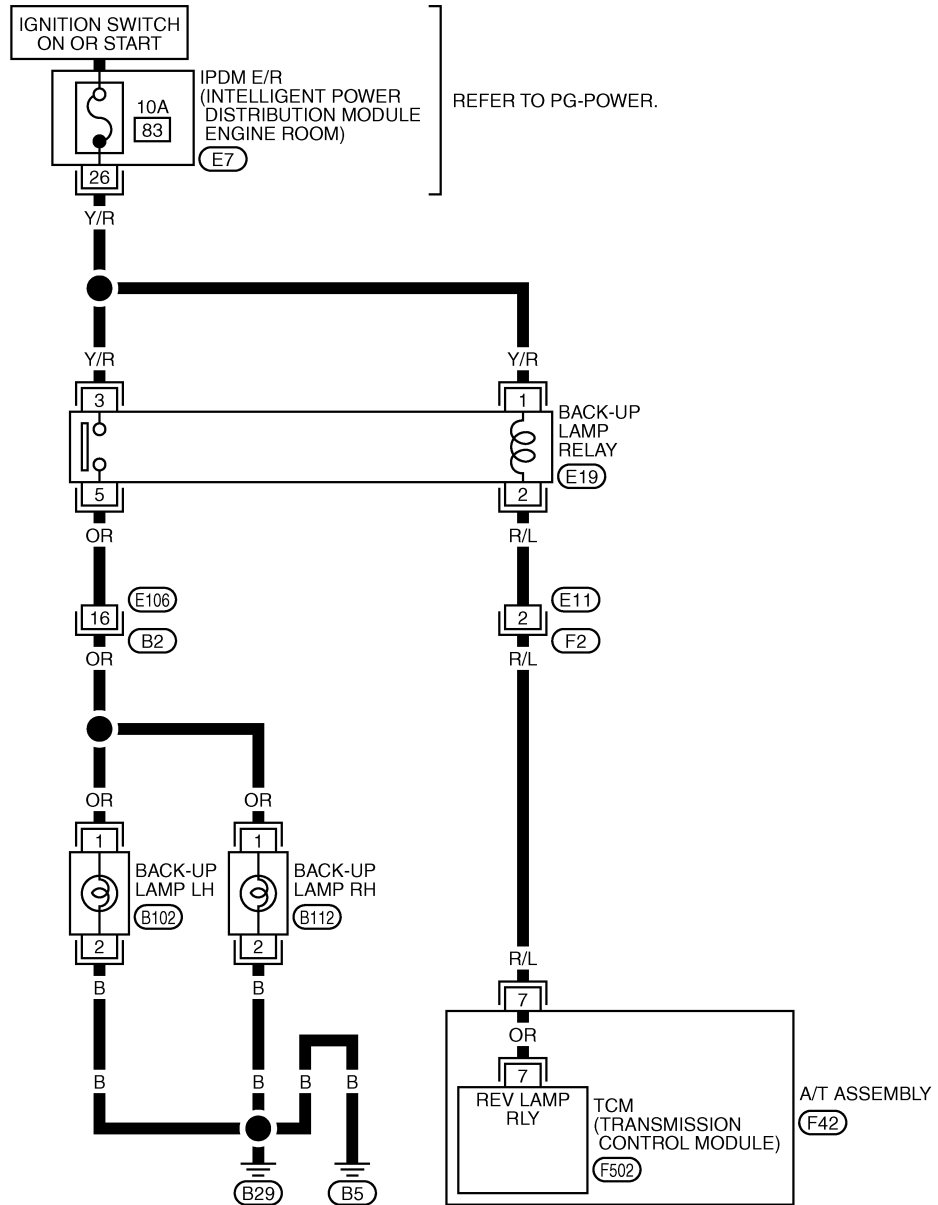

*: THIS CONNECTOR IS NOT SHOWN IN "HARNESS LAYOUT", PG SECTION.

BACK-UP LAMP

M/T MODELS

LT-BACK/L-02

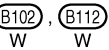
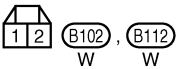
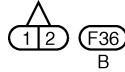
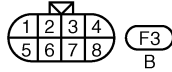
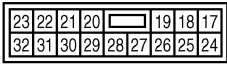
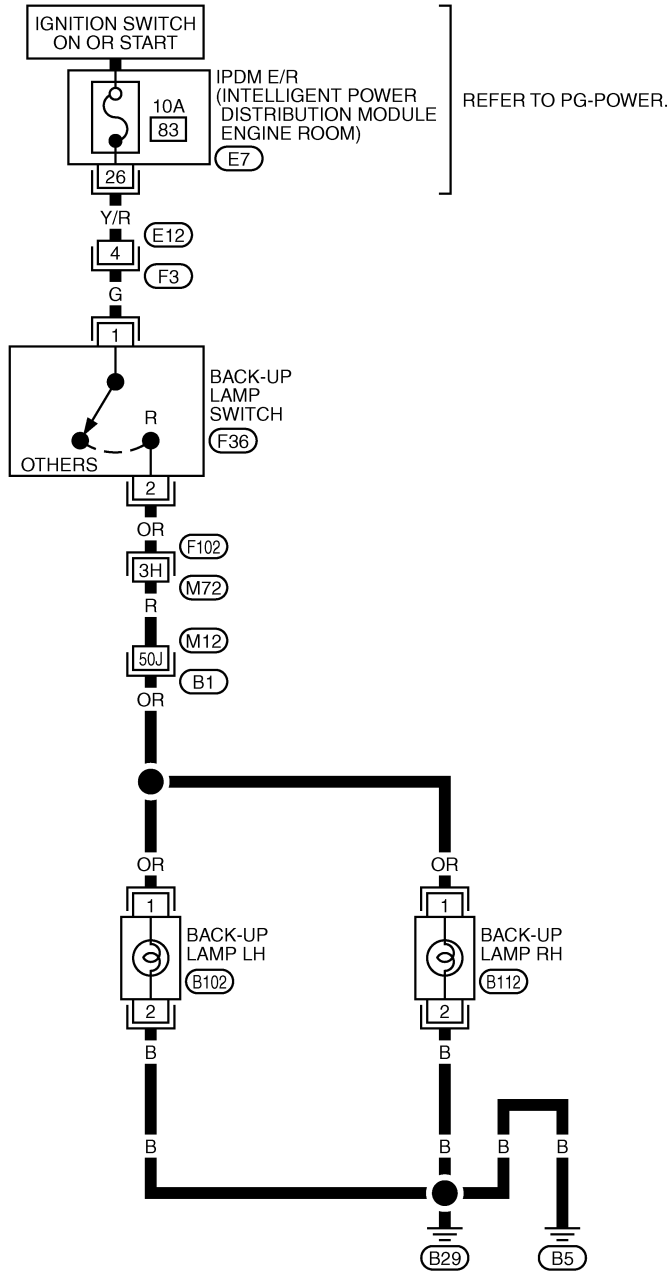

REFER TO THE FOLLOWING.

(F102), (B1) -SUPER MULTIPLE JUNCTION (SMJ)

TKWM2934E

PARKING, LICENSE PLATE AND TAIL LAMPS

PARKING, LICENSE PLATE AND TAIL LAMPS

PPF:26550

Component Parts and Harness Connector Location

AKS009K2

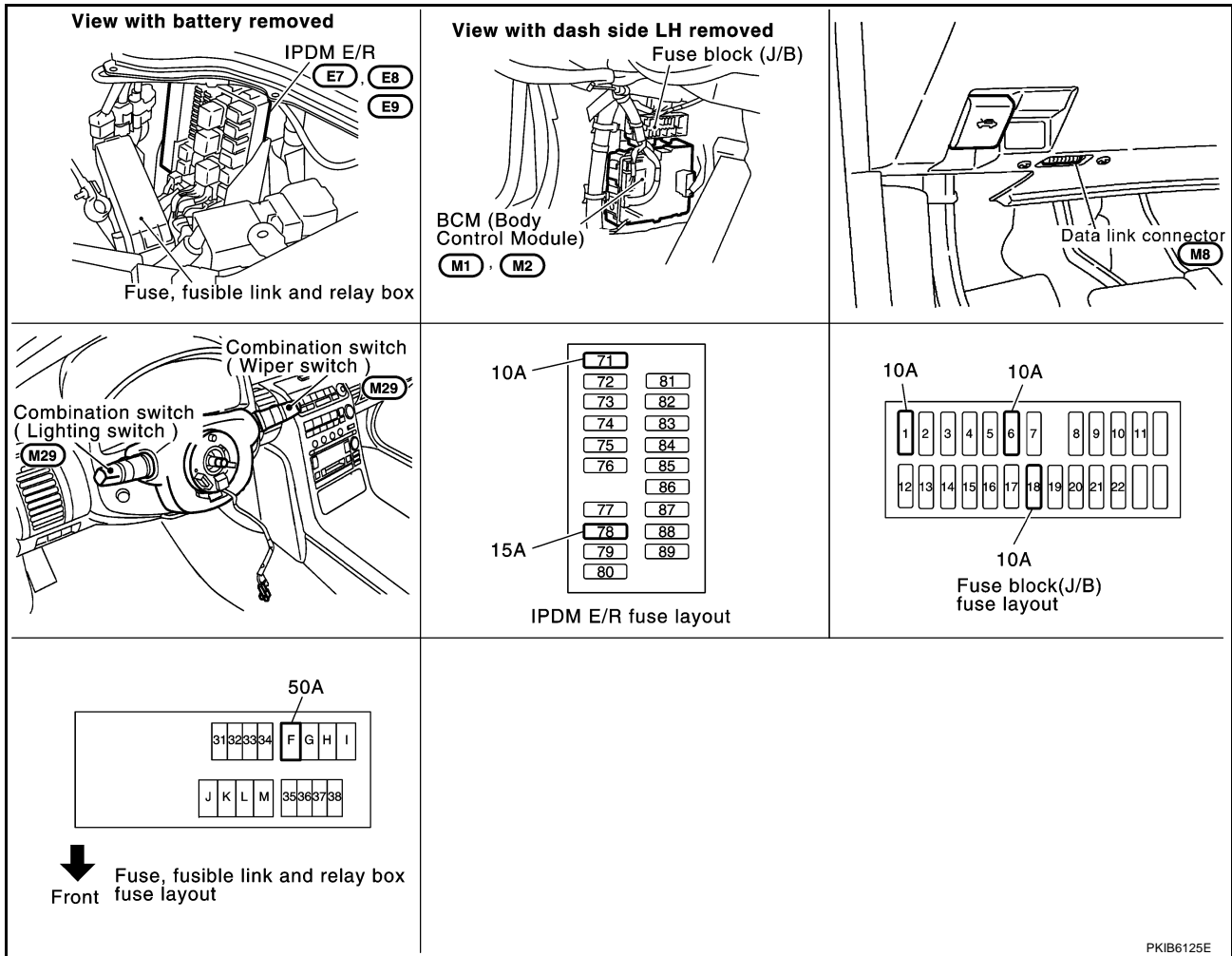

PKIB6125E

System Description

AKS009K6

The control of the parking, license plate, side marker and tail lamp operation is dependent upon the position of lighting switch (combination switch). When the lighting switch is placed in the 1ST position, the BCM (body control module) receives input signal requesting the parking, license plate, side marker and tail lamps to illuminate. This input signal is communicated to the IPDM E/R (intelligent power distribution module engine room) across the CAN communication lines. The CPU (central processing unit) located in the IPDM E/R controls the tail lamp relay coil. This relay, when energized, directs power to parking, license plate, side marker and tail lamps, which then illuminate.

Power is supplied at all times

- through 10A fuse (No. 71, located in IPDM E/R)
- to CPU located in IPDM E/R, and
- to tail lamp relay, located in IPDM E/R,
- through 15A fuse (No. 78 located in IPDM E/R)
- to CPU located in IPDM E/R,
- through 50A fusible link (letter F, located in fuse, fusible link and relay box)
- to BCM terminal 55,
- through 10A fuse [No. 18, located in fuse block (J/B)]
- to BCM terminal 42.

With the ignition switch in the ON or START position, power is supplied

- to CPU located in IPDM E/R, from battery direct,
- through 10A fuse [No. 1, located in fuse block (J/B)]

A
B
C
D
E
F
G
H
I
J

LT

L
M

PARKING, LICENSE PLATE AND TAIL LAMPS

- to BCM terminal 38.

With the ignition switch in the ACC or ON position, power is supplied

- through 10A fuse [No. 6, located in fuse block (J/B)]
- to BCM terminal 11.

Ground is supplied

- to BCM terminal 52
- through grounds M30 and M66,
- to IPDM E/R terminals 38 and 60
- through grounds E17 and E43.

OPERATION BY LIGHTING SWITCH

With the lighting switch in the 1ST or 2ND position (or if auto light system is activated), the BCM receives input signal requesting parking, license plate, side marker and tail lamps to illuminate. This input signal is communicated to the IPDM E/R across CAN communication lines. The CPU located in the IPDM E/R controls tail lamp relay coil, which when energized, directs power

- through IPDM E/R terminal 22
- to front side marker lamp LH terminal 1
- to front combination lamp LH terminal 7
- to license plate lamp LH terminal 1
- to rear combination lamp LH terminal 1
- to front side marker lamp RH terminal 1
- to front combination lamp RH terminal 7
- to license plate lamp RH terminal 1, and
- to rear combination lamp RH terminal 1.

Ground is supplied

- to front side marker lamp LH terminal 2
- through grounds E17 and E43,
- to front combination lamp LH terminal 4
- through grounds E17 and E43,
- to license plate lamp LH terminal 2
- through grounds B5 and B29,
- to rear combination lamp LH terminal 4
- through ground B103,
- to front side marker lamp RH terminal 2
- through grounds E17 and E43,
- to front combination lamp RH terminal 4
- through grounds E17 and E43,
- to license plate lamp RH terminal 2
- through grounds B5 and B29,
- to rear combination lamp RH terminal 4
- through ground B103.

With power and ground supplied, parking, license plate, side marker and tail lamps illuminate.

COMBINATION SWITCH READING FUNCTION

Refer to [BCS-3, "COMBINATION SWITCH READING FUNCTION"](#) .

EXTERIOR LAMP BATTERY SAVER CONTROL

When the combination switch (lighting switch) is in the 1ST or 2ND position (or if auto light system is activated), and ignition switch is turned from ON or ACC to OFF, battery saver control feature is activated.

Under this condition, parking, license plate, side marker and tail lamps remain illuminated for 5 minutes, then the parking, license plate, side marker and tail lamps are turned off.

Exterior lamp battery saver control mode can be changed by the function setting of CONSULT-II.

PARKING, LICENSE PLATE AND TAIL LAMPS

CAN Communication System Description

AKS009K7

CAN (Controller Area Network) is a serial communication line for real time application. It is an on-vehicle multiplex communication line with high data communication speed and excellent error detection ability. Many electronic control units are equipped onto vehicle, and each control unit shares information and links with other control units during operation (not independent). In CAN communication, control units are connected with 2 communication lines (CAN H line, CAN L line) allowing a high rate of information transmission with less wiring. Each control unit transmits/receives data but selectively reads required data only.

CAN Communication Unit

AKS009K8

Refer to [LAN-21, "CAN Communication Unit"](#) .

A

B

C

D

E

F

G

H

I

J

LT

L

M

PARKING, LICENSE PLATE AND TAIL LAMPS

Schematic

AKS009K9

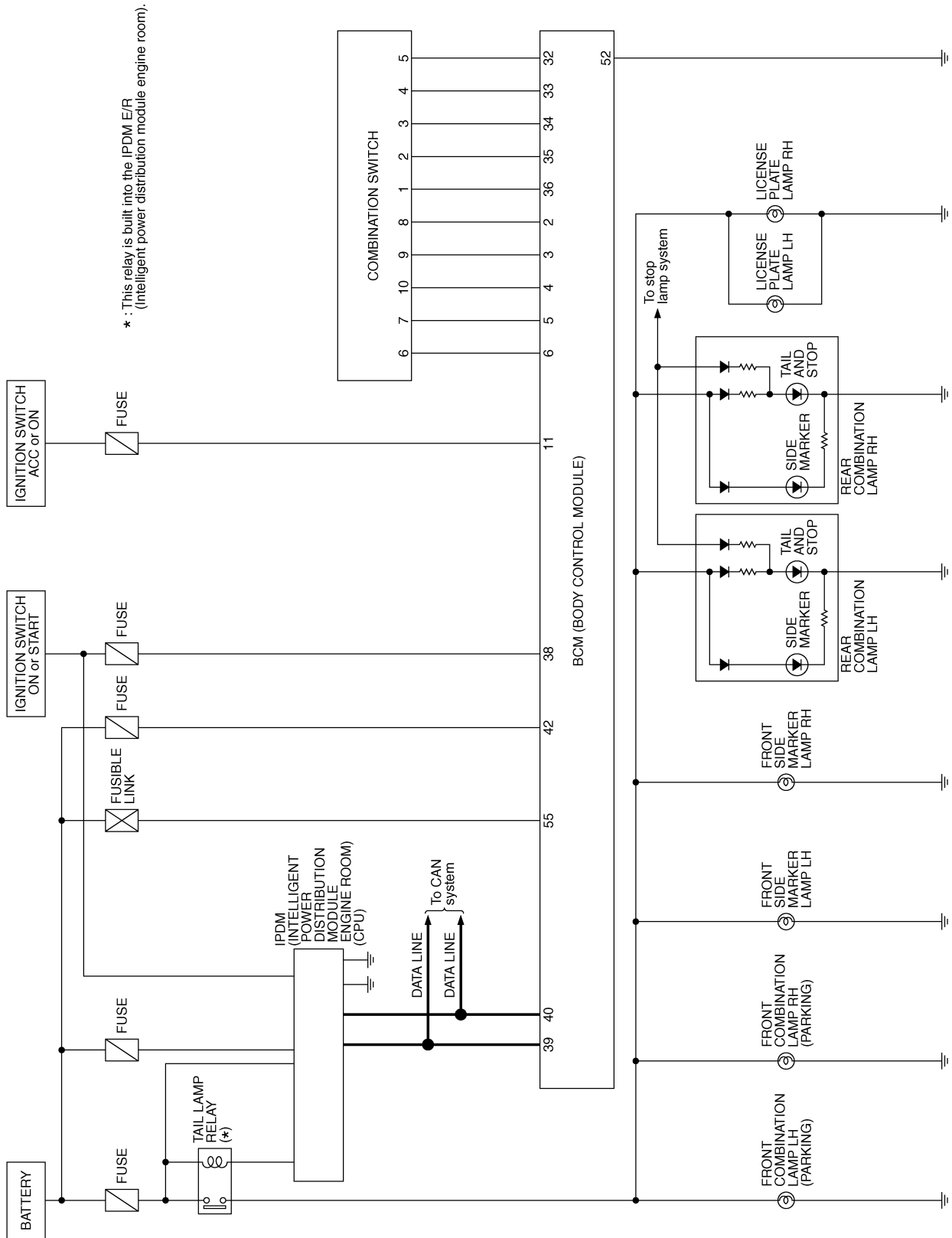

TKWM2529E

PARKING, LICENSE PLATE AND TAIL LAMPS

AKS009KA

Wiring Diagram — TAIL/L —

LT-TAIL/L-01

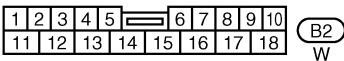
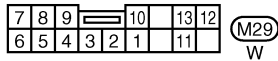
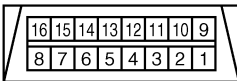
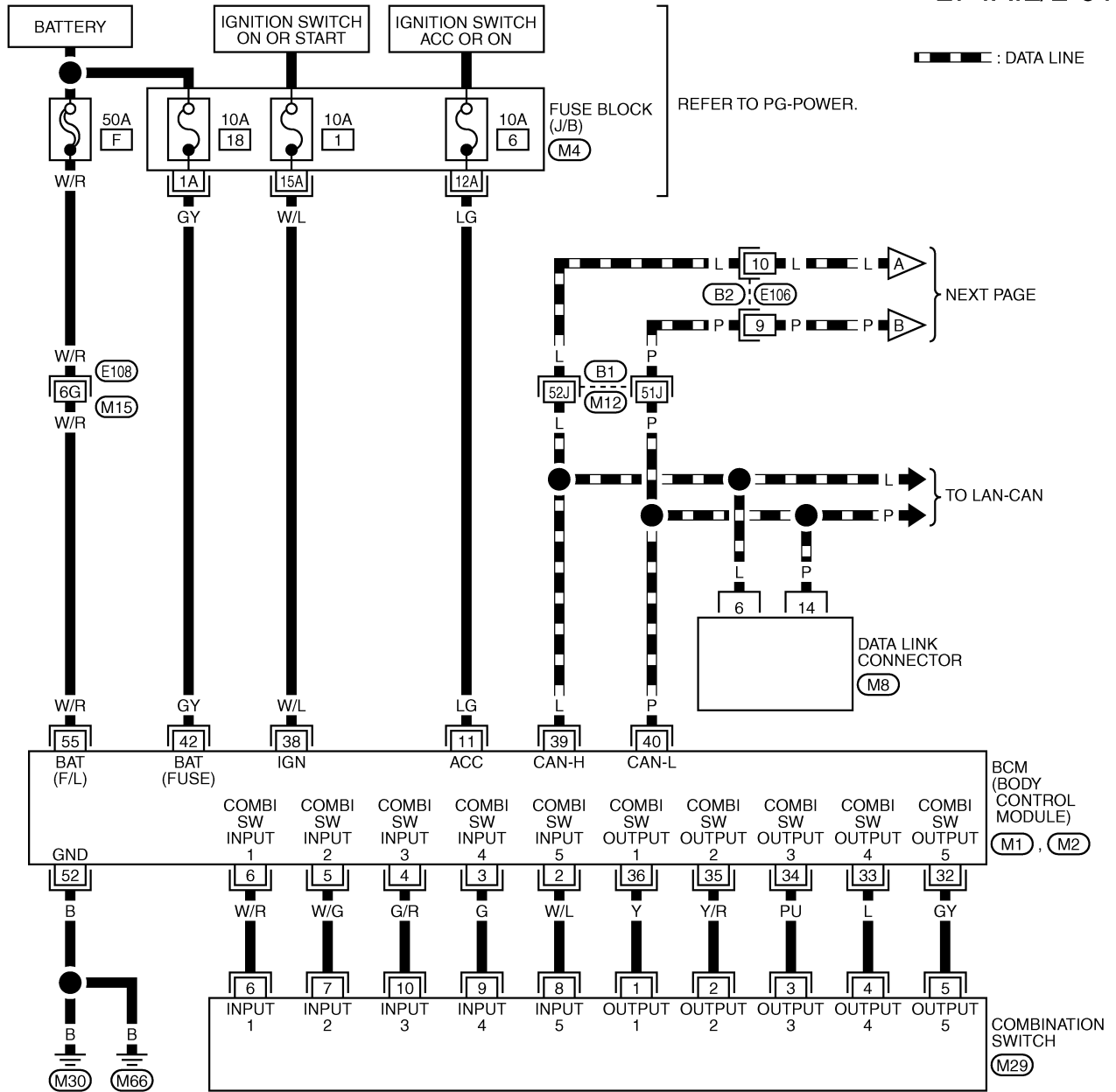

REFER TO THE FOLLOWING.
 (E108), (B1) -SUPER MULTIPLE JUNCTION (SMJ)
 (M4) -FUSE BLOCK-JUNCTION BOX (J/B)
 (M1), (M2) -ELECTRICAL UNITS

TKWM2268E

PARKING, LICENSE PLATE AND TAIL LAMPS

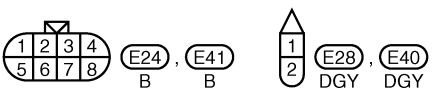
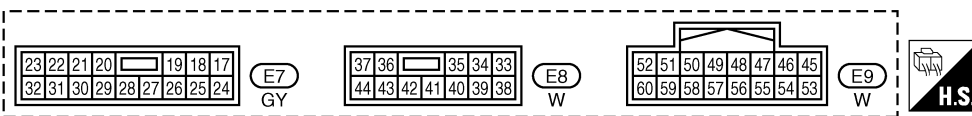
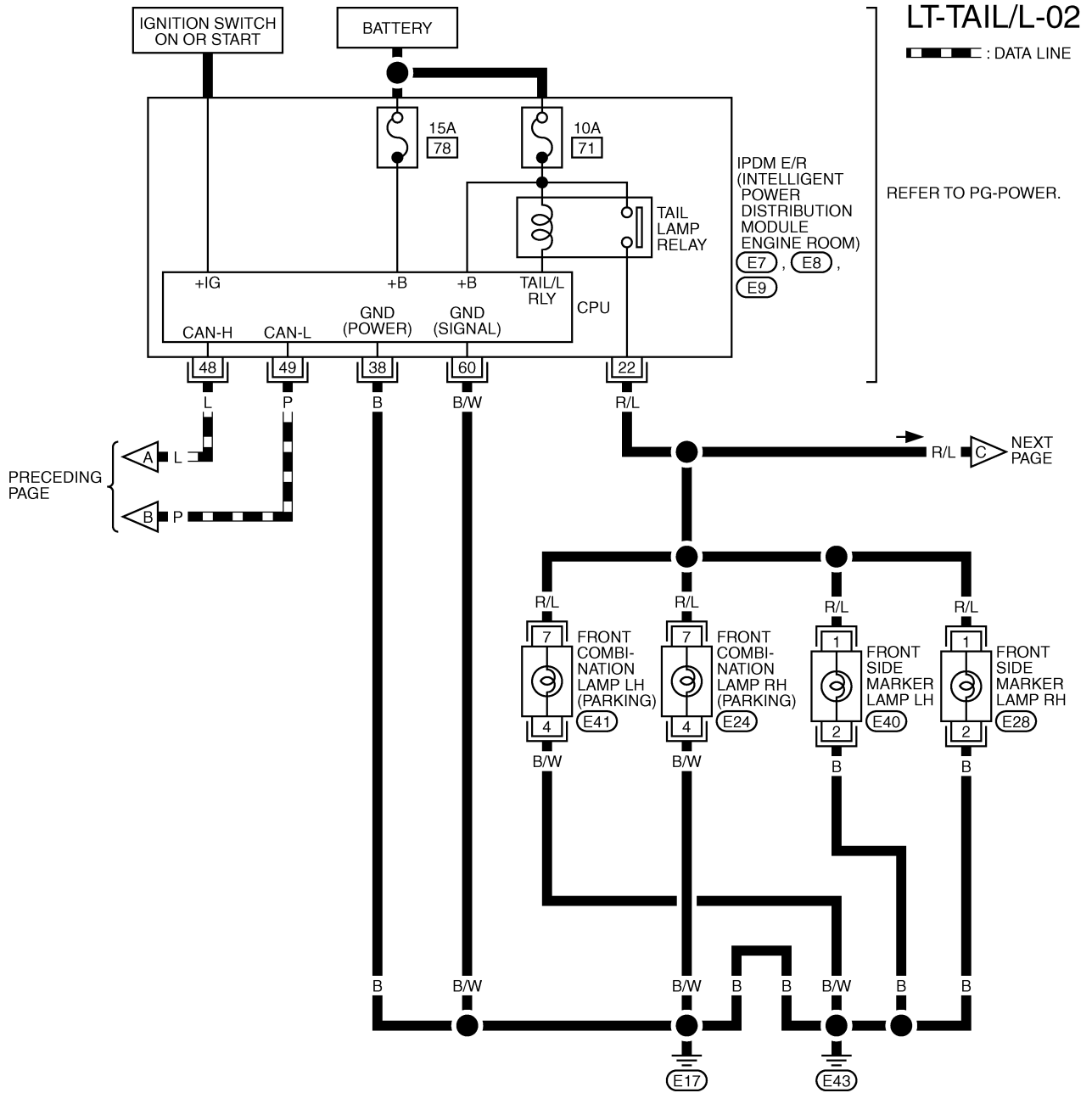

TKWM2269E

PARKING, LICENSE PLATE AND TAIL LAMPS

LT-TAIL/L-03

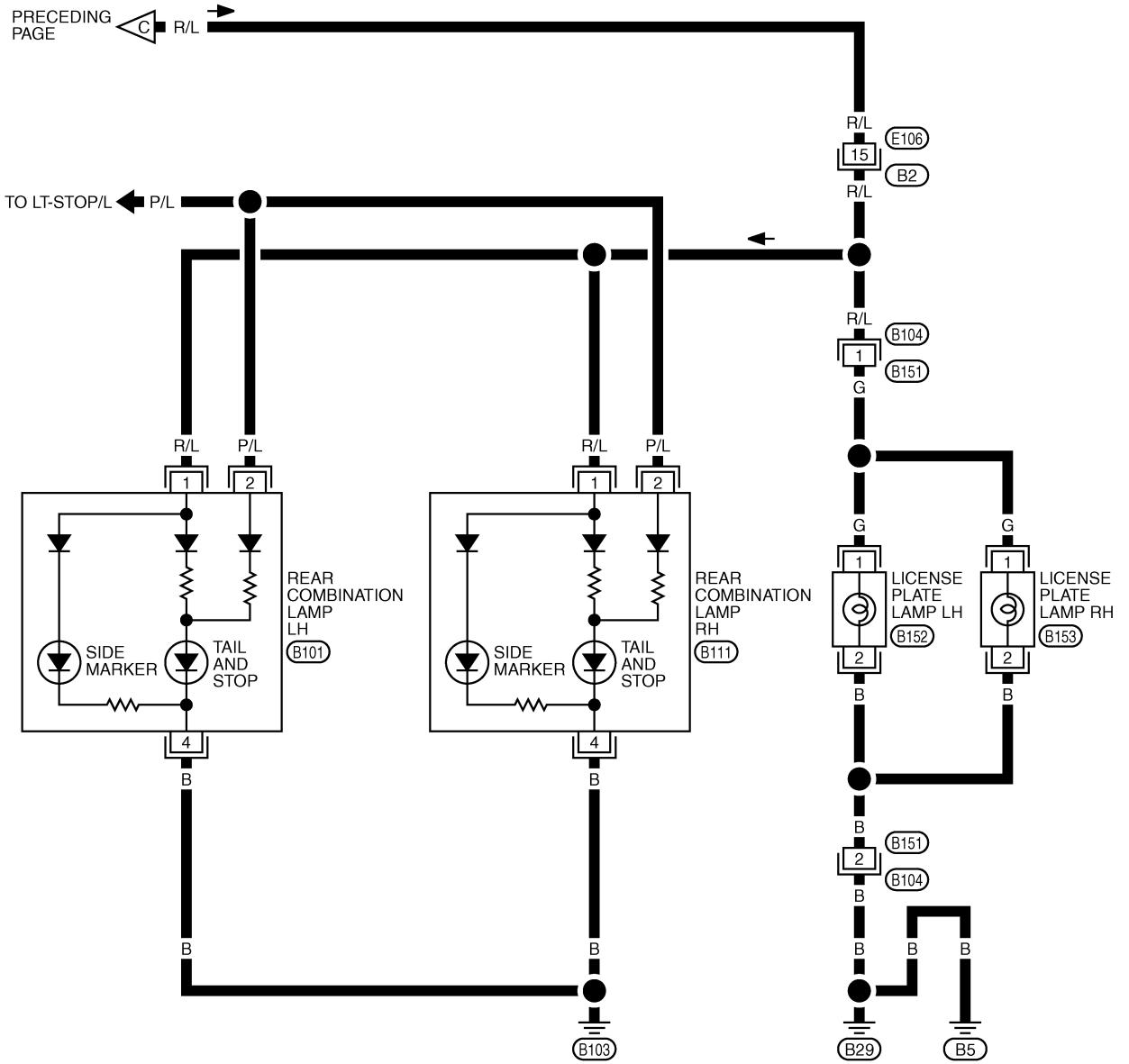

A
B
C
D
E
F
G
H
I
J
LT
L
M

LT

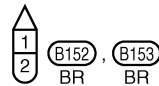
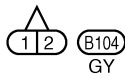
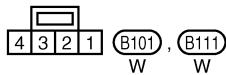
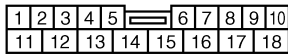



TKWM2270E

PARKING, LICENSE PLATE AND TAIL LAMPS

Terminals and Reference Values for BCM

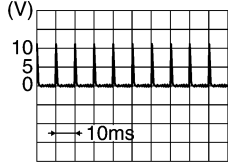
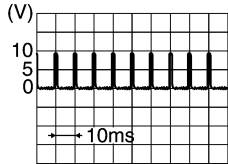
AKS009KB

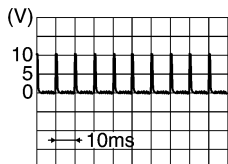
Terminal No.	Wire color	Signal name	Measuring condition		Reference value
			Ignition switch	Operation or condition	
2	W/L	Combination switch input 5	ON	Lighting, turn, wiper OFF Wiper intermittent dial position 4	 <p style="text-align: right;">PKIB3468E</p>
3	G	Combination switch input 4	ON	Lighting, turn, wiper OFF Wiper intermittent dial position 4	 <p style="text-align: right;">PKIB3469E</p>
4	G/R	Combination switch input 3			
5	W/G	Combination switch input 2			
6	W/R	Combination switch input 1			
11	LG	Ignition switch (ACC)	ACC	—	Battery voltage
32	GY	Combination switch output 5	ON	Lighting, turn, wiper OFF Wiper intermittent dial position 4	 <p style="text-align: right;">PKIB3470E</p>
33	L	Combination switch output 4	ON	Lighting, turn, wiper OFF Wiper intermittent dial position 4	 <p style="text-align: right;">PKIB3471E</p>
34	PU	Combination switch output 3			
35	Y/R	Combination switch output 2			
36	Y	Combination switch output 1			
38	W/L	Ignition switch (ON)	ON	—	Battery voltage
39	L	CAN – H	—	—	—
40	P	CAN – L	—	—	—
42	GY	Battery power supply	OFF	—	Battery voltage
52	B	Ground	ON	—	Approx. 0V
55	W/R	Battery power supply	OFF	—	Battery voltage

Terminals and Reference Values for IPDM E/R

AKS009KC

Terminal No.	Wire color	Signal name	Measuring condition		Reference value	
			Ignition switch	Operation or condition		
22	R/L	Parking, license plate, side marker and tail lamp	ON	Lighting switch 1ST position	OFF	Approx. 0V
					ON	Battery voltage
38	B	Ground	ON	—	Approx. 0V	
48	L	CAN – H	—	—	—	
49	P	CAN – L	—	—	—	
60	B/W	Ground	ON	—	Approx. 0V	

PARKING, LICENSE PLATE AND TAIL LAMPS

How to Proceed With Trouble Diagnosis

AKS009KD

1. Confirm the symptom or customer complaint.
2. Understand operation description and function description. Refer to [LT-141, "System Description"](#) .
3. Perform the preliminary check. Refer to [LT-149, "Preliminary Check"](#) .
4. Check symptom and repair or replace the malfunctioning parts.
5. Do the parking, license plate and tail lamps operate normally? If YES, GO TO 6. If NO, GO TO 4.
6. INSPECTION END

Preliminary Check

AKS009KE

CHECK POWER SUPPLY AND GROUND CIRCUIT

1. CHECK FUSES

Check for blown fuses.

Unit	Power source	Fuse and fusible link No.
BCM	Battery	F
		18
	Ignition switch ON or START position	1
	Ignition switch ACC or ON position	6
IPDM E/R	Battery	71

Refer to [LT-145, "Wiring Diagram — TAIL/L —"](#) .

OK or NG

OK >> GO TO 2.

NG >> If fuse or fusible link is blown, be sure to eliminate cause of malfunction before installing new fuse or fusible link. Refer to [PG-3, "POWER SUPPLY ROUTING CIRCUIT"](#) .

2. CHECK POWER SUPPLY CIRCUIT

1. Turn ignition switch OFF.
2. Disconnect BCM connector.
3. Check voltage between BCM harness connector and ground.

Terminal (+)		Terminal (-)	Ignition switch position		
Connector	Terminal (Wire color)		OFF	ACC	ON
M1	11 (LG)	Ground	Approx. 0V	Battery voltage	Battery voltage
	38 (W/L)		Approx. 0V	Approx. 0V	Battery voltage
M2	42 (GY)		Battery voltage	Battery voltage	Battery voltage
	55 (W/R)		Battery voltage	Battery voltage	Battery voltage

OK or NG

OK >> GO TO 3.

NG >> Check harness for open or short between BCM and fuse.

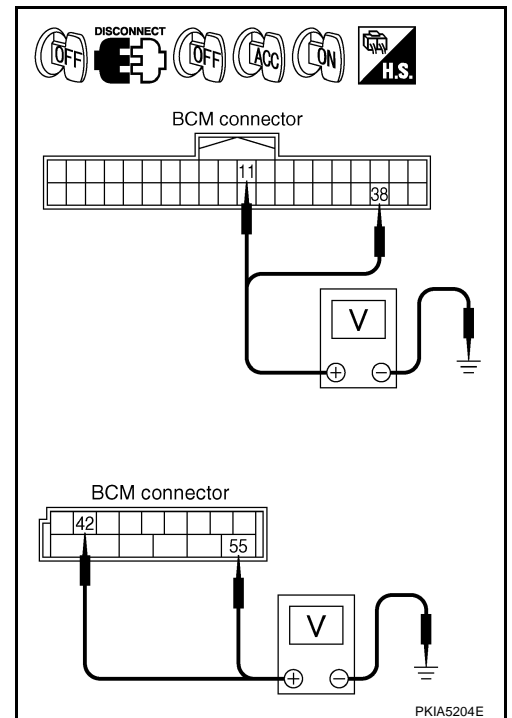

PARKING, LICENSE PLATE AND TAIL LAMPS

3. CHECK GROUND CIRCUIT

Check continuity between BCM harness connector and ground.

Terminal		Ground	Continuity
Connector	Terminal (Wire color)		Yes
M2	52 (B)		

OK or NG

- OK >> INSPECTION END
- NG >> Check harness ground circuit.

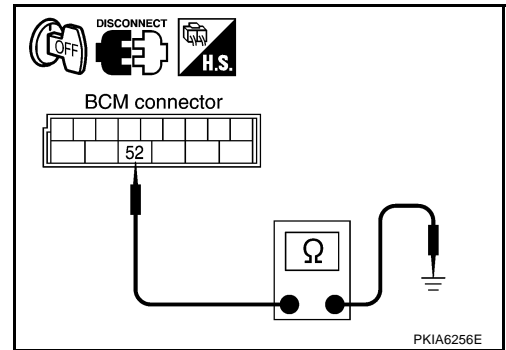

AKS009KF

CONSULT-II Functions (BCM)

Refer to [LT-17, "CONSULT-II Functions \(BCM\)"](#) in HEADLAMP (FOR USA).

Refer to [LT-53, "CONSULT-II Functions \(BCM\)"](#) in HEADLAMP (FOR CANADA).

CONSULT-II Functions (IPDM E/R)

Refer to [LT-20, "CONSULT-II Functions \(IPDM E/R\)"](#) in HEADLAMP (FOR USA).

Refer to [LT-56, "CONSULT-II Functions \(IPDM E/R\)"](#) in HEADLAMP (FOR CANADA).

AKS00CNU

Parking, License Plate and Tail Lamps Do Not Illuminate

AKS009KG

1. CHECK COMBINATION SWITCH INPUT SIGNAL

Ⓟ With CONSULT-II

Select "BCM" on CONSULT-II. With "HEAD LAMP" data monitor, make sure "LIGHT SW 1 ST" turns ON-OFF linked with operation of lighting switch.

When lighting switch is 1ST : LIGHT SW 1 ST ON position

ⓧ Without CONSULT-II

Refer to [LT-133, "Combination Switch Inspection"](#).

OK or NG

- OK >> GO TO 2.
- NG >> Check combination switch (lighting switch). Refer to [LT-133, "Combination Switch Inspection"](#).

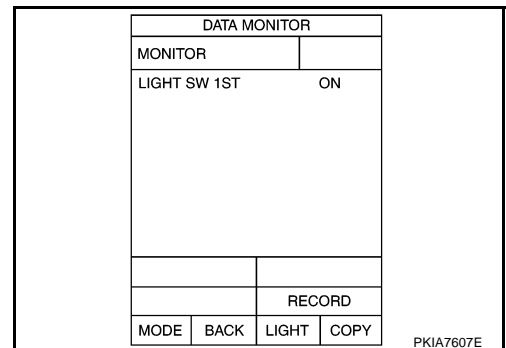

PKIA7607E

PARKING, LICENSE PLATE AND TAIL LAMPS

2. ACTIVE TEST

☑ With CONSULT-II

1. Select "IPDM E/R" on CONSULT-II, and select "ACTIVE TEST" on "SELECT DIAG MODE" screen.
2. Select "TAIL LAMP" on "SELECT TEST ITEM" screen.
3. Touch "ON" screen.
4. Make sure parking, license plate, side marker and tail lamp operates.

Parking, license plate, side marker and tail lamp should operate

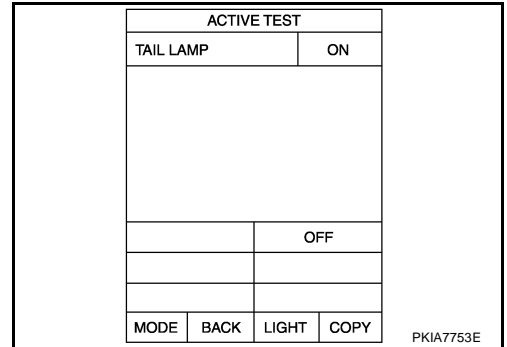

☒ Without CONSULT-II

1. Start auto active test. Refer to [PG-22, "Auto Active Test"](#).
2. Make sure parking, license plate, side marker and tail lamp operates.

Parking, license plate, side marker and tail lamp should operate

OK or NG

- OK >> GO TO 3.
 NG >> GO TO 4.

3. CHECK IPDM E/R

1. Select "IPDM E/R" on CONSULT-II, and select "DATA MONITOR" on "SELECT DIAG MODE" screen.
2. Make sure "TAIL & CLR REQ" turns ON when lighting switch is in 1ST position.

When lighting switch is 1ST : TAIL & CLR REQ ON position

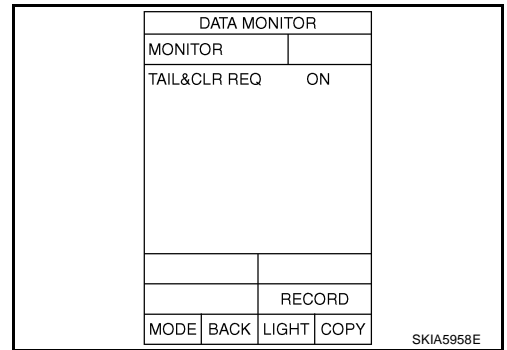

OK or NG

- OK >> Replace IPDM E/R.
 NG >> Replace BCM. Refer to [BCS-16, "Removal and Installation of BCM"](#).

A
B
C
D
E
F
G
H
I
J
K
L
M

LT

PARKING, LICENSE PLATE AND TAIL LAMPS

4. CHECK INPUT SIGNAL

④ With CONSULT-II

1. Turn ignition switch OFF.
2. Disconnect front side marker lamp RH and LH, front combination lamp RH and LH, license plate lamp RH and LH, and rear combination lamp RH and LH connectors.
3. Select "IPDM E/R" on CONSULT-II, and select "ACTIVE TEST" on "SELECT DIAG MODE" screen.
4. Select "TAIL LAMP" on "SELECT TEST ITEM" screen.
5. Touch "ON" screen.
6. When tail lamp relay is operating, check voltage between front side marker lamp, front combination lamp, license plate lamp and rear combination lamp harness connector and ground.

⊗ Without CONSULT-II

1. Turn ignition switch OFF.
2. Disconnect front side marker lamp RH and LH, front combination lamp RH and LH, license plate lamp RH and LH, and rear combination lamp RH and LH connectors.
3. Start auto active test. Refer to [PG-22, "Auto Active Test"](#).
4. When tail lamp relay is operating, check voltage between front side marker lamp, front combination lamp, license plate lamp and rear combination lamp harness connector and ground.

Terminal				Voltage
Front side marker lamp (+)		(-)		
Connector	Terminal (Wire color)			
RH	E28	1 (R/L)	Ground	Battery voltage
LH	E40			

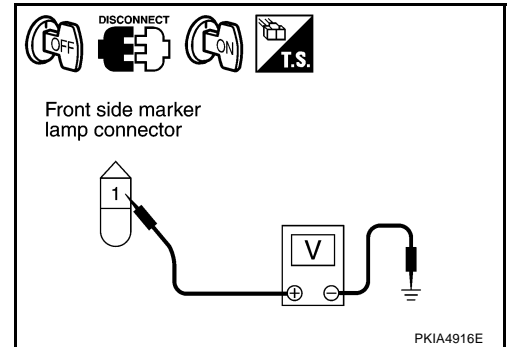

Terminal				Voltage
Front combination lamp (+) (Parking)		(-)		
Connector	Terminal (Wire color)			
RH	E24	7 (R/L)	Ground	Battery voltage
LH	E41			

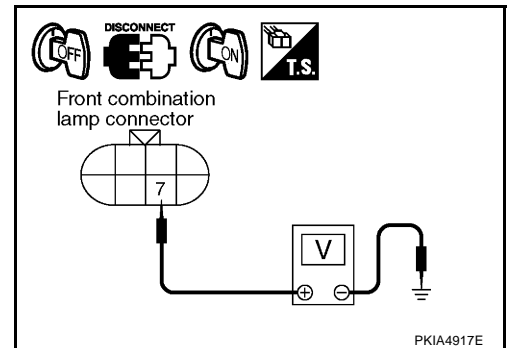

Terminal				Voltage
License plate lamp (+)		(-)		
Connector	Terminal (Wire color)			
RH	B153	1 (G)	Ground	Battery voltage
LH	B152			

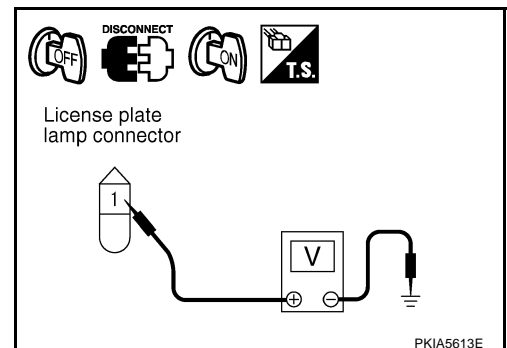

PARKING, LICENSE PLATE AND TAIL LAMPS

Terminal				Voltage
Rear combination lamp (+) (Tail and side marker)			(-)	
Connector		Terminal (Wire color)		
RH	B111	1 (R/L)		
LH	B101			

OK or NG

- OK >> GO TO 6.
- NG >> GO TO 5.

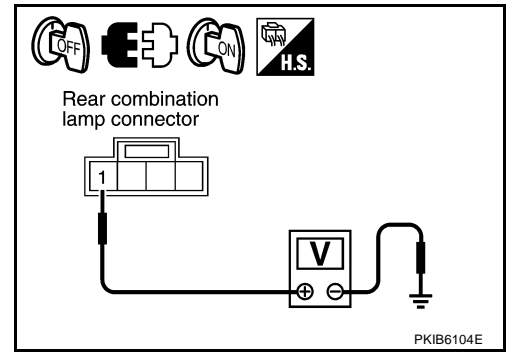

A
B
C
D
E
F
G
H
I
J
LT
L
M

LT

PARKING, LICENSE PLATE AND TAIL LAMPS

5. CHECK PARKING, LICENSE PLATE AND TAIL LAMP CIRCUIT

1. Turn ignition switch OFF.
2. Disconnect IPDM E/R connector.
3. Check continuity between IPDM E/R harness connector and front side marker lamp harness connector.

Terminal					Continuity
IPDM E/R		Front side marker lamp			
Connector	Terminal (Wire color)	Connector	Terminal (Wire color)		
E7	22 (R/L)	RH	E28	1 (R/L)	Yes
		LH	E40		

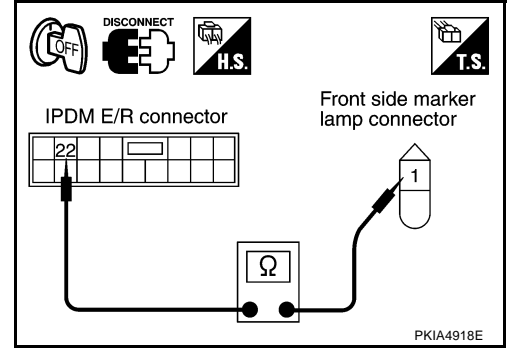

4. Check continuity between IPDM E/R harness connector and front combination lamp harness connector.

Terminal					Continuity
IPDM E/R		Front combination lamp (Parking)			
Connector	Terminal (Wire color)	Connector	Terminal (Wire color)		
E7	22 (R/L)	RH	E24	7 (R/L)	Yes
		LH	E41		

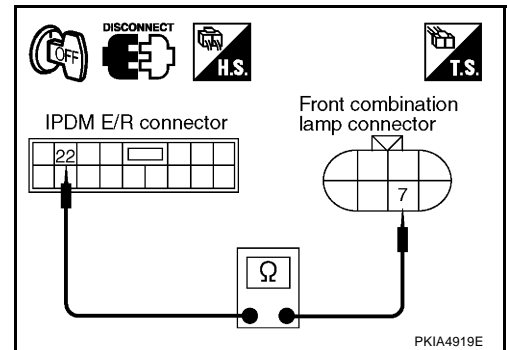

5. Check continuity between IPDM E/R harness connector and license plate lamp harness connector.

Terminal					Continuity
IPDM E/R		License plate lamp			
Connector	Terminal (Wire color)	Connector	Terminal (Wire color)		
E7	22 (R/L)	RH	B153	1 (G)	Yes
		LH	B152		

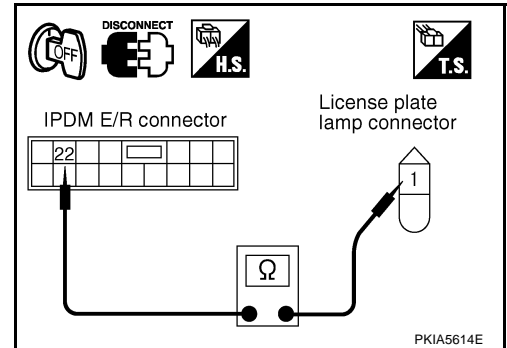

6. Check continuity between IPDM E/R harness connector and rear combination lamp harness connector.

Terminal					Continuity
IPDM E/R		Rear combination lamp (Tail and side marker)			
Connector	Terminal (Wire color)	Connector	Terminal (Wire color)		
E7	22 (R/L)	RH	B111	1 (R/L)	Yes
		LH	B101		

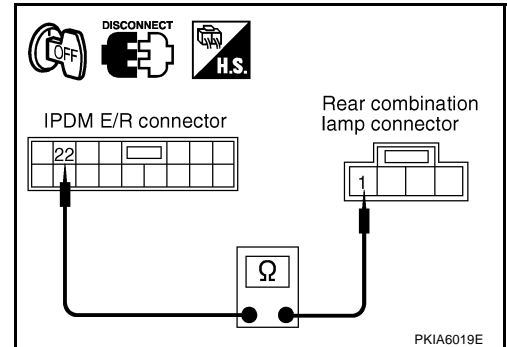

OK or NG

- OK >> Replace IPDM E/R.
 NG >> Repair harness or connector.

PARKING, LICENSE PLATE AND TAIL LAMPS

6. CHECK GROUND

1. Check continuity between front side marker lamp harness connector and ground.

Terminal			Ground	Continuity
Front side marker lamp				
Connector		Terminal (Wire color)	Ground	Yes
RH	E28	2 (B)		
LH	E40			

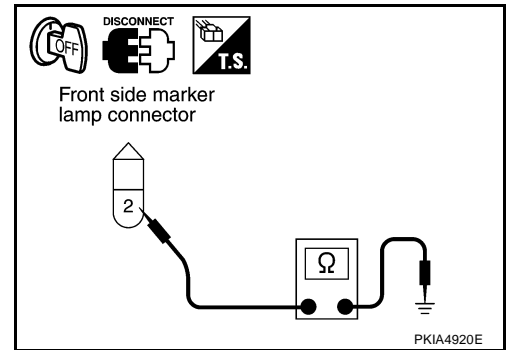

2. Check continuity between front combination lamp harness connector and ground.

Terminal			Ground	Continuity
Front combination lamp (Parking)				
Connector		Terminal (Wire color)	Ground	Yes
RH	E24	4 (B/W)		
LH	E41			

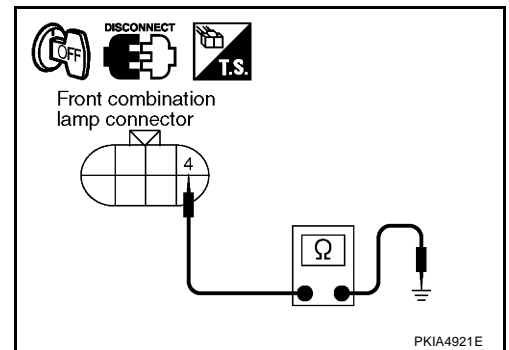

3. Check continuity between license plate lamp harness connector and ground.

Terminal			Ground	Continuity
License plate lamp				
Connector		Terminal (Wire color)	Ground	Yes
RH	B153	2 (B)		
LH	B152			

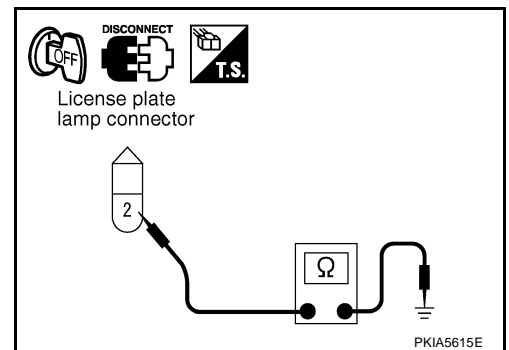

4. Check continuity between rear combination lamp harness connector and ground.

Terminal			Ground	Continuity
Rear combination lamp (Tail and side marker)				
Connector		Terminal (Wire color)	Ground	Yes
RH	B111	4 (B)		
LH	B101			

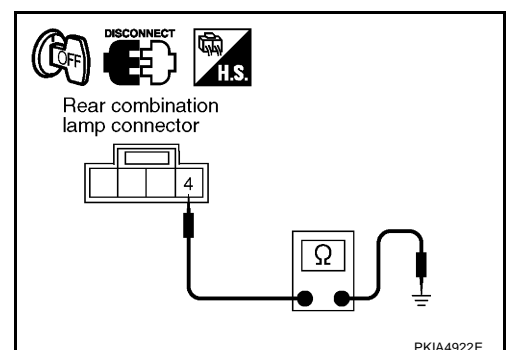

OK or NG

- OK >> Check bulb or replace rear combination lamp.
- NG >> Repair harness or connector.

Parking, License Plate, Side marker and Tail Lamps Do Not Turn OFF (After Approx. 10 Minutes)

AKS004R0

- This symptom indicates the malfunction of ignition relay in IPDM E/R. Refer to [PG-17, "Function of Detecting Ignition Relay Malfunction"](#).

PARKING, LICENSE PLATE AND TAIL LAMPS

- Select "BCM" on CONSULT-II. Select "HEADLAMP" on "SELECT TEST ITEM" screen and select "DATA MONITOR" on "SELECT DIAG MODE" screen. If "LIGHT SW 1ST" is OFF when lighting switch is OFF, replace IPDM E/R.

Bulb Replacement FRONT SIDE MARKER LAMP

AKS0051D

1. Remove front side marker lamp. Refer to [LT-156, "FRONT SIDE MARKER LAMP"](#).
2. Turn bulb socket left to release lock and remove it.
3. Remove bulb.

Front side marker lamp : 12V - 3.8W

4. Installation is the reverse order of removal.

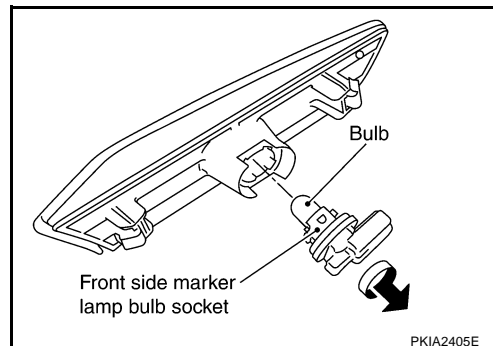

LICENSE PLATE LAMP

1. Remove license plate lamp. Refer to [LT-157, "Removal"](#).
2. Turn bulb socket counterclockwise and unlock it.
3. Remove bulb from it's socket.

License plate lamp : 12V - 5W

4. Installation is the reverse order of removal.

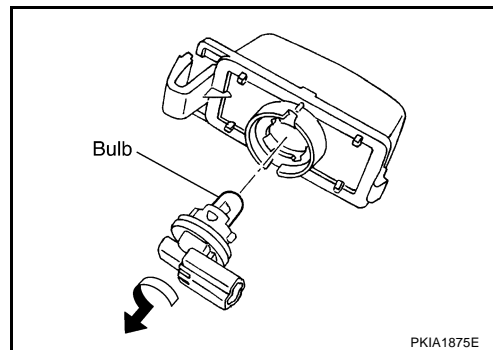

FRONT TURN SIGNAL (PARKING) LAMP

For bulb replacement, refer to [LT-33, "Bulb Replacement"](#) in "HEADLAMP (FOR USA)".

TAIL LAMP

For bulb replacement, refer to [LT-158, "Bulb Replacement"](#) in "REAR COMBINATION LAMP".

Removal and Installation FRONT SIDE MARKER LAMP

AKS0051E

Removal

1. Insert a slotted screwdriver or similar tool into fender protector gap to push front side marker lamp metal clip in direction 1 (see figure) while pulling in direction 2. Remove front side marker lamp from vehicle.
2. Disconnect side marker lamp connector.

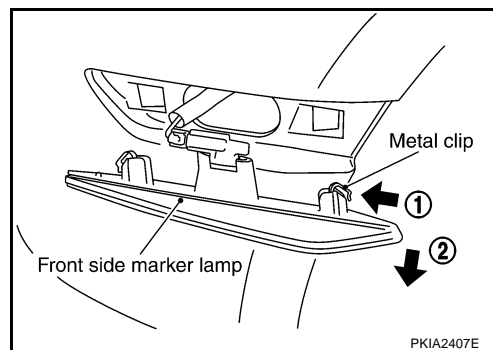

Installation

Installation is the reverse order of removal.

PARKING, LICENSE PLATE AND TAIL LAMPS

LICENSE PLATE LAMP

Removal

1. While pressing pawl on reverse side, push license plate towards you to remove.
2. Disconnect license plate lamp connector.

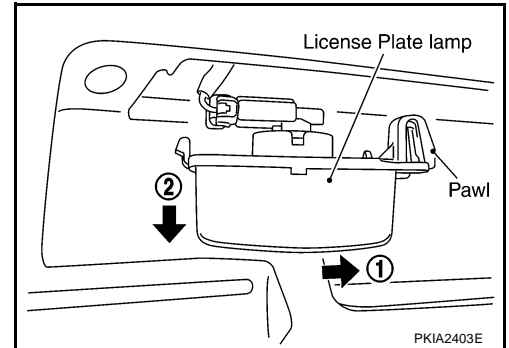

Installation

Installation is the reverse order of removal.

FRONT TURN SIGNAL (PARKING) LAMP

For front turn signal (parking) lamp removal and installation procedures, refer to [LT-34, "Removal and Installation"](#) in "HEADLAMP (FOR USA)".

TAIL LAMP

Removal

For tail lamp removal and installation procedures, refer to [LT-158, "Removal and Installation"](#) in "REAR COMBINATION LAMP".

A
B
C
D
E
F
G
H
I
J
LT
L
M

REAR COMBINATION LAMP

REAR COMBINATION LAMP

PFP:26554

Bulb Replacement

AKS00AB3

REAR FENDER SIDE (REAR TURN SIGNAL LAMP BULB)

1. Open trunk and remove trunk rear finisher. Refer to [EI-47, "TRUNK ROOM TRIM & TRUNK LID FINISHER"](#) in "EI" section.
2. Turn bulb socket counterclockwise and unlock it.
3. Remove bulb.
4. Installation is the reverse order of removal.

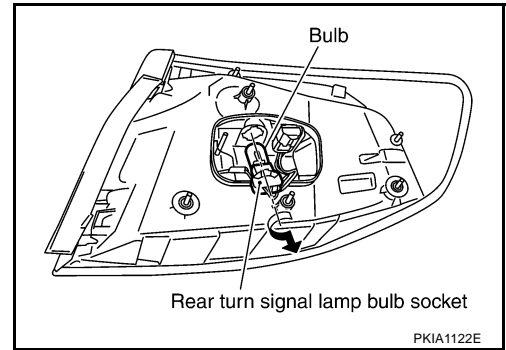

TRUNK LID SIDE (BACK-UP LAMP)

1. Remove trunk lid finisher. Refer to [EI-47, "TRUNK ROOM TRIM & TRUNK LID FINISHER"](#) in "EI" section.
2. Turn bulb socket counterclockwise and unlock it.
3. Remove bulb.
4. Installation is the reverse order of removal.

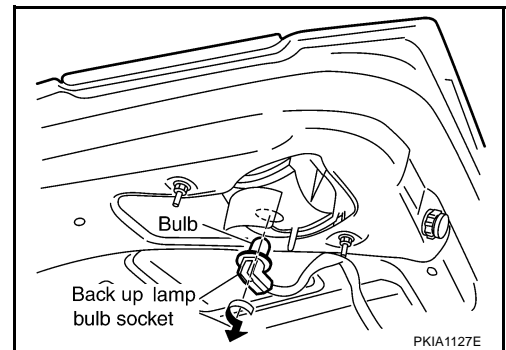

Stop/tail lamp (rear fender side)	: LED
	(Replace together with rear combination lamp assembly.)
Rear turn signal lamp (rear fender side)	: 12V - 21W
Back-up lamp (trunk lid side)	: 12V - 18W
Rear side marker lamp (rear fender side)	: LED
	(Replace together with rear combination lamp assembly.)

Removal and Installation

REMOVAL

AKS00AB4

Rear Fender Side

1. Open trunk and remove trunk rear finisher. Refer to [EI-47, "TRUNK ROOM TRIM & TRUNK LID FINISHER"](#) in "EI" section.
2. Disconnect rear combination lamp connector.
3. Remove rear combination lamp installation nuts.
4. Pull the rear combination lamp toward rear of vehicle and remove from vehicle.
5. Remove seal packing from vehicle.

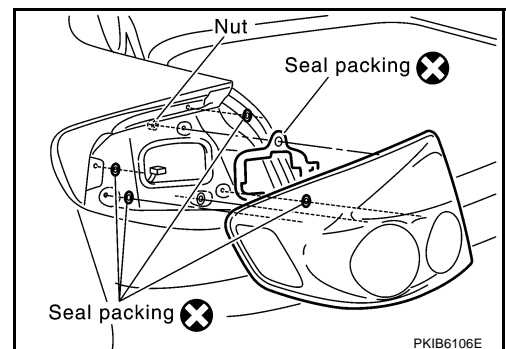

REAR COMBINATION LAMP

Trunk Lid Side

1. Remove trunk lid finisher. Refer to [EI-47, "TRUNK ROOM TRIM & TRUNK LID FINISHER"](#) in "EI" section.
2. Disconnect rear combination lamp connector.
3. Remove rear combination lamp installation nuts.
4. Remove rear combination lamp from trunk lid.
5. Remove seal packing from trunk lid.

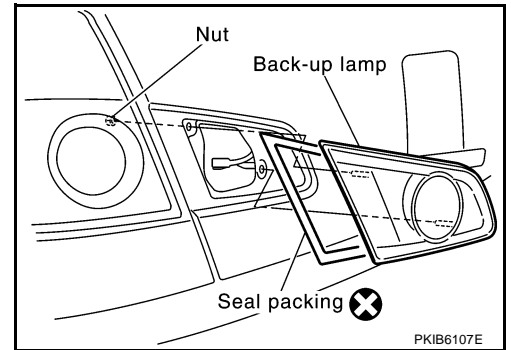

INSTALLATION

Installation is the reverse order of removal.

- Install a new seal packing to rear combination lamp.

CAUTION:

Seal packing cannot be reused.

Rear combination lamp mounting nut  : 3.2 N·m (0.33 kg·m, 28 in·lb)

A
B
C
D
E
F
G
H
I
J
LT
L
M

VANITY MIRROR LAMP

VANITY MIRROR LAMP

PFP:96400

Bulb Replacement

AKS000N3

Wiring diagram. Refer to [LT-175, "Wiring Diagram — ROOM/L —"](#) .

1. Insert a thin screwdriver in lens end and remove lens.
2. Remove bulb together with substrate.

Vanity mirror lamp : 12V - 1.32W

3. Installation is the reverse order of removal.

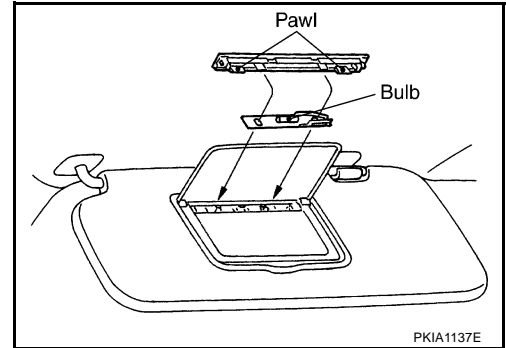

MAP LAMP

MAP LAMP

PFP:26430

Bulb Replacement

AKS0092S

Wiring diagram. Refer to [LT-175, "Wiring Diagram — ROOM/L —"](#) .

1. Insert a small screwdriver into lens hinge gap and remove lens.
2. Remove bulb.

Map lamp : 12V - 8W

3. Installation is the reverse order of removal.

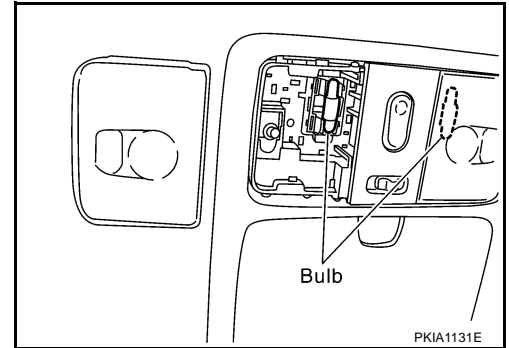

Removal and Installation

REMOVAL

1. Insert a clip driver or a suitable tool and disengage the pawl fittings of the map lamp.
2. Disconnect connector and remove map lamp.

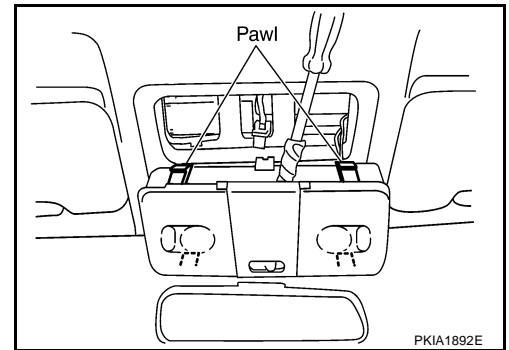

INSTALLATION

Installation is the reverse order of removal.

A
B
C
D
E
F
G
H
I
J
LT
L
M

TRUNK ROOM LAMP

TRUNK ROOM LAMP

PFP:26470

Bulb Replacement, Removal and Installation REMOVAL

AKS0092V

Wiring diagram. Refer to [LT-175, "Wiring Diagram — ROOM/L —"](#).

1. Unfold pawl A and remove lens.
2. Remove trunk room lamp while pressing pawl B in the direction of the arrow.
3. Disconnect trunk room lamp connector.

Trunk room lamp : 12V - 3.4W

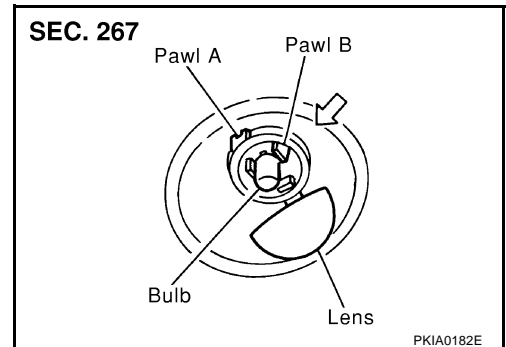

INSTALLATION

Installation is the reverse order of removal.

PERSONAL LAMP

PERSONAL LAMP

PFP:26415

Bulb Replacement

AKS000MY

Wiring diagram. Refer to [LT-175, "Wiring Diagram — ROOM/L —"](#) .

1. Remove personal lamp. Refer to [LT-163, "Removal and Installation"](#) .
2. Insert a screwdriver or similar tool and remove lens.
3. Remove bulb.

Personal lamp : 12V - 8W

4. Installation is the reverse order of removal.

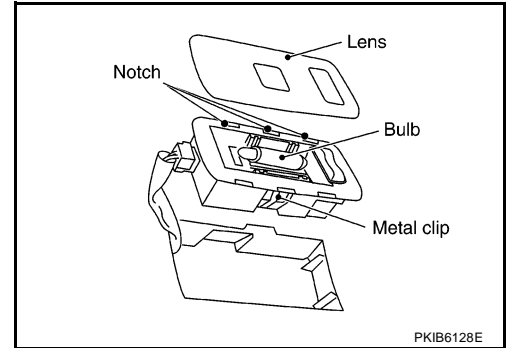

AKS000MZ

Removal and Installation

REMOVAL

1. Use a clip driver or similar tool to press metal clip and remove personal lamp.
2. Disconnect personal lamp connector.

INSTALLATION

Installation is the reverse order of removal.

A
B
C
D
E
F
G
H
I
J
LT
L
M

IGNITION KEY HOLE ILLUMINATION

PFP:48476

AKS000JY

IGNITION KEY HOLE ILLUMINATION

Removal and Installation

REMOVAL (WITHOUT INTELLIGENT KEY SYSTEM)

Wiring diagram. Refer to [LT-175, "Wiring Diagram — ROOM/L —"](#) .

1. Remove cluster lid A and steering lock escutcheon. Refer to [IP-10, "INSTRUMENT PANEL ASSEMBLY"](#) in "IP" section.
2. Pull out ring, turn bulb socket to left to release lock and remove it.

Ignition key hole illumination : 12V - 1.4W

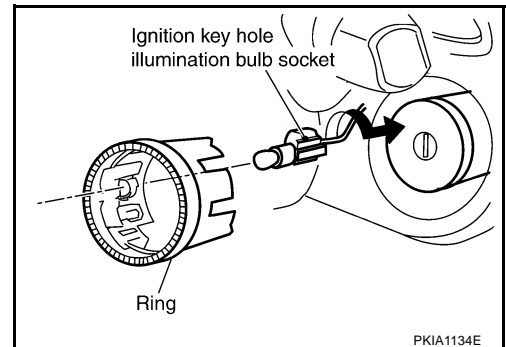

REMOVAL (WITH INTELLIGENT KEY SYSTEM)

Wiring diagram. Refer to [LT-175, "Wiring Diagram — ROOM/L —"](#) .

1. Remove instrument lower driver panel. Refer to [IP-10, "INSTRUMENT PANEL ASSEMBLY"](#) in "IP" section.
2. Turn bulb socket to left to release lock and remove it.

Ignition key hole illumination : 12V - 1.4W

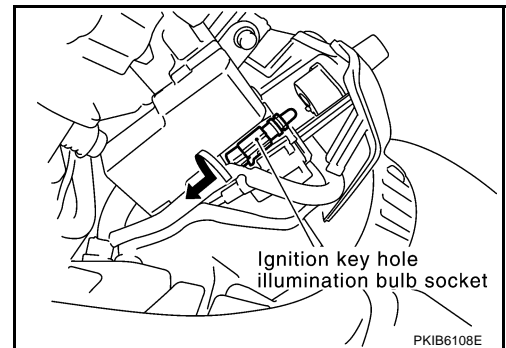

INSTALLATION

Installation is the reverse order of removal.

GLOVE BOX LAMP

GLOVE BOX LAMP

PFP:68520

Bulb Replacement, Removal and Installation REMOVAL

AKS000JZ

Wiring diagram. Refer to [LT-196, "Wiring Diagram — ILL —"](#).

1. Remove instrument lower passenger panel. Refer to [IP-10, "INSTRUMENT PANEL ASSEMBLY"](#) in "IP" section.
2. Turn bulb socket left to release lock and remove it.

Glove box lamp : 12V - 1.4W

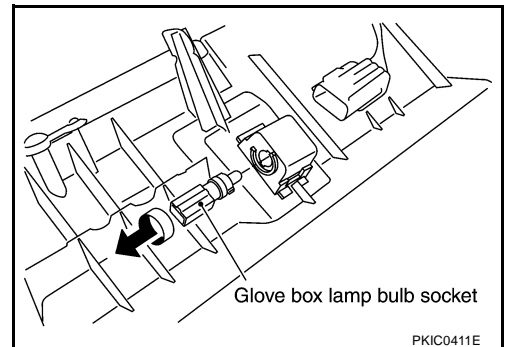

INSTALLATION

Installation is the reverse order of removal.

A
B
C
D
E
F
G
H
I
J
LT
L
M

ASHTRAY ILLUMINATION

ASHTRAY ILLUMINATION

PFP:25860

Bulb Replacement, Removal and Installation REMOVAL

AKS00AB6

Wiring diagram. Refer to [LT-196, "Wiring Diagram — ILL —"](#).

1. Remove console finisher (A/T) or console boot (M/T). Refer to [IP-10, "INSTRUMENT PANEL ASSEMBLY"](#) in "IP" section.
2. Turn bulb socket to left to release lock and remove it.

Ashtray illumination : 12V - 1.4W

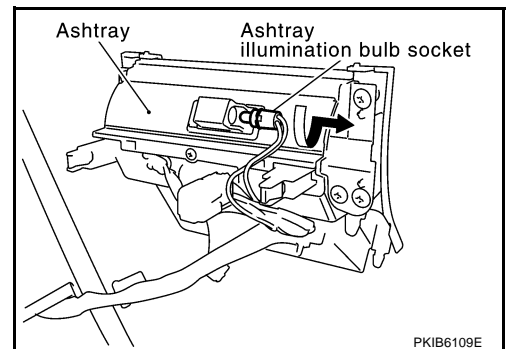

INSTALLATION

Installation is the reverse order of removal.

CIGARETTE LIGHTER ILLUMINATION

CIGARETTE LIGHTER ILLUMINATION

PFP:25331

Bulb Replacement, Removal and Installation REMOVAL

AKS000K1

Wiring diagram. Refer to [LT-196, "Wiring Diagram — ILL —"](#).

1. Remove console finisher (A/T) or console boot (M/T). Refer to [IP-10, "INSTRUMENT PANEL ASSEMBLY"](#) in "IP" section.
2. Open hooks and remove bulb socket.

Cigarette lighter illumination : 12V - 0.8W

CAUTION:

When replacing bulb, replace assembly together with illumination ring.

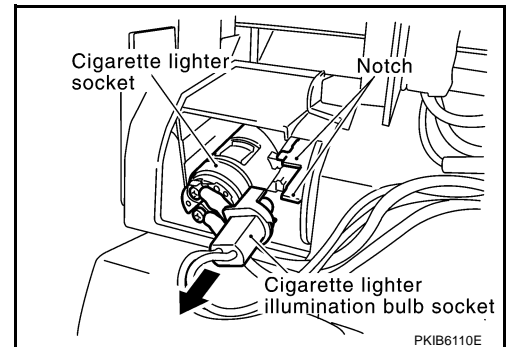

INSTALLATION

Installation is the reverse order of removal.

A
B
C
D
E
F
G
H
I
J
LT
L
M

INTERIOR ROOM LAMP

PF2:26410

INTERIOR ROOM LAMP

Component Parts and Harness Connector Location

AKS005PZ

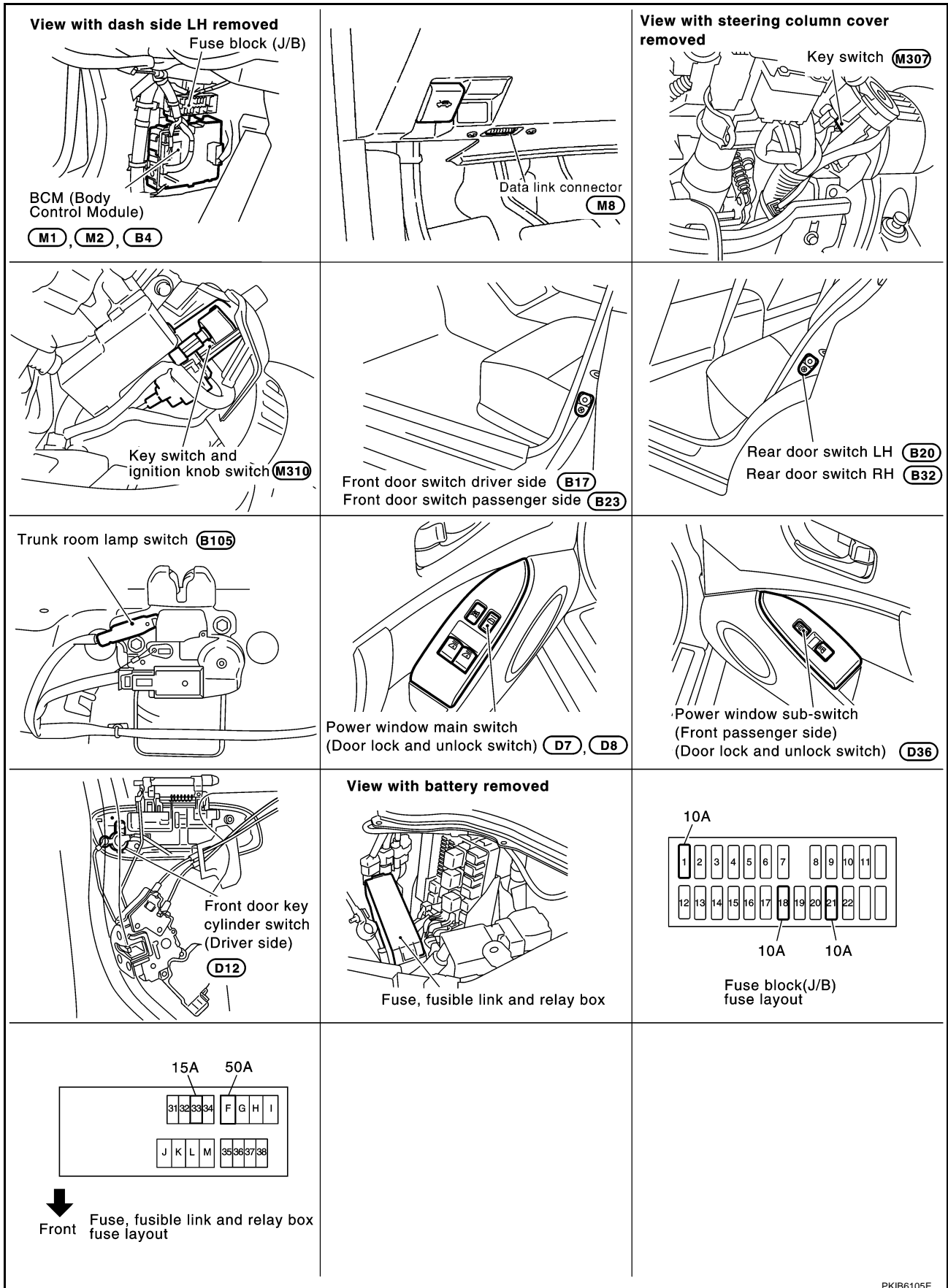

PKIB6105E

INTERIOR ROOM LAMP

System Description

AKS009KY

When map lamp switch is in DOOR position, map lamp ON/OFF is controlled by timer according to signals from switches including key switch, front door switch driver side, unlock signal from keyfob, door lock and unlock switch, key cylinder lock and unlock switch, ignition switch.

When map lamp turns ON, there is a gradual brightening over 1 second. When map lamp turns OFF, there is a gradual dimming over 1 second.

Map lamp timer is controlled by BCM (body control module).

Map lamp timer control settings can be changed with CONSULT-II.

Ignition keyhole illumination turns ON at time when driver door is opened (door switch ON) or removed keyfob from key cylinder. Illumination turns OFF when driver door is closed (door switch OFF).

Step lamp turns ON at time when driver door, passenger door, RH rear door, or LH rear door is opened (door switch ON). Lamp turns OFF when driver, passenger doors are closed (all door switches OFF).

POWER SUPPLY AND GROUND

Power is supplied at all times (without Intelligent Key system)

- through 10A fuse [No. 21, located in fuse block (J/B)]
- to key switch terminal 2,
- through 10A fuse [No. 18, located in fuse block (J/B)]
- to BCM terminal 42,
- through 50A fusible link (letter F, located in fuse, fusible link and relay box)
- to BCM terminal 55.

Power is supplied at all times (with Intelligent Key system)

- through 15A fuse (No.33, located in fuse, fusible link and relay box)
- to key switch and ignition knob switch terminals 1 and 3,
- through 10A fuse [No.18, located in fuse block (J/B)]
- to BCM terminal 42,
- through 50A fusible link (letter F, located in fuse, fusible link and relay box)
- to BCM terminal 55.

When key plate inserted to key switch, power is supplied (without Intelligent Key system)

- through key switch terminal 1
- to BCM terminal 37.

When inserted key plate to key switch, power is supplied (with Intelligent Key system)

- through key switch and ignition knob switch terminal 4
- to BCM terminal 37.

When moved ignition knob switch, power is supplied (with Intelligent Key system)

- through key switch and ignition knob switch terminal 2
- to intelligent key unit terminal 27.

With ignition switch in ON or START position, power is supplied

- through 10A fuse [No. 1, located in fuse block (J/B)]
- to BCM terminal 38.

Ground is supplied

- to BCM terminal 52
- through grounds terminals M30 and M66.

When driver side door is opened, ground is supplied

- to BCM terminal 62
- through front door switch driver side terminal 1
- through case ground of front door switch driver side.

When passenger side door is opened, ground is supplied

- to BCM terminal 12
- through front door switch passenger side terminal 1
- through case ground of front door switch passenger side.

A
B
C
D
E
F
G
H
I
J
LT
L
M

INTERIOR ROOM LAMP

When rear door LH is opened, ground is supplied

- to BCM terminal 63, and
- to personal lamp LH terminal 1
- through rear door switch LH terminal 1
- through case ground of rear door switch LH.

When rear door RH is opened, ground is supplied

- to BCM terminal 13, and
- to personal lamp RH terminal 1
- through rear door switch RH terminal 1
- through case ground of rear door switch RH.

When driver side door is unlocked by door lock and unlock switch, BCM receives a ground signal

- to BCM terminal 22
- from power window main switch (door lock and unlock switch) terminal 14 and power window sub switch (front passenger side) (door lock and unlock switch) terminal 16
- to power window main switch (door lock and unlock switch) terminal 17 and power window sub switch (front passenger side) (door lock and unlock switch) terminal 11
- through grounds terminals M30 and M66.

When front driver side door is unlocked by driver side door lock assembly (door key cylinder switch), BCM receives a ground signal

- to BCM terminal 22
- through power window main switch (door lock and unlock switch) terminal 14
- to power window main switch (door lock and unlock switch) terminal 6
- through front door key cylinder switch (driver side) terminal 3
- to front door key cylinder switch (driver side) terminal 2
- through grounds M30 and M66.

When a signal, or combination of signals is received by BCM, ground is supplied

- to map lamp terminal 2
- through BCM terminal 48.

With power and supplied, the interior lamp illuminates.

SWITCH OPERATION

When driver door switch is ON (door is opened), ground is supplied

- to ignition keyhole illumination terminal 2
- through BCM terminal 1.

And power is supplied

- through BCM terminal 41
- to ignition keyhole illumination terminal 1.

When any door switch is ON (door is opened), ground is supplied

- to step lamp (driver side and passenger side) terminal 2
- through BCM terminal 47.

And power is supplied

- through BCM terminal 41
- to step lamp (driver side and passenger side) terminal 1.

When map lamp switch is ON, ground is supplied

- to map lamp terminal 1
- through grounds M30 and M66.

And power is supplied

- through BCM terminal 41
- to map lamp terminal 3.

When rear door switch LH or RH is ON (door is opened), ground is supplied

INTERIOR ROOM LAMP

- to rear door switch LH or RH terminal 1
- through personal lamp LH or RH terminal 1.

And power is supplied

- through BCM terminal 41
- to personal lamp LH and RH terminal 2.

When vanity mirror lamp (driver side and passenger side) is ON, ground is supplied

- to vanity mirror lamp (driver side and passenger side) terminal 2
- through grounds M30 and M66.

And power is supplied

- through BCM terminal 41
- to vanity mirror lamp (driver side and passenger side) terminal 1.

When trunk room lamp switch is OPEN, ground is supplied

- to BCM terminal 57
- through trunk room lamp switch terminals 1 and 2
- through grounds B5 and B29.

When trunk room lamp is ON, ground is supplied

- to trunk room lamp terminal 2
- through BCM terminal 64.

And power is supplied

- to trunk room lamp terminal 1
- through BCM terminal 41.

ROOM LAMP TIMER OPERATION

Without Intelligent Key System

When map lamp switch is in DOOR position, and when all conditions below are met, BCM performs timer control (maximum 30 seconds) for map lamp ON/OFF.

In addition, when spot turns ON or OFF there is gradual brightening or dimming over 1 second.

Power is supplied

- through 10A fuse [No. 21, located in the fuse block (J/B)]
- to key switch terminal 2.

Key is removed from ignition key cylinder (key switch OFF), power will not be supplied to BCM terminal 37.

Ground is supplied

- to power window main switch (door lock and unlock switch) terminal 14
- through BCM terminal 22.

At the time that driver door is opened, BCM detects that driver door is unlocked. It determines that map lamp timer operation condition is met, and turns the map lamp ON for 30 seconds.

Key is in ignition key cylinder (key switch ON),

Power is supplied

- to BCM terminal 37
- through key switch terminal 1.

When key is removed from key switch (key switch OFF), power supply to BCM terminal 37 is terminated. BCM detects that key has been removed, determines that map lamp timer conditions are met, and turns the map lamp ON for 30 seconds.

When driver door opens → closes, and the key is not inserted in the key switch (key switch OFF), BCM terminal 62 changes between 0V (door open) → 12V (door closed). The BCM determines that conditions for map lamp operation is met, and turns the map lamp ON for 30 seconds.

Timer control is canceled under the following conditions.

- Driver door is locked [when locked power window main switch (door lock and unlock switch) or door key cylinder switch]
- Driver door is opened (driver door switch turns ON)
- Ignition switch ON.

A

B

C

D

E

F

G

H

I

J

LT

L

M

INTERIOR ROOM LAMP

With Intelligent Key System

When the map lamp switch is in DOOR position, and when all conditions below are met, BCM performs timer control (maximum 30 second) for map lamp ON/OFF.

In addition, when spot turns ON or OFF there is gradual brightening or dimming over 1 second.

Power is supplied

- through 15A fuse [No. 33, located in fuse and fuse block (J/B)]
- to key switch and ignition knob switch terminals 1 and 3.

Key is removed from ignition key cylinder (key switch OFF), power will not be supplied to BCM terminal 37. And not turned ignition knob switch, power will not be supplied to Intelligent Key unit.

Ground is supplied

- to power window main switch (door lock and unlock switch) terminal 14
- through BCM terminal 22.

At the time that driver door are opened, BCM detects that driver door is unlocked. It determines that map lamp timer operation conditions is met, and turns map lamp ON for 30 seconds.

Key is in ignition key cylinder (key switch ON), or turned ignition knob switch,

Power is supplied

- through key switch and ignition knob switch terminal 4
- to BCM terminal 37,
- through key switch and ignition knob switch terminal 2
- to intelligent key unit terminal 27.

When the key is removed from key switch (key switch OFF), power supply to BCM terminal 37 is terminated. And turned ignition knob switch, power supply to Intelligent Key unit is terminated. BCM detects that key has been removed, determines that map lamp timer conditions is met, and turns map lamp ON for 30 seconds.

When driver door opens → closes, and key is not inserted in key switch (or not turned ignition knob switch), BCM terminal 62 changes between 0V (door open) → 12V (door closed). BCM determines that conditions for map lamp operation is met, and turns map lamp ON for 30 seconds.

Timer control is canceled under the following conditions.

- Driver door is locked [when locked keyfob, power window main switch (door lock and unlock switch) or door key cylinder switch].
- Driver door is opened (driver door switch turns ON).
- Ignition switch ON.

INTERIOR LAMP BATTERY SAVER CONTROL

If interior lamp is left "ON", it will not be turned out even when door is closed.

BCM turns off interior lamp automatically to save battery 30 minutes after ignition switch is turned off.

BCM controls interior lamps listed below:

- Ignition key hole illumination
- Step lamp
- Map lamp
- Trunk room lamp
- Vanity mirror lamp
- Personal lamp

After lamps turn OFF by the battery saver system, the lamps illuminate again when

- signal from power window main switch (door lock and unlock switch) or key cylinder is locked or unlocked,
- door is opened or closed,
- key is removed from ignition key cylinder or inserted in ignition key cylinder, or turned ignition knob switch.

Interior lamp battery saver control period can be changed by the function setting of CONSULT-II.

INTERIOR ROOM LAMP

Schematic

AKS005Q0

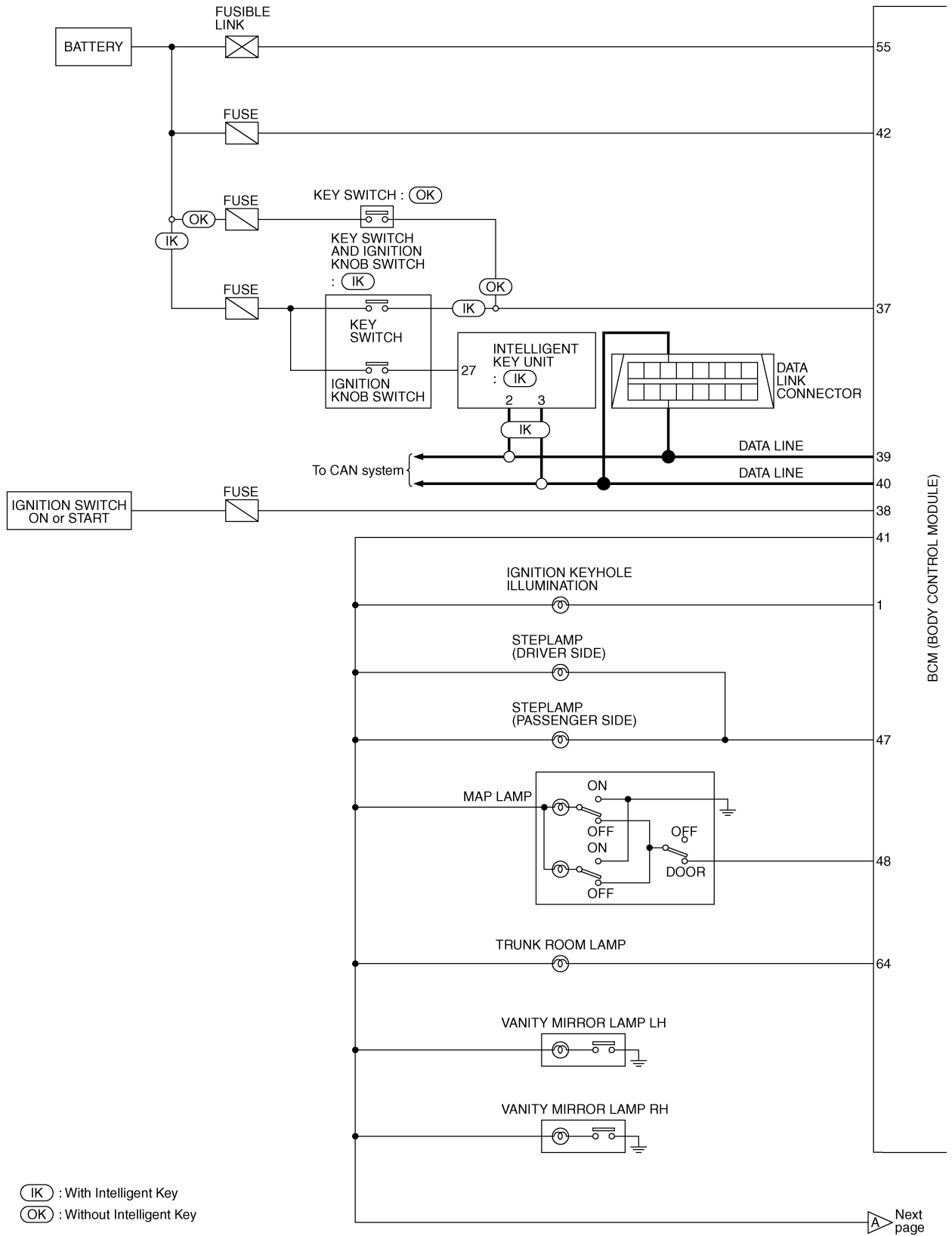

TKWM2271E

INTERIOR ROOM LAMP

(OK) : Without Intelligent Key

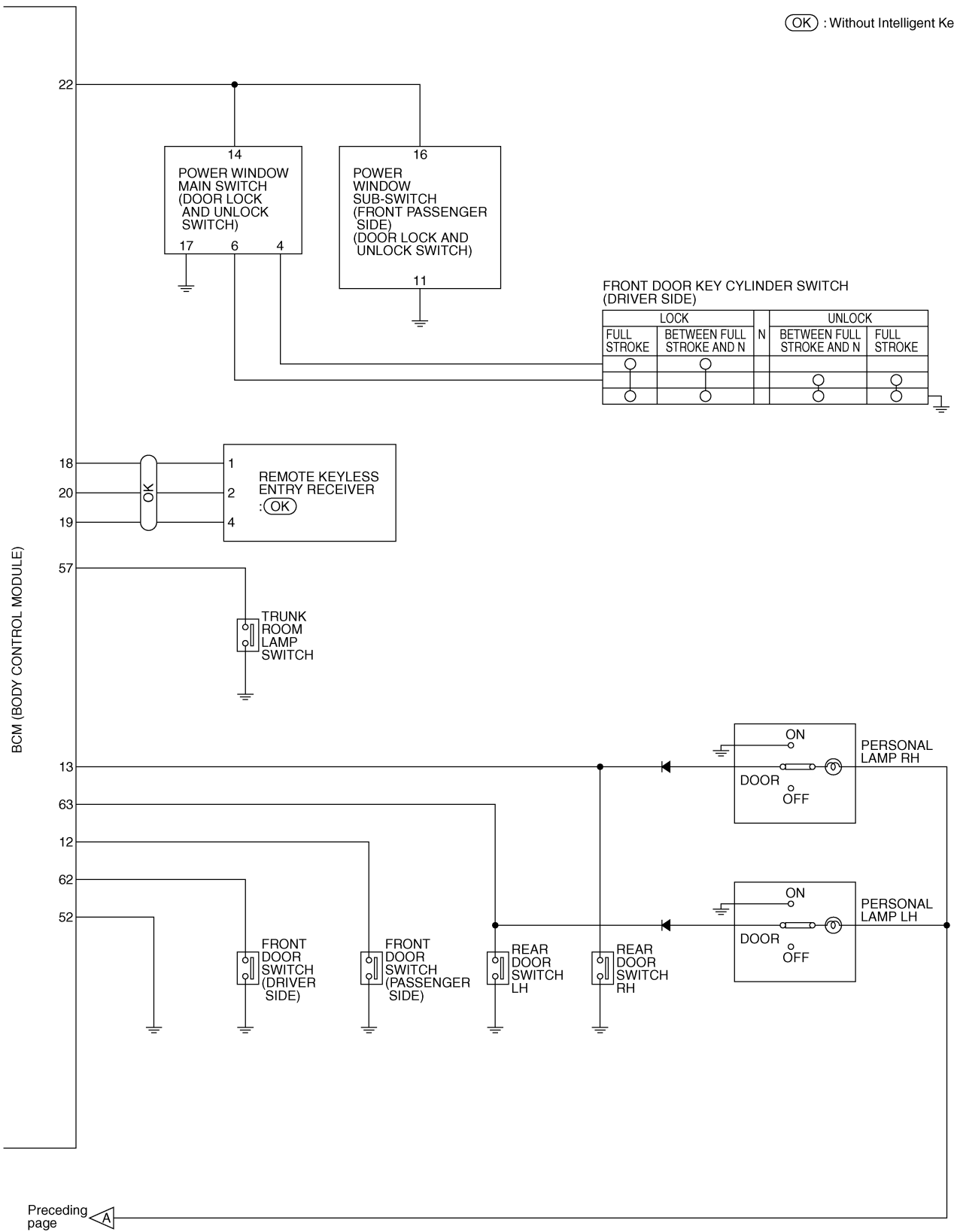

TKWM2272E

INTERIOR ROOM LAMP

Wiring Diagram — ROOM/L —

AKS005Q1

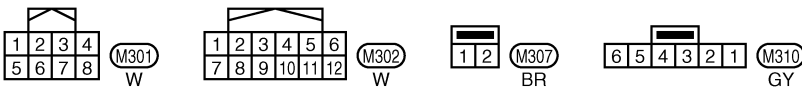
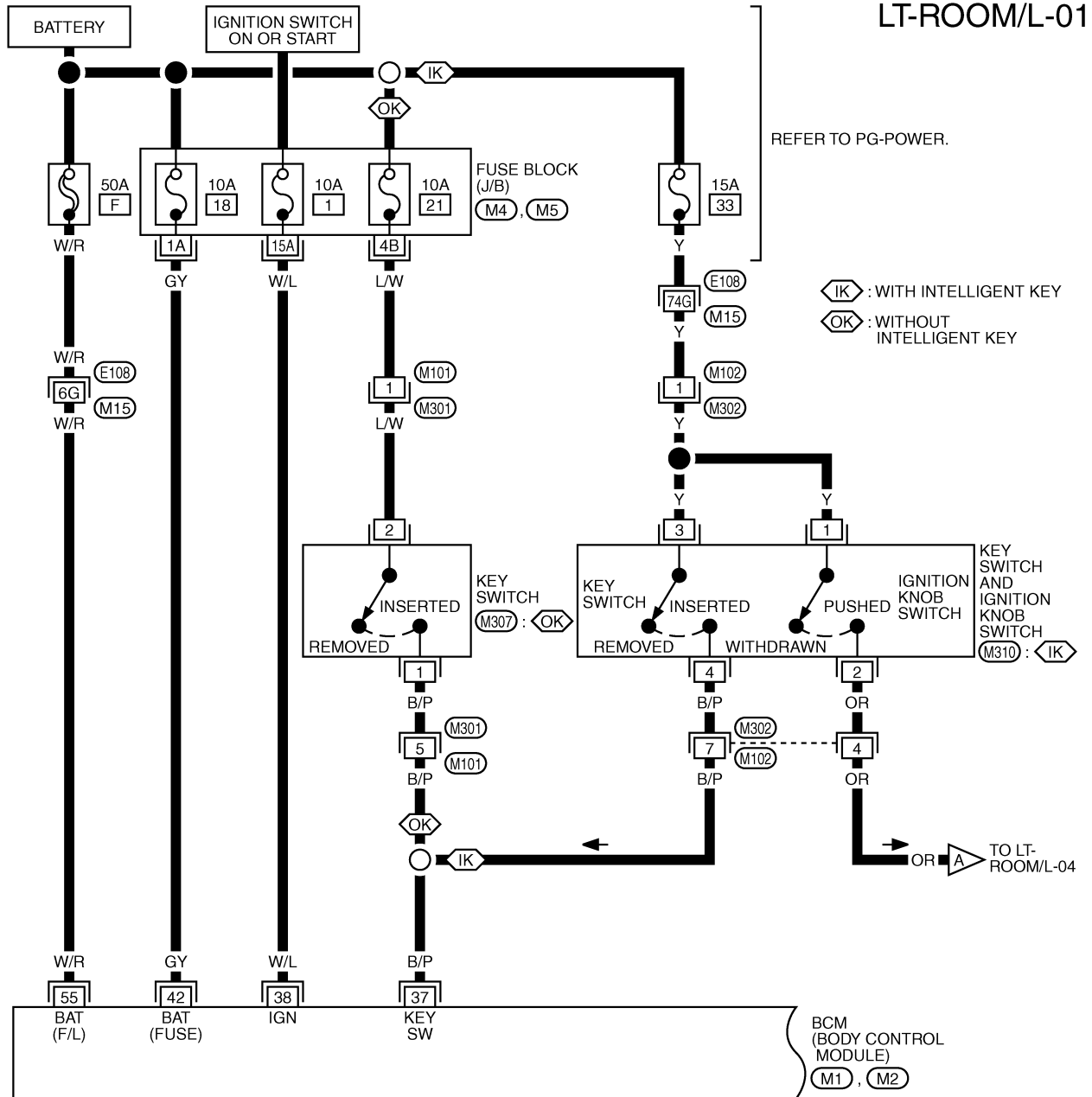

REFER TO THE FOLLOWING.

- (E108) -SUPER MULTIPLE JUNCTION (SMJ)
- (M4), (M5) -FUSE BLOCK-JUNCTION BOX (J/B)
- (M1), (M2) -ELECTRICAL UNITS

TKWM2273E

INTERIOR ROOM LAMP

LT-ROOM/L-02

- IK : WITH INTELLIGENT KEY *1 3: IK
OK : WITHOUT INTELLIGENT KEY 2: OK
 *2 9: IK
 6: OK

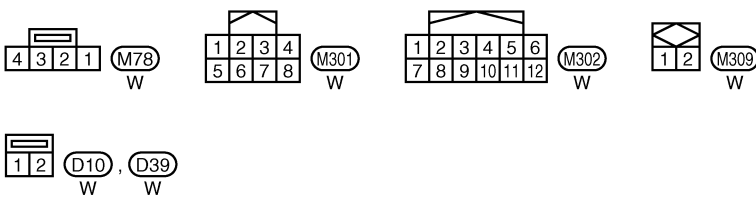
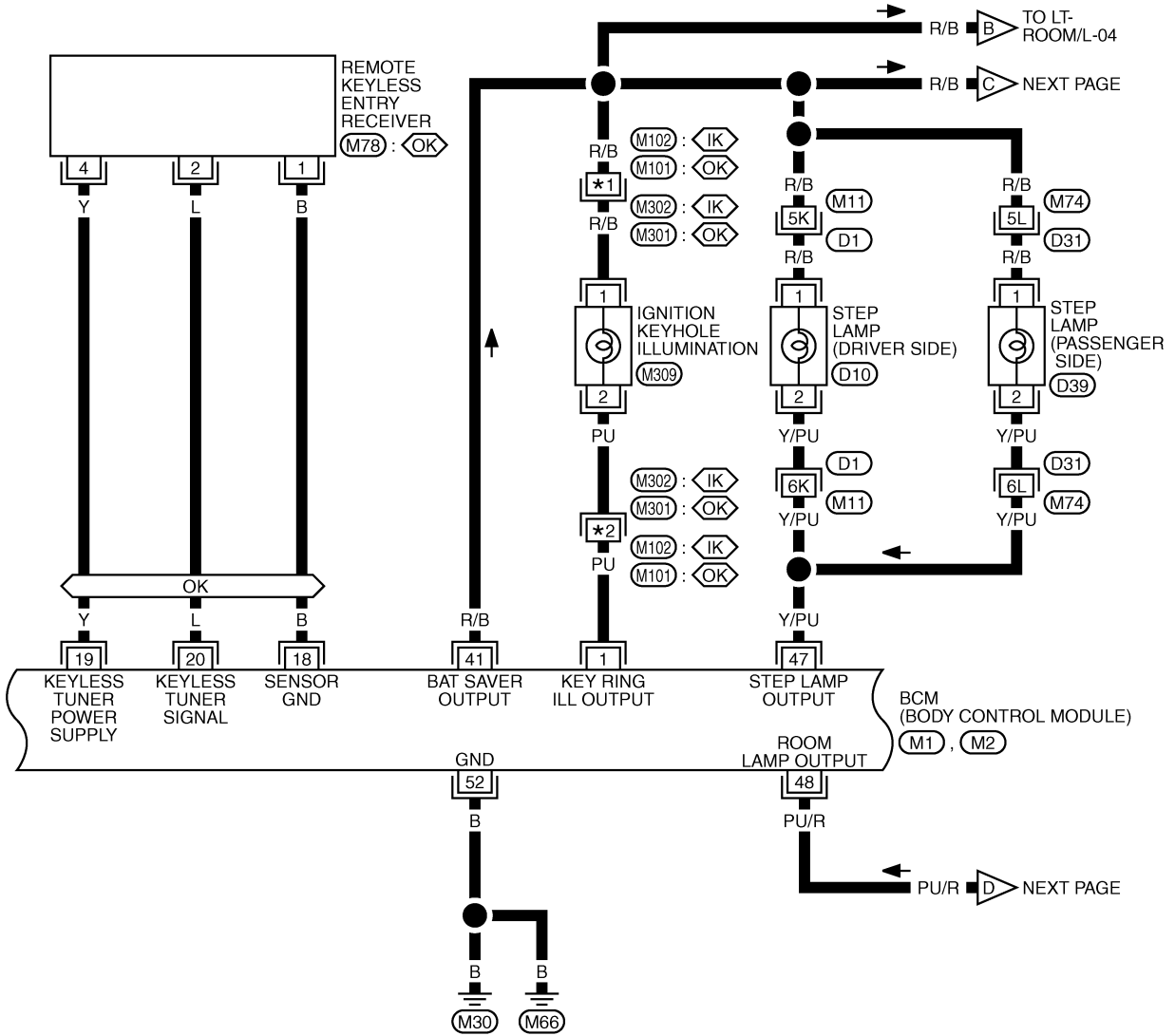

REFER TO THE FOLLOWING.
D1 , D31 -SUPER MULTIPLE JUNCTION (SMJ)
M1 , M2 -ELECTRICAL UNITS

TKWM2274E

INTERIOR ROOM LAMP

LT-ROOM/L-03

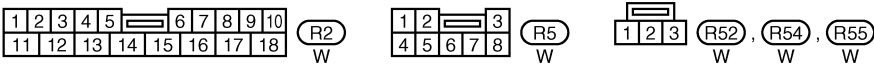
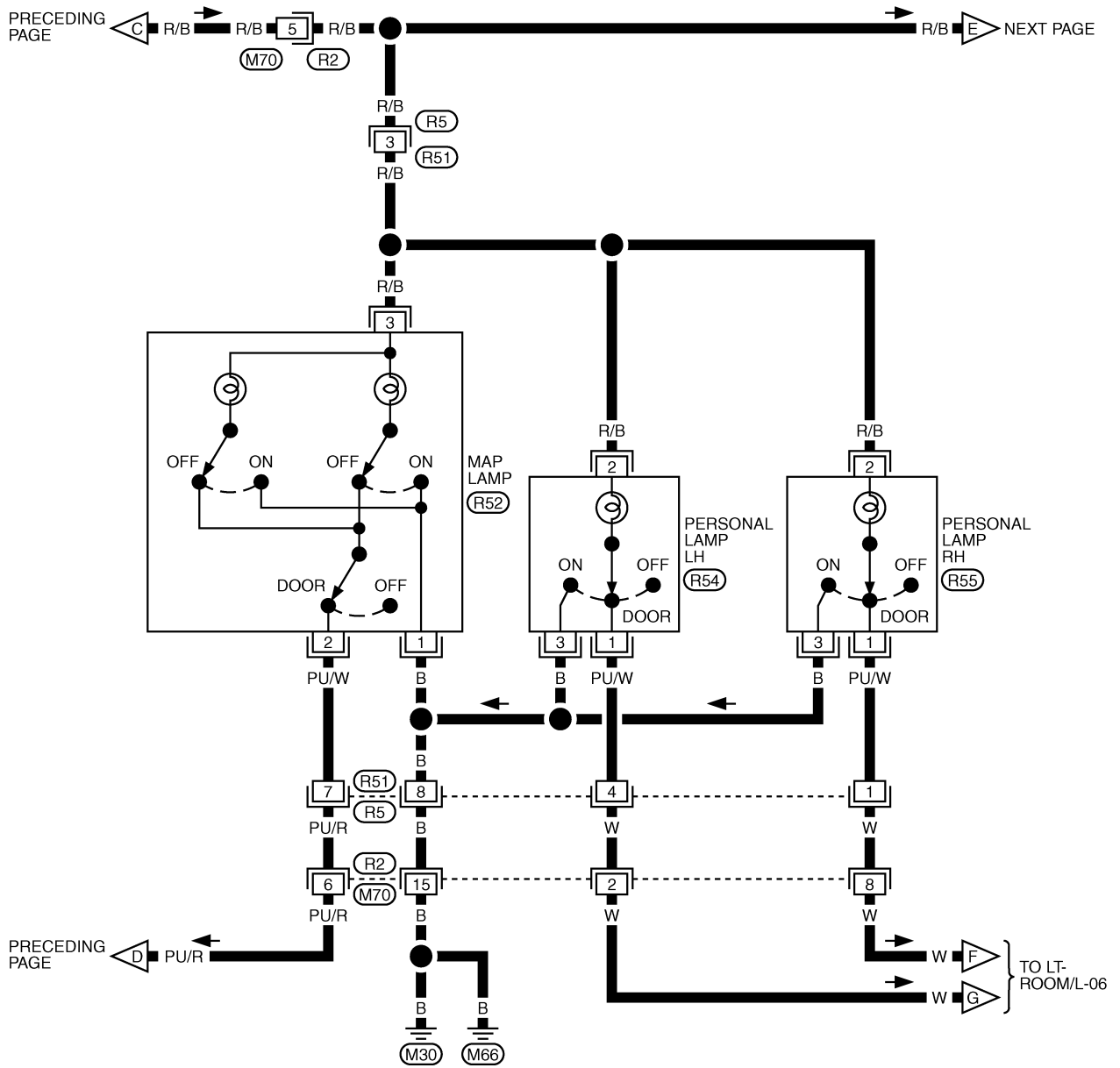

A
B
C
D
E
F
G
H
I
J
LT
L
M

TKWM2275E

INTERIOR ROOM LAMP

LT-ROOM/L-05

A
B
C
D
E
F
G
H
I
J
LT
L
M

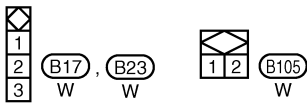
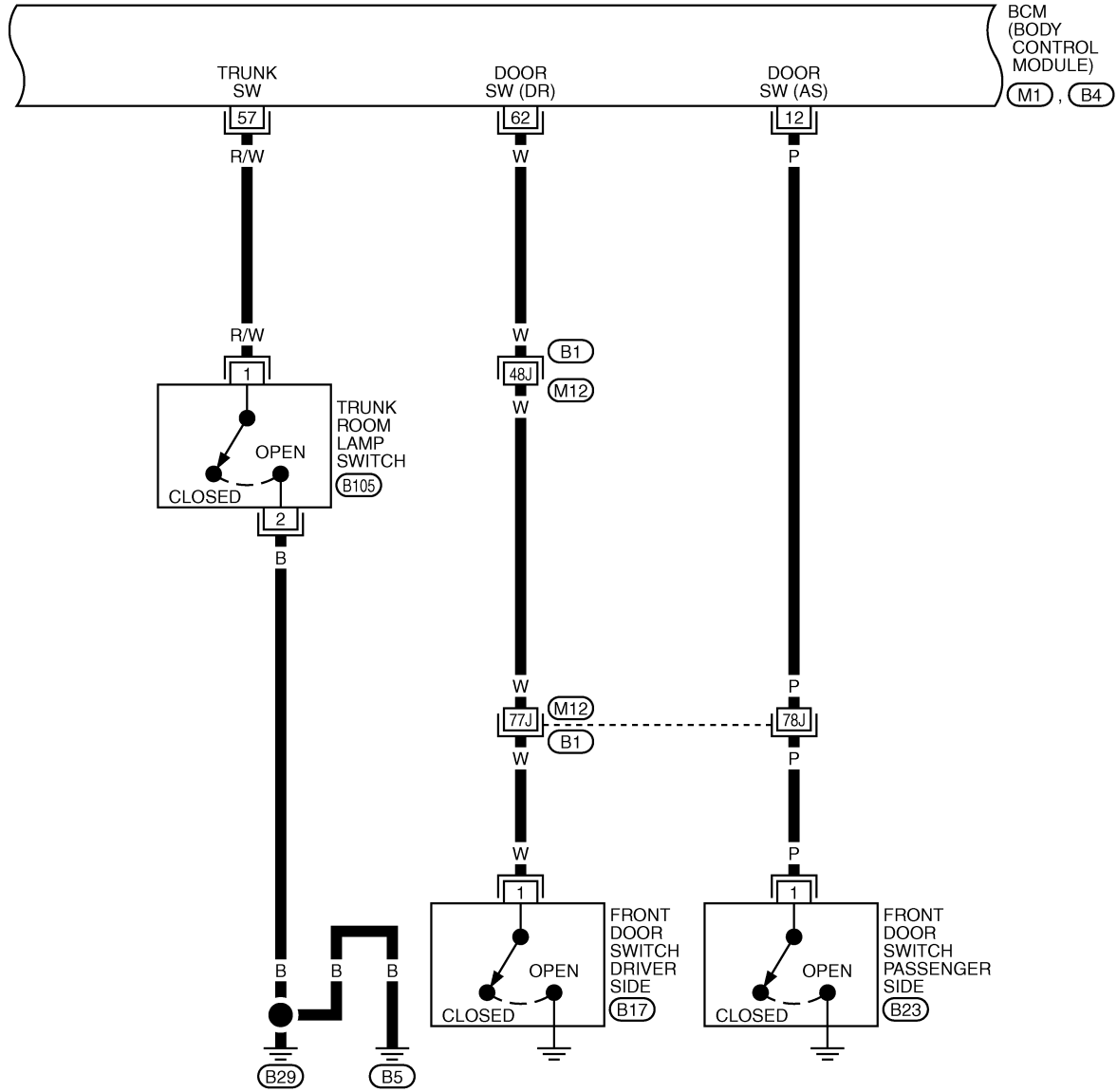

REFER TO THE FOLLOWING.
 (B1) -SUPER MULTIPLE JUNCTION (SMJ)
 (M1), (B4) -ELECTRICAL UNITS

TKWM2277E

INTERIOR ROOM LAMP

LT-ROOM/L-06

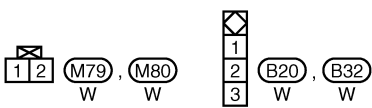
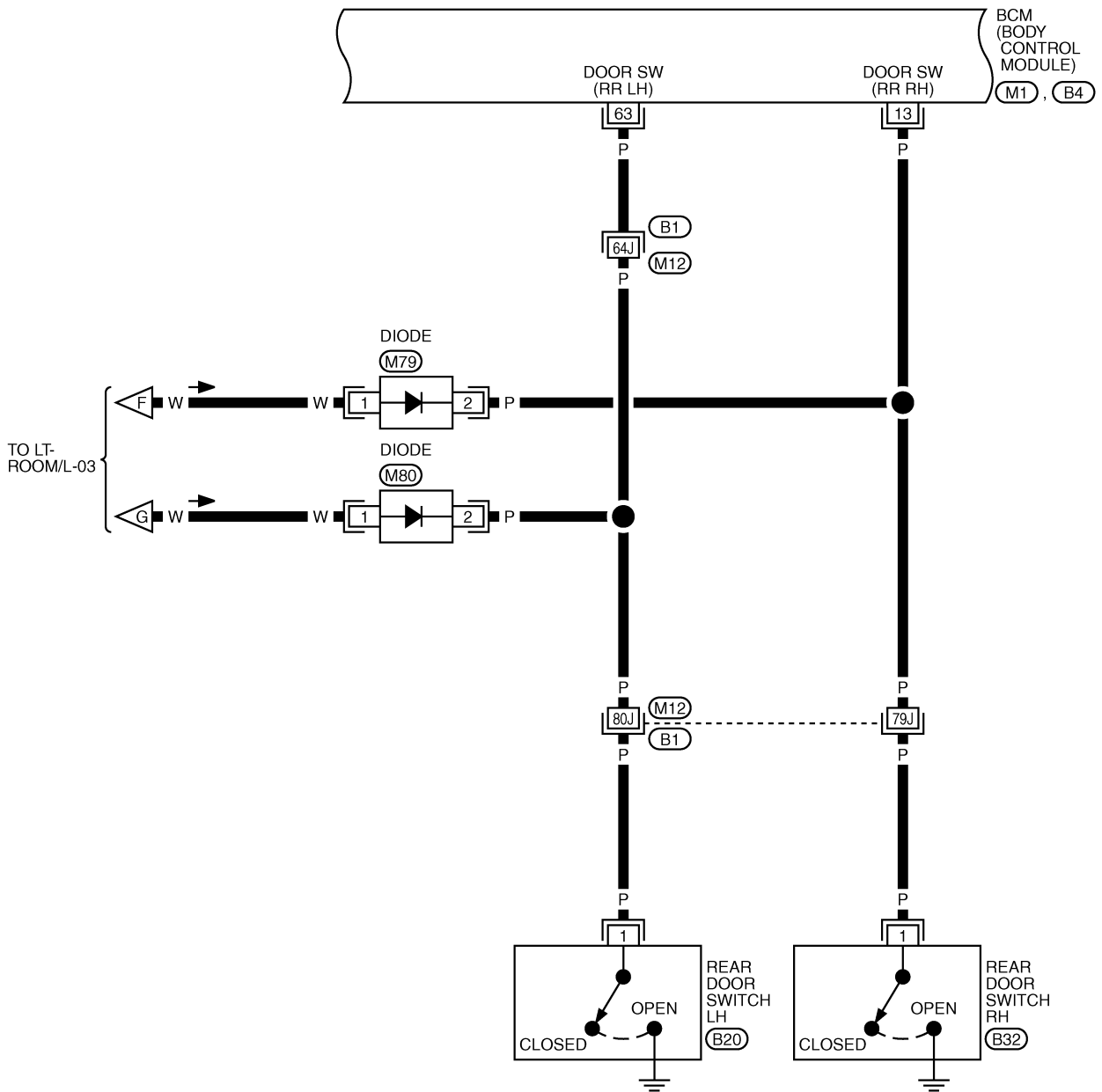

REFER TO THE FOLLOWING.

(B1) -SUPER MULTIPLE JUNCTION (SMJ)

(M1), (B4) -ELECTRICAL UNITS

TKWM2278E

INTERIOR ROOM LAMP

LT-ROOM/L-07

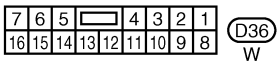
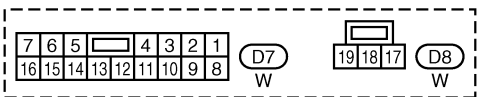
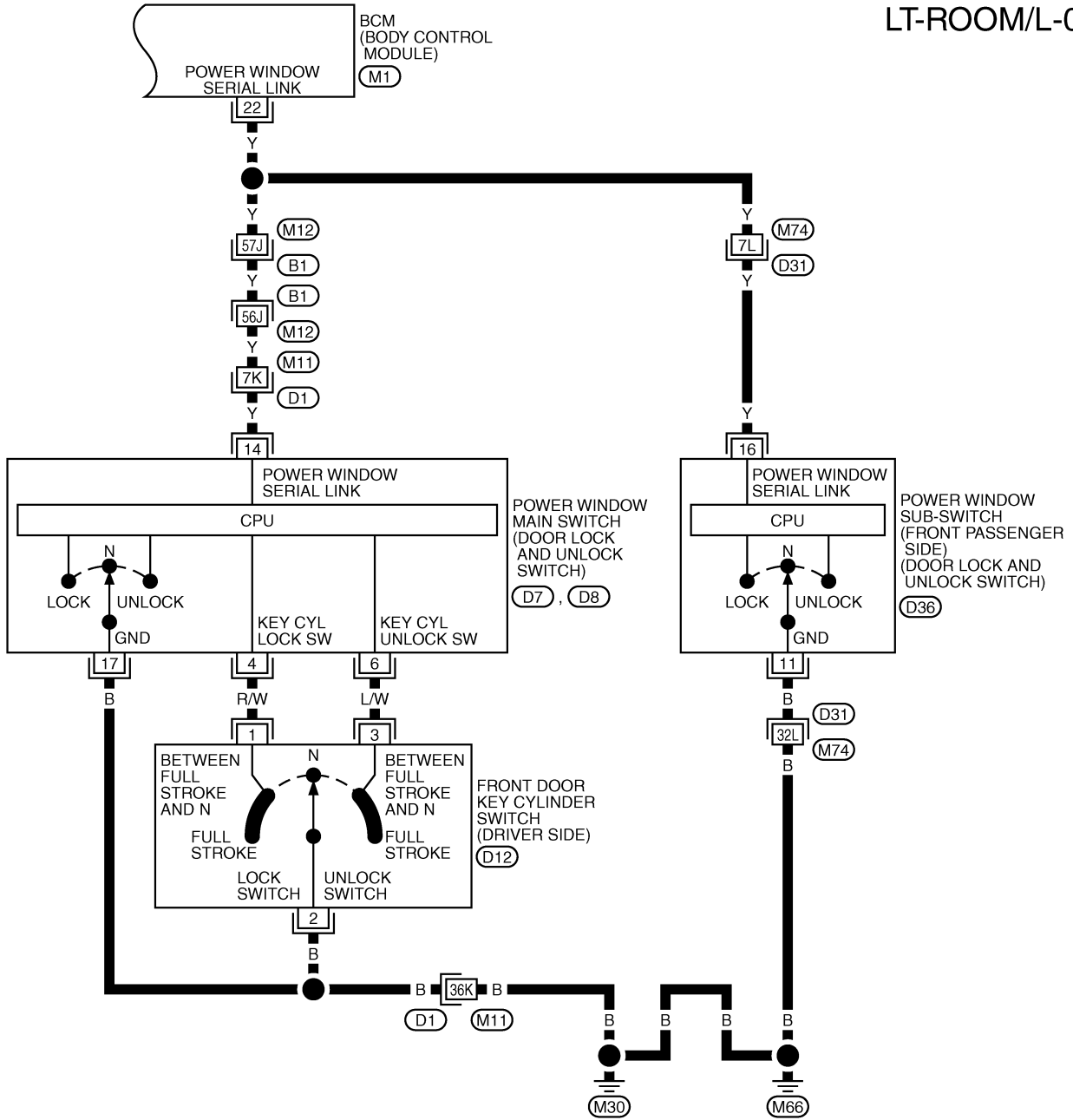

REFER TO THE FOLLOWING.
 (B1), (D1), (D31) -SUPER
 MULTIPLE JUNCTION (SMJ)
 (M1) -ELECTRICAL UNITS

TKWM2279E

INTERIOR ROOM LAMP

Terminals and Reference Values for BCM

AKS009KZ

Terminal No.	Wire color	Signal name	Measuring condition			Reference value	
			Ignition switch	Operation or condition			
1	PU	Ignition keyhole illumination signal	OFF	Door is locked. (SW OFF)		Battery voltage	
				Door is unlocked. (SW ON)		Approx. 0V	
12	P	Front door switch AS signal	OFF	Front door switch AS	ON (open)	Approx. 0V	
					OFF (closed)	Battery voltage	
13	P	Rear door switch RH signal	OFF	Rear door switch RH	ON (open)	Approx. 0V	
					OFF (closed)	Battery voltage	
22	Y	Power window switch serial link	—	—		 <p style="text-align: right; font-size: small;">PIIA2344J</p>	
37	B/P	Key-in detection switch signal	OFF	Vehicle key is removed.		Approx. 0V	
				Vehicle key is inserted.		Battery voltage	
38	W/L	Ignition power supply	ON	—		Battery voltage	
39	L	CAN – H	—	—		—	
40	P	CAN – L	—	—		—	
41	R/B	Battery saver output signal	OFF	30 minutes after ignition switch is turned to OFF		Approx. 0V	
			ON	—		Battery voltage	
42	GY	Battery power supply	OFF	—		Battery voltage	
47	Y/PU	Step lamp signal	OFF	Any door is open (ON)		Approx. 0V	
				All doors are closed (OFF)		Battery voltage	
48	PU/R	map lamp output signal	OFF	Map lamp switch: DOOR position	Any door switch	ON (open)	Approx. 0V
						OFF (closed)	Battery voltage
52	B	Ground	ON	—		Approx. 0V	
55	W/R	Battery power supply	OFF	—		Battery voltage	
57	R/W	Trunk room lamp switch signal	OFF	Trunk room lamp switch	ON (open)	Approx. 0V	
					OFF (closed)	Battery voltage	
62	W	Front door switch DR signal	OFF	Front door switch DR	ON (open)	Approx. 0V	
					OFF (closed)	Battery voltage	
63	P	Rear door switch LH signal	OFF	Rear door switch LH	ON (open)	Approx. 0V	
					OFF (closed)	Battery voltage	
64	R	Trunk room lamp signal	OFF	Trunk room lamp	ON (open)	Approx. 0V	
					OFF (closed)	Battery voltage	

INTERIOR ROOM LAMP

How to Proceed With Trouble Diagnosis

AKS009L0

1. Confirm the symptom or customer complaint.
2. Understand operation description and function description. Refer to [LT-169, "System Description"](#) .
3. Perform the preliminary check. Refer to [LT-183, "Preliminary Check"](#) .
4. Check symptom and repair or replace the malfunctioning parts.
5. Does the interior room lamp operate normally? If YES, GO TO 6. If NO, GO TO 4.
6. INSPECTION END

Preliminary Check

AKS009L1

CHECK POWER SUPPLY AND GROUND CIRCUIT

1. CHECK FUSES

Check for blown fuses.

Unit	Power source	Fuse and fusible link No.
BCM	Battery	F
		18
		21
	Ignition switch ON or START position	1

Refer to [LT-175, "Wiring Diagram — ROOM/L —"](#) .

OK or NG

OK >> GO TO 2.

NG >> If fuse or fusible link is blown, be sure to eliminate cause of malfunction before installing new fuse or fusible link. Refer to [PG-3, "POWER SUPPLY ROUTING CIRCUIT"](#) .

2. CHECK POWER SUPPLY CIRCUIT

1. Turn ignition switch OFF.
2. Disconnect BCM connector.
3. Check voltage between BCM harness connector and ground.

Terminal (+)		Terminal (-)	Ignition switch position	
Connector	Terminal (Wire color)		OFF	ON
M2	42 (GY)	Ground	Battery voltage	Battery voltage
	55 (W/R)		Battery voltage	Battery voltage
M1	38 (W/L)		Approx. 0V	Battery voltage

OK or NG

OK >> GO TO 3.

NG >> Check harness for open or short between BCM and fuse.

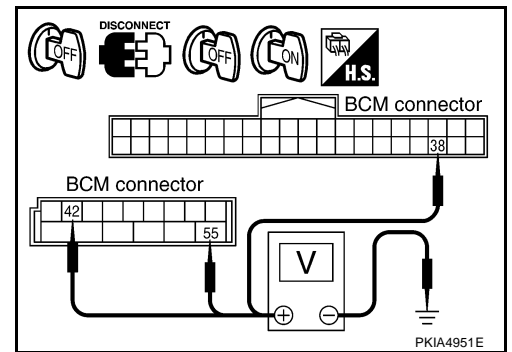

INTERIOR ROOM LAMP

3. CHECK GROUND CIRCUIT

Check continuity between BCM harness connector and ground.

Terminal		Ground	Continuity
Connector	Terminal (Wire color)		Yes
M2	52 (B)		

OK or NG

- OK >> INSPECTION END
- NG >> Check harness ground circuit.

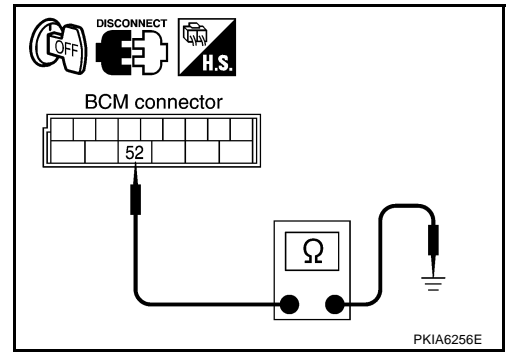

CONSULT-II Functions (BCM)

AKS009L2

CONSULT-II can display each diagnostic item using the diagnostic test modes shown following.

BCM diagnosis part	Diagnosis mode	Description
INT LAMP	WORK SUPPORT	Changes the setting for each function.
	DATA MONITOR	Displays BCM input data in real time.
	ACTIVE TEST	Operation of electrical loads can be checked by sending driving signal to them.

CONSULT-II BASIC OPERATION

CAUTION:

If CONSULT-II is used with no connection of CONSULT-II CONVERTER, malfunctions might be detected in self-diagnosis depending on control unit which carry out CAN communication.

- With ignition switch OFF, connect CONSULT-II and CONSULT-II CONVERTER to data link connector, and then turn ignition switch ON.

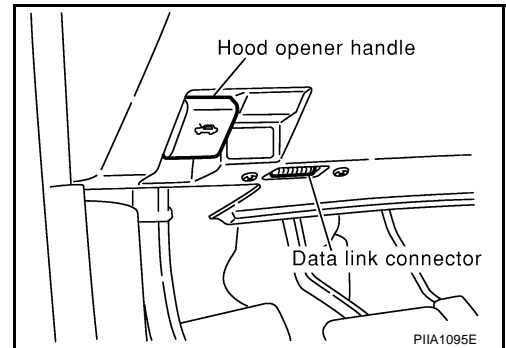

- Touch "START (NISSAN BASED VHCL)".

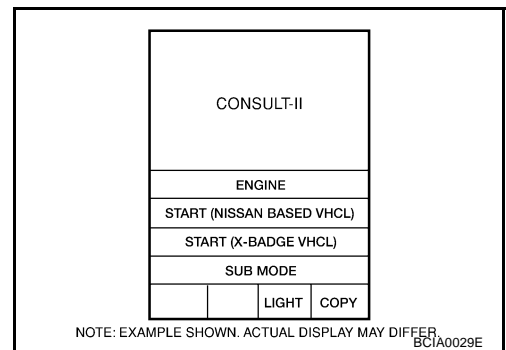

INTERIOR ROOM LAMP

3. Touch "BCM" on "SELECT SYSTEM" screen.
If "BCM" is not indicated, refer to [GI-39, "CONSULT-II Data Link Connector \(DLC\) Circuit"](#).

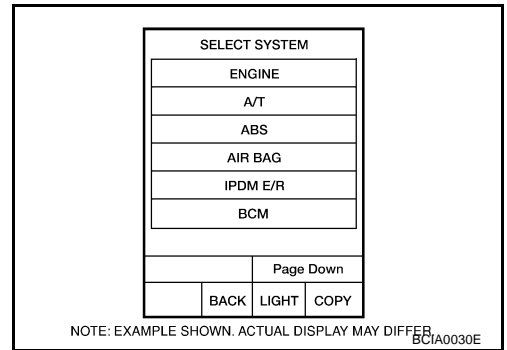

4. Touch "INT LAMP" on "SELECT TEST ITEM" screen.

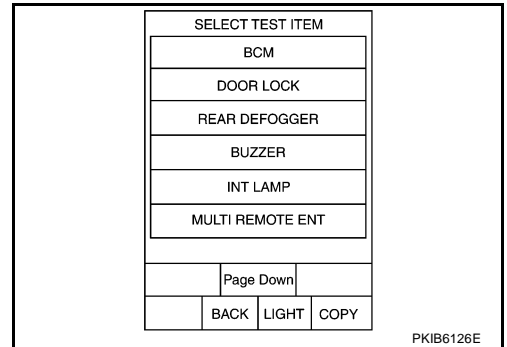

WORK SUPPORT

Operation Procedure

1. Touch "INT LAMP" on "SELECT TEST ITEM" screen.
2. Touch "WORK SUPPORT" on "SELECT DIAG MODE" screen.
3. Touch "SET I/L D- UNLCK INTCON" on "SELECT WORK ITEM" screen.
4. Touch "START".
5. Touch "CHANGE SETT".
6. The setting will be changed and "CUSTOMIZING COMPLETED" will be displayed.
7. Touch "END".

Display Item List

Item	Description	CONSULT-II
SET I/L D-UNLCK INTCON	The 30 seconds glowing function interior room lamps and ignition keyhole illumination can be selected when driver door is released (unlocked).	ON/OFF
ROOM LAMP ON TIME SET	The time in order to escalate illumination can be adjusted when interior room lamps and ignition keyhole illumination is turned on.	MODE 1 - 7
ROOM LAMP OFF TIME SET	The time in order to diminish illumination can be adjusted when interior room lamps and ignition keyhole illumination is turned off.	MODE 1 - 7

Reference between "MODE" and "TIME" for "TURN ON/OFF"

MODE	1	2	3	4	5	6	7
Time (sec.)	0.5	1	2	3	4	5	0

DATA MONITOR

Operation Procedure

1. Touch "INT LAMP" on "SELECT TEST ITEM" screen.
2. Touch "DATA MONITOR" on "SELECT DIAG MODE" screen.
3. Touch either "ALL SIGNALS" or "SELECTION FROM MENU" on "SELECT MONITOR ITEM" screen.

ALL SIGNALS	Monitors all the signals.
SELECTION FROM MENU	Selects items and monitor them.

INTERIOR ROOM LAMP

4. When "SELECTION FROM MENU" is selected, touch items to be monitored. When "ALL SIGNALS" is selected, all items will be monitored.
5. Touch "START".
6. Touch "RECORD" while monitoring, then the status of monitored item can be recorded. To stop recording, touch "STOP".

Display Item List

Monitor item	Contents
IGN ON SW "ON/OFF"	Displays status (ignition switch IGN position: ON/other: OFF) of ignition switch judged from the ignition switch signal.
KEY ON SW "ON/OFF"	Displays status (key inserted: ON/key removed: OFF) of key switch judged from the key switch signal.
DOOR SW - DR "ON/OFF"	Displays status (door is open: ON/door is closed: OFF) of driver side door switch judged from the driver side door switch signal.
DOOR SW - AS "ON/OFF"	Displays status (door is open: ON/door is closed: OFF) of passenger side door switch judged from the passenger side door switch signal.
DOOR SW - RR "ON/OFF"	Displays status (door is open: ON/door is closed: OFF) of rear door switch (RH) judged from the rear door switch (RH) signal.
DOOR SW - RL "ON/OFF"	Displays status (door is open: ON/door is closed: OFF) of rear door switch (LH) judged from the rear door switch (LH) signal.
BACK DOOR SW ^{NOTE} "OFF"	—
KEY CYL LK - SW "ON/OFF"	Displays status (door is locked: ON/other: OFF) of key cylinder lock switch from the door key cylinder switch (driver door) signal.
KEY CYL UN - SW "ON/OFF"	Displays status (door is unlocked: ON/other: OFF) of key cylinder unlock switch from the door key cylinder switch (driver door) signal.
CDL LOCK SW "ON/OFF"	Displays status (door is locked: ON/other: OFF) of lock switch from the door lock and unlock switch signal.
CDL UNLOCK SW "ON/OFF"	Displays status (door is unlocked: ON/other: OFF) of unlock switch from the door lock and unlock switch signal.
I- KEY LOCK "ON/OFF"	Displays status (door is locked: ON/other: OFF) of intelligent key system lock signal from the intelligent key unit signal.
I- KEY UNLOCK "ON/OFF"	Displays status (door is locked: ON/other: OFF) of intelligent key system unlock signal from the intelligent key unit signal.
KEYLESS LOCK "ON/OFF"	Displays status (door is unlocked: ON/other: OFF) of remote keyless entry system lock signal from the remote key less entry receiver signal.
KEYLESS UNLOCK "ON/OFF"	Displays status (door is unlocked: ON/other: OFF) of remote keyless entry system unlock signal from the remote key less entry receiver signal.

NOTE:

This item is displayed, but cannot be monitored.

ACTIVE TEST

Operation Procedure

1. Touch "INT LAMP" on "SELECT TEST ITEM" screen.
2. Touch "ACTIVE TEST" on "SELECT DIAG MODE" screen.
3. Touch item to be tested and check operation of the selected item.
4. During the operation check, touching "BACK" deactivates the operation.

Display Item List

Test item	Description
INT LAMP	Interior room lamp can be operated by any ON-OFF operations.
IGN ILLUM	Ignition key hole illumination can be operated by ON-OFF operation.
STEP LAMP TEST	All step lamp can be operated by ON-OFF operation.
LUGGAGE LAMP TEST ^{NOTE}	—

INTERIOR ROOM LAMP

NOTE:

This item is displayed, but cannot be tested.

Map Lamp Control Does Not Operate

AKS009L3

1. CHECK EACH SWITCH

Select "BCM" on CONSULT-II. With "INT LAMP" data monitor to make sure switches listed in display item list turn ON-OFF linked with switch operation. Refer to [LT-186, "Display Item List"](#) for switches and their functions.

DATA MONITOR			
MONITOR			
IGN ON SW	ON		
KEY ON SW	ON		
DOOR SW-DR	ON		
DOOR SW-AS	ON		
DOOR SW-RR	OFF		
DOOR SW-RL	OFF		
BACK DOOR SW	OFF		
KEY CYL LK-SW	OFF		
KEY CYL UN-SW	OFF		
		Page Down	
RECORD			
MODE	BACK	LIGHT	COPY

PKIB3532E

OK or NG

- OK >> GO TO 2.
- NG >> Inspect malfunctioning switch system.

2. ACTIVE TEST

1. Select "BCM" on CONSULT-II. Select "INT LAMP" active test.
2. When map lamp switch is in "DOOR" position, use active test to make sure map lamp operates.

Map lamp should operate.

OK or NG

- OK >> Replace BCM. Refer to [BCS-16, "Removal and Installation of BCM"](#).
- NG >> GO TO 3.

ACTIVE TEST	
INT LAMP	ON
OFF	
MODE	BACK
LIGHT	COPY

PKIA6881E

3. CHECK MAP LAMP INPUT

1. Turn ignition switch OFF.
2. Check voltage between map lamp harness connector R52 terminal 2 (PU/W) and ground.

2 (PU/W) – Ground : Battery voltage.

OK or NG

- OK >> GO TO 6.
- NG >> GO TO 4.

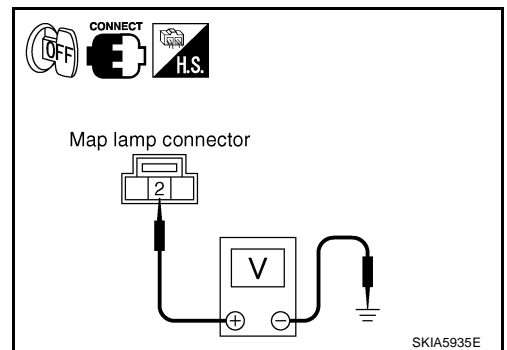

4. CHECK MAP LAMP

1. Disconnect map lamp connector.
2. Check continuity between map lamp.

Terminal	Condition	Continuity
Map lamp		
2	Map lamp switch is DOOR	Yes
3	Map lamp switch is OFF	No

OK or NG

- OK >> GO TO 5.
- NG >> Replace map lamp.

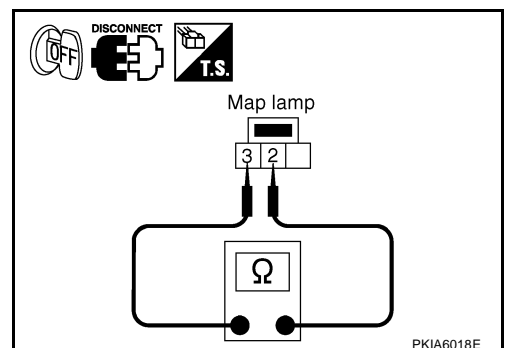

A
B
C
D
E
F
G
H
I
J
L
M

LT

INTERIOR ROOM LAMP

5. CHECK MAP LAMP CIRCUIT

1. Disconnect BCM connector and map lamp connector.
2. Check continuity between BCM harness connector M2 terminal 41 (R/B) and map lamp harness connector R52 terminal 3 (R/B).

41 (R/B) – 3 (R/B) : Continuity should exist.

OK or NG

- OK >> Replace BCM if map lamp does not work after setting the connector again. Refer to [BCS-16, "Removal and Installation of BCM"](#).
- NG >> Repair harness or connector.

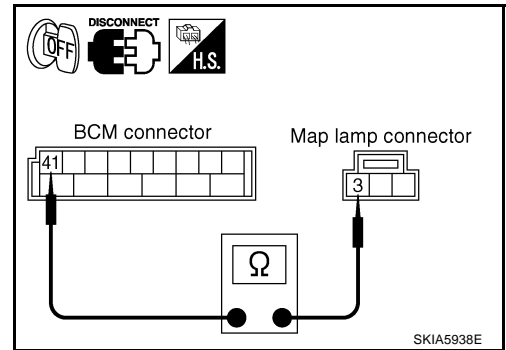

6. CHECK MAP LAMP CIRCUIT

1. Disconnect BCM connector.
2. Check continuity between BCM harness connector M2 terminal 48 (PU/R) and map lamp harness connector R52 terminal 2 (PU/W).

48 (PU/R) – 2 (PU/W) : Continuity should exist.

OK or NG

- OK >> Replace BCM if map lamp does not work after setting the connector again. Refer to [BCS-16, "Removal and Installation of BCM"](#).
- NG >> Repair harness or connector.

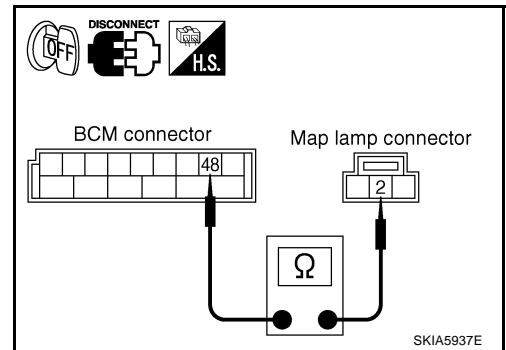

Ignition Key Hole Illumination Control Does Not Operate

AKS009L5

1. CHECK EACH SWITCH

Select "BCM" on CONSULT-II. With "INT LAMP" data monitor, make sure switches listed in display item list turn ON-OFF linked with switch operation. Refer to [LT-186, "Display Item List"](#) for switches and their functions.

OK or NG

- OK >> GO TO 2.
- NG >> Inspect malfunctioning switch system.

DATA MONITOR			
MONITOR			
IGN ON SW	ON		
KEY ON SW	ON		
DOOR SW-DR	ON		
DOOR SW-AS	ON		
DOOR SW-RR	OFF		
DOOR SW-RL	OFF		
BACK DOOR SW	OFF		
KEY CYL LK-SW	OFF		
KEY CYL UN-SW	OFF		
		Page Down	
		RECORD	
MODE	BACK	LIGHT	COPY

PKIB3532E

2. ACTIVE TEST

1. Select "BCM" on CONSULT-II. Select "INT LAMP".
2. Select "IGN ILLUM" active test to make sure lamp operates.

Ignition key hole illumination should operate.

OK or NG

- OK >> Replace BCM. Refer to [BCS-16, "Removal and Installation of BCM"](#).
- NG >> GO TO 3.

ACTIVE TEST			
IGN ILLUM	ON		
		OFF	
MODE	BACK	LIGHT	COPY

PKIA6375E

INTERIOR ROOM LAMP

3. CHECK IGNITION KEY HOLE ILLUMINATION INPUT

1. Turn ignition switch OFF.
2. Open the driver side door.
3. Check voltage between ignition key hole illumination harness connector M309 terminal 1 (R/B) and ground.

1 (R/B) – Ground : Battery voltage.

OK or NG

- OK >> GO TO 4.
NG >> GO TO 6.

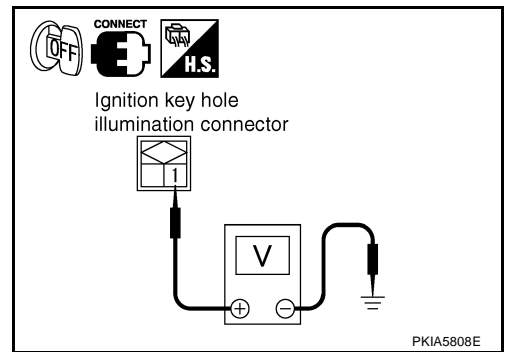

4. CHECK IGNITION KEY HOLE ILLUMINATION BULB

1. Disconnect ignition key hole illumination connector.
2. Check continuity between ignition key hole illumination terminals 1 and 2.

1 – 2 : Continuity should exist.

OK or NG

- OK >> GO TO 5.
NG >> Replace ignition key hole illumination. Refer to [LT-164, "Removal and Installation"](#).

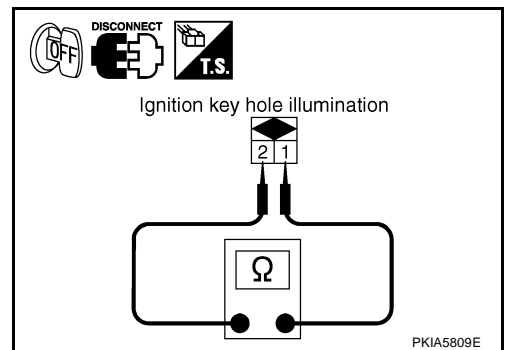

5. CHECK IGNITION KEY HOLE ILLUMINATION CIRCUIT

1. Disconnect BCM connector and key hole illumination connector.
2. Check continuity between BCM harness connector M1 terminal 1 (PU) and key hole illumination harness connector M309 terminal 2 (PU).

1 (PU) – 2 (PU) : Continuity should exist.

OK or NG

- OK >> Replace BCM if ignition key hole illumination does not work after setting the connector again. Refer to [BCS-16, "Removal and Installation of BCM"](#).
NG >> Repair harness or connector.

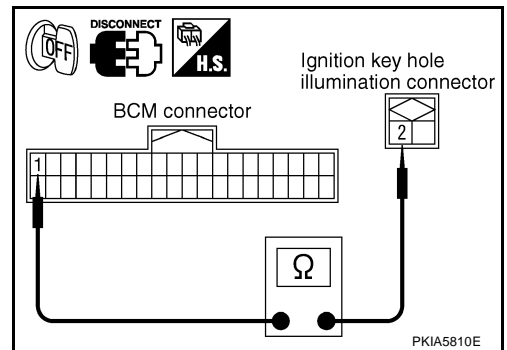

6. CHECK IGNITION KEY HOLE ILLUMINATION CIRCUIT

1. Disconnect BCM connector and key hole illumination connector.
2. Check continuity between BCM harness connector M2 terminal 41 (R/B) and key hole illumination harness connector M309 terminal 1 (R/B).

41 (R/B) – 1 (R/B) : Continuity should exist.

OK or NG

- OK >> Replace BCM if ignition key hole illumination does not work after setting the connector again. Refer to [BCS-16, "Removal and Installation of BCM"](#).
NG >> Repair harness or connector.

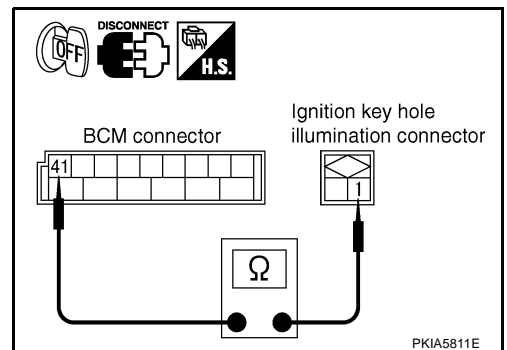

INTERIOR ROOM LAMP

AKS009L6

All Step Lamps Does Not Operate

1. CHECK EACH DOOR SWITCH

Select "BCM" on CONSULT-II. With "INT LAMP" data monitor to make sure switches listed below turn ON-OFF linked with switch operation.

Switch name	CONSULT screen
Driver side door switch	DOOR SW - DR
Passenger side door switch	DOOR SW - AS

OK or NG

- OK >> GO TO 2.
 NG >> Inspect malfunctioning switch system.

DATA MONITOR	
MONITOR	
IGN ON SW	ON
KEY ON SW	ON
DOOR SW-DR	ON
DOOR SW-AS	ON
DOOR SW-RR	OFF
DOOR SW-RL	OFF
BACK DOOR SW	OFF
KEY CYL LK-SW	OFF
KEY CYL UN-SW	OFF
Page Down	
RECORD	
MODE	BACK LIGHT COPY

PKIB3532E

2. CHECK STEP LAMP INPUT

- Turn ignition switch OFF.
- Check voltage between step lamp (driver side) harness connector D10 terminal 1 (R/B) and ground.

1 (R/B) – Ground : Battery voltage.

OK or NG

- OK >> GO TO 3.
 NG >> GO TO 4.

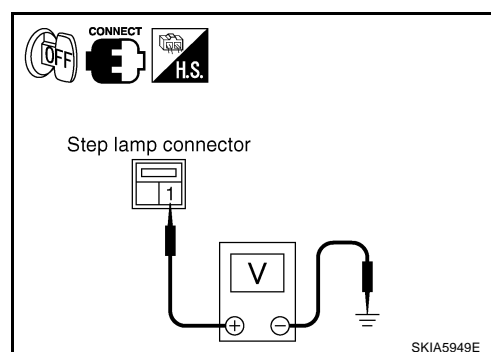

3. CHECK STEP LAMP CIRCUIT

- Disconnect BCM connector and front door driver side step lamp connector.
- Check continuity between BCM harness connector M2 terminal 47 (Y/PU) and front door step lamp (driver side) harness connector D10 terminal 2 (Y/PU).

47 (Y/PU) – 2 (Y/PU) : Continuity should exist.

OK or NG

- OK >> Replace BCM if step lamps does not work after setting the connector again. Refer to [BCS-16, "Removal and Installation of BCM"](#).
- NG >> Repair harness or connector.

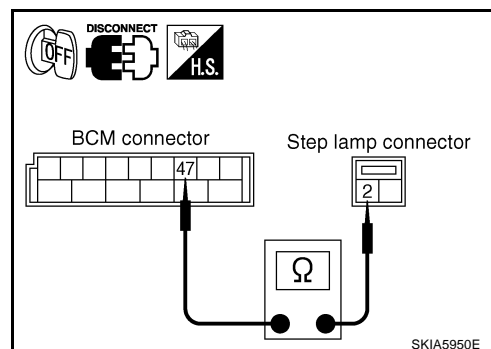

4. CHECK STEP LAMP CIRCUIT

- Disconnect BCM connector and step lamp connector.
- Check continuity between BCM harness connector M2 terminal 41 (R/B) and front door step lamp (driver side) harness connector D10 terminal 1 (R/B).

41 (R/B) – 1 (R/B) : Continuity should exist.

OK or NG

- OK >> Replace BCM if step lamps does not work after setting the connector again. Refer to [BCS-16, "Removal and Installation of BCM"](#).
- NG >> Repair harness or connector.

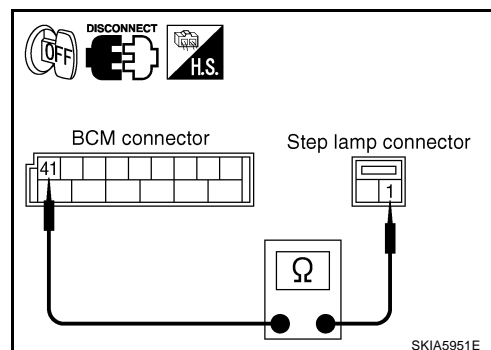

INTERIOR ROOM LAMP

All Interior Room Lamps Does Not Operate

AKS009L7

1. CHECK POWER SUPPLY CIRCUIT

1. All interior room lamps switch are OFF.
2. Turn ignition switch ON.
3. Check voltage between BCM harness connector M2 terminal 41 (R/B) and ground.

41 (R/B) – Ground : Battery voltage.

OK or NG

OK >> Repair harness or connector. In a case of making a short circuit, be sure to disconnect battery negative cable after repairing harness, and then reconnect.

NG >> Replace BCM. Refer to [BCS-16, "Removal and Installation of BCM"](#).

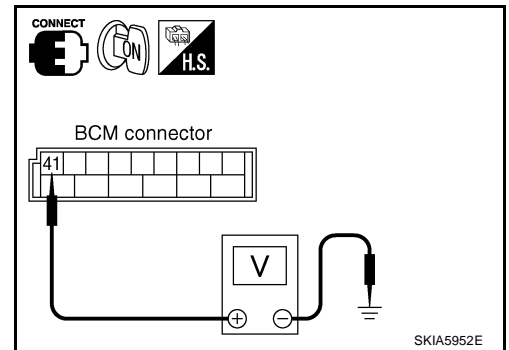

Bulb Replacement MAP LAMP

AKS009L8

Refer to [LT-161, "Bulb Replacement"](#) in "MAP LAMP".

STEP LMP

Refer to [LT-138, "Bulb Replacement"](#) in "STEP LAMP".

Removal and Installation MAP LAMP

AKS009L9

Refer to [LT-161, "Removal and Installation"](#) in "MAP LAMP".

STEP LAMP

Refer to [LT-138, "Removal and Installation"](#) in "STEP LAMP".

A
B
C
D
E
F
G
H
I
J
LT
L
M

ILLUMINATION

PFP:27545

System Description

AKS009MR

The control of illumination lamps operation is dependent upon the position of lighting switch (combination switch). When lighting switch is placed in the 1ST or 2ND position (or if auto light system is activated), BCM (body control module) receives input signal requesting illumination lamps to illuminate. This input signal is communicated to IPDM E/R (intelligent power distribution module engine room) across the CAN communication lines. CPU (central processing unit) located in the IPDM E/R controls tail lamp relay coil. This relay, when energized, directs power to illumination lamps, which then illuminate.

Power is supplied at all times

- through 10A fuse (No. 71, located in IPDM E/R)
- to CPU located in IPDM E/R, and
- to tail lamp relay, located in IPDM E/R,
- through 50A fusible link (letter F, located in fuse, fusible link and relay box)
- to BCM terminal 55,
- through 10A fuse [No.18 located in fuse block (J/B)]
- to BCM terminal 42,
- through 15A fuse (No. 78 located in IPDM E/R)
- to CPU located in IPDM E/R.

With the ignition switch in the ON or START position, power is supplied

- to CPU located in IPDM E/R, from battery direct,
- through 10A fuse [No. 1, located in fuse block (J/B)]
- to BCM terminal 38,
- through 10A fuse [No. 14 located in fuse block (J/B)]
- to combination meter terminals 22 and 23,
- through 10A fuse [No.12 located in fuse block (J/B)]
- to display and A/C auto amp. terminal 2, and
- to NAVI control unit terminal 26 (with navigation system).

With the ignition switch in the ACC or ON position, power is supplied

- through 10A fuse [No. 6, located in fuse block (J/B)]
- to BCM terminal 11
- to combination meter terminal 18
- to NAVI control unit terminal 6 (with navigation system), and
- to display unit terminal 19 (with navigation system).

Ground is supplied

- to BCM terminal 52
- to display and A/C auto amp. terminal 5
- to combination meter terminal 1, 24, and 25
- to NAVI control unit terminal 1 and 4 (with navigation system), and
- to display unit terminal 22 and 24 (with navigation system)
- through grounds M30 and M66,
- to IPDM E/R terminals 38 and 60
- through grounds E17 and E43.

ILLUMINATION OPERATION BY LIGHTING SWITCH

With the lighting switch in the 1ST or 2ND position (or if auto light system is activated), BCM receives input signal requesting illumination lamps to illuminate. This input signal is communicated to IPDM E/R across the CAN communication lines. The CPU located in the IPDM E/R controls tail lamp relay coil, which, when energized, directs power

- through IPDM E/R terminal 22
- to combination meter terminal 10

ILLUMINATION

- to glove box lamp terminal 1
- to A/T illumination terminal 1 (with A/T)
- to illumination control switch terminal 1
- to VDC off switch (illumination) terminal 3
- to hazard switch (illumination) terminal 3
- to heated seat switch (driver side) (illumination) terminal 5 (with heater seat)
- to heated seat switch (passenger side) (illumination) terminal 5 (with heater seat)
- to A/C and audio controller terminal 9
- to display and A/C auto amp. terminal 1
- to ashtray illumination and cigarette lighter socket illumination terminal 5 (with A/T)
- to ashtray illumination and cigarette lighter socket illumination terminal 2 (with M/T)
- to NAVI control unit (illumination) terminal 25 (with navigation system)
- to NAVI switch RH (illumination) terminal 2 (with navigation system)
- to snow mode switch (illumination) terminal 5 (AWD models)
- to audio unit terminal 8
- to upper glove box lamp terminal 1 (without navigation system)
- to trunk lid opener switch (illumination) terminal 3, and
- to combination switch (spiral cable) terminal 26
- through combination switch (spiral cable) terminal 18
- to ASCD steering switch illumination
- to steering wheel audio control switch illumination.

Ground is supplied at all times

- to combination meter terminal 9
- to NAVI switch terminal 3 (with navigation system)
- to VDC off switch (illumination) terminal 4
- to A/T illumination terminal 2 (with A/T)
- to hazard switch (illumination) terminal 4
- to display and A/C auto amp. terminal 21
- to A/C and audio controller terminal 10
- to heated seat switch (driver side) (illumination) terminal 6 (with heated seat)
- to heated seat switch (passenger side) (illumination) terminal 6 (with heated seat)
- to combination switch (spiral cable) terminals 21 and 27
- to snow mode switch (illumination) terminal 6 (AWD models)
- to audio unit terminal 7, and
- to trunk lid opener switch (illumination) terminal 4
- through illumination control switch terminal 2,
- to ashtray illumination and cigarette lighter socket illumination terminal 4 (with A/T)
- to ashtray illumination and cigarette lighter socket illumination terminal 3 (with M/T)
- to illumination control switch terminal 3
- to upper glove box lamp terminal 2 (without navigation system), and
- to glove box lamp terminal 2
- through grounds M30 and M66.

With power and ground supplied, illumination lamps illuminate.

EXTERIOR LAMP BATTERY SAVER CONTROL

When the lighting switch is in the 1ST or 2ND position (or if auto light system is activated), and ignition switch is turned from ON or ACC to OFF, the battery saver control function is activated.

Under this condition, illumination lamps remain illuminated for 5 minutes, then illumination lamps are turned off.

A

B

C

D

E

F

G

H

I

J

LT

L

M

ILLUMINATION

When lighting switch is turned from OFF to 1ST or 2ND position (or if auto light system is activated) after illumination lamps are turned off by battery saver control, and illumination lamps illuminate again. Exterior lamp battery saver control mode can be changed by the function setting of CONSULT-II.

CAN Communication System Description

AKS009MS

CAN (Controller Area Network) is a serial communication line for real time application. It is an on-vehicle multiplex communication line with high data communication speed and excellent error detection ability. Many electronic control units are equipped onto vehicle, and each control unit shares information and links with other control units during operation (not independent). In CAN communication, control units are connected with 2 communication lines (CAN H line, CAN L line) allowing a high rate of information transmission with less wiring. Each control unit transmits/receives data but selectively reads required data only.

CAN Communication Unit

AKS0093P

Refer to [LAN-21, "CAN Communication Unit"](#) .

ILLUMINATION

Schematic

AKS009MT

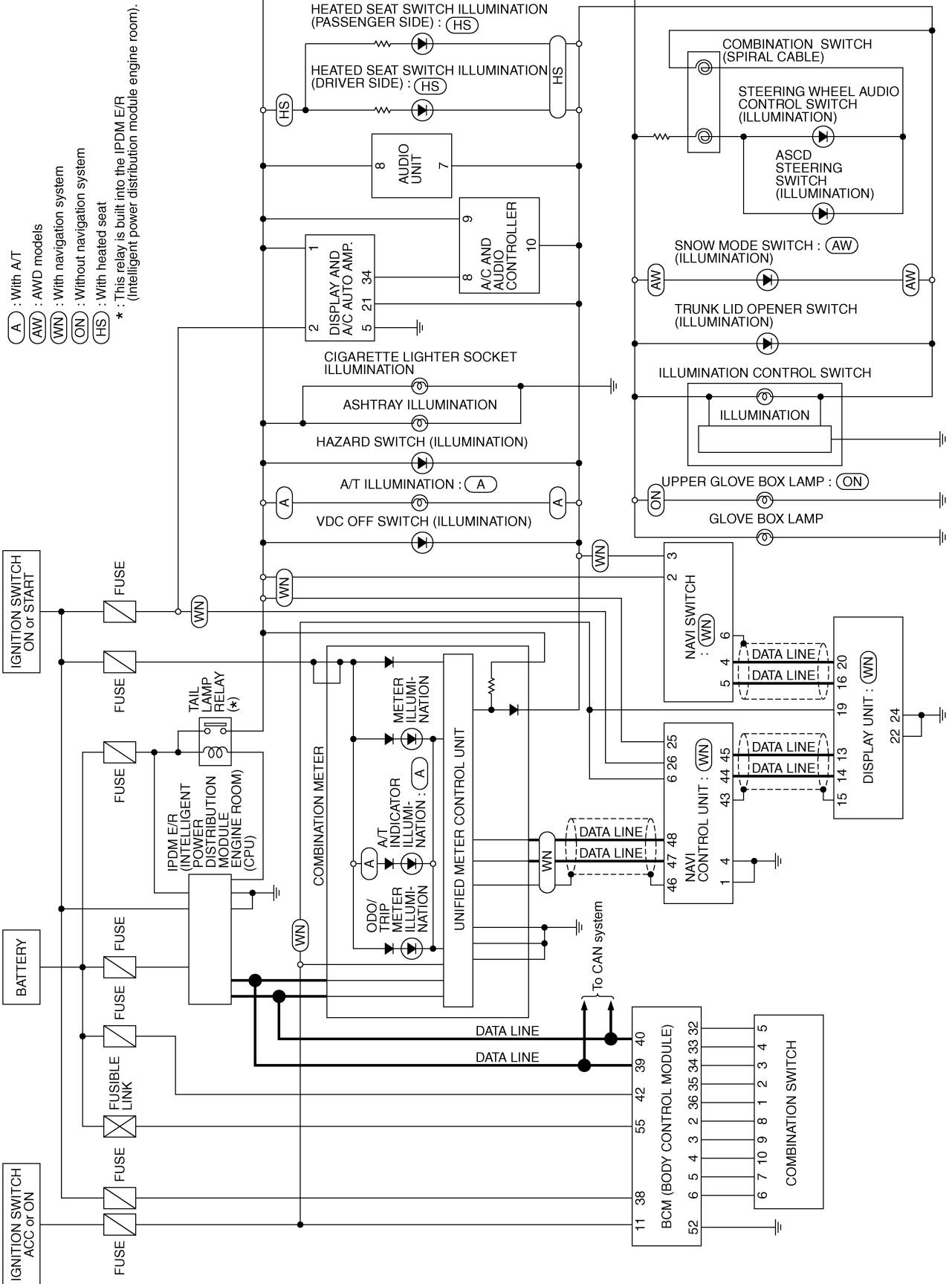

A
B
C
D
E
F
G
H
I
J
K
L
M

LT

TKWM2935E

ILLUMINATION

AKS009MU

Wiring Diagram — ILL —

LT-ILL-01

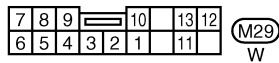
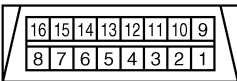
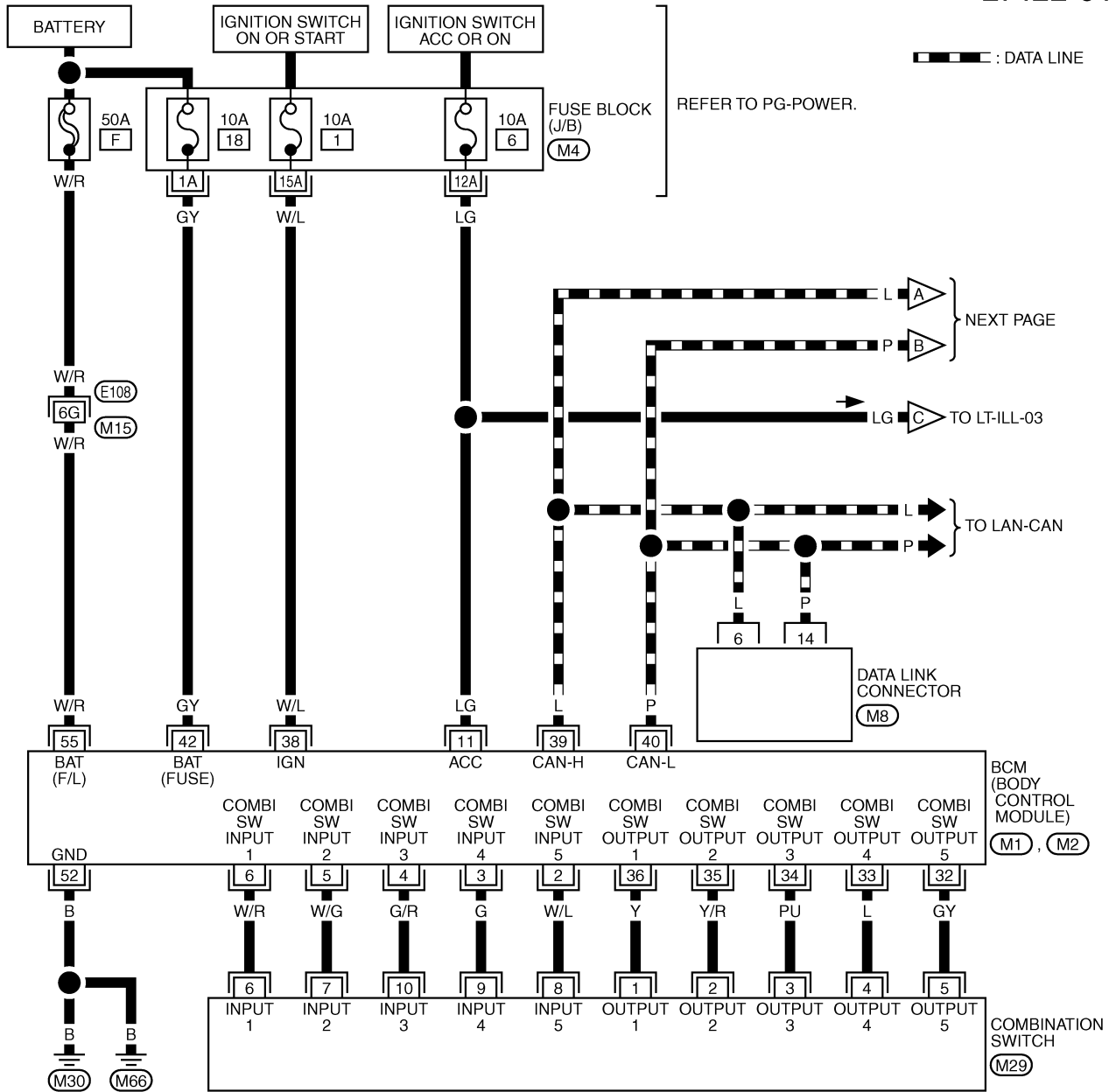

REFER TO THE FOLLOWING.

- (E108) -SUPER MULTIPLE JUNCTION (SMJ)
- (M4) -FUSE BLOCK-JUNCTION BOX (J/B)
- (M1), (M2) -ELECTRICAL UNITS

TKWM2281E

ILLUMINATION

LT-ILL-02

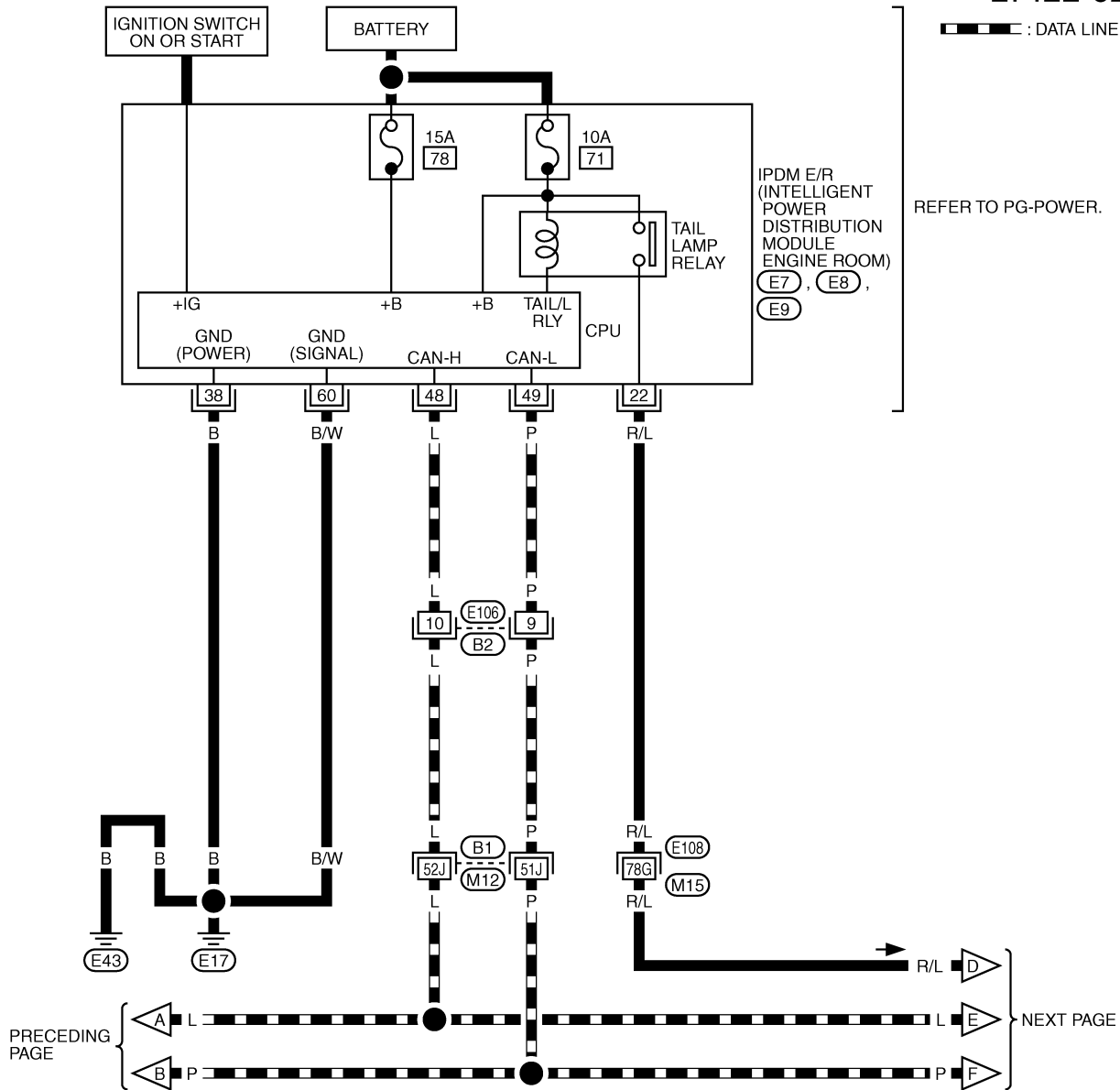

A
B
C
D
E
F
G
H
I
J
K
L
M

LT

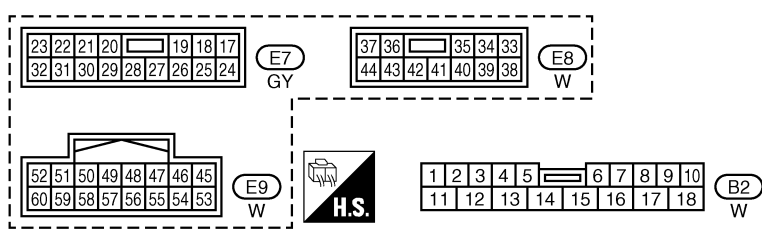

REFER TO THE FOLLOWING.
(E108), (B1) -SUPER MULTIPLE JUNCTION (SMJ)

TKWM2282E

ILLUMINATION

LT-ILL-03

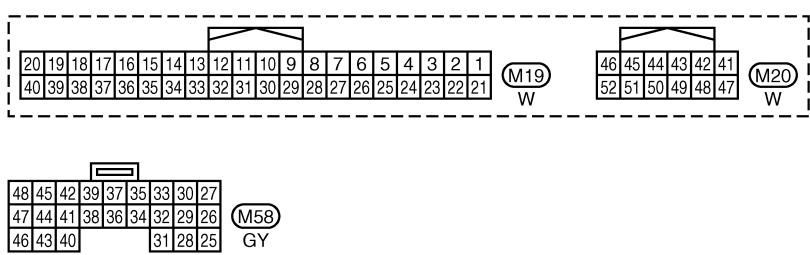
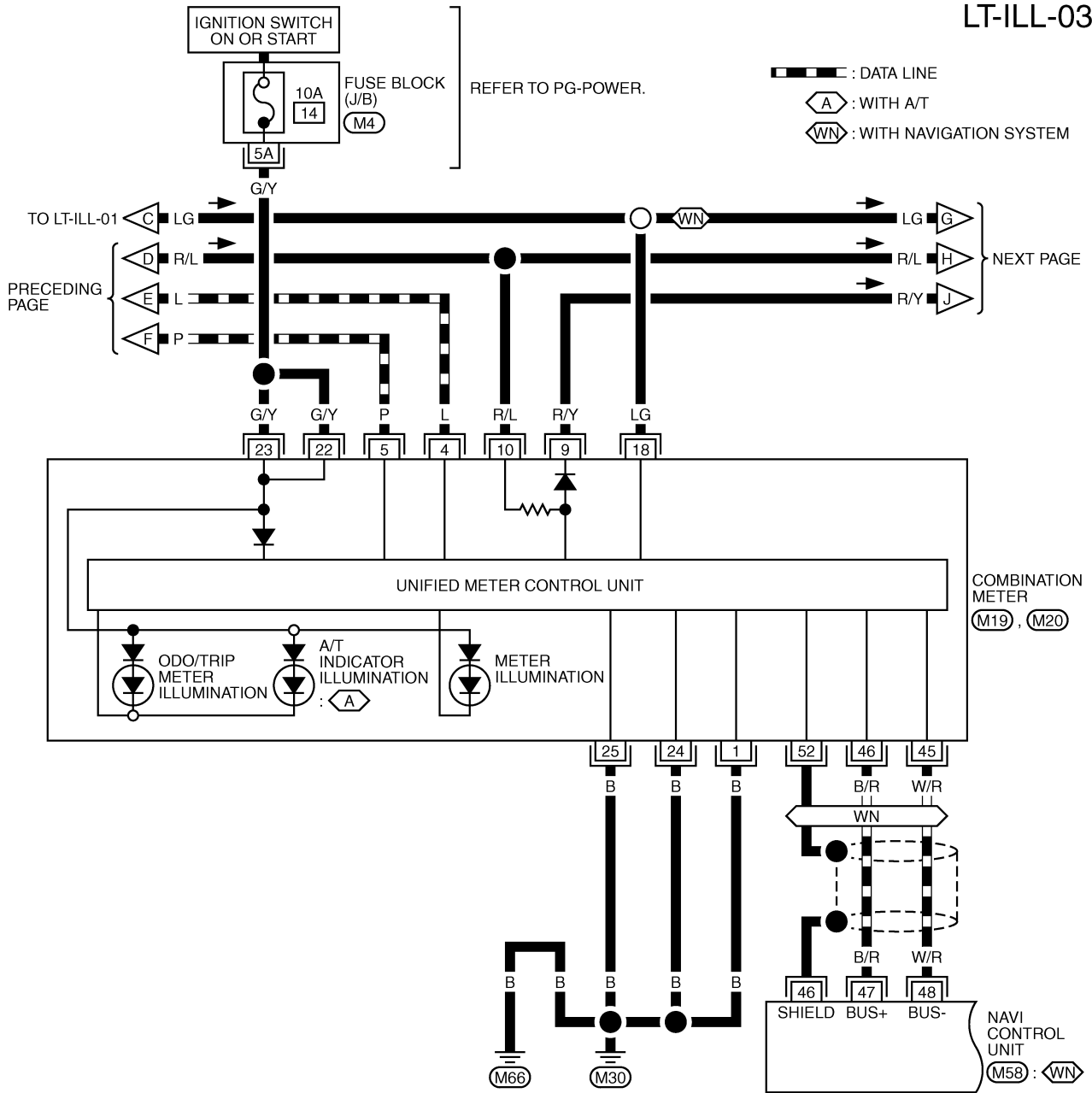

REFER TO THE FOLLOWING.
 (M4) - FUSE BLOCK-JUNCTION BOX (J/B)
 (M58) - (WN)

TKWM2283E

ILLUMINATION

LT-ILL-04

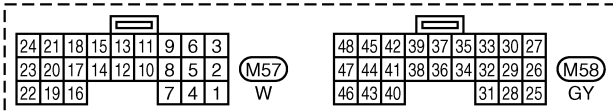
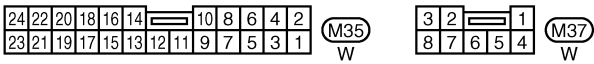
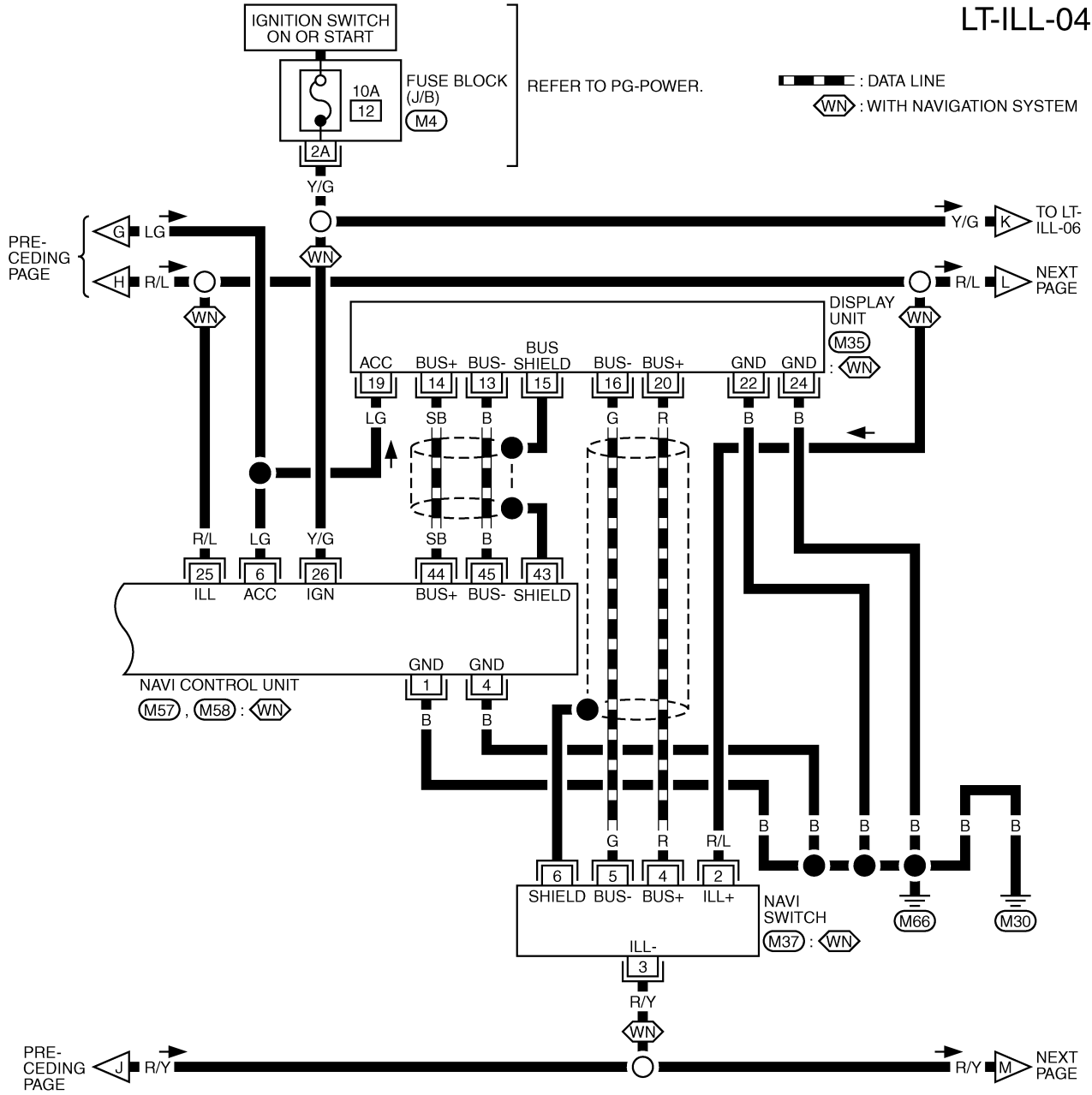

REFER TO THE FOLLOWING.
 (M4) - FUSE BLOCK-JUNCTION BOX (J/B)

TKWM2936E

ILLUMINATION

LT-ILL-05

(A) : WITH A/T
 (M) : WITH M/T
 *1 B: (A)
 R/Y: (M)

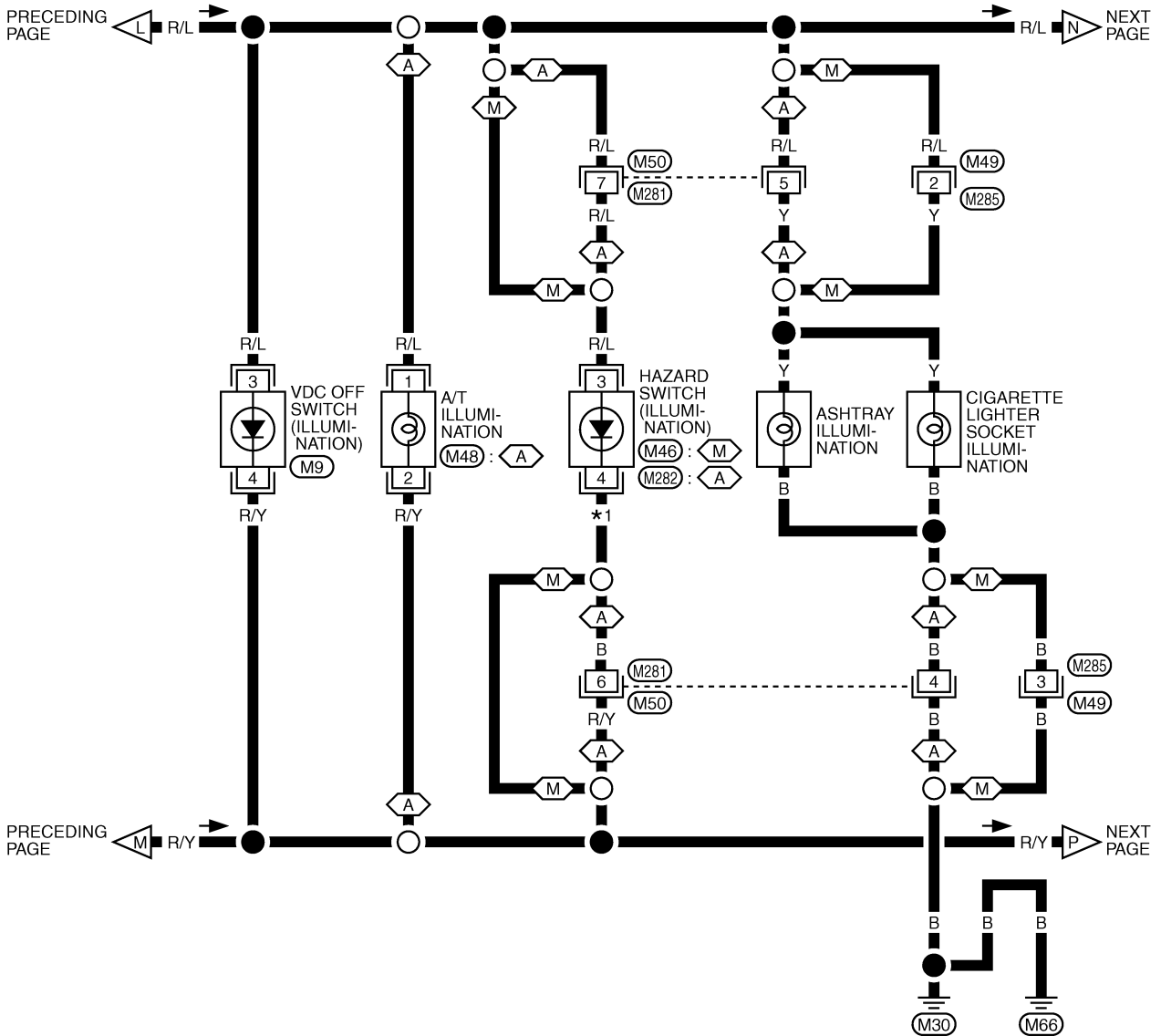

*: THIS CONNECTOR IS NOT SHOWN IN "HARNESS LAYOUT", PG SECTION.

TKWM2937E

ILLUMINATION

LT-ILL-06

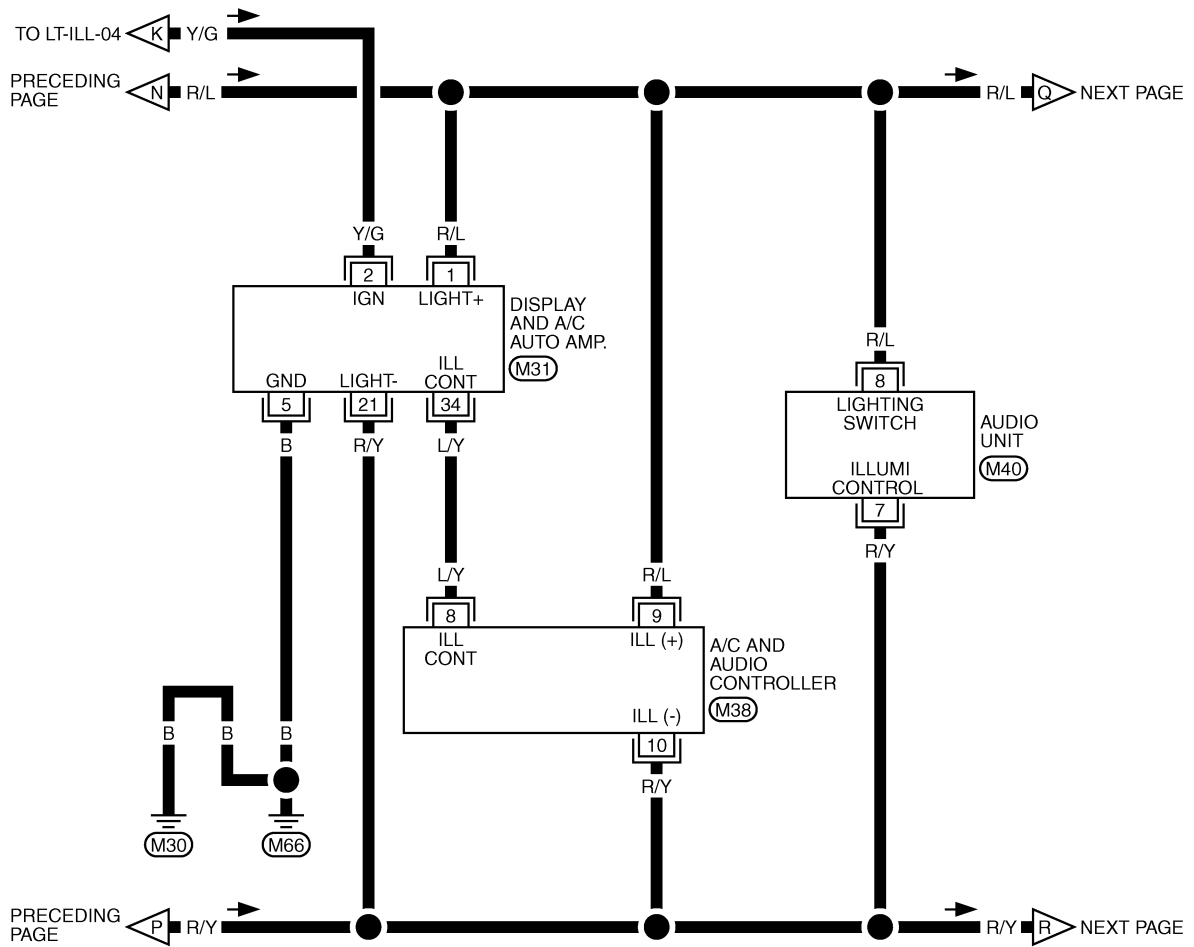

1	2	3	4	5	6	7	8	9	10	11	12	13	14	15	16	17	18	19	20
21	22	23	24	25	26	27	28	29	30	31	32	33	34	35	36	37	38	39	40

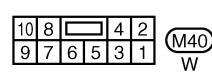
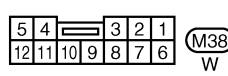

TKWM2286E

ILLUMINATION

LT-ILL-07

⬡(AH) : WITH A/T WITH HEATED SEAT
 ⬡(MH) : WITH M/T WITH HEATED SEAT

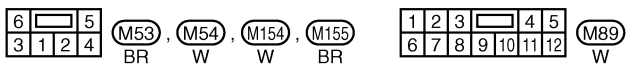
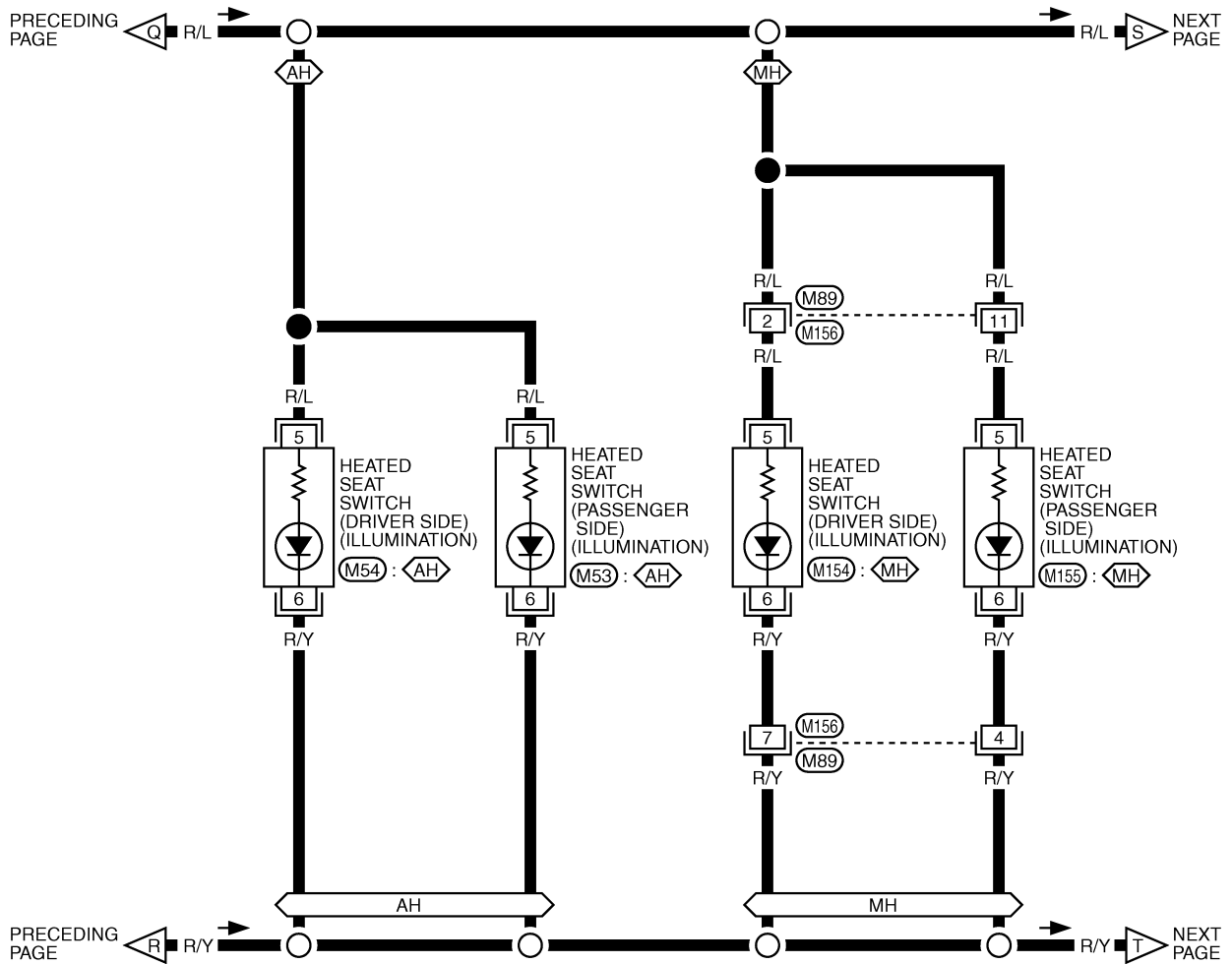

TKWM2287E

ILLUMINATION

LT-ILL-08

 : AWD MODELS

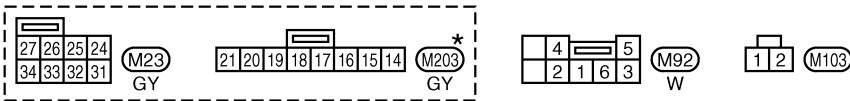
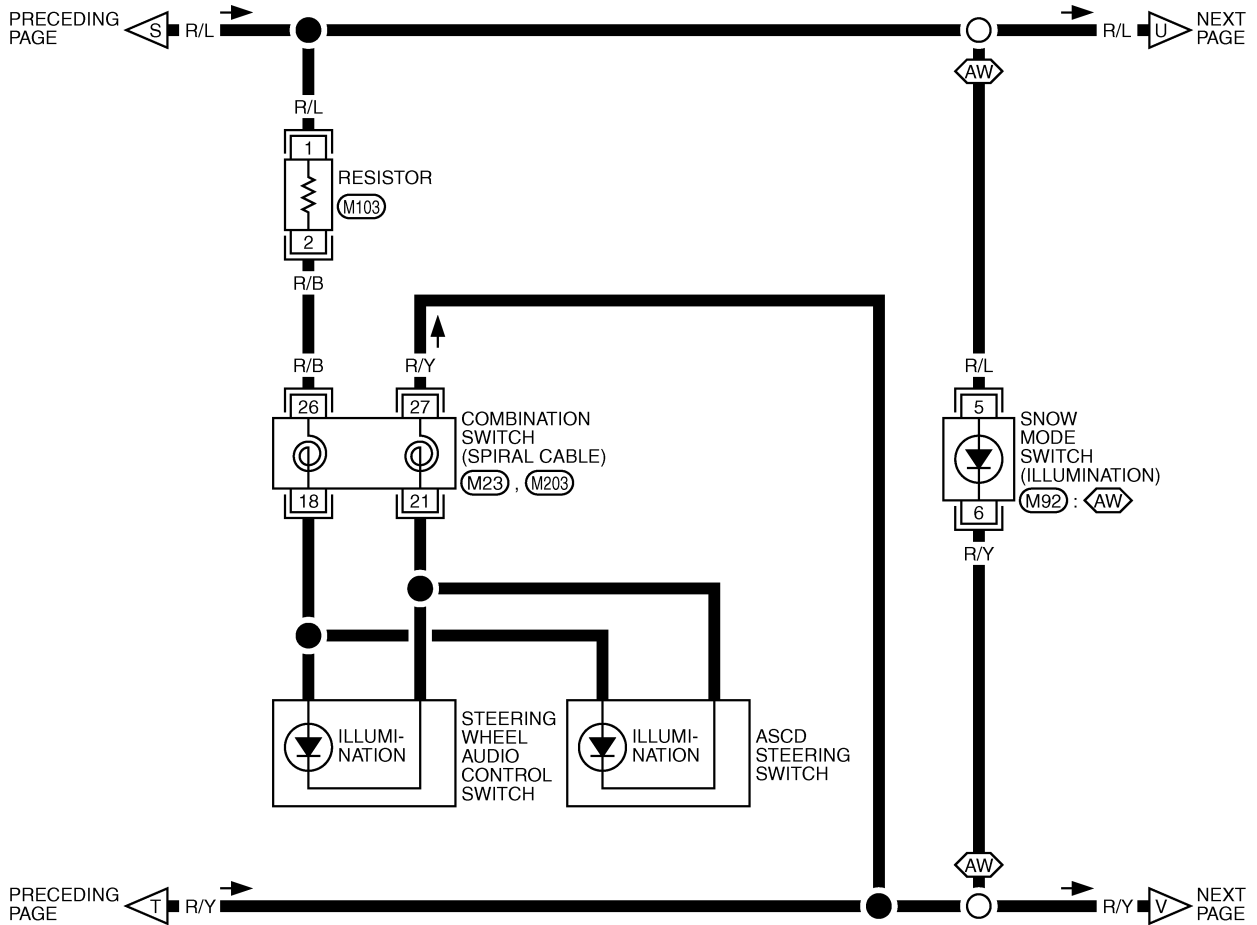

*: THIS CONNECTOR IS NOT SHOWN IN "HARNES LAYOUT", PG SECTION.

TKWM2938E

ILLUMINATION

LT-ILL-09

ⓄN : WITHOUT NAVIGATION SYSTEM

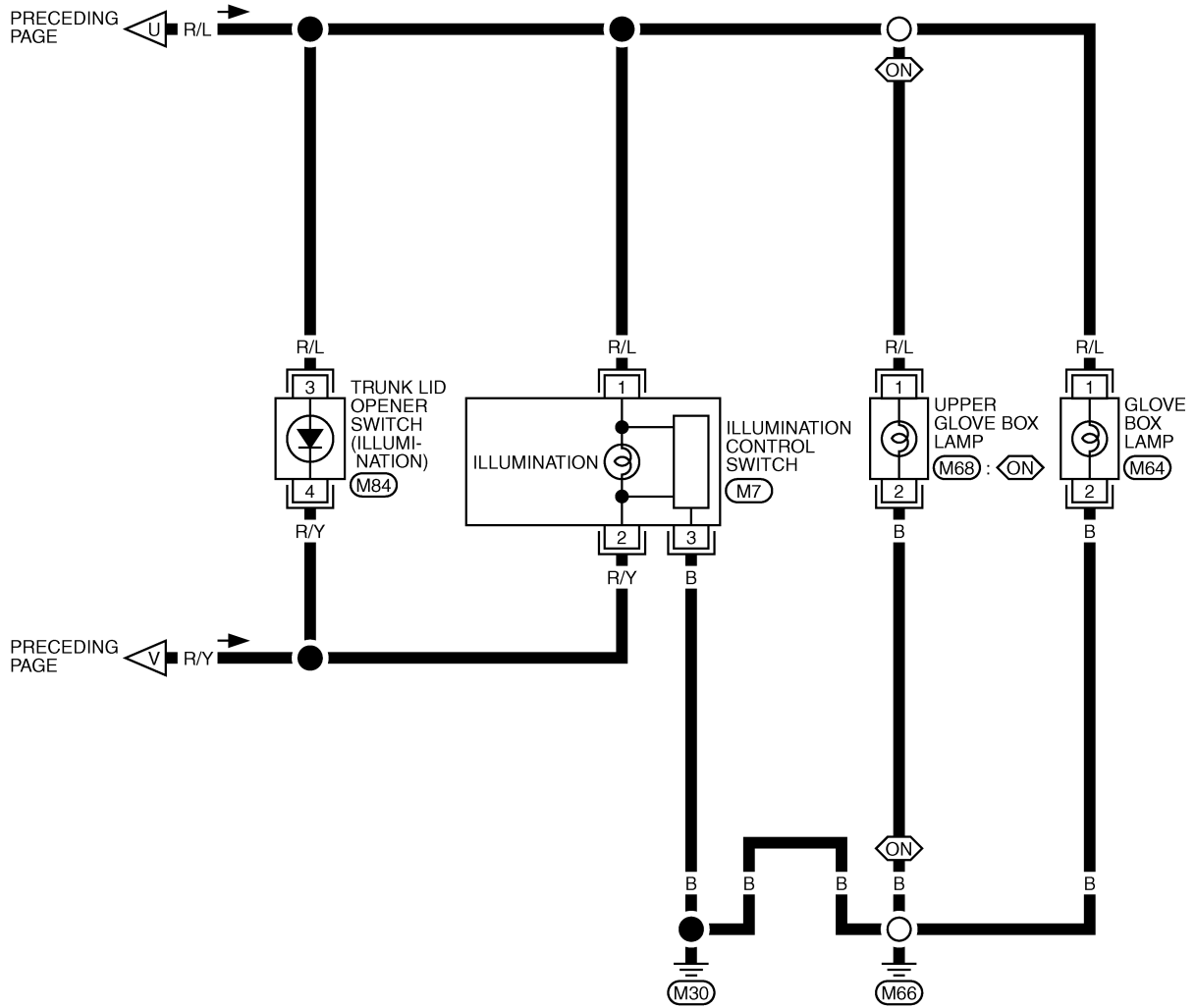

TKWM2289E

ILLUMINATION

Removal and Installation GLOVE BOX LAMP

AKS009MV

Refer to [LT-165, "Bulb Replacement, Removal and Installation"](#) .

A

B

C

D

E

F

G

H

I

J

LT

L

M

BULB SPECIFICATIONS

BULB SPECIFICATIONS

PFP:26297

Headlamp

AKS000MP

Item	Wattage (W)
Low	35 (D2R)
High/Fog	60/55 (HB2)

Exterior Lamp

AKS000MQ

Item	Wattage (W)
Front combination lamp	Turn signal/Parking lamp 21/5
Rear combination lamp	Stop/Tail lamp LED
	Turn signal lamp 21
	Back-up lamp 18
	Rear side marker lamp LED
Front side marker lamp	3.8
License plate lamp	5
High-mounted stop lamp (parcel shelf mount)	LED
High-mounted stop lamp (rear air spoiler mount)	LED

Interior Lamp/Illumination

AKS000MR

Item	Wattage (W)
Glove box lamp	1.4
Ignition key hole illumination lamp	1.4
Ashtray illumination lamp	1.4
Cigarette lighter illumination lamp	0.8
Map lamp	8
Personal lamp	8
Step lamp	5
Trunk room lamp	3.4
Vanity mirror lamp	1.32