

SECTION **BCS**

BODY CONTROL SYSTEM

CONTENTS

PRECAUTIONS	2	SYSTEMS CONTROLLED BY BCM AND INTELLIGENT KEY UNIT	8
Precautions for Supplemental Restraint System (SRS) "AIR BAG" and "SEAT BELT PRE-TENSIONER"	2	MAJOR COMPONENTS AND CONTROL SYSTEM	9
Precautions for Battery Service	2	CAN Communication Unit	10
BCM (BODY CONTROL MODULE)	3	Schematic	11
System Description	3	CONSULT-II Function (BCM)	13
BCM FUNCTION	3	CONSULT-II BASIC OPERATION	13
COMBINATION SWITCH READING FUNCTION	3	ITEMS OF EACH PART	13
CAN COMMUNICATION CONTROL	6	WORK SUPPORT	15
BCM STATUS CONTROL	7	CAN Communication Inspection Using CONSULT-II (Self-Diagnosis)	15
SYSTEMS CONTROLLED BY BCM DIRECTLY	8	Removal and Installation of BCM	16
SYSTEMS CONTROLLED BY BCM AND IPDM E/R	8	REMOVAL	16
SYSTEMS CONTROLLED BY BCM AND COMBINATION METER	8	INSTALLATION	16

A
B
C
D
E
F
G
H
I
J
L
M

BCS

PRECAUTIONS

PRECAUTIONS

PF0:00001

Precautions for Supplemental Restraint System (SRS) “AIR BAG” and “SEAT BELT PRE-TENSIONER”

NKS000MX

The Supplemental Restraint System such as “AIR BAG” and “SEAT BELT PRE-TENSIONER”, used along with a front seat belt, helps to reduce the risk or severity of injury to the driver and front passenger for certain types of collision. This system includes seat belt switch inputs and dual stage front air bag modules. The SRS system uses the seat belt switches to determine the front air bag deployment, and may only deploy one front air bag, depending on the severity of a collision and whether the front occupants are belted or unbelted. Information necessary to service the system safely is included in the SRS and SB section of this Service Manual.

WARNING:

- To avoid rendering the SRS inoperative, which could increase the risk of personal injury or death in the event of a collision which would result in air bag inflation, all maintenance must be performed by an authorized NISSAN/INFINITI dealer.
- Improper maintenance, including incorrect removal and installation of the SRS, can lead to personal injury caused by unintentional activation of the system. For removal of Spiral Cable and Air Bag Module, see the SRS section.
- Do not use electrical test equipment on any circuit related to the SRS unless instructed to in this Service Manual. SRS wiring harnesses can be identified by yellow and/or orange harnesses or harness connectors.

Precautions for Battery Service

NKS000MY

Before disconnecting the battery, lower both the driver and passenger windows. This will prevent any interference between the window edge and the vehicle when the door is opened/closed. During normal operation, the window slightly raises and lowers automatically to prevent any window to vehicle interference. The automatic window function will not work with the battery disconnected.

BCM (BODY CONTROL MODULE)

BCM (BODY CONTROL MODULE)

PFP:284B2

System Description

NKS000MZ

BCM (Body Control Module) controls the operation of various electrical units installed on the vehicle.

BCM FUNCTION

BCM has combination switch reading function for reading the operation of combination switches (light, wiper, washer and turn signal) in addition to a function for controlling the operation of various electrical components. Also it has an interface function allowing it to receive signals from the display and A/C auto amp., and send signals to ECM using CAN communication.

COMBINATION SWITCH READING FUNCTION

Description

- BCM reads combination switch (lighting switch, wiper switch) status, and controls various electrical component, according to the results.
- BCM reads information of a maximum of 20 switches by combining five output terminals (OUTPUT 1-5) and five input terminals (INPUT 1-5).

Operation description

- BCM activates transistors of output terminals (OUTPUT 1-5) periodically, and allows current to flow in turn.
- If any (1 or more) switches are turned ON, circuit of output terminals (OUTPUT 1-5) and input terminals (INPUT 1-5) becomes active.
- At this time, transistors of output terminals (OUTPUT 1-5) are activated to allow current to flow. When voltage of input terminals (INPUT 1-5) corresponding to that switch changes, interface in BCM detects voltage change, and BCM determines that switch is ON.

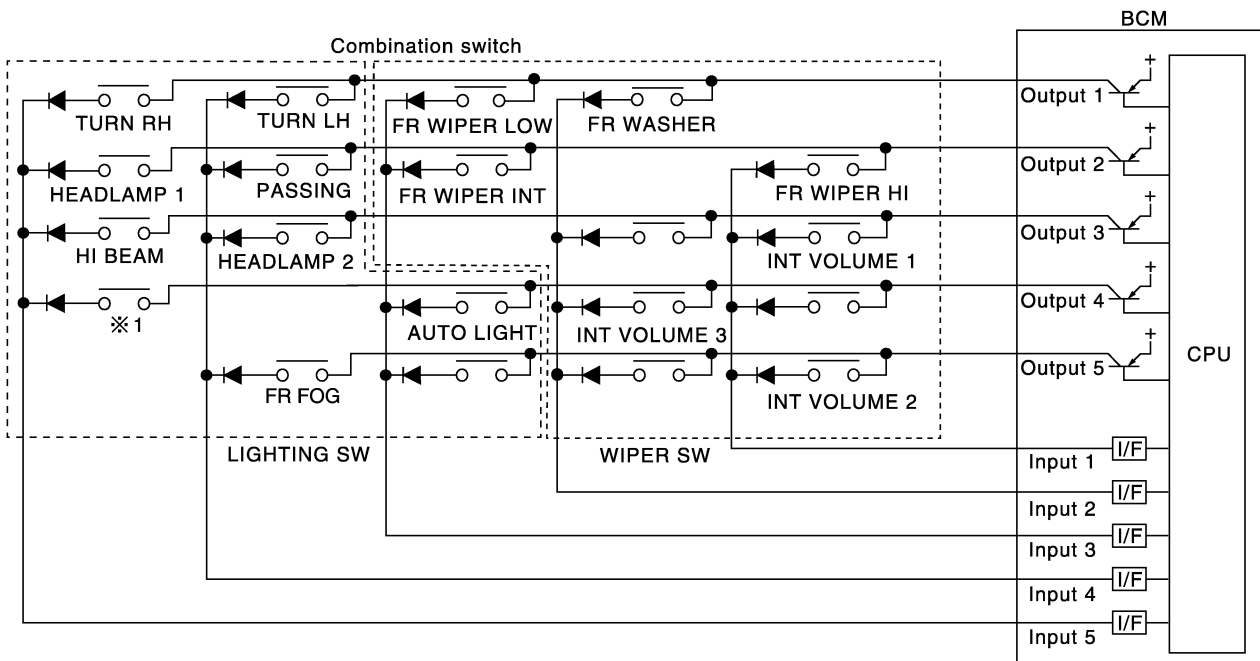

※1 : LIGHTING SWITCH 1ST POSITION

PKIC6010E

BCM (BODY CONTROL MODULE)

Operation table of BCM and combination switches

BCM reads operation status of combination switch using combinations shown in table below.

	COMB SW OUTPUT 1 →		COMB SW OUTPUT 2 →		COMB SW OUTPUT 3 →		COMB SW OUTPUT 4 →		COMB SW OUTPUT 5	
	ON	OFF	ON	OFF	ON	OFF	ON	OFF	ON	OFF
COMB SW INPUT 1	—	—	FR WIPER HI ON	FR WIPER HI OFF	INT VOLUME 1 ON	INT VOLUME 1 OFF	—	—	INT VOLUME 2 ON	INT VOLUME 2 OFF
COMB SW INPUT 2	FR WASHER ON	FR WASHER OFF	—	—	—	—	INT VOLUME 3 ON	INT VOLUME 3 OFF	—	—
COMB SW INPUT 3	FR WIPER LOW ON	FR WIPER LOW OFF	FR WIPER INT ON	FR WIPER INT OFF	—	—	AUTO LIGHT ON	AUTO LIGHT OFF	—	—
COMB SW INPUT 4	TURN LH ON	TURN LH OFF	PASSING ON	PASSING OFF	HEAD-LAMP 2 ON	HEAD-LAMP 2 OFF	—	—	FR FOG ON	FR FOG OFF
COMB SW INPUT 5	TURN RH ON	TURN RH OFF	HEAD-LAMP 1 ON	HEAD-LAMP 1 OFF	HI BEAM ON	HI BEAM OFF	LIGHTING SW (1st) ON	LIGHTING SW (1st) OFF	—	—

SKIA8640E

NOTE:

Headlamp system has a dual switch.

BCM (BODY CONTROL MODULE)

Sample operation: (When lighting switch 1ST position turned ON)

- When lighting switch 1ST position is turned ON, contact in combination switch turns ON. At this time if OUTPUT 4 transistor is activated, BCM detects that voltage changes in INPUT 5.
- When OUTPUT 4 transistor is ON, BCM detects that voltage changes in INPUT 5, and judges that lighting switch 1ST position is ON. Then BCM sends tail lamp and clearance lamp request signal to IPDM E/R using CAN communication.
- When OUTPUT 4 transistor is activated again, BCM detects that voltage changes in INPUT 5, and recognizes that lighting switch 1ST position is continuously ON.

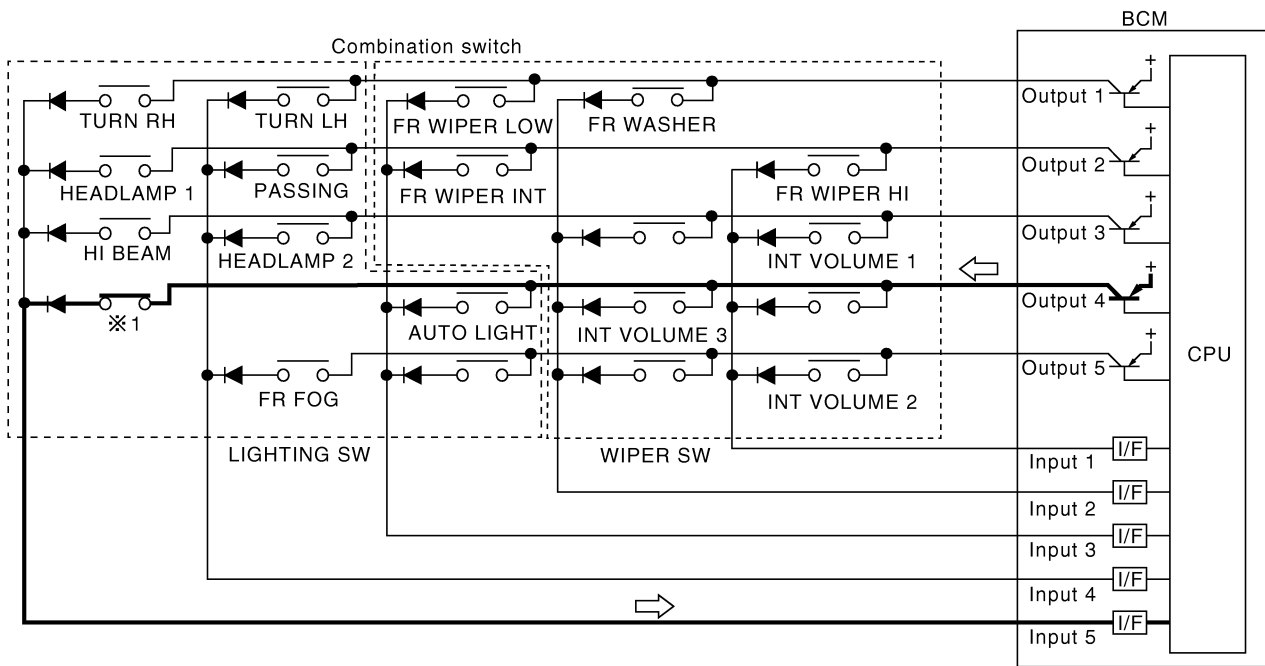

※1 : LIGHTING SWITCH 1ST POSITION

PKIC6036E

NOTE:

Each OUTPUT terminal transistor is activated at 10 ms intervals. Therefore after switch is turned ON, electrical loads are activated with a time delay. But this time delay is so short that it cannot be detected by human senses.

BCS

BCM (BODY CONTROL MODULE)

Operation mode

- Combination switch reading function has operation modes shown below.
1. Normal status
 - When BCM is not in sleep status, OUTPUT terminals (1-5) send out ON signal every 10 ms.
 2. Sleep status
 - When BCM is in sleep status, transistors of OUTPUT 1 and 5 stop the output, and BCM enters low power mode. Mean while OUTPUT 2, 3, and 4 send out ON signal every 60 ms, and accept only input from light switch system.

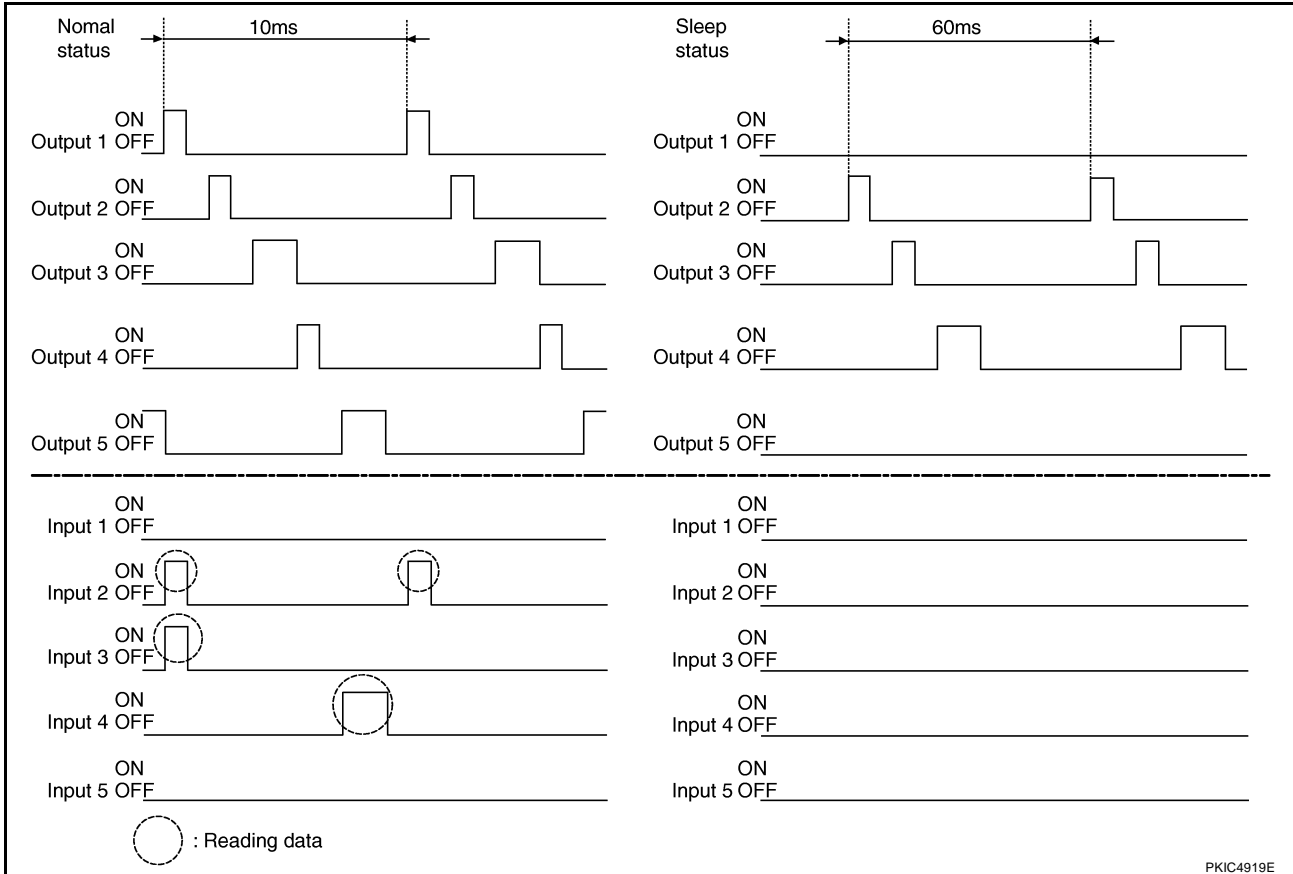

CAN COMMUNICATION CONTROL

CAN communication allows a high rate of information transmission through the two communication lines (CAN L line, CAN H line) connecting the various control units in the system. Each control unit transmits/receives data but selectively reads required data only. For details of signals that are transmitted/received by BCM via CAN communication, refer to [LAN-47, "CAN System Specification Chart"](#).

BCM (BODY CONTROL MODULE)

BCM STATUS CONTROL

BCM changes its status depending on the operation status in order to save power consumption.

1. CAN communication status
 - With ignition switch ON, CAN communicates with other control units normally.
 - Control by BCM is being operated properly.
 - When ignition switch is OFF, switching to sleep mode is possible.
 - Even when ignition switch is OFF, if CAN communication with IPDM E/R and combination meter is active, CAN communication status is active.
2. Sleep transient status
 - This status shuts down CAN communication when ignition switch is turned OFF.
 - It transmits sleep request signal to IPDM E/R and combination meter.
 - Two seconds after CAN communication of all control units stops, sleep transient status is switches to CAN communication inactive status.
3. CAN communication inactive status
 - With ignition switch OFF, CAN communication is not active.
 - With ignition switch OFF, control performed only by BCM is active.
 - Three seconds after CAN communication of all control units stops, CAN communication inactive status is switches to sleep status.
4. Sleep status
 - BCM is activated with low power mode.
 - CAN communication is not active.
 - When CAN communication operation is detected, it switches to CAN communication status.
 - When a state of the following switches changes, it switches to CAN communication state.
 - Key switch
 - Hazard switch
 - Door lock/unlock switch
 - Front door switch (driver side, passenger side)
 - Trunk lid opener switch
 - Combination switch (passing, lighting switch 1ST position, front fog lamp)
 - Key fob (lock/unlock signal)
 - Key cylinder switch
 - When control performed only by BCM is required by switch, it shifts to CAN communication inactive mode.
 - Status of combination switch reading function is changed.

A
B
C
D
E
F
G
H
I
J
L
M

BCS

BCM (BODY CONTROL MODULE)

SYSTEMS CONTROLLED BY BCM DIRECTLY

System	Reference
Power door lock	BL-21, "POWER DOOR LOCK SYSTEM"
Remote keyless entry	BL-50, "REMOTE KEYLESS ENTRY SYSTEM"
Power window ^{NOTE}	GW-17, "POWER WINDOW SYSTEM"
Front power seat ^{NOTE}	SE-84, "POWER SEAT"
Sunroof ^{NOTE}	RF-10, "SUNROOF"
Room lamp timer	LT-127, "INTERIOR ROOM LAMP"

NOTE:

Power supply only. No system control.

SYSTEMS CONTROLLED BY BCM AND IPDM E/R

System	Reference
Panic alarm	BL-50, "REMOTE KEYLESS ENTRY SYSTEM"
Theft warning	BL-188, "VEHICLE SECURITY (THEFT WARNING) SYSTEM"
IVIS (NATS)	BL-214, "IVIS (INFINITI VEHICLE IMMOBILIZER SYSTEM-NATS)"
Headlamp	LT-5, "HEADLAMP - XENON TYPE -"
Daytime light system	LT-35, "DAYTIME LIGHT SYSTEM"
Auto light system	LT-51, "AUTO LIGHT SYSTEM"
<ul style="list-style-type: none"> ● Parking, license plate, side marker and tail lamps ● Battery saver control 	LT-109, "PARKING, LICENSE PLATE AND TAIL LAMPS"
Front fog lamp	LT-64, "FRONT FOG LAMP"
Front wiper	WW-4, "FRONT WIPER AND WASHER SYSTEM"
Rear window defogger	GW-58, "REAR WINDOW DEFOGGER"

SYSTEMS CONTROLLED BY BCM AND COMBINATION METER

System	Reference
Warning chime	DI-37, "WARNING CHIME"
Turn signal and hazard warning lamps	LT-77, "TURN SIGNAL AND HAZARD WARNING LAMPS"
Tire pressure monitoring system	WT-10, "TIRE PRESSURE MONITORING SYSTEM"

SYSTEMS CONTROLLED BY BCM AND INTELLIGENT KEY UNIT

System	Reference
Intelligent Key	BL-80, "INTELLIGENT KEY SYSTEM"

BCM (BODY CONTROL MODULE)

MAJOR COMPONENTS AND CONTROL SYSTEM

System	Input	Output
Remote keyless entry system	key fob	<ul style="list-style-type: none"> ● All door locking actuator ● Trunk lid opener actuator ● Turn signal lamp (LH, RH)
Intelligent Key system	Intelligent Key unit	<ul style="list-style-type: none"> ● All door locking actuator ● Trunk lid opener actuator ● Turn signal lamp (LH, RH) ● Combination meter
Power door lock system	<ul style="list-style-type: none"> ● Power window main switch (door lock and unlock switch) ● Power window sub switch (passenger side) (door lock and unlock switch) 	All door locking actuator
Power supply (IGN) to power window, sunroof	Ignition power supply	Power window and sunroof system
Power supply (BAT) to power window, sunroof and power seat	Battery power supply	Power window, sunroof system and power seat
Panic alarm	<ul style="list-style-type: none"> ● Key switch ● Key fob 	IPDM E/R
Theft warning system	<ul style="list-style-type: none"> ● All door switch ● Hood switch ● Key fob ● Power window main switch (door lock and unlock switch) 	<ul style="list-style-type: none"> ● IPDM E/R ● Security indicator lamp
Auto light system	<ul style="list-style-type: none"> ● Optical sensor ● Combination switch 	IPDM E/R
Battery saver control	<ul style="list-style-type: none"> ● Ignition switch ● Combination switch 	IPDM E/R
<ul style="list-style-type: none"> ● Headlamp ● Parking, license plate, side marker and tail lamps ● Front fog lamp 	Combination switch	IPDM E/R
Turn signal lamp	Combination switch	<ul style="list-style-type: none"> ● Turn signal lamp ● Combination meter
Hazard lamp	Hazard switch	<ul style="list-style-type: none"> ● Turn signal lamp ● Combination meter
Room lamp timer	<ul style="list-style-type: none"> ● Key switch ● key fob ● Power window main switch (door lock and unlock switch) ● Front door switch driver side ● All door switch 	Interior room lamp
Key warning chime	<ul style="list-style-type: none"> ● Key switch ● Front door switch driver side 	Combination meter (warning buzzer)
Light warning chime	<ul style="list-style-type: none"> ● Combination switch ● Key switch ● Front door switch driver side 	Combination meter (warning buzzer)
Seat belt warning chime	<ul style="list-style-type: none"> ● Combination meter (Seat belt buckle (driver side) switch) ● Ignition switch 	Combination meter (warning buzzer)
Vehicle-speed-sensing intermittent wiper	<ul style="list-style-type: none"> ● Combination switch ● Combination meter 	IPDM E/R

A
B
C
D
E
F
G
H
I
J
K
L
M

BCS

BCM (BODY CONTROL MODULE)

System	Input	Output
Rear window defogger	<ul style="list-style-type: none">● Rear window defogger switch● Ignition switch	IPDM E/R
<ul style="list-style-type: none">● A/C switch signal● Blower fan switch signal	Display and A/C auto amp.	ECM
Low tire pressure warning system	Remote keyless entry receiver	Combination meter

CAN Communication Unit

NKS000N0

Refer to [LAN-47, "CAN System Specification Chart"](#) .

BCM (BODY CONTROL MODULE)

Schematic

NKS000N1

A
B
C
D
E
F
G
H
I
J
K
L
M

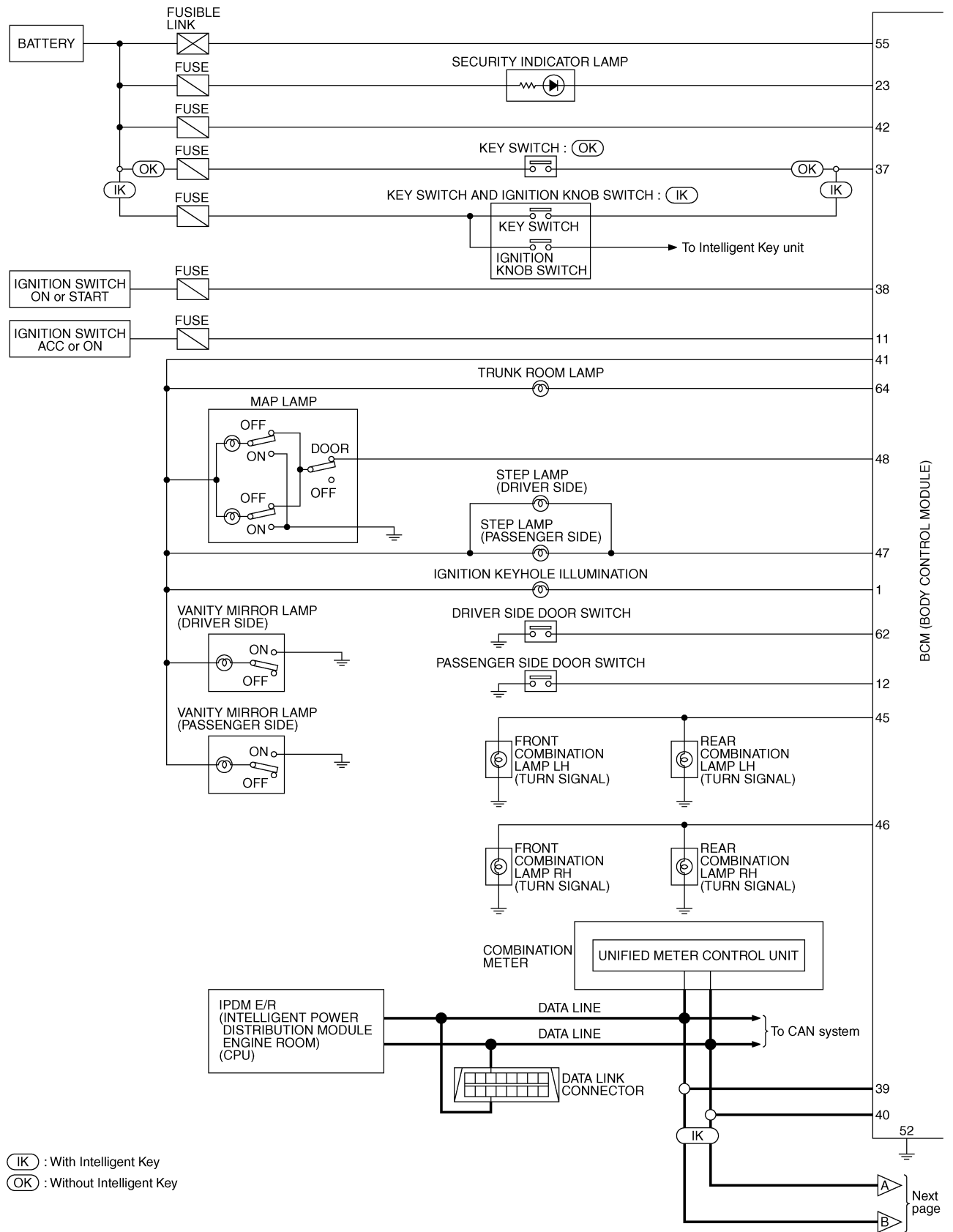

BCS

BCM (BODY CONTROL MODULE)

Next page

TKWM3493E

BCM (BODY CONTROL MODULE)

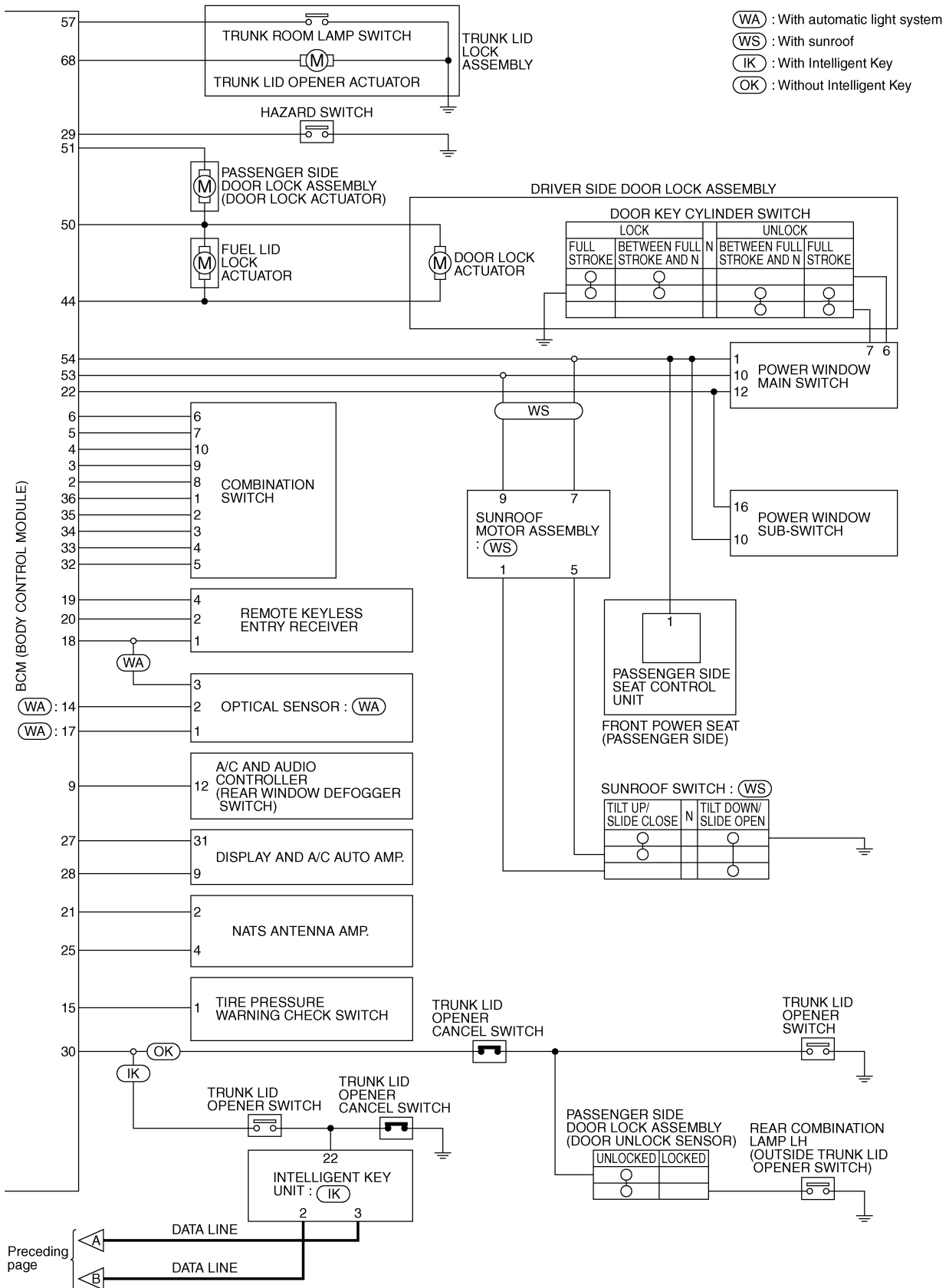

TKWM4939E

BCM (BODY CONTROL MODULE)

CONSULT-II Function (BCM)

NKS000N2

CONSULT-II can display each diagnostic item using the diagnostic test mode shown following.

BCM diagnostic test item	Check item, diagnostic test mode	Content
Inspection by part	WORK SUPPORT	Changes setting of each function.
	SELF- DIAG RESULTS	BCM performs self-diagnosis of CAN communication.
	DATA MONITOR	Displays the input data of BCM in real time.
	CAN DIAG SUPPORT MNTR	The result of transmit/receive diagnosis of CAN communication can be read.
	ACTIVE TEST	Gives a drive signal to a load to check the operation.
	ECU PART NUMBER	BCM part number can be read.
	CONFIGURATION	(Not be used.)

CONSULT-II BASIC OPERATION

Refer to [GI-37, "CONSULT-II Start Procedure"](#) .

ITEMS OF EACH PART

NOTE:

CONSULT-II displays systems equipped in the vehicle.

×:Applicable

System and item	CONSULT-II display	Diagnostic test mode (Inspection by part)						
		WORK SUPPORT	SELF-DIAG RESULTS	DATA MONITOR	CAN DIAG SUPPORT MNTR	ACTIVE TEST	ECU PART NUMBER	CONFIGURATION
BCM	BCM	×	×		×		×	× ^{Note}
Power door lock system	DOOR LOCK	×		×		×		
Rear window defogger	REAR DEFOGGER			×		×		
Warning chime	BUZZER			×		×		
Room lamp timer	INT LAMP	×		×		×		
Remote keyless entry system	MULTI REMOTE ENT	×		×		×		
Headlamp	HEAD LAMP	×		×		×		
Wiper	WIPER	×		×		×		
Turn signal lamp Hazard lamp	FLASHER			×		×		
Blower fan switch signal A/C switch signal	AIR CONDITONER			×				
Intelligent Key system	INTELLIGENT KEY			×				
Combination switch	COMB SW			×				
IVIS	IMMU			×		×		
Interior lamp battery saver	BATTERY SAVER	×		×		×		
Trunk lid opener	TRUNK			×		×		
Vehicle security system	THEFT ALM	×		×		×		
Retained power control	RETAINED PWR	×		×		×		
Oil pressure switch	SIGNAL BUFFER			×		×		
Low tire pressure warning system	AIR PRESSURE MONITOR	×	×	×		×		
Panic system	PANIC ALARM					×		

BCM (BODY CONTROL MODULE)

NOTE:

This item is displayed, but should not be used.

BCM (BODY CONTROL MODULE)

WORK SUPPORT

Operation Procedure

1. Touch "BCM" on "SELECT TEST ITEM" screen.
2. Touch "WORK SUPPORT" on "SELECT DIAG MODE" screen.
3. Touch item on "SELECT WORK ITEM" screen.
4. Touch "START".
5. Touch "CHANGE SET".
6. The setting will be changed and "RESETTING COMPLETED" will be displayed.
7. Touch "END".

Display Item List

Item	Description
RESET SETTING VALUE	Return a value set with WORK SUPPORT of each system to a default value in factory shipment.

CAN Communication Inspection Using CONSULT-II (Self-Diagnosis)

NKS000N3

1. CHECK SELF-DIAGNOSTIC RESULT

CAUTION:

If CONSULT-II is used with no connection of CONSULT-II CONVERTER, malfunctions might be detected in self-diagnosis depending on control unit which carry out CAN communication.

1. Connect to CONSULT-II, and select "BCM" on "SELECT SYSTEM" screen.
2. Select "BCM" on "SELECT DIAG MODE" screen, and select "SELF-DIAG RESULTS".
3. Check display content in self-diagnostic results.

CONSULT-II display code	Diagnosis item
U1000	INITIAL DIAG
	TRANSMIT DIAG
	ECM
	IPDM E/R
	METER / M&A
	I - KEY

Contents displayed

No malfunction>>INSPECTION END

Malfunction in CAN communication system>>After printing the monitor items, go to "CAN System". Refer to [LAN-42, "Precautions When Using CONSULT-II"](#).

BCM (BODY CONTROL MODULE)

NKS000N4

Removal and Installation of BCM

REMOVAL

1. Remove the dash side finisher. Refer to [EI-31, "BODY SIDE TRIM"](#) .
2. Disconnect BCM connector.
3. Remove bracket mounting screws to remove BCM and fuse block with bracket.

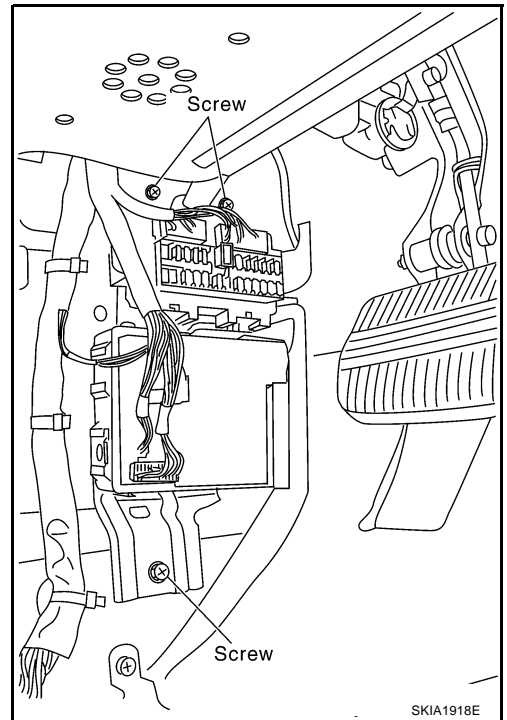

4. Raise the pawl of fuse block and remove bracket from fuse block to remove BCM.

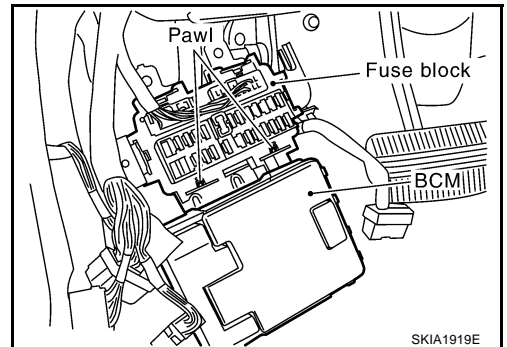

INSTALLATION

Installation is the reverse order of removal.

NOTE:

When replacing BCM perform initialization of NATS system and registration of all NATS ignition key IDs.