

SECTION **DLN**  
DRIVELINE

A  
B  
C

DLN

CONTENTS

E

<b>TRANSFER: ETX13B</b>		
<b>BASIC INSPECTION</b> .....	7	
<b>DIAGNOSIS AND REPAIR WORKFLOW</b> .....	7	
Work Flow .....	7	
<b>FUNCTION DIAGNOSIS</b> .....	8	
<b>AWD SYSTEM</b> .....	8	
System Diagram .....	8	
System Description .....	9	
Component Parts Location .....	10	
Component Description .....	11	
<b>DIAGNOSIS SYSTEM (AWD CONTROL UNIT)</b> .....	12	
CONSULT-III Function (ALL MODE AWD/4WD) ....	12	
<b>COMPONENT DIAGNOSIS</b> .....	14	
<b>C1201 AWD CONTROL UNIT</b> .....	14	
Description .....	14	
DTC Logic .....	14	
Diagnosis Procedure .....	14	
<b>C1203 ABS ACTUATOR AND ELECTRIC UNIT (CONTROL UNIT)</b> .....	15	
Description .....	15	
DTC Logic .....	15	
Diagnosis Procedure .....	15	
<b>C1204 AWD SOLENOID</b> .....	16	
Description .....	16	
DTC Logic .....	16	
Diagnosis Procedure .....	16	
Component Inspection .....	18	
<b>C1205 AWD ACTUATOR RELAY</b> .....	19	
Description .....	19	
DTC Logic .....	19	
Diagnosis Procedure .....	19	
<b>C1210 ECM</b> .....	20	
Description .....	20	
DTC Logic .....	20	
Diagnosis Procedure .....	20	
<b>U1000 CAN COMM CIRCUIT</b> .....	21	
Description .....	21	
DTC Logic .....	21	
Diagnosis Procedure .....	21	
<b>U1010 CONTROL UNIT (CAN)</b> .....	22	
Description .....	22	
DTC Logic .....	22	
Diagnosis Procedure .....	22	
<b>POWER SUPPLY AND GROUND CIRCUIT</b> ....	23	
Description .....	23	
Diagnosis Procedure .....	23	
<b>AWD WARNING LAMP</b> .....	25	
Description .....	25	
Diagnosis Procedure .....	25	
<b>ECU DIAGNOSIS</b> .....	27	
<b>AWD CONTROL UNIT</b> .....	27	
Reference Value .....	27	
Wiring Diagram — AWD SYSTEM — .....	28	
Fail Safe .....	32	
DTC Inspection Priority Chart .....	33	
DTC Index .....	33	
<b>SYMPTOM DIAGNOSIS</b> .....	35	
<b>AWD SYSTEM SYMPTOMS</b> .....	35	
Symptom Table .....	35	
<b>AWD WARNING LAMP DOES NOT TURN ON</b> .....	36	
Description .....	36	
Diagnosis Procedure .....	36	

F

G

H

I

J

K

L

M

N

O

P

<b>AWD WARNING LAMP DOES NOT TURN OFF</b> .....	<b>37</b>	<b>REMOVAL AND INSTALLATION</b> .....	<b>55</b>
Description .....	37	<b>TRANSFER ASSEMBLY</b> .....	<b>55</b>
Diagnosis Procedure .....	37	Exploded View .....	55
<b>HEAVY TIGHT-CORNER BRAKING SYMPTOM OCCURS</b> .....	<b>38</b>	Removal and Installation .....	55
Description .....	38	<b>DISASSEMBLY AND ASSEMBLY</b> .....	<b>58</b>
Diagnosis Procedure .....	38	<b>FRONT CASE AND REAR CASE</b> .....	<b>58</b>
<b>VEHICLE DOES NOT ENTER AWD MODE</b> ....	<b>39</b>	Exploded View .....	58
Description .....	39	Disassembly .....	58
Diagnosis Procedure .....	39	Assembly .....	62
<b>AWD WARNING LAMP BLINKS QUICKLY</b> ....	<b>40</b>	Inspection .....	67
Description .....	40	<b>MAINSHAFT</b> .....	<b>69</b>
<b>AWD WARNING LAMP BLINKS SLOWLY</b> ....	<b>41</b>	Exploded View .....	69
Description .....	41	Disassembly .....	69
Diagnosis Procedure .....	41	Assembly .....	70
<b>NORMAL OPERATING CONDITION</b> .....	<b>42</b>	Inspection .....	70
Description .....	42	<b>FRONT DRIVE SHAFT AND DRIVE CHAIN</b> ....	<b>72</b>
<b>NOISE, VIBRATION AND HARSHNESS (NVH) TROUBLESHOOTING</b> .....	<b>43</b>	Exploded View .....	72
NVH Troubleshooting Chart .....	43	Disassembly .....	72
<b>PRECAUTION</b> .....	<b>44</b>	Assembly .....	73
<b>PRECAUTIONS</b> .....	<b>44</b>	Inspection .....	74
Precaution for Supplemental Restraint System (SRS) "AIR BAG" and "SEAT BELT PRE-TENSIONER" .....	44	<b>FRONT DRIVE SHAFT AND DRIVE CHAIN</b> ....	<b>72</b>
Service Notice or Precautions for Transfer .....	44	Exploded View .....	72
<b>PREPARATION</b> .....	<b>45</b>	Disassembly .....	72
<b>PREPARATION</b> .....	<b>45</b>	Assembly .....	73
Special Service Tools .....	45	Inspection .....	74
Commercial Service Tools .....	46	<b>SERVICE DATA AND SPECIFICATIONS (SDS)</b> .....	<b>76</b>
<b>ON-VEHICLE MAINTENANCE</b> .....	<b>48</b>	<b>SERVICE DATA AND SPECIFICATIONS (SDS)</b> .....	<b>76</b>
<b>TRANSFER FLUID</b> .....	<b>48</b>	General Specifications .....	76
Inspection .....	48	<b>FRONT PROPELLER SHAFT: 2S56A</b>	
Draining .....	48	<b>SYMPTOM DIAGNOSIS</b> .....	<b>77</b>
Refilling .....	48	<b>NOISE, VIBRATION AND HARSHNESS (NVH) TROUBLESHOOTING</b> .....	<b>77</b>
<b>ON-VEHICLE REPAIR</b> .....	<b>49</b>	NVH Troubleshooting Chart .....	77
AWD CONTROL UNIT .....	49	<b>PREPARATION</b> .....	<b>78</b>
Exploded View .....	49	<b>PREPARATION</b> .....	<b>78</b>
Removal and Installation .....	49	Commercial Service Tools .....	78
<b>FRONT OIL SEAL</b> .....	<b>50</b>	<b>ON-VEHICLE MAINTENANCE</b> .....	<b>79</b>
Exploded View .....	50	<b>FRONT PROPELLER SHAFT</b> .....	<b>79</b>
Removal and Installation .....	50	Inspection .....	79
<b>REAR OIL SEAL</b> .....	<b>52</b>	<b>ON-VEHICLE REPAIR</b> .....	<b>80</b>
Exploded View .....	52	<b>FRONT PROPELLER SHAFT</b> .....	<b>80</b>
Removal and Installation .....	52	Exploded View .....	80
<b>AWD WARNING LAMP DOES NOT TURN OFF</b> .....	<b>37</b>	Removal and Installation .....	80
Description .....	37	Inspection .....	81
Diagnosis Procedure .....	37	<b>SERVICE DATA AND SPECIFICATIONS (SDS)</b> .....	<b>82</b>

<b>SERVICE DATA AND SPECIFICATIONS (SDS)</b> .....	82
General Specifications .....	82
Propeller Shaft Runout .....	82
Journal Axial Play .....	82
<b>REAR PROPELLER SHAFT: 3S80A</b>	
<b>SYMPTOM DIAGNOSIS</b> .....	83
<b>NOISE, VIBRATION AND HARSHNESS (NVH) TROUBLESHOOTING</b> .....	83
NVH Troubleshooting Chart .....	83
<b>PREPARATION</b> .....	84
<b>PREPARATION</b> .....	84
Commercial Service Tools .....	84
<b>ON-VEHICLE MAINTENANCE</b> .....	85
<b>REAR PROPELLER SHAFT</b> .....	85
Inspection .....	85
<b>ON-VEHICLE REPAIR</b> .....	86
<b>REAR PROPELLER SHAFT</b> .....	86
Exploded View .....	86
Removal and Installation .....	86
Inspection .....	88
<b>SERVICE DATA AND SPECIFICATIONS (SDS)</b> .....	89
<b>SERVICE DATA AND SPECIFICATIONS (SDS)</b> .....	89
General Specifications .....	89
Propeller Shaft Runout .....	89
Journal Axial Play .....	89
<b>REAR PROPELLER SHAFT: 3S80A-R</b>	
<b>SYMPTOM DIAGNOSIS</b> .....	90
<b>NOISE, VIBRATION AND HARSHNESS (NVH) TROUBLESHOOTING</b> .....	90
NVH Troubleshooting Chart .....	90
<b>PREPARATION</b> .....	91
<b>PREPARATION</b> .....	91
Commercial Service Tools .....	91
<b>ON-VEHICLE MAINTENANCE</b> .....	92
<b>REAR PROPELLER SHAFT</b> .....	92
Inspection .....	92
<b>ON-VEHICLE REPAIR</b> .....	93
<b>REAR PROPELLER SHAFT</b> .....	93
Exploded View .....	93
Removal and Installation .....	93
Inspection .....	96

<b>SERVICE DATA AND SPECIFICATIONS (SDS)</b> .....	97
<b>SERVICE DATA AND SPECIFICATIONS (SDS)</b> .....	97
General Specifications .....	97
Propeller Shaft Runout .....	97
Journal Axial Play .....	97
<b>REAR PROPELLER SHAFT: 3F80A-1VL107</b>	
<b>SYMPTOM DIAGNOSIS</b> .....	98
<b>NOISE, VIBRATION AND HARSHNESS (NVH) TROUBLESHOOTING</b> .....	98
NVH Troubleshooting Chart .....	98
<b>PREPARATION</b> .....	99
<b>PREPARATION</b> .....	99
Commercial Service Tools .....	99
<b>ON-VEHICLE MAINTENANCE</b> .....	100
<b>REAR PROPELLER SHAFT</b> .....	100
Inspection .....	100
<b>ON-VEHICLE REPAIR</b> .....	101
<b>REAR PROPELLER SHAFT</b> .....	101
Exploded View .....	101
Removal and Installation .....	101
Inspection .....	104
<b>SERVICE DATA AND SPECIFICATIONS (SDS)</b> .....	105
<b>SERVICE DATA AND SPECIFICATIONS (SDS)</b> .....	105
General Specifications .....	105
Propeller Shaft Runout .....	105
Journal Axial Play .....	105
<b>FRONT FINAL DRIVE: F160A</b>	
<b>SYMPTOM DIAGNOSIS</b> .....	106
<b>NOISE, VIBRATION AND HARSHNESS (NVH) TROUBLESHOOTING</b> .....	106
NVH Troubleshooting Chart .....	106
<b>PRECAUTION</b> .....	107
<b>PRECAUTIONS</b> .....	107
Precaution Necessary for Steering Wheel Rotation after Battery Disconnect .....	107
Service Notice or Precautions for Front Final Drive .....	107
<b>PREPARATION</b> .....	108
<b>PREPARATION</b> .....	108
Special Service Tools .....	108

A

B

C

DLN

E

F

G

H

I

J

K

L

M

N

O

P

Commercial Service Tools .....	110	Preload Torque .....	144
<b>FUNCTION DIAGNOSIS .....</b>	<b>111</b>	Backlash .....	144
<b>FRONT FINAL DRIVE ASSEMBLY .....</b>	<b>111</b>	Companion Flange Runout .....	144
System Diagram .....	111	<b>REAR FINAL DRIVE: R200</b>	
<b>ON-VEHICLE MAINTENANCE .....</b>	<b>112</b>	<b>SYMPTOM DIAGNOSIS .....</b>	<b>145</b>
<b>FRONT DIFFERENTIAL GEAR OIL .....</b>	<b>112</b>	<b>NOISE, VIBRATION AND HARSHNESS</b>	
Inspection .....	112	<b>(NVH) TROUBLESHOOTING .....</b>	<b>145</b>
Draining .....	112	NVH Troubleshooting Chart .....	145
Refilling .....	112	<b>PRECAUTION .....</b>	<b>147</b>
<b>ON-VEHICLE REPAIR .....</b>	<b>113</b>	<b>PRECAUTIONS .....</b>	<b>147</b>
<b>SIDE OIL SEAL .....</b>	<b>113</b>	Service Notice or Precautions for Rear Final Drive .....	147
<b>RIGHT SIDE .....</b>	<b>113</b>	<b>PREPARATION .....</b>	<b>148</b>
RIGHT SIDE : Exploded View .....	113	<b>PREPARATION .....</b>	<b>148</b>
RIGHT SIDE : Removal and Installation .....	114	Special Service Tools .....	148
<b>LEFT SIDE .....</b>	<b>114</b>	Commercial Service Tools .....	151
LEFT SIDE : Exploded View .....	114	<b>FUNCTION DIAGNOSIS .....</b>	<b>152</b>
LEFT SIDE : Removal and Installation .....	116	<b>REAR FINAL DRIVE ASSEMBLY .....</b>	<b>152</b>
<b>REMOVAL AND INSTALLATION .....</b>	<b>117</b>	System Diagram .....	152
<b>FRONT FINAL DRIVE ASSEMBLY .....</b>	<b>117</b>	<b>ON-VEHICLE MAINTENANCE .....</b>	<b>154</b>
Exploded View .....	117	<b>REAR DIFFERENTIAL GEAR OIL .....</b>	<b>154</b>
Removal and Installation .....	117	Inspection .....	154
<b>DISASSEMBLY AND ASSEMBLY .....</b>	<b>119</b>	Draining .....	154
<b>SIDE SHAFT .....</b>	<b>119</b>	Refilling .....	154
Exploded View .....	119	<b>ON-VEHICLE REPAIR .....</b>	<b>155</b>
Disassembly .....	120	<b>FRONT OIL SEAL .....</b>	<b>155</b>
Assembly .....	120	<b>2WD .....</b>	<b>155</b>
Inspection After Disassembly .....	121	2WD : Exploded View .....	155
<b>DIFFERENTIAL ASSEMBLY .....</b>	<b>122</b>	2WD : Removal and Installation .....	156
Exploded View .....	122	<b>AWD .....</b>	<b>160</b>
Disassembly .....	123	AWD : Exploded View .....	160
Assembly .....	125	AWD : Removal and Installation .....	161
Adjustment .....	130	<b>SIDE OIL SEAL .....</b>	<b>166</b>
Inspection After Disassembly .....	134	<b>2WD .....</b>	<b>166</b>
<b>DRIVE PINION .....</b>	<b>136</b>	2WD : Exploded View .....	166
Exploded View .....	136	2WD : Removal and Installation .....	167
Disassembly .....	137	<b>AWD .....</b>	<b>168</b>
Assembly .....	138	AWD : Exploded View .....	168
Adjustment .....	140	AWD : Removal and Installation .....	169
Inspection After Disassembly .....	143	<b>REMOVAL AND INSTALLATION .....</b>	<b>171</b>
<b>SERVICE DATA AND SPECIFICATIONS</b>		<b>REAR FINAL DRIVE ASSEMBLY .....</b>	<b>171</b>
<b>(SDS) .....</b>	<b>144</b>	<b>2WD .....</b>	<b>171</b>
<b>SERVICE DATA AND SPECIFICATIONS</b>		2WD : Exploded View .....	171
<b>(SDS) .....</b>	<b>144</b>	2WD : Removal and Installation .....	171
General Specifications .....	144		
Drive Gear Runout .....	144		
Differential Side Gear Clearance .....	144		

<b>AWD</b> .....	172	Service Notice or Precautions for Rear Final Drive	220
AWD : Exploded View .....	172		
AWD : Removal and Installation .....	172		
<b>DISASSEMBLY AND ASSEMBLY</b> .....	174		
<b>DIFFERENTIAL ASSEMBLY</b> .....	174		
<b>2WD</b> .....	174		
2WD : Exploded View .....	174		
2WD : Disassembly .....	175		
2WD : Assembly .....	177		
2WD : Adjustment .....	181		
2WD : Inspection After Disassembly .....	186		
<b>AWD</b> .....	186		
AWD : Exploded View .....	186		
AWD : Disassembly .....	187		
AWD : Assembly .....	190		
AWD : Adjustment .....	194		
AWD : Inspection After Disassembly .....	198		
<b>DRIVE PINION</b> .....	199		
<b>2WD</b> .....	199		
2WD : Exploded View .....	199		
2WD : Disassembly .....	200		
2WD : Assembly .....	201		
2WD : Adjustment .....	203		
2WD : Inspection After Disassembly .....	206		
<b>AWD</b> .....	207		
AWD : Exploded View .....	207		
AWD : Disassembly .....	208		
AWD : Assembly .....	209		
AWD : Adjustment .....	211		
AWD : Inspection After Disassembly .....	214		
<b>SERVICE DATA AND SPECIFICATIONS (SDS)</b> .....	216		
<b>SERVICE DATA AND SPECIFICATIONS (SDS)</b> .....	216		
General Specification .....	216		
Drive Gear Runout .....	216		
Differential Side Gear Clearance .....	216		
Preload Torque .....	216		
Backlash .....	216		
Drive Pinion Runout (2WD Models) .....	216		
Companion flange Runout (AWD Models) .....	216		
<b>REAR FINAL DRIVE: R200V</b>			
<b>SYMPTOM DIAGNOSIS</b> .....	218		
<b>NOISE, VIBRATION AND HARSHNESS (NVH) TROUBLESHOOTING</b> .....	218		
NVH Troubleshooting Chart .....	218		
<b>PRECAUTION</b> .....	220		
<b>PRECAUTIONS</b> .....	220		
		PREPARATION .....	221
		Special Service Tools .....	221
		Commercial Service Tools .....	224
		<b>FUNCTION DIAGNOSIS</b> .....	225
		<b>REAR FINAL DRIVE ASSEMBLY</b> .....	225
		System Diagram .....	225
		<b>ON-VEHICLE MAINTENANCE</b> .....	226
		<b>REAR DIFFERENTIAL GEAR OIL</b> .....	226
		Inspection .....	226
		Draining .....	226
		Refilling .....	226
		<b>ON-VEHICLE REPAIR</b> .....	227
		<b>FRONT OIL SEAL</b> .....	227
		<b>M/T</b> .....	227
		M/T : Exploded View .....	227
		M/T : Removal and Installation .....	228
		<b>A/T</b> .....	232
		A/T : Exploded View .....	232
		A/T : Removal and Installation .....	233
		<b>SIDE OIL SEAL</b> .....	238
		<b>M/T</b> .....	238
		M/T : Exploded View .....	238
		M/T : Removal and Installation .....	239
		<b>A/T</b> .....	240
		A/T : Exploded View .....	240
		A/T : Removal and Installation .....	241
		<b>REMOVAL AND INSTALLATION</b> .....	243
		<b>REAR FINAL DRIVE ASSEMBLY</b> .....	243
		<b>M/T</b> .....	243
		M/T : Exploded View .....	243
		M/T : Removal and Installation .....	243
		<b>A/T</b> .....	244
		A/T : Exploded View .....	244
		A/T : Removal and Installation .....	244
		<b>DISASSEMBLY AND ASSEMBLY</b> .....	246
		<b>DIFFERENTIAL ASSEMBLY</b> .....	246
		<b>M/T</b> .....	246
		M/T : Exploded View .....	246
		M/T : Disassembly .....	247
		M/T : Assembly .....	249
		M/T : Adjustment .....	253
		M/T : Inspection After Disassembly .....	257

A  
B  
C  
DLN

E  
F  
G  
H  
I  
J  
K  
L

M  
N  
O  
P

<b>A/T</b> .....	<b>258</b>	A/T : Disassembly .....	279
A/T : Exploded View .....	258	A/T : Assembly .....	280
A/T : Disassembly .....	259	A/T : Adjustment .....	282
A/T : Assembly .....	261	A/T : Inspection After Disassembly .....	286
A/T : Adjustment .....	265		
A/T : Inspection After Disassembly .....	269		
<b>DRIVE PINION</b> .....	<b>270</b>		
<b>M/T</b> .....	<b>270</b>	<b>SERVICE DATA AND SPECIFICATIONS</b>	
M/T : Exploded View .....	270	<b>(SDS)</b> .....	<b>287</b>
M/T : Disassembly .....	271	<b>SERVICE DATA AND SPECIFICATIONS</b>	
M/T : Assembly .....	272	<b>(SDS)</b> .....	<b>287</b>
M/T : Adjustment .....	274	General Specification .....	287
M/T : Inspection After Disassembly .....	277	Drive Gear Runout .....	287
<b>A/T</b> .....	<b>278</b>	Differential Side Gear Clearance .....	287
A/T : Exploded View .....	278	Preload Torque .....	287
		Backlash .....	287
		Companion flange Runout (M/T Models) .....	287
		Drive Pinion Runout (A/T Models) .....	287

# BASIC INSPECTION

## DIAGNOSIS AND REPAIR WORKFLOW

### Work Flow

INFOID:000000000957225

#### DETAILED FLOW

### 1. COLLECT THE INFORMATION FROM THE CUSTOMER

It is also important to clarify customer complaints before inspection. First of all, reproduce symptoms, and understand them fully. Ask customer about his/her complaints carefully. In some cases, it will be necessary to check symptoms by driving vehicle with customer.

**CAUTION:**

**Customers are not professional. It is dangerous to make an easy guess like “maybe the customer means that...,” or “maybe the customer mentions this symptom”.**

>> GO TO 2.

### 2. CHECK AWD WARNING LAMP STATUS

Start engine and drive at 30 km/h (19 MPH) or more for approx. 1 minute.

Is AWD warning lamp illuminated?

YES >> GO TO 3.

NO >> GO TO 6.

### 3. PERFORM THE SELF-DIAGNOSIS

**With CONSULT-III**

1. Perform self-diagnosis of AWD control unit.
2. Perform malfunction detected by self-diagnosis.
3. Erase AWD control unit self-diagnosis results.

>> GO TO 4.

### 4. CHECK TERMINALS AND HARNESS CONNECTORS

Check pin terminals for damage or loose connection with harness connector.

>> GO TO 5.

### 5. RECHECK THE SYMPTOM

**With CONSULT-III**

Perform DTC confirmation procedure.

Is any malfunction detected by self-diagnosis?

YES >> GO TO 2.

NO >> GO TO 6.

### 6. DIAGNOSIS CHART BY SYMPTOM

Perform diagnosis by symptom.

Is any malfunction present?

YES >> GO TO 2.

NO >> GO TO 7.

### 7. FINAL CHECK

**With CONSULT-III**

Check AWD control unit input/output standard values.

Are AWD control unit input/output values within standard ranges respectively?

YES >> INSPECTION END

NO >> GO TO 2.

# FUNCTION DIAGNOSIS

## AWD SYSTEM

### System Diagram

INFOID:000000000957226

### CONTROL DIAGRAM

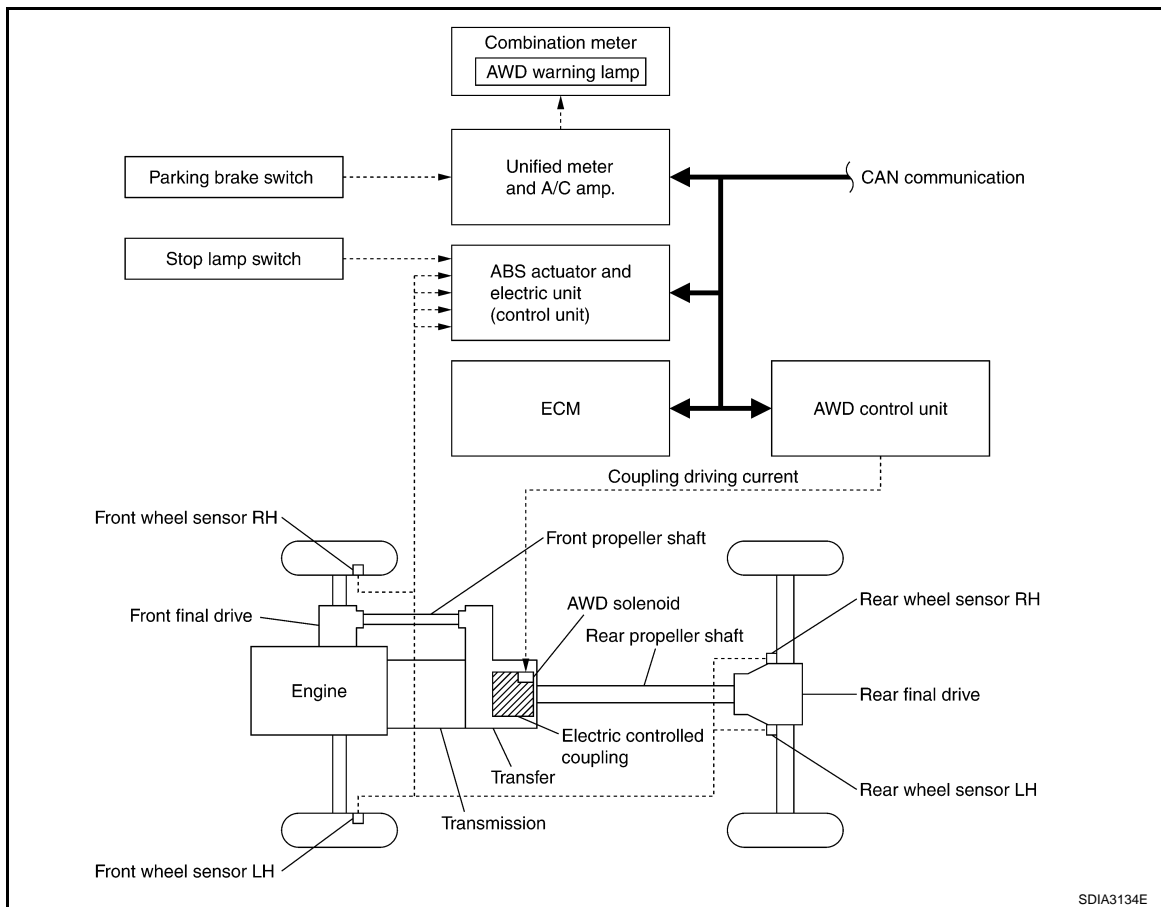

### CROSS-SECTIONAL VIEW



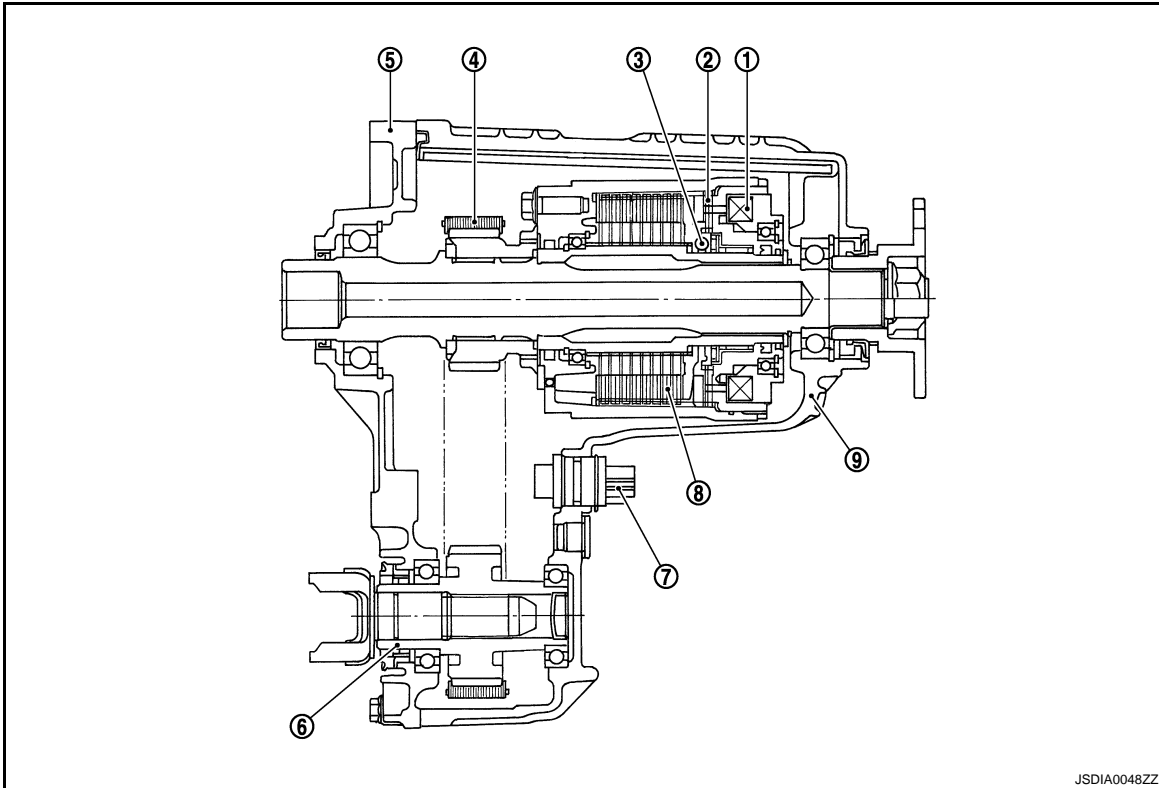

- |                           |                   |                      |
|---------------------------|-------------------|----------------------|
| 1. Electromagnet          | 2. Control clutch | 3. Cam               |
| 4. Drive chain            | 5. Front case     | 6. Front drive shaft |
| 7. AWD solenoid connector | 8. Main clutch    | 9. Rear case         |

## System Description

INFOID:000000000957227

### DESCRIPTION

- Electronic control allows optimal distribution of torque to front/rear wheels to match road conditions.
- Makes possible stable driving, with no wheel spin, on snowy roads or other slippery surfaces.
- On roads which do not require AWD, it contributes to improved fuel economy by driving in conditions close to rear-wheel drive.
- Sensor inputs determine the vehicle's turning condition, and in response tight cornering/braking are controlled by distributing optimum torque to front wheels.
- It transmits/receives each signal from the following control unit via CAN communication line.

Component parts	Function
ABS actuator and electric unit (control unit)	Transmits the following signals via CAN communication to AWD control unit. <ul style="list-style-type: none"> <li>• Vehicle speed signal</li> <li>• Stop lamp switch signal (brake signal)</li> </ul>
ECM	Transmits the following signals via CAN communication to AWD control unit. <ul style="list-style-type: none"> <li>• Accelerator pedal position signal</li> <li>• Engine speed signal</li> </ul>
Unified meter and A/C amp.	Transmits conditions of parking brake switch via CAN communication to AWD control unit.

### NOTE:

- When driving, if there is a large difference between front and rear wheel speed which continues for a long time, fluid temperature of drive system parts becomes too high and AWD warning lamp blinks quickly. (When AWD warning lamp blinks, vehicle changes to rear-wheel drive conditions.) Also, optional distribution of torque sometimes becomes rigid before lamp blinks quickly, but it is not malfunction.
- If AWD warning lamp is blinking quickly, stop vehicle and allow it to idle for some time. Blinking will stop and AWD system will be restored.

# AWD SYSTEM

[TRANSFER: ETX13B]

## < FUNCTION DIAGNOSIS >

- When driving, AWD warning lamp may blink slowly if there is a significant difference in diameter of the tires. At this time, vehicle performance is not fully available and cautious driving is required. (Continues until engine is turned OFF.)
- If the warning lamp blinks slowly during driving but remains OFF after engine is restarted, the system is normal. If it again blinks slowly after driving for some time, vehicle must be inspected.
- When the difference of revolution speed between the front and rear wheel the shift occasionally changes to direct 4-wheel driving conditions automatically. This is not malfunction.

## OPERATION PRINCIPLE

### ELECTRIC CONTROLLED COUPLING

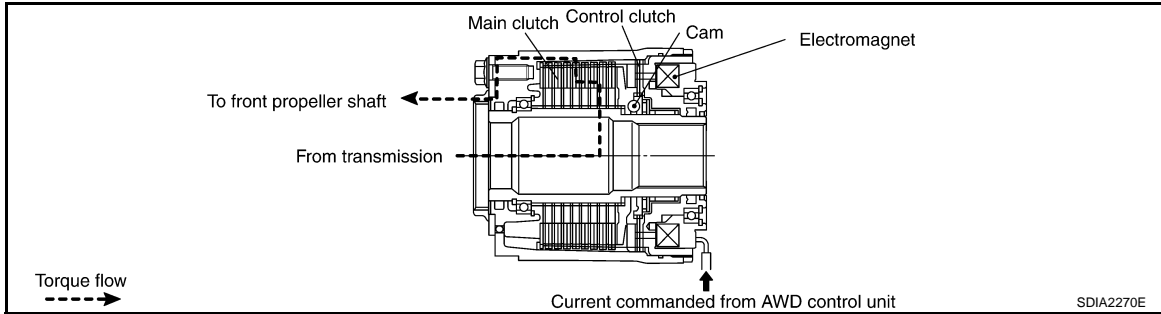

1. AWD control unit supplies command current to electric controlled coupling (AWD solenoid).
2. Control clutch is engaged by electromagnet and torque is detected in control clutch.
3. The cam operates in response to control clutch torque and applies pressure to main clutch.
4. Main clutch transmits torque to front wheels according to pressing power.
  - Transmission torque to front wheels is determined according to command current.

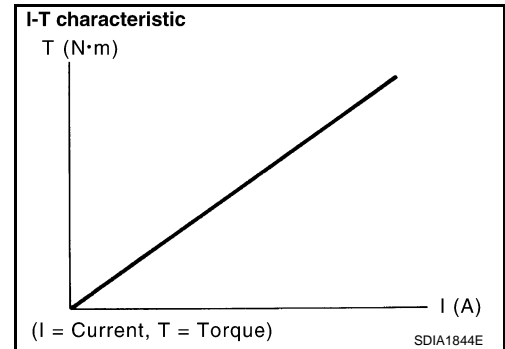

## Component Parts Location

INFOID:000000000957228

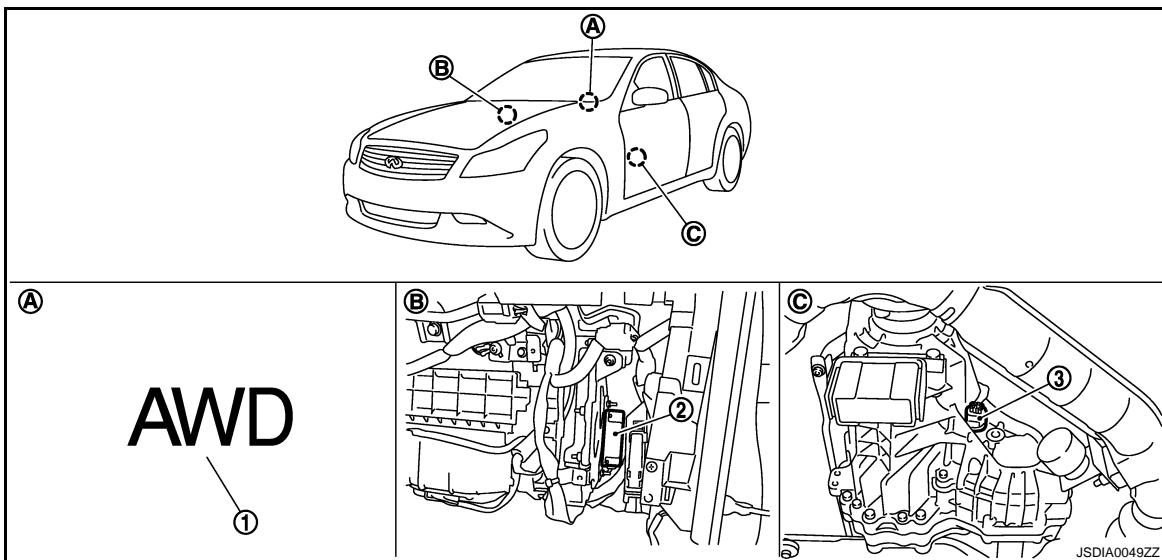

1. AWD warning lamp

2. AWD control unit

3. AWD solenoid harness connector

# AWD SYSTEM

< FUNCTION DIAGNOSIS >

[TRANSFER: ETX13B]

A. Combination meter

B. Glove box assembly removed

C. Transfer assembly

## Component Description

INFOID:000000000957229

Component parts	Reference/Function
AWD control unit	<a href="#">DLN-14. "Description"</a>
Wheel sensors	Detects wheel speed.
AWD solenoid	<a href="#">DLN-16. "Description"</a>
Electric controlled coupling	Transmits driving force to front final drive.
AWD warning lamp	<a href="#">DLN-25. "Description"</a>
ABS actuator and electric unit (control unit)	<a href="#">DLN-15. "Description"</a>
ECM	<a href="#">DLN-20. "Description"</a>
Unified meter and A/C amp.	Transmits conditions of parking brake switch via CAN communication to AWD control unit.

A

B

C

**DLN**

E

F

G

H

I

J

K

L

M

N

O

P

# DIAGNOSIS SYSTEM (AWD CONTROL UNIT)

< FUNCTION DIAGNOSIS >

[TRANSFER: ETX13B]

## DIAGNOSIS SYSTEM (AWD CONTROL UNIT)

### CONSULT-III Function (ALL MODE AWD/4WD)

INFOID:000000000957230

#### FUNCTION

CONSULT-III can display each diagnostic item using the diagnostic test modes shown following.

Diagnostic test mode	Function
Self-diagnostic results	<ul style="list-style-type: none"><li>Self-diagnostic results can be read and erased quickly.</li></ul>
Data monitor	<ul style="list-style-type: none"><li>Input/Output data in the AWD control unit can be read.</li></ul>
CAN diagnostic support monitor	<ul style="list-style-type: none"><li>The results of transmit/receive diagnosis of CAN communication can be read.</li></ul>
Active test	<ul style="list-style-type: none"><li>Diagnostic Test Mode in which CONSULT-III drives some actuators apart from the AWD control unit and also shifts some parameters in a specified range.</li></ul>
ECU part number	<ul style="list-style-type: none"><li>AWD control unit part number can be read.</li></ul>

#### SELF-DIAG RESULT MODE

- Drive at 30 km/h or more for approximately 1 minute before performing the self-diagnosis.

#### Display Item List

Items (CONSULT-III screen terms)	Diagnostic item is detected when...	Possible cause
CONTROLLER FAILURE [C1201]	Malfunction has occurred inside AWD control unit.	Internal malfunction of AWD control unit
ABS SYSTEM [C1203]	Malfunction related to wheel sensor has been detected by ABS actuator and electric unit (control unit).	ABS malfunction <ul style="list-style-type: none"><li>Vehicle speed signal error</li><li>Stop lamp switch signal (brake signal) error</li></ul>
4WD SOLENOID [C1204]	Malfunction related to AWD solenoid has been detected.	Internal malfunction of electronic controlled coupling
4WD ACTUATOR RLY [C1205]	Malfunction has been detected from AWD actuator relay integrated with AWD control unit, or malfunction related to AWD solenoid has been detected.	Internal malfunction of AWD control unit
ENGINE SIGNAL 1 [C1210]	Malfunction has been detected from ECM.	Malfunction of engine control system <ul style="list-style-type: none"><li>Accelerator pedal position signal error</li><li>Engine speed signal error</li></ul>
CAN COMM CIRCUIT [U1000]	When AWD control unit is not transmitting or receiving CAN communication signal for 2 seconds or more.	CAN communication line error
CONTROL UNIT (CAN) [U1010]	When detecting error during the initial diagnosis of CAN controller of AWD control unit.	AWD control unit error
NO DTC IS DETECTED. FURTHER TESTING MAY BE REQUIRED.	No NG item has been detected.	—

#### CAUTION:

- If “CAN COMM CIRCUIT [U1000]” or “CONTROL UNIT (CAN) [U1010]” is displayed with other DTCs, first perform the trouble diagnosis for CAN communication line.
- Make sure that ABS warning lamp turns OFF by driving for a minute at vehicle speed of 30 km/h (19 MPH) or more after turning ignition switch OFF if AWD warning lamp turns ON with system malfunction of “ABS SYSTEM [C1203]”. AWD warning lamp may not turn OFF if it is normal unless ignition switch turns OFF at once and engine restarts after that.

#### How to Erase Self-Diagnostic Results

- Before erasing DTC memory, start the engine and drive at 30 km/h or more for approximately 1 minute. Check that ABS warning lamp turns OFF.

#### NOTE:

Make sure that ABS warning lamp turns OFF by driving for a minute at vehicle speed of 30 km/h (19 MPH) or more after turning ignition switch OFF if AWD warning lamp turns ON with system malfunction of “ABS

# DIAGNOSIS SYSTEM (AWD CONTROL UNIT)

< FUNCTION DIAGNOSIS >

[TRANSFER: ETX13B]

SYSTEM [C1203]". AWD warning lamp may not turn OFF if it is normal unless ignition switch turns OFF at once and engine restarts after that.

## DATA MONITOR MODE

Display Item List

×: Standard □: Optional item

Monitor item (Unit)	Monitor Menu		Remarks
	ECU INPUT SIGNALS	MAIN SIGNALS	
FR RH SENSOR [km/h] or [mph]	×	×	Wheel speed calculated by front wheel sensor RH signal is displayed.
FR LH SENSOR [km/h] or [mph]	×	×	Wheel speed calculated by front wheel sensor LH signal is displayed.
RR RH SENSOR [km/h] or [mph]	×	×	Wheel speed calculated by rear wheel sensor RH signal is displayed.
RR LH SENSOR [km/h] or [mph]	×	×	Wheel speed calculated by rear wheel sensor LH signal is displayed.
BATTERY VOLT [V]	□	□	Power supply voltage for AWD control unit
THRTL POS SEN [%]	□	□	Throttle opening status is displayed.
ETS SOLENOID [A]	□	□	Monitored value of current at AWD solenoid
STOP LAMP SW [On/Off]	□	□	Stop lamp switch signal status via CAN communication line is displayed.
ENG SPEED SIG [Run/Stop]	□	□	Engine status is displayed.
ETS ACTUATOR [On/Off]	□	□	Operating condition of AWD actuator relay (integrated in AWD control unit) is displayed.
4WD WARN LAMP [On/Off]	□	□	Control status of AWD warning lamp is displayed.
4WD MODE SW [AUTO]	□	□	Mode switch is not equipped, but displayed.
4WD MODE MON [AUTO]	□	□	Control status of AWD is displayed.
DIS-TIRE MONI [mm]	□	□	Improper size tire installed condition is displayed.
P BRAKE SW [On/Off]	□	□	Parking switch signal status via CAN communication line is displayed.

## ACTIVE TEST MODE

Description

- Use this mode to determine and identify the details of a malfunction based on self-diagnostic results or data monitor. AWD control unit gives drive signal to actuator with receiving command from CONSULT-III to check operation of actuator.

Test Item

Test item	Condition	Description
ETS S/V (Detects AWD solenoid)	<ul style="list-style-type: none"> <li>Vehicle stopped</li> <li>Engine running</li> <li>No DTC detected</li> </ul>	<ul style="list-style-type: none"> <li>Change command current value to AWD solenoid, and then change driving mode. (Monitor value is normal if it is within approximately ±10% of command value.)</li> <li>Qu: Increase current value in increments of 0.20 A</li> <li>Qd: Decrease current value in increments of 0.20 A</li> <li>UP: Increase current value in increments of 0.02 A</li> <li>DOWN: Decrease current value in increments of 0.02 A</li> </ul>

### CAUTION:

Never continuously energize for a long time.

## COMPONENT DIAGNOSIS

### C1201 AWD CONTROL UNIT

#### Description

INFOID:000000000957231

- Controls driving force distribution by signals from each sensor from rear wheel driving mode (0:100) to AWD mode (50:50).
- 2WD mode is available by fail-safe function if malfunction is detected in AWD system.

#### DTC Logic

INFOID:000000000957232

#### DTC DETECTION LOGIC

DTC	Items (CONSULT-III screen terms)	Diagnostic item is detected when...	Possible cause
C1201	CONTROLLER FAILURE	Malfunction has occurred inside AWD control unit.	Internal malfunction of AWD control unit

#### DTC CONFIRMATION PROCEDURE

##### 1. DTC REPRODUCTION PROCEDURE

**Ⓟ With CONSULT-III**

1. Turn the ignition switch OFF to ON.
2. Perform the self-diagnosis.

Is DTC "C1201" detected?

- YES >> Proceed to diagnosis procedure. Refer to [DLN-14, "Diagnosis Procedure"](#).  
 NO >> INSPECTION END

#### Diagnosis Procedure

INFOID:000000000957233

##### 1. PERFORM SELF-DIAGNOSIS

**Ⓟ With CONSULT-III**

1. Erase AWD control unit self-diagnosis results.
2. Wait 10 minutes or more after turning the ignition switch OFF.
3. Perform the self-diagnosis again.

Is DTC "C1201" detected?

- YES >> Replace AWD control unit. Refer to [DLN-49, "Exploded View"](#).  
 NO >> Check AWD control unit pin terminals for damage or loose connection with harness connector. If any items are damaged, repair or replace damaged parts.

# C1203 ABS ACTUATOR AND ELECTRIC UNIT (CONTROL UNIT)

< COMPONENT DIAGNOSIS >

[TRANSFER: ETX13B]

## C1203 ABS ACTUATOR AND ELECTRIC UNIT (CONTROL UNIT)

### Description

INFOID:000000000957234

Transmits the following signals via CAN communication to AWD control unit.

- Vehicle speed signal
- Stop lamp switch signal (brake signal)

### DTC Logic

INFOID:000000000957235

### DTC DETECTION LOGIC

DTC	Items (CONSULT-III screen terms)	Diagnostic item is detected when...	Possible cause
C1203	ABS SYSTEM	Malfunction related to wheel sensor has been detected by ABS actuator and electric unit (control unit).	ABS malfunction <ul style="list-style-type: none"><li>• Vehicle speed signal error</li><li>• Stop lamp switch signal (brake signal) error</li></ul>

### DTC CONFIRMATION PROCEDURE

#### 1. DTC REPRODUCTION PROCEDURE

##### With CONSULT-III

1. Start engine and drive at 30 km/h (19 MPH) or more for approx. 1 minute.
2. Perform the self-diagnosis.

##### Is DTC "C1203" detected?

- YES >> Proceed to diagnosis procedure. Refer to [DLN-15, "Diagnosis Procedure"](#).  
NO >> INSPECTION END

### Diagnosis Procedure

INFOID:000000000957236

#### 1. ABS ACTUATOR AND ELECTRIC UNIT (CONTROL UNIT) SELF-DIAGNOSIS

##### With CONSULT-III

Perform self-diagnosis with ABS actuator and electric unit (control unit).

##### Is any malfunction detected by self-diagnosis?

- YES >> Check the malfunctioning system.  
NO >> GO TO 2.

#### 2. AWD CONTROL UNIT SELF-DIAGNOSIS

##### With CONSULT-III

1. Erase AWD control unit self-diagnosis results.
2. Start engine and drive vehicle at 30 km/h (19 MPH) for at least 1 minute.
3. Make sure that ABS warning lamp turns OFF.
4. Perform self-diagnosis of AWD control unit.

##### Is DTC "C1203" detected?

- YES >> Replace AWD control. Refer to [DLN-49, "Exploded View"](#).  
NO >> Check AWD control unit pin terminals for damage or loose connection with harness connector. If any items are damaged, repair or replace damaged parts.

# C1204 AWD SOLENOID

< COMPONENT DIAGNOSIS >

[TRANSFER: ETX13B]

## C1204 AWD SOLENOID

### Description

INFOID:000000000957237

- Controls electric controlled coupling by command current from AWD control unit.

### DTC Logic

INFOID:000000000957238

### DTC DETECTION LOGIC

DTC	Items (CONSULT-III screen terms)	Diagnostic item is detected when...	Possible cause
C1204	4WD SOLENOID	Malfunction related to AWD solenoid has been detected.	Internal malfunction of electronic controlled coupling

### DTC CONFIRMATION PROCEDURE

#### 1. DTC REPRODUCTION PROCEDURE

##### With CONSULT-III

1. Turn the ignition switch OFF to ON.
2. Perform the self-diagnosis.

##### Is DTC "C1204" detected?

- YES >> Proceed to diagnosis procedure. Refer to [DLN-16. "Diagnosis Procedure"](#).  
NO >> INSPECTION END

### Diagnosis Procedure

INFOID:000000000957239

#### 1. AWD SOLENOID VALVE POWER SUPPLY INSPECTION

1. Turn the ignition switch OFF.
2. Disconnect AWD control unit harness connector.
3. Turn the ignition switch ON.  
**CAUTION:**  
**Never start the engine.**
4. Check the voltage between AWD control unit harness connector and ground.

AWD control unit		Voltage (Approx.)
Connector	Terminal	
F108	9 – Ground	Battery voltage

##### Is the inspection result normal?

- YES >> GO TO 2.  
NO >> Check the following. If any items are damaged, repair or replace damaged parts.
- 10A fuse (#33) open
  - Short among 10A fuse (#33) connector, AWD control unit harness connector No. 9 terminal and the ground
  - Open between the battery and AWD control unit harness connector No. 9 terminal

#### 2. AWD SOLENOID VALVE GROUND INSPECTION

1. Turn the ignition switch OFF.
2. Check the continuity between AWD control unit harness connector and ground.

AWD control unit		Continuity
Connector	Terminal	
F108	10 – Ground	Existed
	11 – Ground	

##### Is the inspection result normal?

- YES >> GO TO 3.



# C1204 AWD SOLENOID

[TRANSFER: ETX13B]

## < COMPONENT DIAGNOSIS >

NO >> Repair or replace damaged parts.

### 3.CHECK AWD SOLENOID CIRCUIT (1)

Check the resistance between AWD control unit harness connector terminals.

AWD control unit		Resistance (Approx.)
Connector	Terminal	
F108	1 – 2	2.45 Ω

Is the inspection result normal?

YES >> GO TO 5.

NO >> GO TO 4.

### 4.CHECK AWD SOLENOID CIRCUIT (2)

1. Disconnect AWD solenoid harness connector.
2. Check the continuity between AWD control unit harness connector and AWD solenoid harness connector terminals.

AWD control unit		AWD solenoid		Continuity
Connector	Terminal	Connector	Terminal	
F108	1	F57	1	Existed
F108	2	F57	2	

3. Check the continuity between AWD control unit harness connector and the ground.

AWD control unit		Continuity
Connector	Terminal	
F108	1 – Ground	Not existed
	2 – Ground	

4. Check the continuity between AWD solenoid harness connector and the ground.

AWD solenoid		Continuity
Connector	Terminal	
F57	1 – Ground	Not existed
	2 – Ground	

Is the inspection result normal?

YES >> GO TO 5.

NO >> Repair or replace damaged parts.

### 5.CHECK AWD SOLENOID

Check the resistance between AWD solenoid harness connector terminals.

AWD solenoid		Resistance (Approx.)
Connector	Terminal	
F57	1 – 2	2.45 Ω

Is the inspection result normal?

YES >> GO TO 6.

NO >> AWD solenoid is malfunctioning. Replace electric controlled coupling. Refer to [DLN-69, "Exploded View"](#).

### 6.CHECK TERMINALS AND HARNESS CONNECTORS

1. Check AWD control unit pin terminals for damage or loose connection with harness connector.
2. Check AWD solenoid pin terminals for damage or loose connection with harness connector.

A  
B  
C  
DLN  
E  
F  
G  
H  
I  
J  
K  
L  
M  
N  
O  
P

# C1204 AWD SOLENOID

[TRANSFER: ETX13B]

< COMPONENT DIAGNOSIS >

Is the inspection result normal?

YES >> Replace AWD control unit. Refer to [DLN-49, "Exploded View"](#).

NO >> Repair or replace damaged parts.

## Component Inspection

INFOID:000000000957240

### 1. CHECK AWD SOLENOID

1. Turn the ignition switch OFF.
2. Disconnect AWD solenoid harness connector.
3. Check the resistance between AWD solenoid harness connector terminals.

AWD solenoid		Resistance (Approx.)
Connector	Terminal	
F57	1 - 2	2.45 Ω

Is the inspection result normal?

YES >> INSPECTION END

NO >> AWD solenoid is malfunctioning. Replace electric controlled coupling. Refer to [DLN-69, "Exploded View"](#).

# C1205 AWD ACTUATOR RELAY

< COMPONENT DIAGNOSIS >

[TRANSFER: ETX13B]

## C1205 AWD ACTUATOR RELAY

### Description

INFOID:000000000957241

- AWD solenoid is supplied with voltage by the internal circuit of AWD control unit.

### DTC Logic

INFOID:000000000957242

### DTC DETECTION LOGIC

DTC	Items (CONSULT-III screen terms)	Diagnostic item is detected when...	Possible cause
C1205	4WD ACTUATOR RLY	Malfunction has been detected from AWD actuator relay integrated with AWD control unit, or malfunction related to AWD solenoid has been detected.	Internal malfunction of AWD control unit

### DTC CONFIRMATION PROCEDURE

#### 1. DTC REPRODUCTION PROCEDURE

##### With CONSULT-III

1. Turn the ignition switch OFF to ON.
2. Perform the self-diagnosis.

##### Is DTC "C1205" detected?

- YES >> Proceed to diagnosis procedure. Refer to [DLN-19, "Diagnosis Procedure"](#).  
NO >> INSPECTION END

### Diagnosis Procedure

INFOID:000000000957243

#### 1. PERFORM SELF-DIAGNOSIS

##### With CONSULT-III

1. Erase AWD control unit self-diagnosis results.
2. Wait 10 minutes or more after turning the ignition switch OFF.
3. Perform self-diagnosis of AWD control unit.

##### Is DTC "C1205" detected?

- YES >> Replace AWD control. Refer to [DLN-49, "Exploded View"](#).  
NO >> Check AWD control unit pin terminals for damage or loose connection with harness connector. If any items are damaged, repair or replace damaged parts.

## C1210 ECM

### Description

INFOID:000000000957244

- Transmits the following signals via CAN communication to AWD control unit.
  - Accelerator pedal position signal
  - Engine speed signal

### DTC Logic

INFOID:000000000957245

### DTC DETECTION LOGIC

DTC	Items (CONSULT-III screen terms)	Diagnostic item is detected when...	Possible cause
C1210	ENGINE SIGNAL 1	Malfunction has been detected from ECM.	Malfunction of engine control system <ul style="list-style-type: none"><li>• Accelerator pedal position signal error</li><li>• Engine speed signal error</li></ul>

### DTC CONFIRMATION PROCEDURE

#### 1. DTC REPRODUCTION PROCEDURE

##### With CONSULT-III

1. Start the engine. Drive the vehicle for a while.
2. Perform the self-diagnosis.

##### Is DTC "C1210" detected?

- YES >> Proceed to diagnosis procedure. Refer to [DLN-20, "Diagnosis Procedure"](#).
- NO >> INSPECTION END

### Diagnosis Procedure

INFOID:000000000957246

#### 1. ECM SELF-DIAGNOSIS

##### With CONSULT-III

Perform self-diagnosis of ECM.

##### Is any malfunction detected by self-diagnosis?

- YES >> Check the malfunctioning system.
- NO >> GO TO 2.

#### 2. AWD CONTROL UNIT SELF-DIAGNOSIS

##### With CONSULT-III

1. Erase AWD control unit self-diagnosis results.
2. Turn the ignition switch OFF.
3. Start the engine. Drive the vehicle for a while.
4. Make sure that malfunction indicator lamp (MIL) turns OFF.
5. Stop the vehicle. Perform AWD control unit self-diagnosis.

##### Is DTC "C1210" detected?

- YES >> Replace AWD control. Refer to [DLN-49, "Exploded View"](#).
- NO >> Check AWD control unit pin terminals for damage or loose connection with harness connector. If any items are damaged, repair or replace damaged parts.

# U1000 CAN COMM CIRCUIT

< COMPONENT DIAGNOSIS >

[TRANSFER: ETX13B]

## U1000 CAN COMM CIRCUIT

### Description

INFOID:000000000957247

- CAN (Controller Area Network) is a serial communication line for real time application. It is an on-vehicle multiplex communication line with high data communication speed and excellent error detection ability. Many electronic control units are equipped onto a vehicle, and each control unit shares information and links with other control units during operation (not independent). In CAN communication, control units are connected with 2 communication lines (CAN-H line, CAN-L line) allowing a high rate of information transmission with less wiring. Each control unit transmits/receives data but selectively reads required data only.

### DTC Logic

INFOID:000000000957248

### DTC DETECTION LOGIC

DTC	Items (CONSULT-III screen terms)	Diagnostic item is detected when...	Possible cause
U1000	CAN COMM CIRCUIT	When AWD control unit is not transmitting or receiving CAN communication signal for 2 seconds or more.	CAN communication line error

### DTC CONFIRMATION PROCEDURE

#### 1. DTC REPRODUCTION PROCEDURE

##### With CONSULT-III

1. Turn the ignition switch OFF to ON.
2. Perform the self-diagnosis.

##### Is DTC "U1000" detected?

- YES >> Proceed to diagnosis procedure. Refer to [DLN-21, "Diagnosis Procedure"](#).  
NO >> INSPECTION END

### Diagnosis Procedure

INFOID:000000000957249

#### 1. PERFORM SELF-DIAGNOSIS

##### With CONSULT-III

Perform self-diagnosis of AWD control unit.

##### Is DTC "U1000" detected?

- YES >> CAN specification chart.  
NO >> INSPECTION END

# U1010 CONTROL UNIT (CAN)

< COMPONENT DIAGNOSIS >

[TRANSFER: ETX13B]

## U1010 CONTROL UNIT (CAN)

### Description

INFOID:000000000957250

- CAN (Controller Area Network) is a serial communication line for real time application. It is an on-vehicle multiplex communication line with high data communication speed and excellent error detection ability. Many electronic control units are equipped onto a vehicle, and each control unit shares information and links with other control units during operation (not independent). In CAN communication, control units are connected with 2 communication lines (CAN-H line, CAN-L line) allowing a high rate of information transmission with less wiring. Each control unit transmits/receives data but selectively reads required data only.

### DTC Logic

INFOID:000000000957251

### DTC DETECTION LOGIC

DTC	Items (CONSULT-III screen terms)	Diagnostic item is detected when...	Possible cause
U1010	CONTROL UNIT (CAN)	When detecting error during the initial diagnosis of CAN controller of AWD control unit.	AWD control unit error

### DTC CONFIRMATION PROCEDURE

#### 1. DTC REPRODUCTION PROCEDURE

##### Ⓟ With CONSULT-III

1. Turn the ignition switch OFF to ON.
2. Perform the self-diagnosis.

##### Is DTC "U1010" detected?

- YES >> Proceed to diagnosis procedure. Refer to [DLN-22, "Diagnosis Procedure"](#).  
NO >> INSPECTION END

### Diagnosis Procedure

INFOID:000000000957252

#### 1. AWD CONTROL UNIT INSPECTION

Check AWD control unit harness connector for disconnection and deformation.

##### Is the inspection result normal?

- YES >> Replace AWD control unit. Refer to [DLN-49, "Exploded View"](#).  
NO >> Repair or replace damaged parts.

# POWER SUPPLY AND GROUND CIRCUIT

< COMPONENT DIAGNOSIS >

[TRANSFER: ETX13B]

## POWER SUPPLY AND GROUND CIRCUIT

### Description

INFOID:000000000957253

- Supplies power to AWD control unit.

### Diagnosis Procedure

INFOID:000000000957254

#### 1. AWD CONTROL UNIT POWER SUPPLY INSPECTION

1. Turn the ignition switch OFF.
2. Disconnect AWD control unit harness connector.
3. Check the voltage between AWD control unit harness connector and ground.

AWD control unit		Voltage (Approx.)
Connector	Terminal	
F108	7 – Ground	0 V

4. Turn the ignition switch ON.  
**CAUTION:**  
**Never start the engine.**
5. Check the voltage between AWD control unit harness connector and ground.

AWD control unit		Voltage (Approx.)
Connector	Terminal	
F108	7 – Ground	Battery voltage

Is the inspection result normal?

YES >> GO TO 2.

NO >> Check the following. If any items are damaged, repair or replace damaged parts.

- 10A fuse (#45) open
- Short among 10A fuse (#45) connector, AWD control unit harness connector No. 7 terminal and the ground
- Open between the ignition switch and AWD control unit harness connector No. 7 terminal

#### 2. AWD SOLENOID VALVE POWER SUPPLY INSPECTION

Check the voltage between AWD control unit harness connector and ground.

AWD control unit		Voltage (Approx.)
Connector	Terminal	
F108	9 – Ground	Battery voltage

Is the inspection result normal?

YES >> GO TO 3.

NO >> Check the following. If any items are damaged, repair or replace damaged parts.

- 10A fuse (#33) open
- Short among 10A fuse (#33) connector, AWD control unit harness connector No. 9 terminal and the ground
- Open between the battery and AWD control unit harness connector No. 9 terminal

#### 3. AWD SOLENOID VALVE GROUND INSPECTION

1. Turn the ignition switch OFF.
2. Check the continuity between AWD control unit harness connector and ground.

AWD control unit		Continuity
Connector	Terminal	
F108	10 – Ground	Existed
	11 – Ground	

A

B

C

DLN

E

F

G

H

I

J

K

L

M

N

O

P

## POWER SUPPLY AND GROUND CIRCUIT

< COMPONENT DIAGNOSIS >

[TRANSFER: ETX13B]

---

Is the inspection result normal?

YES >> INSPECTION END

NO >> Repair or replace damaged parts.



# AWD WARNING LAMP

< COMPONENT DIAGNOSIS >

[TRANSFER: ETX13B]

## AWD WARNING LAMP

### Description

INFOID:000000000957255

- Turns ON when there is a malfunction in AWD system. It indicates that fail-safe mode is engaged and vehicle change to rear-wheel drive or shifting driving force-AWD (Front-wheels still have some driving torque).
- Also turns ON when ignition switch is turned ON, for purpose of lamp check. Turns OFF approximately for 1 second after the engine starts if system is normal.

### AWD WARNING LAMP INDICATION

Condition	AWD warning lamp
Lamp check	Turns ON when ignition switch is turned ON. Turns OFF approx. 1 second after engine start.
AWD system malfunction	ON
Protection function is activated due to heavy load to electric controlled coupling. (AWD system is not malfunctioning and AWD system changes to 2WD mode.)	Quick blinking: 2 times/second (Blinking in approx. 1 minute and then turning OFF)
Large difference in diameter of front/rear tires	Slow blinking: 1 time/2 seconds (Continuing to blink until turning ignition switch OFF)
Other than above (system normal)	OFF

#### CAUTION:

AWD warning lamp also turns ON due to data reception error, CAN communication error etc.

### Diagnosis Procedure

INFOID:000000000957256

#### 1. UNIFIED METER AND A/C AMP. SELF-DIAGNOSIS

##### With CONSULT-III

Perform the self-diagnosis of the unified meter and A/C amp.

Is any error system detected?

- YES >> Check the error system.
- NO >> GO TO 2.

#### 2. SELF-DIAGNOSIS STARTS

##### With CONSULT-III

Perform AWD control unit self-diagnosis.

Is DTC "U1000" detected?

- YES >> Check the error system.
- NO >> GO TO 3.

#### 3. COMBINATION METER CIRCUIT INSPECTION

##### With CONSULT-III

Perform the system diagnosis for "B2202". Refer to [MWI-44, "Diagnosis Procedure"](#).

Is the inspection result normal?

- YES >> GO TO 4.
- NO >> Repair or replace the specific malfunctioning part.

#### 4. AWD WARNING LAMP INSPECTION

##### With CONSULT-III

1. Connect the unified meter and A/C amp. harness connector.
2. Connect the combination meter harness connector.
3. Disconnect AWD solenoid harness connector.
4. Turn the ignition switch ON.

#### CAUTION:

**Never start the engine.**

5. Check "4WD W/L" of AWD control unit CONSULT-III "DATA MONITOR".

Does the item on "DATA MONITOR" indicate "On"?

## AWD WARNING LAMP

< COMPONENT DIAGNOSIS >

[TRANSFER: ETX13B]

---

YES >> GO TO 5.

NO >> Replace AWD control unit. Refer to [DLN-49, "Exploded View"](#).

### 5. COMBINATION METER POWER SUPPLY INSPECTION

---

#### With CONSULT-III

Perform the trouble diagnosis of the combination meter power supply. Refer to [MWI-49, "COMBINATION METER : Diagnosis Procedure"](#).

Is the inspection result normal?

YES >> INSPECTION END

NO >> Repair or replace the specific malfunctioning part.

ECU DIAGNOSIS

AWD CONTROL UNIT

Reference Value

INFOID:000000000957257

VALUES ON THE DIAGNOSIS TOOL

Monitor item	Condition	Value/Status
FR RH SENSOR [km/h] or [mph]	Vehicle stopped	0.00 km/h (0.00 mph)
	Vehicle running <b>CAUTION:</b> Check air pressure of tire under standard condition.	Approximately equal to the indication on speedometer (Inside of ±10%)
FR LH SENSOR [km/h] or [mph]	Vehicle stopped	0.00 km/h (0.00 mph)
	Vehicle running <b>CAUTION:</b> Check air pressure of tire under standard condition.	Approximately equal to the indication on speedometer (Inside of ±10%)
RR RH SENSOR [km/h] or [mph]	Vehicle stopped	0.00 km/h (0.00 mph)
	Vehicle running <b>CAUTION:</b> Check air pressure of tire under standard condition.	Approximately equal to the indication on speedometer (Inside of ±10%)
RR LH SENSOR [km/h] or [mph]	Vehicle stopped	0.00 km/h (0.00 mph)
	Vehicle running <b>CAUTION:</b> Check air pressure of tire under standard condition.	Approximately equal to the indication on speedometer (Inside of ±10%)
BATTERY VOLT [V]	Ignition switch: ON	Battery voltage
THRTL POS SEN [%]	When depressing accelerator pedal (Value rises gradually in response to throttle position.)	0 – 100 %
ETS SOLENOID [A]	Engine running • At idle speed	Approx. 0.000 A
	Engine running • When depressing accelerator pedal	Approx. 0.000 – 0.500 A*
STOP LAMP SW [ON/OFF]	Brake pedal: Depressed	ON
	Brake pedal: Released	OFF
ENG SPEED SIG [RUN/STOP]	Engine stopped (Engine speed: Less than 400 rpm)	STOP
	Engine running (Engine speed: 400 rpm or more)	RUN
ETS ACTUATOR [ON/OFF]	Engine stopped (Ignition switch: ON)	OFF
	Engine running	ON
4WD WARN LAMP [ON/OFF]	AWD warning lamp: ON	ON
	AWD warning lamp: OFF	OFF
4WD MODE SW [AUTO]	Always	AUTO
4WD MODE MON [AUTO]	Engine running	AUTO
DIS-TIRE MONI [mm]	Vehicle running with normal size tire installed	0 – 4 mm
	Vehicle running with improper size tire installed (Front/rear tire size difference, wear condition)	4 – 8 mm, 8 – mm
P BRAKE SW [ON/OFF]	Parking brake operated	ON
	Parking brake not operated	OFF

\*: The values are changed by throttle opening and engine speed.

TERMINAL LAYOUT

A  
B  
C  
DLN  
E  
F  
G  
H  
I  
J  
K  
L  
M  
N  
O  
P

# AWD CONTROL UNIT

< ECU DIAGNOSIS >

[TRANSFER: ETX13B]

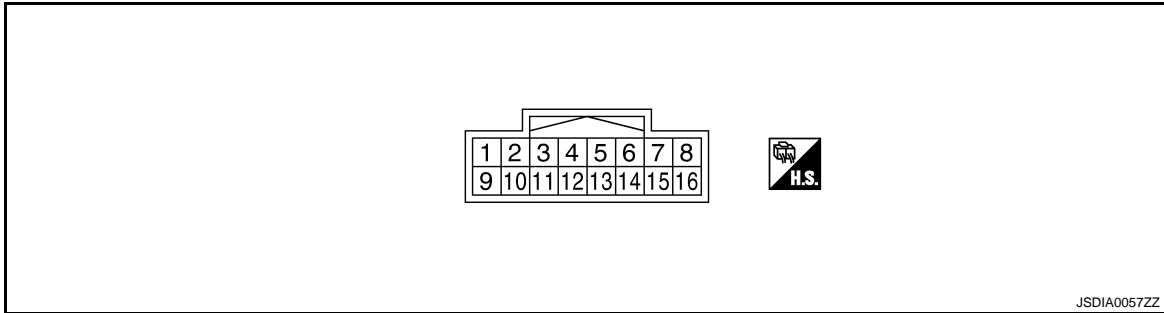

## PHYSICAL VALUES

Terminal No.		Wire color	Description		Condition	Value (Approx.)
+	-		Signal name	Input/ Output		
1	Ground	BR	AWD solenoid power supply	Output	Engine speed: At idle	2.5 V
					Engine speed: 3,000 rpm or more constant	8 V*
2	Ground	Y	AWD solenoid ground	—	Engine speed: At idle	0 V
					Engine speed: 3,000 rpm or more constant	0 V
4	Ground	W	Fluid temperature	—	—	—
6	Ground	SB	K-LINE (CONSULT-III signal)	—	—	—
7	Ground	G	Ignition switch	Input	Ignition switch: ON	Battery voltage
					Ignition switch: OFF	0 V
8	Ground	L	CAN-H	—	—	—
9	Ground	O	Power supply (AWD solenoid power)	Input	Ignition switch: ON	Battery voltage
					Ignition switch: OFF	Battery voltage
10	Ground	B	Ground	—	Always	0 V
11	Ground	B	Ground	—	Always	0 V
12	Ground	LG	Oil temperature	—	—	—
16	Ground	P	CAN-L	—	—	—

\*: The values are changed by throttle opening and engine speed.

**CAUTION:**

When using circuit tester to measure voltage for inspection, be sure not to extend forcibly any connector terminals.

## Wiring Diagram — AWD SYSTEM —

INFOID:000000000957258



# AWD CONTROL UNIT

< ECU DIAGNOSIS >

[TRANSFER: ETX13B]

## AWD SYSTEM

Connector No.	B1
Connector Name	WIRE TO WIRE
Connector Type	T180FW-CS16-TM4

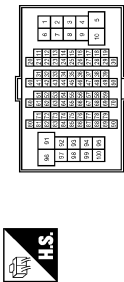

Terminal No.	Color of Wire	Signal Name
23	L	-
24	P	-
25	L	-
26	P	-

Connector No.	E3
Connector Name	WIRE TO WIRE
Connector Type	SAA38MB-RS10-SJ22



Terminal No.	Color of Wire	Signal Name
27	O	-

Connector No.	E5
Connector Name	IPDM E/R INTELLIGENT POWER DISTRIBUTION MODULE (ENGINE ROOM)
Connector Type	TH20FW-CS12-M4-TV



Terminal No.	Color of Wire	Signal Name
25	G	-

Connector No.	E41
Connector Name	ABS ACTUATOR AND ELECTRIC UNIT
Connector Type	BAA42FB-AH24-LH

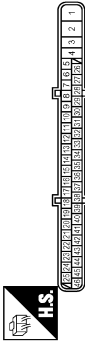

Terminal No.	Color of Wire	Signal Name
14	P	CAN-L
35	L	CAN-H

Connector No.	E106
Connector Name	WIRE TO WIRE
Connector Type	T180FW-CS16-TM4

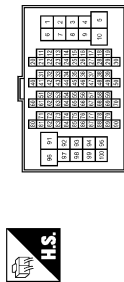

Terminal No.	Color of Wire	Signal Name
6	P	-
7	L	-
43	G	-

Connector No.	F1
Connector Name	WIRE TO WIRE
Connector Type	SAA38FB-RS10-SJ22



Terminal No.	Color of Wire	Signal Name
27	O	-

Connector No.	F57
Connector Name	AWD SOLENOID
Connector Type	RK08FB



Terminal No.	Color of Wire	Signal Name
1	BR	-
2	Y	-
6	LG	-
7	W	-

Connector No.	F03
Connector Name	WIRE TO WIRE
Connector Type	TK36FW-NS10

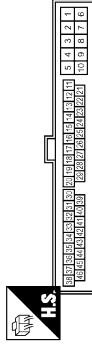

Terminal No.	Color of Wire	Signal Name
33	B	-
34	B	-
35	L	-
36	P	-
37	SB	-
38	G	-

JCDWA0010GE

# AWD CONTROL UNIT

< ECU DIAGNOSIS >

[TRANSFER: ETX13B]

## AWD SYSTEM

Connector No.	F108
Connector Name	AWD CONTROL UNIT
Connector Type	TH18FW-NH

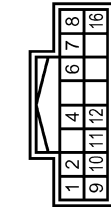

Terminal No.	Color of Wire	Signal Name
1	BR	AWD SOL (+)
2	Y	AWD SOL (-)
4	W	OIL TEMP(-)
6	SB	K LINE
7	G	IGN
8	L	CAN-H
9	O	AWD SOL BAT
10	B	GND
11	B	GND
12	LG	OIL TEMP(+)
16	P	CAN-L

Connector No.	M7
Connector Name	WIRE TO WIRE
Connector Type	TH80MW-CS16-TM4



Terminal No.	Color of Wire	Signal Name
23	L	-
24	P	-
25	L	-
26	P	-

Connector No.	M1
Connector Name	FUSE BLOCK (J/B)
Connector Type	NS58FW-M2

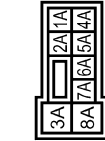

Terminal No.	Color of Wire	Signal Name
2A	G	-

Connector No.	M24
Connector Name	DATA LINK CONNECTOR
Connector Type	BD18FW

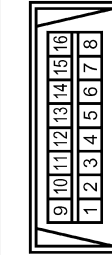

Terminal No.	Color of Wire	Signal Name
7	V	-

Connector No.	M2
Connector Name	FUSE BLOCK (J/B)
Connector Type	NS10FW-CS



Terminal No.	Color of Wire	Signal Name
6B	Y	-

Connector No.	M53
Connector Name	COMBINATION METER
Connector Type	SAB4DFW

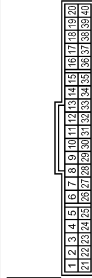

Terminal No.	Color of Wire	Signal Name
2	LG	COMM (METER->AMP)
3	GR	COMM (AMP->METER)

Connector No.	M6
Connector Name	WIRE TO WIRE
Connector Type	TH80MW-CS16-TM4



Terminal No.	Color of Wire	Signal Name
6	P	-
7	L	-
43	G	-

Connector No.	M36
Connector Name	UNIFIED METER AND A/C AMP.
Connector Type	TH40FW-NH



Terminal No.	Color of Wire	Signal Name
7	GR	COMM (AMP->METER)
27	LG	COMM (METER->AMP)

A  
B  
C  
DLN  
E  
F  
G  
H  
I  
J  
K  
L  
M  
N  
O  
P

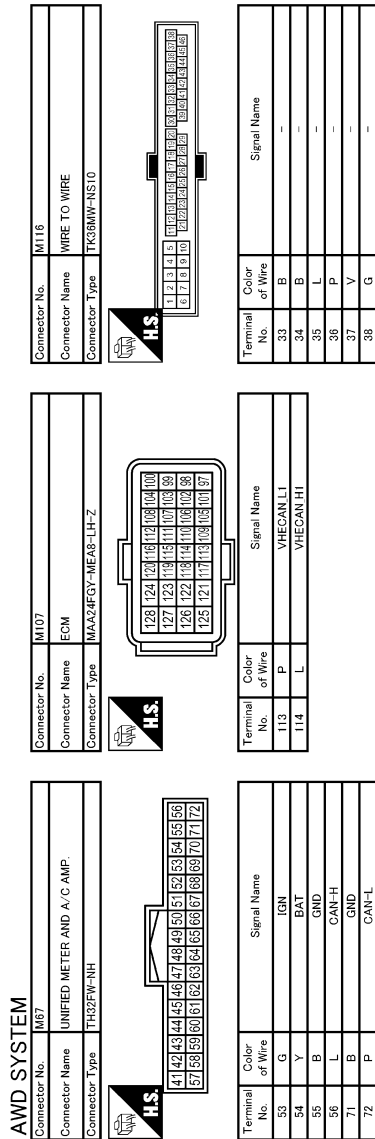

JCDWA0012GE

INFOID:000000000957259

## Fail Safe

### AWD system

- If any malfunction occurs in AWD electrical system, and control unit detects the malfunction, AWD warning lamp on combination meter turns ON to indicate system malfunction.
- When AWD warning lamp is ON, vehicle changes to rear-wheel drive or shifting driving force-AWD (Front-wheels still have some driving torque).



# AWD CONTROL UNIT

< ECU DIAGNOSIS >

[TRANSFER: ETX13B]

- AWD system activates its protection function (shuts down AWD system temporarily) if AWD system detects high load continuously or the front wheel tire size differs from the rear tire size. (AWD system is automatically restored if AWD system no longer detects any overload or the tire size difference is eliminated.)

Function	Warning lamp	DTC No.	Detected area (Error area)	Error area and root cause
Protection function	Blinking*1	—	AWD control unit	Transfer assembly in protection mode (Internal temperature rise of electronic controlled coupling)
Protection function	Blinking*2	—	Outer diameters of front and rear wheel tires	Malfunction in each tire or different tire diameter
Fail-safe function	ON	C1201	AWD control unit	Internal malfunction of AWD control unit
Fail-safe function	ON	C1203	ABS actuator and electric unit (control unit)	ABS malfunction • Vehicle speed signal error • Stop lamp switch signal (brake signal) error
Fail-safe function	ON	C1204	AWD solenoid	Internal malfunction of electronic controlled coupling
Fail-safe function	ON	C1205	AWD control unit	Internal malfunction of AWD control unit
Fail-safe function	ON	C1210	ECM	Malfunction of engine control system • Accelerator pedal position signal error • Engine speed signal error
Fail-safe function	ON	U1000	CAN communication line	CAN communication line error
Fail-safe function	ON	U1010	AWD control unit	AWD control unit error

\*1: Quick blinking: 2 times/second (blinking in approx. 1 minute and then turning OFF)

\*2: Slow blinking: 1 time/2 seconds (Continuing to blink until turning ignition switch OFF)

## DTC Inspection Priority Chart

INFOID:000000000957260

If some DTCs are displayed at the same time, perform inspections one by one based on the following priority chart.

Priority	Detected items (DTC)
1	<ul style="list-style-type: none"> <li>• U1000 CAN COMM CIRCUIT</li> <li>• U1010 CONTROL UNIT (CAN)</li> </ul>
2	<ul style="list-style-type: none"> <li>• C1201 AWD CONTROL UNIT</li> <li>• C1205 AWD ACTUATOR RELAY</li> </ul>
3	<ul style="list-style-type: none"> <li>• C1203 ABS ACTUATOR AND ELECTRIC UNIT (CONTROL UNIT)</li> <li>• C1210 ECM</li> </ul>
4	<ul style="list-style-type: none"> <li>• C1204 AWD SOLENOID VALVE</li> </ul>

## DTC Index

INFOID:000000000957261

DTC	Items (CONSULT-III screen terms)	Reference
C1201	CONTROLLER FAILURE	<a href="#">DLN-14. "Description"</a>
C1203	ABS SYSTEM	<a href="#">DLN-15. "Description"</a>
C1204	4WD SOLENOID	<a href="#">DLN-16. "Description"</a>
C1205	4WD ACTUATOR RLY	<a href="#">DLN-19. "Description"</a>
C1210	ENGINE SIGNAL 1	<a href="#">DLN-20. "Description"</a>

# AWD CONTROL UNIT

< ECU DIAGNOSIS >

[TRANSFER: ETX13B]

DTC	Items (CONSULT-III screen terms)	Reference
U1000	CAN COMM CIRCUIT	<a href="#">DLN-21. "Description"</a>
U1010	CONTROL UNIT (CAN)	<a href="#">DLN-22. "Description"</a>

# AWD SYSTEM SYMPTOMS

< SYMPTOM DIAGNOSIS >

[TRANSFER: ETX13B]

## SYMPTOM DIAGNOSIS

### AWD SYSTEM SYMPTOMS

#### Symptom Table

INFOID:000000000957262

If AWD warning lamp turns ON, perform self-diagnosis.

Symptom	Condition	Check item	Reference
AWD warning lamp does not turn ON when the ignition switch is turned to ON. (AWD warning lamp check)	Ignition switch: ON	Unified meter and A/C amp.	<a href="#">DLN-36, "Description"</a>
		CAN communication line	
		Combination meter	
AWD warning lamp does not turn OFF several seconds after engine started.	Engine running	AWD control unit self-diagnosis	<a href="#">DLN-37, "Description"</a>
		AWD warning lamp	
		Power supply and ground for AWD control unit	
Heavy tight-corner braking symptom occurs when the vehicle is driven and the steering wheel is turned fully to either side after the engine is started. (See NOTE.)	<ul style="list-style-type: none"> <li>• While driving</li> <li>• Steering wheel is turned fully to either sides</li> </ul>	ECM self-diagnosis	<a href="#">DLN-38, "Description"</a>
		AWD control unit self-diagnosis	
		AWD solenoid	
		Mechanical malfunction of electric controlled coupling (clutch sticking etc.)	
Vehicle does not enter AWD mode even though AWD warning lamp turned to OFF.	While driving	CAN communication line	<a href="#">DLN-39, "Description"</a>
		AWD solenoid	
		Mechanical malfunction of electric controlled coupling (Mechanical engagement of clutch is not possible.)	
While driving, AWD warning lamp blinks quickly. (When blinking in approx. 1 minute and then turning OFF.) Quick blinking: 2 times/second	While driving	Protection function is activated due to heavy load to electric controlled coupling. (AWD system is not malfunctioning. Also, optional distribution of torque sometimes becomes rigid before lamp blinks quickly, but it is not malfunctioning.)	<a href="#">DLN-40, "Description"</a>
While driving, AWD warning lamp blinks slowly. (When continuing to blink until turning ignition switch OFF) Slow blinking: 1 time/2 seconds	<ul style="list-style-type: none"> <li>• While driving</li> <li>• Vehicle speed: 20 km/h (12 MPH) or more</li> </ul>	Tire size is different between front and rear of vehicle.	<a href="#">DLN-41, "Description"</a>

**NOTE:**

Light tight-corner braking symptom may occur depending on driving conditions. This is not malfunction.

A  
B  
C  
DLN  
E  
F  
G  
H  
I  
J  
K  
L  
M  
N  
O  
P

## AWD WARNING LAMP DOES NOT TURN ON

< SYMPTOM DIAGNOSIS >

[TRANSFER: ETX13B]

---

### AWD WARNING LAMP DOES NOT TURN ON

#### Description

INFOID:000000000957263

- AWD warning lamp does not turn ON when the ignition switch is turned to ON.

#### Diagnosis Procedure

INFOID:000000000957264

#### 1. CHECK AWD WARNING LAMP

---

Perform trouble diagnosis for AWD warning lamp. Refer to [DLN-25, "Diagnosis Procedure"](#).

Is the inspection result normal?

- YES >> Check each harness connector pin terminal for disconnection.  
NO >> Repair or replace damaged parts.

# AWD WARNING LAMP DOES NOT TURN OFF

< SYMPTOM DIAGNOSIS >

[TRANSFER: ETX13B]

## AWD WARNING LAMP DOES NOT TURN OFF

### Description

INFOID:000000000957265

- AWD warning lamp does not turn OFF several seconds after engine started.

### Diagnosis Procedure

INFOID:000000000957266

#### 1.SELF-DIAGNOSIS START

##### With CONSULT-III

Perform AWD control unit self-diagnosis.

##### Is any error system detected?

YES >> Check the error system.

NO >> GO TO 2.

#### 2.CHECK AWD WARNING LAMP

Perform AWD warning lamp trouble diagnosis. Refer to [DLN-25, "Description"](#).

##### Is the inspection result normal?

YES >> Repair or replace the specific malfunctioning part.

NO >> GO TO 3.

#### 3.AWD CONTROL UNIT POWER SUPPLY INSPECTION

Perform AWD control unit power supply trouble diagnosis. Refer to [DLN-23, "Description"](#).

##### Is the inspection result normal?

YES >> Check each harness connector pin terminal for disconnection.

NO >> Repair or replace the specific malfunctioning part.

A  
B  
C  
DLN  
E  
F  
G  
H  
I  
J  
K  
L  
M  
N  
O  
P

# HEAVY TIGHT-CORNER BRAKING SYMPTOM OCCURS

< SYMPTOM DIAGNOSIS >

[TRANSFER: ETX13B]

## HEAVY TIGHT-CORNER BRAKING SYMPTOM OCCURS

### Description

INFOID:000000000957267

- Heavy tight-corner braking symptom occurs when the vehicle is driven and the steering wheel is turned fully to either side after the engine is started.

#### NOTE:

Light tight-corner braking symptom may occur depending on driving conditions. This is not malfunction.

### Diagnosis Procedure

INFOID:000000000957268

#### 1. ECM SELF-DIAGNOSIS

##### With CONSULT-III

Perform ECM self-diagnosis.

##### Is any error system detected?

- YES >> Check the error system.
- NO >> GO TO 2.

#### 2. SELF-DIAGNOSIS STARTS

##### With CONSULT-III

Perform AWD control unit self-diagnosis.

##### Is DTC "U1000" detected?

- YES >> Check the error system.
- NO >> GO TO 3.

#### 3. AWD SOLENOID INSPECTION

Perform AWD solenoid trouble diagnosis. Refer to [DLN-16. "Description"](#).

##### Is the inspection result normal?

- YES >> GO TO 4.
- NO >> Repair or replace the specific malfunctioning part.

#### 4. CHECK ELECTRIC CONTROLLED COUPLING

1. Turn the ignition switch OFF.
2. Set the transmission to neutral. Release the parking brake.
3. Lift up the vehicle.
4. Rotate the rear propeller shaft.
5. Hold the front propeller shaft lightly.

##### Does the front propeller shaft rotate?

- YES >> Replace electric controlled coupling for mechanical malfunction (clutch sticking etc.). Refer to [DLN-69. "Disassembly"](#).
- NO >> Check each harness connector pin terminal for disconnection.

# VEHICLE DOES NOT ENTER AWD MODE

< SYMPTOM DIAGNOSIS >

[TRANSFER: ETX13B]

## VEHICLE DOES NOT ENTER AWD MODE

### Description

INFOID:000000000957269

- Vehicle does not enter AWD mode even though AWD warning lamp turned to OFF.

### Diagnosis Procedure

INFOID:000000000957270

#### 1.CHECK AWD WARNING LAMP

Turn the ignition switch ON.

Does AWD warning lamp turn ON?

YES >> GO TO 2.

NO >> Go to [DLN-36, "Description"](#).

#### 2.SELF-DIAGNOSIS STARTS

 **With CONSULT-III**

Perform AWD control unit self-diagnosis.

Is DTC "U1000" detected?

YES >> Check the error system.

NO >> GO TO 3.

#### 3.CHECK AWD SOLENOID

Perform AWD solenoid trouble diagnosis. Refer to [DLN-16, "Description"](#).

Is the inspection result normal?

YES >> GO TO 4.

NO >> Repair or replace the specific malfunctioning part.

#### 4.CRUISE TEST

Drive the vehicle for a period of time.

Does any symptom occur?

YES >> Replace electric controlled coupling for mechanical malfunction (mechanical engagement of clutch is not possible). Refer to [DLN-69, "Disassembly"](#).

NO >> Check each harness connector pin terminal for disconnection.

A  
B  
C  
DLN  
E  
F  
G  
H  
I  
J  
K  
L  
M  
N  
O  
P

## AWD WARNING LAMP BLINKS QUICKLY

< SYMPTOM DIAGNOSIS >

[TRANSFER: ETX13B]

---

### AWD WARNING LAMP BLINKS QUICKLY

#### Description

INFOID:000000000957271

- While Driving, AWD warning lamp blinks 2 times in 1 second and it turns OFF after 1 minute while driving.
- This symptom protects drivetrain parts when a heavy load is applied to the electric controlled coupling and multiple disc clutch temperature increases. Also, optional distribution of torque sometimes becomes rigid before lamp blinks quickly. Both cases are not malfunction.
- When this symptom occurs, stop vehicle and allow it to idle for some times. Blinking will stop and system will be restored.



# AWD WARNING LAMP BLINKS SLOWLY

< SYMPTOM DIAGNOSIS >

[TRANSFER: ETX13B]

## AWD WARNING LAMP BLINKS SLOWLY

### Description

INFOID:000000000957272

- AWD warning lamp blinks at approximately 2 seconds intervals while driving.

### Diagnosis Procedure

INFOID:000000000957273

#### 1. CHECK TIRE

- Check the following.
  - Tire pressure
  - Wear condition
  - Longitudinal tire size (There is no difference between longitudinal tires.)

Is the inspection result normal?

YES >> GO TO 2.

NO >> Drive at vehicle speed of 20 km/h (12 MPH) or more for 5 seconds or more after repairing or replacing damaged parts. (Initialize improper size tire information.)

#### 2. CHECK INPUT SIGNAL OF TIRE DIAMETER

 **With CONSULT-III**

1. Start engine.
2. Drive at 20 km/h (12 MPH) or more for approx. 200 seconds.
3. Check "DIS-TIRE MONI" of AWD control unit CONSULT-III "DATA MONITOR".

Does the item on "DATA MONITOR" indicate "0 - 4 mm"?

YES >> INSPECTION END

NO >> GO TO 3.

#### 3. TERMINAL INSPECTION

Check AWD control unit harness connector for disconnection.

Is the inspection result normal?

YES >> Replace AWD control unit. Refer to [DLN-49. "Exploded View"](#).

NO >> Repair or replace the specific malfunctioning part.

A  
B  
C  
DLN  
E  
F  
G  
H  
I  
J  
K  
L  
M  
N  
O  
P

## NORMAL OPERATING CONDITION

< SYMPTOM DIAGNOSIS >

[TRANSFER: ETX13B]

---

### NORMAL OPERATING CONDITION

#### Description

INFOID:000000000957274

- While Driving, AWD warning lamp blinks 2 times in 1 second and it turns OFF after 1 minute while driving.
- This symptom protects drivetrain parts when a heavy load is applied to the electric controlled coupling and multiple disc clutch temperature increases. Also, optional distribution of torque sometimes becomes rigid before lamp blinks quickly. Both cases are not malfunction.
- When this symptom occurs, stop vehicle and allow it to idle for some times. Blinking will stop and system will be restored.

# NOISE, VIBRATION AND HARSHNESS (NVH) TROUBLESHOOTING

< SYMPTOM DIAGNOSIS >

[TRANSFER: ETX13B]

## NOISE, VIBRATION AND HARSHNESS (NVH) TROUBLESHOOTING

### NVH Troubleshooting Chart

INFOID:000000000957275

Use the chart below to help you find the cause of the symptom. The numbers indicate the order of the inspection. If necessary, repair or replace these parts.

Reference		<a href="#">DLN-48, "Inspection"</a>			<a href="#">DLN-58, "Exploded View"</a>	<a href="#">DLN-58, "Exploded View"</a>	<a href="#">DLN-67, "Inspection"</a>	<a href="#">DLN-67, "Inspection"</a>	<a href="#">DLN-67, "Inspection"</a>
SUSPECTED PARTS (Possible cause)		TRANSFER FLUID (Level low)	TRANSFER FLUID (Wrong)	TRANSFER FLUID (Level too high)	LIQUID GASKET (Damaged)	OIL SEAL (Worn or damaged)	GEAR (Worn or damaged)	BEARING (Worn or damaged)	TRANSFER CASE (Damaged)
Symptom	Noise	1	2				3	3	3
	Transfer fluid leakage		4	1	2	2			3

A  
B  
C  
E  
F  
G  
H  
I  
J  
K  
L  
M  
N  
O  
P

DLN

## PRECAUTION

### PRECAUTIONS

#### Precaution for Supplemental Restraint System (SRS) "AIR BAG" and "SEAT BELT PRE-TENSIONER"

INFOID:000000000957276

The Supplemental Restraint System such as "AIR BAG" and "SEAT BELT PRE-TENSIONER", used along with a front seat belt, helps to reduce the risk or severity of injury to the driver and front passenger for certain types of collision. This system includes seat belt switch inputs and dual stage front air bag modules. The SRS system uses the seat belt switches to determine the front air bag deployment, and may only deploy one front air bag, depending on the severity of a collision and whether the front occupants are belted or unbelted. Information necessary to service the system safely is included in the SRS and SB section of this Service Manual.

**WARNING:**

- To avoid rendering the SRS inoperative, which could increase the risk of personal injury or death in the event of a collision which would result in air bag inflation, all maintenance must be performed by an authorized NISSAN/INFINITI dealer.
- Improper maintenance, including incorrect removal and installation of the SRS, can lead to personal injury caused by unintentional activation of the system. For removal of Spiral Cable and Air Bag Module, see the SRS section.
- Do not use electrical test equipment on any circuit related to the SRS unless instructed to in this Service Manual. SRS wiring harnesses can be identified by yellow and/or orange harnesses or harness connectors.

#### Service Notice or Precautions for Transfer

INFOID:000000000957277

**CAUTION:**

- Never reuse transfer fluid, once it has been drained.
- Check the fluid level or replace the fluid only with the vehicle parked on level ground.
- During removal or installation, keep inside of transfer clear of dust or dirt.
- Replace all tires at the same time. Always use tires of the proper size and the same brand and pattern. Fitting improper size and unusual wear tires applies excessive force to vehicle mechanism and can cause longitudinal vibration.
- Disassembly should be done in a clean work area, it is preferable to work in dustproof area.
- Before proceeding with disassembly, thoroughly clean the transfer. It is important to prevent the internal parts from becoming contaminated by dirt or other foreign matter.
- All parts should be carefully cleaned with a general purpose, non-flammable solvent before inspection or reassembly.
- Check for the correct installation status prior to removal or disassembly. If matching marks are required, be certain they do not interfere with the function of the parts when applied.
- Check appearance of the disassembled parts for damage, deformation, and unusual wear. Replace them with a new ones if necessary.
- Gaskets, seals and O-rings should be replaced any time when the transfer is disassembled.
- In principle, tighten bolts or nuts gradually in several steps working diagonally from inside to outside. If tightening sequence is specified, use it.
- Observe the specified torque when assembling.
- Clean and flush the parts sufficiently and blow-dry them.
- Be careful not to damage sliding surfaces and mating surfaces.
- Clean inner parts with lint-free cloth or towels. Do not use cotton work gloves and rags to prevent adhering fibers.

# PREPARATION

< PREPARATION >

[TRANSFER: ETX13B]

## PREPARATION

### PREPARATION

#### Special Service Tools

INFOID:000000000957278

The actual shapes of Kent-Moore tools may differ from those of special service tools illustrated here.

Tool number (Kent-Moore No.) Tool name	Description
ST27862000 ( — ) Drift a: 62.5 mm (2.461 in) dia. b: 42 mm (1.65 in) dia.	Installing front oil seal
KV381054S0 (J-34286) Puller	Removing rear oil seal
ST30720000 (J-25405) Drift a: 77 mm (3.03 in) dia. b: 55.5 mm (2.185 in) dia.	<ul style="list-style-type: none"> <li>Installing rear oil seal</li> <li>Installing mainshaft oil seal</li> </ul>
KV40104830 ( — ) Drift a: 70 mm (2.76 in) dia. b: 63.5 mm (2.500 in) dia.	Installing rear oil seal
KV38100300 (J-25523) Drift a: 54 mm (2.13 in) dia. b: 46 mm (1.81 in) dia. c: 32 mm (1.26 in) dia.	Removing mainshaft bearing
ST33052000 ( — ) Drift a: 28 mm (1.10 in) dia. b: 22 mm (0.87 in) dia.	Removing mainshaft assembly

A  
B  
C  
DLN  
E  
F  
G  
H  
I  
J  
K  
L  
M  
N  
O  
P

# PREPARATION

< PREPARATION >

[TRANSFER: ETX13B]

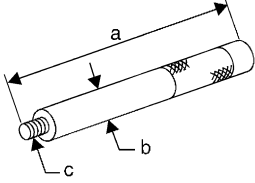
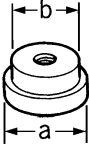
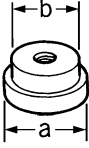
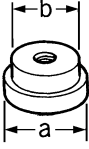
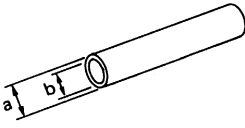
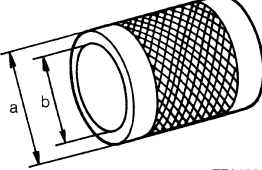
Tool number (Kent-Moore No.) Tool name	Description
<p>ST30611000 (J-25742-1) Drift bar a: 350 mm (13.78 in) b: 25 mm (0.98 in) dia. c: M12 × 1.5P</p>	<p>Removing rear bearing</p>
 <p style="text-align: right; font-size: small;">NT663</p>	
<p>ST35321000 ( — ) Drift a: 49 mm (1.93 in) dia. b: 41 mm (1.61 in) dia.</p>	<ul style="list-style-type: none"> <li>• Removing rear bearing</li> <li>• Installing mainshaft assembly</li> </ul>
 <p style="text-align: right; font-size: small;">ZZA1000D</p>	
<p>KV38104010 ( — ) Drift a: 67 mm (2.64 in) dia. b: 49 mm (1.93 in) dia.</p>	<ul style="list-style-type: none"> <li>• Installing front drive shaft rear bearing</li> <li>• Installing rear bearing</li> </ul>
 <p style="text-align: right; font-size: small;">ZZA1000D</p>	
<p>ST30621000 (J-25742-5) Drift a: 80 mm (3.15 in) dia. b: 59 mm (2.32 in) dia.</p>	<p>Installing mainshaft bearing</p>
 <p style="text-align: right; font-size: small;">ZZA1000D</p>	
<p>ST31214000 (J-25269-B) Drift a: 34 mm (1.34 in) dia. b: 25.5 mm (1.004 in) dia.</p>	<ul style="list-style-type: none"> <li>• Removing front drive shaft front bearing</li> <li>• Removing front drive shaft rear bearing</li> </ul>
 <p style="text-align: right; font-size: small;">ZZA0534D</p>	
<p>ST33200000 (J-26082) Drift a: 60 mm (2.36 in) dia. b: 44.5 mm (1.752 in) dia.</p>	<p>Installing front drive shaft front bearing</p>
 <p style="text-align: right; font-size: small;">ZZA1002D</p>	

Commercial Service Tools

INFOID:000000000957279

# PREPARATION

< PREPARATION >

[TRANSFER: ETX13B]

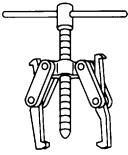
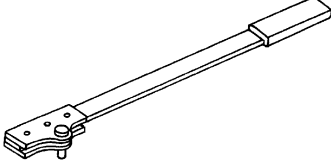
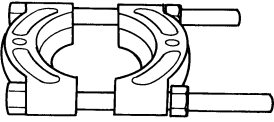
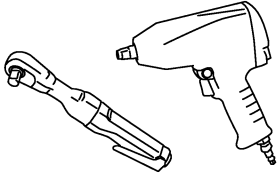
Tool name	Description	
Puller   NT077	Removing companion flange	A B C
Flange wrench   NT771	Removing and installing self-lock nut	DLN E
Puller   ZZB0823D	<ul style="list-style-type: none"> <li>• Removing front drive shaft front bearing</li> <li>• Removing front drive shaft rear bearing</li> </ul>	F G H
Power tool   PBIC0190E	Loosening bolts and nuts	I J K L M N O P

## ON-VEHICLE MAINTENANCE

### TRANSFER FLUID

#### Inspection

INFOID:000000000957280

#### FLUID LEAKAGE

- Check if fluid is leaking from transfer or around it.

#### FLUID LEVEL

- Check fluid level from filler plug (1) mounting hole as shown in the figure.

**CAUTION:**

**Never start engine while checking fluid level.**

- Before installing filler plug, set a new gasket. Install filler plug on transfer and tighten to the specified torque. Refer to [DLN-58, "Exploded View"](#).

**CAUTION:**

**Never reuse gasket.**

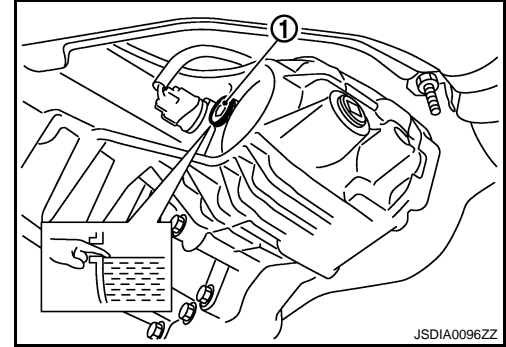

JSDIA0096ZZ

#### Draining

INFOID:000000000957281

1. Run the vehicle to warm up the transfer unit sufficiently.
2. Stop the engine, and remove the drain plug (1) to drain the transfer fluid.

**CAUTION:**

**When draining fluid, protect exhaust tube flange with cover.**

3. Apply sealant to drain plug. Install drain plug on transfer and tighten to the specified torque. Refer to [DLN-58, "Exploded View"](#).

- Use Genuine Silicone RTV or equivalent. Refer to [GI-15, "Recommended Chemical Products and Sealants"](#).

**CAUTION:**

**Remove old sealant adhering to mounting surfaces. Also remove any moisture, oil, or foreign material adhering to application and mounting surfaces.**

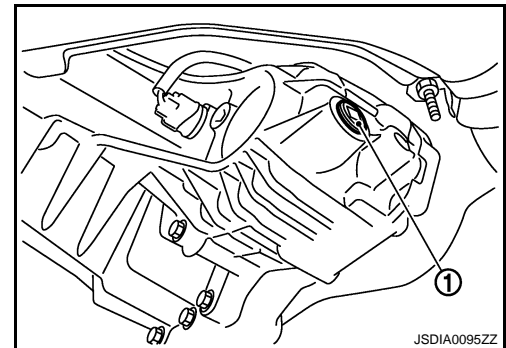

JSDIA0095ZZ

#### Refilling

INFOID:000000000957282

1. Remove filler plug (1) and add transfer fluid until fluid level reaches the specified limit near filler plug mounting hole.

**Fluid capacity**

**: Refer to [DLN-76, "General Specifications"](#).**

**CAUTION:**

**Carefully fill the fluid. (Fill up for approx. 3 minutes.)**

2. Leave the vehicle for 3 minutes, and check the fluid level again.
3. Set a new gasket onto filler plug and install it on transfer and tighten to the specified torque. Refer to [DLN-58, "Exploded View"](#).

**CAUTION:**

**Never reuse gasket.**

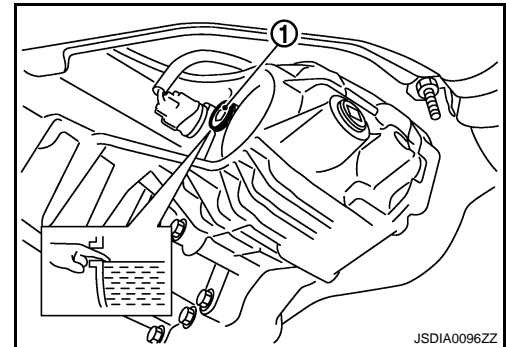

JSDIA0096ZZ



ON-VEHICLE REPAIR

AWD CONTROL UNIT

Exploded View

INFOID:000000000957283

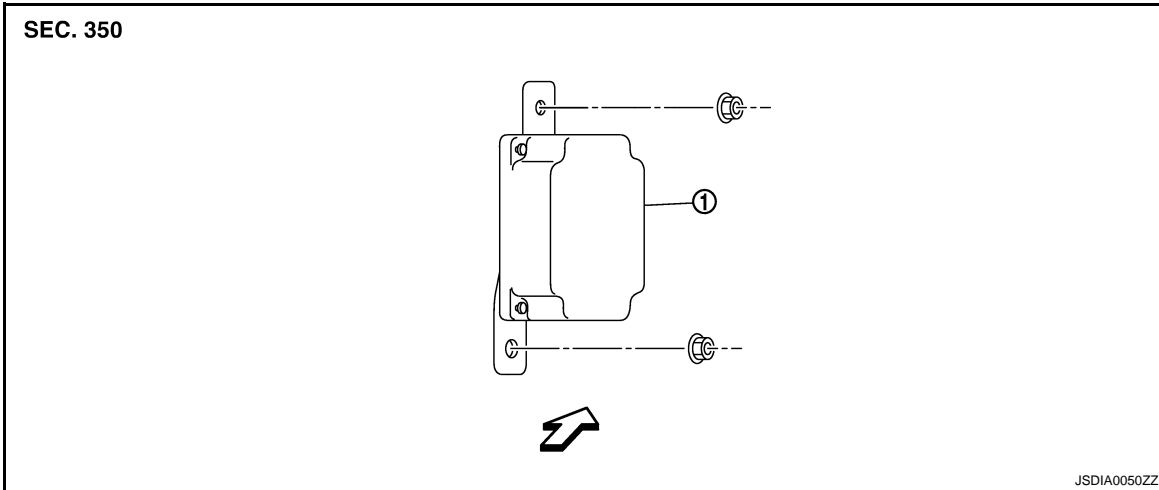

- 1. AWD control unit

←: Vehicle front

Removal and Installation

INFOID:000000000957284

REMOVAL

1. Remove the glove box assembly. Refer to [IP-11, "Exploded View"](#).
2. Disconnect AWD control unit harness connector.
3. Remove AWD control unit (1) mounting nuts.
4. Remove AWD control unit.

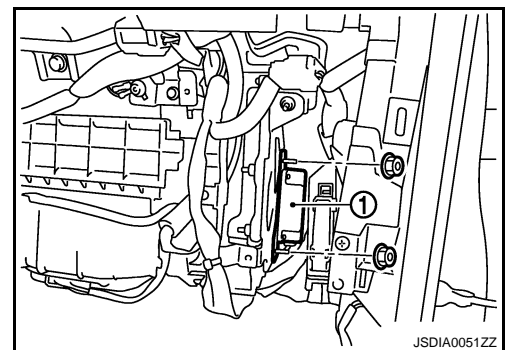

INSTALLATION

Install is the reverse order of removal.

A  
B  
C  
DLN  
E  
F  
G  
H  
I  
J  
K  
L  
M  
N  
O  
P

# FRONT OIL SEAL

< ON-VEHICLE REPAIR >

[TRANSFER: ETX13B]

## FRONT OIL SEAL

### Exploded View

INFOID:000000000957285

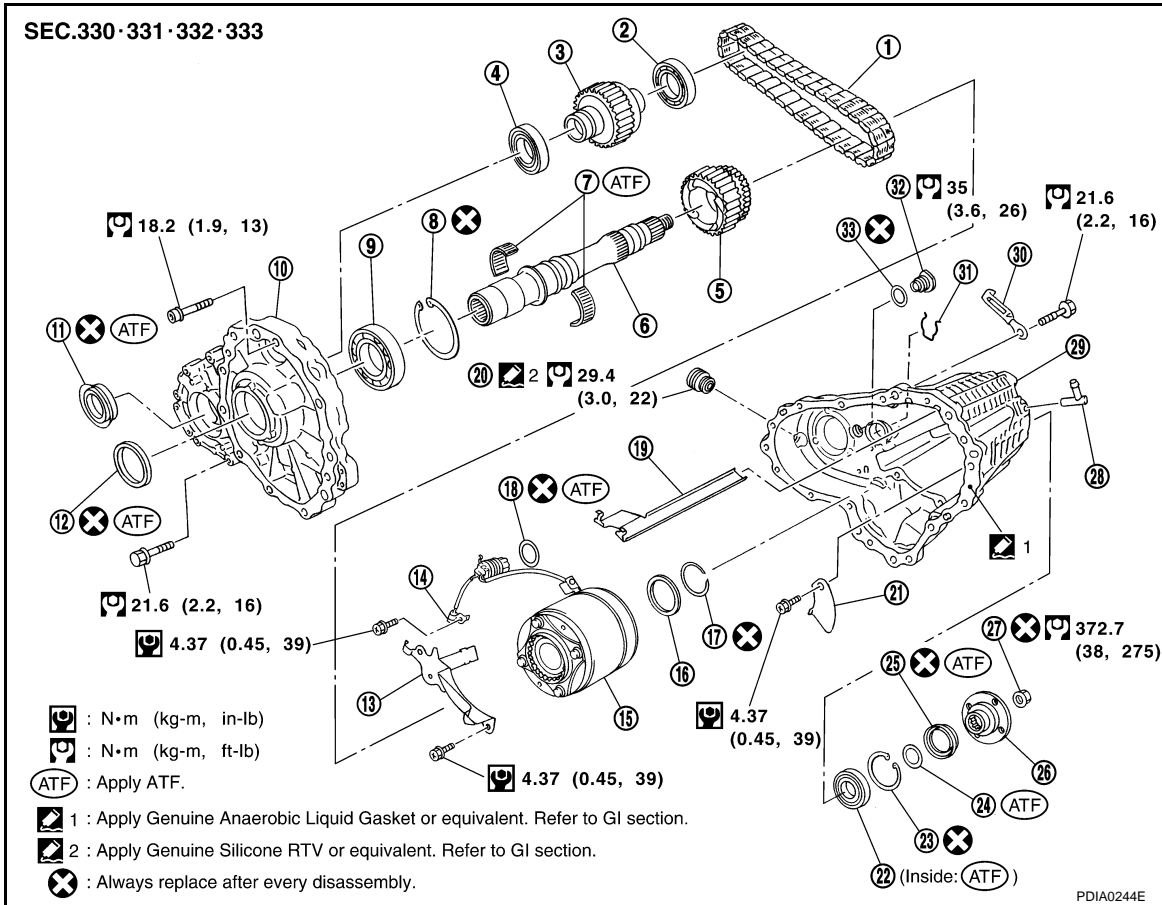

- |                                    |                                   |                                  |
|------------------------------------|-----------------------------------|----------------------------------|
| 1. Drive chain                     | 2. Front drive shaft rear bearing | 3. Front drive shaft             |
| 4. Front drive shaft front bearing | 5. Sprocket                       | 6. Mainshaft                     |
| 7. Needle bearing                  | 8. Snap ring                      | 9. Mainshaft bearing             |
| 10. Front case                     | 11. Front oil seal                | 12. Mainshaft oil seal           |
| 13. Oil cover                      | 14. Temperature sensor            | 15. Electric controlled coupling |
| 16. Spacer                         | 17. Snap ring                     | 18. O-ring                       |
| 19. Oil gutter                     | 20. Drain plug                    | 21. Baffle plate                 |
| 22. Rear bearing                   | 23. Snap ring                     | 24. Spacer                       |
| 25. Rear oil seal                  | 26. Companion flange              | 27. Self-lock nut                |
| 28. Breather tube                  | 29. Rear case                     | 30. Harness bracket              |
| 31. Retainer                       | 32. Filler plug                   | 33. Gasket                       |

## Removal and Installation

INFOID:000000000957286

### REMOVAL

1. Remove the drain plug to drain the transfer fluid. Refer to [DLN-48, "Draining"](#).
2. Remove the front propeller shaft. Refer to [DLN-80, "Exploded View"](#).

# FRONT OIL SEAL

< ON-VEHICLE REPAIR >

[TRANSFER: ETX13B]

3. Remove front oil seal using a flat-bladed screwdriver.  
**CAUTION:**  
Never damage the front case and front drive shaft.

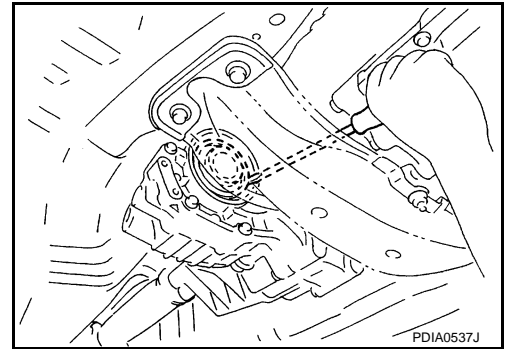

## INSTALLATION

1. Apply ATF to front oil seal, install it with a drift [SST: ST27862000 ( — )] until the end face of front case.  
**CAUTION:**
  - Never reuse front oil seal.
  - When installing, never incline front oil seal.
2. Install front propeller shaft. Refer to [DLN-80, "Exploded View"](#).
3. Install transfer fluid, check fluid level and for fluid leakage. Refer to [DLN-48, "Inspection"](#).

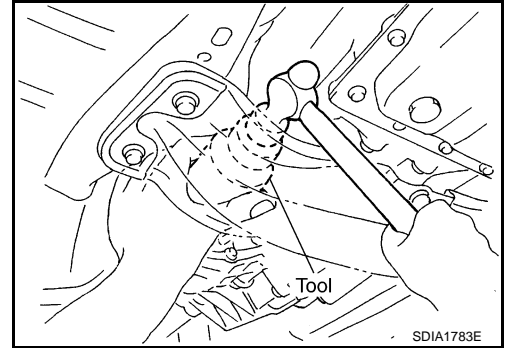

A  
B  
C  
DLN  
E  
F  
G  
H  
I  
J  
K  
L  
M  
N  
O  
P

# REAR OIL SEAL

< ON-VEHICLE REPAIR >

[TRANSFER: ETX13B]

## REAR OIL SEAL

### Exploded View

INFOID:000000000957287

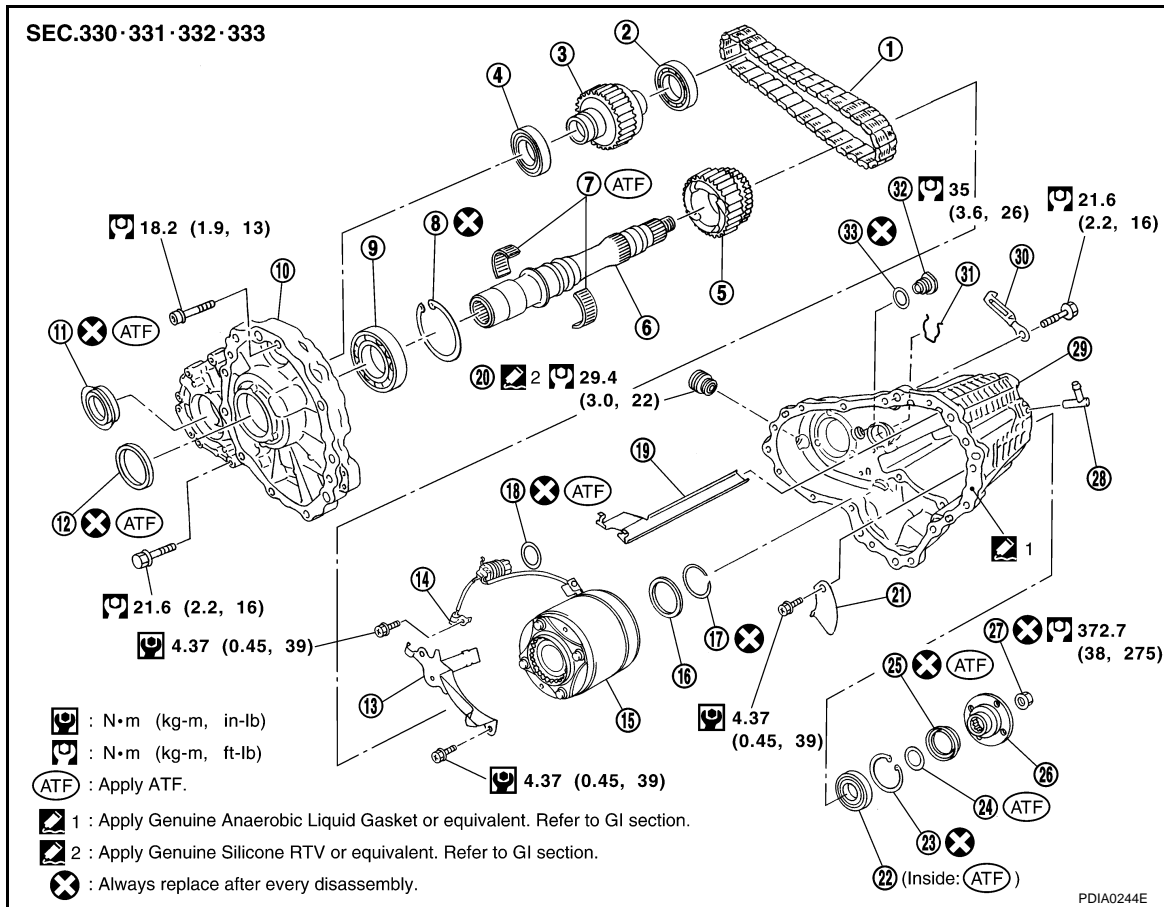

- |                                    |                                   |                                  |
|------------------------------------|-----------------------------------|----------------------------------|
| 1. Drive chain                     | 2. Front drive shaft rear bearing | 3. Front drive shaft             |
| 4. Front drive shaft front bearing | 5. Sprocket                       | 6. Mainshaft                     |
| 7. Needle bearing                  | 8. Snap ring                      | 9. Mainshaft bearing             |
| 10. Front case                     | 11. Front oil seal                | 12. Mainshaft oil seal           |
| 13. Oil cover                      | 14. Temperature sensor            | 15. Electric controlled coupling |
| 16. Spacer                         | 17. Snap ring                     | 18. O-ring                       |
| 19. Oil gutter                     | 20. Drain plug                    | 21. Baffle plate                 |
| 22. Rear bearing                   | 23. Snap ring                     | 24. Spacer                       |
| 25. Rear oil seal                  | 26. Companion flange              | 27. Self-lock nut                |
| 28. Breather tube                  | 29. Rear case                     | 30. Harness bracket              |
| 31. Retainer                       | 32. Filler plug                   | 33. Gasket                       |

## Removal and Installation

INFOID:000000000957288

### REMOVAL

1. Remove the rear propeller shaft. Refer to [DLN-101, "Exploded View"](#).

# REAR OIL SEAL

< ON-VEHICLE REPAIR >

[TRANSFER: ETX13B]

2. Remove self-lock nut of companion flange using flange wrench.

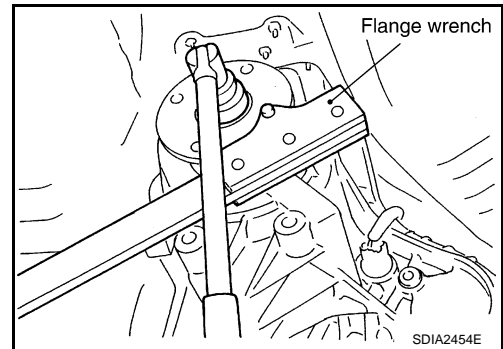

3. Put matching mark on the end of the mainshaft. The mark should be in line with the mark on the companion flange.

**CAUTION:**

**For matching mark, use paint. Never damage mainshaft.**

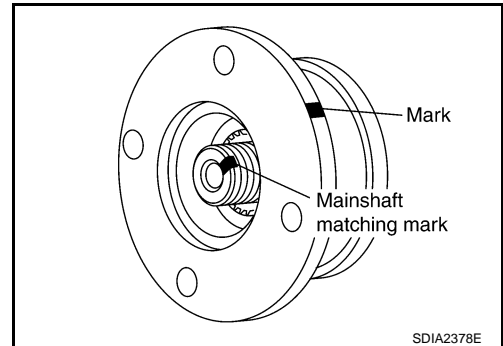

4. Remove the companion flange using a puller.

**CAUTION:**

**Never damage the companion flange.**

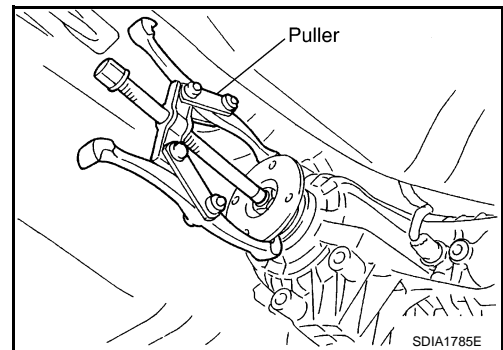

5. Remove the rear oil seal using the puller [SST: KV381054S0 (J-34286)].

**CAUTION:**

**Never damage the rear case.**

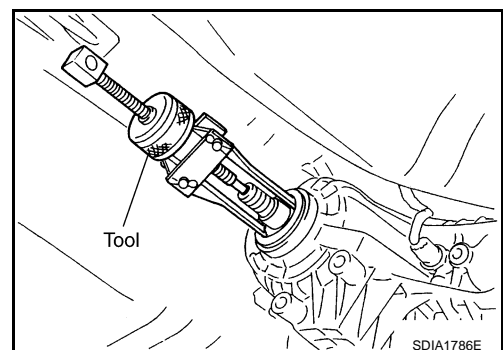

INSTALLATION

A  
B  
C  
DLN  
E  
F  
G  
H  
I  
J  
K  
L  
M  
N  
O  
P

# REAR OIL SEAL

< ON-VEHICLE REPAIR >

[TRANSFER: ETX13B]

1. Apply ATF to rear oil seal, install it with drifts.

A: Drift [ST30720000 (J-25405)]

B: Drift [KV40104830 ( — )]

**Dimension "L" : 6.7 – 7.3 mm (0.264 – 0.287 in)**

**CAUTION:**

- Never reuse rear oil seal.
- When installing, never incline rear oil seal.

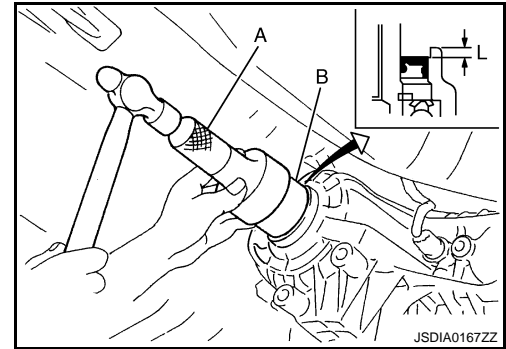

2. Align the matching mark of mainshaft with the mark of companion flange, then install the companion flange.

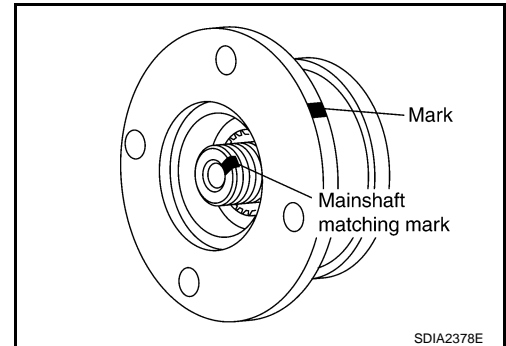

3. Using a flange wrench, install the self-lock nut of companion flange and tighten to the specified torque.

**CAUTION:**

**Never reuse self-lock nut.**

4. Install the rear propeller shaft. Refer to [DLN-101, "Exploded View"](#).
5. Check fluid level. Refer to [DLN-48, "Inspection"](#).

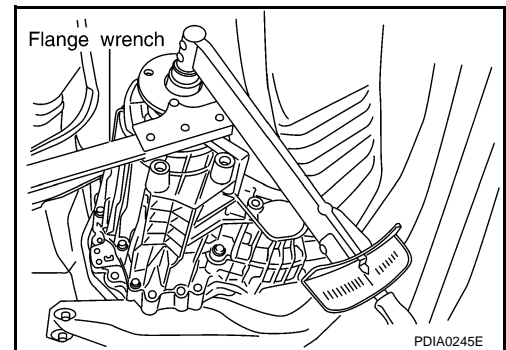

# TRANSFER ASSEMBLY

< REMOVAL AND INSTALLATION >

[TRANSFER: ETX13B]

## REMOVAL AND INSTALLATION

### TRANSFER ASSEMBLY

#### Exploded View

INFOID:000000000957289

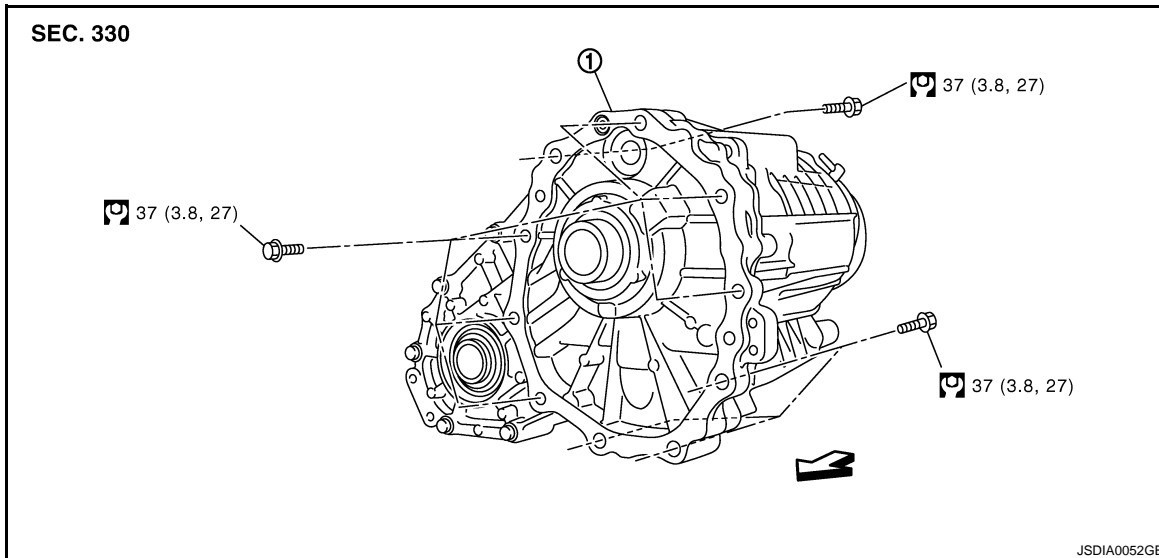

1. Transfer assembly

↔: Vehicle front

Refer to [GI-4, "Components"](#) for symbols in the figure.

### Removal and Installation

INFOID:000000000957290

#### REMOVAL

1. Remove exhaust front tube with power tool. Refer to [EX-5, "Exploded View"](#).
2. Remove front propeller shaft. Refer to [DLN-80, "Exploded View"](#).
3. Remove rear propeller shaft. Refer to [DLN-101, "Exploded View"](#).
4. Disconnect AWD solenoid harness connector and separate harness from transfer assembly.
5. Remove transfer air breather hose.
6. Remove control rod. Refer to [TM-236, "AWD : Exploded View"](#).
7. Support transfer assembly and transmission assembly with a jack.
8. Remove rear engine mounting member and engine mounting insulator with power tool. Refer to [EM-81, "AWD : Exploded View"](#).
9. Lower jack to the position where the top transfer mounting bolts can be removed.
10. Remove transfer mounting bolts with power tool and separate transfer from transmission.

#### CAUTION:

**Secure transfer assembly and transmission assembly to a jack.**

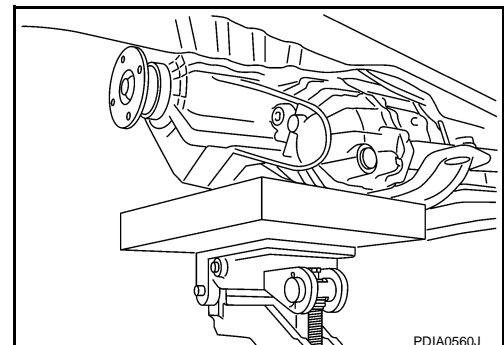

#### INSTALLATION

Note the following, and install in the reverse order of removal.

# TRANSFER ASSEMBLY

## < REMOVAL AND INSTALLATION >

[TRANSFER: ETX13B]

- When installing the transfer to the transmission, install the mounting bolts following the standard below, tighten bolts to the specified torque.

Bolt No.	1	2	3	4
Quantity	4	3	2	1
Bolt length "ℓ" mm (in)	75 (2.95)	45 (1.77)	40 (1.57)	30 (1.18)

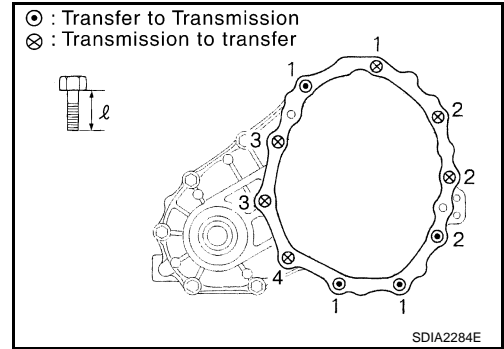

- When installing transfer air breather hose, make sure there are no pinched or restricted areas on the transfer air breather hose caused by bending or winding.
  - Set transfer air breather hose with paint mark facing upward.
  - Be sure to insert transfer air breather hose (1) into breather tube (2) until hose end reaches the tube's base.

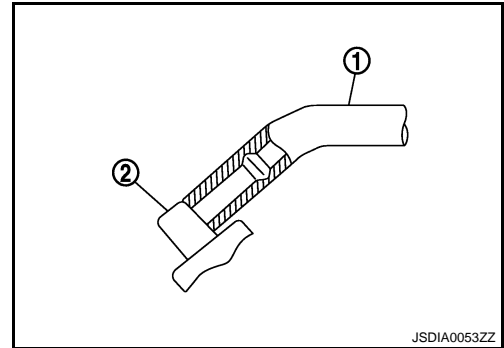

- Do not deviate from the range (L) of the transfer air breather when installing the transfer air breather hose (1) to the harness bracket (2) of the transfer.

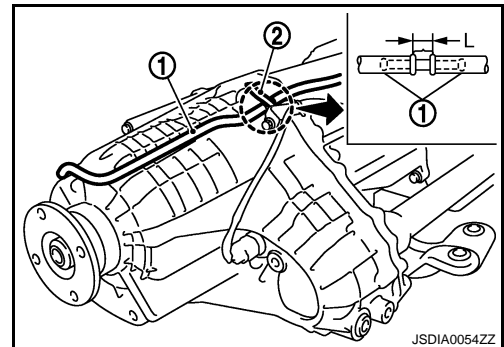

- Install transfer air breather hose (1) with bracket between the adapter case (2) and the transmission case (3).

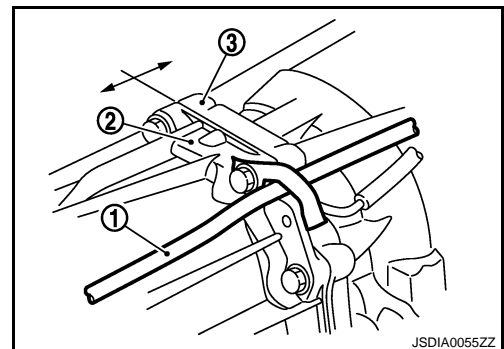



## TRANSFER ASSEMBLY

### < REMOVAL AND INSTALLATION >

[TRANSFER: ETX13B]

- Check that transfer breather hose is on the (←) side when installing the transfer air breather hose (1) to A/T fluid charging pipe (2).
- Be sure to insert air breather hose to transfer tube until hose end reaches the tube's base and another hose end reaches the tube bend R portion of A/T fluid charging pipe.
- After the installation, check the fluid level, fluid leakage and the A/T positions. Refer to [DLN-48, "Inspection"](#).

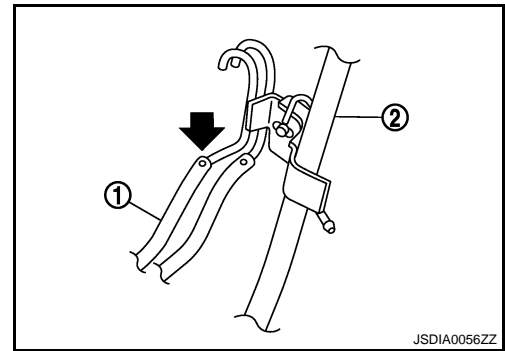

A

B

C

DLN

E

F

G

H

I

J

K

L

M

N

O

P

# FRONT CASE AND REAR CASE

< DISASSEMBLY AND ASSEMBLY >

[TRANSFER: ETX13B]

## DISASSEMBLY AND ASSEMBLY

### FRONT CASE AND REAR CASE

Exploded View

INFOID:000000000957291

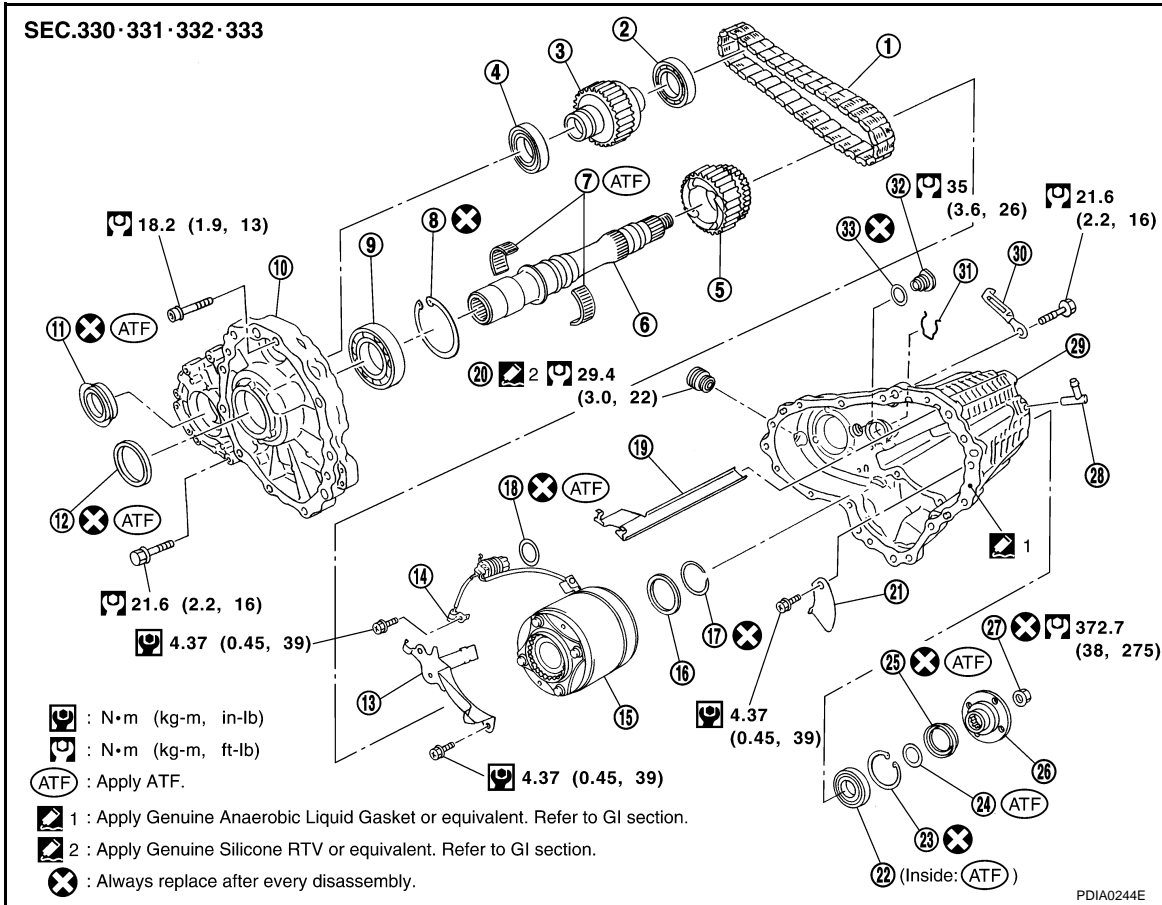

- |                                    |                                   |                                  |
|------------------------------------|-----------------------------------|----------------------------------|
| 1. Drive chain                     | 2. Front drive shaft rear bearing | 3. Front drive shaft             |
| 4. Front drive shaft front bearing | 5. Sprocket                       | 6. Mainshaft                     |
| 7. Needle bearing                  | 8. Snap ring                      | 9. Mainshaft bearing             |
| 10. Front case                     | 11. Front oil seal                | 12. Mainshaft oil seal           |
| 13. Oil cover                      | 14. Temperature sensor            | 15. Electric controlled coupling |
| 16. Spacer                         | 17. Snap ring                     | 18. O-ring                       |
| 19. Oil gutter                     | 20. Drain plug                    | 21. Baffle plate                 |
| 22. Rear bearing                   | 23. Snap ring                     | 24. Spacer                       |
| 25. Rear oil seal                  | 26. Companion flange              | 27. Self-lock nut                |
| 28. Breather tube                  | 29. Rear case                     | 30. Harness bracket              |
| 31. Retainer                       | 32. Filler plug                   | 33. Gasket                       |

### Disassembly

1. Remove drain plug and filler plug.

INFOID:000000000957292

## FRONT CASE AND REAR CASE

< DISASSEMBLY AND ASSEMBLY >

[TRANSFER: ETX13B]

2. Remove mainshaft oil seal from front case, using a flat-bladed screwdriver.

**CAUTION:**

**Never damage the front case and mainshaft.**

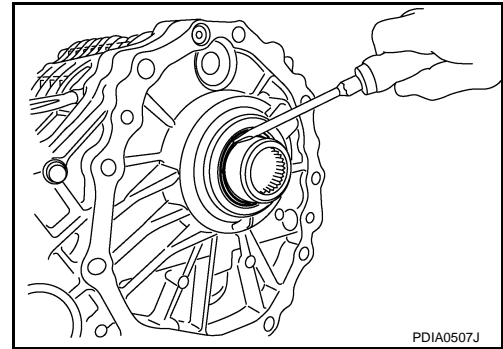

3. Remove front oil seal from front case, using a flat-bladed screwdriver.

**CAUTION:**

**Never damage the front case and front drive shaft.**

4. Remove self-lock nut.

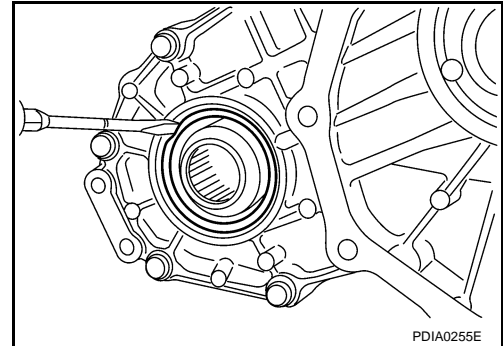

5. Put a matching mark on the end of mainshaft. The mark should be in line with the mark on the companion flange.

**CAUTION:**

**For matching mark, use paint. Never damage mainshaft.**

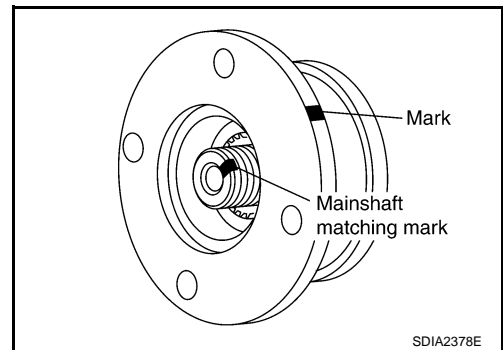

6. Remove companion flange, using a puller.

**CAUTION:**

**Never damage the companion flange.**

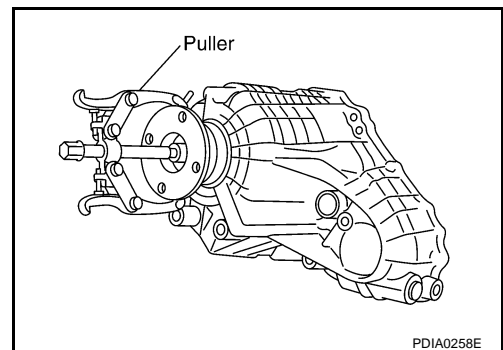

7. Remove rear oil seal from rear case, using the puller [SST: KV381054S0 (J-34286)].

**CAUTION:**

**Never damage the rear case.**

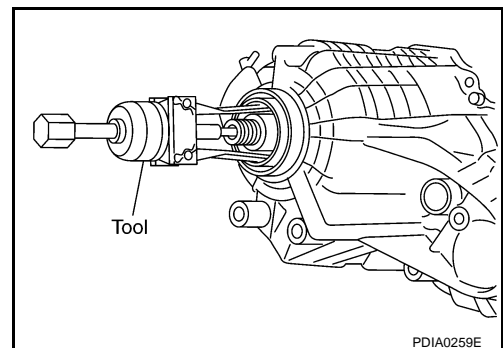

A

B

C

DLN

E

F

G

H

I

J

K

L

M

N

O

P

# FRONT CASE AND REAR CASE

< DISASSEMBLY AND ASSEMBLY >

[TRANSFER: ETX13B]

8. Remove spacer (1) from mainshaft.

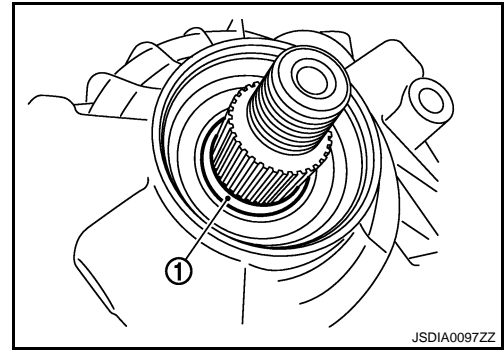

9. Remove front case and rear case fixing bolts, then remove harness bracket.

Bolts symbol	Quantity	Bolt length "ℓ" mm (in)
A	11	42 (1.65)
B	1	162 (6.38)
C	1	97 (3.82)
TORX bolts	1	40 (1.57)

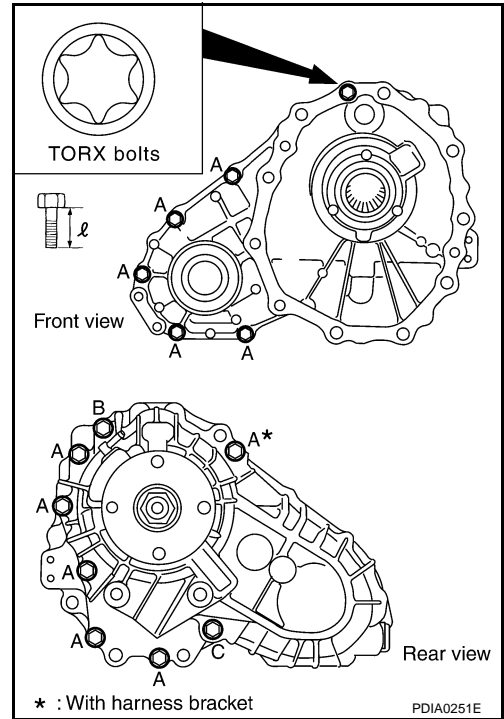

10. Separate front case and rear case. Then, remove front case by levering it up with a tire lever or the like.

**CAUTION:**  
Never damage the mating surface.

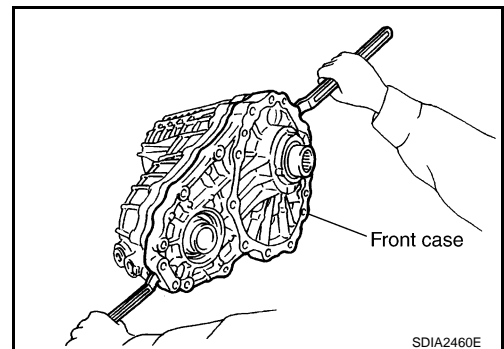

11. Remove snap ring from front case.

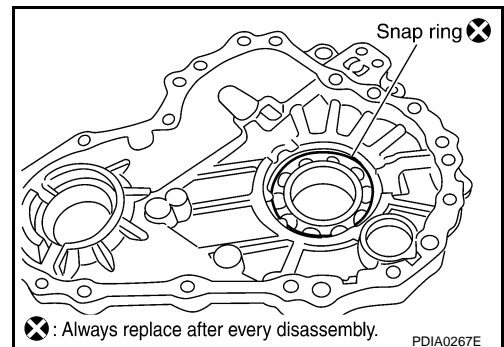

# FRONT CASE AND REAR CASE

< DISASSEMBLY AND ASSEMBLY >

[TRANSFER: ETX13B]

12. Remove mainshaft bearing from front case, using the drift [SST: KV38100300 (J-25523)].

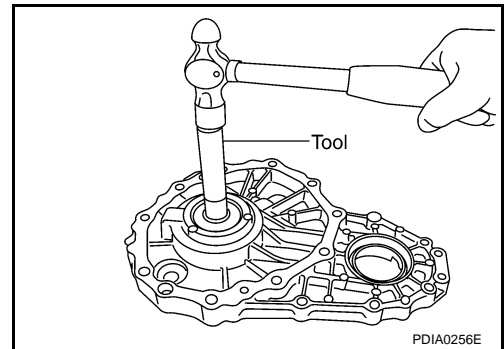

13. Remove drive chain and front drive shaft while tapping front drive shaft with plastic hammer.

**CAUTION:**

**Never tap drive chain.**

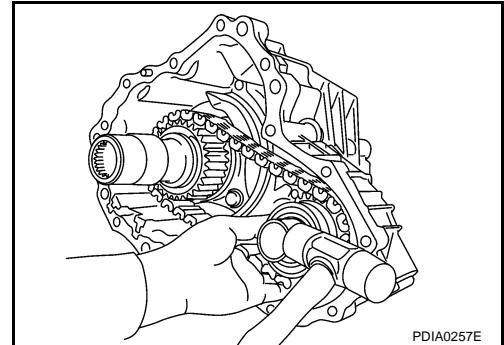

14. Remove oil gutter (1) from rear case.

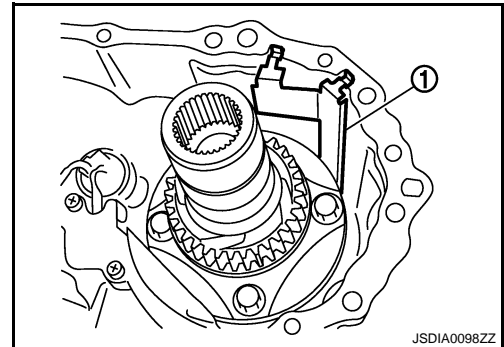

15. Remove oil cover bolt and sensor fixing bolt from rear case. And then, remove oil cover.

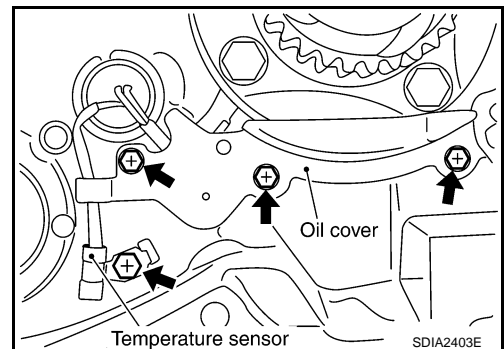

16. Remove retainer (1) from AWD solenoid harness connector.

17. Remove AWD solenoid harness connector from rear case.

18. Remove O-ring from AWD solenoid harness connector.

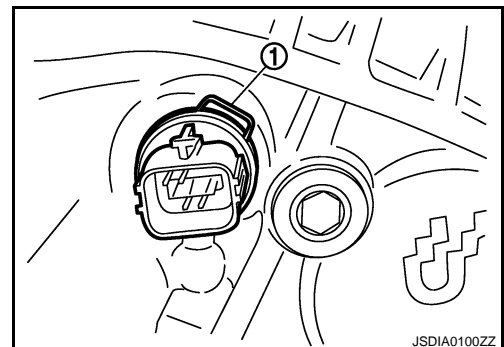

A  
B  
C  
DLN

E  
F  
G  
H  
I  
J  
K  
L  
M  
N  
O  
P

# FRONT CASE AND REAR CASE

< DISASSEMBLY AND ASSEMBLY >

[TRANSFER: ETX13B]

19. Remove mainshaft assembly from rear case, using the drift [SST: ST33052000 ( — )].

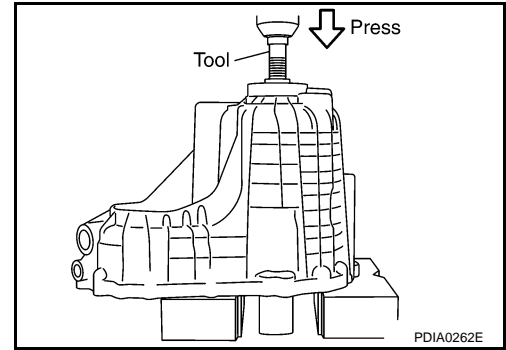

20. Remove snap ring from rear case.

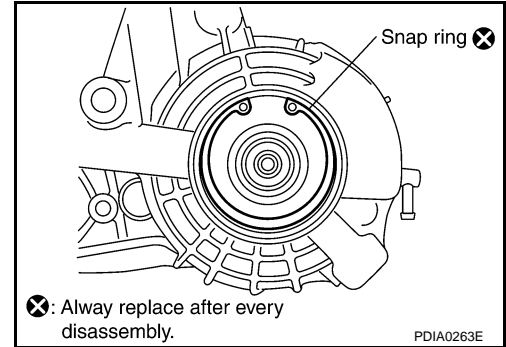

21. Remove rear bearing from rear case, using the drifts.

A: Drift bar [ST30611000 (J-25742-1)]

B: Drift [ST35321000 ( — )]

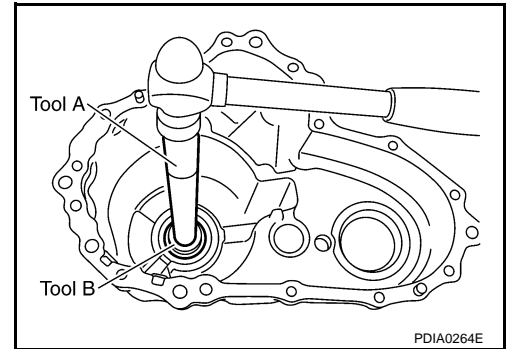

22. Remove baffle plate from rear case.

23. Remove breather tube from rear case.

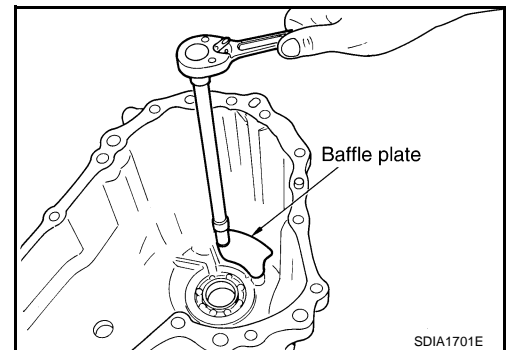

Assembly

INFOID:000000000957293

# FRONT CASE AND REAR CASE

< DISASSEMBLY AND ASSEMBLY >

[TRANSFER: ETX13B]

1. Install breather tube, with plastic hammer.  
**CAUTION:**  
**Pay attention to the direction of breather tube.**
2. Install baffle plate to rear case.

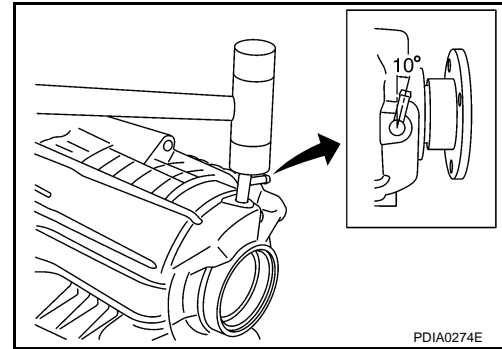

3. Install rear bearing to rear case, using the drift [SST: KV38104010 ( — )].  
**CAUTION:**  
**Apply ATF to inside of rear bearing.**

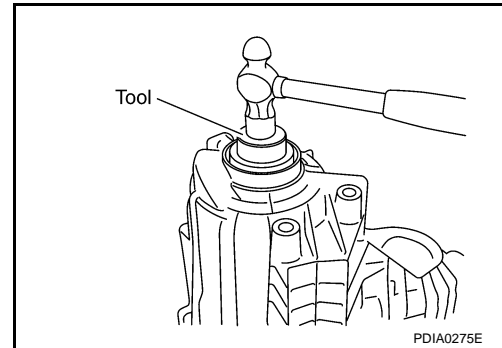

4. Install snap ring to rear case.  
**CAUTION:**  
**Never reuse snap ring.**

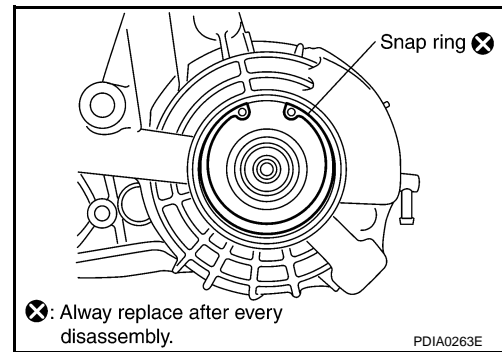

5. Install mainshaft assembly to rear case, using the drift [SST: ST35321000 ( — )].  
**CAUTION:**  
**ATF should be applied to contact surface of mainshaft and rear bearing.**
6. Install O-ring to AWD solenoid harness connector.  
**CAUTION:**
  - Never reuse O-ring.
  - Apply ATF to O-ring.

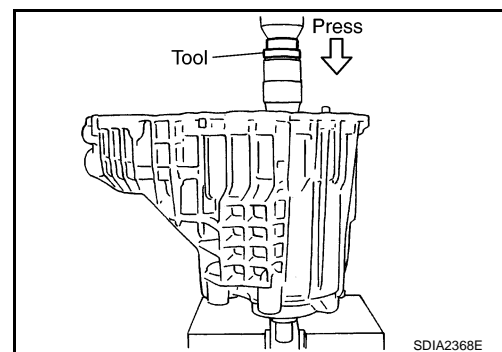

7. Install AWD solenoid harness connector into rear case.
8. Install retainer (1) to AWD solenoid harness connector.

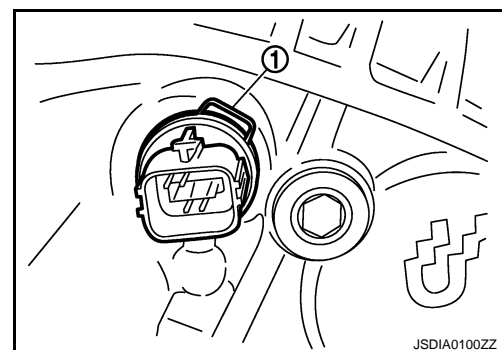

A  
B  
C  
DLN  
E  
F  
G  
H  
I  
J  
K  
L  
M  
N  
O  
P

## FRONT CASE AND REAR CASE

< DISASSEMBLY AND ASSEMBLY >

[TRANSFER: ETX13B]

9. Set temperature sensor and tighten bolt.
10. Hold electric controlled coupling harness with oil cover hold plate, install oil cover to rear case.

**CAUTION:**

The harness should be guided by a cut portion.

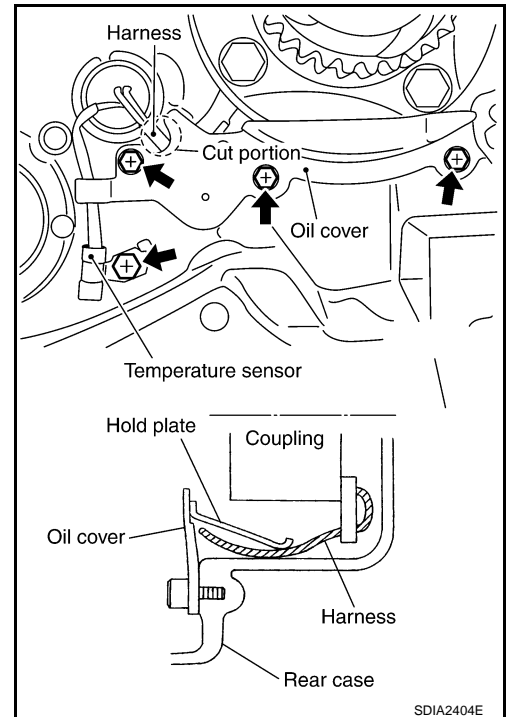

11. Install oil gutter (1) to rear case.

**CAUTION:**

The tip of oil gutter should be put into rear case groove.

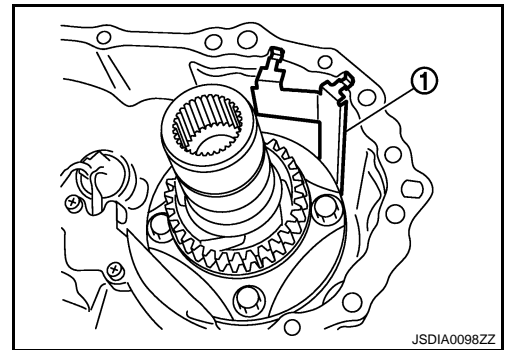

12. Install drive chain to front drive shaft.

**CAUTION:**

Identification mark of drive chain should be in the side of front bearing of front drive shaft.

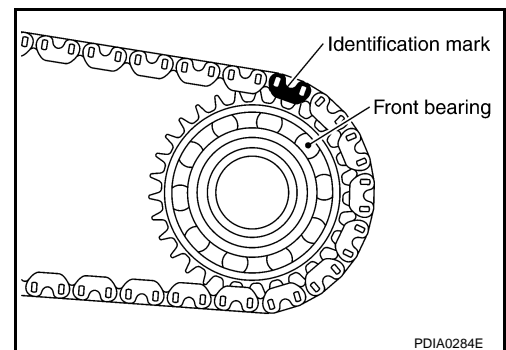

13. Install drive chain to mainshaft, and then install tap front drive shaft with plastic hammer. Press-fit rear bearing of front drive shaft to rear case.

**CAUTION:**

Never tap drive chain.

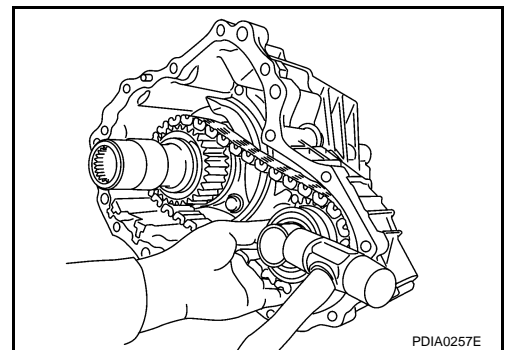



# FRONT CASE AND REAR CASE

< DISASSEMBLY AND ASSEMBLY >

[TRANSFER: ETX13B]

14. Install mainshaft bearing to front case, using the drift [SST: ST30621000 (J-25742-5)].

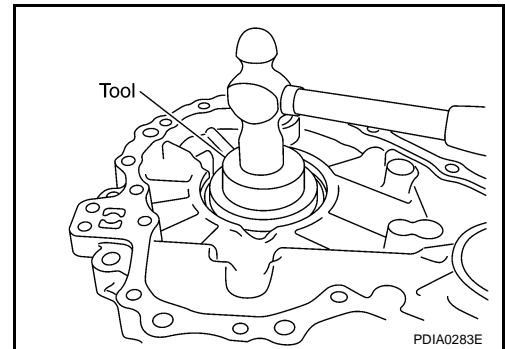

15. Install snap ring to front case.

**CAUTION:**

**Never reuse snap ring.**

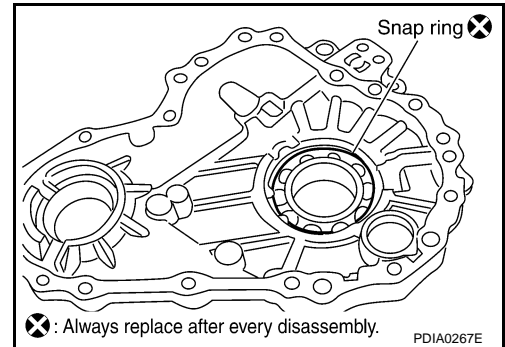

16. Apply liquid gasket to mating surface of rear case.

• Use **Genuine Anaerobic Liquid Gasket or equivalent.**

Refer to [GI-15, "Recommended Chemical Products and Sealants"](#).

**CAUTION:**

**Remove old sealant adhering to mounting surfaces. Also remove any moisture, oil, or foreign material adhering to application and mounting surfaces.**

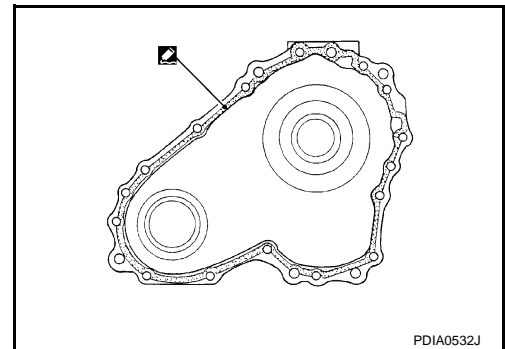

17. Set front case to rear case.

**CAUTION:**

**Never damage the mating surface transmission side.**

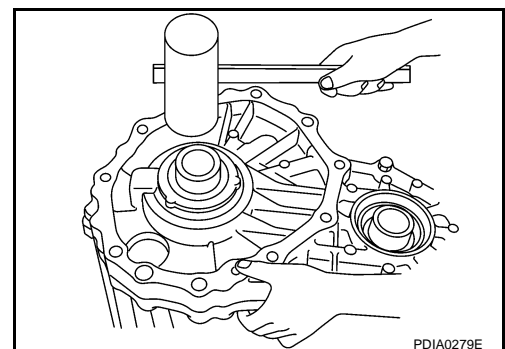

A  
B  
C  
DLN  
E  
F  
G  
H  
I  
J  
K  
L  
M  
N  
O  
P

# FRONT CASE AND REAR CASE

< DISASSEMBLY AND ASSEMBLY >

[TRANSFER: ETX13B]

18. Tighten front case and rear case fixing bolts.

Bolts symbol	Quantity	Bolt length "ℓ" mm (in)
A	11	42 (1.65)
B	1	162 (6.38)
C	1	97 (3.82)
TORX bolts	1	40 (1.57)

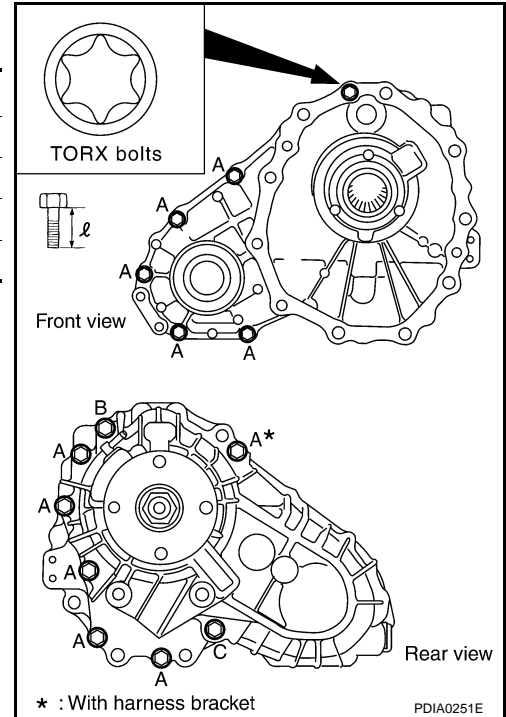

19. Install spacer (1) to mainshaft.

**CAUTION:**  
Apply ATF to spacer.

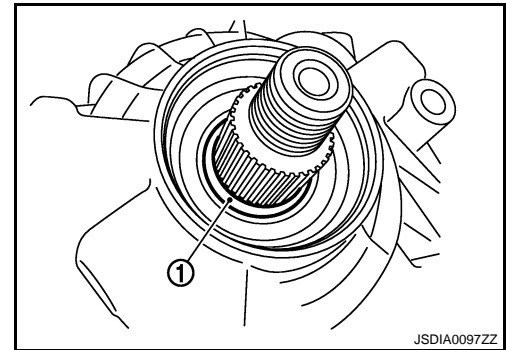

20. Install rear oil seal to rear case, using the drifts.

A: Drift [ST30720000 (J-25405)]

B: Drift [KV40104830 ( — )]

**Dimension "L" : 6.7 – 7.3 mm (0.264 – 0.287 in)**

**CAUTION:**

- Never reuse rear oil seal.
- Apply ATF to rear oil seal.
- When installing, never incline rear oil seal.

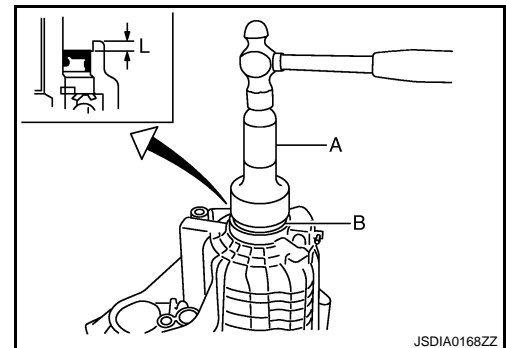

21. Install companion flange while align the matching mark of mainshaft with the mark of companion flange.

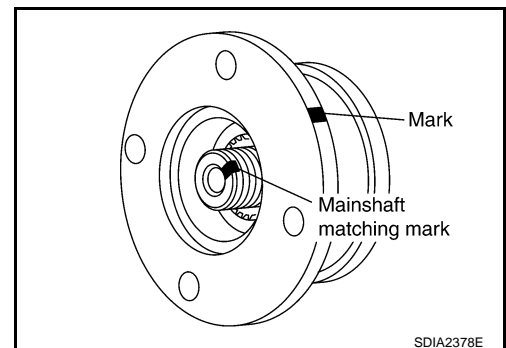

# FRONT CASE AND REAR CASE

< DISASSEMBLY AND ASSEMBLY >

[TRANSFER: ETX13B]

22. Tighten self-lock nut to the specified torque, with flange wrench.

**CAUTION:**

**Never reuse self-lock nut.**

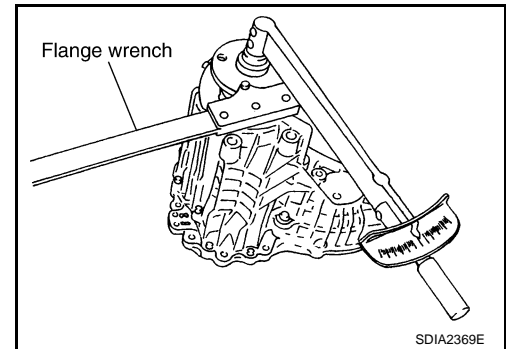

23. Install mainshaft oil seal until it is flush with end face of front case, using the drift [SST: ST30720000 (J-25405)].

**CAUTION:**

- **Never reuse mainshaft oil seal.**
- **Apply ATF to mainshaft oil seal.**
- **When installing, never incline mainshaft oil seal.**

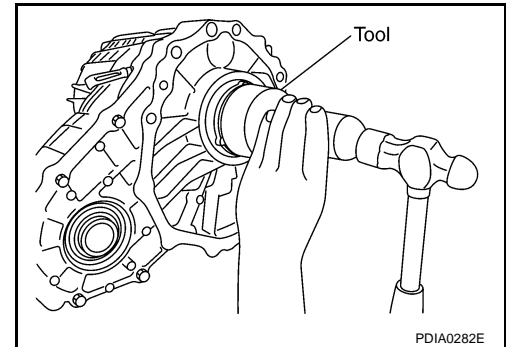

24. Install front oil seal until it is flush with end face of front case, using the drift [SST: ST27862000 ( — )].

**CAUTION:**

- **Never reuse front oil seal.**
- **Apply ATF to front oil seal.**
- **When installing, never incline front oil seal.**

25. Apply sealant to threads of drain plug. Then install it to rear case.

- **Use Genuine Silicone RTV or equivalent. Refer to [GI-15, "Recommended Chemical Products and Sealants"](#).**

**CAUTION:**

**Remove old sealant and oil adhering to threads.**

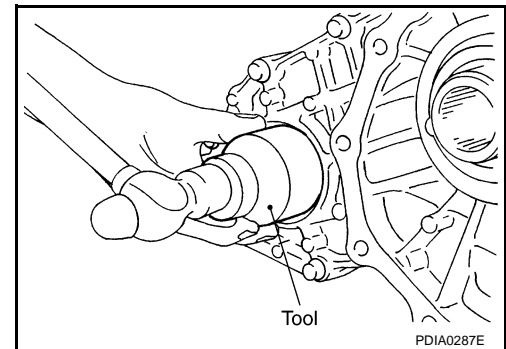

26. Set gasket to filler plug. Install it to rear case.

**CAUTION:**

- **Never reuse gasket.**
- **After oil is filled, tighten filler plug to specified torque.**

## Inspection

INFOID:000000000957294

Check items below. If necessary, replace them with new ones.

### CASES

- Contact surfaces of bearing for wear, damage, etc.
- Damage and cracks of case.

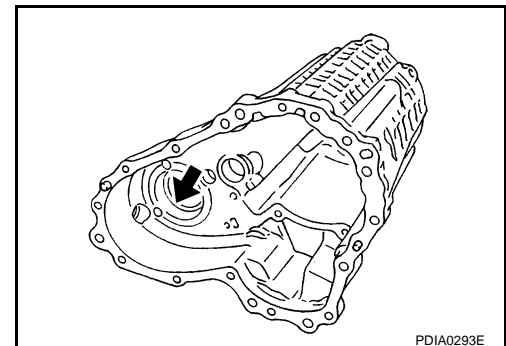

### BEARING

A  
B  
C  
DLN  
E  
F  
G  
H  
I  
J  
K  
L  
M  
N  
O  
P

## FRONT CASE AND REAR CASE

< DISASSEMBLY AND ASSEMBLY >

[TRANSFER: ETX13B]

- Damage and rough rotation of bearing.

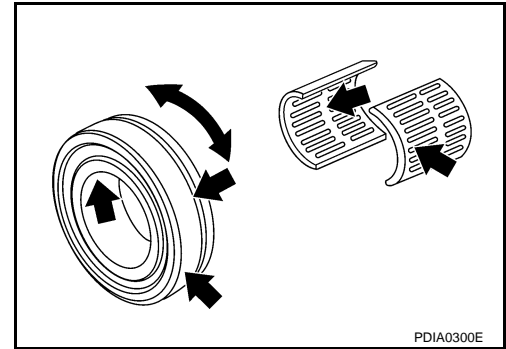

### SHAFT

- Damage, peeling, dent, uneven wear, bending, etc. of shaft.

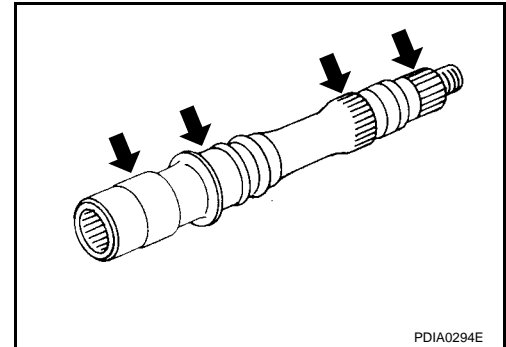

### GEARS AND CHAIN

- Excessive wear, damage, peeling, etc. of gear and chain.

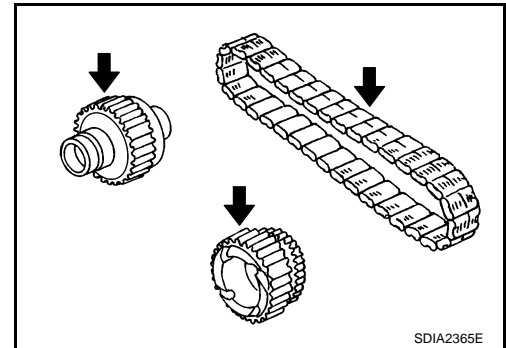



# MAINSHAFT

[TRANSFER: ETX13B]

## < DISASSEMBLY AND ASSEMBLY >

2. Remove snap ring from mainshaft.
3. Remove spacer from mainshaft.
4. Remove electric controlled coupling and sprocket from mainshaft.
5. Remove needle bearing from mainshaft.

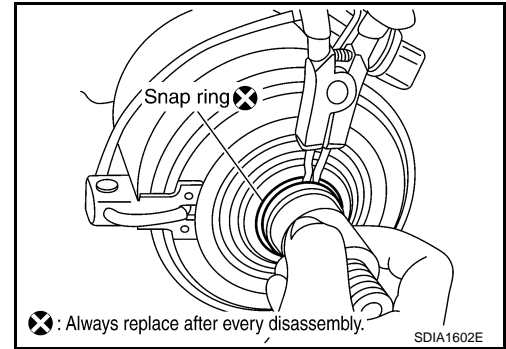

## Assembly

1. Install needle bearing to mainshaft.  
**CAUTION:**  
**Apply ATF to periphery of needle bearing.**
2. Install sprocket and electric controlled coupling to mainshaft.
3. Install spacer to main shaft.

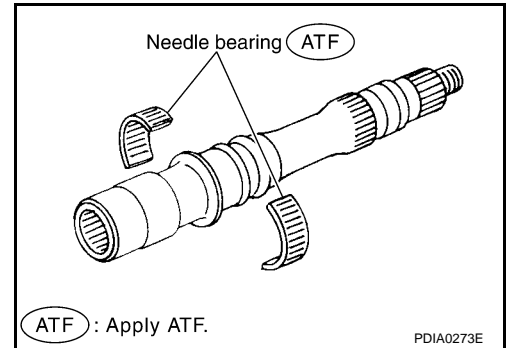

4. Install snap ring to mainshaft.  
**CAUTION:**  
**Never reuse snap ring.**
5. Install mainshaft assembly to rear case, then install front case and rear case. Refer to [DLN-62, "Assembly"](#).

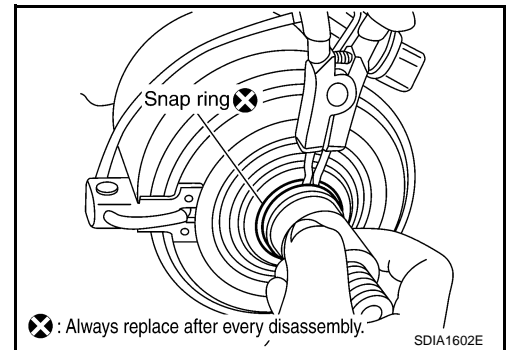

## Inspection

Check items below. If necessary, replace them with new ones.

### CASES

- Contact surfaces of bearing for wear, damage, etc.
- Damage and cracks of case.

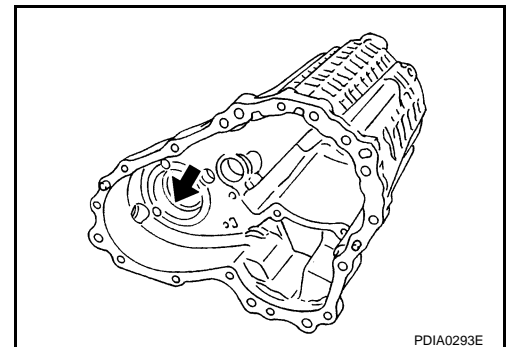

## BEARING

# MAINSHAFT

< DISASSEMBLY AND ASSEMBLY >

[TRANSFER: ETX13B]

- Damage and rough rotation of bearing.

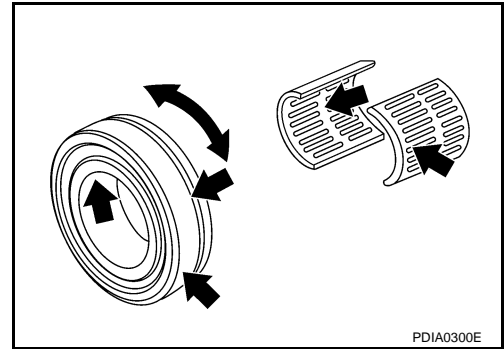

A  
B  
C

DLN

## SHAFT

- Damage, peeling, dent, uneven wear, bending, etc. of shaft.

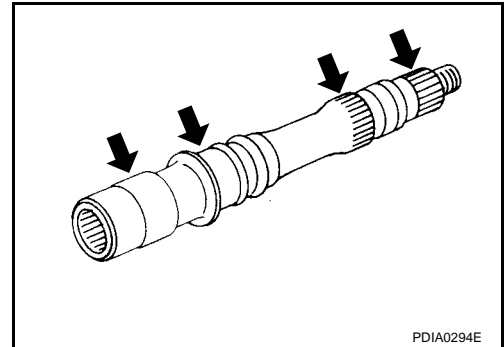

E  
F  
G  
H

## GEARS AND CHAIN

- Excessive wear, damage, peeling, etc. of gear and chain.

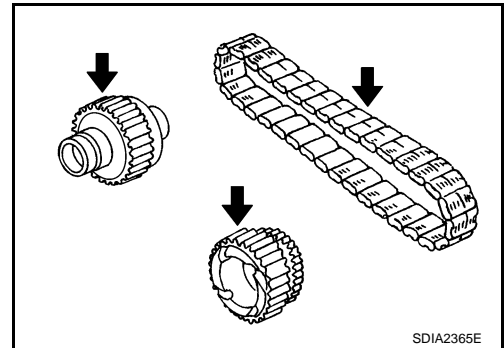

I  
J  
K  
L

M  
N  
O  
P

# FRONT DRIVE SHAFT AND DRIVE CHAIN

< DISASSEMBLY AND ASSEMBLY >

[TRANSFER: ETX13B]

## FRONT DRIVE SHAFT AND DRIVE CHAIN

Exploded View

INFOID:000000000957299

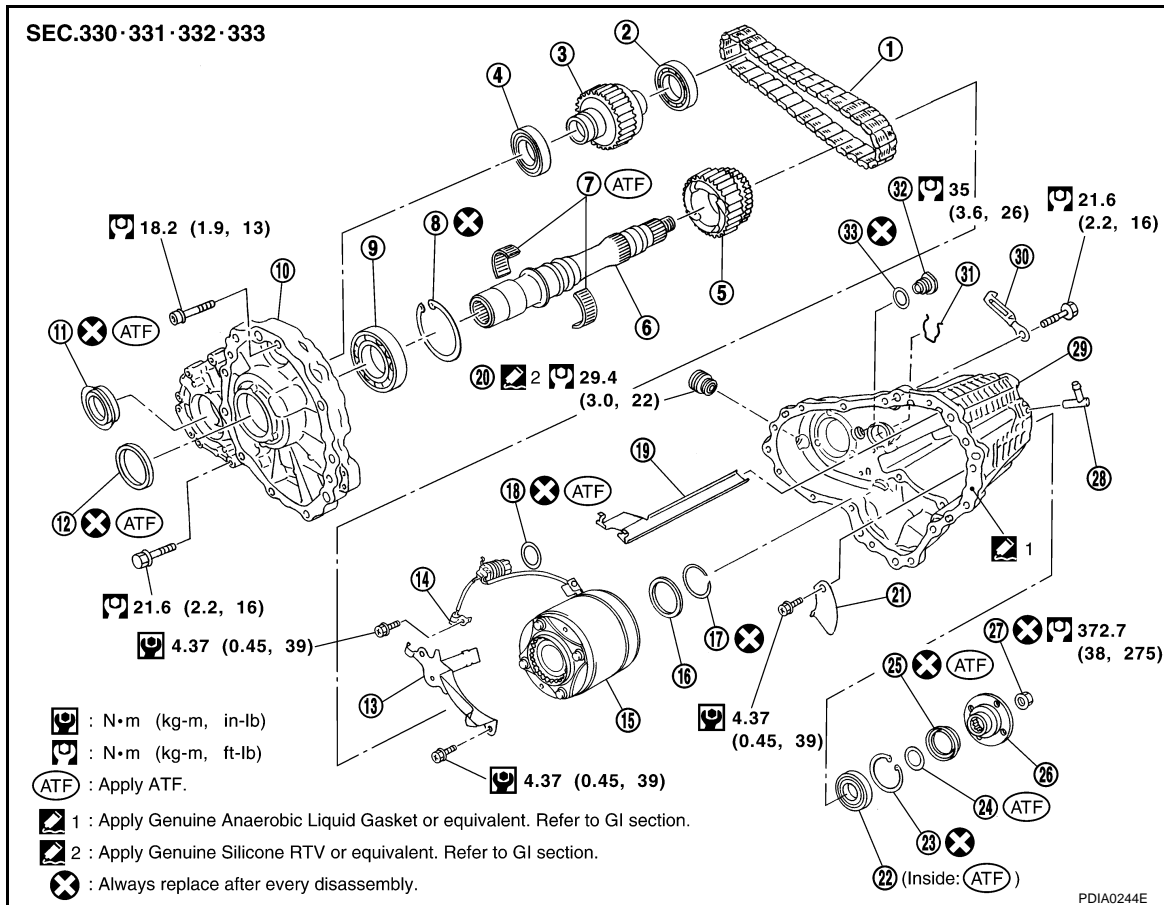

- |                                    |                                   |                                  |
|------------------------------------|-----------------------------------|----------------------------------|
| 1. Drive chain                     | 2. Front drive shaft rear bearing | 3. Front drive shaft             |
| 4. Front drive shaft front bearing | 5. Sprocket                       | 6. Mainshaft                     |
| 7. Needle bearing                  | 8. Snap ring                      | 9. Mainshaft bearing             |
| 10. Front case                     | 11. Front oil seal                | 12. Mainshaft oil seal           |
| 13. Oil cover                      | 14. Temperature sensor            | 15. Electric controlled coupling |
| 16. Spacer                         | 17. Snap ring                     | 18. O-ring                       |
| 19. Oil gutter                     | 20. Drain plug                    | 21. Baffle plate                 |
| 22. Rear bearing                   | 23. Snap ring                     | 24. Spacer                       |
| 25. Rear oil seal                  | 26. Companion flange              | 27. Self-lock nut                |
| 28. Breather tube                  | 29. Rear case                     | 30. Harness bracket              |
| 31. Retainer                       | 32. Filler plug                   | 33. Gasket                       |

### Disassembly

INFOID:000000000957300

1. Separate front case and rear case. Refer to [DLN-58, "Disassembly"](#).



# FRONT DRIVE SHAFT AND DRIVE CHAIN

[TRANSFER: ETX13B]

## < DISASSEMBLY AND ASSEMBLY >

2. Remove drive chain and front drive shaft while tapping front drive shaft with plastic hammer.

**CAUTION:**

**Never tap drive chain.**

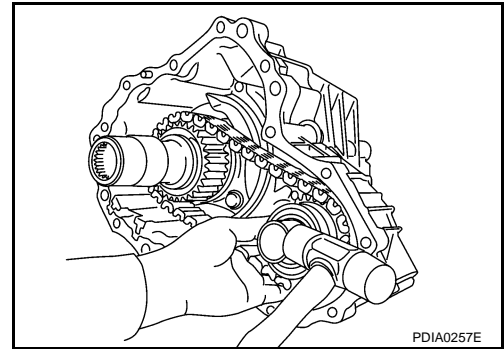

3. Remove front drive shaft front bearing, using the drift [SST: ST31214000 (J-25269-B)] and puller.

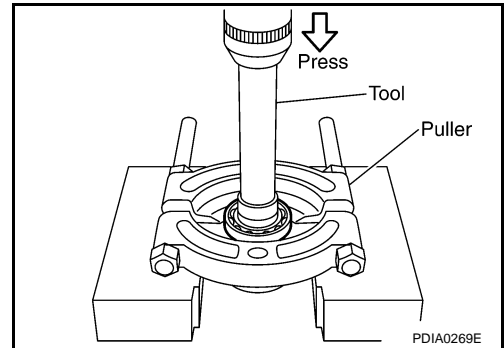

4. Remove front drive shaft rear bearing, using the drift [SST: ST31214000 (J-25269-B)] and puller.

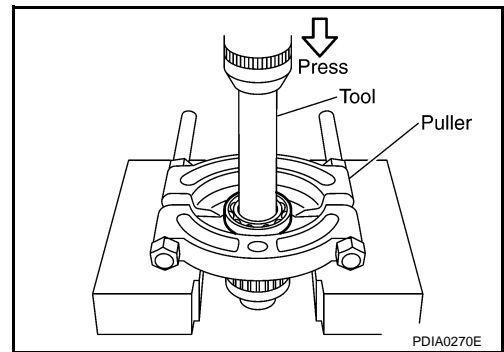

## Assembly

INFOID:000000000957301

1. Install front drive shaft front bearing, using the drift [SST: ST33200000 (J-26082)].

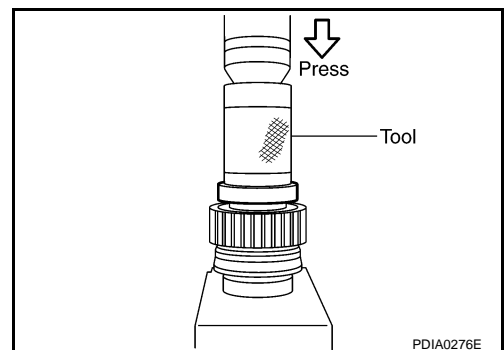

A  
B  
C  
DLN  
E  
F  
G  
H  
I  
J  
K  
L  
M  
N  
O  
P

# FRONT DRIVE SHAFT AND DRIVE CHAIN

< DISASSEMBLY AND ASSEMBLY >

[TRANSFER: ETX13B]

2. Install front drive shaft rear bearing, using the drift [SST: KV38104010 ( — )].

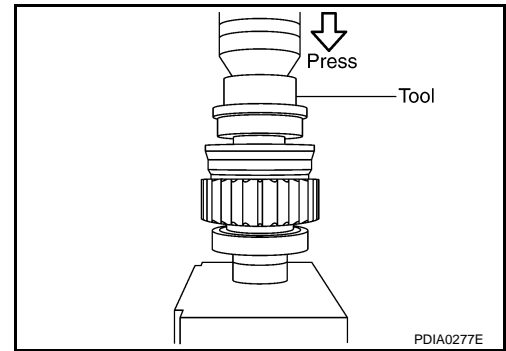

3. Install drive chain to front drive shaft.

**CAUTION:**

Identification mark of drive chain should be in the side of front bearing of front drive shaft.

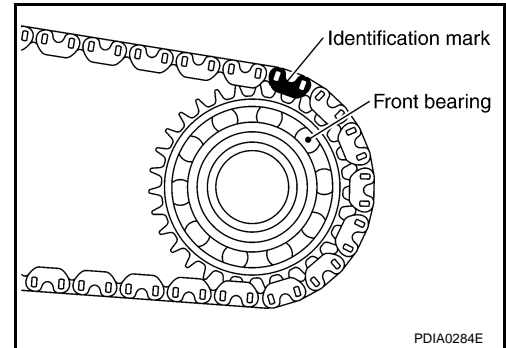

4. Install drive chain to mainshaft, and then install tap front drive shaft with plastic hammer. Press-fit rear bearing of front drive shaft to rear case.

**CAUTION:**

Never tap drive chain.

5. Install front case to rear case. Refer to [DLN-62. "Assembly"](#).

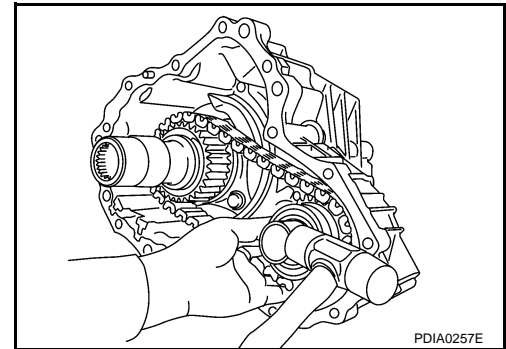

## Inspection

INFOID:000000000957302

Check items below. If necessary, replace them with new ones.

### CASES

- Contact surfaces of bearing for wear, damage, etc.
- Damage and cracks of case.

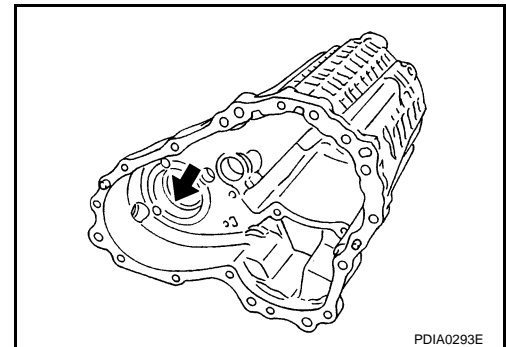

## BEARING

# FRONT DRIVE SHAFT AND DRIVE CHAIN

< DISASSEMBLY AND ASSEMBLY >

[TRANSFER: ETX13B]

- Damage and rough rotation of bearing.

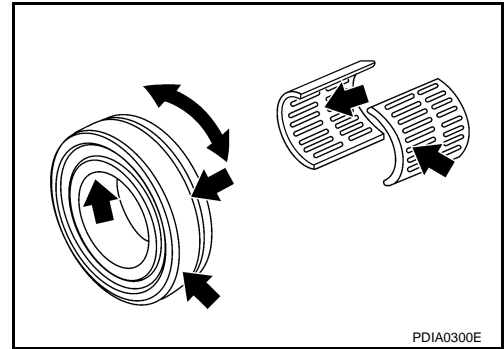

A  
B  
C

DLN

## SHAFT

- Damage, peeling, dent, uneven wear, bending, etc. of shaft.

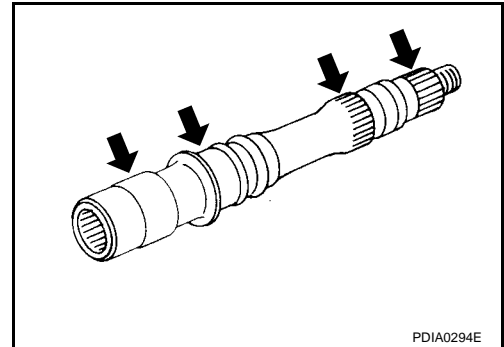

E  
F  
G  
H

## GEARS AND CHAIN

- Excessive wear, damage, peeling, etc. of gear and chain.

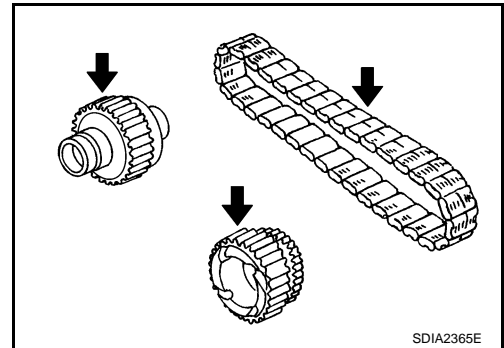

I  
J  
K  
L

M  
N  
O  
P

# SERVICE DATA AND SPECIFICATIONS (SDS)

< SERVICE DATA AND SPECIFICATIONS (SDS)

[TRANSFER: ETX13B]

## SERVICE DATA AND SPECIFICATIONS (SDS)

### SERVICE DATA AND SPECIFICATIONS (SDS)

#### General Specifications

INFOID:000000000957303

Applied model	AWD
	VQ35HR
	A/T
Transfer model	ETX13B
Fluid capacity (Approx.)	$\ell$ (US pt, Imp pt) 1.25 (2-5/8, 2-1/4)

# NOISE, VIBRATION AND HARSHNESS (NVH) TROUBLESHOOTING

< SYMPTOM DIAGNOSIS >

[FRONT PROPELLER SHAFT: 2S56A]

## SYMPTOM DIAGNOSIS

### NOISE, VIBRATION AND HARSHNESS (NVH) TROUBLESHOOTING

#### NVH Troubleshooting Chart

INFOID:000000000957304

Use the chart below to help you find the cause of the symptom. If necessary, repair or replace these parts.

Symptom	Possible cause and SUSPECTED PARTS														
	Noise	Uneven rotating torque	Center bearing improper installation	Excessive center bearing axial end play	Center bearing mounting (insulator) cracks, damage or deterioration	Excessive joint angle	Rotation imbalance	Excessive runout	DIFFERENTIAL	AXLE AND SUSPENSION	TIRES	ROAD WHEEL	DRIVE SHAFT	BRAKES	STEERING
Reference		<a href="#">DLN-79, "Inspection"</a>	—	—	—	—	<a href="#">DLN-81, "Inspection"</a>	<a href="#">DLN-81, "Inspection"</a>	NVH in DLN section.	NVH in FAX, RAX, FSU and RSU section.	NVH in WT section.	NVH in WT section.	NVH in RAX section.	NVH in BR section.	NVH in ST section.
		×	×	×	×	×	×	×	×	×	×	×	×	×	×
	Shake		×			×				×	×	×	×	×	×
	Vibration	×	×	×	×	×	×	×		×	×		×		×

×: Applicable

A  
B  
C  
DLN  
E  
F  
G  
H  
I  
J  
K  
L  
M  
N  
O  
P

# PREPARATION

< PREPARATION >

[FRONT PROPELLER SHAFT: 2S56A]

## PREPARATION

### PREPARATION

#### Commercial Service Tools

INFOID:000000000957305

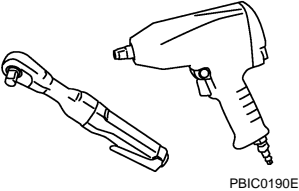
Tool name	Description
Power tool  PBIC0190E	Loosening bolts and nuts

# FRONT PROPELLER SHAFT

< ON-VEHICLE MAINTENANCE >

[FRONT PROPELLER SHAFT: 2S56A]

## ON-VEHICLE MAINTENANCE

### FRONT PROPELLER SHAFT

#### Inspection

INFOID:000000000957306

#### NOISE

- Check the propeller shaft tube surface for dents or cracks. If damaged, replace propeller shaft assembly.

#### VIBRATION

- If vibration is present at high speed, inspect propeller shaft runout first.

1. Measure propeller shaft runout at several points by rotating final drive companion flange with hands.

←: Vehicle front

#### Limit

**Propeller shaft runout** : Refer to [DLN-82. "Propeller Shaft Runout"](#).

2. If runout still exceeds specifications, separate propeller shaft at final drive companion flange; then rotate companion flange 90, 180, 270 degrees and install propeller shaft.
3. Check runout again. If runout still exceeds specifications, replace propeller shaft assembly.
4. Check the vibration by driving vehicle.

#### RUNOUT MEASURING POINT

- Propeller shaft runout measuring point (Point "Δ").

#### Dimension

**A: 381.5 mm (15.02 in)**

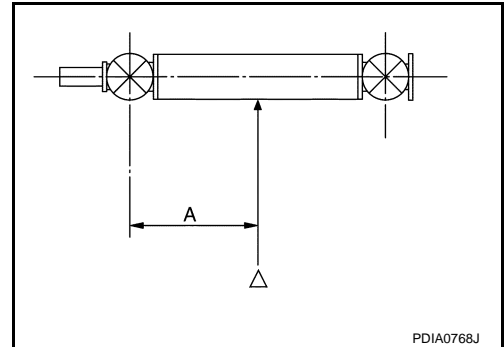
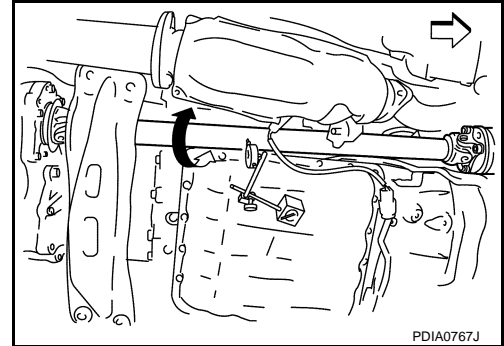

A

B

C

DLN

E

F

G

H

I

J

K

L

M

N

O

P

# FRONT PROPELLER SHAFT

< ON-VEHICLE REPAIR >

[FRONT PROPELLER SHAFT: 2S56A]

## ON-VEHICLE REPAIR

### FRONT PROPELLER SHAFT

Exploded View

INFOID:000000000957307

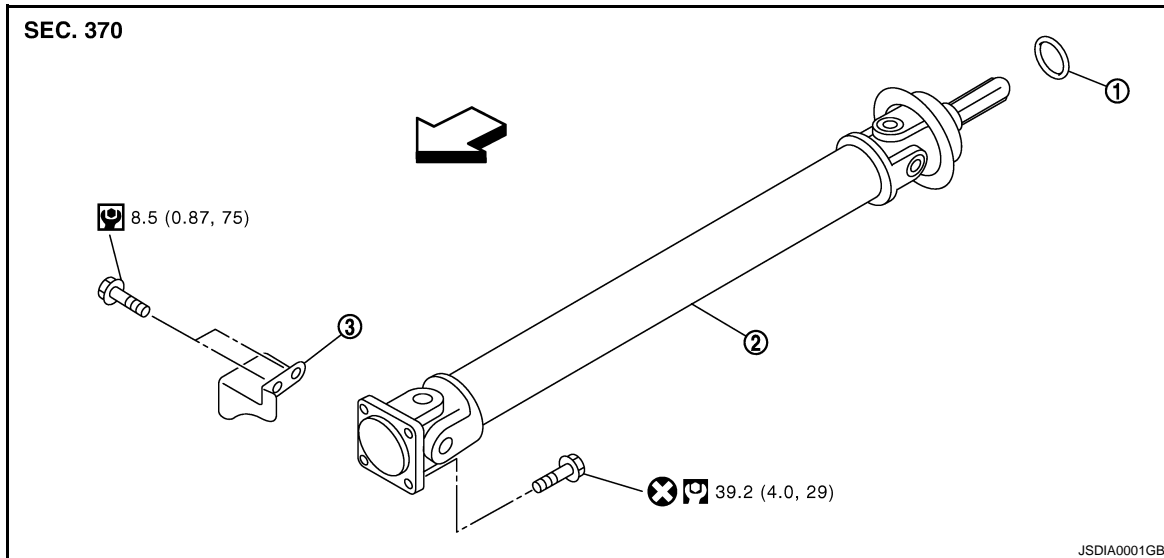

1. O-ring

2. Propeller shaft assembly

3. Heat bracket

⇨: Vehicle front

Refer to [GI-4, "Components"](#) for symbols in the figure.

## Removal and Installation

INFOID:000000000957308

### REMOVAL

1. Move the A/T selector lever to N position and release the parking brake.
2. Remove engine undercover with a power tool.
3. Remove front cross bar.
4. Remove the three way catalyst (right bank) with a power tool. Refer to [EX-5, "Exploded View"](#).
5. Remove heat bracket (1).

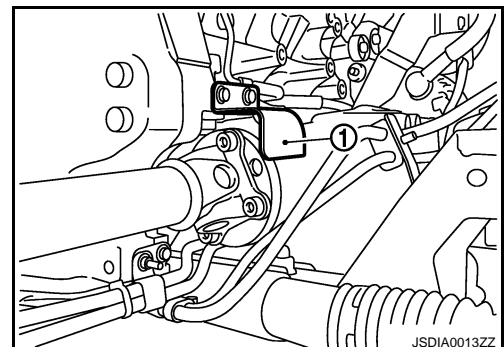



# FRONT PROPELLER SHAFT

[FRONT PROPELLER SHAFT: 2S56A]

< ON-VEHICLE REPAIR >

- Put matching marks onto propeller shaft flange yoke and final drive companion flange.

**CAUTION:**

**For matching marks, use paint. Never damage propeller shaft flange and final drive companion flange.**

- Remove the propeller shaft assembly fixing bolts.
- Remove propeller shaft assembly from the front final drive and transfer.

**CAUTION:**

**Never damage the transfer front oil seal.**

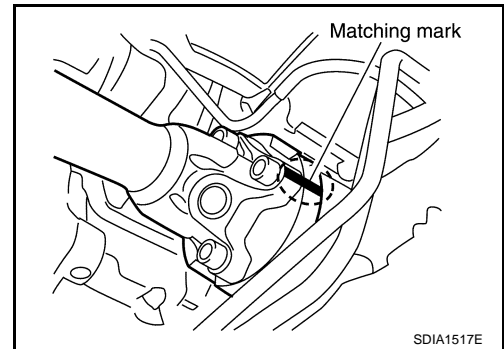

## INSTALLATION

Note the following, and install in the reverse order of removal.

- Align matching marks to install propeller shaft assembly to final drive companion flange.
- After assembly, perform a driving test to check propeller shaft vibration. If vibration occurred, separate propeller shaft from final drive or transfer. Reinstall companion flange after rotating it by 90, 180, 270 degrees. Then perform driving test and check propeller shaft vibration again at each point.

**CAUTION:**

**Never damage the transfer front oil seal.**

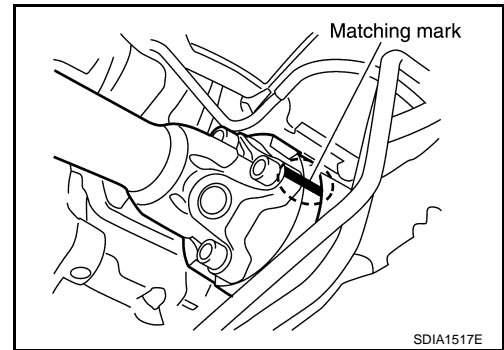

## Inspection

INFOID:00000000957309

## APPEARANCE

Check propeller shaft for bend and damage. If damage is detected, replace propeller shaft assembly.

## PROPELLER SHAFT RUNOUT

Check propeller shaft runout at measuring point. If runout exceeds specifications, replace propeller shaft assembly. For measuring point, refer to [DLN-79, "Inspection"](#).

**Limit**

**Propeller shaft runout**

**: Refer to [DLN-82, "Propeller Shaft Runout"](#).**

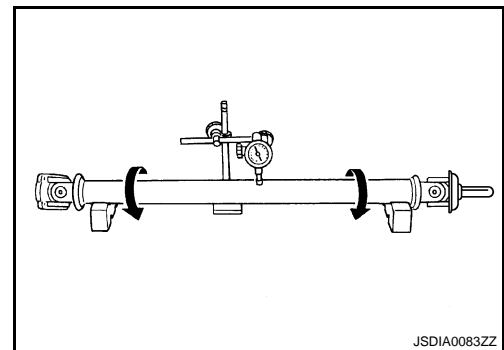

## JOURNAL AXIAL PLAY

As shown in the figure, while fixing yoke on one side, check axial play of joint. If outside the standard, replace propeller shaft assembly.

**Standard**

**Journal axial play**

**: Refer to [DLN-82, "Journal Axial Play"](#).**

**CAUTION:**

**Never disassemble joints.**

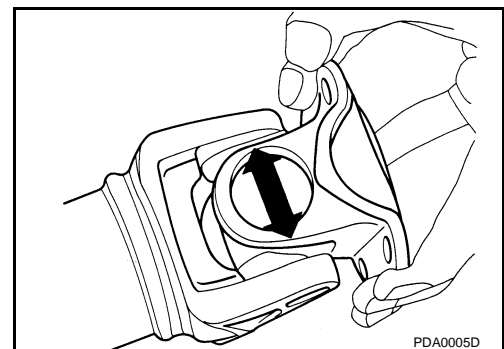

A  
B  
C  
DLN  
E  
F  
G  
H  
I  
J  
K  
L  
M  
N  
O  
P

# SERVICE DATA AND SPECIFICATIONS (SDS)

< SERVICE DATA AND SPECIFICATIONS (SDS)

[FRONT PROPELLER SHAFT: 2S56A]

## SERVICE DATA AND SPECIFICATIONS (SDS)

### SERVICE DATA AND SPECIFICATIONS (SDS)

#### General Specifications

INFOID:000000000957310

Applied model	AWD
	VQ35HR
	A/T
Propeller shaft model	2S56A
Number of joints	2
Type of journal bearings (Non-disassembly type)	Shell type
Coupling method with transfer	Sleeve type
Coupling method with front final drive	Flange type
Shaft length (Spider to spider)	763 mm (30.04 in)
Shaft outer diameter	42.7 mm (1.68 in)

#### Propeller Shaft Runout

INFOID:000000000957311

Unit: mm (in)

Item	Limit
Propeller shaft runout	0.8 (0.031)

#### Journal Axial Play

INFOID:000000000957312

Unit: mm (in)

Item	Standard
Journal axial play	0 (0)

# NOISE, VIBRATION AND HARSHNESS (NVH) TROUBLESHOOTING

< SYMPTOM DIAGNOSIS >

[REAR PROPELLER SHAFT: 3S80A]

## SYMPTOM DIAGNOSIS

### NOISE, VIBRATION AND HARSHNESS (NVH) TROUBLESHOOTING

#### NVH Troubleshooting Chart

INFOID:000000000957313

Use the chart below to help you find the cause of the symptom. If necessary, repair or replace these parts.

Symptom	Possible cause and SUSPECTED PARTS														
	Noise	Uneven rotating torque	Center bearing improper installation	Excessive center bearing axial end play	Center bearing mounting (insulator) cracks, damage or deterioration	Excessive joint angle	Rotation imbalance	Excessive runout	DIFFERENTIAL	AXLE AND SUSPENSION	TIRES	ROAD WHEEL	DRIVE SHAFT	BRAKES	STEERING
Reference		<a href="#">DLN-85, "Inspection"</a>	<a href="#">DLN-88, "Inspection"</a>	—	<a href="#">DLN-88, "Inspection"</a>	—	<a href="#">DLN-88, "Inspection"</a>	<a href="#">DLN-88, "Inspection"</a>	NVH in DLN section.	NVH in FAX, RAX, FSU and RSU section.	NVH in WT section.	NVH in WT section.	NVH in RAX section.	NVH in BR section.	NVH in ST section.
		x	x	x	x	x	x	x	x	x	x	x	x	x	x
	Shake		x			x				x	x	x	x	x	x
	Vibration	x	x	x	x	x	x	x		x	x		x		x

x: Applicable

A  
B  
C  
DLN  
E  
F  
G  
H  
I  
J  
K  
L  
M  
N  
O  
P

# PREPARATION

< PREPARATION >

[REAR PROPELLER SHAFT: 3S80A]

## PREPARATION

### PREPARATION

#### Commercial Service Tools

INFOID:000000000957314

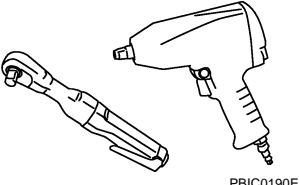
Tool name	Description
<p data-bbox="162 415 272 441">Power tool</p>  <p data-bbox="852 630 922 646">PBIC0190E</p>	<p data-bbox="1015 415 1263 441">Loosening bolts and nuts</p>

# REAR PROPELLER SHAFT

< ON-VEHICLE MAINTENANCE >

[REAR PROPELLER SHAFT: 3S80A]

## ON-VEHICLE MAINTENANCE

### REAR PROPELLER SHAFT

#### Inspection

INFOID:000000000957315

#### NOISE

- Check the propeller shaft tube surface for dents or cracks. If damaged, replace propeller shaft assembly.
- If center bearing is noisy or damaged, replace propeller shaft assembly.

#### VIBRATION

- If vibration is present at high speed, inspect propeller shaft runout first.
1. Measure propeller shaft runout at several points by rotating final drive companion flange with hands.

#### Limit

**Propeller shaft runout** : Refer to [DLN-89, "Propeller Shaft Runout"](#).

2. If runout still exceeds specifications, separate propeller shaft at final drive companion flange; then rotate companion flange 90, 180, 270 degrees and install propeller shaft.
3. Check runout again. If runout still exceeds specifications, replace propeller shaft assembly.
4. Check the vibration by driving vehicle.

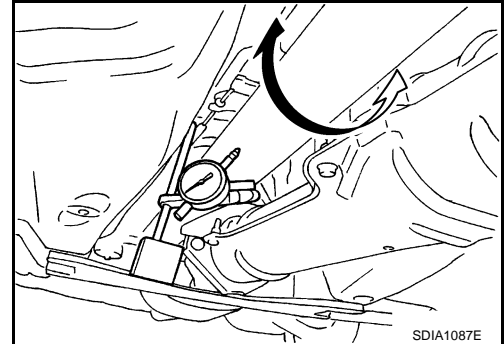

#### RUNOUT MEASURING POINT

- Propeller shaft runout measuring point (Point "△").

↔: Vehicle front

#### Dimension

**A: 192 mm (7.56 in)**

**B: 172 mm (6.77 in)**

**C: 170 mm (6.69 in)**

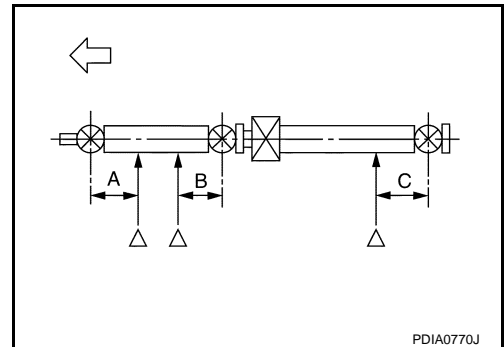

A  
B  
C  
DLN  
E  
F  
G  
H  
I  
J  
K  
L  
M  
N  
O  
P

# REAR PROPELLER SHAFT

< ON-VEHICLE REPAIR >

[REAR PROPELLER SHAFT: 3S80A]

## ON-VEHICLE REPAIR

### REAR PROPELLER SHAFT

Exploded View

INFOID:000000000957316

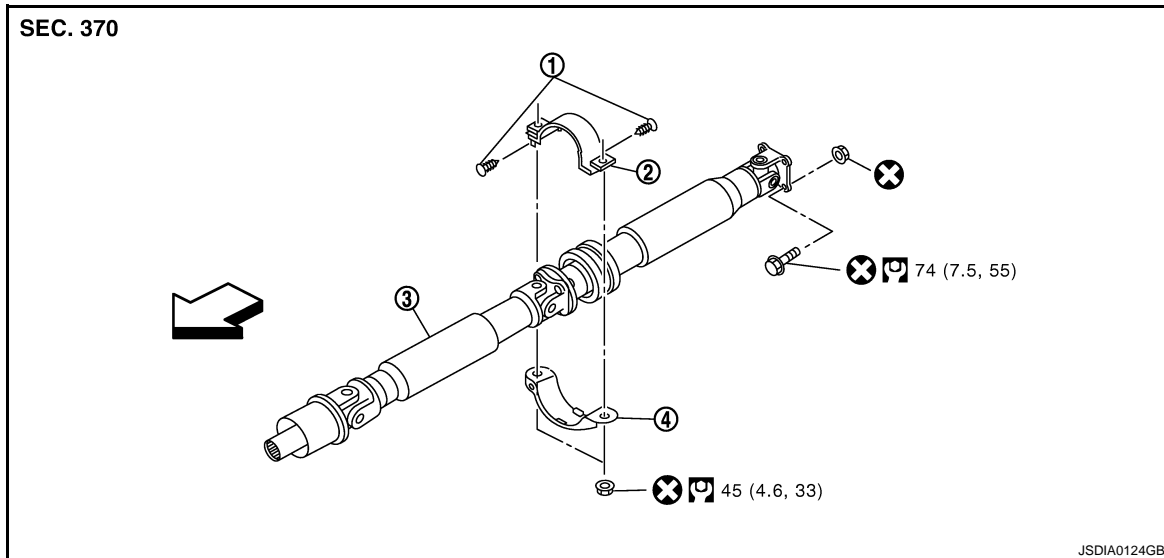

- 1. Clip
- 2. Center bearing mounting bracket (Upper)
- 3. Propeller shaft assembly
- 4. Center bearing mounting bracket (Lower)

↔: Vehicle front

Refer to [GI-4, "Components"](#) for symbols in the figure.

## Removal and Installation

INFOID:000000000957317

### REMOVAL

1. Move the M/T shift lever to neutral position and release the parking brake.
2. Remove the floor reinforcement.
3. Remove the center muffler with power tool. Refer to [EX-5, "Exploded View"](#).
4. Remove the heat plate (1).

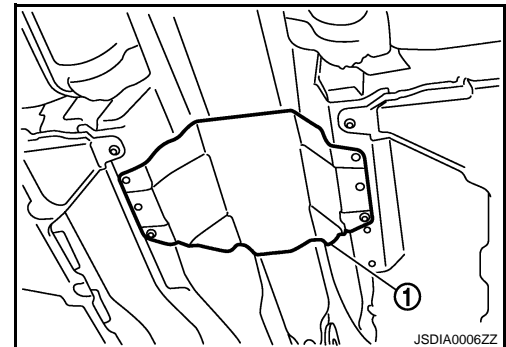

# REAR PROPELLER SHAFT

[REAR PROPELLER SHAFT: 3S80A]

## < ON-VEHICLE REPAIR >

5. Put matching marks on propeller shaft flange yoke with final drive companion flange.

**CAUTION:**

For matching marks, use paint. Never damage propeller shaft flange yoke and final drive companion flange.

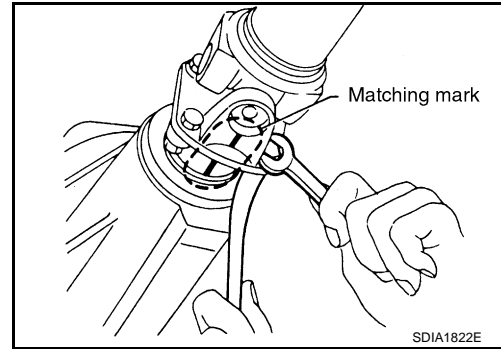

6. Loosen mounting nuts of center bearing mounting brackets.

**CAUTION:**

Tighten mounting nuts temporarily.

7. Remove propeller shaft assembly fixing bolts and nuts.  
8. Remove center bearing mounting bracket fixing nuts.  
9. Remove propeller shaft assembly.

**CAUTION:**

- Never damage the rear oil seal of transmission.
- If constant velocity joint was bent during propeller shaft assembly removal, installation, or transportation, its boot may be damaged. Wrap boot interference area to metal part with shop cloth or rubber to protect boot from breakage.

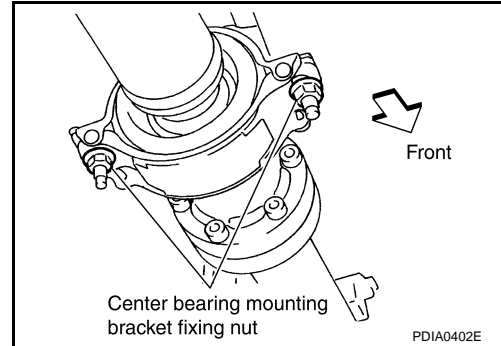

## INSTALLATION

Note the following, and install in the reverse order of removal.

- Install center bearing mounting bracket (Upper) (1) with its arrow mark (A) facing forward.
- Adjust position of center bearing mounting bracket (1, 2) sliding back and forth to prevent play in thrust direction of center bearing insulator (3). Install bracket to vehicle.

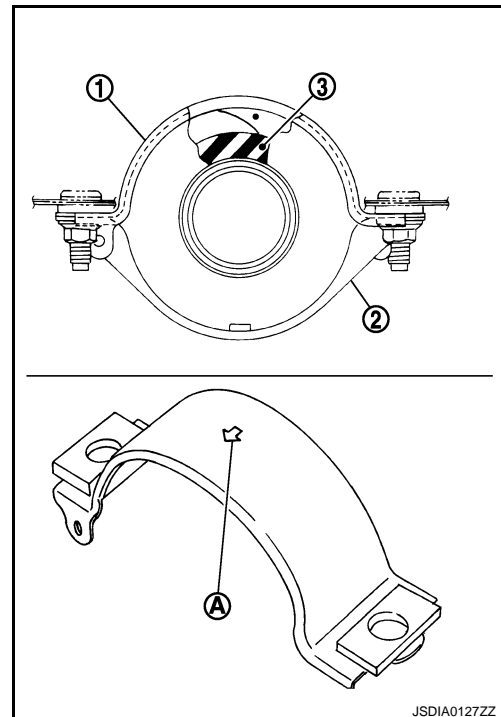

A  
B  
C  
DLN  
E  
F  
G  
H  
I  
J  
K  
L  
M  
N  
O  
P

# REAR PROPELLER SHAFT

[REAR PROPELLER SHAFT: 3S80A]

## < ON-VEHICLE REPAIR >

- Align matching marks to install propeller shaft flange yoke with final drive companion flange.
- After assembly, perform a driving test to check propeller shaft vibration. If vibration occurred, separate propeller shaft from final drive. Reinstall companion flange after rotating it by 90, 180, 270 degrees. Then perform driving test and check propeller shaft vibration again at each point.

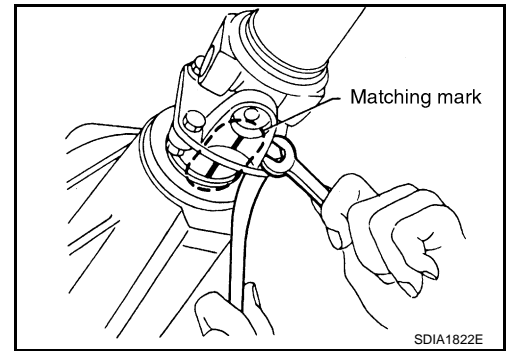

- If propeller shaft or final drive has been replaced, connect them as follows:
  - Install the propeller shaft while aligning its matching mark (A) with the matching mark (B) on the joint as close as possible.

### CAUTION:

Never damage the rear oil seal of transmission.

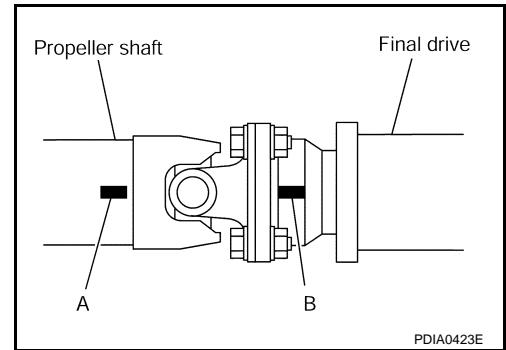

## Inspection

INFOID:000000000957318

### APPEARANCE

Check propeller shaft for bend and damage. If damage is detected, replace propeller shaft assembly.

### PROPELLER SHAFT RUNOUT

Check propeller shaft runout at measuring points. If runout exceeds specifications, replace propeller shaft assembly. For measuring point, refer to [DLN-85. "Inspection"](#).

#### Limit

Propeller shaft runout

: Refer to [DLN-89. "Propeller Shaft Runout"](#).

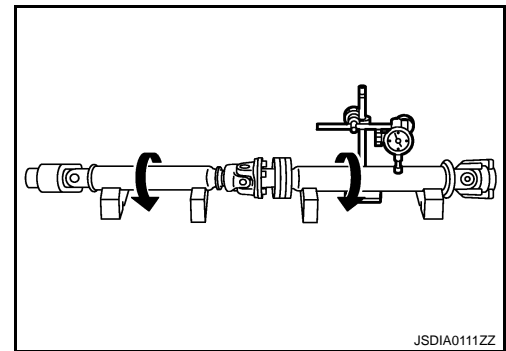

### JOURNAL AXIAL PLAY

As shown in the figure, while fixing yoke on one side, check axial play of joint. If outside the standard, replace propeller shaft assembly.

#### Standard

Journal axial play

: Refer to [DLN-89. "Journal Axial Play"](#).

### CAUTION:

Never disassemble joints.

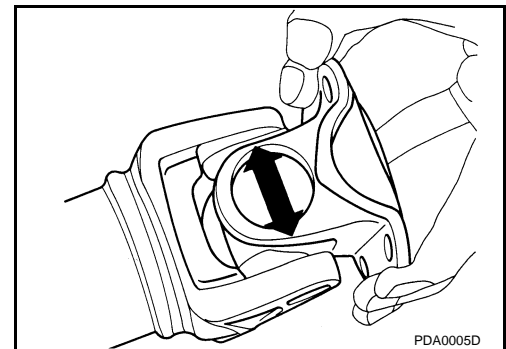

### CENTER BEARING

Check center bearing for noise and damage. If noise or damage is detected, replace propeller shaft assembly.

### CAUTION:

Never disassemble center bearing.



# SERVICE DATA AND SPECIFICATIONS (SDS)

< SERVICE DATA AND SPECIFICATIONS (SDS)

[REAR PROPELLER SHAFT: 3S80A]

## SERVICE DATA AND SPECIFICATIONS (SDS)

### SERVICE DATA AND SPECIFICATIONS (SDS)

#### General Specifications

INFOID:0000000000957319

Applied model	2WD	
	VQ35HR	
	M/T	
Propeller shaft model	3S80A	
Number of joints	3	
Type of journal bearings (Non-disassembly type)	1st joint	Shell type
	2nd joint	Shell type
	3rd joint	Shell type
Coupling method with transmission	Sleeve type	
Coupling method with rear final drive	Flange type	
Shaft length	1st (Spider to spider)	762 mm (30.00 in)
	2nd (Spider to spider)	759 mm (29.88 in)
Shaft outer diameter	1st	82.6 mm (3.25 in)
	2nd	75.0 mm (2.95 in)

#### Propeller Shaft Runout

INFOID:0000000000957320

Unit: mm (in)

Item	Limit
Propeller shaft runout	0.8 (0.031)

#### Journal Axial Play

INFOID:0000000000957321

Unit: mm (in)

Item	Standard
Journal axial play	0 (0)

# NOISE, VIBRATION AND HARSHNESS (NVH) TROUBLESHOOTING

< SYMPTOM DIAGNOSIS >

[REAR PROPELLER SHAFT: 3S80A-R]

## SYMPTOM DIAGNOSIS

### NOISE, VIBRATION AND HARSHNESS (NVH) TROUBLESHOOTING

#### NVH Troubleshooting Chart

INFOID:000000000957322

Use the chart below to help you find the cause of the symptom. If necessary, repair or replace these parts.

Symptom		Possible cause and SUSPECTED PARTS													
		DLN-92, "Inspection"	DLN-96, "Inspection"	—	DLN-96, "Inspection"	—	DLN-96, "Inspection"	DLN-96, "Inspection"	NVH in DLN section.	NVH in FAX, RAX, FSU and RSU section.	NVH in WT section.	NVH in WT section.	NVH in RAX section.	NVH in BR section.	NVH in ST section.
Reference		DLN-92, "Inspection"	DLN-96, "Inspection"	—	DLN-96, "Inspection"	—	DLN-96, "Inspection"	DLN-96, "Inspection"	NVH in DLN section.	NVH in FAX, RAX, FSU and RSU section.	NVH in WT section.	NVH in WT section.	NVH in RAX section.	NVH in BR section.	NVH in ST section.
Possible cause and SUSPECTED PARTS		Uneven rotating torque	Center bearing improper installation	Excessive center bearing axial end play	Center bearing mounting (insulator) cracks, damage or deterioration	Excessive joint angle	Rotation imbalance	Excessive runout	DIFFERENTIAL	AXLE AND SUSPENSION	TIRES	ROAD WHEEL	DRIVE SHAFT	BRAKES	STEERING
Symptom	Noise	x	x	x	x	x	x	x	x	x	x	x	x	x	x
	Shake		x			x				x	x	x	x	x	x
	Vibration	x	x	x	x	x	x	x		x	x		x		x

x: Applicable

# PREPARATION

< PREPARATION >

[REAR PROPELLER SHAFT: 3S80A-R]

## PREPARATION

### PREPARATION

#### Commercial Service Tools

INFOID:000000000957323

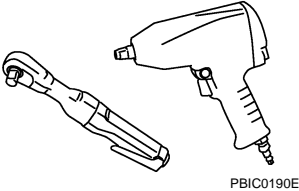
Tool name	Description
<p data-bbox="164 415 272 441">Power tool</p>  <p data-bbox="852 632 922 646">PBIC0190E</p>	<p data-bbox="1013 415 1263 441">Loosening bolts and nuts</p>

A

B

C

DLN

E

F

G

H

I

J

K

L

M

N

O

P

# REAR PROPELLER SHAFT

< ON-VEHICLE MAINTENANCE >

[REAR PROPELLER SHAFT: 3S80A-R]

## ON-VEHICLE MAINTENANCE

### REAR PROPELLER SHAFT

#### Inspection

INFOID:000000000957324

#### NOISE

- Check the propeller shaft tube surface for dents or cracks. If damaged, replace propeller shaft assembly.
- If center bearing is noisy or damaged, replace propeller shaft assembly.

#### VIBRATION

- If vibration is present at high speed, inspect propeller shaft runout first.
1. Measure propeller shaft runout at several points by rotating final drive companion flange with hands.

#### Limit

**Propeller shaft runout** : Refer to [DLN-97, "Propeller Shaft Runout"](#).

2. If runout still exceeds specifications, separate propeller shaft at final drive companion flange; then rotate companion flange 120, 240 degrees and install propeller shaft.
3. Check runout again. If runout still exceeds specifications, replace propeller shaft assembly.
4. Check the vibration by driving vehicle.

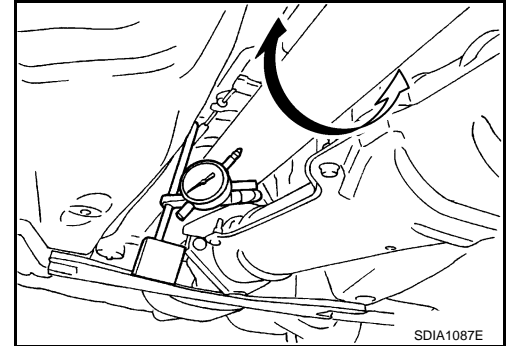

#### RUNOUT MEASURING POINT

- Propeller shaft runout measuring point (Point "Δ").

←: Vehicle front

#### Dimension

**A: 192 mm (7.56 in)**

**B: 172 mm (6.77 in)**

**C: 172 mm (6.77 in)**

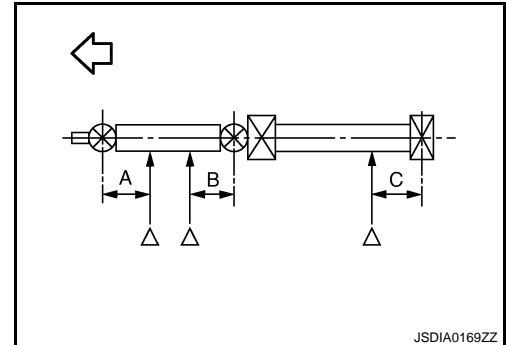

# REAR PROPELLER SHAFT

< ON-VEHICLE REPAIR >

[REAR PROPELLER SHAFT: 3S80A-R]

## ON-VEHICLE REPAIR

### REAR PROPELLER SHAFT

Exploded View

INFOID:000000000957325

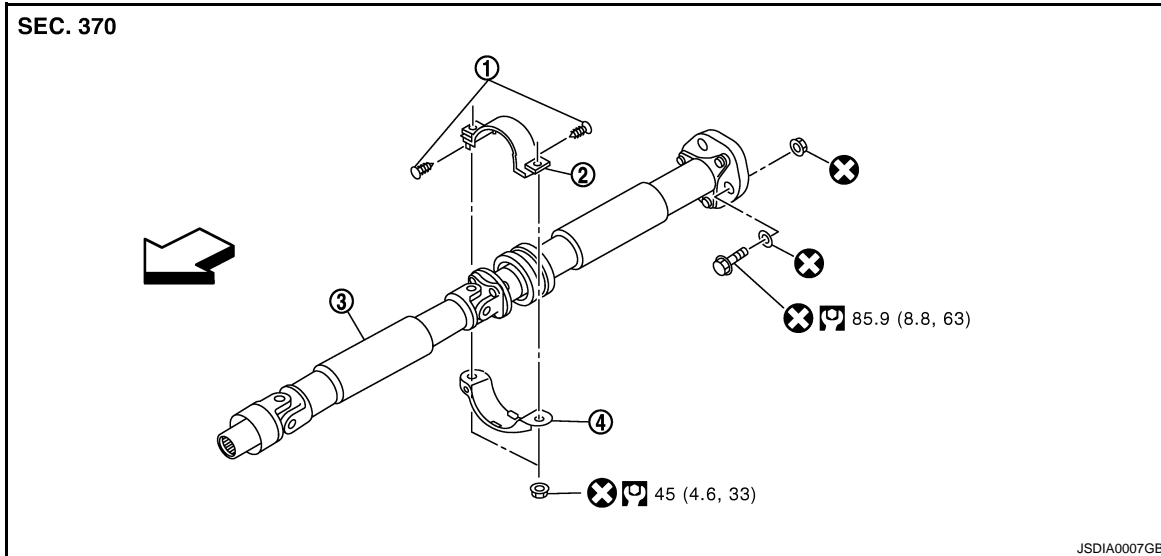

1. Clip
2. Center bearing mounting bracket (Upper)
3. Propeller shaft assembly
4. Center bearing mounting bracket (Lower)

←: Vehicle front

Refer to [GI-4, "Components"](#) for symbols in the figure.

## Removal and Installation

INFOID:000000000957326

### REMOVAL

1. Move the A/T selector lever to N position and release the parking brake.
2. Remove the floor reinforcement.
3. Remove the center muffler with power tool. Refer to [EX-5, "Exploded View"](#).
4. Remove the heat plate (1).

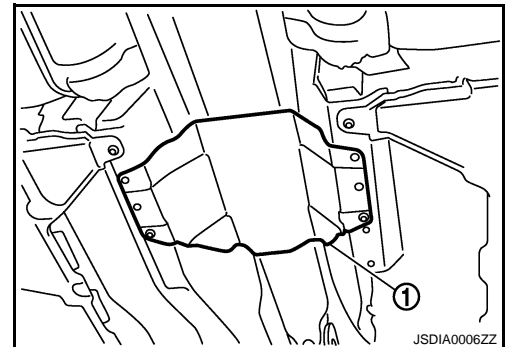

# REAR PROPELLER SHAFT

[REAR PROPELLER SHAFT: 3S80A-R]

< ON-VEHICLE REPAIR >

5. Put matching marks on propeller shaft rubber coupling with final drive companion flange.

**CAUTION:**

For matching marks, use paint. Never damage propeller shaft rubber coupling and final drive companion flange.

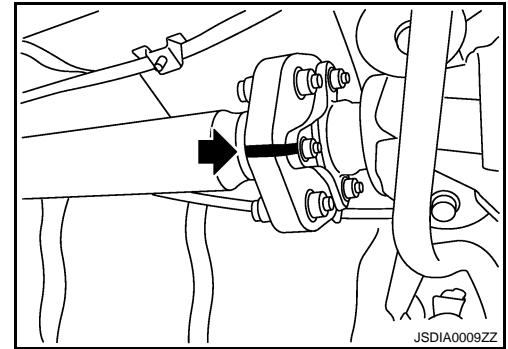

6. Loosen mounting nuts of center bearing mounting brackets.

**CAUTION:**

Tighten mounting nuts temporarily.

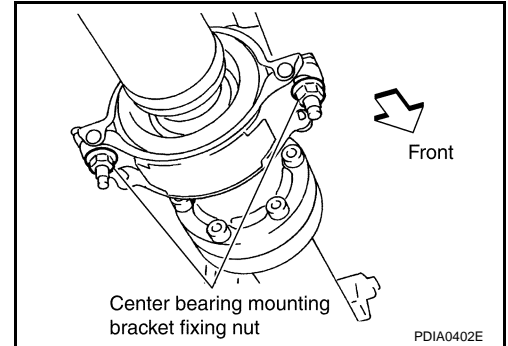

7. Remove propeller shaft assembly fixing bolts and nuts.

**CAUTION:**

Never remove the rubber coupling from the propeller shaft assembly.

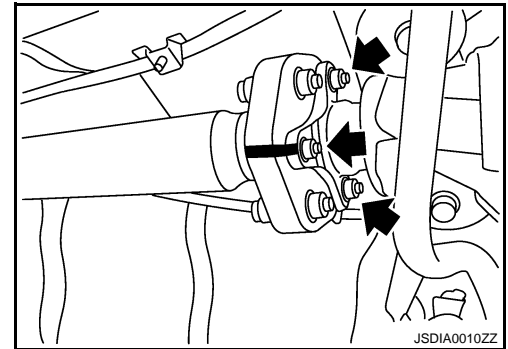

8. Slightly separate the rubber coupling (1) from the final drive companion flange (2).

**CAUTION:**

Never damage the final drive companion flange and rubber coupling.

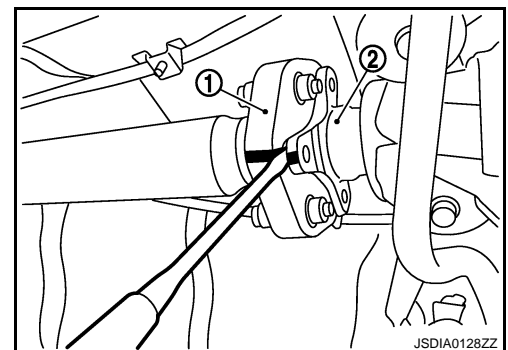

9. Remove center bearing mounting bracket fixing nuts.

**CAUTION:**

- The angle (A), which the third axis rubber coupling (1) forms with the final drive companion flange (2), must be 5° or less.
- Never damage the grease seal (3).
- Never damage the rubber coupling.

10. Slide the propeller shaft forward the vehicle slightly. Separate the propeller shaft from the final drive companion flange.

**CAUTION:**

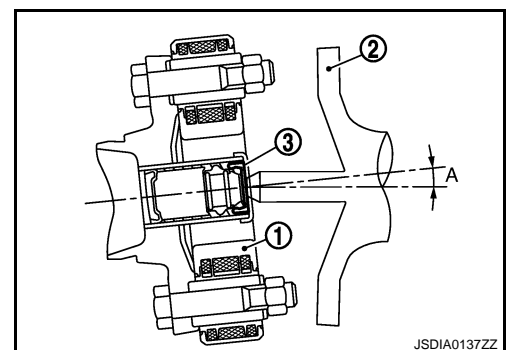

# REAR PROPELLER SHAFT

[REAR PROPELLER SHAFT: 3S80A-R]

< ON-VEHICLE REPAIR >

- The angle, which the third axis rubber coupling forms with the final drive companion flange, must be 5° or less.
- Never damage the grease seal.
- Never damage the rubber coupling.

11. Remove the propeller shaft assembly from the vehicle.

**CAUTION:**

**Never damage the rear oil seal of transmission.**

## INSTALLATION

Note the following, and install in the reverse order of removal.

- Install center bearing mounting bracket (Upper) (1) with its arrow mark (A) facing forward.
- Adjust position of center bearing mounting bracket (1, 2) sliding back and forth to prevent play in thrust direction of center bearing insulator (3). Install bracket to vehicle.

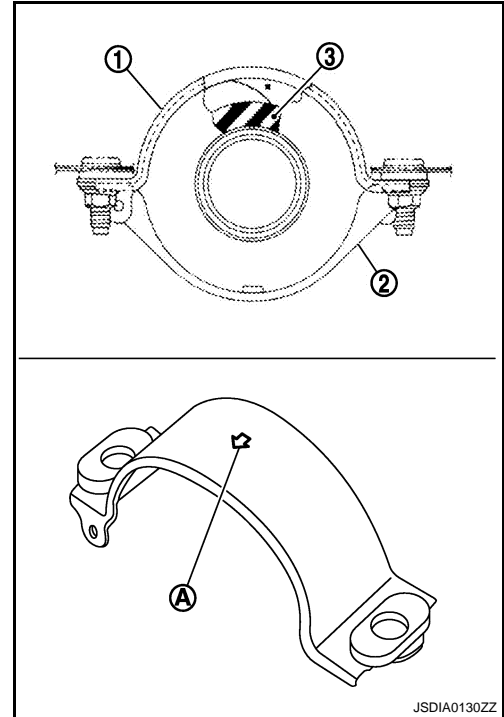

- Align matching marks to install propeller shaft rubber coupling to final drive companion flange.
- After assembly, perform a driving test to check propeller shaft vibration. If vibration occurred, separate propeller shaft from final drive. Reinstall companion flange after rotating it by 120, 240 degrees. Then perform driving test and check propeller shaft vibration again at each point.

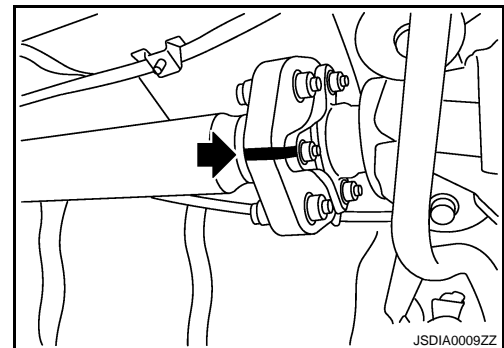

- If propeller shaft or final drive has been replaced, connect them as follows:
  - Install the propeller shaft (1) while aligning its matching mark (A) with the matching mark (B) on the joint as close as possible.

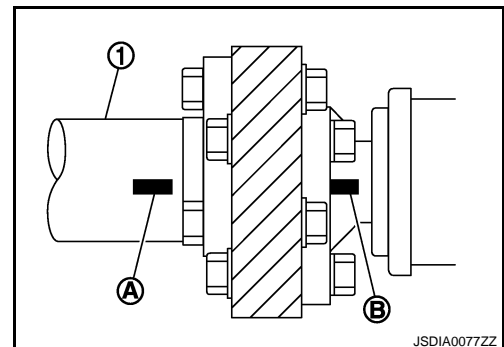

**CAUTION:**

A

B

C

DLN

E

F

G

H

I

J

K

L

M

N

O

P

# REAR PROPELLER SHAFT

[REAR PROPELLER SHAFT: 3S80A-R]

< ON-VEHICLE REPAIR >

- The angle (A), which the third axis rubber coupling (1) forms with the final drive companion flange (2), must be 5° or less.
- Never damage the grease seal (3).
- Never damage the rubber coupling.
- Never damage the rear oil seal of transmission.
- Avoid damaging the rubber coupling, protect it with a shop towel or equivalent.

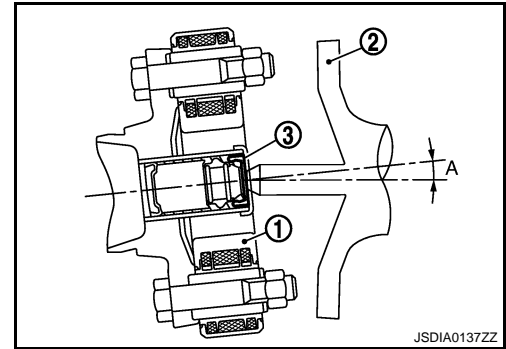

INFOID:000000000957327

## Inspection

### APPEARANCE

Check propeller shaft for bend and damage. If damage is detected, replace propeller shaft assembly.

### PROPELLER SHAFT RUNOUT

Check propeller shaft runout at measuring points. If runout exceeds specifications, replace propeller shaft assembly. For measuring point, refer to [DLN-92. "Inspection"](#)

#### Limit

**Propeller shaft runout** : Refer to [DLN-97, "Propeller Shaft Runout"](#).

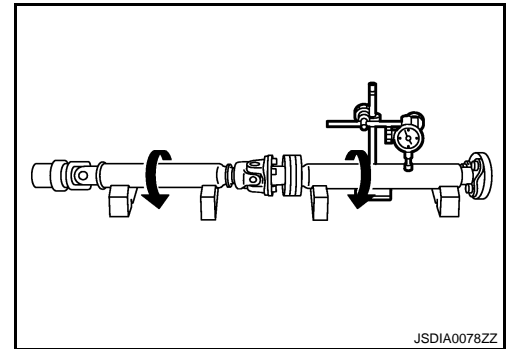

### JOURNAL AXIAL PLAY

As shown in the figure, while fixing yoke on one side, check axial play of joint. If outside the standard, replace propeller shaft assembly.

#### Standard

**Journal axial play** : Refer to [DLN-97, "Journal Axial Play"](#).

#### CAUTION:

Never disassemble joints.

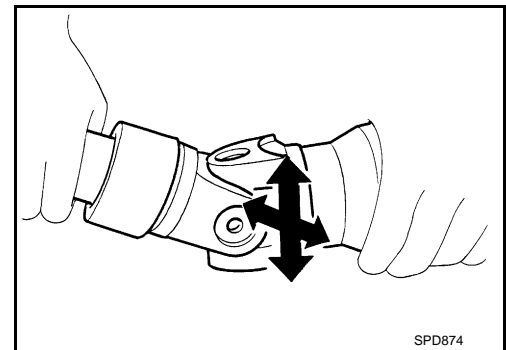

### CENTER BEARING

Check center bearing for noise and damage. If noise or damage is detected, replace propeller shaft assembly.

#### CAUTION:

Never disassemble center bearing.



# SERVICE DATA AND SPECIFICATIONS (SDS)

< SERVICE DATA AND SPECIFICATIONS (SDS)

[REAR PROPELLER SHAFT: 3S80A-R]

## SERVICE DATA AND SPECIFICATIONS (SDS)

### SERVICE DATA AND SPECIFICATIONS (SDS)

#### General Specifications

INFOID:0000000000957328

Applied model		2WD
		VQ35HR
		A/T
Propeller shaft model		3S80A-R
Number of joints		3
Type of journal bearings (Non-disassembly type)	1st joint	Shell type
	2nd joint	Shell type
	3rd joint	Rubber coupling type
Coupling method with transmission		Sleeve type
Coupling method with rear final drive		Rubber coupling type
Shaft length	1st (Spider to spider)	724 mm (28.50 in)
	2nd (Spider to rubber coupling center)	769 mm (30.28 in)
Shaft outer diameter	1st	82.6 mm (3.25 in)
	2nd	75.0 mm (2.95 in)

#### Propeller Shaft Runout

INFOID:0000000000957329

Unit: mm (in)

Item	Limit
Propeller shaft runout	0.8 (0.031)

#### Journal Axial Play

INFOID:0000000000957330

Unit: mm (in)

Item	Standard
Journal axial play	0 (0)

# NOISE, VIBRATION AND HARSHNESS (NVH) TROUBLESHOOTING

< SYMPTOM DIAGNOSIS >

[REAR PROPELLER SHAFT: 3F80A-1VL107]

## SYMPTOM DIAGNOSIS

### NOISE, VIBRATION AND HARSHNESS (NVH) TROUBLESHOOTING

#### NVH Troubleshooting Chart

INFOID:000000000957331

Use the chart below to help you find the cause of the symptom. If necessary, repair or replace these parts.

Symptom		Possible cause and SUSPECTED PARTS													
		DLN-100, "Inspection"	DLN-104, "Inspection"	—	DLN-104, "Inspection"	—	DLN-104, "Inspection"	DLN-104, "Inspection"	NVH in DLN section.	NVH in FAX, RAX, FSU and RSU section.	NVH in WT section.	NVH in WT section.	NVH in RAX section.	NVH in BR section.	NVH in ST section.
Reference		DLN-100, "Inspection"	DLN-104, "Inspection"	—	DLN-104, "Inspection"	—	DLN-104, "Inspection"	DLN-104, "Inspection"	NVH in DLN section.	NVH in FAX, RAX, FSU and RSU section.	NVH in WT section.	NVH in WT section.	NVH in RAX section.	NVH in BR section.	NVH in ST section.
Possible cause and SUSPECTED PARTS		Uneven rotating torque	Center bearing improper installation	Excessive center bearing axial end play	Center bearing mounting (insulator) cracks, damage or deterioration	Excessive joint angle	Rotation imbalance	Excessive runout	DIFFERENTIAL	AXLE AND SUSPENSION	TIRES	ROAD WHEEL	DRIVE SHAFT	BRAKES	STEERING
Symptom	Noise	x	x	x	x	x	x	x	x	x	x	x	x	x	x
	Shake		x			x				x	x	x	x	x	x
	Vibration	x	x	x	x	x	x	x		x	x		x		x

x: Applicable

# PREPARATION

[REAR PROPELLER SHAFT: 3F80A-1VL107]

< PREPARATION >

## PREPARATION

### PREPARATION

#### Commercial Service Tools

INFOID:000000000957332

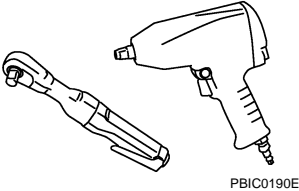
Tool name	Description
<p data-bbox="164 413 272 438">Power tool</p>  <p data-bbox="852 632 922 646">PBIC0190E</p>	<p data-bbox="1011 413 1263 441">Loosening bolts and nuts</p>

A

B

C

DLN

E

F

G

H

I

J

K

L

M

N

O

P

# REAR PROPELLER SHAFT

< ON-VEHICLE MAINTENANCE >

[REAR PROPELLER SHAFT: 3F80A-1VL107]

## ON-VEHICLE MAINTENANCE

### REAR PROPELLER SHAFT

#### Inspection

INFOID:000000000957333

#### NOISE

- Check the propeller shaft tube surface for dents or cracks. If damaged, replace propeller shaft assembly.
- If center bearing is noisy or damaged, replace propeller shaft assembly.

#### VIBRATION

- If vibration is present at high speed, inspect propeller shaft runout first.
1. Measure propeller shaft runout at several points by rotating final drive companion flange with hands.

#### Limit

**Propeller shaft runout** : Refer to [DLN-105. "Propeller Shaft Runout"](#).

2. If runout still exceeds specifications, separate propeller shaft at final drive companion flange; then rotate companion flange 60, 120, 180, 240, 300 degrees and install propeller shaft.
3. Check runout again. If runout still exceeds specifications, replace propeller shaft assembly.
4. Check the vibration by driving vehicle.

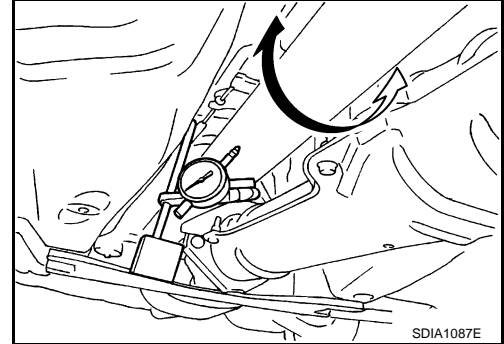

#### RUNOUT MEASURING POINT

- Propeller shaft runout measuring point (Point "Δ").

←: Vehicle front

#### Dimension

**A: 162 mm (6.38 in)**

**B: 245 mm (9.65 in)**

**C: 185 mm (7.28 in)**

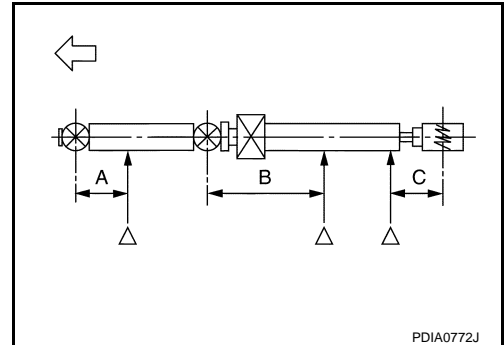

# REAR PROPELLER SHAFT

< ON-VEHICLE REPAIR >

[REAR PROPELLER SHAFT: 3F80A-1VL107]

## ON-VEHICLE REPAIR

### REAR PROPELLER SHAFT

Exploded View

INFOID:000000000957334

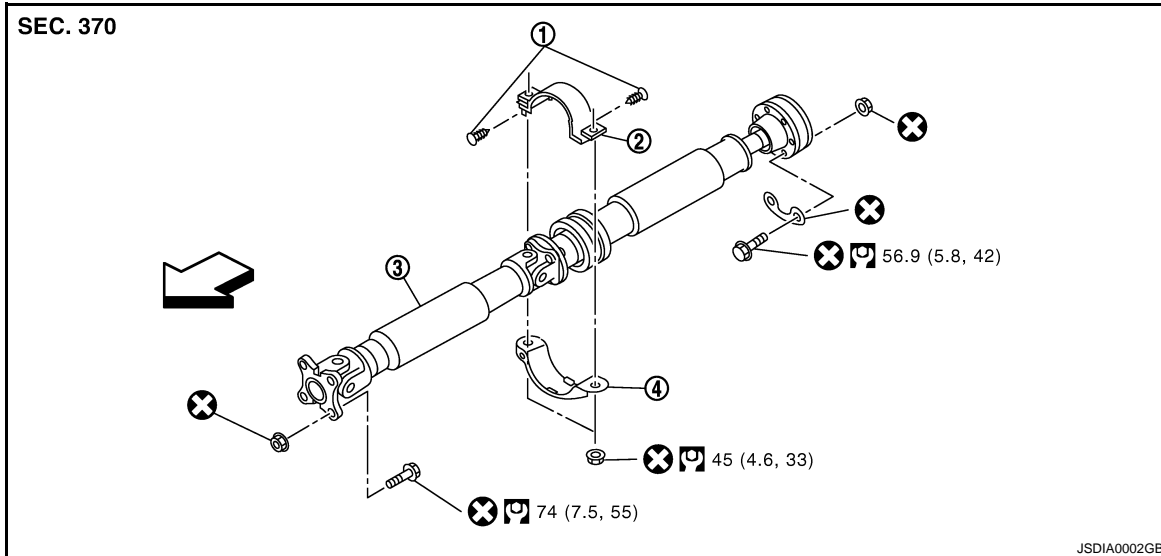

1. Clip
2. Center bearing mounting bracket (Upper)
3. Propeller shaft assembly
4. Center bearing mounting bracket (Lower)

←: Vehicle front

Refer to [GI-4, "Components"](#) for symbols in the figure.

## Removal and Installation

INFOID:000000000957335

### REMOVAL

1. Move the A/T selector lever to N position and release the parking brake.
2. Remove the floor reinforcement.
3. Remove the center muffler with power tool. Refer to [EX-5, "Removal and Installation"](#).
4. Remove the heat plate (1).

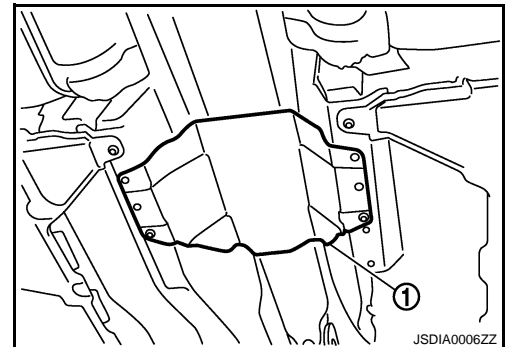

# REAR PROPELLER SHAFT

< ON-VEHICLE REPAIR >

[REAR PROPELLER SHAFT: 3F80A-1VL107]

5. Put matching marks on propeller shaft flange yoke with transfer companion flange.

**CAUTION:**

**For matching marks, use paint. Never damage propeller shaft flange yoke and transfer companion flange.**

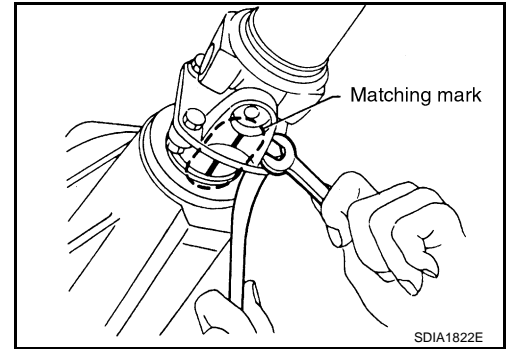

6. Put matching marks on propeller shaft rebro joint with final drive companion flange.

**CAUTION:**

**For matching marks, use paint. Never damage propeller shaft rebro joint and final drive companion flange.**

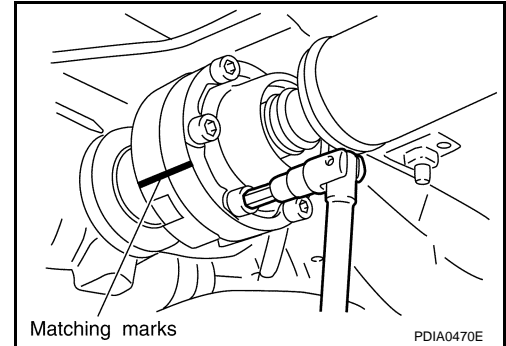

7. Loosen mounting nuts of center bearing mounting brackets.

**CAUTION:**

**Tighten mounting nuts temporarily.**

8. Remove propeller shaft assembly fixing bolts and nuts.  
9. Remove center bearing mounting bracket fixing nuts.  
10. Remove propeller shaft assembly.

**CAUTION:**

**If constant velocity joint was bent during propeller shaft assembly removal, installation, or transportation, its boot may be damaged. Wrap boot interference area to metal part with shop cloth or rubber to protect boot from breakage.**

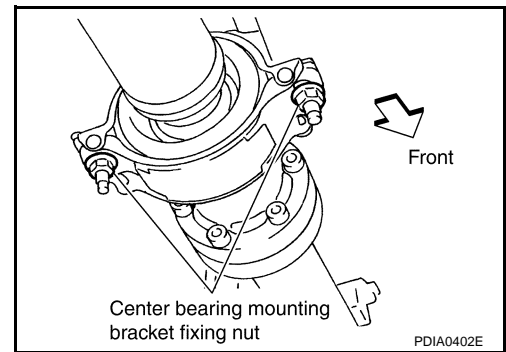

## INSTALLATION

Note the following, and install in the reverse order of removal.

# REAR PROPELLER SHAFT

< ON-VEHICLE REPAIR >

[REAR PROPELLER SHAFT: 3F80A-1VL107]

- Install center bearing mounting bracket (Upper) (1) with its arrow mark (A) facing forward.
- Adjust position of center bearing mounting bracket (1, 2) sliding back and forth to prevent play in thrust direction of center bearing insulator (3). Install bracket to vehicle.

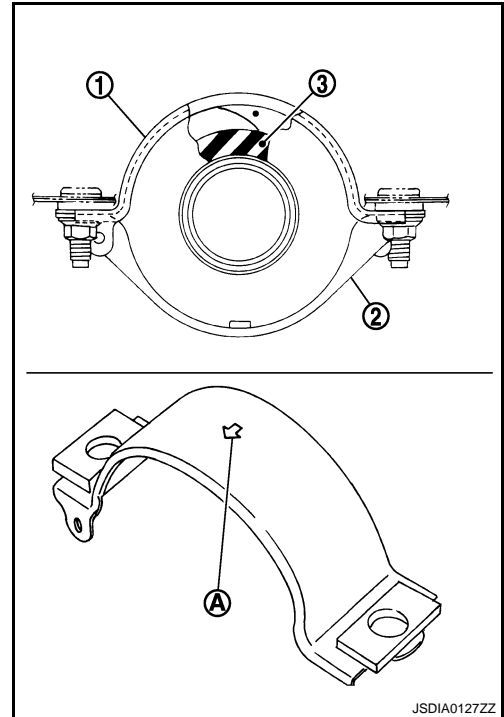

- Align matching marks to install propeller shaft flange yoke with transfer companion flange.

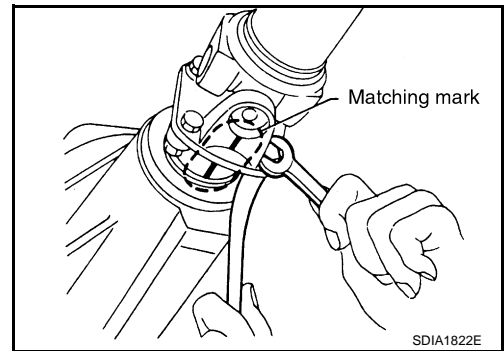

- Align matching marks to install propeller shaft rebro joint with final drive companion flange.
- After assembly, perform a driving test to check propeller shaft vibration. If vibration occurred, separate propeller shaft from final drive. Reinstall companion flange after rotating it by 60, 120, 180, 240, 300 degrees. Then perform driving test and check propeller shaft vibration again at each point.

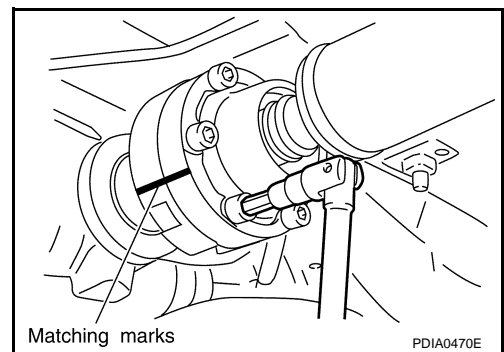

A  
B  
C  
DLN  
E  
F  
G  
H  
I  
J  
K  
L  
M  
N  
O  
P

# REAR PROPELLER SHAFT

< ON-VEHICLE REPAIR >

[REAR PROPELLER SHAFT: 3F80A-1VL107]

- If propeller shaft or final drive has been replaced, connect them as follows:
  - Install the propeller shaft while aligning its matching mark A with the matching mark B on the joint as close as possible.

**CAUTION:**

**Avoid damaging the rebro joint boot, protect it with a shop towel or equivalent.**

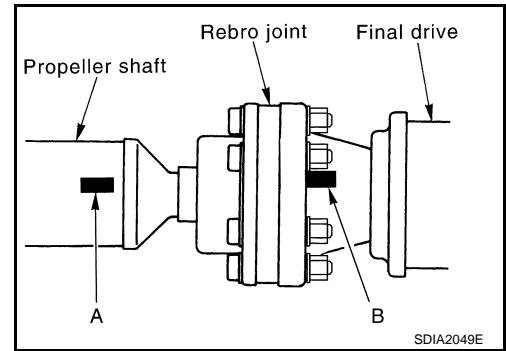

INFOID:000000000957336

## Inspection

### APPEARANCE

Check propeller shaft for bend and damage. If damage is detected, replace propeller shaft assembly.

### PROPELLER SHAFT RUNOUT

Check propeller shaft runout at measuring points. If runout exceeds specifications, replace propeller shaft assembly. For measuring point, refer to [DLN-100, "Inspection"](#).

**Limit**

**Propeller shaft runout** : Refer to [DLN-105, "Propeller Shaft Runout"](#).

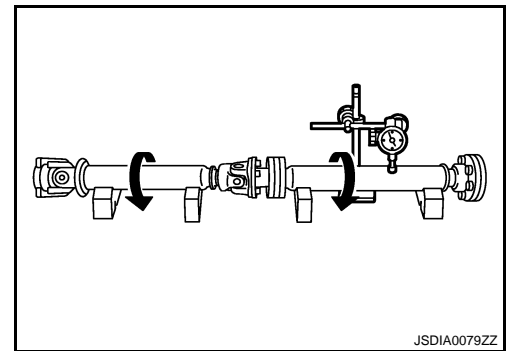

### JOURNAL AXIAL PLAY

As shown in the figure, while fixing yoke on one side, check axial play of joint. If outside the standard, replace propeller shaft assembly.

**Standard**

**Journal axial play** : Refer to [DLN-105, "Journal Axial Play"](#).

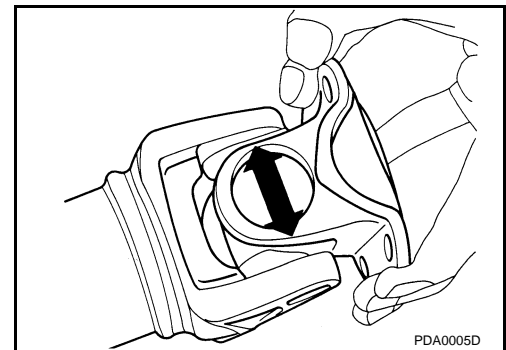

**CAUTION:**

**Never disassemble joints.**

### CENTER BEARING

Check center bearing for noise and damage. If noise or damage is detected, replace propeller shaft assembly.

**CAUTION:**

**Never disassemble center bearing.**



# SERVICE DATA AND SPECIFICATIONS (SDS)

< SERVICE DATA AND SPECIFICATIONS (SDS)

[REAR PROPELLER SHAFT: 3F80A-1VL107]

## SERVICE DATA AND SPECIFICATIONS (SDS)

### SERVICE DATA AND SPECIFICATIONS (SDS)

#### General Specifications

INFOID:0000000000957337

Applied model		AWD
		VQ35HR
		A/T
Propeller shaft model		3F80A-1VL107
Number of joints		3
Type of journal bearings (Non-disassembly type)	1st joint	Shell type
	2nd joint	Shell type
	3rd joint	Rebro joint type
Coupling method with transfer		Flange type
Coupling method with rear final drive		Rebro joint type
Shaft length	1st (Spider to spider)	399 mm (15.71 in)
	2nd (Spider to rebro joint center)	753 mm (29.65 in)
Shaft outer diameter	1st	82.6 mm (3.25 in)
	2nd	75.0 mm (2.95 in)

#### Propeller Shaft Runout

INFOID:0000000000957338

Unit: mm (in)

Item	Limit
Propeller shaft runout	0.8 (0.031)

#### Journal Axial Play

INFOID:0000000000957339

Unit: mm (in)

Item	Standard
Journal axial play	0 (0)

# NOISE, VIBRATION AND HARSHNESS (NVH) TROUBLESHOOTING

< SYMPTOM DIAGNOSIS >

[FRONT FINAL DRIVE: F160A]

## SYMPTOM DIAGNOSIS

### NOISE, VIBRATION AND HARSHNESS (NVH) TROUBLESHOOTING

#### NVH Troubleshooting Chart

INFOID:000000000957340

Use the chart below to help you find the cause of the symptom. If necessary, repair or replace these parts.

Symptom	Noise													
Possible cause and SUSPECTED PARTS		Gear tooth rough	Gear contact improper	Tooth surfaces worn	Backlash incorrect	Companion flange excessive runout	Gear oil improper	PROPELLER SHAFT	AXLE AND SUSPENSION	TIRES	ROAD WHEEL	DRIVE SHAFT	BRAKES	STEERING
Reference		<a href="#">DLN-134, "Inspection After Disassembly"</a>	<a href="#">DLN-130, "Adjustment"</a>	<a href="#">DLN-134, "Inspection After Disassembly"</a>	<a href="#">DLN-130, "Adjustment"</a>	<a href="#">DLN-130, "Adjustment"</a>	<a href="#">DLN-130, "Adjustment"</a>	NVH in DLN section.	NVH in FAX, RAX, FSU and RSU sections.	NVH in WT section.	NVH in WT section.	NVH in FAX and RAX section.	NVH in BR section.	NVH in ST section.
		x	x	x	x	x	x	x	x	x	x	x	x	x

x: Applicable

PRECAUTION

PRECAUTIONS

Precaution Necessary for Steering Wheel Rotation after Battery Disconnect

INFOID:000000000957341

**NOTE:**

- Before removing and installing any control units, first turn the push-button ignition switch to the LOCK position, then disconnect both battery cables.
- After finishing work, confirm that all control unit connectors are connected properly, then re-connect both battery cables.
- Always use CONSULT-III to perform self-diagnosis as a part of each function inspection after finishing work. If a DTC is detected, perform trouble diagnosis according to self-diagnosis results.

This vehicle is equipped with a push-button ignition switch and a steering lock unit.

If the battery is disconnected or discharged, the steering wheel will lock and cannot be turned.

If turning the steering wheel is required with the battery disconnected or discharged, follow the procedure below before starting the repair operation.

OPERATION PROCEDURE

1. Connect both battery cables.

**NOTE:**

Supply power using jumper cables if battery is discharged.

2. Carry the Intelligent Key or insert it to the key slot and turn the push-button ignition switch to ACC position. (At this time, the steering lock will be released.)
3. Disconnect both battery cables. The steering lock will remain released with both battery cables disconnected and the steering wheel can be turned.
4. Perform the necessary repair operation.
5. When the repair work is completed, re-connect both battery cables. With the brake pedal released, turn the push-button ignition switch from ACC position to ON position, then to LOCK position. (The steering wheel will lock when the push-button ignition switch is turned to LOCK position.)
6. Perform self-diagnosis check of all control units using CONSULT-III.

Service Notice or Precautions for Front Final Drive

INFOID:000000000957342

**CAUTION:**

- Check for the correct installation status prior to removal or disassembly. If matching marks are required, be certain they do not interfere with the function of the parts when applied.
- Overhaul should be done in a clean work area, it is preferable to work in dustproof area.
- Before disassembly, using steam or white gasoline, completely remove sand and mud from the exterior of the unit, preventing them from entering into the unit during disassembly or assembly.
- Check appearance of the disassembled parts for damage, deformation, and unusual wear. Replace them with a new ones if necessary.
- Gaskets, seals and O-rings should be replaced any time when the unit is disassembled.
- In principle, tighten bolts or nuts gradually in several steps working diagonally from inside to outside. If tightening sequence is specified, observe it.
- Clean and flush the parts sufficiently and blow-dry them.
- Be careful not to damage sliding surfaces and mating surfaces.
- When applying sealant, remove the old sealant from the mounting surface; then remove any moisture, oil, and foreign materials from the application and mounting surfaces.
- Always use shop paper for cleaning the inside of components.
- Avoid using cotton gloves or shop rags to prevent entering of lint.
- During assembly, observe the specified tightening torque, and apply new gear oil, petroleum jelly, or multi-purpose grease as specified for each vehicle, if necessary.

**NOTE:**

Front oil seal cannot be replaced on vehicle, because of no room.

A  
B  
C  
DLN  
E  
F  
G  
H  
I  
J  
K  
L  
M  
N  
O  
P

# PREPARATION

< PREPARATION >

[FRONT FINAL DRIVE: F160A]

## PREPARATION

### PREPARATION

#### Special Service Tools

INFOID:000000000957343

The actual shapes of Kent-Moore tools may differ from those of special service tools illustrated here.

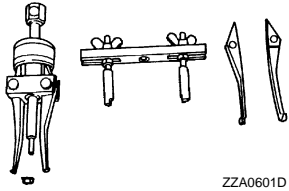
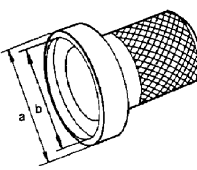
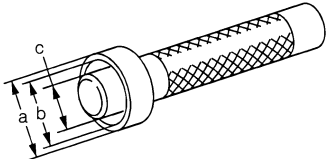
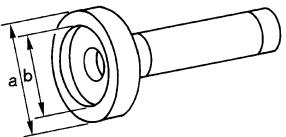
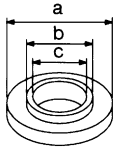
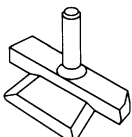
Tool number (Kent-Moore No.) Tool name	Description
KV381054S0 (J-34286) Puller   ZZA0601D	<ul style="list-style-type: none"> <li>• Removing side oil seal (right side)</li> <li>• Removing side bearing outer race</li> </ul>
ST33400001 (J-26082) Drift a: 60 mm (2.36 in) dia. b: 47 mm (1.85 in) dia.   ZZA0702D	<ul style="list-style-type: none"> <li>• Installing side oil seal (right side)</li> <li>• Installing front oil seal</li> </ul>
KV38102100 (J-25803-01) Drift a: 44 mm (1.73 in) dia. b: 36 mm (1.42 in) dia. c: 24.5 mm (0.965 in) dia.   ZZA1046D	Installing side oil seal (left side)
KV38100200 ( — ) Drift a: 65 mm (2.56 in) dia. b: 49 mm (1.93 in) dia.   ZZA1143D	Installing side shaft oil seal
ST30032000 (J-26010-01) Drift a: 80 mm (3.15 in) dia. b: 38 mm (1.50 in) dia. c: 31 mm (1.22 in) dia.   S-NT107	<ul style="list-style-type: none"> <li>• Installing side shaft</li> <li>• Installing pinion rear bearing inner race</li> </ul>
KV10111100 (J-37228) Seal cutter   S-NT046	Removing carrier cover

# PREPARATION

< PREPARATION >

[FRONT FINAL DRIVE: F160A]

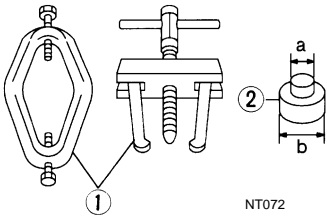
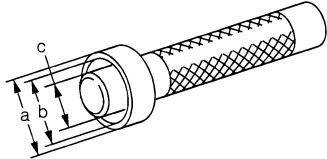
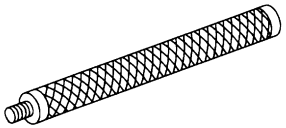
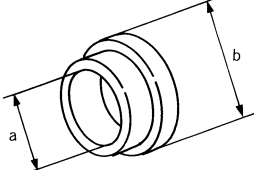
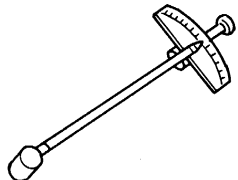
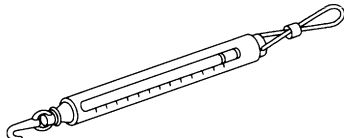
Tool number (Kent-Moore No.) Tool name	Description	
ST3306S001 (J-22888-D) Differential side bearing puller set 1: ST33051001 (J-22888-20) Puller 2: ST33061000 (J-8107-2) Base a: 28.5 mm (1.122 in) dia. b: 38 mm (1.50 in) dia.	 <p style="text-align: center;">NT072</p>	A B C <b>DLN</b>
ST33230000 (J-25805-01) Drift a: 51 mm (2.01 in) dia. b: 41 mm (1.61 in) dia. c: 28.5 mm (1.122 in) dia.	 <p style="text-align: center;">ZZA1046D</p>	E F
ST30611000 (J-25742-1) Drift bar	 <p style="text-align: center;">S-NT090</p>	G H I
KV31103000 (J-38982) Drift a: 49 mm (1.93 in) dia. b: 70 mm (2.76 in) dia.	 <p style="text-align: center;">ZZA1113D</p>	J K
ST3127S000 (J-25765-A) Preload gauge	 <p style="text-align: center;">ZZA0806D</p>	L M
(J-8129) Spring gauge	 <p style="text-align: center;">NT127</p>	N O P

# PREPARATION

< PREPARATION >

[FRONT FINAL DRIVE: F160A]

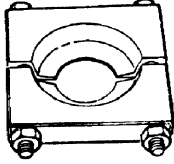
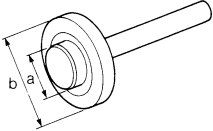
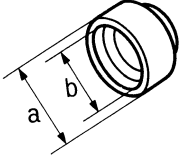
Tool number (Kent-Moore No.) Tool name	Description
ST30031000 (J-22912-01) Replacer	Removing pinion rear bearing inner race
 ZZA0700D	
ST37820000 ( — ) Drift a: 39 mm (1.54 in) dia. b: 72 mm (2.83 in) dia.	Installing pinion front and rear bearing outer race
 ZZA0836D	
KV38102510 ( — ) Drift a: 71 mm (2.80 in) dia. b: 65 mm (2.56 in) dia.	Installing front oil seal
 ZZA0838D	

## Commercial Service Tools

*INFOID:000000000957344*

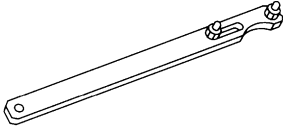
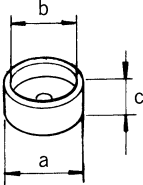
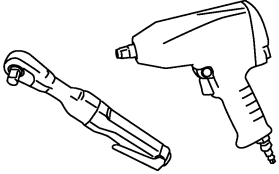
Tool name	Description
Flange wrench	Removing and installing drive pinion lock nut
 NT035	
Spacer a: 60 mm (2.36 in) dia. b: 36 mm (1.42 in) dia. c: 30 mm (1.18 in)	Installing pinion front bearing inner race
 ZZA1133D	
Power tool	Loosening bolts and nuts
 PBIC0190E	

# FRONT FINAL DRIVE ASSEMBLY

< FUNCTION DIAGNOSIS >

[FRONT FINAL DRIVE: F160A]

## FUNCTION DIAGNOSIS

### FRONT FINAL DRIVE ASSEMBLY

#### System Diagram

INFOID:000000000957345

#### CROSS-SECTION VIEW

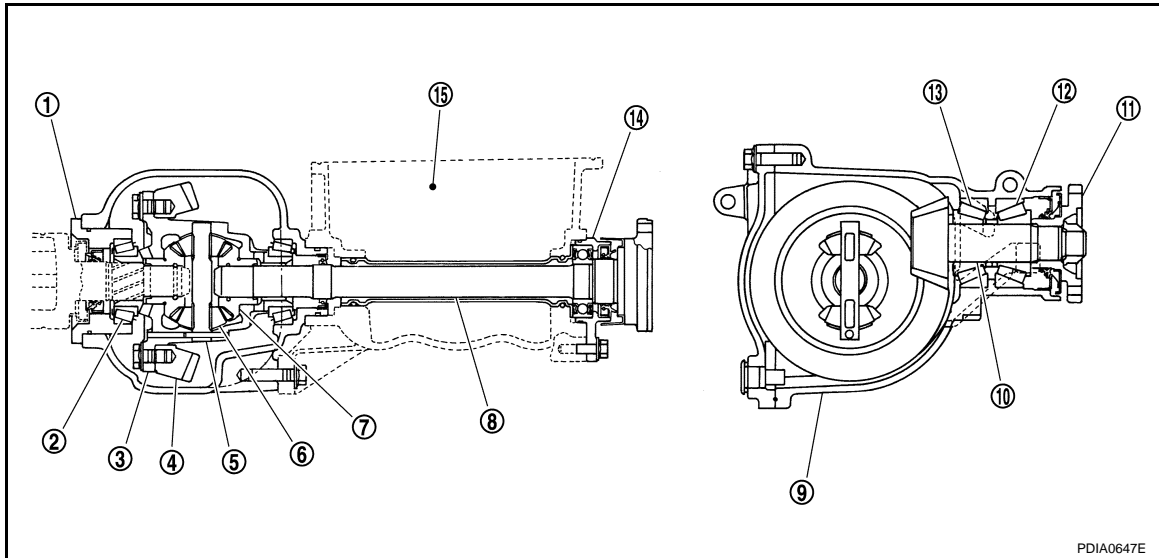

- |                         |                             |                          |
|-------------------------|-----------------------------|--------------------------|
| 1. Side retainer        | 2. Side bearing             | 3. Differential case     |
| 4. Drive gear           | 5. Pinion mate shaft        | 6. Pinion mate gear      |
| 7. Side gear            | 8. Side shaft               | 9. Gear carrier          |
| 10. Drive pinion        | 11. Companion flange        | 12. Pinion front bearing |
| 13. Pinion rear bearing | 14. Extension tube retainer | 15. Engine assembly      |

A  
B  
C  
DLN  
E  
F  
G  
H  
I  
J  
K  
L  
M  
N  
O  
P

# FRONT DIFFERENTIAL GEAR OIL

< ON-VEHICLE MAINTENANCE >

[FRONT FINAL DRIVE: F160A]

## ON-VEHICLE MAINTENANCE

### FRONT DIFFERENTIAL GEAR OIL

#### Inspection

INFOID:000000000957346

#### OIL LEAKAGE

Make sure that oil is not leaking from final drive assembly or around it.

#### OIL LEVEL

- Remove filler plug (1) and check oil level from filler plug mounting hole as shown in the figure.

**CAUTION:**

**Never start engine while checking oil level.**

- Set a gasket on filler plug (1) and install it on final drive assembly. Refer to [DLN-119, "Exploded View"](#).

**CAUTION:**

**Never reuse gasket.**

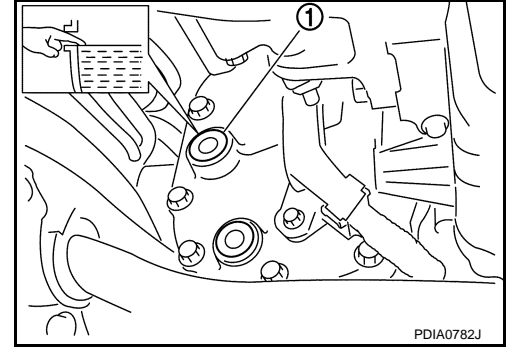

#### Draining

INFOID:000000000957347

- Stop engine.
- Remove drain plug (1) and drain gear oil.
- Set a gasket on drain plug (1) and install it to final drive assembly and tighten to the specified torque. Refer to [DLN-119, "Exploded View"](#).

**CAUTION:**

**Never reuse gasket.**

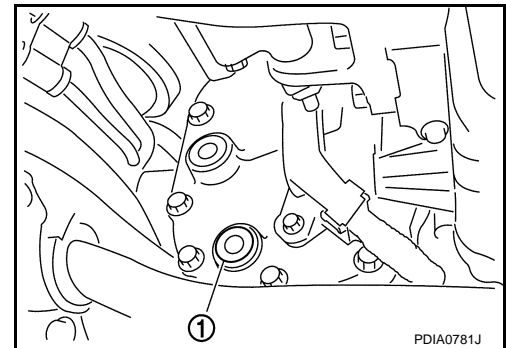

#### Refilling

INFOID:000000000957348

- Remove filler plug (1). Fill with new gear oil until oil level reaches the specified level near filler plug mounting hole.

**Oil grade and Viscosity** : Refer to [MA-10, "Fluids and Lubricants"](#).

**Oil capacity** : Refer to [DLN-144, "General Specifications"](#).

- After refilling oil, check oil level. Set a gasket to filler plug (1), then install it to final drive assembly. Refer to [DLN-119, "Exploded View"](#).

**CAUTION:**

**Never reuse gasket.**

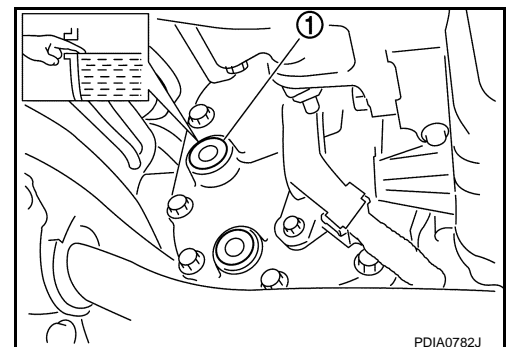





# SIDE OIL SEAL

< ON-VEHICLE REPAIR >

[FRONT FINAL DRIVE: F160A]

- |                               |                                   |                               |
|-------------------------------|-----------------------------------|-------------------------------|
| 28. Pinion mate thrust washer | 29. Pinion mate gear              | 30. Pinion mate shaft         |
| 31. Lock pin                  | 32. Side bearing adjusting washer | 33. Side oil seal (left side) |
| 34. Side shaft bearing        | 35. Extension tube retainer       | 36. Side shaft oil seal       |
| 37. Dust sealed               | 38. Side shaft                    |                               |

A: Oil seal lip

B: Screw hole



Apply gear oil.



Apply anti-corrosion oil.



Apply Genuine Silicone RTV or equivalent. Refer to [GI-15. "Recommended Chemical Products and Sealants"](#).



Apply Genuine Medium Strength Thread Locking Sealant or equivalent. Refer to [GI-15. "Recommended Chemical Products and Sealants"](#).

Refer to [GI-4. "Components"](#) for symbols not described on the above.

## RIGHT SIDE : Removal and Installation

INFOID:000000000957350

### REMOVAL

1. Remove the front drive shaft. Refer to [FAX-23. "Exploded View"](#).
2. Remove the side oil seal using a puller (A) [SST: KV381054S0 (J-34286)].

**CAUTION:**

**Never damage gear carrier.**

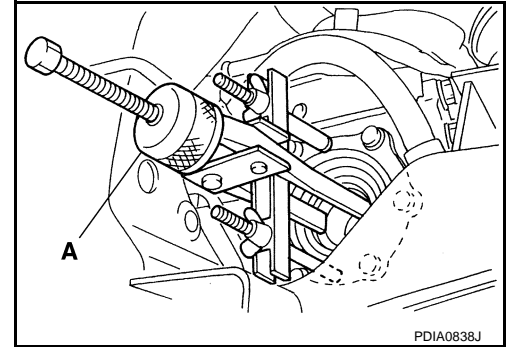

### INSTALLATION

1. Apply multi-purpose grease to sealing lips of side oil seal.
2. Using the drift (A) [SST: ST33400001 (J-26082)], press-fit side oil seal so that its surface comes face to face with the end surface of the side retainer.

**CAUTION:**

- **Never reuse oil seal.**
- **When installing, never incline oil seal.**

3. Install the front drive shaft. Refer to [FAX-23. "Exploded View"](#).
4. When oil leaks while removing, check oil level after the installation. Refer to [DLN-112. "Inspection"](#).

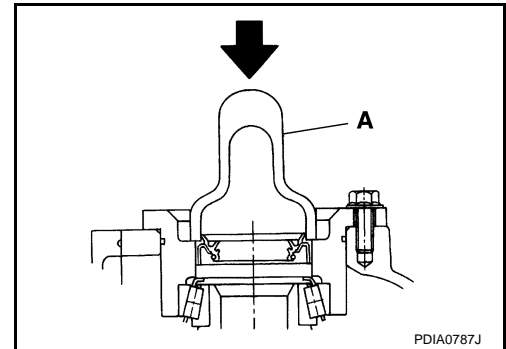

## LEFT SIDE

### LEFT SIDE : Exploded View

INFOID:000000000957351

# SIDE OIL SEAL

< ON-VEHICLE REPAIR >

[FRONT FINAL DRIVE: F160A]

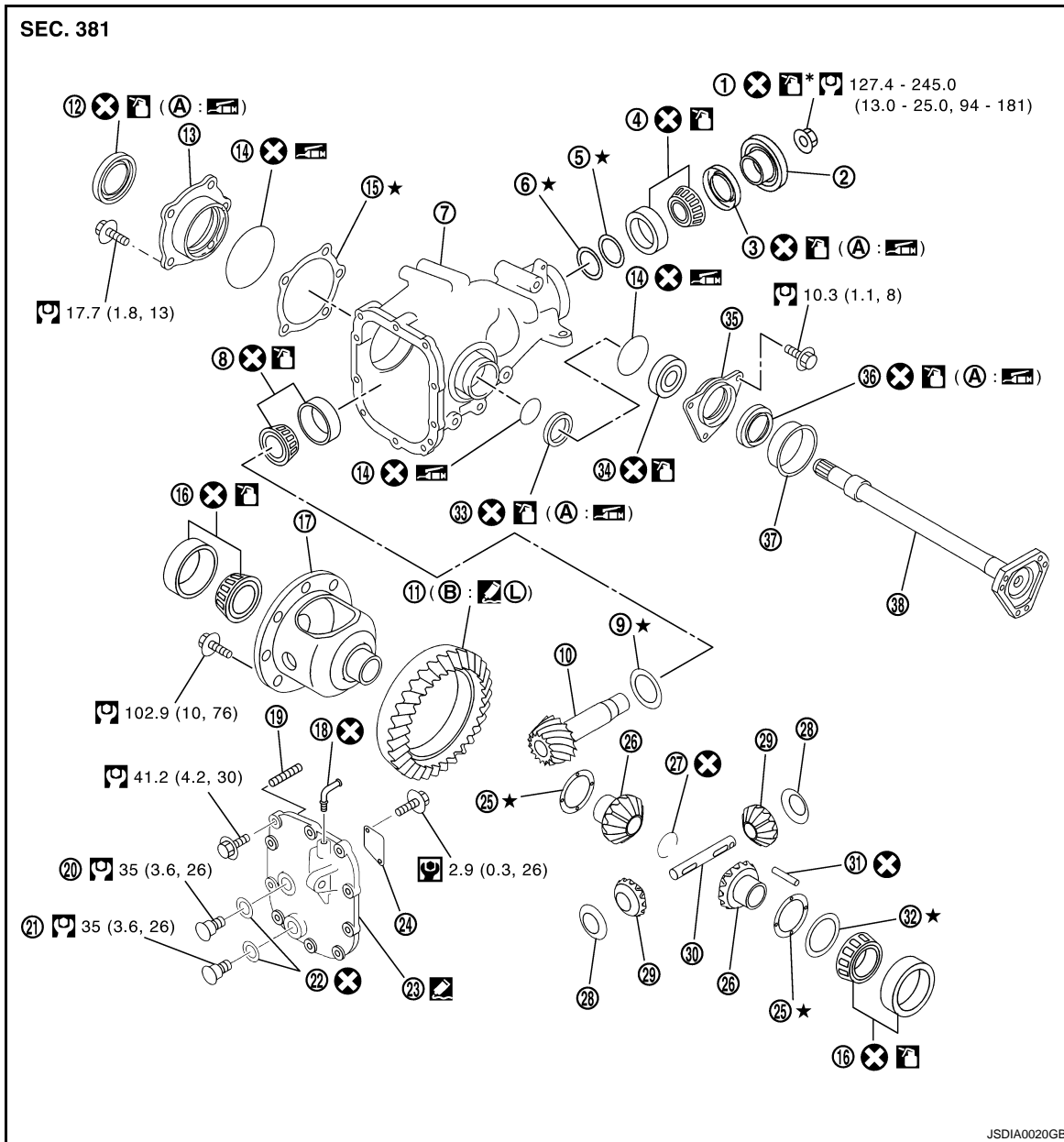

- |                               |  |                                   |
|-------------------------------|--|-----------------------------------|
| 1. Drive pinion lock nut      | 2. Companion flange                      | 3. Front oil seal                 |
| 4. Pinion front bearing       | 5. Drive pinion bearing adjusting washer | 6. Drive pinion adjusting washer  |
| 7. Gear carrier               | 8. Pinion rear bearing                   | 9. Pinion height adjusting washer |
| 10. Drive pinion              | 11. Drive gear                           | 12. Side oil seal (right side)    |
| 13. Side retainer             | 14. O-ring                               | 15. Side bearing adjusting shim   |
| 16. Side bearing              | 17. Differential case                    | 18. Breather connector            |
| 19. Dowel pin                 | 20. Filler plug                          | 21. Drain plug                    |
| 22. Gasket                    | 23. Carrier cover                        | 24. Gear oil defense              |
| 25. Side gear thrust washer   | 26. Side gear                            | 27. Circular clip                 |
| 28. Pinion mate thrust washer | 29. Pinion mate gear                     | 30. Pinion mate shaft             |
| 31. Lock pin                  | 32. Side bearing adjusting washer        | 33. Side oil seal (left side)     |
| 34. Side shaft bearing        | 35. Extension tube retainer              | 36. Side shaft oil seal           |
| 37. Dust sealed               | 38. Side shaft                           |                                   |

A: Oil seal lip

B: Screw hole

A

B

C

DLN

E

F

G

H

I

J

K





L

M

N

O

P

-  Apply gear oil.
  -  Apply anti-corrosion oil.
  -  Apply Genuine Silicone RTV or equivalent. Refer to [GI-15, "Recommended Chemical Products and Sealants"](#).
  -  Apply Genuine Medium Strength Thread Locking Sealant or equivalent. Refer to [GI-15, "Recommended Chemical Products and Sealants"](#).
- Refer to [GI-4, "Components"](#) for symbols not described on the above.

## LEFT SIDE : Removal and Installation

INFOID:000000000957352

## REMOVAL

1. Remove the front final drive assembly from vehicle with power tool. Refer to [DLN-117, "Exploded View"](#).  
**NOTE:**  
**Left side oil seal is attached to engine assembly. Replace it after removing front final drive assembly from vehicle.**
2. Remove the side oil seal using a flat-bladed screwdriver.  
**CAUTION:**  
**Never damage gear carrier.**

## INSTALLATION

1. Apply multi-purpose grease to sealing lips of side oil seal.
2. Using the drift (A) [SST: KV38102100 (J-25803-01)], press-fit side oil seal so that its surface comes face to face with the end surface of the gear carrier.  
**CAUTION:**
  - Never reuse oil seal.
  - When installing, never incline oil seal.
3. Install the front final drive assembly on vehicle. Refer to [DLN-117, "Exploded View"](#).
4. Install the front drive shaft. Refer to [FAX-23, "Exploded View"](#).
5. When oil leaks while removing, check oil level after the installation. Refer to [DLN-112, "Inspection"](#).

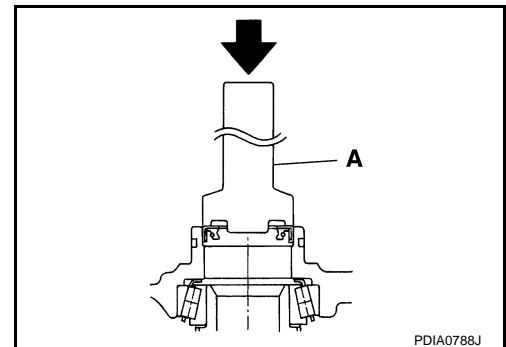

# FRONT FINAL DRIVE ASSEMBLY

< REMOVAL AND INSTALLATION >

[FRONT FINAL DRIVE: F160A]

## REMOVAL AND INSTALLATION

### FRONT FINAL DRIVE ASSEMBLY

#### Exploded View

INFOID:000000000957353

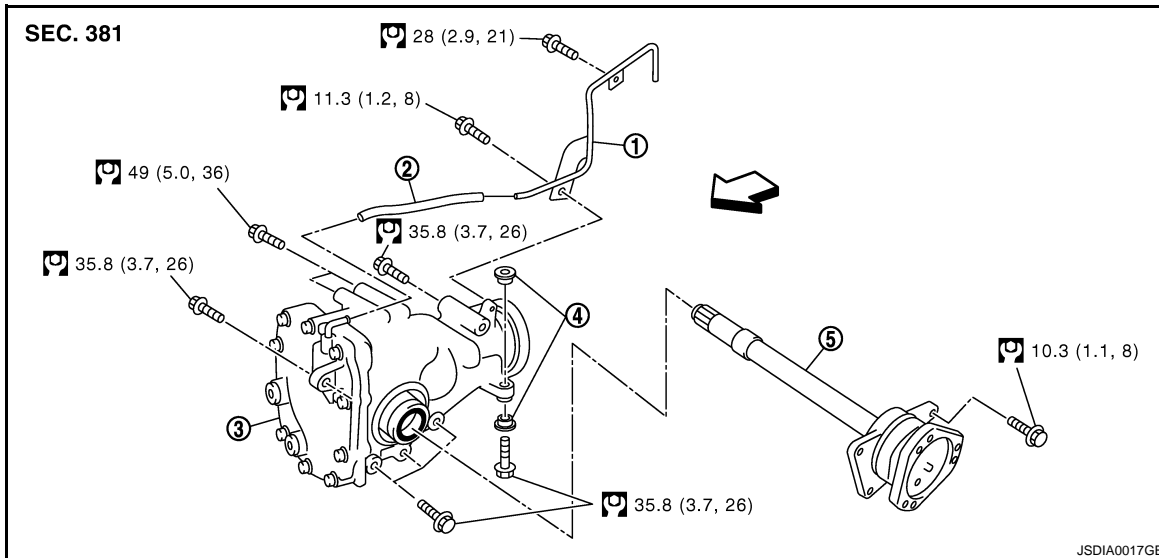

- |                  |                  |                               |
|------------------|------------------|-------------------------------|
| 1. Breather tube | 2. Breather hose | 3. Front final drive assembly |
| 4. Bushing       | 5. Side shaft    |                               |

←: Vehicle front

Refer to [GI-4, "Components"](#) for symbols in the figure.

### Removal and Installation

INFOID:000000000957354

#### REMOVAL

1. Remove front drive shaft both. Refer to [FAX-23, "Exploded View"](#).
2. Remove front crossbar with power tool.
3. Separate steering outer socket and steering knuckle. Refer to [ST-33, "AWD : Exploded View"](#).
4. Remove side shaft.
5. Remove three way catalyst (right bank) with power tool. Refer to [EX-5, "Exploded View"](#).
6. Remove front propeller shaft. Refer to [DLN-80, "Exploded View"](#).
7. Separate power steering solenoid valve connector.
8. Separate power steering hydraulic line. Refer to [ST-56, "AWD : Exploded View"](#).
9. Remove stabilizer assembly with power tool. Refer to [FSU-39, "Exploded View"](#).
10. Separate steering lower joint and steering gear assembly. Refer to [ST-33, "AWD : Exploded View"](#).
11. Set a suitable jack to engine.
12. Remove front suspension member with power tool. Refer to [FSU-39, "Exploded View"](#).
13. Remove breather hose and tube.
14. Remove engine mounting bracket (RH) (Lower) and engine mounting insulator (RH) with power tool. Refer to [EM-81, "AWD : Exploded View"](#).
15. Remove final drive assembly mounting bolts with power tool and separate front final drive assembly from engine.

#### INSTALLATION

Note the following, and installation is in the reverse order of removal.

# FRONT FINAL DRIVE ASSEMBLY

## < REMOVAL AND INSTALLATION >

[FRONT FINAL DRIVE: F160A]

- When installing the side shaft, apply multi-purpose grease to contact surface of side shaft and side shaft oil seal.
- Tighten mounting bolts in the order as described below when installing front final drive assembly: side of gear carrier (1), upper side of gear carrier (2), part of carrier cover (3), lower part of gear carrier (4).

**CAUTION:**

Align the mating faces of gear carrier and oil pan for installation.

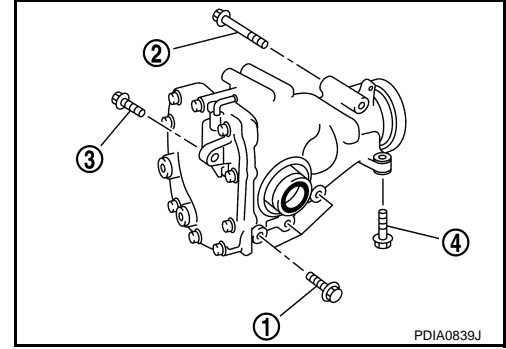

- When installing breather hose (1) and tube (2), refer to the figure.

**CAUTION:**

Make sure there are no pinched or restricted areas on the breather hose caused by bending or winding when installing it.

- Make sure the paint mark facing up (←).
- Securely install the hose until it seats the rounded portion of the tube. (←).
- Face the bend of the breather hose (↔) to the engine.
- When oil leaks while removing final drive assembly, check oil level after the installation. Refer to [DLN-112, "Inspection"](#).

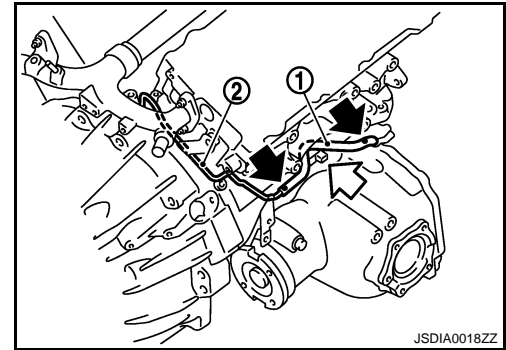

# SIDE SHAFT

< DISASSEMBLY AND ASSEMBLY >

[FRONT FINAL DRIVE: F160A]

## DISASSEMBLY AND ASSEMBLY

### SIDE SHAFT

#### Exploded View

INFOID:000000000957355

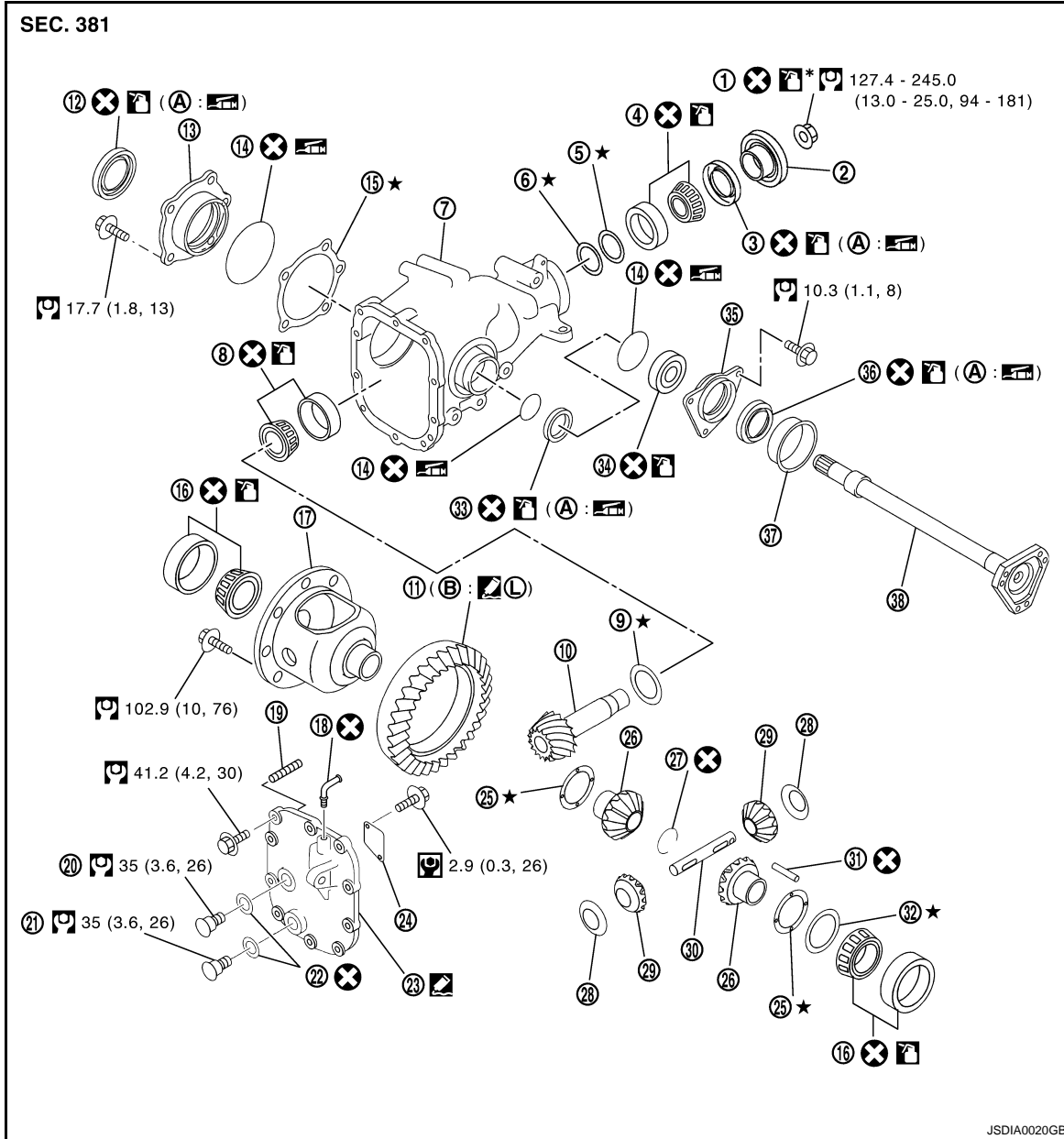

- |                               |  |                                   |
|-------------------------------|--|-----------------------------------|
| 1. Drive pinion lock nut      | 2. Companion flange                      | 3. Front oil seal                 |
| 4. Pinion front bearing       | 5. Drive pinion bearing adjusting washer | 6. Drive pinion adjusting washer  |
| 7. Gear carrier               | 8. Pinion rear bearing                   | 9. Pinion height adjusting washer |
| 10. Drive pinion              | 11. Drive gear                           | 12. Side oil seal (right side)    |
| 13. Side retainer             | 14. O-ring                               | 15. Side bearing adjusting shim   |
| 16. Side bearing              | 17. Differential case                    | 18. Breather connector            |
| 19. Dowel pin                 | 20. Filler plug                          | 21. Drain plug                    |
| 22. Gasket                    | 23. Carrier cover                        | 24. Gear oil defense              |
| 25. Side gear thrust washer   | 26. Side gear                            | 27. Circular clip                 |
| 28. Pinion mate thrust washer | 29. Pinion mate gear                     | 30. Pinion mate shaft             |

# SIDE SHAFT

## < DISASSEMBLY AND ASSEMBLY >

[FRONT FINAL DRIVE: F160A]

- |                        |                                   |                               |
|------------------------|-----------------------------------|-------------------------------|
| 31. Lock pin           | 32. Side bearing adjusting washer | 33. Side oil seal (left side) |
| 34. Side shaft bearing | 35. Extension tube retainer       | 36. Side shaft oil seal       |
| 37. Dust sealed        | 38. Side shaft                    |                               |
- A: Oil seal lip  
B: Screw hole

 Apply gear oil.

 Apply anti-corrosion oil.

 Apply Genuine Silicone RTV or equivalent. Refer to [GI-15. "Recommended Chemical Products and Sealants"](#).

 Apply Genuine Medium Strength Thread Locking Sealant or equivalent. Refer to [GI-15. "Recommended Chemical Products and Sealants"](#).

Refer to [GI-4. "Components"](#) for symbols not described on the above.

## Disassembly

INFOID:000000000957356

1. Hold extension tube retainer with puller, then press out side shaft using a press.

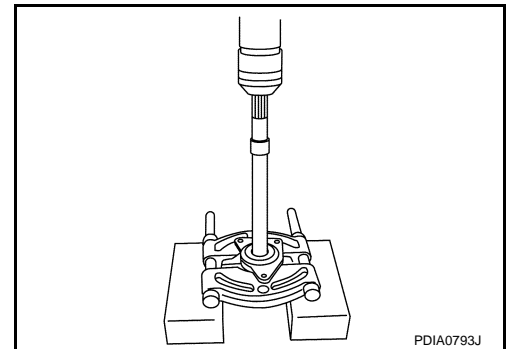

2. Remove side shaft oil seal (1) from extension tube retainer with a flat-blade screwdriver.  
**CAUTION:**  
**Never damage extension tube retainer.**
3. Remove side shaft bearing from extension tube retainer.
4. Remove O-ring from extension tube retainer.
5. Remove dust sealed from side shaft.

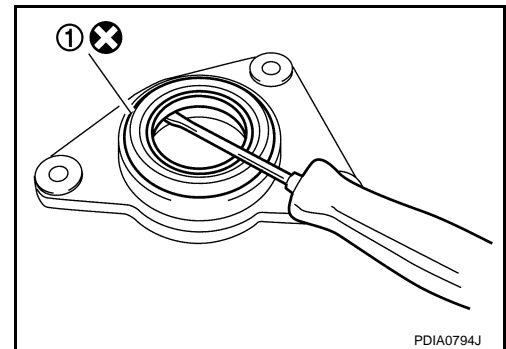

## Assembly

INFOID:000000000957357

1. Using the drift (A) [SST: KV38100200 ( — )], install side shaft oil seal.  
**CAUTION:**
  - Never reuse oil seal.
  - When installing, do not incline oil seal.
  - Apply multi-purpose grease onto oil seal lips, and gear oil onto the circumference of oil seal.
2. Install dust sealed.

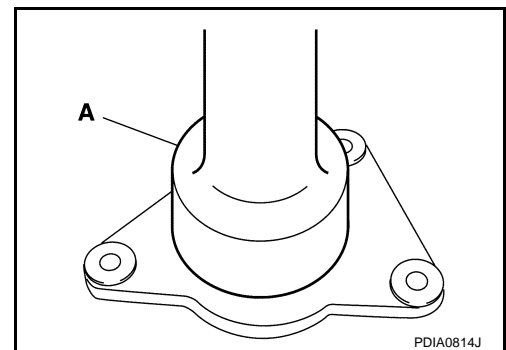



# SIDE SHAFT

## < DISASSEMBLY AND ASSEMBLY >

[FRONT FINAL DRIVE: F160A]

3. Support side shaft bearing with the drift (A) [SST: ST30032000 (J-26010-01)], then press side shaft (1) into the side shaft bearing using a press.
4. Apply multi-purpose grease to O-ring, and install it to extension tube retainer.

**CAUTION:**

**Never reuse O-ring.**

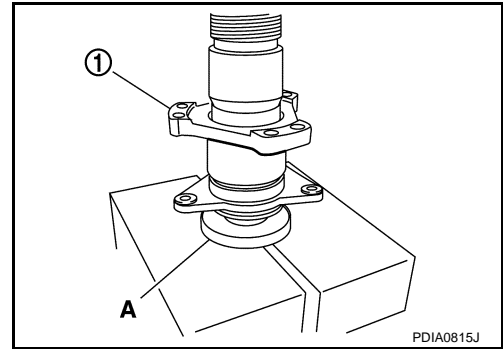

## Inspection After Disassembly

INFOID:000000000957358

Clean up the disassembled parts. Then, inspect if the parts are worn or damaged. If so, follow the measures below.

Content	Conditions and Measures
Hypoid gear	<ul style="list-style-type: none"> <li>• If the gear teeth do not mesh or line-up correctly, determine the cause and adjust or replace as necessary.</li> <li>• If the gears are worn, cracked, damaged, pitted or chipped (by friction) noticeably, replace with new drive gear and drive pinion as a set.</li> </ul>
Bearing	<ul style="list-style-type: none"> <li>• If any chipped (by friction), pitted, worn, rusted or scratched mark, or unusual noise from the bearing is observed, replace as a bearing assembly (as a new set).</li> </ul>
Side gear and Pinion mate gear	<ul style="list-style-type: none"> <li>• If any cracks or damage on the surface of the tooth is found, replace.</li> <li>• If any worn or chipped mark on the contact sides of the thrust washer is found, replace.</li> </ul>
Side gear thrust washer and pinion mate thrust washer	<ul style="list-style-type: none"> <li>• If it is chipped (by friction), damaged, or unusually worn, replace.</li> </ul>
Oil seal	<ul style="list-style-type: none"> <li>• Whenever disassembled, replace.</li> <li>• If wear, deterioration of adherence (sealing force lips), or damage is detected on the lips, replace them.</li> </ul>
Differential case	<ul style="list-style-type: none"> <li>• If any wear or crack on the contact sides of the differential case is found, replace.</li> </ul>
Companion flange	<ul style="list-style-type: none"> <li>• If any chipped mark (about 0.1 mm, 0.004 in) or other damage on the contact sides of the lips of the companion flange is found, replace.</li> </ul>

# DIFFERENTIAL ASSEMBLY

< DISASSEMBLY AND ASSEMBLY >

[FRONT FINAL DRIVE: F160A]

## DIFFERENTIAL ASSEMBLY

Exploded View

INFOID:00000000957359

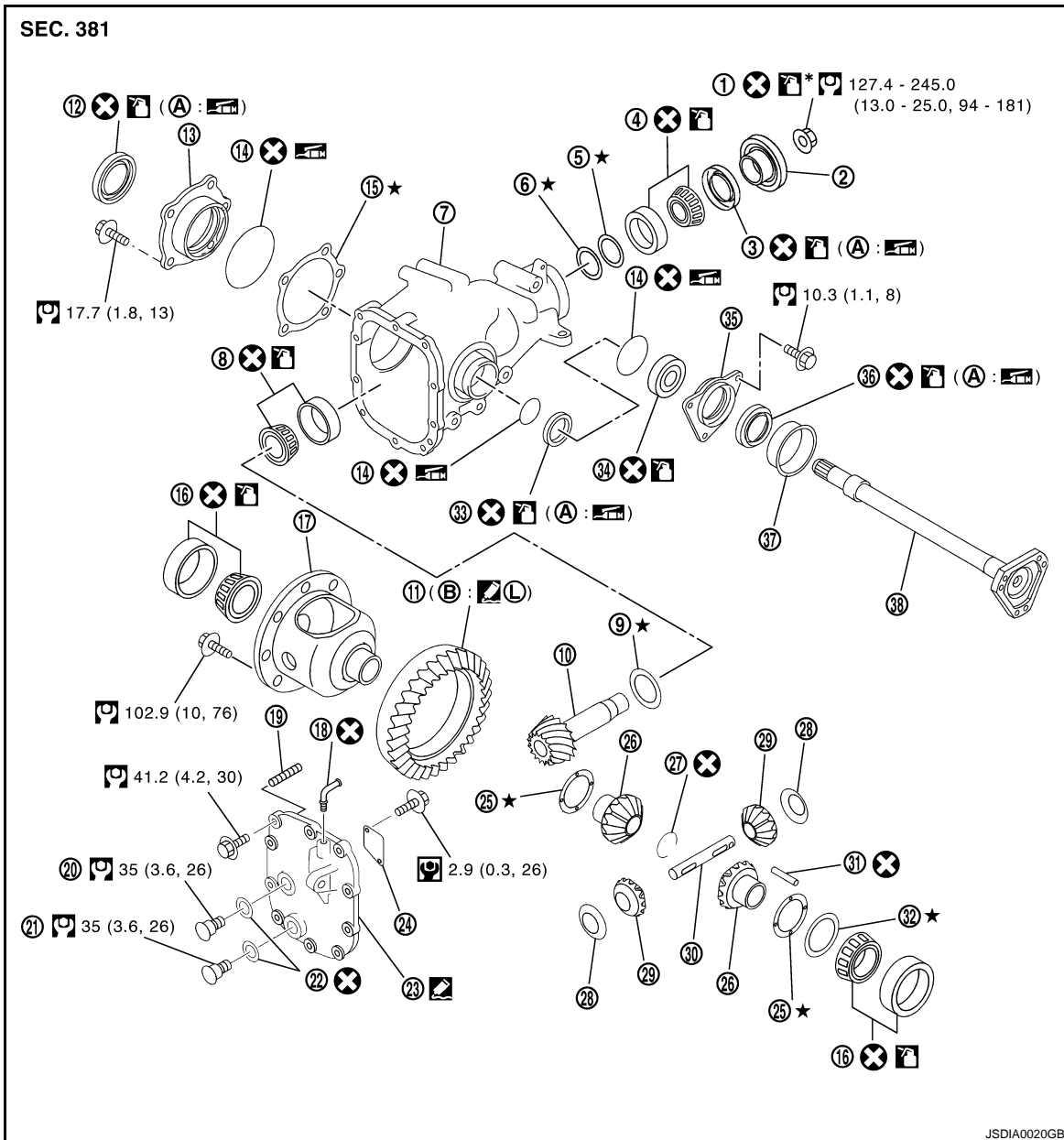

JSDIA0020GB

- |                               |  |                                   |
|-------------------------------|--|-----------------------------------|
| 1. Drive pinion lock nut      | 2. Companion flange                      | 3. Front oil seal                 |
| 4. Pinion front bearing       | 5. Drive pinion bearing adjusting washer | 6. Drive pinion adjusting washer  |
| 7. Gear carrier               | 8. Pinion rear bearing                   | 9. Pinion height adjusting washer |
| 10. Drive pinion              | 11. Drive gear                           | 12. Side oil seal (right side)    |
| 13. Side retainer             | 14. O-ring                               | 15. Side bearing adjusting shim   |
| 16. Side bearing              | 17. Differential case                    | 18. Breather connector            |
| 19. Dowel pin                 | 20. Filler plug                          | 21. Drain plug                    |
| 22. Gasket                    | 23. Carrier cover                        | 24. Gear oil defense              |
| 25. Side gear thrust washer   | 26. Side gear                            | 27. Circular clip                 |
| 28. Pinion mate thrust washer | 29. Pinion mate gear                     | 30. Pinion mate shaft             |
| 31. Lock pin                  | 32. Side bearing adjusting washer        | 33. Side oil seal (left side)     |

# DIFFERENTIAL ASSEMBLY

## < DISASSEMBLY AND ASSEMBLY >

[FRONT FINAL DRIVE: F160A]

- |                        |                             |                         |
|------------------------|-----------------------------|-------------------------|
| 34. Side shaft bearing | 35. Extension tube retainer | 36. Side shaft oil seal |
| 37. Dust sealed        | 38. Side shaft              |                         |
- A: Oil seal lip  
B: Screw hole

 Apply gear oil.

 Apply anti-corrosion oil.

 Apply Genuine Silicone RTV or equivalent. Refer to [GI-15. "Recommended Chemical Products and Sealants"](#).

 Apply Genuine Medium Strength Thread Locking Sealant or equivalent. Refer to [GI-15. "Recommended Chemical Products and Sealants"](#).

Refer to [GI-4. "Components"](#) for symbols not described on the above.

## Disassembly

INFOID:000000000957360

1. Drain gear oil, if necessary.
2. Remove carrier cover mounting bolts.
3. Remove carrier cover to insert the seal cutter (A) [SST: KV10111100 (J-37228)] between gear carrier and carrier cover.

### CAUTION:

- Never damage the mating surface.
- Never insert flat-bladed screwdriver, this way damage the mating surface.

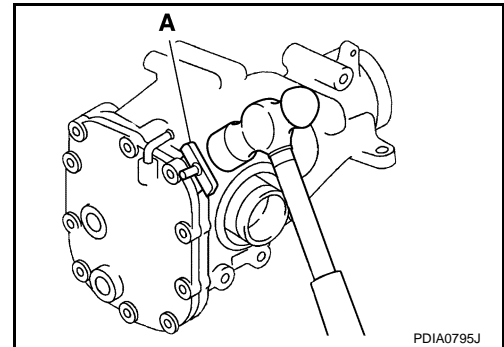

4. Remove side retainer.
5. Remove side bearing adjusting shim.
6. Remove O-ring from side retainer.

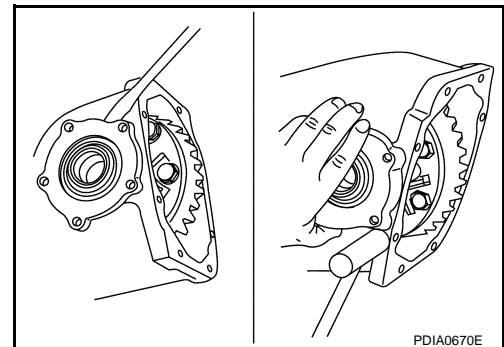

7. Remove differential case assembly from gear carrier.

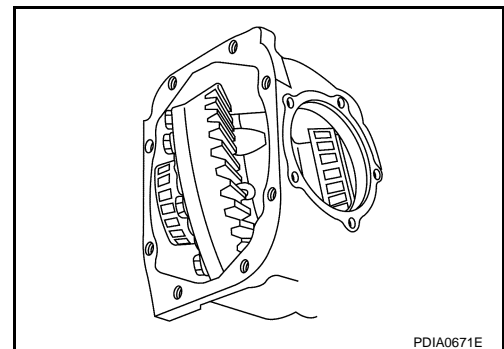

A  
B  
C  
DLN  
E  
F  
G  
H  
I  
J  
K  
L  
M  
N  
O  
P

# DIFFERENTIAL ASSEMBLY

< DISASSEMBLY AND ASSEMBLY >

[FRONT FINAL DRIVE: F160A]

8. Remove side oil seal (right side) from side retainer.

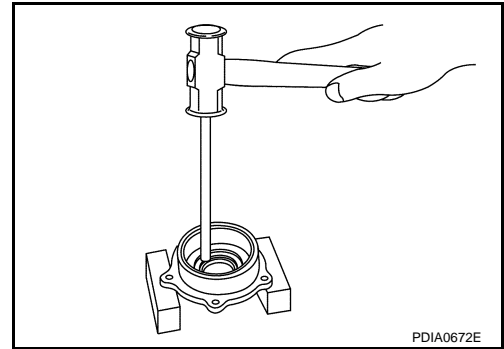

9. Remove side bearing outer race with puller (A) [SST: KV381054S0 (J-34286)].

10. Remove O-ring from gear carrier.

11. Remove side oil seal (left side) from gear carrier.

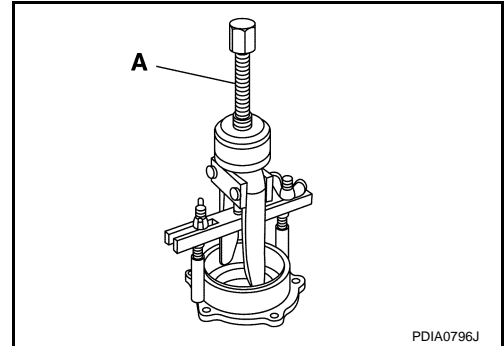

12. Remove side bearing outer race with puller (A) [SST: KV381054S0 (J-34286)].

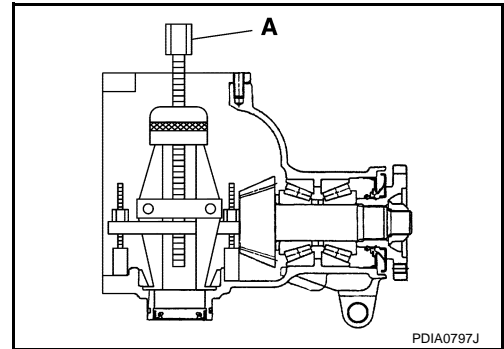

13. Remove side bearing inner race.

To prevent damage to bearing, engage puller jaws in groove (←).

A: Puller [SST: ST33051001 (J-22888-20)]

B: Base [SST: ST33061000 (J-8107-2)]

### CAUTION:

- To prevent damage to the side bearing and drive gear, place copper plates between these parts and vise.
- It is not necessary to remove side bearing inner race except it is replaced.

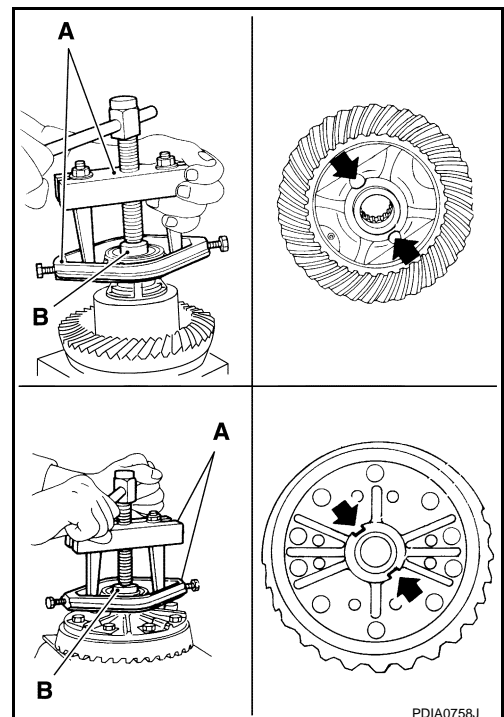

# DIFFERENTIAL ASSEMBLY

< DISASSEMBLY AND ASSEMBLY >

[FRONT FINAL DRIVE: F160A]

14. For proper reinstallation, paint matching marks on one differential case assembly.

**CAUTION:**

**For matching marks, use paint. Do not damage differential case and drive gear.**

15. Remove drive gear mounting bolts.

16. Tap drive gear off differential case assembly with a soft hammer.

**CAUTION:**

**Tap evenly all around to keep drive gear from bending.**

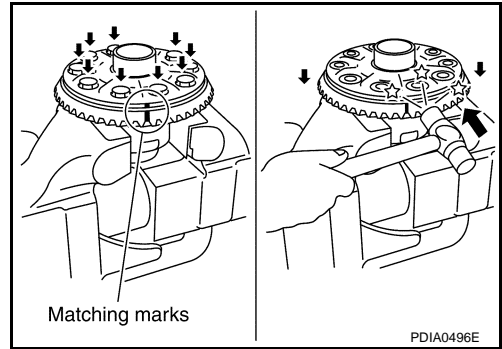

17. Remove lock pin of pinion mate shaft with a punch from drive gear side.

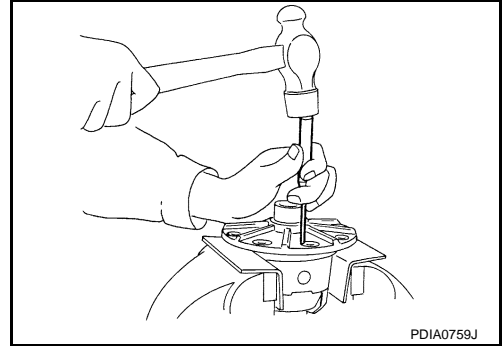

18. Remove pinion mate shaft.

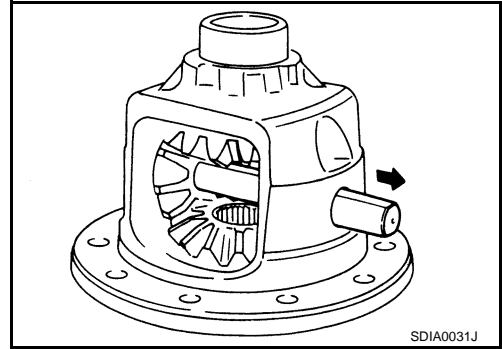

19. Turn pinion mate gear, then remove pinion mate gears, pinion mate thrust washers, side gears and side gear thrust washers from differential case.

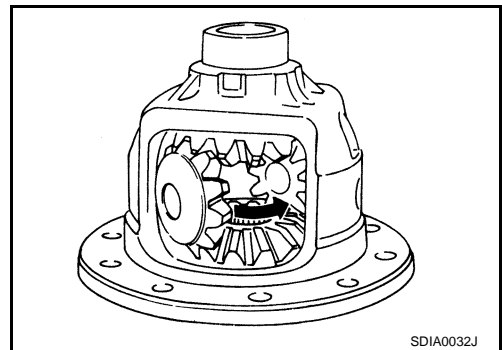

Assembly

INFOID:000000000957361

A  
B  
C  
DLN  
E  
F  
G  
H  
I  
J  
K  
L  
M  
N  
O  
P

# DIFFERENTIAL ASSEMBLY

< DISASSEMBLY AND ASSEMBLY >

[FRONT FINAL DRIVE: F160A]

1. Install side gear thrust washers with the same thickness as the ones installed prior to disassembly or reinstall the old ones on the side gears.

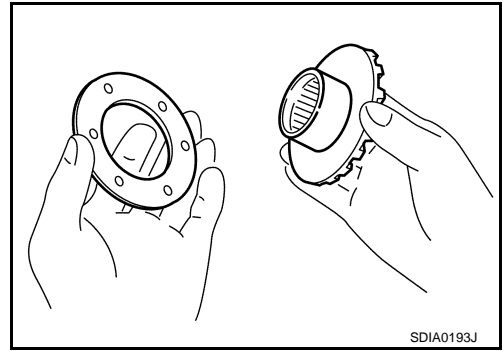

2. Install side gears and thrust washers into differential case.  
**CAUTION:**
  - Never reuse circular clip.
  - Make sure that the circular clip is installed to side gear (side retainer side).
3. Align 2 pinion mate gears in diagonally opposite positions, then rotate and install them into differential case after installing thrust washer to pinion mate gear.

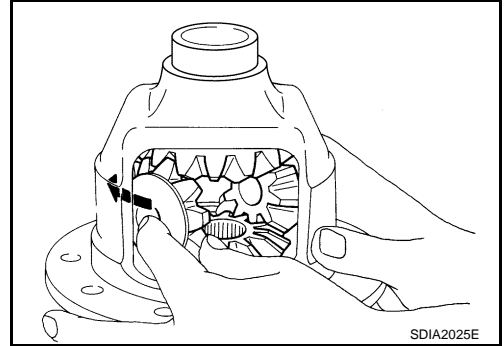

4. Align the lock pin holes on differential case with shaft, and install pinion mate shaft.

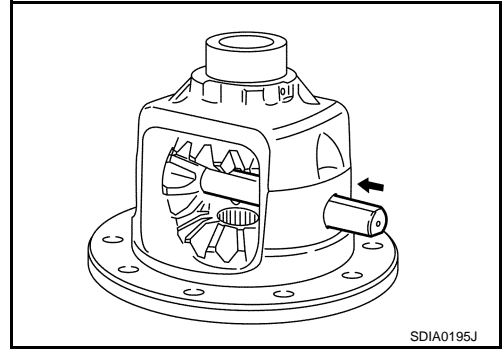

5. Measure side gear end play. If necessary, select the appropriate side gear thrust washers.
  - a. Place differential case straight up so that side gear to be measured comes upward.

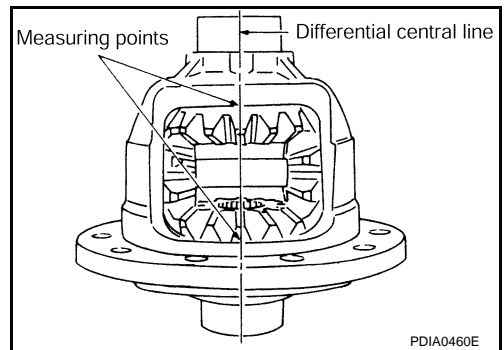

# DIFFERENTIAL ASSEMBLY

< DISASSEMBLY AND ASSEMBLY >

[FRONT FINAL DRIVE: F160A]

- b. Using feeler gauge, measure the clearance between side gear back and differential case at 3 different points, while rotating side gear. Average the 3 readings, and then measure the clearance of the other side as well.

**Standard**

**Side gear back clearance** : Refer to [DLN-144, "Differential Side Gear Clearance"](#).

**CAUTION:**

To prevent side gear from tilting, insert feeler gauges with the same thickness from both sides.

- c. If the back clearance is outside the specification, use a thicker/thinner side gear thrust washer to adjust.

**When the back clearance is large:** Use a thicker thrust washer.

**When the back clearance is small:** Use a thinner thrust washer.

**CAUTION:**

Select a side gear thrust washer for right and left individually.

- 6. Drive a lock pin into pinion mate shaft, using a punch. Make sure lock pin is flush with differential case.

**CAUTION:**

Never reuse lock pin.

- 7. Align the matching mark of drive gear with the mark of differential case, then place drive gear.

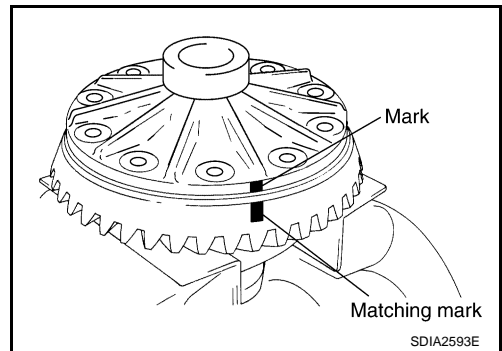
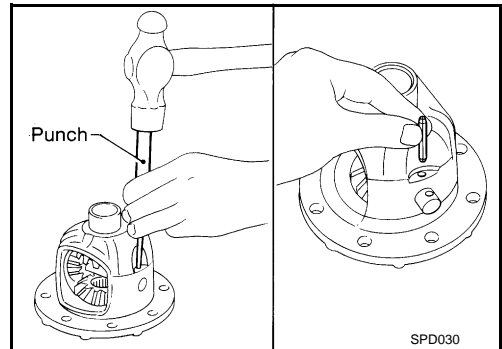
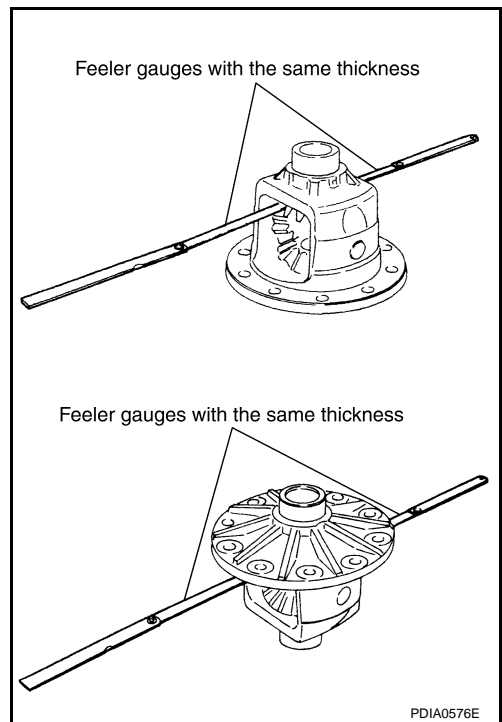

A  
B  
C  
DLN  
E  
F  
G  
H  
I  
J  
K  
L  
M  
N  
O  
P

# DIFFERENTIAL ASSEMBLY

< DISASSEMBLY AND ASSEMBLY >

[FRONT FINAL DRIVE: F160A]

8. Apply thread locking sealant into the thread hole of drive gear.
- Use Genuine Medium Strength Thread Locking Sealant or equivalent. Refer to [GI-15, "Recommended Chemical Products and Sealants"](#).

**CAUTION:**

Drive gear back and threaded holes shall be cleaned and degreased sufficiently.

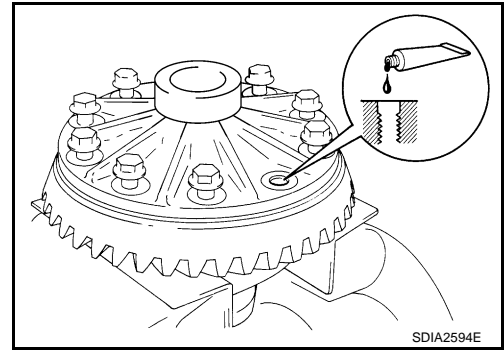

9. Install drive gear on the mounting bolts.

**CAUTION:**

Tighten bolts in a crisscross fashion.

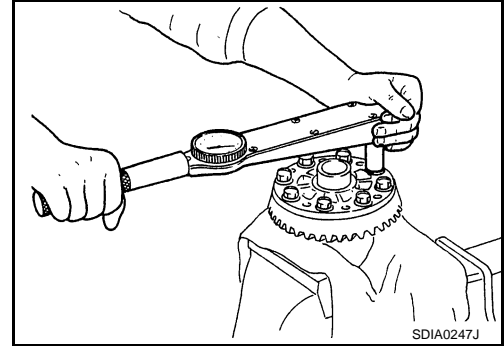

10. Press side bearing inner races to differential case, using the drift and the base.

A: Drift [SST: ST33230000 (J-25805-01)]

B: Base [SST: ST33061000 (J-8107-2)]

**CAUTION:**

Never reuse side bearing inner race.

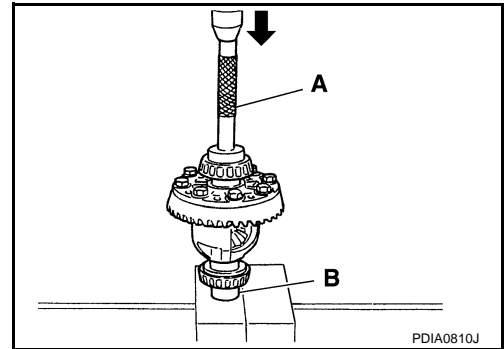

11. Press-fit side bearing outer race into side retainer with the drift and the drift bar.

A: Drift bar [SST: ST30611000 (J-25742-1)]

B: Drift [SST: KV31103000 (J-38982)]

**CAUTION:**

- At first, using a hammer, tap bearing outer race until it becomes flat to side retainer.
- Never reuse side bearing outer race.

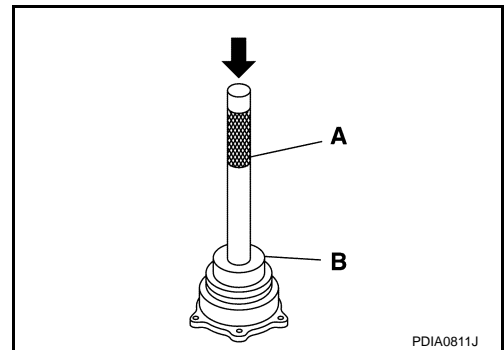

12. Press-fit side bearing outer race into gear carrier with the drift and the drift bar.

A: Drift bar [SST: ST30611000 (J-25742-1)]

B: Drift [SST: KV31103000 (J-38982)]

**CAUTION:**

- At first, using a hammer, tap bearing outer race until it becomes flat to gear carrier.
- Never reuse side bearing outer race.

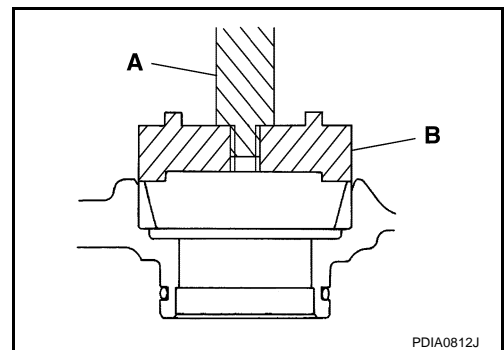



# DIFFERENTIAL ASSEMBLY

< DISASSEMBLY AND ASSEMBLY >

[FRONT FINAL DRIVE: F160A]

13. Place the differential case assembly into gear carrier.
14. Measure side bearing preload. If necessary, select the appropriate side bearing adjusting shim. Refer to [DLN-130. "Adjustment"](#).

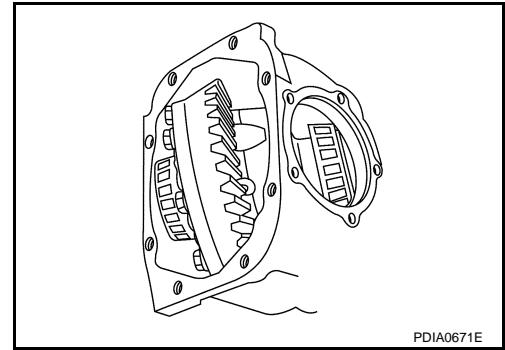

15. Install selected side bearing adjusting shim (1).
16. Apply multi-purpose grease to O-ring (2), and install it to side retainer.  
**CAUTION:**  
**Never reuse O-ring.**
17. Install side retainer assembly to gear carrier.

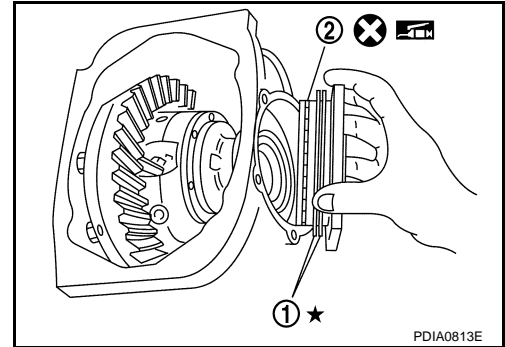

18. Install side retainer mounting bolts.

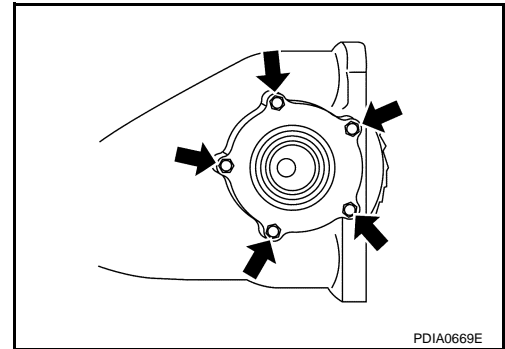

19. Using the drift (A) [SST: ST33400001 (J-26082)], press-fit side oil seal so that its surface comes face to face with the end surface of the side retainer.  
**CAUTION:**
  - Never reuse oil seal.
  - When installing, never incline oil seal.
  - Apply multi-purpose grease onto oil seal lips, and gear oil onto the circumference of oil seal.

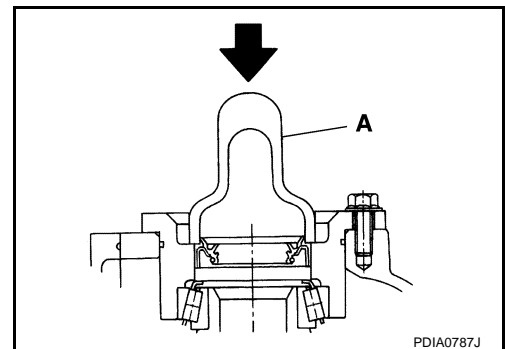

20. Using the drift (A) [SST: KV38102100 (J-25803-01)], press-fit side oil seal so that its surface comes face to face with the end surface of gear carrier.  
**CAUTION:**
  - Never reuse oil seal.
  - When installing, never incline oil seal.
  - Apply multi-purpose grease onto oil seal lips, and gear oil onto the circumference of oil seal.

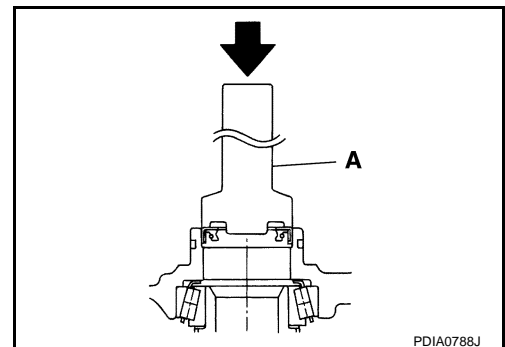

21. Apply multi-purpose grease to O-ring, and install it to gear carrier.  
**CAUTION:**

A  
B  
C  
DLN  
E  
F  
G  
H  
I  
J  
K  
L  
M  
N  
O  
P

# DIFFERENTIAL ASSEMBLY

< DISASSEMBLY AND ASSEMBLY >

[FRONT FINAL DRIVE: F160A]

**Never reuse O-ring.**

22. Check and adjust drive gear runout, tooth contact, drive gear to drive pinion backlash, and total preload torque. Refer to [DLN-130, "Adjustment"](#).  
Recheck above items. Readjust the above description, if necessary.

23. Apply sealant to mating surface of carrier cover.

• **Use Genuine Silicone RTV or equivalent. Refer to [GI-15, "Recommended Chemical Products and Sealants"](#).**

**CAUTION:**

Remove old sealant adhering to mounting surfaces. Also remove any moisture, oil, or foreign material adhering to application and mounting surfaces.

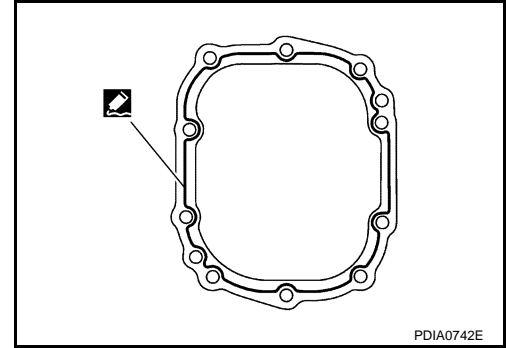

24. Install carrier cover on gear carrier and tighten mounting bolts.

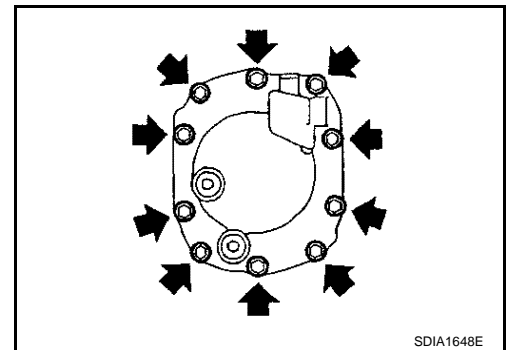

## Adjustment

INFOID:000000000957362

### TOTAL PRELOAD TORQUE

• Before inspection and adjustment, drain gear oil.

1. Rotate drive pinion back and forth 2 to 3 times to check for unusual noise and rotation malfunction.
2. Rotate drive pinion at least 20 times to check for smooth operation of the bearing.
3. Measure total preload with preload gauge (A) [SST: ST3127S000 (J-25765-A)].

**Standard**

**Total preload torque**

**: Refer to [DLN-144, "Preload Torque"](#).**

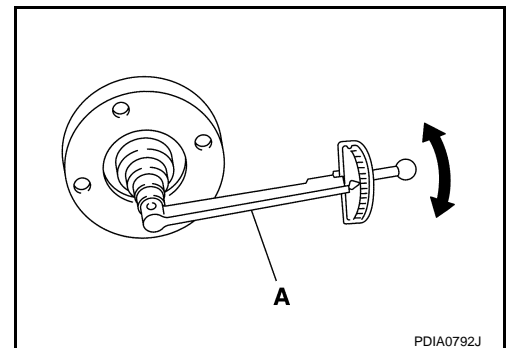

**NOTE:**

**Total preload torque = Pinion bearing preload torque + Side bearing preload torque**

• If measured value is out of the specification, disassemble it to check and adjust each part. Adjust the pinion bearing preload and side bearing preload.

Adjust the pinion bearing preload first, then adjust the side bearing preload.

**When the preload torque is large**

**On pinion bearings:** Decrease the drive pinion bearing adjusting washer and drive pinion adjusting washer thickness.

**On side bearings:** Increase the side bearing adjusting shim thickness.

**When the preload torque is small**

# DIFFERENTIAL ASSEMBLY

< DISASSEMBLY AND ASSEMBLY >

[FRONT FINAL DRIVE: F160A]

**On pinion bearings:** Increase the drive pinion bearing adjusting washer and drive pinion adjusting washer thickness.

**On side bearings:** Decrease the side bearing adjusting shim thickness.

## SIDE BEARING PRELOAD

- Before inspection and adjustment, drain gear oil.
1. Remove carrier cover and side retainer. Refer to [DLN-123, "Disassembly"](#).
  2. Make sure all parts are clean. Also, make sure the bearings are well lubricated with gear oil.
  3. Place the differential case assembly into gear carrier.

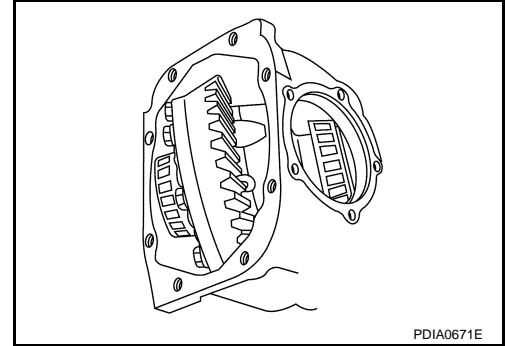

4. Install side bearing adjusting shim before disassembling or shim which thickness is the same as the one before disassembling.
5. Install side retainer assembly to gear carrier.

**CAUTION:**  
Never install O-ring.

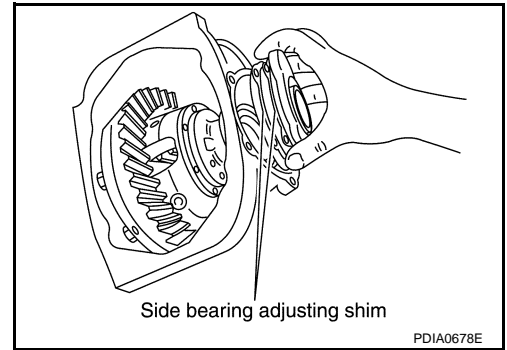

6. Install side retainer mounting bolts to the specified torque.

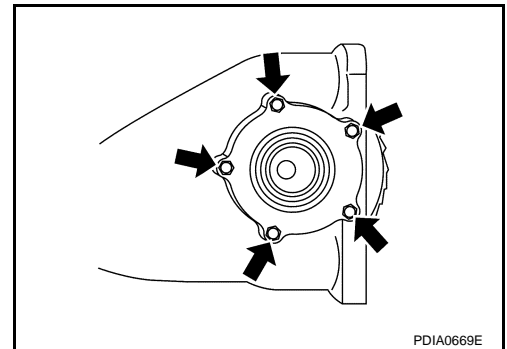

7. Measure the turning torque of the gear carrier at the drive gear mounting bolts with a spring gauge [SST: — (J-8129)].

**Specification** : 34.2 – 39.2 N (3.5 – 4.0 kg, 7.7 – 8.8 lb) of pulling force at the drive gear bolt

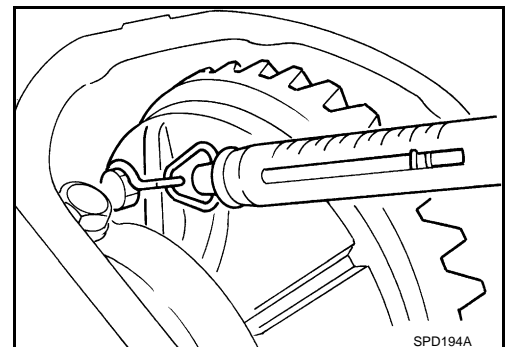

A  
B  
C  
DLN  
E  
F  
G  
H  
I  
J  
K  
L  
M  
N  
O  
P

# DIFFERENTIAL ASSEMBLY

## < DISASSEMBLY AND ASSEMBLY >

[FRONT FINAL DRIVE: F160A]

8. If the turning torque is outside the specification, use a thicker/thinner side bearing adjusting shim to adjust.

**If the turning torque is less than the specified range:**

**Decrease the side bearing adjusting shim thickness.**

**If the turning torque is greater than the specification:**

**Increase the side bearing adjusting shim thickness.**

9. Record the total amount of shim thickness required for the correct carrier side bearing preload.

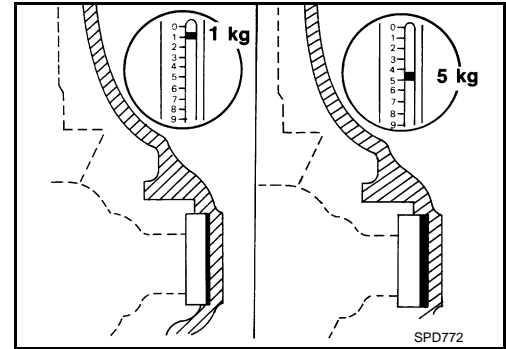

## DRIVE GEAR RUNOUT

1. Remove carrier cover. Refer to [DLN-123, "Disassembly"](#).
2. Fit a dial indicator to the drive gear back face.
3. Rotate the drive gear to measure runout.

### Limit

**Drive gear runout** : Refer to [DLN-144, "Drive Gear Runout"](#).

- If the runout is outside of the repair limit, check drive gear assembly condition; foreign material may be caught between drive gear and differential case, or differential case or drive gear may be deformed, etc.

### CAUTION:

**Replace drive gear and drive pinion gear as a set.**

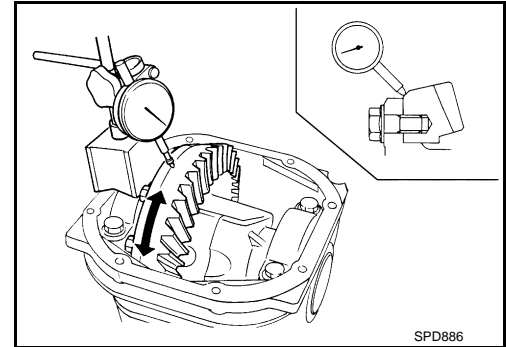

## TOOTH CONTACT

- Before inspection and adjustment, drain gear oil.
1. Remove carrier cover. Refer to [DLN-123, "Disassembly"](#).
  2. Apply red lead to drive gear.

### CAUTION:

**Apply red lead to both the faces of 3 to 4 gears at 4 locations evenly spaced on drive gear.**

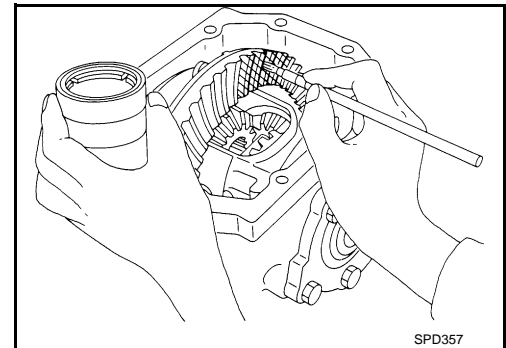

3. Rotate drive gear back and forth several times, check drive pinion gear to drive gear tooth contact.

### CAUTION:

**Check tooth contact on drive side and reverse side.**

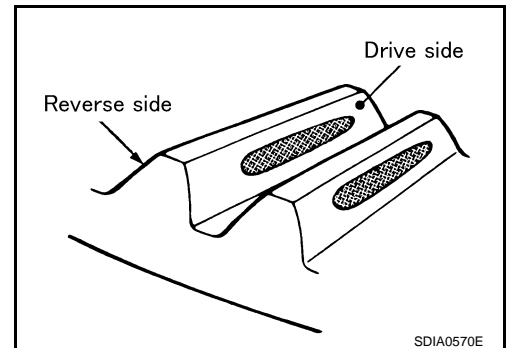

# DIFFERENTIAL ASSEMBLY

< DISASSEMBLY AND ASSEMBLY >

[FRONT FINAL DRIVE: F160A]

Tooth contact pattern				Pinion height adjusting washer selection value [mm (in)]	Adjustment requirement (Yes/No)
Back side		Drive side			
Heel side	Toe side	Toe side	Heel side		
				+0.15 (+0.0059)	Yes
				+0.12 (+0.0047)	
				+0.09 (+0.0035)	
				+0.06 (+0.0024)	No
				+0.03 (+0.0012)	
				0	
				-0.03 (-0.0012)	Yes
				-0.06 (-0.0024)	
				-0.09 (-0.0035)	
				-0.12 (-0.0047)	Yes
				-0.15 (-0.0059)	

PDIA0667E

4. If tooth contact is improperly adjusted, follow the procedure below to adjust the pinion height (dimension X).

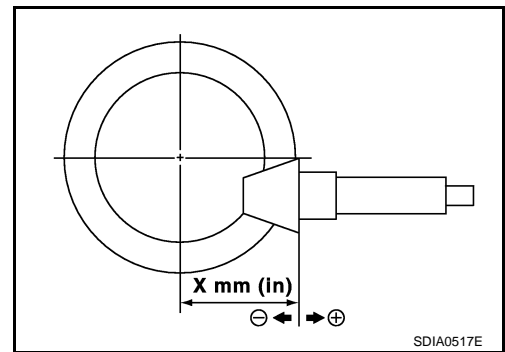

A  
B  
C  
DLN  
E  
F  
G  
H  
I  
J  
K  
L  
M  
N  
O  
P

# DIFFERENTIAL ASSEMBLY

< DISASSEMBLY AND ASSEMBLY >

[FRONT FINAL DRIVE: F160A]

- If the tooth contact is near the face (face contact), or near the heel (heel contact), thicken pinion height adjusting washers to move drive pinion closer to drive gear.

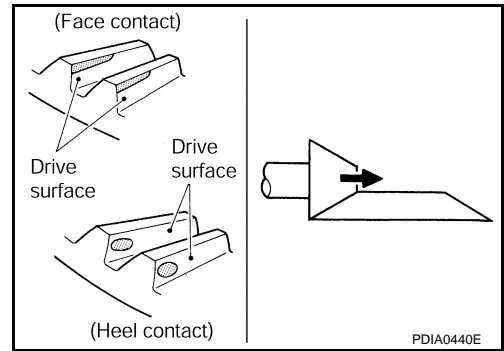

- If the tooth contact is near the flank (flank contact), or near the toe (toe contact), thin pinion height adjusting washers to move drive pinion farther from drive gear.

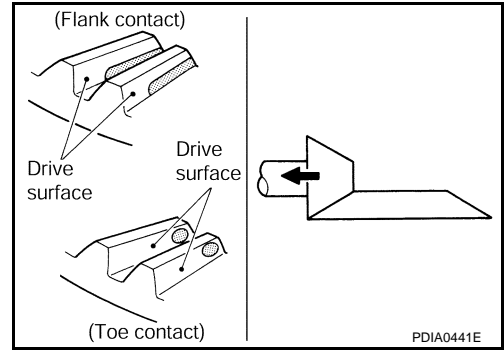

## BACKLASH

- Before inspection and adjustment, drain gear oil.
1. Remove carrier cover. Refer to [DLN-123. "Disassembly"](#).
  2. Fit a dial indicator to the drive gear face to measure the backlash.

**Standard Backlash**

: Refer to [DLN-144. "Backlash"](#).

- If the backlash is outside of the specified value, change the thickness of side bearing adjusting washer.

**When the backlash is large:**

**Decrease side bearing adjusting washer thickness.**

**When the backlash is small:**

**Increase side bearing adjusting washer thickness.**

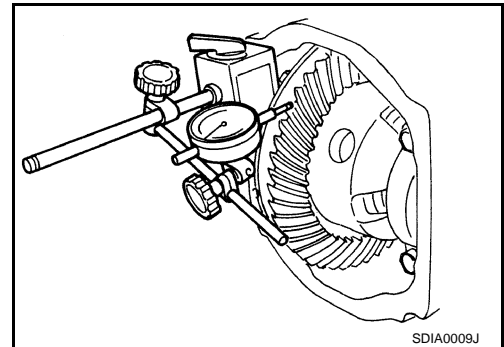

## Inspection After Disassembly

INFOID:000000000957363

Clean up the disassembled parts. Then, inspect if the parts are worn or damaged. If so, follow the measures below.

Content	Conditions and Measures
Hypoid gear	<ul style="list-style-type: none"> <li>• If the gear teeth do not mesh or line-up correctly, determine the cause and adjust or replace as necessary.</li> <li>• If the gears are worn, cracked, damaged, pitted or chipped (by friction) noticeably, replace with new drive gear and drive pinion as a set.</li> </ul>
Bearing	<ul style="list-style-type: none"> <li>• If any chipped (by friction), pitted, worn, rusted or scratched mark, or unusual noise from the bearing is observed, replace as a bearing assembly (as a new set).</li> </ul>
Side gear and Pinion mate gear	<ul style="list-style-type: none"> <li>• If any cracks or damage on the surface of the tooth is found, replace.</li> <li>• If any worn or chipped mark on the contact sides of the thrust washer is found, replace.</li> </ul>

# DIFFERENTIAL ASSEMBLY

< DISASSEMBLY AND ASSEMBLY >

[FRONT FINAL DRIVE: F160A]

Content	Conditions and Measures
Side gear thrust washer and pinion mate thrust washer	<ul style="list-style-type: none"><li>• If it is chipped (by friction), damaged, or unusually worn, replace.</li></ul>
Oil seal	<ul style="list-style-type: none"><li>• Whenever disassembled, replace.</li><li>• If wear, deterioration of adherence (sealing force lips), or damage is detected on the lips, replace them.</li></ul>
Differential case	<ul style="list-style-type: none"><li>• If any wear or crack on the contact sides of the differential case is found, replace.</li></ul>
Companion flange	<ul style="list-style-type: none"><li>• If any chipped mark (about 0.1 mm, 0.004 in) or other damage on the contact sides of the lips of the companion flange is found, replace.</li></ul>

A  
B  
C

**DLN**

E  
F  
G  
H  
I  
J  
K  
L  
M  
N  
O  
P

# DRIVE PINION

< DISASSEMBLY AND ASSEMBLY >

[FRONT FINAL DRIVE: F160A]

## DRIVE PINION

Exploded View

INFOID:00000000957364

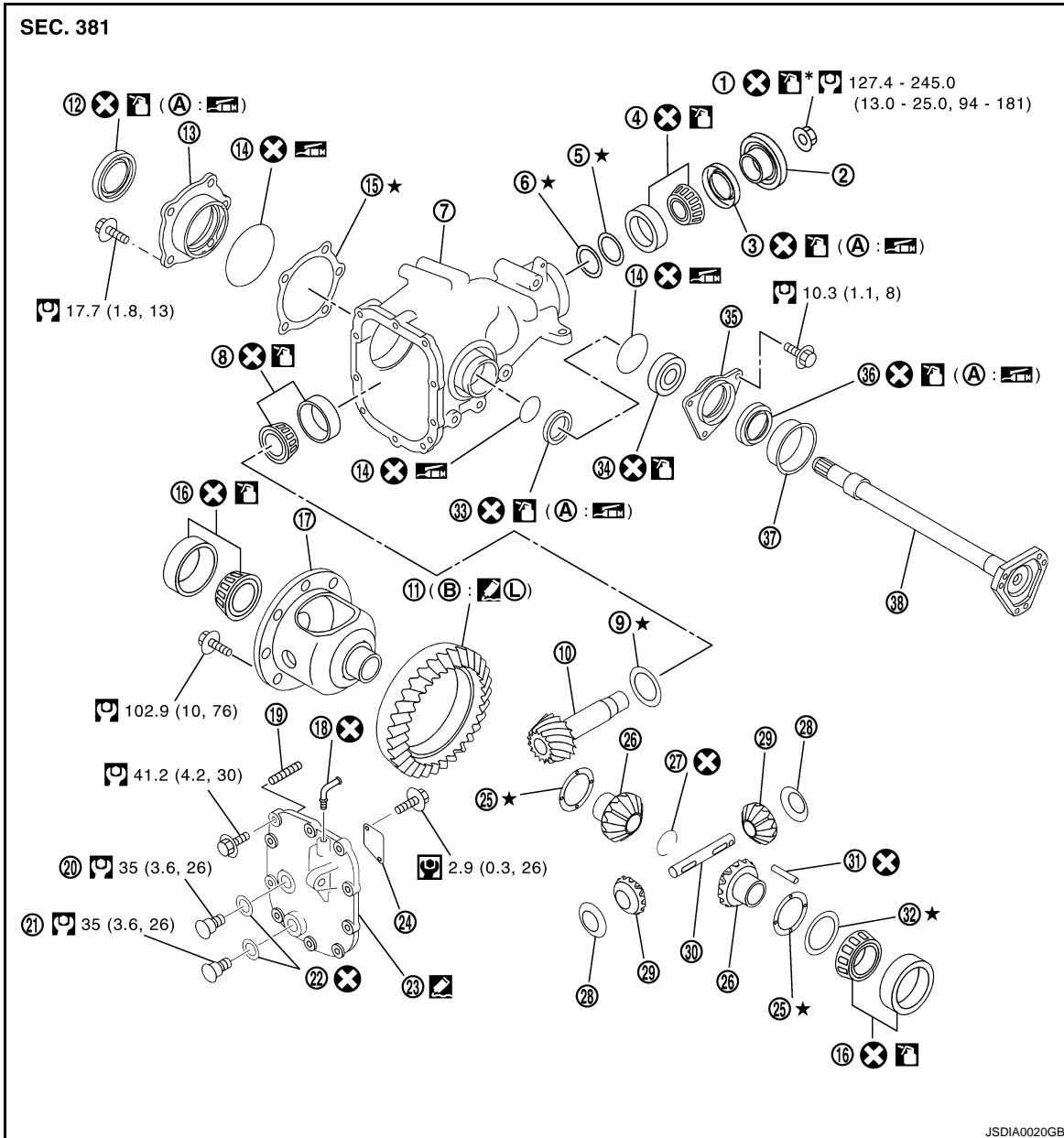

- |                               |  |                                   |
|-------------------------------|--|-----------------------------------|
| 1. Drive pinion lock nut      | 2. Companion flange                      | 3. Front oil seal                 |
| 4. Pinion front bearing       | 5. Drive pinion bearing adjusting washer | 6. Drive pinion adjusting washer  |
| 7. Gear carrier               | 8. Pinion rear bearing                   | 9. Pinion height adjusting washer |
| 10. Drive pinion              | 11. Drive gear                           | 12. Side oil seal (right side)    |
| 13. Side retainer             | 14. O-ring                               | 15. Side bearing adjusting shim   |
| 16. Side bearing              | 17. Differential case                    | 18. Breather connector            |
| 19. Dowel pin                 | 20. Filler plug                          | 21. Drain plug                    |
| 22. Gasket                    | 23. Carrier cover                        | 24. Gear oil defense              |
| 25. Side gear thrust washer   | 26. Side gear                            | 27. Circular clip                 |
| 28. Pinion mate thrust washer | 29. Pinion mate gear                     | 30. Pinion mate shaft             |
| 31. Lock pin                  | 32. Side bearing adjusting washer        | 33. Side oil seal (left side)     |



# DRIVE PINION

## < DISASSEMBLY AND ASSEMBLY >

[FRONT FINAL DRIVE: F160A]

- |                        |                             |                         |
|------------------------|-----------------------------|-------------------------|
| 34. Side shaft bearing | 35. Extension tube retainer | 36. Side shaft oil seal |
| 37. Dust sealed        | 38. Side shaft              |                         |
- A: Oil seal lip  
B: Screw hole

 Apply gear oil.

 Apply anti-corrosion oil.

 Apply Genuine Silicone RTV or equivalent. Refer to [GI-15. "Recommended Chemical Products and Sealants"](#).

 Apply Genuine Medium Strength Thread Locking Sealant or equivalent. Refer to [GI-15. "Recommended Chemical Products and Sealants"](#).

Refer to [GI-4. "Components"](#) for symbols not described on the above.

## Disassembly

INFOID:000000000957365

1. Remove differential assembly. Refer to [DLN-123. "Disassembly"](#).
2. Remove drive pinion lock nut with a flange wrench.

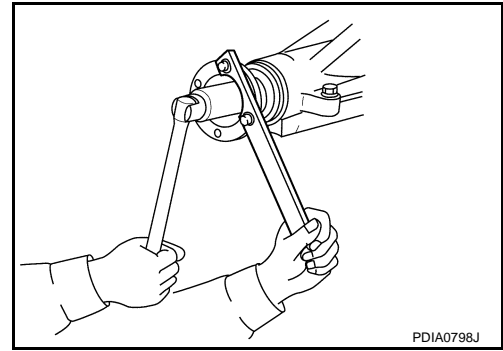

3. Put matching mark (B) on the end of drive pinion. The matching mark should be in line with the matching mark (A) on companion flange (1).

### CAUTION:

**For matching mark, use paint. Never damage companion flange and drive pinion.**

### NOTE:

The matching mark (A) on the final drive companion flange (1) indicates the maximum vertical runout position.

When replacing companion flange, matching mark is not necessary.

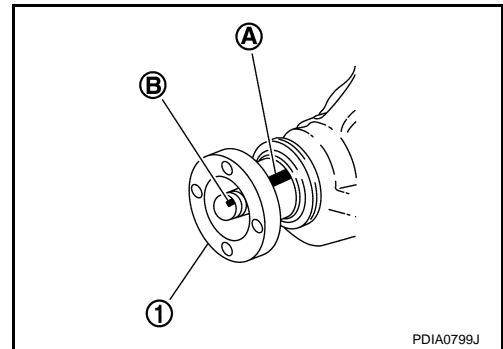

4. Remove companion flange using the suitable puller.

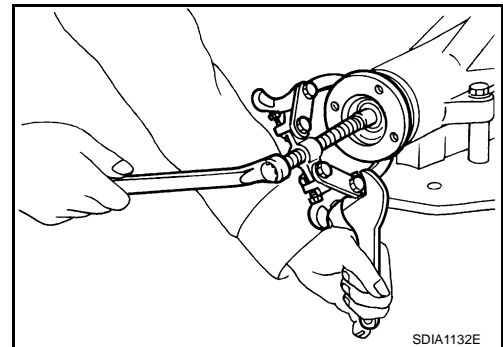

# DRIVE PINION

## < DISASSEMBLY AND ASSEMBLY >

[FRONT FINAL DRIVE: F160A]

5. Press drive pinion assembly out of gear carrier.  
**CAUTION:**  
**Never drop drive pinion assembly.**
6. Remove front oil seal.
7. Remove pinion front bearing inner race.
8. Remove drive pinion bearing adjusting washer and drive pinion adjusting washer.

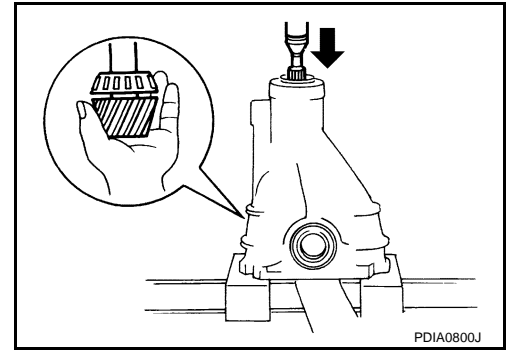

9. Remove pinion rear bearing inner race and pinion height adjusting washer with replacer (A) [SST: ST30031000 (J-22912-01)].

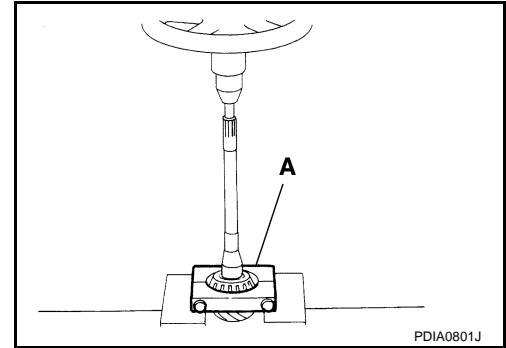

10. Tap pinion front/rear bearing outer races uniformly a brass rod or equivalent to removed.  
**CAUTION:**  
**Never damage gear carrier.**

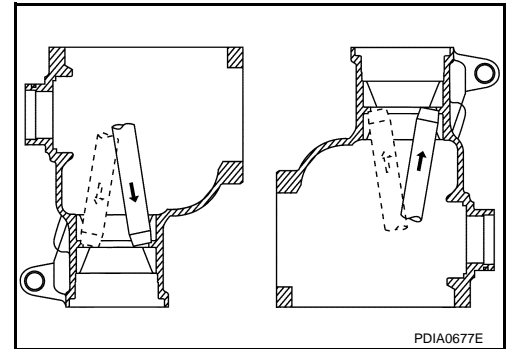

## Assembly

INFOID:000000000957366

1. Install pinion front and rear bearing outer races using drift (A) [SST: ST37820000 ( — )].  
**CAUTION:**
  - At first, using a hammer, tap bearing outer race until it becomes flat to gear carrier.
  - Never reuse pinion front and rear bearing outer race.

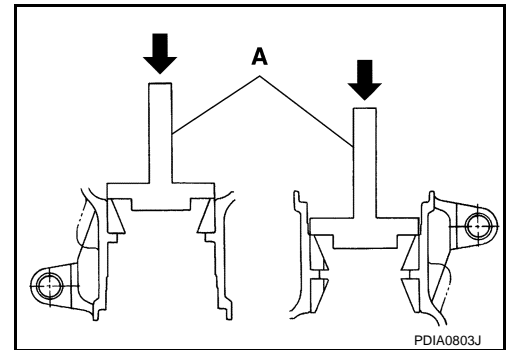

# DRIVE PINION

## < DISASSEMBLY AND ASSEMBLY >

## [FRONT FINAL DRIVE: F160A]

- Temporarily install pinion height adjusting washer (1).

**When hypoid gear set has been replaced**

- Select pinion height adjusting washer. Refer to [DLN-140](#), "[Adjustment](#)".

**When hypoid gear set has been reused**

- Temporarily install the removed pinion height adjusting washer or same thickness washer to drive pinion.

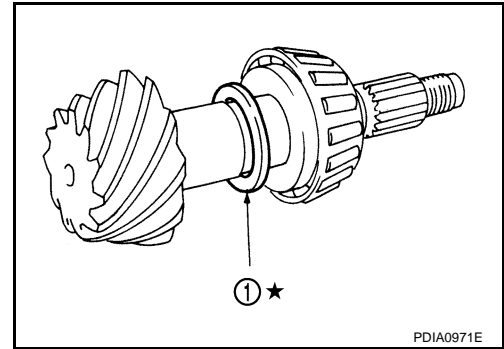

- Install selected pinion height adjusting washer (2) to drive pinion. Press pinion rear bearing inner race (1) to it, using drift (A) [SST: ST30032000 (J-26010-01)].

**CAUTION:**

- Pay attention to the direction of pinion height adjusting washer. (Assemble as shown in the figure.)
- Never reuse pinion rear bearing inner race.

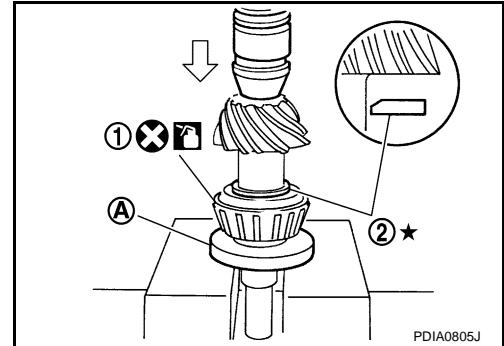

- Temporarily assemble removed drive pinion adjusting washer and drive pinion bearing adjusting washer or same thickness them to drive pinion.
- Apply gear oil to pinion rear bearing, and assemble drive pinion into gear carrier.
- Apply gear oil to pinion front bearing, and assemble pinion front bearing inner race to drive pinion assembly.

**CAUTION:**

**Never reuse pinion front bearing inner race.**

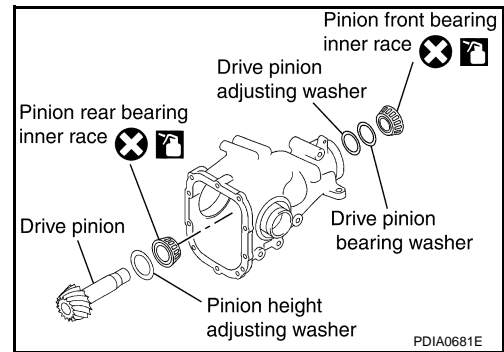

- Using suitable spacer (A), press the pinion front bearing inner race to drive pinion as far as drive pinion nut can be tightened.
- Adjust pinion bearing preload. If necessary, select the appropriate drive pinion adjusting washer and drive pinion bearing adjusting washer. Refer to [DLN-140](#), "[Adjustment](#)".

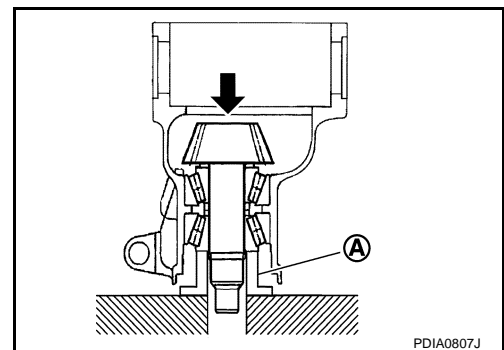

- Using the drifts, install front oil seal as shown in figure.

A: Drift [SST: ST33400001 (J-26082)]

B: Drift [SST: KV38102510 ( — )]

**CAUTION:**

- Never reuse oil seal.
- When installing, never incline oil seal.
- Apply multi-purpose grease onto oil seal lips, and gear oil onto the circumference of oil seal.

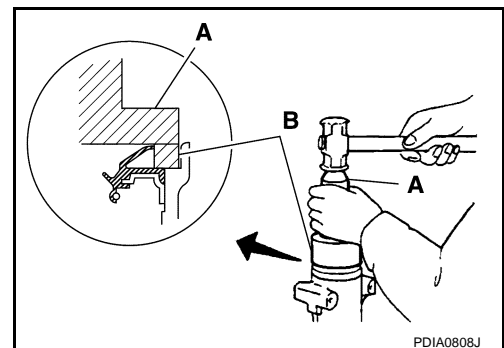

# DRIVE PINION

< DISASSEMBLY AND ASSEMBLY >

[FRONT FINAL DRIVE: F160A]

10. Install companion flange (1).

**NOTE:**

When reusing drive pinion, align the matching mark (B) of drive pinion with the matching mark (A) of companion flange, and then install companion flange (1).

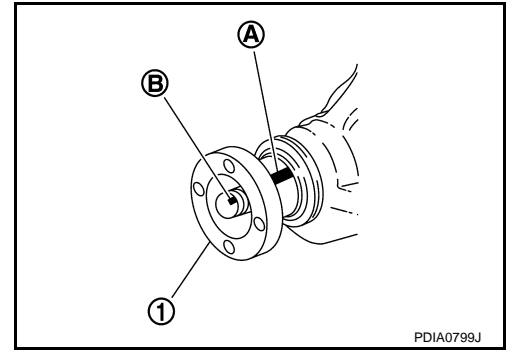

11. Apply anti-corrosion oil to the thread and seat of new drive pinion lock nut, and temporarily tighten drive pinion lock nut to drive pinion.

**CAUTION:**

**Never reuse drive pinion lock nut.**

12. Tighten to drive pinion lock nut, while adjust pinion bearing preload torque.

A: Preload gauge [SST: ST3127S000 (J-25765-A)]

**Standard**

**Pinion bearing preload** : Refer to [DLN-144, "Pre-load Torque"](#).

**CAUTION:**

- Adjust to the lower limit of the drive pinion lock nut tightening torque first.
- After adjustment, rotate drive pinion back and forth 2 to 3 times to check for unusual noise, rotation malfunction, and other malfunctions.

13. Install differential case assembly. Refer to [DLN-125, "Assembly"](#).

**CAUTION:**

**Never install carrier cover yet.**

14. Check and adjust drive gear runout, tooth contact, drive gear to drive pinion backlash, and companion flange runout. Refer to [DLN-130, "Adjustment"](#).

Recheck above items. Readjust the above description, if necessary.

15. Check total preload torque. Refer to [DLN-130, "Adjustment"](#).

16. Install carrier cover. Refer to [DLN-125, "Assembly"](#).

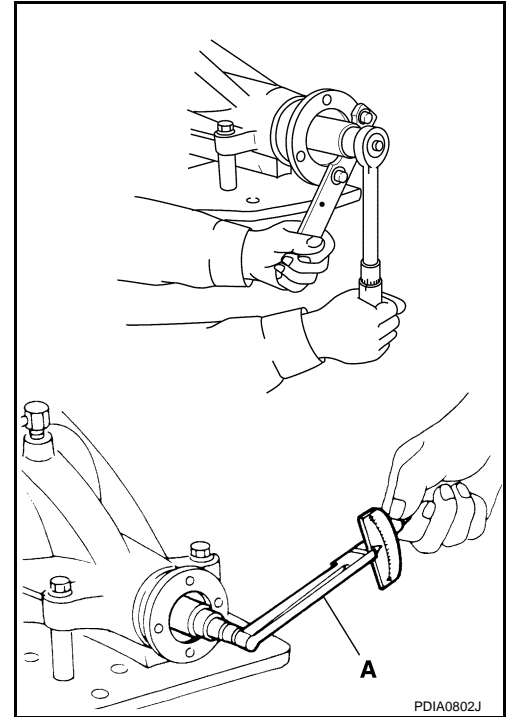

## Adjustment

INFOID:000000000957367

### PINION GEAR HEIGHT

- If the hypoid gear set has been replaced, select the pinion height adjusting washer.

1. Use the formula below to calculate pinion height adjusting washer thickness.

**Washer selection equation:**

$$T = T_0 + (t_1 - t_2)$$

**T:** Correct washer thickness

**T<sub>0</sub>:** Removed washer thickness

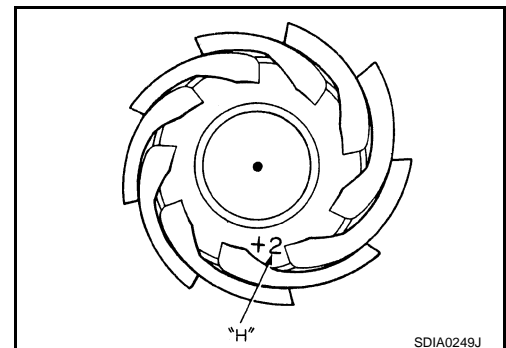

# DRIVE PINION

< DISASSEMBLY AND ASSEMBLY >

[FRONT FINAL DRIVE: F160A]

- t1: Old drive pinion head letter "H × 0.01"  
("H": machined tolerance 1/100 mm × 100)
- t2: New drive pinion head letter "H × 0.01"  
("H": machined tolerance 1/100 mm × 100)

**Example:**

$$T = 3.21 + [(2 \times 0.01) - (-1 \times 0.01)] = 3.24$$

T0: 3.21

t1: +2

t2: -1

2. Select the proper pinion height adjusting washer.  
If impossible find the desired thickness of washer, use washer with thickness closest to the calculated value.

**Example:**

Calculated value... T = 3.22 mm

Used washer... T = 3.21 mm

## PINION BEARING PRELOAD

- Assemble the drive pinion parts if they are disassembled. Refer to [DLN-138, "Assembly"](#).
- 1. Make sure all parts are clean. Also, make sure the bearings are well lubricated with gear oil.
- 2. Install companion flange (1).

**NOTE:**

When reusing drive pinion, align the matching mark (B) of drive pinion with the matching mark (A) of companion flange, and then install companion flange (1).

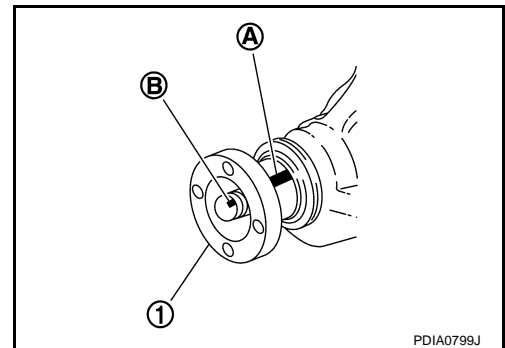

# DRIVE PINION

< DISASSEMBLY AND ASSEMBLY >

[FRONT FINAL DRIVE: F160A]

- Temporarily tighten removed drive pinion lock nut to drive pinion.  
**NOTE:**  
Use removed drive pinion lock nut only for the preload measurement.
- Rotate drive pinion at least 20 times to check for smooth operation of the bearing.
- Tighten to drive pinion lock nut, while adjust pinion bearing preload torque.

A: Preload gauge [SST: ST3127S000 (J-25765-A)]

## Standard

**Pinion bearing preload** : Refer to [DLN-144, "Preload Torque"](#).

## CAUTION:

- Adjust to the lower limit of the drive pinion lock nut tightening torque first.
  - After adjustment, rotate drive pinion back and forth 2 to 3 times to check for unusual noise, rotation malfunction, and other malfunctions.
- If the pinion bearing preload torque is outside the specification, use a thicker/thinner drive pinion bearing adjusting washer and drive pinion adjusting washer to adjust. Refer to Refer to Service Manual and Refer to Service Manual.

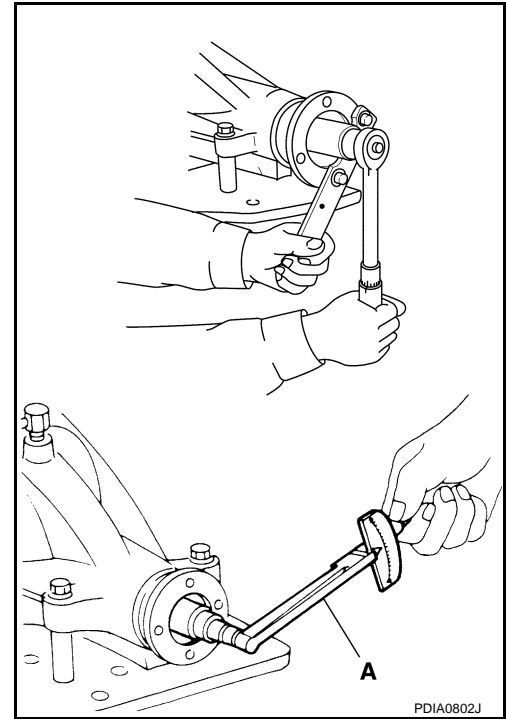

## When the preload torque is large:

Decrease the drive pinion bearing adjusting washer and drive pinion adjusting washer thickness.

## When the preload is small:

Increase the drive pinion bearing adjusting washer and drive pinion adjusting washer thickness.

- Remove companion flange, after adjustment.

## COMPANION FLANGE RUNOUT

- Fit a dial indicator onto the companion flange face (inner side of the propeller shaft mounting bolt holes).
- Rotate companion flange to check for runout.

## Limit

**Companion flange runout** : Refer to [DLN-144, "Companion Flange Runout"](#).

- Fit a test indicator to the inner side of companion flange (socket diameter).
- Rotate companion flange to check for runout.

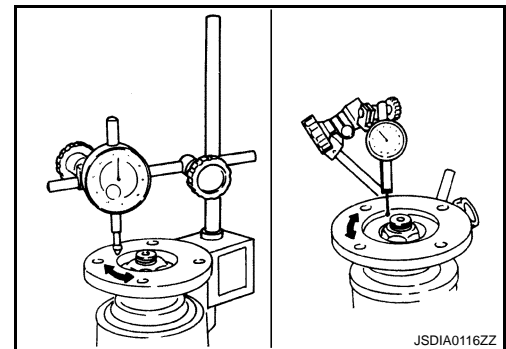

## Limit

**Companion flange runout** : Refer to [DLN-144, "Companion Flange Runout"](#).

- If the runout value is outside the runout limit, follow the procedure below to adjust.
  - Check for runout while changing the phase between companion flange and drive pinion by 90° step, and search for the position where the runout is the minimum.
  - If the runout value is still outside of the limit after the phase has been changed, possible cause will be an assembly malfunction of drive pinion and pinion bearing and malfunction of pinion bearing. Check for these items and repair if necessary.

# DRIVE PINION

< DISASSEMBLY AND ASSEMBLY >

[FRONT FINAL DRIVE: F160A]

c. If the runout value is still outside of the limit after the check and repair, replace companion flange.

## Inspection After Disassembly

INFOID:000000000957368

Clean up the disassembled parts. Then, inspect if the parts are worn or damaged. If so, follow the measures below.

Content	Conditions and Measures
Hypoid gear	<ul style="list-style-type: none"><li>• If the gear teeth do not mesh or line-up correctly, determine the cause and adjust or replace as necessary.</li><li>• If the gears are worn, cracked, damaged, pitted or chipped (by friction) noticeably, replace with new drive gear and drive pinion as a set.</li></ul>
Bearing	<ul style="list-style-type: none"><li>• If any chipped (by friction), pitted, worn, rusted or scratched mark, or unusual noise from the bearing is observed, replace as a bearing assembly (as a new set).</li></ul>
Side gear and Pinion mate gear	<ul style="list-style-type: none"><li>• If any cracks or damage on the surface of the tooth is found, replace.</li><li>• If any worn or chipped mark on the contact sides of the thrust washer is found, replace.</li></ul>
Side gear thrust washer and pinion mate thrust washer	<ul style="list-style-type: none"><li>• If it is chipped (by friction), damaged, or unusually worn, replace.</li></ul>
Oil seal	<ul style="list-style-type: none"><li>• Whenever disassembled, replace.</li><li>• If wear, deterioration of adherence (sealing force lips), or damage is detected on the lips, replace them.</li></ul>
Differential case	<ul style="list-style-type: none"><li>• If any wear or crack on the contact sides of the differential case is found, replace.</li></ul>
Companion flange	<ul style="list-style-type: none"><li>• If any chipped mark (about 0.1 mm, 0.004 in) or other damage on the contact sides of the lips of the companion flange is found, replace.</li></ul>

A  
B  
C  
DLN  
E  
F  
G  
H  
I  
J  
K  
L  
M  
N  
O  
P

# SERVICE DATA AND SPECIFICATIONS (SDS)

< SERVICE DATA AND SPECIFICATIONS (SDS)

[FRONT FINAL DRIVE: F160A]

## SERVICE DATA AND SPECIFICATIONS (SDS)

### SERVICE DATA AND SPECIFICATIONS (SDS)

#### General Specifications

INFOID:000000000957369

Applied model	AWD
	VQ35HR
	A/T
Final drive model	F160A
Gear ratio	3.692
Number of teeth (Drive gear/Drive pinion)	48/13
Oil capacity (Approx.) ℓ (US pt, Imp pt)	0.65 (1-3/8, 1-1/8)
Number of pinion gears	2
Drive pinion adjustment spacer type	Solid

#### Drive Gear Runout

INFOID:000000000957370

Unit: mm (in)

Item	Limit
Drive gear back face runout	0.05 (0.0020)

#### Differential Side Gear Clearance

INFOID:000000000957371

Unit: mm (in)

Item	Standard
Side gear backlash (Clearance between side gear and differential case)	0.2 (0.008) or less (Each gear should rotate smoothly without excessive resistance during differential motion.)

#### Preload Torque

INFOID:000000000957372

Unit: N·m (kg·m, in·lb)

Item	Standard
Pinion bearing (P1)	0.78 – 1.57 (0.08 – 0.16, 7 – 13)
Side bearing (P2)	0.78 – 1.08 (0.08 – 0.11, 7 – 9)
Side bearing to pinion bearing (Total preload) (Total preload = P1 + P2)	1.56 – 2.65 (0.16 – 0.27, 14 – 23)

#### Backlash

INFOID:000000000957373

Unit: mm (in)

Item	Standard
Drive gear to drive pinion gear	0.10 – 0.15 (0.0039 – 0.0059)

#### Companion Flange Runout

INFOID:000000000957374

Unit: mm (in)

Item	Limit
Companion flange face runout	0.18 (0.0070)
Inner side of the companion flange runout	0.13 (0.0051)



# NOISE, VIBRATION AND HARSHNESS (NVH) TROUBLESHOOTING

< SYMPTOM DIAGNOSIS >

[REAR FINAL DRIVE: R200]

## SYMPTOM DIAGNOSIS

### NOISE, VIBRATION AND HARSHNESS (NVH) TROUBLESHOOTING

#### NVH Troubleshooting Chart

INFOID:000000000957375

#### 2WD MODELS

Use the chart below to help you find the cause of the symptom. If necessary, repair or replace these parts.

Reference	Possible cause and SUSPECTED PARTS	Symptom
<a href="#">DLN-186, "2WD : Inspection After Disassembly"</a>	Gear tooth rough	Noise x
<a href="#">DLN-181, "2WD : Adjustment"</a>	Gear contact improper	x
<a href="#">DLN-186, "2WD : Inspection After Disassembly"</a>	Tooth surfaces worn	x
<a href="#">DLN-181, "2WD : Adjustment"</a>	Backlash incorrect	x
<a href="#">DLN-181, "2WD : Adjustment"</a>	Companion flange excessive runout	x
<a href="#">DLN-154, "Inspection"</a>	Gear oil improper	x
	PROPELLER SHAFT	x
	AXLE AND SUSPENSION	x
	TIRES	x
	ROAD WHEEL	x
	DRIVE SHAFT	x
	BRAKES	x
	STEERING	x

x: Applicable

#### AWD MODELS

Use the chart below to help you find the cause of the symptom. If necessary, repair or replace these parts.

A  
B  
C  
DLN  
E  
F  
G  
H  
I  
J  
K  
L  
M  
N  
O  
P

# NOISE, VIBRATION AND HARSHNESS (NVH) TROUBLESHOOTING

< SYMPTOM DIAGNOSIS >

[REAR FINAL DRIVE: R200]

Symptom	Noise	Possible cause and SUSPECTED PARTS	Reference
×	×	Gear tooth rough	<a href="#">DLN-198, "AWD : Inspection After Disassembly"</a>
×	×	Gear contact improper	<a href="#">DLN-194, "AWD : Adjustment"</a>
×	×	Tooth surfaces worn	<a href="#">DLN-198, "AWD : Inspection After Disassembly"</a>
×	×	Backlash incorrect	<a href="#">DLN-194, "AWD : Adjustment"</a>
×	×	Companion flange excessive runout	<a href="#">DLN-194, "AWD : Adjustment"</a>
×	×	Gear oil improper	<a href="#">DLN-154, "Inspection"</a>
×	×	PROPELLER SHAFT	NVH in DLN section.
×	×	AXLE AND SUSPENSION	NVH in FAX, RAX, FSU and RSU sections.
×	×	TIRES	NVH in WT section.
×	×	ROAD WHEEL	NVH in WT section.
×	×	DRIVE SHAFT	NVH in FAX and RAX section.
×	×	BRAKES	NVH in BR section.
×	×	STEERING	NVH in ST section.

×: Applicable

# PRECAUTION

## PRECAUTIONS

### Service Notice or Precautions for Rear Final Drive

INFOID:000000000957376

**CAUTION:**

- Check for the correct installation status prior to removal or disassembly. If matching marks are required, be certain they do not interfere with the function of the parts when applied.
- Overhaul should be done in a clean work area, it is preferable to work in dustproof area.
- Before disassembly, using steam or white gasoline, completely remove sand and mud from the exterior of the unit, preventing them from entering into the unit during disassembly or assembly.
- Check appearance of the disassembled parts for damage, deformation, and unusual wear. Replace them with a new ones if necessary.
- Gaskets, seals and O-rings should be replaced any time when the unit is disassembled.
- In principle, tighten bolts or nuts gradually in several steps working diagonally from inside to outside. If tightening sequence is specified, observe it.
- Clean and flush the parts sufficiently and blow-dry them.
- Be careful not to damage sliding surfaces and mating surfaces.
- When applying sealant, remove the old sealant from the mounting surface; then remove any moisture, oil, and foreign materials from the application and mounting surfaces.
- Always use shop paper for cleaning the inside of components.
- Avoid using cotton gloves or shop rags to prevent entering of lint.
- During assembly, observe the specified tightening torque, and apply new gear oil, petroleum jelly, or multi-purpose grease as specified for each vehicle, if necessary.

A  
B  
C  
DLN  
E  
F  
G  
H  
I  
J  
K  
L  
M  
N  
O  
P

DLN

# PREPARATION

< PREPARATION >

[REAR FINAL DRIVE: R200]

## PREPARATION

### PREPARATION

#### Special Service Tools

INFOID:000000000957377

The actual shapes of Kent-Moore tools may differ from those of special service tools illustrated here.

Tool number (Kent-Moore No.) Tool name	Description
KV40104100 ( — ) Attachment	Removing side flange
ST36230000 (J-25840-A) Sliding hammer	Removing side flange
ST3127S000 (J-25765-A) Preload gauge	Measuring pinion bearing preload and total preload
KV381054S0 (J-34286) Puller	Removing front oil seal
ST30720000 (J-25405) Drift a: 77 mm (3.03 in) dia. b: 55.5 mm (2.185 in) dia.	<ul style="list-style-type: none"> <li>• Installing front oil seal</li> <li>• Installing pinion rear bearing outer race</li> </ul>
KV38107900 (J-39352) Protector	Installing side flange

# PREPARATION

< PREPARATION >



[REAR FINAL DRIVE: R200]

Tool number (Kent-Moore No.) Tool name	Description	
KV38100200 (J-26233) Drift a: 65 mm (2.56 in) dia. b: 49 mm (1.93 in) dia.	Installing side oil seal	A B C
KV10111100 (J-37228) Seal cutter	Removing rear cover	DLN E F
KV38100800 (J-25604-01) Attachment a: 541 mm (21.30 in) b: 200 mm (7.87 in)	Fixing unit assembly	G H
ST3306S001 (J-22888-D) Differential side bearing puller set 1: ST33051001 (J-22888-20) Puller 2: ST33061000 (J-8107-2) Base a: 28.5 mm (1.122 in) dia. b: 38 mm (1.50 in) dia.	Removing and installing side bearing inner race	I J K
KV38100300 (J-25523) Drift a: 54 mm (2.13 in) dia. b: 46 mm (1.81 in) dia. c: 32 mm (1.26 in) dia.	Installing side bearing inner race	L M N
(J-8129) Spring gauge	Measuring turning torque	O P

# PREPARATION

< PREPARATION >

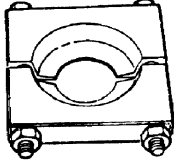
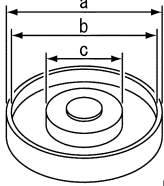
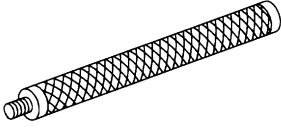
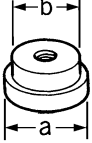
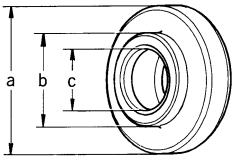
[REAR FINAL DRIVE: R200]

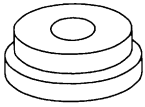
Tool number (Kent-Moore No.) Tool name		Description
ST30031000 (J-22912-01) Replacer	 <p style="text-align: right; font-size: small;">ZZA0700D</p>	Removing pinion rear bearing inner race
KV40105230 ( — ) Drift a: 92 mm (3.62 in) dia. b: 86 mm (3.39 in) dia. c: 45 mm (1.77 in) dia.	 <p style="text-align: right; font-size: small;">PDIA0591E</p>	Installing pinion rear bearing outer race
ST30611000 (J-25742-1) Drift bar	 <p style="text-align: right; font-size: small;">S-NT090</p>	Installing pinion front bearing outer race (Use with ST30613000)
ST30613000 (J-25742-3) Drift a: 72 mm (2.83 in) dia. b: 48 mm (1.89 in) dia.	 <p style="text-align: right; font-size: small;">ZZA1000D</p>	Installing pinion front bearing outer race
ST30901000 (J-26010-01) Drift a: 79 mm (3.11 in) dia. b: 45 mm (1.77 in) dia. c: 35.2 mm (1.386 in) dia.	 <p style="text-align: right; font-size: small;">ZZA0978D</p>	Installing pinion rear bearing inner race
(J-34309) Differential shim selector tool	 <p style="text-align: right; font-size: small;">NT134</p>	Adjusting bearing preload and pinion gear height
(J-25269-4) Side bearing disc (2 Req'd)	 <p style="text-align: right; font-size: small;">NT136</p>	Selecting pinion height adjusting washer

# PREPARATION

< PREPARATION >

[REAR FINAL DRIVE: R200]

## Commercial Service Tools

INFOID:000000000957378

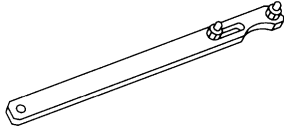
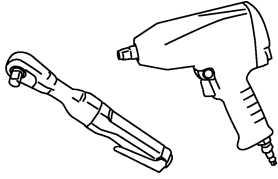
Tool name	Description
Flange wrench   NT035	Removing and installing drive pinion lock nut
Spacer a: 60 mm (2.36 in) dia. b: 36 mm (1.42 in) dia. c: 30 mm (1.18 in)	Installing pinion front bearing inner race
Power tool   PBIC0190E	Loosening bolts and nuts

A

B

C

**DLN**

E

F

G

H

I

J

K

L

M

N

O

P

# REAR FINAL DRIVE ASSEMBLY

< FUNCTION DIAGNOSIS >

[REAR FINAL DRIVE: R200]

## FUNCTION DIAGNOSIS

### REAR FINAL DRIVE ASSEMBLY

#### System Diagram

INFOID:000000000957379

#### CROSS-SECTION VIEW

2WD Models

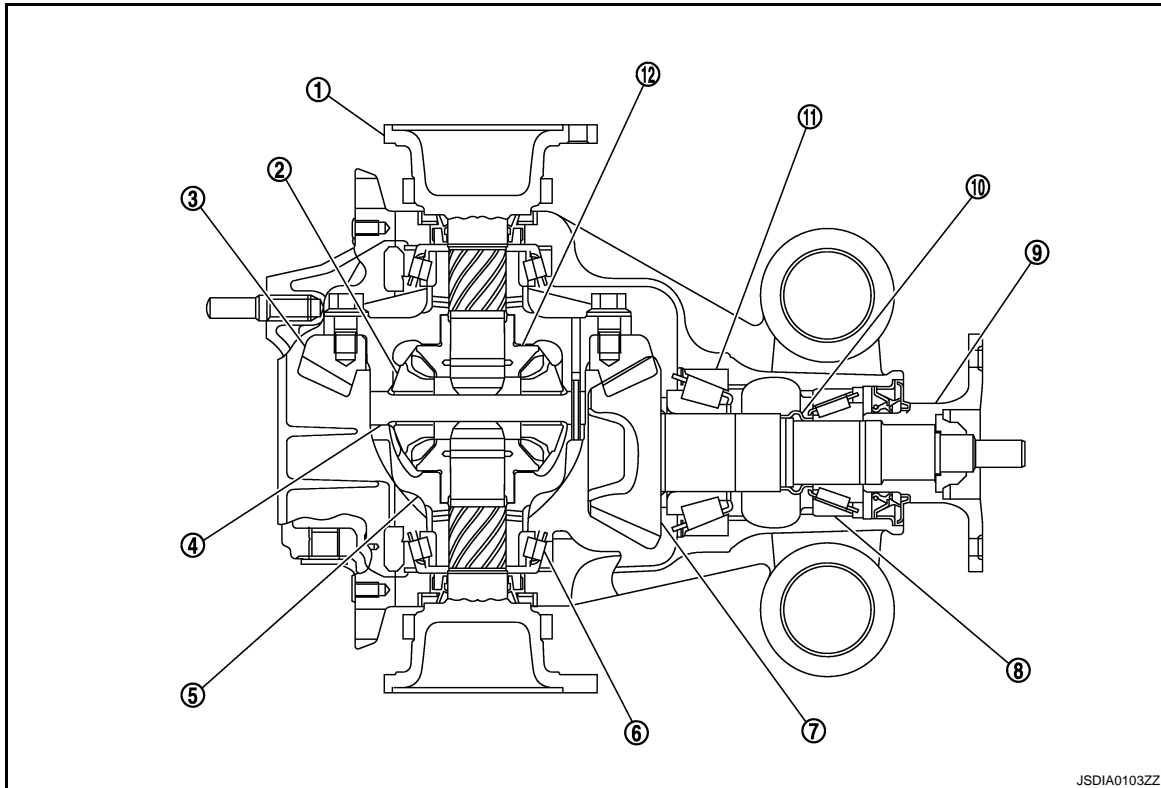

JSDIA0103ZZ

- |                        |                         |                     |
|------------------------|-------------------------|---------------------|
| 1. Side flange         | 2. Pinion mate gear     | 3. Drive gear       |
| 4. Pinion mate shaft   | 5. Differential case    | 6. Side bearing     |
| 7. Drive pinion        | 8. Pinion front bearing | 9. Companion flange |
| 10. Collapsible spacer | 11. Pinion rear bearing | 12. Side gear       |



# REAR FINAL DRIVE ASSEMBLY

< FUNCTION DIAGNOSIS >

[REAR FINAL DRIVE: R200]

AWD Models

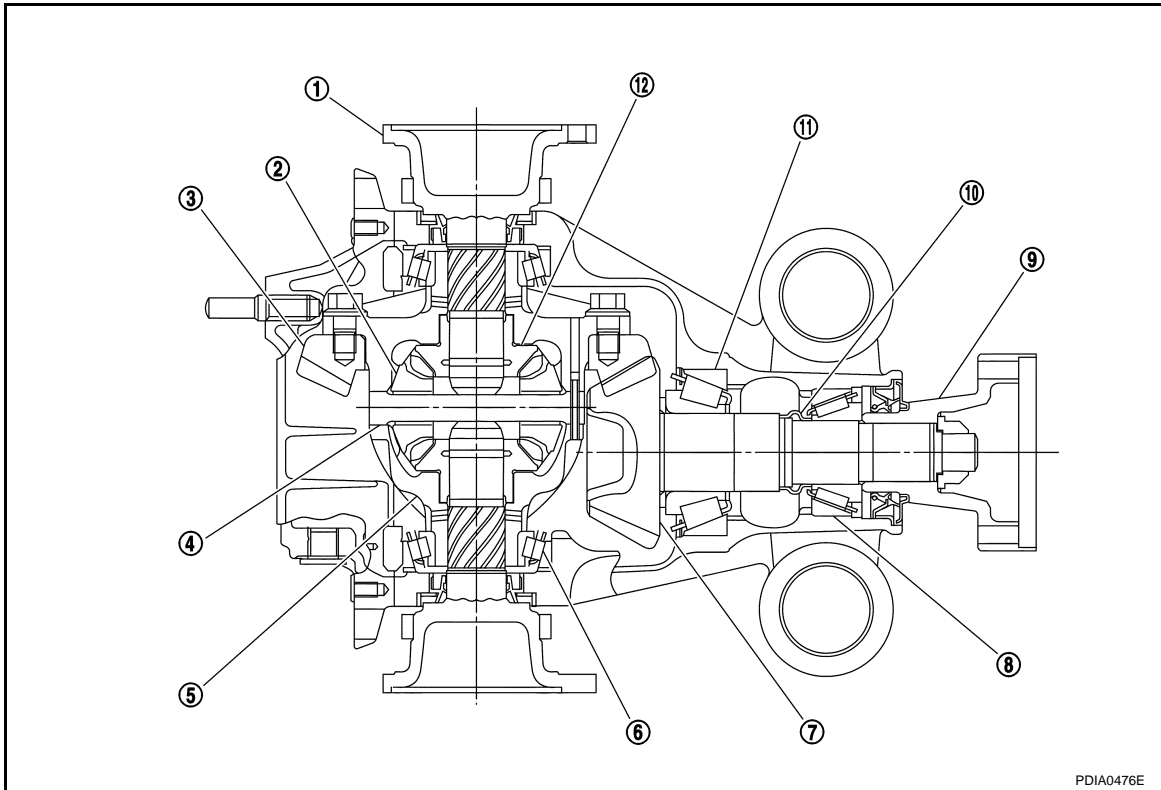

- |                        |                         |                     |
|------------------------|-------------------------|---------------------|
| 1. Side flange         | 2. Pinion mate gear     | 3. Drive gear       |
| 4. Pinion mate shaft   | 5. Differential case    | 6. Side bearing     |
| 7. Drive pinion        | 8. Pinion front bearing | 9. Companion flange |
| 10. Collapsible spacer | 11. Pinion rear bearing | 12. Side gear       |

A

B

C

DLN

E

F

G

H

I

J

K

L

M

N

O

P

## ON-VEHICLE MAINTENANCE

### REAR DIFFERENTIAL GEAR OIL

#### Inspection

INFOID:000000000957380

#### OIL LEAKAGE

- Make sure that oil is not leaking from final drive assembly or around it.

#### OIL LEVEL

- Remove filler plug (1) and check oil level from filler plug mounting hole as shown in the figure.

**CAUTION:**

**Never start engine while checking oil level.**

- Set a gasket on filler plug (1) and install it on final drive assembly. Refer to [DLN-174, "2WD : Exploded View"](#) (2WD models), [DLN-186, "AWD : Exploded View"](#) (AWD models).

**CAUTION:**

**Never reuse gasket.**

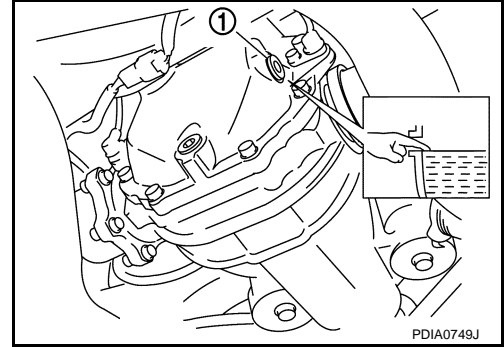

INFOID:000000000957381

#### Draining

1. Stop engine.
2. Remove drain plug (1) and drain gear oil.
3. Set a gasket on drain plug (1) and install it to final drive assembly and tighten to the specified torque. Refer to [DLN-174, "2WD : Exploded View"](#) (2WD models), [DLN-186, "AWD : Exploded View"](#) (AWD models).

**CAUTION:**

**Never reuse gasket.**

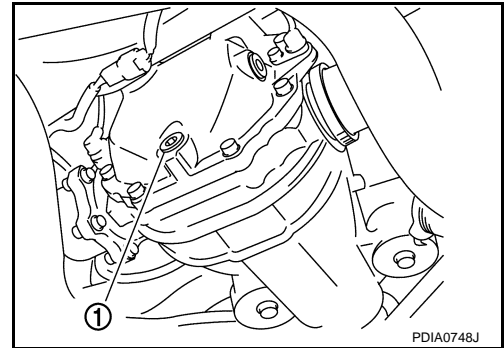

INFOID:000000000957382

#### Refilling

1. Remove filler plug (1). Fill with new gear oil until oil level reaches the specified level near filler plug mounting hole.

**Oil grade and Viscosity** : Refer to [MA-10, "Fluids and Lubricants"](#).

**Oil capacity** : Refer to [DLN-216, "General Specification"](#).

2. After refilling oil, check oil level. Set a gasket to filler plug (1), then install it to final drive assembly. Refer to [DLN-174, "2WD : Exploded View"](#) (2WD models), [DLN-186, "AWD : Exploded View"](#) (AWD models).

**CAUTION:**

**Never reuse gasket.**

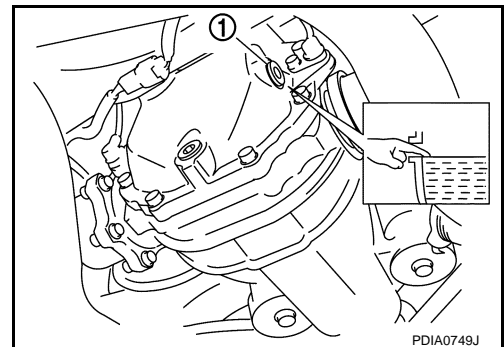

# FRONT OIL SEAL

< ON-VEHICLE REPAIR >

[REAR FINAL DRIVE: R200]

## ON-VEHICLE REPAIR

### FRONT OIL SEAL

2WD

2WD : Exploded View

INFOID:000000000957383

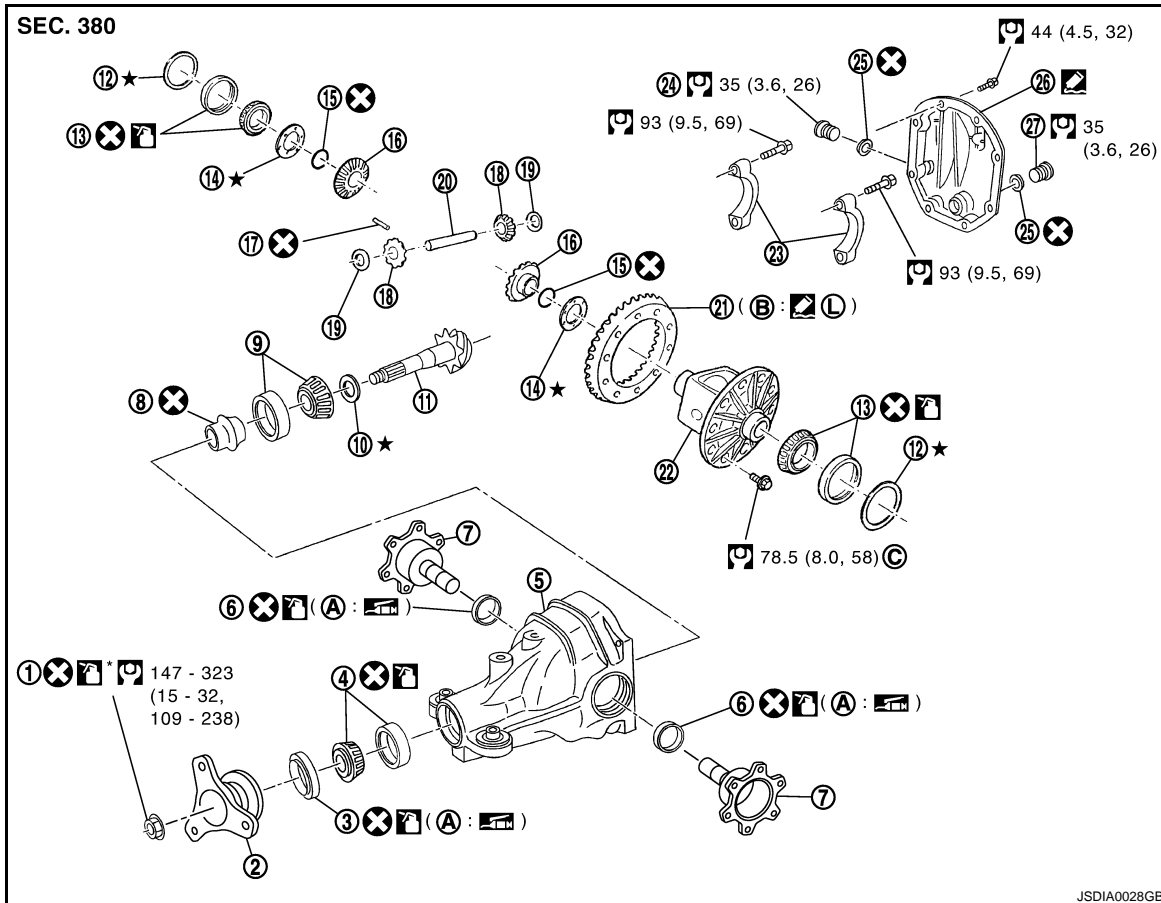

- |                                    |                             |                                   |
|------------------------------------|-----------------------------|-----------------------------------|
| 1. Drive pinion lock nut           | 2. Companion flange         | 3. Front oil seal                 |
| 4. Pinion front bearing            | 5. Gear carrier             | 6. Side oil seal                  |
| 7. Side flange                     | 8. Collapsible spacer       | 9. Pinion rear bearing            |
| 10. Pinion height adjusting washer | 11. Drive pinion            | 12. Side bearing adjusting washer |
| 13. Side bearing                   | 14. Side gear thrust washer | 15. Circular clip                 |
| 16. Side gear                      | 17. Lock pin                | 18. Pinion mate gear              |
| 19. Pinion mate thrust washer      | 20. Pinion mate shaft       | 21. Drive gear                    |
| 22. Differential case              | 23. Bearing cap             | 24. Filler plug                   |
| 25. Gasket                         | 26. Rear cover              | 27. Drain plug                    |

A: Oil seal lip

B: Screw hole

C: After tightening the bolts to the specified torque, tighten the bolts additionally by turning the bolts 31 to 36 degrees.

Apply gear oil.

Apply anti-corrosion oil.

Apply Genuine Silicone RTV or equivalent. Refer to [GI-15. "Recommended Chemical Products and Sealants"](#).

# FRONT OIL SEAL

< ON-VEHICLE REPAIR >

[REAR FINAL DRIVE: R200]



Apply Genuine High Strength Thread Locking Sealant or equivalent. Refer to [GI-15, "Recommended Chemical Products and Sealants"](#).

Refer to [GI-4, "Components"](#) for symbols not described on the above.

## 2WD : Removal and Installation

INFOID:000000000957384

### REMOVAL

#### CAUTION:

Verify identification stamp of replacement frequency put in the lower part of gear carrier to determine replacement for collapsible spacer when replacing front oil seal. Refer to "Identification stamp of replacement frequency of front oil seal". If necessary collapsible spacer replacement, remove final drive assembly and disassemble it to replace front oil seal and collapsible spacer. Refer to [DLN-171, "2WD : Removal and Installation"](#) and [DLN-175, "2WD : Disassembly"](#).

#### NOTE:

The reuse of collapsible spacer is prohibited in principle. However, it is reusable on a one-time basis only in cases when replacing front oil seal.

Identification stamp of replacement frequency of front oil seal

- The diagonally shaded area in the figure shows stamping point for replacement frequency of front oil seal.
- The following table shows if collapsible spacer replacement is needed before replacing front oil seal.

When collapsible spacer replacement is required, disassemble final drive assembly to replace collapsible spacer and front oil seal. Refer to [DLN-175, "2WD : Disassembly"](#).

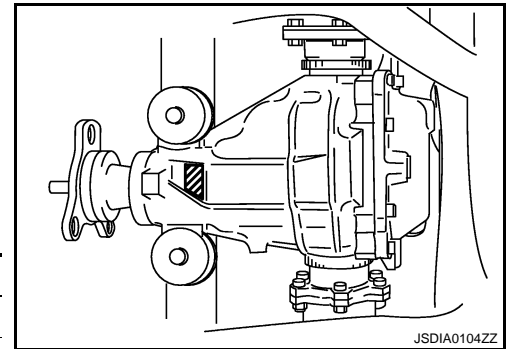

JSDIA0104ZZ

Stamp	collapsible spacer replacement
No stamp	Not required
"0" or "0" on the far right of stamp	Required
"01" or "1" on the far right of stamp	Not required

#### CAUTION:

**Never make a stamping after replacing front oil seal.**

- After replacing front oil seal, make a stamping on the stamping point in accordance with the table below in order to identify replacement frequency.

#### CAUTION:

**Stamping shall be made from left to right.**

Stamp before stamping	Stamping on the far right	Stamping
No stamp	0	0
"0" (Front oil seal was replaced once.)	1	01
"01" (Collapsible spacer and front oil seal were replaced last time.)	0	010
"0" is on the far right. (Only front oil seal was replaced last time.)	1	...01
"1" is on the far right. (Collapsible spacer and front oil seal were replaced last time.)	0	...010

- Drain gear oil. Refer to [DLN-154, "Draining"](#).
- Make a judgment if a collapsible spacer replacement is required.
- Remove center muffler with a power tool. Refer to [EX-5, "Removal and Installation"](#).
- Remove rear wheel sensor. Refer to [BRC-100, "Removal and Installation"](#).
- Remove drive shaft from final drive. Then suspend it by wire etc. Refer to [RAX-9, "Removal and Installation"](#).

# FRONT OIL SEAL

< ON-VEHICLE REPAIR >

[REAR FINAL DRIVE: R200]

6. Install attachment (A) [SST: KV40104100 ( — )] to side flange, and then pull out the side flange with the sliding hammer (B) [SST: ST36230000 (J-25840-A)].

**NOTE:**

**Circular clip installation position: Final drive side**

7. Remove propeller shaft. Refer to [DLN-93, "Removal and Installation"](#).

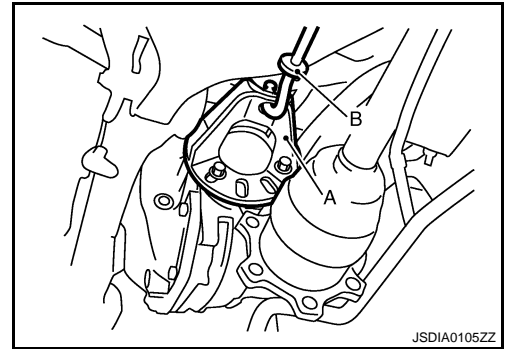

8. Measure the total preload with the preload gauge (A) [SST: ST3127S000 (J-25765-A)].

**NOTE:**

**Record the preload measurement.**

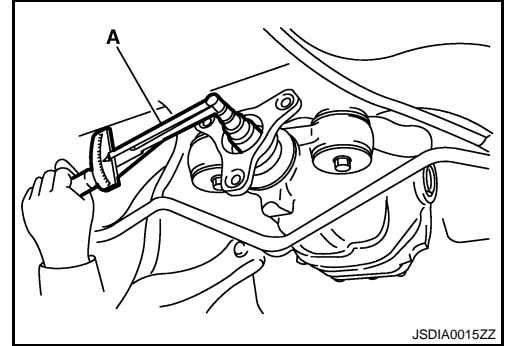

9. Put matching mark (B) on the end of the drive pinion. The matching mark (B) should be in line with the matching mark (A) on companion flange (1).

**CAUTION:**

**For matching mark, use paint. Never damage companion flange and drive pinion.**

**NOTE:**

The matching mark (A) on the final drive companion flange (1) indicates the maximum vertical runout position.

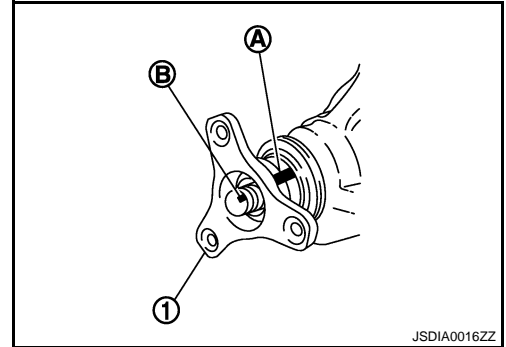

10. Remove drive pinion lock nut using the flange wrench.

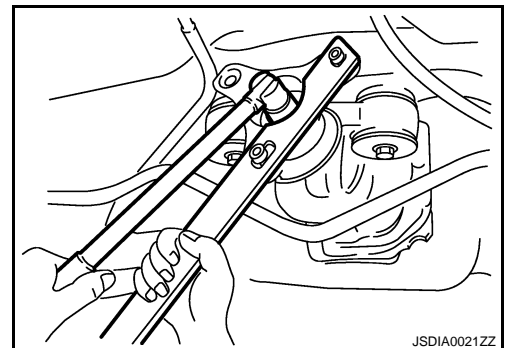

11. Remove companion flange using pullers.

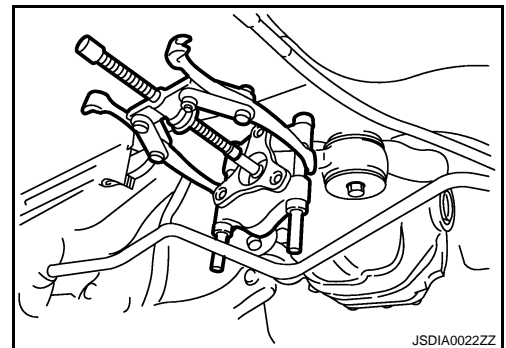

A  
B  
C  
DLN  
E  
F  
G  
H  
I  
J  
K  
L  
M  
N  
O  
P

# FRONT OIL SEAL

< ON-VEHICLE REPAIR >

[REAR FINAL DRIVE: R200]

12. Remove front oil seal using the puller (A) [SST: KV381054S0 (J-34286)].

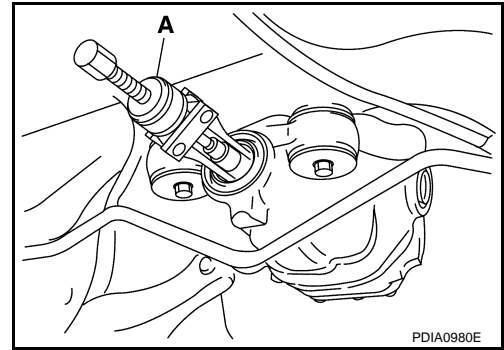

## INSTALLATION

1. Apply multi-purpose grease to front oil seal lips.
2. Install front oil seal using the drift (A) [SST: ST30720000 (J-25405)] as shown in figure.

### CAUTION:

- Never reuse oil seal.
- Never incline oil seal when installing.

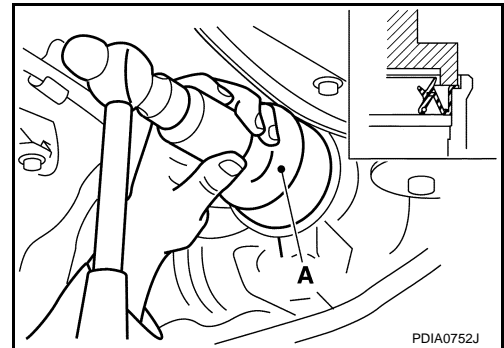

3. Align the matching mark (B) of drive pinion with the matching mark (A) of companion flange (1), and then install the companion flange (1).

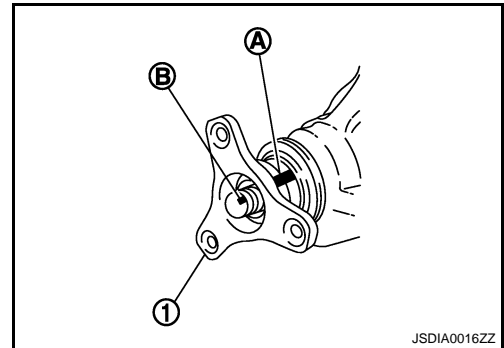

# FRONT OIL SEAL

< ON-VEHICLE REPAIR >

[REAR FINAL DRIVE: R200]

4. Apply anti-corrosion oil to the thread and seat of new drive pinion lock nut, and temporarily tighten drive pinion lock nut to drive pinion.

**CAUTION:**

**Never reuse drive pinion lock nut.**

5. Tighten to drive pinion lock nut, while adjust total preload torque.

A: Preload gauge [SST: ST3127S000 (J-25765-A)]

**Total preload torque** : Total preload torque should equal the measurement taken during removal plus an additional 0.1 – 0.4 N·m (0.01 – 0.04 kg·m, 1 – 3 in-lb).

**CAUTION:**

- Adjust to the lower limit of the drive pinion lock nut tightening torque first.
- If the preload torque exceeds the specified value, replace collapsible spacer and tighten it again to adjust. Never loosen drive pinion lock nut to adjust the preload torque.

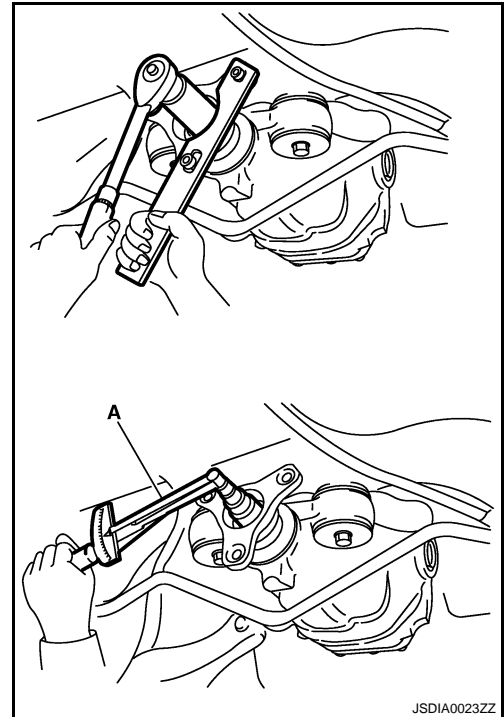

6. Set a dial indicator (A) vertically to the tip of the drive pinion.
7. Rotate drive pinion to check for runout.

**Limit**

**Drive pinion runout** : Refer to [DLN-216, "Drive Pinion Runout \(2WD Models\)"](#).

- If the runout value is still outside of the limit after the phase has been changed, possible cause will be an assembly malfunction of drive pinion and pinion bearing and malfunction of pinion bearing. Check for these items and repair if necessary.

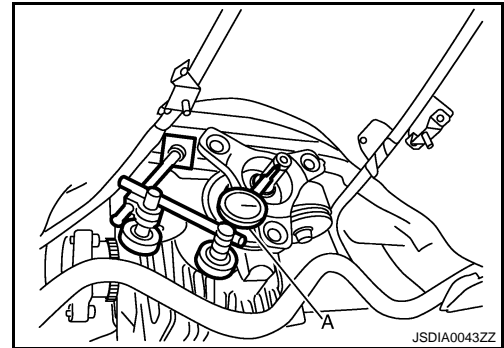

8. Make a stamping for identification of front oil seal replacement frequency. Refer to "Identification stamp of replacement frequency of front oil seal".

**CAUTION:**

**Never make a stamping after replacing front oil seal.**

9. Install propeller shaft. Refer to [DLN-93, "Removal and Installation"](#).
10. Install side flange with the following procedure.

- a. Attach the protector [SST: KV38107900 (J-39352)] to side oil seal.
- b. After the side flange is inserted and the serrated part of side gear has engaged the serrated part of flange, remove the protector.
- c. Put a suitable drift on the center of side flange, then drive it until sound changes.

**NOTE:**

When installation is completed, driving sound of the side flange turns into a sound which seems to affect the whole final drive.

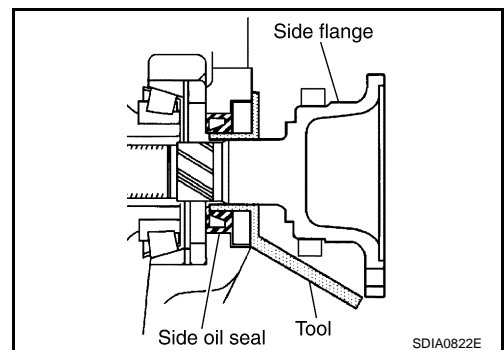

A  
B  
C  
DLN  
E  
F  
G  
H  
I  
J  
K  
L  
M  
N  
O  
P

# FRONT OIL SEAL

< ON-VEHICLE REPAIR >

[REAR FINAL DRIVE: R200]

d. Confirm that the dimension of the side flange (1) installation (Measurement A) in the figure comes into the following.

**Measurement "A" : 326 – 328 mm (12.83 – 12.91 in)**

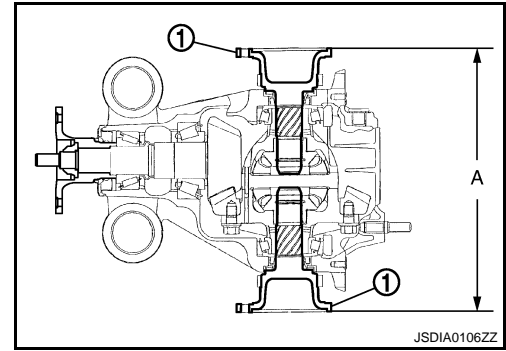

11. Install drive shaft. Refer to [RAX-9, "Removal and Installation"](#).
12. Install rear wheel sensor. Refer to [BRC-100, "Removal and Installation"](#).
13. Install center muffler. Refer to [EX-5, "Removal and Installation"](#).
14. Refill gear oil to the final drive and check oil level. Refer to [DLN-154, "Refilling"](#).
15. Check the final drive for oil leakage. Refer to [DLN-154, "Inspection"](#).

AWD

AWD : Exploded View

INFOID:000000000957385

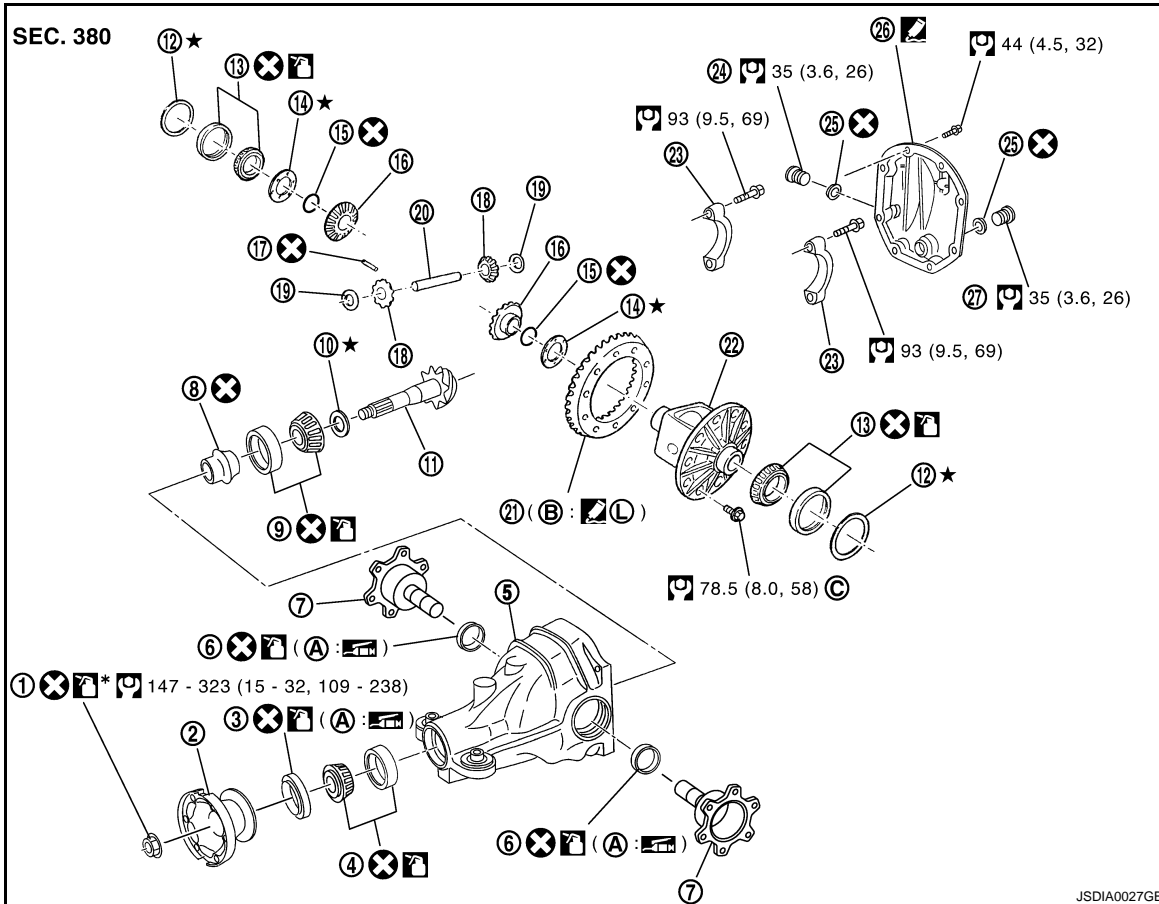

- |                                    |                             |                                   |
|------------------------------------|-----------------------------|-----------------------------------|
| 1. Drive pinion lock nut           | 2. Companion flange         | 3. Front oil seal                 |
| 4. Pinion front bearing            | 5. Gear carrier             | 6. Side oil seal                  |
| 7. Side flange                     | 8. Collapsible spacer       | 9. Pinion rear bearing            |
| 10. Pinion height adjusting washer | 11. Drive pinion            | 12. Side bearing adjusting washer |
| 13. Side bearing                   | 14. Side gear thrust washer | 15. Circular clip                 |
| 16. Side gear                      | 17. Lock pin                | 18. Pinion mate gear              |
| 19. Pinion mate thrust washer      | 20. Pinion mate shaft       | 21. Drive gear                    |
| 22. Differential case              | 23. Bearing cap             | 24. Filler plug                   |
| 25. Gasket                         | 26. Rear cover              | 27. Drain plug                    |

A: Oil seal lip



# FRONT OIL SEAL

< ON-VEHICLE REPAIR >

[REAR FINAL DRIVE: R200]

B: Screw hole

C: After tightening the bolts to the specified torque, tighten the bolts additionally by turning the bolts 31 to 36 degrees.

 Apply gear oil.

 Apply anti-corrosion oil.

 Apply Genuine Silicone RTV or equivalent. Refer to [GI-15. "Recommended Chemical Products and Sealants"](#).

 Apply Genuine High Strength Thread Locking Sealant or equivalent. Refer to [GI-15. "Recommended Chemical Products and Sealants"](#).

Refer to [GI-4. "Components"](#) for symbols not described on the above.

## AWD : Removal and Installation

INFOID:000000000957386

A  
B  
C  
DLN

### REMOVAL

#### CAUTION:

Verify identification stamp of replacement frequency put in the lower part of gear carrier to determine replacement for collapsible spacer when replacing front oil seal. Refer to "Identification stamp of replacement frequency of front oil seal". If necessary collapsible spacer replacement, remove final drive assembly and disassemble it to replace front oil seal and collapsible spacer. Refer to [DLN-172. "AWD : Removal and Installation"](#) and [DLN-187. "AWD : Disassembly"](#).

#### NOTE:

The reuse of collapsible spacer is prohibited in principle. However, it is reusable on a one-time basis only in cases when replacing front oil seal.

Identification stamp of replacement frequency of front oil seal

- The diagonally shaded area in the figure shows stamping point for replacement frequency of front oil seal.
- The following table shows if collapsible spacer replacement is needed before replacing front oil seal. When collapsible spacer replacement is required, disassemble final drive assembly to replace collapsible spacer and front oil seal. Refer to [DLN-187. "AWD : Disassembly"](#).

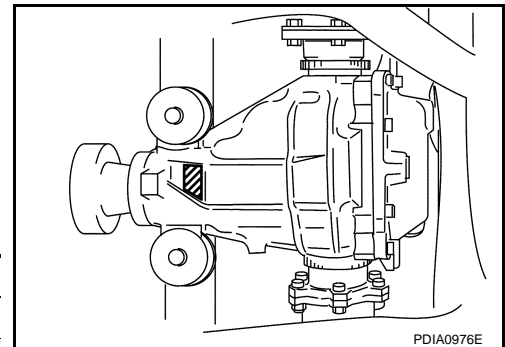

Stamp	collapsible spacer replacement
No stamp	Not required
"0" or "0" on the far right of stamp	Required
"01" or "1" on the far right of stamp	Not required

E  
F  
G  
H  
I  
J  
K  
L

#### CAUTION:

**Never make a stamping after replacing front oil seal.**

- After replacing front oil seal, make a stamping on the stamping point in accordance with the table below in order to identify replacement frequency.

#### CAUTION:

**Stamping shall be made from left to right.**

Stamp before stamping	Stamping on the far right	Stamping
No stamp	0	0
"0" (Front oil seal was replaced once.)	1	01
"01" (Collapsible spacer and front oil seal were replaced last time.)	0	010
"0" is on the far right. (Only front oil seal was replaced last time.)	1	...01
"1" is on the far right. (Collapsible spacer and front oil seal were replaced last time.)	0	...010

M  
N  
O  
P

- Drain gear oil. Refer to [DLN-154. "Draining"](#).
- Make a judgment if a collapsible spacer replacement is required.

# FRONT OIL SEAL

< ON-VEHICLE REPAIR >

[REAR FINAL DRIVE: R200]

3. Remove center muffler with a power tool. Refer to [EX-5, "Removal and Installation"](#).
4. Remove rear wheel sensor. Refer to [BRC-100, "Removal and Installation"](#).
5. Remove drive shaft from final drive. Then suspend it by wire etc. Refer to [RAX-9, "Removal and Installation"](#).
6. Install attachment (A) [SST: KV40104100 ( — )] to side flange, and then pull out the side flange with the sliding hammer (B) [SST: ST36230000 (J-25840-A)].

**NOTE:**

**Circular clip installation position: Final drive side**

7. Remove propeller shaft. Refer to [DLN-101, "Removal and Installation"](#).

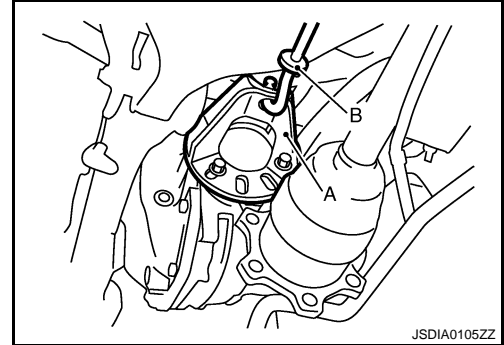

8. Measure the total preload with the preload gauge (A) [SST: ST3127S000 (J-25765-A)].

**NOTE:**

**Record the preload measurement.**

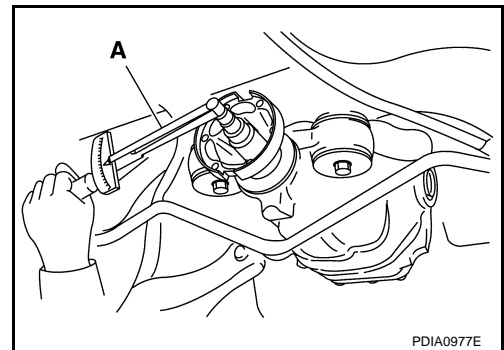

9. Put matching mark (B) on the end of the drive pinion. The matching mark (B) should be in line with the matching mark (A) on companion flange (1).

**CAUTION:**

**For matching mark, use paint. Never damage companion flange and drive pinion.**

**NOTE:**

The matching mark (A) on the final drive companion flange (1) indicates the maximum vertical runout position.

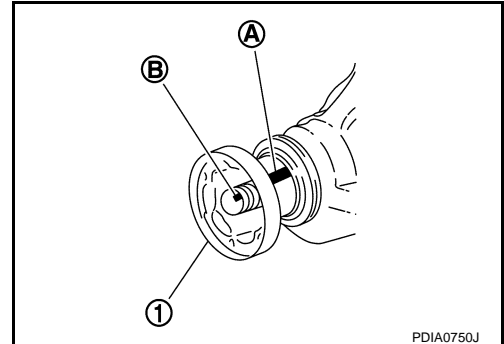

10. Remove drive pinion lock nut using the flange wrench.

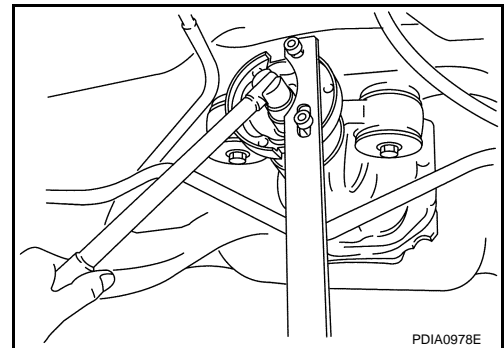

# FRONT OIL SEAL

< ON-VEHICLE REPAIR >

[REAR FINAL DRIVE: R200]

11. Remove companion flange using a puller.

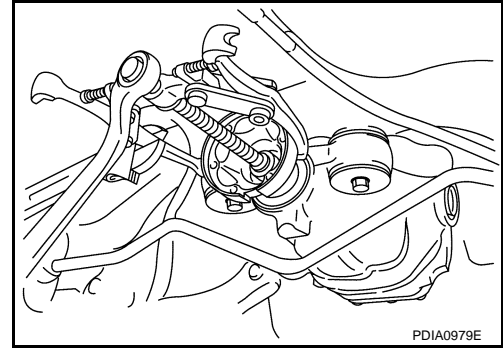

12. Remove front oil seal using the puller (A) [SST: KV381054S0 (J-34286)].

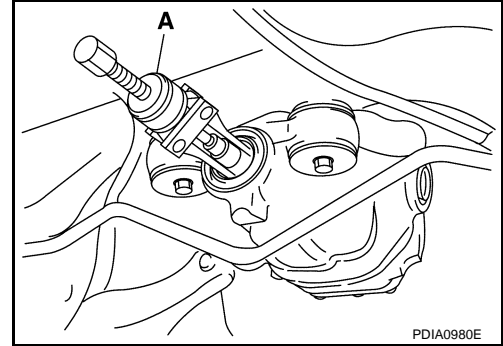

## INSTALLATION

1. Apply multi-purpose grease to front oil seal lips.
2. Install front oil seal using the drift (A) [SST: ST30720000 (J-25405)] as shown in figure.

### CAUTION:

- Never reuse oil seal.
- Never incline oil seal when installing.

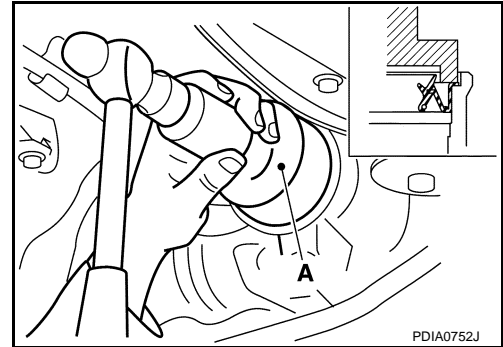

3. Align the matching mark (B) of drive pinion with the matching mark (A) of companion flange (1), and then install the companion flange (1).

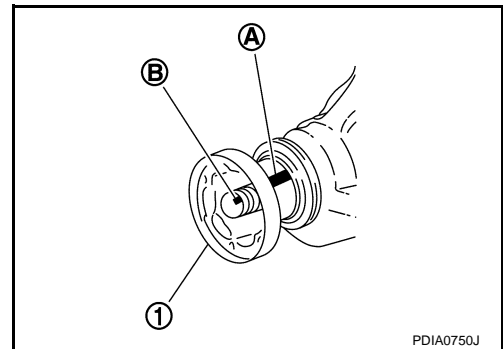

A  
B  
C  
DLN  
E  
F  
G  
H  
I  
J  
K  
L  
M  
N  
O  
P

# FRONT OIL SEAL

< ON-VEHICLE REPAIR >

[REAR FINAL DRIVE: R200]

4. Apply anti-corrosion oil to the thread and seat of new drive pinion lock nut, and temporarily tighten drive pinion lock nut to drive pinion.

**CAUTION:**

**Never reuse drive pinion lock nut.**

5. Tighten to drive pinion lock nut, while adjust total preload torque.

A: Preload gauge [SST: ST3127S000 (J-25765-A)]

**Total preload torque** : Total preload torque should equal the measurement taken during removal plus an additional 0.1 – 0.4 N·m (0.01 – 0.04 kg·m, 1 – 3 in·lb).

**CAUTION:**

- Adjust to the lower limit of the drive pinion lock nut tightening torque first.
- If the preload torque exceeds the specified value, replace collapsible spacer and tighten it again to adjust. Never loosen drive pinion lock nut to adjust the preload torque.

6. Fit a test indicator to the inner side of companion flange (socket diameter).
7. Rotate companion flange to check for runout.

**Limit**

**Companion flange runout** : Refer to [DLN-216, "Companion flange Runout \(AWD Models\)"](#).

- If the runout value is outside the runout limit, follow the procedure below to adjust.
  - Check for runout while changing the phase between companion flange and drive pinion by 90° step, and search for the position where the runout is the minimum.
  - If the runout value is still outside of the limit after the phase has been changed, possible cause will be an assembly malfunction of drive pinion and pinion bearing and malfunction of pinion bearing. Check for these items and repair if necessary.
  - If the runout value is still outside of the limit after the check and repair, replace companion flange.

8. Make a stamping for identification of front oil seal replacement frequency. Refer to "Identification stamp of replacement frequency of front oil seal".

**CAUTION:**

**Never make a stamping after replacing front oil seal.**

9. Install propeller shaft. Refer to [DLN-101, "Removal and Installation"](#).
10. Install side flange with the following procedure.
  - a. Attach the protector [SST: KV38107900 (J-39352)] to side oil seal.
  - b. After the side flange is inserted and the serrated part of side gear has engaged the serrated part of flange, remove the protector.

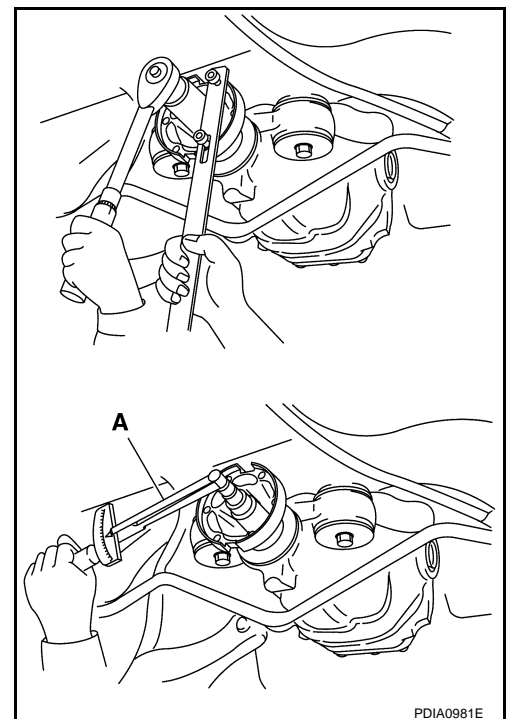

PDIA0981E

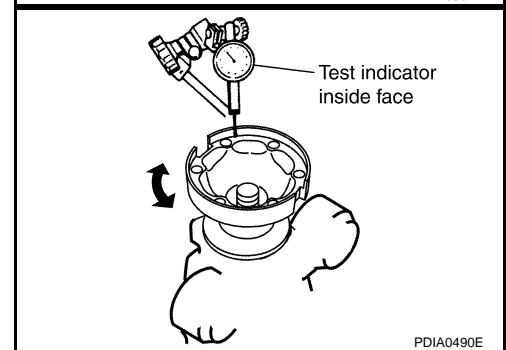

PDIA0490E

- c. Put a suitable drift on the center of side flange, then drive it until sound changes.

**NOTE:**

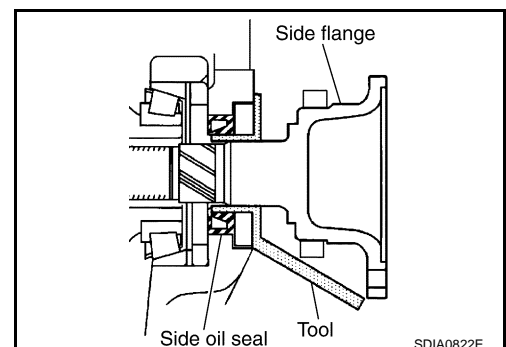

SDIA0822E

# FRONT OIL SEAL

< ON-VEHICLE REPAIR >

[REAR FINAL DRIVE: R200]

When installation is completed, driving sound of the side flange turns into a sound which seems to affect the whole final drive.

- d. Confirm that the dimension of the side flange installation (Measurement A) in the figure comes into the following.

**Measurement "A"** : 326 – 328 mm (12.83 – 12.91 in)

11. Install drive shaft. Refer to [RAX-9, "Removal and Installation"](#).
12. Install rear wheel sensor. Refer to [BRC-100, "Removal and Installation"](#).
13. Install center muffler. Refer to [EX-5, "Removal and Installation"](#).
14. Refill gear oil to the final drive and check oil level. Refer to [DLN-154, "Refilling"](#).
15. Check the final drive for oil leakage. Refer to [DLN-154, "Inspection"](#).

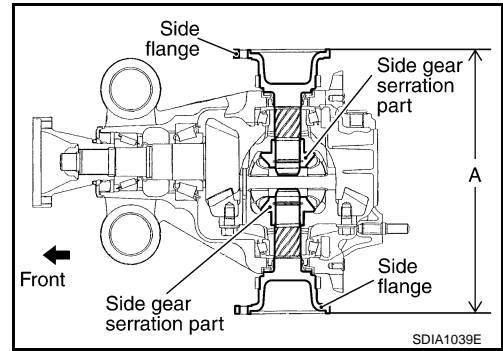

A

B

C

DLN

E

F

G

H

I

J

K

L

M

N

O

P

# SIDE OIL SEAL

< ON-VEHICLE REPAIR >

[REAR FINAL DRIVE: R200]

## SIDE OIL SEAL

2WD

2WD : Exploded View

INFOID:000000000957387

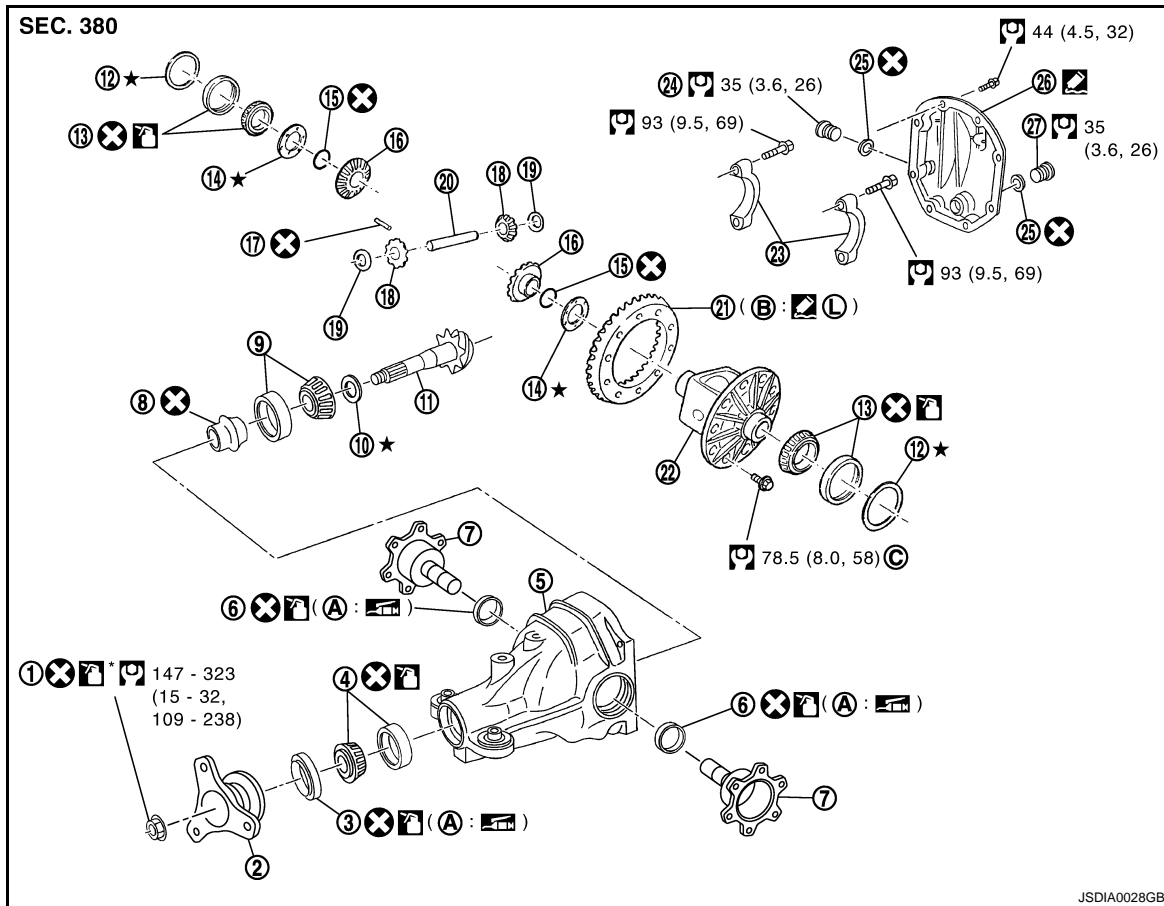

JSDIA0028GB

- |                                    |                             |                                   |
|------------------------------------|-----------------------------|-----------------------------------|
| 1. Drive pinion lock nut           | 2. Companion flange         | 3. Front oil seal                 |
| 4. Pinion front bearing            | 5. Gear carrier             | 6. Side oil seal                  |
| 7. Side flange                     | 8. Collapsible spacer       | 9. Pinion rear bearing            |
| 10. Pinion height adjusting washer | 11. Drive pinion            | 12. Side bearing adjusting washer |
| 13. Side bearing                   | 14. Side gear thrust washer | 15. Circular clip                 |
| 16. Side gear                      | 17. Lock pin                | 18. Pinion mate gear              |
| 19. Pinion mate thrust washer      | 20. Pinion mate shaft       | 21. Drive gear                    |
| 22. Differential case              | 23. Bearing cap             | 24. Filler plug                   |
| 25. Gasket                         | 26. Rear cover              | 27. Drain plug                    |

A: Oil seal lip

B: Screw hole

C: After tightening the bolts to the specified torque, tighten the bolts additionally by turning the bolts 31 to 36 degrees.



Apply gear oil.



Apply anti-corrosion oil.



Apply Genuine Silicone RTV or equivalent. Refer to [GI-15, "Recommended Chemical Products and Sealants"](#).



Apply Genuine High Strength Thread Locking Sealant or equivalent. Refer to [GI-15, "Recommended Chemical Products and Sealants"](#).

Refer to [GI-4, "Components"](#) for symbols not described on the above.

# SIDE OIL SEAL

< ON-VEHICLE REPAIR >

[REAR FINAL DRIVE: R200]

INFOID:000000000957388

## 2WD : Removal and Installation

### REMOVAL

1. Remove center muffler with a power tool. Refer to [EX-5. "Removal and Installation"](#).
2. Remove rear wheel sensor. Refer to [BRC-100. "Removal and Installation"](#).
3. Remove drive shaft from final drive with a power tool. Then suspend it by wire etc. Refer to [RAX-9. "Removal and Installation"](#).
4. Install attachment (A) [SST: KV40104100 ( — )] to side flange, and then pull out the side flange with the sliding hammer (B) [SST: ST36230000 (J-25840-A)].

**NOTE:**

**Circular clip installation position: Final drive side**

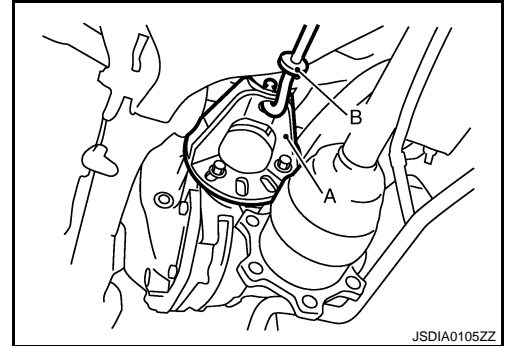

5. Remove side oil seal, using a flat-bladed screwdriver.

**CAUTION:**

**Never damage gear carrier.**

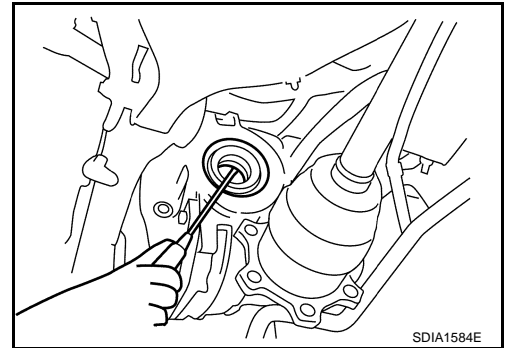

### INSTALLATION

1. Apply multi-purpose grease to side oil seal lips.
2. Install side oil seal until it becomes flush with the case end, using the drift [SST: KV38100200 (J-26233)].

**CAUTION:**

- **Never reuse oil seal.**
- **When installing, never incline oil seal.**

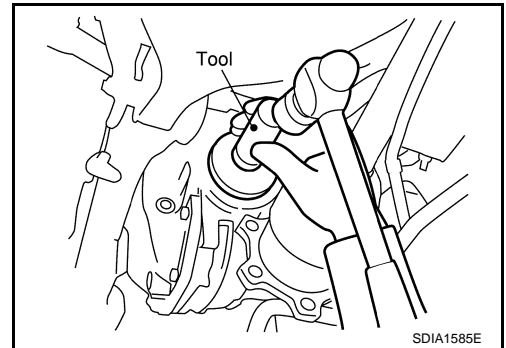

3. Install side flange with the following procedure.
  - a. Attach the protector [SST: KV38107900 (J-39352)] to side oil seal.
  - b. After the side flange is inserted and the serrated part of side gear has engaged the serrated part of flange, remove the protector.

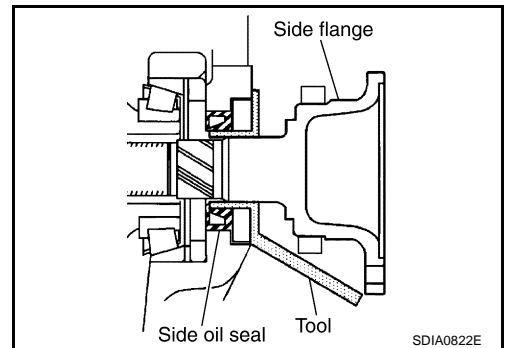

- c. Put a suitable drift on the center of side flange, then drive it until sound changes.

A  
B  
C  
DLN  
E  
F  
G  
H  
I  
J  
K  
L  
M  
N  
O  
P

# SIDE OIL SEAL

< ON-VEHICLE REPAIR >

[REAR FINAL DRIVE: R200]

**NOTE:**

When installation is completed, driving sound of the side flange turns into a sound which seems to affect the whole final drive.

- d. Confirm that the dimension of the side flange (1) installation (Measurement A) in the figure comes into the following.

**Measurement "A" : 326 – 328 mm (12.83 – 12.91 in)**

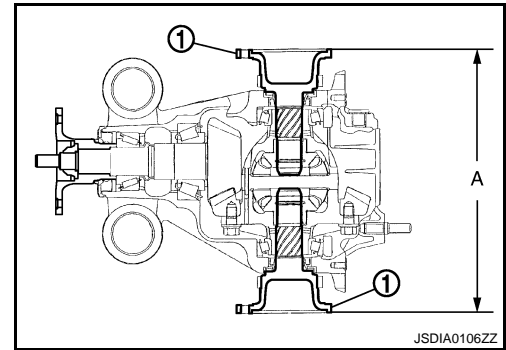

- 4. Install drive shaft. Refer to [RAX-9, "Removal and Installation"](#).
- 5. Install rear wheel sensor. Refer to [BRC-100, "Removal and Installation"](#).
- 6. Install center muffler. Refer to [EX-5, "Removal and Installation"](#).
- 7. When oil leaks while removing, check oil level after the installation. Refer to [DLN-154, "Inspection"](#).

**AWD**

**AWD : Exploded View**

INFOID:000000000957389

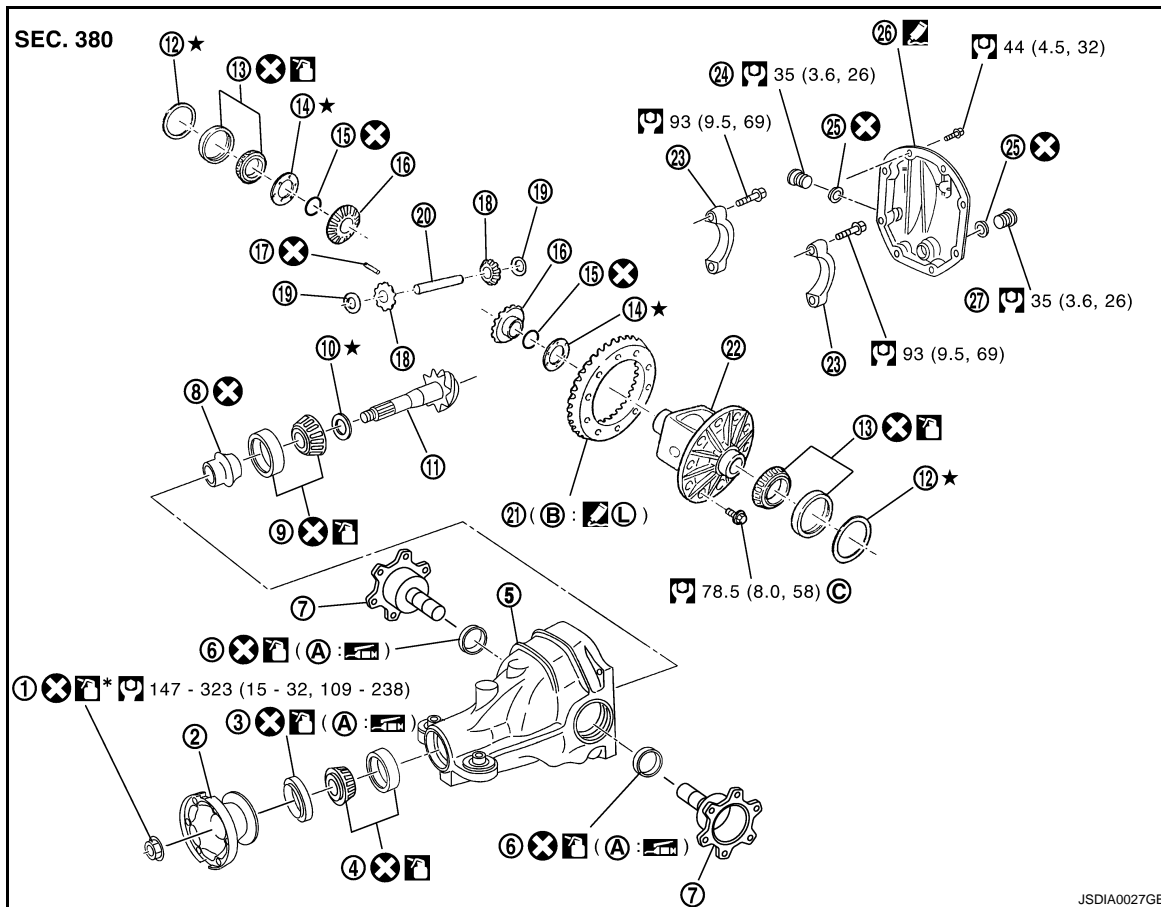

JSDIA0027GB

- |                                    |                             |                                   |
|------------------------------------|-----------------------------|-----------------------------------|
| 1. Drive pinion lock nut           | 2. Companion flange         | 3. Front oil seal                 |
| 4. Pinion front bearing            | 5. Gear carrier             | 6. Side oil seal                  |
| 7. Side flange                     | 8. Collapsible spacer       | 9. Pinion rear bearing            |
| 10. Pinion height adjusting washer | 11. Drive pinion            | 12. Side bearing adjusting washer |
| 13. Side bearing                   | 14. Side gear thrust washer | 15. Circular clip                 |
| 16. Side gear                      | 17. Lock pin                | 18. Pinion mate gear              |
| 19. Pinion mate thrust washer      | 20. Pinion mate shaft       | 21. Drive gear                    |
| 22. Differential case              | 23. Bearing cap             | 24. Filler plug                   |



# SIDE OIL SEAL

< ON-VEHICLE REPAIR >

[REAR FINAL DRIVE: R200]

25. Gasket

26. Rear cover

27. Drain plug

A: Oil seal lip

B: Screw hole

C: After tightening the bolts to the specified torque, tighten the bolts additionally by turning the bolts 31 to 36 degrees.

 Apply gear oil.

 Apply anti-corrosion oil.

 Apply Genuine Silicone RTV or equivalent. Refer to [GI-15. "Recommended Chemical Products and Sealants"](#).

 Apply Genuine High Strength Thread Locking Sealant or equivalent. Refer to [GI-15. "Recommended Chemical Products and Sealants"](#).

Refer to [GI-4. "Components"](#) for symbols not described on the above.

## AWD : Removal and Installation

INFOID:000000000957390

### REMOVAL

1. Remove center muffler with a power tool. Refer to [EX-5. "Removal and Installation"](#).
2. Remove rear wheel sensor. Refer to [BRC-100. "Removal and Installation"](#).
3. Remove drive shaft from final drive with a power tool. Then suspend it by wire etc. Refer to [RAX-9. "Removal and Installation"](#).
4. Install attachment (A) [SST: KV40104100 ( — )] to side flange, and then pull out the side flange with the sliding hammer (B) [SST: ST36230000 (J-25840-A)].

#### NOTE:

**Circular clip installation position: Final drive side**

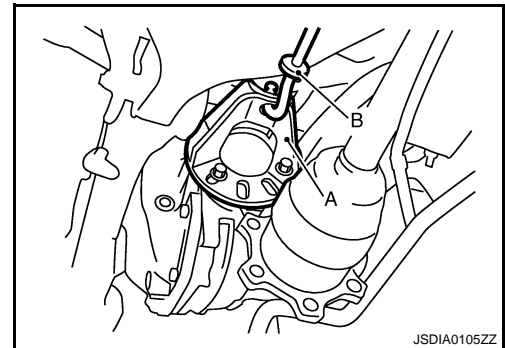

5. Remove side oil seal, using a flat-bladed screwdriver.  
**CAUTION:**  
**Never damage gear carrier.**

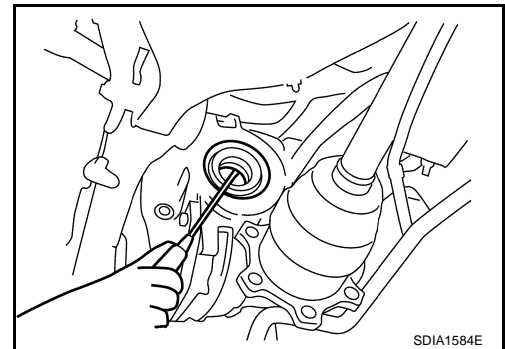

### INSTALLATION

1. Apply multi-purpose grease to side oil seal lips.
2. Install side oil seal until it becomes flush with the case end, using the drift [SST: KV38100200 (J-26233)].

#### CAUTION:

- **Never reuse oil seal.**
- **When installing, never incline oil seal.**

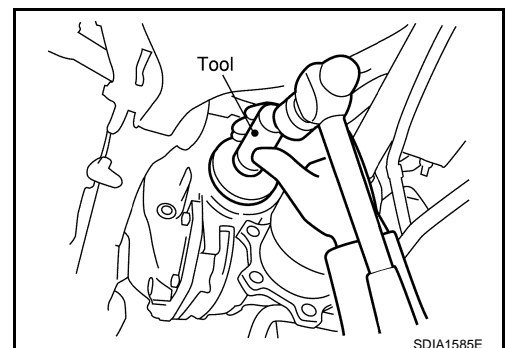

## SIDE OIL SEAL

< ON-VEHICLE REPAIR >

[REAR FINAL DRIVE: R200]

3. Install side flange with the following procedure.
  - a. Attach the protector [SST: KV38107900 (J-39352)] to side oil seal.
  - b. After the side flange is inserted and the serrated part of side gear has engaged the serrated part of flange, remove the protector.

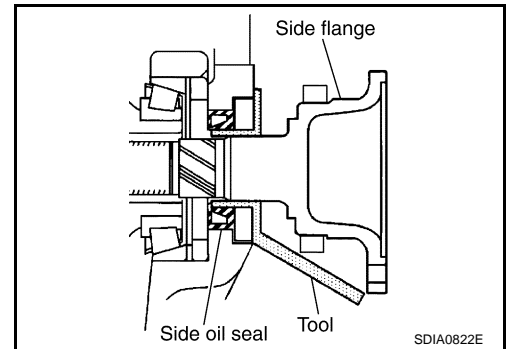

- c. Put a suitable drift on the center of side flange, then drive it until sound changes.

**NOTE:**

When installation is completed, driving sound of the side flange turns into a sound which seems to affect the whole final drive.

- d. Confirm that the dimension of the side flange installation (Measurement A) in the figure comes into the following.

**Measurement "A" : 326 – 328 mm (12.83 – 12.91 in)**

4. Install drive shaft. Refer to [RAX-9, "Removal and Installation"](#).
5. Install rear wheel sensor. Refer to [BRC-100, "Removal and Installation"](#).
6. Install center muffler. Refer to [EX-5, "Removal and Installation"](#).
7. When oil leaks while removing, check oil level after the installation. Refer to [DLN-154, "Inspection"](#).

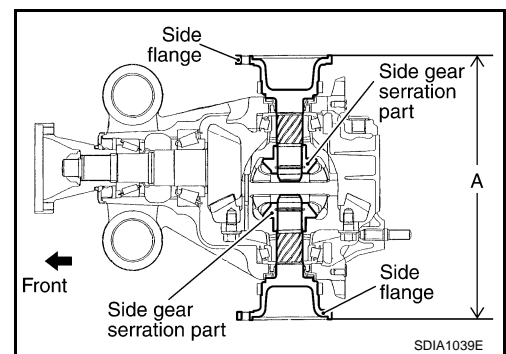

# REAR FINAL DRIVE ASSEMBLY

< REMOVAL AND INSTALLATION >

[REAR FINAL DRIVE: R200]

## REMOVAL AND INSTALLATION

### REAR FINAL DRIVE ASSEMBLY

2WD

2WD : Exploded View

INFOID:000000000957391

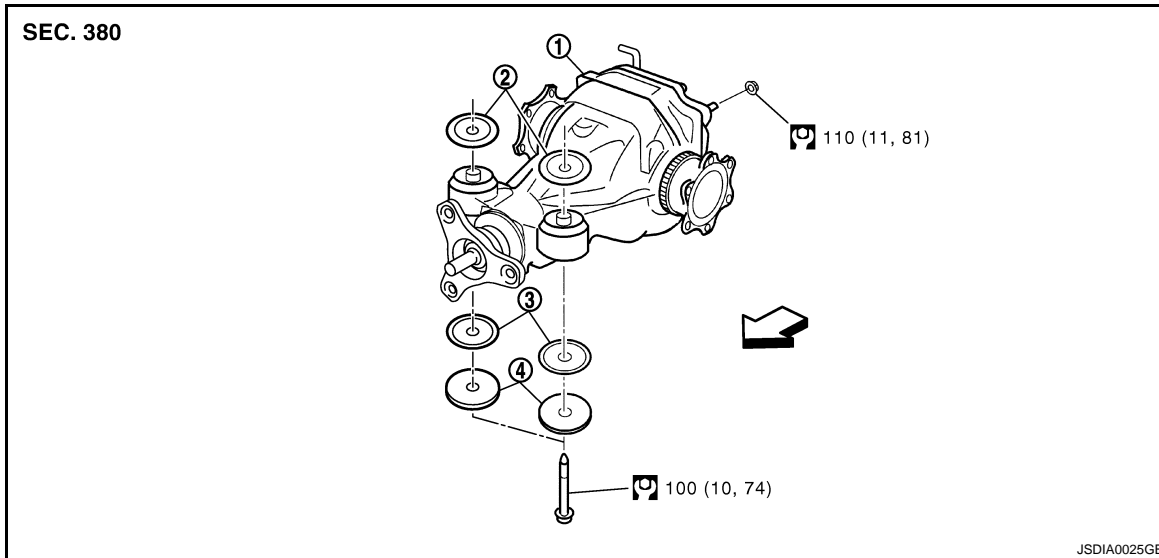

1. Rear final drive assembly
2. Upper stopper
3. Lower stopper
4. Washer

↔: Vehicle front

Refer to [GI-4. "Components"](#) for symbols in the figure.

### 2WD : Removal and Installation

INFOID:000000000957392

#### REMOVAL

1. Remove center muffler with a power tool. Refer to [EX-5. "Removal and Installation"](#).
2. Remove rear stabilizer bar with a power tool. Refer to [RSU-15. "Removal and Installation"](#).
3. Remove propeller shaft from the final drive. Refer to [DLN-93. "Removal and Installation"](#).
4. Remove drive shaft from final drive with a power tool. Then suspend it by wire etc. Refer to [RAX-9. "Removal and Installation"](#).
5. Remove breather hose from the final drive.
6. Remove rear wheel sensor. Refer to [BRC-100. "Removal and Installation"](#).

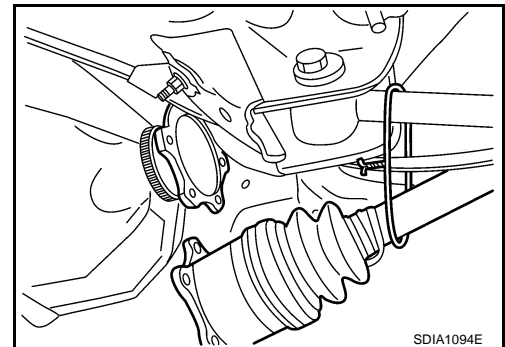

# REAR FINAL DRIVE ASSEMBLY

## < REMOVAL AND INSTALLATION >

[REAR FINAL DRIVE: R200]

7. Set a suitable jack to rear final drive assembly.

**CAUTION:**

Never place a suitable jack on the rear cover (aluminum case).

8. Remove the mounting bolts and nuts connecting to the suspension member, and remove rear final drive assembly with a power tool.

**CAUTION:**

Secure rear final drive assembly to a suitable jack while removing it.

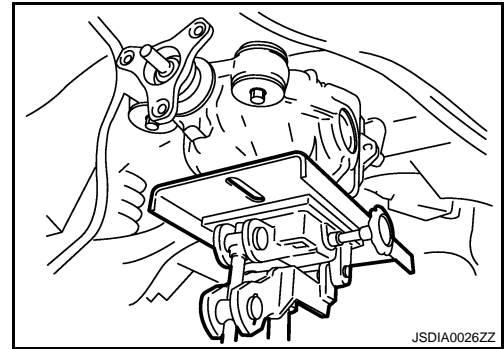

## INSTALLATION

Note the following, and installation is in the reverse order of removal.

- When installing breather hoses (1), refer to the figure.

↔: Vehicle front

**CAUTION:**

Make sure there are no pinched or restricted areas on the breather hose caused by bending or winding when installing it.

- For installation, the vehicle side end shall be inserted to suspension member (2). Install metal connector (3) side of this hose to rear cover by inserting it with aiming painted marking to the front of vehicle.

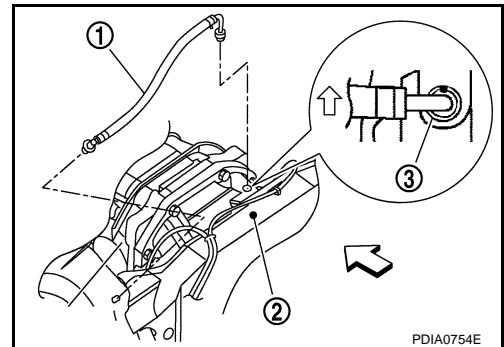

- When oil leaks while removing final drive assembly, check oil level after the installation. Refer to [DLN-154, "Inspection"](#).

## AWD

### AWD : Exploded View

INFOID:000000000957393

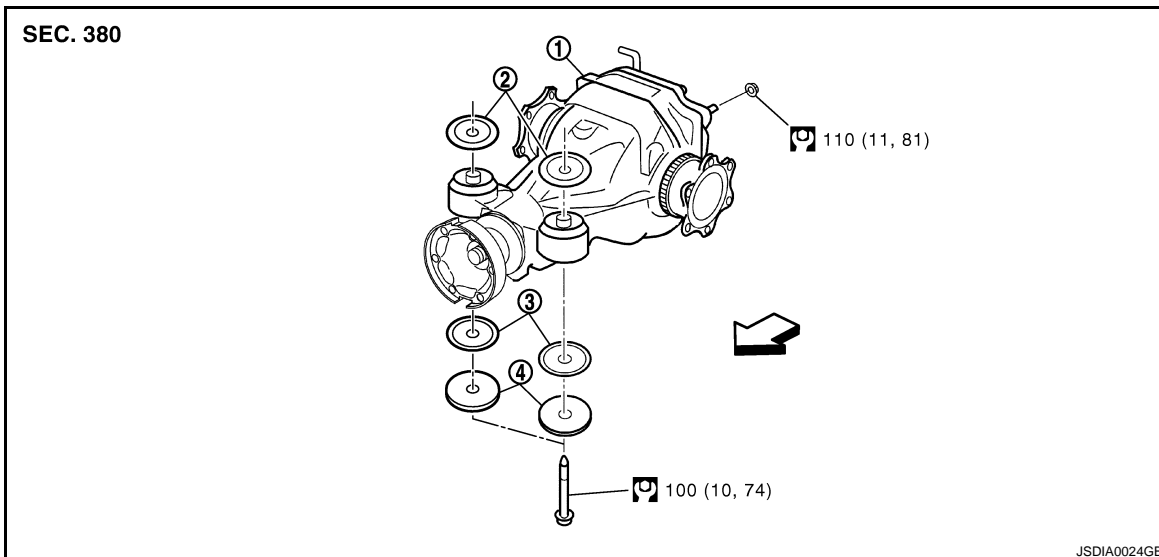

- |                              |                  |                  |
|------------------------------|------------------|------------------|
| 1. Rear final drive assembly | 2. Upper stopper | 3. Lower stopper |
| 4. Washer                    |                  |                  |

↔: Vehicle front

Refer to [GI-4, "Components"](#) for symbols in the figure.

### AWD : Removal and Installation

INFOID:000000000957394

# REAR FINAL DRIVE ASSEMBLY

< REMOVAL AND INSTALLATION >

[REAR FINAL DRIVE: R200]

## REMOVAL

1. Remove center muffler with a power tool. Refer to [EX-5, "Removal and Installation"](#).
2. Remove rear stabilizer bar with a power tool. Refer to [RSU-15, "Removal and Installation"](#).
3. Remove propeller shaft from the final drive. Refer to [DLN-93, "Removal and Installation"](#).
4. Remove drive shaft from final drive with a power tool. Then suspend it by wire etc. Refer to [RAX-9, "Removal and Installation"](#).
5. Remove breather hose from the final drive.
6. Remove rear wheel sensor. Refer to [BRC-100, "Removal and Installation"](#).

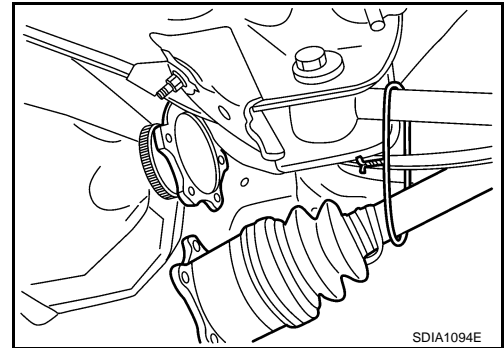

7. Set a suitable jack to rear final drive assembly.  
**CAUTION:**  
**Never place a suitable jack on the rear cover (aluminum case).**
8. Remove the mounting bolts and nuts connecting to the suspension member, and remove rear final drive assembly with a power tool.  
**CAUTION:**  
**Secure rear final drive assembly to a suitable jack while removing it.**

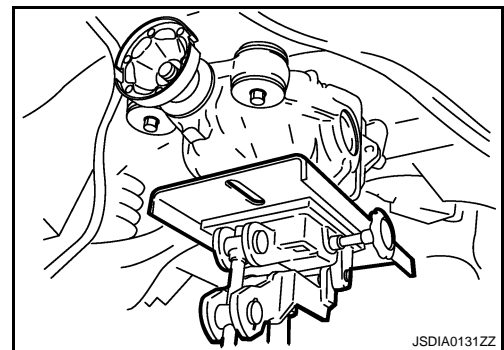

## INSTALLATION

Note the following, and installation is in the reverse order of removal.

- When installing breather hoses (1), refer to the figure.

←: Vehicle front

**CAUTION:**  
**Make sure there are no pinched or restricted areas on the breather hose caused by bending or winding when installing it.**

- For installation, the vehicle side end shall be inserted to suspension member (2). Install metal connector (3) side of this hose to rear cover by inserting it with aiming painted marking to the front of vehicle.
- When oil leaks while removing final drive assembly, check oil level after the installation. Refer to [DLN-154, "Inspection"](#).

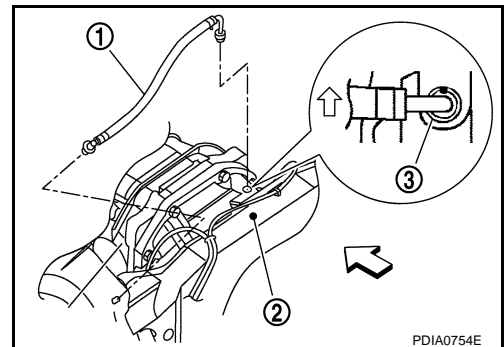

# DIFFERENTIAL ASSEMBLY

< DISASSEMBLY AND ASSEMBLY >

[REAR FINAL DRIVE: R200]

## DISASSEMBLY AND ASSEMBLY

### DIFFERENTIAL ASSEMBLY

2WD

2WD : Exploded View

INFOID:000000000957395

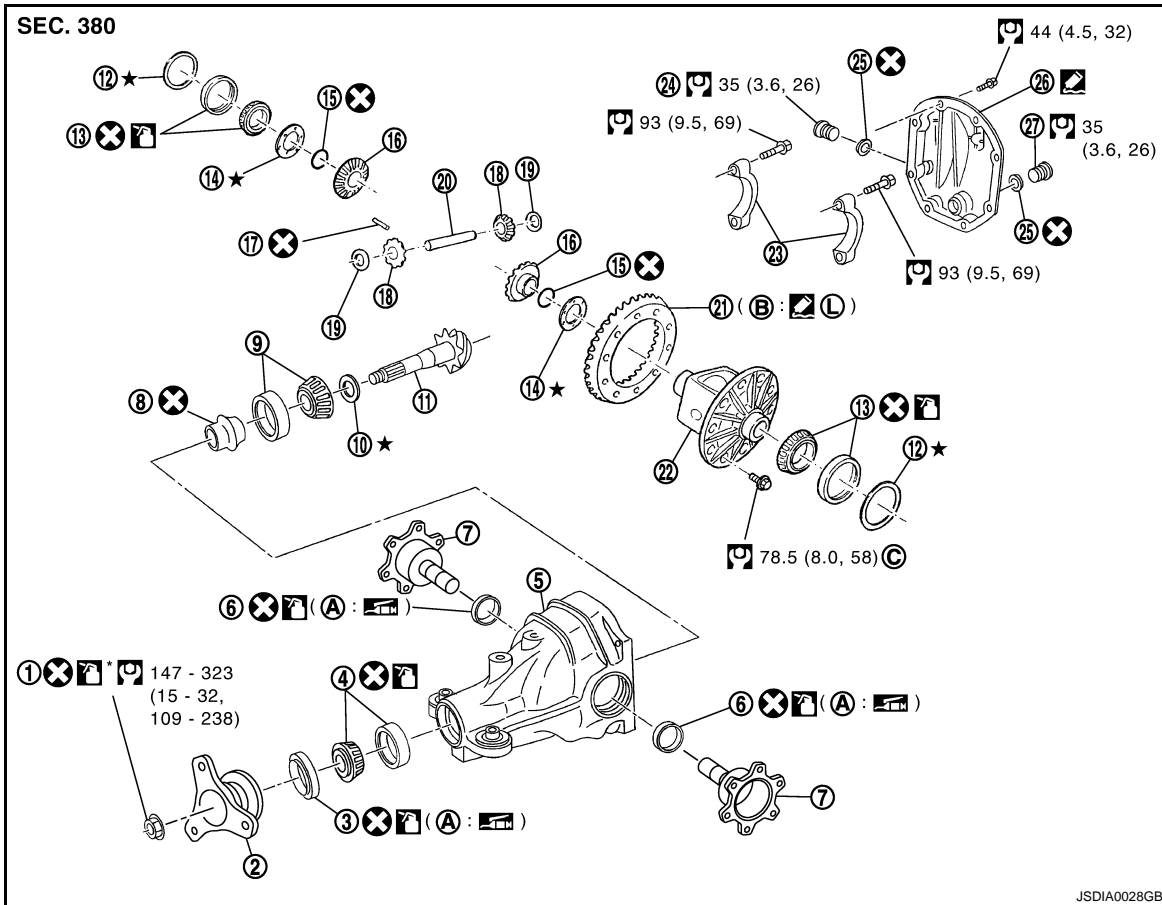

- |                                    |                             |                                   |
|------------------------------------|-----------------------------|-----------------------------------|
| 1. Drive pinion lock nut           | 2. Companion flange         | 3. Front oil seal                 |
| 4. Pinion front bearing            | 5. Gear carrier             | 6. Side oil seal                  |
| 7. Side flange                     | 8. Collapsible spacer       | 9. Pinion rear bearing            |
| 10. Pinion height adjusting washer | 11. Drive pinion            | 12. Side bearing adjusting washer |
| 13. Side bearing                   | 14. Side gear thrust washer | 15. Circular clip                 |
| 16. Side gear                      | 17. Lock pin                | 18. Pinion mate gear              |
| 19. Pinion mate thrust washer      | 20. Pinion mate shaft       | 21. Drive gear                    |
| 22. Differential case              | 23. Bearing cap             | 24. Filler plug                   |
| 25. Gasket                         | 26. Rear cover              | 27. Drain plug                    |

A: Oil seal lip

B: Screw hole

C: After tightening the bolts to the specified torque, tighten the bolts additionally by turning the bolts 31 to 36 degrees.

Apply gear oil.

Apply anti-corrosion oil.

Apply Genuine Silicone RTV or equivalent. Refer to [GI-15, "Recommended Chemical Products and Sealants"](#).

# DIFFERENTIAL ASSEMBLY

< DISASSEMBLY AND ASSEMBLY >

[REAR FINAL DRIVE: R200]

 Apply Genuine High Strength Thread Locking Sealant or equivalent. Refer to [GI-15. "Recommended Chemical Products and Sealants"](#).

Refer to [GI-4. "Components"](#) for symbols not described on the above.

## 2WD : Disassembly

INFOID:000000000957396

1. Drain gear oil, if necessary.
2. Remove side flange.
3. Remove rear cover mounting bolts.
4. Remove rear cover to insert the seal cutter (A) [SST: KV10111100 (J-37228)] between gear carrier and rear cover.

### CAUTION:

- Never damage the mating surface.
- Never insert flat-bladed screwdriver, this way damage the mating surface.

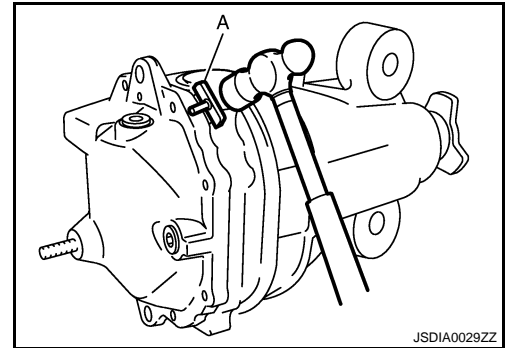

5. Using two 45 mm (1.77 in) spacers, mount carrier on the attachment (A) [SST: KV38100800 (J-25604-01)].

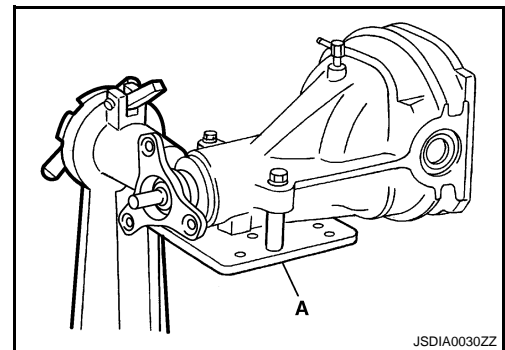

6. For proper reinstallation, paint matching marks on one side of the bearing cap.

### CAUTION:

- For matching marks, use paint. Never damage bearing caps and gear carrier.
- Bearing caps are line-board during manufacture. The matching marks are used to reinstall them in their original positions.

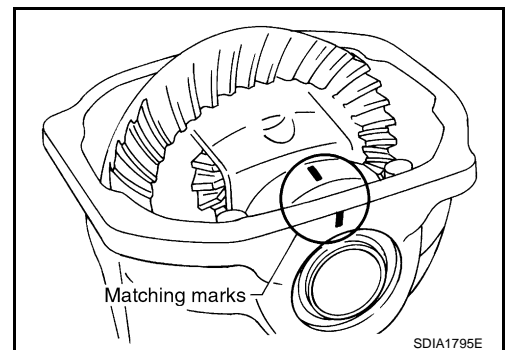

7. Remove bearing caps.

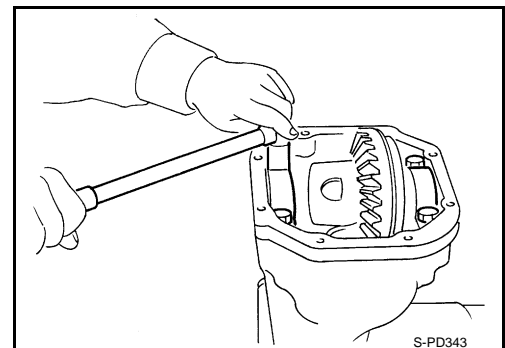

A

B

C

DLN

E

F

G

H

I

J

K

L

M

N

O

P

# DIFFERENTIAL ASSEMBLY

< DISASSEMBLY AND ASSEMBLY >

[REAR FINAL DRIVE: R200]

8. Lift differential case assembly out with a suitable tool.

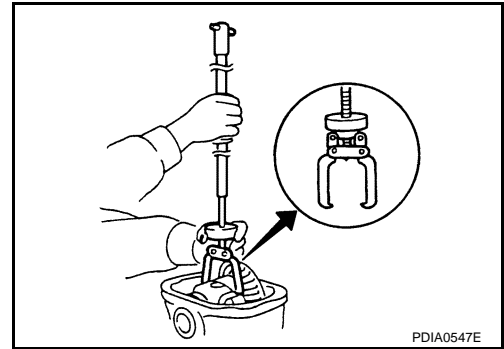

- Keep side bearing outer races together with inner race. Do not mix them up.  
Also, keep side bearing adjusting washers together with bearings.

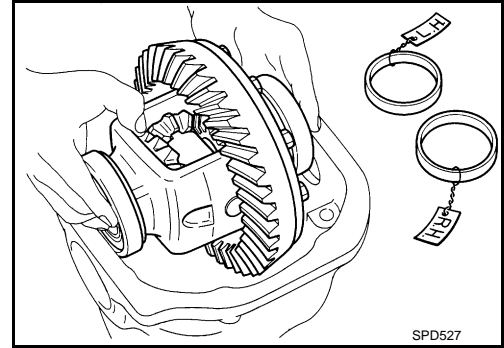

9. Remove side bearing inner race.  
To prevent damage to bearing, engage puller jaws in groove (←).

A: Puller [SST: ST33051001 (J-22888-20)]

B: Base [SST: ST33061000 (J-8107-2)]

**CAUTION:**

- To prevent damage to the side bearing and drive gear, place copper plates between these parts and vise.
- It is not necessary to remove side bearing inner race except it is replaced.

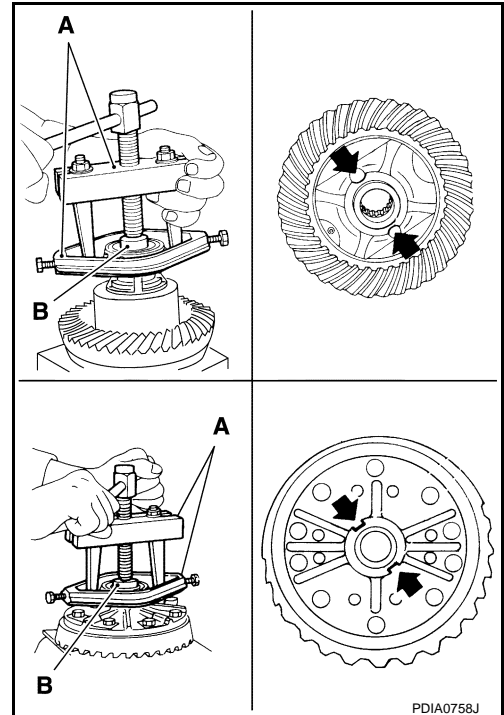

10. For proper reinstallation, paint matching marks on one differential case assembly.

**CAUTION:**

For matching marks, use paint. Never damage differential case and drive gear.

11. Remove drive gear mounting bolts.

12. Tap drive gear off differential case assembly with a soft hammer.

**CAUTION:**

Tap evenly all around to keep drive gear from bending.

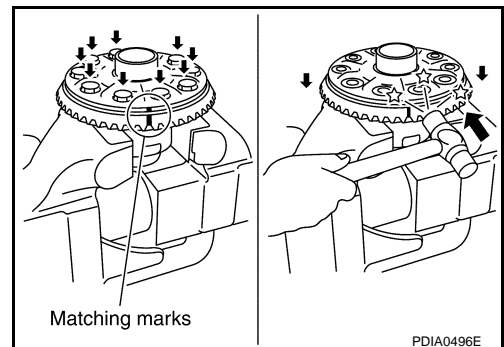



# DIFFERENTIAL ASSEMBLY

< DISASSEMBLY AND ASSEMBLY >

[REAR FINAL DRIVE: R200]

13. Remove lock pin of pinion mate shaft with a punch from drive gear side.

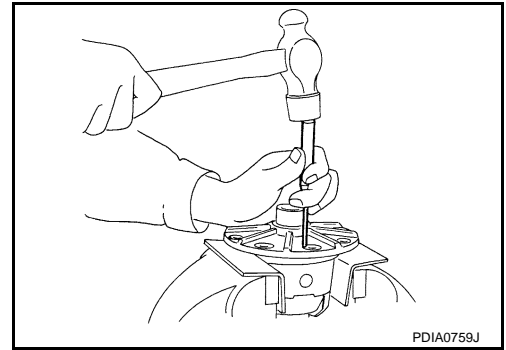

14. Remove pinion mate shaft.

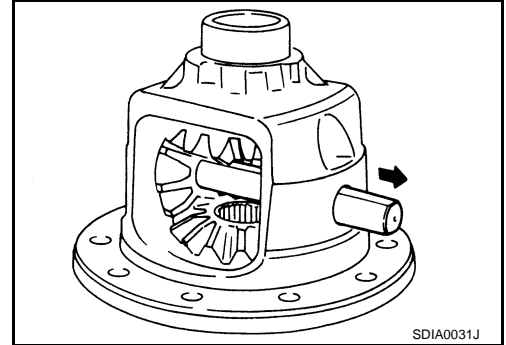

15. Turn pinion mate gear, then remove pinion mate gear, pinion mate thrust washer, side gear and side gear thrust washer from differential case.

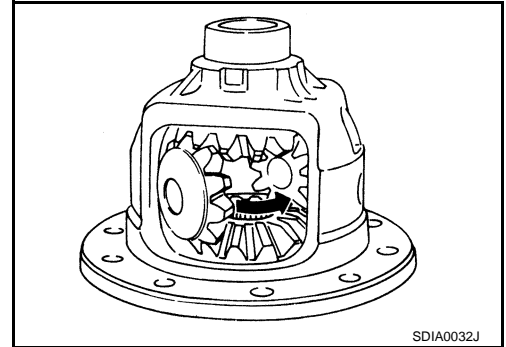

## 2WD : Assembly

INFOID:000000000957397

1. Install side gear thrust washers with the same thickness as the ones installed prior to disassembly or reinstall the old ones on the side gears.

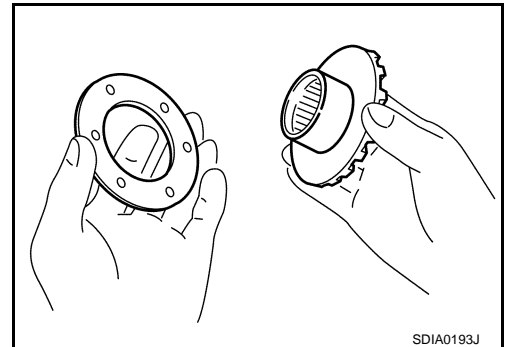

A  
B  
C  
DLN  
E  
F  
G  
H  
I  
J  
K  
L  
M  
N  
O  
P

# DIFFERENTIAL ASSEMBLY

< DISASSEMBLY AND ASSEMBLY >

[REAR FINAL DRIVE: R200]

2. Install side gears and thrust washers into differential case.

**CAUTION:**

**Make sure that the circular clip is installed to side gears.**

3. Align 2 pinion mate gears in diagonally opposite positions, then rotate and install them into differential case after installing thrust washer to pinion mate gear.

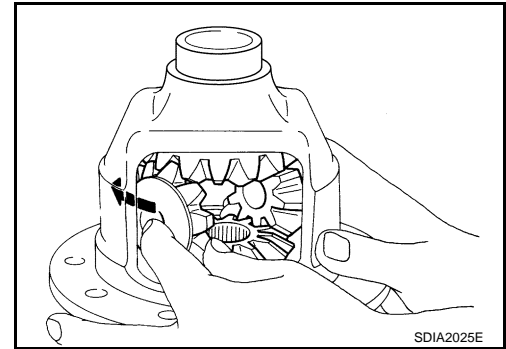

4. Align the lock pin holes on differential case with shaft, and install pinion mate shaft.

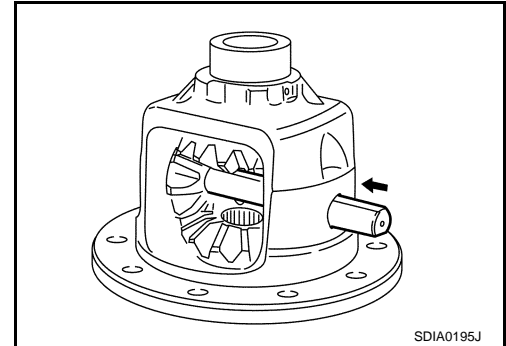

5. Measure side gear end play. If necessary, select the appropriate side gear thrust washers.

- a. Place differential case straight up so that side gear to be measured comes upward.

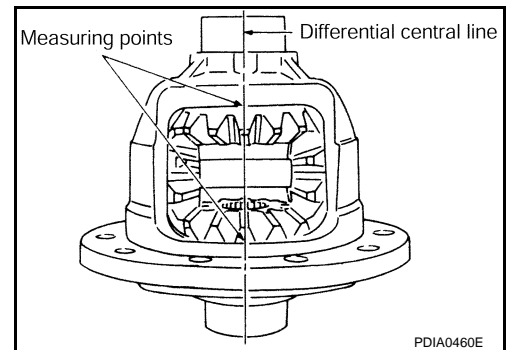

# DIFFERENTIAL ASSEMBLY

< DISASSEMBLY AND ASSEMBLY >

[REAR FINAL DRIVE: R200]

- b. Using feeler gauge, measure the clearance between side gear back and differential case at 3 different points, while rotating side gear. Average the 3 readings, and then measure the clearance of the other side as well.

### Standard

Side gear back clearance : Refer to [DLN-216, "Differential Side Gear Clearance"](#).

### CAUTION:

To prevent side gear from tilting, insert feeler gauges with the same thickness from both sides.

- c. If the back clearance is outside the specification, use a thicker/thinner side gear thrust washer to adjust.

When the back clearance is large: Use a thicker thrust washer.

When the back clearance is small: Use a thinner thrust washer.

### CAUTION:

Select a side gear thrust washer for right and left individually.

6. Drive a lock pin into pinion mate shaft, using a punch. Make sure lock pin is flush with differential case.

### CAUTION:

Never reuse lock pin.

7. Align the matching mark of differential case with the mark of drive gear, then place drive gear.

8. Apply thread locking sealant into the thread hole of drive gear.  
• Use Genuine High Strength Thread Locking Sealant or equivalent. Refer to [GI-15, "Recommended Chemical Products and Sealants"](#).

### CAUTION:

Drive gear back and threaded holes shall be cleaned and degreased sufficiently.

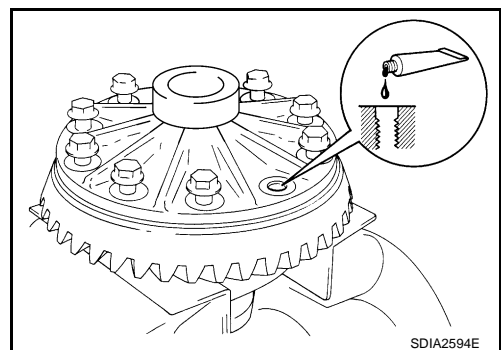
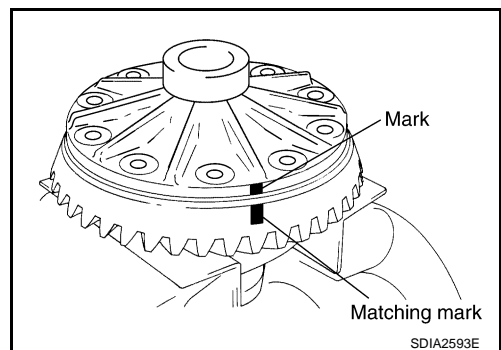
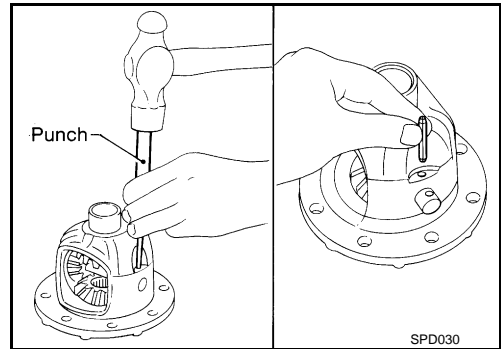
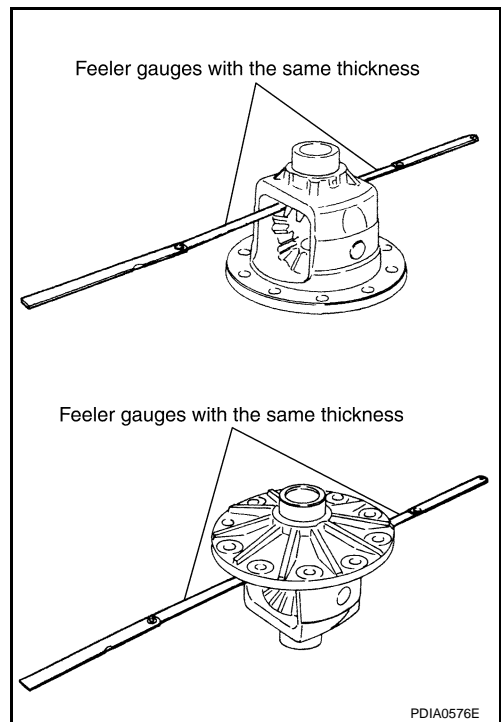

A

B

C

DLN

E

F

G

H

I

J

K

L

M

N

O

P

# DIFFERENTIAL ASSEMBLY

< DISASSEMBLY AND ASSEMBLY >

[REAR FINAL DRIVE: R200]

9. Install drive gear on the mounting bolts.

**CAUTION:**

- Tighten bolts in a crisscross fashion.
- After tightening the bolts to the specified torque, tighten the bolts additionally by turning the bolts 31 to 36 degrees.

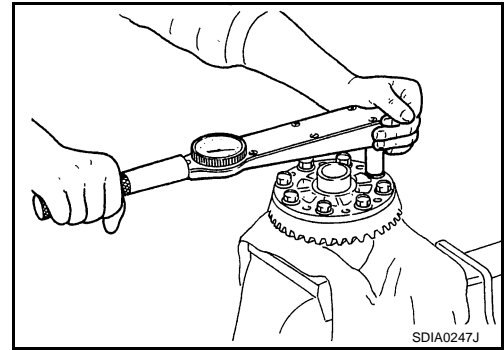

10. Press side bearing inner races to differential case, using the drift (A) [SST: KV38100300 (J-25523)] and the base (B) [SST: ST33061000 (J-8107-2)].

**CAUTION:**

**Never reuse side bearing inner race.**

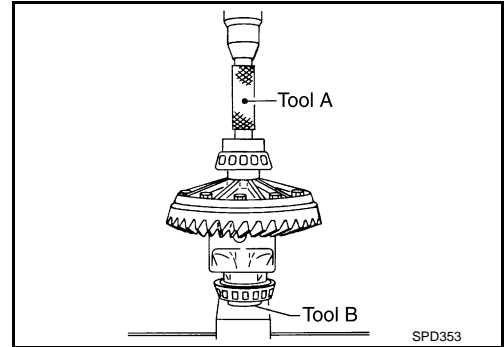

11. Install differential case assembly with side bearing outer races into gear carrier.

12. Measure side bearing preload. If necessary, select the appropriate side bearing adjusting washers. Refer to [DLN-181, "2WD : Adjustment"](#).

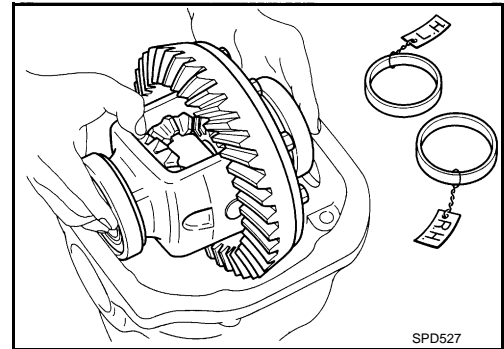

13. Insert selected left and right side bearing adjusting washers in place between side bearings and gear carrier.

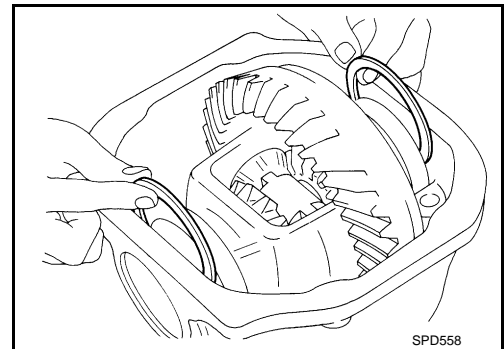

14. Align matching marks on bearing cap with that on gear carrier.

15. Install bearing caps and tighten bearing cap mounting bolts.

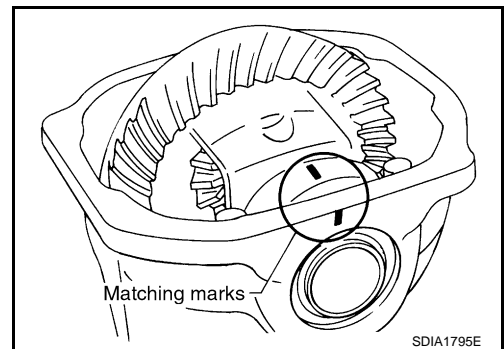

# DIFFERENTIAL ASSEMBLY

< DISASSEMBLY AND ASSEMBLY >

[REAR FINAL DRIVE: R200]

16. Using the drift [SST: KV38100200 (J-26233)], drive side oil seals until it becomes flush with the case end.

**CAUTION:**

- Never reuse oil seal.
- When installing, never incline oil seal.
- Apply multi-purpose grease onto oil seal lips, and gear oil onto the circumference of oil seal.

17. Check and adjust drive gear runout, tooth contact, drive gear to drive pinion backlash, and total preload torque. Refer to [DLN-181, "2WD : Adjustment"](#).

Recheck above items. Readjust the above description, if necessary.

18. Apply sealant to mating surface of rear cover.

- Use Genuine Silicone RTV or equivalent. Refer to [GI-15, "Recommended Chemical Products and Sealants"](#).

**CAUTION:**

Remove old sealant adhering to mounting surfaces. Also remove any moisture, oil, or foreign material adhering to application and mounting surfaces.

19. Install rear cover on gear carrier and tighten mounting bolts.

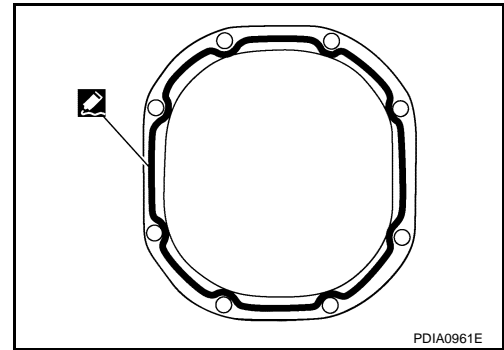
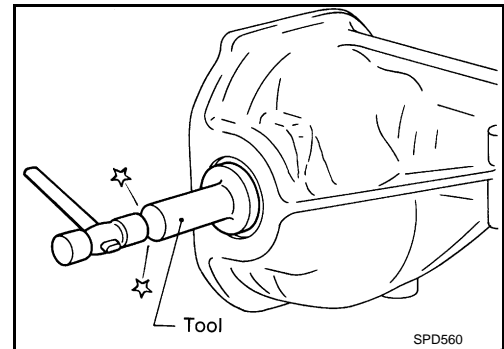

20. Install side flange with the following procedure.

- a. Attach the protector [SST: KV38107900 (J-39352)] to side oil seal.
- b. After the side flange is inserted and the serrated part of side gear has engaged the serrated part of flange, remove the protector.

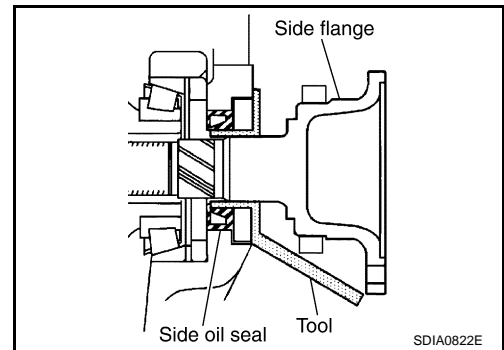

- c. Put a suitable drift on the center of side flange, then drive it until sound changes.

**NOTE:**

When installation is completed, driving sound of the side flange turns into a sound which seems to affect the whole final drive.

- d. Confirm that the dimension of the side flange (1) installation (Measurement A) in the figure comes into the following.

**Measurement "A"** : 326 – 328 mm (12.83 – 12.91 in)

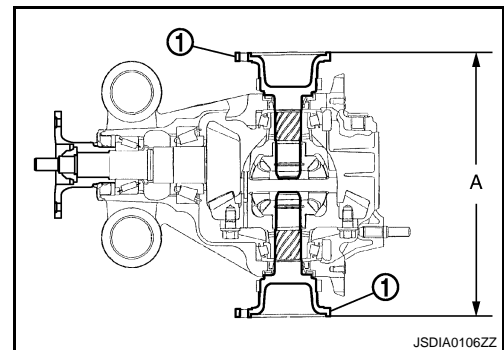

## 2WD : Adjustment

### TOTAL PRELOAD TORQUE

- Before inspection and adjustment, drain gear oil.

1. Secure final drive assembly onto an attachment [SST: KV38100800 (J-25604-01)].
2. Remove side flanges.

A  
B  
C  
DLN  
E  
F  
G  
H  
I  
J  
K  
L  
M  
N  
O  
P

# DIFFERENTIAL ASSEMBLY

< DISASSEMBLY AND ASSEMBLY >

[REAR FINAL DRIVE: R200]

3. Rotate drive pinion back and forth 2 to 3 times to check for unusual noise and rotation malfunction.
4. Rotate drive pinion at least 20 times to check for smooth operation of the bearing.
5. Measure total preload with the preload gauge (A) [SST: ST3127S000 (J-25765-A)].

## Standard

**Total preload torque** : Refer to [DLN-216, "Pre-load Torque"](#).

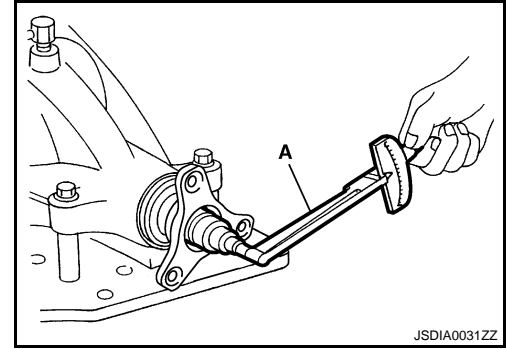

## NOTE:

**Total preload torque = Pinion bearing preload torque + Side bearing preload torque**

- If measured value is out of the specification, disassemble it to check and adjust each part. Adjust the pinion bearing preload and side bearing preload. Adjust the pinion bearing preload first, then adjust the side bearing preload.

## When the preload torque is large

**On pinion bearings:** Replace the collapsible spacer.

**On side bearings:** Use thinner side bearing adjusting washers by the same amount to each side.

## When the preload is small

**On pinion bearings:** Tighten the drive pinion lock nut.

**On side bearings:** Use thicker side bearing adjusting washers by the same amount to each side.

## SIDE BEARING PRELOAD

- Before inspection and adjustment, drain gear oil.
1. Remove rear cover. Refer to [DLN-175, "2WD : Disassembly"](#).
  2. Make sure all parts are clean. Also, make sure the bearings are well lubricated with gear oil.
  3. Place the differential case, with side bearings and bearing races installed, into gear carrier.

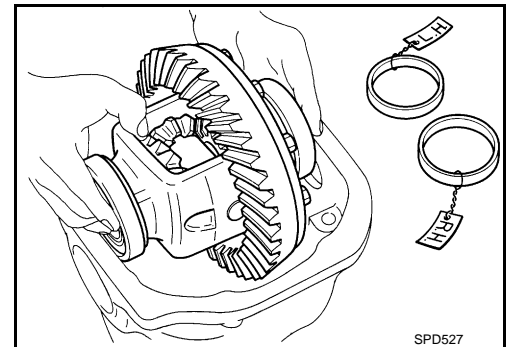

4. Insert left and right original side bearing adjusting washers in place between side bearings and gear carrier.

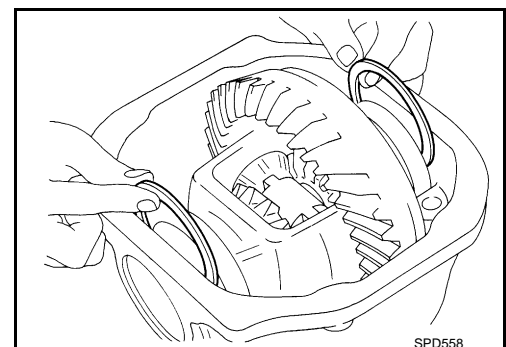

# DIFFERENTIAL ASSEMBLY

## < DISASSEMBLY AND ASSEMBLY >

[REAR FINAL DRIVE: R200]

5. Install bearing caps in their correct locations and tighten bearing cap mounting bolts.
6. Turn the carrier several times to seat the bearings.

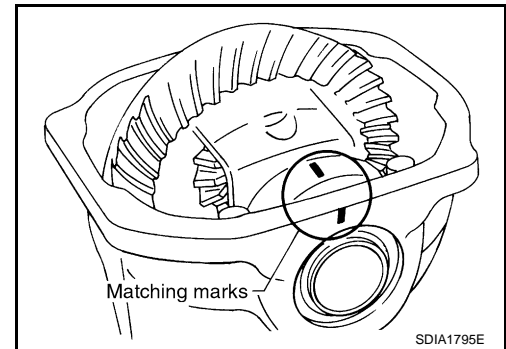

7. Measure the turning torque of the carrier at the drive gear mounting bolts with a spring gauge [SST: — (J-8129)].

**Specification** : 34.2 – 39.2 N (3.5 – 4.0 kg, 7.7 – 8.8 lb) of pulling force at the drive gear bolt

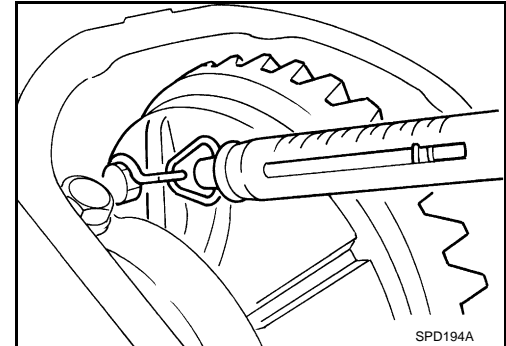

8. If the turning torque is outside the specification, use a thicker/thinner side bearing adjusting washer to adjust.

**If the turning torque is less than the specified range:** Use a thicker thrust washer.  
**If the turning torque is greater than the specification:** Use a thinner thrust washer.

**CAUTION:**

Select a side bearing adjusting washer for right and left individually.

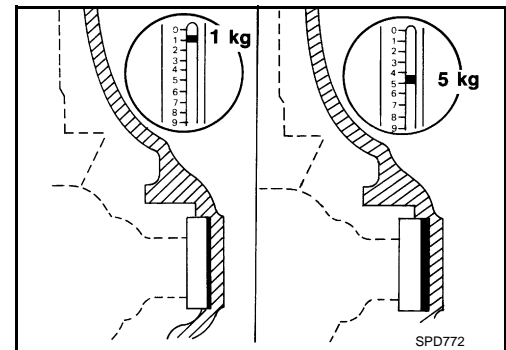

9. Record the total amount of washer thickness required for the correct carrier side bearing preload.

## DRIVE GEAR RUNOUT

1. Remove rear cover. Refer to [DLN-175, "2WD : Disassembly"](#).
2. Fit a dial indicator to the drive gear back face.
3. Rotate the drive gear to measure runout.

**Limit**

**Drive gear runout** : Refer to [DLN-216, "Drive Gear Runout"](#).

- If the runout is outside of the repair limit, check drive gear assembly condition; foreign material may be caught between drive gear and differential case, or differential case or drive gear may be deformed, etc.

**CAUTION:**

Replace drive gear and drive pinion gear as a set.

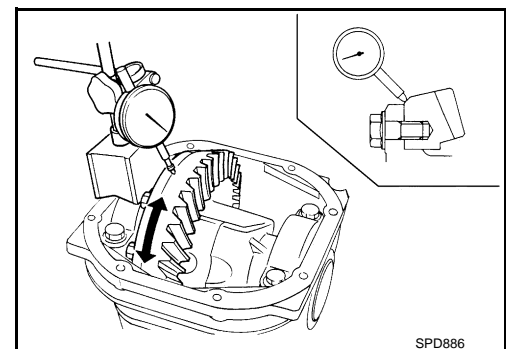

## TOOTH CONTACT

- Before inspection and adjustment, drain gear oil.
1. Remove rear cover. Refer to [DLN-175, "2WD : Disassembly"](#).

A  
B  
C  
DLN  
E  
F  
G  
H  
I  
J  
K  
L  
M  
N  
O  
P

# DIFFERENTIAL ASSEMBLY

< DISASSEMBLY AND ASSEMBLY >

[REAR FINAL DRIVE: R200]

2. Apply red lead to drive gear.

**CAUTION:**

Apply red lead to both the faces of 3 to 4 gears at 4 locations evenly spaced on drive gear.

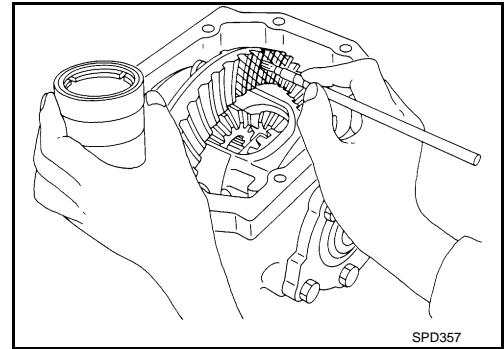

3. Rotate drive gear back and forth several times, check drive pinion gear to drive gear tooth contact.

**CAUTION:**

Check tooth contact on drive side and reverse side.

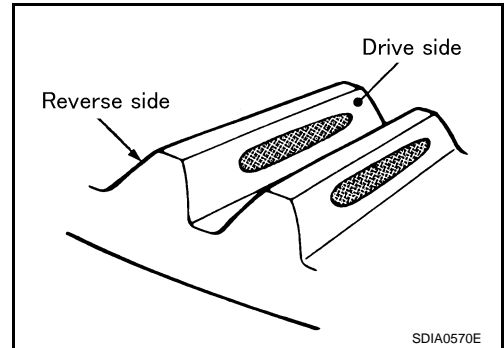

Tooth contact condition		Pinion height adjusting washer selection valve [ mm (in) ]	Adjustment (Yes/No)	Possible cause	
Drive side	Back side				
Heel side 	Toe side 	↑ Thicker	Yes	Occurrence of noise and scoring sound in all speed ranges.	
				+0.06 (+0.0024)	Occurrence of noise when accelerating.
				+0.03 (+0.0012)	
		0	No	-	
		↓ Thinner	Yes	Occurrence of noise at constant speed and decreasing speed.	
				-0.03 (-0.0012)	
				-0.06 (-0.0024)	Occurrence of noise and scoring sound in all speed ranges.
		-0.09 (-0.0035)			

SDIA0207E



# DIFFERENTIAL ASSEMBLY

< DISASSEMBLY AND ASSEMBLY >

[REAR FINAL DRIVE: R200]

4. If tooth contact is improperly adjusted, follow the procedure below to adjust the pinion height (dimension X).

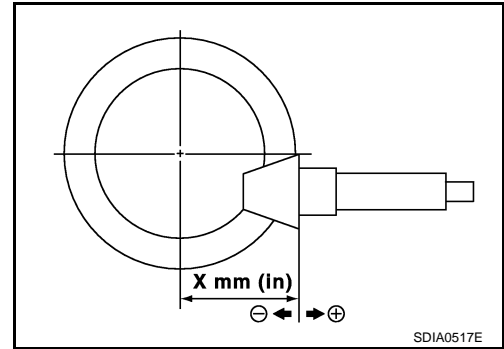

- If the tooth contact is near the face (face contact), or near the heel (heel contact), thicken pinion height adjusting washers to move drive pinion closer to drive gear.

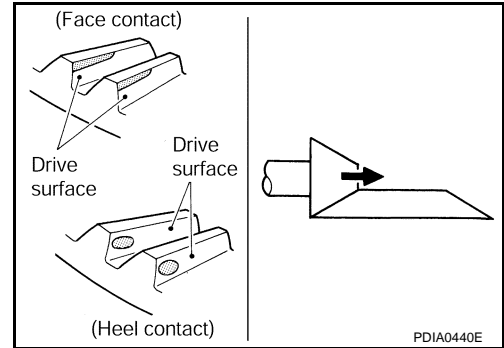

- If the tooth contact is near the flank (flank contact), or near the toe (toe contact), thin pinion height adjusting washers to move drive pinion farther from drive gear.

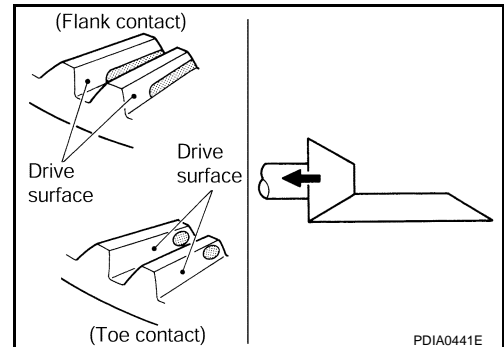

## BACKLASH

- Before inspection and adjustment, drain gear oil.
1. Remove rear cover. Refer to [DLN-175, "2WD : Disassembly"](#).
  2. Fit a dial indicator to the drive gear face to measure the backlash.

**Standard Backlash**

**: Refer to [DLN-216, "Backlash"](#).**

- If the backlash is outside of the specified value, change the thickness of side bearing adjusting washer.

**When the backlash is large:**

**Make drive gear back side adjusting washer thicker, and drive gear tooth side adjusting washer thinner by the same amount.**

**When the backlash is small:**

**Make drive gear back side adjusting washer thinner, and drive gear tooth side adjusting washer thicker by the same amount.**

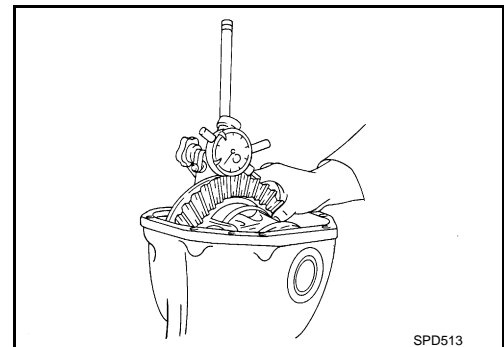

A  
B  
C  
DLN  
E  
F  
G  
H  
I  
J  
K  
L  
M  
N  
O  
P

# DIFFERENTIAL ASSEMBLY

< DISASSEMBLY AND ASSEMBLY >

[REAR FINAL DRIVE: R200]

**CAUTION:**

**Never change the total amount of washers as it will change the bearing preload.**

## 2WD : Inspection After Disassembly

INFOID:000000000957399

Clean up the disassembled parts. Then, inspect if the parts are worn or damaged. If so, follow the measures below.

Content	Conditions and Measures
Hypoid gear	<ul style="list-style-type: none"> <li>• If the gear teeth do not mesh or line-up correctly, determine the cause and adjust or replace as necessary.</li> <li>• If the gears are worn, cracked, damaged, pitted or chipped (by friction) noticeably, replace with new drive gear and drive pinion as a set.</li> </ul>
Bearing	<ul style="list-style-type: none"> <li>• If any chipped (by friction), pitted, worn, rusted or scratched mark, or unusual noise from the bearing is observed, replace as a bearing assembly (as a new set).</li> </ul>
Side gear and Pinion mate gear	<ul style="list-style-type: none"> <li>• If any cracks or damage on the surface of the tooth is found, replace.</li> <li>• If any worn or chipped mark on the contact sides of the thrust washer is found, replace.</li> </ul>
Side gear thrust washer and pinion mate thrust washer	<ul style="list-style-type: none"> <li>• If it is chipped (by friction), damaged, or unusually worn, replace.</li> </ul>
Oil seal	<ul style="list-style-type: none"> <li>• Whenever disassembled, replace.</li> <li>• If wear, deterioration of adherence (sealing force lips), or damage is detected on the lips, replace them.</li> </ul>
Differential case	<ul style="list-style-type: none"> <li>• If any wear or crack on the contact sides of the differential case is found, replace.</li> </ul>
Companion flange	<ul style="list-style-type: none"> <li>• If any chipped mark (about 0.1 mm, 0.004 in) or other damage on the contact sides of the lips of the companion flange is found, replace.</li> </ul>

## AWD

### AWD : Exploded View

INFOID:000000000957400

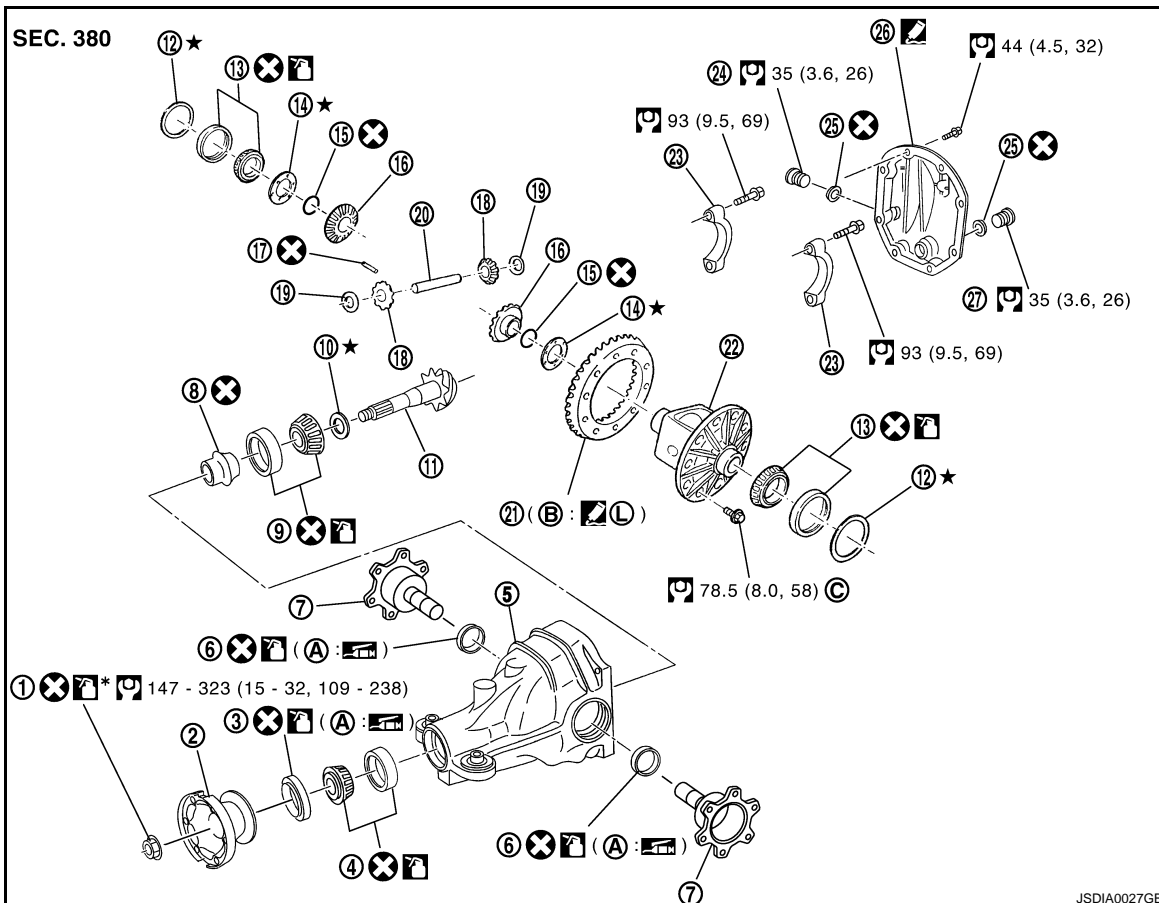

# DIFFERENTIAL ASSEMBLY

< DISASSEMBLY AND ASSEMBLY >

[REAR FINAL DRIVE: R200]

- |                                    |                             |                                   |
|------------------------------------|-----------------------------|-----------------------------------|
| 1. Drive pinion lock nut           | 2. Companion flange         | 3. Front oil seal                 |
| 4. Pinion front bearing            | 5. Gear carrier             | 6. Side oil seal                  |
| 7. Side flange                     | 8. Collapsible spacer       | 9. Pinion rear bearing            |
| 10. Pinion height adjusting washer | 11. Drive pinion            | 12. Side bearing adjusting washer |
| 13. Side bearing                   | 14. Side gear thrust washer | 15. Circular clip                 |
| 16. Side gear                      | 17. Lock pin                | 18. Pinion mate gear              |
| 19. Pinion mate thrust washer      | 20. Pinion mate shaft       | 21. Drive gear                    |
| 22. Differential case              | 23. Bearing cap             | 24. Filler plug                   |
| 25. Gasket                         | 26. Rear cover              | 27. Drain plug                    |

A: Oil seal lip

B: Screw hole

C: After tightening the bolts to the specified torque, tighten the bolts additionally by turning the bolts 31 to 36 degrees.

 Apply gear oil.

 Apply anti-corrosion oil.

 Apply Genuine Silicone RTV or equivalent. Refer to [GI-15. "Recommended Chemical Products and Sealants"](#).

 Apply Genuine High Strength Thread Locking Sealant or equivalent. Refer to [GI-15. "Recommended Chemical Products and Sealants"](#).

Refer to [GI-4. "Components"](#) for symbols not described on the above.

## AWD : Disassembly

INFOID:000000000957401

1. Drain gear oil, if necessary.
2. Remove side flange.
3. Remove rear cover mounting bolts.
4. Remove rear cover to insert the seal cutter (A) [SST: KV10111100 (J-37228)] between gear carrier and rear cover.

### CAUTION:

- Never damage the mating surface.
- Never insert flat-bladed screwdriver, this way damage the mating surface.

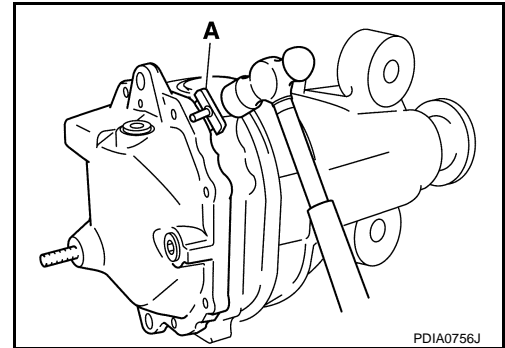

5. Using two 45 mm (1.77 in) spacers, mount carrier on the attachment (A) [SST: KV38100800 (J-25604-01)].

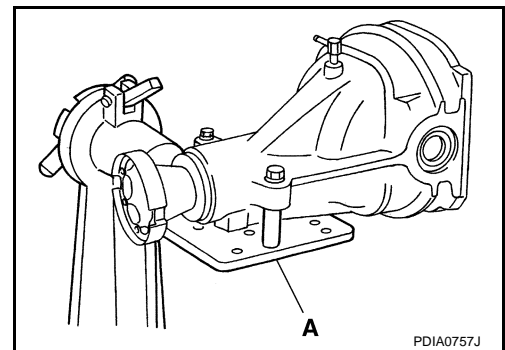

A  
B  
C  
DLN  
E  
F  
G  
H  
I  
J  
K  
L  
M  
N  
O  
P

# DIFFERENTIAL ASSEMBLY

## < DISASSEMBLY AND ASSEMBLY >

[REAR FINAL DRIVE: R200]

6. For proper reinstallation, paint matching marks on one side of the bearing cap.

**CAUTION:**

- For matching marks, use paint. Never damage bearing caps and gear carrier.
- Bearing caps are line-board during manufacture. The matching marks are used to reinstall them in their original positions.

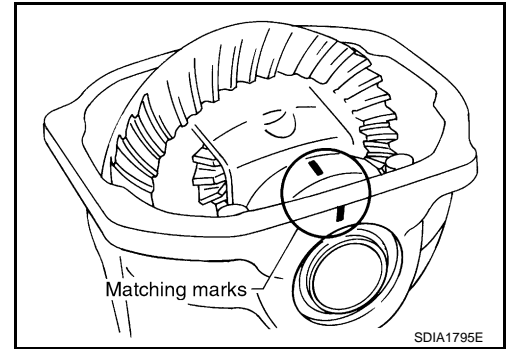

7. Remove bearing caps.

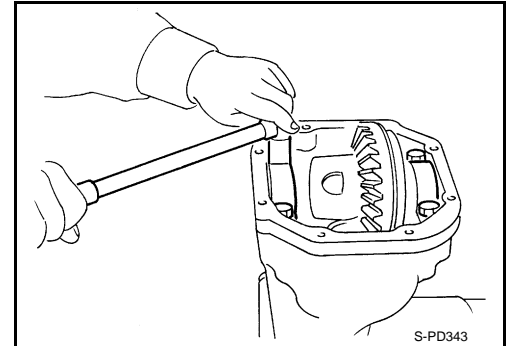

8. Lift differential case assembly out with a suitable tool.

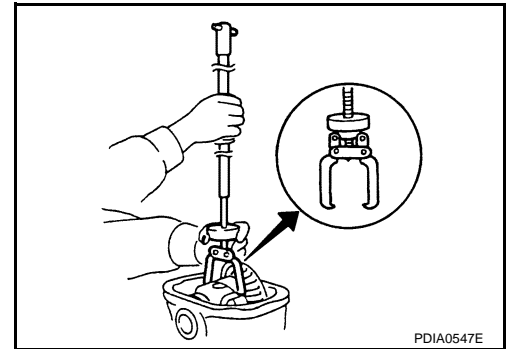

- Keep side bearing outer races together with inner race. Do not mix them up. Also, keep side bearing adjusting washers together with bearings.

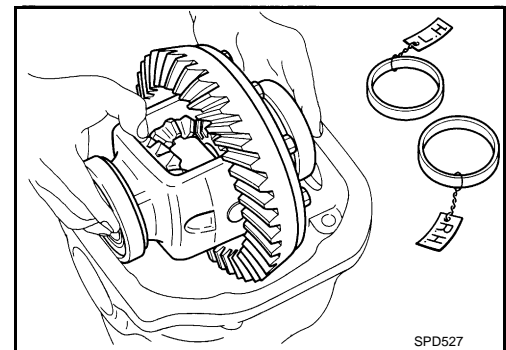

# DIFFERENTIAL ASSEMBLY

< DISASSEMBLY AND ASSEMBLY >

[REAR FINAL DRIVE: R200]

9. Remove side bearing inner race.  
To prevent damage to bearing, engage puller jaws in groove (←).

A: Puller [SST: ST33051001 (J-22888-20)]

B: Base [SST: ST33061000 (J-8107-2)]

**CAUTION:**

- To prevent damage to the side bearing and drive gear, place copper plates between these parts and vise.
- It is not necessary to remove side bearing inner race except it is replaced.

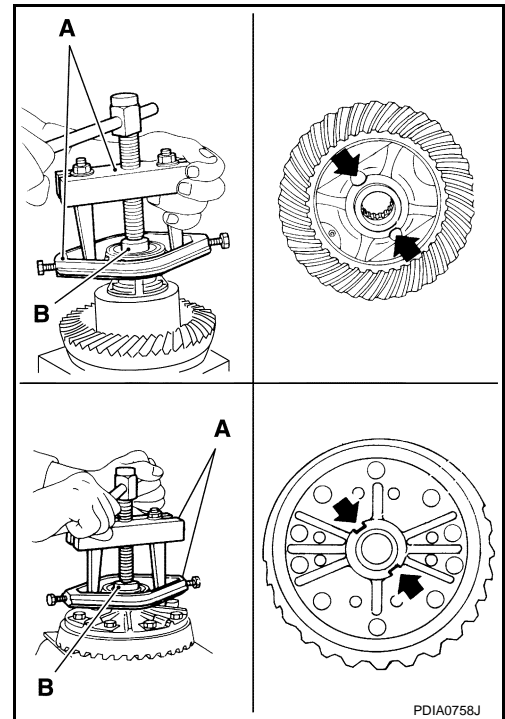

10. For proper reinstallation, paint matching marks on one differential case assembly.

**CAUTION:**

For matching marks, use paint. Never damage differential case and drive gear.

11. Remove drive gear mounting bolts.  
12. Tap drive gear off differential case assembly with a soft hammer.

**CAUTION:**

Tap evenly all around to keep drive gear from bending.

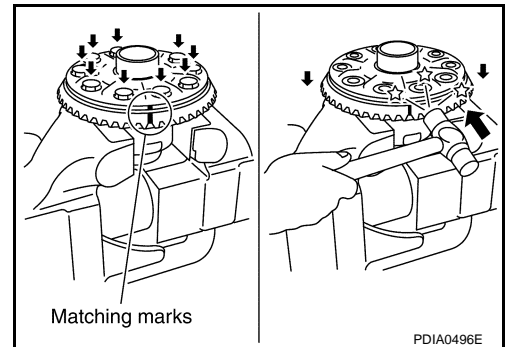

13. Remove lock pin of pinion mate shaft with a punch from drive gear side.

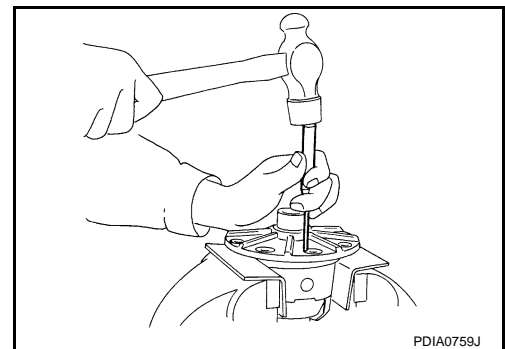

14. Remove pinion mate shaft.

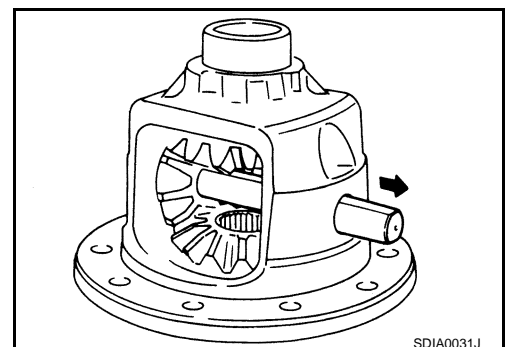

A  
B  
C  
DLN  
E  
F  
G  
H  
I  
J  
K  
L  
M  
N  
O  
P

# DIFFERENTIAL ASSEMBLY

< DISASSEMBLY AND ASSEMBLY >

[REAR FINAL DRIVE: R200]

15. Turn pinion mate gear, then remove pinion mate gear, pinion mate thrust washer, side gear and side gear thrust washer from differential case.

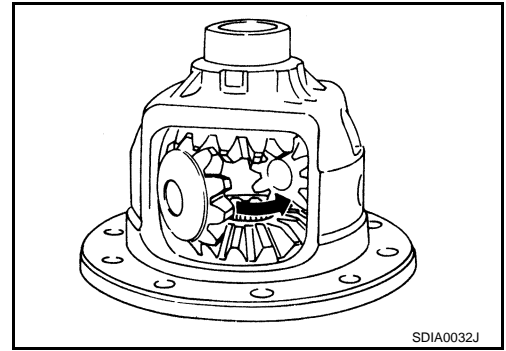

## AWD : Assembly

INFOID:000000000957402

1. Install side gear thrust washers with the same thickness as the ones installed prior to disassembly or reinstall the old ones on the side gears.

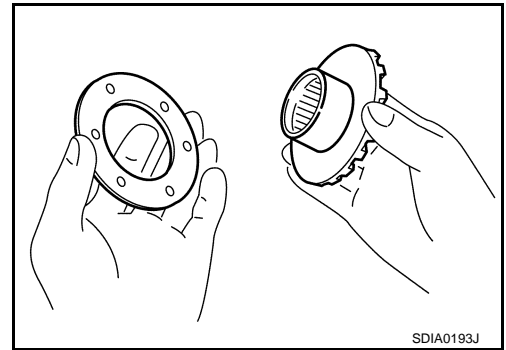

2. Install side gears and thrust washers into differential case.  
**CAUTION:**  
**Make sure that the circular clip is installed to side gears.**
3. Align 2 pinion mate gears in diagonally opposite positions, then rotate and install them into differential case after installing thrust washer to pinion mate gear.

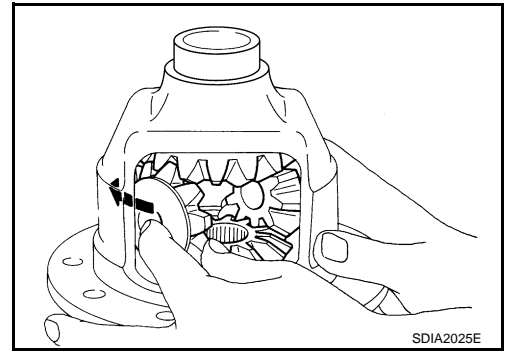

4. Align the lock pin holes on differential case with shaft, and install pinion mate shaft.

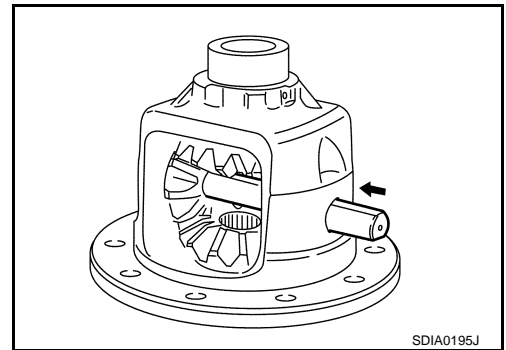

5. Measure side gear end play. If necessary, select the appropriate side gear thrust washers.

# DIFFERENTIAL ASSEMBLY

< DISASSEMBLY AND ASSEMBLY >

[REAR FINAL DRIVE: R200]

- a. Place differential case straight up so that side gear to be measured comes upward.

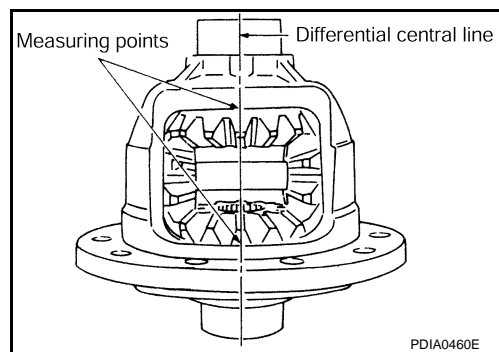

- b. Using feeler gauge, measure the clearance between side gear back and differential case at 3 different points, while rotating side gear. Average the 3 readings, and then measure the clearance of the other side as well.

**Standard**

**Side gear back clearance** : Refer to [DLN-216, "Differential Side Gear Clearance"](#).

**CAUTION:**

To prevent side gear from tilting, insert feeler gauges with the same thickness from both sides.

- c. If the back clearance is outside the specification, use a thicker/thinner side gear thrust washer to adjust.

**When the back clearance is large:** Use a thicker thrust washer.

**When the back clearance is small:** Use a thinner thrust washer.

**CAUTION:**

Select a side gear thrust washer for right and left individually.

6. Drive a lock pin into pinion mate shaft, using a punch. Make sure lock pin is flush with differential case.

**CAUTION:**

Never reuse lock pin.

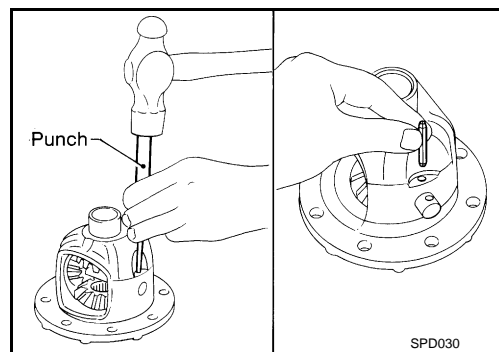
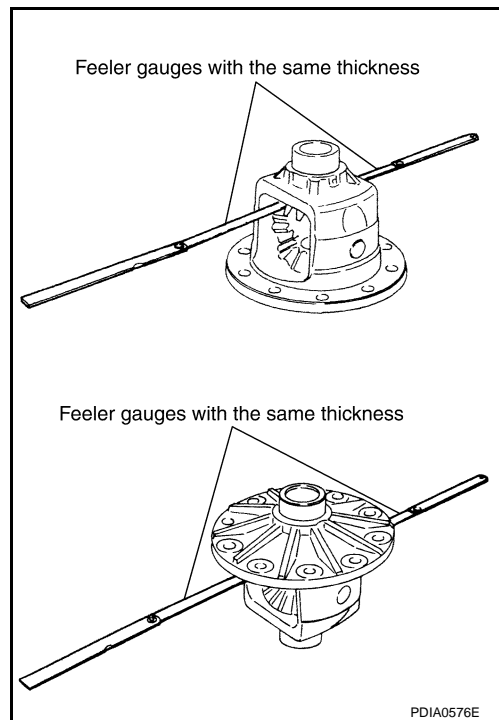

7. Align the matching mark of differential case with the mark of drive gear, then place drive gear.

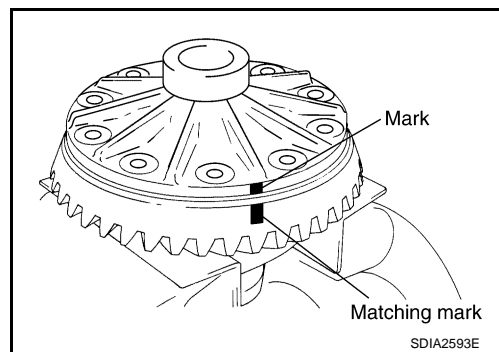

A  
B  
C  
DLN  
E  
F  
G  
H  
I  
J  
K  
L  
M  
N  
O  
P

# DIFFERENTIAL ASSEMBLY

< DISASSEMBLY AND ASSEMBLY >

[REAR FINAL DRIVE: R200]

8. Apply thread locking sealant into the thread hole of drive gear.
- Use **Genuine High Strength Thread Locking Sealant or equivalent**. Refer to [GI-15, "Recommended Chemical Products and Sealants"](#).

**CAUTION:**

Drive gear back and threaded holes shall be cleaned and degreased sufficiently.

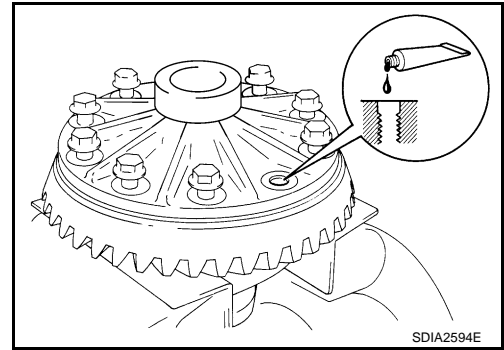

9. Install drive gear on the mounting bolts.

**CAUTION:**

- Tighten bolts in a crisscross fashion.
- After tightening the bolts to the specified torque, tighten the bolts additionally by turning the bolts 31 to 36 degrees.

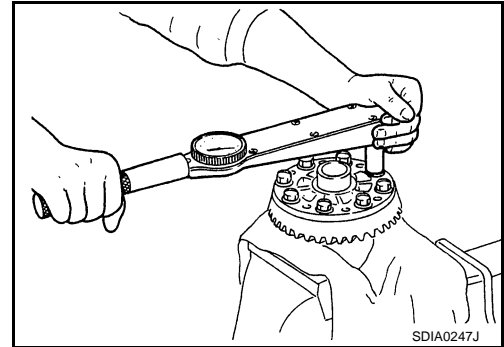

10. Press side bearing inner races to differential case, using the drift (A) [SST: KV38100300 (J-25523)] and the base (B) [SST: ST33061000 (J-8107-2)].

**CAUTION:**

Never reuse side bearing inner race.

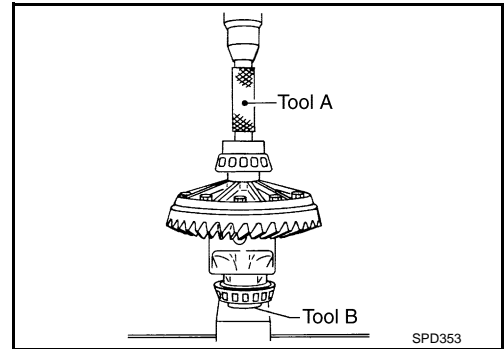

11. Install differential case assembly with side bearing outer races into gear carrier.

12. Measure side bearing preload. If necessary, select the appropriate side bearing adjusting washers. Refer to [DLN-194, "AWD : Adjustment"](#).

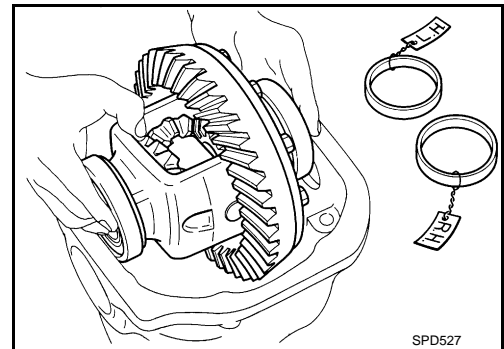

13. Insert selected left and right side bearing adjusting washers in place between side bearings and gear carrier.

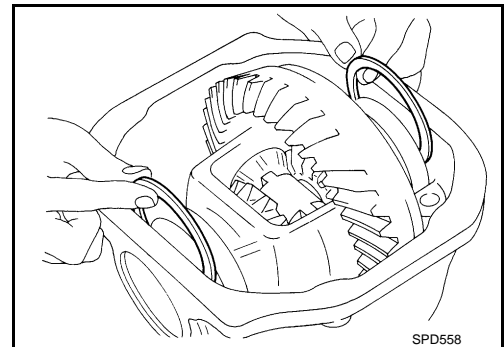



# DIFFERENTIAL ASSEMBLY

< DISASSEMBLY AND ASSEMBLY >

[REAR FINAL DRIVE: R200]

14. Align matching marks on bearing cap with that on gear carrier.
15. Install bearing caps and tighten bearing cap mounting bolts.

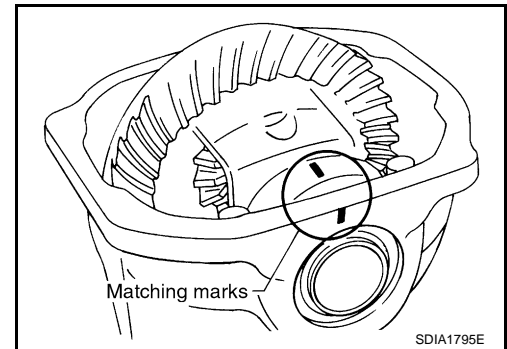

16. Using the drift [SST: KV38100200 (J-26233)], drive side oil seals until it becomes flush with the case end.

**CAUTION:**

- Never reuse oil seal.
- When installing, never incline oil seal.
- Apply multi-purpose grease onto oil seal lips, and gear oil onto the circumference of oil seal.

17. Check and adjust drive gear runout, tooth contact, drive gear to drive pinion backlash, and total preload torque. Refer to [DLN-194. "AWD : Adjustment"](#).  
Recheck above items. Readjust the above description, if necessary.

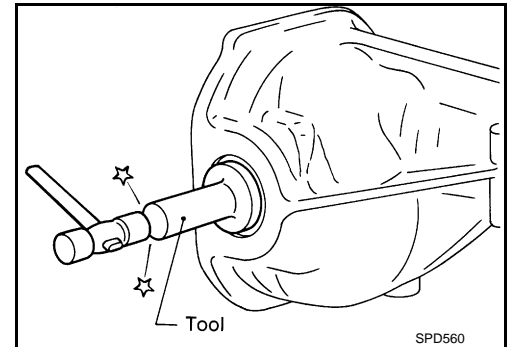

18. Apply sealant to mating surface of rear cover.

- Use Genuine Silicone RTV or equivalent. Refer to [GI-15. "Recommended Chemical Products and Sealants"](#).

**CAUTION:**

Remove old sealant adhering to mounting surfaces. Also remove any moisture, oil, or foreign material adhering to application and mounting surfaces.

19. Install rear cover on gear carrier and tighten mounting bolts.

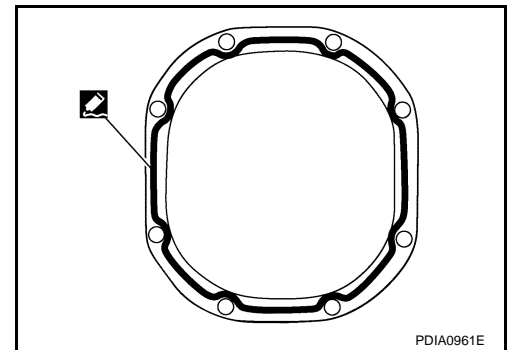

20. Install side flange with the following procedure.

- a. Attach the protector [SST: KV38107900 (J-39352)] to side oil seal.
- b. After the side flange is inserted and the serrated part of side gear has engaged the serrated part of flange, remove the protector.

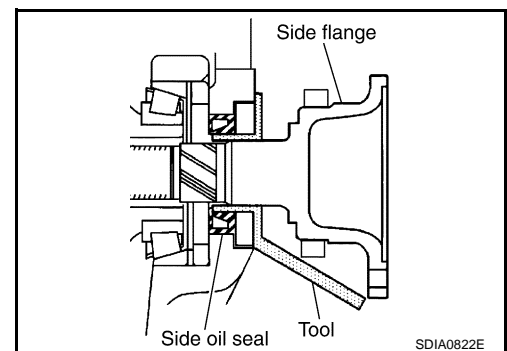

- c. Put a suitable drift on the center of side flange, then drive it until sound changes.

**NOTE:**

When installation is completed, driving sound of the side flange turns into a sound which seems to affect the whole final drive.

A  
B  
C  
DLN  
E  
F  
G  
H  
I  
J  
K  
L  
M  
N  
O  
P

# DIFFERENTIAL ASSEMBLY

< DISASSEMBLY AND ASSEMBLY >

[REAR FINAL DRIVE: R200]

- d. Confirm that the dimension of the side flange installation (Measurement A) in the figure comes into the following.

**Measurement "A"** : 326 – 328 mm (12.83 – 12.91 in)

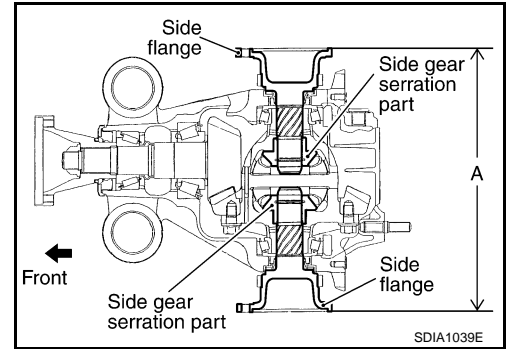

INFOID:00000000957403

## AWD : Adjustment

### TOTAL PRELOAD TORQUE

- Before inspection and adjustment, drain gear oil.
1. Secure final drive assembly onto an attachment [SST: KV38100800 (J-25604-01)].
  2. Remove side flanges.
  3. Rotate drive pinion back and forth 2 to 3 times to check for unusual noise and rotation malfunction.
  4. Rotate drive pinion at least 20 times to check for smooth operation of the bearing.
  5. Measure total preload with the preload gauge (A) [SST: ST3127S000 (J-25765-A)].

**Standard**  
**Total preload torque** : Refer to [DLN-216, "Preload Torque"](#).

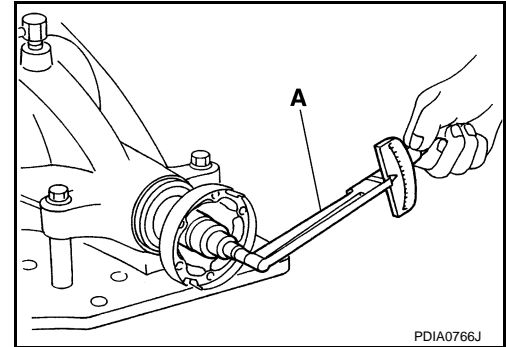

### NOTE:

**Total preload torque = Pinion bearing preload torque + Side bearing preload torque**

- If measured value is out of the specification, disassemble it to check and adjust each part. Adjust the pinion bearing preload and side bearing preload. Adjust the pinion bearing preload first, then adjust the side bearing preload.

### When the preload torque is large

- On pinion bearings:** Replace the collapsible spacer.
- On side bearings:** Use thinner side bearing adjusting washers by the same amount to each side.

### When the preload is small

- On pinion bearings:** Tighten the drive pinion lock nut.
- On side bearings:** Use thicker side bearing adjusting washers by the same amount to each side.

### SIDE BEARING PRELOAD

- Before inspection and adjustment, drain gear oil.
1. Remove rear cover. Refer to [DLN-187, "AWD : Disassembly"](#).

# DIFFERENTIAL ASSEMBLY

## < DISASSEMBLY AND ASSEMBLY >

[REAR FINAL DRIVE: R200]

2. Make sure all parts are clean. Also, make sure the bearings are well lubricated with gear oil.
3. Place the differential case, with side bearings and bearing races installed, into gear carrier.

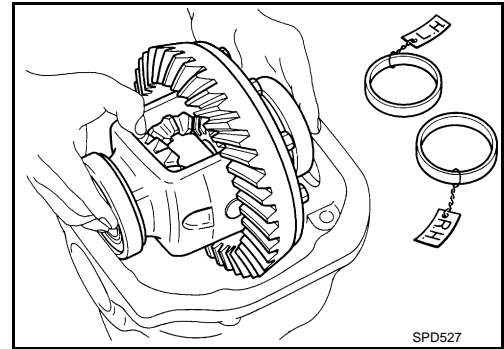

4. Insert left and right original side bearing adjusting washers in place between side bearings and gear carrier.

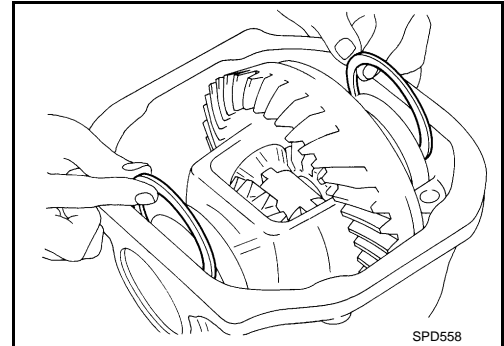

5. Install bearing caps in their correct locations and tighten bearing cap mounting bolts.
6. Turn the carrier several times to seat the bearings.

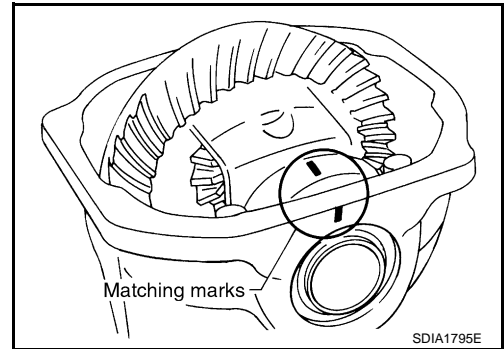

7. Measure the turning torque of the carrier at the drive gear mounting bolts with a spring gauge [SST: — (J-8129)].

**Specification** : 34.2 – 39.2 N (3.5 – 4.0 kg, 7.7 – 8.8 lb) of pulling force at the drive gear bolt

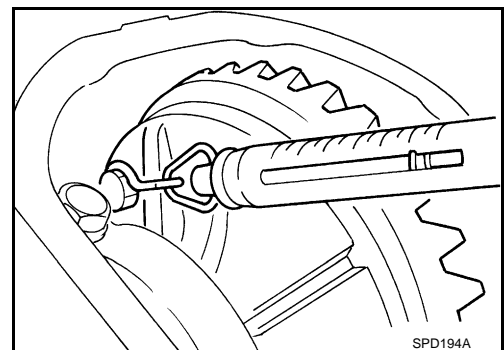

8. If the turning torque is outside the specification, use a thicker/thinner side bearing adjusting washer to adjust.

**If the turning torque is less than the specified range:** Use a thicker thrust washer.  
**If the turning torque is greater than the specification:** Use a thinner thrust washer.

**CAUTION:** Select a side bearing adjusting washer for right and left individually.

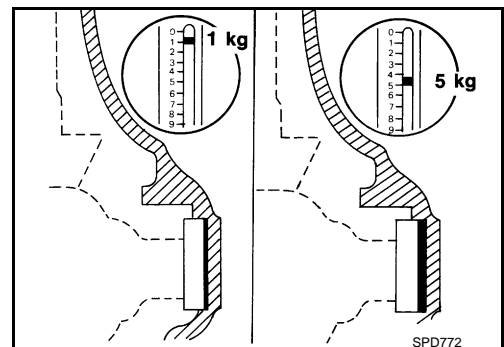

A  
B  
C  
DLN  
E  
F  
G  
H  
I  
J  
K  
L  
M  
N  
O  
P

# DIFFERENTIAL ASSEMBLY

< DISASSEMBLY AND ASSEMBLY >

[REAR FINAL DRIVE: R200]

- Record the total amount of washer thickness required for the correct carrier side bearing preload.

## DRIVE GEAR RUNOUT

- Remove rear cover. Refer to [DLN-187, "AWD : Disassembly"](#).
- Fit a dial indicator to the drive gear back face.
- Rotate the drive gear to measure runout.

### Limit

Drive gear runout : Refer to [DLN-216, "Drive Gear Runout"](#).

- If the runout is outside of the repair limit, check drive gear assembly condition; foreign material may be caught between drive gear and differential case, or differential case or drive gear may be deformed, etc.

### CAUTION:

Replace drive gear and drive pinion gear as a set.

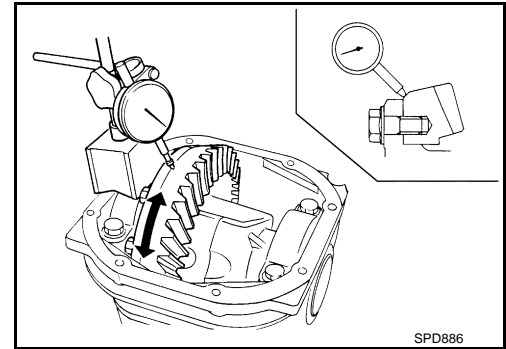

## TOOTH CONTACT

- Before inspection and adjustment, drain gear oil.
- Remove rear cover. Refer to [DLN-187, "AWD : Disassembly"](#).
  - Apply red lead to drive gear.

### CAUTION:

Apply red lead to both the faces of 3 to 4 gears at 4 locations evenly spaced on drive gear.

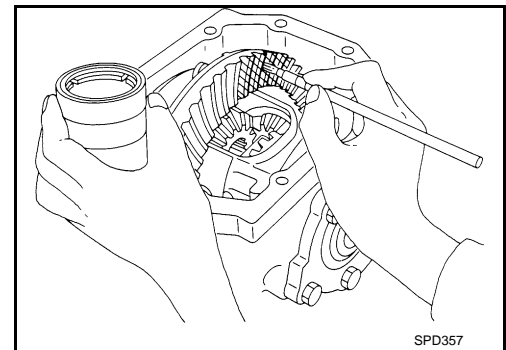

- Rotate drive gear back and forth several times, check drive pinion gear to drive gear tooth contact.

### CAUTION:

Check tooth contact on drive side and reverse side.

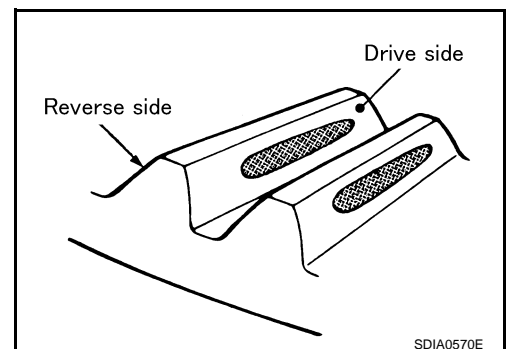

# DIFFERENTIAL ASSEMBLY

< DISASSEMBLY AND ASSEMBLY >

[REAR FINAL DRIVE: R200]

Tooth contact condition		Pinion height adjusting washer selection valve [ mm (in) ]	Adjustment (Yes/No)	Possible cause
Drive side	Back side			
Heel side 	Toe side 	↑ Thicker	Yes	Occurrence of noise and scoring sound in all speed ranges.
		0	No	-
		↓ Thinner	Yes	Occurrence of noise at constant speed and decreasing speed.

SDIA0207E

4. If tooth contact is improperly adjusted, follow the procedure below to adjust the pinion height (dimension X).

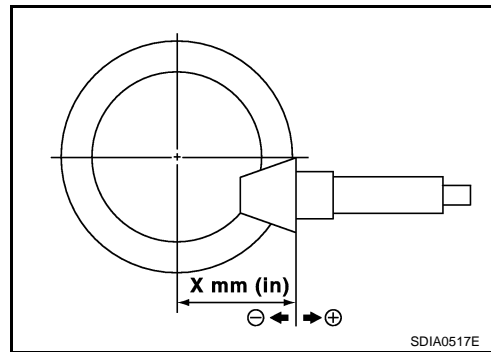

- If the tooth contact is near the face (face contact), or near the heel (heel contact), thicken pinion height adjusting washers to move drive pinion closer to drive gear.

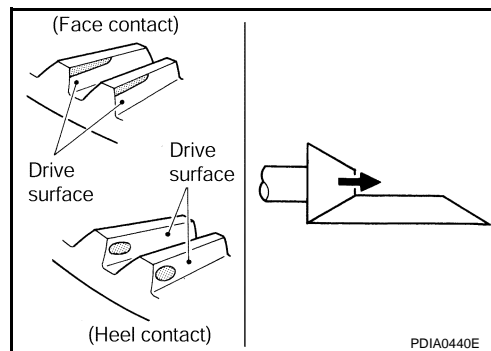

A  
B  
C  
DLN  
E  
F  
G  
H  
I  
J  
K  
L  
M  
N  
O  
P

# DIFFERENTIAL ASSEMBLY

< DISASSEMBLY AND ASSEMBLY >

[REAR FINAL DRIVE: R200]

- If the tooth contact is near the flank (flank contact), or near the toe (toe contact), thin pinion height adjusting washers to move drive pinion farther from drive gear.

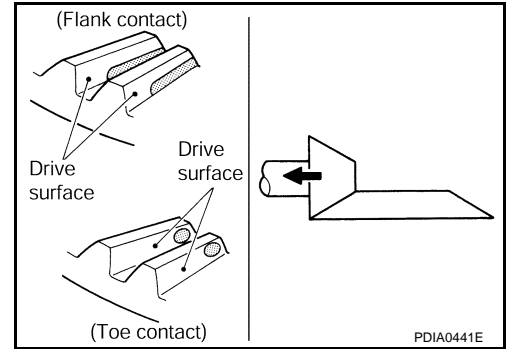

## BACKLASH

- Before inspection and adjustment, drain gear oil.
1. Remove rear cover. Refer to [DLN-187, "AWD : Disassembly"](#).
  2. Fit a dial indicator to the drive gear face to measure the backlash.

**Standard Backlash**

**: Refer to [DLN-216, "Backlash"](#).**

- If the backlash is outside of the specified value, change the thickness of side bearing adjusting washer.

**When the backlash is large:**

**Make drive gear back side adjusting washer thicker, and drive gear tooth side adjusting washer thinner by the same amount.**

**When the backlash is small:**

**Make drive gear back side adjusting washer thinner, and drive gear tooth side adjusting washer thicker by the same amount.**

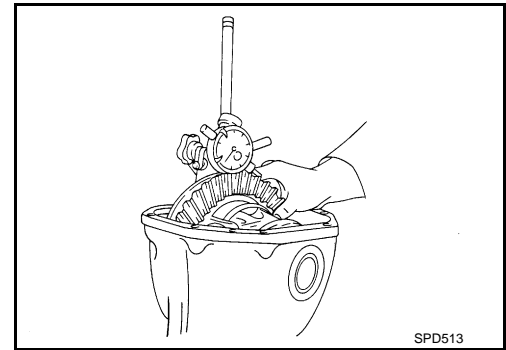

**CAUTION:**

**Never change the total amount of washers as it will change the bearing preload.**

## AWD : Inspection After Disassembly

INFOID:000000000957404

Clean up the disassembled parts. Then, inspect if the parts are worn or damaged. If so, follow the measures below.

Content	Conditions and Measures
Hypoid gear	<ul style="list-style-type: none"> <li>• If the gear teeth do not mesh or line-up correctly, determine the cause and adjust or replace as necessary.</li> <li>• If the gears are worn, cracked, damaged, pitted or chipped (by friction) noticeably, replace with new drive gear and drive pinion as a set.</li> </ul>
Bearing	<ul style="list-style-type: none"> <li>• If any chipped (by friction), pitted, worn, rusted or scratched mark, or unusual noise from the bearing is observed, replace as a bearing assembly (as a new set).</li> </ul>
Side gear and Pinion mate gear	<ul style="list-style-type: none"> <li>• If any cracks or damage on the surface of the tooth is found, replace.</li> <li>• If any worn or chipped mark on the contact sides of the thrust washer is found, replace.</li> </ul>
Side gear thrust washer and pinion mate thrust washer	<ul style="list-style-type: none"> <li>• If it is chipped (by friction), damaged, or unusually worn, replace.</li> </ul>
Oil seal	<ul style="list-style-type: none"> <li>• Whenever disassembled, replace.</li> <li>• If wear, deterioration of adherence (sealing force lips), or damage is detected on the lips, replace them.</li> </ul>
Differential case	<ul style="list-style-type: none"> <li>• If any wear or crack on the contact sides of the differential case is found, replace.</li> </ul>
Companion flange	<ul style="list-style-type: none"> <li>• If any chipped mark (about 0.1 mm, 0.004 in) or other damage on the contact sides of the lips of the companion flange is found, replace.</li> </ul>

# DRIVE PINION

< DISASSEMBLY AND ASSEMBLY >

[REAR FINAL DRIVE: R200]

## DRIVE PINION

2WD

2WD : Exploded View

INFOID:000000000957405

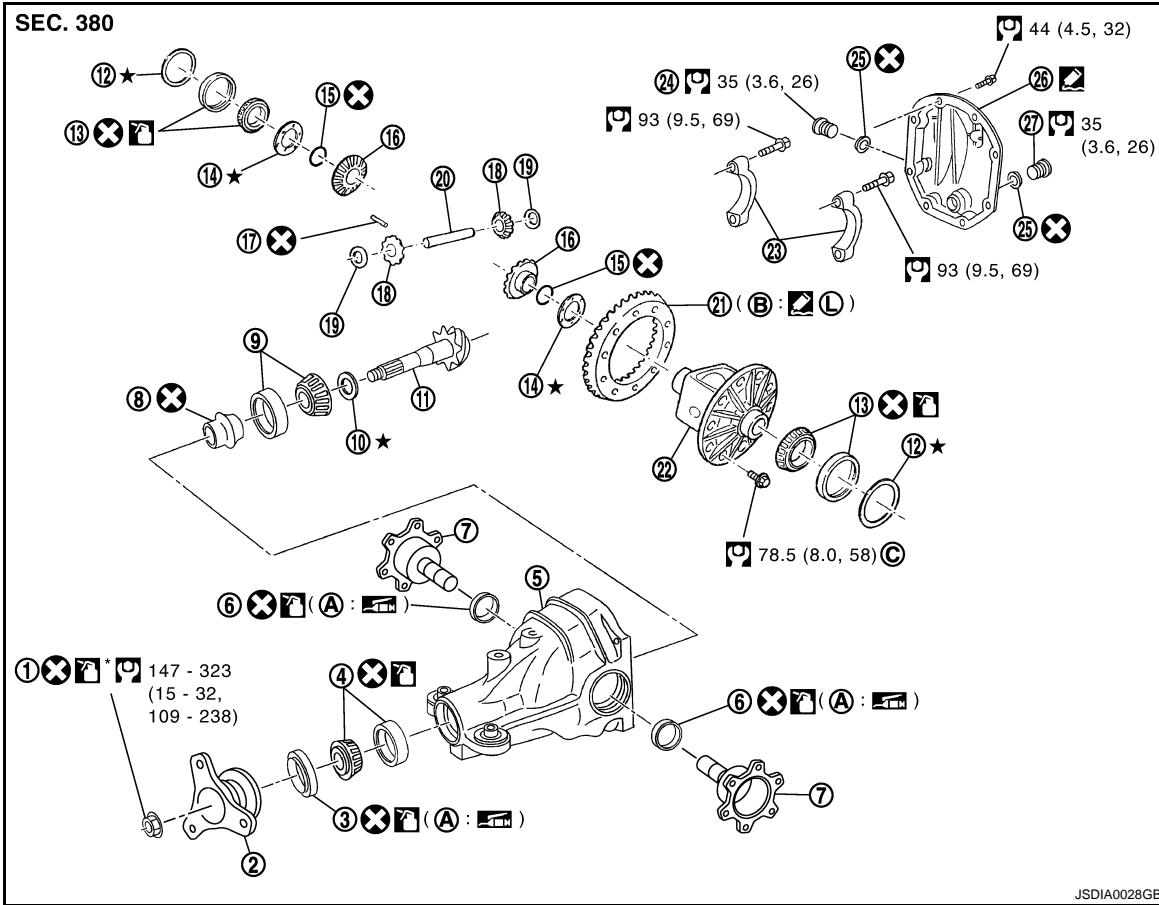

- |                                    |                             |                                   |
|------------------------------------|-----------------------------|-----------------------------------|
| 1. Drive pinion lock nut           | 2. Companion flange         | 3. Front oil seal                 |
| 4. Pinion front bearing            | 5. Gear carrier             | 6. Side oil seal                  |
| 7. Side flange                     | 8. Collapsible spacer       | 9. Pinion rear bearing            |
| 10. Pinion height adjusting washer | 11. Drive pinion            | 12. Side bearing adjusting washer |
| 13. Side bearing                   | 14. Side gear thrust washer | 15. Circular clip                 |
| 16. Side gear                      | 17. Lock pin                | 18. Pinion mate gear              |
| 19. Pinion mate thrust washer      | 20. Pinion mate shaft       | 21. Drive gear                    |
| 22. Differential case              | 23. Bearing cap             | 24. Filler plug                   |
| 25. Gasket                         | 26. Rear cover              | 27. Drain plug                    |

A: Oil seal lip

B: Screw hole

C: After tightening the bolts to the specified torque, tighten the bolts additionally by turning the bolts 31 to 36 degrees.

Apply gear oil.

Apply anti-corrosion oil.

Apply Genuine Silicone RTV or equivalent. Refer to [GI-15, "Recommended Chemical Products and Sealants"](#).

Apply Genuine High Strength Thread Locking Sealant or equivalent. Refer to [GI-15, "Recommended Chemical Products and Sealants"](#).

Refer to [GI-4, "Components"](#) for symbols not described on the above.

# DRIVE PINION

< DISASSEMBLY AND ASSEMBLY >

[REAR FINAL DRIVE: R200]

## 2WD : Disassembly

INFOID:00000000957406

1. Remove differential assembly. Refer to [DLN-175, "2WD : Disassembly"](#).
2. Remove drive pinion lock nut with the flange wrench.

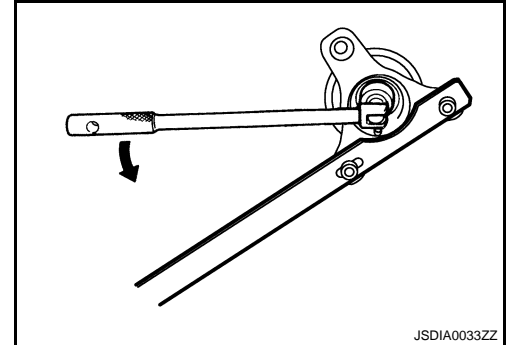

3. Put matching mark (B) on the end of drive pinion. The matching mark should be in line with the matching mark (A) on companion flange (1).

**CAUTION:**

**For matching mark, use paint. Never damage companion flange and drive pinion.**

**NOTE:**

The matching mark (A) on the final drive companion flange (1) indicates the maximum vertical runout position.

When replacing companion flange, matching mark is not necessary.

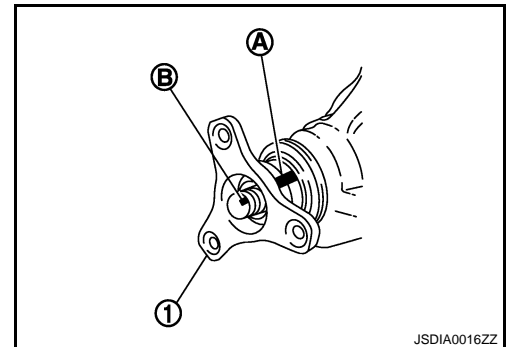

4. Remove companion flange using the suitable pullers.

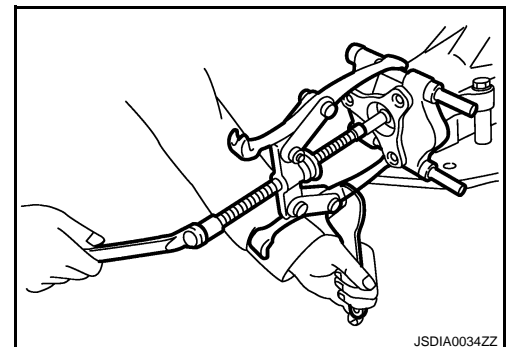

5. Press drive pinion assembly out of gear carrier.

**CAUTION:**

**Never drop drive pinion assembly.**

6. Remove front oil seal.
7. Remove side oil seal.
8. Remove pinion front bearing inner race.
9. Remove collapsible spacer.

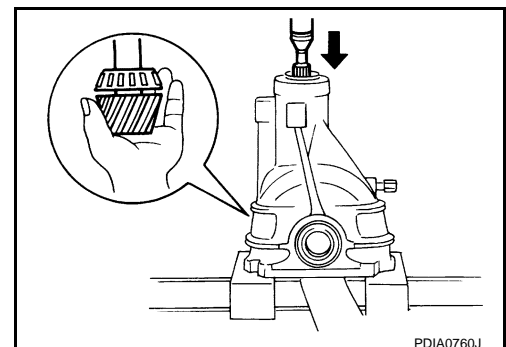



# DRIVE PINION

## < DISASSEMBLY AND ASSEMBLY >

[REAR FINAL DRIVE: R200]

10. Remove pinion rear bearing inner race and pinion height adjusting washer with the replacer (A) [SST: ST30031000 (J-22912-01)].

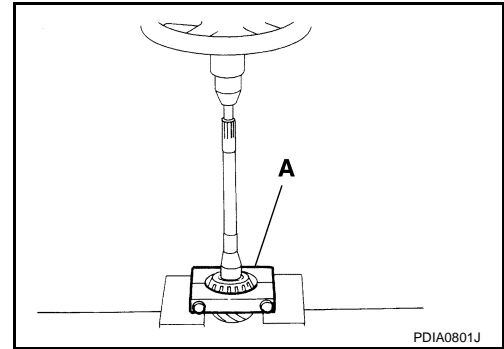

11. Tap pinion front/rear bearing outer races uniformly a brass rod or equivalent to removed.

**CAUTION:**

**Never damage gear carrier.**

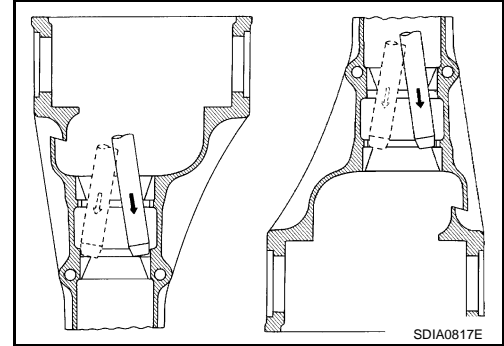

## 2WD : Assembly

1. Install front bearing outer race (1) and rear bearing outer race (2) using drifts.

A: Drift [SST: ST30720000 (J-25405)]

B: Drift [SST: KV40105230 ( — )]

C: Drift bar [SST: ST30611000 (J-25742-1)]

D: Drift [SST: ST30613000 (J-25742-3)]

**CAUTION:**

- At first, using a hammer, tap bearing outer race until it becomes flat to gear carrier.
- Never reuse pinion front and rear bearing outer race.

2. Select drive pinion height adjusting washer. Refer to [DLN-203, "2WD : Adjustment"](#).

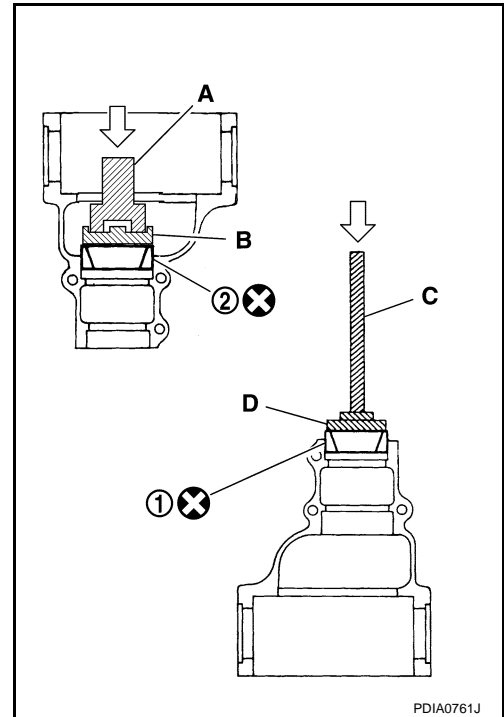

# DRIVE PINION

## < DISASSEMBLY AND ASSEMBLY >

[REAR FINAL DRIVE: R200]

3. Install selected drive pinion height adjusting washer (2) to drive pinion. Press pinion rear bearing inner race (1) to it, using drift (A) [SST: ST30901000 (J-26010-01)].

**CAUTION:**

- Pay attention to the direction of pinion height adjusting washer. (Assemble as shown in the figure.)
- Never reuse pinion rear bearing inner race.

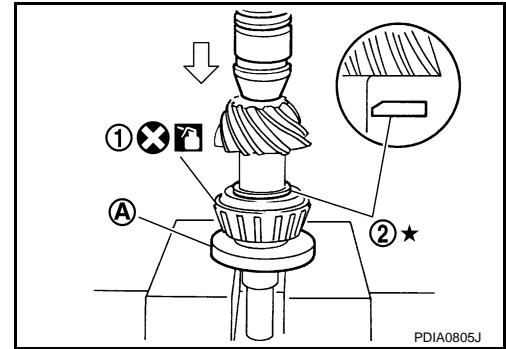

4. Assemble collapsible spacer to drive pinion.

**CAUTION:**

**Never reuse collapsible spacer.**

5. Apply gear oil to pinion rear bearing, and assemble drive pinion into gear carrier.
6. Apply gear oil to pinion front bearing, and assemble pinion front bearing inner race to drive pinion assembly.

**CAUTION:**

**Never reuse pinion front bearing inner race.**

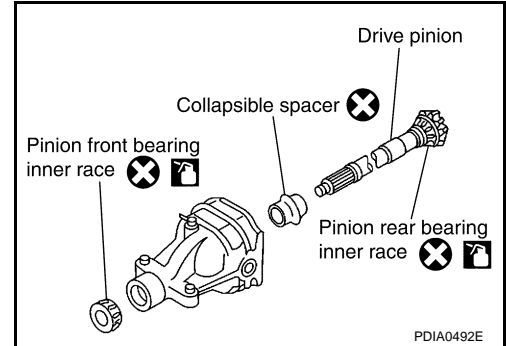

7. Using suitable spacer (A), press the pinion front bearing inner race to drive pinion as far as drive pinion nut can be tightened.

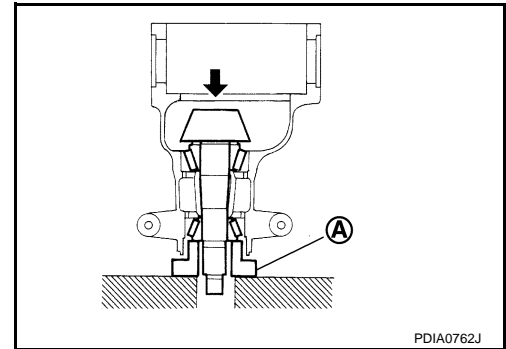

8. Using the drift (A) [SST: ST30720000 (J-25405)], install front oil seal as shown in figure.

**CAUTION:**

- Never reuse oil seal.
- When installing, never incline oil seal.
- Apply multi-purpose grease onto oil seal lips, and gear oil onto the circumference of oil seal.

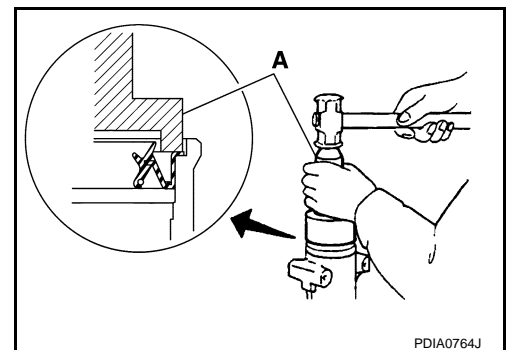

9. Install companion flange (1).

**NOTE:**

When reusing drive pinion, align the matching mark (B) of drive pinion with the matching mark (A) of companion flange, and then install companion flange (1).

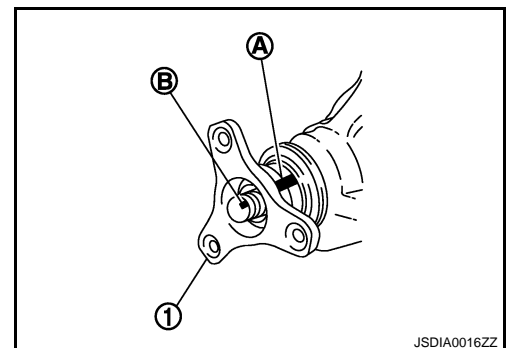

# DRIVE PINION

< DISASSEMBLY AND ASSEMBLY >

[REAR FINAL DRIVE: R200]

10. Apply anti-corrosion oil to the thread and seat of drive pinion lock nut, and temporarily tighten drive pinion lock nut to drive pinion.

**CAUTION:**

**Never reuse drive pinion lock nut.**

11. Adjust to the drive pinion lock nut tightening torque and pinion bearing preload torque.

A: Preload gauge [SST: ST3127S000 (J-25765-A)]

**Standard**

**Pinion bearing preload** : Refer to [DLN-216, "Pre-load Torque"](#).

**CAUTION:**

- Adjust to the lower limit of the drive pinion lock nut tightening torque first.
- If the preload torque exceeds the specified value, replace collapsible spacer and tighten it again to adjust. Never loosen drive pinion lock nut to adjust the preload torque.
- After adjustment, rotate drive pinion back and forth 2 to 3 times to check for unusual noise, rotation malfunction, and other malfunctions.

12. Install differential case assembly. Refer to [DLN-177, "2WD : Assembly"](#).

**CAUTION:**

**Never install rear cover yet.**

13. Check and adjust drive gear runout, tooth contact, drive gear to drive pinion backlash, and companion flange runout. Refer to [DLN-181, "2WD : Adjustment"](#).  
Recheck above items. Readjust the above description, if necessary.
14. Check total preload torque. Refer to [DLN-181, "2WD : Adjustment"](#).
15. Install rear cover. Refer to [DLN-177, "2WD : Assembly"](#).

## 2WD : Adjustment

INFOID:000000000957408

## PINION GEAR HEIGHT

1. Make sure all parts are clean and that the bearings are well lubricated.
2. Assemble the pinion gear bearings into the differential shim selector tool [SST: — (J-34309)].

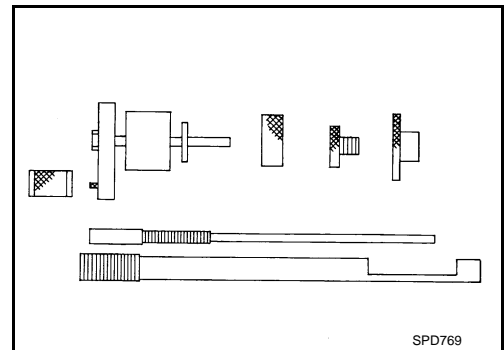
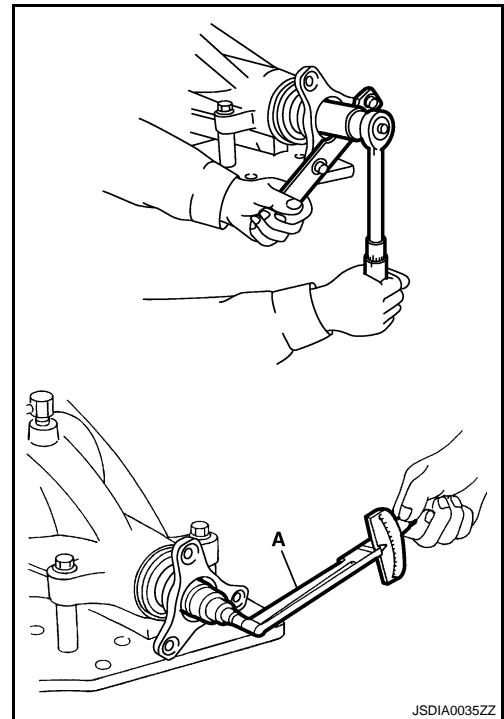

# DRIVE PINION

## < DISASSEMBLY AND ASSEMBLY >

[REAR FINAL DRIVE: R200]

- **Pinion front bearing;** make sure the J-34309-3 pinion front bearing seat is secured tightly against the J-34309-2 gauge anvil. Then turn the pinion front bearing pilot, J-34309-5, to secure the bearing in its proper position.
  - **Pinion rear bearing;** the pinion rear bearing pilot, J-34309-8, is used to center the pinion rear bearing only. The pinion rear bearing locking seat, J-34309-4, is used to lock the bearing to the assembly.
  - **Installation of J-34309-9 and J-34309-16;** place a suitable 2.5 mm (0.098 in) thick plain washer between J-34309-9 and J-34309-16. Both surfaces of J-34309-9 and J-34309-16 must be parallel with a clearance of 2.5 mm (0.098 in).
3. Install the pinion rear bearing inner race into gear carrier. Then place the pinion preload shim selector tool, J-34309-1, gauge screw assembly.

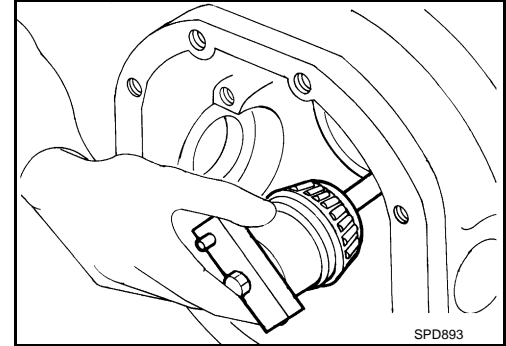
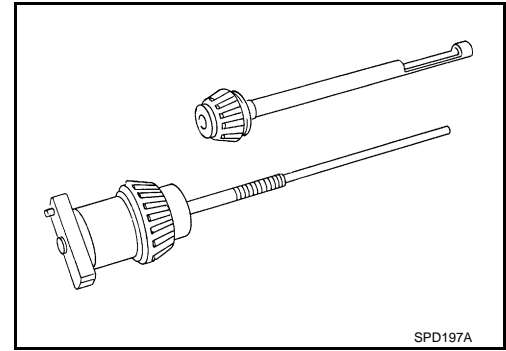

4. Assemble the pinion front bearing inner race and the J-34309-2 gauge anvil. Assemble them together with the J-34309-1 gauge screw in gear carrier. Make sure that the pinion height gauge plate, J-34309-16, will turn a full 360 degrees. Tighten the two sections together by hand.

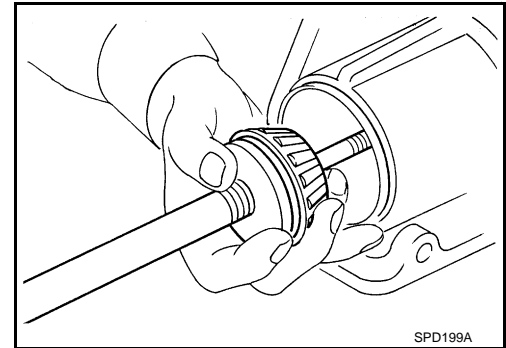

5. Turn the assembly several times to seat the bearings.

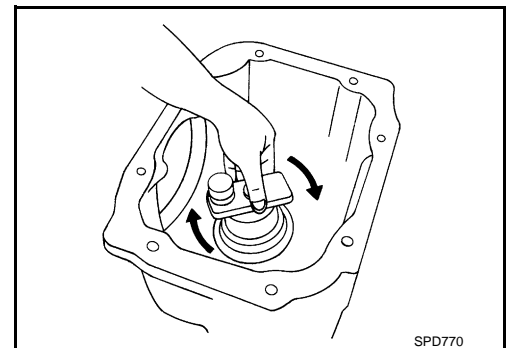

6. Measure the turning torque at the end of the J-34309-2 gauge anvil using preload gauge [SST: ST3127S000 (J-25765-A)].

**Turning torque specification** : 1.0 – 1.3 N·m (0.11 – 0.13 kg·m, 9 – 11 in·lb)

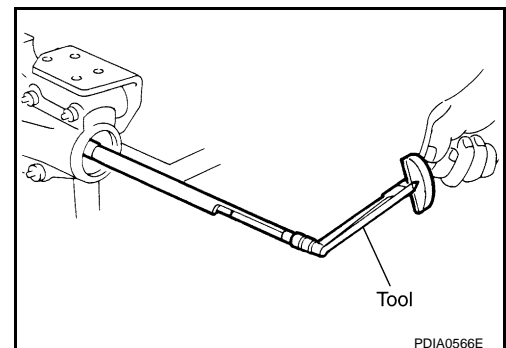

# DRIVE PINION

## < DISASSEMBLY AND ASSEMBLY >

[REAR FINAL DRIVE: R200]

7. Place the J-34309-11 "R200A" pinion height adapter onto the gauge plate and tighten it by hand.

**CAUTION:**

**Make sure all machined surfaces are clean.**

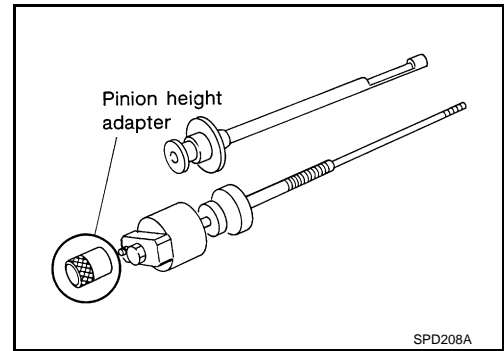

8. Position the side bearing discs, J-25269-4, and arbor firmly into the side bearing bores. Install the bearing caps and tighten bearing cap mounting bolts to the specified torque. Refer to [DLN-199, "2WD : Exploded View"](#).

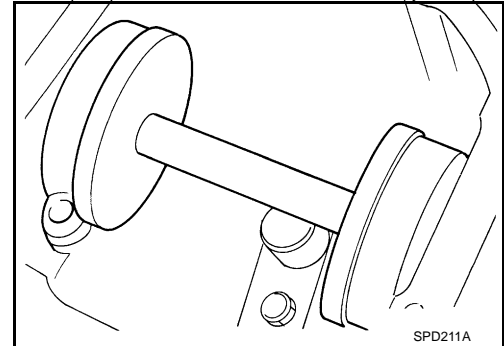

9. Select the correct standard pinion height adjusting washer thickness. Select by using a standard gauge of 3 mm (0.12 in) and your J-34309-101 feeler gauge. Measure the distance between the J-34309-11 pinion height adapter including the standard gauge and the arbor.

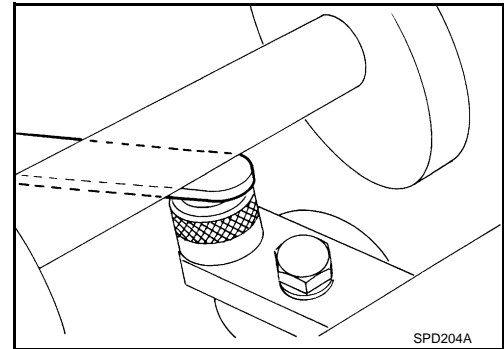

10. Write down exact measurement (the value of feeler gauge).

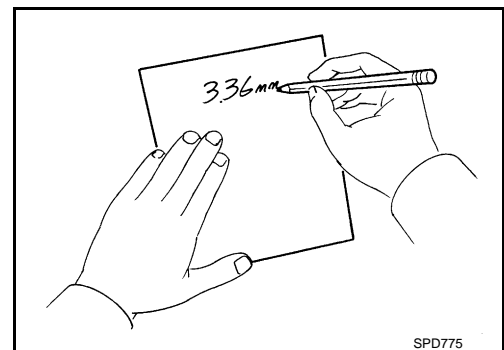

11. Correct the pinion height washer size by referring to the "pinion head number".

**There are two numbers painted on the drive pinion. The first one refers to the drive pinion and drive gear as a matched set. This number should be the same as the number on the drive gear. The second number is the "pinion head height number". It refers to the ideal pinion height from standard for quietest operation. Use the following chart to determine the correct pinion height washer.**

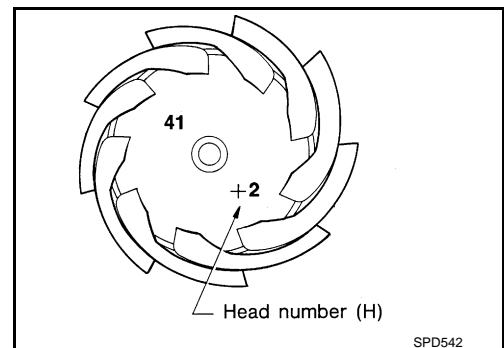

A

B

C

DLN

E

F

G

H

I

J

K

L

M

N

O

P

# DRIVE PINION

< DISASSEMBLY AND ASSEMBLY >

[REAR FINAL DRIVE: R200]

Pinion head height number	Add or remove from the standard pinion height adjusting washer thickness measurement
-6	Add 0.06 mm (0.0024 in)
-5	Add 0.05 mm (0.0020 in)
-4	Add 0.04 mm (0.0016 in)
-3	Add 0.03 mm (0.0012 in)
-2	Add 0.02 mm (0.0008 in)
-1	Add 0.01 mm (0.0004 in)
0	Use the selected washer thickness
+1	Subtract 0.01 mm (0.0004 in)
+2	Subtract 0.02 mm (0.0008 in)
+3	Subtract 0.03 mm (0.0012 in)
+4	Subtract 0.04 mm (0.0016 in)
+5	Subtract 0.05 mm (0.0020 in)
+6	Subtract 0.06 mm (0.0024 in)

12. Select the correct pinion height adjusting washer.
13. Remove the J-34309 differential shim selector tool from the final drive housing. Then disassemble to retrieve the pinion bearings.

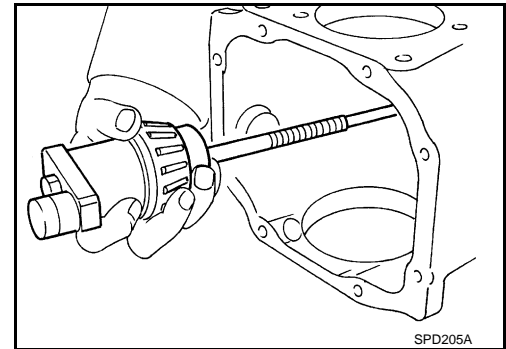

## DRIVE PINION RUNOUT

1. Set a dial indicator (A) vertically to the tip of the drive pinion.
2. Rotate drive pinion to check for runout.

### Limit

**Drive pinion runout** : Refer to [DLN-216, "Drive Pinion Runout \(2WD Models\)"](#).

3. If the runout value is outside of the limit, possible cause will be an assembly malfunction of drive pinion and pinion bearing and malfunction of pinion bearing. Check for these items and repair if necessary.

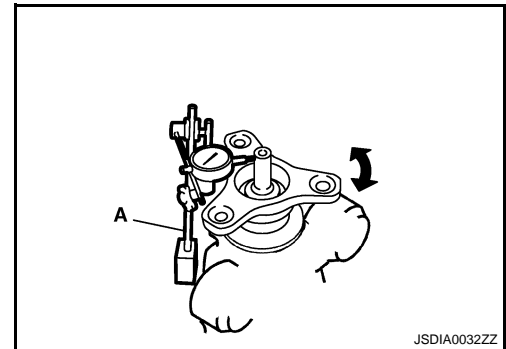

## 2WD : Inspection After Disassembly

INFOID:000000000957409

Clean up the disassembled parts. Then, inspect if the parts are worn or damaged. If so, follow the measures below.

Content	Conditions and Measures
Hypoid gear	<ul style="list-style-type: none"> <li>• If the gear teeth do not mesh or line-up correctly, determine the cause and adjust or replace as necessary.</li> <li>• If the gears are worn, cracked, damaged, pitted or chipped (by friction) noticeably, replace with new drive gear and drive pinion as a set.</li> </ul>
Bearing	<ul style="list-style-type: none"> <li>• If any chipped (by friction), pitted, worn, rusted or scratched mark, or unusual noise from the bearing is observed, replace as a bearing assembly (as a new set).</li> </ul>
Side gear and Pinion mate gear	<ul style="list-style-type: none"> <li>• If any cracks or damage on the surface of the tooth is found, replace.</li> <li>• If any worn or chipped mark on the contact sides of the thrust washer is found, replace.</li> </ul>
Side gear thrust washer and pinion mate thrust washer	<ul style="list-style-type: none"> <li>• If it is chipped (by friction), damaged, or unusually worn, replace.</li> </ul>



# DRIVE PINION

< DISASSEMBLY AND ASSEMBLY >

[REAR FINAL DRIVE: R200]

 Apply Genuine Silicone RTV or equivalent. Refer to [GI-15, "Recommended Chemical Products and Sealants"](#).

 Apply Genuine High Strength Thread Locking Sealant or equivalent. Refer to [GI-15, "Recommended Chemical Products and Sealants"](#).

Refer to [GI-4, "Components"](#) for symbols not described on the above.

## AWD : Disassembly

INFOID:000000000957411

1. Remove differential assembly. Refer to [DLN-175, "2WD : Disassembly"](#).
2. Remove drive pinion lock nut with the flange wrench.

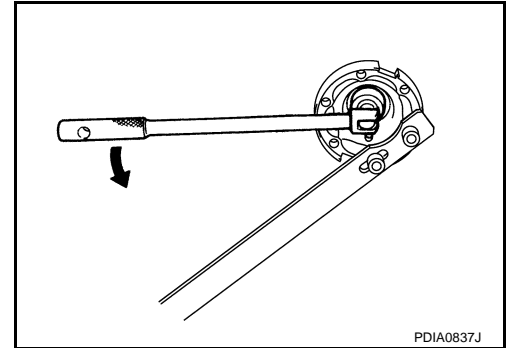

3. Put matching mark (B) on the end of drive pinion. The matching mark should be in line with the matching mark (A) on companion flange (1).

**CAUTION:**

**For matching mark, use paint. Never damage companion flange and drive pinion.**

**NOTE:**

The matching mark (A) on the final drive companion flange (1) indicates the maximum vertical runout position.

When replacing companion flange, matching mark is not necessary.

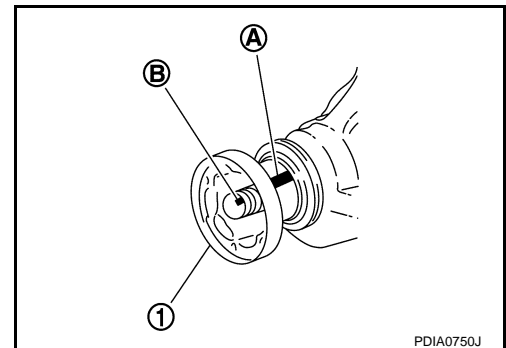

4. Remove companion flange using the suitable pullers.

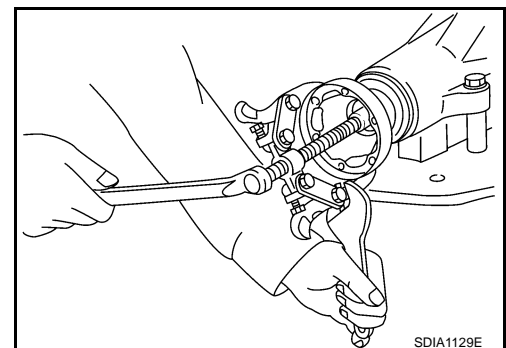

5. Press drive pinion assembly out of gear carrier.

**CAUTION:**

**Never drop drive pinion assembly.**

6. Remove front oil seal.
7. Remove side oil seal.
8. Remove pinion front bearing inner race.
9. Remove collapsible spacer.

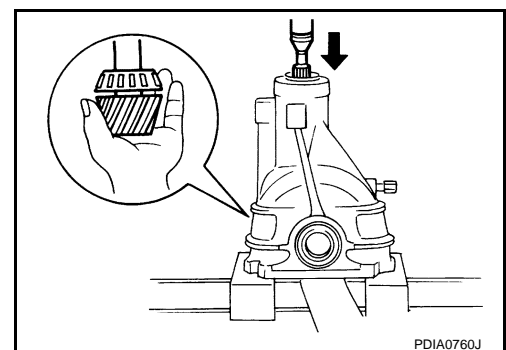



# DRIVE PINION

## < DISASSEMBLY AND ASSEMBLY >

[REAR FINAL DRIVE: R200]

10. Remove pinion rear bearing inner race and pinion height adjusting washer with the replacer (A) [SST: ST30031000 (J-22912-01)].

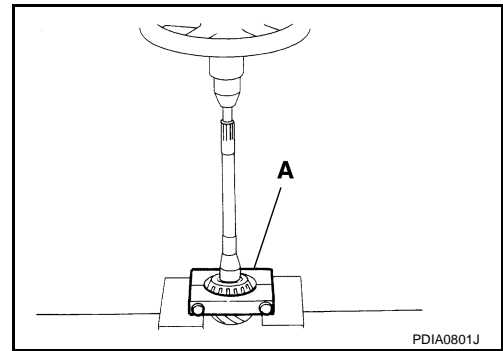

11. Tap pinion front/rear bearing outer races uniformly a brass rod or equivalent to removed.

**CAUTION:**

**Never damage gear carrier.**

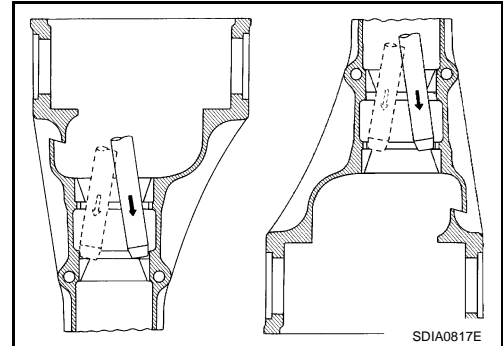

## AWD : Assembly

1. Install front bearing outer race (1) and rear bearing outer race (2) using drifts.

A: Drift [SST: ST30720000 (J-25405)]

B: Drift [SST: KV40105230 ( — )]

C: Drift bar [SST: ST30611000 (J-25742-1)]

D: Drift [SST: ST30613000 (J-25742-3)]

**CAUTION:**

- At first, using a hammer, tap bearing outer race until it becomes flat to gear carrier.
- Never reuse pinion front and rear bearing outer race.

2. Select drive pinion height adjusting washer. Refer to [DLN-211](#), "[AWD : Adjustment](#)".

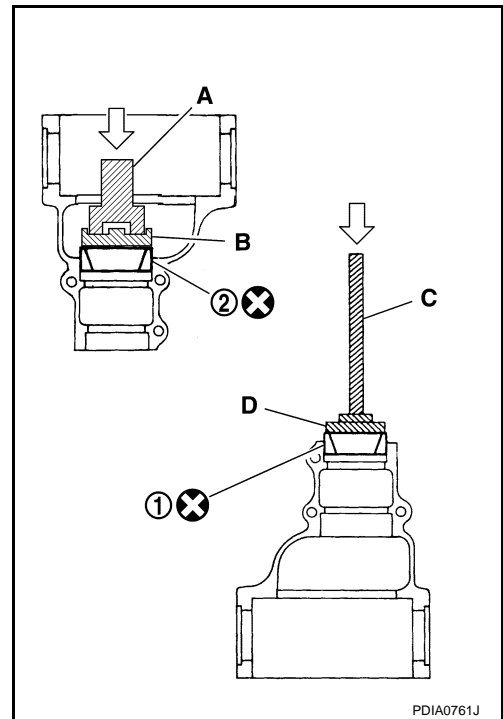

# DRIVE PINION

## < DISASSEMBLY AND ASSEMBLY >

[REAR FINAL DRIVE: R200]

3. Install selected drive pinion height adjusting washer (2) to drive pinion. Press pinion rear bearing inner race (1) to it, using drift (A) [SST: ST30901000 (J-26010-01)].

**CAUTION:**

- Pay attention to the direction of pinion height adjusting washer. (Assemble as shown in the figure.)
- Never reuse pinion rear bearing inner race.

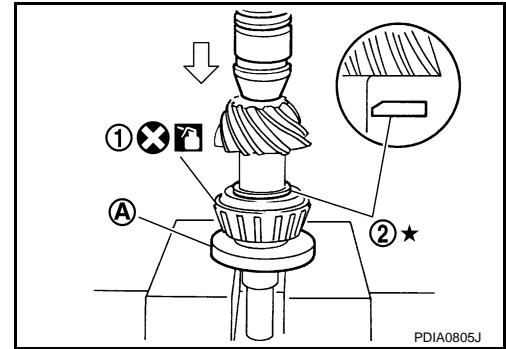

4. Assemble collapsible spacer to drive pinion.

**CAUTION:**

**Never reuse collapsible spacer.**

5. Apply gear oil to pinion rear bearing, and assemble drive pinion into gear carrier.
6. Apply gear oil to pinion front bearing, and assemble pinion front bearing inner race to drive pinion assembly.

**CAUTION:**

**Never reuse pinion front bearing inner race.**

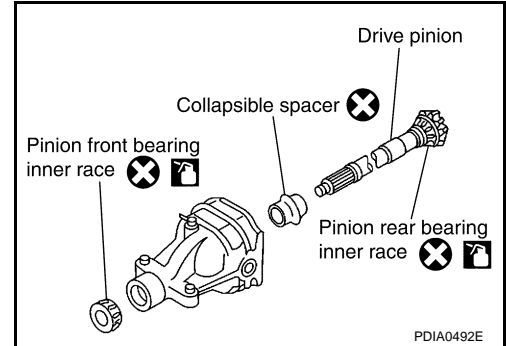

7. Using suitable spacer (A), press the pinion front bearing inner race to drive pinion as far as drive pinion nut can be tightened.

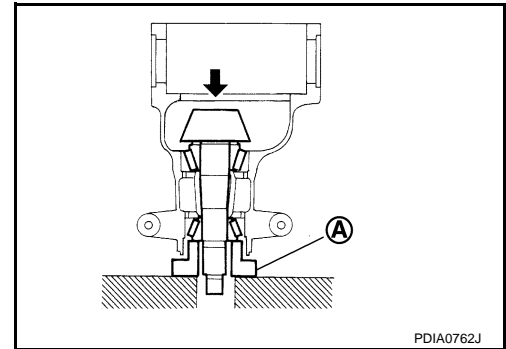

8. Using the drift (A) [SST: ST30720000 (J-25405)], install front oil seal as shown in figure.

**CAUTION:**

- Never reuse oil seal.
- When installing, never incline oil seal.
- Apply multi-purpose grease onto oil seal lips, and gear oil onto the circumference of oil seal.

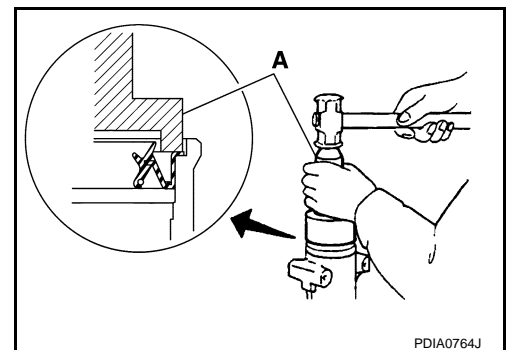

9. Install companion flange (1).

**NOTE:**

When reusing drive pinion, align the matching mark (B) of drive pinion with the matching mark (A) of companion flange, and then install companion flange (1).

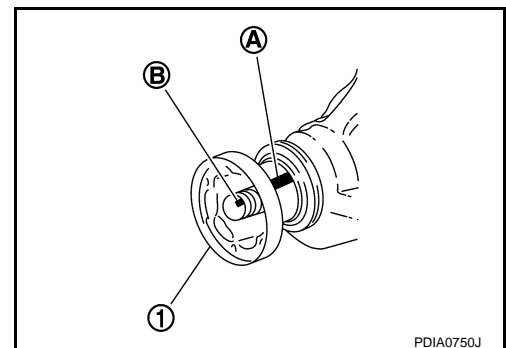

# DRIVE PINION

< DISASSEMBLY AND ASSEMBLY >

[REAR FINAL DRIVE: R200]

10. Apply anti-corrosion oil to the thread and seat of drive pinion lock nut, and temporarily tighten drive pinion lock nut to drive pinion.

**CAUTION:**

**Never reuse drive pinion lock nut.**

11. Adjust to the drive pinion lock nut tightening torque and pinion bearing preload torque.

A: Preload gauge [SST: ST3127S000 (J-25765-A)]

**Standard**

**Pinion bearing preload** : Refer to [DLN-216, "Pre-load Torque"](#).

**CAUTION:**

- Adjust to the lower limit of the drive pinion lock nut tightening torque first.
- If the preload torque exceeds the specified value, replace collapsible spacer and tighten it again to adjust. Never loosen drive pinion lock nut to adjust the preload torque.
- After adjustment, rotate drive pinion back and forth 2 to 3 times to check for unusual noise, rotation malfunction, and other malfunctions.

12. Install differential case assembly. Refer to [DLN-177, "2WD : Assembly"](#).

**CAUTION:**

**Never install rear cover yet.**

13. Check and adjust drive gear runout, tooth contact, drive gear to drive pinion backlash, and companion flange runout. Refer to [DLN-181, "2WD : Adjustment"](#).  
Recheck above items. Readjust the above description, if necessary.
14. Check total preload torque. Refer to [DLN-181, "2WD : Adjustment"](#).
15. Install rear cover. Refer to [DLN-177, "2WD : Assembly"](#).

## AWD : Adjustment

INFOID:000000000957413

## PINION GEAR HEIGHT

1. Make sure all parts are clean and that the bearings are well lubricated.
2. Assemble the pinion gear bearings into the differential shim selector tool [SST: — (J-34309)].

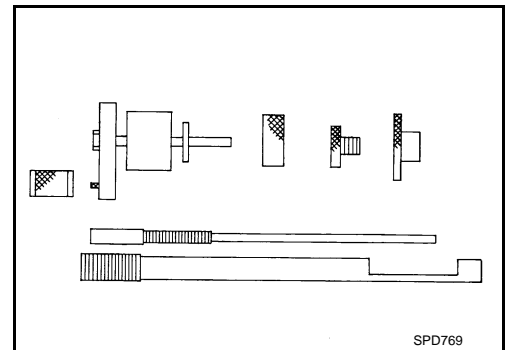
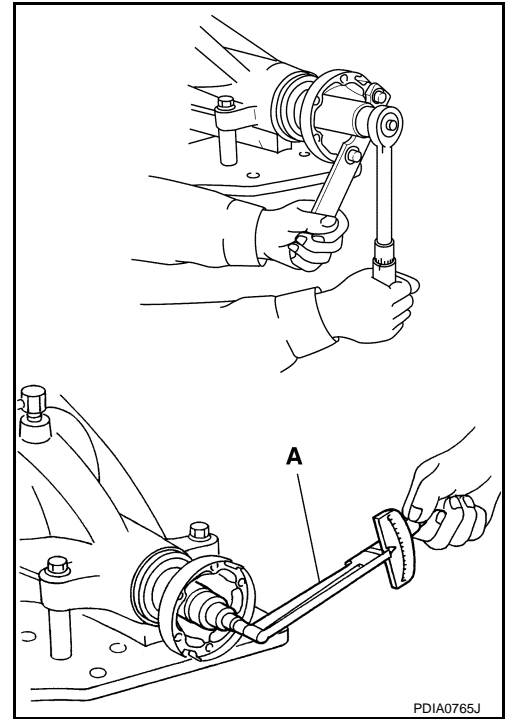

# DRIVE PINION

## < DISASSEMBLY AND ASSEMBLY >

[REAR FINAL DRIVE: R200]

- **Pinion front bearing;** make sure the J-34309-3 pinion front bearing seat is secured tightly against the J-34309-2 gauge anvil. Then turn the pinion front bearing pilot, J-34309-5, to secure the bearing in its proper position.
  - **Pinion rear bearing;** the pinion rear bearing pilot, J-34309-8, is used to center the pinion rear bearing only. The pinion rear bearing locking seat, J-34309-4, is used to lock the bearing to the assembly.
  - **Installation of J-34309-9 and J-34309-16;** place a suitable 2.5 mm (0.098 in) thick plain washer between J-34309-9 and J-34309-16. Both surfaces of J-34309-9 and J-34309-16 must be parallel with a clearance of 2.5 mm (0.098 in).
3. Install the pinion rear bearing inner race into gear carrier. Then place the pinion preload shim selector tool, J-34309-1, gauge screw assembly.

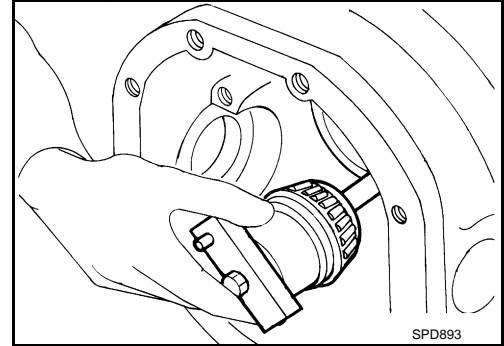
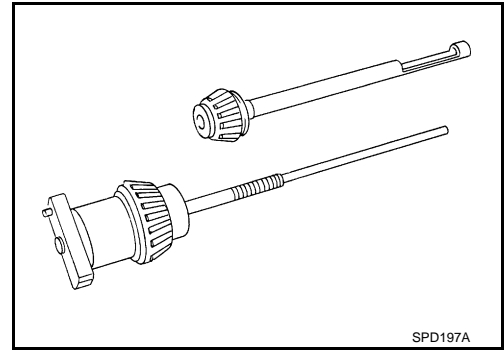

4. Assemble the pinion front bearing inner race and the J-34309-2 gauge anvil. Assemble them together with the J-34309-1 gauge screw in gear carrier. Make sure that the pinion height gauge plate, J-34309-16, will turn a full 360 degrees. Tighten the two sections together by hand.

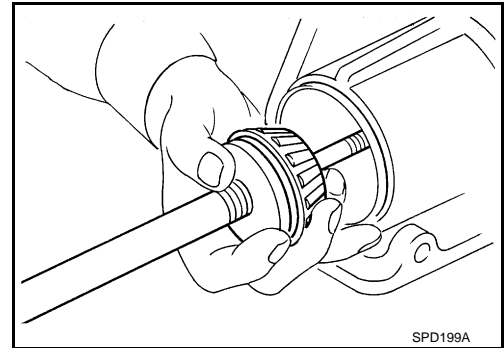

5. Turn the assembly several times to seat the bearings.

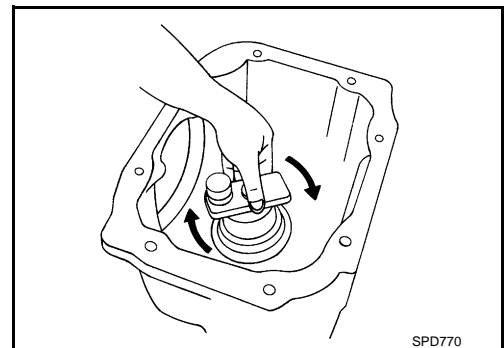

6. Measure the turning torque at the end of the J-34309-2 gauge anvil using preload gauge [SST: ST3127S000 (J-25765-A)].

**Turning torque specification** : 1.0 – 1.3 N·m (0.11 – 0.13 kg·m, 9 – 11 in·lb)

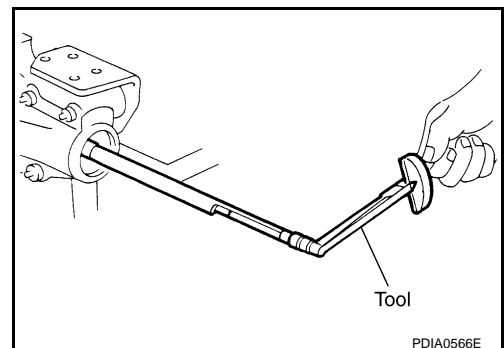

# DRIVE PINION

## < DISASSEMBLY AND ASSEMBLY >

[REAR FINAL DRIVE: R200]

7. Place the J-34309-11 "R200A" pinion height adapter onto the gauge plate and tighten it by hand.

**CAUTION:**

**Make sure all machined surfaces are clean.**

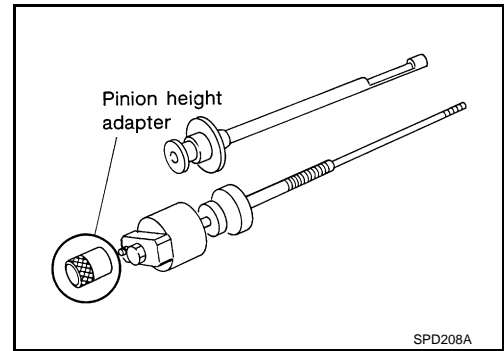

8. Position the side bearing discs, J-25269-4, and arbor firmly into the side bearing bores. Install the bearing caps and tighten bearing cap mounting bolts to the specified torque. Refer to [DLN-207, "AWD : Exploded View"](#).

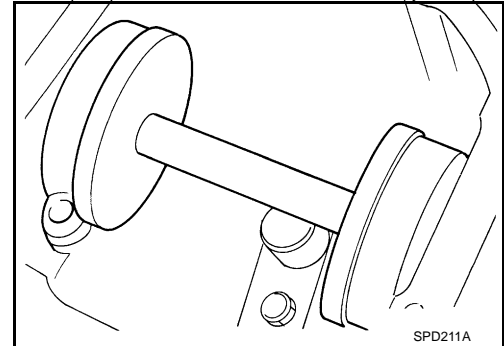

9. Select the correct standard pinion height adjusting washer thickness. Select by using a standard gauge of 3 mm (0.12 in) and your J-34309-101 feeler gauge. Measure the distance between the J-34309-11 pinion height adapter including the standard gauge and the arbor.

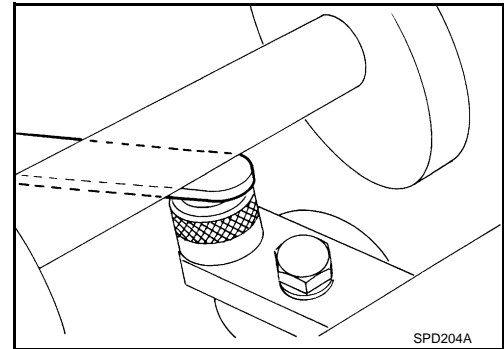

10. Write down exact measurement (the value of feeler gauge).

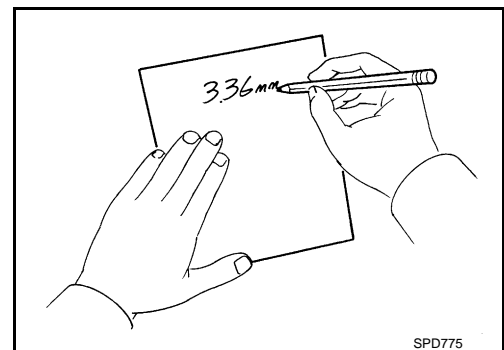

11. Correct the pinion height washer size by referring to the "pinion head number".

**There are two numbers painted on the drive pinion. The first one refers to the drive pinion and drive gear as a matched set. This number should be the same as the number on the drive gear. The second number is the "pinion head height number". It refers to the ideal pinion height from standard for quietest operation. Use the following chart to determine the correct pinion height washer.**

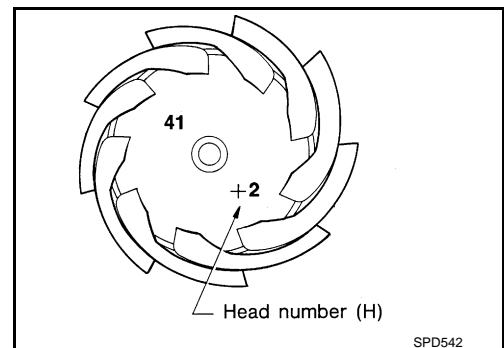

A

B

C

DLN

E

F

G

H

I

J

K

L

M

N

O

P

# DRIVE PINION

< DISASSEMBLY AND ASSEMBLY >

[REAR FINAL DRIVE: R200]

Pinion head height number	Add or remove from the standard pinion height adjusting washer thickness measurement
-6	Add 0.06 mm (0.0024 in)
-5	Add 0.05 mm (0.0020 in)
-4	Add 0.04 mm (0.0016 in)
-3	Add 0.03 mm (0.0012 in)
-2	Add 0.02 mm (0.0008 in)
-1	Add 0.01 mm (0.0004 in)
0	Use the selected washer thickness
+1	Subtract 0.01 mm (0.0004 in)
+2	Subtract 0.02 mm (0.0008 in)
+3	Subtract 0.03 mm (0.0012 in)
+4	Subtract 0.04 mm (0.0016 in)
+5	Subtract 0.05 mm (0.0020 in)
+6	Subtract 0.06 mm (0.0024 in)

12. Select the correct pinion height adjusting washer.
13. Remove the J-34309 differential shim selector tool from the final drive housing. Then disassemble to retrieve the pinion bearings.

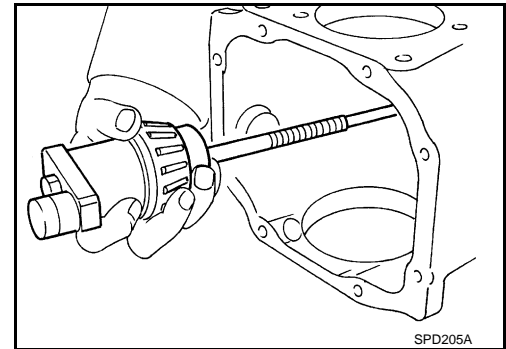

## COMPANION FLANGE RUNOUT

1. Fit a test indicator to the inner side of companion flange (socket diameter).
2. Rotate companion flange to check for runout.

### Limit

**Companion flange runout** : Refer to [DLN-216, "Companion flange Runout \(AWD Models\)"](#).

3. If the runout value is outside the runout limit, follow the procedure below to adjust.
  - a. Check for runout while changing the phase between companion flange and drive pinion by 90° step, and search for the position where the runout is the minimum.
  - b. If the runout value is still outside of the limit after the phase has been changed, possible cause will be an assembly malfunction of drive pinion and pinion bearing and malfunction of pinion bearing. Check for these items and repair if necessary.
  - c. If the runout value is still outside of the limit after the check and repair, replace companion flange.

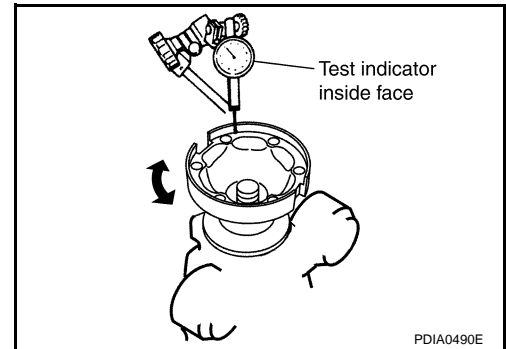

## AWD : Inspection After Disassembly

INFOID:000000000957414

Clean up the disassembled parts. Then, inspect if the parts are worn or damaged. If so, follow the measures below.

# DRIVE PINION

< DISASSEMBLY AND ASSEMBLY >

[REAR FINAL DRIVE: R200]

Content	Conditions and Measures
Hypoid gear	<ul style="list-style-type: none"> <li>If the gear teeth do not mesh or line-up correctly, determine the cause and adjust or replace as necessary.</li> <li>If the gears are worn, cracked, damaged, pitted or chipped (by friction) noticeably, replace with new drive gear and drive pinion as a set.</li> </ul>
Bearing	<ul style="list-style-type: none"> <li>If any chipped (by friction), pitted, worn, rusted or scratched mark, or unusual noise from the bearing is observed, replace as a bearing assembly (as a new set).</li> </ul>
Side gear and Pinion mate gear	<ul style="list-style-type: none"> <li>If any cracks or damage on the surface of the tooth is found, replace.</li> <li>If any worn or chipped mark on the contact sides of the thrust washer is found, replace.</li> </ul>
Side gear thrust washer and pinion mate thrust washer	<ul style="list-style-type: none"> <li>If it is chipped (by friction), damaged, or unusually worn, replace.</li> </ul>
Oil seal	<ul style="list-style-type: none"> <li>Whenever disassembled, replace.</li> <li>If wear, deterioration of adherence (sealing force lips), or damage is detected on the lips, replace them.</li> </ul>
Differential case	<ul style="list-style-type: none"> <li>If any wear or crack on the contact sides of the differential case is found, replace.</li> </ul>
Companion flange	<ul style="list-style-type: none"> <li>If any chipped mark (about 0.1 mm, 0.004 in) or other damage on the contact sides of the lips of the companion flange is found, replace.</li> </ul>

A  
B  
C  
DLN  
E  
F  
G  
H  
I  
J  
K  
L  
M  
N  
O  
P

DLN

# SERVICE DATA AND SPECIFICATIONS (SDS)

< SERVICE DATA AND SPECIFICATIONS (SDS)

[REAR FINAL DRIVE: R200]

## SERVICE DATA AND SPECIFICATIONS (SDS)

### SERVICE DATA AND SPECIFICATIONS (SDS)

#### General Specification

INFOID:000000000957415

Applied model	2WD		AWD
	VQ35HR		
	M/T	A/T	A/T
Final drive model	R200		
Gear ratio	3.692		
Number of teeth (Drive gear/Drive pinion)	48/13		
Oil capacity (Approx.)	ℓ (US pt, Imp pt)		
	1.4 (3, 2-1/2)		
Number of pinion gears	2		
Drive pinion adjustment spacer type	Collapsible		

#### Drive Gear Runout

INFOID:000000000957416

Unit: mm (in)

Item	Limit
Drive gear back face runout	0.05 (0.0020)

#### Differential Side Gear Clearance

INFOID:000000000957417

Unit: mm (in)

Item	Standard
Side gear backlash (Clearance between side gear and differential case)	0.2 (0.008) or less (Each gear should rotate smoothly without excessive resistance during differential motion.)

#### Preload Torque

INFOID:000000000957418

Unit: N·m (kg·m, in·lb)

Item	Standard
Pinion bearing (P1)	2.65 – 3.23 (0.27 – 0.32, 24 – 28)
Side bearing (P2)	0.20 – 0.52 (0.02 – 0.05, 2 – 4)
Side bearing to pinion bearing (Total preload) (Total preload = P1 + P2)	2.84 – 3.75 (0.29 – 0.38, 26 – 33)

#### Backlash

INFOID:000000000957419

Unit: mm (in)

Item	Standard
Drive gear to drive pinion gear	0.10 – 0.15 (0.0039 – 0.0059)

#### Drive Pinion Runout (2WD Models)

INFOID:000000000957420

Unit: mm (in)

Item	Limit
Tip of drive pinion runout	0.8 (0.031)

#### Companion flange Runout (AWD Models)

INFOID:000000000957421

Unit: mm (in)



# SERVICE DATA AND SPECIFICATIONS (SDS)

< SERVICE DATA AND SPECIFICATIONS (SDS)

[REAR FINAL DRIVE: R200]

Item	Limit
Inner side of the companion flange runout	0.08 (0.0031)

A

B

C

**DLN**

E

F

G

H

I

J

K

L

M

N

O

P

# NOISE, VIBRATION AND HARSHNESS (NVH) TROUBLESHOOTING

< SYMPTOM DIAGNOSIS >

[REAR FINAL DRIVE: R200V]

## SYMPTOM DIAGNOSIS

### NOISE, VIBRATION AND HARSHNESS (NVH) TROUBLESHOOTING

#### NVH Troubleshooting Chart

INFOID:000000000957422

#### M/T MODELS

Use the chart below to help you find the cause of the symptom. If necessary, repair or replace these parts.

Symptom	Noise	Reference	Possible cause and SUSPECTED PARTS
	×	<a href="#">DLN-257, "M/T : Inspection After Disassembly"</a>	Gear tooth rough
	×	<a href="#">DLN-253, "M/T : Adjustment"</a>	Gear contact improper
	×	<a href="#">DLN-257, "M/T : Inspection After Disassembly"</a>	Tooth surfaces worn
	×	<a href="#">DLN-253, "M/T : Adjustment"</a>	Backlash incorrect
	×	<a href="#">DLN-253, "M/T : Adjustment"</a>	Companion flange excessive runout
	×	<a href="#">DLN-226, "Inspection"</a>	Gear oil improper
	×	NVH in DLN section.	PROPELLER SHAFT
	×	NVH in FAX, RAX, FSU and RSU sections.	AXLE AND SUSPENSION
	×	NVH in WT section.	TIRES
	×	NVH in WT section.	ROAD WHEEL
	×	NVH in FAX and RAX section.	DRIVE SHAFT
	×	NVH in BR section.	BRAKES
	×	NVH in ST section.	STEERING

×: Applicable

#### A/T MODELS

Use the chart below to help you find the cause of the symptom. If necessary, repair or replace these parts.

# NOISE, VIBRATION AND HARSHNESS (NVH) TROUBLESHOOTING

< SYMPTOM DIAGNOSIS >

[REAR FINAL DRIVE: R200V]

Symptom	Noise	A	B	C	DLN	E	F	G	H	I	J	K	L	M	N	O	P	
Possible cause and SUSPECTED PARTS		<a href="#">DLN-269, "A/T : Inspection After Disassembly"</a>																
		<a href="#">DLN-265, "A/T : Adjustment"</a>																
		<a href="#">DLN-269, "A/T : Inspection After Disassembly"</a>																
		<a href="#">DLN-265, "A/T : Adjustment"</a>																
		<a href="#">DLN-265, "A/T : Adjustment"</a>																
		<a href="#">DLN-226, "Inspection"</a>																
		NVH in DLN section.																
		NVH in FAX, RAX, FSU and RSU sections.																
		NVH in WT section.																
		NVH in WT section.																
		NVH in FAX and RAX section.																
		NVH in BR section.																
		NVH in ST section.																
		Gear tooth rough	x															
		Gear contact improper	x															
		Tooth surfaces worn	x															
		Backlash incorrect	x															
		Companion flange excessive runout	x															
		Gear oil improper	x															
		PROPELLER SHAFT	x															
		AXLE AND SUSPENSION	x															
		TIRES	x															
		ROAD WHEEL	x															
		DRIVE SHAFT	x															
		BRAKES	x															
		STEERING	x															

x: Applicable

## PRECAUTION

### PRECAUTIONS

#### Service Notice or Precautions for Rear Final Drive

INFOID:000000000957423

**CAUTION:**

- Check for the correct installation status prior to removal or disassembly. If matching marks are required, be certain they do not interfere with the function of the parts when applied.
- Overhaul should be done in a clean work area, it is preferable to work in dustproof area.
- Before disassembly, using steam or white gasoline, completely remove sand and mud from the exterior of the unit, preventing them from entering into the unit during disassembly or assembly.
- Check appearance of the disassembled parts for damage, deformation, and unusual wear. Replace them with a new ones if necessary.
- Gaskets, seals and O-rings should be replaced any time when the unit is disassembled.
- In principle, tighten bolts or nuts gradually in several steps working diagonally from inside to outside. If tightening sequence is specified, observe it.
- Clean and flush the parts sufficiently and blow-dry them.
- Be careful not to damage sliding surfaces and mating surfaces.
- When applying sealant, remove the old sealant from the mounting surface; then remove any moisture, oil, and foreign materials from the application and mounting surfaces.
- Always use shop paper for cleaning the inside of components.
- Avoid using cotton gloves or shop rags to prevent entering of lint.
- During assembly, observe the specified tightening torque, and apply new gear oil, petroleum jelly, or multi-purpose grease as specified for each vehicle, if necessary.

# PREPARATION

< PREPARATION >

[REAR FINAL DRIVE: R200V]

## PREPARATION

### PREPARATION

#### Special Service Tools

INFOID:000000000957424

The actual shapes of Kent-Moore tools may differ from those of special service tools illustrated here.

Tool number (Kent-Moore No.) Tool name	Description
KV40104100 ( — ) Attachment	Removing side flange
ST36230000 (J-25840-A) Sliding hammer	Removing side flange
ST3127S000 (J-25765-A) Preload gauge	Measuring pinion bearing preload and total preload
KV381054S0 (J-34286) Puller	Removing front oil seal
ST30720000 (J-25405) Drift a: 77 mm (3.03 in) dia. b: 55.5 mm (2.185 in) dia.	<ul style="list-style-type: none"> <li>• Installing front oil seal</li> <li>• Installing pinion rear bearing outer race</li> </ul>
KV38107900 (J-39352) Protector	Installing side flange

A

B

C

DLN

E

F

G

H

I

J

K

L

M

N

O

P

# PREPARATION

< PREPARATION >

[REAR FINAL DRIVE: R200V]

Tool number (Kent-Moore No.) Tool name	Description
KV38100200 (J-26233) Drift a: 65 mm (2.56 in) dia. b: 49 mm (1.93 in) dia. <div data-bbox="613 310 899 449" data-label="Image"> </div> <div data-bbox="846 470 915 485" data-label="Text"> <p>ZZA1143D</p> </div>	Installing side oil seal
KV10111100 (J-37228) Seal cutter <div data-bbox="708 569 834 705" data-label="Image"> </div> <div data-bbox="846 722 906 737" data-label="Text"> <p>S-NT046</p> </div>	Removing rear cover
KV38100800 (J-25604-01) Attachment a: 541 mm (21.30 in) b: 200 mm (7.87 in) <div data-bbox="646 800 818 974" data-label="Image"> </div> <div data-bbox="846 974 922 989" data-label="Text"> <p>SDIA0267E</p> </div>	Fixing unit assembly
ST3306S001 (J-22888-D) Differential side bearing puller set 1: ST33051001 (J-22888-20) Puller 2: ST33061000 (J-8107-2) Base a: 28.5 mm (1.122 in) dia. b: 38 mm (1.50 in) dia. <div data-bbox="607 1066 932 1276" data-label="Image"> </div> <div data-bbox="846 1260 894 1274" data-label="Text"> <p>NT072</p> </div>	Removing and installing side bearing inner race
KV38100300 (J-25523) Drift a: 54 mm (2.13 in) dia. b: 46 mm (1.81 in) dia. c: 32 mm (1.26 in) dia. <div data-bbox="610 1381 932 1541" data-label="Image"> </div> <div data-bbox="846 1541 915 1556" data-label="Text"> <p>ZZA1046D</p> </div>	Installing side bearing inner race
(J-8129) Spring gauge <div data-bbox="600 1640 941 1780" data-label="Image"> </div> <div data-bbox="846 1793 894 1808" data-label="Text"> <p>NT127</p> </div>	Measuring turning torque

# PREPARATION

< PREPARATION >

[REAR FINAL DRIVE: R200V]

Tool number (Kent-Moore No.) Tool name	Description	
ST30031000 (J-22912-01) Replacer	Removing pinion rear bearing inner race	A B C
KV40105230 ( — ) Drift a: 92 mm (3.62 in) dia. b: 86 mm (3.39 in) dia. c: 45 mm (1.77 in) dia.	Installing pinion rear bearing outer race	DLN E F
ST30611000 (J-25742-1) Drift bar	Installing pinion front bearing outer race (Use with ST30613000)	G H
ST30613000 (J-25742-3) Drift a: 72 mm (2.83 in) dia. b: 48 mm (1.89 in) dia.	Installing pinion front bearing outer race	I J K
ST30901000 (J-26010-01) Drift a: 79 mm (3.11 in) dia. b: 45 mm (1.77 in) dia. c: 35.2 mm (1.386 in) dia.	Installing pinion rear bearing inner race	L M
(J-34309) Differential shim selector tool	Adjusting bearing preload and pinion gear height	N O
(J-25269-4) Side bearing disc (2 Req'd)	Selecting pinion height adjusting washer	P

# PREPARATION

< PREPARATION >

[REAR FINAL DRIVE: R200V]

## Commercial Service Tools

INFOID:000000000957425

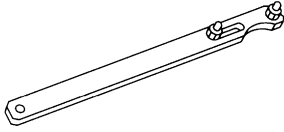
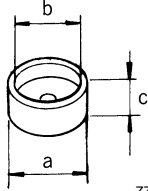
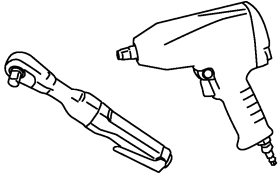
Tool name	Description
Flange wrench  NT035	Removing and installing drive pinion lock nut
Spacer a: 60 mm (2.36 in) dia. b: 36 mm (1.42 in) dia. c: 30 mm (1.18 in)  ZZA1133D	Installing pinion front bearing inner race
Power tool  PBIC0190E	Loosening bolts and nuts



# REAR FINAL DRIVE ASSEMBLY

< FUNCTION DIAGNOSIS >

[REAR FINAL DRIVE: R200V]

## FUNCTION DIAGNOSIS

### REAR FINAL DRIVE ASSEMBLY

#### System Diagram

INFOID:000000000957426

#### CROSS-SECTION VIEW

M/T Models

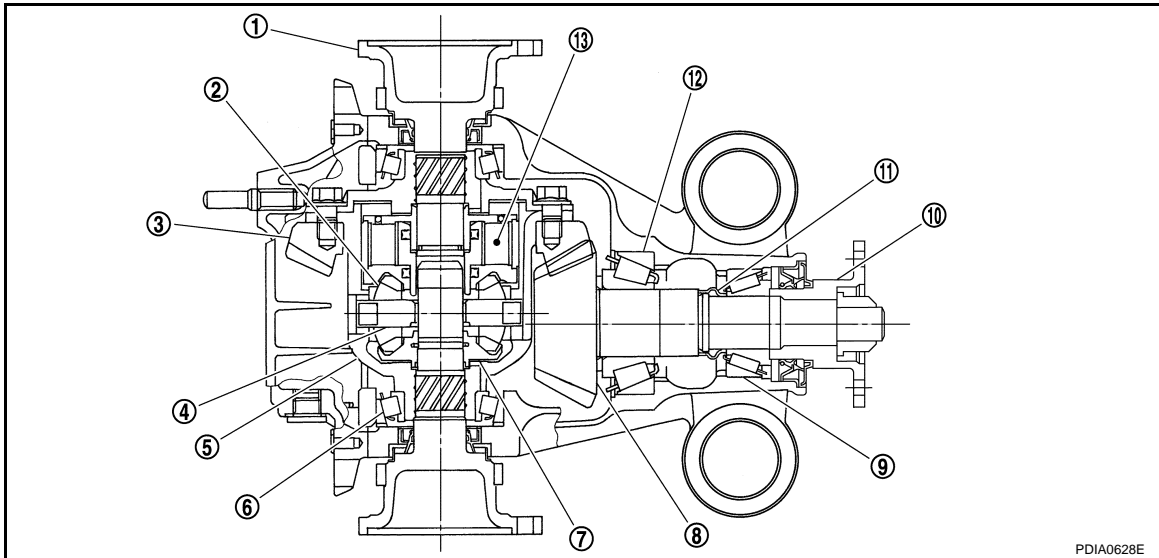

PDIA0628E

- |                      |                        |                         |
|----------------------|------------------------|-------------------------|
| 1. Side flange       | 2. Pinion mate gear    | 3. Drive gear           |
| 4. Pinion mate shaft | 5. Differential case   | 6. Side bearing         |
| 7. Side gear         | 8. Drive pinion        | 9. Pinion front bearing |
| 10. Companion flange | 11. Collapsible spacer | 12. Pinion rear bearing |
| 13. Viscous coupling |                        |                         |

A/T Models

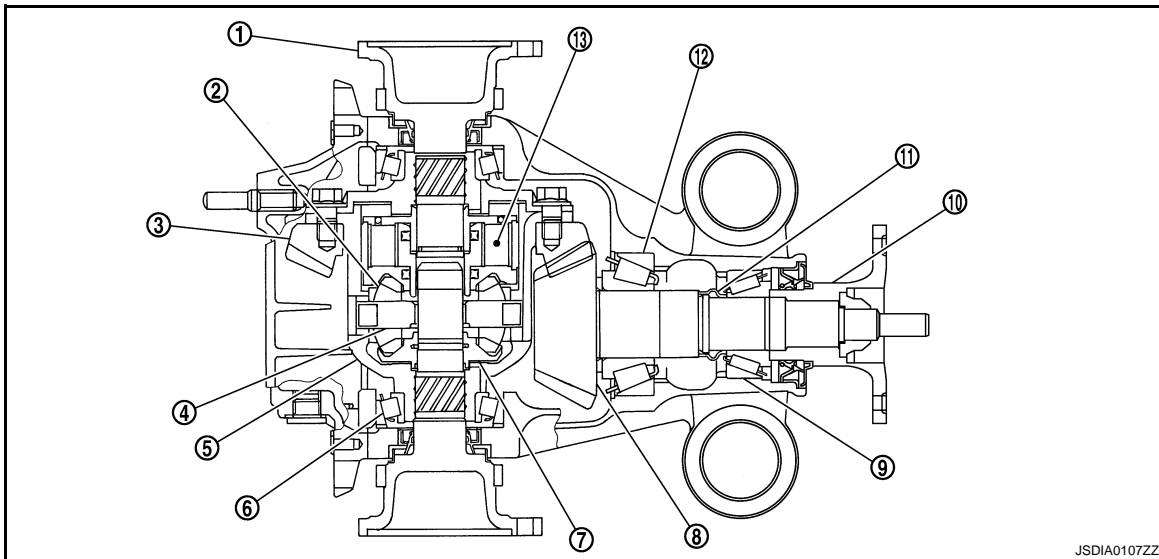

JSDIA0107ZZ

- |                      |                        |                         |
|----------------------|------------------------|-------------------------|
| 1. Side flange       | 2. Pinion mate gear    | 3. Drive gear           |
| 4. Pinion mate shaft | 5. Differential case   | 6. Side bearing         |
| 7. Side gear         | 8. Drive pinion        | 9. Pinion front bearing |
| 10. Companion flange | 11. Collapsible spacer | 12. Pinion rear bearing |
| 13. Viscous coupling |                        |                         |

A  
B  
C  
DLN  
E  
F  
G  
H  
I  
J  
K  
L  
M  
N  
O  
P

# REAR DIFFERENTIAL GEAR OIL

< ON-VEHICLE MAINTENANCE >

[REAR FINAL DRIVE: R200V]

## ON-VEHICLE MAINTENANCE

### REAR DIFFERENTIAL GEAR OIL

#### Inspection

INFOID:000000000957427

#### OIL LEAKAGE

- Make sure that oil is not leaking from final drive assembly or around it.

#### OIL LEVEL

- Remove filler plug (1) and check oil level from filler plug mounting hole as shown in the figure.

**CAUTION:**

**Never start engine while checking oil level.**

- Set a gasket on filler plug (1) and install it on final drive assembly. Refer to [DLN-246, "M/T : Exploded View"](#) (M/T models), [DLN-258, "A/T : Exploded View"](#) (A/T models).

**CAUTION:**

**Never reuse gasket.**

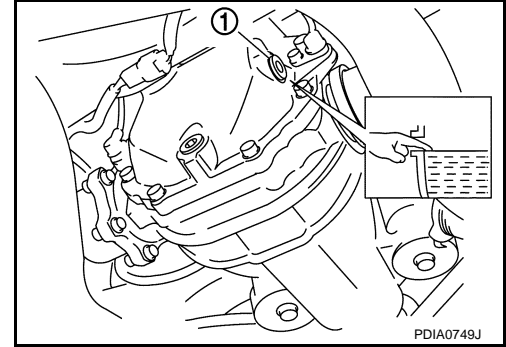

#### Draining

INFOID:000000000957428

1. Stop engine.
2. Remove drain plug (1) and drain gear oil.
3. Set a gasket on drain plug (1) and install it to final drive assembly and tighten to the specified torque. Refer to [DLN-246, "M/T : Exploded View"](#) (M/T models), [DLN-258, "A/T : Exploded View"](#) (A/T models).

**CAUTION:**

**Never reuse gasket.**

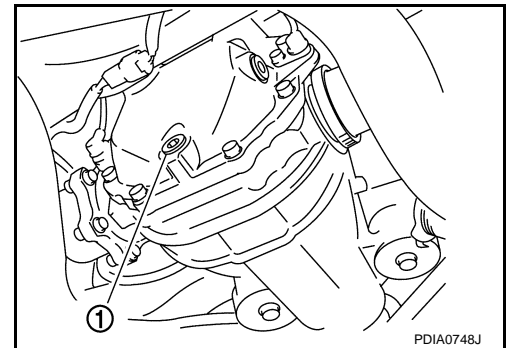

#### Refilling

INFOID:000000000957429

1. Remove filler plug (1). Fill with new gear oil until oil level reaches the specified level near filler plug mounting hole.

**Oil grade and Viscosity** : Refer to [MA-10, "Fluids and Lubricants"](#).

**Oil capacity** : Refer to [DLN-287, "General Specification"](#).

2. After refilling oil, check oil level. Set a gasket to filler plug (1), then install it to final drive assembly. Refer to [DLN-246, "M/T : Exploded View"](#) (M/T models), [DLN-258, "A/T : Exploded View"](#) (A/T models).

**CAUTION:**

**Never reuse gasket.**

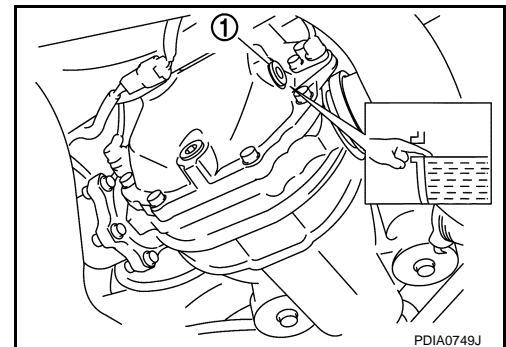

# FRONT OIL SEAL

< ON-VEHICLE REPAIR >

[REAR FINAL DRIVE: R200V]

## ON-VEHICLE REPAIR

### FRONT OIL SEAL

M/T

M/T : Exploded View

INFOID:000000000957430

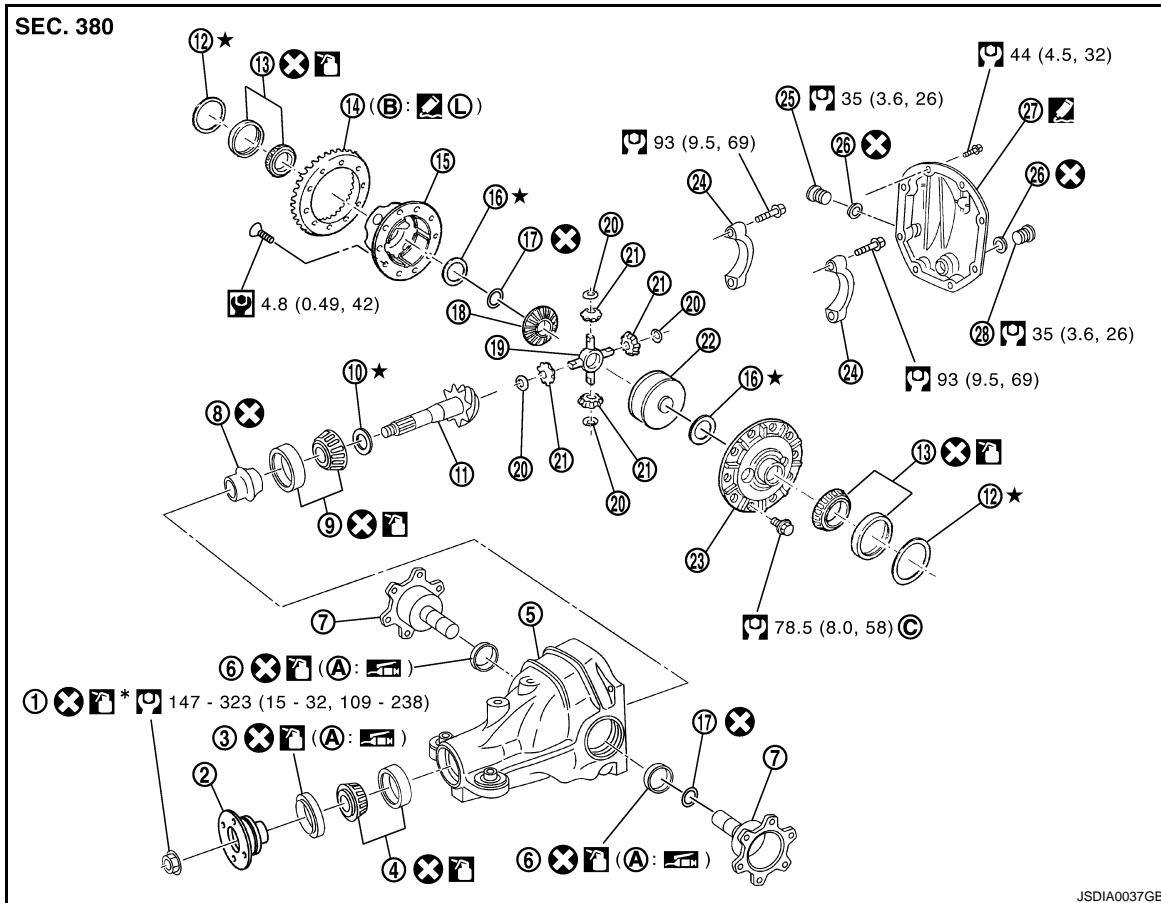

- |                                    |                               |                                   |
|------------------------------------|-------------------------------|-----------------------------------|
| 1. Drive pinion lock nut           | 2. Companion flange           | 3. Front oil seal                 |
| 4. Pinion front bearing            | 5. Gear carrier               | 6. Side oil seal                  |
| 7. Side flange                     | 8. Collapsible spacer         | 9. Pinion rear bearing            |
| 10. Pinion height adjusting washer | 11. Drive pinion              | 12. Side bearing adjusting washer |
| 13. Side bearing                   | 14. Drive gear                | 15. Differential case B           |
| 16. Side gear thrust washer        | 17. Circular clip             | 18. Side gear                     |
| 19. Pinion mate shaft              | 20. Pinion mate thrust washer | 21. Pinion mate gear              |
| 22. Viscous coupling               | 23. Differential case A       | 24. Bearing cap                   |
| 25. Filler plug                    | 26. Gasket                    | 27. Rear cover                    |
| 28. Drain plug                     |                               |                                   |

A: Oil seal lip

B: Screw hole

C: After tightening the bolts to the specified torque, tighten the bolts additionally by turning the bolts 31 to 36 degrees.

Apply gear oil.

Apply anti-corrosion oil.

Apply Genuine Silicone RTV or equivalent. Refer to [GI-15. "Recommended Chemical Products and Sealants"](#).

# FRONT OIL SEAL

< ON-VEHICLE REPAIR >

[REAR FINAL DRIVE: R200V]



Apply Genuine High Strength Thread Locking Sealant or equivalent. Refer to [GI-15, "Recommended Chemical Products and Sealants"](#).

Refer to [GI-4, "Components"](#) for symbols not described on the above.

## M/T : Removal and Installation

INFOID:000000000957431

### REMOVAL

#### CAUTION:

Verify identification stamp of replacement frequency put in the lower part of gear carrier to determine replacement for collapsible spacer when replacing front oil seal. Refer to "Identification stamp of replacement frequency of front oil seal". If necessary collapsible spacer replacement, remove final drive assembly and disassemble it to replace front oil seal and collapsible spacer. Refer to [DLN-243, "M/T : Removal and Installation"](#) and [DLN-247, "M/T : Disassembly"](#).

#### NOTE:

The reuse of collapsible spacer is prohibited in principle. However, it is reusable on a one-time basis only in cases when replacing front oil seal.

Identification stamp of replacement frequency of front oil seal

- The diagonally shaded area in the figure shows stamping point for replacement frequency of front oil seal.
- The following table shows if collapsible spacer replacement is needed before replacing front oil seal.

When collapsible spacer replacement is required, disassemble final drive assembly to replace collapsible spacer and front oil seal. Refer to [DLN-247, "M/T : Disassembly"](#).

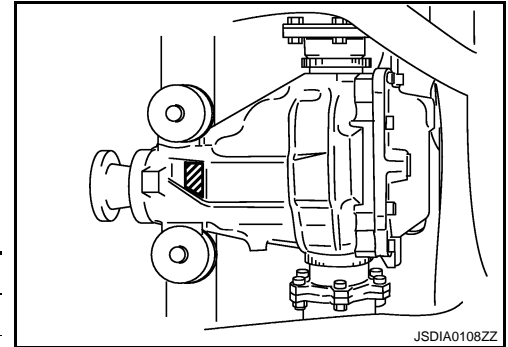

JSDIA0108ZZ

Stamp	collapsible spacer replacement
No stamp	Not required
"0" or "0" on the far right of stamp	Required
"01" or "1" on the far right of stamp	Not required

#### CAUTION:

**Never make a stamping after replacing front oil seal.**

- After replacing front oil seal, make a stamping on the stamping point in accordance with the table below in order to identify replacement frequency.

#### CAUTION:

**Stamping shall be made from left to right.**

Stamp before stamping	Stamping on the far right	Stamping
No stamp	0	0
"0" (Front oil seal was replaced once.)	1	01
"01" (Collapsible spacer and front oil seal were replaced last time.)	0	010
"0" is on the far right. (Only front oil seal was replaced last time.)	1	...01
"1" is on the far right. (Collapsible spacer and front oil seal were replaced last time.)	0	...010

1. Drain gear oil. Refer to [DLN-226, "Draining"](#).
2. Make a judgment if a collapsible spacer replacement is required.
3. Remove center muffler with a power tool. Refer to [EX-5, "Removal and Installation"](#).
4. Remove rear wheel sensor. Refer to [BRC-100, "Removal and Installation"](#).
5. Remove drive shaft from final drive. Then suspend it by wire etc. Refer to [RAX-9, "Removal and Installation"](#).

# FRONT OIL SEAL

< ON-VEHICLE REPAIR >

[REAR FINAL DRIVE: R200V]

6. Install attachment (A) [SST: KV40104100 ( — )] to side flange, and then pull out the side flange with the sliding hammer (B) [SST: ST36230000 (J-25840-A)].

**NOTE:**

**Circular clip installation position: Final drive side**

7. Remove propeller shaft. Refer to [DLN-86. "Removal and Installation"](#).

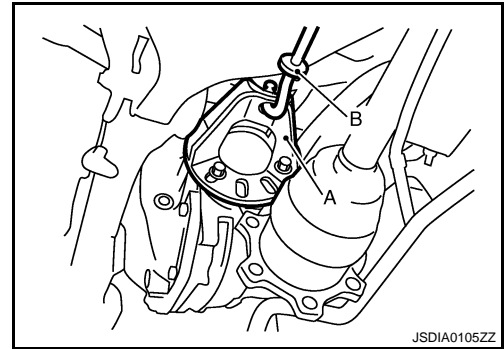

8. Measure the total preload with the preload gauge (A) [SST: ST3127S000 (J-25765-A)].

**NOTE:**

**Record the preload measurement.**

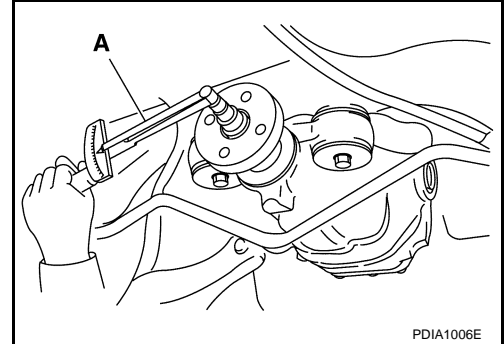

9. Put matching mark (B) on the end of the drive pinion. The matching mark (B) should be in line with the matching mark (A) on companion flange (1).

**CAUTION:**

**For matching mark, use paint. Never damage companion flange and drive pinion.**

**NOTE:**

The matching mark (A) on the final drive companion flange (1) indicates the maximum vertical runout position.

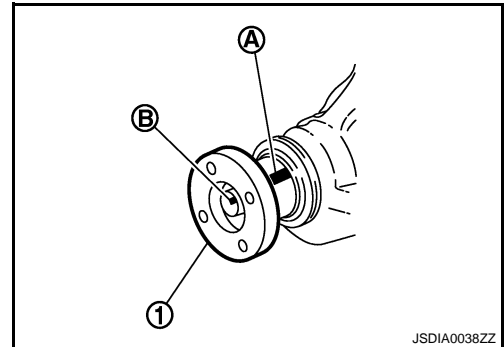

10. Remove drive pinion lock nut using the flange wrench.

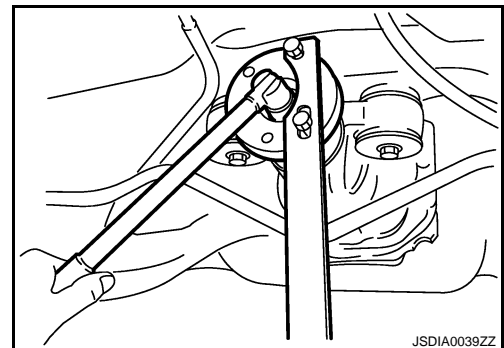

11. Remove companion flange using a puller.

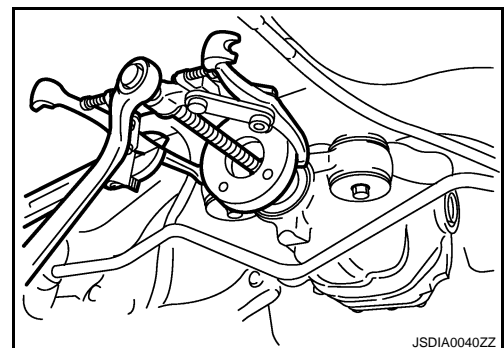

A

B

C

DLN

E

F

G

H

I

J

K

L

M

N

O

P

# FRONT OIL SEAL

< ON-VEHICLE REPAIR >

[REAR FINAL DRIVE: R200V]

12. Remove front oil seal using the puller (A) [SST: KV381054S0 (J-34286)].

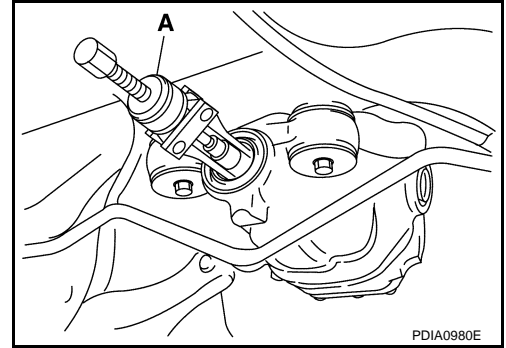

## INSTALLATION

1. Apply multi-purpose grease to front oil seal lips.
2. Install front oil seal using the drift (A) [SST: ST30720000 (J-25405)] as shown in figure.

**CAUTION:**

- Never reuse oil seal.
- Never incline oil seal when installing.

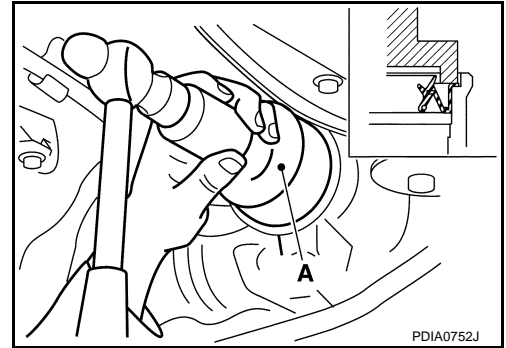

3. Align the matching mark (B) of drive pinion with the matching mark (A) of companion flange (1), and then install the companion flange (1).

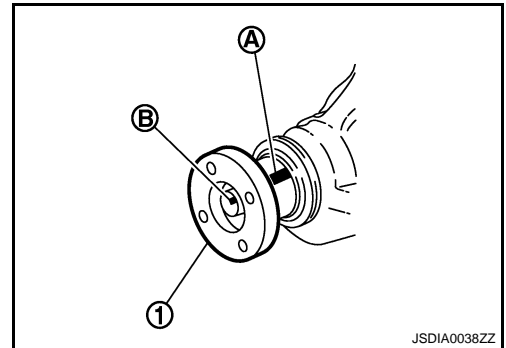

# FRONT OIL SEAL

< ON-VEHICLE REPAIR >

[REAR FINAL DRIVE: R200V]

4. Apply anti-corrosion oil to the thread and seat of new drive pinion lock nut, and temporarily tighten drive pinion lock nut to drive pinion.

**CAUTION:**

**Never reuse drive pinion lock nut.**

5. Tighten to drive pinion lock nut, while adjust total preload torque.

A: Preload gauge [SST: ST3127S000 (J-25765-A)]

**Total preload torque** : Total preload torque should equal the measurement taken during removal plus an additional 0.1 – 0.4 N·m (0.01 – 0.04 kg·m, 1 – 3 in·lb).

**CAUTION:**

- Adjust to the lower limit of the drive pinion lock nut tightening torque first.
- If the preload torque exceeds the specified value, replace collapsible spacer and tighten it again to adjust. Never loosen drive pinion lock nut to adjust the preload torque.

6. Fit a dial indicator onto the companion flange face (inner side of the propeller shaft mounting bolt holes).
7. Rotate the companion flange to check for runout.

**Limit**

**Companion flange runout** : Refer to [DLN-287, "Companion flange Runout \(M/T Models\)"](#).

8. Fit a test indicator to the inner side of the companion flange (socket diameter).
9. Rotate the companion flange to check for runout.

**Limit**

**Companion flange runout** : Refer to [DLN-287, "Companion flange Runout \(M/T Models\)"](#).

10. If the runout value is outside the repair limit, follow the procedure below to adjust.
  - a. Check for runout while changing the phase between companion flange and drive pinion gear by 90° step, and search for the position where the runout is the minimum.
  - b. If the runout value is still outside of the limit after the phase has been changed, possible cause will be an assembly malfunction of drive pinion and pinion bearing and malfunction of pinion bearing. Check for these items and repair if necessary.
  - c. If the runout value is still outside of the limit after the check and repair, replace companion flange.
11. Make a stamping for identification of front oil seal replacement frequency. Refer to "Identification stamp of replacement frequency of front oil seal".

**CAUTION:**

**Never make a stamping after replacing front oil seal.**

12. Install propeller shaft. Refer to [DLN-86, "Removal and Installation"](#).

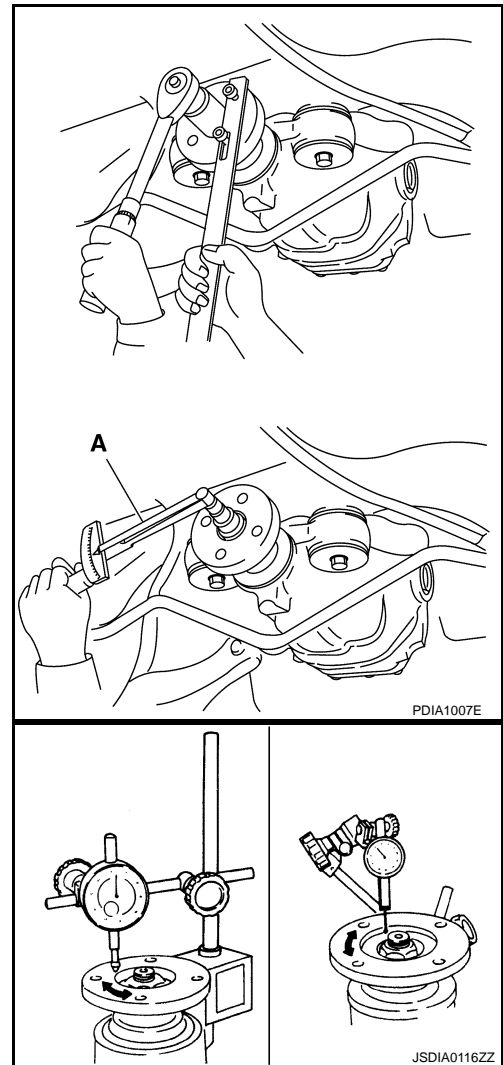

A  
B  
C  
DLN  
E  
F  
G  
H  
I  
J  
K  
L  
M  
N  
O  
P

# FRONT OIL SEAL

< ON-VEHICLE REPAIR >

[REAR FINAL DRIVE: R200V]

13. Install side flange with the following procedure.
  - a. Attach the protector [SST: KV38107900 (J-39352)] to side oil seal.
  - b. After the side flange is inserted and the serrated part of side gear has engaged the serrated part of flange, remove the protector.

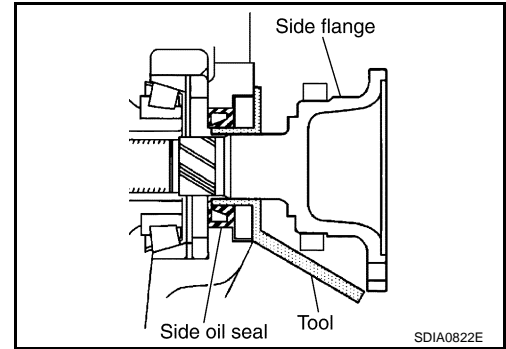

- c. Put a suitable drift on the center of side flange, then drive it until sound changes.

**NOTE:**

When installation is completed, driving sound of the side flange turns into a sound which seems to affect the whole final drive.

- d. Confirm that the dimension of the side flange (1) installation (Measurement A) in the figure comes into the following.

**Measurement "A"** : 326 – 328 mm (12.83 – 12.91 in)

14. Install drive shaft. Refer to [RAX-9, "Removal and Installation"](#).
15. Install rear wheel sensor. Refer to [BRC-100, "Removal and Installation"](#).
16. Install center muffler. Refer to [EX-5, "Removal and Installation"](#).
17. Refill gear oil to the final drive and check oil level. Refer to [DLN-226, "Refilling"](#).
18. Check the final drive for oil leakage. Refer to [DLN-226, "Inspection"](#).

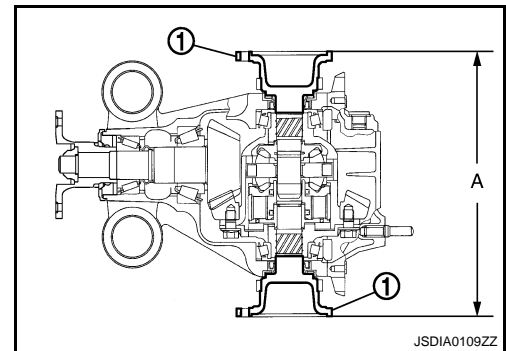

A/T

A/T : Exploded View

INFOID:000000000957432



# FRONT OIL SEAL

< ON-VEHICLE REPAIR >

[REAR FINAL DRIVE: R200V]

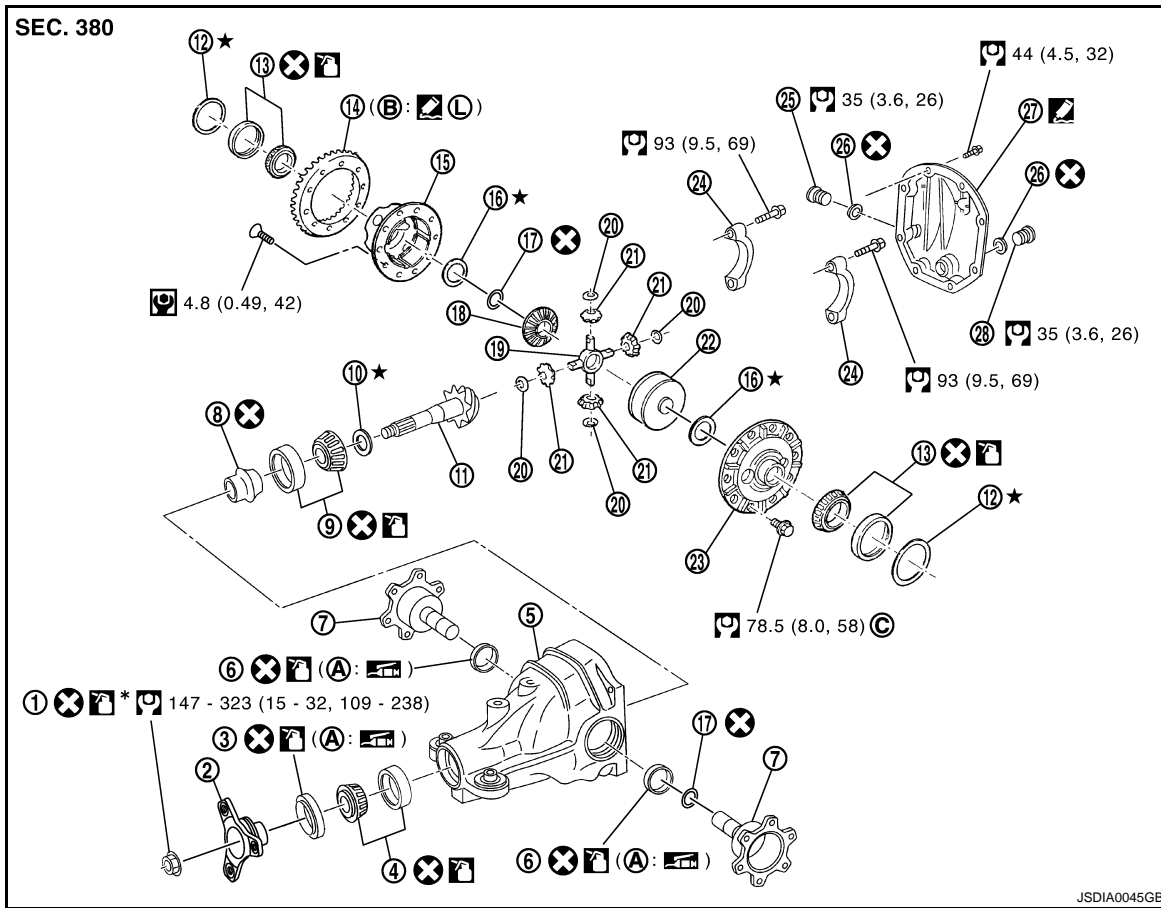

- |                                    |                               |                                   |
|------------------------------------|-------------------------------|-----------------------------------|
| 1. Drive pinion lock nut           | 2. Companion flange           | 3. Front oil seal                 |
| 4. Pinion front bearing            | 5. Gear carrier               | 6. Side oil seal                  |
| 7. Side flange                     | 8. Collapsible spacer         | 9. Pinion rear bearing            |
| 10. Pinion height adjusting washer | 11. Drive pinion              | 12. Side bearing adjusting washer |
| 13. Side bearing                   | 14. Drive gear                | 15. Differential case B           |
| 16. Side gear thrust washer        | 17. Circular clip             | 18. Side gear                     |
| 19. Pinion mate shaft              | 20. Pinion mate thrust washer | 21. Pinion mate gear              |
| 22. Viscous coupling               | 23. Differential case A       | 24. Bearing cap                   |
| 25. Filler plug                    | 26. Gasket                    | 27. Rear cover                    |

A: Oil seal lip

B: Screw hole

C: After tightening the bolts to the specified torque, tighten the bolts additionally by turning the bolts 31 to 36 degrees.

Apply gear oil.

Apply anti-corrosion oil.

Apply Genuine Silicone RTV or equivalent. Refer to [GI-15. "Recommended Chemical Products and Sealants"](#).

Apply Genuine High Strength Thread Locking Sealant or equivalent. Refer to [GI-15. "Recommended Chemical Products and Sealants"](#).

Refer to [GI-4. "Components"](#) for symbols not described on the above.

## A/T : Removal and Installation

INFOID:000000000957433

### REMOVAL

**CAUTION:**

# FRONT OIL SEAL

< ON-VEHICLE REPAIR >

[REAR FINAL DRIVE: R200V]

Verify identification stamp of replacement frequency put in the lower part of gear carrier to determine replacement for collapsible spacer when replacing front oil seal. Refer to "Identification stamp of replacement frequency of front oil seal". If necessary collapsible spacer replacement, remove final drive assembly and disassemble it to replace front oil seal and collapsible spacer. Refer to [DLN-244, "A/T : Removal and Installation"](#) and [DLN-259, "A/T : Disassembly"](#).

**NOTE:**

The reuse of collapsible spacer is prohibited in principle. However, it is reusable on a one-time basis only in cases when replacing front oil seal.

Identification stamp of replacement frequency of front oil seal

- The diagonally shaded area in the figure shows stamping point for replacement frequency of front oil seal.
- The following table shows if collapsible spacer replacement is needed before replacing front oil seal. When collapsible spacer replacement is required, disassemble final drive assembly to replace collapsible spacer and front oil seal. Refer to [DLN-259, "A/T : Disassembly"](#).

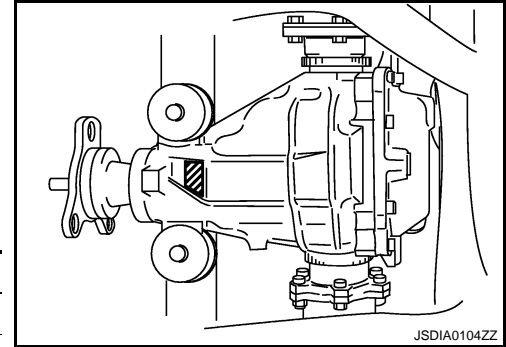

Stamp	collapsible spacer replacement
No stamp	Not required
"0" or "0" on the far right of stamp	Required
"01" or "1" on the far right of stamp	Not required

**CAUTION:**

**Never make a stamping after replacing front oil seal.**

- After replacing front oil seal, make a stamping on the stamping point in accordance with the table below in order to identify replacement frequency.

**CAUTION:**

**Stamping shall be made from left to right.**

Stamp before stamping	Stamping on the far right	Stamping
No stamp	0	0
"0" (Front oil seal was replaced once.)	1	01
"01" (Collapsible spacer and front oil seal were replaced last time.)	0	010
"0" is on the far right. (Only front oil seal was replaced last time.)	1	...01
"1" is on the far right. (Collapsible spacer and front oil seal were replaced last time.)	0	...010

1. Drain gear oil. Refer to [DLN-226, "Draining"](#).
2. Make a judgment if a collapsible spacer replacement is required.
3. Remove center muffler with a power tool. Refer to [EX-5, "Removal and Installation"](#).
4. Remove rear wheel sensor. Refer to [BRC-100, "Removal and Installation"](#).
5. Remove drive shaft from final drive. Then suspend it by wire etc. Refer to [RAX-9, "Removal and Installation"](#).
6. Install attachment (A) [SST: KV40104100 ( — )] to side flange, and then pull out the side flange with the sliding hammer (B) [SST: ST36230000 (J-25840-A)].

**NOTE:**

**Circular clip installation position: Final drive side**

7. Remove propeller shaft. Refer to [DLN-86, "Removal and Installation"](#).

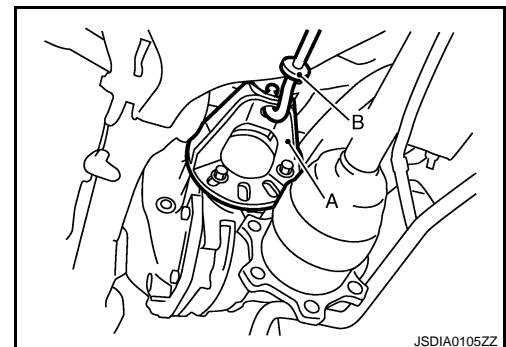

# FRONT OIL SEAL

< ON-VEHICLE REPAIR >

[REAR FINAL DRIVE: R200V]

8. Measure the total preload with the preload gauge (A) [SST: ST3127S000 (J-25765-A)].

**NOTE:**

**Record the preload measurement.**

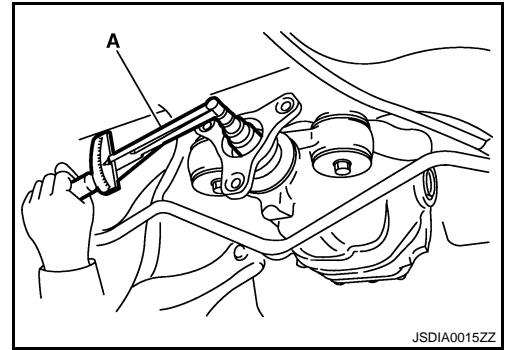

9. Put matching mark (B) on the end of the drive pinion. The matching mark (B) should be in line with the matching mark (A) on companion flange (1).

**CAUTION:**

**For matching mark, use paint. Never damage companion flange and drive pinion.**

**NOTE:**

The matching mark (A) on the final drive companion flange (1) indicates the maximum vertical runout position.

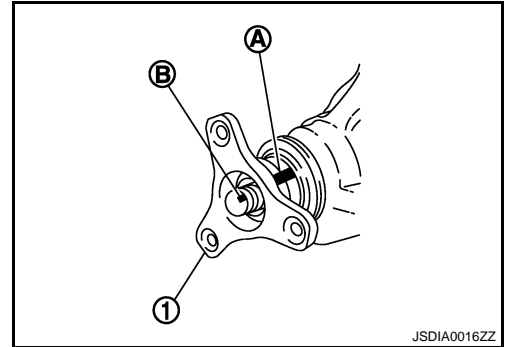

10. Remove drive pinion lock nut using the flange wrench.

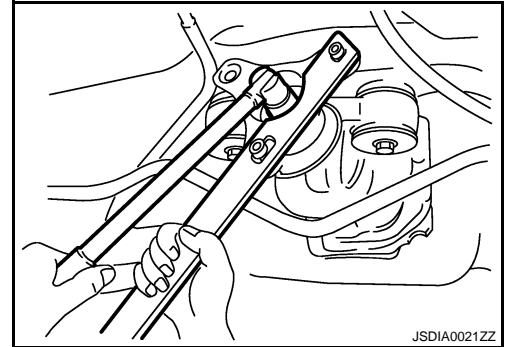

11. Remove companion flange using pullers.

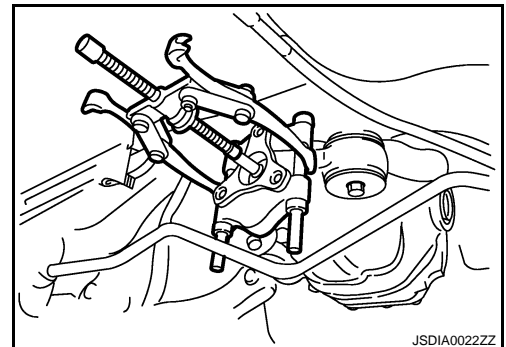

12. Remove front oil seal using the puller (A) [SST: KV381054S0 (J-34286)].

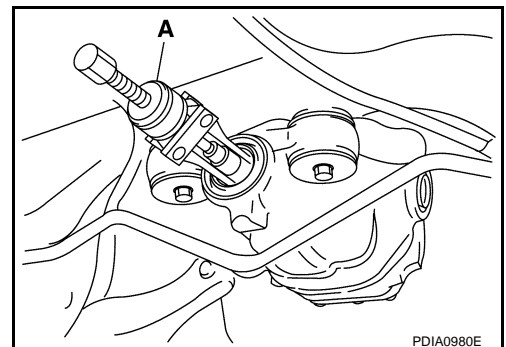

A  
B  
C  
DLN  
E  
F  
G  
H  
I  
J  
K  
L  
M  
N  
O  
P

# FRONT OIL SEAL

< ON-VEHICLE REPAIR >

[REAR FINAL DRIVE: R200V]

## INSTALLATION

1. Apply multi-purpose grease to front oil seal lips.
2. Install front oil seal using the drift (A) [SST: ST30720000 (J-25405)] as shown in figure.

**CAUTION:**

- Never reuse oil seal.
- Never incline oil seal when installing.

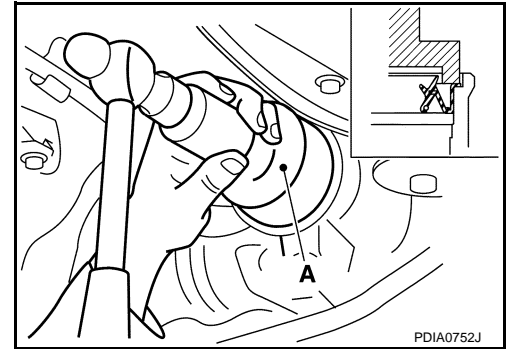

3. Align the matching mark (B) of drive pinion with the matching mark (A) of companion flange (1), and then install the companion flange (1).

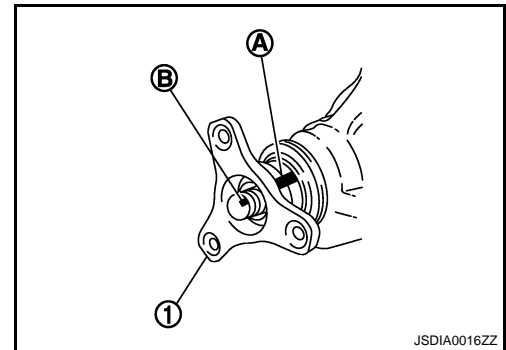

4. Apply anti-corrosion oil to the thread and seat of new drive pinion lock nut, and temporarily tighten drive pinion lock nut to drive pinion.

**CAUTION:**

**Never reuse drive pinion lock nut.**

5. Tighten to drive pinion lock nut, while adjust total preload torque.

A: Preload gauge [SST: ST3127S000 (J-25765-A)]

**Total preload torque**

**: Total preload torque should equal the measurement taken during removal plus an additional 0.1 – 0.4 N·m (0.01 – 0.04 kg·m, 1 – 3 in·lb).**

**CAUTION:**

- Adjust to the lower limit of the drive pinion lock nut tightening torque first.
- If the preload torque exceeds the specified value, replace collapsible spacer and tighten it again to adjust. Never loosen drive pinion lock nut to adjust the preload torque.

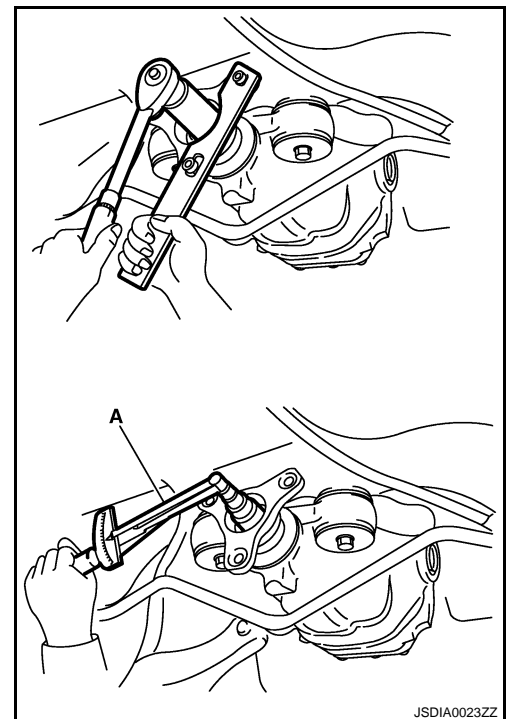

# FRONT OIL SEAL

< ON-VEHICLE REPAIR >

[REAR FINAL DRIVE: R200V]

6. Set a dial indicator (A) vertically to the tip of the drive pinion.
7. Rotate drive pinion to check for runout.

## Limit

**Drive pinion runout** : Refer to [DLN-287, "Drive Pinion Runout \(A/T Models\)"](#).

- If the runout value is still outside of the limit after the phase has been changed, possible cause will be an assembly malfunction of drive pinion and pinion bearing and malfunction of pinion bearing. Check for these items and repair if necessary.

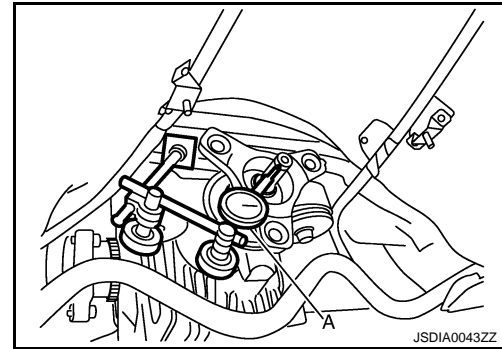

8. Make a stamping for identification of front oil seal replacement frequency. Refer to "Identification stamp of replacement frequency of front oil seal".

## CAUTION:

**Never make a stamping after replacing front oil seal.**

9. Install propeller shaft. Refer to [DLN-86, "Removal and Installation"](#).
10. Install side flange with the following procedure.
  - a. Attach the protector [SST: KV38107900 (J-39352)] to side oil seal.
  - b. After the side flange is inserted and the serrated part of side gear has engaged the serrated part of flange, remove the protector.

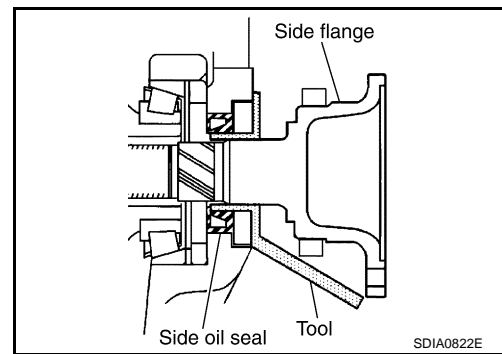

- c. Put a suitable drift on the center of side flange, then drive it until sound changes.

## NOTE:

When installation is completed, driving sound of the side flange turns into a sound which seems to affect the whole final drive.

- d. Confirm that the dimension of the side flange (1) installation (Measurement A) in the figure comes into the following.

**Measurement "A"** : 326 – 328 mm (12.83 – 12.91 in)

11. Install drive shaft. Refer to [RAX-9, "Removal and Installation"](#).
12. Install rear wheel sensor. Refer to [BRC-100, "Removal and Installation"](#).
13. Install center muffler. Refer to [EX-5, "Removal and Installation"](#).
14. Refill gear oil to the final drive and check oil level. Refer to [DLN-226, "Refilling"](#).
15. Check the final drive for oil leakage. Refer to [DLN-226, "Inspection"](#).

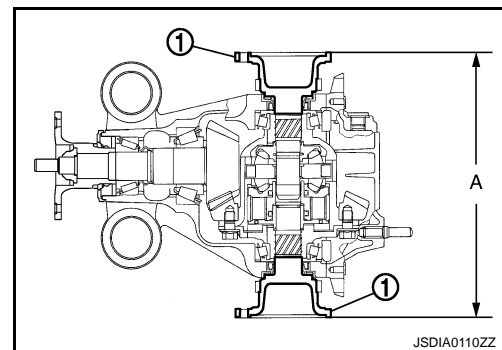

# SIDE OIL SEAL

< ON-VEHICLE REPAIR >

[REAR FINAL DRIVE: R200V]

## SIDE OIL SEAL

M/T

M/T : Exploded View

INFOID:000000000957434

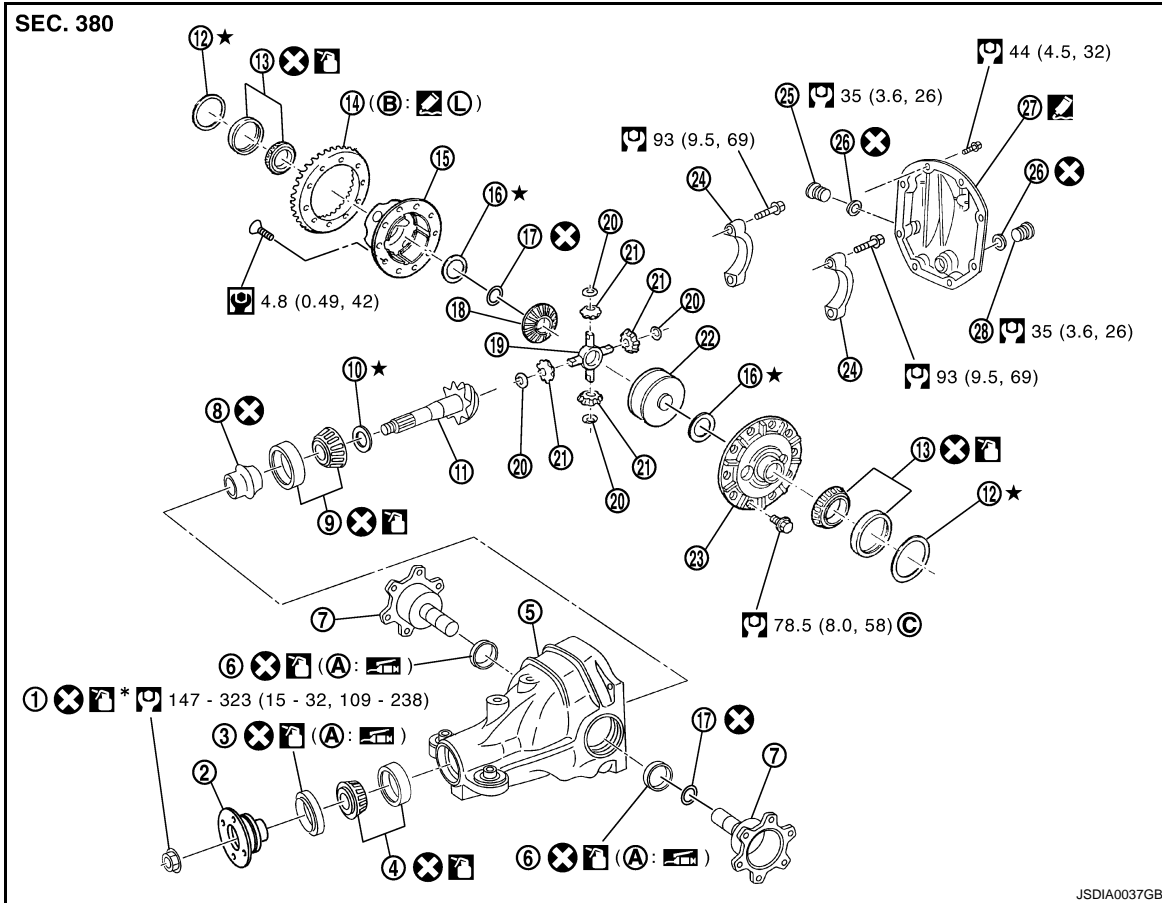

- |                                    |                               |                                   |
|------------------------------------|-------------------------------|-----------------------------------|
| 1. Drive pinion lock nut           | 2. Companion flange           | 3. Front oil seal                 |
| 4. Pinion front bearing            | 5. Gear carrier               | 6. Side oil seal                  |
| 7. Side flange                     | 8. Collapsible spacer         | 9. Pinion rear bearing            |
| 10. Pinion height adjusting washer | 11. Drive pinion              | 12. Side bearing adjusting washer |
| 13. Side bearing                   | 14. Drive gear                | 15. Differential case B           |
| 16. Side gear thrust washer        | 17. Circular clip             | 18. Side gear                     |
| 19. Pinion mate shaft              | 20. Pinion mate thrust washer | 21. Pinion mate gear              |
| 22. Viscous coupling               | 23. Differential case A       | 24. Bearing cap                   |
| 25. Filler plug                    | 26. Gasket                    | 27. Rear cover                    |
| 28. Drain plug                     |                               |                                   |

A: Oil seal lip

B: Screw hole

C: After tightening the bolts to the specified torque, tighten the bolts additionally by turning the bolts 31 to 36 degrees.

Apply gear oil.

\*: Apply anti-corrosion oil.

Apply Genuine Silicone RTV or equivalent. Refer to [GI-15, "Recommended Chemical Products and Sealants"](#).

Apply Genuine High Strength Thread Locking Sealant or equivalent. Refer to [GI-15, "Recommended Chemical Products and Sealants"](#).

Refer to [GI-4, "Components"](#) for symbols not described on the above.

# SIDE OIL SEAL

< ON-VEHICLE REPAIR >

[REAR FINAL DRIVE: R200V]

INFOID:000000000957435

## M/T : Removal and Installation

### REMOVAL

1. Remove center muffler with a power tool. Refer to [EX-5. "Removal and Installation"](#).
2. Remove rear wheel sensor. Refer to [BRC-100. "Removal and Installation"](#).
3. Remove drive shaft from final drive with a power tool. Then suspend it by wire etc. Refer to [RAX-9. "Removal and Installation"](#).
4. Install attachment (A) [SST: KV40104100 ( — )] to side flange, and then pull out the side flange with the sliding hammer (B) [SST: ST36230000 (J-25840-A)].

#### NOTE:

**Circular clip installation position: Final drive side**

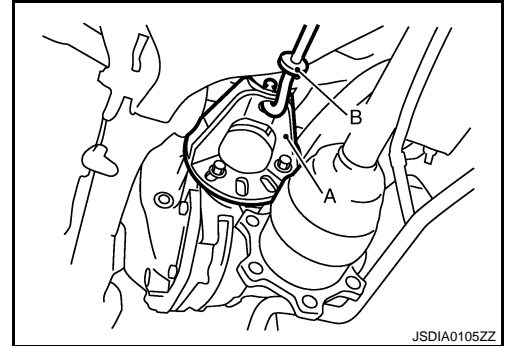

5. Remove side oil seal, using a flat-bladed screwdriver.

#### CAUTION:

**Never damage gear carrier.**

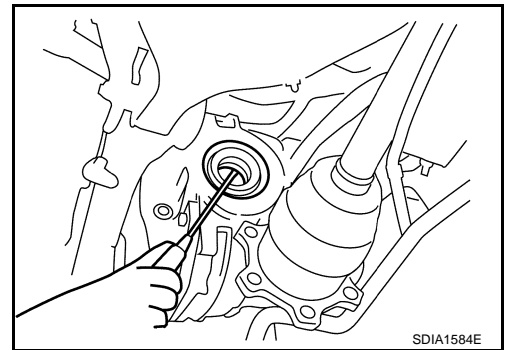

### INSTALLATION

1. Apply multi-purpose grease to side oil seal lips.
2. Install side oil seal until it becomes flush with the case end, using the drift [SST: KV38100200 (J-26233)].

#### CAUTION:

- **Never reuse oil seal.**
- **When installing, never incline oil seal.**

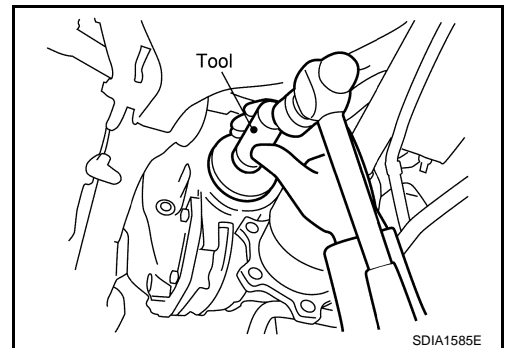

3. Install side flange with the following procedure.
  - a. Attach the protector [SST: KV38107900 (J-39352)] to side oil seal.
  - b. After the side flange is inserted and the serrated part of side gear has engaged the serrated part of flange, remove the protector.

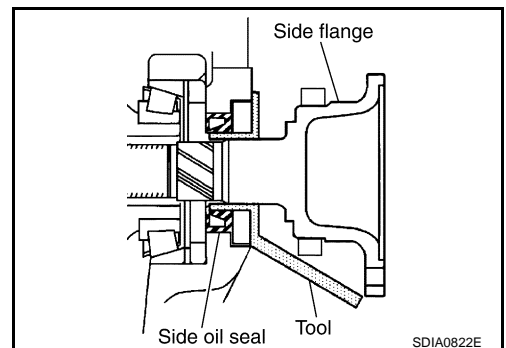

- c. Put a suitable drift on the center of side flange, then drive it until sound changes.

A  
B  
C  
DLN  
E  
F  
G  
H  
I  
J  
K  
L  
M  
N  
O  
P

# SIDE OIL SEAL

< ON-VEHICLE REPAIR >

[REAR FINAL DRIVE: R200V]

**NOTE:**

When installation is completed, driving sound of the side flange turns into a sound which seems to affect the whole final drive.

- d. Confirm that the dimension of the side flange (1) installation (Measurement A) in the figure comes into the following.

**Measurement "A" : 326 – 328 mm (12.83 – 12.91 in)**

- 4. Install drive shaft. Refer to [RAX-9, "Removal and Installation"](#).
- 5. Install rear wheel sensor. Refer to [BRC-100, "Removal and Installation"](#).
- 6. Install center muffler. Refer to [EX-5, "Removal and Installation"](#).
- 7. When oil leaks while removing, check oil level after the installation. Refer to [DLN-226, "Inspection"](#).

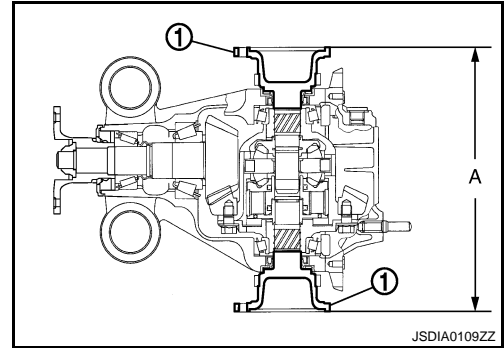

A/T

A/T : Exploded View

INFOID:000000000957436

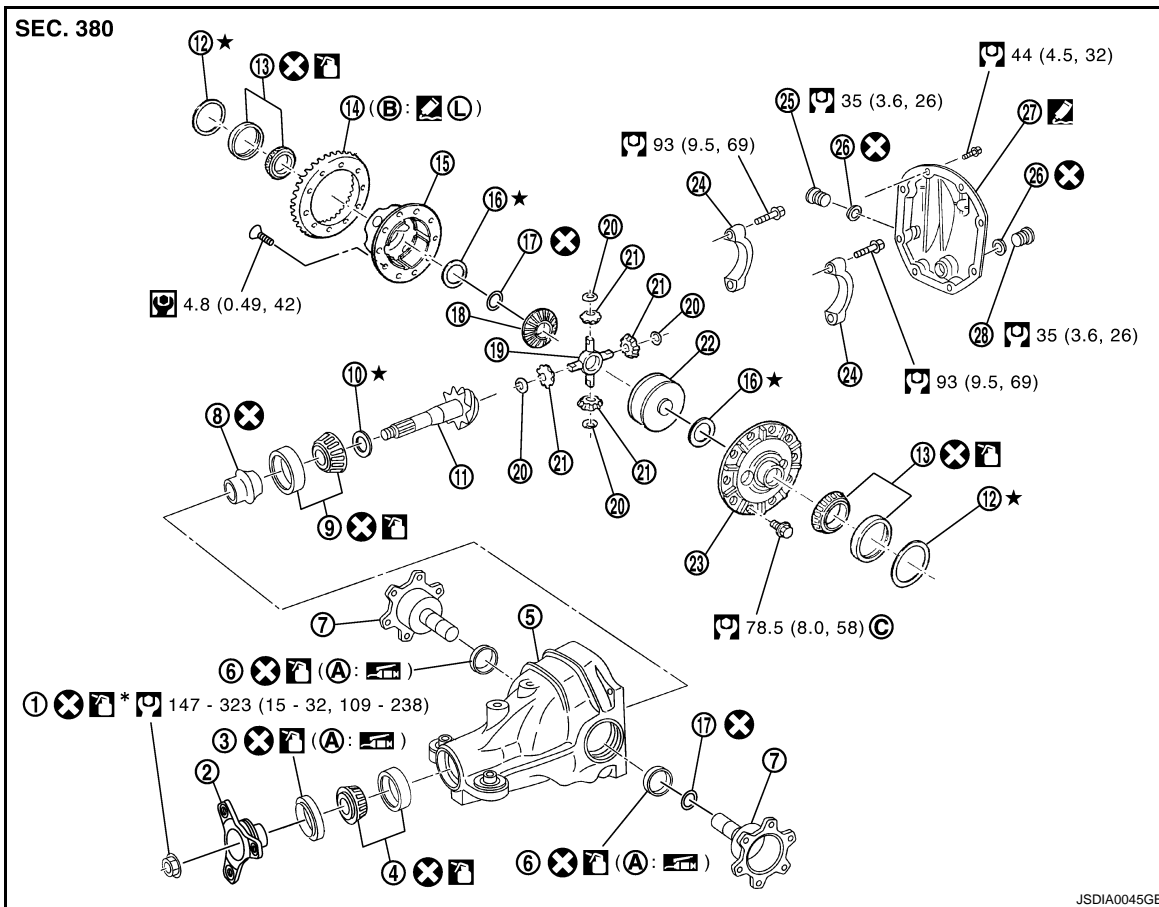

- |                                    |                               |                                   |
|------------------------------------|-------------------------------|-----------------------------------|
| 1. Drive pinion lock nut           | 2. Companion flange           | 3. Front oil seal                 |
| 4. Pinion front bearing            | 5. Gear carrier               | 6. Side oil seal                  |
| 7. Side flange                     | 8. Collapsible spacer         | 9. Pinion rear bearing            |
| 10. Pinion height adjusting washer | 11. Drive pinion              | 12. Side bearing adjusting washer |
| 13. Side bearing                   | 14. Drive gear                | 15. Differential case B           |
| 16. Side gear thrust washer        | 17. Circular clip             | 18. Side gear                     |
| 19. Pinion mate shaft              | 20. Pinion mate thrust washer | 21. Pinion mate gear              |
| 22. Viscous coupling               | 23. Differential case A       | 24. Bearing cap                   |



# SIDE OIL SEAL

< ON-VEHICLE REPAIR >

[REAR FINAL DRIVE: R200V]

25. Filler plug  
26. Gasket  
27. Rear cover  
28. Drain plug  
A: Oil seal lip  
B: Screw hole  
C: After tightening the bolts to the specified torque, tighten the bolts additionally by turning the bolts 31 to 36 degrees.

 Apply gear oil.

 Apply anti-corrosion oil.

 Apply Genuine Silicone RTV or equivalent. Refer to [GI-15. "Recommended Chemical Products and Sealants"](#).

 Apply Genuine High Strength Thread Locking Sealant or equivalent. Refer to [GI-15. "Recommended Chemical Products and Sealants"](#).

Refer to [GI-4. "Components"](#) for symbols not described on the above.

## A/T : Removal and Installation

INFOID:000000000957437

### REMOVAL

1. Remove center muffler with a power tool. Refer to [EX-5. "Removal and Installation"](#).
2. Remove rear wheel sensor. Refer to [BRC-100. "Removal and Installation"](#).
3. Remove drive shaft from final drive with a power tool. Then suspend it by wire etc. Refer to [RAX-9. "Removal and Installation"](#).
4. Install attachment (A) [SST: KV40104100 ( — )] to side flange, and then pull out the side flange with the sliding hammer (B) [SST: ST36230000 (J-25840-A)].

#### NOTE:

**Circular clip installation position: Final drive side**

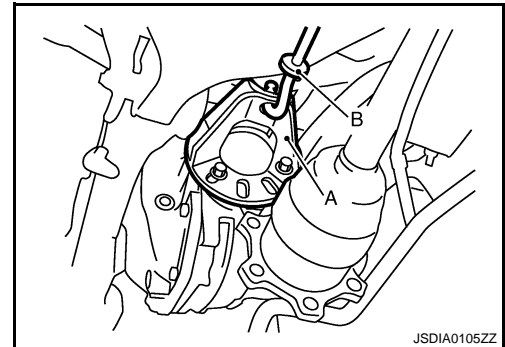

5. Remove side oil seal, using a flat-bladed screwdriver.  
**CAUTION:**  
**Never damage gear carrier.**

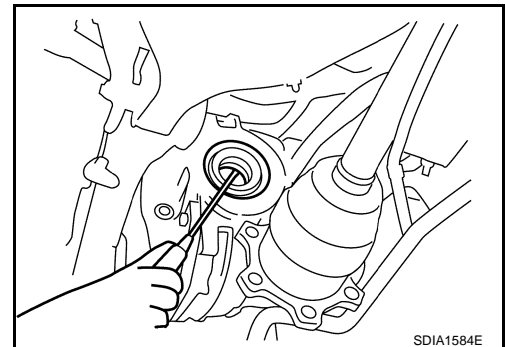

### INSTALLATION

1. Apply multi-purpose grease to side oil seal lips.

A  
B  
C  
DLN  
E  
F  
G  
H  
I  
J  
K  
L  
M  
N  
O  
P

## SIDE OIL SEAL

< ON-VEHICLE REPAIR >

[REAR FINAL DRIVE: R200V]

2. Install side oil seal until it becomes flush with the case end, using the drift [SST: KV38100200 (J-26233)].

**CAUTION:**

- Never reuse oil seal.
- When installing, never incline oil seal.

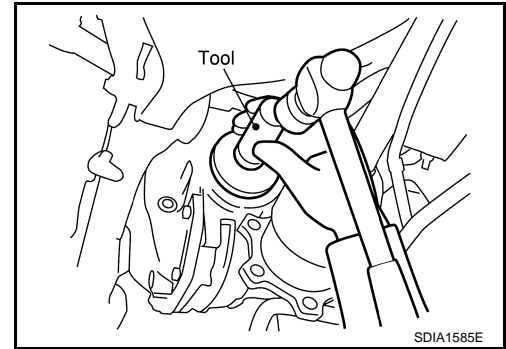

3. Install side flange with the following procedure.
  - a. Attach the protector [SST: KV38107900 (J-39352)] to side oil seal.
  - b. After the side flange is inserted and the serrated part of side gear has engaged the serrated part of flange, remove the protector.

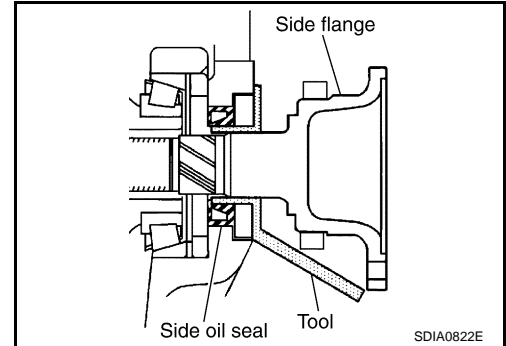

- c. Put a suitable drift on the center of side flange, then drive it until sound changes.

**NOTE:**

When installation is completed, driving sound of the side flange turns into a sound which seems to affect the whole final drive.

- d. Confirm that the dimension of the side flange (1) installation (Measurement A) in the figure comes into the following.

**Measurement "A"** : 326 – 328 mm (12.83 – 12.91 in)

4. Install drive shaft. Refer to [RAX-9. "Removal and Installation"](#).
5. Install rear wheel sensor. Refer to [BRC-100. "Removal and Installation"](#).
6. Install center muffler. Refer to [EX-5. "Removal and Installation"](#).
7. When oil leaks while removing, check oil level after the installation. Refer to [DLN-226. "Inspection"](#).

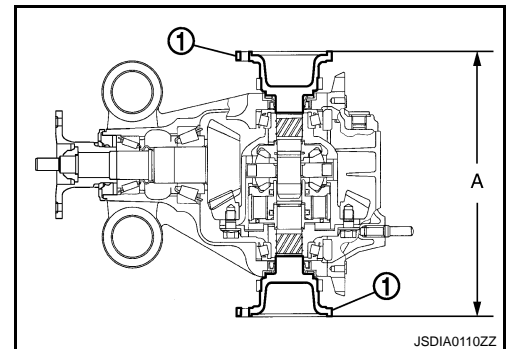

# REAR FINAL DRIVE ASSEMBLY

< REMOVAL AND INSTALLATION >

[REAR FINAL DRIVE: R200V]

## REMOVAL AND INSTALLATION

### REAR FINAL DRIVE ASSEMBLY

M/T

M/T : Exploded View

INFOID:000000000957438

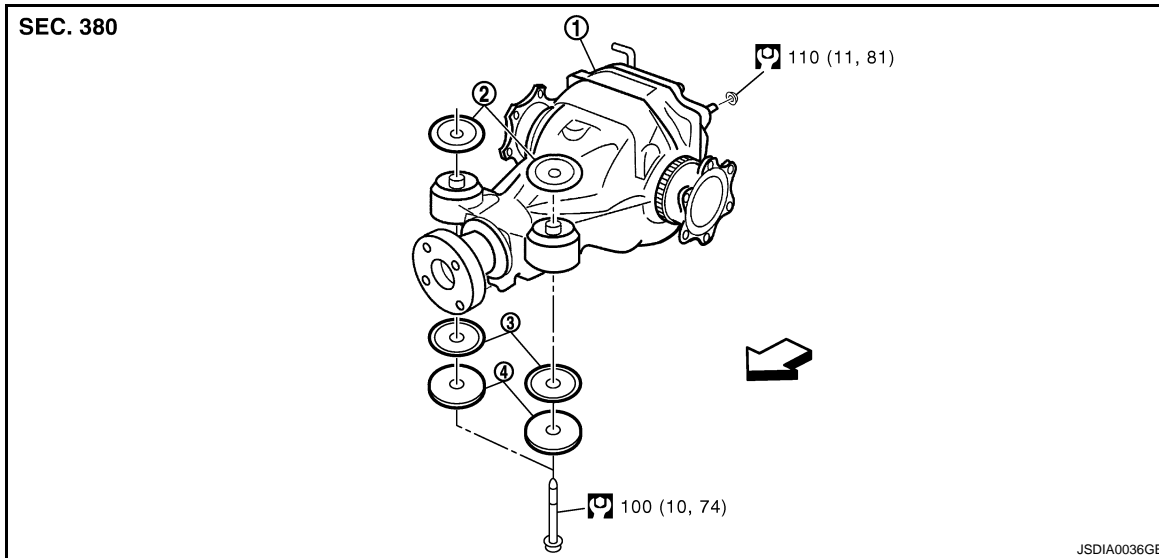

1. Rear final drive assembly
2. Upper stopper
3. Lower stopper
4. Washer

↶: Vehicle front

Refer to [GI-4. "Components"](#) for symbols in the figure.

### M/T : Removal and Installation

INFOID:000000000957439

#### REMOVAL

1. Remove center muffler with a power tool. Refer to [EX-5. "Removal and Installation"](#).
2. Remove rear stabilizer bar with a power tool. Refer to [RSU-15. "Removal and Installation"](#).
3. Remove propeller shaft from the final drive. Refer to [DLN-86. "Removal and Installation"](#).
4. Remove drive shaft from final drive with a power tool. Then suspend it by wire etc. Refer to [RAX-9. "Exploded View"](#).
5. Remove breather hose from the final drive.
6. Remove rear wheel sensor. Refer to [BRC-100. "Removal and Installation"](#).

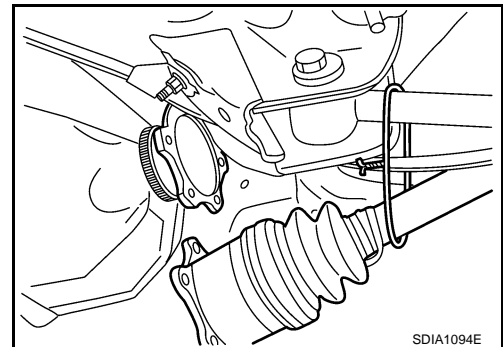

# REAR FINAL DRIVE ASSEMBLY

## < REMOVAL AND INSTALLATION >

[REAR FINAL DRIVE: R200V]

7. Set a suitable jack to rear final drive assembly.

**CAUTION:**

Never place a suitable jack on the rear cover (aluminum case).

8. Remove the mounting bolts and nuts connecting to the suspension member, and remove rear final drive assembly with a power tool.

**CAUTION:**

Secure rear final drive assembly to a suitable jack while removing it.

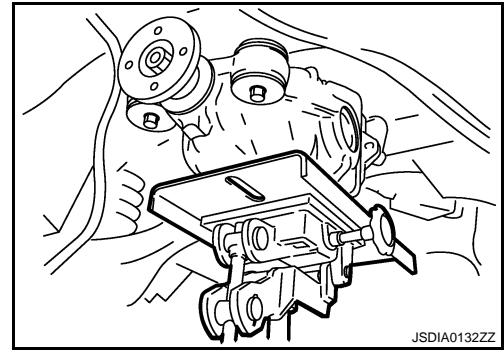

## INSTALLATION

Note the following, and installation is in the reverse order of removal.

- When installing breather hoses (1), refer to the figure.

↔: Vehicle front

**CAUTION:**

Make sure there are no pinched or restricted areas on the breather hose caused by bending or winding when installing it.

- For installation, the vehicle side end shall be inserted to suspension member (2). Install metal connector (3) side of this hose to rear cover by inserting it with aiming painted marking to the front of vehicle.

- When oil leaks while removing final drive assembly, check oil level after the installation. Refer to [DLN-226, "Inspection"](#).

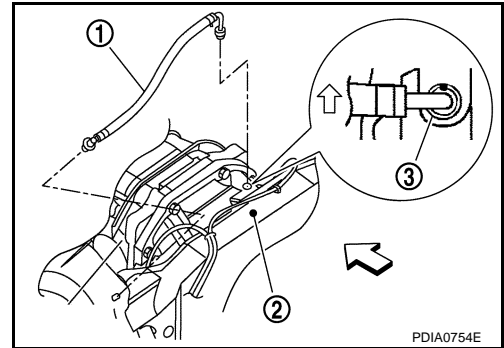

A/T

A/T : Exploded View

INFOID:000000000957440

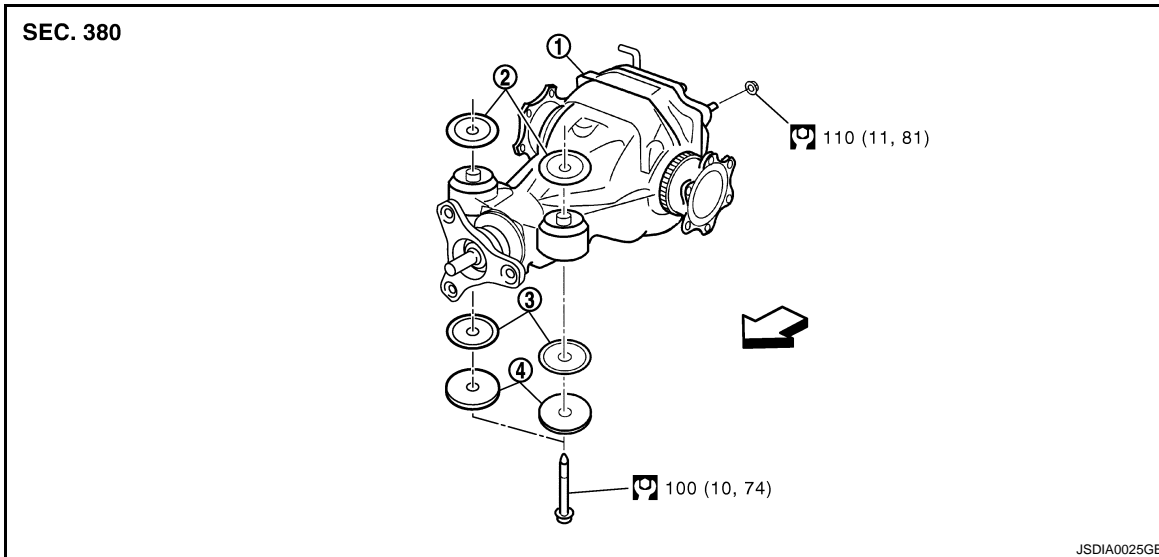

- |                              |                  |                  |
|------------------------------|------------------|------------------|
| 1. Rear final drive assembly | 2. Upper stopper | 3. Lower stopper |
| 4. Washer                    |                  |                  |

↔: Vehicle front

Refer to [GI-4, "Components"](#) for symbols in the figure.

A/T : Removal and Installation

INFOID:000000000957441

# REAR FINAL DRIVE ASSEMBLY

< REMOVAL AND INSTALLATION >

[REAR FINAL DRIVE: R200V]

## REMOVAL

1. Remove center muffler with a power tool. Refer to [EX-5, "Removal and Installation"](#).
2. Remove rear stabilizer bar with a power tool. Refer to [RSU-15, "Removal and Installation"](#).
3. Remove propeller shaft from the final drive. Refer to [DLN-86, "Removal and Installation"](#).
4. Remove drive shaft from final drive with a power tool. Then suspend it by wire etc. Refer to [RAX-9, "Exploded View"](#).
5. Remove breather hose from the final drive.
6. Remove rear wheel sensor. Refer to [BRC-100, "Removal and Installation"](#).

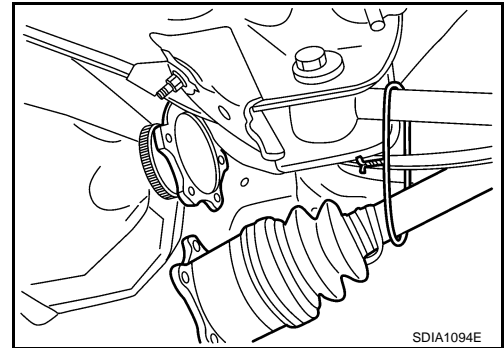

7. Set a suitable jack to rear final drive assembly.  
**CAUTION:**  
**Never place a suitable jack on the rear cover (aluminum case).**
8. Remove the mounting bolts and nuts connecting to the suspension member, and remove rear final drive assembly with a power tool.  
**CAUTION:**  
**Secure rear final drive assembly to a suitable jack while removing it.**

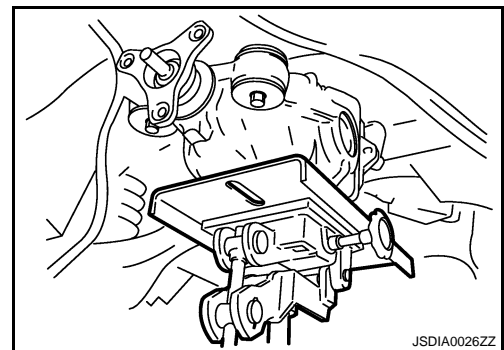

## INSTALLATION

Note the following, and installation is in the reverse order of removal.

- When installing breather hoses (1), refer to the figure.

←: Vehicle front

**CAUTION:**  
**Make sure there are no pinched or restricted areas on the breather hose caused by bending or winding when installing it.**

- For installation, the vehicle side end shall be inserted to suspension member (2). Install metal connector (3) side of this hose to rear cover by inserting it with aiming painted marking to the front of vehicle.
- When oil leaks while removing final drive assembly, check oil level after the installation. Refer to [DLN-226, "Inspection"](#).

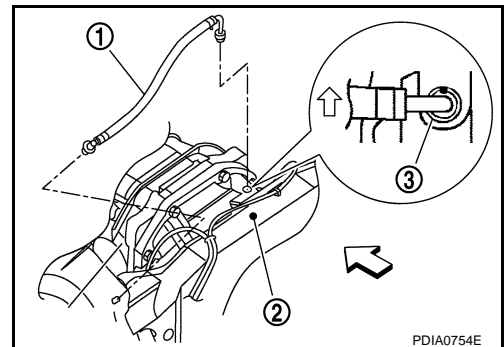

# DIFFERENTIAL ASSEMBLY

< DISASSEMBLY AND ASSEMBLY >

[REAR FINAL DRIVE: R200V]

## DISASSEMBLY AND ASSEMBLY

### DIFFERENTIAL ASSEMBLY

M/T

M/T : Exploded View

INFOID:000000000957442

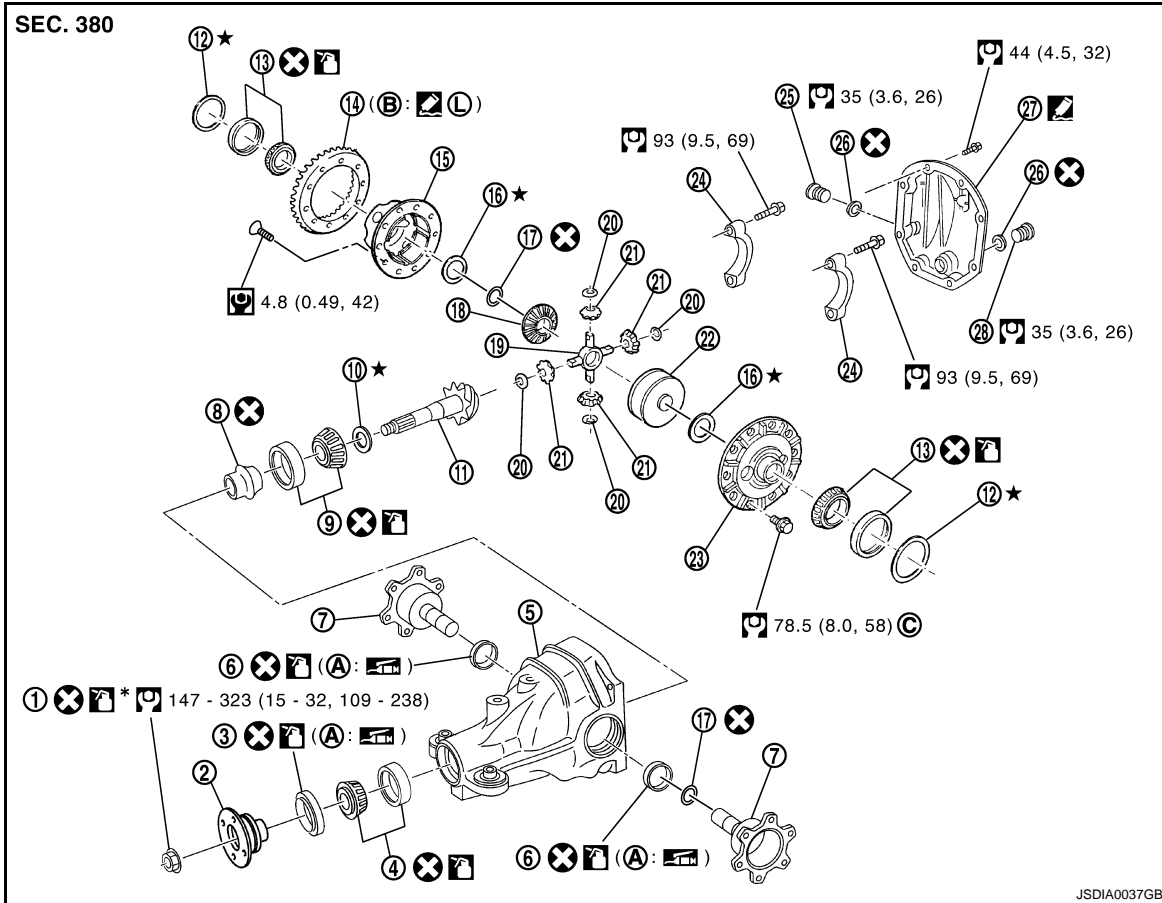

- |                                    |                               |                                   |
|------------------------------------|-------------------------------|-----------------------------------|
| 1. Drive pinion lock nut           | 2. Companion flange           | 3. Front oil seal                 |
| 4. Pinion front bearing            | 5. Gear carrier               | 6. Side oil seal                  |
| 7. Side flange                     | 8. Collapsible spacer         | 9. Pinion rear bearing            |
| 10. Pinion height adjusting washer | 11. Drive pinion              | 12. Side bearing adjusting washer |
| 13. Side bearing                   | 14. Drive gear                | 15. Differential case B           |
| 16. Side gear thrust washer        | 17. Circular clip             | 18. Side gear                     |
| 19. Pinion mate shaft              | 20. Pinion mate thrust washer | 21. Pinion mate gear              |
| 22. Viscous coupling               | 23. Differential case A       | 24. Bearing cap                   |
| 25. Filler plug                    | 26. Gasket                    | 27. Rear cover                    |
| 28. Drain plug                     |                               |                                   |

A: Oil seal lip

B: Screw hole

C: After tightening the bolts to the specified torque, tighten the bolts additionally by turning the bolts 31 to 36 degrees.



Apply gear oil.



Apply anti-corrosion oil.



Apply Genuine Silicone RTV or equivalent. Refer to [GI-15, "Recommended Chemical Products and Sealants"](#).

# DIFFERENTIAL ASSEMBLY

< DISASSEMBLY AND ASSEMBLY >

[REAR FINAL DRIVE: R200V]

 Apply Genuine High Strength Thread Locking Sealant or equivalent. Refer to [GI-15. "Recommended Chemical Products and Sealants"](#).

Refer to [GI-4. "Components"](#) for symbols not described on the above.

## M/T : Disassembly

INFOID:000000000957443

1. Drain gear oil, if necessary.
2. Remove side flange.
3. Remove rear cover mounting bolts.
4. Remove rear cover to insert the seal cutter (A) [SST: KV10111100 (J-37228)] between gear carrier and rear cover.

### CAUTION:

- Never damage the mating surface.
- Never insert flat-bladed screwdriver, this way damage the mating surface.

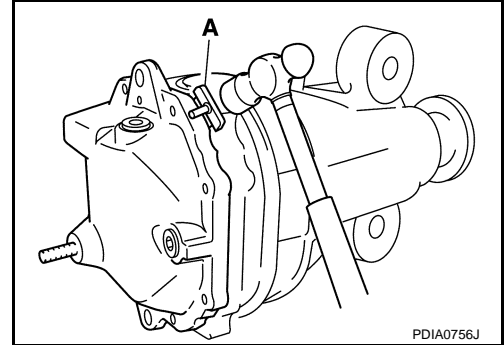

5. Using two 45 mm (1.77 in) spacers, mount carrier on the attachment (A) [SST: KV38100800 (J-25604-01)].

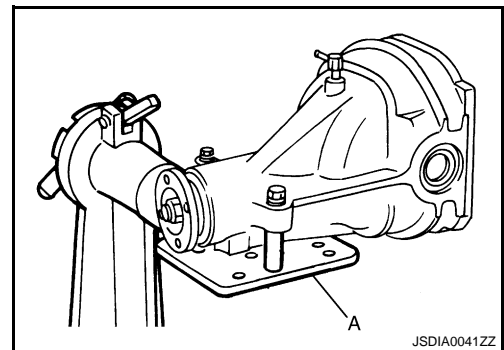

6. For proper reinstallation, paint matching marks on one side of the bearing cap.

### CAUTION:

- For matching marks, use paint. Never damage bearing caps and gear carrier.
- Bearing caps are line-board during manufacture. The matching marks are used to reinstall them in their original positions.

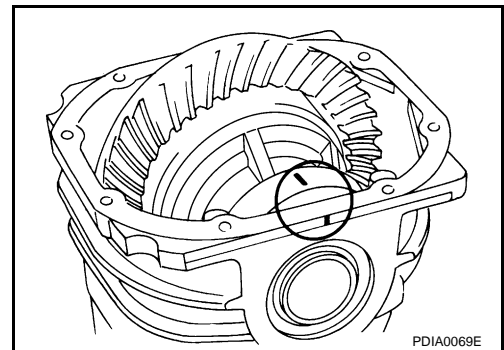

7. Remove bearing caps.

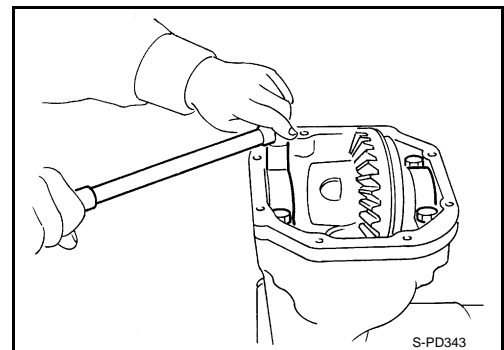

A

B

C

DLN

E

F

G

H

I

J

K

L

M

N

O

P

# DIFFERENTIAL ASSEMBLY

< DISASSEMBLY AND ASSEMBLY >

[REAR FINAL DRIVE: R200V]

8. Lift differential case assembly out with a suitable tool.

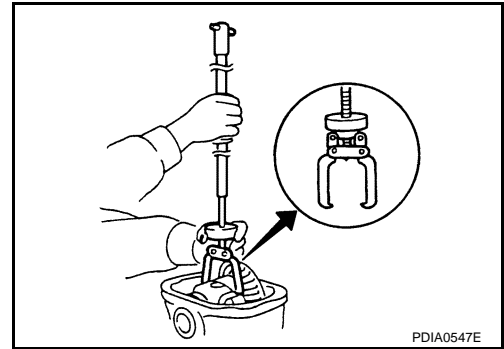

- Keep side bearing outer races together with inner race. Do not mix them up.  
Also, keep side bearing adjusting washers together with bearings.

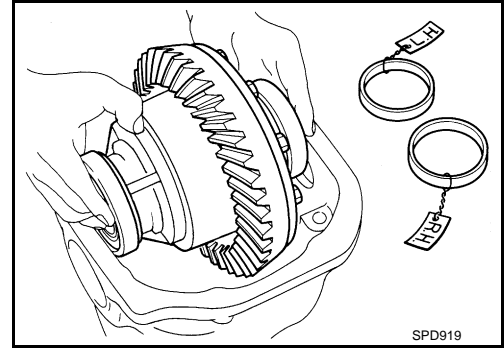

9. Remove side bearing inner race.  
To prevent damage to bearing, engage puller jaws in groove (←).

A: Puller [SST: ST33051001 (J-22888-20)]

B: Base [SST: ST33061000 (J-8107-2)]

**CAUTION:**

- To prevent damage to the side bearing and drive gear, place copper plates between these parts and vise.
- It is not necessary to remove side bearing inner race except it is replaced.

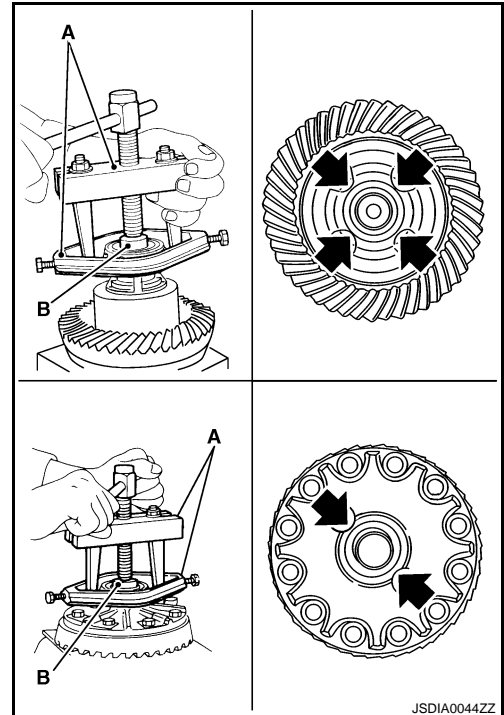

10. For proper reinstallation, paint matching marks on one differential case assembly.

**CAUTION:**

For matching marks, use paint. Never damage differential case and drive gear.

11. Remove drive gear mounting bolts.

12. Tap drive gear off differential case assembly with a soft hammer.

**CAUTION:**

Tap evenly all around to keep drive gear from bending.

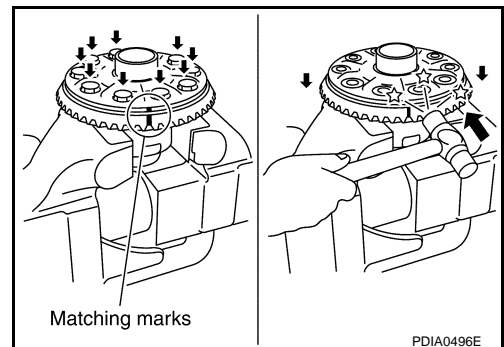



# DIFFERENTIAL ASSEMBLY

< DISASSEMBLY AND ASSEMBLY >

[REAR FINAL DRIVE: R200V]

13. Put matching marks with paint.

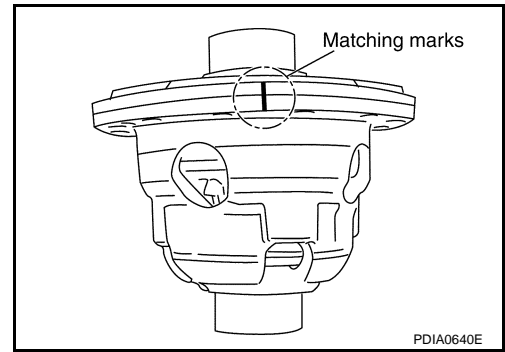

A  
B  
C

14. Loosen screws on differential cases A and B.

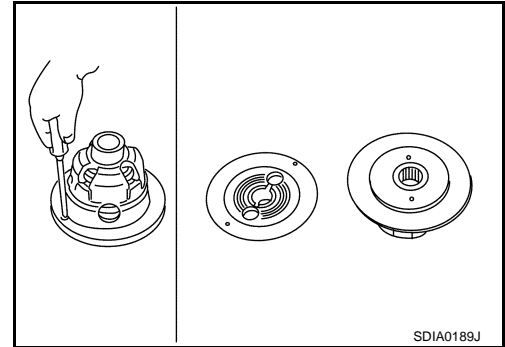

DLN

E  
F  
G

15. Separate differential case A and B, then remove viscous coupling, pinion mate gear, pinion mate thrust washer, side gear and side gear thrust washer from differential cases.

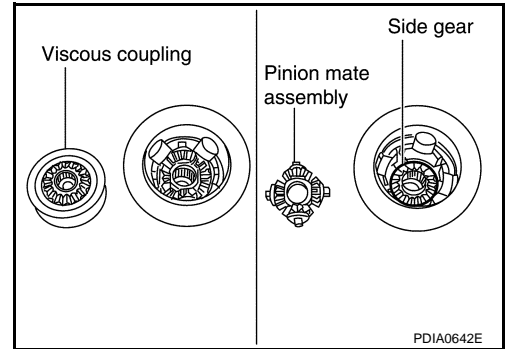

H  
I  
J

## M/T : Assembly

INFOID:000000000957444

1. Install side gear thrust washer with the same thickness as the ones installed prior to disassembly or reinstall the old ones on the side gear.

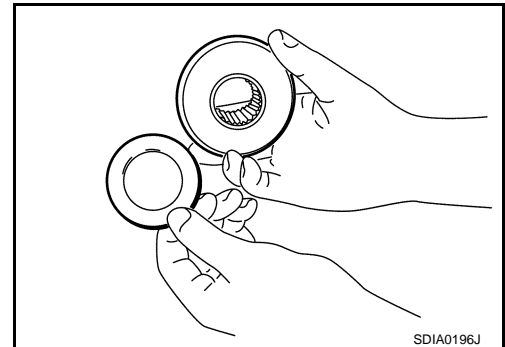

L  
M  
N  
O  
P

# DIFFERENTIAL ASSEMBLY

< DISASSEMBLY AND ASSEMBLY >

[REAR FINAL DRIVE: R200V]

2. Install side gear and thrust washer into differential case B.  
**CAUTION:**  
**Make sure that the circular clip is installed to side gear.**
3. Install pinion mate assembly (pinion mate shaft, pinion mate gears and pinion mate thrust washers) into differential case B.  
**CAUTION:**  
**The pinion mate shaft groove side shall be installed to side gear.**

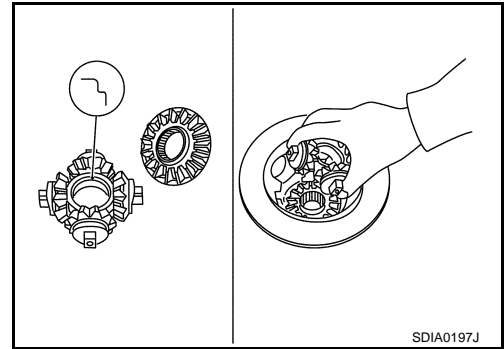

4. Install viscous coupling into differential case B.
5. Install side gear thrust washer with the same thickness as the ones installed prior to disassembly or reinstall the old ones on the viscous coupling.

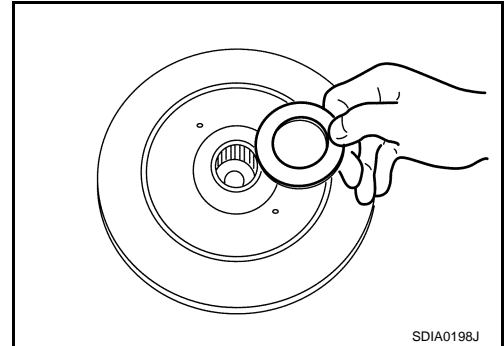

6. Align the matching marks and install differential case A into differential case B.

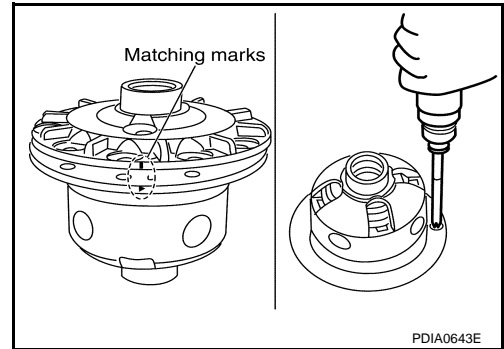

7. Measure side gear end play. If necessary, select the appropriate side gear thrust washer.
  - a. Place differential assembly so that right side gear is on the upper side.
  - b. Measure the clearance between right side gear back and differential case using feeler gauge, while rotating right side gear with a suitable tool attached to splines.

## Standard

**Side gear back clearance** : Refer to [DLN-287, "Differential Side Gear Clearance"](#).

## CAUTION:

- Never place feeler gauge at groove side of differential case.
  - To prevent side gear from tilting, insert feeler gauges with the same thickness from both sides.
- c. If the back clearance is outside the specification, use a thicker/thinner side gear thrust washer to adjust.

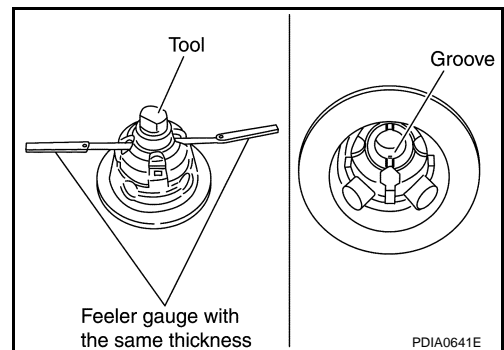

**When the back clearance is large:** Use a thicker thrust washer.

**When the back clearance is small:** Use a thinner thrust washer.

## CAUTION:

# DIFFERENTIAL ASSEMBLY

< DISASSEMBLY AND ASSEMBLY >

[REAR FINAL DRIVE: R200V]

- Adjust the clearance with the left side gear thrust washer only.
  - Only one side gear thrust washer can be selected.
8. Align the matching mark of differential case with the mark of drive gear, then place drive gear.

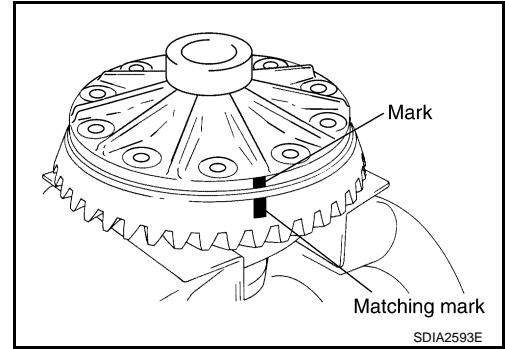

9. Apply thread locking sealant into the thread hole of drive gear.
- Use Genuine High Strength Thread Locking Sealant or equivalent. Refer to [GI-15, "Recommended Chemical Products and Sealants"](#).
- CAUTION:**  
Drive gear back and threaded holes shall be cleaned and degreased sufficiently.

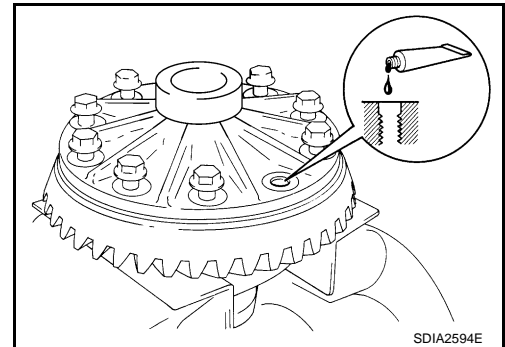

10. Install drive gear on the mounting bolts.
- CAUTION:**
- Tighten bolts in a crisscross fashion.
  - After tightening the bolts to the specified torque, tighten the bolts additionally by turning the bolts 31 to 36 degrees.

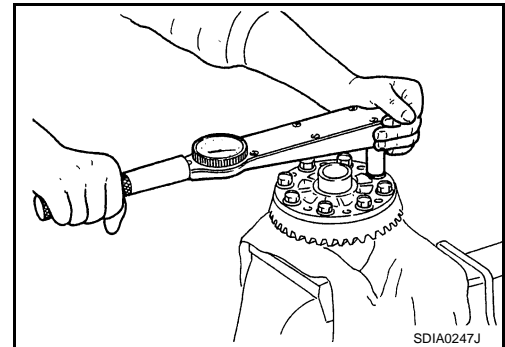

11. Press side bearing inner races to differential case, using the drift (A) [SST: KV38100300 (J-25523)] and the base (B) [SST: ST33061000 (J-8107-2)].
- CAUTION:**  
Never reuse side bearing inner race.

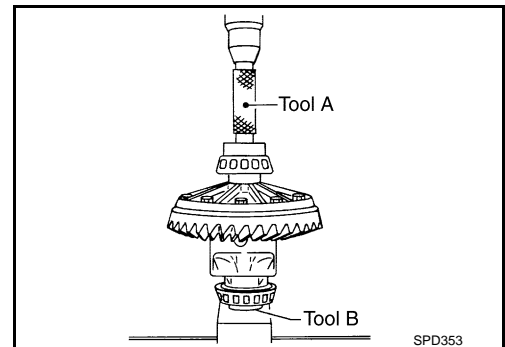

A  
B  
C  
DLN  
E  
F  
G  
H  
I  
J  
K  
L  
M  
N  
O  
P

## DIFFERENTIAL ASSEMBLY

### < DISASSEMBLY AND ASSEMBLY >

[REAR FINAL DRIVE: R200V]

12. Install differential case assembly with side bearing outer races into gear carrier.
13. Measure side bearing preload. If necessary, select the appropriate side bearing adjusting washers. Refer to [DLN-253, "M/T : Adjustment"](#).

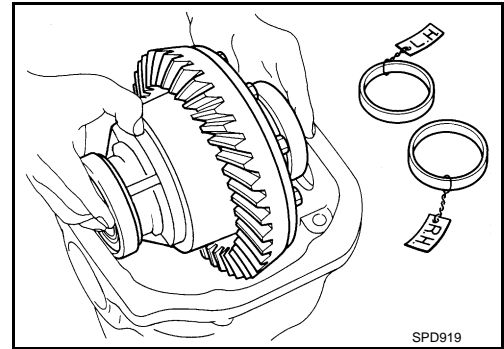

14. Insert selected left and right side bearing adjusting washers in place between side bearings and gear carrier.

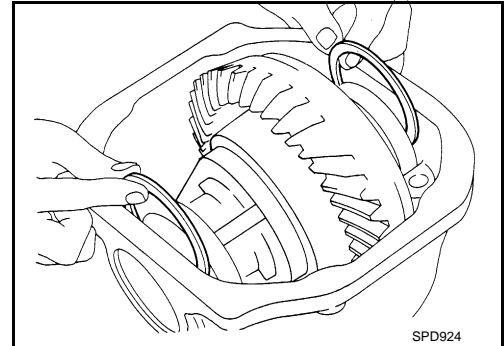

15. Align matching marks on bearing cap with that on gear carrier.
16. Install bearing caps and tighten bearing cap mounting bolts.

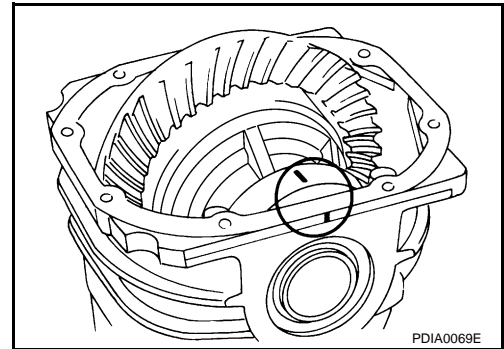

17. Using the drift [SST: KV38100200 (J-26233)], drive side oil seals until it becomes flush with the case end.

**CAUTION:**

- Never reuse oil seal.
- When installing, never incline oil seal.
- Apply multi-purpose grease onto oil seal lips, and gear oil onto the circumference of oil seal.

18. Check and adjust drive gear runout, tooth contact, drive gear to drive pinion backlash, and total preload torque. Refer to [DLN-253, "M/T : Adjustment"](#).

Recheck above items. Readjust the above description, if necessary.

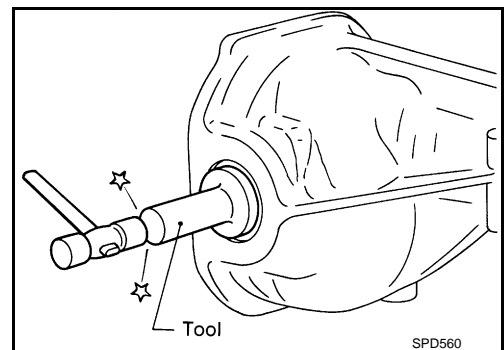

19. Apply sealant to mating surface of rear cover.
  - Use Genuine Silicone RTV or equivalent. Refer to [GI-15, "Recommended Chemical Products and Sealants"](#).

**CAUTION:**

Remove old sealant adhering to mounting surfaces. Also remove any moisture, oil, or foreign material adhering to application and mounting surfaces.

20. Install rear cover on gear carrier and tighten mounting bolts.

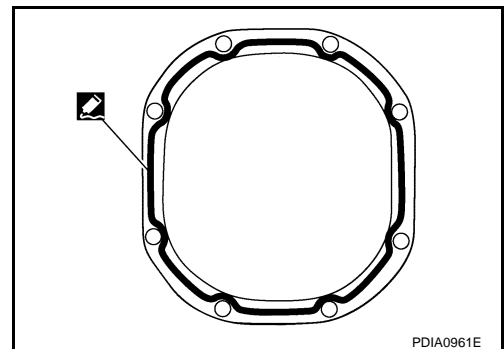

# DIFFERENTIAL ASSEMBLY

< DISASSEMBLY AND ASSEMBLY >

[REAR FINAL DRIVE: R200V]

21. Install side flange with the following procedure.

- a. Attach the protector [SST: KV38107900 (J-39352)] to side oil seal.
- b. After the side flange is inserted and the serrated part of side gear has engaged the serrated part of flange, remove the protector.

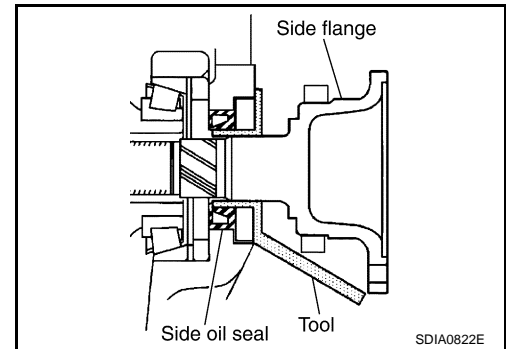

c. Put a suitable drift on the center of side flange, then drive it until sound changes.

**NOTE:**

When installation is completed, driving sound of the side flange turns into a sound which seems to affect the whole final drive.

- d. Confirm that the dimension of the side flange (1) installation (Measurement A) in the figure comes into the following.

**Measurement "A"** : 326 – 328 mm (12.83 – 12.91 in)

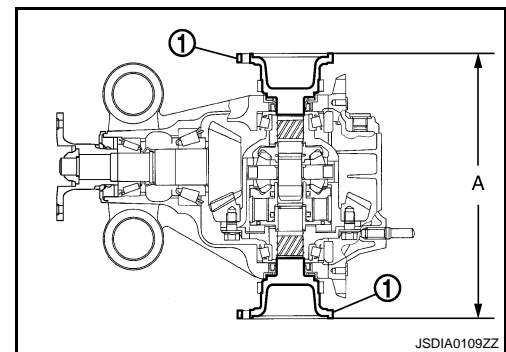

## M/T : Adjustment

### TOTAL PRELOAD TORQUE

• Before inspection and adjustment, drain gear oil.

1. Secure final drive assembly onto an attachment [SST: KV38100800 (J-25604-01)].
2. Remove side flanges.
3. Rotate drive pinion back and forth 2 to 3 times to check for unusual noise and rotation malfunction.
4. Rotate drive pinion at least 20 times to check for smooth operation of the bearing.
5. Measure total preload with the preload gauge (A) [SST: ST3127S000 (J-25765-A)].

**Standard**

**Total preload torque** : Refer to [DLN-287, "Pre-load Torque"](#).

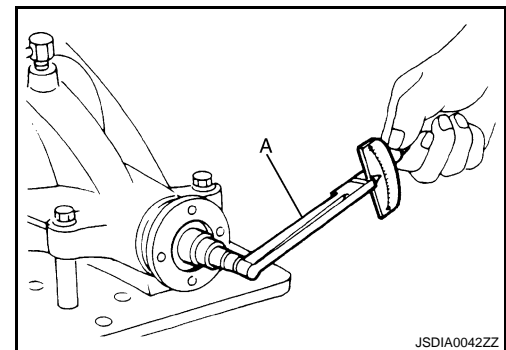

**NOTE:**

**Total preload torque = Pinion bearing preload torque + Side bearing preload torque**

- If measured value is out of the specification, disassemble it to check and adjust each part. Adjust the pinion bearing preload and side bearing preload. Adjust the pinion bearing preload first, then adjust the side bearing preload.

**When the preload torque is large**

**On pinion bearings:** Replace the collapsible spacer.

**On side bearings:** Use thinner side bearing adjusting washers by the same amount to each side.

# DIFFERENTIAL ASSEMBLY

< DISASSEMBLY AND ASSEMBLY >

[REAR FINAL DRIVE: R200V]

## When the preload is small

**On pinion bearings:** Tighten the drive pinion lock nut.

**On side bearings:** Use thicker side bearing adjusting washers by the same amount to each side.

## SIDE BEARING PRELOAD

- Before inspection and adjustment, drain gear oil.
1. Remove rear cover. Refer to [DLN-247, "M/T : Disassembly"](#).
  2. Make sure all parts are clean. Also, make sure the bearings are well lubricated with gear oil.
  3. Place the differential case, with side bearings and bearing races installed, into gear carrier.
  4. Insert left and right original side bearing adjusting washers in place between side bearings and gear carrier.
  5. Install bearing caps in their correct locations and tighten bearing cap mounting bolts.
  6. Turn the carrier several times to seat the bearings.
  7. Measure the turning torque of the carrier at the drive gear mounting bolts with a spring gauge [SST: — (J-8129)].

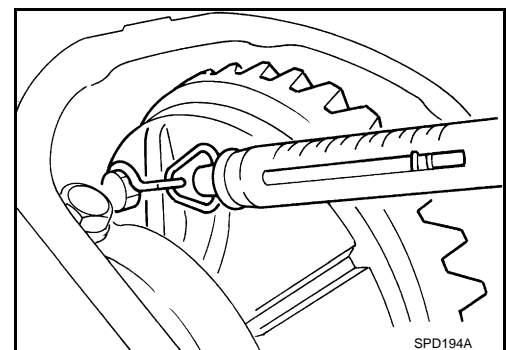
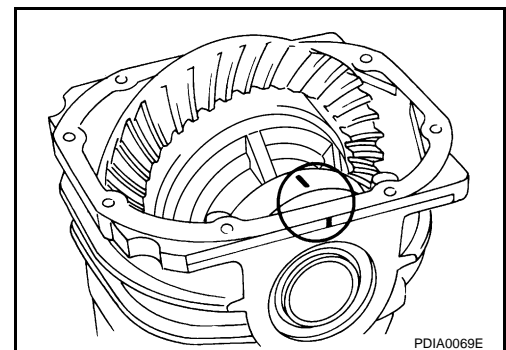
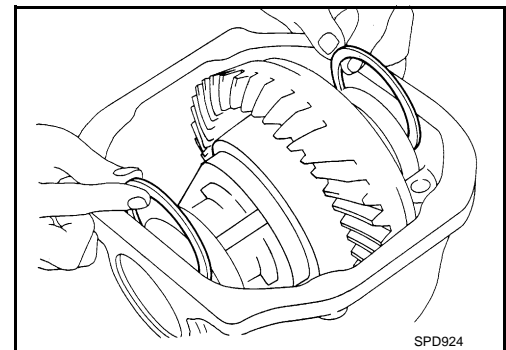
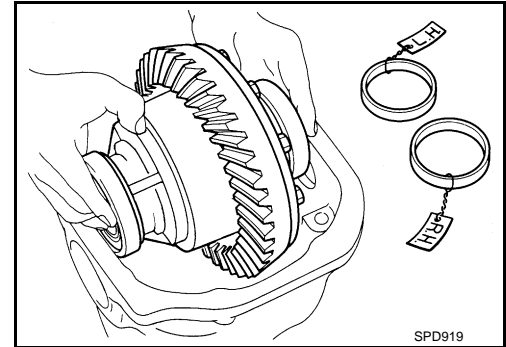

## Specification

**: 34.2 – 39.2 N (3.5 – 4.0 kg, 7.7 – 8.8 lb) of pulling force at the drive gear bolt**

# DIFFERENTIAL ASSEMBLY

< DISASSEMBLY AND ASSEMBLY >

[REAR FINAL DRIVE: R200V]

8. If the turning torque is outside the specification, use a thicker/thinner side bearing adjusting washer to adjust.

**If the turning torque is less than the specified range:**

**Use a thicker thrust washer.**

**If the turning torque is greater than the specification:**

**Use a thinner thrust washer.**

**CAUTION:**

**Select a side bearing adjusting washer for right and left individually.**

9. Record the total amount of washer thickness required for the correct carrier side bearing preload.

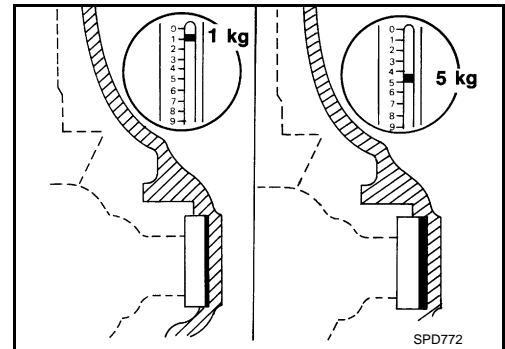

## DRIVE GEAR RUNOUT

1. Remove rear cover. Refer to [DLN-247, "M/T : Disassembly"](#).
2. Fit a dial indicator to the drive gear back face.
3. Rotate the drive gear to measure runout.

**Limit**

**Drive gear runout : Refer to [DLN-287, "Drive Gear Runout"](#).**

- If the runout is outside of the repair limit, check drive gear assembly condition; foreign material may be caught between drive gear and differential case, or differential case or drive gear may be deformed, etc.

**CAUTION:**

**Replace drive gear and drive pinion gear as a set.**

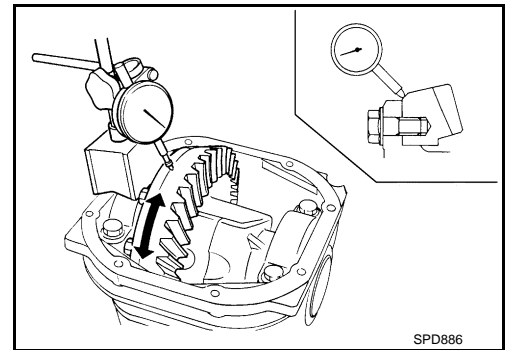

## TOOTH CONTACT

- Before inspection and adjustment, drain gear oil.
1. Remove rear cover. Refer to [DLN-247, "M/T : Disassembly"](#).
  2. Apply red lead to drive gear.

**CAUTION:**

**Apply red lead to both the faces of 3 to 4 gears at 4 locations evenly spaced on drive gear.**

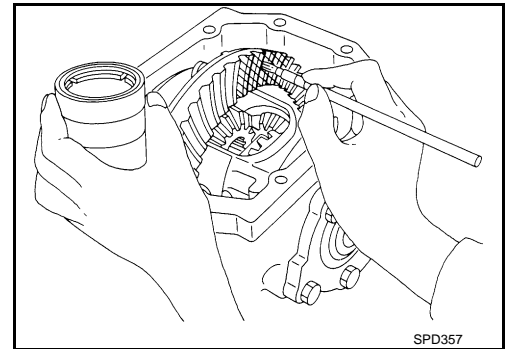

3. Rotate drive gear back and forth several times, check drive pinion gear to drive gear tooth contact.

**CAUTION:**

**Check tooth contact on drive side and reverse side.**

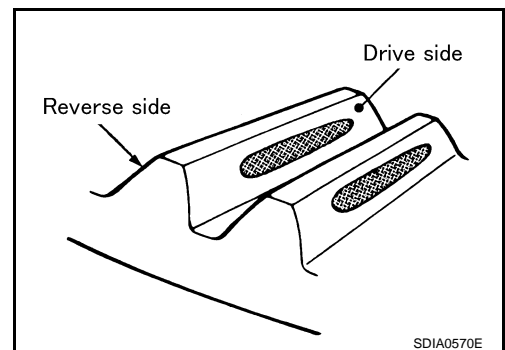

















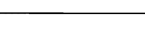
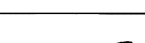

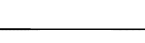
A  
B  
C  
DLN  
E  
F  
G  
H  
I  
J  
K  
L  
M  
N  
O  
P

# DIFFERENTIAL ASSEMBLY

< DISASSEMBLY AND ASSEMBLY >

[REAR FINAL DRIVE: R200V]

Tooth contact condition		Pinion height adjusting washer selection valve [ mm (in) ]	Adjustment (Yes/No)	Possible cause	
Drive side	Back side				
Heel side 	Toe side 	↑ Thicker	Yes	Occurrence of noise and scoring sound in all speed ranges.	
					+0.09 (+0.0035)
				+0.06 (+0.0024)	
		↓ Thinner	No	-	
					+0.03 (+0.0012)
					0
		↓ Thinner	Yes	Occurrence of noise at constant speed and decreasing speed.	
					-0.03 (-0.0012)
		-0.06 (-0.0024)	Yes	Occurrence of noise and scoring sound in all speed ranges.	
		-0.09 (-0.0035)			

SDIA0207E

4. If tooth contact is improperly adjusted, follow the procedure below to adjust the pinion height (dimension X).

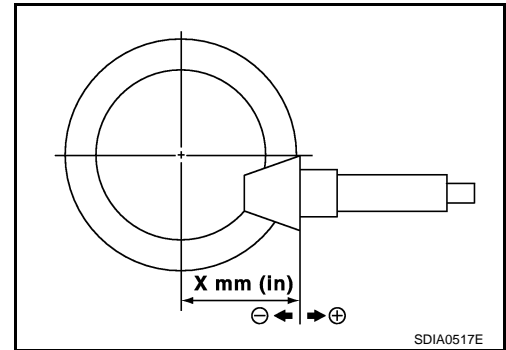

- If the tooth contact is near the face (face contact), or near the heel (heel contact), thicken pinion height adjusting washers to move drive pinion closer to drive gear.

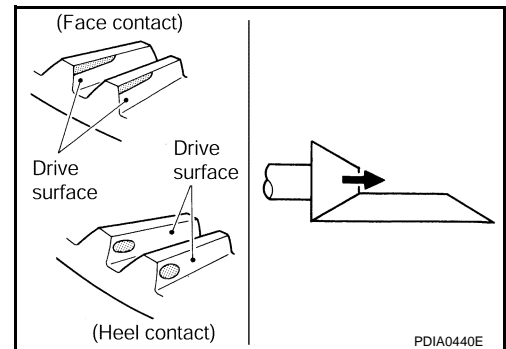



# DIFFERENTIAL ASSEMBLY

< DISASSEMBLY AND ASSEMBLY >

[REAR FINAL DRIVE: R200V]

- If the tooth contact is near the flank (flank contact), or near the toe (toe contact), thin pinion height adjusting washers to move drive pinion farther from drive gear.

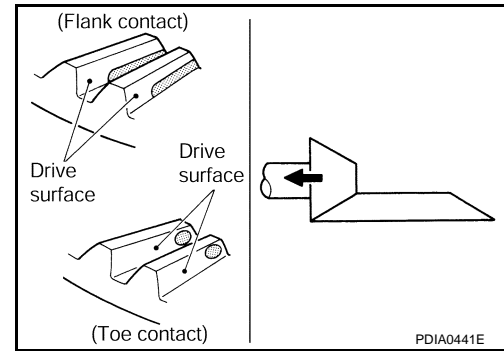

## BACKLASH

- Before inspection and adjustment, drain gear oil.
1. Remove rear cover. Refer to [DLN-247. "M/T : Disassembly"](#).
  2. Fit a dial indicator to the drive gear face to measure the backlash.

**Standard Backlash**

**: Refer to [DLN-287. "Backlash"](#).**

- If the backlash is outside of the specified value, change the thickness of side bearing adjusting washer.

**When the backlash is large:**

**Make drive gear back side adjusting washer thicker, and drive gear tooth side adjusting washer thinner by the same amount.**

**When the backlash is small:**

**Make drive gear back side adjusting washer thinner, and drive gear tooth side adjusting washer thicker by the same amount.**

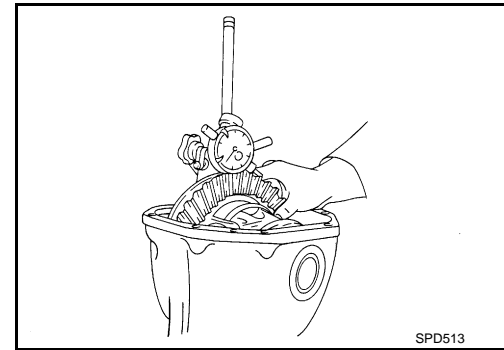

### CAUTION:

**Never change the total amount of washers as it will change the bearing preload.**

## M/T : Inspection After Disassembly

INFOID:0000000000957446

Clean up the disassembled parts. Then, inspect if the parts are worn or damaged. If so, follow the measures below.

Content	Conditions and Measures
Hypoid gear	<ul style="list-style-type: none"> <li>• If the gear teeth do not mesh or line-up correctly, determine the cause and adjust or replace as necessary.</li> <li>• If the gears are worn, cracked, damaged, pitted or chipped (by friction) noticeably, replace with new drive gear and drive pinion as a set.</li> </ul>
Bearing	<ul style="list-style-type: none"> <li>• If any chipped (by friction), pitted, worn, rusted or scratched mark, or unusual noise from the bearing is observed, replace as a bearing assembly (as a new set).</li> </ul>
Side gear and Pinion mate gear	<ul style="list-style-type: none"> <li>• If any cracks or damage on the surface of the tooth is found, replace.</li> <li>• If any worn or chipped mark on the contact sides of the thrust washer is found, replace.</li> </ul>
Side gear thrust washer and pinion mate thrust washer	<ul style="list-style-type: none"> <li>• If it is chipped (by friction), damaged, or unusually worn, replace.</li> </ul>
Oil seal	<ul style="list-style-type: none"> <li>• Whenever disassembled, replace.</li> <li>• If wear, deterioration of adherence (sealing force lips), or damage is detected on the lips, replace them.</li> </ul>
Differential case	<ul style="list-style-type: none"> <li>• If any wear or crack on the contact sides of the differential case is found, replace.</li> </ul>
Companion flange	<ul style="list-style-type: none"> <li>• If any chipped mark (about 0.1 mm, 0.004 in) or other damage on the contact sides of the lips of the companion flange is found, replace.</li> </ul>

A  
B  
C  
DLN

E  
F  
G  
H  
I  
J  
K

L  
M  
N  
O  
P

# DIFFERENTIAL ASSEMBLY

< DISASSEMBLY AND ASSEMBLY >

[REAR FINAL DRIVE: R200V]

A/T

A/T : Exploded View

INFOID:000000000957447

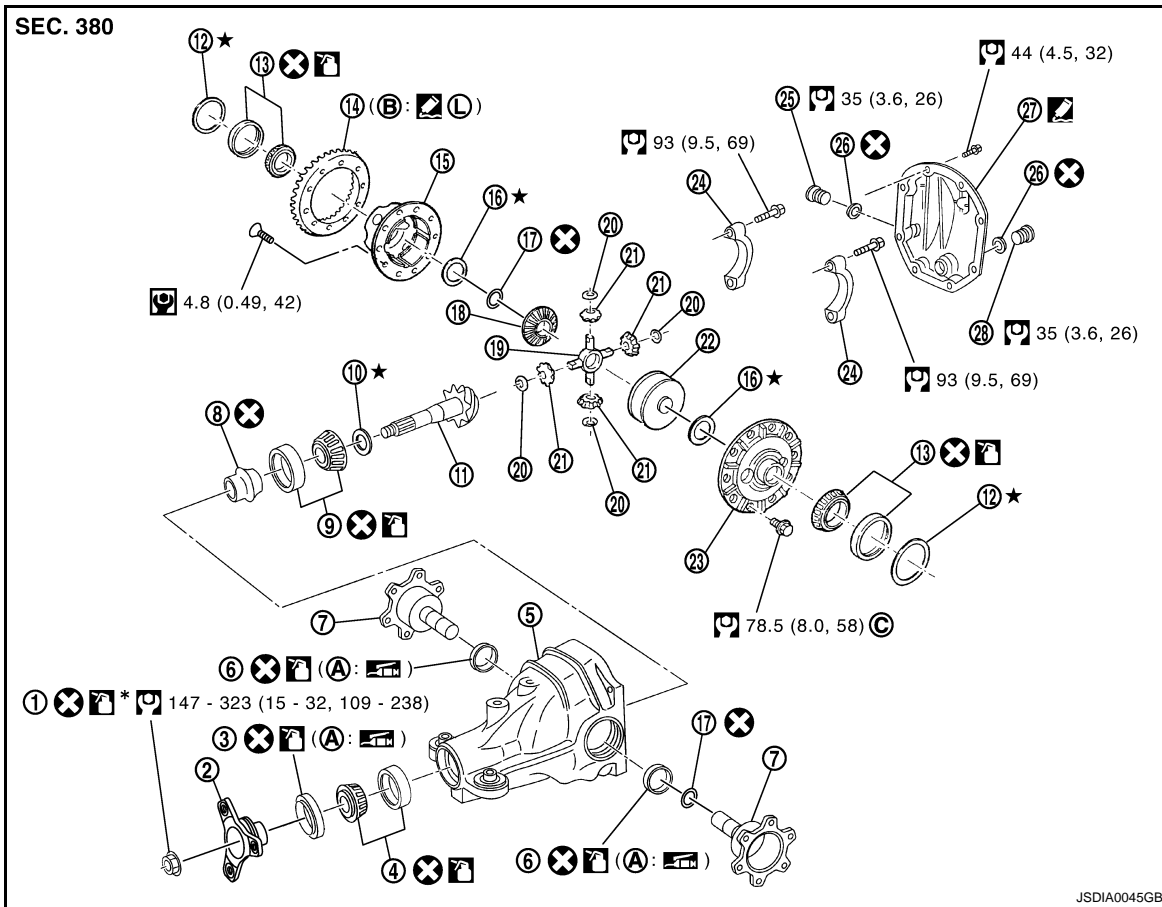

JSDIA0045GB

- |                                    |                               |                                   |
|------------------------------------|-------------------------------|-----------------------------------|
| 1. Drive pinion lock nut           | 2. Companion flange           | 3. Front oil seal                 |
| 4. Pinion front bearing            | 5. Gear carrier               | 6. Side oil seal                  |
| 7. Side flange                     | 8. Collapsible spacer         | 9. Pinion rear bearing            |
| 10. Pinion height adjusting washer | 11. Drive pinion              | 12. Side bearing adjusting washer |
| 13. Side bearing                   | 14. Drive gear                | 15. Differential case B           |
| 16. Side gear thrust washer        | 17. Circular clip             | 18. Side gear                     |
| 19. Pinion mate shaft              | 20. Pinion mate thrust washer | 21. Pinion mate gear              |
| 22. Viscous coupling               | 23. Differential case A       | 24. Bearing cap                   |
| 25. Filler plug                    | 26. Gasket                    | 27. Rear cover                    |
| 28. Drain plug                     |                               |                                   |

A: Oil seal lip

B: Screw hole

C: After tightening the bolts to the specified torque, tighten the bolts additionally by turning the bolts 31 to 36 degrees.

Apply gear oil.

Apply anti-corrosion oil.

Apply Genuine Silicone RTV or equivalent. Refer to [GI-15, "Recommended Chemical Products and Sealants"](#).

Apply Genuine High Strength Thread Locking Sealant or equivalent. Refer to [GI-15, "Recommended Chemical Products and Sealants"](#).

Refer to [GI-4, "Components"](#) for symbols not described on the above.

# DIFFERENTIAL ASSEMBLY

< DISASSEMBLY AND ASSEMBLY >

[REAR FINAL DRIVE: R200V]

INFOID:00000000957448

## A/T : Disassembly

1. Drain gear oil, if necessary.
2. Remove side flange.
3. Remove rear cover mounting bolts.
4. Remove rear cover to insert the seal cutter (A) [SST: KV10111100 (J-37228)] between gear carrier and rear cover.

**CAUTION:**

- Never damage the mating surface.
- Never insert flat-bladed screwdriver, this way damage the mating surface.

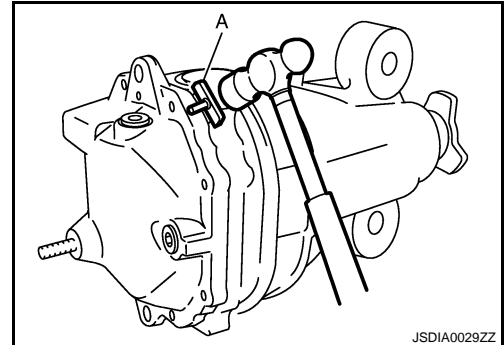

5. Using two 45 mm (1.77 in) spacers, mount carrier on the attachment (A) [SST: KV38100800 (J-25604-01)].

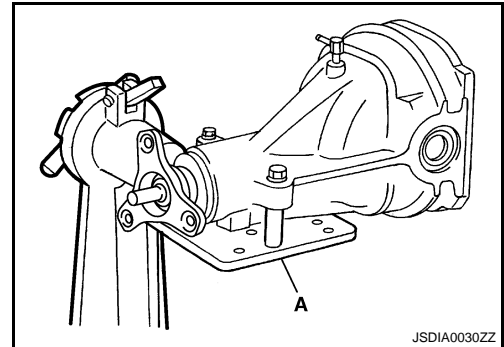

6. For proper reinstallation, paint matching marks on one side of the bearing cap.

**CAUTION:**

- For matching marks, use paint. Never damage bearing caps and gear carrier.
- Bearing caps are line-board during manufacture. The matching marks are used to reinstall them in their original positions.

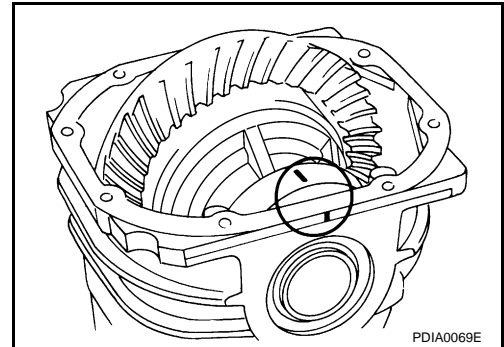

7. Remove bearing caps.

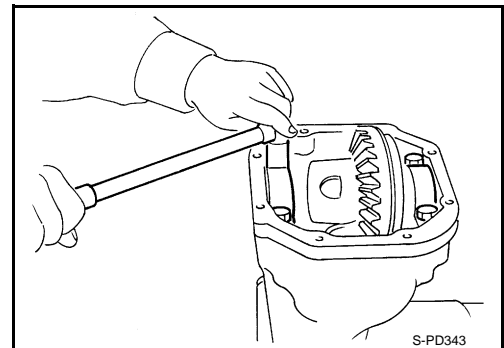

A  
B  
C  
DLN  
E  
F  
G  
H  
I  
J  
K  
L  
M  
N  
O  
P

# DIFFERENTIAL ASSEMBLY

< DISASSEMBLY AND ASSEMBLY >

[REAR FINAL DRIVE: R200V]

8. Lift differential case assembly out with a suitable tool.

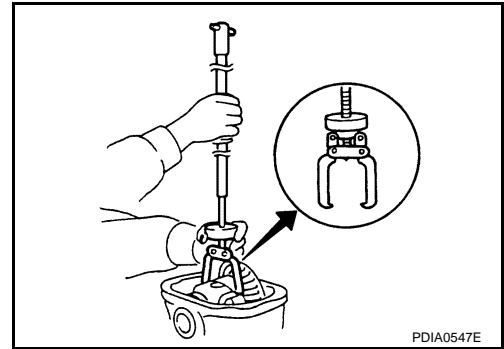

- Keep side bearing outer races together with inner race. Do not mix them up.  
Also, keep side bearing adjusting washers together with bearings.

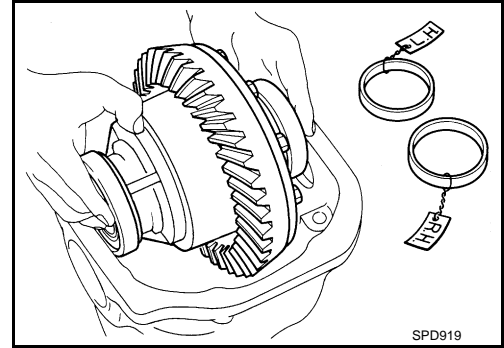

9. Remove side bearing inner race.  
To prevent damage to bearing, engage puller jaws in groove (←).

A: Puller [SST: ST33051001 (J-22888-20)]

B: Base [SST: ST33061000 (J-8107-2)]

**CAUTION:**

- To prevent damage to the side bearing and drive gear, place copper plates between these parts and vise.
- It is not necessary to remove side bearing inner race except it is replaced.

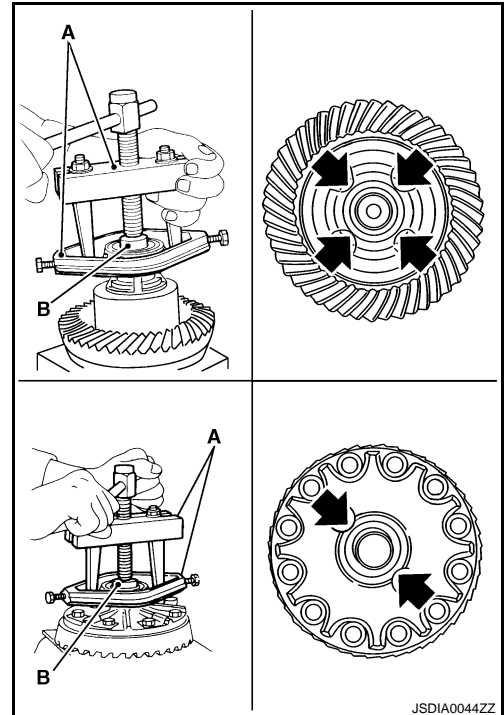

10. For proper reinstallation, paint matching marks on one differential case assembly.

**CAUTION:**

For matching marks, use paint. Never damage differential case and drive gear.

11. Remove drive gear mounting bolts.

12. Tap drive gear off differential case assembly with a soft hammer.

**CAUTION:**

Tap evenly all around to keep drive gear from bending.

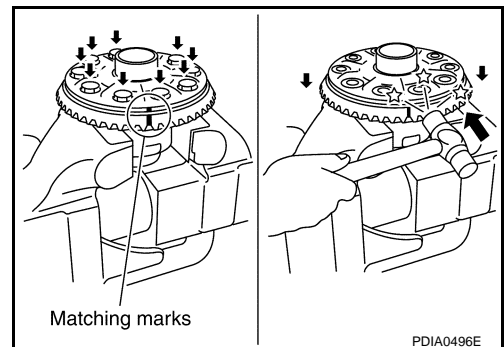

# DIFFERENTIAL ASSEMBLY

< DISASSEMBLY AND ASSEMBLY >

[REAR FINAL DRIVE: R200V]

13. Put matching marks with paint.

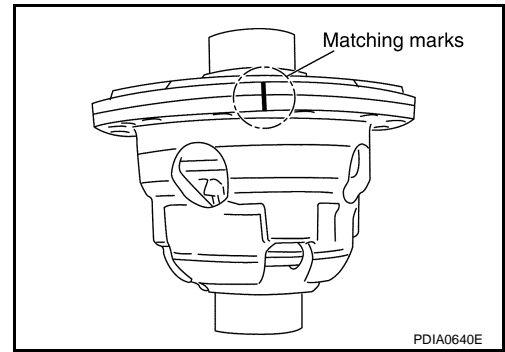

A  
B  
C

DLN

14. Loosen screws on differential cases A and B.

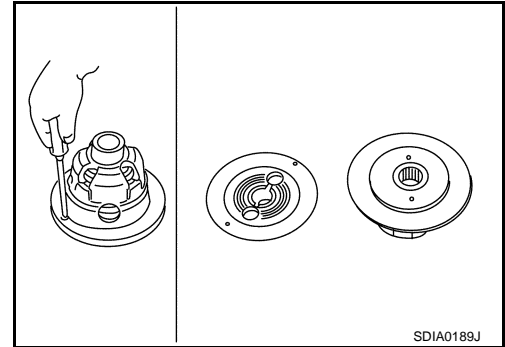

E  
F  
G

15. Separate differential case A and B, then remove viscous coupling, pinion mate gear, pinion mate thrust washer, side gear and side gear thrust washer from differential cases.

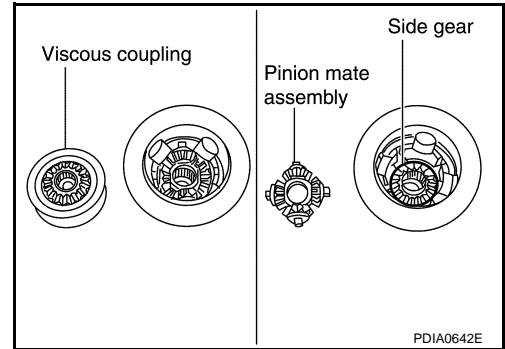

H  
I  
J

K

INFOID:000000000957449

## A/T : Assembly

1. Install side gear thrust washer with the same thickness as the ones installed prior to disassembly or reinstall the old ones on the side gear.

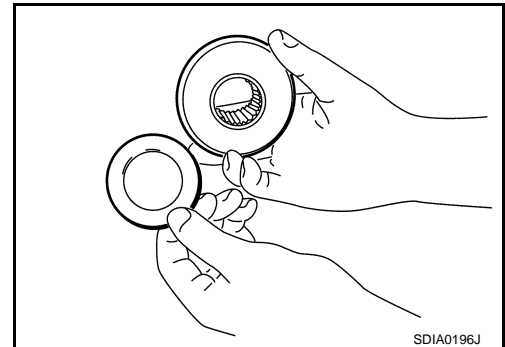

L  
M  
N  
O  
P

# DIFFERENTIAL ASSEMBLY

< DISASSEMBLY AND ASSEMBLY >

[REAR FINAL DRIVE: R200V]

2. Install side gear and thrust washer into differential case B.  
**CAUTION:**  
**Make sure that the circular clip is installed to side gear.**
3. Install pinion mate assembly (pinion mate shaft, pinion mate gears and pinion mate thrust washers) into differential case B.  
**CAUTION:**  
**The pinion mate shaft groove side shall be installed to side gear.**

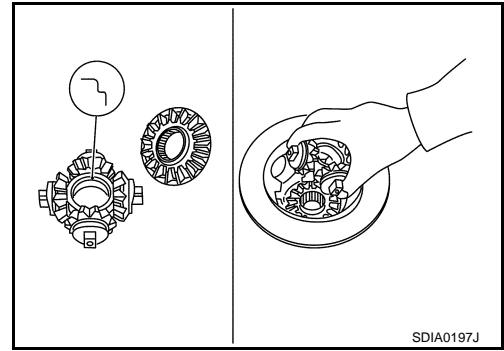

4. Install viscous coupling into differential case B.
5. Install side gear thrust washer with the same thickness as the ones installed prior to disassembly or reinstall the old ones on the viscous coupling.

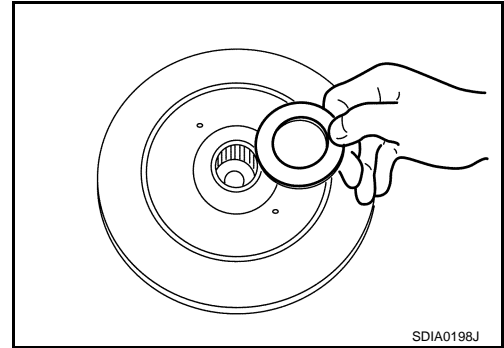

6. Align the matching marks and install differential case A into differential case B.

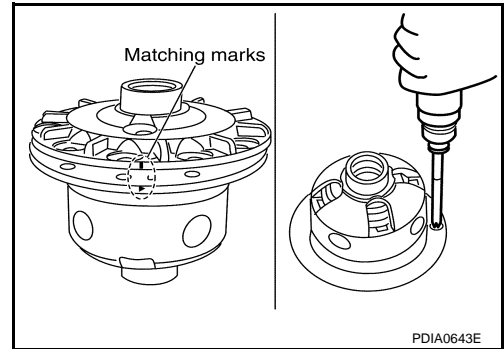

7. Measure side gear end play. If necessary, select the appropriate side gear thrust washer.
  - a. Place differential assembly so that right side gear is on the upper side.
  - b. Measure the clearance between right side gear back and differential case using feeler gauge, while rotating right side gear with a suitable tool attached to splines.

## Standard

**Side gear back clearance** : Refer to [DLN-287, "Differential Side Gear Clearance"](#).

## CAUTION:

- Never place feeler gauge at groove side of differential case.
  - To prevent side gear from tilting, insert feeler gauges with the same thickness from both sides.
- c. If the back clearance is outside the specification, use a thicker/thinner side gear thrust washer to adjust.

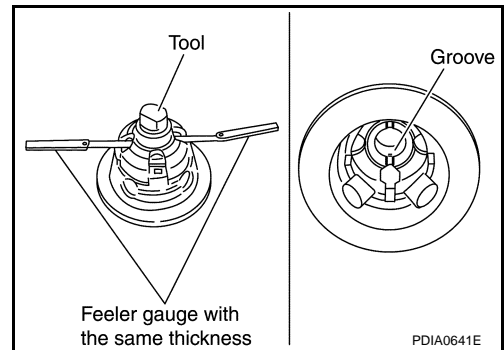

**When the back clearance is large:** Use a thicker thrust washer.

**When the back clearance is small:** Use a thinner thrust washer.

## CAUTION:

# DIFFERENTIAL ASSEMBLY

< DISASSEMBLY AND ASSEMBLY >

[REAR FINAL DRIVE: R200V]

- Adjust the clearance with the left side gear thrust washer only.
  - Only one side gear thrust washer can be selected.
8. Align the matching mark of differential case with the mark of drive gear, then place drive gear.

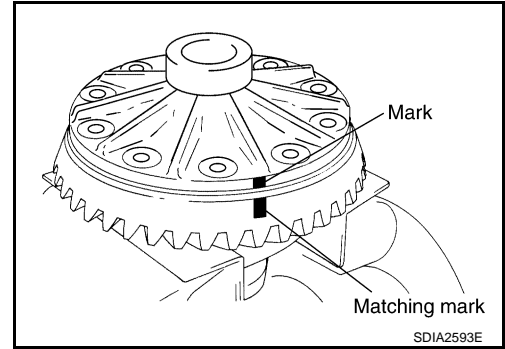

9. Apply thread locking sealant into the thread hole of drive gear.
- Use Genuine High Strength Thread Locking Sealant or equivalent. Refer to [GI-15, "Recommended Chemical Products and Sealants"](#).

**CAUTION:**

Drive gear back and threaded holes shall be cleaned and degreased sufficiently.

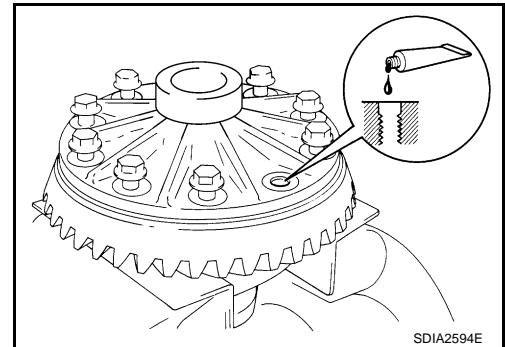

10. Install drive gear on the mounting bolts.

**CAUTION:**

- Tighten bolts in a crisscross fashion.
- After tightening the bolts to the specified torque, tighten the bolts additionally by turning the bolts 31 to 36 degrees.

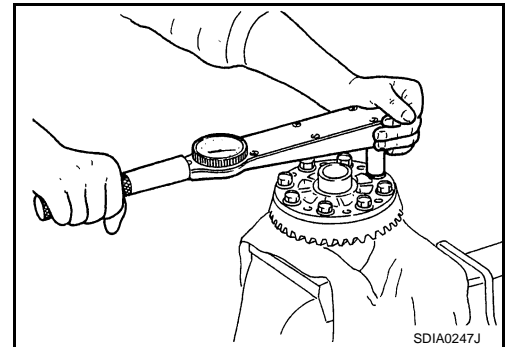

11. Press side bearing inner races to differential case, using the drift (A) [SST: KV38100300 (J-25523)] and the base (B) [SST: ST33061000 (J-8107-2)].

**CAUTION:**

Never reuse side bearing inner race.

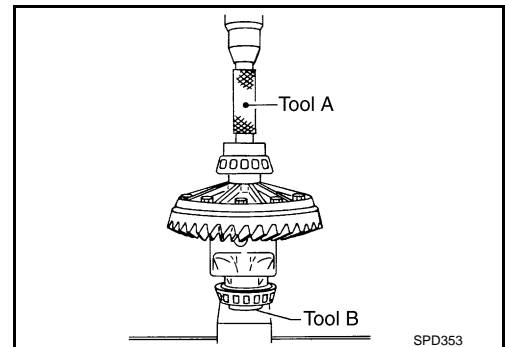

A  
B  
C  
DLN  
E  
F  
G  
H  
I  
J  
K  
L  
M  
N  
O  
P

# DIFFERENTIAL ASSEMBLY

[REAR FINAL DRIVE: R200V]

## < DISASSEMBLY AND ASSEMBLY >

12. Install differential case assembly with side bearing outer races into gear carrier.
13. Measure side bearing preload. If necessary, select the appropriate side bearing adjusting washers. Refer to [DLN-265, "A/T : Adjustment"](#).

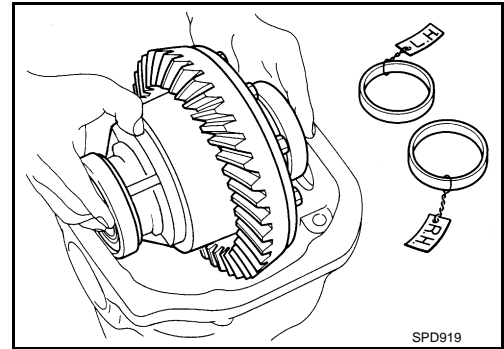

14. Insert selected left and right side bearing adjusting washers in place between side bearings and gear carrier.

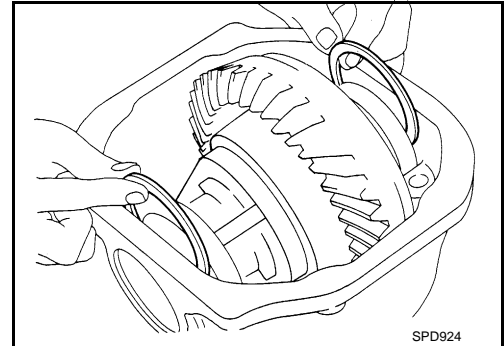

15. Align matching marks on bearing cap with that on gear carrier.
16. Install bearing caps and tighten bearing cap mounting bolts.

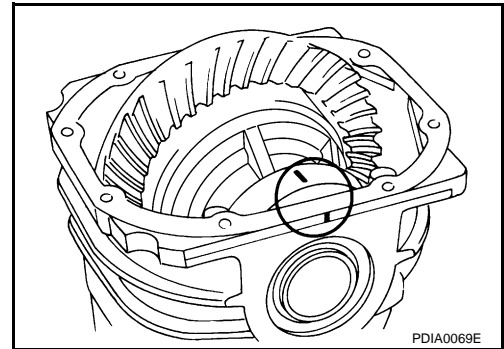

17. Using the drift [SST: KV38100200 (J-26233)], drive side oil seals until it becomes flush with the case end.

**CAUTION:**

- Never reuse oil seal.
- When installing, never incline oil seal.
- Apply multi-purpose grease onto oil seal lips, and gear oil onto the circumference of oil seal.

18. Check and adjust drive gear runout, tooth contact, drive gear to drive pinion backlash, and total preload torque. Refer to [DLN-265, "A/T : Adjustment"](#).

Recheck above items. Readjust the above description, if necessary.

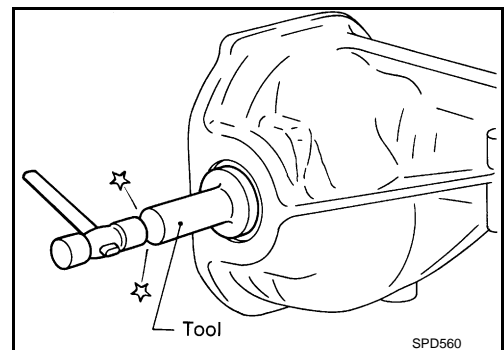

19. Apply sealant to mating surface of rear cover.
  - Use Genuine Silicone RTV or equivalent. Refer to [GI-15, "Recommended Chemical Products and Sealants"](#).

**CAUTION:**

Remove old sealant adhering to mounting surfaces. Also remove any moisture, oil, or foreign material adhering to application and mounting surfaces.

20. Install rear cover on gear carrier and tighten mounting bolts.

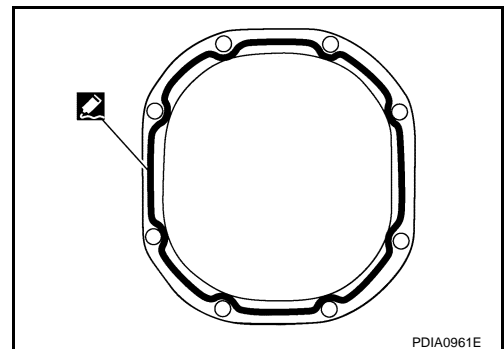



# DIFFERENTIAL ASSEMBLY

< DISASSEMBLY AND ASSEMBLY >

[REAR FINAL DRIVE: R200V]

21. Install side flange with the following procedure.

- a. Attach the protector [SST: KV38107900 (J-39352)] to side oil seal.
- b. After the side flange is inserted and the serrated part of side gear has engaged the serrated part of flange, remove the protector.

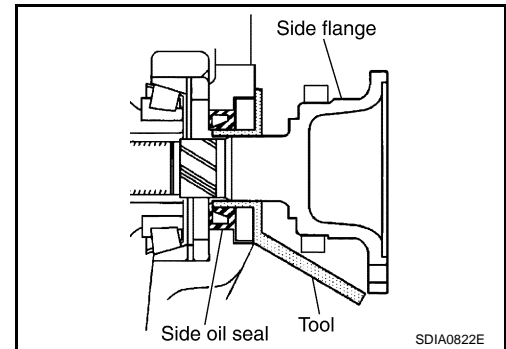

c. Put a suitable drift on the center of side flange, then drive it until sound changes.

**NOTE:**

When installation is completed, driving sound of the side flange turns into a sound which seems to affect the whole final drive.

d. Confirm that the dimension of the side flange (1) installation (Measurement A) in the figure comes into the following.

**Measurement "A"** : 326 – 328 mm (12.83 – 12.91 in)

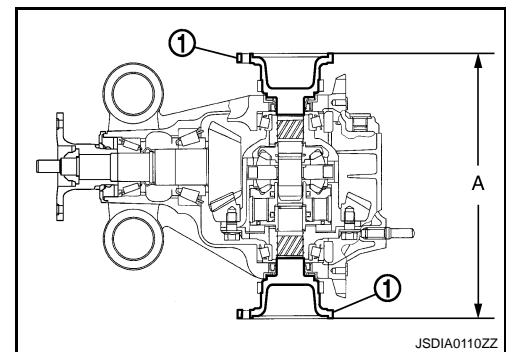

INFOID:000000000957450

## A/T : Adjustment

### TOTAL PRELOAD TORQUE

• Before inspection and adjustment, drain gear oil.

1. Secure final drive assembly onto an attachment [SST: KV38100800 (J-25604-01)].
2. Remove side flanges.
3. Rotate drive pinion back and forth 2 to 3 times to check for unusual noise and rotation malfunction.
4. Rotate drive pinion at least 20 times to check for smooth operation of the bearing.
5. Measure total preload with the preload gauge (A) [SST: ST3127S000 (J-25765-A)].

**Standard**

**Total preload torque** : Refer to [DLN-287, "Pre-load Torque"](#).

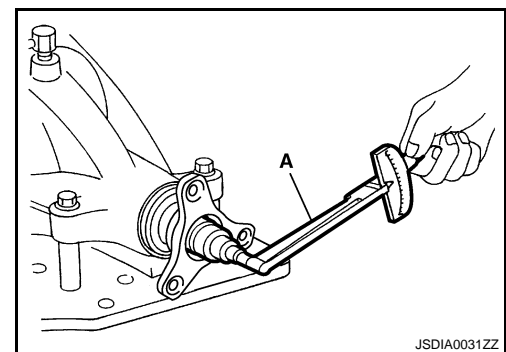

**NOTE:**

**Total preload torque = Pinion bearing preload torque + Side bearing preload torque**

- If measured value is out of the specification, disassemble it to check and adjust each part. Adjust the pinion bearing preload and side bearing preload. Adjust the pinion bearing preload first, then adjust the side bearing preload.

**When the preload torque is large**

**On pinion bearings:** Replace the collapsible spacer.

**On side bearings:** Use thinner side bearing adjusting washers by the same amount to each side.

# DIFFERENTIAL ASSEMBLY

< DISASSEMBLY AND ASSEMBLY >

[REAR FINAL DRIVE: R200V]

## When the preload is small

**On pinion bearings:** Tighten the drive pinion lock nut.

**On side bearings:** Use thicker side bearing adjusting washers by the same amount to each side.

## SIDE BEARING PRELOAD

- Before inspection and adjustment, drain gear oil.
1. Remove rear cover. Refer to [DLN-259, "A/T : Disassembly"](#).
  2. Make sure all parts are clean. Also, make sure the bearings are well lubricated with gear oil.
  3. Place the differential case, with side bearings and bearing races installed, into gear carrier.
  4. Insert left and right original side bearing adjusting washers in place between side bearings and gear carrier.
  5. Install bearing caps in their correct locations and tighten bearing cap mounting bolts.
  6. Turn the carrier several times to seat the bearings.
  7. Measure the turning torque of the carrier at the drive gear mounting bolts with a spring gauge [SST: — (J-8129)].

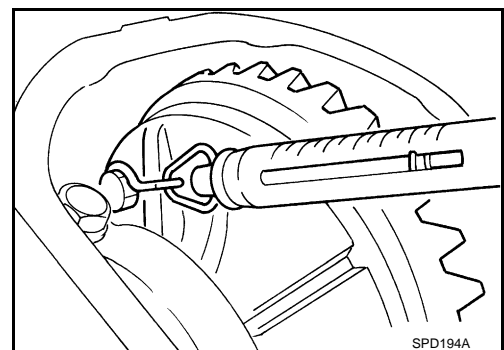
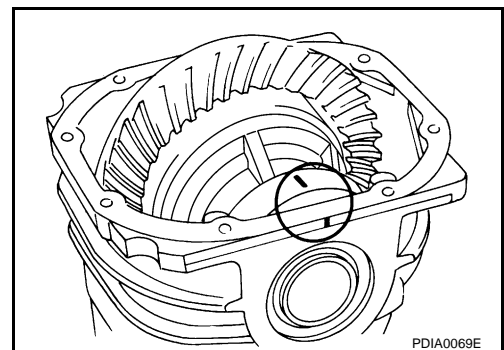
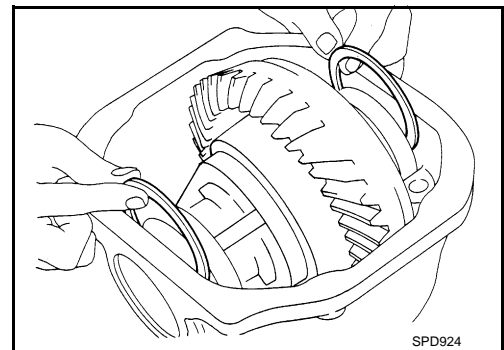
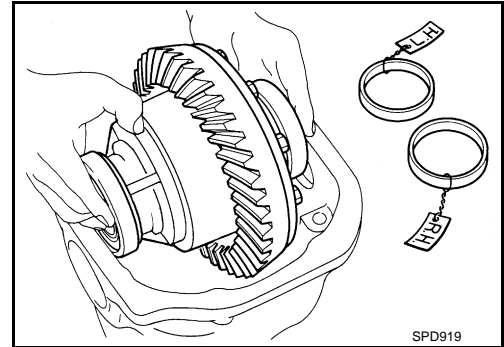

## Specification

**: 34.2 – 39.2 N (3.5 – 4.0 kg, 7.7 – 8.8 lb) of pulling force at the drive gear bolt**

# DIFFERENTIAL ASSEMBLY

< DISASSEMBLY AND ASSEMBLY >

[REAR FINAL DRIVE: R200V]

8. If the turning torque is outside the specification, use a thicker/thinner side bearing adjusting washer to adjust.

**If the turning torque is less than the specified range:**

**Use a thicker thrust washer.**

**If the turning torque is greater than the specification:**

**Use a thinner thrust washer.**

**CAUTION:**

**Select a side bearing adjusting washer for right and left individually.**

9. Record the total amount of washer thickness required for the correct carrier side bearing preload.

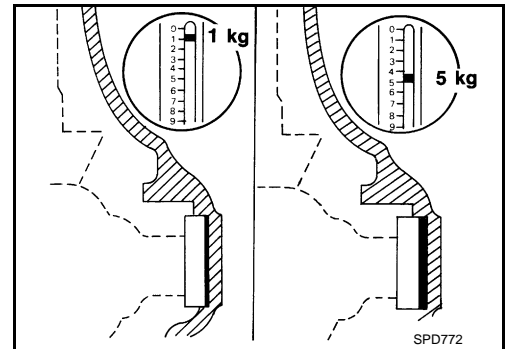

## DRIVE GEAR RUNOUT

1. Remove rear cover. Refer to [DLN-259, "A/T : Disassembly"](#).
2. Fit a dial indicator to the drive gear back face.
3. Rotate the drive gear to measure runout.

**Limit**

**Drive gear runout : Refer to [DLN-287, "Drive Gear Runout"](#).**

- If the runout is outside of the repair limit, check drive gear assembly condition; foreign material may be caught between drive gear and differential case, or differential case or drive gear may be deformed, etc.

**CAUTION:**

**Replace drive gear and drive pinion gear as a set.**

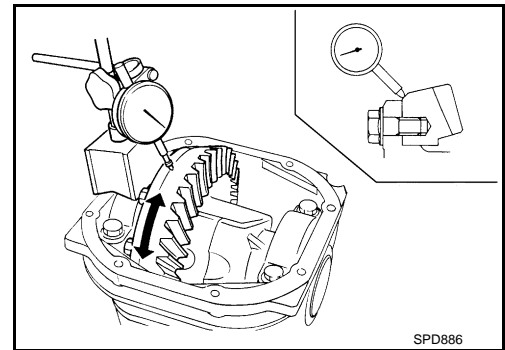

## TOOTH CONTACT

- Before inspection and adjustment, drain gear oil.
1. Remove rear cover. Refer to [DLN-259, "A/T : Disassembly"](#).
  2. Apply red lead to drive gear.

**CAUTION:**

**Apply red lead to both the faces of 3 to 4 gears at 4 locations evenly spaced on drive gear.**

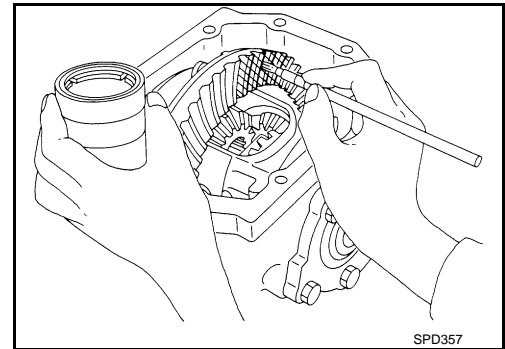

3. Rotate drive gear back and forth several times, check drive pinion gear to drive gear tooth contact.

**CAUTION:**

**Check tooth contact on drive side and reverse side.**

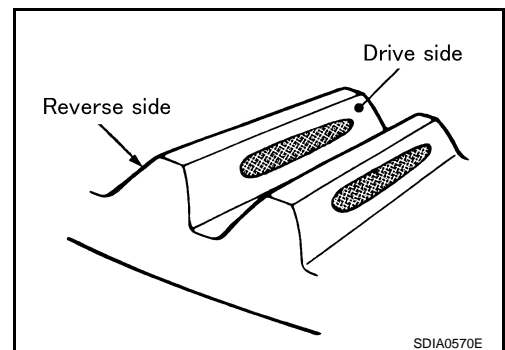

A  
B  
C  
DLN  
E  
F  
G  
H  
I  
J  
K  
L  
M  
N  
O  
P

# DIFFERENTIAL ASSEMBLY

< DISASSEMBLY AND ASSEMBLY >

[REAR FINAL DRIVE: R200V]

Tooth contact condition				Pinion height adjusting washer selection valve [ mm (in) ]	Adjustment (Yes/No)	Possible cause
Drive side		Back side				
Heel side	Toe side	Toe side	Heel side			
				↑ Thicker	Yes	Occurrence of noise and scoring sound in all speed ranges.
						+0.09 (+0.0035)
				+0.06 (+0.0024)	No	-
				+0.03 (+0.0012)		
				0		
				↓ Thinner	Yes	-
				-0.03 (-0.0012)		
				-0.06 (-0.0024)		
				-0.09 (-0.0035)		Occurrence of noise at constant speed and decreasing speed.
						Occurrence of noise and scoring sound in all speed ranges.

SDIA0207E

4. If tooth contact is improperly adjusted, follow the procedure below to adjust the pinion height (dimension X).

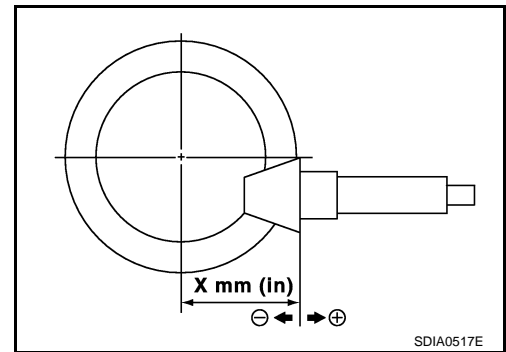

- If the tooth contact is near the face (face contact), or near the heel (heel contact), thicken pinion height adjusting washers to move drive pinion closer to drive gear.

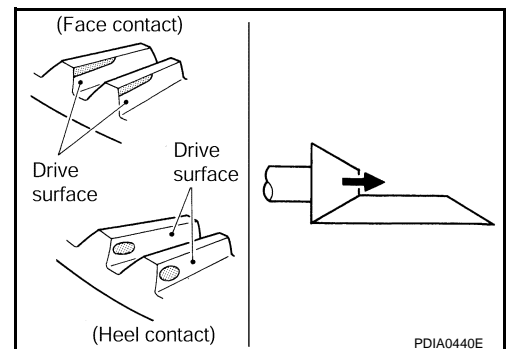

# DIFFERENTIAL ASSEMBLY

< DISASSEMBLY AND ASSEMBLY >

[REAR FINAL DRIVE: R200V]

- If the tooth contact is near the flank (flank contact), or near the toe (toe contact), thin pinion height adjusting washers to move drive pinion farther from drive gear.

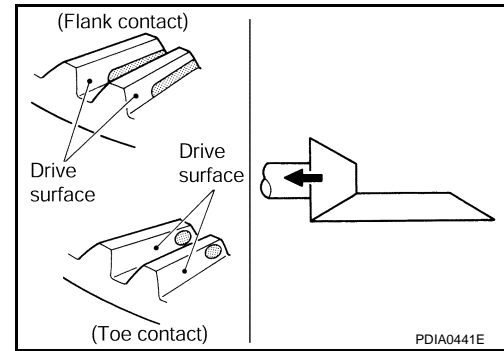

## BACKLASH

- Before inspection and adjustment, drain gear oil.
1. Remove rear cover. Refer to [DLN-259. "A/T : Disassembly"](#).
  2. Fit a dial indicator to the drive gear face to measure the backlash.

**Standard Backlash**

**: Refer to [DLN-287. "Backlash"](#).**

- If the backlash is outside of the specified value, change the thickness of side bearing adjusting washer.

**When the backlash is large:**

**Make drive gear back side adjusting washer thicker, and drive gear tooth side adjusting washer thinner by the same amount.**

**When the backlash is small:**

**Make drive gear back side adjusting washer thinner, and drive gear tooth side adjusting washer thicker by the same amount.**

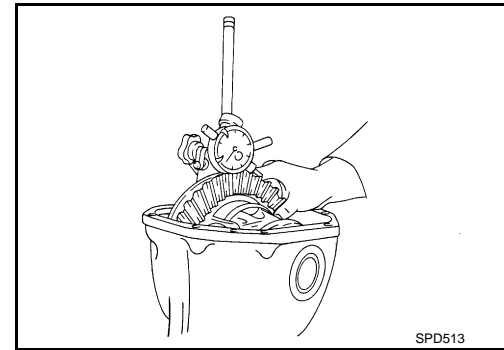

### CAUTION:

**Never change the total amount of washers as it will change the bearing preload.**

## A/T : Inspection After Disassembly

INFOID:000000000957451

Clean up the disassembled parts. Then, inspect if the parts are worn or damaged. If so, follow the measures below.

Content	Conditions and Measures
Hypoid gear	<ul style="list-style-type: none"> <li>• If the gear teeth do not mesh or line-up correctly, determine the cause and adjust or replace as necessary.</li> <li>• If the gears are worn, cracked, damaged, pitted or chipped (by friction) noticeably, replace with new drive gear and drive pinion as a set.</li> </ul>
Bearing	<ul style="list-style-type: none"> <li>• If any chipped (by friction), pitted, worn, rusted or scratched mark, or unusual noise from the bearing is observed, replace as a bearing assembly (as a new set).</li> </ul>
Side gear and Pinion mate gear	<ul style="list-style-type: none"> <li>• If any cracks or damage on the surface of the tooth is found, replace.</li> <li>• If any worn or chipped mark on the contact sides of the thrust washer is found, replace.</li> </ul>
Side gear thrust washer and pinion mate thrust washer	<ul style="list-style-type: none"> <li>• If it is chipped (by friction), damaged, or unusually worn, replace.</li> </ul>
Oil seal	<ul style="list-style-type: none"> <li>• Whenever disassembled, replace.</li> <li>• If wear, deterioration of adherence (sealing force lips), or damage is detected on the lips, replace them.</li> </ul>
Differential case	<ul style="list-style-type: none"> <li>• If any wear or crack on the contact sides of the differential case is found, replace.</li> </ul>
Companion flange	<ul style="list-style-type: none"> <li>• If any chipped mark (about 0.1 mm, 0.004 in) or other damage on the contact sides of the lips of the companion flange is found, replace.</li> </ul>

A  
B  
C  
DLN

E  
F  
G  
H  
I  
J  
K

L  
M  
N  
O  
P

# DRIVE PINION

< DISASSEMBLY AND ASSEMBLY >

[REAR FINAL DRIVE: R200V]

## DRIVE PINION

M/T

M/T : Exploded View

INFOID:000000000957452

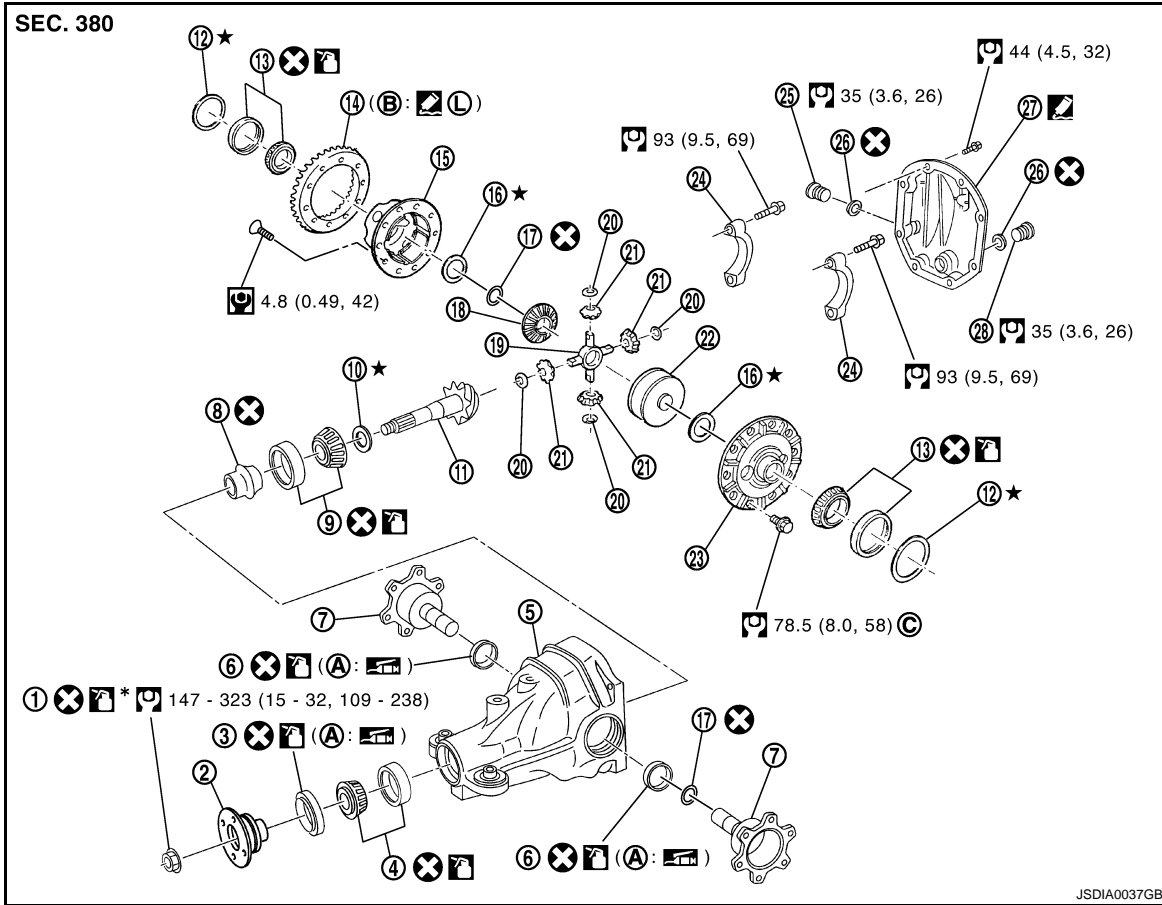

- |                                    |                               |                                   |
|------------------------------------|-------------------------------|-----------------------------------|
| 1. Drive pinion lock nut           | 2. Companion flange           | 3. Front oil seal                 |
| 4. Pinion front bearing            | 5. Gear carrier               | 6. Side oil seal                  |
| 7. Side flange                     | 8. Collapsible spacer         | 9. Pinion rear bearing            |
| 10. Pinion height adjusting washer | 11. Drive pinion              | 12. Side bearing adjusting washer |
| 13. Side bearing                   | 14. Drive gear                | 15. Differential case B           |
| 16. Side gear thrust washer        | 17. Circular clip             | 18. Side gear                     |
| 19. Pinion mate shaft              | 20. Pinion mate thrust washer | 21. Pinion mate gear              |
| 22. Viscous coupling               | 23. Differential case A       | 24. Bearing cap                   |
| 25. Filler plug                    | 26. Gasket                    | 27. Rear cover                    |
| 28. Drain plug                     |                               |                                   |

A: Oil seal lip

B: Screw hole

C: After tightening the bolts to the specified torque, tighten the bolts additionally by turning the bolts 31 to 36 degrees.

Apply gear oil.

Apply anti-corrosion oil.

Apply Genuine Silicone RTV or equivalent. Refer to [GI-15, "Recommended Chemical Products and Sealants"](#).

Apply Genuine High Strength Thread Locking Sealant or equivalent. Refer to [GI-15, "Recommended Chemical Products and Sealants"](#).

Refer to [GI-4, "Components"](#) for symbols not described on the above.

# DRIVE PINION

< DISASSEMBLY AND ASSEMBLY >

[REAR FINAL DRIVE: R200V]

## M/T : Disassembly

INFOID:000000000957453

1. Remove differential assembly. Refer to [DLN-247](#), "M/T : Disassembly".
2. Remove drive pinion lock nut with the flange wrench.

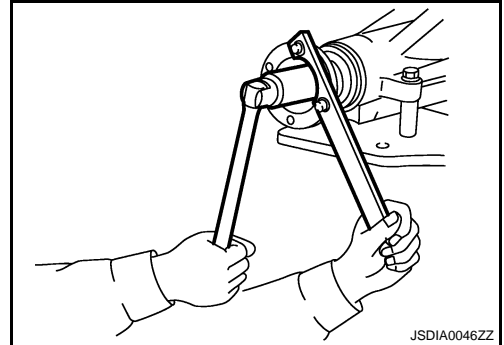

3. Put matching mark (B) on the end of drive pinion. The matching mark should be in line with the matching mark (A) on companion flange (1).

**CAUTION:**

**For matching mark, use paint. Never damage companion flange and drive pinion.**

**NOTE:**

The matching mark (A) on the final drive companion flange (1) indicates the maximum vertical runout position.

When replacing companion flange, matching mark is not necessary.

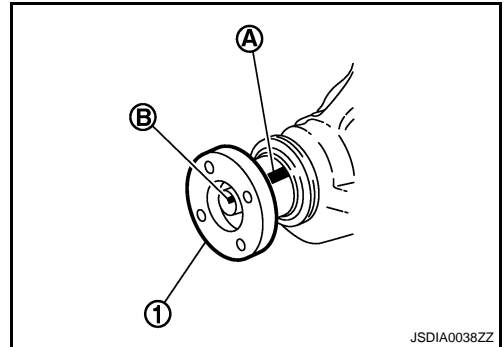

4. Remove companion flange using the suitable pullers.

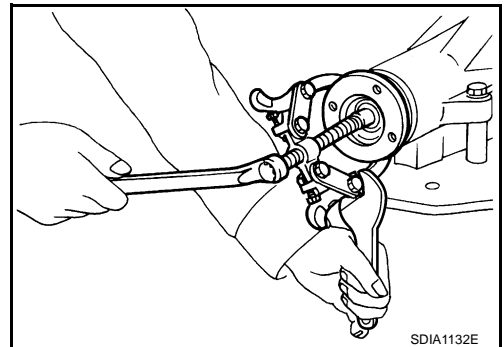

5. Press drive pinion assembly out of gear carrier.

**CAUTION:**

**Never drop drive pinion assembly.**

6. Remove front oil seal.
7. Remove side oil seal.
8. Remove pinion front bearing inner race.
9. Remove collapsible spacer.

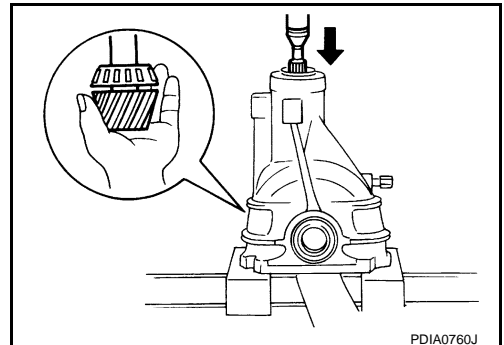

A  
B  
C  
DLN  
E  
F  
G  
H  
I  
J  
K  
L  
M  
N  
O  
P

# DRIVE PINION

## < DISASSEMBLY AND ASSEMBLY >

[REAR FINAL DRIVE: R200V]

10. Remove pinion rear bearing inner race and pinion height adjusting washer with the replacer (A) [SST: ST30031000 (J-22912-01)].

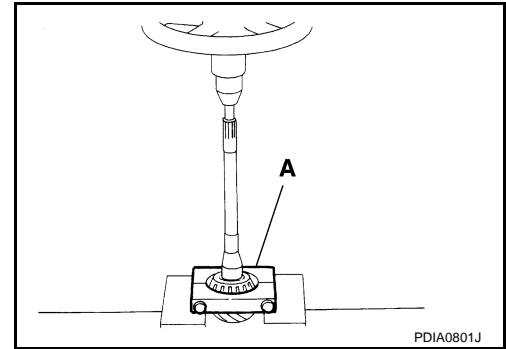

11. Tap pinion front/rear bearing outer races uniformly a brass rod or equivalent to removed.

**CAUTION:**

**Never damage gear carrier.**

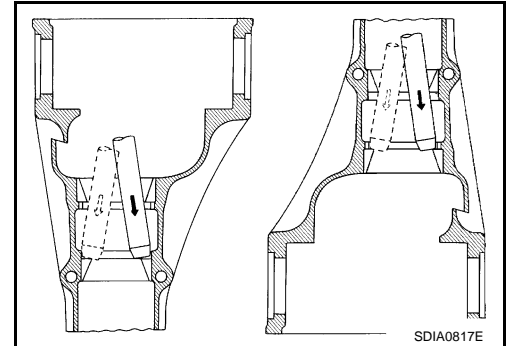

## M/T : Assembly

INFOID:000000000957454

1. Install front bearing outer race (1) and rear bearing outer race (2) using drifts.

A: Drift [SST: ST30720000 (J-25405)]

B: Drift [SST: KV40105230 ( — )]

C: Drift bar [SST: ST30611000 (J-25742-1)]

D: Drift [SST: ST30613000 (J-25742-3)]

**CAUTION:**

- At first, using a hammer, tap bearing outer race until it becomes flat to gear carrier.
- Never reuse pinion front and rear bearing outer race.

2. Select drive pinion height adjusting washer. Refer to [DLN-274, "M/T : Adjustment"](#).

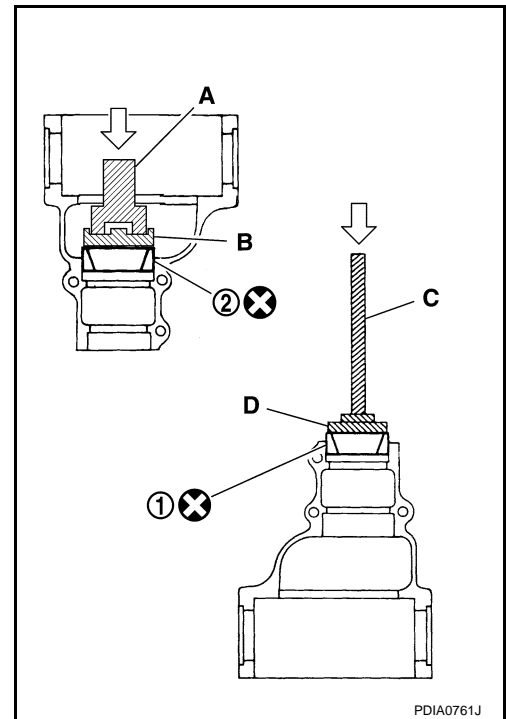



# DRIVE PINION

## < DISASSEMBLY AND ASSEMBLY >

[REAR FINAL DRIVE: R200V]

3. Install selected drive pinion height adjusting washer (2) to drive pinion. Press pinion rear bearing inner race (1) to it, using drift (A) [SST: ST30901000 (J-26010-01)].

**CAUTION:**

- Pay attention to the direction of pinion height adjusting washer. (Assemble as shown in the figure.)
- Never reuse pinion rear bearing inner race.

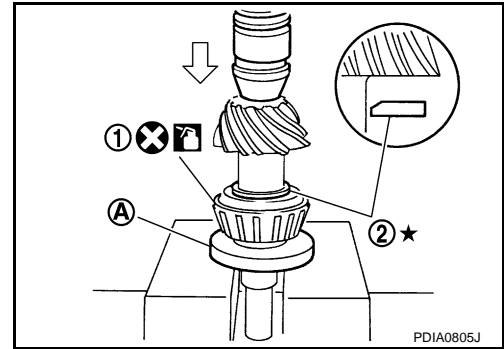

4. Assemble collapsible spacer to drive pinion.

**CAUTION:**

**Never reuse collapsible spacer.**

5. Apply gear oil to pinion rear bearing, and assemble drive pinion into gear carrier.
6. Apply gear oil to pinion front bearing, and assemble pinion front bearing inner race to drive pinion assembly.

**CAUTION:**

**Never reuse pinion front bearing inner race.**

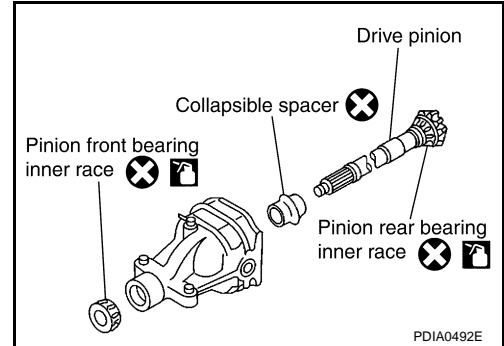

7. Using suitable spacer (A), press the pinion front bearing inner race to drive pinion as far as drive pinion nut can be tightened.

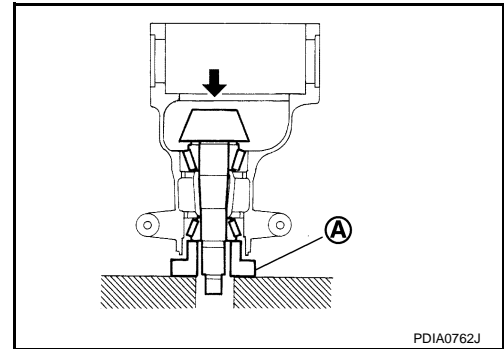

8. Using the drift (A) [SST: ST30720000 (J-25405)], install front oil seal as shown in figure.

**CAUTION:**

- Never reuse oil seal.
- When installing, never incline oil seal.
- Apply multi-purpose grease onto oil seal lips, and gear oil onto the circumference of oil seal.

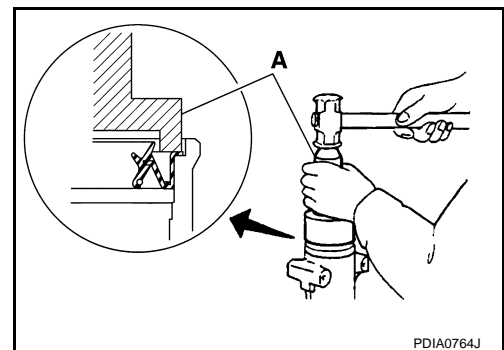

9. Install companion flange (1).

**NOTE:**

When reusing drive pinion, align the matching mark (B) of drive pinion with the matching mark (A) of companion flange, and then install companion flange (1).

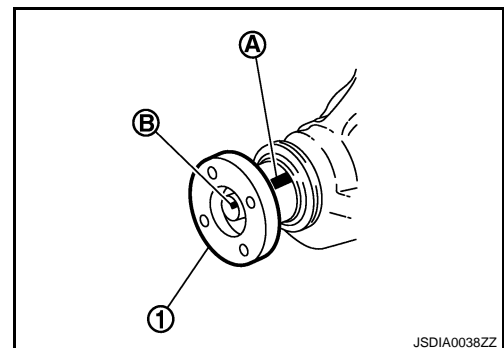

A  
B  
C  
DLN  
E  
F  
G  
H  
I  
J  
K  
L  
M  
N  
O  
P

# DRIVE PINION

< DISASSEMBLY AND ASSEMBLY >

[REAR FINAL DRIVE: R200V]

10. Apply anti-corrosion oil to the thread and seat of drive pinion lock nut, and temporarily tighten drive pinion lock nut to drive pinion.

**CAUTION:**

**Never reuse drive pinion lock nut.**

11. Adjust to the drive pinion lock nut tightening torque and pinion bearing preload torque.

A: Preload gauge [SST: ST3127S000 (J-25765-A)]

**Standard**

**Pinion bearing preload** : Refer to [DLN-287, "Pre-load Torque"](#).

**CAUTION:**

- Adjust to the lower limit of the drive pinion lock nut tightening torque first.
- If the preload torque exceeds the specified value, replace collapsible spacer and tighten it again to adjust. Never loosen drive pinion lock nut to adjust the preload torque.
- After adjustment, rotate drive pinion back and forth 2 to 3 times to check for unusual noise, rotation malfunction, and other malfunctions.

12. Install differential case assembly. Refer to [DLN-272, "M/T : Assembly"](#).

**CAUTION:**

**Never install rear cover yet.**

13. Check and adjust drive gear runout, tooth contact, drive gear to drive pinion backlash, and companion flange runout. Refer to [DLN-274, "M/T : Adjustment"](#).  
Recheck above items. Readjust the above description, if necessary.
14. Check total preload torque. Refer to [DLN-274, "M/T : Adjustment"](#).
15. Install rear cover. Refer to [DLN-272, "M/T : Assembly"](#).

## M/T : Adjustment

INFOID:000000000957455

## PINION GEAR HEIGHT

1. Make sure all parts are clean and that the bearings are well lubricated.
2. Assemble the pinion gear bearings into the differential shim selector tool [SST: — (J-34309)].

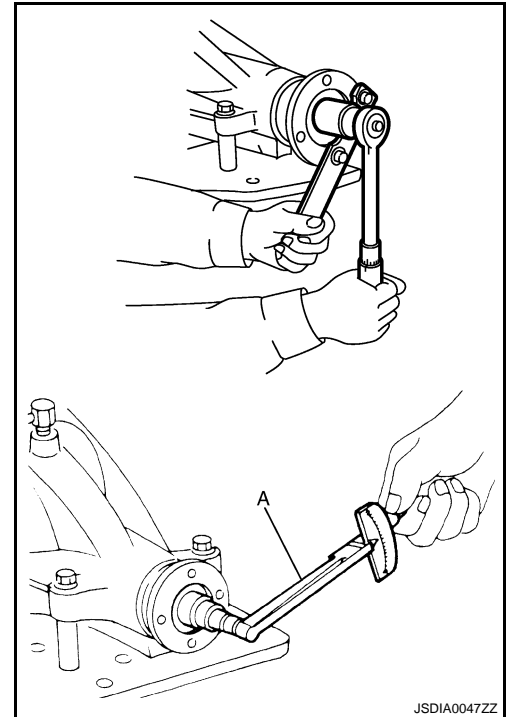

JSDIA0047ZZ

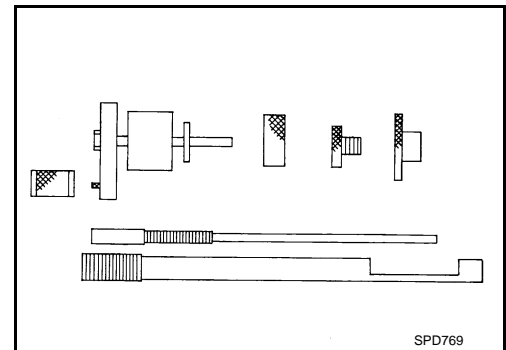

SPD769

# DRIVE PINION

## < DISASSEMBLY AND ASSEMBLY >

[REAR FINAL DRIVE: R200V]

- **Pinion front bearing;** make sure the J-34309-3 pinion front bearing seat is secured tightly against the J-34309-2 gauge anvil. Then turn the pinion front bearing pilot, J-34309-5, to secure the bearing in its proper position.
  - **Pinion rear bearing;** the pinion rear bearing pilot, J-34309-8, is used to center the pinion rear bearing only. The pinion rear bearing locking seat, J-34309-4, is used to lock the bearing to the assembly.
  - **Installation of J-34309-9 and J-34309-16;** place a suitable 2.5 mm (0.098 in) thick plain washer between J-34309-9 and J-34309-16. Both surfaces of J-34309-9 and J-34309-16 must be parallel with a clearance of 2.5 mm (0.098 in).
3. Install the pinion rear bearing inner race into gear carrier. Then place the pinion preload shim selector tool, J-34309-1, gauge screw assembly.

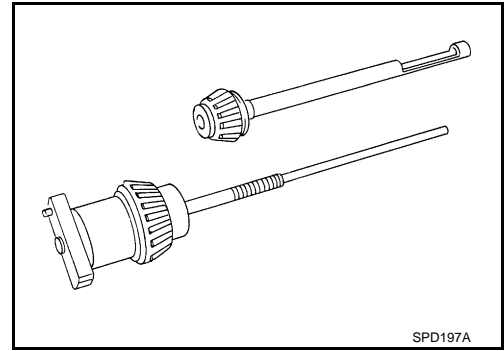

A  
B  
C

DLN

4. Assemble the pinion front bearing inner race and the J-34309-2 gauge anvil. Assemble them together with the J-34309-1 gauge screw in gear carrier. Make sure that the pinion height gauge plate, J-34309-16, will turn a full 360 degrees. Tighten the two sections together by hand.

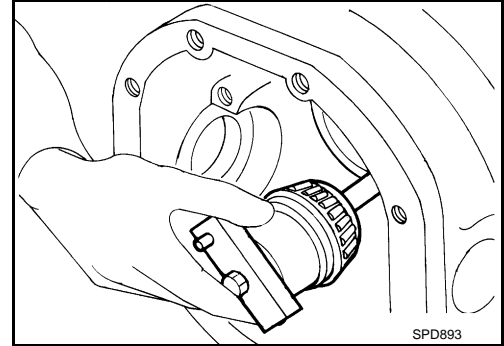

E  
F  
G

5. Turn the assembly several times to seat the bearings.

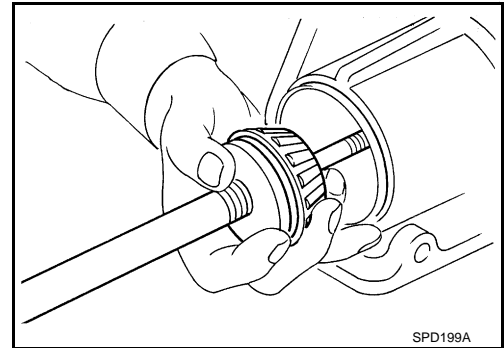

H  
I  
J

6. Measure the turning torque at the end of the J-34309-2 gauge anvil using preload gauge [SST: ST3127S000 (J-25765-A)].

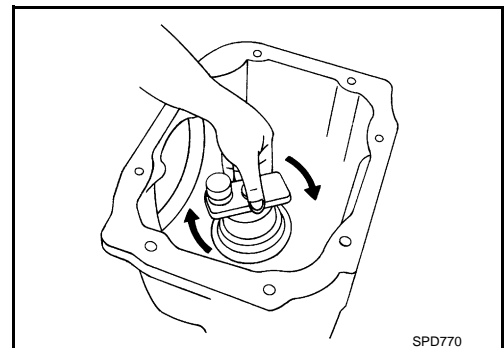

L  
M  
N

**Turning torque specification : 1.0 – 1.3 N·m (0.11 – 0.13 kg·m, 9 – 11 in·lb)**

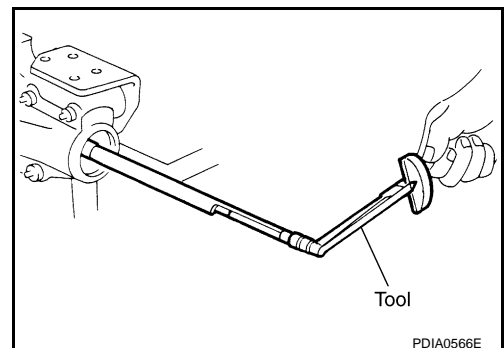

O  
P

# DRIVE PINION

## < DISASSEMBLY AND ASSEMBLY >

[REAR FINAL DRIVE: R200V]

7. Place the J-34309-11 "R200A" pinion height adapter onto the gauge plate and tighten it by hand.

**CAUTION:**

**Make sure all machined surfaces are clean.**

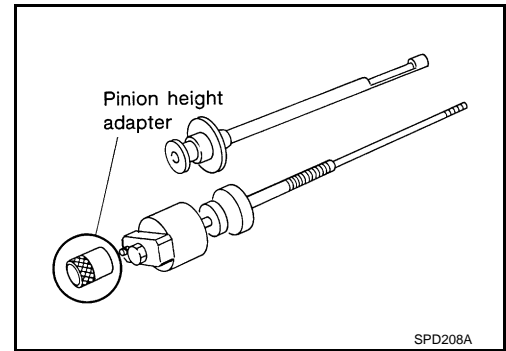

8. Position the side bearing discs, J-25269-4, and arbor firmly into the side bearing bores. Install the bearing caps and tighten bearing cap mounting bolts to the specified torque.

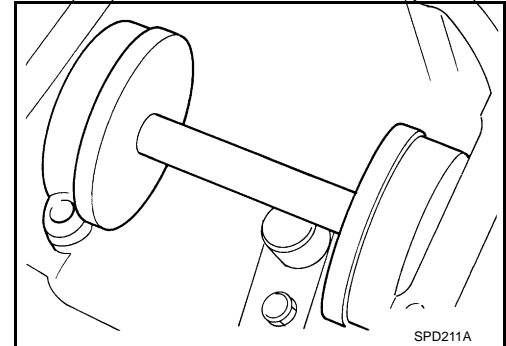

9. Select the correct standard pinion height adjusting washer thickness. Select by using a standard gauge of 3 mm (0.12 in) and your J-34309-101 feeler gauge. Measure the distance between the J-34309-11 pinion height adapter including the standard gauge and the arbor.

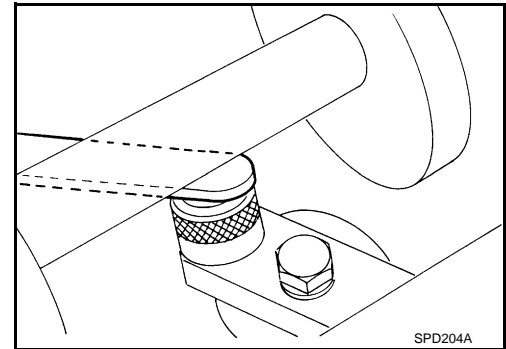

10. Write down exact measurement (the value of feeler gauge).

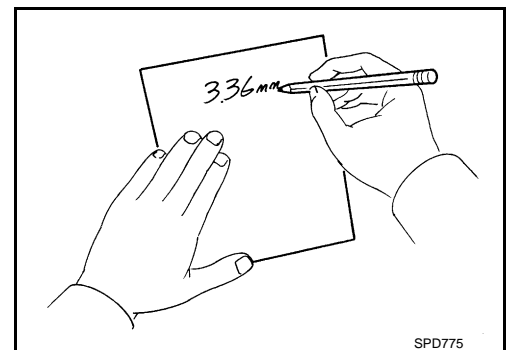

11. Correct the pinion height washer size by referring to the "pinion head number".

**There are two numbers painted on the drive pinion. The first one refers to the drive pinion and drive gear as a matched set. This number should be the same as the number on the drive gear. The second number is the "pinion head height number". It refers to the ideal pinion height from standard for quietest operation. Use the following chart to determine the correct pinion height washer.**

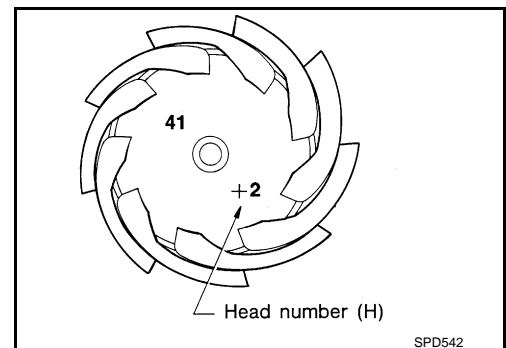

# DRIVE PINION

< DISASSEMBLY AND ASSEMBLY >

[REAR FINAL DRIVE: R200V]

Pinion head height number	Add or remove from the standard pinion height adjusting washer thickness measurement
-6	Add 0.06 mm (0.0024 in)
-5	Add 0.05 mm (0.0020 in)
-4	Add 0.04 mm (0.0016 in)
-3	Add 0.03 mm (0.0012 in)
-2	Add 0.02 mm (0.0008 in)
-1	Add 0.01 mm (0.0004 in)
0	Use the selected washer thickness
+1	Subtract 0.01 mm (0.0004 in)
+2	Subtract 0.02 mm (0.0008 in)
+3	Subtract 0.03 mm (0.0012 in)
+4	Subtract 0.04 mm (0.0016 in)
+5	Subtract 0.05 mm (0.0020 in)
+6	Subtract 0.06 mm (0.0024 in)

- Select the correct pinion height adjusting washer.
- Remove the J-34309 differential shim selector tool from the final drive housing. Then disassemble to retrieve the pinion bearings.

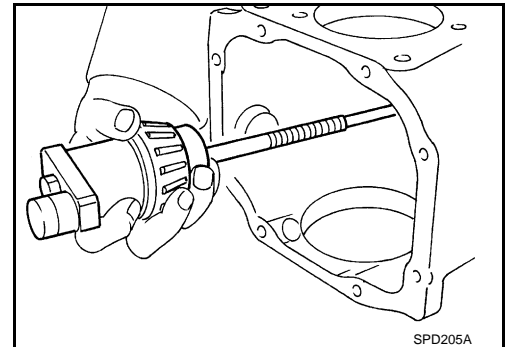

## COMPANION FLANGE RUNOUT

- Fit a dial indicator onto the companion flange face (inner side of the propeller shaft mounting bolt holes).
- Rotate the companion flange to check for runout.

### Limit

**Companion flange runout** : Refer to [DLN-287, "Companion flange Runout \(M/T Models\)"](#).

- Fit a test indicator to the inner side of the companion flange (socket diameter).
- Rotate the companion flange to check for runout.

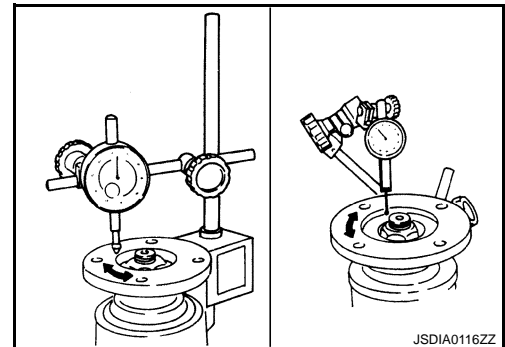

### Limit

**Companion flange runout** : Refer to [DLN-287, "Companion flange Runout \(M/T Models\)"](#).

- If the runout value is outside the repair limit, follow the procedure below to adjust.
  - Check for runout while changing the phase between companion flange and drive pinion gear by 90° step, and search for the position where the runout is the minimum.
  - If the runout value is still outside of the limit after the phase has been changed, possible cause will be an assembly malfunction of drive pinion and pinion bearing and malfunction of pinion bearing. Check for these items and repair if necessary.
  - If the runout value is still outside of the limit after the check and repair, replace companion flange.

M/T : Inspection After Disassembly

INFOID:000000000957456



# DRIVE PINION

[REAR FINAL DRIVE: R200V]

## < DISASSEMBLY AND ASSEMBLY >

- |                             |                               |                         |
|-----------------------------|-------------------------------|-------------------------|
| 13. Side bearing            | 14. Drive gear                | 15. Differential case B |
| 16. Side gear thrust washer | 17. Circular clip             | 18. Side gear           |
| 19. Pinion mate shaft       | 20. Pinion mate thrust washer | 21. Pinion mate gear    |
| 22. Viscous coupling        | 23. Differential case A       | 24. Bearing cap         |
| 25. Filler plug             | 26. Gasket                    | 27. Rear cover          |
| 28. Drain plug              |                               |                         |

A: Oil seal lip

B: Screw hole

C: After tightening the bolts to the specified torque, tighten the bolts additionally by turning the bolts 31 to 36 degrees.

 Apply gear oil.

 Apply anti-corrosion oil.

 Apply Genuine Silicone RTV or equivalent. Refer to [GI-15. "Recommended Chemical Products and Sealants"](#).

 Apply Genuine High Strength Thread Locking Sealant or equivalent. Refer to [GI-15. "Recommended Chemical Products and Sealants"](#).

Refer to [GI-4. "Components"](#) for symbols not described on the above.

## A/T : Disassembly

INFOID:000000000957458

1. Remove differential assembly. Refer to [DLN-247. "M/T : Disassembly"](#).
2. Remove drive pinion lock nut with the flange wrench.

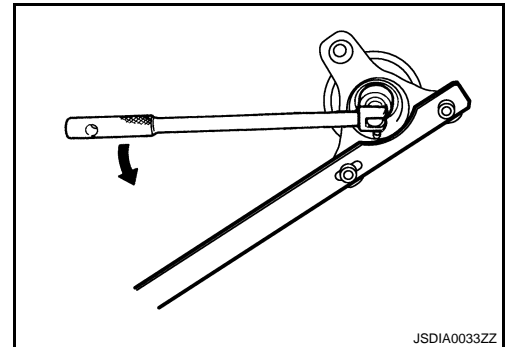

3. Put matching mark (B) on the end of drive pinion. The matching mark should be in line with the matching mark (A) on companion flange (1).

### CAUTION:

**For matching mark, use paint. Never damage companion flange and drive pinion.**

### NOTE:

The matching mark (A) on the final drive companion flange (1) indicates the maximum vertical runout position.

When replacing companion flange, matching mark is not necessary.

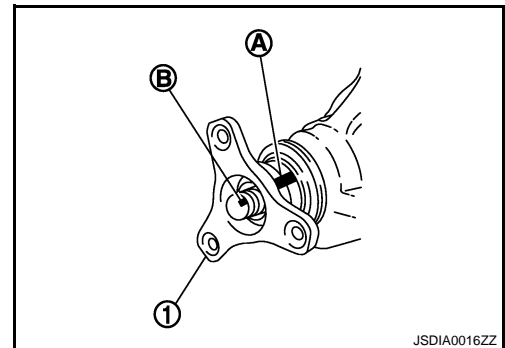

4. Remove companion flange using the suitable pullers.

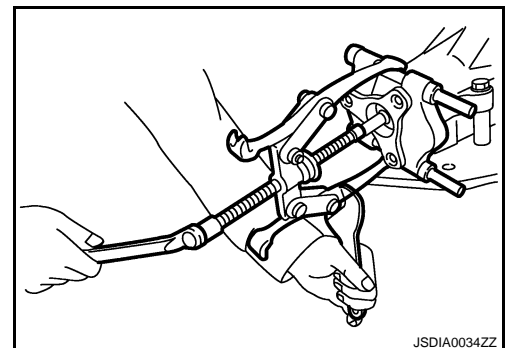

A  
B  
C  
DLN  
E  
F  
G  
H  
I  
J  
K  
L  
M  
N  
O  
P

# DRIVE PINION

## < DISASSEMBLY AND ASSEMBLY >

[REAR FINAL DRIVE: R200V]

5. Press drive pinion assembly out of gear carrier.

**CAUTION:**

**Never drop drive pinion assembly.**

6. Remove front oil seal.  
7. Remove side oil seal.  
8. Remove pinion front bearing inner race.  
9. Remove collapsible spacer.

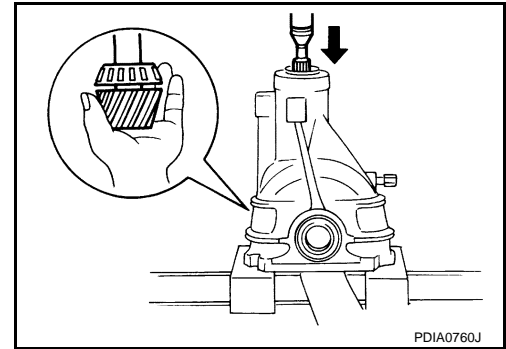

10. Remove pinion rear bearing inner race and pinion height adjusting washer with the replacer (A) [SST: ST30031000 (J-22912-01)].

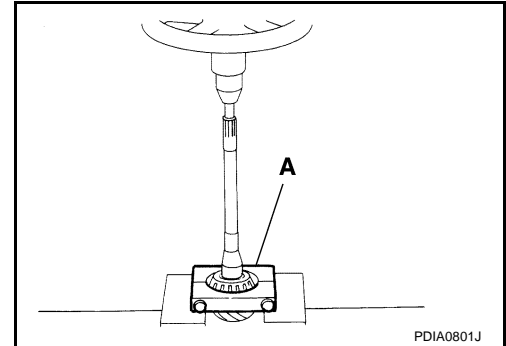

11. Tap pinion front/rear bearing outer races uniformly a brass rod or equivalent to removed.

**CAUTION:**

**Never damage gear carrier.**

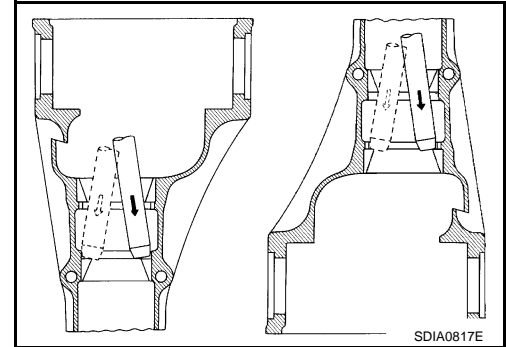

A/T : Assembly

INFOID:000000000957459



# DRIVE PINION

[REAR FINAL DRIVE: R200V]

## < DISASSEMBLY AND ASSEMBLY >

1. Install front bearing outer race (1) and rear bearing outer race (2) using drifts.

A: Drift [SST: ST30720000 (J-25405)]  
 B: Drift [SST: KV40105230 ( — )]  
 C: Drift bar [SST: ST30611000 (J-25742-1)]  
 D: Drift [SST: ST30613000 (J-25742-3)]

**CAUTION:**

- At first, using a hammer, tap bearing outer race until it becomes flat to gear carrier.
- Never reuse pinion front and rear bearing outer race.

2. Select drive pinion height adjusting washer. Refer to [DLN-282](#). "[A/T : Adjustment](#)".

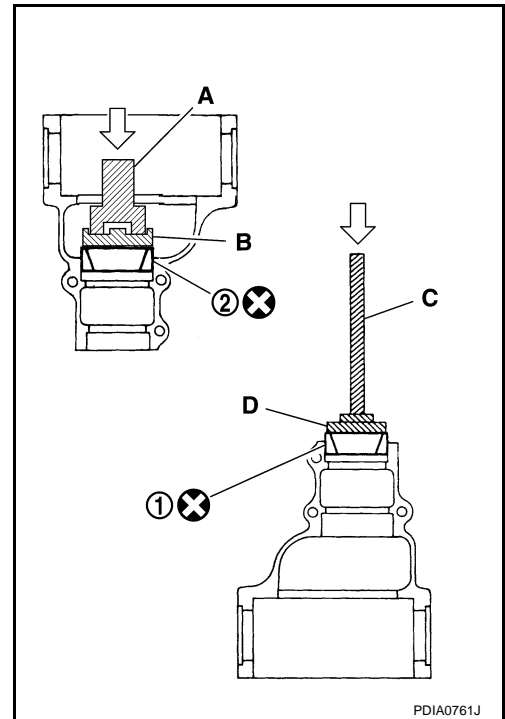

PDIA0761J

3. Install selected drive pinion height adjusting washer (2) to drive pinion. Press pinion rear bearing inner race (1) to it, using drift (A) [SST: ST30901000 (J-26010-01)].

**CAUTION:**

- Pay attention to the direction of pinion height adjusting washer. (Assemble as shown in the figure.)
- Never reuse pinion rear bearing inner race.

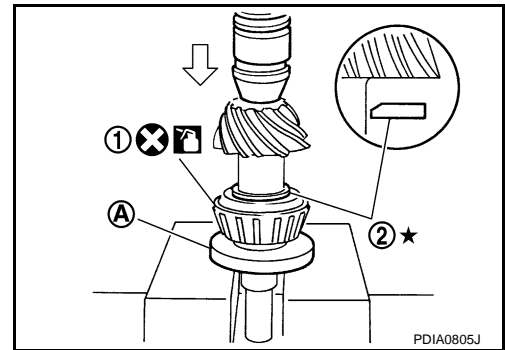

PDIA0805J

4. Assemble collapsible spacer to drive pinion.

**CAUTION:**

**Never reuse collapsible spacer.**

5. Apply gear oil to pinion rear bearing, and assemble drive pinion into gear carrier.

6. Apply gear oil to pinion front bearing, and assemble pinion front bearing inner race to drive pinion assembly.

**CAUTION:**

**Never reuse pinion front bearing inner race.**

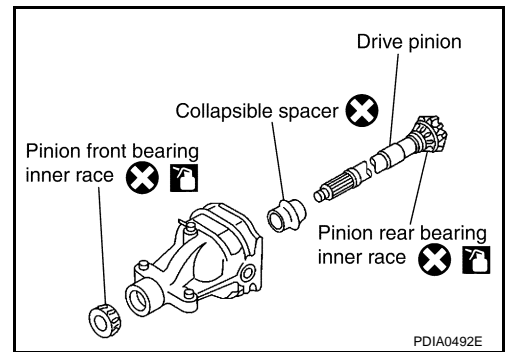

PDIA0492E

7. Using suitable spacer (A), press the pinion front bearing inner race to drive pinion as far as drive pinion nut can be tightened.

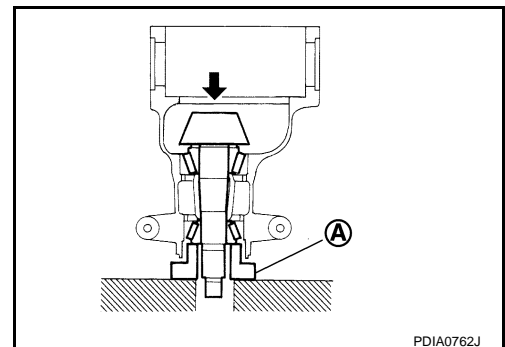

PDIA0762J

# DRIVE PINION

## < DISASSEMBLY AND ASSEMBLY >

[REAR FINAL DRIVE: R200V]

8. Using the drift (A) [SST: ST30720000 (J-25405)], install front oil seal as shown in figure.

**CAUTION:**

- Never reuse oil seal.
- When installing, never incline oil seal.
- Apply multi-purpose grease onto oil seal lips, and gear oil onto the circumference of oil seal.

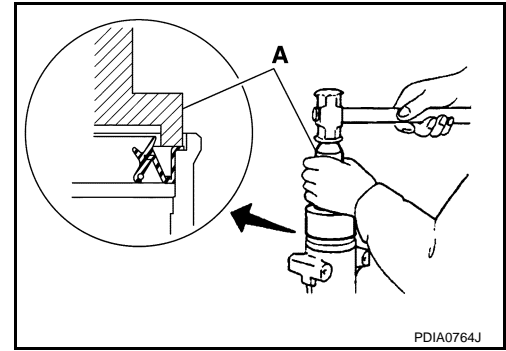

9. Install companion flange (1).

**NOTE:**

When reusing drive pinion, align the matching mark (B) of drive pinion with the matching mark (A) of companion flange, and then install companion flange (1).

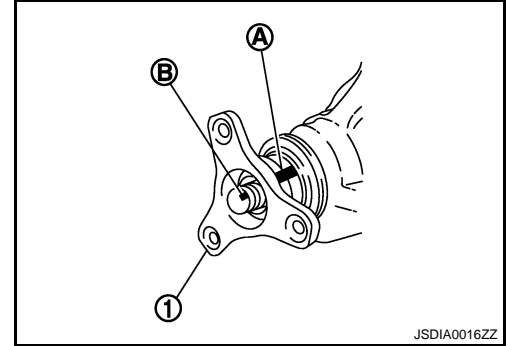

10. Apply anti-corrosion oil to the thread and seat of drive pinion lock nut, and temporarily tighten drive pinion lock nut to drive pinion.

**CAUTION:**

**Never reuse drive pinion lock nut.**

11. Adjust to the drive pinion lock nut tightening torque and pinion bearing preload torque.

A: Preload gauge [SST: ST3127S000 (J-25765-A)]

**Standard**

**Pinion bearing preload** : Refer to [DLN-287. "Pre-load Torque"](#).

**CAUTION:**

- Adjust to the lower limit of the drive pinion lock nut tightening torque first.
- If the preload torque exceeds the specified value, replace collapsible spacer and tighten it again to adjust. Never loosen drive pinion lock nut to adjust the preload torque.
- After adjustment, rotate drive pinion back and forth 2 to 3 times to check for unusual noise, rotation malfunction, and other malfunctions.

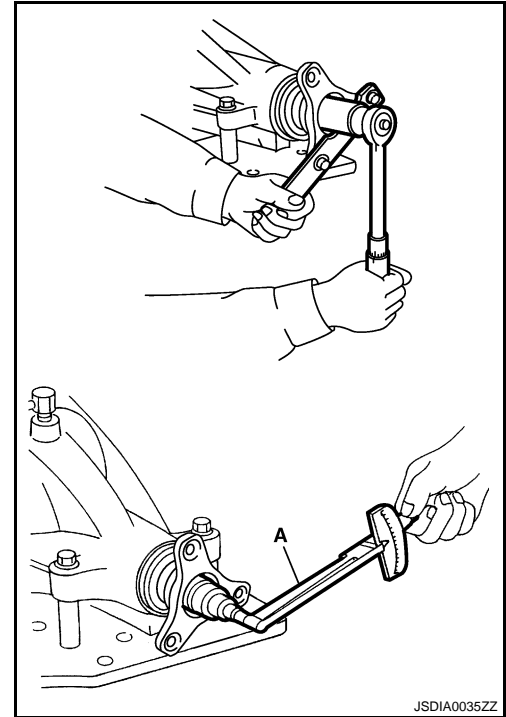

12. Install differential case assembly. Refer to [DLN-280. "A/T : Assembly"](#).

**CAUTION:**

**Never install rear cover yet.**

13. Check and adjust drive gear runout, tooth contact, drive gear to drive pinion backlash, and companion flange runout. Refer to [DLN-282. "A/T : Adjustment"](#).

Recheck above items. Readjust the above description, if necessary.

14. Check total preload torque. Refer to [DLN-282. "A/T : Adjustment"](#).

15. Install rear cover. Refer to [DLN-280. "A/T : Assembly"](#).

A/T : Adjustment

INFOID:000000000957460

# DRIVE PINION

< DISASSEMBLY AND ASSEMBLY >

[REAR FINAL DRIVE: R200V]

## PINION GEAR HEIGHT

1. Make sure all parts are clean and that the bearings are well lubricated.
2. Assemble the pinion gear bearings into the differential shim selector tool [SST: — (J-34309)].

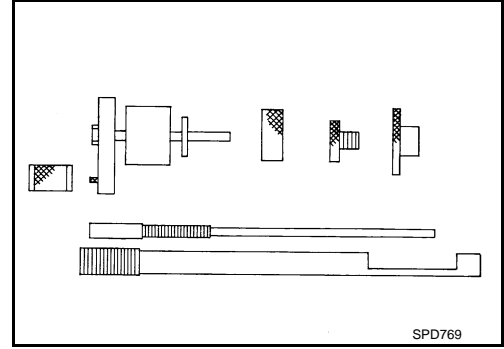

- **Pinion front bearing;** make sure the J-34309-3 pinion front bearing seat is secured tightly against the J-34309-2 gauge anvil. Then turn the pinion front bearing pilot, J-34309-5, to secure the bearing in its proper position.
- **Pinion rear bearing;** the pinion rear bearing pilot, J-34309-8, is used to center the pinion rear bearing only. The pinion rear bearing locking seat, J-34309-4, is used to lock the bearing to the assembly.
- **Installation of J-34309-9 and J-34309-16;** place a suitable 2.5 mm (0.098 in) thick plain washer between J-34309-9 and J-34309-16. Both surfaces of J-34309-9 and J-34309-16 must be parallel with a clearance of 2.5 mm (0.098 in).

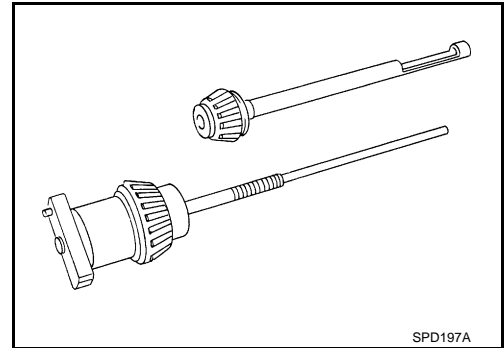

3. Install the pinion rear bearing inner race into gear carrier. Then place the pinion preload shim selector tool, J-34309-1, gauge screw assembly.

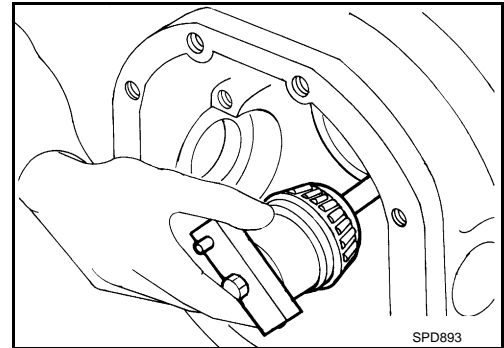

4. Assemble the pinion front bearing inner race and the J-34309-2 gauge anvil. Assemble them together with the J-34309-1 gauge screw in gear carrier. Make sure that the pinion height gauge plate, J-34309-16, will turn a full 360 degrees. Tighten the two sections together by hand.

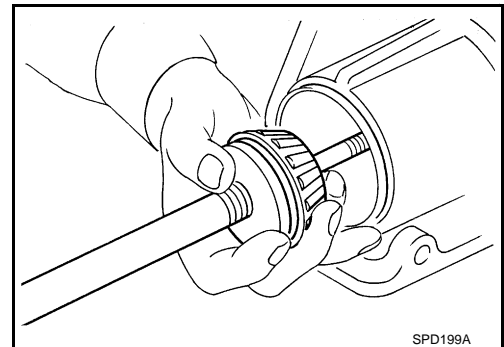

A  
B  
C  
DLN  
E  
F  
G  
H  
I  
J  
K  
L  
M  
N  
O  
P

# DRIVE PINION

## < DISASSEMBLY AND ASSEMBLY >

[REAR FINAL DRIVE: R200V]

5. Turn the assembly several times to seat the bearings.

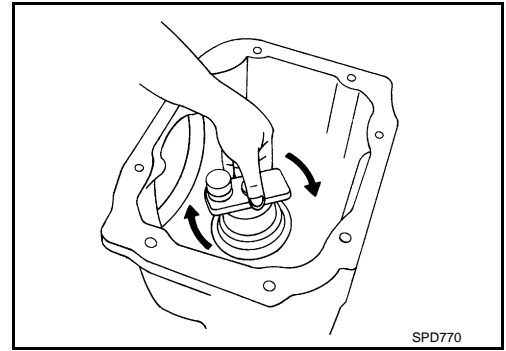

6. Measure the turning torque at the end of the J-34309-2 gauge anvil using preload gauge [SST: ST3127S000 (J-25765-A)].

**Turning torque specification** : 1.0 – 1.3 N·m (0.11 – 0.13 kg-m, 9 – 11 in-lb)

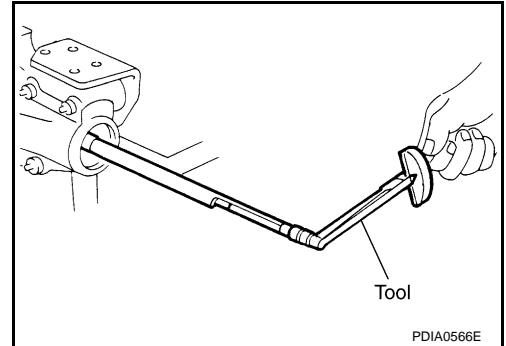

7. Place the J-34309-11 "R200A" pinion height adapter onto the gauge plate and tighten it by hand.

**CAUTION:**  
Make sure all machined surfaces are clean.

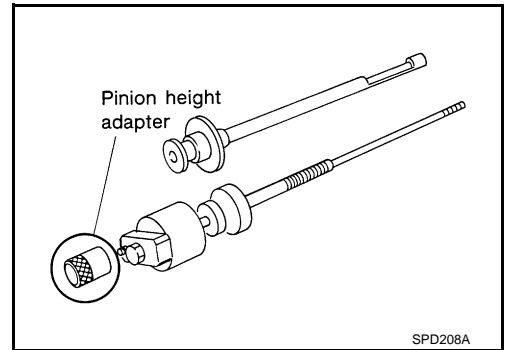

8. Position the side bearing discs, J-25269-4, and arbor firmly into the side bearing bores. Install the bearing caps and tighten bearing cap mounting bolts to the specified torque.

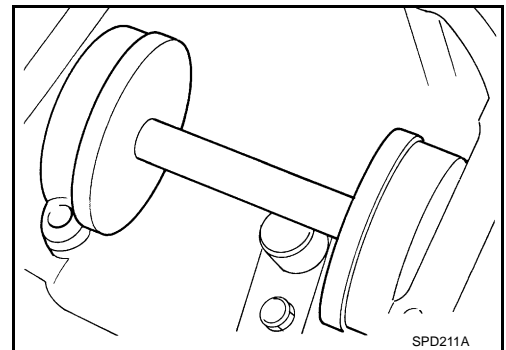

9. Select the correct standard pinion height adjusting washer thickness. Select by using a standard gauge of 3 mm (0.12 in) and your J-34309-101 feeler gauge. Measure the distance between the J-34309-11 pinion height adapter including the standard gauge and the arbor.

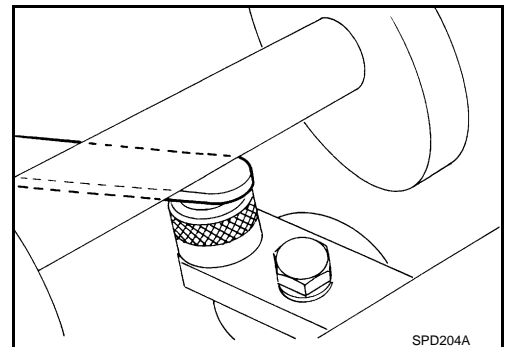

# DRIVE PINION

< DISASSEMBLY AND ASSEMBLY >

[REAR FINAL DRIVE: R200V]

10. Write down exact measurement (the value of feeler gauge).

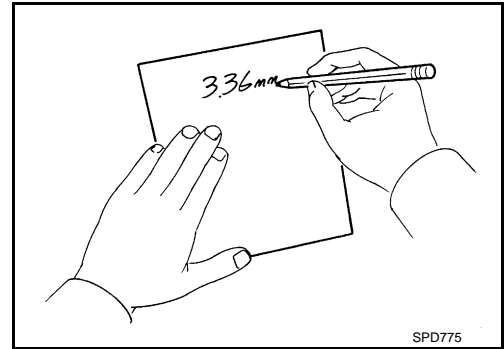

11. Correct the pinion height washer size by referring to the “pinion head number”.

**There are two numbers painted on the drive pinion. The first one refers to the drive pinion and drive gear as a matched set. This number should be the same as the number on the drive gear. The second number is the “pinion head height number”. It refers to the ideal pinion height from standard for quietest operation. Use the following chart to determine the correct pinion height washer.**

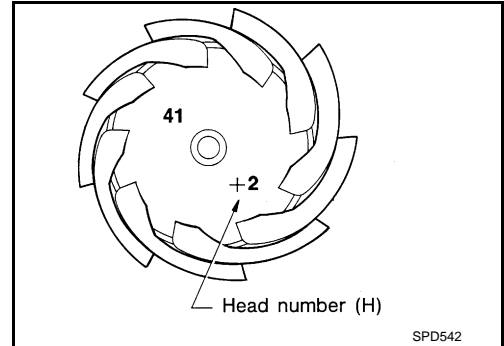

Pinion head height number	Add or remove from the standard pinion height adjusting washer thickness measurement
-6	Add 0.06 mm (0.0024 in)
-5	Add 0.05 mm (0.0020 in)
-4	Add 0.04 mm (0.0016 in)
-3	Add 0.03 mm (0.0012 in)
-2	Add 0.02 mm (0.0008 in)
-1	Add 0.01 mm (0.0004 in)
0	Use the selected washer thickness
+1	Subtract 0.01 mm (0.0004 in)
+2	Subtract 0.02 mm (0.0008 in)
+3	Subtract 0.03 mm (0.0012 in)
+4	Subtract 0.04 mm (0.0016 in)
+5	Subtract 0.05 mm (0.0020 in)
+6	Subtract 0.06 mm (0.0024 in)

12. Select the correct pinion height adjusting washer.

13. Remove the J-34309 differential shim selector tool from the final drive housing. Then disassemble to retrieve the pinion bearings.

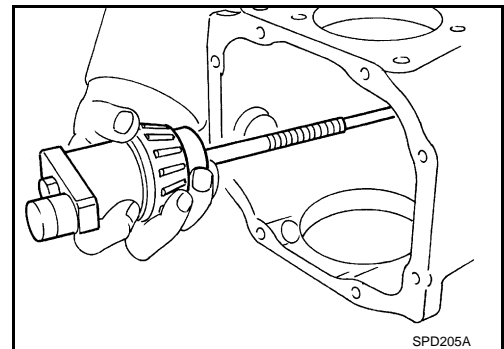

DRIVE PINION RUNOUT

A  
B  
C  
DLN  
E  
F  
G  
H  
I  
J  
K  
L  
M  
N  
O  
P

# DRIVE PINION

## < DISASSEMBLY AND ASSEMBLY >

[REAR FINAL DRIVE: R200V]

1. Set a dial indicator (A) vertically to the tip of the drive pinion.
2. Rotate drive pinion to check for runout.

### Limit

### Drive pinion runout

: Refer to [DLN-287, "Drive Pinion Runout \(A/T Models\)"](#).

3. If the runout value is outside of the limit, possible cause will be an assembly malfunction of drive pinion and pinion bearing and malfunction of pinion bearing. Check for these items and repair if necessary.

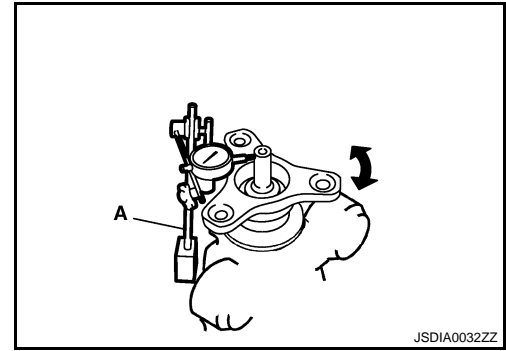

JSDIA0032ZZ

## A/T : Inspection After Disassembly

INFOID:000000000957461

Clean up the disassembled parts. Then, inspect if the parts are worn or damaged. If so, follow the measures below.

Content	Conditions and Measures
Hypoid gear	<ul style="list-style-type: none"> <li>• If the gear teeth do not mesh or line-up correctly, determine the cause and adjust or replace as necessary.</li> <li>• If the gears are worn, cracked, damaged, pitted or chipped (by friction) noticeably, replace with new drive gear and drive pinion as a set.</li> </ul>
Bearing	<ul style="list-style-type: none"> <li>• If any chipped (by friction), pitted, worn, rusted or scratched mark, or unusual noise from the bearing is observed, replace as a bearing assembly (as a new set).</li> </ul>
Side gear and Pinion mate gear	<ul style="list-style-type: none"> <li>• If any cracks or damage on the surface of the tooth is found, replace.</li> <li>• If any worn or chipped mark on the contact sides of the thrust washer is found, replace.</li> </ul>
Side gear thrust washer and pinion mate thrust washer	<ul style="list-style-type: none"> <li>• If it is chipped (by friction), damaged, or unusually worn, replace.</li> </ul>
Oil seal	<ul style="list-style-type: none"> <li>• Whenever disassembled, replace.</li> <li>• If wear, deterioration of adherence (sealing force lips), or damage is detected on the lips, replace them.</li> </ul>
Differential case	<ul style="list-style-type: none"> <li>• If any wear or crack on the contact sides of the differential case is found, replace.</li> </ul>
Companion flange	<ul style="list-style-type: none"> <li>• If any chipped mark (about 0.1 mm, 0.004 in) or other damage on the contact sides of the lips of the companion flange is found, replace.</li> </ul>

# SERVICE DATA AND SPECIFICATIONS (SDS)

< SERVICE DATA AND SPECIFICATIONS (SDS)

[REAR FINAL DRIVE: R200V]

## SERVICE DATA AND SPECIFICATIONS (SDS)

### SERVICE DATA AND SPECIFICATIONS (SDS)

#### General Specification

INFOID:000000000957462

Applied model	2WD	AWD	
	VQ35HR		
	M/T	A/T	A/T
Final drive model	R200V (With LSD)		
Gear ratio	3.692		
Number of teeth (Drive gear/Drive pinion)	48/13		
Oil capacity (Approx.)	ℓ (US pt, Imp pt)	1.4 (3, 2-1/2)	
Number of pinion gears	4		
Drive pinion adjustment spacer type	Collapsible		

#### Drive Gear Runout

INFOID:000000000957463

Unit: mm (in)

Item	limit
Drive gear back face runout	0.05 (0.0020)

#### Differential Side Gear Clearance

INFOID:000000000957464

Unit: mm (in)

Item	Standard
Side gear backlash (Clearance between side gear and differential case)	0.15 (0.0059 in) or less (Each gear should rotate smoothly without excessive resistance during differential motion.)

#### Preload Torque

INFOID:000000000957465

Unit: N·m (kg·m, in·lb)

Item	Standard
Pinion bearing (P1)	2.65 – 3.23 (0.27 – 0.32, 24 – 28)
Side bearing (P2)	0.20 – 0.52 (0.02 – 0.05, 2 – 4)
Side bearing to pinion bearing (Total preload) (Total preload = P1 + P2)	2.84 – 3.75 (0.29 – 0.38, 26 – 33)

#### Backlash

INFOID:000000000957466

Unit: mm (in)

Item	Standard
Drive gear to drive pinion gear	0.10 – 0.15 (0.0039 – 0.0059)

#### Companion flange Runout (M/T Models)

INFOID:000000000957467

Unit: mm (in)

Item	Limit
Companion flange face runout	0.08 (0.0031)
Inner side of the companion flange runout	0.08 (0.0031)

#### Drive Pinion Runout (A/T Models)

INFOID:000000000957468

# SERVICE DATA AND SPECIFICATIONS (SDS)

< SERVICE DATA AND SPECIFICATIONS (SDS)

[REAR FINAL DRIVE: R200V]

Unit: mm (in)

Item	Limit
Tip of drive pinion runout	0.8 (0.031)