

WT

SECTION

ROAD WHEELS & TIRES

A
B
C
D

WT

CONTENTS

<p>BASIC INSPECTION 3</p> <p>DIAGNOSIS AND REPAIR WORKFLOW 3</p> <p style="padding-left: 20px;">Repair Work Flow3</p> <p>INSPECTION AND ADJUSTMENT 5</p> <p>TRANSMITTER WAKE UP OPERATION5</p> <p style="padding-left: 20px;">TRANSMITTER WAKE UP OPERATION : De- scription5</p> <p style="padding-left: 20px;">TRANSMITTER WAKE UP OPERATION : Spe- cial Repair Requirement5</p> <p>ID REGISTRATION PROCEDURE5</p> <p style="padding-left: 20px;">ID REGISTRATION PROCEDURE : Description.....5</p> <p style="padding-left: 20px;">ID REGISTRATION PROCEDURE : Special Re- pair Requirement5</p> <p>FUNCTION DIAGNOSIS 7</p> <p>TPMS 7</p> <p style="padding-left: 20px;">System Diagram7</p> <p style="padding-left: 20px;">System Description7</p> <p style="padding-left: 20px;">Component Parts Location8</p> <p style="padding-left: 20px;">Component Description9</p> <p>DIAGNOSIS SYSTEM (BCM)10</p> <p>COMMON ITEM10</p> <p style="padding-left: 20px;">COMMON ITEM : CONSULT-III Function (BCM - COMMON ITEM)10</p> <p>AIR PRESSURE MONITOR10</p> <p style="padding-left: 20px;">AIR PRESSURE MONITOR : Diagnosis Descrip- tion10</p> <p style="padding-left: 20px;">AIR PRESSURE MONITOR : CONSULT-III Func- tion (BCM - AIR PRESSURE MONITOR)12</p> <p>COMPONENT DIAGNOSIS14</p> <p>C1704, C1705, C1706, C1707 LOW TIRE PRESSURE14</p> <p style="padding-left: 20px;">Description14</p>	<p style="padding-left: 20px;">DTC Logic14</p> <p style="padding-left: 20px;">Diagnosis Procedure14</p> <p>C1708, C1709, C1710, C1711 TRANSMITTER (NO DATA)16</p> <p style="padding-left: 20px;">Description16</p> <p style="padding-left: 20px;">DTC Logic16</p> <p style="padding-left: 20px;">Diagnosis Procedure16</p> <p style="padding-left: 20px;">Special Repair Requirement17</p> <p>C1712, C1713, C1714, C1715 TRANSMITTER (CHECKSUM)19</p> <p style="padding-left: 20px;">Description19</p> <p style="padding-left: 20px;">DTC Logic19</p> <p style="padding-left: 20px;">Diagnosis Procedure19</p> <p style="padding-left: 20px;">Special Repair Requirement21</p> <p>C1716, C1717, C1718, C1719 TRANSMITTER (PRESSDATA)22</p> <p style="padding-left: 20px;">Description22</p> <p style="padding-left: 20px;">DTC Logic22</p> <p style="padding-left: 20px;">Diagnosis Procedure22</p> <p style="padding-left: 20px;">Component Inspection23</p> <p style="padding-left: 20px;">Special Repair Requirement23</p> <p>C1720, C1721, C1722, C1723 TRANSMITTER (CODE)24</p> <p style="padding-left: 20px;">Description24</p> <p style="padding-left: 20px;">DTC Logic24</p> <p style="padding-left: 20px;">Diagnosis Procedure24</p> <p style="padding-left: 20px;">Special Repair Requirement26</p> <p>C1724, C1725, C1726, C1727 TRANSMITTER (BATT VOLT)27</p> <p style="padding-left: 20px;">Description27</p> <p style="padding-left: 20px;">DTC Logic27</p> <p style="padding-left: 20px;">Diagnosis Procedure27</p> <p style="padding-left: 20px;">Special Repair Requirement29</p> <p>C1729 VEHICLE SPEED SIG ERR30</p> <p style="padding-left: 20px;">Description30</p>
---	--

F
G
H
I
J
K
L
M
N
O
P

DTC Logic	30	Description	80
Diagnosis Procedure	30	Diagnosis Procedure	80
Special Repair Requirement	30		
C1734 CONTROL UNIT	31	LOW TIRE PRESSURE WARNING LAMP	
Description	31	BLINKS	82
DTC Logic	31	Description	82
Diagnosis Procedure	31	Diagnosis Procedure	82
Special Repair Requirement	32	TURN SIGNAL LAMP BLINKS	83
POWER SUPPLY AND GROUND CIRCUIT	33	Description	83
		Diagnosis Procedure	83
BCM (BODY CONTROL MODULE)	33	ID REGISTRATION CANNOT BE COMPLET-	
BCM (BODY CONTROL MODULE) : Diagnosis		ED	84
Procedure	33	Description	84
BCM (BODY CONTROL MODULE) : Special Re-		Diagnosis Procedure	84
pair Requirement	33	NORMAL OPERATING CONDITION	85
UNIFIED METER AND A/C AMP.	33	Description	85
UNIFIED METER AND A/C AMP. : Description	33	NOISE, VIBRATION AND HARSHNESS	
UNIFIED METER AND A/C AMP. : Diagnosis Pro-		(NVH) TROUBLESHOOTING	86
cedure	34	NVH Troubleshooting Chart	86
TPMS	35	PRECAUTION	87
Description	35	PRECAUTIONS	87
Wiring Diagram - TIRE PRESSURE MONITOR-		Service Notice or Precautions	87
ING SYSTEM -	36	PREPARATION	88
TIRE PRESSURE RECEIVER	40	PREPARATION	88
Description	40	Special Service Tools	88
Diagnosis Procedure	40	Commercial Service Tools	88
TIRE PRESSURE WARNING CHECK		ON-VEHICLE MAINTENANCE	89
SWITCH	42	ROAD WHEEL	89
Description	42	Inspection	89
Diagnosis Procedure	42	ON-VEHICLE REPAIR	90
ECU DIAGNOSIS	43	ROAD WHEEL TIRE ASSEMBLY	90
		Adjustment	90
BCM (BODY CONTROL MODULE)	43	REMOVAL AND INSTALLATION	93
Reference Value	43	TRANSMITTER	93
Wiring Diagram — BCM —	66	Exploded View	93
Fail Safe	71	Removal and Installation	93
DTC Inspection Priority Chart	73	SERVICE DATA AND SPECIFICATIONS	
DTC Index	74	(SDS)	95
SYMPTOM DIAGNOSIS	77	SERVICE DATA AND SPECIFICATIONS	
		(SDS)	95
TPMS	77	Road Wheel	95
Symptom Table	77	Tire	95
LOW TIRE PRESSURE WARNING LAMP			
DOES NOT TURN ON	79		
Description	79		
Diagnosis Procedure	79		
LOW TIRE PRESSURE WARNING LAMP			
STAYS ON	80		

DIAGNOSIS AND REPAIR WORKFLOW

< BASIC INSPECTION >

BASIC INSPECTION

DIAGNOSIS AND REPAIR WORKFLOW

Repair Work Flow

INFOID:000000000957854

DETAILED FLOW

1. VERIFY CUSTOMER COMPLAINTS

- Interview the customer to obtain detailed information about the symptom.

>> GO TO 2.

2. DETERMINE REFERENCE ITEM RELATED TO SYMPTOM

- Check the symptom on the vehicle from the information obtained.
(cruise test, warning lamp illumination or blinking, etc.)

Is the symptom confirmed?

YES >> GO TO 3.

NO >> GO TO 4.

3. PRELIMINARY INSPECTION

- Perform basic inspection.
 - Check all tire pressures. Refer to [WT-95, "Tire"](#).
 - Check the low tire pressure warning lamp for illumination or blinking. Refer to [WT-77, "Symptom Table"](#).

Is the malfunction corrected?

YES >> INSPECTION END

NO >> GO TO 4.

4. PERFORM SELF-DIAGNOSIS

1. Perform self-diagnosis. Record any DTCs and data displayed on CONSULT-III.
2. Perform inspection according to the displayed DTC. Refer to [WT-74, "DTC Index"](#).

Is the causal factor identified from DTC?

YES >> GO TO 6.

NO >> GO TO 5.

5. CHECK SYMPTOM

- Perform troubleshooting by symptom. Refer to [WT-77, "Symptom Table"](#).

Is the causal factor identified?

YES >> GO TO 6.

NO >> GO TO 4.

6. REPAIR OR REPLACE MULFUNCTIONING PARTS

- Repair or replace the applicable part.

>> GO TO 7.

7. CHECK SELF-DIAGNOSIS RESULT

1. Erase DTCs. Refer to [WT-10, "AIR PRESSURE MONITOR : Diagnosis Description"](#).
2. Perform self-diagnosis again.

Is any DTC displayed?

YES >> GO TO 4.

NO >> GO TO 8.

8. FINAL CHECK

1. Perform a cruise test.
2. Check the warning lamp for illumination or blinking.

A

B

C

D

WT

F

G

H

I

J

K

L

M

N

O

P

DIAGNOSIS AND REPAIR WORKFLOW

< BASIC INSPECTION >

Is the malfunction corrected?

YES >> INSPECTION END

NO >> GO TO 4.

INSPECTION AND ADJUSTMENT

< BASIC INSPECTION >

INSPECTION AND ADJUSTMENT TRANSMITTER WAKE UP OPERATION

TRANSMITTER WAKE UP OPERATION : Description

INFOID:000000000957856

This procedure must be done after replacement of a transmitter, BCM, or rotating wheels.

TRANSMITTER WAKE UP OPERATION : Special Repair Requirement

INFOID:000000000957856

1. TRANSMITTER WAKE UP OPERATION

1. With the activation tool (J-45295) pushed against the front-left transmitter, press and hold the button 5 seconds.

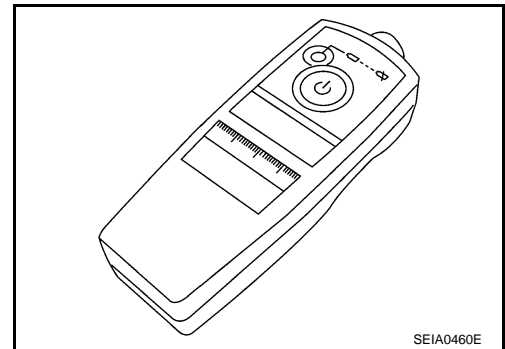

2. When ignition switch ON, as the low tire pressure warning lamp blinks per the follow diagram, the respective transmitter then must be woken up.

Low tire pressure warning lamp blinking timing		Activation tire position
ON OFF		a : 0.3 sec. b : 1.3 sec. Front LH
ON OFF		a : 0.3 sec. b : 1.3 sec. Front RH
ON OFF		a : 0.3 sec. b : 1.3 sec. Rear RH
ON OFF		a : 0.3 sec. b : 1.3 sec. Rear LH
ON OFF		a : 2 sec. b : 0.2 sec. All tires

3. Register the ID of wheel that warning lamp flashes. When wake up of registered wheel has been completed, turn signal lamp flashes two times.

SEIA0762E

4. After completing wake up all transmitters, make sure low tire pressure warning lamp goes out.

>> Perform ID registration procedure. Refer to [WT-5, "ID REGISTRATION PROCEDURE : Special Repair Requirement"](#).

ID REGISTRATION PROCEDURE

ID REGISTRATION PROCEDURE : Description

INFOID:000000000957857

This procedure must be done after replacing or rotating wheels, replacing transmitter or BCM.

ID REGISTRATION PROCEDURE : Special Repair Requirement

INFOID:000000000957858

1. ID REGISTRATION PREPARATION

1. Touch "WORK SUPPORT" on "SELECT DIAG MODE" screen, and select "ID REGIST".

Is the transmitter activation tool used for ID registration?

INSPECTION AND ADJUSTMENT

< BASIC INSPECTION >

- YES >> GO TO 2.
NO >> GO TO 3.

2.ID REGISTRATION (WITH TRANSMITTER ACTIVATION TOOL)

- With the transmitter activation tool (J-45295) pushed against the front-left transmitter position of the air valve, press and hold the button for 5 seconds.
- Register the IDs in order from FR LH, FR RH, RR RH, to RR LH.
When ID registration of each wheel has been completed, turn signal lamp blinks.

Activation tire position		Turn signal lamp	CONSULT-III
1	Front LH	2 times flashing	"Red" ↓ "Green"
2	Front RH		
3	Rear RH		
4	Rear LH		

- After completing all ID registrations, press "END" to complete the procedure.

NOTE:

Be sure to register the IDs in order from FR LH, FR RH, RR RH, to RR LH, or the self-diagnostic results display will not function properly.

Can ID registration of all transmitters be completed?

- YES >> ID registration END
NO >> Inspect the tire pressure monitoring system. Refer to [WT-16, "Diagnosis Procedure"](#).

3.ID REGISTRATION (WITHOUT TRANSMITTER ACTIVATION TOOL)

- Adjust the tire pressure to the values shown in the table below for ID registration, and drive the vehicle at 40 km/h (25 MPH) or more for several minutes.

NOTE:

If ID registration is unable, buzzer beeps.

Tire position	Tire pressure kPa (kg/cm ² , psi)
Front LH	240 (2.4, 34)
Front RH	220 (2.2, 31)
Rear RH	200 (2.0, 29)
Rear LH	180 (1.8, 26)

- After completing all ID registrations, press "END" to complete procedure.

Activation tire position	CONSULT-III
Front LH	"Red" ↓ "Green"
Front RH	
Rear RH	
Rear LH	

- Inflate all tires to proper pressure. Refer to [WT-95, "Tire"](#).

Can ID registration of all transmitters be completed?

- >> ID registration END
>> Inspect the tire pressure monitoring system. Refer to [WT-16, "Diagnosis Procedure"](#).

TPMS

< FUNCTION DIAGNOSIS >

FUNCTION DIAGNOSIS

TPMS

System Diagram

INFOID:000000000957859

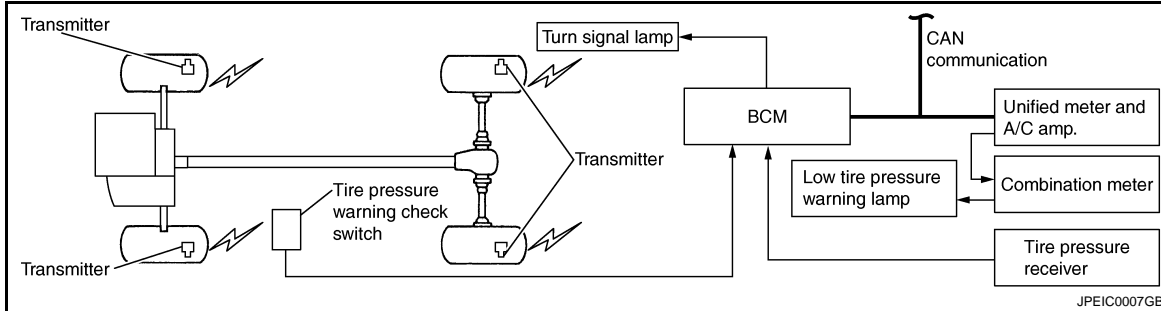

System Description

INFOID:000000000957860

DISCRIPTION

During driving, the TPMS (Tire Pressure Monitoring System) receives the signal transmitted from transmitter installed in each wheel, when the tire pressure becomes low. The BCM (Body Control Module) of this system has pressure judgment and trouble diagnosis functions. When the tire pressure monitoring system detects low inflation pressure or another unusual symptom, the warning lamps in the combination meter comes on.

TRANSMITTER

A sensor-transmitter (1) integrated with a valve is installed on a wheel (2), and transmits a detected air pressure signal in the form of a radio wave.

↔ : Outside

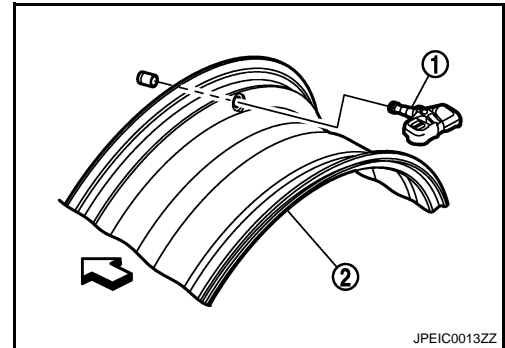

TIRE PRESSURE RECEIVER

The tire pressure receiver (1) receives the air pressure signal transmitted by the transmitter in each wheel.

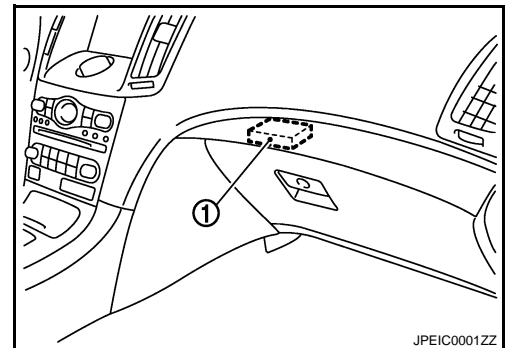

BCM (BODY CONTROL MODULE)

A
B
C
D
WT
F
G
H
I
J
K
L
M
N
O
P

TPMS

< FUNCTION DIAGNOSIS >

The BCM (1) reads the air pressure signal received by the tire pressure receiver, and controls the low tire pressure warning lamp and the buzzer operations. It also has a judgment function to detect a system malfunction.

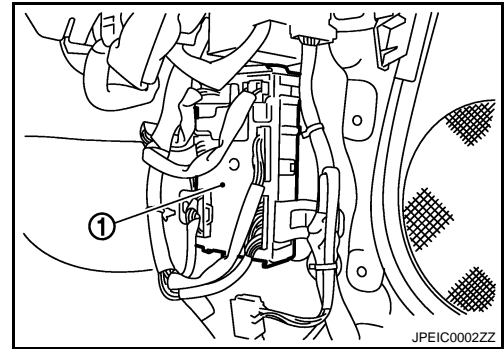

LOW TIRE PRESSURE WARNING LAMP

The combination meter receives tire pressure status from the BCM using CAN communication. When a low tire pressure condition is sensed by the BCM, the combination meter low tire pressure warning lamp is activated.

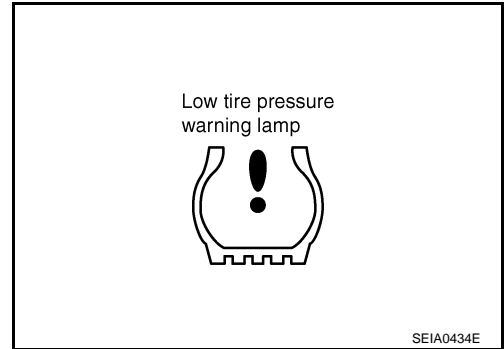

Low tire pressure warning lamp indication

Condition	Low tire pressure warning lamp
Less than 181 kPa (1.8 kg/cm ² , 26 psi) [NOTE]	ON
Low tire pressure warning system malfunction [Other diagnostic item]	Warning lamp flashes 1 min, then turns ON.

NOTE: Standard air pressure is for 230 kPa (2.3 kg/cm², 33 psi) vehicles.

TIRE PRESSURE WARNING CHECK SWITCH

The following item can be checked by grounding the tire pressure warning check switch (1) harness connector terminal.

- The low tire pressure warning lamp in the combination meter will flicker according to the self-diagnostic results.

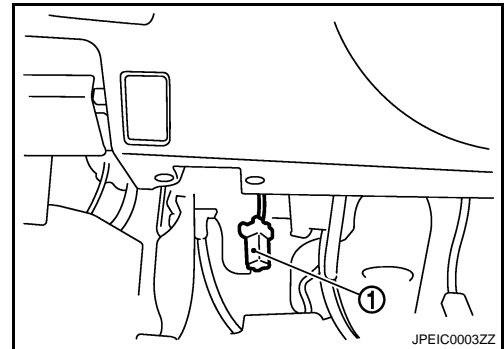

Component Parts Location

INFOID:000000000957861

TPMS

< FUNCTION DIAGNOSIS >

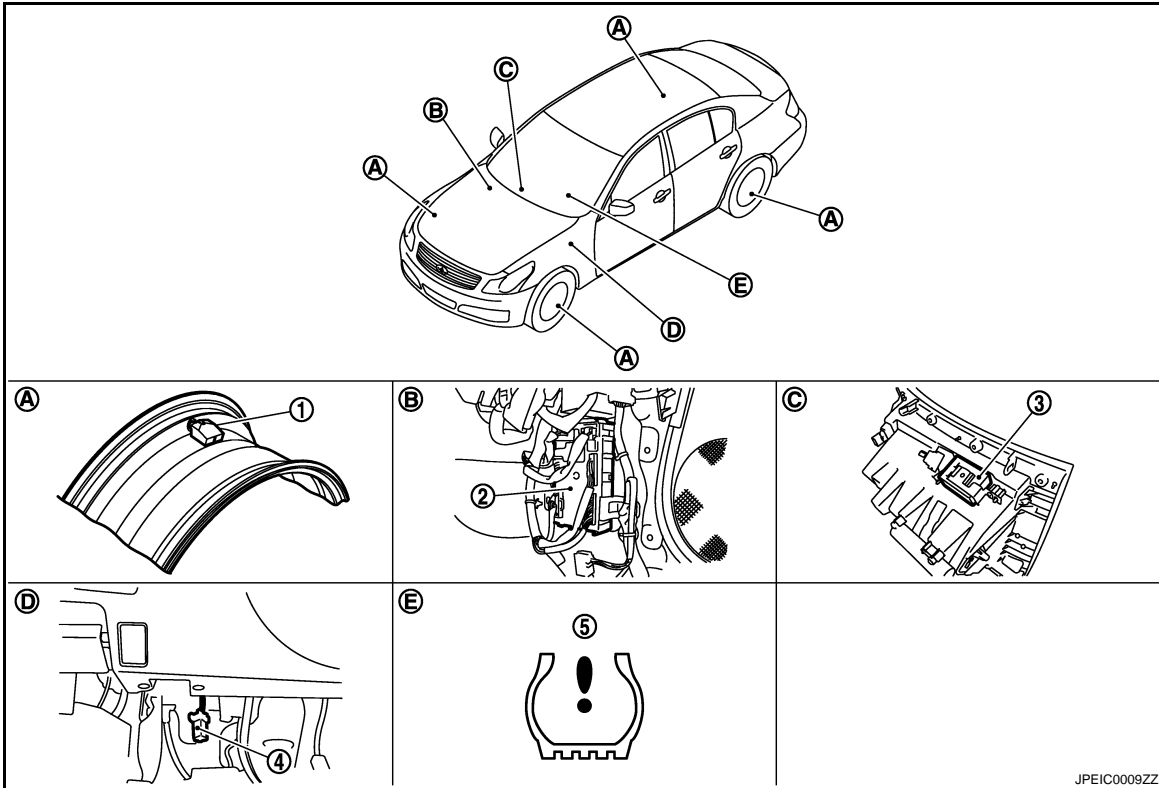

- | | | |
|--|-------------------------------------|---------------------------|
| 1. Transmitter | 2. BCM | 3. Tire pressure receiver |
| 4. Tire pressure warning check switch | 5. Low tire pressure warning lamp | |
| A. Wheel | B. Dash side lower (passenger side) | C. Upper glove box body |
| D. Behind instrument lower panel (driver side) | E. Inside combination meter | |

Component Description

INFOID:000000000957862

Component parts	Function
BCM (Body Control Module)	A tire pressure monitoring system is built in to the BCM, and the BCM monitors tire pressure.
Transmitter	Converts tire pressure signals to radio wave signals.
Tire pressure receiver	Receives radio wave signals converted from tire pressure signals.
Tire pressure warning check switch	Allows a mode to be switched to a diagnosis mode.
Turn signal lamp	ID registration of each wheel has been completed, turn signal lamp flashes.
Combination meter	Controls a low tire pressure warning lamp, turn signal lamp, and buzzer by signals from the unified meter and A/C amp.
Low tire pressure warning lamp	Illuminates if malfunction is detected in electrical system of TPMS.
Unified meter and A/C amp.	Transmits the vehicle speed signal via CAN communication to BCM. Receives the tire pressure signal via CAN communication to BCM.

DIAGNOSIS SYSTEM (BCM)

< FUNCTION DIAGNOSIS >

DIAGNOSIS SYSTEM (BCM)

COMMON ITEM

COMMON ITEM : CONSULT-III Function (BCM - COMMON ITEM)

INFOID:000000000957863

APPLICATION ITEM

CONSULT-III performs the following functions via CAN communication with BCM.

Diagnosis mode	Function Description
WORK SUPPORT	Changes the setting for each system function.
SELF-DIAG RESULTS	Displays the diagnosis results judged by BCM. Refer to BCS-74, "DTC Index" .
CAN DIAG SUPPORT MNTR	Monitors the reception status of CAN communication viewed from BCM.
DATA MONITOR	The BCM input/output signals are displayed.
ACTIVE TEST	The signals used to activate each device are forcibly supplied from BCM.
ECU IDENTIFICATION	The BCM part number is displayed.
CONFIGURATION	This function is not used even though it is displayed.

SYSTEM APPLICATION

BCM can perform the following functions for each system.

NOTE:

It can perform the diagnosis modes except the following for all sub system selection items.

System	Sub system selection item	Diagnosis mode		
		WORK SUPPORT	DATA MONITOR	ACTIVE TEST
Door lock	DOOR LOCK	×	×	×
Rear window defogger	REAR DEFOGGER		×	×
Warning chime	BUZZER		×	×
Interior room lamp timer	INT LAMP	×	×	×
Exterior lamp	HEAD LAMP	×	×	×
Wiper and washer	WIPER	×	×	×
Turn signal and hazard warning lamps	FLASHER	×	×	×
Air conditioner*	AIR CONDITONER		×	
Intelligent Key system	INTELLIGENT KEY	×	×	×
Combination switch	COMB SW		×	
BCM	BCM	×		
IVIS - NATS	IMMU		×	×
Interior room lamp battery saver	BATTERY SAVER	×	×	×
Trunk open	TRUNK		×	
Vehicle security system	THEFT ALM	×	×	×
RAP system	RETAINED PWR		×	
Signal buffer system	SIGNAL BUFFER		×	×
TPMS	TPMS (AIR PRESSURE MONI-TOR)	×	×	×

*: This item is displayed, but is not used.

AIR PRESSURE MONITOR

AIR PRESSURE MONITOR : Diagnosis Description

INFOID:000000000957864

DESCRIPTION

DIAGNOSIS SYSTEM (BCM)

< FUNCTION DIAGNOSIS >

During driving, the TPMS receives the signal transmitted from the transmitter installed in each wheel, when the tire pressure becomes low. The control unit (BCM) of this system has pressure judgment and trouble diagnosis functions.

When the TPMS detects low inflation pressure or another unusual symptom, the warning lamps in the combination meter comes on.

SELF DIAGNOSTIC PROCEDURE (WITH CONSULT-III)

☑ With CONSULT-III

- Touch "SELF-DIAG RESULT" display shows malfunction experienced since the last erasing operation. Refer to [WT-74, "DTC Index"](#).

SELF DIAGNOSTIC PROCEDURE (WITHOUT CONSULT-III)

☒ Without CONSULT-III

To start the self-diagnostic results mode, ground terminal of the tire pressure warning check connector. The malfunction location is indicated by the warning lamp flashing.

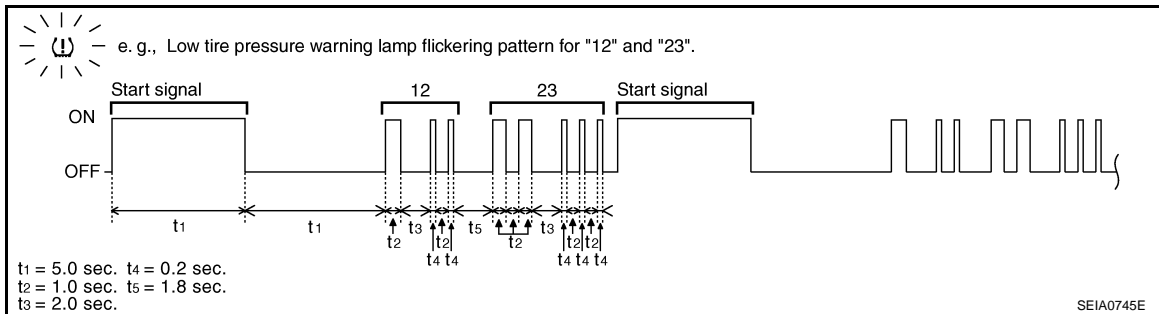

NOTE:

When the low tire warning lamp flashes 5 Hz and continues repeating it, the system is normal.

Flickering pattern	Items	Diagnostic items detected when...	Check item
15	Tire pressure value (Front LH)	Front LH tire pressure drops to 181 kPa (1.8 kg/cm ² , 26 psi) or less.	-
16	Tire pressure value (Front RH)	Front RH tire pressure drops to 181 kPa (1.8 kg/cm ² , 26 psi) or less.	
17	Tire pressure value (Rear RH)	Rear RH tire pressure drops to 181 kPa (1.8 kg/cm ² , 26 psi) or less.	
18	Tire pressure value (Rear LH)	Rear LH tire pressure drops to 181 kPa (1.8 kg/cm ² , 26 psi) or less.	
21	Transmitter no data (Front LH)	Data from front LH transmitter can not be received.	WT-16
22	Transmitter no data (Front RH)	Data from front RH transmitter can not be received.	
23	Transmitter no data (Rear RH)	Data from Rear RH transmitter can not be received.	
24	Transmitter no data (Rear LH)	Data from Rear LH transmitter can not be received.	
31	Transmitter checksum error (Front LH)	Checksum data from front LH transmitter is malfunctioning.	WT-19
32	Transmitter checksum error (Front RH)	Checksum data from front RH transmitter is malfunctioning.	
33	Transmitter checksum error (Rear RH)	Checksum data from rear RH transmitter is malfunctioning.	
34	Transmitter checksum error (Rear LH)	Checksum data from rear RH transmitter is malfunctioning.	
35	Transmitter pressure data error (Front LH)	Air pressure data from front LH transmitter is malfunction.	WT-22
36	Transmitter pressure data error (Front RH)	Air pressure data from front RH transmitter is malfunction.	
37	Transmitter pressure data error (Rear RH)	Air pressure data from rear RH transmitter is malfunction.	
38	Transmitter pressure data error (Rear LH)	Air pressure data from rear LH transmitter is malfunction.	

DIAGNOSIS SYSTEM (BCM)

< FUNCTION DIAGNOSIS >

Flickering pattern	Items	Diagnostic items detected when...	Check item
41	Transmitter function code error (Front LH)	Function code data from front LH transmitter is malfunction.	WT-24
42	Transmitter function code error (Front RH)	Function code data from front RH transmitter is malfunction.	
43	Transmitter function code error (Rear RH)	Function code data from rear RH transmitter is malfunction.	
44	Transmitter function code error (Rear LH)	Function code data from rear LH transmitter is malfunction.	
45	Transmitter battery voltage low (Front LH)	Battery voltage of front LH transmitter drops.	WT-27
46	Transmitter battery voltage low (Front RH)	Battery voltage of front RH transmitter drops.	
47	Transmitter battery voltage low (Rear RH)	Battery voltage of rear RH transmitter drops.	
48	Transmitter battery voltage low (Rear LH)	Battery voltage of rear LH transmitter drops.	
52	Vehicle speed signal error	Speed signal is not detected.	WT-30
53	BCM failure about TPMS	Tire pressure monitoring system malfunction in BCM	WT-31
No flickering	Tire pressure warning check switch	Tire pressure warning switch circuit is open.	-

ERASE SELF-DIAGNOSIS

With CONSULT-III

1. Perform applicable inspection of malfunctioning item and then repair or replace.
2. Turn ignition switch "ON" and select "SELF-DIAG RESULTS" mode for "AIR PRESSURE MONITOR" with CONSULT-III.
3. Touch "ERASE" on CONSULT-III screen to erase memory.

Without CONSULT-III

- In order to make it easier to find the cause of hard-to-duplicate malfunctions, malfunction information is stored into the control unit as necessary during use by the user. This memory is not erased no matter how many times the ignition switch is turned "ON" and "OFF".
- However, this information is erased by turning ignition switch "OFF" after performing self-diagnostic or by erasing the memory using the CONSULT-III.

AIR PRESSURE MONITOR : CONSULT-III Function (BCM - AIR PRESSURE MONITOR)

INFOID:000000000957865

WORK SUPPORT MODE

ID Read

The registered ID number is displayed.

ID Regist

Refer to [WT-5, "ID REGISTRATION PROCEDURE : Special Repair Requirement"](#).

SELF-DIAG RESULTS MODE

Operation Procedure

Refer to [WT-74, "DTC Index"](#).

DATA MONITOR MODE

Screen of data monitor mode is displayed.

NOTE:

When malfunction is detected, CONSULT-III perform REAL-TIME DIAGNOSIS. Also, any malfunction detected while in this mode will be displayed at real time.

DIAGNOSIS SYSTEM (BCM)

< FUNCTION DIAGNOSIS >

Display item list

Monitor	Condition	Specification	
VEHICLE SPEED	Drive vehicle.	Vehicle speed (km/h, MPH)	A
AIR PRESS FL AIR PRESS FR AIR PRESS RR AIR PRESS RL	<ul style="list-style-type: none"> • Drive vehicle for a few minutes. or • Ignition switch ON and activation tool is transmitting activation signals. 	Tire pressure (kPa or Psi)	B
ID REGST FL ID REGST FR ID REGST RR ID REGST RL	Ignition switch ON	Registration ID : DONE No registration : YET	C
WARNING LAMP		Low tire pressure warning lamp on: ON Low tire pressure warning lamp off: OFF	D
BUZZER		Buzzer in combination meter on: ON Buzzer in combination meter off: OFF	WT

NOTE:

Before performing the self-diagnosis, be sure to register the ID, or erase the actual malfunction location may be different from that displayed on CONSULT-III.

ACTIVE TEST MODE

NOTE:

Before performing the self-diagnosis, be sure to register the ID, or erase the actual malfunction may be different from that displayed on CONSULT-III.

TEST ITEM LIST

Test item	Content	
WARNING LAMP	This test is able to check to make sure that the warning lamp turns on.	I
ID REGIST WARNING	This test is able to check to make sure that the buzzer sounds or the warning lamp turns on.	
RUN FLAT/T WARN BUZZER	This test is able to check to make sure that the buzzer sounds.	
FLASHER	This test is able to check to make sure that each turn signal lamp turns on.	J
HORN	This test is able to check to make sure that the horn sounds.	

C1704, C1705, C1706, C1707 LOW TIRE PRESSURE

< COMPONENT DIAGNOSIS >

COMPONENT DIAGNOSIS

C1704, C1705, C1706, C1707 LOW TIRE PRESSURE

Description

INFOID:000000000957866

When the tire pressure monitoring system detects low inflation pressure, the warning lamps in the combination meter comes on.

DTC Logic

INFOID:000000000957867

DTC DETECTION LOGIC

DTC number	Trouble diagnosis name	DTC detecting condition	Possible cause
C1704	LOW PRESSURE FL	Front LH tire pressure drops to 181 kPa (1.8 kg/cm ² , 26 psi) or less.	• Tire pressure is low
C1705	LOW PRESSURE FR	Front RH tire pressure drops to 181 kPa (1.8 kg/cm ² , 26 psi) or less.	
C1706	LOW PRESSURE RR	Rear RH tire pressure drops to 181 kPa (1.8 kg/cm ² , 26 psi) or less.	
C1707	LOW PRESSURE RL	Rear LH tire pressure drops to 181 kPa (1.8 kg/cm ² , 26 psi) or less.	

DTC CONFIRMATION PROCEDURE

1. CHECK ID REGISTRATION AND VEHICLE DRIVING

 With CONSULT-III

Drive at a speed of 40 km/h (25 MPH) or more for 3 minutes, and then drive the vehicle at any speed for 10 minutes. Then check all tire pressure with CONSULT-III "DATA MONITOR" within 5 minutes.

Monitored item	Condition	Display value
AIR PRESS FL	Start engine and drive at 40 km/h (25 MPH) or more for several minutes.	Approximately equal to the indication on vehicle information display.
AIR PRESS FR		
AIR PRESS RR		
AIR PRESS RL		

Does "DATA MONITOR" displayed the standardized value without turning tire pressure warning lamp ON?

YES >> INSPECTION END

NO >> Go to diagnosis procedure. Refer to [WT-14, "Diagnosis Procedure"](#).

Diagnosis Procedure

INFOID:000000000957868

1. ADJUST TIRE AIR PRESSURE

1. Adjust all tire air pressures. Refer to [WT-95, "Tire"](#).

2. Check all tire air pressures.

Does all tire pressure data meet the specification?

YES >> GO TO 2.

NO >> Inspect or replace the tire or wheels and adjust the tire pressure to the specification.

2. CHECK AIR PRESSURE SIGNAL

Drive at a speed of 40 km/h (25 MPH) or more 3 minutes, and then drive the vehicle at any speed for 10 minutes. Then check all tire pressure with CONSULT-III "DATA MONITOR" within 5 minutes.

Monitored item	Condition	Display value
AIR PRESS FL	Start engine and drive at 40 km/h (25 MPH) or more for several minutes.	Approximately equal to the indication on vehicle information display.
AIR PRESS FR		
AIR PRESS RR		
AIR PRESS RL		

C1704, C1705, C1706, C1707 LOW TIRE PRESSURE

< COMPONENT DIAGNOSIS >

Does "DATA MONITOR" displayed the standardized value with out turning tire pressure warning lamp ON?

YES >> INSPECTION END

NO >> Inspect or replace the tire or wheels. Refer to [WT-87. "Service Notice or Precautions"](#).

A

B

C

D

WT

F

G

H

I

J

K

L

M

N

O

P

C1708, C1709, C1710, C1711 TRANSMITTER (NO DATA)

< COMPONENT DIAGNOSIS >

C1708, C1709, C1710, C1711 TRANSMITTER (NO DATA)

Description

INFOID:000000000957869

A sensor-transmitter integrated with a valve is installed on a wheel, and transmits a detected air pressure signal in the form of a radio wave.

DTC Logic

INFOID:000000000957870

DTC DETECTION LOGIC

DTC number	Trouble diagnosis name	DTC detecting condition	Possible cause
C1708	[NO DATA] FL	Data from front-left transmitter can not received.	<ul style="list-style-type: none">• Harness or connector (Tire pressure receiver, BCM)• ID registration is not finished• Transmitter malfunction
C1709	[NO DATA] FR	Data from front-right transmitter can not received.	
C1710	[NO DATA] RR	Data from rear-right transmitter can not received.	
C1711	[NO DATA] RL	Data from rear-left transmitter can not received.	

DTC CONFIRMATION PROCEDURE

1. CHECK ID REGISTRATION AND VEHICLE DRIVING

Ⓟ With CONSULT-III

1. Perform ID registration of all transmitters. Refer to [WT-5. "ID REGISTRATION PROCEDURE : Special Repair Requirement"](#).
2. Drive at a speed of 40 km/h (25 MPH) or more for 3 minutes, and then drive the vehicle at any speed for 10 minutes. Then check all tire pressure with CONSULT-III "DATA MONITOR" within 5 minutes.

Monitored item	Condition	Display value
AIR PRESS FL	Start engine and drive at 40 km/h (25 MPH) or more for several minutes.	Approximately equal to the indication on vehicle information display.
AIR PRESS FR		
AIR PRESS RR		
AIR PRESS RL		

Does "DATA MONITOR" displayed the standardized value without turning tire pressure warning lamp ON?

YES >> INSPECTION END

NO >> Go to diagnosis procedure. Refer to [WT-16. "Diagnosis Procedure"](#).

Diagnosis Procedure

INFOID:000000000957871

1. CHECK AIR PRESSURE SIGNAL

Ⓟ With CONSULT-III

1. Start engine
2. Select "DATA MONITOR" mode for "AIR PRESSURE MONITOR" with CONSULT-III.
3. Read out the value of "AIR PRESS FL", "AIR PRESS FR", "AIR PRESS RR", "AIR PRESS RL".

Monitored item	Condition	Display value
AIR PRESS FL	Start engine and drive at 40 km/h (25 MPH) or more for several minutes.	Approximately equal to the indication on vehicle information display
AIR PRESS FR		
AIR PRESS RR		
AIR PRESS RL		

Are all tire pressures displayed 0 kPa?

YES >> GO TO 2.

NO >> GO TO 4.

2. CHECK HARNESS BETWEEN BCM AND TIRE PRESSURE RECEIVER

1. Turn ignition switch "OFF".

C1708, C1709, C1710, C1711 TRANSMITTER (NO DATA)

< COMPONENT DIAGNOSIS >

2. Disconnect BCM harness connector and tire pressure receiver harness connector.
3. Check continuity between BCM harness connector and tire pressure receiver harness connector.

BCM		Tire pressure receiver		Continuity
Connector	Terminal	Connector	Terminal	
M123	137	M101	1	Existed
	138		4	
	139		2	

Also check harness for short to ground and short to power.

Is the inspection result normal?

- YES >> GO TO 3.
NO >> Repair or replace damaged parts.

3.CHECK TIRE PRESSURE RECEIVER

Check tire pressure receiver. Refer to [WT-40, "Diagnosis Procedure"](#).

Is the inspection result normal?

- YES >> Check BCM pin terminals for damage or loose connection with harness connector. If any items are damaged, repair or replace damage parts.
NO >> Replace the tire pressure receiver.

4.CHECK ID REGISTRATION

Perform ID registration of all transmitters. Refer to [WT-5, "ID REGISTRATION PROCEDURE : Special Repair Requirement"](#).

Can ID registration of all transmitters be completed?

- YES >> GO TO 5.
NO >> Replace malfunctioning transmitter, then GO TO 6.

5.CHECK TIRE PRESSURE MONITORING SYSTEM

 With CONSULT-III

1. Drive at a speed 40 km/h (25 MPH) or more for several minutes without stopping.
2. Check all tire pressures with CONSULT-III "DATA MONITOR" within 15 minutes after vehicle speed becomes 17 km/h (11 MPH).

Does "DATA MONITOR" displayed the standardized value without turning tire pressure warning lamp ON?

- YES >> INSPECTION END
NO >> Replace BCM. Refer to [BCS-79, "Removal and Installation"](#).

6.CHECK ID REGISTRATION

 With CONSULT-III

1. Perform ID registration of all transmitters. Refer to [WT-5, "ID REGISTRATION PROCEDURE : Special Repair Requirement"](#).
2. Drive at a speed 40 km/h (25 MPH) or more for 3 minutes, and then drive the vehicle at any speed for 10 minutes. Then check all tire pressures with CONSULT-III "DATA MONITOR" within 5 minutes.

Does "DATA MONITOR" displayed the standardized value without turning tire pressure warning lamp ON?

- YES >> INSPECTION END
NO >> Perform the self-diagnosis, inspect detected malfunction.

Special Repair Requirement

INFOID:000000000957872

1.CHECK TIRE AIR PRESSURE

Check all tire air pressures. Refer to [WT-95, "Tire"](#).

Does all tire pressure data meet the specification?

- YES >> GO TO 2.
NO >> Inspect or repair the tires or wheels and adjust the tire pressure to the specification.

2.PERFORM ID REGISTRATION

C1708, C1709, C1710, C1711 TRANSMITTER (NO DATA)

< COMPONENT DIAGNOSIS >

Perform ID registration. Refer to [WT-5. "ID REGISTRATION PROCEDURE : Special Repair Requirement"](#).

Can ID registration of all transmitters be completed?

YES >> END
NO >> GO TO 1.

C1712, C1713, C1714, C1715 TRANSMITTER (CHECKSUM)

< COMPONENT DIAGNOSIS >

C1712, C1713, C1714, C1715 TRANSMITTER (CHECKSUM)

Description

INFOID:000000000957873

A sensor-transmitter integrated with a valve is installed on a wheel, and transmits a detected air pressure signal in the form of a radio wave.

DTC Logic

INFOID:000000000957874

DTC DETECTION LOGIC

DTC	Trouble diagnosis name	DTC detecting condition	Possible case
C1712	[CHECKSUM ERR] FL	Checksum data from front-left transmitter is malfunction.	<ul style="list-style-type: none">• Tire pressure receiver malfunction• Transmitter malfunction• BCM malfunction
C1713	[CHECKSUM ERR] FR	Checksum data from front-right transmitter is malfunction.	
C1714	[CHECKSUM ERR] RR	Checksum data from rear-right transmitter is malfunction.	
C1715	[CHECKSUM ERR] RL	Checksum data from rear-left transmitter is malfunction.	

DTC CONFIRMATION PROCEDURE

1. VEHICLE DRIVING

Ⓜ With CONSULT-III

1. Driving at a speed 40 km/h (25 MPH) or more for 3 minutes, and then driving the vehicle at any speed for 10 minutes.
2. Check all tire pressure with CONSULT-III "DATA MONITOR" within 5 minutes.

Monitored item	Condition	Display value
AIR PRESS FL	Start engine and drive at 40 km/h (25 MPH) or more for several minutes.	Approximately equal to the indication on vehicle information display.
AIR PRESS FR		
AIR PRESS RR		
AIR PRESS RL		

Does "DATA MONITOR" displayed the standardized value without turning tire pressure warning lamp ON?

YES >> INSPECTION END

NO >> Go to diagnosis procedure. Refer to [WT-19, "Diagnosis Procedure"](#).

Diagnosis Procedure

INFOID:000000000957875

1. CHECK ID REGISTRATION

Ⓜ With CONSULT-III

1. Perform the ID registration of all transmitters. Refer to [WT-5, "ID REGISTRATION PROCEDURE : Special Repair Requirement"](#).
2. Drive at a speed of 40 km/h (25 MPH) or more for 3 minutes, and then drive the vehicle at any speed for 10 minutes. Then check all tire pressure with CONSULT-III "DATA MONITOR" within 5 minutes.

Can ID registration of all transmitters be completed?

YES >> GO TO 6.

NO >> GO TO 2.

2. CHECK AIR PRESSURE SIGNAL

Ⓜ With CONSULT-III

1. Start engine.
2. Select "DATA MONITOR" mode for "AIR PRESSURE MONITOR" with CONSULT-III.
3. Read out the value of "AIR PRESS FL", "AIR PRESS FR", "AIR PRESS RR" and "AIR PRESS RL".

C1712, C1713, C1714, C1715 TRANSMITTER (CHECKSUM)

< COMPONENT DIAGNOSIS >

Monitored item	Condition	Display value
AIR PRESS FL	Start engine and drive at 40 km/h (25 MPH) or more for several minutes.	Approximately equal to the indication on vehicle information display
AIR PRESS FR		
AIR PRESS RR		
AIR PRESS RL		

Are all tire pressures displayed 0 kPa?

- YES >> GO TO 3.
NO >> GO TO 5.

3.CHECK HARNESS BETWEEN BCM AND TIRE PRESSURE RECEIVER

1. Turn ignition switch "OFF".
2. Disconnect BCM harness connector and tire pressure receiver harness connector.
3. Check continuity between BCM harness connector and tire pressure receiver harness connector.

BCM		Tire pressure receiver		Continuity
Connector	Terminal	Connector	Terminal	
M123	137	M101	1	Existed
	138		4	
	139		2	

Also check harness for short to ground and short to power.

Is the inspection result normal?

- YES >> GO TO 4.
NO >> Repair or replace damaged parts.

4.CHECK TIRE PRESSURE RECEIVER

Check tire pressure receiver. Refer to [WT-40. "Diagnosis Procedure"](#).

Is the inspection result normal?

- YES >> Check BCM pin terminals for damage or loose connection with harness connector. If any items are damaged, repair or replace damaged parts.
NO >> Replace the tire pressure receiver.

5.CHECK ID REGISTRATION

Perform ID registration of all transmitters. Refer to [WT-5. "ID REGISTRATION PROCEDURE : Special Repair Requirement"](#).

Can ID registration of all transmitters be completed?

- YES >> GO TO 6.
NO >> GO TO 7 after malfunctioning transmitter replacement.

6.CHECK TIRE PRESSURE MONITORING SYSTEM

Ⓜ With CONSULT-III

1. Drive at a speed of 40 km/h (25 MPH) or more for several minutes without stopping.
2. Check all tire pressure with CONSULT-III "DATA MONITOR" within 15 minutes after vehicle speed becomes 17 km/h (11 MPH).

Does "DATA MONITOR" displayed the standardized value without turning tire pressure warning lamp ON?

- YES >> INSPECTION END
NO >> Replace BCM. Refer to [BCS-79. "Removal and Installation"](#).

7.CHECK ID REGISTRATION

Ⓜ With CONSULT-III

1. Perform ID registration of all transmitters. Refer to [WT-5. "ID REGISTRATION PROCEDURE : Special Repair Requirement"](#).
2. Drive at a speed of 40 km/h (25 MPH) or more for 3 minutes, and then drive the vehicle at any speed for 10 minutes. Then check all tire pressure with CONSULT-III "DATA MONITOR" within 5 minutes.

C1712, C1713, C1714, C1715 TRANSMITTER (CHECKSUM)

< COMPONENT DIAGNOSIS >

Does "DATA MONITOR" displayed the standardized value without turning tire pressure warning lamp ON?

YES >> INSPECTION END
NO >> GO TO 2.

A

Special Repair Requirement

INFOID:000000000957876

B

1. CHECK TIRE AIR PRESSURE

Check all tire air pressures. Refer to [WT-95, "Tire"](#).

C

Does all tire pressure data meet the specification?

YES >> GO TO 2.
NO >> Inspect or repair the tires or wheels and adjust the tire pressure to the specification.

D

2. PERFORM ID REGISTRATION

Perform ID registration. Refer to [WT-5, "ID REGISTRATION PROCEDURE : Special Repair Requirement"](#).

WT

Can ID registration of all transmitters be completed?

YES >> END
NO >> GO TO 1.

F

G

H

I

J

K

L

M

N

O

P

C1716, C1717, C1718, C1719 TRANSMITTER (PRESSDATA)

< COMPONENT DIAGNOSIS >

C1716, C1717, C1718, C1719 TRANSMITTER (PRESSDATA)

Description

INFOID:000000000957877

A sensor-transmitter integrated with a valve is installed on a wheel, and transmits a detected air pressure signal in the form of a radio wave.

DTC Logic

INFOID:000000000957878

DTC DETECTION LOGIC

DTC number	Trouble diagnosis name	DTC detecting condition	Possible case
C1716	[PRESSDATA ERR] FL	Air pressure data from front-left transmitter malfunction	<ul style="list-style-type: none">• ID registration is not finished• Transmitter malfunction
C1717	[PRESSDATA ERR] FR	Air pressure data from front-right transmitter malfunction	
C1718	[PRESSDATA ERR] RR	Air pressure data from rear-right transmitter malfunction	
C1719	[PRESSDATA ERR] RL	Air pressure data from rear-left transmitter malfunction	

DTC CONFIRMATION PROCEDURE

1. VEHICLE DRIVING

ⓐ With CONSULT-III

1. Drive at a speed 40 km/h (25 MPH) or more for 3 minutes, and then drive the vehicle at any speed for 10 minutes. Then check all tire pressure with CONSULT-III "DATA MONITOR" within 5 minutes.

Monitored item	Condition	Display value
AIR PRESS FL	Start engine and drive at 40 km/h (25MPH) or more for several minutes.	Approximately equal to the indication on vehicle information display.
AIR PRESS FR		
AIR PRESS RR		
AIR PRESS RL		

Does "DATA MONITOR" displayed tire pressure as normal without any warning lamp?

YES >> INSPECTION END

NO >> GO TO Diagnosis procedure. Refer to [WT-22, "Diagnosis Procedure"](#).

Diagnosis Procedure

INFOID:000000000957879

1. CHECK TIRE PRESSURE

ⓐ With CONSULT-III

1. Adjust tire pressure to specified value. Refer to [WT-95, "Tire"](#).
2. Perform the ID registration of all transmitters. Refer to [WT-5, "ID REGISTRATION PROCEDURE : Special Repair Requirement"](#).
3. Drive at a speed of 40 km/h (25 MPH) or more for several minutes without stopping.
4. Check all tire pressure with CONSULT-III "DATA MONITOR" within 15 minutes after vehicle speed become 17 km/h (11 MPH).

Monitored item	Condition	Display value
AIR PRESS FL	Start engine and drive at 40 km/h (25 MPH) or more for several minutes.	Approximately equal to the indication on vehicle information display.
AIR PRESS FL		
AIR PRESS FL		
AIR PRESS FL		

Is tire pressure indicated as 438.60 kPa (4.47kg/cm², 63.60 psi) on the "DATA MONITOR" screen?

YES >> Replace malfunctioning transmitter.

NO >> GO TO 2.

C1716, C1717, C1718, C1719 TRANSMITTER (PRESSDATA)

< COMPONENT DIAGNOSIS >

2.CHECK TIRE PRESSURE MONITORING SYSTEM

☑ With CONSULT-III

1. Perform the ID registration of all transmitters. Refer to [WT-5, "ID REGISTRATION PROCEDURE : Special Repair Requirement"](#).
2. Drive at a speed of 40 km/h (25 MPH) or more for 3 minutes, and then drive the vehicle at any speed for 10 minutes. Then check all tire pressures with CONSULT-III "DATA MONITOR" within 5 minutes.

Does "DATA MONITOR" displayed the standardized value without turning tire pressure warning lamp ON?

YES >> INSPECTION END

NO >> Perform the self-diagnosis, inspect detected malfunction. Refer to [WT-10, "AIR PRESSURE MONITOR : Diagnosis Description"](#).

Component Inspection

INFOID:000000000957880

1.CHECK TRANSMITTER

☑ With CONSULT-III

1. Adjust tire pressure to specified value. Refer to [WT-95, "Tire"](#).
2. Perform ID registration of all transmitters. Refer to [WT-5, "ID REGISTRATION PROCEDURE : Special Repair Requirement"](#).
3. Drive at a 40 km/h (25 MPH) or more for several minutes without stopping.
4. Check all tire pressure with CONSULT-III "DATA MONITOR" within 15 minutes after vehicle speed become 17 km/h (11 MPH).

Is tire pressure indicated as 438.60 kPa (4.47 kg/cm², 63.60 psi) on the "DATA MONITOR" screen?

YES >> Replace malfunctioning transmitter.

NO >> Check BCM and tire pressure receiver.

Special Repair Requirement

INFOID:000000000957881

1.CHECK TIRE AIR PRESSURE

Check all tire air pressures. Refer to [WT-95, "Tire"](#).

Does all tire pressure data meet the specification?

YES >> GO TO 2.

NO >> Inspect or repair the tires or wheels and adjust the tire pressure to the specification.

2.PERFORM ID REGISTRATION

Perform ID registration. Refer to [WT-5, "ID REGISTRATION PROCEDURE : Special Repair Requirement"](#).

Can ID registration of all transmitters be completed?

YES >> END

NO >> GO TO 1.

C1720, C1721, C1722, C1723 TRANSMITTER (CODE)

< COMPONENT DIAGNOSIS >

C1720, C1721, C1722, C1723 TRANSMITTER (CODE)

Description

INFOID:000000000957882

A sensor-transmitter integrated with a valve is installed on a wheel, and detected air pressure signal in the form of a radio wave.

DTC Logic

INFOID:000000000957883

DTC DETECTION LOGIC

DTC number	Trouble diagnosis name	DTC detecting condition	Possible case
C1720	[CODE ERR] FL	function code data from front-left transmitter is malfunction.	<ul style="list-style-type: none">• Tire pressure receiver malfunction• Transmitter malfunction• BCM malfunction
C1721	[CODE ERR] FR	function code data from front-right transmitter is malfunction.	
C1722	[CODE ERR] RR	function code data from rear-right transmitter is malfunction.	
C1723	[CODE ERR] RL	function code data from rear-left transmitter is malfunction.	

DTC CONFIRMATION PROCEDURE

1. VEHICLE DRIVING

Ⓜ With CONSULT-III

1. Driving at a speed of 40 km/h (25 MPH) or more for 3 minutes, and then drive the vehicle at any speed for 10 minutes.
2. Check all tire pressure with CONSULT-III "DATA MONITOR" within 5 minutes.

Monitored item	Condition	Display value
AIR PRESS FL	Start engine and drive at 40 km/h (25 MPH) or more for several minutes.	Approximately equal to the indication on vehicle information display.
AIR PRESS FR		
AIR PRESS RR		
AIR PRESS RL		

Does "DATA MONITOR" display the standardized value without turning tire pressure warning lamp ON?

- YES >> INSPECTION END
NO >> GO TO diagnosis procedure. Refer to [WT-24, "Diagnosis Procedure"](#).

Diagnosis Procedure

INFOID:000000000957884

1. CHECK ID REGISTRATION

Ⓜ With CONSULT-III

1. Perform the ID registration of all transmitters. Refer to [WT-5, "ID REGISTRATION PROCEDURE : Special Repair Requirement"](#).
2. Drive at a speed of 40 km/h (25 MPH) or more for 3 minutes, and then drive the vehicle at any speed for 10 minutes. Then check all tire pressure with CONSULT-III "DATA MONITOR" within 5 minutes.

Can ID registration of all transmitters be completed?

- YES >> GO TO 6.
NO >> GO TO 2.

2. CHECK ALL TIRE PRESSURE SIGNAL

Ⓜ With CONSULT-III

1. Start engine.
2. Select "DATA MONITOR" mode for "AIR PRESSUR MONITOR" with CONSULT-III.
3. Read out the value of "AIR PRESS FL", "AIR PRESS FR", "AIR PRESS RR" and "AIR PRESS RL".

C1720, C1721, C1722, C1723 TRANSMITTER (CODE)

< COMPONENT DIAGNOSIS >

Monitored item	Condition	Display value
AIR PRESS FL	Start engine and drive at 40 km/h (25 MPH) or more for several minutes.	Approximately equal to the indication on vehicle information display.
AIR PRESS FR		
AIR PRESS RR		
AIR PRESS RL		

Are all tire pressure displayed 0 kPa?

YES >> GO TO 3.

NO >> GO TO 5.

3. CHECK HARNESS BETWEEN BCM AND TIRE PRESSURE RECEIVER

1. Turn ignition switch "OFF".
2. Disconnect BCM harness connector and tire pressure receiver harness connector.
3. Check continuity between BCM harness connector and tire pressure receiver harness connector.

BCM		Tire pressure receiver		Continuity
Connector	Terminal	Connector	Terminal	
M123	137	M101	1	Existed
	138		4	
	139		2	

Also check harness for short to ground and short to power.

Is the inspection result normal?

YES >> GO TO 4.

NO >> Repair or replace damage parts.

4. CHECK TIRE PRESSURE RECEIVER

Check tire pressure receiver. Refer to [WT-40, "Diagnosis Procedure"](#).

Is the inspection result normal?

YES >> Check BCM pin terminals for damage or loose connection with harness connector. If any items are damaged, repair or replace damaged parts.

NO >> Replace the tire pressure receiver.

5. CHECK ID REGISTRATION

Perform ID registration of all transmitters. Refer to [WT-5, "ID REGISTRATION PROCEDURE : Special Repair Requirement"](#).

Can ID registration of all transmitters be completed?

YES >> GO TO 6.

NO >> GO TO 7 after malfunctioning transmitter replacement.

6. CHECK TIRE PRESSURE MONITORING SYSTEM

Ⓜ With CONSULT-III

1. Drive at a speed of 40 km/h (25 MPH) or more for several minutes without stopping.
2. Check all tire pressures with CONSULT-III "DATA MONITOR" within 15 minutes after vehicle speed become 17 km/h (11 MPH).

Does "DATA MONITOR" displayed the standardized value without turning tire pressure warning lamp ON?

YES >> INSPECTION END.

NO >> Replace BCM. Refer to [BCS-79, "Removal and Installation"](#).

7. CHECK ID REGISTRATION

Ⓜ With CONSULT-III

1. Perform ID registration of all transmitters. Refer to [WT-5, "ID REGISTRATION PROCEDURE : Special Repair Requirement"](#).
2. Drive at a speed of 40 km/h (25 MPH) or more for 3 minutes, and then drive the vehicle at any speed for 10 minutes. Then check all tire pressures with CONSULT-III "DATA MONITOR" within 5 minutes.

C1720, C1721, C1722, C1723 TRANSMITTER (CODE)

< COMPONENT DIAGNOSIS >

Does "DATA MONITOR" displayed the standardized value without turning tire pressure warning lamp ON?

YES >> INSPECTION END.

NO >> GO TO 2.

Special Repair Requirement

INFOID:000000000957885

1. CHECK TIRE AIR PRESSURE

Check all tire air pressures. Refer to [WT-95, "Tire"](#).

Does all tire pressure data meet the specification?

YES >> GO TO 2.

NO >> Inspect or repair the tires or wheels and adjust the tire pressure to the specification.

2. PERFORM ID REGISTRATION

Perform ID registration. Refer to [WT-5, "ID REGISTRATION PROCEDURE : Special Repair Requirement"](#).

Can ID registration of all transmitters be completed?

YES >> END

NO >> GO TO 1.

C1724, C1725, C1726, C1727 TRANSMITTER (BATT VOLT)

< COMPONENT DIAGNOSIS >

C1724, C1725, C1726, C1727 TRANSMITTER (BATT VOLT)

Description

INFOID:000000000957886

A sensor -transmitter integrated with a valve is installed on a wheel, and transmits a detected air pressure signal in the form of a radio wave.

DTC Logic

INFOID:000000000957887

DTC DETECTION LOGIC

DTC number	Trouble diagnosis name	DTC detecting condition	Possible case
C1724	[BATT VOLT LOW] FL	Battery voltage of front-left transmitter drops.	<ul style="list-style-type: none">• Transmitter malfunction• Tire pressure receiver malfunction• BCM malfunction
C1725	[BATT VOLT LOW] FR	Battery voltage of front-right transmitter drops.	
C1726	[BATT VOLT LOW] RR	Battery voltage of rear-right transmitter drops.	
C1727	[BATT VOLT LOW] RL	Battery voltage of rear-left transmitter drops.	

DTC CONFIRMATION PROCEDURE

1.VEHICLE DRIVING

ⓂWith CONSULT-III

Driving at a speed of 40 km/h (25 MPH) or more for 3 minutes, and then drive the vehicle at any speed 10minutes. Then check all tire pressure with CONSULT-III "DATA MONITOR" within 5 minutes.

Monitored item	Condition	Display value
AIR PRESS FL	Start engine and drive at 40 km/h (25 MPH) or more for several minutes.	Approximately equal to the indication on vehicle information display.
AIR PRESS FL		
AIR PRESS FL		
AIR PRESS FL		

Does "DATA MONITOR" displayed the standardized value without turning tire pressure warning lamp ON?

YES >> INSPECTION END

NO >> GO TO diagnosis procedure. Refer to [WT-27. "Diagnosis Procedure"](#).

Diagnosis Procedure

INFOID:000000000957888

1.CHECK ID REGISTRATION

ⓂWith CONSULT-III

1. Perform the ID registration of all transmitters. Refer to [WT-5. "ID REGISTRATION PROCEDURE : Special Repair Requirement"](#).
2. Drive at a speed of 40 km/h (25 MPH) or more for 3 minutes, and then drive the vehicle at any speed for 10 minutes. Then check all tire pressures with CONSULT-III "DATA MONITOR" within 5 minutes.

Can ID registration of all transmitters be completed?

YES >> GO TO 6.

NO >> GO TO 2.

2.CHECK AIR PRESSURE SIGNAL

ⓂWith CONSULT-III

1. Start engine.
2. Select "DATAMONITOR" mode for "AIR PRESSURE MONITOR" with CONSULT-III.
3. Read out the value of "AIR PRESS FL", "AIR PRESS FR", "AIR PRESS RR" and "AIR PRESS RL".

C1724, C1725, C1726, C1727 TRANSMITTER (BATT VOLT)

< COMPONENT DIAGNOSIS >

Monitored item	Condition	Display value
AIR PRESS FL	Start engine and drive at 40 km/h (25 MPH) or more for several minutes.	Approximately equal to the indication on vehicle information display
AIR PRESS FR		
AIR PRESS RR		
AIR PRESS RL		

Are all tire pressures displayed 0 kPa?

YES >> GO TO 3.

NO >> GO TO 5.

3. CHECK HARNESS BETWEEN BCM AND TIRE PRESSURE RECEIVER

1. Turn ignition switch "OFF".
2. Disconnect BCM harness connector and tire pressure receiver harness connector.
3. Check continuity between BCM harness connector and tire pressure receiver harness connector.

BCM		Tire pressure receiver		Continuity
Connector	Terminal	Connector	Terminal	
M123	137	M101	1	Existed
	138		4	
	139		2	

Also check harness for short to ground and short to power.

Is the inspection result normal?

YES >> GO TO 4.

NO >> Repair or replace damaged parts.

4. CHECK TIRE PRESSURE RECEIVER

Check tire pressure receiver. Refer to [WT-40. "Diagnosis Procedure"](#).

Is the inspection result normal?

YES >> Check BCM pin terminals for damage or loose connection with harness connector. If any items are damaged, repair or replace damaged parts.

NO >> Replace the tire pressure receiver.

5. CHECK ID REGISTRATION

Perform ID registration of all transmitters. Refer to [WT-5. "ID REGISTRATION PROCEDURE : Special Repair Requirement"](#).

Can ID registration of all transmitters be completed?

YES >> GO TO 6.

NO >> GO TO 7 after malfunctioning transmitter replacement.

6. CHECK TIRE PRESSURE MONITORING SYSTEM

Ⓜ With CONSULT-III

1. Drive at a speed for 40 km/h (25 MPH) or more several minutes without stopping.
2. Check all tire pressure with CONSULT-III "DATA MONITOR" within 15 minutes after vehicle speed becomes 17 km/h (11 MPH).

Does "DATA MONITOR" displayed the standardized value without turning tire pressure warning lamp ON?

YES >> INSPECTION END

NO >> Replace BCM. Refer to [BCS-79. "Removal and Installation"](#).

7. CHECK ID REGISTRATION

Ⓜ With CONSULT-III

1. Perform ID registration of all transmitters. Refer to [WT-5. "ID REGISTRATION PROCEDURE : Special Repair Requirement"](#).
2. Drive at a speed of 40 km/h (25 MPH) or more for 3 minutes, and then drive the vehicle at any speed for 10 minutes. Then check all tire pressures with CONSULT-III "DATA MONITOR" within 5 minutes.

C1724, C1725, C1726, C1727 TRANSMITTER (BATT VOLT)

< COMPONENT DIAGNOSIS >

Does "DATA MONITOR" displayed the standardized value without turning tire pressure warning lamp ON?

YES >> INSPECTION END

NO >> GO TO 2.

A

Special Repair Requirement

INFOID:000000000957889

B

1. CHECK TIRE AIR PRESSURE

Check all tire air pressures. Refer to [WT-95, "Tire"](#).

C

Does all tire pressure data meet the specification?

YES >> GO TO 2.

NO >> Inspect or repair the tires or wheels and adjust the tire pressure to the specification.

D

2. PERFORM ID REGISTRATION

Perform ID registration. Refer to [WT-5, "ID REGISTRATION PROCEDURE : Special Repair Requirement"](#).

WT

Can ID registration of all transmitters be completed?

YES >> END

NO >> GO TO 1.

F

G

H

I

J

K

L

M

N

O

P

C1729 VEHICLE SPEED SIG ERR

< COMPONENT DIAGNOSIS >

C1729 VEHICLE SPEED SIG ERR

Description

INFOID:000000000957890

BCM detects no vehicle speed signal.

DTC Logic

INFOID:000000000957891

DTC DETECTION LOGIC

DTC number	Trouble diagnosis name	DTC detecting condition	Possible case
C1729	VHCL SPEED SIG ERR	Vehicle speed signal error	<ul style="list-style-type: none">CAN communication errorCombination meter malfunctionVehicle speed signal malfunction Refer to SEC-51, "Description" .

DTC CONFIRMATION PROCEDURE

1.CHECK SELF-DIAGNOSTIC RESULTS

④With CONSULT-III

- On "SELECT DIAG MODE", select the "SELF-DIAG RESULT" screen.
- Check display contents in self-diagnostic results.

Is the "CAN COMM CIRCUIT" displayed in the self-diagnosis display?

YES >> Perform trouble diagnosis for CAN communication system. Refer to [LAN-18, "Trouble Diagnosis Flow Chart"](#).

NO >> Check unified meter. Refer to [MWI-46, "Diagnosis Procedure"](#).

Diagnosis Procedure

INFOID:000000000957892

1.CHECK SELF-DIAGNOSTIC RESULTS

④With CONSULT-III

- On "SELECT DIAG MODE", select the "SELF-DIAG RESULT" screen.
- Check display contents in self-diagnostic results.

Is the "CAN COMM CIRCUIT" displayed in the self-diagnosis display?

YES >> Perform trouble diagnosis for CAN communication system. Refer to [LAN-18, "Trouble Diagnosis Flow Chart"](#).

NO >> Check unified meter. Refer to [MWI-46, "Diagnosis Procedure"](#).

Special Repair Requirement

INFOID:000000000957893

1.CHECK TIRE AIR PRESSURE

Check all tire air pressures. Refer to [WT-95, "Tire"](#).

Does all tire pressure data meet the specification?

YES >> GO TO 2.

NO >> Inspect or repair the tires or wheels and adjust the tire pressure to the specification.

2.PERFORM ID REGISTRATION

Perform ID registration. Refer to [WT-5, "ID REGISTRATION PROCEDURE : Special Repair Requirement"](#).

Can ID registration of all transmitters be completed?

YES >> END

NO >> GO TO 1.

C1734 CONTROL UNIT

< COMPONENT DIAGNOSIS >

C1734 CONTROL UNIT

Description

INFOID:000000000957894

The BCM reads the air pressure signal received by the tire pressure receiver, and controls the low tire pressure warning lamp and the buzzer operations. It also has a judgment function to detect a system malfunction.

DTC Logic

INFOID:000000000957895

DTC DETECTION LOGIC

DTC number	Trouble diagnosis name	DTC detecting condition	Possible case
C1734	CONTROL UNIT	Tire pressure monitoring system in BCM is malfunctioning	BCM malfunction

DTC CONFIRMATION PROCEDURE

1.VEHICLE DRIVING

ⓂWith CONSULT-III

1. Drive at a speed 40 km/h (25 MPH) or more for several minutes without stopping.
2. Check all tire pressures with CONSULT-III "DATA MONITOR" within 15 minutes after vehicle speed become 17 km/h (11 MPH).

Does "DATA MONITOR" displayed the standardized value without turning tire pressure warning lamp ON?

YES >> INSPECTION END

NO >> Go to diagnosis procedure. Refer to [WT-31, "Diagnosis Procedure"](#).

Diagnosis Procedure

INFOID:000000000957896

1.CHECK SELF-DIAGNOSTIC RESULTS

ⓂWith CONSULT-III

1. On "SELECT DIAG" mode, select the "SELF-DIAG RESULT" screen.
2. Check display contents in self-diagnostic results.

Does self-diagnostic results indicate any malfunction?

YES >> Perform trouble diagnosis. Refer to [WT-74, "DTC Index"](#).

NO >> GO TO 2.

2.CHECK POWER SUPPLY

1. Turn ignition switch "OFF".
2. Disconnect BCM harness connector.
3. Check voltage between BCM harness connector terminals and ground.

(+)		(-)	Voltage (Approx.)
BCM		Ground	
Connector	Terminal		
M118	1		Battery voltage
M119	11		

Is the power supply normal?

YES >> GO TO 3.

NO >> Check the following. If any items are damaged, repair or replace damage parts.

- 40A fusible link [No. K located in the fuse block]. Refer to [PG-94, "Fuse and Fusible Link Arrangement"](#).
- 10A fuse [No. 10 located in the fuse block (J/B)]. Refer to [PG-93, "Fuse, Connector and Terminal Arrangement"](#).
- Harness for short or open between battery and BCM harness connector M118 terminal 1.
- Harness for short or open between battery and BCM harness connector M119 terminal 11.
- Check Battery voltage.

3.CHECK GROUND CIRCUIT

C1734 CONTROL UNIT

< COMPONENT DIAGNOSIS >

1. Turn ignition switch "OFF".
2. Disconnect BCM harness connector.
3. Check continuity between BCM harness connector M119 terminal 13 and ground.

BCM		Ground	Continuity
Connector	Terminal		Existed
M119	13		

Also check harness for short to ground.

Is the inspection result normal?

YES >> GO TO 5.

NO >> Repair open circuit or short to power in harness or connectors.

4.CHECK HARNESS BETWEEN BCM AND TIRE PRESSURE RECEIVER

1. Turn ignition switch "OFF"
2. Disconnect BCM harness connector and tire pressure receiver harness connector.
3. Check continuity between BCM harness connector and tire pressure receiver harness connector.

BCM		Tire pressure receiver		Continuity
Connector	Terminal	Connector	Terminal	
M123	137	M101	1	Existed
	138		4	
	139		2	

Also check harness for short to ground and short to power.

Is the inspection result normal?

YES >> GO TO 5.

NO >> Repair or replace damaged parts.

5.CHECK BCM

Check BCM input/output signal. Refer to [WT-43, "Reference Value"](#).

Is the inspection result normal?

YES >> INSPECTION END

NO >> GO TO 6.

6.CHECK BCM HARNESS CONNECTOR

Check BCM pin terminals for damage or loose connection with harness connector.

Is the inspection result normal?

YES >> Replace BCM. Refer to [BCS-79, "Removal and Installation"](#).

NO >> Repair or replace damaged parts.

Special Repair Requirement

INFOID:000000000957897

1.CHECK TIRE AIR PRESSURE

Check all tire air pressures. Refer to [WT-95, "Tire"](#).

Does all tire pressure data meet the specification?

YES >> GO TO 2.

NO >> Inspect or repair the tires or wheels and adjust the tire pressure to the specification.

2.PERFORM ID REGISTRATION

Perform ID registration. Refer to [WT-5, "ID REGISTRATION PROCEDURE : Special Repair Requirement"](#).

Can ID registration of all transmitters be completed?

YES >> END

NO >> GO TO 1.

POWER SUPPLY AND GROUND CIRCUIT

< COMPONENT DIAGNOSIS >

POWER SUPPLY AND GROUND CIRCUIT

BCM (BODY CONTROL MODULE)

BCM (BODY CONTROL MODULE) : Diagnosis Procedure

INFOID:000000000957898

1. CHECK FUSE AND FUSIBLE LINK

Check that the following fuse and fusible link are not blown.

Terminal No.	Signal name	Fuse and fusible link No.
1	Battery power supply	K
11		10

Is the fuse fusing?

YES >> Replace the blown fuse or fusible link after repairing the affected circuit if a fuse or fusible link is blown.

NO >> GO TO 2.

2. CHECK POWER SUPPLY CIRCUIT

1. Turn ignition switch OFF.
2. Disconnect BCM connectors.
3. Check voltage between BCM harness connector and ground.

Terminals		Voltage (Approx.)
(+)	(-)	
BCM		Ground Battery voltage
Connector	Terminal	
M118	1	
M119	11	

Is the measurement value normal?

YES >> GO TO 3.

NO >> Repair harness or connector.

3. CHECK GROUND CIRCUIT

Check continuity between BCM harness connector and ground.

BCM		Ground	Continuity
Connector	Terminal		
M119	13		Existed

Does continuity exist?

YES >> INSPECTION END

NO >> Repair harness or connector.

BCM (BODY CONTROL MODULE) : Special Repair Requirement

INFOID:000000000957899

1. REQUIRED WORK WHEN REPLACING BCM

Initialize IVIS by CONSULT-III. For the details of initialization refer to CONSULT-III operation manual NATS-IVIS/NVIS.

>> Work end.

UNIFIED METER AND A/C AMP.

UNIFIED METER AND A/C AMP. : Description

INFOID:000000000957900

POWER SUPPLY AND GROUND CIRCUIT

< COMPONENT DIAGNOSIS >

UNIFIED METER AND A/C AMP. : Diagnosis Procedure

INFOID:000000000957901

1.CHECK FUSE

Check for blown fuses.

Power source	Fuse No.
Battery	6
Ignition switch ACC or ON	19
Ignition switch ON or START	3

Is the inspection result normal?

YES >> GO TO 2.

NO >> Be sure to eliminate cause of malfunction before installing new fuse.

2.CHECK POWER SUPPLY CIRCUIT

Check voltage between unified meter and A/C amp. harness connector M67 terminals 54, 41, 53 and ground.

Terminal No.	Signal name	Ignition switch position	Value (Approx.)
54	Battery power supply	OFF	Battery voltage
41	ACC power supply	ACC	Battery voltage
53	Ignition signal	ON	Battery voltage

Is the inspection result normal?

YES >> GO TO 3.

NO >> Check harness between unified meter and A/C amp. and fuse.

3.CHECK GROUND CIRCUIT

1. Turn ignition switch OFF.
2. Disconnect unified meter and A/C amp. connector.
3. Check continuity between unified meter and A/C amp. harness connector M67 terminals 55, 71 and ground.

55, 71 - Ground : Continuity should exist.

Is the inspection result normal?

YES >> INSPECTION END

NO >> Repair harness or connector.

TPMS

Description

INFOID:000000000957902

During driving, the TPMS receives the signal transmitted from the transmitter installed in each wheel, when the tire pressure becomes low. The control unit (BCM) of this system has pressure judgment and trouble diagnosis functions.

When the TPMS detects low inflation pressure or another unusual symptom, the warning lamps in the combination meter comes on.

A

B

C

D

WT

F

G

H

I

J

K

L

M

N

O

P

TPMS

< COMPONENT DIAGNOSIS >

Wiring Diagram - TIRE PRESSURE MONITORING SYSTEM -

INFOID:00000000957903

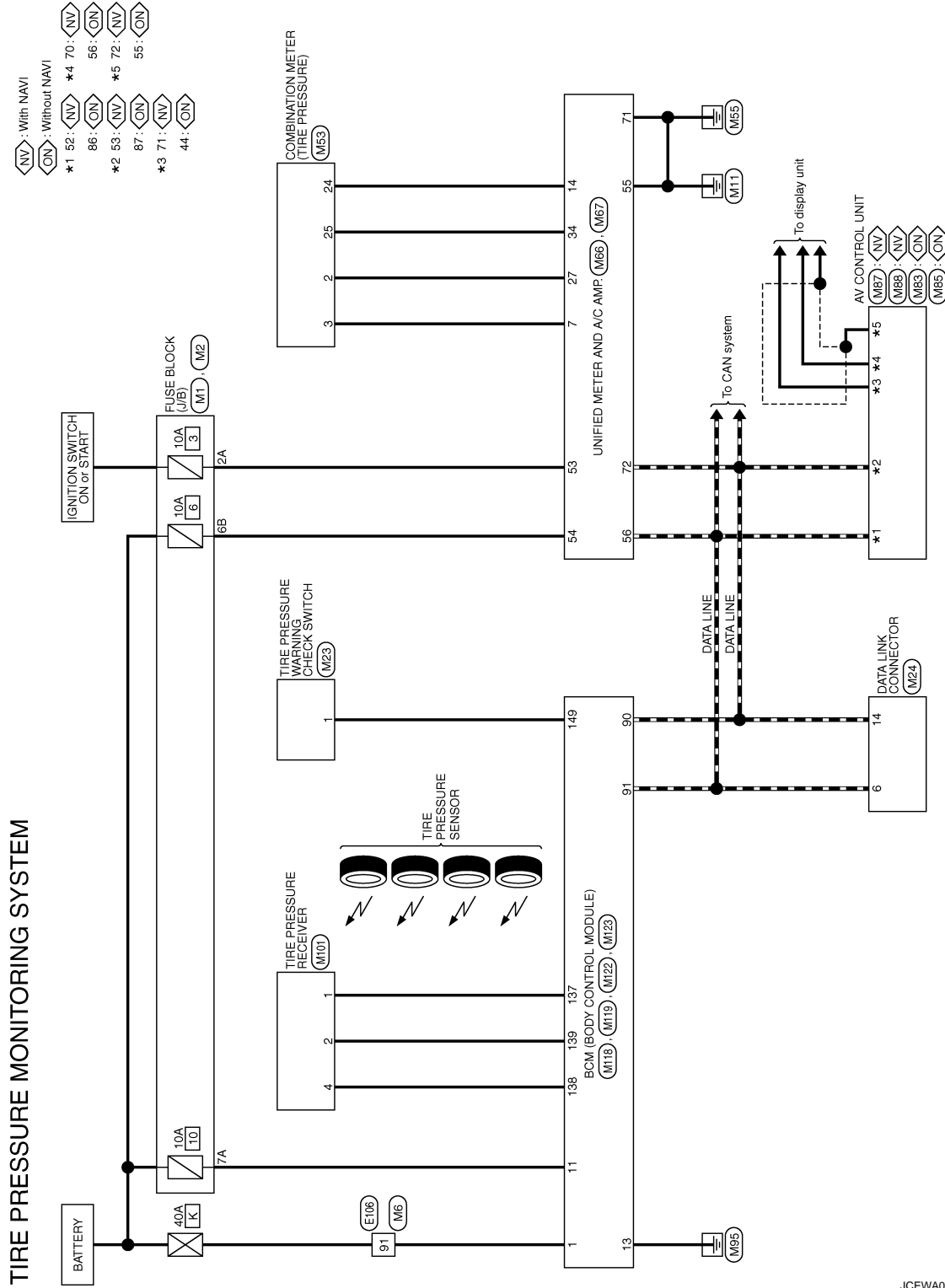

2006/09/15

JCEWA0001GE

TIRE PRESSURE MONITORING SYSTEM

Connector No.	E106
Connector Name	WIRE TO WIRE
Connector Type	TH80FW-CS16-TM4

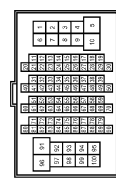

Terminal No.	91	W	Signal Name	-
--------------	----	---	-------------	---

Connector No.	M1
Connector Name	FUSE BLOCK (J/B)
Connector Type	NSJ06FW-M2



Terminal No.	2A	G	Signal Name	-
Terminal No.	7A	R	Signal Name	-

Connector No.	M2
Connector Name	FUSE BLOCK (J/B)
Connector Type	NSJ06FW-CS



Terminal No.	6B	Y	Signal Name	-
--------------	----	---	-------------	---

Connector No.	M6
Connector Name	WIRE TO WIRE
Connector Type	TH80MW-CS16-TM4

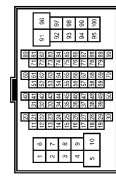

Terminal No.	91	W	Signal Name	-
--------------	----	---	-------------	---

Connector No.	M23
Connector Name	TIRE PRESSURE WARNING CHECK SWITCH
Connector Type	TK02FW



Terminal No.	1	W	Signal Name	-
--------------	---	---	-------------	---

Connector No.	M24
Connector Name	DATA LINK CONNECTOR
Connector Type	BD16FW

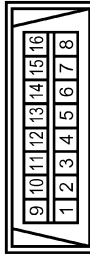

Terminal No.	6	L	Signal Name	-
Terminal No.	14	P	Signal Name	-

Connector No.	M63
Connector Name	COMBINATION METER
Connector Type	SAB40FW

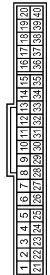

Terminal No.	2	LG	Signal Name	COMM (METER->METER)
Terminal No.	3	GR	Signal Name	COMM (AMP->METER)
Terminal No.	24	BR	Signal Name	COMM (LCD->AMP)
Terminal No.	23	Y	Signal Name	COMM (AMP->LCD)

Connector No.	M66
Connector Name	UNIFIED METER AND A/C AMP.
Connector Type	TH40FW-NH



Terminal No.	7	GR	Signal Name	COMM (AMP->METER)
Terminal No.	14	BR	Signal Name	COMM (LCD->AMP)
Terminal No.	27	LG	Signal Name	COMM (METER->AMP)
Terminal No.	34	Y	Signal Name	COMM (AMP->LCD)

JCEWA0002GE

A
B
C
D
WT
F
G
H
I
J
K
L
M
N
O
P

TIRE PRESSURE MONITORING SYSTEM

Connector No.	M67
Connector Name	UNIFIED METER AND A/C AMP.
Connector Type	TH32FW-NH

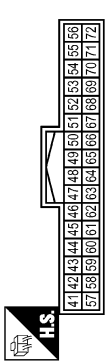

Terminal No.	Color of Wire	Signal Name
53	G	IGN
54	Y	BAT
55	B	GND
56	L	CAN-H
71	B	GND
72	P	CAN-L

Connector No.	M83
Connector Name	AV CONTROL UNIT
Connector Type	TH24FW-NH

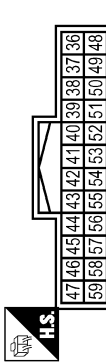

Terminal No.	Color of Wire	Signal Name
44	BR	COMM (DISP->CONT)
55	SHIELD	SHIELD
56	Y	COMM (CONT->DISP)

Connector No.	M85
Connector Name	AV CONTROL UNIT
Connector Type	TH32FW-NH

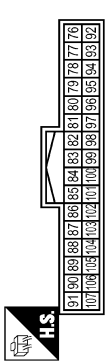

Terminal No.	Color of Wire	Signal Name
86	L	CAN-H
87	P	CAN-L

Connector No.	M87
Connector Name	AV CONTROL UNIT
Connector Type	TH40FW-NH

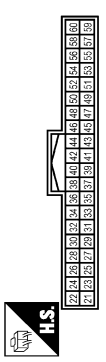

Terminal No.	Color of Wire	Signal Name
52	L	CAN-H
53	P	CAN-L

Connector No.	M88
Connector Name	AV CONTROL UNIT
Connector Type	TH12FW-NH



Terminal No.	Color of Wire	Signal Name
70	BR	COMM (CONT->DISP)
71	Y	COMM (DISP->CONT)
72	SHIELD	SHIELD

Connector No.	M101
Connector Name	TIRE PRESSURE RECEIVER
Connector Type	TK04FW

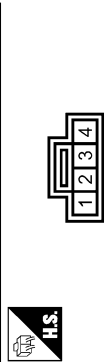

Terminal No.	Color of Wire	Signal Name
1	O	GND
2	L	SIGNAL
4	V	BATTERY

Connector No.	M118
Connector Name	BCM (BODY CONTROL MODULE)
Connector Type	M03FB-LC

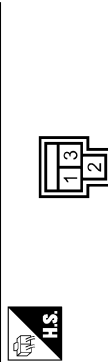

Terminal No.	Color of Wire	Signal Name
1	W	BAT (F/L)

Connector No.	M119
Connector Name	BCM (BODY CONTROL MODULE)
Connector Type	NS18FW-GS

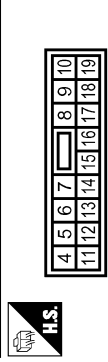

Terminal No.	Color of Wire	Signal Name
11	R	BAT (FUSE)
13	B	GND

A
B
C
D
WT
F
G
H
I
J
K
L
M
N
O
P

TIRE PRESSURE MONITORING SYSTEM

Connector No.	M122
Connector Name	BCM (BODY CONTROL MODULE)
Connector Type	TH40FB-NH

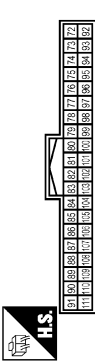

Terminal No.	Color of Wire	Signal Name
90	P	CAN-L
91	L	CAN-H

Connector No.	M123
Connector Name	BCM (BODY CONTROL MODULE)
Connector Type	TH40FG-NH

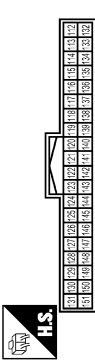

Terminal No.	Color of Wire	Signal Name
137	O	SENSOR GND
138	V	AUTO LIGHT SENSOR POWER SUPPLY
139	L	RECEIVER SIGNAL
149	W	MODE TRG SW

JCEWA0004GE

TIRE PRESSURE RECEIVER

< COMPONENT DIAGNOSIS >

TIRE PRESSURE RECEIVER

Description

INFOID:000000000957904

The tire pressure receiver receives the air pressure signal transmitted by the transmitter in each wheel.

Diagnosis Procedure

INFOID:000000000957905

1. CHECK TIRE PRESSURE RECEIVER

1. Turn ignition OFF.
2. Check tire pressure receiver connector M101 terminal 2 and ground signal with oscilloscope.

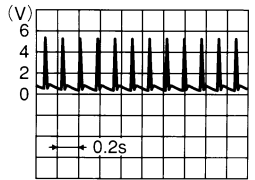
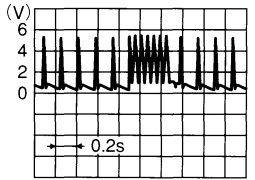
Connector	Terminal		Condition	Voltage (Approx.)
M101	2	Ground	Standby state	 <p>OCC3879D</p>
			When receiving signal from transmitter	 <p>OCC3880D</p>

Is the reference signal inputted?

- YES >> INSPECTION END
 NO >> GO TO 2.

2. CHECK TIRE PRESSURE RECEIVER INPUT VOLTAGE

1. Disconnect tire pressure receiver connector.
2. Check voltage between tire pressure receiver connector M101 terminal 4 and ground.

(+)		(-)	Voltage (Approx.)
Tire pressure receiver		Ground	
Connector	Terminal		
M101	4		4.5 V

Is the reference voltage inputted?

- YES >> GO TO 3.
 NO >> Check BCM harness and connector.

3. CHECK TIRE PRESSURE RECEIVER GROUND CIRCUIT

1. Disconnect BCM harness connector and tire pressure receiver connector.
2. Check continuity between BCM harness connector M123 terminal 137 and tire pressure receiver connector M101 terminal 1.

BCM		Tire pressure receiver		Continuity
Connector	Terminal	Connector	Terminal	
M123	137	M101	1	Existed

Also check harness for short to ground.

Is the inspection result normal?

TIRE PRESSURE RECEIVER

< COMPONENT DIAGNOSIS >

YES >> GO TO 4.

NO >> Repair or replace damaged parts.

4.CHECK BCM CIRCUIT

Inspect the BCM circuit. Refer to [WT-33. "BCM \(BODY CONTROL MODULE\) : Diagnosis Procedure"](#).

Is the BCM circuit normal?

YES >> Replace tire pressure receiver.

NO >> Repair or replace BCM circuit. Replace BCM. Refer to [BCS-79. "Removal and Installation"](#).

A

B

C

D

WT

F

G

H

I

J

K

L

M

N

O

P

TIRE PRESSURE WARNING CHECK SWITCH

< COMPONENT DIAGNOSIS >

TIRE PRESSURE WARNING CHECK SWITCH

Description

INFOID:000000000957906

The following item can be checked by grounding the tire pressure warning check switch harness connector terminal.

- The low tire pressure warning lamp in the combination meter will flicker according to the self-diagnostic results.

NOTE:

If warning lamp blinks below, the system is normal.

- This mode shows transmitter status is in OFF-mode.
Perform transmitter wake up operation. Refer to [WT-5. "TRANSMITTER WAKE UP OPERATION : Special Repair Requirement"](#).

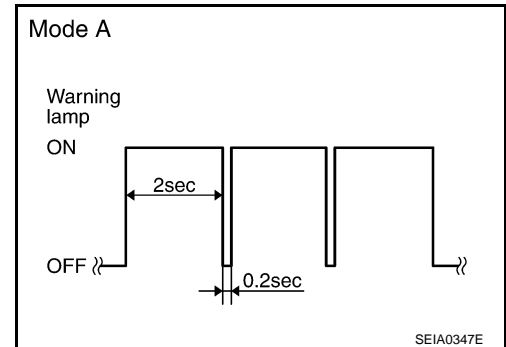

Diagnosis Procedure

INFOID:000000000957907

1. CHECK TIRE PRESSURE WARNING CHECK SWITCH CIRCUIT

1. Turn ignition switch "OFF".
2. Disconnect BCM harness connector
3. Check continuity between BCM harness connector M123 terminal 149 and ground.

BCM		Ground	Continuity
Connector	Terminal		Not existed
M123	149		

Also check harness for short to ground.

Is the inspection result normal?

- YES >> GO TO 2.
- NO >> Repair or replace damaged parts.

2. CHECK SYMPTOM

Check the low tire pressure warning lamp for blinking pattern.

Does the low tire pressure warning lamp remain blinking?

- YES >> GO TO 3.
- NO >> INSPECTION END

3. CHECK BCM

Check BCM input/output signal. Refer to [WT-43. "Reference Value"](#).

Is the inspection result normal?

- YES >> GO TO 2.
- NO >> Check BCM pin terminals for damage or loose connection with harness connector. If any items are damaged, repair or replace damaged parts. Replace BCM Refer to [BCS-79. "Removal and Installation"](#).

BCM (BODY CONTROL MODULE)

< ECU DIAGNOSIS >

ECU DIAGNOSIS

BCM (BODY CONTROL MODULE)

Reference Value

INFOID:000000000957908

VALUES ON THE DIAGNOSIS TOOL

Monitor Item	Condition	Value/Status
FR WIPER HI	Other than front wiper switch HI	OFF
	Front wiper switch HI	ON
FR WIPER LOW	Other than front wiper switch LO	OFF
	Front wiper switch LO	ON
FR WASHER SW	Front washer switch OFF	OFF
	Front washer switch ON	ON
FR WIPER INT	Other than front wiper switch INT	OFF
	Front wiper switch INT	ON
FR WIPER STOP	Front wiper is not in STOP position	OFF
	Front wiper is in STOP position	ON
INT VOLUME	Wiper intermittent dial is in a dial position 1 - 7	Wiper intermittent dial position
TURN SIGNAL R	Other than turn signal switch RH	OFF
	Turn signal switch RH	ON
TURN SIGNAL L	Other than turn signal switch LH	OFF
	Turn signal switch LH	ON
TAIL LAMP SW	Other than lighting switch 1ST and 2ND	OFF
	Lighting switch 1ST or 2ND	ON
HI BEAM SW	Other than lighting switch HI	OFF
	Lighting switch HI	ON
HEAD LAMP SW 1	Other than lighting switch 2ND	OFF
	Lighting switch 2ND	ON
HEAD LAMP SW 2	Other than lighting switch 2ND	OFF
	Lighting switch 2ND	ON
PASSING SW	Other than lighting switch PASS	OFF
	Lighting switch PASS	ON
AUTO LIGHT SW	Other than lighting switch AUTO	OFF
	Lighting switch AUTO	ON
FR FOG SW	Front fog lamp switch OFF	OFF
	Front fog lamp switch ON	ON
RR FOG SW	NOTE: The item is indicated, but not monitored.	OFF
DOOR SW-DR	Driver door closed	OFF
	Driver door opened	ON
DOOR SW-AS	Passenger door closed	OFF
	Passenger door opened	ON
DOOR SW-RR	Rear RH door closed	OFF
	Rear RH door opened	ON

BCM (BODY CONTROL MODULE)

< ECU DIAGNOSIS >

Monitor Item	Condition	Value/Status
DOOR SW-RL	Rear LH door closed	OFF
	Rear LH door opened	ON
DOOR SW-BK	NOTE: The item is indicated, but not monitored.	OFF
CDL LOCK SW	Other than power door lock switch LOCK	OFF
	Power door lock switch LOCK	ON
CDL UNLOCK SW	Other than power door lock switch UNLOCK	OFF
	Power door lock switch UNLOCK	ON
KEY CYL LK-SW	Other than driver door key cylinder LOCK position	OFF
	Driver door key cylinder LOCK position	ON
KEY CYL UN-SW	Other than driver door key cylinder UNLOCK position	OFF
	Driver door key cylinder UNLOCK position	ON
KEY CYL SW-TR	NOTE: The item is indicated, but not monitored.	OFF
HAZARD SW	Hazard switch is not pressed	OFF
	Hazard switch is pressed	ON
REAR DEF SW	NOTE: The item is indicated, but not monitored.	OFF
H/L WASH SW	NOTE: The item is indicated, but not monitored.	OFF
TR CANCEL SW	Trunk lid opener cancel switch OFF	OFF
	Trunk lid opener cancel switch ON	ON
TR/BD OPEN SW	Trunk lid opener switch OFF	OFF
	While the trunk lid opener switch is turned ON	ON
TRNK/HAT MNTR	Trunk lid closed	OFF
	Trunk lid opened	ON
RKE-LOCK	LOCK button of Intelligent Key is not pressed	OFF
	LOCK button of Intelligent Key is pressed	ON
RKE-UNLOCK	UNLOCK button of Intelligent Key is not pressed	OFF
	UNLOCK button of Intelligent Key is pressed	ON
RKE-TR/BD	TRUNK OPEN button of Intelligent Key is not pressed	OFF
	TRUNK OPEN button of Intelligent Key is pressed	ON
RKE-PANIC	PANIC button of Intelligent Key is not pressed	OFF
	PANIC button of Intelligent Key is pressed	ON
RKE-P/W OPEN	UNLOCK button of Intelligent Key is not pressed	OFF
	UNLOCK button of Intelligent Key is pressed and held	ON
RKE-MODE CHG	LOCK/UNLOCK button of Intelligent Key is not pressed and held simultaneously	OFF
	LOCK/UNLOCK button of Intelligent Key is pressed and held simultaneously	ON
OPTICAL SENSOR	Outside of the vehicle bright	Close to 5 V
	Outside of the vehicle dark	Close to 0 V
REQ SW-DR	Driver door request switch is not pressed	OFF
	Driver door request switch is pressed	ON
REQ SW-AS	Passenger door request switch is not pressed	OFF
	Passenger door request switch is pressed	ON

BCM (BODY CONTROL MODULE)

< ECU DIAGNOSIS >

Monitor Item	Condition	Value/Status	
REQ SW-BD/TR	Trunk request switch is not pressed	OFF	A
	Trunk request switch is pressed	ON	
PUSH SW	Push-button ignition switch (push switch) is not pressed	OFF	B
	Push-button ignition switch (push switch) is pressed	ON	
IGN RLY2 -F/B	Ignition switch in OFF or ACC position	OFF	C
	Ignition switch in ON position	ON	
ACC RLY -F/B	Ignition switch in OFF position	OFF	D
	Ignition switch in ACC or ON position	ON	
CLUCH SW	The clutch pedal is not depressed	OFF	
	The clutch pedal is depressed	ON	
BRAKE SW 1	The brake pedal is not depressed	ON	WT
	The brake pedal is depressed	OFF	
DETE/CANCL SW	Selector lever in P position	OFF	F
	Selector lever in any position other than P	ON	
SFT PN/N SW	Selector lever in any position other than P and N	OFF	G
	Selector lever in P or N position	ON	
S/L -LOCK	Steering is locked	OFF	H
	Steering is unlocked	ON	
S/L -UNLOCK	Steering is unlocked	OFF	I
	Steering is locked	ON	
S/L RELAY-F/B	Ignition switch is OFF or ACC position	OFF	J
	Ignition switch is ON position	ON	
UNLK SEN-DR	Driver door is unlocked	OFF	K
	Driver door is locked	ON	
PUSH SW -IPDM	Push-button ignition switch (push-switch) is not pressed	OFF	L
	Push-button ignition switch (push-switch) is pressed	ON	
IGN RLY1 -F/B	Ignition switch is OFF or ACC position	OFF	M
	Ignition switch is ON position	ON	
DETE SW -IPDM	Selector lever in P position	OFF	N
	Selector lever in any position other than P	ON	
SFT PN -IPDM	Selector lever in any position other than P and N	OFF	O
	Selector lever in P or N position	ON	
SFT P -MET	Selector lever in any position other than P	OFF	P
	Selector lever in P position	ON	
SFT N -MET	Selector lever in any position other than N	OFF	
	Selector lever in N position	ON	
ENGINE STATE	Engine stopped	STOP	
	While the engine stalls	STALL	
	At engine cranking	CRANK	
	Engine running	RUN	
S/L LOCK-IPDM	Steering is locked	OFF	
	Steering is unlocked	ON	
S/L UNLK-IPDM	Steering is unlocked	OFF	
	Steering is locked	ON	

BCM (BODY CONTROL MODULE)

< ECU DIAGNOSIS >

Monitor Item	Condition	Value/Status
S/L RELAY-REQ	Ignition switch in OFF or ACC position	OFF
	Ignition switch in ON position	ON
VEH SPEED 1	While driving	Equivalent to speedometer reading
VEH SPEED 2	While driving	Equivalent to speedometer reading
DOOR STAT-DR	Driver door is locked	LOCK
	Wait with selective UNLOCK operation (5 seconds)	READY
	Driver door is unlocked	UNLK
DOOR STAT-AS	Passenger door is locked	LOCK
	Wait with selective UNLOCK operation (5 seconds)	READY
	Passenger door is unlocked	UNLK
ID OK FLAG	Ignition switch in ACC or ON position	RESET
	Ignition switch in OFF position	SET
PRMT ENG STRT	The engine start is prohibited	RESET
	The engine start is permitted	SET
PRMT RKE STRT	NOTE: The item is indicated, but not monitored.	RESET
KEY SW -SLOT	Intelligent Key is not inserted into key slot	OFF
	Intelligent Key is inserted into key slot	ON
RKE OPE COUN1	During the operation of Intelligent Key	Operation frequency of Intelligent Key
RKE OPE COUN2	NOTE: The item is indicated, but not monitored.	—
AIR PRESS FL	Ignition switch ON (Only when the signal from the transmitter is received)	Air pressure of front LH tire
AIR PRESS FR	Ignition switch ON (Only when the signal from the transmitter is received)	Air pressure of front RH tire
AIR PRESS RR	Ignition switch ON (Only when the signal from the transmitter is received)	Air pressure of rear RH tire
AIR PRESS RL	Ignition switch ON (Only when the signal from the transmitter is received)	Air pressure of rear LH tire
ID REGST FL1	ID of front LH tire transmitter is registered	DONE
	ID of front LH tire transmitter is not registered	YET
ID REGST FR1	ID of front RH tire transmitter is registered	DONE
	ID of front RH tire transmitter is not registered	YET
ID REGST RR1	ID of rear RH tire transmitter is registered	DONE
	ID of rear RH tire transmitter is not registered	YET
ID REGST RL1	ID of rear LH tire transmitter is registered	DONE
	ID of rear LH tire transmitter is not registered	YET
WARNING LAMP	Tire pressure indicator OFF	OFF
	Tire pressure indicator ON	ON
BUZZER	Tire pressure warning alarm is not sounding	OFF
	Tire pressure warning alarm is sounding	ON

BCM (BODY CONTROL MODULE)

< ECU DIAGNOSIS >

TERMINAL LAYOUT

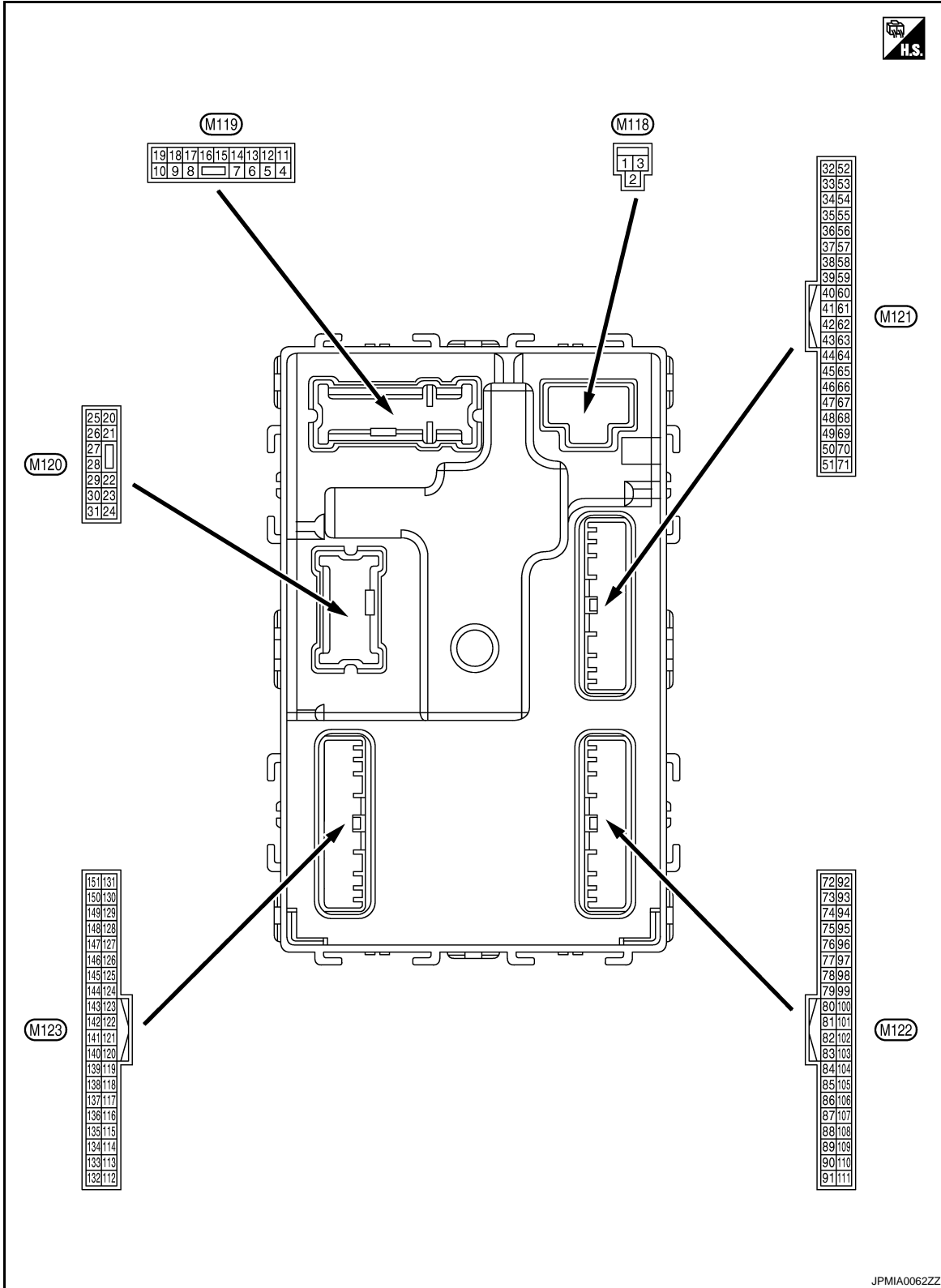

PHYSICAL VALUES

A
B
C
D
WT
F
G
H
I
J
K
L
M
N
O
P

BCM (BODY CONTROL MODULE)

< ECU DIAGNOSIS >

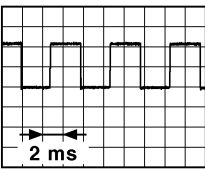
Terminal No. (Wire color)		Description		Condition		Value (Approx.)
+	-	Signal name	Input/ Output			
1 (W)	Ground	Battery power supply	Input	Ignition switch OFF		Battery voltage
2 (Y)	Ground	P/W power supply (BAT)	Output	Ignition switch OFF		Battery voltage
3 (O)	Ground	P/W power supply (RAP)	Output	Ignition switch ON		Battery voltage
4 (LG)	Ground	Interior room lamp power supply	Output	After passing the interior room lamp battery saver operation time		0 V
				Any other time after passing the interior room lamp battery saver operation time		Battery voltage
5 (V)	Ground	Passenger door UN- LOCK	Output	Passenger door	UNLOCK (Actuator is activated)	Battery voltage
					Other than UNLOCK (Actuator is not activated)	0 V
7 (Y)	Ground	Step lamp	Output	Step lamp	ON	0 V
					OFF	Battery voltage
8 (V)	Ground	All doors, fuel lid LOCK	Output	All doors, fuel lid	LOCK (Actuator is activated)	Battery voltage
					Other than LOCK (Actuator is not activated)	0 V
9 (G)	Ground	Driver door, fuel lid UNLOCK	Output	Driver door, fuel lid	UNLOCK (Actuator is activated)	Battery voltage
					Other than UNLOCK (Actuator is not activated)	0 V
10 (BR)	Ground	Rear RH door and rear LH door UN- LOCK	Output	Rear RH door and rear LH door	UNLOCK (Actuator is activated)	Battery voltage
					Other than UNLOCK (Actuator is not activated)	0 V
11 (R)	Ground	Battery power supply	Input	Ignition switch OFF		Battery voltage
13 (B)	Ground	Ground	—	Ignition switch ON		0 V
14 (W)	Ground	Push-button ignition switch illumination ground	Output	Tail lamp	OFF	0 V
					ON	<p>NOTE: When the illumination brightening/dimming level is in the neutral position</p>  <p style="text-align: right;"><small>JSNIA0010GB</small></p>
15 (Y)	Ground	ACC indicator lamp	Output	Ignition switch	OFF	Battery voltage
					ACC or ON	0 V

BCM (BODY CONTROL MODULE)

< ECU DIAGNOSIS >

Terminal No. (Wire color)		Description		Condition	Value (Approx.)	
+	-	Signal name	Input/ Output			
17 (W)	Ground	Turn signal (front RH)	Output	Ignition switch ON	Turn signal switch OFF	0 V
				Turn signal switch RH	<p style="text-align: center;">6.5 V</p>	
18 (O)	Ground	Turn signal (front LH)	Output	Ignition switch ON	Turn signal switch OFF	0 V
				Turn signal switch LH	<p style="text-align: center;">6.5 V</p>	
19 (V)	Ground	Room lamp timer control	Output	Interior room lamp	OFF	Battery voltage
				ON	0 V	
20 (V)	Ground	Turn signal (rear RH)	Output	Ignition switch ON	Turn signal switch OFF	0 V
				Turn signal switch RH	<p style="text-align: center;">6.5 V</p>	
23 (G)	Ground	Trunk lid opening.	Output	Trunk lid	Open (Trunk lid opener actuator is activated)	Battery voltage
				Close (Trunk lid opener actuator is not activated)	0 V	
25 (G)	Ground	Turn signal (rear LH)	Output	Ignition switch ON	Turn signal switch OFF	0 V
				Turn signal switch LH	<p style="text-align: center;">6.5 V</p>	
30 (R)	Ground	Trunk room lamp	Output	Trunk room lamp	ON	0 V
				OFF	Battery voltage	

A
B
C
D
WT
F
G
H
I
J
K
L
M
N
O
P

BCM (BODY CONTROL MODULE)

< ECU DIAGNOSIS >

Terminal No. (Wire color)		Description		Condition	Value (Approx.)
+	-	Signal name	Input/ Output		
34 (SB)	Ground	Trunk room antenna 1 (-)	Output	Ignition switch OFF	<p style="text-align: right; font-size: small;">JMKIA0062GB</p>
				When Intelligent Key is not in the passenger compart- ment	<p style="text-align: right; font-size: small;">JMKIA0063GB</p>
35 (V)	Ground	Trunk room antenna 1 (+)	Output	Ignition switch OFF	<p style="text-align: right; font-size: small;">JMKIA0062GB</p>
				When Intelligent Key is not in the passenger compart- ment	<p style="text-align: right; font-size: small;">JMKIA0063GB</p>
38 (B)	Ground	Rear bumper anten- na (-)	Output	When the trunk lid request switch is operated with ignition switch OFF	<p style="text-align: right; font-size: small;">JMKIA0062GB</p>
				When Intelligent Key is not in the antenna detection area	<p style="text-align: right; font-size: small;">JMKIA0063GB</p>

BCM (BODY CONTROL MODULE)

< ECU DIAGNOSIS >

Terminal No. (Wire color)		Description		Condition	Value (Approx.)
		Signal name	Input/ Output		
+	-				
39 (W)	Ground	Rear bumper antenna (+)	Output	When the trunk lid request switch is operated with ignition switch OFF	<p style="text-align: right; font-size: small;">JMKIA0062GB</p>
				When Intelligent Key is not in the antenna detection area	<p style="text-align: right; font-size: small;">JMKIA0063GB</p>
47 (Y)	Ground	Ignition relay (IPDM E/R) control	Output	Ignition switch	OFF or ACC Battery voltage ON 0 V
50 (R)	Ground	Trunk room lamp switch	Input	Trunk room lamp switch	<p style="text-align: right; font-size: small;">JPMIA0011GB</p> <p style="text-align: center;">11.8 V</p>
				ON (Trunk is open)	0 V
52 (SB)	Ground	Starter relay control	Output	Ignition switch OFF (M/T models)	When the clutch pedal is depressed Battery voltage When the clutch pedal is not depressed 0 V
				Ignition switch ON (A/T models)	When selector lever is in P or N position and the brake is depressed Battery voltage
					When selector lever is in P or N position and the brake is not depressed 0 V
					ON (Pressed) 0 V
61 (W)	Ground	Trunk request switch	Input	Trunk request switch	ON (Pressed) 0 V OFF (Not pressed) <p style="text-align: right; font-size: small;">JPMIA0016GB</p> <p style="text-align: center;">1.0 V</p>
64 (V)	Ground	Request switch buzzer	Output	Request switch buzzer	Sounding 0 V Not sounding Battery voltage

A
B
C
D
WT
F
G
H
I
J
K
L
M
N
O
P

BCM (BODY CONTROL MODULE)

< ECU DIAGNOSIS >

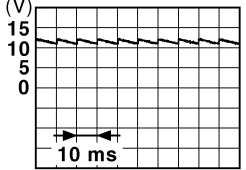
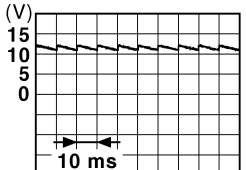
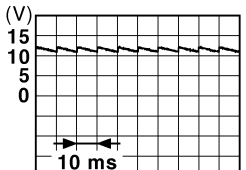
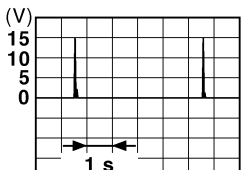
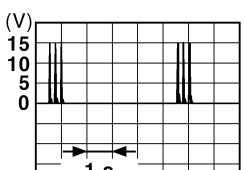
Terminal No. (Wire color)		Description		Condition	Value (Approx.)	
+	-	Signal name	Input/ Output			
67 (GR)	Ground	Trunk lid opener switch	Input	Trunk lid opener switch	Pressed	0 V
					Not pressed	 <p style="text-align: right; font-size: small;">JPMIA0011GB</p>
68 (BR)	Ground	Rear RH door switch	Input	Rear RH door switch	OFF (When rear RH door closes)	 <p style="text-align: right; font-size: small;">JPMIA0011GB</p>
					ON (When rear RH door opens)	0 V
69 (R)	Ground	Rear LH door switch	Input	Rear LH door switch	OFF (When rear LH door closes)	 <p style="text-align: right; font-size: small;">JPMIA0011GB</p>
					ON (When rear LH door opens)	0 V
72 (R)	Ground	Room antenna 2 (-) (center console)	Output	Ignition switch OFF	When Intelligent Key is in the passenger compart- ment	 <p style="text-align: right; font-size: small;">JMKIA0062GB</p>
					When Intelligent Key is not in the passenger compart- ment	 <p style="text-align: right; font-size: small;">JMKIA0063GB</p>

BCM (BODY CONTROL MODULE)

< ECU DIAGNOSIS >

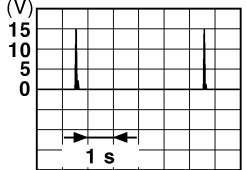
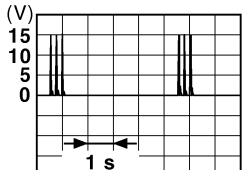
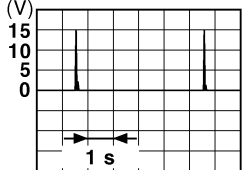
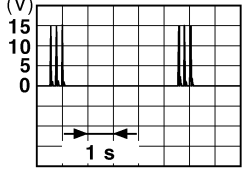
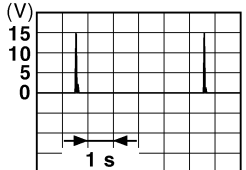
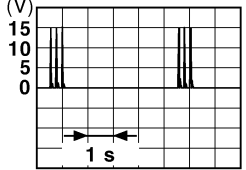
Terminal No. (Wire color)		Description		Condition	Value (Approx.)
		Signal name	Input/ Output		
+	-				
73 (G)	Ground	Room antenna 2 (+) (center console)	Output	Ignition switch OFF	 <p style="text-align: right; font-size: small;">JMKIA0062GB</p>
				When Intelligent Key is not in the passenger compart- ment	 <p style="text-align: right; font-size: small;">JMKIA0063GB</p>
74 (SB)	Ground	Passenger door an- tenna (-)	Output	When the pas- senger door re- quest switch is operated with ig- nition switch OFF	 <p style="text-align: right; font-size: small;">JMKIA0062GB</p>
				When Intelligent Key is not in the antenna detection area	 <p style="text-align: right; font-size: small;">JMKIA0063GB</p>
75 (BR)	Ground	Passenger door an- tenna (+)	Output	When the pas- senger door re- quest switch is operated with ig- nition switch OFF	 <p style="text-align: right; font-size: small;">JMKIA0062GB</p>
				When Intelligent Key is not in the antenna detection area	 <p style="text-align: right; font-size: small;">JMKIA0063GB</p>

A
B
C
D
WT
F
G
H
I
J
K
L
M
N
O
P

BCM (BODY CONTROL MODULE)

< ECU DIAGNOSIS >

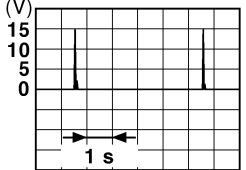
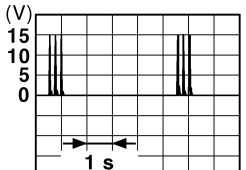
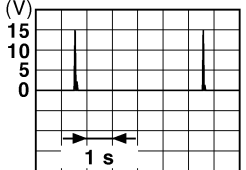
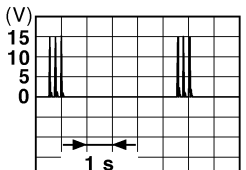
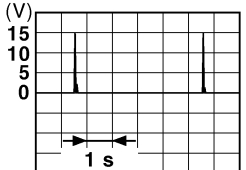
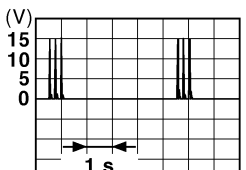
Terminal No. (Wire color)		Description		Condition	Value (Approx.)
		Signal name	Input/ Output		
+	-				
76 (V)	Ground	Driver door antenna (-)	Output	When the driver door request switch is operated with ignition switch OFF	 <p style="text-align: right; font-size: small;">JMKIA0062GB</p>
				When Intelligent Key is not in the antenna detection area	 <p style="text-align: right; font-size: small;">JMKIA0063GB</p>
77 (LG)	Ground	Driver door antenna (+)	Output	When the driver door request switch is operated with ignition switch OFF	 <p style="text-align: right; font-size: small;">JMKIA0062GB</p>
				When Intelligent Key is not in the antenna detection area	 <p style="text-align: right; font-size: small;">JMKIA0063GB</p>
78 (Y)	Ground	Room antenna (-) (instrument panel)	Output	Ignition switch OFF	 <p style="text-align: right; font-size: small;">JMKIA0062GB</p>
				When Intelligent Key is not in the passenger compartment	 <p style="text-align: right; font-size: small;">JMKIA0063GB</p>

BCM (BODY CONTROL MODULE)



< ECU DIAGNOSIS >

Terminal No. (Wire color)		Description		Condition	Value (Approx.)	
+	-	Signal name	Input/ Output			
79 (BR)	Ground	Room antenna (+) (instrument panel)	Output	Ignition switch OFF	<p style="text-align: right; font-size: small;">JMKIA0062GB</p>	
				When Intelligent Key is not in the passenger compart- ment	<p style="text-align: right; font-size: small;">JMKIA0063GB</p>	
80 (GR)	Ground	NATS antenna amp (built in key slot)	Input/ Output	During waiting	Ignition switch is pressed while inserting the Intelli- gent Key into the key slot.	Just after pressing ignition switch. Pointer of tester should move.
81 (W)	Ground	NATS antenna amp (built in key slot)	Input/ Output	During waiting	Ignition switch is pressed while inserting the Intelli- gent Key into the key slot.	Just after pressing ignition switch. Pointer of tester should move.
82 (R)	Ground	Ignition relay (relay box) control	Output	Ignition switch	OFF or ACC	0 V
					ON	Battery voltage
83 (Y)	Ground	Remote keyless entry receiver signal	Input/ Output	During waiting		<p style="text-align: right; font-size: small;">JMKIA0064GB</p>
				When operating either button on Intelligent Key		<p style="text-align: right; font-size: small;">JMKIA0065GB</p>

A
B
C
D
WT
F
G
H
I
J
K
L
M
N
O
P

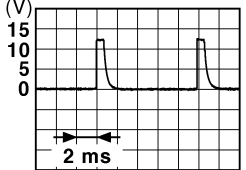

BCM (BODY CONTROL MODULE)

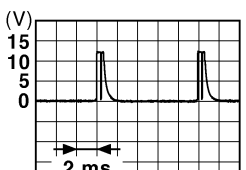
< ECU DIAGNOSIS >

Terminal No. (Wire color)		Description		Condition	Value (Approx.)
+	-	Signal name	Input/ Output		
87 (BR)	Ground	Combination switch INPUT 5	Input	All switch OFF (Wiper intermittent dial 4)	 <p style="text-align: right; font-size: small;">JPMIA0041GB</p> <p style="text-align: center;">1.4 V</p>
				Front fog lamp switch ON (Wiper intermittent dial 4)	 <p style="text-align: right; font-size: small;">JPMIA0037GB</p> <p style="text-align: center;">1.3 V</p>
				Any of the conditions below with all switch OFF <ul style="list-style-type: none"> • Wiper intermittent dial 1 • Wiper intermittent dial 2 • Wiper intermittent dial 6 • Wiper intermittent dial 7 	 <p style="text-align: right; font-size: small;">JPMIA0040GB</p> <p style="text-align: center;">1.3 V</p>

BCM (BODY CONTROL MODULE)

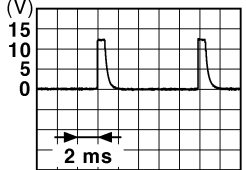
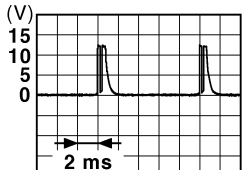
< ECU DIAGNOSIS >

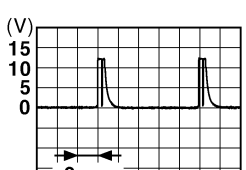
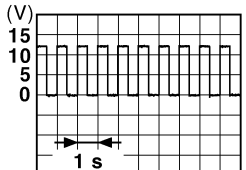
Terminal No. (Wire color)		Description		Condition	Value (Approx.)	
+	-	Signal name	Input/ Output			
88 (V)	Ground	Combination switch INPUT 3	Input	Combination switch	All switch OFF (Wiper intermittent dial 4)  1.4 V	
					Lighting switch HI (Wiper intermittent dial 4)  1.3 V	
					Lighting switch 2ND (Wiper intermittent dial 4)  1.3 V	
					Any of the conditions below with all switches OFF • Wiper intermittent dial 1 • Wiper intermittent dial 2 • Wiper intermittent dial 3  1.3 V	
89 (BR)	Ground	Push-button ignition switch (push switch)	Input	Push-button igni- tion switch (push switch)	Pressed Not pressed	0 V Battery voltage
90 (P)	Ground	CAN - L	Input/ Output	—	—	—
91 (L)	Ground	CAN - H	Input/ Output	—	—	—
92 (LG)	Ground	Key slot illumination	Output	Key slot illumina- tion	OFF	0 V
					Blinking  6.5 V	
					ON	Battery voltage

A
B
C
D
WT
F
G
H
I
J
K
L
M
N
O
P



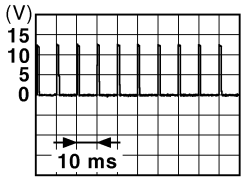
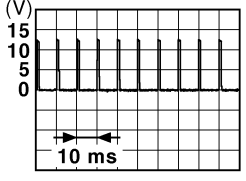

BCM (BODY CONTROL MODULE)

< ECU DIAGNOSIS >

Terminal No. (Wire color)		Description		Condition		Value (Approx.)
+	-	Signal name	Input/ Output			
93 (V)	Ground	ON indicator lamp	Output	Ignition switch	OFF or ACC	0 V
					ON	Battery voltage
95 (O)	Ground	ACC relay control	Output	Ignition switch	OFF	0 V
					ACC or ON	Battery voltage
96 (GR)	Ground	A/T device (detention switch) power supply	Output	—		Battery voltage
97 (L)	Ground	Steering lock condition No. 1	Input	Steering lock	LOCK status	0 V
					UNLOCK status	Battery voltage
98 (P)	Ground	Steering lock condition No. 2	Input	Steering lock	LOCK status	Battery voltage
					UNLOCK status	0 V
99 (R)	Ground	Selector lever P position switch	Input	Selector lever	P position	0 V
					Any position other than P	Battery voltage
100 (G)	Ground	Passenger door request switch	Input	Passenger door request switch	ON (Pressed)	0 V
					OFF (Not pressed)	 <p style="text-align: center;">1.0 V</p>
101 (SB)	Ground	Driver door request switch	Input	Driver door request switch	ON (Pressed)	0 V
					OFF (Not pressed)	 <p style="text-align: center;">1.0 V</p>
102 (O)	Ground	Blower fan motor relay control	Output	Ignition switch	OFF or ACC	0 V
					ON	Battery voltage
103 (LG)	Ground	Remote keyless entry receiver power supply	Output	Ignition switch OFF		Battery voltage
106 (W)	Ground	Steering wheel lock unit power supply	Output	Ignition switch	OFF or ACC	Battery voltage
					ON	0 V

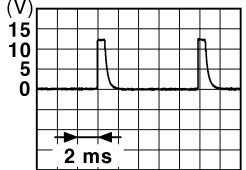
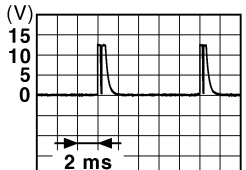
BCM (BODY CONTROL MODULE)

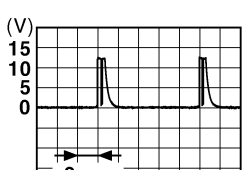
< ECU DIAGNOSIS >

Terminal No. (Wire color)		Description		Condition	Value (Approx.)
+	-	Signal name	Input/ Output		
107 (LG)	Ground	Combination switch INPUT 1	Input	Combination switch (Wiper intermittent dial 4)	All switch OFF <div style="text-align: right;">  <p>1.4 V</p> </div>
					Turn signal switch LH <div style="text-align: right;">  <p>1.3 V</p> </div>
					Turn signal switch RH <div style="text-align: right;">  <p>1.3 V</p> </div>
					Front wiper switch LO <div style="text-align: right;">  <p>1.3 V</p> </div>
					Front washer switch ON <div style="text-align: right;">  <p>1.3 V</p> </div>

A
B
C
D
WT
F
G
H
I
J
K
L
M
N
O
P



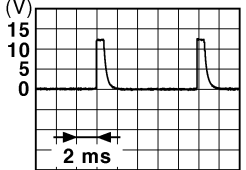
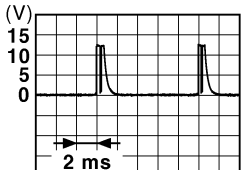
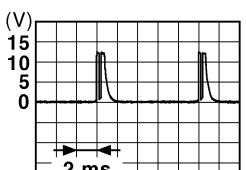

BCM (BODY CONTROL MODULE)

< ECU DIAGNOSIS >

Terminal No. (Wire color)		Description		Condition	Value (Approx.)	
		Signal name	Input/ Output			
+	-					
108 (R)	Ground	Combination switch INPUT 4	Input	Combination switch	All switch OFF (Wiper intermittent dial 4)	 <p style="text-align: right; margin-right: 50px;">1.4 V</p> <p style="text-align: right; font-size: small;">JPMIA0041GB</p>
					Lighting switch AUTO (Wiper intermittent dial 4)	 <p style="text-align: right; margin-right: 50px;">1.3 V</p> <p style="text-align: right; font-size: small;">JPMIA0038GB</p>
					Lighting switch 1ST (Wiper intermittent dial 4)	 <p style="text-align: right; margin-right: 50px;">1.3 V</p> <p style="text-align: right; font-size: small;">JPMIA0036GB</p>
					Any of the conditions below with all switches OFF	<ul style="list-style-type: none"> • Wiper intermittent dial 1 • Wiper intermittent dial 5 • Wiper intermittent dial 6

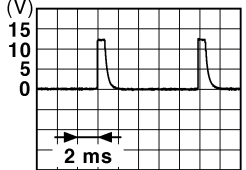
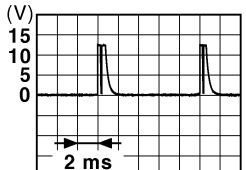
BCM (BODY CONTROL MODULE)

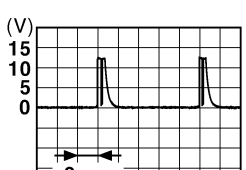
< ECU DIAGNOSIS >

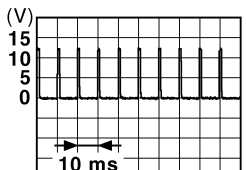
Terminal No. (Wire color)		Description		Condition	Value (Approx.)	
		Signal name	Input/ Output			
+	-					
109 (Y)	Ground	Combination switch INPUT 2	Input	Combination switch (Wiper intermittent dial 4)	All switch OFF	 1.4 V
					Lighting switch PASS	 1.3 V
					Lighting switch 2ND	 1.3 V
					Front wiper switch INT	 1.3 V
					Front wiper switch HI	 1.3 V
					Pressed	0 V
110 (G)	Ground	Hazard switch	Input	Hazard switch	Not pressed	 1.1 V

A
B
C
D
WT
F
G
H
I
J
K
L
M
N
O
P

BCM (BODY CONTROL MODULE)

< ECU DIAGNOSIS >

Terminal No. (Wire color)		Description		Condition	Value (Approx.)	
+	-	Signal name	Input/ Output			
111 (Y)	Ground	Steering lock unit communication	Input/ Output	Steering lock	LOCK status	Battery voltage
					LOCK or UNLOCK	<p style="text-align: right; font-size: small;">JMkia0066GB</p>
					For 15 seconds after UN- LOCK	Battery voltage
				15 seconds or later after UNLOCK	0 V	
113 (P)	Ground	Optical sensor signal	Input	Ignition switch ON	When bright outside of the vehicle	Close to 5 V
					When dark outside of the vehicle	Close to 0 V
114 (R)	Ground	Clutch interlock switch	Input	Clutch interlock switch	OFF (Clutch pedal is not depressed)	0 V
					ON (Clutch pedal is de- pressed)	Battery voltage
116 (SB)	Ground	Stop lamp switch 1	Input	—	Battery voltage	
118 (P)	Ground	Stop lamp switch 2	Input	Stop lamp switch	OFF (Brake pedal is not depressed)	0 V
					ON (Brake pedal is de- pressed)	Battery voltage
				ICC brake hold relay (With ICC)	OFF	0 V
					ON	Battery voltage
119 (SB)	Ground	Front door lock as- sembly driver side (unlock sensor)	Input	Driver door	LOCK status	<p style="text-align: right; font-size: small;">JPMIA0011GB</p>
					UNLOCK status	0 V
					11.8 V	
121 (R)	Ground	Key slot switch	Input	When Intelligent Key is inserted into key slot	Battery voltage	
				When Intelligent Key is not inserted into key slot	0 V	
122 (V)	Ground	ACC feedback signal	Input	Ignition switch	OFF	0 V
					ACC or ON	Battery voltage
123 (W)	Ground	IGN feedback signal	Input	Ignition switch	OFF or ACC	0 V
					ON	Battery voltage

BCM (BODY CONTROL MODULE)



< ECU DIAGNOSIS >

Terminal No. (Wire color)		Description		Condition	Value (Approx.)
+	-	Signal name	Input/ Output		
124 (LG)	Ground	Passenger door switch	Input	Passenger door switch	<p style="text-align: right;">JPMIA0011GB</p> <p style="text-align: center;">11.8 V</p>
				OFF (When passenger door closes)	0 V
129 (O)	Ground	Trunk lid opener cancel switch	Input	Trunk lid opener cancel switch	<p style="text-align: right;">JPMIA0012GB</p> <p style="text-align: center;">1.1 V</p>
				CANCEL	0 V
132 (V)	Ground	Power window switch communication	Input/ Output	Ignition switch ON	<p style="text-align: right;">JPMIA0013GB</p> <p style="text-align: center;">10.2 V</p>
				Ignition switch OFF or ACC	0 V
133 (W)	Ground	Push-button ignition switch illumination	Output	Push-button ignition switch illumination	<p>NOTE: The pulse width of this wave is varied by the illumination brightening/dimming level.</p> <p style="text-align: right;">JPMIA0159GB</p>
				ON (When tail lamps OFF)	5.5 V
				ON (When tail lamps ON)	0 V
134 (GR)	Ground	LOCK indicator lamp	Output	LOCK indicator lamp	ON
				OFF	Battery voltage
137 (O)	Ground	Receiver and sensor ground	Input	Ignition switch ON	0 V
138 (V)	Ground	Receiver and sensor power supply output	Output	Ignition switch	OFF
				ACC or ON	5.0 V

A
B
C
D
WT
F
G
H
I
J
K
L
M
N
O
P

BCM (BODY CONTROL MODULE)

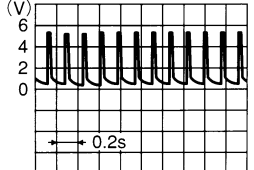
< ECU DIAGNOSIS >

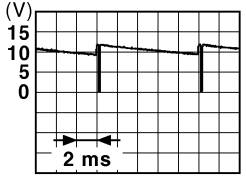
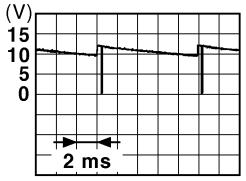
Terminal No. (Wire color)		Description		Condition	Value (Approx.)	
+	-	Signal name	Input/ Output			
139 (L)	Ground	Tire pressure receiver signal	Input/ Output	Ignition switch ON	Standby state  OCC3881D	
				When receiving the signal from the transmitter  OCC3880D		
140 (GR)	Ground	Selector lever P/N position signal	Input	Selector lever	P or N position: 12.0 V Except P and N positions: 0 V	
				141 (G)	Ground	Security indicator signal
OFF: Battery voltage						
142 (O)	Ground	Combination switch OUTPUT 5	Output	Combination switch (Wiper intermittent dial 4)	All switch OFF: 0 V	
					Lighting switch 1ST	 JPMIA0031GB 10.7 V
					Lighting switch HI	
					Lighting switch 2ND	
Turn signal switch RH						
143 (P)	Ground	Combination switch OUTPUT 1	Output	Combination switch	All switch OFF (Wiper intermittent dial 4): 0 V	
					Front wiper switch HI (Wiper intermittent dial 4)	 JPMIA0032GB 10.7 V
					Any of the conditions below with all switch OFF <ul style="list-style-type: none"> • Wiper intermittent dial 1 • Wiper intermittent dial 2 • Wiper intermittent dial 3 • Wiper intermittent dial 6 • Wiper intermittent dial 7 	

BCM (BODY CONTROL MODULE)

< ECU DIAGNOSIS >

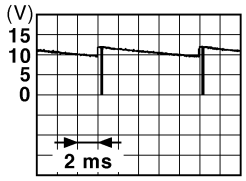
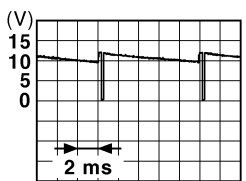
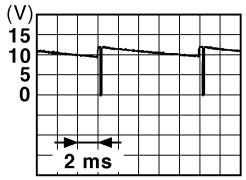
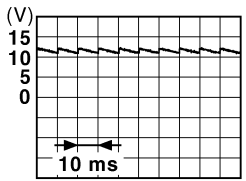
Terminal No. (Wire color)		Description		Condition	Value (Approx.)	
+	-	Signal name	Input/ Output			
144 (G)	Ground	Combination switch OUTPUT 2	Output	Combination switch	All switch OFF (Wiper intermittent dial 4)	0 V
					Front washer switch ON (Wiper intermittent dial 4)	 <p style="text-align: right; font-size: small;">JPMIA0033GB</p>
Any of the conditions below with all switches OFF					10.7 V	
<ul style="list-style-type: none"> • Wiper intermittent dial 1 • Wiper intermittent dial 5 • Wiper intermittent dial 6 						
145 (L)	Ground	Combination switch OUTPUT 3	Output	Combination switch (Wiper intermit- tent dial 4)	All switches OFF	0 V
					Front wiper switch INT	 <p style="text-align: right; font-size: small;">JPMIA0034GB</p>
					Front wiper switch LO	
					Lighting switch AUTO	
					10.7 V	
146 (SB)	Ground	Combination switch OUTPUT 4	Output	Combination switch (Wiper intermit- tent dial 4)	All switch OFF	0 V
					Front fog lamp switch ON	 <p style="text-align: right; font-size: small;">JPMIA0035GB</p>
					Lighting switch 2ND	
					Lighting switch PASS	
					Turn signal switch LH	
					10.7 V	
149 (W)	Ground	Tire pressure warn- ing check switch	Input	—	5 V	
150 (GR)	Ground	Driver door switch	Input	Driver door switch	OFF (When driver door closes)	 <p style="text-align: right; font-size: small;">JPMIA0011GB</p>
					ON (When driver door opens)	
151 (G)	Ground	Rear window defog- ger relay	Output	Rear window de- fogger	Active	0 V
					Not activated	Battery voltage

A
B
C
D
WT
F
G
H
I
J
K
L
M
N
O
P

BCM (BODY CONTROL MODULE)

< ECU DIAGNOSIS >

Wiring Diagram — BCM —

INFOID:00000000957909

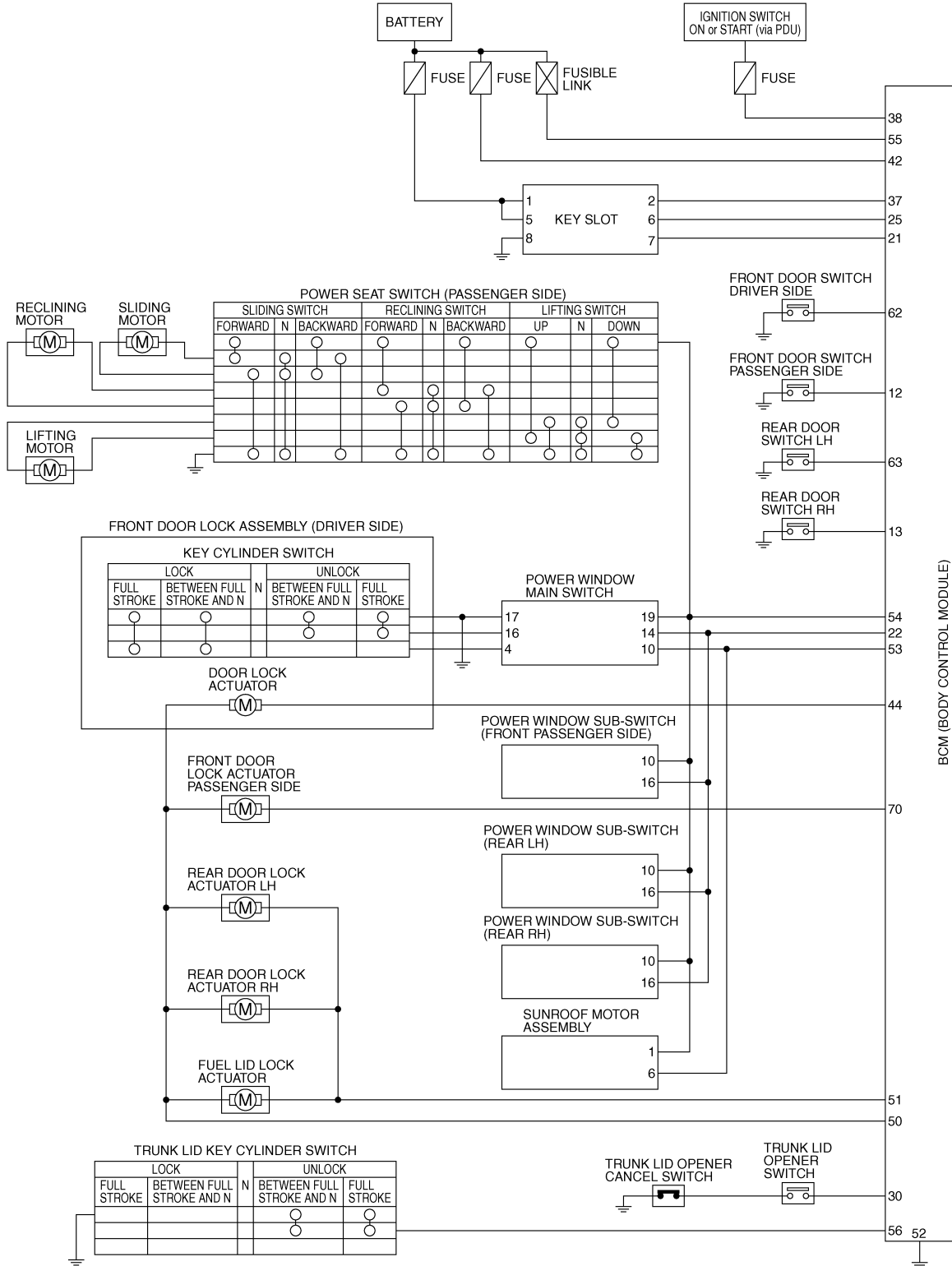

TKW73486E

BCM (BODY CONTROL MODULE)

< ECU DIAGNOSIS >

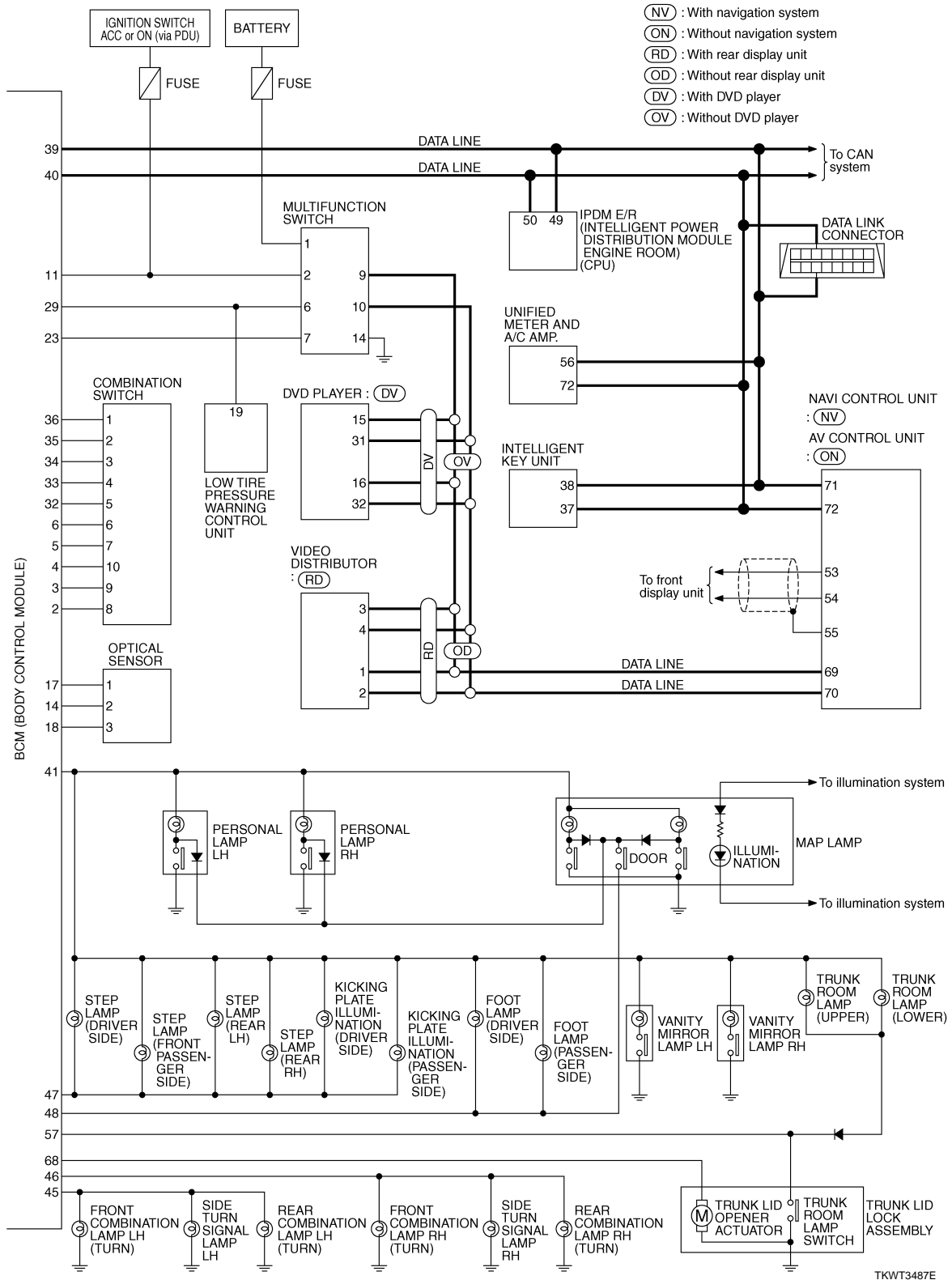

TKWT3487E

A
B
C
D
WT
F
G
H
I
J
K
L
M
N
O
P

BCM (BODY CONTROL MODULE)

< ECU DIAGNOSIS >

- ◊ A : With AT
- ◊ NV : With NAVI
- ◊ ON : Without NAVI
- ◊ RE : With sunroof
- ◊ AN : With rear anti-pinch system
- ◊ OA : Without rear anti-pinch system
- ◊ SP : With sports seat
- ◊ PM : With automatic drive positioner

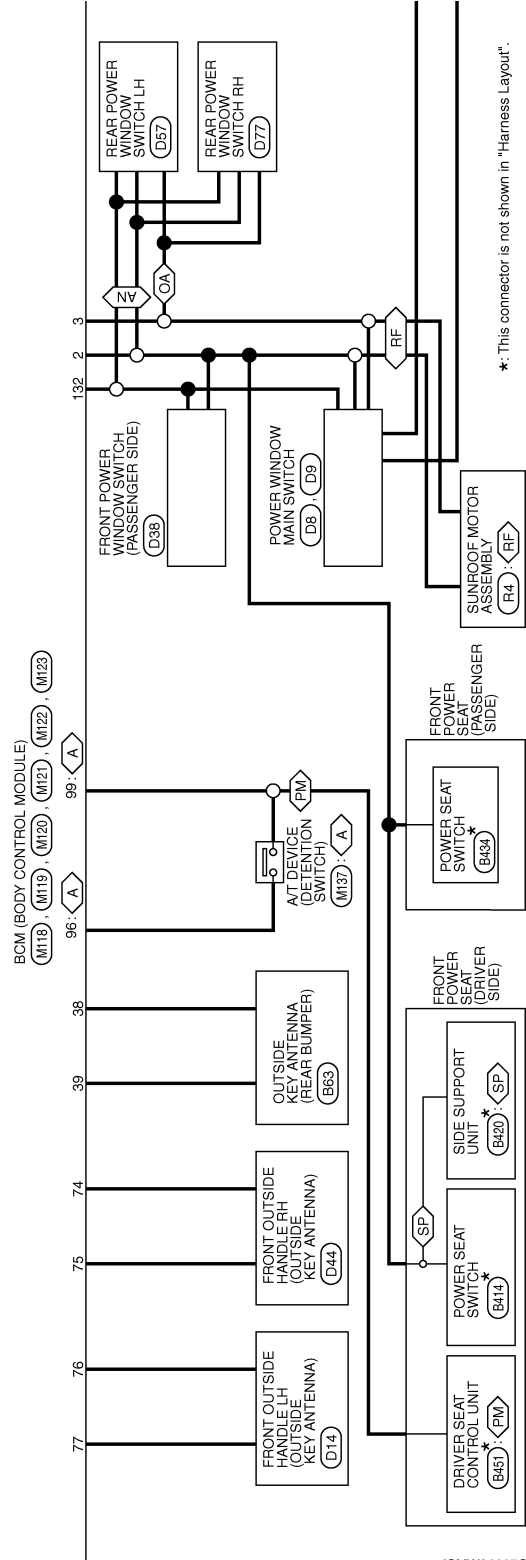
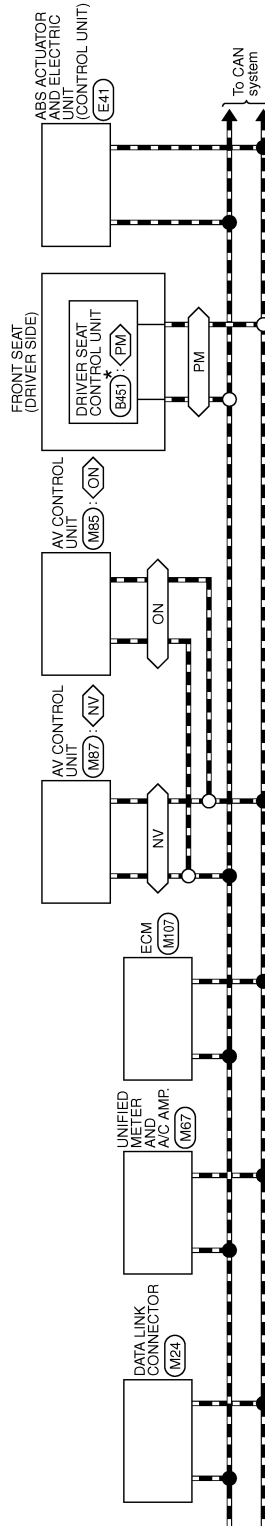

*: This connector is not shown in "Harness Layout".

JCMWA0007G6

BCM (BODY CONTROL MODULE)

< ECU DIAGNOSIS >

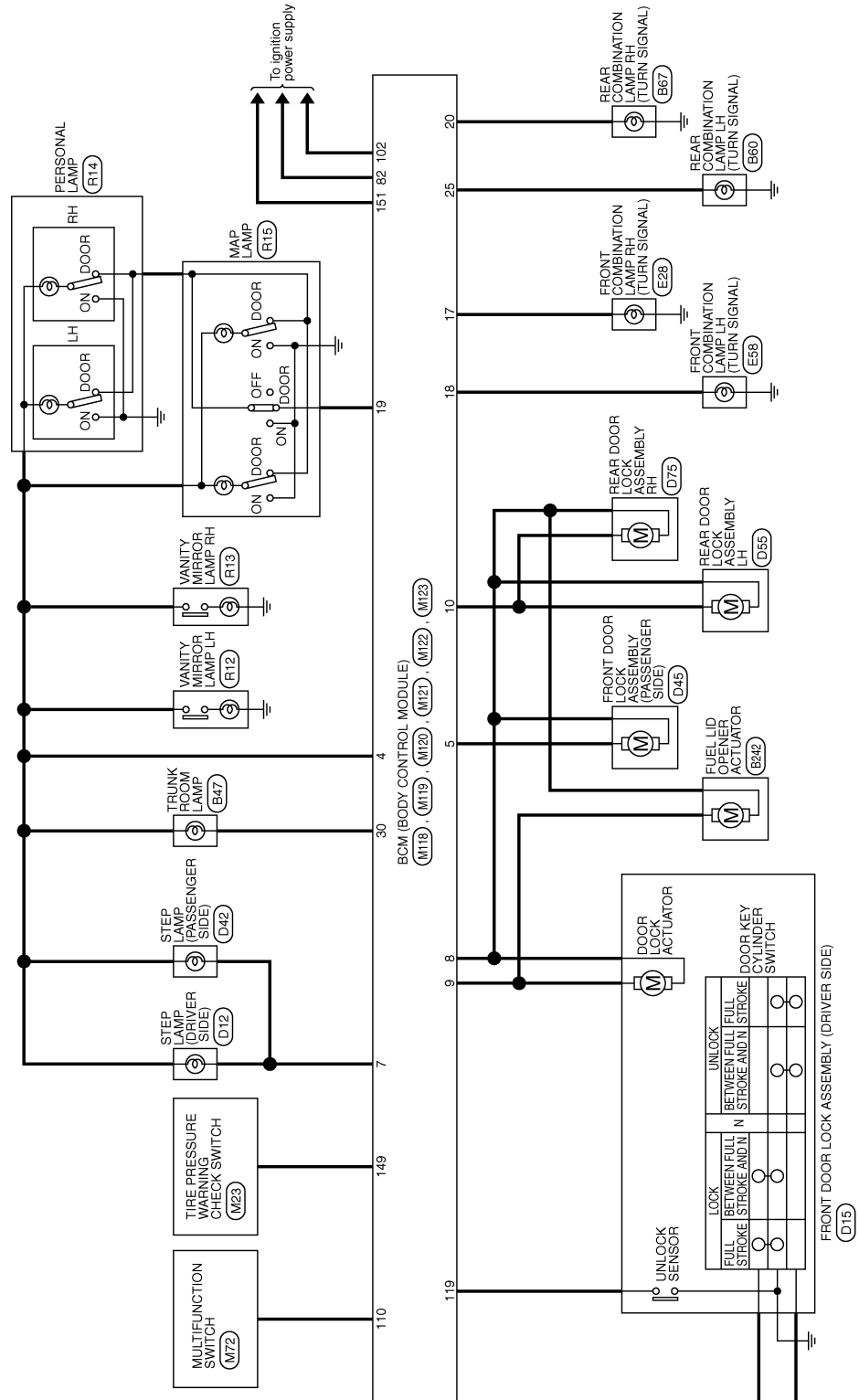

JCMWA0008GE

A
B
C
D
WT
F
G
H
I
J
K
L
M
N
O
P

BCM (BODY CONTROL MODULE)

< ECU DIAGNOSIS >

BCM (BODY CONTROL MODULE)

Connector No.	M33
Connector Name	COMBINATION SWITCH
Connector Type	TH16FW-NH

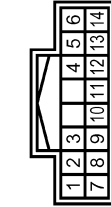

Terminal No.	Color of Wire	Signal Name
2	SB	OUTPUT 4
5	L	OUTPUT 3
7	V	INPUT 3
8	O	OUTPUT 5
9	Y	INPUT 2
10	R	INPUT 4
11	LG	INPUT 1
12	P	OUTPUT 1
13	BR	INPUT 5
14	G	OUTPUT 2

Connector No.	M120
Connector Name	BCM (BODY CONTROL MODULE)
Connector Type	NS12FW-CS

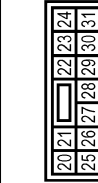

Terminal No.	Color of Wire	Signal Name
20	V	REAR FLASHER OUTPUT(RIGHT)
23	G	TRUNK OPENER OUTPUT
24	G	REAR FLASHER OUTPUT(LEFT)
30	R	TRUNK LAMP OUTPUT

Connector No.	M118
Connector Name	BCM (BODY CONTROL MODULE)
Connector Type	M03FB-LC



Terminal No.	Color of Wire	Signal Name
1	W	BAT (E/L)
2	Y	POWER WINDOW POWER SUPPLY(BAT)
3	O	POWER WINDOW POWER SUPPLY(RAP)

Connector No.	M121
Connector Name	BCM (BODY CONTROL MODULE)
Connector Type	TH40FGY-NH

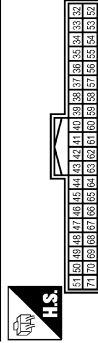

Terminal No.	Color of Wire	Signal Name
34	SB	TRUNK ANTI-
35	V	TRUNK ANTI+
38	B	BACK ANTI-
39	W	BACK ANTI+
47	Y	ING USM CONTI
50	R	TRUNK SW
52	SB	ST CONT USM
61	W	TRUNK REQUEST SW
64	V	BUZZER
67	GR	INTERIOR TRUNK SW
68	BR	DOOR SW (RR RH)

Connector No.	M119
Connector Name	BCM (BODY CONTROL MODULE)
Connector Type	NS18FW-CS

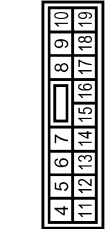

Terminal No.	Color of Wire	Signal Name
4	LG	BAT SAVER OUTPUT
5	V	DOOR UNLOCK OUTPUT (AS)
7	Y	STEP LAMP OUTPUT
8	Y	DOOR LOCK OUTPUT (ALL)
9	G	DOOR UNLOCK OUTPUT (DR)
10	BR	DOOR UNLOCK OUTPUT (RR)
11	R	BAT FUSE
13	B	GND
14	W	RING/SW LED GND
15	Y	ACC LED
17	W	FRONT FLASHER OUTPUT(RIGHT)

69	R	DOOR SW (RR LH)
----	---	-----------------

18	O	FRONT FLASHER OUTPUT(LEFT)
19	V	ROOM LAMP OUTPUT

JCMWA0009G1

BCM (BODY CONTROL MODULE)

< ECU DIAGNOSIS >

A
B
C
D
WT
F
G
H
I
J
K
L
M
N
O
P

BCM (BODY CONTROL MODULE)

Connector No.	M122
Connector Name	BCM (BODY CONTROL MODULE)
Connector Type	TH40FB-NH

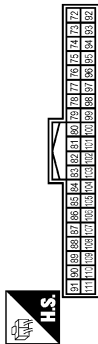

Terminal No.	Color of Wire	Signal Name
72	R	ROOM ANT2-
73	G	ROOM ANT2+
74	SB	AS DOOR ANT-
75	BR	AS DOOR ANT+
76	V	DR DOOR ANT-
77	LG	DR DOOR ANT+
78	Y	ROOM ANT1-
79	BR	ROOM ANT1+
80	GR	IMMOBI ANTENNA CONTROL
81	W	IMMOBI ANTENNA SIGNAL
82	R	IGN ELEC CONT

83	Y	KEYLESS TUNER SIGNAL
87	BR	COMBI SW INPUT 5
88	V	COMBI SW INPUT 3
89	BR	ENG SW
90	P	GAN-H
91	L	GAN-L
92	LG	KEY SLOT ILL ON LED
93	V	ACC CONT
95	O	A-T DEVICE
96	GR	S/L CONDITION 1
97	L	S/L CONDITION 2
98	P	AS REQUEST SW
99	R	SHIFT P
100	G	DR REQUEST SW
101	SB	IGN2 CONT
102	O	KEYLESS TUNER POWER SUPPLY
103	LG	S/L TRV (CRUI)
106	W	COMBI SW INPUT 1
107	LG	COMBI SW INPUT 4
108	R	COMBI SW INPUT 2
109	Y	HAZARD SW
110	G	S/L (K LINE)
111	Y	

Connector No.	M123
Connector Name	BCM (BODY CONTROL MODULE)
Connector Type	TH40FC-NH

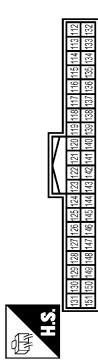

Terminal No.	Color of Wire	Signal Name
113	P	AUTO LIGHT SENSOR INPUT
114	R	CLUTCH SW
116	SB	STOP LAMP LOW
118	P	STOP LAMP HIGH
119	SB	DR CONDITION SW
121	R	KEY SWITCH SIGNAL
122	V	ACC F/B
123	W	IGN F/B
124	LG	DOOR SW (AS)
129	O	TRUNK CANDEL SW
132	V	POWER WINDOW SERIAL LINK

133	W	RMG/SW LED
134	GR	LOCK LED
137	O	SENSOR GND
138	V	AUTO LIGHT SENSOR POWER SUPPLY
139	L	RECEIVER SIGNAL
140	GR	SHIFT N/P
141	G	SECURITY INDICATOR OUTPUT
142	O	COMBI SW OUTPUT 5
143	P	COMBI SW OUTPUT 1
144	G	COMBI SW OUTPUT 2
145	L	COMBI SW OUTPUT 3
146	SB	COMBI SW OUTPUT 4
149	W	MODE TRG SW
150	GR	DOOR SW (DR)
151	G	REAR DEFOGGER OUTPUT

Fail Safe

JCMWA0010GE

INFOID:000000000957910

Display contents of CONSULT	Fail-safe	Cancellation
B2013: ID DISCORD BCM-S/L	Inhibit engine cranking	Erase DTC
B2014: CHAIN OF S/L-BCM	Inhibit engine cranking	Erase DTC
B2190: NATS ANTENNA AMP	Inhibit engine cranking	Erase DTC

BCM (BODY CONTROL MODULE)

< ECU DIAGNOSIS >

Display contents of CONSULT	Fail-safe	Cancellation
B2191: DIFFERENCE OF KEY	Inhibit engine cranking	Erase DTC
B2192: ID DISCORD BCM-ECM	Inhibit engine cranking	Erase DTC
B2193: CHAIN OF BCM-ECM	Inhibit engine cranking	Erase DTC
B2557: VEHICLE SPEED	Inhibit steering lock	When normal vehicle speed signals have been received from ABS actuator and electric unit (control unit) for 500 ms
B2560: STARTER CONT RELAY	Inhibit engine cranking	500 ms after the following CAN signal communication status has become consistent <ul style="list-style-type: none"> • Starter control relay signal • Starter relay status signal
B2563: HI VOLTAGE	<ul style="list-style-type: none"> • Inhibit engine cranking • Inhibit steering lock 	500 ms after the power supply voltage decreases to less than 18 V
B2601: SHIFT POSITION	Inhibit steering lock	500 ms after the following signal reception status becomes consistent <ul style="list-style-type: none"> • Selector lever P position switch signal • P range signal (CAN)
B2602: SHIFT POSITION	Inhibit steering lock	5 seconds after the following BCM recognition conditions are fulfilled <ul style="list-style-type: none"> • Ignition switch is in the ON position • Selector lever P position switch signal: Except P position (battery voltage) • Vehicle speed: 4 /h or more
B2603: SHIFT POSI STATUS	Inhibit steering lock	500 ms after the following BCM recognition conditions are fulfilled <ul style="list-style-type: none"> • Ignition switch is in the ON position • Selector lever P position switch signal: Except P position (battery voltage) • Selector lever P/N position signal: Except P and N positions (0 V)
B2604: PNP SW	Inhibit steering lock	500 ms after any of the following BCM recognition conditions is fulfilled <ul style="list-style-type: none"> • Status 1 <ul style="list-style-type: none"> - Ignition switch is in the ON position - Selector lever P/N position signal: P and N position (battery voltage) - P range signal or N range signal (CAN): ON • Status 2 <ul style="list-style-type: none"> - Ignition switch is in the ON position - Selector lever P/N position signal: Except P and N positions (0 V) - P range signal and N range signal (CAN): OFF
B2605: PNP SW	Inhibit steering lock	500 ms after any of the following BCM recognition conditions is fulfilled <ul style="list-style-type: none"> • Ignition switch is in the ON position <ul style="list-style-type: none"> - Power position: IGN - Selector lever P/N position signal: Except P and N positions (0 V) - Interlock/PNP switch signal (CAN): OFF • Status 2 <ul style="list-style-type: none"> - Ignition switch is in the ON position - Selector lever P/N position signal: P or N position (battery voltage) - PNP switch signal (CAN): ON
B2606: S/L RELAY	Inhibit engine cranking	500 ms after the following CAN signal communication status has become consistent <ul style="list-style-type: none"> • Steering lock relay signal (Request signal) • Steering lock relay signal (Condition signal)
B2607: S/L RELAY	Inhibit engine cranking	500 ms after the following CAN signal communication status has become consistent <ul style="list-style-type: none"> • Steering lock relay signal (Request signal) • Steering lock relay signal (Condition signal)

BCM (BODY CONTROL MODULE)

< ECU DIAGNOSIS >

Display contents of CONSULT	Fail-safe	Cancellation
B2608: STARTER RELAY	Inhibit engine cranking	500 ms after the following signal communication status becomes consistent <ul style="list-style-type: none"> • Starter motor relay control signal • Starter relay status signal (CAN)
B2609: S/L STATUS	<ul style="list-style-type: none"> • Inhibit engine cranking • Inhibit steering lock 	When the following steering lock conditions agree <ul style="list-style-type: none"> • BCM steering lock control status • Steering lock condition No. 1 signal status • Steering lock condition No. 2 signal status
B260A: IGNITION RELAY	Inhibit engine cranking	500 ms after the following conditions are fulfilled <ul style="list-style-type: none"> • IGN relay (IPDM E/R) control signal: OFF (Battery voltage) • Ignition ON signal (CAN to IPDM E/R): OFF (Request signal) • Ignition ON signal (CAN from IPDM E/R): OFF (Condition signal)
B260F: ENG STATE SIG LOST	Maintains the power supply position attained at the time of DTC detection	When any of the following conditions is fulfilled <ul style="list-style-type: none"> • Power position changes to ACC • Receives engine status signal (CAN)
B2612: S/L STATUS	<ul style="list-style-type: none"> • Inhibit engine cranking • Inhibit steering lock 	When any of the following conditions is fulfilled <ul style="list-style-type: none"> • Steering lock unit status signal (CAN) is received normally • The BCM steering lock control status matches the steering lock status recognized by the steering lock unit status signal (CAN from IPDM E/R)
B2617: STARTER RELAY CIRC	Inhibit engine cranking	1 second after the starter motor relay control inside BCM becomes normal
B2618: BCM	Inhibit engine cranking	1 second after the ignition relay (IPDM E/R) control inside BCM becomes normal
B2619: BCM	Inhibit engine cranking	1 second after the steering lock unit power supply output control inside BCM becomes normal
B261E: VEHICLE TYPE	Inhibit engine cranking	BCM initialization
B26E1: ENG STATE NO RECIV	Inhibit engine cranking	When any of the following conditions is fulfilled <ul style="list-style-type: none"> • Power position changes to ACC • Receives engine status signal (CAN)

DTC Inspection Priority Chart

INFOID:000000000957911

If some DTCs are displayed at the same time, perform inspections one by one based on the following priority chart.

Priority	DTC
1	<ul style="list-style-type: none"> • B2562: LOW VOLTAGE • B2563: HI VOLTAGE
2	<ul style="list-style-type: none"> • U1000: CAN COMM CIRCUIT • U1010: CONTROL UNIT (CAN)
3	<ul style="list-style-type: none"> • B2190: NATS ANTENA AMP • B2191: DIFFERENCE OF KEY • B2192: ID DISCORD BCM-ECM • B2193: CHAIN OF BCM-ECM

BCM (BODY CONTROL MODULE)

< ECU DIAGNOSIS >

Priority	DTC
4	<ul style="list-style-type: none"> • B2013: ID DISCORD BCM-S/L • B2014: CHAIN OF S/L-BCM • B2553: IGNITION RELAY • B2555: STOP LAMP • B2556: PUSH-BTN IGN SW • B2557: VEHICLE SPEED • B2560: STARTER CONT RELAY • B2601: SHIFT POSITION • B2602: SHIFT POSITION • B2603: SHIFT POSI STATUS • B2604: PNP SW • B2605: PNP SW • B2606: S/L RELAY • B2607: S/L RELAY • B2608: STARTER RELAY • B2609: S/L STATUS • B260A: IGNITION RELAY • B260B: STEERING LOCK UNIT • B260C: STEERING LOCK UNIT • B260D: STEERING LOCK UNIT • B260F: ENG STATE SIG LOST • B2611: ACC RELAY • B2612: S/L STATUS • B2614: ACC RELAY CIRC • B2615: BLOWER RELAY CIRC • B2616: IGN RELAY CIRC • B2617: STARTER RELAY CIRC • B2618: BCM • B2619: BCM • B261A: PUSH-BTN IGN SW • B261E: VEHICLE TYPE • B26E1: ENG STATE NO RECIV • C1729: VHCL SPEED SIG ERR • U0415: VEHICLE SPEED SIG
5	<ul style="list-style-type: none"> • C1704: LOW PRESSURE FL • C1705: LOW PRESSURE FR • C1706: LOW PRESSURE RR • C1707: LOW PRESSURE RL • C1708: [NO DATA] FL • C1709: [NO DATA] FR • C1710: [NO DATA] RR • C1711: [NO DATA] RL • C1712: [CHECKSUM ERR] FL • C1713: [CHECKSUM ERR] FR • C1714: [CHECKSUM ERR] RR • C1715: [CHECKSUM ERR] RL • C1716: [PRESSDATA ERR] FL • C1717: [PRESSDATA ERR] FR • C1718: [PRESSDATA ERR] RR • C1719: [PRESSDATA ERR] RL • C1720: [CODE ERR] FL • C1721: [CODE ERR] FR • C1722: [CODE ERR] RR • C1723: [CODE ERR] RL • C1724: [BATT VOLT LOW] FL • C1725: [BATT VOLT LOW] FR • C1726: [BATT VOLT LOW] RR • C1727: [BATT VOLT LOW] RL • C1734: CONTROL UNIT
6	<ul style="list-style-type: none"> • B2621: INSIDE ANTENNA • B2622: INSIDE ANTENNA • B2623: INSIDE ANTENNA

BCM (BODY CONTROL MODULE)

< ECU DIAGNOSIS >

NOTE:

- Details of time display
- CRNT: Displays when there is a malfunction now or after returning to the normal condition until turning ignition switch OFF → ON again.
 - 1 - 39: Displayed if any previous malfunction is present when current condition is normal. It increases like 1 → 2 → 3...38 → 39 after returning to the normal condition whenever ignition switch OFF → ON. The counter remains at 39 even if the number of cycles exceeds it. It is counted from 1 again when turning ignition switch OFF → ON after returning to the normal condition if the malfunction is detected again.

CONSULT display	Fail-safe	Intelligent Key warning lamp ON	Tire pressure monitor warning lamp ON	Reference page
No DTC is detected. further testing may be required.	—	—	—	—
U1000: CAN COMM CIRCUIT	—	—	—	BCS-33
U1010: CONTROL UNIT (CAN)	—	—	—	BCS-34
U0415: VEHICLE SPEED SIG	—	—	—	BCS-35
B2013: ID DISCORD BCM-S/L	×	—	—	SEC-43
B2014: CHAIN OF S/L-BCM	×	—	—	SEC-44
B2190: NATS ANTENA AMP	×	—	—	SEC-37
B2191: DIFFERENCE OF KEY	×	—	—	SEC-40
B2192: ID DISCORD BCM-ECM	×	—	—	SEC-41
B2193: CHAIN OF BCM-ECM	×	—	—	SEC-42
B2553: IGNITION RELAY	—	—	—	PCS-48
B2555: STOP LAMP	—	—	—	SEC-47
B2556: PUSH-BTN IGN SW	—	×	—	SEC-49
B2557: VEHICLE SPEED	×	×	—	SEC-51
B2560: STARTER CONT RELAY	×	×	—	SEC-52
B2562: LOW VOLTAGE	—	—	—	BCS-36
B2563: HI VOLTAGE	×	×	—	BCS-37
B2601: SHIFT POSITION	×	×	—	SEC-53
B2602: SHIFT POSITION	×	×	—	SEC-56
B2603: SHIFT POSI STATUS	×	×	—	SEC-58
B2604: PNP SW	×	×	—	SEC-61
B2605: PNP SW	×	×	—	SEC-63
B2606: S/L RELAY	×	×	—	SEC-65
B2607: S/L RELAY	×	×	—	SEC-66
B2608: STARTER RELAY	×	×	—	SEC-68
B2609: S/L STATUS	×	×	—	SEC-70
B260A: IGNITION RELAY	×	×	—	PCS-50
B260B: STEERING LOCK VNIT	—	×	—	SEC-74
B260C: STEERING LOCK VNIT	—	×	—	SEC-75
B260D: STEERING LOCK VNIT	—	×	—	SEC-76
B260F: ENG STATE SIG LOST	×	×	—	SEC-77
B2611: ACC RELAY	—	—	—	PCS-52
B2612: S/L STATUS	×	×	—	SEC-79
B2614: ACC RELAY CIRC	—	×	—	PCS-54
B2615: BLOWER RELAY CIRC	—	×	—	PCS-57

BCM (BODY CONTROL MODULE)

< ECU DIAGNOSIS >

CONSULT display	Fail-safe	Intelligent Key warning lamp ON	Tire pressure monitor warning lamp ON	Reference page
B2616: IGN RELAY CIRC	—	×	—	PCS-60
B2617: STARTER RELAY CIRC	×	×	—	SEC-83
B2618: BCM	×	×	—	PCS-63
B2619: BCM	×	×	—	SEC-85
B261A: PUSH-BTN IGN SW	—	×	—	SEC-86
B261E: VEHICLE TYPE	×	× (Turn ON for 15 seconds)	—	SEC-88
B2621: INSIDE ANTENNA	—	—	—	DLK-58
B2622: INSIDE ANTENNA	—	—	—	DLK-60
B2623: INSIDE ANTENNA	—	—	—	DLK-62
B26E1: ENG STATE NO RES	×	×	—	SEC-78
C1704: LOW PRESSURE FL	—	—	×	WT-14
C1705: LOW PRESSURE FR	—	—	×	WT-14
C1706: LOW PRESSURE RR	—	—	×	WT-14
C1707: LOW PRESSURE RL	—	—	×	WT-14
C1708: [NO DATA] FL	—	—	×	WT-16
C1709: [NO DATA] FR	—	—	×	WT-16
C1710: [NO DATA] RR	—	—	×	WT-16
C1711: [NO DATA] RL	—	—	×	WT-16
C1712: [CHECKSUM ERR] FL	—	—	×	WT-19
C1713: [CHECKSUM ERR] FR	—	—	×	WT-19
C1714: [CHECKSUM ERR] RR	—	—	×	WT-19
C1715: [CHECKSUM ERR] RL	—	—	×	WT-19
C1716: [PRESSDATA ERR] FL	—	—	×	WT-22
C1717: [PRESSDATA ERR] FR	—	—	×	WT-22
C1718: [PRESSDATA ERR] RR	—	—	×	WT-22
C1719: [PRESSDATA ERR] RL	—	—	×	WT-22
C1720: [CODE ERR] FL	—	—	×	WT-24
C1721: [CODE ERR] FR	—	—	×	WT-24
C1722: [CODE ERR] RR	—	—	×	WT-24
C1723: [CODE ERR] RL	—	—	×	WT-24
C1724: [BATT VOLT LOW] FL	—	—	×	WT-27
C1725: [BATT VOLT LOW] FR	—	—	×	WT-27
C1726: [BATT VOLT LOW] RR	—	—	×	WT-27
C1727: [BATT VOLT LOW] RL	—	—	×	WT-27
C1729: VHCL SPEED SIG ERR	—	—	×	WT-30
C1734: CONTROL UNIT	—	—	×	WT-31

TPMS

< SYMPTOM DIAGNOSIS >

SYMPTOM DIAGNOSIS









TPMS

Symptom Table

INFOID:000000000957913



Symptom	Reference
Warning lamp does not turn on for approx.1 second when ignition switch is turned on.	WT-79
Warning lamp stays on when ignition switch is turned on.	WT-80
Warning lamp blinks when ignition switch is turned on	WT-82
Turn signal lamp blinks when ignition switch is turned on	WT-83
ID registration can not be completed.	WT-84

LOW TIRE PRESSURE WARNING LAMP SYMPTOM CHART

Diagnosis Item	Symptom (Ignition switch ON)	Low tire pressure warning lamp	Cause	Action
Low tire pressure warning lamp	Warning lamp comes on immediately and turns off after 1 second.	 ON 1 sec > stays OFF SEIA0592E	All wheel transmitters are "activated" (working).	None (system OK)
	Warning lamp blinks on for 2 seconds, then turns off for 0.2 seconds-repeats.	 Blinks:  ON 2 sec > OFF 0.2 sec SEIA0593E	All wheel transmitters are not activated.	Activate all wheel tire pressure transmitters. Refer to WT-5 , " TRANSMITTER WAKE UP OPERATION : Special Repair Requirement ".
	Warning lamp blinks 1 time.	 Blinks 1 time ON 0.3 sec > OFF 1.3 sec SEIA0594E	Tire pressure transmitter front LH is not activated.	Activate tire pressure transmitter front LH. Refer to WT-5 , " TRANSMITTER WAKE UP OPERATION : Special Repair Requirement ".
	Warning lamp blinks 2 times.	  Blinks 2 times ON 0.3 sec > OFF 0.3 sec SEIA0595E	Tire pressure transmitter front RH is not activated.	Activate tire pressure transmitter front RH. Refer to WT-5 , " TRANSMITTER WAKE UP OPERATION : Special Repair Requirement ".
	Warning lamp blinks 3 times.	   Blinks 3 times ON 0.3 sec > OFF 0.3 sec SEIA0596E	Tire pressure transmitter rear RH is not activated.	Activate tire pressure transmitter rear RH. Refer to WT-5 , " TRANSMITTER WAKE UP OPERATION : Special Repair Requirement ".

TPMS

< SYMPTOM DIAGNOSIS >

Diagnosis Item	Symptom (Ignition switch ON)	Low tire pressure warning lamp	Cause	Action
Low tire pressure warning lamp	Warning lamp blinks 4 times.	 Blinks 4 times ON 0.3 sec > OFF 0.3 sec <small>SEIA0597E</small>	Tire pressure transmitter rear LH is not activated.	Activate tire pressure transmitter rear LH. Refer to WT-5, "TRANSMITTER WAKE UP OPERATION : Special Repair Requirement" .
	Warning lamp comes on and does not turn off.	 Comes ON and stays ON <small>SEIA0598E</small>	Tire pressure is low.	Check tire pressure with CONSULT-III. Refer to WT-12, "AIR PRESSURE MONITOR : CONSULT-III Function (BCM - AIR PRESSURE MONITOR)" .
	Warning lamp blinks on for 0.5 seconds then turns off for 0.5 seconds-repeats for 1 minute, and then stays on.	 Blinks 1 min ON 0.5 sec > OFF 0.5 sec and stays ON <small>SEIA0788E</small>	The fuse for combination meter from battery is pulled out. BCM connector pulled out. Low tire pressure or tire pressure monitoring system malfunction.	Check the fuse for combination meter from battery. Install or replace (if needed). Check BCM connector. Reconnect if needed. <ul style="list-style-type: none"> • Perform CONSULT-III Self-Diagnosis. Refer to WT-12, "AIR PRESSURE MONITOR : CONSULT-III Function (BCM - AIR PRESSURE MONITOR)". - Perform ID Registration if needed. Refer to WT-5, "ID REGISTRATION PROCEDURE : Special Repair Requirement".
Turn signal lamp	Turn signal lamp does not flash 2 times or buzzer does not sound after transmitter activation.	—	<ol style="list-style-type: none"> 1. Tool J-45295 [SST] 2. Ignition OFF during activation. 3. Tool J-45295 [SST] not positioned correctly. 4. Transmitters already activated. 	<ol style="list-style-type: none"> 1. Install new battery. 2. Make sure ignition is ON during activation. 3. Position tool correctly during activation. 4. None

NOTE:

If more than one wheel transmitter is NOT activated, the warning lamp blinking patterns for those wheels will combine. (Example: one blink/OFF/three blinks = Tire pressure transmitter rear LH and rear RH are not activated.)

LOW TIRE PRESSURE WARNING LAMP DOES NOT TURN ON

< SYMPTOM DIAGNOSIS >

LOW TIRE PRESSURE WARNING LAMP DOES NOT TURN ON

Description

INFOID:000000000957914

DESCRIPTION

The low tire pressure warning lamp illuminates for approximately 1 second and then turns OFF when the ignition switch is turned ON. This is to check that no abnormal condition is present in the tire pressure monitoring system.

The lamp bulb may be burnt out or the tire pressure monitoring system may be malfunctioning if the warning lamp does not illuminate when the ignition switch is turned ON.

Diagnosis Procedure

INFOID:000000000957915

1.CHECK SELF-DIAGNOSIS RESULTS

④ With CONSULT-III

1. On the "SELECT DIAG" mode, select the "SELF-DIAG RESULTS" screen.
2. Check display contents in self-diagnostic results.

Is "CAN COMM CIRCUIT" displayed in the self-diagnosis display items?

YES >> Perform trouble diagnosis for CAN communication system. Refer to [LAN-18, "Trouble Diagnosis Flow Chart"](#).

NO >> GO TO 2.

2.CHECK COMBINATION METER

Check unified meter function. Refer to [MWI-37, "CONSULT-III Function \(METER/M&A\)"](#).

Is the inspection result normal?

YES >> GO TO 3.

NO >> Repair or replace damaged parts.

3.CHECK LOW TIRE PRESSURE WARNING LAMP

1. Turn ignition switch "OFF".
2. Disconnect BCM harness connectors.
3. Turn ignition switch "ON". (Do not start engine.)

Does low tire pressure warning lamp turn on?

YES >> GO TO 4.

NO >> Check combination meter and repair or replace. Refer to [MWI-35, "Diagnosis Description"](#).

4.CHECK SYMPTOM

Check again.

Is the inspection result normal?

YES >> INSPECTION END

NO >> GO TO 5.

5.CHECK BCM

Check BCM input/output signal. Refer to [WT-43, "Reference Value"](#).

Is the inspection result normal?

YES >> GO TO 4.

NO >> GO TO 6.

6.CHECK BCM HARNESS CONNECTOR

Check BCM pin terminals for damage or loose connection with harness connector.

Is the inspection result normal?

YES >> Replace BCM. Refer to [BCS-79, "Removal and Installation"](#).

NO >> Repair or replace damaged parts.

A
B
C
D
E
F
G
H
I
J
K
L
M
N
O
P

WT

LOW TIRE PRESSURE WARNING LAMP STAYS ON

< SYMPTOM DIAGNOSIS >

LOW TIRE PRESSURE WARNING LAMP STAYS ON

Description

INFOID:000000000957916

DESCRIPTION

The tire pressure monitoring system is checked and the warning lamp is illuminated for approximately 1 second when the ignition switch is turned ON. The warning lamp turns OFF after the system check finishes. The system may be malfunctioning if the warning lamp does not turn off approximately 1 second after the ignition switch is turned ON.

Diagnosis Procedure

INFOID:000000000957917

1.CHECK SYSTEM FOR BCM

ⓅWith CONSULT-III

1. On "SELF-DIAG" mode, select the "SELF-DIAG RESULTS" screen.
2. Check display contents in self-diagnostic results.

Does self-diagnostic results indicate any malfunction?

YES >> Perform trouble diagnosis. Refer to [WT-12, "AIR PRESSURE MONITOR : CONSULT-III Function \(BCM - AIR PRESSURE MONITOR\)"](#).

NO >> GO TO 2.

2.CHECK ID REGISTRATION

Perform ID registration all transmitters. Refer to [WT-5, "ID REGISTRATION PROCEDURE : Special Repair Requirement"](#).

Does low tire warning lamp turn OFF?

YES >> INSPECTION END

NO >> GO TO 3.

3.CHECK POWER SUPPLY CIRCUIT

1. Turn ignition switch "OFF".
2. Disconnect BCM harness connector.
3. Check voltage between BCM and harness connector terminals and ground.

(+)		(-)	Voltage (Approx.)
BCM		Ground	
Connector	Terminal		
M118	1		Battery voltage
M119	11		

Is the power supply normal?

YES >> GO TO 3.

NO >> Check the following. If any items are damaged, repair or replace damage parts.

- 40 A fusible link [No. K located in the fuse block]. Refer to [PG-94, "Fuse and Fusible Link Arrangement"](#).
- 10 A fuse [No. 10 located in the fuse block (J/B)]. Refer to [PG-93, "Fuse, Connector and Terminal Arrangement"](#).
- Harness for short or open between battery and BCM harness connector M118 terminal 1.
- Harness for short or open between battery and BCM harness connector M119 terminal 11.
- Check battery voltage.

4.CHECK GROUND CIRCUIT

1. Turn ignition switch "OFF".
2. Disconnect BCM harness connector.
3. Check continuity between BCM harness connector M119 terminal 13 and ground.

LOW TIRE PRESSURE WARNING LAMP STAYS ON

< SYMPTOM DIAGNOSIS >

BCM		Ground	Continuity
Connector	Terminal		Existed
M119	13		

A

B

Also check harness short to power.

Is the inspection result normal?

C

YES >> GO TO 5.

NO >> Repair open circuit or short to power in harness or connectors.

5.CHECK SYMPTOM

D

Check again.

Is the inspection result normal?

WT

YES >> INSPECTION END

NO >> GO TO 6.

6.CHECK BCM

F

Check BCM input/output signal. Refer to [WT-43, "Reference Value"](#).

Is the inspection result normal?

G

YES >> GO TO 5.

NO >> GO TO 7.

7.CHECK BCM HARNESS CONNECTOR

H

Check BCM pin terminals for damage or loose connection with harness connector.

Is the inspection result normal?

I

YES >> Replace BCM. Refer to [BCS-79, "Removal and Installation"](#).

NO >> Repair or replace damaged parts.

J

K

L

M

N

O

P

LOW TIRE PRESSURE WARNING LAMP BLINKS

< SYMPTOM DIAGNOSIS >

LOW TIRE PRESSURE WARNING LAMP BLINKS

Description

INFOID:000000000957918

DESCRIPTION

The low tire pressure warning lamp illuminates or blinks.

However, a check is necessary because the symptom may not be caused by a system malfunction. For example, the transmitter may not be initialized.

NOTE:

If warning lamp blinks below, the system is normal.

Blink Mode A

- This mode shows transmitter status is in OFF- mode. Perform transmitter wake up operation. Refer to [WT-5, "TRANSMITTER WAKE UP OPERATION : Special Repair Requirement"](#).

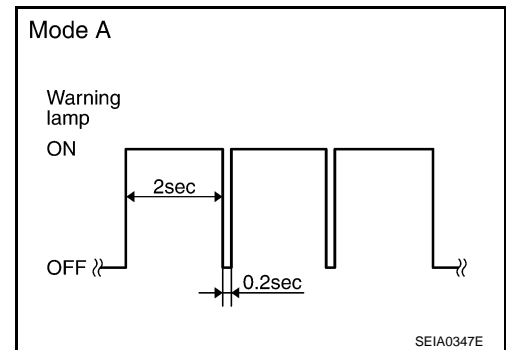

Diagnosis Procedure

INFOID:000000000957919

1.CHECK TIRE PRESSURE WARNING CHECK SWITCH CIRCUIT

1. Turn ignition switch "OFF".
2. Disconnect BCM harness connectors.
3. Check continuity between BCM harness connector M123 terminal 149 and ground.

BCM		Ground	Continuity
Connector	terminal		Not existed
M123	149		Not existed

Also check harness for short to ground.

Is the inspection result normal?

- YES >> GO TO 2.
NO >> Repair or replace short to ground harness connector.

2.CHECK SYMPTOM

Check again.

Does the low tire pressure warning lamp remain blinking?

- YES >> GO TO 3.
NO >> INSPECTION END

3.CHECK BCM

Check BCM input/output signal. Refer to [WT-43, "Reference Value"](#).

Is the inspection result normal?

- YES >> GO TO 2.
NO >> GO TO 4.

4.CHECK BCM HARNESS CONNECTOR

Check BCM pin terminals for damage or loose connection with harness connector.

Is the inspection result normal?

- YES >> Replace BCM. Refer to [BCS-79, "Removal and Installation"](#).
NO >> repair or replace damaged parts.

TURN SIGNAL LAMP BLINKS

< SYMPTOM DIAGNOSIS >

TURN SIGNAL LAMP BLINKS

Description

INFOID:000000000957920

DESCRIPTION

The turn signal lamp blinks when the ignition switch is turned ON.
The BCM connector or circuit may have a malfunction.

Diagnosis Procedure

INFOID:000000000957921

Turn signal lamp blinks

1.CHECK TIRE PRESSURE WARNING CHECK SWITCH CIRCUIT

1. Turn ignition switch "OFF".
2. Disconnect BCM harness connector.
3. Check continuity between BCM harness connector M123 terminal149 and ground.

BCM		Ground	Continuity
Connector	Terminal		
M123	149		Not existed

Also check harness for short to ground.

Is the inspection result normal?

- YES >> GO TO 2.
NO >> Repair or replace ground in harness or connector.

2.CHECK SYMPTOM

Check again.

Does the turn signal lamp remain blinking?

- YES >> Check turn signal lamp operation. Refer to [MWI-37, "CONSULT-III Function \(METER/M&A\)".](#)
NO >> INSPECTION END

ID REGISTRATION CANNOT BE COMPLETED

< SYMPTOM DIAGNOSIS >

ID REGISTRATION CANNOT BE COMPLETED

Description

INFOID:000000000957922

DESCRIPTION

The ID of the transmitter installed in each wheel cannot be registered in the tire pressure monitoring system. Inspect the transmitter or the tire pressure monitoring system circuit.

Diagnosis Procedure

INFOID:000000000957923

1. CHECK ID REGISTRATION

1. Perform ID registration of all transmitter. Refer to [WT-5, "ID REGISTRATION PROCEDURE : Special Repair Requirement"](#).
2. Drive at a speed of 40 km/h (25 MPH) or more for 3 minutes, and then drive the vehicle at any speed for 10 minutes. Then check all tire pressures with CONSULT-III "DATA MONITOR" within 5 minutes.

Monitored item	Condition	Display value
AIR PRESS FL	Start engine and drive at 40 km/h (25 MPH) or more for several minutes.	Approximately equal to the indication on vehicle information display.
AIR PRESS FR		
AIR PRESS RR		
AIR PRESS RL		

Does "DATA MONITOR" displayed the standardized value without turning tire pressure warning lamp ON?

- YES >> INSPECTION END
NO >> GO TO 2.

2. CHECK TRANSMITTER

1. Perform trouble diagnosis for transmitter. Refer to [WT-16, "Diagnosis Procedure"](#).
2. Perform ID registration of all transmitter. Refer to [WT-5, "ID REGISTRATION PROCEDURE : Special Repair Requirement"](#).

Can ID registration of all transmitters be completed?

- YES >> INSPECTION END
NO >> Repair or replace the malfunctioning connector. Repair or replace the malfunctioning part. Go to step 1.

NORMAL OPERATING CONDITION

< SYMPTOM DIAGNOSIS >

NORMAL OPERATING CONDITION

Description

INFOID:000000000957924

LOW TIRE PRESSURE WARNING LAMP BLINKS

The tire pressure monitoring system is not malfunctioning if the low tire pressure warning lamp blinks in the pattern as shown in the figure.

The incident occurs because the transmitter of each wheel is not wake up.

Perform transmitter wake up operation. Refer to [WT-5, "TRANSMITTER WAKE UP OPERATION : Special Repair Requirement"](#).

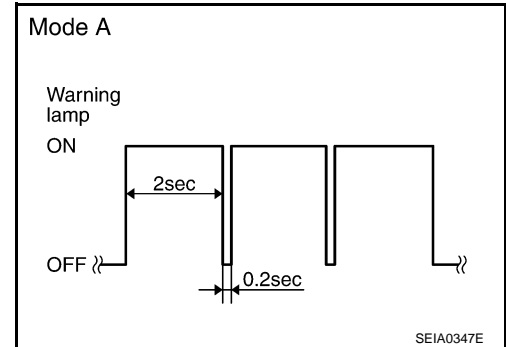

A
B
C
D
WT
F
G
H
I
J
K
L
M
N
O
P

NOISE, VIBRATION AND HARSHNESS (NVH) TROUBLESHOOTING

< SYMPTOM DIAGNOSIS >

NOISE, VIBRATION AND HARSHNESS (NVH) TROUBLESHOOTING

NVH Troubleshooting Chart

INFOID:00000000957925

Use chart below to help you find the cause of the symptom. If necessary, repair or replace these parts.

Symptom		Possible cause and SUSPECTED PARTS														Reference page				
		Improper installation, looseness	Out-of-round	unbalance	Incorrect tire pressure	Uneven tire wear	Deformation or damage	Non-uniformity	Incorrect tire size	PROPELLER SHAFT	DIFFERENTIAL	FRONT AXLE AND FRONT SUSPENSION	REAR AXLE AND REAR SUSPENSION	TIRES	ROAD WHEELS	DRIVE SHAFT	BRAKE	STEERING	2WD models: FAX-6 , FSU-7 . AWD models: FAX-16 , FSU-27 .	WT-89, "Inspection" WT-90, "Adjustment" WT-95, "Tire" WT-90, "Adjustment" — — WT-95, "Tire" NVH in DLN section. NVH in DLN section. NVH in FAX and FSU sections. NVH in RAX and RSU sections. Refer to TIRES in this chart. Refer to ROAD WHEEL in this chart. NVH in FAX, RAX section. NVH in BR section. NVH in ST section.
Symptom	TIRES	Noise	x	x	x	x	x	x	x	x	x	x	x	x	x	x	x	x		
		Shake	x	x	x	x	x	x	x	x	x	x	x	x	x	x	x	x	x	
		Vibration				x				x	x		x	x			x			
		Shimmy	x	x	x	x	x	x	x	x			x	x		x		x	x	
		Judder	x	x	x	x	x	x		x			x	x		x		x	x	
		Poor quality ride or handling	x	x	x	x	x	x		x			x		x	x				
	ROAD WHEEL	Noise	x	x	x				x			x	x	x	x		x	x	x	
		Shake	x	x	x				x			x		x	x		x	x	x	
		Shimmy, Judder	x	x	x				x				x	x	x			x	x	
		Poor quality ride or handling	x	x	x				x				x	x	x					

x: Applicable

PRECAUTIONS

< PRECAUTION >

PRECAUTION

PRECAUTIONS

Service Notice or Precautions

INFOID:000000000957926

- Low tire pressure warning lamp flashes 1min, then turns ON when occurring any malfunction except low tire pressure. Delete the memory with CONSULT-III, or register the ID to turn low tire pressure warning lamp OFF. Refer to [WT-10, "AIR PRESSURE MONITOR : Diagnosis Description"](#), [WT-5, "ID REGISTRATION PROCEDURE : Special Repair Requirement"](#).
- ID registration is required when replacing or rotating wheels, replacing transmitter or BCM. Refer to
- Replace grommet seal, valve core and cap of transmitter in TPMS every tire replacement by reaching wear limit of tire. Refer to [WT-93, "Exploded View"](#).

A
B
C
D
E
F
G
H
I
J
K
L
M
N
O
P

WT

PREPARATION

< PREPARATION >

PREPARATION

PREPARATION

Special Service Tools

INFOID:000000000957927

The actual shapes of Kent-Moore tools may differ from those of special service tools illustrated here.

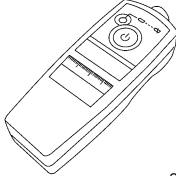
Tool number (Kent-Moore No.) Tool name	Description
— (J-45295) Transmitter activation tool  SEIA0462E	ID registration

Commercial Service Tools

INFOID:000000000957928

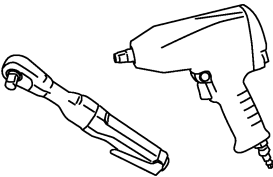
Tool name	Description
Power tool  PBIC0190E	Loosening bolts and nuts

ROAD WHEEL

< ON-VEHICLE MAINTENANCE >

ON-VEHICLE MAINTENANCE

ROAD WHEEL

Inspection

INFOID:000000000957929

ALUMINUM WHEEL

1. Check tires for wear and improper inflation.
2. Check wheels for deformation, cracks and other damage. If deformed, remove wheel and check wheel runout.
 - a. Remove tire from aluminum wheel and mount on a tire balance machine.
 - b. Set dial indicator as shown in the figure.
 - c. If the total runout value exceeds the limit, replace aluminum wheel.

Lateral runout limit (A) Refer to [WT-95, "Road Wheel"](#).

Vertical runout limit (B) Refer to [WT-95, "Road Wheel"](#).

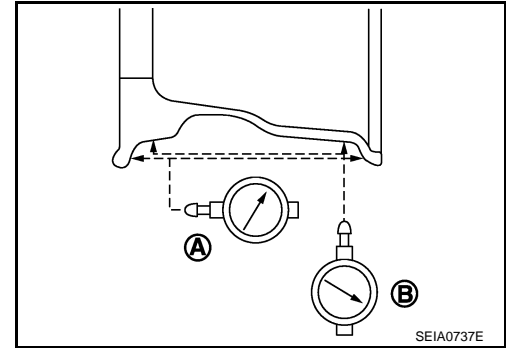

A
B
C
D
WT
F
G
H
I
J
K
L
M
N
O
P

ROAD WHEEL TIRE ASSEMBLY

< ON-VEHICLE REPAIR >

ON-VEHICLE REPAIR

ROAD WHEEL TIRE ASSEMBLY

Adjustment

INFOID:000000000957930

BARANCING WHEELS (BONDING WEIGHT TYPE)

Preparation Before Adjustment

Using releasing agent, remove double-faced adhesive tape from the road wheel.

CAUTION:

- **B e careful not scratch the road wheel during removal.**
- **After removing double-faced adhesive tape, wipe clean traces of releasing agent from the road wheel.**

Wheel Balance Adjustment

- If a tire balance machine has adhesion balance weight mode settings and drive-in weight mode setting, select and adjust a drive-in weight mode suitable for road wheels.

1. Set road wheel on tire balance machine using the center hole as a guide. Start the tire balance machine.
2. When inner and outer unbalance values are shown on the tire balance machine indicator, multiply outer unbalance value by $5/3$ to determine balance weight that should be used. Select the outer balance weight with a value closest to the calculated value above and install in to the designated outer position of, or at the designated angle in relation to the road wheel.

CAUTION:

- **Do not install the inner balance weight before installing the outer balance weight.**
- **Before installing the balance weight, be sure to clean the mating surface of the road wheel.**

- a. Indicated un balance value $\times 5/3 =$ balance weight to be installed

Calculation example:

$23 \text{ g (0.81 oz)} \times 5/3 = 38.33 \text{ g (1.35 oz)} \Rightarrow 37.5 \text{ g (1.32 oz)}$ balance weight (closer to calculated balance weight value)

NOTE:

Note that balance weight value must be closer to the calculated balance weight value.

Example:

$36.2 \Rightarrow 35 \text{ g (1.23 oz)}$

$36.3 \Rightarrow 37.5 \text{ g (1.32 oz)}$

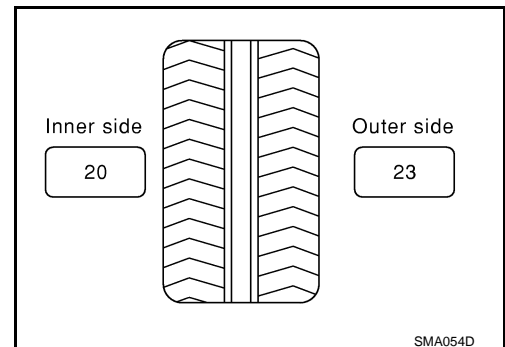

- b. Installed balance weight in the position.

ROAD WHEEL TIRE ASSEMBLY

< ON-VEHICLE REPAIR >

- When installing balance weight (1) to road wheels, set it into the grooved area (A) on the inner wall of the road wheel as shown in the figure so that the balance weight center (B) is aligned with the tire balance machine indication position (angle)(C).

CAUTION:

- Always use genuine NISSAN adhesion balance weights.
- Balance weights are non-reusable; always replace with new ones.
- Do not install more than three sheets of balance weight.

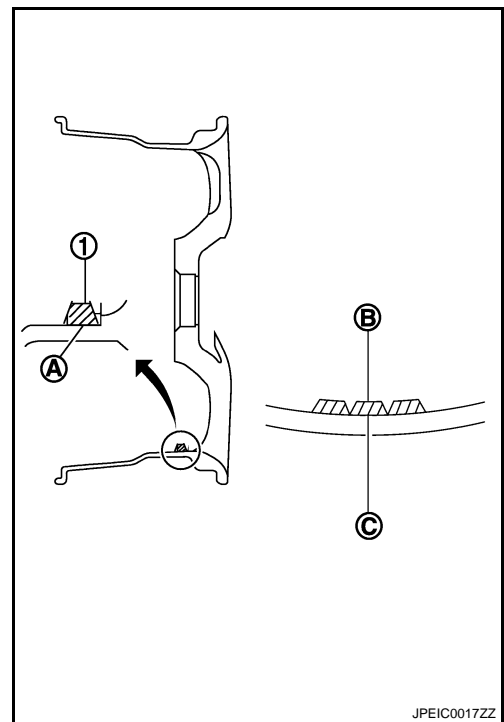

- If calculated balance weight value exceeds 50 g (1.76 oz), install two balance weight sheets in line with each other as shown in the figure.

CAUTION:

Do not install one balance weight sheet on top another.

- Start tire balance machine again.
- Install drive-in balance weight on inner side of road wheel in the tire balance machine indication position (angle).

CAUTION:

Do not install more than two balance weight.

- Start tire balance machine. Make sure that inner and outer residual unbalance values are 5 g (0.17 oz) each or below.
- If either residual unbalance value exceeds 5 g (0.17 oz), repeat installation procedures.

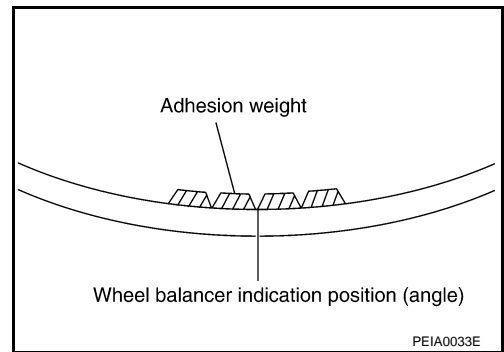

Wheel balance	Dynamic (At flange)	Static (At flange)
Maximum allowable unbalance	Refer to WT-95, "Road Wheel" .	

TIRE ROTATION (for 17 inch wheel models)

- Follow the maintenance schedule for tire rotation service intervals. Refer to MA-XX PERIODIC MAINTENANCE.
- When installing the wheel, tighten wheel nuts to the specified torque.

CAUTION:

- Do not include the T-type spare tire when rotating the tires.
- When installing wheels, tighten them diagonally by dividing the work two to three times in order to prevent the wheels from developing any distortion.
- Be careful not to tighten wheel nut at torque exceeding the criteria for preventing strain of disc rotor.

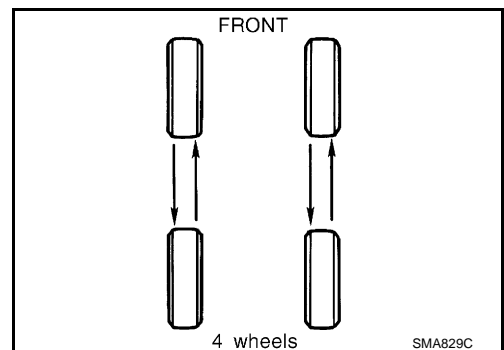

Wheel nuts tightening torque : Refer to [WT-95, "Road Wheel"](#).

ROAD WHEEL TIRE ASSEMBLY

< ON-VEHICLE REPAIR >

- Perform the ID registration, after tire rotation. Refer to [WT-5. "ID REGISTRATION PROCEDURE : Special Repair Requirement"](#).

TIRE ROTATION (for 18 inch wheel models)

- Tire cannot be rotated in vehicle, as front tire are different size from rear tire and the direction of wheel rotation is fixed in each tire.

Wheel nuts tightening torque : Refer to [WT-95. "Road Wheel"](#).

CAUTION:

Do not include the T-type spare tire when rotating the tires.

Safety Device Preventing from Being Incorrectly installed

FRONT BRAKE DISC ROTOR AND FRONT WHEEL

- Front and rear wheel size for this model differs, therefore special pin (1) has been installed on the front brake disc rotor (2). To accommodate this pin a hole (3) has been provided on the front wheel (4) (the rear wheel does not have this hole.) and in some case the rear wheel is being mistakenly installed on the front.

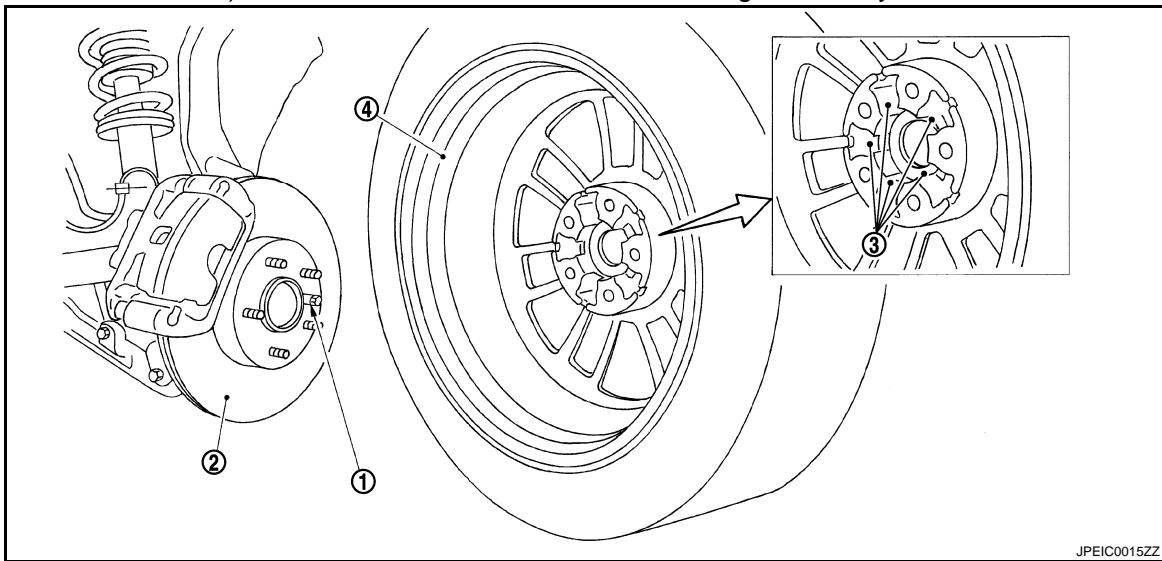

T-TYPE SPARE TIRE WHEEL

- Regarding spare tire (for emergency) wheel, wrong assembly protection pin through hole (1) has been set in addition to regular bolt holes (2) in order to enable installation to front wheel.

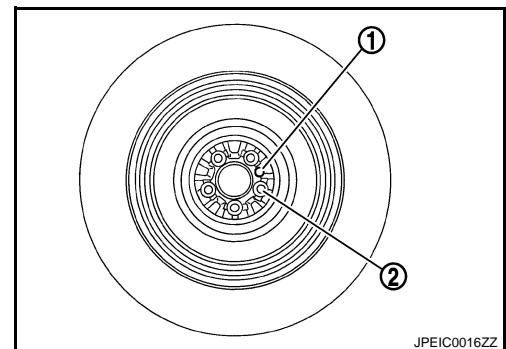

TRANSMITTER

< REMOVAL AND INSTALLATION >

REMOVAL AND INSTALLATION

TRANSMITTER

Exploded View

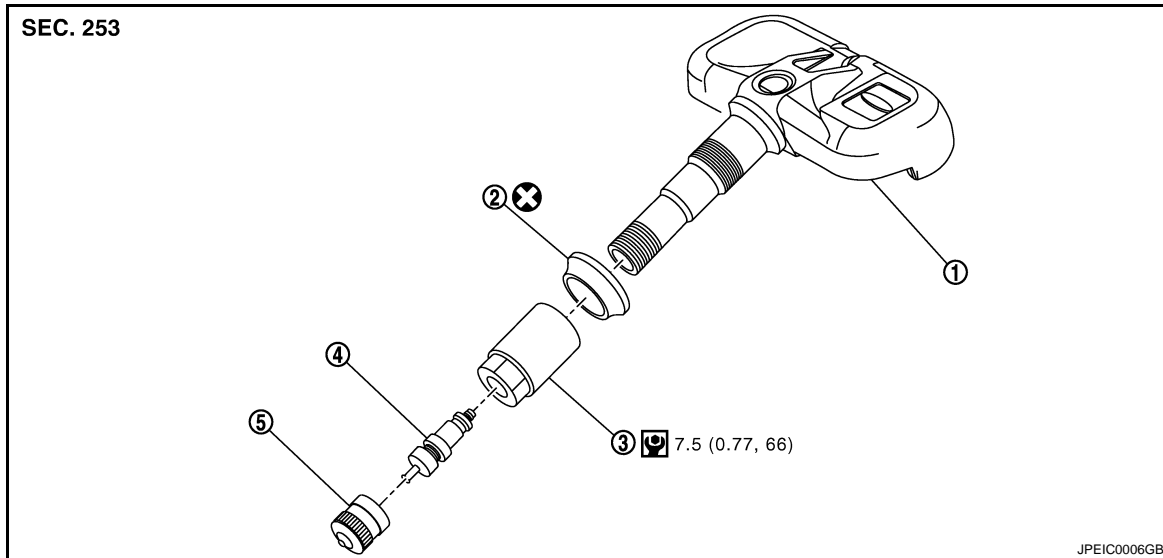

- | | | |
|----------------|-----------------|--------------|
| 1. Transmitter | 2. Grommet seal | 3. Valve nut |
| 4. Valve core | 5. Cap | |

Refer to [GI-4, "Components"](#) for symbols in figure.

Removal and Installation

INFOID:000000000957932

REMOVAL

1. Deflate tire. Unscrew transmitter retaining nut and allow transmitter to fall into tire.
2. Gently bounce tire so that transmitter falls to bottom of tire. Place on tire changing machine and break both tire beads ensuring that the transmitter remains at the bottom of the tire.

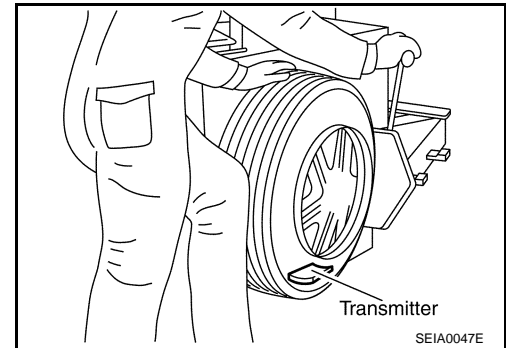

3. Turn tire so that valve hole is at bottom and bounce so that transmitter (1) is near valve hole. Carefully lift tire onto turntable and position valve hole (and transmitter) 270 degree from mounting/dismounting head (2).
4. Lubricate tire well and remove first side of the tire. Reach inside the tire and remove the transmitter.

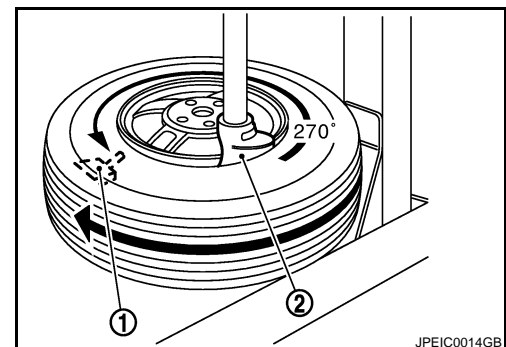

INSTALLATION

A
B
C
D
WT
F
G
H
I
J
K
L
M
N
O
P

TRANSMITTER

< REMOVAL AND INSTALLATION >

1. Put first side of tire onto rim.

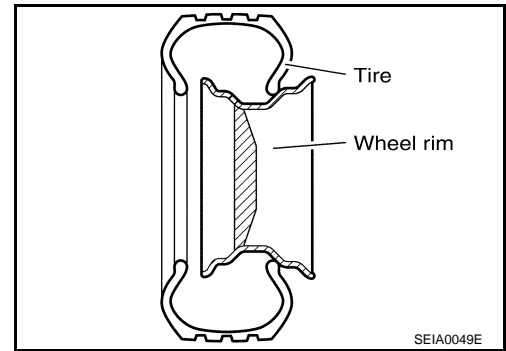

2. Mount transmitter on rim and tighten nut.

CAUTION:

Speed for tightening nut should be less than 15 rpm.

3. Place wheel on turntable of tire machine. Ensure that transmitter (1) is 270 degree from mounting head (2) when second side of tire is fitted.

NOTE:

Do not touch transmitter at mounting head.

4. Lubricate tire well and fit second side of tire as normal. Ensure that tire does not rotate relative to rim.
5. Inflate tire and fit to appropriate wheel position.

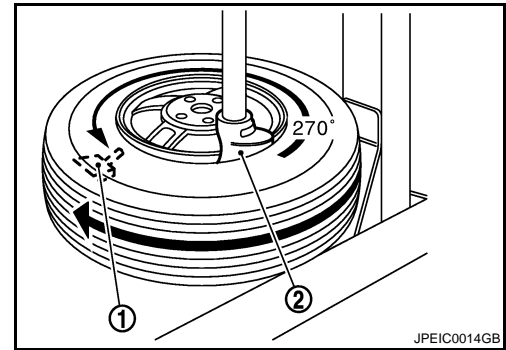

SERVICE DATA AND SPECIFICATIONS (SDS)

< SERVICE DATA AND SPECIFICATIONS (SDS)

SERVICE DATA AND SPECIFICATIONS (SDS)

SERVICE DATA AND SPECIFICATIONS (SDS)

Road Wheel

INFOID:000000000957933

Kind of wheel	Aluminum	
Maximum radial runout limit	Lateral deflection	Less than 0.3 mm (0.012 in)
	Vertical deflection	
Maximum allowable unbalance limit	Dynamic (At flange)	Less than 5 g (0.17 oz) (one side)
	Static (At flange)	Less than 10 g (0.35 oz)
Wheel nuts tightening torque	108 N·m (11 kg-m, 80 ft-lb)	

Tire

INFOID:000000000957934

Unit: kPa (kg/cm², psi)

Tire size	Air pressure	
	Front	Rear
P225/55R17 95V	230 (2.3, 33)	230 (2.3, 33)
225/50R18 95W	230 (2.3, 33)	–
245/45R18 96W	–	230 (2.3, 33)
T145/80D17 107M	420 (4.2, 60)	420 (4.2, 60)