

ENGINE LUBRICATION & COOLING SYSTEMS

SECTION LC

GI

MA

EM

LC

EC

FE

AT

AX

SU

BR

ST

RS

BT

HA

SC

EL

IDX

CONTENTS

ENGINE LUBRICATION SYSTEM	2	CHECKING COOLING SYSTEM FOR LEAKS	9
Precautions.....	2	Water Pump.....	9
LIQUID GASKET APPLICATION PROCEDURE.....	2	REMOVAL.....	9
Preparation.....	2	INSPECTION.....	10
SPECIAL SERVICE TOOLS.....	2	INSTALLATION.....	10
Lubrication Circuit.....	3	Thermostat.....	11
Oil Pressure Check.....	3	REMOVAL.....	11
Oil Pump.....	4	INSPECTION.....	11
REMOVAL AND INSTALLATION.....	4	INSTALLATION.....	12
DISASSEMBLY AND ASSEMBLY.....	4	Radiator.....	12
INSPECTION.....	5	REMOVAL AND INSTALLATION.....	12
REGULATOR VALVE INSPECTION.....	5	INSPECTION.....	13
OIL FILTER.....	6	Refilling Engine Coolant.....	14
ENGINE COOLING SYSTEM	7	Overheating Cause Analysis.....	14
Precautions.....	7	Cooling Fan Control System.....	15
LIQUID GASKET APPLICATION PROCEDURE.....	7	SERVICE DATA AND SPECIFICATIONS (SDS)	16
Preparation.....	7	Oil Pressure.....	16
SPECIAL SERVICE TOOLS.....	7	Regulator Valve.....	16
Cooling Circuit.....	8	Oil Pump.....	16
System Check.....	8	Thermostat.....	16
CHECKING COOLING SYSTEM HOSES.....	8	Radiator.....	16
CHECKING RADIATOR CAP.....	8		

ENGINE LUBRICATION SYSTEM

Precautions

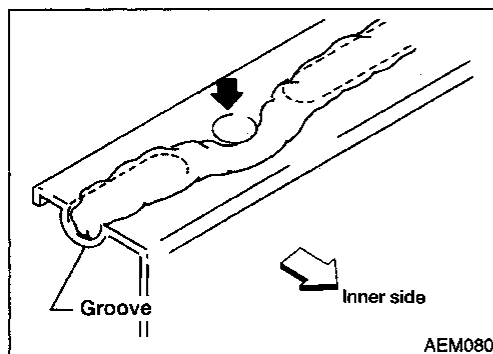
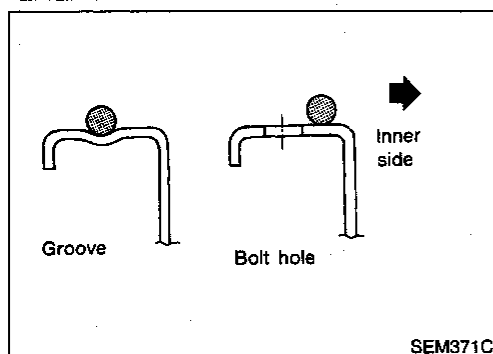

Precautions

LIQUID GASKET APPLICATION PROCEDURE

NDLC0001

1. Use a scraper to remove all traces of old liquid gasket from mating surface and grooves. Also, completely clean any oil from these areas.
2. Apply a continuous bead of liquid gasket to mating surfaces. (Use Genuine RTV silicone sealant Part No. 999MP-A7007 or equivalent.)
 - Be sure liquid gasket is 3.5 to 4.5 mm (0.138 to 0.177 in) dia. (for oil pan).
 - Be sure liquid gasket is 2.0 to 3.0 mm (0.079 to 0.118 in) dia. (in areas except oil pan).
3. Apply liquid gasket around the inner side of bolt holes (unless otherwise specified).
4. Assembly should be done within 5 minutes after coating.
5. Wait at least 30 minutes before refilling engine oil and engine coolant.

Preparation

SPECIAL SERVICE TOOLS

The actual shapes of Kent-Moore tools may differ from those of special service tools illustrated here.

NDLC0002

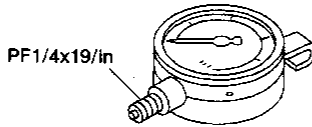
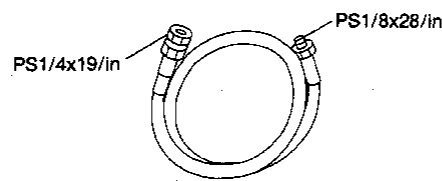
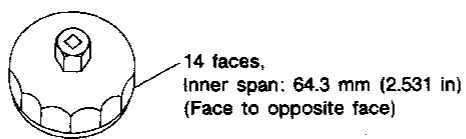
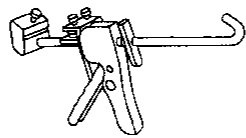
Tool number (Kent-Moore No.) Tool name	Description	
ST25051001 (J25695-1) Oil pressure gauge		Measuring oil pressure Maximum measuring range: 2,452 kPa (25 kg/cm ² , 356 psi)
ST25052000 (J25695-2) Hose		Adapting oil pressure gauge to cylinder block
KV10115801 (J38956) Oil filter wrench		Removing oil filter
WS39930000 (—) Tube presser		Pressing the tube of liquid gasket

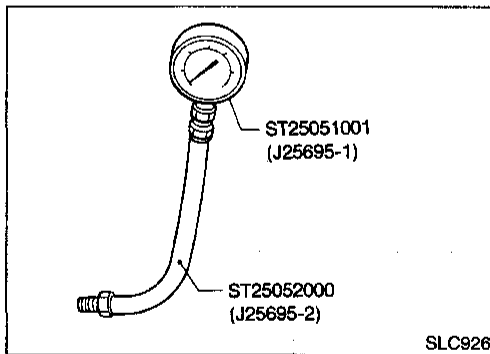
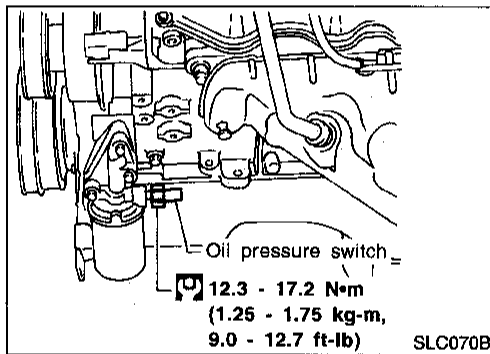
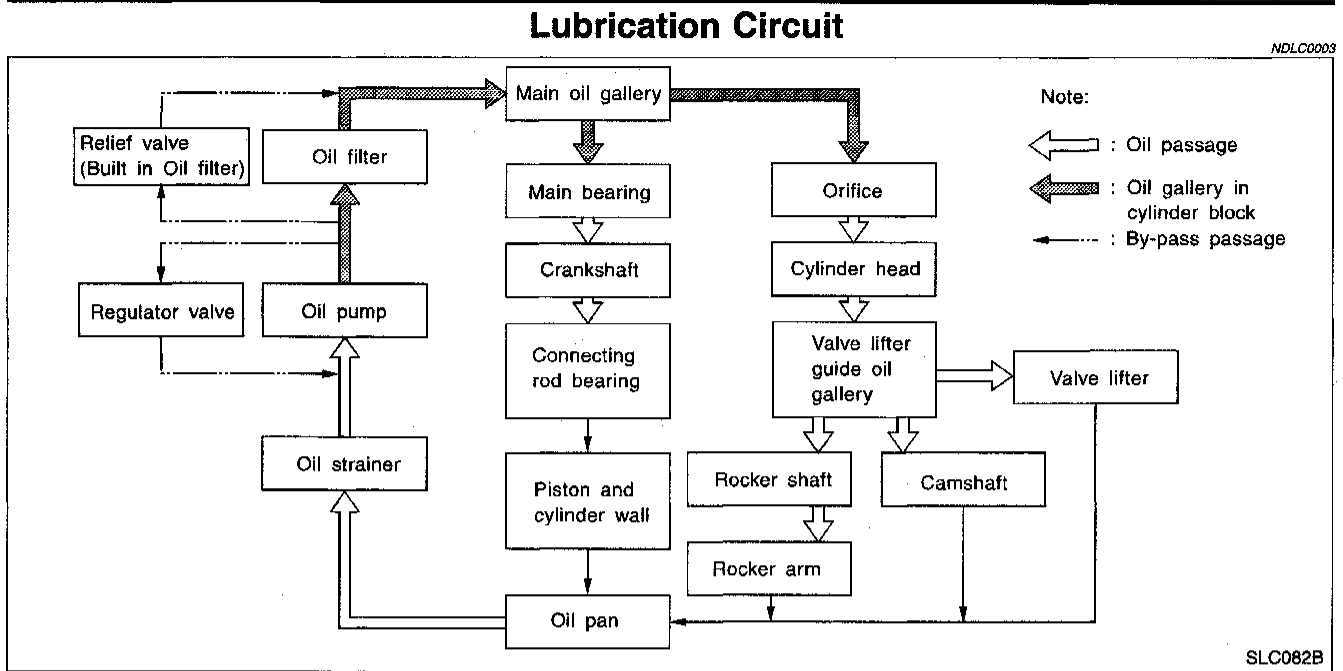

Oil Pressure Check

NDLC0004

WARNING:

- Be careful not to burn yourself, as the engine and oil may be hot.
 - Put selector lever in Park P position.
1. Check oil level.
 2. Remove oil pressure switch.

3. Install pressure gauge.
4. Start engine and warm it up to normal operating temperature.
5. Check oil pressure with engine running under no-load.

Engine speed rpm	Approximate discharge pressure kPa (kg/cm ² , psi)
Idle speed	More than 59 (0.6, 9)
2,000	412 - 451 (4.2 - 4.6, 60 - 65)

If difference is extreme, check oil passage and oil pump for oil leaks.

6. Install oil pressure switch with sealant.

ENGINE LUBRICATION SYSTEM

Oil Pump

REMOVAL AND INSTALLATION

NDLC0005

1. Drain engine oil.
2. Remove oil pan. Refer to EM section ("Removal", "OIL PAN").
3. After removing oil pan, install center member assembly and engine mounting insulator bolts and nuts.
4. Remove timing belt. Refer to EM section ("Removal", "TIMING BELT").
5. Remove timing belt tensioner.
6. Remove crankshaft sprocket and timing belt plate.
7. Remove oil pump assembly and gasket.

DISASSEMBLY AND ASSEMBLY

NDLC0006

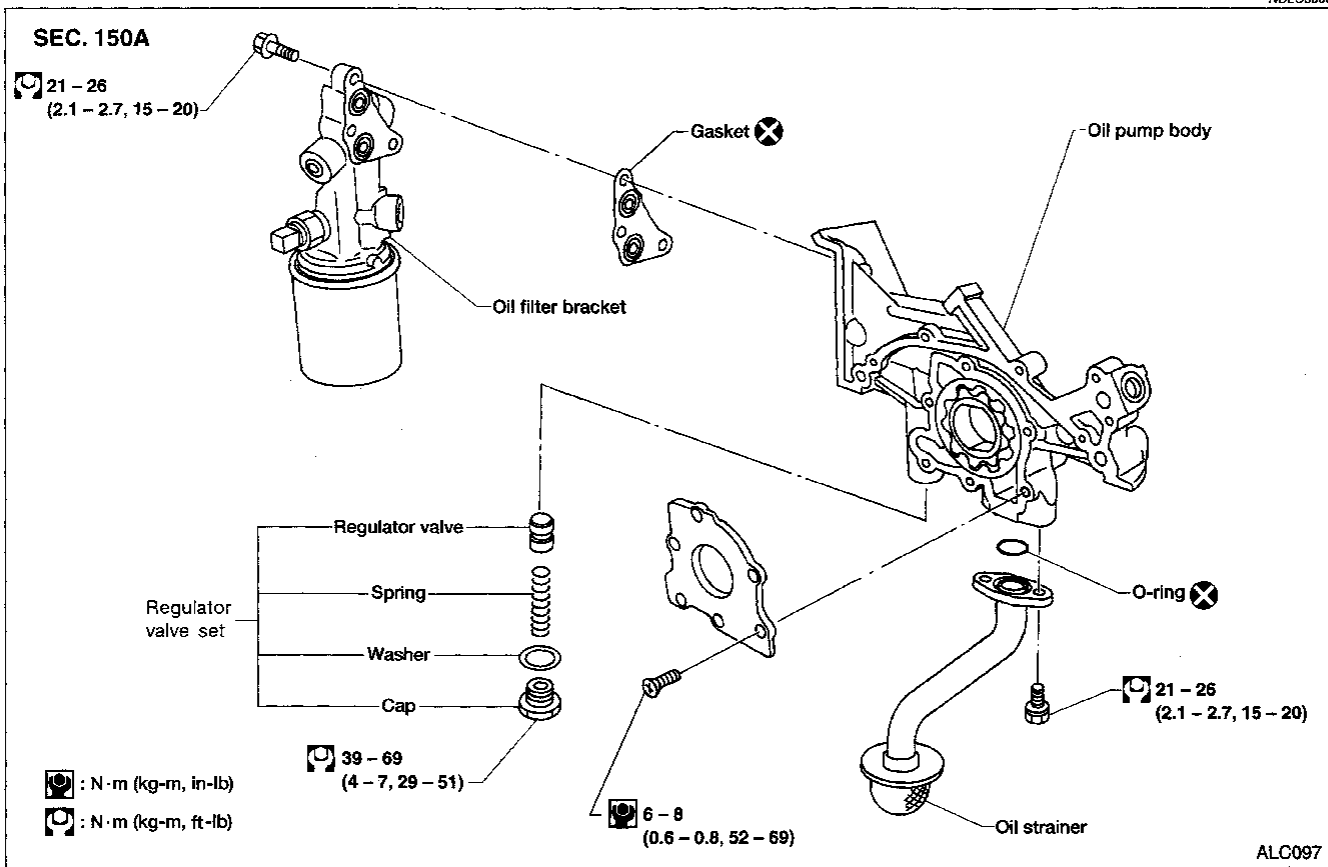

- Always replace with new oil seal and gasket.
- When installing oil pump, apply engine oil to inner and outer gears.
- Be sure that O-ring is properly installed.

ENGINE LUBRICATION SYSTEM

Oil Pump (Cont'd)

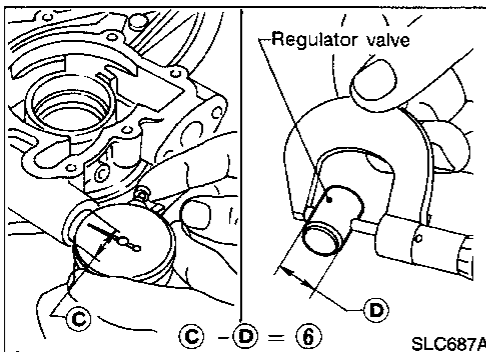
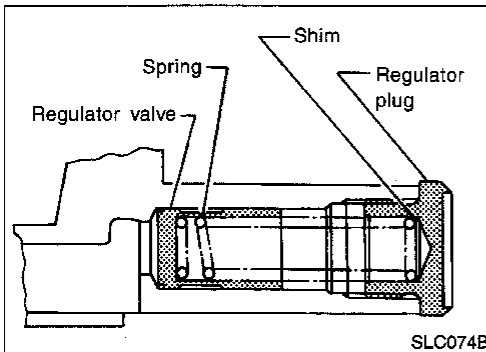
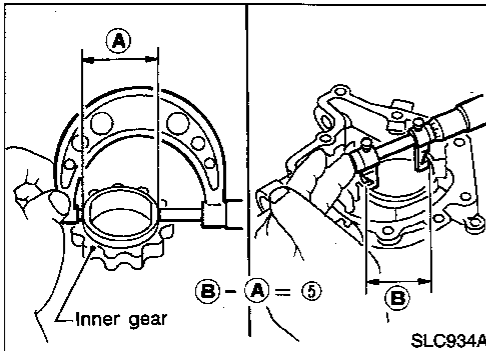
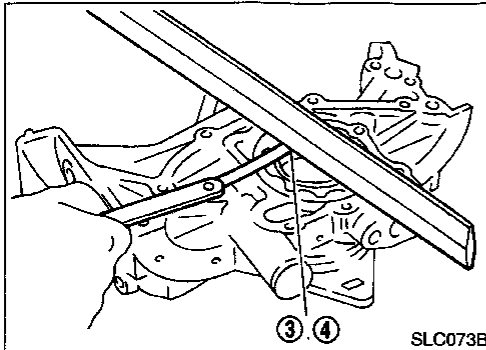
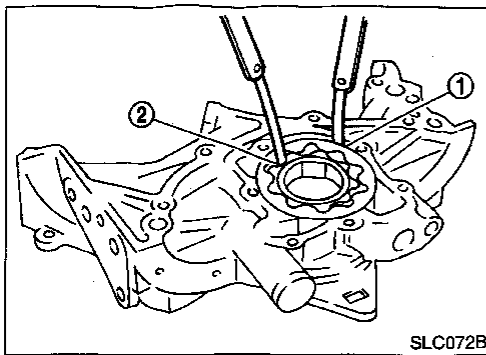

INSPECTION

Using a feeler gauge, straightedge and micrometers, check the following clearances:

Unit: mm (in)

Body to outer gear radial clearance 1	0.114 - 0.200 (0.0045 - 0.0079)
Inner gear to outer gear tip clearance 2	Below 0.18 (0.0071)
Body to inner gear axial clearance 3	0.05 - 0.09 (0.0020 - 0.0035)
Body to outer gear axial clearance 4	0.050 - 0.110 (0.0020 - 0.0043)
Inner gear to brazed portion of housing clearance 5	0.045 - 0.091 (0.0018 - 0.0036)

- If the tip clearance (2) exceeds the limit, replace gear set.
- If body to gear clearances (1, 3, 4, 5) exceed the limit, replace oil pump body assembly.

REGULATOR VALVE INSPECTION

1. Visually inspect components for wear and damage.
2. Check oil pressure regulator valve sliding surface and valve spring.
3. Coat regulator valve with engine oil. Check that it falls smoothly into the valve hole by its own weight.

If damaged, replace regulator valve set or oil pump assembly.

4. Check regulator valve to oil pump cover clearance.

Clearance:

6 : 0.040 - 0.097 mm (0.0016 - 0.0038 in)

If it exceeds the limit, replace oil pump assembly.

ENGINE LUBRICATION SYSTEM

Oil Pump (Cont'd)

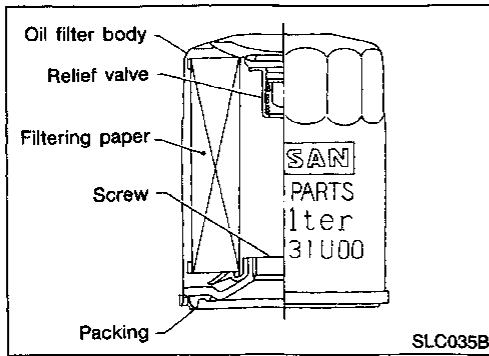

OIL FILTER

The oil filter is a small, full-flow cartridge type and is provided with a relief valve. NDLC0009

- The new and previous oil filter designs differ from each other and are not interchangeable.
- Use Tool KV10115801 (J38956) for removing oil filter.

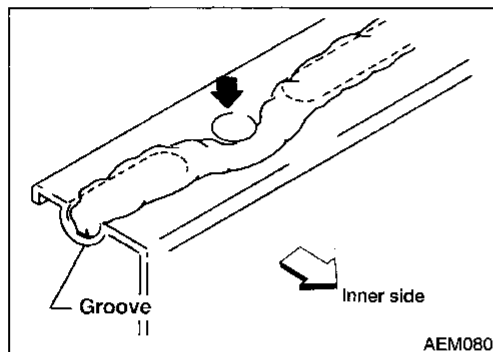
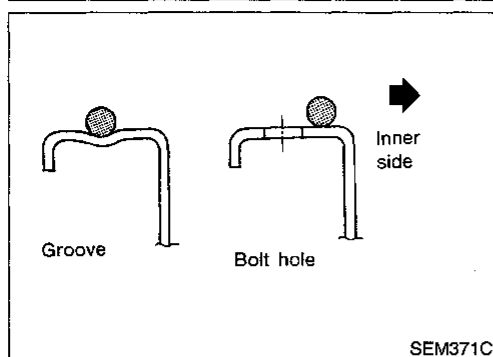

Precautions

LIQUID GASKET APPLICATION PROCEDURE

NDL0014

1. Use a scraper to remove all traces of old liquid gasket from mating surface and grooves. Also, completely clean any oil from these areas.
2. Apply a continuous bead of liquid gasket to mating surfaces. (Use Genuine RTV silicone sealant Part No. 999MP-A7007 or equivalent.)
 - Be sure liquid gasket is 3.5 to 4.5 mm (0.138 to 0.177 in) dia. (for oil pan).
 - Be sure liquid gasket is 2.0 to 3.0 mm (0.079 to 0.118 in) dia. (in areas except oil pan).
3. Apply liquid gasket around the inner side of bolt holes (unless otherwise specified).
4. Assembly should be done within 5 minutes after coating.
5. Wait at least 30 minutes before refilling engine oil and engine coolant.

GI

MA

EM

LC

EC

FE

AT

AX

Preparation

SPECIAL SERVICE TOOLS

The actual shapes of Kent-Moore tools may differ from those of special service tools illustrated here.

NDL0015

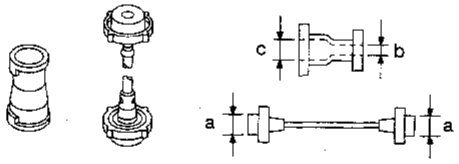
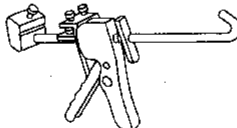
Tool number (Kent-Moore No.) Tool name	Description
EG17650301 (J33984-A) Radiator cap tester adapter	 <p>Adapting radiator cap tester to radiator filler neck a: 28 (1.10) dia. b: 31.4 (1.236) dia. c: 41.3 (1.626) dia. Unit: mm (in)</p>
WS39930000 () Tube presser	 <p>Pressing the tube of liquid gasket</p>

BR

ST

RS

BT

HA

SC

EL

IDX

ENGINE COOLING SYSTEM

Cooling Circuit

Cooling Circuit

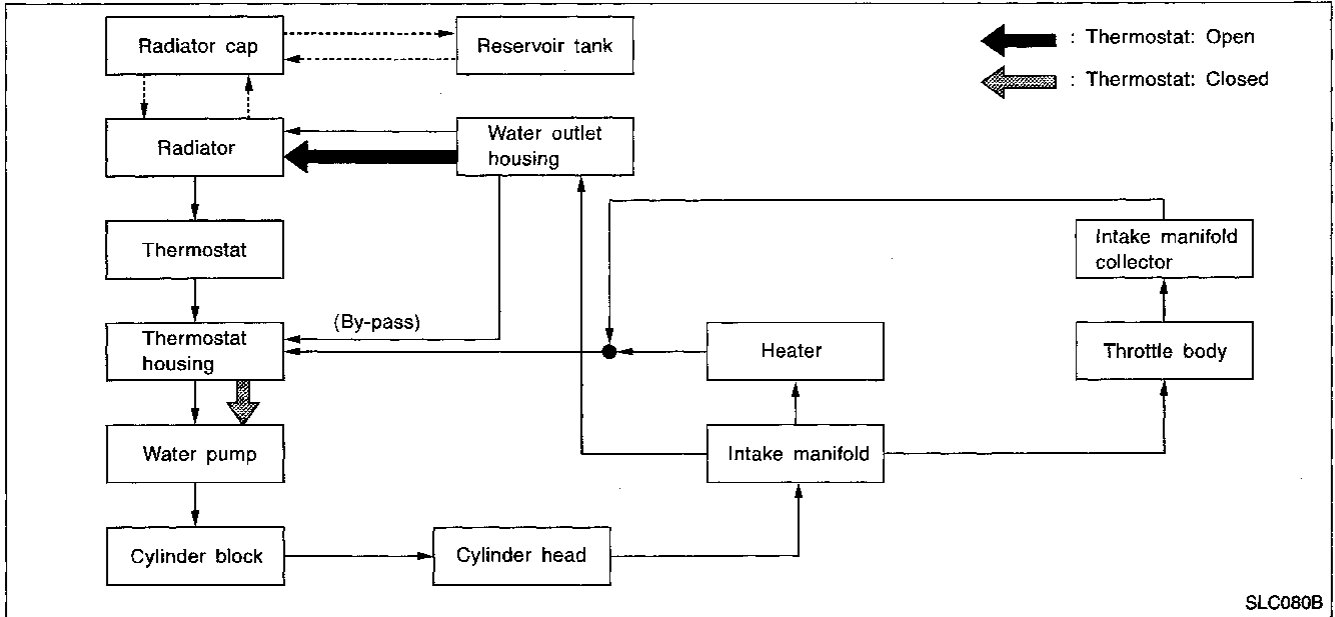

System Check

WARNING:

Never remove the radiator cap when the engine is hot. Serious burns could occur from high pressure coolant escaping from the radiator.

Wrap a thick cloth around the cap. Slowly turn it a quarter turn to allow built-up pressure to escape. Carefully remove the cap by turning it all the way.

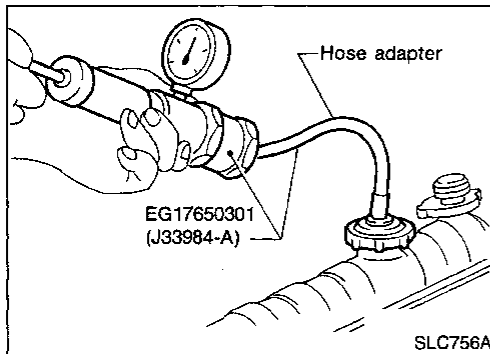

CHECKING COOLING SYSTEM HOSES

Check hoses for improper attachment, leaks, cracks, damage, loose connections, chafing and deterioration.

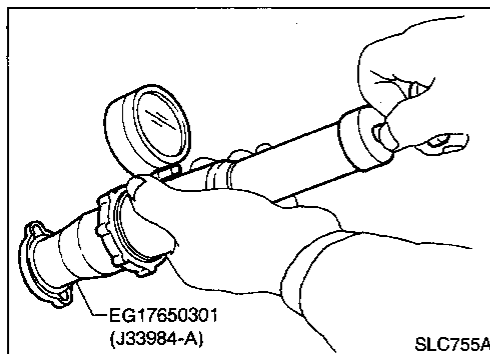

CHECKING RADIATOR CAP

To check radiator cap, apply pressure to cap with a tester.

Radiator cap relief pressure:

Standard

78 - 98 kPa (0.8 - 1.0 kg/cm², 11 - 14 psi)

Limit

59 - 98 kPa (0.6 - 1.0 kg/cm², 9 - 14 psi)

ENGINE COOLING SYSTEM

System Check (Cont'd)

CHECKING COOLING SYSTEM FOR LEAKS

NDLC0017S03

To check for leakage, apply pressure to the cooling system with a tester.

Testing pressure: 157 kPa (1.6 kg/cm², 23 psi)

CAUTION:

Higher pressure than specified may cause radiator damage.

Water Pump REMOVAL

NDLC0018

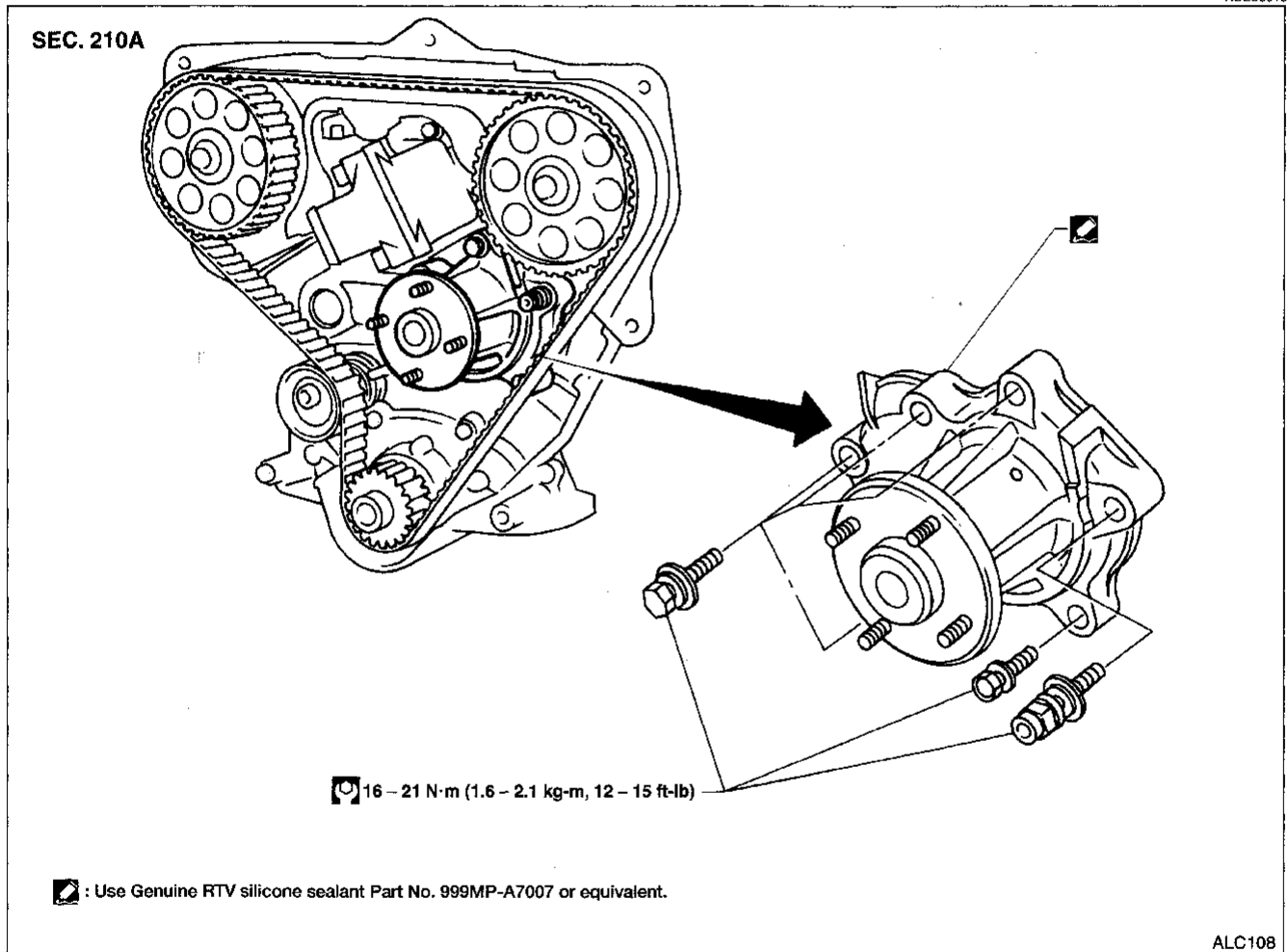

CAUTION:

- When removing water pump assembly, be careful not to get coolant on timing belt.
 - Water pump cannot be disassembled and should be replaced as a unit.
 - After installing water pump, connect hose and clamp securely, then check for leaks using radiator cap tester.
 - To avoid deforming timing cover, make sure there is adequate clearance between it and the hose clamp.
1. Drain coolant from cylinder block and radiator. Refer to MA section ("Changing Engine Coolant").

ENGINE COOLING SYSTEM

Water Pump (Cont'd)

2. Remove radiator hoses (upper and lower) and fan shroud. Refer to "Radiator", LC-12.
3. Remove drive belts. Refer to MA section ("Checking Drive Belts").
4. Remove water pump pulley.
5. Remove crankshaft pulley and front (upper and lower) belt cover. Refer to EM section ("TIMING BELT").
6. Remove water pump.

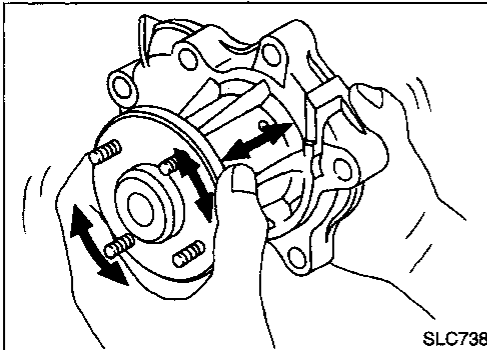

INSPECTION

1. Check for badly rusted or corroded body assembly and vanes. NDLC0019
2. Check for rough operation due to excessive end play.

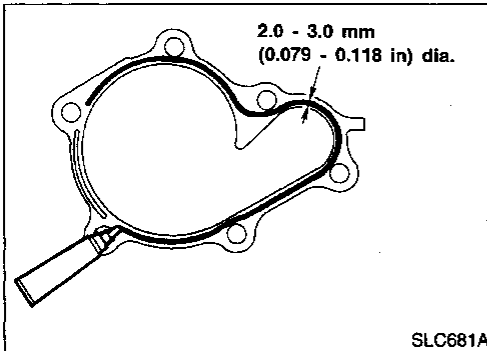

INSTALLATION

1. Use a scraper to remove old liquid gasket from water pump. NDLC0036
 - Also remove old liquid gasket from mating surface of cylinder block.
2. Apply a continuous bead of liquid gasket to mating surface of water pump. **Use Genuine RTV Silicone Sealant Part No. 999MP-A7007 or equivalent.**
3. Install water pump.
4. Install remaining parts in reverse order of removal.

When installing drive belts, refer to MA section ("Checking Drive Belts").

When filling radiator with coolant, refer to MA section ("Changing Engine Coolant").

Thermostat REMOVAL

NDLC0020

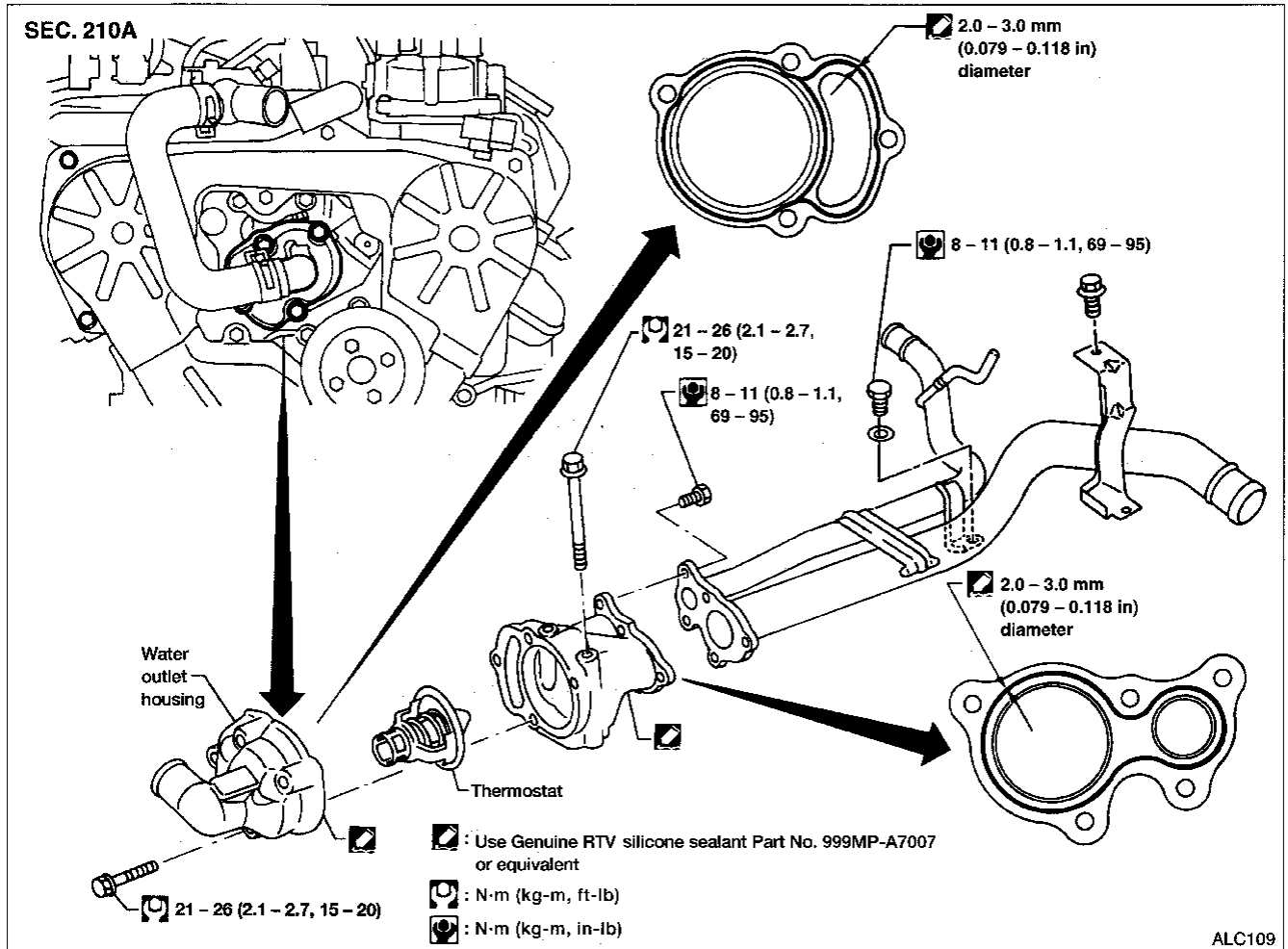

Be careful not to spill coolant over engine compartment. Use a rag to absorb coolant.

1. Drain engine coolant from drain plugs on radiator.
2. Remove radiator hoses (upper and lower) and fan shroud.
3. Remove drive belts.
4. Remove pulley bracket.
5. Remove water inlet and thermostat assembly.

INSPECTION

1. Check valve seating condition at ordinary temperatures. It should seat tightly.
2. Check valve opening temperature and valve lift.

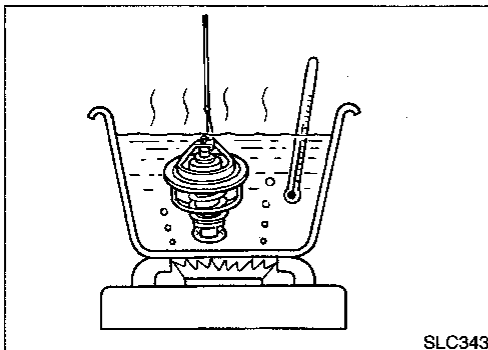

Valve opening temperature	°C (°F)	82 (180)
Valve lift	mm/°C (in/°F)	More than 10/90 (0.39/194)

3. Then check if valve is closed at 5°C (9°F) below valve opening temperature.

ENGINE COOLING SYSTEM

Thermostat (Cont'd)

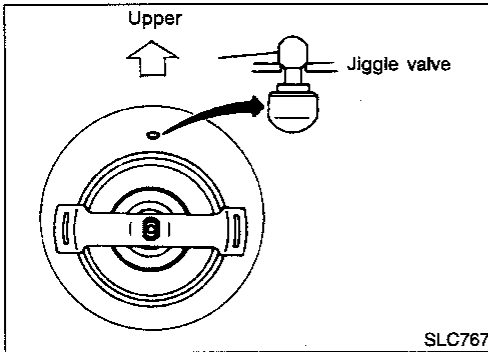
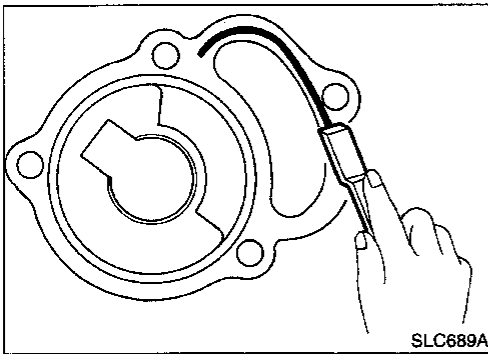

INSTALLATION

NDLC0022

1. Use a scraper to remove old liquid gasket from water outlet housing.
 2. Apply a continuous bead of liquid gasket to mating surface of water outlet housing.
Use Genuine RTV Silicone Sealant Part No. 999MP-A7007 or equivalent.
 3. Install thermostat with jiggle valve or air bleeder at upper side.
 4. Install water outlet housing.
 5. Install water hose to water outlet housing.
 6. Refill engine coolant. Refer to MA section ("Changing Engine Coolant", "ENGINE MAINTENANCE").
- **After installation, run engine for a few minutes, and check for leaks.**

Radiator REMOVAL AND INSTALLATION

NDLC0023

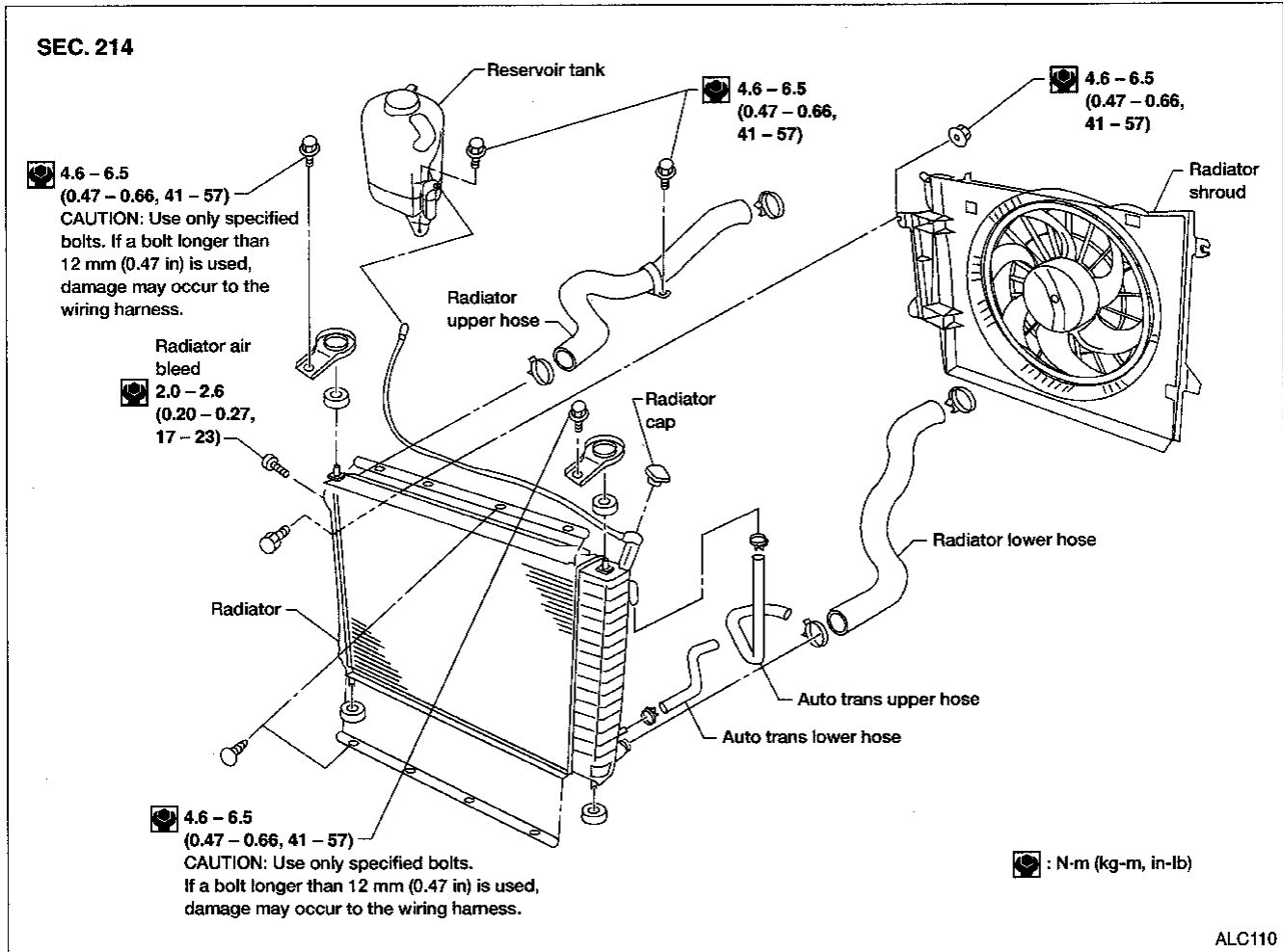

ENGINE COOLING SYSTEM

Radiator (Cont'd)

- Radiators are manufactured with saw cuts in the upper and lower center supports. Do not replace radiators because they have saw cuts in them.
1. Remove under cover.
 2. Drain coolant from radiator.
 3. Disconnect radiator upper and lower hoses.
 4. Remove A/T oil cooler hoses.
 5. Disconnect reservoir tank hose.
 6. Remove right bolt from fuse box and position fuse box aside.
 7. Disconnect cooling fan harness connector.
 8. Remove radiator.
 9. After repairing or replacing radiator, install all parts in reverse order of removal.
 10. Fill radiator with engine coolant.
- Refer to MA section ("Changing Engine Coolant", "ENGINE MAINTENANCE").
 - Proper heater performance and engine cooling requires accurately following "Refilling Engine Coolant", LC-14.

GI

MA

EM

LC

EC

FE

AT

AX

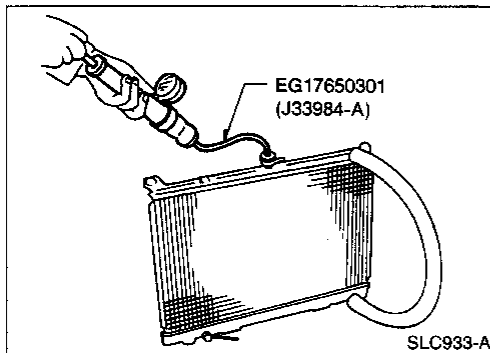

INSPECTION

1. Apply pressure with Tool.

Specified pressure value:

157 kPa (1.6 kg/cm², 23 psi)

WARNING:

To prevent the risk of the hose coming undone while under pressure, securely fasten it down with a hose clamp. Attach a hose to the oil cooler as well.

NDLC0028

SU

BR

ST

RS

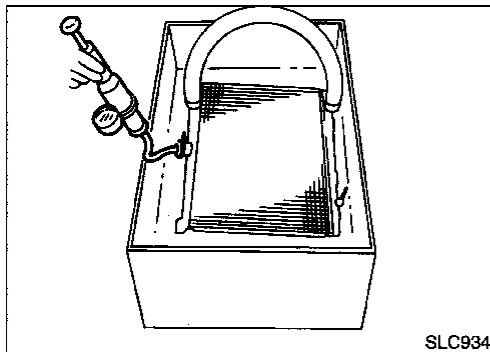

2. Check for leakage.

BT

HA

SC

EL

IDX

ENGINE COOLING SYSTEM

Refilling Engine Coolant

Refilling Engine Coolant

For details on refilling engine coolant, refer to MA section ("REFILLING ENGINE COOLANT", "Changing Engine Coolant").

=NDLC0031

Overheating Cause Analysis

NDLC0032

	Symptom		Check items		
Cooling system parts malfunction	Poor heat transfer	Water pump malfunction	—	—	
		Thermostat stuck closed	—		
		Damaged fins	Dust contamination or paper clogging		—
			Mechanical damage		
		Clogged radiator cooling tube	Excess foreign material (rust, dirt, sand, etc.)		
	Reduced air flow	Cooling fan does not operate	—	—	
		High resistance to fan rotation			
		Damaged fan blades			
		Damaged radiator shroud	—	—	
		Improper coolant mixture ratio	—	—	
		Poor coolant quality	—	—	
	Insufficient coolant	Coolant leaks	Cooling hose	Loose clamp	
				Cracked hose	
			Water pump	Poor sealing	
			Radiator cap	Loose	
Poor sealing					
Radiator		O-ring for damage, deterioration or improper fitting			
		Cracked radiator tank			
	Cracked radiator core				
	Reservoir tank	Cracked reservoir tank			
Overflowing reservoir tank	Exhaust gas leaks into cooling system	Cylinder head deterioration			
		Cylinder head gasket deterioration			

ENGINE COOLING SYSTEM

Overheating Cause Analysis (Cont'd)

	Symptom		Check items		
Except cooling system parts malfunction	—	Overload on engine	Abusive driving	High engine rpm under no load	GI
				Driving in low gear for extended time	MA
				Driving at extremely high speed	EM
			Powertrain system malfunction	—	LC
			Installed improper size wheels and tires		EC
			Dragging brakes		FE
	Improper ignition timing.				
	Blocked or restricted air flow	Blocked bumper	—		FE
		Blocked radiator grille	Installed car brassiere		AT
			Mud contamination or paper clogging	—	AX
Blocked radiator		—		SU	
Blocked condenser		—		SU	
Installed large fog lamp	—		SU		

GI
 MA
 EM
LC
 EC
 FE
 AT
 AX
 SU
 BR
 ST
 RS
 BT
 HA
 SC
 EL
 IDX

Cooling Fan Control System

NDLC0037

Cooling fan is controlled by the ECM.
 For details, refer to EC section ("Cooling Fan", "TROUBLE DIAGNOSIS FOR OVERHEAT").

SERVICE DATA AND SPECIFICATIONS (SDS)

Oil Pressure

Oil Pressure		NDLC0011
Engine speed rpm	Approximate discharge pressure kPa (kg/cm ² , psi)	
Idle speed	More than 59 (0.6, 9)	
2,000	412 - 451 (4.2 - 4.6, 60 - 65)	

Regulator Valve

Regulator Valve		NDLC0012 Unit: mm (in)
Regulator valve to oil pump cover clearance	0.040 - 0.097 (0.0016 - 0.0038)	

Oil Pump

Oil Pump		NDLC0013 Unit: mm (in)
Body to outer gear radial clearance	0.114 - 0.200 (0.0045 - 0.0079)	
Inner gear to outer gear tip clearance	Below 0.18 (0.0071)	
Body to inner gear axial clearance	0.05 - 0.09 (0.0020 - 0.0035)	
Body to outer gear axial clearance	0.050 - 0.110 (0.0020 - 0.0043)	
Inner gear to brazed portion of housing clearance	0.045 - 0.091 (0.0018 - 0.0036)	

Thermostat

Thermostat		NDLC0033
Valve opening temperature °C (°F)	82 (180)	
Valve lift mm/°C (in/°F)	More than 10/90 (0.39/194)	

Radiator

Radiator		NDLC0034 Unit: kPa (kg/cm ² , psi)
Cap relief pressure	Standard	78 - 98 (0.8 - 1.0, 11 - 14)
	Limit	59 - 98 (0.6 - 1.0, 9 - 14)
Leakage test pressure		157 (1.6, 23)