

SECTION **FAX**
FRONT AXLE

A
B
C

FAX

CONTENTS

E

PRECAUTIONS	2	REMOVAL	8	F
Precautions for Supplemental Restraint System (SRS) "AIR BAG" and "SEAT BELT PRE-TENSIONER"	2	INSPECTION AFTER REMOVAL	9	
Precautions	2	INSTALLATION	9	
PREPARATION	3	Removal and Installation (Right Side)	9	G
Special Service Tools	3	REMOVAL	10	
Commercial Service Tools	3	INSPECTION AFTER REMOVAL	10	
NOISE, VIBRATION, AND HARSHNESS (NVH)		INSTALLATION	10	H
TROUBLESHOOTING	4	Disassembly and Assembly (Left Side)	11	
NVH Troubleshooting Chart	4	DISASSEMBLY	11	
FRONT WHEEL HUB AND KNUCKLE	5	INSPECTION AFTER DISASSEMBLY	13	I
On-Vehicle Inspection and Service	5	ASSEMBLY	13	
FRONT WHEEL BEARING	5	Disassembly and Assembly (Right Side)	17	
Removal and Installation	5	DISASSEMBLY	17	
REMOVAL	5	INSPECTION AFTER DISASSEMBLY	19	J
INSPECTION AFTER REMOVAL	6	ASSEMBLY	20	
INSTALLATION	6	SERVICE DATA AND SPECIFICATIONS (SDS)	23	
FRONT DRIVE SHAFT	8	Wheel Bearing	23	K
Removal and Installation (Left Side)	8	Drive Shaft	23	
		Damper	23	L

L

M

PRECAUTIONS

PRECAUTIONS

PF0:00001

Precautions for Supplemental Restraint System (SRS) “AIR BAG” and “SEAT BELT PRE-TENSIONER”

EDS003AV

The Supplemental Restraint System such as “AIR BAG” and “SEAT BELT PRE-TENSIONER”, used along with a front seat belt, helps to reduce the risk or severity of injury to the driver and front passenger for certain types of collision. This system includes seat belt switch inputs and dual stage front air bag modules. The SRS system uses the seat belt switches to determine the front air bag deployment, and may only deploy one front air bag, depending on the severity of a collision and whether the front occupants are belted or unbelted. Information necessary to service the system safely is included in the SRS and SB section of this Service Manual.

WARNING:

- To avoid rendering the SRS inoperative, which could increase the risk of personal injury or death in the event of a collision which would result in air bag inflation, all maintenance must be performed by an authorized NISSAN/INFINITI dealer.
- Improper maintenance, including incorrect removal and installation of the SRS, can lead to personal injury caused by unintentional activation of the system. For removal of Spiral Cable and Air Bag Module, see the SRS section.
- Do not use electrical test equipment on any circuit related to the SRS unless instructed to in this Service Manual. SRS wiring harnesses can be identified by yellow and/or orange harnesses or harness connectors.

Precautions

EDS0034U

CAUTION:

- When installing each rubber part, the final tightening must be carried out under unladen condition* with tires on the ground.
*Fuel, radiator coolant and engine oil full. Spare tire, jack, hand tools and mats in designated positions.
- After installing the removed suspension parts, check the front wheel alignment.
- Do not jack up the vehicle by the transverse link .

Observe the following precautions when disassembling and servicing drive shaft.

- Perform work in a location which is as dust-free as possible.
- Before disassembling and servicing, clean the outside of parts.
- Prevention of the entry of foreign objects must be taken into account during disassembly of the service location.
- Disassembled parts must be carefully reassembled in the correct order. If work is interrupted, a clean cover must be placed over parts.
- Paper shop cloths must be used. Fabric shop cloths must not be used because of the danger of lint adhering to parts.
- Disassembled parts (except for rubber parts) should be cleaned with kerosene which shall be removed by blowing with air or wiping with paper shop cloths.

PREPARATION

PREPARATION

PFP:00002

Special Service Tools

EDS003AT

The actual shapes of Kent-Moore tools may differ from those of special service tools illustrated here.

Tool number (Kent-Moore No.) Tool name	Description
HT72520000 (J-25730-A) Ball joint remover	Removing outer tie-rod
KV38106700 (J-34296) KV38106800 (J-34297) Differential side oil seal protector	Installing drive shaft LH: KV38106700 (J-34296) RH: KV38106800 (J-34297)
KV40107300 (—) Boot Band crimping tool	Installing boot bands
KV40107500 (—) Drive shaft attachment	Removing drive shaft

A
B
C
FAX
E
F
G
H
I
J
K
L
M

Commercial Service Tools

EDS003AU

Tool name	Description
Power tool	Removing nuts and bolts

NOISE, VIBRATION, AND HARSHNESS (NVH) TROUBLESHOOTING

NOISE, VIBRATION, AND HARSHNESS (NVH) TROUBLESHOOTING

PF0:00003

NVH Troubleshooting Chart

EDS0034X

Use chart below to help you find the cause of the symptom. If necessary, repair or replace these parts.

Symptom		Possible cause and SUSPECTED PARTS		Reference page										
		Excessive joint angle	Joint sliding resistance	Imbalance	Improper installation, looseness	Parts interference	Wheel bearing damage	SUSPENSION	FRONT AXLE	TIRES	ROAD WHEEL	DRIVE SHAFT	BRAKES	STEERING
DRIVE SHAFT	Noise	×	×					×	×	×	×	×	×	×
	Shake	×		×				×	×	×	×		×	×
FRONT AXLE	Noise				×	×		×		×	×	×	×	×
	Shake				×	×		×		×	×	×	×	×
	Vibration				×	×		×		×		×		×
	Shimmy				×	×		×		×	×		×	×
	Shudder				×			×		×	×		×	×
	Poor quality ride or handling				×	×	×	×		×	×			

×: Applicable

FRONT WHEEL HUB AND KNUCKLE

PFP:40202

FRONT WHEEL HUB AND KNUCKLE

On-Vehicle Inspection and Service

EDS0034Y

Make sure the mounting conditions (looseness, backlash) of each component and component status (wear, damage) are normal.

FRONT WHEEL BEARING

- Move wheel hub in the axial direction by hand. Make sure there is no looseness of wheel bearing.

Axial end play limit : 0.05 mm (0.002 in) or less

- Rotate wheel hub and make sure there is no unusual noise or other irregular conditions. If there are any irregular conditions, replace wheel hub and bearing assembly.

Removal and Installation

EDS0034Z

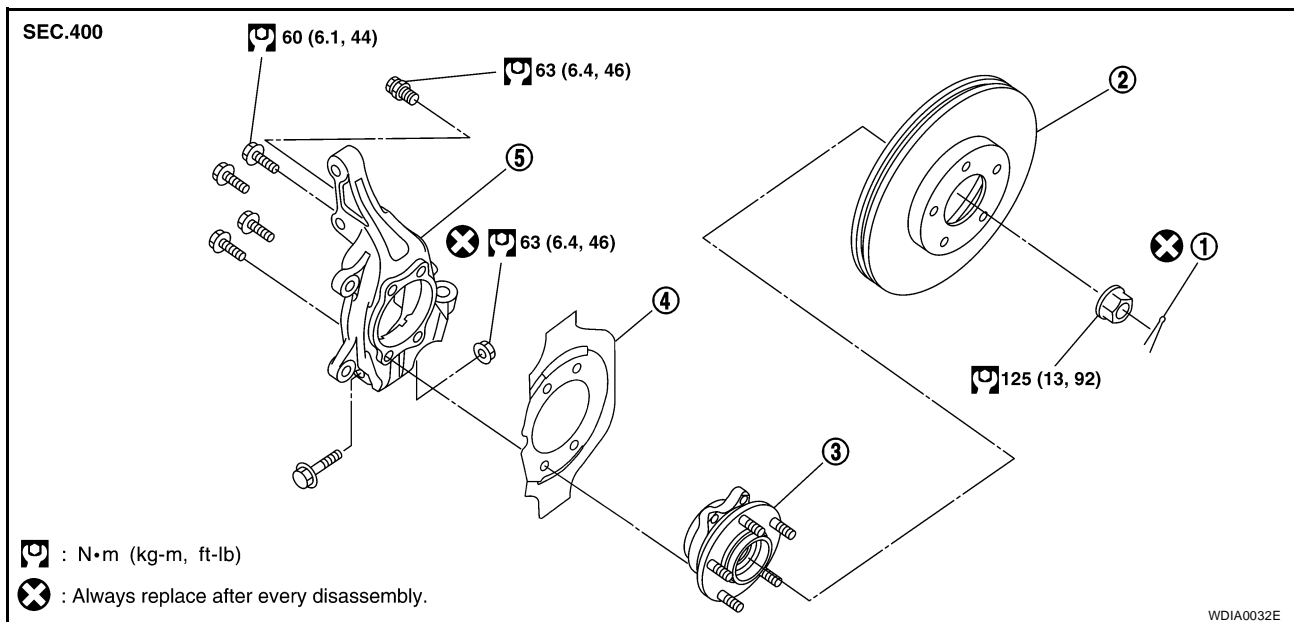

1. Cotter pin
2. Disc rotor
3. Wheel hub and bearing assembly
4. Splash guard
5. Steering knuckle

REMOVAL

1. Remove wheel and tire from vehicle using power tool. Refer to [WT-8, "ROTATION"](#).
2. Without disassembling the hydraulic lines, remove brake caliper using power tool. Reposition it aside with wire. Refer to [BR-30, "REMOVAL"](#).

NOTE:

Avoid depressing brake pedal while brake caliper is removed.

3. Put alignment marks on disc rotor and wheel hub and bearing assembly, then remove disc rotor.
4. Remove wheel sensor from steering knuckle. Refer to [BRC-94, "Removal and Installation"](#).

CAUTION:

Do not pull on wheel sensor harness.

5. Remove cotter pin, then remove lock nut from drive shaft using power tool.
6. Remove steering outer tie-rod cotter pin at steering knuckle, then loosen nut using power tool. Refer to [PS-15, "Removal and Installation"](#).

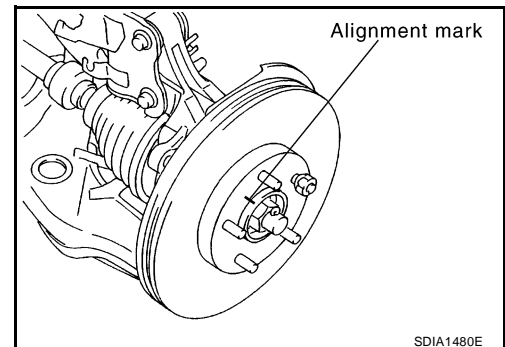

FRONT WHEEL HUB AND KNUCKLE

7. Disconnect the outer tie-rod end from steering knuckle using Tool. Be careful not to damage ball joint boot.

CAUTION:

To prevent damage to threads and to prevent Tool from coming off suddenly, temporarily tighten mounting nut.

Tool number : HT72520000 (J-25730-A)

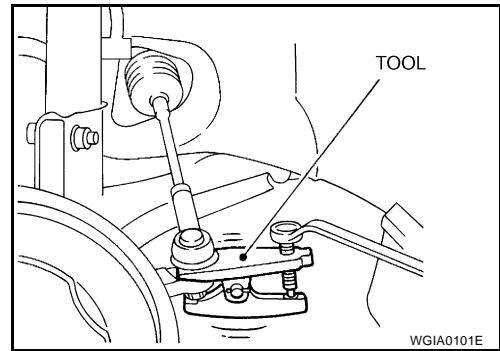

8. Remove transverse link and steering knuckle pinch bolt and nut using power tool. Refer to [FSU-13, "Removal and Installation"](#) .

9. Remove wheel hub and bearing assembly from drive shaft using a puller or suitable tool.

CAUTION:

- When removing wheel hub and bearing assembly, do not apply an excessive angle to drive shaft joint. Also be careful not to excessively extend slide joint.
- Support drive shaft when removing.

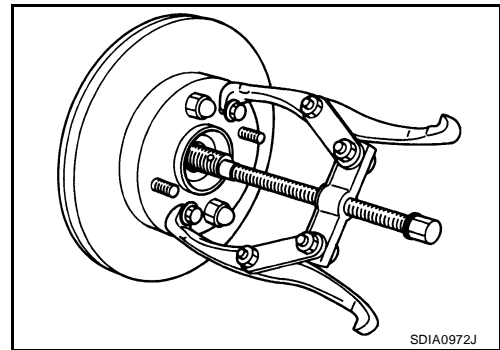

10. Remove wheel hub and bearing assembly bolts using power tool.

11. Remove splash guard and wheel hub and bearing assembly from steering knuckle.

12. Remove the lower strut bolts and nuts using power tool. Refer to [FSU-5, "Components"](#) .

13. Remove steering knuckle from vehicle.

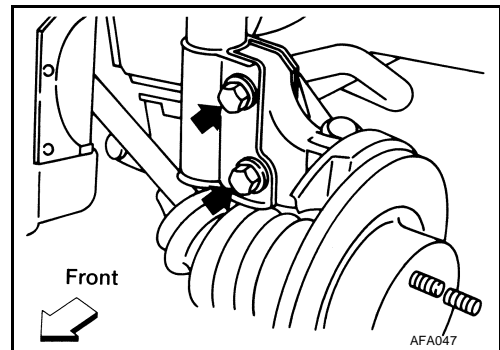

INSPECTION AFTER REMOVAL

Check for deformity, cracks and damage on each part, replace if necessary.

Ball Joint Inspection

- Check for boot breakage, axial looseness, and torque of transverse link ball joint. Refer to [FSU-13, "INSPECTION AFTER REMOVAL"](#) .

INSTALLATION

Installation is in the reverse order of removal. Note the following:

- Refer to [FAX-5, "Removal and Installation"](#) for tightening torques.

CAUTION:

Do not reuse non-reusable parts.

- When installing wheel hub and bearing assembly to steering knuckle, align cutout in toner ring cover with wheel sensor mounting hole in steering knuckle.

FRONT WHEEL HUB AND KNUCKLE

- When installing disc rotor on wheel hub and bearing assembly, align the marks.
(When not using the alignment mark, refer to [BR-31, "DISC ROTOR INSPECTION"](#) .)

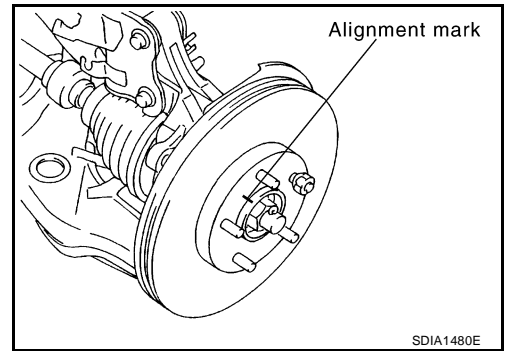

A

B

C

FAX

E

F

G

H

I

J

K

L

M

FRONT DRIVE SHAFT

FRONT DRIVE SHAFT

PFP:39100

Removal and Installation (Left Side)

EDS00350

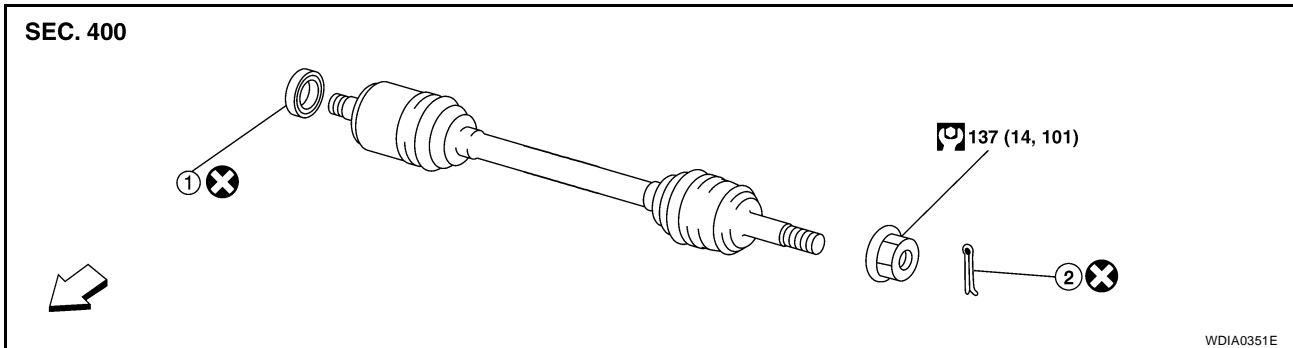

1. Differential side oil seal

2. Cotter pin

←: Front

REMOVAL

1. Remove wheel and tire using power tool. Refer to [WT-8, "ROTATION"](#).
2. Remove wheel sensor from steering knuckle. Refer to [BRC-94, "Removal and Installation"](#).
3. Remove cotter pin. Then remove lock nut from drive shaft.
4. Remove brake hose lock plate. Then remove brake hose from strut.
5. Remove the lower ball joint pinch bolt using power tool, then separate lower ball joint from steering knuckle. Refer to [FAX-5, "Removal and Installation"](#).
6. Remove drive shaft from wheel hub and bearing assembly, using a puller or suitable tool.

CAUTION:

- When removing drive shaft, do not apply an excessive angle to drive shaft joint. Also be careful not to excessively extend slide joint.

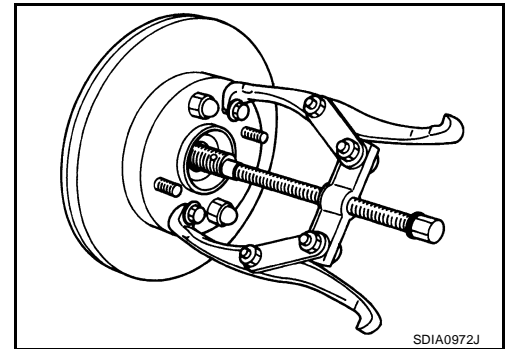

7. Remove drive shaft from transaxle using Tool and drive shaft puller or suitable tool.
 - Set Tool and a drive shaft puller or suitable tool between drive shaft (slide joint side) and transaxle as shown and remove drive shaft.

Tool number : KV40107500 (—)

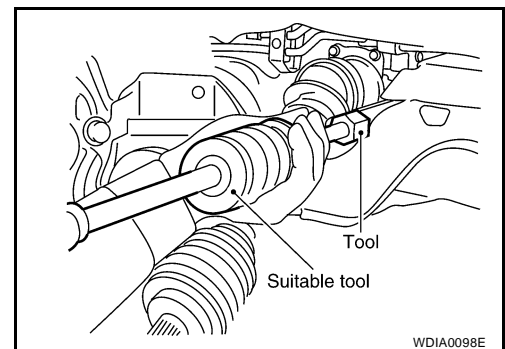

FRONT DRIVE SHAFT

INSPECTION AFTER REMOVAL

- Move joint up/down, left/right, and in axial direction. Check for any rough movement or significant looseness.
- Check boot for cracks or other damage, and for grease leakage.
- If damaged, disassemble drive shaft to verify damage, and repair or replace as necessary.

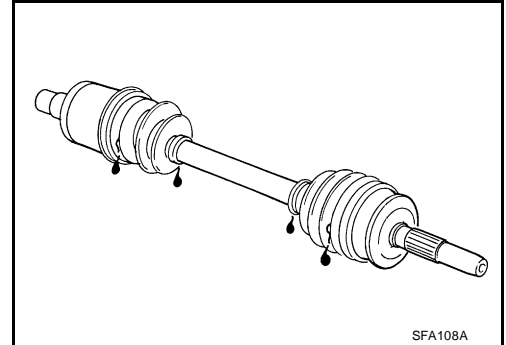

INSTALLATION

Installation is in the reverse order of removal. Note the following:

- Refer to [FAX-8, "Removal and Installation \(Left Side\)"](#) for tightening torque.

CAUTION:

Do not reuse non-reusable parts.

- In order to prevent damage to differential side oil seal, place Tool "A" onto oil seal before inserting drive shaft as shown. Slide drive shaft into slide joint and tap with a hammer to install securely.

Tool number : KV38106700 (J-34296)

- Install new circlip on drive shaft in the circular clip groove on transaxle side. Refer to [FAX-11, "Disassembly and Assembly \(Left Side\)"](#).

CAUTION:

Make sure the new circlip on the drive shaft is securely fastened.

- After its insertion, try to pull the flange out of the slide joint by hand. If it pulls out, the circlip is not properly meshed with the transaxle side gear.

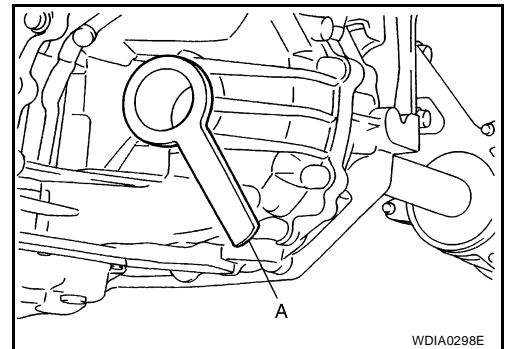

Removal and Installation (Right Side)

EDS00351

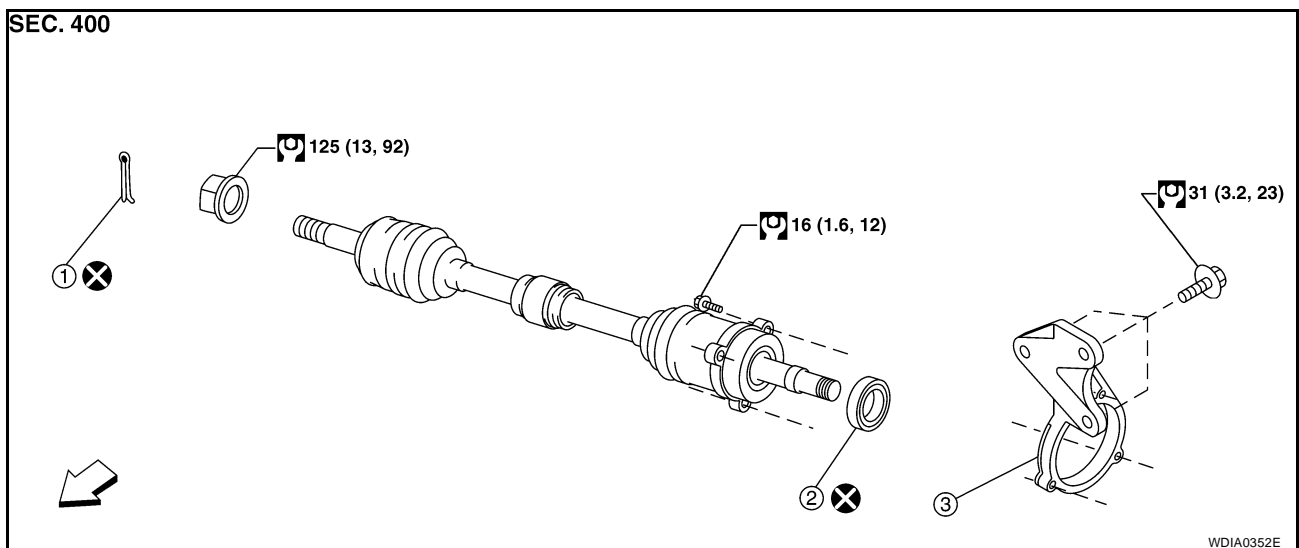

1. Cotter pin

2. Dust shield

3. Support bearing bracket

⇐: Front

FRONT DRIVE SHAFT

REMOVAL

1. Remove wheel and tire using power tool. Refer to [WT-8, "ROTATION"](#) .
2. Remove wheel sensor from steering knuckle. Refer to [BRC-94, "Removal and Installation"](#) .
3. Remove cotter pin. Then remove lock nut from drive shaft using power tool.
4. Remove brake hose lock plate. Then remove brake hose from strut.
5. Remove the lower ball joint pinch bolt using power tool, then separate lower ball joint from steering knuckle. Refer to [FAX-5, "Removal and Installation"](#) .
6. Remove drive shaft from wheel hub and bearing assembly, using a puller or suitable tool.

CAUTION:

- When removing drive shaft, do not apply an excessive angle to drive shaft joint. Also be careful not to excessively extend slide joint.

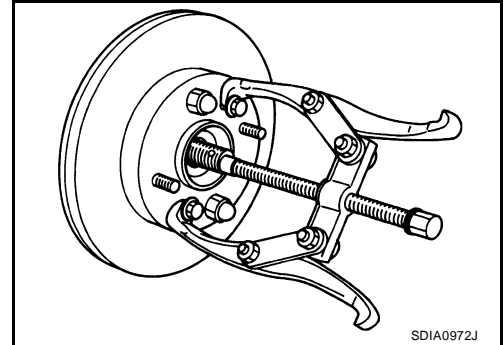

7. Remove support bearing bolts using power tool, and pry drive shaft from transaxle.
 - Pry off drive shaft from transaxle.

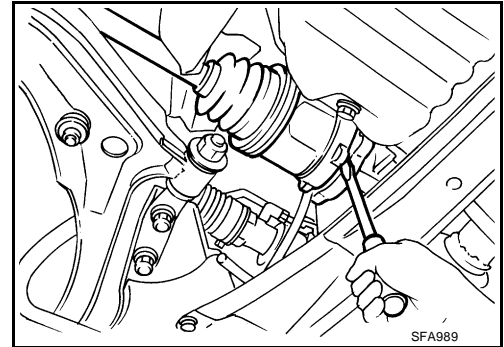

INSPECTION AFTER REMOVAL

- Move joint up/down, left/right, and in axial direction. Check for any rough movement or significant looseness.
- Check boot for cracks or other damage, and for grease leakage.
- If damaged, disassemble drive shaft to verify damage, and repair or replace as necessary.

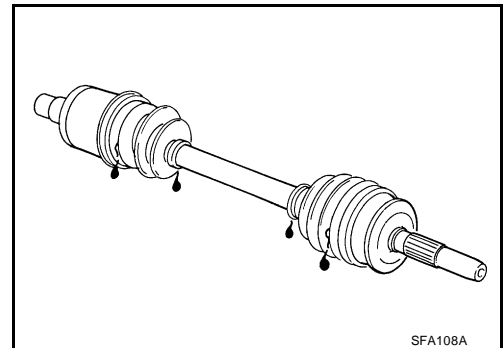

INSTALLATION

Installation is in the reverse order of removal. Note the following:

- Refer to [FAX-9, "Removal and Installation \(Right Side\)"](#) for tightening torque. Install in the reverse order of removal.

CAUTION:

- Do not reuse non-reusable parts.

FRONT DRIVE SHAFT

- In order to prevent damage to differential side oil seal, place Tool "A" onto oil seal before inserting drive shaft as shown. Slide drive shaft into slide joint and tap with a hammer to install securely.

Tool number : KV38106800 (J-34297)

- Install new circlip on drive shaft in the circular clip groove on transaxle side. Refer to [FAX-11, "Disassembly and Assembly \(Left Side\)"](#).

CAUTION:

Make sure the new circlip on the drive shaft is securely fastened.

- After its insertion, try to pull the flange out of the slide joint by hand. If it pulls out, the circlip is not properly meshed with the transaxle side gear.

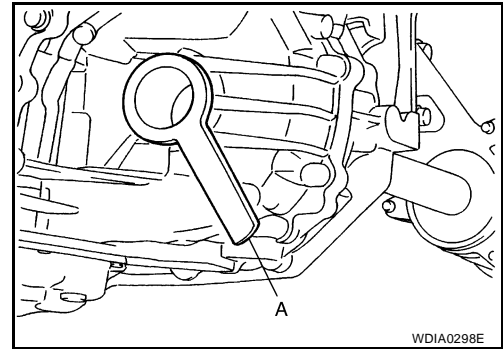

Disassembly and Assembly (Left Side)

EDS00352

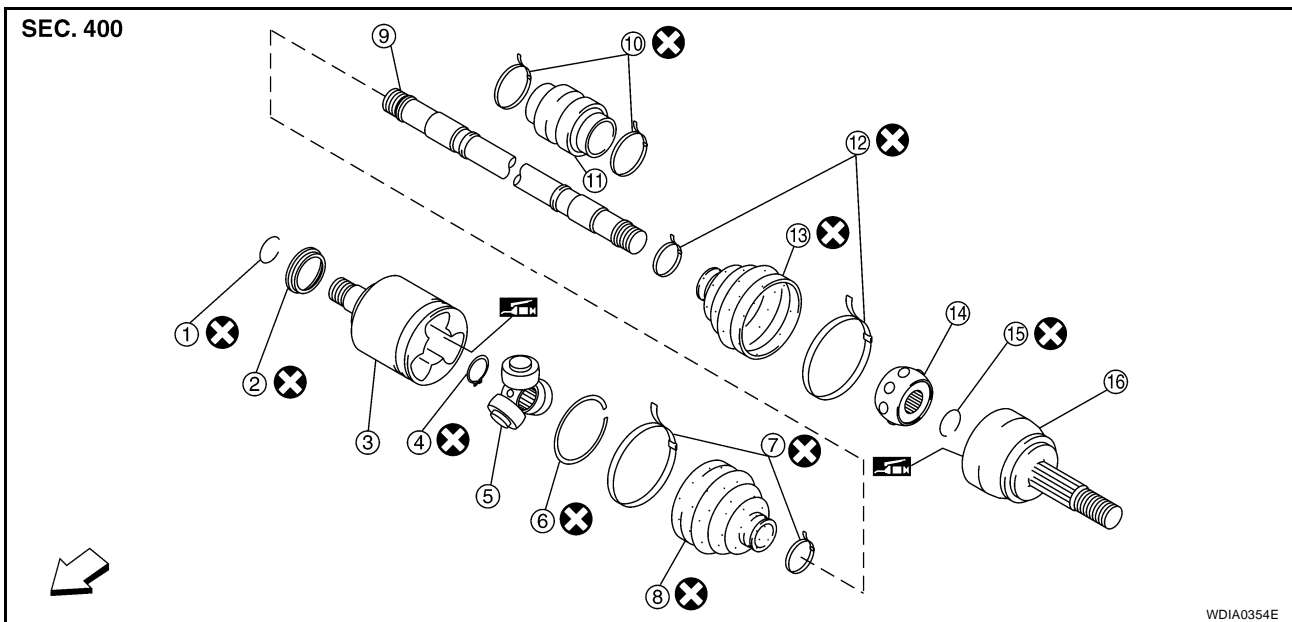

- | | | |
|------------------------|--|------------------------|
| 1. Circlip | 2. Dust shield | 3. Slide joint housing |
| 4. Snap ring | 5. Spider assembly | 6. Stopper ring |
| 7. Boot band | 8. Boot | 9. Shaft |
| 10. Damper band | 11. Damper | 12. Boot band |
| 13. Boot | 14. Ball cage / Steel ball / Inner race assembly | 15. Circlip |
| 16. Joint sub-assembly | ⇐: Front | |

DISASSEMBLY

Transaxle Side

- Mount front drive shaft in a vise.

CAUTION:

When mounting shaft in a vise, always use copper or aluminum plates between vise and shaft.

- Remove boot bands and slide the boot back.
- Remove circlip and dust shield from slide joint housing.
- Put matching marks on slide joint housing and shaft before separating joint assembly.

FRONT DRIVE SHAFT

5. Remove stopper ring with a suitable tool, then pull out slide joint housing.

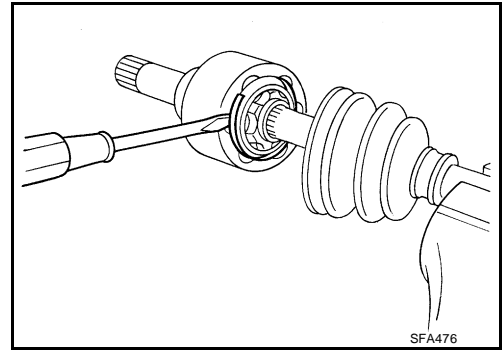

6. Put matching marks on spider assembly and shaft.

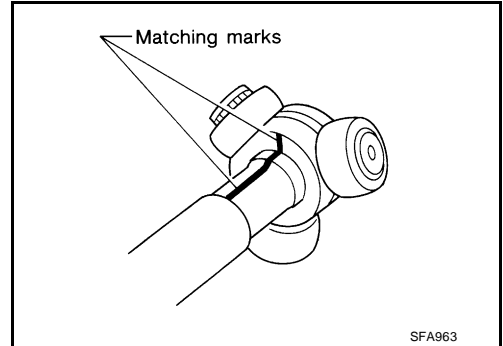

7. Remove snap ring using a suitable tool, then remove spider assembly from shaft.
8. Remove boot from shaft.
9. Clean the old grease off of the slide joint assembly.

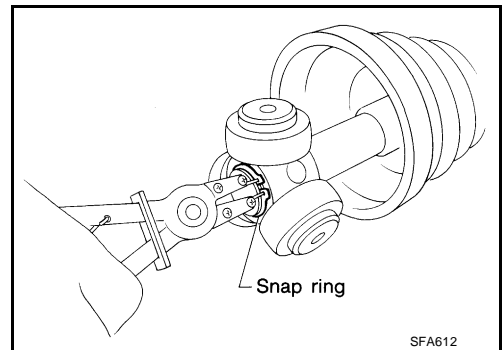

Wheel Side

1. Mount the front drive shaft in a vise.

CAUTION:

When mounting shaft in a vise, always use copper or aluminum plates between vise and shaft.

2. Remove boot bands and slide the boot back.
3. Screw a sliding hammer or suitable tool 30 mm (1.18 in) or more into threaded part of joint sub-assembly. Pull joint sub-assembly out of shaft.

CAUTION:

- **Align sliding hammer or suitable tool and drive shaft then remove joint sub-assembly by pulling directly.**
- **If joint sub-assembly cannot be removed after five or more unsuccessful attempts, replace the entire drive shaft assembly.**

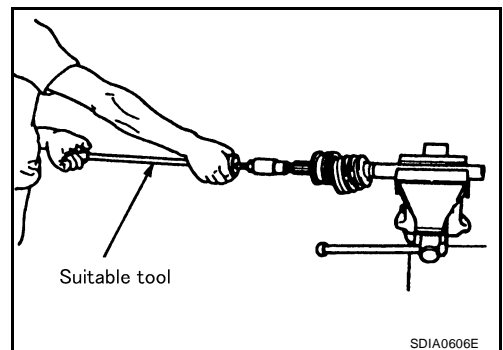

4. Remove boot from shaft.
5. Remove circlip from shaft.
6. While rotating ball cage, clean the old grease off of the joint sub-assembly.

Damper

- Remove damper bands, then remove damper from shaft.

FRONT DRIVE SHAFT

INSPECTION AFTER DISASSEMBLY

Shaft

- Replace shaft if there is bending, cracking, or other damage.

Joint Sub-Assembly

- Make sure there is no rough rotation or unusual axial looseness.
- Make sure there is no foreign material inside joint sub-assembly.
- Check joint sub-assembly for compression scars, cracks or fractures.

CAUTION:

If there are any irregular conditions of joint sub-assembly components, replace the entire joint sub-assembly.

Slide Joint Housing

- Make sure there are no compression scars, cracks or fractures or unusual wear of ball rolling surface.
- Make sure there is no damage to shaft screws.
- Make sure there is no deformation of boot installation parts.

Ball Cage

- Make sure there are no compression scars, cracks, fractures of sliding surface.

Steel Ball

- Make sure there are no compression scars, cracks, fractures or unusual wear.

Inner Race

- Check ball sliding surface for compression scars, cracks or fractures.
- Make sure there is no damage to serrated part.

CAUTION:

If there are any irregular conditions in the component, replace with a new set of joint sub-assembly, ball cage, steel ball and inner race.

Damper

- Check damper for cracks or wear. Install damper with new damper bands.

ASSEMBLY

Transaxle Side

1. Install new boot and new small boot band on shaft.

CAUTION:

● **Cover drive shaft serration with tape to prevent damage to boot during installation.**

2. Remove protective tape wound around serrated part of shaft.

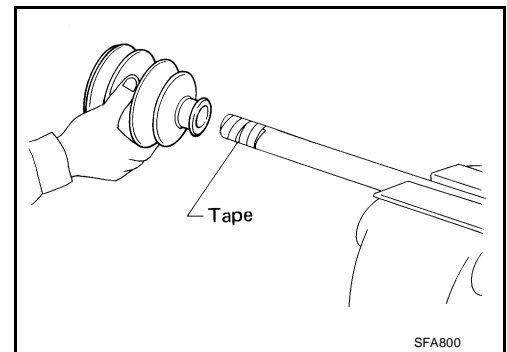

3. Install spider assembly securely, making sure the matching marks which were made during disassembly are properly aligned.

FRONT DRIVE SHAFT

4. Install new snap ring using a suitable tool.
5. Pack drive shaft with specified amount of new grease (Genuine NISSAN Grease or equivalent).

Grease amount : 134 – 144 g (4.73 – 5.08 oz)

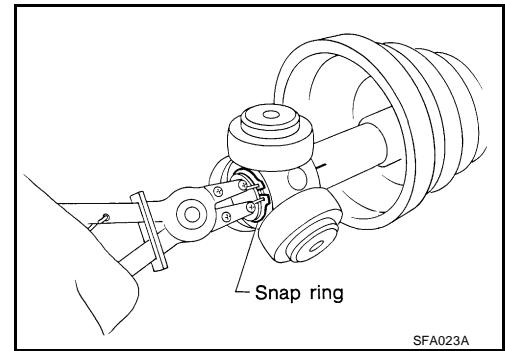

6. Install new stopper ring to housing of slide joint assembly.
7. After installation, pull shaft to check engagement between slide joint assembly and stopper ring.
8. Install boot securely into grooves (indicated by * marks) as shown.

CAUTION:

If there is grease on boot mounting surfaces (indicated by * marks) of shaft and housing, boot may come off. Clean all grease from surfaces.

9. Make sure boot installation length "L" is the length specified below. Insert a flat-bladed screwdriver or similar tool into the large end of boot. Bleed air from boot to prevent boot deformation.

Boot installation length "L" : 167.9 mm (6.61 in)

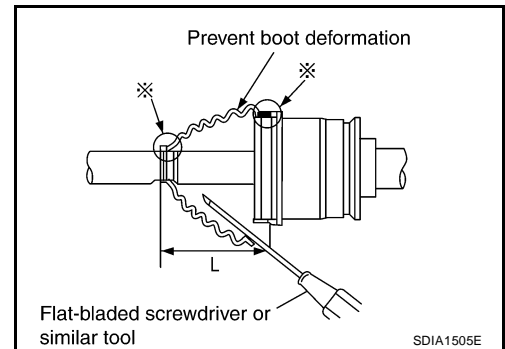

CAUTION:

- Boot may break if boot installation length is less than standard value.
- Be careful that screwdriver tip does not contact inside surface of boot.

10. Secure large and small ends of boot with new boot bands as shown.

CAUTION:

Discard old boot bands and replace with new ones.

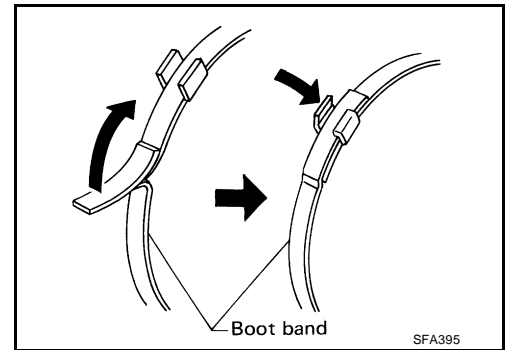

11. Install new dust shield to slide joint housing.
12. After installing housing and shaft, make sure boot position is correct. If boot position is not correct, remove old boot bands then reposition the boot and secure with new boot bands.

Wheel Side

1. Insert the amount of grease (Genuine NISSAN Grease or equivalent) into joint sub-assembly serration hole until grease begins to ooze from ball groove and serration hole. After inserting grease, use a shop cloth to wipe off old grease that has oozed out.

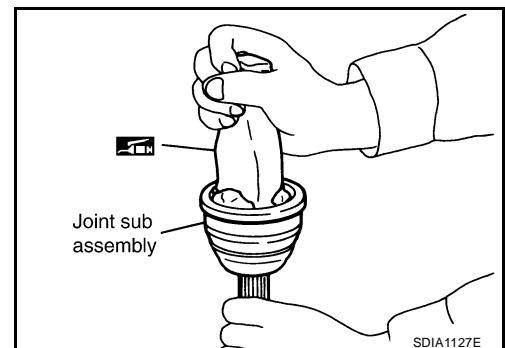

FRONT DRIVE SHAFT

2. Cover serrated part of shaft with tape. Install new boot band and boot to shaft. Be careful not to damage boot.

CAUTION:

Discard old boot band and boot; replace with new one.

3. Remove protective tape wound around serrated part of shaft.

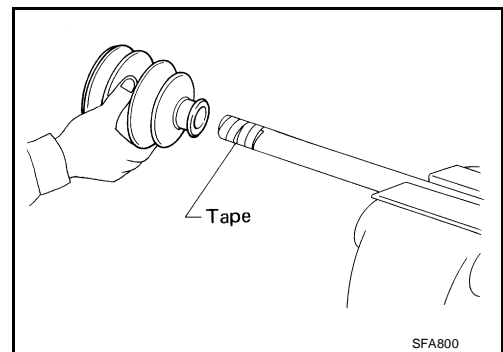

4. Attach new circlip to shaft. The circlip must fit securely into shaft groove. Attach nut to joint sub-assembly. Use a suitable tool to press-fit.

CAUTION:

Discard old circlip and replace with new one.

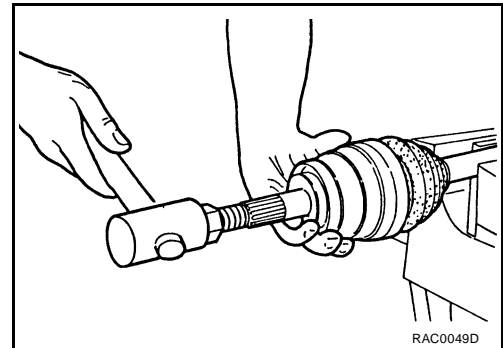

5. Insert the amount of new grease (Genuine NISSAN Grease or equivalent) listed below into housing from large end of boot.

Grease amount : 170 – 190 g (6.00 – 6.70 oz)

6. Install boot securely into grooves (indicated by * marks) as shown.

CAUTION:

If there is grease on boot mounting surfaces (indicated by * marks) of shaft and housing, boot may come off. Remove all grease from surfaces.

7. Make sure boot installation length "L" is the specified length indicated below. Insert a flat-bladed screwdriver or similar tool into the large end of boot. Bleed air from boot to prevent boot deformation.

Boot installation length "L" : 163 mm (6.42 in)

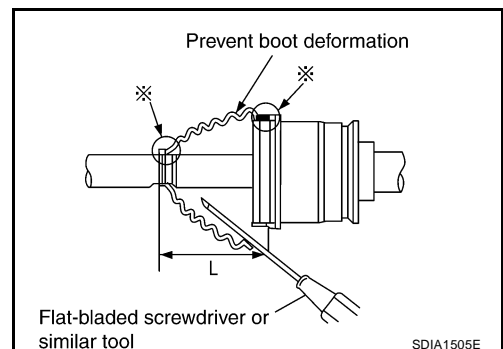

CAUTION:

- **Boot may break if boot installation length is less than standard value.**
- **Be careful that screwdriver tip does not contact inside surface of boot.**

8. Install new large and small boot bands securely using Tool.

Tool number : KV40107300 (—)

NOTE:

Do not reuse boot bands.

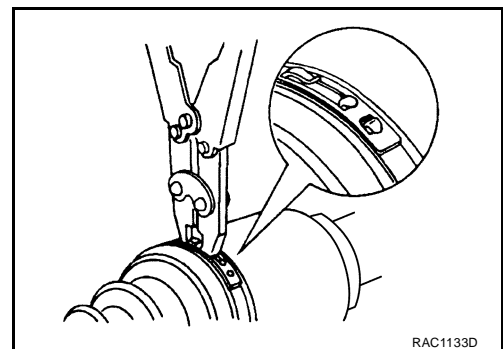

A
B
C
FAX
E
F
G
H
I
J
K
L
M

FRONT DRIVE SHAFT

CAUTION:

- Secure boot band so that dimension “M” meets specification as shown.

Dimension “M” : 1.0 – 4.0 mm (0.039 – 0.157 in)

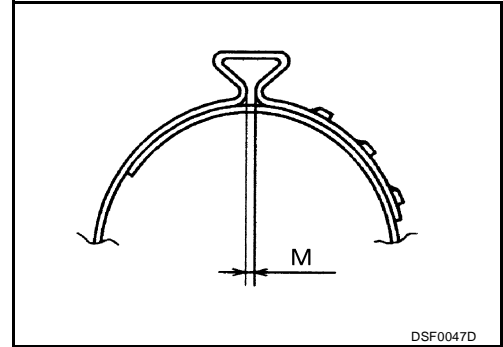

9. After installing housing and shaft, rotate boot to check whether or not the actual position is correct. If boot position is not correct, remove old boot bands then reposition the boot and secure with new boot bands.

Damper

1. Use new damper bands for installation.
2. Install damper from stationary-joint side while holding it securely.

“A” : 205 – 215 mm (8.07 – 8.46 in)

“B” : 70 mm (2.76 in)

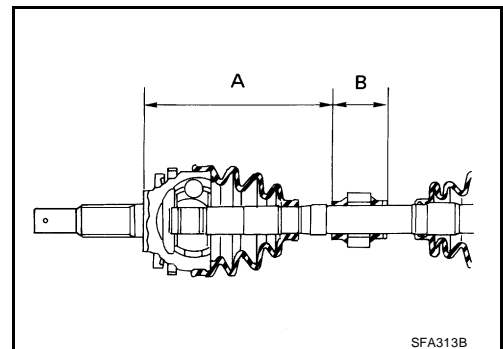

FRONT DRIVE SHAFT

Disassembly and Assembly (Right Side)

EDS00353

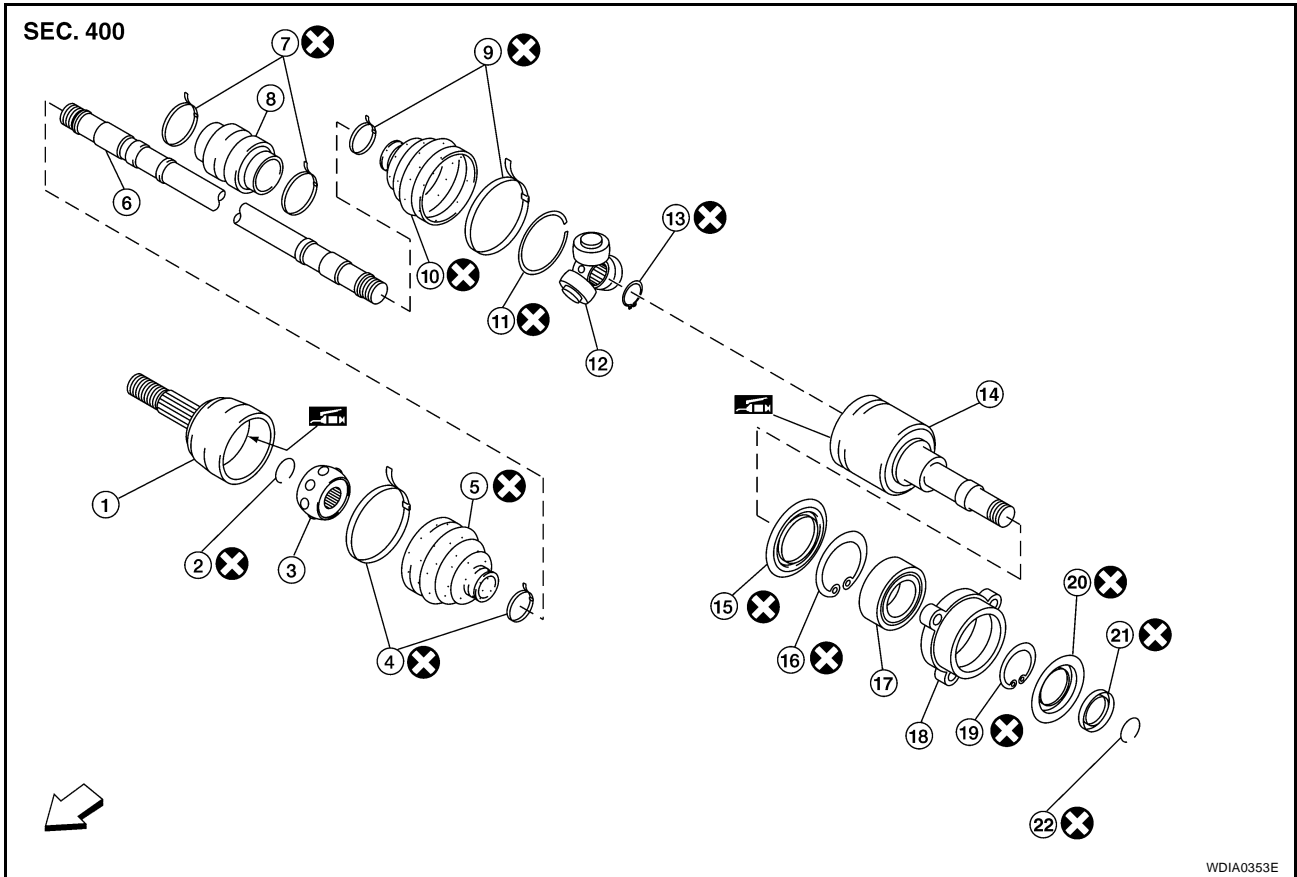

- | | | |
|-----------------------|-------------------------|---|
| 1. Joint sub-assembly | 2. Circlip | 3. Ball cage / Steel ball / Inner race assembly |
| 4. Boot bands | 5. Boot | 6. Shaft |
| 7. Damper bands | 8. Damper | 9. Boot band |
| 10. Boot | 11. Stopper ring | 12. Spider assembly |
| 13. Snap ring | 14. Slide joint housing | 15. Dust cover |
| 16. Snap ring | 17. Bearing | 18. Bracket |
| 19. Snap ring | 20. Dust shield | 21. Dust shield |
| 22. Circlip | ⇐: Front | |

DISASSEMBLY

Transaxle Side

1. Press shaft in a vise.

CAUTION:

When retaining shaft in a vise, always use copper or aluminum plates between vise and shaft.

2. Remove circlip and dust shield from slide joint housing.
3. Remove boot bands and slide the boots back.
4. Put matching marks on slide joint housing and shaft before separating slide joint housing.
5. Remove stopper ring using a suitable tool, then pull out slide joint housing.

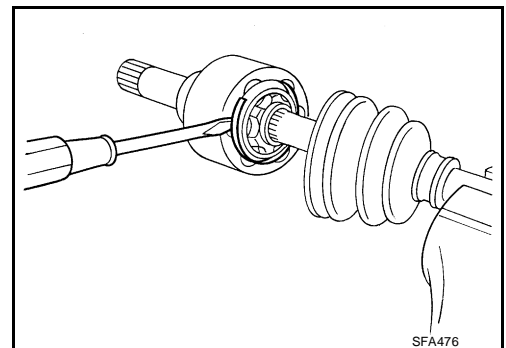

A
B
C
FAX
E
F
G
H
I
J
K
L
M

FRONT DRIVE SHAFT

- Put matching marks on spider assembly and shaft.

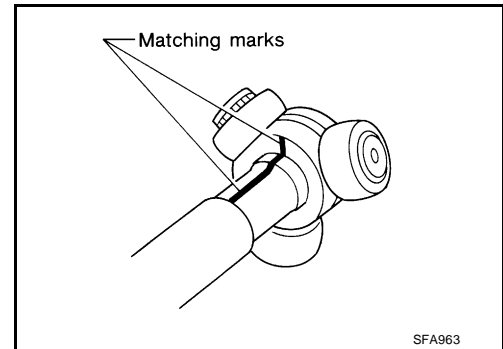

- Remove snap ring using a suitable tool, then remove spider assembly from shaft.
- Remove boot from shaft.
- Clean old grease off of the slide joint housing.

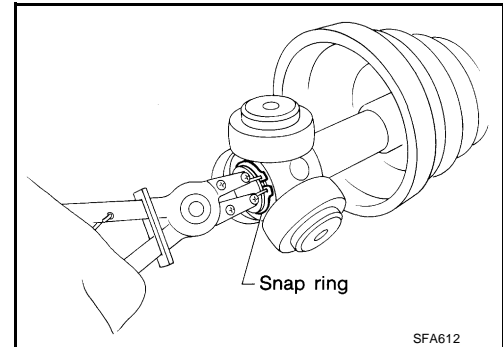

Wheel Side

- Mount the front drive shaft in a vise.

CAUTION:

When mounting shaft in a vise, always use copper or aluminum plates between vise and shaft.

- Remove boot bands and slide the boot back.
- Screw a sliding hammer or suitable tool 30 mm (1.18 in) or more into threaded part of joint sub-assembly. Pull joint sub-assembly out of shaft.

CAUTION:

- Align sliding hammer or suitable tool and drive shaft then remove joint sub-assembly by pulling directly.
- If joint sub-assembly cannot be removed after five or more unsuccessful attempts, replace the entire drive shaft assembly.

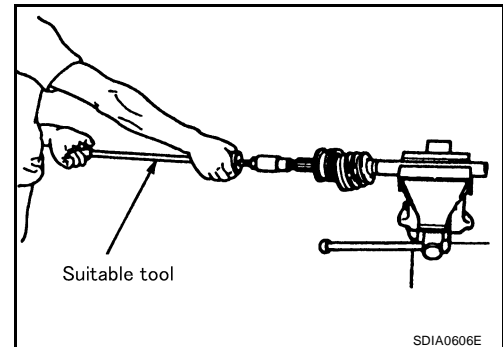

- Remove boot from shaft.
- Remove circlip from shaft.
- While rotating ball cage, clean the old grease off of the joint sub-assembly.

Support Bearing

- Remove dust shield from slide joint assembly using a suitable tool.

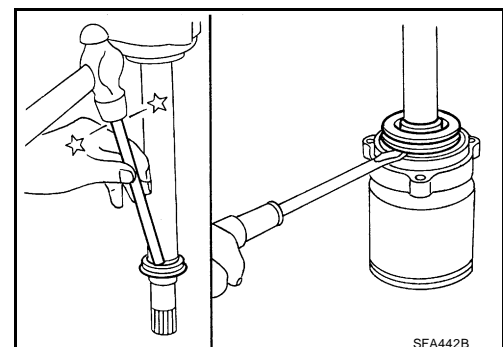

FRONT DRIVE SHAFT

2. Remove snap ring using a suitable tool.

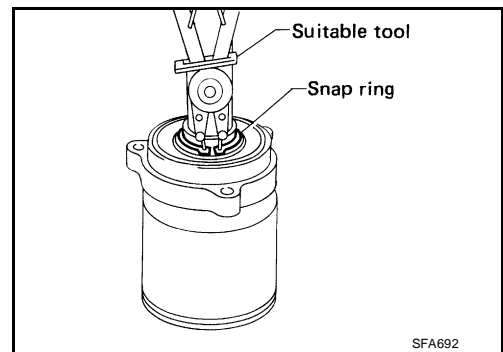

3. Press support bearing assembly off slide joint assembly using a suitable tool.

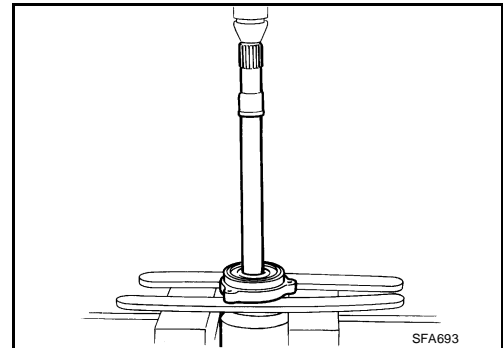

4. Separate support bearing from bracket using a suitable tool.

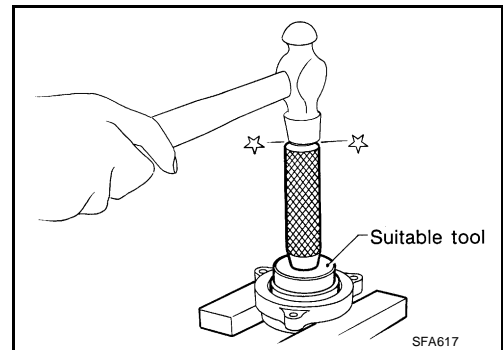

Damper

- Remove damper bands, then remove damper from shaft.

INSPECTION AFTER DISASSEMBLY

Shaft

- Replace shaft if there is any bending, cracking, or other damage.

Joint Sub-assembly

- Make sure there is no rough rotation or unusual axial looseness.
- Make sure there is no foreign material inside joint sub-assembly.
- Check joint sub-assembly for compression scars, cracks or fractures.

CAUTION:

If there are any irregular conditions of joint sub-assembly components, replace the entire joint sub-assembly.

Sliding Joint Housing and Spider Assembly

- If roller surface of spider assembly has scratches or wear, replace housing and spider assembly.

NOTE:

Housing and spider assembly are components which are used as a set.

Support Bearing

- Make sure wheel bearing rolls freely and is free from noise, cracks, pitting or wear.

FRONT DRIVE SHAFT

Damper

- Check damper for cracks or wear. Install damper with new damper bands.

ASSEMBLY

Transaxle Side

1. Cover serrated part of shaft with tape. Install new boot and boot band onto shaft. Be careful not to damage boot.

CAUTION:

- **Discard old boot and boot band; replace with new ones.**

2. Remove protective tape wound around serrated part of shaft.

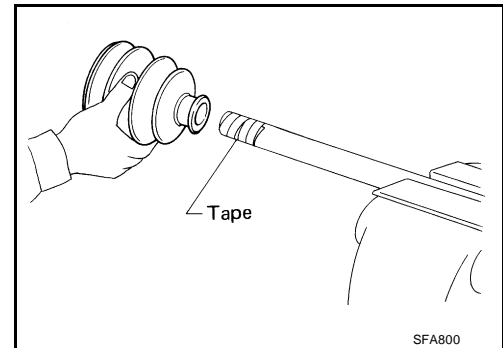

3. Install spider assembly securely, making sure the matching marks which were made during disassembly are properly aligned.
4. Install new snap ring using a suitable tool.
5. Pack drive shaft with specified amount of grease (Genuine NISSAN Grease or equivalent).

Grease amount : 134 - 144 g (4.73 - 5.08 oz)

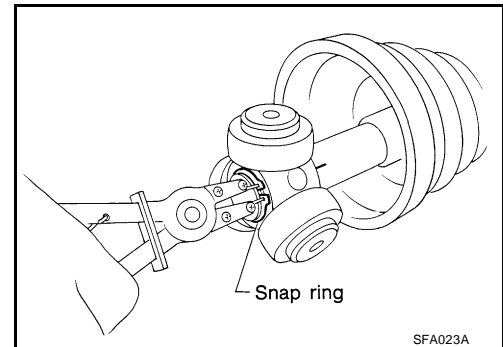

6. Install new stopper ring to slide joint assembly.
7. After installation, pull shaft to check engagement between slide joint assembly and stopper ring.
8. Install boot securely into grooves (indicated by * marks) as shown.

CAUTION:

If there is grease on boot mounting surfaces (indicated by * marks) of shaft and housing, boot may come off. Remove all grease from surfaces.

9. Make sure boot installation length "L" is the length indicated below. Insert a flat-bladed screwdriver or similar tool into the large end of boot. Bleed air from boot to prevent boot deformation.

Boot installation length "L" : 189.30 mm (7.45 in)

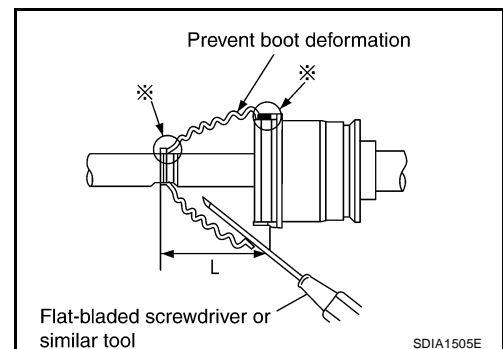

CAUTION:

- **Boot may break if boot installation length is less than standard value.**
- **Be careful that screwdriver tip does not contact inside surface of boot.**

FRONT DRIVE SHAFT

- Secure big and small ends of boot with new boot bands as shown.

CAUTION:

Discard old boot bands; replace with new ones.

- Install new dust shield to slide joint housing.
- After installing housing and shaft, rotate boot to check whether or not the actual position is correct. If boot position is not correct, remove old boot bands then reposition the boot and secure with new boot bands.

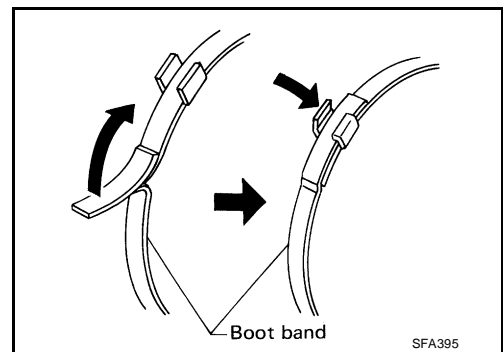

Wheel Side

- Insert the amount of grease (Genuine NISSAN Grease or equivalent) into joint sub-assembly serration hole until grease begins to ooze from ball groove and serration hole. After inserting grease, use a shop cloth to wipe off old grease that has oozed out.

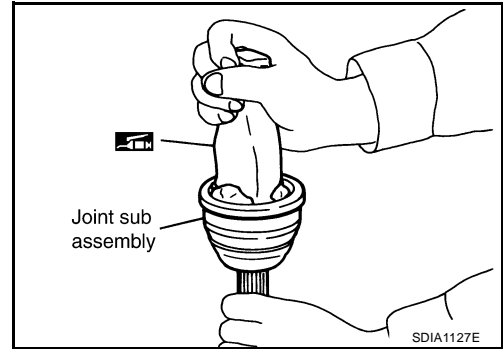

- Cover serrated part of shaft with tape. Install new boot and boot band onto shaft. Be careful not to damage boot.

CAUTION:

Discard old boot and boot band; replace with new ones.

- Remove protective tape wound around serrated part of shaft.

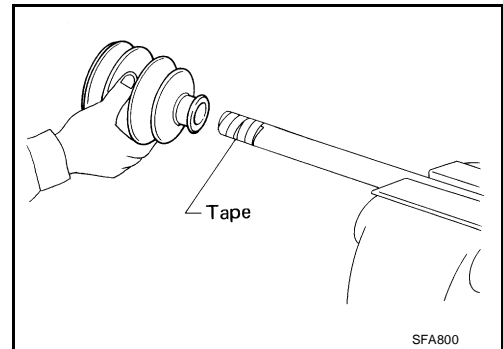

- Attach new circlip to shaft. The circlip must fit securely into shaft groove. Attach nut to joint sub-assembly. Use a suitable tool to press-fit.

CAUTION:

Discard old circlip; replace with new ones.

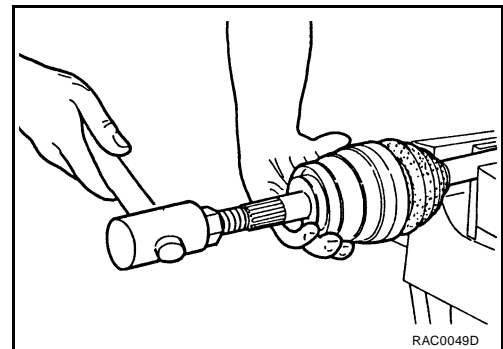

- Insert the amount of new grease (Genuine NISSAN Grease or equivalent) listed below into housing from large end of boot.

Grease amount : 170 – 190 g (6.00 – 6.70 oz)

FRONT DRIVE SHAFT

6. Install boot securely into grooves (indicated by * marks) as shown.

CAUTION:

If there is grease on boot mounting surfaces (indicated by * marks) of shaft and housing, boot may come off. Remove all grease from surfaces.

7. Make sure boot installation length "L" is the specified length. Insert a flat-bladed screwdriver or similar tool into the large end of boot. Bleed air from boot to prevent boot deformation.

Boot installation length "L" : 163 mm (6.42 in)

CAUTION:

- Boot may break if boot installation length is less than standard value.
- Be careful that screwdriver tip does not contact inside surface of boot.

8. Install new large and small boot bands securely using Tool.

Tool number : KV40107300 (—)

NOTE:

Do not reuse boot bands.

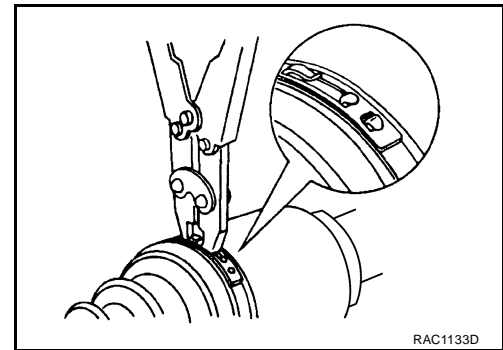
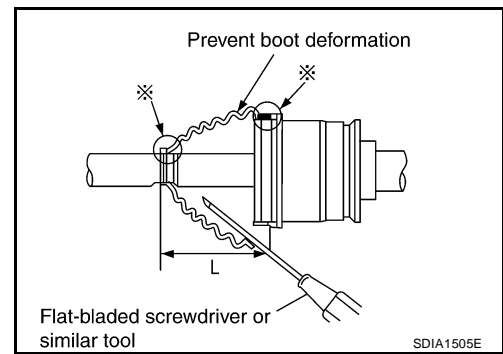

CAUTION:

- Secure boot band so that dimension "M" meets specification as shown.

Dimension "M" : 1.0 – 4.0 mm (0.039 – 0.157 in)

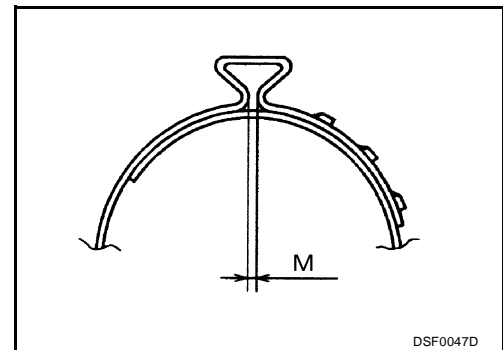

9. After installing housing and shaft, rotate boot to check whether or not the actual position is correct. If boot position is not correct, remove old boot bands then reposition the boot and secure with new boot bands.

Damper

1. Use new damper bands for installation.
2. Install damper from stationary-joint side while holding it securely.

"A" : 205 – 215 mm (8.07 – 8.46 in)

"B" : 70 mm (2.76 in)

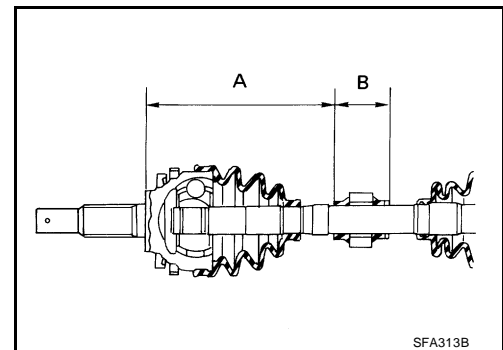

SERVICE DATA AND SPECIFICATIONS (SDS)

SERVICE DATA AND SPECIFICATIONS (SDS)

PFP:00030

Wheel Bearing

EDS00354

Axial end play limit	0.05 mm (0.002 in) or less
----------------------	----------------------------

Drive Shaft

EDS00355

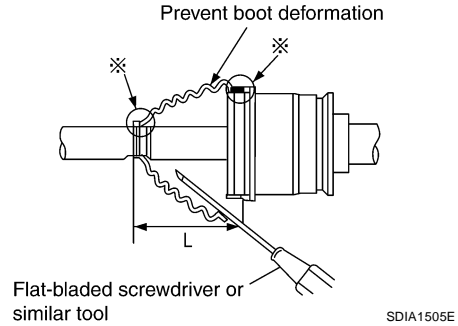

Joint type	Wheel side		Transaxle side	
	LH	RH	LH	RH
Grease quantity	170 - 190 g (6.00 - 6.70 oz)		134 - 144 g (4.73 - 5.08 oz)	
Boots installed length	163 mm (6.42 in)		167.9 mm (6.61 in)	189.30 (7.45 in)

Damper

EDS00356

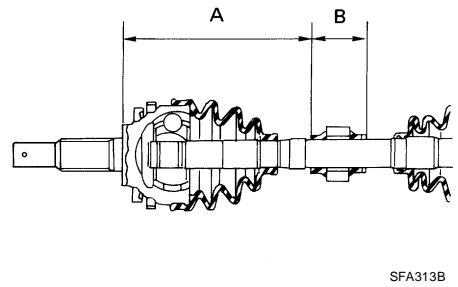

"A"	205 - 215 mm (8.07 - 8.46 in)
"B"	70 mm (2.76 in)

SERVICE DATA AND SPECIFICATIONS (SDS)
