

SECTION **BRC**

BRAKE CONTROL SYSTEM

A
B
C
D
E

CONTENTS

TCS/ABS		
SERVICE INFORMATION	3	
PRECAUTIONS	3	
Precaution for Supplemental Restraint System (SRS) "AIR BAG" and "SEAT BELT PRE-TENSIONER"	3	
Precaution for Brake System	3	
Precaution for Brake Control	3	
Precaution for CAN System	4	
PREPARATION	5	
Special Service Tool	5	
Commercial Service Tool	5	
SYSTEM DESCRIPTION	6	
Schematic	6	
ABS Function	6	
EBD Function	6	
TCS Function	6	
Wheel Sensors	7	
Fail-Safe Function	7	
Hydraulic Circuit Diagram	8	
CAN COMMUNICATION	9	
System Description	9	
TROUBLE DIAGNOSIS	10	
How to Perform Trouble Diagnosis for Quick and Accurate Repair	10	
Component Parts and Harness Connector Location	13	
Schematic	14	
Wiring Diagram - TCS -	15	
Basic Inspection	18	
Warning Lamp and Indicator Timing	19	
Control Unit Input/Output Signal Standard	19	
CONSULT-III Function (ABS)	21	
TROUBLE DIAGNOSIS FOR SELF-DIAGNOSTIC ITEMS	28	
Wheel Sensor System Inspection	28	
Engine System Inspection	29	
ABS/TCS Control Unit Inspection	29	
Solenoid Valve System Inspection	30	
Actuator Motor, Motor Relay, and Circuit Inspection	31	
Stop Lamp Switch System Inspection	32	
ABS/TCS Control Unit Power and Ground Systems Inspection	32	
CAN Communication System Inspection	33	
Component Inspection	33	
TROUBLE DIAGNOSES FOR SYMPTOMS	35	
ABS Works Frequently	35	
Unexpected Pedal Action	35	
Long Stopping Distance	36	
ABS Does Not Work	36	
Pedal Vibration or ABS Operation Noise	36	
ABS Warning Lamp Does Not Come On When Ignition Switch Is Turned On	37	
ABS Warning Lamp Stays On When Ignition Switch Is Turned On	37	
Vehicle Jerks During TCS Activation	38	
WHEEL SENSORS	39	
Removal and Installation	39	
SENSOR ROTOR	40	
Removal and Installation	40	
ACTUATOR AND ELECTRIC UNIT (ASSEMBLY)	41	
Removal and Installation	41	
VDC/TCS/ABS		
SERVICE INFORMATION	43	
PRECAUTIONS	43	
Precaution for Supplemental Restraint System (SRS) "AIR BAG" and "SEAT BELT PRE-TENSIONER"	43	
Precaution for Brake System	43	

BRC

G
H
I
J
K
L
M
N
O
P

Precaution for Brake Control	43	Solenoid and VDC Change-Over Valve System	
Precaution for CAN System	44	Inspection	74
PREPARATION	45	Actuator Motor, Motor Relay, and Circuit Inspec-	
Special Service Tool	45	tion	75
Commercial Service Tool	45	Stop Lamp Switch System Inspection	76
SYSTEM DESCRIPTION	46	ABS/TCS/VDC Control Unit Power and Ground	
System Component	46	Systems Inspection	77
ABS Function	46	Brake Fluid Level Switch System Inspection	78
EBD Function	46	CAN Communication System Inspection	78
TCS Function	47	Component Inspection	79
VDC Function	47	TROUBLE DIAGNOSES FOR SYMPTOMS	80
Wheel Sensors	47	ABS Works Frequently	80
Fail-Safe Function	47	Unexpected Pedal Action	80
Hydraulic Circuit Diagram	48	Long Stopping Distance	81
CAN COMMUNICATION	49	ABS Does Not Work	81
System Description	49	Pedal Vibration or ABS Operation Noise	81
TROUBLE DIAGNOSIS	50	ABS Warning Lamp Does Not Come On When Ig-	
How to Perform Trouble Diagnosis for Quick and		nition Switch Is Turned On	82
Accurate Repair	50	ABS Warning Lamp Stays On When Ignition	
Component Parts and Harness Connector Loca-		Switch Is Turned On	82
tion	53	Vehicle Jerks During TCS/VDC Activation	83
Schematic	54	ON-VEHICLE SERVICE	84
Wiring Diagram - VDC -	55	Adjustment of Steering Angle Sensor Neutral Po-	
Basic Inspection	59	sition	84
Warning Lamp and Indicator Timing	60	WHEEL SENSORS	85
Control Unit Input/Output Signal Standard	60	Removal and Installation	85
CONSULT-III Function (ABS)	63	SENSOR ROTOR	86
TROUBLE DIAGNOSIS FOR SELF-DIAG-		Removal and Installation	86
NOSTIC ITEMS	70	ACTUATOR AND ELECTRIC UNIT (ASSEM-	
Wheel Sensor System Inspection	70	BLY)	87
Engine System Inspection	71	Removal and Installation	87
ABS/TCS/VDC Control Unit Inspection	71	STEERING ANGLE SENSOR	89
Steering Angle Sensor System Inspection	72	Removal and Installation	89
Yaw Rate/Side/Decel G Sensor System Inspec-		G SENSOR	90
tion	73	Removal and Installation	

SERVICE INFORMATION

PRECAUTIONS

Precaution for Supplemental Restraint System (SRS) "AIR BAG" and "SEAT BELT PRE-TENSIONER"

INFOID:000000004278942

The Supplemental Restraint System such as "AIR BAG" and "SEAT BELT PRE-TENSIONER", used along with a front seat belt, helps to reduce the risk or severity of injury to the driver and front passenger for certain types of collision. This system includes seat belt switch inputs and dual stage front air bag modules. The SRS system uses the seat belt switches to determine the front air bag deployment, and may only deploy one front air bag, depending on the severity of a collision and whether the front occupants are belted or unbelted. Information necessary to service the system safely is included in the SR and SB section of this Service Manual.

WARNING:

- To avoid rendering the SRS inoperative, which could increase the risk of personal injury or death in the event of a collision which would result in air bag inflation, all maintenance must be performed by an authorized NISSAN/INFINITI dealer.
- Improper maintenance, including incorrect removal and installation of the SRS, can lead to personal injury caused by unintentional activation of the system. For removal of Spiral Cable and Air Bag Module, see the SR section.
- Do not use electrical test equipment on any circuit related to the SRS unless instructed to in this Service Manual. SRS wiring harnesses can be identified by yellow and/or orange harnesses or harness connectors.

Precaution for Brake System

INFOID:000000004278943

CAUTION:

- Refer to [MA-12](#) for recommended brake fluid.
- Never reuse drained brake fluid.
- Be careful not to splash brake fluid on painted areas; it may cause paint damage. If brake fluid is splashed on painted areas, wash it away with water immediately.
- To clean or wash all parts of master cylinder and disc brake caliper, use clean brake fluid.
- Never use mineral oils such as gasoline or kerosene. They will ruin rubber parts of the hydraulic system.
- Use flare nut wrench when removing and installing brake tube.
- If a brake fluid leak is found, the part must be disassembled without fail. Then it has to be replaced with a new one if a defect exists.
- Turn the ignition switch OFF and remove the connector of the ABS actuator and electric unit (control unit) or the battery terminal before performing the work.
- Always tighten brake lines to specified torque when installing.
- Burnish the brake contact surfaces after refinishing or replacing rotors, after replacing pads, or if a soft pedal occurs at very low mileage.

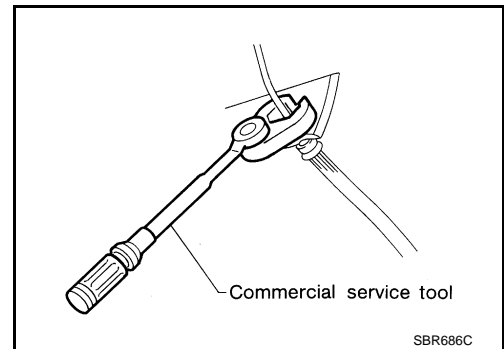

Refer to [BR-30. "Brake Burnishing"](#) (front disc brakes) or [BR-37. "Brake Burnishing"](#) (rear disc brakes).

WARNING:

- Clean brake pads and shoes with a waste cloth, then wipe with a dust collector.

Precaution for Brake Control

INFOID:000000004278944

- During ABS operation, the brake pedal may vibrate lightly and a mechanical noise may be heard. This is normal.
- Just after starting vehicle, the brake pedal may vibrate or a motor operating noise may be heard from engine compartment. This is a normal status of operation check.
- Stopping distance may be longer than that of vehicles without ABS when vehicle drives on rough, gravel, or snow-covered (fresh, deep snow) roads.

A
B
C
D
E
BRC
G
H
I
J
K
L
M
N
O
P

PRECAUTIONS

[TCS/ABS]

< SERVICE INFORMATION >

- When an error is indicated by ABS or another warning lamp, collect all necessary information from customer (what symptoms are present under what conditions) and check for simple causes before starting diagnosis. Besides electrical system inspection, check booster operation, brake fluid level, and fluid leaks.
- If incorrect tire sizes or types are installed on the vehicle or brake pads are not Genuine NISSAN parts, stopping distance or steering stability may deteriorate.
- If there is a radio, antenna or related wiring near control module, ABS function may have a malfunction or error.
- If aftermarket parts (car stereo, CD player, etc.) have been installed, check for incidents such as harness pinches, open circuits or improper wiring.

Precaution for CAN System

INFOID:000000004278945

- Do not apply voltage of 7.0V or higher to terminal to be measured.
- Maximum open terminal voltage of tester in use must be less than 7.0V.
- Before checking harnesses, turn ignition switch OFF and disconnect battery negative cable.
- Area to be repaired must be soldered and wrapped with tape. Make sure that fraying of twisted wire is within 110 mm (4.33 in).

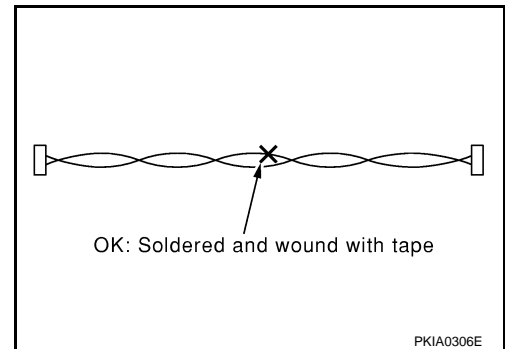

- Do not make a bypass connection to repaired area. (If the circuit is bypassed, characteristics of twisted wire will be lost.)

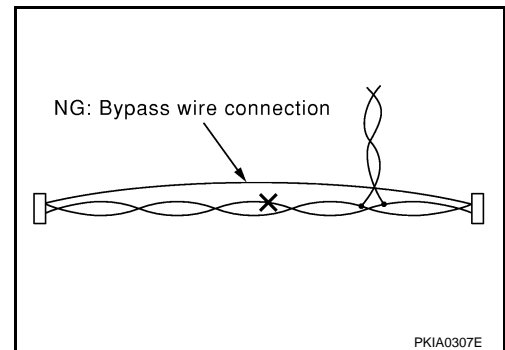

PREPARATION

< SERVICE INFORMATION >

[TCS/ABS]

PREPARATION

Special Service Tool

INFOID:000000004278946

The actual shapes of Kent-Moore tools may differ from those of special service tools illustrated here.

Tool number (Kent-Moore No.) Tool name	Description
KV991J0070 (J-45741) ABS active wheel sensor tester	Checking operation of ABS active wheel sensors

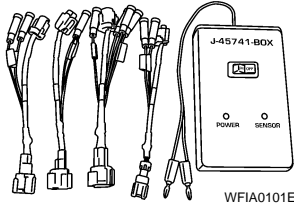

Commercial Service Tool

INFOID:000000004278947

BRC

Tool name	Description
1. Flare nut crowfoot 2. Torque wrench	Removing and installing brake piping a: 10mm (0.39 in)/12mm (0.47 in)

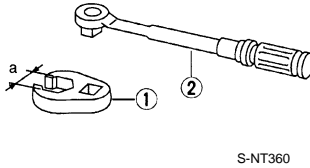

SYSTEM DESCRIPTION

Schematic

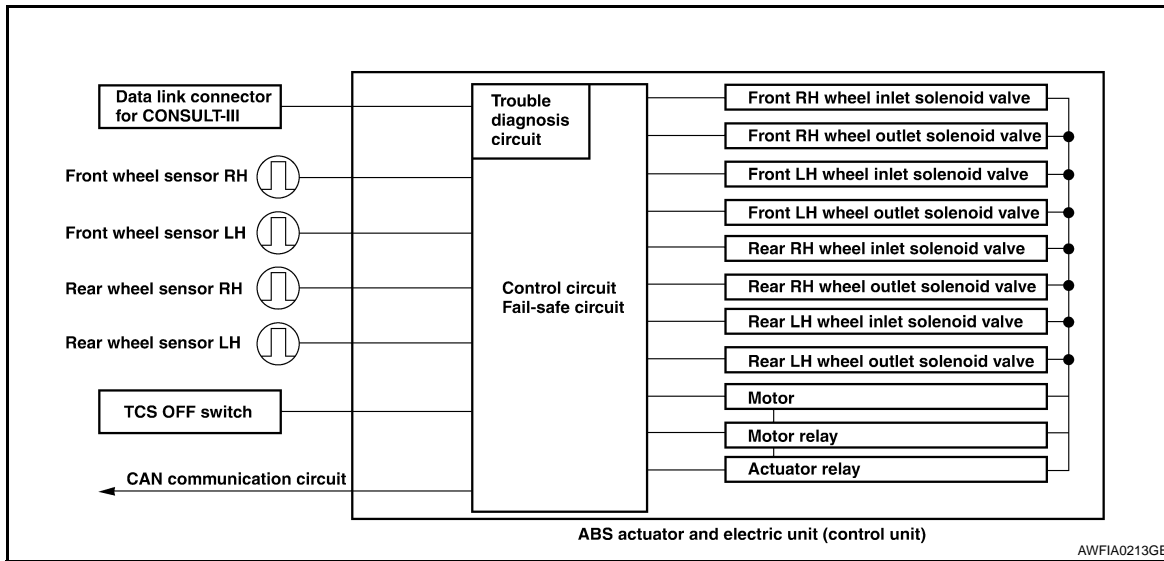

ABS Function

INFOID:000000004278949

- The Anti-Lock Brake System detects wheel revolution while braking and improves handling stability during sudden braking by electrically preventing wheel lockup. Maneuverability is also improved for avoiding obstacles.
- If the electrical system malfunctions, the Fail-Safe function is activated, the ABS becomes inoperative and the ABS warning lamp turns on.
- The electrical system can be diagnosed using CONSULT-III.
- During ABS operation, the brake pedal may vibrate lightly and a mechanical noise may be heard. This is normal.
- Just after starting the vehicle, the brake pedal may vibrate or a motor operating noise may be heard from engine compartment. This is a normal status of operation check.
- Stopping distance may be longer than that of vehicles without ABS when vehicle drives on rough, gravel, or snow-covered (fresh, deep snow) roads.

EBD Function

INFOID:000000004278950

- Electronic Brake Distribution is a function that detects subtle slippages between the front and rear wheels during braking, and it improves handling stability by electronically controlling the brake fluid pressure which results in reduced rear wheel slippage.
- If the electrical system malfunctions, the Fail-Safe function is activated, the EBD and ABS become inoperative, and the ABS warning lamp and BRAKE warning lamp are turned on.
- The electrical system can be diagnosed using CONSULT-III.
- During EBD operation, the brake pedal may vibrate lightly and a mechanical noise may be heard. This is normal.
- Just after starting the vehicle, the brake pedal may vibrate or a motor operating noise may be heard from engine compartment. This is a normal status of operation check.

TCS Function

INFOID:000000004278951

- Spinning of the drive wheels is detected by the ABS/TCS control unit using inputs from the wheel speed sensors. If wheel spin occurs, engine fuel cut is conducted while the throttle value is restricted to reduce the engine torque and decrease the amount of wheel spin. In addition, the throttle opening is controlled to achieve the optimum engine torque.
- Depending on road condition, the vehicle may have a sluggish feel. This is normal, because optimum traction has the highest priority during TCS operation.
- TCS may be activated during sudden vehicle acceleration, wide open throttle acceleration, sudden transmission shifts or when the vehicle is driven on a road with a varying surface friction coefficient.
- The SLIP indicator lamp flashes to inform the driver of TCS operation.

SYSTEM DESCRIPTION

< SERVICE INFORMATION >

[TCS/ABS]

Wheel Sensors

INFOID:000000004278952

Each wheel sensor unit consists of a wheel hub with a series of internal magnets and a sensor element. The wheel sensors are installed on the inner side of the wheel knuckles. As the wheel rotates, the sensor generates a square-wave signal. The frequency increases as the wheel speed increases.

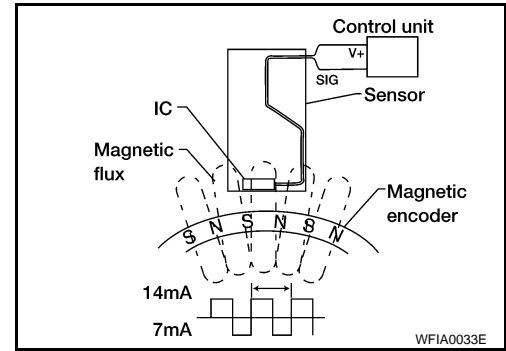

Fail-Safe Function

INFOID:000000004278953

CAUTION:

If the Fail-Safe function is activated, perform the Self Diagnosis for ABS/TCS system.

ABS/EBD SYSTEM

In case of an electrical malfunction with the ABS, the ABS warning lamp and SLIP indicator lamp will turn on. In case of an electrical malfunction with the EBD system, the BRAKE warning lamp, ABS warning lamp and SLIP indicator lamp will turn on.

The system will revert to one of the following conditions of the Fail-Safe function.

1. For ABS malfunction, only the EBD is operative and the condition of the vehicle is the same condition of vehicles without ABS/TCS system.
2. For EBD malfunction, the EBD and ABS become inoperative, and the condition of the vehicle is the same as the condition of vehicles without ABS/TCS and EBD system.

TCS SYSTEM

In case of TCS system malfunction, the SLIP indicator lamp is turned on and the condition of the vehicle is the same as the condition of vehicles without TCS system. In case of an electrical malfunction with the TCS system, the ABS control continues to operate normally without TCS control.

A
B
C
D
E
BRC
G
H
I
J
K
L
M
N
O
P

SYSTEM DESCRIPTION

< SERVICE INFORMATION >

[TCS/ABS]

Hydraulic Circuit Diagram

INFOID:000000004278954

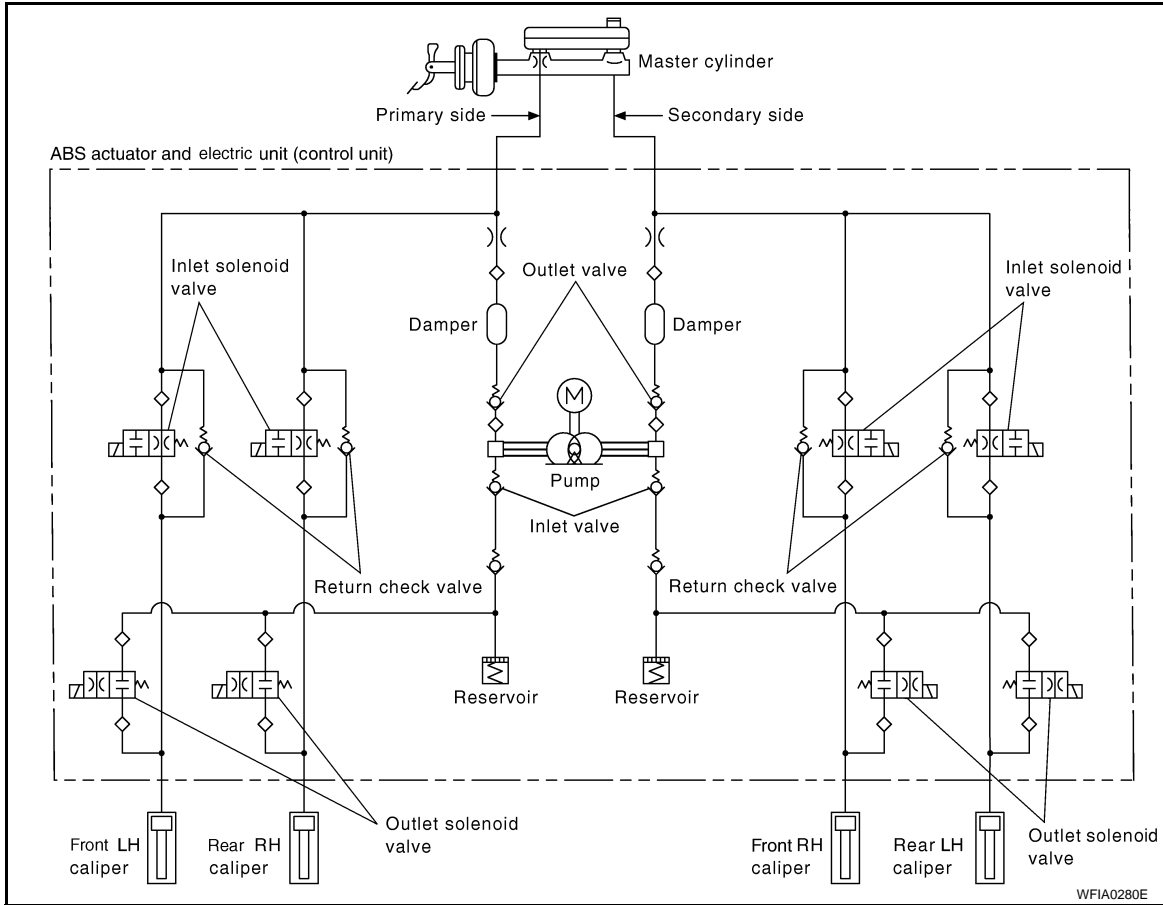

CAN COMMUNICATION

System Description

INFOID:000000004278955

Refer to [LAN-3. "CAN Communication System"](#).

A

B

C

D

E

BRC

G

H

I

J

K

L

M

N

O

P

TROUBLE DIAGNOSIS

How to Perform Trouble Diagnosis for Quick and Accurate Repair

INFOID:000000004278956

INTRODUCTION

The ABS/TCS system has an electronic control unit to control major functions. The control unit accepts input signals from sensors and controls actuator operation. It is also important to check for conventional problems such as air leaks in the booster or lines, lack of brake fluid, or other problems with the brake system.

It is much more difficult to diagnose a problem that occurs intermittently rather than continuously. Most intermittent problems are caused by poor electrical connections or faulty wiring. In this case, careful checking of suspicious circuits may help prevent the replacement of good parts.

A visual check only may not find the cause of the problem, so a road test should be performed.

Before undertaking actual checks, take just a few minutes to talk with a customer who approaches with an ABS/TCS complaint. The customer is a very good source of information on such problems, especially intermittent ones. Through the talks with the customer, find out what symptoms are present and under what conditions they occur. Start your diagnosis by looking for "conventional" problems first. This is one of the best ways to troubleshoot brake problems on an ABS/TCS equipped vehicle. Also check related Service Bulletins for information.

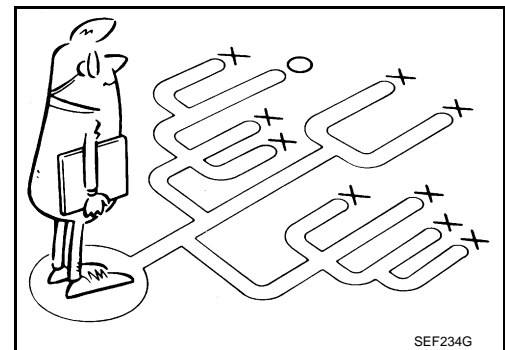
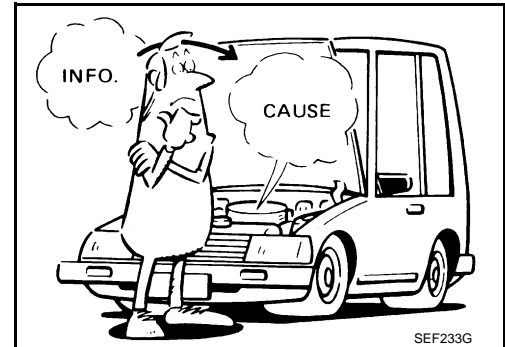

TROUBLE DIAGNOSIS

< SERVICE INFORMATION >

[TCS/ABS]

WORK FLOW

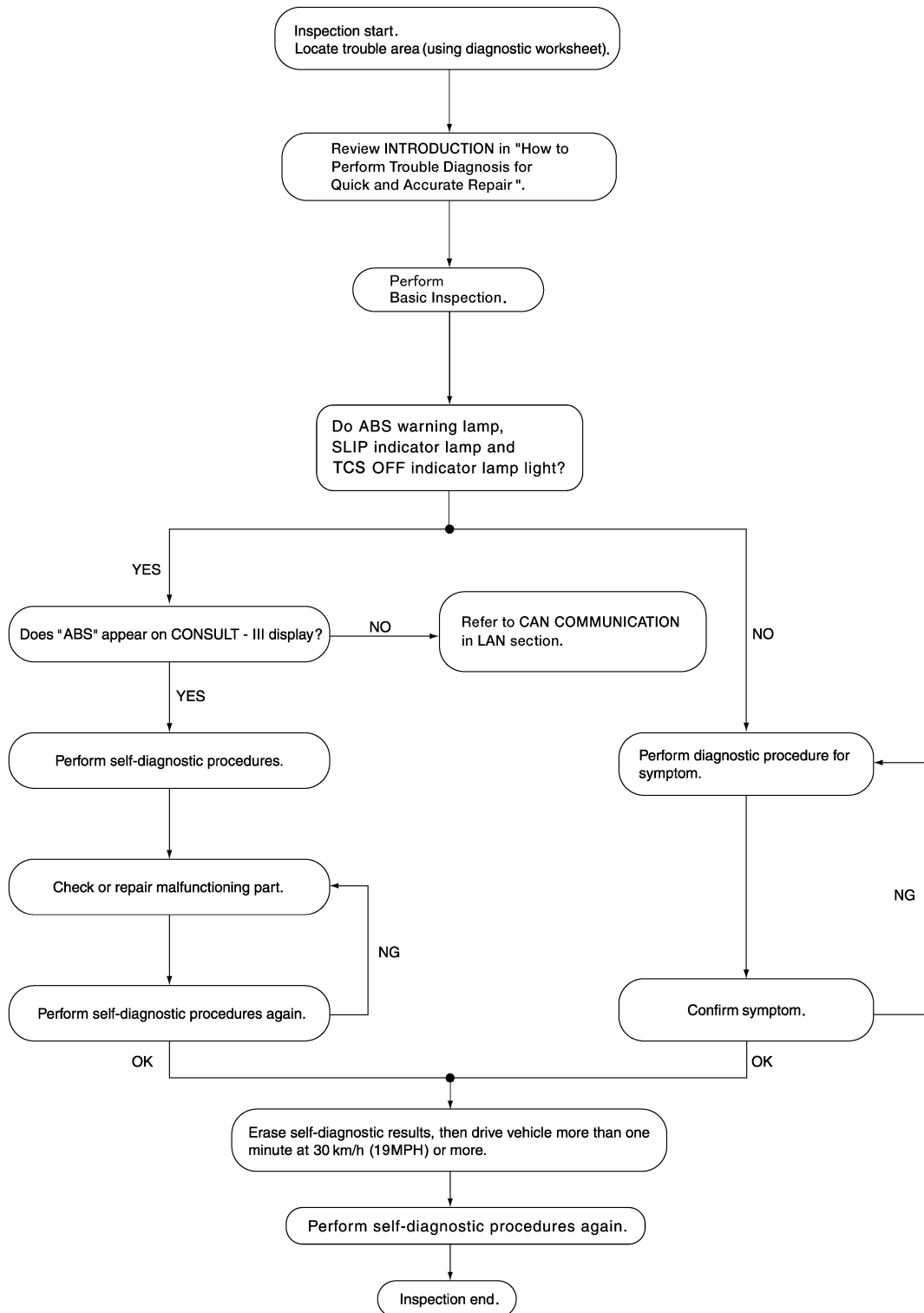

A

B

C

D

E

BRC

G

H

I

J

K

L

M

N

O

P

CLARIFY CONCERN

AWFIA0209GB

TROUBLE DIAGNOSIS

[TCS/ABS]

< SERVICE INFORMATION >

- A customer's description of a vehicle concern may vary depending on the individual. It is important to clarify the customer's concern.
- Ask the customer about what symptoms are present under what conditions. Use this information to reproduce the symptom while driving.
- It is also important to use the diagnosis sheet to understand what type of trouble the customer is having.

KEY POINTS

WHAT Vehicle model
WHEN Date, Frequencies
WHERE Road conditions
HOW Operating conditions,
Weather conditions,
Symptoms

SBR339B

EXAMPLE OF DIAGNOSIS SHEET

Customer name	Model & Year	VIN	
Engine #	Trans.	Mileage	
Incident Date	Manuf. Date	In Service Date	
Symptoms	<input type="checkbox"/> Noise and vibration (from engine compartment) <input type="checkbox"/> Noise and vibration (from axle)	<input type="checkbox"/> ABS warning lamp activates <input type="checkbox"/> SLIP warning lamp activates	<input type="checkbox"/> Pedal operation <input type="checkbox"/> Large stroke pedal operation <input type="checkbox"/> Firm pedal
	<input type="checkbox"/> TCS does not work (drive wheels slip when accelerating)	<input type="checkbox"/> ABS does not work (wheels slip when braking)	<input type="checkbox"/> Lack of sense of acceleration
Engine conditions	<input type="checkbox"/> When starting <input type="checkbox"/> After starting		
Road conditions	<input type="checkbox"/> Low friction road (<input type="checkbox"/> Snow <input type="checkbox"/> Gravel <input type="checkbox"/> Other) <input type="checkbox"/> Bumps/potholes		
Driving conditions	<input type="checkbox"/> Full-acceleration <input type="checkbox"/> High speed cornering <input type="checkbox"/> Vehicle speed: Greater than 10 km/h (6 MPH) <input type="checkbox"/> Vehicle speed: 10 km/h (6 MPH) or less <input type="checkbox"/> Vehicle is stopped		
Applying brake conditions	<input type="checkbox"/> Suddenly <input type="checkbox"/> Gradually		
Other conditions	<input type="checkbox"/> Operation of electrical equipment <input type="checkbox"/> Shift change <input type="checkbox"/> Other descriptions		

WFIA0097E

TROUBLE DIAGNOSIS

< SERVICE INFORMATION >

[TCS/ABS]

Component Parts and Harness Connector Location

INFOID:000000004278957

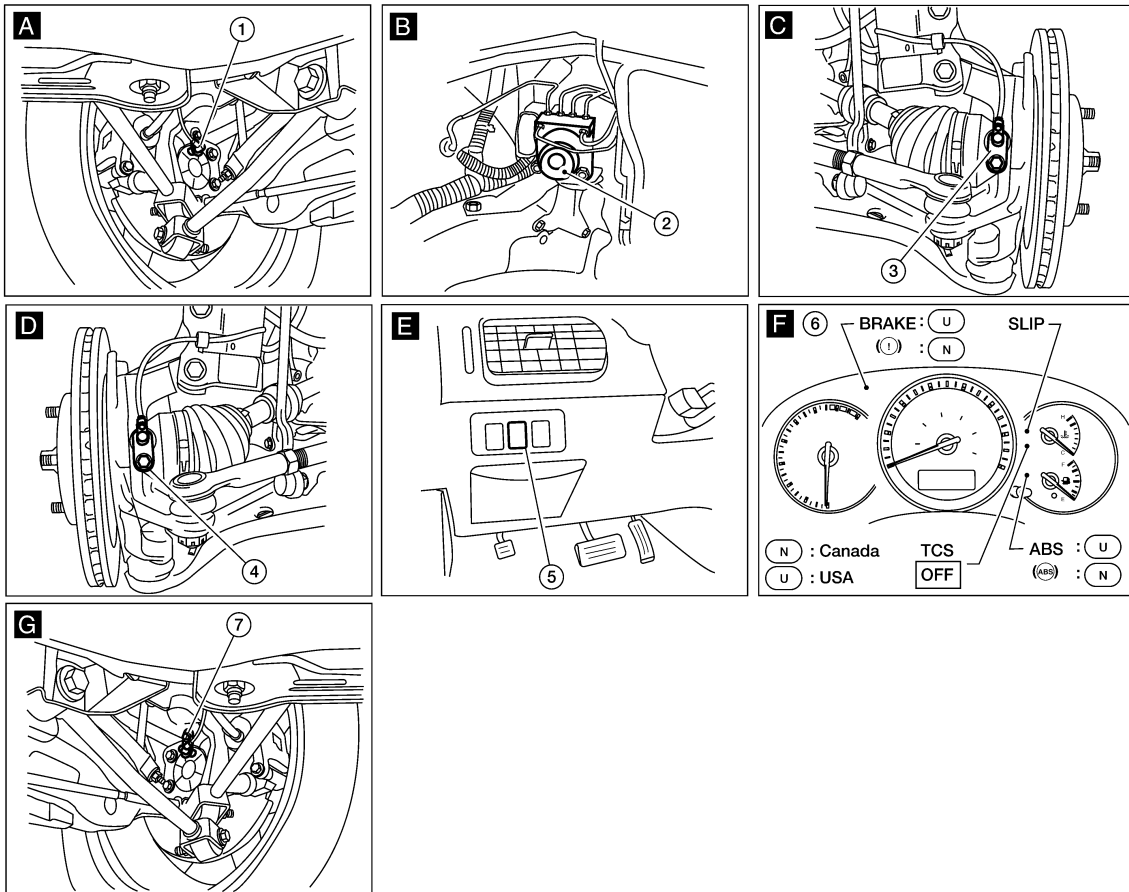
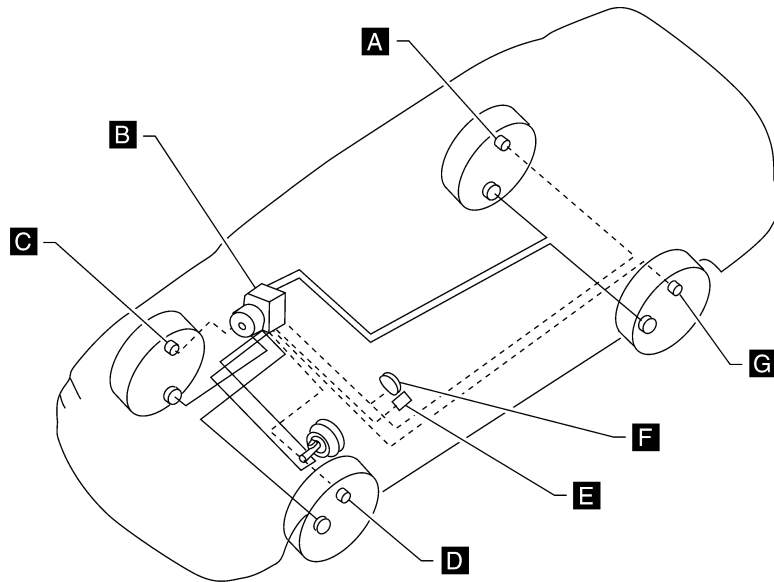

- | | | |
|------------------------------|--|-------------------------------|
| 1. Rear wheel sensor RH B122 | 2. ABS actuator and electric unit (control unit) E125 (engine removed for clarity) | 3. Front wheel sensor RH E117 |
| 4. Front wheel sensor LH E18 | 5. TCS OFF switch M6 | 6. Combination meter M24 |
| 7. Rear wheel sensor LH B123 | | |

WFIA0480E

A
B
C
D
E
BRC
G
H
I
J
K
L
M
N
O
P

TROUBLE DIAGNOSIS

< SERVICE INFORMATION >

[TCS/ABS]

Schematic

INFOID:000000004278958

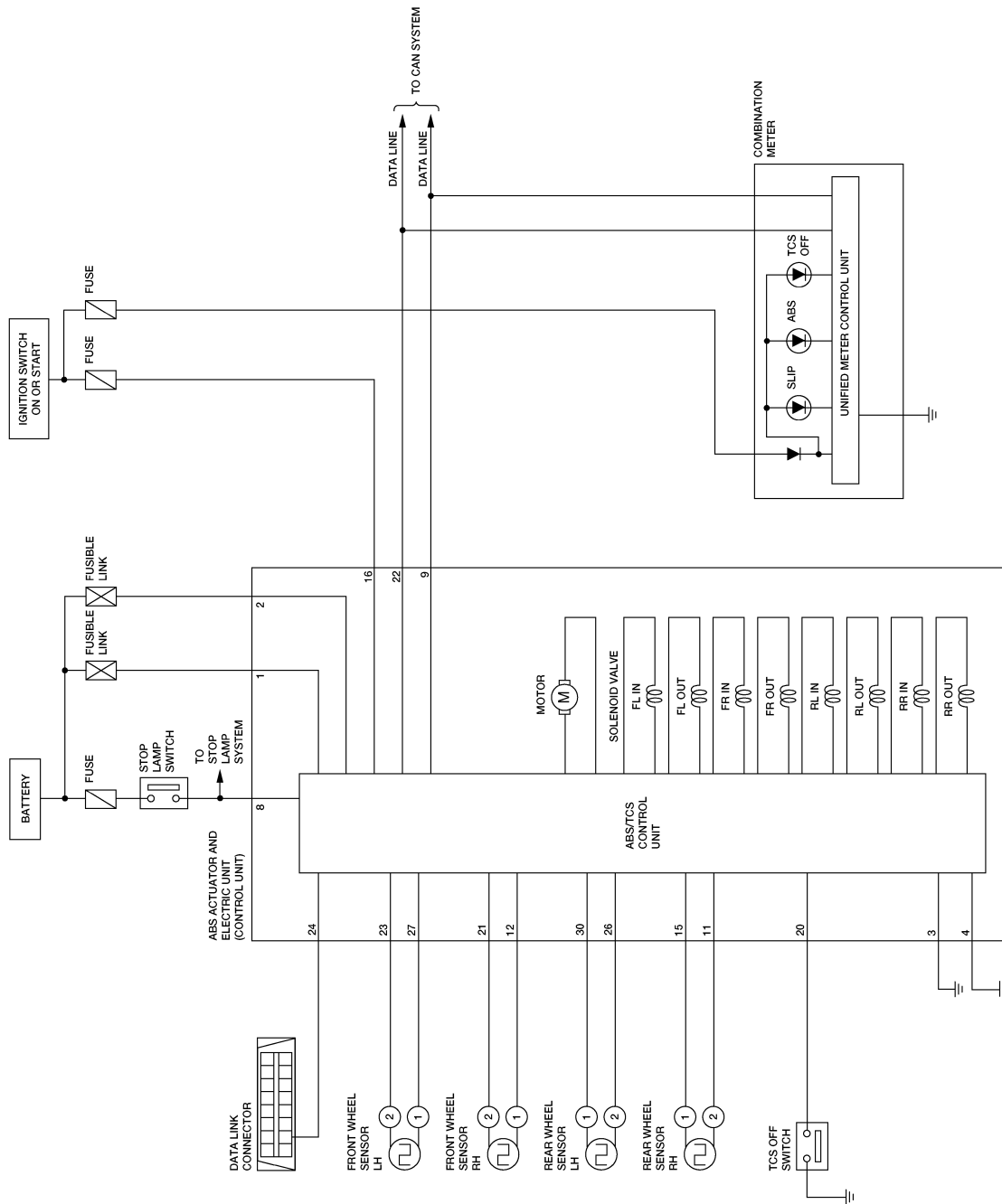

WFWA0407E

TROUBLE DIAGNOSIS

< SERVICE INFORMATION >

[TCS/ABS]

Wiring Diagram - TCS -

INFOID:000000004278959

BRC-TCS-01

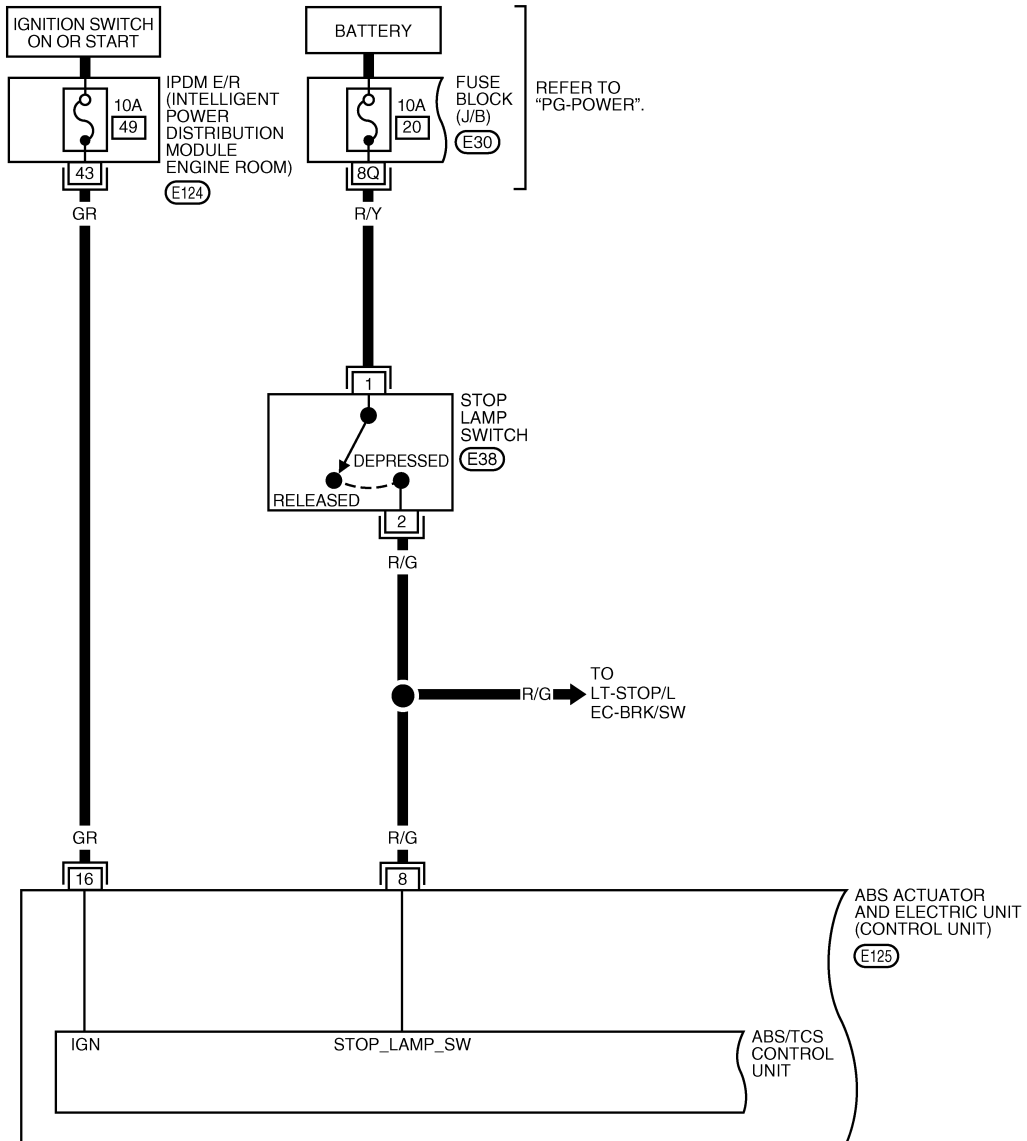

A
B
C
D
E
BRC
G
H
I
J
K
L
M
N
O
P

WFWA0408E

TROUBLE DIAGNOSIS

< SERVICE INFORMATION >

[TCS/ABS]

BRC-TCS-02

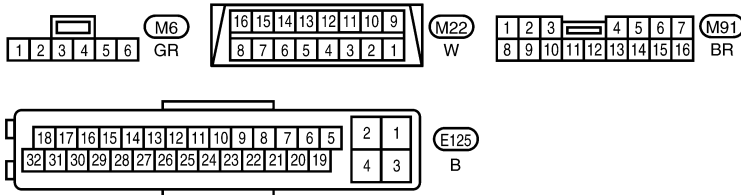
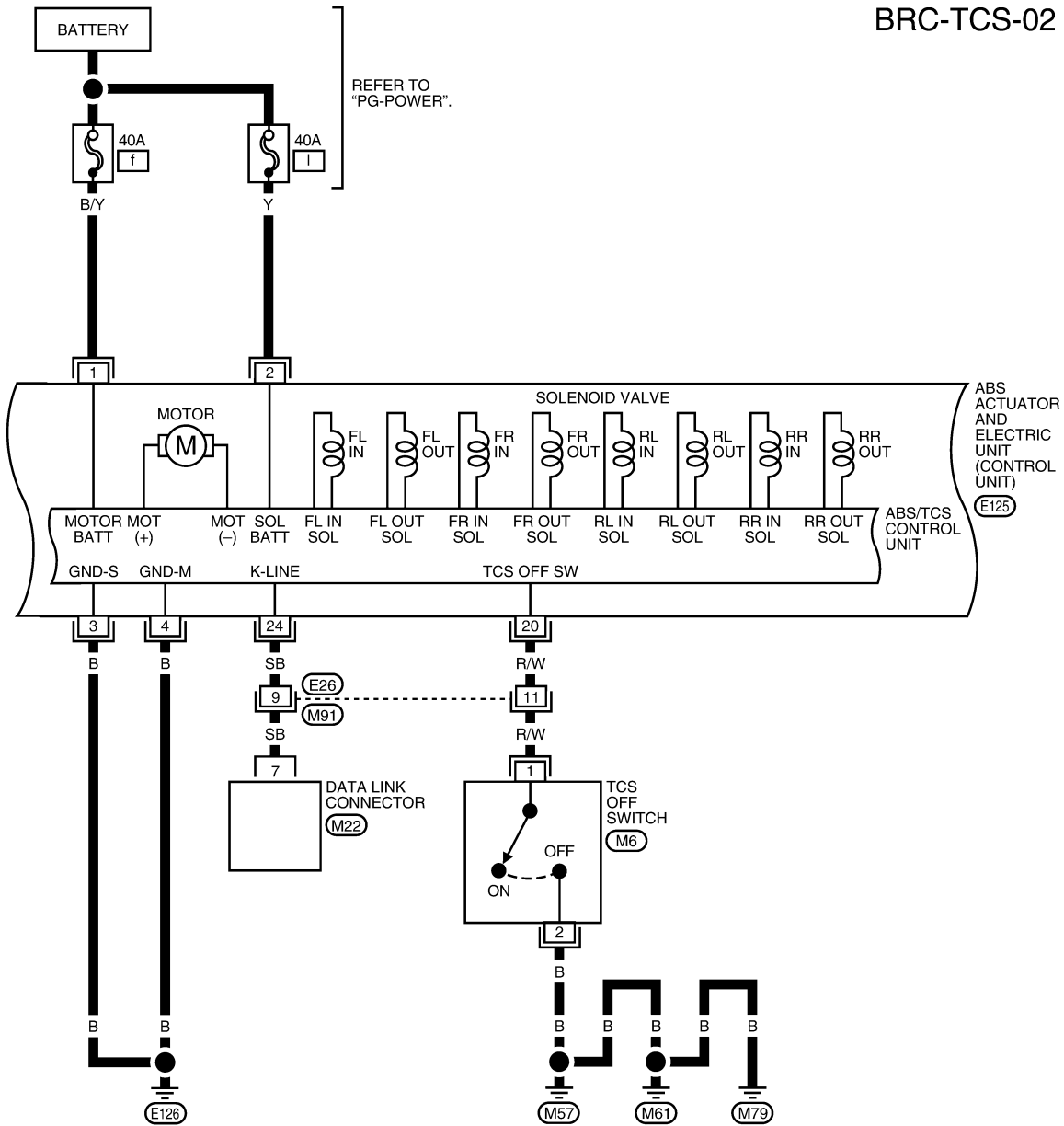

WFWA0409E

TROUBLE DIAGNOSIS

< SERVICE INFORMATION >

[TCS/ABS]

BRC-TCS-03

▬ : DATA LINE

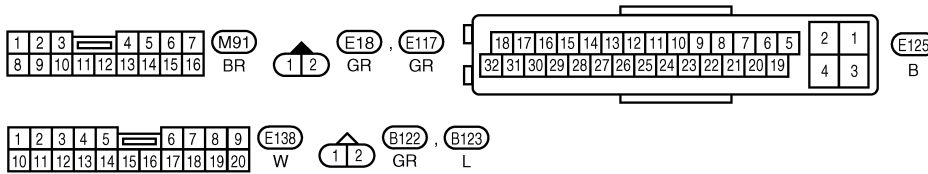
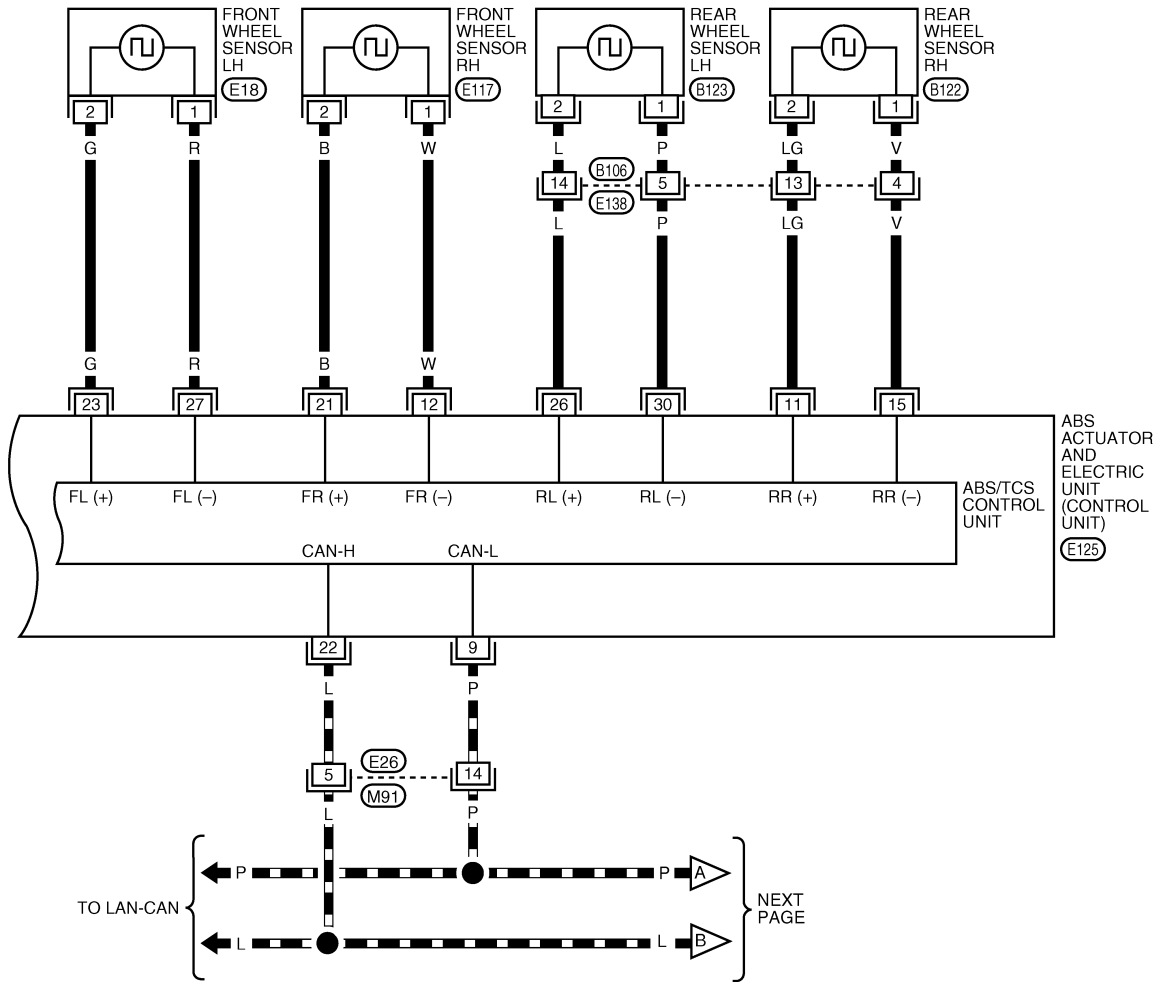

WFWA0410E

A
B
C
D
E
BRC
G
H
I
J
K
L
M
N
O
P

TROUBLE DIAGNOSIS

< SERVICE INFORMATION >

[TCS/ABS]

BRC-TCS-04

— : DATA LINE

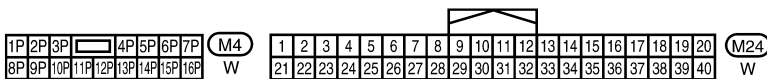
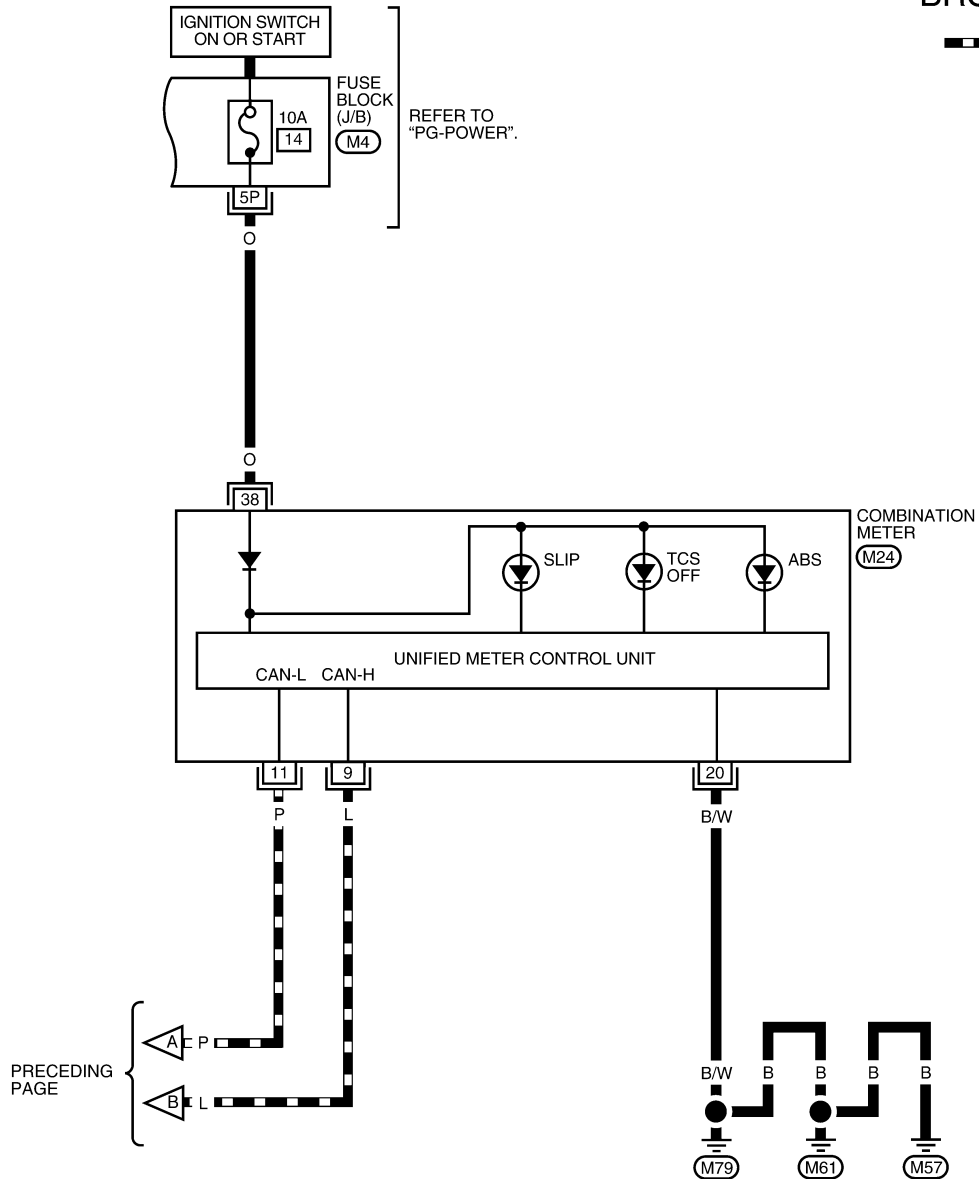

WFWA0411E

INFOID:000000004278960

Basic Inspection

BRAKE FLUID LEVEL, FLUID LEAK, AND BRAKE PAD INSPECTION

1. Check fluid level in the brake fluid reservoir. If fluid level is low, add fluid.
2. Check the brake piping and around the ABS actuator and electric unit (control unit) for leaks. If there is leaking or seeping fluid, check the following items.
 - If ABS actuator and electric unit (control unit) connection is loose, tighten the piping to the specified torque and recheck for leaks.

TROUBLE DIAGNOSIS

[TCS/ABS]

< SERVICE INFORMATION >

- If there is damage to the connection flare nut or ABS actuator and electric unit (control unit) threads, replace the damaged part and recheck for leaks.
- When there is fluid leaking or seeping from a fluid connection, use a clean cloth to wipe off the fluid and recheck for leaks. If fluid is still seeping out, replace the damaged part. If the fluid is leaking at the ABS actuator and electric unit (control unit), replace the ABS actuator and electric unit (control unit) assembly.

CAUTION:

The ABS actuator and electric unit (control unit) cannot be disassembled and must be replaced as an assembly.

3. Check the brake pads for excessive wear.

POWER SYSTEM TERMINAL LOOSENESS AND BATTERY INSPECTION

Make sure the battery positive cable, negative cable and ground connection are not loose. In addition, make sure the battery is sufficiently charged.

ABS WARNING LAMP, SLIP INDICATOR LAMP AND TCS OFF INDICATOR LAMP INSPECTION

1. Make sure ABS warning lamp, SLIP indicator lamp and TCS OFF indicator lamp (when TCS OFF switch is off), turn on for approximately 2 seconds when the ignition switch is turned ON. If they do not, check the TCS OFF indicator lamp and the TCS OFF switch. Refer to [BRC-33. "Component Inspection"](#). Check CAN communications. If there are no errors with the TCS OFF switch or the CAN communication system, check combination meter. Refer to [DI-5](#).
2. Make sure the lamps turn off approximately 2 seconds after the ignition switch is turned ON. If the lamp does not turn off, conduct self-diagnosis.
3. With the engine running, make sure the TCS OFF indicator lamp turns on and off when the TCS OFF switch is turned on and off. If the indicator lamp status does not correspond to switch operation, check the TCS OFF switch. Refer to [BRC-33. "Component Inspection"](#).
4. Make sure ABS warning lamp, SLIP indicator lamp and TCS OFF indicator lamp turn off approximately 2 seconds after the engine is started. If ABS warning lamp, SLIP indicator lamp or TCS OFF indicator lamp have not turned off 10 seconds after the engine has been started, conduct self-diagnosis of the ABS actuator and electric unit (control unit).
5. After conducting the self-diagnosis, be sure to erase the error memory. Refer to [BRC-21. "CONSULT-III Function \(ABS\)"](#).

Warning Lamp and Indicator Timing

INFOID:000000004278961

Condition	ABS warning lamp	TCS OFF indicator lamp	SLIP indicator lamp	Remarks
When the ignition switch is OFF	—	—	—	—
After the ignition switch is turned ON for approx. 1 second	×	×	×	—
After the ignition switch is turned ON for approx. 2 seconds	—	—	—	Lamp goes off approx. 2 seconds after the engine is started.
When the TCS OFF switch is pressed (TCS function OFF)	—	×	—	—
TCS/ABS malfunction	×	×	×	—
	×	×	—	When the TCS/ABS control unit is malfunctioning (power supply or ground malfunction).
When the TCS is malfunctioning	—	×	×	—

X: ON

—: OFF

Control Unit Input/Output Signal Standard

INFOID:000000004278962

REFERENCE VALUE FROM CONSULT-III

CAUTION:

TROUBLE DIAGNOSIS

< SERVICE INFORMATION >

[TCS/ABS]

The display shows the control unit calculation data, so a normal value might be displayed even in the event the output circuit (harness) is open or short circuited.

Monitor item	Display content	Data monitor		Note: Error inspection checklist	
		Condition	Reference value in normal operation		
P POSI SIG	A/T gear position	P position	ON	BRC-33. "CAN Communication System Inspection"	
		Other than P position	OFF		
N POSI SIG	A/T gear position	N position	ON		
		Other than N position	OFF		
GEAR	A/T gear position	1st gear	1		
		2nd gear	2		
		3rd gear	3		
		4th gear	4		
FR RH SENSOR FR LH SENSOR RR RH SENSOR RR LH SENSOR	Wheel speed	Vehicle stopped	0 [km/h (MPH)]		BRC-28. "Wheel Sensor System Inspection"
		Vehicle running (Note 1)	Almost in accordance with speedometer display (within $\pm 10\%$)		
ACCEL POS SIG	Open/close condition of throttle valve (linked with accelerator pedal).	Accelerator pedal not depressed (ignition switch is ON)	0%	BRC-33. "CAN Communication System Inspection"	
		Depress accelerator pedal (ignition switch is ON)	0 to 100%		
ENGINE SPEED	With engine running	With engine stopped	0 rpm	BRC-29. "Engine System Inspection"	
		Engine running	Almost in accordance with tachometer display		
BATTERY VOLT	Battery voltage supplied to ABS actuator and electric unit (control unit)	Ignition switch ON	10 to 16V	BRC-32. "ABS/TCS Control Unit Power and Ground Systems Inspection"	
CRANKING SIG	Cranking status	Cranking	ON	—	
		Not cranking	OFF		
STOP LAMP SW	Brake pedal operation	Brake pedal depressed	ON	BRC-32. "Stop Lamp Switch System Inspection"	
		Brake pedal not depressed	OFF		
ABS WARN LAMP	ABS warning lamp ON condition (Note 2)	ABS warning lamp ON	ON	BRC-37. "ABS Warning Lamp Does Not Come On When Ignition Switch Is Turned On"	
		ABS warning lamp OFF	OFF		
MOTOR RELAY	Operation status of motor and motor relay	Ignition switch ON or engine running (ABS not activated)	OFF	BRC-31. "Actuator Motor, Motor Relay, and Circuit Inspection"	
		Ignition switch ON or engine running (ABS activated)	ON		
ACTUATOR RLY	Actuator relay operation status	Vehicle stopped (Ignition switch ON)	OFF		
		Vehicle stopped (Engine running)	ON		
SLIP LAMP	SLIP indicator lamp status (Note 3)	When SLIP indicator lamp is ON	ON	DI-9. "Arrangement of Combination Meter"	
		When SLIP indicator lamp is OFF	OFF		

TROUBLE DIAGNOSIS

< SERVICE INFORMATION >

[TCS/ABS]

Monitor item	Display content	Data monitor		Note: Error inspection checklist
		Condition	Reference value in normal operation	
OFF LAMP	TCS OFF indicator lamp status	When TCS OFF indicator lamp is ON	ON	BRC-33. "CAN Communication System Inspection"
		When TCS OFF indicator lamp is OFF	OFF	
EBD WARN LAMP	EBD warning lamp status	When EBD warning lamp is ON	ON	BRC-33. "CAN Communication System Inspection"
		When EBD warning lamp is OFF	OFF	
OFF SW	TCS OFF switch ON/OFF status	TCS OFF switch ON (When TCS OFF indicator lamp is ON)	ON	BRC-33. "Component Inspection"
		TCS OFF switch OFF (When TCS OFF indicator lamp is OFF)	OFF	
ASCD SIGNAL	ASCD operation condition	ASCD activated	ON	ASCD and circuit
		ASCD not activated	OFF	
FR LH IN SOL FR LH OUT SOL FR RH IN SOL FR RH OUT SOL RR RH IN SOL RR RH OUT SOL RR LH IN SOL RR LH OUT SOL	Solenoid valve operation	Actuator (solenoid) is active ("ACTIVE TEST" with CONSULT-III) or actuator relay is inactive (in fail-safe mode).	ON	—
		When actuator (solenoid) is not active and actuator relay is active (ignition switch ON).	OFF	
TCS SIGNAL ABS SIGNAL EBD SIGNAL	Signal status	TCS active ABS active EBD active	ON	TCS system ABS system EBD system
		TCS not active ABS not active EBD not active	OFF	
TCS FAIL SIG ABS FAIL SIG EBD FAIL SIG	Fail signal status	TCS fail ABS fail EBD fail	OFF	TCS system ABS system EBD system

Note 1: Confirm tire pressure is normal.

Note 2: ON/OFF timing of ABS warning lamp

ON: For approximately 2 seconds after ignition switch is turned ON, or when a malfunction is detected.

OFF: Approximately 2 seconds after ignition switch is turned ON (when system is in normal operation) and TCS function is not activated.

Note 3: SLIP indicator lamp ON/OFF timing

ON: For approximately 2 seconds after ignition switch is turned ON, or when a malfunction is detected and TCS function is activated while driving.

OFF: Approximately 2 seconds after ignition switch is turned ON (when system is in normal operation) and TCS function is not activated.

Flashing: TCS function is active during driving.

CONSULT-III Function (ABS)

INFOID:000000004278963

CONSULT-III can display each diagnostic item using the diagnostic test modes shown following.

ABS diagnostic mode	Description
SELF-DIAG RESULTS	Displays ABS actuator and electric unit (control unit) self-diagnosis results.
DATA MONITOR	Displays ABS actuator and electric unit (control unit) input/output data in real time.
CAN DIAG SUPPORT MNTR	The result of transmit/receive diagnosis of CAN communication can be read.
ACTIVE TEST	Operation of electrical loads can be checked by sending drive signal to them.

TROUBLE DIAGNOSIS

[TCS/ABS]

< SERVICE INFORMATION >

ABS diagnostic mode	Description
FUNCTION TEST	Conducted by CONSULT-III instead of a technician to determine whether each system is "OK" or "NG".
ECU PART NUMBER	ABS actuator and electric unit (control unit) part number can be read.

SELF-DIAGNOSIS

Description

If an error is detected in the system, the ABS warning lamp will turn on. In this case, perform self-diagnosis as follows:

Operation Procedure

1. Turn ignition switch OFF.
2. Connect CONSULT-III to the data link connector.
3. Turn ignition switch ON.
4. Start engine and drive at approximately 30 km/h (19 MPH) or more for approximately 1 minute.
5. After stopping the vehicle, with the engine running, touch "ABS", "SELF-DIAG RESULTS" in order on the CONSULT-III screen.
6. The self-diagnostic results are displayed. (If necessary, the self-diagnostic results can be printed out by touching "COPY".)
 - When "NO DTC IS DETECTED" is displayed, check the ABS warning lamp, SLIP indicator lamp and TCS OFF indicator lamp.
7. Conduct the appropriate inspection from the display item list, and repair or replace the malfunctioning component.
8. Start engine and drive at approximately 30 km/h (19 MPH) or more for approximately 1 minute.

CAUTION:

 - **When a wheel sensor "short-circuit" is detected, if the vehicle is not driven at 30 km/h (19 MPH) or more for at least 1 minute, the ABS warning lamp will not turn off even if the malfunction is repaired.**
9. Turn ignition switch OFF to prepare for erasing the memory.
10. Start the engine and touch "ABS", "SELF-DIAG RESULTS", "ERASE" in order on the CONSULT-III screen to erase the error memory.

If "ABS" is not indicated, go to [GI-35. "CONSULT-III Data Link Connector \(DLC\) Circuit"](#).

CAUTION:

If the error memory is not erased, re-conduct the operation from step 4.
11. For the final inspection, drive at approximately 30 km/h (19 MPH) or more for approximately 1 minute and confirm that the ABS warning lamp and SLIP indicator lamp turn off.

Display Item List

TROUBLE DIAGNOSIS

< SERVICE INFORMATION >

[TCS/ABS]

Self-diagnostic item	Malfunction detecting condition	Check system	
FR LH SENSOR 1 [C1104]	Circuit of front LH wheel sensor is open	BRC-28. "Wheel Sensor System Inspection" (Note 1)	
RR RH SENSOR 1 [C1101]	Circuit of rear RH wheel sensor is open		
FR RH SENSOR 1 [C1103]	Circuit of front RH wheel sensor is open		
RR LH SENSOR 1 [C1102]	Circuit of rear LH wheel sensor is open		
FR LH SENSOR 2 [C1108]	Circuit of front LH wheel sensor is shorted, or sensor power voltage is unusual. ABS actuator and electric unit (control unit) cannot identify sensor pulses, because of large gap between wheel sensor and sensor rotor.		
RR RH SENSOR 2 [C1105]	Circuit of rear RH wheel sensor is shorted, or sensor power voltage is unusual. ABS actuator and electric unit (control unit) cannot identify sensor pulses, because of large gap between wheel sensor and sensor rotor.		
FR RH SENSOR 2 [C1107]	Circuit of front RH wheel sensor is shorted, or sensor power voltage is unusual. ABS actuator and electric unit (control unit) cannot identify sensor pulses, because of large gap between wheel sensor and sensor rotor.		
RR LH SENSOR 2 [C1106]	Circuit of rear LH wheel sensor is shorted, or sensor power voltage is unusual. ABS actuator and electric unit (control unit) cannot identify sensor pulses, because of large gap between wheel sensor and sensor rotor.		
FR LH IN ABS SOL [C1120]	Circuit of front LH IN ABS solenoid is open or shorted, or control line is open or shorted to power supply or ground.		BRC-30. "Solenoid Valve System Inspection"
FR LH OUT ABS SOL [C1121]	Circuit of front LH OUT ABS solenoid is open or shorted, or control line is open or shorted to power supply or ground.		
RR RH IN ABS SOL [C1126]	Circuit of rear RH IN ABS solenoid is open or shorted, or control line is open or shorted to power supply or ground.		
RR RH OUT ABS SOL [C1127]	Circuit of rear RH OUT ABS solenoid is open or shorted, or control line is open or shorted to power supply or ground.		
FR RH IN ABS SOL [C1122]	Circuit of front RH IN ABS solenoid is open or shorted, or control line is open or shorted to power supply or ground.		
FR RH OUT ABS SOL [C1123]	Circuit of front RH OUT ABS solenoid is open or shorted, or control line is open or shorted to power supply or ground.		
RR LH IN ABS SOL [C1124]	Circuit of rear LH IN ABS solenoid is open or shorted, or control line is open or shorted to power supply or ground.		
RR LH OUT ABS SOL [C1125]	Circuit of rear LH OUT ABS solenoid is open or shorted, or control line is open or shorted to power supply or ground.		
PUMP MOTOR (Note 3) [C1111]	During actuator motor operation with ON, when actuator motor turns OFF or when control line for actuator motor relay is open.	BRC-31. "Actuator Motor, Motor Relay, and Circuit Inspection"	
	During actuator motor operation with OFF, when actuator motor turns ON or when control line for relay is shorted to ground.		
STOP LAMP SW [C1116]	Stop lamp switch or circuit malfunction.	BRC-32. "Stop Lamp Switch System Inspection"	
BATTERY VOLTAGE [ABNORMAL] [C1109]	ABS actuator and electric unit (control unit) power voltage is too low.	BRC-32. "ABS/TCS Control Unit Power and Ground Systems Inspection"	
CONTROLLER FAILURE [C1110]	Internal malfunction of ABS actuator and electric unit (control unit) or wheel speed signal malfunction.	BRC-29. "ABS/TCS Control Unit Inspection"	

A

B

C

D

E

BRC

G

H

I

J

K

L

M

N

O

P

TROUBLE DIAGNOSIS

< SERVICE INFORMATION >

[TCS/ABS]

Self-diagnostic item	Malfunction detecting condition	Check system
CAN COMM CIRCUIT [U1000]	<ul style="list-style-type: none"> • CAN communication line is open or shorted. • ABS actuator and electric unit (control unit) internal malfunction • Battery voltage for ECM is suddenly interrupted for approximately 0.5 second or more. 	BRC-33. "CAN Communication System Inspection" (Note 2)
ENGINE SIGNAL 1 [C1130]	ECM judges the communication between ABS/TCS control unit and ECM is abnormal.	BRC-29. "Engine System Inspection"
ENGINE SIGNAL 2 [C1131]	ECM judges the communication between ABS/TCS control unit and ECM is abnormal.	
ENGINE SIGNAL 3 [C1132]	ECM judges the communication between ABS/TCS control unit and ECM is abnormal.	
ENGINE SIGNAL 4 [C1133]	ECM judges the communication between ABS/TCS control unit and ECM is abnormal.	
ENGINE SIGNAL 5 [C1134]	ECM judges the communication between ABS/TCS control unit and ECM is abnormal.	
ACTUATOR RLY [C1140]	ABS actuator relay or circuit malfunction.	BRC-31. "Actuator Motor, Motor Relay, and Circuit Inspection"

Note 1. If wheel sensor 2 for each wheel is indicated, check ABS actuator and electric unit (control unit) power supply voltage in addition to wheel sensor circuit check.

Note 2. If multiple malfunctions are detected including CAN communication line [U1000], perform diagnosis for CAN communication line first.

Note 3: "ACTUATOR RLY" on the CONSULT-III self-diagnosis results indicates a malfunction of the actuator motor relay or circuit.

DATA MONITOR

Operation Procedure

1. After turning OFF the ignition switch, connect CONSULT-III to the data link connector.
2. Touch "ABS", "DATA MONITOR" in order on the CONSULT-III screen.
If "ABS" is not indicated, go to [GI-35. "CONSULT-III Data Link Connector \(DLC\) Circuit"](#).
3. From the "DATA MONITOR" screen, touch "ECU INPUT SIGNALS", "MAIN SIGNALS" or "SELECTION FROM MENU". Refer to the following information.
4. When "START" is touched, the data monitor screen is displayed.

Display Item List

Item (Unit)	Data monitor item selection			Remarks
	ECU INPUT SIGNALS	MAIN SIGNALS	SELECTION FROM MENU	
GEAR	×	×	×	Gear position judged by PNP switch signal is displayed.
FR RH SENSOR (km/h, MPH)	×	×	×	Wheel speed calculated by front RH wheel sensor signal is displayed.
FR LH SENSOR (km/h, MPH)	×	×	×	Wheel speed calculated by front LH wheel sensor signal is displayed.
RR RH SENSOR (km/h, MPH)	×	×	×	Wheel speed calculated by rear RH wheel sensor signal is displayed.
RR LH SENSOR (km/h, MPH)	×	×	×	Wheel speed calculated by rear LH wheel sensor signal is displayed.
BATTERY VOLT (V)	×	×	×	Voltage supplied to ABS actuator and electric unit (control unit) is displayed.
ACCEL POS SIG (%)	×	-	×	Throttle valve open/close status judged by CAN communication signal is displayed.

TROUBLE DIAGNOSIS

< SERVICE INFORMATION >

[TCS/ABS]

Item (Unit)	Data monitor item selection			Remarks
	ECU INPUT SIGNALS	MAIN SIGNALS	SELECTION FROM MENU	
ENGINE SPEED (rpm)	×	×	×	Engine speed judged by CAN communication signal is displayed.
STOP LAMP SW (ON/OFF)	×	×	×	Stop lamp switch (ON/OFF) status is displayed.
ABS WARN LAMP (ON/OFF)	-	×	×	ABS warning lamp (ON/OFF) status is displayed.
SLIP LAMP (ON/OFF)	-	×	×	SLIP indicator lamp (ON/OFF) status is displayed.
FR LH IN SOL (ON/OFF)	-	×	×	Front LH IN ABS solenoid (ON/OFF) status is displayed.
FR LH OUT SOL (ON/OFF)	-	×	×	Front LH OUT ABS solenoid (ON/OFF) status is displayed.
RR RH IN SOL (ON/OFF)	-	×	×	Rear RH IN ABS solenoid (ON/OFF) status is displayed.
RR RH OUT SOL (ON/OFF)	-	×	×	Rear RH OUT ABS solenoid (ON/OFF) status is displayed.
FR RH IN SOL (ON/OFF)	-	×	×	Front RH IN ABS solenoid (ON/OFF) status is displayed.
FR RH OUT SOL (ON/OFF)	-	×	×	Front RH OUT ABS solenoid (ON/OFF) status is displayed.
RR LH IN SOL (ON/OFF)	-	×	×	Rear LH IN ABS solenoid (ON/OFF) status is displayed.
RR LH OUT SOL (ON/OFF)	-	×	×	Rear LH OUT ABS solenoid (ON/OFF) status is displayed.
OFF LAMP (ON/OFF)	-	×	×	OFF Lamp (ON/OFF) status is displayed.
OFF SW (ON/OFF)	×	×	×	TCS OFF switch (ON/OFF) status is displayed.
MOTOR RELAY (ON/OFF)	-	×	×	ABS motor relay signal (ON/OFF) status is displayed.
ACTUATOR RLY (ON/OFF)	-	×	×	ABS actuator relay signal (ON/OFF) status is displayed.
EBD WARN LAMP (ON/OFF)	-	-	×	Brake warning lamp (ON/OFF) status is displayed.
P POSI SIG (ON/OFF)	-	-	×	Shift position judged by PNP switch signal.
N POSI SIG (ON/OFF)	-	-	×	Shift position judged by PNP switch signal.
CRANKING SIG (ON/OFF)	-	-	×	Ignition switch START position signal input status is displayed.
TCS FAIL SIG (ON/OFF)	-	-	×	TCS fail signal (ON/OFF) status is displayed.
ABS FAIL SIG (ON/OFF)	-	-	×	ABS fail signal (ON/OFF) status is displayed.
EBD FAIL SIG (ON/OFF)	-	-	×	EBD fail signal (ON/OFF) status is displayed.
EBD SIGNAL (ON/OFF)	-	-	×	EBD operation (ON/OFF) status is displayed.
ABS SIGNAL (ON/OFF)	-	-	×	ABS operation (ON/OFF) status is displayed.

A

B

C

D

E

BRC

G

H

I

J

K

L

M

N

O

P

TROUBLE DIAGNOSIS

< SERVICE INFORMATION >

[TCS/ABS]

Item (Unit)	Data monitor item selection			Remarks
	ECU INPUT SIGNALS	MAIN SIGNALS	SELECTION FROM MENU	
TCS SIGNAL (ON/OFF)	-	-	×	TCS operation (ON/OFF) status is displayed.
ASCD SIG	-	-	×	ASCD (ON/OFF) status is displayed.

×: Applicable

-: Not applicable

ACTIVE TEST

CAUTION:

- Do not perform active test while driving.
- Make sure to completely bleed air from the brake system.
- The ABS and brake warning lamps turn on during the active test.

Operation Procedure

1. Connect the CONSULT-III to the data link connector and start the engine.
2. Touch "ABS".
If "ABS" is not indicated, go to [GI-35, "CONSULT-III Data Link Connector \(DLC\) Circuit"](#).
3. Touch "ACTIVE TEST".
4. The "SELECT TEST ITEM" screen is displayed.
5. Touch necessary test item.
6. With the "MAIN SIGNALS" display selected, touch "START".
7. The Active Test screen will be displayed, so conduct the following test.

Solenoid Valve Operation Chart

Operation		ABS solenoid valve			ABS solenoid valve (ACT)		
		UP	KEEP	DOWN	UP	ACTUA- TOR UP	ACTUA- TOR KEEP
FR RH SOL FR RH ABS SOLE- NOID (ACT)	FR RH IN SOL	OFF	ON	ON	OFF	OFF	OFF
	FR RH OUT SOL	OFF	OFF	ON*	OFF	OFF	OFF
FR LH SOL FR LH ABS SOLE- NOID (ACT)	FR LH IN SOL	OFF	ON	ON	OFF	OFF	OFF
	FR LH OUT SOL	OFF	OFF	ON*	OFF	OFF	OFF
RR RH SOL RR RH ABS SOLE- NOID (ACT)	RR RH IN SOL	OFF	ON	ON	OFF	OFF	OFF
	RR RH OUT SOL	OFF	OFF	ON*	OFF	OFF	OFF
RR LH SOL RR LH ABS SOLE- NOID (ACT)	RR LH IN SOL	OFF	ON	ON	OFF	OFF	OFF
	RR LH OUT SOL	OFF	OFF	ON*	OFF	OFF	OFF

*: ON for 1 to 2 seconds after the touch, and then OFF

NOTE:

- If active test is performed with brake pedal depressed, pedal stroke may change. This is normal.
- "TEST IS STOPPED" is displayed approximately 10 seconds after operation starts.
- After "TEST IS STOPPED" is displayed, to perform test again, repeat Step 6.

ABS Motor

Touch "ON" and "OFF" on the screen. Check that ABS motor relay operates as shown in table below.

Operation	ON	OFF
ABS actuator relay	ON	ON
ABS motor relay	ON	OFF

NOTE:

TROUBLE DIAGNOSIS

< SERVICE INFORMATION >

[TCS/ABS]

- If active test is performed with brake pedal depressed, pedal stroke may change. This is normal.
- "TEST IS STOPPED" is displayed approximately 10 seconds after operation starts.

A

B

C

D

E

BRC

G

H

I

J

K

L

M

N

O

P

TROUBLE DIAGNOSIS FOR SELF-DIAGNOSTIC ITEMS

< SERVICE INFORMATION >

[TCS/ABS]

TROUBLE DIAGNOSIS FOR SELF-DIAGNOSTIC ITEMS

Wheel Sensor System Inspection

INFOID:000000004278964

INSPECTION PROCEDURE

1. CONNECTOR INSPECTION

Disconnect the ABS actuator and electric unit (control unit) connector E125 and wheel sensor of malfunctioning code.

Check the terminals for deformation, disconnection, looseness or damage.

OK or NG

OK >> GO TO 2.

NG >> Repair or replace as necessary.

2. CHECK WHEEL SENSOR OUTPUT SIGNAL

1. Connect ABS active wheel sensor tester (J-45741) to wheel sensor using appropriate adapter.

2. Turn on the ABS active wheel sensor tester power switch.

NOTE:

The green POWER indicator should illuminate. If the POWER indicator does not illuminate, replace the battery in the ABS active wheel sensor tester before proceeding.

3. Spin the wheel of the vehicle by hand and observe the red SENSOR indicator on the ABS active wheel sensor tester. The red SENSOR indicator should flash on and off to indicate an output signal.

NOTE:

If the red SENSOR indicator illuminates but does not flash, reverse the polarity of the tester leads and retest.

Does the ABS active wheel sensor tester detect a signal?

YES >> GO TO 3.

NO >> Replace wheel sensor. Refer to [BRC-39. "Removal and Installation"](#).

3. CHECK TIRES

Check for inflation pressure, wear and size of each tire.

Are tire pressure and size correct and is tire wear within specifications?

YES >> GO TO 4.

NO >> Adjust tire pressure or replace tire(s).

4. CHECK WHEEL BEARINGS

Check wheel bearing axial end play. Refer to [FAX-5. "On-Vehicle Inspection and Service"](#) or [RAX-5. "On-Vehicle Inspection and Service"](#).

OK or NG

OK >> GO TO 5.

NG >> Repair or replace as necessary. Refer to [FAX-5. "On-Vehicle Inspection and Service"](#) or [RAX-5. "On-Vehicle Inspection and Service"](#).

5. CHECK WIRING HARNESS FOR SHORT CIRCUIT

Check continuity between wheel sensor harness connector terminals and ground.

Continuity should not exist.

OK or NG

OK >> GO TO 6.

NG >> Repair the circuit.

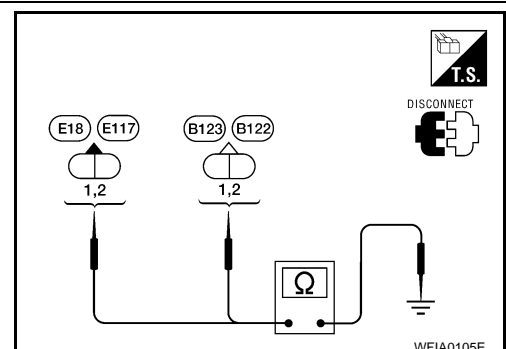

6. CHECK WIRING HARNESS FOR OPEN CIRCUIT

TROUBLE DIAGNOSIS FOR SELF-DIAGNOSTIC ITEMS

[TCS/ABS]

< SERVICE INFORMATION >

Check continuity between ABS actuator and electric unit (control unit) harness connector and wheel sensor harness connector.

Wheel sensor	ABS actuator and electric unit (control unit)		Wheel sensor		Continuity
	Connector	Terminal	Connector	Terminal	
Front LH	E125	27	E18	1	Yes
		23		2	
Front RH		12	E117	1	
		21		2	
Rear LH		30	B123	1	
		26		2	
Rear RH		15	B122	1	
		11		2	

OK or NG

OK >> Replace the ABS actuator and electric unit (control unit). Refer to [BRC-41. "Removal and Installation"](#).

NG >> Repair the circuit.

Engine System Inspection

INFOID:000000004278965

INSPECTION PROCEDURE

1. SELF-DIAGNOSIS RESULT CHECK

Check self-diagnosis results.

Self-diagnosis results
ENGINE SIGNAL 1
ENGINE SIGNAL 2
ENGINE SIGNAL 3
ENGINE SIGNAL 4
ENGINE SIGNAL 5

Is the above displayed in the self-diagnosis display items?

YES >> GO TO 2.

NO >> Inspection End.

2. ENGINE SYSTEM INSPECTION

1. Perform ECM self-diagnosis and repair as necessary.
2. Perform ABS actuator and electric unit (control unit) self-diagnosis again.

OK or NG

OK >> Inspection End.

NG >> Repair or replace as necessary.

ABS/TCS Control Unit Inspection

INFOID:000000004278966

INSPECTION PROCEDURE

1. SELF-DIAGNOSIS RESULT CHECK

Check self-diagnosis results.

Self-diagnosis results
CONTROLLER FAILURE

Is the above displayed in the self-diagnosis display items?

TROUBLE DIAGNOSIS FOR SELF-DIAGNOSTIC ITEMS

[TCS/ABS]

< SERVICE INFORMATION >

- YES >> GO TO 2.
- NO >> Inspection End.

2. CHECK WHEEL SENSORS

Check all wheel sensors. Refer to [BRC-28, "Wheel Sensor System Inspection"](#).

OK or NG

- OK >> Replace ABS Actuator and electric unit (control unit). Refer to [BRC-39, "Removal and Installation"](#).
- NG >> Repair or replace as necessary.

Solenoid Valve System Inspection

INFOID:000000004278967

INSPECTION PROCEDURE

1. SELF-DIAGNOSIS RESULT CHECK

Check self-diagnosis results.

Self-diagnosis results
FR LH IN ABS SOL
FR LH OUT ABS SOL
RR RH IN ABS SOL
RR RH OUT ABS SOL
FR RH IN ABS SOL
FR RH OUT ABS SOL
RR LH IN ABS SOL
RR LH OUT ABS SOL

Is the above displayed in the self-diagnosis display items?

- YES >> GO TO 2.
- NO >> Inspection End.

2. CONNECTOR INSPECTION

1. Disconnect ABS actuator and electric unit (control unit) connector E125.
2. Check the terminals for deformation, disconnection, looseness or damage.

OK or NG

- OK >> GO TO 3.
- NG >> Repair or replace as necessary.

3. CHECKING SOLENOID POWER AND GROUND

1. Check voltage between ABS actuator and electric unit (control unit) connector E125 and ground.

ABS actuator and electric unit (control unit) connector E125	Body ground	Measured value (Approx.)
2	—	12V

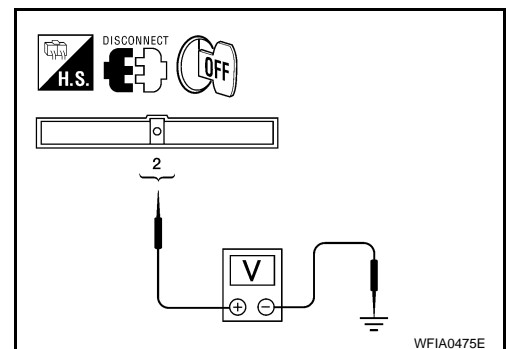

TROUBLE DIAGNOSIS FOR SELF-DIAGNOSTIC ITEMS

[TCS/ABS]

< SERVICE INFORMATION >

- Check resistance between ABS actuator and electric unit (control unit) connector E125 and body ground.

ABS actuator and electric unit (control unit) connector E125	Body ground	Measured value Ω (Approx.)
3	—	0 Ω
4	—	0 Ω

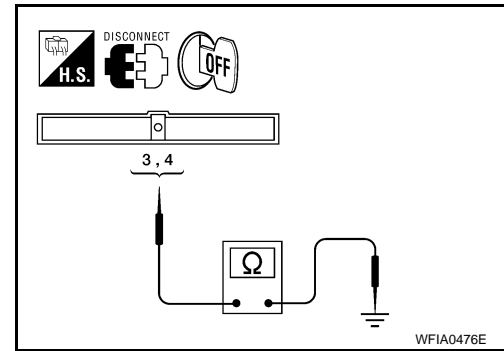

OK or NG

- OK >> Perform self-diagnosis again. If the same results appear, replace ABS actuator and electric unit (control unit). Refer to [BRC-41. "Removal and Installation"](#).
- NG >> Repair the circuit.

Actuator Motor, Motor Relay, and Circuit Inspection

INFOID:000000004278968

INSPECTION PROCEDURE

1. CHECKING SELF-DIAGNOSIS RESULTS

Check self-diagnosis results.

Self-diagnosis results
PUMP MOTOR
ACTUATOR RLY

Is the above displayed in the self-diagnosis display items?

- YES >> GO TO 2.
- NO >> Inspection End.

2. CONNECTOR INSPECTION

Disconnect the ABS actuator and electric unit (control unit) connector E125. Check the terminals for deformation, disconnection, looseness or damage.

OK or NG

- OK >> GO TO 3.
- NG >> Repair or replace as necessary.

3. CHECKING ABS MOTOR AND MOTOR RELAY POWER SYSTEM

- Check voltage between ABS actuator and electric unit (control unit) connector E125 and body ground.

ABS actuator and electric unit (control unit) connector E125	Body ground	Measured value (Approx.)
1	—	12V

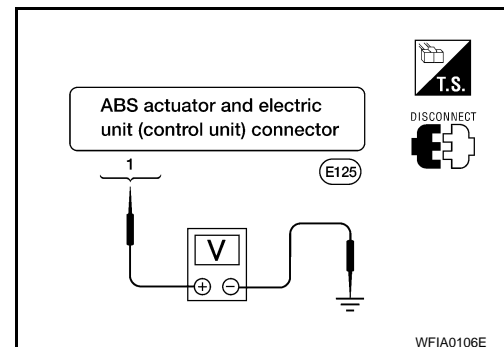

A
B
C
D
E
G
H
I
J
K
L
M
N
O
P

BRC

TROUBLE DIAGNOSIS FOR SELF-DIAGNOSTIC ITEMS

[TCS/ABS]

< SERVICE INFORMATION >

- Check resistance between ABS actuator and electric unit (control unit) connector E125 and ground.

ABS actuator and electric unit (control unit) connector E125	Body ground	Measured value (Approx.)
4	—	0Ω

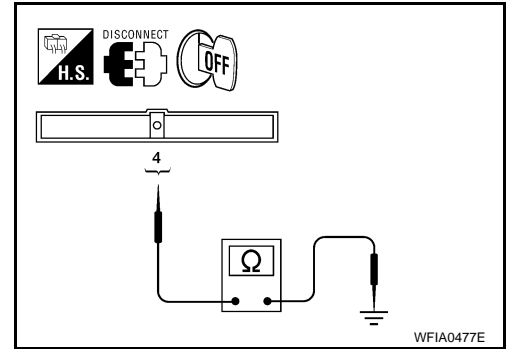

OK or NG

- OK >> Perform self-diagnosis again. If the same results appear, replace ABS actuator and electric unit (control unit). Refer to [BRC-41, "Removal and Installation"](#).
- NG >> Repair the circuit.

Stop Lamp Switch System Inspection

INFOID:000000004278969

INSPECTION PROCEDURE

1. SELF-DIAGNOSIS RESULT CHECK

Check self-diagnosis results.

Self-diagnosis results
STOP LAMP SW

Is the above displayed in the self-diagnosis display items?

- YES >> GO TO 2.
- NO >> Inspection End.

2. CONNECTOR INSPECTION

- Disconnect the ABS actuator and electric unit (control unit) connector E125 and stop lamp switch connector E38.
- Check the terminals for deformation, disconnection, looseness or damage.

OK or NG

- OK >> GO TO 3.
- NG >> Repair or replace as necessary.

3. STOP LAMP SWITCH INSPECTION

Turn the ignition switch ON and check the voltage between the ABS actuator and electric unit (control unit) connector E125 terminal 8 and ground.

- 8 - Ground**
- Brake pedal depressed : Battery voltage (approx. 12V)**
- Brake pedal not depressed : Approx. 0V**

OK or NG

- OK >> Perform self-diagnosis again. If the same results appear, replace ABS actuator and electric unit (control unit). Refer to [BRC-41, "Removal and Installation"](#).
- NG >> Repair the circuit.

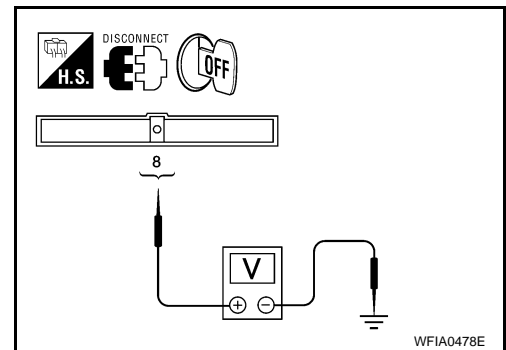

ABS/TCS Control Unit Power and Ground Systems Inspection

INFOID:000000004278970

INSPECTION PROCEDURE

1. SELF-DIAGNOSIS RESULT CHECK

Check self-diagnosis results.

TROUBLE DIAGNOSIS FOR SELF-DIAGNOSTIC ITEMS

< SERVICE INFORMATION >

[TCS/ABS]

Self-diagnosis results

BATTERY VOLTAGE

Is the above displayed in the self-diagnosis display items?

YES >> GO TO 2.

NO >> Inspection End.

2. CONNECTOR INSPECTION

1. Disconnect the ABS actuator and electric unit (control unit) connector E125.
2. Check the terminals for deformation, disconnection, looseness or damage.

OK or NG

OK >> GO TO 3.

NG >> Repair or replace as necessary.

3. ABS/TCS CONTROL UNIT POWER AND GROUND CIRCUIT INSPECTION

Measure the voltage and continuity between the ABS actuator and electric unit (control unit) connector E125 and ground.

Signal name	ABS actuator and electric unit (control unit) connector E125	Ground	Measured value
Power supply	16	—	Battery voltage (Approx. 12V)
Ground	3		Continuity should exist.
	4		

OK or NG

OK >> Check the battery for loose terminals, low voltage, etc. Repair as necessary.

NG >> Repair the circuit.

CAN Communication System Inspection

INFOID:000000004278971

INSPECTION PROCEDURE

1. CHECK CONNECTOR

1. Turn ignition switch OFF, disconnect the ABS actuator and electric unit (control unit) connector and check the terminals for deformation, disconnection, looseness or damage. If there is a malfunction, repair or replace the terminal.
2. Reconnect connector to perform self-diagnosis.

Is "CAN COMM CIRCUIT" displayed in the self-diagnosis display items?

YES >> Print out the self-diagnosis results, and refer to [LAN-39](#).

NO >> Connector terminal connection is loose, damaged, open, or shorted.

Component Inspection

INFOID:000000004278972

TCS OFF SWITCH

TROUBLE DIAGNOSIS FOR SELF-DIAGNOSTIC ITEMS

< SERVICE INFORMATION >

[TCS/ABS]

Check the continuity between terminals 1 and 2.

- 1 - 2 : Continuity should exist when pushing the switch.**
- Continuity should not exist when releasing the switch.**

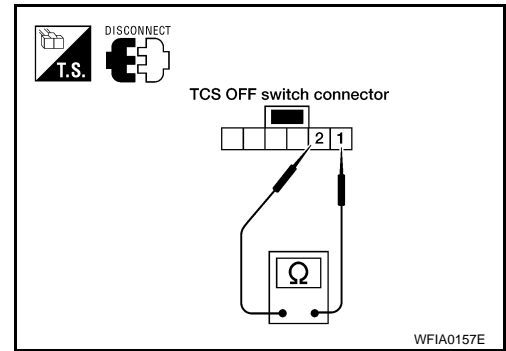

TROUBLE DIAGNOSES FOR SYMPTOMS

< SERVICE INFORMATION >

[TCS/ABS]

TROUBLE DIAGNOSES FOR SYMPTOMS

ABS Works Frequently

INFOID:000000004278973

1.CHECK WARNING LAMP ACTIVATION

Make sure warning lamp remains off while driving.

OK or NG

OK >> GO TO 2.

NG >> Carry out self-diagnosis. Refer to [BRC-21. "CONSULT-III Function \(ABS\)".](#)

2.CHECK WHEEL SENSORS

Check the following.

- Wheel sensor mounting for looseness
- Wheel sensors for physical damage
- Wheel sensor connectors for terminal damage or loose connections

OK or NG

OK >> GO TO 3.

NG >> Repair or replace as necessary.

3.CHECK WHEEL BEARINGS

Check wheel bearing axial end play. Refer to [FAX-5. "On-Vehicle Inspection and Service"](#) or [RAX-5. "On-Vehicle Inspection and Service"](#).

OK or NG

OK >> GO TO 4.

NG >> Repair as necessary.

4.CHECK BRAKE FLUID PRESSURE

Check brake fluid pressure distribution.

Refer to [BR-13. "Inspection"](#).

Is brake fluid pressure distribution normal?

YES >> Inspection End.

NO >> Perform Basic Inspection. Refer to [BRC-18. "Basic Inspection"](#).

Unexpected Pedal Action

INFOID:000000004278974

1.CHECK WARNING LAMP ACTIVATION

Make sure warning lamp remains off while driving.

OK or NG

OK >> GO TO 2.

NG >> Carry out self-diagnosis. Refer to [BRC-21. "CONSULT-III Function \(ABS\)".](#)

2.CHECK BRAKE PEDAL STROKE

Check brake pedal stroke.

Is pedal stroke excessive?

YES >> Perform Basic Inspection. Refer to [BRC-18. "Basic Inspection"](#).

NO >> GO TO 3.

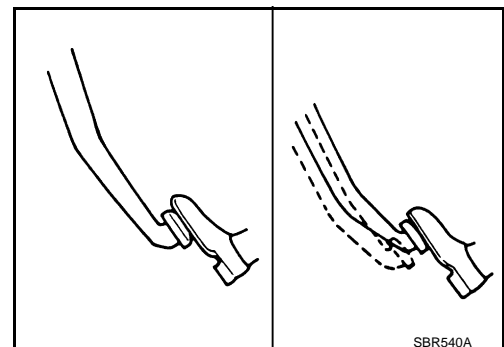

TROUBLE DIAGNOSES FOR SYMPTOMS

[TCS/ABS]

< SERVICE INFORMATION >

3. CHECK CONNECTOR AND BRAKING PERFORMANCE

1. Disable ABS by disconnecting ABS actuator and electric unit (control unit) connector.
2. Drive vehicle and check brake operation.

NOTE:

- Stopping distance may be longer than vehicles without ABS when road condition is slippery.
- Driving the vehicle with the ABS actuator and electric unit (control unit) disconnected may induce DTCs in electrical control units using CAN communication. After the inspection, clear all DTCs. Refer to [LAN-39](#).

OK or NG

- OK >> GO TO 4.
NG >> Perform Basic Inspection. Refer to [BRC-18, "Basic Inspection"](#).

4. CHECK WHEEL SENSORS

Check the following.

- Wheel sensor mounting for looseness
- Wheel sensors for physical damage
- Wheel sensor connectors for terminal damage or loose connections

OK or NG

- OK >> Check ABS actuator and electric unit (control unit) connector terminals for deformation, disconnection, looseness or damage. Reconnect ABS actuator and electric unit (control unit) harness connector. Then retest.
NG >> Repair or replace as necessary.

Long Stopping Distance

INFOID:000000004278975

1. CHECK BASE BRAKING SYSTEM PERFORMANCE

1. Disable ABS by disconnecting ABS actuator and electric unit (control unit) connector.
2. Drive vehicle and check brake operation.

NOTE:

- Stopping distance may be longer than vehicles without ABS when road condition is slippery.
- Driving the vehicle with the ABS actuator and electric unit (control unit) disconnected may induce DTCs in electrical control units using CAN communication. After the inspection, clear all DTCs. Refer to [LAN-39](#).

OK or NG

- OK >> Go to [BRC-35, "ABS Works Frequently"](#).
NG >> Perform Basic Inspection. Refer to [BRC-18, "Basic Inspection"](#).

ABS Does Not Work

INFOID:000000004278976

CAUTION:

The ABS does not operate when the vehicle speed is 10 km/h (6 MPH) or less.

1. CHECK WARNING LAMP ACTIVATION

Turn ignition switch ON and check for warning lamp activation.

- Warning lamp should activate for approximately 2 seconds after turning the ignition switch ON.

OK or NG

- OK >> Carry out self-diagnosis. Refer to [BRC-21, "CONSULT-III Function \(ABS\)"](#).
NG >> Go to [BRC-37, "ABS Warning Lamp Does Not Come On When Ignition Switch Is Turned On"](#).

Pedal Vibration or ABS Operation Noise

INFOID:000000004278977

NOTE:

During ABS activation, pedal vibration may be felt and a noise may be heard. This is normal and does not indicate a malfunction.

1. CHECK SYMPTOM

TROUBLE DIAGNOSES FOR SYMPTOMS

[TCS/ABS]

< SERVICE INFORMATION >

1. Apply brake.
2. Start engine.

Does the symptom occur only when engine is started?

- YES >> Carry out self-diagnosis. Refer to [BRC-21, "CONSULT-III Function \(ABS\)"](#).
NO >> GO TO 2.

2. RECHECK SYMPTOM

Does the symptom occur only when electrical equipment switches (such as headlamps) are turned on?

- YES >> Check for radio, antenna or related wiring that is routed too close to the ABS actuator and electric unit (control unit) and reroute as necessary.
NO >> Go to [BRC-35, "ABS Works Frequently"](#).

ABS Warning Lamp Does Not Come On When Ignition Switch Is Turned On

INFOID:000000004278978

1. CHECK ABS ACTUATOR AND ELECTRIC UNIT (CONTROL UNIT) FUSIBLE LINKS

Check 40A fusible link f and 40A fusible link I for ABS actuator and electric unit (control unit). For fusible link layout, refer to [PG-3](#).

OK or NG

- OK >> GO TO 2.
NG >> If fusible link is blown, be sure to eliminate cause of problem before replacing.

2. CHECK ABS ACTUATOR AND ELECTRIC UNIT (CONTROL UNIT) POWER SUPPLY CIRCUITS

1. Disconnect ABS actuator and electric unit (control unit) connector.
2. Check voltage between ABS actuator and electric unit (control unit) connector terminal 1 and ground and terminal 2 and ground.

Does battery voltage exist?

- YES >> GO TO 3.
NO >> Repair harness or connectors between fusible link and ABS actuator and electric unit (control unit).

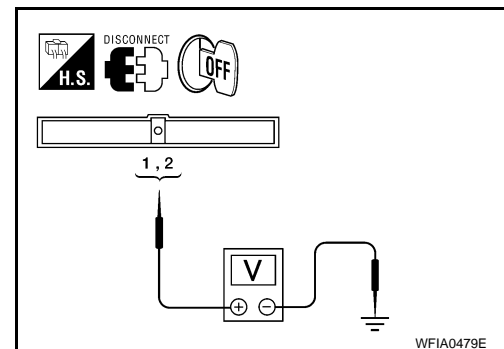

3. CHECK ABS ACTUATOR AND ELECTRIC UNIT (CONTROL UNIT) GROUND CIRCUIT

Check continuity between ABS actuator and electric unit (control unit) connector terminal 3 and ground and terminal 4 and ground.

Does continuity exist?

- YES >> Replace ABS actuator and electric unit (control unit). Refer to [BRC-41, "Removal and Installation"](#).
NO >> Repair harness or connectors between ABS actuator and electric unit (control unit) and ground.

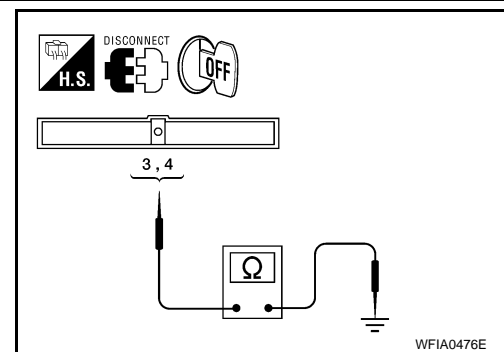

ABS Warning Lamp Stays On When Ignition Switch Is Turned On

INFOID:000000004278979

1. CARRY OUT SELF-DIAGNOSIS

Carry out self-diagnosis. Refer to [BRC-21, "CONSULT-III Function \(ABS\)"](#).

Are malfunctions detected in self-diagnosis?

A
B
C
D
E
G
H
I
J
K
L
M
N
O
P

TROUBLE DIAGNOSES FOR SYMPTOMS

[TCS/ABS]

< SERVICE INFORMATION >

- YES >> Refer to [BRC-21. "CONSULT-III Function \(ABS\)".](#)
- NO >> Refer to [DI-23.](#)

Vehicle Jerks During TCS Activation

INFOID:000000004278980

1. ABS ACTUATOR AND ELECTRIC UNIT (CONTROL UNIT) SELF-DIAGNOSIS

Perform ABS actuator and electric unit (control unit) self-diagnosis.

Are self-diagnosis result items displayed?

- YES >> After checking and repairing the applicable item, perform the ABS actuator and electric unit (control unit) self-diagnosis again.
- NO >> GO TO 2.

2. ENGINE SPEED SIGNAL INSPECTION

Perform data monitor with CONSULT-III for the ABS actuator and electric unit (control unit).

Is the engine speed at idle 400 rpm or higher?

- YES >> GO TO 4.
- NO >> GO TO 3.

3. ECM SELF-DIAGNOSIS

Perform ECM self-diagnosis.

Are self-diagnosis result items displayed?

- YES >> After checking and repairing the applicable item, perform the ECM self-diagnosis again.
- NO >> GO TO 4.

4. TCM SELF-DIAGNOSIS

Perform TCM self-diagnosis.

Are self-diagnosis result items displayed?

- YES >> After checking and repairing the applicable item, perform the TCM self-diagnosis again.
- NO >> GO TO 5.

5. CONNECTOR INSPECTION

Disconnect the ABS actuator and electric unit (control unit) connector and the ECM connectors and check the terminals for deformation, disconnection, looseness or damage.

OK or NG

- OK >> GO TO 6.
- NG >> Repair or replace as necessary.

6. CAN COMMUNICATION INSPECTION

Check the CAN communication system. Refer to [LAN-39.](#)

OK or NG

- OK >> Inspection End.
- NG >> Refer to [LAN-39.](#)

WHEEL SENSORS

Removal and Installation

INFOID:000000004278981

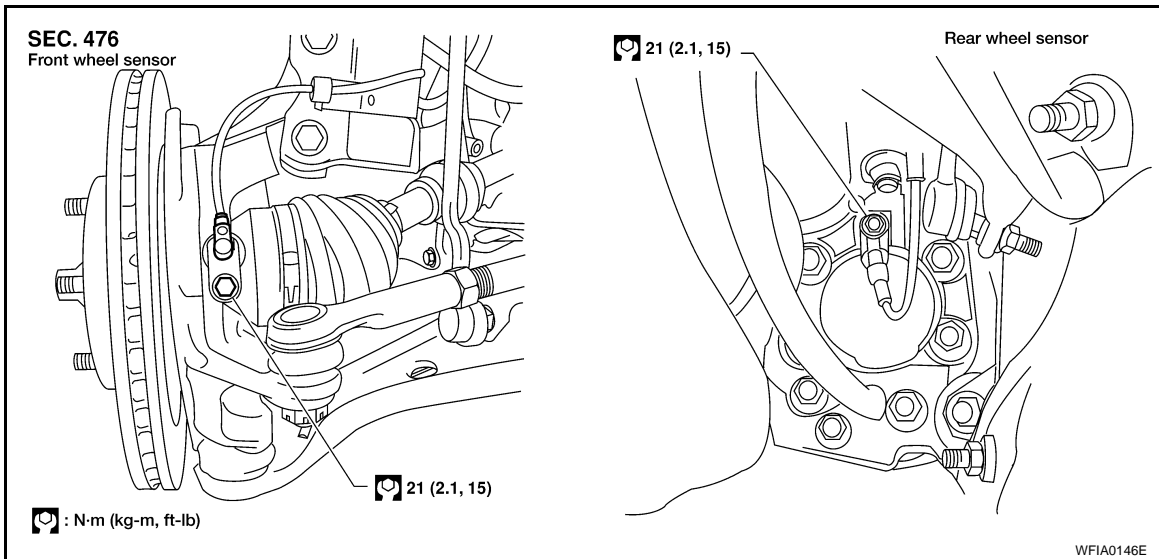

CAUTION:

- Be careful not to damage the sensor edge and sensor rotor teeth.
- When removing the front or rear wheel hub assembly, first remove the wheel sensor from the assembly. Failure to do so may result in damage to the sensor wires, making the sensor inoperative.
- Pull out the sensor, be careful to turn it as little as possible. Do not pull on the sensor harness.
- Installation should be performed while paying attention to the following, and then tighten the wheel sensor bolt to the specified torque.
- Before installing the wheel sensor, make sure there are no foreign materials (such as iron fragments) adhered to the pick-up part of the wheel sensor, to the inside of the wheel sensor mounting hole or on the rotor mounting surface.

FRONT WHEEL SENSOR

Removal

1. Remove the front wheel and tire. Refer to [WT-6, "Conventional Tire and Wheel"](#).
2. Partially remove the front wheel fender protector. Refer to [EI-21, "Removal and Installation"](#).
3. Remove the wheel sensor bolt and wheel sensor.
4. Remove the harness wire from mounts and disconnect the wheel sensor harness connector.

Installation

Installation is in the reverse order of removal.

REAR WHEEL SENSOR

Removal

1. Remove the wheel sensor bolt and wheel sensor from the rear wheel hub and bearing assemblies.
2. Remove the harness wire from mounts and harness wire clips from the rear suspension member.
3. Disconnect the wheel sensor harness connector.

Installation

Installation is in the reverse order of removal.

A
B
C
D
E
BRC
G
H
I
J
K
L
M
N
O
P

SENSOR ROTOR

Removal and Installation

INFOID:000000004278982

The front wheel sensor rotor is built into the front wheel hub. For removal and installation procedure, refer to [RAX-6, "Removal and Installation"](#).

The rear wheel sensor rotor is built into the rear wheel hub. For removal and installation procedure, refer to [RAX-6, "Removal and Installation"](#).

ACTUATOR AND ELECTRIC UNIT (ASSEMBLY)

< SERVICE INFORMATION >

[TCS/ABS]

ACTUATOR AND ELECTRIC UNIT (ASSEMBLY)

Removal and Installation

INFOID:000000004278983

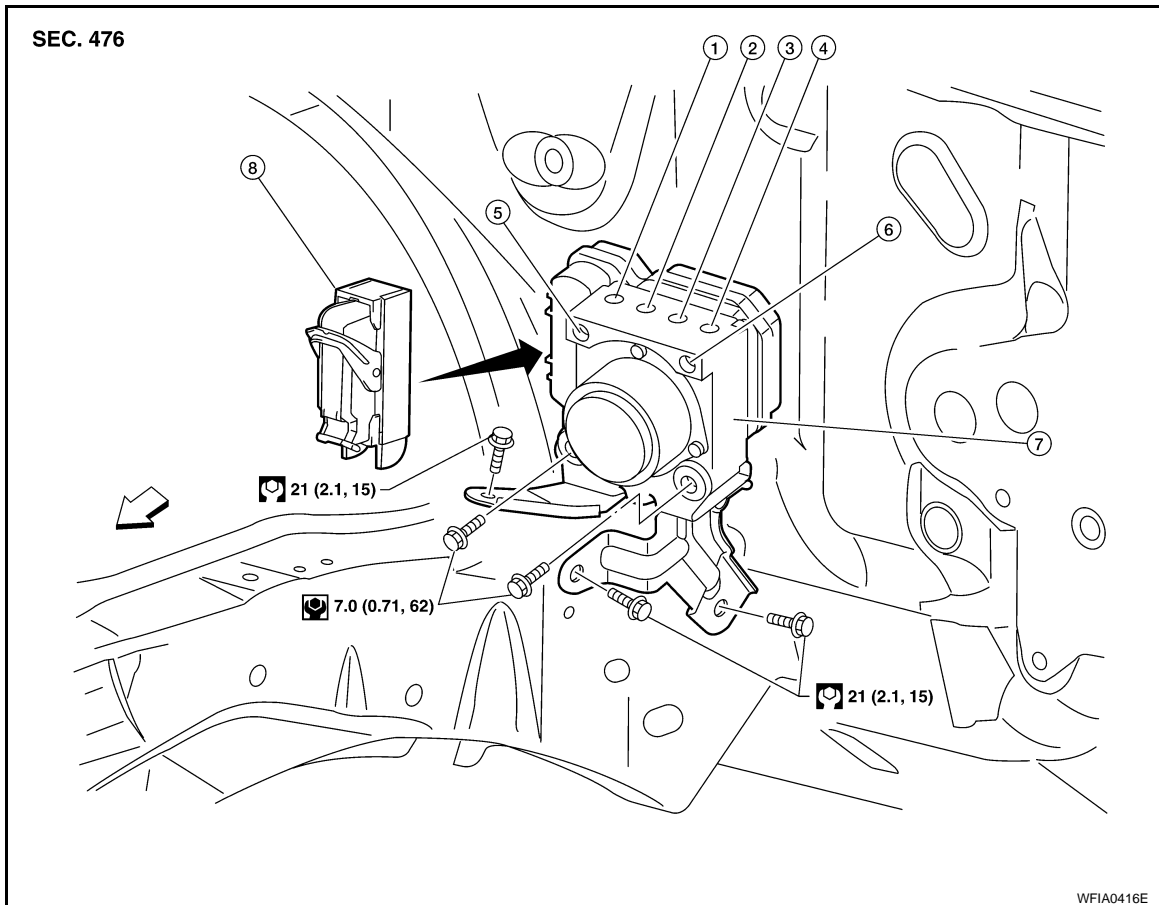

- | | | |
|--|--|--------------------------------------|
| 1. To front left caliper | 2. To rear right caliper | 3. To rear left caliper |
| 4. To front right caliper | 5. From master cylinder secondary side | 6. From master cylinder primary side |
| 7. ABS actuator and electric unit (control unit) | 8. Actuator harness connector | ↩ Front |

REMOVAL

1. Disconnect the battery negative terminal.
2. Remove the cowl top extension. Refer to [EI-18. "Removal and Installation"](#).
3. Drain the brake fluid. Refer to [BR-10. "Changing Brake Fluid"](#).
4. Disconnect the actuator harness from the ABS actuator and electric unit (control unit).
5. Disconnect the brake tubes.

CAUTION:

- To remove the brake tubes, use a flare nut wrench to prevent the flare nuts and brake tubes from being damaged.
- Be careful not to splash brake fluid on painted areas.

6. Remove the ABS actuator and electric unit (control unit) and bracket bolts and remove the ABS actuator and electric unit (control unit) with the bracket.

INSTALLATION

Installation is in the reverse order of removal.

- Refer to [BR-11. "Hydraulic Circuit"](#) for torque specifications when connecting the brake tubes.
- After installation of the ABS actuator and electric unit (control unit), refill the brake system with new brake fluid. Then bleed the air from the brake hydraulic system. Refer to [BR-10. "Bleeding Brake System"](#).

CAUTION:

ACTUATOR AND ELECTRIC UNIT (ASSEMBLY)

< SERVICE INFORMATION >

[TCS/ABS]

- To install the brake tubes, use a flare nut wrench (commercial service tool).
- Always tighten the brake tubes to the specified torque when installing.
- Never reuse drained brake fluid.

SERVICE INFORMATION

PRECAUTIONS

Precaution for Supplemental Restraint System (SRS) "AIR BAG" and "SEAT BELT PRE-TENSIONER"

INFOID:000000004278984

The Supplemental Restraint System such as "AIR BAG" and "SEAT BELT PRE-TENSIONER", used along with a front seat belt, helps to reduce the risk or severity of injury to the driver and front passenger for certain types of collision. This system includes seat belt switch inputs and dual stage front air bag modules. The SRS system uses the seat belt switches to determine the front air bag deployment, and may only deploy one front air bag, depending on the severity of a collision and whether the front occupants are belted or unbelted. Information necessary to service the system safely is included in the SR and SB section of this Service Manual.

WARNING:

- To avoid rendering the SRS inoperative, which could increase the risk of personal injury or death in the event of a collision which would result in air bag inflation, all maintenance must be performed by an authorized NISSAN/INFINITI dealer.
- Improper maintenance, including incorrect removal and installation of the SRS, can lead to personal injury caused by unintentional activation of the system. For removal of Spiral Cable and Air Bag Module, see the SR section.
- Do not use electrical test equipment on any circuit related to the SRS unless instructed to in this Service Manual. SRS wiring harnesses can be identified by yellow and/or orange harnesses or harness connectors.

Precaution for Brake System

INFOID:000000004278985

CAUTION:

- Refer to [MA-12](#) for recommended brake fluid.
- Never reuse drained brake fluid.
- Be careful not to splash brake fluid on painted areas; it may cause paint damage. If brake fluid is splashed on painted areas, wash it away with water immediately.
- To clean or wash all parts of master cylinder and disc brake caliper, use clean brake fluid.
- Never use mineral oils such as gasoline or kerosene. They will ruin rubber parts of the hydraulic system.
- Use flare nut wrench when removing and installing brake tube.
- If a brake fluid leak is found, the part must be disassembled without fail. Then it has to be replaced with a new one if a defect exists.
- Turn the ignition switch OFF and remove the connector of the ABS actuator and electric unit (control unit) or the battery terminal before performing the work.
- Always tighten brake lines to specified torque when installing.
- Burnish the brake contact surfaces after refinishing or replacing rotors, after replacing pads, or if a soft pedal occurs at very low mileage.

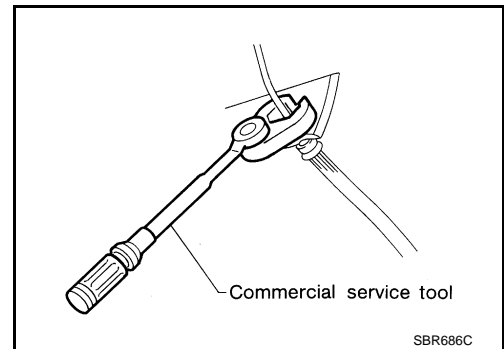

Refer to [BR-30](#), "[Brake Burnishing](#)" (front disc brake) or [BR-37](#), "[Brake Burnishing](#)" (rear disc brake).

WARNING:

- Clean brake pads and shoes with a waste cloth, then wipe with a dust collector.

Precaution for Brake Control

INFOID:000000004278986

- During ABS operation, the brake pedal may vibrate lightly and a mechanical noise may be heard. This is normal.
- Just after starting vehicle, the brake pedal may vibrate or a motor operating noise may be heard from engine compartment. This is a normal status of operation check.
- Stopping distance may be longer than that of vehicles without ABS when vehicle drives on rough, gravel, or snow-covered (fresh, deep snow) roads.

PRECAUTIONS

< SERVICE INFORMATION >

[VDC/TCS/ABS]

- When an error is indicated by ABS or another warning lamp, collect all necessary information from customer (what symptoms are present under what conditions) and check for simple causes before starting diagnosis. Besides electrical system inspection, check booster operation, brake fluid level, and fluid leaks.
- If incorrect tire sizes or types are installed on the vehicle or brake pads are not Genuine NISSAN parts, stopping distance or steering stability may deteriorate.
- If there is a radio, antenna or related wiring near control module, ABS function may have a malfunction or error.
- If aftermarket parts (car stereo, CD player, etc.) have been installed, check for incidents such as harness pinches, open circuits or improper wiring.
- If the following components are replaced with non-genuine components or modified, the VDC OFF indicator lamp and SLIP indicator lamp may turn on or the VDC system may not operate properly. Components related to suspension (shock absorbers, struts, springs, bushings, etc.), tires, wheels (exclude specified size), components related to brake system (pads, rotors, calipers, etc.), components related to engine (muffler, ECM, etc.), components related to body reinforcement (roll bar, tower bar, etc.).
- Driving with broken or excessively worn suspension components, tires or brake system components may cause the VDC OFF indicator lamp and the SLIP indicator lamp to turn on, and the VDC system may not operate properly.
- When the TCS or VDC is activated by sudden acceleration or sudden turn, some noise may occur. The noise is a result of the normal operation of the TCS and VDC.
- When driving on roads which have extreme slopes (such as mountainous roads) or high banks (such as sharp curves on a freeway), the VDC may not operate normally, or the VDC warning lamp and the SLIP indicator lamp may turn on. This is not a problem if normal operation can be resumed after restarting the engine.
- Sudden turns (such as spin turns, acceleration turns), drifting, etc. with VDC turned off may cause the yaw rate/side G sensor to indicate a problem. This is not a problem if normal operation can be resumed after restarting the engine.

Precaution for CAN System

INFOID:000000004278987

- Do not apply voltage of 7.0V or higher to terminal to be measured.
- Maximum open terminal voltage of tester in use must be less than 7.0V.
- Before checking harnesses, turn ignition switch OFF and disconnect battery negative cable.
- Area to be repaired must be soldered and wrapped with tape. Make sure that fraying of twisted wire is within 110 mm (4.33 in).

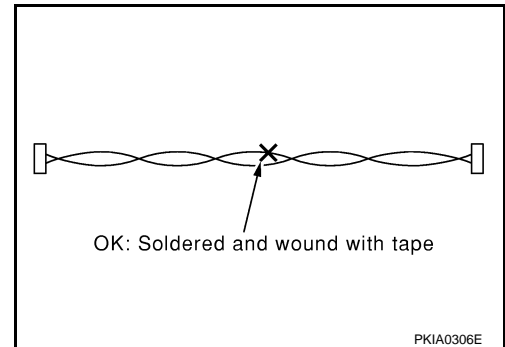

- Do not make a bypass connection to repaired area. (If the circuit is bypassed, characteristics of twisted wire will be lost.)

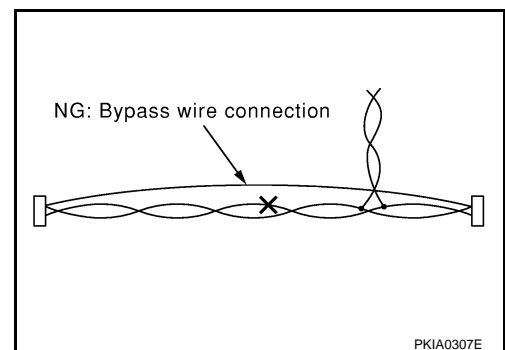

PREPARATION

< SERVICE INFORMATION >

[VDC/TCS/ABS]

PREPARATION

Special Service Tool

INFOID:000000004278988

The actual shapes of Kent-Moore tools may differ from those of special service tools illustrated here.

Tool number (Kent-Moore No.) Tool name	Description
KV991J0070 (J-45741) ABS active wheel sensor tester	Checking operation of ABS active wheel sensors

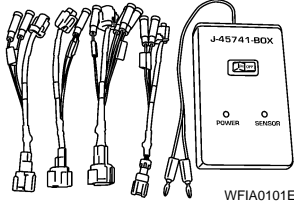

Commercial Service Tool

INFOID:000000004278989

BRC

Tool name	Description
1. Flare nut crowfoot 2. Torque wrench	Removing and installing brake piping a: 10mm (0.39 in)/12mm (0.47 in)

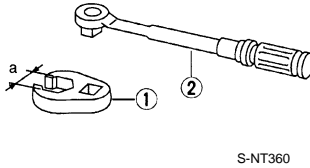

A
B
C
D
E
G
H
I
J
K
L
M
N
O
P

SYSTEM DESCRIPTION

System Component

INFOID:000000004278990

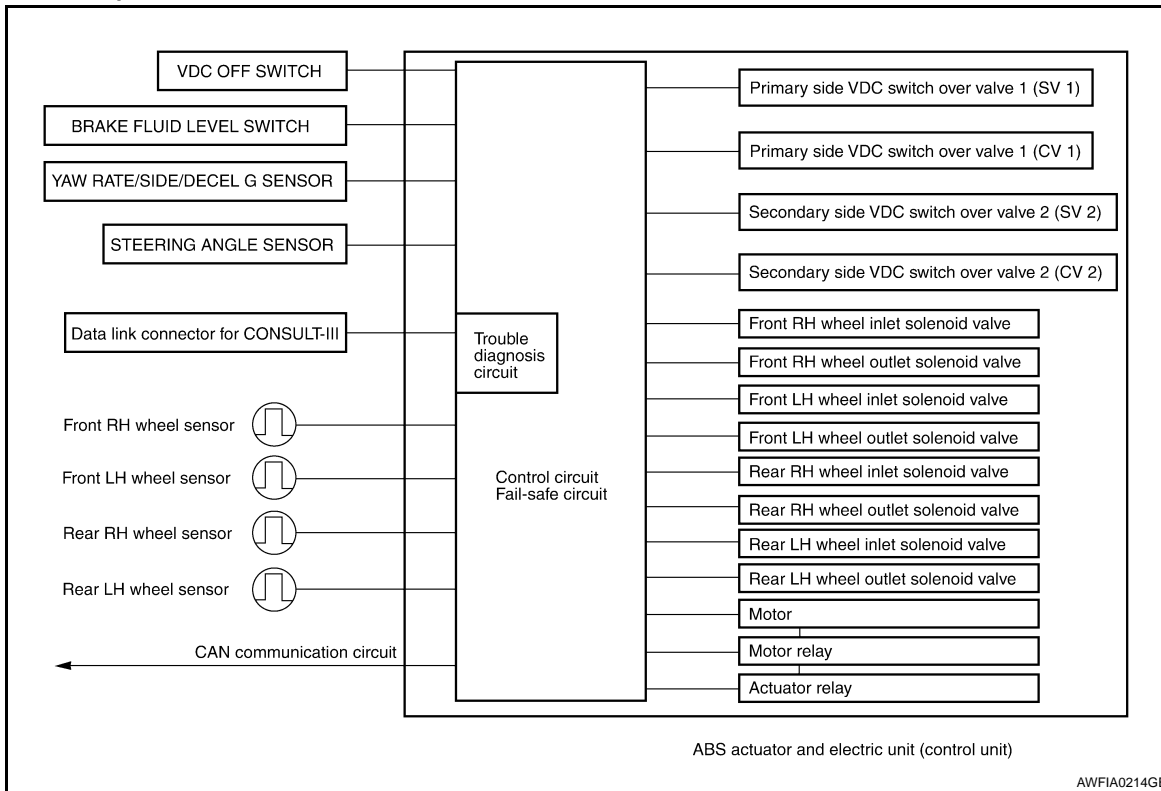

AWFIA0214GE

ABS Function

INFOID:000000004278991

- The Anti-Lock Brake System detects wheel revolution while braking and improves handling stability during sudden braking by electrically preventing wheel lockup. Maneuverability is also improved for avoiding obstacles.
- If the electrical system malfunctions, the Fail-Safe function is activated, the ABS becomes inoperative and the ABS warning lamp turns on.
- The electrical system can be diagnosed using CONSULT-III.
- During ABS operation, the brake pedal may vibrate lightly and a mechanical noise may be heard. This is normal.
- Just after starting the vehicle, the brake pedal may vibrate or a motor operating noise may be heard from engine compartment. This is a normal status of operation check.
- Stopping distance may be longer than that of vehicles without ABS when vehicle drives on rough, gravel, or snow-covered (fresh, deep snow) roads.

EBD Function

INFOID:000000004278992

- Electronic Brake Distribution is a function that detects subtle slippages between the front and rear wheels during braking, and it improves handling stability by electronically controlling the brake fluid pressure which results in reduced rear wheel slippage.
- If the electrical system malfunctions, the Fail-Safe function is activated, the EBD and ABS become inoperative, and the ABS warning lamp and BRAKE warning lamp are turned on.
- The electrical system can be diagnosed using CONSULT-III.
- During EBD operation, the brake pedal may vibrate lightly and a mechanical noise may be heard. This is normal.
- Just after starting the vehicle, the brake pedal may vibrate or a motor operating noise may be heard from engine compartment. This is a normal status of operation check.

TCS Function

INFOID:000000004278993

- Spinning of the drive wheels is detected by the ABS/TCS/VDC control unit using inputs from the wheel speed sensors. If wheel spin occurs, the drive wheel right and left brake fluid pressure control and engine fuel cut are conducted while the throttle value is restricted to reduce the engine torque and decrease the amount of wheel spin. In addition, the throttle opening is controlled to achieve the optimum engine torque.
- Depending on road condition, the vehicle may have a sluggish feel. This is normal, because optimum traction has the highest priority during TCS operation.
- TCS may be activated during sudden vehicle acceleration, wide open throttle acceleration, sudden transmission shifts or when the vehicle is driven on a road with a varying surface friction coefficient.
- The SLIP indicator lamp flashes to inform the driver of TCS operation.

VDC Function

INFOID:000000004278994

- In addition to the ABS/TCS function, the driver steering amount and brake operation amount are detected from the steering angle sensor and pressure sensor, and the vehicle's driving status (amount of under steering/over steering) is determined using inputs from the yaw rate/side/decel G sensor, wheel speed sensors, etc. and this information is used to improve vehicle stability by controlling the braking and engine torque application to the wheels.
- The SLIP indicator lamp flashes to inform the driver of VDC operation.
- During VDC operation, the vehicle body and brake pedal may vibrate lightly and a mechanical noise may be heard. This is normal.
- The ABS warning lamp, VDC OFF indicator lamp and SLIP indicator lamp may turn on when the vehicle is subject to strong shaking or large vibration, such as when the vehicle is on a turn table or a ship while the engine is running or on a steep slope. In this case, restart the engine on a normal road and if the ABS warning lamp, VDC OFF indicator lamp and SLIP indicator lamp turn off, there is no problem.

Wheel Sensors

INFOID:000000004278995

Each wheel sensor unit consists of a wheel hub with a series of internal magnets and a sensor element. The wheel sensors are installed on the inner side of the wheel knuckles. As the wheel rotates, the sensor generates a square-wave signal. The frequency increases as the wheel speed increases.

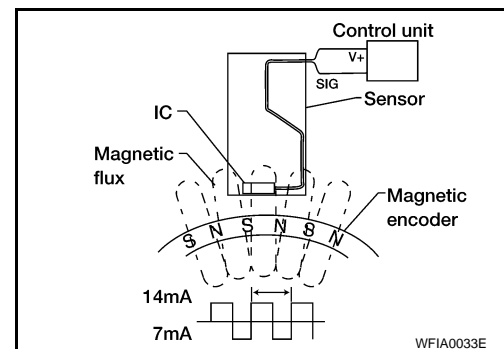

Fail-Safe Function

INFOID:000000004278996

CAUTION:

If the Fail-Safe function is activated, perform the Self Diagnosis for ABS/TCS/VDC system.

ABS/EBD SYSTEM

In case of an electrical malfunction with the ABS, the ABS warning lamp, VDC OFF indicator lamp and SLIP indicator lamp will turn on. In case of an electrical malfunction with the EBD system, the BRAKE warning lamp, ABS warning lamp, VDC OFF indicator lamp and SLIP indicator lamp will turn on. The system will revert to one of the following conditions of the Fail-Safe function.

1. For ABS malfunction, only the EBD is operative and the condition of the vehicle is the same condition of vehicles without ABS/TCS/VDC system.
2. For EBD malfunction, the EBD and ABS become inoperative, and the condition of the vehicle is the same as the condition of vehicles without ABS/TCS/VDC or EBD system.

VDC/TCS SYSTEM

In case of TCS/VDC system malfunction, the VDC OFF indicator lamp and SLIP indicator lamp are turned on and the condition of the vehicle is the same as the condition of vehicles without TCS/VDC system. In case of an electrical malfunction with the TCS/VDC system, the ABS continues to operate normally without TCS/VDC control.

SYSTEM DESCRIPTION

< SERVICE INFORMATION >

[VDC/TCS/ABS]

Hydraulic Circuit Diagram

INFOID:000000004278997

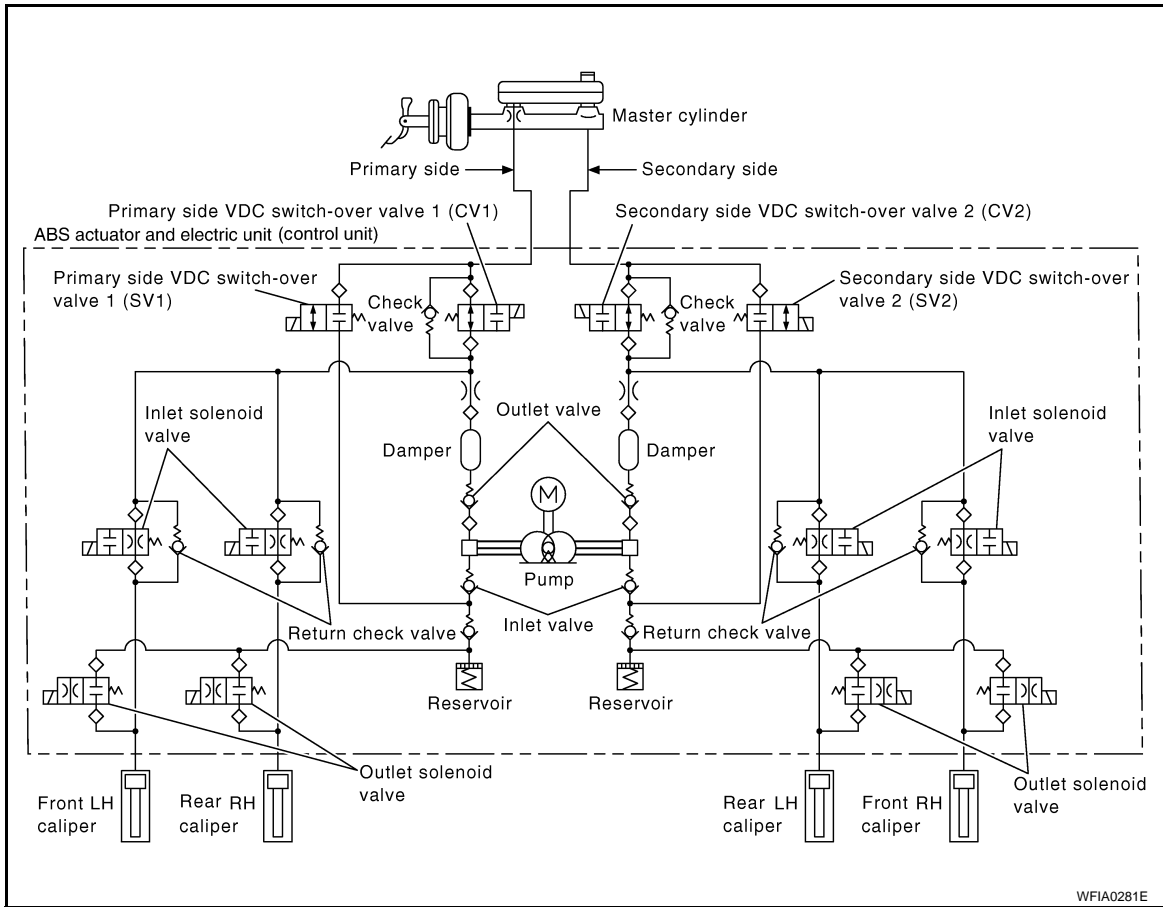

CAN COMMUNICATION

System Description

INFOID:000000004278998

Refer to [LAN-3. "CAN Communication System"](#).

A

B

C

D

E

BRC

G

H

I

J

K

L

M

N

O

P

TROUBLE DIAGNOSIS

How to Perform Trouble Diagnosis for Quick and Accurate Repair

INFOID:000000004278999

INTRODUCTION

The ABS/TCS/VDC system has an electronic control unit to control major functions. The control unit accepts input signals from sensors and controls actuator operation. It is also important to check for conventional problems such as air leaks in the booster or lines, lack of brake fluid, or other problems with the brake system.

It is much more difficult to diagnose a problem that occurs intermittently rather than continuously. Most intermittent problems are caused by poor electrical connections or faulty wiring. In this case, careful checking of suspicious circuits may help prevent the replacement of good parts.

A visual check only may not find the cause of the problem, so a road test should be performed.

Before undertaking actual checks, take just a few minutes to talk with a customer who approaches with an ABS/TCS/VDC complaint. The customer is a very good source of information on such problems, especially intermittent ones. Through the talks with the customer, find out what symptoms are present and under what conditions they occur.

Start your diagnosis by looking for "conventional" problems first. This is one of the best ways to troubleshoot brake problems on an ABS/TCS/VDC equipped vehicle. Also check related Service Bulletins for information.

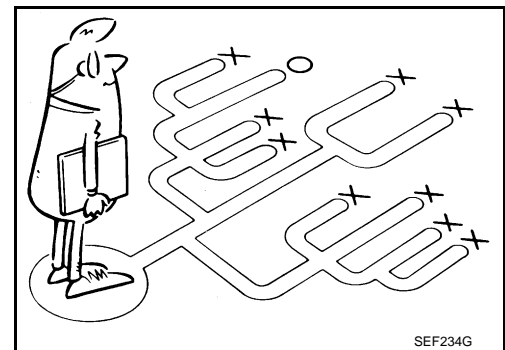
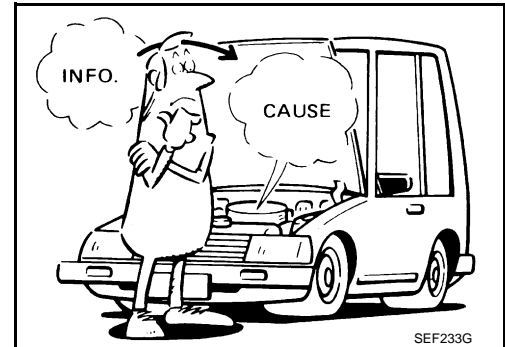

TROUBLE DIAGNOSIS

< SERVICE INFORMATION >

[VDC/TCS/ABS]

WORK FLOW

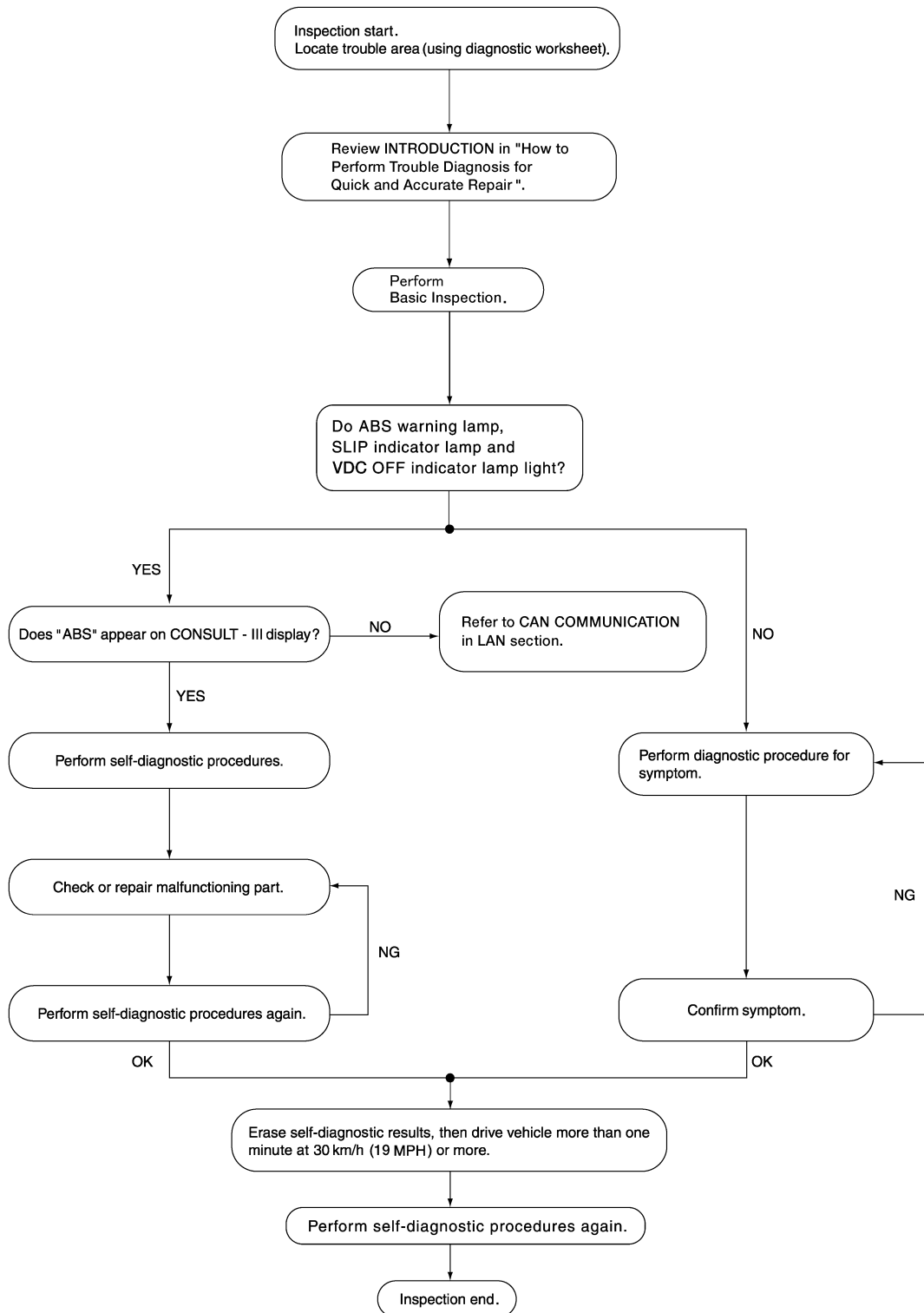

A
B
C
D
E
BRC
G
H
I
J
K
L
M
N
O
P

CLARIFY CONCERN

AWFIA0205GB

TROUBLE DIAGNOSIS

[VDC/TCS/ABS]

< SERVICE INFORMATION >

- A customer's description of a vehicle concern may vary depending on the individual. It is important to clarify the customer's concern.
- Ask the customer about what symptoms are present under what conditions. Use this information to reproduce the symptom while driving.
- It is also important to use the diagnosis sheet to understand what type of trouble the customer is having.

KEY POINTS

WHAT Vehicle model
WHEN Date, Frequencies
WHERE Road conditions
HOW Operating conditions,
Weather conditions,
Symptoms

SBR339B

EXAMPLE OF DIAGNOSIS SHEET

Customer name	Model & Year	VIN	
Engine #	Trans.	Mileage	
Incident Date	Manuf. Date	In Service Date	
Symptoms	<input type="checkbox"/> Noise and vibration (from engine compartment)	<input type="checkbox"/> ABS warning lamp activates	<input type="checkbox"/> Pedal operation
	<input type="checkbox"/> Noise and vibration (from axle)	<input type="checkbox"/> SLIP warning lamp activates	<input type="checkbox"/> Large stroke pedal operation
	<input type="checkbox"/> TCS does not work (drive wheels slip when accelerating)	<input type="checkbox"/> ABS does not work (wheels slip when braking)	<input type="checkbox"/> Firm pedal
		<input type="checkbox"/> Lack of sense of acceleration	
Engine conditions	<input type="checkbox"/> When starting <input type="checkbox"/> After starting		
Road conditions	<input type="checkbox"/> Low friction road (<input type="checkbox"/> Snow <input type="checkbox"/> Gravel <input type="checkbox"/> Other) <input type="checkbox"/> Bumps/potholes		
Driving conditions	<input type="checkbox"/> Full-acceleration <input type="checkbox"/> High speed cornering <input type="checkbox"/> Vehicle speed: Greater than 10 km/h (6 MPH) <input type="checkbox"/> Vehicle speed: 10 km/h (6 MPH) or less <input type="checkbox"/> Vehicle is stopped		
Applying brake conditions	<input type="checkbox"/> Suddenly <input type="checkbox"/> Gradually		
Other conditions	<input type="checkbox"/> Operation of electrical equipment <input type="checkbox"/> Shift change <input type="checkbox"/> Other descriptions		

WFIA0097E

TROUBLE DIAGNOSIS

< SERVICE INFORMATION >

[VDC/TCS/ABS]

Component Parts and Harness Connector Location

INFOID:000000004279000

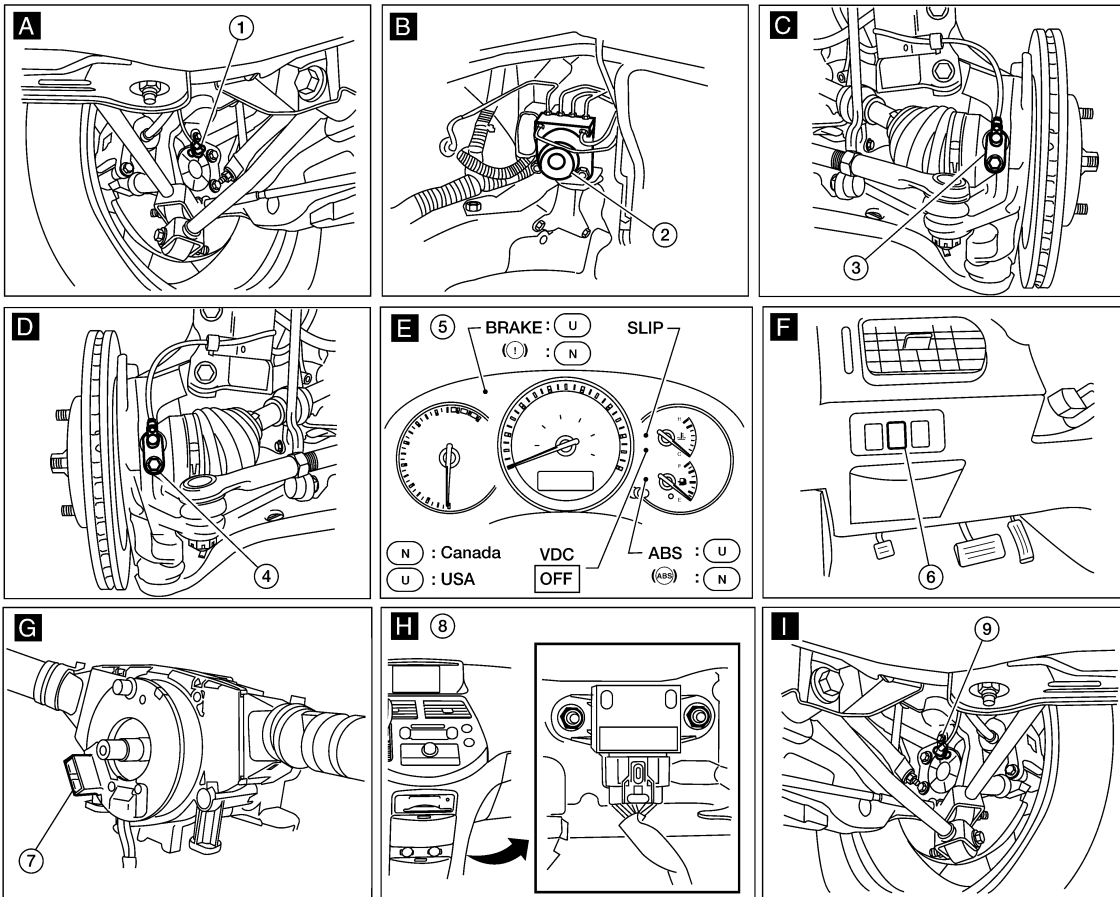
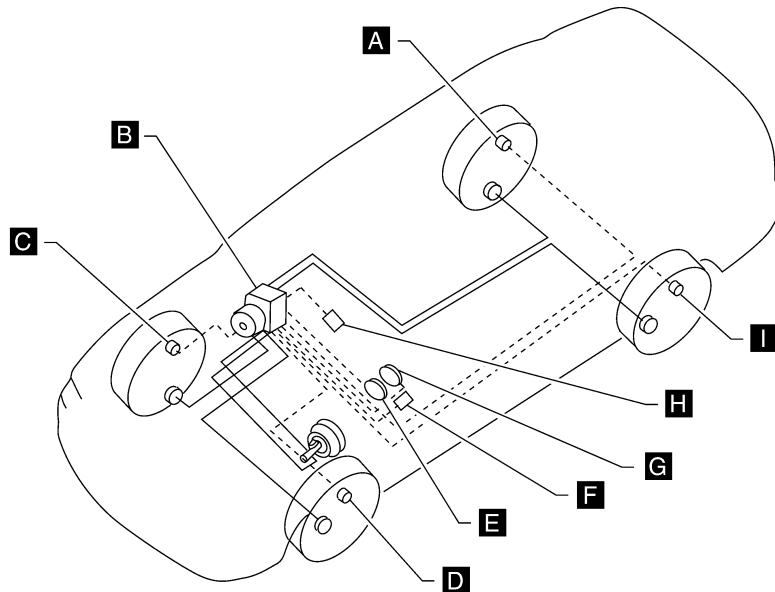

1. Rear wheel sensor RH B122
2. ABS actuator and electric unit (control unit) E125 (engine removed for clarity)
3. Front wheel sensor RH E117

WFIA0481E

TROUBLE DIAGNOSIS

< SERVICE INFORMATION >

[VDC/TCS/ABS]

- | | | |
|---|--------------------------------------|------------------------------|
| 4. Front wheel sensor LH E18 | 5. Combination meter M24 | 6. VDC OFF switch M6 |
| 7. Spiral cable (includes steering angle sensor) M47 (steering wheel removed for clarity) | 8. Yaw rate/side/decel G sensor B125 | 9. Rear wheel sensor LH B123 |

Schematic

INFOID:000000004279001

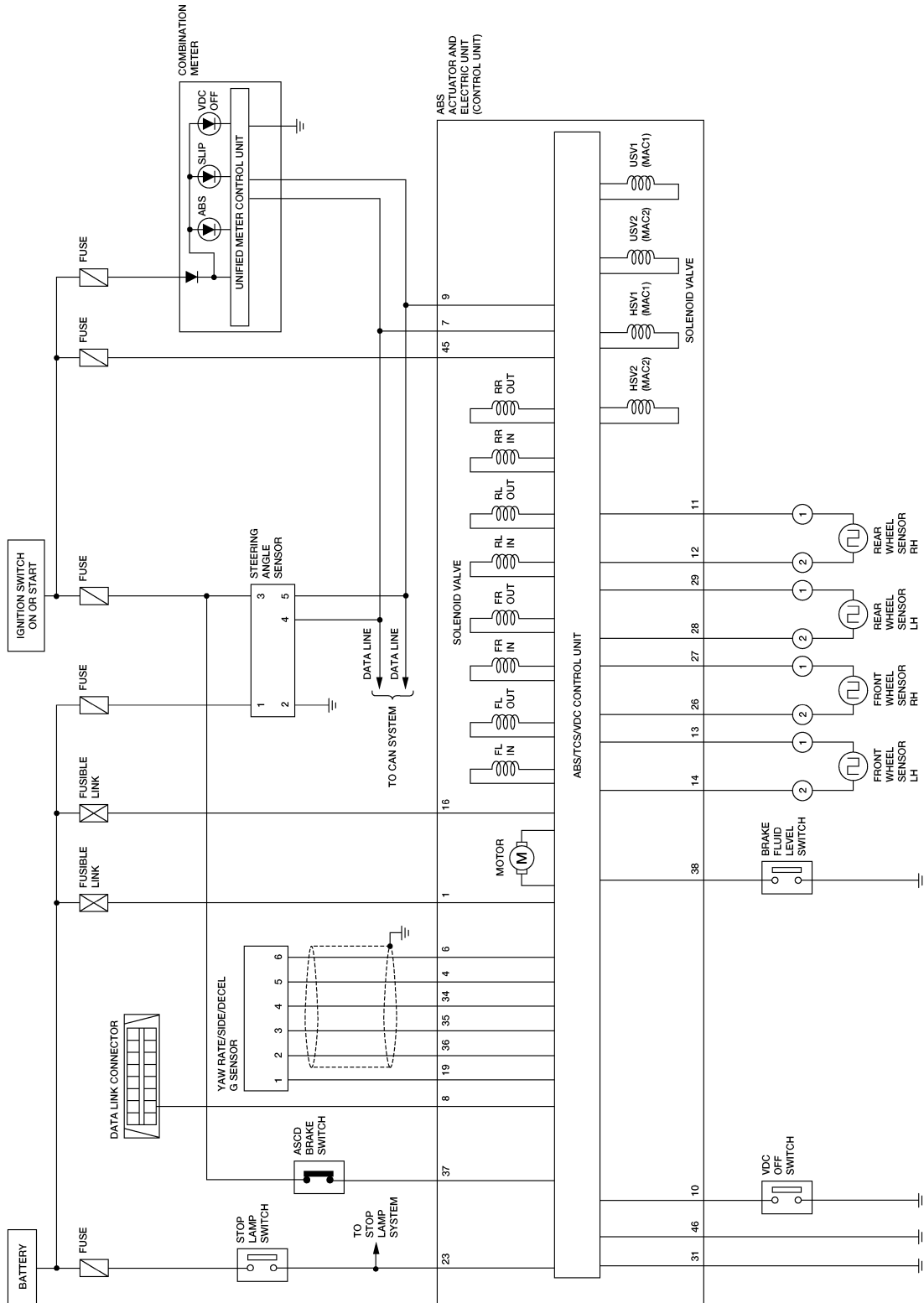

WFWA0412E

TROUBLE DIAGNOSIS

< SERVICE INFORMATION >

[VDC/TCS/ABS]

Wiring Diagram - VDC -

INFOID:000000004279002

BRC-VDC-01

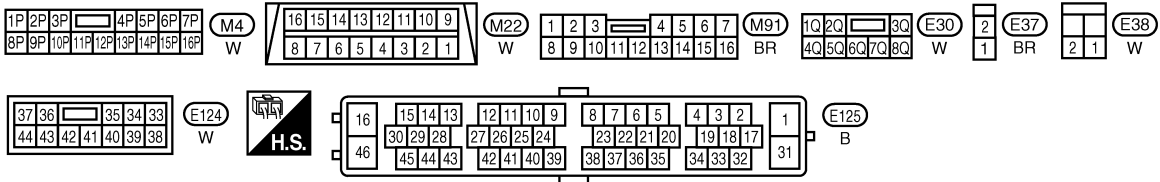
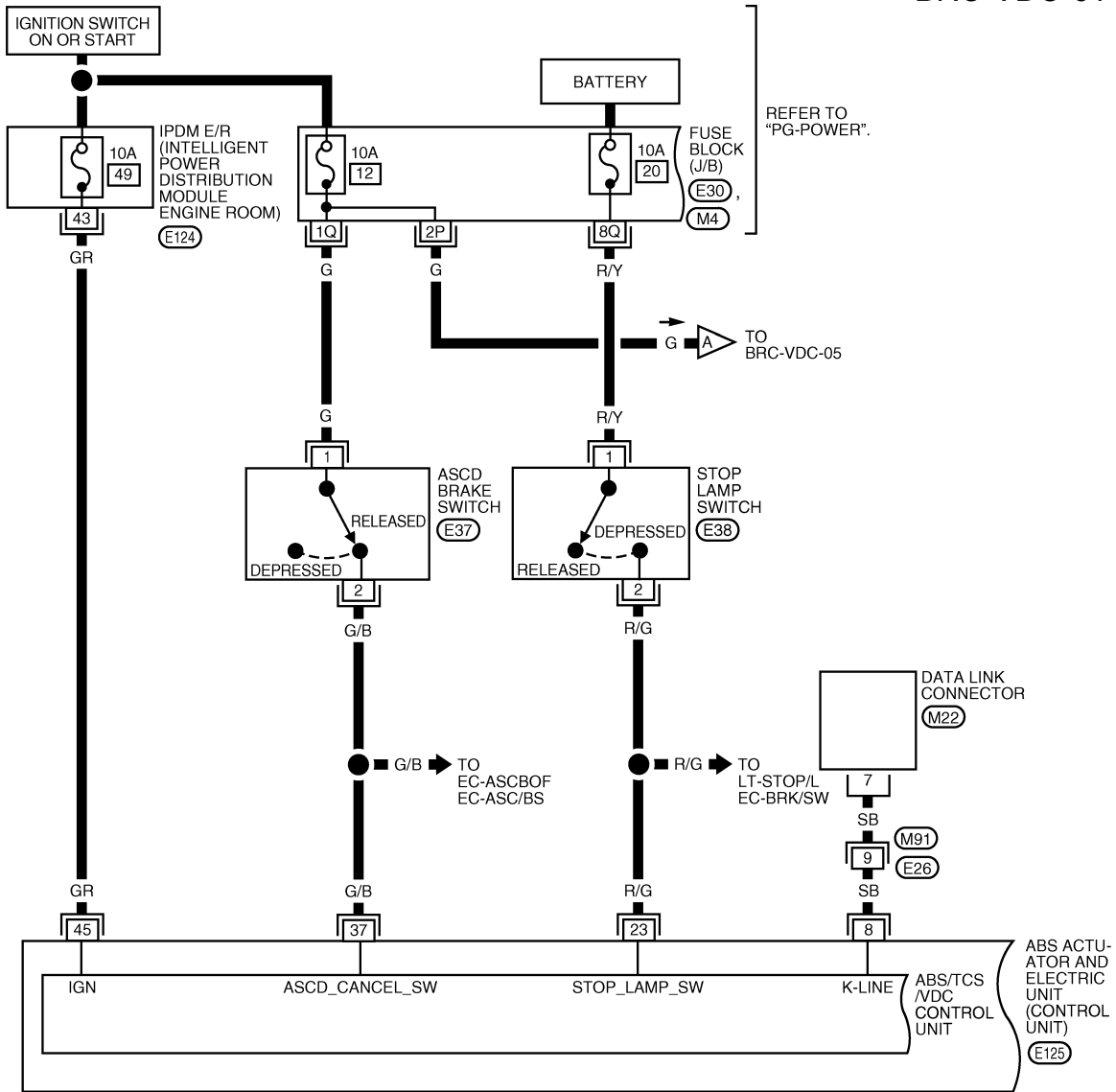

WFWA0413E

TROUBLE DIAGNOSIS

< SERVICE INFORMATION >

[VDC/TCS/ABS]

BRC-VDC-02

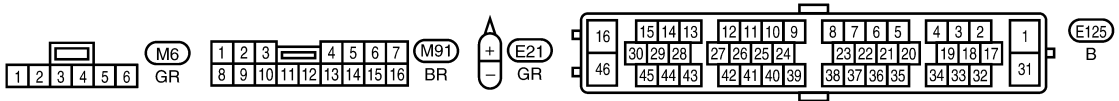
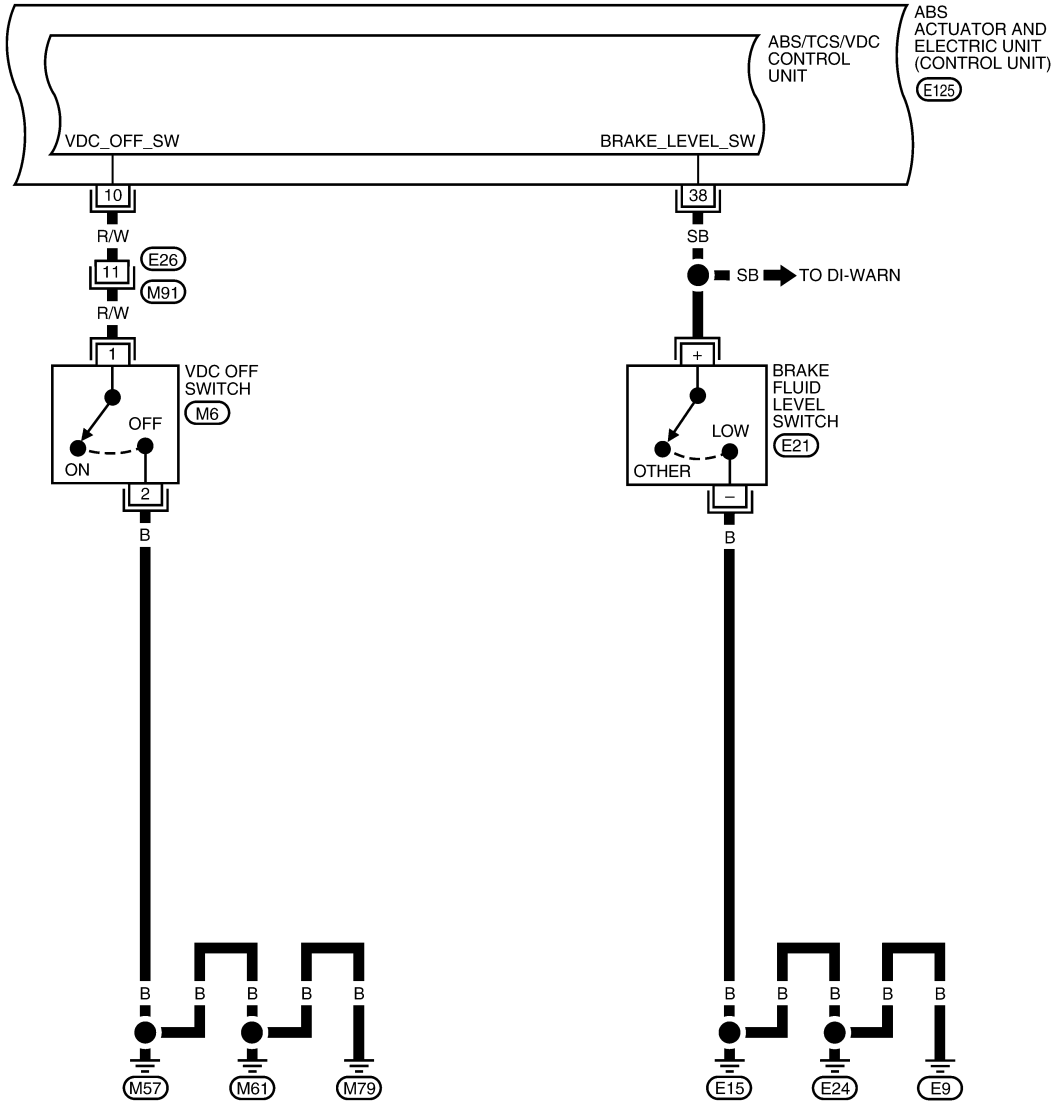

WFWA0414E

TROUBLE DIAGNOSIS

< SERVICE INFORMATION >

[VDC/TCS/ABS]

BRC-VDC-03

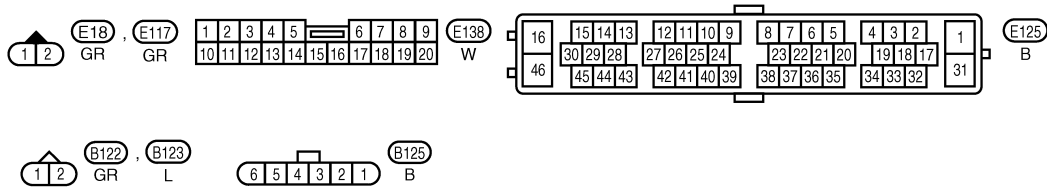
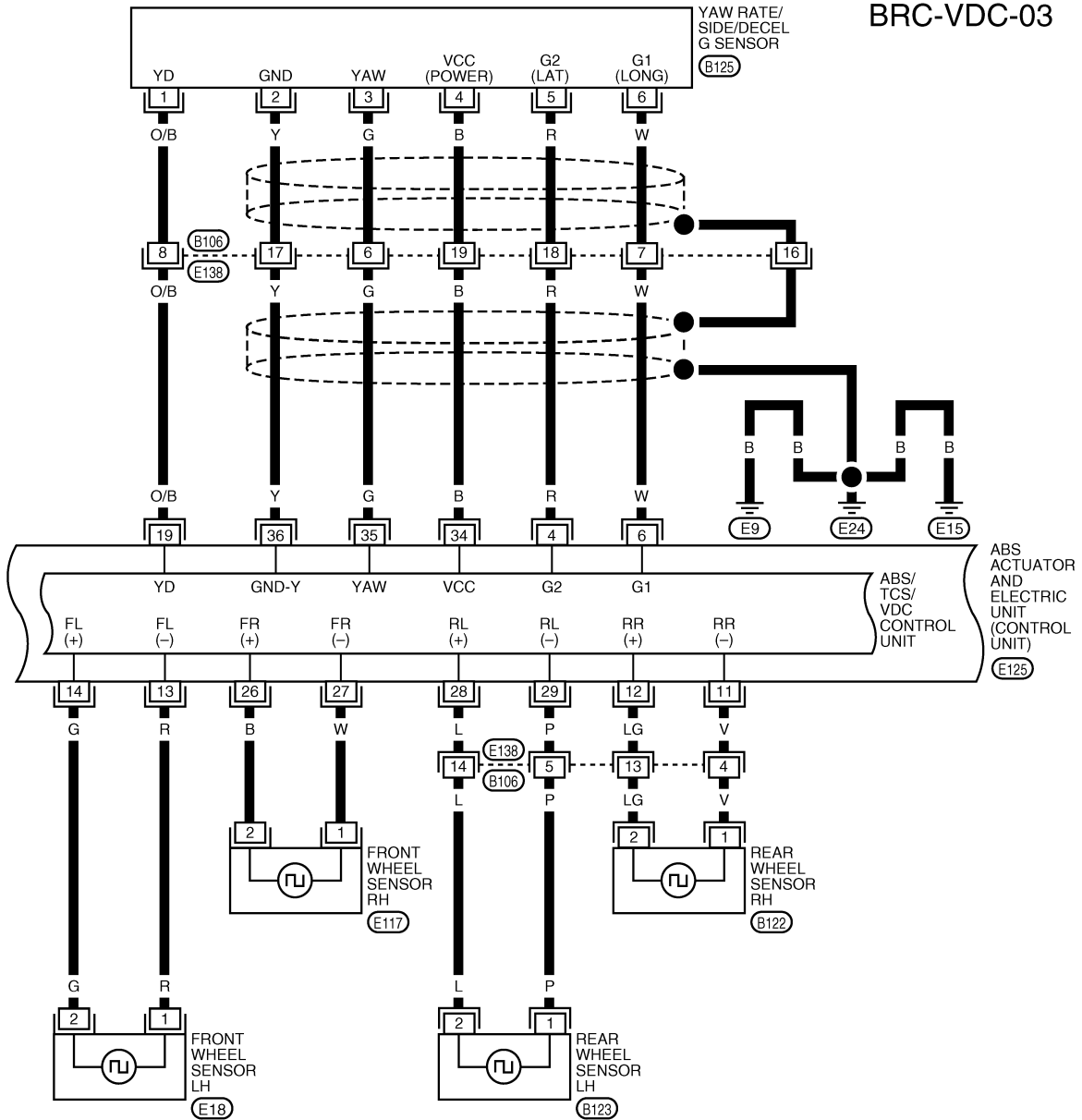

WFWA0415E

TROUBLE DIAGNOSIS

< SERVICE INFORMATION >

[VDC/TCS/ABS]

BRC-VDC-04

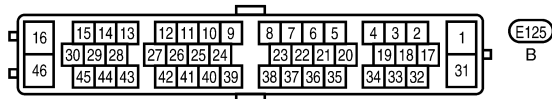
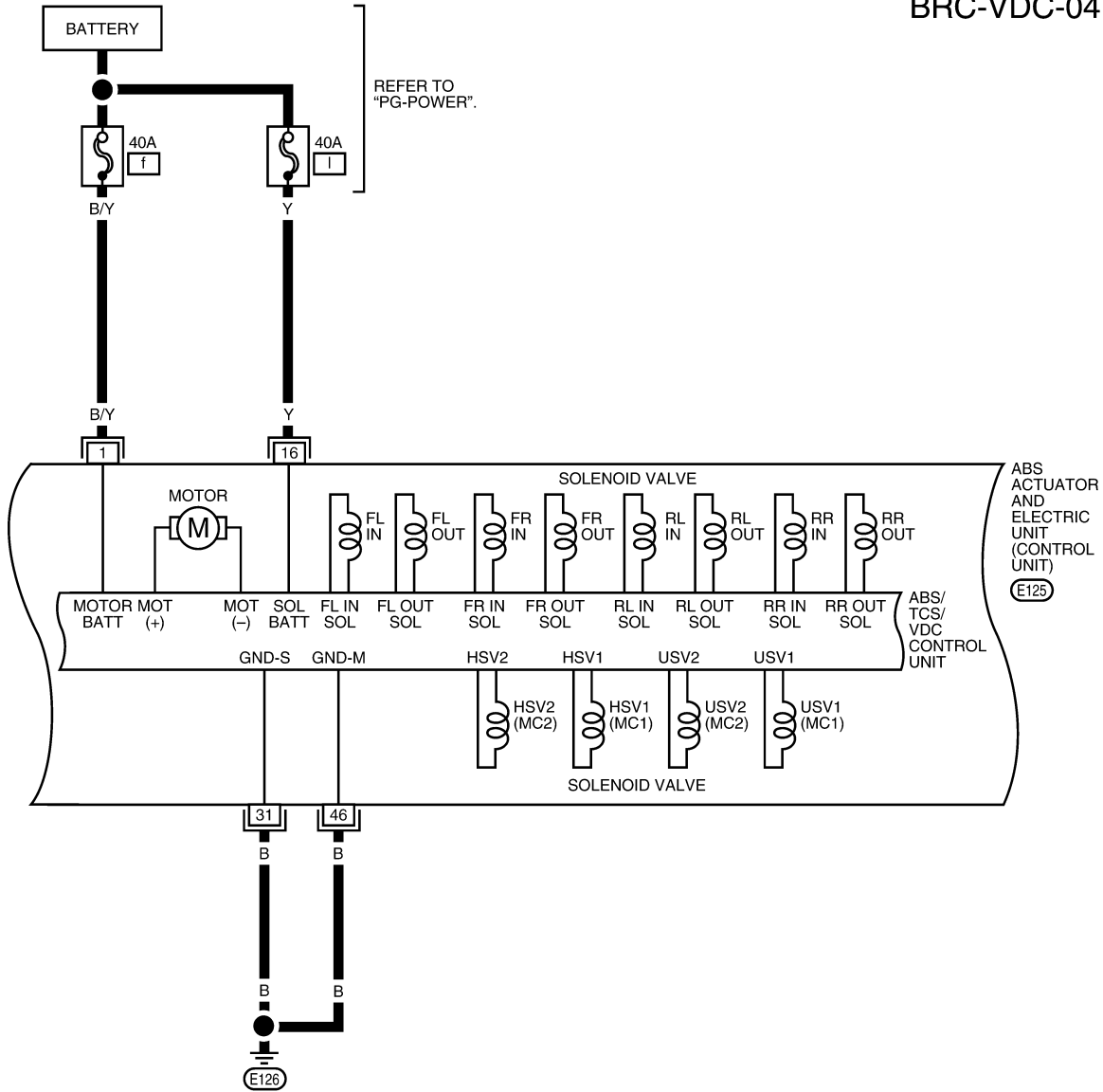

WFWA0416E

TROUBLE DIAGNOSIS

< SERVICE INFORMATION >

[VDC/TCS/ABS]

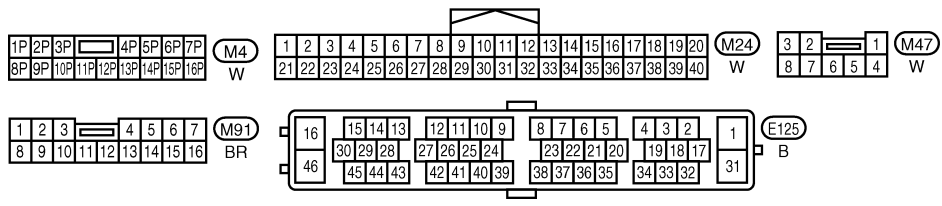
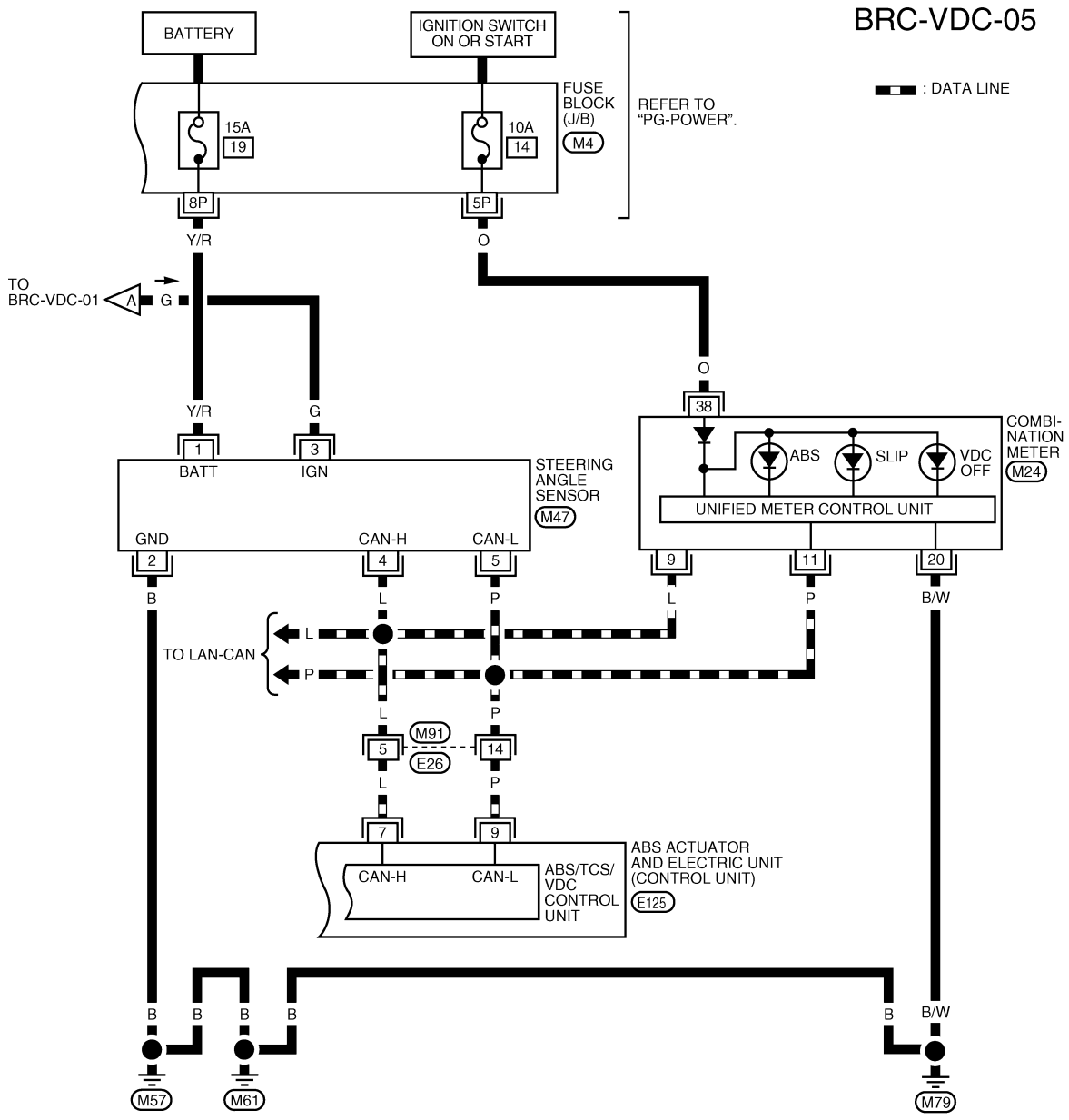

WFWA0417E

INFOID:000000004279003

Basic Inspection

BRAKE FLUID LEVEL, FLUID LEAK, AND BRAKE PAD INSPECTION

1. Check fluid level in the brake fluid reservoir. If fluid level is low, add fluid.
2. Check the brake piping and around the ABS actuator and electric unit (control unit) for leaks. If there is leaking or seeping fluid, check the following items.
 - If ABS actuator and electric unit (control unit) connection is loose, tighten the piping to the specified torque and recheck for leaks.

TROUBLE DIAGNOSIS

[VDC/TCS/ABS]

< SERVICE INFORMATION >

- If there is damage to the connection flare nut or ABS actuator and electric unit (control unit) threads, replace the damaged part and recheck for leaks.
- When there is fluid leaking or seeping from a fluid connection, use a clean cloth to wipe off the fluid and recheck for leaks. If fluid is still seeping out, replace the damaged part. If the fluid is leaking at the ABS actuator and electric unit (control unit), replace the ABS actuator and electric unit (control unit) assembly.

CAUTION:

The ABS actuator and electric unit (control unit) cannot be disassembled and must be replaced as an assembly.

3. Check the brake pads for excessive wear.

POWER SYSTEM TERMINAL LOOSENESS AND BATTERY INSPECTION

Make sure the battery positive cable, negative cable and ground connection are not loose. In addition, make sure the battery is sufficiently charged.

ABS WARNING LAMP, SLIP INDICATOR LAMP AND VDC OFF INDICATOR LAMP INSPECTION

1. Make sure ABS warning lamp, SLIP indicator lamp and VDC OFF indicator lamp (when VDC OFF switch is off), turn on for approximately 2 seconds when the ignition switch is turned ON. If they do not, check the VDC OFF indicator lamp and the VDC OFF switch. Refer to [BRC-79. "Component Inspection"](#). Check CAN communications. If there are no errors with the VDC OFF switch or CAN communication system, check combination meter. Refer to [DI-5](#).
2. Make sure the lamps turn off approximately 2 seconds after the ignition switch is turned ON. If the lamp does not turn off, conduct self-diagnosis.
3. With the engine running, make sure the VDC OFF indicator lamp turns on and off when the VDC OFF switch is turned on and off. If the indicator lamp status does not correspond to switch operation, check the VDC OFF switch. Refer to [BRC-79. "Component Inspection"](#).
4. Make sure ABS warning lamp, SLIP indicator lamp and VDC OFF indicator lamp turn off approximately 2 seconds after the engine is started. If ABS warning lamp, SLIP indicator lamp or VDC OFF indicator lamp have not turned off 10 seconds after the engine has been started, conduct self-diagnosis of the ABS actuator and electric unit (control unit).
5. After conducting the self-diagnosis, be sure to erase the error memory. Refer to [BRC-63. "CONSULT-III Function \(ABS\)"](#).

Warning Lamp and Indicator Timing

INFOID:000000004279004

Condition	ABS warning lamp	VDC OFF indicator lamp	SLIP indicator lamp	Remarks
When the ignition switch is OFF	—	—	—	—
After the ignition switch is turned ON for approx. 1 second	×	×	×	—
After the ignition switch is turned ON for approx. 2 seconds	—	—	—	Lamp goes off approx. 2 seconds after the engine is started.
When the VDC OFF switch is pressed (VDC function OFF)	—	×	—	—
ABS/TCS/VDC malfunction	×	×	×	—
	×	×	—	When the ABS/TCS/VDC control unit is malfunctioning (power supply or ground malfunction).
When the VDC is malfunctioning	—	×	×	—

X: ON

—: OFF

Control Unit Input/Output Signal Standard

INFOID:000000004279005

REFERENCE VALUE FROM CONSULT-III

CAUTION:

TROUBLE DIAGNOSIS

< SERVICE INFORMATION >

[VDC/TCS/ABS]

The display shows the control unit calculation data, so a normal value might be displayed even in the event the output circuit (harness) is open or short circuited.

Monitor item	Display content	Data monitor		Note: Error inspection checklist	
		Condition	Reference value in normal operation		
P POSI SIG	A/T gear position	P position	ON	BRC-33. " CAN Communication System Inspection "	
		Other than P position	OFF		
N POSI SIG	A/T gear position	N position	ON		
		Other than N position	OFF		
GEAR	A/T gear position	1st gear	1		
		2nd gear	2		
		3rd gear	3		
		4th gear	4		
FR RH SENSOR FR LH SENSOR RR RH SENSOR RR LH SENSOR	Wheel speed	Vehicle stopped	0 [km/h (MPH)]		BRC-70. " Wheel Sensor System Inspection "
		Vehicle running (Note 1)	Almost in accordance with speedometer display (within ±10%)		
ACCEL POS SIG	Open/close condition of throttle valve (linked with accelerator pedal).	Accelerator pedal not depressed (ignition switch is ON)	0%	BRC-78. " CAN Communication System Inspection "	
		Depress accelerator pedal (ignition switch is ON)	0 to 100%		
ENGINE SPEED	With engine running	With engine stopped	0 rpm	BRC-71. " Engine System Inspection "	
		Engine running	Almost in accordance with tachometer display		
STR ANGLE SIG	Steering angle detected by steering angle sensor	Straight-ahead	Approx. 0 deg	BRC-72. " Steering Angle Sensor System Inspection "	
		Steering wheel turned	-756 to 756 deg		
YAW RATE SEN	Yaw rate detected by yaw rate sensor	Vehicle stopped	Approx. 0 d/s	BRC-73. " Yaw Rate/Side/Decel G Sensor System Inspection "	
		Vehicle running	-100 to 100 d/s		
SIDE G-SENSOR	Transverse G detected by side G-sensor	Vehicle stopped	Approx. 0 m/s ²		
		Vehicle running	-16.7 to 16.7 m/s ²		
BATTERY VOLT	Battery voltage supplied to ABS actuator and electric unit (control unit)	Ignition switch ON	10 to 16V	BRC-77. " ABS/TCS/VDC Control Unit Power and Ground Systems Inspection "	
CRANKING SIG	Cranking status	Cranking	ON	—	
		Not cranking	OFF		
STOP LAMP SW	Brake pedal operation	Brake pedal depressed	ON	BRC-76. " Stop Lamp Switch System Inspection "	
		Brake pedal not depressed	OFF		
OFF SW	VDC OFF switch ON/OFF status	VDC OFF switch ON (When VDC OFF indicator lamp is ON)	ON	BRC-79. " Component Inspection "	
		VDC OFF switch OFF (When VDC OFF indicator lamp is OFF)	OFF		
ABS WARN LAMP	ABS warning lamp ON condition (Note 2)	ABS warning lamp ON	ON	BRC-82. " ABS Warning Lamp Does Not Come On When Ignition Switch Is Turned On "	
		ABS warning lamp OFF	OFF		

TROUBLE DIAGNOSIS

< SERVICE INFORMATION >

[VDC/TCS/ABS]

Monitor item	Display content	Data monitor		Note: Error inspection checklist
		Condition	Reference value in normal operation	
EBD WARN LAMP	EBD warning lamp status	When EBD warning lamp is ON	ON	BRC-78. "CAN Communication System Inspection"
		When EBD warning lamp is OFF	OFF	
MOTOR RELAY	Operation status of motor and motor relay	Ignition switch ON or engine running (ABS not activated)	OFF	BRC-75. "Actuator Motor, Motor Relay, and Circuit Inspection"
		Ignition switch ON or engine running (ABS activated)	ON	
ACTUATOR RLY	Actuator relay operation status	Vehicle stopped (Ignition switch ON)	OFF	
		Vehicle stopped (Engine running)	ON	
OFF LAMP	VDC OFF indicator lamp status (Note 3)	When VDC OFF indicator lamp is ON	ON	BRC-78. "CAN Communication System Inspection"
		When VDC OFF indicator lamp is OFF	OFF	
SLIP LAMP	SLIP indicator lamp status (Note 4)	When SLIP indicator lamp is ON	ON	
		When SLIP indicator lamp is OFF	OFF	
FR LH IN SOL FR LH OUT SOL FR RH IN SOL FR RH OUT SOL RR RH IN SOL RR RH OUT SOL RR LH IN SOL RR LH OUT SOL	Solenoid valve operation	Actuator (solenoid) is active ("ACTIVE TEST" with CONSULT-III) or actuator relay is inactive (in fail-safe mode).	ON	BRC-74. "Solenoid and VDC Change-Over Valve System Inspection"
		When actuator (solenoid) is not active and actuator relay is active (ignition switch ON).	OFF	
CV1 CV2 SV1 SV2	VDC switch-over valve status	When actuator (switch-over valve) is active ("ACTIVE TEST" with CONSULT-III) or actuator relay is inactive (when in fail-safe mode).	ON	
		When actuator (switch-over valve) is not active and actuator relay is active (ignition switch ON).	OFF	
DECCEL G-SEN	Longitudinal acceleration detected by Decel G-Sensor	Vehicle stopped	ON	BRC-73. "Yaw Rate/Side/Decel G Sensor System Inspection"
		Vehicle running	OFF	
FLUID LEV SW	ON/OFF status of brake fluid level switch	When brake fluid level switch ON	ON	DI-23
		When brake fluid level switch OFF	OFF	
STOP LAMP SW2	ASCDC operation condition	ASCDC activated	ON	ASCDC and circuit
		ASCDC not activated	OFF	

TROUBLE DIAGNOSIS

< SERVICE INFORMATION >

[VDC/TCS/ABS]

Monitor item	Display content	Data monitor		Note: Error inspection checklist
		Condition	Reference value in normal operation	
VDC SIGNAL TCS SIGNAL ABS SIGNAL EBD SIGNAL	Signal status	VDC active TCS active ABS active EBD active	ON	VDC system TCS system ABS system EBD system
		VDC not active TCS not active ABS not active EBD not active	OFF	
VDC FAIL SIG TCS FAIL SIG ABS FAIL SIG EBD FAIL SIG	Fail signal status	VDC fail TCS fail ABS fail EBD fail	ON	VDC system TCS system ABS system EBD system

Note 1: Confirm tire pressure is normal.

Note 2: ON/OFF timing of ABS warning lamp

ON: For approximately 2 seconds after ignition switch is turned ON, or when a malfunction is detected.

OFF: Approximately 2 seconds after ignition switch is turned ON (when system is in normal operation) and TCS/VDC function is not activated.

Note 3: ON/OFF timing of VDC OFF indicator lamp

ON: For approximately 2 seconds after ignition switch is turned ON, or when a malfunction is detected and VDC OFF switch is ON.

OFF: Approximately 2 seconds after ignition switch is turned ON (when system is in normal operation.) And when VDC OFF switch is OFF.

Note 4: SLIP indicator lamp ON/OFF timing

ON: For approximately 2 seconds after ignition switch is turned ON, or when a malfunction is detected and TCS/VDC function is activated while driving.

OFF: Approximately 2 seconds after ignition switch is turned ON (when system is in normal operation) and TCS/VDC function is not activated.

Flashing: TCS/VDC function is active during driving

CONSULT-III Function (ABS)

INFOID:000000004279006

CONSULT-III can display each diagnostic item using the diagnostic test modes shown following.

ABS diagnostic mode	Description
WORK SUPPORT	Supports inspection and adjustments. Commands are transmitted to the ABS actuator and electric unit (control unit) for setting the status suitable for required operation, input/output signals are received from the ABS actuator and electric unit (control unit) and received data is displayed.
SELF-DIAG RESULTS	Displays ABS actuator and electric unit (control unit) self-diagnosis results.
DATA MONITOR	Displays ABS actuator and electric unit (control unit) input/output data in real time.
CAN DIAG SUPPORT MNTR	The result of transmit/receive diagnosis of CAN communication can be read.
ACTIVE TEST	Operation of electrical loads can be checked by sending drive signal to them.
FUNCTION TEST	Conducted by CONSULT-III instead of a technician to determine whether each system is "OK" or "NG".
ECU PART NUMBER	ABS actuator and electric unit (control unit) part number can be read.

SELF-DIAGNOSIS

Description

If an error is detected in the system, the ABS warning lamp will turn on. In this case, perform self-diagnosis as follows:

Operation Procedure

1. Turn ignition switch OFF.
2. Connect CONSULT-III to the data link connector.
3. Turn ignition switch ON.
4. Start engine and drive at approximately 30 km/h (19 MPH) or more for approximately 1 minute.

TROUBLE DIAGNOSIS

[VDC/TCS/ABS]

< SERVICE INFORMATION >

5. After stopping the vehicle, with the engine running, touch “ABS”, “SELF-DIAG RESULTS” in order on the CONSULT-III screen.
6. The self-diagnostic results are displayed. (If necessary, the self-diagnostic results can be printed out by touching “COPY”.)
 - When “NO DTC IS DETECTED” is displayed, check the ABS warning lamp, SLIP indicator lamp and VDC OFF indicator lamp.
7. Conduct the appropriate inspection from the display item list, and repair or replace the malfunctioning component.
8. Start engine and drive at approximately 30 km/h (19 MPH) or more for approximately 1 minute.

CAUTION:

 - **When a wheel sensor “short-circuit” is detected, if the vehicle is not driven at 30 km/h (19 MPH) or more for at least 1 minute, the ABS warning lamp will not turn off even if the malfunction is repaired.**
9. Turn ignition switch OFF to prepare for erasing the memory.
10. Start the engine and touch “ABS”, “SELF-DIAG RESULTS”, “ERASE” in order on the CONSULT-III screen to erase the error memory.
If “ABS” is not indicated, go to [GI-35, "CONSULT-III Data Link Connector \(DLC\) Circuit"](#).

CAUTION:

If the error memory is not erased, re-conduct the operation from step 4.
11. For the final inspection, drive at approximately 30 km/h (19 MPH) or more for approximately 1 minute and confirm that the ABS warning lamp, SLIP indicator lamp, and VDC OFF indicator lamp turn off.

Display Item List

Self-diagnostic item	Malfunction detecting condition	Check system	
FR LH SENSOR 1 [C1104]	Circuit of front LH wheel sensor is open	BRC-70, "Wheel Sensor System Inspection" (Note 1)	
RR RH SENSOR 1 [C1101]	Circuit of rear RH wheel sensor is open		
FR RH SENSOR 1 [C1103]	Circuit of front RH wheel sensor is open		
RR LH SENSOR 1 [C1102]	Circuit of rear LH wheel sensor is open		
FR LH SENSOR 2 [C1108]	Circuit of front LH wheel sensor is shorted, or sensor power voltage is unusual. ABS actuator and electric unit (control unit) cannot identify sensor pulses, because of large gap between wheel sensor and sensor rotor.		
RR RH SENSOR 2 [C1105]	Circuit of rear RH wheel sensor is shorted, or sensor power voltage is unusual. ABS actuator and electric unit (control unit) cannot identify sensor pulses, because of large gap between wheel sensor and sensor rotor.		
FR RH SENSOR 2 [C1107]	Circuit of front RH wheel sensor is shorted, or sensor power voltage is unusual. ABS actuator and electric unit (control unit) cannot identify sensor pulses, because of large gap between wheel sensor and sensor rotor.		
RR LH SENSOR 2 [C1106]	Circuit of rear LH wheel sensor is shorted, or sensor power voltage is unusual. ABS actuator and electric unit (control unit) cannot identify sensor pulses, because of large gap between wheel sensor and sensor rotor.		
STOP LAMP SW 1 [C1116]	Stop lamp switch or circuit malfunction.		BRC-76, "Stop Lamp Switch System Inspection"
ST ANGLE SEN CIRCUIT [C1143, C1163]	Neutral position of steering angle sensor is dislocated, or steering angle sensor is malfunctioning.		BRC-72, "Steering Angle Sensor System Inspection"
YAW RATE SENSOR [C1145]	Yaw rate sensor has generated an error, or yaw rate sensor signal line is open or shorted.	BRC-73, "Yaw Rate/Side/Decel G Sensor System Inspection"	

TROUBLE DIAGNOSIS

< SERVICE INFORMATION >

[VDC/TCS/ABS]

Self-diagnostic item	Malfunction detecting condition	Check system	
FR LH IN ABS SOL [C1120]	Circuit of front LH IN ABS solenoid is open or shorted, or control line is open or shorted to power supply or ground.	BRC-74. "Solenoid and VDC Change-Over Valve System Inspection"	
FR LH OUT ABS SOL [C1121]	Circuit of front LH OUT ABS solenoid is open or shorted, or control line is open or shorted to power supply or ground.		
RR RH IN ABS SOL [C1126]	Circuit of rear RH IN ABS solenoid is open or shorted, or control line is open or shorted to power supply or ground.		
RR RH OUT ABS SOL [C1127]	Circuit of rear RH OUT ABS solenoid is open or shorted, or control line is open or shorted to power supply or ground.		
FR RH IN ABS SOL [C1122]	Circuit of front RH IN ABS solenoid is open or shorted, or control line is open or shorted to power supply or ground.		
FR RH OUT ABS SOL [C1123]	Circuit of front RH OUT ABS solenoid is open or shorted, or control line is open or shorted to power supply or ground.		
RR LH IN ABS SOL [C1124]	Circuit of rear LH IN ABS solenoid is open or shorted, or control line is open or shorted to power supply or ground.		
RR LH OUT ABS SOL [C1125]	Circuit of rear LH OUT ABS solenoid is open or shorted, or control line is open or shorted to power supply or ground.		
CV1 [C1164]	Front side VDC switch-over solenoid valve (cut valve) is open or shorted, or control line is open or shorted to power supply or ground.		
CV2 [C1165]	Rear side VDC switch-over solenoid valve (cut valve) is open or shorted, or control line is open or shorted to power supply or ground.		
SV1 [C1166]	Front side VDC switch-over solenoid valve (suction valve) is open or shorted, or control line is open or shorted to power supply or ground.		
SV2 [C1167]	Rear side VDC switch-over solenoid valve (suction valve) is open or shorted, or control line is open or shorted to power supply or ground.		
PUMP MOTOR (Note 3) [C1111]	During actuator motor operation with ON, when actuator motor turns OFF or when control line for actuator motor relay is open.		BRC-75. "Actuator Motor, Motor Relay, and Circuit Inspection"
	During actuator motor operation with OFF, when actuator motor turns ON or when control line for relay is shorted to ground.		
BATTERY VOLTAGE [ABNORMAL] [C1109]	ABS actuator and electric unit (control unit) power voltage is too low.	BRC-77. "ABS/TCS/VDC Control Unit Power and Ground Systems Inspection"	
ST ANGLE SEN SIGNAL [C1144]	Neutral position correction of steering angle sensor is not finished.	BRC-72. "Steering Angle Sensor System Inspection"	
ST ANG SEN COM CIR [C1156]	CAN communication line or steering angle sensor has generated an error.		
LONGITUDINAL G-SENSOR [C1113]	Longitudinal G-sensor is malfunctioning, or signal line of longitudinal G-sensor is open or shorted.	BRC-73. "Yaw Rate/Side/Decel G Sensor System Inspection"	
CONTROLLER FAILURE [C1110]	Internal malfunction of ABS actuator and electric unit (control unit) or wheel speed signal malfunction.	BRC-71. "ABS/TCS/VDC Control Unit Inspection"	
CAN COMM CIRCUIT [U1000]	<ul style="list-style-type: none"> • CAN communication line is open or shorted. • ABS actuator and electric unit (control unit) internal malfunction • Battery voltage for ECM is suddenly interrupted for approximately 0.5 second or more. 	BRC-78. "CAN Communication System Inspection" (Note 2)	
LATERAL G-SENSOR [C1146]	Lateral G-sensor is malfunctioning, or signal line of lateral G-sensor is open or shorted.	BRC-73. "Yaw Rate/Side/Decel G Sensor System Inspection"	
BR FLUID LEVEL LOW [C1155]	Brake fluid level drops or circuit between ABS actuator and electric unit (control unit) and brake fluid level switch is shorted.	BRC-78. "Brake Fluid Level Switch System Inspection"	

A
B
C
D
E
BRC
G
H
I
J
K
L
M
N
O
P

TROUBLE DIAGNOSIS

[VDC/TCS/ABS]

< SERVICE INFORMATION >

Self-diagnostic item	Malfunction detecting condition	Check system
ENGINE SIGNAL 1 [C1130]	ECM judges the communication between ABS/TCS/VDC control unit and ECM is abnormal.	BRC-71, "Engine System Inspection"
ENGINE SIGNAL 2 [C1131]	ECM judges the communication between ABS/TCS/VDC control unit and ECM is abnormal.	
ENGINE SIGNAL 3 [C1132]	ECM judges the communication between ABS/TCS/VDC control unit and ECM is abnormal.	
ENGINE SIGNAL 4 [C1133]	ECM judges the communication between ABS/TCS/VDC control unit and ECM is abnormal.	
ENGINE SIGNAL 5 [C1134]	ECM judges the communication between ABS/TCS/VDC control unit and ECM is abnormal.	
ENGINE SIGNAL 6 [C1136]	ECM judges the communication between ABS/TCS/VDC control unit and ECM is abnormal.	
ACTUATOR RLY [C1140]	ABS actuator relay or circuit malfunction.	BRC-75, "Actuator Motor, Motor Relay, and Circuit Inspection"
STOP LAMP SW 2 [C1176]	ASCD brake switch or circuit malfunction.	ACS-2

Note 1. If wheel sensor 2 for each wheel is indicated, check ABS actuator and electric unit (control unit) power supply voltage in addition to wheel sensor circuit check.

Note 2. If multiple malfunctions are detected including CAN communication line [U1000], perform diagnosis for CAN communication line first.

Note 3: "ACTUATOR RLY" on the CONSULT-III self-diagnosis results indicates the malfunction of the actuator motor relay or circuit.

DATA MONITOR

Operation Procedure

1. After turning OFF the ignition switch, connect CONSULT-III to the data link connector.
2. Touch "ABS", "DATA MONITOR" in order on the CONSULT-III screen.
If "ABS" is not indicated, go to [GI-35, "CONSULT-III Data Link Connector \(DLC\) Circuit"](#).
3. From the "DATA MONITOR" screen, touch "ECU INPUT SIGNALS", "MAIN SIGNALS" or "SELECTION FROM MENU". Refer to the following information.
4. When "START" is touched, the data monitor screen is displayed.

Display Item List

Item (Unit)	Data monitor item selection			Remarks
	ECU INPUT SIGNALS	MAIN SIGNALS	SELECTION FROM MENU	
GEAR	×	×	×	Gear position judged by PNP switch signal is displayed.
FR RH SENSOR (km/h, MPH)	×	×	×	Wheel speed calculated by front RH wheel sensor signal is displayed.
FR LH SENSOR (km/h, MPH)	×	×	×	Wheel speed calculated by front LH wheel sensor signal is displayed.
RR RH SENSOR (km/h, MPH)	×	×	×	Wheel speed calculated by rear RH wheel sensor signal is displayed.
RR LH SENSOR (km/h, MPH)	×	×	×	Wheel speed calculated by rear LH wheel sensor signal is displayed.
BATTERY VOLT (V)	×	×	×	Voltage supplied to ABS actuator and electric unit (control unit) is displayed.
ACCEL POS SIG (%)	×	—	×	Throttle valve open/close status judged by CAN communication signal is displayed.

TROUBLE DIAGNOSIS

< SERVICE INFORMATION >

[VDC/TCS/ABS]

Item (Unit)	Data monitor item selection			Remarks
	ECU INPUT SIGNALS	MAIN SIGNALS	SELECTION FROM MENU	
ENGINE SPEED (rpm)	×	×	×	Engine speed judged by CAN communication signal is displayed.
STR ANGLE SIG (deg)	×	-	×	Steering angle detected by steering angle sensor is displayed.
YAW RATE SEN (d/s)	×	×	×	Yaw rate detected by yaw rate sensor is displayed.
DECEL G-SEN (d/s)	×	×	×	Longitudinal acceleration detected by decel G-sensor is displayed.
SIDE G-SENSOR (m/s ²)	×	-	×	Transverse acceleration detected by side G-sensor is displayed.
STOP LAMP SW (ON/OFF)	×	×	×	Stop lamp switch (ON/OFF) status is displayed.
OFF SW (ON/OFF)	×	×	×	VDC OFF switch (ON/OFF) status is displayed.
ABS WARN LAMP (ON/OFF)	-	×	×	ABS warning lamp (ON/OFF) status is displayed.
SLIP LAMP (ON/OFF)	-	×	×	SLIP indicator lamp (ON/OFF) status is displayed.
FR LH IN SOL (ON/OFF)	-	×	×	Front LH IN ABS solenoid (ON/OFF) status is displayed.
FR LH OUT SOL (ON/OFF)	-	×	×	Front LH OUT ABS solenoid (ON/OFF) status is displayed.
RR RH IN SOL (ON/OFF)	-	×	×	Rear RH IN ABS solenoid (ON/OFF) status is displayed.
RR RH OUT SOL (ON/OFF)	-	×	×	Rear RH OUT ABS solenoid (ON/OFF) status is displayed.
FR RH IN SOL (ON/OFF)	-	×	×	Front RH IN ABS solenoid (ON/OFF) status is displayed.
FR RH OUT SOL (ON/OFF)	-	×	×	Front RH OUT ABS solenoid (ON/OFF) status is displayed.
RR LH IN SOL (ON/OFF)	-	×	×	Rear LH IN ABS solenoid (ON/OFF) status is displayed.
RR LH OUT SOL (ON/OFF)	-	×	×	Rear LH OUT ABS solenoid (ON/OFF) status is displayed.
OFF LAMP (ON/OFF)	-	×	×	VDC OFF Lamp (ON/OFF) status is displayed.
MOTOR RELAY (ON/OFF)	-	×	×	ABS motor relay signal (ON/OFF) status is displayed.
ACTUATOR RLY (ON/OFF)	-	×	×	ABS actuator relay signal (ON/OFF) status is displayed.
EBD WARN LAMP (ON/OFF)	-	-	×	Brake warning lamp (ON/OFF) status is displayed.
P POSI SIG (ON/OFF)	-	-	×	Shift position judged by PNP switch signal.
N POSI SIG (ON/OFF)	-	-	×	Shift position judged by PNP switch signal.
CRANKING SIG (ON/OFF)	-	-	×	Ignition switch START position signal input status is displayed.
CV1 (ON/OFF)	-	-	×	Primary side switch-over solenoid valve (cut valve) (ON/OFF) status is displayed.

A

B

C

D

E

BRC

G

H

I

J

K

L

M

N

O

P

TROUBLE DIAGNOSIS

< SERVICE INFORMATION >

[VDC/TCS/ABS]

Item (Unit)	Data monitor item selection			Remarks
	ECU INPUT SIGNALS	MAIN SIGNALS	SELECTION FROM MENU	
CV2 (ON/OFF)	-	-	×	Secondary side switch-over solenoid valve (cut-valve) (ON/OFF) status is displayed.
SV1 (ON/OFF)	-	-	×	Primary side switch-over solenoid valve (suction valve) (ON/OFF) status is displayed.
SV2 (ON/OFF)	-	-	×	Secondary side switch-over solenoid valve (suction valve) (ON/OFF) status is displayed.
VDC FAIL SIG (ON/OFF)	-	-	×	VDC fail signal (ON/OFF) status is displayed.
TCS FAIL SIG (ON/OFF)	-	-	×	TCS fail signal (ON/OFF) status is displayed.
ABS FAIL SIG (ON/OFF)	-	-	×	ABS fail signal (ON/OFF) status is displayed.
EBD FAIL SIG (ON/OFF)	-	-	×	EBD fail signal (ON/OFF) status is displayed.
FLUID LEV SW (ON/OFF)	×	-	×	Brake fluid level switch (ON/OFF) status is displayed.
EBD SIGNAL (ON/OFF)	-	-	×	EBD operation (ON/OFF) status is displayed.
ABS SIGNAL (ON/OFF)	-	-	×	ABS operation (ON/OFF) status is displayed.
TCS SIGNAL (ON/OFF)	-	-	×	TCS operation (ON/OFF) status is displayed.
VDC SIGNAL (ON/OFF)	-	-	×	VDC operation (ON/OFF) status is displayed.
STOP LAMP SW2	-	-	×	ASCD (ON/OFF) status is displayed.

×: Applicable

-: Not applicable

ACTIVE TEST

CAUTION:

- Do not perform active test while driving.
- Make sure to completely bleed air from the brake system.
- The ABS and brake warning lamps turn on during the active test.

Operation Procedure

1. Connect the CONSULT-III to the data link connector and start the engine.
2. Touch "ABS".
If "ABS" is not indicated, go to [GI-35. "CONSULT-III Data Link Connector \(DLC\) Circuit"](#).
3. Touch "ACTIVE TEST".
4. The "SELECT TEST ITEM" screen is displayed.
5. Touch necessary test item.
6. With the "MAIN SIGNALS" display selected, touch "START".
7. The Active Test screen will be displayed, so conduct the following test.

Solenoid Valve Operation Chart

TROUBLE DIAGNOSIS

< SERVICE INFORMATION >

[VDC/TCS/ABS]

Operation		ABS solenoid valve			ABS solenoid valve (ACT)		
		UP	KEEP	DOWN	UP	ACTUA-TOR UP	ACTUA-TOR KEEP
FR RH SOL FR RH ABS SOLE- NOID (ACT)	FR RH IN SOL	OFF	ON	ON	OFF	OFF	OFF
	FR RH OUT SOL	OFF	OFF	ON*	OFF	OFF	OFF
FR LH SOL FR LH ABS SOLE- NOID (ACT)	FR LH IN SOL	OFF	ON	ON	OFF	OFF	OFF
	FR LH OUT SOL	OFF	OFF	ON*	OFF	OFF	OFF
RR RH SOL RR RH ABS SOLE- NOID (ACT)	RR RH IN SOL	OFF	ON	ON	OFF	OFF	OFF
	RR RH OUT SOL	OFF	OFF	ON*	OFF	OFF	OFF
RR LH SOL RR LH ABS SOLE- NOID (ACT)	RR LH IN SOL	OFF	ON	ON	OFF	OFF	OFF
	RR LH OUT SOL	OFF	OFF	ON*	OFF	OFF	OFF

*: ON for 1 to 2 seconds after the touch, and then OFF

NOTE:

- If active test is performed with brake pedal depressed, pedal stroke may change. This is normal.
- “TEST IS STOPPED” is displayed approximately 10 seconds after operation starts.
- After “TEST IS STOPPED” is displayed, to perform test again, repeat Step 6.

ABS Motor

Touch “ON” and “OFF” on the screen. Check that ABS motor relay operates as shown in table below.

Operation	ON	OFF
ABS actuator relay	ON	ON
ABS motor relay	ON	OFF

NOTE:

- If active test is performed with brake pedal depressed, pedal stroke may change. This is normal.
- “TEST IS STOPPED” is displayed approximately 10 seconds after operation starts.

A
B
C
D
E
G
H
I
J
K
L
M
N
O
P

BRC

TROUBLE DIAGNOSIS FOR SELF-DIAGNOSTIC ITEMS

< SERVICE INFORMATION >

[VDC/TCS/ABS]

TROUBLE DIAGNOSIS FOR SELF-DIAGNOSTIC ITEMS

Wheel Sensor System Inspection

INFOID:000000004279007

INSPECTION PROCEDURE

1. CONNECTOR INSPECTION

Disconnect the ABS actuator and electric unit connector E125 and wheel sensor of malfunctioning code. Check the terminals for deformation, disconnection, looseness or damage.

OK or NG

- OK >> GO TO 2.
NG >> Repair or replace as necessary.

2. CHECK WHEEL SENSOR OUTPUT SIGNAL

1. Connect ABS active wheel sensor tester (J-45741) to wheel sensor using appropriate adapter.
2. Turn on the ABS active wheel sensor tester power switch.

NOTE:

The green POWER indicator should illuminate. If the POWER indicator does not illuminate, replace the battery in the ABS active wheel sensor tester before proceeding.

3. Spin the wheel of the vehicle by hand and observe the red SENSOR indicator on the ABS active wheel sensor tester. The red SENSOR indicator should flash on and off to indicate an output signal.

NOTE:

If the red SENSOR indicator illuminates but does not flash, reverse the polarity of the tester leads and retest.

Does the ABS active wheel sensor tester detect a signal?

- YES >> GO TO 3.
NO >> Replace the wheel sensor. Refer to [BRC-85, "Removal and Installation"](#).

3. CHECK TIRES

Check for inflation pressure, wear and size of each tire.

Are tire pressure and size correct and is tire wear within specifications?

- YES >> GO TO 4.
NO >> Adjust tire pressure or replace tire(s).

4. CHECK WHEEL BEARINGS

Check wheel bearing axial end play. Refer to [FAX-5, "On-Vehicle Inspection and Service"](#) or [RAX-5, "On-Vehicle Inspection and Service"](#).

OK or NG

- OK >> GO TO 5.
NG >> Repair or replace as necessary. Refer to [FAX-5, "On-Vehicle Inspection and Service"](#) or [RAX-5, "On-Vehicle Inspection and Service"](#).

5. CHECK WIRING HARNESS FOR SHORT CIRCUIT

Check continuity between wheel sensor harness connector terminals and ground.

Continuity should not exist.

OK or NG

- OK >> GO TO 6.
NG >> Repair the circuit.

6. CHECK WIRING HARNESS FOR OPEN CIRCUIT

1. Check continuity between ABS actuator and electric unit (control unit) harness connector and wheel sensor harness connector.

TROUBLE DIAGNOSIS FOR SELF-DIAGNOSTIC ITEMS

< SERVICE INFORMATION >

[VDC/TCS/ABS]

Wheel sensor	ABS actuator and electric unit (control unit)		Wheel sensor		Continuity
	Connector	Terminal	Connector	Terminal	
Front LH	E125	13	E18	1	Yes
		14		2	
Front RH		27	E117	1	
		26		2	
Rear LH		29	B123	1	
		28		2	
Rear RH		11	B122	1	
		12		2	

OK or NG

- OK >> Replace the ABS actuator and electric unit (control unit). Refer to [BRC-87, "Removal and Installation"](#).
- NG >> Repair the circuit.

BRC

Engine System Inspection

INFOID:000000004279008

INSPECTION PROCEDURE

1. SELF-DIAGNOSIS RESULT CHECK

Check self-diagnosis results.

Self-diagnosis results
ENGINE SIGNAL 1
ENGINE SIGNAL 2
ENGINE SIGNAL 3
ENGINE SIGNAL 4
ENGINE SIGNAL 5
ENGINE SIGNAL 6

Is the above displayed in the self-diagnosis display items?

- YES >> GO TO 2.
- NO >> Inspection End.

2. ENGINE SYSTEM INSPECTION

1. Perform ECM self-diagnosis and repair as necessary.
2. Perform ABS actuator and electric unit (control unit) self-diagnosis again.

OK or NG

- OK >> Inspection End.
- NG >> Repair or replace as necessary.

ABS/TCS/VDC Control Unit Inspection

INFOID:000000004279009

INSPECTION PROCEDURE

1. SELF-DIAGNOSIS RESULT CHECK

Check self-diagnosis results.

Self-diagnosis results
CONTROLLER FAILURE

Is the above displayed in the self-diagnosis display items?

TROUBLE DIAGNOSIS FOR SELF-DIAGNOSTIC ITEMS

< SERVICE INFORMATION >

[VDC/TCS/ABS]

- YES >> GO TO 2.
NO >> Inspection End.

2.CHECK WHEEL SENSORS

Check all wheel sensors. Refer to [BRC-70, "Wheel Sensor System Inspection"](#).

OK or NG

- OK >> Replace ABS Actuator and electric unit (control unit). Refer to [BRC-87, "Removal and Installation"](#).
NG >> Repair or replace as necessary.

Steering Angle Sensor System Inspection

INFOID:000000004279010

INSPECTION PROCEDURE

1.SELF-DIAGNOSIS RESULT CHECK

Check self-diagnosis results.

Self-diagnosis results
ST ANGLE SEN CIRCUIT
ST ANGLE SEN SIGNAL
ST ANG SEN COM CIR

Is the above displayed in the self-diagnosis display items?

- YES >> GO TO 3.
NO >> GO TO 2.

2.DATA MONITOR CHECK

Conduct "Data Monitor" of the "STR ANGLE SIG" to check if the status is normal.

Steering condition	Data monitor
Straight-ahead	-5deg - +5deg
Turn wheel 90° to the right.	Approx. +90°
Turn wheel 90° to the left.	Approx. -90°

OK or NG

- OK >> Inspection End.
NG >> GO TO 3.

3.CONNECTOR INSPECTION

1. Disconnect the ABS actuator and electric unit (control unit) connector E125 and steering angle sensor M47.
2. Check the terminals for deformation, disconnection, looseness or damage.

OK or NG

- OK >> GO TO 4.
NG >> Repair or replace as necessary.

4. CHECKING STEERING ANGLE SENSOR POWER AND GROUND

1. Turn the ignition switch ON.

TROUBLE DIAGNOSIS FOR SELF-DIAGNOSTIC ITEMS

[VDC/TCS/ABS]

< SERVICE INFORMATION >

- Check voltage between steering angle sensor connector M47 and ground.

Terminals			Measured value (Approx.)
(+)		(-)	
Steering angle sensor connector	Terminal		
M47	1	Ground	12V
	3		12V

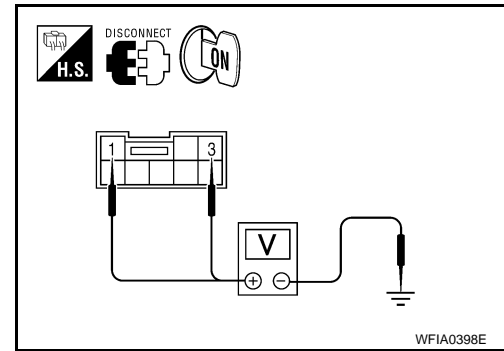

- Turn ignition switch OFF.
- Check resistance between steering angle sensor connector M47 and ground.

Terminals			Measured value Ω (Approx.)
(+)		(-)	
Steering angle sensor connector	Terminal		
M47	2	Ground	0 Ω

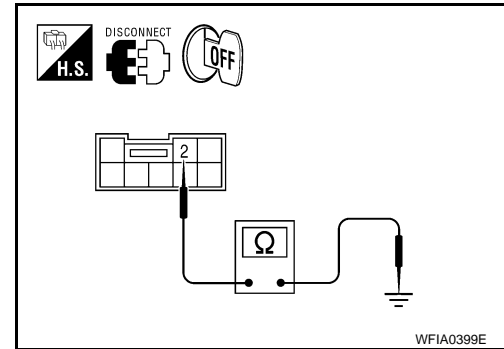

OK or NG

- OK >> Check the CAN communication system. Refer to [BRC-78, "CAN Communication System Inspection"](#). If the CAN communication system is OK, replace spiral cable (steering angle sensor) and adjust neutral position of steering angle sensor. Refer to [BRC-84, "Adjustment of Steering Angle Sensor Neutral Position"](#).
- NG >> Repair the circuit.

Yaw Rate/Side/Decel G Sensor System Inspection

INFOID:000000004279011

CAUTION:

Sudden turns (such as spin turns, acceleration turns), drifting, etc. when VDC function is OFF may cause the yaw rate/side/decel G sensor system to indicate a problem. This is not a problem if normal operation can be resumed after restarting the engine.

INSPECTION PROCEDURE

1. SELF-DIAGNOSIS RESULT CHECK

Check self-diagnosis results.

Self-diagnosis results
YAW RATE SENSOR
LONGITUDINAL G-SENSOR
LATERAL G-SENSOR

CAUTION:

If vehicle is on turntable at entrance to parking garage, or on other moving surface, VDC OFF indicator lamp may illuminate and CONSULT-III self-diagnosis may indicate yaw rate sensor system malfunction. However, in this case there is no malfunction in yaw rate sensor system. Take vehicle off turntable or other moving surface, and start engine. Results will return to normal.

Is the above displayed in the self-diagnosis display items?

- YES >> GO TO 2.
NO >> Inspection End.

2. CONNECTOR INSPECTION

Disconnect the ABS actuator and electric unit (control unit) connector E125 and yaw rate/side/decel G sensor connector B125.

TROUBLE DIAGNOSIS FOR SELF-DIAGNOSTIC ITEMS

< SERVICE INFORMATION >

[VDC/TCS/ABS]

Check the terminals for deformation, disconnection, looseness or damage.

OK or NG

- OK >> GO TO 3.
- NG >> Repair or replace as necessary.

3. YAW RATE/SIDE/DECEL G SENSOR HARNESS INSPECTION

1. Turn ignition switch OFF and disconnect yaw rate/side/decel G sensor connector B125 and ABS actuator and electric unit (control unit) connector E125.
2. Check the continuity between the ABS actuator and electric unit (control unit) connector E125 and the yaw rate/side/decel G sensor connector B125.

ABS actuator and electric unit (control unit) connector E125	Yaw rate/side/decel G sensor connector B125	Continuity
19	1	Continuity should exist.
36	2	
35	3	
34	4	
4	5	
6	6	

OK or NG

- OK >> GO TO 4.
- NG >> Repair or replace as necessary.

4. YAW RATE/SIDE/DECEL G SENSOR INSPECTION

1. Connect the yaw rate/side/decel G sensor connector B125 and ABS actuator and electric unit (control unit) connector E125.
2. Use "Data Monitor" to check if the yaw rate/side/decel G sensor signals are normal.

Vehicle status	YAW RATE SEN (Data monitor standard)	SIDE G-SENSOR (Data monitor standard)	DECEL G-SEN (Data monitor standard)
When stopped	-4 to +4 deg/s	-1.1 to +1.1 m/s ²	-0.11 G to +0.11 G
Right turn	Negative value	Negative value	-
Left turn	Positive value	Positive value	-
Speed up	-	-	Negative value
Speed down	-	-	Positive value

OK or NG

- OK >> Inspection End.
- NG >> Replace the yaw rate/side/decel G sensor. Refer to [BRC-90, "Removal and Installation"](#).

Solenoid and VDC Change-Over Valve System Inspection

INFOID:000000004279012

INSPECTION PROCEDURE

1. SELF-DIAGNOSIS RESULT CHECK

Check self-diagnosis results.

Self-diagnosis results
FR LH IN ABS SOL
FR LH OUT ABS SOL

TROUBLE DIAGNOSIS FOR SELF-DIAGNOSTIC ITEMS

< SERVICE INFORMATION >

[VDC/TCS/ABS]

Self-diagnosis results
RR RH IN ABS SOL
RR RH OUT ABS SOL
FR RH IN ABS SOL
FR RH OUT ABS SOL
RR LH IN ABS SOL
RR LH OUT ABS SOL
CV 1
CV 2
SV 1
SV 2

A
B
C
D
E

Is the above displayed in the self-diagnosis display items?

- YES >> GO TO 2.
- NO >> Inspection End.

2. CONNECTOR INSPECTION

BRC

1. Disconnect ABS actuator and electric unit (control unit) connector E125.
2. Check the terminals for deformation, disconnection, looseness or damage.

OK or NG

- OK >> GO TO 3.
- NG >> Repair or replace as necessary.

3. CHECKING SOLENOID POWER AND GROUND

1. Check voltage between ABS actuator and electric unit (control unit) connector E125 and ground.

ABS actuator and electric unit (control unit) connector E125	Body ground	Measured value (Approx.)
16	—	12V

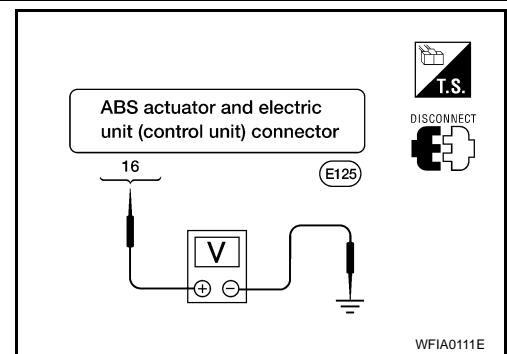

G
H
I
J
K
L

2. Check resistance between ABS actuator and electric unit (control unit) connector E125 and body ground.

ABS actuator and electric unit (control unit) connector E125	Body ground	Measured value Ω (Approx.)
31	—	0Ω
46	—	0Ω

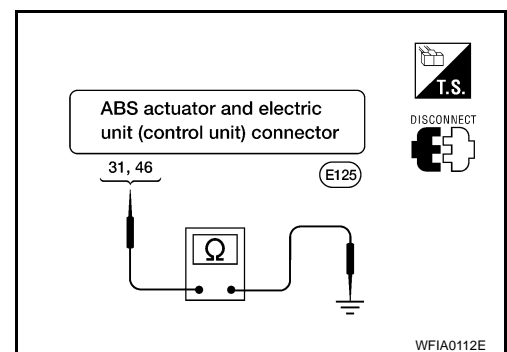

M
N
O
P

OK or NG

- OK >> Perform self-diagnosis again. If the same results appear, replace ABS actuator and electric unit (control unit). Refer to [BRC-87, "Removal and Installation"](#).
- NG >> Repair the circuit.

Actuator Motor, Motor Relay, and Circuit Inspection

INFOID:000000004279013

INSPECTION PROCEDURE

1. CHECKING SELF-DIAGNOSIS RESULTS

TROUBLE DIAGNOSIS FOR SELF-DIAGNOSTIC ITEMS

< SERVICE INFORMATION >

[VDC/TCS/ABS]

Check self-diagnosis results.

Self-diagnosis results
PUMP MOTOR
ACTUATOR RLY

Is the above displayed in the self-diagnosis display items?

- YES >> GO TO 2.
- NO >> Inspection End.

2. CONNECTOR INSPECTION

1. Disconnect ABS actuator and electric unit (control unit) connector E125.
2. Check the terminals for deformation, disconnection, looseness or damage.

OK or NG

- OK >> GO TO 3.
- NG >> Repair or replace as necessary.

3. CHECKING ABS MOTOR AND MOTOR RELAY POWER SYSTEM

1. Check voltage between ABS actuator and electric unit (control unit) connector E125 and ground.

ABS actuator and electric unit (control unit) connector E125	Body ground	Measured value (Approx.)
1	—	12V

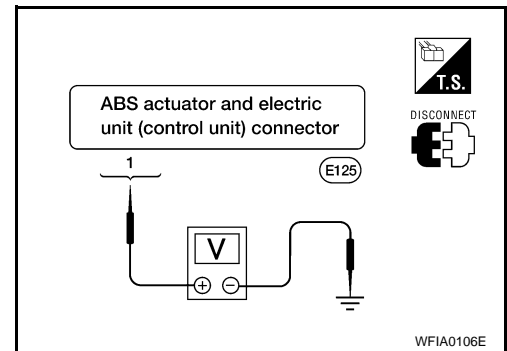

2. Check resistance between ABS actuator and electric unit (control unit) connector E125 and ground.

ABS actuator and electric unit (control unit) connector E125	Body ground	Measured value (Approx.)
46	—	0Ω

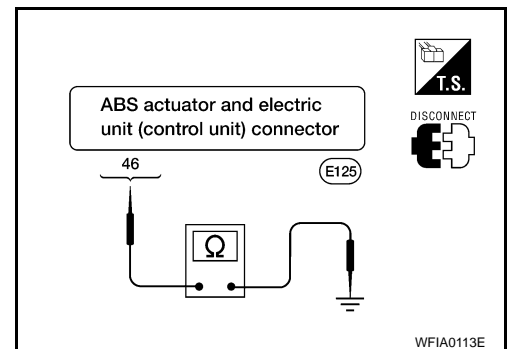

OK or NG

- OK >> Perform self-diagnosis again. If the same results appear, replace ABS actuator and electric unit (control unit). Refer to [BRC-87. "Removal and Installation"](#).
- NG >> Repair the circuit.

Stop Lamp Switch System Inspection

INFOID:000000004279014

INSPECTION PROCEDURE

1. SELF-DIAGNOSIS RESULT CHECK

Check self-diagnosis results.

Self-diagnosis results
STOP LAMP SW 1

Is the above displayed in the self-diagnosis display items?

- YES >> GO TO 2.
- NO >> Inspection End.

TROUBLE DIAGNOSIS FOR SELF-DIAGNOSTIC ITEMS

< SERVICE INFORMATION >

[VDC/TCS/ABS]

2. CONNECTOR INSPECTION

1. Disconnect the ABS actuator and electric unit (control unit) connector E125 and stop lamp switch connector E38.
2. Check the terminals for deformation, disconnection, looseness or damage.

OK or NG

- OK >> GO TO 3.
 NG >> Repair or replace as necessary.

3. STOP LAMP SWITCH INSPECTION

Check the voltage between the ABS actuator and electric unit (control unit) connector E125 terminal 23 and ground.

- 23 - Ground**
Brake pedal depressed : Battery voltage (approx. 12V)
Brake pedal not depressed : Approx. 0V

OK or NG

- OK >> Perform self-diagnosis again. If the same results appear, replace ABS actuator and electric unit (control unit). Refer to [BRC-87, "Removal and Installation"](#).
 NG >> Repair the circuit.

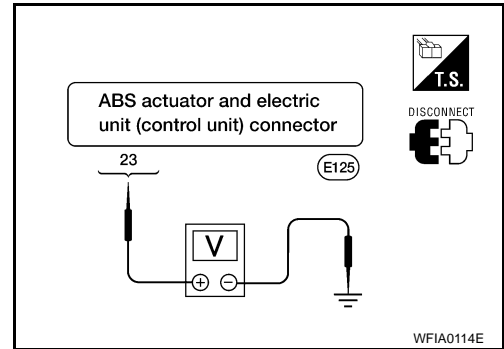

ABS/TCS/VDC Control Unit Power and Ground Systems Inspection

INFOID:0000000004279015

INSPECTION PROCEDURE

1. SELF-DIAGNOSIS RESULT CHECK

Check self-diagnosis results.

Self-diagnosis results
BATTERY VOLTAGE

Is the above displayed in the self-diagnosis display items?

- YES >> GO TO 2.
 NO >> Inspection End.

2. CONNECTOR INSPECTION

1. Disconnect the ABS actuator and electric unit (control unit) connector E125.
2. Check the terminals for deformation, disconnection, looseness or damage.

OK or NG

- OK >> GO TO 3.
 NG >> Repair or replace as necessary.

3. ABS/TCS/VDC CONTROL UNIT POWER AND GROUND CIRCUIT INSPECTION

Measure the voltage and continuity between the ABS actuator and electric unit (control unit) connector E125 and ground.

Signal name	ABS actuator and electric unit (control unit) connector E125	Ground	Measured value
Power supply	45	—	Battery voltage (Approx. 12V)
Ground	31		Continuity should exist.
	46		

OK or NG

TROUBLE DIAGNOSIS FOR SELF-DIAGNOSTIC ITEMS

< SERVICE INFORMATION >

[VDC/TCS/ABS]

- OK >> Check the battery for loose terminals, low voltage, etc. Repair as necessary.
- NG >> Repair the circuit.

Brake Fluid Level Switch System Inspection

INFOID:000000004279016

INSPECTION PROCEDURE

1.SELF-DIAGNOSIS RESULT CHECK

1. Check the brake fluid reservoir fluid level. If the level is low, add brake fluid.
2. Erase the self-diagnosis results and check the self-diagnosis results.

Self-diagnosis results

BR FLUID LEVEL LOW

Is the above displayed in the self-diagnosis display items?

- YES >> GO TO 2.
- NO >> Inspection End.

2.CONNECTOR INSPECTION

1. Disconnect the ABS actuator and electric unit (control unit) connector E125 and brake fluid level switch connector E21.
2. Check the terminals for deformation, disconnection, looseness or damage.

OK or NG

- OK >> GO TO 3.
- NG >> Repair or replace as necessary.

3.CHECK THE HARNESS BETWEEN THE BRAKE FLUID LEVEL SWITCH AND THE ABS ACTUATOR AND ELECTRIC UNIT (CONTROL UNIT)

Check the continuity between the brake fluid level switch connector E21 and the ABS actuator and electric unit (control unit) connector E125.

ABS actuator and electric unit (control unit) connector E125	Brake fluid level switch connector E21	Continuity
38	+	Continuity should exist.
38	Ground	Continuity should not exist.
Ground	-	Continuity should exist.

OK or NG

- OK >> GO TO 4.
- NG >> Repair the circuit.

4.CHECK BRAKE FLUID LEVEL SWITCH

Check continuity between brake fluid level switch terminals + and -.

Continuity should not exist.

OK or NG

- OK >> Perform self-diagnosis again. If the same results appear, replace ABS actuator and electric unit (control unit). Refer to [BRC-87, "Removal and Installation"](#).
- NG >> Replace brake fluid level switch.

CAN Communication System Inspection

INFOID:000000004279017

INSPECTION PROCEDURE

1.CHECK CONNECTOR

TROUBLE DIAGNOSIS FOR SELF-DIAGNOSTIC ITEMS

< SERVICE INFORMATION >

[VDC/TCS/ABS]

1. Turn ignition switch OFF, disconnect the ABS actuator and electric unit (control unit) connector and check the terminals for deformation, disconnection, looseness or damage. If there is a malfunction, repair or replace the terminal.
2. Reconnect connector to perform self-diagnosis.

Is "CAN COMM CIRCUIT" displayed in the self-diagnosis display items?

- YES >> Print out the self-diagnosis results, and refer to [LAN-39](#).
NO >> Connector terminal connection is loose, damaged, open, or shorted.

Component Inspection

INFOID:000000004279018

VDC OFF SWITCH

Check the continuity between terminals 1 and 2.

- 1 - 2 : Continuity should exist when pushing the switch.
Continuity should not exist when releasing the switch.**

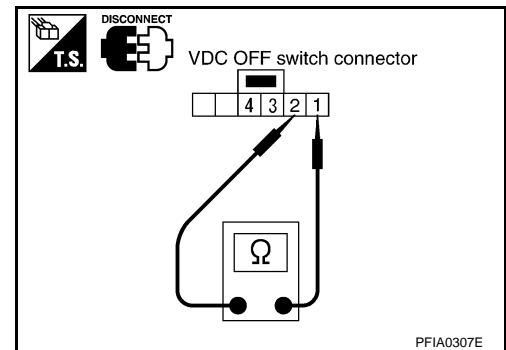

TROUBLE DIAGNOSES FOR SYMPTOMS

ABS Works Frequently

INFOID:000000004279019

1.CHECK WARNING LAMP ACTIVATION

Make sure warning lamp remains off while driving.

OK or NG

OK >> GO TO 2.

NG >> Carry out self-diagnosis. Refer to [BRC-63. "CONSULT-III Function \(ABS\)"](#).

2.CHECK WHEEL SENSORS

Check the following.

- Wheel sensor mounting for looseness
- Wheel sensors for physical damage
- Wheel sensor connectors for terminal damage or loose connections

OK or NG

OK >> GO TO 3.

NG >> Repair or replace as necessary.

3.CHECK WHEEL BEARINGS

Check wheel bearing axial end play. Refer to [FAX-5. "On-Vehicle Inspection and Service"](#) or [RAX-5. "On-Vehicle Inspection and Service"](#).

OK or NG

OK >> GO TO 4.

NG >> Repair as necessary.

4.CHECK BRAKE FLUID PRESSURE

Check brake fluid pressure distribution.

Refer to [BR-13. "Inspection"](#).

Is brake fluid pressure distribution normal?

YES >> Inspection End.

NO >> Perform Basic Inspection. Refer to [BRC-59. "Basic Inspection"](#).

Unexpected Pedal Action

INFOID:000000004279020

1.CHECK WARNING LAMP ACTIVATION

Make sure warning lamp remains off while driving.

OK or NG

OK >> GO TO 2.

NG >> Carry out self-diagnosis. Refer to [BRC-63. "CONSULT-III Function \(ABS\)"](#).

2.CHECK BRAKE PEDAL STROKE

Check brake pedal stroke.

Is pedal stroke excessive?

YES >> Perform Basic Inspection. Refer to [BRC-59. "Basic Inspection"](#).

NO >> GO TO 3.

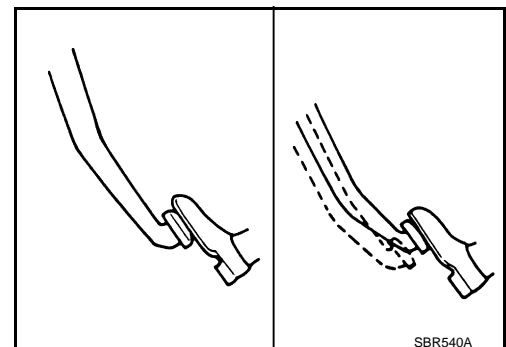

TROUBLE DIAGNOSES FOR SYMPTOMS

< SERVICE INFORMATION >

[VDC/TCS/ABS]

3. CHECK CONNECTOR AND BRAKING PERFORMANCE

1. Disable ABS by disconnecting ABS actuator and electric unit (control unit) connector.
2. Drive vehicle and check brake operation.

NOTE:

- Stopping distance may be longer than vehicles without ABS when road condition is slippery.
- Driving the vehicle with the ABS actuator and electric unit (control unit) disconnected may induce DTCs in electrical control units using CAN communication. After the inspection, clear all DTCs. Refer to [LAN-39](#).

OK or NG

OK >> GO TO 4.

NG >> Perform Basic Inspection. Refer to [BRC-59, "Basic Inspection"](#).

4. CHECK WHEEL SENSORS

Check the following.

- Wheel sensor mounting for looseness
- Wheel sensors for physical damage
- Wheel sensor connectors for terminal damage or loose connections

OK or NG

OK >> Check ABS actuator and electric unit (control unit) connector terminals for deformation, disconnection, looseness or damage. Reconnect ABS actuator and electric unit (control unit) harness connector. Then retest.

NG >> Repair or replace as necessary.

Long Stopping Distance

INFOID:000000004279021

1. CHECK BASE BRAKING SYSTEM PERFORMANCE

1. Disable ABS by disconnecting ABS actuator and electric unit (control unit) connector.
2. Drive vehicle and check brake operation.

NOTE:

- Stopping distance may be longer than vehicles without ABS when road condition is slippery.
- Driving the vehicle with the ABS actuator and electric unit (control unit) disconnected may induce DTCs in electrical control units using CAN communication. After the inspection, clear all DTCs. Refer to [LAN-39](#).

OK or NG

OK >> Go to [BRC-80, "ABS Works Frequently"](#).

NG >> Perform Basic Inspection. Refer to [BRC-59, "Basic Inspection"](#).

ABS Does Not Work

INFOID:000000004279022

CAUTION:

The ABS does not operate when the vehicle speed is 10 km/h (6 MPH) or less.

1. CHECK WARNING LAMP ACTIVATION

Turn ignition switch ON and check for warning lamp activation.

- Warning lamp should activate for approximately 2 seconds after turning the ignition switch ON.

OK or NG

OK >> Carry out self-diagnosis. Refer to [BRC-63, "CONSULT-III Function \(ABS\)"](#).

NG >> Go to [BRC-82, "ABS Warning Lamp Does Not Come On When Ignition Switch Is Turned On"](#).

Pedal Vibration or ABS Operation Noise

INFOID:000000004279023

NOTE:

During ABS activation, pedal vibration may be felt and a noise may be heard. This is normal and does not indicate a malfunction.

TROUBLE DIAGNOSES FOR SYMPTOMS

[VDC/TCS/ABS]

< SERVICE INFORMATION >

1. CHECK SYMPTOM

1. Apply brake.
2. Start engine.

Does the symptom occur only when engine is started?

- YES >> Carry out self-diagnosis. Refer to [BRC-63, "CONSULT-III Function \(ABS\)"](#).
NO >> GO TO 2.

2. RECHECK SYMPTOM

Does the symptom occur only when electrical equipment switches (such as headlamps) are turned on?

- YES >> Check for radio, antenna or related wiring that is routed too close to the ABS actuator and electric unit (control unit) and reroute as necessary.
NO >> Go to [BRC-80, "ABS Works Frequently"](#).

ABS Warning Lamp Does Not Come On When Ignition Switch Is Turned On

INFOID:000000004279024

1. CHECK ABS ACTUATOR AND ELECTRIC UNIT (CONTROL UNIT) FUSIBLE LINKS

Check 40A fusible link **f** and 40A fusible link **I** for ABS actuator and electric unit (control unit). For fusible link layout, refer to [PG-3](#).

OK or NG

- OK >> GO TO 2.
NG >> If fusible link is blown, be sure to eliminate cause of problem before replacing.

2. CHECK ABS ACTUATOR AND ELECTRIC UNIT (CONTROL UNIT) POWER SUPPLY CIRCUITS

1. Disconnect ABS actuator and electric unit (control unit) connector.
2. Check voltage between ABS actuator and electric unit (control unit) connector terminal 1 and ground and terminal 16 and ground.

Does battery voltage exist?

- YES >> GO TO 3.
NO >> Repair harness or connectors between fusible link and ABS actuator and electric unit (control unit).

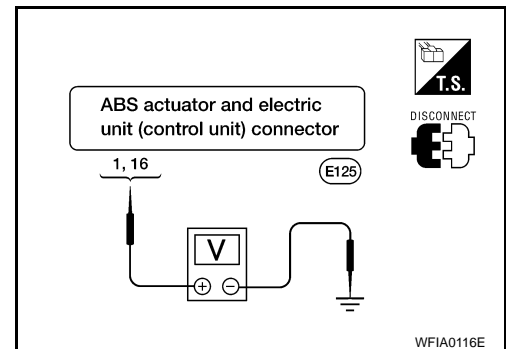

3. CHECK ABS ACTUATOR AND ELECTRIC UNIT (CONTROL UNIT) GROUND CIRCUIT

Check continuity between ABS actuator and electric unit (control unit) connector terminal 31 and ground and terminal 46 and ground.

Does continuity exist?

- YES >> Replace ABS actuator and electric unit (control unit). Refer to [BRC-87, "Removal and Installation"](#).
NO >> Repair harness or connectors between ABS actuator and electric unit (control unit) and ground.

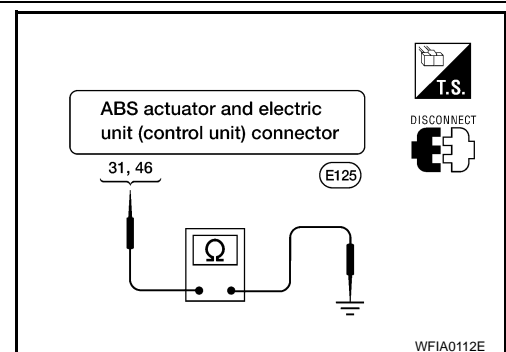

ABS Warning Lamp Stays On When Ignition Switch Is Turned On

INFOID:000000004279025

1. CARRY OUT SELF-DIAGNOSIS

TROUBLE DIAGNOSES FOR SYMPTOMS

[VDC/TCS/ABS]

< SERVICE INFORMATION >

Carry out self-diagnosis. Refer to [BRC-63. "CONSULT-III Function \(ABS\)".](#)

Are malfunctions detected in self-diagnosis?

YES >> Refer to [BRC-63. "CONSULT-III Function \(ABS\)".](#)

NO >> Refer to [DI-23.](#)

Vehicle Jerks During TCS/VDC Activation

INFOID:000000004279026

1. ABS ACTUATOR AND ELECTRIC UNIT (CONTROL UNIT) SELF-DIAGNOSIS

Perform ABS actuator and electric unit (control unit) self-diagnosis.

Are self-diagnosis result items displayed?

YES >> After checking and repairing the applicable item, perform the ABS actuator and electric unit (control unit) self-diagnosis again.

NO >> GO TO 2.

2. ENGINE SPEED SIGNAL INSPECTION

Perform data monitor with CONSULT-III for the ABS actuator and electric unit (control unit).

Is the engine speed at idle 400 rpm or higher?

YES >> GO TO 4.

NO >> GO TO 3.

3. ECM SELF-DIAGNOSIS

Perform ECM self-diagnosis.

Are self-diagnosis result items displayed?

YES >> After checking and repairing the applicable item, perform the ECM self-diagnosis again.

NO >> GO TO 4.

4. TCM SELF-DIAGNOSIS

Perform TCM self-diagnosis.

Are self-diagnosis result items displayed?

YES >> After checking and repairing the applicable item, perform the TCM self-diagnosis again.

NO >> GO TO 5.

5. CONNECTOR INSPECTION

Disconnect the ABS actuator and electric unit (control unit) connector and the ECM connectors and check the terminals for deformation, disconnection, looseness or damage.

OK or NG

OK >> GO TO 6.

NG >> Repair or replace as necessary.

6. CAN COMMUNICATION INSPECTION

Check the CAN communication system. Refer to [LAN-39.](#)

OK or NG

OK >> Inspection End.

NG >> Refer to [LAN-39.](#)

A
B
C
D
E
BRC
G
H
I
J
K
L
M
N
O
P

ON-VEHICLE SERVICE

Adjustment of Steering Angle Sensor Neutral Position

INFOID:000000004279027

After removing/installing or replacing ABS actuator and electric unit (control unit), steering angle sensor, steering and suspension components which affect wheel alignment or after adjusting wheel alignment, be sure to adjust neutral position of steering angle sensor before running vehicle.

NOTE:

Adjustment of steering angle sensor neutral position requires CONSULT-III.

1. Stop vehicle with front wheels in straight-ahead position.
2. Connect CONSULT-III to data link connector on vehicle, and turn ignition switch ON (do not start engine).
3. Touch "ABS", "WORK SUPPORT" and "ST ANGLE SENSOR ADJUSTMENT" on CONSULT-III screen in this order.

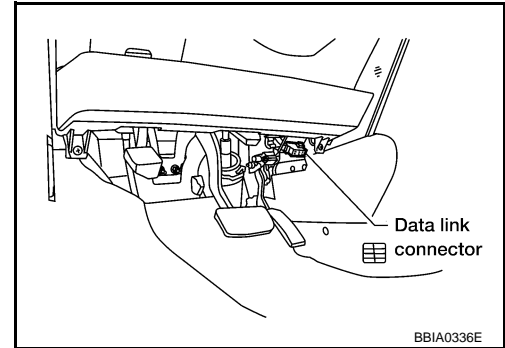

4. Touch "START".

CAUTION:

Do not touch steering wheel while adjusting steering angle sensor.

5. After approximately 10 seconds, touch "END". (After approximately 60 seconds, it ends automatically.)
6. Turn ignition switch OFF, then turn it ON again.
7. Run vehicle with front wheels in straight-ahead position, then stop.
8. Select "DATA MONITOR", "SELECTION FROM MENU", and "STR ANGLE SIG" on CONSULT-III screen. Then check that "STR ANGLE SIG" is within 0 ± 2.5 deg. If value is more than specification, repeat steps 1 to 5.
9. Erase memory of ABS actuator and electric unit (control unit) and ECM.
10. Turn ignition switch to OFF.

WHEEL SENSORS

Removal and Installation

INFOID:000000004688043

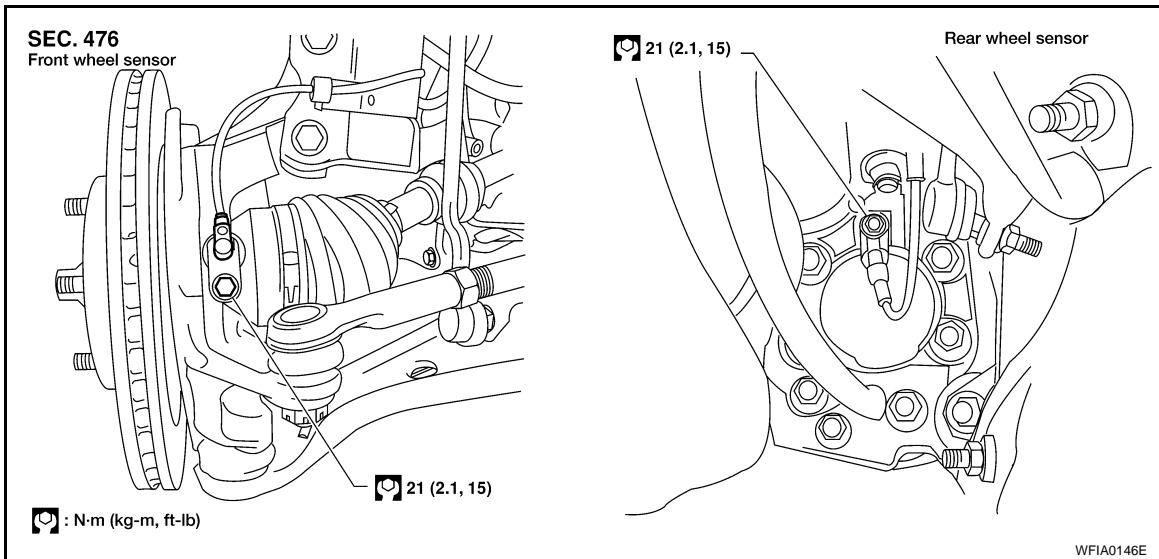

CAUTION:

- Be careful not to damage the sensor edge and sensor rotor teeth.
- When removing the front or rear wheel hub assembly, first remove the wheel sensor from the assembly. Failure to do so may result in damage to the sensor wires, making the sensor inoperative.
- Pull out the sensor, be careful to turn it as little as possible. Do not pull on the sensor harness.
- Installation should be performed while paying attention to the following, and then tighten the wheel sensor bolt to the specified torque.
- Before installing the wheel sensor, make sure there are no foreign materials (such as iron fragments) adhered to the pick-up part of the wheel sensor, to the inside of the wheel sensor mounting hole or on the rotor mounting surface.

FRONT WHEEL SENSOR

Removal

1. Remove the front wheel and tire. Refer to [WT-6, "Conventional Tire and Wheel"](#).
2. Partially remove the front wheel fender protector. Refer to [EI-21, "Removal and Installation"](#).
3. Remove the wheel sensor bolt and wheel sensor.
4. Remove the harness wire from mounts and disconnect the wheel sensor harness connector.

Installation

Installation is in the reverse order of removal.

REAR WHEEL SENSOR

Removal

1. Remove the wheel sensor bolt and wheel sensor from the rear wheel hub and bearing assemblies.
2. Remove the harness wire from mounts and harness wire clips from the rear suspension member.
3. Disconnect the wheel sensor harness connector.

Installation

Installation is in the reverse order of removal.

A
B
C
D
E
G
H
I
J
K
L
M
N
O
P

BRC

SENSOR ROTOR

Removal and Installation

INFOID:000000004688044

The front wheel sensor rotor is built into the front wheel hub. For removal and installation procedure, refer to [RAX-6, "Removal and Installation"](#).

The rear wheel sensor rotor is built into the rear wheel hub. For removal and installation procedure, refer to [RAX-6, "Removal and Installation"](#).

ACTUATOR AND ELECTRIC UNIT (ASSEMBLY)

< SERVICE INFORMATION >

[VDC/TCS/ABS]

ACTUATOR AND ELECTRIC UNIT (ASSEMBLY)

Removal and Installation

INFOID:000000004688045

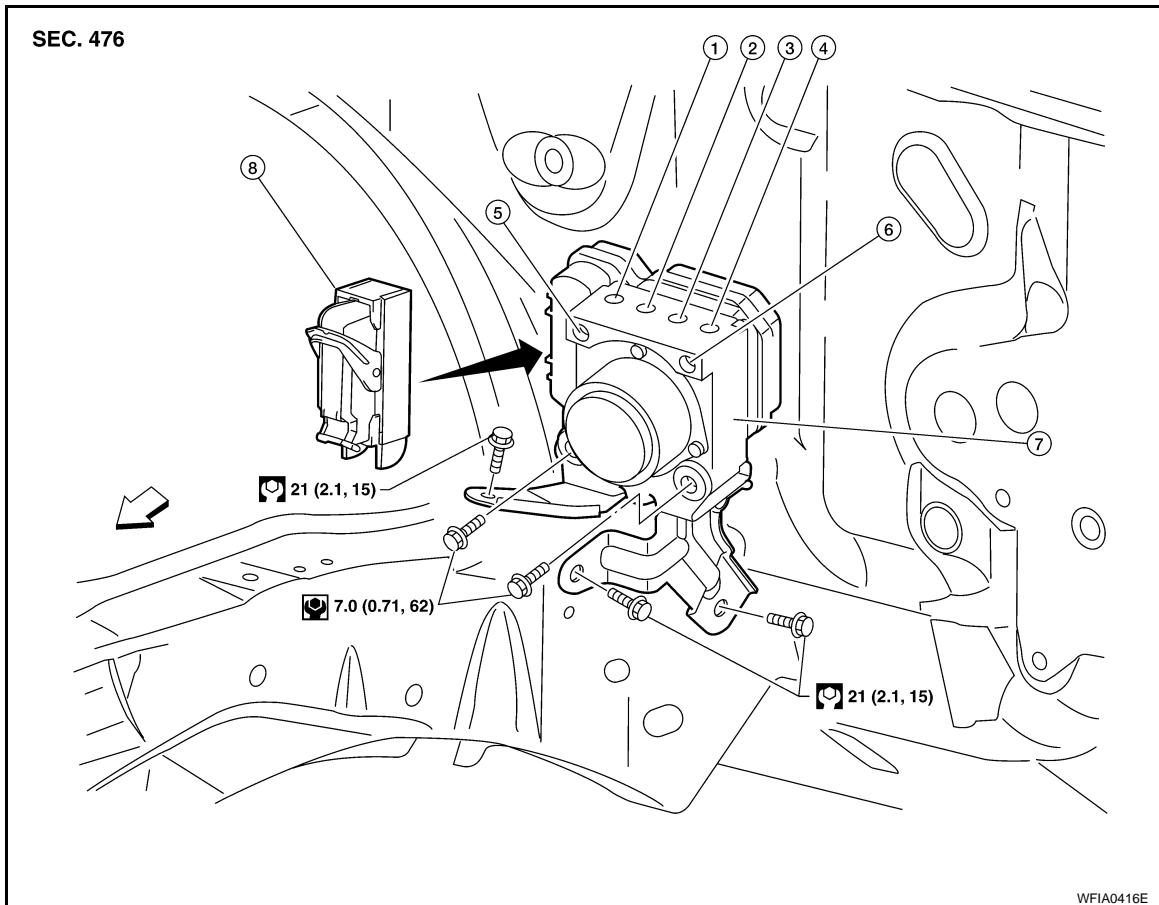

- | | | |
|--|--|--------------------------------------|
| 1. To front left caliper | 2. To rear right caliper | 3. To rear left caliper |
| 4. To front right caliper | 5. From master cylinder secondary side | 6. From master cylinder primary side |
| 7. ABS actuator and electric unit (control unit) | 8. Actuator harness connector | ⇐ Front |

REMOVAL

1. Disconnect the battery negative terminal.
2. Remove the cowl top extension. Refer to [EI-18. "Removal and Installation"](#).
3. Drain the brake fluid. Refer to [BR-10. "Changing Brake Fluid"](#).
4. Disconnect the actuator harness from the ABS actuator and electric unit (control unit).
5. Disconnect the brake tubes.

CAUTION:

- To remove the brake tubes, use a flare nut wrench to prevent the flare nuts and brake tubes from being damaged.
- Be careful not to splash brake fluid on painted areas.

6. Remove the ABS actuator and electric unit (control unit) and bracket bolts and remove the ABS actuator and electric unit (control unit) with the bracket.

INSTALLATION

Installation is in the reverse order of removal.

- Refer to [BR-11. "Hydraulic Circuit"](#) for torque specifications when connecting the brake tubes.
- After installation of the ABS actuator and electric unit (control unit), refill the brake system with new brake fluid. Then bleed the air from the brake hydraulic system. Refer to [BR-10. "Bleeding Brake System"](#).

CAUTION:

ACTUATOR AND ELECTRIC UNIT (ASSEMBLY)

< SERVICE INFORMATION >

[VDC/TCS/ABS]

- To install the brake tubes, use a flare nut wrench (commercial service tool).
- Always tighten the brake tubes to the specified torque when installing.
- Never reuse drained brake fluid.

STEERING ANGLE SENSOR

Removal and Installation

INFOID:000000004279031

REMOVAL

1. Remove the spiral cable. Refer to [SRS-36, "Removal and Installation"](#).
2. Remove the screws (A) and release clips (B) to remove the steering angle sensor (1) from spiral cable (2).

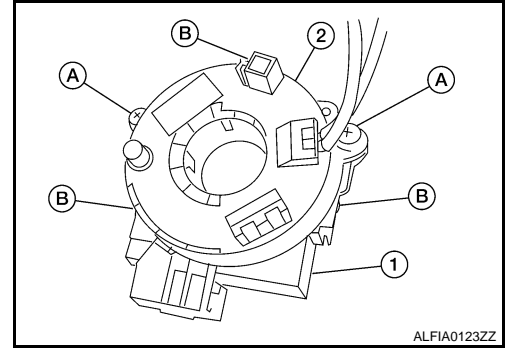

INSTALLATION

Installation is in the reverse order of removal.

CAUTION:

In the case that the ABS actuator and electronic unit (control unit) is replaced, make sure to adjust position of steering angle sensor. Refer to [BRC-84, "Adjustment of Steering Angle Sensor Neutral Position"](#).

A
B
C
D
E
BRC
G
H
I
J
K
L
M
N
O
P

G SENSOR

Removal and Installation

INFOID:000000004279032

REMOVAL

1. Remove center console lower cover. Refer to [IP-10, "Instrument Panel"](#).
2. Remove yaw rate/side/decel G sensor nuts.

CAUTION:

- Do not use power tools to remove the yaw rate/side/decel G sensor.
 - Do not drop or strike the yaw rate/side/decel G sensor.
3. Disconnect harness connector and remove the yaw rate/side/decel G sensor.

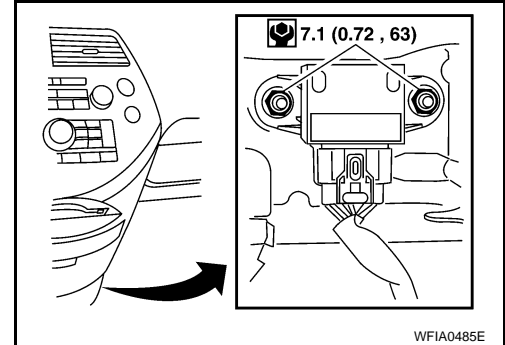

INSTALLATION

Installation is in the reverse order of removal.

- Tighten yaw rate/side/decel G sensor nuts to specification.

CAUTION:

- Do not use power tools to install the yaw rate/side/decel G sensor.
- Do not drop or strike the yaw rate/side/decel G sensor.